

AD-A054 703

ARINC RESEARCH CORP ANNAPOLIS MD  
SHF TERMINAL/ANTENNA STUDY. TASKS 7 AND 8. (U)  
APR 78 J H WITT, S H KOWALSKI  
1338-01-2-1736

F/G 17/2.1

UNCLASSIFIED

F04701-77-C-0152  
NL

| OF |  
AD  
A054703

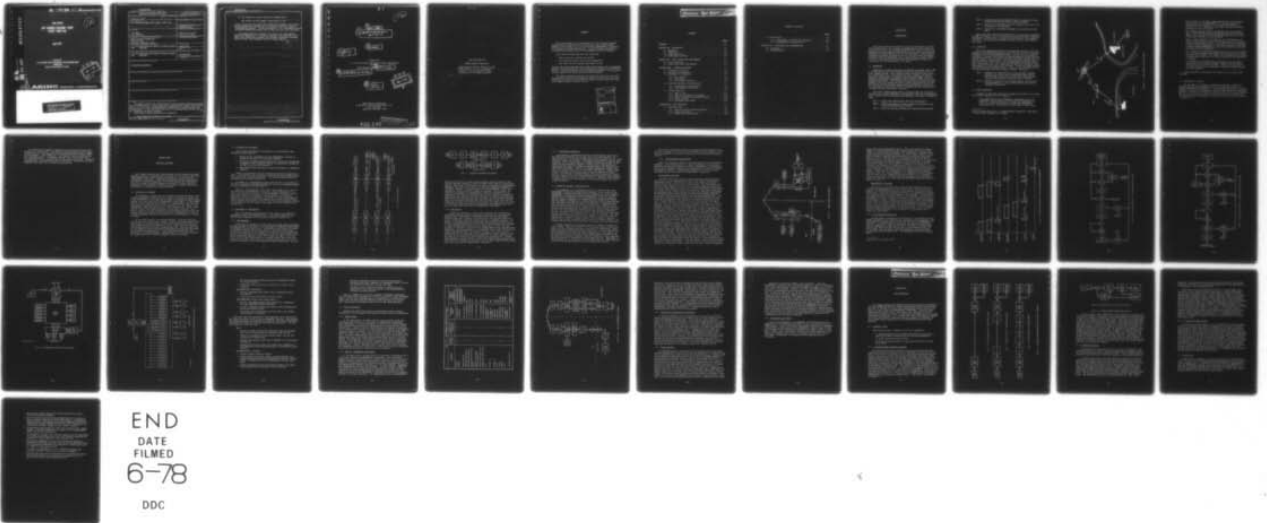

END  
DATE  
FILMED  
6-78  
DDC

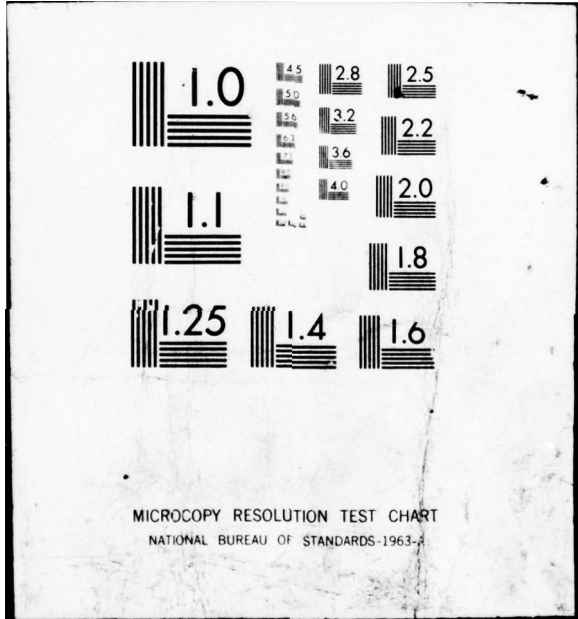

FOR FURTHER TRAN

Publication 1338-01-2-1736

AD A 054703

12

FINAL REPORT  
SHF TERMINAL/ANTENNA STUDY  
TASKS 7 AND 8 (U)

April 1978

AD No. \_\_\_\_\_  
DDC FILE COPY

Prepared for  
U.S. AIR FORCE SPACE AND MISSILE SYSTEMS ORGANIZATION  
SAMSO/SKX  
under Contract F04701-77-C-0152

DDC  
APPROVED  
JUN 6 1978  
RECEIVED  
F

**ARINC** RESEARCH CORPORATION

This document has been approved  
for public release and sale; its  
distribution is unlimited.

UNCLASSIFIED

UNCLASSIFIED

SECURITY CLASSIFICATION OF THIS PAGE (When Data Entered)

REPORT DOCUMENTATION PAGE		READ INSTRUCTIONS BEFORE COMPLETING FORM
1. REPORT NUMBER 1338-01-2-1736	2. GOVT ACCESSION NO.	3. RECIPIENT'S CATALOG NUMBER
4. TITLE (and Subtitle) SHF TERMINAL/ANTENNA STUDY TASKS 7 AND 8 (U)		5. TYPE OF REPORT & PERIOD COVERED
7. AUTHOR(s) J.H. Witt S.H. Kowalski		6. PERFORMING ORG. REPORT NUMBER 1338-01-2-1736
9. PERFORMING ORGANIZATION NAME AND ADDRESS ARINC Research Corporation 2551 Riva Road Annapolis, Maryland 21401		8. CONTRACT OR GRANT NUMBER(s) F04701-77-C-0152
11. CONTROLLING OFFICE NAME AND ADDRESS U.S. AIR FORCE SPACE AND MISSILE SYSTEMS ORGANIZATION SAMSO/SKX		10. PROGRAM ELEMENT, PROJECT, TASK AREA & WORK UNIT NUMBERS
14. MONITORING AGENCY NAME & ADDRESS (if different from Controlling Office) U.S. AIR FORCE SPACE AND MISSILE SYSTEMS ORGANIZATION SAMSO/SKX		12. REPORT DATE April 1978
		13. NUMBER OF PAGES 22
		15. SECURITY CLASS. (of this report) UNCLASSIFIED
		15a. DECLASSIFICATION/DOWNGRADING SCHEDULE
16. DISTRIBUTION STATEMENT (of this Report)  UNCLASSIFIED/UNLIMITED		
17. DISTRIBUTION STATEMENT (of the abstract entered in Block 20, if different from Report)		
18. SUPPLEMENTARY NOTES		
19. KEY WORDS (Continue on reverse side if necessary and identify by block number)		
20. ABSTRACT (Continue on reverse side if necessary and identify by block number)  This report defines the characteristics of the interface equipment necessary for the ABCC aircraft to relay secure voice communications between tactical elements in a crisis scene and AUTOSEVOCOM I subscribers via satellite using SHF transmissions. It also describes objectives to be demonstrated through tests of the recommended interface equipment.  Three general design questions were considered;  * Where should the interface be located?		

UNCLASSIFIED

How should the control function be accomplished?

How should the multichannel requirements be met?

Several alternative approaches were defined and assessed, and a recommended approach was selected and the associated interface equipment characteristics defined. Possible extensions of the recommended approach to provide capabilities beyond those of SHF relay were also considered.

The report specifies laboratory and flight test objectives to verify and demonstrate the interface equipment operational SHF crisis scene relay capabilities, presents the principal conclusions resulting from the study, and recommends specific further actions.

April 1978  
SS

U.S. AIR FORCE SPACE AND MISSILE SYSTEMS ORGANIZATION  
RAMSO/SKY

UNCLASSIFIED

U.S. AIR FORCE SPACE AND MISSILE SYSTEMS ORGANIZATION  
RAMSO/SKY

UNCLASSIFIED/UNLIMITED

This report defines the characteristics of the interface equipment necessary for the ABCC aircraft to relay secure voice communications between tactical elements in a crisis scene and AUTORESCOM I subscribers via satellite using SHF transmissions. It also describes objectives to be demonstrated through tests of the recommended interface equipment. Three general design questions were considered:

Where should the interface be located?

UNCLASSIFIED

UNCLASSIFIED

12

9  
FINAL REPORT  
6 SHF TERMINAL/ANTENNA STUDY  
TASKS 7 AND 8

11  
Apr 1978

12/42p

Prepared for  
U.S. Air Force Space and Missile Systems Organization  
SAM/S&M  
under Contract Number F04701-77-C-0152

14  
1338-01-2-1736

10  
by  
J.H./Witt  
S.H./Kowalski

DDC  
RECEIVED  
JUN 6 1978  
F

ARINC Research Corporation  
a Subsidiary of Aeronautical Radio, Inc.  
2551 Riva Road  
Annapolis, Maryland 21401

This document has been approved  
for public release and sale; its  
distribution is unlimited.

400 247

slt

77  
Copyright © 1978

ARINC Research Corporation

Prepared under Contract F04701-77-C-0152  
which grants to the U.S. Government a  
license to use any material in this  
publication for Government purposes.

ABSTRACT

This report defines the characteristics of the interface equipment necessary for the ABCC aircraft to relay secure voice communications between tactical elements in a crisis scene and AUTOSEVOCOM I subscribers via satellite using SHF transmissions. It also describes objectives to be demonstrated through tests of the recommended interface equipment.

Three general design questions were considered:

- Where should the interface be located?
- How should the control function be accomplished?
- How should the multichannel requirements be met?

Several alternative approaches were defined and assessed, and a recommended approach was selected and the associated interface equipment characteristics defined. Possible extensions of the recommended approach to provide capabilities beyond those of SHF relay were also considered.

The report specifies laboratory and flight test objectives to verify and demonstrate the interface equipment operational SHF crisis scene relay capabilities, presents the principal conclusions resulting from the study, and recommends specific further actions.

ACCESSION for	
NTIS	White Section <input checked="" type="checkbox"/>
DDC	Buff Section <input type="checkbox"/>
UNANNOUNCED	<input type="checkbox"/>
JUSTIFICATION _____	
BY _____	
DISTRIBUTION/AVAILABILITY CODES	
Dist.	AVAIL. and/or SPECIAL
A	

NOT  
Preceding Page BLANK - FILMED

CONTENTS

	<u>Page</u>
ABSTRACT . . . . .	iii
CHAPTER ONE: INTRODUCTION . . . . .	1-1
1.1 Background . . . . .	1-1
1.2 Objectives . . . . .	1-2
1.3 Study Constraints . . . . .	1-2
1.4 Organization of Report . . . . .	1-4
CHAPTER TWO: STUDY APPROACH AND REQUIREMENTS . . . . .	2-1
2.1 General Approach . . . . .	2-1
2.2 Secure Voice Relay Requirements . . . . .	2-1
CHAPTER THREE: INTERFACE EQUIPMENT . . . . .	3-1
3.1 Discussion of Problem . . . . .	3-1
3.2 Alternatives Considered . . . . .	3-2
3.3 Assessment of Alternatives . . . . .	3-2
3.3.1 KY-3 Location . . . . .	3-2
3.3.2 PTT Control . . . . .	3-4
3.3.3 Multichannel Operation . . . . .	3-5
3.4 Interface Equipment Characterization . . . . .	3-5
3.4.1 Single-Channel Configuration . . . . .	3-6
3.4.2 Multichannel Configuration . . . . .	3-8
3.5 Concept Extensions . . . . .	3-17
3.5.1 ABCC as User . . . . .	3-17
3.5.2 ABCC as a Conference Participant . . . . .	3-17
3.5.3 Secure Voice Monitoring and Recording . . . . .	3-20
3.5.4 Status Advisory . . . . .	3-20
3.5.5 Non-Secure Voice Relay . . . . .	3-21
CHAPTER FOUR: TEST OBJECTIVES . . . . .	4-1
4.1 Laboratory Tests . . . . .	4-1
4.1.1 Confirm Syllabic Detector Operation . . . . .	4-1
4.1.2 Timing and Control . . . . .	4-3
4.1.3 Secure Voice Device Delays . . . . .	4-4

CONTENTS (continued)

	<u>Page</u>
4.2 Flight Tests . . . . .	4-4
4.2.1 Verification of Operational Capability . . . . .	4-5
4.2.2 AUTOSEVOCOM I Interoperability . . . . .	4-5
CHAPTER FIVE: CONCLUSIONS AND RECOMMENDATIONS . . . . .	5-1
5.1 Conclusions . . . . .	5-1
5.2 Recommendations . . . . .	5-1

## CHAPTER ONE

### INTRODUCTION

This report presents the results of a brief investigation to define the characteristics of the interface equipment required for an ABCC aircraft to relay secure voice communications between a crisis scene and the AUTOSEVOCOM network using SHF transmissions and delineates the associated laboratory and flight demonstration and test objectives. ARINC Research Corporation performed the study for the U.S. Air Force Space and Missile Systems Organization (SAMSO/SKX) under a modification to contract F04701-77-C-0152. This chapter discusses the project background, objectives, constraints, and the organization of the report.

#### 1.1 BACKGROUND

SAMSO/SKX is currently developing an Advanced Development Model (ADM) of an SHF terminal and antenna system suitable for installation on Air Force command aircraft. This program is being conducted in three phases. The initial effort will be to develop and test a terminal and antenna system for dissemination of emergency action messages (EAMs) using the AFSATCOM single-channel transponders (SCTs) carried on DSCS-III and other designated satellites. The second phase, which has been termed "the ABCC Upgrade", will be to develop and test a terminal and antenna system that will satisfy the SHF satellite communications requirements of the ABCC. The final phase of the program will be to develop and test advanced antennas employing micro-strip array technology.

The previous ARINC Research effort, conducted under the cited basic contract, was to assist SAMSO/SKX in establishing goals for the ADM program and to conduct supporting analyses and trade-offs. The effort included six tasks:

- Task 1 - Compile SHF Communications Technical Requirements
- Task 2 - Compile Descriptions of Major Components Suitable for Use in an SHF Terminal/Antenna System
- Task 3 - Define and Develop Candidate SHF Terminal/Antenna Systems

- Task 4 - Perform Analyses and Trade-Off Studies to Identify the Most Promising SHF Terminal/Antenna System Candidates
- Task 5 - Identify Key Technology Issues and Opportunities which Could be Pursued in the ADM Effort
- Task 6 - Develop Cost and Schedule Estimates for Achieving the ADM Goals

These tasks were completed and documented in a Final Report submitted to SAMSO in December, 1977.\* The contract was then modified to incorporate two additional tasks intended to support the ADM Phase II, ABCC Upgrade, activities. The results and findings for these two tasks are provided in this report.

## 1.2 OBJECTIVES

One of the designated functions of the ABCC SHF terminal is the relay of secure voice communications between ground forces in a crisis area and subscribers within the AUTOSEVOCOM network. For such relay, as depicted in Figure 1-1, secure voice traffic is passed between the crisis scene and the ABCC over HF, VHF, or UHF links and over SHF between the ABCC and earth station through a DSCS satellite. The crisis scene user operates with a push-to-talk (PTT) simplex link while the AUTOSEVOCOM subscriber operates with a full duplex link. This simplex/duplex mismatch will require interface equipment on the ground, in the aircraft, or both to properly maintain and control the flow of communications. Hence, the specific tasks of this study were directed toward this interface problem. They were:

- Task 7 - Determine the characteristics of the interface equipment located at the crisis scene, AUTOSEVOCOM entry, and on-board the ABCC necessary for secure voice communications using the SHF terminal on-board the ABCC as a relay.
- Task 8 - Detail the objectives for the demonstration and testing of the ADM terminal as a relay element between tactical and AUTOSEVOCOM subscribers.

## 1.3 STUDY CONSTRAINTS

A number of constraints affected the conduct and content of the study. The following summarize the most important:

- Only communications with AUTOSEVOCOM I subscribers were to be considered. This constraint had two important ramifications. First, it excluded consideration of other non-AUTOSEVOCOM subscribers (i.e., other point-to-point secure or clear voice,

---

\*SHF Terminal/Antenna Study (U), ARINC Research Corporation, Publication 1338-01-1-1680, December 1977 (SECRET).

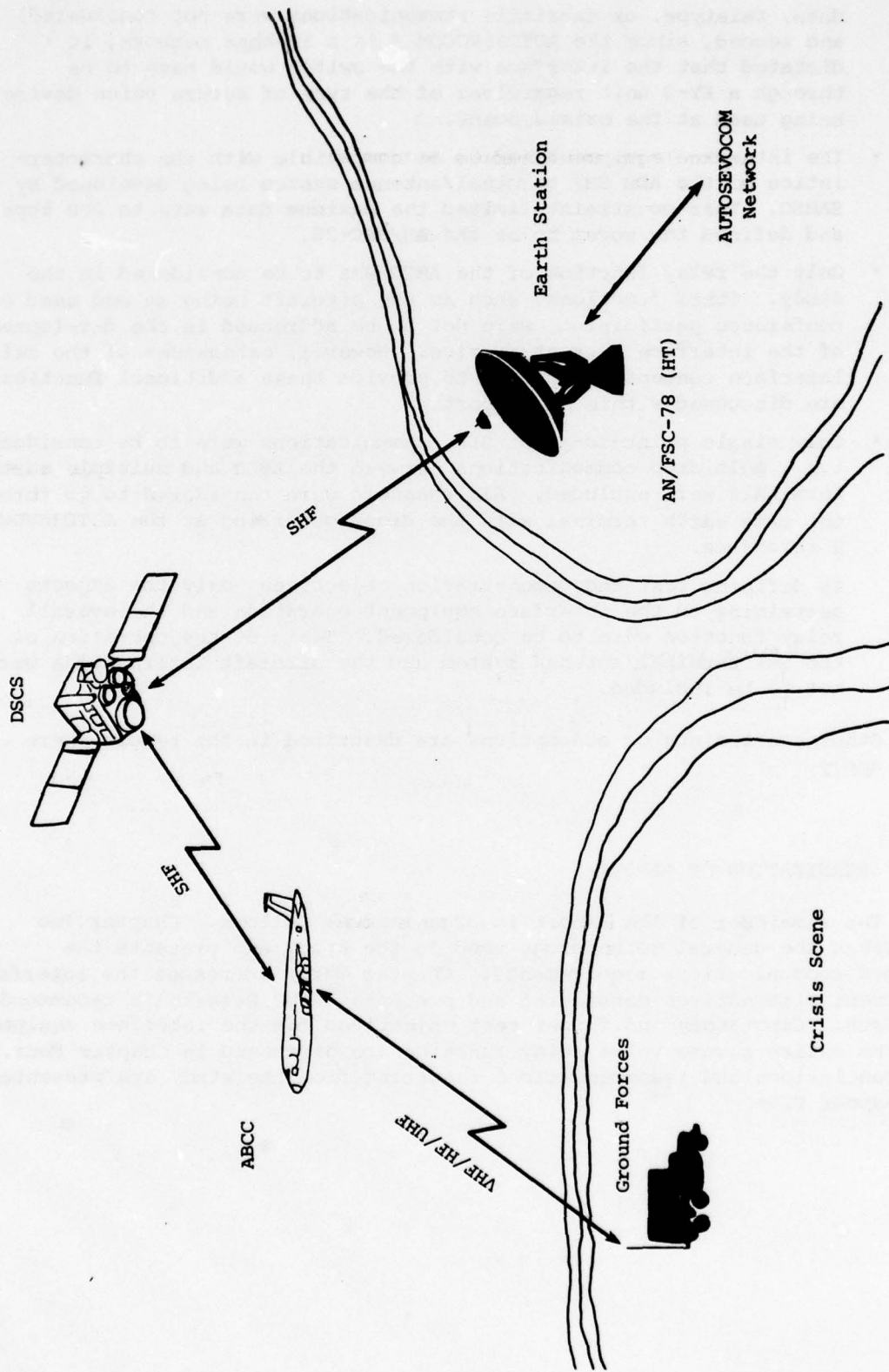

Figure 1-1. ABCC SECURE VOICE SHF RELAY

data, teletype, or facsimile communications were not considered) and second, since the AUTOSEVOCOM I is a 50-kbps network, it dictated that the interface with the switch would have to be through a KY-3 unit regardless of the type of secure voice device being used at the crisis scene.

- The interface equipment had to be compatible with the characteristics of the ADM SHF terminal/antenna system being developed by SAMSO. This constraint limited the maximum data rate to 200 kbps and defined the modem to be the AN/USC-28.
- Only the relay function of the ABCC was to be considered in the study. Other functions, such as the aircraft being an end user or conference participant, were not to be addressed in the development of the interface characteristics. However, extensions of the relay interface concepts developed to provide these additional functions are discussed within the report.
- Only single point-to-point SHF communications were to be considered; i.e., multidrop communications between the ABCC and multiple earth terminals were excluded. All channels were considered to go through the same earth terminal with the drops occurring at the AUTOSEVOCOM I interface.
- In defining test and demonstration objectives, only the aspects pertaining to the interface equipment operation and the overall relay function were to be considered. Tests of the operation of the SHF terminal/antenna system and the aircraft interactions were not to be included.

Other constraints or assumptions are described in the report where they apply.

#### 1.4 ORGANIZATION OF REPORT

The remainder of the report is organized as follows. Chapter Two describes the general methodology used in the study and presents the defined communications requirements. Chapter Three addresses the interface equipment alternatives considered and presents ARINC Research's recommended approach. Laboratory and flight test objectives for the interface equipment and the entire secure voice relay function are discussed in Chapter Four. The conclusions and recommendations resulting from the study are presented in Chapter Five.

## CHAPTER TWO

### STUDY APPROACH AND REQUIREMENTS

This chapter provides an overview of the approach employed in the study and presents the technical requirements for relaying communications between tactical elements and AUTOSEVOCOM I subscribers. These requirements provide the basis for the subsequent definition of interface equipment characteristics.

#### 2.1 GENERAL APPROACH

The overall project methodology, as shown in Figure 2-1, consisted of several serial steps. The first was to establish the communications requirements for the ABCC SHF relay function and to define the goals and constraints for the interface equipments. This information was obtained primarily from ESD/WW and MITRE. Several alternatives to satisfying the stated requirements were then developed. These alternatives were evaluated vis-a-vis the defined goals and constraints and a preferred one was selected. A means for implementing the selected approach on a single-channel basis was developed and reviewed with cognizant ESD/WW, DCA, and NSA personnel. The resulting single-channel characterization was expanded to the multichannel capability specified by the communications requirements. ARINC Research then formulated laboratory and flight demonstration and test objectives on the basis of the resultant multichannel characterization. Finally, the company prepared and presented a briefing of the study results.

#### 2.2 SECURE VOICE RELAY REQUIREMENTS

The ABCC SHF secure voice relay will forward from one to four channels of secure voice communications between subscribers located in a crisis area and subscribers within AUTOSEVOCOM I, e.g., the National Military Command Center. This relay will use the lighter weight airborne SHF terminal being developed by SAMSO, the DSCS satellites, and an earth terminal such as the AN/FSC-78. The SHF terminal is being designed to perform at a maximum data rate of 200 kbps. The system must operate with a variety of different secure voice devices with data rates ranging from 2.4 to 32 kbps and have an interface with the 50-kbps KY-3 for AUTOSEVOCOM I entry. The several channels can operate with voice devices that are all identical, all

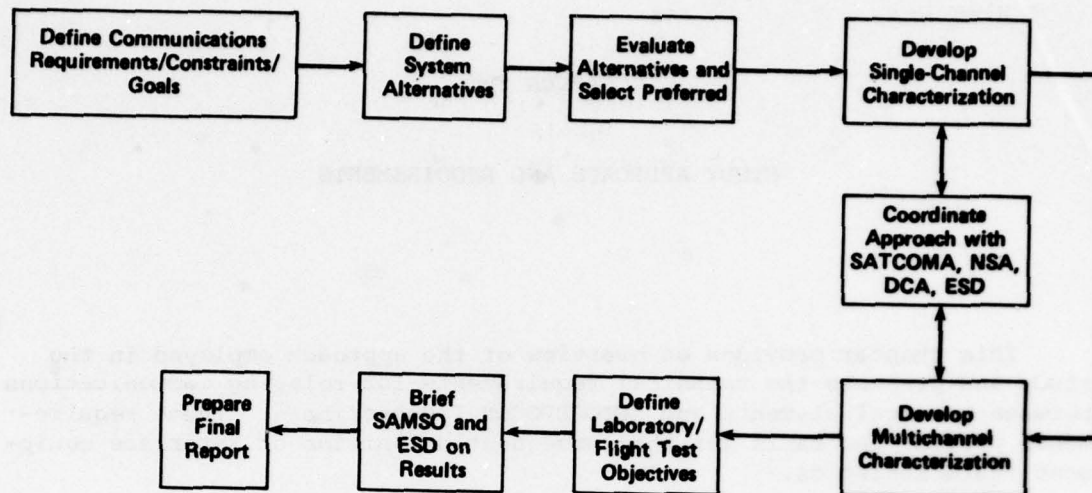

Figure 2-1. METHODOLOGY

different, or in any combination. Secure voice devices (and their transmission rates) that may be employed at the crisis scene are:

- HY-2 (Channel Vocoder) - 2.4 kbps
- KY-8, 28 (NESTOR) - 18.75 kbps
- KY-57, 58 (VINSON) - 16 kbps
- KY-75 (PARKHILL) - Analog
- KG-68 (CVSD) - 16 and 32 kbps

Tests have shown that the KY-3 is acceptable when operated in tandem with all of these devices except the HY-2 vocoders, which are marginal themselves. They show further that the CVSD-32 is acceptable when operated in tandem with the PARKHILL, thereby enabling A/D and D/A conversion to be accomplished for the SHF link.\*

\*J.K. Webb, *Drafts for Crisis Relay/ABCC, 17 June Revision (U)*, MITRE Corporation, D-52-M571, 17 June 1977 (SECRET).

The modem that is assumed to operate with the airborne and earth SHF terminals is the AN/USC-28. This modem is a spread spectrum device capable of handling up to five channels with a maximum output data rate per channel of five megabits. (This capability is in excess of what is needed for the SHF relay application.) In addition, the unit has a 75-baud link order wire capability which is interleaved with the output data stream. Continuous synchronization is maintained by having a master unit (located at the earth terminal) and a slave unit (located in the aircraft).

## CHAPTER THREE

### INTERFACE EQUIPMENT

This chapter addresses the characteristics of the necessary interface equipment located on the ground and in the ABCC for the relay of SHF secure voice communications between tactical elements at a crisis scene and AUTOSEVOCOM I subscribers. ARINC Research developed several alternatives and selected a preferred approach to the identification and characterization of the needed interface equipment on the basis of their functions. Extensions of the approach to enable the aircraft to become a user and to participate in conferencing are also discussed.

#### 3.1 DISCUSSION OF PROBLEM

The fundamental problem that will determine the characteristics of the interface equipment is where and how to control the keying of the HF, VHF, or UHF transmitters on the ABCC when the ABCC is relaying SHF communications between the crisis scene and the AUTOSEVOCOM I subscribers. It was assumed that the crisis scene user will operate in a simplex mode with a PTT capability with direct keying control over his end of the link. However, the AUTOSEVOCOM I subscriber does not have a PTT capability and, hence, cannot directly control the simplex operation from his end of the link. As a result, keying of the ABCC transmitter for the simplex portion of the link must be sensed and controlled either manually or automatically by means of interface equipment located on the ABCC, at the earth terminal, or in both locations.

If the keying function is performed manually, an operator would be required for each channel being relayed. Further, since the operator would have to monitor the conversation to perform the keying function and since these communications can be expected to be at a high level and sensitive, the operator would have to have an appropriate rank. Using an officer for such an operation would be generally undesirable from both cost and personnel utilization considerations. A final consideration affecting the definition of interface equipment characteristics is the need to minimize the weight and size of interface equipment carried by the ABCC.

### 3.2 ALTERNATIVES CONSIDERED

The interface alternatives considered in the investigation were defined by three questions:

1. Should the KY-3 interfaces with the AUTOSEVOCOM I network be located on the ABCC or at the earth terminal?
2. Should the transmitter keying function be controlled automatically or manually, and if manually, should the operators be located on the ABCC or at the earth terminal?
3. Should multichannel operation use TDM multiplexing or independent channels?

Figure 3-1 illustrates the four alternative solutions to Questions 1 and 2. Alternatives A and B represent configurations for automatic keying and C and D those for manual operation. The two multichannel operation possibilities are shown in Figure 3-2.

In Figure 3-1, configurations A and C have the KY-3 in the ABCC and the PTT is controlled on-board automatically (A) or by an operator monitoring and controlling in the red area (C).

Similarly, Configurations B and D solve the problem of KY-3 and the PTT control at the AUTOSEVOCOM I interface. Other combinations (e.g., KY-3 on the aircraft and control at the AUTOSEVOCOM I interface) are not shown since they do not represent feasible alternatives (unless an additional red area is introduced). In Figure 3-2, the four channels of secure voice are time division multiplexed into a single digital stream into the modem (Configuration A) or they are entered into separate channels of the modem and then use common final stages in the SHF terminal (Configuration B).

### 3.3 ASSESSMENT OF ALTERNATIVES

The six alternatives were assessed in the light of the identified constraints, goals, and characteristics. This section describes the deliberations regarding the three questions posed in Section 3.2.

#### 3.3.1 KY-3 Location

If the KY-3 is located on the ABCC, four such units would be required for each aircraft in the fleet. This would mean an additional 1000 pounds of equipment for just these units. In addition, since there are at least six different types of secure voice devices, twenty-four secure voice devices would also have to be carried on each aircraft plus an additional four A/D-D/A converters for the PARKHILLS. Further, such operation would demand the maximum capability of the SHF terminal (200 kbps). With the KY-3 located at the ground terminal, the required data rates would vary from 9.6 to 128 kbps, well within the terminal's capability, with the attendant improvement in error performance and jamming resistance. Finally,

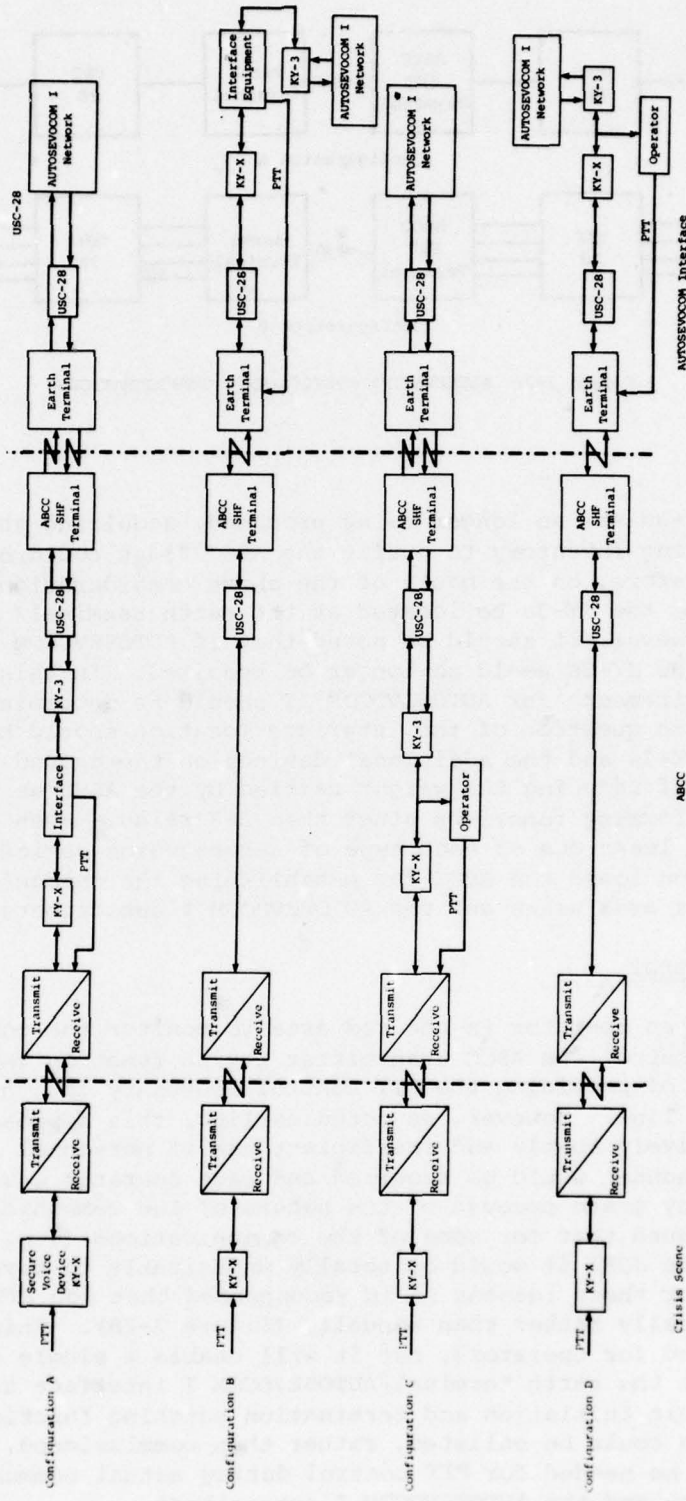

Figure J-1. ALTERNATIVE INTERFACE CONFIGURATIONS

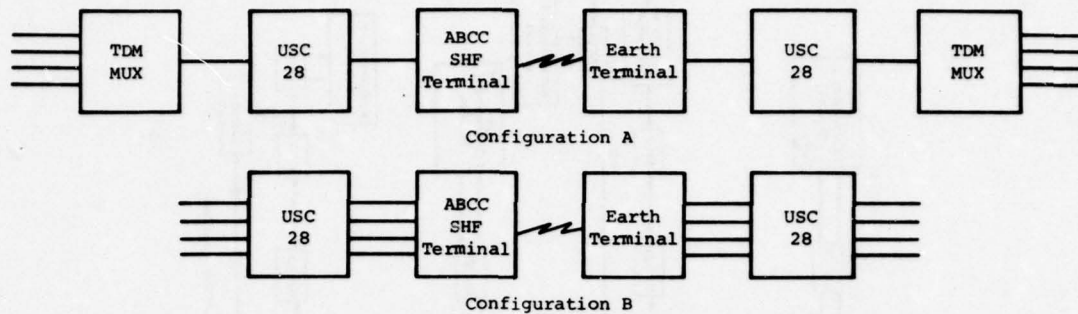

Figure 3-2. ALTERNATIVE MULTICHANNEL CONFIGURATIONS

because the KY-3s are no longer being produced, acquiring enough of them from the existing inventory to outfit the ABCC fleet could be a significant problem. Therefore, on the basis of the above considerations, ARINC Research recommends that the KY-3s be located at the earth terminal/ AUTOSEVOCOM I interface. However, it should be noted that if AUTOSEVOCOM II were to be implemented, the KY-3s would no longer be required. In this event, the interface requirements for AUTOSEVOCOM II should be determined and, if appropriate, the question of the interface location should be re-examined. Locating the KY-3s and the additional devices on the ground would have the added benefit of reducing the weight carried by the ABCC as extra equipment when it is performing functions other than SHF relay. Even with this configuration, at least one of each type of secure voice device will still have to be carried on board the ABCC for establishing the communications links with the crisis area users and the AUTOSEVOCOM I subscribers.

### 3.3.2 PTT Control

Including an operator in the red area to monitor the conversations and manually control the ABCC transmitter keying function represents the simplest means of providing the PTT control necessary for the simplex portion of the link. However, as noted earlier, this approach would represent a relatively costly and inefficient use of personnel resources. An operator per channel would be required and each operator would have to be at least company grade because of the nature of the communications involved. It could be argued that for some of the communications (e.g., from the president or the JCS) it would be totally undesirable to have any monitoring capability. For these reasons it is recommended that the PTT control be provided automatically rather than manually (Figure 3-2B). This will not obviate the need for operators, but it will enable a single operator on the ABCC and one at the earth terminal/AUTOSEVOCOM I interface to provide the necessary circuit initiation and termination patching functions. Further, these operators could be enlisted, rather than commissioned, personnel since they would not be needed for PTT control during actual communications between the crisis scene and the AUTOSEVOCOM I subscribers.

### 3.3.3 Multichannel Operation

A key factor in establishing the means of multichannel operation is the method of termination for the SHF link at the earth terminal. As mentioned earlier, it has been assumed that all four channels will be routed through the same earth terminal. If channel drops existed to several earth terminals, use of a TDM system could become very difficult because of the timing and synchronization problems. However, with a TDM approach the single point-to-point link timing and synchronization will already be established by the modems. Further, if multiple independent channels were used, the channels would have to share power; TDM would not require power sharing and would provide a better error rate and jamming resistance. Finally, with TDM only a single multiplex unit would be required, whereas multiple channels would need three additional USC-28 modem channel drawers and three additional sets of up/down converters. Therefore, ARINC Research recommends time division multiplexing as the preferred approach to multichannel operations.

### 3.4 INTERFACE EQUIPMENT CHARACTERIZATION

As recommended in the preceding section, the system for SHF relay multichannel secure voice communications between a crisis scene and the AUTOSEVOCOM I network should have the KY-3 located at the earth terminal/AUTOSEVOCOM I interface and provide automated PTT control of the ABCC's simplex circuit transmitters and TDM multiplexing of the four channels. Several different approaches to accomplishing the automated PTT control were considered, including voice activated devices, use of start/stop data from the secure voice devices, and the incorporation of additional data bits generated by the PTT control at the crisis scene. Because of the diversity of characteristics and capabilities of the various secure voice devices being considered and the synchronization delays already incurred by them, the use of additional PTT data bits was rejected. Similarly, the use of a simple voice activated device (VOX) was discarded since these devices respond only to the presence of a signal (or a noise). With the comparatively low signal-to-noise ratios expected, a VOX would cause the transmitter to "chatter" through frequent noise activation. However, another type of voice activated device, known as a syllabic detector, has response characteristics that would make it suitable for this application.

Syllabic detectors are activated only by the frequency variation of vowel sounds. They do not respond to either noise inputs or single tone inputs and their response times are in the order of milliseconds. These devices have been produced by several vendors (e.g., Collins and Data Products Corporation), and have had similar applications. For example, one such application was to provide a voice-operated squelch control for the HF links with the Apollo astronauts where the inherent HF noise background would preclude use of conventional voice-operated devices. Employment of syllabic detectors in conjunction with the link order wire (LOW) capability of the USC-28 provides the basis for the automated PTT function.

The next two subsections present the resultant characterization of the interface equipment; first for the single-channel case as a means to illustrate the operation of the devices and then for the required multichannel situation.

#### 3.4.1 Single-Channel Configuration

Figure 3-3 presents a diagram of the configuration for single-channel operation. (This configuration is a simple illustration of the circuit operations and does not represent an actual configuration to be employed.) The following paragraphs describe the operation of the circuit for the two situations of interest: communications originated at the crisis scene, and communications originated by an AUTOSEVOCOM I subscriber.

##### Crisis Scene Initiated

The crisis scene user contacts the ABCC operator using his secure voice device over an appropriate HF, VHF, or UHF channel and requests an AUTOSEVOCOM I patch. The aircraft receives the contact by means of a similar secure voice device set in a receive mode. The ABCC operator contacts the earth terminal (ET) operator by teletype using the USC-28 link order wire (LOW), requests a patch to the desired AUTOSEVOCOM I subscribers, and advises the ET operator of the type of secure voice device being used at the crisis scene. The ET operator contacts the subscriber and patches the appropriate secure voice device with associated syllabic detectors (S<sub>1</sub> and S<sub>2</sub>) to the timing and control unit and the appropriate KY-3. The ET operator contacts the ABCC operator over the LOW and advises him that the patch is completed to the subscriber and patches himself out of the link. The ABCC operator contacts the crisis scene user over the appropriate secure voice device/transceiver and advises him that the circuit is complete. The ABCC operator then patches himself out of the link. It is estimated that the entire patching operation will require less than five minutes for completion. The crisis scene user initiates communications by pressing his PTT, which transmits the preamble for synchronization with the secure voice device at the ET, followed by the encrypted voice traffic. Since the operator has patched himself out of the link, the ABCC is now transparent to this traffic, which is received by the appropriate HF, VHF, or UHF receiver and fed directly into the USC-28 for the SHF relay. At the ET, the corresponding secure voice device decodes and reconstitutes the voice and delivers it to the syllabic detector S<sub>1</sub>. The device detects the presence of speech and passes the traffic to the selected KY-3 for entry into the AUTOSEVOCOM I network. ABCC transmitter keying is inhibited while S<sub>1</sub> is activated. S<sub>1</sub> remains activated as long as there is speech on the line plus an additional adjustable drop out delay  $\Delta t_1$  that will prevent the transmitter from being turned around by a momentary pause in speaking by the crisis scene user. The drop out delays can be adjusted over the range of 0 to several seconds. When the crisis scene user releases the PTT, the radio squelch lock is detected on the ABCC and the event is transmitted over the LOW to the timing and control unit where it is AND gated with the drop out of the S<sub>1</sub> event signal. (The AND gating is used to further prevent inadvertant circuit turnaround.) When this occurs, the timing and control circuits are triggered to send a signal over the LOW to key the transmitter

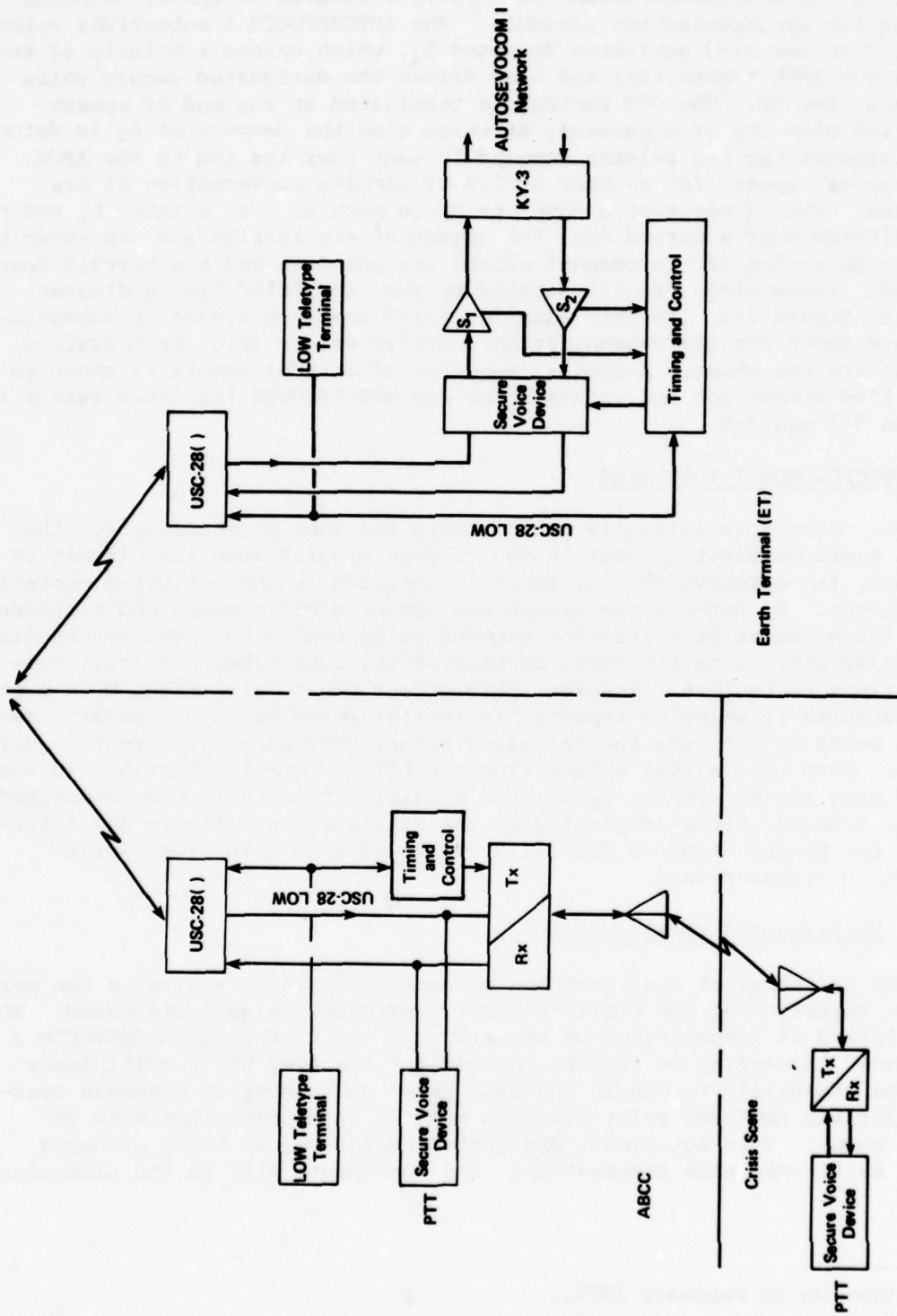

Figure 3-3. SINGLE-CHANNEL CONFIGURATION

and to send (with an appropriate delay to allow for carrier rise time) a signal to the designated secure voice device located at the ET to begin sending its synchronization preamble. The AUTOSEVOCOM I subscriber voice output from the KY-3 activates detector  $S_2$ , which causes a hold-in of the PTT on the ABCC transmitter and also drives the designated secure voice device at the ET. The PTT control is terminated at the end of speech detection plus  $\Delta t_2$  (for pauses), at which time the dropout of  $S_2$  is detected and a transmitter key release command is sent over the LOW to the ABCC. The process repeats for as many cycles of simplex conversation as are required. When dropout of a complete cycle occurs, i.e. neither  $S_1$  nor  $S_2$  is activated over a period  $\Delta t_3$ , the operators are alerted and can enter the loop to determine if the communications are complete and the circuit deactivated. These steps are illustrated by the simplified timing diagram shown in Figure 3-4. In this example, 1-1/2 complete cycles of conversation are shown for the communications; system delays (e.g., propagation delays) are not shown. A similar sequence of control events is shown in logic flow format for the crisis scene and AUTOSEVOCOM initiated relays in Figures 3-5 and 3-6.

#### AUTOSEVOCOM I Initiated

The circuit is initially set up using the same protocol as for the crisis scene origination, but in the reverse order. When the circuit is complete, the AUTOSEVOCOM subscriber is notified and he activates control with speech.  $S_2$  detects the speech and causes a PTT command and a secure voice synchronization initiation command to be generated. The synchronization delay will cause the first portion of the subscriber's initial communications to be lost. However, this effect can be eliminated by a protocol procedure in which he repeats his initial words or says a prearranged set of words to activate the procedure before beginning his actual conversation. Once the initial speech from the AUTOSEVOCOM I subscriber is completed plus the  $S_2$  dropout delay, the operation reverts to that described for the communications originated at the crisis scene. Figure 3-7 illustrates the timing diagrams for 1-1/2 cycles of this situation, again neglecting system delays.

#### 3.4.2 Multichannel Configuration

The multichannel configuration and operation is an analogous but more complex variation of the single-channel configuration just discussed. TDM multiplexing is accomplished on the aircraft and at the ET/AUTOSEVOCOM I interface. According to SATCOMA personnel,\* the Army has a multiplexer with the capability to handle the data rates and number of channels specified for the ABCC SHF relay function that is also compatible with the USC-28 modem. This equipment, designated AN/GSC-24, is being produced by the Martin-Marietta Corporation. The Sacramento ALSC is the procuring agency.

---

\*Interview on 10 February 1978.

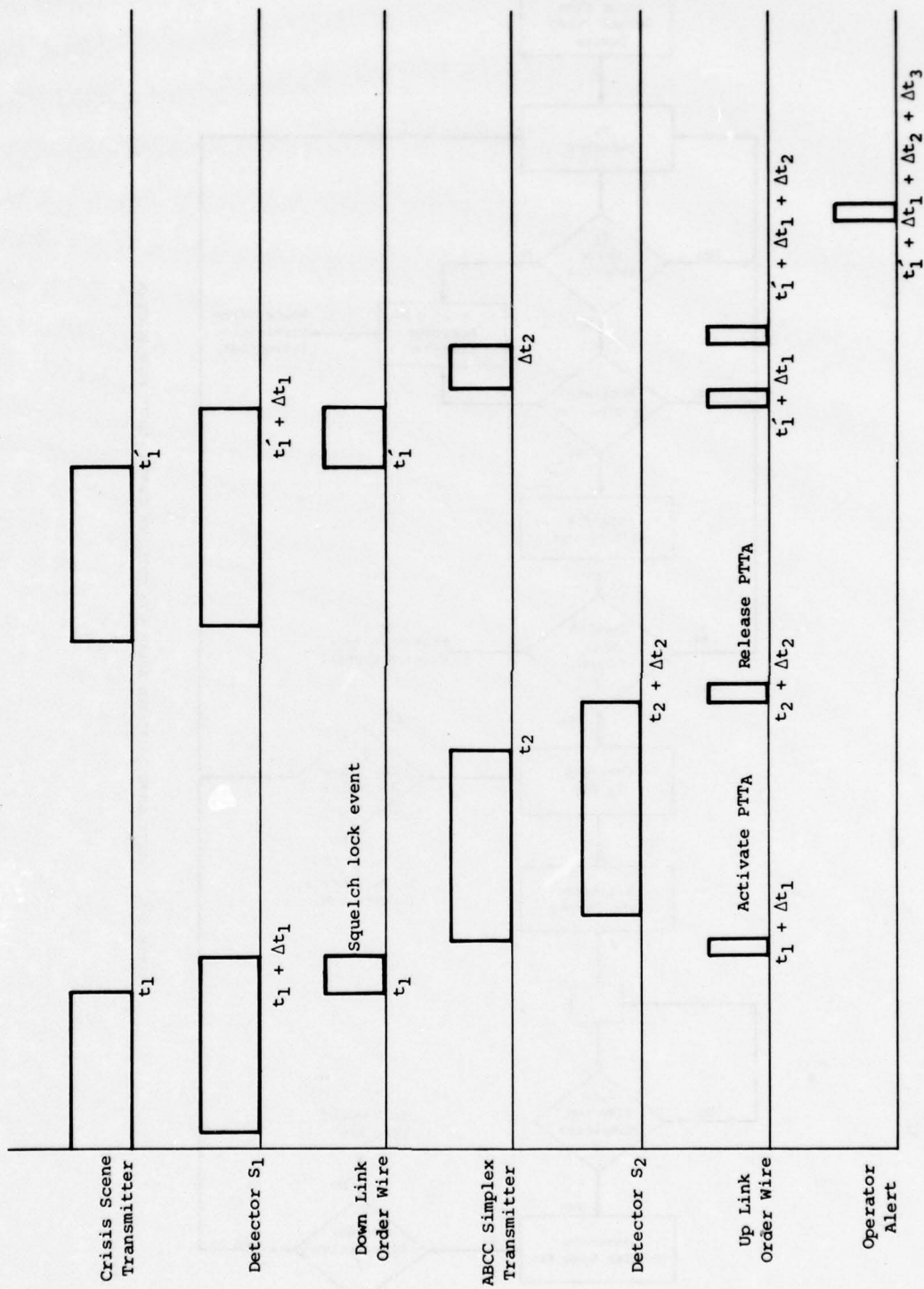

Figure 3-4. SAMPLE TIMING DIAGRAM FOR CRISIS SCENE INITIATED COMMUNICATION

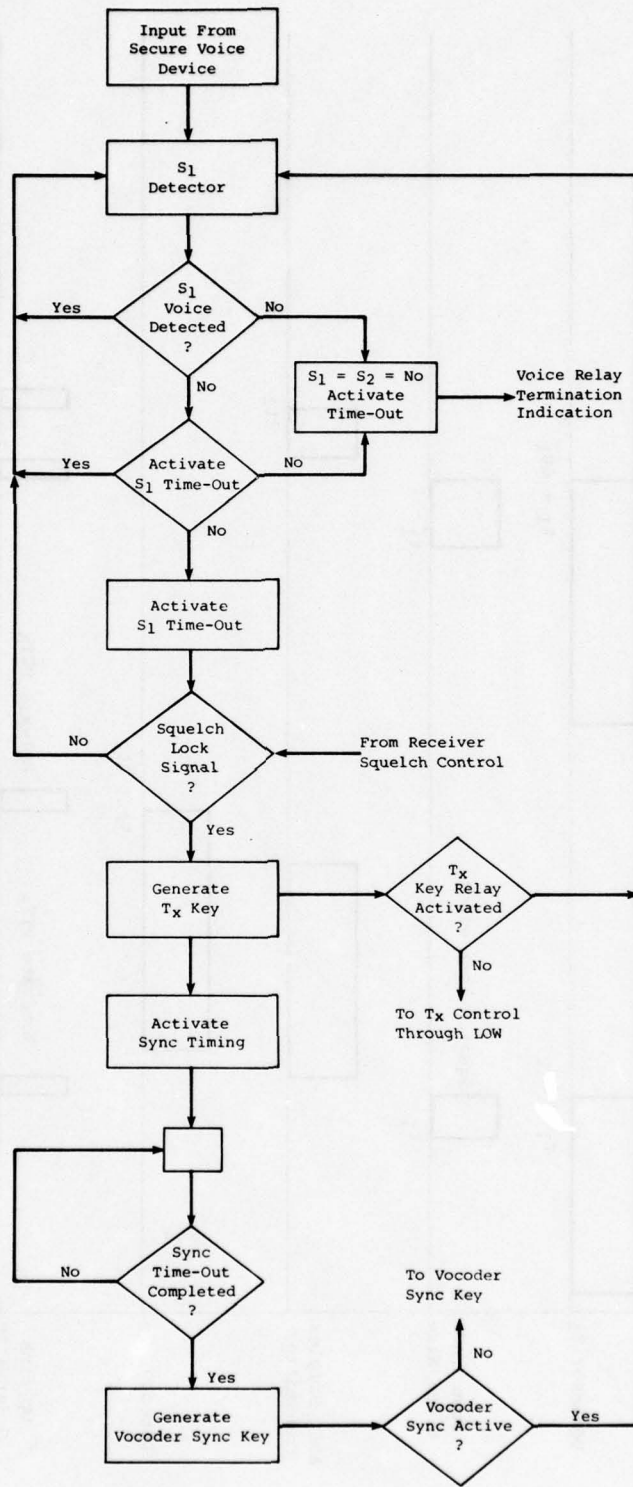

Figure 3-5. CRISIS SCENE INITIATED RELAY - S1 DETECTOR CONTROL-LOGIC FLOW DIAGRAM

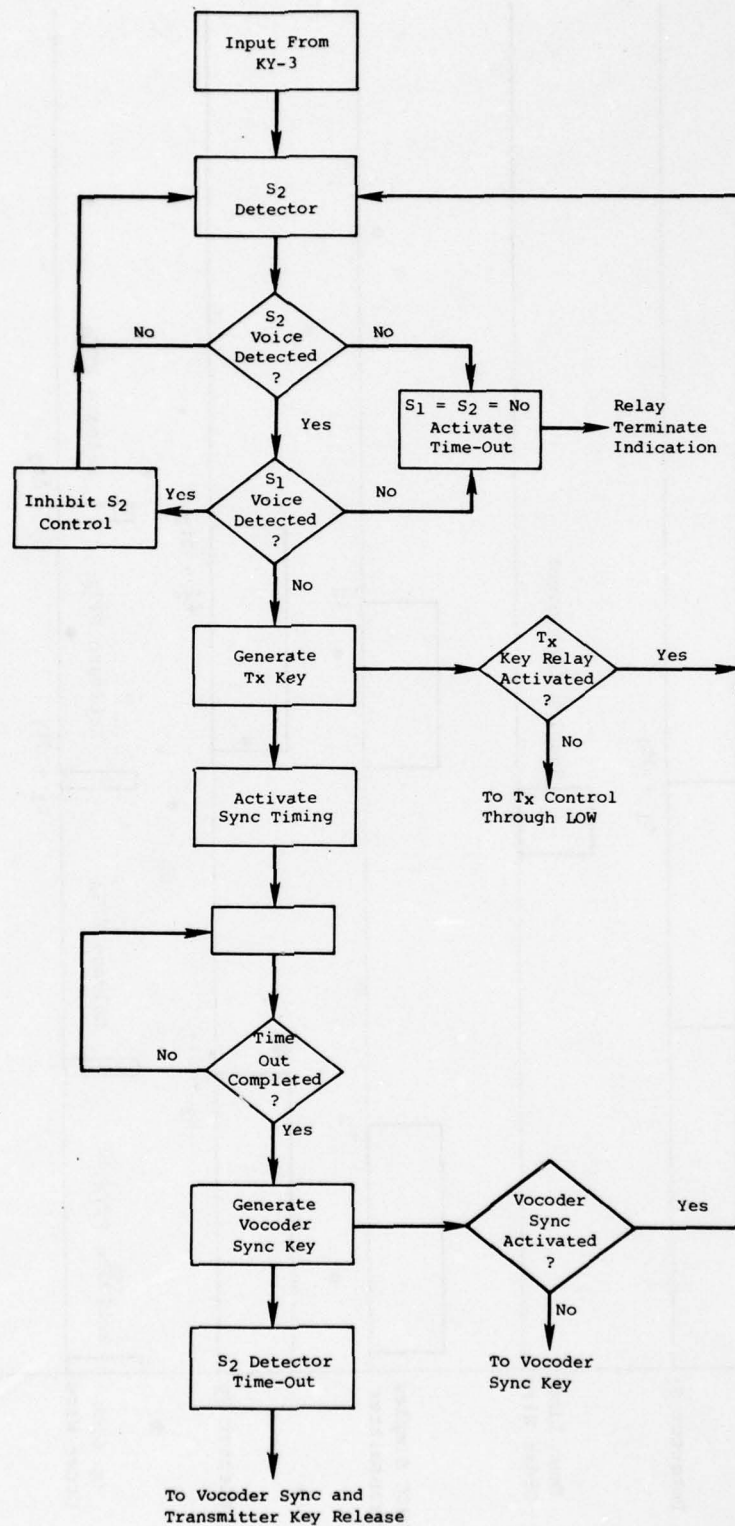

Figure 3-6. AUTOSEVOCOM INITIATED RELAY - S2 DETECTOR CONTROL - LOGIC FLOW DIAGRAM

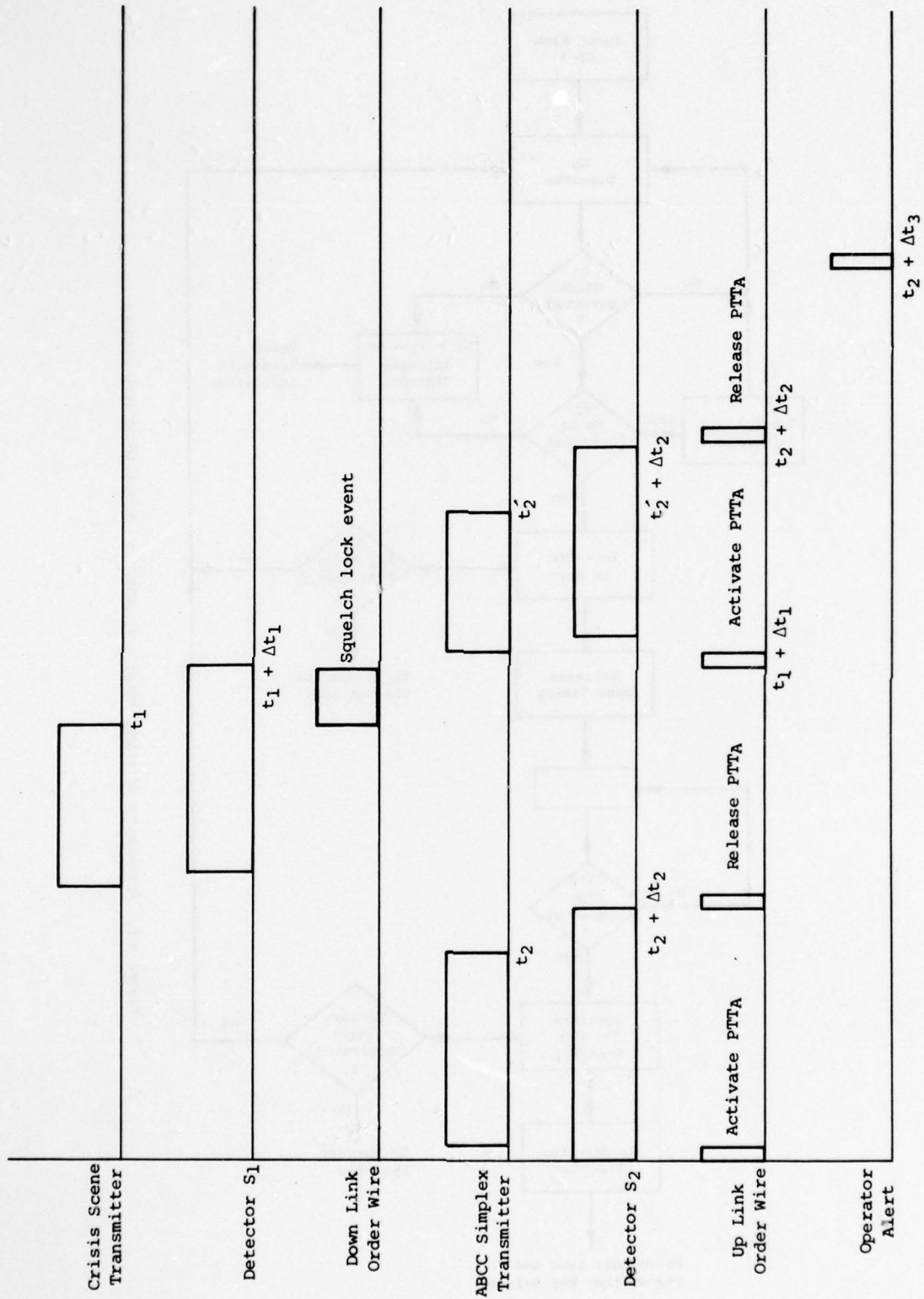

Figure 3-7. SAMPLE TIMING DIAGRAM FOR AUTOVOCOM I SUBSCRIBER INITIATED COMMUNICATION

ARINC Research requested specific documentation describing the technical and physical characteristics of the GSC-24 from the Army, but it has not yet been received. It is the company's understanding that the AN/GSC-24 has capabilities in excess of what is required for this use. Nonetheless, whether or not the GSC-24 is used, the hardware technology exists to provide four-channel TDM multiplexing of asynchronous secure voice digital data having different data rates and compatible with the type of modem to be used for the ABCC SHF relay function.

Figures 3-8 and 3-9 illustrate the multichannel configurations for the ABCC and ET/AUTOSEVOCOM I interfaces. These figures represent the "worst case" situations, in which any one of the four channels may use any of the six types of identified secure voice devices.

The circuit set-up protocol and PTT control using the syllabic detectors are the same as those described for the single-channel configuration with the exception that the timing and control signals transmitted over the LOW will also require address information in order to access the correct transceivers and secure voice devices. This header information can be created automatically when the initial patches are made through the switching matrices. It is presumed the switching matrices will be push-button, automated devices similar to those already found on command post aircraft. Their functions will be to provide the necessary linkages between multiplexed (MUX) channels, transceivers, secure voice devices, and timing and control to provide the means for the operators to patch in and out of the circuit and to observe circuit status visually. The circuit patch would be established by the operator simply pushing the correct buttons, establishing the linkages, and creating the necessary timing and control address information. Circuit status could be indicated by a light (e.g., green when activated, flashing red when no further communications are detected). If desired, the direction of the traffic flow could also be similarly indicated. Specific functions of the four identified switching matrices are described below:

- ABCC MUX Matrix
  - To link the operator's secure voice devices with the outputs of the transceiver matrix and enable the operator to patch in and out of a circuit
  - To link a designated MUX channel with a designated transceiver
  - To provide automatic routing to the CVSD 32s of PARKHILL communications for A/D and D/A conversions
  - To provide visual monitoring of circuit status
- ABCC Transceiver Matrix
  - To link a designated MUX or operator channel with a designated transceiver
  - To link a designated MUX channel with the appropriate timing and control circuit

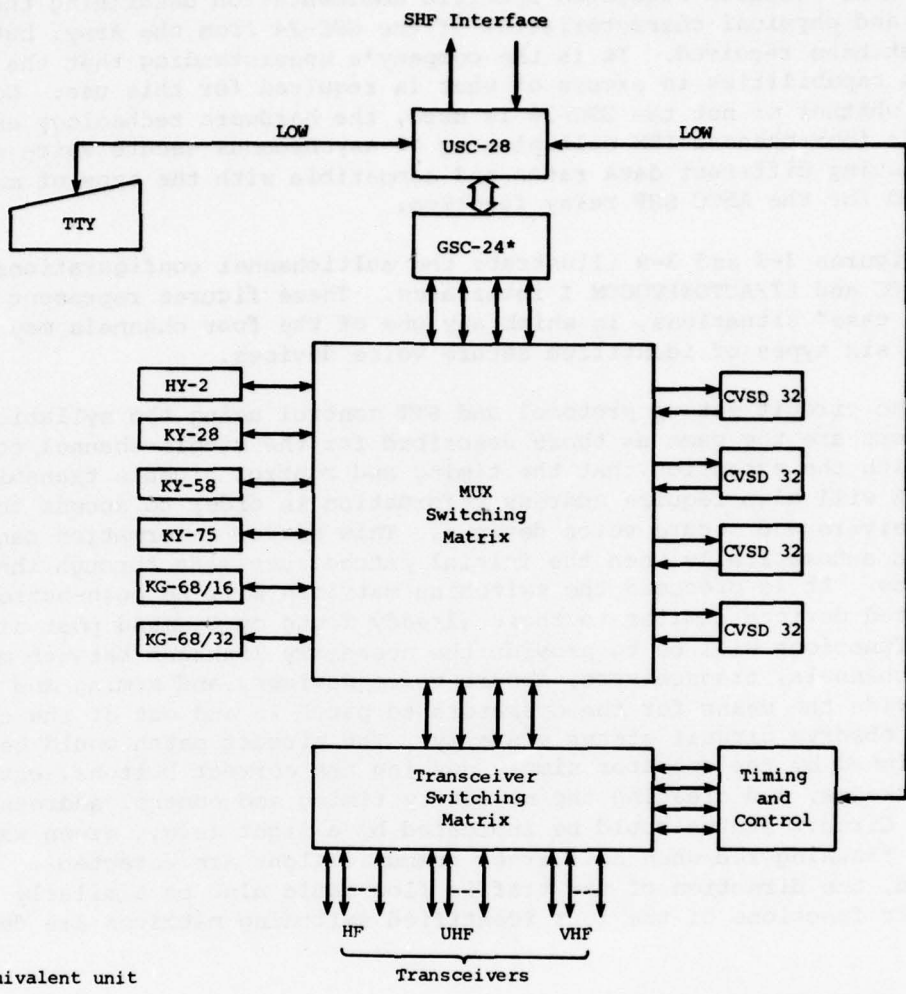

\*Or equivalent unit

Figure 3-8. MULTICHANNEL CONFIGURATION FOR ABCC INTERFACE

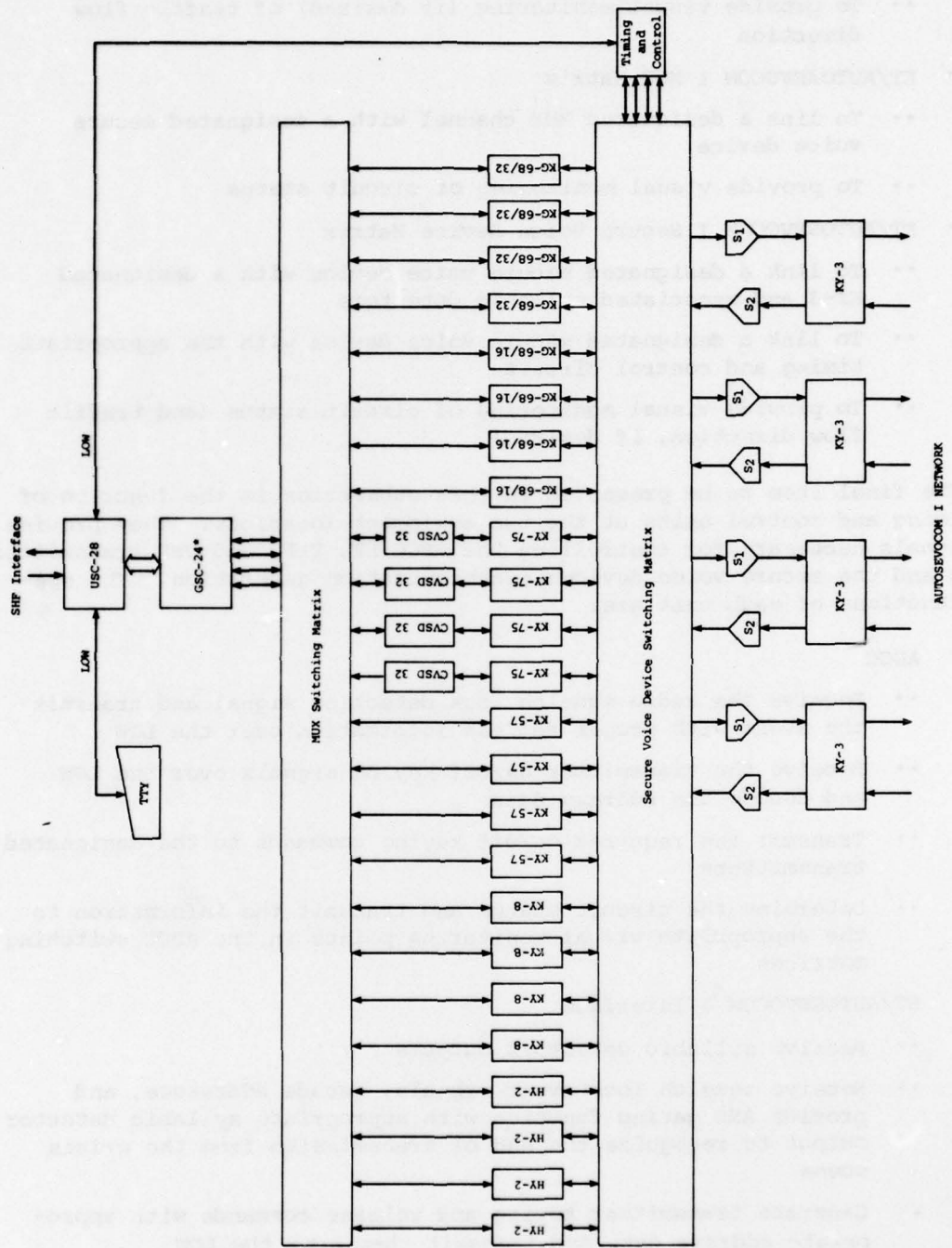

\*Or equivalent unit

Figure 3-9. MULTICHANNEL CONFIGURATION FOR EARTH TERMINAL/AUTOSEVCOM I INTERFACE

- To link a designated transceiver with the appropriate timing and control circuit
- To provide visual monitoring (if desired) of traffic flow direction
- ET/AUTOSEVOCOM I MUX Matrix
  - To link a designated MUX channel with a designated secure voice device
  - To provide visual monitoring of circuit status
- ET/AUTOSEVOCOM I Secure Voice Device Matrix
  - To link a designated secure voice device with a designated KY-3 and associated syllabic detectors
  - To link a designated secure voice device with the appropriate timing and control circuit
  - To provide visual monitoring of circuit status (and traffic flow direction, if desired)

The final item to be presented in this subsection is the function of the timing and control units at the two equipment locations. They provide the signals necessary for controlling the ABCC HF, VHF, and UHF transmitter keying and the secure voice devices synchronization generation. The specific functions of each unit are:

- ABCC
  - Receive the radio squelch lock detection signal and transmit the event with proper address information over the LOW
  - Receive the transmitter on/off keying signals over the LOW and decode the address data
  - Transmit the required on/off keying commands to the designated transmitters
  - Determine the circuit status and transmit the information to the appropriate visual monitoring points in the ABCC switching matrices
- ET/AUTOSEVOCOM I Interface
  - Receive syllabic detectors outputs
  - Receive squelch lock event signals, decode addressee, and provide AND gating function with appropriate syllabic detector output to recognize the end of transmission from the crisis scene
  - Generate transmitter keying and release commands with appropriate address data and transmit them over the LOW

- Generate appropriate secure voice device synchronization generation initiation commands with appropriate delays to allow for designated transceiver carrier rise times
- Determine circuit status and transmit information to the appropriate visual monitoring points in the ET/AUTOSEVOCOM I interface switching matrices

Table 3-1 summarizes the overall equipment requirements associated with the multichannel configuration for the two locations, their development status, and any known cognizant agency or manufacturer. As shown in the table, only the four switching matrices and the two timing and control units would require development funding for the SHF relay application.

### 3.5 CONCEPT EXTENSIONS

Although not within the scope of this particular effort, several extensions of the multichannel configuration concept merit brief discussion.

#### 3.5.1 ABCC as User

In this application, the ABCC would be a user of secure voice communications with either the crisis scene or AUTOSEVOCOM I subscribers. Such communications could be provided by the secure voice devices already being carried for the operator's communications in setting up the initial circuit patch. However, such use would preclude the operator's concurrent use of that device in setting up a relay patch with a crisis scene subscriber using the same type of device. For this reason, the ABCC users may want additional secure voice devices beyond those required for the operator function. In direct communications with a crisis scene user, there would be an appropriate patch on the Transceiver Switching Matrix and not on the MUX matrix. The transmitter keying function in this case would be controlled directly by the ABCC user. For direct communications with an AUTOSEVOCOM I subscriber, the MUX switching matrix would be used rather than the transceiver matrix. Further, depending upon the secure voice devices employed, the communications could be either full or half duplex since the transmitter keying function would not be required for this situation.

#### 3.5.2 ABCC as a Conference Participant

In this application, the ABCC would be a conference participant with a crisis scene user and an AUTOSEVOCOM I subscriber. This conferencing capability would be established by an analog bridge at the KY-3 input using separate channels between the bridge and the crisis scene and ABCC users. Figure 3-10 illustrates how this conferencing would be accomplished for the two communications channels involved (i.e., the other channels, equipments, and timing/control units are not repeated). In this situation, communications from the crisis scene would be relayed directly through the earth terminal to the analog bridge where the signal would be split with one branch connecting to the AUTOSEVOCOM I subscriber and the other retransmitted back to the ABCC subscriber. For communications from the AUTOSEVOCOM I

Table 3-1. MULTICHANNEL CONFIGURATION SUMMARY

Equipment	Quantity on ABCC	Quantity at ET/AUTOSEVOCOM I Interface	Development Status	Cognizant Agency/Manufacturer
USC-28	1	1	Preproduction	SATCOMA/Magnavox
GSC-24	1	1	Production	Sacramento-ALSC/Martin-Marietta
Order Wire TTY	1	1	Off the shelf	Unknown
MUX Switching Matrix	1	0	To be developed	N/A
MUX Switching Matrix	0	1	To be developed	N/A
Transceiver Switching Matrix	1	0	To be developed	N/A
Secure Voice Device Switching Matrix	0	1	To be developed	N/A
Timing and Control Unit	1	0	To be developed	N/A
Timing and Control Unit	0	1	To be developed	N/A
HY-2	1	4	No longer in production	NSA
KY-28, 8	1	4	No longer in production	NSA
KY-58, 57	1	4	Production	NSA
KY-75	1	4	Production	NSA
KY-68	2	8	Preproduction	TRI-TAC
CVSD-32	4	4	Off the shelf	Unknown
KY-3	0	4	No longer in production	DCA/NSA
Syllabic Detector	0	8	Off the shelf	Collins, Data Products

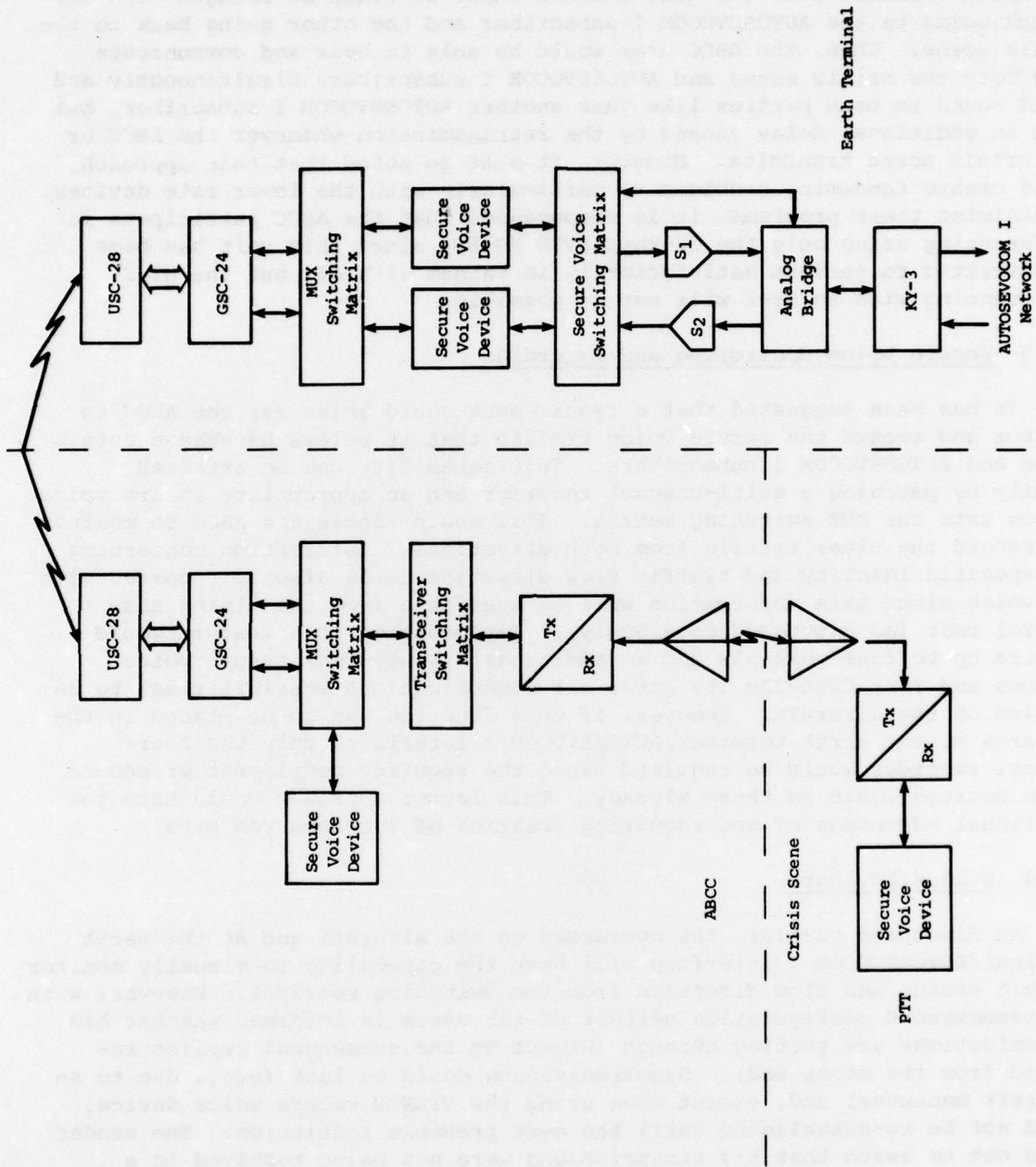

Figure 3-10. ABCC CONFERENCING DIAGRAM

subscriber, the signal would be bridged with one leg going via one channel to the crisis scene user and to the ABCC subscriber via the second channel. Finally, for communications from the ABCC user, the signal would be sent to the earth terminal over the ABCC channel where it would be bridged with one branch going to the AUTOSEVOCOM I subscriber and the other going back to the crisis scene. Thus, the ABCC user would be able to hear and communicate with both the crisis scene and AUTOSEVOCOM I subscribers simultaneously and would sound to both parties like just another AUTOSEVOCOM I subscriber, but with an additional delay caused by the retransmission whenever the ABCC or the crisis scene transmits. However, it must be noted that this approach could create tandeming problems -- particularly with the lower rate devices. To minimize these problems, it is recommended that the ABCC participate in conferencing using only the 32-kbps CVSD KG-68, since this unit has been demonstrated to perform satisfactorily in tandem with all but the HY-2. Conferencing with an HY-2 will not be possible.

### 3.5.3 Secure Voice Monitoring and Recording

It has been suggested that a requirement could arise for the ABCC to monitor and record the secure voice traffic that it relays between a crisis scene and AUTOSEVOCOM I subscribers. This capability can be attained readily by patching a multi-channel recorder and an appropriate secure voice device into the MUX switching matrix. This would enable the ABCC to monitor and record the clear traffic from both directions. Information concerning the specific identity and traffic flow direction could also be recorded with the voice since this information will be available from the timing and control unit (as discussed previously). Implementing this feature would require up to four channels and an additional twenty-four secure voice devices and four CVSD-32s (to cover all communications possibilities) to be carried on the aircraft. However, if this function was to be placed in the red area at the earth terminal/AUTOSEVOCOM I interface, only the four-channel recorder would be required since the required complement of secure voice devices would be there already. This latter approach would have the additional advantage of not requiring creation of a second red area.

### 3.5.4 Status Advisory

As discussed earlier, the operators on the aircraft and at the earth terminal/AUTOSEVOCOM I interface will have the capability to visually monitor circuit status and flow direction from the switching matrices. However, with the recommended configuration neither of the users is informed whether his communications are getting through (except by the subsequent replies received from the other end). Synchronization could be lost (e.g., due to an aircraft maneuver) and, except when using the VINSON secure voice device, could not be re-established until the next preamble initiation. The sender would not be aware that his transmissions were not being received in a useable form until he received a reply from the other end. Communications might also be lost as a result of the ABCC transmitter being keyed while the speaker pauses if, at the same time, the crisis scene user keys his transmitter. This latter situation could be avoided by merely providing a visual signal on the crisis scene equipment that a carrier is being received. However, this would involve modifying existing tactical communications equipment.

Resolution of the first problem is more difficult. Since the AUTOSEVOCOM I subscriber has a full duplex capability, loss of synchronization could be detected and he could be informed, for example, by a tone to alert him to the situation. However, this could be accomplished only if the loss of synchronization were detected at the ABCC and sent back via the LOW. In order to detect the loss at the crisis scene or to advise the crisis scene that the earth terminal has lost synchronization, a separate transceiver may be required. This separate unit would function basically as an order wire with the ABCC, receiving a loss-of-synchronization signal (from the ET over the LOW to the ABCC and then over the order wire channel to the receiver) and alerting the crisis scene user or taking the detected loss of synchronization and transmitting the information back to the ABCC and then over the LOW to the ET to alert the AUTOSEVOCOM I subscriber. Solving this loss of synchronization advisory problem will require further study, addressing such factors as the expected frequency of synchronization loss, its severity, the extent to which protocol procedures can be developed to minimize its effect, and the costs and complexities associated with incorporating such an advisory capability.

#### 3.5.5 Non-Secure Voice Relay

The final consideration to be addressed in this subsection is the capability of the configuration presented to relay SHF in-the-clear voice communications. Each of the secure voice devices identified for communications between a crisis scene and the AUTOSEVOCOM I network using the ABCC for SHF relay has the capability of operating in either a clear or secure mode. Further, since the syllabic detectors are already operating on the analog voice signals, they too will be unaffected by the choice of the clear mode. No problems in relaying non-secure communications are envisioned.

## CHAPTER FOUR

### TEST OBJECTIVES

This chapter presents the demonstration and test objectives associated with the recommended interface equipment configuration for the multichannel SHF relay by the ABCC of secure voice communications between tactical elements at a crisis scene and AUTOSEVOCOM I subscribers. Since the recommended approach employs proven technologies, the laboratory and flight objectives presented are limited to verification and demonstration of system configuration operability. It is assumed that these tests will be performed by the Air Force Avionics Laboratory and will support and complement the test program already planned for the SHF terminal/antenna system under PE63431F.

#### 4.1 LABORATORY TESTS

Three general types of laboratory tests are recommended:

- To confirm operation of the syllabic detectors with each type of secure voice device identified for the SHF relay application
- To verify timing and control designs
- To verify the required delay for each identified type of secure voice device

##### 4.1.1 Confirm Syllabic Detector Operation

The operation of syllabic detectors with clear voice has been well demonstrated, but their operation with reconstituted voice as derived from secure voice devices has not been proven. Although no problems are anticipated, particularly with the devices employing higher data rates, ARINC Research believes that tests are necessary to confirm the satisfactory operation of these devices with the various types of secure voice devices identified in the study. Further, any degradation in detector performance resulting from adding the multiplexers and modems to the configuration should be determined by laboratory test. (The effect of the SHF terminals will be studied during the flight tests.) A three-step test program for each of the six identified types of secure voice devices is recommended. These steps are illustrated in Figure 4-1. A fourth step is recommended for each device to learn the extent of initial voice data loss of communications originated by AUTOSEVOCOM I (as discussed in Chapter Three). This step is illustrated in Figure 4-2.

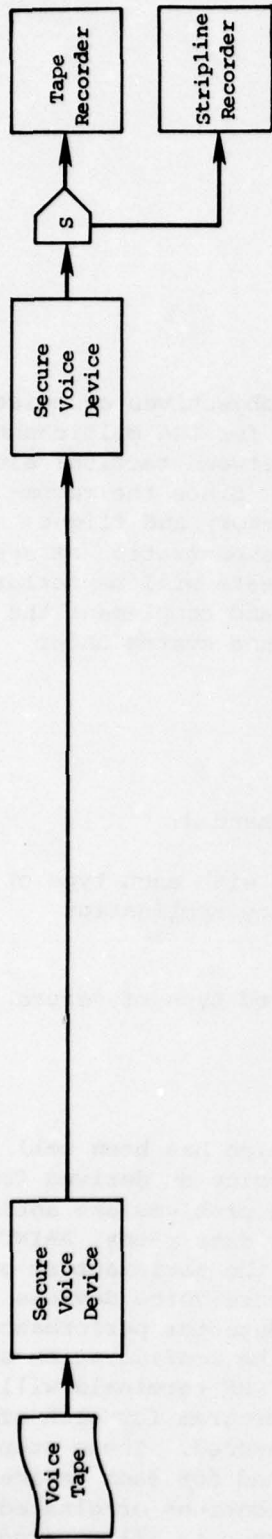

Step 1 - Confirm Operation with Secure Voice Device

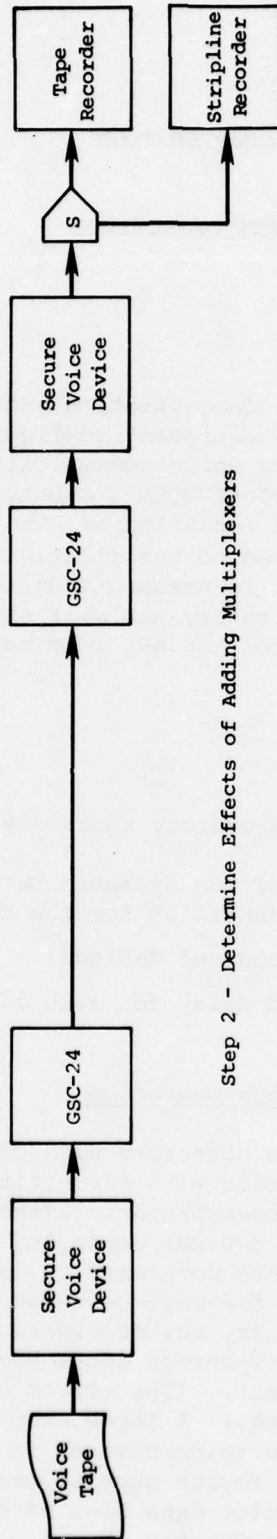

Step 2 - Determine Effects of Adding Multiplexers

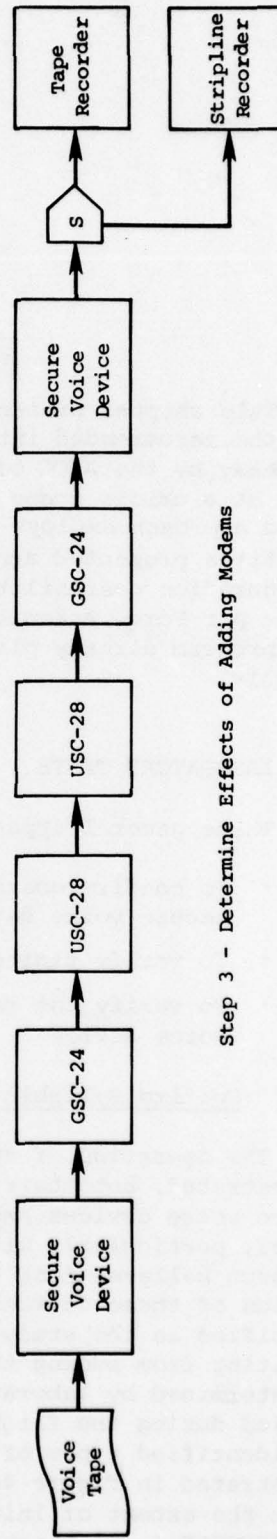

Step 3 - Determine Effects of Adding Modems

Figure 4-1. SYLLABIC DETECTOR OPERATION TESTS (STEPS 1 THROUGH 3)

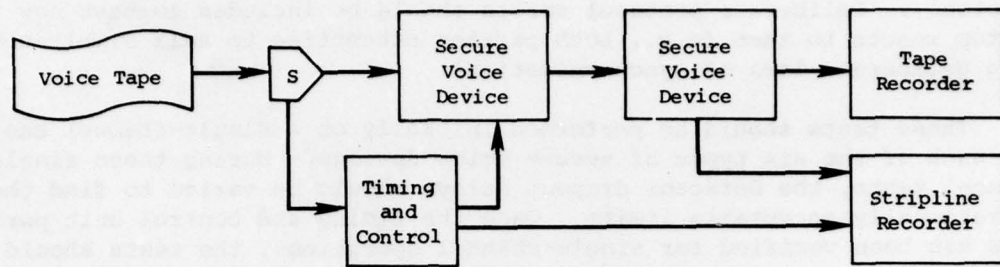

Step 4 - Ascertain Extent of Initial Voice Data Loss

Figure 4-2. SYLLABIC DETECTOR OPERATION TEST (STEP 4)

In each of these steps, standard voice intelligibility test tapes are used as test drivers. If possible, these tapes should be the same ones used to verify the tandeming capabilities of the various devices as discussed by J. Webb in the previously cited MITRE report. Similarly, the analog reconstituted voice outputs should be recorded on a tape recorder for each step. These tapes will be subsequently played back to determine the speech intelligibility (steps 1 through 3) and extent of initial voice loss (step 4). The same intelligibility criteria employed in the previous tandeming tests should also be applied in these tests. In addition to recording the voice outputs, critical event times should be recorded on a stripline recorder to determine detector response and dropout times (steps 1 through 3) and circuit synchronization and voice loss times (step 4). Approximately two months will be required to complete all four steps for the six types of secure voice devices. However, this time does not include the pretest time required to acquire and set up the various test items. This could require from four to six months to complete.

#### 4.1.2 Timing and Control

The objectives of these tests will be to verify the operation of the timing and control units and to ascertain operationally acceptable limits for the dropout delays of the syllabic detectors. As a secondary objective, these tests can also serve to check the designs of the switching matrices.

To conduct these tests, the system should be configured in an operational mock-up without the RF links to permit the system to be tested as operating in a simplex mode at one end and a fully duplex mode at the other end. Provision should be made to monitor and record (strip-chart) all critical timing and control events (e.g., transmitter keying and release times, synchronization generation control, syllabic detector activation and dropout, traffic flow times and directions). Several test scenario scripts should be developed and used as constant standards throughout these tests. The scripts should include originations from both ends, measured pauses, and representative types of speech patterns (e.g., fast, slow,

monotone). Deliberate protocol errors should be included to test how the system reacts to them (e.g., both parties attempting to talk simultaneously or a deliberate loss of synchronization).

These tests should be performed initially on a single-channel basis for each of the six types of secure voice devices. During these single-channel tests, the detector dropout delays should be varied to find the operationally acceptable limits. Once the timing and control unit performance has been verified for single-channel operations, the tests should be repeated for multichannel loadings. These tests should feature configurations of identical secure voice devices and mixtures of secure voice devices. For the multichannel tests, all combinations and types of secure voice devices need not be considered. However, a representative sample of tests should be conducted that represent the range of stress expected to be placed on the timing and control units. The results of the syllabic detector operation tests and the single-channel timing and control tests should provide the insight necessary for the selection of the specific mixes to be tested in the multichannel configurations. It is estimated that three months will be needed to develop the scenario scripts and test the timing and control units.

#### 4.1.3 Secure Voice Device Delays

The objective of these tests will be to establish the necessary timing delays for the secure voice devices to compensate for carrier rise times and receiver settling times before transmission of the device synchronization preambles. Each of the HF, VHF, and UHF transceivers expected to be employed in the crisis scene and on the ABCC should be tested in conjunction with the secure voice devices with which they can be expected to be employed to determine the minimum levels and associated times which would enable passage and recognition of the synchronization preambles. An important point to be resolved by these tests is the determination of whether a single delay corresponding to the maximum expected rise or settle time should be used by the timing and control unit or whether this should be a variable quantity which is registered at the time of circuit patching. These tests should be performed before the timing and control units are developed since their outcome could affect the resultant designs. It is estimated that two months will be needed for completion of these tests.

#### 4.2 FLIGHT TESTS

ARINC Research recommends two types of flight tests of the ABCC SHF relay. These are (1) to verify the operational capability with the addition of the RF links, and (2) to demonstrate the satisfactory interoperability with the AUTOSEVOCOM I network. The flight tests can also demonstrate the ABCC user and conferencing capabilities discussed in Chapter Three. It should be possible to complete these tests within the flight test schedule already planned for the SHF terminal ABCC upgrade.

#### 4.2.1 Verification of Operational Capability

The laboratory tests described in the preceding section will test all of the system components except the RF links. The objective of the flight tests will be to verify that the capability remains with the addition of these links. The tests should be performed using the laboratory setup in two steps. First, from the test setup to the aircraft and directly back to the test setup, and then using the satellite as a relay. Each of the proposed secure voice devices should be tested with the same set of standard intelligibility tapes used in the laboratory tests. The results should again be recorded for subsequent playback for intelligibility scoring and the key timing and control data should again be recorded on strip-charts for subsequent analysis. Similarly, the speech scenarios used in the timing and control laboratory tests should be applied for the same mixes of secure voice devices previously tested to verify proper functioning of the timing and control units and satisfactory multichannel operation.

#### 4.2.2 AUTOSEVOCOM I Interoperability

The objective of this test would be to demonstrate the operability of the entire system including an AUTOSEVOCOM I subscriber. In this test, the simplex equipment used in the laboratory and initial flight tests of the Air Force Avionics Laboratory could be used to simulate the crisis scene users and an AUTOSEVOCOM I entry location earth terminal (e.g., Fort Detrick) could be used to complete the circuit to a subscriber (e.g., at a Pentagon location). Both directions of communications origination should be demonstrated during these tests.

CHAPTER FIVE

CONCLUSIONS AND RECOMMENDATIONS

This chapter presents the conclusions and recommendations resulting from this brief investigation of the interface equipment requirements and associated demonstration and test objectives for SHF relay by the ABCC of secure voice communications between tactical elements located at a crisis scene and AUTOSEVOCOM I subscribers.

5.1 CONCLUSIONS

The following principal conclusions were reached in the investigation:

- The KY-3 equipment necessary for entry into the AUTOSEVOCOM I network should be located at the earth terminal rather than on the ABCC.
- The transmitter keying function should be automatic, using syllabic detectors, rather than manual.
- Multichannel operation should use time division multiplexing. The GSC-24 or an equipment with equivalent capabilities can provide this function.
- The concept presented for accomplishing the SHF relay and simplex/duplex interface can be extended readily to provide ABCC user, conferencing, and monitoring capabilities.
- The Switching Matrices and the Timing and Control Units are the only equipments requiring development efforts.
- Laboratory and flight testing objectives can be limited to verification and demonstration of system configuration operability since no new technologies are used. Laboratory testing in three areas and flight testing in two should be performed.

5.2 RECOMMENDATIONS

The following actions are recommended:

- The Air Force should initiate detailed design and subsequent development of the Timing and Control Units and the four Switching Matrices.

- The Air Force should acquire the syllabic detectors and other identified interface equipment.
- Both the USC-28 and GSC-24 possess capabilities far in excess of what is needed to satisfy the stated requirements. Consideration should be given to developing or acquiring comparable units whose capabilities are more commensurate with the given requirements and should offer attendant savings in size, weight, and cost.
- If monitoring and recording of secure voice communications traffic becomes a firm ABCC requirement, the means for its accomplishment needs to be further investigated.
- If laboratory or flight tests indicate frequent loss of synchronization, means for alerting users of the loss should be developed and evaluated for their comparative costs and utilities.
- The specific complement of secure voice devices and number of communications channels required should be finally determined since the configuration addressed herein represents a "worst case" as to the number of units being carried.
- The impact of AUTOSEVOCOM II on the recommended approach and interface equipment characteristics should be examined.
- Detailed Test Plans and Test Procedures for satisfying the stated test objectives need to be developed and integrated into the existing SHF Terminal ABCC Upgrade test plan.

ED  
78