

AD-A054 704

ARINC RESEARCH CORP SANTA ANA CALIF WESTERN DIV  
MICROELECTRONIC TRANSCEIVER DEVELOPMENT PROGRAM. PHASE I.(U)  
AUG 68 H ROSENBERG, T D PRICE, R A MAMMANO N00123-68-C-2520  
467-01-1-904 NL

UNCLASSIFIED

| OF |  
AD  
A054704



END  
DATE  
FILMED  
6-78  
DDC

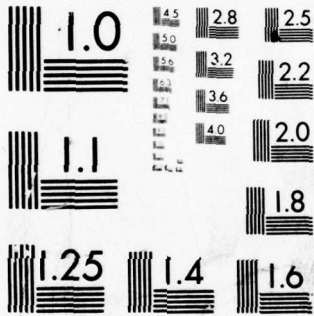

MICROCOPY RESOLUTION TEST CHART  
NATIONAL BUREAU OF STANDARDS-1963-A

FOR FURTHER TRAN

7

Final Report

AD A 054704

MICROELECTRONIC TRANSCEIVER DEVELOPMENT PROGRAM, PHASE I

August 1968

Prepared for

U. S. NAVY ELECTRONICS LABORATORY CENTER  
San Diego, California

Under Contract N00123-68-C-2520

AD No. \_\_\_\_\_  
DDC FILE COPY

Publication 467-01-1-904

DDC  
JUN 6 1978  
F

**ARINC** RESEARCH CORPORATION

This document has been approved  
for public release and sale; its  
distribution is unlimited.

UNCLASSIFIED

SECURITY CLASSIFICATION OF THIS PAGE (When Data Entered)

REPORT DOCUMENTATION PAGE		READ INSTRUCTIONS BEFORE COMPLETING FORM
1. REPORT NUMBER 467-01-1-904	2. GOVT ACCESSION NO.	3. RECIPIENT'S CATALOG NUMBER
4. TITLE (and Subtitle) MICROELECTRONIC TRANSCEIVER DEVELOPMENT PROGRAM, PHASE I		5. TYPE OF REPORT & PERIOD COVERED
		6. PERFORMING ORG. REPORT NUMBER 467-01-1-904
7. AUTHOR(s) H. Rosenberg T.D. Price R.A. Mammano		8. CONTRACT OR GRANT NUMBER(s)  N00123-68-C-2520
9. PERFORMING ORGANIZATION NAME AND ADDRESS ARINC Research Corporation ✓ 2551 Riva Road Annapolis, Maryland 21401		10. PROGRAM ELEMENT, PROJECT, TASK AREA & WORK UNIT NUMBERS
11. CONTROLLING OFFICE NAME AND ADDRESS U.S. NAVY ELECTRONICS LABORATORY CENTER San Diego, California		12. REPORT DATE August 1968
		13. NUMBER OF PAGES 09
14. MONITORING AGENCY NAME & ADDRESS (if different from Controlling Office) U.S. NAVY ELECTRONICS LABORATORY CENTER San Diego, California		15. SECURITY CLASS. (of this report)  UNCLASSIFIED
		15a. DECLASSIFICATION/DOWNGRADING SCHEDULE
16. DISTRIBUTION STATEMENT (of this Report)  UNCLASSIFIED/UNLIMITED		
17. DISTRIBUTION STATEMENT (of the abstract entered in Block 20, if different from Report)		
18. SUPPLEMENTARY NOTES		
19. KEY WORDS (Continue on reverse side if necessary and identify by block number)		
20. ABSTRACT (Continue on reverse side if necessary and identify by block number)		

	<p>REF ID: A67-01-1-904</p> <p>MICROELECTRONIC TRANSDUCER DEVELOPMENT PROGRAM PHASE I</p>
<p>A67-01-1-904</p>	
<p>H00123-68-C-2220</p>	<p>H. Rosenberg T.D. Price R.A. Mammone</p>
<p>August 1968</p>	<p>ARINC Research Corporation 2521 Riva Road Annapolis, Maryland 21401</p>
<p>UNCLASSIFIED</p>	<p>U.S. NAVY ELECTRONIC LABORATORY CENTER San Diego, California</p>
<p>UNCLASSIFIED</p>	<p>U.S. NAVY ELECTRONIC LABORATORY CENTER San Diego, California</p>
<p>UNCLASSIFIED</p>	<p>UNCLASSIFIED/UNLIMITED</p>
<p>UNCLASSIFIED</p>	
<p>UNCLASSIFIED</p>	
<p>UNCLASSIFIED</p>	
<p>UNCLASSIFIED</p>	
<p>UNCLASSIFIED</p>	

9 Final Report,

6 MICROELECTRONIC TRANSCEIVER DEVELOPMENT PROGRAM, PHASE I.

12 17 p.

11 August 1968

Prepared for  
U. S. NAVY ELECTRONICS LABORATORY CENTER  
San Diego, California

13 Under Contract No. 123-68-C-2520

DDC  
JUN 6 1978  
F

10 Prepared by  
H. / Rosenberg,  
T. D. / Price  
R. A. / Mammano

Approved by  
*J. R. Gliessman*  
J. R. Gliessman

ARINC RESEARCH CORPORATION  
Western Division  
P. O. Box 1375  
Santa Ana, California 92702

14 Publication 467-01-1-904

406 547

slt

Preceding Page BLANK - FILMED

467-01-1-904

CONTENTS

	<u>Page</u>
1. INTRODUCTION . . . . .	1
2. LABORATORY EVALUATION . . . . .	2
3. LABORATORY DEVELOPMENT . . . . .	3
4. VOICE CODING TECHNIQUES . . . . .	5
5. VOICE SCRAMBLER DESIGN . . . . .	10

LIST OF ILLUSTRATIONS

<u>Figure</u>	<u>Title</u>	<u>Page</u>
1.	Digital Coding Technique . . . . .	6
2.	Analog Time Permutation . . . . .	7
3.	Frequency Permutation . . . . .	8
4.	Block Diagram, Frequency Inverting Voice Scrambler . . . . .	11
5.	Active Low-Pass Filter (One Section, 12 db/octave Rolloff) . . . . .	12
6.	Double-Balanced Modulator Configurations . . . . .	13

ACCESS	on
NFIS	<input checked="" type="checkbox"/>
DDC	<input type="checkbox"/>
UNANNOUNCED	<input type="checkbox"/>
JUSTIFICATION	
BY	
DISTRIBUTION/AVAILABILITY CODES	
Dist.	AVAIL. and/or SPECIAL
A	

## 1. INTRODUCTION

ARINC Research Corporation has completed Phase I of the Microelectronic Transceiver Development Program, performed under Contract N00123-68-C-2520 for the U. S. Navy Electronics Laboratory Center, San Diego, California. This effort was conducted under the technical direction of Code S-240, and consisted of the following tasks;

- a. A complete evaluation of the equipment, materials, procedures, and general capability of the NELC Hybrid Microelectronics Laboratory;
- b. Expansion of this capability to fulfill the requirements imposed by prototype fabrication of the microelectronic transceiver hardware;
- c. A review of voice-coding techniques applicable toward providing secure communications, and the definition of an optimum approach for use with the transceiver; *and*
- d. The detailed design of the voice scrambler portion of the microelectronic transceiver.

At the request of Code S-240, development of the remaining portions of the transceiver was delayed until completion of the voice scrambler section, since this represented the area of greatest risk in terms of compatibility with state-of-the-art electronics.

The remaining (Phase II) effort of this program consists of the following tasks;

- a. Establishment of procedures and personnel training as required to fabricate prototype transceiver hardware in microelectronic form;
- b. Final development and evaluation of the scrambler portion of the transceiver; *and*
- c. Design and development of the remaining transceiver circuitry.

ACCESSION for	W 12
NTIS	B 12
DDC	
UNANNOUNCED	
JUSTIFICATION	
BY	
DISTRIBUTION/AVAILABILITY CODES	
of SPECIAL	

## 2. LABORATORY EVALUATION

At the beginning of this program, the Hybrid Microelectronic Laboratory contained most of the equipment necessary for thin-film deposition and hybrid component assembly. Available items of equipment included:

- a. Lead bonding machine
- b. Die bonding machine
- c. Vacuum evaporator
- d. Film thickness monitor
- e. Film resistance monitor
- f. Photo resist system
- g. Mask alignment fixture
- h. Chemical sink
- i. Etching system
- j. Cleaning system
- k. Laminar flow hood
- l. Microprobe
- m. Ultrasonic cleaner
- n. Microscope
- o. Coordinatograph

While this equipment provides a significant capability, the laboratory had several major operational deficiencies. Some of these deficiencies were the insufficiency of trained personnel to operate the equipment, the inadequacy of electronic test instrumentation to support circuit development, the lack of documented sources of supply for supporting materials and chemicals, the lack of established procedures and man-machine-material interfaces, and the fact that some of the equipment had never been properly adjusted and calibrated.

In addition to these problems, there were minor difficulties caused by inefficient placement of equipment, inadequate maintenance and repair of the facilities, and the fact that some of the general purpose equipment had not been optimized for the specific requirements of the transceiver circuitry.

### 3. LABORATORY DEVELOPMENT

During Phase I, ARINC Research activity within the Hybrid Microelectronic Laboratory was concentrated on getting all equipment, materials, and processes ready for initiating prototype work on the transceiver circuitry. As a result of this effort, the Lab is now able to process substrates with thin-film component mounting, conductor, and resistor patterns. These substrates are processed in accordance with a previously prepared laboratory flow chart, and represent state-of-the-art techniques in hybrid technology.

As a first step in developing the laboratory capability, all equipment was thoroughly inspected, adjusted, repaired as necessary, and completely evaluated. As each item was put into working order, precautionary steps and operating procedures were established, and critical parts were so labeled.

With the intent of interfacing suitable processing operations at each station, the following conditions were investigated and set up as formal procedure:

- a. Lead bonding: Bonding time, power settings, node pressures, gas flows, wire sizes and compositions, substrate temperatures, mechanical resonances, etc.
- b. Die bonder: Gas types and flow rates; temperatures of die, collet, substrate heater, and hydrogen heater; and the location of each with respect to the die used.
- c. Photolithography: Resist composition, viscosity, and baking temperatures; developing materials and times; spinner speeds and times, etc.
- d. Evaporation: Fixture-evaporant pressures, temperatures, volumes, etc.; sensing procedures for film thickness and resistivity; substrate holding facilities.
- e. Microprobing: Probe location, pressures, electrical wiring to test equipment, microscope positioning.
- f. Etching: Chemical solutions; etch times and temperatures; and cleaning procedures for all materials, including alloys, evaporants, and substrates.

In addition to preparing the equipment for use, ARINC Research determined the most suitable sources for the materials and supplies necessary to make the lab functional in its output of hybrid microelectronic circuits. Items were ordered and inspected upon receipt to determine their ability to meet specified requirements. No formal specifications have been constructed for these materials; however, this is an objective of the next phase, time permitting.

Personnel training was also initiated. Serving as a training aid was a substrate pattern useful for constructing a hybrid audio amplifier. This pattern was produced and applied successfully in the processing of substrates on glass and alumina. The initial film layer of the substrates was nichrome, overlaid with nickel and gold films.

467-01-1-904

Photolithographic operations were performed utilizing KMER and related solutions. Once the pattern was etched chemically, die bonding and lead bonding were carried out to completion.

Although these structures are very simple, they represent early efforts of lab personnel trained over a short time span only. Significant improvements toward more complex and useful circuitry are the primary objectives of the next phase.

## 4. VOICE CODING TECHNIQUES

Prior to the design of the microelectronic transceiver, a survey was undertaken of applicable voice coding techniques. While extensive efforts over several decades have been devoted to the techniques and practices of securing voice communications, no general-purpose approach has been established. In all probability, this is because no one technique satisfies all requirements for this type of device. Some of these requirements are listed below in what is considered to be their order of importance for the transceiver application:

- a. Small size
- b. Compatibility with existing equipment
- c. Intelligibility
- d. Security
- e. Low cost

There are two basic approaches to voice encryption--analog and digital; and of course there are several possible versions of each approach. In general the greatest security is offered by utilizing digital techniques, but at the expense of size, cost, and transmission bandwidth. As a result, various digital approaches have been utilized almost exclusively to provide strategic security, while analog techniques are usually applied to tactical levels where size and cost are more important.

To code a voice signal digitally, the usual approach is to sample repetitively the analog signal voltage, generate a binary word for each sample representing the average or peak voltage during the sample, code the digital words by the application of an arbitrary code key, and transmit the resultant coded digital bit stream. Upon receipt, the signal is decoded and converted back to an analog voltage. This process is illustrated in Figure 1.

The fundamental reason why this approach could not be applied to the transceiver program is that the bandwidth requirements are beyond the capability of existing equipment. For adequate intelligibility, the sampling rate must be at least twice the highest audio frequency desired, or about 6000 samples per second. A minimum of four bits are needed for reasonable accuracy in measuring the value of each sample, which means that the transmitted bandwidth must accommodate 24,000 bits per second--significantly above the 3-kilohertz maximum bandwidth of existing transceivers.

Some bandwidth compression is possible with specialized digital techniques (i. e. , use of a vocoder), but at the expense of degraded quality and/or greatly increased complexity. It was therefore concluded that some form of analog technique was indicated for this application.

Analog voice coding, or scrambling, can be accomplished by two main techniques: time and frequency permutation. (Voice coding should be distinguished from mere masking of the signal with either noise or tones, which are later filtered out. The security afforded by masking was deemed insufficient for further consideration.)

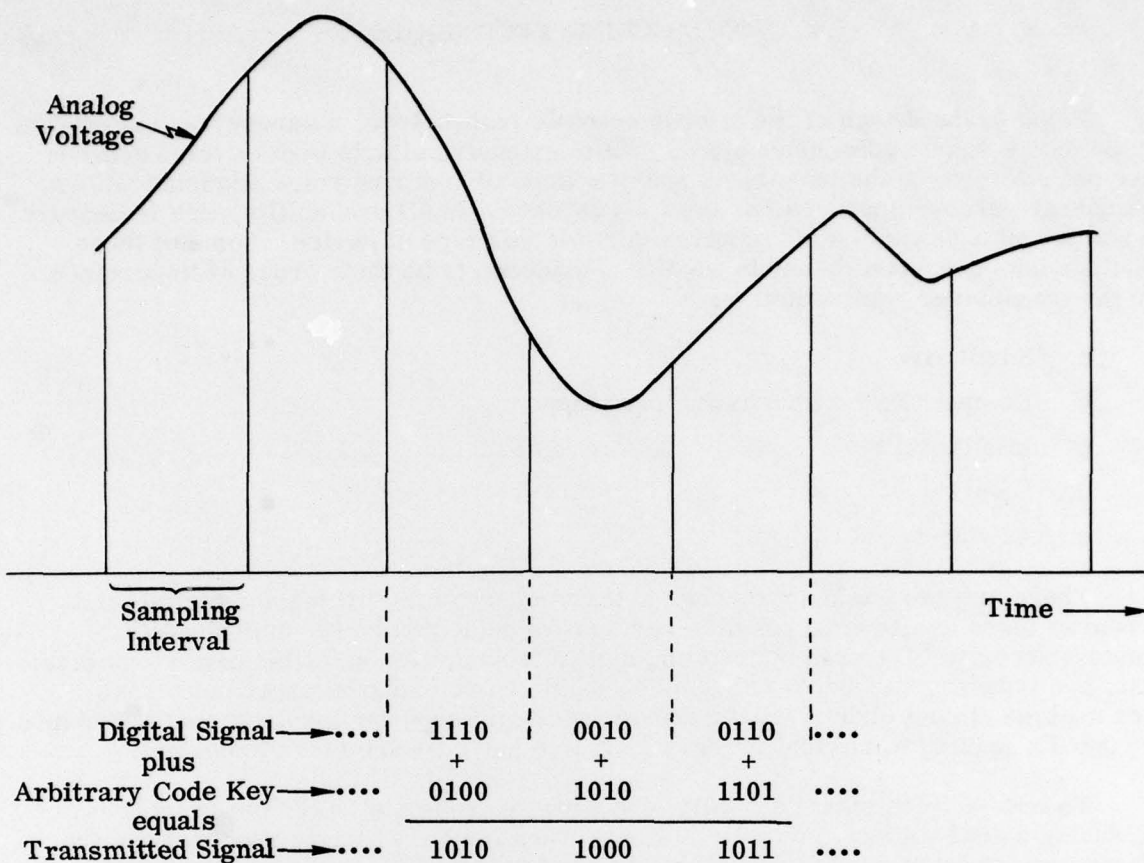

Figure 1. Digital Coding Technique

Time permutation is accomplished by breaking the audio signal into time increments and rearranging the increments according to some arbitrary code. A block diagram of this approach is shown in Figure 2, together with representative waveforms.

As would be expected, frequency permutation is accomplished by dividing the voice spectrum into separate frequency bands, and through mixing and filtering, shifting the bands to other places within the audio spectrum. Representative waveforms with this technique are shown in Figure 3.

For each of these techniques there is no theoretical limit to the number of codes that can be utilized. In practice, however, it is difficult to achieve more than 10 to 20 unique codes. Thus, security is relatively low in both cases as compared to a digital approach.

The main difficulty with time permutation is that at the frequencies of concern the only practical means for temporary storage is the use of a mechanical recording device. Since this is incompatible with the requirement for small size, frequency permutation was selected as the approach most suited for the

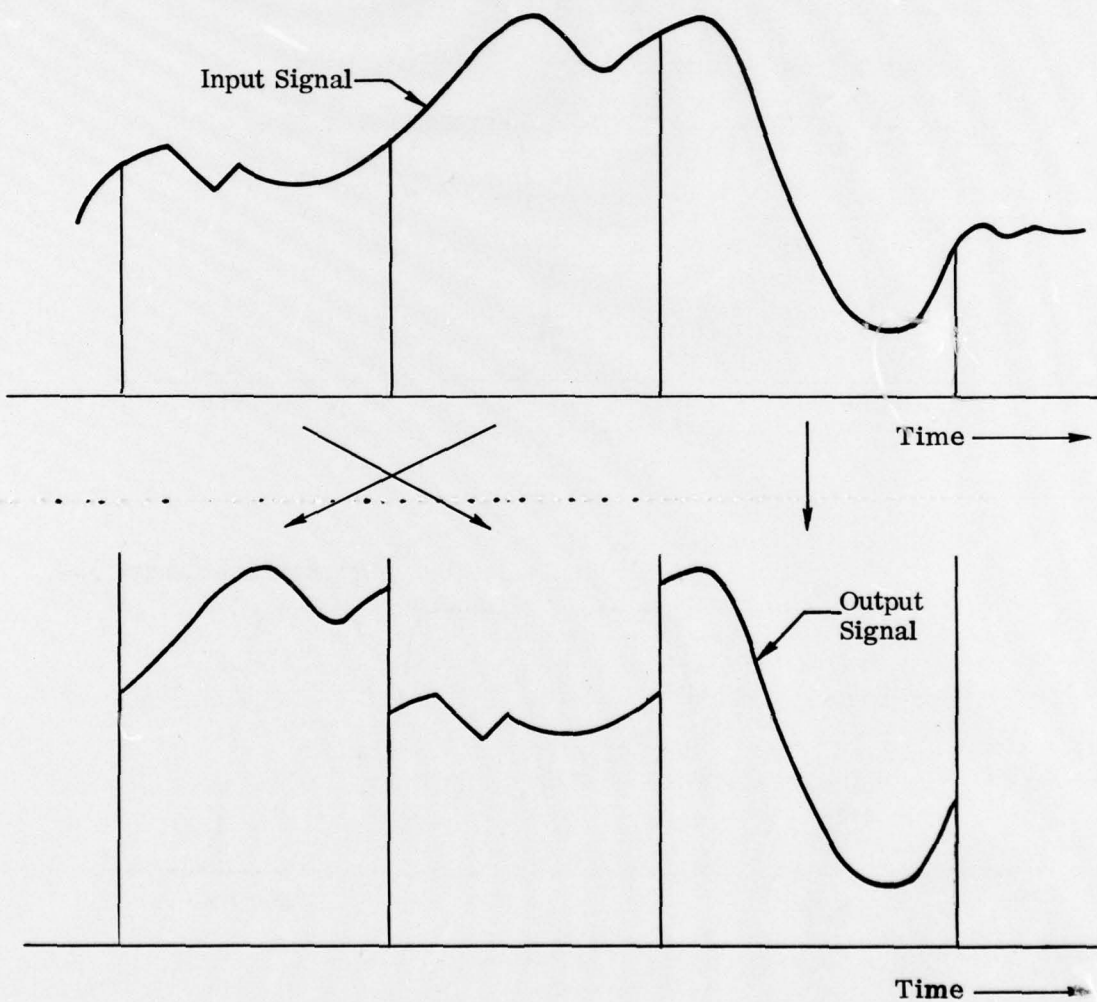
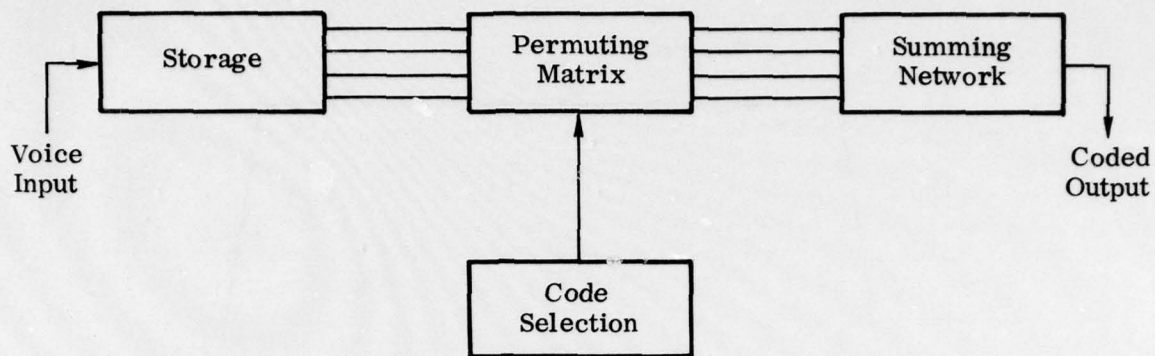

Figure 2. Analog Time Permutation

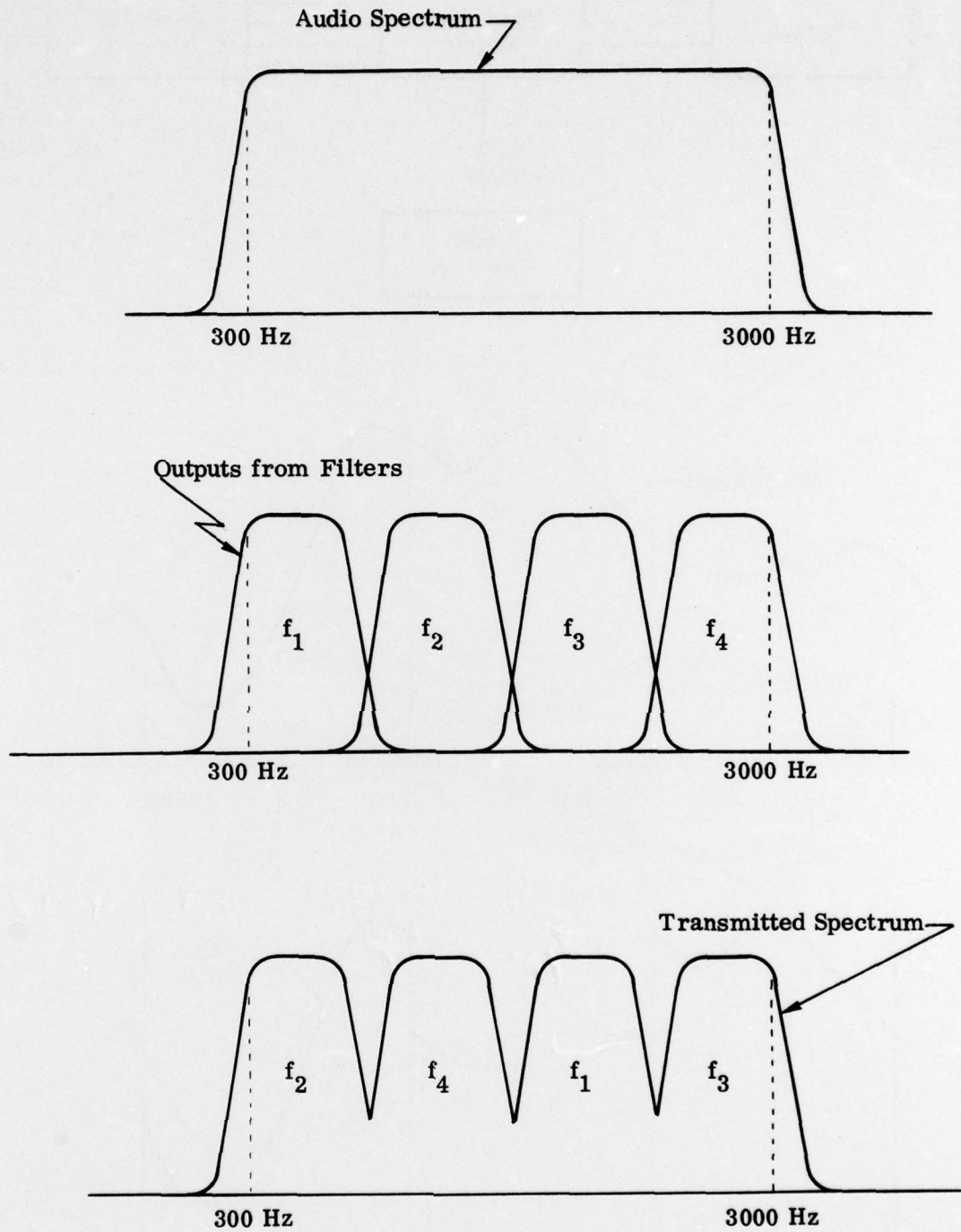

Figure 3. Frequency Permutation

467-01-1-904

microelectronic transceiver application. This approach was further restricted to frequency inversion for the following reasons:

- a. It is the only approach that offers a high degree of confidence that the size limitations can be met.
- b. It represents a basic technique that can be expanded at a later date to provide a greater degree of security.
- c. The development effort could be performed within the allocated schedule.

## 5. VOICE SCRAMBLER DESIGN

Referring to Figure 4, the requirements for mechanizing a frequency-inverting voice scrambler can be broken into three basic functions:

- a. An input low-pass filter for limiting the input high-frequency response;
- b. An oscillator-modulator for sideband generation;
- c. An output low-pass filter for removing the upper sideband.

The voice scrambler designed by ARINC Research performs these functions. It has unity gain, operates with about 1.0 Vac input, and consumes less than 100 mW power. The band of frequencies at the output (500-2500 Hz) is approximately equal to the band of frequencies at the input. These characteristics make this device fully compatible with the transceiver bandwidths in general, and the Motorola HT series specifically.

Block A in Figure 4, an emitter follower with approximately unity gain, isolates the transceiver output from the scrambler input. Block B is an active low-pass filter with unity gain in the passband, a cutoff frequency of 2500 Hz, and a slope of 48 db/octave. This filter is an optimally flat Butterworth type with four identical sections, one of which is shown in Figure 5. The poles of the filter must be equidistantly spaced on the perimeter of a unit semicircle plotted on the S-plane, which requires that each section have a different damping factor and thus different values of resistance and capacitance. The resulting cutoff characteristics are closer to theoretical with less stringent component tolerances, and eases the requirements imposed on the integrated version.

Block C of Figure 4 is a passive network that adjusts the modulator input level to 0.1 Vac. Block D is the double-balanced modulator, for which Figure 6 shows two versions being considered. Each version is transformerless and performs adequately in discrete form with hand-selected components. Selection of the final circuit will be based on the configuration best suited to integration.

The circuit of Figure 6A is similar to a transformer-coupled modulator. Matched resistors  $R_a$ ,  $R_b$ ,  $R_c$  and  $R_d$  replace the respective transformer windings, and if points 1 and 2 are driven equally but 180 degrees out of phase, the difference between points 3 and 4 is the double-balanced output. The performance of the circuit depends not only on the resistor and diode match but also on the common mode rejection of the difference amplifier (Q1 and Q2). Considering these requirements, a practical integrated version is possible.

In Figure 6B the local oscillator signal modulates Q5 and Q6 and hence the current to Q1-Q2 and Q3-Q4, dual difference amplifiers. The input signal is coupled equally to Q1 and Q4, and by virtue of the inherent logarithmic transfer characteristic of the transistor, the two signals are intermodulated. Although this circuit has fewer components than that of Figure 6A, component matching is a greater problem. The desired level of harmonic rejection depends heavily on the match of the transfer characteristics of Q1, Q2, Q3, and Q4, and to a lesser degree on Q5 and Q6. Extensive computerized analyses of matched logarithmic characteristics indicate that experimentation with an integrated version is warranted.

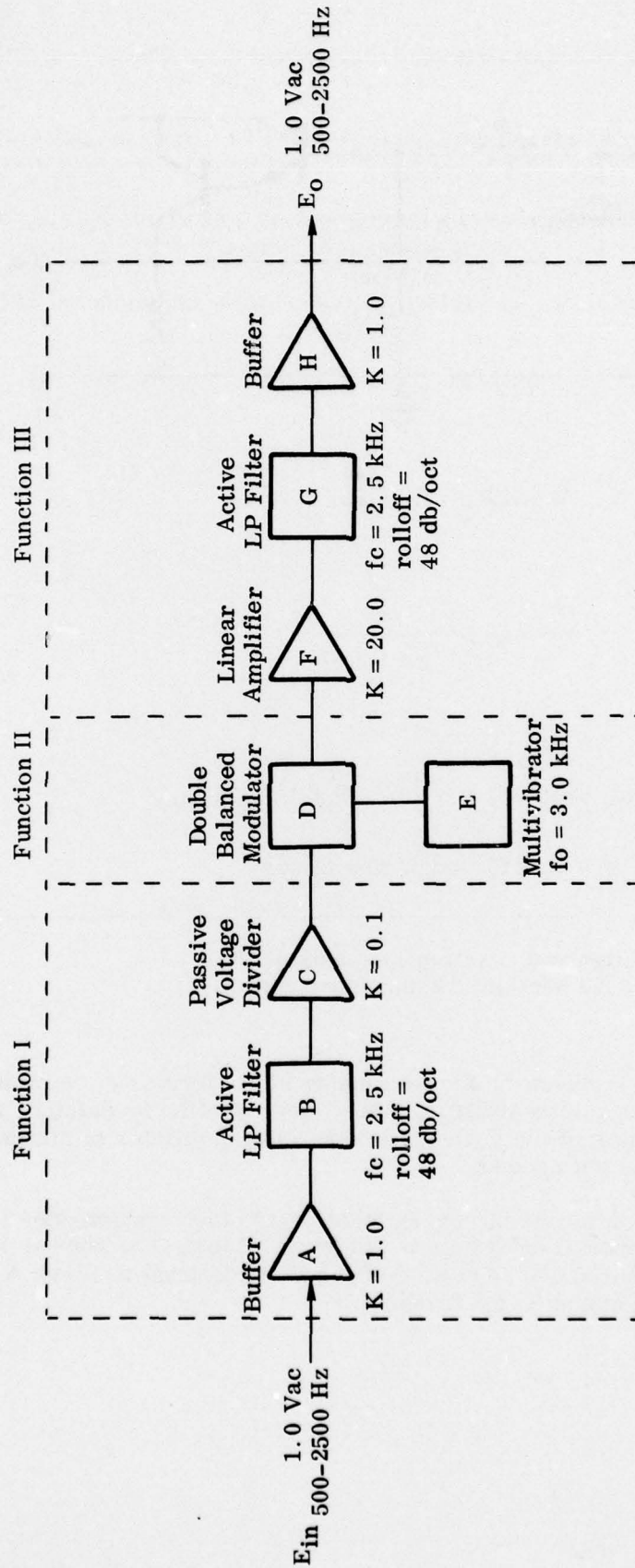

Figure 4. Block Diagram, Frequency Inverting Voice Scrambler

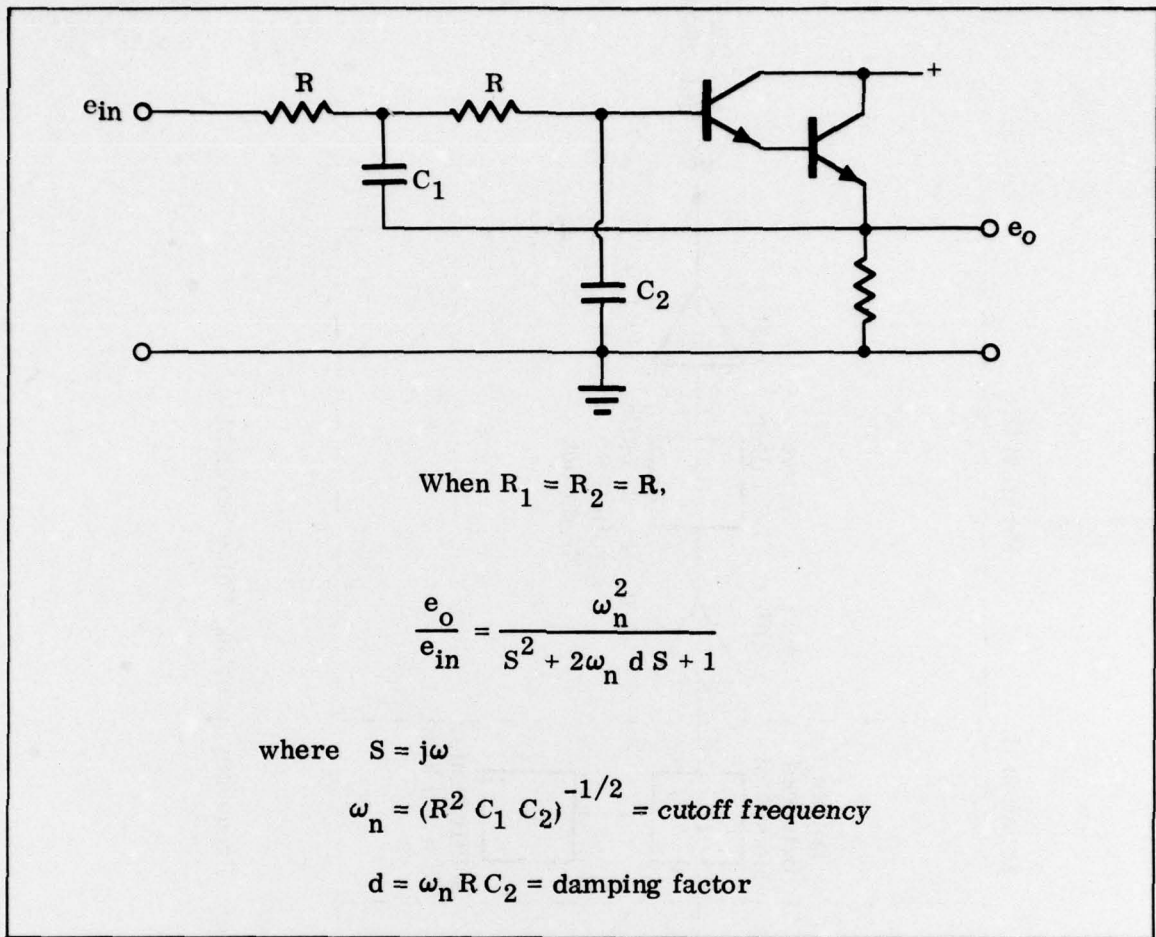

Figure 5. Active Low-Pass Filter  
(One Section, 12 db/octave Rolloff)

Block E is the local oscillator, a free-running multivibrator of conventional design. By eliminating the microminiature transformers in the modulator, and hence the unbalanced nonlinearities of the devices, a sine-wave oscillator to minimize the generation of harmonics is not needed.

Block F is a linear amplifier of conventional design that compensates for other circuit losses so that an overall unity gain is achieved. Block G is similar to Block B, giving a 48 db/octave rolloff above 2500 Hz. Block H is identical to Block A and provides a low impedance output to the transceiver.

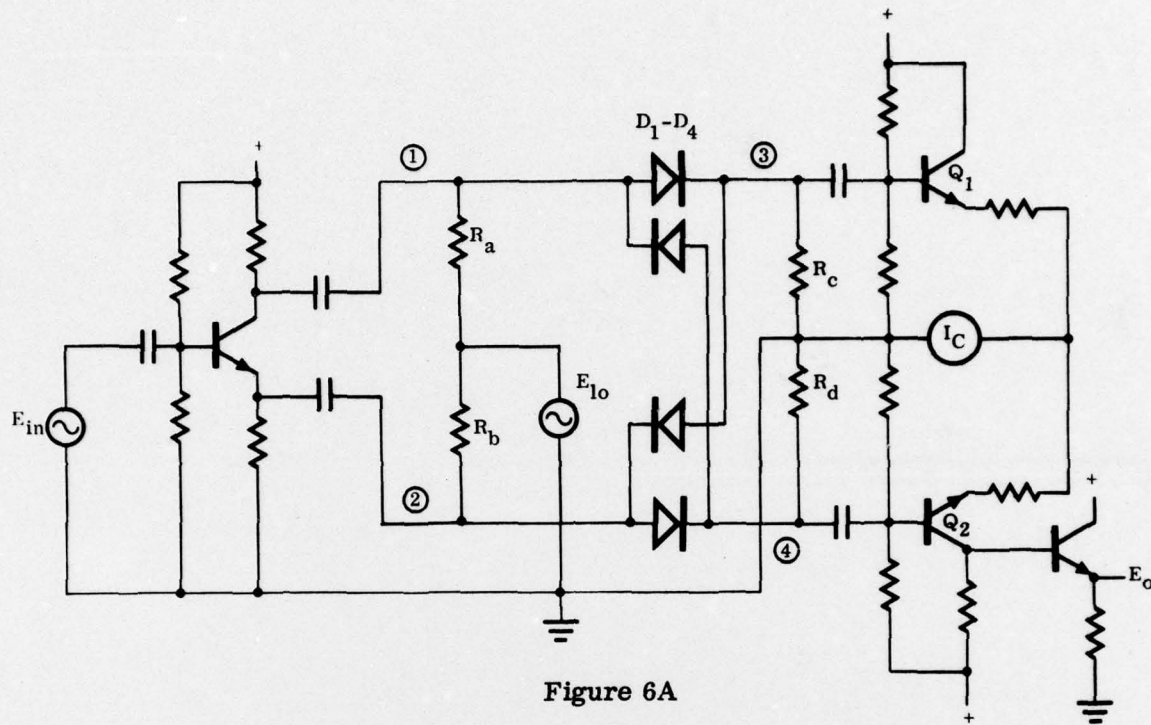

Figure 6A

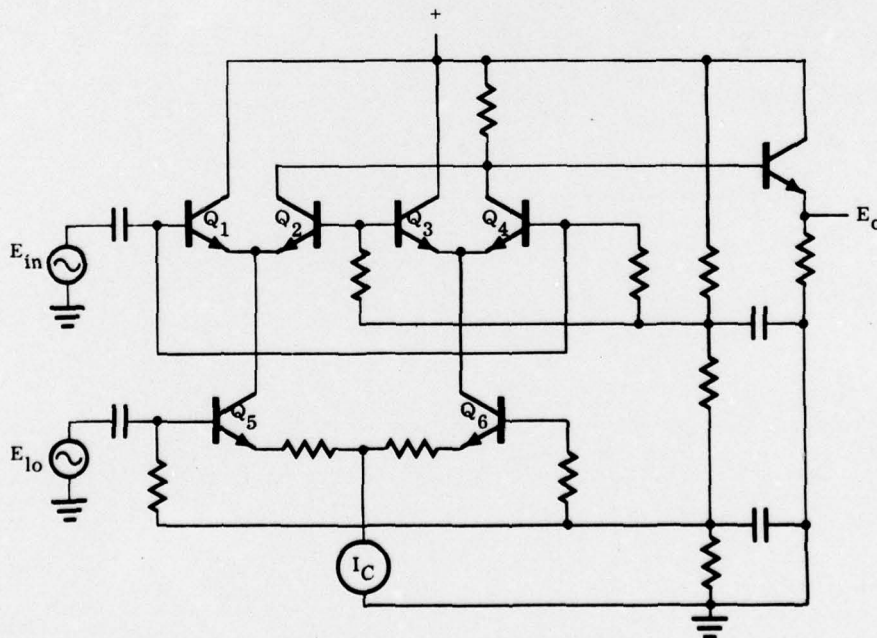

Figure 6B

Figure 6. Double-Balanced Modulator Configurations