

AD-A054 855 NAVAL AIR ENGINEERING CENTER LAKEHURST N J GROUND SUP--ETC F/6 6/11
RELIABILITY TEST REPORT. MODULAR CRYOGENIC GENERATOR.(U)
APR 78 R FERRET

UNCLASSIFIED

NAEC-92-124

NL

1 of 1
AD
A054 855



END
DATE
FILMED
7-78
DDC

FOR FURTHER TRAN 

AD A 054855



NAVAL AIR ENGINEERING CENTER

REPORT NAEC-92-124

14

all
12

9 Final technical rept.,

6 RELIABILITY TEST REPORT,
MODULAR CRYOGENIC GENERATOR.

11 27 APR 1978

12 83 P.

10 R. Ferret

927

GSED

Naval Air Engineering Center, GSED
Lakehurst, New Jersey 08733

FEBRUARY 1978

DDC
RECEIVED
JUN 7 1978
E

AD No. _____
DDC FILE COPY

FINAL TECHNICAL REPORT, JANUARY 1978

A/T 534534B/051D/7WSL730000

Prepared for

Naval Air Systems Command
AIR-534
Washington, D.C. 20361

DISTRIBUTION STATEMENT A
Approved for public release;
Distribution Unlimited

405 919 mt

RELIABILITY TEST REPORT

MODULAR CRYOGENICS GENERATOR

Prepared by:

Roman Ferret

ROMAN FERRET

92723 Branch

Reviewed by:

J. J. Connor

J. J. CONNOR

927 Division Superintendent

Approved by:

F. E. Evans

F. E. EVANS

GSED Superintendent

NOTICE

Reproduction of this document in any form by other than naval activities is not authorized except by special approval of the Secretary of the Navy or the Chief of Naval Operations as appropriate.

The following espionage notice can be disregarded unless this document is plainly marked CONFIDENTIAL or SECRET.

This document contains information affecting the national defense of the United States within the meaning of the Espionage Laws, Title 18, U.S.C., Sections 793 and 794. The transmission or the revelation of its contents in any manner to an unauthorized person is prohibited by law.

SECURITY CLASSIFICATION OF THIS PAGE (When Data Entered)

REPORT DOCUMENTATION PAGE		READ INSTRUCTIONS BEFORE COMPLETING FORM
1. REPORT NUMBER NAEC 92-124 ✓	2. GOVT ACCESSION NO.	3. RECIPIENT'S CATALOG NUMBER
4. TITLE (and Subtitle) Reliability Test Report ✓ LOX-30 Liquid Oxygen Generator ✓		5. TYPE OF REPORT & PERIOD COVERED ✓ Final Technical Report January 1978
		6. PERFORMING ORG. REPORT NUMBER
7. AUTHOR(s) R. Ferret		8. CONTRACT OR GRANT NUMBER(s)
9. PERFORMING ORGANIZATION NAME AND ADDRESS Naval Air Engineering Center ✓ Ground Support Equipment Department Lakehurst, New Jersey 08733		10. PROGRAM ELEMENT, PROJECT, TASK AREA & WORK UNIT NUMBERS A/T534534B/051D/7WSL730 000 WU 14 B
11. CONTROLLING OFFICE NAME AND ADDRESS Naval Air Systems Command AIR-534 Washington, D.C. 20361		12. REPORT DATE 27 Apr 1978 ✓
		13. NUMBER OF PAGES 83
14. MONITORING AGENCY NAME & ADDRESS (if different from Controlling Office)		15. SECURITY CLASS. (of this report) Unclassified
		15a. DECLASSIFICATION/DOWNGRADING SCHEDULE
16. DISTRIBUTION STATEMENT (of this Report)		
<div style="border: 1px solid black; padding: 5px; width: fit-content; margin: auto;"> <p>DISTRIBUTION STATEMENT A</p> <p>Approved for public release; Distribution Unlimited</p> </div>		
17. DISTRIBUTION STATEMENT (of the abstract entered in Block 20, if different from Report) Approved for public release; distribution unlimited.		
18. SUPPLEMENTARY NOTES		
19. KEY WORDS (Continue on reverse side if necessary and identify by block number) Liquid Oxygen, Reliability Growth, Environmental Requirements, Reliability Demonstration, LOX-30 Liquid Oxygen Generator, Failure Distribution.		
20. ABSTRACT (Continue on reverse side if necessary and identify by block number) Reliability Testing of the LOX-30 Liquid Oxygen Plant was evaluated in accordance with MIL-STD-781. Reliability Tests were divided into Environmental Requirements, Reliability Growth and Reliability Demonstration Tests. Accept/reject criteria for the demonstration test was a specified MTBF of 1900 hours at the 30% risk level which was met. Four non-relevant failures occurred but had minor effect on the LOX-30 system. A failure		

DD FORM 1 JAN 73 1473

EDITION OF 1 NOV 65 IS OBSOLETE
S/N 0102-LF-014-6601

Unclassified

SECURITY CLASSIFICATION OF THIS PAGE (When Data Entered)

SECURITY CLASSIFICATION OF THIS PAGE (When Data Entered)

distribution was established for the electro-pneumatic solenoid valves to be Log-normal.

ACCESSION for	
NTIS	White Section <input checked="" type="checkbox"/>
DDC	Buff Section <input type="checkbox"/>
UNANNOUNCED	<input type="checkbox"/>
JUSTIFICATION	
BY	
DISTRIBUTION/AVAILABILITY CODES	
Dist. AVAIL. and/or SPECIAL	
A	

TABLE OF CONTENTS

<u>SECTION</u>	<u>TITLE</u>	<u>PAGE</u>
I.	RELIABILITY ANALYSIS.....	1
I.A	INTRODUCTION	1
I.B	BACKGROUND.....	1
I.C	DESCRIPTION OF EQUIPMENT.....	1
I.D	METHOD.....	3
II.	ENVIRONMENTAL QUALIFICATIONS.....	4
III.	RELIABILITY GROWTH.....	5
IV.	RELIABILITY DEMONSTRATION.....	6
IV.C	PURITY.....	6
IV.D	PRODUCTION RATE.....	8
IV.F	CLASSIFICATION OF FAILURE.....	9
IV.G	FAILURE CATEGORIES.....	10
IV.H	DISCUSSION.....	10
IV.I	OBSERVATION AND DEDUCTIONS.....	12
IV.J	CONCLUSIONS.....	13
IV.K	RECOMMENDATIONS.....	13

	APPENDIX A	
	RELIABILITY DEMONSTRATION TEST OUTLINE	
	APPENDIX B	
	ENVIRONMENTAL TEST DATA	
	APPENDIX C	
	FAILURE REPORTS	
	APPENDIX D	
	FLOW RATE GRAPHS	
	APPENDIX E	
	STATISTICAL ANALYSIS OF SOLENOID MECHANISMS	
	REFERENCES.....	5E

I. RELIABILITY ANALYSIS

A. INTRODUCTION.

1. This report is a compilation of reliability test results of the Reliability Demonstration Test for the Liquid Oxygen Modular Cryogenic Generator. The purpose of this test was to measure the reliability mean time between failure and verify that the Liquid Oxygen Generator (LOX-30) is able to perform its intended mission without excessive failures.

2. The test was conducted in accordance with the provisions of MIL-STD-781 and the procedures of the detailed test plan. Accept/reject criteria were based on Test Plan VIII with specified mean time between failure (MTBF) of 1900 hours. Total test time was 1617 hours.

3. Reliability and maintainability demonstration tests were coordinated and performed by the same personnel using similar criteria and procedures, therefore resulting data are consistent and applicable to either test.

4. The following documents were used to establish test procedures, standardize operating and maintenance requirements, and evaluate test results.

- a. MIL-STD-781B Reliability Tests: Exponential Distribution
- b. Reliability and Maintainability Demonstration Plan
- c. MIL-STD-721 Definitions of Effectiveness Terms of Reliability, Maintainability, Human Factors and Safety
- d. Reliability Engineering Handbooks, NAVAIR 00-65-502
- e. MIL-D-27210 Oxygen, Aviators Breathing, Liquid and Gas

B. BACKGROUND.

1. The Liquid Oxygen Generator is required at Naval Air Stations overseas to produce oxygen used in servicing air crew survival equipment, and medical units. The oxygen is produced as a cryogenic liquid for convenience of storage and when required the liquid oxygen is utilized to fill aircraft liquid oxygen converters and vaporized into a gas and transferred to gas cylinders.

2. The mission of the LOX-30 generator is to provide 600 to 1600 gallons per month of high purity liquid oxygen to fulfill daily operational requirements and maintain a sufficient level of oxygen storage to continue fulfilling operational requirements in the event of equipment maintenance due to failure.

C. DESCRIPTION OF EQUIPMENT.

1. The Liquid Oxygen Generator, LOX-30, consists of the following subsystems and is represented in a block diagram in Figure 1.

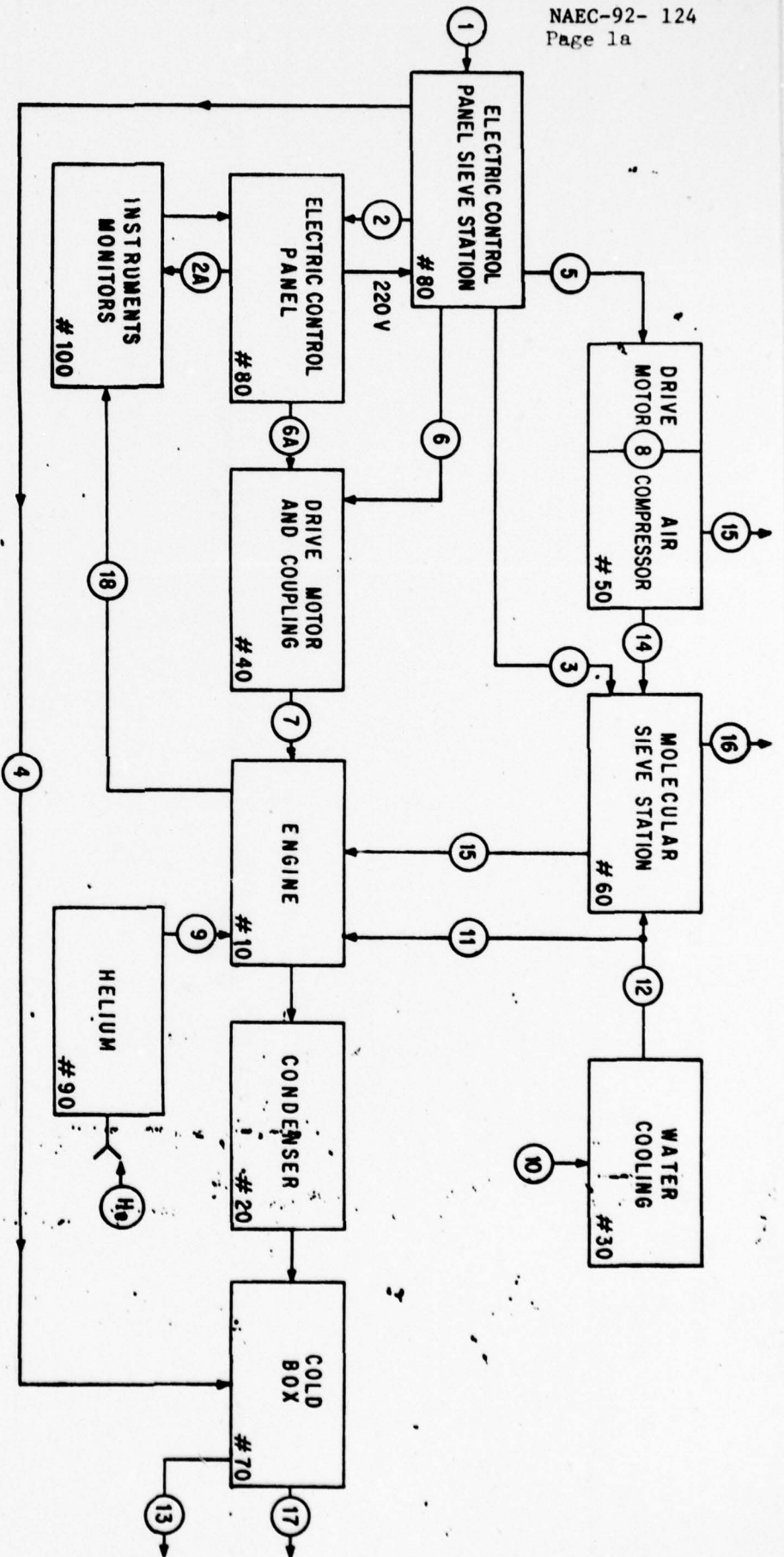

FIGURE 1

FUNCTIONAL BLOCK DIAGRAM

CODE	FUNCTION	DESCRIPTION	CODE	FUNCTION	DESCRIPTION
1.	Line Power	380/460V, 3Ø 103KW, 50/60 Hz	12.	Sieve Station Water Supply	4.0 gal/min
2.	Control Power Cryo Panel	220V, 60 Hz	13.	Liquid O ₂ output	6.93 gal/hr, 14.7 psig
3.	A. Instrument Panel Control Power Sieve Station	115/220V 220V, 1Ø 60 Hz 380/460 3Ø 50/60 Hz	14.	Compressor Discharge Air	60 psig, 252°F
4.	Heater Power Column E1	220V 1Ø 50/60 Hz	15.	A. Over Pressure	100 psig
5.	Drive Motor Power, Compressor	380/460V 50/60 Hz 3Ø, 30KW	16.	Molecular Sieve Station	2 bar
6.	Drive Motor Power, Cryogenerator	460V, 60 Hz 3Ø 51KW	17.	A. Over Pressure Valve 901 Column	3. bar
7.	Torque, Engine	220V	18.	A. Storage Tank Engine Sensor	150°F
8.	Torque, Air Compressor	Function of 3Ø Power Direct Drive Thomas Type Coupling and Shive	A.	Water Flow (gal/hr)	15 psig
9.	Helium Charge Line	Function of 3Ø Power Belt and Shive	B.	Cyl/Crankcase Temp	25 to 70 psig
10.	Water Supply	Static Charge 230-240 psig	C.	Differential Pressure	199-370 psig
11.	Engine Water Supply	20.0 gal/min	D.	Oil Pressure	
		16 gal/min, 30 psig 59°F	E.	Working Pressure	

2. Subsystem Number 10 - Engine. The cryogenerator engine is a self lubricated four cylinder closed cycle expansion engine cooler. An integrated working piston and displacer assembly operating in a single cylinder and connected to a common crankshaft journal form the nucleus of the engine operation and achieve the alternate compression, displacement and expansion of the working gas. The crankshaft is supported by five main and insert bearings. Axial forces are transferred to the crankcase via a thrust bearing. Lubrication is provided by an integral gear type oil pump driven by the engine via a nylon coupling.

3. Subsystem Number 20 - Header. Located atop and around the cylinder housing assemblies, the condenser consists of four condensing heads which form the top of the engine cylinders. Regenerators are positioned within each level and perform their heat transfer function as the working gas flows through each while passing between the expansion and compression chambers. The condenser heads are connected in parallel and are slotted to provide a greater cooling surface area. In the event of a cracked head, a safety valve will relieve condenser insulating space pressure at about 2 psig. An underpressure safety switch monitors condenser head pressure and will shut down the engine should excessive under pressure occur.

4. Subsystem Number 30 - Water Cooling. Continuous operation of the LOX-30 requires approximately 1200 gallons per hour cooling water at 30 to 60 psig and temperature at 59 to 70°F. Water is delivered to a manifold from where it is distributed to four helium coolers atop the cylinder housing assemblies. Each helium cooler receives water flow to remove the working gas heat of compression. Should water temperature exceed $115 \pm 5^\circ\text{F}$, a thermostat in the outlet manifold is set to shut down the engine.

5. Subsystem Number 40 - Drive Motor and Coupler. The 60 HP continuous duty drive motor is horizontally mounted to the cryogenerator bed plate and is connected to the engine through a flexible coupling. The flexible coupling compensates for slight misalignment of the drive motor armature and engine crankshaft. The 60 HP, 3 phase motor is of drip-proof construction having grease packed ball bearings supporting a squirrel cage armature in the motor frame.

6. Subsystem Number 50 - Air Compressor. The Atlas Copco Air Compressor, BT-4, is a two-cylinder, two stage air cooled reciprocating compressor. The BT-4 compressor is built for working pressure up to 125 psig with one low pressure and one high pressure cylinder "V" mounted on the crankcase and equipped with an element type inlet filter. The unit contains an intermediate air cooler, a pressurized lubricating oil system with an oil pressure gage, an air-intake suction filter with silencer, compressor-air shock absorber, safety valves and pressure gauges for intermediate and discharge pressures. The air compressor is driven by a 40 HP electric, 3 phase continuous duty drive with a squirrel cage armature in the motor frame.

7. Subsystem Number 60 - Molecular Sieve Station. The molecular sieve station consists of an air/water aftercooler, a water separator, an oil adsorber, two molecular sieve adsorbers, and an electric heater, all mounted on a common base, and interconnected by the required piping. A power module,

which contains the electrical equipment necessary to distribute power to the other units as well as the electrical controls necessary for regeneration of the adsorbers, is mounted at the rear of the molecular-sieve-station skid.

8. Subsystem Number 70 - Cold Box (separation unit). The cold box consists of a cylindrically shaped steel shell with an externally mounted instrument and control valve panel. The shell is comprised of the following contents. A heat exchanger which cools the process air and warms the tail gas leaving the unit. Rectification column that separates the process air into pure liquid oxygen and impure nitrogen gas. Condenser/evaporator that prepares the media used in the rectification column for mass transfer. An electric heater to increase product transfer to the storage tank is provided and located on the face of the cold box.

9. Subsystem Number 80 - Electrical Control Panel. The control panel contains indicating instruments, indicating/alarm lights, lighted and unlighted push button switches, and an elapsed time meter, all of which are used in the manual and automatic control of the plant. The indicating instruments on the panel are pneumatic (for helium pressures), hydraulic (for oil pressures), and electric (ammeter and elapsed time), each of which is marked to identify the particular variable measured and displayed. Indicating lamps are used to indicate operating or non-operating circuits as well as fault or alarm indications at selected points in the system. Each indicator is marked to identify the condition or point involved. The lower section of the control panel contains a subpanel with control relays. The relay subpanel can be reached through a door on the rear of the panel.

10. Subsystem Number 90 - Helium Distribution. Helium gas is used as the working gas agent within the engine. The helium is provided in replaceable externally mounted pressurized containers. A pressure regulator and safety valve mounted on the cylinder ensures the gas is of correct pressure for introduction into the engine. The engine is pressurized to approximately 199 psig min. static pressure. During engine operation, the pressure will rise to 370 psig max. A helium filter and oil separation unit cleanses the gas before it enters the cylinder housing assembly eccentric chamber prior to introduction into the compression chamber.

11. Subsystem Number 100 - Instrumentation and Monitors. The subsystem consists of various pressure gages, pressure switches, temperature monitors, and water flow sensors, each capable of interrupting system operation should the tolerances be exceeded.

D. METHOD.

1. The reliability demonstration test was comprised of three parts, (1) Environmental Qualification, (2) Reliability Growth and (3) Reliability Demonstration, all of which were run concurrently from March 1977 through August 1977 on one sample LOX-30 system at the Lakehurst Naval Air Station Lakehurst, New Jersey. The LOX-30 system was operated with the assistance of an instruction manual provided by the contractor and in accordance with operational procedures prepared by the Naval Air Engineering Center, Code 92714.

2. Prior to initiation of the reliability and maintainability demonstration tests, the LOX-30 system had been operated by the contractor and Code 92714 a total of 710.3 hours (i.e., cryogenerator time). The balance of operational time, 1616.3 hours, was run in accordance with the reliability demonstration test plan. A brief outline of the reliability demonstration test period is enclosed in Appendix A.

II. ENVIRONMENTAL QUALIFICATIONS TEST

A. AR-113 requires that environments, both natural and induced, imposed during test shall be based on field environments.

1. The LOX-30 Liquid Oxygen Generator will be deployed as a fixed installation, properly housed within a temporary or permanent structure. Consequently, the generator will not be exposed to any adverse ambient environmental condition. Ambient air temperatures and humidity, however, do effect the net productivity of the generator, which is true for all cryogenic generators that are basically air liquefaction plants. The combination of high air temperature and high relative humidities do reduce the production rate of the LOX-30 system. The environmental test portion of the program consisted of operating the system in temperature ranges of 50° to 100° F for 1617 hours after which no relevant failures were observed. This demonstrated a system MTBF of at least 1900 hours at 70% confidence, however, the MTBF for those piece parts which experienced no failure could not be determined with any degree of confidence. Therefore further life testing to obtain additional data should be proposed followed by stress-strength testing on selected components.

2. An investigation of the environmental conditions was made to determine the maximum and minimum air temperatures and relative humidities that might be anticipated at all the overseas Naval Air Stations. These data are available in the publication, "U.S. Navy and Marine Corps Meteorological Station Climatic Summaries". It was determined that the normal weather conditions which prevail at NAEC, Lakehurst would provide sufficient temperature and humidity excursions during the environmental period of the Reliability Test Program that no special test chamber would be necessary. Because the LOX-30 is to be installed indoors, no other environmental tests (i.e., rain, sand, vibration, etc.) were to be conducted. Since the moisture content of the inlet air to the generator is the major factor upon reliability, the tests were conducted accordingly. This is true because the effect of humidity and temperature is great on production.

3. The ambient air temperatures and relative humidities were recorded by a Hygrothermograph, Model Serdex B, Bacharach Instrument Company, at the compressor air inlet.

4. Conclusion.

The test data indicates that although the LOX-30 plant did experience operating periods where atmospheric moisture content was high, no adverse operating situations were experienced during the test period.

The highest average moisture content level recorded at the overseas installations is .0215 pounds water per pound dry air. The highest level recorded during the test program at Lakehurst was .0270.

The mission requirement has been determined to be less than 4 days. Therefore the LOX-30 can adequately meet the mission. Test data are provided in Appendix B.

III. RELIABILITY GROWTH

A. This part constituted the growth test commencing after 710 operating hours on the LOX-30 system. Periodic and 1500 hour maintenance was completed by NAEC.

B. The values predicted on the Mission Analysis and the Program Master Plan are established as follows:

Specified MTBF	$\theta_0 = 1900$ hours
Predicted MTBF	$1.77 \theta_0 = 3375$ hours
Growth Rate	$= .70$

These values establish the Reliability Growth Model which is graphically presented in Figure 2. The objective of the growth program is to set a goal which will guide the development program step by step so that the reliability requirement will be met at least within the final stage development.

C. The LOX-30 System Growth Test began and continued without experiencing a relevant failure. Premature shutdowns due to power failure and water chiller breakdown did occur during the test period. At no time during the Reliability Growth Test was any major corrective maintenance taken on the LOX-30 system.

D. At 875 hours of reliability growth test time, no relevant failures had occurred. Assuming one failure in order to calculate MTBF, the growth rate at 875 hours is equal to the minimum growth rate of .60. It was concluded to continue the test to 1500 hours which would produce a growth above minimum and within the specified rate envelope at the time of the

FIG. 2

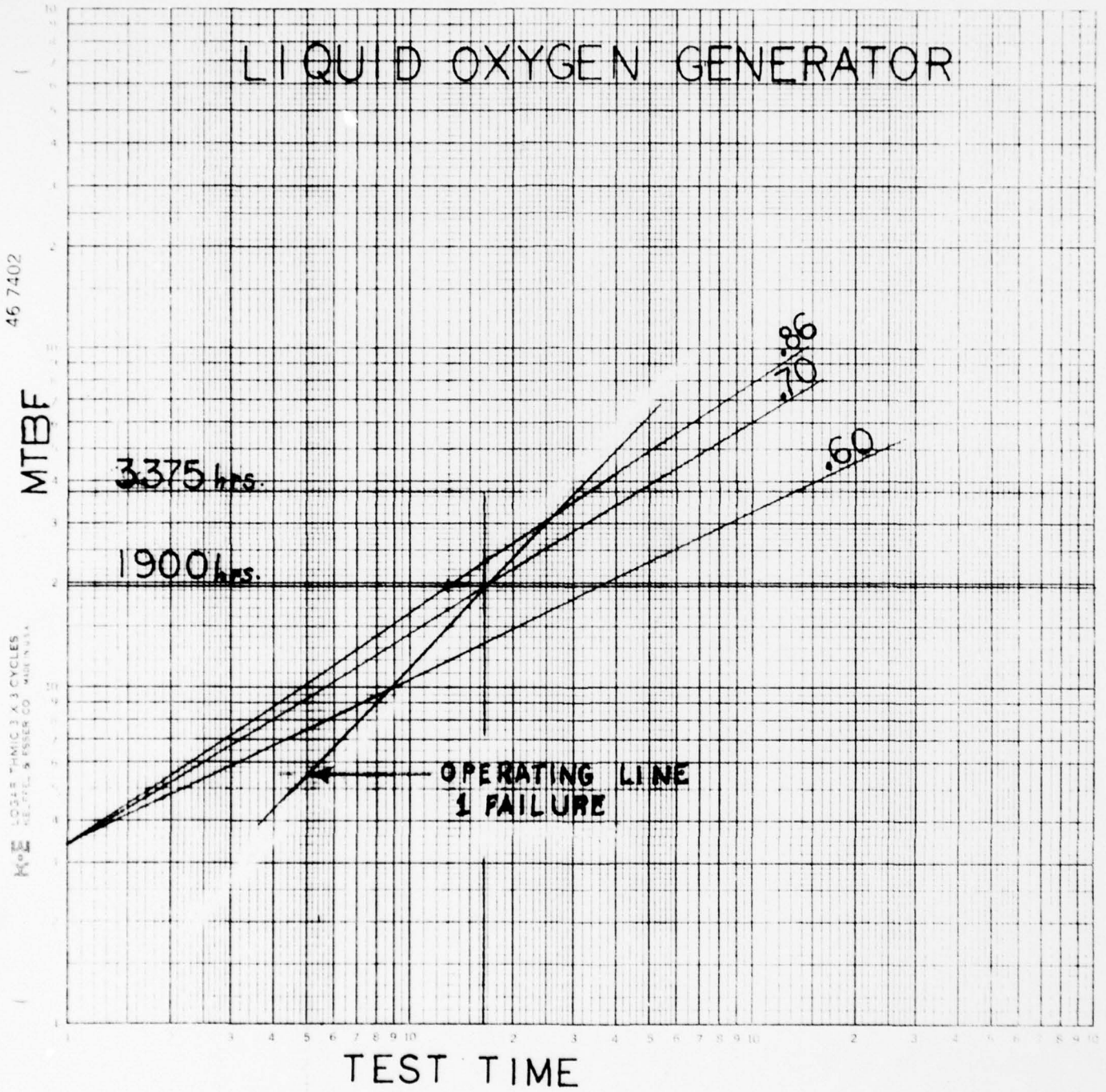

LOGSHE THMIC 3 X 3 CYCLES
L. J. FELT & ESSER CO. MAINT. UNIT

1500 hour preventive maintenance. At this time the growth test was concluded and the test accredited toward reliability demonstration.

IV. RELIABILITY DEMONSTRATION

A. The reliability demonstration was conducted in accordance with provisions of MIL-STD-781 and the procedures of the reliability and maintainability demonstration test plan.

B. During the entire test, a total of eight personnel were used to monitor the LOX-30 system 24 hours per day, four shifts per day. When the LOX-30 was in production the following performance parameters and limits were used as a baseline for the reliability test.

I. Purity - 99.5% pure measured with a Beckmon Analyzer - Thermal Conductivity Principle.

CO ₂	5.0 ppm or less
CH ₄	25.0 ppm or less
N ₂ O	1.0 ppm or less

II. Odor - Any detection of odors shall be cause for rejection.

III. Production Rate - Minimum 6.62 gal/hr.

A graphical illustration of LOX-30 monthly and daily flow rates are presented in Appendix D.

C. PURITY.

Throughout the reliability test, purity was monitored and recorded on a daily run sheet. Numerous occasions arose where liquid oxygen purity would wander below 99.5% primarily due to excess operator adjustment and atmospheric conditions. On the average, after low purity was discovered and adjustments made, liquid oxygen purity would return to minimum 99.5% within 45 to 60 min. Constituent tests were conducted as per MIL-D-27210 on a weekly basis and where practicable. Throughout the test period Carbon Dioxide (CO₂), Methane (CH₄), and Nitrous Oxide (N₂O) were detectable, all other constituents showed no trace.

A summary of constituent test results are in Table 1.

TABLE 1

<u>Date</u>	<u>Levels</u>	<u>Remarks</u>
March 30	CH ₄ 17.5 ppm	
	N ₂ O .54 ppm	
	CO ₂ 1.0 ppm	
April 6	CH ₄ 18.0 ppm	
	N ₂ O .40 ppm	
	CO ₂ .60 ppm	

<u>Date</u>	<u>Levels</u>	<u>Remarks</u>
April 13	CH ₄ 15.5 ppm N ₂ O .49 ppm CO ₂ .79 ppm	
April 26	CH ₄ 14 ppm N ₂ O .28 ppm CO ₂ 13.0 ppm	Excess CO ₂ count due to excess time on adsorber bed.
May 4	CH ₄ 16.5 ppm N ₂ O .52 ppm CO ₂ 2.0 ppm	
June 23	CH ₄ 19.0 ppm N ₂ O .84 ppm CO ₂ 2.4 ppm	
June 29	CH ₄ 19 ppm N ₂ O .9 ppm CO ₂ 2.0 ppm	
July 5	CH ₄ 17.5 ppm N ₂ O .94 ppm CO ₂ 12.0 ppm	Machine liquid level operating range unstable when samples were taken.
July 18	CH ₄ 13.0 ppm N ₂ O .76 ppm CO ₂ 9.0 ppm	Sample spoiled during transit. CO ₂ count high.
July 31	CH ₄ 13.0 ppm N ₂ O .76 ppm CO ₂ 3.3 ppm	Sample taken from 500 gal storage tank and machine.
August 3	CH ₄ 13.5 ppm N ₂ O .6 ppm CO ₂ 11 ppm	CO ₂ high due to change of adsorber bed interval 60 to 90 min per contractor manual.
August 11	CH ₄ 21.5 ppm N ₂ O .6 ppm CO ₂ 11.0 ppm	CO ₂ high due to adsorber bed interval change.
August 17	CH ₄ 29.5 ppm N ₂ O 4.0 ppm CO ₂ 21.0 ppm	All levels high due to adsorber bed interval time change.
August 19	CH ₄ 26.0 ppm N ₂ O 1.4 ppm CO ₂ 12.0 ppm	90 minute time duration too long. Recommend 1 hour.

D. PRODUCTION RATE.

Calculations of liquid oxygen flow rate were initially conducted by attaching the product hose to a 50 gallon tank and recording the time to fill. At the time of the third week, a Rotometer from Fisher and Potter, Warminster, PA. was obtained and used as the primary instrument for obtaining liquid oxygen flow rates. Average flow rates are presented in Table II.

TABLE II

<u>Week of</u>	<u>Rate</u>	<u>Remarks</u>
April 4 & 11	3.17 gal/hr 3.61 gal/hr	Poor instrumentation
April 25	7.2 gal/hr	Rotometer used
June 27	7.18 gal/hr	
July 5	6.60 gal/hr	
July 18	8.12 gal/hr	500 gallon fill in 96 hrs.
August 1	7.71 gal/hr	500 gallon fill in 97 hrs.
August 8	6.93 gal/hr	
August 15	6.87 gal/hr	

Both 500 gallon tank fills will be assumed to be a representative example of field production rates of the LOX-30 system. Hourly graphs of the 500 gallon fills are presented in Fig. 3A and Fig. 3B along with a trend line of production rates. It was assumed, by examination, that the liquid oxygen production rates can follow a linear trend therefore the linear regression line was calculated. Using the method of list squares and the normal equations, the trend lines were calculated to be:

1. July 20 thru July 24
 $Y = 7.59 + .0108X$
2. August 1 to August 5
 $Y = 6.79 + .018X$

Both curves do show a positive upward slope indicating, as product time continued, a gradual increase of production rates was experienced. The calculated statistics for the two 90 hour periods are:

1. July 20 thru July 24
(mean $\bar{X} = 8.11$ gal/hr)
(variance $S^2 = .42$ gal/hr).

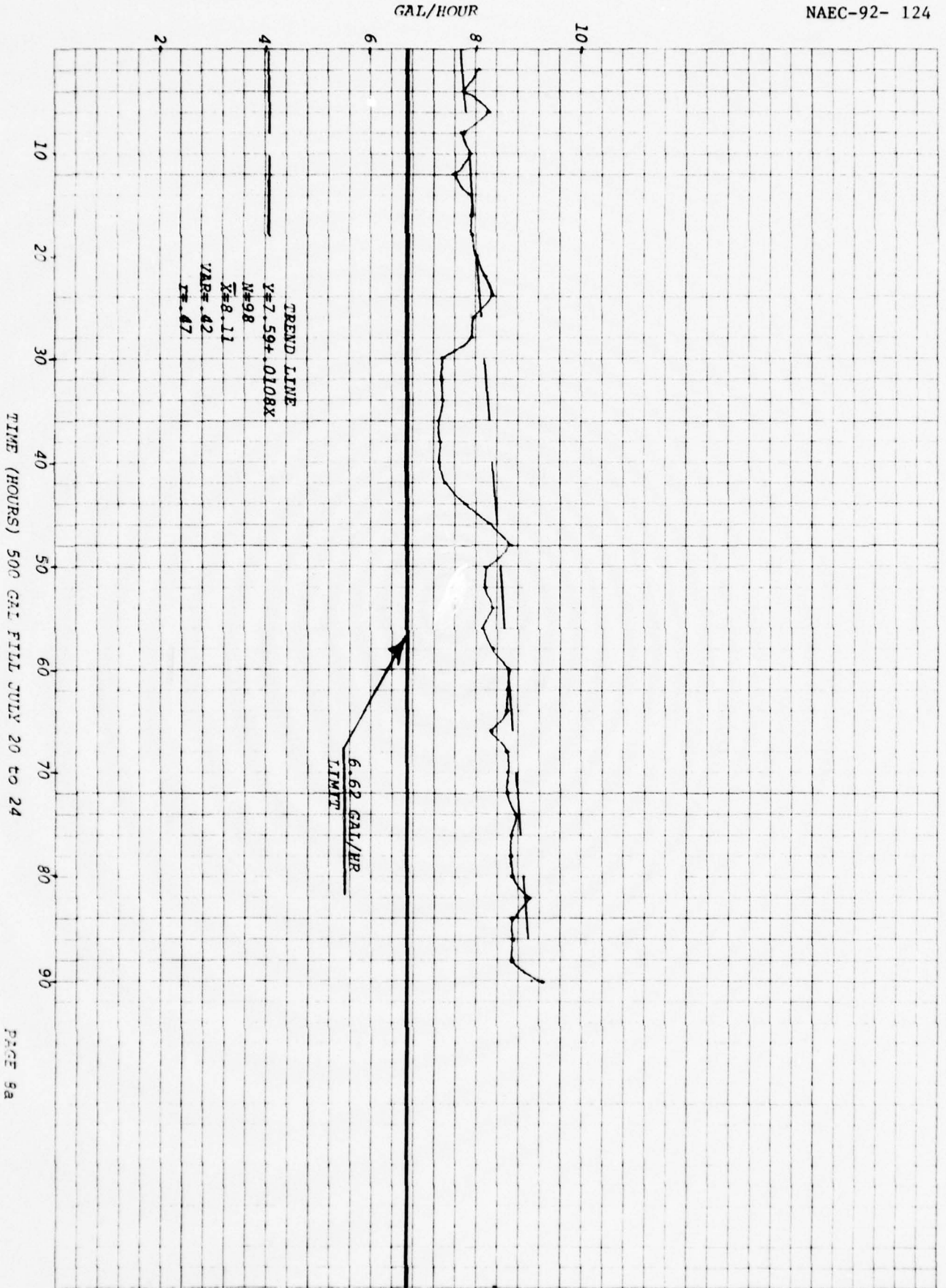
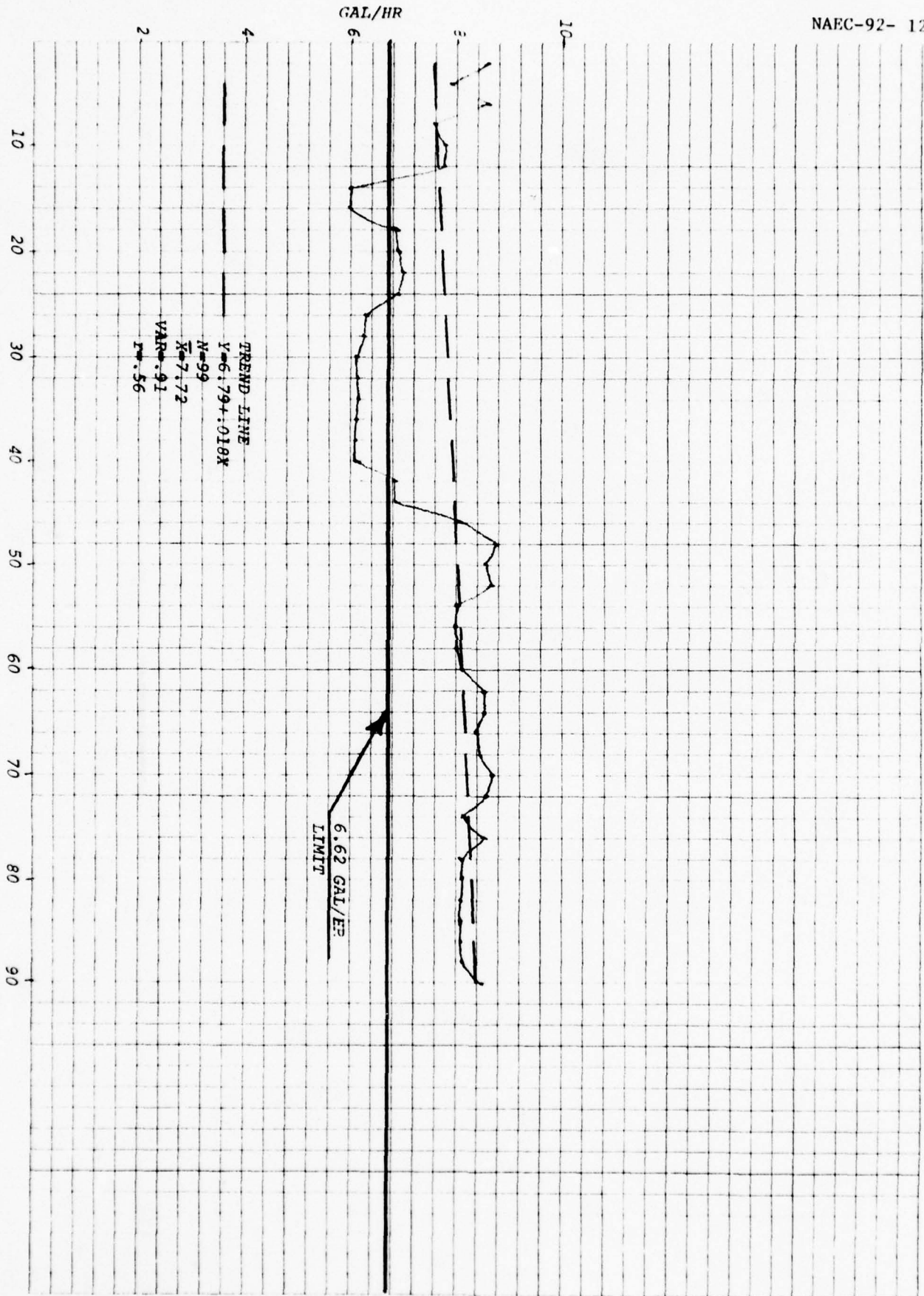

FIG 3A

FIG 3B



2. August_1 thru August 5
(mean \bar{X} = 7.72 gal/hr
(variance) S^2 = .91 gal/hr

NOTE: The trend lines for the above periods are not to be considered the production operating curves for the LOX-30 system. Although the test data could be assumed to follow a linear trend, especially July data, the correlation coefficient for both lines are relatively low.

CORR (July) = .47
CORR (Aug) = .56

Engineering intuition dictates that production rates probably will follow a sinusoidal rather than a linear trend due to the cyclic daily variations of temperature and humidity.

E. Prior to each working week and change of shift, a pre-operational inspection and briefing was conducted for the purpose of proper system operation and parameter trends. Parameters that were of importance were recorded on daily run sheets and any peculiar trends were recorded in a daily log book. The normal test week began at 8 am Monday morning and ran through to Saturday afternoon. Deviations from the weekly test plan occurred twice. Once to simulate a 14 day continuous operating run and training purposes for Pax River personnel.

F. CLASSIFICATION OF FAILURE.

1. A failure of the LOX-30 system is defined as a malfunction which precluded performance of any required function within the limits established. Failures are classified in accordance with paragraph 5.5 of MIL-STD-781 and as follows:

a. Failure Types

Type I - Must stop operations to fix or repair. The equipment is unable to go through one more operating cycle or a condition exists where the safety of the equipment, or operating crew would be in jeopardy if operations were to continue. Failures in this category result in abort of the remaining mission.

Type II - Operations may continue, but monitoring of the failed or malfunctioning equipment is required.

Type III - Failure or malfunction is not serious in terms of continued operations, and repair or replacement can be safely conducted to resume operation.

Type IV - Equipment has experienced a catastrophic or major failure.

G. FAILURE CATEGORIES.

Relevant - inability of the generator to perform one of its intended and specified functions within the specified limits.

Non-relevant - failures due to the following causes:

1. A secondary or dependent failure that is caused by the failure associated items. For every secondary failure classified as not relevant, a primary or independent failure shall be identified.
2. A test operator or test facility induced failure may be classified as non-relevant if it can be substantiated that the equipment was subject to operation or stress conditions beyond specified limits.
3. Changes to the generator to correct a deficiency that caused a failure shall not classify such a failure as not relevant until the changes have been demonstrated as a fully effective correction.
4. Preventative maintenance, servicing and adjustments are non-relevant if such actions are specified as normal maintenance in the existing or planned technical manuals.
5. Type II and Type III failures are considered non-relevant except in the event that they degenerate into Type I or Type IV failure.

H. DISCUSSION.

1. The LOX-30 generator accumulated a total of 2327 hours of which 1617 hours involved reliability testing. Operating hours were recorded by an elapsed time meter installed on the control panel and energized only when the cryogenerator was turned on. The additional compressor time is due to plant pre/post preparation. Therefore the total operating times are as follows:

Total Compressor Operating Time	1732 hours
Total LOX Production Time	1617 hours

A total of four failures were recorded during the test. Each failure is documented by the Failure Reports which are included in Appendix C.

2. The failures and their classifications are as follows:

<u>Failure No.</u>	<u>Description</u>	<u>Type</u>
1	Quick Disconnect Fitting	II
2	Electro-Pneumatic Solenoid Valve	III
3	Solenoid Air Valve	III
4	Pipe, Compressor Discharge	III

Of the above failures none were of the relevant category.

3. Accept/reject criteria for the demonstration were in accordance with test plan VIII of MIL-STD-781. The test is a sequential type with a discrimination ratio of 2.0:1 with an alpha and beta risk of 30%. Requirements of this test plan are presented in Figure 3. Discrimination ratio is defined as the ratio of specified MTBF θ_0 and the minimum acceptable MTBF θ , i.e., θ_0/θ , where $\theta = 1900$ hours and $\theta_1 = 950$ hours. The sequential test plan is predicted on the assumption that the times between failure of the LOX-30 system is exponentially distributed. As per test plan VIII an accept decision was reached at 1617 hours without a relevant failure.

4. Because of the sample size and the number of failures accumulated during the test, the failure distribution of the LOX-30 system is unable, with a good degree of confidence, to be determined. Therefore, until further data is accumulated from other facilities and tests, it will be assumed that the LOX-30 system failure rate follows as exponential distribution.

Therefore the following:

$$R(t) = e^{-\frac{t}{\theta}}$$

where:

t = mission time (90 hours)

θ = minimum acceptable MTBF (950 hours)

$R(t)$ = Probability of a failure free mission

$$R(90) = e^{-\frac{90}{950}}$$

$$R(90) = .90$$

The probability that the LOX-30 system will operate failure free for 90 continuous hours is 90%.

5. Although no relevant failures occurred during the test, corrective action was taken on the following failures:

a. During normal operation, it had been observed by the operators that adjustment of liquid levels in the column and storage tank had become increasingly difficult to stabilize. Hampson Meter readings had begun to read erratic and at times no reading at all. After an investigation of the Hampson Meter, it was discovered that the quick disconnects were bruised and cracked at the ends. Replacement of the quick disconnect was necessary. After replacement, normal readings were observed.

b. During normal operation absorber number two failed to switch over automatically or manually. During pre-reliability tests the solenoids of the electric heater and absorbers 1 and 2 were connected to a moist control air stream. After continued operation, the actuation chamber of the solenoid valves became rusty resulting in the plunger of the actuator to freeze up. To relieve this problem, the control air line was relocated from the wet air side of the adsorbers to the dry air side.

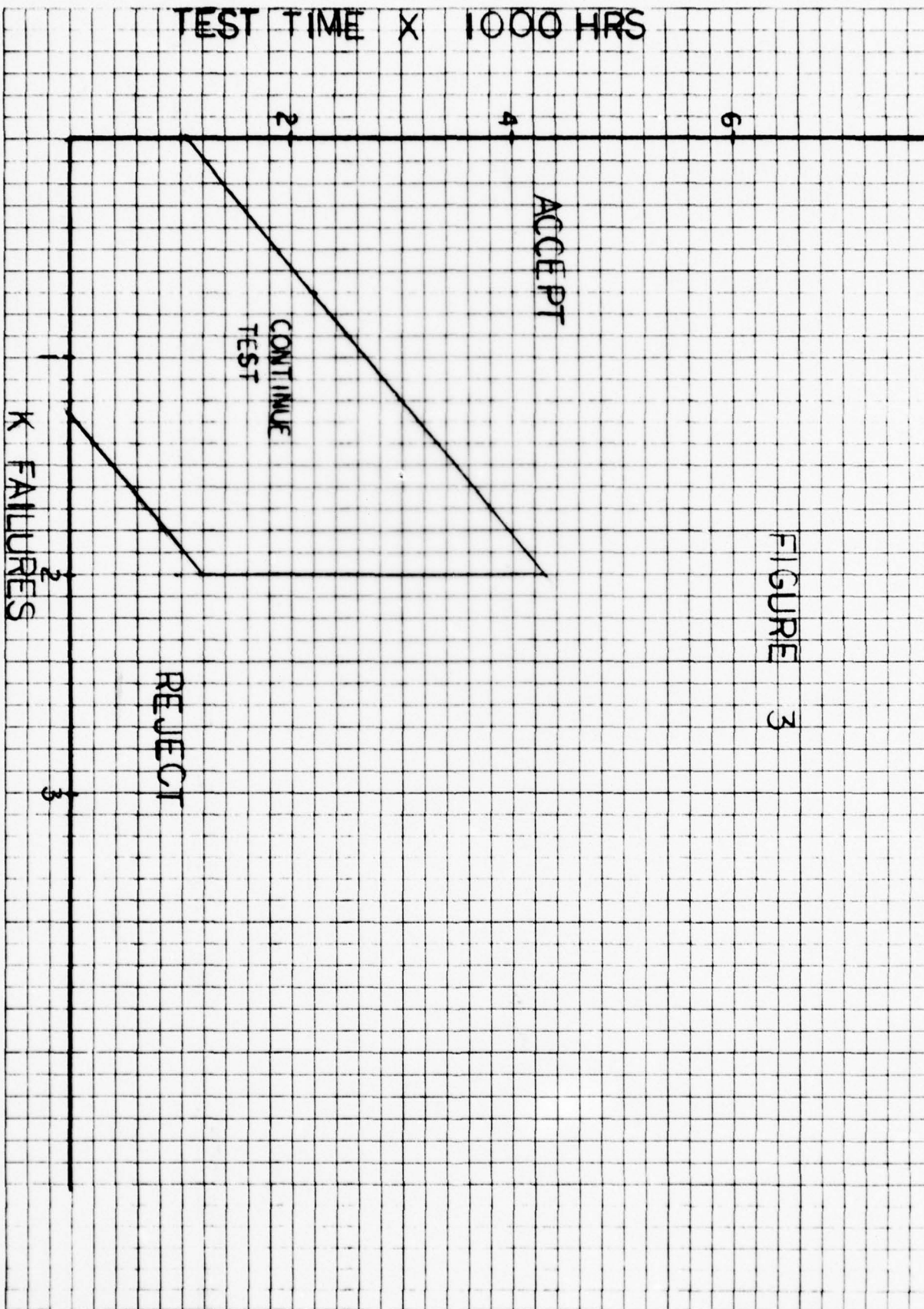

FIGURE 3

11a

In addition, both chambers were disassembled and lubricated. Engineering investigations concluded that lubrication of the plunger shaft will be required at 1500 hour intervals. A statistical analysis of the solenoid mechanisms are in Appendix E.

c. During normal operation, the adsorbers failed to switch automatically. After manually switching of the adsorbers was completed, a slight air leak was found at the fitting that houses the solenoid valve. After disassembly, it was discovered that the threads were stripped thus not permitting enough air pressure to flow into the assembly to allow adsorber switching. The cause for the leak was excessive tightening of the steel thread to an aluminum housing. Like joining metals of the assembly was recommended along with specified torque valves.

d. During normal operation, the discharge pipe connection between the air compressor and molecular sieve station vibrated excessively resulting in pipe fracture. Upon assembly of the LOX-30 unit air compressor, shipment of the proper dampner for the discharge pipe was never supplied. Electrical transducers were mounted on the pipe during post reliability tests and showed that the pipe vibrated at approximately 1660 Hz in the x, y and z direction. A vibration dampner at the compressor discharge pipe is necessary for proper plant operation.

I. OBSERVATION AND DEDUCTIONS.

From the data accumulated and from findings uncovered during the phase of study several observations/deductions may be made:

-- Although cryogenic systems have been in existence for many years, very little statistically significant reliability data is available on liquid oxygen systems and components.

-- Because of usual high cost and large size, liquid oxygen components are traditionally used at near their full capacity. Consequently, adequate derating is an important factor in cryogenic systems.

-- Data show very little field data available for cryogenic systems.

-- Little effort has been expended in the area of physics-of-failure and stress studies of these systems.

-- In-plant life tests are too short duration to yield any significant data for predicting the useful life and wear-out characteristics of cryogenic systems.

-- The survival cumulative distribution of most cryogenic systems is unknown. It is only assumed that their survival cumulative distribution follow those of complex system components.

It is only assumed that their life characteristics exhibit periods of "early life", "constant failure-rate", and "wear-out".

From a reliability, as well as a design engineer's viewpoint, all the points expressed are of interest. To the reliability engineer and those responsible for advancing reliability technology in cryogenic components, the last, is of most interest.

If survival cumulative distribution function could be identified with any degree of accuracy for each application of liquid oxygen or nitrogen components, decisions could be made on what is the optimum period to burn-in each component be replaced just before effects of wear-out become excessive, and how to design for optimizing the useful life period. Finding the survival cumulative distribution function, however, for cryogenic components is not a simple task.

J. CONCLUSIONS.

The LOX-30 liquid oxygen system satisfactorily completed the reliability tests meeting the requirements established in the test plans.

The LOX-30 system experienced four irrelevant failures, none of which caused any excessive down time for repair.

During operation of the LOX-30 system, it is imperative that no less than two operators be assigned for efficient plant operation.

After the LOX-30 system has reached its liquid oxygen production phase, monitoring of instruments is recommended every thirty minutes.

Contractor operational procedures and manuals were incomplete.

K. RECOMMENDATIONS.

Lubricate the electro-pneumatic solenoid actuation chamber of the valves on the molecular sieve skid at an assigned interval of 1500 hours.

Operational procedures for the LOX-30 system must be rewritten for efficient operation.

RELIABILITY TEST REPORT
MODULAR CRYOGENIC GENERATOR

APPENDIX A

WEEK	MON	TUES	WED	THURS	FRI	SAT	SUN	REMARKS
AUG 1 TO AUG 6	ABSORBER TIME 90 MIN START 500 GAL FILL 15:00		CH ₄ 13. PPM N ₂ O .6 PPM CO ₂ 11. PPM		TEST EH-2 500 GAL FULL 16:00	①		CO ₂ HIGH DUE TO TIME ① TIME END 2099.7 7.71 GAL/HOUR
AUG 8 TO AUG 13			CH ₄ 21.5 PPM N ₂ O 1.6 PPM CO ₂ 11. PPM		TEST EH-2	①		N ₂ O & CO ₂ HIGH TREND ① TIME END 2212.7 6.93 GAL/HR
AUG 15 TO AUG 20			CH ₄ 29.5 PPM N ₂ O 4. PPM CO ₂ 21. PPM ①		CH ₄ 26. PPM N ₂ O 1.4 PPM CO ₂ 12. PPM ①	END RELIABILITY TEST 1616.6 HRS ②		TIME END 2326.6 ① SAMPLES HIGH DUE TO 90 MIN CHANGE 6.87 GAL/HR ② TOTAL COMPRESSOR RUNNING TIME 1732 HRS

WEEK	MON	TUES	WED	THURS	FRI	SAT	SUN	REMARKS
JUNE 13 TO JUNE 19						①		① TIME END 1381.3
JUNE 20 TO JUNE 26	MANUAL SW			CH ₄ 19. PPM N ₂ O .84 PPM CO ₂ 2.4 PPM	VALVE # 2 SOLONOID STUCK	①		① 1500 HR MAINTENANCE TIME END 1491.5
JUNE 27 TO JULY 2		CH ₄ 19, PPM N ₂ O .9 PPM CO ₂ 2.0 PPM	POWER LOSS 16:00 DISCONNECT TANK		RESTART 0530			TIME END 1594.2 7.18 GAL/HR
JULY 5 TO JULY 9		CH ₄ 17.5 PPM N ₂ O .94 PPM CO ₂ 12. PPM MACH. NOT STABLE						TIME END 1686.2 6.60 GAL/HR
JULY 11 TO JULY 16	①					②		① PAX RIVER TRAINING ② TIME END 1701.3
JULY 18 TO JULY 30	①	START 500 GAL FILL 14:00		CH ₄ 13. PPM N ₂ O .76 PPM CO ₂ 9.0 PPM ②	TEST EH-2		TANK FULL 15:00 3.12 GAL/HR	① START TWO WEEK RUN ② CO ₂ HIGH RESAMPLE ③ TANK & MACHINE TIME END 1984.8

WEEK	MON	TUES	WED	THURS	FRI	SAT	SUN	REMARKS
MARCH 28 TO APRIL 2	TIME 710.3 START		CH ₄ 17.5 PPM N ₂ O .54 PPM CO ₂ 1.0 PPM		TEST EH-2	TIME 825.1		
APRIL 4 TO APRIL 9			CH ₄ 18. PPM N ₂ O .40 PPM CO ₂ .60 PPM		TEST EH-2	TIME END 940.6		LOX FLOW RATE 3.17 GAL/HR
APRIL 11 TO APRIL 16			CH ₄ 15.5 PPM N ₂ O .49 PPM CO ₂ .79 PPM		TEST EH-2	TIME END 1060.9		FLOW 3.61 GAL/HR
APRIL 18 TO APRIL 23		WATER CHILL - ER DOWN				①		① TIME END 1093.1
APRIL 25 TO APRIL 30	MANUAL SW.	NO PURITY CH ₄ 14 PPM N ₂ O .28 PPM CO ₂ 13. PPM ①	VALVE STICK- ING	NO BED SW SYS. DOWN		TIME END 1150.7		① CO ₂ HIGH DUE TO NO SWITCH. HIGH TIME ON BED FLOW 7.2 GAL/HR
MAY 2 TO MAY 8			CH ₄ 16.5 PPM N ₂ O .52 PPM CO ₂ 2.0 PPM	VALVE STIC- KING		① ②		① MANUAL SWITCH ② TIME END 1267.2
MAY 9 TO JUNE 12	①							① VALVE 677 SOLOINOID THREADS STRIPPED SYSTEM DOWN AT 1267.2

RELIABILITY TEST REPORT
MODULAR CRYOGENIC GENERATOR

APPENDIX B

AIR STATIONS & TEST ENVIRONMENTAL DATA

NAEC-92-124

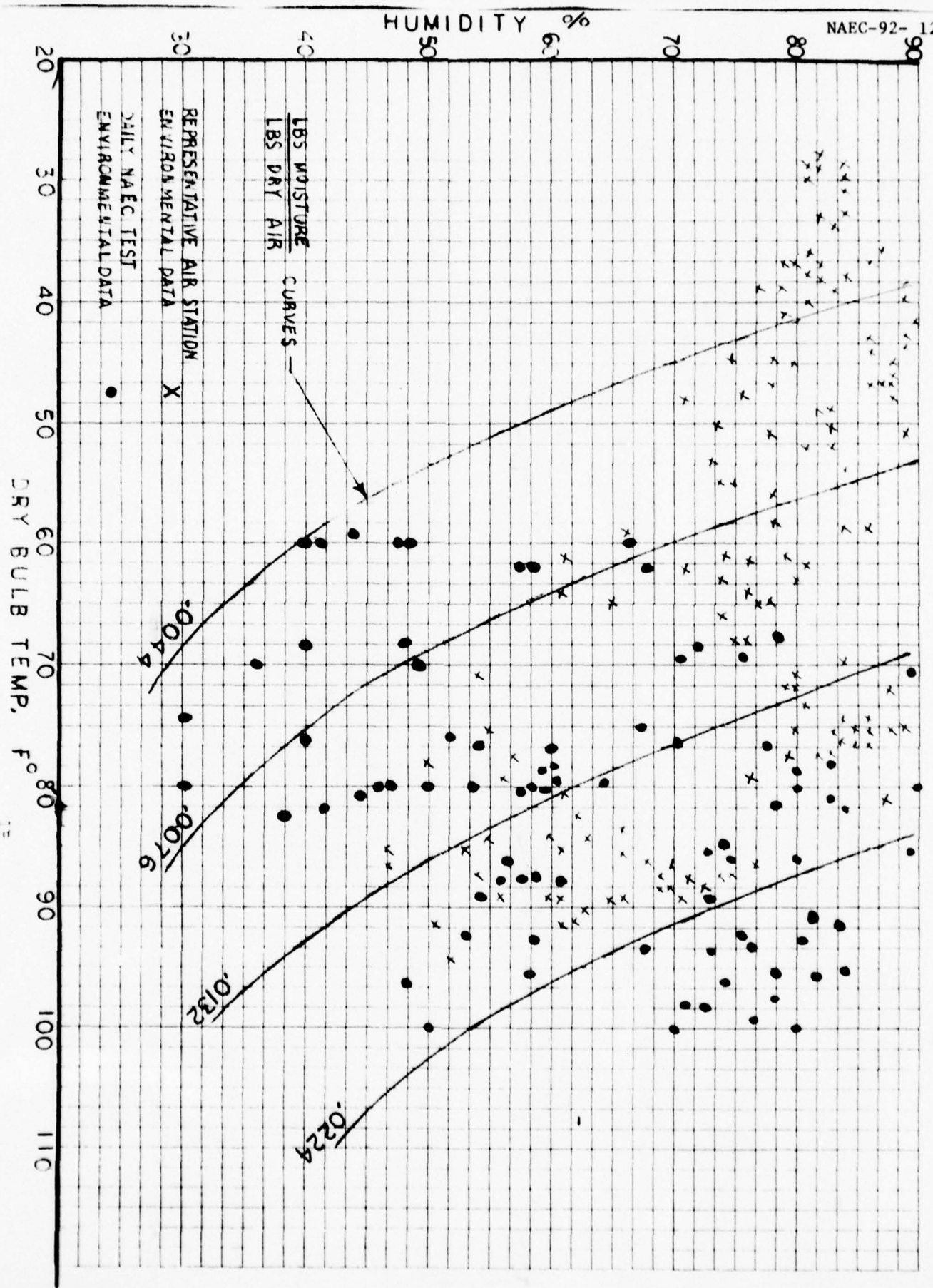

DIETZEN CORPORATION

DIETZEN GRAPH PAPER

RELIABILITY TEST REPORT
MODULAR CRYOGENIC GENERATOR

APPENDIX C

FAILURE REPORTMODULAR CRYOGENIC OXYGEN GENERATORFailure No. 1 Date: 13 April 1977Generator Ser. No. LOX-30 Elapsed Time Meter 1017.8

Identification of failed item:

Nomenclature QUICK DISCONNECT FITTINGSPart No. 320-104 Serial No. _____Mode of Operation when discovered: Normal liquid O₂ production.

Result of failure (abort, degraded, etc.): Incorrect liquid level indication.

Description of failure: Liquid level indication could not be maintained.
Indicating liquid would rise out of the top of meter when connected.

Description of cause: Seat of disconnect was broken and cracked.

Action taken: Replaced quick disconnect with new ones.

Recommendation to prevent recurrence:

Categorization of failure (see paragraph II)

	<u>Hours</u>	<u>No. of Personnel</u>	<u>No. of Manhours</u>
Time for fault location	<u>.2</u>	<u>1</u>	<u>.2</u>
Time for repair	<u>.4</u>	<u>1</u>	<u>.4</u>
Time for checkout	<u>.2</u>	<u>1</u>	<u>.2</u>
Total	<u>.8</u>	<u>1</u>	<u>.8</u>

Total downtime (total time from failure to back in operation) _____

Report prepared by C.R. CORKUM
(Print)

FAILURE REPORTMODULAR CRYOGENIC OXYGEN GENERATORFailure No. 2 Date: 28 April 1977Generator Ser. No. LOX-30 Elapsed Time Meter 1151

Identification of failed item:

Nomenclature ELECTRO-PNEUMATIC SOLENOID VALVEPart No. _____ Serial No. 62.35.50

Mode of Operation when discovered: Normal operating.

Result of failure (abort, degraded, etc.): System shut-down.

Description of failure: Adsorber #2 failed to switch automatically or manually.

Description of cause: During pre-test runs, the solenoids of the electric heater and adsorbers #1 & #2 were in a moist air stream causing corrosion.
 Action taken: A snap ring made from wire was placed inside of rubber plunger. Plunger shaft lubricated every 1500 hrs. of operation. Failed solenoid valve
 Recommendation to prevent recurrence: tubing is in stream with dry air.
 Lubrication of shaft every 1500 hrs. and re-route tubing from moist air stream to in stream dry air source.

Categorization of failure (see paragraph III)

	<u>Hours</u>	<u>No. of Personnel</u>	<u>No. of Manhours</u>
Time for fault location	<u>1 hr.</u>	<u>1</u>	<u>1</u>
Time for repair	<u>.75</u>	<u>1</u>	<u>.75</u>
Time for checkout	<u>.50</u>	<u>1</u>	<u>.50</u>
Total	<u>2$\frac{1}{4}$</u>	<u>1</u>	<u>2$\frac{1}{4}$</u>

Total downtime (total time from failure to back in operation) 4 hrs.Report prepared by ROMAN FERRET
(Print)

FAILURE REPORT

MODULAR CRYOGENIC OXYGEN GENERATOR

Failure No. 3 Date: 9 May 1977

Generator Ser. No. LOX-30 Elapsed Time Meter 1570.2

Identification of failed item:

Nomenclature SOLENOID OPERATED AIR VALVE (TILLER PNEUMATIC)

Part No. _____ Serial No. 33.311.011

Mode of Operation when discovered: Normal operation.

Result of failure (abort, degraded, etc.): Had to change from automatic control to manual control to change adsorber #1 to #2.

Description of failure: Adsorber failed to change.

Description of cause: Fitting that houses the valve was stripped and leaked not allowing enough pressure into the actuation chamber.

Action taken: Remove valve for engineering study.

Recommendation to prevent recurrence: Avoid a steel fitting thread into an aluminum body.

Categorization of failure (see paragraph III)

	<u>Hours</u>	<u>No. of Personnel</u>	<u>No. of Manhours</u>
Time for fault location	<u>.2</u>	<u>1</u>	<u>.2</u>
Time for repair	_____	_____	_____
Time for checkout	_____	_____	_____
Total	_____	_____	_____

Total downtime (total time from failure to back in operation) _____

Report prepared by C.R. CORKUM
(Print)

FAILURE REPORT

MODULAR CRYOGENIC OXYGEN GENERATOR

Failure No. 4 Date: 18 July 1977

Generator Ser. No. LOX-30 Elapsed Time Meter 1705.3

Identification of failed item:

Nomenclature PIPE NIPPLE

Part No. _____ Serial No. _____

Mode of Operation when discovered: Normal O₂ operation.

Result of failure (abort, degraded, etc.): Plant shut-down.

Description of failure: Pipe nipple at the discharge end of the air compressor ruptured.

Description of cause: Rupture due to excessive vibration.

Action taken: Remove and replace nipple.

Recommendation to prevent recurrence: Install discharge piping as described in compressor manual. Still waiting for design change from manufacturer.

Categorization of failure (see paragraph III)

	<u>Hours</u>	<u>No. of Personnel</u>	<u>No. of Manhours</u>
Time for fault location	<u>Immediate</u>	<u>1</u>	<u>Immediate</u>
Time for repair	<u>½ hr.</u>	<u>1</u>	<u>½ hr.</u>
Time for checkout	<u>5 min.</u>	<u>1</u>	<u>5 min.</u>
Total	<u>20</u>	<u>1</u>	<u>20</u>

Total downtime (total time from failure to back in operation) 45 min.

Report prepared by ROMAN FERRET
(Print)

RELIABILITY TEST REPORT
NODULAR CRYOGENIC GENERATOR

APPENDIX D

GAL/HR

JULY 7 14 21 28 AUG 5 8 13 20

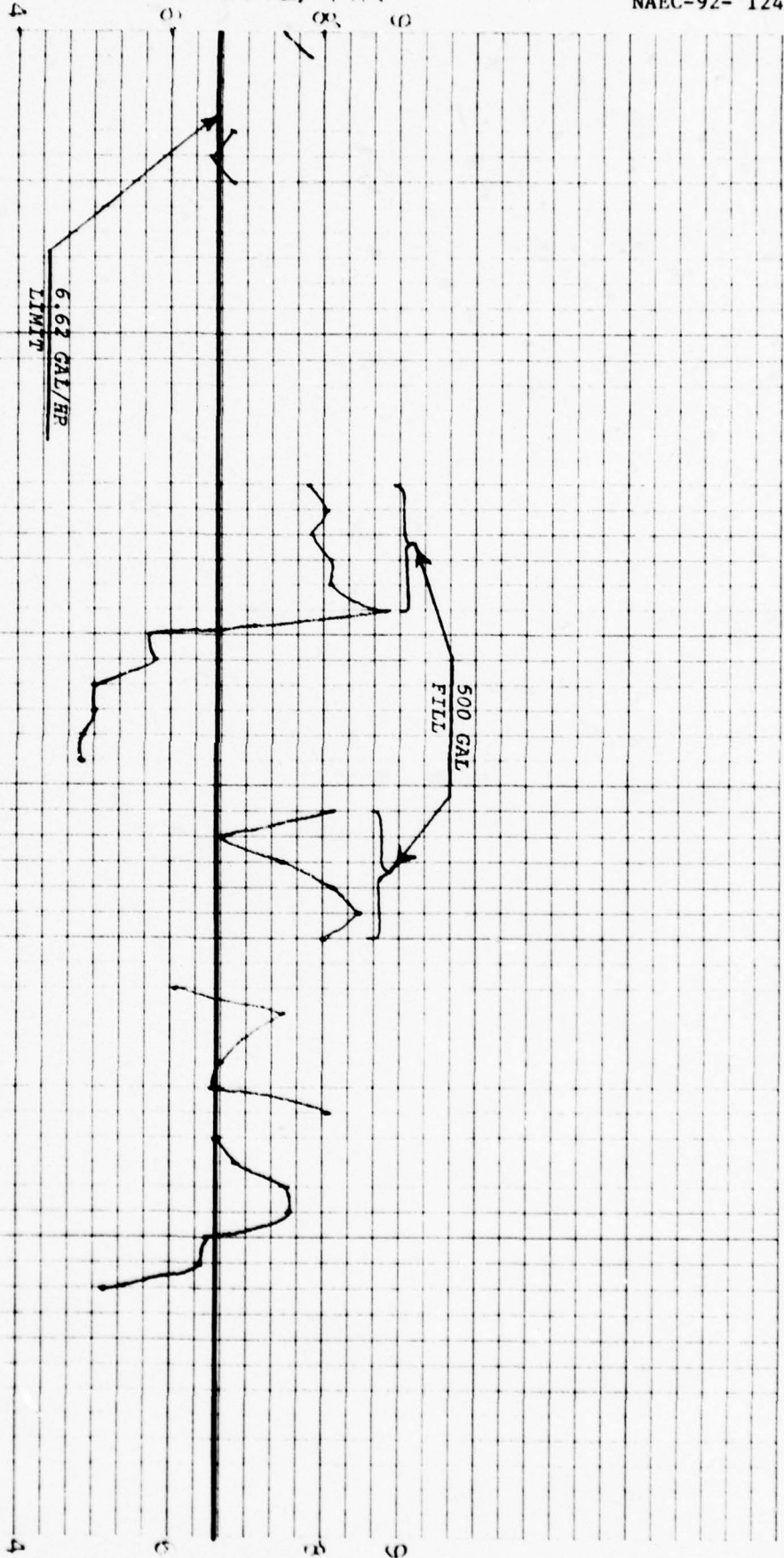

DIETZEN CORPORATION
MADE IN U.S.A.

NO. 340-6 DIETZEN GRAPH PAPER
5 1/2 X 9 1/2 INCH

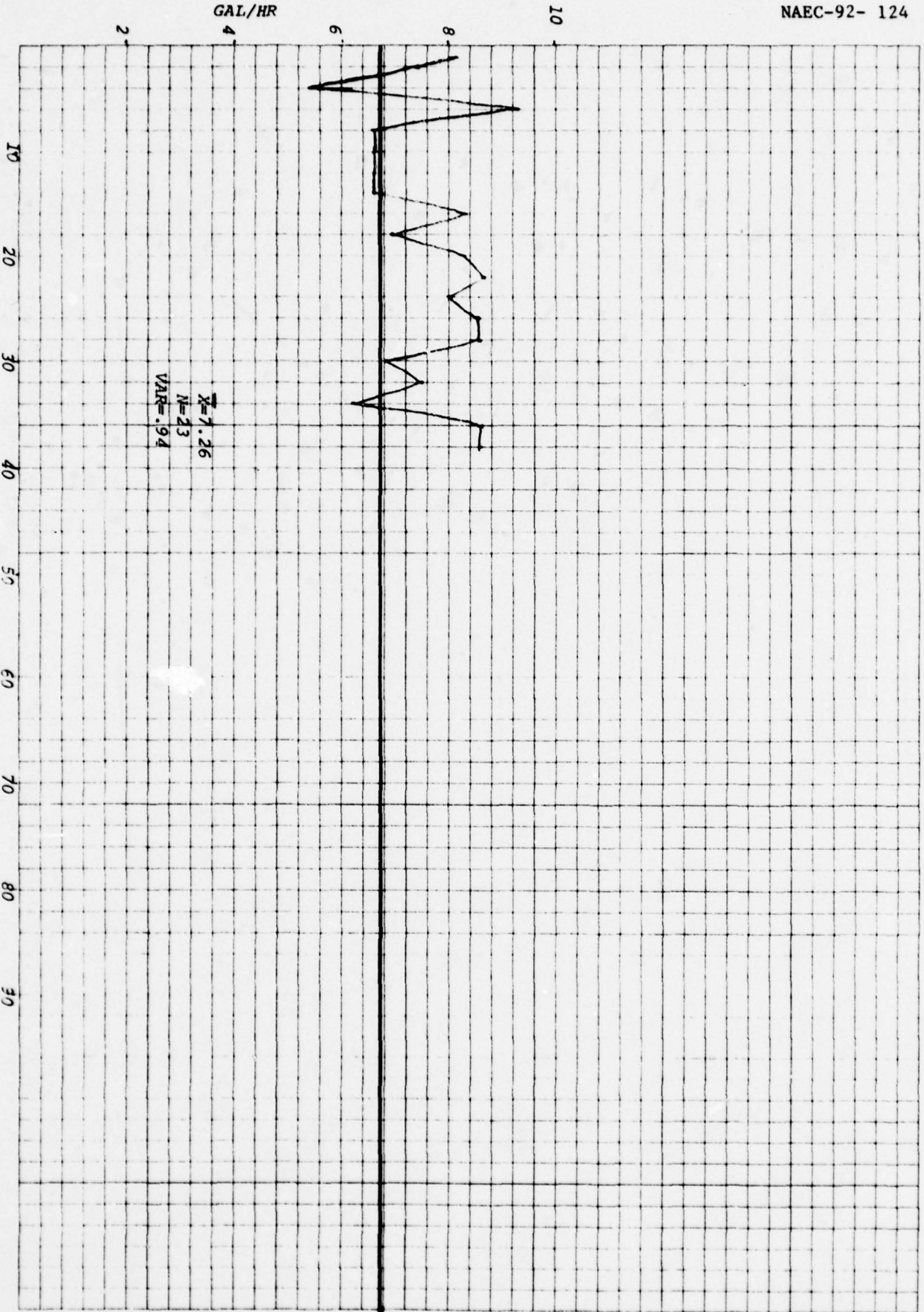

$\bar{x} = 7.26$
 $N = 23$
 $VAR = .94$

TIME (HOURS) JULY 1 to 2

DIETZEN CORPORATION
MADE IN U.S.A.

DIETZEN GRAPH PAPER
340-9 9" X 9" PER INCH

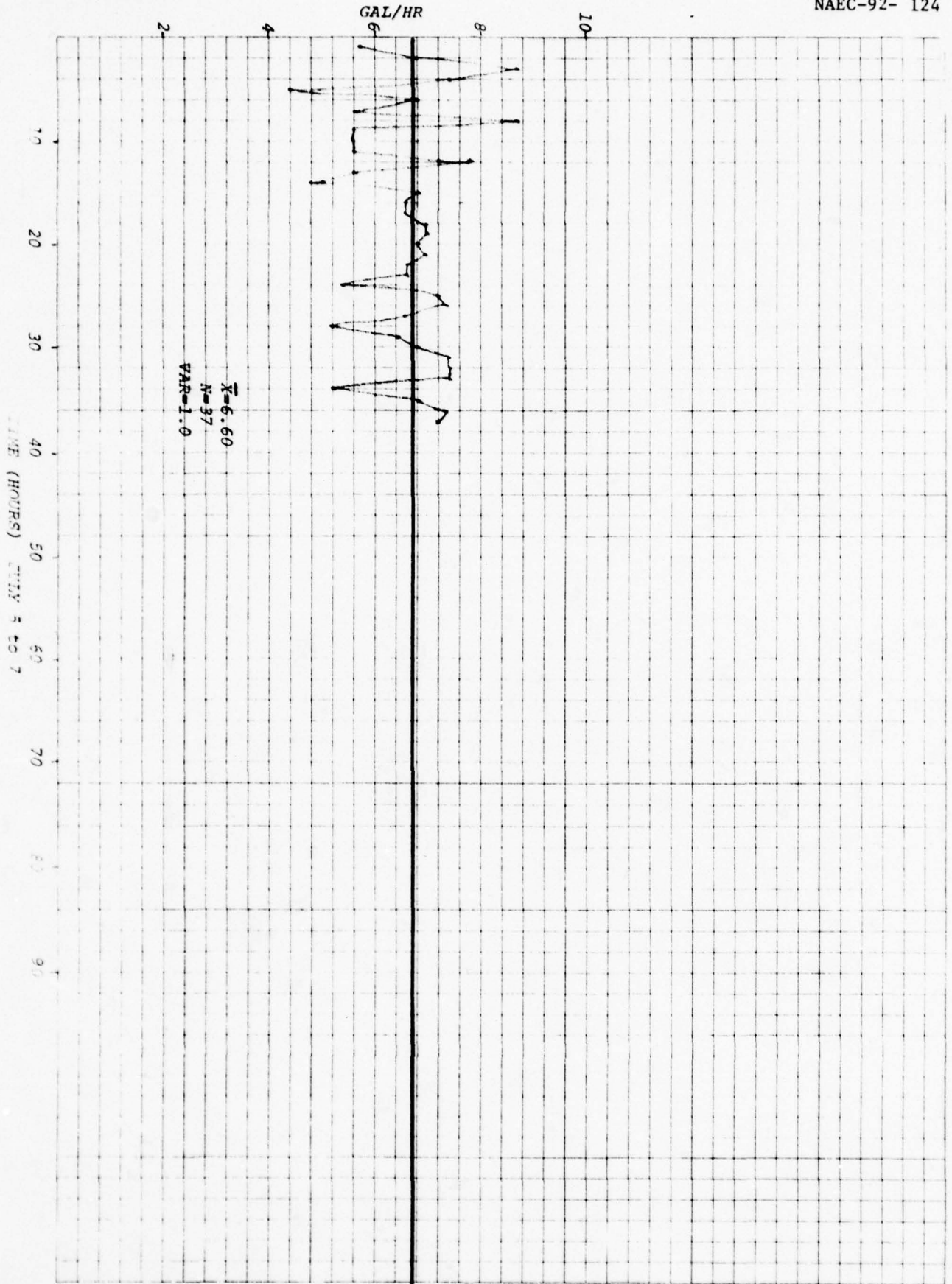

$\bar{X}=6.60$
 $N=97$
 $VAR=1.0$

DIETZGEN CORPORATION
MADE IN U.S.A.

DIETZGEN GRAPH PAPER
3 1/2" X 5 1/2" PER INCH

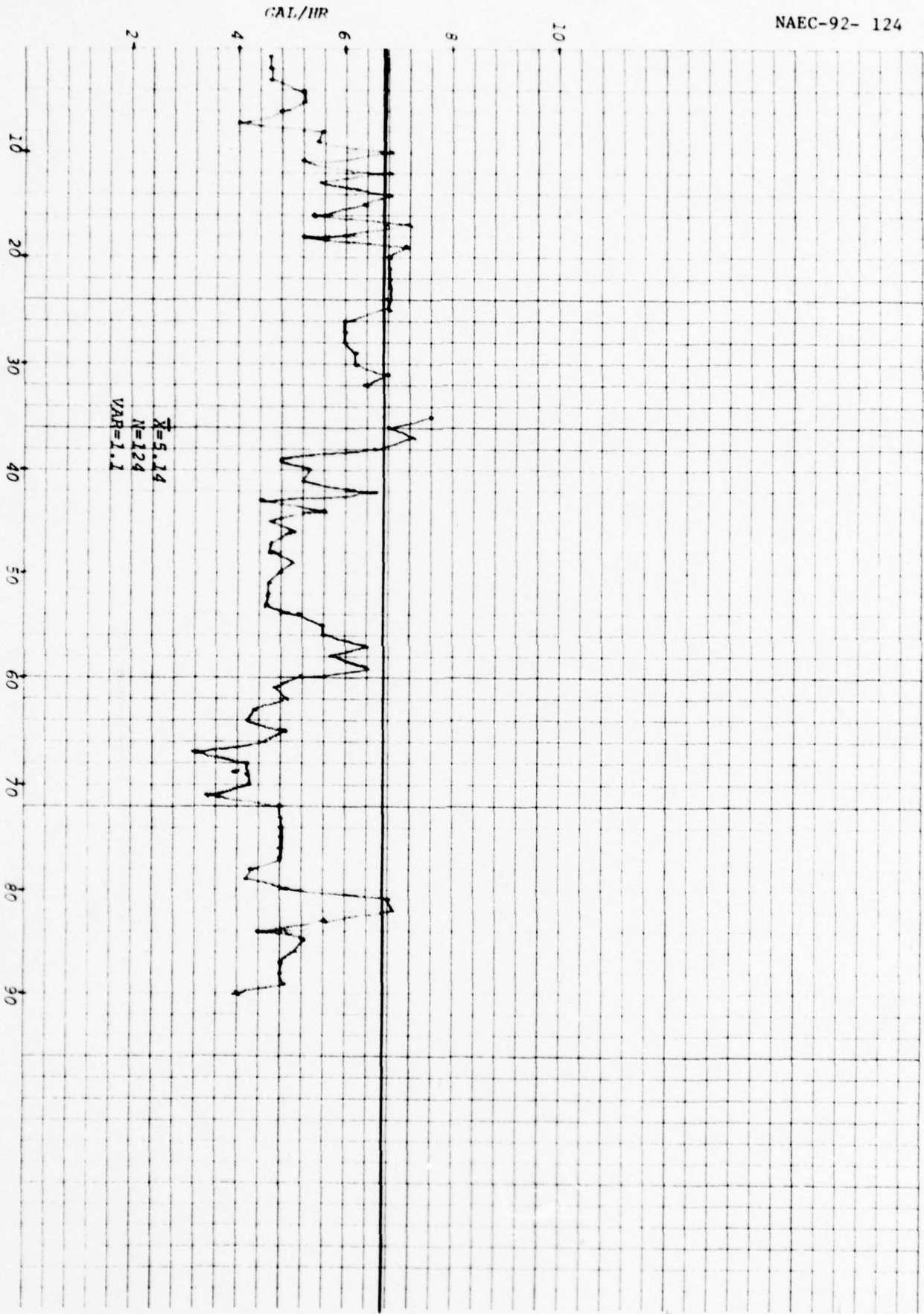

DIETZGEN CORPORATION
MADE IN U.S.A.

DIETZGEN GRAPH PAPER
9 X 9 INCH PER INCH
NO. 340-9

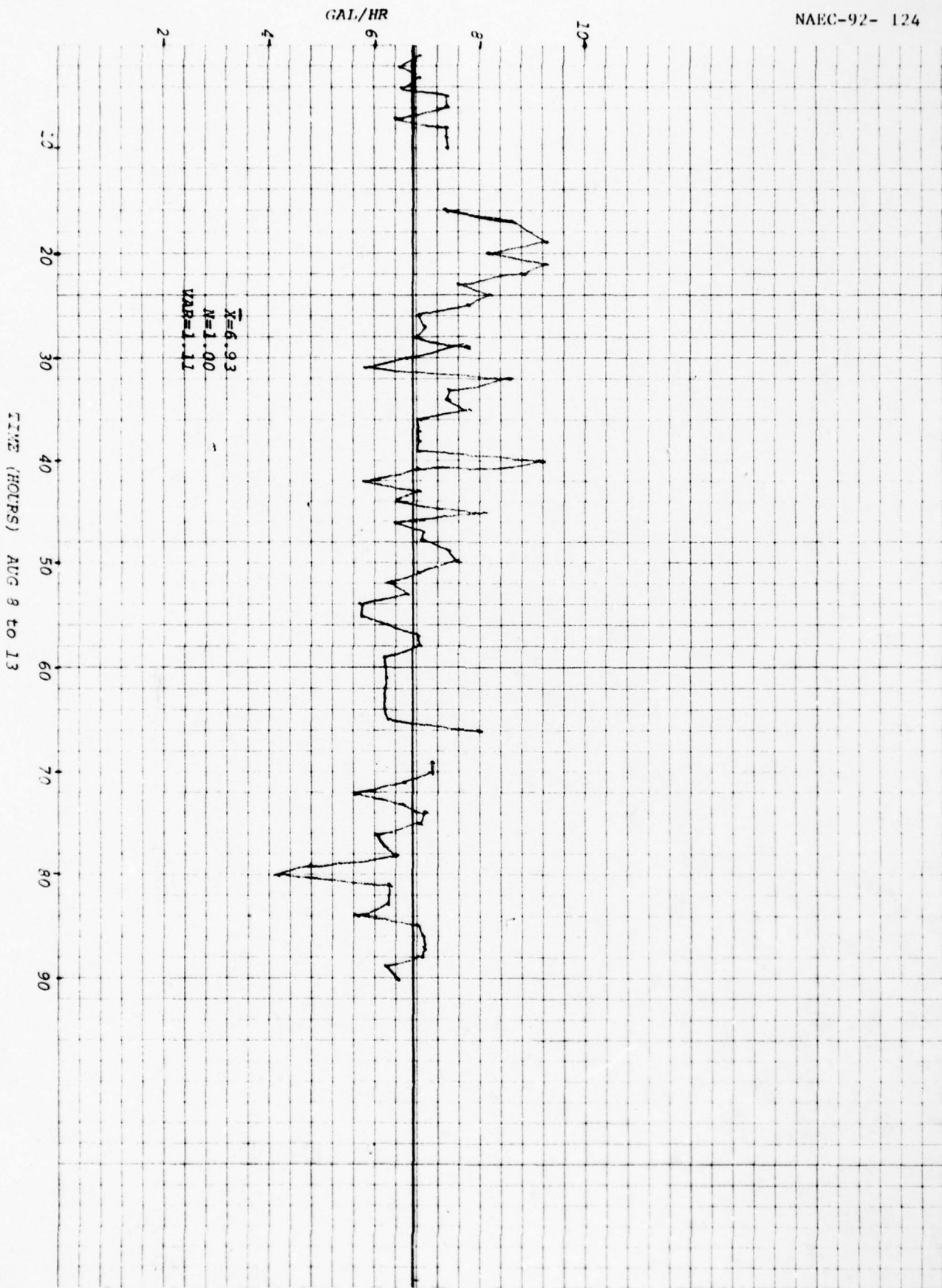

DIETZEN CORPORATION
DIETZEN GRAPH PAPER
NO. 34E

GAL/HR

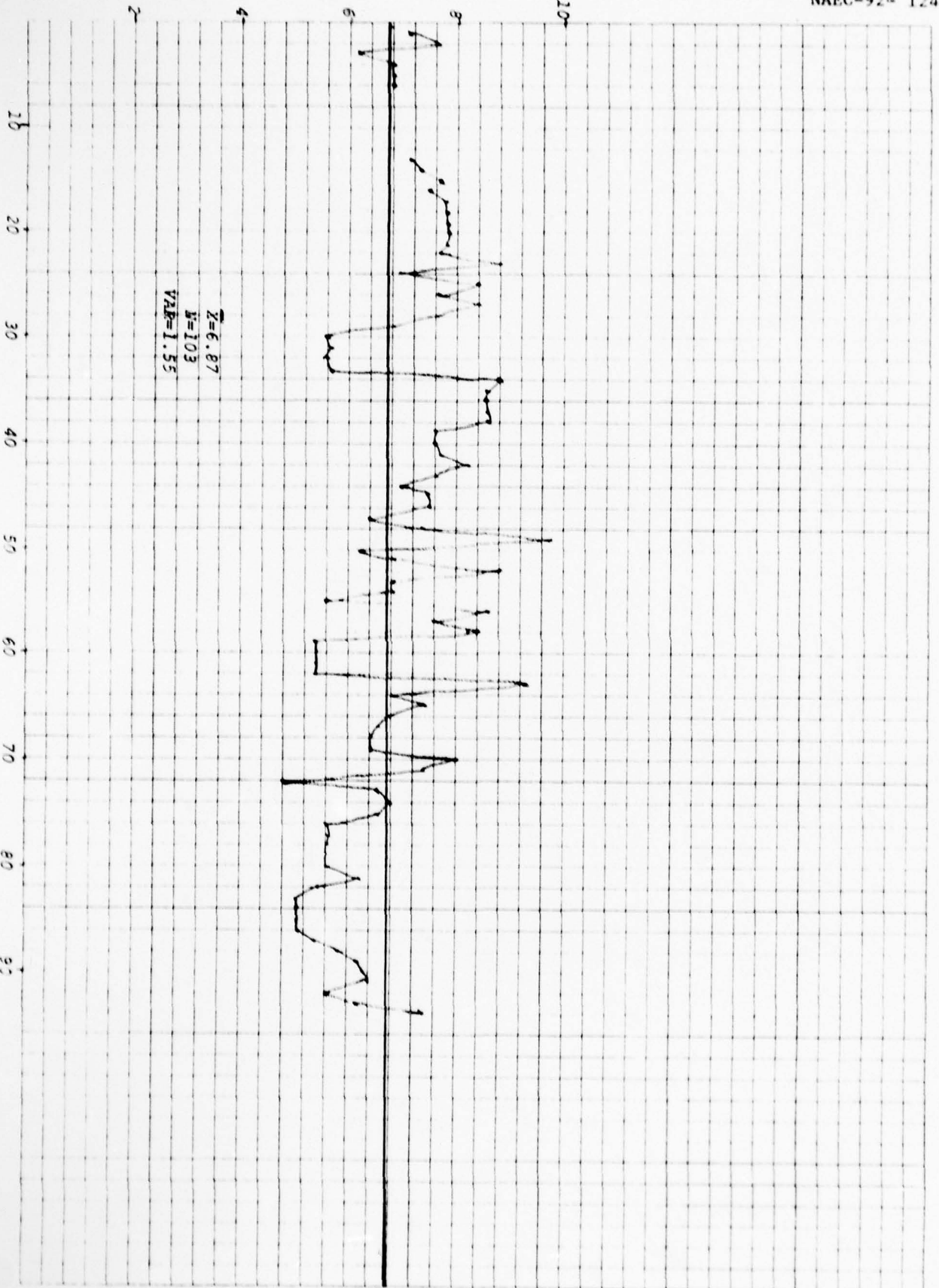

$\bar{X}=6.87$
 $S=1.03$
 $VAR=1.55$

TIME (HOURS) AUG 15 10 20

MOIIVROBROD N8QZL3IC

MON BBS 9 X 9

JULY 1 1977

TIME	AMBIENT TEMP	GA./HR	PURITY																	
0100																				
0200																				
0300																				
0400																				
0500																				
0600																				
0700																				
0800																				
0900	92	8.17	99.6																	
1000	96	7.58	99.6																	
1100	99	5.59	99.6																	
1200	99	9.38	99.5																	
1300	98	6.42	99.2																	
1400	96	6.42	99.2																	
1500	98	6.42	99.4																	
1600	99	6.42	99.2																	
1700	98	8.17	99.3																	
1800	98	7.00	99.25																	
1900	97	8.10	98.8																	
2000	92	8.68	99.0																	
2100	94	8.00	99.0																	
2200	82	8.53	98.7																	
2300	79	8.53	98.9																	
2400	80	6.82	98.9																	

JULY 2 1977

TIME	AMBIENT TEMP	GAL/HR	PURITY																	
0100	78	7.40	98.6																	
0200	80	7.40	98.9																	
0300	76	7.97	99.1																	
0400	76	7.94	99.1																	
0500	76	6.25	99.12																	
0600	76	8.55	99.25																	
0700	78	8.55	99.3																	
0800																				
0900																				
1000																				
1100																				
1200																				
1300																				
1400																				
1500																				
1600																				
1700																				
1800																				
1900																				
2000																				
2100																				
2200																				
2300																				
2400																				

JULY 5 1977

	TIME	AMBIENT TEMP	GAL/HR	PURITY																
	0100																			
	0200																			
	0300																			
	0400																			
	0500																			
	0600																			
	0700																			
	0800																			
	0900																			
	1000																			
	1100																			
	1200																			
$\bar{x} = 6.61$	1300	104		99.95																
	1400	105		99.95																
	1500	100		99.95																
	1600	102		99.95																
	1700	102	5.85	99.9	1															
	1800	100	6.71	99.85	2															
	1900	97	8.73	99.85	3															
	2000	94	7.51	99.9	4															
	2100	90	4.29	99.9	5															
	2200	90	6.89	99.9	6															
	2300	88	5.73	99.95	7															
	2400	85	8.59	99.95	8															

JULY 7 1977

	TIME	AMBIENT TEMP	GAL/HR	PURITY																
	0100	80	7.49	99.99	33															
	0200	76	5.15	99.99	34															
	0300	74	6.86	99.99	35															
	0400	76	7.44	99.99	36															
	0500	74	7.44	99.99	37															
$Y = 6.38 + 01x$	0600																			
	0700																			
$r^2 = .02$	0800																			
	0900																			
	1000																			
	1100																			
	1200																			
	1300																			
	1400																			
	1500																			
	1600																			
	1700																			
	1800																			
	1900																			
	2000																			
	2100																			
	2200																			
	2300																			
	2400																			

JULY 20 1977

	TIME	AMBIENT TEMP	GAL/HR	PURITY																	
	0100																				
	0200																				
	0300																				
	0400																				
	0500																				
	0600																				
	0700																				
	0800																				
	0900																				
	1000																				
	1100																				
	1200																				
	1300																				
Start 500 Gal fill	1400	96	8.02	100	1																
	1500	98	8.02	100	2																
	1600	98	8.03	100	3																
	1700	97	7.73	100	4																
	1800	97	8.29	100	5																
	1900	95	7.99	100	6																
	2000	94	7.70	100	7																
	2100	90	7.98	100	8																
	2200	88	7.98	100	9																
	2300	86	7.96	100	10																
	2400	84	7.96	100	11																

JULY 28 1977

TIME	AMBIENT TEMP	GAL/HR	PURITY																
0100	63	5.04	99.89																
0200	62	5.04	99.89																
0300	62	5.04	99.89																
0400	60	5.04	99.89																
0500	60	5.04	99.89																
0600	58	5.04	99.89																
0700	62	4.48	99.89																
0800	72	4.55	99.89																
0900	80	5.18	99.9																
1000	82	6.94	99.9																
1100	88	6.96	99.95																
1200	88	5.83	99.95																
1300	88	4.38	99.8																
1400	86	5.21	99.8																
1500	88	5.18	99.8																
1600	89	4.62	99.9																
1700	85	4.62	99.9																
1800	87	4.88	99.95																
1900	82	4.00	99.95																
2000	79	5.12	99.95																
2100	74	4.53	99.9																
2200	72	4.53	99.9																
2300	70	4.53	99.9																
2400	68	4.53	99.9																

JULY 30 1977

TIME	AMBIENT TEMP	GAL/HR	PURITY															
0100	80	4.53	99.99															
0200	78	3.96	99.99															
0300	78	4.53	99.99															
0400	78	4.53	99.99															
0500	76	4.53	99.99															
0600	74	4.53	99.99															
0700	76	4.53	99.99															
0800																		
0900																		
1000																		
1100																		
1200																		
1300																		
1400																		
1500																		
1600																		
1700																		
1800																		
1900																		
2000																		
2100																		
2200																		
2300																		
2400																		

AUG 6 1977

TIME	AMBIENT TEMP	GAL/HR	PURITY																	
0100	87	8.02	99.85																	
0200	86	8.01	99.99																	
0300	85	8.01	99.8																	
0400	86	8.01	99.8																	
0500																				
0600																				
0700																				
0800																				
0900																				
1000																				
1100																				
1200																				
1300																				
1400																				
1500																				
1600																				
1700																				
1800																				
1900																				
2000																				
2100																				
2200																				
2300																				
2400																				

RELIABILITY TEST REPORT
MODULAR CRYOGENIC GENERATOR

APPENDIX E

ANALYSIS FOR THE ELECTRO-PNEUMATIC
SOLENOIDS OF THE LOX-30 SYSTEM

ANALYSIS FOR THE ELECTRO-PNEUMATIC
SOLENOIDS OF THE LOX-30 SYSTEM

The Weibull distribution is widely used in engineering situations because of its versatility. It was originally proposed for the interpretation of fatigue data, but now its use has extended to many other engineering problems. The usefulness of the Weibull distribution stems from the use of straightline plots to represent experimental data. Special Weibull plotting paper is required but the graphical interpretation is reasonable straight forward. Although the Weibull distribution can be applied to most any engineering problems, its main application is in the field of failure life situations. In general, the Weibull distribution best describes the parameters of parts or its components, while the exponential distribution is most applied to assemblies and systems.

The Weibull cumulative distribution function is:

$$F(x) = 1 - \exp \left[- \left(\frac{x-x_0}{\theta-x_0} \right)^b \right]$$

Where:

x_0 = expected minimum value of x (location parameter)

b = Weibull slope (shape parameter)

θ = characteristic value (scale parameter)

In working with many life phenomena it is reasonable to assume, as in the case of the solenoid switches of the LOX-30 system, that the lower bound of life x_0 , is equal to zero. This reduces the Weibull cumulative distribution function to the two-parameter equation:

$$F(x) = 1 - \exp \left[- \frac{x^b}{\theta} \right]$$

When attempting to calculate the Weibull slope of life data, very cumbersome calculations are needed. Therefore, there is need for a method of expediting the conversion. This is done with a special coordinate paper known as Weibull Probability Paper.

The following are the malfunction times in hours that the solenoid switches did not operate in the automatic mode. (Manual switch required, operation of plant not affected).

224, 442, 482, 558, 764, 855, 893, 902, 1020, 1111, 1212, 1286, 1491, 1696, 1816, 2124, 2371 and 2437 hours.

With use of Weibull Probability Paper the Weibull slope, characteristic life, mean life and the B_{10} life of these switches are calculated.

<u>Life to Incident</u>	<u>Median Ranks %</u>
224	.04
442	.09
482	.15
558	.20
769	.26
855	.31
893	.36
902	.42
1020	.47
1111	.53
1212	.58
1286	.64
1491	.69
1696	.74
1816	.80
2124	.85
2371	.91
2437	.96

Plotting the data on Weibull Probability Paper, the estimate of the Weibull slope is 1.8. It is known that the log-normal distribution has a Weibull slope of 2.0; therefore, it is reasonable to assume that the solenoid switches failure rate follows the log-normal distribution. For a higher accuracy, this line could be fitted by the least-squares method.

Characteristic Life

By definition, characteristic life θ is the life corresponding to 63.2% failure.
Therefore, $\theta = 1380$ hours

Mean Life

The percent failed is mean = 55.5% for $b=1.8$. From the Weibull Plot corresponding to 55.5% is

Mean Life = 1200 hours

B₁₀ Life

The life corresponding to 10% failure is $B_{10} = 380$ hours.

It can be said that 10% of the population is expected to have life less than or equal to B_{10} life 380 hours.

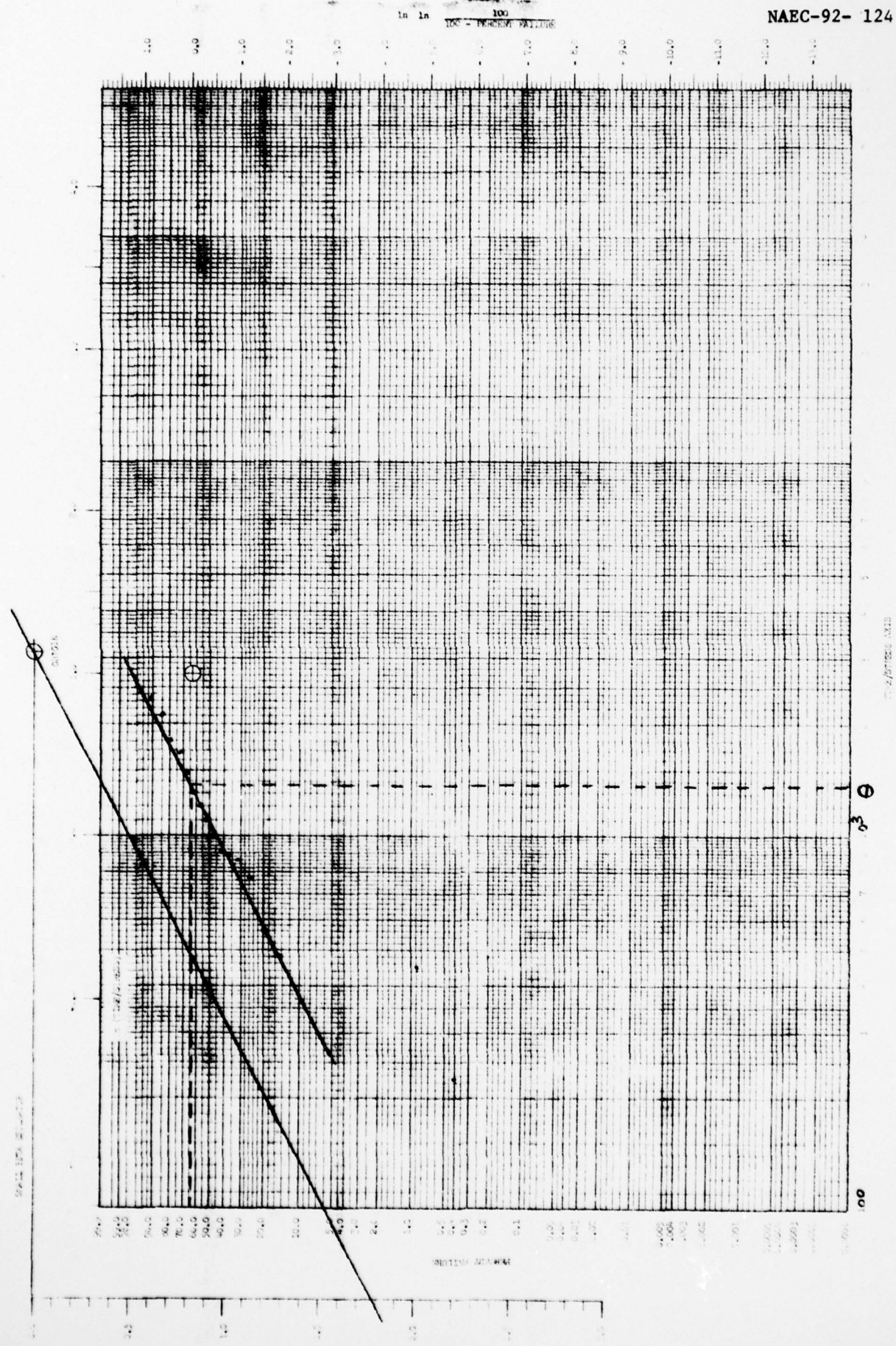

DEPTH IN INCHES

0.00

100.0

REFERENCES

Ireson, W. Grant "Reliability Handbook", McGraw-Hill, Inc., 1966

Mann, Nancy R., Schafer, Ray E., Singpurwalla, Nozer D. "Methods for Statistical Analysis of Reliability and Life Data", John Wiley and Sons, Inc., 1974

Lipson, Charles, Sheth, Narendra J. "Statistical Design and Analysis of Engineering Experiments", McGraw-Hill, Inc., 1973

Shooman, Martin L. "Probabilistic Reliability: An Engineering Approach", McGraw-Hill, Inc., 1968

Green, A.E. and Bourne, A.J. "Reliability Technology", Wiley and Sons, Inc., 1972

"Reliability Growth Test for the LOX-30 Cryogenic Generator", NAEC-MISC-92-0326

"Reliability Demonstration Test Plan for the LOX-30 Cryogenic Generator", NAEC-MISC-92-0327