

AD-A055 406

WYLE LABS HUNTSVILLE ALA
CONTROL STATION DESIGN CONCEPTS FOR CABIN CRUISERS AND FLYING B--ETC(U)
NOV 77 R MACNIELL

F/G 13/10

DOT-CG-40672-A

UNCLASSIFIED

USCG-D-66-77

NL

1 OF 1
AD
A055406



END
DATE
FILMED
7-78
DDC

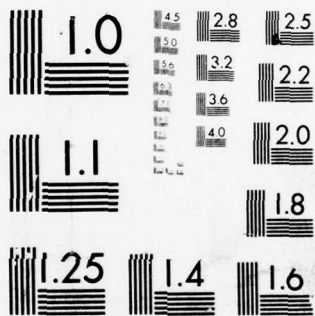

MICROCOPY RESOLUTION TEST CHART
NATIONAL BUREAU OF STANDARDS-1963-A

FOR FURTHER TRAN

13
B.S.

REPORT NO. CG-D-66-77

AD A 055406

CONTROL STATION DESIGN CONCEPTS
FOR CABIN CRUISERS AND
FLYING BRIDGES



DDC
RECEIVED
JUN 19 1978
F

Document is available to the U.S. Public through the
National Technical Information Service,
Springfield, Virginia. 22162

DISTRIBUTION STATEMENT A
Approved for public release
Distribution Unlimited

AD NO. —
DDC FILE COPY

78 06 12 185

PREPARED FOR

U.S. DEPARTMENT OF TRANSPORTATION

UNITED STATES COAST GUARD
OFFICE OF BOATING SAFETY
WASHINGTON, D.C. 20590

cover ①

1. Report No. 18 19 45 CG-D-66-77	2. Government Accession No.	3. Recipient's Catalog No.	
4. Title and Subtitle 6 Control Station Design Concepts for Cabin Cruisers and Flying Bridges,		5. Report Date 11 1 Nov 77	6. Performing Organization Code
7. Author(s) 10 R./MacNiell	8. Performing Organization Report No.		10. Work Unit No. (TRAIS)
9. Performing Organization Name and Address Wyle Laboratories P. O. Box 1008 Huntsville, AL 35807		11. Contract or Grant No. 15 DOT-CG-40672-A (T. O. 26)	13. Type of Report and Period Covered 9 Final Report, AUG 76 - AUG 77.
12. Sponsoring Agency Name and Address U. S. Department of Transportation U. S. Coast Guard Office of Research and Development Washington, D. C. 20590		14. Sponsoring Agency Code U. S. Coast Guard (G-DSA)	
15. Supplementary Notes The U. S. Coast Guard Office of Research and Development's technical representative for the work performed herein was ENS S. F. WIKER.			
16. Abstract : These concepts have been developed to assist boat builders and designers in planning the control stations of the titled boat types. Utilization of these concepts should provide adequate visibility, space and control locations for 90% of the user population while minimizing safety hazards within the control station envelope. These concepts cover the design of control stations that have the characteristics listed below and should be used only for: (1) a. Lower control stations on Cabin Cruisers designed for standup/sitdown operation or sitdown only operation; and (2) b. Flying Bridges designed for standup/sitdown operation or sitdown only operation. The design of control stations for smaller boats such as Runabouts, Bassboats Bowriders, Center Console, Fishing Boats, etc., are not discussed here. If your control station is for a boat or purpose other than that listed in A or B, above, obtain and use: a. Control station design concepts for Bassboats, Bowriders, Runabouts, Ski-boats and other control stations designed for sitdown use only(except Cabin Cruisers). b. Control station design concepts for Center Console, Deck Boats, Pontoon boats and all control stations designed for standup/sitdown use(except Cabin Cruisers).			
17. Key Words Control Station, human factors, anthropometry, recreational boat, cabin cruisers, flying bridges		18. Distribution Statement Document is available to the U.S. Public through the National Technical Information Service, Springfield, Virginia 22161.	
19. Security Classif. (of this report) Unclassified	20. Security Classif. (of this page) Unclassified	21. No. of Pages 32	22. Price

NOTICE

This document is disseminated under the sponsorship of the U. S. Department of Transportation in the interest of information exchange. The United States Government assumes no liability for the contents or use thereof.

The United States Government does not endorse products or manufacturers. Trade or manufacturers' names appear herein solely because they are considered essential to the object of this report.

ACCESSION for	
NTIS	Write Section <input checked="" type="checkbox"/>
DDC	Bull Section <input type="checkbox"/>
UNANNOUNCED	<input type="checkbox"/>
JUSTIFICATION _____	
BY _____	
DISTRIBUTION/AVAILABILITY CODES	
Dist.	SPECIAL
A	

78 06 12 185

cover (2)

3+4X

FOREWORD

These Control Station Design Concepts were developed by the U. S. Coast Guard to assist boatbuilders and designers in planning the control stations of various types of boats. These concepts are non regulatory. Instead they are suggestions based on human factors engineering techniques which if followed will provide adequate visibility, space and control orientations for 90% of the user population. At the same time the designer will be minimizing safety hazards within the control station. Flexibility should be used in applying these concepts to individual designs.

There are three reports in this project. Each covers a different type of boat. Users of these concepts are reminded to make sure that their boats are in compliance with all current regulations. Any questions should be directed to your Coast Guard District Boating Standards Office.

3
4x

CONTROL STATION DESIGN CONCEPTS FOR CABIN CRUISERS AND FLYING BRIDGES

OBJECTIVE: These design concepts have been developed to assist boat builders and designers in planning the control stations of the titled boat types. Utilization of the concepts should provide adequate visibility, space, and control locations for 90% of the user population while minimizing safety hazards within the control station envelope.

SCOPE: These concepts cover the design of control stations that have the characteristics listed below and should be used only for:

- A. Lower control stations on Cabin Cruisers designed for standup/sitdown operation or sitdown only operation, and
- B. Flying Bridges designed for standup/sitdown operation or sitdown only operation.

The design of control stations for smaller boats such as Runabouts, Bassboats, Bowriders, Center Console, Fishing Boats, etc., are not discussed here. If your control station is for a boat or purpose other than that listed in A or B, above, obtain and use:

- Control station design concepts for Bassboats, Bowriders, Runabouts, Ski Boats and all other control stations designed for sitdown use only (except Cabin Cruisers).
- Control station design concepts for Center Console, Deck Boats, Pontoon Boats and all control stations designed for standup/sitdown use (except Cabin Cruisers).

NOTE: The concepts discussed are directed towards boat builders; however, dealer and/or owner installed equipment should conform to the criteria established herein.

There are two parts to these concepts:

PART 1 Is for boat builders who do not use detailed drawings. It consists of a step-by-step procedure to develop a proper control station and is structured as follows:

- SECTION 1** Verifies adequate standing visibility.
- SECTION 2** Locates the steering wheel.
- SECTION 3** Locates the shift/throttle mechanisms.
- SECTION 4** Locates other controls and instruments.
- SECTION 5** Positions the seat.
- SECTION 6** Locates windshields.
- SECTION 7** Locates the top & discusses canvas side curtains.
- SECTION 8** Recommends solutions to the glare problem.
- SECTION 9** Covers all aspects of Flying Bridge design.

PART 2 Profile drawings to $\frac{3}{4}'' = 1'0''$, $1'' = 1'0''$, and $1\frac{1}{2}'' = 1'0''$ are designed to be slipped under working drawings for tracing purposes.

NOTE: Part 2 consists of 3 separate sheets:

PART 2-A For sitdown only control stations.

PART 2-B For standup/sitdown control stations with angled steering wheels.

PART 2-C For standup/sitdown control stations with vertical steering wheels.

If you do use scale drawings you should consult the text for details of:

- Philosophy of wheel type and placement Section 2
- Details of shift/throttle type and placement . . . Section 3
- Instrument and switch placement Section 4
- Seat Positions Section 5
- Windshield details Section 6
- Cabin tops Section 7
- Glare problems Section 8
- Flying Bridge design details Section 9

PART 1

CONSTRUCTION OF A CONTROL STATION FOR THOSE WHO DO NOT USE DETAILED DRAWINGS

ASSUMPTIONS: You have a hull sitting on a cradle or somehow blocked up. Any cabins or structures that would limit the operator's visibility of the bow have been installed. The cockpit sole or deck is in place and you have planned the location of the control console. You are ready to plan the dimensional characteristics of the control station including the panel, seat, and controls.

NOTE: The old axiom "Pictures Say a Thousand Words" is true in using this booklet. An **accurate** scale drawing of your boat in scales corresponding to those specified earlier will greatly simplify the use of this document. By slipping the scale control station drawing under your tracing you should be able to:

- Determine if you have adequate forward visibility.
- Determine where to place the wheel & shift/throttle mechanism.
- Place the seat correctly.
- Place the windshield & grabrails correctly.
- Provide enough headroom under the top.

SET UP HULL: You should have a pretty good idea of how your boat will float when it is loaded with engine, fuel, and a normal load of people and gear. We are talking about the waterline while the boat is **at rest**. Chock up the hull so that this waterline is level. In most cases the boat will now be sitting in a slight bow-up attitude.

If you aren't sure how your boat will sit in the water, look at similar boats in the water or in advertisements. Set yours up at the same angle.

1.0 STANDING VISIBILITY

Follow the procedures outlined below if you intend to be able to operate the boat from a standing as well as a seated position. If the boat will be operated from a seated position only follow the procedures described in Section 9, "Flying Bridges."

Assuming that your control station will be operated from a standing position, the first step will be to determine if the operator standing at the proposed helm station will have adequate visibility over the bow. If your boat doesn't have anything forward of the control station area that could obscure the bow from view, follow the procedures described in Section 1.1. However, if a cabin or any sort of raised structure has been or will be installed forward of the control station, you will have to determine if the smallest operator that we are designing for can see the bow over the cabin top. If he can't, you have to determine the most forward point on the cabin top that he can see and use that point to determine if you will have adequate visibility.

How to determine the most forward point that can be seen. Mark a stick 5 feet from the end and stand it vertically on the spot where the operator will stand. Stand behind the stick and sight forward so that your line of sight crosses the mark on the stick. If you can see the bow over the structures proceed with Section 1.1. If you can't, follow the procedures outlined in Section 1.2.

BEFORE YOU START . . .

Measure the vertical distance from the Static Load Waterline (LWL) to the deck on which the operator will stand. Use that dimension to determine which column under "Columns B" to enter. For instance, if your deck is 6 feet above the LWL you would use the 2'-7" to 10'-0" column.

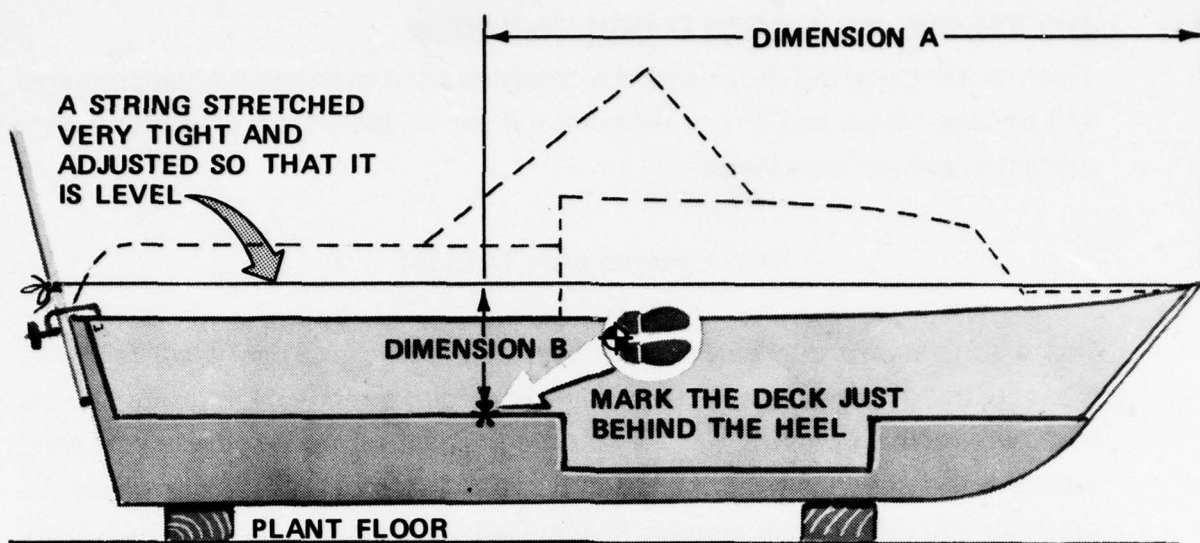

CUT-AWAY VIEW OF BOAT

TABLE I

COLUMN A	COLUMNS B DECK HEIGHTS ABOVE LWL		
	UNDER 2'6"	2'7" to 10'0"	OVER 10'1"
INCHES HORIZONTAL	INCHES VERTICAL	INCHES VERTICAL	INCHES VERTICAL
50	53	50½	47½
60	51½	48½	45
70	50	46½	42½
80	48½	44½	40
90	47½	42½	37½
100	46	40½	35
110	44½	38½	32½
120	43	36½	30
130	41½	34½	27½
140	40½	33	25
150	39	31	22½
160	37½	29	20
170	36	27	17½
180	34½	25	15
190	33½	23	12½
200	32	21	10
210	30½	19	7½
220	29	17	5
230	27½	15½	2½
240	26½	13½	0
250	25	11½	* 2½
260	23½	9½	* 5
270	22	7½	* 7½
280	20½	5½	*10
290	19½	3½	*12½
300	18	1½	*15
310	16½	* 0½	*17½
320	15	* 2	*20
330	13½	* 4	*22½
340	12½	* 6	*25
350	11	* 8	*27½
360	9½	*10	*30

8° Vis. Angle 11° Vis. Angle 14° Vis. Angle

NOTE: For simplicity the sketches show the keel as being level. If you've leveled the boat to an anticipated static load waterline, the keel may not be level.

Dimension B measured on your boat must be **less** than the value shown in the appropriate column B...

EXCEPT

If an asterisk appears before the number in the appropriate column B, your dimension B measured on your boat must be **greater** than that value shown.

Table I is based on a 60" standing eyeheight, 5 degree trim angle, and 100 ft. visibility to water.

1.1 DO THIS IF YOU COULD SEE THE BOW

The first thing you will do is rig a horizontal line aft from the bow. Measurements will be taken from this line to determine if the visibility from your boat meets certain minimum standards.

Check sketch over TABLE I

Use a long board and carpenter's level or a string and line level (shown). Measure the distance from the bow back to a point directly over the spot on the floor where the operator will be standing. That will be **Dimension A**. Next measure the distance from the string down to the spot on the floor where the operator will stand while driving. That is **Dimension B** for use in Table I. If the cabin structure prohibits you from stringing a line back from the bow, see procedure for determining Dimension **B** under 1.2.

After you have determined DIMENSION A and DIMENSION B, find the number in the left column (A) of Table I that is closest to **but more than** your Dimension **A**. (The next higher number). Your Dimension **B** must be less than the number in the same row under column **B**. For instance, if your Dimension **A** is 98 inches, and the deck at the control station is, say 4'-4" above the waterline, you would enter Table I at 100 inches in column **A** and move right to 40½ inches in column **B**. Your Dimension **B** would have to be less than 40½ inches. (Note the exception to the "Less Than" rule explained next to Table I).

1.2 DO THIS IF YOU COULD NOT SEE THE BOW

You won't be able to use the bow as a reference point if you can't see the bow from the operator's standing position or won't be able to see it when the boat is completed because some portion of the boat structure is obscuring it. Instead you will have to use the most forward point on that structure that you can see as a reference point. Use this point instead of the bow to determine if your deck on which the operator stands is high enough.

WHAT TO DO . . .

Sight over the 5 foot mark on the stick and determine and mark the most forward point on the cabin top or other structure that you can see. (See Sketch). Measure Distance **A**. Go to Table I and find the number in the left column (**A**) that is closest **but more than** your Dimension **A** (The next highest number). Your Dimension **B** must be **less** than the number in the same row under the appropriate eye height range in column **B**. Check eye height range determination and example under 1.1.

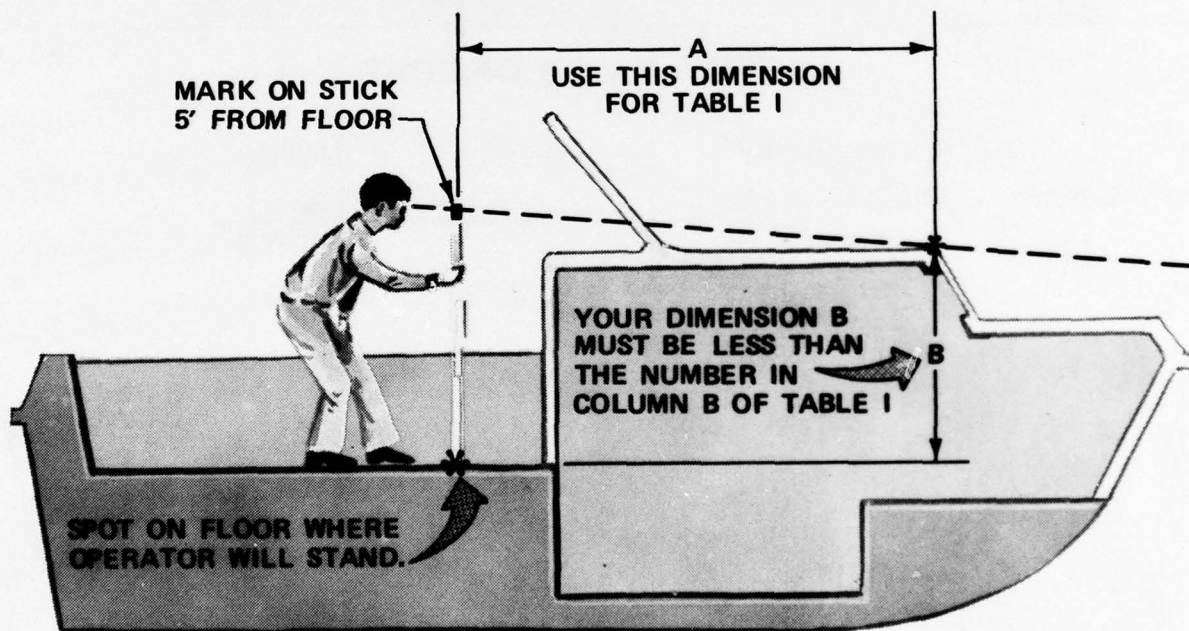

CUT-AWAY VIEW OF BOAT

How can you measure Distance **B** on your boat? Here's a suggestion. Rig a contraption similar to that shown below or use a string instead of the horizontal board. Measure X and Y. Subtract X from Y. The number that you get should be smaller than Dimension **B** from Table I (opposite your Dimension A).

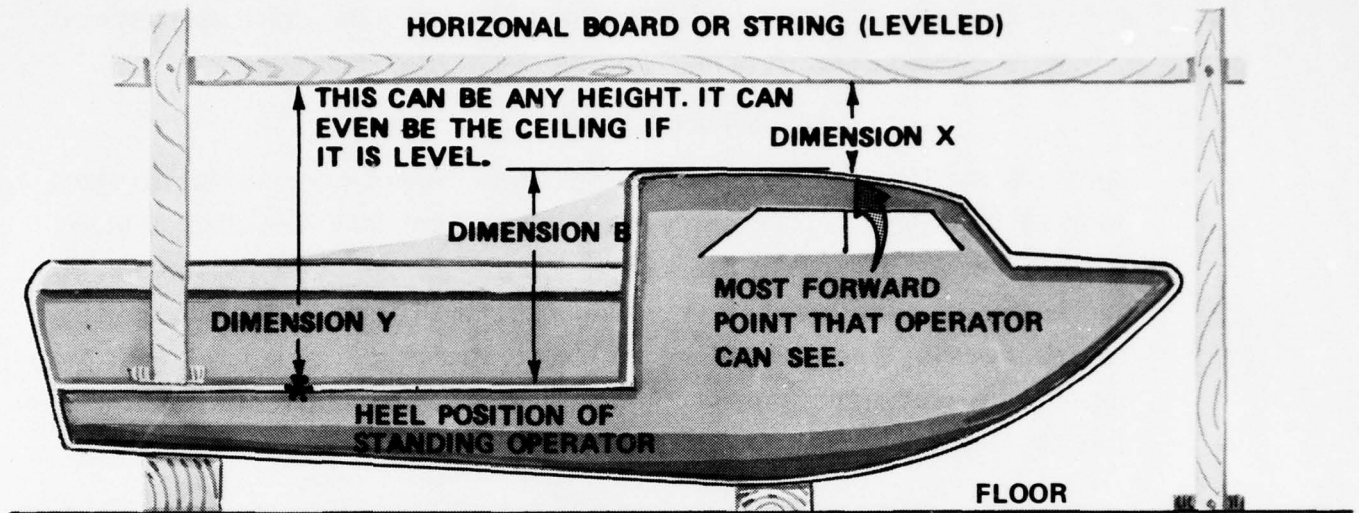

CUT-AWAY VIEW OF BOAT

	DIMENSION Y	INCHES
Subtract	DIMENSION X	INCHES
	<hr/>	
	DIMENSION B	INCHES

SUMMARY — STANDING VISIBILITY

1. Determine and mark operator's standing position.
2. Level waterline and measure from the most forward point that you can see back to a point directly over the operators' heel position.
3. Measure from the floor up to a point level with the most forward point that you can see. Compare this figure with the appropriate figure in Table I. If your dimension is less, you're in good shape. Continue to Section 2. If yours is greater, follow suggestions beside Table I.

2.0 THE STEERING WHEEL

In this section we will attempt to locate the steering wheel so that it is convenient to use while standing, and can also be used when seated. You should decide whether you want a vertical wheel or an angled wheel and the approximate wheel diameter. The location of the steering shaft, and subsequently the position and angle of the control panel mounting surface, will depend on these decisions.

Control stations of this type have been designed with wheels from 9" through 36" in diameter installed at angles ranging from vertical through horizontal. What is best? Here are some recommendations:

1. The angled wheel is more comfortable for the seated operator than is the vertical wheel. This is true only if the seat/angled wheel relationship allows the operator to slide his legs under the wheel.
2. An angled wheel is usually easier to spin quickly because of its' orientation to the standing or sitting operator's arms.
3. The protruding spokes of an external spoked wheel catch on clothing. The use of an external rimmed wheel will avoid the problem.

The important variables that must be considered when planning the position of the steering wheel are:

1. Wheel Height
2. Wheel Angle
3. Wheel Diameter
4. Horizontal distance from operator's heel position to aft edge of wheel.
5. Hand clearance around wheel.

Wheel height, diameter, and distance from heel position to aft edge of wheel depend on wheel angle. Select the wheel angle that you want to use and locate your control panel so that the wheel is positioned within the limits shown in Table II, below.

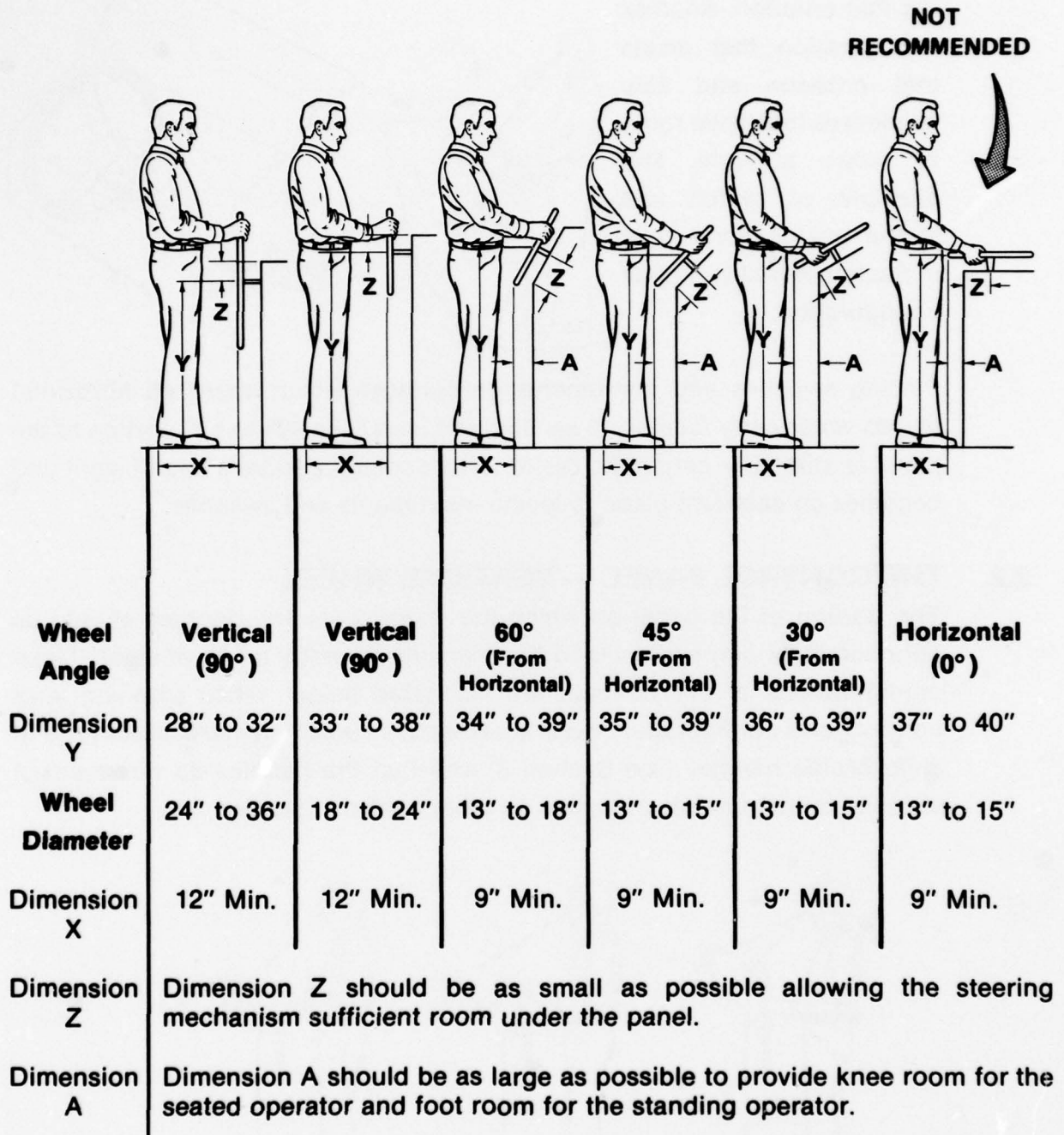
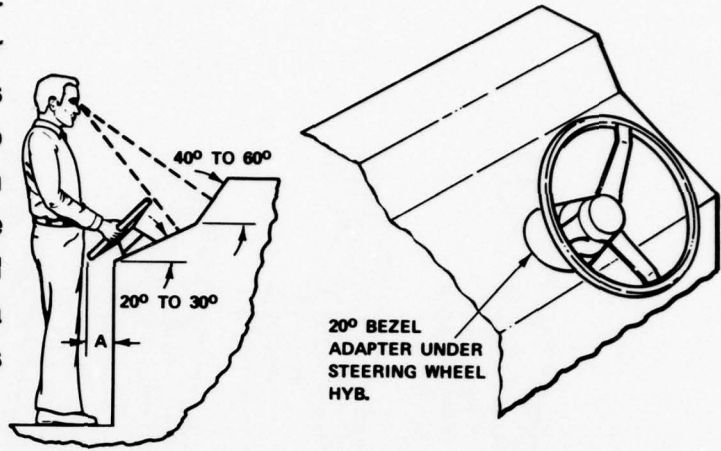

TABLE II STEERING WHEEL PLACEMENT

2.1 THE CONTROL PANEL — ANGLED WHEEL

The panel should be located at an angle that is approximately perpendicular to the operator's line of sight. Notice that the panel under the 30° wheel in Table II, comes very close to meeting that criterion. Another configuration that meets that criterion and also maximizes foot/knee room is shown at right. The example of switch and instrument location criteria in Section 4 builds on this configuration.



Placing switches and instruments on surfaces which approach horizontal invites water entry leading to service problems. The 40° to 60° portion of the panel is still fairly perpendicular to the standing operator's line of sight and becomes an excellent place to locate instruments and switches.

2.2 THE CONTROL PANEL — VERTICAL WHEEL

The portion of the panel on which the instruments are mounted should be approximately perpendicular to the standing operator's line of sight. Three configurations of this concept are illustrated below. When planning your control panel configuration, make sure that there is sufficient clearance around shift/throttle handles (see Section 3) and that the handles do not obstruct visibility to instruments or access to other controls (Section 4).

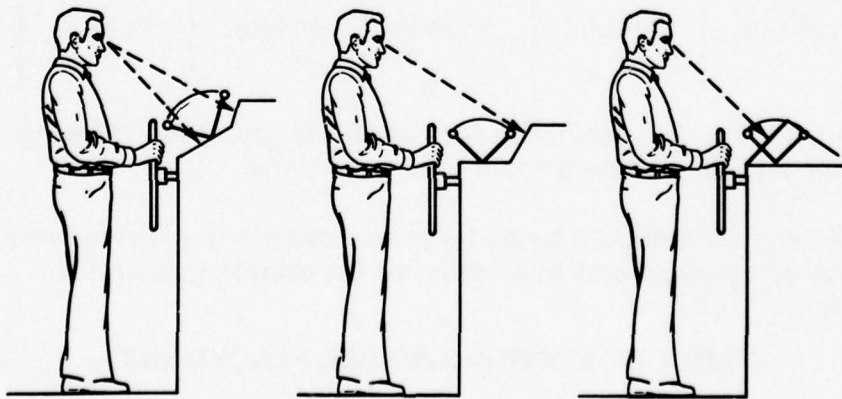

3.0 SHIFT/THROTTLE MECHANISMS

The location of the shift/throttle (S/T) mechanism will depend on:

- The type and size of the steering wheel.
 - Angled
 - Vertical
- The type of S/T mechanism.
 - Deck Mounted
 - Side Mounted

Section 3.1 offers suggestions for placement of deck mounted S/T mechanisms for both wheel configurations. Section 3.2 offers suggestions for placement of side mounted S/T mechanisms.

Pitfalls to avoid are:

- Excessive reach distances; especially for the seated operator.
- Shift handles — Too Close to wheel,
 - Behind the wheel,
 - So high that they are in the operator's field of view,
 - So close to the deck that knuckles are rapped when the handles reach their extreme positions.

Recommendations:

- Position the S/T mechanism beside the angled wheel, not in front of it.
- When a vertical wheel is used, mount the S/T mechanism as far aft and as low as possible. Mounting it on an angle helps to reduce reach distance.

3.1 DECK MOUNTED S/T MECHANISMS TYPICAL DIMENSIONS - S/T MECHANISMS

Several S/T mechanisms are shown below. Their dimensions are typical of the majority of the devices currently manufactured. If your boat is designed to accept such a device, make sure that the ones shown below fit into your panel and comply with the placement criteria shown on the following pages.

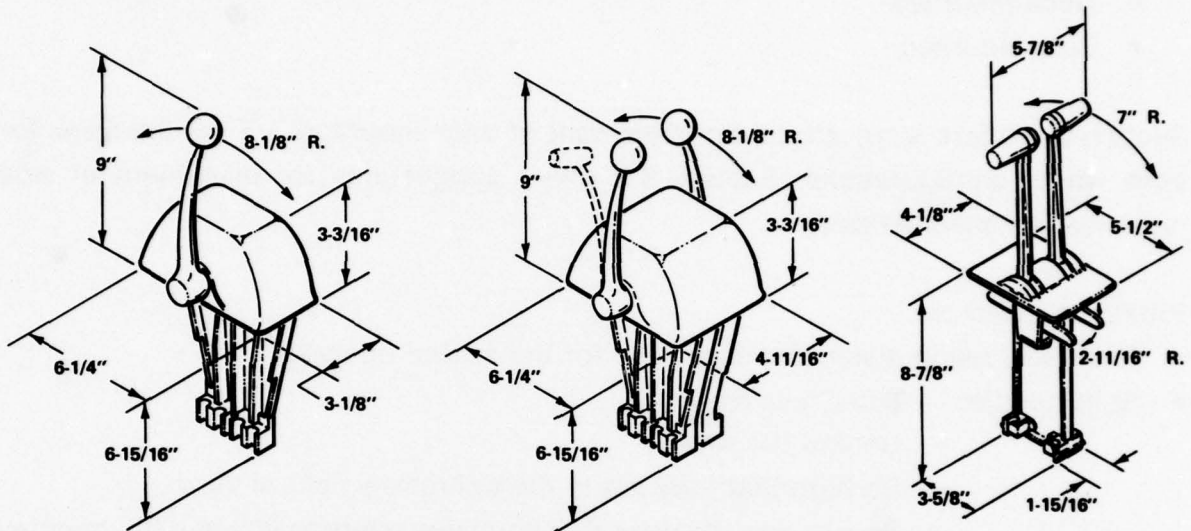

The Mercury deck mounted S/T mechanism for their Model 1750 outboard engine is shown below because of the large handgrip. If your boat is capable of using that engine, make sure you have room for their controller.

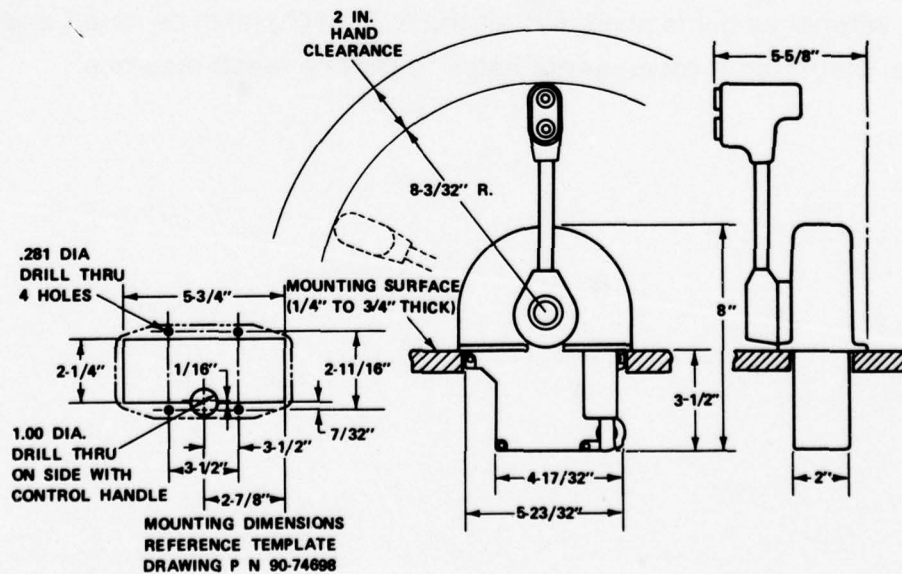

SINGLE ENGINE - Single Lever

Single lever operates throttle and shift mechanism.

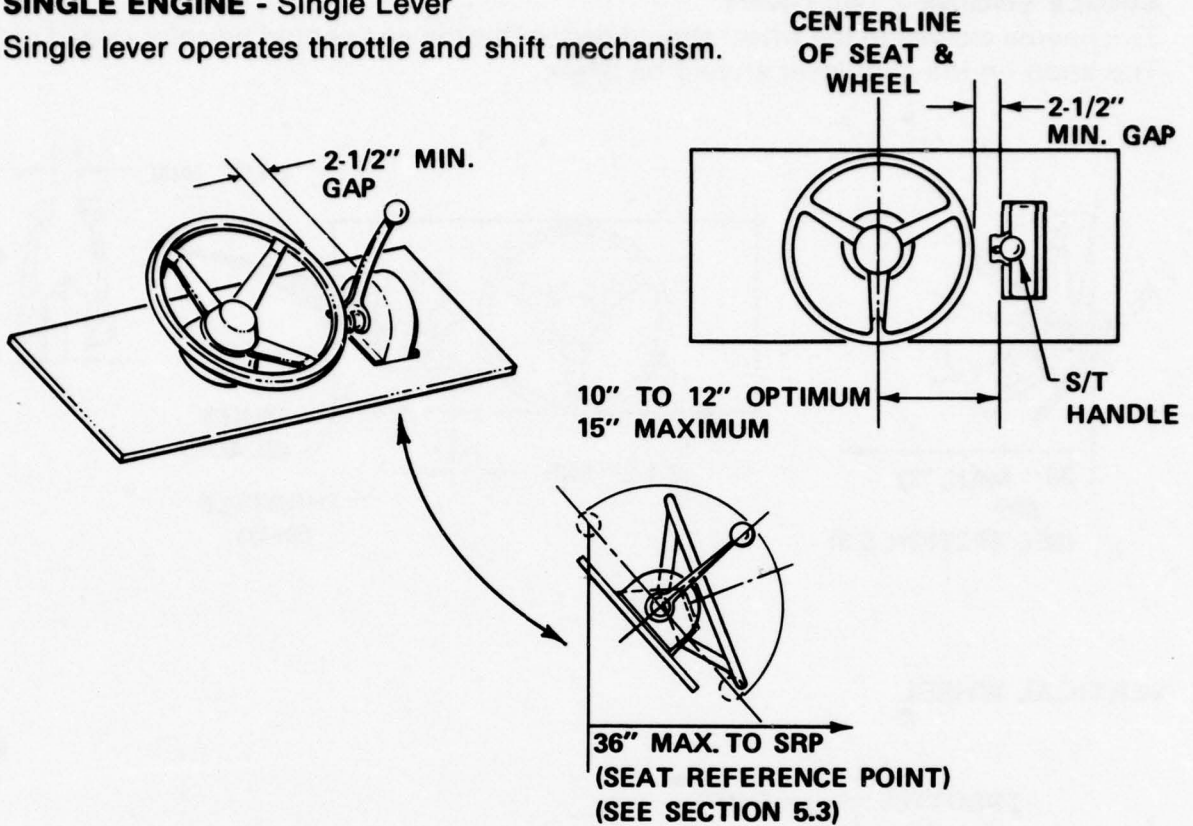

VERTICAL WHEEL

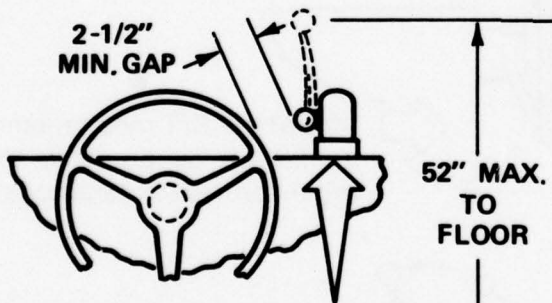

Deck height should be as low as possible. It makes it a lot easier to move the S/T handle. (Especially for a short person.)

NOTE: S/T mechanism may have to be mounted on a block to maintain a 1" gap.

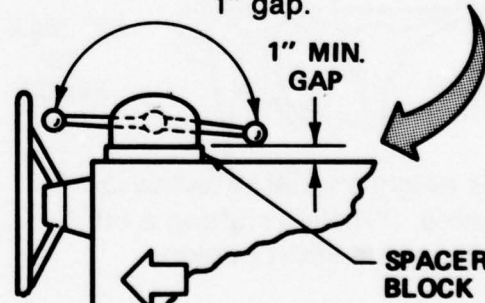

Mount the S/T mechanism as far aft as possible to minimize reach distance.

NOTE: See the recommendation for mounting the S/T mechanism on an angled surface: NEXT TWO PAGES.

SINGLE ENGINE - Two Levers

The handle closest to the wheel should be the throttle and should be color coded red. The knob on the shift lever should be black.

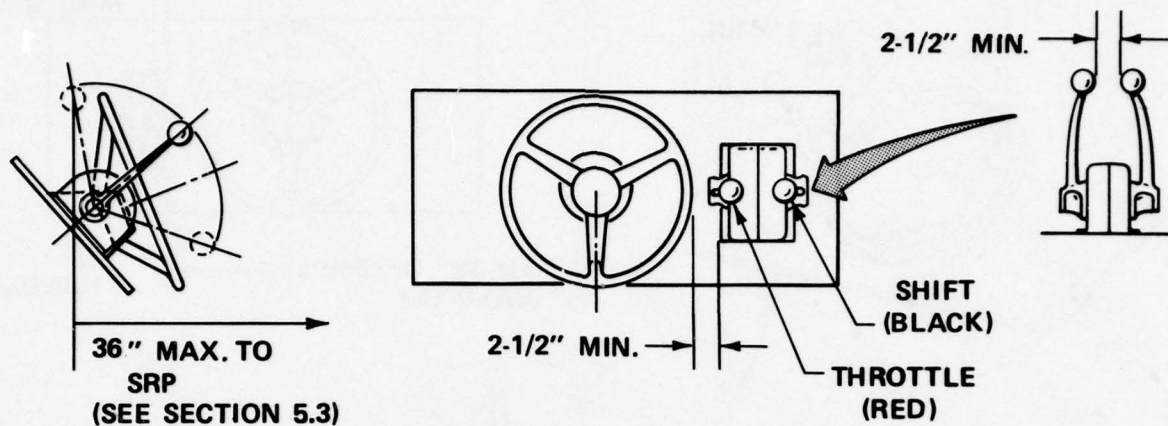

VERTICAL WHEEL

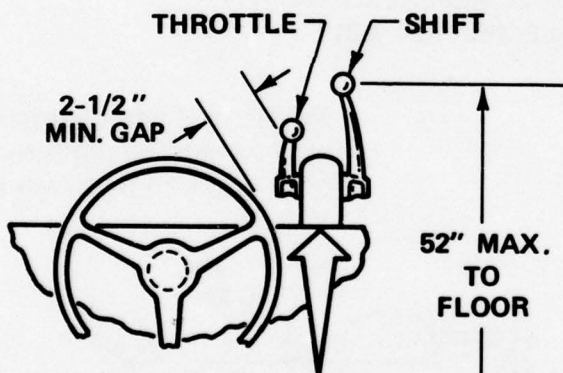

Deck height should be as low as possible. It makes shifting a lot easier for the short person.

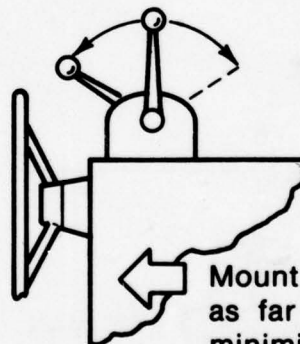

An angled mounting surface reduces reach distance. Instruments may be mounted on the remainder of the angled surface.

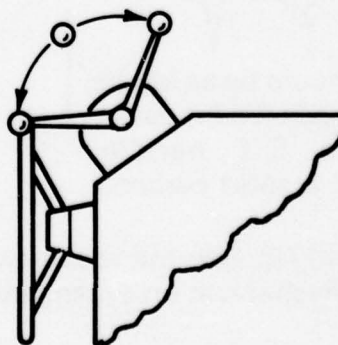

TWIN ENGINE - Single lever for each engine.

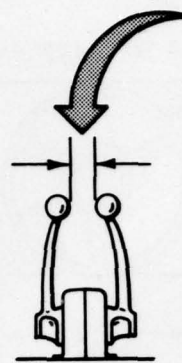
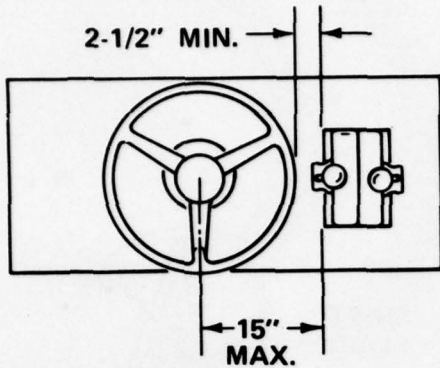

Knobs on handles should be close so they can be moved simultaneously with one hand.

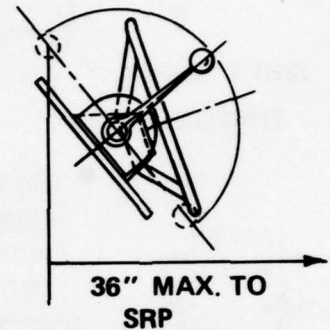

VERTICAL WHEEL

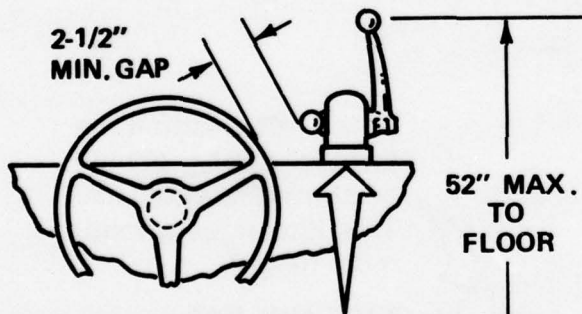

Deck height should be as low as possible. It makes shifting a lot easier for the short person.

NOTE: S/T mechanism may have to be mounted on a block to maintain 1" gap.

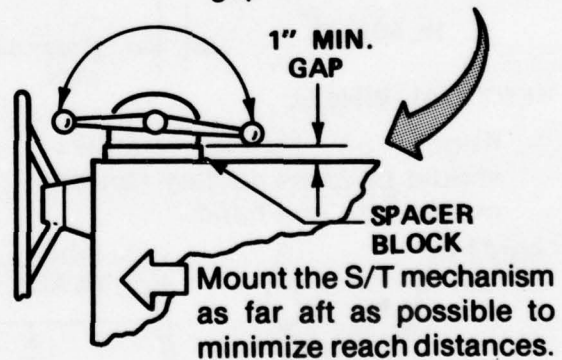

An angled mounting surface reduces reach distance and eliminates the need for a spacer block. Instruments may be mounted on the remainder of the angled surface.

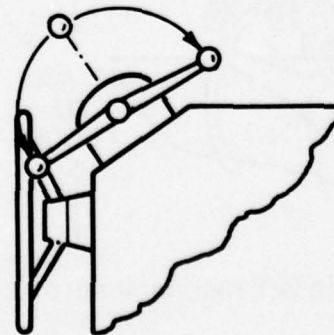

TWIN ENGINE - Two Levers

The handles closest to the wheel should be the throttle and should be color coded red. The knob on the shift lever should be black.

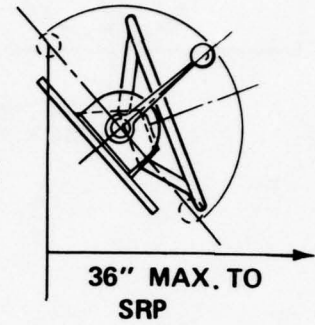
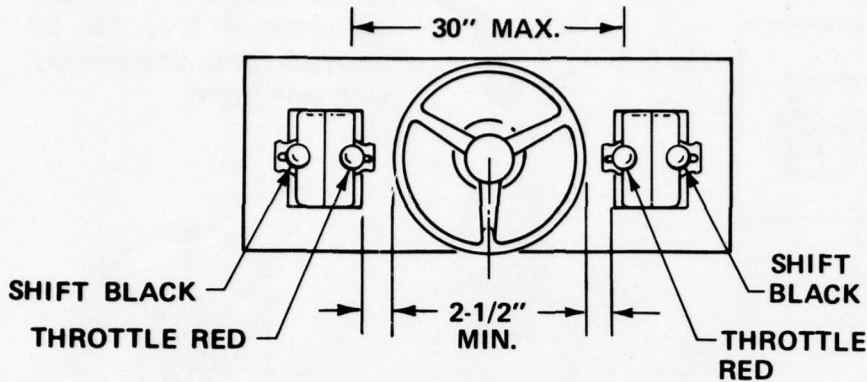

Some people prefer the throttles together so they can be moved simultaneously with the right hand.

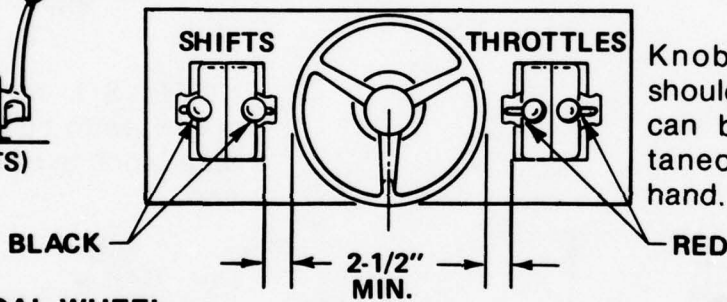
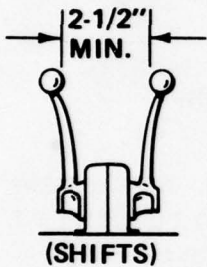

Knobs on handles should be close so they can be moved simultaneously with one hand.

VERTICAL WHEEL

Knobs on throttle handles should be close so they can be moved with one hand.

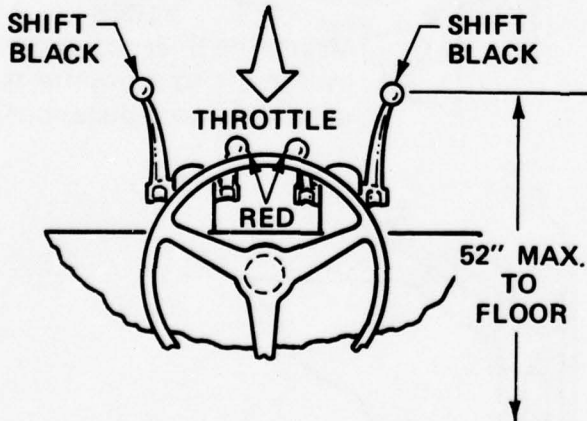

In the idle position the throttle knobs should be above the wheel rim. This illustrates a minimum height.

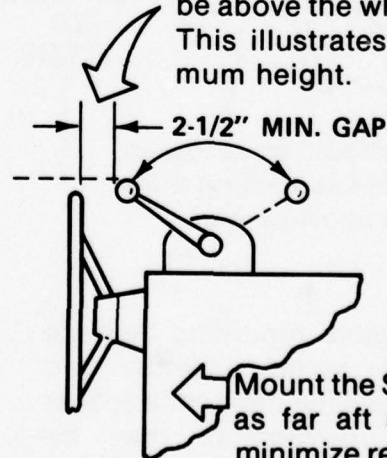

NOTE: Mounting the S/T mechanisms on an angled surface probably won't help in this configuration.

22

SUMMARY

1. Check recommendations and pitfalls under 3.0.
2. Make sure you have adequate space beside (or in front of) wheel to mount S/T mechanism.
3. Install one. If your boat could be controlled by either a deck mounted or side mounted S/T mechanism, install both. Check hand clearances, ease of mounting and cable runs to the engine area.
4. In a side mounted installation, will the S/T handle hit the seat or seat mounting/sliding hardware? Install the seat and check.

4.0 CONTROLS & DISPLAYS

The wheel and shift/throttle controls should receive top priority in terms of placement because they are used most often. The rest of the items that go onto the control panel should be considered as a system and include:

- Ignition/Start Switch
- Bilge Blower Switch and Accompanying Warning Statement
- Bilge Pump Switch
- Navigation Light Switch (Separate Switch for Panel Lights)
- Horn Switch (Button)
- Wiper and/or Other Accessory Switches
- Fuses for Above Circuits
- Tachometer
- Ammeter or Voltmeter
- Temperature Gauge
- Oil Pressure Gauge (Inboards)

Even though some of the above items may not be offered as standard equipment, you should leave space on the panel for dealer installations. In addition, where applicable you should provide space for:

- Compass
- Depth Sounder or Depth Recorder
- Speedometer
- Communication Equipment

Where do you put controls and displays? The examples shown build on control panel configurations shown in Section 2.

If your panel is exposed to the elements you should protect your switches and instruments from moisture entry by locating them on panels that are well angled up from horizontal. Switches in the angled wheel example are shown on the flatter surface. They could be put on the more vertical surface for greater weather protection, or you can provide a transparent cover. If they are mounted as shown you should:

- Purchase sealed switches.
- Provide a cap for the ignition switch and any unsealed pushbuttons.
- Don't mount switches on the vertical surface on the rear of the console.
- They are very difficult to see.
- Seated operators hit them with their knees (Damaging both the switch and the knee).

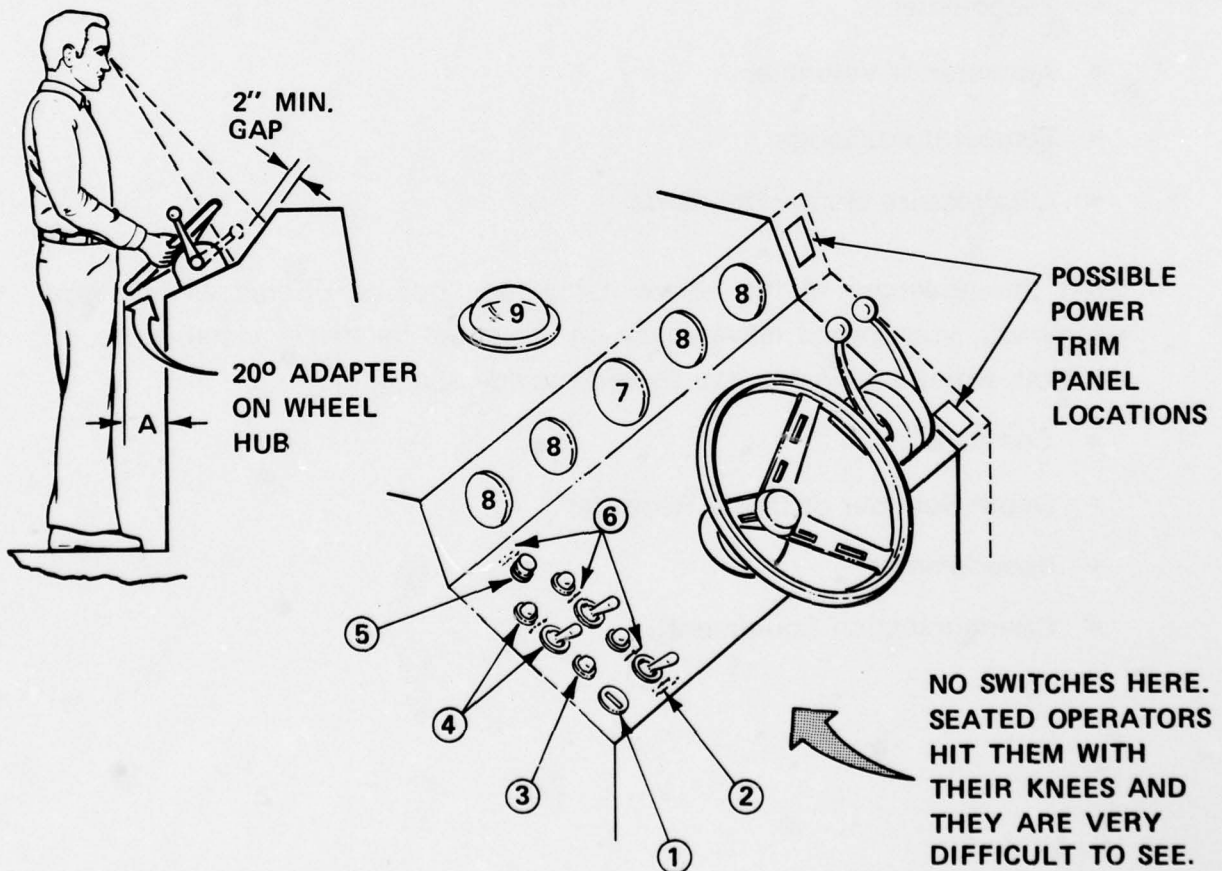

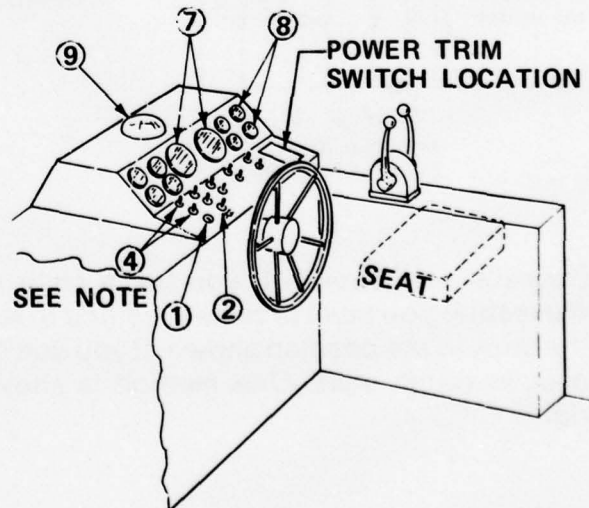
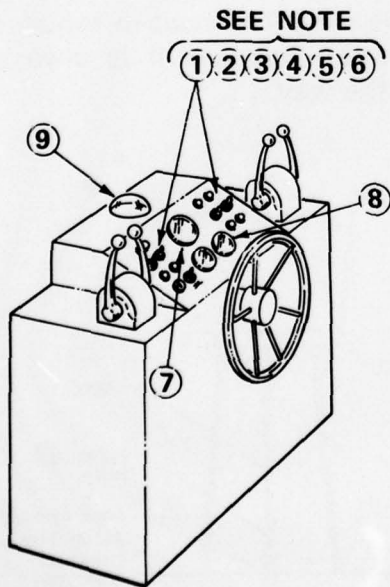
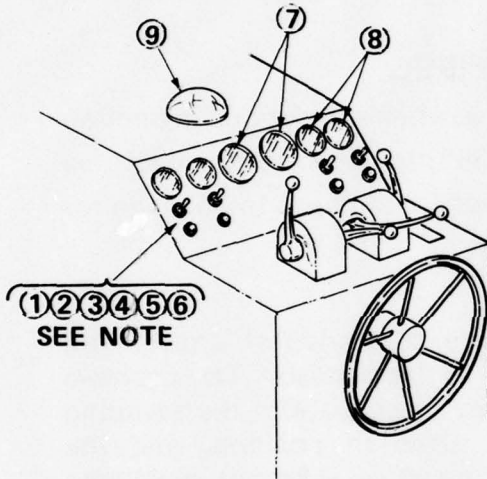
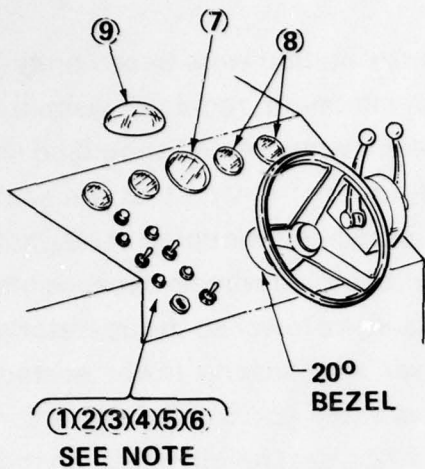

- ① Mount ignition switch on opposite side of wheel from throttle. This lets you operate starter and manipulate throttle simultaneously.
- ② Blower switch and label should be positioned close to ignition switch. (The operator can't help seeing the switch and label as he inserts the key into the ignition switch).
- ③ Panel mounted fuses are economical, easy to wire, and facilitate easy troubleshooting by the owner. (Note: This applies to small cruisers only. A separate circuit breaker panel for each electrical system [12 VDC, 32 VDC, 110 VAC, 220 VAC] should be provided on larger cruisers).
- ④ Auxiliary switches and fuses.
- ⑤ Horn switch should look different and be placed in a prominent location.

NOTE: Items 6, 7, 8, & 9 are not necessarily safety oriented but are included because they are good human engineering principles.

- ⑥ **Label All Switches** above the switch.
- ⑦ Tachometer is most frequently used display. Make sure the wheel rim doesn't hide it from view.
- ⑧ Try to place other gauges, especially temperature and pressure gauges, where the wheel rim won't obscure them from view.
- ⑨ Leave space for compass directly in front of centerline of wheel and seat.

5.0 THE SEAT

Minimum visibility requirements from your control station were based on the standing operator. In order to maintain the minimum required visibility requirements for the seated operator, his eyeheight when seated should be as high or higher than his eyeheight when standing. That means that the seat "should" be 36" high. This works well with vertical wheels mounted at heights suggested in Section 2, but doesn't work well with angled wheels because his knees will be higher than the wheel. The seat should be lower so the operator's knees can slide under the wheel rim. A lower seat means lower seated eyeheight. Since the visibility criteria remain the same you should check for adequate seated visibility after you have decided on a seat height based on the steering wheel configuration chosen.

5.1 SEAT FOR BOATS WITH VERTICAL WHEEL

Use of a 36" high seat is suggested for the vertical wheels described in Section 2. Since the eyeheight of a person seated on a 36" high seat approximates his standing eyeheight, separate visibility calculations don't have to be made for the seated helmsman. Mount the seat as shown.

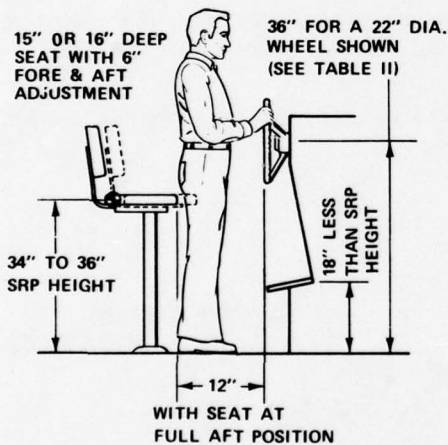

Some manufacturers of pedestal chairs sell footrests that mount to the pedestal. The problem with them is that they interfere with the standing operator's legroom when in position, and the operator must leave the wheel to loosen the clamp and swivel it out of the way. The built-in footrest shown at left is preferred because it is always available and never in the way.

Pedestal seat shown. If you use a chair (4 legs & moveable) you must provide a method to secure it to the deck in the position shown. If you don't it will fall over in rough seas. One method is shown at the right.

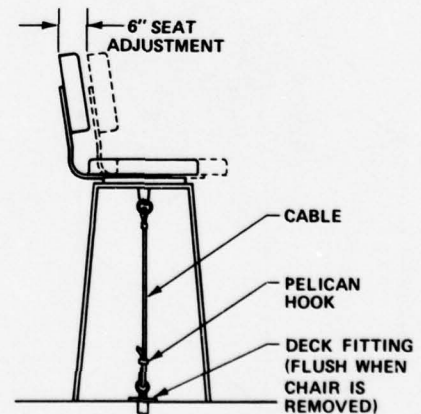

5.2 SEAT FOR BOATS WITH AN ANGLED WHEEL

Important criteria are:

- **Seat Height**...depends on wheel height and can vary from 20" to 26" from deck to SRP (Seat Reference Point) as shown below:

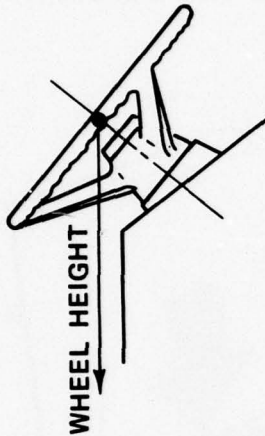

WHEEL HT. (MEASURED AT CENTER OF RIM.)	SEAT HT. (MEASURED AT DEPRESSED SRP.)
INCHES	INCHES
39	24 - 26
38	23 - 26
37	22 - 25
36	21 - 24
35	20 - 23
34	20 - 22

NOTE: NORMALLY THE FRONT EDGE OF THE SEAT IS 1" TO 2" ABOVE THE SRP.

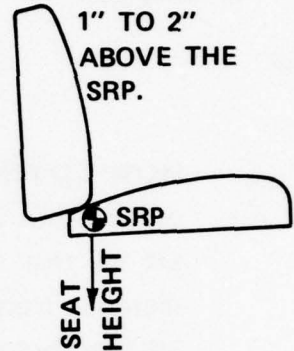

- **Fore/Aft Clearance**...provide a 9" horizontal space between aft edge of wheel and forward edge of seat (if the seat has fore & aft adjustment the measurement should be made with the seat in the full aft position).
- **Seat Dimensions**...See Section 5.5.
- **Fore & Aft Adjustment**...6".
- **Footrest**...located 18" to 20" below seat. Don't let it extend aft of the aft edge of the wheel. Provide toe space under it.
- **Alignment**...when looking from above, the centerline of the seat and the wheel should always coincide within 2". If the wheel is off center it should be towards the side opposite the S/T controls.

5.3 SEATED VISIBILITY — ANGLED WHEEL

The seat for an angled wheel as described in Section 2 will be from 20" to 26" above the deck. The seated operator's eyes will be considerably lower than the standing operator's eyes. Since the seated operator visibility criteria should match standing operator visibility criteria you will have to check seated visibility as follows:

Determine the height of the Seat Reference Point (SRP). This is the intersection of the seat back and the depressed seat.

HOW TO FIND THE SRP. Have a person that weighs 150 - 175 lbs. sit in the seat. Measure the distance from the lowest point on his (her) bottom to the floor. That's the SRP height.

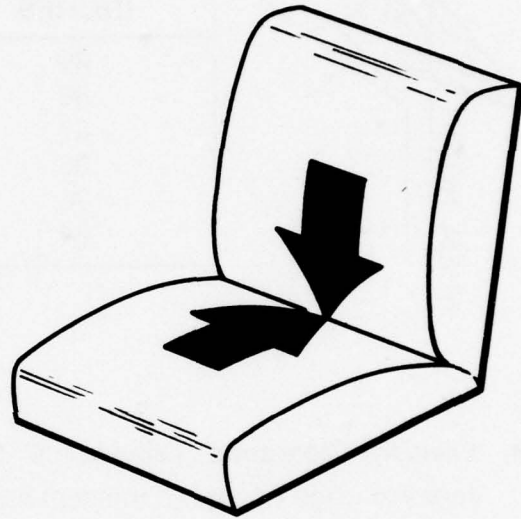

If you haven't purchased the seat yet subtract 1" from the specified seat height. Use that dimension as your SRP height.

Next add 27" to the SRP height. (This is the 5th percentile male seated eye height). For example, if you have chosen a 25" high seat, add 24" (SRP height) and 27" (eyeheight) = 51".

Mark a stick at a point 27" above the SRP. (51" in our example.) Mark a spot on the floor 25" aft of the aft point of an angled wheel or 25" aft of a vertical wheel. Stand the stick on that point and sight across the mark. If you can see the bow, proceed as follows:

Details on Next Page

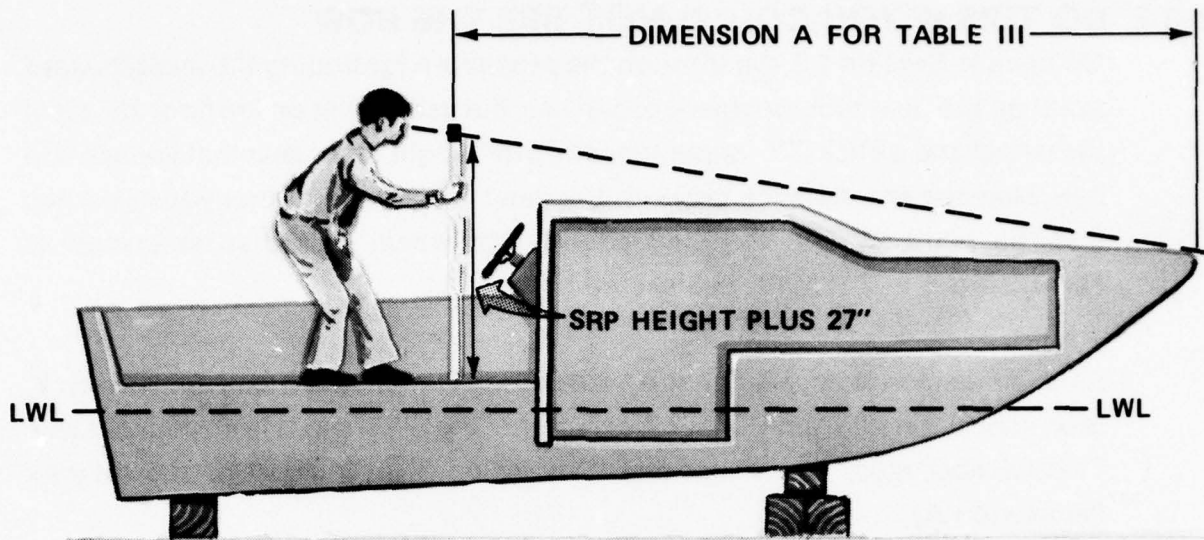

CUT-AWAY VIEW OF BOAT

5.3.1 DO THIS IF YOU COULD SEE THE BOW

Rig a line back from the bow as you did to check standing visibility. Review the procedures in Sections 1.1 or 1.2. Measure the horizontal distance from the bow back to the spot on the floor that is 25" aft of the wheel. That will be Dimension **A**. Next measure the vertical distance from that spot on the floor to the string above it. Subtract the SRP height from that distance. Your answer has to be less than the dimension shown under the appropriate Column **B** in Table III. If it is greater, see list of alternative solutions below.

BUT . . . You probably can't rig a line directly back from the bow because of cabin structure interference. You will have to rig a contraption over your boat similar to that shown on the next page. Measure the distance from the board down to the deck at a point 25" aft of the wheel. That's Dimension **Y**. Subtract **X** from **Y**. Subtract your SRP height from the answer you just got (when you subtracted **X** from **Y**). This number has to be less than the number shown in the appropriate Column **B** in Table III.

Follow the instructions and example on the bottom of the next page to determine if you have adequate visibility.

5.3.2 DO THIS IF YOU COULD NOT SEE THE BOW

Go back to Section 1.2. Go through the procedure for finding the most forward point on the boat that the operator can see, **but** use a point on the floor 25" aft of the wheel and a stick 27" longer than the SRP height of the seat that you want to use. Measure the distance between the most forward point that you could see and the point 25" aft of the aft edge of the wheel. Use that dimension as Dimension **A** in Table III. See sketch below.

Find Dimension **B** on your boat by measuring Dimension **X** and Dimension **Y**, then subtracting **X** from **Y**. After that subtract the SRP height from your answer. This number must be smaller than Dimension **B** in Table III (Opposite your Dimension **A**).

EXAMPLE:

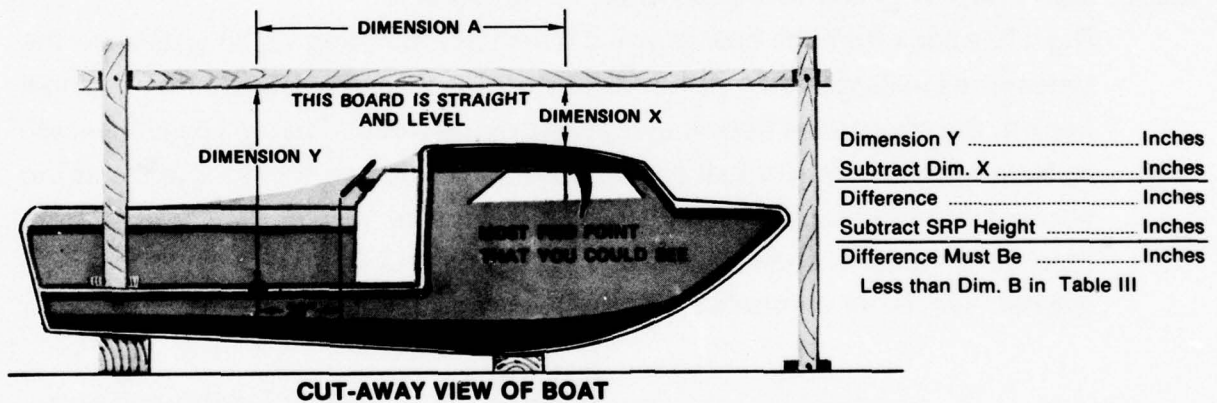

Next use Table III to determine if you have adequate visibility. Find the number in the left column of Table III that is closest to but greater than your Dimension **A** (The next higher number). Your Dimension **B** must be less than the number in the same row under the appropriate Column **B**. For instance, if your Dimension **A** is 72 inches and your deck is 2 feet above the LWL you would enter Table III at 80 inches in Column **A** and move right to 16 inches in the middle Column **B**. The answer to your double subtraction problem described in Section 5.3 should be **less** than 16 inches. (Note exception described adjacent to Table III).

TABLE III

COLUMN A	COLUMNS B DECK HEIGHTS ABOVE LWL		
	UNDER 2'6"	2'7" to 10'0"	OVER 10'1"
INCHES HORIZONTAL	INCHES VERTICAL	INCHES VERTICAL	INCHES VERTICAL
50	20	17½	14½
60	18½	15½	12
70	17	13½	9½
80	16	11½	7
90	14½	9½	4½
100	13	7½	2
110	11½	5½	* 0½
120	10	3½	* 3
130	8½	1½	* 5½
140	7½	0	* 8
150	6	* 2	*10½
160	4½	* 4	*13
170	3	* 6	*15½
180	1½	* 8	*18
190	0½	*10	*20½
200	* 1	*12	*23
210	* 2½	*14	*25½
220	* 4	*16	*28
230	* 5½	*17½	*30½
240	* 6½	*19½	*33
250	* 8	*21½	*35½
260	* 9½	*23½	*38
270	*11	*25½	*40½
280	*12½	*27½	*43
290	*14	*29½	*45½
300	*15	*31½	*48
310	*16½	*33½	*50½
320	*18	*35	*53
330	*19½	*37	*55½
340	*21	*39	*58
350	*22	*41	*60½
360	*23½	*43	*63

Dimension **B** measured on your boat must be **less** than the value shown in the appropriate column **B** . . .

EXCEPT

If an asterisk appears before the number in the appropriate column **B**, your dimension **B** measured on your boat must be **greater** than that value shown.

Table III is based on a 27" sitting eyeheight, 5 degree trim angle, and 100 ft. visibility to water.

5.4 SEAT DIMENSIONS

The control station was designed for the standing operator. When he sits he moves away from the control console. Reach distances become a problem. For that reason, seats designed for this application should not be as deep as normal seats and should be quite erect. This will allow the operator to sit back in the seat & still be able to reach the controls. Dimensions should look like this:

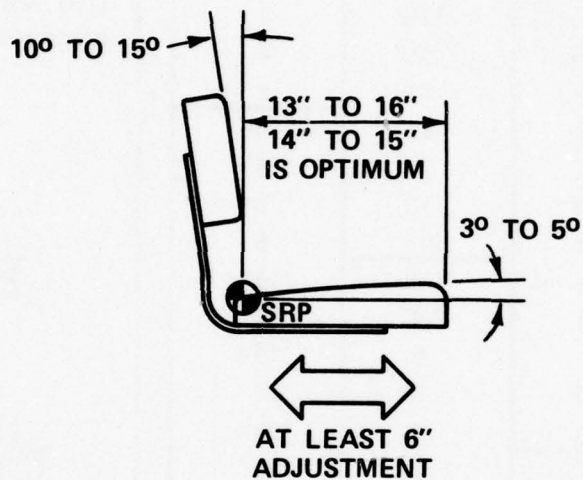

SUMMARY — SEATING

1. The seat used with a vertical wheel as presented in Section 2 should be $36''$ high and have at least $6''$ fore/aft adjustment. There should be $12''$ gap between the wheel and the seat in its' aft position.
2. The height of a seat used with an angled wheel depends on wheel height as detailed in Section 5.1. Provide at least $6''$ of fore/aft adjustment. Leave a $9''$ space between the angled wheel and the seat. This is a **horizontal** measurement.

6.0 WINDSHIELDS

Most lower control stations on cruisers are equipped with full windshields. Many flying bridge windshields are designed so that the operator may look over them. This section will deal only with full windshields through which the standing and seated operator look. See Section 9.2.9 for design criteria of windshields that are below the operator's line of sight.

If the standing operator will look through the windshield, it should be higher than the standing eyeheight of the tallest (95th percentile) operator. The lower frame height is determined by the visibility criteria established in Section 1 (Standing Visibility) and Section 5.1 and 5.3 (Seated Visibility). For practical purposes the maximum height of the bottom frame of a windshield can be determined as follows. Add 21 inches to the SRP height. The frame has to be lower than that figure. If the operator will always stand, keep the frame below 4½ feet from the deck (measured vertically). Note: the above simplified method only works if the horizontal eye to windshield distance is less than 4 feet.

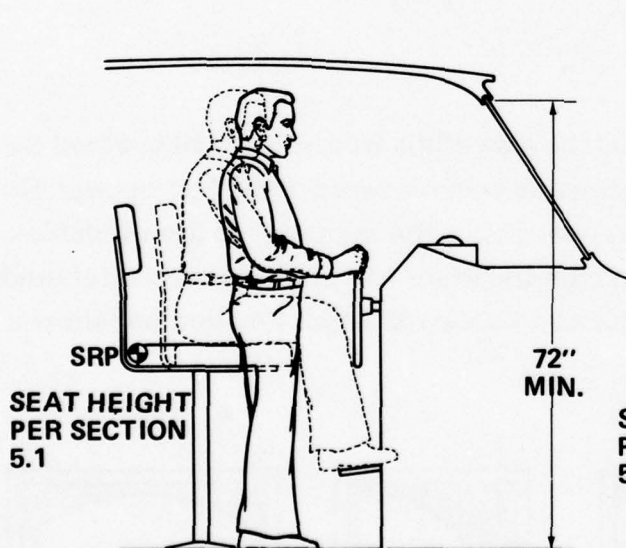

Check frame ht. per Section 1.0 or use simplified method described above.

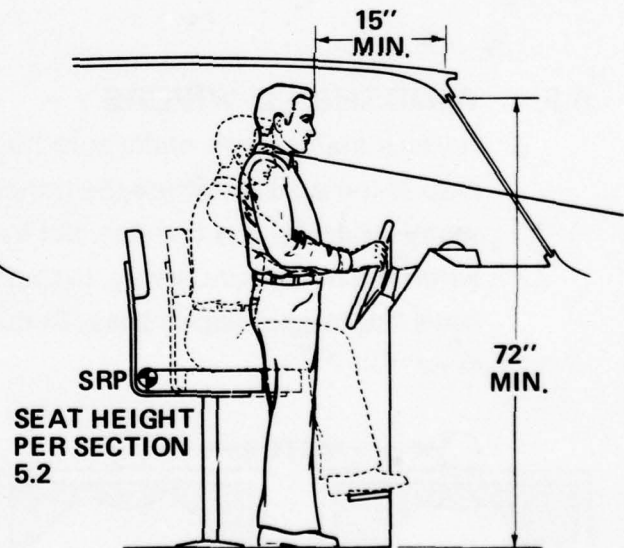

Check frame height per Section 5.3 or use simplified method described above.

6.1 WINDSHIELD FRAMES — THICKNESS

Windshield frames, posts, and many other visual obstructions forward of the SRP should be no wider than 2¼ inches. This does not apply to horizontal frames, but to frames or posts which cut through the primary visual access area in a relatively vertical direction.

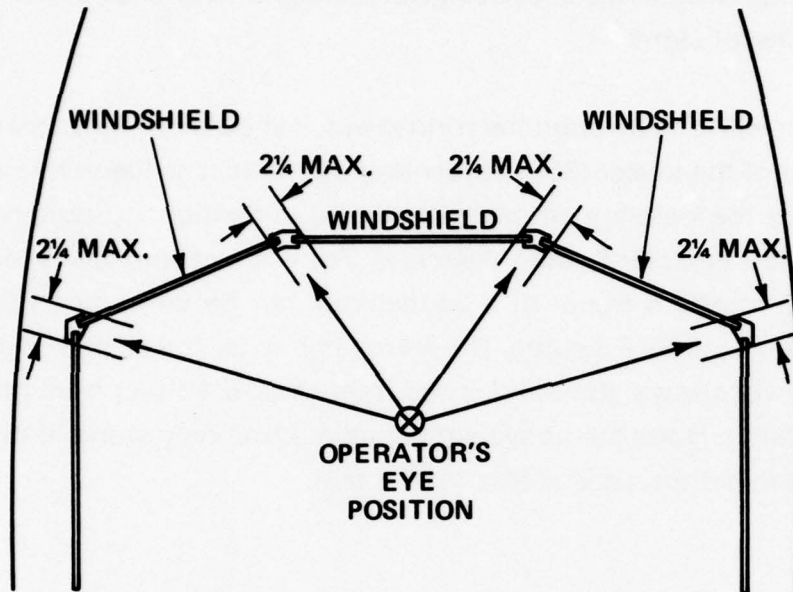

NOTE: Avoid placing vertical frames directly in front of operator. Operator should be aft of the center of a windshield panel.

6.2 WINDSHIELD WIPERS

If you install wipers, make sure that the area of the windshield that is wiped the best is the area on which the horizon and water forward of the bow appear. On many cruisers, the horizon will appear below the midpoint of the windshield when the boat is underway. In that case the lower half of the windshield should have the largest wiped area. Some approaches to wiper location are shown:

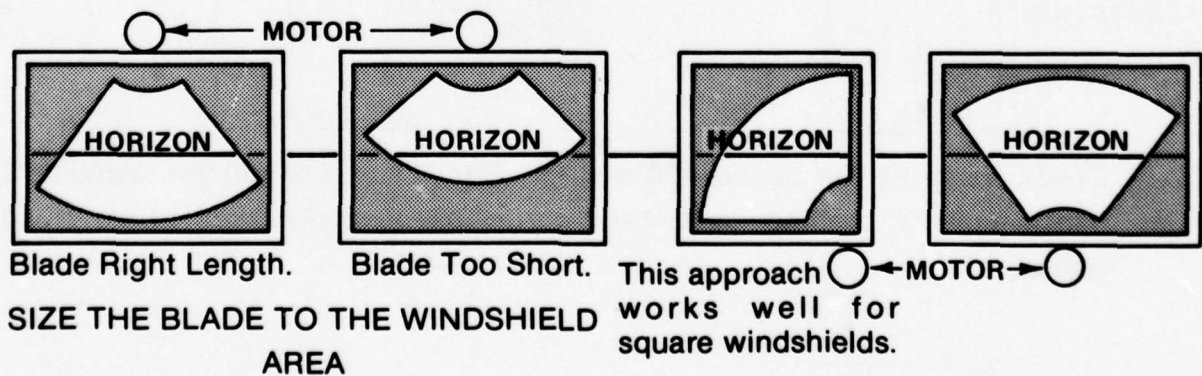

6.3 WINDSHIELD TINTING

Tinting reduces the amount of light that comes through the windshield and reduces operator visibility. Therefore, it is not a good practice to put tinted glass in forward facing windshields.

If you install tinted glass in side facing or aft facing windows through which the operator will have to look, use tints which have greater than 70% transmittance factors. These are generally the lightest tints available.

WINDSHIELDS — SUMMARY

1. Check the visibility
 - The underside of the top frame should be at least 72" above the deck for adequate standing visibility.
 - The distance from the deck to the top of the lower frame is determined by SRP height. See details, Section 6.0
2. Check post thicknesses.
3. Design wiped area of windshield for maximum visibility.
4. Avoid tinted windshields.

7.0 TOPS & CANVAS CURTAINS

Clearance between the deck and permanent or temporary tops should be at least 6'5" with lips around the edges no closer to the deck than 6'2".

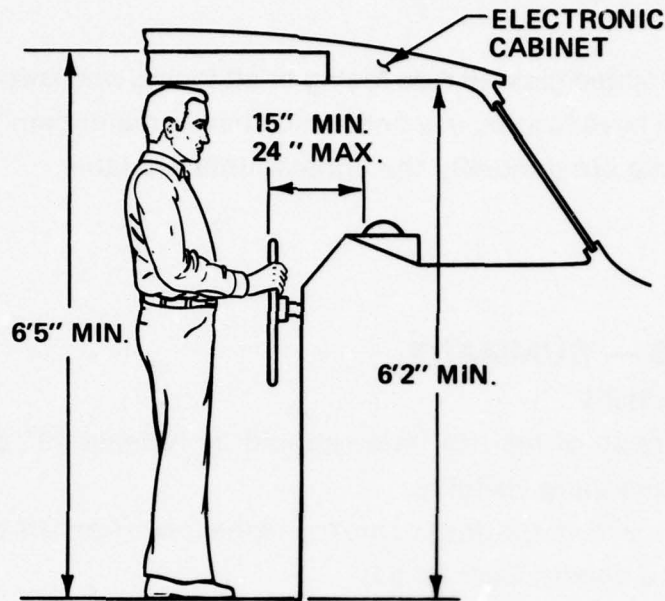

If you provide an overhead electronics cabinet, make sure that the bottom of the cabinet is at least 6'2" above the deck.

If you plan to enclose your control station area with canvas side curtains you should maintain the same visual criteria as recommended for windshield frames and posts. However, from a practical standpoint, some compromises may have to be made where flexible panels join. The width of the opaque reinforcing material on the vertical edges of each panel should be as narrow as possible consistent with the strength of the material. Every effort should be made to maintain a maximum opaque width of 2¼ inches at the joints on panels both forward and aft of the operator.

Aft curtains designed to be used while the boat is underway should have windows at a height so that both the standing and seated operator can see the horizon and water area aft of the boat. This means that the top edge of the clear portion of the side and aft curtains should be at least 6'2" above the deck at the operator's position.

8.0 GLARE PRODUCING SURFACES

Glare producing surfaces forward of the helmsman can reduce forward visibility. In order to reduce the amount of glare that the operator must contend with you should:

- Specify brushed metal surfaces on rails, cleats, horns, etc., when possible.
- Try to avoid placing bright metal accessories (horns) directly in front of the operator.
- Use a tinted color for decks.
- Consider a textured surface for the foredeck on runabouts. It will reduce glare and will provide safer footing.

8.1 GLARE FROM LIGHTS

- Check to make sure that the instrument lights don't reflect into the windshield. If they do, shield them.
- Install the red and green navigation lights so they don't shine onto the deck forward of the operator.
- Try to install the white 360° light so that it doesn't reflect onto the windshield.

9.0 FLYING BRIDGES

The control station on the flying bridge can be designed for sitdown use only or for standup/sitdown use. Factors that influence the choice of sitdown or standup/sitdown control stations are:

- Horizontal distance from seated operator's eyes to forward/top edge of flying bridge cowling coupled with the height of the operator's eyes from the static load waterline. The latter determines the minimum visibility angle to be used.
- Styling influences on the height of the bridge cowling.
- Type of boat. For instance, skippers of large fishing boats want to stand at their helm, facing aft, while backing down on a fish.
- Size of boat.

9.1 PROCEDURES TO DETERMINE IF YOU WILL MEET VISIBILITY CRITERIA.

Standing visibility (if yours is a sitdown only control station, skip this step).

- Measure the vertical distance from the LWL to the cabin top or deck where the operator will stand. This measurement will determine the appropriate **Column B** to enter in Table I.
- Determine the most forward point that you can see as you did in Section 1. (Use the stick marked at 5 feet from the end again) Before you do this you should erect or mock up the flying bridge cowling structure and any other structure forward of the control station that could limit the operator's visibility of the bow. If you could see the bow, follow instructions in Section 1.1. If you couldn't, follow instructions in Section 1.2. Enter Table I in the eyeheight range determined above.

If you don't have adequate standing visibility, move the control station forward, the cowling back, or lower the cowling.

Seated Visibility

We'll assume that you have determined that you have adequate standing visibility from your proposed control station on the flying bridge. (If applicable) The next step is to determine if you have adequate seated visibility. The proposed seat height will determine the configuration of the control station as follows:

- If the Seat Reference Point (SRP) to floor distance is 20 inches or greater, a standup/sitdown control station can be used. Follow the seated visibility procedures in Section 5. To determine if the seated visibility is adequate, you may have to approximate seat height and SRP location, but you will get an immediate indication of whether you meet minimum visibility requirements. Follow Sections 2, 3, 4, 5, 6, 7, and 8 of this manual to develop the rest of the flying bridge control station.
- If the SRP is 18 inches or less the control station should be designed for sitdown use only as described in Section 9.2.

9.2 DESIGN PROCEDURE For Flying Bridge Control Stations Having an SRP Height of Less Than 18 Inches.

This section will lead you through the design of the flying bridge control station. Since operation will be only from the seated position the seat will be used as the reference point from which most other components are positioned. Seat position will be determined first, followed by steering wheel position, shift/throttle control position, instrumentation position, and finally windshield and top positions.

9.2.1 THE SEAT

You already have a pretty good idea of where you want the seat to go. The procedure that follows will inform you if you have adequate legroom. We'll assume that you have installed a bulkhead aft of the forward flying bridge coaming. How far should the seat be placed from the bulkhead to insure adequate legroom? Minimum recommended distances are shown in Table IV. Position the seat using these figures as your guide.

NOTE: All seat measurements will be made from the SRP. Refer to Section 5.3 for an explanation of how to locate the SRP.

The seat cushion should be angled up in the front. The backrest should angle back. How much depends on the seat to floor distance. The recommended ranges of seat bottom and back angles are shown in the sketch adjacent to Table IV.

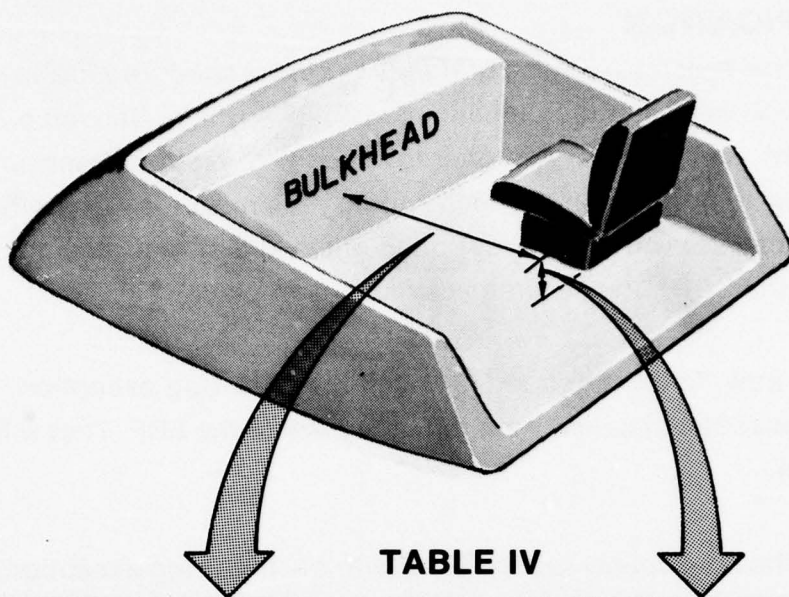

NOTE: If seat has fore & aft adjustment, the minimum SRP to bulkhead distance should be measured with the seat adjusted to the **mid** position.

TABLE IV

MINIMUM DISTANCE FROM SRP TO BULKHEAD	SEAT HEIGHT — DISTANCE FROM FLOOR TO SRP.
INCHES	INCHES
30	18
38	16
42	14
45	12
46	10
47	8
47	6

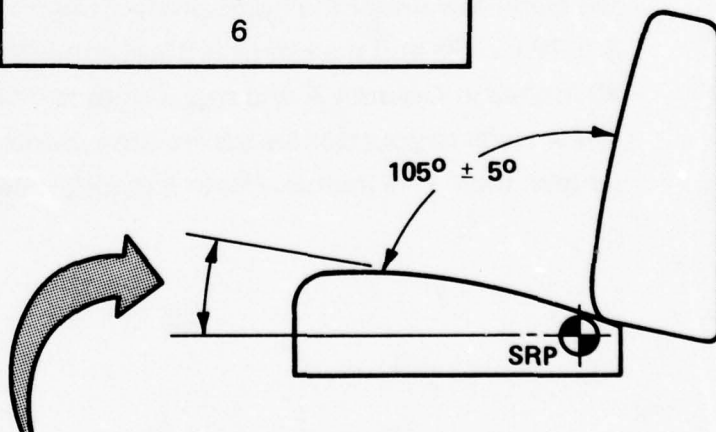

Seat angle varies with seat height:

If SRP is less than 10 inches, seat angle should be 5° to 7° .

If SRP height is greater than 10 inches, seat angle should be 3° to 5° .

9.2.2 VISIBILITY VERIFICATION

You have positioned the seat on the flying bridge. The next procedure will allow you to determine if you meet the recommended visibility criteria. Section 5.3 details the procedure (but for a standup/sitdown control station using an angled wheel). Follow that procedure for determining the most forward point on the boat that you can see with this exception. Sight over a 27 inch stick that has been placed on the SRP. (We assume your seat is in place).

If you could see the bow, follow Section 5.3.1 with the following exception:

- Measure the horizontal distance from the bow back to the SRP. That will be Dimension **A**.

If you could **not** see the bow, follow section 5.3.2 with the following exception:

- Measure the horizontal distance from the most forward point that you could see back to the SRP. Use that as Dimension **A**.

Find Dimension **B** on your boat by measuring Dimension **X** and Dimension **Y**, then subtracting **X** from **Y**. After that, subtract the SRP height from your answer. The sketches in Section 5.3 describe Dimensions **X** and **Y**.

Next use Table III to determine if you have adequate visibility. Find the number in the left column of Table III that is closest to but greater than your Dimension **A** (The next higher number). Your Dimension **B** must be less than the number in the same row under the appropriate Column **B**. For instance, if your Dimension **A** is 72 inches and your deck is 8 feet above the LWL you would enter Table III at 80 inches in Column **A** and move right to 11½ inches in the middle Column **B**. The answer to your double subtraction problem described in Section 5.3 should be **less** than 11½ inches. (Note exception described adjacent to Table III).

9.2.3 FOOTREST

If the SRP is 12 inches or less from the floor you should install an angled footrest. The angle and distance to the heel point vary with seat height. See Table V.

TABLE V

SEAT HEIGHT - DISTANCE FROM FLOOR TO SRP	FLOOR LENGTH - MINIMUM DISTANCE SRP TO HEEL POINT	FOOTREST ANGLE
INCHES	INCHES	DEGREES
18	Not Needed	Not Needed
16	Not Needed	Not Needed
14	Not Needed	Not Needed
12	35 inches	35° from Horizontal
10	37 inches	40° from Horizontal
8	38.5 inches	45° from Horizontal
6	40 inches	50° from Horizontal

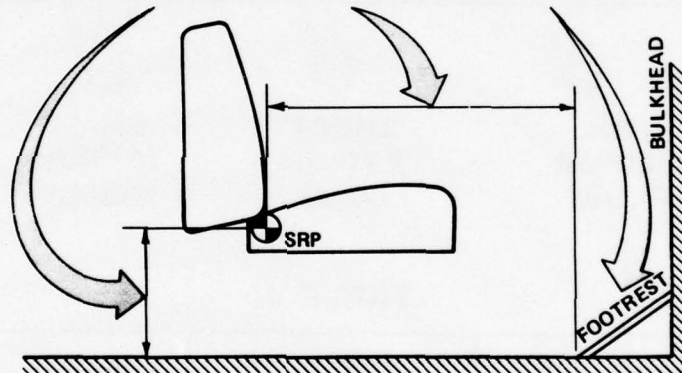

9.2.4 STEERING WHEEL

The steering wheel, being the most used control, should be positioned properly. Important factors are:

- Horizontal Distance From SRP to Wheel
- Vertical Distance From Seat to Wheel
- Angle of Wheel
- Diameter of Wheel
- Leg Room Under Steering Mechanism
- Hand Clearance Around Wheel.

Most of the factors are interrelated. If you change one, it will affect something else. The concept is illustrated below. Table VI puts dimensions to the concept in the form of ranges. Position your steering wheel within the limits of the ranges.

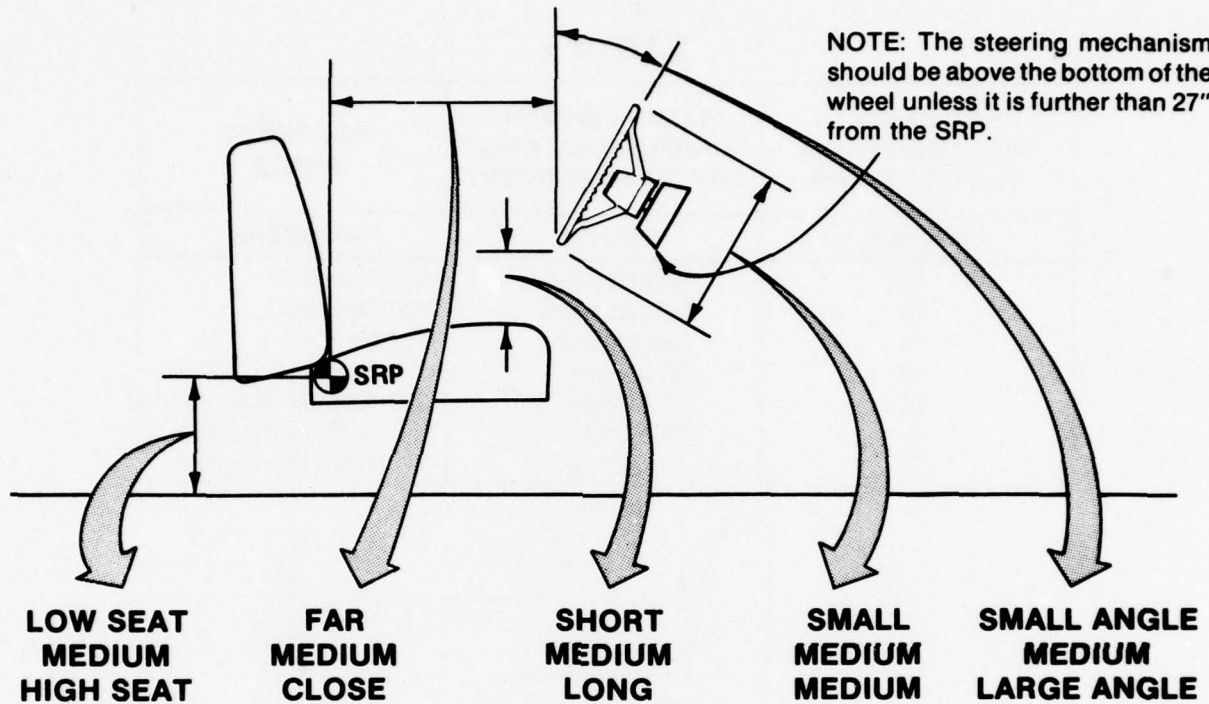
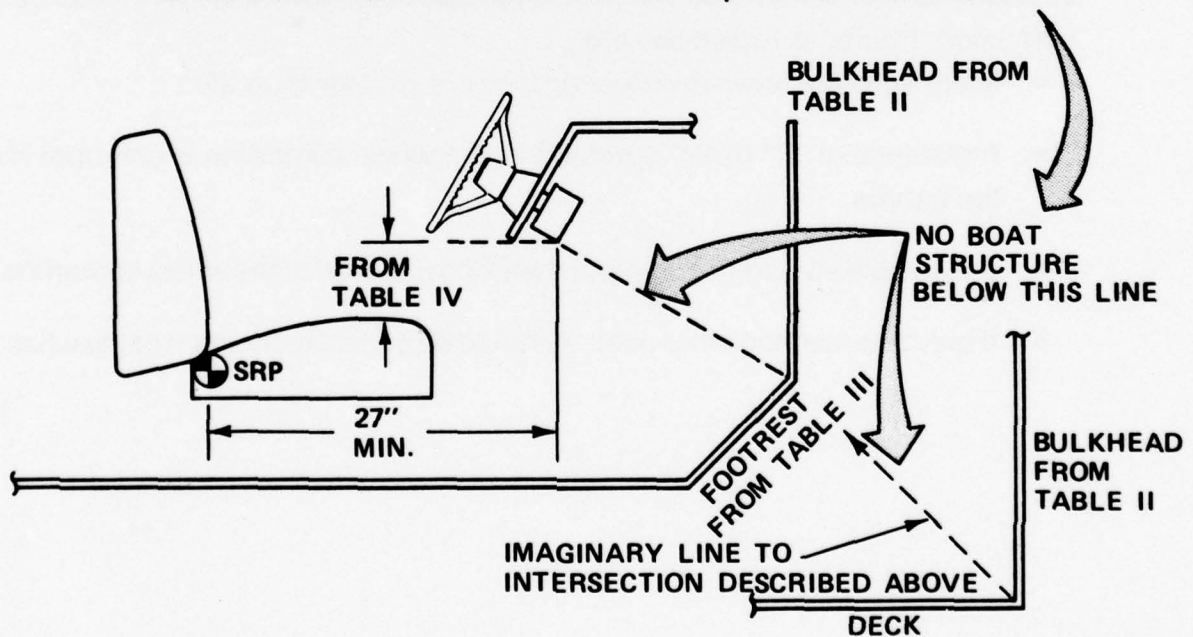

TABLE VI

SRP HEIGHT	HORIZ. DIST. SRP TO WHEEL	VERT. DIST. SEAT TO WHEEL	WHEEL DIAMETER	WHEEL ANGLE (From Vertical)
Under 8"	18" to 21"	7" to 9"	12" to 15"	15° to 25°
8" to 12"	17" to 20"	6" to 9"	12" to 15"	20° to 35°
12" to 18"	15" to 18"	6" to 8"	13" to 15"	20° to 35°

Mock up a control panel to support the steering mechanism so the wheel is positioned within the limits shown in Table VI. Note that the angle of the steering wheel will always determine the panel angle.

- When looking from above, the centerline of the seat and the centerline of the wheel should always coincide within 2 inches.
- Make sure there is at least a 2½" clearance all around the steering wheel rim. If the shift/throttle mechanism will mount on the coaming make sure there is a gap of 2½" plus the width of the widest shift throttle mechanism that may be installed. Check the dimensions of the various shift/throttle mechanisms illustrated in Section 9.2.5.
- Nothing should extend below the bottom of the wheel for a distance of 27" forward of the SRP. This is to protect the operator's knees. From that point (see sketch) construct an imaginary line to the top of the footrest (as described in Table V) or the intersection of the bulkhead and the deck. No boat structure should extend below that line for at least 1 foot on either side of the centerline of the seat. This concept is illustrated below.



9.2.5 SHIFT/THROTTLE MECHANISM - CONTROL PANEL MOUNTED

The location of the S/T Mechanism will depend upon the configuration of the control station. This section will cover the location criteria for S/T mechanisms mounted on the control console. See Section 9.2.5 if you plan to locate your S/T mechanism on the coaming beside the seat.

The most important design criteria for the seated operator is reach distance to the S/T controls. The control station should be designed so that the horizontal distance from the SRP to the S/T handle in its full forward position is not more than 30 inches.

Traditionally, console mounted S/T mechanisms have been mounted on horizontal surfaces, forward of the wheel, which almost dictates that the forward handle position to SRP distance will be greater than 30". The criteria for horizontal mounting was that neutral was vertical so shift lever position was easy to distinguish.

Many builders are now placing S/T mechanisms on the angled control panel adjacent to the wheel with no problems resulting from shift lever position confusion. Points to remember are:

- Make sure the lever-to-wheel distance is greater than 2½".
- A distance of 10" to 12" outboard of the wheel centerline is optimum for the handle.
- The handle should not be more than 15" outboard of the wheel centerline.
- If only one mechanism is used, it should be placed to the right of the wheel.

TYPICAL DIMENSIONS - S/T MECHANISMS

Several S/T mechanisms are shown below. Their dimensions are typical of the majority of the devices currently manufactured. If your boat is designed to accept such a device, make sure that the ones shown below fit into your panel and comply with the placement criteria shown on the following pages.

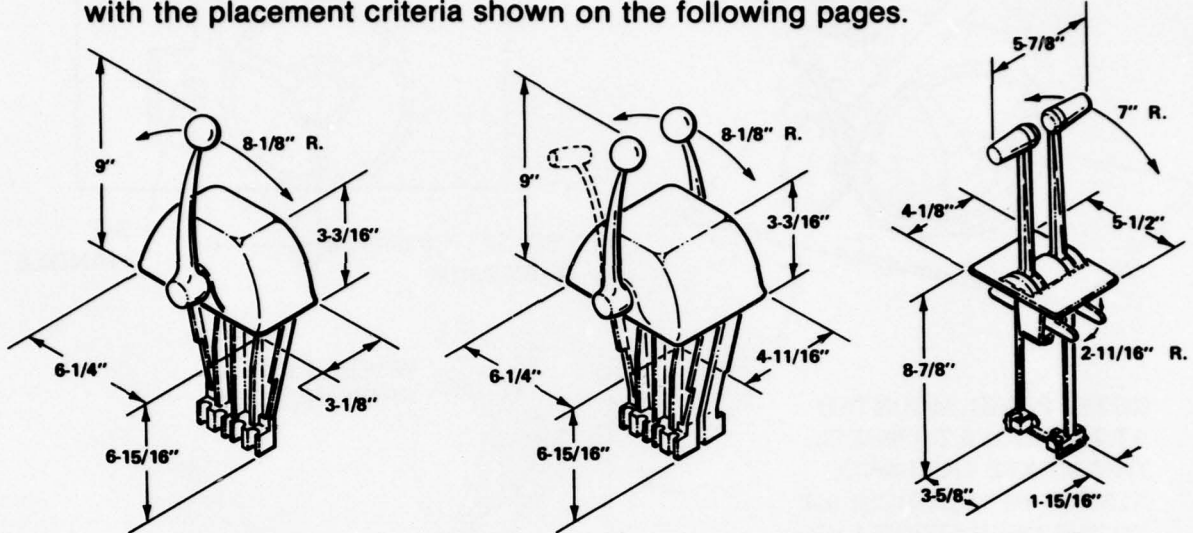

Outboard Powered Boats — See Section 9.2.6 for more detail. The Mercury deck mounted S/T mechanism for their Model 1750 outboard engine is shown below because of the large handgrip. If your boat is capable of using that engine, make sure you have room for their controller.

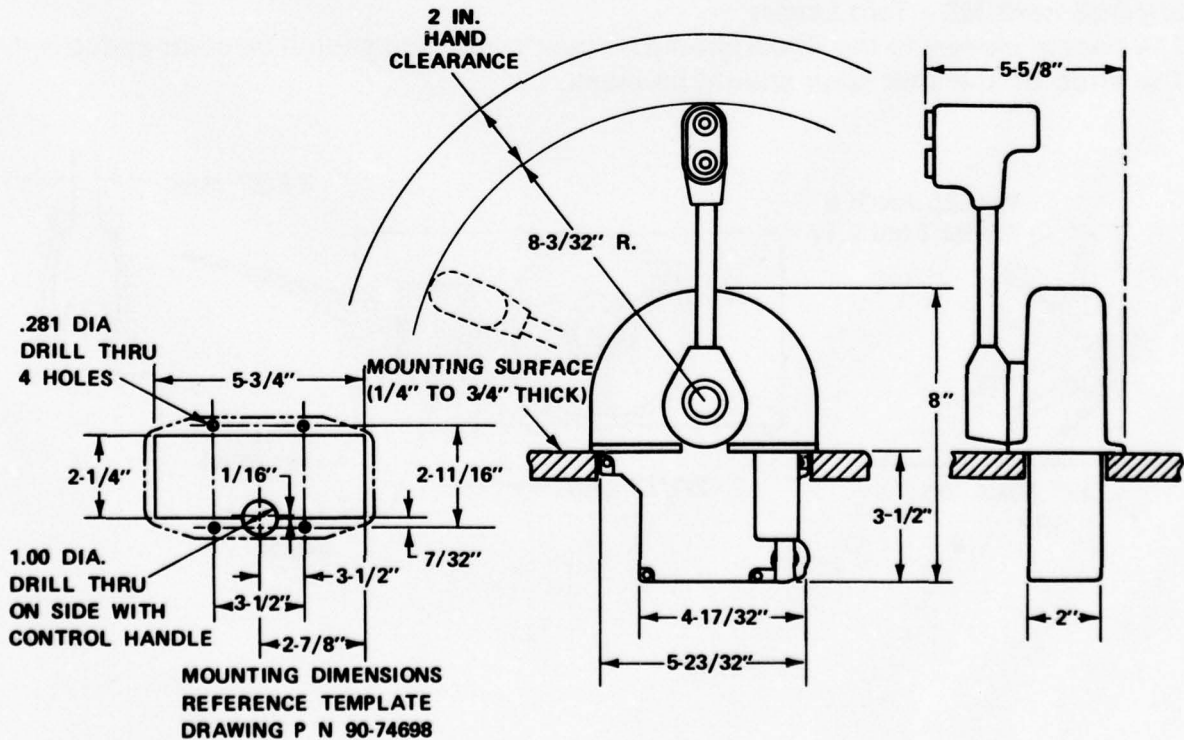

SINGLE ENGINE - Single Lever

Single lever operates throttle and shift mechanism.

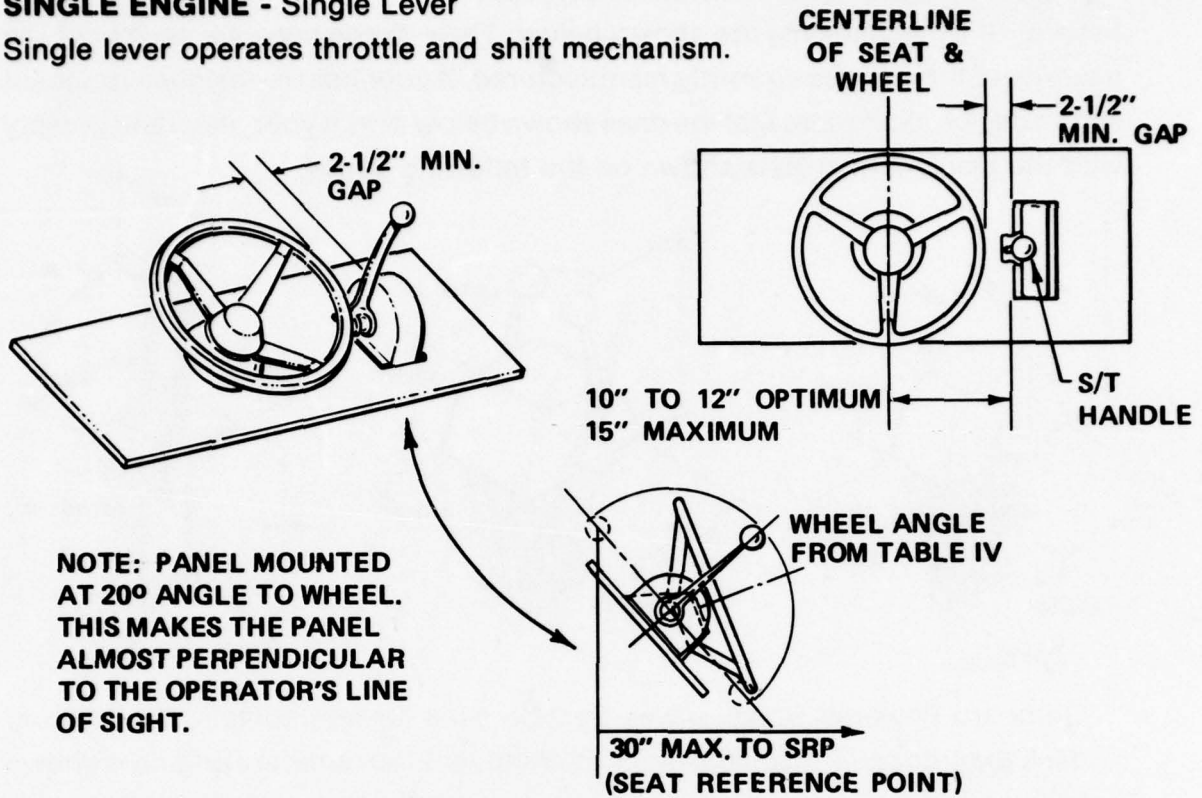

SINGLE ENGINE - Two Levers

The handle closest to the wheel should be the throttle and should be color coded red. The knob on the shift lever should be black.

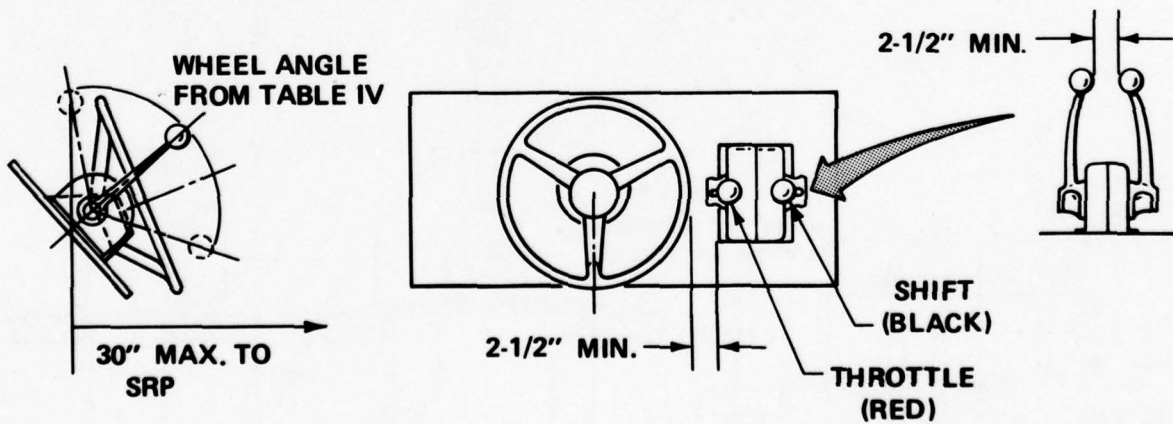

TWIN ENGINE - Single lever for each engine.

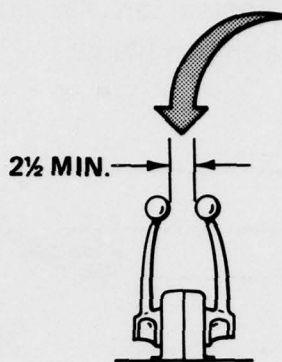
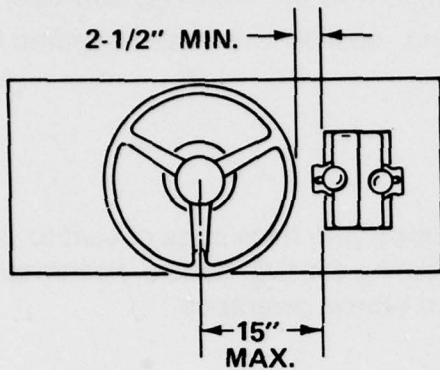

Knobs on handles should be close so they can be moved simultaneously with one hand.

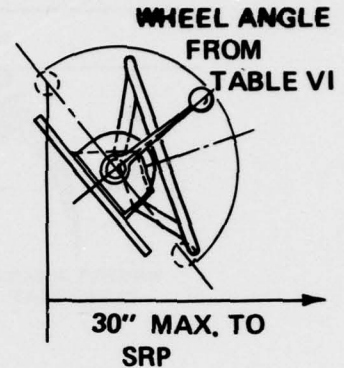

TWIN ENGINE - Two Levers

The handles closest to the wheel should be the throttle and should be color coded red. The knob on the shift lever should be black.

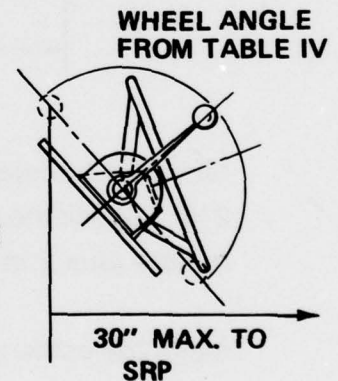
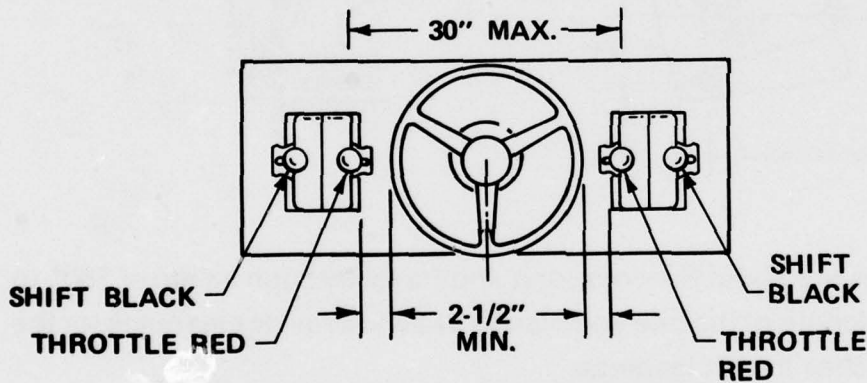

Some people prefer the throttles together so they can be moved simultaneously with the right hand.

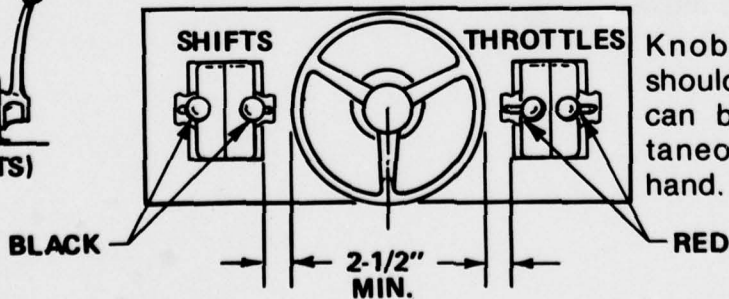
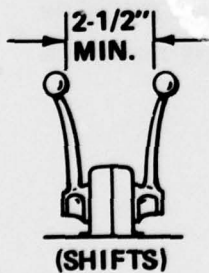

Knobs on handles should be close so they can be moved simultaneously with one hand.

9.2.6 SHIFT/THROTTLE MECHANISM — COAMING MOUNTED

If your Control Station is to starboard and adjacent to the coaming you can position the S/T mechanism on the coaming beside the seat. Specific dimensional criteria are shown below.

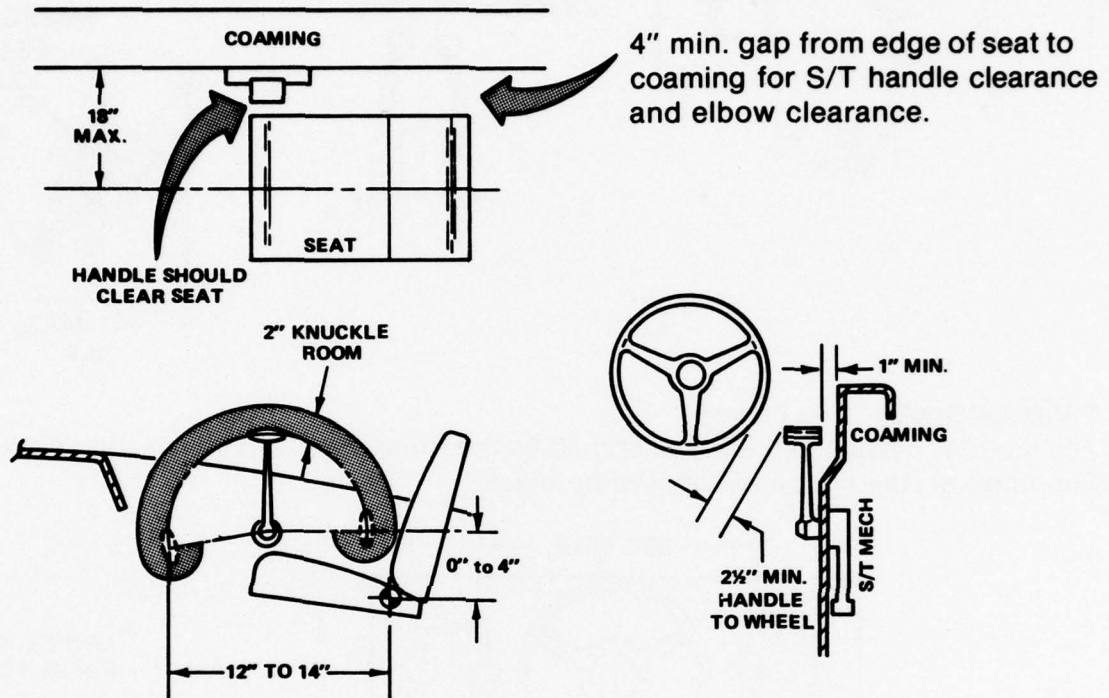

Most S/T handles are about 8 inches long and travel through an arc of 180° to 210°. Check the length of the one you plan to use and provide clearance for the handle plus 2 inches hand clearance.

Make the cable path to the engine(s) or lower console as short and straight as possible. Drag due to excessive cable lengths and/or sharp bends make the controls difficult to move.

9.2.7 SHIFT/THROTTLE MECHANISM — OUTBOARD BOATS

If your boat is to be outboard powered, your dealer or customer will probably mount the engine(s) and controls. You should make sure that adequate space exists to mount the S/T mechanisms. Cable runs should be carefully planned and documented to insure proper installation.

Panel mounted S/T mechanisms - follow Section 9.2.4.

Coaming Mounted S/T Mechanisms — You should indicate the proper S/T Mechanism placement on the coaming so that the dealer or owner will know where to mount it. Some suggested approaches appear below.

- Mold a boss into the coaming.
- If a separate mounting pad is used, limit its size to force the proper mounting location.
- Design a break or relief into the coaming upholstery at the right place.
- Provide written instructions in your Dealer Manual.
- Place a decal or tag at the right place.

9.2.8 OTHER CONTROLS & DISPLAYS

The wheel and shift/throttle controls receive top priority in terms of placement because they are used most often. The rest of the items that go onto the control panel must be considered as a system and include:

- Ignition/Start Switch
- Bilge Blower Switch and Related Warning Statement
- Bilge Pump Switch
- Navigation Light Switch (Separate Switch for Panel Lights)
- Horn Switch (Button)
- Wiper and/or Other Accessory Switches
- Fuses for Above Circuits
- Tachometer
- Ammeter or Voltmeter
- Temperature Gauge
- Oil Pressure Gauge (Inboards)

Even though some of the above items may not be offered as standard equipment, you should leave space on the panel for dealer installations. In addition, where applicable, you should provide space for:

- Compass
- Depth Sounder
- Speedometer
- Communication Equipment

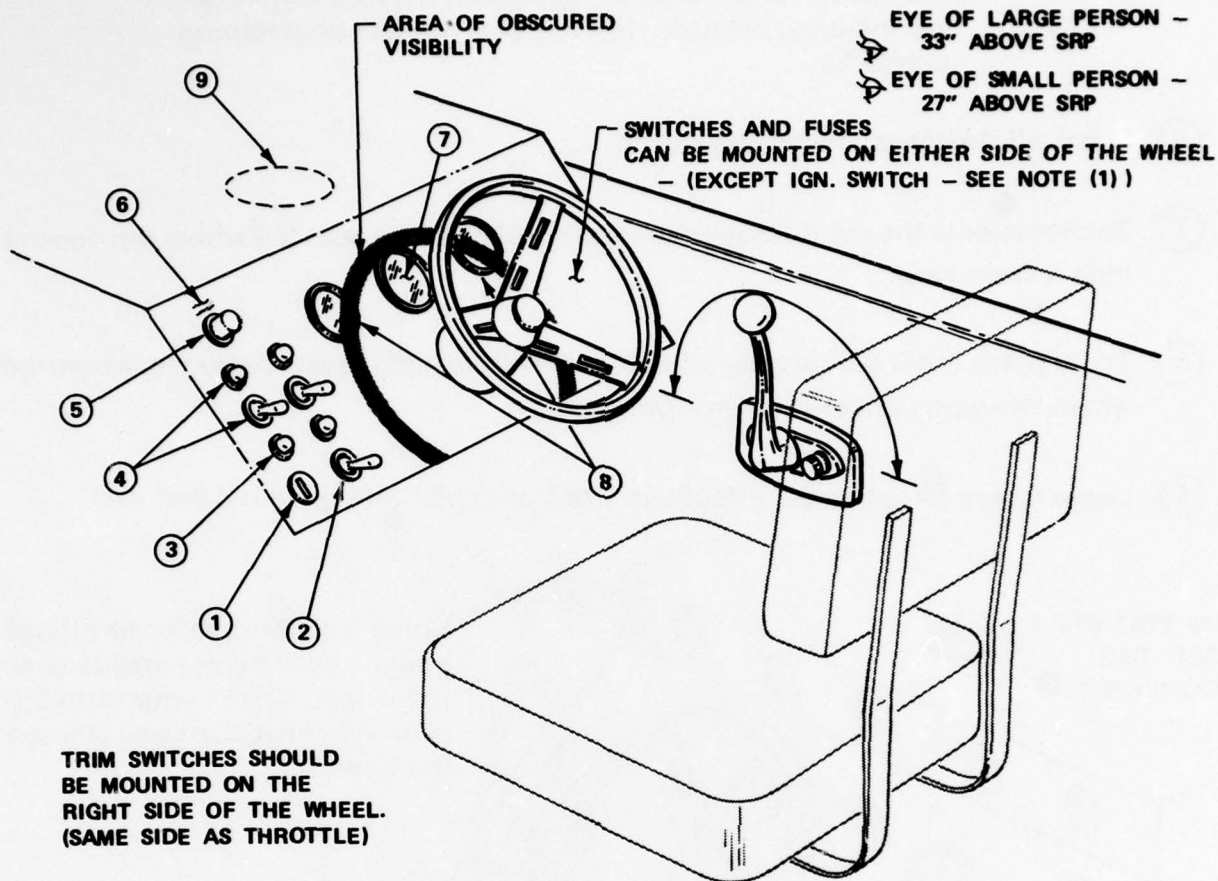

- ①. Mount ignition switch on opposite side of wheel from throttle. This lets you operate starter and manipulate throttle simultaneously.
- ②. Blower switch & label should be positioned close to ignition switch. (The operator can't help seeing the switch & label as he inserts the key into the ignition switch).
- ③. Panel mounted fuses are economical, easy to wire, and facilitate easy troubleshooting by the owner.
- ④. Auxiliary switches and fuses.
- ⑤. Horn switch should look different & be placed in a prominent location.

NOTE: 6, 7, 8, & 9 are not necessarily safety oriented but are included because they are good human engineering practices.

- ⑥ Label All Switches, above the switch.
- ⑦ Tachometer is the most frequently used display. Make sure the wheel rim doesn't hide it from view.
- ⑧ Try to place other gauges, especially temperature and pressure gauges, where the wheel rim won't obscure them from view.
- ⑨ Leave space for compass directly in front of center line of wheel and seat.

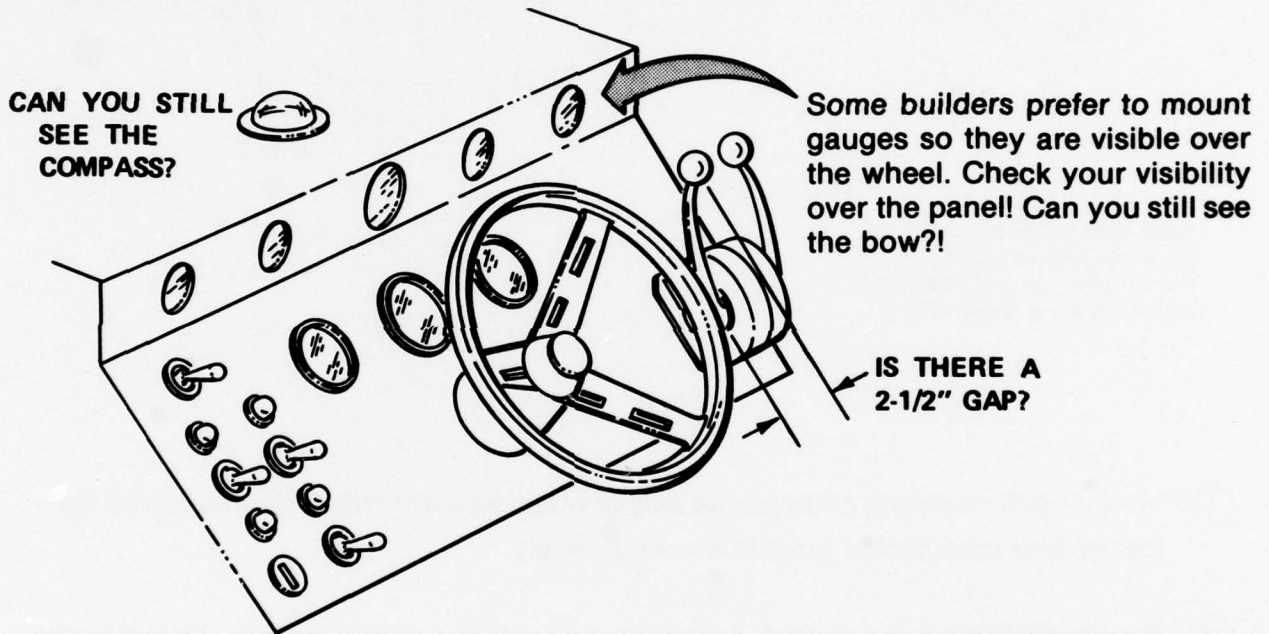

Since the bottom of many new tachometers contains no important information you can hide that portion behind the wheel. Sight forward from a position 27" above the SRP. The tachometer can be lowered until you can see the top half of the gauge. (Assuming a 90° meter movement, not applicable for 270° meter movement).

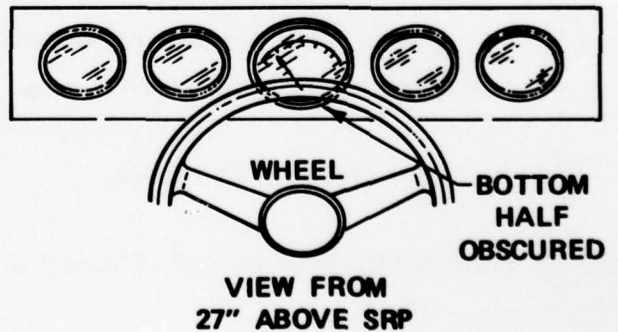

56

9.2.9 WINDSHIELDS

Important criteria for windshield placement are:

- Windshield Height
- Horizontal Distance from SRP to Top of Windshield
- Windshield Frame Thickness

The top frame of low decorative windshields should not interfere with visibility of the water by the small operator. Neither should the top frame of a "Regular" windshield interfere with visibility of the horizon by the tall operator. A "No Frame" zone can be constructed ahead of the operator. Make sure there are no horizontal opaque windshield frames in this area.

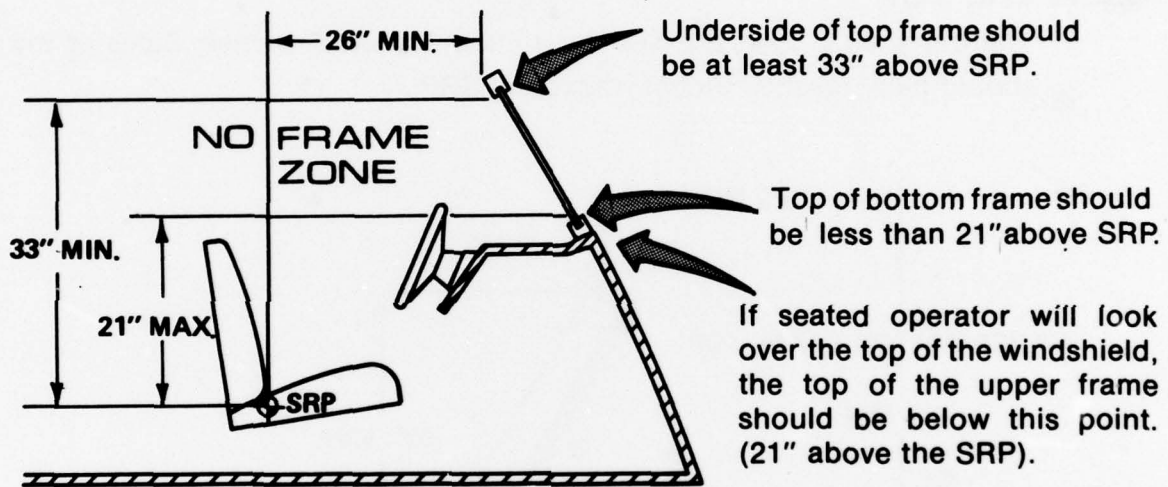

Tinted Glass is not recommended for use in forward facing windows through which the operator looks. **Exception.** You can use dark tints in low decorative windshields. Make sure that the top of the windshield is below the "visibility line" that you establish in Section 9.2.2.

WINDSHIELD FRAMES — DISTANCE FROM SRP

If the top frame is too close to the seat, people will tend to hit their heads on it while attempting to get into or out of the seat. In addition, they will tend to grab the top frame and use it to assist them in getting up, out of the seat. Many frames aren't strong enough to support that kind of load.

Make sure that the top frame of your windshield is at least **26 inches** forward of the SRP measured horizontally along the fore/aft seat centerline.

WINDSHIELD FRAME THICKNESS — See Section 6.0

9.2.10 THE TOP

The top should clear the SRP by a minimum of 42 inches. Sides of the top should be at least 33 inches above the SRP.

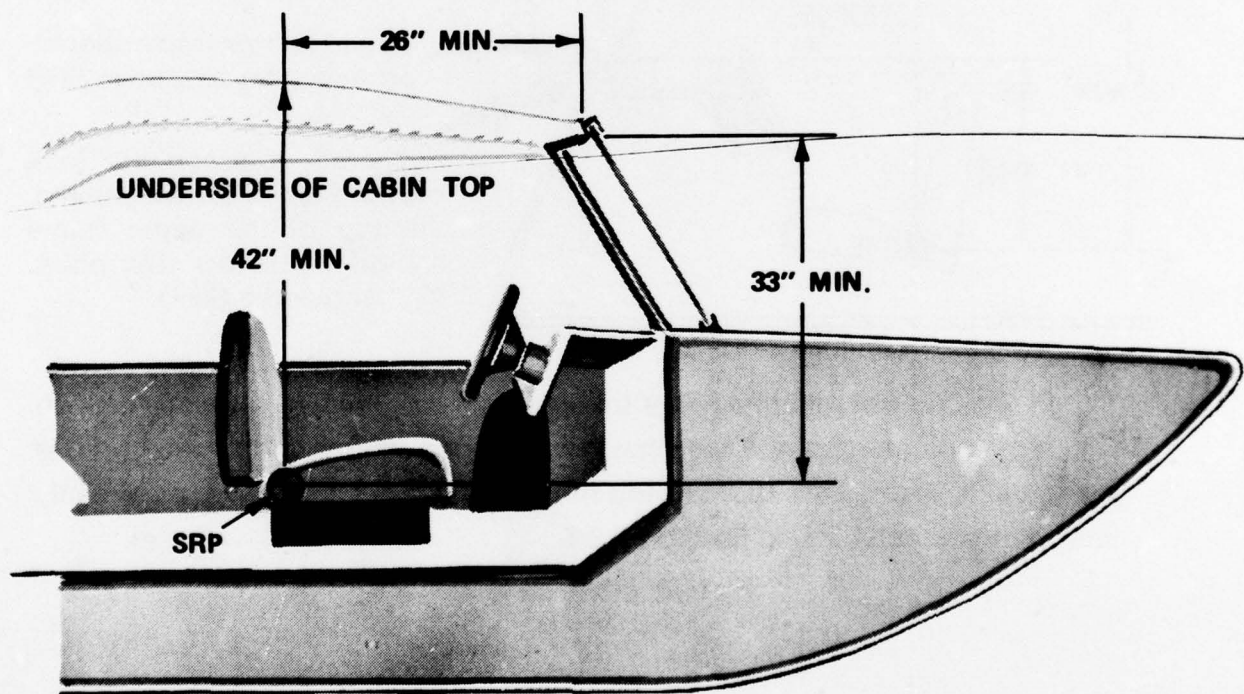

9.2.11 360° VISIBILITY

Soft tops are usually radiused at the sides. The lowest extremity of the sides and aft portion of the top should not extend below a point 33 inches above the SRP. Sometimes the aft corners of a soft top will extend down and attach to the coaming and will create "Blind Spots." Make sure the "Blind Spots" are aft of the SRP and are of minimum width consistent with the strength of the material. Better yet, avoid the "Blind Spots" by attaching the aft end of the soft top with nylon webbing.

Side curtains will reduce visibility somewhat because the clear plastic must be edged with opaque material onto which is mounted the zippers, snaps, etc. Make the width of the opaque material as narrow as possible consistent with the strength of the material. The top edge and forward edge are critical. Make sure the clear portion of the side curtain extends above a point 33" above the SRP, and the width of the windshield frame plus the opaque area of the side curtain is as close to the 2¼" maximum width as possible.

9.2.12 GLARE PRODUCING SURFACES — See Section 8.0

9.2.13 SUMMARY — SITDOWN FLYING BRIDGES

1. Locate the seat using Table IV.
2. Determine SRP Height.
3. Verify visibility, change seat height if necessary.
4. Locate steering wheel.
5. Locate shift/throttle control.
6. Locate other controls & displays.
7. Consider windshields & tops.

APPENDIX A

JUSTIFICATIONS AND SUPPORTING MATERIAL

This portion of the Control Station Design Concepts was written to inform you of the origin of some of the dimensions and criteria contained within this document. Basically it summarizes the research effort on three basic parameters that had to be defined prior to writing the design concepts; i.e.,

- the boat operator population,
- the definition of "adequate visibility," and
- the trim angle of the boat from which to base visibility calculations.

Boat Operator Population

In order to generate eye heights, seat heights, and other dimensional criteria, the boat operator population had to be defined. We needed to know who was driving the boats at what percentage of the time. Eight hundred and seventy-nine photographs of boats underway taken at various sites around the country were reviewed and yielded a frequency count of the age and sex of those who normally operate boats. Results are presented below in terms of percentages of time that members of each group were observed operating the boats.

	Adult Males	All Females	Teenagers (M&F)	Children
Percent of Total	77	6	15	2

To design for extremes in body sizes would place an undue burden on boat manufacturers. Most vehicle design standards are based on designing for 90% of the expected user population. The biggest 5% and the smallest 5% are excluded. A body size by expected use frequency comparison was made to define just what that meant in terms of body sizes of our operator population. Results showed that we could design for approximately 90% of the boat operator population by designing for:

- the 95th percentile adult male (largest person designed for), and
- the smaller of the 5th percentile male or 50th percentile adult female.

These values were chosen because they were very close to actual values and much anthropometric data exists on those populations. Teenagers over sixteen are automatically included in the group being designed for since they tend to be taller than the lower cutoff point mentioned above.

What does this mean to you? A control station designed to meet this concept will accommodate people from 5'4" (1.6 m) to 6'2" (1.9 m) tall. For instance, minimum eye height and reach distances are based on the 5'4" (1.6 m) operator while head room and leg clearance are based on the 6'2" (1.9 m) person.

Adequate Visibility

How much forward visibility can the bow obstruct? The American Boat and Yacht Council (ABYC) currently has a standard that says that the obscured area cannot project more than 100 ft. (30.5 m) in front of the bow when the boat is at the "normal" trim angle.

Wyle researchers studied reaction times vs. speed, maneuvering distances and distances that one can distinguish a human head in the water and concluded that the current ABYC Standard is adequate with one change. The 100 ft. (30.5 m) should be measured from the operator's eye instead of from the bow.

Trim Angles

The next problem was to define "normal" trim angle. If that is "average" trim angle then the operator will not be able to see that spot 100 ft. (30.5m) in front of him for approximately one-half the time that he is boating, because his boat will be at a higher trim angle in those cases.

Instead of defining normal or average "trim angle," Wyle researchers decided that the range of trim angles should be defined and that the design criteria should be based on the highest value after some portion of the extremely high trim angles was eliminated. Running trim angles were measured from 300 photographs of boats underway. Angles were measured between the boot top or "scum" line on the hulls and the horizon. Boat operators didn't know they were being photographed so their behavior wasn't biased as a result of the study. Boats were categorized by boat type and bottom shape in an effort to reveal any differences in trim angles.

Results showed that boat type and size correlated with trim angles. When 10% of the extremes were eliminated, we found that small flat bottomed boats trimmed the highest (7° to 8°), cabin cruisers over 30 ft. trimmed the lowest (5°), and everything in between trimmed between 6° and 7° . (The purpose of the exercise was to define a minimum visibility angle for design purposes). Since eye height is proportional to boat length, we found that a system that uses a constant angle that was independent of boat type or size was feasible. The concept is shown in Figure A-1 and Table A-1. The visibility formulas contained in these concepts are based on these calculations with one exception. The visibility criteria from the seated position of center console type boats have been relaxed somewhat. The visibility criteria in these boats are based on standing eye heights. If the same visibility criteria were recommended boat builders would have two choices: raise the seat so the seated operator's eye height is even with the standing operator's eye height (a 36" (91.4 m) high seat), or lower the bow so he can see over it. Raising the seat makes it difficult to use for fishing. Lowering the bow doesn't help the sea-keeping qualities of the boat. Since it is so easy to stand from a seated position in such a boat, relaxing the seated visibility criteria seemed to be the most logical compromise.

Notice the right column in Table A-1. It says that in order for an operator of those types of boats listed to see the water 100 ft. (30.5 m) in front of him, the angle formed by the intersection of a line from his eyes to a spot on the water 100 ft. (30.5 m) in front of him and a line extending from his static load waterline will be somewhere between 9.3° and 10.4° .

In order to determine the impact on the boating industry from a concept based on this visibility angle, Wyle researchers measured the boats sampled earlier. Results are shown below:

The initial look at the data showed that at a 9° visibility angle:

- Twenty-nine percent of the boats met the concepts and appeared to be smaller than those that did not meet them. (The boats that met the recommendations averaged 16.7 ft. (5.1 m). The average length in the sample of 52 was 19.6 ft. (6.0 m).)
- In the runabout class, 33% met the recommendations. The worse case was one in which the operator's eyes would have to be raised $9\frac{1}{2}$ inches (24.1 cm).

- Only 22% of bowriders met the recommendations. The worst case was 9 inches (22.9 cm).
- Twenty percent of cabin cruisers less than 30 ft. met the recommendations. The worst case was 8 inches (20.3 cm).
- The worst case overall was from the lower control station of 60 ft. (18.3 m) cruiser. The operator's eye point would have to be raised 17 in. (43.2 cm) to meet the recommendations which would put his head at the flying bridge operator's seat level.

A 9° visibility angle would have a major impact on the boating industry. Seventy-four percent of the boats in our sample didn't meet the criteria. Because we felt that design concepts which require major changes in the basic proportions of today's boats would probably be rejected by the boating industry, the 9° criterion was relaxed to 8°. About 50% of the boats in our sample met the 8° criterion. Therefore, 8° was judged as the best compromise from both the safety aspects and the impact on the boating industry.

TABLE A-1

EYE HEIGHT ABOVE LWL	VISIBILITY ANGLE TO SEE 100 FT. (30.5 M)	BOAT TYPES							MAX. ANGLE	VISIBILITY ANGLE = MAXIMUM ANGLE
		JOHNBOATS	SMALL OPEN BOAT	RUNABOUT	BOWRIDER	CENTER CONSOLE	CRUISER UNDER 30 FT. (10.9 M)	CRUISER OVER 30 FT. (10.9 M)		
3.0	1.7	X	X						8	9.7
4.0	2.3			X	X				7	9.3
5.0	2.9					X			7	9.9
6.0	3.4						X		7	10.4
8.0	4.5 (approx.)							X	5	9.5

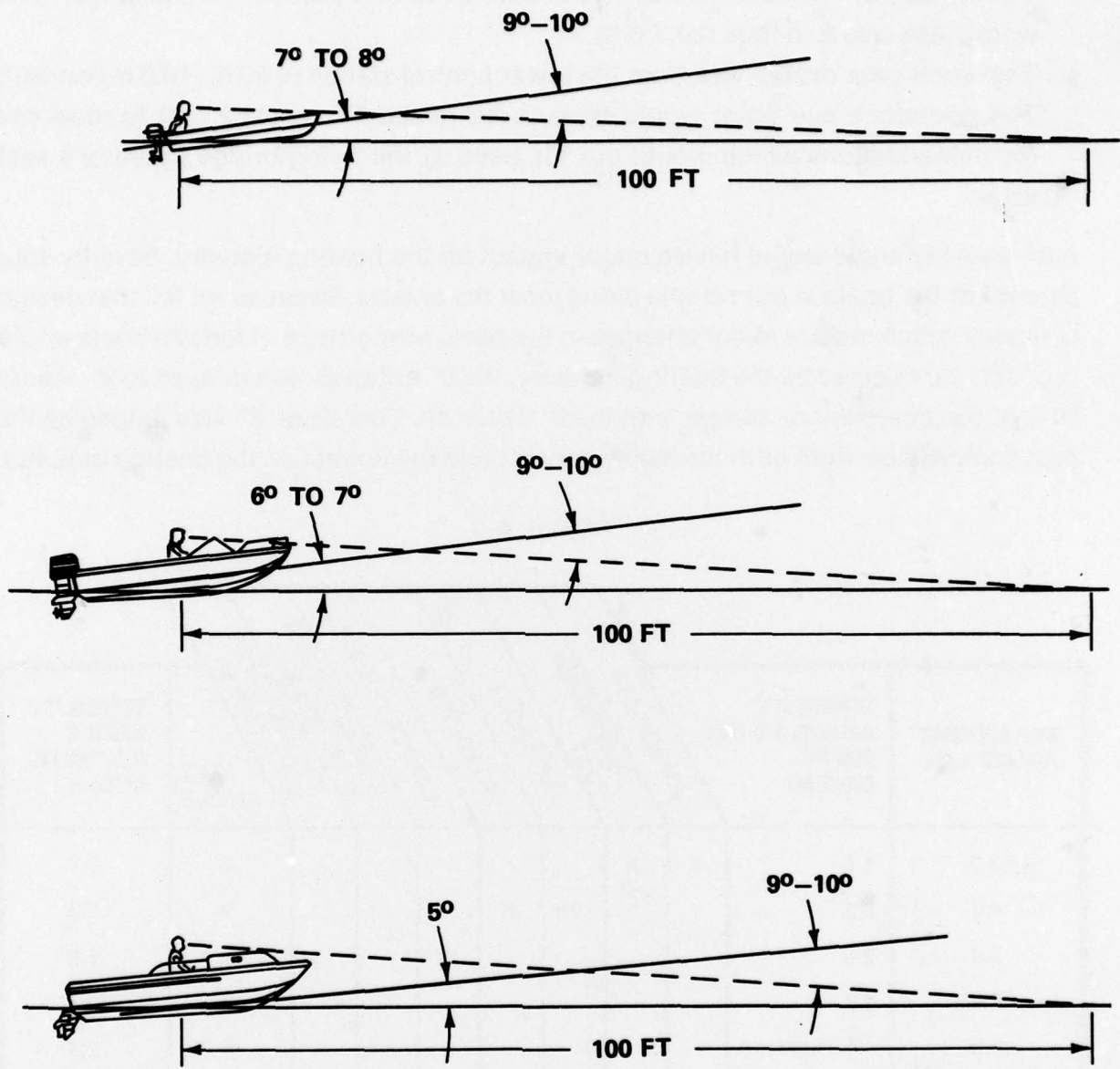
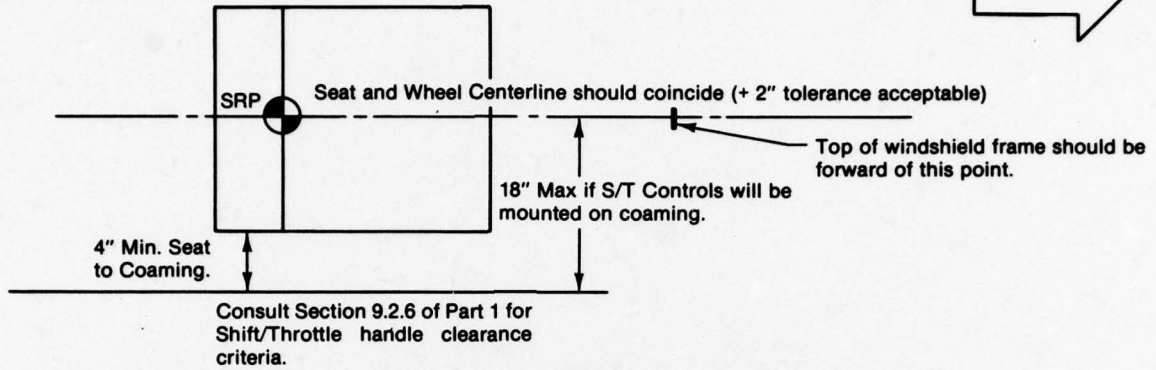
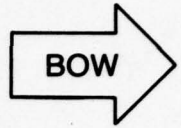

FIGURE A-1

(65)
66x

Centerline of boat should be parallel with this line.



PLAN VIEW

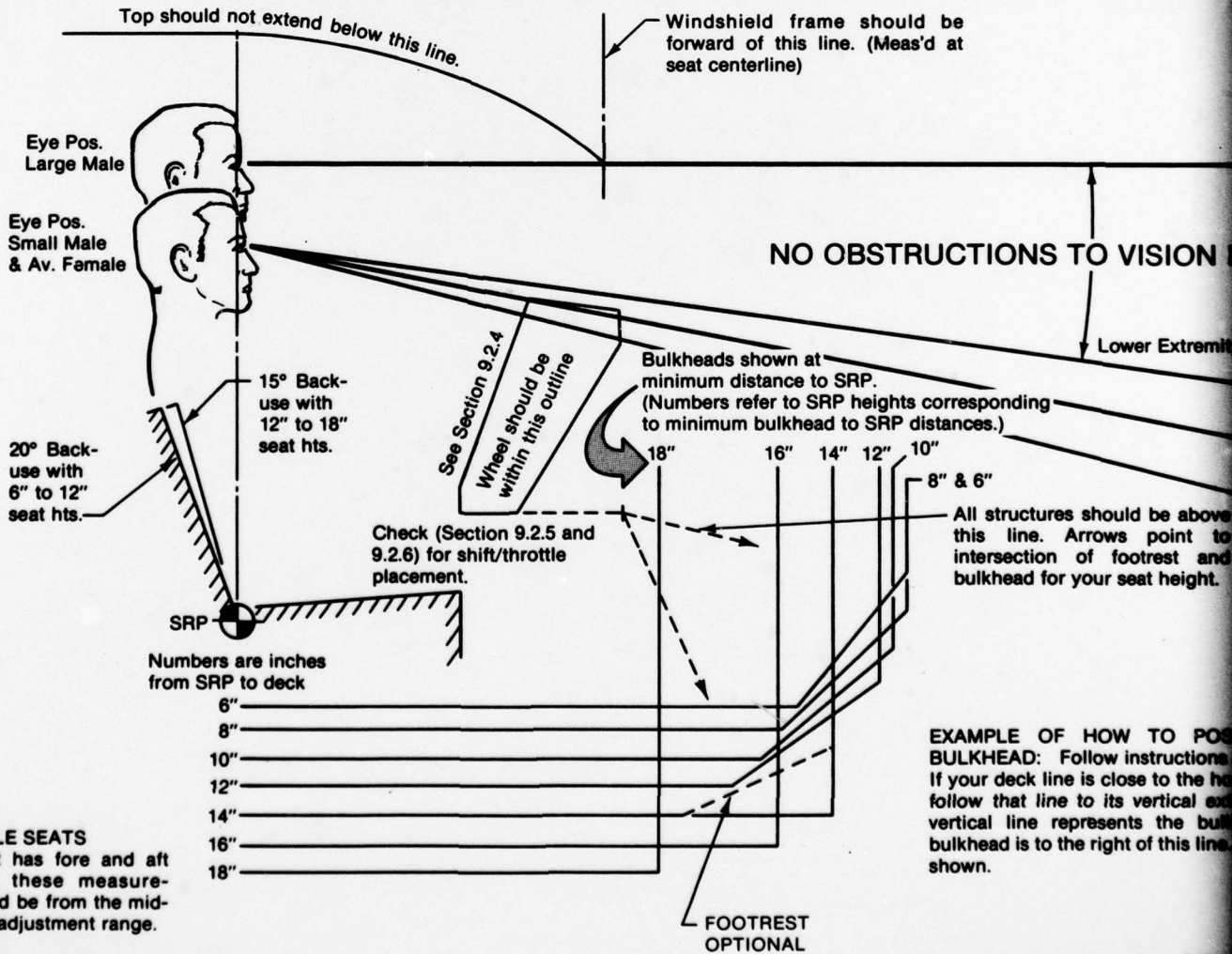

ADJUSTABLE SEATS

If your seat has fore and aft adjustment these measurements should be from the mid-point in the adjustment range.

EXAMPLE OF HOW TO POSITION BULKHEAD: Follow instructions. If your deck line is close to the horizontal line, follow that line to its vertical intersection. This vertical line represents the bulkhead position. The bulkhead is to the right of this line, as shown.

2

PART 2-A
CONTROL STATION DESIGN CONCEPTS
 FOR
CABIN CRUISERS AND FLYING BRIDGES
 THIS TEMPLATE IS FOR SITDOWN ONLY CONTROL STATIONS

SUGGESTED USAGE

1. Position this sheet under your profile drawing so that the base line of this drawing is parallel to the static load waterline of your boat.
2. Position this drawing so that the appropriate visibility line is above all boat structure. Also, adjust this drawing so that you get sufficient bulkhead to SRP distance for your particular seat height. See example below.
5. Position the seat, wheel controls, etc. as shown and as detailed in the concepts (Part 1).
6. Consult the guidance (Part 1) for:

Seat Heights vs Angled Footrests	Section 9.2.3
Steering Wheel Dimensions and Angles	9.2.4
Shift/Throttle Mechanism Alternatives	9.2.5
Instrument and Switch Placement	9.2.8
Windshield & Frame Details	9.2.9
Tops & Side Curtains	9.2.10

TO VISION IN THIS AREA

Lower Extremity Connects to Appropriate Visibility Line.

should be above
 Arrows point to
 of footrest and
 your seat height.

Use this visibility line if the cockpit deck to LWL distance is 2'6" or less.

Use this visibility line if the cockpit deck to LWL distance is between 2'7" and 10'0".

Use this visibility line if the cockpit deck to LWL distance is greater than 10'0".

HOW TO POSITION THE DECK &
 Follow instructions above.
 is close to the horizontal line marked 10",
 to its vertical extremity marked 10. That
 represents the bulkhead. Make sure your
 the right of this line. Position the footrests as

SCALE 1" = 1' 0"

SET UP DRAWING SO THAT THIS LINE IS PARALLEL TO YOUR DESIGNED LOAD WATERLINE (LWL)

NOTE: Seated visibility criteria is identical to standing visibility criteria. i.e.,

1. If the deck on which the operator stands is 2'6" or less above the LWL, use the 9° visibility line.
2. Use the 14° visibility line for decks between 2'7" and 10'0" above the LWL.
3. Use the 18° visibility line for decks greater than 10'0" above the LWL.

Temporary and permanent tops should be above this line.

Sides of cloth tops should not extend below this line.

Minimum windshield height if standing

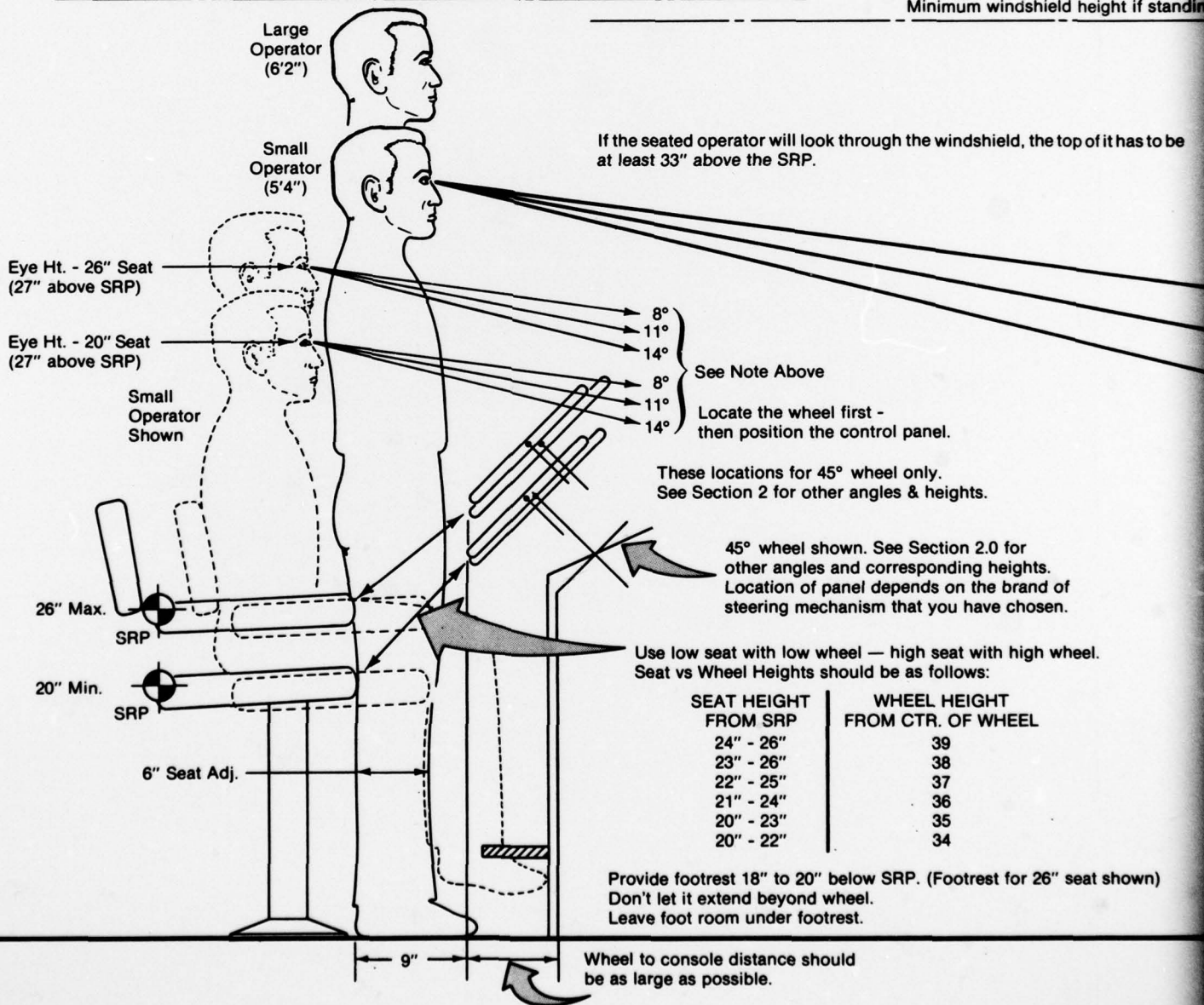

PART 2-B
CONTROL STATION DESIGN CONCEPTS
FOR
CABIN CRUISERS AND FLYING BRIDGES
THIS TEMPLATE IS FOR STANDUP/SITDOWN CONTROL
STATIONS WITH ANGLED STEERING WHEELS

SUGGESTED USAGE

1. Position this sheet under your profile drawing so that the base line of this drawing is parallel to the load waterline of your boat.
2. Adjust this drawing so that the baseline under the operator's feet coincides with your boat's deck height and projected operator placement.
3. Make sure the visibility line for your specific deck height is above all boat structure.
4. Check to assure your wheel is within the limits shown. If your wheel is at a different angle, check Part 1 of the Guideline for dimensions.
5. Adjust this drawing so that one of the seats shown coincides with your seat height. Make sure all boat structure is below the appropriate seated visibility line.
6. Check the Concept Manual for shift/throttle location, instrument locations, etc.

All boat structure should be below the lower of:
1. The appropriate standing visibility line.
2. The appropriate seated visibility line.

Use this visibility line if the deck on which the operator stands is 2'6" or less above the LWL.

Use this visibility line if the deck is between 2'7" and 10'0" above the LWL.

Use this visibility line if the deck is over 10'0" above the LWL.

SCALE 1" = 1'0"

SET UP DRAWING SO THAT THIS LINE IS PARALLEL TO YOUR DESIGNED LOAD WATERLINE.

Temporary and permanent tops should be above this line.

Sides of cloth tops should not extend below this line.

Window frames should be above this line.

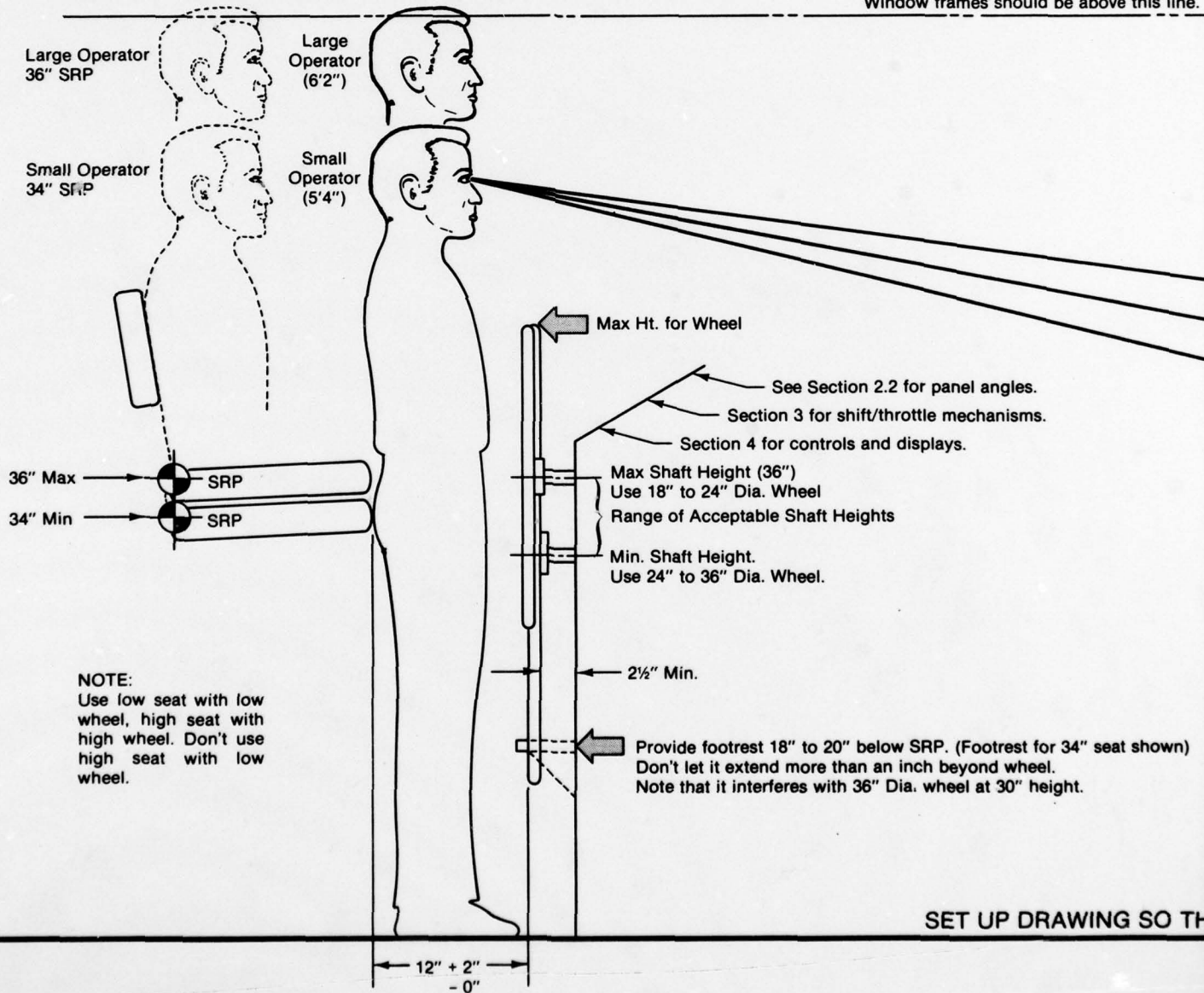

PART 2-C
CONTROL STATION DESIGN CONCEPTS
FOR
CABIN CRUISERS AND FLYING BRIDGES
THIS TEMPLATE IS FOR STANDUP/SITDOWN CONTROL
STATIONS WITH VERTICAL STEERING WHEELS

SUGGESTED USAGE

1. Position this sheet under your profile drawing so that the baseline of this drawing is parallel to the load waterline of your boat.
2. Adjust this drawing so that the baseline under the operator's feet coincides with your boats' deck height and projected operator placement.
3. Make sure the visibility line for your specific deck height is above all boat structure.
4. Consult the Manual, Part 1, for:

Control Panel Details	Section 2.1
Shift/Throttle Mechanism Details	3.0
Controls and Displays	4.0
Seat Details	5.0
Windshields	6.0
Tops	7.0

be above this line.

All boat structure should be below the appropriate standing visibility line.



Use this visibility line if the deck on which the operator stands is 2'6" or less from the LWL.

Use this visibility line if the deck is between 2'7" and 10'0" above the LWL.

Use this visibility line if the deck is over 10'1" above the LWL.

8'
11'
14'

34" seat shown)
ght.

SCALE 1" = 1'0"

AWING SO THAT THIS LINE IS PARALLEL TO YOUR DESIGNED LOAD WATERLINE.

17 4 1587. (71) (2281) 72x all
(A10)