

AD-A055 797

H2M CORP MELVILLE NY

F/G 13/10

SURVEY, ANALYSIS AND EVALUATION OF DOMESTIC WASTEWATERS ON COAS--ETC(U)

OCT 76 H D FREUDENTHAL, D A MORAN, C POWERS

DOT-CG-41342-A

UNCLASSIFIED

USCG-D-63-77

NL

1 OF 4
ADA
055797



FOR FURTHER TRAN #117

B

Report No. CG-D-63-77

AD A 055797

SURVEY, ANALYSIS AND EVALUATION OF DOMESTIC WASTE WATERS ON COAST GUARD VESSELS

Hugo D. Freudenthal, Dennis A. Moran, Christopher Powers, Anthony P. Uzzo

H2M Corp.

Consulting Engineers & Environmental Scientists
Melville, New York 11746

AD No.
DDC FILE COPY



DDC
JUN 28 1978
F

Document is available to the U.S. public through the
National Technical Information Service,
Springfield, Virginia 22161.

Prepared for
U.S. DEPARTMENT OF TRANSPORTATION
UNITED STATES COAST GUARD
Office of Research and Development
Washington, D.C. 20590

78 06 26 078

NOTICE

This document is disseminated under the sponsorship of the Department of Transportation in the interest of information exchange. The United States Government assumes no liability for its contents or use thereof.

The United States Government does not endorse products or manufacturers. Trade or manufacturers' names appear herein solely because they are considered essential to the object of this report.

The contents of this report do not necessarily reflect the official view or policy of the U. S. Coast Guard and do not constitute a standard, specification, or regulation.



**SURVEY, ANALYSIS AND EVALUATION OF
DOMESTIC WASTEWATERS ON COAST GUARD VESSELS**

**Hugo D. Freudenthal
Dennis A. Moran
Christopher Powers
Anthony P. Uzzo**

**H2M Corporation
500 Broad Hollow Road
Melville, New York 11746**

October 1976

Final Report

For

U. S. Department of Transportation

U. S. Coast Guard

Office of Research and Development

Washington, D. C. 20590

Contract No. DOT-CG-41342-A

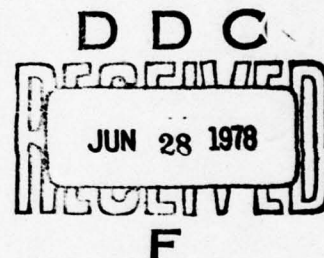

78 06 26 078

18-4SCG

Header list
See page 663

1. Report No. CG/D-63-77		2. Government Accession No.		3. Recipient's Catalog No.	
4. Title and Subtitle Survey, Analysis and Evaluation of Domestic Wastewaters on Coast Guard Vessels				5. Report Date October 1976	
7. Author(s) Hugo D. Freudenthal, Dennis A. Moran, Christopher Powers, Anthony P. Uzzo				8. Performing Organization Report No. 12 331p	
9. Performing Organization Name and Address H2M Corp. 500 Broad Hollow Road Melville, New York 11746				10. Work Unit No. (TRAINS)	
12. Sponsoring Agency Name and Address Department of Transportation U.S. Coast Guard Office of Research & Development Washington, D.C. 20590				11. Contract or Grant No. DOT-CG-41342-A	
15. Supplementary Notes				13. Type of Report and Period Covered Final Report	
16. Abstract Five Coast Guard cutters, ranging from a 82 foot, 8 man patrol boat to a 387 foot, 160 man high endurance cutter, were monitored for water consumption and wastewater flow and composition. Data was taken dockside and underway, and the waste water was segmented into sanitary, galley, and turbid system. Crew size and flow were monitored in half hour time blocks, and used to reduce actual flow data to a per-man basis. As the ships did not have full crews on board during the sampling periods, flow volume was also normalized to full crew size. Wide variation was found, with no consistency in the data when analyzed for crew size, dockside versus underway to operation, or type of operation (patrol vs. buoy tending). Standard deviations of means were very large, an indication that the ships do not represent a regular population of data. Flow and composition also varied greatly through the day. The report contains 81 plots (each with a separate plot for each ship), showing flow and chemical parameters for the three sanitary systems, for dockside and underway, by time of day. Other plots show crew size, saltwater usage and freshwater usage.				14. Sponsoring Agency Code G-DOE-1	
17. Key Words Sanitary waste, wastewater, ship's wastewater, sewerage, water, galley wastewater, turbid wastewater.			18. Distribution Statement Document is available to the U.S. public through the National Technical Information Service, Springfield, Virginia 22161		
19. Security Classif. (of this report) Unclassified		20. Security Classif. (of this page) Unclassified		21. No. of Pages 188	22. Price

410738

Jur

METRIC CONVERSION FACTORS

Approximate Conversions to Metric Measures		Approximate Conversions from Metric Measures	
Symbol	When You Know	Multiply by	To Find
LENGTH			
in	inches	2.5	centimeters
ft	feet	30	centimeters
yd	yards	0.9	meters
m	miles	1.6	kilometers
AREA			
in ²	square inches	6.5	square centimeters
ft ²	square feet	0.09	square meters
yd ²	square yards	0.8	square meters
mi ²	square miles	2.6	square kilometers
	acres	0.4	hectares
MASS (weight)			
oz	ounces	28	grams
lb	pounds	0.45	kilograms
	short tons (2000 lb)	0.9	tonnes
VOLUME			
tsp	teaspoons	5	milliliters
Tbsp	tablespoons	15	milliliters
fl oz	fluid ounces	30	milliliters
c	cups	0.24	liters
pt	pints	0.47	liters
qt	quarts	0.95	liters
gal	gallons	3.8	liters
ft ³	cubic feet	0.03	cubic meters
yd ³	cubic yards	0.76	cubic meters
TEMPERATURE (exact)			
°F	Fahrenheit temperature	5/9 (after subtracting 32)	Celsius temperature
°C	Celsius temperature	9/5 (then add 32)	Fahrenheit temperature

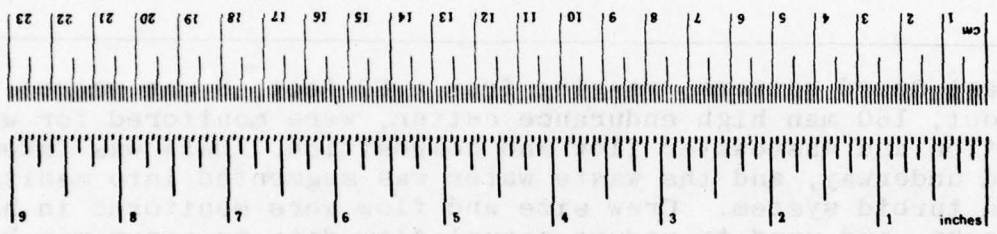

* 1 in. = 2.54 centimeters. For other exact conversions and more data, see NBS Misc. Publ. 286, Units of Weights and Measures, Price \$2.25, SD Catalog No. C13.10.286.

TABLE OF CONTENTS

1.	INTRODUCTION	1
2.	MATERIALS AND METHODS	10
	a. Ship Selection and Modification	10
	Point Herron	11
	White Sage	12
	Firebush	16
	Vigorous	20
	Gallatin	25
	b. Sampling Procedures	29
	c. Analytical Procedures	31
	d. Collection and Preservation	32
	e. Transportation	37
	f. Analysis	37
	g. Computational Methods	40
	h. Ship Sampling	44
	Point Herron	44
	Firebush	46
	White Sage	47
	Vigorous	49
	Gallatin	51
3.	RESULTS	54
	a. Crew Size	54
	b. Fresh Water and Salt Water Usage	58
	c. Wastewater Chemical Composition	103

ACCESSION for	
NTIS	White Section <input checked="" type="checkbox"/>
DDC	Buff Section <input type="checkbox"/>
UNANNOUNCED	<input type="checkbox"/>
JUSTIFICATION	<input type="checkbox"/>
BY	
DISTRIBUTION/AVAILABILITY CODES	
Dist.	SIAL
A	

TABLE OF CONTENTS

4. DISCUSSION	
a. Crew Size	149
b. Water Usage and Waste Water Flow	150
c. Chemical Composition of Waste Water	158
d. Comparison to Domestic Sewage	170
e. Correlation of BOD to COD and Suspended Solids	170
f. Statistical Analysis	175
g. Comparison with Other Studies	179
5. SUMMARY AND RECOMMENDATIONS	185
6. REFERENCES	189
APPENDIX A	
Engineering Drawings for Modifications to Ships' Water and Wastewater Systems, to Accommodate Metering and Sampling Devices	
Point Herron	A-1
Vigorous	A-3
Gallatin	A-15
Firebush	A-30
White Sage	A-43
APPENDIX B	
Computer Programs for Calculations and Plots of pH, Wastewater and Water Flows, Crew Size and Chemical Data Regression Line	
pH Plots	B-1
Wastewater Flow - Calculations and Plot	B-3
Water Flow - Salt and Fresh - Crew Size Plots	B-8
Chemical Data Regression Line	B-11

TABLE OF CONTENTS

APPENDIX C

Laboratory Reports of Analyses Performed on Coast
Guard Vessels, June through November, 1975

Point Herron	C-1
White Sage	C-9
Firebush	C-16
Vigorous	C-26
Gallatin	C-37

LIST OF FIGURES

<u>FIGURE NO.</u>	<u>TITLE</u>	
1	82' Patrol Boat, WPB Class, Similar to USCGC POINT HERRON	5
2	USCGC WHITE SAGE (WLM 544) 133' Buoy Tender	6
3	USCGC FIREBUSH (WLB 393) 180' Buoy Tender	7
4	USCGC VIGOROUS (WMEC 627) 210' Medium Endurance Cutter	8
5	USCGC GALLATIN (WHEL 721) 387' High Endurance Cutter	9
6	Sampling Systems	30
7	Sample Flow Diagram, Turbid Waste	33
8	Sample Flow Diagram, Sanitary Waste	34
9	Sample Flow Diagram, Galley Waste	35
10	Sample Flow Diagram, Potable Water	36
11	Dockside Crew Size	55
12	Underway Crew Size	57
13	Dockside Segmented Fresh Water Usage	61
14	Underway Segmented Fresh Water Usage	62
15	Dockside Cumulative Fresh Water Usage	63
16	Underway Cumulative Fresh Water Usage	64
17	Dockside Segmented Salt Water Usage	65
18	Underway Segmented Salt Water Usage	66
19	Dockside Cumulative Salt Water Usage	67
20	Underway Cumulative Salt Water Usage	68
21	Actual Total Wastewater Flow; Segmented, Dockside	71

LIST OF FIGURES

<u>FIGURE NO.</u>	<u>TITLE</u>	
22	Actual Total Waste Water Flow; Segmented, Underway	72
23	Actual Total Waste Water Flow; Cumulative, Dockside	73
24	Actual Total Waste Water Flow; Cumulative, Underway	74
25	Normalized Total Waste Water Flow; Segmented, Dockside	75
26	Normalized Total Waste Water Flow; Segmented, Underway	76
27	Normalized Total Waste Water Flow; Cumulative, Dockside	77
28	Normalized Total Wastewater Flow; Cumulative, Underway	78
29	Actual Sanitary Waste Water Flow; Segmented, Dockside	79
30	Actual Sanitary Waste Water Flow; Segmented, Underway	80
31	Actual Sanitary Waste Water Flow; Cumulative, Dockside	81
32	Actual Sanitary Waste Water Flow; Cumulative, Underway	82
33	Normalized Sanitary Waste Water Flow; Segmented, Dockside	83
34	Normalized Sanitary Waste Water Flow; Segmented, Underway	84
35	Normalized Sanitary Waste Water Flow; Cumulative, Dockside	85
36	Normalized Sanitary Waste Water Flow; Cumulative Underway	86

LIST OF FIGURES

<u>FIGURE NO.</u>	<u>TITLE</u>	
37	Actual Turbid Waste Water Flow; Segmented, Dockside	87
38	Actual Turbid Waste Water Flow; Segmented, Underway	88
39	Actual Turbid Waste Water Flow; Cumulative, Dockside	89
40	Actual Turbid Waste Water Flow; Cumulative, Underway	90
41	Normalized Turbid Waste Water Flow; Segmented, Dockside	91
42	Normalized Turbid Waste Water Flow; Segmented, Underway	92
43	Normalized Turbid Waste Water Flow; Cumulative, Dockside	93
44	Normalized Turbid Waste Water Flow; Cumulative, Underway	94
45	Actual Galley Waste Water Flow; Segmented, Dockside	95
46	Actual Galley Waste Water Flow; Segmented, Underway	96
47	Actual Galley Waste Water Flow; Cumulative, Dockside	97
48	Actual Galley Waste Water Flow; Cumulative, Underway	98
49	Normalized Galley Waste Water Flow; Segmented, Dockside	99
50	Normalized Galley Waste Water Flow; Segmented, Underway	100
51	Normalized Galley Waste Water Flow; Cumulative, Dockside	101

LIST OF FIGURES

<u>FIGURE NO.</u>	<u>TITLE</u>	
52	Normalized Galley Waste Water Flow; Cumulative, Underway	102
53	Dockside Sanitary Total Solids Loads	105
54	Underway Sanitary Total Solids Loads	106
55	Dockside Turbid Total Solids Loads	107
56	Underway Turbid Total Solids Loads	108
57	Dockside Galley Total Solids Loads	109
58	Underway Galley Total Solids Loads	110
59	Dockside Sanitary Suspended Solids Loads	111
60	Underway Sanitary Suspended Solids Loads	112
61	Dockside Turbid Suspended Solids Loads	113
62	Underway Turbid Suspended Solids Loads	114
63	Dockside Galley Suspended Solids Loads	115
64	Underway Galley Suspended Solids Loads	116
65	Dockside Sanitary pH	117
66	Underway Sanitary pH	118
67	Dockside Turbid pH	119
68	Underway Turbid pH	120
69	Dockside Galley pH	121
70	Underway Galley pH	122
71	Dockside Turbid Hardness Loads	123
72	Underway Turbid Hardness Loads	124
73	Dockside Turbid Oil and Grease Loads	125
74	Underway Turbid Oil and Grease Loads	126

LIST OF FIGURES

<u>FIGURE NO.</u>	<u>TITLE</u>	
75	Dockside Galley Oil and Grease Loads	127
76	Underway Galley Oil and Grease Loads	128
77	Dockside Turbid MBAS Loads	129
78	Underway Turbid MBAS Loads	130
79	Dockside Galley MBAS Loads	131
80	Underway Galley MBAS Loads	132
81	Dockside Sanitary Chloride Loads	133
82	Underway Sanitary Chloride Loads	134
83	Dockside Sanitary COD Loads	135
84	Underway Sanitary COD Loads	136
85	Dockside Turbid COD Loads	137
86	Underway Turbid COD Loads	138
87	Dockside Galley COD Loads	139
88	Underway Galley COD Loads	140
89	Dockside Sanitary BOD Loads	141
90	Dockside Turbid BOD Loads	142
91	Dockside Galley BOD Loads	143
92	Correlation of BOD vs. COD and Suspended Solids	173
93	Summary Influent Hydrograph and Wastewater Characteristics.	180

LIST OF TABLES

<u>TABLE NO.</u>	<u>TITLE</u>	<u>PAGE</u>
1	Coast Guard Ships Used in the Waste Water Characterization Study	4
2	Methods of Analysis of Wastewater Samples	38
3	Key to the Location of Wastewater Flow Data Graphs	70
4	Key to the Location of Chemical Composition Data Graphs	104
5	Concentration of Chemicals in Wastewater, Point Herron	144
6	Concentration of Chemicals in Wastewater, Firebush	145
7	Concentration of Chemicals in Wastewater, White Sage	146
8	Concentration of Chemicals in Wastewater, Vigorous	147
9	Concentration of Chemicals in Wastewater, Gallatin	148
10	Summary of Average Hydraulic Data	152
11	Statistical Analysis of Average Water Flow Data	153
12	Summary of Average Daily Hydraulic Flow	155
13	Comparison of Wastewater Generation to Water Usage	156
14	Hydraulic Composition of Wastewater	157
15	Summary of Average Chemical Loads for Sanitary System	159
16	Summary of Average Chemical Loads for Turbid System	160
17	Summary of Average Chemical Loads for Galley Systems	161

LIST OF TABLES

<u>TABLE NO.</u>	<u>TITLE</u>	
18	Statistical Comparison of Average Sanitary Chemical Loads From All Ships	162
19	Statistical Comparison of Average Turbid Chemical Loads From All Ships	163
20	Statistical Comparison of Average Galley Chemical Loads From All Ships	164
21	Summary of Total Chemical Loads From All Systems	166
22	Statistical Comparison of Total Chemical Loads From All Ships	167
23	Percent Composition of Chemical Loads Delivered by Individual Collection Systems	169
24	Comparison of Shipboard Wastewater to Typical Domestic Sewage	171
25	Correlation of BOD vs. COD and Suspended Solids	174
26	Calculated F Rational for Linearity and Statistical Regularity of Flow	178
27	Summary of the Properties of Sewage From A Naval Vessel	182

ABBREVIATIONS AND SYMBOLS

ANOVA	Analysis of Variable
BOD	Biochemical Oxygen Demand
CO	Commanding Officer
COD	Chemical Oxygen Demand
CPO	Chief Petty Officer
EPA	United States Environmental Protection Agency
GPD	Gallons per Day
GPM	Gallons per Man
MBAS	Methylene Blue - Active Substances

1. INTRODUCTION

In keeping with the national objective of reducing the concentration of polluting substances discharged into surface waters, the United States Coast Guard has been given the responsibility of conducting research and development on methods of controlling waste waters from ships. To do this effectively, accurate data must be available on the qualitative and quantitative aspects of ships' waste waters. This information will ultimately influence the decision on the cost-effectiveness of the various alternatives, including on-board treatment or holding tanks which discharge either into an on-shore treatment facility or overboard in unrestricted waters. Although there have been several reports on this subject recently, the data is far from comprehensive.

An appropriate place to accumulate such data is on the ships operated by the Coast Guard. In addition to gathering information that is needed in fulfilling its responsibility of managing its own waste, the duty patterns of Coast Guard crews are similar to those of many commercial or naval vessels. Therefore, data taken on Coast Guard ships should be useful in evaluating methodologies that are applicable to the entire maritime service.

In 1973, such a program was initiated by the Commandant, through the Office of Research and Development, United States

Coast Guard Headquarters, Washington, D.C. 20590. The objective of this program was to survey, analyze, and evaluate Coast Guard wastewaters from five different classes of Coast Guard vessels. Flow patterns were to be analyzed underway and moored, as these represent substantial differences in crew activity. Also, flow patterns were to be established for the three basic collection systems on each vessel; toilet and urinal ("black" or sanitary water), lavatory and shower ("gray" or turbid water), and galley and scullery (culinary water). The first of these three, the sanitary system, currently uses salt water as flush water; the other two are entirely fresh water. Also, water usage data was to be taken to determine if there was a correlation between water consumption and volume of sewage generated on the vessels.

The waste water constituents that were to be analyzed are:

1. Biochemical Oxygen Demand (BOD)
2. Chemical Oxygen Demand (COD)
3. Total Solids
4. Suspended Solids
5. pH
6. Chlorides: Only on sanitary water
7. Oil and Grease: Only on culinary and turbid water
8. Methylene Blue-Active Substances (MBAS): Only on culinary and turbid water
9. Hardness: Only on turbid water

In addition, in order to determine the contribution of substance from the ships' potable water, the potable water was analyzed for iron, manganese, copper, zinc, and hardness. Water usage data was also taken from flow meters installed on the ships.

The five classes of ships are summarized in Table 1, and photographs of the selected ships are shown in Figures 1 thru 5. They represent a cross section of Coast Guard's wide range of size and operation. In size, they ranged from 8 men to 160 men in full complement (although the ships normally operate with less than full complement on board). They cover small rescue boats and work boats that rarely stay out overnight, to high-endurance cutters that make extended patrols. An objective of the study was to determine if there is a similarity or difference in the waste loads of various types of ships.

Each ship's waste system was modified to accommodate special sampling equipment which measured flow and delivered an aliquot of blended homogeneous wastewater. Sampling was done round-the-clock for three days underway and four days moored. Logs were kept of ship activity and number of men on board and of water usage, where meters had been installed.

Wastewater and water samples were analyzed by "Standard Methods" or United States Environmental Protection Agency (EPA) procedures. Data was then analyzed for statistical significance, and plotted. The specifics of the program and the results follow.

TABLE 1
COAST GUARD SHIPS USED IN THE WASTEWATER CHARACTERIZATION STUDY

<u>DESIGNATION</u>	<u>NAME & BASE</u>	<u>LENGTH</u>	<u>TYPE</u>	<u>FULL CREW SIZE</u>	<u>USUAL TYPE OF OPERATION</u>
(WPB 82318)	POINT HERRON Fire Island, NY	82'	Patrol	8	Enforcing boating safety rules, search and rescue operations.
(WLM 544)	WHITE SAGE Woods Hole, MA	133'	Buoy-Tender	21	Tending navigational aids.
(WLB 393)	FIREBUSH Governors Isl., NY	180'	Buoy-Tender	46	Tending navigational aids.
(WMEC 627)	VIROROUS New London, CT	210'	Medium Endurance Cutter	60	Offshore Patrol
(WHEC 721)	GALLATIN Governors Isl., NY	387'	High Endurance Cutter	160	Offshore Patrol



FIGURE 1. 82' PATROL BOAT, WPB CLASS SIMILAR TO USCGC POINT HERRON

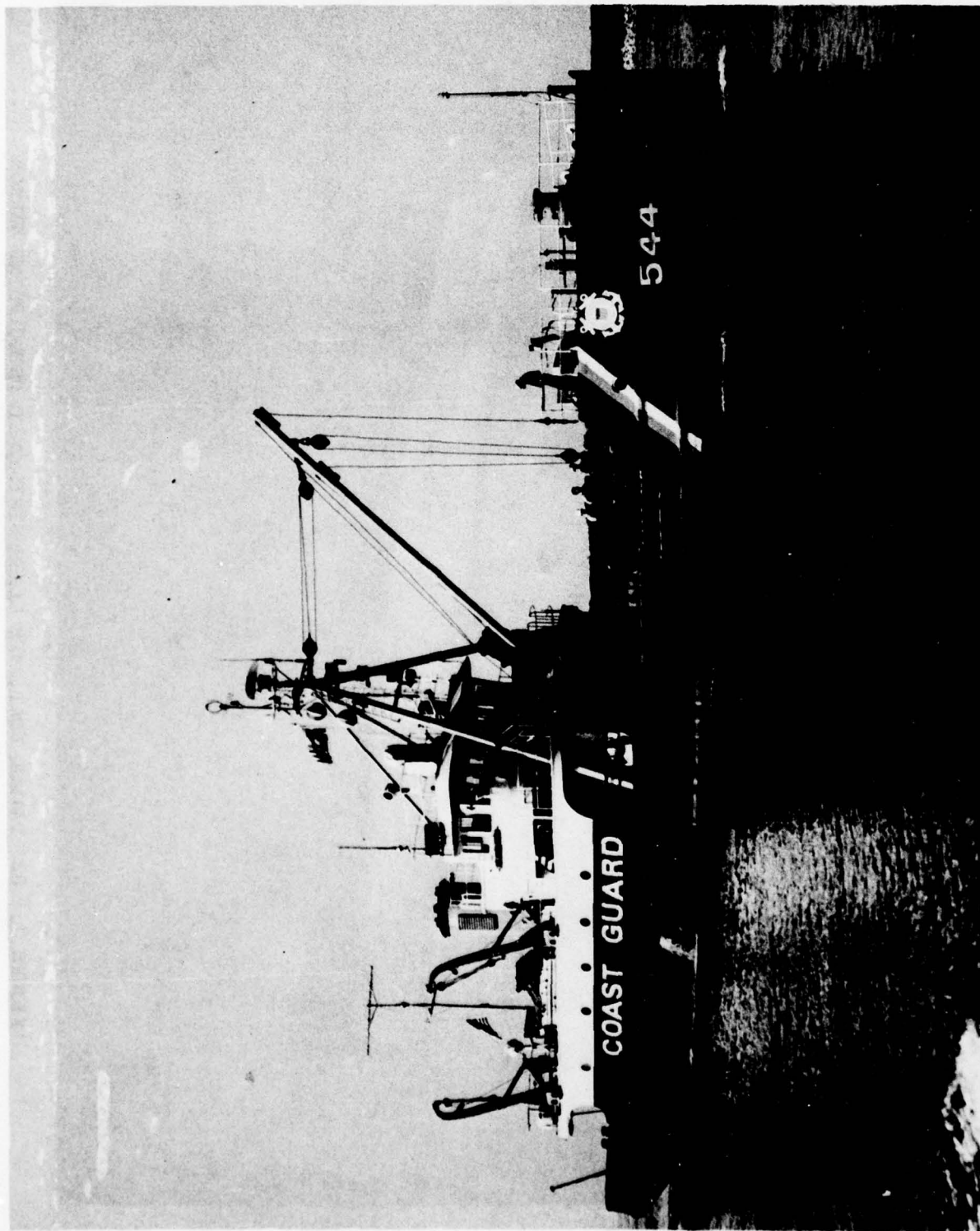

FIGURE 2. USCGC WHITE SAGE (WLM 544) 133' Buoy Tender

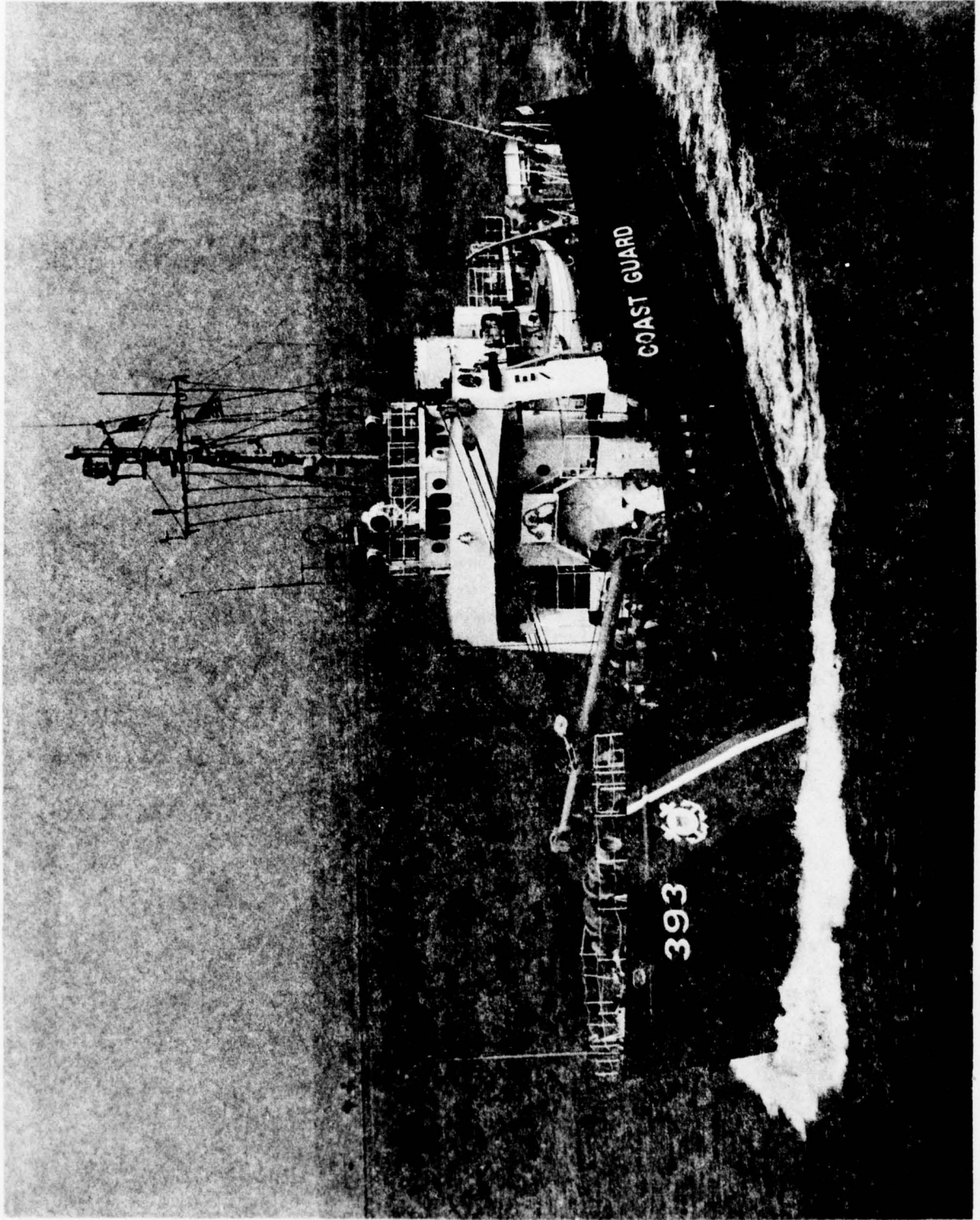

FIGURE 3. USCGC FIREBUSH (WLB 393) 180' Buoy Tender

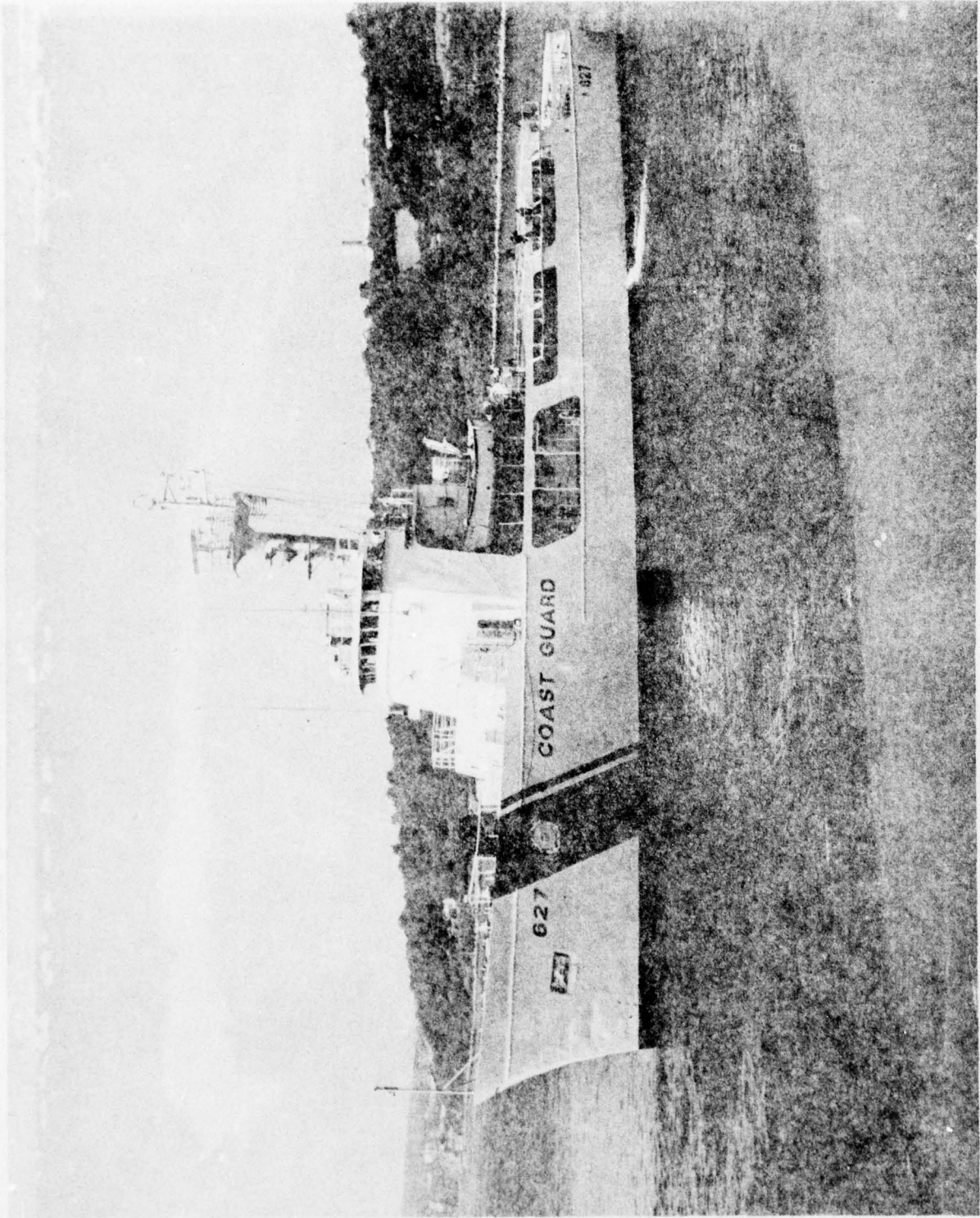

FIGURE 4. USCGC VIGOROUS (WMEC 627) 210' Medium Endurance Cutter



FIGURE 5. USCGC GALLATIN (WHEC 721) 387' High Endurance Cutter

2. MATERIALS AND METHODS

a. Ship Selection and Modification

All of the ships used in the study were in the northeast United States, to facilitate return of samples to the laboratory and minimize transportation costs. The GALLATIN and VIGOROUS were relatively new and had been fitted with holding tanks when they were constructed. Holding tanks had been retrofitted into the WHITE SAGE and FIREBUSH. The presence of holding tanks implied that all wastewater pipes converged to a central point which was essential for the sampling program. Older ships without holding tanks discharge waste from several points in the hull, which would have made sampling an extremely expensive operation. The POINT HERRON did not have a holding tank installed within the year.

The intent of the program was to separately sample sanitary waste, turbid water, and culinary water. These three systems did not arrive at the holding tanks as discrete systems, instead they joined common waste pipes wherever it was convenient. It was therefore necessary to first locate ships that had waste systems that could be modified for sampling with a minimum of cost, and then design modifications which could segregate the three wastes during sampling and restore the system at the end of the program. In some cases it was impossible to completely segregate the systems, and it was necessary to secure some heads, sinks, and showers during sampling. The

crew was directed to use only those facilities which flowed into the segregated waste lines.

Prior to making the modifications, the engineering drawings and specifications were reviewed and approved by each ship's command and headquarters engineering. Substantial planning went into scheduling the modification work and the sampling dates, so as not to interfere with normal ship operation and provide rapid transport of samples back to the laboratory.

The modifications to the ships are described in the following sections, and the engineering specifications are attached as Appendix A.

Point Herron

Wastewater Collection System

The POINT HERRON had not yet been fitted with a sewage holding tank.

The POINT HERRON has two lavatories, each with one toilet, washbasin, and shower. The galley has one sink which is drained by turning on a small pump which is located in the cabinet beneath the sink. The toilets are grinder-chlorinator type with a pump mounted on the back of the toilet to supply sea water for flushing and a chlorine solution reservoir on the front. When the toilet is activated, the waste is automatically comminuted and chlorinated.

Flexible rubber hoses connect the discharge lines of both the galley sink pump and the automatic toilet to over-

board discharge through seacock type fittings. The shower and washbasin drains join and then are discharged through the hull.

Piping Modifications

The Captain's lavatory could not be conveniently sampled and was, therefore, secured during the sampling period. A tee was installed in the turbid (shower and washbasin) drain line with a shut-off valve on the free leg. A 3/4" (1.9 cm.) hose was attached to the valve and run into a 5-gallon (18.9 l.) sampling container. During the sampling, the seacock was shut and the new valve opened on the tee, thereby diverting all the flow to the sample container.

The galley and sanitary samples were obtained by shutting the seacock, removing the flexible rubber hose connections from them, and attaching hoses long enough to reach to 5 gallon sample containers. The chlorine reservoir on the toilet was disconnected during the sampling program. A drawing showing the sampling points on the POINT HERRON is included in Appendix A.

White Sage

Wastewater Collection System

The WHITE SAGE has two holding tanks. A smaller 270 gallon (1025 l.) tank, 3'9" (1.14 m.) high, 3'6" (1.07 m) diameter, is located in the engine room, and a larger 881 gallon (3349 l.), 6' high (1.83 m.), 5' (1.52 m) diameter tank loca-

ted forward. All waste waters drain to the smaller holding tank through three lines, a 1 1/2" (3.81 cm.) line from the galley, a 2" (5.08 cm.) turbid water line and a 4" (10.16 cm.) sanitary line.* No waste lines drain directly to the larger holding tank.

When the smaller holding tank is full, the waste water is pumped to the larger forward holding tank. The discharge piping is set up so that waste can be pumped from one holding tank to the other or from either tank to overboard.

The fixtures served by the galley drainage system are:

- Galley sink
- Deck drain in galley
- Drinking fountain

The fixtures served by the turbid drainage system are:

- Clothes washer
- Crew's shower
- Crew's washbasin
- Deck drain in Crew's washroom
- CO's washbasin
- CO's shower
- CPO's shower
- CPO's washbasin

*These holding tanks were retrofitted onto the WHITE SAGE and segregate the waste into the three separate systems.

Piping Modifications

Drawings of all the piping system modifications and water meter installations on the WHITE SAGE are shown in Appendix A.

The sanitary drainage system was modified for sampling by installing a 4" X 4" X 3" tee in the sanitary line just above the sewage collection tank. Valve and hose connections were put on the 3" leg of the tee. Sampling was conducted by attaching a 3" hose to the hose connection and connecting it to the sampling tanks, shutting the existing 4" valve, and opening the new 3" valve.

As the galley line joined the turbid water line just prior to emptying into the sewage collection tank, it was necessary to disconnect the galley line and provide a new opening for it into the top of the collection tank. A 2" tee was installed in the turbid water line just above an existing shut-off valve. Valve and hose connections were installed on the horizontal run of the tee. Sampling was conducted by connecting a 2" hose to the hose connection and attaching the other end to the sampling system. When the new valve was opened and the existing shut-off valve closed, all the turbid water flow was diverted to the sampling tanks.

A similar arrangement was made for obtaining the galley water samples. An existing 2" elbow was removed and replaced with a 2" tee. A 2" valve and hose connection was put on the free leg of the tee.

The fixtures served by the sanitary drainage system are:

CPO's toilet
Deck drain in CPO's toilet
CO's toilet
Deck drain in CO's toilet
Crew's toilet (2)
Crew's urinal
Deck drain in crew's toilet

Saltwater System

Salt water for toilet flushing is provided by pumps which pump into a saltwater hydropneumatic tank. The hydro-pneumatic tank maintains pressure on the saltwater system. A water meter was installed in the discharge line from the hydropneumatic tank as part of this study to monitor salt-water flow.

Freshwater System

The WHITE SAGE is equipped with five (5) separate freshwater holding tanks with a combined capacity of 10,000 gallons. There is no freshwater distilling capacity on board. Water from the five tanks is pumped to a hydropneumatic tank and then through the distribution system. A water meter was also installed in the discharge line from the hydropneumatic tank.

Sanitary and turbid waste water was returned to the sewage collection tank through an existing opening where a 2" valve, 2" tee and hose connections had been installed. The galley waste water was returned through a new 2" opening in the top of the galley waste holding tank.

Drawing of the salt and fresh water meter installations are also shown in the appendix. Both installations had valved bypasses, so, if required, the meter could be completely removed.

Firebush

Wastewater Collection System

The FIREBUSH has two holding tanks in the forward hold. The larger tank contains 1823 gallons (6928 l.) and is 6' 6" (1.98 cm.) X 7' 6" (2.27 cm.) X 5' 0" (1.52 cm.) high. It is used for holding sewage while at sea. The smaller tank, of 249 gallons (947 l.), is 2' 10" (0.86 cm.) X 2' 10" (0.86 cm.) X 4' 2" (0.66 cm.) and is used in port. There are two sewage ejector pumps, and each pump can empty either tank. These tanks had been retrofitted onto the ship.

Drainage from the officer's toilet, staterooms, and pantry in the stern of the ship, do not drain by gravity directly to the holding tanks. The officer's toilet is a "Brocto" type toilet which macerates and pumps the waste through a 2" (5.08 cm.) force line forward to bulkhead 92, where it discharges in

a 4" (.10.16 cm.) gravity sanitary line. Drainage from the other fixtures goes to a small sump tank and is pumped forward through a 1 1/2" (3.81 cm.) force main to a 3" (7.62 cm) gravity turbid water line. These fixtures include:

Officer's washbasins (5)

Officer's Pantry sink

Officer's shower

*Officer's toilet deck drains (2)

The fixtures served by the sanitary drainage system are:

Officer's toilet (via 2" force line)

CO's toilet

Sick bay washbasin

Sick bay deck drain

Sick bay toilet

CPO's toilet

CPO's toilet deck drain

Crew's toilets (3)

Crew's urinal

Crew's toilet deck drain

The fixtures served by the turbid drainage system are:

Clothes washers (2)

Laundry deck drain

CO's shower

*Wastewater flow contributed from the officer's pantry sink was negligible. All meal preparation and dishwater for the officers' meals was done in the main galley.

CO's washbasin

CPO's shower

CPO's washbasins (2)

Crew's shower

Crew's washbasins (5)

Crew's washroom deck drain

All fixtures served by 1 1/2 force main.

The fixtures served by the galley drainage system are:

Dishwasher

Scullery sink

CPO's mess deck drain

Galley deck drains (2)

Galley sink

Crew's mess deck drain

Coffee urn drain

Saltwater System

Salt water for toilet flushing is provided by a pump which pumps into a hydropneumatic tank. The hydropneumatic tank maintains pressure on the saltwater system. A water meter was installed in the discharge line from the hydropneumatic tank as a part of this study.

Freshwater System

The FIREBUSH has three freshwater holding tanks with a

combined capacity of 50,000 gallons (190,000 l.). Tank level readings are made by dip stick. Water from the tanks is pumped into a hydropneumatic tank and then goes through the distribution system. A water meter was installed in the discharge line of the hydropneumatic tank as a part of this contract. Results of the water meter readings are shown elsewhere in this report.

Piping Modifications

Drawings of all the piping system modifications and water meter installations on the FIREBUSH are shown in appendix A.

The sanitary drainage system was modified for the sampling program by installing a 4" (10.16 cm.) X 4" (10.16 cm.) X 3" (7.62 cm.) tee in the existing 4" (10.16 cm.) sanitary line just before it enters the sewage collection tank. A 3" (7.62 cm.) plug valve and hose connection were installed on the 3" (7.62 cm.) leg of the tee. Sampling was accomplished by hooking up the sampling tanks to the sanitary line with a 3" (7.62 cm.) hose, shutting the existing 4" (10.16 cm.) shut-off valve and opening the new 3" (7.62 cm.) valve.

The galley drainage system was modified by removing an existing 3" (7.62cm.) blind flange and installing a specially-made 3" (7.62 cm.) flange with a 2" (5.08 cm.) hose connection. Sampling was accomplished by connecting the sampling tanks to the galley line with a 2" (5.08 cm.) hose and diverting the flow to the sampling tanks with existing valves.

The turbid drainage system was modified by installing a 3' (7.62 cm.) X 3" (7.62 cm.) X 2" (5.08 cm.) tee in the existing 3" (7.62 cm.) drainage line just before it enters the sewage collection tank. A 2" (5.08 cm.) plug valve and a hose connection were attached to the tee. Sampling was accomplished by connecting the sampling tanks to the turbid line with a 2" (5.08 cm.) hose, closing the existing shut-off valves and opening the new 2" (5.08 cm.) valve.

All waste water was returned to the sewage retention tank through 2" (5.08 cm.) connections that had been installed where an existing fire hose connection had been removed.

Vigorous

Wastewater Collection System

The VIGOROUS was constructed with a wastewater collection system which was modified under Shipalt 210B-X-54 in March-April, 1973. The present collection system, as modified, is as follows:

a) Sanitary

This system collects all waste waters from toilets, urinals, and deck drains in all bathrooms. Also, the condensate drip pans from four air conditioner units are drained into the sanitary collection system. The lines from this system converge to four 4" (10.16 cm.) lines and one 2" (5.08 cm.) line, which all join in a 6" (14.7 cm.) diameter header just prior to a 600 gallon (2271.18 l.) sanitary hold-

ing tank in the sewage treatment room. The sanitary holding tank is equipped with a flushing strainer system and two sewage ejector pumps of 100 G.P.M. capacity each. Discharge piping is all 4" (10.16 cm.). The sanitary holding tank is equipped with a high level alarm which sounds a bell when the tank is full. There are four outlets, one at deck level and one at water level on each side of the ship.

There is a 2" (5.08 cm.) saltwater line directly to the sanitary collection header so the holding tank can be rinsed out.

Altogether, 17 toilets, 3 urinals, 15 deck drains in toilet areas, and 4 air conditioner condensate lines drain into the sanitary drainage system.

b) Turbid

Turbid and galley waste lines connect in the sewage treatment room into one 4" (10.16 cm.) line. The 4" (10.16 cm.) line goes to a 100 gallon (378.53 l.) turbid water holding tank. There is a valved bypass to divert the turbid water flow to the 600 gallon (2271.18 l.) sanitary holding tank. Flow into the turbid water tank is through a flushing strainer, and there is one ejector pump of 30 G.P.M. capacity. There are high and low water level alarms on the turbid water tank. Normally the pump is left in the automatic mode so the tank is automatically emptied when it is full. The turbid water and sanitary holding tanks are vented through a common 4" (10.16

cm.) vent. In an emergency, it is possible for waste water to flow from one tank to another through the vent line prior to having water back out any of the plumbing fixtures.

By some re-arranging of drains and careful selection of the sampling points, it was possible to almost entirely separate the turbid and galley waste flows.

Altogether, 19 washbasins, 4 drinking fountains, 13 showers, 5 washroom deck drains, 3 clothes washers, 8 air conditioner condensate lines drain into the turbid water system.

c) Galley

As mentioned previously, the galley sample collection point was selected so as to minimize any turbid flow contribution. The fixtures that drain into the galley system are:

Drinking fountains (2)

Deck drains (5)

Galley sinks (2)

Coffee urn

Steam table

Griddle range and fryer hood (2)

Steam kettle hood

Air conditioner condensate drains (3)

Garbage grinder

Scullery sink

Dishwashers (2)

CPO's mess sink

Officer's pantry sink

Shower

Washbasins (4)

The shower and washbasins could not be easily reconnected to a turbid waste line, so their use was minimized during the time sampling was underway.

Saltwater System

Salt water is used for flushing toilets in the sanitary system and for several cooling purposes. There are two saltwater pumps with common suction and discharge lines. At all times one of the pumps is running to maintain the system pressure. A water meter was installed on the main saltwater flushing line.

Freshwater System

There are two freshwater holding tanks, one forward with 4,600 gallons (17412 l.) capacity and one aft with 3,600 gallons (13627 l.) capacity. Also, the ship is equipped with a distilling plant of 3,000 gallons (11335 l.)/day capacity. Tank level readings are made with a series of petcocks to indicate the water level in the tank. Fresh water from the tanks goes through a hydropneumatic tank which maintains the water pressure in the system. A water meter was installed on the discharge line from the hydropneumatic tank as a part of this study.

Piping Modifications

Drawings of all the piping system modifications and water meter installations on the VIGOROUS are shown in Appendix A.

The sanitary drainage system was modified by removing a spool piece on the existing 6" (14.7 cm.) sanitary header and installing a 6" (14.7 cm.) knife gate valve. Also, a 3" (7.62 cm.) valve and hose connection was brazed to the bottom of the 6" (14.7 cm.) header with a saddle. Sampling was accomplished by connecting the sampling tanks to the header with a 3" (7.62 cm.) hose, closing the 6" (14.7 cm.) knife gate valve, and opening the new 3" (7.62 cm.) valve, thereby diverting all the flow to the sampling tanks.

The turbid drainage system was modified by replacing a 4" (10.16 cm.) X 4" (10.16 cm.) tee with a 4" (10.16 cm.) X 4" (10.16 cm.) cross and attaching a reducer, valve and hose connection to the free leg. The turbid line was connected to the sampling tanks with a 2" (5.08 cm.) hose, and the flow was diverted by closing an existing shut-off valve and opening the new valve.

The galley drainage system was modified by removing the officer's pantry drain line and re-installing it in the main line from the galley with a 3" (7.62 cm.) X 3" (7.62 cm.) X 2" (5.08 cm.) X 2" (5.08 cm.) cross. The pantry drain was put in one of the 2" (5.08 cm.) legs and the hose connection was

provided on the other 2" (5.08 cm.) leg. Sampling was accomplished by connecting the sampling tanks to the galley line with a 2" (5.08 cm.) hose, closing the existing gag check valve, and opening the new 2" (5.08 cm.) valve.

All wastewater was returned through hose connections that were installed in the sanitary holding tank hatchway.

Drawings of the salt and freshwater meter installations are shown on pages A-12 and A-13 of Appendix A.

Gallatin

Wastewater Collection System

The GALLATIN was constructed with two separate sewage holding tanks. One 150 cubic-foot (5297.1 cu.m) capacity tank in the sewage sump and ejector room (5-144-0-Q) and a smaller, 60 cubic-foot (2118.84 cu.m) capacity tank in auxiliary machinery space No. 3 (3-272-0-E). The two tanks are not interconnected and each is equipped with 4" (10.16 cm.) discharge lines. Each tank is equipped with flushing strainers and two (2) sewage ejector pumps. All turbid water drains on the second deck and above drain directly overboard.

a) Sanitary

The sanitary drainage system collects the wastewater from all the toilets, urinals, and deck drains in all bathrooms. The bathroom in the after berthing area on the second deck drains into the sewage holding tank located in auxiliary machinery space No.3, all other bathrooms drain into the forward

sewage holding tank in the sewage sump and ejector room. Because of this, the sanitary sample collected was from less than the full crew and had to be adjusted.

The number of fixtures actually sampled were:

Toilets (25)

Urinals (6)

Deck drains in toilet areas (4)

The CO's, Officers and CPO's pantries drain into the sanitary system. However, all meals were prepared in the main galley and dishes washed in the main scullery so the flow contributed by the pantries was negligible. Also, six washbasins and three showers drain into the sanitary system. It was impossible to segregate these flows from the sanitary system.

b) Turbid

The only area that drains into the turbid system is the bathrooms in the berthing areas on the third deck. All other turbid water is drained directly overboard.

The fixtures served by the turbid drainage system are:

Washbasins (4)

Showers (3)

Deck drains (2)

Drinking fountain.

c) Galley

The galley drainage system services the main galley,

crew's mess, and scullery. Fixtures are:

- Deck drains (4)
- Sinks in vegetable prep. dresser
- Sinks in pot washed dresser
- Milk and coffee stand
- Sink in main utility dresser
- Griddle
- Garbage grinder
- Scullery sink
- Dishwasher

Saltwater System

The saltwater system for flushing toilets is supplied by two centrifugal pumps which draw seawater from outside the hull and pump into the system. One of the pumps is running at all times to maintain the system pressure. A water meter was installed in the saltwater line as part of this study.

Freshwater System

The ship has three freshwater tanks, one 8400 gallon (31796.52 L) capacity tank forward and 4200 gallon (15898.26 L) capacity tanks aft. Level readings are made by using a series of petcocks. The ship has a distilling unit which is capable of making fresh water when the ship is underway. A water meter was installed in the discharge line from the ship's hydropneumatic tank.

Piping Modifications

Drawings of all the piping modifications and water meter installations on the GALLATIN are shown in Appendix A.

The sanitary drainage system was modified by removing a 6" (14.7 cm.) elbow and installing a 6" (2.27 cm.) tee, 6" (14.7 cm.) X 3" (7.62 cm.) reducer, valve and hose connection as shown in Appendix A. Sampling was accomplished by connecting the sampling tanks to the hose connection with a 3" (7.62 cm.) hose, opening the new 3" (7.62 cm.) valve and closing an existing 6" (14.7 cm.) shut-off valve.

The turbid drainage system was modified by adding a valved hose connection and shut-off valve into the existing turbid water line just before it connects to the 6" (14.7 cm.) sanitary line. Sampling was accomplished by connecting the sampling tanks to the turbid line with a 2" (5.08 cm.) hose, closing the shut-off valve and opening the other valve to divert the flow to the sampling tanks.

The galley drainage system was modified by installing a new 4" (10.16 cm.) tee, 4" (10.16 cm.) X 2" (5.08 cm.) reducer, valve and hose connection. Sampling was accomplished by connecting the sampling tanks to the galley line with a 2" (5.08 cm.) hose, and turning valves to divert the flow into the tanks.

b. Sampling Equipment

The sampling equipment for all ships except the POINT HERRON incorporated the following design considerations:

- a. Receive, contain, and measure volume of waste water.
- b. Blend to make a homogeneous mix, and deliver an aliquot.
- c. Discharge into holding tanks.
- d. Fit through access hatches.
- e. Be compatible with ships' electrical and plumbing systems.

The POINT HERRON, because of its small size, did not justify a complex sampling system. Therefore, samples were collected directly into a 5 gallon (19) polyethylene containers. The system described below was used on the other four ships.

A standard 55 gallon (208) steel drum just barely passed through the smallest hatch of the selected ships, and also fit into the limited space around the holding tanks. As such, it was selected as the basic container for the sampling system. The drums were coated with Hersite (a painting system approved for use in potable water tanks) to prevent contamination of the samples.

Three systems (Figure 16) were constructed for each of the three kinds of waste water (sanitary, culinary, and turbid). These were identical, except the supply line to the sanitary tanks was 3" (7.62 cm.) in diameter instead of 2" (5.08 cm.).

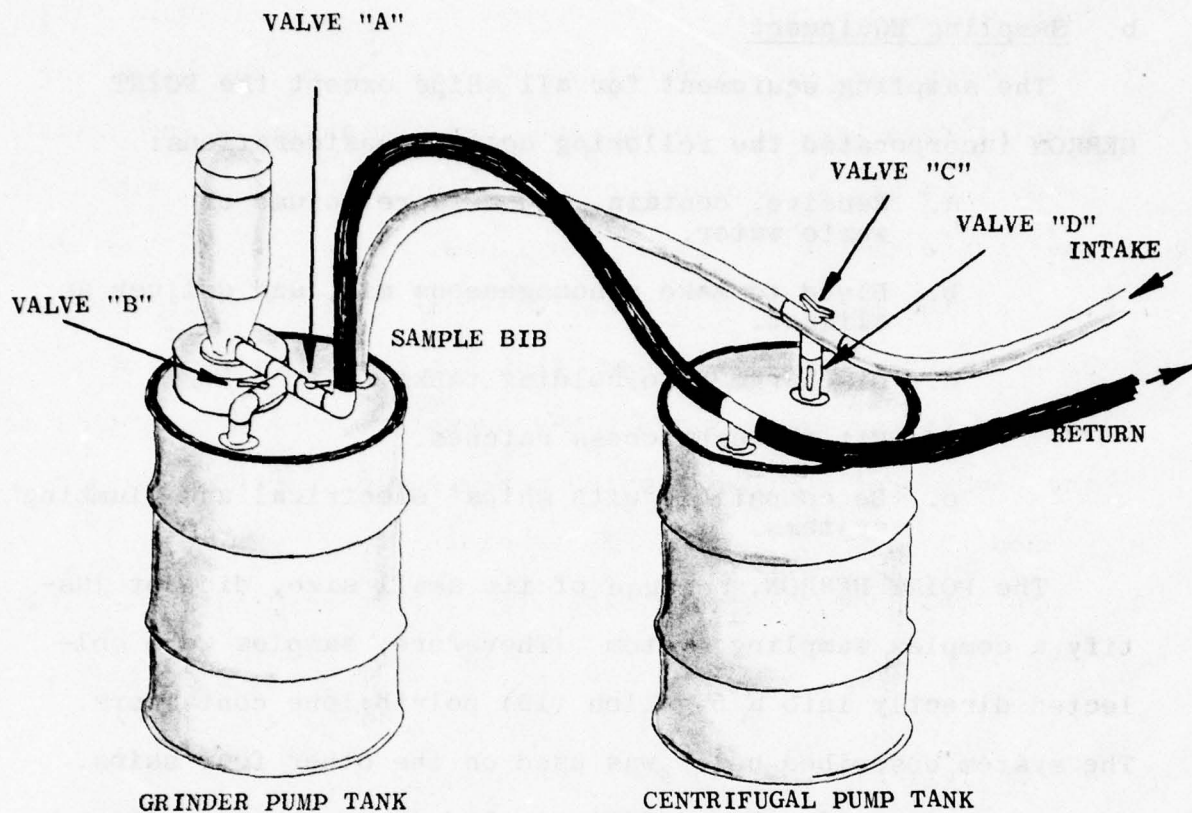

OPERATION:

A) WHEN TIME REQUIRED TO FILL GRINDER PUMP TANK IS GREATER THAN TIME REQUIRED TO EMPTY GRINDER PUMP TANK

The waste flow is introduced to the sampler by opening the inlet valve at the sampling point. At the centrifugal pump tank Valve "C" is open and Valve "D" is shut. While the grinder pump tank is filling up, the grinder pump is operated with Valve "A" shut and Valve "B" open to recirculate and grind the waste water. When the drum is filled, Valve "C" is shut, Valve "A" is opened, and Valve "B" is shut. As the drum is being emptied, a sample is taken from the sample bib. Waste water flow accumulates in the piping while the drum is emptied. When the drum is empty, Valve "B" is opened, Valve "A" is shut, Valve "C" is opened, and the process is repeated.

B) WHEN TIME REQUIRED TO FILL GRINDER PUMP TANK IS LESS THAN TIME REQUIRED TO EMPTY GRINDER PUMP TANK

Operation is similar to above but instead of allowing the waste water to accumulate in the piping while the grinder pump tank is being emptied, when Valve "C" is shut, Valve "D" is opened and the flow is collected in the centrifugal pump tank. When the centrifugal pump tank is full the flow is redirected to the grinder pump tank by closing Valve "D" and opening Valve "C".

FIGURE 6. SAMPLING SYSTEMS

Each system consisted of two drums, an "A", or grinder pump unit which was used to receive the flow, grind and blend the sample, read the flow volume and take the sample. The grinder pumps used had a pumping capacity of only 15 G.P.M., which was inadequate to keep up with peak flows, and so an additional tank called the "B" or centrifugal pump tank was also used as an overflow. When the sewage flow was greater than could be handled by the grinder pump, the operator diverted the flow to the centrifugal pump tank which measured the excess flow and pumped the sewage to the ship's holding tank. The centrifugal pumps used have a pumping capacity of approximately 100 G.P.M.

c. Analytical Procedures

All analyses (with the exception of pH) were performed in the laboratories of the H2M Corp. in Melville, New York. These laboratories are registered by the State of New York for the analysis of water and waste water and are under the direction of Samuel C. McLendon, P.E. The laboratories are also registered in the States of New Jersey and Connecticut, and they participate in Connecticut and Federal EPA quality assurance programs.

The only exception, pH, was measured on the ships immediately after collection. This was done to avoid false readings due to changes in pH that occur during storage.

Flow diagrams for the analytical procedures are shown in Figures 7, 8, 9 and 10.

d. Collection and Preservation

Samples were collected from spigots on the discharge lines of the sampling systems. As described in Figures 7, 8, and 9 the waste water is passed through the macerator/grinder pump several times during at least three minutes recirculation. and sampling occurs as the blended material is discharged from the sampling system into the ship's holding tank (or overboard discharge). Samples taken were "midstream" flow, i.e., neither the very beginning nor the very end of the flow was sampled.

Three types of sample containers were used:

- a. One (1) Quart "Cubetainers". These are collapsible, polyethylene cubes, with a self-gasket polyethylene screw-cap closure. These were used for the pH, MBAS, suspended solids, total solids, and BOD samples.
- b. One (1) quart glass bottles, with screw cap closure were used for the oil and grease samples.
- c. 125 ml. polyethylene bottles, with a self-gasket polyethylene screw-cap closure were used for the COD and hardness samples.

The samples contained in "b" and "c" above were immediately acidified after collection with sufficient concentrated sulfuric acid to establish a pH of less than 2.0, as indicated by pHydrion

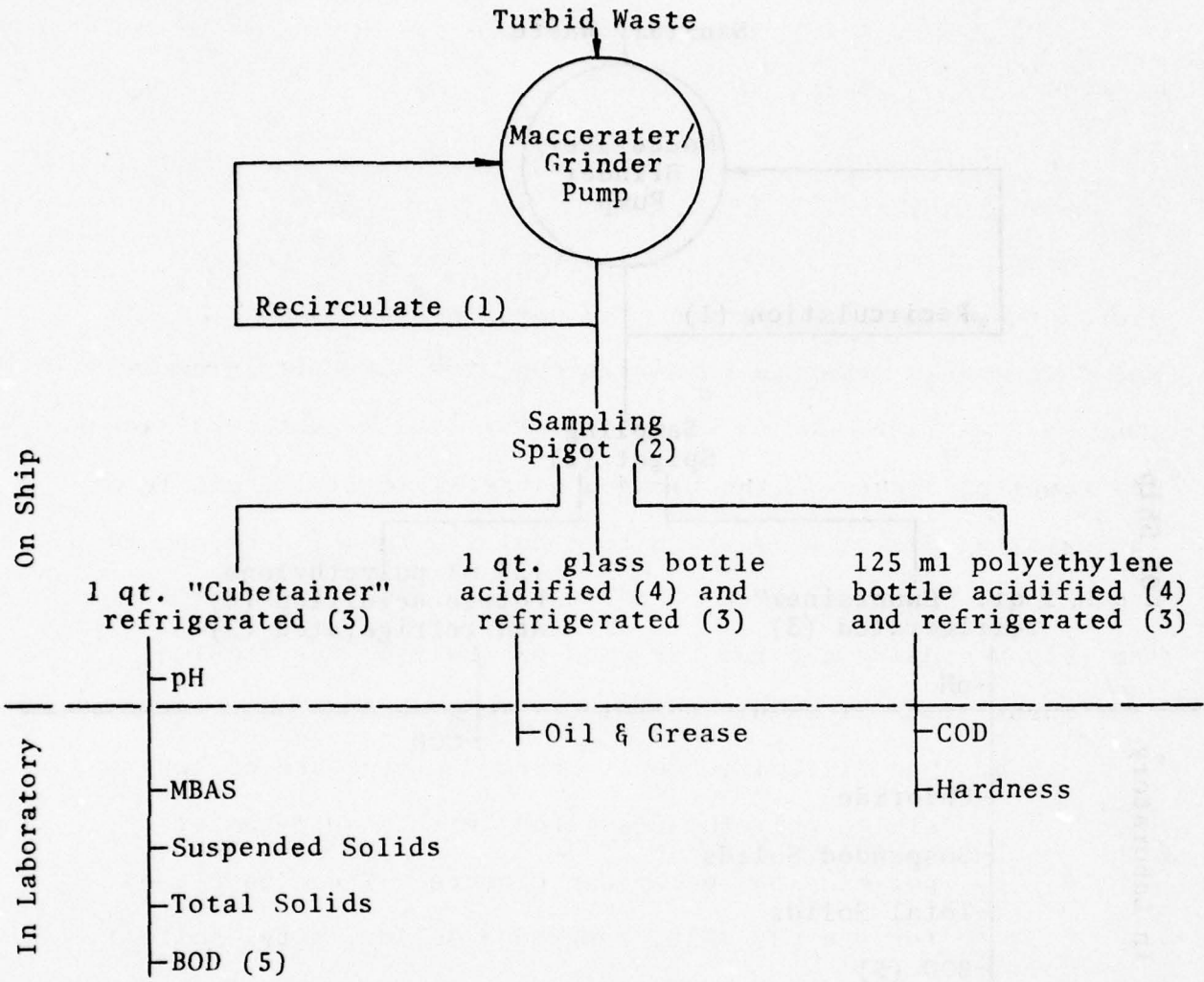

NOTES:

- (1) Recirculation for a minimum of three minutes to blend samples.
- (2) Sample taken while waste water is being transferred to ship's holding tank.
- (3) Containers surrounded by crushed ice and packed in insulated boxes.
- (4) Contents made acid with concentrated H₂SO₄ to a pH of less than 2, as indicated by pHDrion paper.
- (5) BOD done on moored samples only and inoculated within six hours.

Figure 7 . Sample Flow Diagram, Turbid Waste.

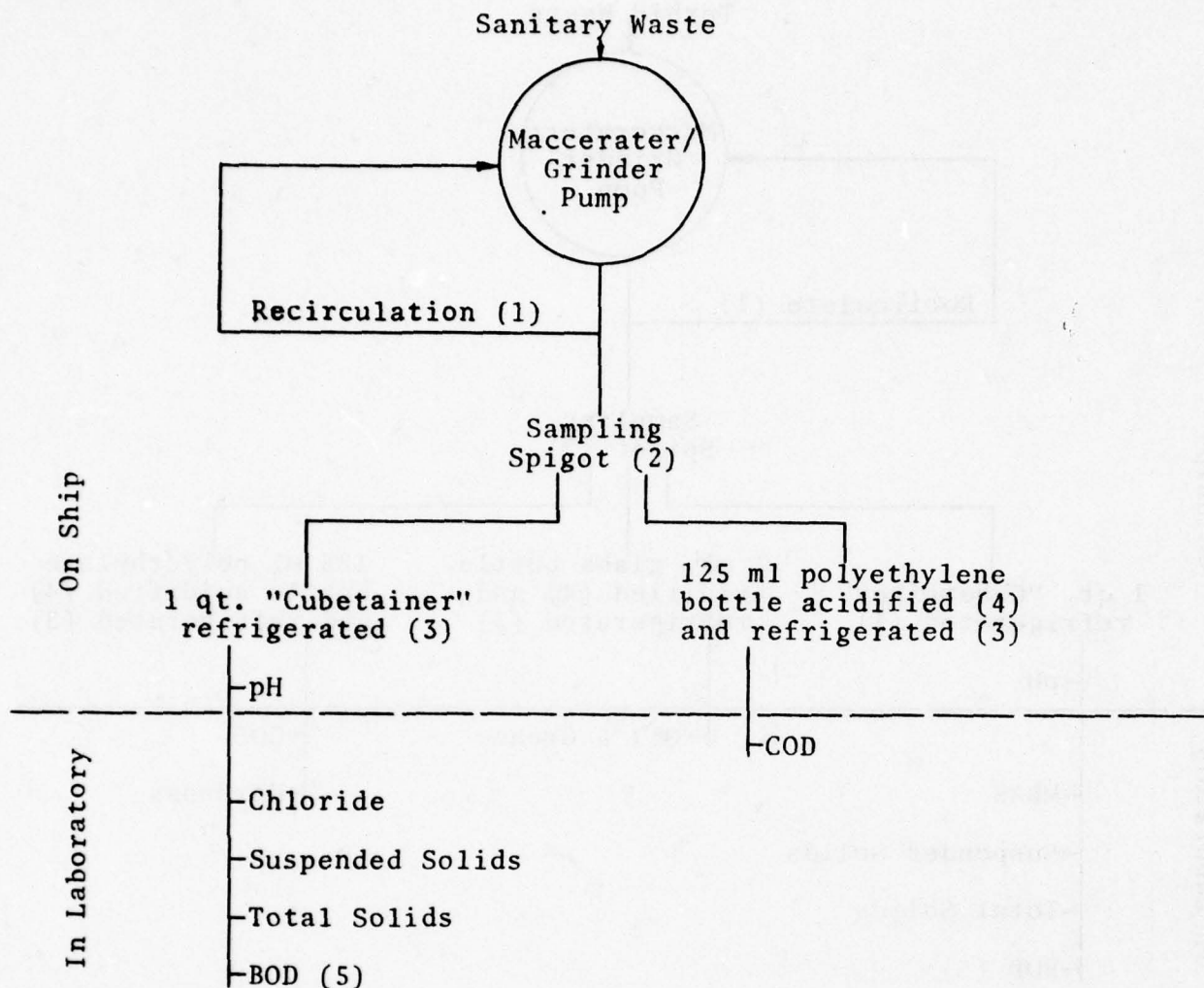

NOTES:

- (1) Recirculation for a minimum of three minutes to blend sample.
- (2) Sample taken while waste water is being transferred to ship's holding tank.
- (3) Containers surrounded by crushed ice and packed in insulated boxes.
- (4) Contents made acid with concentrated H_2SO_4 to a pH of less than 2, as indicated by pHyrion paper.
- (5) BOD done on moored samples only and inoculated within six hours.

Figure 8. Sample Flow Diagram, Sanitary Waste.

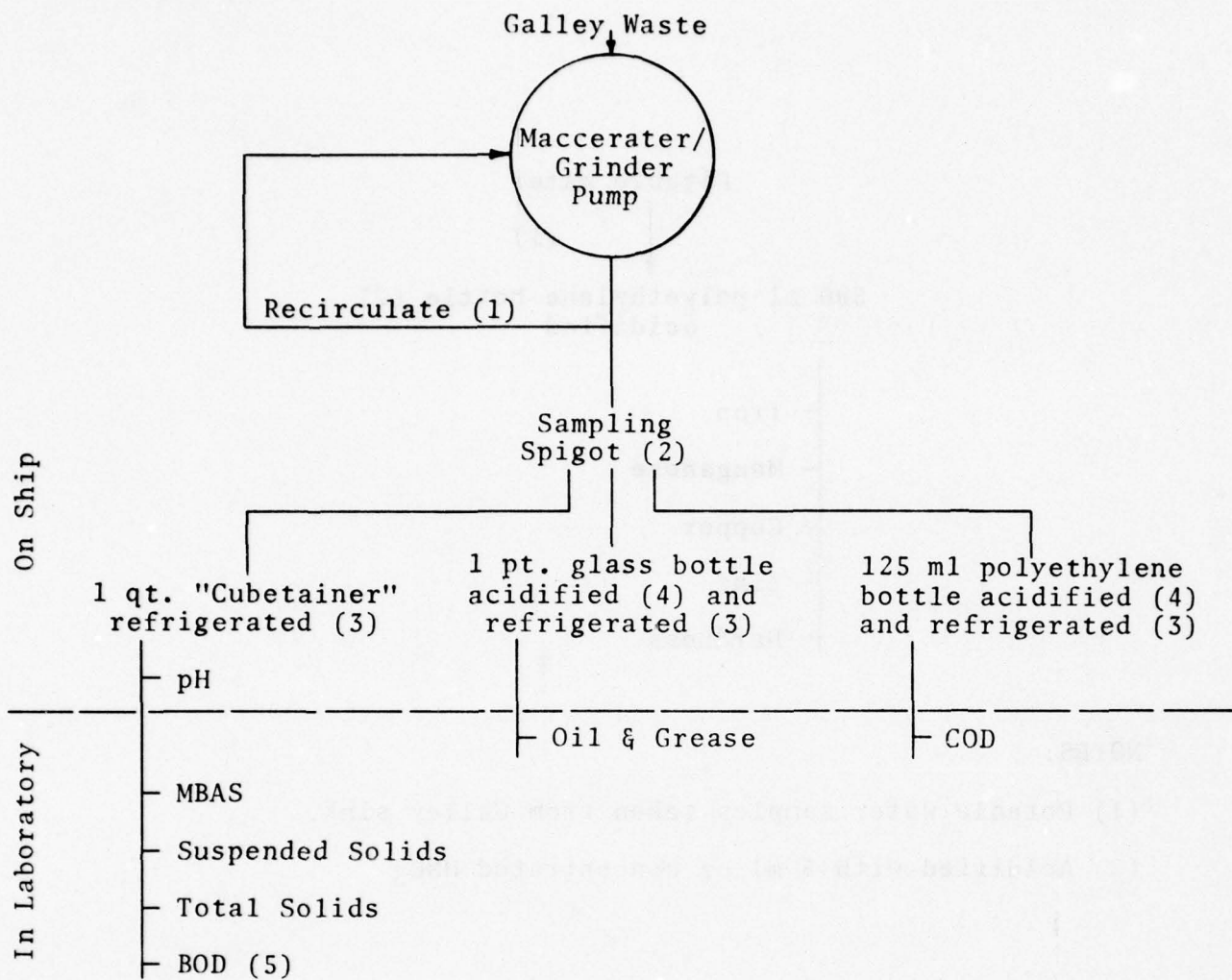

NOTES:

- (1) Recirculation for a minimum of three minutes to blend samples.
- (2) Sample taken while waste water is being transferred to ship's holding tank.
- (3) Containers surrounded by crushed ice and packed in insulated boxes.
- (4) Contents made acid with concentrated H_2SO_4 to a pH of less than 2, as indicated by pHDrion paper.
- (5) BOD done on moored samples only and inoculated within six hours.

Figure 9. Sample Flow Diagram, Galley Waste.

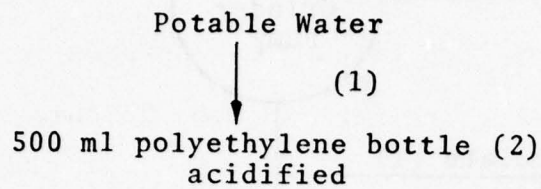

- Iron
- Manganese
- Copper
- Zinc
- Hardness

NOTES:

(1) Potable water samples taken from Galley sink.

(2) Acidified with 5 ml of concentrated HNO_3 .

Figure 10. Sample Flow Diagram, Potable Water.

test paper. Numbers 305 and 315 pHdrion paper were used; the former has a pH range from 0.0 to 3.0 and the latter covers 1.0 to 2.5.

All samples containers were packed in crushed ice in styro-foam insulated containers (common "picnic cooler" type).

e. Transportation

Moored samples from the POINT HERRON at Fire Island, Long Island, New York, and from the GALLATIN and FIREBUSH, at Governors Island, New York City, were transported to the laboratory in H2M vehicles several times a day. Moored samples from the VIGOROUS at the Coast Guard Academy in New London, Connecticut and from the WHITE SAGE at Woods Hole, Massachusetts, were flown to the laboratory by the H2M airplane.

Underway samples were returned to the laboratory by the above means immediately upon arrival of the ship at its dock.

f. Analysis

All analyses, with the exception of COD, were performed in accordance with the procedures of "Standard Methods for the Examination of Water and Waste Water", 13th edition (Ref.), shown in Table 2.

The only determination that was done on the ship was pH. It was performed immediately after taking the sample to avoid changes which might occur during storage.

BOD bottles were incubated for five days at 20°C. Be-

TABLE 2

METHODS OF ANALYSIS OF WASTEWATER SAMPLES

<u>Constituent</u>	<u>Standard Methods Section No.</u>	<u>Remarks</u>
Hardness	122A	Calculation method. Ca & Mg determined by flame spectrophotometry (Perkin-Elmer Model 305).
Surfactants (MBAS)	159A	Methylene blue-active substance method.
Total Solids	224A	
Suspended Solids	224C	
BOD-5	219	Oxygen determinations by membrane electrode method (Yellow Springs Instrument Co. Models 51A and 51B).
pH	144A	Glas electrode method (Beckman pHistol" and Perkin-Elmer Model 85A)
Chlorides	112A	Argentometric Method
Oil and Grease	209A	Soxhlet Extraction Method
COD	220	

tween four and six strengths of each sample were incubated, the number being a function of the technicians judgment of the appearance of the sample, based upon prior experience. The ranges of dilution strengths for sanitary and galley waste was 0.1%, 0.2%, 0.5%, 1%, 2%, and 5%. One galley sample, which was milky white, was incubated at a 0.01% dilution also. The range of turbid water dilutions were 1%, 2%, 5%, 10%, and 20%.

All BOD's were incubated at the H2M laboratory except those of the WHITE SAGE. Logistically, it would have been difficult to guarantee timely delivery of the samples to the laboratory as the Falmouth Airport is not suitable for instrument operation. Instead, the samples were incubated locally in incubators provided by the Marine Biological Laboratory at Woods Hole.

g. Computational Methods

General

All computations and curve plotting were done on a Hewlett Packard 9821A X-Y plotter. Appendix B gives a listing of the programs used.

Initially all collected data for each parameter was collected into half hour time slots starting at 0000 and ending at 2330. Data collected at off time intervals were moved appropriately to the nearest half hour point. Since data collection for each parameter (dockside and underway) was done for several days, there were typically several data points for each parameter at each time. These data were reduced initially to mean, maximum and minimum values. All data were recorded as files on tape (cassette) including the average, maximum and minimum value for each parameter (dockside and underway), actual crew size data (in half hour increments) and appropriate identification data.

Water Flow Data

Water flow data for galley, turbid and sanitary effluents were computed and plotted for instantaneous and cumulative flows. The data for instantaneous flow was plotted to show the range of the data (maximum-minimum values) and the average value. The cumulative flow for each effluent was plotted using the relationship

$$Y_{\text{cum}} = \sum_{i=1}^k y_i$$

where Y is the total cumulative flow, y is the instantaneous flow and the summary parameter i covers all time intervals. These cumulative flow data were plotted for the maximum mean and minimum values. A straight line connecting the origin and the cumulative average daily total was also plotted on these curves. The cumulative average daily flow was divided by 24 to obtain the flow in gallons/hour. In addition, the sum

$$Y_{\text{cum/man}} = \sum_{i=1}^k \frac{y_i}{N_i}$$

where Y cum/man is the total cumulative flow per man, y_i and i are as defined before and N_i is the instantaneous number of men aboard at each data point. Flow data for instantaneous and cumulative calculations and plotting were also normalized for full crew. This was done by multiplying each data point by the normalizing factor R_i where:

$$R_i = \frac{\text{Full crew}}{N_i}$$

Total flow (sanitary, alley and turbid) was calculated as described earlier in this paragraph using

$$Y_i = A_i + b_i + C_i$$

where A_i = sanitary flow, b_i = galley flow and C_i = turbid flow. Saltwater and fresh water flow data were obtained as differential readings from flow-meters. Data for both flows were treated and plotted as described earlier in this paragraph.

Chemical Data

Instantaneous data on chemical parameters except pH,

(maximum, minimum and mean values) were plotted as mg/l (PPM) vs time as described earlier in this section for sanitary, galley and turbid flows. Average total loading, C_{tot} were calculated as:

$$C_{tot} = \sum_{i=1}^N C_i$$

where C_i is the instantaneous average value of the chemical parameter and the total loading in lbs/day were calculated as:

$$C_{tot} \times 8.34 \times 10^6 \times \text{Flow}$$

where Flow is the average flow per day for the particular effluent under consideration. Average loading/man-day were calculated by using

$$C'_{tot} = \sum_{i=1}^N \frac{C_i}{N}$$

in the equation above.

The pH was plotted as pH vs time. The average (maximum, minimum and average) daily pH was calculated and reached for each effluent.

The possible relationships between BOD and COD and BOD and suspended solids was examined by regression analysis. BOD vs COD and BOD vs suspended solids for each effluent plotted (GALLATIN data only) and the best regression line was drawn using the relationship:

$$y = aX + b$$

where y is BOD, X is either COD or suspended solids and a and b are the slope and intercept of the regression line. The coefficients were calculated using the relationship.

$$a = \frac{\sum x_i y_i - \frac{\sum x_i \sum y_i}{N}}{\sum x_i^2 - \frac{(\sum x_i)^2}{N}}$$

$$\text{and } b = \bar{y} - a_1 \bar{X}$$

where $\bar{y} = \frac{\sum y_i}{N}$ and $\bar{X} = \frac{\sum x_i}{N}$ and where x_i and y_i are as defined above and N_i is the total number of data points.

The correlation coefficients (r^2) were calculated as

$$r^2 = \frac{\left[\sum x_i y_i - \frac{\sum x_i \sum y_i}{N} \right]^2}{\left[\sum x_i^2 - \frac{(\sum x_i)^2}{N} \right] \left[\sum y_i^2 - \frac{(\sum y_i)^2}{N} \right]}$$

with x , y and N defined as above.

Statistical tests

The data accumulated for water flow from the sanitary, galley and turbid effluents were evaluated by comparison of daily outputs for a given ship to determine the reliability of the mean estimates. To do this, an analysis of variance (ANOVA) was done on individual regression lines formed for each day for each effluents. For a given effluent, the variances were evaluated by the standard F test for ANOVA using a linear model that compared the results within groups (stability of the regression for a daily effluent) and between groups (day to day for the same effluent under the same operating conditions). These statistics were calculated using full crew normalized data to suppress variations due to crew size.

h. Ship Sampling

Point Herron

Point Herron - Docked

The United States Coast Guard Cutter POINT HERRON is an 82 foot patrol boat with a full crew size of eight (8). Routine activity aboard the ship while docked is generally light, due to its small size and small number of crew. Because housing, recreational and office facilities are just a short walk away from the docks, few crew members actually live on board. Those that have berths on the ship spend few off-duty hours on board.

The crew normally reports to the ship in the morning, where work details are assigned or leaves are granted. Lunch is served at 1130 hours. Because lunch is the biggest meal of the day, most of the crew eat this meal on board if they are on base. The number of crewmen on board varies greatly throughout the day. Dinner is not served on board, but food is made available for those who want to prepare something for themselves. Most of the crew eat dinner on shore.

Sampling was begun at 1200 hours on March 24, 1975 and continued around the clock until 1200 hours March 26. During this 48 hour sampling period, the average number of crew on board was about 4. Nothing happened during this time to disturb the daily routine. The weather was generally wet and rainy.

Point Herron - Underway

Routine underway activities on board the POINT HERRON begin around 0730 hours when dishes from the previous afternoon and evening are washed in the galley. By 0930 hours most of the crew have reported to the ship and are preparing to get underway. The ship is generally underway with 6-8 personnel by 1030 hours, and a light lunch is served at 1130 hours.

Normal patrol is west along the Atlantic Coast from Jones Inlet. The ship returns to port after rounding Ambrose light unless it receives a distress call. Dinner is not normally served on board on days that the ship is underway.

Underway sampling began on June 21, 1975 at 2400 hours while the ship was docked. The POINT HERRON was underway by 0930 hours with five crewman, two H2M employees, and a Coast Guard observer. Around 1100 hours it was discovered that salt water was leaking from the hull to the turbid water collecting jug, thus diluting the sample with salt water. H2M tried but failed to completely shut-off the valve. The POINT HERRON received a distress call around 1500 hours, and conducted a search for the disabled craft. With the help of a Coast Guard helicopter, the boat was located, and tow lines placed by 2000 hours. Towing at only six (6) knots, the ship did not return to port until 0200 hours on June 22nd.

Because of the long previous night, the ship did not get underway again until 1230 hours on the 22nd, after a large

lunch at 1200 hours. The POINT HERRON returned to port by 1830 hours. Sampling was terminated at 2400 hours. The average number of crewmen on board during the 48 hour sampling period was about four (4).

Firebush

Firebush - Underway

The United States Coast Guard Buoy-Tender FIREBUSH is a 180 foot buoy-tender with a full crew size of 46. The ship normally docks at Governor's Island, New York. Routine underway activities start with reveille at 0630 hours, breakfast between 0700 and 0730 hours and the ship underway by 0800 hours. The crew of the FIREBUSH scraps, paints and replaces lights on harbor, sound and ocean bouys. Lunch is served at 1130 hours, and the ship generally returns to port around 1600 hours. Dinner is served at 1630 hours after which most of the crew go ashore.

Underway sampling was begun at 2100 hours on Sunday, November 2, 1975. The first day of sampling went very routinely as far as ships activity was concerned. On November 4th, the FIREBUSH did not return to Governor's Island. After placing a new bouy off Huntington, the ship anchored for the night about 20 miles off New London, Connecticut, in Long Island Sound.

Reveille was sounded at 0500 hours on November 5, and

breakfast was served from 0600 to 0800 hours. The ship docked at New London, Connecticut at 1100 hours due to rough seas. After lunch, 2 of the 3 duty sections went ashore. Underway sampling was terminated at 2100 hours.

Firebush - Docked

The United States Coast Guard Cutter FIREBUSH was docked at Governors Island, New York. Routine dockside activities begin at 0600 hours with reveille, and breakfast is served at 0700 hours. The crew performs normal ship maintenance such as painting, scraping rust, washing decks, maintaining ships engines and generators, etc. Lunch is served at 1130 hours, and dinner at 1630.

Dockside sampling began at 1230 hours on November 10, 1975. A failure in the saltwater holding system forced that system to be secured, but was back in operation by 1400 hours. The main deck was sprayed for roaches at 0430 of November 11. Flu shots were given to all crew members at 1245 of November 12. The crew size fluctuated greatly during the sampling period. Sampling ended at 1300 hours on November 14.

White Sage

White Sage - Underway

The United States Coast Guard Cutter WHITE SAGE is a 133 foot buoy tender that operates out of Woods Hole, Massa-

chusetts. Revielle is normally called at 0600 hours, and breakfast is served by 0700 hours. The ship is normally underway by 0715 hours. The WHITE SAGE replaces, scrapes, paints and generally maintains navigational buoys. Lunch is served at 1130 hours, and dinner at 1630 hours. The ship usually docks at 1930 hours. Most of the 21 man crew go ashore during evening hours, and return in the morning.

Underway sampling began at 0715 on Monday, August 11, 1975. After a day of routine buoy tending, the ship docked at Bristol, Rhode Island, at 1945 hours. The ship left Bristol with 22 crewman at 0710 and did not return to that port until 2045 hours. At 0700 hours, the WHITE SAGE left Bristol to tend some buoys and return to Woods Hole, where it docked at 1845 hours. Most of the crew went ashore, leaving only eight (8) on board. Underway sampling ended at 0730 on August 14, 1975.

White Sage - Docked

Docked at Woods Hole, Massachusetts, routine activities on board the WHITE SAGE consist of general repairs and cleaning, such as washing the decks, sanding and painting, engine overhaul, etc. Reveille is called at 0600, breakfast is served at 0700, and dinner at 1630 hours. The number of crewmen on board varies throughout the day, but many are on leave while the ship is docked.

Dockside sampling began at 0800 hours on Thursday,

August 14, 1975. The WHITE SAGE was to be underway that day; but underway plans were cancelled due to bad weather. The crew size averaged from 6 to 10 at night and 13 to 19 during the day. Only seven (7) crewmen were present all day Saturday because most of the crew were on weekend leave. Dinner was served later than usual at 1900 hours. There was little ships' activity on Sunday. Breakfast was served at 1000 hours and dinner at 1835 hours. Dockside sampling was terminated at 0300 hours on Monday, August 18.

Vigorous

Vigorous - Underway

The United States Coast Guard Cutter VIGOROUS is a medium endurance 210 foot cutter, with a full crew size of 60. Its underway duties are to patrol the north Atlantic Coast. A routine day starts with reveille at 0645 hours. Breakfast is served at 0700 hours, lunch at 1130 hours, and dinner at 1630 hours.

Underway sampling was begun at 1330 hours on October 6, 1975, while the VIGOROUS was docked in Halifax, Nova Scotia. The entire crew ate and slept on board while in port. At 0800 hours, the ship was underway, and at 0940 hours the clocks were adjusted an hour to account for the change in time zones.

The VIGOROUS was met by 10 foot seas and 25 knot winds after leaving the harbor. Sampling was discontinued at 1930 hours because about 50 per cent of the ship's crew were seasick.

By 0400 hours on Wednesday, October 8, the seas had calmed to four (4) feet, and sampling was resumed at 0500 hours. The ship docked at the United States Coast Guard Academy in New London, Connecticut at 1510. Many of the crew left the ship at 1530 hours on liberty. Sampling was terminated at 1530 hours.

Vigorous - Docked

The United States Coast Guard Cutter VIGOROUS is normally docked at the Coast Guard Academy in New London, Connecticut. Routine dockside activities consist of general cleanup, engine overhaul, sanding and painting, meetings of crew details and instructions on Coast Guard procedures. Reveille is called at 0645 hours. Breakfast is served at 0700 hours, lunch at 1130 hours and dinner at 1630 hours. A ship coffee break is piped at 1000 hours. The crew size varies from around 9 to 47.

When dockside sampling began at 1300 hours on October 20, 1975, there was 41 crew members on board. At 1600 hours it was discovered that the sanitary pipe was clogged. The sanitary system was shut down for four hours until the clog could be located and cleared. By 2000 hours the number of crewmen on board was nine (9). By 0700 the following morning the crew size had grown to 47. Sampling and ships activity continued routinely until 2200 hours, when the check valves in the sani-

tary "B" tank was found to be clogged, slowly leaking sewage back into the tank. Repairs were made and the tank was put back in operation by 2330 hours. At 0600 hours on October 22nd, 19 crew members were on board. But by 0700 hours there were 42 crewmen.

Ships activity remained routine, with crew size averaging 19 in the evening and 41 in the morning, until the ship got underway to refuel at Groton. The VIGOROUS left New London at 0825 with a crew size of 58. Drills were run while underway. The ship docked at Groton around 0900 hours. Dockside sampling ended at 1300 hours October 24th, before the ship left Groton.

Gallatin

Gallatin - Underway

The United States Coast Guard Cutter GALLATIN, the largest of the Coast Guard ships, is a 387 foot high endurance cutter with a full crew size of 160. Its function is to patrol the mid Atlantic Coast, but the primary purpose of this particular voyage was to check out systems installed or renovated in the Curtis Bay Ship Yard. Reveille is normally piped at 0630 hours. Breakfast is served at 0700 hours, lunch at 1130 hours and dinner at 1600 hours.

Underway sampling began at 0830 hours on September 3rd. The crew size at this time was 148. At 1000 hours the GALLATIN got underway and cruised from Curtis Bay, Maryland into

the Chesapeake. Sea drills were run from 1330 to 1530 hours. The ship cruised all night from Norfolk Operations Base. At 1130 hours the ship docked at Norfolk to take on lubricating oil. The GALLATIN was back underway by 1330 hours for New York. The crew stood routine watches until 2000 hours, when a series of speed trials and engine, turbine and electronics tests were conducted. Routine cruise activities were resumed at 0200 hours on September 5th. The ship docked at Governors Island, New York, at 1400 hours. Underway sampling ended when the crew was granted liberty at 1505 hours.

Gallatin - Docked

The United States Coast Guard Cutter GALLATIN was moored at Governors Island, New York. Routine dockside activities involve systems maintenance, cleaning, sanding and painting. Reveille is piped at 0630 hours. Breakfast is served at 0700 hours, coffee break is piped at 1000 hours and lunch and dinner are served at 1130 and 1630 hours, respectively. The crew size fluctuates greatly throughout the day, depending on the activities and the number on liberty.

Dockside sampling began at 1200 hours on Sunday, September 21st. Because most of the crew were ashore, there was little on-board activity. Only 33 crewmen were on-board, including H2M personnel. At 0730 on Monday, September 22, a general muster of the crew was called, gathering about 139

personnel. At 1015 there was an overflow of the galley sampling system and a blockage in the sanitary piping. The sanitary sampling system had to be shut down for 45 minutes while the blockage was located and removed. About 1000 gallons of saltwater was flushed through the fire fighting system in the afternoon. Liberty was granted at 1600 hours. H2M personnel noticed a slow but steady inflow of water into the sanitary collection system, indicating a possible leaky head. After notifying the chief engineer, the leaky head was located and removed from service by 2100 hours.

On September 23rd, the crews work day ended after lunch. The rest of the day passed routinely. A party was held onshore for all crew members at 1230 of September 24th. All but one duty section went ashore. Lunch was served on paper plates with plastic utensils, so that dishwashing would be minimal. The crew reported that 450 gallons of water were flushed through the fire fighting system. Around 1200 gallons of water went through the sanitary system between 1905 and 1945 hours, due to a stuck flush arm on one of the toilets. At 0755 of September 25th, a fuse was blown in the forward sewage ejection room. The ship's own holding tank had to be opened until power was restored 15 minutes later. Sampling was ended at 1200 hours on September 25th.

3. RESULTS

The results of this program are presented in three different formats.

1. Analytical data. The results of the chemical analyses are compiled on laboratory report forms, and presented in Appendix C.
2. Graphic Analysis. Computer drawn graphs of each test condition appear in the following text.* These graphs are always arranged in the same order on a page:

POINT HERRON	
WHITE SAGE	FIREBUSH
VIGOROUS	GALLATIN

3. Tabulated data. Data extracted from the computer analysis are tabulated in the Discussion Section.

a. Crew Size

Dockside crew size was derived from logs of personnel boarding or leaving the ship, so that the number of men on board during each half-hour segment of the 24 hour time period was averaged during the four days of dockside sampling to obtain the average crew size as a function of time. This produced the crew size curves shown in Figure 11.

* Sampling period for WHITE SAGE underway should read 14-17 Aug.

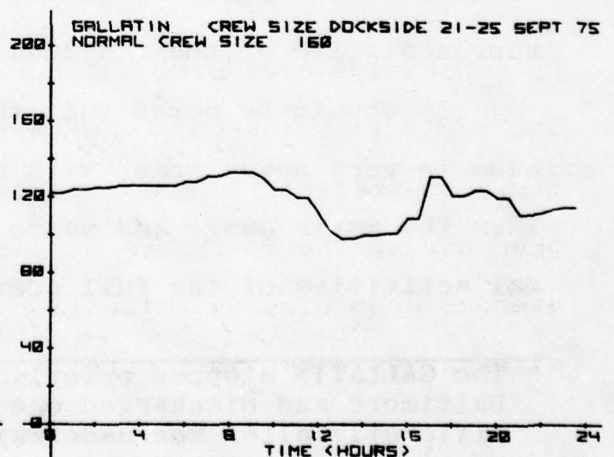
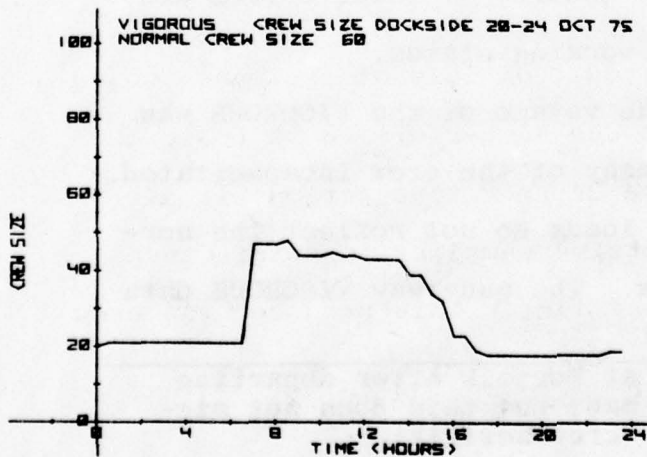
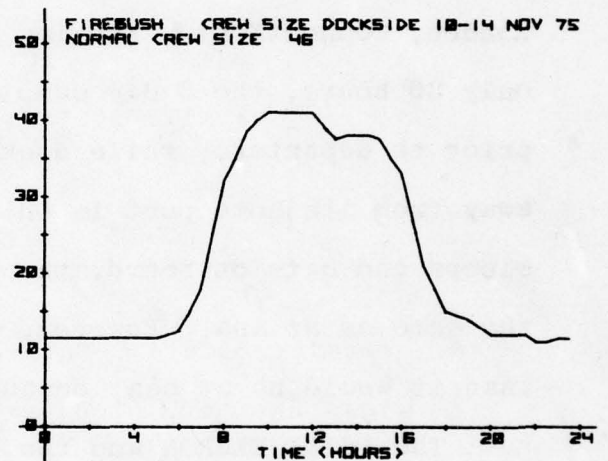
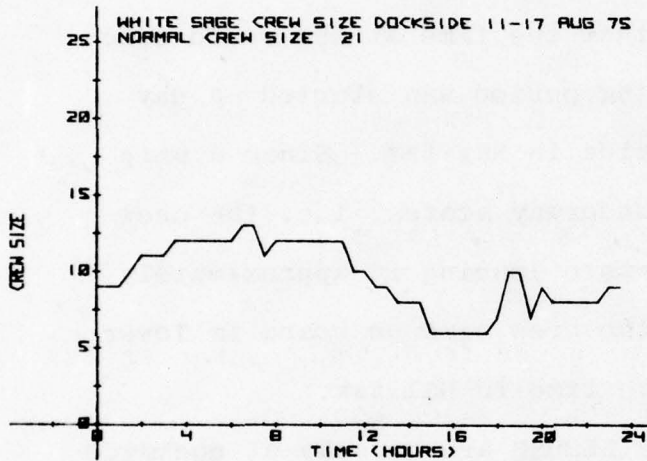
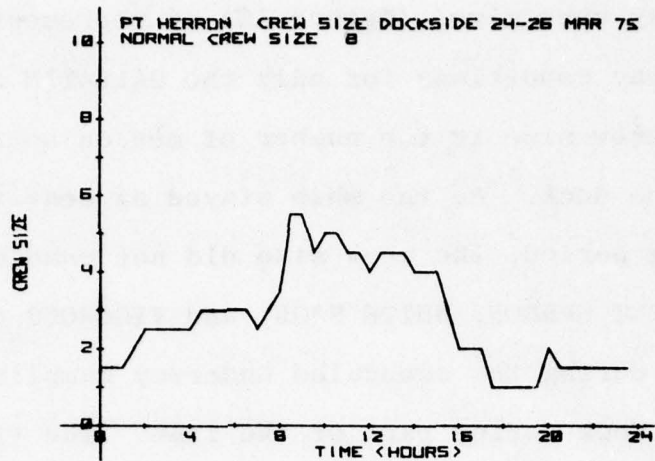

FIGURE 11. DOCKSIDE CREW SIZE

Underway crew size, (Figure 12) is representative of truly underway conditions for only the GALLATIN and WHITE SAGE. The crew size is the number of men on board when the ship left the dock. As the ship stayed at sea* throughout the sampling period, the crew size did not change.

The POINT HERRON, WHITE SAGE, and VIGOROUS did not remain at sea during the scheduled underway sampling dates, but were at the dock during part of the itme. The VIGOROUS underway was sampled on a voyage from Halifax, Nova Scotia, to New London, Connecticut. Knowing that the time at sea would take only 36 hours, the 3 day sampling period was started a day prior to departure, while dockside in Halifax. Since a ship away from its home port is on underway status, i.e. the crew sleeps and eats on board, the waste loading is approximately the same as at sea. However, the crew size on board is lower than it would be at sea, because time in Halifax.

The POINT HERRON and the FIREBUSH are usually at dockside at night, with part of the crew ashore, so these curves are representative of their actual working status.

It should be noted that the voyage of the VIGOROUS was made in very heavy seas, with many of the crew incapacitated. Thus the water usage and waste loads do not reflect the normal activities of the full crew. The underway VIGOROUS data

* The GALLATIN stopped briefly at Norfolk after departing Baltimore and discharged one man, but this does not significantly alter the underway crew activities.

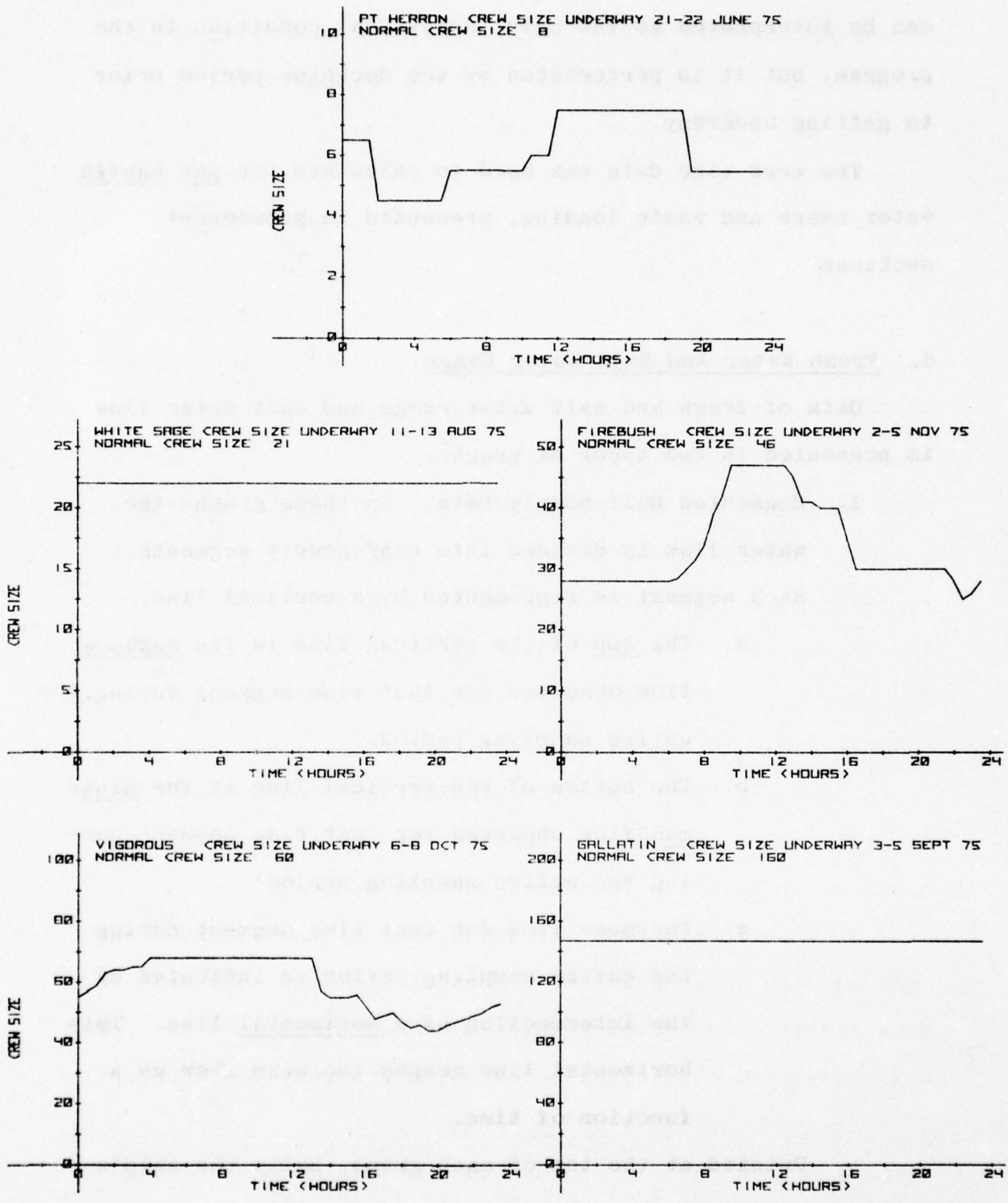

FIGURE 12. UNDERWAY CREW SIZE

can be interpreted as the only "Heavy Sea" condition in the program, but it is perturbed by the dockside period prior to getting underway.

The crew size data was used to calculate the per capita water usage and waste loading, presented in subsequent sections.

d. Fresh Water and Salt Water Usage

Data of fresh and salt water usage and salt water flow is presented in two types of graphs:

1. Segmented Half-hourly Data. On these graphs the water flow is divided into half-hourly segments. Each segment is represented by a vertical line.
 - a. The top of the vertical line is the maximum flow observed for that time segment during the entire sampling period.
 - b. The bottom of the vertical line is the minimum flow observed for that time segment during the entire sampling period.
 - c. The mean flow for that time segment during the entire sampling period is indicated by the intersection of a horizontal line. This horizontal line graphs the mean flow as a function of time.

Printed at the top of each graph, below the ship's

name, condition, and sampling dates, are two items of calculated data.

- a. The average total flow, expressed in gallons per hour (gal/hr), is the average flow for the entire time period, obtained by numerical integration of the area below the mean line divided by 24.
 - b. The average flow is expressed in gallons per day (note that the computer print-out reads gal/man-day). It should be gal/man/day. This was obtained by dividing the mean flow for each half-hour segment by the crew size for the corresponding half-hour segment, and averaging the resulting 48 numbers.
2. Cumulative Half-hour Data. On these graphs the flow during each half-hour segment is added to the previous half-hour segment, to produce a cumulative record of flow from midnight to midnight. There are three sets of dotted lines, and a straight solid line.
- a. The top set of dotted lines is the cumulative sum of the maximum flow points plotted on the segmented graph.
 - b. The bottom set of dotted lines is the cumulative sum of the minimum flow points plotted on the segmented graph.
 - c. The middle set of dotted line is the cumula-

tive sum of the mean points plotted on the segmented graph.

- d. The solid line is merely a linear extrapolation from zero to the last (2400 hr) mean point. This was done solely to aid in visualizing average cumulative flow over 24 hours. Initially a best fit straight line was plotted by linear regression, but as this line frequently intersected the X axis and continued into negative numbers, it was difficult to comprehend in a practical sense.

Water usage data is plotted for all ships except the POINT HERRON. This ship did not have a meter on the potable water supply, and therefore, there is no fresh water flow data. Similarly, the total salt water flow could not be segregated.

The eight sets of graphs that comprise this water usage section are keyed in the following matrix:

	Dockside	Underway
Fresh Water		
Segmented	Figure 13	Figure 14
Cumulative	Figure 15	Figure 16
Salt Water		
Segmented	Figure 17	Figure 18
Cumulative	Figure 19	Figure 20

POINT HERRON NOT MEASURED

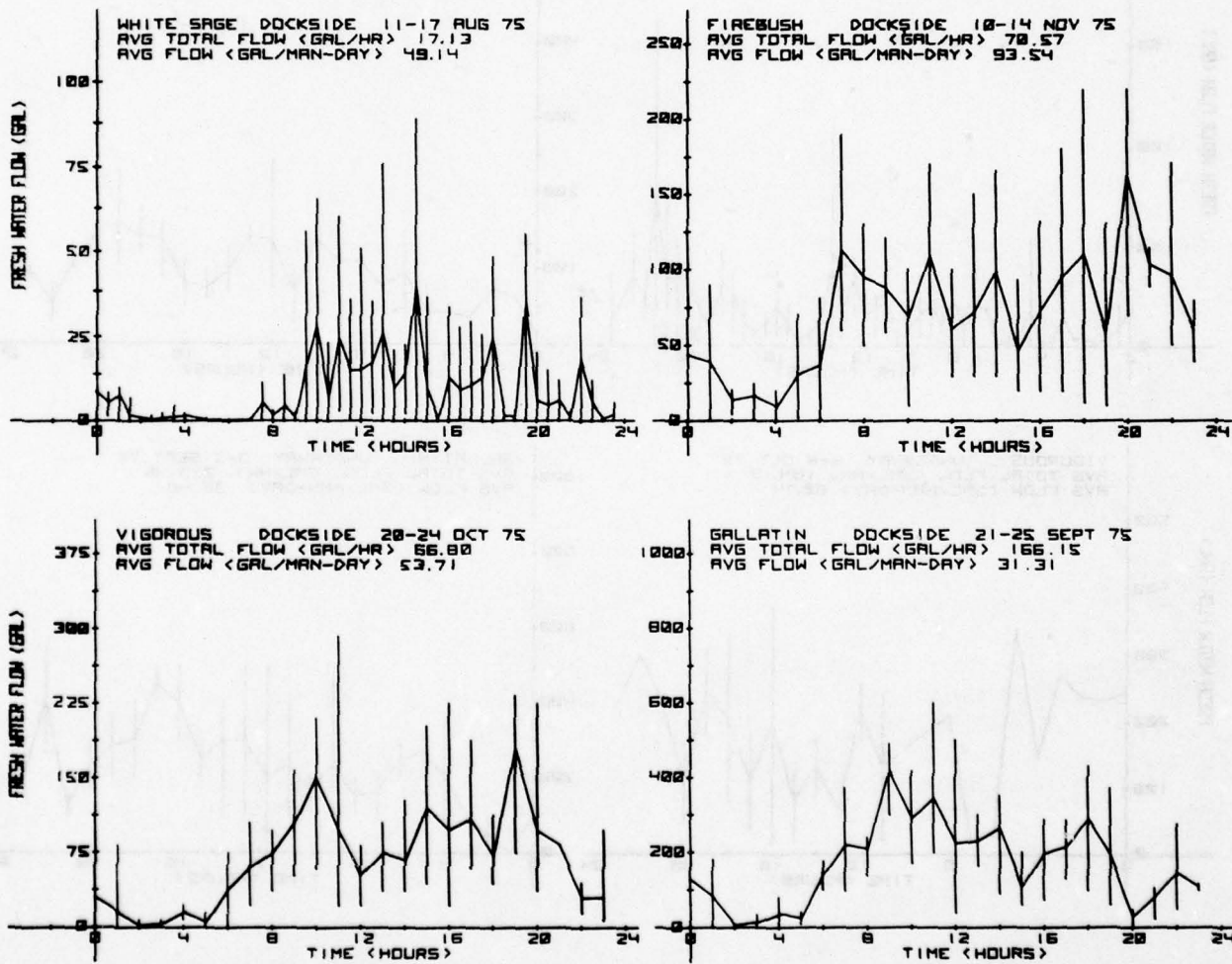

FIGURE 13. DOCKSIDE SEGMENTED FRESH WATER USAGE

POINT HERRON NOT MEASURED

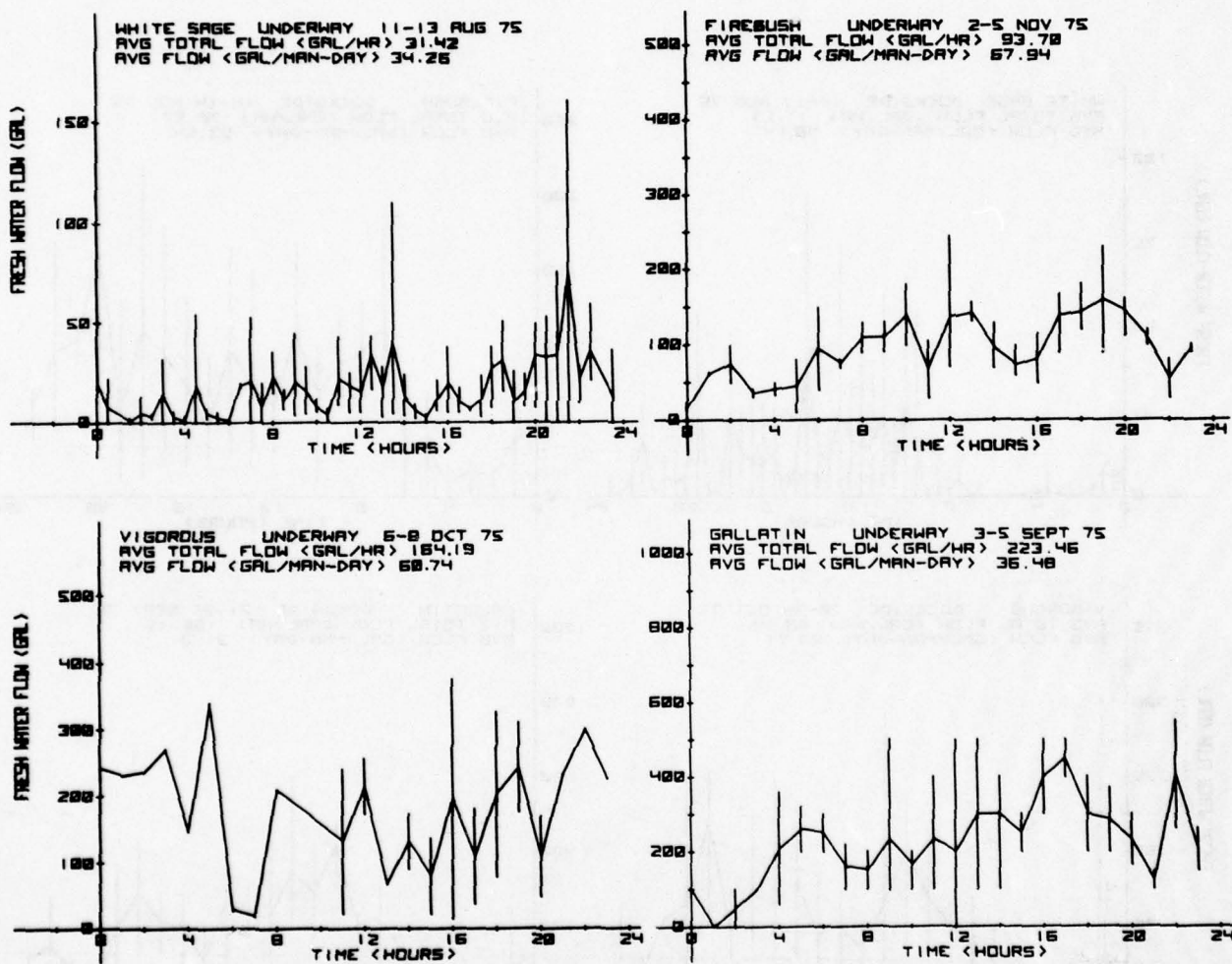

FIGURE 14. UNDERWAY SEGMENTED FRESH WATER USAGE

POINT HERRON NOT MEASURED

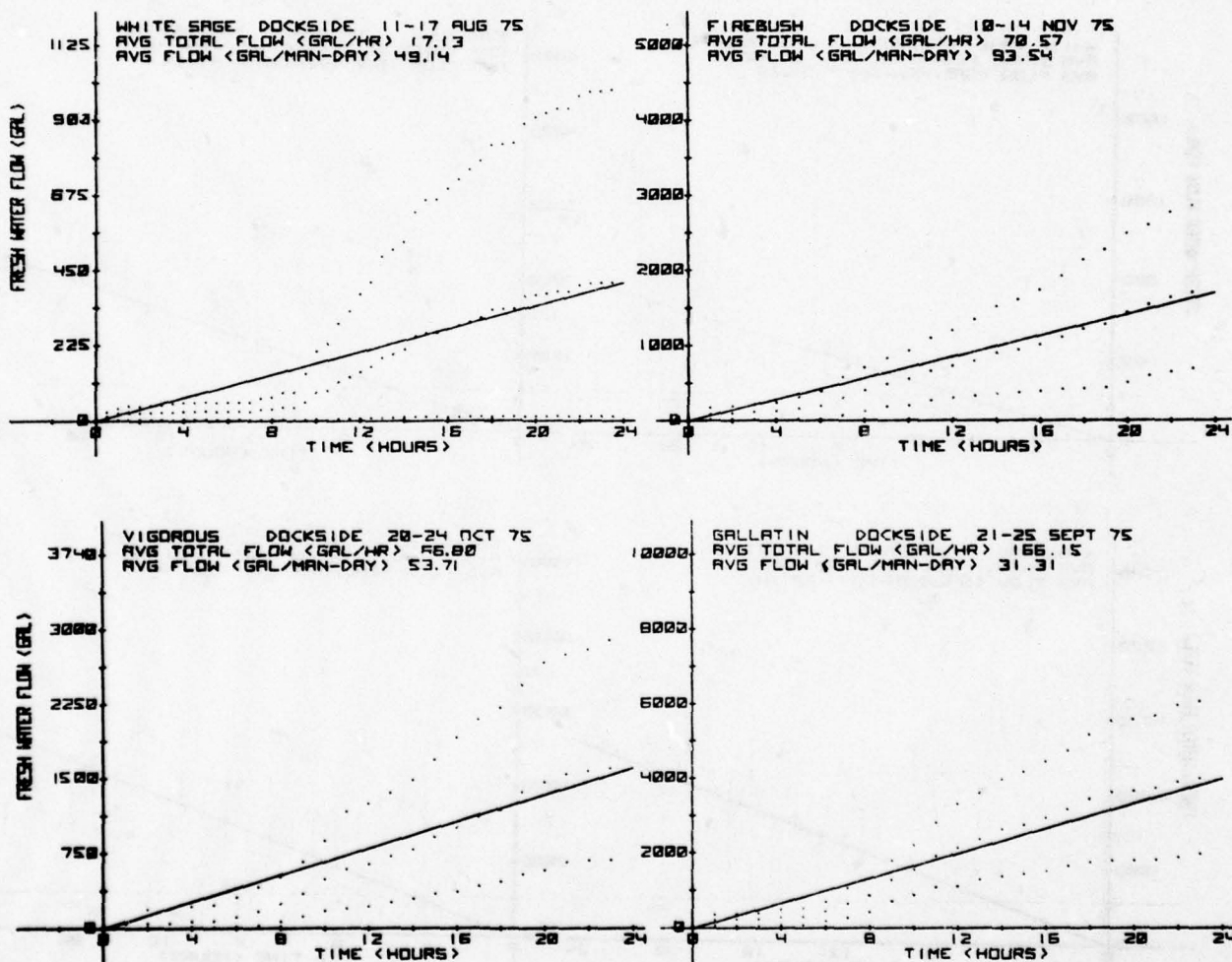

FIGURE 15. DOCKSIDE CUMULATIVE FRESH WATER USAGE

POINT HERRON NOT MEASURED

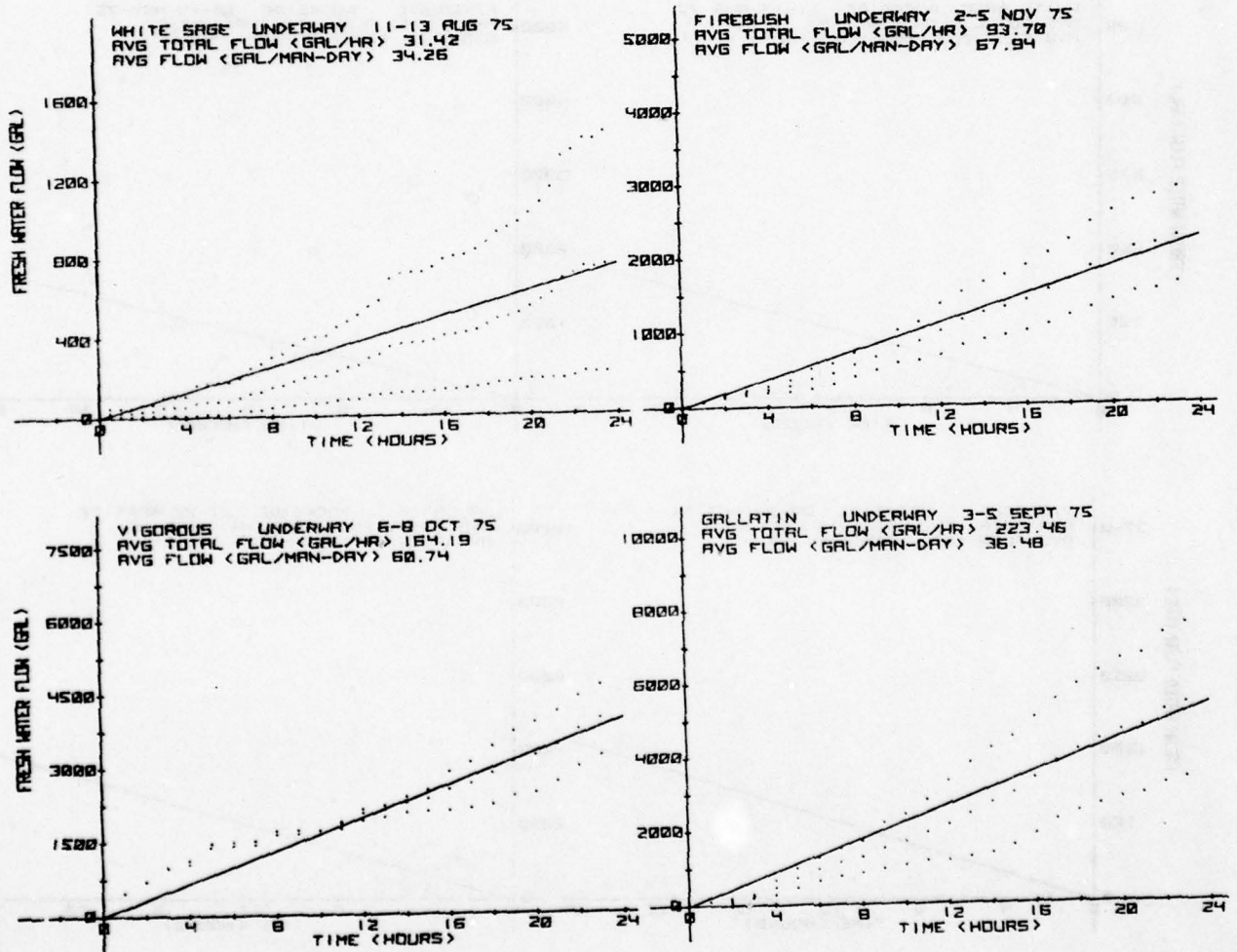

FIGURE 16. UNDERWAY CUMULATIVE FRESH WATER USAGE

POINT HERRON NOT MEASURED

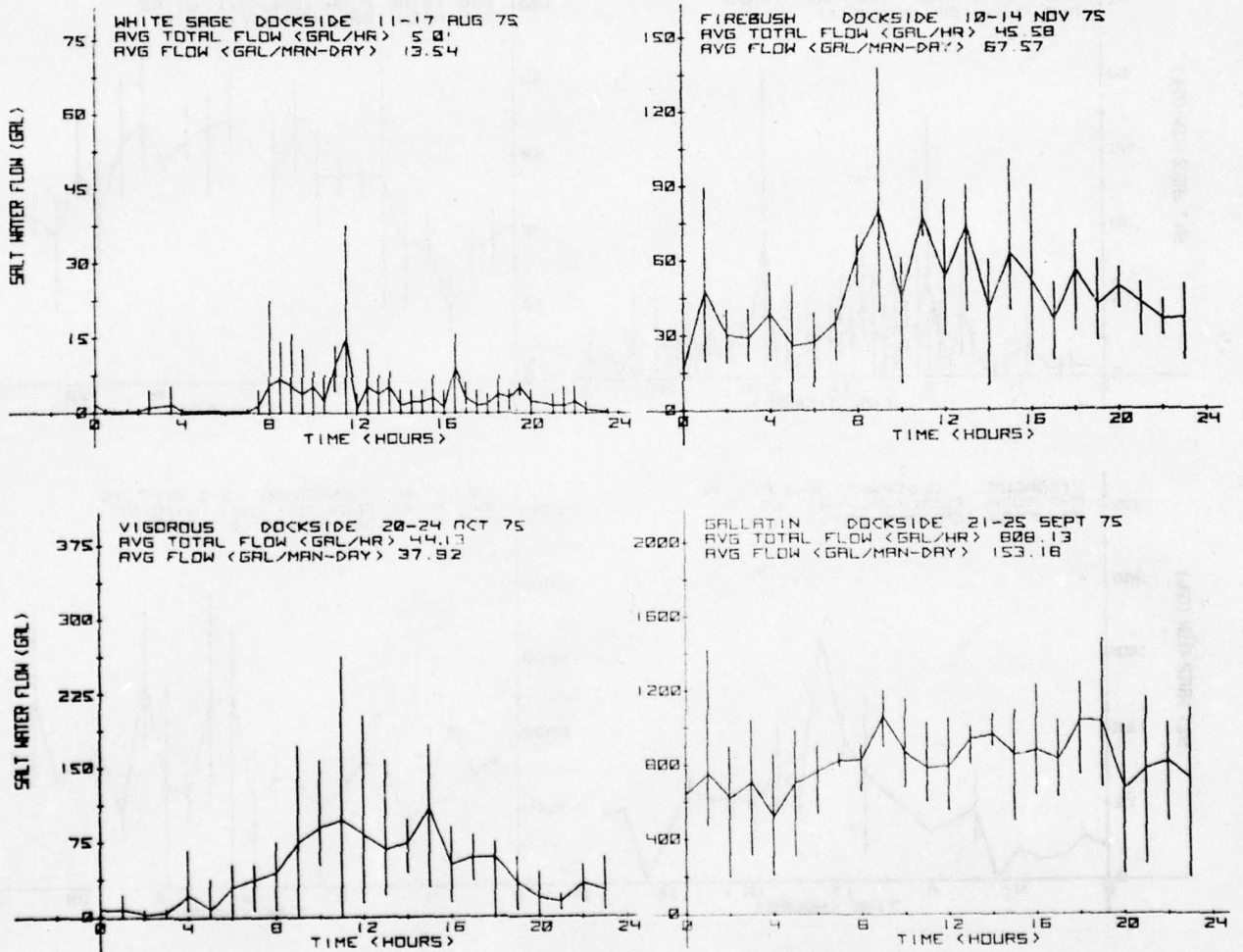

FIGURE 17. DOCKSIDE SEGMENTED SALT WATER USAGE

POINT HERRON NOT MEASURED

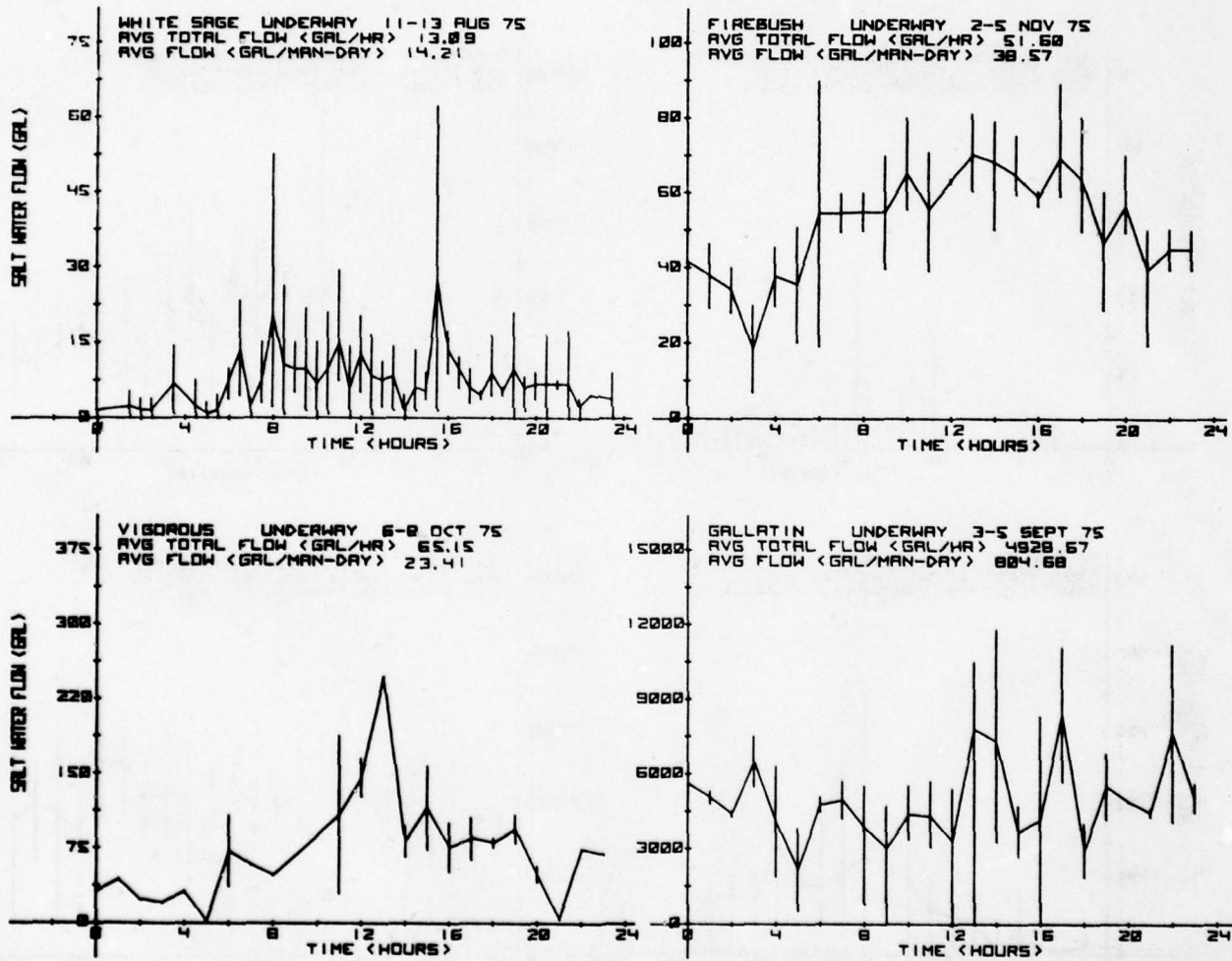

FIGURE 18. UNDERWAY SEGMENTED SALT WATER USAGE

POINT HERRON NOT MEASURED

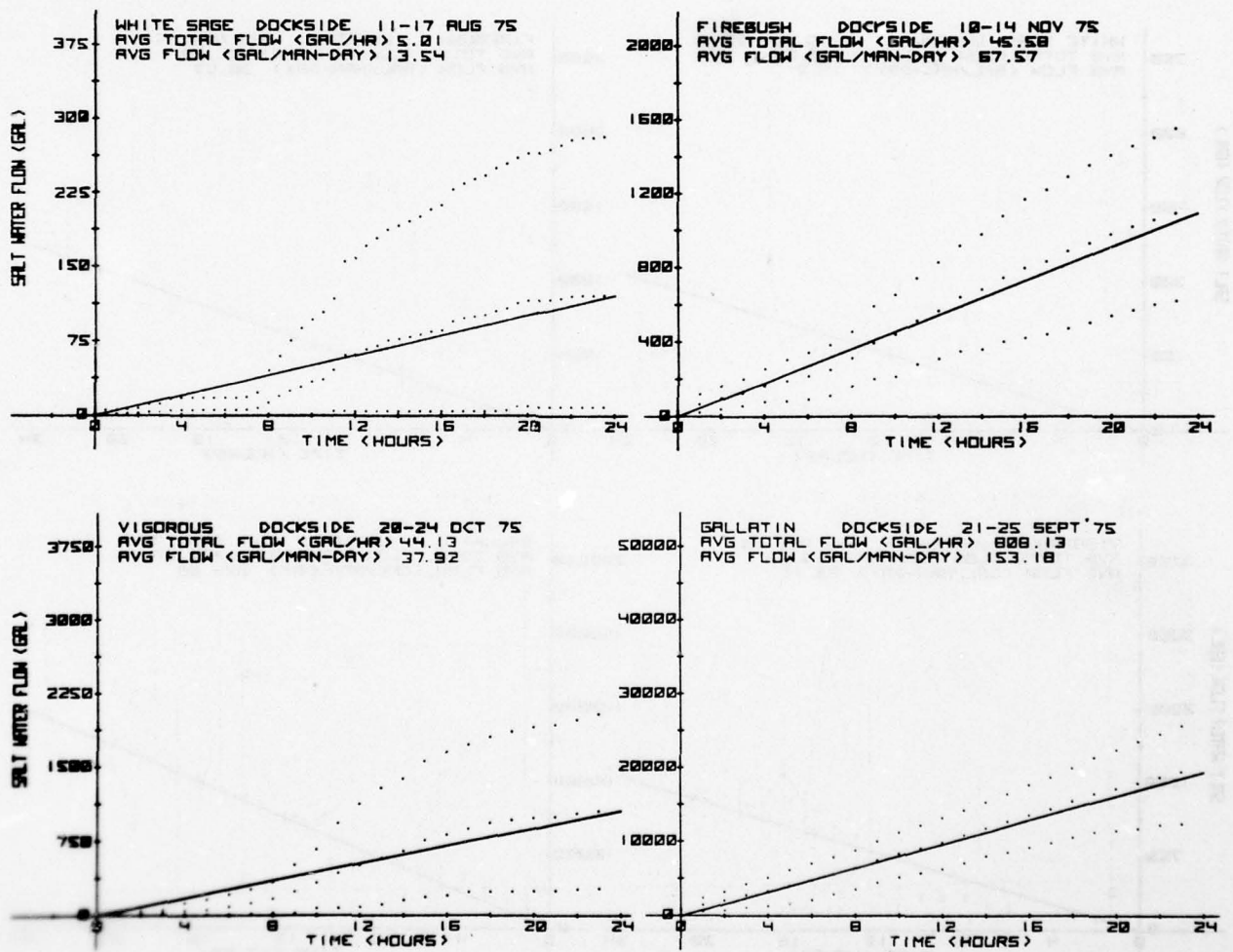

FIGURE 19. DOCKSIDE CUMULATIVE SALT WATER USAGE

POINT HERRON NOT MEASURED

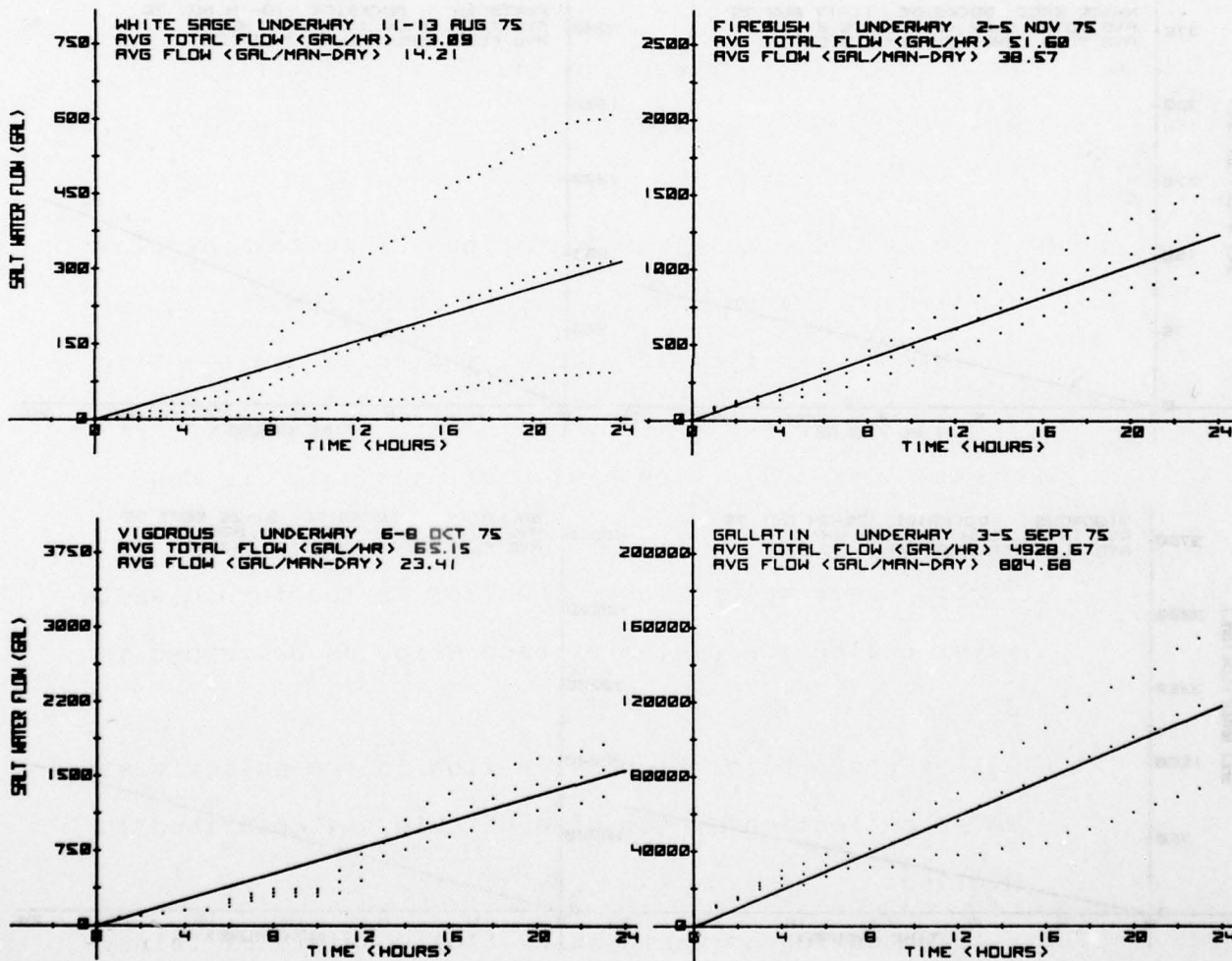

FIGURE 20. UNDERWAY CUMULATIVE SALT WATER USAGE

Waste Water Flow

Waste water flow is plotted on a segmented and cumulative basis, as was water usage.

There is an additional set of graphs to complement these, labeled Normalized to Full Crew. This is derived by a multiplication of each half hour segment of actual crew data by a factor obtained by dividing the designated or normal crew size of each ship by the actual number of men on board in each corresponding half-hour segment throughout the sampling period. It was done to facilitate visualization of flow quantity for a full size crew. The normal size crew for each ship is given on page 4.

Thus, the graphs consist of four types of wastewater flow:

1. Total waste water flow. This is an arithmetic sum of the wastewater flow in each of the three systems below.
2. Sanitary waste water flow. The flow in the sanitary waste water collection system of each ship, as described in Section
3. Turbid waste water flow. The flow in the turbid waste water collection system of each ship, as described in Section
4. Galley waste water flow. The flow in the galley waste water collection system of each ship, as described in Section

Thus, this section on waste water flow consists of thirty-two (32) figures, keyed in the following matrix.

TABLE 3
KEY TO THE LOCATION OF WASTE WATER FLOW DATA GRAPHS

Docksides	Underway	Segmented	Cumulative	Actual Crew	Normalized to Full Crew	Total	System		
							Sanitary	Turbid	Galley
X	X	X	X	X		Figure 21			
X	X	X	X	X		Figure 22			
X	X	X	X	X	X	Figure 23			
X	X	X	X	X	X	Figure 24			
X	X	X	X	X	X	Figure 25			
X	X	X	X	X	X	Figure 26			
X	X	X	X	X	X	Figure 27			
X	X	X	X	X	X	Figure 28			
X	X	X	X	X	X		Figure 29		
X	X	X	X	X	X		Figure 30		
X	X	X	X	X	X		Figure 31		
X	X	X	X	X	X		Figure 32		
X	X	X	X	X	X		Figure 33		
X	X	X	X	X	X		Figure 34		
X	X	X	X	X	X		Figure 35		
X	X	X	X	X	X		Figure 36		
X	X	X	X	X	X			Figure 37	
X	X	X	X	X	X			Figure 38	
X	X	X	X	X	X			Figure 39	
X	X	X	X	X	X			Figure 40	
X	X	X	X	X	X			Figure 41	
X	X	X	X	X	X			Figure 42	
X	X	X	X	X	X			Figure 43	
X	X	X	X	X	X			Figure 44	
X	X	X	X	X	X				Figure 45
X	X	X	X	X	X				Figure 46
X	X	X	X	X	X				Figure 47
X	X	X	X	X	X				Figure 48
X	X	X	X	X	X				Figure 49
X	X	X	X	X	X				Figure 50
X	X	X	X	X	X				Figure 51
X	X	X	X	X	X				Figure 52

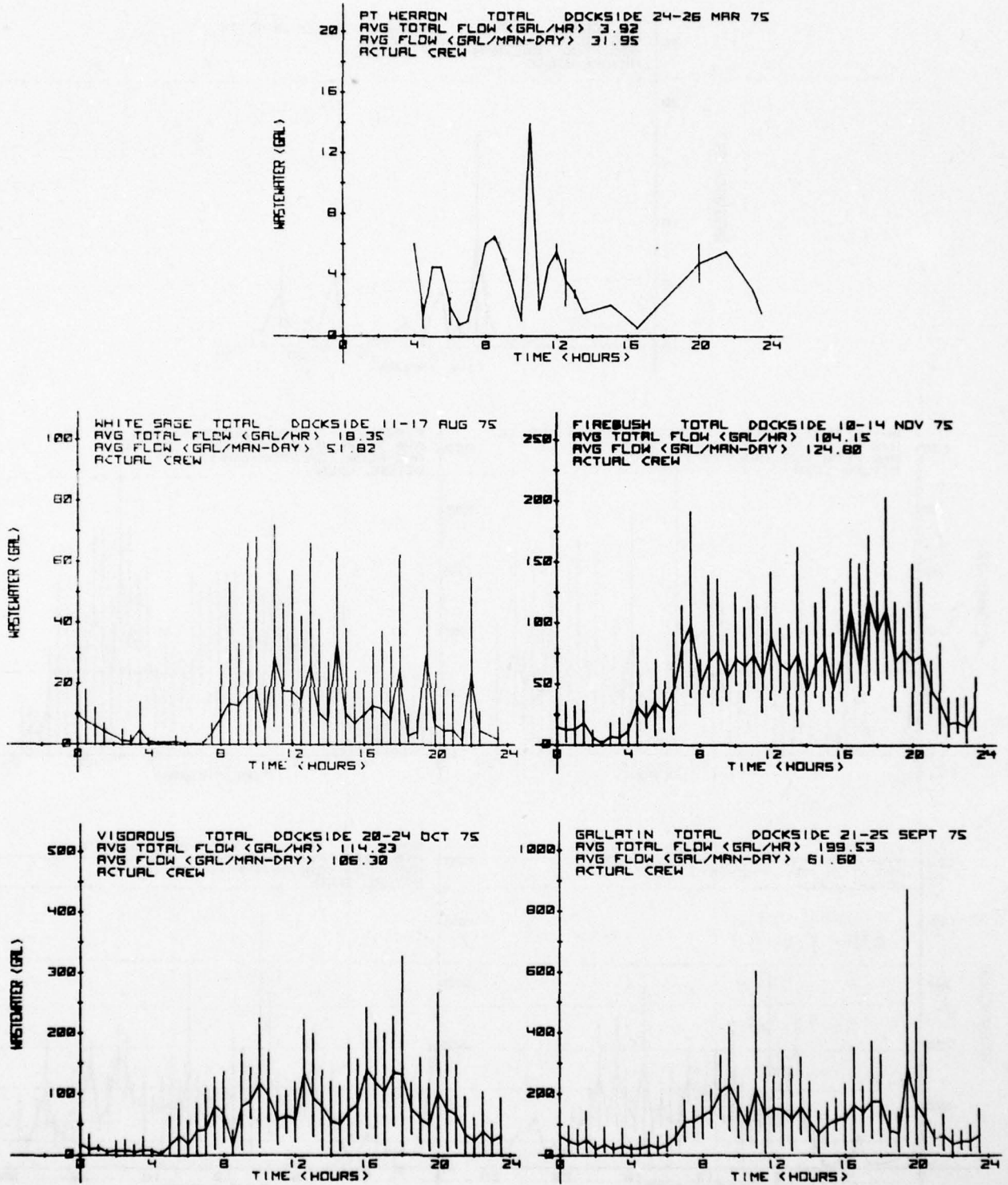

FIGURE 21. ACTUAL TOTAL WASTEWATER FLOW; SEGMENTED, DOCKSIDE

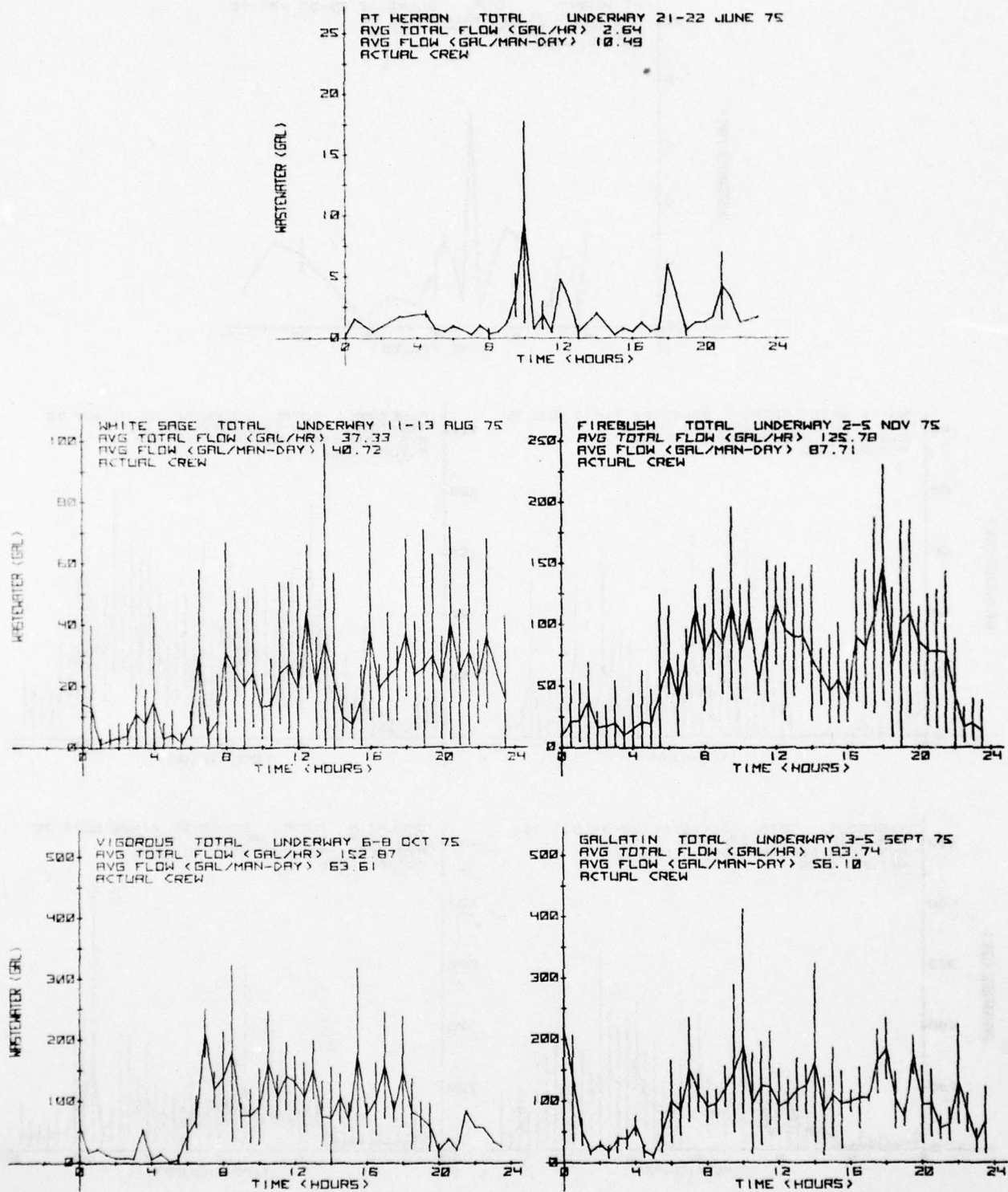

FIGURE 22. ACTUAL TOTAL WASTEWATER FLOW; SEGMENTED, UNDERWAY

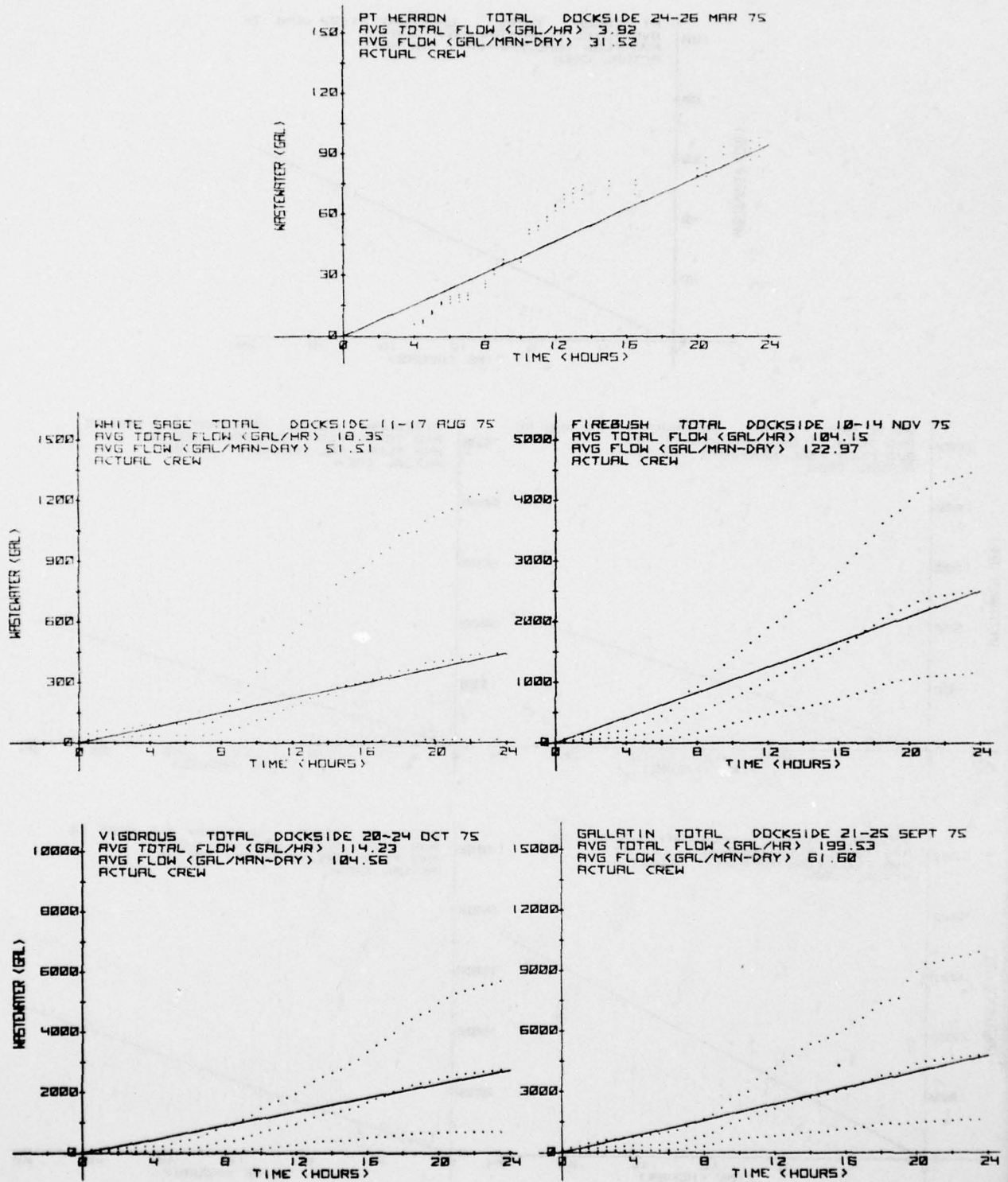

FIGURE 23. ACTUAL TOTAL WASTEWATER FLOW; CUMULATIVE, UNDERWAY

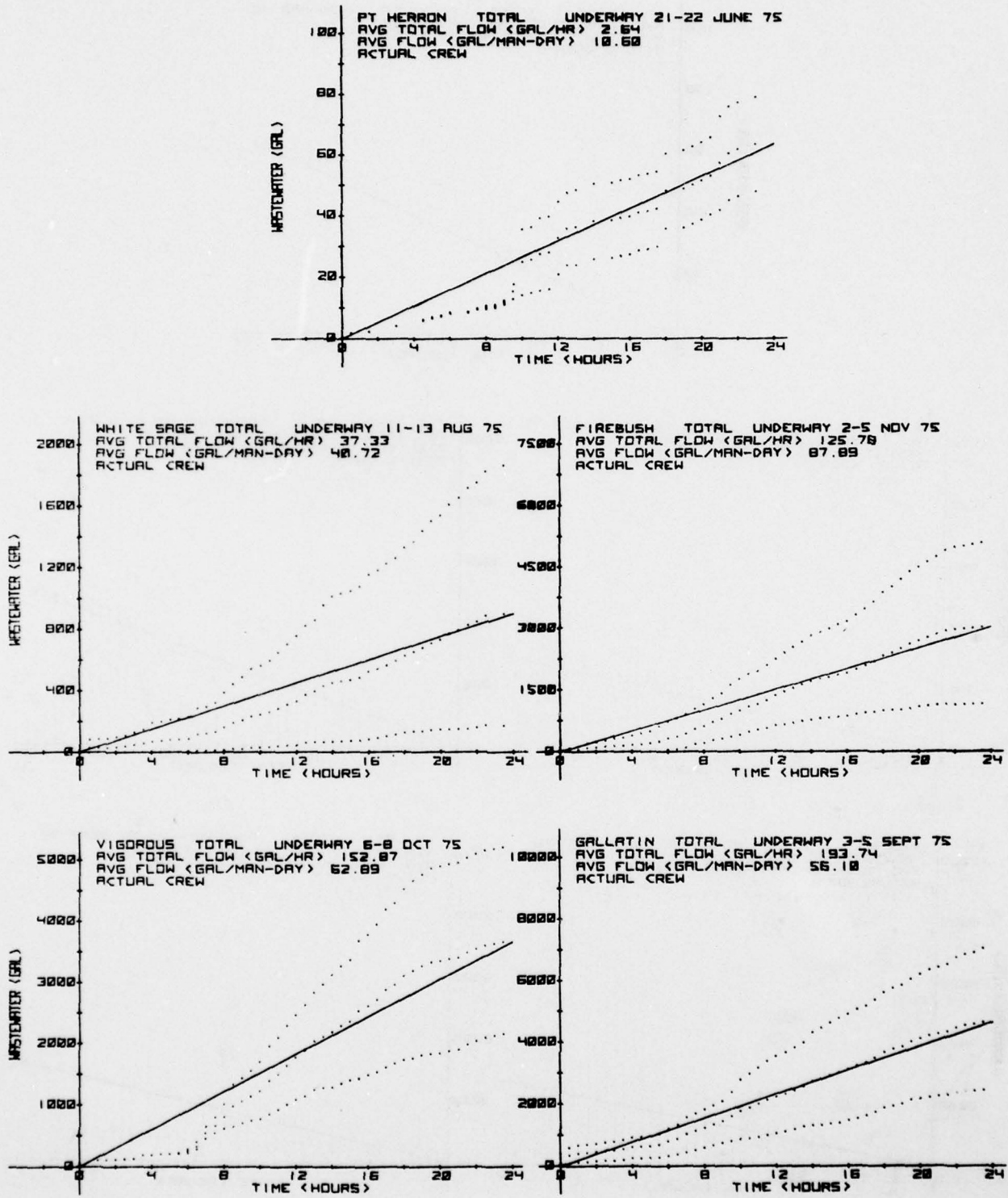

FIGURE 24. ACTUAL TOTAL WASTEWATER FLOW; CUMULATIVE, UNDERWAY

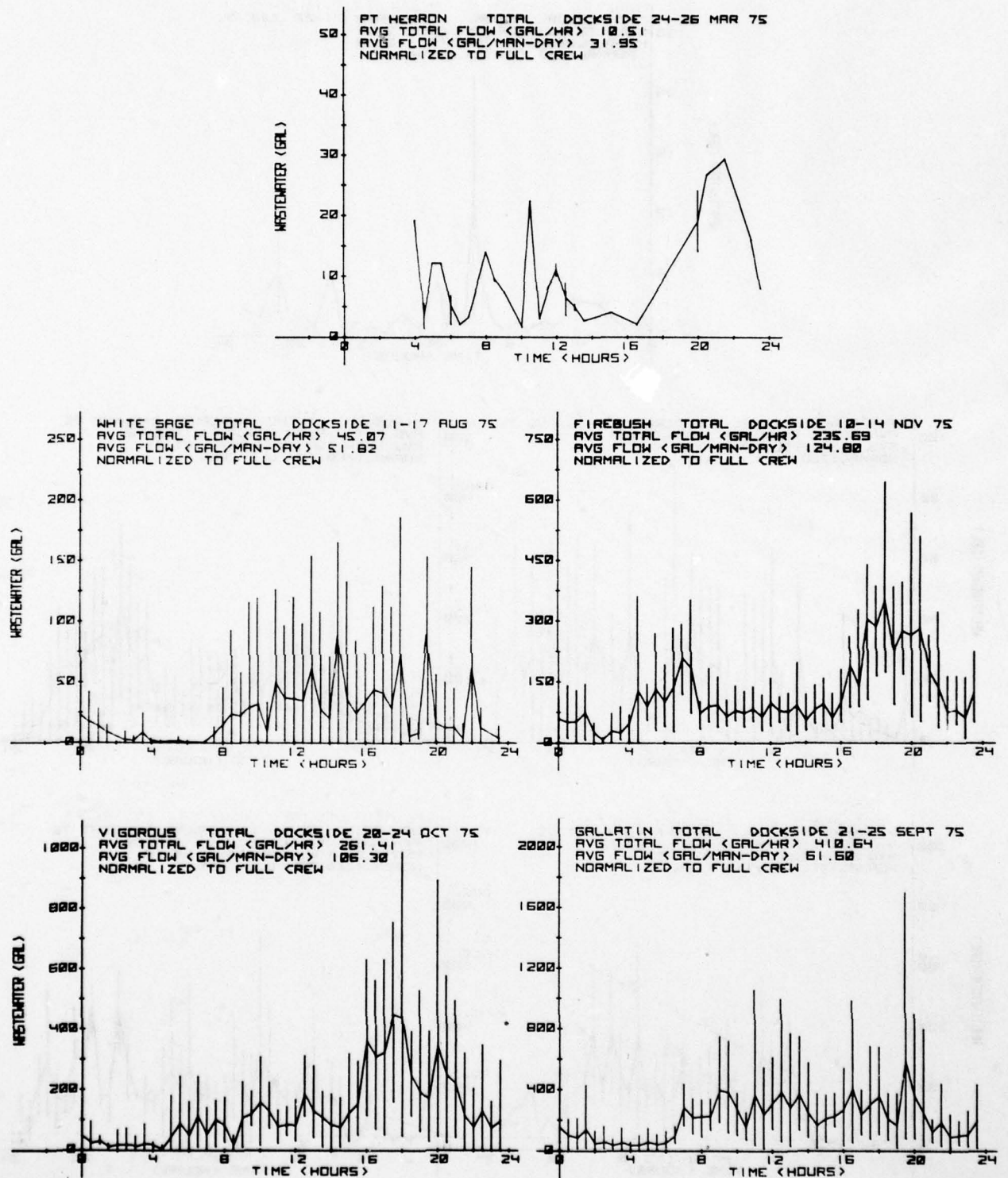

FIGURE 25. NORMALIZED TOTAL WASTEWATER FLOW; SEGMENTED, DOCKSIDE

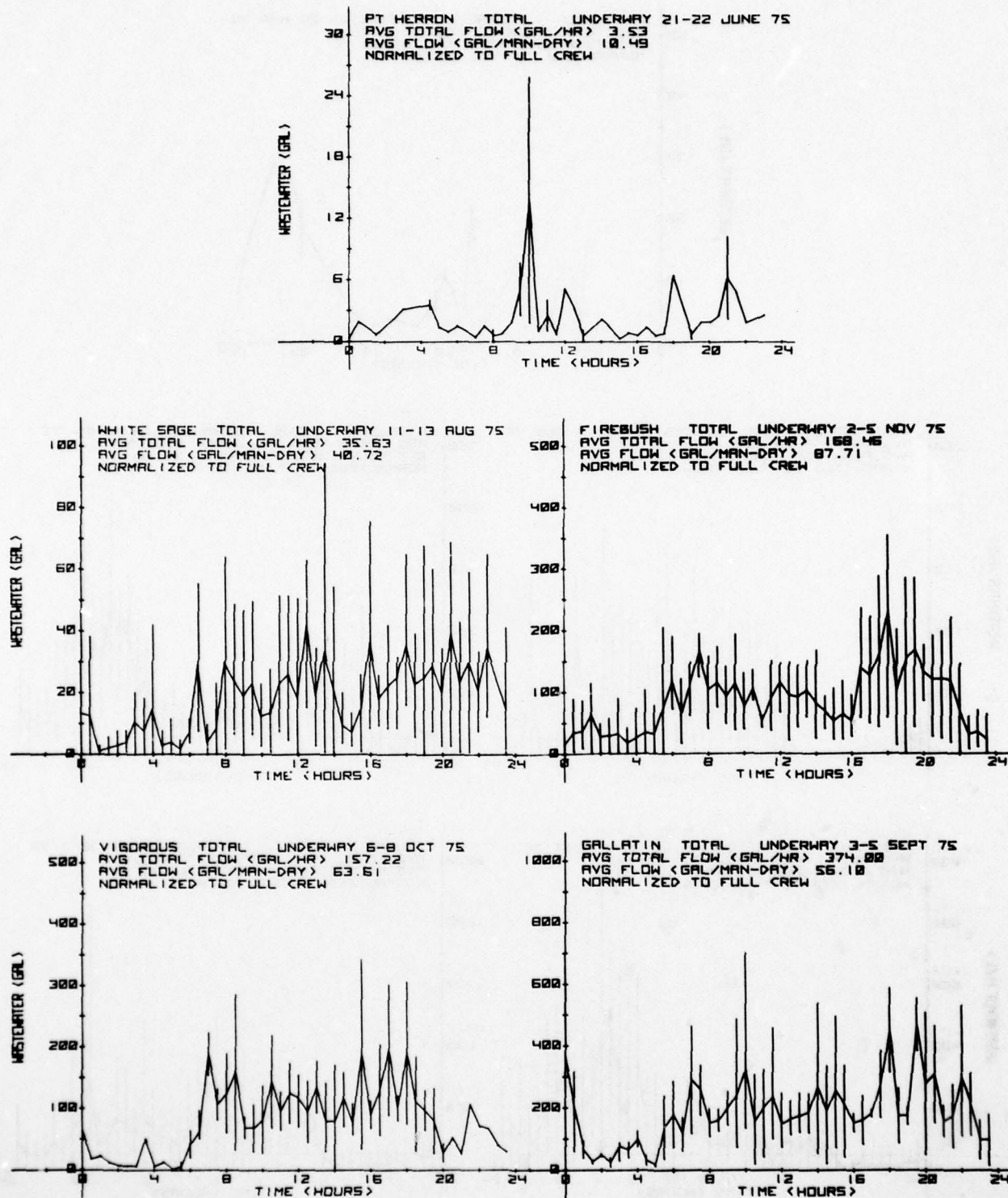

FIGURE 26. NORMALIZED TOTAL WASTEWATER FLOW; SEGMENTED, UNDERWAY

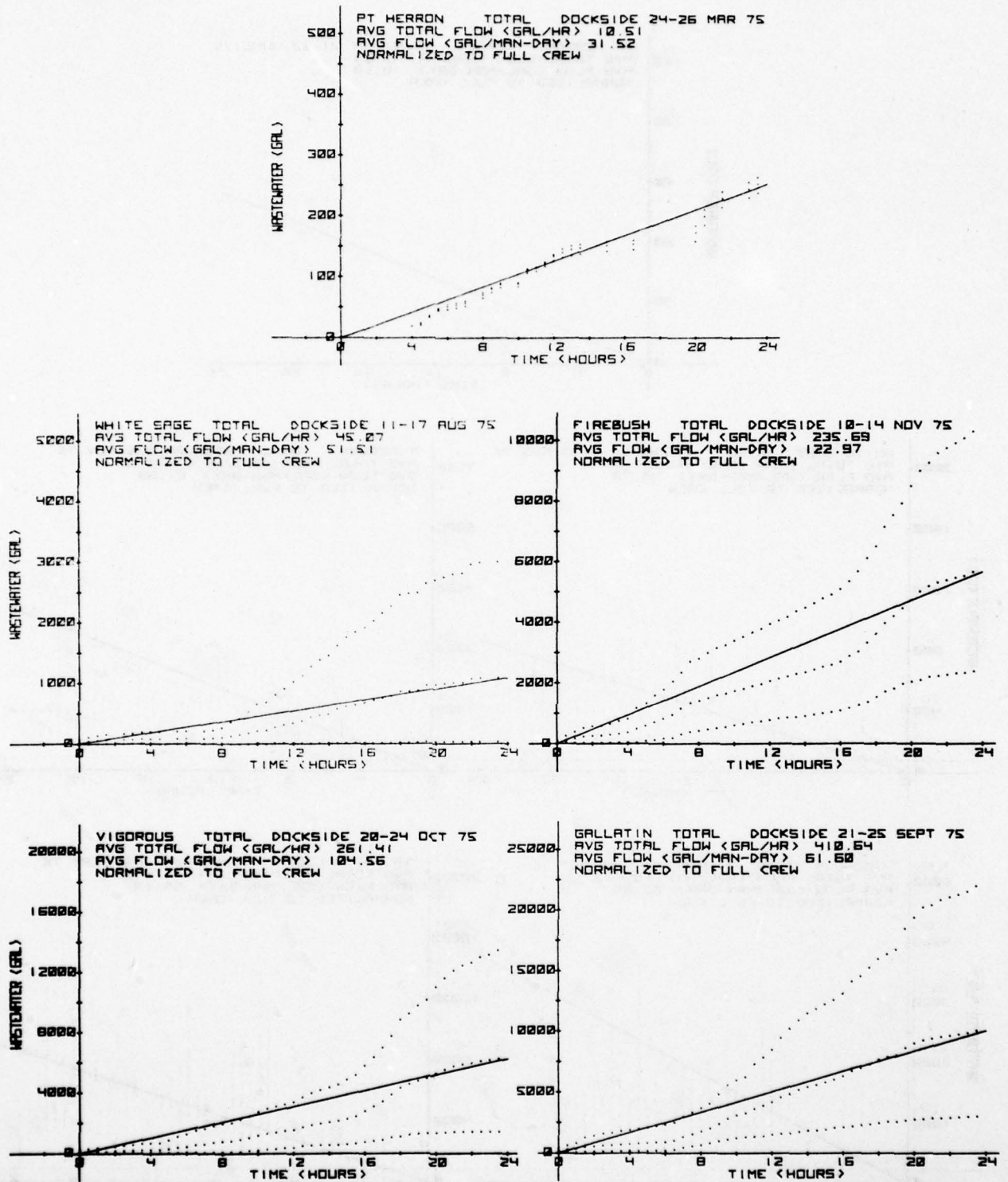

FIGURE 27. NORMALIZED TOTAL WASTEWATER FLOW; CUMULATIVE, DOCKSIDE

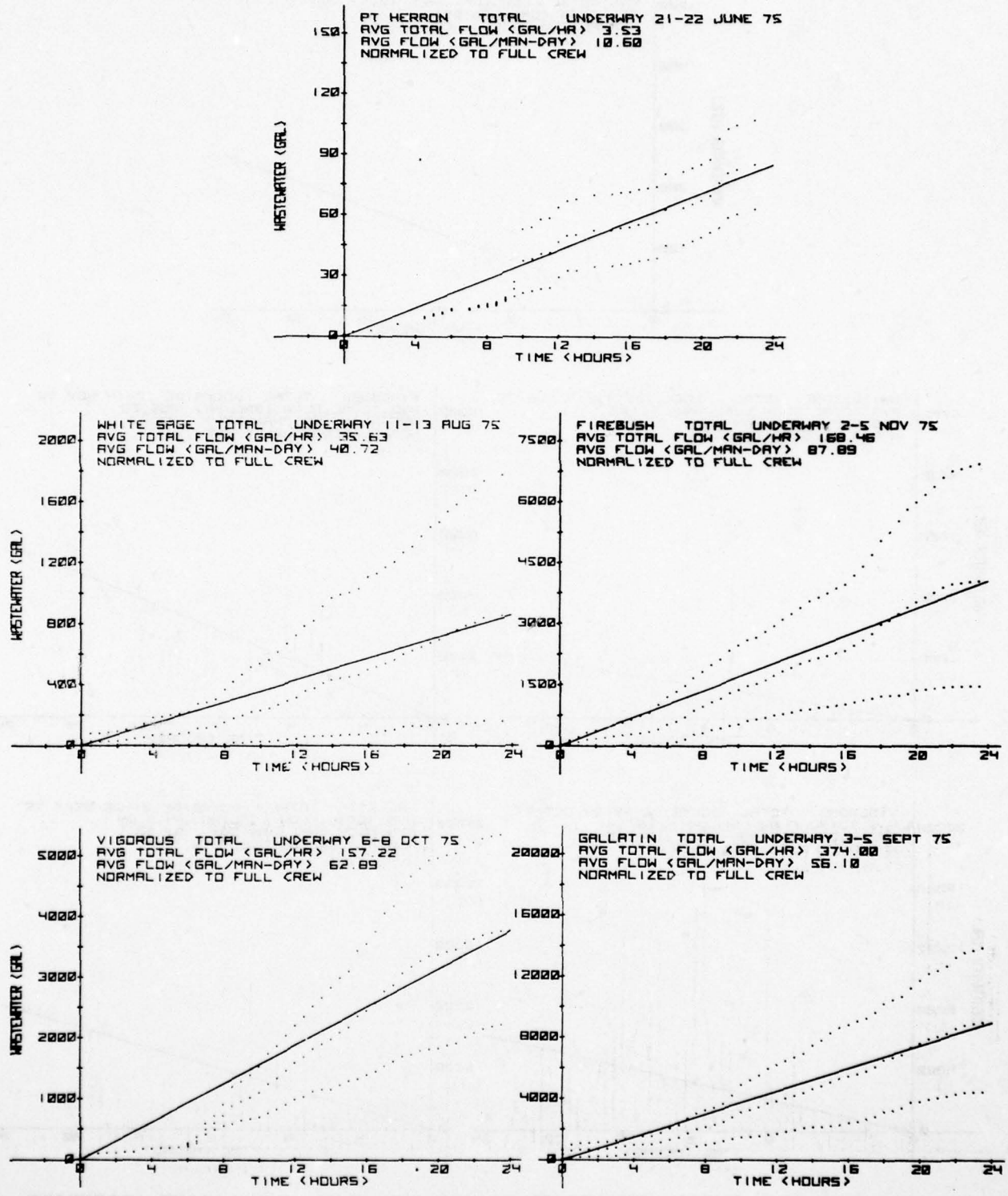

FIGURE 28. NORMALIZED TOTAL WASTEWATER FLOW; CUMULATIVE, UNDERWAY

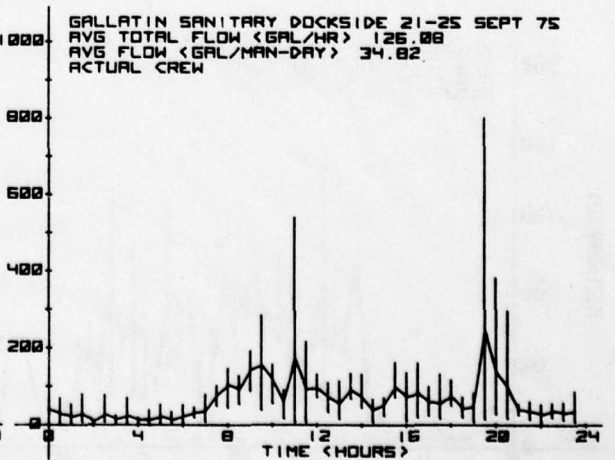
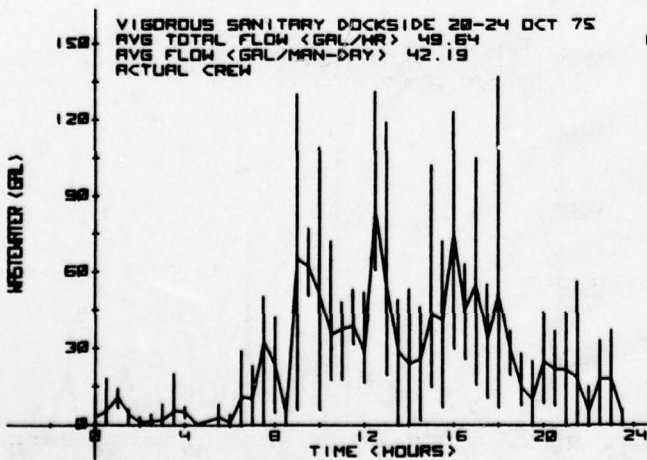
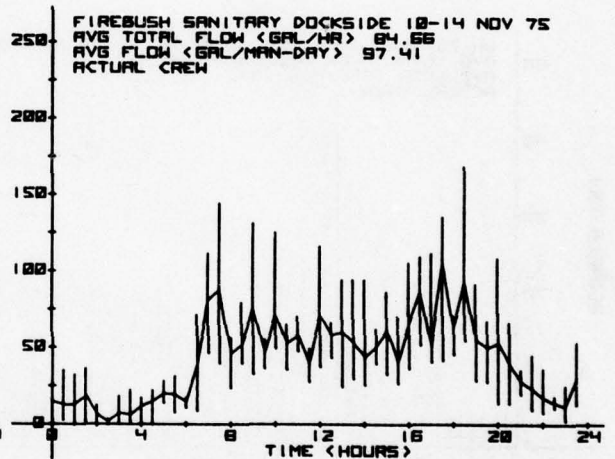
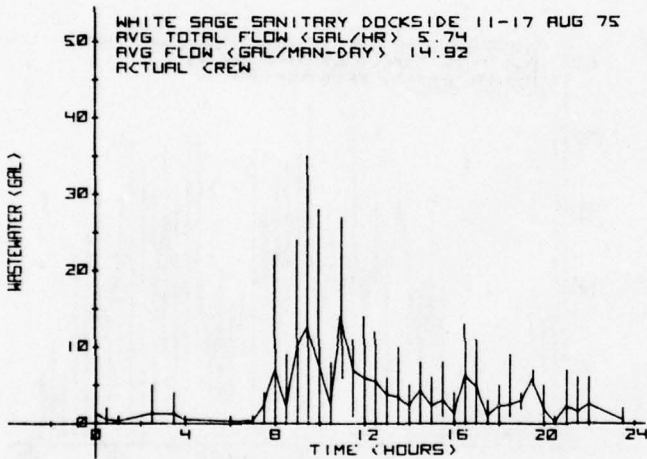
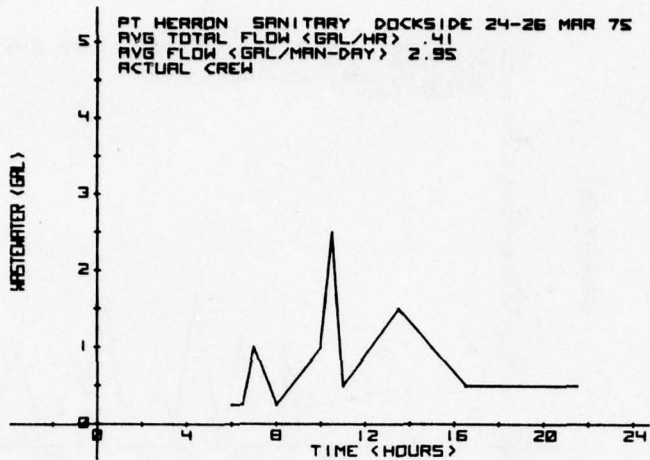

FIGURE 29. ACTUAL SANITARY WASTEWATER FLOW; SEGMENTED, DOCKSIDE

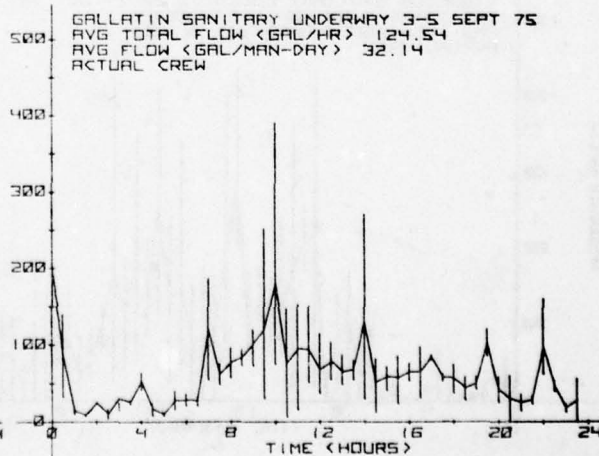
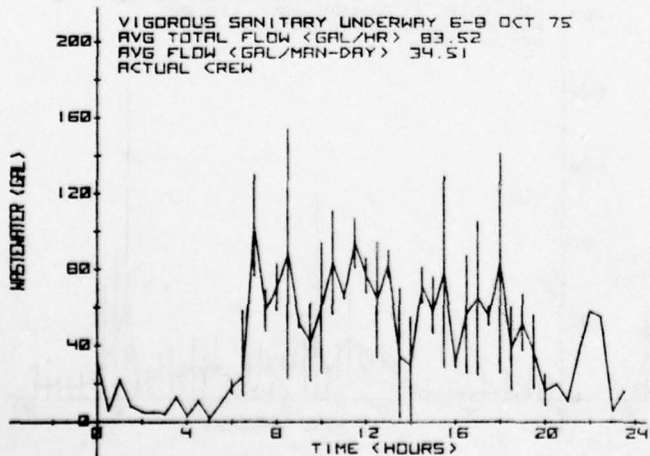
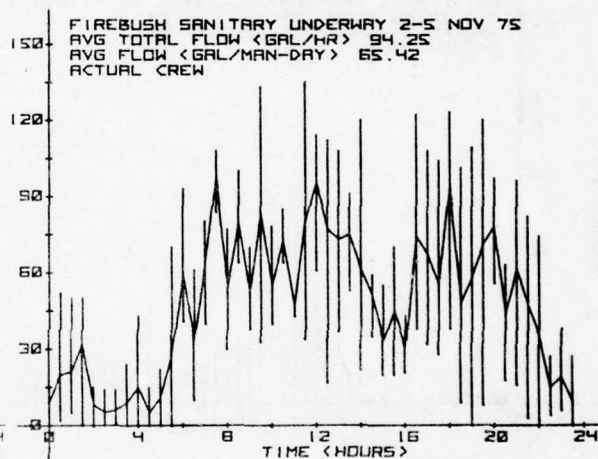
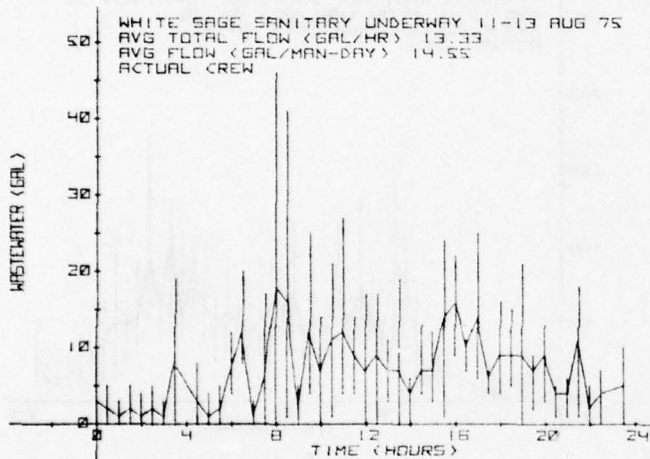
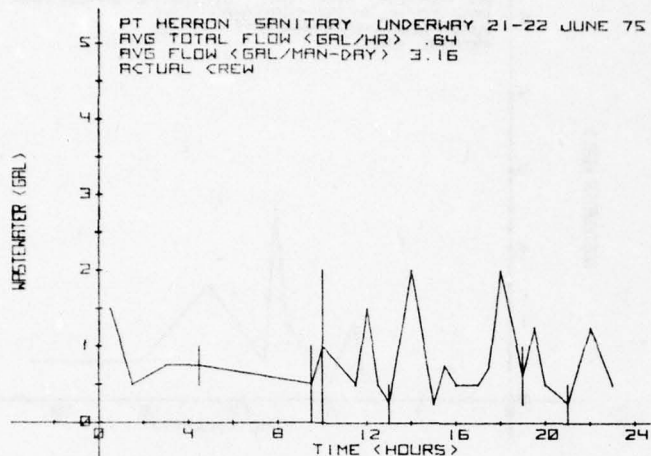

FIGURE 30. ACTUAL SANITARY WASTEWATER FLOW; SEGMENTED, UNDERWAY

AD-A055 797

H2M CORP MELVILLE NY

F/G 13/10

SURVEY, ANALYSIS AND EVALUATION OF DOMESTIC WASTEWATERS ON COAS--ETC(U)

OCT 76 H D FREUDENTHAL, D A MORAN, C POWERS

DOT-CG-41342-A

USCG-D-63-77

NL

UNCLASSIFIED

2 OF 4
ADA
055797

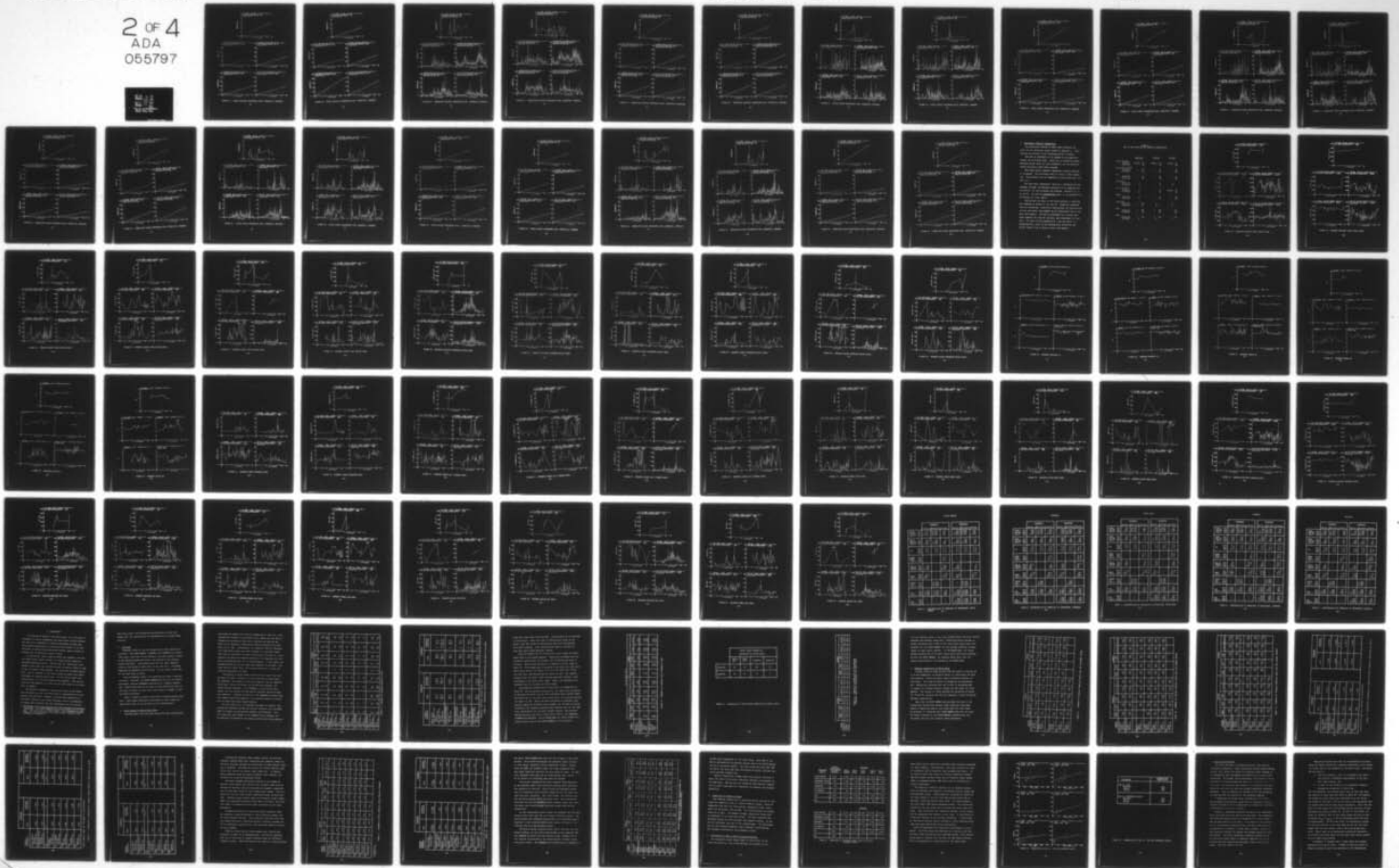

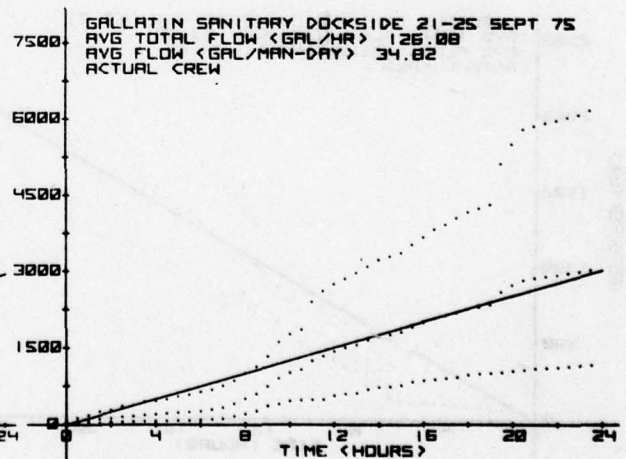
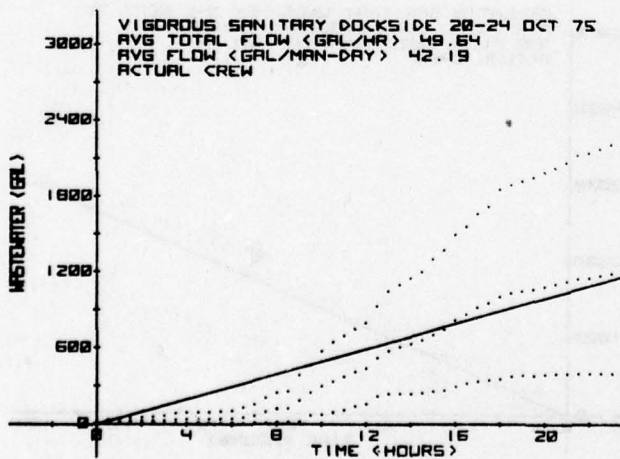
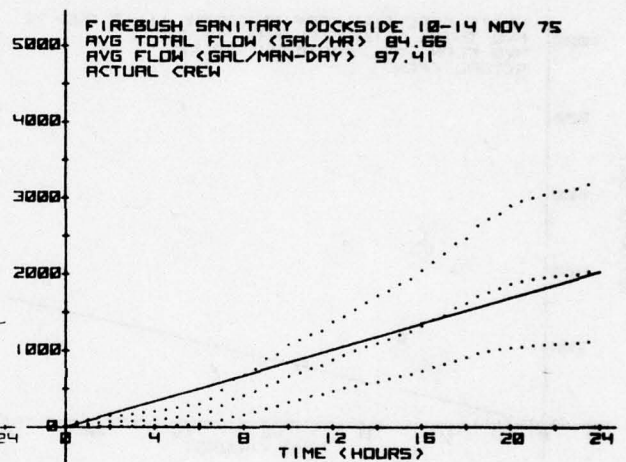
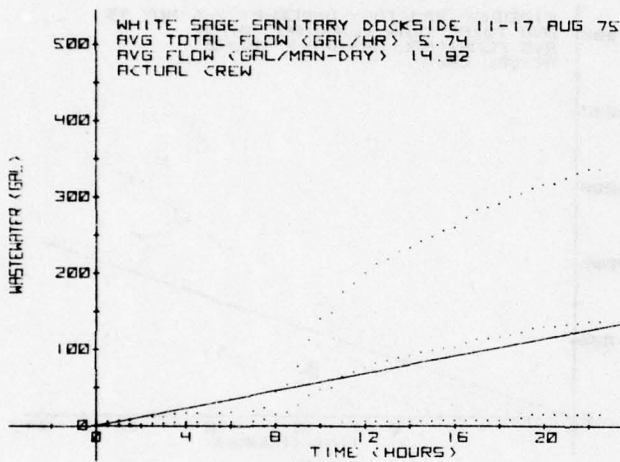
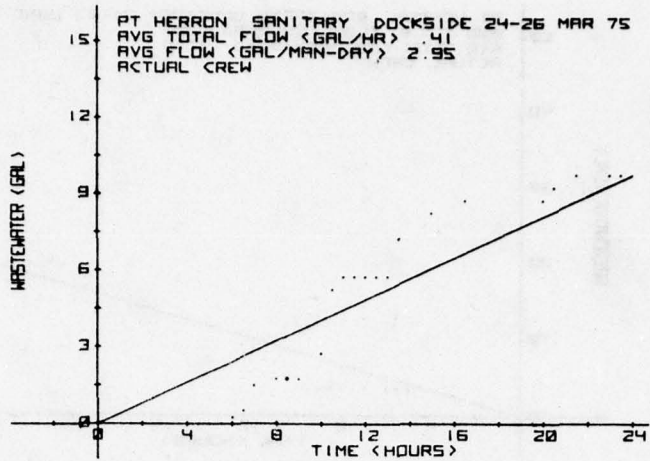

FIGURE 31. ACTUAL SANITARY WASTEWATER FLOW; CUMULATIVE, DOCKSIDE

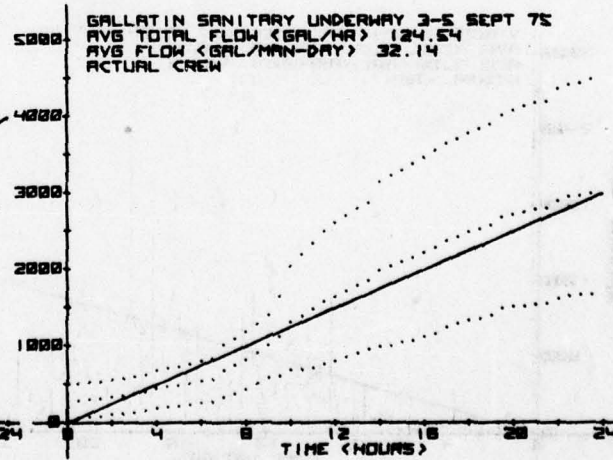
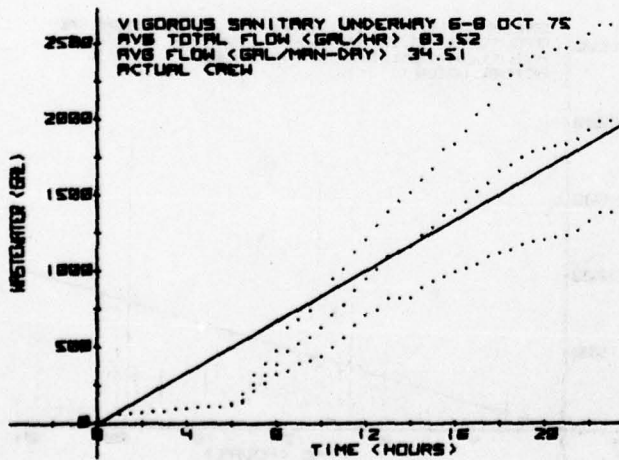
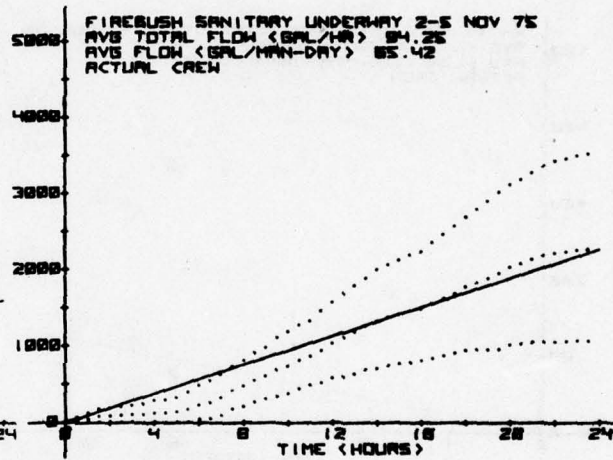
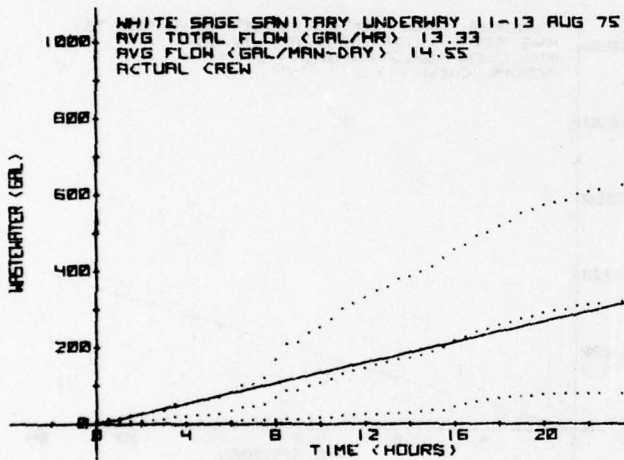
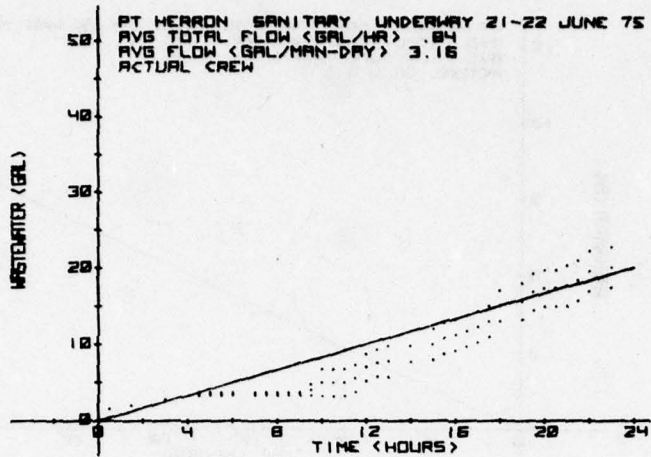

FIGURE 32. ACTUAL SANITARY WASTEWATER FLOW; CUMULATIVE, UNDERWAY

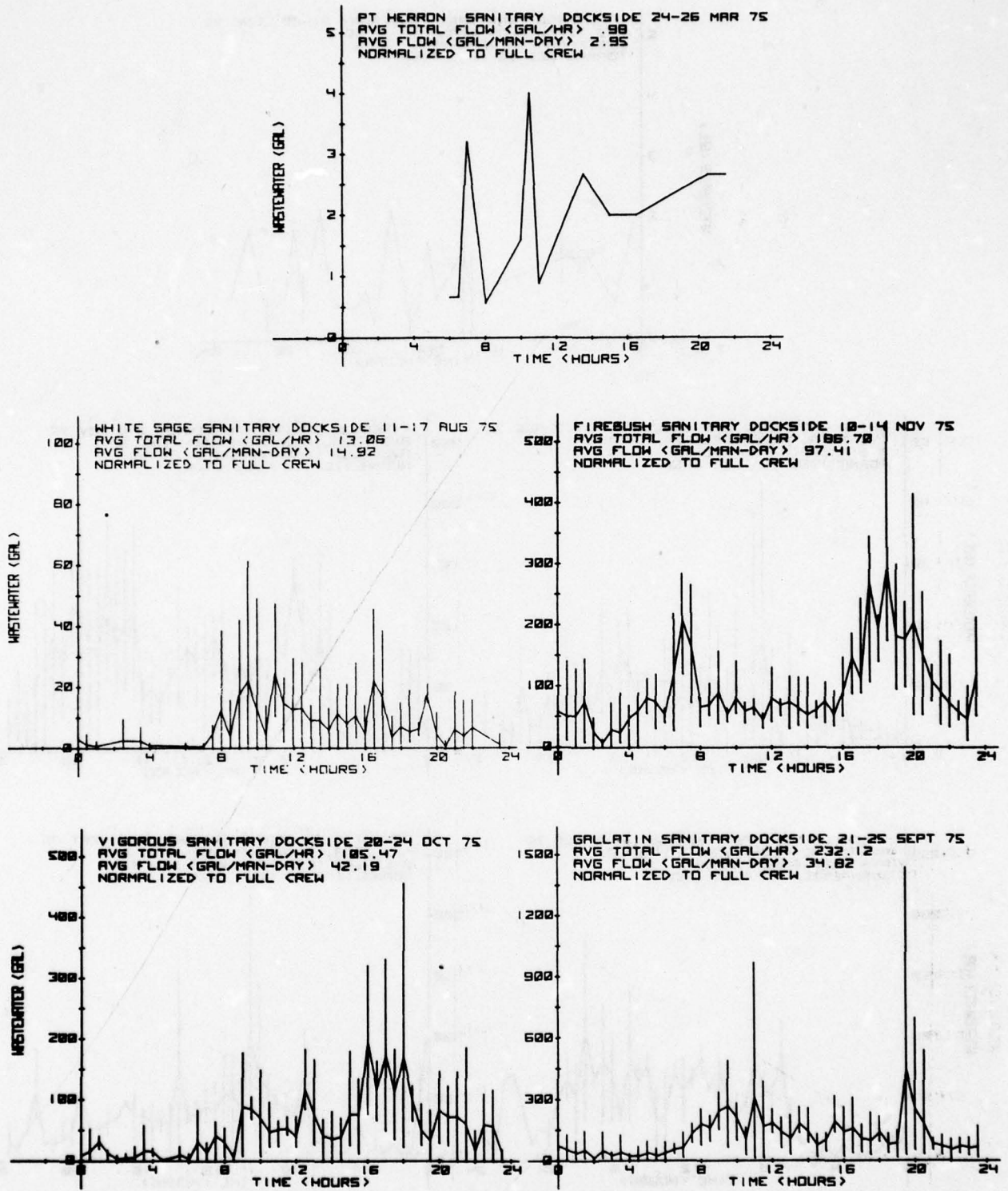

FIGURE 33. NORMALIZED SANITARY WASTEWATER FLOW; SEGMENTED, DOCKSIDE

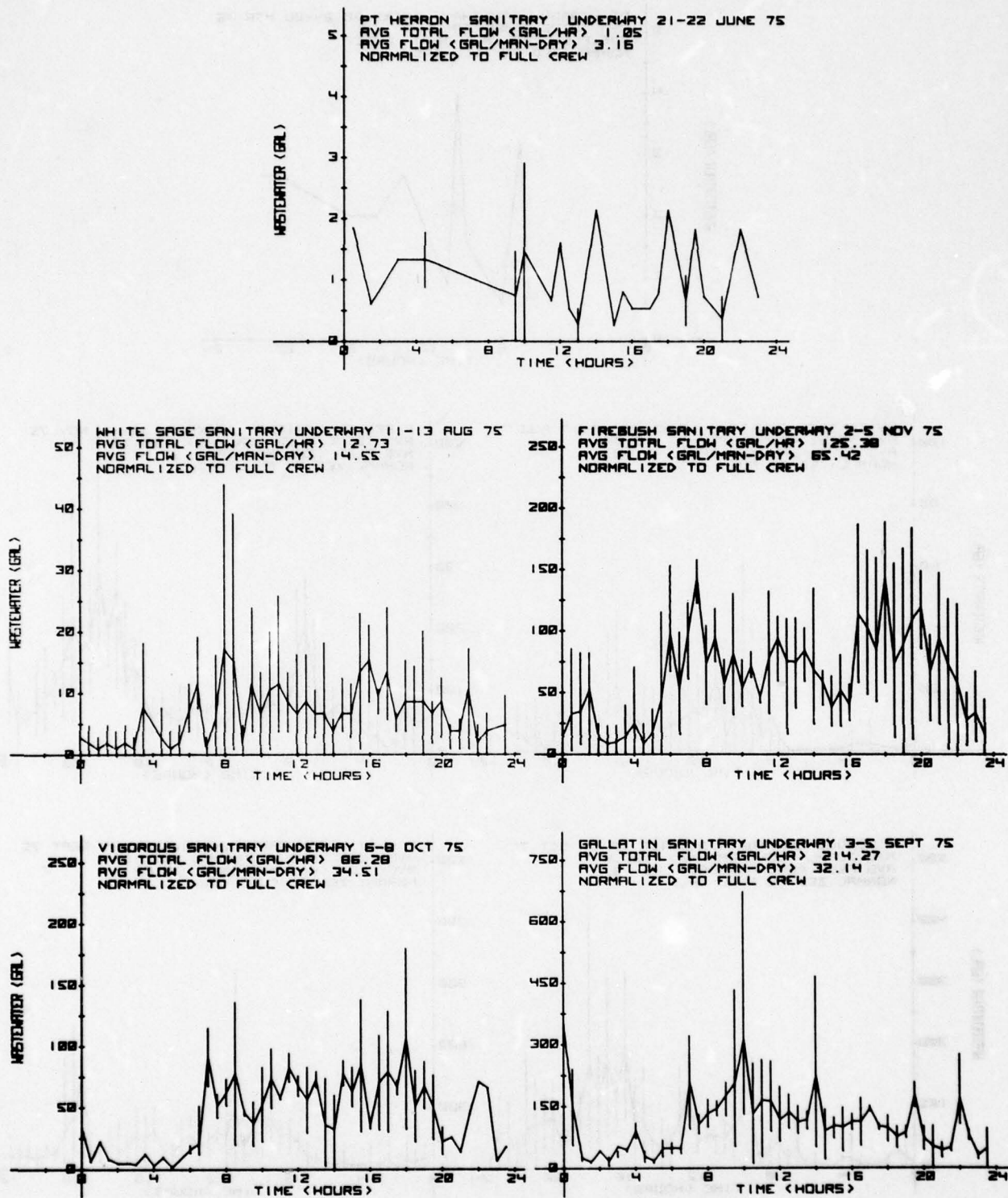

FIGURE 34. NORMALIZED SANITARY WASTEWATER FLOW; SEGMENTED, UNDERWAY

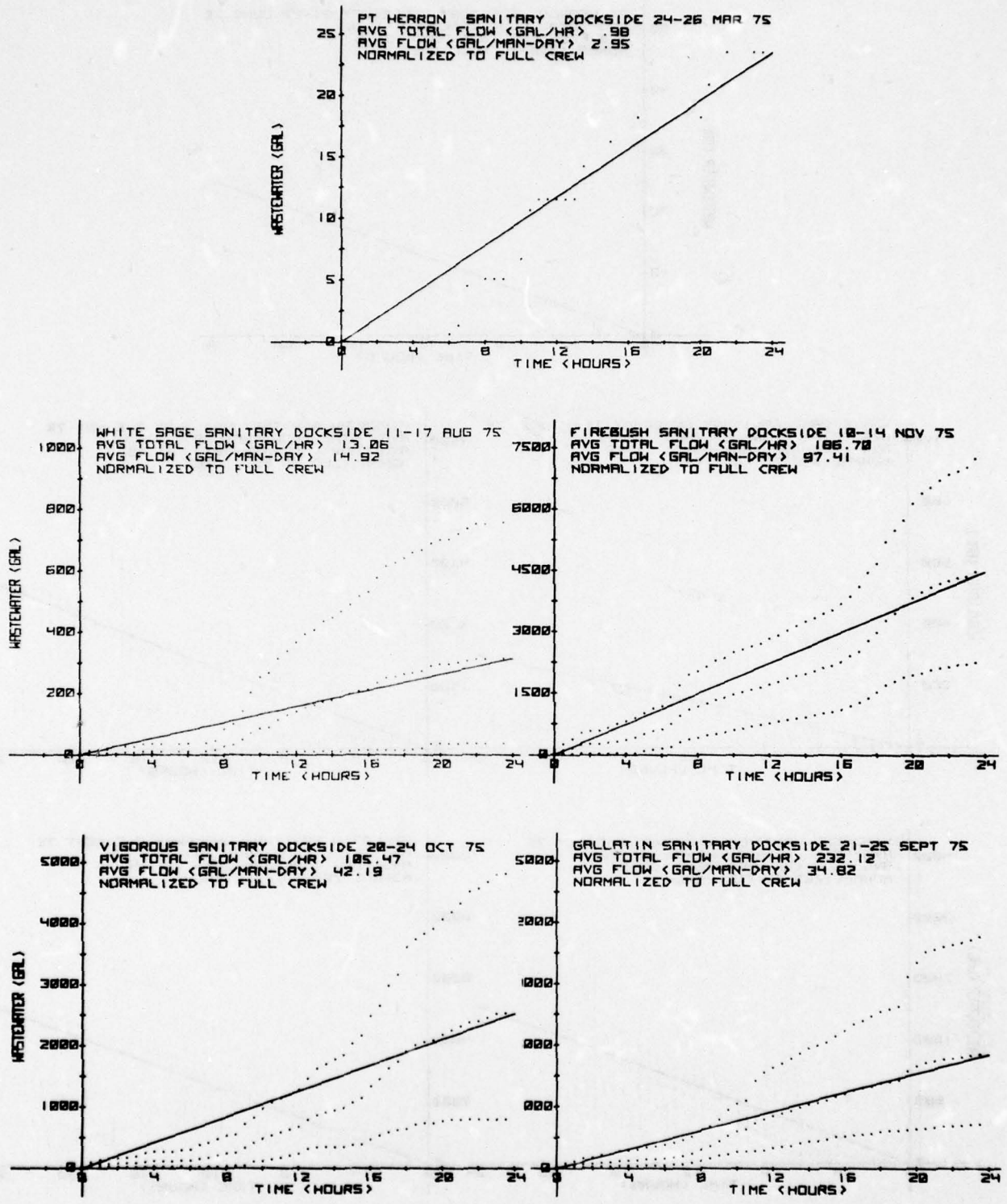

FIGURE 35. NORMALIZED SANITARY WASTEWATER FLOW; CUMULATIVE, DOCKSIDE

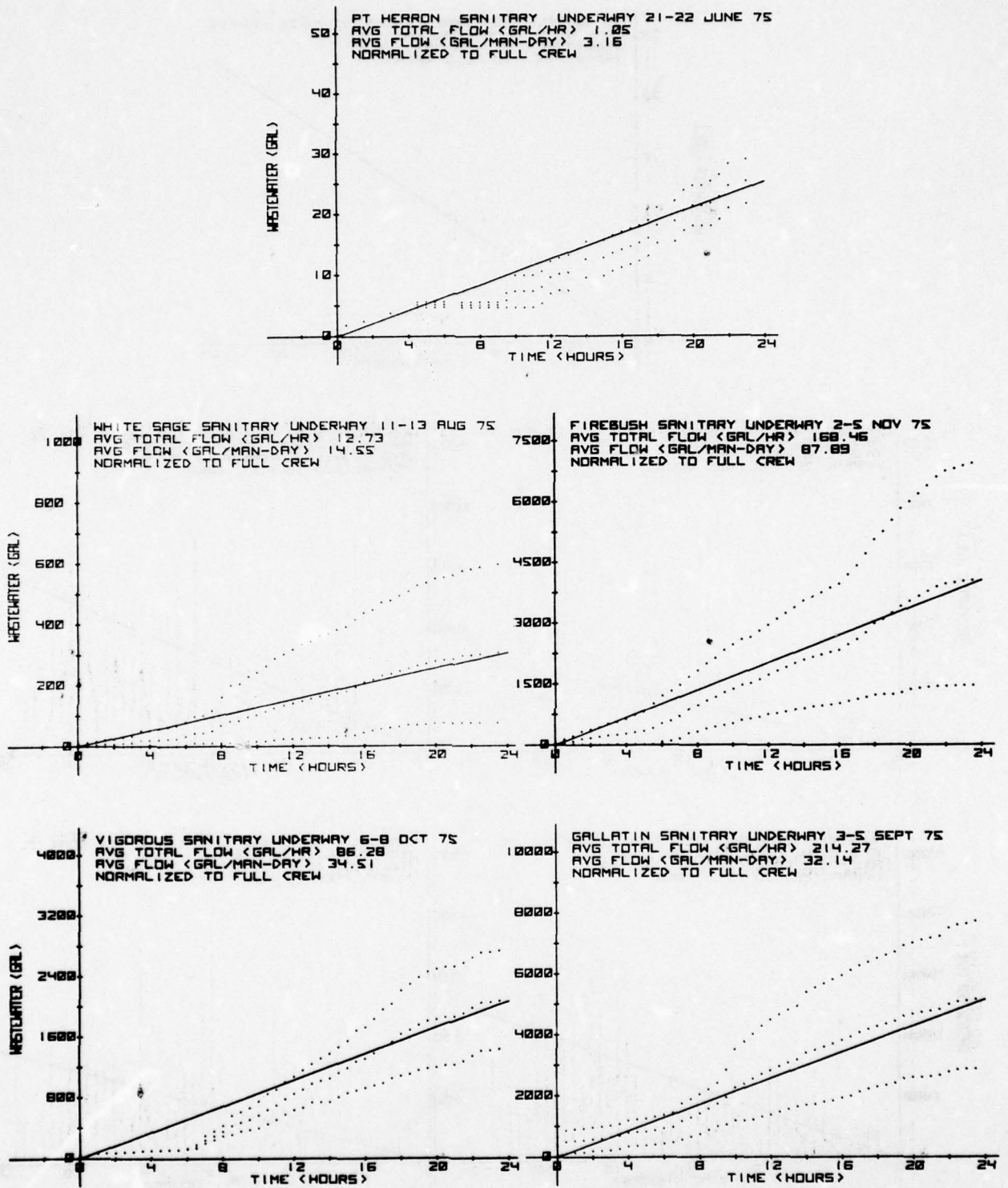

FIGURE 36. NORMALIZED SANITARY WASTEWATER FLOW; CUMULATIVE, UNDERWAY

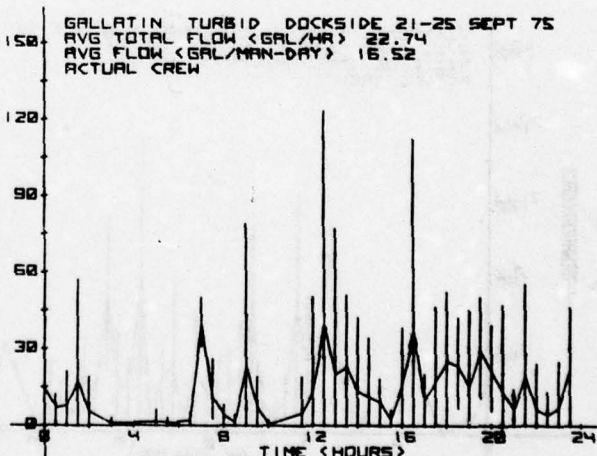
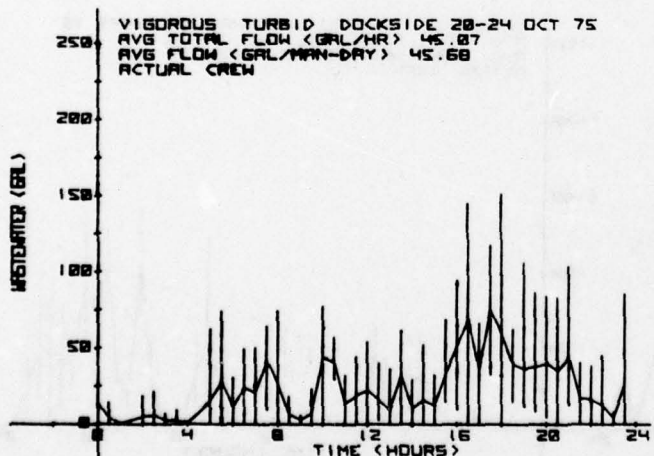
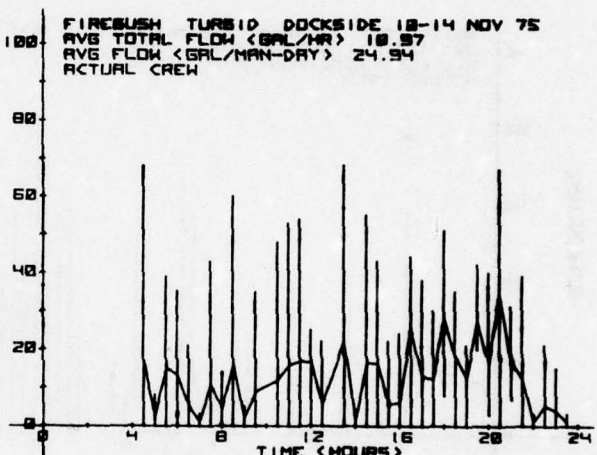
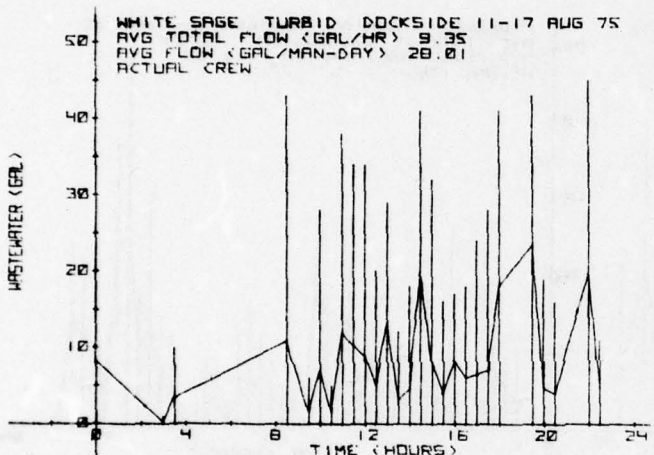
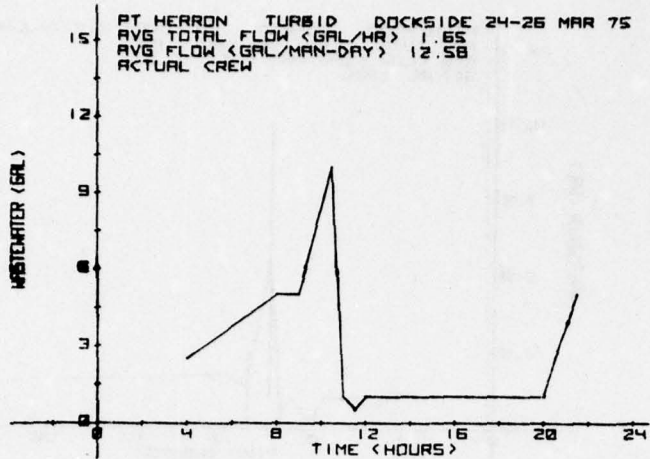

FIGURE 37. ACTUAL TURBID WASTEWATER FLOW; SEGMENTED, DOCKSIDE

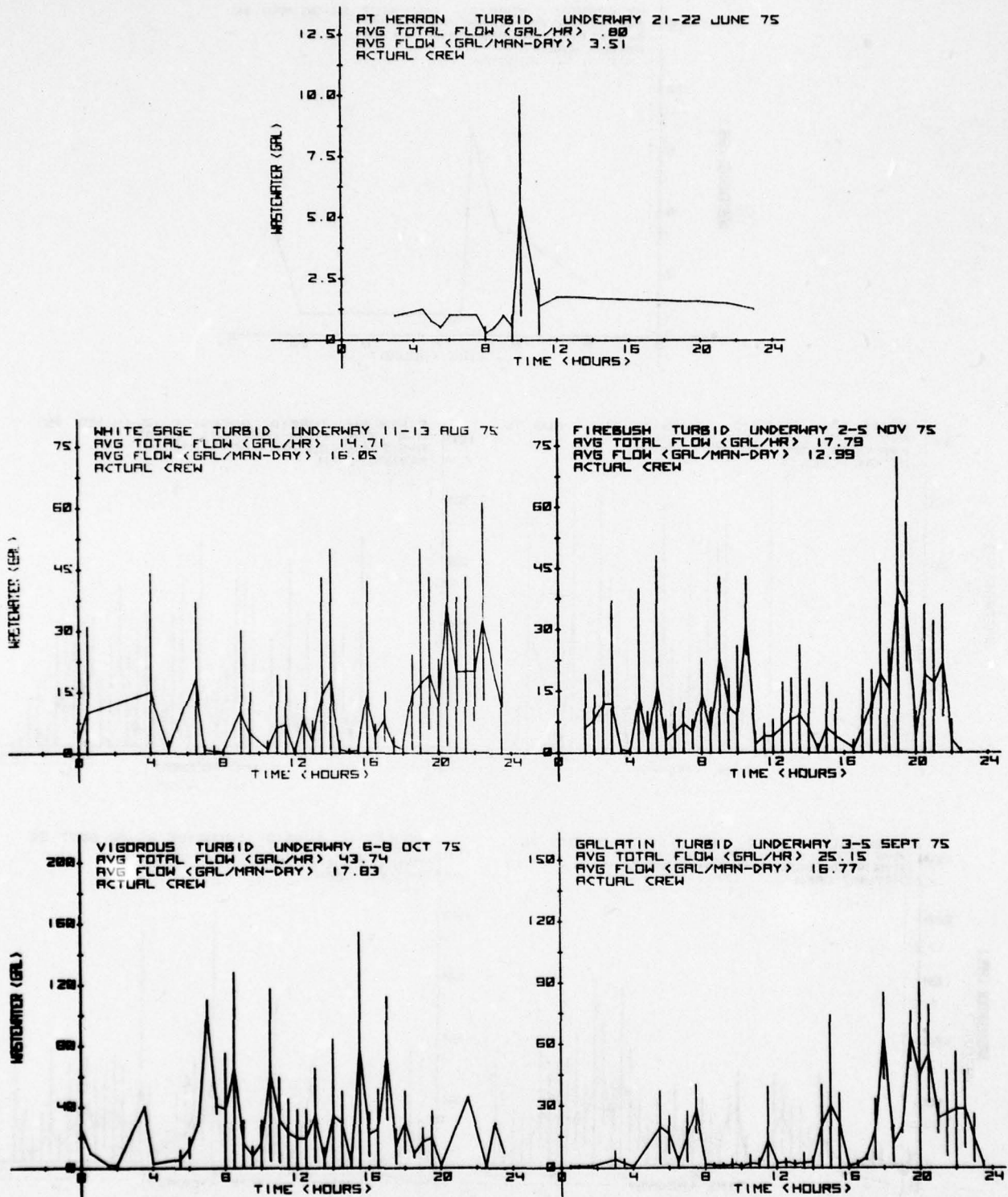

FIGURE 38. ACTUAL TURBID WASTEWATER FLOW; SEGMENTED, UNDERWAY

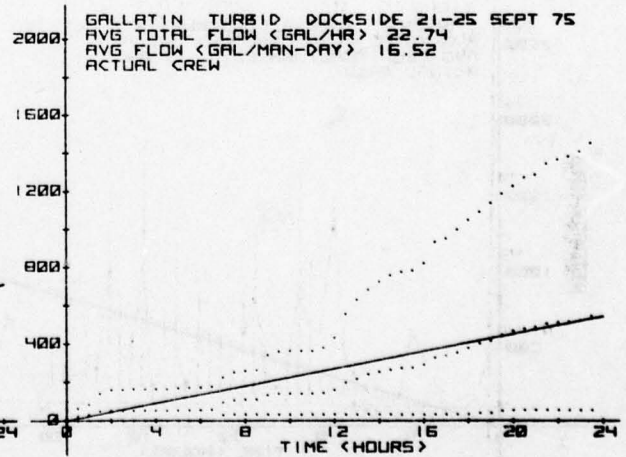
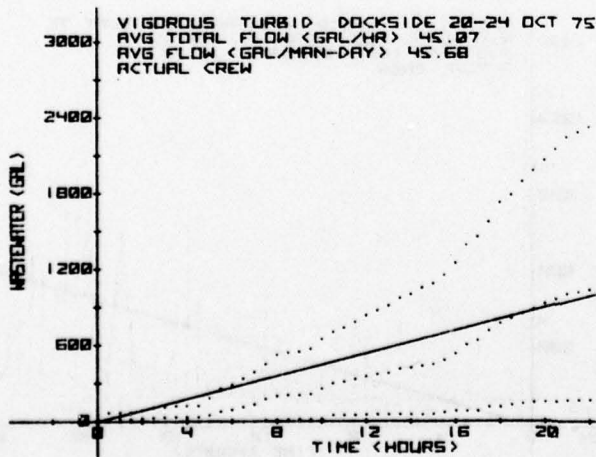
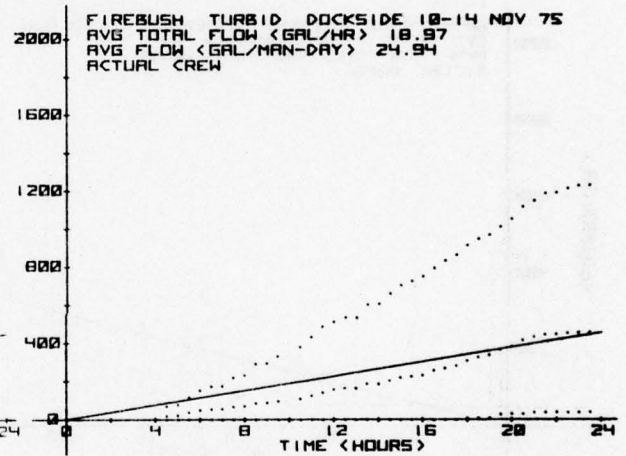
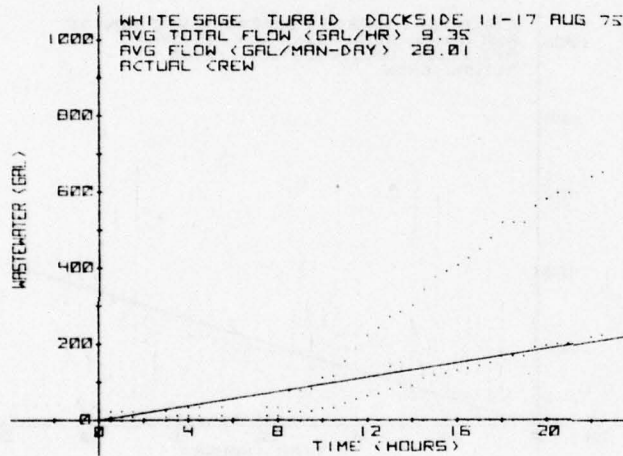
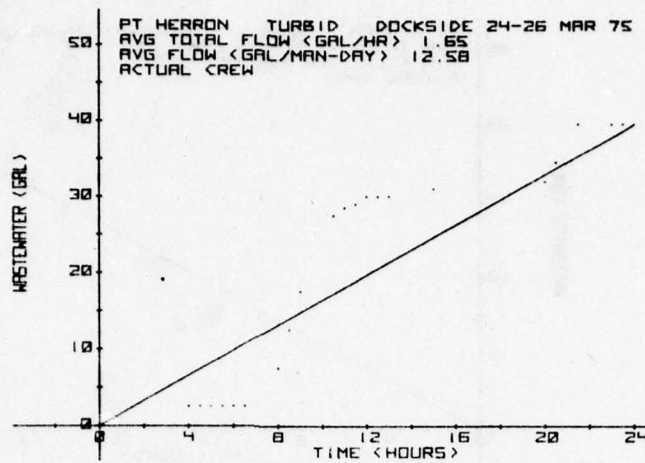

FIGURE 39. ACTUAL TURBID WASTEWATER FLOW; CUMULATIVE, DOCKSIDE

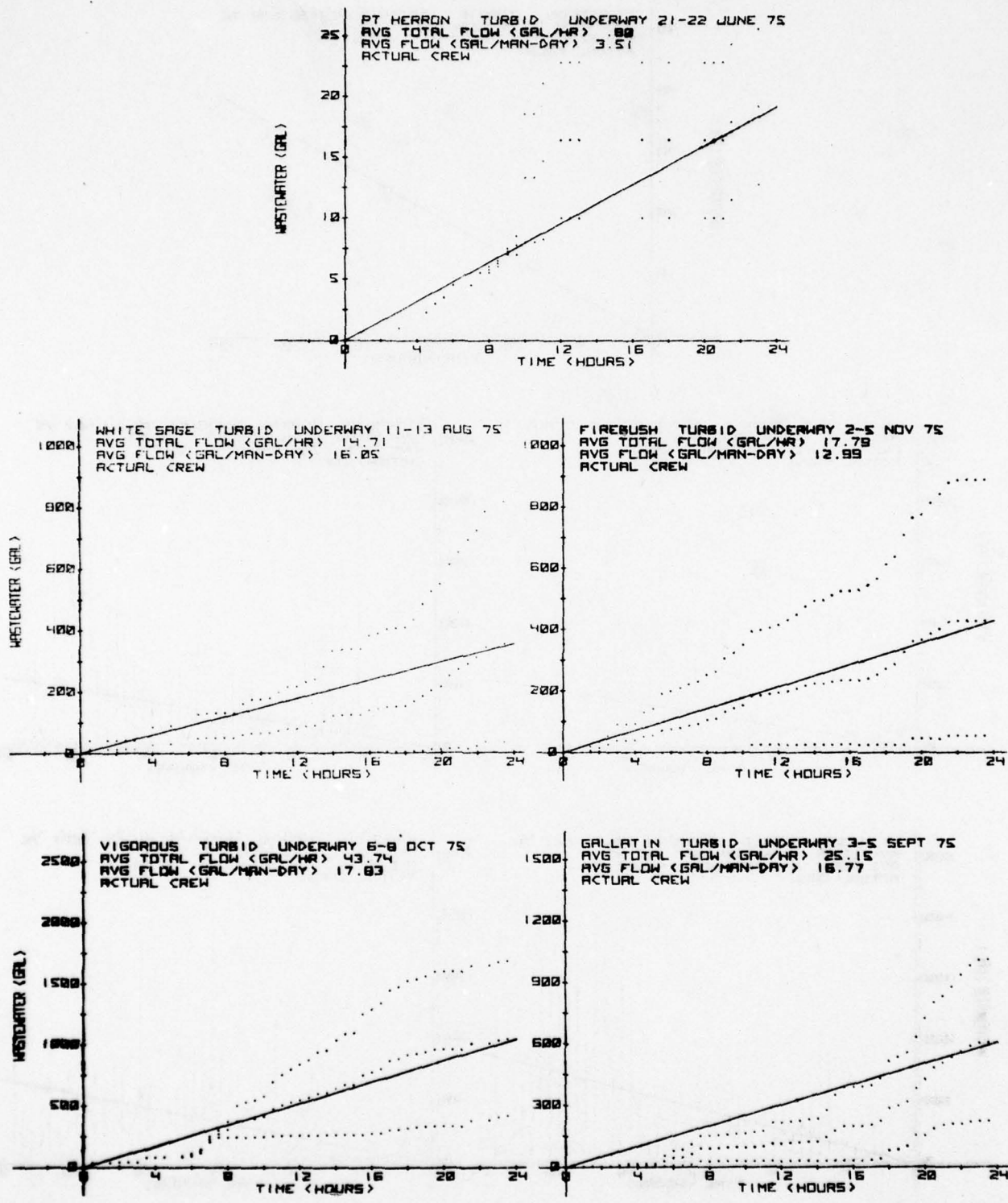

FIGURE 40. ACTUAL TURBID WASTEWATER FLOW; CUMULATIVE, UNDERWAY

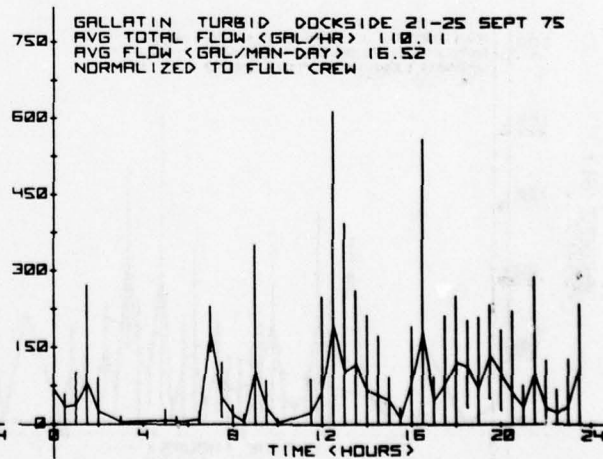
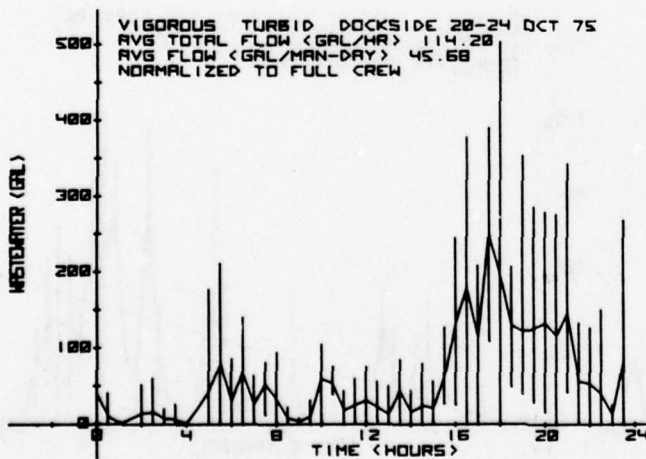
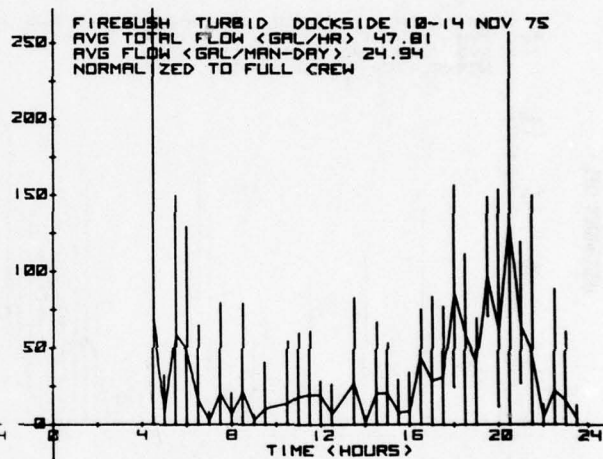
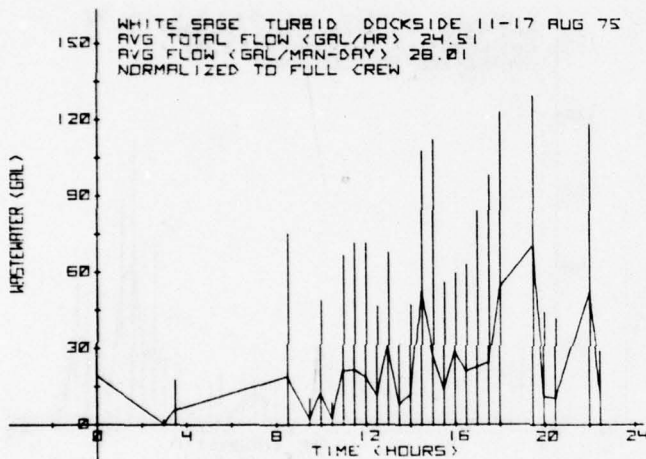
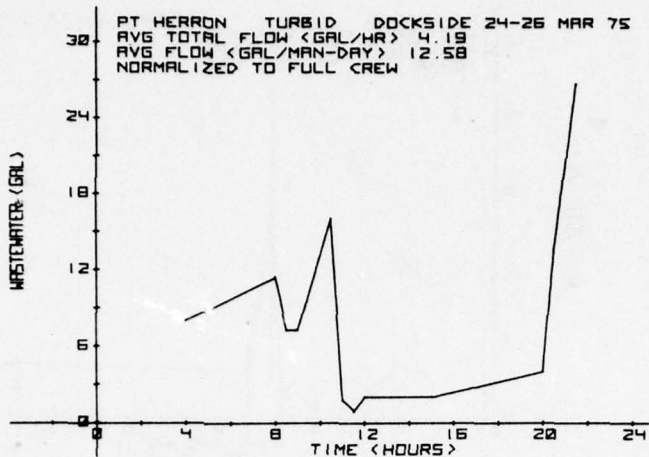

FIGURE 41. NORMALIZED TURBID WASTEWATER FLOW; SEGMENTED, DOCKSIDE

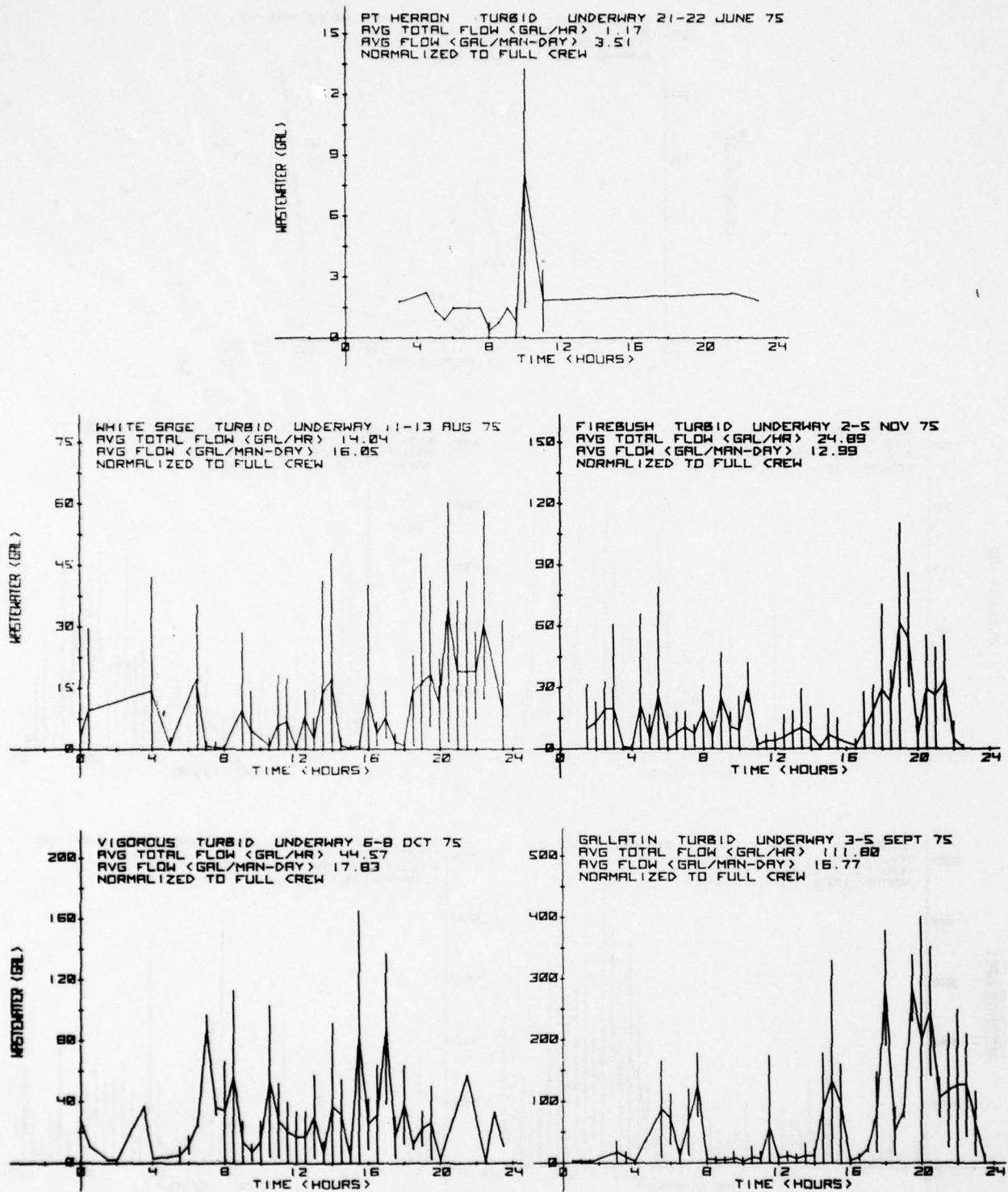

FIGURE 42. NORMALIZED TURBID WASTEWATER FLOW; SEGMENTED, UNDERWAY

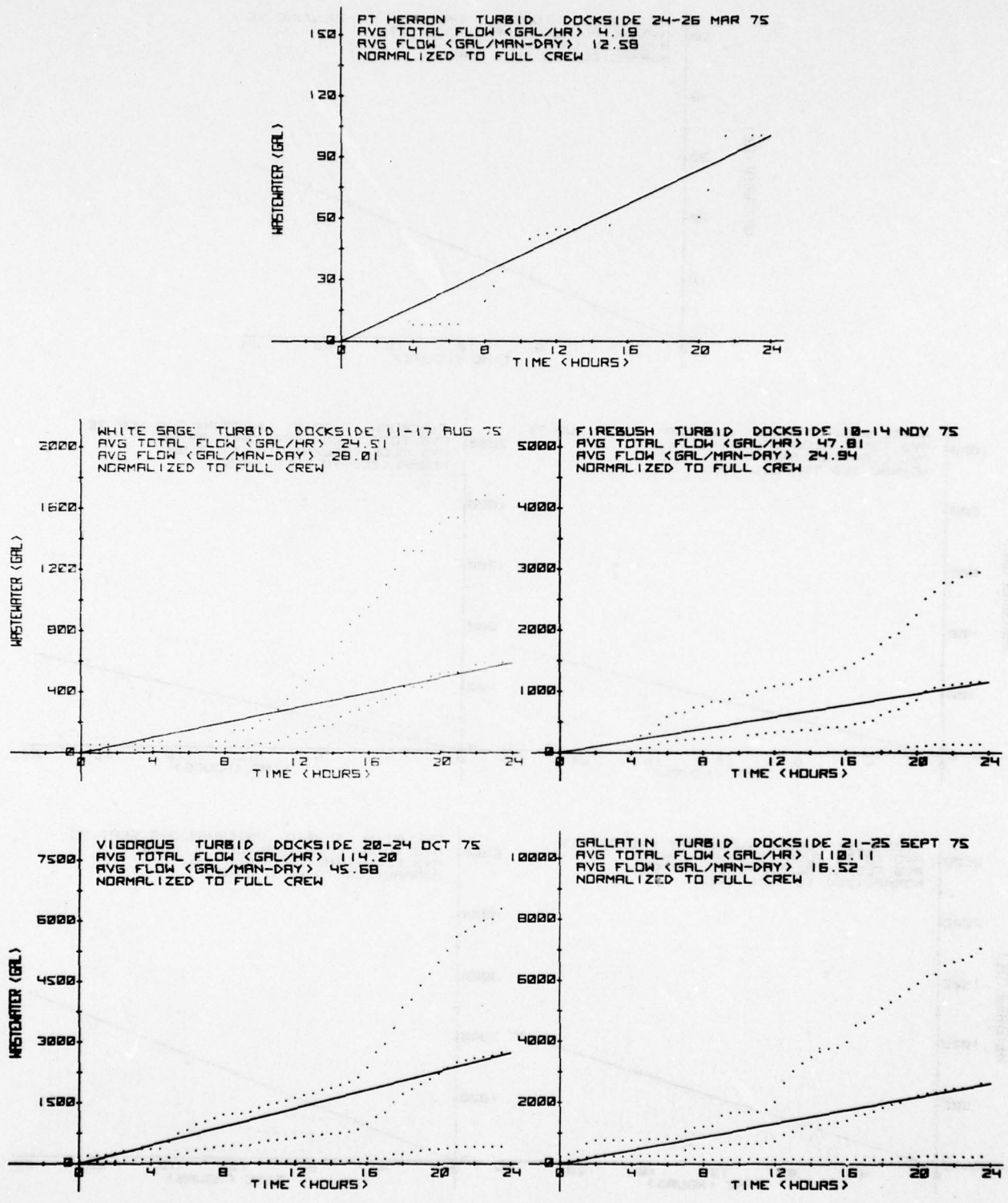

FIGURE 43. NORMALIZED TURBID WASTEWATER FLOW; CUMULATIVE, DOCKSIDE

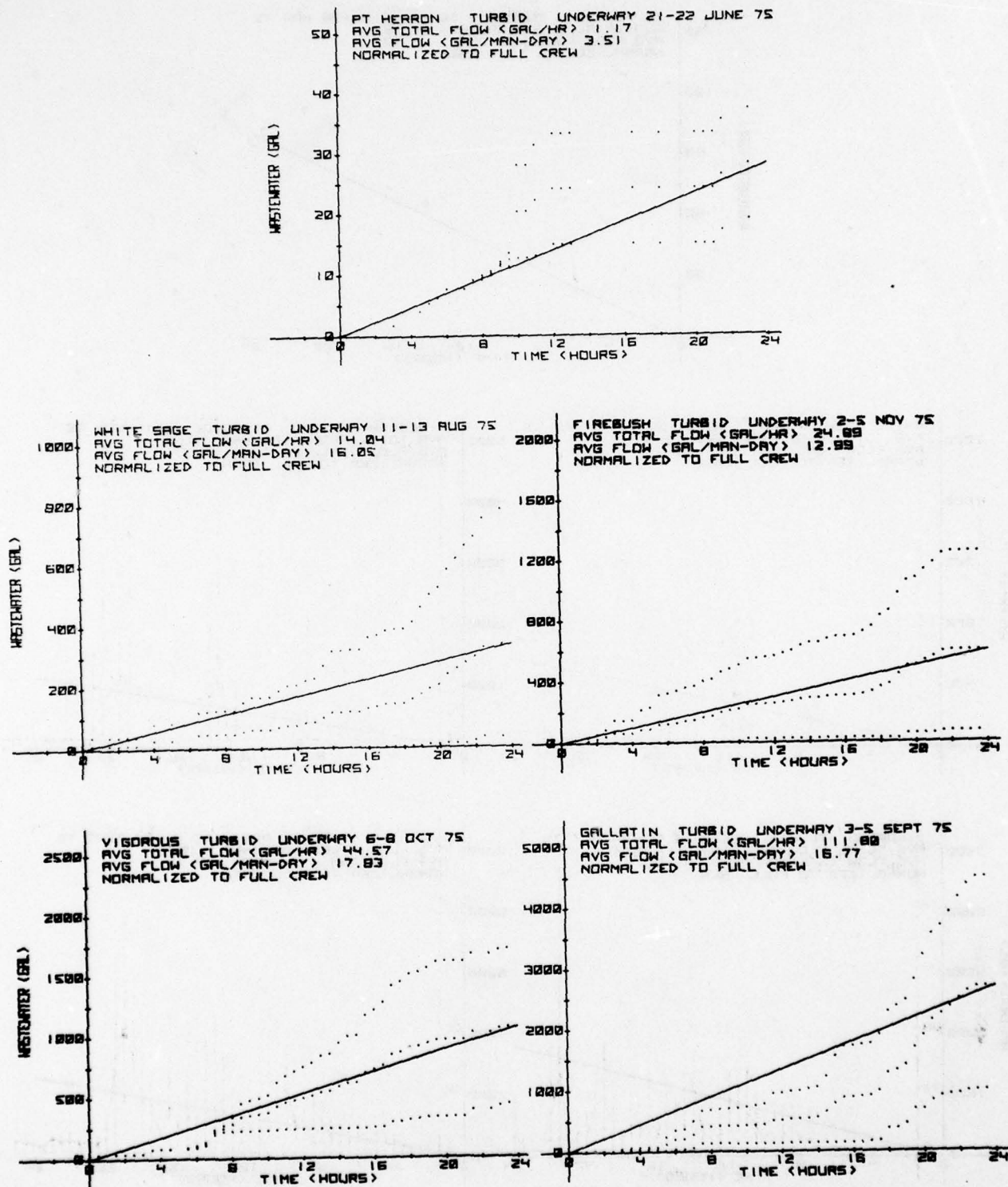

FIGURE 44. NORMALIZED TURBID WASTEWATER FLOW; CUMULATIVE, UNDERWAY

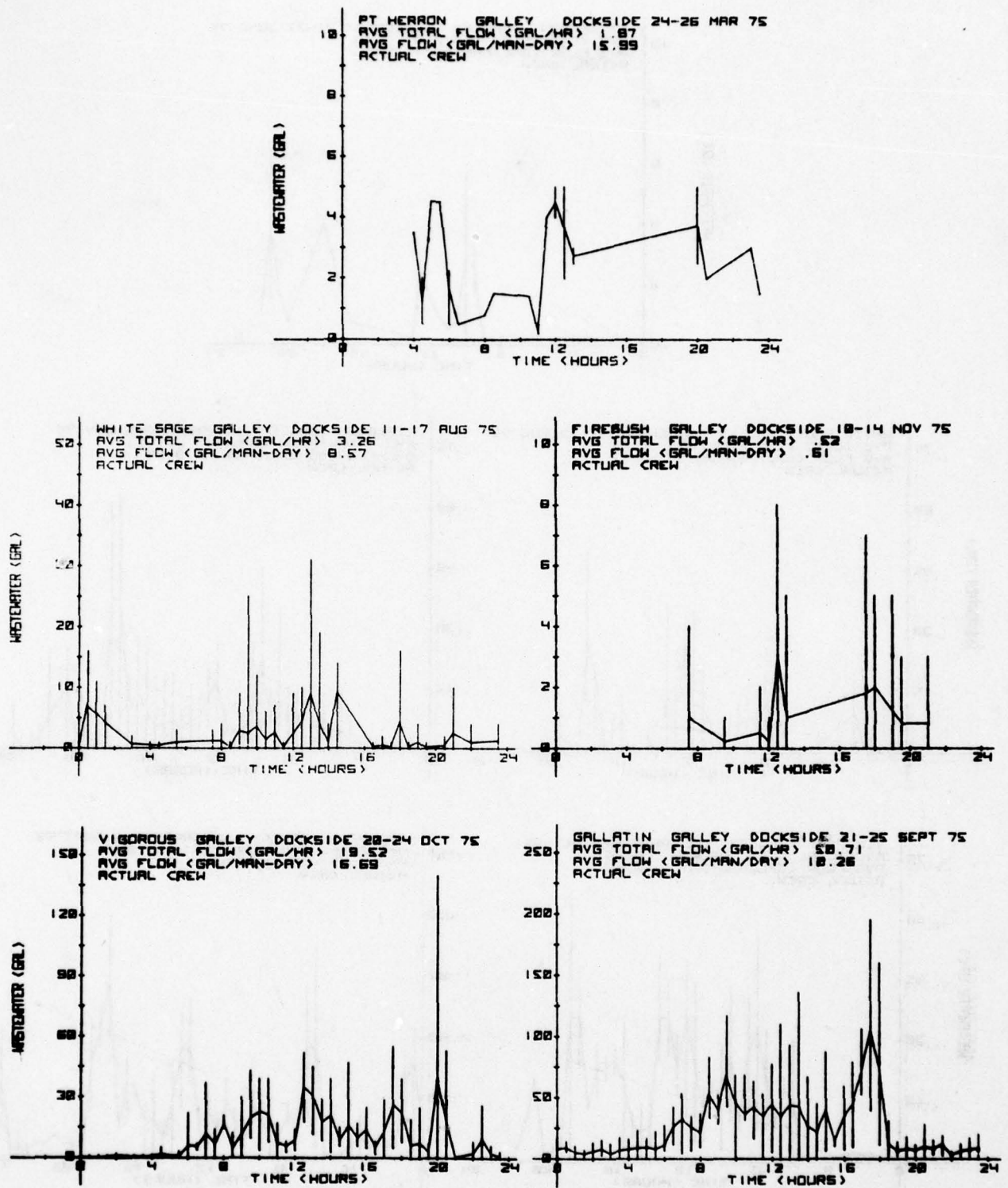

FIGURE 45. ACTUAL GALLEY WASTEWATER FLOW; SEGMENTED, DOCKSIDE

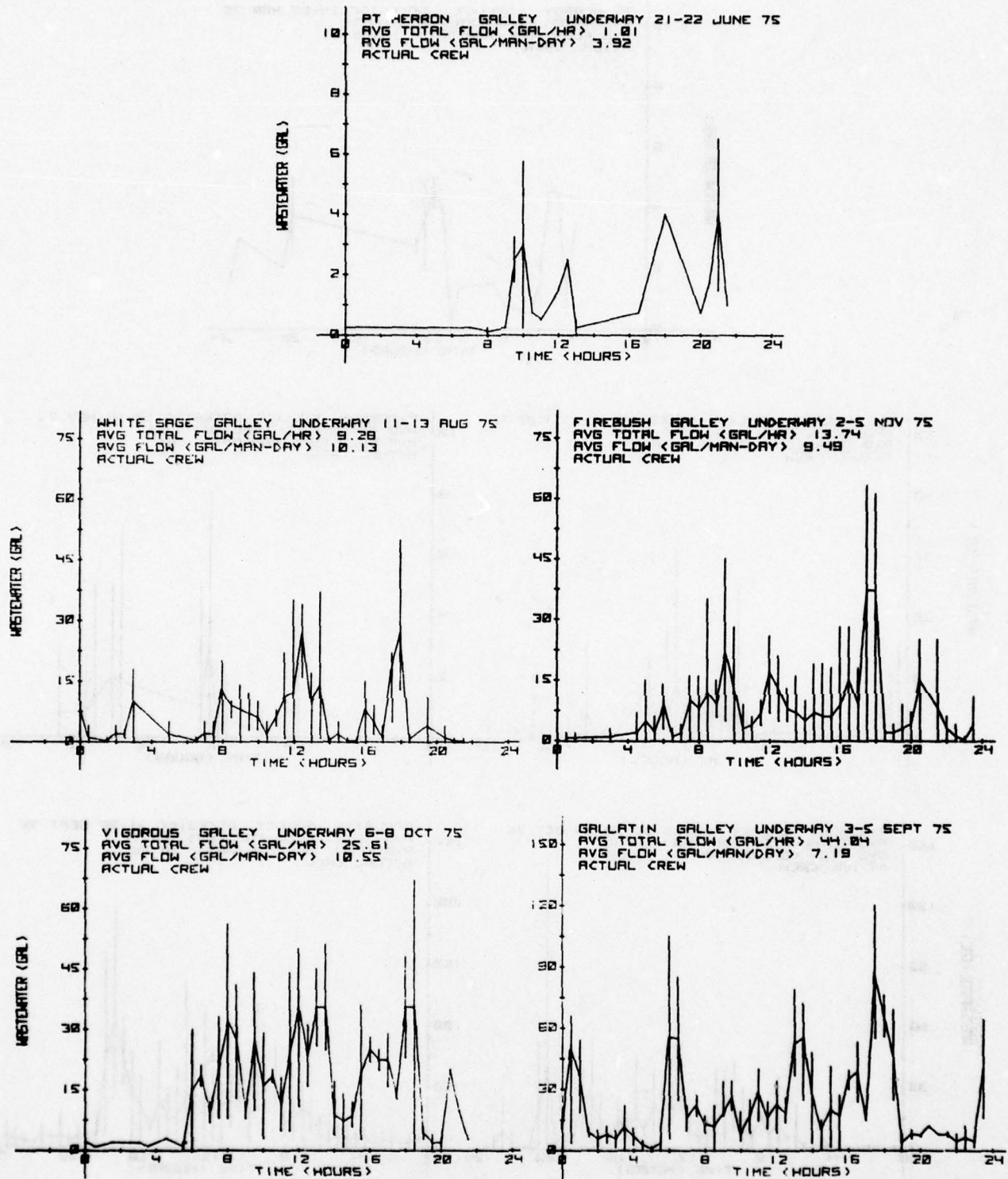

FIGURE 46. ACTUAL GALLEY WASTEWATER FLOW; SEGMENTED, UNDERWAY

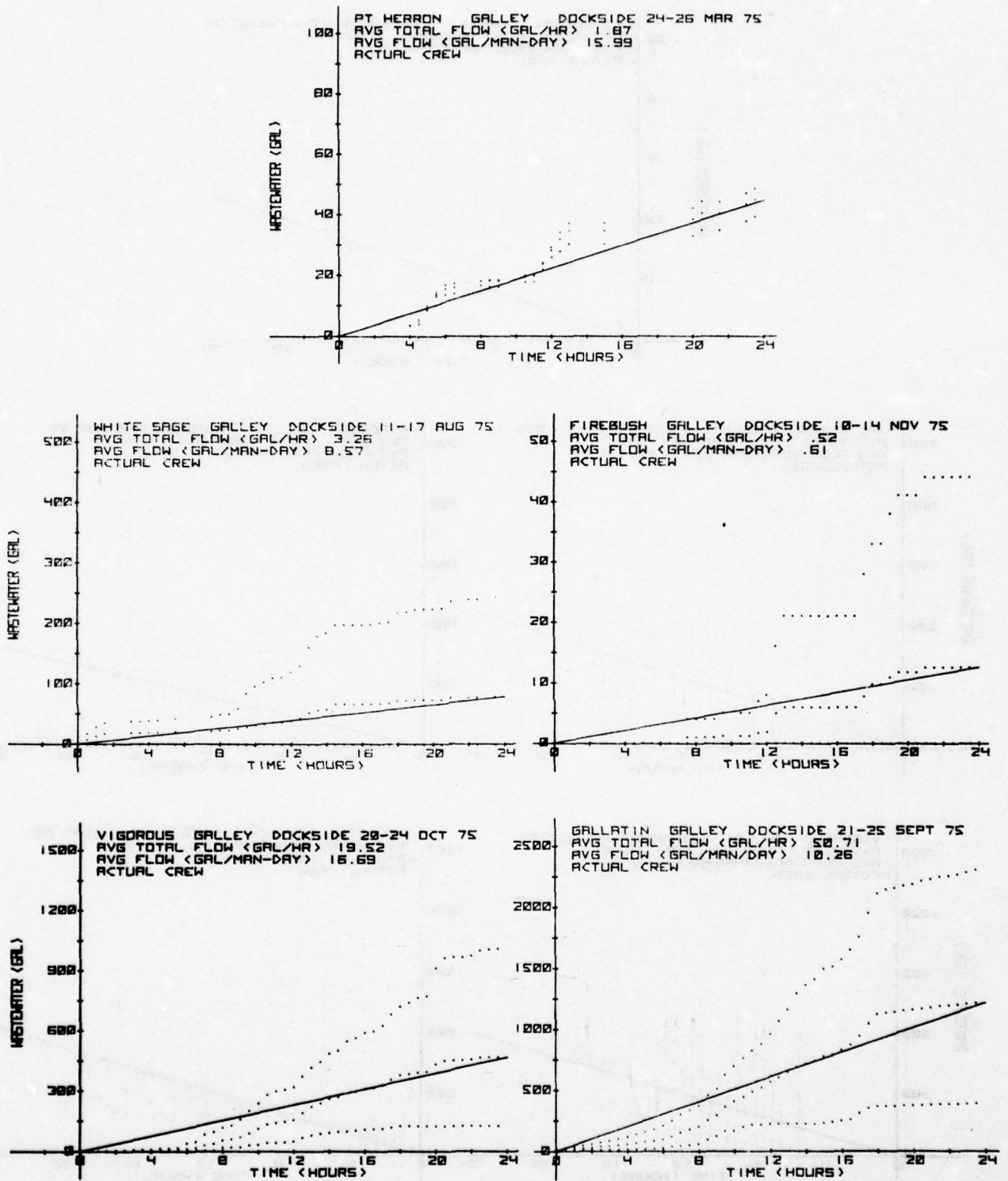

FIGURE 47. ACTUAL GALLEY WASTEWATER FLOW; CUMULATIVE, DOCKSIDE

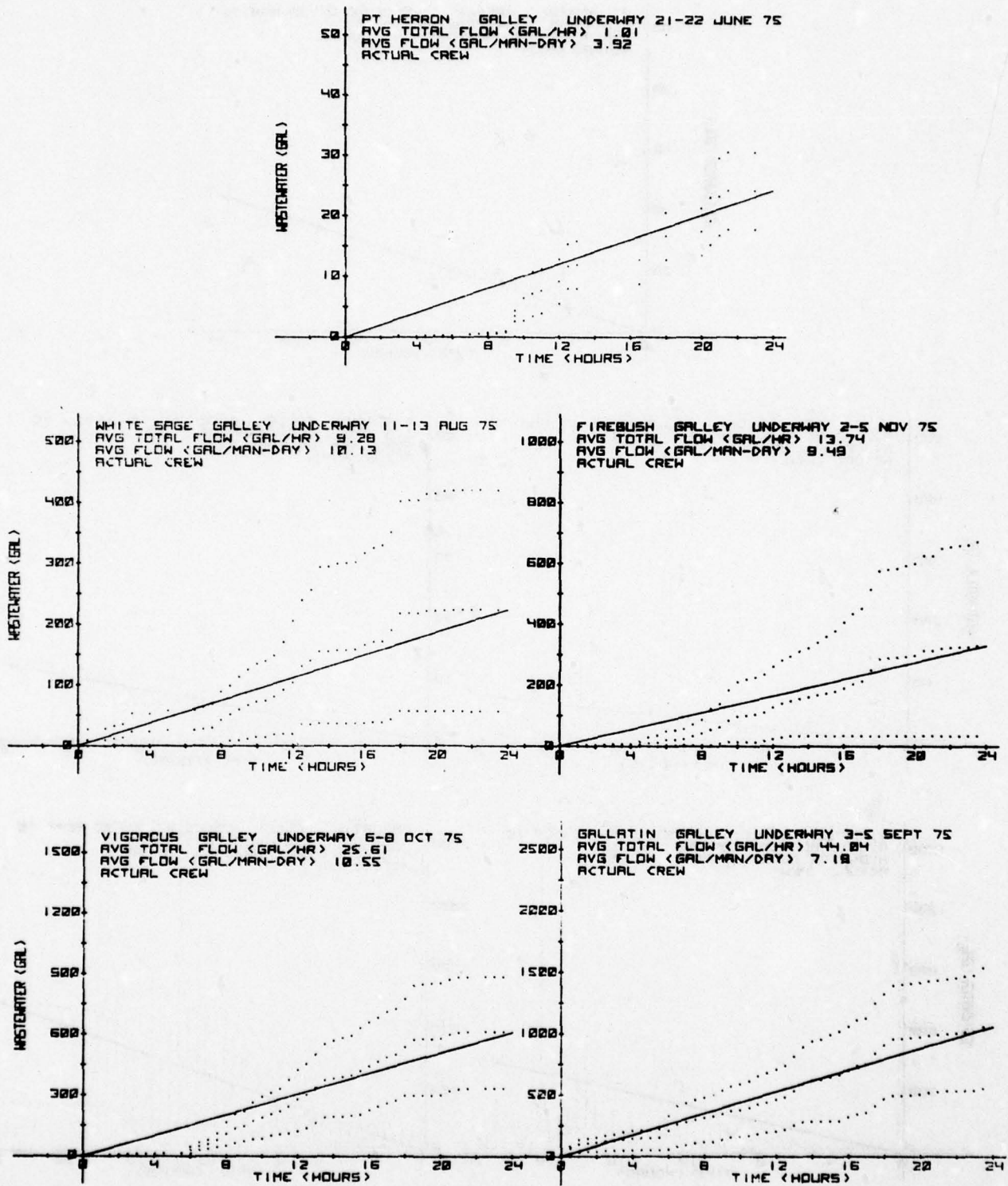

FIGURE 48. ACTUAL GALLEY WASTEWATER FLOW; CUMULATIVE, UNDERWAY

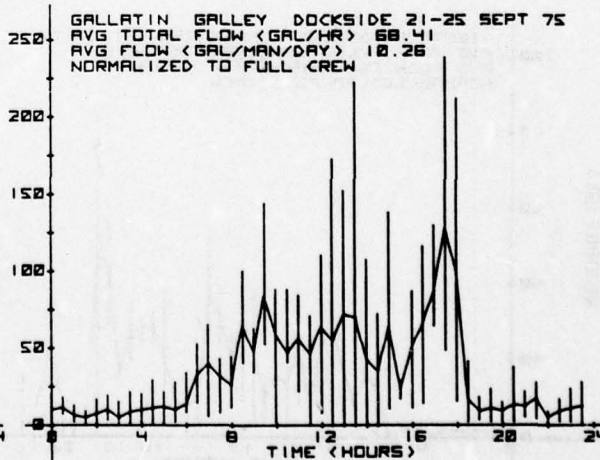
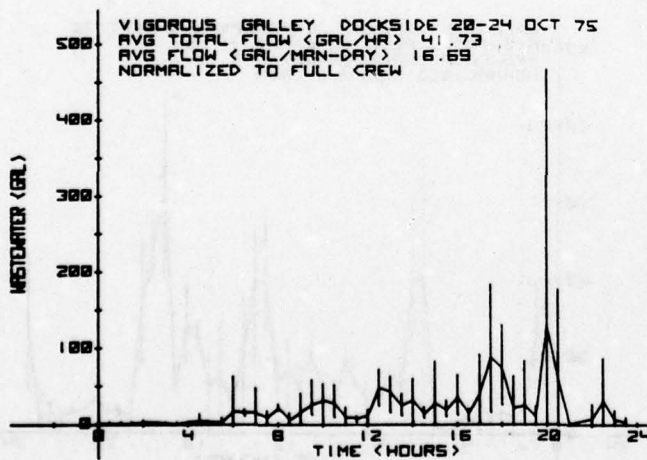
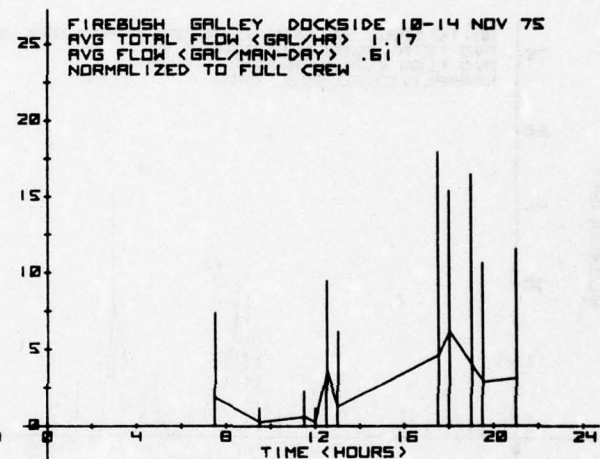
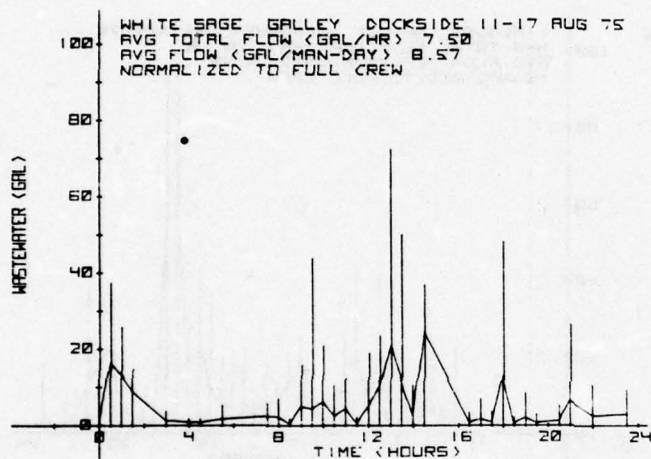
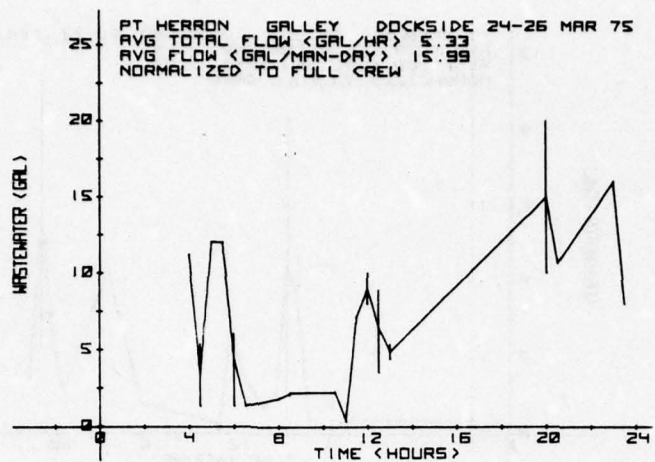

FIGURE 49. NORMALIZED GALLEY WASTEWATER FLOW; SEGMENTED, DOCKSIDE

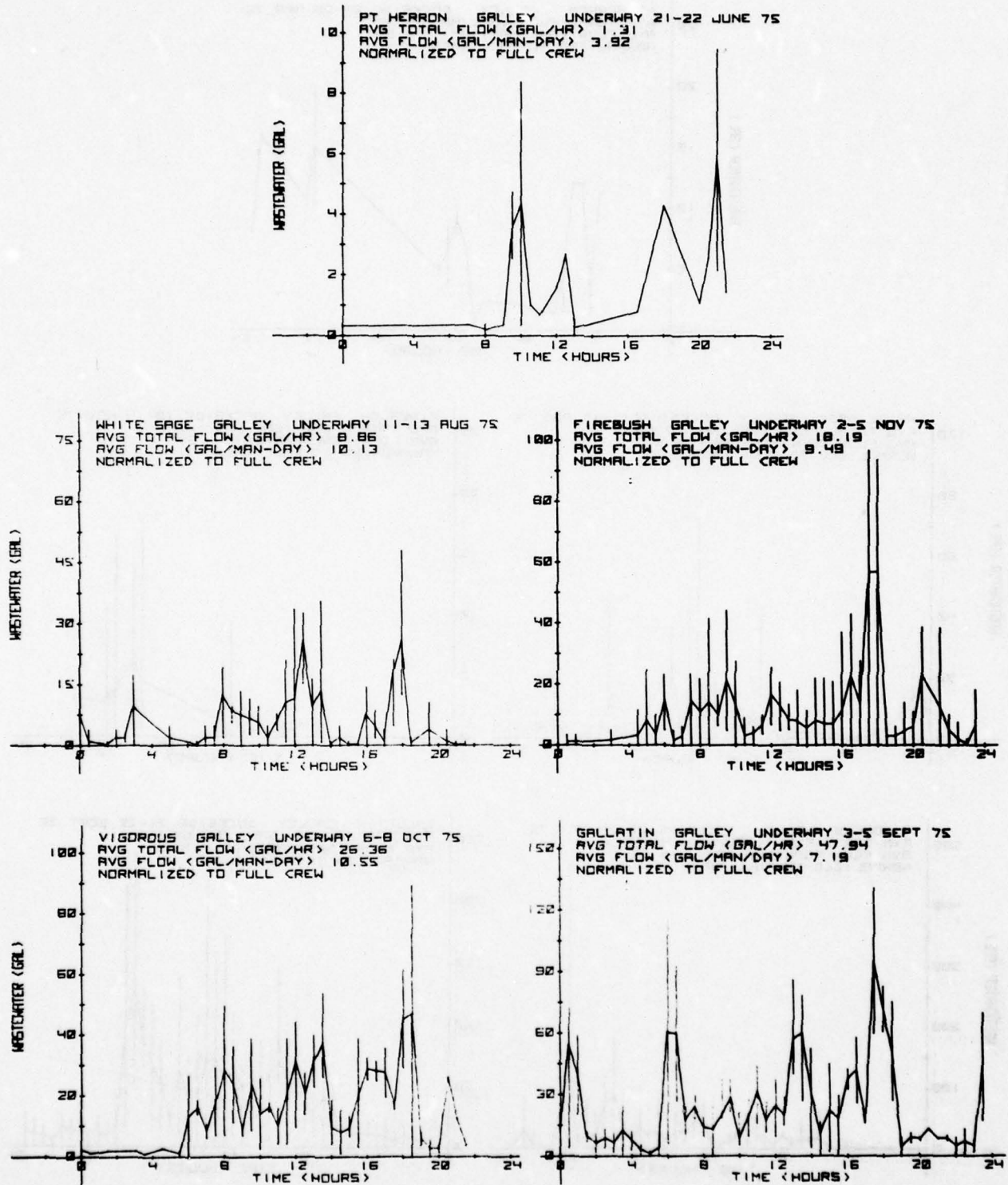

FIGURE 50. NORMALIZED GALLEY WASTEWATER FLOW; SEGMENTED, UNDERWAY

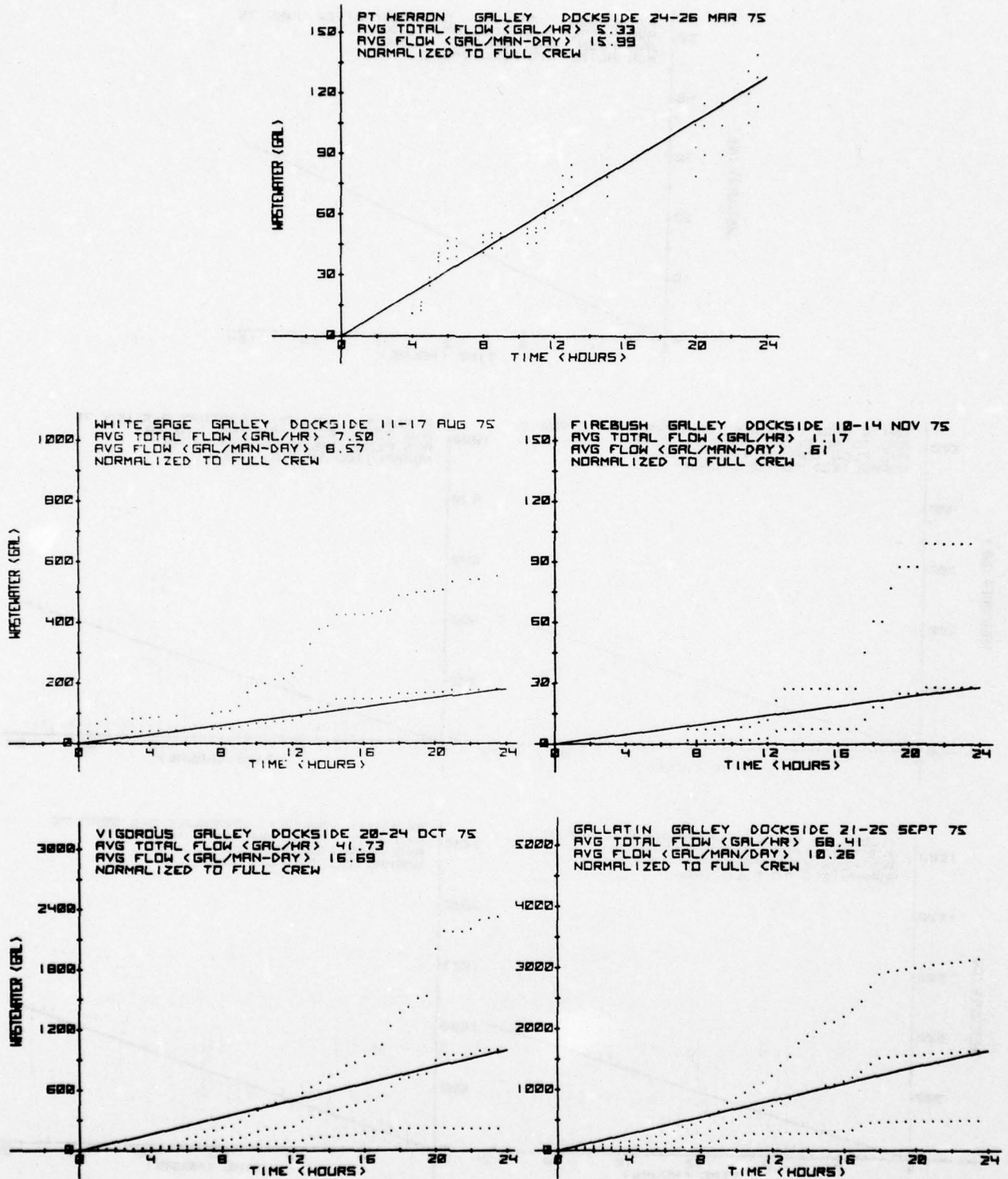

FIGURE 51. NORMALIZED GALLEY WASTEWATER FLOW; CUMULATIVE, DOCKSIDE

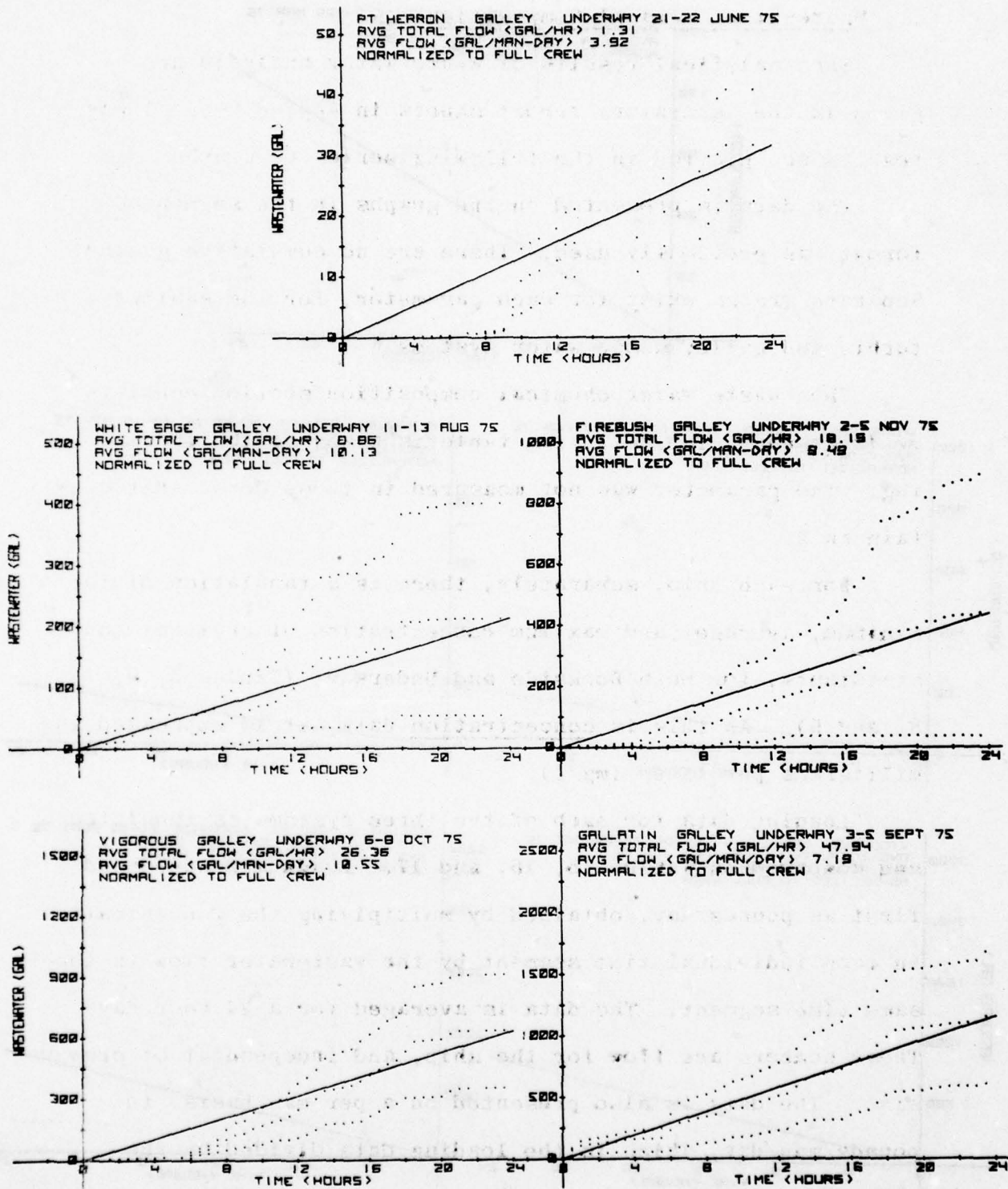

FIGURE 52. NORMALIZED GALLEY WASTEWATER FLOW; CUMULATIVE, UNDERWAY

c. Wastewater Chemical Composition

The analytical results of waste water analysis are given in the laboratory report sheets in Appendix C. These results are plotted in the following series of graphs.

The data is presented on the graphs in the segmented format, as previously used. There are no cumulative graphs. Separate graphs exist for each parameter, for the sanitary, turbid and galley waste water systems.

This waste water chemical composition section consists of 42 graphs. The following table is a key to their numbering. The parameter was not measured in those boxes that contain an X.

For each ship, separately, there is a tabulation of the minimum, average, and maximum concentration of chemical constituents, for both Dockside and Underway, (Tables 5, 6, 7, 8, and 9). As this is concentration data, it is expressed in milligrams per liter (mg/l).

Loading data for each of the three systems is tabulated and compared on Tables 15, 16, and 17. Loads are expressed first as pounds/day, obtained by multiplying the concentration in each individual time segment by the wastewater flow in the same time segment. The data is averaged for a 24 hour day. These numbers are flow for the ship, and independent of crew size. The data is also presented on a per man basis, in pounds/man/day, which is the loading data divided by the actual number of men on board in each time segment.

TABLE 4
KEY TO THE LOCATION OF CHEMICAL COMPOSITION

	<u>Sanitary</u>	<u>Turbid</u>	<u>Galley</u>
Total Solids			
Dockside	Figure 53	Figure 55	Figure 57
Underway	" 54	" 56	" 58
Suspended Solids			
Dockside	" 59	" 61	" 63
Underway	" 60	" 62	" 64
pH			
Dockside	" 65	" 67	" 69
Underway	" 66	" 68	" 70
Hardness			
Dockside	X	" 71	X
Underway	X	" 72	X
Oil & Grease			
Dockside	X	" 73	Figure 75
Underway	X	" 74	" 76
MBAS			
Dockside	X	" 77	" 79
Underway	X	" 78	" 80
Chloride			
Dockside	" 81	X	X
Underway	" 82	X	X
COD			
Dockside	" 83	" 85	" 87
Underway	" 84	" 85	" 88
BOD			
Dockside	" 89	" 90	" 91
Underway	X	X	X

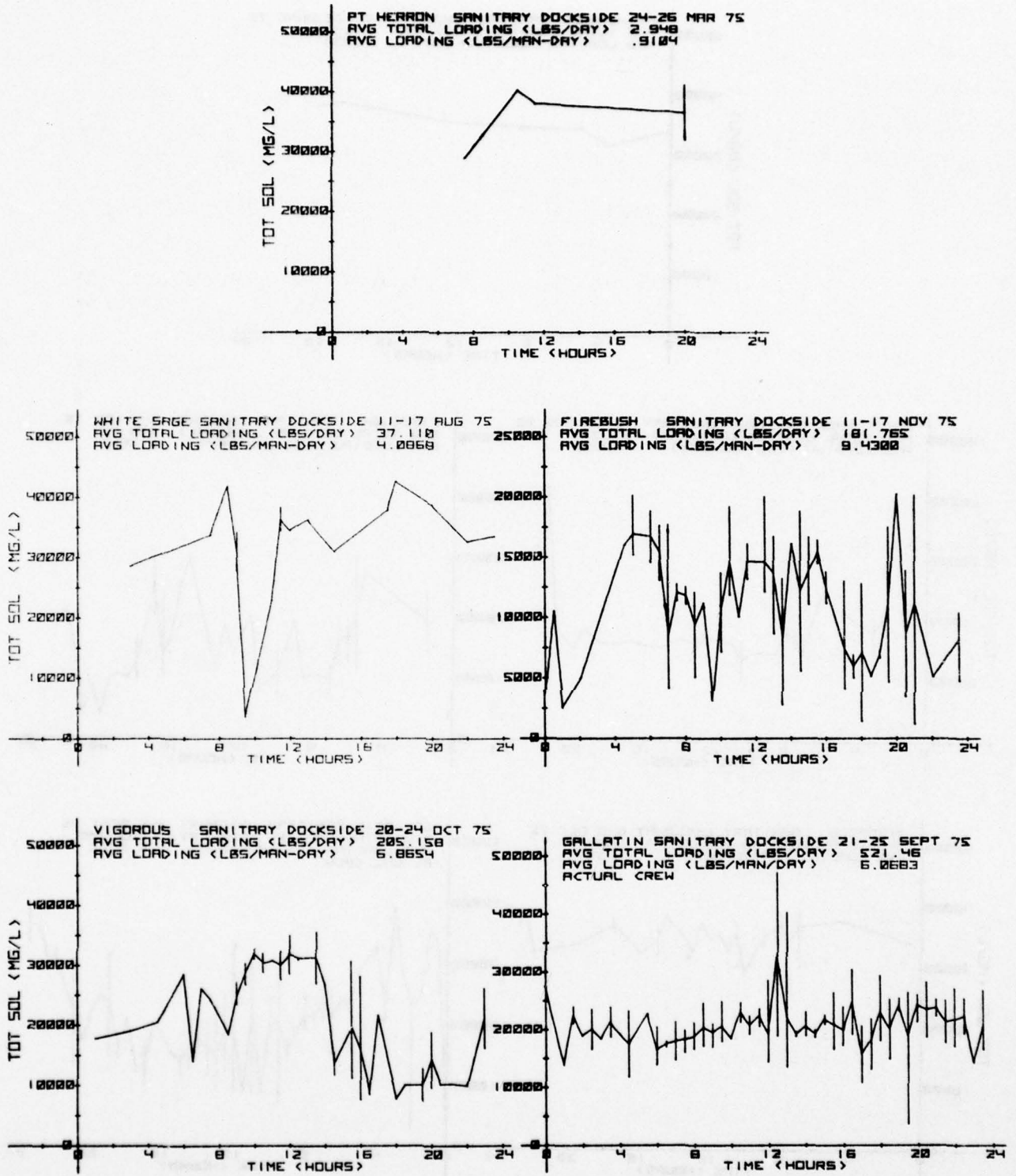

FIGURE 53. DOCKSIDE SANITARY TOTAL SOLIDS LOADS

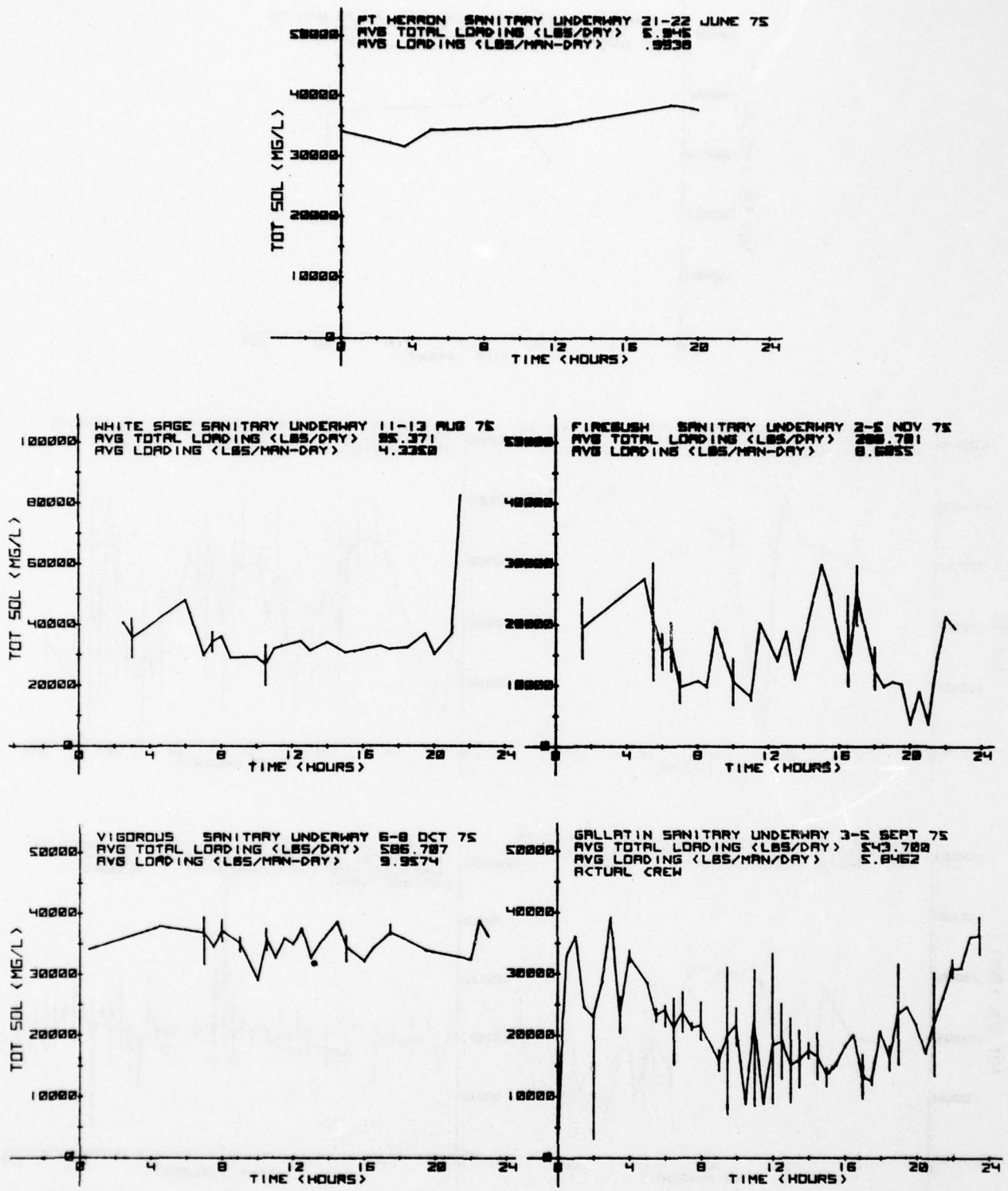

FIGURE 54. UNDERWAY SANITARY TOTAL SOLIDS LOADS

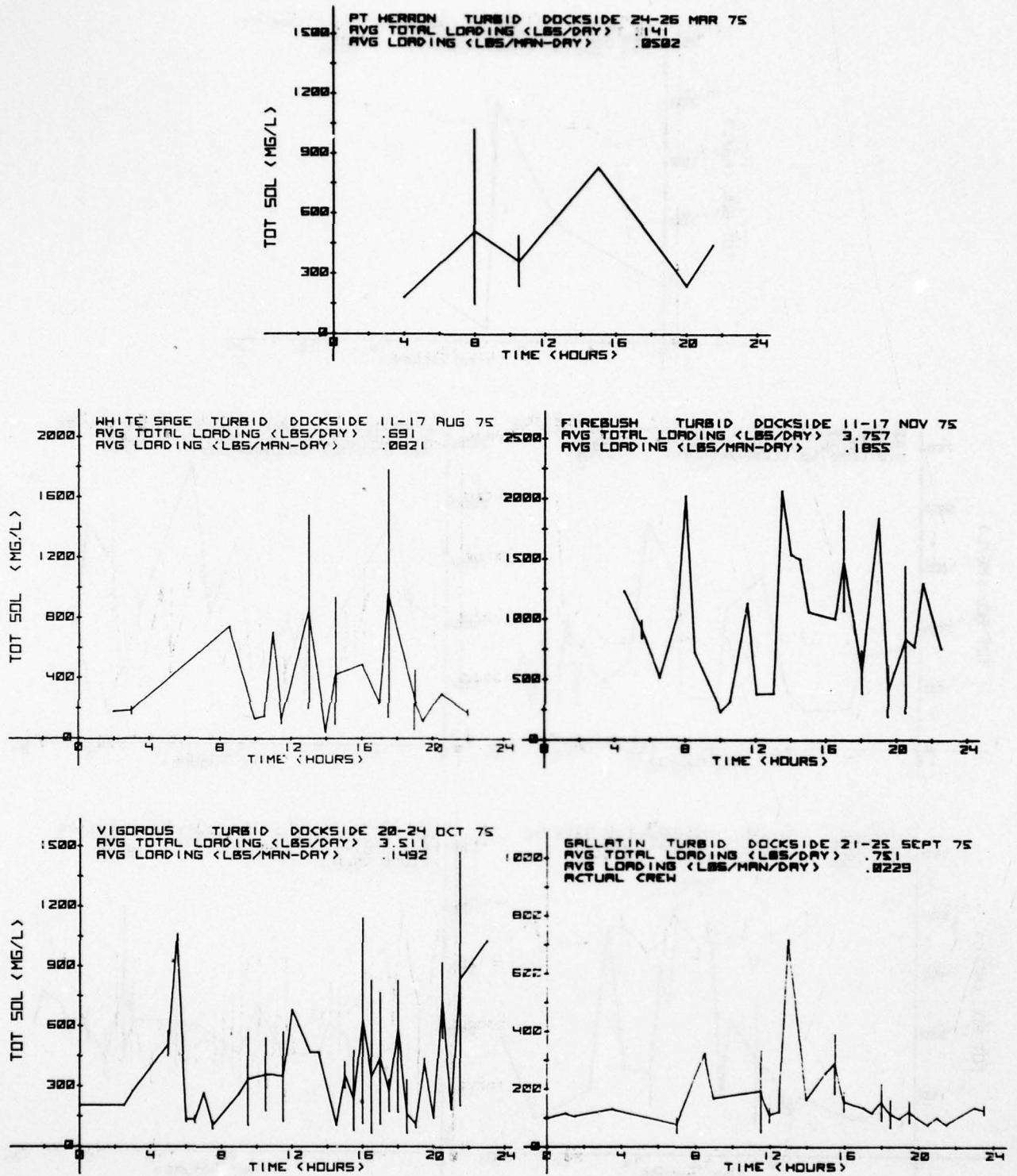

FIGURE 55. DOCKSIDE TURBID TOTAL SOLIDS LOADS

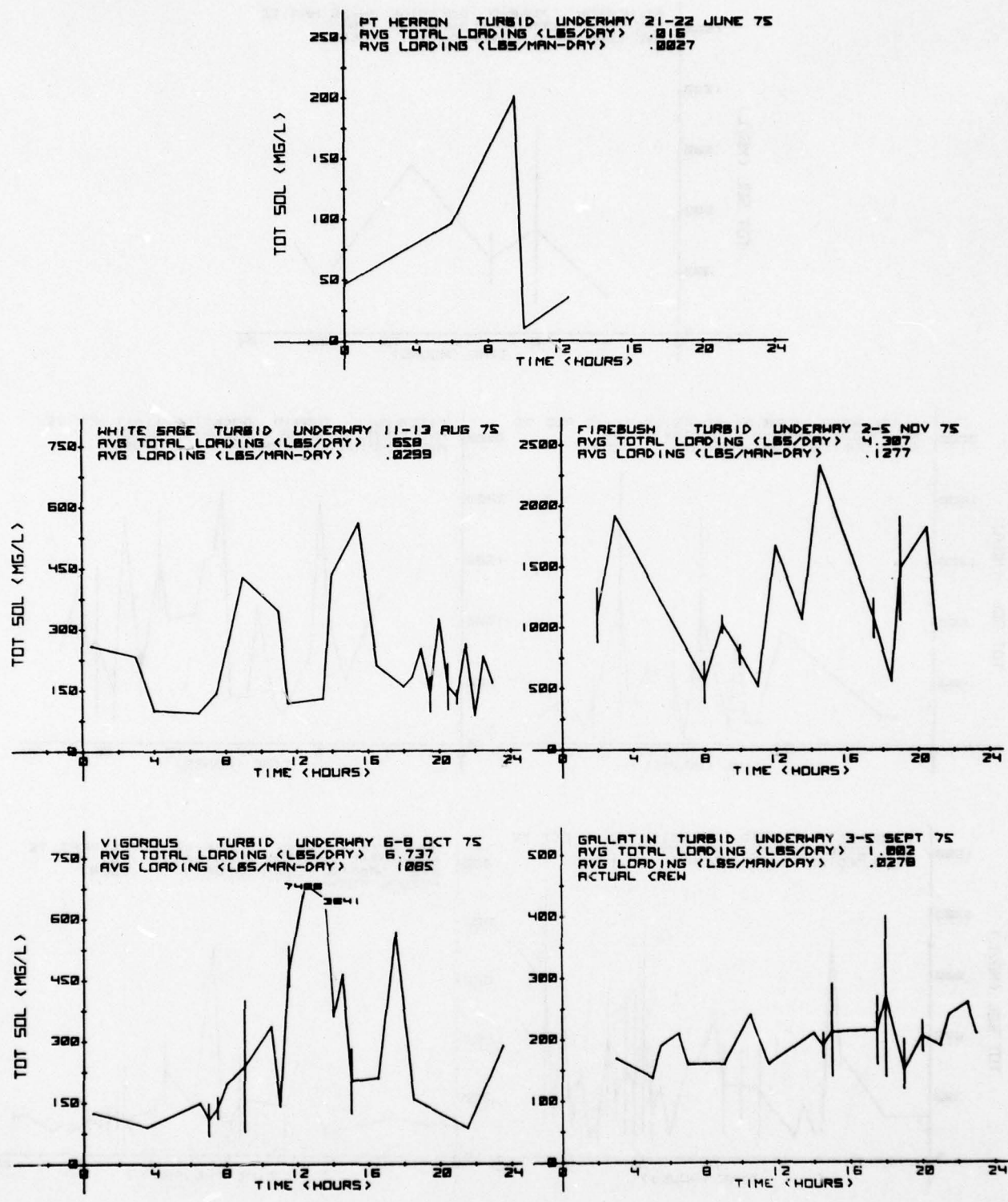

FIGURE 56. UNDERWAY TURBID TOTAL SOLIDS LOADS

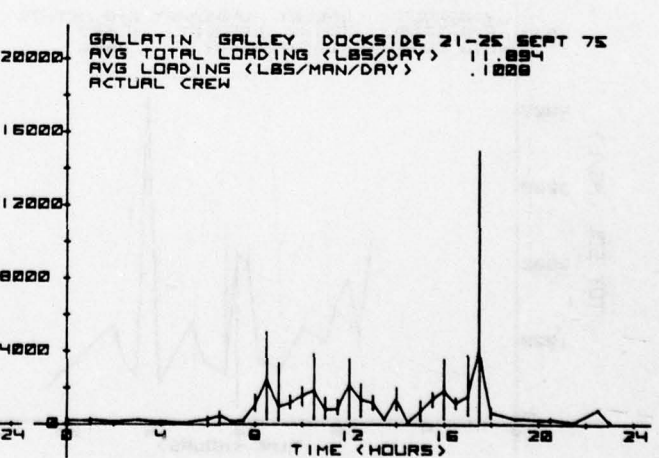
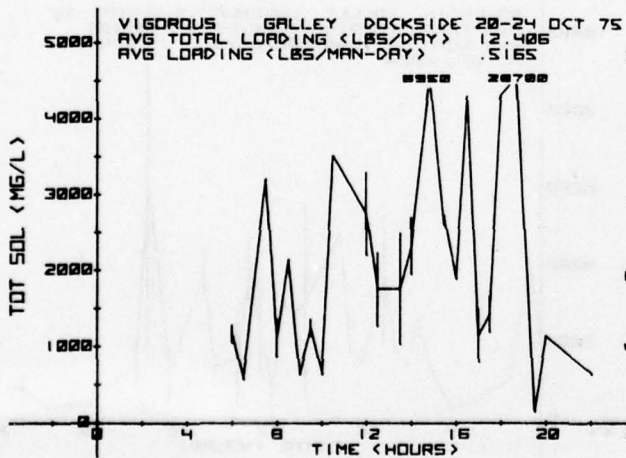
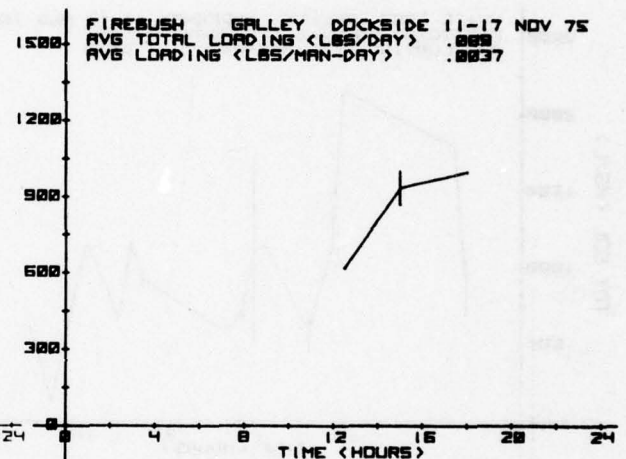
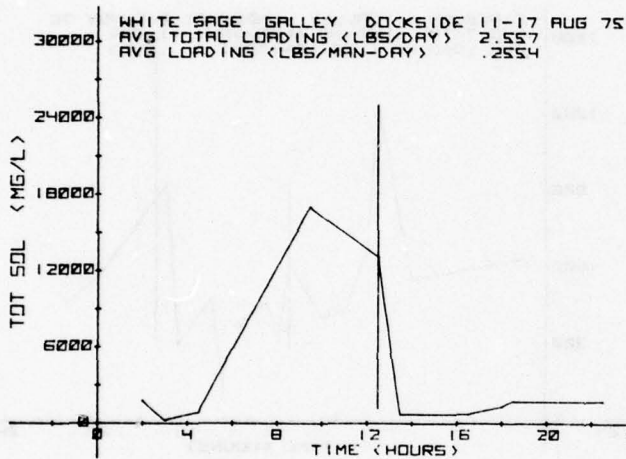
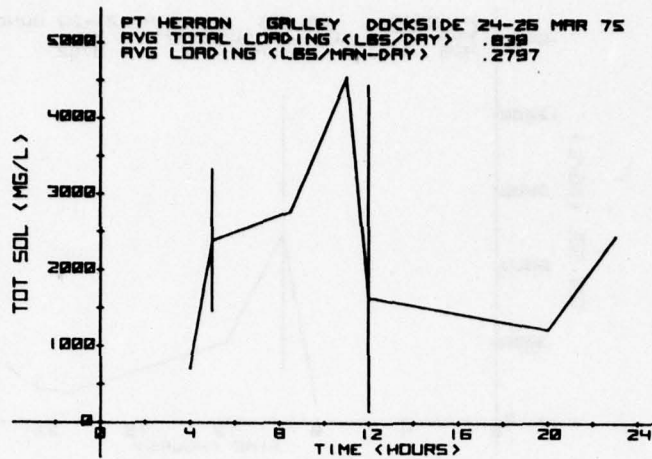

FIGURE 57. DOCKSIDE GALLEY TOTAL SOLIDS LOADS

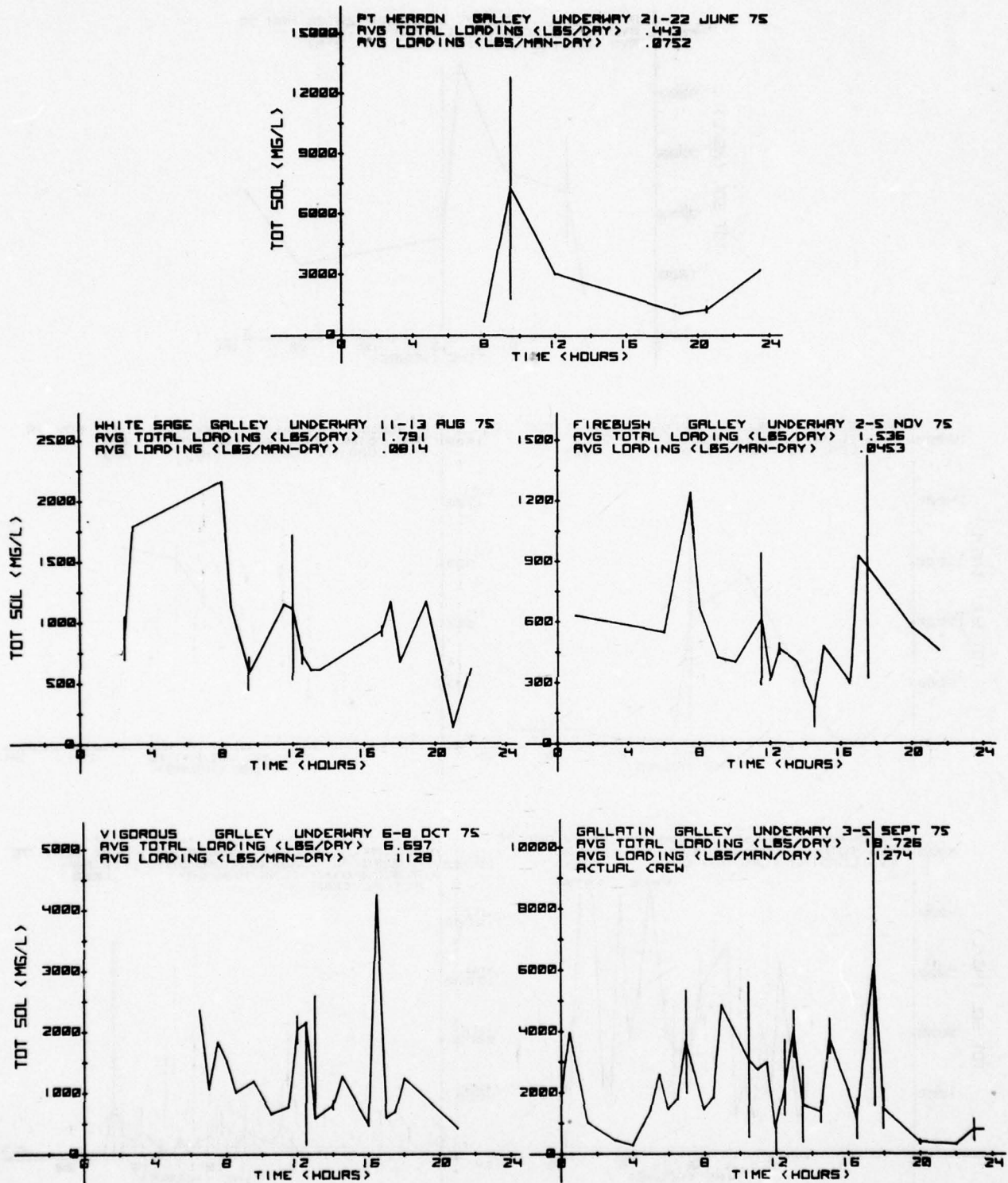

FIGURE 58. UNDERWAY GALLEY TOTAL SOLIDS LOADS

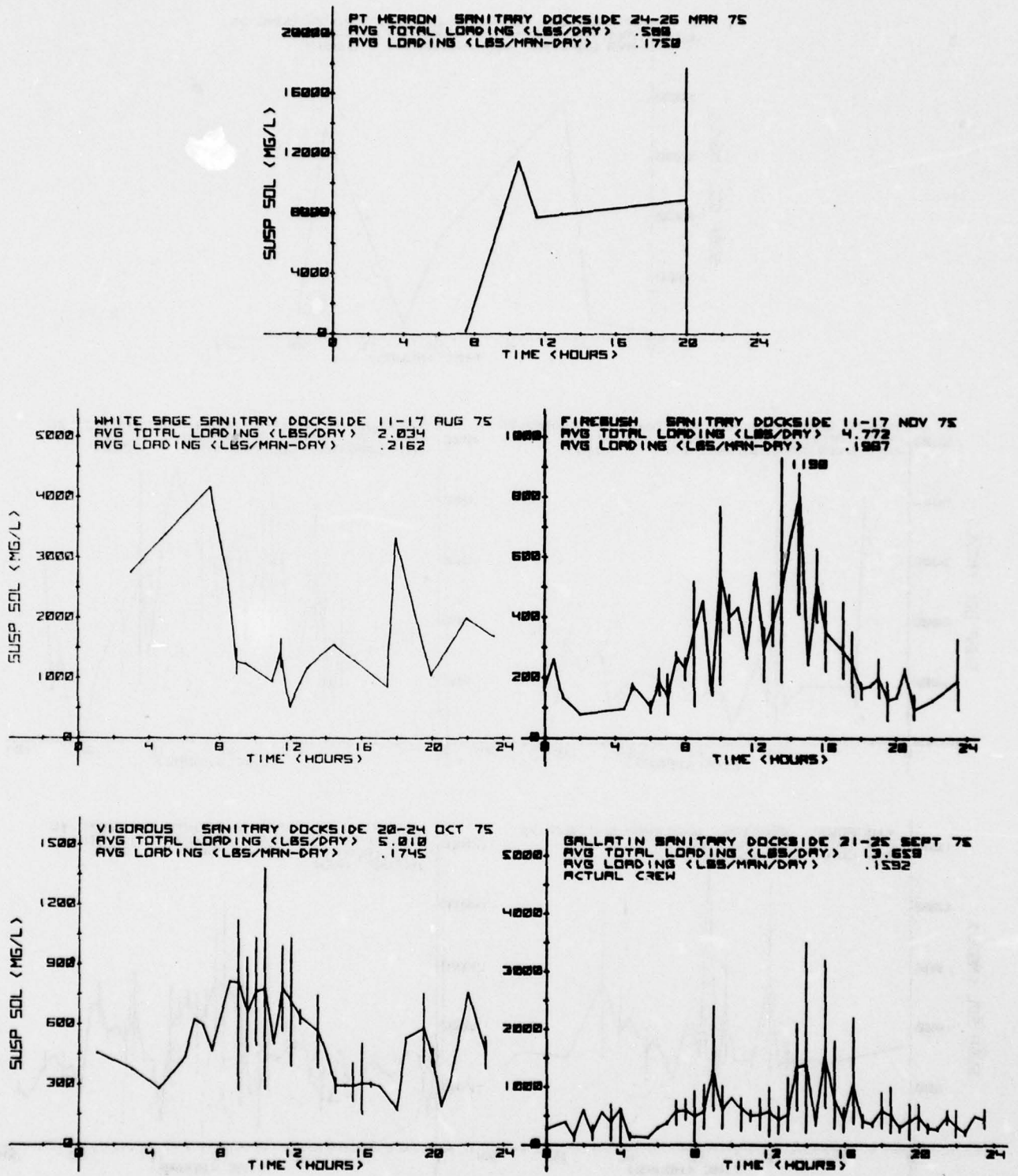

FIGURE 59. DOCKSIDE SANITARY SUSPENDED SOLIDS LOADS

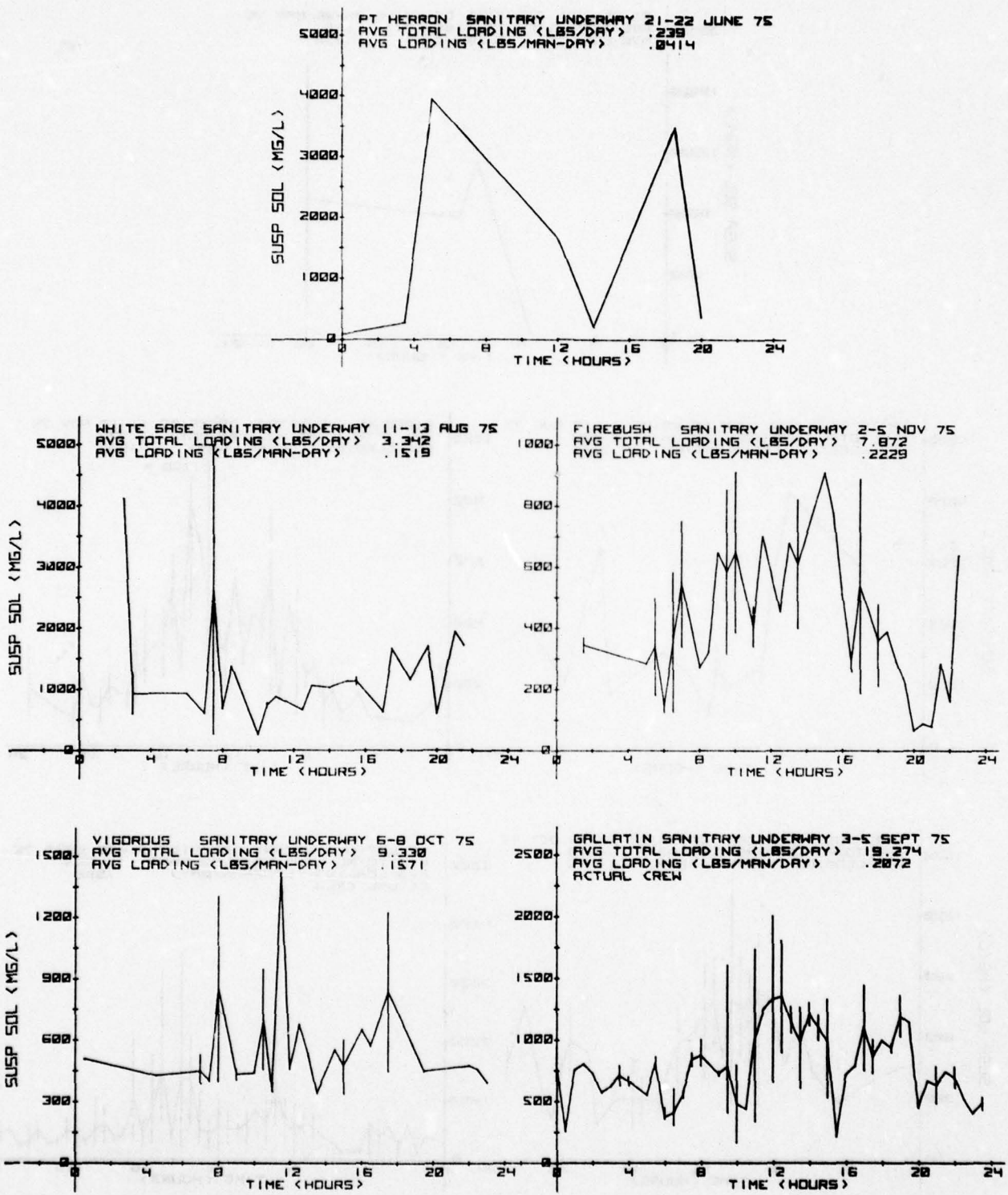

FIGURE 60. UNDERWAY SANITARY SUSPENDED SOLIDS LOADS

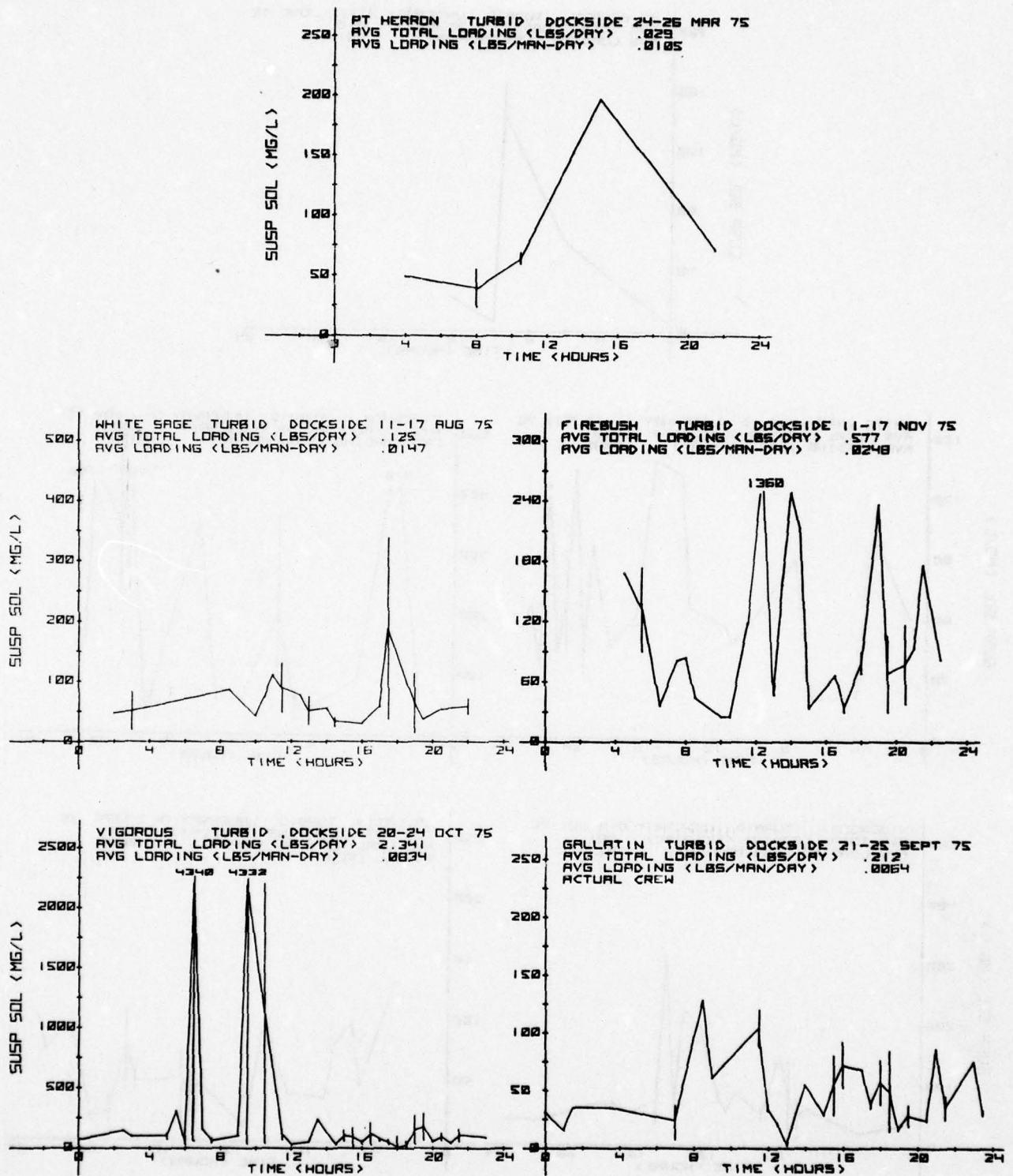

FIGURE 61. DOCKSIDE TURBID SUSPENDED SOLIDS LOADS

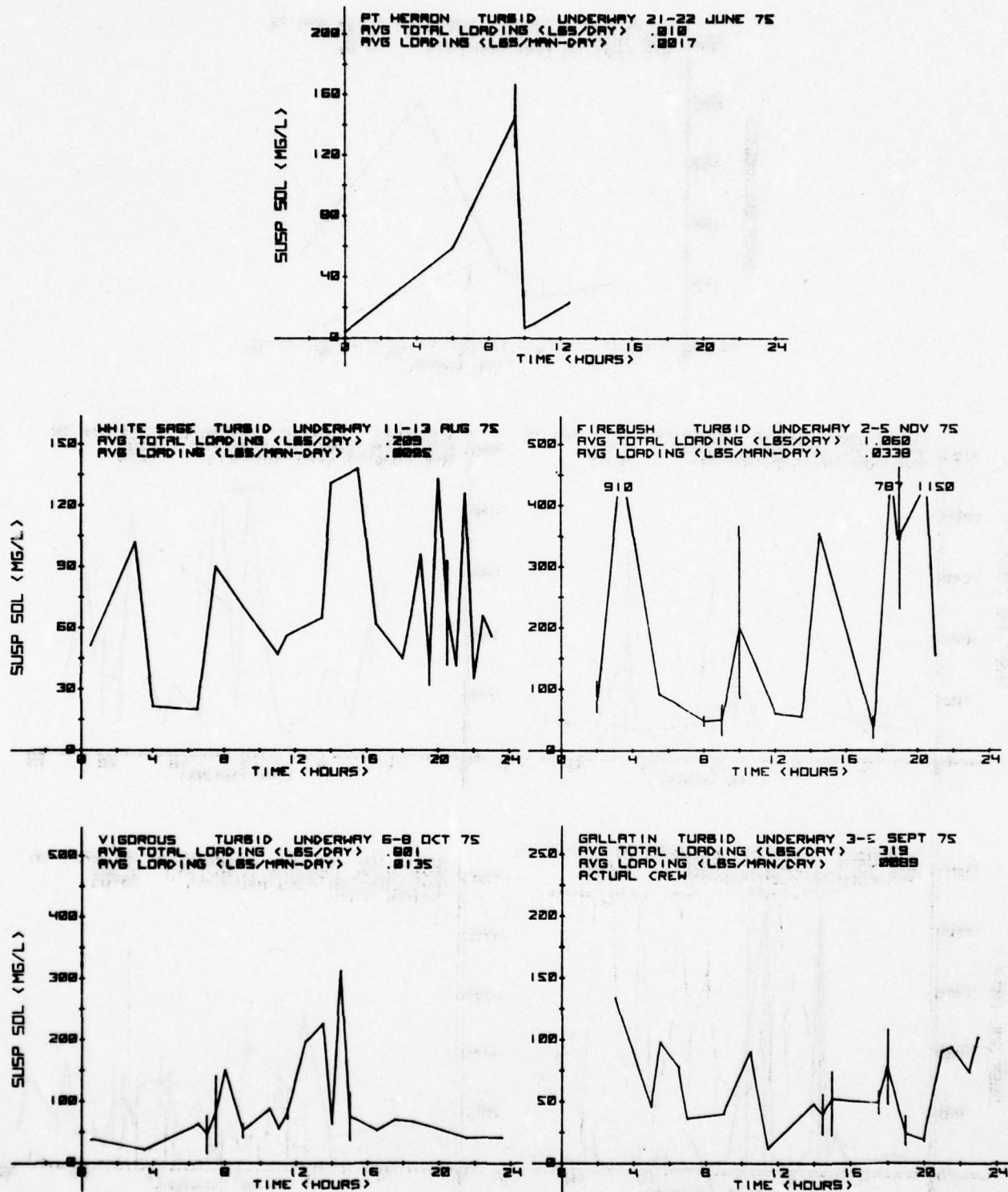

FIGURE 62. UNDERWAY TURBID SUSPENDED SOLIDS LOADS

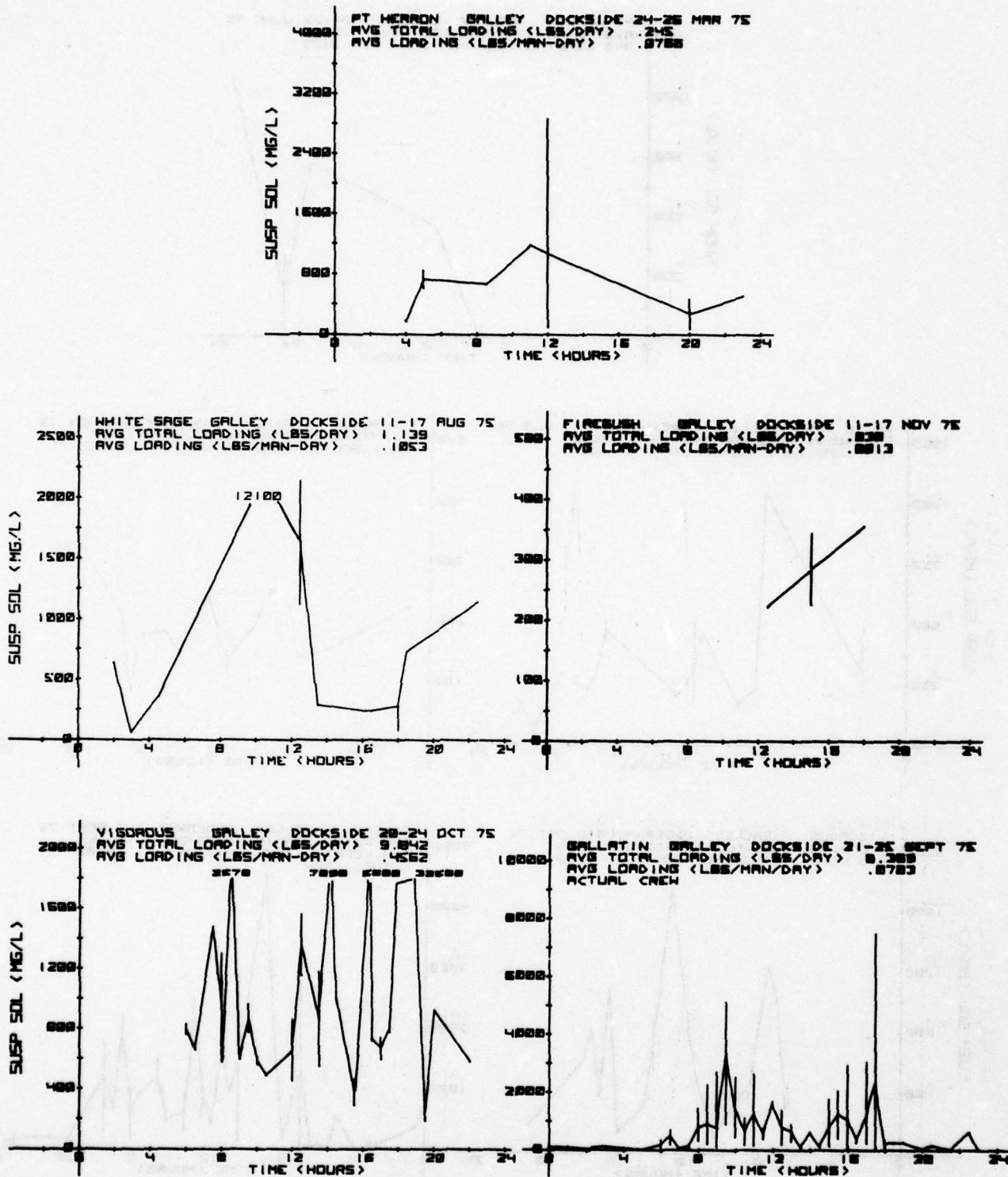

FIGURE 63. DOCKSIDE GALLEY SUSPENDED SOLIDS LOADS

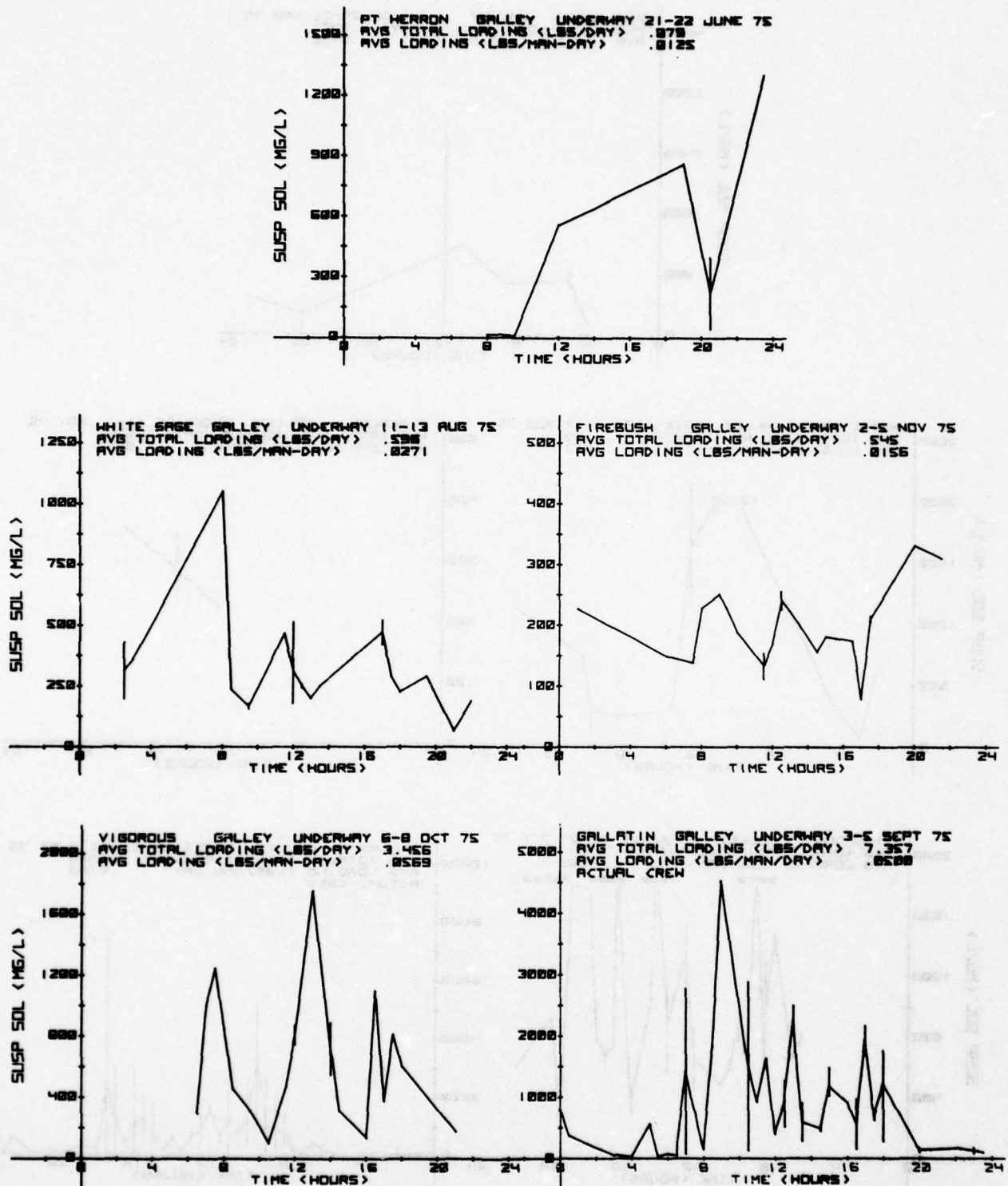

FIGURE 64. UNDERWAY GALLEY SUSPENDED SOLIDS LOADS

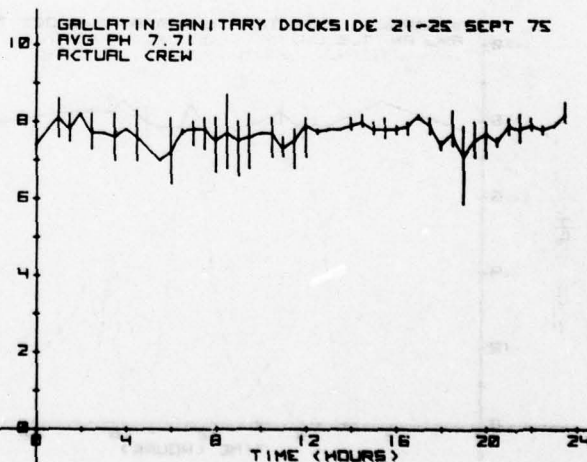
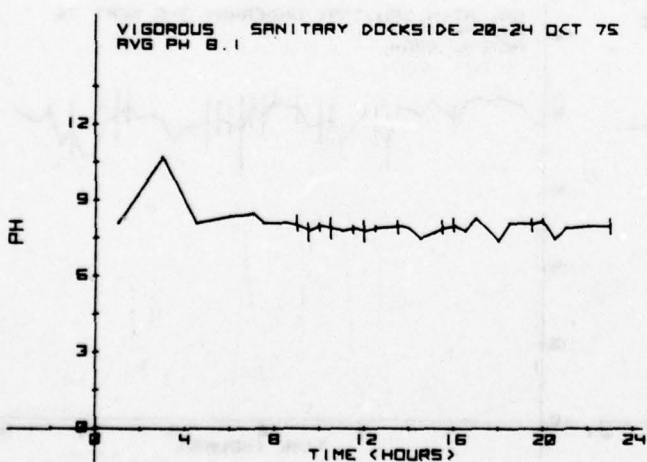
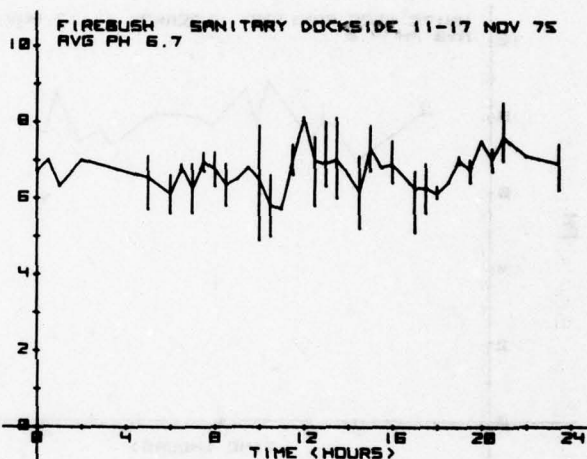
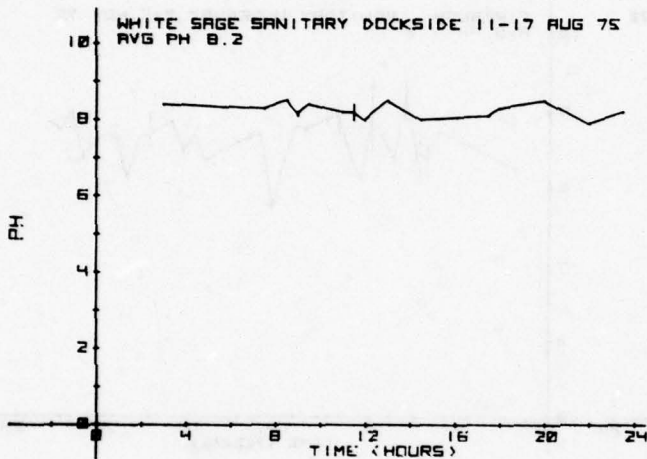
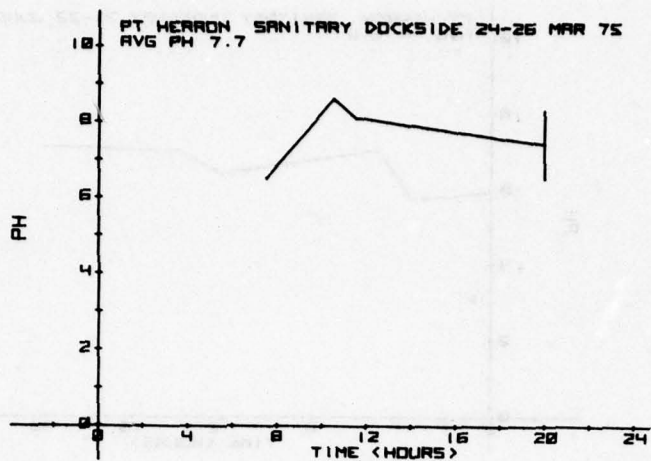

FIGURE 65. DOCKSIDE SANITARY pH

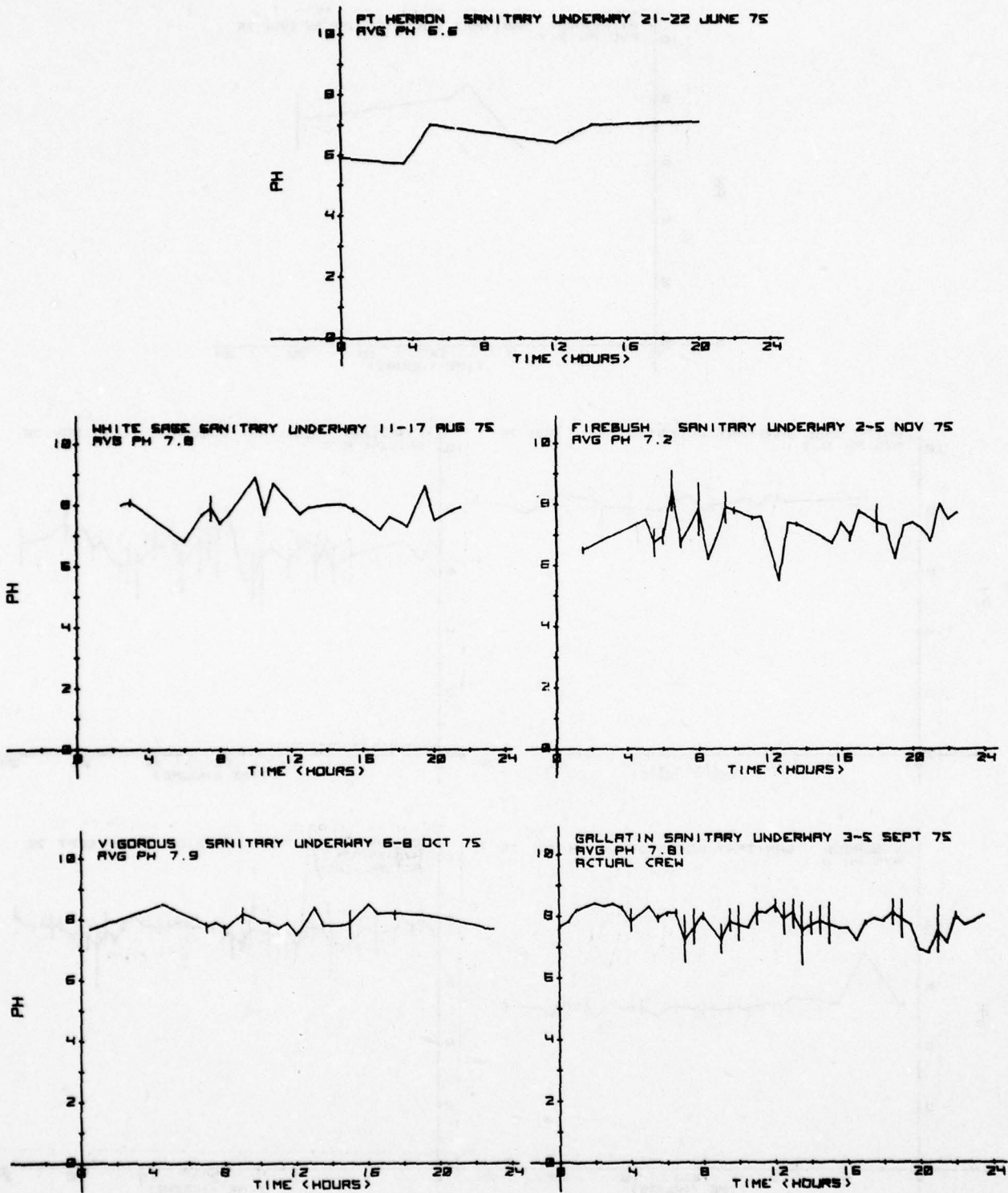

FIGURE 66. UNDERWAY SANITARY pH

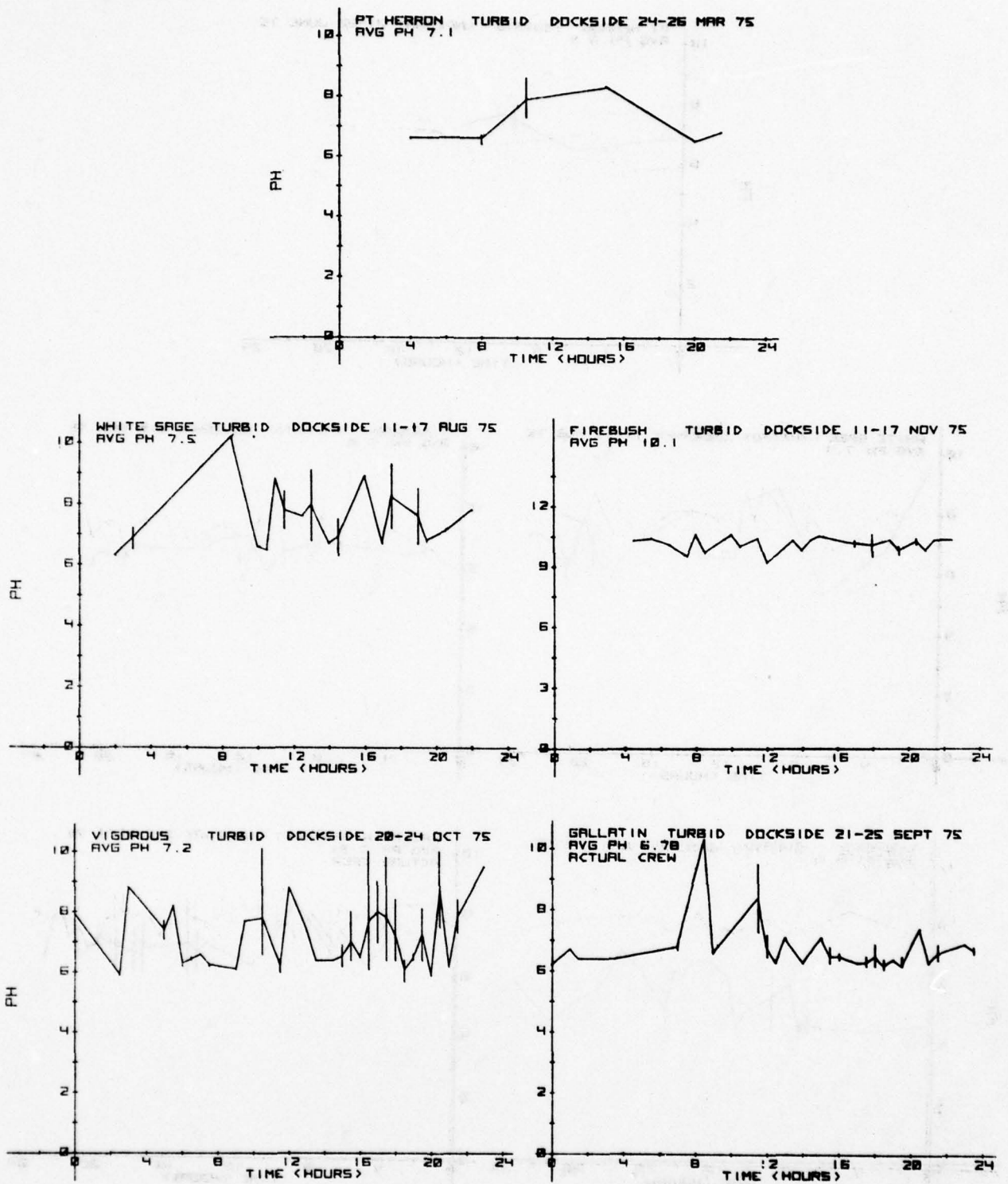

FIGURE 67. DOCKSIDE TURBID pH

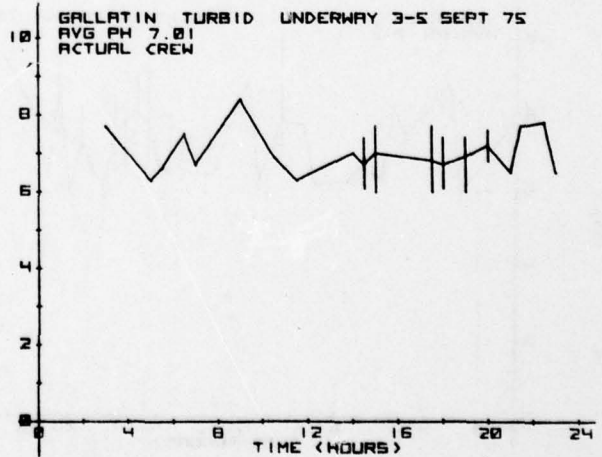
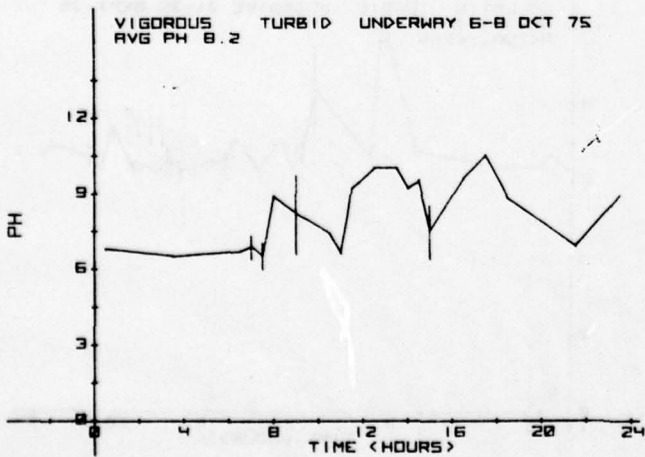
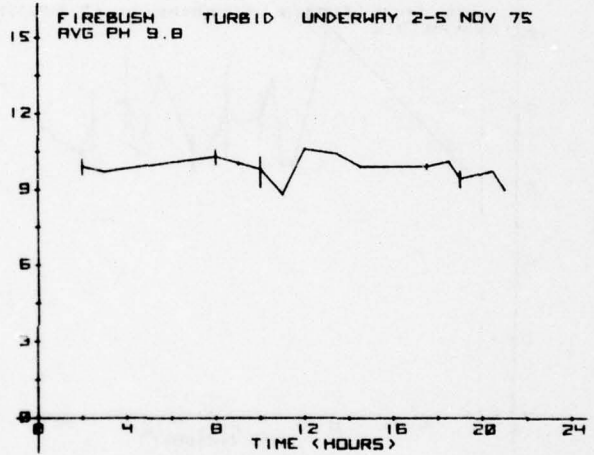
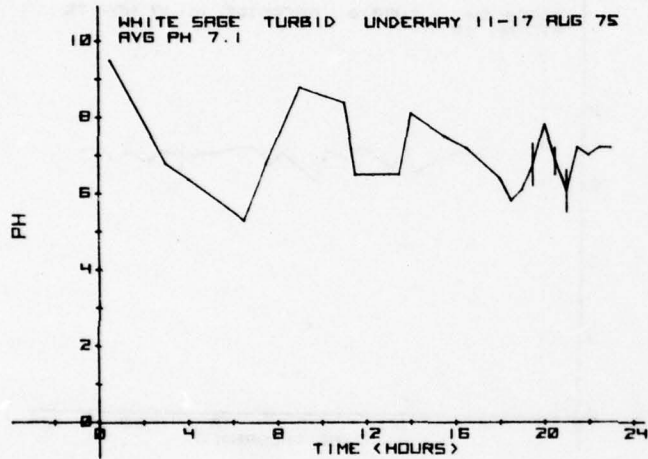
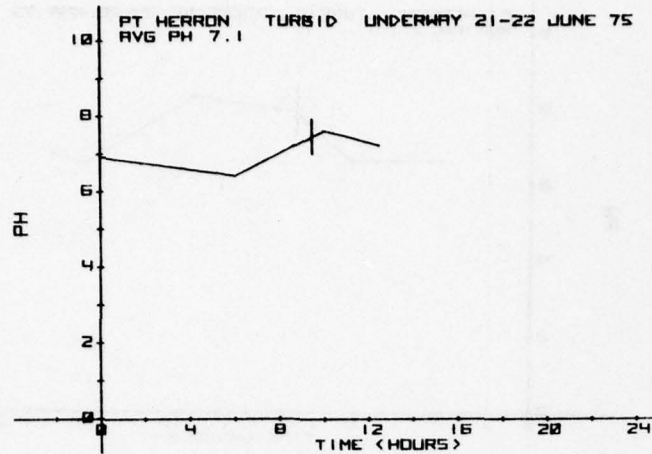

FIGURE 68. UNDERWAY TURBID pH
120

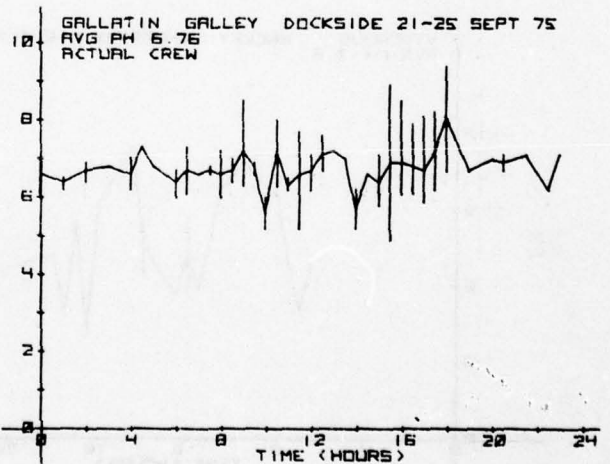
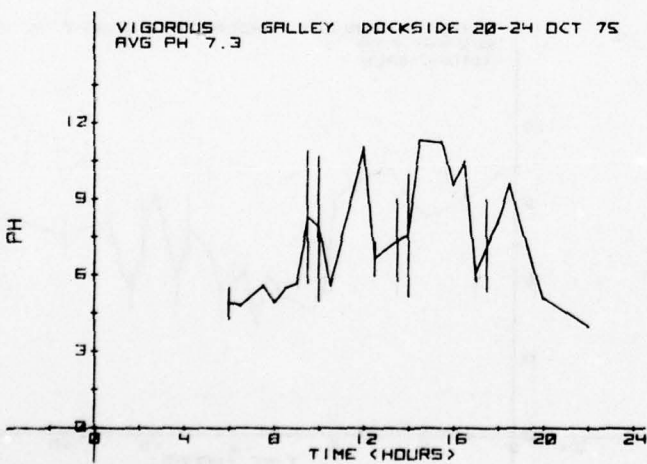
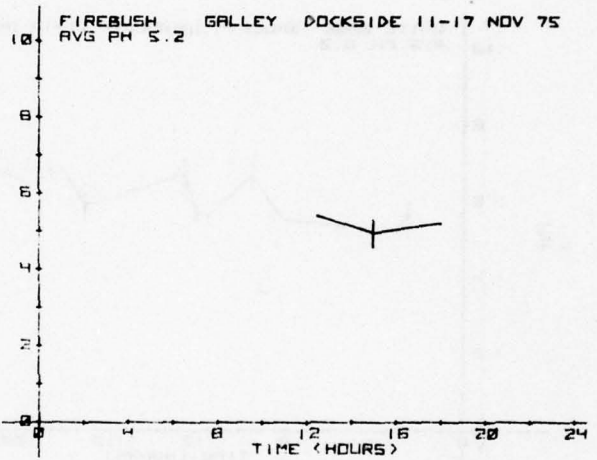
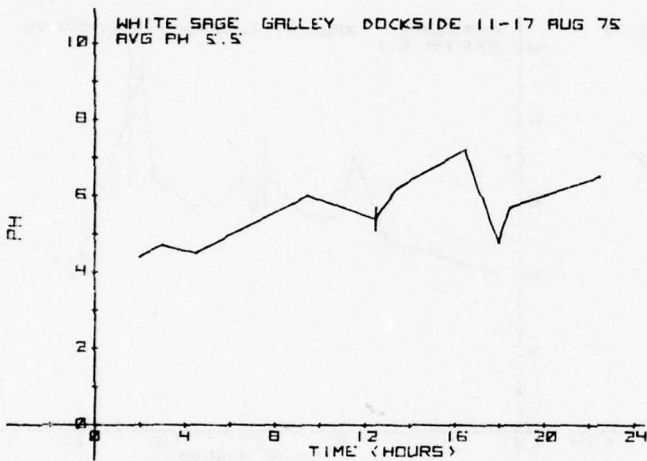
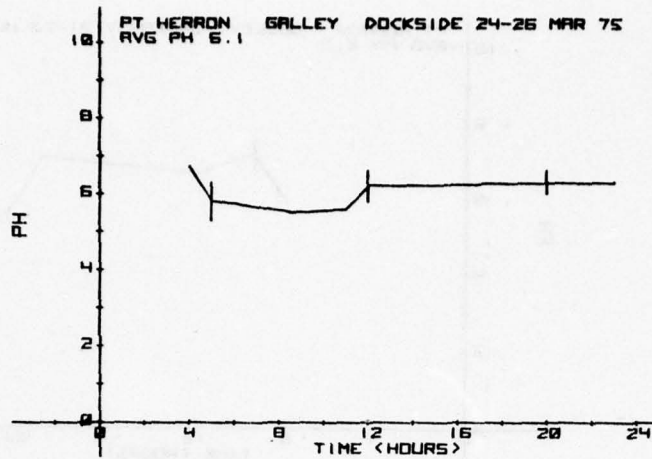

FIGURE 69. DOCKSIDE GALLEY pH

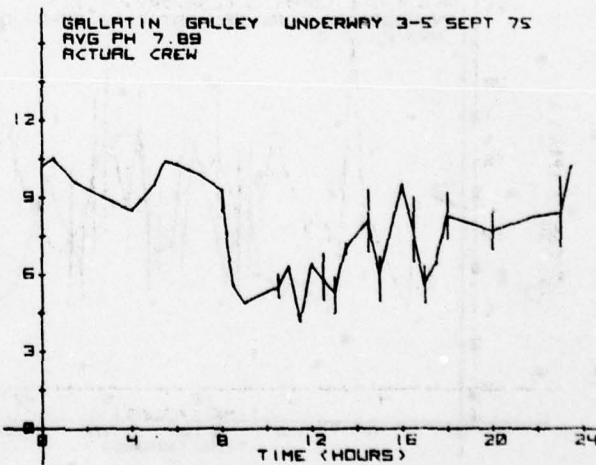
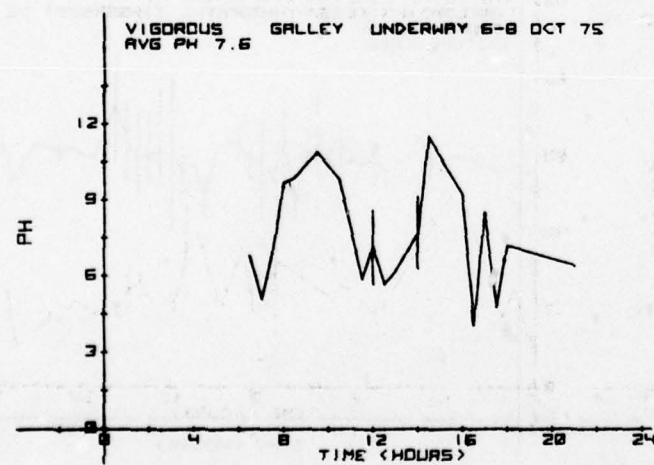
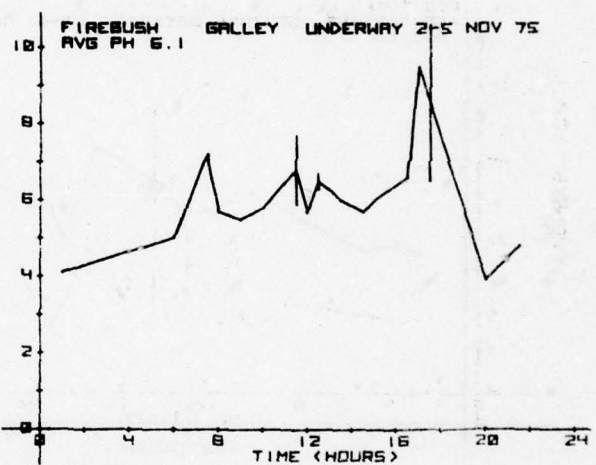
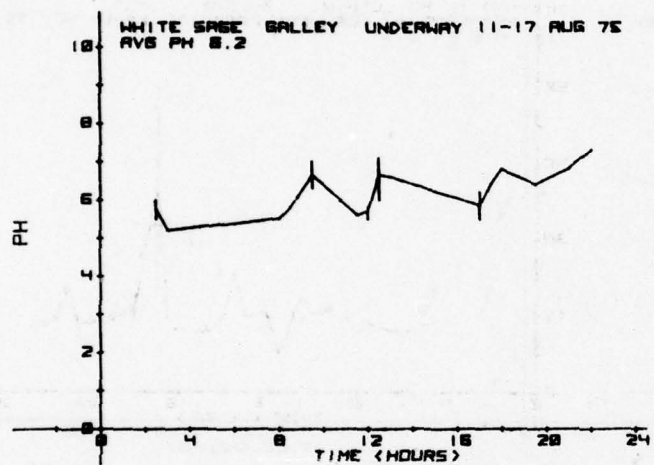
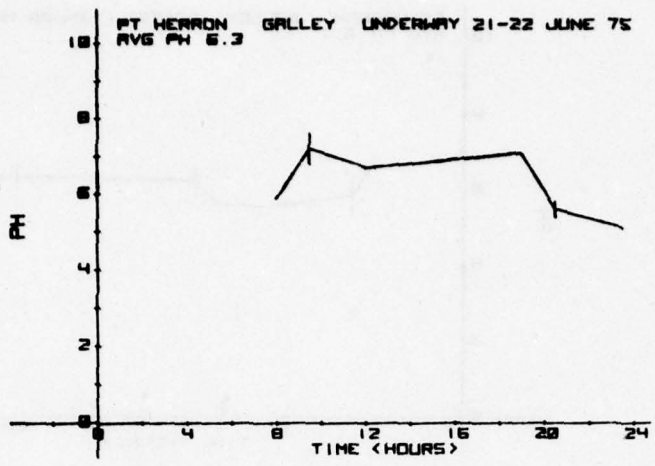

FIGURE 70. UNDERWAY GALLEY pH

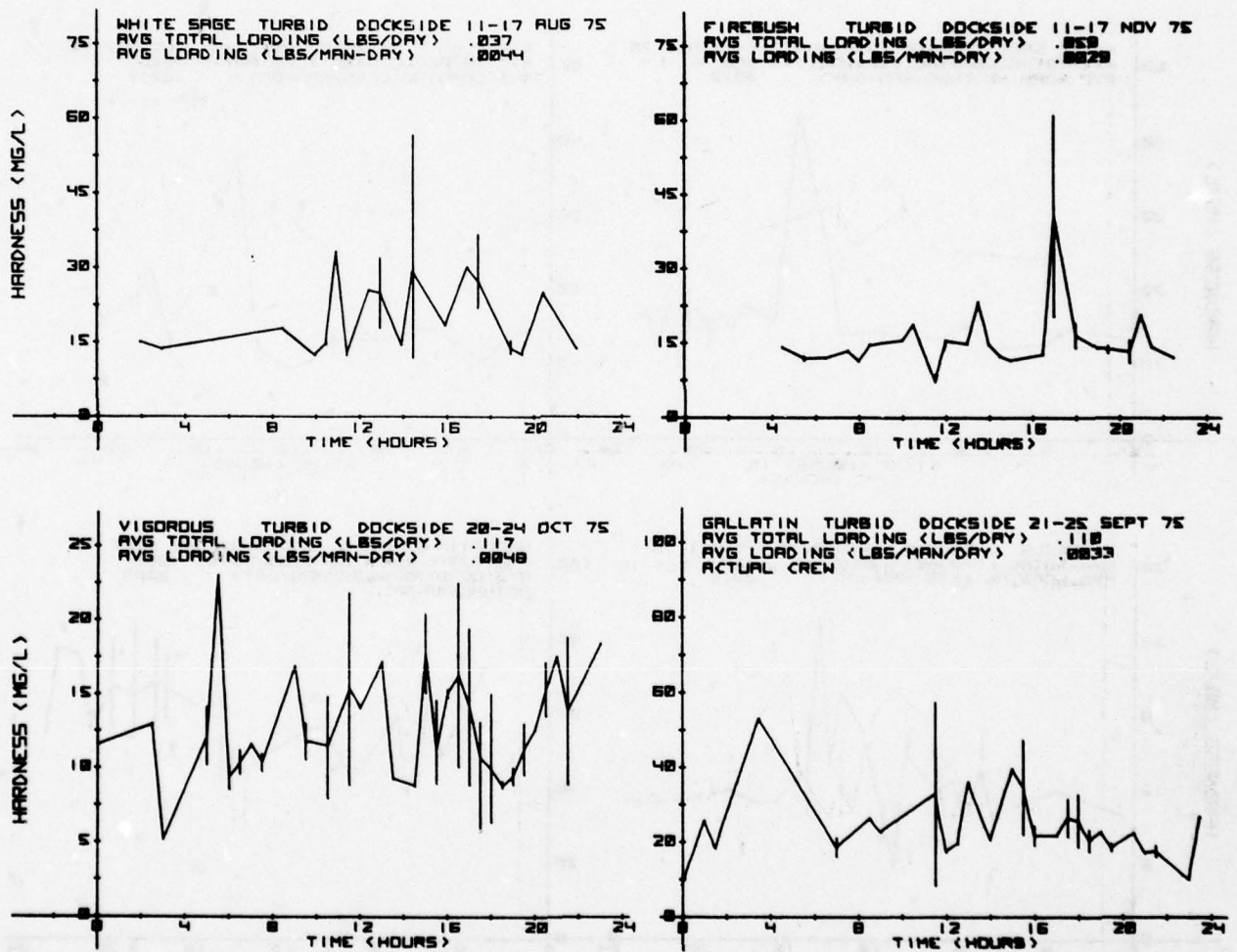

FIGURE 71. DOCKSIDE TURBID HARDNESS LOADS

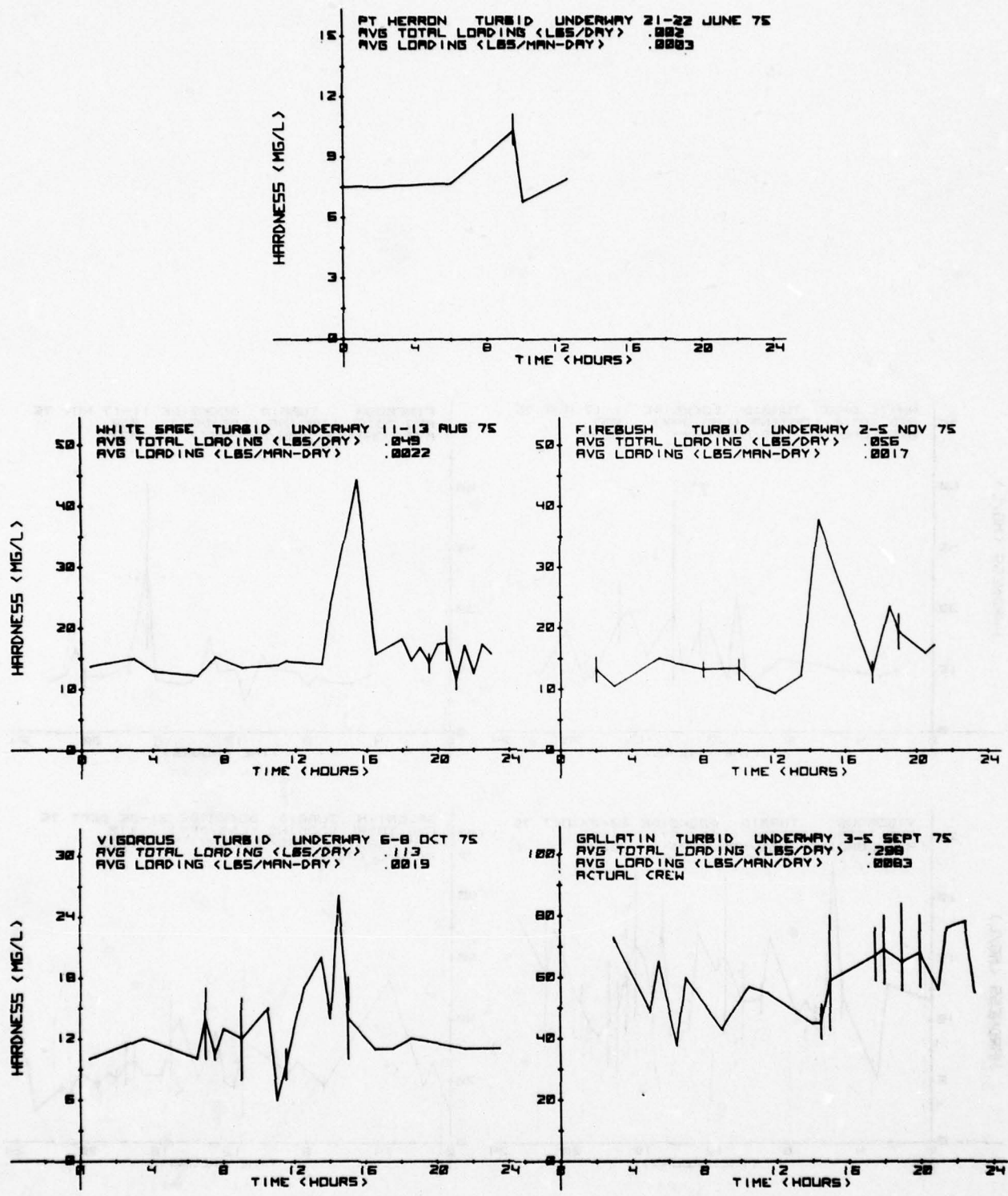

FIGURE 72. UNDERWAY TURBID HARDNESS LOADS

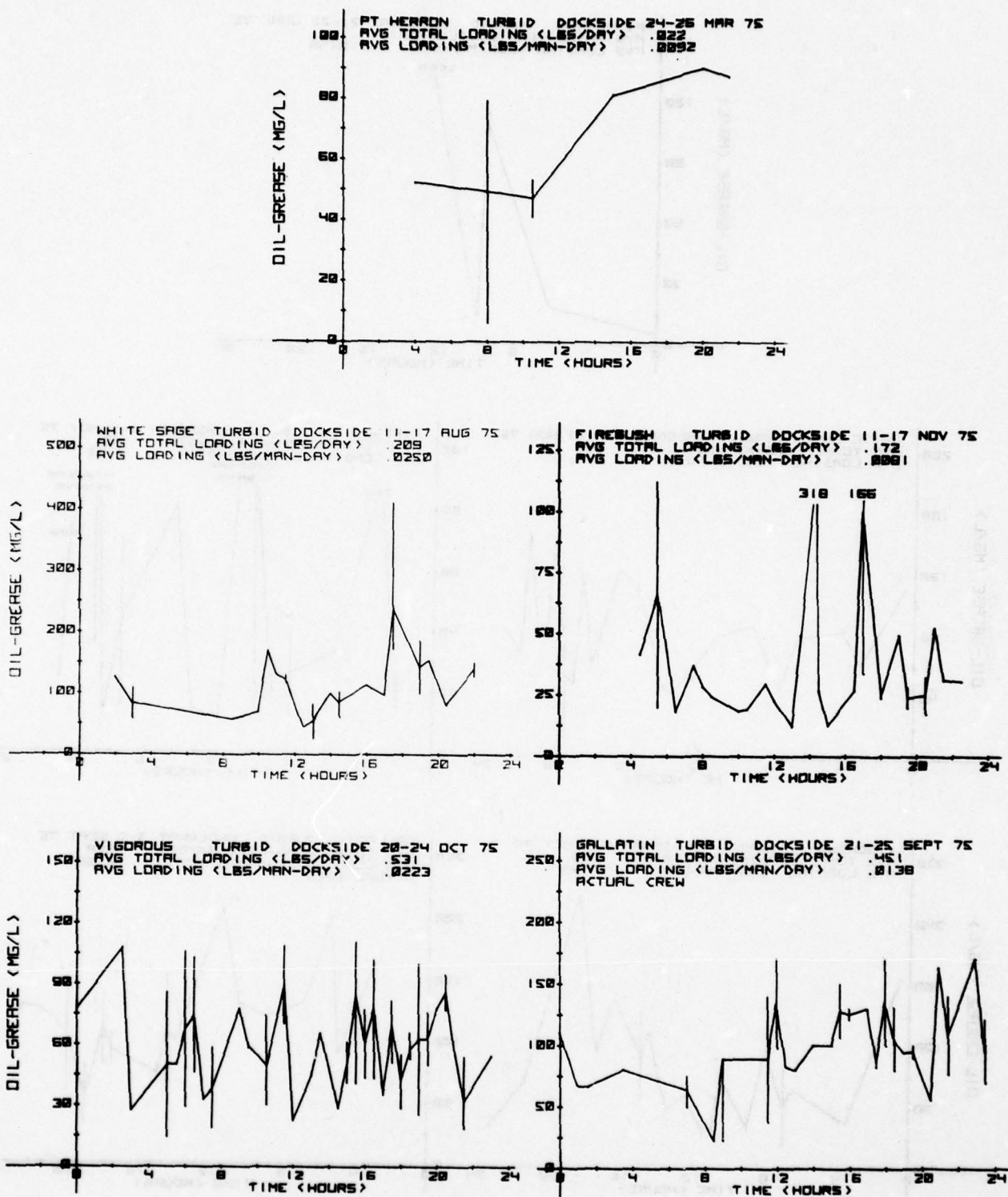

FIGURE 73. DOCKSIDE TURBID OIL & GREASE LOADS

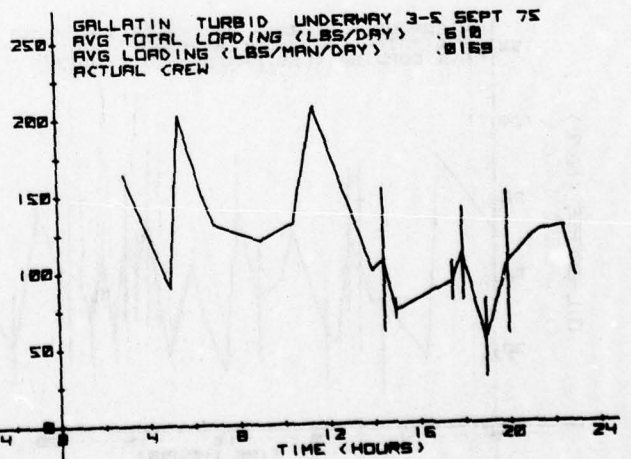
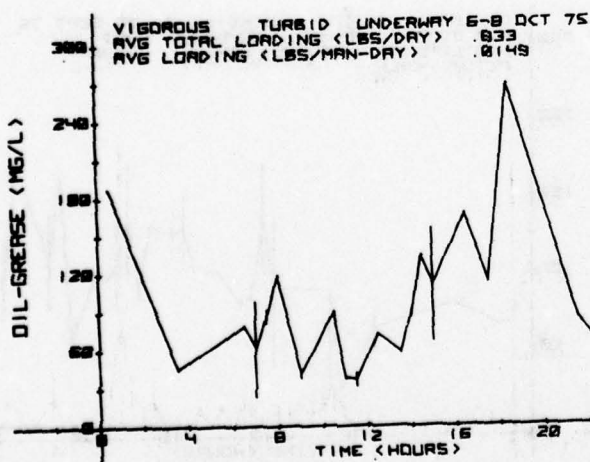
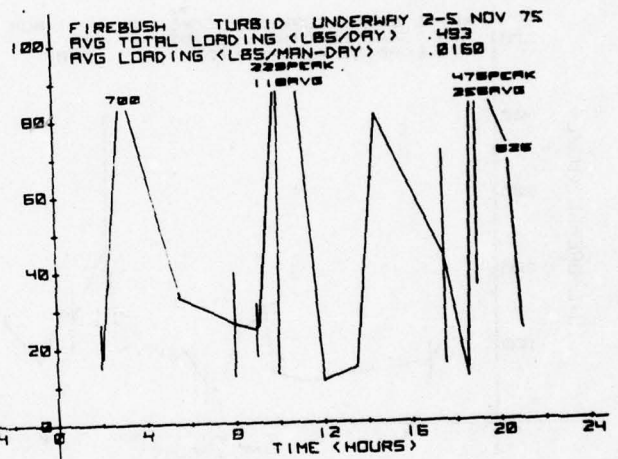
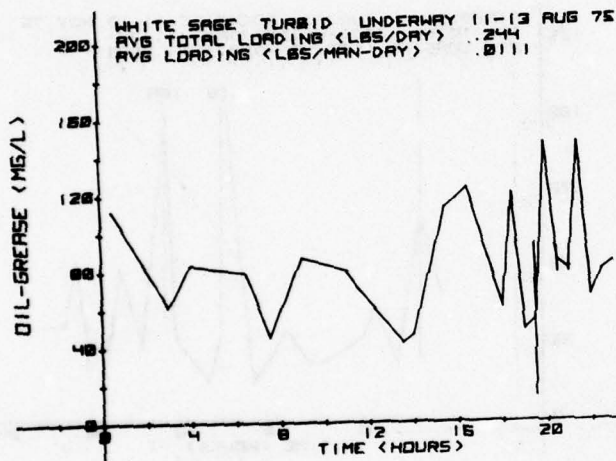
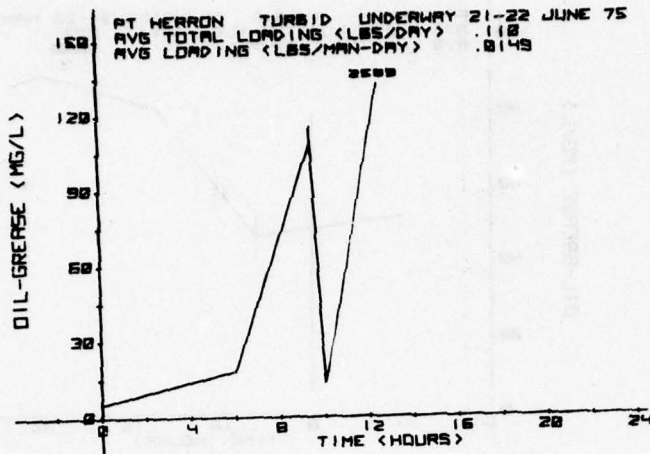

FIGURE 74. UNDERWAY TURBID OIL & GREASE LOADS

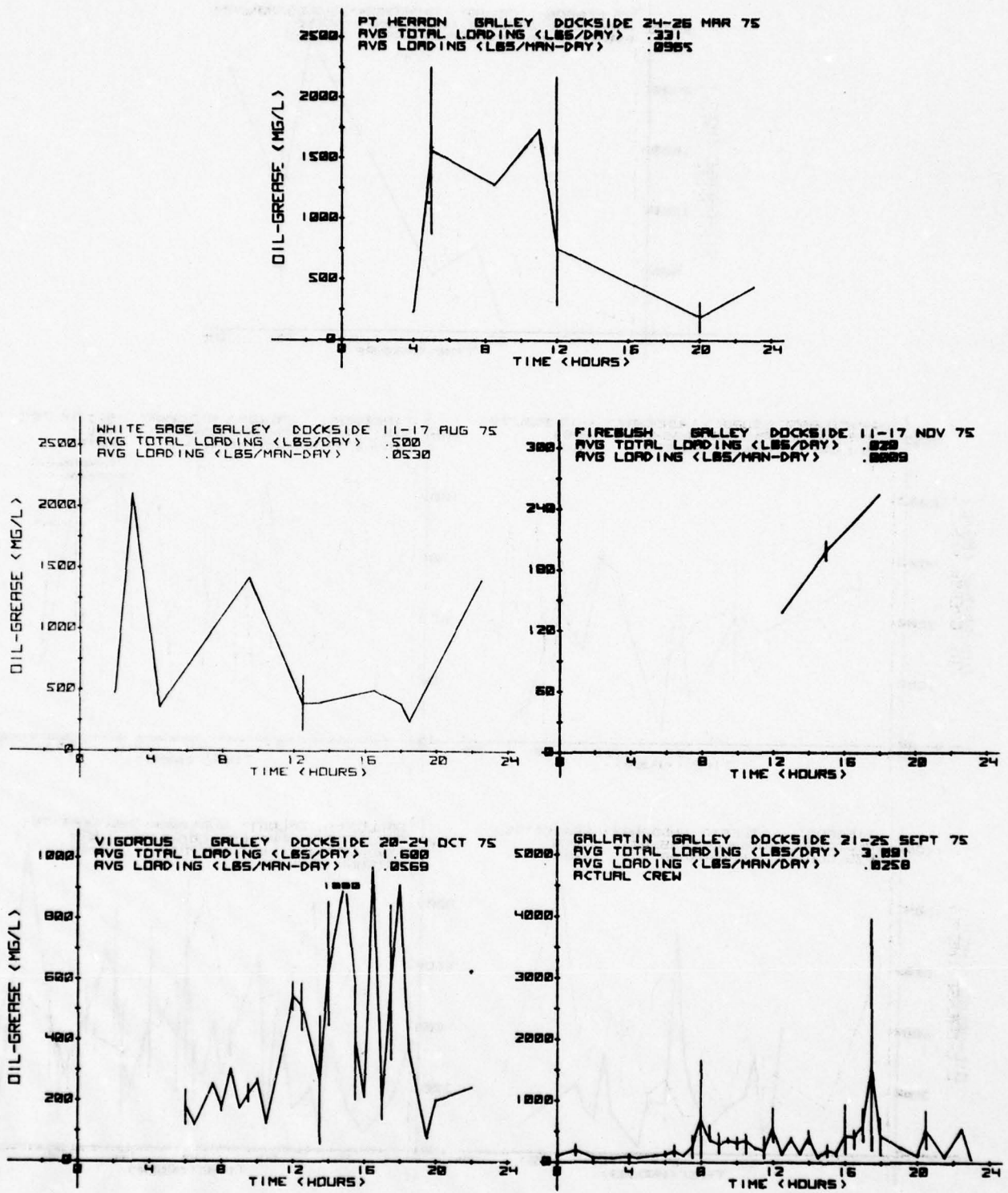

FIGURE 75. DOCKSIDE GALLEY OIL & GREASE LOADS

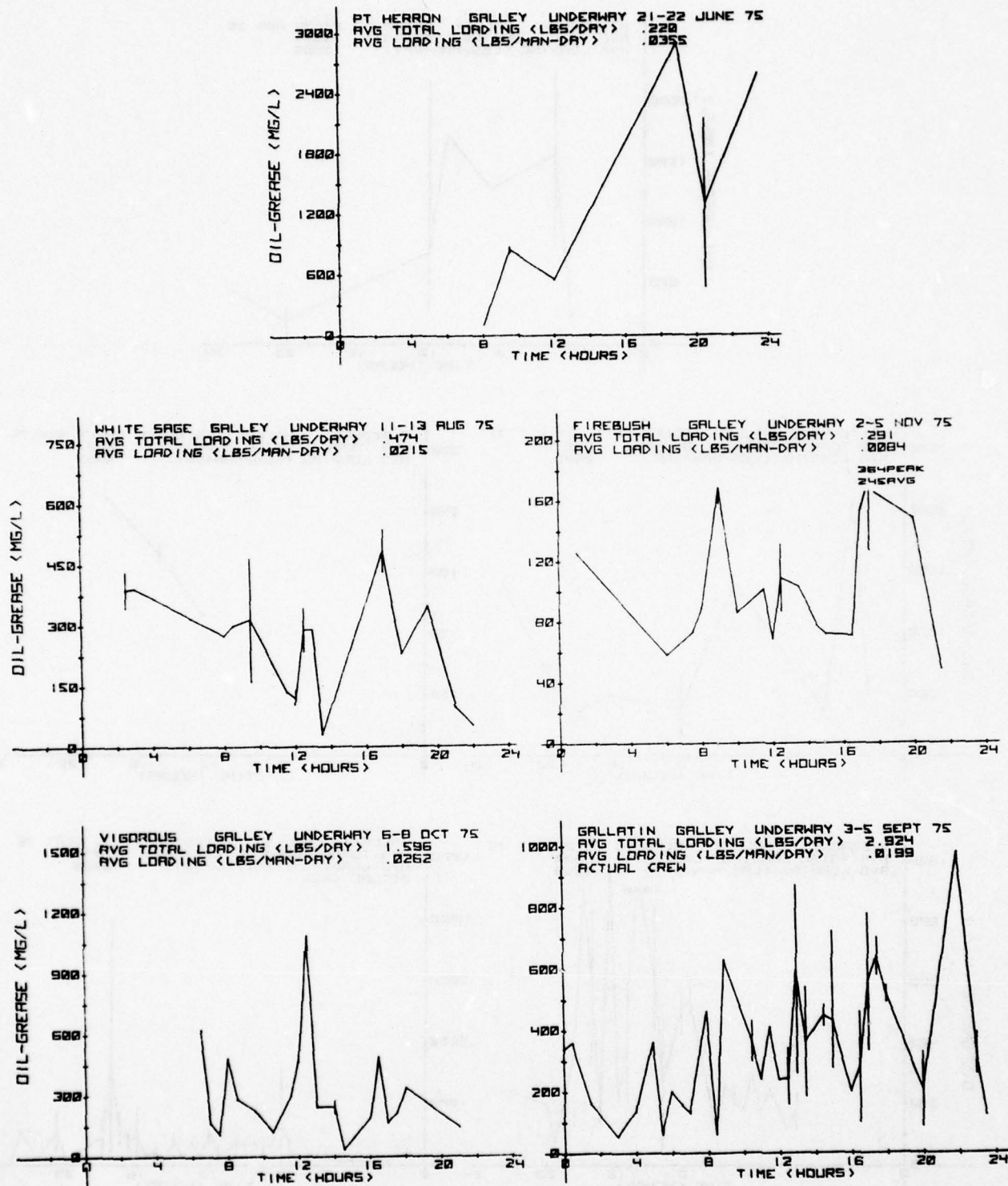

FIGURE 76. UNDERWAY GALLEY OIL & GREASE LOADS

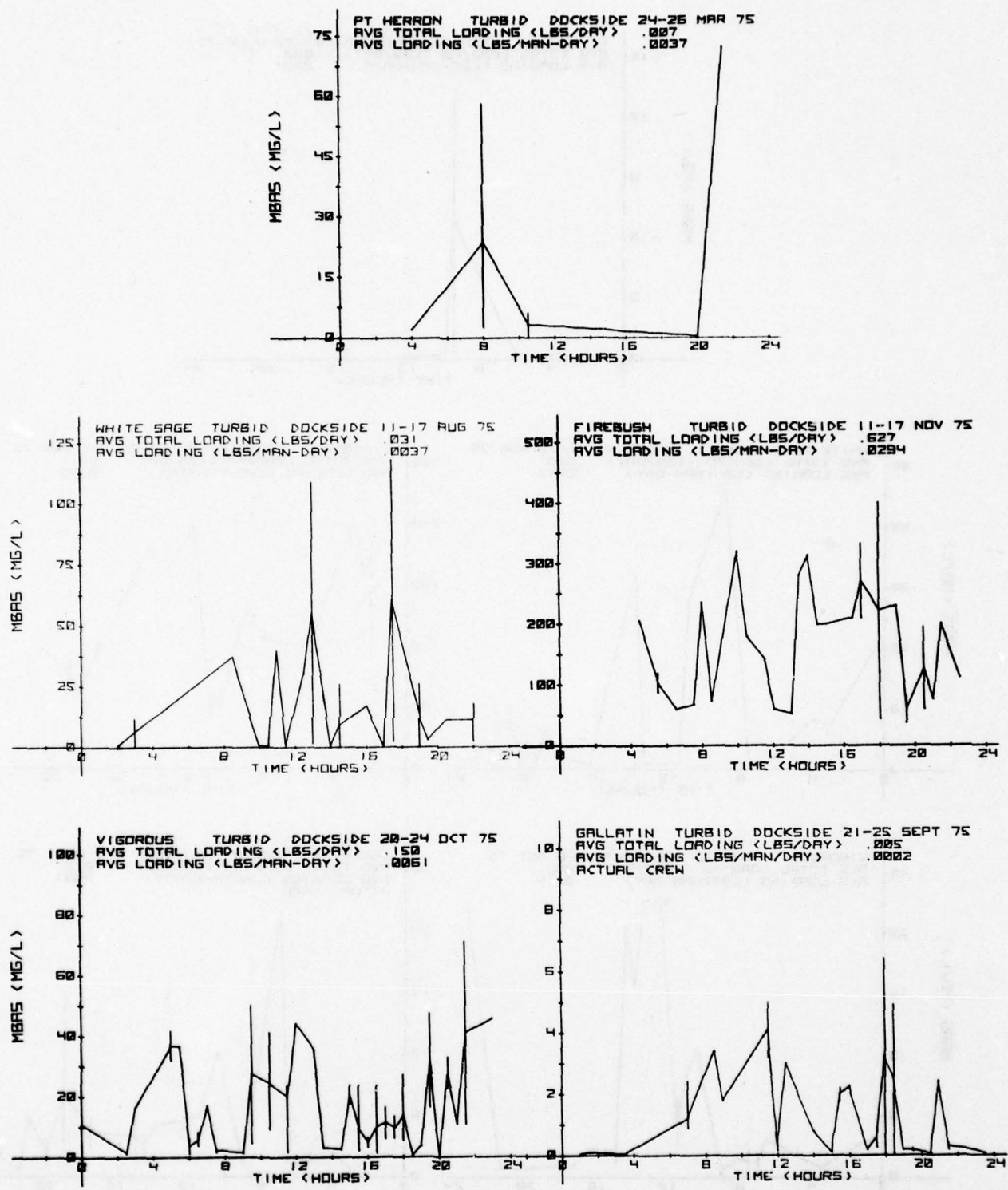

FIGURE 77. DOCKSIDE TURBID MBAS LOADS

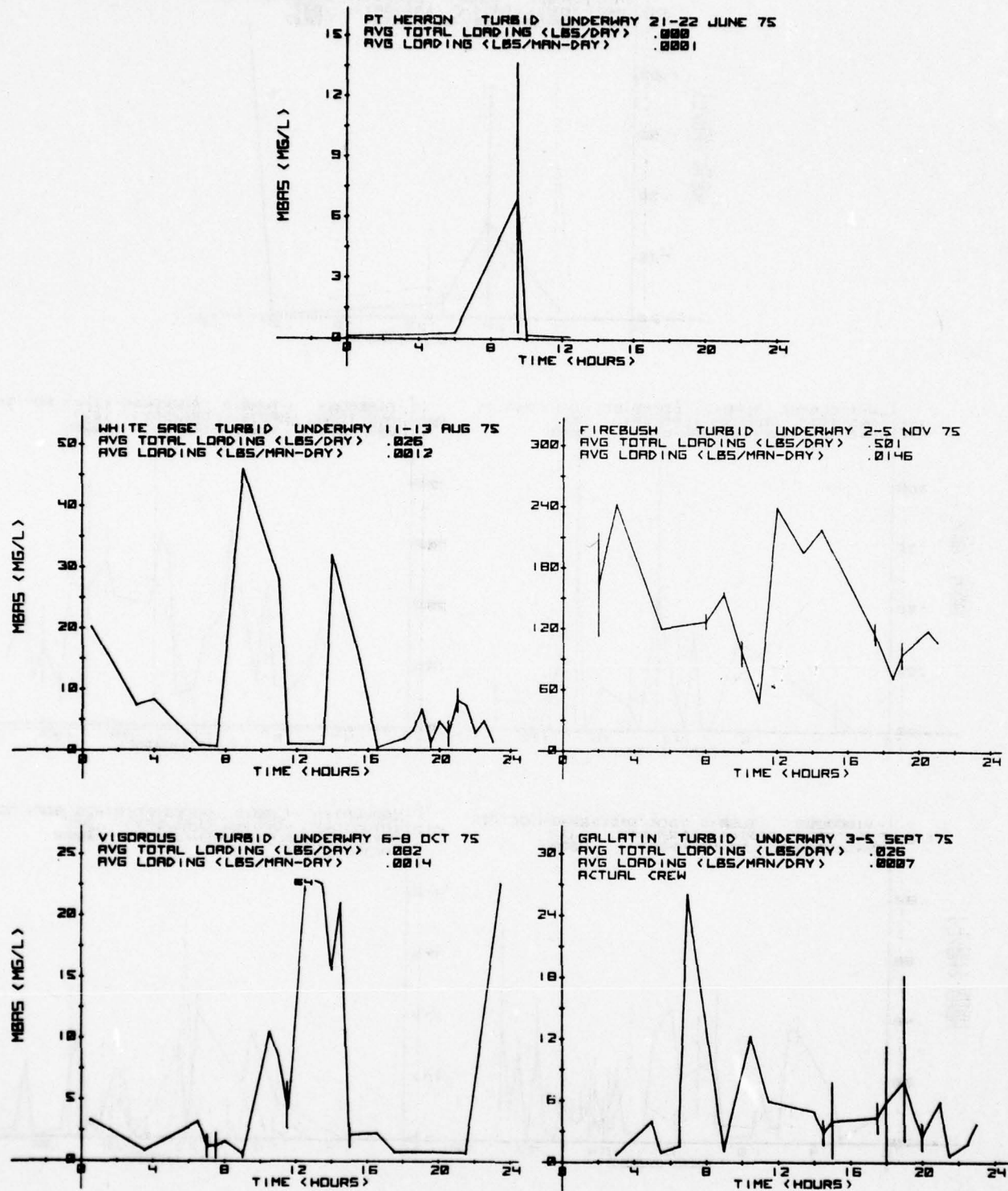

FIGURE 78. UNDERWAY TURBID MBAS LOADS

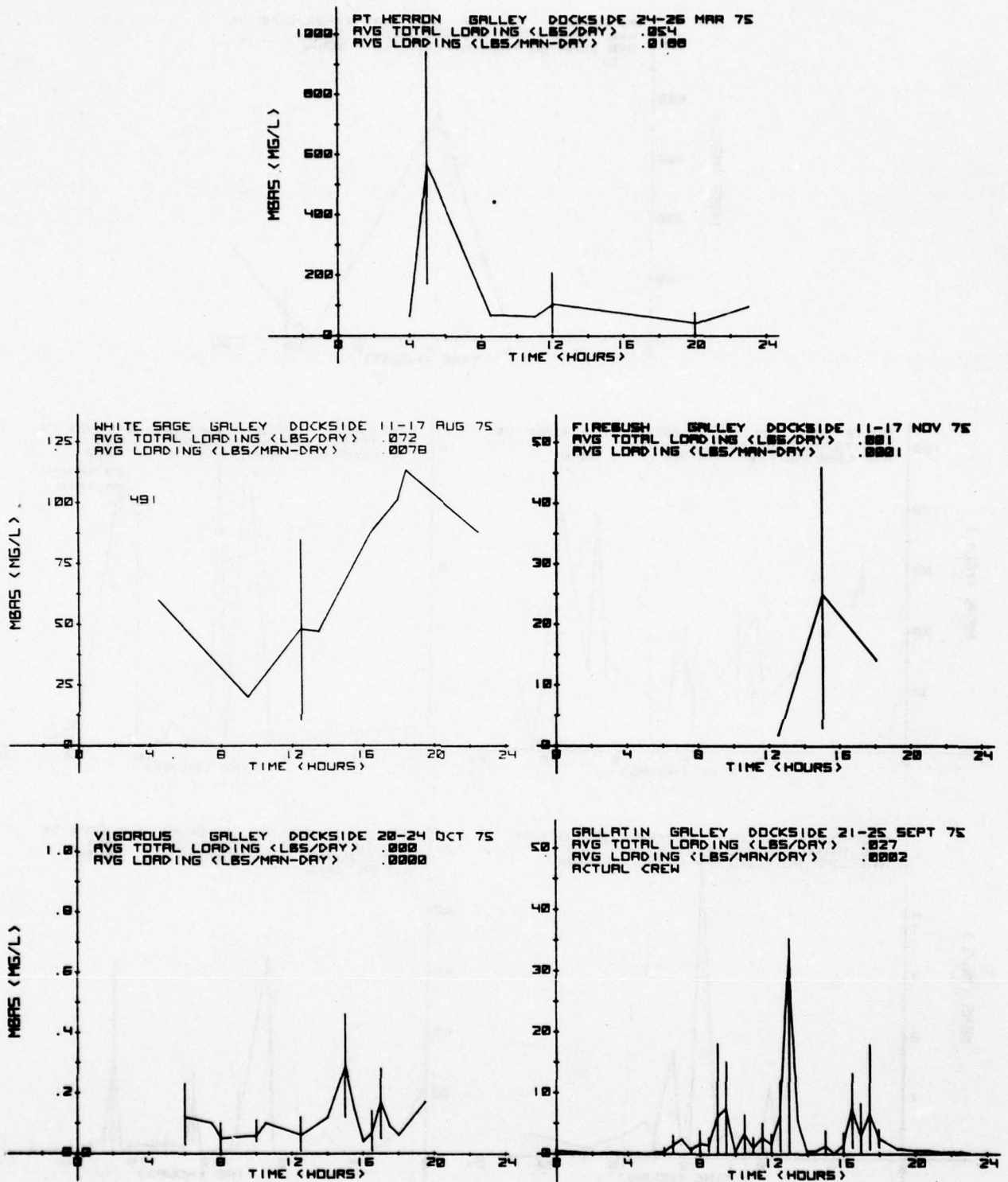

FIGURE 79. DOCKSIDE GALLEY MBAS LOADS

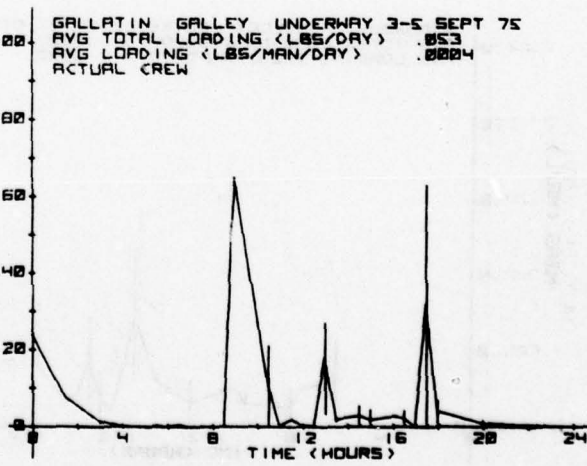
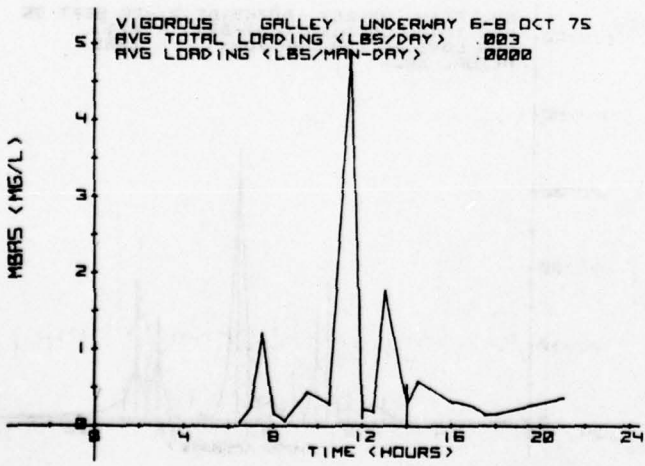
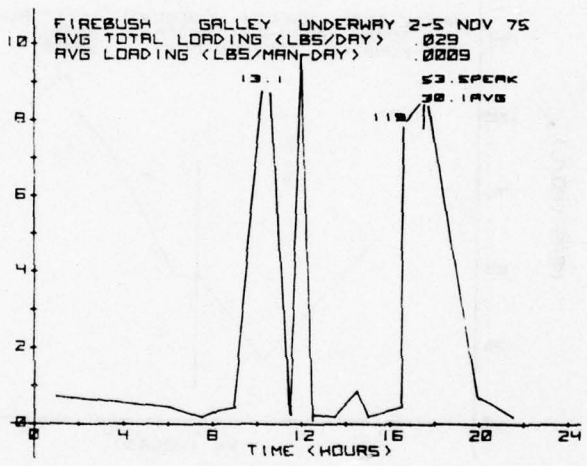
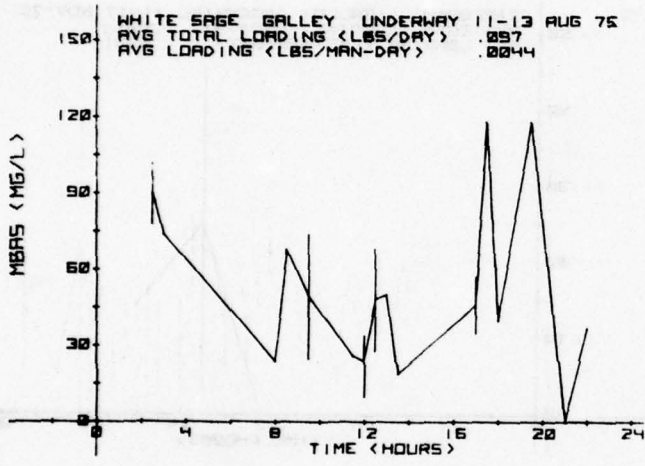
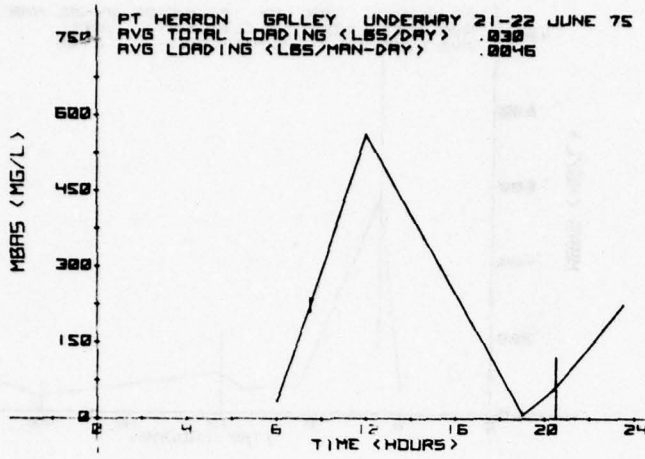

FIGURE 80. UNDERWAY GALLEY MBAS LOADS

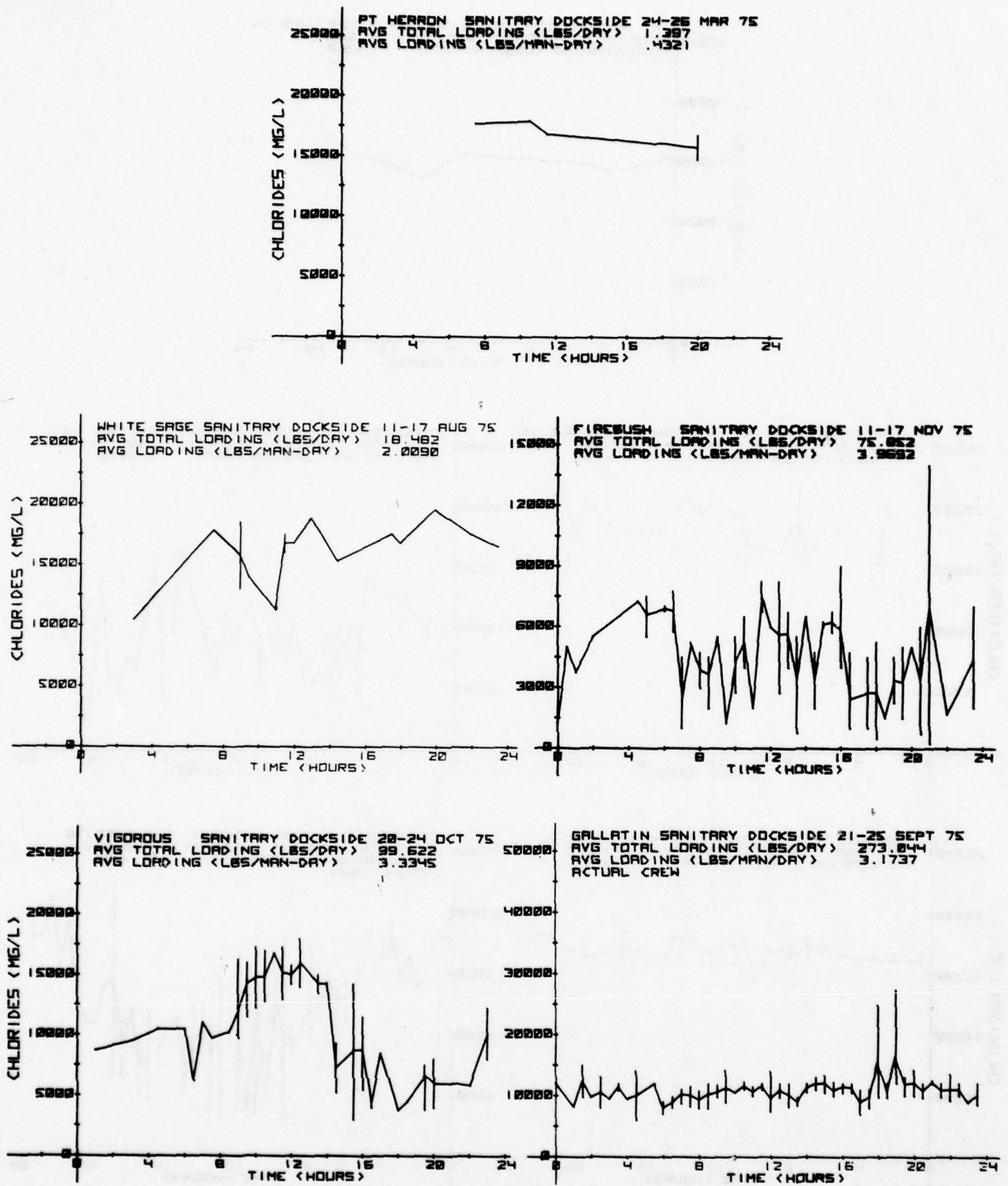

FIGURE 81. DOCKSIDE SANITARY CHLORIDE LOADS

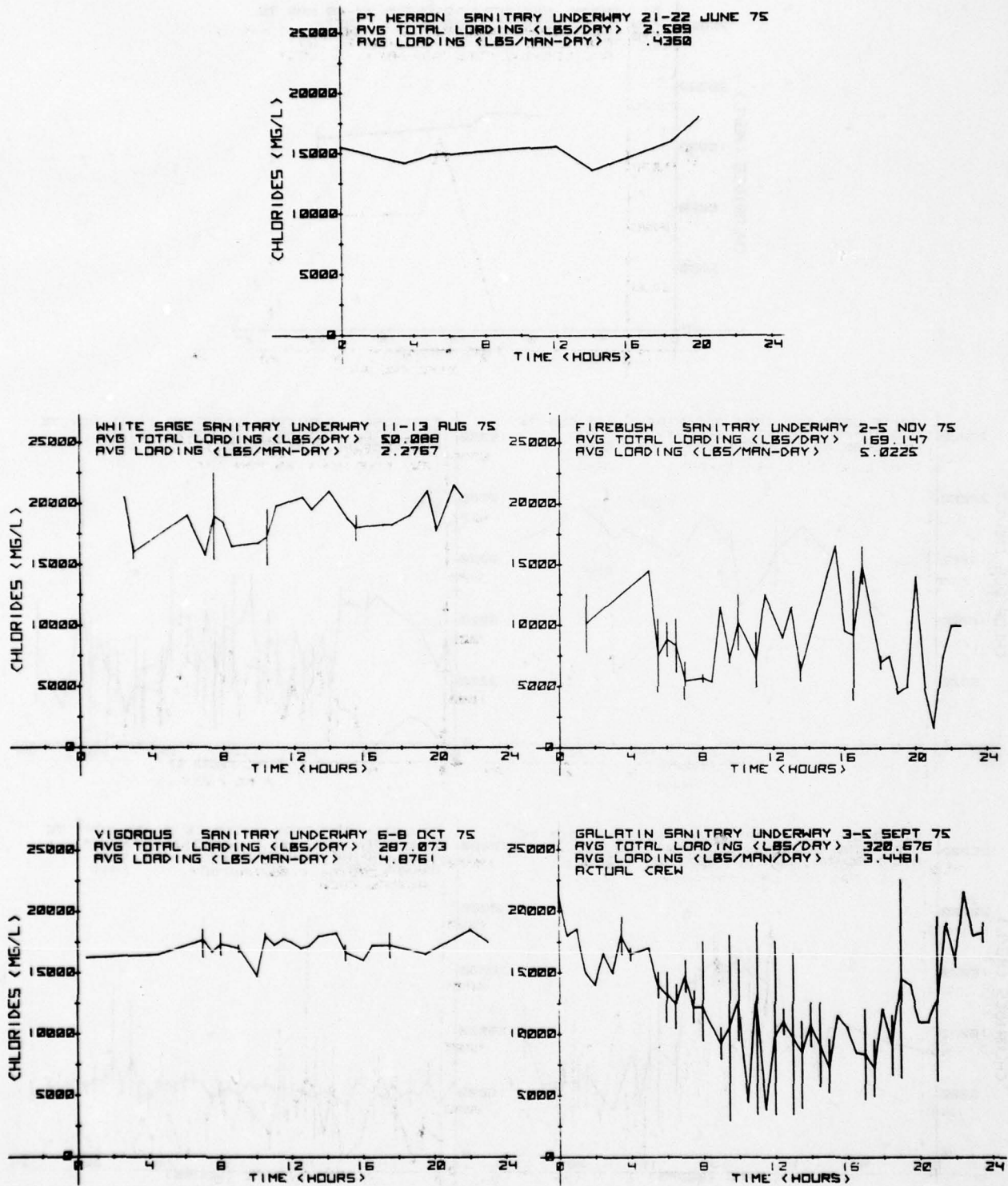

FIGURE 82. UNDERWAY SANITARY CHLORIDE LOADS

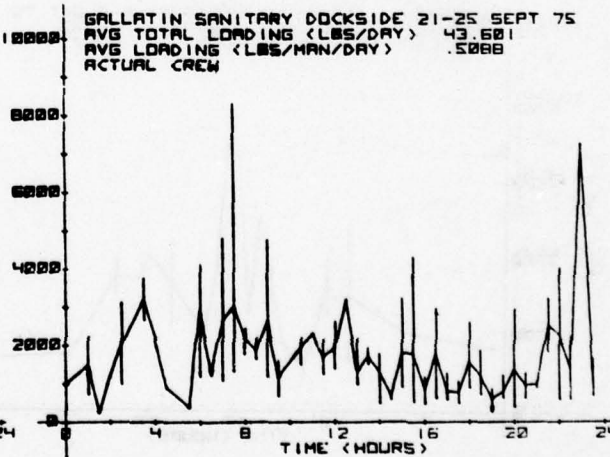
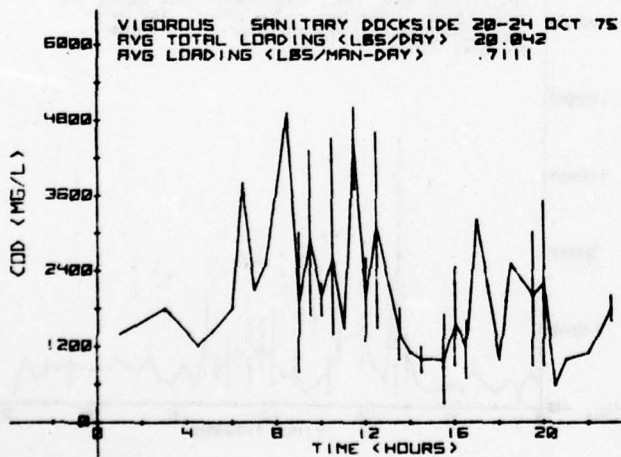
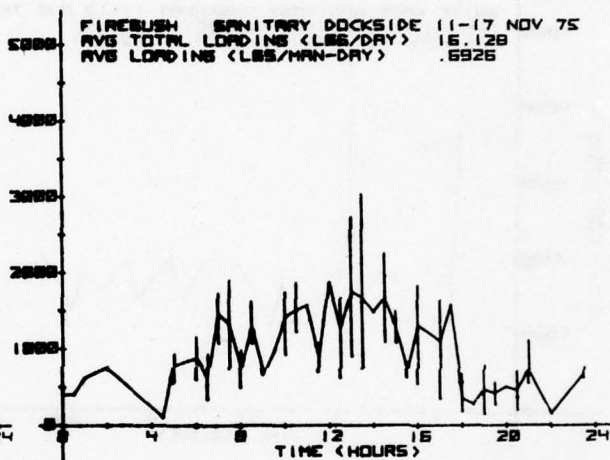
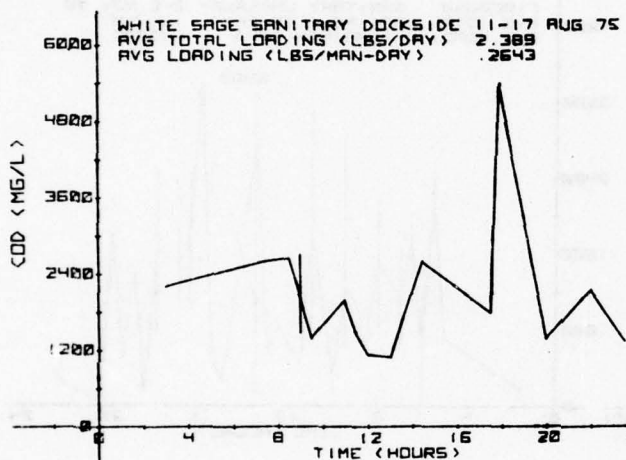
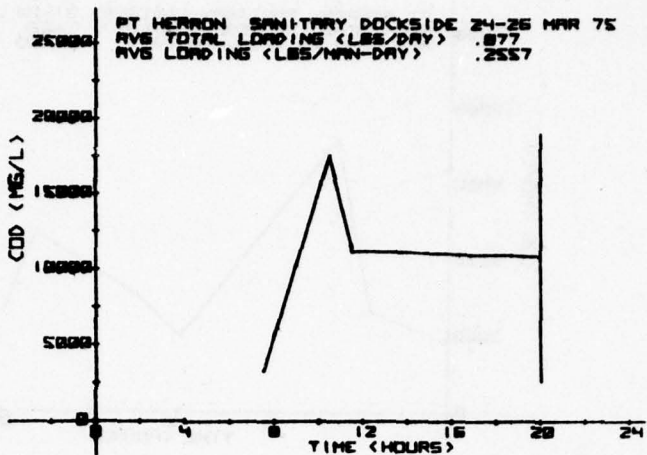

FIGURE 83. DOCKSIDE SANITARY COD LOADS

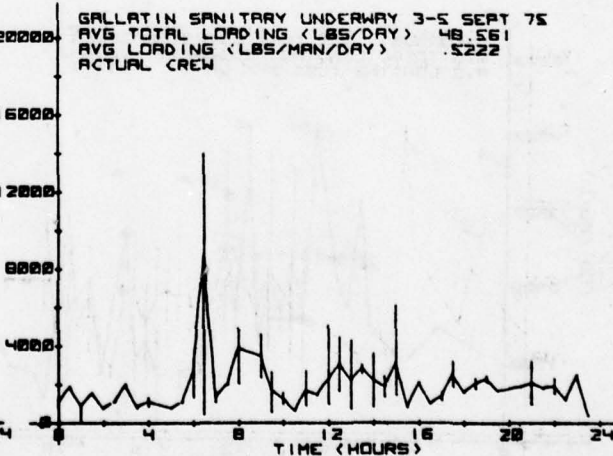
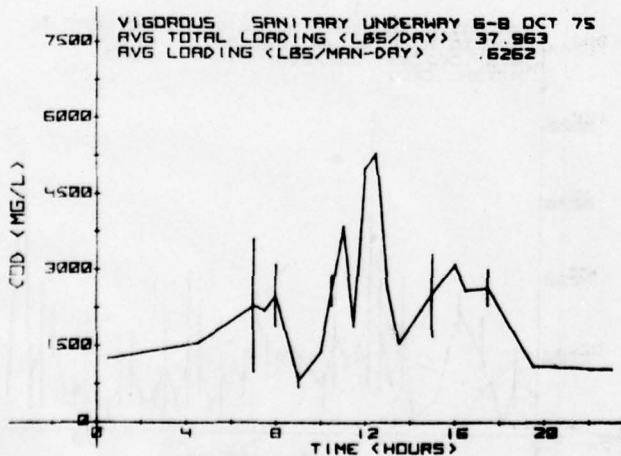
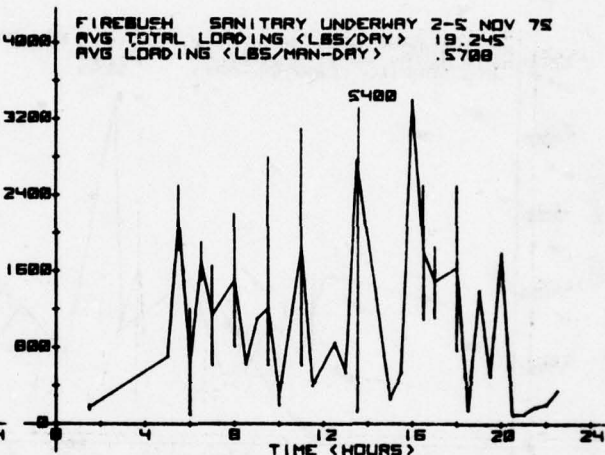
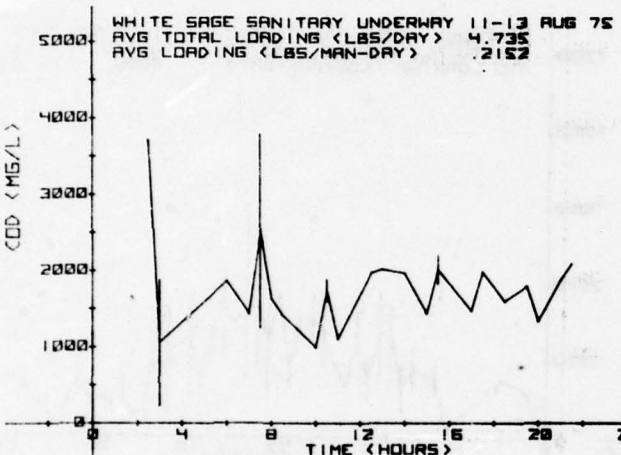
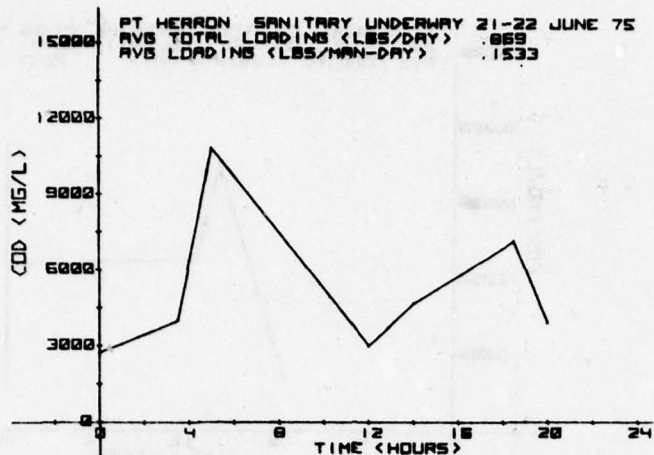

FIGURE 84. UNDERWAY SANITARY COD LOADS

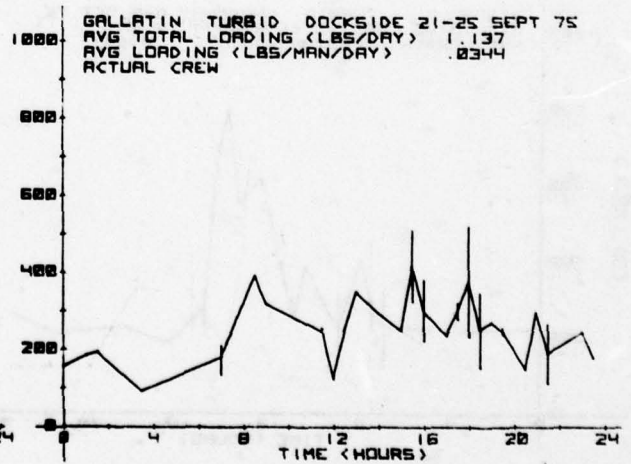
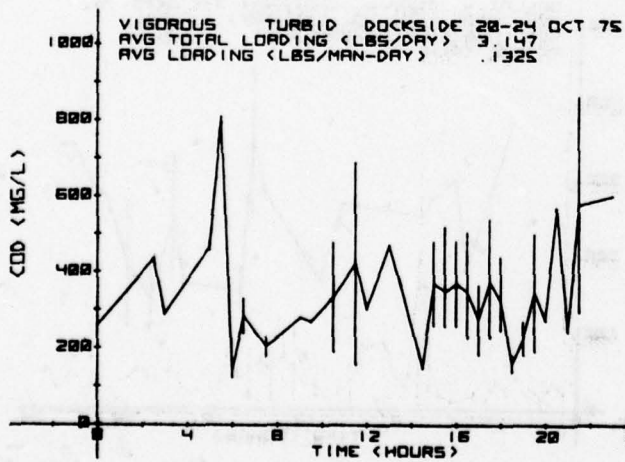
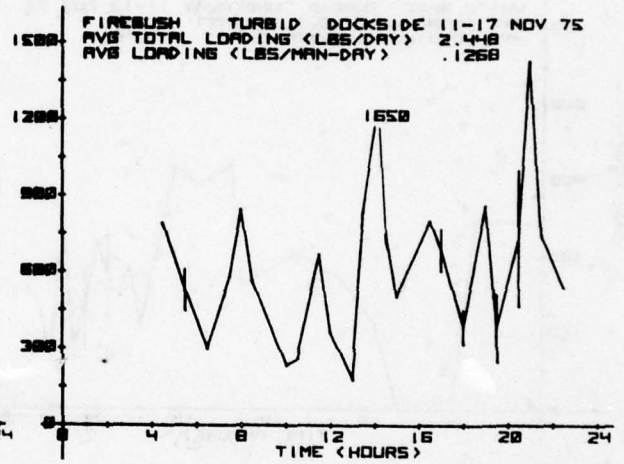
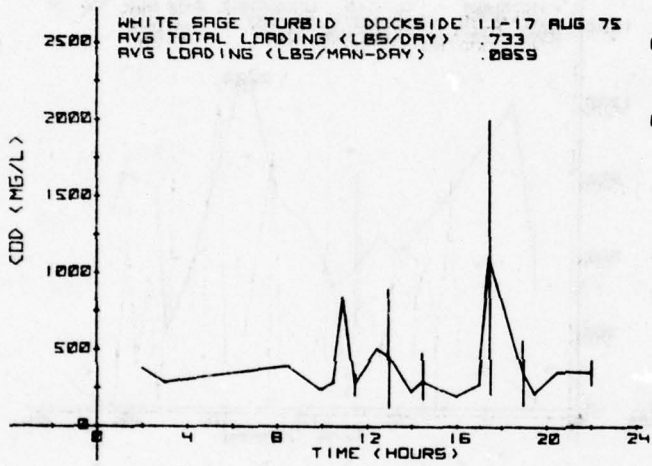
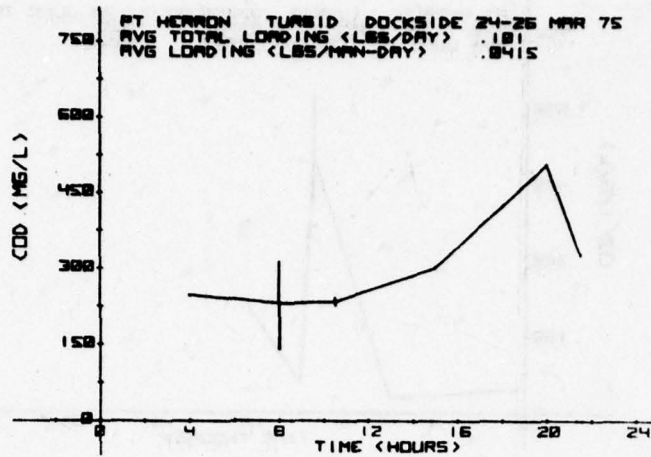

FIGURE 85. DOCKSIDE TURBID COD LOADS

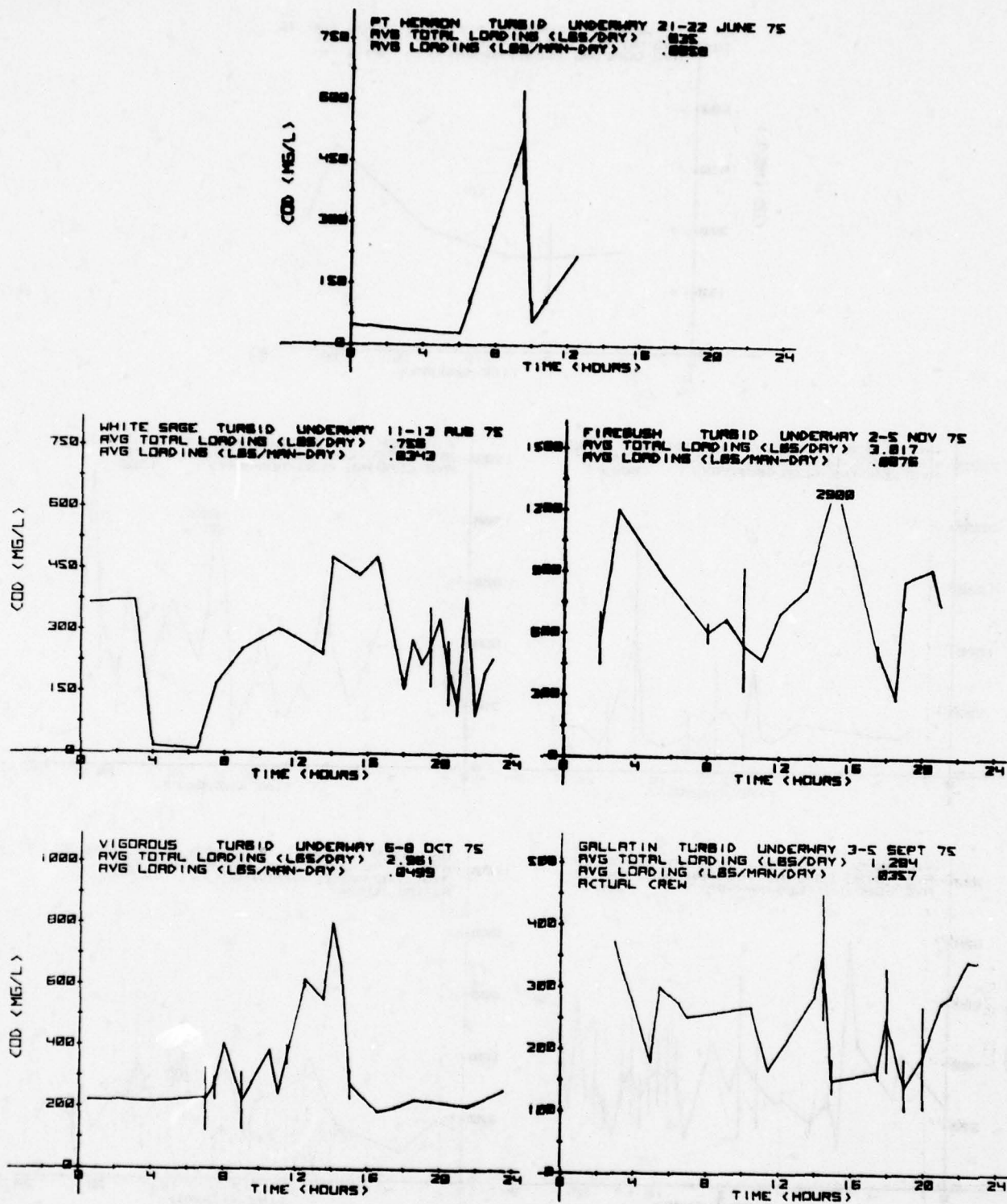

FIGURE 86. UNDERWAY TURBID COD LOADS

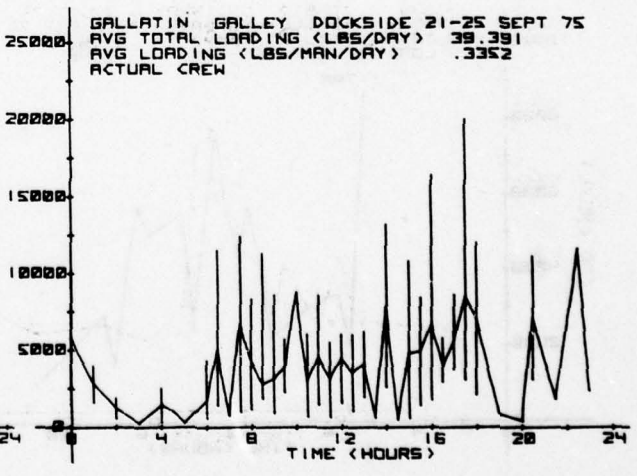
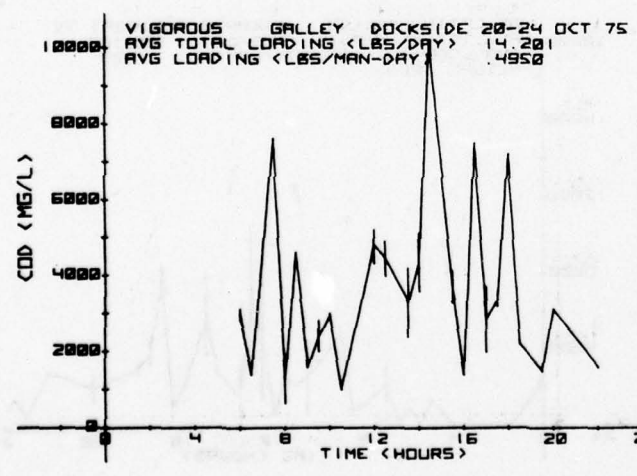
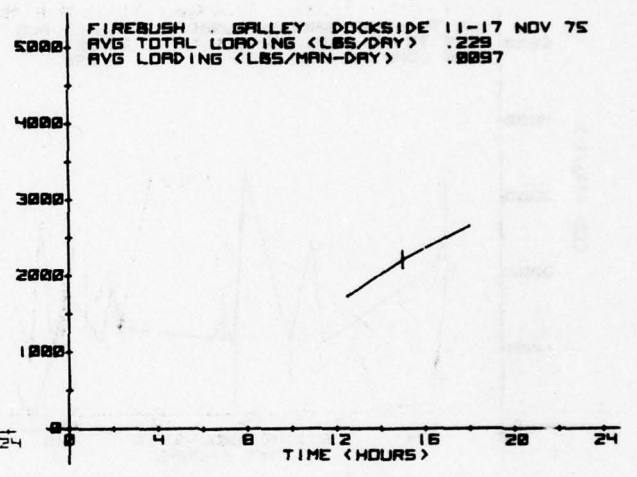
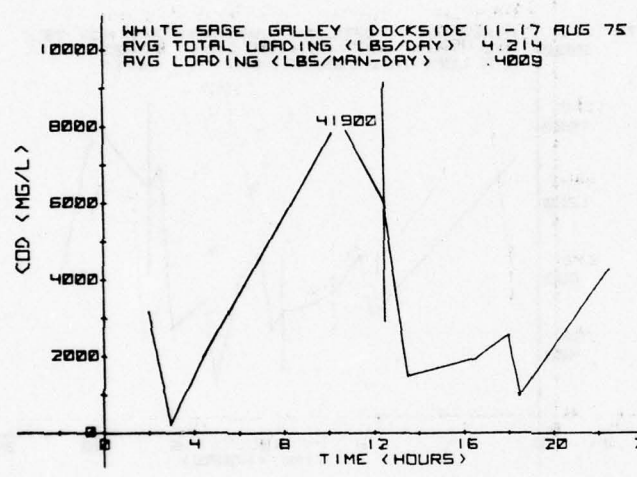
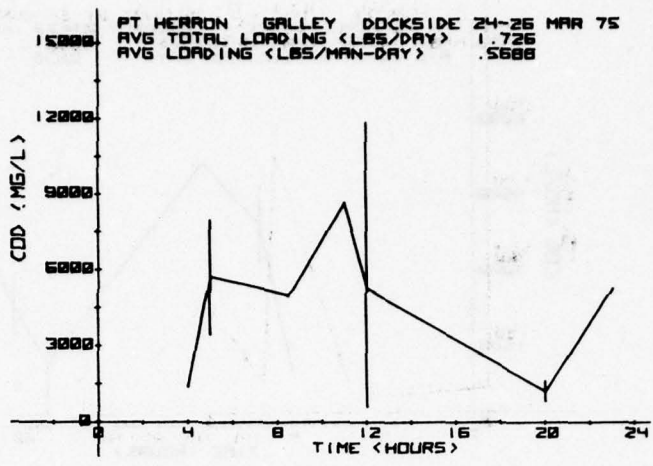

FIGURE 87. DOCKSIDE GALLEY COD LOADS

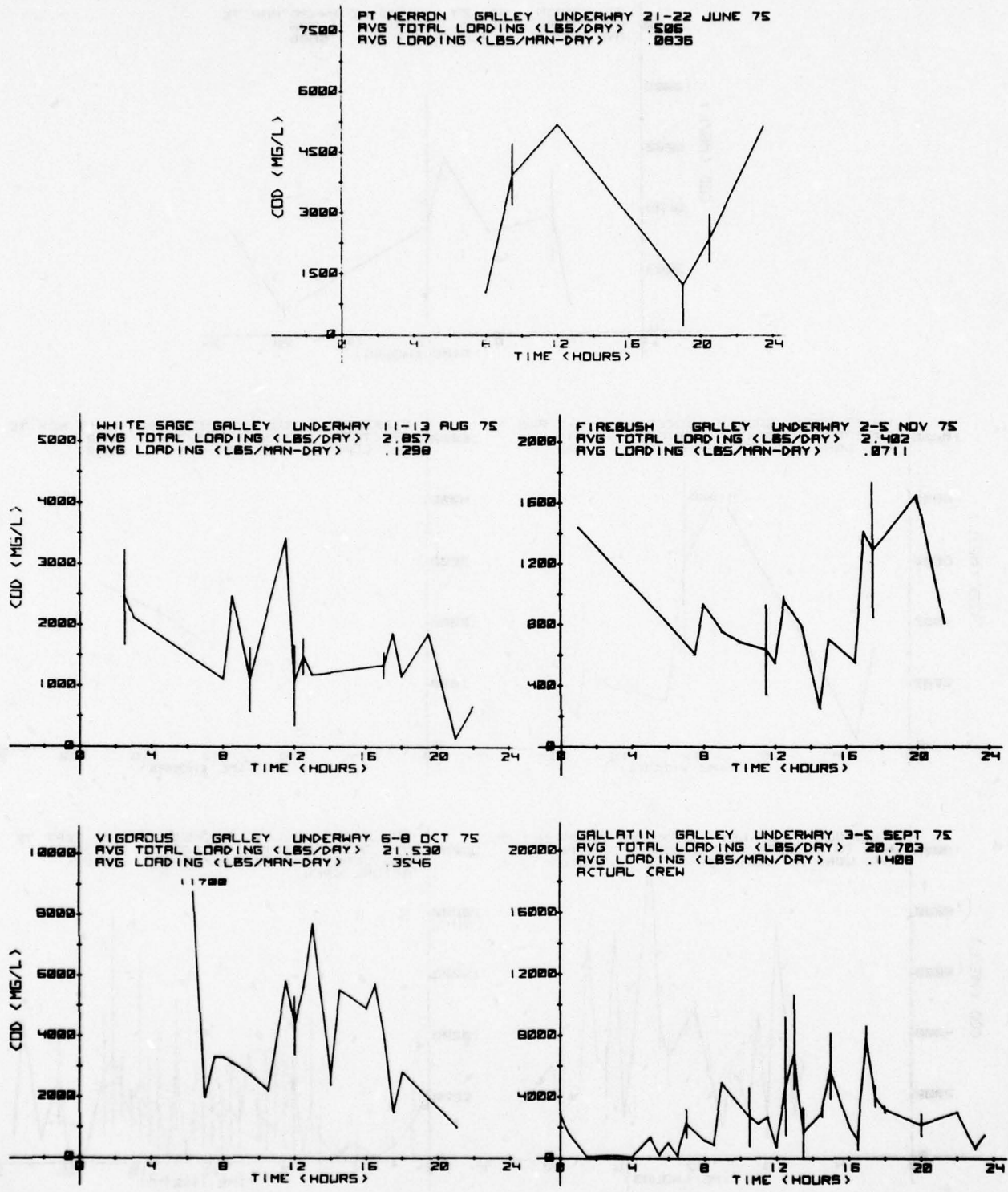

FIGURE 88. UNDERWAY GALLEY COD LOADS

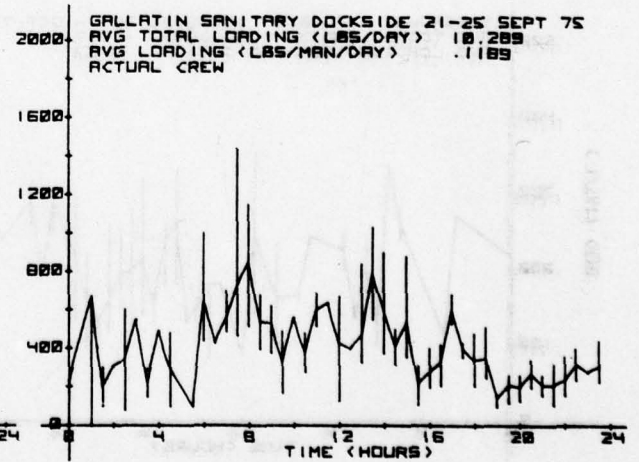
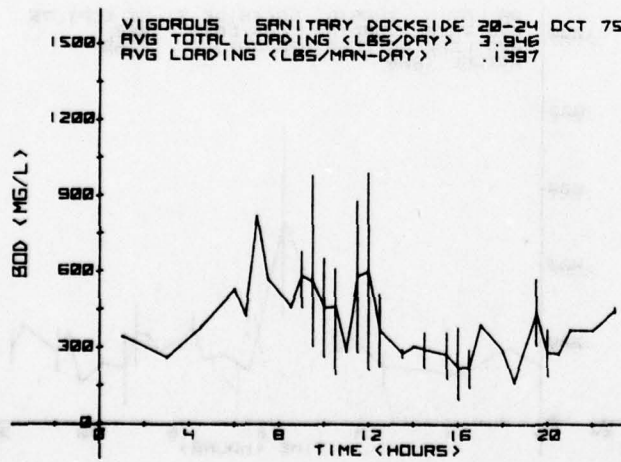
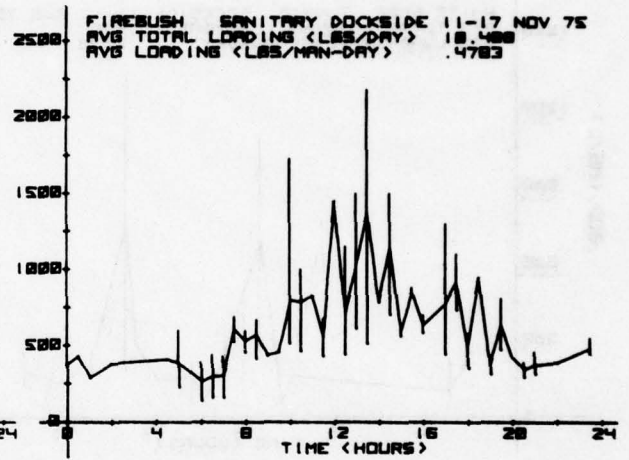
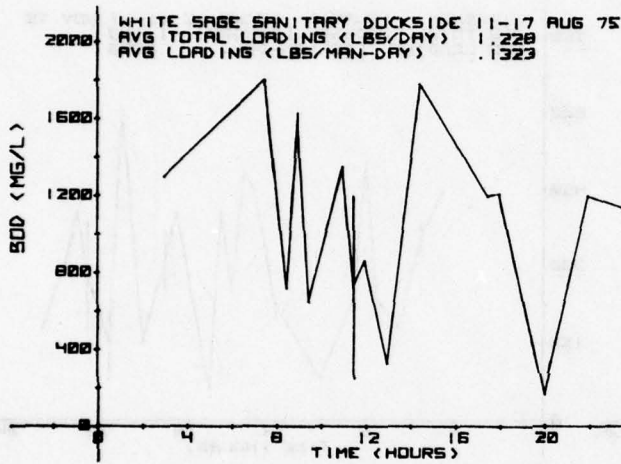
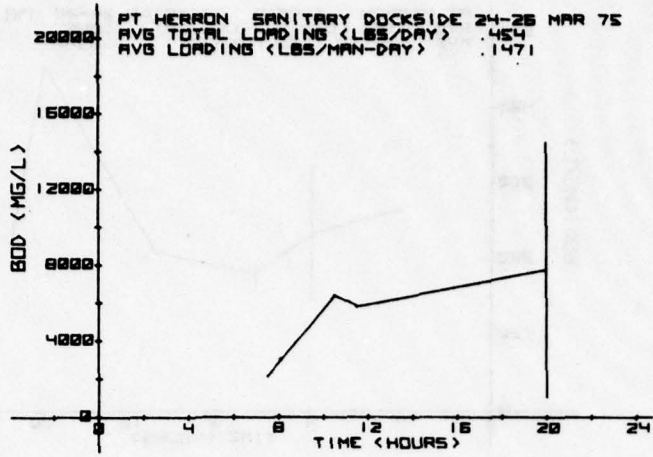

FIGURE 89. DOCKSIDE SANITARY BOD LOADS

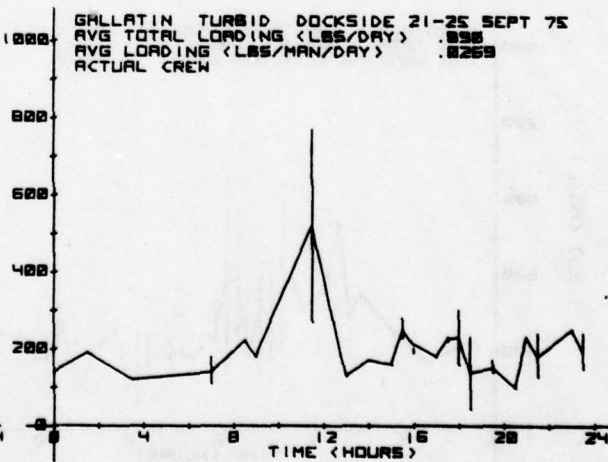
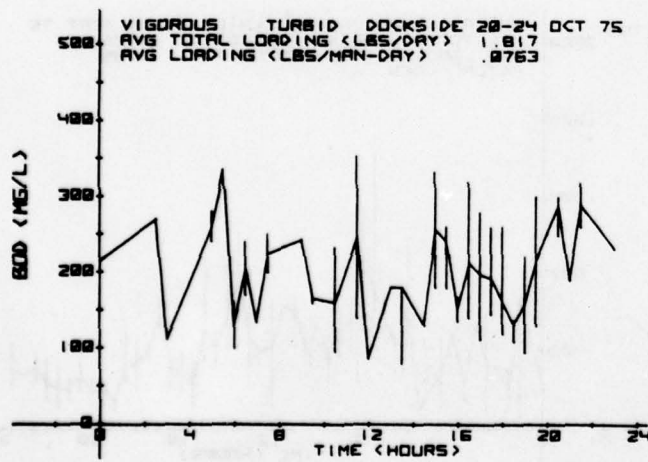
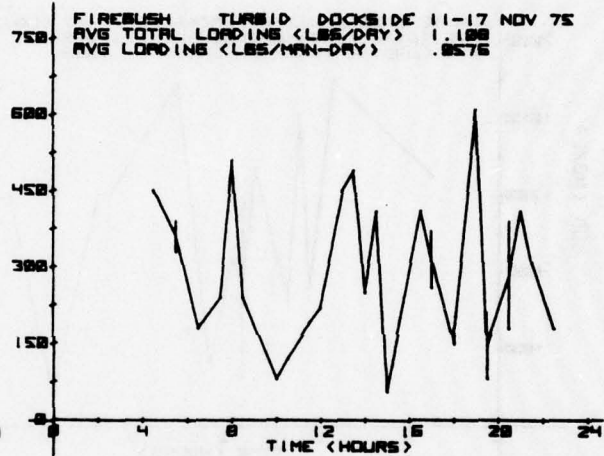
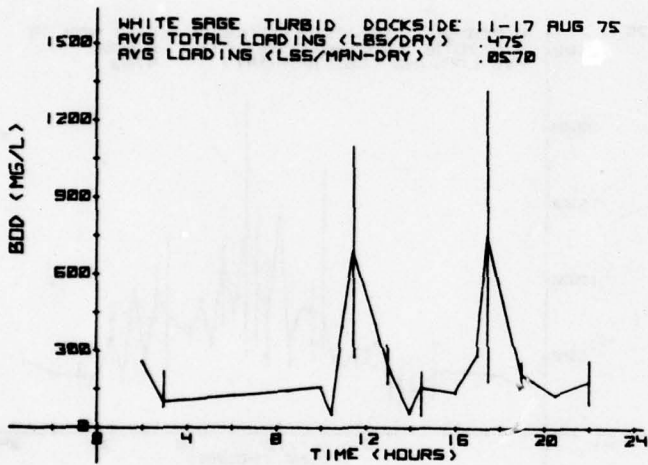
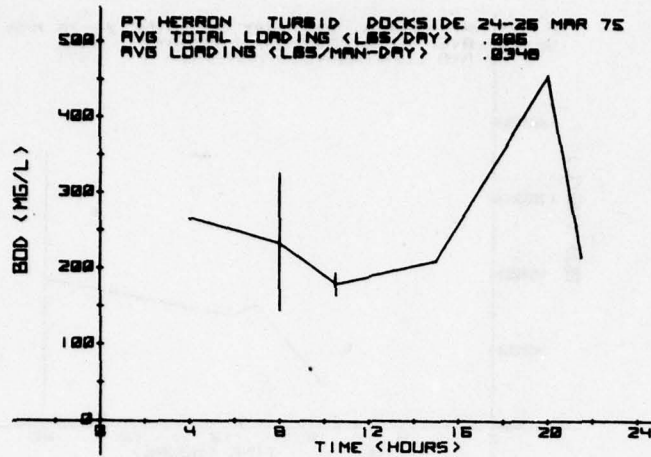

FIGURE 90. DOCKSIDE TURBID BOD LOADS

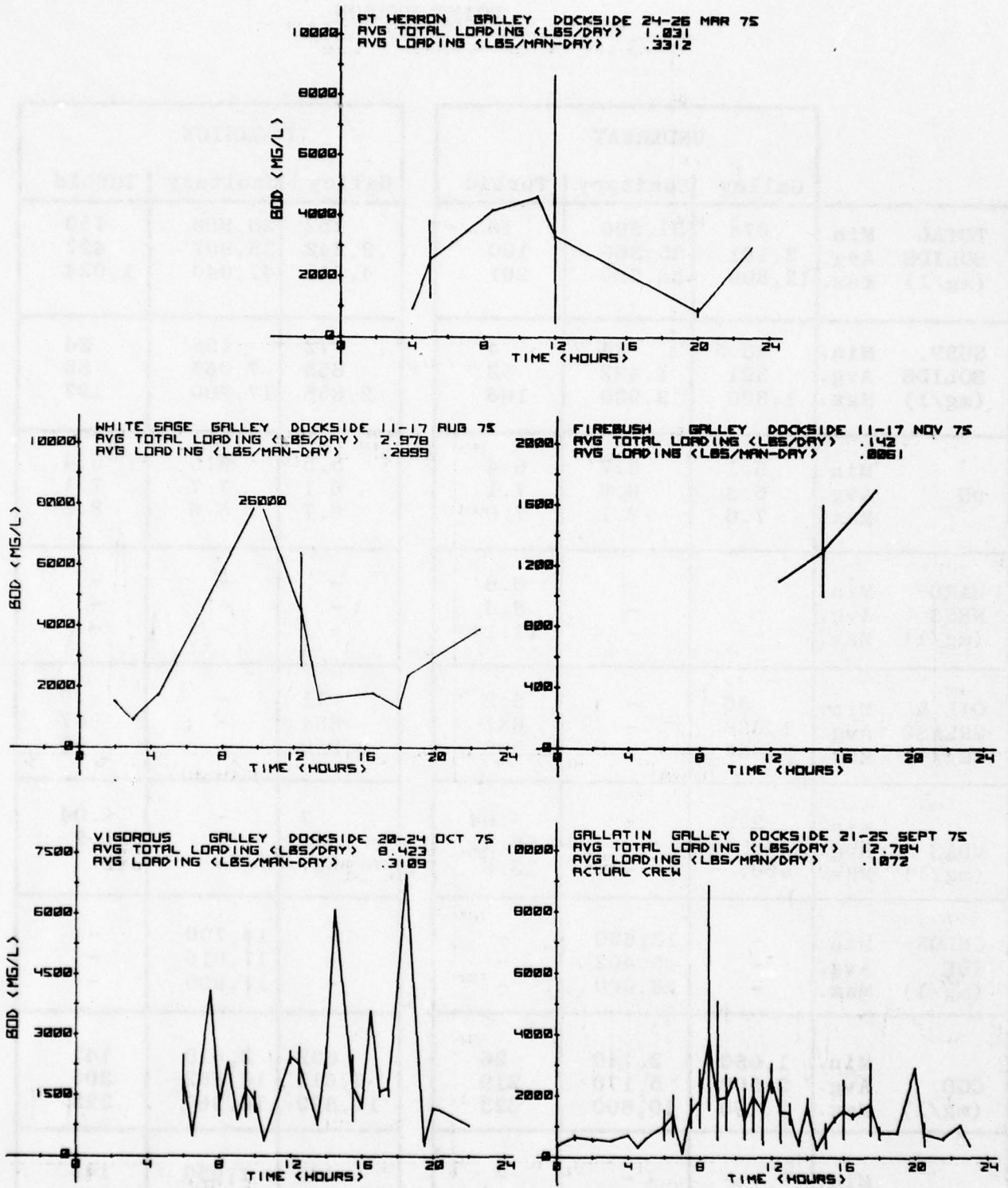

FIGURE 91. DOCKSIDE GALLEY BOD LOADS

POINT HERRON

		UNDERWAY			DOCKSIDE		
		Galley	Sanitary	Turbid	Galley	Sanitary	Turbid
TOTAL SOLIDS (mg/l)	Min.	674	31,500	10	152	28,988	150
	Avg.	2,191	35,366	100	2,242	35,907	427
	Max.	12,800	38,500	201	4,540	41,040	1,024
SUSP. SOLIDS (mg/l)	Min.	13.5	84	4	72	158	24
	Avg.	391	1,422	62	655	7,065	88
	Max.	1,300	3,930	166	2,858	17,700	197
pH	Min.	5.1	5.7	6.4	5.5	6.5	6.4
	Avg.	6.3	6.6	7.1	6.1	7.7	7.1
	Max.	7.6	7.1	7.9	6.7	8.6	8.6
HARDNESS (mg/l)	Min.	-	-	6.8	-	-	-
	Avg.	-	-	8.4	-	-	-
	Max.	-	-	11.1	-	-	-
OIL & GREASE (mg/l)	Min.	86	-	5.2	71	-	6
	Avg.	1,088	-	687	884	-	67
	Max.	2,887	-	2,569	2,250	-	90
MBAS (mg/l)	Min.	2.9	-	<.04	7	-	<.04
	Avg.	148.4	-	<2.41	144.3	-	21.2
	Max.	560.	-	13.6	960.	-	72
CHLORIDE (mg/l)	Min.	-	13,600	-	-	14,700	-
	Avg.	-	15,402	-	-	17,016	-
	Max.	-	18,000	-	-	17,900	-
COD (mg/l)	Min.	1,050	2,740	26	602	2,610	141
	Avg.	2,502	5,170	219	4,611	10,682	306
	Max.	5,190	10,800	623	11,820	18,960	325
BOD (mg/l)	Min.	-	-	-	465	1,050	145
	Avg.	-	-	-	2,754	5,530	260
	Max.	-	-	-	8,640	14,500	456

TABLE 5, CONCENTRATION OF CHEMICALS IN WASTEWATER, POINT HERRON

FIREBUSH

		UNDERWAY			DOCKSIDE		
		Galley	Sanitary	Turbid	Galley	Sanitary	Turbid
TOTAL SOLIDS (mg/l)	Min.	182	3,636	384	620	1,200	195
	Avg.	558	15,197	1,210	872	10,726	989
	Max.	1,420	30,160	2,330	1,000	20,200	2,060
SUSP. SOLIDS (mg/l)	Min.	79	65	20	222	61	25
	Avg.	198	417	298	287	282	152
	Max.	331	852	1,150	356	1,190	1,360
pH	Min.	3.9	5.5	8.8	4.6	4.9	9.2
	Avg.	6.1	7.2	9.8	5.2	6.7	10.1
	Max.	10.6	9.1	10.6	5.4	8.5	10.6
HARDNESS (mg/l)	Min.	-	-	9.4	-	-	11.2
	Avg.	-	-	15.7	-	-	15.5
	Max.	-	-	37.7	-	-	61.0
OIL & GREASE (mg/l)	Min.	48.5	-	11	138	-	12.3
	Avg.	106	-	138	197	-	45
	Max.	364	-	700	254	-	318
MBAS (mg/l)	Min.	0.09	-	48.0	1.82	-	38
	Avg.	10.5	-	140.7	16.3	-	165.1
	Max.	119.	-	242.0	46.0	-	400.
CHLORIDE (mg/l)	Min.	-	1,400	-	-	250	-
	Avg.	-	8,966	-	-	4,476	-
	Max.	-	16,500	-	-	14,000	-
COD (mg/l)	Min.	256	<100	290	1,730	<100	180
	Avg.	873	1,020	848	2,202	952	645
	Max.	1,730	5,400	2,900	2,650	3,030	1,650
BOD (mg/l)	Min.	-	-	-	1,000	140	57
	Avg.	-	-	-	1,350	619	292
	Max.	-	-	-	1,700	2,180	610

TABLE 6, CONCENTRATION OF CHEMICALS IN WASTEWATER, FIREBUSH

WHITE SAGE

		UNDERWAY			DOCKSIDE		
		Galley	Sanitary	Turbid	Galley	Sanitary	Turbid
TOTAL SOLIDS (mg/l)	Min.	135	19,968	87	268	3,610	42
	Avg.	964	35,745	223	3,919	32,300	369
	Max.	2,160	82,400	560	25,000	42,500	1,780
SUSP. SOLIDS (mg/l)	Min.	66	260	20	62	516	15
	Avg.	321	1,253	71	1,746	1,770	67
	Max.	1,050	4,990	138	12,100	4,160	338
pH	Min.	5.2	6.8	5.3	4.4	7.9	6.3
	Avg.	6.2	7.8	7.1	5.5	8.2	7.5
	Max.	7.3	8.9	9.5	7.2	8.5	10.2
HARDNESS (mg/l)	Min.	-	-	9.9	-	-	12.0
	Avg.	-	-	16.6	-	-	19.8
	Max.	-	-	44.1	-	-	36.7
OIL & GREASE (mg/l)	Min.	31	-	13	169	-	26
	Avg.	255	-	83	766	-	112
	Max.	535	-	146	2,100	-	238
MBAS (mg/l)	Min.	0.14	-	0.36	11.	-	0.10
	Avg.	52.2	-	8.83	110.3	-	16.6
	Max.	118.	-	46.	491	-	118.
CHLORIDE (mg/l)	Min.	-	15,000	-	-	10,500	-
	Avg.	-	18,773	-	-	16,087	-
	Max.	-	22,500	-	-	19,500	-
COD (mg/l)	Min.	140	235	<15	222	1,090	125
	Avg.	1,538	1,775	257	6,458	2,079	392
	Max.	3,424	3,780	480	41,900	5,380	2,000
BOD (mg/l)	Min.	-	-	-	880	170	50
	Avg.	-	-	-	4,564	1,069	254
	Max.	-	-	-	26,000	1,800	1,320

TABLE 7, CONCENTRATION OF CHEMICALS IN WASTEWATER, WHITE SAGE

VIGOROUS

		UNDERWAY			DOCKSIDE		
		Galley	Sanitary	Turbid	Galley	Sanitary	Turbid
TOTAL SOLIDS (mg/l)	Min.	414	29,100	69	158	7,470	68
	Avg.	1,306	35,096	770	3,175	20,648	389
	Max.	4,240	39,400	7,406	28,700	35,500	1,474
SUSP. SOLIDS (mg/l)	Min.	104	339	16	192	154	15
	Avg.	674	558	91	2,353	504	259
	Max.	1,752	1,418	312	32,500	1,380	4,340
pH	Min.	4.1	7.4	6.0	4.0	7.4	5.7
	Avg.	7.6	7.9	8.2	7.3	8.1	7.2
	Max.	11.5	8.5	10.5	11.3	10.7	10.1
HARDNESS (mg/l)	Min.	-	-	6	-	-	5.2
	Avg.	-	-	13	-	-	12.9
	Max.	-	-	26	-	-	23.0
OIL & GREASE (mg/l)	Min.	32	-	23.2	58	-	19.4
	Avg.	311	-	95.1	410	-	58.9
	Max.	1,082	-	267.	1,880	-	111.0
MBAS (mg/l)	Min.	0.04	-	0.24	<0.04	-	0.27
	Avg.	0.585	-	9.37	<0.09	-	16.6
	Max.	4.85	-	64.0	0.46	-	71.0
CHLORIDE (mg/l)	Min.	-	14,750	-	-	3,000	-
	Avg.	-	17,172	-	-	10,026	-
	Max.	-	18,500	-	-	18,000	-
COD (mg/l)	Min.	1,000	700	125	1,000	300	125
	Avg.	4,200	2,271	338	3,635	2,017	349
	Max.	11,700	5,300	800	10,200	4,900	860
BOD (mg/l)	Min.	-	-	-	280	100	87
	Avg.	-	-	-	2,156	397	201
	Max.	-	-	-	7,000	990	353

TABLE 8, CONCENTRATION OF CHEMICALS IN WASTEWATER, VIGOROUS

GALLATIN

		UNDERWAY			DOCKSIDE		
		Galley	Sanitary	Turbid	Galley	Sanitary	Turbid
TOTAL SOLIDS (mg/l)	Min.	266	7,120	120	92	3,780	50
	Avg.	2,124	21,811	199	1,172	20,663	165
	Max.	10,800	39,200	400	14,950	40,200	717
SUSP. SOLIDS (mg/l)	Min.	30	170	12	20	70	3
	Avg.	835	773	63	824	571	47
	Max.	4,520	2,000	134	3,300	3,500	128
pH	Min.	4.2	6.4	6.0	4.9	5.9	6.1
	Avg.	7.89	7.81	7.01	6.76	7.71	6.78
	Max.	10.5	8.5	8.4	9.4	8.6	10.3
HARDNESS (mg/l)	Min.	-	-	38	-	-	8.6
	Avg.	-	-	59.2	-	-	24.2
	Max.	-	-	84	-	-	359.6
OIL & GREASE (mg/l)	Min.	55	-	30	50	-	22.9
	Avg.	332	-	121	304	-	99
	Max.	976	-	207	3,970	-	170
MBAS (mg/l)	Min.	<.04	-	0.38	0.04	-	<.04
	Avg.	6.01	-	5.16	2.66	-	1.1
	Max.	65.0	-	26.0	32.25	-	6.40
CHLORIDE (mg/l)	Min.	-	3,000	-	-	7,000	-
	Avg.	-	12,864	-	-	10,820	-
	Max.	-	22,500	-	-	27,300	-
COD (mg/l)	Min.	105	420	105	260	260	92
	Avg.	2,349	1,948	255	3,881	1,728	250
	Max.	10,620	6,080	450	20,000	8,300	520
BOD (mg/l)	Min.	-	-	-	150	80	45
	Avg.	-	-	-	1,259	408	196
	Max.	-	-	-	8,850	1,440	770

TABLE 9, CONCENTRATION OF CHEMICALS IN WASTEWATER, GALLATIN

4. DISCUSSION

If anything is apparent from this study, it is the lack of uniformity in water consumption and waste water characteristics. Not only is it impossible to develop meaningful average data that would be applicable to the entire Coast Guard, it is also difficult to develop patterns within similar types of ships or similar duty of different types of ships.

In this study, three types of ships were sampled*, one was the "white hull" patrol cutters, the larger ships capable of prolonged operation at sea. Another was the "black hull" buoy tenders, work boats that normally return to dock at night or stay at sea for shorter time periods. The third was the small patrol boat, that is normally at the dock, going out mainly for search and rescue or limited patrol duty. Of the "white hulls" and "black hulls", two in each category were sampled. Only one patrol boat was sampled, but there are no other boats in its category to compare.

The program attempted to examine each ship in its normal duty situation, so that the data would be representative of the regular flow patterns. However, each ship was sampled for a very short period in its entire lifespan, and it is impossible to assess how accurately the data represents the true picture.

* The graphs in the previous section were arranged to facilitate comparison. The POINT HERRON patrol boat stood alone at the top. Next were the two "black hulls", the FIREBUSH and WHITE SAGE. At the bottom were two "white hulls", cutters, the VIGOROUS and GALLATIN.

With this caveat, the discussion and evaluation of data will assume that the observed data is representative of normal ships' activity.

a. Crew Size

Dockside, three of the five ships show a wide variation in crew size. The POINT HERRON, FIREBUSH, and VIGOROUS are clearly "day boats", with half to two-thirds of the crew coming on board in the morning around 0700 hours, and leaving in the evening, around 1700 hours. Such ships would have far less "domestic" activity than ships on which most of the crew live. The WHITE SAGE and the GALLATIN are such ships. On the latter, about 80% of the crew stays on board.

Even on Underway status, the ships may not have a constant crew size. Normally, the POINT HERRON goes out only for search and rescue, and the FIREBUSH works hours of a regular working day. Those ships which go on short or long patrols may vary in crew size on board, as they visit other ports or engage in various other activities.

Thus, a cutter is rarely a ship with a uniform diurnal crew size. This causes substantial variations in water usage and waste water flow, as can be seen in the following data.

d. Water Usage and Waste Water Flow

Average fresh, salt and waste water flow data derived from

the graphs in Figures 13 to 52 are summarized on Table 10. Flow figures were rounded to the nearest whole number and the data is presented in gallons per hour and in gallons per man per day. There is no consistent relationship between hydraulic flow and ship size or type. Furthermore, the hydraulic data is inconsistent from ship to ship even when reduced to a "per man" basis. This lack of uniformity is shown statistically in Table 11, which presents the mean and standard deviation of a comparison of flow data in gallons/man/day for all ships sampled. In all cases, the standard deviation is very large when compared to the mean. For fresh and salt water flow, the standard deviation is large and sometimes approaches the mean.

Differences in water usage (fresh and salt water flow) per man does not seem to relate to either crew size or ship class. The GALLATIN, the largest of the ships sampled, had the smallest fresh water flow of all ships (31 gal/man/day dockside, and 36 gal/man/day underway). The FIREBUSH, a black hulled buoy tender, had the largest (94 gal/man/day dockside and 68 gal/man/day underway). Although the decks of the FIREBUSH are hosed down with fresh water while underway, this practice would not account for the high fresh water usage dockside.

For salt water use, the GALLATIN averaged the highest (153 gal/man/day dockside and 805 gal/man/day underway) and the WHITE SAGE the lowest (14 gal/man/day underway and dockside). The very high salt water usage on the GALLATIN while underway can be partially attributed to the engine cooling water being metered

AVERAGE PARAMETER	DOCKSIDE					UNDERWAY						
	POINT HERRON	WHITE SAGE	FIRE- BUSH	VIGOROUS	GALLATIN	POINT HERRON	WHITE SAGE	FIRE- BUSH	VIGOROUS	GALLATIN		
WATER USAGE												
Fresh Water Flow gal/hr	-	17	71	67	166	-	31	94	164	223	-	94
gal/man/day	-	49	94	54	31	-	34	68	61	36	-	68
Salt Water Flow												
gal/hr	-	5	46	44	808	-	13	52	65	4929	-	52
gal/man/day	-	14	68	38	153	-	14	39	23	805	-	39
SANITARY WASTEWATER												
Actual Total Flow gal/hr.	0	6	85	50	126	1	13	94	84	125		94
gal/man/day	3	15	97	42	35	3	15	65	35	32		65
Normalized Total Flow												
gal/hr	1	13	187	105	232	1	13	125	86	214		125
gal/man/day	3	15	98	42	35	3	15	65	35	32		65
TURBID WASTEWATER												
Actual Total Flow gal/hr.	2	9	19	45	23	1	15	18	44	25		18
gal/man/day	13	28	25	46	17	4	16	13	18	17		13
Normalized Total Flow												
gal/hr.	4	25	48	114	110	1	14	25	45	112		25
gal/man/day	13	28	25	46	17	3	16	13	18	17		13
GALLEY WASTEWATER												
Actual Total Flow gal/hr.	2	3	1	20	51	1	9	14	26	44		14
gal/man/day	16	9	1	17	10	4	10	9	11	7		9
Normalized Total Flow												
gal/hr.	5	8	1	42	68	1	9	18	26	48		18
gal/man/day	16	9	1	17	10	4	10	9	11	7		9
TOTAL WASTEWATER FLOW												
Actual Total Flow gal/hr	4	18	104	114	200	3	37	126	153	194		126
gal/man/day	32	52	125	106	62	10	41	88	64	56		88
Normalized Total Flow												
gal/hr.	11	45	263	261	411	4	36	168	157	374		168
gal/man/day	32	52	125	106	62	10	41	88	64	56		88

TABLE 10. SUMMARY OF AVERAGE HYDRAULIC DATA

AVERAGE PARAMETER	DOCKSIDE		UNDERWAY	
	MEAN	STANDARD DEVIATION	MEAN	STANDARD DEVIATION
WATER USAGE Fresh Water Flow gal/hr gal/man/day	80.3	± 62.2	128.0	± 83.4
	57.0	± 26.6	49.6	± 17.3
Salt Water Flow gal/hr gal/man/day	225.8	± 388.6*	1,264.8	± 2,443.0*
	68.3	± 60.7	220.3	± 390.0*
SANITARY WASTEWATER Actual Total Flow gal/hr gal/man/day	53.4	± 53.3	63.4	± 53.8
	38.4	± 36.3	30.0	± 23.5
TURBID WASTEWATER Actual Total Flow gal/hr gal/man/day	19.6	± 16.4	20.6	± 15.7
	25.8	± 12.8	13.6	± 5.7
GALLEY WASTEWATER Actual Total Flow gal/hr gal/man/day	15.4	± 21.4	18.8	± 16.8
	10.6	± 6.4	8.2	± 2.8
TOTAL WASTEWATER Actual Total Flow gal/hr gal/man/day	88.0	± 79.3	102.6	± 80.1
	75.4	± 38.8	51.8	± 28.9

*Invalid - See text, bottom of pg. 151

TABLE 11. STATISTICAL ANALYSIS OF AVERAGE WATER FLOW DATA OF ALL SHIPS

along with other salt water systems. Cooling water is not metered on other ships. Since the flow of cooling water alone is not known, there was no way of subtracting this flow from metered salt water readings. This cooling water does not account for high salt water usage dockside, however.

Table 12 summarizes the average daily water usage and waste water flow for all ships sampled. These daily averages were calculated by multiplying the average flow in gallons per hour by 24 hours. Waste water generation is compared to water usage in Table 13. Percentages were calculated by dividing the total daily waste water flow by the daily total salt and fresh water usage for each ship, and multiplying the result by 100. The figures indicate that the ships' waste systems generally receive a high percentage of the total water usage. Again, the GALLATIN is an exception due to its high salt water usage.

The hydraulic composition of waste water is summarized on Table 14. The percentages presented on this Table were generated by dividing the daily flow of each individual waste system (taken from Table 12) by the total daily waste water flow and multiplying the result by 100. There are wide variations in hydraulic composition among the different ship classes, but the data is fairly consistent when comparing dockside and underway data for the same ship, particularly for the three larger classes. The sanitary system generates the bulk of waste water flow for the FIREBUSH, VIGOROUS and GALLATIN. On the WHITE SAGE the turbid system produces the most, and on the POINT HERRON it is the galley.

FLOW IN GALLONS PER DAY

AVERAGE PARAMETER	DOCKSIDE						UNDERWAY							
	POINT HERRON	WHITE SAGE	FIRE-BUSH	VIGOROUS	GALLATIN	POINT HERRON	WHITE SAGE	FIRE-BUSH	VIGOROUS	GALLATIN				
WATER USAGE														
Fresh Water	-	411	1,693	1,603	3,988	-	754	2,249	3,941	5,363				
Salt Water	-	120	1,094	1,059	19,395	-	314	1,238	1,564	118,288				
WASTE WATER FLOW														
Actual Crew														
Sanitary	10	138	2,032	1,191	3,026	20	320	2,262	2,004	2,989				
Turbid	40	224	455	1,082	546	19	353	427	1,050	604				
Galley	45	78	12	468	1,217	24	223	330	615	1,057				
Total	95	440	2,499	2,741	4,789	63	896	3,019	3,669	4,650				
Normalized to Full Crew														
Sanitary	24	313	4,482	2,531	5,571	25	306	3,009	2,071	5,142				
Turbid	101	588	1,147	2,741	2,643	28	337	597	1,070	2,683				
Galley	128	180	28	1,002	1,642	31	213	437	633	1,151				
Total	253	1,081	5,657	6,274	9,856	84	856	4,043	3,774	8,976				

TABLE 12. SUMMARY OF AVERAGE DAILY HYDRAULIC FLOW

WASTE WATER GENERATION PERCENTAGE OF WATER USAGE				
	WHITE SAGE	FIRE- BUSH	VIGOROUS	GALLATIN
DOCKSIDE	83	90	103	20
UNDERWAY	84	86	67	4

TABLE 13. COMPARISON OF WASTE WATER GENERATION TO WATER USAGE

SYSTEM	DOCKSIDE					UNDERWAY				
	POINT HERRON	WHITE SAGE	FIRE- BUSH	VIGOROUS	GALLATIN	POINT HERRON	WHITE SAGE	FIRE- BUSH	VIGOROUS	GALLATIN
SANITARY	10.5	31.4	81.3	43.4	63.2	31.7	35.7	74.9	54.6	64.3
TURBID	42.1	50.9	18.2	39.5	11.4	30.2	39.4	14.2	28.6	13.0
GALLEY	47.4	17.7	0.5	17.1	25.4	38.1	24.9	10.9	16.8	22.7

TABLE 14. HYDRAULIC COMPOSITION OF WASTEWATER
(Numbers shown are percentages of total flow)

The two smallest ships in the study showed greater variation between dockside and underway operations. Turbid and galley systems together received close to 90% of the total daily waste water flow dockside for the POINT HERRON, but all systems received an equal amount of waste while underway. On the WHITE SAGE, the turbid system received 51% of the daily waste water flow while dockside. As with the POINT HERRON, the underway waste water flow was equally distributed to all systems on the WHITE SAGE.

c. Chemical Composition of Waste Water

Average chemical loads derived from the graphs in Figures 53 to 91 are summarized on Tables 15, 16 and 17, which group the data into sanitary, turbid and galley waste collection systems, respectively. The loads are given in pounds/day and pounds/man/day. Statistical analyses were run on data in pounds/man/day to compare the average chemical loading per man among all ships sampled. The results of these analyses are presented in Tables 18, 19 and 20, grouping the data into sanitary, turbid and galley systems, respectively.

Data from the POINT HERRON was excluded from many of the statistical calculations because these loads were sometimes orders of magnitude smaller than loads from the other ships. An asterisk (*) indicates when POINT HERRON data were not used. The likely reasons for the POINT HERRON's inconsistency are its small crew size and irregular waste generation.

AVERAGE PARAMETER	DOCKSIDE						UNDERWAY								
	POINT HERRON	WHITE SAGE	FIRE- BUSH	VIGOROUS	GALLATIN	POINT HERRON	WHITE SAGE	FIRE- BUSH	VIGOROUS	GALLATIN	POINT HERRON	WHITE SAGE	FIRE- BUSH	VIGOROUS	GALLATIN
TOTAL SOLIDS Loading lbs/day lbs/day/man	2.948 .9104	37.110 4.0868	181.765 9.4300	205.158 6.8654	521.46 6.0683	5.945 .9938	95.371 4.3350	286.701 8.6055	586.707 9.9574	543.700 5.8462					
SUSPENDED SOLIDS Loading lbs/day lbs/man/day	.580 .1750	2.034 .2162	4.772 .1987	5.010 .1745	13.659 .1592	.239 .0414	3.342 .1519	7.872 .2229	9.330 .1571	19.274 .2072					
pH	7.7	8.2	6.7	8.1	7.7	6.6	7.8	7.2	7.9	7.8					
CHLORIDES Loading lbs/day lbs/man/day	1.397 .4321	18.482 2.0090	75.852 3.9692	99.622 3.3345	273.044 3.1737	2.589 .4350	50.088 2.2767	169.147 5.0225	287.073 4.8761	320.676 3.4481					
COD Loading lbs/day lbs/man/day	.877 .2557	2.389 .2643	16.128 .6926	20.042 .7111	43.601 .5088	.869 .1533	4.735 .2152	19.245 .5708	37.963 .6262	48.561 .5222					
BOD Loading lbs/day lbs/man/day	.454 .1471	1.228 .1323	10.488 .4783	3.946 .1397	10.289 .1189										

TABLE 15. SUMMARY OF AVERAGE CHEMICAL LOADS FOR THE SANITARY SYSTEM

AVERAGE PARAMETER	DOCKSIDE						UNDERWAY					
	POINT HERRON	WHITE SAGE	FIRE- BUSH	VIGOROUS	GALLATIN	POINT HERRON	WHITE SAGE	FIRE- BUSH	VIGOROUS	GALLATIN		
TOTAL SOLIDS Loading lbs/day lbs/man/day	.141 .0502	.691 .0821	3.757 .1855	3.511 .1492	.751 .0229	.016 .0027	.658 .0299	4.307 .1277	6.737 .1085	1.002 .0278		
SUSPENDED SOLIDS Loading lbs/day lbs/man/day	.029 .0105	.125 .0147	.577 .0248	2.341 .0834	.212 .0064	.010 .0017	.209 .0095	1.060 .0338	.801 .0135	.319 .0089		
pH	7.1	7.5	10.1	7.2	6.8	7.1	7.1	9.8	8.2	7.0		
HARDNESS Loading lbs/day lbs/man/day	- -	.037 .0044	.059 .0029	.117 .0048	.110 .0033	.002 .0003	.049 .0022	.056 .0017	.113 .0019	.298 .0083		
OIL-CREASE Loading lbs/day lbs/man/day	.022 .0092	.209 .0250	.172 .0081	.531 .0223	.451 .0138	.110 .0149	.244 .0111	.493 .0160	.833 .0149	.610 .0169		
MBAS Loading lbs/day lbs/man/day	.007 .0037	.031 .0037	.627 .0294	.150 .0061	.005 .0002	.000 .0001	.026 .0012	.501 .0146	.082 .0014	.026 .0007		
COD Loading lbs/day lbs/man/day	.101 .0415	.733 .0859	2.448 .1268	3.147 .1325	1.137 .0344	.035 .0058	.756 .0343	3.017 .0876	2.961 .0499	1.284 .0357		
BOD Loading lbs/day lbs/man/day	.086 .0348	.475 .0570	1.108 .0576	1.817 .0763	.890 .0269							

TABLE 16. SUMMARY OF AVERAGE CHEMICAL LOADS FOR THE TURBID SYSTEM

AVERAGE PARAMETER	DOCKSIDE						UNDERWAY					
	POINT HERRON	WHITE SAGE	FIRE-BUSH	VIGOROUS	GALLATIN	POINT HERRON	WHITE SAGE	FIRE-BUSH	VIGOROUS	GALLATIN		
TOTAL SOLIDS Loading lbs/day lbs/man/day	.839 .2797	2.557 .2554	.089 .0037	12.406 .5165	11.894 .1008	.443 .0752	1.791 .0814	1.536 .0453	6.697 .1128	18.726 .1274		
SUSPENDED SOLIDS Loading lbs/day lbs/man/day	.245 .0766	1.139 .1053	.030 .0013	9.1942 .4562	8.369 .0703	.079 .0125	.596 .0271	.545 .0156	3.456 .0569	7.357 .0500		
pH	6.1	5.5	5.2	7.3	6.8	6.3	6.2	6.1	7.6	7.9		
OIL & GREASE Loading lbs/day lbs/man/day	.331 .0965	.500 .0530	.020 .0009	1.600 .0569	3.091 .0258	.220 .0355	.474 .0215	.291 .0084	1.596 .0262	2.924 .0199		
MBAS Loading lbs/day lbs/man/day	.054 .0188	.072 .0078	.001 .0001	.000 .000	.027 .0002	.030 .0046	.097 .0044	.029 .0009	.003 .0000	.053 .0004		
COD Loading lbs/day lbs/man/day	1.726 .5688	4.214 .4009	.229 .0097	14.201 .4950	39.391 .3352	.506 .0836	2.857 .1298	2.402 .0711	21.530 .3546	20.703 .1408		
BOD Loading lbs/day lbs/man/day	1.031 .3312	2.978 .2899	.142 .0061	8.423 .3101	12.784 .1072							

TABLE 17. SUMMARY OF AVERAGE CHEMICAL LOADS FOR THE GALLEY SYSTEM

AVERAGE PARAMETER	<u>DOCKSIDE</u>		<u>UNDERWAY</u>	
	MEAN	STANDARD DEVIATION	MEAN	STANDARD DEVIATION
TOTAL SOLIDS Loading lbs/man/day	6.6126*	±2.2112*	7.1860*	±2.5573*
SUSPENDED SOLIDS Loading lbs/man/day	.1847	± .0226	.1848*	± .0356*
pH	7.7	±0.6	7.7	±0.3*
CHLORIDES Loading lbs/man/day	3.1216*	± .8174*	3.9058*	±1.2977*
COD Loading lbs/man/day	.4865	± .2214	.4836*	± .1839*
BOD Loading lbs/man/day	.2033	± .1541	-	-

* Point Herron data not included in calculations.

TABLE 18. STATISTICAL COMPARISON OF AVERAGE SANITARY CHEMICAL LOADS FROM ALL SHIPS

AVERAGE PARAMETER	<u>DOCKSIDE</u>		<u>UNDERWAY</u>	
	MEAN	STANDARD DEVIATION	MEAN	STANDARD DEVIATION
TOTAL SOLIDS Loading lbs/man/day	.0980	± .0679	.0735*	± .0521*
SUSPENDED SOLIDS Loading lbs/man/day	.0280	± .0317	.0164*	± .0118*
pH	7.7	±1.3	7.8*	±1.2*
HARDNESS Loading lbs/man/day	.0038	± .0009	.0035*	± .0032*
OIL & GREASE Loading lbs/man/day	.0157	± .0076	.0147*	± .0026*
MBAS Loading lbs/man/day	.0086	± .0118	.0045*	± .0068*
COD Loading lbs/man/day	.0842	± .0460	.0519*	± .0248*
BOD Loading lbs/man/day	.0505	± .0198	-	-

*Point Herron data not included in calculations.

TABLE 19. STATISTICAL COMPARISON OF AVERAGE TURBID CHEMICAL LOADS FROM ALL SHIPS

AVERAGE PARAMETER	<u>DOCKSIDE</u>		<u>UNDERWAY</u>	
	MEAN	STANDARD DEVIATION	MEAN	STANDARD DEVIATION
TOTAL SOLIDS Loading lbs/man/day	.2312	± .1956	.0884	± .0324
SUSPENDED SOLIDS Loading lbs/man/day	.1419	± .1798	.0324	± .0201
pH	6.2	± 0.9	6.8	± 0.9
OIL & GREASE Loading lbs/man/day	.0466	± .0359	.0223	± .0099
MBAS Loading lbs/man/day	.0054	± .0082	.0021	± .0023
COD Loading lbs/man/day	.3619	± .2161	.1560	± .1149
BOD Loading lbs/man/day	.2091	± .1444	-	-

TABLE 20. STATISTICAL COMPARISON OF AVERAGE GALLEY CHEMICAL LOADS FROM ALL SHIPS

Dockside and underway means compare closely for sanitary chemical loading (Table 18), indicating that chemical loads collected by sanitary systems are effectively the same whether underway or dockside. The same can be said for turbid chemical loads (Table 19), but not for galley loads (Table 20). In general, galley chemical loads are smaller underway than dockside, particularly for total and suspended solids.

The small standard deviations relative to the means for sanitary loads (Table 18) indicate that chemical loads received through the sanitary collection systems are somewhat comparable on a per man basis among the four larger ship classes. This situation is true for total solids, suspended solids, pH and chlorides. Chemical oxygen demand (COD) and biological oxygen demand (BOD) have standard deviations around 50% of the mean, and therefore cannot be predicted with as much confidence as the other parameters.

Standard deviations for turbid and galley chemical loads are generally a high percentage of their respective means, and at times exceeded the mean. This situation indicates that chemical loads received by turbid and galley collection systems cannot be confidently predicted on a per man basis among the different ship classes.

Chemical loads from all three systems were totalled and presented in Table 21 in pounds/man/day. Statistical analyses were run on this data to compare loadings among the different classes of ships. Table 22 presents the results of these analyses,

TOTALLED AVERAGE PARAMETER	DOCKSIDE						UNDERWAY								
	POINT HERRON	WHITE SAGE	FIRE- BUSH	VIGOROUS	GALLATIN	POINT HERRON	WHITE SAGE	FIRE- BUSH	VIGOROUS	GALLATIN	POINT HERRON	WHITE SAGE	FIRE- BUSH	VIGOROUS	GALLATIN
TOTAL SOLIDS Total loading lbs/man/day	1.2403	4.4243	9.6192	7.5311	6.192	1.0717	4.4463	8.7785	10.179	6.0014					
SUSPENDED SOLIDS Total loading lbs/man/day	.2621	.3362	.2248	.7141	.2359	.0556	.1885	.2723	.2275	.2661					
HARDNESS Total loading lbs/man/day	-	.0044 ¹	.0029 ¹	.0048 ¹	.0033 ¹	.0003 ¹	.002 ¹	.0017 ¹	.0019 ¹	.0083 ¹					
CHLORIDES Total loading lbs/man/day	.4321 ²	2.0090 ²	3.9692 ²	3.3345 ²	3.1737 ²	.4350 ²	2.2767 ²	5.0225 ²	4.8761 ²	3.4481 ²					
OIL & GREASE Total loading lbs/man/day	.1057	.0780	.0090	.0792	.0396	.0504	.0326	.0244	.0411	.0368					
MBAS Total loading lbs/man/day	.0225	.0115	.0295	.0061	.0004	.0047	.0056	.0155	.0014	.0011					
COD Total loading lbs/man/day	.8660	.7511	.8291	1.3386	.8784	.2427	.3793	.7295	1.0307	.6987					
BOD Total loading lbs/man/day	.5131	.4792	.5420	.5261	.2530	-	-	-	-	-					

TABLE 21. SUMMARY OF TOTAL CHEMICAL LOADS FROM ALL SYSTEMS

¹ Turbid only
² Sanitary only

TOTALLED AVERAGE PARAMETER	DOCKSIDE		UNDERWAY	
	MEAN	STANDARD DEVIATION	MEAN	STANDARD DEVIATION
TOTAL SOLIDS Total loading lbs/man/day	5.8014 6.9416*	±3.1788 ±2.1921*	6.0954 7.3513*	±3.6000 ±2.6009
SUSPENDED SOLIDS Total loading lbs/man/day	.3546	± .2056	.2020	± .0885
HARDNESS Total loading lbs/man/day	.0038*	± .0009*	.0035*	± .0032*
CHLORIDES Total loading lbs/man/day	3.1216*	± .8174*	3.9058*	±1.2977*
OIL & GREASE Total loading lbs/man/day	.0623 .0514*	± .0380 ± .0337*	.0371	± .0097
MBAS Total loading lbs/man/day	.0140	± .0119	.0057	± .0058
COD Total loading lbs/man/day	.9326	± .2323	.6162	± .3111
BOD Total loading lbs/man/day	.4627	± .1195	-	-

* Point Herron data not included in calculations.

TABLE 22. STATISTICAL COMPARISON OF TOTALS CHEMICAL LOADS FROM ALL SHIPS

and again, POINT HERRON data were left out of many of the calculations. The standard deviations are generally small relative to their means, implying a better population of data. Exceptions are MBAS and hardness loads, but these parameters have very small loads and therefore are more prone to error. In addition, hardness tests were run on turbid wastes only, and so do not benefit by totalling loads from all systems.

The percent composition of daily chemical loads delivered by the separate waste water collection systems were calculated and presented in Table 23. Total solids and suspended solids were the parameters whose present composition of the three systems were most consistent. For total solids, the sanitary system delivered roughly 95% of the daily load. This system also collected the bulk of suspended solids loading, about 70%, while the galley and turbid systems delivered roughly 20% and 10% respectively.

No real comparisons could be made for hardness and chlorides, because these tests were run on a single collection system. But this procedure was followed because most of the hardness load is expected to come from the turbid waste system, and most of the chloride load from the sanitary system.

The galley system collected about 65% of the daily oil and grease loading, and the turbid system made up the remaining 35%. The FIREBUSH deviated from this general trend. Roughly 75% of the load was contributed by the turbid system, and 25% through the galley system. The FIREBUSH also showed percent composition

AVERAGE PARAMETER	DOCKSIDE						UNDERWAY								
	POINT HERRON	WHITE SAGE	FIRE- BUSH	VIGOROUS	GALLATIN	POINT HERRON	WHITE SAGE	FIRE- BUSH	VIGOROUS	GALLATIN	POINT HERRON	WHITE SAGE	FIRE- BUSH	VIGOROUS	GALLATIN
TOTAL SOLIDS															
Sanitary	73.4	92.4	98.0	91.2	98.0	92.7	97.5	98.0	97.8	97.4	92.7	97.5	98.0	97.8	97.4
Turbid	4.0	1.9	1.9	2.0	0.4	0.3	0.7	1.5	1.1	0.5	0.3	0.7	1.5	1.1	0.5
Galley	22.6	5.8	0.0	6.9	1.6	7.0	1.8	0.5	1.1	2.1	7.0	1.8	0.5	1.1	2.1
SUSPENDED SOLIDS															
Sanitary	66.8	64.3	88.4	24.4	67.5	74.5	80.6	81.9	69.1	77.9	74.5	80.6	81.9	69.1	77.9
Turbid	4.0	4.4	11.0	11.7	2.7	3.1	5.0	12.4	5.9	3.3	3.1	5.0	12.4	5.9	3.3
Galley	29.2	31.3	0.6	63.9	29.8	22.5	14.4	5.7	25.0	18.8	22.5	14.4	5.7	25.0	18.8
HARDNESS															
Sanitary	-	-	100.0	100.0	100.0	100.0	100.0	100.0	100.0	100.0	100.0	100.0	100.0	100.0	100.0
Turbid	-	-	-	-	-	-	-	-	-	-	-	-	-	-	-
Galley	-	-	-	-	-	-	-	-	-	-	-	-	-	-	-
CHLORIDES															
Sanitary	100.0	100.0	100.0	100.0	100.0	100.0	100.0	100.0	100.0	100.0	100.0	100.0	100.0	100.0	100.0
Turbid	-	-	-	-	-	-	-	-	-	-	-	-	-	-	-
Galley	-	-	-	-	-	-	-	-	-	-	-	-	-	-	-
OIL & GREASE															
Sanitary	-	-	-	-	-	-	-	-	-	-	-	-	-	-	-
Turbid	8.7	32.1	90.0	28.2	34.8	29.6	34.0	65.6	36.3	45.9	29.6	34.0	65.6	36.3	45.9
Galley	91.3	67.9	10.0	71.8	65.2	70.4	66.0	34.4	63.7	54.1	70.4	66.0	34.4	63.7	54.1
MBAS															
Sanitary	-	-	-	-	-	-	-	-	-	-	-	-	-	-	-
Turbid	16.4	32.2	99.7	100.0	50.0	2.1	21.4	94.2	100.0	63.6	2.1	21.4	94.2	100.0	63.6
Galley	83.6	67.8	0.3	0.0	50.0	97.9	78.6	5.8	0.0	36.4	97.9	78.6	5.8	0.0	36.4
COD															
Sanitary	29.5	35.2	83.5	53.1	57.9	63.2	56.7	78.2	60.8	74.7	63.2	56.7	78.2	60.8	74.7
Turbid	4.8	11.4	15.3	9.9	3.9	2.4	9.0	12.0	4.8	5.1	2.4	9.0	12.0	4.8	5.1
Galley	65.7	53.4	1.2	37.0	38.2	34.4	34.2	9.7	34.4	20.2	34.4	34.2	9.7	34.4	20.2
BOD															
Sanitary	28.7	27.6	88.2	26.6	47.0	-	-	-	-	-	-	-	-	-	-
Turbid	6.8	11.9	10.6	14.5	10.6	-	-	-	-	-	-	-	-	-	-
Galley	64.5	60.5	1.1	58.9	42.4	-	-	-	-	-	-	-	-	-	-

TABLE 23. PERCENT COMPOSITION OF CHEMICAL LOADS DELIVERED BY INDIVIDUAL COLLECTION SYSTEM

of BOD loads independent of the other ships. About 88% of the BOD is delivered by the sanitary system, 11% by the turbid system and 1% by the galley system. All other ships had about 60%, 30% and 10% of the daily BOD load contributed by galley, sanitary and turbid systems, respectively.

Percent composition of MBAS loads vary greatly from ship to ship, but prove to be fairly consistent underway and dockside for the same ship. COD was the only parameter whose percent composition of daily loads were not consistent for underway and dockside operations.

d. Comparison of Domestic Sewage

The chemical composition of shipboard wastes obtained in this study was compared to that of typical domestic sewage. Table 24 summarizes this data for total solids, suspended solids, chlorides, oil and grease, COD and BOD. All concentrations of contaminants are in mg/l. The domestic sewage composition listed here is considered to be relatively strong. The data indicates that shipboard wastes are much stronger than domestic wastes. In the case of chlorides, they may be 100 times stronger. Oil and grease was the one standard parameter where shipboard concentrations were somewhat consistently below domestic values.

e. Correlation of BOD to COD and Suspended Solids

The biological oxygen demand (BOD) of waste water is routinely monitored as a way of determining the strength of the

<u>PARAMETER</u> (mg/l)	<u>TYPICAL</u> <u>COMPOSITION</u> <u>OF DOMESTIC</u> <u>SEWAGE</u>	<u>DOCKSIDE</u>				
		<u>POINT</u> <u>HERRON</u>	<u>WHITE</u> <u>SAGE</u>	<u>FIRE-</u> <u>BUSH</u>	<u>VIGOR-</u> <u>OUS</u>	<u>GALLA-</u> <u>TIN</u>
TOTAL SOLIDS	1,225	4,906	11,201	2,916	9,690	13,342
SUSPENDED SOLIDS	350	1,066	915	258	725	556
CHLORIDES	92	1,745	5,130	3,644	4,366	6,821
OIL-GREASE	150	441	197	9	33	88
COD	1,000	3,377	2,036	903	1,639	2,101
BOD	350	1,962	1,299	564	622	599

<u>UNDERWAY</u>						
TOTAL SOLIDS	1,225	10,666	13,208	11,598	19,595	18,397
SUSPENDED SOLIDS	350	546	560	376	444	880
CHLORIDES	92	4,312	6,763	6,705	9,375	10,472
OIL-GREASE	150	550	97	31	79	115
COD	1,000	2,348	1,127	978	2,039	2,303
BOD	350	-	-	-	-	-

TABLE 24. COMPARISON OF SHIPBOARD WASTE WATER TO TYPICAL DOMESTIC SEWAGE

waste water and to check that treatment meets existing standards for waste removal. Unfortunately, this test involves five days of incubation and is therefore time consuming and costly. If it could be shown that there is a strong correlation between BOD and cheaper, quicker tests such as chemical oxygen demand (COD) or suspended solids, BOD tests could be replaced as a routine requirement.

The results of chemical analysis run on dockside samples from the GALLATIN were examined, and BOD was plotted versus COD and suspended solids. These graphs are presented in Figure 92. The three graphs on the left show BOD plotted versus COD for sanitary, turbid and galley waste water. The three graphs on the right depict BOD versus suspended solids. The correlation coefficient for each graph was calculated and noted above each graph. This coefficient is a numerical estimate of how closely the two parameters are related to each other. A coefficient of 1.000 would indicate a very strong correlation. A coefficient of .500 would indicate a good correlation, while anything below .250 would show essentially little correlation.

Table 25 summarizes the correlation coefficients of all 6 graphs. The Table shows that BOD does not correlate with COD, and has a weak correlation with suspended solids. This limited study seems to indicate that the test for BOD cannot realistically be eliminated as a monitoring tool for waste water.

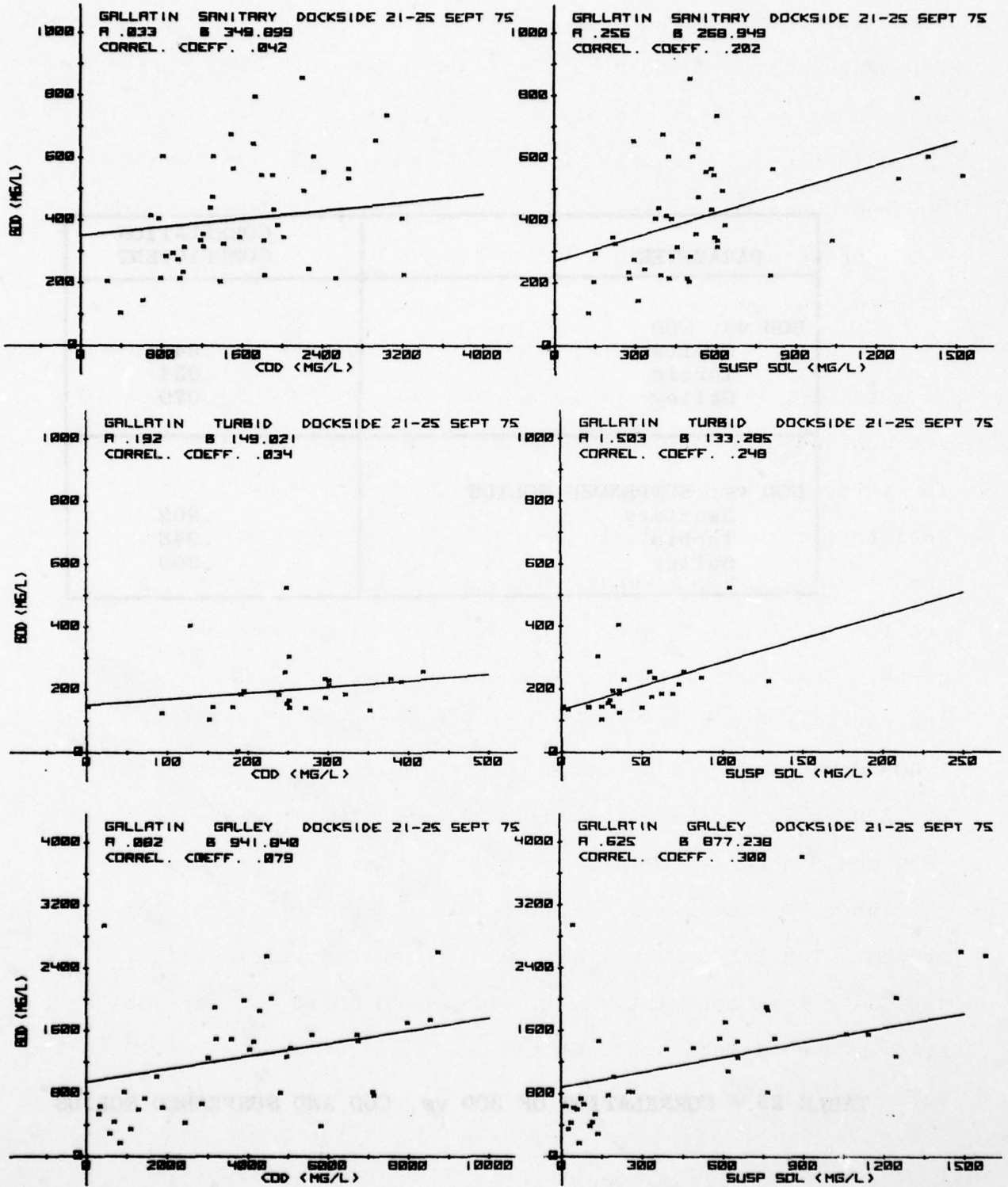

FIGURE 92. CORRELATION OF BOD vs. COD AND SUSPENDED SOLIDS

PARAMETER	CORRELATION COEFFICIENT
BOD vs. COD	
Sanitary	.042
Turbid	.034
Galley	.079
BOD vs. SUSPENDED SOLIDS	
Sanitary	.202
Turbid	.248
Galley	.300

TABLE 25. CORRELATION OF BOD vs. COD AND SUSPENDED SOLIDS

f. Statistical Analysis

An effort was made to evaluate the water flow data for statistical regularity. Most statistical testing between groups of data (e.g. water flow rates for different ships) depends on the assumption that the samples are drawn from the same parent population. An attempt to see statistical relationships between the data for different ships for water flow data was found to be fruitless, even when data was reduced to a normalized flow/man basis and even when the data were grouped separately (dockside - underway). This is probably so, because of the wide disparity in crew function and mission for the different samples.

A comparison of average water flow/man day (for each) was attempted statistically, again with no meaningful results, probably because we do not understand the underlying statistical relationships that may be relevant.

Finally, a regression analysis was done on the cumulative water flow data from each source for each ship. The cumulative flow data was analyzed from the standpoint of a linear model and the distribution of the data. It is apparent from examination of the related cumulative water flow data, that there is an appearance of linearity in many cases, however, there is a wide disparity between the maximum and minimum cumulative flow data points. This great dispersion (probably exaggerated by the relatively small number of samples) indicates that it is unlikely that any statistical meaningful result would be obtained. This was found to be true

Regression analyses were done on the cumulative flow data using the median values and a weighted combination of all values at a given time as the estimator of the point value. The analysis was done to:

1. test for linearity - that is a straight line (with a zero origin) a reasonable approximator of the flow from these sources, and,
2. to test for the fidelity of the presently computed averages as estimators of total flow.

For both analysis, the variance ratio test (F test) was used. The results of these tests are shown in Table 26. The degrees of freedom for these tests were calculated to be 46, 96 for the linearity test and 1, 96 for the test of the hypothesis that all values came from the same parent population. The F (46, 96) and F (1, 96) values for 95 percentage points (5% level of significance) are shown on Table 26. As seen in this Table, the tests for linearity were in many cases below the level of significance ($F_{\text{calc}} < F_{\text{test}}$) at the 95 percentage point (5% level of significance). On the other hand, the calculated F values for the distribution of the total data set are all very much larger than the test values, even at 99.9 percentage point level. Thus, there is no discernable statistical regularity to the data that would imply the data was from a parent population of common distribution.

In summary, it appears that a linear model for average cumulative flow may be valid. A model of this sort could be based on average or peak flow depending on the consequences

AD-A055 797

H2M CORP MELVILLE NY

F/G 13/10

SURVEY, ANALYSIS AND EVALUATION OF DOMESTIC WASTEWATERS ON COAS--ETC(U)

OCT 76 H D FREUDENTHAL, D A MORAN, C POWERS DOT-CG-41342-A

USCG-D-63-77

NL

UNCLASSIFIED

3 OF 4
ADA
055797



of overload on a short term basis. On the other hand, the data shows that there is a wide variability in the input at a given instant and that it is not possible within the framework of the available data to predict or to develop a model that predicts the instantaneous system load with confidence.

DATE	TIME	LOAD	TYPE	REMARKS
1957	11:00	100
1957	11:15	120
1957	11:30	150

DATE	TIME	LOAD	TYPE	REMARKS
1957	11:45	180
1957	12:00	200
1957	12:15	220
1957	12:30	250
1957	12:45	280
1957	13:00	300

Linearity - $F(0.95) = 1.38$
 Residuals - $F(0.95) = 3.84$
 ... too little data to evaluate

TABLE 20. CALCULATED F-RATIOS FOR LINEARITY AND STATISTICAL REGULARITY OF LOAD

DOCKSIDE

	<u>SANITARY</u>		<u>TURBID</u>		<u>GALLEY</u>	
	<u>Lin.</u>	<u>Regr.</u>	<u>Lin.</u>	<u>Regr.</u>	<u>Lin.</u>	<u>Regr.</u>
GALLATIN	1.44	2505	.88	1169	6.28	8449
FIREBUSH	1.87	3094	.297	47	0.229	87
WHITE SAGE	2.09	1486	1.47	78	0.6	47.9
VIGOROUS	8.87	6846	2.72	1790	0.76	794
POINT HERRON	*	*	*	*	5.11	3580

UNDERWAY

	<u>SANITARY</u>		<u>TURBID</u>		<u>GALLEY</u>	
	<u>Lin.</u>	<u>Regr.</u>	<u>Lin.</u>	<u>Regr.</u>	<u>Lin.</u>	<u>Regr.</u>
GALLATIN	4.29	1100	1.37	207	2.39	4020
FIREBUSH	4.6	1038	2.3	2107	0.54	655
WHITE SAGE	3.28	468	2.7	317	2.3	1869
VIGOROUS	13.6	2258	0.485	1089	14.7	8807
POINT HERRON	12.02	6641	13.2	4531	15.5	7877

Linearity - $F(46, 96) - 1.38$
 Regression - $F(1, 96) - 3.94$

* too little data to evaluate

TABLE 26. CALCULATED F RATIONAL FOR LINEARITY AND STATISTICAL REGULARITY OF FLOW.

g. Comparison with Other Studies

The studies on ship's waste waters are few, and the data on flow characteristics is meager. In most cases the data was directly related to the performance of a particular treatment system with more post-treatment data than pre-treatment information.

General Electric (1971), in their development test of their "electrochemical treatment process", presents raw waste water flow and chemical data from the U.S. Army hopper dredge GERIG. Only one figure and summary data is given (Figure 93) and there is no reference to the number of data points that went into this summary. For comparison, the GREIG is 351 feet in length with a crew of 97 persons. The ship operates three shifts a day, seven days a week with three meals a day.

In the study, the General Electric equipment was sized to waste water characteristics of the USCGC SASSAFRAS. However, a Coast Guard ship was not actually used in the demonstration test because of "unpredictable operating schedule". The operations data is not given in the General Electric Report.

In 1965, the U.S. Navy Marine Engineering Laboratory published findings on Quantities and Properties of Sewage from Naval Vessels (Jakobson and Posner, 1965), but this study concerned itself only with sanitary waste. Based upon three ships over a 30-day period, one with 40 men and the other two with

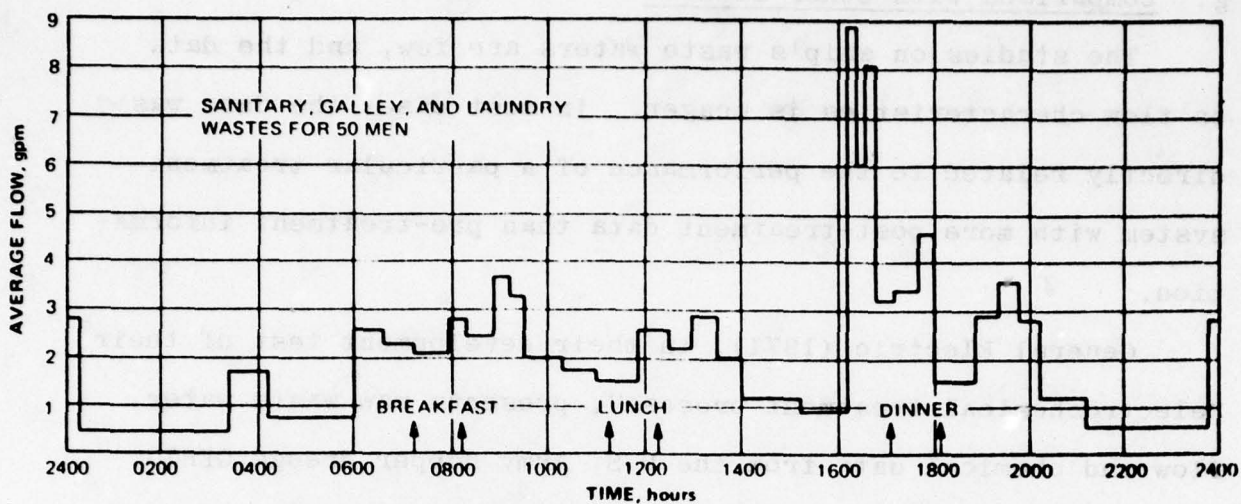

Parameter	Average	Range
Flow	2500 gal/day	0-8.9 gal/min
Total Oxygen Demand, ppm	890	175-2300
Biochemical Oxygen Demand, ppm	650	175-880
Total Suspended Solids, ppm	600	125-1400
Total Volatile Suspended Solids, ppm	450	90-1200
pH	7.8	6.9-8.5
Conductivity μ mhos/cm	21000	9000-38000

FIGURE 93. Summary Influent Hydrograph and Wastewater Characteristics. U.S. Army Dredge GERIG. August 1969 (General Electric Co. 1971).

20-30 men each, the per capita flow averaged 13.1 G.P.D., ranging between an average maximum of 17.0 and an average minimum of 11.3, for a difference of 5.7 gallons per capita per day. Thus the flow can range 43.5% of the mean flow. These figures were based on flush water flow recorders.

Peak flow was between 0500 and 0900 hours and between 2100 and 2300 hours, with peak rates between 200 to 300 percent of the daily average. If a number of personnel were on liberty, another peak occurred between 2400 and 0100 hours.

Waste water parameters were measured on a fourth ship, so that there is no correlation with flow. Thames River flush water values were taken, but it is not clear how these related to final averages. The summary data from the report is shown in Table 27. We have multiplied the chemical data by the average per capita flow to obtain loading data which could be compared to the data in this study.

The Coast Guard test of a proprietary waste treatment system, (Schaller, et al., 1971), on the 210A USCGC ALERT (WMEC-630) used a device sized for a total hydraulic flow of 1750 gal/day. With a crew of 50 men, the only flow data given for operational parameters is 35 gal/man/day, or 2.9 gal/min., over a ten hour flow period.

The design data for the ALERT system was based upon the SASSAFRAS system, as both ships had similar size crews (60 vs. 50, respectively). Experience rapidly showed that the hydraulic

TABLE 27

SUMMARY OF THE PROPERTIES OF SEWAGE
FROM A NAVAL VESSEL

		<u>Estimate Loading Per Capita*</u>
Per Capita Flow, GPD Max.	17.0	-
Per Capita Flow, GPD Min.	11.3	-
Per Capita Flow, GPD Av.	13.1	-
Suspended Solids, Mg/l Av.	236	11.7 gm
Biochemical Oxygen Demand, PPM Av.	102	5.1 gm
Coliform Density Index, MPN per 100 ml, Geometric, Av.	4.8×10^5	-
Settleable Solids, Ml/l Av.	5.4	.3 gm
pH, Av.	7.38	-
Nitrogen as Ammonia, PPM Av.	15.2	.7 gm
Nitrogen as Nitrate, PPM Av.	12.5	.6 gm
Nitrogen as Nitrite, PPM Av.	0.01	.4 mg
Nitrogen, Organic, PPM Av.	112.1	5.6 gm
Nitrogen, Total, PPM Av.	127.3	6.3 gm
Total Solids, PPM Av.	33,000	1636.2 gm
Volatile and Organic Solids, PPM Av.	5,825	288.8 gm
Dissolved Oxygen, PPM Av.	5.38	

* As per our calculations, multiplying chemical data by average per capita flow.

load on the ALERT was greater than anticipated, the log recording approximately 5000 gallons per day, where as the SASSAFRAS system ran only 1500-2000 gallons per day.

Following a comparison inventory of fixtures of both ships the authors concluded that estimating hydraulic loading solely on the basis of per capita contribution is invalid, and that the waste water flow is a function of both the crew size and the number of water using facilities.

Although not so stated in the report, it should be noted that the SASSAFRAS and ALERT are two different types of ships, and this influences the flow more than the number of fixtures or men. The SASSAFRAS is a buoy tender, and generally returns to base at the end of a working day. The ALERT is a medium endurance cutter, with a high percentage of live-on-board personnel.

During the test, average BOD₅ of the influent was 954 mg/l., and suspended solids averaged 793 mg/l.

Another report giving waste flow, without citing the source of the data (Rosenbuch, 1973), lists the following per capita body waste.

	<u>Minimum</u>	<u>Maximum</u>	<u>Average</u>
urine	1198 gm	1530 gm	1416 gm.
feces	75	180	170
paper	18	·100	34
TOTAL	<u>1291 gm</u>	<u>1810 gm</u>	<u>1620 gm</u>

Ten percent of these weights are solids. The other characteristics of waste are:

BOD 100 - 1000 mg/l (0.2 lb/man-day)
 Soluble BOD 300 - 6000 mg/l
 Suspended Solids 200 - 1100mg/l
 Coliform bacteria 107-108/100 ml.
 Toilet waste 20 - 50 gal/capita/day
 Combined waste 55 - 100 gal/man/day

The General American Transportation Corp. (Heeney, et al., 1974), tested a physical-chemical marine sanitation system, basins 133 liters (35.13 gal) water use per man per day on data from the Bioastronautics Data Book (Webb, 1964). Another prototype test system on board the USCGC RED BEECH (White, 1975), was sized to treat 1440 gal/day for a crew of 34, or nominally 42.4 gal per man per day. In shipboard test the COD concentration averaged 498 ppm, but flow rates are not given.

5. SUMMARY AND RECOMMENDATIONS

In summary, the hydraulic and chemical data compiled in this study show little consistency from ship to ship, even if the black-hulled buoy tenders and the white-hulled cutters are grouped separately. Water usage and waste water flow was particularly inconsistent and appeared unrelated to crew size and ship function. Chemical loads of the individual collection systems were also erratic, but when these loads were combined to give total daily loads per man, the data became more comparable from ship to ship.

Since chemical loads can be predicted with greater confidence when collected at the end of a day, and since waste water flow is so erratic throughout the day, a treatment system designed to handle wastes in "batches" would be more desirable than a continuous treatment system. Prolonged holding periods with current wastewater flow is impractical, as large volumes of wastewater will accumulate and shipboard storage would be insufficient. Water saving devices should therefore be incorporated into the collection systems. Recommended treatment systems and water saving devices will be further discussed at the end of this section.

Hydraulic data show that a high percentage of water usage appears as wastewater. This allows water supply meter readings to be used to estimate total waste water quantity.

The hydraulic composition of the three systems (percentage of total waste water delivered by each collection system) was effectively the same for dockside and underway operations. The

same can be said for chemical loading.

The sanitary system consistently delivered most of the total and suspended solids loads. The turbid system delivered very low percentages of chemical loads for all parameters except hardness and MBAS. However, the total loading of these parameters were small, in the range of one one-hundredth to one one-thousandth of a part per million. The low delivery of chemical loads from the turbid collection system indicates that this waste water may bypass the treatment system without adversely impacting the receiving waters if discharged while underway. This alternative to shipboard treatment would eliminate a significant volume of waste water to be held on board.

In general, shipboard wastes were much stronger than typical domestic wastes. Ship treatment systems which are adapted from domestic systems may encounter difficulty if not designed for the additional load.

From the results of this study, the following recommendations may be made concerning the treatment of shipboard wastes:

1. A "batch" treatment system should be employed to treat waste water on board, since wastes collected over a period of time make chemical loads more predictable.
2. Reduce the volume of waste water delivered by the collection systems. Waste water reduction can be accomplished by discharging turbid water without treatment, reusing turbid water in the sanitary system, and using water saving devices such as self-closing faucets and reduce-flow shower heads.

3. Use a physical-chemical treatment system on board, rather than a biological system. Since flow is very erratic and there are periods of no flow, a biological treatment system would prove impossible to maintain.
4. The waste water should receive secondary treatment. Tertiary treatment seems too extensive for discharge into a harbor or ocean. Secondary treatment could be accomplished by filtration or using flocculants. The treated wastes should be disinfected before being discharged.
5. The data does not substantiate any reliable average value to be used in designing ship waste treatment systems. If a conservative total waste water number was required for planning, 80 gal/man/day underway and 110 gal/man/day dockside would seem appropriate, using current waste water systems. However, this number must be evaluated in terms of the ship size and mission. Guidelines are:

- a. Large patrol cutters will produce less waste water per man than smaller patrol cutters.
- b. Large buoy tenders will produce more waste water per man than small buoy tenders.

It is apparent that ship waste water treatment can not be broadly categorized, but that each ship size and type represent individual variations.

6. REFERENCES

- American Public Health Association, American Water Works Association, Water Pollution Control Federation; Standard Methods for Examination of Water and Wastewater, 14th edition. Washington, D.C., APHA, 1974.
- General Electric Co.; Watercraft Waste Treatment System Development and Demonstration Report. U.S. Environmental Protection Agency, 1971. (Report 15020 DHG 09/71).
- Heeney, J.M. et al., Development and Evaluation Report: Physical-Chemical Marine Sanitation System. Niles, Illinois, General American Transportation Corp, 1974. (U.S.E.P.A. Report EPA 670/2-74-043.)
- Jakobson, K. and M.J. Posner; Survey to Determine Quantities and Properties of Sewage From Naval Vessels. Annapolis, Md., U.S. Navy, Marine Engineering Laboratory, 1965. (Report 346/64.)
- Quasim, Syed R., Neil L. Drobny, and Alan Cornish, Advanced Waste Treatment System for Naval Vessels. Journal of the Environmental Engineering Division, October 1973, 717 - 27.
- Rosenbuck, J.M., State of the Art Report on Marine Sanitation Devices. Silver Spring, Md., Automation Industries, Inc., 1973. (Coast Guard Report CG-D-11-73.)
- Schaller, C.L., T.S. Scarano and O.M. Halstad; Evaluation of a Proprietary Waste Treatment System Aboard the USCGC ALERT. Washington, D.C., U.S. Coast Guard, Applied Technology Division, 1971. (Project No. 714121/100).
- Webb, Paul, ed., Bioastronautics Data Book, National Aeronautics and Space Administration, 1964. (NASA SP 3006).
- White, J.A., Operational Experience with a U.S. Coast Guard R & D Prototype Shipboard Wastewater Treatment System, American Society of Mechanical Engineers, 1975. (Report No. 75-ENAs-27.)

APPENDIX A

Engineering Drawings

For

**Modifications to Ships'
Water and Wastewater
Systems, to Accomodate
Metering and Sampling
Devices**

UNITED STATES COAST GUARD CONTRACT

DOT - CG 41342-A

**SURVEY, ANALYSIS AND EVALUATION OF DOMESTIC
WASTEWATERS ON COAST GUARD VESSELS**

POINT HERRON

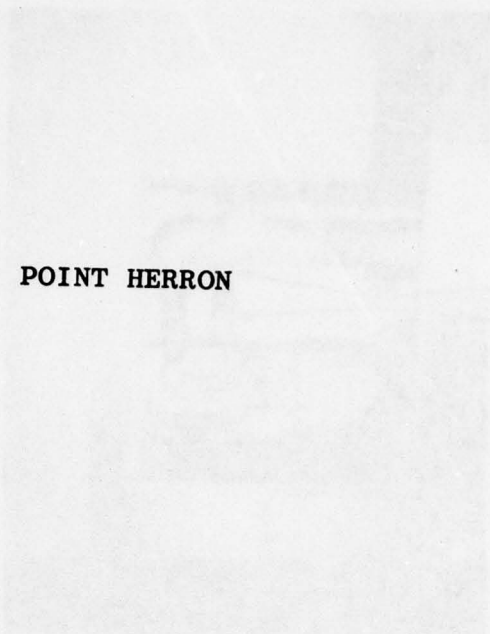

Handwritten notes and lines pointing to the top right corner of the aerial photograph.

Handwritten notes and lines pointing to the right side of the aerial photograph.

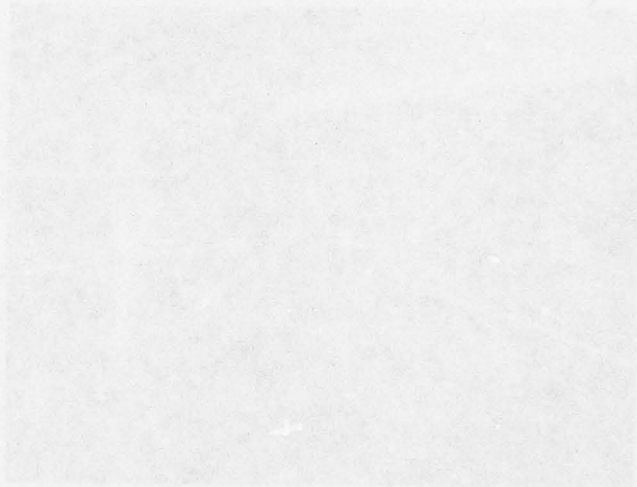

Handwritten notes and lines pointing to the left side of the aerial photograph.

Handwritten notes and lines pointing to the bottom right corner of the aerial photograph.

POINT HERRON

DEPARTMENT OF TRANSPORTATION
UNITED STATES COAST GUARD
SURVEY, ANALYSIS AND EVALUATION OF COAST GUARD VESSEL WASTE WATERS
DATE October 17, 1974 CONTRACT NO. DCA 4182-A
SCALE 1:5000
HSM CORP. ENVIRONMENTAL ENGINEERS AND SCIENTISTS NEWTON N.J.
HOTELMACHER, MILLER, AND MARSHALL
MELVILLE N.Y.

A-1

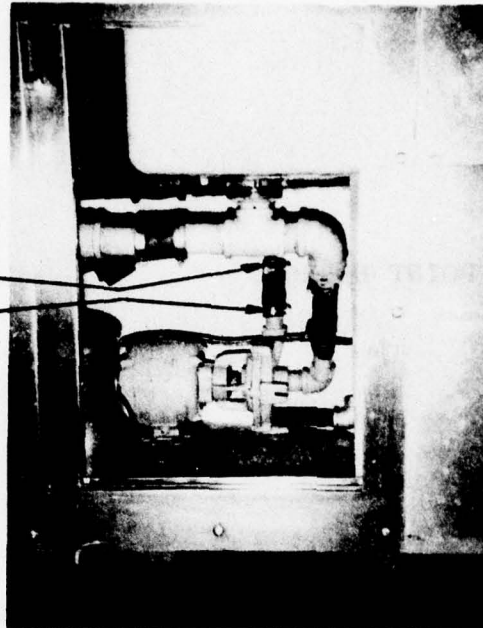

GALLEY WASTE
RETURN POINT
GALLEY WASTE
SAMPLE POINT

REMOVE EXIST.
ELBOW & INST.
3/4" TEE, 3/4" PLUG
VALVE & 3" LONG
STRAIGHT RUN

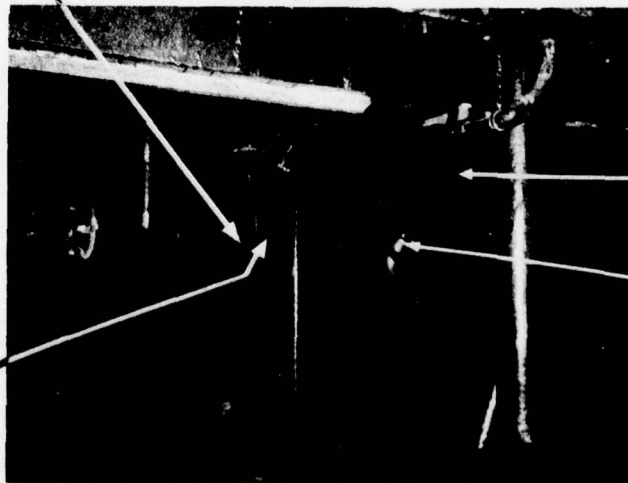

SANITARY
WASTE
SAMPLE
POINT

SANITARY
WASTE
RETURN
POINT

TURBID
WATER
SAMPLE
POINT

POINT HERRON

DEPARTMENT OF TRANSPORTATION UNITED STATES COAST GUARD
SURVEY, ANALYSIS AND EVALUATION OF COAST GUARD VESSEL WASTE WATERS

DATE October 17, 1974 CONTRACT NO. DOT - CG 41342-A

SCALE NONE

H2M CORP. HOLZMACHER, McLENDON and MURRELL MELVILLE, N. Y.
ENVIRONMENTAL ENGINEERS and SCIENTISTS NEWTON, N. J.

VIGOROUS

A-3

HSM CORP. ENVIRONMENTAL ENGINEERS & SCIENTISTS
DATE OCT 9 1978
CONTRACT NO. D-100-78-1
SURVEY, ANALYSIS AND EVALUATION OF COAST GUARD VESSEL WASTE WATERS
DEPARTMENT OF TRANSPORTATION
UNITED STATES COAST GUARD
SABITARY WASTE SAMPLE POINT
VIGOROUS (INLET 027)

NOTE:

- 1.) BALL VALVES SHALL BE WALWORTH 150 LB., BRONZE, FIG. 4150 F AS MANUFACTURED BY "WALWORTH CO." BALA CYNWYD, PA.
- 2.) AFTER SAMPLING PROGRAM IS COMPLETE, REMOVE HOSE CONNECTION & INST. BLIND FLANGE.
- 3.) NEW PIPING & FITTINGS SHALL BE 90-10 CU-NI CONFORMING TO MIL-T-16420 CL 200.
- 4.) AFTER SAMPLING PROGRAM IS COMPLETE, REMOVE 6" KNIFE GATE VALVE, SPACER & REINSTALL EXISTING SPOOL PIECE.

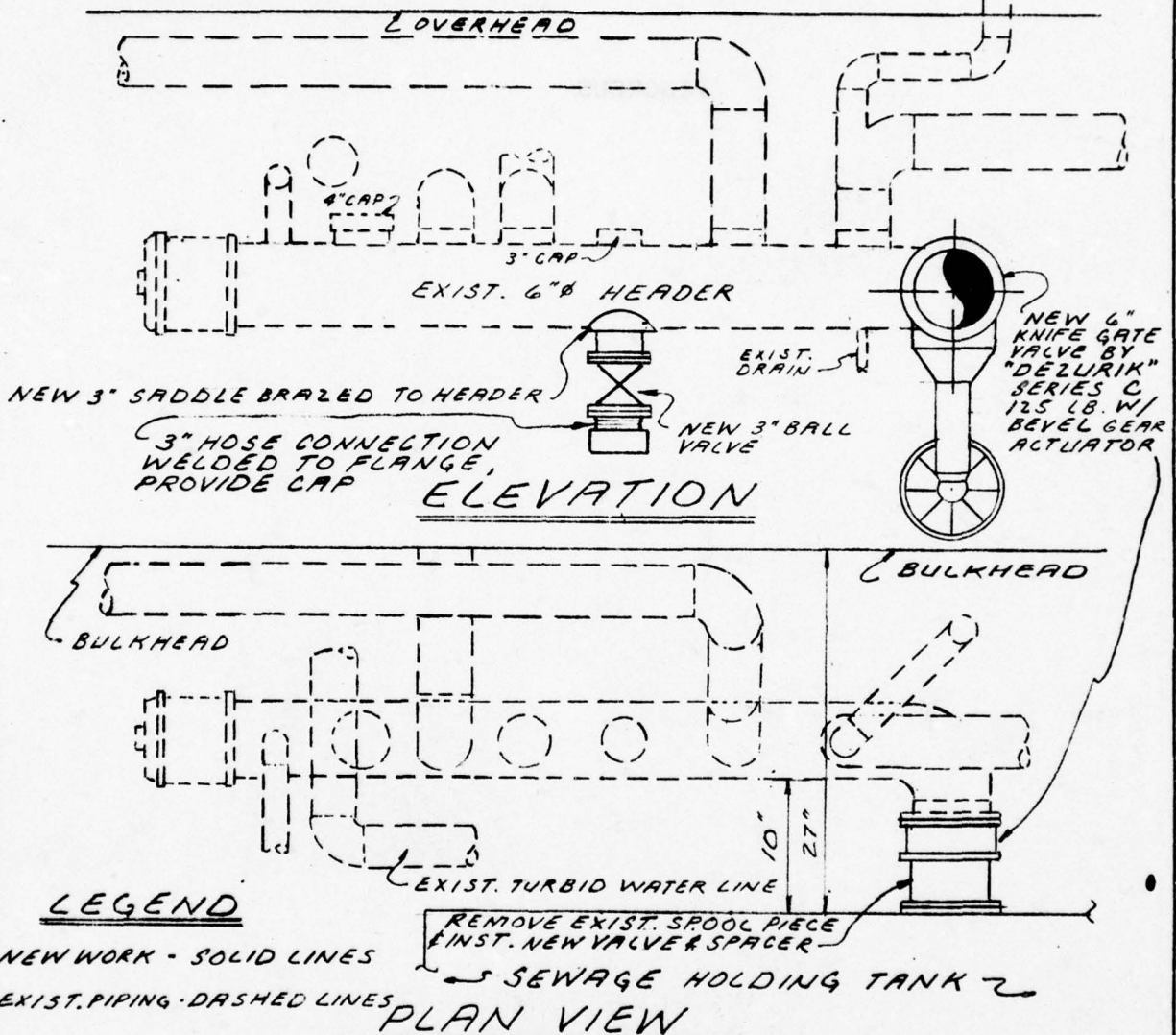

**VIGOROUS (WMEC 627)
SANITARY WASTE SAMPLE POINT**

DEPARTMENT OF TRANSPORTATION UNITED STATES COAST GUARD
 SURVEY, ANALYSIS AND EVALUATION OF COAST GUARD VESSEL WASTE WATERS
 DATE OCT. 8, 1974 CONTRACT NO. DOT - CG 41342-A SCALE - NONE

H2M CORP. HOLZMACHER, McLENDON and MURRELL MELVILLE, N. Y.
 ENVIRONMENTAL ENGINEERS and SCIENTISTS NEWTON, N. J.

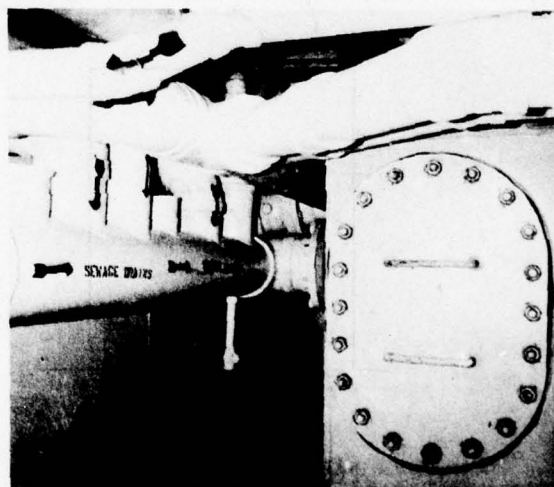
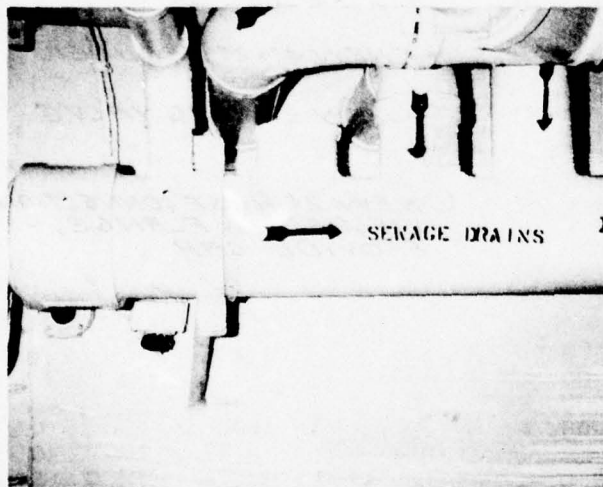
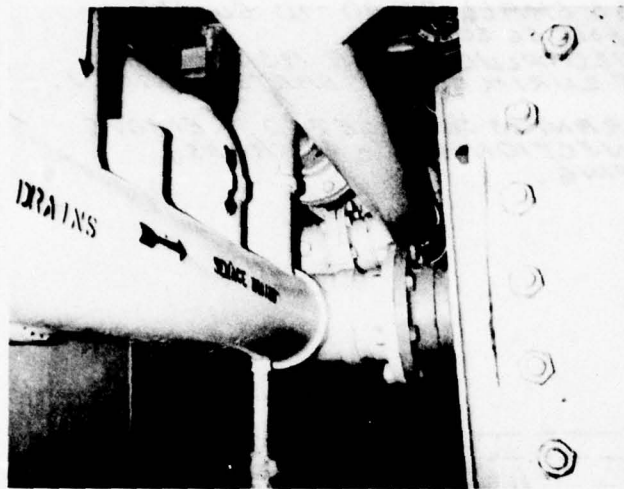

**VIGOROUS (WMEC 627)
SANITARY WASTE SAMPLE POINT**

DEPARTMENT OF TRANSPORTATION UNITED STATES COAST GUARD
SURVEY, ANALYSIS AND EVALUATION OF COAST GUARD VESSEL WASTE WATERS

DATE OCT. 8, 1974

CONTRACT NO. DOT - CG 41342 - A

SCALE - NONE

H2M CORP.

HOLZMACHER, McLENDON and MURRELL

MELVILLE, N. Y.

ENVIRONMENTAL ENGINEERS and SCIENTISTS

NEWTON, N. J.

NOTES:

- 1.) ALL NEW PIPE & FITTINGS SHALL BE 90-10 CU-NI CONFORMING TO MIL-T-16420 CL 200.
- 2.) VALVE SHALL BE 2" FIG. 120 PLUG VALVE AS MANUFACTURED BY "DE ZURIK CORP" SARTELL, MINN.
- 3.) AFTER SAMPLING PROGRAM IS COMPLETED, REMOVE PLUG VALVE, HOSE CONNECTION & 4"x4" CROSS, REINSTALL ORIGINAL PIPING.

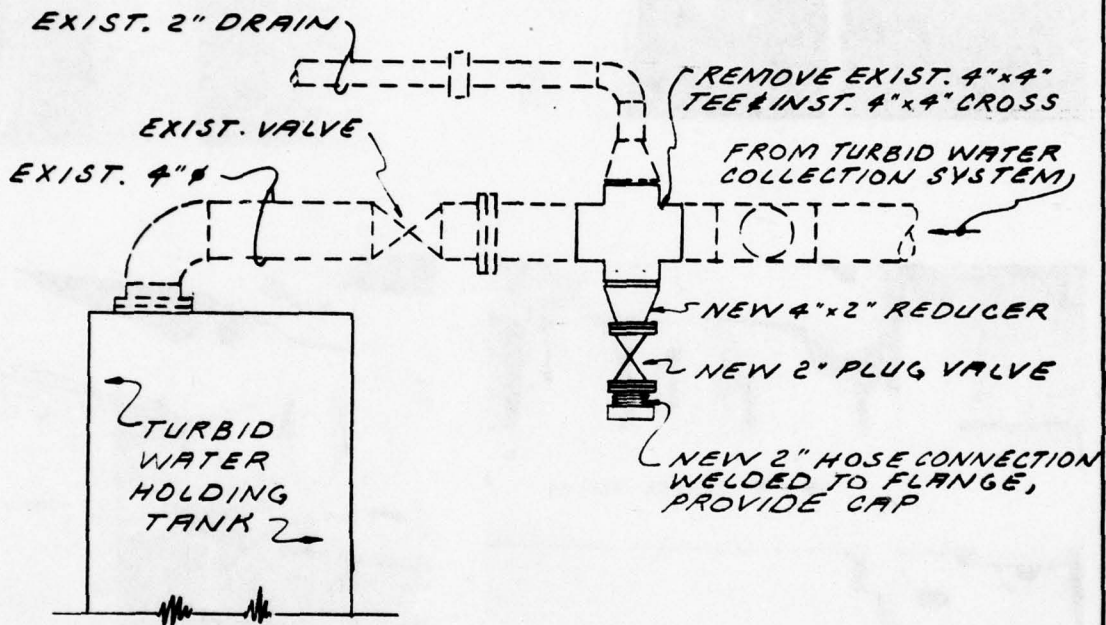

**VIGOROUS (WMEC 627)
TURBID WATER SAMPLE POINT**

DEPARTMENT OF TRANSPORTATION	UNITED STATES COAST GUARD
SURVEY, ANALYSIS AND EVALUATION OF COAST GUARD VESSEL WASTE WATERS	
DATE OCT. 8, 1974	CONTRACT NO. DOT - CG 41342 - A
	SCALE - NONE

H2M CORP.	HOLZMACHER, McLENDON and MURRELL	MELVILLE, N. Y.
	ENVIRONMENTAL ENGINEERS and SCIENTISTS	NEWTON, N. J.

TURBID WATER
SAMPLE POINT

TURBID
WATER
HOLDING
TANK

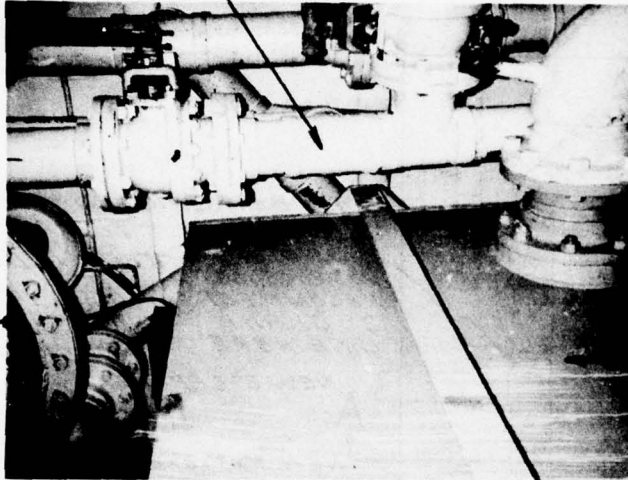

SEWAGE
HOLDING
TANK

VIEW LOOKING UP

VIGOROUS (WMEC 627)
TURBID WATER SAMPLE POINT

DEPARTMENT OF TRANSPORTATION UNITED STATES COAST GUARD
SURVEY, ANALYSIS AND EVALUATION OF COAST GUARD VESSEL WASTE WATERS
DATE-OCT. 8, 1974 CONTRACT NO. DOT - CG 41342 - A SCALE NONE

H2M CORP. HOLZMACHER, McLENDON and MURRELL MELVILLE, N. Y.
ENVIRONMENTAL ENGINEERS and SCIENTISTS NEWTON, N. J.

NOTE:

- 1.) NEW PIPING & FITTINGS SHALL BE 90-10 CU-NI. CONFORMING TO MIL-T-16420 CL 200
- 2.) VALVE SHALL BE 2", FIG. 120. PLUG VALVE AS MANUFACTURED BY "DE ZURIK CORP." SARTELL, MINN.
- 3.) AFTER SAMPLING PROGRAM IS COMPLETE, REMOVE PLUG VALVE, HOSE CONNECTION, & 3"x3"x2"x2" CROSS & REPLACE WITH 3"x2" TEE.

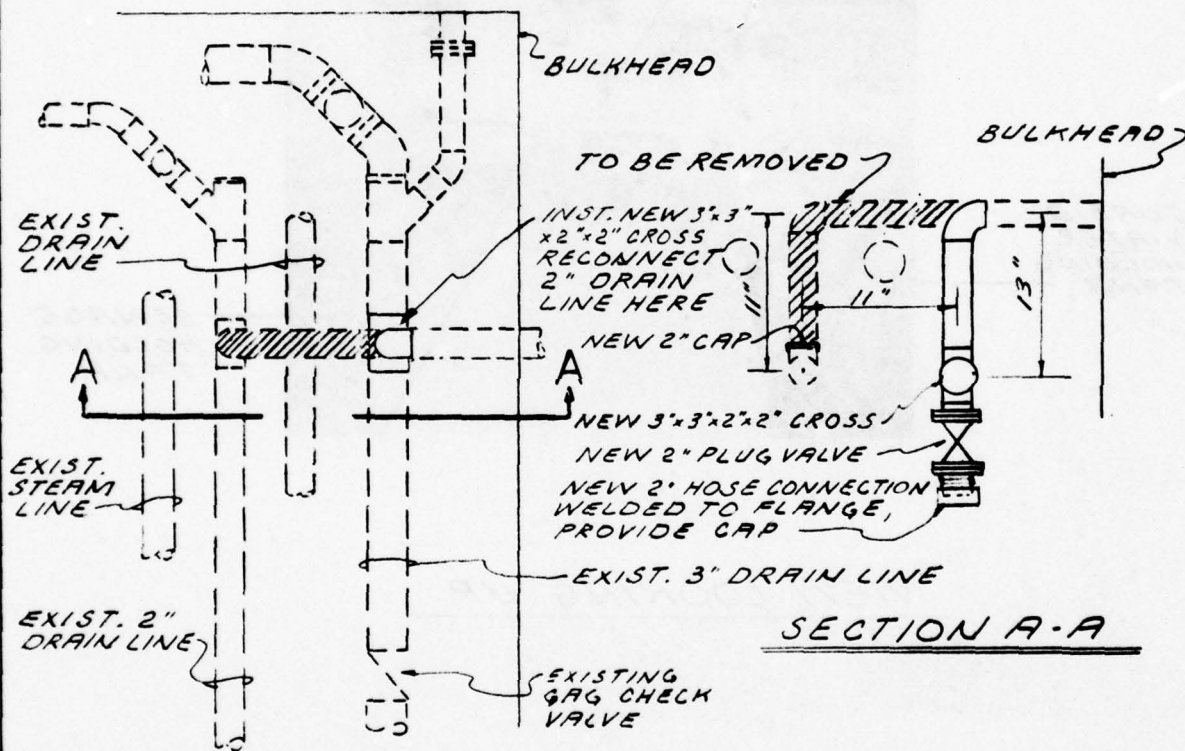

PLAN VIEW

**VIGOROUS (WMEC 627)
GALLEY WASTE SAMPLE POINT**

DEPARTMENT OF TRANSPORTATION UNITED STATES COAST GUARD
SURVEY, ANALYSIS AND EVALUATION OF COAST GUARD VESSEL WASTE WATERS

DATE - OCT. 8, 1974

CONTRACT NO. DOT - CG 41342 - A

SCALE NONE

H2M CORP. HOLZMACHER, McLENDON and MURRELL MELVILLE, N. Y.
ENVIRONMENTAL ENGINEERS and SCIENTISTS NEWTON, N. J.

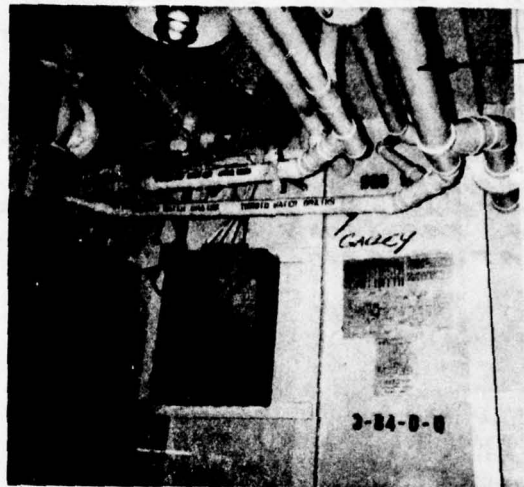

GALLEY
WASTE
SAMPLE
POINT

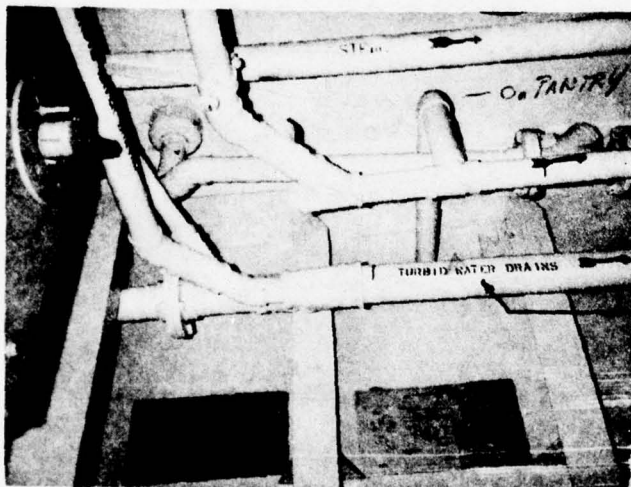

GALLEY WASTE
SAMPLE POINT

VIGOROUS (WMEC 627)
GALLEY WASTE SAMPLE POINT

DEPARTMENT OF TRANSPORTATION UNITED STATES COAST GUARD
SURVEY, ANALYSIS AND EVALUATION OF COAST GUARD VESSEL WASTE WATERS

DATE- OCT. 8, 1974

CONTRACT NO. DOT - CG 41342 - A

SCALE NONE

H2M CORP. HOLZMACHER, McLENDON and MURRELL MELVILLE, N. Y.
ENVIRONMENTAL ENGINEERS and SCIENTISTS NEWTON, N. J.

NOTES:

- 1.) VALVE TO BE 2" FIG. 120 PLUG VALVE AS MANUFACTURED BY "DE ZURIK CORP.", SARTELL, MINN.
- 2.) WHEN SAMPLING PROGRAM IS COMPLETE, VALVE & HOSE CONNECTION SHALL BE REMOVED & OPENING COVERED WITH A BLIND FLANGE.
- 3.) REPAINT AREAS DAMAGED BY WELDING. CLEAN TO WHITE METAL & COAT INTERIOR TANK SURFACE WITH COAL TAR EPOXY, TYPE 1, CLASS 2, MIL-P-23236, COAT EXTERIOR TO MATCH EXISTING.

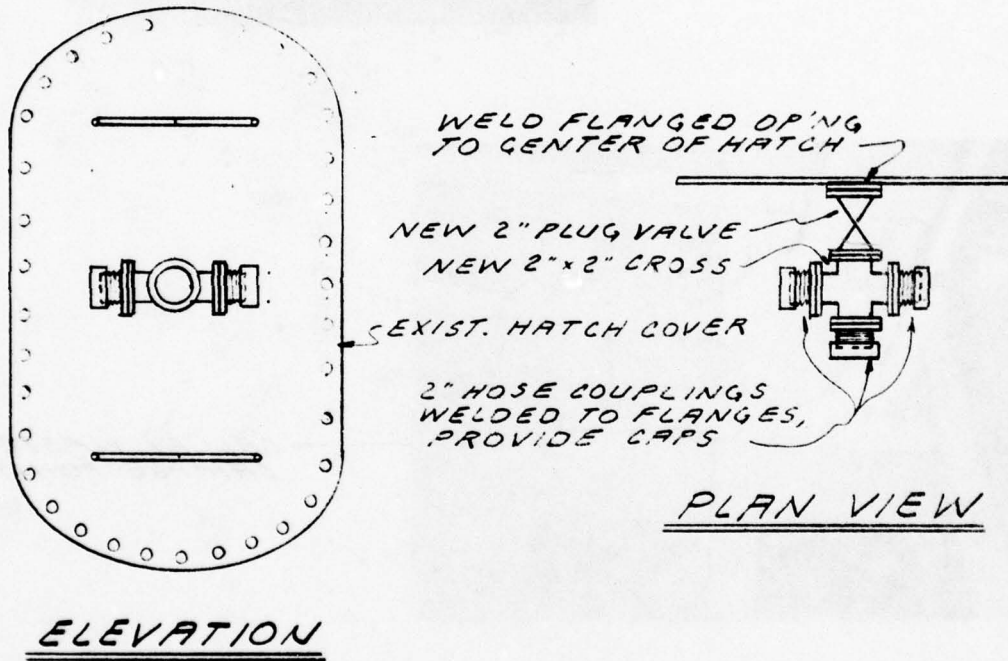

**VIGOROUS (WMEC 627)
WASTE WATER RETURN POINT**

DEPARTMENT OF TRANSPORTATION UNITED STATES COAST GUARD
SURVEY, ANALYSIS AND EVALUATION OF COAST GUARD VESSEL WASTE WATERS
DATE-OCT. 8, 1974 CONTRACT NO. DOT - CG 41342-A SCALE NONE

H2M CORP. HOLZMACHER, McLENDON and MURRELL MELVILLE, N. Y.
ENVIRONMENTAL ENGINEERS and SCIENTISTS NEWTON, N. J.

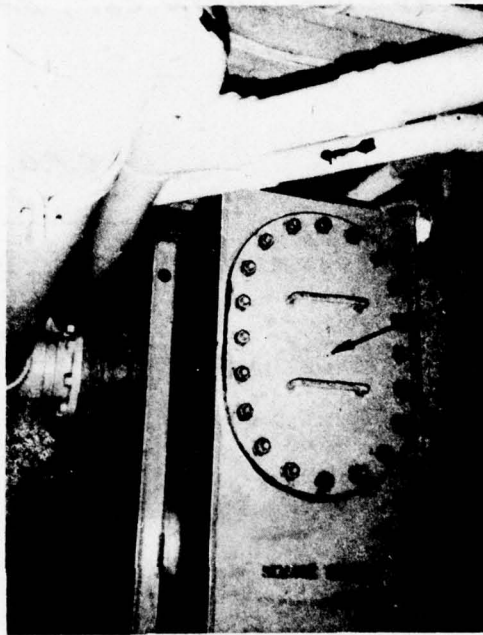

WASTE
WATER
RETURN
POINT

VIGOROUS (WMEC 627)
WASTE WATER RETURN POINT

DEPARTMENT OF TRANSPORTATION UNITED STATES COAST GUARD
SURVEY, ANALYSIS AND EVALUATION OF COAST GUARD VESSEL WASTE WATERS
DATE - OCT. 8, 1974 CONTRACT NO. DOT - CG 41342 - A SCALE NONE

H2M CORP. HOLZMACHER, McLENDON and MURRELL MELVILLE, N. Y.
ENVIRONMENTAL ENGINEERS and SCIENTISTS NEWTON, N. J.

NOTES:

- 1.) METER SHALL BE 2" NEPTUNE TRISEAL AS MANUFACTURED BY "NEPTUNE METER CO." C.I. CITY, N.Y.
- 2.) WALL PANEL IS REMOVABLE.
- 3.) METER TO BE LOCATED IN THE ENGINE ROOM.
- 4.) EXIST. IS & NEW PIPING SHALL BE 90-10 CU-NI CONFORMING TO MIL-T-16420 CL 200.
- 5.) VALVES SHALL BE BRONZE GATE VALVES FIG. 44WS AS MANUFACTURED BY "WALWORTH CO.", BALA CYNWYD., PA.

EXIST. CEILING PANEL

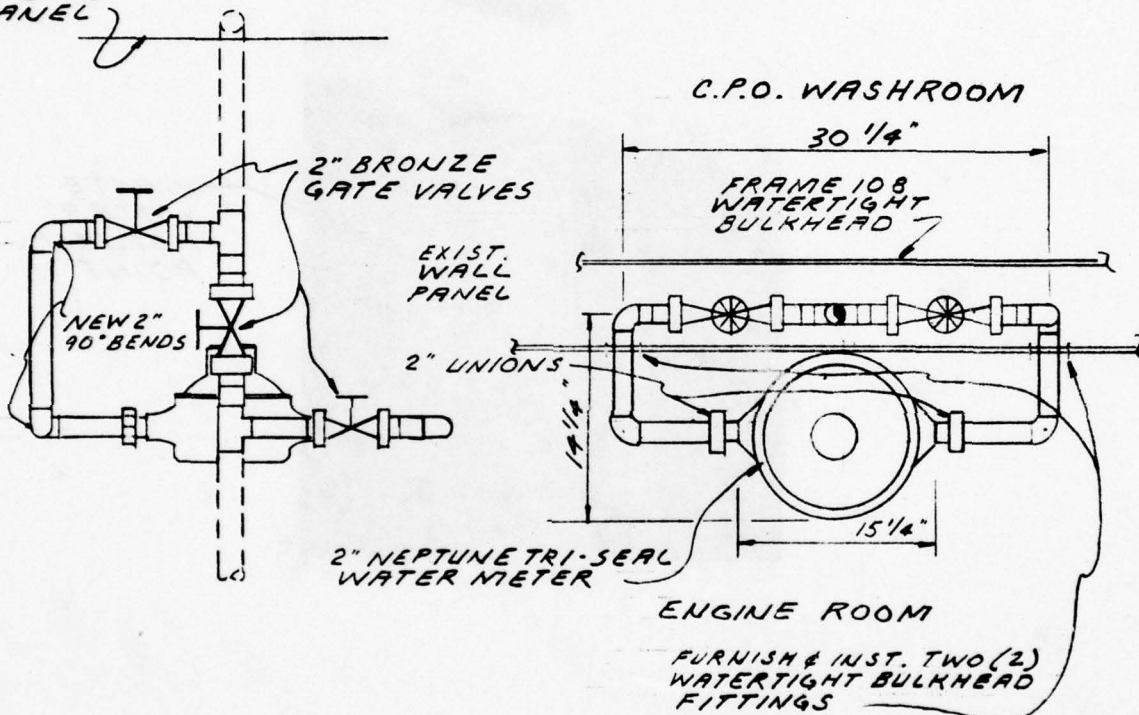

VIGOROUS (WMEC 627)
SALT WATER METER LOCATION

DEPARTMENT OF TRANSPORTATION UNITED STATES COAST GUARD
SURVEY, ANALYSIS AND EVALUATION OF COAST GUARD VESSEL WASTE WATERS
DATE - OCT. 8, 1974 CONTRACT NO. DOT - CG 41342 - A SCALE NONE

H2M CORP. HOLZMACHER McLENDON and MURRELL MELVILLE, N. Y.
ENVIRONMENTAL ENGINEERS and SCIENTISTS NEWTON, N. J.

NOTES:

- 1.) EXIST. PIPING IS 1 1/2" Ø COPPER.
- 2.) METER SHALL BE NEPTUNE TRI-SEAL AS MANUFACTURED BY THE "NEPTUNE METER COMPANY." METER CAPACITY IS 100 G.P.M.
- 3.) VALVES SHALL BE BRONZE GATE VALVES, WALWORTH FIG. 14, AS MANUFACTURED BY THE "WALWORTH CO.", BALA CYNWYD, PA.

A) CONTRACTOR SHALL INSPECT WORK AREA PRIOR TO BID TO VERIFY SPACE LIMITATIONS.

S.) NEW PIPING SHALL BE 1 1/2" COPPER, TYPE K.

* **NOTE:**

THE SAME GENERAL ARRANGEMENT OF VALVES, PIPING & METERS IS TO BE USED, HOWEVER, THE METER WILL BE LOCATED ON THE SUPPLY LINE TO THE HYDROPNEUMATIC TANK IN LIEU OF DISCHARGE LINE AS SHOWN

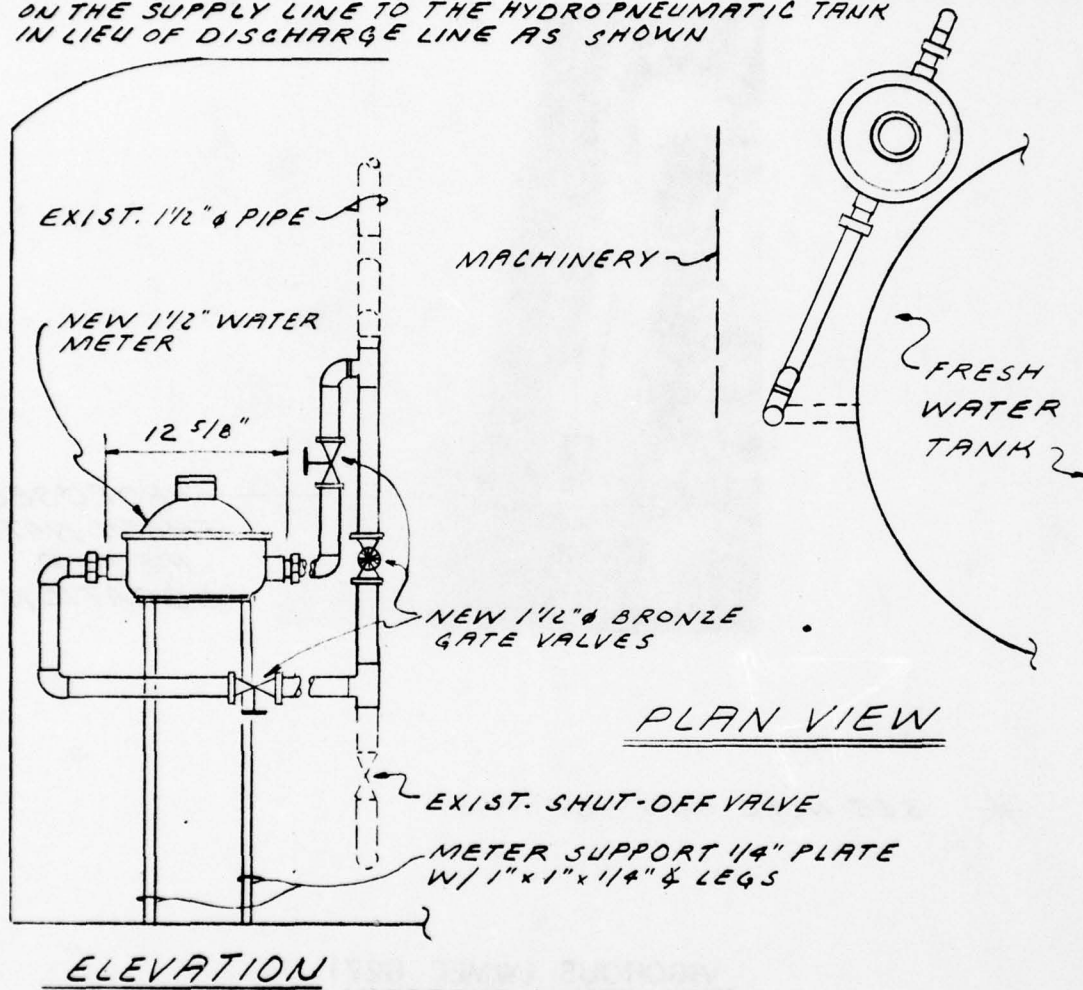

**VIGOROUS (WMEC 627)
FRESH WATER METER LOCATION**

DEPARTMENT OF TRANSPORTATION UNITED STATES COAST GUARD
 SURVEY, ANALYSIS AND EVALUATION OF COAST GUARD VESSEL WASTE WATERS
 DATE-OCT. 8, 1974 CONTRACT NO. DOT - CG 41342-A SCALE NONE

H2M CORP. HOLZMACHER, McLENDON and MURRELL MELVILLE, N. Y.
 ENVIRONMENTAL ENGINEERS and SCIENTISTS NEWTON, N. J.

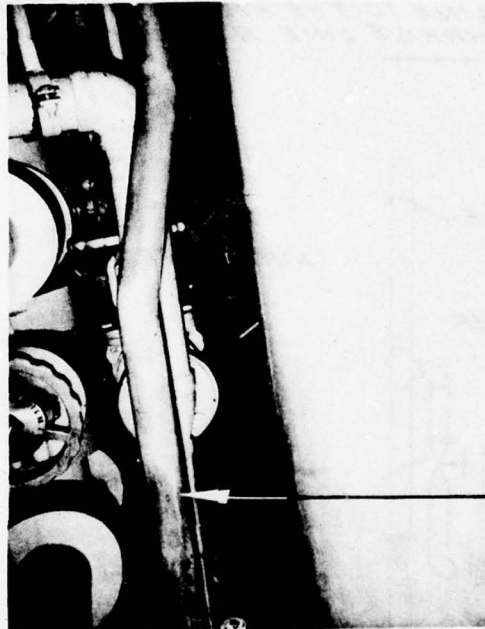

PROPOSED
FRESH WATER
METER
LOCATION

* SEE NOTE ON PAGE A-13

VIGOROUS (WMEC 627)
FRESH WATER METER LOCATION

DEPARTMENT OF TRANSPORTATION UNITED STATES COAST GUARD
SURVEY, ANALYSIS AND EVALUATION OF COAST GUARD VESSEL WASTE WATERS

DATE OCT. 8, 1974 CONTRACT NO. DOT - CG 41342 - A SCALE NONE

H2M CORP. HOLZMACHER, McLENDON and MURRELL MELVILLE, N. Y.
ENVIRONMENTAL ENGINEERS and SCIENTISTS NEWTON, N. J.

NOTES:

- 1) NEW TEE & REDUCER TO BE 90-10 CU-NI CONFORMING TO MIL-T-16420 CL 200.
- 2) VALVE SHALL BE 3", FIG. 120, PLUG VALVE AS MANUFACTURED BY "DE ZURIK CORP" SARTELL, MINN.
- 3) AFTER SAMPLING PROGRAM IS COMPLETE, HOSE CONNECTION, VALVE, & TEE TO BE REMOVED & ORIGINAL 6" ELBOW REINSTALLED.

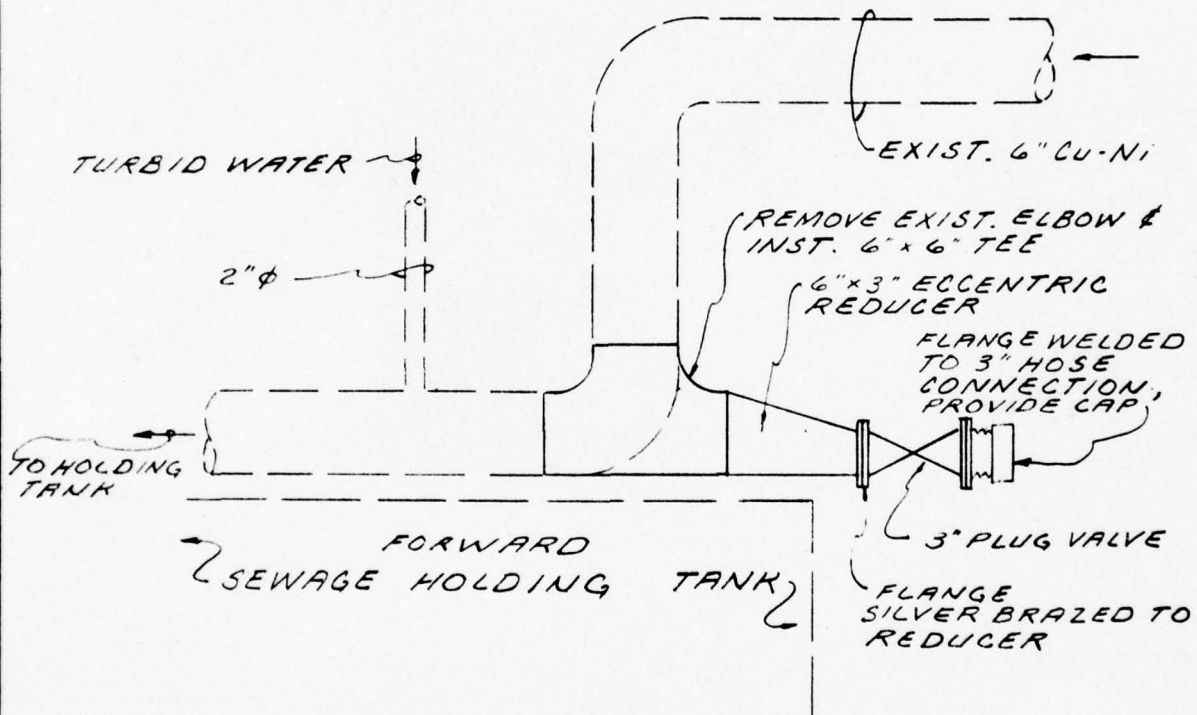

**GALLATIN (WHEC 721)
SANITARY WATER SAMPLE POINT
FORWARD HOLD**

DEPARTMENT OF TRANSPORTATION UNITED STATES COAST GUARD
SURVEY, ANALYSIS AND EVALUATION OF COAST GUARD VESSEL WASTE WATERS

DATE OCT. 8, 1974

CONTRACT NO. DOT - CG 41342 - A

SCALE NONE

H2M CORP. HOLZMACHER, McLENDON and MURRELL MELVILLE, N. Y.
ENVIRONMENTAL ENGINEERS and SCIENTISTS NEWTON, N. J.

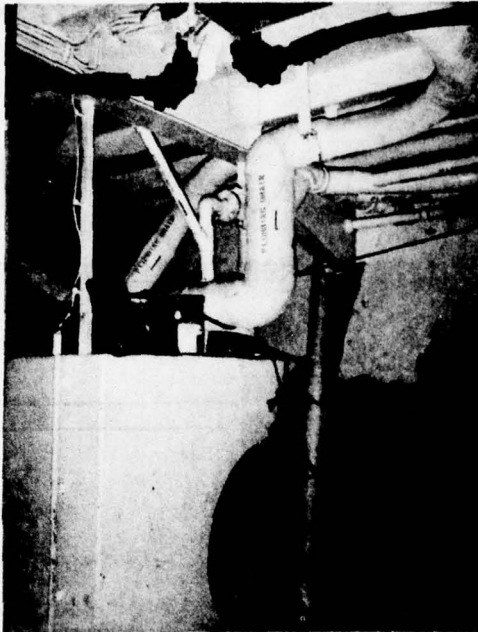

SANITARY
WATER
SAMPLE
POINT

GALLATIN (WHEC 721)
SANITARY WATER SAMPLE POINT
FORWARD HOLD

DEPARTMENT OF TRANSPORTATION UNITED STATES COAST GUARD
SURVEY, ANALYSIS AND EVALUATION OF COAST GUARD VESSEL WASTE WATERS

DATE OCT. 8, 1974

CONTRACT NO. DOT - CG 41342 - A

SCALE NONE

H2M CORP.

HOLZMACHER, McLENDON and MURRELL
ENVIRONMENTAL ENGINEERS and SCIENTISTS

MELVILLE, N. Y.
NEWTON, N. J.

- NOTES:**
- 1) NEW PIPE & FITTINGS TO BE 90-10 CU-NI CONFORMING TO MIL-T-16420 CL 200.
 - 2) VALVE TO BE 2" FIG. 120, PLUG VALVE AS MANUFACTURED BY "DE ZURIK CORP." SARTELL, MINN.
 - 3) AFTER SAMPLING PROGRAM IS COMPLETE, FLANGED HOSE CONNECTION TO BE REMOVED & REPLACED W/ A BLIND FLANGE.

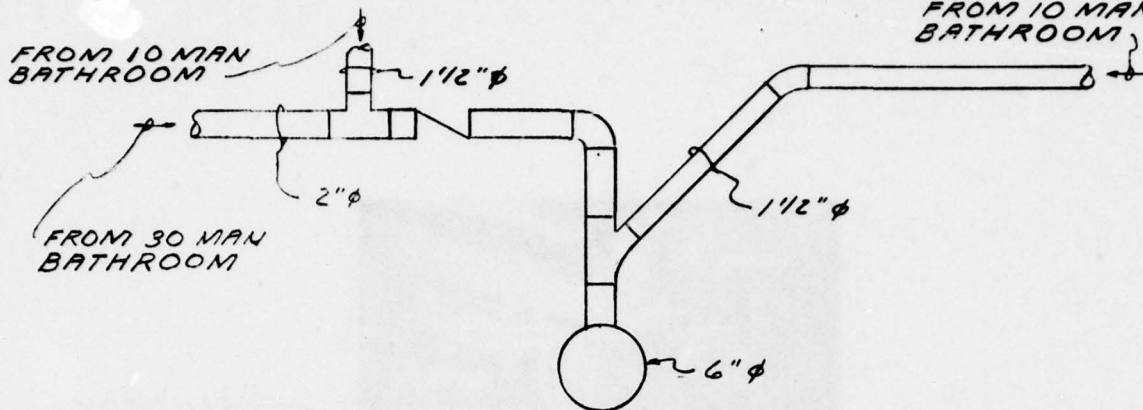

EXISTING TURBID WATER PIPING

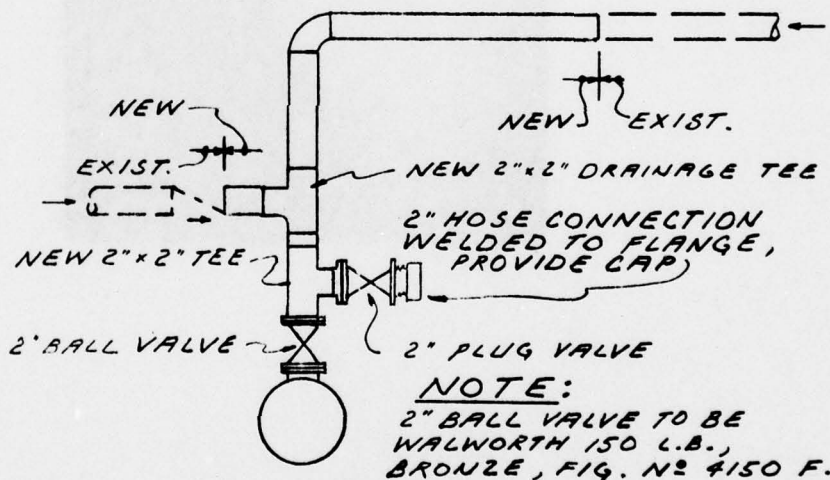

GALLATIN (WHEC 721)
TURBID WATER SAMPLE POINT
FORWARD HOLD

DEPARTMENT OF TRANSPORTATION UNITED STATES COAST GUARD
SURVEY, ANALYSIS AND EVALUATION OF COAST GUARD VESSEL WASTE WATERS
DATE OCT. 8, 1974 CONTRACT NO. DOT - CG 41342-A SCALE NONE

H2M CORP. HOLZMACHER, McLENDON and MURRELL MELVILLE, N. Y.
ENVIRONMENTAL ENGINEERS and SCIENTISTS NEWTON, N. J.

TURBID
WATER
SAMPLE
POINT

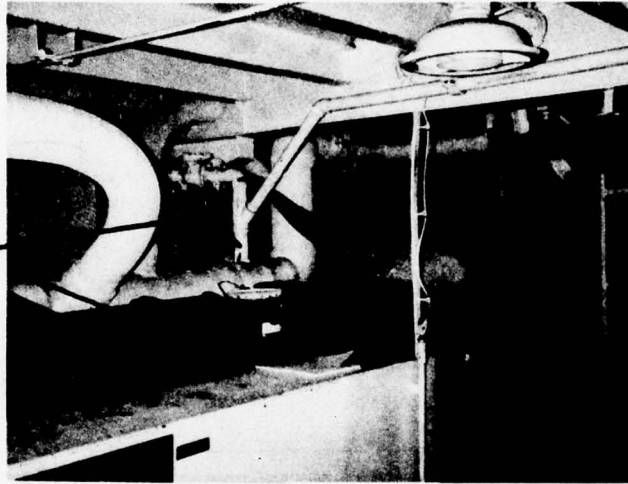

GALLATIN (WHEC 721)
TURBID WATER SAMPLE POINT
FORWARD HOLD

DEPARTMENT OF TRANSPORTATION UNITED STATES COAST GUARD
SURVEY, ANALYSIS AND EVALUATION OF COAST GUARD VESSEL WASTE WATERS

DATE OCT. 8, 1974

CONTRACT NO. DOT - CG 41342-A

SCALE NONE

H2M CORP. HOLZMACHER, McLENDON and MURRELL MELVILLE, N. Y.
ENVIRONMENTAL ENGINEERS and SCIENTISTS NEWTON, N. J.

NOTES:

- 1.) VALVE SHALL BE 2", FIG. 120, PLUG VALVE AS MANUFACTURED BY "DE ZURIK CORP." SARTELL, MINN.
- 2.) AFTER SAMPLING PROGRAM IS COMPLETE, FLANGED HOSE CONNECTIONS, TEE & VALVE TO BE REMOVED & REPLACED WITH A BLIND FLANGE.
- 3.) REPAINT AREAS DAMAGED BY WELDING. CLEAN TO WHITE METAL & COAT INTERIOR TANK SURFACE WITH COAL TAR EPOXY, TYPE 1, CLASS 2, MIL-P-23236, COAT EXTERIOR TO MATCH EXISTING.

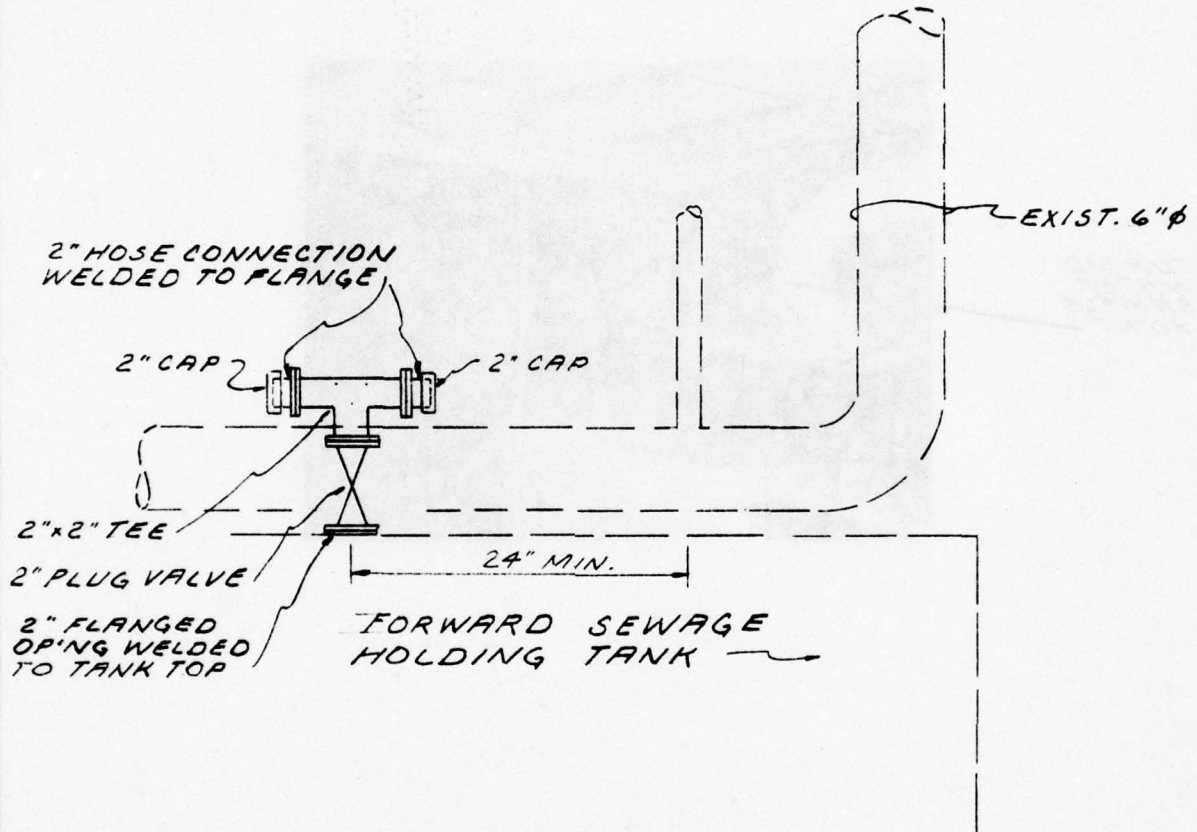

**GALLATIN (WHEC 721)
WASTE WATER RETURN POINT
FOR SANITARY & TURBID WATER SAMPLES
FORWARD HOLD**

DEPARTMENT OF TRANSPORTATION	UNITED STATES COAST GUARD	
SURVEY, ANALYSIS AND EVALUATION OF COAST GUARD VESSEL WASTE WATERS		
DATE OCT. 8, 1974	CONTRACT NO. DOT - CG 41342-A	SCALE NONE

H2M CORP.	HOLZMACHER, McLENDON and MURRELL	MELVILLE, N. Y.
	ENVIRONMENTAL ENGINEERS and SCIENTISTS	NEWTON, N. J.

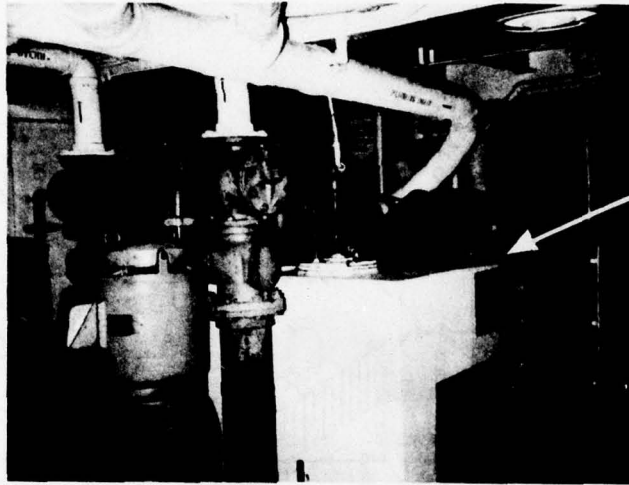

SAMPLE
RETURN
POINT

**GALLATIN (WHEC 721)
WASTE WATER RETURN POINT
FOR SANITARY & TURBID WATER SAMPLES
FORWARD HOLD**

DEPARTMENT OF TRANSPORTATION UNITED STATES COAST GUARD
SURVEY, ANALYSIS AND EVALUATION OF COAST GUARD VESSEL WASTE WATERS
DATE OCT. 8, 1974 CONTRACT NO. DOT - CG 41342 - A SCALE NONE

H2M CORP. HOLZMACHER, McLENDON and MURRELL MELVILLE, N. Y.
ENVIRONMENTAL ENGINEERS and SCIENTISTS NEWTON, N. J.

NOTES :

- 1.) NEW PIPING & FITTINGS SHALL BE 90-10 CU-NI, CONFORMING TO MIL-7-16420 CL 200.
- 2.) VALVE SHALL BE 2", FIG. 120 PLUG VALVE AS MANUFACTURED BY "DE ZURIK CORP." SARTELL, MINN.
- 3.) AFTER SAMPLING PROGRAM IS COMPLETE, REMOVE PLUG VALVE, HOSE CONNECTION, REDUCER, ELBOW, SPOOL PIECES & TEE. REINSTALL ORIGINAL PIPING. ALSO REMOVE NEW CHECK VALVE TOP & REINSTALL ORIGINAL TOP.

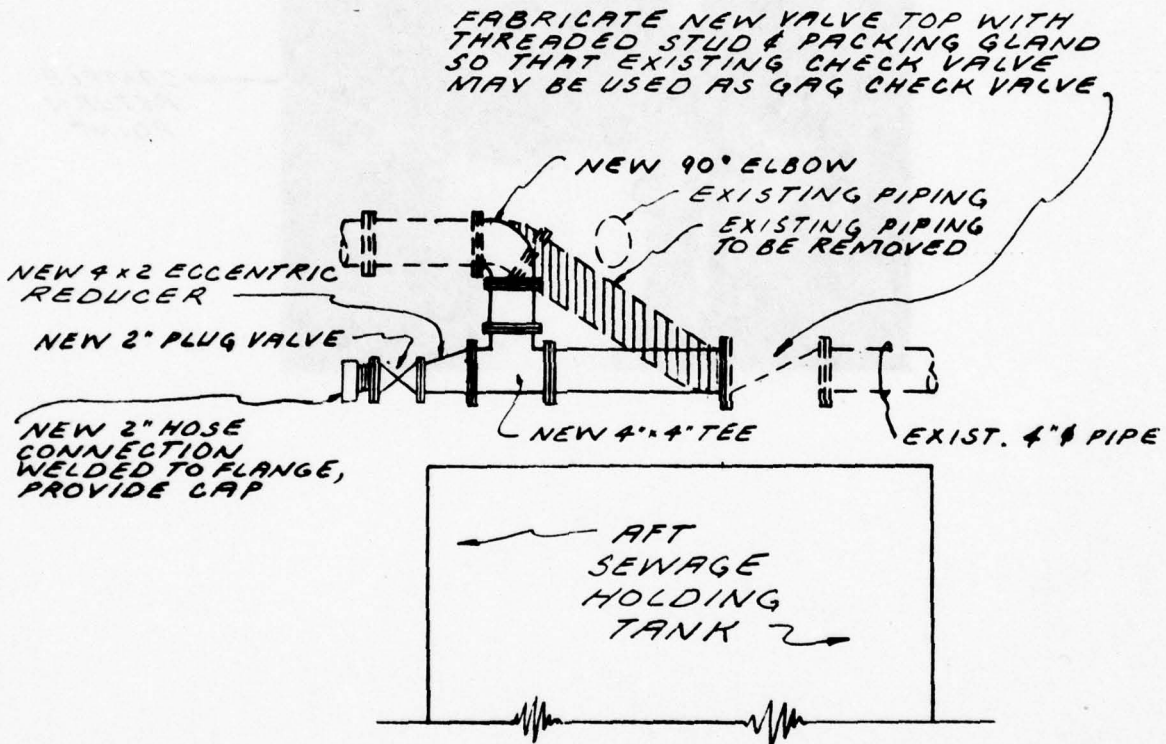

**GALLATIN (WHEC 721)
GALLEY WASTE SAMPLE POINT
AFT HOLD**

DEPARTMENT OF TRANSPORTATION UNITED STATES COAST GUARD
SURVEY, ANALYSIS AND EVALUATION OF COAST GUARD VESSEL WASTE WATERS

DATE OCT. 8, 1974

CONTRACT NO. DOT - CG 41342-A

SCALE NONE

H2M CORP. HOLZMACHER, McLENDON and MURRELL MELVILLE, N. Y.
ENVIRONMENTAL ENGINEERS and SCIENTISTS NEWTON, N. J.

GALLEY
WASTE
SAMPLE
POINT

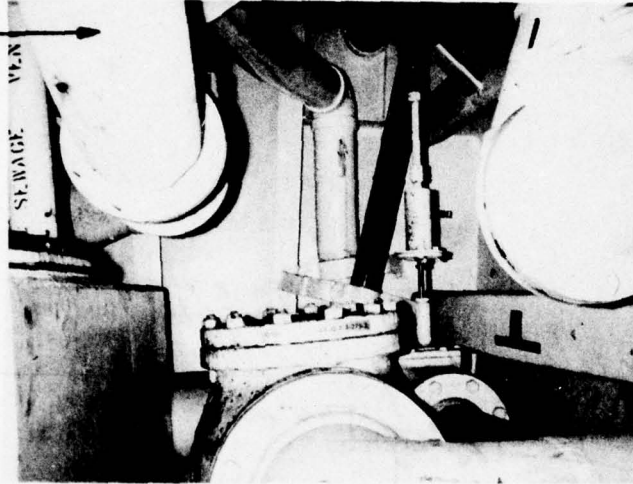

GALLATIN (WHEC 721)
GALLEY WASTE SAMPLE POINT
AFT HOLD

DEPARTMENT OF TRANSPORTATION UNITED STATES COAST GUARD
SURVEY, ANALYSIS AND EVALUATION OF COAST GUARD VESSEL WASTE WATERS

DATE OCT. 8, 1974

CONTRACT NO. DOT - CG 41342 - A

SCALE NONE

H2M CORP. HOLZMACHER, McLENDON and MURRELL MELVILLE, N. Y.
ENVIRONMENTAL ENGINEERS and SCIENTISTS NEWTON, N. J.

NOTES:

- 1.) PLUG VALVE SHALL BE 2", FIG. 120 AS MANUFACTURED BY "DE ZURIK CORP.", SARTELL, MINN.
- 2.) WHEN SAMPLING PROGRAM IS COMPLETE, REMOVE PLUG VALVE, HOSE CONNECTION & INST. BLIND FLANGE.
- 3.) REPRINT AREAS DAMAGED BY WELDING. CLEAN TO WHITE METAL & COAT INTERIOR TANK SURFACE WITH COAL TAR EPOXY TYPE 1, CLASS 2, MIL-P-23236, COAT EXTERIOR TO MATCH EXISTING.

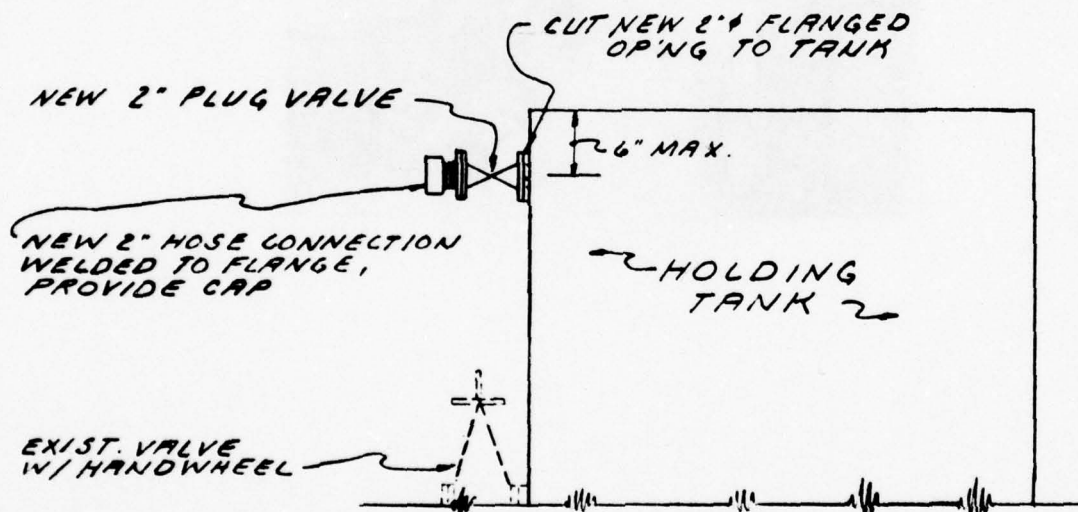

**GALLATIN (WHEC 721)
GALLEY WASTE RETURN POINT
AFT HOLD**

DEPARTMENT OF TRANSPORTATION UNITED STATES COAST GUARD
SURVEY, ANALYSIS AND EVALUATION OF COAST GUARD VESSEL WASTE WATERS
DATE OCT. 8, 1974 CONTRACT NO. DOT - CG 41342 - A SCALE NONE

H2M CORP. HOLZMACHER, McLENDON and MURRELL MELVILLE, N. Y.
ENVIRONMENTAL ENGINEERS and SCIENTISTS NEWTON, N. J.

GALLEY WASTE
RETURN POINT

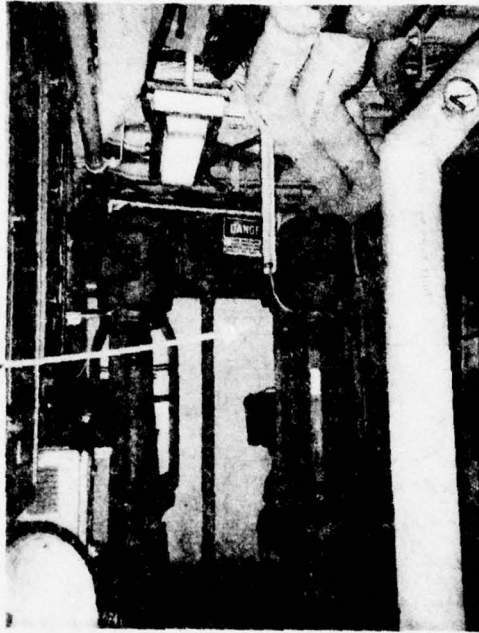

GALLATIN (WHEC 721)
GALLEY WASTE RETURN POINT

DEPARTMENT OF TRANSPORTATION UNITED STATES COAST GUARD
SURVEY, ANALYSIS AND EVALUATION OF COAST GUARD VESSEL WASTE WATERS

DATE OCT. 8, 1974

CONTRACT NO. DOT - CG 41342 - A

SCALE NONE

H2M CORP. HOLZMACHER, McLENDON and MURRELL MELVILLE, N. Y.
ENVIRONMENTAL ENGINEERS and SCIENTISTS NEWTON, N. J.

- NOTES:**
- 1) EXISTING PIPING IS 3" ϕ CU-NI
 - 2) METER SHALL BE TRI-SEAL AS MANUFACTURED BY THE "NEPTUNE METER CO." METER CAPACITY IS 160 G.P.M.
 - 3) 2" VALVES SHALL BE BRONZE GATE VALVES, FIG. 44 WS AS MANUFACTURED BY "WALWORTH CO.", BALA CYNWYD, PA.
 - 4) NEW PIPE & FITTINGS SHALL BE 90-10 CU-NI CONFORMING TO MIL-T-16420 CL 200.

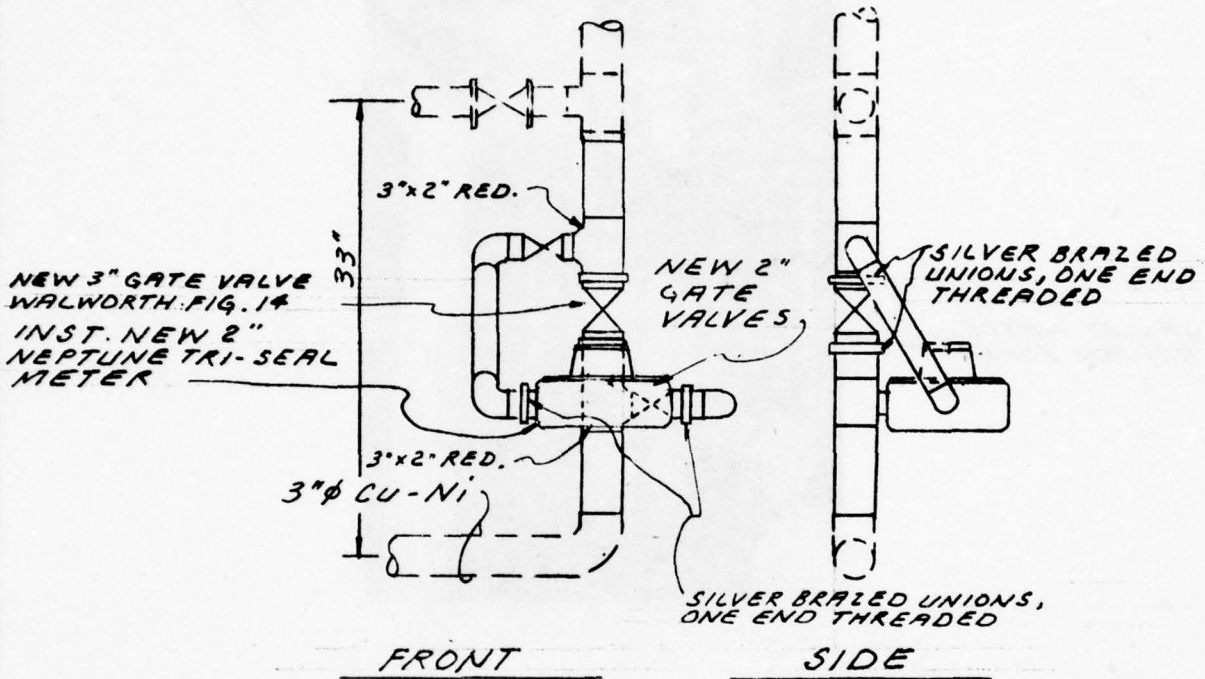

ELEVATIONS

GALLATIN (WHEC 721)
SALT WATER METER LOCATION

DEPARTMENT OF TRANSPORTATION	UNITED STATES COAST GUARD
SURVEY, ANALYSIS AND EVALUATION OF COAST GUARD VESSEL WASTE WATERS	
DATE OCT. 8, 1974	CONTRACT NO. DOT - CG 41342-A
	SCALE NONE

H2M CORP. HOLZMACHER, McLENDON and MURRELL MELVILLE, N. Y.
ENVIRONMENTAL ENGINEERS and SCIENTISTS NEWTON, N. J.

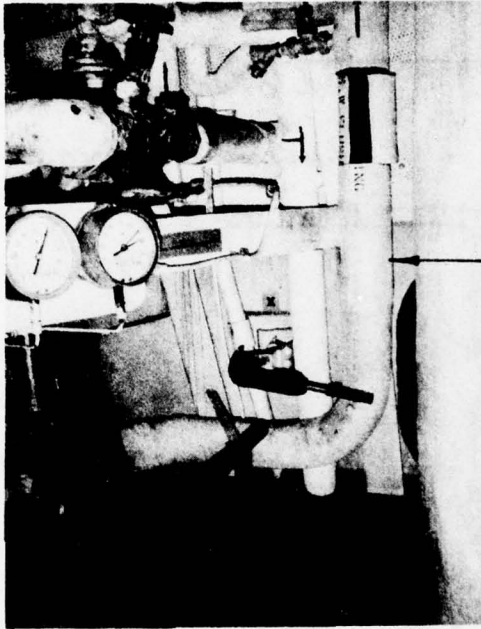

*PROPOSED
SALT WATER
METER
LOCATION*

**GALLATIN (WHEC 721)
SALT WATER METER LOCATION**

**DEPARTMENT OF TRANSPORTATION UNITED STATES COAST GUARD
SURVEY, ANALYSIS AND EVALUATION OF COAST GUARD VESSEL WASTE WATERS**

DATE OCT. 8, 1974

CONTRACT NO. DOT - CG 41342 - A

SCALE NONE

H2M CORP.

**HOLZMACHER, McLENDON and MURRELL
ENVIRONMENTAL ENGINEERS and SCIENTISTS**

**MELVILLE, N. Y.
NEWTON, N. J.**

NOTES:

- 1.) EXISTING PIPING IS 2 1/2" ϕ COPPER.
- 2.) METER SHALL BE NEPTUNE TRI-SEAL AS MANUFACTURED BY THE NEPTUNE METER CO. METER CAPACITY IS 160 G.P.M.
- 3.) VALVES SHALL BE BRONZE GATE VALVES, FIG 14, AS MANUFACTURED BY "WALWORTH Co.", BALA CYNWYD, PA.
- 4.) NEW PIPING SHALL BE 2" COPPER TYPE "K" MIL. SPEC. WWT 797.
- 5.) NEW PIPING SHALL BE INSULATED TO MATCH EXISTING.

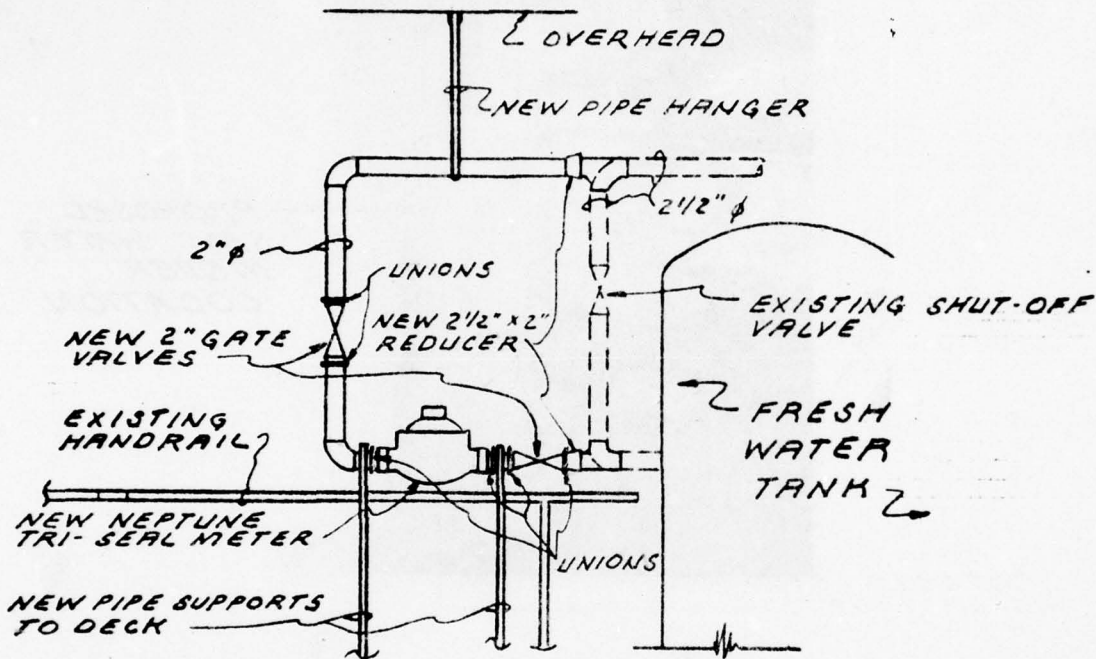

**GALLATIN (WHEC 721)
FRESH WATER METER LOCATION**

DEPARTMENT OF TRANSPORTATION UNITED STATES COAST GUARD
SURVEY, ANALYSIS AND EVALUATION OF COAST GUARD VESSEL WASTE WATERS
REV. DEC. 4, 1974 CONTRACT NO. DOT - CG 41342-A SCALE NONE
DATE OCT. 8, 1974

H2M CORP. HOLZMACHER, McLENDON and MURRELL MELVILLE, N. Y.
ENVIRONMENTAL ENGINEERS and SCIENTISTS NEWTON, N. J.

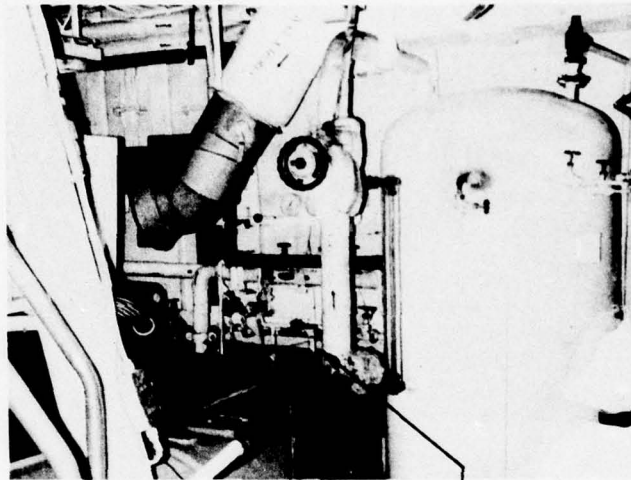

*PROPOSED FRESH WATER
METER LOCATION*

**GALLATIN (WHEC 721)
FRESH WATER METER LOCATION**

DEPARTMENT OF TRANSPORTATION	UNITED STATES COAST GUARD
SURVEY, ANALYSIS AND EVALUATION OF COAST GUARD VESSEL WASTE WATERS	
REV. DEC. 4, 1974	CONTRACT NO. DOT - CG 41342 - A
DATE OCT. 8, 1974	SCALE NONE

H2M CORP.	HOLZMACHER, McLENDON and MURRELL	MELVILLE, N. Y.
ENVIRONMENTAL ENGINEERS and SCIENTISTS		NEWTON, N. J.

FIREBUSH

GALLATIN (WHCC 751)
FRESH WATER METER LOCATION

DEPARTMENT OF TRANSPORTATION
SURVEY ANALYSIS AND EVALUATION OF COAST GUARD VESSEL WASTE WATERS
REV. DEC. 1974
DATE OCT. 2, 1974
CONTRACT NO. DOT-CG-3347-A
SCALE NONE
UNITED STATES COAST GUARD

H&M CORP. ENVIRONMENTAL ENGINEERS & SCIENTISTS NEWTON, N.J.
NEWTON, N.J.

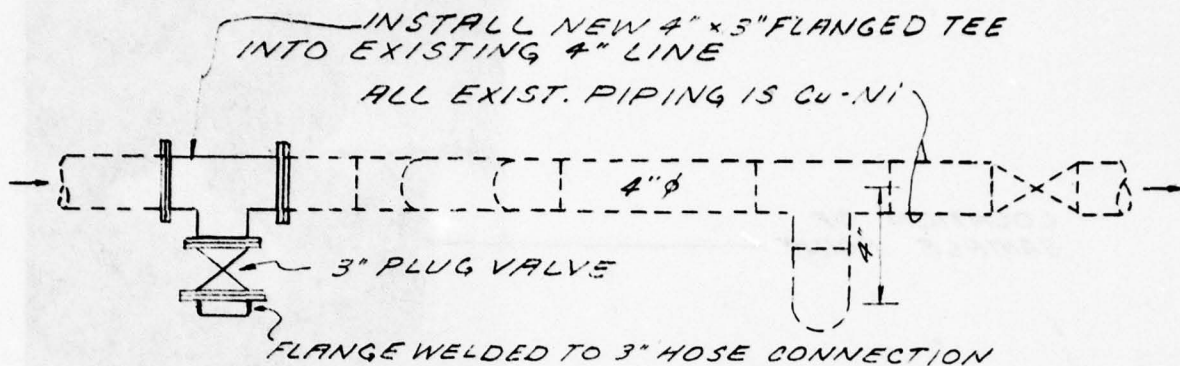

ELEVATION

NOTE:

AFTER SAMPLING PROGRAM IS COMPLETE, FLANGED HOSE CONNECTION & VALVE TO BE REMOVED & REPLACED WITH A BLIND FLANGE, ROLL TEE UP 180 DEGREES.

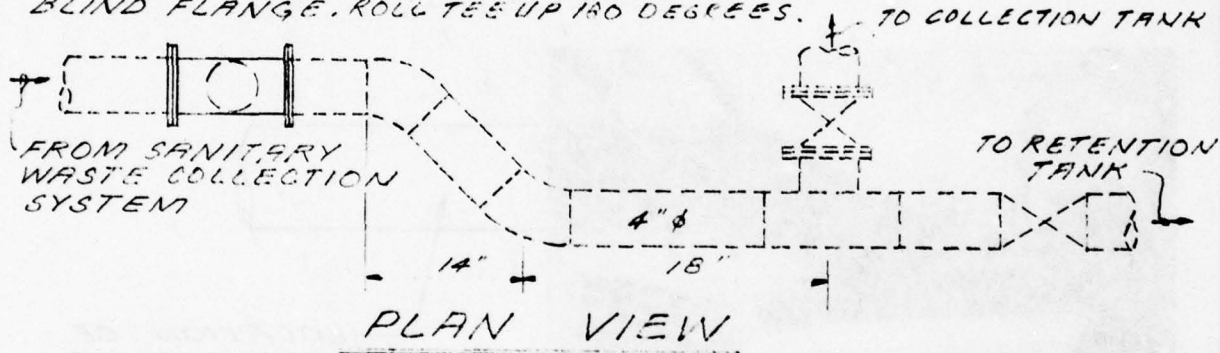

NOTE

- 1.) NEW PIPING TO BE 90-10 CU-NI IN ACCORDANCE WITH MIL-T-16420 CL 200.
- 2.) VALVE SHALL BE 3" PLUG VALVE FIG. 120 AS MANUFACTURED BY "DE ZURIK CORP." SARTELL, MINN.

**FIREBUSH (WLB 393)
SANITARY WATER SAMPLE POINT**

REVISED - OCTOBER 17, 1974

DEPARTMENT OF TRANSPORTATION UNITED STATES COAST GUARD
SURVEY, ANALYSIS AND EVALUATION OF COAST GUARD VESSEL WASTE WATERS
DATE-SEPT. 11, 1974 CONTRACT NO. DOT-CG 41342-A SCALE - NONE

H2M CORP. HOLZMACHER, McLENDON and MURRELL MELVILLE, N. Y.
ENVIRONMENTAL ENGINEERS and SCIENTISTS NEWTON, N. J.

LOCATION OF
SAMPLE POINT

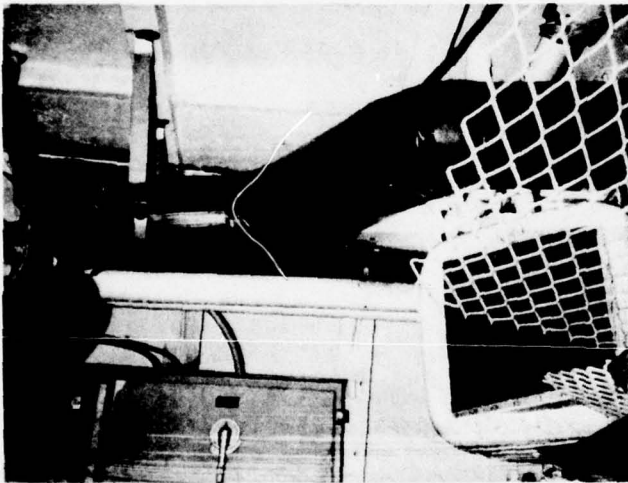
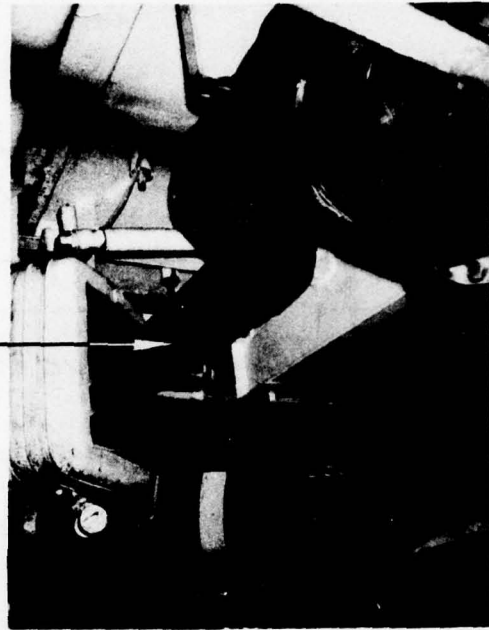

LOCATION OF
SAMPLE POINT

**FIREBUSH (WLB 393)
SANITARY WATER SAMPLE POINT**

REVISED - OCTOBER 17, 1974

DEPARTMENT OF TRANSPORTATION UNITED STATES COAST GUARD
SURVEY, ANALYSIS AND EVALUATION OF COAST GUARD VESSEL WASTE WATERS

DATE - SEPT. 11, 1974

CONTRACT NO. DOT - CG 41342 - A

SCALE - NONE

H2M CORP.

HOLZMACHER, McLENDON and MURRELL
ENVIRONMENTAL ENGINEERS and SCIENTISTS

MELVILLE, N. Y.
NEWTON, N. J.

INST. NEW 3" x 2" FLANGED
TEE INTO EXIST. 3" Ø DRAIN LINE

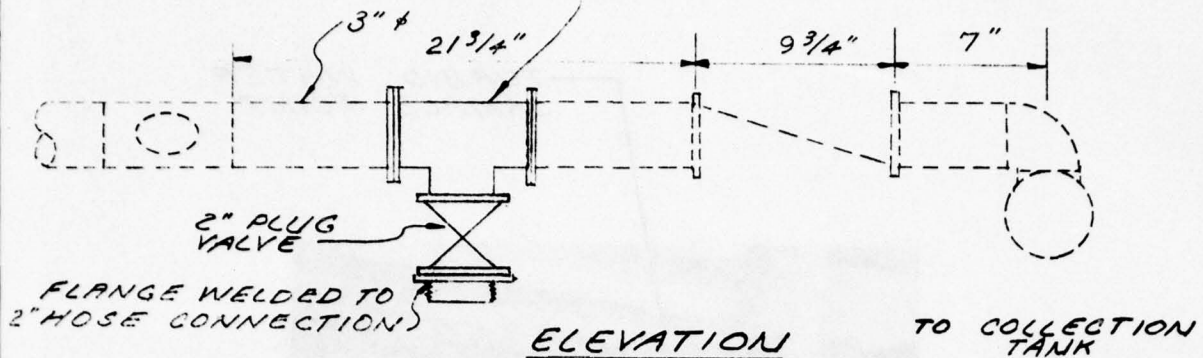

NOTE:

NEW 3" x 2" TEE SHALL BE 90-10 CU-NI
CONFORMING TO MIL-T-16220, CL 200.
VALVE SHALL BE PLUG VALVE
FIGURE 120 AS MANUFACTURED BY
"DE ZURIK CORP." SARTELL, MINN. AFTER
SAMPLING PROGRAM IS COMPLETE, FLANGED
HOSE CONNECTION & VALVE TO BE REMOVED
& REPLACED WITH A BLIND FLANGE. ROLL TEE
UP 180 DEGREES.

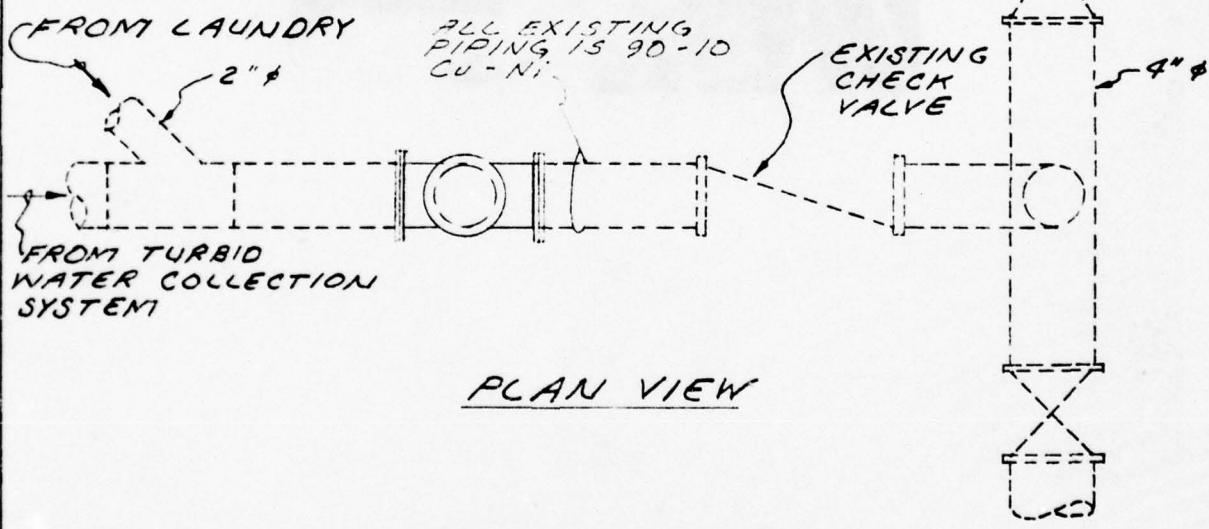

**FIREBUSH (WLB 393)
TURBID WATER SAMPLE POINT**

REVISED - OCTOBER 17, 1974

DEPARTMENT OF TRANSPORTATION	UNITED STATES COAST GUARD
SURVEY, ANALYSIS AND EVALUATION OF COAST GUARD VESSEL WASTE WATERS	
DATE - SEPT. 11, 1974	CONTRACT NO. DOT - CG 41342 - A
	SCALE - NONE

H2M CORP. HOLZMACHER, McLENDON and MURRELL MELVILLE, N. Y.
ENVIRONMENTAL ENGINEERS and SCIENTISTS NEWTON, N. J.

TURBID WATER
SAMPLE POINT

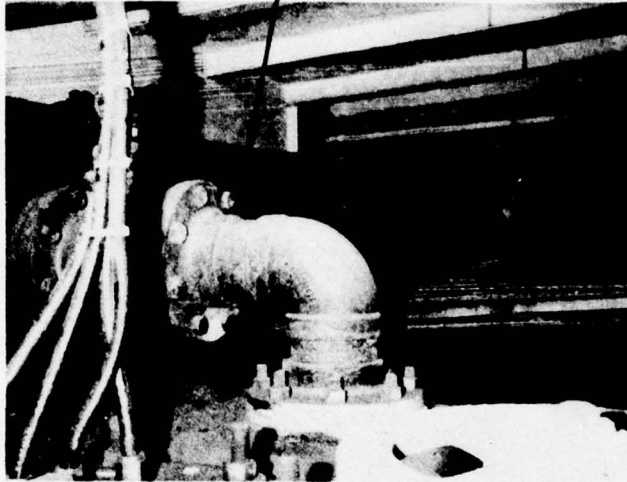

**FIREBUSH (WLB 393)
TURBID WATER SAMPLE POINT**

REVISED - OCTOBER 17, 1974

DEPARTMENT OF TRANSPORTATION UNITED STATES COAST GUARD
SURVEY, ANALYSIS AND EVALUATION OF COAST GUARD VESSEL WASTE WATERS

DATE - SEPT. 11, 1974

CONTRACT NO. DOT - CG 41342 - A

SCALE - NONE

H2M CORP. HOLZMACHER, McLENDON and MURRELL MELVILLE, N. Y.
ENVIRONMENTAL ENGINEERS and SCIENTISTS NEWTON, N. J.

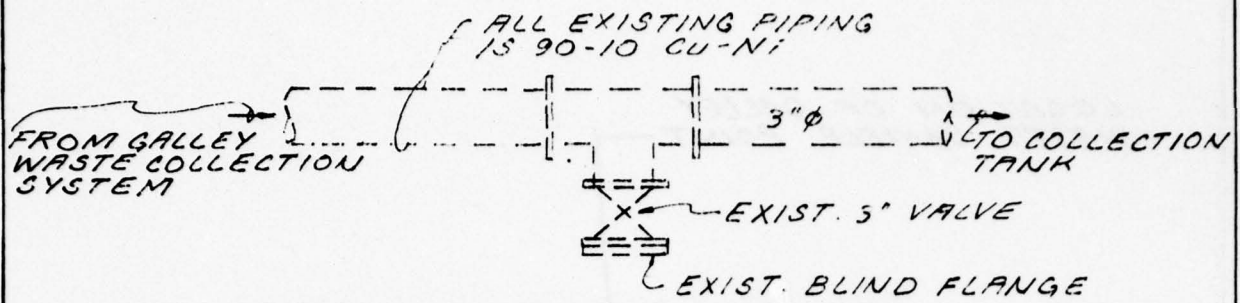

PLAN VIEW

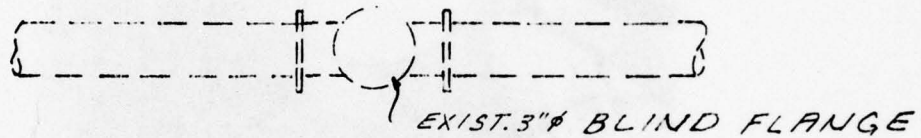

ELEVATION

NOTE :

NO CHANGES TO EXISTING PIPING ARE REQUIRED.
 EXISTING BLIND FLANGE WILL BE REMOVED &
 REPLACED WITH FLANGED HOSE CONNECTION. BLIND
 FLANGE TO BE REPLACED AFTER SAMPLING IS COMPLETE.

**FIREBUSH (WLB 393)
 GALLEY WASTE SAMPLE POINT**

REVISED - OCTOBER 17, 1974

DEPARTMENT OF TRANSPORTATION UNITED STATES COAST GUARD
 SURVEY, ANALYSIS AND EVALUATION OF COAST GUARD VESSEL WASTE WATERS

DATE - SEPT. 11, 1974

CONTRACT NO. DOT - CG 41342 - A

SCALE - NONE

H2M CORP. HOLZMACHER, McLENDON and MURRELL MELVILLE, N. Y.
 ENVIRONMENTAL ENGINEERS and SCIENTISTS NEWTON, N. J.

LOCATION OF GALLEY
WASTE SAMPLE POINT

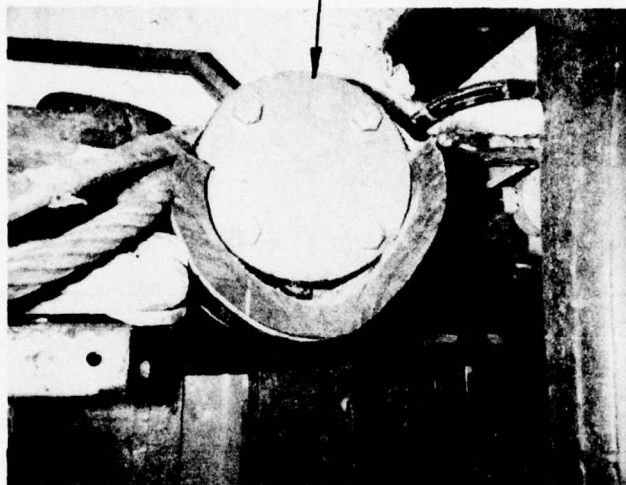

**FIREBUSH (WLB 393)
GALLEY WASTE SAMPLE POINT**

REVISED - OCTOBER 17, 1974

DEPARTMENT OF TRANSPORTATION UNITED STATES COAST GUARD
SURVEY, ANALYSIS AND EVALUATION OF COAST GUARD VESSEL WASTE WATERS

DATE - SEPT. 11, 1974

CONTRACT NO. DOT - CG 41342 - A

SCALE - NONE

H2M CORP. HOLZMACHER, McLENDON and MURRELL MELVILLE, N. Y.
ENVIRONMENTAL ENGINEERS and SCIENTISTS NEWTON, N. J.

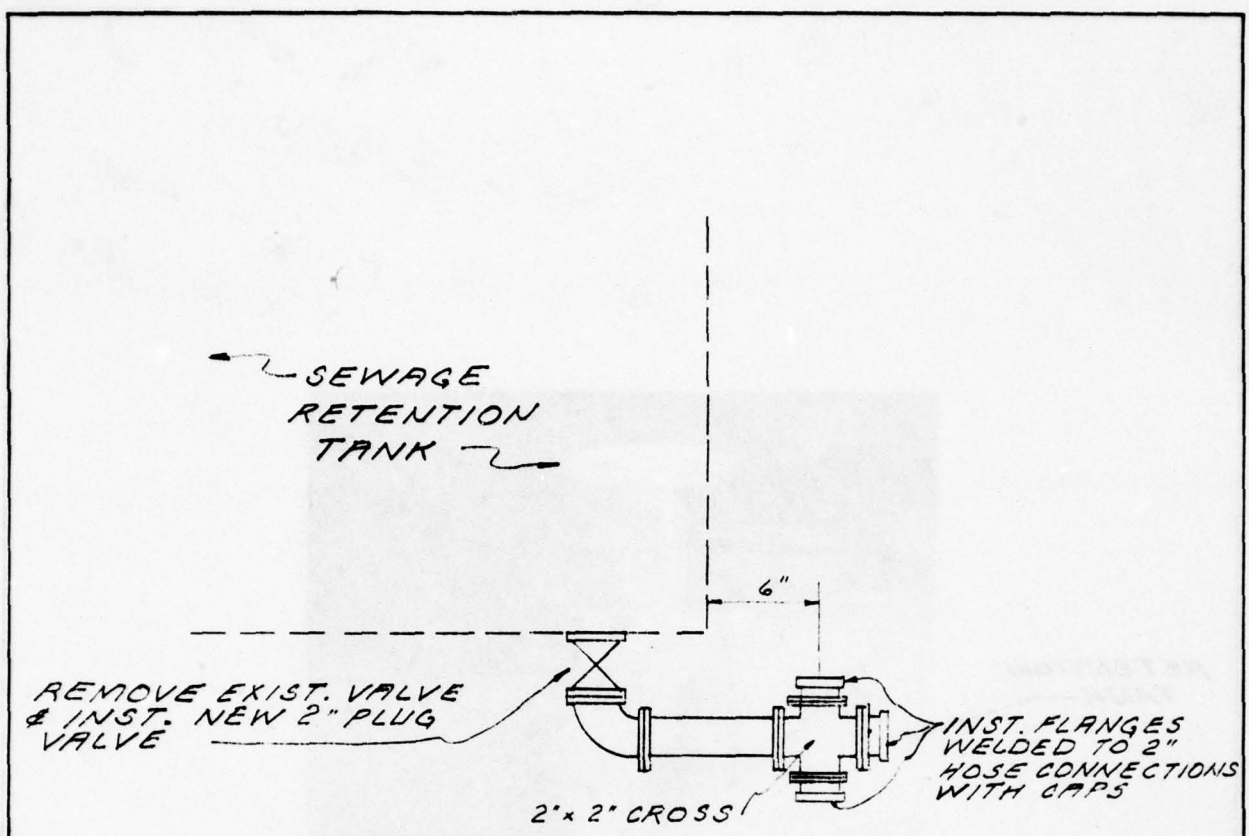

NOTE:
 VALVE SHALL BE 2" PLUG VALVE
 FIG. 120 AS MANUFACTURED BY "DE ZURIK CORP."
 SARTELL, MINN. EXISTING VALVE TO BE
 REPLACED AFTER SAMPLING IS COMPLETE.

**FIREBUSH (WLB 393)
 WASTE WATER RETURN POINT**

REVISED - OCTOBER 17, 1974

DEPARTMENT OF TRANSPORTATION UNITED STATES COAST GUARD
 SURVEY, ANALYSIS AND EVALUATION OF COAST GUARD VESSEL WASTE WATERS

DATE - SEPT. 11, 1974 CONTRACT NO. DOT - CG 41342 - A SCALE - NONE

H2M CORP. HOLZMACHER, McLENDON and MURRELL MELVILLE, N. Y.
 ENVIRONMENTAL ENGINEERS and SCIENTISTS NEWTON, N. J.

RETENTION
TANK

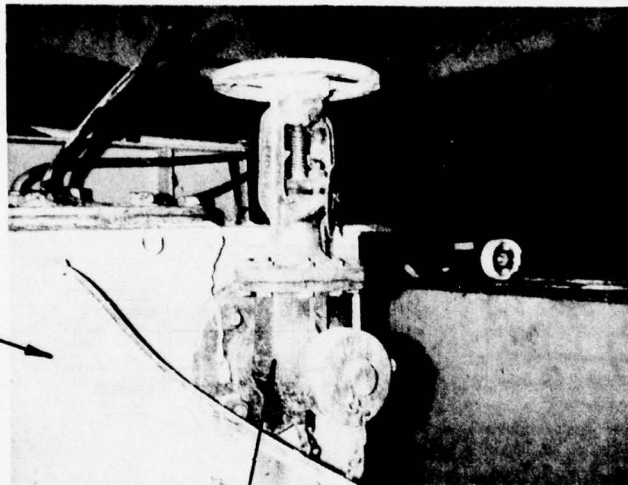

EXISTING VALVE TO
BE REMOVED

**FIREBUSH (WLB 393)
WASTE WATER RETURN POINT**

REVISED - OCTOBER 17, 1974

DEPARTMENT OF TRANSPORTATION UNITED STATES COAST GUARD
SURVEY, ANALYSIS AND EVALUATION OF COAST GUARD VESSEL WASTE WATERS

DATE - SEPT. 11, 1974

CONTRACT NO. DOT - CG 41342 - A

SCALE - NONE

H2M CORP.

HOLZMACHER, McLENDON and MURRELL
ENVIRONMENTAL ENGINEERS and SCIENTISTS

MELVILLE, N. Y.
NEWTON, N. J.

NOTE :

ALL NEW PIPING TO BE 90-10 CU-NI
 METER SHALL BE NEPTUNE TRIDENT B
 AS MANUFACTURED BY NEPTUNE
 METER COMPANY. METER CAPACITY
 IS 50 G.P.M. VALVES SHALL BE BRONZE GATE
 VALVES, FIG 44-WS AS MFD. BY "WALWORTH
 CO." BALY CYNWVD, PA.

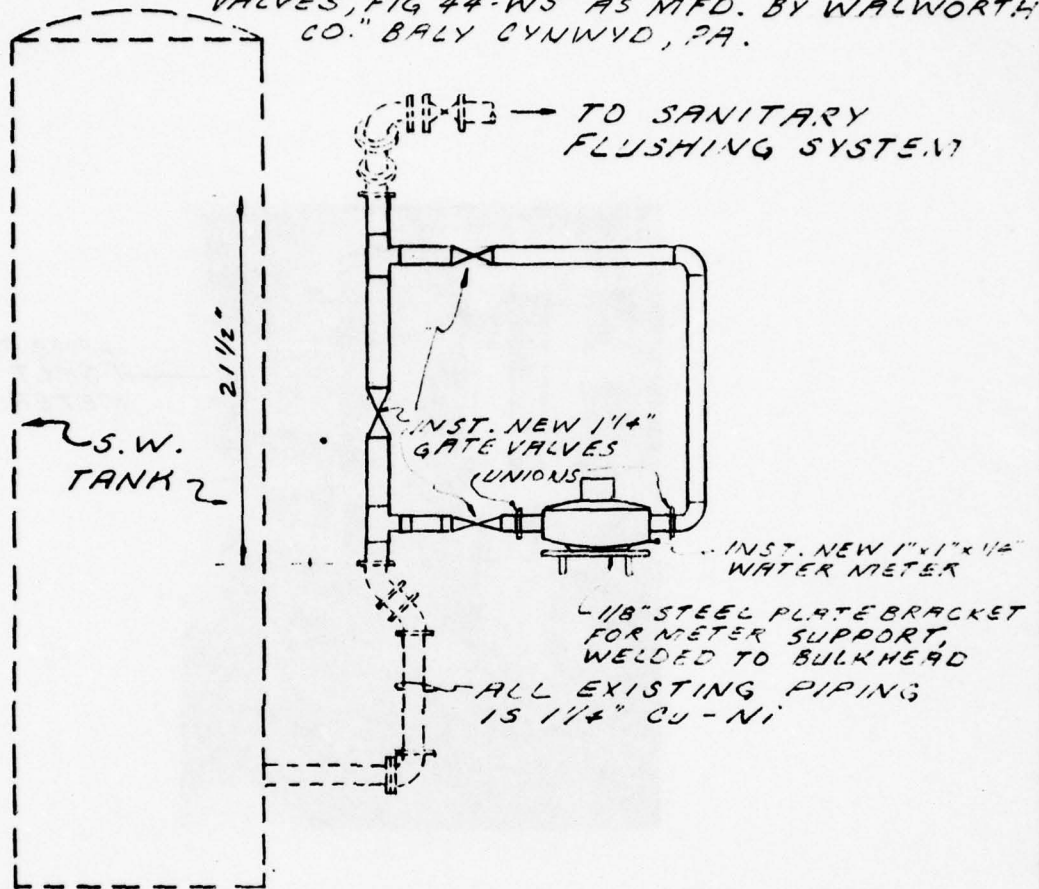

ELEVATION

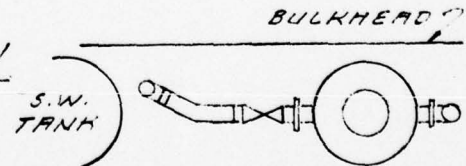

FIREBUSH (WLB 393)

PLAN

SALT WATER METER LOCATION

REVISED - OCTOBER 17, 1974

DEPARTMENT OF TRANSPORTATION UNITED STATES COAST GUARD
 SURVEY, ANALYSIS AND EVALUATION OF COAST GUARD VESSEL WASTE WATERS
 DATE - SEPT. 11, 1974 CONTRACT NO. DOT - CG 41342-A SCALE - NONE

H2M CORP. HOLZMACHER, McLENDON and MURRELL MELVILLE, N. Y.
 ENVIRONMENTAL ENGINEERS and SCIENTISTS NEWTON, N. J.

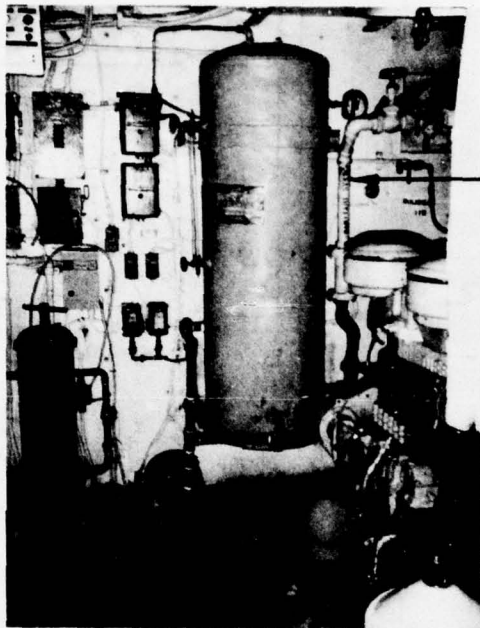

PROPOSED
SALT WATER
METER LOCATION

**FIREBUSH (WLB 393)
SALT WATER METER LOCATION**

REVISED - OCTOBER 17, 1974

DEPARTMENT OF TRANSPORTATION UNITED STATES COAST GUARD
SURVEY, ANALYSIS AND EVALUATION OF COAST GUARD VESSEL WASTE WATERS

DATE - SEPT. 11, 1974 CONTRACT NO. DOT - CG 41342 - A SCALE - NONE

H2M CORP. HOLZMACHER, McLENDON and MURRELL MELVILLE, N. Y.
ENVIRONMENTAL ENGINEERS and SCIENTISTS NEWTON, N. J.

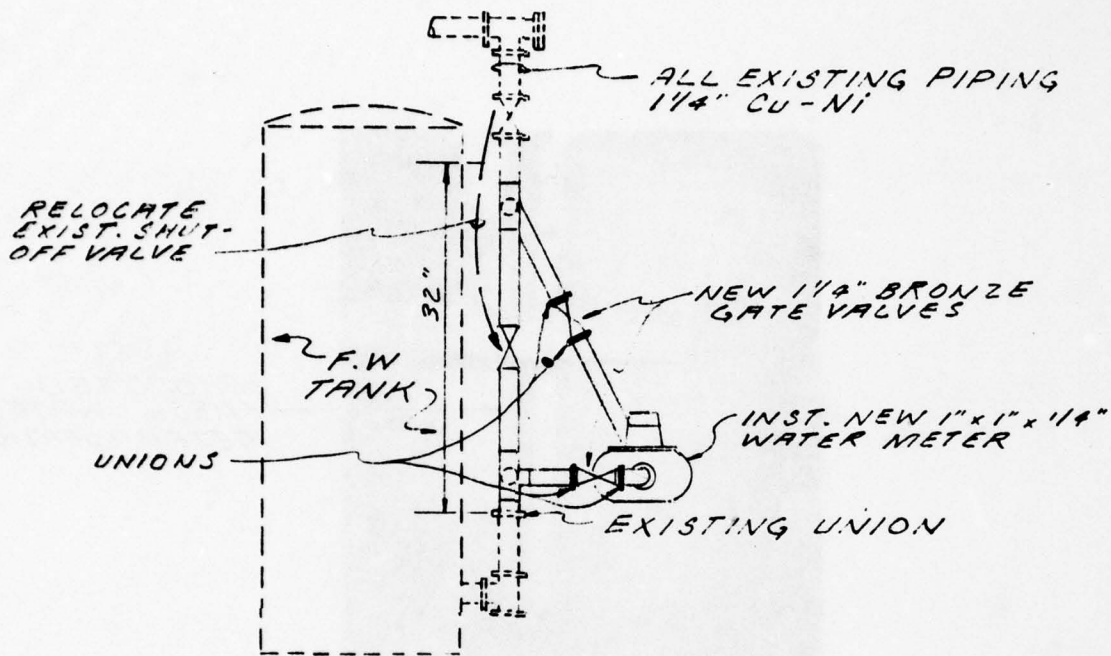

ELEVATION

NOTE:

ALL NEW PIPING TO BE 30-10, CU-NI. METER SHALL BE NEPTUNE, TRIDENT S AS MANUFACTURED BY NEPTUNE METER COMPANY. METER CAPACITY IS 50 G.P.M. VALVES SHALL BE BRONZE GATE VALVES, FIGURE 14 AS MANUFACTURED BY "WALWORTH CO.", BALY CYNWYD, PA.

FIREBUSH (WLB 393)

FRESH WATER METER LOCATION

REVISED - OCTOBER 17, 1974

DEPARTMENT OF TRANSPORTATION	UNITED STATES COAST GUARD
SURVEY, ANALYSIS AND EVALUATION OF COAST GUARD VESSEL WASTE WATERS	
DATE - SEPT. 11, 1974	CONTRACT NO. DOT - CG 41342-A
	SCALE - NONE

H2M CORP. HOLZMACHER, McLENDON and MURRELL MELVILLE, N. Y.
 ENVIRONMENTAL ENGINEERS and SCIENTISTS NEWTON, N. J.

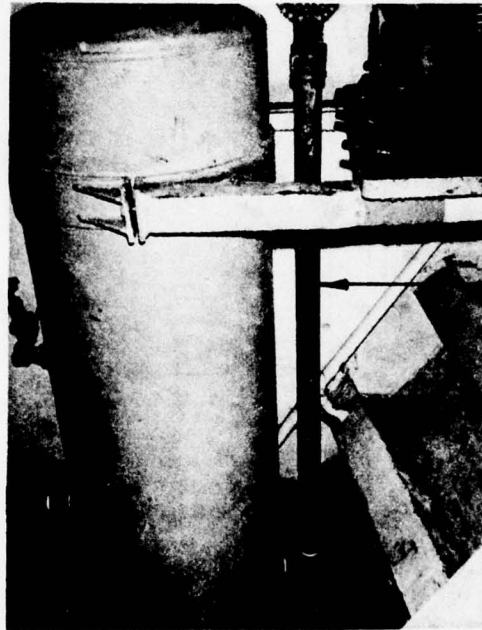

PROPOSED
FRESH WATER
METER LOCATION

**FIREBUSH (WLB 393)
FRESH WATER METER LOCATION**

REVISED - OCTOBER 17, 1974

DEPARTMENT OF TRANSPORTATION UNITED STATES COAST GUARD
SURVEY, ANALYSIS AND EVALUATION OF COAST GUARD VESSEL WASTE WATERS

DATE - SEPT. 11, 1974

CONTRACT NO. DOT - CG 41342 - A

SCALE - NONE

H2M CORP. HOLZMACHER, McLENDON and MURRELL MELVILLE, N. Y.
ENVIRONMENTAL ENGINEERS and SCIENTISTS NEWTON, N. J.

NOTES

1. THE LOCATION OF THE WASTE TREATMENT PLANT IS SHOWN ON THE ATTACHED MAP.
2. THE LOCATION OF THE WASTE TREATMENT PLANT IS SHOWN ON THE ATTACHED MAP.
3. THE LOCATION OF THE WASTE TREATMENT PLANT IS SHOWN ON THE ATTACHED MAP.

WHITE SAGE



WHITE SAGE (WLM 244)
SANITARY WASTE TREATMENT PLANT

UNITED STATES COAST BOARD
DEPARTMENT OF TRANSPORTATION
SANITARY WASTE AND EVALUATION OF COAST GUARD VESSEL WASTE WATERS
CONTRACT NO. DWT-43
SCALE NONE
UNITED STATES COAST BOARD
DEPARTMENT OF TRANSPORTATION
SANITARY WASTE AND EVALUATION OF COAST GUARD VESSEL WASTE WATERS
CONTRACT NO. DWT-43
SCALE NONE
UNITED STATES COAST BOARD
DEPARTMENT OF TRANSPORTATION
SANITARY WASTE AND EVALUATION OF COAST GUARD VESSEL WASTE WATERS
CONTRACT NO. DWT-43
SCALE NONE

A-43

NOTES:

- 1.) EXISTING PIPING IS 90-10 CU-NI
- 2.) VALVE SHALL BE "DE ZURIK", FIG. 120, 3" PLUG VALVE.
- 3.) AFTER COMPLETION OF SAMPLING, THE TEE & HOSE CONNECTION SHALL BE REMOVED & THE ORIGINAL PIPING REINSTALLED.

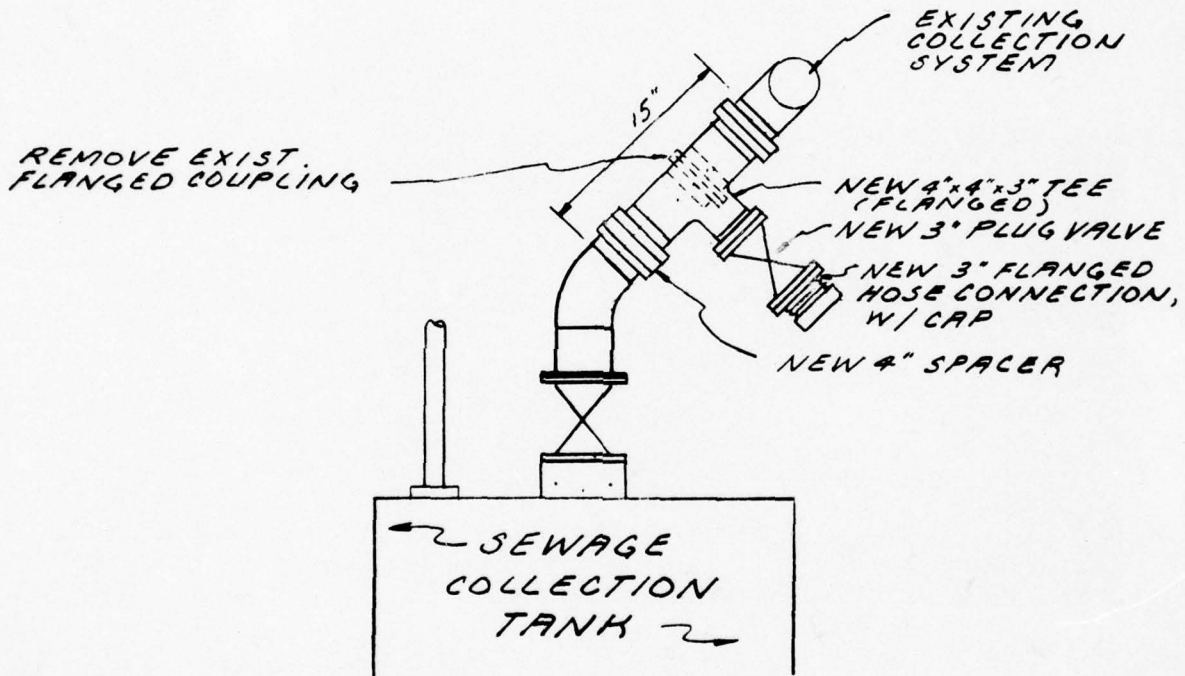

WHITE SAGE (WLM 544)
SANITARY WATER SAMPLE POINT

DEPARTMENT OF TRANSPORTATION UNITED STATES COAST GUARD
SURVEY, ANALYSIS AND EVALUATION OF COAST GUARD VESSEL WASTE WATERS
DATE OCT. 8, 1974 CONTRACT NO. DOT - CG 41342 - A SCALE NONE

H2M CORP. HOLZMACHER, McLENDON and MURRELL MELVILLE, N. Y.
ENVIRONMENTAL ENGINEERS and SCIENTISTS NEWTON, N. J.

*PROPOSED SANITARY
WATER SAMPLE POINT*

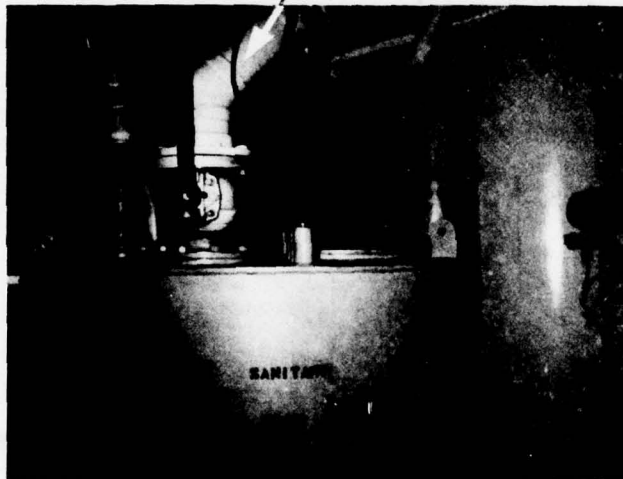
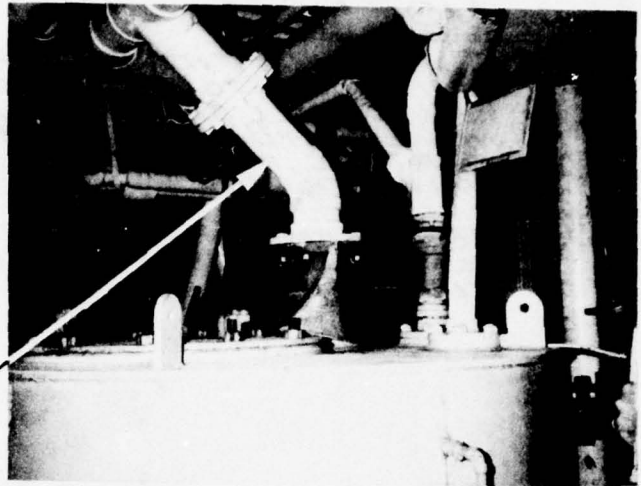

**WHITE SAGE (WLM 544)
SANITARY WATER SAMPLE POINT**

DEPARTMENT OF TRANSPORTATION UNITED STATES COAST GUARD
SURVEY, ANALYSIS AND EVALUATION OF COAST GUARD VESSEL WASTE WATERS

DATE OCT. 8, 1974

CONTRACT NO. DOT - CG 41342 - A

SCALE NONE

H2M CORP. HOLZMACHER, McLENDON and MURRELL MELVILLE, N. Y.
ENVIRONMENTAL ENGINEERS and SCIENTISTS NEWTON, N. J.

NOTES:

- 1.) NEW PIPING & FITTINGS SHALL BE 90-10 CU-NI CONFORMING TO MIL-T-16420 CL 200.
- 2.) VALVES SHALL BE 2", FIG. 120. PLUG VALVE AS MANUFACTURED BY "DE ZURIK CORP." SARTELL, MINN. & 1 1/2" FULL PORT BALL VALVE, WALWORTH 150 LB., BRONZE, FIG. 4150 F.
- 3.) AFTER SAMPLING PROGRAM IS COMPLETE, REMOVE PLUG VALVE, HOSE CONNECTION & INST. BLIND FLANGE.

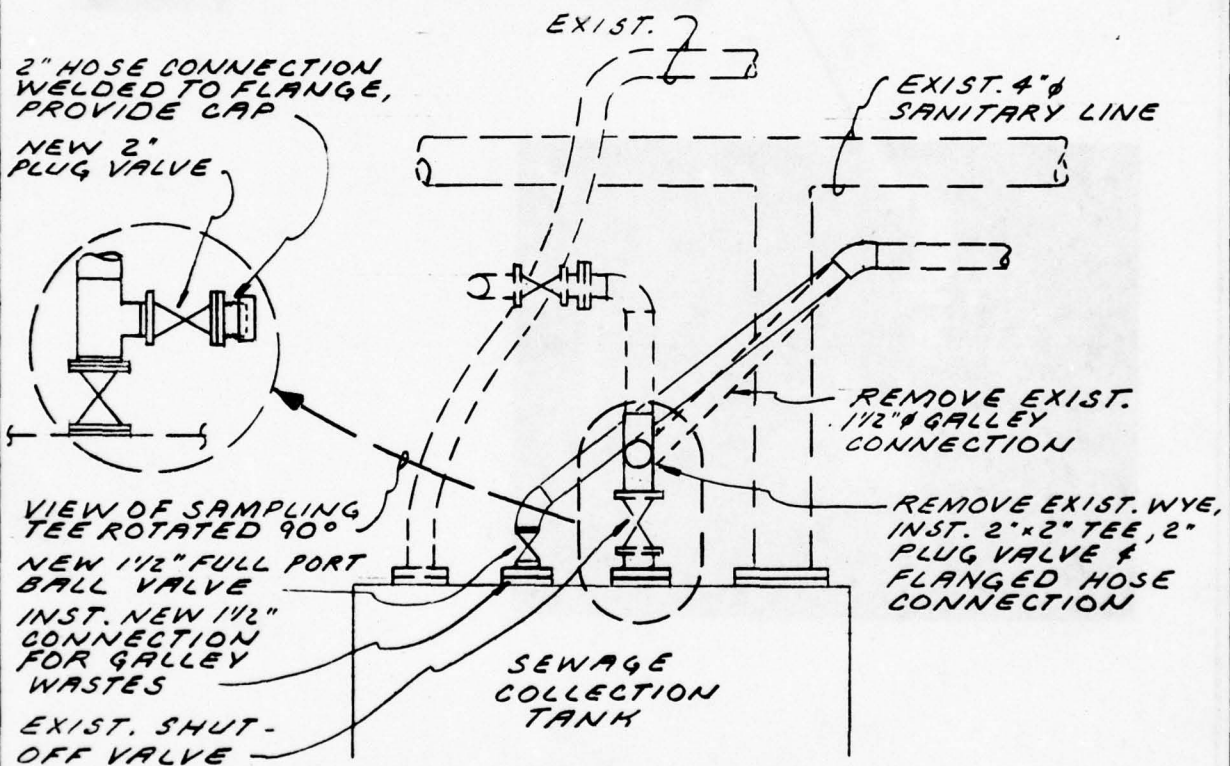

WHITE SAGE (WLM 544)
TURBID WATER SAMPLE POINT

DEPARTMENT OF TRANSPORTATION UNITED STATES COAST GUARD
 SURVEY, ANALYSIS AND EVALUATION OF COAST GUARD VESSEL WASTE WATERS
 DATE OCT. 8, 1974 CONTRACT NO. DOT - CG 41342-A SCALE NONE

H2M CORP. HOLZMACHER McLENDON and MURRELL MELVILLE, N. Y.
 ENVIRONMENTAL ENGINEERS and SCIENTISTS NEWTON, N. J.

TURBID
WATER
SAMPLE
POINT

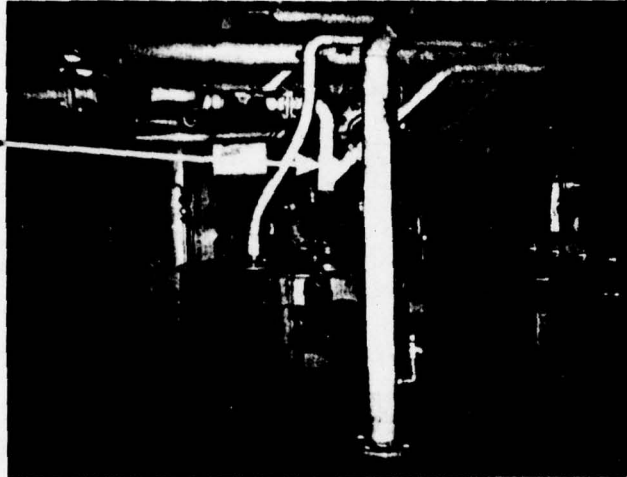

WHITE SAGE (WLM 544)
TURBID WATER SAMPLE POINT

DEPARTMENT OF TRANSPORTATION UNITED STATES COAST GUARD
SURVEY, ANALYSIS AND EVALUATION OF COAST GUARD VESSEL WASTE WATERS

DATE OCT. 8, 1974

CONTRACT NO. DOT - CG 41342 - A

SCALE NONE

H2M CORP. HOLZMACHER, McLENDON and MURRELL MELVILLE, N. Y.
ENVIRONMENTAL ENGINEERS and SCIENTISTS NEWTON, N. J.

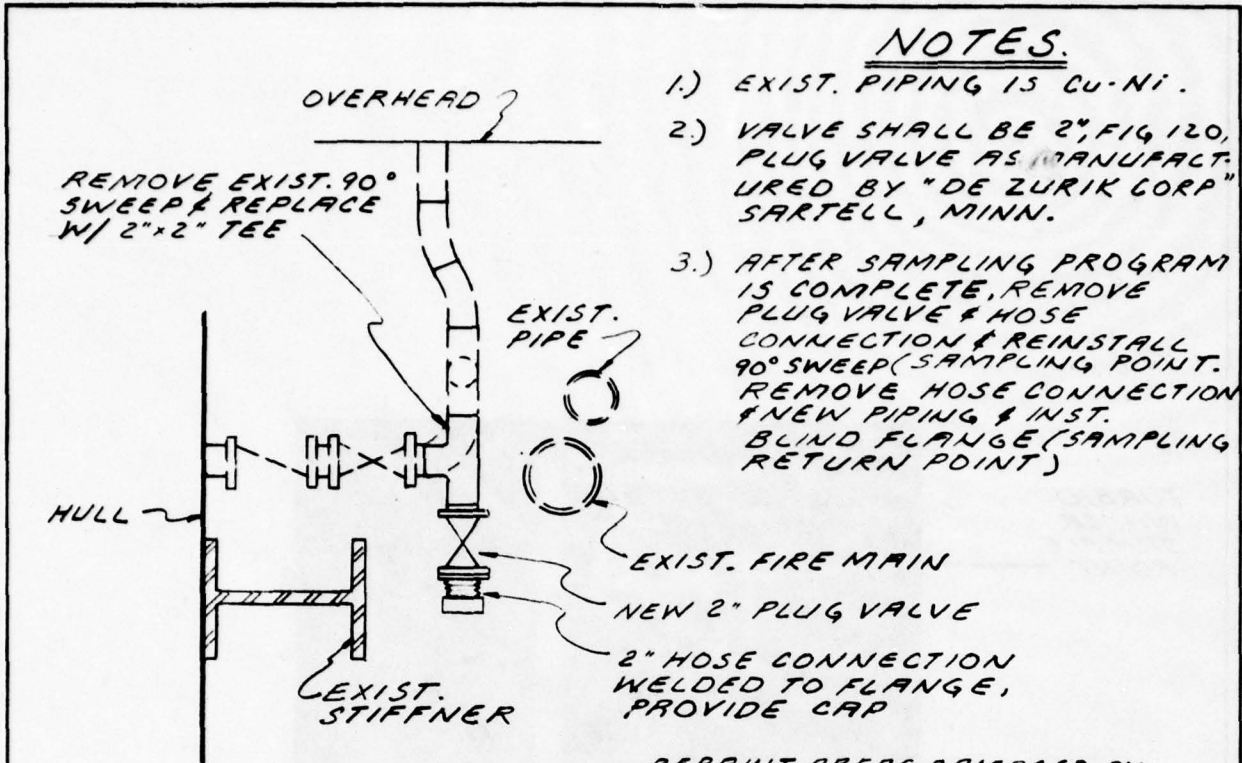

SAMPLING POINT

- NOTES.
- 1.) EXIST. PIPING IS CU-NI.
 - 2.) VALVE SHALL BE 2", FIG 120, PLUG VALVE AS MANUFACTURED BY "DE ZURIK CORP" SARTELL, MINN.
 - 3.) AFTER SAMPLING PROGRAM IS COMPLETE, REMOVE PLUG VALVE & HOSE CONNECTION & REINSTALL 90° SWEEP (SAMPLING POINT). REMOVE HOSE CONNECTION & NEW PIPING & INST. BLIND FLANGE (SAMPLING RETURN POINT)

REPAINT AREAS DAMAGED BY WELDING, CLEAN TO WHITE METAL & COAT INTERIOR TANK SURFACE WITH COAL TAR EPOXY TYPE 1 CLASS 2, MIL-P-23236, COAT EXT. TO MATCH EXISTING.

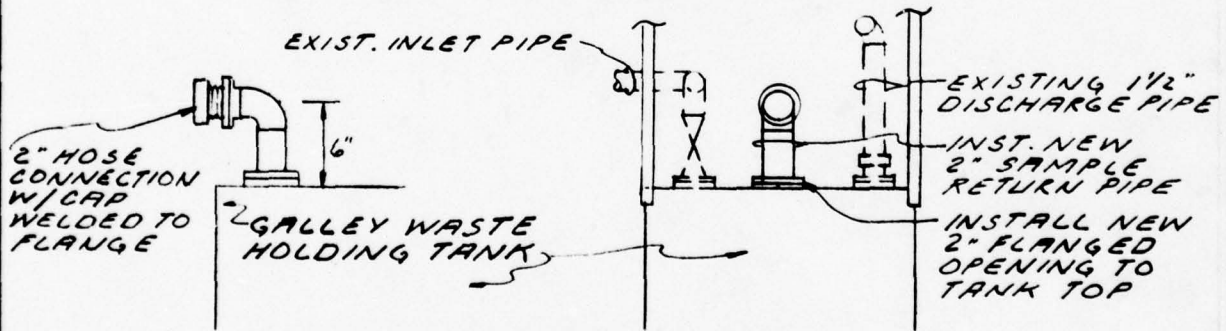

SAMPLING RETURN POINT

**WHITE SAGE (WLM 544)
GALLEY WASTE SAMPLE POINT**

DEPARTMENT OF TRANSPORTATION UNITED STATES COAST GUARD
SURVEY, ANALYSIS AND EVALUATION OF COAST GUARD VESSEL WASTE WATERS

DATE OCT. 8, 1974

CONTRACT NO. DOT - CG 41342-A

SCALE NONE

H2M CORP. HOLZMACHER, McLENDON and MURRELL MELVILLE, N. Y.
ENVIRONMENTAL ENGINEERS and SCIENTISTS NEWTON, N. J.

GALLEY WASTE
SAMPLE POINT

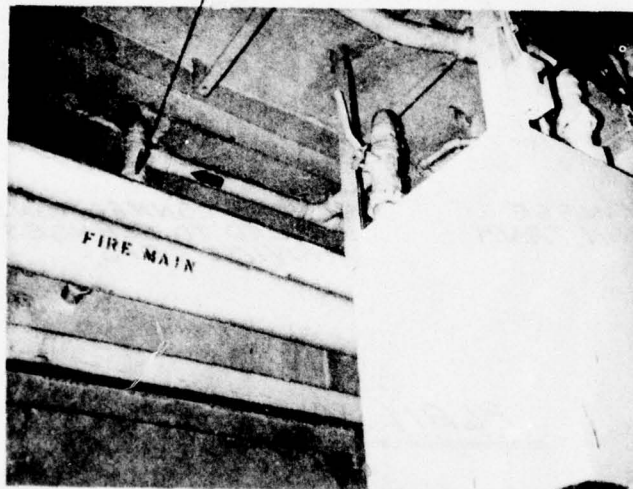
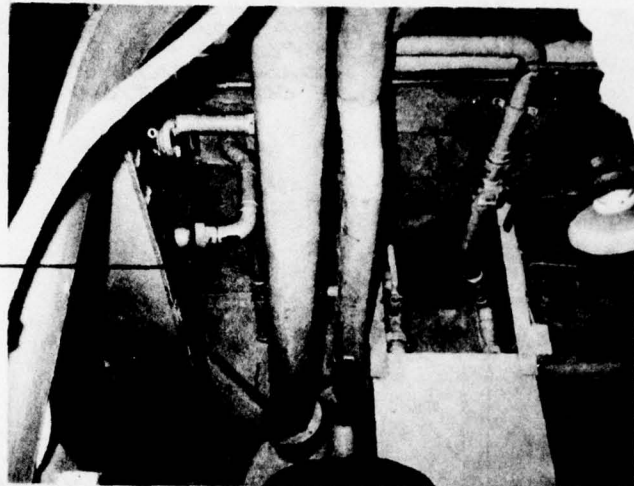

**WHITE SAGE (WLM 544)
GALLEY WASTE SAMPLE POINT**

DEPARTMENT OF TRANSPORTATION UNITED STATES COAST GUARD
SURVEY, ANALYSIS AND EVALUATION OF COAST GUARD VESSEL WASTE WATERS

DATE OCT. 8, 1974

CONTRACT NO. DOT - CG 41342 - A

SCALE NONE

H2M CORP. HOLZMACHER, McLENDON and MURRELL MELVILLE, N. Y.
ENVIRONMENTAL ENGINEERS and SCIENTISTS NEWTON, N. J.

NOTES:

- 1) PLUG VALVE SHALL BE 2", FIG. 120 AS MANUFACTURED BY "DE ZURIK CORP." SARTELL, MINN.
- 2) WHEN SAMPLING PROGRAM IS COMPLETE, THE SAMPLE RETURN CONNECTION SHALL BE REMOVED & THE FIRE HOSE CONNECTION SHALL BE REINSTALLED.

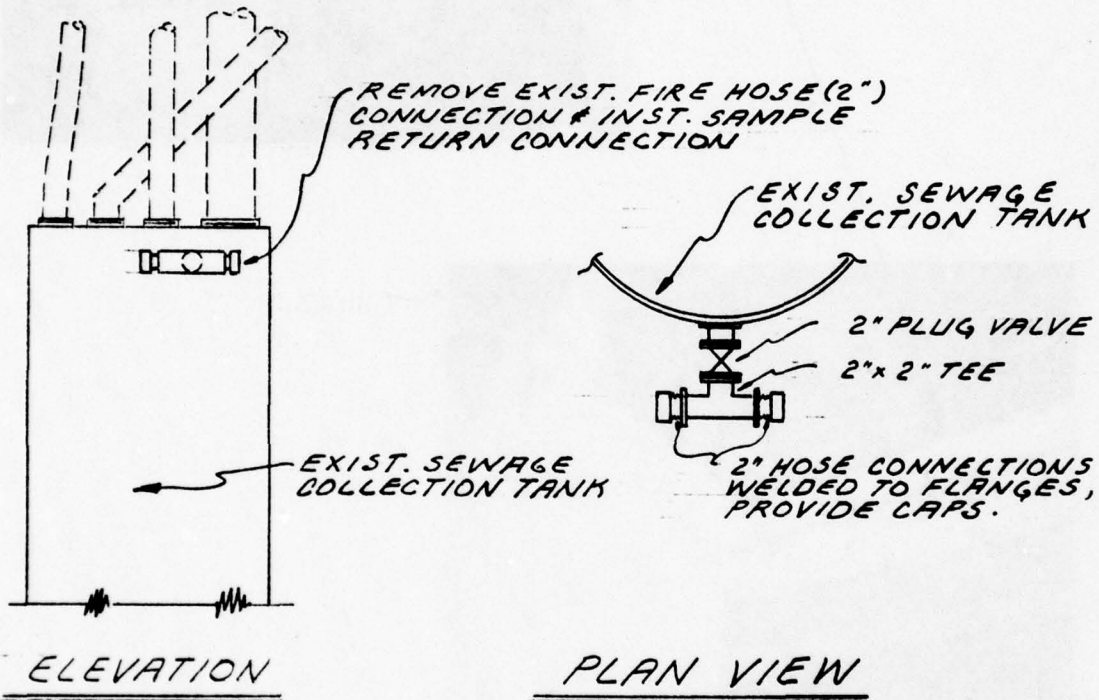

**WHITE SAGE (WLM 544)
WASTE WATER RETURN POINT**

DEPARTMENT OF TRANSPORTATION UNITED STATES COAST GUARD
 SURVEY, ANALYSIS AND EVALUATION OF COAST GUARD VESSEL WASTE WATERS
 DATE OCT 8, 1974 CONTRACT NO. DOT - CG 41342-A SCALE NONE

H2M CORP. HOLZMACHER, McLENDON and MURRELL MELVILLE, N. Y.
 ENVIRONMENTAL ENGINEERS and SCIENTISTS NEWTON, N. J.

PROPOSED
SAMPLE
RETURN
POINT

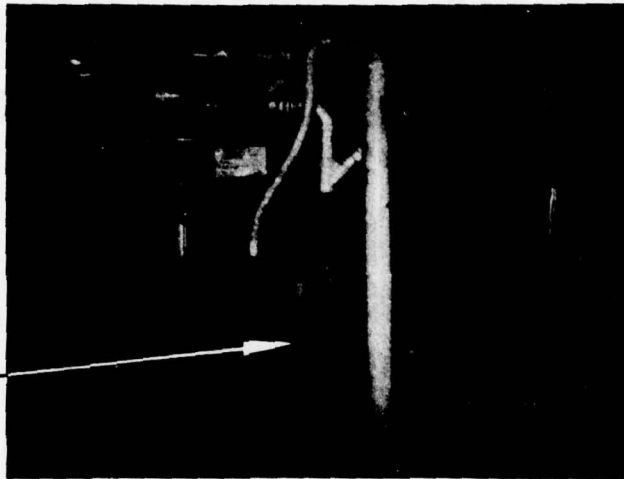

WHITE SAGE (WLM 544)
WASTE WATER RETURN POINT

DEPARTMENT OF TRANSPORTATION UNITED STATES COAST GUARD
SURVEY, ANALYSIS AND EVALUATION OF COAST GUARD VESSEL WASTE WATERS

DATE OCT. 8, 1974

CONTRACT NO. DOT - CG 41342-A

SCALE NONE

H2M CORP.

HOLZMACHER, McLENDON and MURRELL
ENVIRONMENTAL ENGINEERS and SCIENTISTS

MELVILLE, N. Y.
NEWTON, N. J.

NOTES:

- 1.) NEW PIPING & FITTINGS SHALL BE 90-10 CU-NI CONFORMING TO MIL-T-16420 CL 200
- 2.) METER SHALL BE NEPTUNE TRIDENT B AS MANUFACTURED BY "NEPTUNE METER CO." L.I. CITY, N.Y. METER CAPACITY IS 50 G.P.M.
- 3.) NEW GATE VALVES SHALL BE BRONZE, FIG 44 WS AS MANUFACTURED BY "WALWORTH CO", BALA CYNWYD, PA.

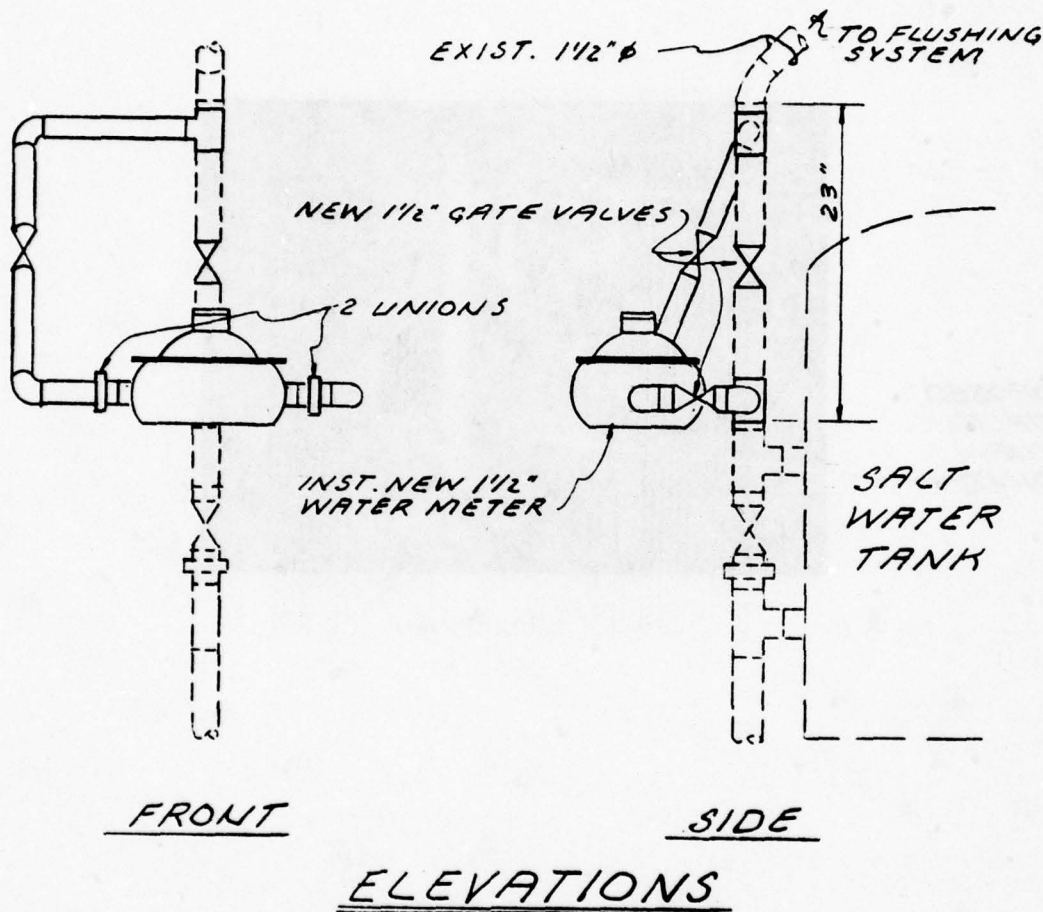

WHITE SAGE (WLM 544)
SALT WATER METER LOCATION

DEPARTMENT OF TRANSPORTATION UNITED STATES COAST GUARD
SURVEY, ANALYSIS AND EVALUATION OF COAST GUARD VESSEL WASTE WATERS
DATE OCT. 8, 1974 CONTRACT NO. DOT - CG 41342 - A SCALE NONE

H2M CORP. HOLZMACHER, McLENDON and MURRELL MELVILLE, N. Y.
ENVIRONMENTAL ENGINEERS and SCIENTISTS NEWTON, N. J.

*PROPOSED
SALT WATER
METER LOCATION*

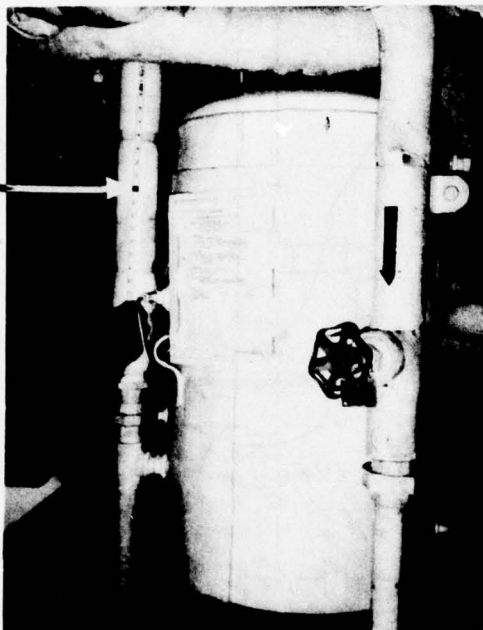

**WHITE SAGE (WLM 544)
SALT WATER METER LOCATION**

**DEPARTMENT OF TRANSPORTATION UNITED STATES COAST GUARD
SURVEY, ANALYSIS AND EVALUATION OF COAST GUARD VESSEL WASTE WATERS**

DATE OCT. 8, 1974

CONTRACT NO. DOT - CG 41342 - A

SCALE NONE

**H2M CORP. HOLZMACHER, McLENDON and MURRELL MELVILLE, N. Y.
ENVIRONMENTAL ENGINEERS and SCIENTISTS NEWTON, N. J.**

NOTES:

- 1.) ALL EXISTING PIPING IS 1 1/4" STEEL.
- 2.) METER SHALL BE NEPTUNE TRIDENT-B AS MANUFACTURED BY "NEPTUNE METER CO.", C.I. CITY, N.Y. METER CAPACITY IS 50 G.P.M.
- 3.) BRONZE GATE VALVES SHALL BE FIG. 14 AS MANUFAC MANUFACTURED BY "WALWORTH Co.", BALA CYNWYD, PA.
- 4.) ALL NEW PIPING SHALL BE SCH. 40 STEEL CONFORMING TO FED. SPEC. WW-P-406 B

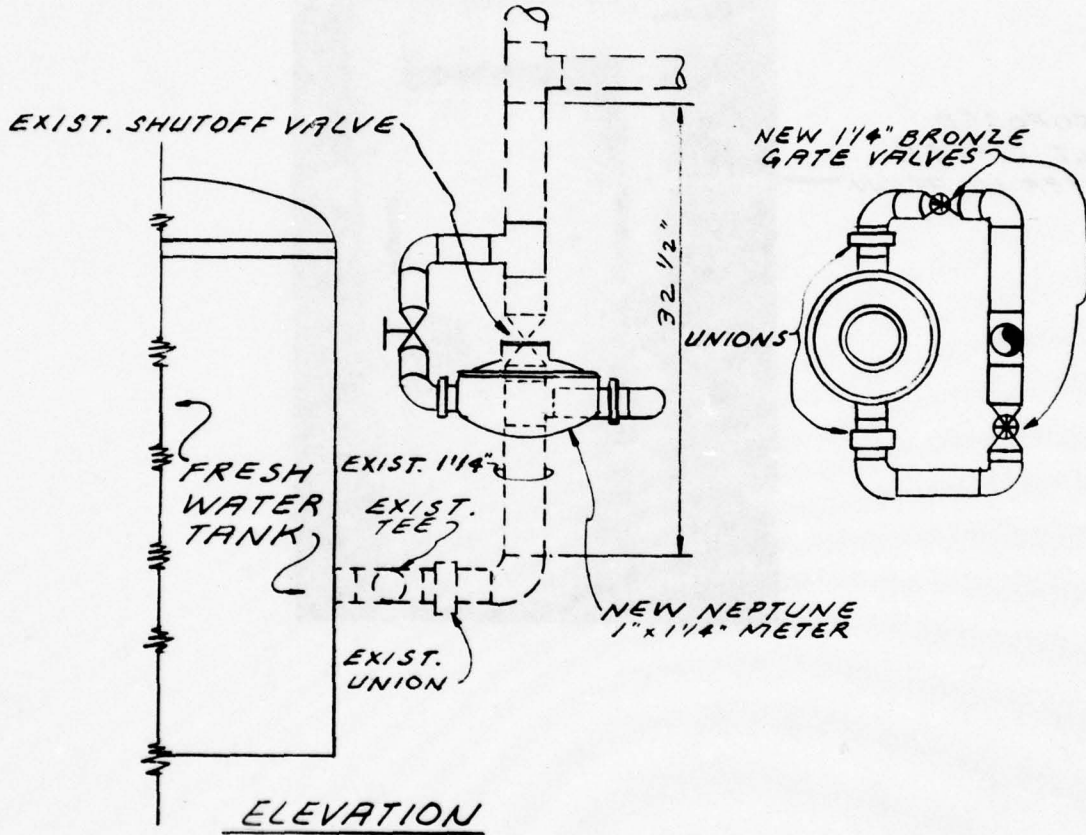

**WHITE SAGE (WLM 544)
FRESH WATER METER LOCATION**

DEPARTMENT OF TRANSPORTATION UNITED STATES COAST GUARD
 SURVEY, ANALYSIS AND EVALUATION OF COAST GUARD VESSEL WASTE WATERS
 DATE OCT. 8, 1974 CONTRACT NO. DOT - CG 41342-A SCALE NONE

H2M CORP. HOLZMACHER, McLENDON and MURRELL MELVILLE, N. Y.
 ENVIRONMENTAL ENGINEERS and SCIENTISTS NEWTON, N. J.

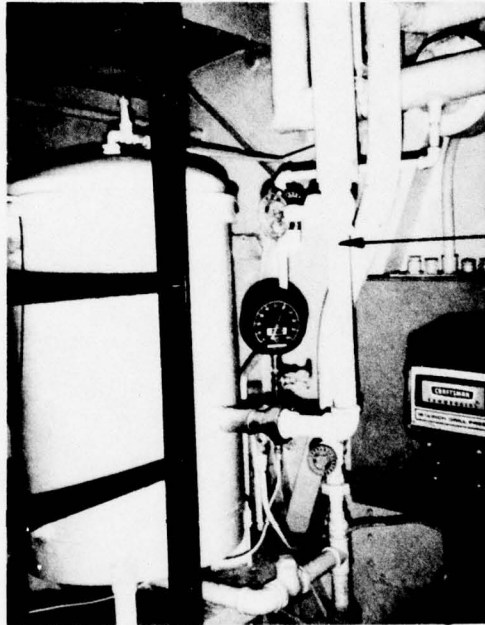

PROPOSED
FRESH WATER
METER LOCATION

WHITE SAGE (WLM 544)
FRESH WATER METER LOCATION

DEPARTMENT OF TRANSPORTATION UNITED STATES COAST GUARD
SURVEY, ANALYSIS AND EVALUATION OF COAST GUARD VESSEL WASTE WATERS
DATE OCT. 8, 1974 CONTRACT NO. DOT - CG 41342 - A SCALE NONE

H2M CORP. HOLZMACHER, McLENDON and MURRELL MELVILLE, N. Y.
ENVIRONMENTAL ENGINEERS and SCIENTISTS NEWTON, N. J.

APPENDIX B

Computer Programs

For

Calculations and Plots of
pH, Wastewater and Water
Flow, Crew Size and Chemical
Data Regression Line

Programmed on a Hewlett Packard
HP 9820/21 Equipped with a
Cassette Input for Data Storage
and a HP 9822 Plotter. Written
in HP9820 Language.

UNITED STATES COAST GUARD CONTRACT

DOT - CG 41342-A

SURVEY, ANALYSIS AND EVALUATION OF DOMESTIC
WASTEWATERS ON COAST GUARD VESSELS

pH PLOTS

50	GSB "VAX" F	GTO 41 F
R1212	21:	40:
0:	STP F	GTO 37 F.
0+R4 F	22:	41:
1:	GSB "FRM" F	LTR 9.6, -.08 X, 32
ENT "SAN DATA FI	23:	1; PLT "TIME (HOU
LE=", R1; ENT "TUR	360+R6; R29*24+R2	RS) " F
DATA FILE=", R2 F	5; R359+R23 F	42:
2:	24:	0+R8 F
ENT "GAL DATA FI	GSB "IND" F	43:
LE=", R3 F	25:	LTR -.8, R8-.008 X
3:	GSB "DAT" F	, 321; FXD 0; PLT R
LDF R1, R39 F	26:	8; FLT F
4:	GSB "FAT3" F	44:
LDF R2, R199 F	27:	R8+.2 X+R8 F
5:	GSB "VAX" F	45:
LDF R3, R359 F	28:	FLT ; IF R8>A*X.
6:	STP F	05; GTO 47 F
0+R4 F	29:	46:
7:	"FRM"; ENT "Y=", X	LTR -.5 Y-.3, R8-
STP F	F	.008 X, 321; FXD 0;
8:	30:	PLT R8; FLT ; GTO
GSB "FRM" F	ENT "Y MULT 1 ="	44 F
9:	, Y; ENT "Y MULT 2	47:
40+R6; R27*24+R25	=", Z; ENT "ENT S	LTR -.5 Z-.3, R8-
; R39+R23 F	M=", R F	.008 X, 321; FXD 0;
10:	31:	PLT R8; R8+.2 X+R8
GSB "IND" F	SCL -3.9, 24.7, -.	F
11:	.09 X, 1.09 X F	48:
GSB "DAT" F	32:	FLT ; IF R8>X+.05
12:	AXE 0, 0, 2, .1 X F	; GTO 50 F
GSB "FAT1" F	33:	49:
13:	0+R8 F	GTO 47 F
GSB "VAX" F	34:	50:
14:	LTR R8-.192, -.04	RET F
STP F	X, 321; FXD 0; PLT	51:
15:	R8 F	"IND"; 0+R8+R9+R1
GSB "FRM" F	35:	0+R11+R12+R13+R1
16:	FLT ; IF R8>7.5;	4+R15+R16 F
200+R6; R28*24+R2	GTO 37 F	52:
5; R199+R23 F	36:	IF R(R11+R6+1) <.
17:	R8+4+R8; GTO 34 F	01; GTO 55 F
GSB "IND" F	37:	53:
18:	R8+4+R8 F	PLT R10, R(R11+R6
GSB "DAT" F	38:)*R23; PLT R10, R(
19:	LTR R8-.39, -.04 X	R11+R6+2)*R23;
GSB "FAT2" F	, 321; FXD 0; PLT R	PEN ; R15+1+R15 F
20:	0 F	54:
	39:	R12+R(R11+R6+1)*
	FLT ; IF R8>21;	R23+R12 F

pH PLOTS

```

55: R10+.5+R10;R11+3
    +R11;R8+1+R8F
56: IF R10>23.5;GTO
58F
57: GTO 52F
58: 0+R8+R9+R10+R11F
59: IF R(R11+R6+1)<.
    01;GTO 61F
60: PLT R10,R(R11+R6
    +1)*R23F
61: R10+.5+R10;R11+3
    +R11;R8+1+R8F
62: IF R10>23.5;GTO
64F
63: GTO 59F
64: R12/R15+R13F
65: R16*8.34*R25/R15
    +R14F
66: RET F
67: "DAT";LTR 1,1.04
    X,321;PLT "WHITE
    SAGE D
    OCKSIDE 11-17 AU
    G 75"F
68: LTR 1,X,321;PLT
    "AVG PH"F
69: LTR 5,X,321;FXD
    1;PLT R13F
70: FLT ;LTR 1,.96X,
    321;PLT "
    F
71: RET F
72: "VAX";LTR -3.3,.
    35X,332F
73: PLT " PH "
    F
74: RET F
75: "FAT1";LTR 7.0,1
    .04X,321;PLT "SA
    NITARY"F
76: RET F
77: "FAT2";LTR 7.5,1
    .04X,321;PLT "TU
    RBID"F
78: RET F
79: "FAT3";LTR 7.5,1
    .04X,321;PLT "GA
    LLEY"F
80: RET F
81: END F
    231095
    R1212

```

WASTEWATER FLOW - CALCULATIONS AND PLOT

<pre> 0: ENT "SAN DATA FI LE=",R1F 1: ENT "TUR DATA FI LE=",R2F 2: ENT "GAL DATA FI LE=",R3F 3: ENT "CREW DATA F ILE=",R4F 4: ENT "TRUE CREW S IZE=",R5F 5: LDF R1,R40F 6: LDF R2,R200F 7: LDF R3,R360F 8: LDF R4,R520F 9: ENT "DATA REG FI LE=",R6F 10: ENT "NLZ?",R7F 11: STP F 12: GSB "FRM" F 13: GSB "IND" F 14: GSB "DAT" F 15: GSB "VAX" F 16: STP F 17: GSB "FRM" F 18: GSB "CUM" F 19: GSB "DAT" F 20: GSB "VAX" F </pre>	<pre> 21: STP F 22: GSB "FRM" F 23: GSB "ALL" F 24: GSB "DAT" F 25: GSB "VAX" F 26: STP F 27: GSB "FRM" F 28: GSB "ACM" F 29: GSB "DAT" F 30: GSB "VAX" F 31: STP F 32: GTO 137F 33: "FRM";ENT "Y=",X F 34: ENT "Y MULT 1 =" ,Y;ENT "Y MULT 2 =",Z;ENT "ENT S M=",AF 35: SCL -3.9,24.7,-. 09X,1.09XF 36: AXE 0,0,2,.1XF 37: 0+R8F 38: LTR R8-.192,-.04 X,321;FXD 0;PLT R8F 39: FLT ;IF R8>7.5; GTO 41F 40: R8+4+R8;GTO 38F 41: </pre>	<pre> R8+4+R8F 42: LTR R8-.39,-.04X ,321;FXD 0;PLT R 8F 43: FLT ;IF R8>21; GTO 45F 44: GTO 41F 45: LTR 9.6,-.08X,32 1;PLT "TIME (HOU RS)" F 46: 0+R8F 47: LTR -.8,R8-.008X ,321;FXD 0;PLT R 8;FLT F 48: R8+.2X+R8F 49: FLT ;IF R8>A*X+. 05;GTO 51F 50: LTR -.5Y-.3,R8-. 008X,321;FXD 0; PLT R8;FLT ;GTO 48F 51: LTR -.5Z-.3,R8-. 008X,321;FXD 0; PLT R8;R8+.2X+R8 F 52: FLT ;IF R8>X+.05 ;GTO 54F 53: GTO 51F 54: RET F 55: "IND";0+R8+R9+R1 0+R11+R12+R13+R1 4+R15+R16F 56: IF R7<.1;1+R9; GTO 58F </pre>
--	--	--

WASTEWATER FLOW - CALCULATIONS AND PLOT

```

57: R5/R(R8+520)+R9F
58: IF R(R11+R6+1) < .01;GTO 61F
59: PLT R10,R(R11+R6+1)*R9;PLT R10,R(R11+R6+2)*R9;PEN F
60: R12+R(R11+R6+1)*R9+R12;R16+R(R11+R6+1)/R(R8+520)+R16F
61: R10+.5+R10;R11+3+R11;R8+1+R8F
62: IF R10 > 23.5;GTO 64F
63: GTO 56F
64: 0+R8+R9+R10+R11F
65: IF R7 < .1;1+R9;GTO 67F
66: R5/R(R8+520)+R9F
67: IF R(R11+R6+1) < .01;GTO 69F
68: PLT R10,R(R11+R6+1)*R9F
69: R10+.5+R10;R11+3+R11;R8+1+R8F
70: IF R10 > 23.5;GTO 72F
71: GTO 65F
72: R12/24+R13F
73: R16+R14F
74: RET F
75: "DAT";LTR 1,1.04X;321;PLT "GALLA TIN TOTAL UND ERWAY 3-5 SEPT 7 5"F
76: LTR 1,X,321;PLT "AVG TOTAL FLOW (GAL/HR)";FLT F
77: LTR 14.5,X,321;FXD 2;PLT R13F
78: FLT ;LTR 1,.96X,321;PLT "AVG FLOW M (GAL/MAN-DAY)";FLT F
79: LTR 14,.96X,321;FXD 2;PLT R14;FLT F
80: IF R7 < .1;GTO 82F
81: LTR 1,.92X,321;PLT "NORMALIZED TO FULL CREW";GTO 83F
82: LTR 1,.92X,321;PLT "ACTUAL CREW"F
83: RET F
84: "CUM";0+R8+R9+R10+R11+R12+R15+R16+R17+R18F
85: IF R7 < .1;1+R9;GTO 87F
86: R5/R(R8+520)+R9F
87: IF R(R11+R6+1)+R(R11+2011)+R(R11+361) < .01;GTO 92F
88: R15+R(R11+R6)*R9+R15F
89: R16+R(R11+R6+1)*R9+R16;R18+R(R11+R6+1)/R(R8+520)+R18F
90: R17+R(R11+R6+2)*R9+R17F
91: PLT R10,R15;PEN ;PLT R10,R16;PEN ;PLT R10,R17;PEN F
92: R10+.5+R10;R11+3+R11;R8+1+R8F
93: IF R10 > 23.5;GTO 95F
94: GTO 85F
95: PLT 0,0;PLT 24,R16;PEN ;R16/24+R13;R18+R14F
96: RET F
97: "VAX";LTR -3.3,.35X,322F
98: PLT "WASTEWATER (GAL)"F
99: RET F
100: "ALL";0+R8+R9+R10+R11+R12+R13+R14+R15+R16+R17+R18+R19+R20F
101: IF R7 < .1;1+R9;GTO 103F

```

WASTEWATER FLOW - CALCULATIONS AND PLOT

```

102:
R5/R(R8+520)+R9F
103:
IF R(R11+41)+R(R
11+201)+R(R11+36
1) < .01; GTO 108F
104:
R(R11+40)+R(R11+
200)+R(R11+360)+
R15F
105:
R(R11+41)+R(R11+
201)+R(R11+361)+
R16F
106:
R(R11+42)+R(R11+
202)+R(R11+362)+
R17F
107:
PLT R10,R15*R9;
PLT R10,R17*R9;
PEN F
108:
R10+.5+R10;R11+3
+R11;R8+1+R8F
109:
IF R10 > 23.5; GTO
111F
110:
GTO 101F
111:
0+R8+R9+R10+R11+
R20+R21+R22F
112:
IF R7 < .1; 1+R9;
GTO 114F
113:
R5/R(R8+520)+R9F
114:
R(R11+41)+R(R11+
201)+R(R11+361)+
R20; IF R20 < .01;
GTO 116F
115:
PLT R10,(R(R11+4
1)+R(R11+201)+R(
R11+361))+R9F
116:
R10+.5+R10;R11+3
+R11;R8+1+R8;R21
+R20+R9+R21F
117:
R22+R20/R(R8+520
)+R22; IF R10 > 23.
5; GTO 119F
118:
GTO 112F
119:
R21/24+R13F
120:
R22+R14F
121:
RET F
122:
"ACM"; 0+R8+R9+R1
0+R11+R15+R16+R1
7+R18F
123:
IF R7 < .1; 1+R9;
GTO 125F
124:
R5/R(R8+520)+R9F
125:
IF R(R11+41)+R(R
11+201)+R(R11+36
1) < .01; GTO 131F
126:
R15+(R(R11+40)+R
(R11+200)+R(R11+
360))*R9+R15F
127:
R16+(R(R11+41)+R
(R11+201)+R(R11+
361))*R9+R16F
128:
R17+(R(R11+42)+R
(R11+202)+R(R11+
362))*R9+R17F
129:
PLT R10,R15;PEN
;PLT R10,R16;
PEN ;PLT R10,R17
;PEN F
130:
R18+(R(R11+41)+R
(R11+201)+R(R11+
361))/R(R8+520)+
R18F
131:
R10+.5+R10;R11+3
+R11;R8+1+R8F
132:
IF R10 > 23.5; GTO
134F
133:
GTO 123F
134:
R16/24+R13;R18+R
14F
135:
PLT 0,0;PLT 24,R
16;PEN F
136:
RET F
137:
END F
332105
R994

```

WASTEWATER FLOW - PLOT AND CALCULATIONS

30	19:	8F
R1186	GSB "FAT2" F	39:
0:	20:	FLT ;IF R8>21;
ENT "SAN FL",R27	GSB "VAX" F	GTO 41F
;ENT "TUR FL",R2	21:	40:
8;ENT "GAL FL",R	STP F	GTO 37F
29;ENT "CREW SIZ	22:	41:
E FILE",R4F	GSB "FRM" F	LTR 9.6,-.00X,32
1:	23:	1;PLT "TIME (HOU
LDF R4,R520F	360+R6;R29*24+R2	RS)" F
2:	5;R359+R23F	42:
ENT "SAN DATA FI	24:	0+R8F
LE=",R1;ENT "TUR	GSB "IND" F	43:
DATA FILE=",R2F	25:	LTR -.8,R8-.008X
3:	GSB "DAT" F	,321;FXD 0;PLT R
ENT "GAL DATA FI	26:	8;FLT F
LE=",R3F	GSB "FAT3" F	44:
4:	27:	R8+.2X+R8F
LDF R1,R39F	GSB "VAX" F	45:
5:	28:	FLT ;IF R8>A*X+.
LDF R2,R199F	STP F	05;GTO 47F
6:	29:	46:
LDF R3,R359F	"FRM";ENT "Y=",X	LTR -.5Y-.3,R8-.
7:	F	008X,321;FXD 0;
STP F	30:	PLT R8;FLT ;GTO
8:	ENT "Y MULT 1 ="	44F
GSB "FRM" F	,Y;ENT "Y MULT 2	47:
9:	=";Z;ENT "ENT S	LTR -.5Z-.3,R8-.
40+R6;R27*24+R25	W=",AF	008X,321;FXD 0;
;R39+R23F	31:	PLT R8;R8+.2X+R8
10:	SCL -3.9,24.7,-.	F
GSB "IND" F	09X,1.09XF	48:
11:	32:	FLT ;IF R8>X+.05
GSB "DAT" F	AXE 0,0,2,.1XF	;GTO 50F
12:	33:	49:
0+R8F	0+R8F	GTO 47F
34:	GSB "FAT1" F	50:
LTR R8-.192,-.04	13:	RET F
X,321;FXD 0;PLT	GSB "VAX" F	51:
R8F	14:	"IND";0+R8+R9+R1
35:	STP F	0+R11+R12+R13+R1
FLT ;IF R8>7.5;	15:	4+R15+R16F
GTO 37F	GSB "FRM" F	52:
36:	16:	IF R(R11+R6+1) <.
R8+4+R8;GTO 34F	200+R6;R28*24+R2	01;GTO 55F
37:	5;R199+R23F	53:
R8+4+R8F	17:	PLT R10,R1R11+R6
38:	GSB "IND" F	1+R23;PLT R10,R(
LTR R8-.39,-.04X	18:	R11+R6+2)+R23;
,321;FXD 0;PLT R	GSB "DAT" F	PEN ;R15+1+R15F

WASTEWATER FLOW - PLOT AND CALCULATIONS

```

54: R12+R(R11+R6+1)* LTR 17,X,321;
R23+R12;R16+R(R1 FXD 3;PLT R13*1E
1+R6+1)*R23/R(R8 -6;
+520)+R16; FLT 70:
55: R10+.5+R10;R11+3 FLT ;LTR 1,.96X,
+R11;R8+1+R8; 321;PLT "AVG LOA
56: IF R10>23.5;GTO DING (LBS/MAN-DA
58; LTR 17,.96X,321; Y)";FLT F
57: FXD 4;PLT R14*1E 71:
GTO 52; -6;FLT F LTR 17,.96X,321;
58: RET F 72:
U+R8+R9+R10+R11; RET F
59: IF R(R11+R6+1)<. 73:
01;GTO 61; "VAX";LTR -3.3,.
60: PLT R10,R(R11+R6 25X,332;
+1)*R23; 74:
61: PLT "SUSP SOL (M G/L)"F
R10+.5+R10;R11+3 RET F
+R11;R8+1+R8; 75:
62: IF R10>23.5;GTO RET F
64; "FAT1";LTR 7.0,1
63: GTO 59; .04X,321;PLT "SA
64: R12+R25*8.34/R15 NITARY"
+R13; 77:
65: R16*8.34*R25/R15 RET F
+R14; 78:
66: RET F "FAT2";LTR 7.5,1
67: "DAT";LTR 1,1.04 .04X,321;PLT "TU
X,321;PLT "WHITE RBID"
SAGE D 79:
OCKSIDE 11-17 AU RET F
G 75" 80:
68: LTR 1,X,321;PLT "FAT3";LTR 7.5,1
LTR 1,X,321;PLT .04X,321;PLT "GR
"AVG TOTAL LOADI LLEY"
NG (LBS/DAY)"; 81:
FLT F RET F
69: 82:
END F
Σ2490
R1186

```

WATER FLOW - SALT AND FRESH - CREW SIZE PLOTS

2:	GSB "LUN" F	39:
3:	15:	FLT ;IF R8>7.5;
4:	GSB "DAT" F	GTO 41 F
5:	20:	40:
6:	GSB "VAX1" F	R8+4+R8;GTO 38 F
7:	21:	41:
8:	STP F	R8+4+R8 F
9:	22:	42:
10:	ENT "ENT R6 FD",	LTR R8-.39,-.04X
11:	R6;GSB "FRM" F	,321;FXD 0;PLT R
12:	23:	8 F
13:	GSB "IND" F	43:
14:	24:	FLT ;IF R8>21;
15:	GSB "DAT" F	GTO 45 F
16:	25:	44:
17:	GSB "VAX2" F	GTO 41 F
18:	26:	45:
19:	STP F	LTR 9.6,-.08X,32
20:	27:	1;PLT "TIME (HOU
21:	GSB "FRM" F	RS)" F
22:	28:	46:
23:	GSB "CUM" F	0+R8 F
24:	29:	47:
25:	GSB "DAT" F	LTR -.8,R8-.008X
26:	30:	,321;FXD 0;PLT R
27:	GSB "VAX2" F	8;FLT F
28:	31:	48:
29:	STP F	R8+.2X+R8 F
30:	32:	49:
31:	GTO 113 F	FLT ;IF R8>A*X+.05;GTO 51 F
32:	33:	50:
33:	"FRM";ENT "Y=",X	LTR -.5Y-.3,R8-.008X,321;FXD 0;
34:	F	PLT R8;FLT ;GTO
35:	ENT "Y MULT 1 ="	48 F
36:	,Y;ENT "Y MULT 2	51:
37:	=",Z;ENT "ENT S	LTR -.5Z-.3,R8-.008X,321;FXD 0;
38:	W=",AF	PLT R8;R8+.2X+R8
39:	35:	F
40:	SCL -3.9,24.7,-.	52:
41:	09X,1.09X F	FLT ;IF R8>X+.05
42:	36:	;GTO 54 F
43:	AXE 0,0,2,.1X F	53:
44:	37:	GTO 51 F
45:	0+R8 F	54:
46:	38:	RET F
47:	LTR R8-.192,-.04	55:
48:	X,321;FXD 0;PLT	
49:	R8 F	

WATER FLOW - SALT AND FRESH - CREW SIZE PLOTS

"IND";0+R8+R9+R1	GTO 65F	88:
0+R11+R12+R13+R1	72:	R15+R(R11+R6)*R9
4+R15+R16F	R12/24+R13F	+R15F
56:	73:	89:
IF R7<.1;1+R9;	R16+R14F	R16+R(R11+R6+1)*
GTO 58F	74:	R9+R16;R18+R(R11
57:	RET F	+R6+1)/R(R8+R30)
R5/R(R8+R30)+R9F	75:	+R18F
58:	"DAT";LTR 1,1.04	90:
IF R(R11+R6+1)<.01;GTO 61F	X,321;PLT "FIREB	R17+R(R11+R6+2)*
59:	USH" F	R9+R17F
PLT R10,R(R11+R6	76:	91:
1)*R9;PLT R10,R(R	LTR 1,X,321;PLT	PLT R10,R15;PEN
11+R6+2)*R9;PEN	"AVG TOTAL FLOW	;PLT R10,R16;
F	(GAL/HR)";FLT F	PEN ;PLT R10,R17
60:	77:	;PEN F
R12+R(R11+R6+1)*	LTR 14.5,X,321;	92:
R9+R12;R16+R(R11	FXD 2;PLT R13F	R10+1.+R10;R11+3
+R6+1)/R(R8+R30)	78:	+R11;R8+1+R8F
+R16F	FLT ;LTR 1,.96X,	93:
61:	321;PLT "AVG FLO	IF R10>23.5;GTO
R10+1.+R10;R11+3	W (GAL/MAN-DAY)"	95F
+R11;R8+1+R8F	;FLT F	94:
62:	79:	GTO 85F
IF R10>23.5;GTO	LTR 14,.96X,321;	95:
64F	FXD 2;PLT R14;	PLT 0,0;PLT 24,R
63:	FLT F	16;PEN ;R16/24+R
GTO 56F	80:	13;R18+R14F
64:	0+R7F	96:
0+R8+R9+R10+R11F	81:	RET F
65:	LTR 1,.92X,321;	97:
IF R7<.1;1+R9;	PLT " " F	"VAX1";LTR 7.50,
GTO 67F	82:	1.04X,321F
66:	LTR 8,.92X,321;	98:
R5/R(R8+R30)+R9F	FXD 0;PLT " " F	PLT "DOCKSIDE 1
67:	83:	0-14 NOV 75" F
IF R(R11+R6+1)<.01;GTO 69F	RET F	99:
68:	84:	LTR -3.3,.35X,32
PLT R10,R(R11+R6	"CUM";0+R8+R9+R1	2;PLT "SALT WATE
+1)*R9F	0+R11+R12+R15+R1	R FLOW (GAL)" F
69:	6+R17+R18F	100:
R10+1.+R10;R11+3	85:	RET F
+R11;R8+1+R8F	IF R7<.1;1+R9;	101:
70:	GTO 87F	"VAX2";LTR 7.50,
IF R10>23.5;GTO	86:	1.04X,321F
72F	R5/R(R8+R30)+R9F	102:
71:	87:	PLT "DOCKSIDE 1
	IF R(R11+R6+1)+R	0-14 NOV 75" F
	(R11+201)+R(R11+	103:
	361);.01;GTO 92F	LTR -3.3,.35X,32

WATER FLOW - SALT AND FRESH - CREW SIZE PLOTS

2;PLT "FRESH WAT	123:	LTR -3.3,.35X,32
ER FLOW (GAL)"F	ENT "ENT R6 FU",	2;PLT "CREW SIZE
104:	R6;GSB "FRM" F	"F
RET F	124:	143:
105:	GSB "IND" F	STP F
"VAX3";LTR 7.50,	125:	144:
1.04X,321F	GSB "DAT" F	GSB "FRM" F
106:	126:	145:
PLT "UNDERWAY 2	GSB "VAX4" F	0+R8+R9F
-5 NOV 75" F	127:	146:
107:	STP F	PLT R8,R(R9+840)
LTR -3.3,.35X,32	128:	F
2;PLT "SALT WATE	GSB "FRM" F	147:
R FLOW (GAL)"F	129:	R8+.5+R8;R9+1+R9
108:	GSB "CUM" F	F
RET F	130:	148:
109:	GSB "DAT" F	IF R8>23.5;GTO 1
"VAX4";LTR 7.50,	131:	50F
1.04X,321F	GSB "VAX4" F	149:
110:	132:	GTO 146F
PLT "UNDERWAY 2	STP F	150:
-5 NOV 75" F	133:	LTR 1,1.04X,321;
111:	GSB "FRM" F	PLT "FIREBUSH
LTR -3.3,.35X,32	134:	CREW SIZE UNDERM
2;PLT "FRESH WAT	0+R8+R9F	AY 2-5 NOV 75" F
ER FLOW (GAL)"F	135:	151:
112:	PLT R8,R(R9+680)	LTR 1,X,321;PLT
RET F	F	"NORMAL CREW SIZ
113:	136:	E" F
ENT "ENT R6 SU",	R8+.5+R8;R9+1+R9	152:
R6;GSB "FRM" F	F	LTR 11,X,321;
114:	137:	FXD 0;PLT R5;
840+R30;GSB "IND	IF R8>23.5;GTO 1	FLT F
"F	39F	153:
115:	138:	LTR -3.3,.35X,32
GSB "DAT" F	GTO 135F	2;PLT "CREW SIZE
116:	139:	"F
GSB "VAX3" F	LTR 1,1.04X,321;	154:
117:	PLT "FIREBUSH	END F
STP F	CREW SIZE DOCKSI	Σ23743
118:	DE 10-14 NOV 75"	R1003
GSB "FRM" F	F	
119:	140:	
GSB "CUM" F	LTR 1,X,321;PLT	
120:	"NORMAL CREW SIZ	
GSB "DAT" F	E" F	
121:	141:	
GSB "VAX3" F	LTR 11,X,321;	
122:	FXD 0;PLT R5;	
STP F	FLT F	
	142:	

CHEMICAL DATA REGRESSION LINE

```

0: ENT "X SW=",R8F LTR -.025R5*Y-.0
ENT "BOD FILE",R 1+R5,R9-.008X,32
2F SCL -.19R5,1.09R 1;FXD 0;PLT R9;
1: 5,-.09X,1.09XF FLT ;JMP -2F
LDF R2,R200F 22: 38:
2: AXE 0,0,.1R5,.1X LTR -.025R5*Z-.0
ENT "BOD MULT",R F 1+R5,R9-.008X,32
4F 23: 1;FXD 0;PLT R9F
3: 0+R9F 39:
ENT "COD FILE",R 24: FLT ;R9+.2X+R9F
1F LTR R9-.01R5,-.0 40:
4: 4X,321;FXD 0; IF R9>X+.05;JMP
ENT "COD MULT",R PLT R9;FLT F 2F
3;ENT "NO DATA P 25: 41:
TS",R14F R9+.2*R5+R9F JMP -3F
5: 26: 42:
LDF R1,R40F IF R9>R8*R5+.05; LTR -.15*R5,.35X
6: JMP 2F ,322;PLT "BOD (M
STP F 27: G/L)"F
7: LTR R9-.012*R6*R 43:
GSB "FRMN" F 5,-.04X;FXD 0; RET F
8: PLT R9;FLT ;JMP 44:
STP F -2F "CALC" F
9: 28: 45:
GSB "CALC" F LTR R9-.012*R7*R 0+R8+R9+R10+R11+
10: 5,-.04X,321;FXD R12+R13+R15+R16+
STP F 0;PLT R9F R17+R18F
11: 29: 46:
GSB "HDG" F FLT ;R9+.2*R5+R9 IF R(R15+41)*R3+
12: F R(R15+201)*R4<.0
STP F 30: 1;JMP 7F
13: IF R9>R5+.05; 47:
GSB "DATA" F JMP 2F LTR R(R15+41)*R3
14: 31: ,R(R15+201)*R4,1
GTO 71F JMP -3F 11;PLT "X";PEN F
15: 32: 48:
"FRMN";ENT "Y=", LTR .41*R5,-.08X R8+R(R15+41)*R3+
XF ,321;PLT "COD (M R8;FXD 3;PRT R(R
16: G/L)" F 15+41);FLT F
ENT "Y MULT 1=", 33: 49:
Y;ENT "Y MULT 2=" 0+R9F R9+R(R15+201)*R4
",Z F 34: +R9;FXD 3;PRT R(
17: LTR -.03R5,R9-.0 R15+201);FLT ;
ENT "Y SW=",R F 08X,321;FXD 0; SPC 1F
18: PLT R9;FLT F 50:
ENT "X=",R5F 35: R10+R(R15+41)*R(
19: R9+.2X+R9F R15+201)*R3*R4+R
ENT "X MULT 1=", 36: 10F
R6;ENT "X MULT 2 51:
=",R7F IF R9>A*X+.05; R11+(R3+R(R15+41
20: JMP 2F ))+2+R11F
37:

```

CHEMICAL DATA REGRESSION LINE

```

52:      R12+(R4+R(R15+20
1))†2+R12;R13+1†
R13†
53:      R15+3+R15†
54:      IF R13+1>R14;
JMP 2†
55:      JMP -9†
56:      (R10-R8+R9/R13)/
(R11-R8†2/R13)+R
16†
57:      R9/R13-R16+R8/R1
3+R17†
58:      (R10-R8+R9/R13)†
2/((R11-R8†2/R13
)*(R12-R9†2/R13)
)+R18†
59:      PLT 0;R17;PLT R5
;R17+R16+R5†
60:      RET †
61:      "HDG";LTR .05*R5
;1.04X;321†
62:
PLT "CALLATIN S
ANITARY DOCKSID
E 21-25 SEPT 75"
†
63:      RET †
64:      "DATA";LTR .05*R
5;.99X;321†
65:      PLT "A ";LTR .09
5*R5;.99X;321;
FXD 3;PLT R16†
66:      LTR .30*R5;.99X;
321;PLT "B "†
67:      LTR .36*R5;.99X;
321;PLT R17†
68:      LTR .05*R5;.94X;
321;PLT "CORREL.
COEFF. "†
69:      LTR .42*R5;.94X;
321;PLT R18;FLT
†
70:      RET †
71:      END †
223321
R1208

```

APPENDIX C

Laboratory Reports

of

**Analyses Performed On
Coast Guard Vessels
March through November, 1975**

UNITED STATES COAST GUARD CONTRACT

DOT - CG 41342-A

SURVEY, ANALYSIS AND EVALUATION OF DOMESTIC

WASTEWATERS ON COAST GUARD VESSELS



H2M CORP. / Environmental Engineers & Scientists

HOLZMACHER, McLENDON & MURRELL

500 BROAD HOLLOW ROAD, MELVILLE, NEW YORK 11746 (516) MY 4-3043

WATER RESOURCES • WATER SUPPLY & TREATMENT • SEWERAGE & TREATMENT
AQUATIC & MARINE ECOLOGY • MODEL STUDIES • PILOT PLANT STUDIES
WATER/WASTE WATER LABORATORY AND ANALYTICAL SERVICES

LABORATORY REPORT

Lab. No. 501565	Date Collected 3/24/75	Date Received 3/24/75
Premises of Sampling Point U.S.C.G. Station	Client United States Coast Guard	
Address Pt. Herron, Fire Island, New York		
Point of Collection Galley Sink Aboard - U.S.C.G. - Pt. Herron		
Type Wastewater: Potable Water		

Lab. No.	501565	Spiked With	Concentration in spike
Iron	.50 mg/l	.10 mg/l	.60 mg/l
Manganese	.05 mg/l	.10 mg/l	.15 mg/l
Copper	0.06 mg/l	.10 mg/l	.16 mg/l
Zinc	1.56 mg/l	1.0 mg/l	2.56 mg/l

Samples collected by:

REMARKS:

**Water run 1 min. before sampling
Source was ship's potable water
storage tank.**

RZ for S.C. McLendon
S. C. McLENDON, P.E., Director
Sanitary Engineer

4/4/75

Date Reported



H2M CORP. / Environmental Engineers & Scientists

HOLZMACHER, McLENDON & MURRELL

500 BROAD HOLLOW ROAD, MELVILLE, NEW YORK 11746 (516) NY 4 1 1 1

WATER RESOURCES • WATER SUPPLY & TREATMENT • SEWERAGE & TREATMENT

AQUATIC & MARINE ECOLOGY • MODEL STUDIES • PILOT PLANT STUDIES

WASTE/WASTEWATER LABORATORY AND ANALYTICAL SERVICES

LABORATORY REPORT Contract No. DOT-CG-41342A

Lab. No.	Date Collected	Date Received
Premises of Sampling Point	Client	
Address		
Point of Collection		
Type Wastewater:		

Lab. No.	Time of Collection	BOD	COD	Total Solids	Susp. Solids	pH	Oil & Grease	MBAS
<u>1st Period, Starting Noon, Monday 24 Mar 75</u>								
501596	2130	215.	325.	442.	71.	6.8	87.	72.
501598	1040	193.	240.	490.	69.	8.6	53.	6.
501599	1041	165.	226.	240.	60.	7.3	41.	<.04
<u>2nd Period, Starting Noon, Tuesday 25 Mar 75</u>								
501610	1500	210.	300.	830.	197.	8.3	81.	<.04
501609	2015	456.	504.	240.	102.	6.5	90.	<.21
501627	0400	265.	246.	180.	49.	6.6	52.	2.
501633	0813	325.	311.	360.	38.	6.7	79.	10.6
501634	0814	145.	141.	150.	24.	6.6	6.	2.6
501635	0815	226.	236.	1024.	55.	6.4	61.	58.
<u>Ending Noon, Wednesday 26 Mar 75</u>								

All units mg/l except pH

Samples collected by: SCW, DAM, BSK

REMARKS:

S. C. McLendon
 S. C. McLENDON, P.E., Director
 Sanitary Engineer

Date Reported



H2M CORP. / Environmental Engineers & Scientists

HOLZMACHER, McLENDON & MURRELL

100 WEST 17TH STREET, NEW YORK, NEW YORK 10011

WATER SUPPLY & TREATMENT • SEWERAGE & TREATMENT

INDUSTRIAL WASTE • POTENTIAL STUDIES • PILOT PLANT

ADVANCED WATER LABORATORY AND ANALYTICAL SERVICES

LABORATORY REPORT Contract No. DOT-CG-41342A

Lab. No.	Date Collected	24-26 Mar75	Date Received	24-26 Mar75
Premises of Sampling Point	Pt. Herron	Client	U.S. Coast Guard	
Address	Fire Island Coast Guard Station, New York			
Point of Collection	Bathroom			
Type Wastewater:	Raw Sanitary Wastewater			

Lab. No.	Time of Collection	BOD	COD	Total Solids	Susp. Solids	pH	Chlorides Cl-
<u>1st Period, Starting Noon, Monday 24 Mar 75</u>							
501591	2000	1050.	2610.	31,881.	158.	6.5	14,700.
501597	0740	2150.	3276.	28,988.	166.	6.5	17,700.
501600	1055	6380.	17520.	40,210.	11,440.	8.6	17,900.
<u>2nd Period, Starting Noon Tuesday 25 Mar 75</u>							
501607	2000	14500.	18960.	41,040.	17,700.	8.3	16,700.
501637	1137	5820.	11148.	38,060.	7,740.	8.1	16,800.
<u>Ending Noon, Wednesday 26 Mar 75</u>							

All units mg/l except pH

Samples collected by: SCW, DAM, BSK

REMARKS:

 S. C. McLENDON, P.E., Director
 Sanitary Engineer

Date Reported



H2M CORP. / Environmental Engineers & Scientists

HOLZMACHER, McLENDON & MURRELL

100 FORT BELLEVILLE ROAD, MELVILLE, NEW YORK 11746 (516) 431-1100

WATER SUPPLY • WATER SUPPLY & TREATMENT • SEWERAGE & TREATMENT
WASTEWATER TREATMENT • MODEL STUDIES • PILOT PLANT STUDIES
WASTEWATER LABORATORY AND ANALYTICAL SERVICES

LABORATORY REPORT Contract No. DOT-CG-41342A

Lab. No.	Date Collected 24-26 Mar 75	Date Received 24-26 Mar 75
Premises of Sampling Point Pt. Herron	Client U.S. Coast Guard	
Address Fire Island Coast Guard Station, New York		
Point of Collection Galley		
Type Wastewater: Raw Galley Waste Water		

Lab. No.	Time of Collection	BOD	COD	Total Solids	Susp. Solids	pH	Oil & Grease	MBAS
----------	--------------------	-----	-----	--------------	--------------	----	--------------	------

1st Period, Starting Noon, Monday 24 Mar 75

501592	1225	1700.	5120.	152.	532.	5.8	293.	208.
501593	2000	960.	1590.	1116.	72.	6.6	71.	74.
501594	0400	920.	1370.	705.	171.	6.7	231.	64.
501601	1115	4610.	8640.	4540.	1180.	5.6	1735.	64.

2nd Period, Starting Noon, Tuesday 25 Mar 75

501611	1210	8640.	11820.	4440.	1924.	5.9	340.	28.
501612	1210	636.	602.	280.	124.	6.6	340.	140.
501608	2000	698.	823.	588.	460.	6.0	306.	7.
501595	2315	2950.	5220.	2440.	508.	6.3	439.	96.
501631	0500	3800.	7956.	3320.	844.	5.3	2250.	960.
501632	0503	1268.	3432.	1460.	608.	6.3	871.	170.
501636	0830	4150.	4944.	2772.	662.	5.5	1280.	70.
501638	1200	5500.	9552.	3470.	2858.	6.3	2170.	201.
501639	1201	2800.	2856.	1230.	835.	6.2	1080.	40.
501640	1202	465.	1428.	200.	96.	6.4	295.	14.

Ending Noon, Wednesday 26 Mar 75

All units mg/l except pH

Samples collected by: **SCW, DAM, BSK**

REMARKS:

 S. C. McLENDON, P.E., Director
 Sanitary Engineer

Date Reported



H2M CORP. / Environmental Engineers & Scientists

HOLZMACHER, McLENDON & MURRELL

500 BROAD HOLLOW ROAD, MELVILLE, NEW YORK 11746 (516) MY 4-3043

WATER RESOURCES • WATER SUPPLY & TREATMENT • SEWERAGE & TREATMENT
AQUATIC & MARINE ECOLOGY • MODEL STUDIES • PILOT PLANT STUDIES
WATER/WASTE WATER LABORATORY AND ANALYTICAL SERVICES

LABORATORY REPORT

Lab. No. 503513, 503526	Date Collected 6/21/75 6/22/75	Date Received 6/22/75 6/23/75
Premises of Sampling Point U.S.C.G. Station	Client United States Coast Guard	
Address Pt. Herron, Fire Island, New York		
Point of Collection Galley Sink Aboard - U.S.C.G. Pt. Herron		
Type Wastewater: Potable Water		

<u>DATE</u>	<u>6/21/75</u>	<u>6/22/75</u>
<u>LAB NO.</u>	503513	503526
Iron	0.84 mg/l	0.70 mg/l
Manganese	0.12 mg/l	0.10 mg/l
Copper	0.13 mg/l	0.13 mg/l
Zinc	2.40 mg/l	2.30 mg/l
Magnesium	4.90 mg/l as CaCO ₃	6.00 mg/l as CaCO ₃
Calcium	1.70 mg/l as CaCO ₃	5.10 mg/l as CaCO ₃
Hardness	6.60 mg/l as CaCO ₃	11.10 mg/l as CaCO ₃

Samples collected by: **DAM, WET**

REMARKS:

Water run 1 min. before sampling
Source was ship's potable water
storage tank.

RZ for S.C. McLendon
S. C. McLENDON, P.E., Director
Sanitary Engineer

6/30/75
Date Reported



H2M CORP. / Environmental Engineers & Scientists

HOLZMACHER, McLENDON & MURRELL

500 BROAD HOLLOW ROAD, MELVILLE, NEW YORK 11746 (516) MY 4-3043

WATER RESOURCES • WATER SUPPLY & TREATMENT • SEWERAGE & TREATMENT
AQUATIC & MARINE ECOLOGY • MODEL STUDIES • PILOT PLANT STUDIES
WATER/WASTE WATER LABORATORY AND ANALYTICAL SERVICES

LABORATORY REPORT Contract No. DOT-CG-41342A

Lab. No.	Date Collected 21-22 June 75	Date Received 21-23 June 75
Premises of Sampling Point Pt. Herron	Client U.S. Coast Guard	
Address Fire Island Coast Guard Station, New York		
Point of Collection Bathroom		
Type Wastewater: Raw Turbid Wastewater		

Lab. No.	Time of Collection	COD	Total Solids	Susp. Solids	pH	Oil & Grease	MBAS	Hardness
<u>1st Period, Starting Midnight Friday 20 June 75</u>								
503506	0950	623	201	166.	7.9	115.	0.3	9.6
503507	0950	395	199	125.	7.0	104.	13.6	11.1
<u>2nd Period, Starting Midnight Saturday 21 June 75</u>								
503512	0600	26	97	59.	6.4	18.1	0.3	7.7
503516	1015	58	10	6.	7.6	13.4	.18	6.8
503519	1230	216	35	23.	7.2	2,568.9	<.04	7.9
503524	2400	46	47	4.	6.9	5.2	<.04	7.5

Ending Midnight Sunday 22 June 75

All Units mg/l except pH
Hardness as CaCO₃

Samples collected by: SCW, DAM, WRS, WET

REMARKS:

R2 for S.C. McLendon
S. C. McLENDON, P.E., Director
Sanitary Engineer

6/30/75
Date Reported



H2M CORP. / Environmental Engineers & Scientists

HOLZMACHER, McLENDON & MURRELL

500 BROAD HOLLOW ROAD, MELVILLE, NEW YORK 11746 (516) MY 4-3043

WATER RESOURCES • WATER SUPPLY & TREATMENT • SEWERAGE & TREATMENT
AQUATIC & MARINE ECOLOGY • MODEL STUDIES • PILOT PLANT STUDIES
WATER/WASTE WATER LABORATORY AND ANALYTICAL SERVICES

LABORATORY REPORT

Contract No. DOT-CG-41342A

Lab. No.	Date Collected	Date Received
Premises of Sampling Point	Client	
Address		
Point of Collection		
Type Wastewater:		

Lab.No.	Time of Collection	COD	Total Solids	Susp. Solids	pH	Chlorides Cl ⁻
---------	--------------------	-----	--------------	--------------	----	---------------------------

1st Period, Starting Midnight, Friday 20 June 75

503504	0515	10,800.	34,300	3930	7.0	14,900
503508	1400	4,650.	36,200	207	7.0	13,600
503509	2000	3,900.	37,700	358	7.1	18,000

2nd Period, Starting Midnight, Saturday, 21 June 75

503511	0330	3,990.	31,500	271	5.7	14,200
503517	1200	2,890.	35,200	1650	6.4	15,600
503520	1830	7,100.	38,500	3470	7.1	16,000
503525	2400	2,740.	34,100	84	5.9	15,500

Ending Midnight, Sunday 22 June 75

All units mg/l except pH

Samples collected by: SCW, DAM, WRS, WET

REMARKS:

S.C. for S.C. McLendon
S. C. McLENDON, P.E., Director
Sanitary Engineer

6/30/75
Date Reported

C-7



H2M CORP. / Environmental Engineers & Scientists

HOLZMACHER, McLENDON & MURRELL

500 BROAD HOLLOW ROAD, MELVILLE, NEW YORK 11746 (516) MY 4-3043

WATER RESOURCES • WATER SUPPLY & TREATMENT • SEWERAGE & TREATMENT
AQUATIC & MARINE ECOLOGY • MODEL STUDIES • PILOT PLANT STUDIES
WATER/WASTE WATER LABORATORY AND ANALYTICAL SERVICES

LABORATORY REPORT Contract No. DOT-CG-41342A

Lab. No.	Date Collected	Date Received
Premises of Sampling Point Pt. Herron	Client U.S. Coast Guard	
Address Fire Island Coast Guard Station, New York		
Point of Collection Galley		
Type Wastewater: Raw Galley Waste Water		

Lab.No.	Time of Collection	COD	Total Solids	Susp. Solids	pH	Oil & Grease	MBAS
---------	--------------------	-----	--------------	--------------	----	--------------	------

1st Period, Starting Midnight Friday 20 June 75

503505	0810	1050	674	13.5	5.9	86.	34.
503510	2030	1800	1,430	43.5	5.4	2140.	2.9

2nd Period, Starting Midnight - Saturday 21 June 75

503514	0930	4720.	12,800.	805.	6.8	867.	210.
503515	0950	3200.	1,800.	549.	7.6	820.	236.
503518	1200	5190.	3,050.	554.	6.7	546.	560.
503521	1900	1230.	1,090.	860.	7.1	2887.2	6.7
503522	2045	2960.	1,130.	396.	5.8	470.	118.
503523	2345	5140.	3,210.	1300.	5.1	2580.	222.

Ending Midnight Sunday 22 June 75

All units mg/l except pH

Samples collected by: SCW, DAM, WRS, WET

REMARKS:

R.L. for S.C. McLendon
 S. C. McLENDON, P.E., Director
 Sanitary Engineer

6/20/75

Date Reported

C-8



H2M CORP. / Environmental Engineers & Scientists

HOLZMACHER, McLENDON & MURRELL

500 BROAD HOLLOW ROAD, MELVILLE, NEW YORK 11746 (516) MY 4-3043

WATER RESOURCES • WATER SUPPLY & TREATMENT • SEWERAGE & TREATMENT

AQUATIC & MARINE ECOLOGY • MODEL STUDIES • PILOT PLANT STUDIES

WATER/WASTE WATER LABORATORY AND ANALYTICAL SERVICES

LABORATORY REPORT Contract# DOT-CG-41342A

Lab. No.	Date Collected 13, 17 Aug 75	Date Received 14, 18 Aug 75
Premises of Sampling Point White Sage	Client U.S. Coast Guard	
Address Woods Hole Coast Guard Station, Mass.		
Point of Collection Engine Room		
Type Wastewater: Potable Water		

<u>LAB NO.</u>	<u>DATE</u>	<u>TIME OF COLLECTION</u>	<u>IRON</u>	<u>COPPER</u>	<u>MANGANESE</u>	<u>ZINC</u>	<u>HARDNESS</u>
504691	8/13	7:30 PM	0.31	0.44	.02	.35	6.5 mg/l
504809	8/17	3:50 AM	.22	0.78	.03	.48	8.6 mg/l

Samples collected by: **H 2 M Corp.**

REMARKS:

 S. C. McLENDON, P.E., Director
 Sanitary Engineer

8/29/75
 Date Reported

C-9



H2M CORP. / Environmental Engineers & Scientists

HOLZMACHER, McLENDON & MURRELL

500 BROAD HOLLOW ROAD, MELVILLE, NEW YORK 11746 (516) MY 4-3043

WATER RESOURCES • WATER SUPPLY & TREATMENT • SEWERAGE & TREATMENT
AQUATIC & MARINE ECOLOGY • MODEL STUDIES • PILOT PLANT STUDIES
WATER/WASTE WATER LABORATORY AND ANALYTICAL SERVICES

LABORATORY REPORT Contract # DOT-CG-41342A

Lab. No.	Date Collected 11-14 Aug 75	Date Received 13-14 Aug 75
Premises of Sampling Point White Sage	Client U.S. Coast Guard	
Address Woods Hole Coast Guard Station, Mass.		
Point of Collection Engine Room		
Type Wastewater: Raw Turbid Wastewater, Underway		

LAB#	DATE	TIME OF COLLECTION	pH	COD	TOTAL SOLIDS	SUSP. SOLIDS	MBAS	OIL & GREASE	HARDNESS
504598	8/11	4:45 PM	7.2	480	210	62	0.36	123	15.7
504599	8/11	7:50 PM	7.3	358	180	32	0.45	13	15.7
504600	8/11	8:15 PM	7.8	331	325	133	4.6	146	17.2
504601	8/11	9:00 PM	5.5	140	148	41.5	6.2	78	9.9
504602	8/11	10:15 PM	7.0	96	87	35.5	2.8	66	12.5
504603	8/12	12:30 AM	9.5	366	259	51.5	20.2	112	13.7
504604	8/12	4:05 AM	6.4	17	100	21.5	8.3	83	12.9
504605	8/12	6:35 AM	5.3	<15	93.5	20	0.8	79	12.1
504606	8/12	9:20 AM	8.8	253	428	71	46	87	13.5
504607	8/12	11:15 AM	8.4	305	344	47	28	80	13.8
504608	8/12	6:30 PM	5.8	279	181	68	3.2	120	14.6
504609	8/12	8:50 PM	6.5	122	102	42	0.68	78	14.7
504610	8/12	9:00 PM	6.6	96	115.5	42	10	81	12.9
504679	8/13	3:00 AM	6.8	372	232	102	7.4	61	14.9
504680	8/13	11:40 AM	6.5	294	118	56	1.0	71	14.5
504681	8/13	1:30 PM	6.5	242	128	65	1.0	42	14.0
504682	8/13	2:00 PM	8.1	480	436	131	32	46	23.8
504683	8/13	3:50 PM	7.5	437	560	138	15	113	44.1
504684	8/13	6:15 PM	6.4	160	158	45	1.9	60	18.1
504685	8/13	7:00 PM	6.1	220	250	96	6.7	48	16.7
504686	8/13	7:30 PM	6.2	167	96	52	1.9	93	12.6
504687	8/13	8:30 PM	7.2	276	214	93	4.7	91	20.3
504688	8/13	9:30 PM	7.2	384	262	126	7.3	146	17.0
504689	8/13	10:30 PM	7.2	195	231	66	4.8	79	17.2
504690	8/13	11:15 PM	7.2	234	166	56	1.4	83	15.7
504696	8/14	7:30 AM	6.8	168	143	90	0.64	45	15.3

Samples collected by: H 2 M Corp.

REMARKS:

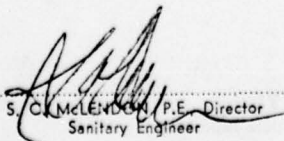
 S. C. McLENDON, P.E. Director
 Sanitary Engineer

8/29/75
 Date Reported



H2M CORP. / Environmental Engineers & Scientists

HOLZMACHER, McLENDON & MURRELL

500 BROAD HOLLOW ROAD, MELVILLE, NEW YORK 11746 (516) MY 4-3043

WATER RESOURCES • WATER SUPPLY & TREATMENT • SEWERAGE & TREATMENT
AQUATIC & MARINE ECOLOGY • MODEL STUDIES • PILOT PLANT STUDIES
WATER/WASTE WATER LABORATORY AND ANALYTICAL SERVICES

LABORATORY REPORT Contract # DOT -CG-41342A

Lab. No.	Date Collected	Date Received
Premises of Sampling Point	White Sage	U.S. Coast Guard
Address	Woods Hole Coast Guard Station, Mass.	
Point of Collection	Engine Room	
Type Wastewater:	Raw Sanitary Wastewater, Underway	

LAB NO.	DATE	TIME OF COLLECTION	COD	TOTAL SOLIDS	SUSP. SOLIDS	pH	CHLORIDES
504575	8/11	7:50 AM	1250	30874	272	7.5	15,500
504576	8/11	10:15 AM	997	29282	260	8.9	16,750
504577	8/11	11:00 AM	1108	32052	880	8.7	19,750
504578	8/11	3:30 PM	1832	31432	1192	7.9	17,000
504579	8/11	5:45 PM	1986	31792	1660	7.6	18,250
504580	8/11	8:00 PM	1335	30098	602	7.5	17,750
504581	8/12	3:15 AM	1883	29080	1244	8.2	15,500
504582	8/12	7:25 AM	1438	29812	604	7.7	15,750
504583	8/12	8:30 AM	1420	29052	1372	7.7	16,500
504584	8/12	10:45 AM	1883	19968	778	7.7	15,000
504585	8/12	1:00 PM	2020	31296	1056	7.9	19,500
504586	8/12	3:25 PM	1438	30700	1132	8.0	18,750
504587	8/12	5:00 PM	1472	32810	632	7.2	18,250
504692	8/12	9:20 PM	1870	37000	1940	7.8	21,500
504659	8/13	3:00 AM	235	42126	600	8.0	16,500
504660	8/13	6:15 AM	1866	48032	930	6.8	19,000
504661	8/13	8:15 AM	1639	36030	680	7.4	18,500
504662	8/13	10:30 AM	1604	33258	708	7.8	19,500
504663	8/13	12:30 PM	1971	34400	660	7.7	20,500
504664	8/13	2:25 PM	1970	34100	1030	8.0	21,000
504665	8/13	3:50 PM	2200	31000	1070	7.8	19,000
504666	8/13	6:30 PM	1590	32300	1160	7.3	19,000
504667	8/13	7:30 PM	1790	36900	1700	8.6	21,000
504668	8/13	9:30 PM	2090	82400	1720	7.9	20,500
504669	8/14	2:30 AM	3710	40700	4110	8.0	20,500
504693	8/14	7:30 AM	3780	37500	4990	8.3	22,500

Samples collected by: H. 2. M. Corp.

REMARKS:

 S. C. McLENDON, P.E., Director
 Sanitary Engineer

8/29/75
Date Reported

C-11



H2M CORP. / Environmental Engineers & Scientists

HOLZMACHER, McLENDON & MURRELL

500 BROAD HOLLOW ROAD, MELVILLE, NEW YORK 11746 (516) MY 4-3043

WATER RESOURCES • WATER SUPPLY & TREATMENT • SEWERAGE & TREATMENT
AQUATIC & MARINE ECOLOGY • MODEL STUDIES • PILOT PLANT STUDIES
WATER/WASTE WATER LABORATORY AND ANALYTICAL SERVICES

LABORATORY REPORT Contract No. DOT-CG-41342A

Lab. No.	Date Collected 11-14 Aug 75	Date Received 13-14 Aug 75
Premises of Sampling Point White Sage	Client U.S. Coast Guard	
Address Woods Hole Coast Guard Station, Mass.		
Point of Collection Engine Room		
Type Wastewater: Raw Galley Wastewater, Underway		

LAB#	DATE	TIME OF COLLECTION	COD	TOTAL SOLIDS	SUSP. SOLIDS	pH	MBAS	OIL & GREASE
504588	8/11	9:45 AM	1618	718	156	6.3	74	465
504589	8/11	12:30 PM	1780	660	258	6.0	68	342
504590	8/11	5:15 PM	1121	970	522	6.2	57	535
504591	8/11	6:00 PM	1156	672	226	6.8	40	228
504592	8/12	2:45 AM	3236	696	198	6.0	78	345
504593	8/12	8:30 AM	2465	1130	237	5.8	68	298
504594	8/12	11:30 AM	3424	1148	466	5.6	26	136
504595	8/12	12:00 N	1660	1720	514	5.5	28	105
504596	8/12	1:30 PM	1190	607	250	6.5	19	31
504597	8/12	5:25 PM	1543	888	421	5.5	35	431
504694	8/12	9:20 PM	140	135	66	6.8	0.14	96
504695	8/12	10:00 PM	666	611	188	7.3	37	51
504670	8/13	3:00 AM	2110	1790	359	5.2	74	392
504671	8/13	8:00 AM	1110	2160	1050	5.5	24	275
504672	8/13	9:30 AM	584	450	178	7.0	25	162
504673	8/13	12:00 N	1190	1080	242	5.8	34	113
504674	8/13	12:20 PM	358	532	180	5.8	10	140
504675	8/13	12:50 PM	1190	796	244	7.1	28	235
504697	8/13	1:10 PM	1180	606	200	6.6	50	289
504676	8/13	5:35 PM	1690	1210	436	5.8	25	281
504677	8/13	7:30 PM	1860	1170	290	6.4	118	345
504678	8/14	2:30 AM	1680	1050	430	5.5	102	433

Samples collected by: **H 2 M Corp.**

REMARKS:

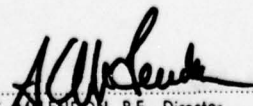
 S. C. McLENDON, P.E., Director
 Sanitary Engineer

8/29/75

Date Reported



H2M CORP. / Environmental Engineers & Scientists

HOLZMACHER, McLENDON & MURRELL

500 BROAD HOLLOW ROAD, MELVILLE, NEW YORK 11746 (516) MY 4-3043

WATER RESOURCES • WATER SUPPLY & TREATMENT • SEWERAGE & TREATMENT
AQUATIC & MARINE ECOLOGY • MODEL STUDIES • PILOT PLANT STUDIES
WATER/WASTE WATER LABORATORY AND ANALYTICAL SERVICES

LABORATORY REPORT Contract No. DOT-CG-41342A

Lab. No.	Date Collected 14-18 Aug 75	Date Received 15-18 Aug 75
Premises of Sampling Point White Sage	Client U.S. Coast Guard	
Address Woods Hole Coast Guard Station, Mass.		
Point of Collection Engine Room		
Type Wastewater: Raw Turbid Wastewater, Dockside		

LAB #	DATE	TIME OF COLLECTION	pH	BOD	COD	TOTAL SOLIDS	SUSP. SOLIDS	MBAS	OIL & GREASE	HARDNESS
504757	8/14	8:30 AM	10.2	144	394	741	86	37	58	17.8
504758	8/14	11:00 AM	8.8	395	839	703	110	40	132	33.2
504759	8/14	12:40 PM	7.6	410	508	599	77	30	45	25.5
504760	8/14	1:00 PM	6.8	176	125	202	28	1.5	26	31.9
504761	8/14	2:45 PM	7.0	203	226	234	34	0.26	61	19.5
504762	8/14	5:45 PM	9.3	1320	2000	1780	338	118	238	36.7
504763	8/14	7:15 PM	8.5	260	562	453	112	26	100	15.3
504764	8/14	10:00 PM	7.8	287	432	159	71	2.4	150	13.7
504765	8/15	3:00 AM	6.5	217	293	162	82	0.3	109	13.6
504766	8/15	10:15 AM	6.6	160	240	131	43	0.9	69	12.5
504793	8/15	11:45 AM	7.2	278	208	152	130	.21	117	13.2
504794	8/15	1:15 PM	9.1	325	897	1480	74	109	83	18.0
504795	8/15	2:30 PM	7.5	220	480	936	40	26	95	56.7
504796	8/15	4:00 PM	8.9	139	198	490	30	17	113	18.5
504797	8/15	5:45 PM	7.2	187	217	142	38	2.5	172	27.4
504798	8/15	7:15 PM	6.7	164	142	60	15	.16	186	12.8
504808	8/16	2:15 AM	6.3	258	378	180	47	.10	127	15.1
504799	8/16	11:30 AM	8.4	1100	340	100	49	2	130	12.5
504800	8/16	5:00 PM	6.7	285	274	232	58	.16	98	30.1
504801	8/16	7:30 PM	6.8	186	217	114	37	2.95	154	12.6
504802	8/17	10:30 AM	6.5	55	283	107	74	0.575	170	14.6
504803	8/17	2:00 PM	6.7	59	227	42	56	0.85	100	14.6
504804	8/17	2:30 PM	6.3	50	179	94	25	0.43	103	12.0
504805	8/17	8:30 PM	7.1	130	359	300	54	11.2	81	24.8
504806	8/17	10:05 PM	7.8	97	274	198	46	17.8	127	13.7
504807	8/18	3:00 AM	7.2	82	283	212	20	12	58	13.8

Samples collected by: H 2 M Corp.

REMARKS:

 S. S. McLENDON, P.E., Director
 Sanitary Engineer

8/29/75

Date Reported



H2M CORP. / Environmental Engineers & Scientists

HOLZMACHER, McLENDON & MURRELL

500 BROAD HOLLOW ROAD, MELVILLE, NEW YORK 11746 (516) MY 4-3043

WATER RESOURCES • WATER SUPPLY & TREATMENT • SEWERAGE & TREATMENT
AQUATIC & MARINE ECOLOGY • MODEL STUDIES • PILOT PLANT STUDIES
WATER/WASTE WATER LABORATORY AND ANALYTICAL SERVICES

LABORATORY REPORT Contract # DOT-CG-41342A

Lab. No.	Date Collected 14-18 Aug 75	Date Received 15-18 Aug 75
Premises of Sampling Point White Sage	Client U. S. Coast Guard	
Address Woods Hole Coast Guard Station, Mass.		
Point of Collection Engine Room		
Type Wastewater: Raw Sanitary Wastewater, Dockside		

<u>LAB NO.</u>	<u>DATE</u>	<u>TIME OF COLLECTION</u>	<u>BOD</u>	<u>COD</u>	<u>TOTAL SOLIDS</u>	<u>SUSP. SOLIDS</u>	<u>PH</u>	<u>CHLORIDES</u>
504743	8/14	9:15 AM	1550	1480	34200	1070	8.2	18500
504744	8/14	11:00 AM	1350	1980	22900	940	8.2	11300
504745	8/14	12:20 PM	860	1130	34500	516	8.0	16800
504746	8/14	2:30 PM	1780	2590	31000	1550	8.0	15300
504747	8/14	5:30 PM	1200	1780	37700	860	8.1	17500
504748	8/14	10:00 PM	1200	2140	32600	1980	7.9	17500
504749	8/15	7:45 AM	1800	2600	33700	4160	8.3	17800
504750	8/15	9:15 AM	1630	2700	27900	1480	8.1	13000
504751	8/15	9:40 AM	650	1390	3610	1240	8.4	14000
504781	8/15	11:45 AM	1200	1490	34400	1650	8.0	16000
504782	8/16	11:30 PM	1140	1340	33400	1690	8.2	16500
504783	8/16	11:30 AM	253	1440	38300	1180	8.4	17500
504784	8/16	6:15 PM	1210	5380	42500	3310	8.3	16800
504785	8/17	8:30 AM	720	2640	41800	2660	8.5	16500
504786	8/17	1:00 PM	330	1090	36200	1170	8.5	18800
504787	8/17	8:00 PM	170	1370	38700	1044	8.5	19500
504780	8/18	3:00 AM	1300	2210	28600	2750	8.4	10500

Samples collected by: **H 2 M Corp.**

REMARKS:

 S.C. McLENDON, P.E., Director
 Sanitary Engineer

8/29/75
 Date Reported

AD-A055 797

H2M CORP MELVILLE NY

F/G 13/10

SURVEY, ANALYSIS AND EVALUATION OF DOMESTIC WASTEWATERS ON COAS--ETC(U)

OCT 76 H D FREUDENTHAL, D A MORAN, C POWERS DOT-CG-41342-A

USCG-D-63-77

NL

UNCLASSIFIED

4 OF 4
ADA
065797

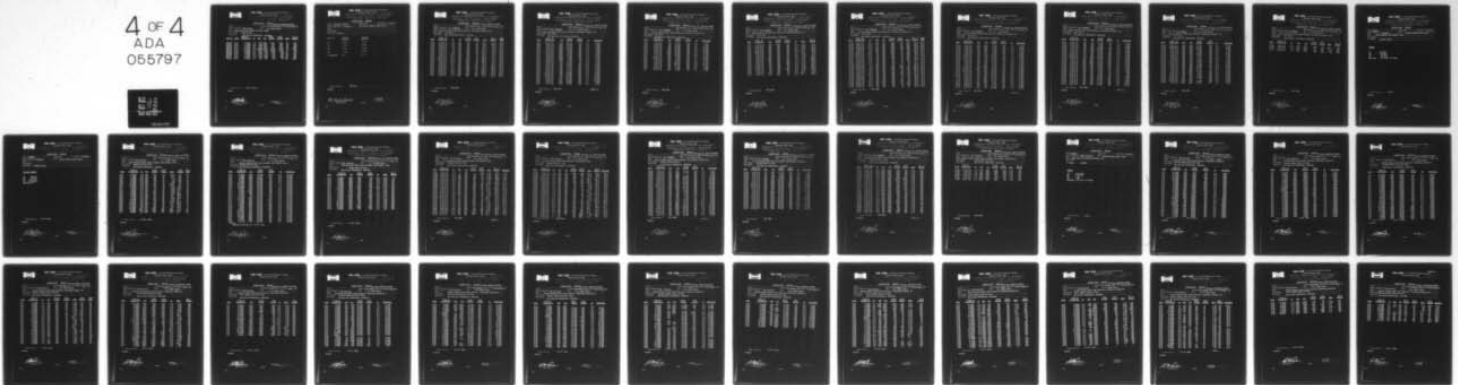

END
DATE
FILMED

8 -78

DDC



H2M CORP. / Environmental Engineers & Scientists

HOLZMACHER, McLENDON & MURRELL

500 BROAD HOLLOW ROAD, MELVILLE, NEW YORK 11746 (516) MY 4-3043

WATER RESOURCES • WATER SUPPLY & TREATMENT • SEWERAGE & TREATMENT
AQUATIC & MARINE ECOLOGY • MODEL STUDIES • PILOT PLANT STUDIES
WATER/WASTE WATER LABORATORY AND ANALYTICAL SERVICES

LABORATORY REPORT

Contract #DOT-CG-41342A

Lab. No.	Date Collected 14-18 Aug 75	Date Received 15-18 Aug 75
Premises of Sampling Point White Sage	Client U.S. Coast Guard	
Address Woods Hole Coast Guard Station, Mass.		
Point of Collection Engine Room		
Type Wastewater: Raw Galley Wastewater, Dockside		

<u>LAB NO.</u>	<u>DATE</u>	<u>TIME OF COLLECTION</u>	<u>pH</u>	<u>BOD</u>	<u>COD</u>	<u>TOTAL SOLIDS</u>	<u>SUSP. SOLIDS</u>	<u>MBAS</u>	<u>OIL & GREASE</u>
504752	8/14	12:45PM	5.7	2700	2930	1220	1120	85	616
504753	8/14	1:40PM	6.2	1570	1490	710	290	47	393
504754	8/14	4:30PM	7.2	1800	1930	732	238	88	496
504755	8/14	10:30PM	6.5	3900	4260	1720	1140	88	1400
504756	8/15	9:30AM	6.0	26000	41900	17000	12100	20	1420
504788	8/15	12:30PM	5.1	6400	9160	25000	2140	11	169
504789	8/16	2:00AM	4.4	1520	3170	1780	640	54	475
504810	8/16	6:30PM	5.7	2375	972	1710	728	113	243
504790	8/17	4:30AM	4.5	1750	2040	860	352	60	363
504791	8/17	6:00PM	4.8	1300	2550	1300	280	101	385
504792	8/18	3:00AM	4.7	880	222	268	62	491	2100

Samples collected by: **H 2 M Corp.**

REMARKS:

 S. C. McLENDON, P.E., Director
 Sanitary Engineer

8/29/75

Date Reported

C-15



H2M CORP. / Environmental Engineers & Scientists

HOLZMACHER, McLENDON & MURRELL

500 BROAD HOLLOW ROAD, MELVILLE, NEW YORK 11746 (516) MY 4-3043

WATER RESOURCES • WATER SUPPLY & TREATMENT • SEWERAGE & TREATMENT
AQUATIC & MARINE ECOLOGY • MODEL STUDIES • PILOT PLANT STUDIES
WATER/WASTE WATER LABORATORY AND ANALYTICAL SERVICES

LABORATORY REPORT

Lab. No. 507132 & 507133	Date Collected	Date Received 11/17/75
Premises of Sampling Point Firebush	Client United States Coast Guard	
Address		
Point of Collection		
Type Wastewater: Potable		

Lab. No.	507132 Underway	507133 Dockside
Cu	0.09	0.11
Fe	0.32	0.28
Mn	0.04	0.04
Zn	1.03	0.91
= Hardness	17.6	17.7

Samples collected by: **H2M Corp.**

REMARKS:

RZ for S.C. McLendon
S. C. McLENDON, P.E., Director
Sanitary Engineer

11/28/75

Date Reported

C-16



H2M CORP. / Environmental Engineers & Scientists

HOLZMACHER, McLENDON & MURRELL

500 BROAD HOLLOW ROAD, MELVILLE, NEW YORK 11746 (516) MY 4-3043

WATER RESOURCES • WATER SUPPLY & TREATMENT • SEWERAGE & TREATMENT
AQUATIC & MARINE ECOLOGY • MODEL STUDIES • PILOT PLANT STUDIES
WATER/WASTE WATER LABORATORY AND ANALYTICAL SERVICES

LABORATORY REPORT Contract #DOT-CG-41342A

Lab. No.	Date Collected 2-5 Nov. 75	Date Received 3-5 Nov. 75
Premises of Sampling Point CGC FIREBUSH	Client U.S. Coast Guard	
Address United States Coast Guard Station, Governors Island, N.Y.		
Point of Collection Bouy Hold		
Type Wastewater: Raw Turbid Wastewater, Underway		

DATE	TIME OF COLLECTION	pH	COD	TOTAL SOLIDS	SUSP. SOLIDS	MBAS	OIL & GREASE	HARDNESS
11/3	8:00 A.M.	10.6	650	720	40	120.0	12.5	14.5
11/3	10:10 A.M.	9.1	920	860	366	84.0	229.0	13.8
11/3	11:00 A.M.	8.8	475	520	133	48.0	86.7	10.5
11/3	5:40 P.M.	9.8	550	919	54	105.0	71.2	11.1
11/3	7:00 P.M.	9.1	735	1060	231	107.0	36.2	16.6
11/3	9:00 P.M.	9.0	750	981	155	107.0	23.8	17.2
11/4	2:00 A.M.	9.6	705	882	113	113.0	15.0	15.3
11/4	5:30 A.M.	10.0	880	1230	92	120.0	33.3	15.0
11/4	8:00 A.M.	10.0	560	384	55	134.0	39.7	12.1
11/4	9:00 A.M.	10.1	660	1100	74	156.0	17.7	13.4
11/4	10:00 A.M.	10.3	325	798	85	108.0	13.0	11.5
11/4	12:15 P.M.	10.6	700	1670	60	239.0	11.0	9.4
11/4	1:45 P.M.	10.4	820	1070	55	195.0	14.5	12.2
11/4	5:30 P.M.	10.0	485	1240	20	125.0	15.0	14.5
11/4	6:35 P.M.	10.1	290	564	787	72.0	11.7	23.5
11/4	8:30 P.M.	9.7	920	1820	1,150	118.0	626.0	15.9
11/5	2:00 A.M.	10.2	455	1330	63	214.0	26.2	11.3
11/5	3:00 A.M.	9.7	1200	1920	910	242.0	700.0	10.5
11/5	9:00 A.M.	10.0	680	958	25	152.0	31.3	13.4
11/5	10:15 A.M.	10.0	375	700	145	100.0	112.0	14.9
11/5	2:30 P.M.	9.9	2900	2330	354	218.0	80.7	37.7
11/5	7:05 P.M.	9.7	990	1910	462	82.0	476.0	22.3

Samples collected by: H2M CORP.

REMARKS:

S. C. McLendon
 S. C. McLENDON, P.E., Director
 Sanitary Engineer



H2M CORP. / Environmental Engineers & Scientists

HOLZMACHER, McLENDON & MURRELL

500 BROAD HOLLOW ROAD, MELVILLE, NEW YORK 11746 (516) MY 4-3043

WATER RESOURCES • WATER SUPPLY & TREATMENT • SEWERAGE & TREATMENT
AQUATIC & MARINE ECOLOGY • MODEL STUDIES • PILOT PLANT STUDIES
WATER/WASTE WATER LABORATORY AND ANALYTICAL SERVICES

LABORATORY REPORT Contract No. DOT-CG-41342A

Lab. No.	Date Collected 2-5 Nov. 75	Date Received 3-5 Nov. 75
Premises of Sampling Point CGC FIREBUSH	Client U.S. Coast Guard	
Address United States Coast Guard Station, Governors Island, N.Y.		
Point of Collection Bouy Hold		
Type Wastewater: Raw Sanitary Wastewater, Underway		

DATE	TIME OF COLLECTION	COD	TOTAL SOLIDS	SUSP. SOLIDS	pH	CHLORIDES
10/2	10:10 P.M.	200	21,300	162	7.5	10,000
10/3	5:30 A.M.	2500	30,160	181	7.2	4,600
10/3	6:00 A.M.	1200	12,700	166	7.2	7,500
10/3	6:45 A.M.	1500	12,400	127	9.1	6,200
10/3	8:15 A.M.	2200	10,800	271	8.7	5,400
10/3	9:45 A.M.	2800	14,500	852	8.4	7,600
10/3	11:00 A.M.	3100	8,500	340	7.6	9,400
10/3	1:30 P.M.	5400	11,004	820	7.4	5,500
10/3	4:00 P.M.	3400	17,432	512	7.4	9,600
10/3	4:45 P.M.	2500	9,938	259	6.8	4,000
10/3	6:00 P.M.	2500	9,452	212	7.1	6,500
10/3	8:00 P.M.	1800	3,636	65	7.4	1,400
10/3	9:00 P.M.	<100	3,704	78	6.8	1,700
10/4	1:30 A.M.	150	14,478	368	6.6	7,800
10/4	6:00 A.M.	<100	18,596	125	6.7	10,200
10/4	7:10 A.M.	620	7,192	339	6.9	4,000
10/4	8:10 A.M.	815	10,704	273	7.0	6,000
10/4	8:45 A.M.	628	9,754	322	6.2	5,400
10/4	9:30 A.M.	625	15,112	316	7.4	7,000
10/4	10:15 A.M.	200	14,382	386	7.9	8,000
10/4	11:45 A.M.	408	20,202	702	7.6	12,500
10/4	12:30 P.M.	853	14,086	454	5.5	9,000
10/4	3:30 P.M.	540	25,108	778	6.7	16,500
10/4	4:30 P.M.	1100	24,738	318	7.1	14,500
10/4	5:15 P.M.	1860	19,922	188	7.7	13,500
10/4	6:15 P.M.	1650	16,284	478	7.1	7,500
10/4	7:10 P.M.	1400	10,522	293	6.2	4,500

Samples collected by: H2M CORP.

(CONT'D.)

REMARKS:

S. C. McLENDON, P.E., Director
Sanitary Engineer



H2M CORP. / Environmental Engineers & Scientists

HOLZMACHER, McLENDON & MURRELL

500 BROAD HOLLOW ROAD, MELVILLE, NEW YORK 11746 (516) MY 4-3043

WATER RESOURCES • WATER SUPPLY & TREATMENT • SEWERAGE & TREATMENT
AQUATIC & MARINE ECOLOGY • MODEL STUDIES • PILOT PLANT STUDIES
WATER/WASTE WATER LABORATORY AND ANALYTICAL SERVICES

LABORATORY REPORT Contract No. DOT-CG-41342A

Lab. No.	Date Collected 2-5 Nov. 75	Date Received 3-5 Nov. 75
Premises of Sampling Point CGC FIREBUSH	Client U.S. Coast Guard	
Address United States Coast Guard Station, Governors Island, N.Y.		
Point of Collection Bouy Hold		
Type Wastewater: Raw Sanitary Wastewater, Underway		

DATE	TIME OF COLLECTION	COD	TOTAL SOLIDS	SUSP. SOLIDS	pH	CHLORIDES
10/4	7:50 P.M.	507	10,150	220	7.3	5,000
10/4	9:30 P.M.	178	14,454	283	8.0	7,400
10/4	10:40 P.M.	350	19,386	638	7.7	10,000
10/5	1:30 A.M.	<200	24,394	321	6.4	12,500
10/5	5:00 A.M.	706	27,580	283	7.5	14,500
10/5	5:45 A.M.	1830	10,926	496	6.3	10,500
10/5	6:35 A.M.	1900	20,320	582	7.8	10,500
10/5	7:25 A.M.	1650	12,238	750	6.6	7,000
10/5	9:10 A.M.	1100	19,500	646	6.9	11,500
10/5	10:20 A.M.	400	6,926	910	7.7	12,500
10/5	11:20 A.M.	620	7,630	470	7.5	5,000
10/5	1:00 P.M.	540	18,832	678	7.4	11,500
10/5	1:45 P.M.	130	11,162	400	7.3	7,000
10/5	3:00 P.M.	261	29,850	910	6.9	19,000
10/5	5:05 P.M.	1120	29,780	888	7.8	16,500
10/5	6:00 P.M.	775	11,158	390	8.0	7,000
10/5	6:45 P.M.	150	9,794	388	7.3	7,500
10/5	8:45 P.M.	<100	8,886	88	7.2	5,000

Samples collected by: H2M CORP.

REMARKS:

S. C. McLENDON, P.E., Director
Sanitary Engineer

C-19



H2M CORP. / Environmental Engineers & Scientists

HOLZMACHER, McLENDON & MURRELL

500 BROAD HOLLOW ROAD, MELVILLE, NEW YORK 11746 (516) MY 4-3043

WATER RESOURCES • WATER SUPPLY & TREATMENT • SEWERAGE & TREATMENT
AQUATIC & MARINE ECOLOGY • MODEL STUDIES • PILOT PLANT STUDIES
WATER/WASTE WATER LABORATORY AND ANALYTICAL SERVICES

LABORATORY REPORT Contract No. DOT-GC-41342A

Lab. No.	Date Collected 2-5 Nov. 75	Date Received 3-5 Nov. 75
Premises of Sampling Point CGC FIREBUSH	Client U.S. Coast Guard	
Address United States Coast Guard Station, Governors Island, N.Y.		
Point of Collection Bouy Hold		
Type Wastewater: Raw Galley Wastewater, Underway		

DATE	TIME OF COLLECTION	COD	TOTAL SOLIDS	SUSP. SOLIDS	pH	MBAS	OIL & GREASE
11/3	7:45 A.M.	608	1240	138	7.2	0.18	73.4
11/3	11:45 A.M.	930	540	154	7.7	0.32	101.0
11/3	12:50 P.M.	933	440	226	6.7	0.40	86.6
11/3	9:30 P.M.	809	460	310	4.8	0.18	48.5
11/4	10:05 A.M.	688	400	188	5.8	13.8	86.2
11/4	12:00 Noon	550	313	170	5.7	9.70	68.5
11/4	2:30 P.M.	256	182	156	5.7	0.87	77.3
11/4	4:30 P.M.	554	298	174	6.6	0.46	70.7
11/4	5:30 P.M.	850	324	215	6.5	7.80	127.0
11/4	8:15 P.M.	1650	570	331	3.9	0.70	148.0
11/5	1:00 A.M.	1440	630	227	4.1	0.72	126.0
11/5	6:00 A.M.	808	548	149	5.0	0.45	58.3
11/5	8:10 A.M.	937	668	228	5.7	0.31	89.0
11/5	9:20 A.M.	758	424	251	5.5	0.44	168.0
11/5	11:30 A.M.	344	290	112	5.9	0.25	101.0
11/5	12:30 P.M.	986	494	256	6.3	0.09	131.0
11/5	1:45 P.M.	787	402	201	6.0	0.19	103.0
11/5	3:15 P.M.	708	480	181	6.0	0.20	71.9
11/5	5:05 P.M.	1410	924	79	9.5	119.	154.0
11/5	5:45 P.M.	1730	1420	205	10.6	53.5	364.0

Samples collected by: H2M CORP.

REMARKS:

 S. C. McLENDON, P.E., Director
 Sanitary Engineer



H2M CORP. / Environmental Engineers & Scientists

HOLZMACHER, McLENDON & MURRELL

500 BROAD HOLLOW ROAD, MELVILLE, NEW YORK 11746 (516) MY 4-3043

WATER RESOURCES • WATER SUPPLY & TREATMENT • SEWERAGE & TREATMENT
AQUATIC & MARINE ECOLOGY • MODEL STUDIES • PILOT PLANT STUDIES
WATER/WASTE WATER LABORATORY AND ANALYTICAL SERVICES

LABORATORY REPORT Contract No. DOT-CG-41342A

Lab. No.	Date Collected 10-14 Nov. 75	Date Received 11-14 Nov. 75
Premises of Sampling Point CGC FIREBUSH	Client U.S. Coast Guard	
Address United States Coast Guard Station, Governors Island, N.Y.		
Point of Collection Bouy Hold		
Type Wastewater: Raw Turbid Wastewater, Dockside		

DATE	TIME OF COLLECTION	pH	BOD	COD	TOTAL SOLIDS	SUSP. SOLIDS	MBAS	OIL & GREASE	HARDNESS
11/10	1:30 P.M.	10.3	490	835	2060	156	280.	49.1	23.3
11/10	2:30 P.M.	10.3	410	750	1500	213	200.	26.9	12.5
11/10	4:30 P.M.	10.2	410	800	1000	66	210.	26.9	12.8
11/10	7:00 P.M.	10.3	610	860	1840	236	230.	49.5	14.1
11/10	9:30 P.M.	10.3	310	745	1300	176	200.	31.2	14.3
11/11	7:30 A.M.	9.5	240	580	1020	81	68.	36.8	13.5
11/11	8:20 A.M.	10.6	510	845	2020	84	236.	28.4	11.5
11/11	10:10 A.M.	10.6	80	235	230	25	320.	18.5	15.6
11/11	10:50 A.M.	10.0	120	260	320	25	180.	19.2	18.8
11/11	3:00 P.M.	10.5	57	505	1060	34	200.	12.7	11.6
11/11	5:15 P.M.	10.0	260	605	1070	30	210.	34.0	61.0
11/11	6:15 P.M.	10.6	150	450	740	68	400.	23.8	19.0
11/11	7:30 P.M.	9.6	82	250	195	30	80.	20.1	13.2
11/11	8:30 P.M.	10.1	180	468	229	38	60.	17.5	15.6
11/12	8:30 A.M.	9.7	240	565	726	44	74.	24.4	14.7
11/12	12:00 Noon	9.2	220	367	380	1360	60.	22.9	15.6
11/12	2:00 P.M.	9.8	250	1650	1530	248	313.	318.0	14.8
11/12	5:00 P.M.	10.3	370	770	1900	38	333.	166.0	20.5
11/12	9:00 P.M.	9.8	410	1430	770	93	76.	52.4	20.7
11/13	4:30 A.M.	10.3	450	790	1230	168	205.	41.6	14.2
11/13	5:35 A.M.	10.4	390	450	838	173	88.	112.0	12.4
11/13	11:30 A.M.	10.4	190	670	1130	118	142.	29.6	17.3
11/13	1:00 P.M.	9.9	450	180	382	47	52.	12.3	14.9
11/13	6:00 P.M.	9.5	160	320	388	89	44.	26.9	14.3
11/13	7:30 P.M.	10.0	210	505	614	105	38.	28.2	14.5
11/13	8:30 P.M.	10.4	390	1000	1440	116	194.	32.3	11.2
11/13	10:30 P.M.	10.3	180	540	760	82	112.	30.6	12.2
11/14	5:30 A.M.	10.4	330	610	986	90	120.	20.6	11.6
11/14	6:30 A.M.	10.1	180	300	514	36	60.	18.4	12.1

Samples collected by: H2M CORP.

REMARKS:

 S. C. McLENDON, P.E., Director
 Sanitary Engineer



H2M CORP. / Environmental Engineers & Scientists

HOLZMACHER, McLENDON & MURRELL

500 BROAD HOLLOW ROAD, MELVILLE, NEW YORK 11746 (516) MY 4-3043

WATER RESOURCES • WATER SUPPLY & TREATMENT • SEWERAGE & TREATMENT
AQUATIC & MARINE ECOLOGY • MODEL STUDIES • PILOT PLANT STUDIES
WATER/WASTE WATER LABORATORY AND ANALYTICAL SERVICES

LABORATORY REPORT Contract No. DOT-CG-41342A

Lab. No.	Date Collected	10-14 Nov. 75	Date Received	11-14 Nov. 75
Premises of Sampling Point	CGC FIREBUSH	Client	U.S. Coast Guard	
Address	United States Coast Guard Station, Governors Island, N.Y.			
Point of Collection	Bouy Hold			
Type Wastewater:	Raw Sanitary Wastewater, Dockside			

DATE	TIME OF COLLECTION	BOD	COD	TOTAL SOLIDS	SUSP. SOLIDS	pH	CHLORIDES
11/10	1:00 P.M.	1500	2730	8,690	470	6.4	4,000
11/10	1:45 P.M.	520	1000	7,930	188	8.1	4,000
11/10	3:00 P.M.	570	1080	11,100	258	6.7	6,000
11/10	4:00 P.M.	620	1830	13,800	454	6.4	9,000
11/10	5:30 P.M.	740	1570	6,920	352	6.9	4,500
11/10	7:00 P.M.	320	780	7,230	136	7.1	4,500
11/10	9:00 P.M.	320	1100	20,100	72	7.3	14,000
11/10	11:30 P.M.	550	628	10,400	328	7.4	7,000
11/11	12:30 A.M.	430	403	10,500	260	7.0	5,000
11/11	5:20 A.M.	330	567	20,100	180	5.7	7,500
11/11	6:10 A.M.	390	1150	14,600	120	5.6	6,750
11/11	7:00 A.M.	380	1730	4,150	84	5.6	1,000
11/11	7:15 A.M.	250	1570	6,090	158	5.7	2,000
11/11	8:30 A.M.	420	1620	12,100	108	5.8	4,500
11/11	10:00 A.M.	520	1280	9,860	180	6.0	4,000
11/11	10:45 A.M.	1000	1870	12,800	376	5.8	5,250
11/11	11:25 A.M.	830	1570	10,100	432	5.7	2,000
11/11	12:30 P.M.	670	1280	12,500	364	5.8	6,000
11/11	1:15 P.M.	620	908	15,600	364	8.0	6,250
11/11	2:00 P.M.	790	1485	16,100	668	6.6	6,500
11/11	3:00 P.M.	620	1490	16,640	244	7.9	6,250
11/11	4:00 P.M.	700	1560	12,110	224	6.7	4,500
11/11	5:00 P.M.	670	1620	13,000	236	6.5	4,750
11/11	5:15 P.M.	690	1410	4,150	200	6.7	1,000
11/11	5:30 P.M.	1100	1580	5,030	140	5.6	1,000
11/11	6:00 P.M.	580	672	7,020	132	6.0	2,500
11/11	7:30 P.M.	480	553	17,500	188	7.0	5,000
11/11	8:00 P.M.	430	501	20,200	136	7.5	5,000

Samples collected by: H2M CORP.

(Cont'd.)

REMARKS:

S. C. McLENDON, P.E., Director
Sanitary Engineer



H2M CORP. / Environmental Engineers & Scientists

HOLZMACHER, McLENDON & MURRELL

500 BROAD HOLLOW ROAD, MELVILLE, NEW YORK 11746 (516) MY 4-3043

WATER RESOURCES • WATER SUPPLY & TREATMENT • SEWERAGE & TREATMENT
AQUATIC & MARINE ECOLOGY • MODEL STUDIES • PILOT PLANT STUDIES
WATER/WASTE WATER LABORATORY AND ANALYTICAL SERVICES

LABORATORY REPORT Contract No. DOT-CG-41342A

Lab. No.	Date Collected 10-14 Nov. 75	Date Received 11-14 Nov. 75
Premises of Sampling Point CGC FIREBUSH	Client U.S. Coast Guard	
Address United States Coast Guard Station, Governors Island, N.Y.		
Point of Collection Bouy Hold		
Type Wastewater: Raw Sanitary Wastewater, Dockside		

DATE	TIME OF COLLECTION	BOD	COD	TOTAL SOLIDS	SUSP. SOLIDS	pH	CHLORIDES
11/11	9:00 P.M.	460	550	12,200	142	7.0	6,500
11/11	11:30 P.M.	450	752	4,790	97	7.1	2,000
11/12	2:00 A.M.	380	755	4,990	78	7.0	5,500
11/12	5:10 A.M.	600	931	15,200	160	7.1	5,500
11/12	6:25 A.M.	140	603	18,800	84	6.6	7,000
11/12	7:10 A.M.	430	1080	17,700	211	6.9	4,500
11/12	8:00 A.M.	460	502	12,500	194	7.2	3,000
11/12	9:00 A.M.	440	671	11,200	453	6.5	5,500
11/12	10:00 A.M.	610	930	13,700	645	7.9	5,500
11/12	10:50 A.M.	470	1230	19,200	351	6.6	6,500
11/12	12:30 P.M.	610	1660	13,800	263	7.6	5,500
11/12	1:00 P.M.	960	1620	16,700	308	6.3	6,750
11/12	1:45 P.M.	1500	1840	9,100	930	6.4	3,250
11/12	2:45 P.M.	1500	2250	18,800	1190	5.2	4,750
11/12	3:30 P.M.	830	624	16,400	385	6.8	6,750
11/12	5:00 P.M.	1300	1000	8,100	450	5.1	2,500
11/12	6:00 P.M.	360	184	12,800	181	6.3	5,250
11/12	6:30 P.M.	950	273	5,170	174	6.4	1,500
11/12	7:30 P.M.	810	271	4,700	61	6.4	1,500
11/12	8:30 P.M.	390	706	3,500	233	6.7	750
11/12	9:15 P.M.	350	550	1,200	64	8.5	250
11/12	12:00 M.N.	370	402	3,900	168	6.7	1,250
11/13	4:30 A.M.	410	<100	16,000	97	6.6	7,250
11/13	6:40 A.M.	440	350	17,600	232	6.7	7,750
11/13	7:30 A.M.	690	754	12,740	251	7.2	5,250
11/13	8:00 A.M.	600	980	11,100	265	6.3	4,750
11/13	8:45 A.M.	670	1080	11,000	520	6.9	4,500
11/13	10:00 A.M.	1270	1730	12,100	768	4.9	4,750

Samples collected by: H2M CORP.

(Cont'd.)

REMARKS:

S. C. McLendon
 S. C. McLENDON, P.E., Director
 Sanitary Engineer



H2M CORP. / Environmental Engineers & Scientists

HOLZMACHER, McLENDON & MURRELL

500 BROAD HOLLOW ROAD, MELVILLE, NEW YORK 11746 (516) MY 4.3043

WATER RESOURCES • WATER SUPPLY & TREATMENT • SEWERAGE & TREATMENT
AQUATIC & MARINE ECOLOGY • MODEL STUDIES • PILOT PLANT STUDIES
WATER/WASTE WATER LABORATORY AND ANALYTICAL SERVICES

LABORATORY REPORT Contract No. DOT-CG-41342A

Lab. No.	Date Collected 10-14 Nov. 75	Date Received 11-14 Nov. 75
Premises of Sampling Point CGC FIREBUSH	Client U.S. Coast Guard	
Address United States Coast Guard Station, Governors Island, N.Y.		
Point of Collection Bouy Hold		
Type Wastewater: Raw Sanitary Wastewater, Dockside		

DATE	TIME OF COLLECTION	BOD	COD	TOTAL SOLIDS	SUSP. SOLIDS	pH	CHLORIDES
11/13	10:45 A.M.	900	1420	11,900	476	5.0	4,000
11/13	11:55 A.M.	680	1070	16,100	305	7.4	8,250
11/13	12:30 P.M.	450	620	20,000	190	7.4	8,250
11/13	1:30 P.M.	1330	752	2,850	222	6.0	750
11/13	2:30 P.M.	710	1090	5,600	414	7.1	2,000
11/13	3:30 P.M.	880	803	14,500	628	6.8	5,750
11/13	4:15 P.M.	590	550	11,200	378	7.5	4,000
11/13	5:00 P.M.	450	350	4,470	264	6.7	1,500
11/13	6:00 P.M.	520	204	1,470	185	6.0	500
11/13	7:00 P.M.	430	151	6,670	263	6.9	2,250
11/13	8:30 P.M.	300	203	13,880	215	7.3	6,000
11/13	10:00 P.M.	390	150	5,110	124	7.1	1,700
11/13	11:30 P.M.	450	620	9,422	147	6.2	4,250
11/14	1:00 A.M.	290	622	2,590	134	6.3	3,750
11/14	5:00 A.M.	230	850	15,500	181	6.8	6,750
11/14	6:30 A.M.	160	930	13,100	143	6.9	5,750
11/14	7:00 A.M.	160	1480	6,150	79	6.7	2,500
11/14	7:45 A.M.	530	1900	11,400	285	6.7	5,000
11/14	8:50 A.M.	640	1230	5,100	434	6.3	2,000
11/14	9:30 A.M.	460	980	3,200	143	6.8	1,250
11/14	10:00 A.M.	790	1740	7,200	568	7.0	2,750
11/14	11:45 A.M.	440	709	13,200	266	6.6	6,750
11/14	12:15 P.M.	1450	1870	36	548	8.1	6,000
11/14	12:45 P.M.	1150	1520	12,132	366	7.1	2,750
11/14	1:30 P.M.	2180	3030	13,200	610	7.5	5,500

Samples collected by: H2M CORP.

REMARKS:

 S. C. McLENDON, P.E., Director
 Sanitary Engineer



H2M CORP. / Environmental Engineers & Scientists

HOLZMACHER, McLENDON & MURRELL

500 BROAD HOLLOW ROAD, MELVILLE, NEW YORK 11746 (516) MY 4-3043

WATER RESOURCES • WATER SUPPLY & TREATMENT • SEWERAGE & TREATMENT
AQUATIC & MARINE ECOLOGY • MODEL STUDIES • PILOT PLANT STUDIES
WATER/WASTE WATER LABORATORY AND ANALYTICAL SERVICES

LABORATORY REPORT Contract No. DOT-CG-41342A

Lab. No.	Date Collected	Date Received
Premises of Sampling Point	CGC FIREBUSH	10-14 Nov. 75
Client	U.S. Coast Guard	
Address	United States Coast Guard Station, Governors Island, N.Y.	
Point of Collection	Bouy Hold	
Type Wastewater:	Raw Galley, Wastewater, Dockside	

<u>DATE</u>	<u>TIME OF COLLECTION</u>	<u>pH</u>	<u>BOD</u>	<u>COD</u>	<u>TOTAL SOLIDS</u>	<u>SUSP. SOLIDS</u>	<u>MBAS</u>	<u>OIL & GREASE</u>
11/11	3:00 P.M.	5.3	1000	2100	1000	226	46.0	189
11/12	6:00 P.M.	5.2	1700	2650	998	356	14.2	254
11/13	3:00 P.M.	4.6	1600	2330	870	344	3.04	208
11/14	12:30 P.M.	5.4	1100	1730	620	222	1.82	138

Samples collected by: H2M CORP.

REMARKS:

 S. C. McLENDON, P.E., Director
 Sanitary Engineer

C-25



H2M CORP. / Environmental Engineers & Scientists

HOLZMACHER, McLENDON & MURRELL

500 BROAD HOLLOW ROAD, MELVILLE, NEW YORK 11746 (516) MY 4-3043

WATER RESOURCES • WATER SUPPLY & TREATMENT • SEWERAGE & TREATMENT
AQUATIC & MARINE ECOLOGY • MODEL STUDIES • PILOT PLANT STUDIES
WATER/WASTE WATER LABORATORY AND ANALYTICAL SERVICES

LABORATORY REPORT

Lab. No. 506238	Date Collected	Date Received 10/9/75
Premises of Sampling Point Vigorous	Client United States Coast Guard	
Address USCG Academy, New London, Conn.		
Point of Collection		
Type water	potable water	

506238

Cu .13 mg/l
 Fe <.02 mg/l
 Mn .04 mg/l
 Zn .20 mg/l
 Hardness 10.7 mg/l as CaCO₃

Samples collected by: **H 2 M**

REMARKS:

 S. E. McLENDON, P.E., Director
 Sanitary Engineer

10/24/75

Date Reported

C-26



H2M CORP. / Environmental Engineers & Scientists

HOLZMACHER, McLENDON & MURRELL

500 BROAD HOLLOW ROAD, MELVILLE, NEW YORK 11746 (516) MY 4-3043

WATER RESOURCES • WATER SUPPLY & TREATMENT • SEWERAGE & TREATMENT
AQUATIC & MARINE ECOLOGY • MODEL STUDIES • PILOT PLANT STUDIES
WATER/WASTE WATER LABORATORY AND ANALYTICAL SERVICES

LABORATORY REPORT

Lab. No. 506606	Date Collected	Date Received 10/24/75
Premises of Sampling Point Vigorous	Client United States Coast Guard	
Address		
Point of Collection		
Type Wastewater: Potable Water		

LAB NO. 506606

Cu .19 mg/l
 Fe .19 mg/l
 Mn <.02 mg/l
 Zn 0.28 mg/l
 Hardness 10

Samples collected by: **H 2 M Corp.**

REMARKS:

 S. C. McLENDON, P.E., Director
 Sanitary Engineer

11/16/75

Date Reported

C-27



H2M CORP. / Environmental Engineers & Scientists

HOLZMACHER, McLENDON & MURRELL

500 BROAD HOLLOW ROAD, MELVILLE, NEW YORK 11746 (516) MY 4-3043

WATER RESOURCES • WATER SUPPLY & TREATMENT • SEWERAGE & TREATMENT
AQUATIC & MARINE ECOLOGY • MODEL STUDIES • PILOT PLANT STUDIES
WATER/WASTE WATER LABORATORY AND ANALYTICAL SERVICES

LABORATORY REPORT Contract #DOT -CG-41342A

Lab. No.	Date Collected 8 Oct. 75	Date Received 8 Oct. 75
Premises of Sampling Point CGC Vigorous	Client U. S. Coast Guard	
Address United States Coast Guard Academy, New London, Conn.		
Point of Collection Sewage Ejection Room		
Type Wastewater: Raw Turbid Wastewater, Underway		

<u>DATE</u>	<u>TIME OF COLLECTION</u>	<u>pH</u>	<u>COD</u>	<u>TOTAL SOLIDS</u>	<u>SUSP SOLIDS</u>	<u>MBAS</u>	<u>OIL & GREASE</u>	<u>HARDNESS</u>
10/6	2:15PM	9.2	800	362	64	15.6	87	14
10/6	3:15PM	6.4	230	124	38	3.07	154	10
10/6	4:45PM	9.6	185	210	53	2.3	166	11
10/6	5:35PM	10.5	200	566	70	.75	112	11
10/6	6:30PM	8.8	225	157	67	.78	267	12
10/6	9:45PM	6.9	205	86	41	0.62	83	11
10/6	11:30PM	8.9	260	287	42	22.6	38	11
10/7	12:45AM	6.8	220	125	39	3.33	187	10
10/7	3:50AM	6.5	215	90	22	0.84	44.8	12
10/7	7:00AM	6.4	125	69	16	0.32	23.2	10
10/7	7:50AM	7.0	225	113	28	0.24	81.0	16
10/7	9:25AM	9.7	310	400	63	0.78	37.7	16
10/7	3:00PM	8.5	320	280	114	1.20	66.1	18
10/8	6:45AM	6.7	230	149	63	3.2	78.5	10
10/8	7:10AM	7.3	325	147	76	2.1	97.4	17
10/8	7:30AM	6.0	295	164	140	2.26	90.8	11
10/8	8:10AM	8.9	405	196	150	1.6	118	13
10/8	9:05AM	6.6	130	80	42	0.28	43.9	8
10/8	10:40AM	7.4	385	336	88	10.5	88.9	15
10/8	11:00AM	6.6	245	141	56	8.5	37.4	6
10/8	11:30AM	9.2	400	534	88	2.7	40.8	11
10/8	11:45AM	9.2	340	436	72	6.4	30.7	8
10/8	12:30PM	10.0	615	7406	196	64.0	71.9	17
10/8	1:30PM	10.0	550	3641	226	22.6	57.2	20
10/3	2:35PM	9.5	660	463	312	21.0	133	26

Samples collected by: H 2 M Corp.

REMARKS:

 S. C. McLENDON, P.E., Director
 Sanitary Engineer



H2M CORP. / Environmental Engineers & Scientists

HOLZMACHER, McLENDON & MURRELL

500 BROAD HOLLOW ROAD, MELVILLE, NEW YORK 11746 (516) MY 4 3043

WATER RESOURCES • WATER SUPPLY & TREATMENT • SEWERAGE & TREATMENT
AQUATIC & MARINE ECOLOGY • MODEL STUDIES • PILOT PLANT STUDIES
WATER/WASTE WATER LABORATORY AND ANALYTICAL SERVICES

LABORATORY REPORT Contract #DOT-CG-41342A

Lab. No.	Date Collected	Date Received
Premises of Sampling Point	Client	
Address		
Point of Collection		
Type Wastewater:		

CGC Vigorous

U. S. Coast Guard

United States Coast Guard Academy, New London, Conn.

Sewage Ejection Room

Raw Sanitary Wastewater, Underway

<u>DATE</u>	<u>TIME OF COLLECTION</u>	<u>COD</u>	<u>TOTAL SOLIDS</u>	<u>SUSP. SOLIDS</u>	<u>pH</u>	<u>CHLORIDES</u>
10/6	3:15PM	3300	32,200	600	8.3	16,000
10/6	4:00PM	3100	38,800	64.9	8.5	16,000
10/6	4:45PM	2600	34,300	570	8.2	17,250
10/6	5:30PM	2300	35,600	447	8.3	16,250
10/6	7:30PM	1100	33,900	450	8.1	16,500
10/6	10:00PM	1040	32,500	476	7.8	18,500
10/6	10:30PM	1040	38,800	456	7.7	18,000
10/6	11:00PM	1040	36,300	395	7.7	17,500
10/7	12:30AM	1260	34,200	506	7.7	16,250
10/7	4:45AM	1560	37,900	427	8.5	16,500
10/7	7:05AM	2240	31,700	388	7.9	16,250
10/7	7:35AM	2200	34,500	402	7.9	16,750
10/7	8:10AM	1900	35,400	399	7.5	16,500
10/7	9:15AM	700	36,200	407	8.4	17,250
10/7	9:10AM	960	33,800	456	7.9	16,750
10/7	10:50AM	2900	37,500	944	7.8	18,250
10/7	11:30AM	1900	35,900	1418	7.9	17,750
10/7	1:30PM	1560	35,100	341	7.8	18,000
10/7	3:15PM	2600	36,400	339	7.4	16,750
10/7	5:30PM	3000	38,200	1221	8.0	18,250
10/8	7:00AM	3600	39,400	528	7.8	18,500
10/8	7:20AM	1000	39,200	430	7.6	18,250
10/8	8:20AM	3100	39,000	1300	7.8	18,250
10/8	10:00AM	1400	29,100	439	7.9	14,750
10/8	10:45AM	2300	33,900	457	7.9	17,750
10/8	11:25AM	3860	32,700	351	7.7	17,250
10/8	12:15PM	5000	34,900	458	7.5	17,500
10/8	12:35PM	5300	37,500	675	7.9	17,000
10/8	1:00PM	2680	32,700	533	8.4	17,250
10/8	2:30PM	2200	38,600	551	7.8	18,250
10/8	3:15 PM	1700	35,000	483	7.9	17,250

REMARKS:

Samples collected by: H 2 M Corp.

 M.C. McLENDON, P.E., Director
 Sanitary Engineer

C-29



H2M CORP. / Environmental Engineers & Scientists

HOLZMACHER, McLENDON & MURRELL

500 BROAD HOLLOW ROAD, MELVILLE, NEW YORK 11746 (516) MY 4-3043

WATER RESOURCES • WATER SUPPLY & TREATMENT • SEWERAGE & TREATMENT

AQUATIC & MARINE ECOLOGY • MODEL STUDIES • PILOT PLANT STUDIES

WATER/WASTE WATER LABORATORY AND ANALYTICAL SERVICES

LABORATORY REPORT Contract No. DOT-CG-41342A

Lab. No.	Date Collected 6-8 Oct. 75	Date Received 8 Oct. 75
Premises of Sampling Point CGC Vigorous	Client U. S. Coast Guard	
Address United States Coast Guard Academy, New London, Conn.		
Point of Collection Sewage Ejection Room		
Type Wastewater: Raw Galley Wastewater, Underway		

<u>DATE</u>	<u>TIME OF COLLECTION</u>	<u>COD</u>	<u>TOTAL SOLIDS</u>	<u>SUSP SOLIDS</u>	<u>pH</u>	<u>MBAS</u>	<u>OIL & GREASE</u>
10/6	2:45PM	5500	1260	309	11.5	0.58	32
10/6	4:00PM	4900	468	136	9.2	0.30	190
10/6	5:00PM	3900	594	378	8.5	0.24	165
10/6	6:05PM	2800	1230	603	7.2	0.15	332
10/6	9:15PM	1000	414	178	6.4	0.36	141
10/7	7:00AM	2000	1060	1000	5.1	0.24	164
10/7	9:30AM	2700	1190	308	10.9	0.44	223
10/7	12:15PM	5300	2250	746	8.6	0.10	464
10/7	2:15PM	3000	862	550	9.1	0.04	210
10/7	4:30PM	5700	4240	1098	4.1	0.28	486
10/7	5:40PM	1500	690	1118	4.8	0.14	213
10/8	6:40AM	11700	2350	296	6.8	0.04	624
10/8	7:45AM	3300	1830	1246	6.9	1.20	110
10/8	8:20AM	3300	1510	848	9.7	0.16	482
10/8	8:45AM	3100	1010	454	9.9	0.06	282
10/8	10:55AM	2200	656	104	9.8	0.28	123
10/8	11:45AM	5800	768	474	5.9	4.85	299
10/8	12:10PM	3400	1810	871	5.7	0.32	500
10/8	12:57PM	5600	2150	1288	5.7	0.18	1082
10/8	1:20PM	7700	2580	1752	6.2	1.76	244
10/8	2:00PM	2400	726	888	6.3	0.54	272

Samples collected by: **H 2 M Corp.**

REMARKS:

 S. C. McLENDON, P.E., Director
 Sanitary Engineer



H2M CORP. / Environmental Engineers & Scientists

HOLZMACHER, McLENDON & MURRELL

500 BROAD HOLLOW ROAD, MELVILLE, NEW YORK 11746 (516) MY 4-3043

WATER RESOURCES • WATER SUPPLY & TREATMENT • SEWERAGE & TREATMENT
AQUATIC & MARINE ECOLOGY • MODEL STUDIES • PILOT PLANT STUDIES
WATER/WASTE WATER LABORATORY AND ANALYTICAL SERVICES

LABORATORY REPORT Contract No. DOT-CG-41342A

Lab. No.	Date Collected 20-24 Oct. 75	Date Received 21-24 Oct. 75
Premises of Sampling Point CGC Vigorous	Client U.S. Coast Guard	
Address United States Coast Guard Academy, New London, Conn.		
Point of Collection Sewage Ejection Room		
Type Wastewater: Raw Turbid Wastewater, Dockside		

DATE	TIME OF COLLECTION	pH	BOD	COD	TOTAL SOLIDS	SUSP. SOLIDS	MBAS	OIL & GREASE	HARDNESS
10/20	1:30 P.M.	6.4	-	368	-	238	3.12	65.9	9.3
10/20	2:30 P.M.	6.4	130	150	108	31.5	2.44	29.1	8.8
10/20	3:30 P.M.	6.4	180	260	82	17.5	2.44	102.0	9.0
10/20	5:30 P.M.	7.2	260	540	331	69	6.40	82.0	13.1
10/20	6:15 P.M.	6.4	120	250	828	21	5.50	55.0	8.5
10/20	6:35 P.M.	6.2	110	160	84	19	1.12	66.0	8.7
10/20	6:45 P.M.	6.4	150	180	330	15	0.34	53.2	8.7
10/20	7:15 P.M.	6.6	220	270	125	35	3.55	100.0	10.0
10/20	7:55 P.M.	8.1	300	500	438	285	47.2	75.9	13.6
10/20	9:15 P.M.	6.2	190	246	190	45	10.8	55.1	17.5
10/21	2:30 A.M.	5.9	270	435	205	147	1.40	108.0	13.0
10/21	5:00 A.M.	7.1	240	457	452	76	32.0	86.0	10.2
10/21	6:15 A.M.	6.4	100	125	125	30	6.20	29.7	8.6
10/21	6:55 A.M.	6.4	240	330	120	58	4.00	103.0	11.2
10/21	7:30 A.M.	6.3	200	180	90	44	1.65	58.6	9.8
10/21	10:30 A.M.	6.6	97	193	180	40	9.40	30.7	11.7
10/21	12:15 P.M.	8.8	87	305	681	31	44.0	23.0	14.1
10/21	1:15 P.M.	7.4	180	470	471	54	35.5	45.0	17.2
10/21	3:10 P.M.	6.9	116	260	292	58	17.6	41.5	20.4
10/21	4:00 P.M.	6.5	136	480	1142	62	3.30	77.3	15.3
10/21	4:30 P.M.	6.9	175	303	153	32	1.34	90.1	10.1
10/21	5:20 P.M.	7.0	113	186	114	61	6.20	35.6	8.9
10/21	5:45 P.M.	6.4	146	355	177	34	8.40	51.4	13.1
10/21	6:00 P.M.	6.8	102	275	173	48	9.20	28.9	6.4
10/21	7:15 P.M.	6.4	95	185	95.2	265	4.40	25.9	8.9
10/21	8:45 P.M.	10.0	249	570	920	68	22.6	94.9	13.5
10/21	11:15 P.M.	9.5	232	602	1030	90	45.6	54.3	18.4
10/22	3:15 A.M.	8.8	112	290	277	99	16.4	28.1	5.2

Samples collected by: H2M CORP.

(CONT'D.)

REMARKS:

 S. C. McLENDON, P.E., Director
 Sanitary Engineer

C-31



H2M CORP. / Environmental Engineers & Scientists

HOLZMACHER, McLENDON & MURRELL

500 BROAD HOLLOW ROAD, MELVILLE, NEW YORK 11746 (516) MY 4-3043

WATER RESOURCES • WATER SUPPLY & TREATMENT • SEWERAGE & TREATMENT
AQUATIC & MARINE ECOLOGY • MODEL STUDIES • PILOT PLANT STUDIES
WATER/WASTE WATER LABORATORY AND ANALYTICAL SERVICES

LABORATORY REPORT Contract No. DOT-CG-41342A

Lab. No.	Date Collected 20-24 Oct. 75	Date Received 21-24 Oct. 75
Premises of Sampling Point CGC Vigorous	Client U.S. Coast Guard	
Address United States Coast Guard Academy, New London, Conn.		
Point of Collection Sewage Ejection room		
Type Wastewater: Raw Turbid Wastewater, Dockside		

DATE	TIME OF COLLECTION	pH	BOD	COD	TOTAL SOLIDS	SUSP. SOLIDS	MBAS	OIL & GREASE	HARDNESS
10/22	5:30 A.M.	8.2	335	810	1060	306	36.5	50.2	23.0
10/22	7:15 A.M.	6.6	135	245	267	156	17.0	33.3	11.6
10/22	9:00 A.M.	6.1	243	280	266	107	1.42	78.0	16.9
10/22	10:30 A.M.	6.7	233	478	309	97	22.6	74.5	14.8
10/22	11:55 A.M.	6.4	353	690	571	155	23.6	109.0	21.8
10/22	3:00 P.M.	6.2	332	480	420	147	23.6	61.4	15.1
10/22	3:45 P.M.	8.0	280	520	478	166	23.6	41.5	14.6
10/22	4:10 P.M.	6.5	167	260	117	35	6.40	43.9	14.8
10/22	4:45 P.M.	6.1	141	230	68	210	5.90	43.7	10.5
10/22	6:30 P.M.	5.7	136	140	68	57	0.30	54.2	9.1
10/22	8:10 P.M.	5.9	252	275	145	56	0.27	77.8	12.6
10/22	9:45 P.M.	7.3	318	295	208	58	10.8	19.4	8.9
10/22	12 Midnt.	7.9	215	260	206	71	10.8	78.1	11.6
10/23	6:20 A.M.	6.2	160	160	148	68	1.46	106.0	10.1
10/23	7:30 A.M.	6.2	250	230	125	78	2.93	19.4	10.9
10/23	9:40 A.M.	7.7	160	270	568	40	50.0	59.7	10.6
10/23	11:30 A.M.	6.0	140	160	128	74	1.75	70.8	8.9
10/23	3:30 P.M.	6.7	260	270	145	78	2.20	111.0	10.4
10/23	4:30 P.M.	10.0	320	505	830	128	23.5	102.0	22.5
10/23	5:10 P.M.	9.0	280	365	766	86	16.4	38.0	19.4
10/23	5:45 P.M.	9.8	170	230	316	41	13.5	76.1	5.9
10/23	6:25 P.M.	8.4	260	440	768	98	27.0	44.6	15.0
10/23	7:30 P.M.	6.4	130	195	393	69	16.4	50.4	9.6
10/23	8:45 P.M.	7.5	300	570	544	124	32.8	77.4	17.1
10/23	9:45 P.M.	8.4	260	860	1474	153	71.0	45.2	18.8
10/24	5:20 A.M.	7.7	280	480	574	122	41.6	14.9	14.1
10/24	6:30 A.M.	6.5	170	240	150	4340	8.20	46.7	9.6
10/24	9:30 A.M.		170		108	4332	4.60	58.9	13.0
10/24	10:40 A.M.	10.1	150		541	2169	41.0	43.4	8.0

Samples collected by: H2M CORP.

REMARKS:

S. C. McLendon
 S. C. McLENDON, P.E., Director
 Sanitary Engineer



H2M CORP. / Environmental Engineers & Scientists

HOLZMACHER, McLENDON & MURRELL

500 BROAD HOLLOW ROAD, MELVILLE, NEW YORK 11746 (516) MY 4-3043

WATER RESOURCES • WATER SUPPLY & TREATMENT • SEWERAGE & TREATMENT
AQUATIC & MARINE ECOLOGY • MODEL STUDIES • PILOT PLANT STUDIES
WATER/WASTE WATER LABORATORY AND ANALYTICAL SERVICES

LABORATORY REPORT Contract No. DOT-CG-41342A

Lab. No.	Date Collected 20-24 Oct. 75	Date Received 21-24 Oct. 75
Premises of Sampling Point CGC VIGOROUS	Client U.S. Coast Guard	
Address United States Coast Guard Academy, New London, Connecticut		
Point of Collection Sewage Ejection Room		
Type Wastewater: Raw Sanitary Wastewater, Dockside		

DATE	TIME OF COLLECTION	BOD	COD	TOTAL SOLIDS	SUSP. SOLIDS	pH	CHLORIDES
10/20	2:45 P.M.	360	1200	11,800	330	7.5	5,250
10/20	3:35 P.M.	360	1100	11,300	220	7.7	6,000
10/20	9:00 P.M.	370	1000	-	318	7.9	6,000
10/20	11:00 P.M.	440	1600	16,200	382	7.7	8,000
10/21	4:30 A.M.	380	1200	20,500	278	8.1	10,500
10/21	9:00 A.M.	460	1600	25,300	940	7.8	12,500
10/21	9:25 A.M.	616	800	27,100	1120	7.7	16,300
10/21	9:55 A.M.	388	1700	30,300	934	7.4	16,000
10/21	10:45 A.M.	198	1400	30,400	676	7.5	17,000
10/21	11:45 A.M.	284	3700	27,700	992	7.7	17,300
10/21	12:15 P.M.	218	1300	28,600	393	7.4	15,800
10/21	1:35 P.M.	263	1000	27,000	386	7.7	13,500
10/21	2:30 P.M.	225	800	15,500	259	7.5	9,300
10/21	3:30 P.M.	183	300	16,600	266	7.8	9,300
10/21	4:15 P.M.	188	900	7,700	154	7.8	9,300
10/21	4:50 P.M.	290	1600	8,530	291	7.8	4,000
10/21	6:00 P.M.	290	1000	7,790	173	7.4	3,800
10/21	7:30 P.M.	310	900	7,470	413	7.8	3,800
10/21	8:30 P.M.	275	600	10,200	194	7.5	6,000
10/21	10:15 P.M.	370	1100	9,910	756	8.0	5,800
10/22	3:15 A.M.	260	1800	19,100	376	10.7	9,500
10/22	6:50 A.M.	425	3800	14,100	622	8.4	6,250
10/22	8:40 A.M.	460	4900	18,500	814	8.1	10,300
10/22	9:30 A.M.	310	2600	29,800	580	7.9	15,500
10/22	10:20 A.M.	265	2200	32,700	496	7.8	17,300
10/22	11:15 A.M.	285	1500	30,800	504	7.8	16,800
10/22	12:45 P.M.	230	1500	31,300	670	7.8	18,000
10/22	2:15 P.M.	305	1100	26,700	448	7.9	14,300
10/22	3:30 P.M.	230	800	19,800	407	8.0	3,000

Samples collected by: H2M CORP.

(Cont'd.)

REMARKS:

S. C. McLendon
 S. C. McLENDON, P.E., Director
 Sanitary Engineer

C-33



H2M CORP. / Environmental Engineers & Scientists

HOLZMACHER, McLENDON & MURRELL

500 BROAD HOLLOW ROAD, MELVILLE, NEW YORK 11746 (516) MY 4-3043

WATER RESOURCES • WATER SUPPLY & TREATMENT • SEWERAGE & TREATMENT
AQUATIC & MARINE ECOLOGY • MODEL STUDIES • PILOT PLANT STUDIES
WATER/WASTE WATER LABORATORY AND ANALYTICAL SERVICES

LABORATORY REPORT Contract No. DOT-CG- 41342A

Lab. No.	Date Collected 20-24 Oct. 75	Date Received 21-24 Oct. 75
Premises of Sampling Point CGC VIGOROUS	Client U.S. Coast Guard	
Address United States Coast Guard Academy, New London, Connecticut		
Point of Collection Sewage Ejection Room		
Type Wastewater: Raw Sanitary Wastewater, Dockside		

DATE	TIME OF COLLECTION	BOD	COD	TOTAL SOLIDS	SUSP. SOLIDS	pH	CHLORIDES
10/22	4:05 P.M.	100	1300	11,400	254	7.8	5,500
10/22	4:45 P.M.	145	700	9,470	310	7.8	4,750
10/22	6:35 P.M.	165	2520	10,000	531	8.1	4,500
10/22	8:15 P.M.	190	900	9,660	473	8.1	4,000
10/23	1:00 A.M.	343	1400	17,800	456	8.1	8,750
10/23	7:15 A.M.	820	2100	26,100	596	8.5	11,000
10/23	9:15 A.M.	680	2300	23,500	890	8.4	10,000
10/23	10:00 A.M.	650	1700	31,100	1030	8.1	12,250
10/23	10:50 A.M.	610	1900	32,000	1380	8.3	15,000
10/23	12:25 P.M.	990	2600	34,900	1030	8.2	14,250
10/23	1:30 P.M.	290	1800	35,500	744	8.2	15,000
10/23	3:45 P.M.	320	1700	30,600	287	8.2	14,250
10/23	4:20 P.M.	380	2450	28,100	503	8.3	11,500
10/23	5:10 P.M.	390	3200	21,600	290	8.3	8,500
10/23	7:45 P.M.	570	3000	12,700	753	8.3	7,500
10/23	8:00 P.M.	370	3500	18,800	393	8.3	8,000
10/23	11:00 P.M.	460	2000	26,100	536	8.3	12,250
10/24	6:05 A.M.	530	1800	28,500	437	8.4	10,500
10/24	7:40 A.M.	570	2500	24,300	469	8.1	9,750
10/24	9:10 A.M.	580	3000	23,500	274	8.1	9,750
10/24	9:50 A.M.	980	4300	26,800	466	8.1	11,500
10/24	10:40 A.M.	580	4540	28,900	278	8.0	12,750
10/24	11:30 A.M.	880	5000	32,300	567	8.0	13,000
10/24	12:35 P.M.	510	4600	31,000	601	8.0	14,000

Samples collected by: H2M CORP.

REMARKS:

S. C. McLENDON, P.E., Director
Sanitary Engineer



H2M CORP. / Environmental Engineers & Scientists

HOLZMACHER, McLENDON & MURRELL

500 BROAD HOLLOW ROAD, MELVILLE, NEW YORK 11746 (516) MY 4-3043

WATER RESOURCES • WATER SUPPLY & TREATMENT • SEWERAGE & TREATMENT
AQUATIC & MARINE ECOLOGY • MODEL STUDIES • PILOT PLANT STUDIES
WATER/WASTE WATER LABORATORY AND ANALYTICAL SERVICES

LABORATORY REPORT Contract No. DOT-CG-41342A

Lab. No.	Date Collected 20-24 Oct. 75	Date Received 21-24 Oct. 75
Premises of Sampling Point CGC VIGOROUS	Client U.S. Coast Guard	
Address United States Coast Guard Academy, New London, Connecticut		
Point of Collection Sewage Ejection Room		
Type Wastewater: Raw Galley Wastewater, Dockside		

DATE	TIME OF COLLECTION	pH	BOD	COD	TOTAL SOLIDS	SUSP. SOLIDS	MBAS	OIL & GREASE
10/20	2:00 P.M.	10.0	2200	3600	1960	502	0.04	447
10/20	2:50 P.M.	11.3	6100	10200	6950	988	0.12	1880
10/20	3:30 P.M.	11.2	2500	3200	2726	296	0.12	580
10/20	4:45 P.M.	10.5	3600	7500	4290	730	0.04	968
10/20	5:45 P.M.	9.0	1900	3200	1660	840	0.28	333
10/20	6:00 P.M.	8.1	4200	7200	4280	2050	0.09	908
10/20	6:40 P.M.	9.6	7000	2200	28700	32500	0.06	362
10/21	6:15 A.M.	5.5	2500	2800	1060	830	0.23	123
10/21	7:40 A.M.	5.6	4100	7600	3200	1480	0.10	254
10/21	8:45 A.M.	5.5	2300	4600	2140	2570	<.04	303
10/21	10:15 A.M.	10.7	1600	3000	660	565	0.11	271
10/21	12:30 P.M.	6.0	2700	4900	2230	1154	<.04	586
10/21	2:00 P.M.	5.2	2700	5100	2700	7050	<.04	853
10/21	5:30 P.M.	5.4	1500	3500	1200	776	0.05	841
10/21	8:15 P.M.	5.1	1200	3100	1140	924	0.17	200
10/22	6:00 A.M.	4.3	1300	3100	1280	764	<.04	235
10/22	8:00 A.M.	4.7	1000	2200	666	580	0.10	190
10/22	9:15 A.M.	5.7	900	1600	654	600	<.04	176
10/22	10:15 A.M.	5.0	1100	2900	654	606	0.04	260
10/22	12:15 P.M.	11.2	2300	5200	2210	456	<.04	497
10/22	1:30 P.M.	5.8	870	4200	1040	552	<.04	58
10/22	3:30 P.M.	11.3	880	4100	2610	462	0.46	204
10/22	5:00 P.M.	6.4	1700	3700	810	596	0.14	140
10/22	7:45 P.M.	6.5	280	1500	158	192	<.04	77
10/22	10:15 P.M.	4.0	760	1600	646	585	<.04	245
10/23	6:45 A.M.	4.8	540	1400	588	660	<.04	121
10/23	9:30 A.M.	10.9	970	2000	1360	962	<.04	253
10/23	10:30 A.M.	5.6	380	1000	3510	490	0.10	125

Samples collected by: H2M CORP.

REMARKS:

(Cont'd.)

 S. C. McLENDON, P.E., Director
 Sanitary Engineer

C-35



H2M CORP. / Environmental Engineers & Scientists

HOLZMACHER, McLENDON & MURRELL

500 BROAD HOLLOW ROAD, MELVILLE, NEW YORK 11746 (516) MY 4-3043

WATER RESOURCES • WATER SUPPLY & TREATMENT • SEWERAGE & TREATMENT
AQUATIC & MARINE ECOLOGY • MODEL STUDIES • PILOT PLANT STUDIES
WATER/WASTE WATER LABORATORY AND ANALYTICAL SERVICES

LABORATORY REPORT Contract No. DOT-CG-41342A

Lab. No.	Date Collected	Date Received
Premises of Sampling Point	CGC VIGOROUS	Client
Address		
Point of Collection		
Type Wastewater:		

DATE	TIME OF COLLECTION	pH	BOD	COD	TOTAL SOLIDS	SUSP. SOLIDS	MBAS	OIL & GREASE
10/23	12:30 P.M.	7.3	1770	4000	1280	1560	0.12	432
10/23	1:45 P.M.	9.0	780	2400	2490	1180	0.05	478
10/23	4:00 P.M.	9.6	1200	1400	1900	5600	0.15	212
10/23	5:15 P.M.	5.8	1500	2000	1490	738	<.04	261
10/24	8:00 A.M.	5.0	1500	1900	808	1300	<.04	167
10/24	9:45 A.M.	5.7	2500	2800	1150	776	<.04	195
10/24	12:10 P.M.	11.1	2600	4300	3290	860	<.04	591

Samples collected by: H2M CORP.

REMARKS:

 S. C. McLENDON, P.E., Director
 Sanitary Engineer

C-36



H2M CORP. / Environmental Engineers & Scientists

HOLZMACHER, McLENDON & MURRELL

500 BROAD HOLLOW ROAD, MELVILLE, NEW YORK 11746 (516) MY 4-3043

WATER RESOURCES • WATER SUPPLY & TREATMENT • SEWERAGE & TREATMENT
AQUATIC & MARINE ECOLOGY • MODEL STUDIES • PILOT PLANT STUDIES
WATER/WASTE WATER LABORATORY AND ANALYTICAL SERVICES

LABORATORY REPORT

Lab. No. 506016	Date Collected	Date Received 9/25/75
Premises of Sampling Point USCGC Gallatin	Client United States Coast Guard	
Address USCG Station Governors Island, N.Y.		
Point of Collection		
Type Water potable		

506016

Cu 0.99 mg/l
 Fe 0.05 mg/l
 Mn .02
 Zn <.02
 Hardness 24.5 mg/l as CaCO₃

Samples collected by: **H 2 M**

REMARKS:

 S. C. McLENDON, P.E., Director
 Sanitary Engineer

10/24/75

Date Reported

C-37



H2M CORP. / Environmental Engineers & Scientists

HOLZMACHER, McLENDON & MURRELL

500 BROAD HOLLOW ROAD, MELVILLE, NEW YORK 11746 (516) MY 4 3043

WATER RESOURCES • WATER SUPPLY & TREATMENT • SEWERAGE & TREATMENT
AQUATIC & MARINE ECOLOGY • MODEL STUDIES • PILOT PLANT STUDIES
WATER/WASTE WATER LABORATORY AND ANALYTICAL SERVICES

LABORATORY REPORT Contract #DOT-CG-41342A

Lab. No.	Date Collected 3-5 Sept. 75	Date Received 5 Sept. 75
Premises of Sampling Point CGC Gallatin	Client U. S. Coast Guard	
Address United States Coast Guard Station, Governors Island NY		
Point of Collection Forward Sewage Ejection Room		
Type Wastewater: Raw Sanitary Wastewater, Underway		

<u>DATE</u>	<u>TIME OF COLLECTION</u>	<u>COD</u>	<u>TOTAL SOLIDS</u>	<u>SUSP. SOLIDS</u>	<u>pH</u>	<u>CHLORIDES</u>
9/3	9:45AM	1420	7120	550	8.0	3000
9/3	10:45AM	660	8800	440	7.6	4500
9/3	11:15AM	2700	8500	1730	7.7	3500
9/3	11:45AM	1500	8900	1250	8.1	3900
9/3	12:05PM	1140	8920	660	8.5	3500
9/3	12:25PM	1000	9140	930	8.5	4000
9/3	1:00PM	780	9020	1270	8.5	3500
9/3	1:30PM	2580	11500	1080	8.4	4000
9/3	2:30PM	1380	12800	1200	8.3	5750
9/3	3:00PM	2300	11600	1330	8.4	5250
9/3	3:15PM	1480	13900	1000	7.3	6000
9/3	5:00PM	1600	9700	1440	7.8	4750
9/3	5:30PM	1920	11900	730	7.9	5000
9/3	6:40PM	2320	14200	900	8.5	6750
9/3	7:15PM	2180	15200	1360	8.5	6500
9/3	9:00PM	3200	13400	780	8.3	6250
9/3	10:05PM	2320	29400	780	8.1	15500
9/3	10:25PM	1560	32300	610	7.9	16500
9/3	11:45PM	420	33200	430	8.0	17500
9/3	11:50PM	460	39200	530	8.0	19000
9/3	12MIDN	1320	34400	330	7.7	20000
9/4	12:30AM	1900	32900	260	7.8	18000
9/4	1:45AM	1560	24500	800	8.3	15000
9/4	2:45AM	1120	28600	570	8.3	16500
9/4	3:30AM	800	26200	630	8.3	16500
9/4	4:00AM	1320	33800	700	7.5	16000
9/4	5:30AM	1100	24300	770	8.0	15000
9/4	5:45AM	1120	22200	860	7.8	13000
9/4	6:00AM	3200	24800	450	8.1	15000

Samples collected by: H 2 M Corp.

REMARKS:

S. C. McLendon
 S. C. McLENDON, P.E., Director
 Sanitary Engineer

11/6/75
 Date Reported

C-38



H2M CORP. / Environmental Engineers & Scientists

HOLZMACHER, McLENDON & MURRELL

500 BROAD HOLLOW ROAD, MELVILLE, NEW YORK 11746 (516) MY 4 3043

WATER RESOURCES • WATER SUPPLY & TREATMENT • SEWERAGE & TREATMENT
AQUATIC & MARINE ECOLOGY • MODEL STUDIES • PILOT PLANT STUDIES
WATER/WASTE WATER LABORATORY AND ANALYTICAL SERVICES

LABORATORY REPORT Contract #DOT-CG-41342A

Lab. No.	Date Collected	3-5 Sept. 75	Date Received	5 Sept. 75
Premises of Sampling Point	CGC Gallatin		Client	U.S. Coast Guard
Address	United States Coast Guard Station, Governors Island NY			
Point of Collection	Forward Sewage Ejection Room			
Type Wastewater:	Raw Sanitary Wastewater, Underway			

DATE	TIME OF COLLECTION	COD	TOTAL SOLIDS	SUSP. SOLIDS	pH	CHLORIDES
9/4	6:25AM	3400	26200	300	8.1	13500
9/4	6:45AM	1200	22500	600	8.2	13000
9/4	6:55AM	480	26000	310	8.0	14000
9/4	7:15AM	1100	20500	530	6.5	13500
9/4	7:45AM	2060	21900	890	7.1	11000
9/4	8:10AM	4660	20100	790	8.0	9500
9/4	8:25AM	4900	19200	820	7.9	9500
9/4	9:00AM	4600	14200	710	7.7	8000
9/4	9:45AM	2640	22700	580	7.5	12000
9/4	10:25AM	1580	18300	790	8.3	9500
9/4	11:00AM	1890	21500	1400	8.3	12500
9/4	12NOON	5060	12900	1680	8.2	6500
9/4	12:30PM	4480	12900	905	7.4	10000
9/4	1:00PM	4300	13700	1060	7.6	9000
9/4	1:40PM	2960	15500	1260	7.8	10500
9/4	2:00PM	880	18700	1120	7.4	12500
9/4	3:00PM	6080	13900	532	7.1	9500
9/4	3:45PM	840	15000	216	7.6	11500
9/4	4:15PM	2100	18000	710	7.6	10600
9/4	4:40PM	1040	20000	784	7.2	8500
9/4	5:20PM	1200	16800	752	7.7	12000
9/4	5:45PM	3200	13100	1000	7.9	9500
9/4	6:15PM	1640	20600	992	7.8	12000
9/4	6:45PM	1820	18100	962	7.7	11500
9/4	7:05PM	2460	31500	1030	7.3	22500
9/4	7:30PM	1720	24500	1140	7.7	14000
9/4	8:00PM	1800	21700	450	6.9	11000
9/4	8:30PM	1900	17100	660	6.8	11000
9/4	9:05PM	1000	30100	484	6.8	19500

Samples collected by: H 2 M Corp.

REMARKS:

 S. C. McLENDON, P.E., Director
 Sanitary Engineer

11/6/75
Date Reported



H2M CORP. / Environmental Engineers & Scientists

HOLZMACHER, McLENDON & MURRELL

500 BROAD HOLLOW ROAD, MELVILLE, NEW YORK 11746 (516) MY 4 3043

WATER RESOURCES • WATER SUPPLY & TREATMENT • SEWERAGE & TREATMENT
AGRICULTURE & MARINE ECOLOGY • MODEL SERVICES • PLANT PLANT STUDIES
WASTEWATER LABORATORY AND ANALYTICAL SERVICES

LABORATORY REPORT Contract #DOT-CG-41342A

Lab. No.	Date Collected 3-5 Sept. 75	Date Received 5 Sept. 75
Premises of Sampling Point CGC Gallatin	Client U.S. Coast Guard	
Address United States Coast Guard Station, Governors Island NY		
Point of Collection Forward Sewage Ejection Room		
Type Wastewater: Raw Sanitary Wastewater, Underway		

DATE	TIME OF COLLECTION	COD	TOTAL SOLIDS	SUSP. SOLIDS	pH	CHLORIDES
9/4	9:50AM	1840	26100	738	7.1	19000
9/4	10:30AM	1240	30900	520	7.7	21500
9/4	11:25AM	2500	35900	405	7.8	18000
9/4	12:05AM	860	31700	1300	7.6	22500
9/4	1:00AM	920	36000	750	8.2	18500
9/4	2:00AM	800	23000	730	8.4	14000
9/4	3:00AM	2000	39100	620	8.4	15000
9/4	3:40AM	940	20300	790	8.2	19500
9/4	4:00AM	900	31800	630	8.2	17000
9/4	5:20AM	800	28500	550	8.3	17000
9/4	6:00AM	1340	21400	360	8.0	11000
9/4	6:45AM	1400	15200	310	8.2	10500
9/4	7:10AM	1600	27000	580	8.0	16000
9/5	7:45AM	2000	20800	790	8.2	13500
9/5	8:20AM	2100	25300	1000	8.1	17500
9/5	9:00AM	2400	17500	740	6.8	10500
9/5	9:30AM	2220	18300	1600	8.2	9000
9/5	9:45AM	600	31000	410	7.7	18000
9/5	10:25AM	1000	24400	170	7.2	16000
9/5	11:00AM	900	28700	340	8.4	17500
9/5	11:25AM	1260	30600	530	8.2	19000
9/5	12 NOON	2240	33300	2000	8.1	17000
9/5	12:20PM	2000	27400	1400	8.2	17500
9/5	12:45PM	1700	25100	1800	8.4	12000
9/5	1:08PM	1700	22700	1100	8.2	16500
9/5	1:45PM	3020	20700	610	6.4	11000
9/5	2:15PM	3600	16200	1300	8.1	9000
9/5	2:30PM	2400	20300	1000	7.4	12500
9/5	3:05PM	2740	14600	1060	8.2	8000

Samples collected by: **H 2 M Corp.**

REMARKS:

 J. C. McLENDON, P.E., Director
 Sanitary Engineer

11/6/75
Date Reported



H2M CORP. / Environmental Engineers & Scientists

HOLZMACHER, McLENDON & MURRELL

500 BROAD HOLLOW ROAD, MELVILLE, NEW YORK 11746 (516) MY 4-3043

WATER RESOURCES • WATER SUPPLY & TREATMENT • SEWERAGE & TREATMENT
AQUATIC & MARINE ECOLOGY • MODEL STUDIES • PILOT PLANT STUDIES
WATER/WASTE WATER LABORATORY AND ANALYTICAL SERVICES

LABORATORY REPORT Contract #DOT -CG-41342A

Lab. No.	Date Collected	Date Received
Premises of Sampling Point	Client	
Address		
Point of Collection		
Type Wastewater:		

3-5Sept, 75

5 Sept, 75

CGC Gallatin

U.S. Coast Guard

United States Coast Guard Station, Governors Island, NY

Forward Sewage Ejection Room

Raw Turbid Wastewater, Underway

DATE	TIME OF COLLECTION	pH	COD	TOTAL SOLIDS	SUSP SOLIDS	MBAS	OIL & GREASE	HARDNESS
9/3	3:15PM	7.7	138	290	58	0.51	68	80
9/3	5:35PM	7.7	176	270	58	5.80	105	76
9/3	6:15PM	7.4	332	400	108	0.38	140	80
9/3	7:10PM	7.4	186	200	38	2.11	80	84
9/3	8:25PM	7.6	107	180	21	3.76	58	80
9/3	9:45PM	7.7	287	240	94	0.65	125	76
9/3	10:30PM	7.8	344	260	74	1.81	128	78
9/4	3:15AM	7.7	373	170	134	0.72	164	73
9/4	5:50AM	6.6	300	190	98	0.98	202	65
9/4	7:25AM	6.7	252	160	36	26.0	131	60
9/4	10:45AM	6.9	268	240	90	12.3	131	57
9/4	11:30AM	6.3	167	160	12	5.94	207	55
9/4	2:30PM	6.1	250	170	24	1.78	153	51
9/4	3:15PM	6.0	131	140	23	3.64	70	54
9/4	5:50PM	6.0	154	160	40	2.92	80	59
9/4	6:00PM	6.1	167	140	48	11.3	80	58
9/4	7:15PM	6.0	130	120	18	18.2	50	56
9/4	7:25PM	7.2	105	130	15	3.30	30	56
9/4	8:15PM	6.8	270	230	18	1.20	150	57
9/4	9:15PM	6.5	276	190	90	5.84	120	56
9/4	11:00PM	6.5	342	210	102	3.76	95	55
9/5	5:15AM	6.3	180	138	46	4.0	90	49.1
9/5	6:55AM	7.5	275	210	78	1.58	150	38
9/5	9:00AM	8.4	-	160	40	1.18	120	43
9/5	2:10PM	7.0	285	210	48	4.95	100	43
9/5	2:45PM	7.4	450	210	56	4.10	60	40
9/5	3:05PM	7.3	185	206	74	7.81	80	43

Samples collected by: H 2 M Corp.

REMARKS:

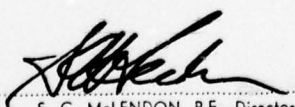
 S. C. McLENDON, P.E., Director
 Sanitary Engineer

11/6/75

Date Reported

C-41



H2M CORP. / Environmental Engineers & Scientists

HOLZMACHER, McLENDON & MURRELL

500 BROAD HOLLOW ROAD, MELVILLE, NEW YORK 11746 (516) MY 4-3043

WATER RESOURCES • WATER SUPPLY & TREATMENT • SEWERAGE & TREATMENT
AQUATIC & MARINE ECOLOGY • MODEL STUDIES • PILOT PLANT STUDIES
WATER/WASTE WATER LABORATORY AND ANALYTICAL SERVICES

LABORATORY REPORT Contract No. DOT-CG-41342A

Lab. No.	Date Collected	Date Received
Premises of Sampling Point	Client	
Address		
Point of Collection		
Type Wastewater:		

Date Collected: **3-5 Sept. 75** Date Received: **5 Sept. 75**
 Premises of Sampling Point: **CGC Gallatin** Client: **U. S. Coast Guard**
 Address: **United States Coast Guard Station, Governors Island NY**
 Point of Collection: **After Sewage Ejection Room**
 Type Wastewater: **Raw Galley Wastewater, Underway**

DATE	TIME OF COLLECTION	COD	TOTAL SOLIDS	SUSP SOLIDS	pH	MBAS	OIL & GREASE
9/3	12:45PM	2700	1460	910	6.8	0.16	225
9/3	1:30PM	120	390	280	7.2	2.20	186
9/3	2:30PM	3140	1030	450	9.3	5.30	415
9/3	3:15PM	8140	3630	1050	6.7	4.36	295
9/3	4:00PM	2200	2090	910	9.5	2.80	201
9/3	4:45PM	600	500	160	9.0	4.20	102
9/3	5:25PM	8600	3790	1690	4.9	0.11	336
9/3	5:50PM	3400	1570	740	6.4	63.0	581
9/3	6:15PM	3000	2100	1220	9.2	6.72	545
9/3	8:15PM	2900	310	110	8.5	1.56	88
9/3	10:15PM	3000	310	170	8.3	0.29	976
9/3	11:45PM	1500	798	100	10.2	<.04	123
9/4	12:25AM	2900	1910	790	10.2	23.8	339
9/4	1:45AM	720	1020	240	9.6	7.50	164
9/4	3:00AM	200	444	60	8.9	1.44	55
9/4	4:00AM	105	266	30	8.5	0.14	135
9/4	5:45AM	250	2580	30	10.4	0.26	64
9/4	6:30AM	210	1790	50	10.1	0.44	163
9/4	7:15AM	3200	5330	2770	9.3	<.04	138
9/4	8:30AM	920	1820	1820	5.6	0.06	62
9/4	9:30AM	750	646	130	8.7	0.18	202
9/4	10:30AM	840	540	140	6.0	0.096	301
9/4	11:00AM	2260	2730	930	6.3	0.22	240
9/4	12NOON	740	840	408	6.4	0.30	240
9/4	12:45PM	9160	3690	1270	5.0	0.12	160
9/4	1:00PM	4520	3150	2260	5.8	24.0	261
9/4	1:10PM	5080	4100	2020	5.9	3.50	652
9/4	1:45PM	3280	2820	900	6.8	1.56	539

Samples collected by: **H 2 M Corp.**

REMARKS:

S. C. McLendon
 S. C. McLENDON, P.E., Director
 Sanitary Engineer

11/8/75
Date Reported



H2M CORP. / Environmental Engineers & Scientists

HOLZMACHER, McLENDON & MURRELL

500 BROAD HOLLOW ROAD, MELVILLE, NEW YORK 11746 (516) MY 4-3043

WATER RESOURCES • WATER SUPPLY & TREATMENT • SEWERAGE & TREATMENT
AQUATIC & MARINE ECOLOGY • MODEL STUDIES • PILOT PLANT STUDIES
WATER/WASTE WATER LABORATORY AND ANALYTICAL SERVICES

LABORATORY REPORT Contract No. DOT-CG-41342A

Lab. No.	Date Collected 3-5 Sept. 75	Date Received 5 Sept. 75
Premises of Sampling Point CGC Gallatin	Client U. S. Coast Guard	
Address United States Coast Guard Station, Governors Island NY		
Point of Collection After Sewage Ejection Room		
Type Wastewater: Raw Galley Wastewater, Underway		

DATE	TIME OF COLLECTION	COD	TOTAL SOLIDS	SUSP SOLIDS	pH	MBAS	OIL & GREASE
9/4	2:30PM	2740	1700	540	6.9	0.44	481
9/4	3:25PM	3900	3270	1480	6.3	0.30	277
9/4	4:30PM	1760	1770	960	6.5	0.14	458
9/4	5:10PM	7000	3550	2160	6.3	<.04	777
9/4	5:45PM	4700	10800	625	6.5	<.04	699
9/4	6:00PM	3400	834	288	7.4	1.22	494
9/4	8:00PM	1500	444	172	7.0	0.14	325
9/4	11:00PM	640	438	82	7.1	<.04	390
9/4	11:15PM	700	1140	176	9.8	<.04	260
9/5	12:45AM	1600	3960	376	10.5	<.04	360
9/5	5:00AM	1360	1410	560	9.5	<.04	360
9/5	6:15AM	1000	1460	76	10.3	<.04	200
9/5	7:15AM	1380	1990	80	10.5	<.04	130
9/5	8:15AM	1200	1450	160	9.3	<.04	460
9/5	9:00AM	4900	4840	4520	4.9	65.0	630
9/5	10:45AM	4560	5580	2880	5.1	21.0	430
9/5	11:45AM	2660	2950	1630	4.2	1.88	410
9/5	12:30PM	1500	1250	520	5.5	0.31	340
9/5	1:00PM	10620	4660	2490	4.5	27.0	870
9/5	3:15PM	5230	4400	1020	5.0	0.70	720

Samples collected by: **H 2 M Corp.**

REMARKS:

 S. C. McLENDON, P.E., Director
 Sanitary Engineer

11/6/75
Date Reported

C-43



H2M CORP. / Environmental Engineers & Scientists

HOLZMACHER, McLENDON & MURRELL

500 BROAD HOLLOW ROAD, MELVILLE, NEW YORK 11746 (516) MY 4-3043

WATER RESOURCES • WATER SUPPLY & TREATMENT • SEWERAGE & TREATMENT
AQUATIC & MARINE ECOLOGY • MODEL STUDIES • PILOT PLANT STUDIES
WATER/WASTE WATER LABORATORY AND ANALYTICAL SERVICES

LABORATORY REPORT Contract #DOT-CG-41342A

Lab. No.	Date Collected 21-25 Sept. 75	Date Received 22-25 Sept. 75
Premises of Sampling Point CGC Gallatin	Client U. S. Coast Guard	
Address United States Coast Guard Station, Governors Island N.Y.		
Point of Collection Forward Sewage Ejection Room		
Type Wastewater: Raw Sanitary Wastewater, Dockside		

DATE	TIME OF COLLECTION	BOD	COD	TOTAL SOLIDS	SUSP SOLIDS	pH	CHLORIDES
9/21	1:00PM	330	1200	23,600	288	7.8	11,000
9/21	1:15PM	350	800	40,200	458	7.8	10,000
9/21	3:00PM	360	900	21,000	652	8.0	12,250
9/21	3:50PM	110	540	26,400	304	7.6	12,250
9/21	4:00PM	230	500	23,900	402	7.7	12,000
9/21	4:30PM	210	640	24,700	520	8.0	11,500
9/21	5:00PM	530	800	20,600	516	8.1	11,000
9/21	5:30PM	400	500	21,800	330	8.0	11,000
9/21	6:00PM	320	1200	29,300	556	7.4	12,000
9/21	6:30PM	250	1000	25,200	222	7.4	12,000
9/21	7:00PM	160	860	24,400	332	7.9	12,000
9/21	7:30PM	260	900	26,400	712	8.0	12,000
9/21	8:00PM	210	400	26,000	282	8.0	12,000
9/21	8:30PM	200	640	28,200	378	7.4	12,000
9/21	9:00PM	160	900	25,200	286	8.1	12,000
9/21	9:30PM	110	1840	25,000	374	7.5	12,000
9/21	10:15PM	160	2140	27,000	348	8.1	12,000
9/21	10:45PM	240	2200	25,300	270	7.7	12,000
9/21	11:30PM	230	1640	26,800	300	8.0	12,000
9/21	12MID.	230	1000	27,500	270	7.4	12,000
9/22	1:00AM	-	2220	-	-	7.6	-
9/22	1:30AM	100	2500	24,000	70	7.5	15,000
9/22	2:30AM	80	3100	23,500	90	7.3	13,000
9/22	3:30AM	150	2660	23,900	80	7.0	12,000
9/22	4:30AM	100	900	23,200	93	7.0	14,000
9/22	5:30AM	100	380	22,700	120	7.0	12,000
9/22	6:25AM	1000	4100	20,396	290	6.4	9,000

Samples collected by: **H 2 M CORP.**

REMARKS:

 S. C. McLENDON, P.E., Director
 Sanitary Engineer

11/6/75

Date Reported



H2M CORP. / Environmental Engineers & Scientists

HOLZMACHER, McLENDON & MURRELL

500 BROAD HOLLOW ROAD, MELVILLE, NEW YORK 11746 (516) MY 4-3043

WATER RESOURCES • WATER SUPPLY & TREATMENT • SEWERAGE & TREATMENT
AQUATIC & MARINE ECOLOGY • MODEL STUDIES • PILOT PLANT STUDIES
WATER/WASTE WATER LABORATORY AND ANALYTICAL SERVICES

LABORATORY REPORT Contract #DOT-CG-41342A

Lab. No.	Date Collected	Date Received
Premises of Sampling Point	CGC Gallatin	Client
U.S. Coast Guard		
Address		
United States Coast Guard Station, Governors Island N.Y.		
Point of Collection		
Forward Sewage Ejection Room		
Type Wastewater:		
Raw Sanitary Wastewater, Dockside		

DATE	TIME OF COLLECTION	BOD	COD	TOTAL SOLIDS	SUSP SOLIDS	pH	CHLORIDES
9/22	7:10AM	700	4800	21,300	350	7.4	11,000
9/22	7:50AM	1440	8300	18,400	470	7.3	10,000
9/22	8:15AM	520	2440	21,200	500	7.6	10,800
9/22	8:55AM	400	2200	24,600	290	6.8	12,000
9/22	9:30AM	170	700	24,900	290	7.4	12,000
9/22	11:40AM	-	1260	23,600	280	6.8	12,000
9/22	12NOON	130	1400	28,500	160	7.1	14,000
9/22	12:30PM	400	3200	47,100	200	7.7	12,000
9/22	1:00PM	350	1000	16,600	260	7.9	9,800
9/22	1:30PM	1030	1520	18,900	610	7.8	9,800
9/22	2:00PM	380	500	23,000	450	7.8	12,000
9/22	2:55PM	320	760	18,700	350	7.9	13,000
9/22	3:30PM	230	600	16,700	310	8.1	10,000
9/22	4:10PM	200	1160	17,400	240	7.9	12,000
9/22	4:50PM	420	-	19,300	380	7.9	12,000
9/22	5:15PM	680	1260	11,000	320	8.2	7,000
9/22	5:55PM	360	1040	19,700	380	7.7	10,500
9/22	6:20PM	210	900	21,700	300	7.3	24,800
9/22	7:10PM	100	560	23,300	240	5.9	27,300
9/22	7:50PM	250	900	23,900	300	7.9	12,800
9/22	9:00PM	260	1040	22,400	260	7.7	12,500
9/22	10:00PM	210	-	22,900	150	7.8	13,500
9/22	11:45PM	310	700	16,600	620	8.1	9,200
9/23	1:45AM	300	-	21,100	208	8.2	9,800
9/23	3:00AM	550	-	18,500	564	7.7	9,500
9/23	4:00AM	490	2200	19,300	620	7.8	9,500
9/23	6:30AM	430	1240	17,900	364	7.8	9,800

Samples collected by: H 2 M CORP.

REMARKS:

S. J. McLendon
 S. J. McLENDON, P.E., Director
 Sanitary Engineer

11/6/75
 Date Reported

C-45



H2M CORP. / Environmental Engineers & Scientists

HOLZMACHER, McLENDON & MURRELL

500 BROAD HOLLOW ROAD, MELVILLE, NEW YORK 11746 (516) MY 4-3043

WATER RESOURCES • WATER SUPPLY & TREATMENT • SEWERAGE & TREATMENT
AQUATIC & MARINE ECOLOGY • MODEL STUDIES • PILOT PLANT STUDIES
WATER/WASTE WATER LABORATORY AND ANALYTICAL SERVICES

LABORATORY REPORT Contract #DOT-CG-41342A

Lab. No.	Date Collected 21-25 Sept. 75	Date Received 22-25 Sept. 75
Premises of Sampling Point CGC Gallatin	Client U.S. Coast Guard	
Address United States Coast Guard Station, Governors Island N.Y.		
Point of Collection Forward Sewage Ejection Room		
Type Wastewater: Raw Sanitary Wastewater, Dockside		

<u>DATE</u>	<u>TIME OF COLLECTION</u>	<u>BOD</u>	<u>COD</u>	<u>TOTAL SOLIDS</u>	<u>SUSP SOLIDS</u>	<u>pH</u>	<u>CHLORIDES</u>
9/23	7:30AM	550	1680	-	-	8.1	-
9/23	7:50AM	700	1940	19,100	684	7.7	10,500
9/23	8:25AM	900	2400	19,600	934	6.7	9,200
9/23	9:05AM	380	1200	17,100	602	6.6	9,800
9/23	9:45AM	490	1300	19,600	728	6.8	14,200
9/23	10:40AM	360	1520	21,400	654	8.0	12,000
9/23	12NOON	490	1820	15,200	432	8.1	7,500
9/23	12:15PM	670	1800	14,590	1000	8.0	8,000
9/23	1:10PM	840	2160	13,610	1160	7.8	12,000
9/23	1:40PM	555	1920	19,600	2100	7.8	8,500
9/23	2:00PM	900	1640	18,990	3500	7.8	10,500
9/23	3:15PM	390	3200	21,900	700	7.7	10,500
9/23	3:45PM	310	4300	19,700	1800	7.7	10,500
9/23	4:55PM	360	2960	20,400	2200	7.7	10,500
9/23	6:00PM	480	2580	18,200	900	7.5	9,800
9/23	6:45PM	510	1860	20,500	1000	7.5	10,500
9/23	7:45PM	210	1200	17,400	700	7.6	10,000
9/23	8:15PM	130	800	21,400	500	7.9	10,000
9/23	8:25PM	260	2920	25,400	700	7.1	14,200
9/23	9:30PM	320	3200	17,800	600	8.2	9,800
9/23	10:00PM	360	4000	17,200	600	8.0	9,500
9/23	11:00PM	280	7240	14,400	500	7.9	9,000
9/23	11:45PM	260	800	17,500	400	8.0	8,500
9/24	2:00AM	310	1200	18,840	600	8.2	9,750
9/24	3:45AM	290	3740	18,800	700	8.2	10,800
9/24	6:15AM	440	3460	15,100	300	8.1	8,000
9/24	7:00AM	500	2060	17,800	760	8.0	11,000

Samples collected by: **H 2 M Corp.**

REMARKS:

S. C. McLendon
 S. C. McLENDON, P.E., Director
 Sanitary Engineer

11/6/75

Date Reported

C-46



H2M CORP. / Environmental Engineers & Scientists

HOLZMACHER, McLENDON & MURRELL

500 BROAD HOLLOW ROAD, MELVILLE, NEW YORK 11746 (516) 437-5000

WATER RESOURCES • WATER SUPPLY & TREATMENT • SEWERAGE & DRAINAGE

PLANNING & DESIGN SERVICES • RESEARCH STUDIES • PILOT PLANT STUDIES

WASTEWATER TREATMENT LABORATORY AND ANALYTICAL SERVICES

LABORATORY REPORT Contract #DOT-CG-41342A

Lab. No.	Date Collected	21-25 Sept. 75	Date Received	22-25 Sept. 75
Premises of Sampling Point	CGC Gallatin	Client	U.S. Coast Guard	
Address	United States Coast Guard Station, Governors Island NY			
Point of Collection	Forward Sewage Ejection Room			
Type Wastewater:	Raw Sanitary Wastewater, Dockside			

DATE	TIME OF COLLECTION	BOD	COD	TOTAL SOLIDS	SUSP SOLIDS	pH	CHLORIDES
9/24	7:15AM	490	1100	14,800	620	7.9	8,750
9/24	7:30AM	500	1340	19,800	790	7.9	11,500
9/24	8:00AM	850	1800	18,200	70	7.8	9,750
9/24	8:15AM	-	2140	-	-	-	-
9/24	8:45AM	550	1800	19,400	1,040	7.7	11,000
9/24	9:15AM	620	2000	20,800	2,400	8.0	11,750
9/24	10:00AM	560	-	18,600	810	7.7	10,500
9/24	10:50AM	480	-	21,900	800	7.1	12,300
9/24	11:25AM	690	-	22,300	420	7.6	11,500
9/24	11:40AM	-	-	20,700	800	7.8	11,800
9/24	1:30PM	470	-	17,100	470	7.8	8,250
9/24	2:00PM	510	1760	19,800	230	8.1	11,500
9/24	2:45PM	500	600	19,900	470	8.2	11,000
9/24	12:15PM	-	-	17,300	600	8.1	8,750
9/24	12:45PM	-	3160	19,000	660	7.8	9,750
9/24	3:15PM	880	1240	22,500	3,200	7.8	13,300
9/24	4:15PM	400	840	18,600	640	7.8	10,500
9/24	5:35PM	430	740	13,200	390	8.1	8,000
9/24	6:30PM	290	740	15,000	340	8.3	9,750
9/24	7:10PM	150	700	23,800	320	7.3	13,300
9/24	7:20PM	160	280	25,400	330	7.2	13,000
9/24	7:35PM	120	260	3,780	284	7.1	-
9/24	7:48PM	230	640	23,600	110	7.1	13,000
9/24	8:45PM	340	1260	18,800	220	7.6	9,750
9/24	10:00PM	220	600	19,900	230	7.9	9,250
9/24	10:45PM	400	600	19,400	180	7.9	10,000
9/24	11:45PM	440	900	20,700	490	8.5	9,850
9/25	1:15AM	670	740	14,000	400	8.6	8,250

Samples collected by: H 2 M Corp.

REMARKS:

 S. C. McLENDON, P.E., Director
 Sanitary Engineer

11/6/75 Date Reported



H2M CORP. / Environmental Engineers & Scientists

HOLZMACHER, McLENDON & MURRELL

500 BROAD HOLLOW ROAD, MELVILLE, NEW YORK 11746 (516) MY 1-3000

WATER RESOURCES • WATER SUPPLY & TREATMENT • BEVERAGE & TREATMENT
INDUSTRIAL & MARINE EFFLUENT • MODEL STUDIES • FIELD PLANT STUDIES
WASTEWATER, WATER LABORATORY AND ANALYTICAL SERVICES

LABORATORY REPORT Contract #DOT-CG-41342A

Lab. No.	Date Collected	Date Received
Premises of Sampling Point	Client	
Address		
Point of Collection		
Type Wastewater:		

DATE	TIME OF COLLECTION	BOD	COD	TOTAL SOLIDS	SUSP SOLIDS	pH	CHLORIDES
9/25	2:45AM	600	1000	16,700	340	8.2	8,000
9/25	4:45AM	480	-	11,900	200	8.3	6,000
9/25	6:00AM	520	1200	14,000	280	8.1	7,000
9/25	6:40AM	440	1300	17,100	400	7.7	8,000
9/25	7:40AM	470	1900	16,100	440	8.0	8,250
9/25	8:15AM	1150	-	16,800	500	8.1	8,000
9/25	8:45AM	680	1660	17,300	430	8.7	8,000
9/25	9:00AM	590	4740	21,000	840	7.8	10,300
9/25	9:35AM	310	1100	20,000	380	7.9	10,000
9/25	9:55AM	360	1600	18,100	1020	8.2	9,000
9/25	10:35AM	280	2200	24,400	810	8.1	11,000
9/25	10:45AM	400	2100	24,700	250	7.8	11,250
9/25	11:15AM	520	2300	19,300	600	7.1	10,000
9/25	11:40AM	640	2140	22,900	520	7.8	11,000
9/25	12 NOON	-	2600	20,900	690	8.1	9,750

Samples collected by: H 2 M Corp.

REMARKS:

 S. C. McLENDON, P.E., Director
 Sanitary Engineer

11/6/75
 Date Reported



H2M CORP. / Environmental Engineers & Scientists

HOLZMACHER, McLENDON & MURRELL

500 BROAD HOLLOW ROAD, MELVILLE, NEW YORK 11746 (516) MY 4-3043

WATER RESOURCES • WATER SUPPLY & TREATMENT • SEWERAGE & TREATMENT
AQUATIC & MARINE ECOLOGY • MODEL STUDIES • PILOT PLANT STUDIES
WATER/WASTE WATER LABORATORY AND ANALYTICAL SERVICES

LABORATORY REPORT Contract #DOT-CG-41342A

Lab. No.	Date Collected 21-25 Sept, 75	Date Received 22-25 Sept, 75
Premises of Sampling Point CGC Gallatin	Client U.S. Coast Guard	
Address United States Coast Guard Station, Governors Island, NY		
Point of Collection After Sewage Ejection Room		
Type Wastewater: Raw Galley Wastewater, Dockside		

<u>DATE</u>	<u>TIME OF COLLECTION</u>	<u>pH</u>	<u>BOD</u>	<u>COD</u>	<u>TOTAL SOLIDS</u>	<u>SUSP. SOLIDS</u>	<u>MBAS</u>	<u>OIL & GREASE</u>
9/21	3:45PM	4.9	1320	1460	1016	430	0.96	120
9/21	4:00PM	6.1	1940	4200	2708	2920	0.86	410
9/21	4:45PM	6.1	1300	3200	918	420	1.12	240
9/21	5:15PM	6.4	-	4300	3804	3050	-	620
9/21	6:00PM	6.7	620	2140	366	120	4.00	150
9/21	7:00PM	6.7	800	900	310	260	0.83	260
9/21	8:15PM	7.0	2920	400	244	40	0.50	113
9/21	9:30PM	7.1	600	1840	126	40	0.22	100
9/21	11:00PM	7.1	410	2400	128	30	0.15	60
9/21	12MIDN	7.0	370	1460	100	40	0.14	80
9/22	2:00AM	6.9	540	600	124	30	0.15	60
9/22	3:15AM	6.8	520	260	234	120	0.22	70
9/22	4:15AM	7.0	720	320	118	40	0.10	50
9/22	5:15AM	6.8	620	300	92	10	0.04	-
9/22	6:15AM	6.7	630	600	292	150	0.14	100
9/22	6:45AM	6.6	700	2100	602	680	3.00	110
9/22	7:15AM	6.6	150	800	168	60	2.35	110
9/22	8:15AM	6.5	1620	2000	742	340	1.56	1650
9/22	8:30AM	6.9	1550	2200	1214	520	2.68	374
9/22	9:00AM	7.6	920	1560	424	230	10.6	284
9/22	9:15AM	8.5	1170	960	536	130	18	209
9/22	10:30AM	8.0	830	2240	338	200	6.4	157
9/22	10:45AM	7.4	620	700	3858	-	-	451
9/22	11:45AM	7.0	450	700	620	-	-	80
9/22	12:30PM	6.6	1170	2320	540	230	9.9	132
9/22	12:45PM	7.6	500	1100	464	210	11.9	135
9/22	1:15PM	7.8	1110	2000	850	320	32.25	344
9/22	1:30PM	7.0	420	650	286	110	5.4	142

Samples collected by: **H 2 M Corp.**

REMARKS:

 S. C. McLENDON, P.E., Director
 Sanitary Engineer

11/6/75

Date Reported

C-49



H2M CORP. / Environmental Engineers & Scientists

HOLZMACHER, McLENDON & MURRELL

500 BROAD HOLLOW ROAD, MELVILLE, NEW YORK 11746 (516) MY 4-3043

WATER RESOURCES • WATER SUPPLY & TREATMENT • SEWERAGE & TREATMENT
AQUATIC & MARINE ECOLOGY • MODEL STUDIES • PILOT PLANT STUDIES
WATER/WASTE WATER LABORATORY AND ANALYTICAL SERVICES

LABORATORY REPORT Contract #DOT-CG-41342A

Lab. No.	Date Collected 21-25 Sept. 75	Date Received 22-25 Sept. 75
Premises of Sampling Point CGC Gallatin	Client U.S. Coast Guard	
Address United States Coast Guard Station, Governors Island NY		
Point of Collection After Sewage Ejection Room		
Type Wastewater: Raw Galley Wastewater, Dockside		

DATE	TIME OF COLLECTION	pH	BOD	COD	TOTAL SOLIDS	SUSP. SOLIDS	MBAS	OIL & GREASE
9/22	2:15PM	6.5	410	800	304	180	1.4	133
9/22	2:45PM	6.6	270	540	138	130	0.54	87
9/22	3:00PM	6.4	320	620	234	150	0.04	100
9/22	4:05PM	6.8	630	4300	762	320	1.18	151
9/22	4:45PM	7.9	1440	3000	1154	470	13.1	536
9/22	5:30PM	7.3	2370	4500	1310	740	6.8	805
9/22	5:45PM	8.2	1500	3200	978	280	17.8	313
9/22	12 MIDN	6.1	-	10100	356	160	0.78	136
9/23	6:15AM	6.0	1240	800	448	360	0.1	93
9/23	6:45AM	6.1	1340	1460	720	580	0.31	164
9/23	7:30AM	6.6	980	1000	638	200	0.91	75
9/23	8:15AM	6.5	1000	1200	766	340	0.42	78
9/23	8:45AM	6.4	8850	11360	5038	220	0.49	460
9/23	9:15AM	6.3	5090	8580	3356	2690	0.73	333
9/23	9:45AM	6.6	2290	5700	1574	2950	0.08	339
9/23	10:00AM	6.0	2590	8760	2062	2500	0.18	412
9/23	10:30AM	6.3	2250	6000	1432	1100	0.20	460
9/23	11:00AM	6.3	2530	8520	1492	940	0.32	243
9/23	11:30AM	5.2	2500	5500	1372	760	0.28	385
9/23	12NOON	6.2	3060	6000	3590	1670	0.18	881
9/23	12:20PM	-	2420	5700	2514	1580	1.48	439
9/23	12:40PM	6.7	2450	6000	2200	1370	0.50	-
9/23	1:15PM	6.6	1770	6200	1568	890	0.38	411
9/23	2:00PM	6.2	1940	2640	2014	630	0.60	310
9/23	2:15PM	5.2	1430	13200	820	580	0.24	525
9/23	3:00PM	5.8	950	10800	1282	1750	0.12	297
9/23	3:45PM	8.9	1180	8400	1744	2050	0.15	195
9/23	4:10PM	6.1	2530	16400	3576	890	0.18	940

Samples collected by: **H 2 M Corp.**

REMARKS:

 S. C. McLendon, P.E., Director
 Sanitary Engineer

11/6/75
 Date Reported

C-50



H2M CORP. / Environmental Engineers & Scientists

HOLZMACHER, McLENDON & MURRELL

500 BROAD HOLLOW ROAD, MELVILLE, NEW YORK 11746 (516) MY 4-3043

WATER RESOURCES • WATER SUPPLY & TREATMENT • SEWERAGE & TREATMENT

AQUATIC & MARINE ECOLOGY • MODEL STUDIES • PILOT PLANT STUDIES

WATER/WASTE WATER LABORATORY AND ANALYTICAL SERVICES

LABORATORY REPORT Contract #DOT-CG-41342A

Lab. No.	Date Collected	Date Received
Premises of Sampling Point	CGC Gallatin	Client
Address		United States Coast Guard Station, Governors Island NY
Point of Collection		After Sewage Ejection Room
Type Wastewater:		Raw Galley Wastewater, Dockside

DATE	TIME OF COLLECTION	pH	BOD	COD	TOTAL SOLIDS	SUSP. SOLIDS	MBAS	OIL & GREASE
9/23	4:40PM	6.3	1290	5800	1466	1410	0.18	550
9/23	5:00PM	6.3	1480	8600	1016	600	0.20	880
9/23	5:15PM	5.9	-	5500	578	634	0.25	360
9/23	5:30PM	6.2	740	20000	14950	7500	0.80	3970
9/23	5:35PM	6.6	3080	11640	2634	3270	1.12	2520
9/23	6:10PM	9.4	990	12000	916	370	1.20	740
9/23	8:30PM	7.1	390	11100	362	188	0.60	840
9/23	10:30PM	6.2	1060	11600	814	614	0.35	540
9/24	1:15AM	6.5	570	4000	126	29	0.19	110
9/24	2:00AM	6.4	620	1900	160	74	0.11	90
9/24	4:00AM	6.2	-	2500	194	96	0.20	140
9/24	6:10AM	6.1	570	4300	326	220	0.30	150
9/24	8:00AM	6.0	1850	5500	1610	936	1.05	450
9/24	8:30AM	6.6	2830	6000	3610	2240	1.5	350
9/24	9:05AM	6.8	600	1400	300	164	0.88	160
9/24	9:30AM	-	920	2300	940	916	15.0	400
9/24	10:25AM	5.2	-	8640	1070	476	0.60	230
9/24	11:00AM	6.2	690	1500	370	172	0.16	230
9/24	11:30AM	7.7	-	3300	660	408	5.0	418
9/24	3:00PM	7.1	1110	2900	644	388	3.8	220
9/24	4:00PM	8.5	1030	1800	340	97	3.4	250
9/24	5:00PM	8.1	1580	3800	818	269	8.2	520
9/24	5:45PM	7.5	920	3100	222	55	6.4	220
9/24	8:45PM	6.7	1130	3100	210	152	0.36	233
9/25	1:15AM	6.2	720	1640	334	124	0.36	287
9/25	4:45AM	7.3	330	1060	110	20	0.16	72
9/25	6:15AM	6.9	1530	1100	108	32	1.0	176

Samples collected by: H 2 M Corp.

REMARKS:

 S. C. McLENDON, P.E., Director
 Sanitary Engineer

11/6/75
 Date Reported

C-51



H2M CORP. / Environmental Engineers & Scientists

HOLZMACHER, McLENDON & MURRELL

500 BROAD HOLLOW ROAD, MELVILLE, NEW YORK 11746 (516) MY 4 3043

WATER RESOURCES • WATER SUPPLY & TREATMENT • SEWERAGE & TREATMENT
AQUATIC & MARINE ECOLOGY • MODEL STUDIES • PILOT PLANT STUDIES
WATER/WASTE WATER LABORATORY AND ANALYTICAL SERVICES

LABORATORY REPORT Contract No. DOT-CG-41342A

Lab. No.	Date Collected 21-25 Sept. 75 Date Received 22-25 Sept. 75
Premises of Sampling Point CGC Gallatin	Client U. S. Coast Guard
Address United States Coast Guard Station, Governors Island, N.Y.	
Point of Collection Forward Sewage Ejection Room	
Type Wastewater: Raw Turbid Wastewater, Dockside	

DATE	TIME OF COLLECTION	pH	BOD	COD	TOTAL SOLIDS	SUSP. SOLIDS	MBAS	OIL & GREASE	HARDNESS
9/21	1:15PM	7.1	130	350	717	3	<.04	80	359.6
9/21	3:00PM	7.1	160	250	254	29	0.10	100	39.6
9/21	6:15PM	6.9	300	520	218	76	6.40	170	32.6
9/21	7:40PM	6.5	170	240	158	19	0.13	90	17.7
9/21	11:30PM	6.6	150	180	115	33	0.05	70	26.7
9/22	1:15AM	6.7	-	185	115	16	0.04	67	25.6
9/22	7:00AM	7.0	110	210	100	8	0.9	75	21.2
9/22	9:15AM	6.6	180	320	168	61	1.8	89	22.8
9/22	3:45PM	6.3	280	510	390	29	1.76	107	47.3
9/22	4:15PM	6.4	190	380	190	53	2.28	121	24.3
9/22	5:45PM	6.5	220	320	118	35	0.25	92	21.5
9/22	6:40PM	6.1	230	345	162	84	4.9	131	23.1
9/22	7:25PM	6.4	-	270	99	16	0.19	94	22.8
9/22	8:30PM	7.4	100	150	78	24	0.05	56	22.4
9/22	11:30PM	6.8	240	-	144	29	0.08	121	-
9/23	3:45AM	6.4	120	92	130	27	0.05	80	53.0
9/23	7:00AM	6.6	130	180	91	24	0.38	70	19.9
9/23	2:20PM	6.3	170	295	167	55	0.81	100	20.7
9/23	3:45PM	6.8	230	325	186	80	2.20	150	22.2
9/23	4:15PM	6.6	240	225	124	92	0.48	130	19.3
9/23	5:05PM	6.3	180	237	136	68	0.18	130	21.8
9/23	6:10PM	6.2	160	235	92	38	0.18	100	18.8
9/23	6:50PM	6.4	45	155	67	15	0.05	80	17.6
9/23	7:45PM	6.2	140	255	84	37	0.22	100	19.6
9/23	9:45PM	6.9	240	265	-	25	0.18	140	19.0
9/23	11:00PM	6.9	250	245	137	75	0.16	170	10.1
9/23	12 MIDN.	6.2	140	155	98	31	0.03	110	8.7
9/24	1:45AM	6.4	190	194	106	35	.09	66	18.4

CON'T.

Samples collected by: **H 2 M CORP.**

REMARKS:

 S. C. McLENDON, P.E., Director
 Sanitary Engineer

11/6/75
Date Reported



H2M CORP. / Environmental Engineers & Scientists

HOLZMACHER, McLENDON & MURRELL

500 BROAD HOLLOW ROAD, MELVILLE, NEW YORK 11746 (516) MY 4-3043

WATER RESOURCES • WATER SUPPLY & TREATMENT • SEWERAGE & TREATMENT
AQUATIC & MARINE ECOLOGY • MODEL STUDIES • PILOT PLANT STUDIES
WATER/WASTE WATER LABORATORY AND ANALYTICAL SERVICES

LABORATORY REPORT Contract #DOT-CG-41342A

Lab. No.	Date Collected 21-25 Sept. 75	Date Received 22-25 Sept. 75
Premises of Sampling Point CGC Gallatin	Client U.S. Coast Guard	
Address United States Coast Guard Station, Governors Island NY		
Point of Collection After Sewage Ejection Room		
Type Wastewater: Raw Galley Wastewater, Dockside		

<u>DATE</u>	<u>TIME OF COLLECTION</u>	<u>pH</u>	<u>BOD</u>	<u>COD</u>	<u>TOTAL SOLIDS</u>	<u>SUSP. SOLIDS</u>	<u>MBAS</u>	<u>OIL & GREASE</u>
9/25	6:55AM	7.3	2030	11500	150	198	1.0	279
9/25	7:30AM	6.8	1920	12400	212	70	0.32	433
9/25	8:20AM	7.2	2880	8300	1010	1440	3.8	613
9/25	8:50AM	7.0	1950	1900	302	616	1.1	601
9/25	9:25AM	6.9	1640	3200	255	586	0.20	480
9/25	9:55AM	6.9	2690	3600	1028	3300	7.1	332
9/25	11:20AM	6.5	2570	3600	678	2620	2.7	252
9/25	12NOON	7.1	2130	1600	344	1490	3.2	336

Samples collected by: **H 2 M Corp.**

REMARKS:

S. C. McLENDON, P.E., Director
Sanitary Engineer

11/6/75

Date Reported

C-53

H2M CORP. / Environmental Engineers & Scientists

HOLZMACHER, McLENDON & MURRELL

NEW YORK, NEW YORK 11746-1516 NY 4 0043

LABORATORY REPORT Contract No. DOT-CG-41342A

Lab. No.	Date Collected 21-25 Sept. 75	Date Received 22-25 Sept. 75
Premises of Sampling Point CGC Gallatin	Client U.S. Coast Guard	
Address United States Coast Guard Station, Governors Island, N.Y.		
Point of Collection Forward Sewage Ejection Room		
Type Wastewater: Raw Turbid Wastewater, Dockside		

<u>DATE</u>	<u>TIME OF COLLECTION</u>	<u>pH</u>	<u>BOD</u>	<u>COD</u>	<u>TOTAL SOLIDS</u>	<u>SUSP. SOLIDS</u>	<u>MBAS</u>	<u>OIL & GREASE</u>	<u>HARDNESS</u>
9/24	7:00AM	7.0	180	200	50	37	2.4	59.5	17.6
9/24	11:30AM	7.3	270	255	152	120	5.0	140	8.6
9/24	12 NOON	7.2	-	130	134	38	.52	170	18.0
9/24	12:25PM	6.5	-	125	87	33	.16	98	17.4
9/24	12:50PM	6.3	-	250	120	22	3.0	83	19.6
9/24	5:45PM	6.2	230	280	118	41	0.9	83	31.4
9/24	9:00PM	6.3	230	295	102	86	2.4	163	17.2
9/24	9:30PM	6.4	130	115	79	45	0.4	77	16.2
9/25	7:00AM	6.7	130	135	71	29	1.2	50	16.3
9/25	8:50AM	10.3	220	390	323	128	3.4	22.9	26.3
9/25	11:45AM	9.5	770	240	334	88	3.2	38.3	57.4

 Samples collected by: **H 2 M CORP.**

REMARKS:

 S. C. McLENDON, P.E., Director
 Sanitary Engineer

11/6/75
 Date Reported

C-54

H2M CORP. / Environmental Engineers & Scientists

HOLZMACHER, McLENDON & MURRELL

500 BROAD HOLLOW ROAD, MELVILLE, NEW YORK 11746 (516) MY 4 3043

 WATER RESOURCES * WATER SUPPLY & TREATMENT * SEWERAGE & TREATMENT
 AQUATIC & MARINE ECOLOGY * MODEL STUDIES * PILOT PLANT STUDIES
 WATER/WASTE WATER LABORATORY AND ANALYTICAL SERVICES

LABORATORY REPORT Contract No. DOT-CG-41342A

Lab. No.	Date Collected 21-25 Sept. 75	Date Received 22-25 Sept. 75
Premises of Sampling Point CGC Gallatin	Client U.S. Coast Guard	
Address United States Coast Guard Station, Governors Island, N.Y.		
Point of Collection Forward Sewage Ejection Room		
Type Wastewater: Raw Turbid Wastewater, Dockside		

<u>DATE</u>	<u>TIME OF COLLECTION</u>	<u>pH</u>	<u>BOD</u>	<u>COD</u>	<u>TOTAL SOLIDS</u>	<u>SUSP. SOLIDS</u>	<u>MBAS</u>	<u>OIL & GREASE</u>	<u>HARDNESS</u>
9/24	7:00AM	7.0	180	200	50	37	2.4	59.5	17.6
9/24	11:30AM	7.3	270	255	152	120	5.0	140	8.6
9/24	12 NOON	7.2	-	130	134	38	.52	170	18.0
9/24	12:25PM	6.5	-	125	87	33	.16	98	17.4
9/24	12:50PM	6.3	-	250	120	22	3.0	83	19.6
9/24	5:45PM	6.2	230	280	118	41	0.9	83	31.4
9/24	9:00PM	6.3	230	295	102	86	2.4	163	17.2
9/24	9:30PM	6.4	130	115	79	45	0.4	77	16.2
9/25	7:00AM	6.7	130	135	71	29	1.2	50	16.3
9/25	8:50AM	10.3	220	390	323	128	3.4	22.9	26.3
9/25	11:45AM	9.5	770	240	334	88	3.2	38.3	57.4

 Samples collected by: **H 2 M CORP.**

REMARKS:

S. C. McLENDON, P.E., Director
Sanitary Engineer

11/6/75
Date Reported

C-55