

AD-A056 302

GENERAL MOTORS CORP GOLETA CALIF DELCO ELECTRONICS DIV F/G 10/2
15KW GENERAL PURPOSE POWER CONDITIONER (FREQUENCY CHANGER). AC---ETC(U)
APR 78 DAAK70-77-C-0035

UNCLASSIFIED

R78-38

NL

1 of 2
AD
A056 302



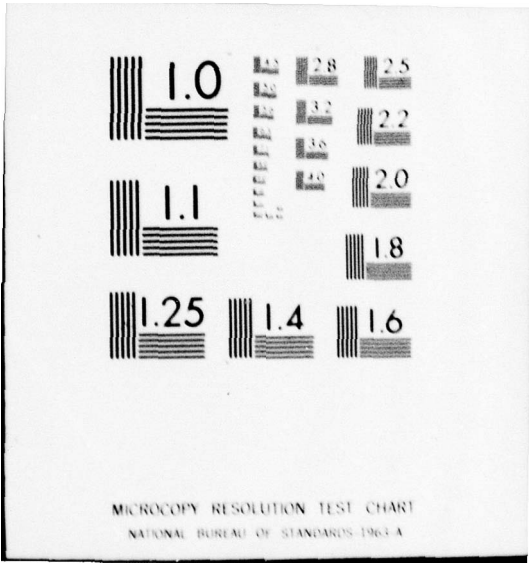

MICROCOPY RESOLUTION TEST CHART
NATIONAL BUREAU OF STANDARDS-1963-A

LEVEL

12
JK

R78-38
APRIL 1978

AD A 056302

15kW GENERAL PURPOSE POWER CONDITIONER

(FREQUENCY CHANGER)

AD No. _____
DDC FILE COPY,

FINAL REPORT AC-DC SECTION

CONTRACT DAAK 70-77-C-0035

DDC
APPROVED
JUL 17 1978
RESOLVED
JEF

Prepared for
U.S. Army Mobility Equipment
Research and Development Command
Fort Belvoir, Virginia

Am

This document has been approved
for public release and sale; its
distribution is unlimited.



Delco Electronics

General Motors Corporation
X Santa Barbara Operations
Santa Barbara, California

Goleta
78 06 19 032

14 R78-38
11 APR 1978

(12)

12 111p

6

15kW GENERAL PURPOSE POWER CONDITIONER

(FREQUENCY CHANGER) . AC-DC Section.

9 FINAL REPORT .

AC-DC SECTION

15 CONTRACT DAAK 70-77-C-0035

Prepared for
U.S. Army Mobility Equipment
Research and Development Command
Fort Belvoir, Virginia

DDC
RECEIVED
JUL 17 1978
F

Contract Initiated: *January 1977*
Contract Completed: *April 1978*
Project Engineer: *A.H. Barrett, Delco Electronics*
Program Manager: *R.F. Brewster, Delco Electronics*
Contracting Officer's Representative: *W.D. Lee, MERADCOM*

78 06 19 032
me 406 400 Jim

TABLE OF CONTENTS

<u>Section</u>	<u>Title</u>	<u>Page</u>
	PREFACE	iv
	SUMMARY	v
I	INTRODUCTION	1-1
II	LINE CURRENT HARMONICS	2-1
	2.1 Problem Definition	2-1
	2.2 Basic Converter	2-2
III	STANDARD SOLUTIONS	3-1
	3.1 Harmonic Filter Method	3-1
	3.2 Multiphase Rectification Method	3-2
	3.3 Harmonic Compensators	3-3
IV	DELCO SOLUTION	4-1
	4.1 Background	4-1
	4.2 Delco Converter Configuration	4-2
	4.3 Operating Principle	4-5
V	CONVERTER POWER CIRCUITRY	5-1
	5.1 General	5-1
	5.2 A Two-SCR Resonant Inverter	5-2
	5.3 Four-SCR Resonant Converter	5-3
	5.4 Delco Converter Power Circuitry	5-4
VI	CONVERTER CONTROL CIRCUITRY	6-1
	6.1 General	6-1
	6.2 Isolation and Attenuation Circuitry	6-3
	6.3 Regulator Section	6-5
	6.4 Gate Control Section	6-9
	6.5 Gate Driver Section	6-12
VII	DEVELOPMENT ASPECTS	7-1
	7.1 General	7-1
	7.2 SCR Commutation Failure	7-2
	7.3 Resonant Component Optimization	7-3
	7.4 Three Module Operation	7-5
	7.5 GFE Inverter Checkout	7-7
	7.6 Integration Effort	7-7

ACCESSION for	
NTIS	White Section <input checked="" type="checkbox"/>
DDC	Black Section <input type="checkbox"/>
UNANNOUNCED	<input type="checkbox"/>
JUSTIFICATION	
<i>Letter on file</i>	
BY	
DISTRIBUTION/AVAILABILITY CODES	
D	CHAL
A	

Table of Contents (Continued)

<u>Section</u>	<u>Title</u>	<u>Page</u>
VIII	MECHANICAL PACKAGING	8-1
	8.1 Resonant Converter Module	8-1
	8.2 Input/Output Module	8-1
	8.3 AC-DC Section	8-3
IX	PERFORMANCE SUMMARY	9-1
	9.1 Equipment Description	9-1
	9.2 Summary of Test Data	9-3
X	CONCLUSIONS AND RECOMMENDATIONS	10-1
	10.1 Frequency Changer Input Frequency and Input Current	10-1
	10.2 Voltage Unbalance with Unbalanced Load	10-1
	10.3 Voltage Adjustment Range	10-1
	10.4 Short Circuit Current	10-1
	10.5 No Load Losses, Efficiency at Full Load, Efficiency at Rated Load	10-2
	10.6 Recommendations for Work Prior to Integration	10-2
	10.7 Recommendations for Work After Integration	10-4

APPENDIXES

<u>Appendix</u>		
A	Parts List, Converter Power Components	A-1
B	Parts List, Converter Regulation and Control CCAA1	B-i
C	Parts List, Converter Gate Control CCAA2	C-1
D	Parts List, Converter Gate Drivers CCAA3	D-1
E	Parts List, Converter SCR Isolators CCAA4	E-1
F	Parts List, Input/Output Sense Circuits CCAA5	F-1

PREFACE

The work reported herein was performed by Delco Electronics Division, Santa Barbara Operations, under contract to the United States Army Mobility Equipment Research and Development Command (Contract DAAK70-77-C-0035). The Contracting Officer's Representative was Dr. David Lee at Fort Belvoir, Virginia.

SUMMARY

This report covers effort under Contract DAAK70-77-C-0035 to further develop the ac-to-dc section or converter portion of a 15 kW general purpose power conditioner or frequency changer. Previous Delco effort under Contract DAAK02-72-C-0210 had provided a breadboard system which established the feasibility of using resonant converter concepts coupled with Delco's power center inverter for the 15 kW general purpose frequency changer. MERADCOM testing of the breadboard frequency changer revealed performance deficiencies relative to transient loading and input power line harmonic current generation. The equipment shortcomings were traced to the ac-to-dc section and led, through competitive bid, to the award of the subject contract.

In implementing a new ac-to-dc converter, Delco has again relied upon resonant converters similar to the low frequency, 4-SCR resonant converter used in the early breadboard. To overcome transient performance deficiencies, the new approach uses multiple 4-SCR resonant converters operating at much higher frequencies along with more sophisticated sensing, feedback, and control circuits.

In order to achieve the newly specified low levels of input power line harmonic current distortion without resorting to conventional, excessively heavy methods, Delco has relied upon a new resonant converter configuration which evolved through past internal research and development (IR&D) programs. The present concept was demonstrated and reported as part of the Delco 1977 IR&D activity and has resulted in submission of the concept for GMC patent.

Delco's approach to more effective ac-to-dc conversion is to use a separate converter on each phase of the three-phase input line, with the dc voltage outputs of the three converters appropriately paralleled and controlled for necessary regulation. The ac-to-dc converter on each phase consists of a fullwave bridge rectifier followed by a 4-SCR resonant inverter circuit. The resonant inverter operates at high frequency and incorporates an output transformer for electrical isolation and voltage transformation. Following the transformer is a second fullwave rectifier which provides the required dc

voltage output. Proper control of the high frequency resonant inverters provides the desired conversion and regulation while reducing harmonic currents generated on the input power lines.

This report covers the adaptation of the new Delco converter to the specific requirements of the ac-to-dc converter section of the 15 kW general purpose power conditioner.

The report introduces the problem of current harmonic generation on power lines by non-linear converter systems and illustrates the magnitude of the problem by describing typical performance of various bridge rectifier converters. This is followed by a discussion of typical standard solutions which are applied to achieve reduction of line current harmonics before presenting the new Delco concept and operating principle.

The report then covers the converter electrical implementation in terms of both the power and control circuits. This is followed by a description of the development problem areas, their solution, and a description of the mechanical packaging concept. The report concludes with a summary of the test results reported in detail, in Delco Electronics Report R78-28, and recommendations for further development and improvement.

SECTION I
INTRODUCTION

The MERADCOM purchase description for the AC-DC Section of a 15 kW General Purpose Power Conditioner is essentially a specification for a complete de-link frequency changer system. A block diagram of the required system is shown below.

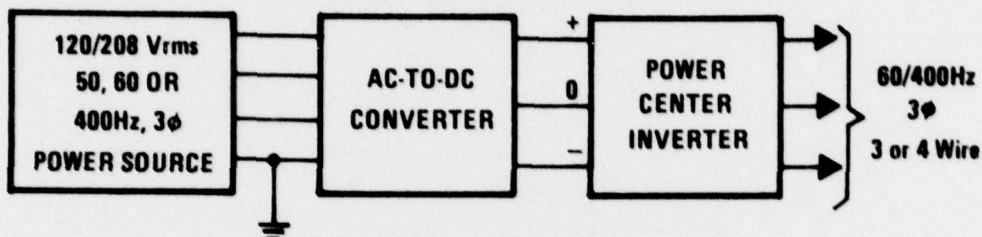

The inverter portion of the frequency changer to be used during development of the AC-DC Section is an Army/Delco-developed power center inverter which produces precision three-phase sinewaves. The power center inverter subsystem has no means of controlling the magnitude of the output sinewaves and, therefore, no means of providing system voltage regulation or current limiting.

The need for voltage regulation is apparent since compensation must be made for input line voltage fluctuations, as well as internal voltage drops, in order to maintain highly stable output voltages. The advantage of current limiting is clear in most power systems; for solid state power systems it is an absolute necessity.

The problem common to all solid state inverter systems is that the dc input to the inverter must have sufficient energy storage capacity to meet specified transient response requirements. When an overload or short circuit occurs, this energy is dumped through a low impedance inverter into the output. Unless some type of current control is provided, the current through the inverter is limited only by the inverter impedance, which is necessarily low in order to provide good transient response.

Current limiting can best be achieved by limiting the input voltage to the power center inverter, since voltage control is required at this point anyway in order to achieve the specified regulation. However, since no voltage control mechanism can act instantaneously, some energy storage reservoir is required in the dc input to handle the transient load.

An effective design must provide a rapidly responding (sub-cycle) voltage control method to minimize energy storage requirements since excessive energy release in the short-circuit mode would, in turn, require needlessly high energy SCR commutation circuits in the inverter.

In previous frequency changer development effort under Contract DAAK02-72-C-0210, Delco made use of a 4-SCR resonant converter to provide the voltage regulation and current limiting functions described. MERADCOM testing of the breadboard frequency changer provided under that contract revealed performance deficiencies relative to transient loading and overloading which were caused, in part, by a lack of sub-cycle sensing and control response in the basic 4-SCR resonant converter. To overcome such performance deficiencies, the new converter approach reported herein uses multiple 4-SCR resonant converters which operate at much higher frequencies along with more sophisticated sensing, feedback, and control circuits.

The MERADCOM purchase description for the AC-DC Section incorporates a new requirement relative to the magnitude of harmonic currents which are generated on the input power lines during operation of the system. This new Army specification was of major concern during the new converter development and was the primary factor which dictated power circuit design configuration and also necessitated control circuit capability beyond the voltage regulation and current limiting functions discussed previously. Since harmonic line current requirements were the major development consideration, the following sections introduce the general problem area and its magnitude as well as standard approaches to partial reduction before presenting the Delco solution and its development in detail.

SECTION II LINE CURRENT HARMONICS

2.1 PROBLEM DEFINITION

All forms of ac-to-dc converters, standard rectifiers, phase-controlled rectifiers, and rectifiers followed by dc choppers (dc-to-dc converters) act as nonlinear loads when operating from an ac power system. Nonlinear loads generate harmonic currents which are fed back to the ac power distribution system. These harmonic currents create voltage drops across source impedances and line inductances which in turn produce distortions of the voltage waveforms in the distribution or transmission lines of the network. The voltage distortions which result not only can cause faulty performance of sensitive electronic systems on the power lines, but can also produce system shutdown and possible destruction. Increasing numbers of very high power solid state converter systems are being used in military and industrial applications. As the power levels and number of users increase the basic problem becomes more and more severe. It therefore becomes highly desirable to provide converters which are essentially current harmonic free if voltage transients and waveform distortion are to be controlled and eliminated on power distribution networks.

Definition of the magnitude of current harmonics which are acceptable or tolerable on a distribution network is an extremely complex task. Power distribution models may be generated and analyzed using computers, but each network is different and, unfortunately, can vary continuously in terms of both user requirements and availability of power generation sources and characteristics. Present commercial power distribution networks place no direct restrictions upon converter equipment current harmonic generation. However, some minimum control results since commercial utility power costs are a function of the load power factor. Since true power factor measurements consist of two elements, a conventional current/voltage phase displacement and a harmonic distortion factor, high harmonic currents result in low power factor and high costs.

Military users are becoming more definitive in specifying the harmonic currents allowable with any given converter. At present, Army specifications require that harmonic currents generated have a total harmonic distortion (THD) of no greater than 5 percent with no

single harmonic greater than 2 percent. The maximum absolute value of the harmonics is determined by applying the percentages to input line current with the converter delivering rated load. Navy requirements are based upon extensive computer analysis of ship-board distribution systems. The values specified for converter equipment appear less restrictive than Army requirements and some developmental systems allow individual amplitudes of 3 percent (each) out to the 32nd harmonic with no restriction on THD.

2.2 BASIC CONVERTER

The bridge converter is the basic unit of any ac-to-dc converter system. In recent years abundant information has become available concerning the performance of such converters using either solid state diodes in the converter or silicon controlled rectifiers (SCRs). In the former case ac-to-dc conversion is achieved with no self-regulation capability in the converter. In the latter case self-regulation is achieved through phase control of the SCRs. Of the two cases, the diode bridge converter exhibits a lower THD with respect to current harmonics produced on the ac power line. The following paragraphs provide a brief description of the basic diode bridge converters commonly used as well as an indication of the distribution and magnitude of the current harmonics each configuration produces on the input ac power line. The discussion is presented in order to indicate the magnitude of the problem which exists. Diode bridge converters are referenced as opposed to SCR bridge converters since they exhibit a lower current harmonic THD and thus illustrate the best performance achievable via the basic converter.

In ac-to-dc bridge converter circuits the generation of harmonic currents in the ac power line is determined to a large extent by the input energy storage element of the filter following the rectifiers. Because of this, the rectifier circuits are usually identified as a choke input type or a capacitor input type and if no filter is used, a resistive input type. Figure 1 provides a concise summary of the line current harmonics produced by each filter type. Figure 1(a) shows the basic diode bridge converter with a generalized load. The converter is usually isolated from the three-phase ac power line by an input transformer which also provides any desired voltage step-up or step-down. For simplicity the transformer has not been included in the circuit.

Figure 1(b) summarizes the inductive input filter converter performance. The diagram on the left provides the "load" schematic for Figure 1(a). In this case it is an inductor followed by the dc load resistance. The center diagram shows the line voltage and line

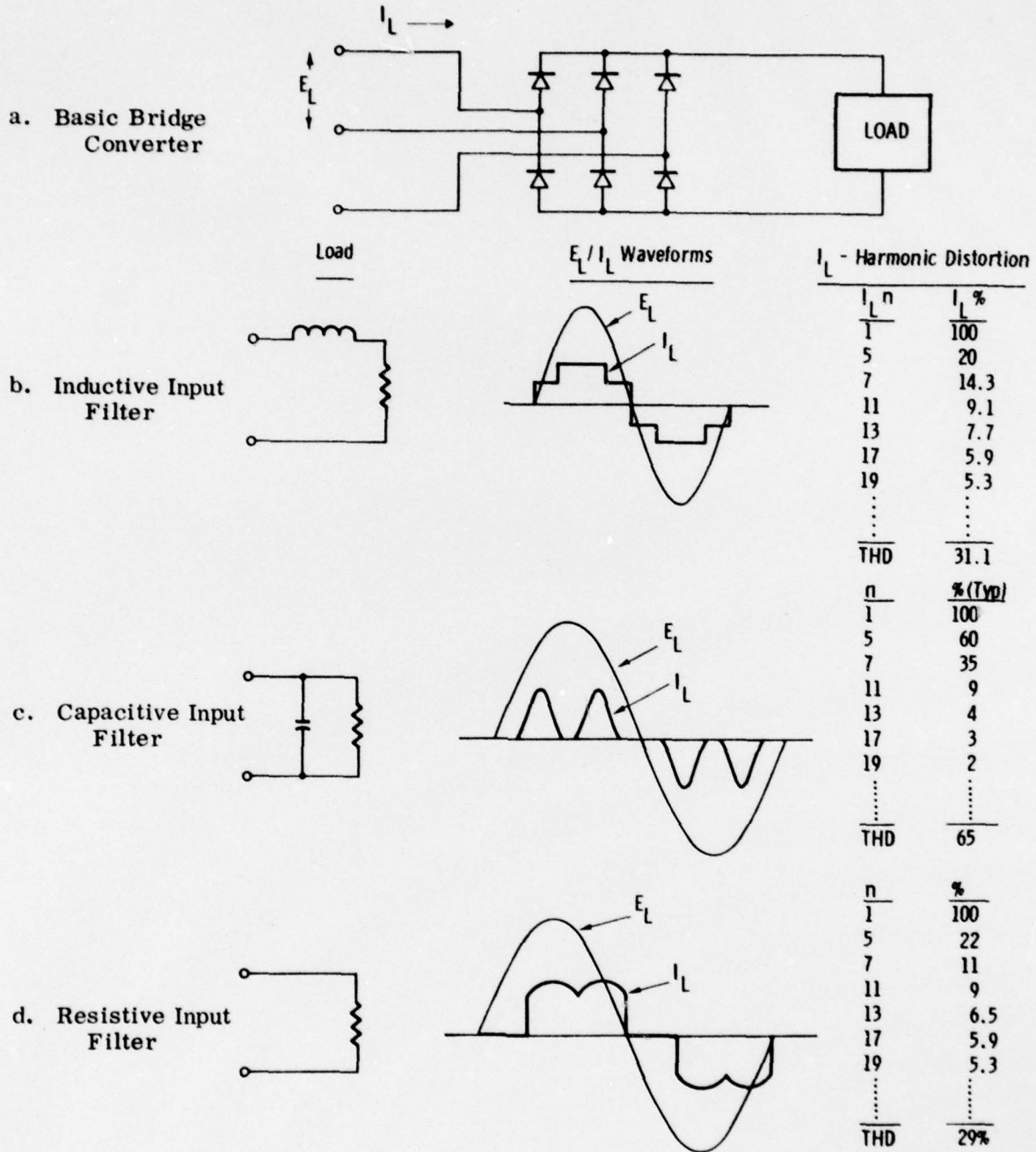

Figure 1. 3Ø Bridge Converter Summary

current waveforms which result. The source voltage waveform is shown as a pure sine-wave which assumes very low source, line, and input transformer impedances (that is, ideal source). The stepped current waveform would result in any converter which uses a very large value of inductance in the filter. The listing at the right shows the magnitude of the significant current harmonics which exist in the current waveform and the THD which results.

Figure 1(c) summarizes performance with a capacitive input filter. The current waveform and harmonic current magnitude information are shown for a typical high value of filter input capacitance. If the value of capacitance is increased the conduction times for the "double hump" current waveforms becomes shorter and current harmonics become larger. Conversely, decreasing capacitance increases conduction times and the magnitude of the current harmonics decreases.

Figure 1(d) provides similar information for a resistive input filter. In most three-phase input converters this is not a practical approach and it is extremely limited in application. The summary is included here for comparison purposes and later reference.

The conclusion to be drawn from Figure 1 is that all basic converter circuits produce large magnitude current harmonics on the ac power lines. The current THD for an inductive input filter is greater than 30 percent, a typical capacitive filter is greater than 60 percent and a purely resistive load is greater than 25 percent. It is again reiterated that a basic bridge converter which includes a self-regulation capability uses SCR's to achieve phase controlled rectification and results in higher current THD's on the primary lines than those summarized in Figure 1.

SECTION III
STANDARD SOLUTIONS

The power line harmonic currents which result when using basic bridge converters are obviously of unacceptably large magnitude. The THD's are such that most users have applied various corrective solutions. The primary motivation has been the cost of utility power. As was previously stated, high line current THD's result in excessively low power factors which in turn increases costs per kilowatt of power delivered to the load. The standard solutions which have evolved and been applied are summarized below.

3.1 HARMONIC FILTER METHOD

Conventional series-resonant filters, as depicted in Figure 2 are commonly connected to the ac terminals of the rectifier in order to supply a shunt path for the harmonic currents. Filters tuned to the fifth and seventh harmonics are as shown. The eleventh and higher harmonics are attenuated by line-to-neutral connected capacitors. Independent automatic tuning of each series-resonant filter branch, through variation of the branch inductance or capacitance, can be used to ensure that the filter remains effective for ± 5 percent variations in input power frequency. The ac line filters are, in general, large and not completely effective. Properly tuned line filters for power converters can achieve reduction of approximately 45 percent of the fifth harmonic, 85 percent of the eleventh harmonic, and correspondingly greater reduction in the higher harmonics.

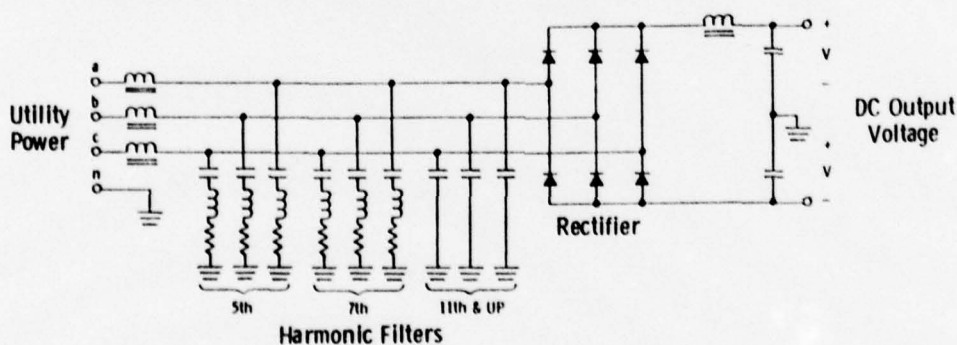

- I_L (Input) THD reduction (typical) from 31 to 45%
- Complex for multifrequency inputs
- Power filters "track" poorly
- Large and heavy

Figure 2. Harmonic Filter Method

3.2 MULTIPHASE RECTIFICATION METHOD

The basic converter uses a three-phase full-wave bridge rectifier circuit. It is possible to produce any number of phases from the basic three-phase system by introducing "stub" windings on the secondary basic leg windings. As the number of phases increases the amplitude of the current harmonics produced on the input power lines decreases. Typical installations use multiphase transformers and rectifiers that are odd multiples of three phases in order to obtain a doubling effect in the dc output voltage ripple frequency as well as achieve input line current harmonic reduction. A nine-phase rectification solution is shown in Figure 3. It is considered as a standard solution since the next odd multiple of three phases would be fifteen-phases where it becomes extremely difficult to wind the required transformer or achieve predicted improvements in current harmonic reduction.

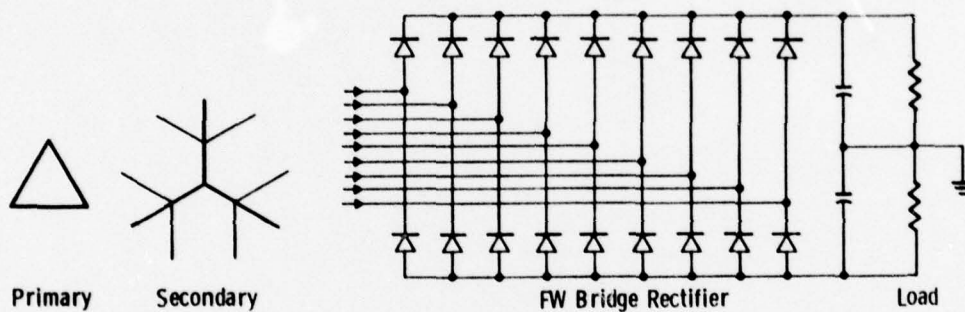

- I_L (Input) THD 7%, 17th harmonic and up
- Secondary utilization factor - 0.463
- 15 kW, 0.8 pF unit requires 40 kVA transformer
- Large weight penalty

Figure 3. Nine-Phase Rectification Solution

The nine-phase solution provides fairly low line current THD's with individual harmonics being relatively high in frequency. The penalty paid for the improved performance is associated with the transformer weight. This comes about because of a required increase in the voltampere capacity of the secondary windings. As the number of secondary windings increases beyond a theoretical optimum of 2.69 phases, each winding is utilized for less time, the secondary voltampere capacity increases and the weight and volume increase as well. The multiphase rectification solution has been found acceptable in those industrial and military applications where the weight/volume penalty can be accommodated.

3.3 HARMONIC COMPENSATORS

A third solution which has been implemented in some industrial applications involves the introduction of harmonic compensator generators. In this approach harmonic currents are injected to cancel the harmonic currents generated by the main converter. The injected currents are produced by suitable combinations of auxiliary generators and energy storage elements across the three-phase power system, usually on the secondary of the input transformer. The generalized approach is shown in Figure 4 where the current source generators can be called harmonic compensators. The harmonic compensators can be readily designed to eliminate the dominant harmonic at a specific load, but the design becomes very complex if all major harmonics are to be reduced to maintain low THD and power factor over a large load range. For the general application which involves multiple and varying input frequency plus a large load range, the design becomes extremely complicated, expensive, and excessively heavy.

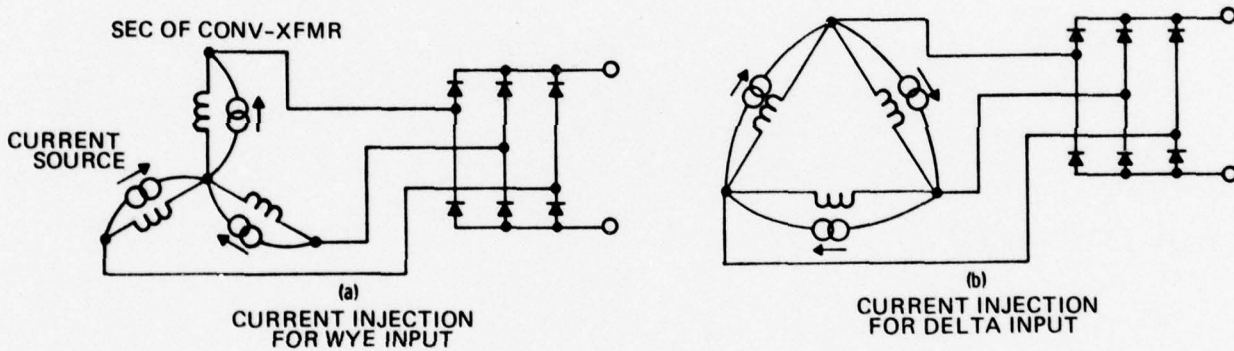

Figure 4. Harmonic Compensation Generators

SECTION IV
DELCO SOLUTION

4.1 BACKGROUND

Through internal research and development programs over the past 6 years, Delco Electronics has studied solid state power conditioner systems and their application to a broad range of power requirements. This activity has included development of ac-to-dc converters which provide for significant reduction of the current harmonics produced on the input power lines. The converter configurations which Delco has pursued make use of basic bridge converters followed by dc-to-dc converters (or choppers) which provide necessary regulation and control.

In general the dc-to-dc converter must have a low output impedance and provide rapid, precise voltage regulation from full voltage down to very low voltage in order to meet current limiting requirements imposed on the overall converter. To achieve rapid response, high efficiency and small size, the chopper section must use high-frequency dc switching regulation. The dc-to-dc converter could be implemented using standard transistor or SCR chopper circuits which use pulse frequency modulation (PFM) or pulse width modulation (PWM) to achieve the required regulation and control. However, Delco has selected the resonant sinewave inverter as the basic module for performing the high frequency dc switching function. The converter module uses pulse frequency modulation (PFM) into a series resonant power circuit to achieve output pulse amplitude modulation (PAM) and control response, which yields the desired performance.

Figure 5 provides a concise summary of the typical performance achievable through use of a standard chopper-configured ac-to-dc converter. The upper portion of Figure 5 shows a simplified diagram of the conventional three-phase full-wave bridge rectifier followed by a high frequency dc-to-dc converter. The dc-to-dc converter used to obtain the data supplied in the lower portion of the figure was the resonant converter discussed above, but similar data would result from all well designed high frequency chopper configurations. The waveforms and harmonic current data were taken with a 6 kW load on the converter as shown. The line voltage waveform suffered some degradation in voltage THD due to the relatively high impedance of the laboratory source interacting with the extremely

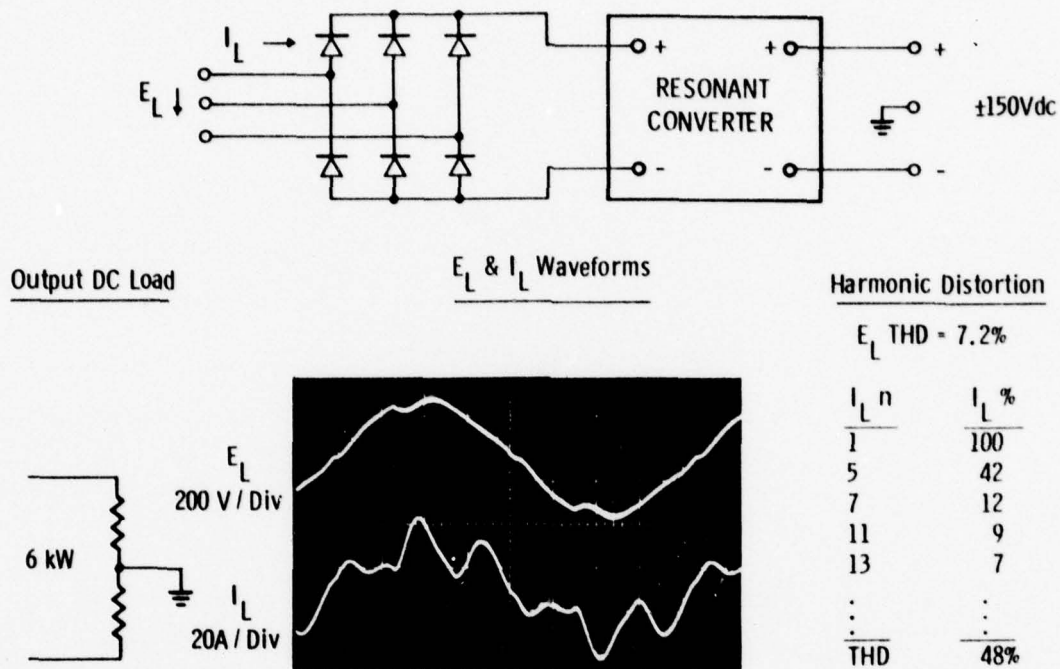

Figure 5. Standard Chopper Converter Configuration and Performance

distorted line current wave shapes which resulted. As stated in the figure, the line current THD was a totally unacceptable 48 percent for this standard configuration.

4.2 DELCO CONVERTER CONFIGURATION

Using the resonant converter modules in combination with bridge rectifiers, Delco has conceived a new ac-to-dc converter configuration which achieves significant reduction of current harmonics produced on the input power lines while simultaneously providing required regulation and control. A block diagram of the Delco ac-to-ac converter configuration is shown in Figure 6.

The Delco approach uses a separate ac-to-dc converter on each phase of the three-phase input line with the dc voltage outputs of the three converters appropriately paralleled and controlled to provide necessary regulation. Proper control of the high frequency resonant converters or choppers results in the desired ac-to-dc conversion as well as providing superior performance in terms of harmonic currents generated on the input power lines.

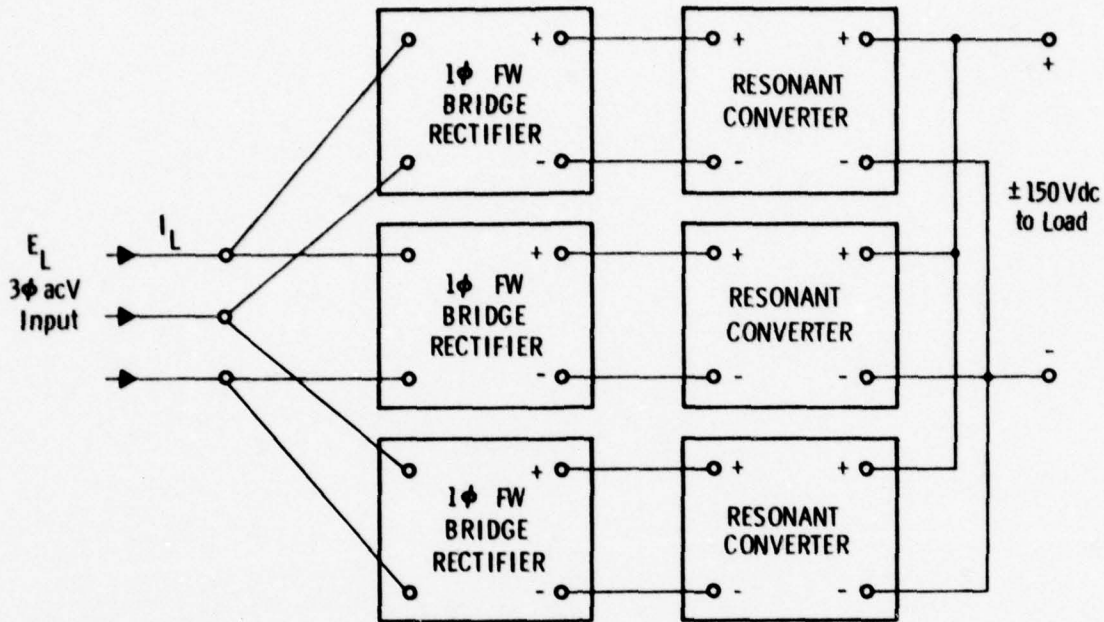

Figure 6. Delco Converter Configuration

Figure 7 shows a summary of the performance achieved with the Delco configuration at a load of 6 kW. Figure 7 may be directly compared with Figure 5 to illustrate the tremendous improvement in both line voltage THD and line current THD which results from the new approach. The reduction in line voltage THD from 7.2 percent to 2.8 percent is a direct result of the large reduction in current harmonics generated on the power line. The improvement in line voltage THD serves to illustrate that even soft or relatively high impedance power sources (that is, the Delco laboratory three-phase Variac and isolation transformer) can maintain sine waves of voltage if the harmonic currents injected on the lines are small.

The only difference between the hardware implementation of the ac-to-dc converters of Figure 5 and Figure 6 is associated with the fact that six diode rectifiers are used in Figure 5 and twelve diode rectifiers (four per each 1ϕ fullwave bridge) are used in Figure 6. The resonant converter of Figure 5 actually used three converter modules identical to those of Figure 6 except that both the input and output were paralleled. Three modules were used in Figure 5 in order to achieve the same output power levels as the new converter of Figure 7.

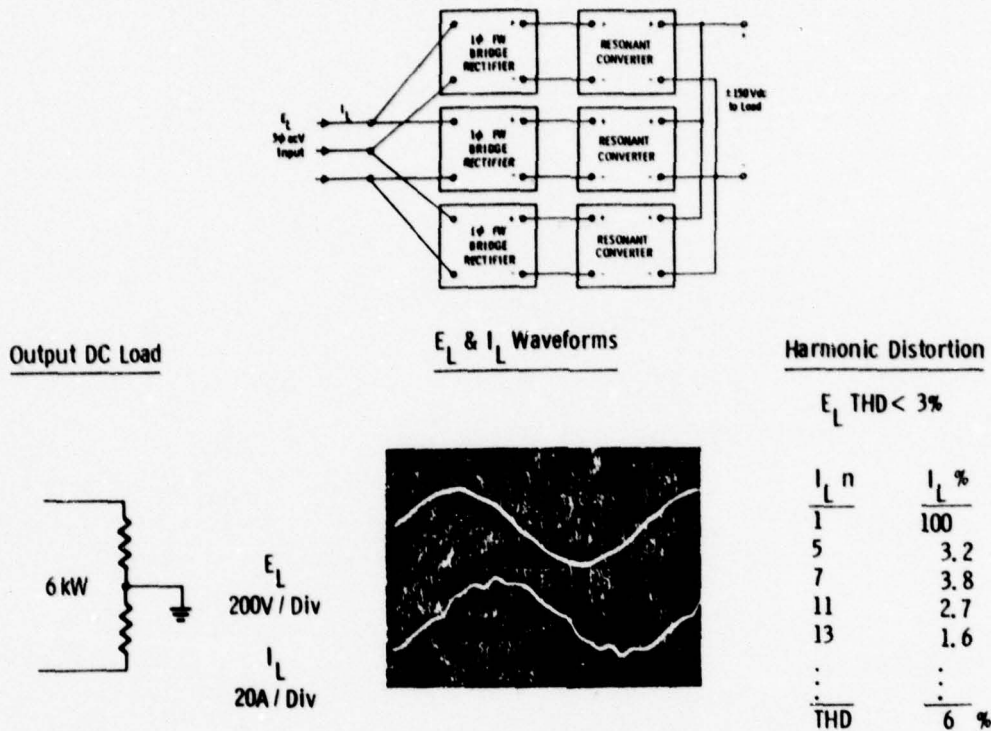

Figure 7. Delco Converter Performance at 6 kW

The new Delco converter as shown by Figure 6 was designed to provide 18 kW at 300 volts dc. (Any desired dc voltage can be provided simply by changing the turns ratio of the high frequency transformer used in each resonant converter module.) Figure 8 provides a performance summary of both the input voltage and current THD achieved at various load power levels for the converter. It can be seen that near rated load, the line current THD is below 3 percent. It should be pointed out that the higher current THD (6 percent of actual load current) at the light, 6 kW, load of Figure 7 converts to 2 percent THD when normalized to the 18 kW rated load.

The impressive current harmonic performance of the new Delco ac-to-dc converter is achieved without resorting to one of the large, heavy and complex standard solutions presented in Figures 2, 3, and 4. In fact, the new converter configuration is no more complex than the common rectifier plus dc-to-dc chopper converter shown by Figure 5. Discussion of the basic differences between the configuration of Figure 5 and the new concept of Figure 6 provides an understanding of the reason for such superior performance.

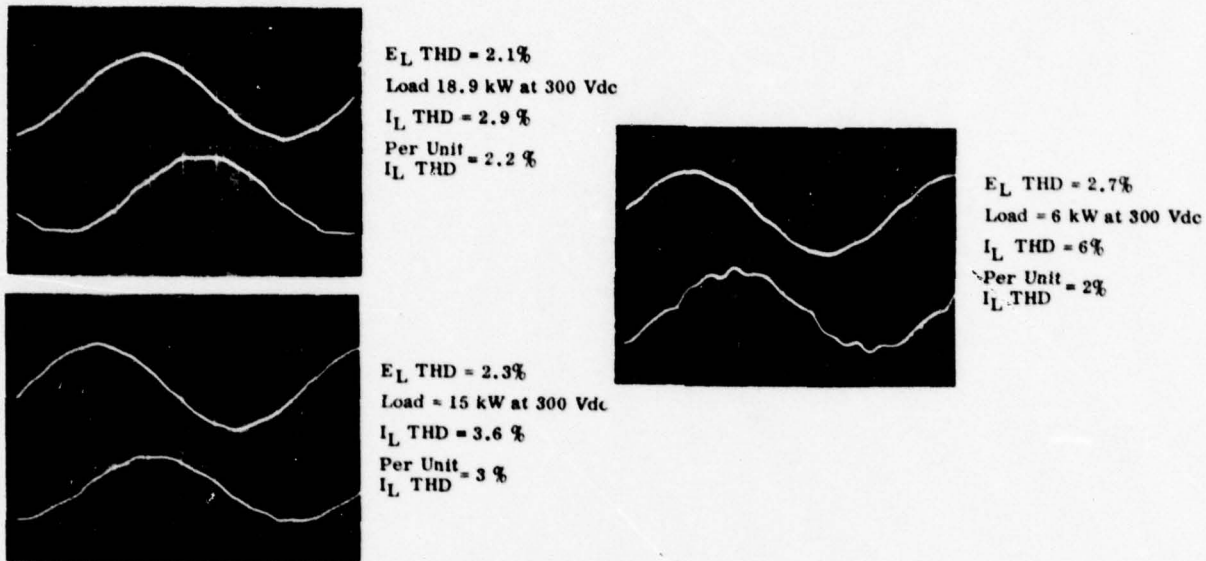

Figure 8. Rated Load Performance

4.3 OPERATING PRINCIPLE

A functional understanding of why the new configuration provides such a dramatic reduction in line current harmonics can be realized through discussion of the rectification mechanism at the input to the converter. The previous discussion associated with Figure 1 provided a summary of the current harmonics which appear on the input power lines as a result of the three-phase, full-wave bridge, rectification process. Figure 1(d) indicated that the lowest current THD obtainable was 29 percent with a purely resistive load on the rectifiers. The new converter concept uses single-phase, full-wave bridge rectifiers on each phase of three-phase power line input. Figure 9 summarizes the current harmonic performance achievable using single-phase, full-wave bridge rectification with an ideal, purely resistive load.

As the figure indicates, this type of rectification process results in line current waveforms which conform to the shape of the input line voltage waveform. With a resistive load and ideal diodes in the bridge circuit there is a path for current to flow from the

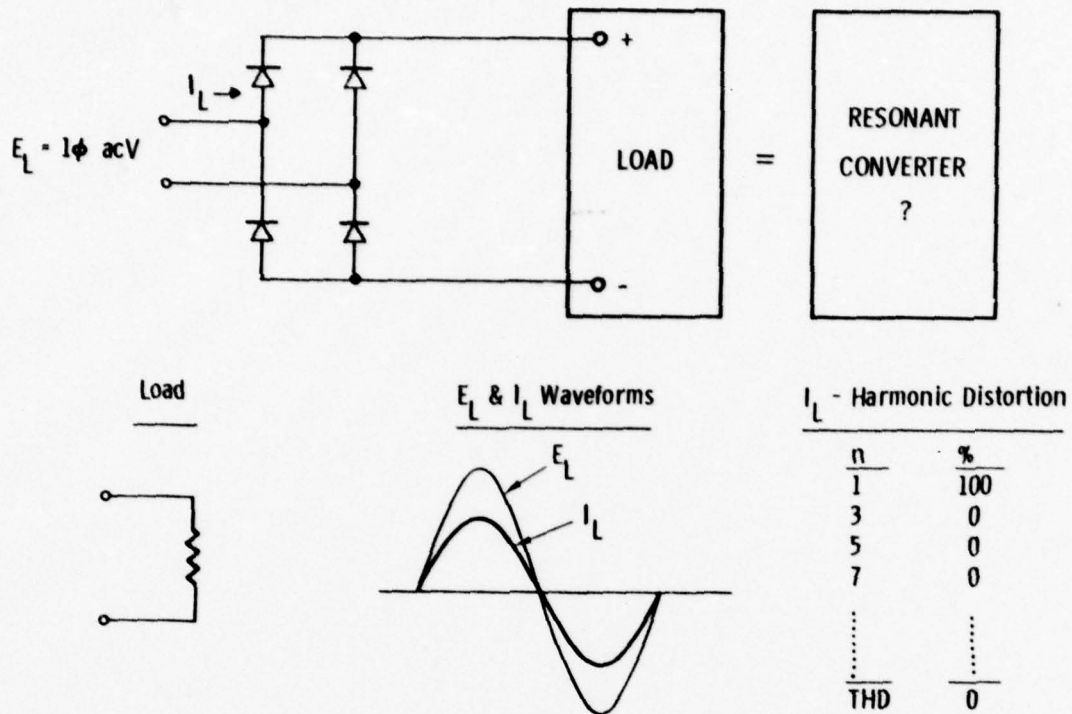

Figure 9. 1Ø, Full-Wave Bridge, Rectification Current Harmonic Performance

source through the load during both positive and negative swings of the source voltage. This form of rectification process is not normally useful since the voltage developed across the load is in the form of half sinusoids which is not acceptable for most dc loads. Adding filter elements across the resistive load results in the injection of current harmonics on the input lines similar to that summarized by Figures 1(b) and (c).

Since large filter elements cannot be included after rectification without adversely affecting line current harmonics, it is desirable for any dc-to-dc chopper or converter included at this point in the circuit to present essentially a resistive impedance to the bridge rectifiers. The resonant converter block in Figure 9 poses the question: Does the Delco high frequency resonant converter approximate a resistive load? Figure 10 shows a brief summary which is intended to show that dc-to-dc choppers followed by transformer rectifier circuits can, as a first approximation, be considered to present a resistive load to the input rectifier circuit. The transformer and rectifier combination shown at the output

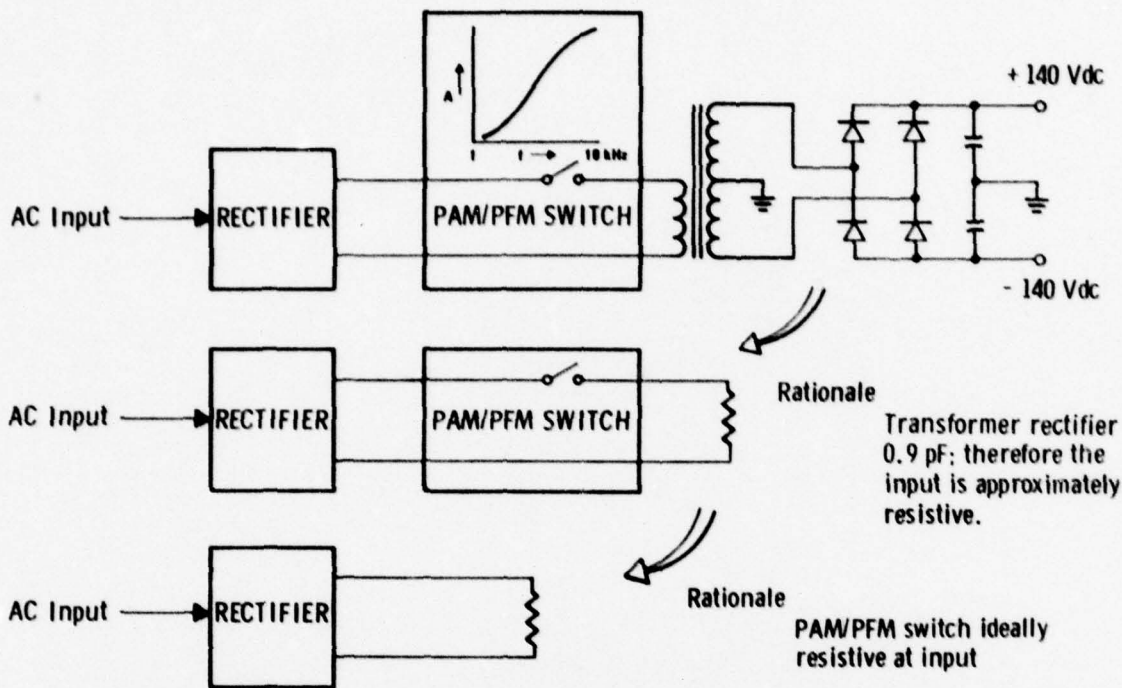

Figure 10. DC-to-DC Converter, Simplified

of the circuit (top right, Figure 10) represents a 0.9 power factor (that is, highly resistive) load to the chopper or converter circuit. Figure 10 implies a resonant converter as the switching element, but all forms of the high frequency chopper circuit can be approximated by the ideal switch shown. In any case the ideal switch transforms the resistive transformer/rectifier load as a resistor directly across the input single-phase, full-wave bridge rectifier. The rationale of Figure 10 suggests that, to the extent that the chopper circuit approximates an ideal switch, the load on the input rectifiers may be sufficiently resistive to greatly reduce the harmonic line currents generated.

Figure 11 provides a measure of just how close the resonant converter comes to presenting a purely resistive load to the single-phase, fullwave bridge rectifiers. The current harmonics injected on the input line are considerably less than those resulting from the three-phase, full-wave bridge connection of Figure 5 (26.5 percent THD vs 48 percent THD); however, the result is far greater than that achieved with a resistive load on the single-phase bridge connection. The 26.5 percent THD results from the fact that the resonant converter requires some nominal capacitance at the input (as shown in Figure 11)

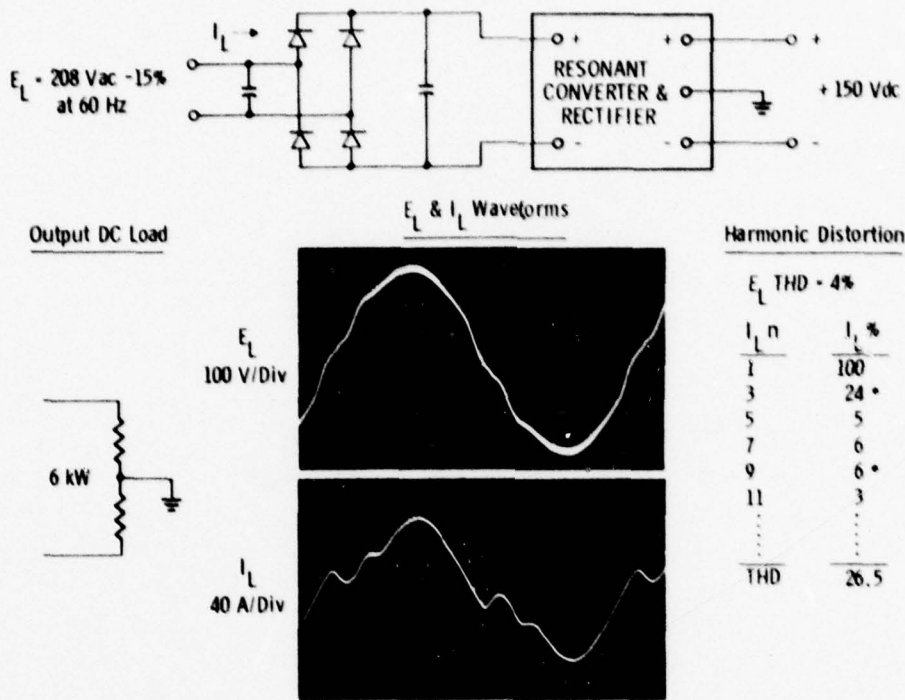

Figure 11. 1 ϕ Converter Actual Performance

in order to function properly. The nominal capacitance shortens the conduction angle of each diode to something less than the ideal 180 degrees achieved with a resistive load and results in the line current waveform shown in the figure. The waveforms of Figure 11 reinforce the previous conclusion that it is desirable for the dc-to-dc converter to present a purely resistive load to the rectifier bridge. Clearly, the resonant converter does not. It is possible that other forms of dc-to-dc converter may provide superior performance when operating as the single-phase ac-to-dc converter module of Figure 11.

Despite the relatively high current THD resulting from each single-phase converter module, when the circuit as shown in Figure 11 is expanded to the three-phase ac-to-dc converter configuration shown in Figure 6, the performance results reflect the tremendous reduction in line current THD shown by Figures 7 and 8. The reason for such a dramatic improvement with the three-phase connection lies in the distribution of the current harmonics which result from each single-phase converter module. The right-hand table of Figure 11 shows that the major current harmonic distortion contributors are the third and ninth harmonics of the fundamental power line frequency. These harmonics are commonly referred to as

triplen harmonics (that is, $3n \times$ fundamental, where n is an integer). In a balanced three-phase system, the triplen harmonics produced in any one phase are completely cancelled by the triplen harmonics produced by the remaining two phases (the instantaneous sum of the triplen components in a balanced three-phase system is equal to zero). Therefore, the basic criterion for successful operation of the new Delco converter configuration is that the dc-to-dc converter following the one-phase, full-wave bridge rectifier must present either a purely resistive load or have such a low reactive component that primarily triplen harmonic currents are generated when operating in a single-phase mode.

SECTION V
CONVERTER POWER CIRCUITRY

5.1 GENERAL

It was pointed out previously in the background discussion in Section IV that the resonant sinewave inverter has been selected as the basic module for achieving the necessary dc-to-dc converter function in each phase of the input line voltage. The input voltage from each phase is rectified and yields unregulated dc voltage at the input to the dc-to-dc converter. The unregulated dc voltage is converted to high frequency quasi-sinewaves by the resonant inverters and passed through coupling capacitors and a high frequency isolation transformer to a second full-wave rectifier and filter, thus providing regulated dc voltage. Regulation is achieved by changing the operating frequency of the inverter, hence causing the reactance of the resonant circuit formed by the coupling capacitors and power circuit inductances to change and thus also change the output voltage from the isolation transformer.

The dc-to-dc converter uses bridge-type inverters similar to those found in various power converter and inverter applications. The major difference between a standard bridge circuit and the resonant bridge circuit is that with the conventional types, the internal current pulses are square in shape, whereas in the resonant inverter the current pulses are half sinusoids.

The resultant soft switching of devices reduces stress and EMI, and allows higher frequency operation of the basic inverter. Although the resonant inverter may be implemented with either transistors or SCRs as the power switching devices, the approach is ideally suited to SCRs for the following reasons:

- Turn-on losses are low due to the slow rising currents
- Small snubbers are required because dv/dt is low
- Pulsed drive, as opposed to continuous gate drive, is adequate
- Natural commutation is inherent; no additional forced commutation is required
- Commutation losses are very low
- Current limiting is inherent; commutation is fail-safe
- Available SCRs have power-bandwidth products in excess of requirements.

The approach is best understood when developed in terms of a basic resonant inverter module which generates the half-sinusoids of current.

5.2 A TWO-SCR RESONANT INVERTER

Figure 12 shows a simple resonant inverter circuit. L_1 , C_1 , and R_L constitute a series RLC resonant circuit which is driven by a square wave generated by SCRs Q_1 and Q_2 . If Q_1 and Q_2 are triggered at a frequency below resonance, they are self- (or naturally) commutated. Q_1 generates a positive half-cycle at the end of which the RLC tank circuit current reverses and diode CR_1 conducts. Q_1 is reverse-biased and, hence, commutated off while CR_1 is conducting and C_1 charges to a high positive value. Q_2 is triggered some time after Q_1 is reverse-biased, which recharges C_1 to a high negative value when Q_2 commutates off, thus allowing Q_1 to be turned on again. The period required for commutation of Q_1 and Q_2 limits the upper operating frequency.

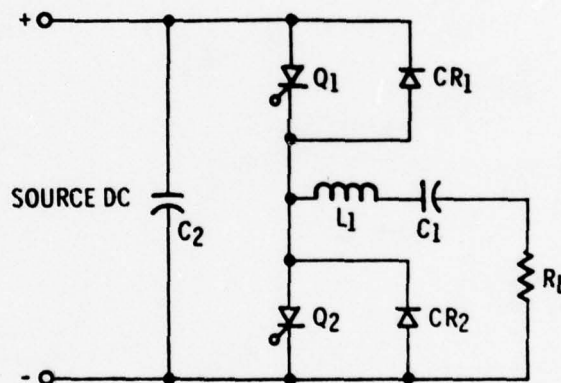

Figure 12. Two-SCR Resonant Inverter

For reliable commutation all that is necessary is the assurance that this period is never less than the minimum recovery time required by the SCRs chosen for Q_1 and Q_2 . There is no lower limit on operating frequency.

There is a functional relationship between the energy dissipated in the resistor R_L and the trigger frequency. This relationship, the only one by which output control is achieved, is smooth and monotonic. R_L may be replaced by an output rectifier, filter, and load resistor to provide a half-wave dc-to-dc converter as shown by Figure 13.

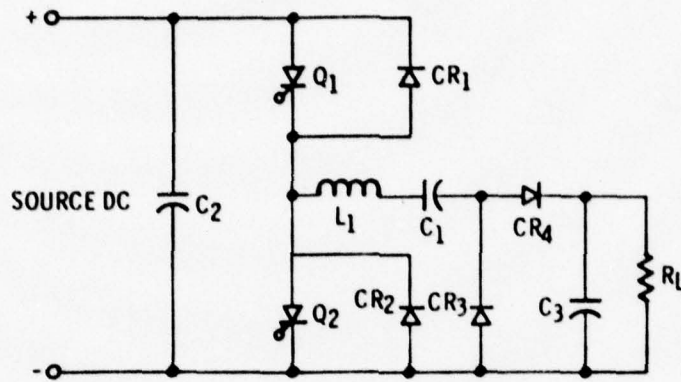

Figure 13. Half-Wave dc-to-dc Converter

5.3 FOUR-SCR RESONANT CONVERTER

The simple circuits of Figures 12 and 13 are extended to the circuit of Figure 14, a full-wave resonant converter. Note that full-wave operation is obtained by triggering Q_1 and Q_4 simultaneously and alternating that triggering with the simultaneous triggering of Q_2 and Q_3 . Full-wave operation not only doubles the output power capacity of the converter, but drastically reduces the size of the filter capacitors required. Since capacitors C_1 and C_2 provide isolation, R_L may be referenced to any point and not necessarily to the negative line shown.

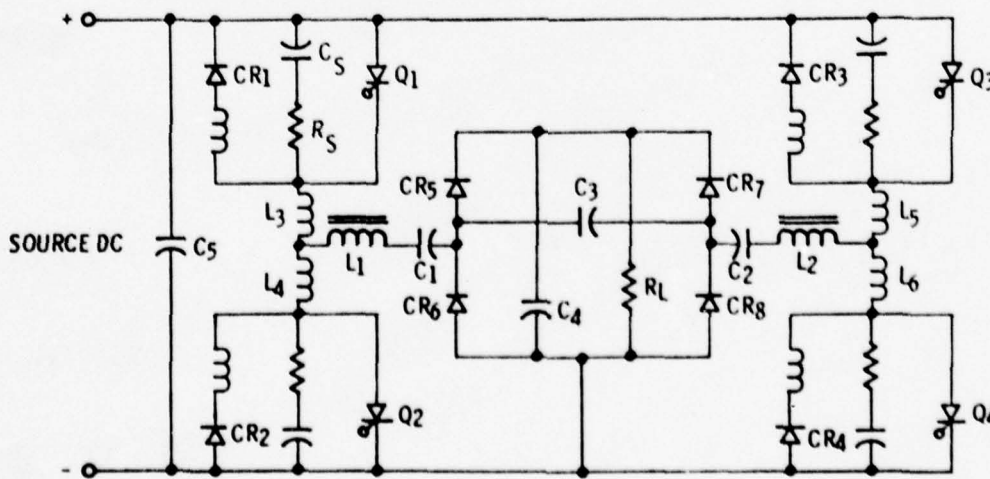

Figure 14. A Four-SCR Resonant dc-to-dc Converter

In addition to the extension to a full-wave circuit, Figure 14 indicates several circuit refinements which have been found to be highly desirable. The primary functions of the additional components are as follows:

- C_s and R_s are RC-type snubbers which reduce reapplied dv/dt
- L_3 , L_4 , L_5 , and L_6 aid snubber action, limit di/dt , and reduce turnon losses.
- C_3 increases turnoff time.

Although the circuit of Figure 14 is useful for supplying power to well-behaved loads, rapidly varying loads can cause commutation failure. This problem is circumvented by the use of commutation monitor circuitry which functions as follows:

- The conduction states of Q_1 , Q_2 , Q_3 and Q_4 are continuously monitored
- If, for example, Q_1 and Q_4 are conducting, Q_2 and Q_3 are not permitted to receive triggers.
- Q_2 and Q_3 are not permitted to receive triggers until Q_1 and Q_4 have been reverse-biased at least long enough to assure their ability to block the forward voltage produced when Q_2 and Q_3 are triggered.

5.4 DELCO CONVERTER POWER CIRCUITRY

By adding input rectifiers and an isolation transformer, the circuit of Figure 14 can be altered to achieve the basic power circuit which forms the basis for each one-phase ac-to-dc converter. The resulting power circuit which incorporates these changes is shown in Figure 15.

Operation of the 4-SCR resonant inverter portion of the module is identical to that presented in reference to Figure 14. The circuit of Figure 15 appears somewhat simpler since the resonant circuit components L_1 , L_2 , C_1 , and C_2 of Figure 14 are replaced by L_Y , C_Y , and T_1 in the final configuration. C_Y of Figure 15 resonates with the sum of the leakage inductance of isolation transformer T_1 and L_Y which is designed to be equivalent to the sum of L_1 and L_2 of Figure 14.

T_2 is added to sense shut-off intervals for the positive side SCRs, Q_1 and Q_3 , and for the negative side SCRs, Q_2 and Q_4 . Control logic, discussed in Section VI, is used to ensure a minimum duration in excess of the design T_q .

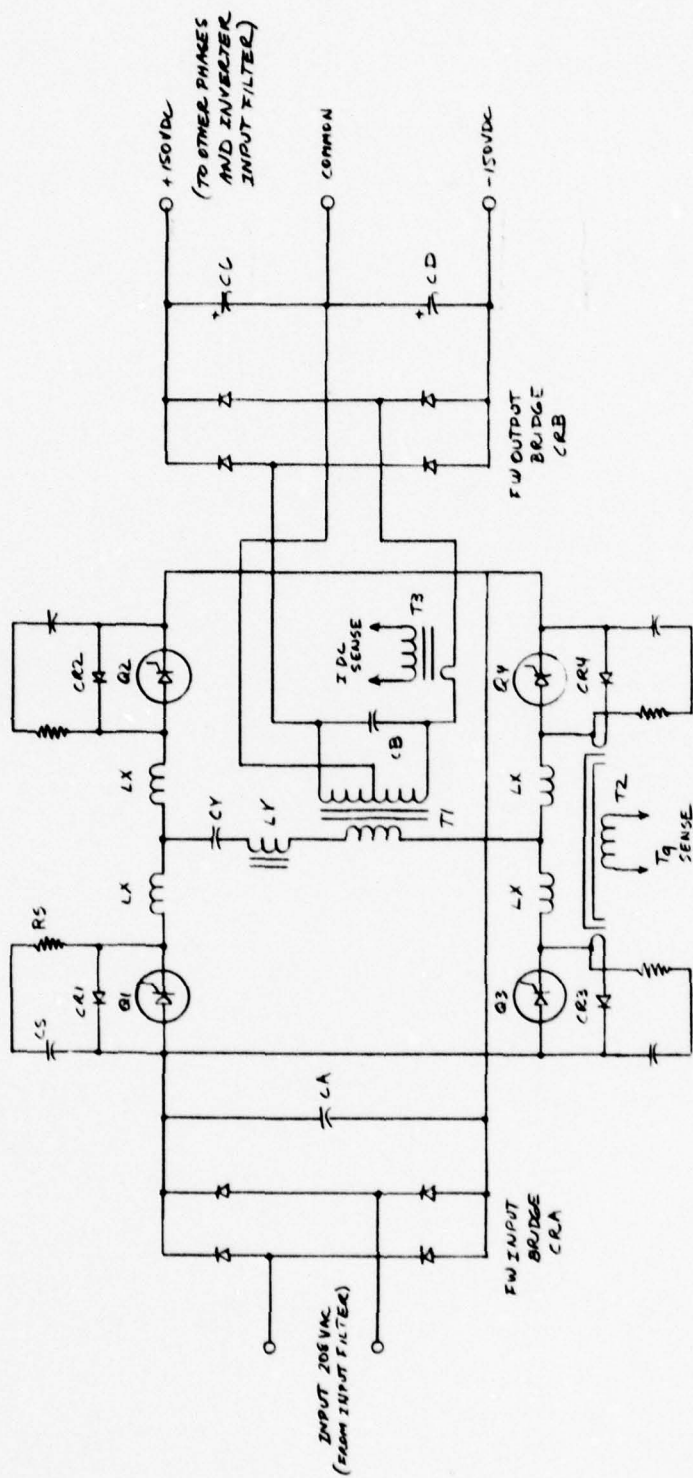
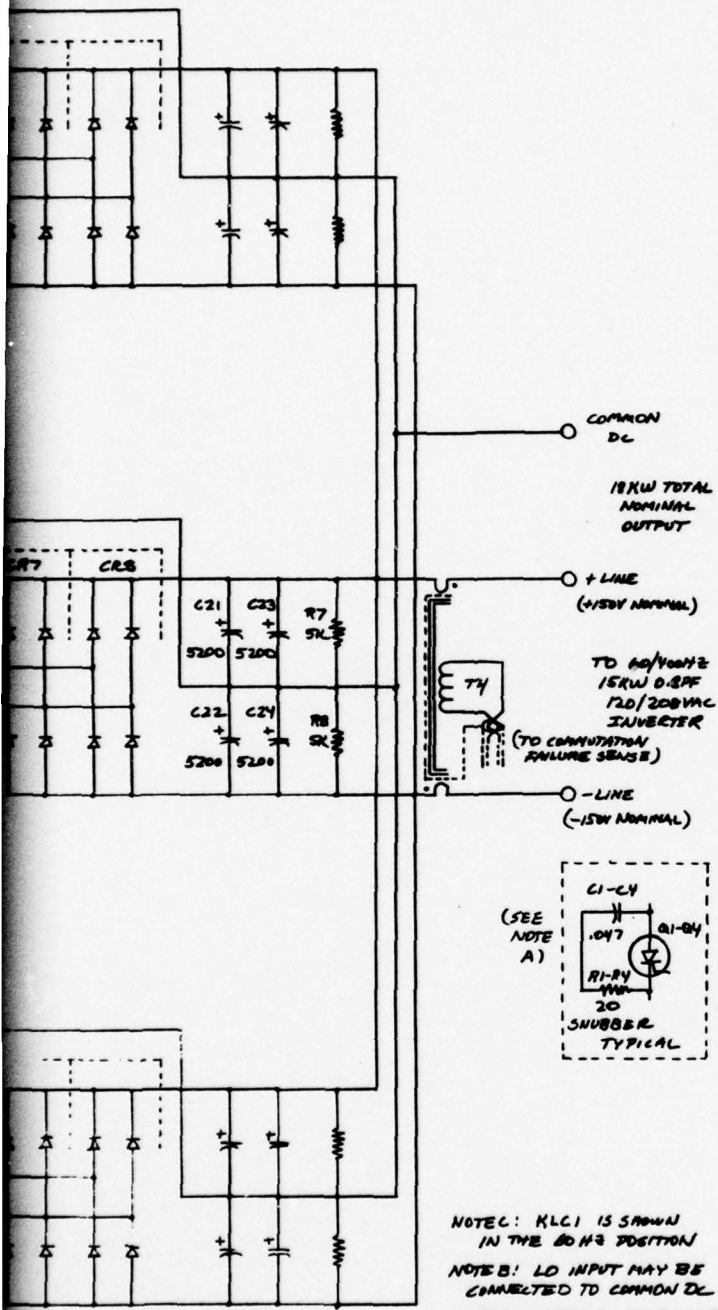

Figure 15. Single-Phase Converter Schematic

T_3 is added to sense transformer T_1 primary current. This sense signal is rectified in the control logic to provide a control voltage approximately proportional to the phase direct current output.

Figure 15 represents a single-phase converter equivalent to one block of the full three-phase converter depicted in Figure 6. A power schematic diagram including an input filter for the full three-phase converter is shown in Figure 16. A detailed electrical parts list for the circuit of Figure 16 is given in Appendix A.



COMMON DC
18KW TOTAL NOMINAL OUTPUT

+ LINE (+150V NOMINAL)

T4
TO COMMUTATION FAILURE SENSE

- LINE (-150V NOMINAL)

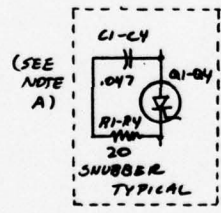

NOTE C: KLC1 IS SHOWN IN THE 60HZ POSITION

NOTE B: LD INPUT MAY BE CONNECTED TO COMMON DC

NOTE A: SNUBBERS ON ALL SCRS

Figure 16. Three-Phase Converter Schematic

2

SECTION VI
 CONVERTER CONTROL CIRCUITRY

6.1 GENERAL

When the converter is used in a frequency changer as compared with its use as an independent regulated dc power supply, there is a major impact on the complexity of its control circuitry. In the former, several additional control inputs are necessary. Requirements are compared in Table 1.

	<u>Control Input</u>	<u>Regulated dc Supply</u>	<u>Frequency Changer</u>
1.	Converter commutation protection	Desirable	Necessary
2.	Converter output voltage, V_{DC}	Necessary	Necessary
3.	Converter output current, I_{DC}	Desirable	Necessary
4.	Converter output current – each phase, I_{AC}	Desirable	Desirable
5.	Converter di_{dc}/dt (failed inverter commutation)	Unnecessary	Necessary
6.	Inverter output voltage (average of three phases), V_{AC}	Not applicable	Necessary
7.	Inverter output current – each phase (highest of 3 controlled)	Not applicable	Necessary

Table 1. DC Power Supply and Frequency Changer Control Requirements

It is evident from Table 1 that the control circuitry which might be developed for a stand-alone regulated dc power supply would be necessary, but not sufficient in a frequency changer. It was necessary therefore, in developing control circuitry for the AC-DC Converter, to design it for the frequency changer use.

A block diagram showing the implementation of the seven different control inputs of Table 1 is given in Figure 17. Each of the control signals is passed through isolation and attenuation circuits. V_{DC} is not completely isolated, but is differentially sensed by an amplifier with good common-mode rejection. All other signals are isolated by transformers and then attenuated with resistive dividers.

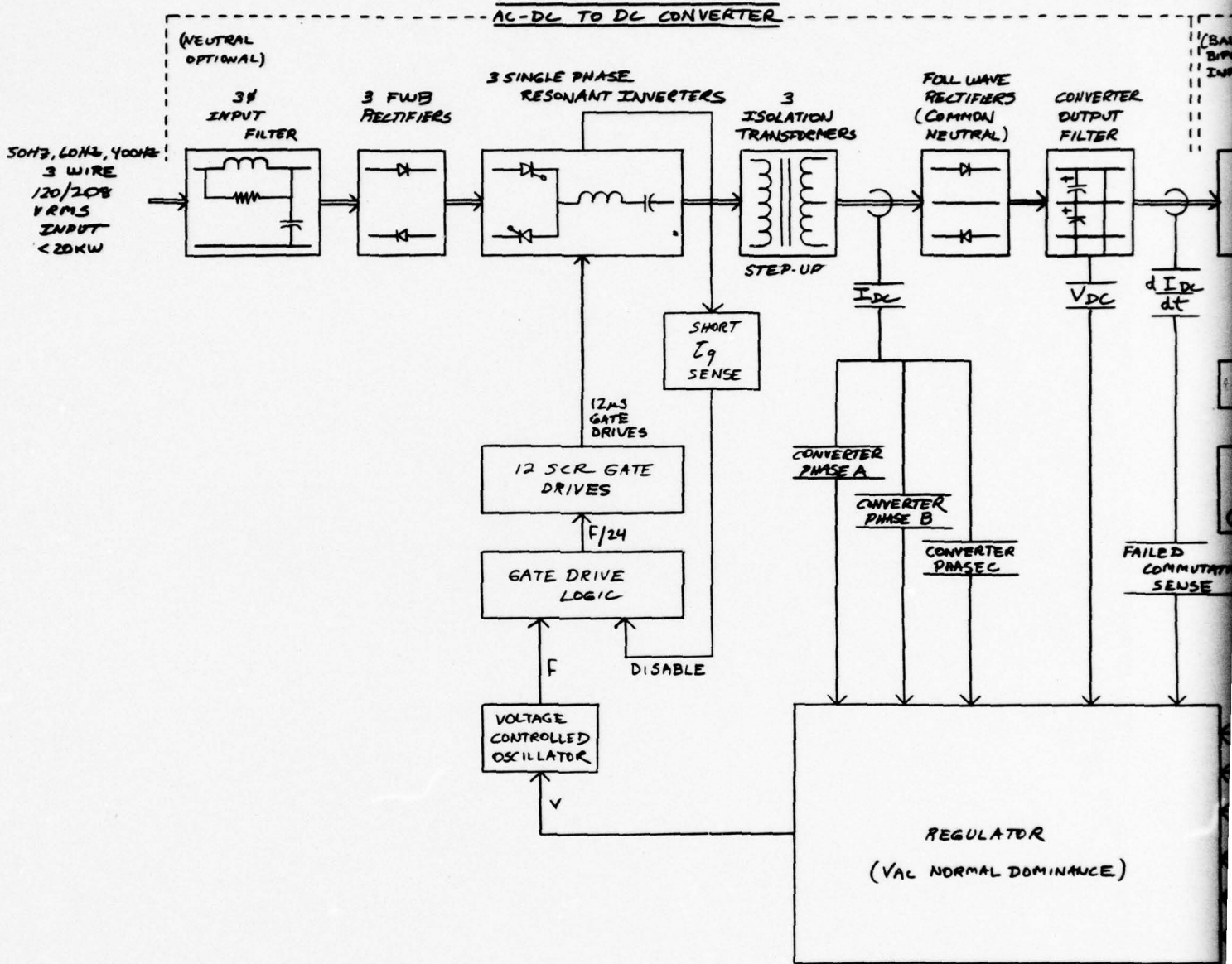

NOTES ON REGULATOR:

- A. FOR NORMAL LOAD CONDITIONS, THE VAC LOOPS ARE DOMINANT.
- B. FOR SLIGHT OVERLOADS, I_{AC} , I_{DC} OR $I_{DC} \times V_{AC}$ LOOPS ARE DOMINANT.
- C. FOR SEVERE OVERLOADS AND SHORT CIRCUITS, I_{AC} OR I_{DC} LOOPS ARE DOMINANT.
- D. FOR SEVERE TRANSIENTS THE FAILED COMMUTATION LOOP IS DOMINANT SO AS TO FACILITATE INVERTER COMMUTATION.
- E. FOR INDEPENDENT CONVERTER OPERATION, AND FOR OVERVOLTAGE PROTECTION IF INVERTER FAILURE OCCURS, THE VDC LOOP IS DOMINANT.
- F. THE $I_{DC} \times V_{AC}$ (OR POWER) LOOP MAY NOT BE USED.

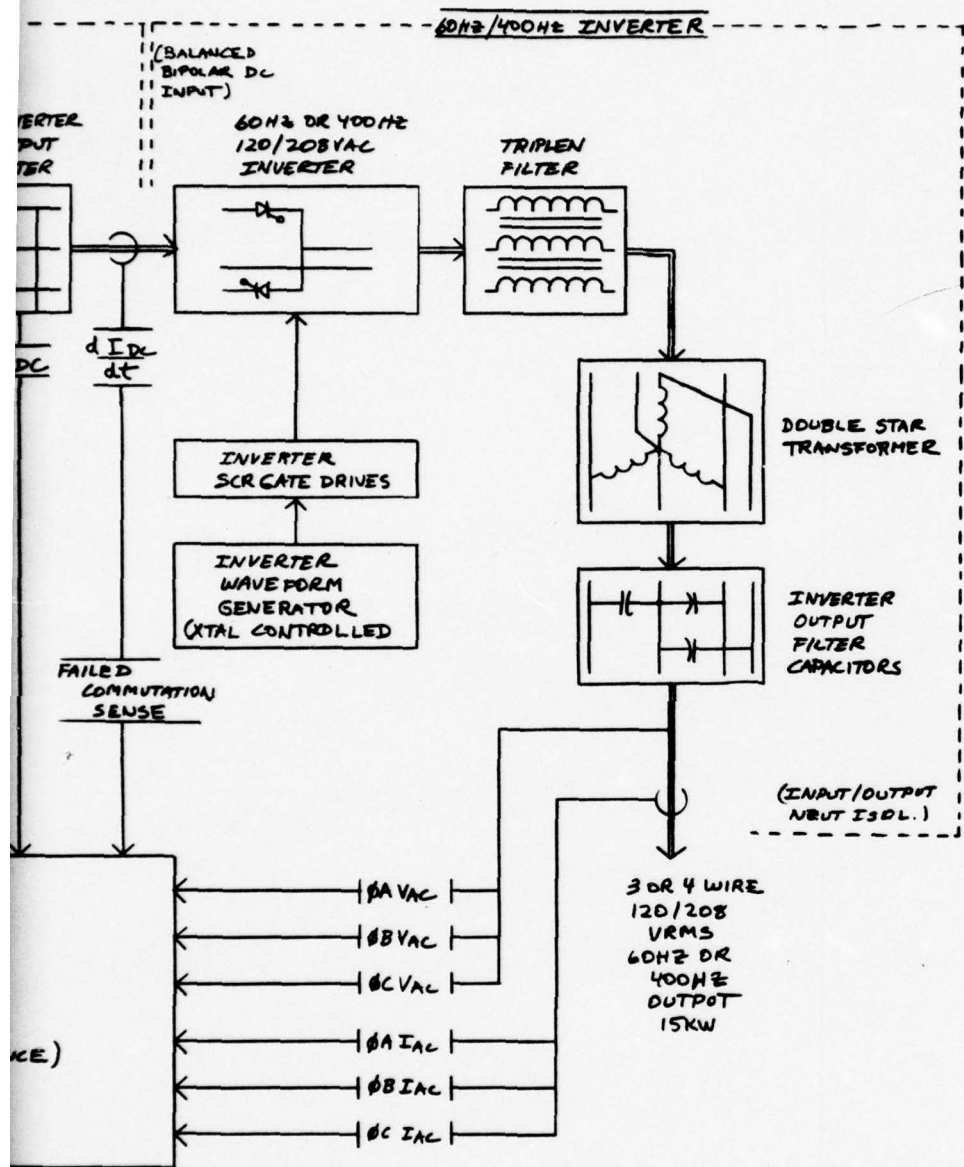

Figure 17. Frequency Changer Block Diagram

2

The regulator section is completely analog in design. The appropriate control signal is compared with a precision reference. The output of the regulator section is a control voltage related to the difference from this comparison or error. Signal conditioning is also accomplished in this section. Both control input and error signals are filtered as required for stability and low control noise.

The voltage-controlled oscillator (VCO), short commutation protection, and SCR gate drive logic are combined in the gate control section. The VCO provides output pulses whose frequency is proportional to the input command (error signal from the regulator). Thus, A to D conversion takes place at this analog port. All other internal circuits in this section use digital logic. The output is pulses of 12 microsecond duration whose frequency is that of the VCO divided by 24. This may be interrupted to provide sufficient commutation time for the converter SCRs when required.

The gate driver section provides power amplification and isolation of its 12 microsecond input pulses to drive the 12 converter SCR gates. This section is digital in nature with the exception that it uses linear current sources to supply gate drive current.

6.2 ISOLATION AND ATTENUATION CIRCUITRY

Isolation and attenuation circuitry, which is used to sense and condition various control inputs discussed in Section 6.1, is shown in schematic form in Figure 18. With exception of V_{DC} (the converter output voltage), isolation is accomplished by transformers as shown. All rectification and resistive attenuation is implemented on a circuit card assembly (CCA), designated A5.

Diode clamps are used to limit the output voltage of the commutation sense transformers. Their outputs are fed to comparators which sense the conduction duration of converter antiparallel diodes and, hence, SCR reverse bias time. All other transformer outputs are rectified so as to provide dc signals proportional to transformer primary current or voltage, as is applicable.

Although not used in conjunction with the regulator section, converter input voltage sensing transformers are shown in Figure 18. These are used to provide frequency changer overvoltage and undervoltage protection and lost phase protection. Thus they will be used in the integration of the AC-DC Section with the inverter.

CONVERTER SENSING

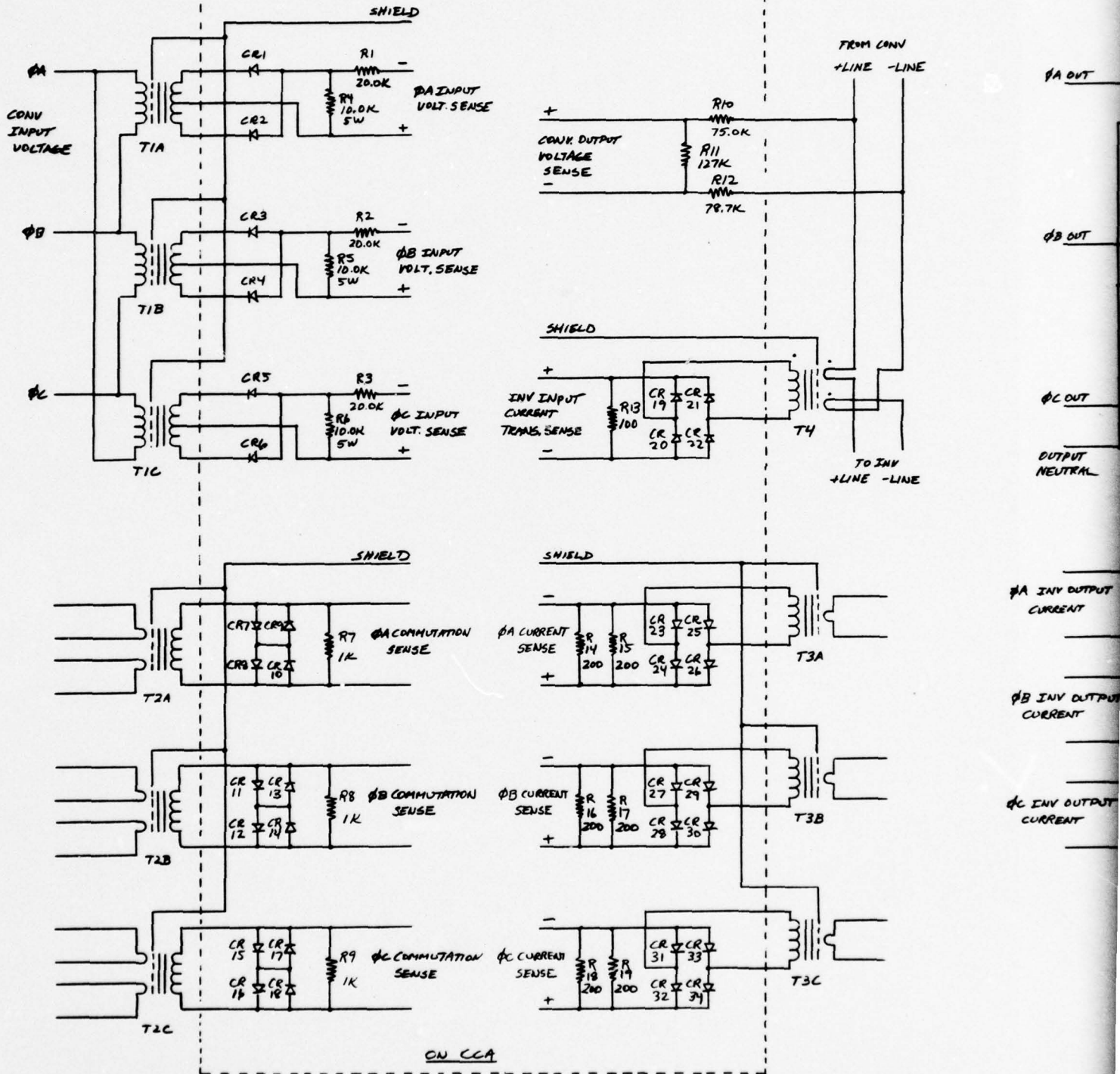

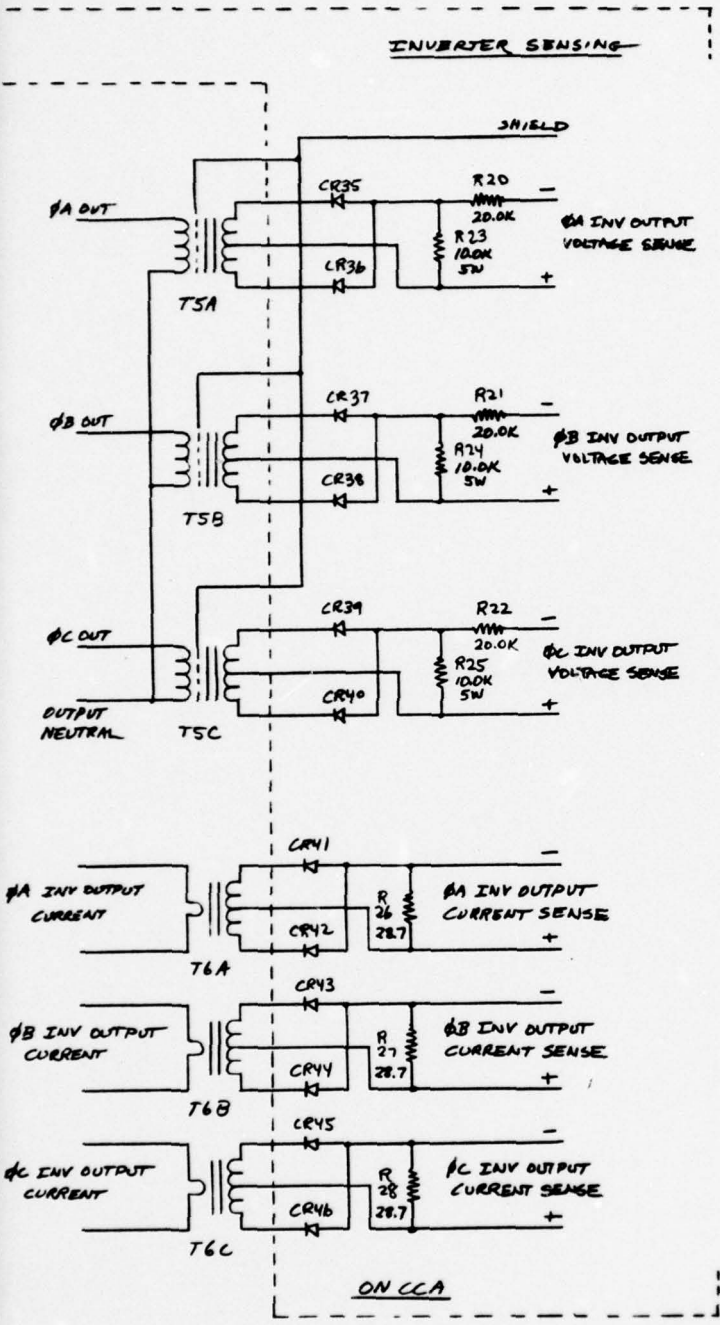

Figure 18. Input/Output Sense Circuits - CCAA5

2

An electrical parts list for CCAA5 is provided in Appendix F. With exception of the converter output voltage transformers, which are commercially available MIL-T-27 isolation transformers, all transformers are made by Delco.

6.3 REGULATOR SECTION

The regulator section consists of one analog CCA, designated A1. The circuitry is depicted schematically in Figure 19 (on 3 sheets). The following is a brief description of the function of the various IC components.

- U1 - temperature stable, precision, +6.00V, $\pm 1\%$, reference voltage source
- U2A, B - differential amplifier for attenuated V_{DC} signal, output is $+V_{DC}/60$
- U2C - V_{DC} error amplifier, with principle loop phase lag compensation
- U2D - V_{DC} error inversion amplifier
- U3A, B, C - 3 single phase converter output current amplifiers in highest of three outputs circuit configuration
- U3D - normal, slow responding, converter phase current error amplifier with phase lag compensation
- U4A - transient, fast responding, converter phase current error amplifier with phase lag compensation
- U4B - dc voltage to current mode transition hysteresis amplifier, provides clean control mode transition
- U4C - rate of change of dc output voltage sense amplifier, triggers a monostable multivibrator (MSMV) in the gate control circuit on CCAA2.
- U4D - V_{DC} , I_{DC} control voltage buffer
- U5A, U5B - V_{DC} , I_{DC} control voltage low pass filter for smoothing
- U5C - V_{DC} , I_{DC} control voltage severe transient filter bypass amplifier
- U5D - V_{DC} , I_{DC} control voltage inverter, buffer
- U6A, B - VCO control input amplifier sums dominant loop control signal and output of the VDC high pass filter, U6C
- U6C - V_{DC} high pass filter for phase lead compensation
- U7A, B, C - 3 single phase converter output current amplifiers in highest of three output circuit configuration
- U7D - V_{AC} , inverter output voltage, amplifier in average of three output circuit, output is $\frac{+V_{rms}}{24}$

DELCO ELECTRONICS DIVISION • SANTA BARBARA OPERATIONS • GENERAL MOTORS CORPORATION

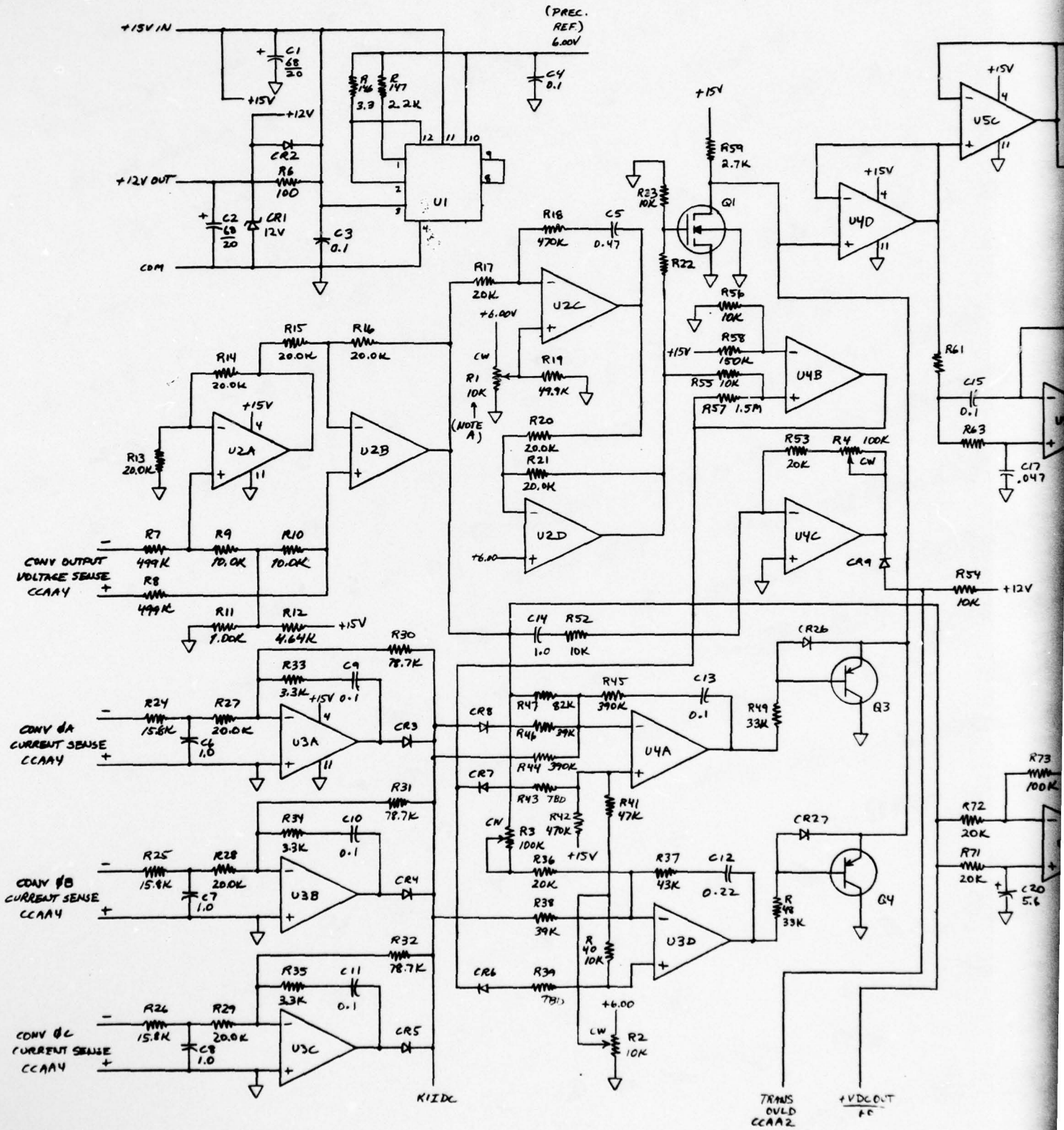

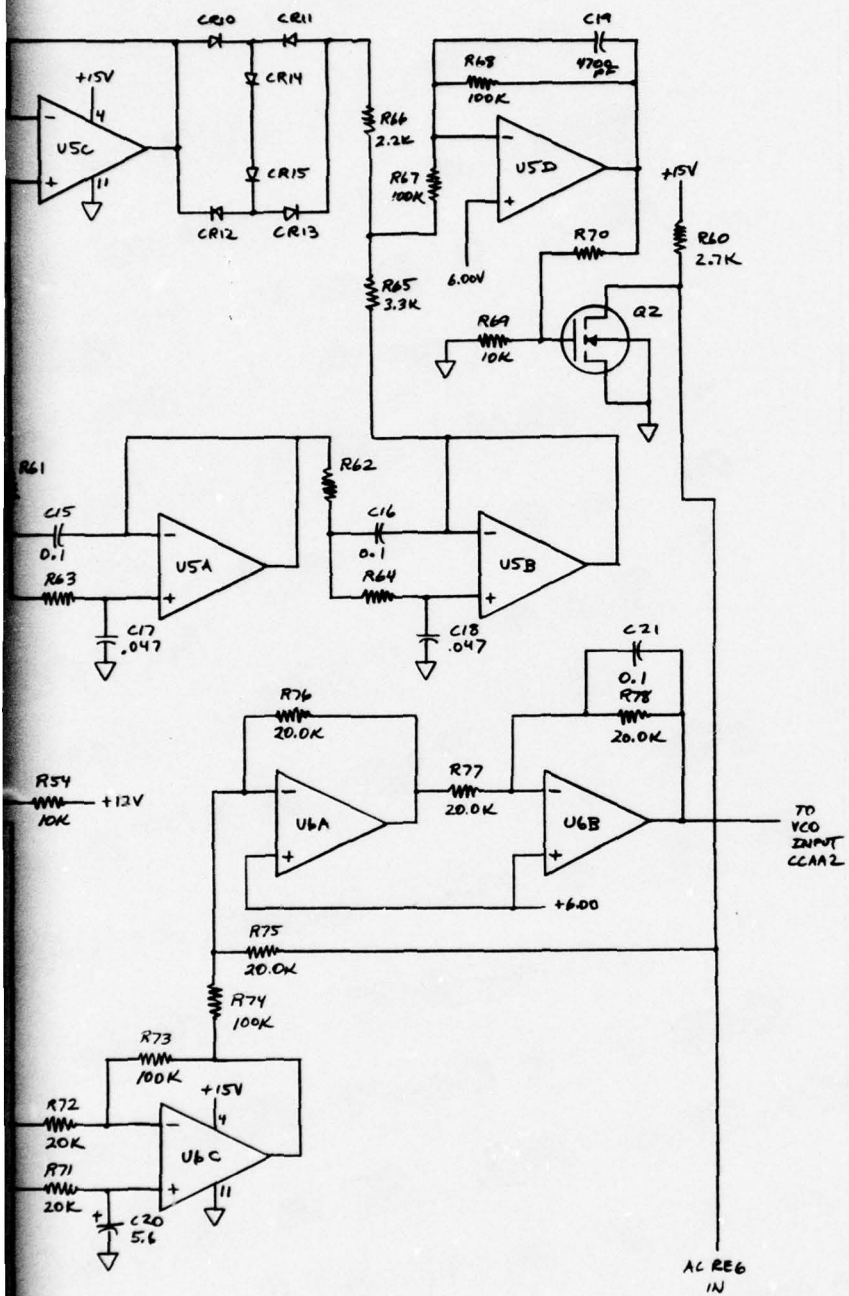

NOTE A: LOCATE NEAR EDGE OF CCA

Figure 19 (Sheet 1 of 3). Converter Regulator and Control Schematic

2

DELCO ELECTRONICS DIVISION • SANTA BARBARA OPERATIONS • GENERAL MOTORS CORPORATION

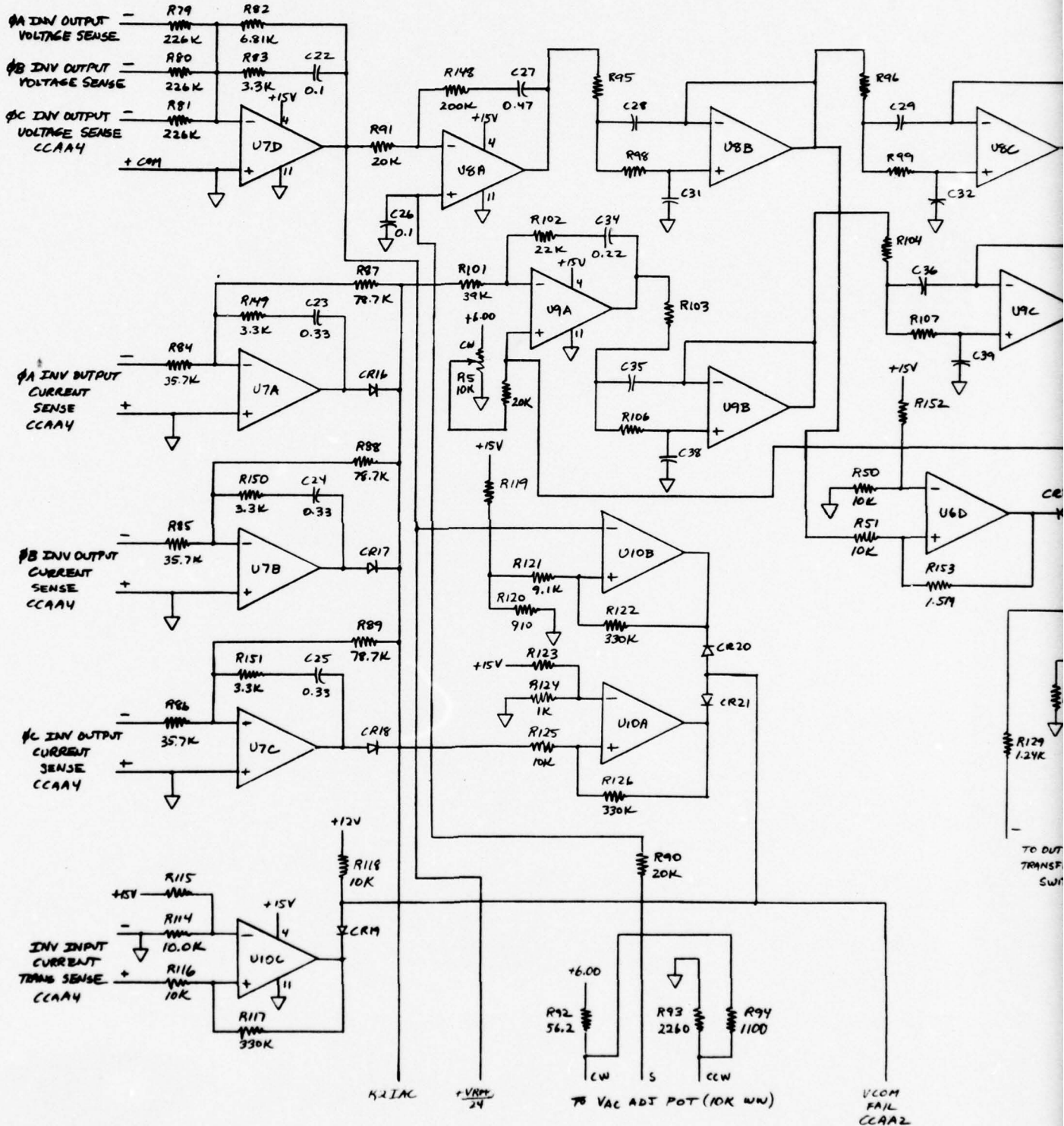

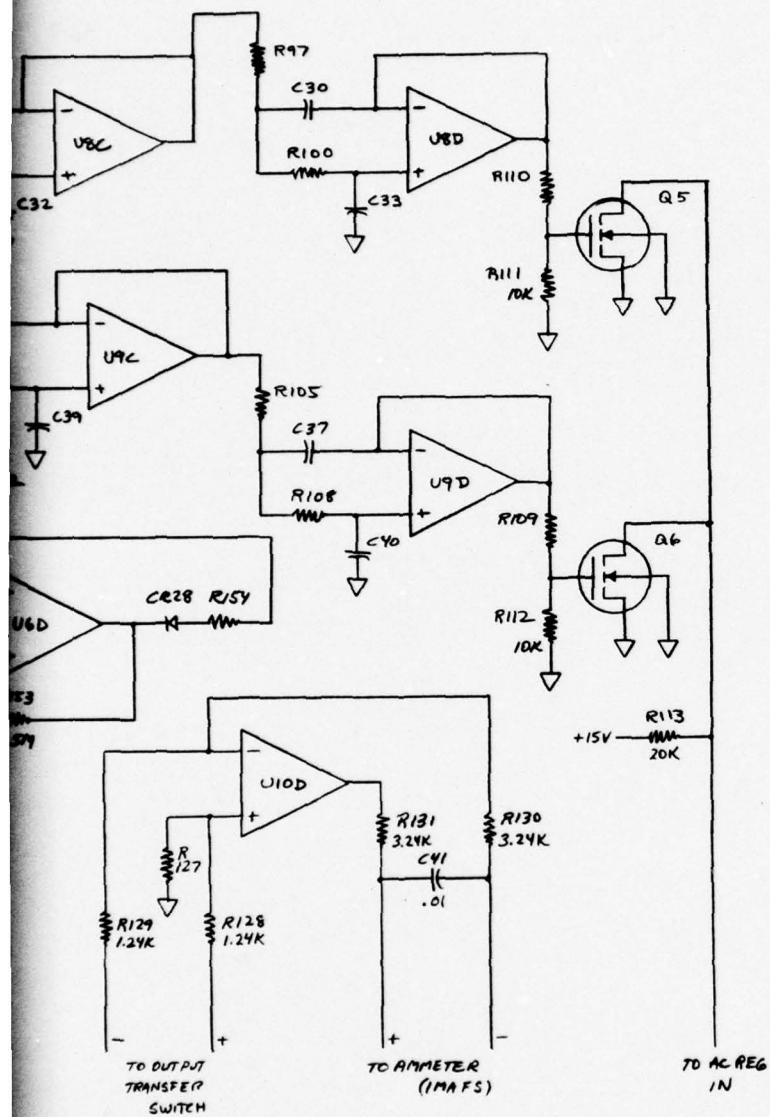

Figure 19 (Sheet 2 of 3). Converter Regulator and Control Schematic

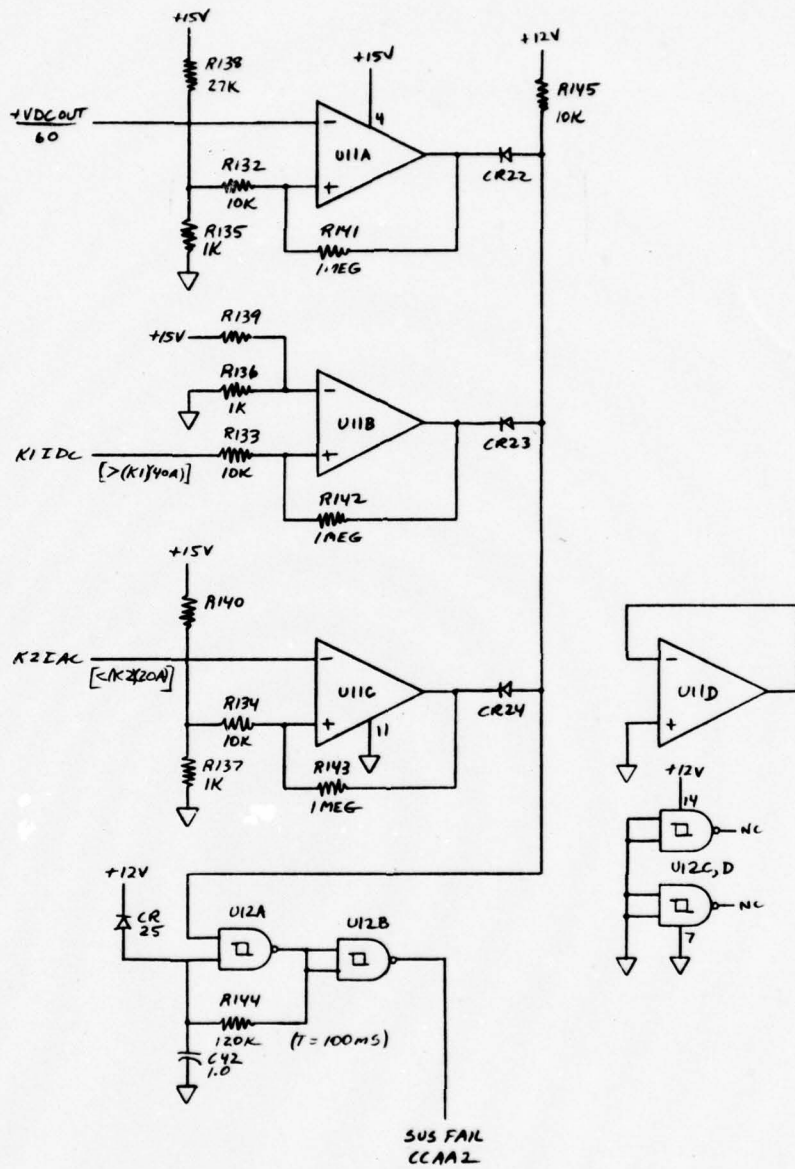

Figure 19 (Sheet 3 of 3). Converter Regulator and Control Schematic

- U6D - ac voltage to current mode transition hysteresis amplifier, provides clean control mode transition
- U8A - V_{AC} error amplifier, principal loop phase lag compensation
- U8B, C, D - V_{AC} control voltage low pass filter for smoothing
- U9A - I_{AC} error amplifier, principal loop phase lag compensation
- U9B, C, D - I_{AC} control voltage low pass filter for smoothing
- U10A, B, C - The logic AND output indicates a transient inverter commutation failure if $(I_{AC} > C2) \cdot (V_{AC} < C4) \cdot (I_{DCpk} > C1)$
 $= CFI = 1$ and triggers a MSMV in the gate control circuit on CCAA2.
- U10D - ammeter (mounted on front panel) current amplifier
- U11A, B, C - the logic AND output indicates a sustained inverter commutation failure if $(V_{DC} < C7) \cdot (I_{DC} > C5) \cdot (I_{AC} < C6)$
 $= CF2 = 1$
- U12A, B - converts $CF2 = 1$ into a pulse which occurs at 10 Hz to retrigger an MSMV in the gate control circuit on CCAA2.

An electrical parts list for CCAA1 is provided in Appendix B.

6.4 GATE CONTROL SECTION

The gate control section consists of one principally digital CCA, designated A2. The circuitry is depicted schematically in Figure 20 (on 2 sheets). The following is a brief description of the function of the various IC components.

- U1A, B, C, D - provide logic 0's of duration corresponding to the recovery of
 and
 U2A, B corresponding SCRs; i. e., U1A corresponds to θA , Q1 and Q3;
 U1B corresponds to θA , Q2 and Q4; etc.
- U8A, U9A, - recovery time MSMVs
 U10A
- U8B, U9B, - protection time MSMVs
 U10B
- U11A, U12A, - recovery time reset MSMVs
 U13A
- U11B, U12B, - protection time reset MSMVs
 U13B

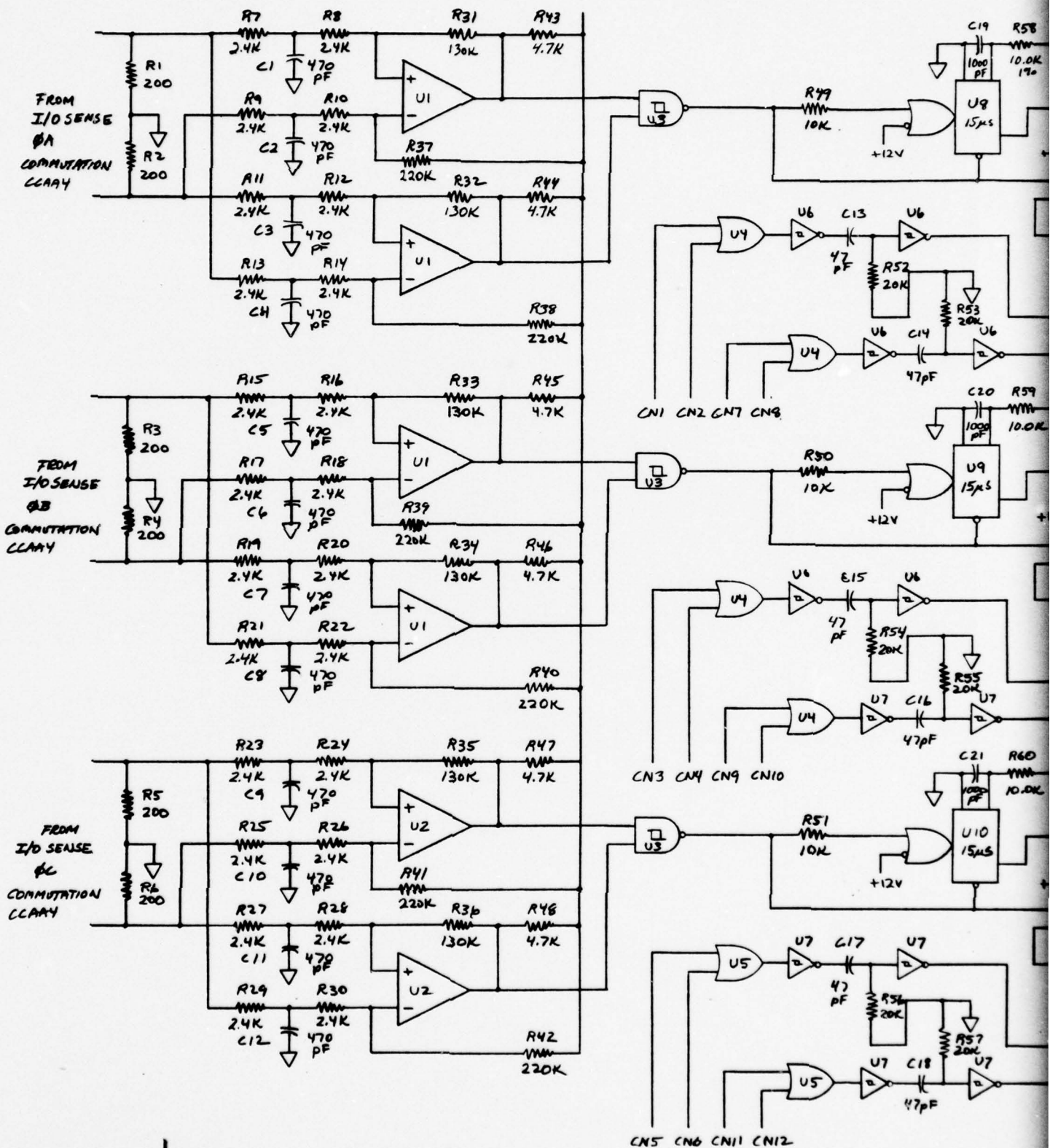

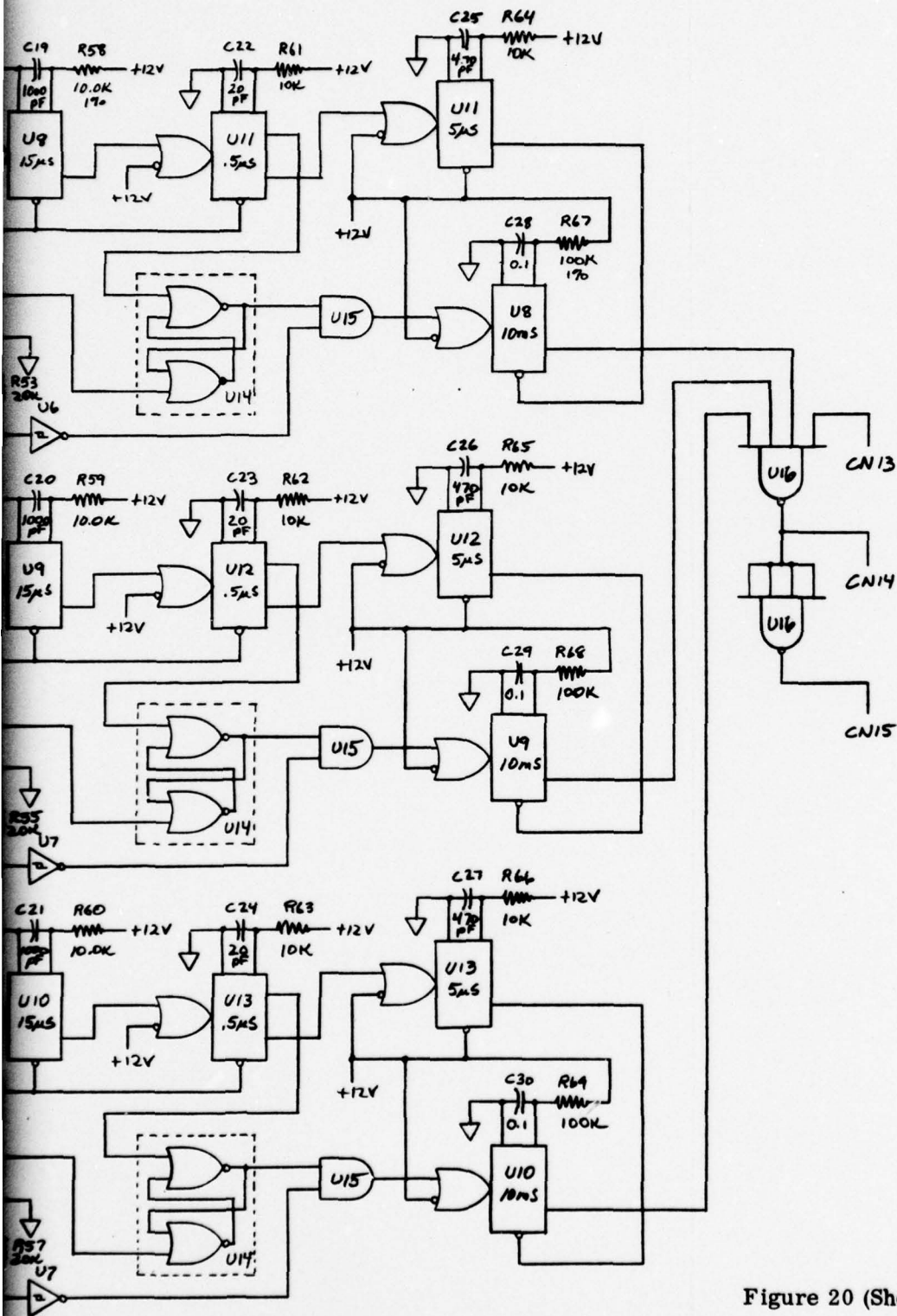
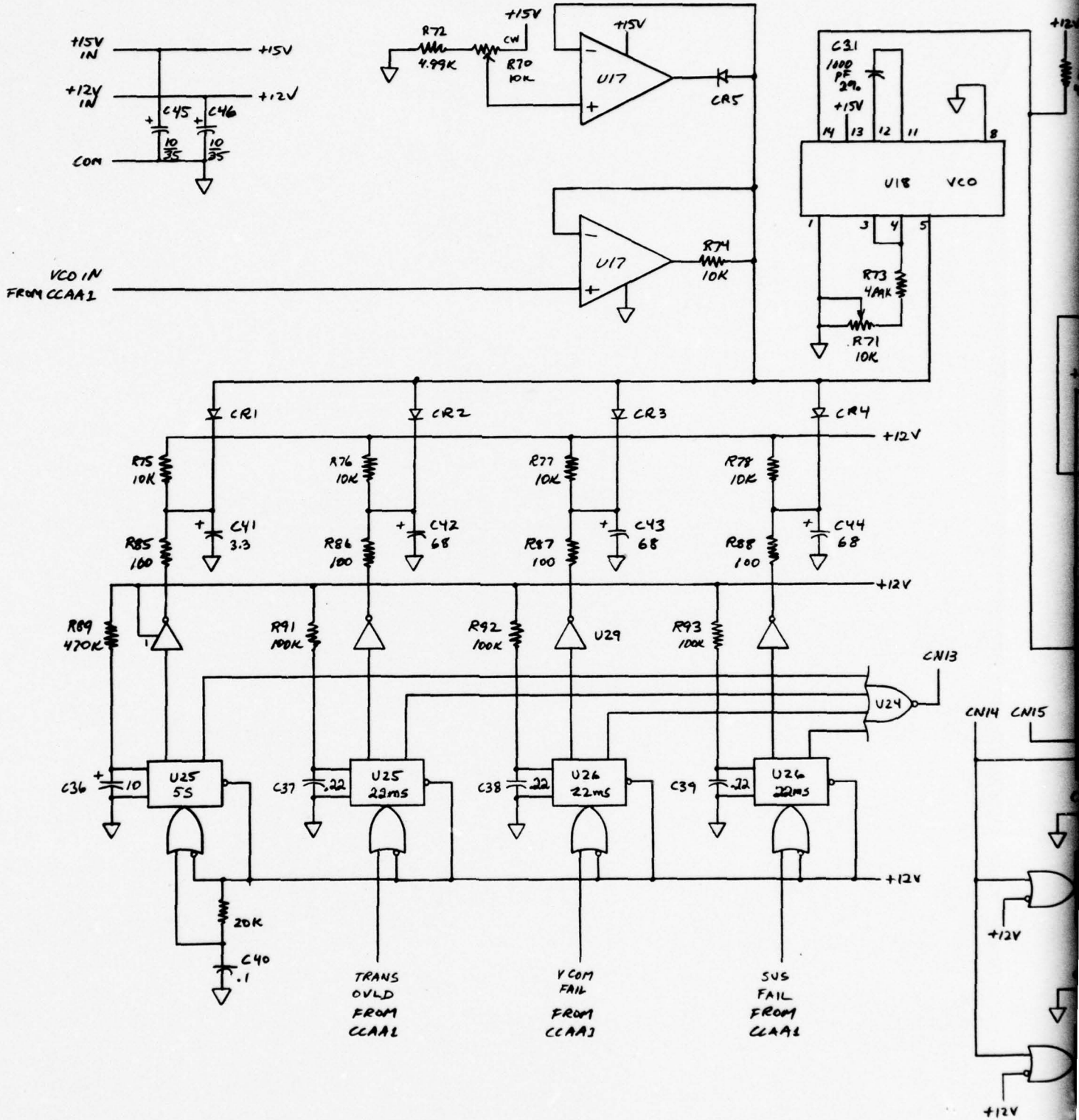

Figure 20 (Sheet 1 of 2). Converter Gate Control Schematic - CCAA2

DELCO ELECTRONICS DIVISION • SANTA BARBARA OPERATIONS • GENERAL MOTORS CORPORATION



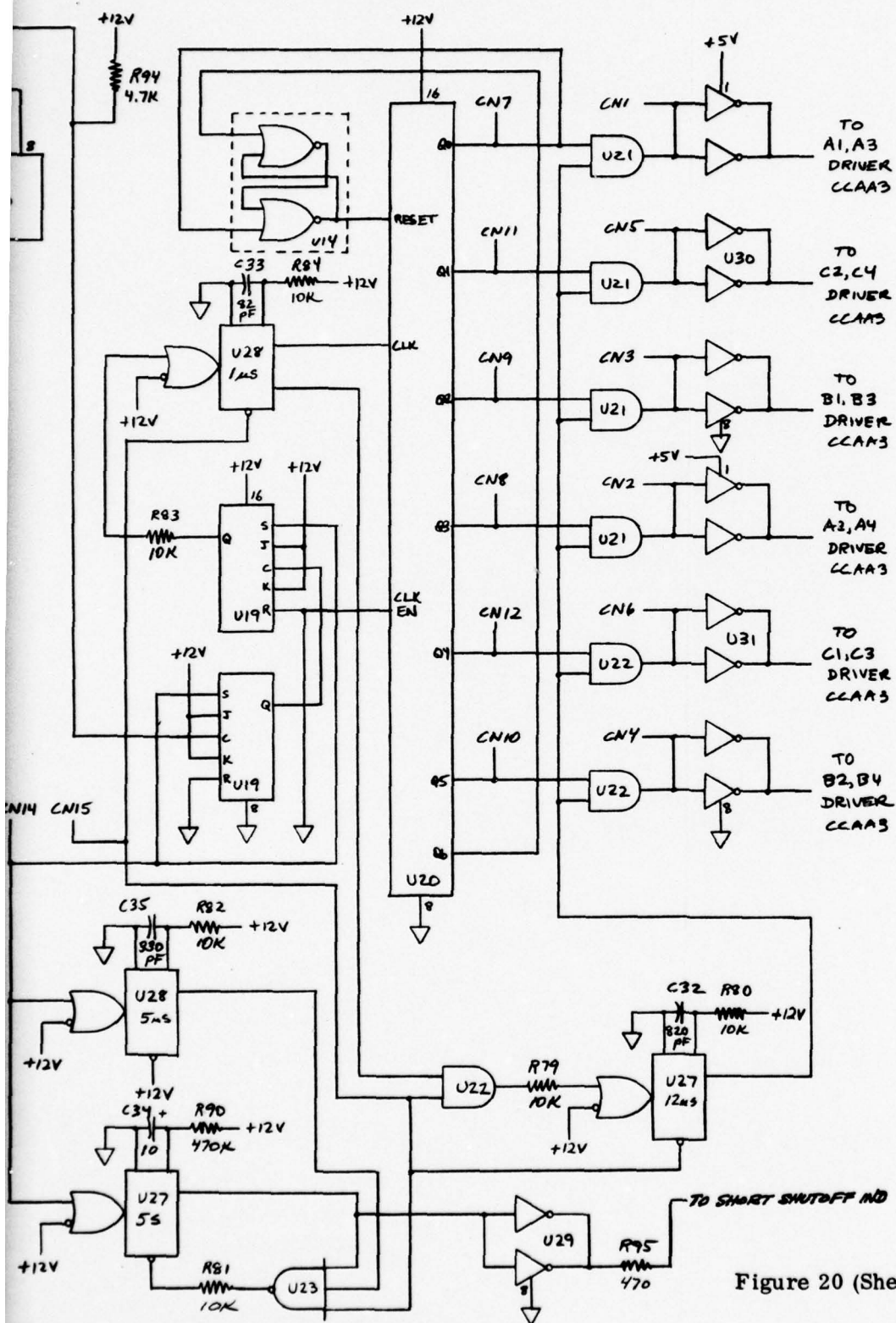

Figure 20 (Sheet 2 of 2). Converter Gate Control Schematic - CCAA2

2

- U17A - peak limiter reference amplifier, limits peak VCO frequency
- U18 - VCO
- U19A, B - VCO output frequency divide by 4, 2 J-K flip-flops
- U20 - configured with U14D as a divide by 6 fully decoded counter, each of 6 staggered outputs is VCO frequency divided by 24
- U25A - turn on soft start MSMV, delays gate firing until all turn-on transients have subsided
- U25B, U26A, U26B - overload and transient commutation failures detected in the regulator section cause these MSMVs to shut down converter drive for 22 milliseconds and then for converter frequency to slowly ramp up until control is resumed.
- U27A, U28A - causes a short shutoff indicator lamp to light for 5 seconds if the shutoff protection is activated for any SCR
- U27B - times out 12 microsecond on pulses for the SCR gate driver section
- U28B - provides a 1 microsecond delay after a counter transition before the corresponding gate driver input pulse is initiated.
- U30, U31 - used as inverters, buffers, and CMOS to TTL logic level converters.

An electrical parts list for CCAA2 is provided in Appendix C.

6.5 GATE DRIVER SECTION

The gate driver section consists of a single gate driver CCA with 12 drivers, designated A3 and three isolator CCAs, designated A4. The isolator CCAs are located, one each, in each of the three converter SCR modules. The circuits for these two different CCAs are depicted schematically in Figure 21 (on 2 sheets) and Figure 22.

The description of the operation of these CCAs is not provided here. It is quite simple and has been provided in several earlier publications and submissions to MERADCOM. * Electrical parts lists for CCAA3 and CCAA4 are provided in Appendix D and Appendix E, respectively.

*Delco Electronics Technical Proposal. Inverter Section for a 15 kW General Purpose Power Conditioner P77-2, page 3-3, Feb. 1977.

Delco Electronics Final Report. Frequency Converter, Portable, Alternating Current, Multi-Frequency, 10 kW R74-40, Vol. I, page 2-16, May 1974.

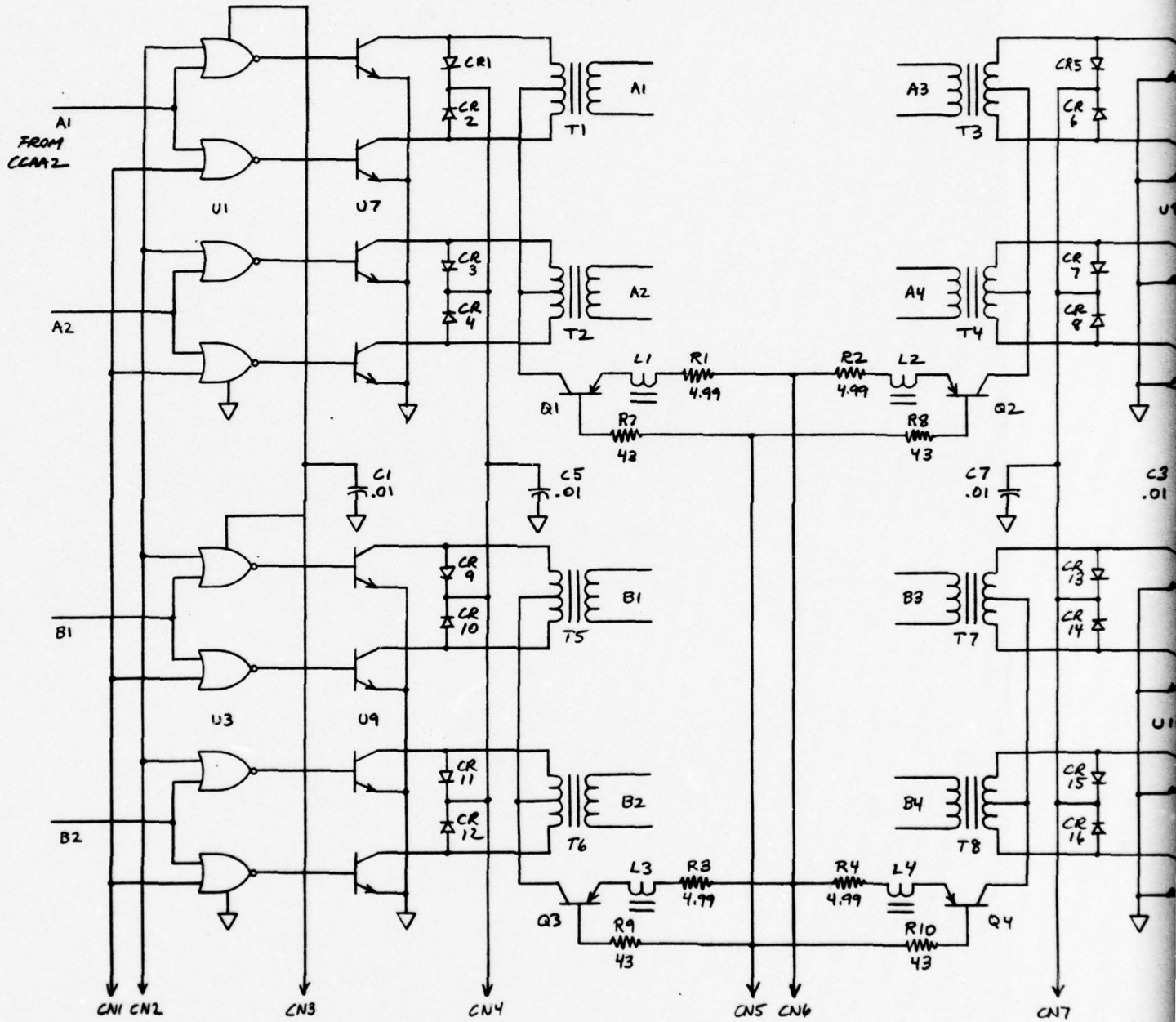

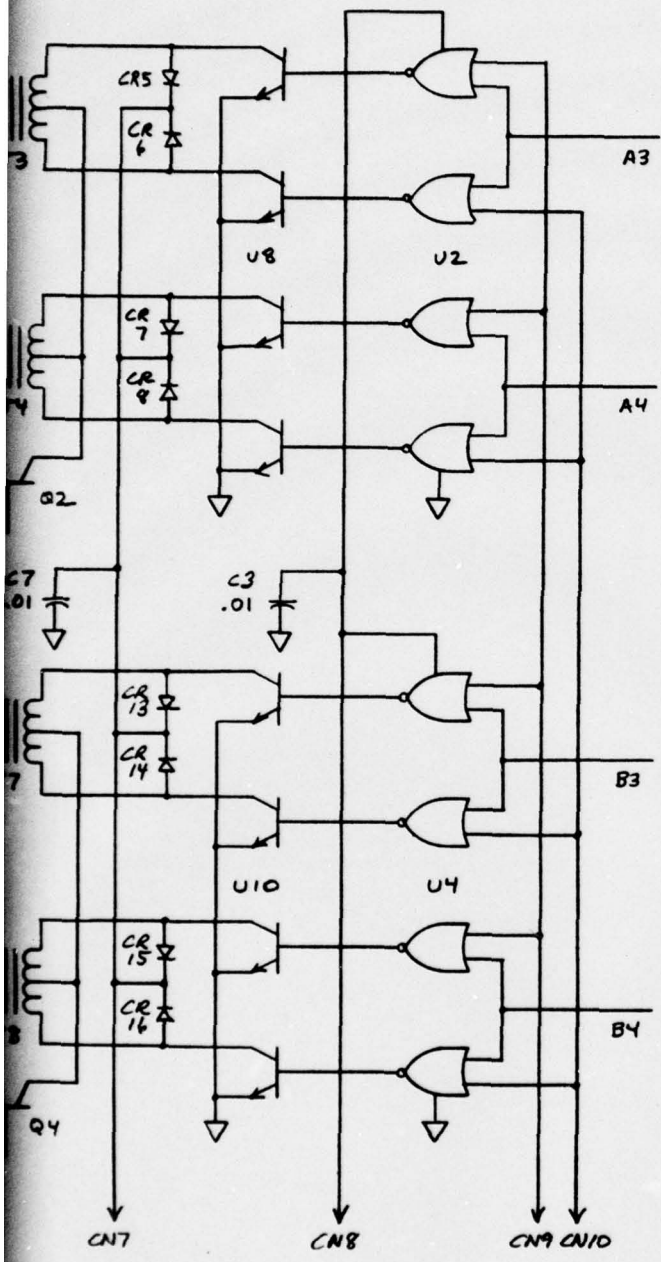
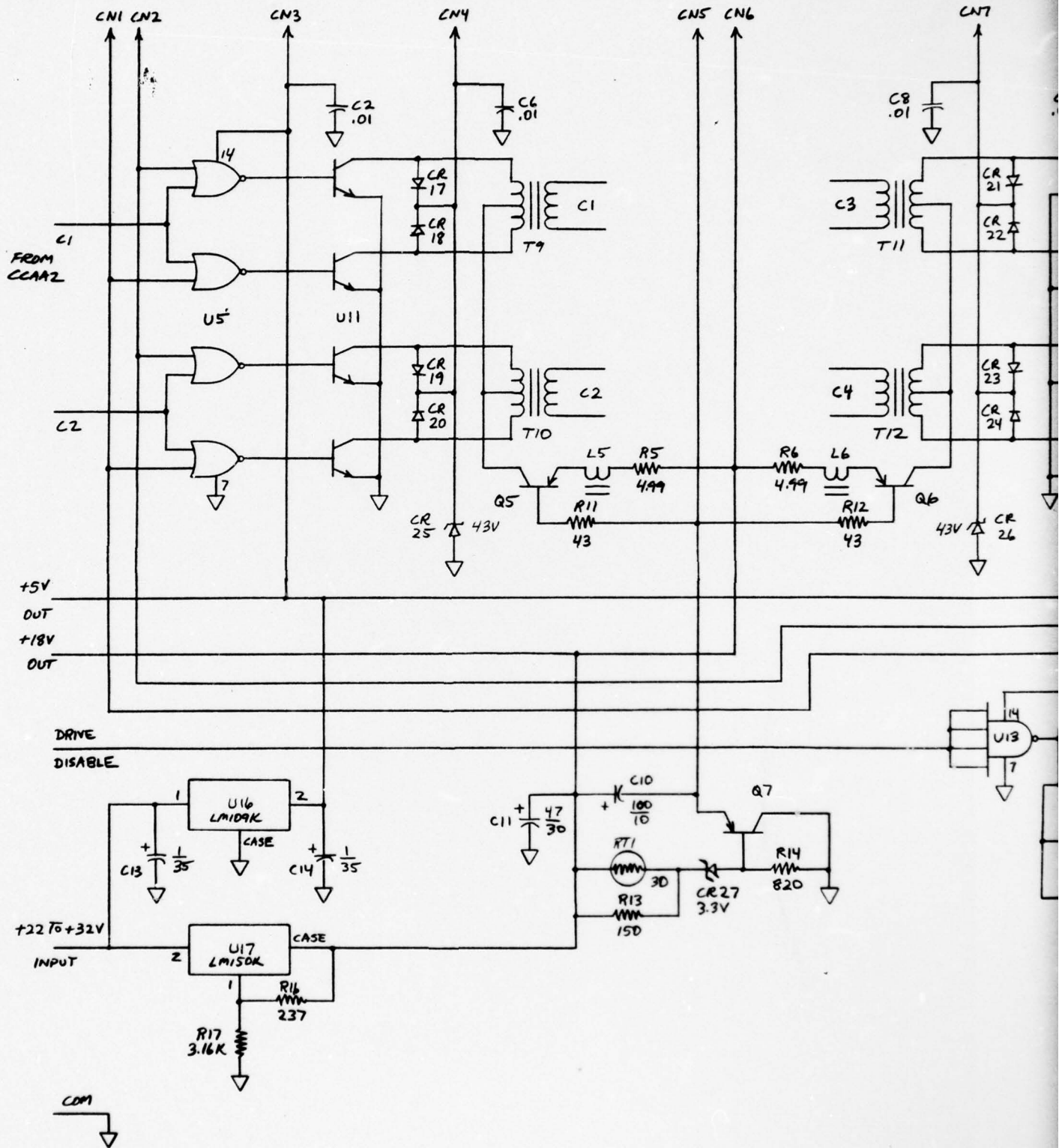

Figure 21 (Sheet 1 of 2). Converter Gate Driver Schematic - CCAA3

2



NOTE A: TIE PINS 2,3,4,5,9,10,11 AND 13 TO PIN 14 (+5V)

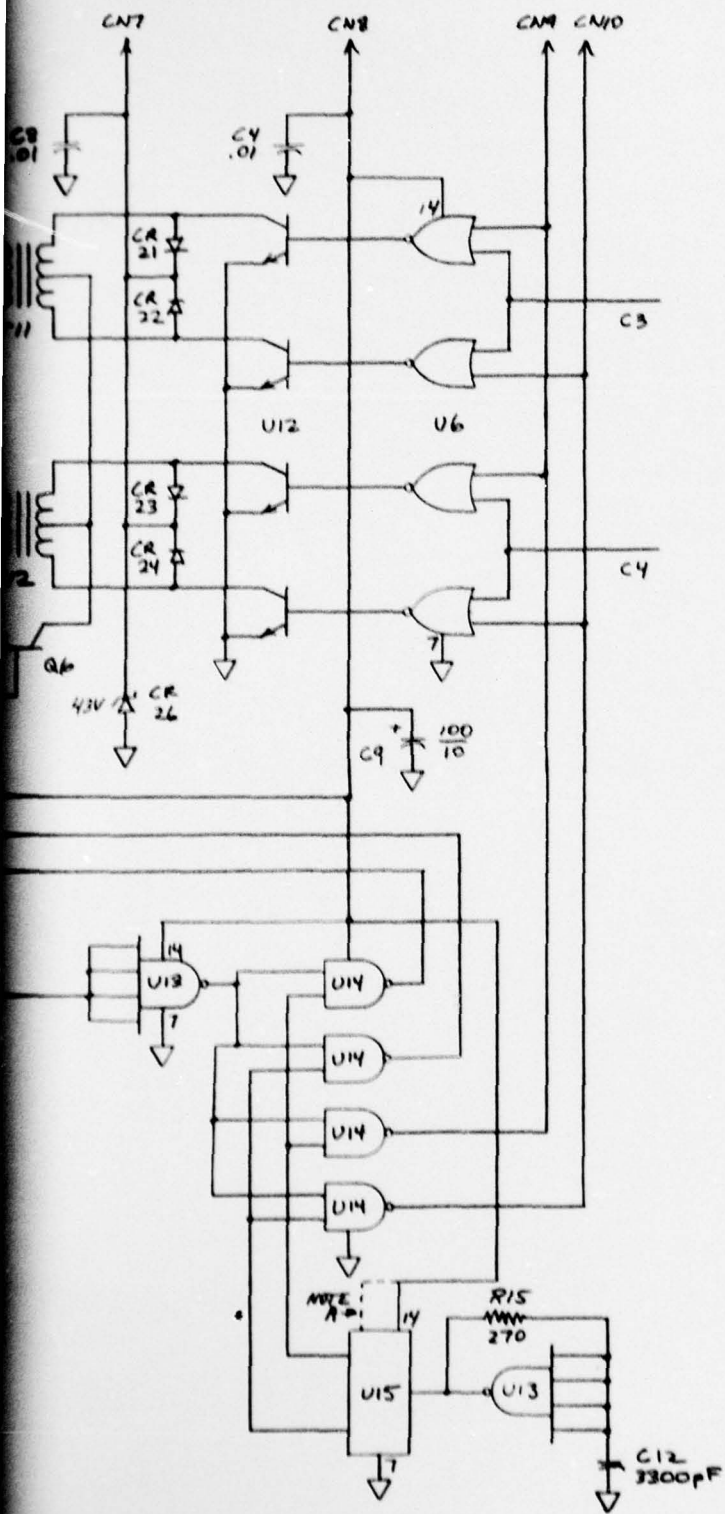
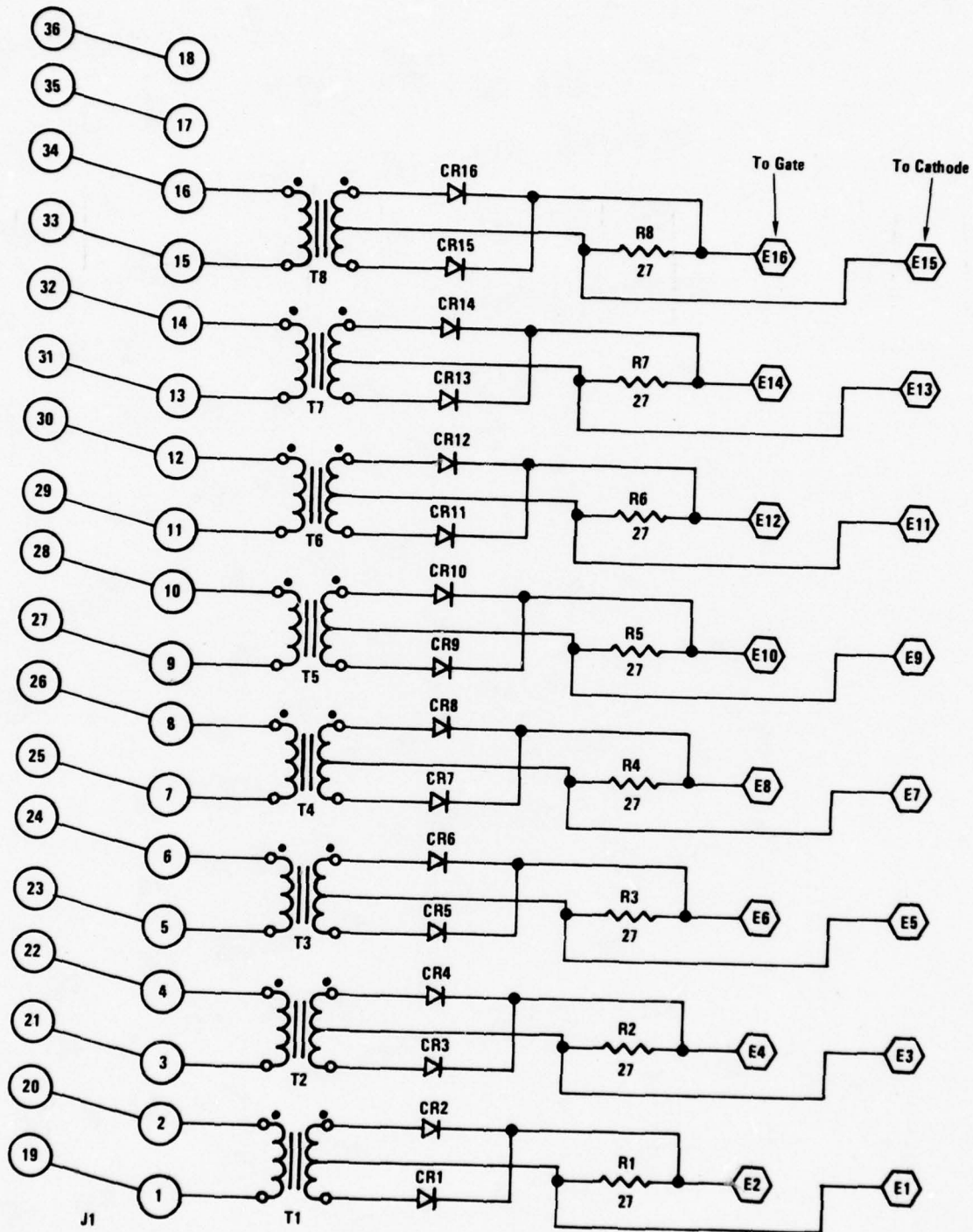

Figure 21 (Sheet 2 of 2). Converter Gate Driver Schematic - CCAA3

2



NOTE: As used in the Converter E1, E2, E3, E4, E13, E14, E15, E16 are not connected; thus on this particular application the following parts may be omitted: T1, T2, T7, T8, CR1-CR4, CR13-CR16, R1, R2, R7, & R8.

Figure 22. Converter SCR Isolators CCA4 Schematic

SECTION VII
DEVELOPMENT ASPECTS

7.1 GENERAL

The AC-DC Section (Converter) development under this contract was a natural continuation of previous Delco internal research and development (IR&D) effort which conceived (and submitted for patent) the approach to input line current harmonic reduction discussed previously in this report. Delco's IR&D effort during MY1977 (9/76 to 9/77) included research and development relative to resonant converter modules operating at multi-kilowatt levels. Delco's goal has been to perfect high power, high frequency control modules for use in power conditioning systems. Part of the IR&D design effort was applicable to the AC-DC Section (Converter) electrical design approach as well as the modular packaging concept. The program plans for the converter preliminary design and development efforts were structured to take full advantage of Delco's IR&D efforts. Delco IR&D effort provided the basic electrical power circuit and magnetic component design as well as the required control circuit design. IR&D effort also included the mechanical thermal design necessary to extend Delco's existing power module packaging concepts to include the new resonant converters. The AC-DC Section or Converter effort under this contract was therefore associated with fabrication and assembly of the deliverable power circuit hardware; modification of existing Delco control circuit breadboards to achieve Army specified performance; development testing of both the early Delco breadboard power circuits and the deliverable power circuits with the upgraded control circuits; and final testing of the AC-DC Section with a Delco power center inverter.

During the development and testing several minor control and power circuit problems were encountered which were routinely corrected and incorporated in the final designs previously presented. Several major developmental problem areas were also encountered and reported in detail in the required monthly reports. These areas are briefly summarized in the following paragraphs.

7.2 SCR COMMUTATION FAILURE

During testing of the resonant converter modules, operation was as anticipated under normal temperature and operating conditions, but commutation failures occurred at certain light loads and with all components at their normal operating temperatures. Further testing revealed that the SCRs used in the IR&D breadboard power circuitry (early vintage Motorola 10-microsecond shut-off devices) exhibited shut-off times which were approximately twice the specified times. Since SCR shut-off time is approximately directly proportional to device junction temperature, the reason for the temperature sensitivity of the commutation failure mechanism became apparent. The SCRs were replaced with the same type of devices used in the Firefinder 400 Hz inverter (and on order for the converter). The replacement devices were tested and found to have shut-off times slightly less than the specified 10 microseconds.

Resonant converter module performance improved considerably with the shorter shut-off time SCRs in the power circuits, but failures still occurred at light loads and again at high input voltages slightly in excess of the high input line condition. The latter failure mechanism was traced to a control circuit problem which was corrected by a simple change in logic circuit implementation.

A detailed examination of in-circuit waveforms recorded under the light load operating conditions which produced commutation failure was conducted. It became apparent that the isolation transformer created an undesirable spurious resonance that prevented natural commutation of SCRs under certain conditions. The conditions existed with light loads and during the time that the input voltage to the resonant converter was very low and approaching zero.

Three possible solutions to the problem described are as follows:

- Eliminate the isolation transformer from the system and use capacitors to achieve input to output isolation.
- Design the isolation transformer such that the primary self-inductance is very low and comparable to the leakage inductance.
- Conversely, design the isolation transformer in a fashion such that the primary self-inductance is orders of magnitude higher than the leakage inductance and load impedance.

The first of the possible solutions, elimination of the isolation transformer in each module, poses no major problem in a three-phase system. The resonating capacitors then must provide the added function of supporting an ac component of voltage and current at the input power line frequency. In a three-phase system there is complete cancellation of these current components so that true input to output isolation is achieved. During the program this solution was implemented on a single power module and found to work well. Relative to an isolation transformer approach, the required capacitors are larger and more costly. Efficiency measurements were not made, but without the step-up in voltage achieved via a transformer (approximately 1:2), converter efficiency may be compromised to some extent. Elimination of the isolation transformer is considered to be a viable approach and may be advantageous in certain applications.

The second solution, use of an isolation transformer with very low primary self-inductance, also holds promise and should be tested at a future date. Powdered Iron cores of very low permeability are available if future Army funds should allow optimization of the parameter. It is felt however, that like the transformerless approach, the converter efficiency may be somewhat lower than that achievable with the recommended solution.

Based upon testing and performance to date it is felt that the best approach is to use an isolation transformer with an exceptionally high primary self-inductance. The transformer designed for this approach is 3 pounds heavier and slightly larger than the earlier transformer which introduced the commutation failure mechanism. The new design again uses Litz wire, but is wound on an uncut "C" core of 2 mil laminated 3 percent silicon iron. It has excellent efficiency and is much lower in cost than the earlier design which used an 80 percent nickel toroidal core.

7.3 RESONANT COMPONENT OPTIMIZATION

After achieving proper and reliable SCR commutation, effort was concentrated on optimizing the critical resonant circuit components to achieve monotonic control response, adequate SCR shut-off time, and high efficiency. Early testing established that adequate SCR shut-off time could be achieved without using air core inductors in series with the antiparallel diodes, thus eliminating these components which were used in the earlier power circuit. The remaining resonant circuit components were varied over wide ranges during development testing. In general it was found that the series resonating capacitor

should be about 10 microfarads in order to resonate (at a frequency of 10 kilohertz or above) with the power circuit inductances. The value of capacitance across the transformer secondary influences both SCR shut-off time and power circuit efficiency, but unfortunately in opposite directions. A nominal value of 1 to 2 microfarads is required to ensure adequate SCR shut-off time, 1.5 microfarads is used in the final circuit.

Isolation transformer, T1, is wound on an uncut "C" core of 2 mil laminated 3 percent silicon iron as mentioned previously. The core is actually a standard A156 (Arnold) with about one-half of the laminations removed. T1 is wound to provide low leakage inductance, but high self-inductance. Within this constraint the turns ratio was varied to establish that higher power circuit efficiencies are obtained using a nominal 1:1.5 step-up ratio between primary and secondary.

The SCR shut-off time was measured to be close to 18 microseconds under all anticipated operating conditions. Delco feels that a minimum of 16 microseconds is necessary if safe and positive shut-off of 10 microsecond SCRs with antiparallel diodes is to be achieved at required ambient temperatures of 125^oF.

Test data indicated that efficiency remained fairly flat over the entire range of operating conditions which is of course desirable. The efficiency at a rated load of approximately 5.5 kW was near 89 percent. In order to achieve the desired 80 percent efficiency for a complete 15 kW frequency changer, it is felt that the AC-to-DC Section should provide close to 90 percent efficiency.

The apparent methods available for increasing efficiency are to use low loss materials for the core in the isolation transformer; decrease the value of capacitance across the isolation transformer which increases efficiency, but decreases SCR shut-off time; make minor changes in transformer turns ratio. The first approach would be undoubtedly effective, but was not pursued on a cost basis. The 2 mil Silectron "C" cores are available at \$49.80 each (Qty 1-4), 2 mil Deltamax cores would cost \$385.30 each (Qty 1-4). The indicated costs would be much lower for larger quantities, but since development dollars and time were limited, Delco recommended deferring optimization of the core materials to possible future efforts. Further decreases in the value of capacitance across the transformer may be beneficial, but the present value of 1.5 microfarads was achieved only by adding a 10 microhenry inductor in the series resonant circuit to assure adequate SCR shut-off time.

7.4 THREE MODULE OPERATION

Upon completion of the development testing and optimization of the single module, three similar 4-SCR modules were breadboarded and operated as a complete converter. Extensive development testing was performed to obtain the desired overall performance while minimizing the size, weight, and cost of passive filter components required. The development testing resulted in the selection of the following values for the filter components on each phase of the input 60 Hz line: L = 500 microhenry shunted by a 5 ohm resistor, C = 40 microfarads. The value of capacitance at the converter output must be optimized while integrating the converter with an operating inverter. During development tests, using a resistive load bank, this capacitance consisted of 40 microfarads of polycarbonate capacitors in parallel with approximately 8200 microfarads of electrolytic capacitors. System efficiency and performance relative to input line current harmonics is summarized below. The data were taken with a nominal input line voltage of 120/208 Vac and an output voltage of 300 Vdc.

Power Output (watts)	Input to Output % Eff	Input Line Current Harmonics (%)				Resonant Converter Freq (Hz)
		THD	5th	7th	11th and Up	
18,000	91.4	3.4	2.0	2.3	1.0	5119
12,000	92.6	4.2	2.2	2.8	0.5	3459
6,000	92.1	9.0	5.1	5.0	2.0	1726
3,000	88.0	18.0	9.0	9.0	4.0	911
1,100	82.1	44.0	16.0	14.0	38.0	345

The measured values of harmonic line currents at the nominal rated load are very close to the desired values of 5 percent THD and no greater than 2 percent for individual harmonics. As the output power is decreased, the resonant converter frequency decreases and the harmonic currents as a percent of actual line current increase. It should be pointed out that when the lower output power values are normalized to the rated power line current, the percentages tend to remain nearly constant.

It was suspected that the decrease in efficiency below 3,000 watts system output was due in part to the transformer T1, being a cut "C" core design with steel clamps used to minimize the gap. Low frequency mechanical resonances were apparent from the audio

noise generated and could contribute to the losses. The high frequency transformers were rewound on fluidized bedded, 2 mil Sillectron, uncut "C" cores and checked out in the circuit. The new transformers provide improved monotonic control performance over the entire operating range. The low power (thus low operating frequency) efficiency did not improve as anticipated, but the low frequency mechanical resonances experienced with the previous design were not apparent when operating with the new transformers.

While testing the converter at high power levels, it was observed that the SCR trigger inhibit protection circuits were being falsely called upon to prevent a short circuit across the internal dc voltage bus (that is, two SCRs on simultaneously). Subsequent test and analysis revealed that the feedback power diodes, which are in inverse parallel with the SCRs, were creating an objectionable dv/dt pulse when clearing which was activating the trigger inhibit protection mode. These Westinghouse R502 diodes were replaced with faster clearing Motorola SR2885 diodes. The replacement diodes have greatly reduced the clearing pulse in amplitude and improved overall performance. Test data shows that the clearing pulse now begins to show up only at much higher operating frequencies and power levels above 18 kW.

High power testing (18 kW) revealed a second problem associated with the circuitry. One of the converter modules was observed to have undesirable oscillations on the SCR current sensing signal to the protection circuitry. The oscillations falsely activated the protection circuit such that no more than 4 to 5 kW could be obtained from that particular module. The current sensing transformers were found to be very sensitive to the gap in the magnetic path. The small Sillectron "C" cores were intentionally tightly banded to achieve minimum air gap (approximately 1 mil typical) and the "problem" converter module apparently had a core which was not tightly banded or had some foreign material in the gap. The transformer was dismantled, cleaned, rebanded, and potted which greatly improved performance. The sensitivity to air gap in this critical sensing transformer suggested that toroidal cores should be used for this purpose. While testing of the converter dc control loops into a resistive load it was discovered that noise and response problems were recurring in the SCR current sensing and protection circuits. The sensing transformers were redesigned using toroidal cores and placed in the circuit. Subsequent testing established that the SCR sensing and protection circuitry then functioned well over the entire operating range. After making the above modifications the dc control loops were then adjusted for proper performance into resistive loads.

7.5 GFE INVERTER CHECKOUT

As part of the development effort, Delco was to integrate the new AC-DC Section with the power center inverter section of the breadboard frequency changer provided as GFE under the contract. Up to this point the GFE frequency changer had been used only to provide mechanical and passive electrical interface inputs for packaging design and layout purposes. After successfully testing the new converter, the GFE unit was activated in an attempt to obtain electrical and control loop response characteristics essential for future integration. The unit operated intermittently for short periods of time with internal arcing occurring at random times. While operating, the waveform from both 60 and 400 Hz appeared to have a notch or missing step on the rising portion of the sine wave. While troubleshooting in an attempt to find the cause, the output voltage dropped to an extremely low value after a reoccurrence of the arcing problem. It was discovered the triplen transformer (which was received with a broken bracket and loosely mounted by one screw) had internal winding short circuits created by abrasion on the external mechanical bracket. Since the triplen transformer damage would require significant repair effort and since approximately 1 week of unscheduled troubleshooting time had already been used, further test effort was deferred pending COTR review and direction.

Delco review of the sensing and control circuits which existed in the GFE unit concluded that they were lacking in sophistication and were inadequate for integration with an inverter that meets the requirements of the frequency changer purchase description. Added control circuit design and development beyond that originally proposed appeared necessary in order to obtain specified overall performance and demonstrate the true capability of the new Delco converter concept. MERADCOM concurred with the conclusion and directed Delco to proceed with the required development using an existing Delco breadboard inverter in lieu of the nonfunctional GFE.

7.6 INTEGRATION EFFORT

Upon receipt of the direction described above, effort was directed toward designing both the ac and dc sensing and control circuitry essential for integration with the Delco inverter. The design includes both the necessary voltage and current sensing to achieve inverter output regulation, current limit, and short circuit operation. The resulting designs were then fabricated as breadboard control circuits. After further checkout of the dc control loops, the converter was electrically integrated with the modified Delco

60/400 Hz inverter to test the ac control circuitry when operating as a complete frequency changer. The combined units performed well over the entire load range and with application of no-load to full-load to no-load transients up to 16 kW, 0.8 PF at both 60 and 400 Hertz. The combined units were then subjected to output short circuit testing which resulted in modifications to the ac control loops to overcome excessive ripple in the sensing and feedback signals. After successful output short circuit performance a test was implemented to simulate a commutation failure in the inverter. For such a momentary failure the converter automatically reduces the dc voltage to a low level and then builds back up when the inverter clears. The circuit functioned as required, but apparently not fast enough since nuisance tripping of the input circuit breaker sometimes occurred. A sensing circuit was added to the dc control loop to monitor capacitor discharge current at the output of the converter as a fast command signal. Considerable development testing was required to optimize loop performance and prevent adverse effects upon control loop operation under normal transient loading and output short circuit testing. After achieving successful performance, the integrated converter/inverter was subjected to the series of performance tests specified in the Purchase Description. Successful performance was achieved under most required operating modes. Marginal performance resulted during output short circuit testing in that maximum current ratings of the converter output rectifier were being approached. It is likely that a second rectifier package should be used in parallel with the existing rectifier to assure safe operation over the full temperature range desired of the system. More detailed discussion of the final performance testing is provided in a later section of this report.

SECTION VIII MECHANICAL PACKAGING

The AC-DC Section (Converter) packaging format makes use of the inherent modular nature of the new converter concept. Each phase of the three-phase input incorporates a separate 4-SCR resonant converter consisting of all components shown previously in Figure 15. Each single phase converter is packaged into two separate modules: a resonant converter module, and an input-output filter module. The components were allocated to the two modules in a manner which minimizes interconnections and allows for proper air flow through heatsinks and across critical components.

8.1 RESONANT CONVERTER MODULE

The resonant converter module accepts unfiltered, two-wire dc voltage from the input/output module, converts it to well regulated three-wire dc voltage which it feeds back to the input/output module for filtering. Each resonant converter module contains SCRs, diodes, snubber components, passive resonant circuit components as well as the high frequency isolation transformers and output full wave bridge rectifiers. The mechanical layout is shown by the photograph of Figure 23. The SCR, diode and snubber components heatsinks are commercial extrusions which have been sized to safely dissipate the heat from the associated components. Visible at the top of the module is the printed circuit board which contains the trigger circuit isolators for the four SCRs. At the very bottom of the module is the high frequency isolation transformer. The overall outside dimensions of the module are 5-1/2" x 7-1/2" x 20-1/2" and the weight is approximately 32 pounds.

8.2 INPUT/OUTPUT MODULE

The input/output module shown in Figure 24 contains the input LC filter components, rectifiers and the converter output filter capacitors. The input, single-phase, full wave bridge rectifier consists of two rectifier packages mounted on separate heatsinks at the top of the module. At present each module also contains a 100-ampere fuse which may be deleted in the final deliverable hardware since all failure modes tested to-date have resulted in safe tripping of an input line circuit breaker. The lower section of the module is provided to house additional capacitors which must await final integration with the inverter for proper definition. The module's dimensions are identical to those of the resonant converter module. The weight is approximately 20 pounds.

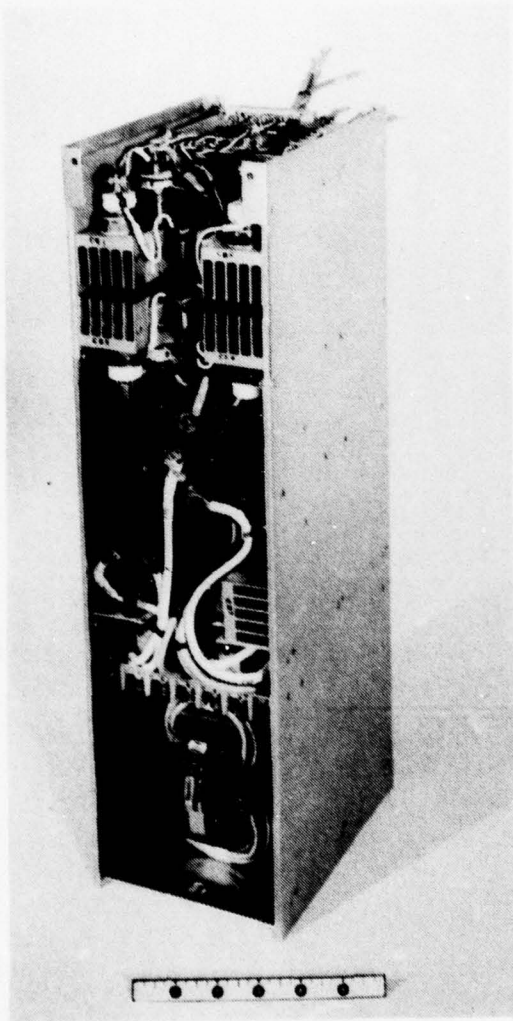

Figure 23. Resonant Converter Module

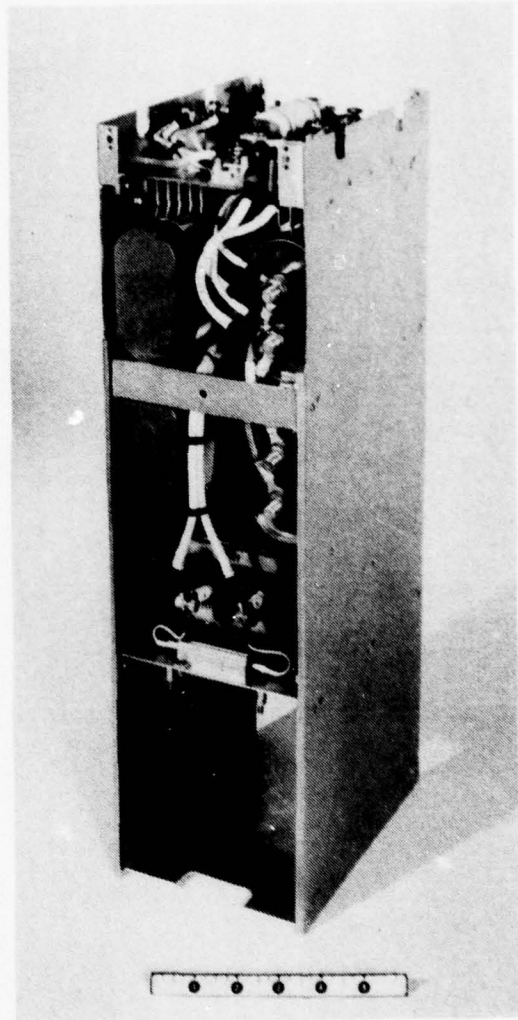

Figure 24. Input/Output Module

8.3 AC-DC SECTION (CONVERTER)

The two modules described above combine to provide a single-phase, ac-to-dc converter. Three of the single-phase converters are required to implement the three-phase ac-to-dc converter proposed by Delco. The figure below shows the power modules appropriately interconnected (Figure 25).

The overall dimensions are 16-1/2 in. wide by 15-1/4 in. deep by 20-1/2 in. high. The final packaging design which will result after integration with an inverter (separate contact) will provide for air intake across the entire frontal surface area of the figure.

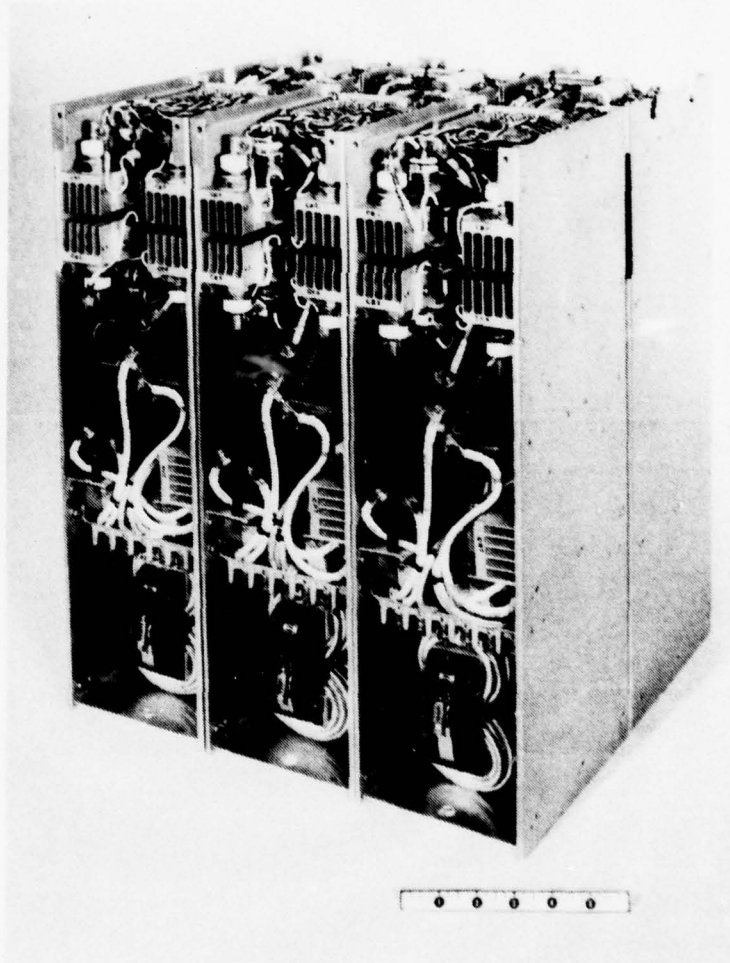
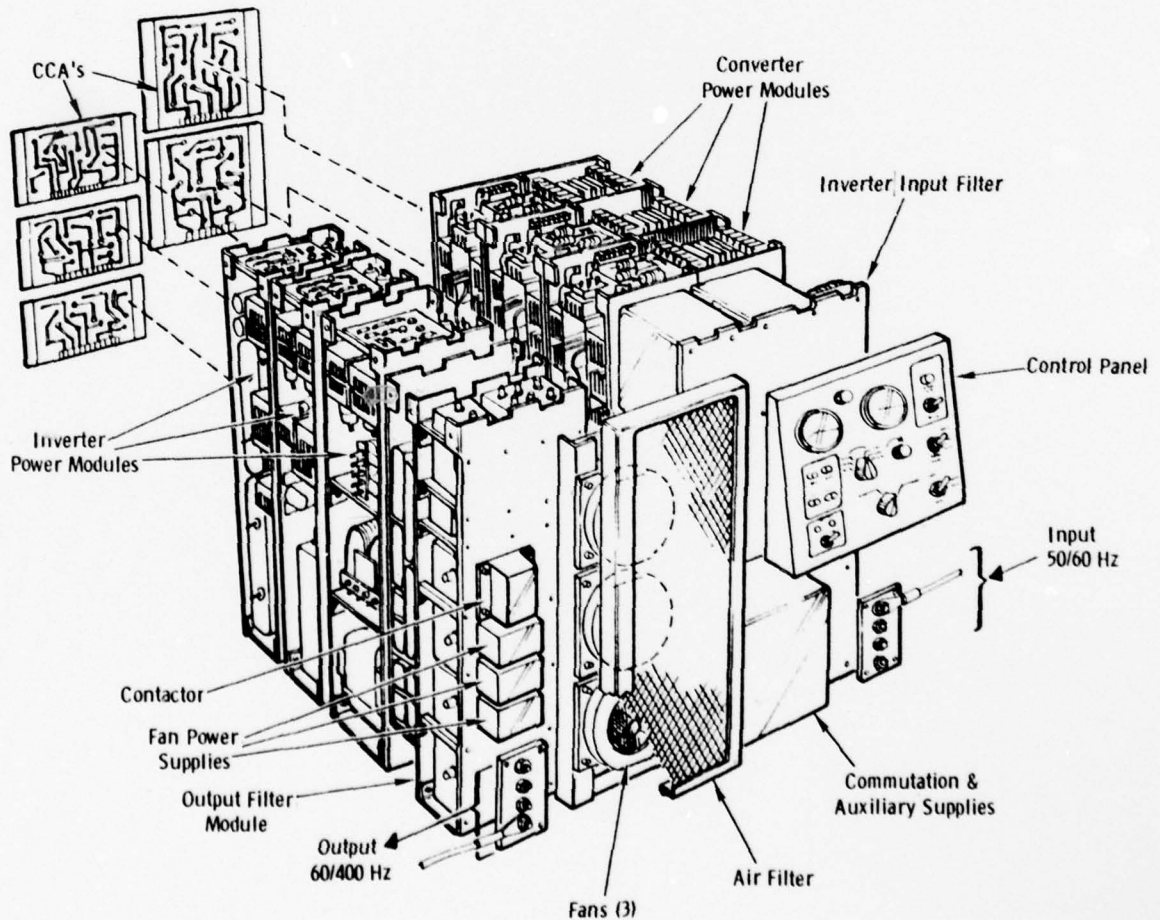

Figure 25. AC-DC Section Power Circuit Packaging

An artist's concept of the power conditioner unit is shown in the illustration below. The modules and components shown will fit into a 30-inch wide by 30-inch deep by 24-inch high enclosure. The anticipated weight of the complete unit is summarized below.

Converter	156 lbs
Inverter	167 lbs
Controls, fans, filter and auxilliary power supply	52 lbs
Enclosure	<u>75 lbs</u>
TOTAL	450 lbs



SECTION IX
PERFORMANCE SUMMARY

9.1 EQUIPMENT DESCRIPTION

The equipment tested consists of control and power circuitry which constitutes a 15 kW general purpose frequency changer. A simplified block diagram for the frequency changer is shown in Figure 26.

Utility class (or better) power 120/208V, 3 phase, 50, 60, or 400 Hz is supplied to the ac-dc converter developed under MERADCOM Contract DAAK 70-77-C-0035. The newly developed converter incorporates input current harmonic reduction and its control circuitry and output filter are specifically designed to make it suitable as an input power source for an inverter which provides 120/208V, 3 phase, 60 or 400 Hz power of high quality. The inverter is presently being developed under MERADCOM Contract DAAK-70-77-C-0157, dated 27 July 1977, which also provides for its integration with the converter to form a deliverable frequency changer package.

The actual electronic hardware tested is as follows:

1. The deliverable converter power circuitry,
2. Breadboard converter control circuitry,
3. A Delco-owned and modified (for 60 Hertz operation) MALOR Type R and D inverter,
4. A Delco-owned and modified (for 60 Hertz operation) breadboard inverter control circuit,
5. Delco-owned, low level, power supplies necessary for control circuit and inverter auxiliary commutation power requirements.

The Delco-owned R and D inverter is essentially identical with respect to circuitry and parts utilization to the inverter being designed and fabricated for MERADCOM for use in the 15 kW frequency changer. Thus, the configuration is a representative test setup for determining the suitability of the ac-dc converter design for inclusion in the frequency changer.

Input Mains, 50, 60, or 400Hz, 120/208V

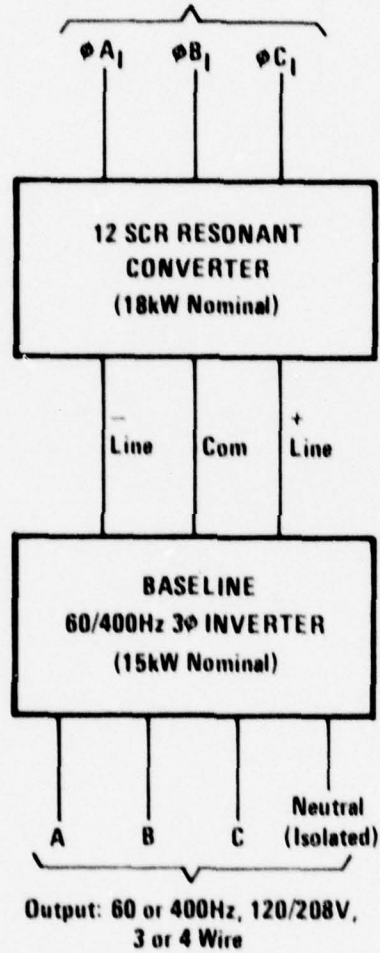

Figure 26. Frequency Changer Block Diagram

A more detailed block diagram of the frequency changer which is being developed for MERADCOM is shown in Figure 27. The schematic diagram in Figure 28 shows the ac-dc converter power portion of the frequency changer circuitry in its entirety. (The 400 Hz input, the feed-through capacitors (C1), contactor KLC1, and the center tap on the inductor (L10) are not used in these tests.) The schematic diagram in Figure 29 shows the inverter power portion of the frequency changer circuitry in its entirety (the feed-through capacitors (C17-C20) are not used in these tests).

It should be understood that these tests were conducted not for purposes of testing the ac-dc converter as an end item. Rather, they were conducted to show that the specific ac-dc converter design is suitable, when combined with a particular inverter, for a general purpose 15 kW frequency changer.

9.2 SUMMARY OF TEST DATA

The tests summarized in this section were performed to demonstrate the functional suitability of the test item as specified in the following documents.

- MERADCOM Purchase Description, EED 76022701, for AC-DC Section of 15 kW General Purpose Power Conditioner, dated February 1976
- MERADCOM Purchase Description for Inverter Section of 15 kW General Purpose Power Conditioner, dated October 1976.

The tests performed comply with CLIN0002 of Contract DAAK 70-C-0035 (Reference PD EED 76022701), and are reported in detail in Test Report R78-28 submitted in March 1978.

The results of the frequency changer electrical performance tests are summarized in Table 2. For some performance characteristics, specifications are not provided explicitly in the purchase descriptions referenced above and comparison with MIL-STD-1332 Precise of Utility Classes of power is suggested. For a few characteristics there are no specifications at all, and results are simply tabulated and called adequate.

Regulation, losses, efficiencies, and THD are plotted against frequency changer output load in Figures 30 through 39.

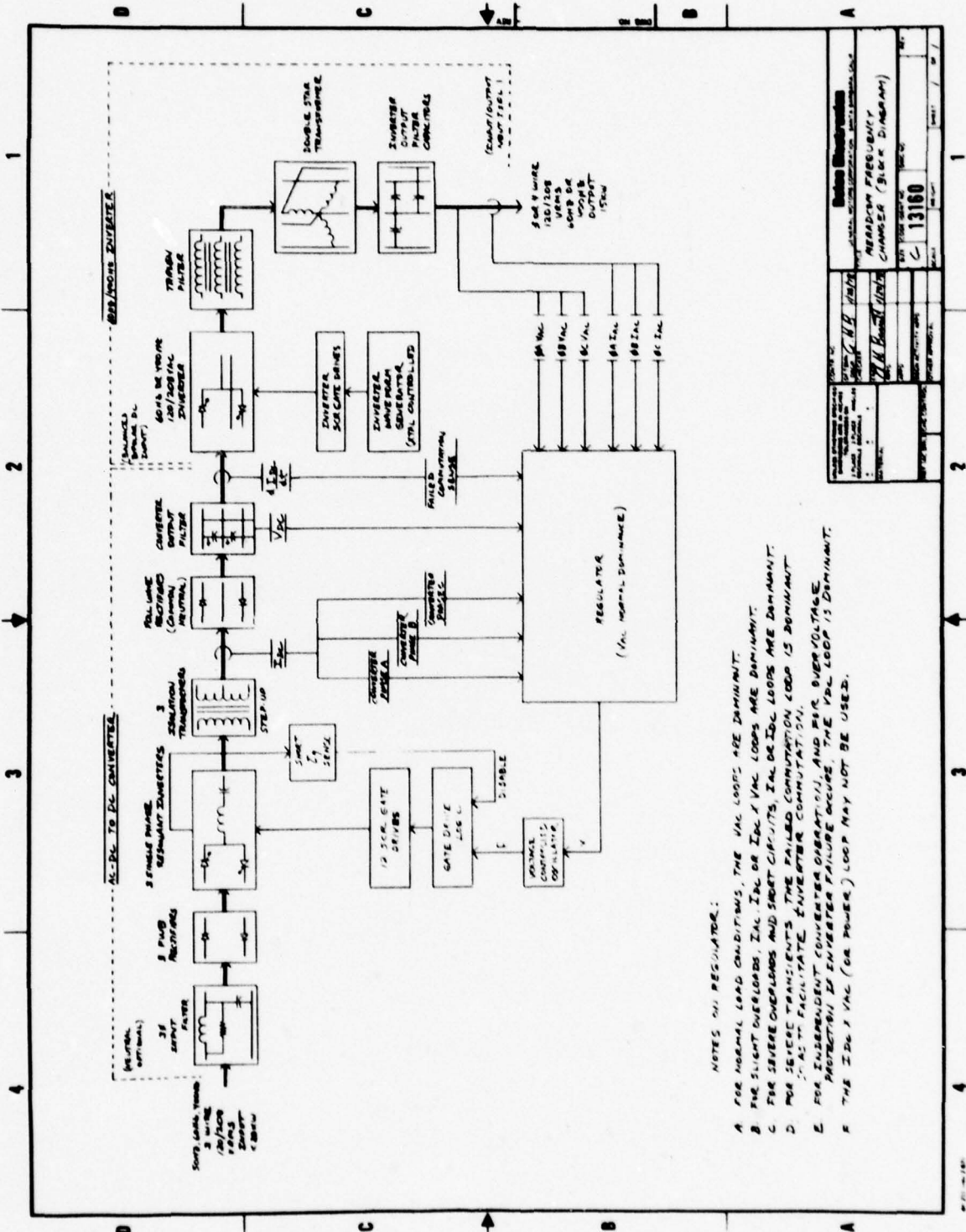

NOTES ON REGULATOR:
 A FOR NORMAL LOAD CONDITIONS, THE IAL LOOPS ARE DOMINANT.
 B FOR SLIGHT OVERLOADS, IAL, IAL OR IAL IAL LOOPS ARE DOMINANT.
 C FOR SEVERE OVERLOADS AND SHORT CIRCUITS, IAL OR IAL LOOPS ARE DOMINANT.
 D FOR SEVERE TRANSIENTS THE FAILED COMPUTATION LOOP IS DOMINANT.
 E AS TO FACILITATE INVERTER COMMUTATION.
 F FOR INDEPENDENT CONVERTER OPERATION, AND PER OVERVOLTAGE PROTECTION IF INVERTER FAILURE OCCURS, THE VCL LOOP IS DOMINANT.
 G THE IAL IAL (OR POWER) LOOP MAY NOT BE USED.

Figure 27. Frequency Changer Functional Block Diagram

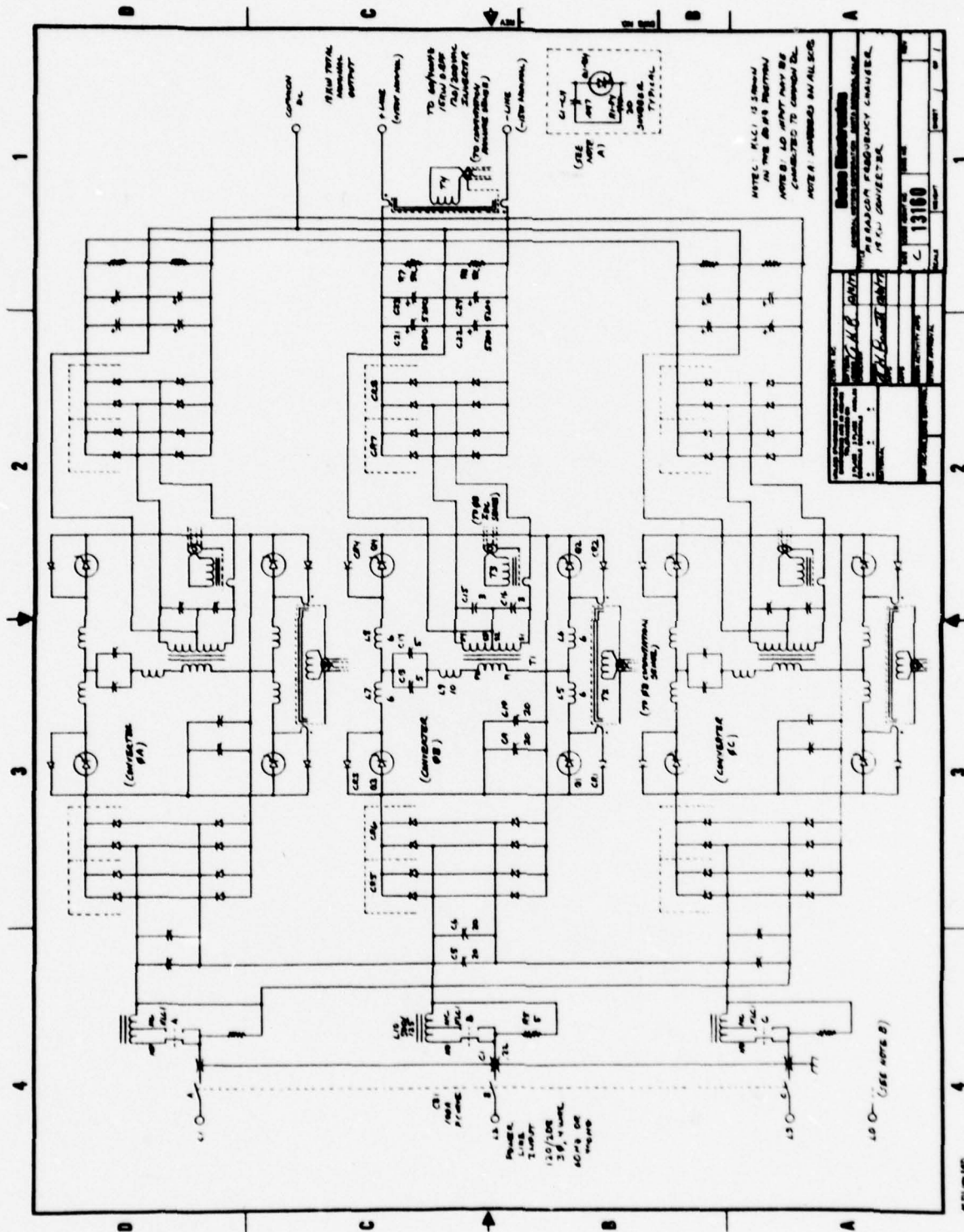

Figure 28. AC-DC Converter for the General Purpose Frequency Changer

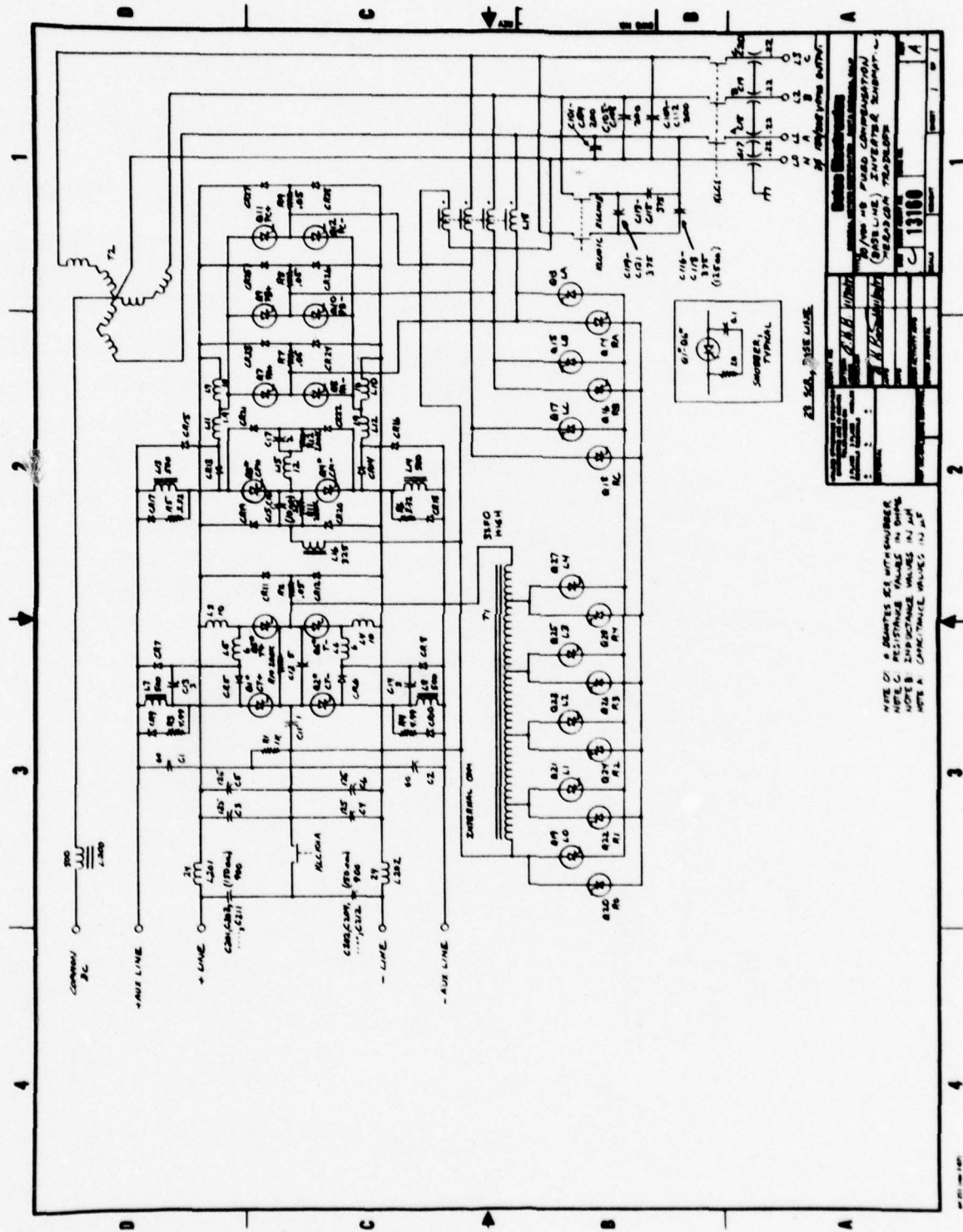

Figure 29. Inverter for the General Purpose Frequency Changer

INPUT CHARACTERISTIC PARAMETER	MIL-STD-1332 PRECISE (CLASS 1)	MIL-STD-1332 UTILITY (CLASS 2)	PURCHASE DESCRIPTION	MEASURED PERFORMANCE	COMMENTS/ OTHER
1) Frequency Changer Input Voltage	N/A	N/A	120/208V +19%, -15%	120/208V +10%, -15%	Complies
2) Frequency Changer Input Frequency	N/A	N/A	50, 60, 400 Hz	60 Hz was tested	Not limited by design
THD	N/A	N/A	5% over normal load range	3.5% at RL only	Limited (See Note A)
Worse Single Harmonic	N/A	N/A	2% over normal load range	3.5%, 5th harmonic, RL only	Limited (See Note A)
3) Frequency Changer Input Current (60 Hz input frequency)	N/A	N/A	5% over normal load range	Not tested	See Note A
Deviation Factor	N/A	N/A	Not specified	125% of rated load input current 125 ms rec. time	Adequate, but PD does not specify
Peak inrush on application of rated load from no load	N/A	N/A	Not specified	Unity (<5° leading)	Adequate, but PD does not specify
4) Frequency Changer Input Power Factor (60 Hz input frequency)	N/A	N/A	Not specified	±150 Vdc, 60A (nom. at RL)	Complies
Converter Output Format (same as Inverter Input)	N/A	N/A	±150 Vdc, 60A (nom. at RL)	±150 Vdc, 60A (nom. at RL)	Complies
6) Voltage Regulation	1% 1%	3% N/A	1.5% 1.5%	<0.5% <0.5%	Complies
Short term (30 sec)	1%	2%	1%	<0.5%	Complies
400 Hz	1%	N/A	1%	<0.5%	Complies
7) Steady State Stability	2% 2%	4% N/A	1% 1%	<0.5% <0.5%	Complies
Long term (4 hrs)	2%	N/A	1%	<0.5%	Complies
Application of rated load, dip	15%/0.5 sec 12%/0.5 sec	20%/3 sec N/A	20%/2 sec 20%/2 sec	13.7%/250 ms 12.3%/250 ms	Complies
8) Transient Performance	15%/0.5 sec 12%/0.5 sec	20%/3 sec N/A	20%/2 sec 20%/2 sec	17.5%/250 ms 17.9%/250 ms	Complies
Rejection of rated load, rise	30%/0.7 sec 25%/0.7 sec	40%/5 sec N/A	40%/5 sec 40%/5 sec	2.5%/100 ms 60A/-0.07 PF Not measured	Complies
Dip for low power factor load	5% 5%	N/A	5% 5%	2.0% 2.05%	Complies
Total Harmonic Distortion	2% 2%	2% N/A	2% 2%	1.6%/5th 1.3%/5th	Complies
9) Waveform	5% 5%	5% N/A	5% 5%	<5% <5%	Complies
Max Individual Harmonic	-	N/A	3V pk-pk (L-N) 3V pk-pk (L-N)	<0.5V <0.7V	Complies
Deviation Factor	5% 5%	5% N/A	5% 5%	<1.5% <3.0%	Complies (see Note B)
Voltage Modulation (or ripple)	1% 1%	1% N/A	1% 1%	<1% <1%	Complies with 1332 Precise
10) Voltage Unbalance with Unbalanced Load	5% 5%	5% N/A	5% 5%	<1.5% <3.0%	Complies (see Note B)
60 Hz	1% 1%	1% N/A	1% 1%	<1% <1%	Complies with 1332 Precise
400 Hz	5% +15% -5%, +10%	-5% N/A	+5% +5%	Not tested Not tested	Not limited by design (should be -5, +15%)
11) Phase Balance Voltage	60 Hz	60 Hz	60 Hz	60 Hz	60 Hz
400 Hz	400 Hz	400 Hz	400 Hz	400 Hz	400 Hz
12) Voltage Adjustment Range	60 Hz	60 Hz	60 Hz	60 Hz	60 Hz
400 Hz	400 Hz	400 Hz	400 Hz	400 Hz	400 Hz

EQUIP FREQUENCY CHANGER

MFGR DELCO

MODEL NO. _____

SERIAL NO. _____

REF: MIL-STD-705B 608.1g

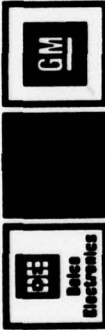

SANTA BARBARA, CALIFORNIA

TEST NO. _____

DATE FEB. 3, 1978

BY A. H. BARRETT

TEST REC OUTPUT VOLTAGE

REGULATION NL → RL

φ NL → FL

60 Hz

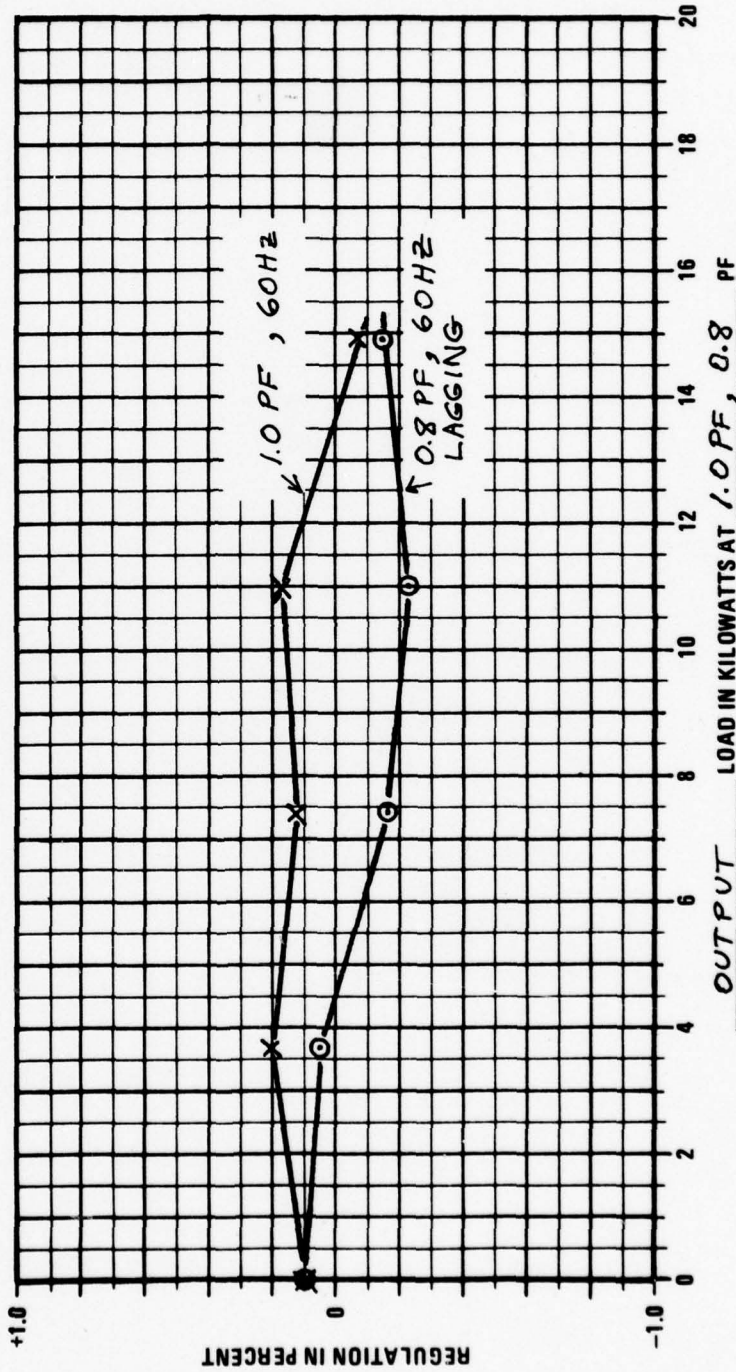

Figure 30. Output Voltage Regulation, 60 Hz

EQUIP FREQUENCY CHANGER

MFGR DELCO

MODEL NO. _____

SERIAL NO. _____

REF: MIL-STD-705B 608.1a



SANTA BARBARA, CALIFORNIA

TEST NO. _____

DATE FEB. 3, 1978

BY A.H. BARRETT

TEST REC OUTPUT VOLTAGE

REGULATION NL → RL

4 NL → FL

400 Hz

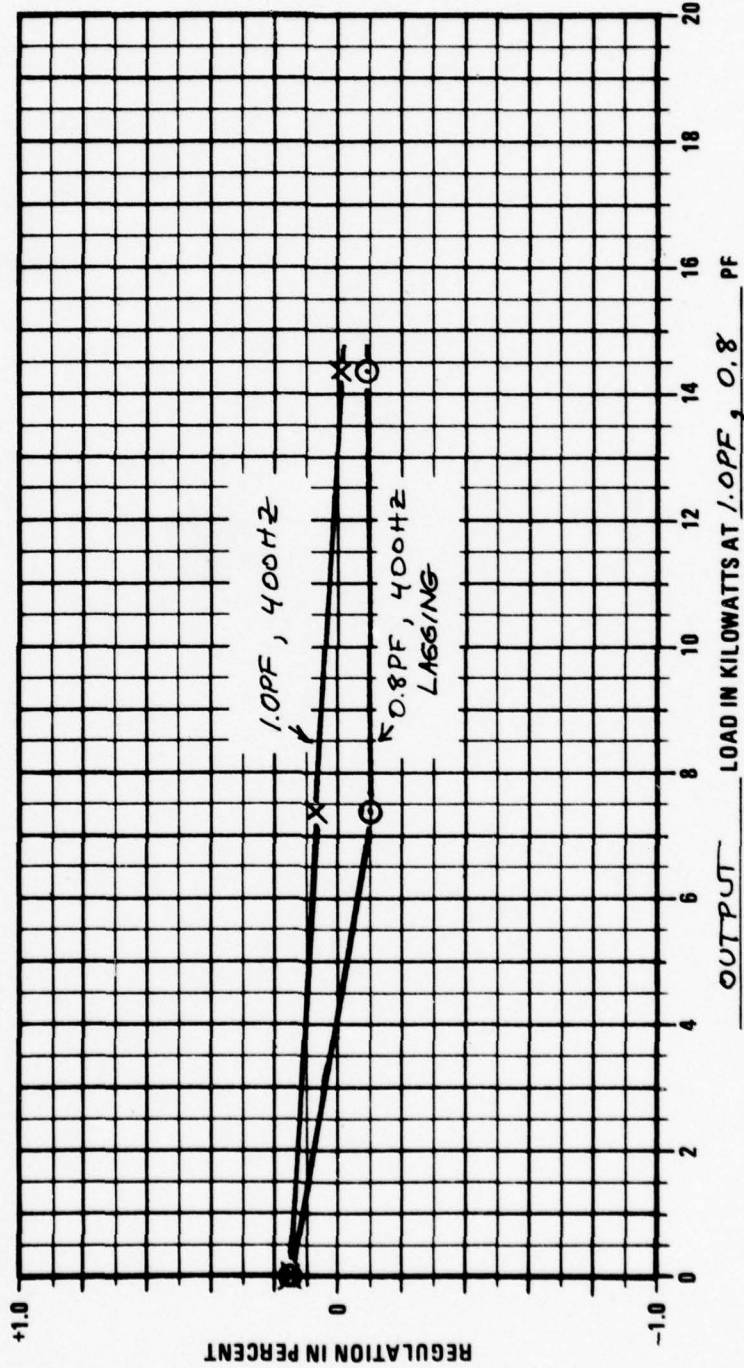

Figure 31. Output Voltage Regulation, 400 Hz

TEST REC. FREQUENCY
CHANGER LOSSES
 (EXCLUDING LOW LEVEL)
 VS LOAD
60HZ OUTPUT



SANTA BARBARA, CALIFORNIA

EQUIP FREQUENCY CHANGER
 MFGR DELCO
 MODEL NO. _____
 SERIAL NO. _____
 REF: MIL-STD-705B
 TEST NO. _____
 DATE FEB. 3, 1978
 BY A.H. BARRETT

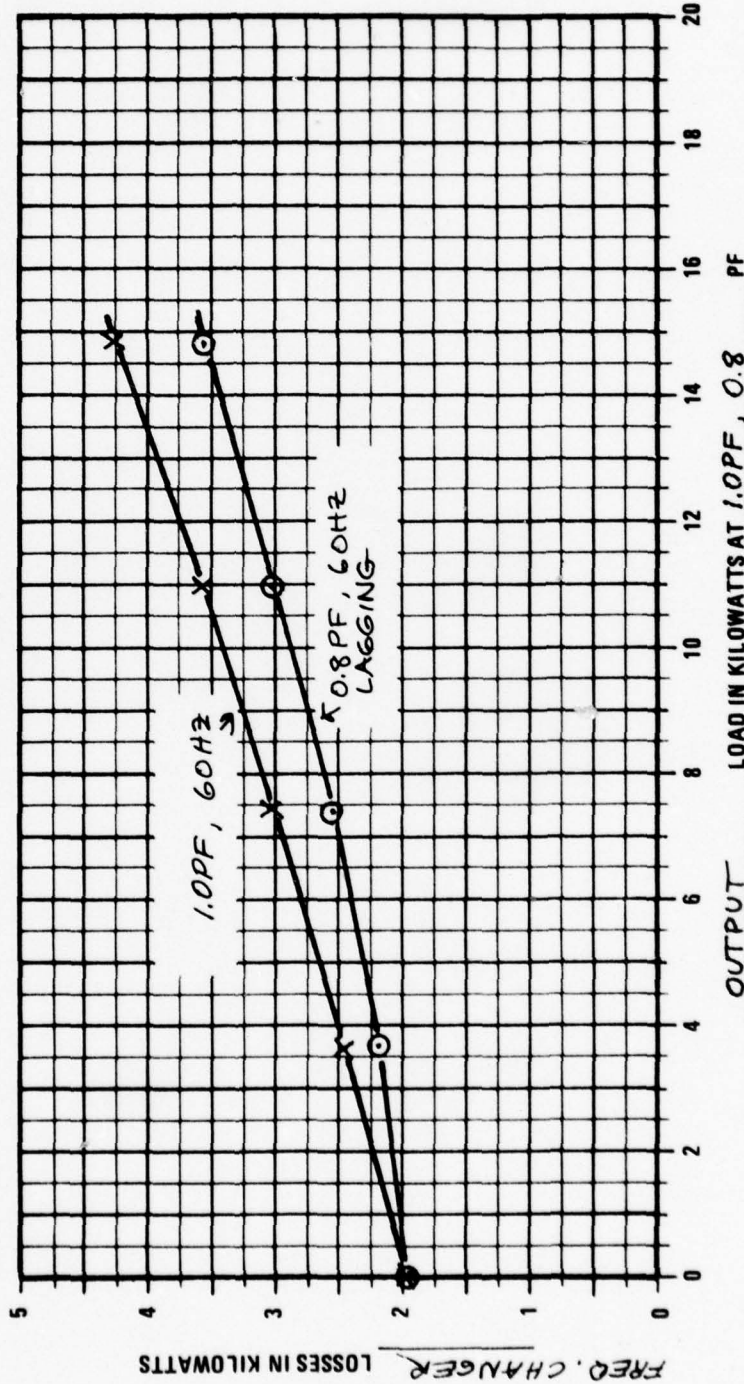

Figure 32. Frequency Changer Losses, 60 Hz Output



EQUIP FREQUENCY CHANGER

MFGR DELCO

MODEL NO. _____

SERIAL NO. _____

REF: MIL-STD-705B

TEST REC FREQUENCY

CHANGER LOSSES

(EXCLUDING LOW LEVEL)

VS LOAD

400 HZ OUTPUT

TEST NO. _____

DATE FEB. 3, 1978

BY A.H. BARRETT

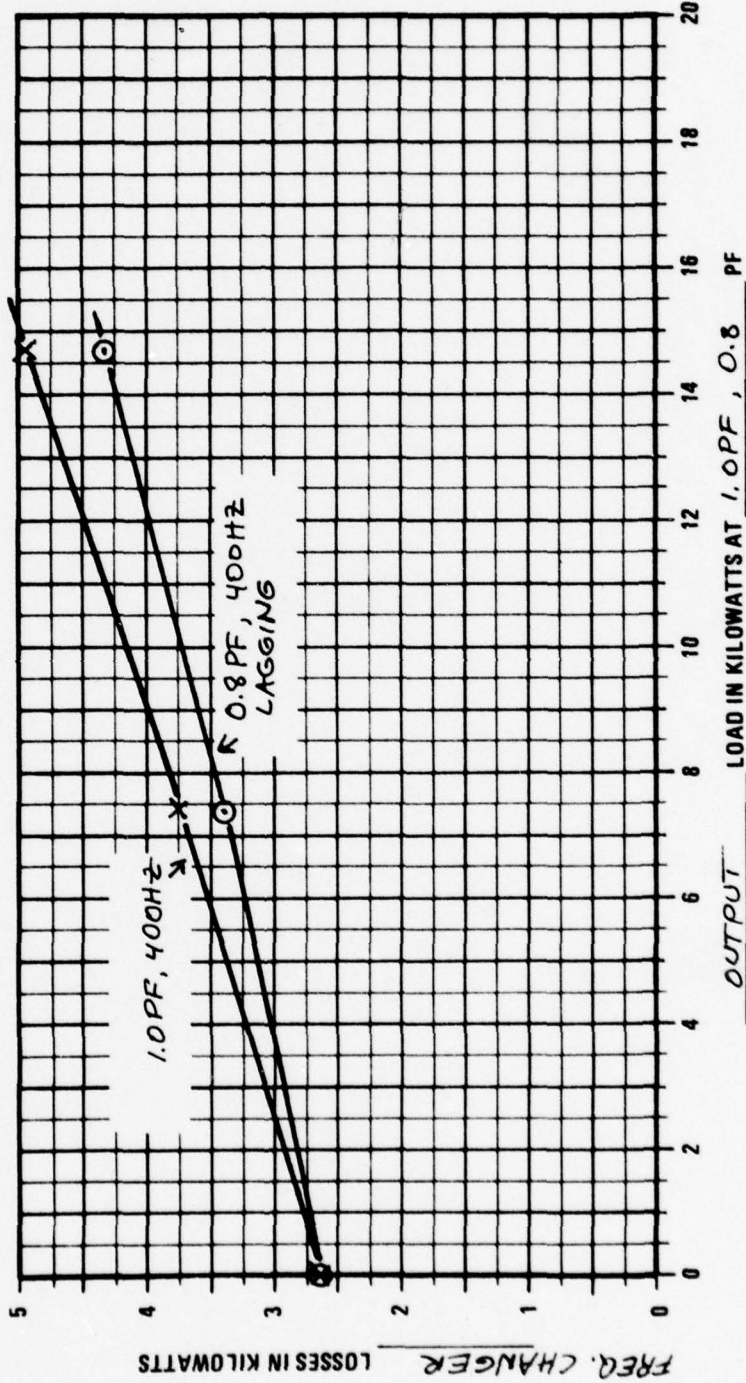

Figure 33. Frequency Changer Losses, 400 Hz Output

EQUIP FREQUENCY CHANGER

MFGR DELCO

MODEL NO. _____

SERIAL NO. _____

REF: MIL-STD-705B



SANTA BARBARA, CALIFORNIA

TEST NO. _____

DATE FEB. 3, 1978

BY A.H. BARRETT

TEST REC CONVERTER

LOSSES, INVERTER

LOSSES VS FREQUENCY

CHANGER LOAD

60HZ OUTPUT

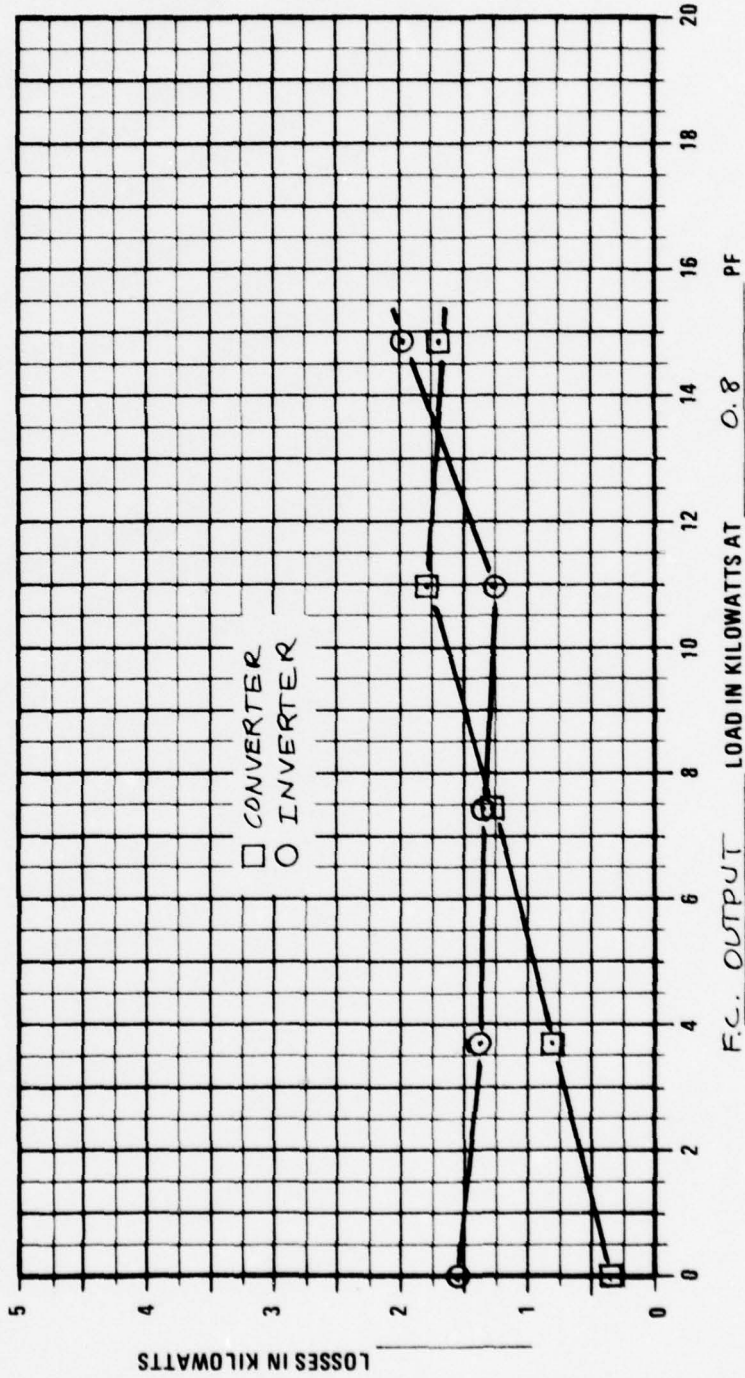

Figure 34. Converter/Inverter Losses vs Load, 60 Hz Output

EQUIP FREQUENCY CHANGER

MFGR DELCO

MODEL NO. _____

SERIAL NO. _____

REF: MIL-STD-705B



SANTA BARBARA, CALIFORNIA

TEST REC. CONVERTER

LOSSES, INVERTER

LOSSES VS FREQUENCY

CHANGER LOAD

400 Hz OUTPUT

TEST NO. _____

DATE FEB. 3, 1978

BY A. H. BARRETT

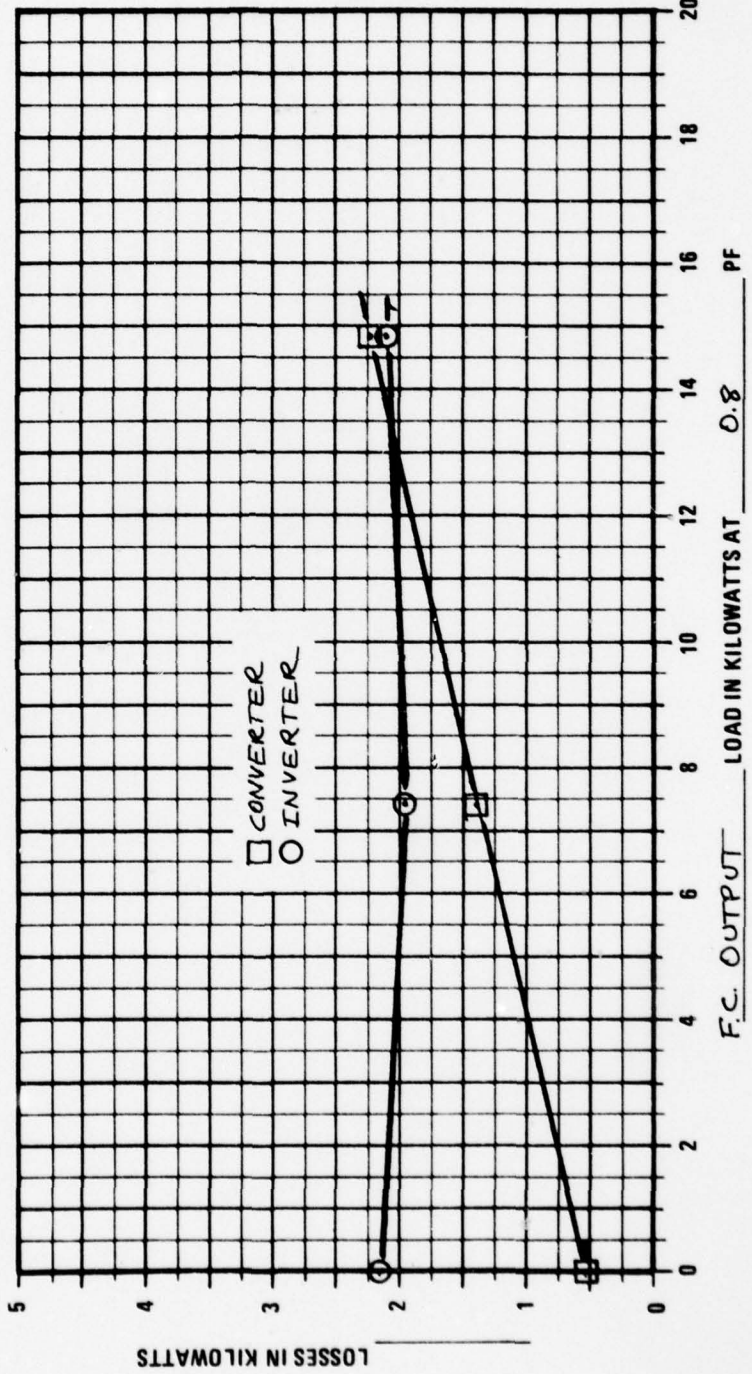

Figure 35. Converter/Inverter Losses vs Load, 400 Hz Output

EQUIP FREQUENCY CHANGER
 MFR DELCO
 MODEL NO. _____
 SERIAL NO. _____
 REF: MIL-STD-705B
 TEST NO. _____
 DATE FEB. 3, 1978
 BY A. H. BARRETT
 TEST REC CONVERTER,
INVERTER & FREQ.
CHANGER EFFICIENCY
VS F.C. LOAD
60 HZ OUTPUT



SANTA BARBARA, CALIFORNIA

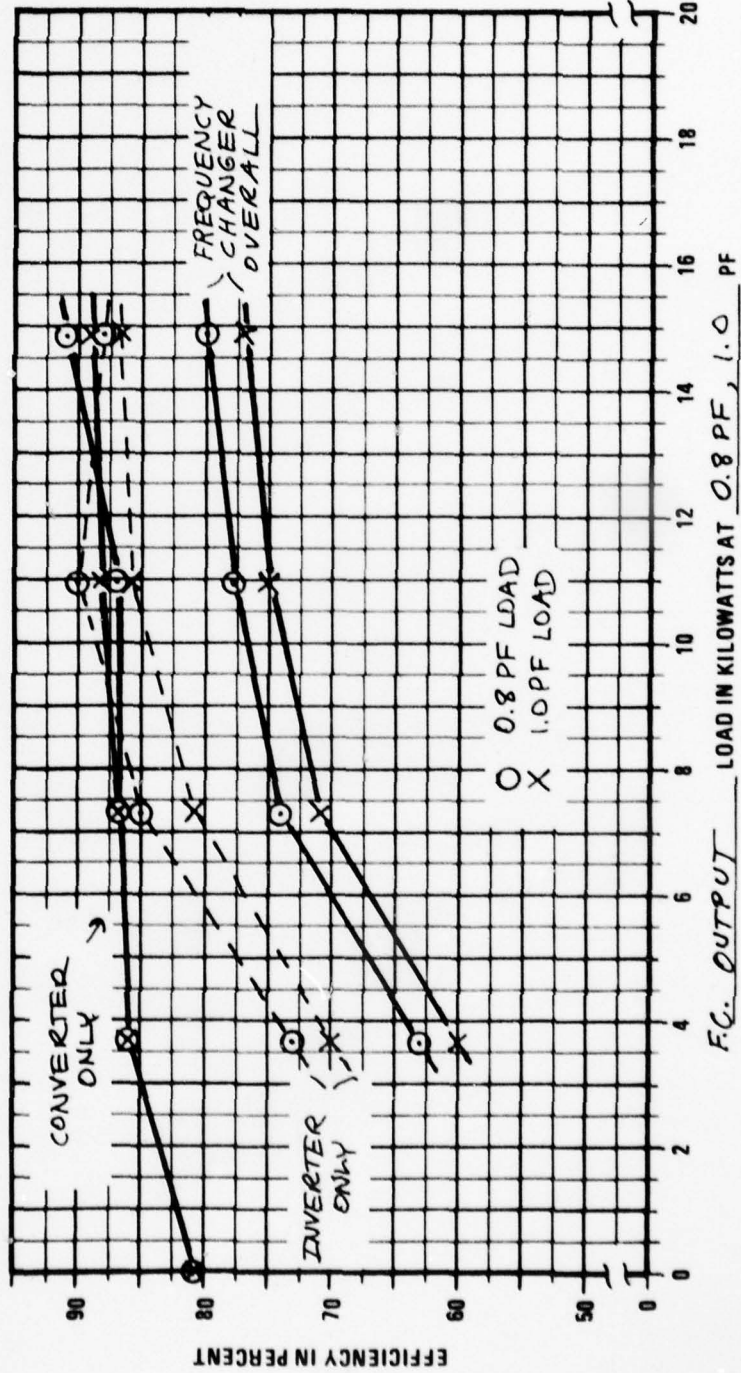

Figure 36. Converter/Inverter and Frequency Changer Efficiency, 60 Hz Output

TEST REC CONVERTER,
INVERTER & FREQ.
CHANGER EFFICIENCY
 VS F.C. LOAD
400 HZ OUTPUT



SANTA BARBARA, CALIFORNIA

EQUIP FREQUENCY CHANGER
 MFR DELCO
 MODEL NO. _____
 SERIAL NO. _____
 REF: MIL-STD-705B

TEST NO. _____
 DATE FEB. 3, 1978
 BY A.H. BARRETT

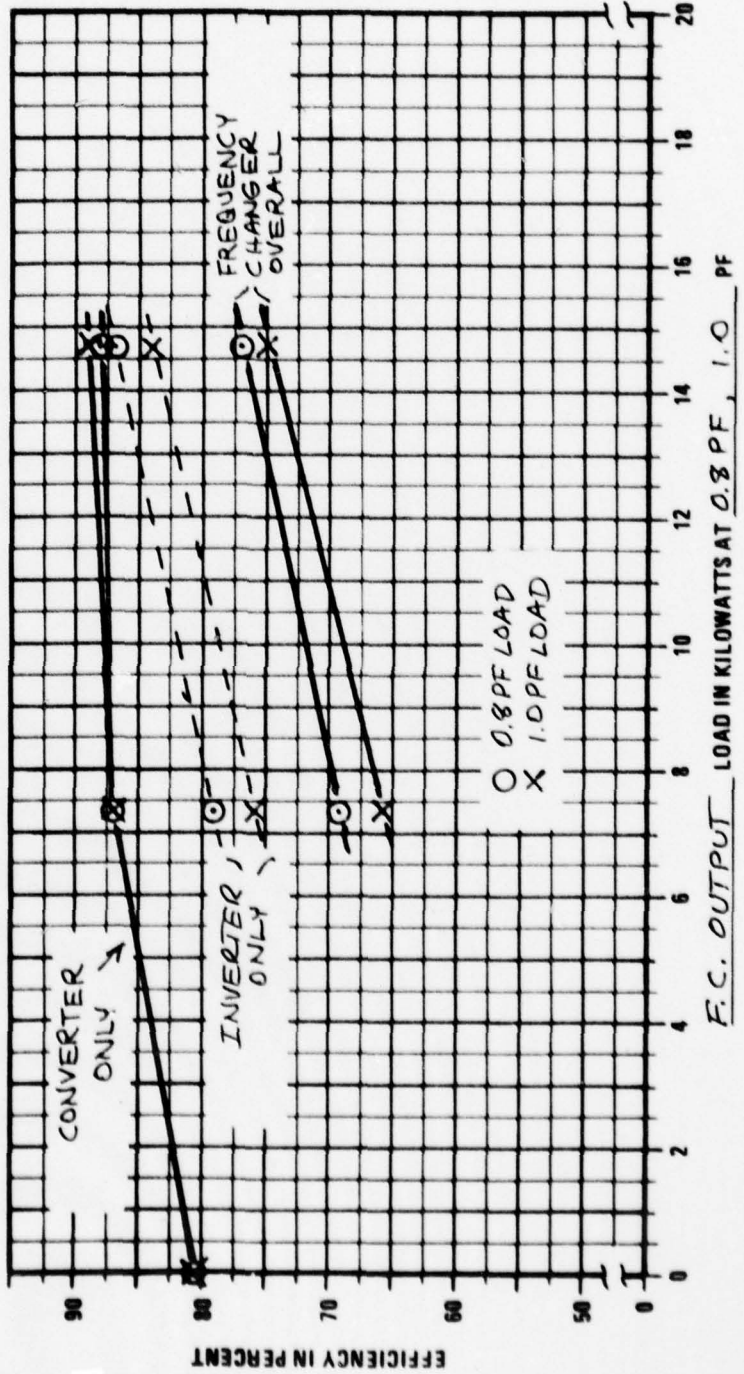

Figure 37. Converter/Inverter and Frequency Changer Efficiency, 400 Hz Output

EQUIP FREQUENCY CHANGER TEST REC TOTAL
 MFGR DELCO HARMONIC DISTORTION
 MODEL NO. VS FREQUENCY
 SERIAL NO. CHANGER LOAD
 REF: MIL-STD-705B 601.4a BY A.H. BARRETT 60HZ OUTPUT



SANTA BARBARA, CALIFORNIA

TEST NO. _____
 DATE FEB. 3, 1978
 TEST NO. _____
 BY A.H. BARRETT

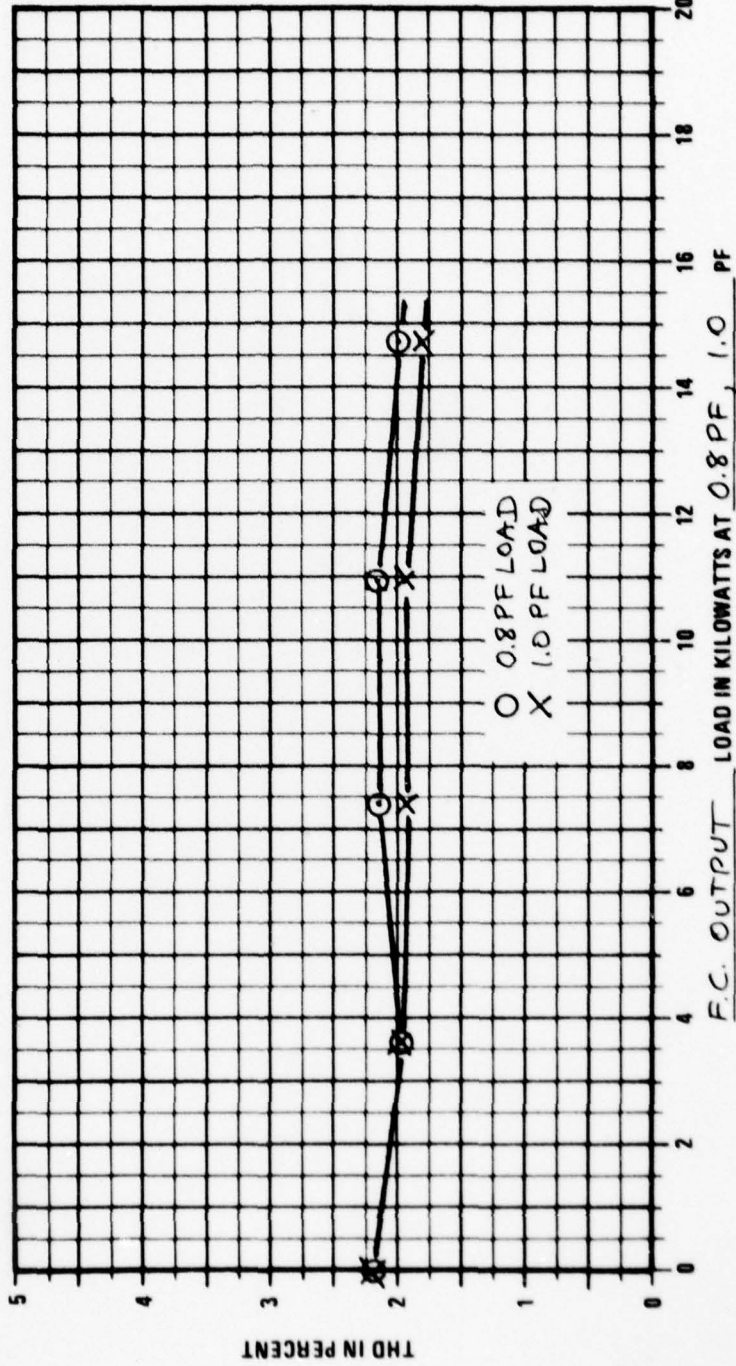

Figure 38. Total Harmonic Distortion versus Load, 60 Hz Output

EQUIP FREQUENCY CHANGER

MFGR DELCO

MODEL NO. _____

SERIAL NO. _____

REF: MIL-STD-705B 601.4a



SANTA BARBARA, CALIFORNIA

TEST NO. _____

DATE FEB. 3, 1978

BY A. H. BARRETT

TEST REC TOTAL

HARMONIC DISTORTION

VS FREQUENCY

CHANGER LOAD

400HZ OUTPUT

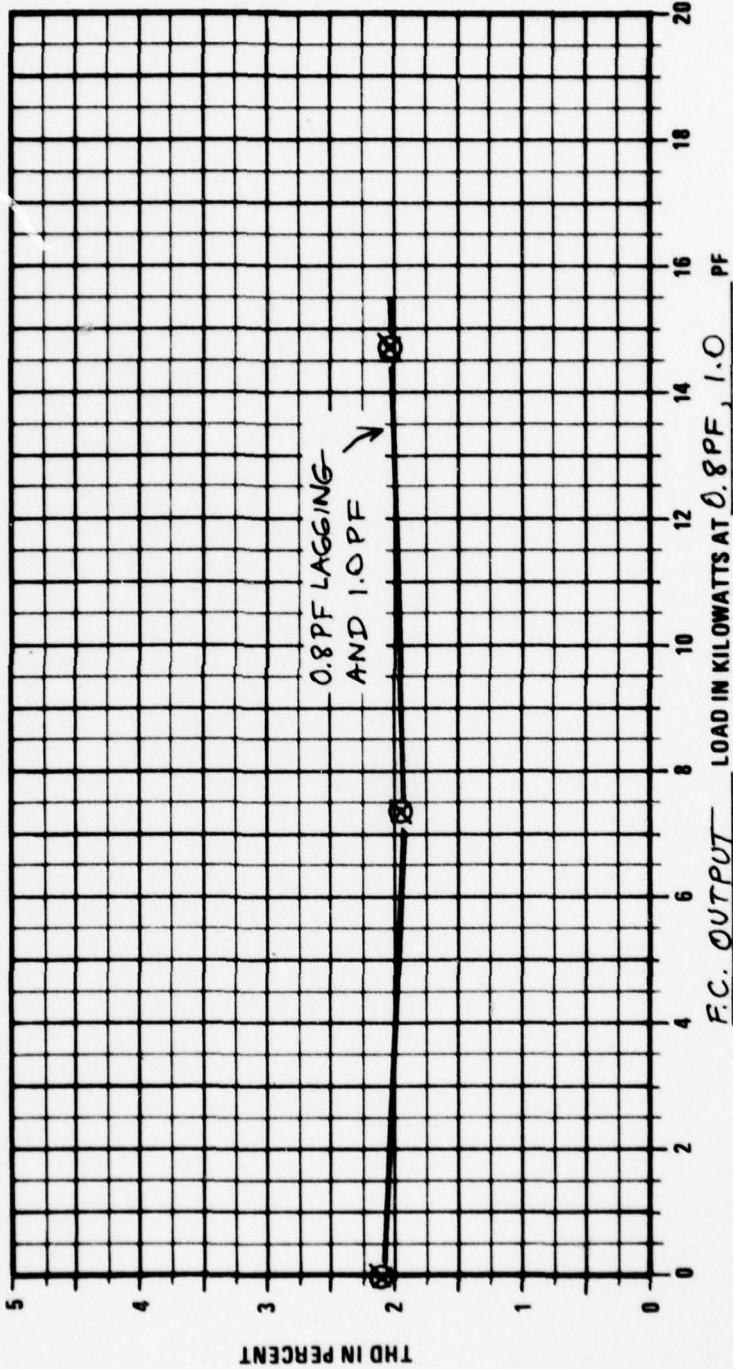

Figure 39. Total Harmonic Distortion versus Load, 400 Hz Output

SECTION X
CONCLUSIONS AND RECOMMENDATIONS

Most test results summarized in the previous section are better than, or at least compliant with, PD or other requirements. There are deviations, measured or suspected, which are discussed herein.

10.1 FREQUENCY CHANGER INPUT FREQUENCY AND INPUT CURRENT

The set was tested only at 60 Hz because adequate 50 Hz to 400 Hz power sources are not available at Delco. There is no design limitation which precludes operation at 50 Hz and 400 Hz. It is quite possible that the present converter input filter would not function as is at 400 Hz, but the inductor tap scheme shown in Figure 28 of Section IX probably would function.

Deviation from the ideal sinusoidal input current is above that specified in the PD. Additional filter optimization effort could improve this situation. However, the procurement specification probably should be amended.

10.2 VOLTAGE UNBALANCE WITH UNBALANCED LOAD

Inverter performance is entirely satisfactory, as is the performance of the converter power circuitry; a converter control instability was noted above 15A unbalance. An improvement which will be made in the control circuitry during future integration efforts can be expected to eliminate the instability.

10.3 VOLTAGE ADJUSTMENT RANGE

Adjustment range is related to that provided by the breadboarded converter. This is from close to zero output voltage to approximately 120 percent rated output voltage.

10.4 SHORT CIRCUIT CURRENT

Testing of single-, two-, and three-phase short circuits (from RL) was done only at 60 Hz output frequency. Earlier testing indicated similar results at 400 Hz output frequency. The inverter portion always seems to function well, but two problems exist in the converter.

The bridge rectifiers presently used in the converter have a combined maximum safe operating output current of about 90A dc. About 125A dc is required to safely meet the 2 PU current specification for the frequency changer.

There is an instability in the low level control circuit for the converter. This results in bursts of output approximately 0.5-second long spaced by "not output" periods of approximately 0.25 second.

A balanced three-phase short circuit does not cause control instability and approximately 75A rms per phase was recorded. This was intentionally limited below the 104 A rms (2 PU) specified to protect the converter output rectifiers.

10.5 NO LOAD LOSSES, EFFICIENCY AT FULL LOAD, EFFICIENCY AT RATED LOAD

The purchase description states that the no load loss shall not exceed 500 watts and that efficiency with the set operating above 25 percent of rated power shall be 80 percent minimum.

Tests were conducted on a frequency changer with breadboard cooling and logic. Power lost for cooling and low level power supplies for logic, contactors, and so on, was not accounted for in either the loss calculations or the efficiency calculations. This lost power would be reflected in about a 10 percent increase in no-load losses and about a 2 percent decrease in overall efficiency.

No load losses are well in excess of those specified and, in a fully packaged frequency changer using the same power circuits as those tested, may run as high as 3 kW. It should be noted that rated load efficiency is likely to be 75 to 78 percent in a fully packaged set.

10.6 RECOMMENDATIONS FOR WORK PRIOR TO INTEGRATION

Harmonic distortion of the input currents to the frequency changer is very low, although it is greater in some cases than that specified. The input filter for the converter certainly can be improved upon. More should be learned about the effects of source impedance on input current harmonics. It is recommended that Delco be funded to refine the input filter while studying source impedance effects. MERADCOM should consider changing the

current harmonic specifications. It is recommended that Navy specifications for frequency changers, from the NAVSEC offices, be reviewed.

Delco should further refine the low level control circuits so as to eliminate instabilities that have been shown to occur with heavy unbalanced loads and short circuits. MERADCOM should change the output voltage adjustment range to -5 percent and at least +10 percent of rated output voltage.

Rather high no-load and light-load losses are related to the specific inverter approach used. The two major contributions are from the following:

- Load-independent, high level, forced commutation circuits
- A very large, fixed, leading power factor, output filter.

It is not recommended that any changes be made in the commutation circuitry, which accounts for a few hundred watts of loss at 400 Hz output and much less at 60 Hz output. The present output filter, which draws 1.1 PU rated current at 0 PF, leading, is responsible for as much as 2 kW loss at no-load. At no-load and light loads a smaller filter would greatly reduce inverter and converter losses and substantially improve light load efficiency. A 0.9 to 1.0 PU output filter would improve rated load efficiency. Unity PF load efficiency would be greatly improved by a smaller output filter.

It is, therefore, strongly recommended that Delco be funded to develop and test a bread-board incrementally variable filter and its manual control circuitry. This would provide a very credible tradeoff of this approach as compared with the baseline which was adopted, and is being developed under separate contract.

It would be desirable if the above recommendations were funded and implemented prior to integration of the converter and inverter. It must be recognized that the results and conclusions obtained could impact development and funding planning for the integration effort.

The schematic for the regulator (CCAA1) includes corrections for all known stability problems. Prior to integration Delco will optimize the compensation circuitry on CCAA1 and eliminate the stability problems.

Input and output filter characteristics have such a significant impact on frequency changer performance that it is very strongly recommended that Delco be given the funding required to study these filters. This should commence as soon as possible.

10.7 RECOMMENDATIONS FOR WORK AFTER INTEGRATION

The applicability of the frequency changer would be greatly augmented, its performance improved, and/or its costs reduced by contract funding in the following task areas:

1. More Complete Characterization of Performance

A discussion of more complete characterization of performance was given in the Delco test report R78-28 Appendixes A, B, and C. This is desirable due to the versatility of the frequency changer in that it can accommodate different frequencies and voltages, as well as different load requirements. As part of this task frequency changer test definition beyond the existing PD and MIL-STD-705B is required and the advanced development unit should be tested to the new definition.

2. EMI Testing and Control

EMI control and reduction can become expensive and greatly influence production costs. Extensive testing should be undertaken so that the minimum necessary EMI control can be implemented.

3. A Diagnostic Test Set (off-line)

It is felt that on a system as complex as the frequency changer, where fault diagnosis can be very difficult, that an off-line test set should be developed. The set would plug into diagnostic connectors which could be furnished on the frequency changer. A separate test set approach would have little impact on the production cost of a unit, but could conceivably reduce life cycle cost greatly.

4. Capability for UPS Use (battery or fuel cell source and possibly a single phase ac input capability)

There is clearly an ever increasing need for uninterruptible power systems (UPS) which use at their input variable frequency ac or dc and provide high quality output power. The Delco/MERADCOM frequency changer with little modification and with a suitable power source could well satisfy nearly all UPS requirements.

5. A 50 Hz, NATO Compatible, Output Capability

A significant amount of equipment developed by the NATO countries requires 50 Hz at a voltage higher than 120/208 Vac. The Delco/MERADCOM frequency changer could, in its present implementation, provide 50 Hz at about 10 kW. With a suitable step-up transformer it could supply NATO requirements. If the frequency changer magnetics were designed for 50 Hz operation and the output filter sized for 50 Hz, it would be possible to supply 15 kW.

6. Single Phase Output Capability

The frequency changer as now configured provides 120/208Vac, three-phase; but could be made to supply 120/240 Vac, single phase. This would best be accomplished with a separate "black box" which would house a three-phase to single-phase transformer with suitable phase compensation inductors and capacitors. This would reflect a sufficiently well balanced three-phase load to the frequency changer.

7. Frequency Changer Paralleling Capability

It would be a rather simple task to parallel two identical frequency changers. It would only be necessary to debug paralleling logic which is presently implemented and use small paralleling transformers (autotransformers) between the outputs of corresponding phases of the two frequency changers. It should be practical to parallel more than two frequency changers by this approach.

8. Motor-Generator Set Paralleling Capability

Somewhat more difficult would be the task of paralleling a motor-generator set and a frequency changer. The former would determine the output frequency so a means would have to be devised to synchronize the frequency changer. This could be accomplished by means of a phase locked loop and a VCO (rather than the crystal reference now used). This scheme would also permit synchronization to a utility power bus. Load sharing poses a problem which could be handled by a more complex regulator in the frequency changer.

9. Remote Sensing of Output Voltage

Remote sensing of voltage, which would give more tightly regulated power at the load end of long power lines, involves many of the same concepts as would be employed to permit load sharing.

Undertaking of any or all of these tasks would be very worthwhile. The Delco/MERADCOM frequency changer as is now being configured should be integrated and completed. These tasks are suggested as best undertaken after this completion. The set could then be easily modified by the external addition of the circuitry necessary to demonstrate the desired results. The set would then remain fully operable and deliverable in its presently conceived configuration.

APPENDIX A
PARTS LIST — CONVERTER POWER COMPONENTS

Drafting/Date		Engineering/Date		Delco Electronics GENERAL MOTORS CORPORATION SANTA BARBARA, CALIFORNIA		Code		
RFB 4/13/78		RFB 4/13/78		13160		S = New Standard Dwg. (SCD) P = Dwg. in Process R = Rework Existing Dwg. C = Dwg. Completed		
Item	Quantity	Code	Part Number	Rev	Part Name	Material	Remarks	
1	2		SCBK8		DIODE BRIDGE	CR5, CR6	SEMTECH	
2	4		97F8542FC		CAPACITOR, 204F, 350V	C5, C6, C9, C10	GE	
3	1		XL 7301D		INDUCTOR, 5MH	L10	DELCO	
4	1		RER75F4R99M		RESISTOR 4.99Ω, 30W	R5	DALE	
5	4		86F6268H/10W/105T5		CAPACITOR, 5200PF, 200VDC	C21, C22, C23, C24	GE	
6	2		RWR98S5001FM		RESISTOR, 5KΩ, 10W	R7, R8	Sprague	
↑					INPUT/OUTPUT MODULE (3 REQ'D)			
↑					SINGLE-PHASE CONVERTER MODULE (3 REQ'D)			
7	4		C164M2X3		SCR, FLAG LEAD	Q1, Q2, Q3, Q4	GE	
8	4		SR2885		DIODE	CR1, CR2, CR3, CR4	MOTOROLA	
9	4		RER50F20ROM		RESISTOR, 20Ω, 20W, 1%	R1, R2, R3, R4	DALE	
10	4		CQ09A1KF73K3M		CAPACITOR, 0.047μF, 600VDC	C1, C2, C3, C4		
11	2		XT77011		TRANSFORMER	T2, T3	DELCO	
12	4		XL77002		INDUCTOR, 6μH, AIR CORE	L5, L6, L7, L8	DELCO	
13	1		XL75002		INDUCTOR, 10μH, AIR CORE	L9	DELCO	
14	2		SCBK5F		DIODE BRIDGE	CR7, CR8	SEMTECH	
15	2		28F1247		CAPACITOR, 3μF, 600V	C15, C16	GE	
16	2		28F1248		CAPACITOR, 5μF, 600V	C13, C14		
17	1		XT78001		TRANSFORMER	T1	DELCO	
LAYOUT PARTS LIST				Title GP FREQUENCY CHANGER (S) CONVERTER POWER COMPONENTS				DL-
							Rev	

APPENDIX B

PARTS LIST — CONVERTER REGULATION AND CONTROL CCAA1

Code
S = New Standard Dwg. (SCD)
P = Dwg. in Process
C = Dwg. Completed

Code
N = New Dwg.
W = Word Dwg.
R = Rework Existing Dwg.

Delco Electronics
GENERAL MOTORS CORPORATION
SANTA BARBARA, CALIFORNIA
CODE IDENT NO. **13160**

Engineering/Date
A.H.B. / 4/3/78

Item	Quantity	Code	Part Number	Rev	Part Name	Material	Remarks
1	2		M39003/06-0055		68 μ F, $\pm 10\%$, 20V, Tant. cap	C1, C2	
2	11		M39014/02-1230		0.1 μ F, $\pm 10\%$, 100V, CK06 cap	C3, C4, C9, C10, C11, C13, C15, C16	
2						C21, C22, C26	
3	2		M39014/02-1240		0.47 μ F, $\pm 10\%$, 50V, CK06 cap	C5, C27	
4	5		M39014/02-1407		1.0 μ F, $\pm 10\%$, 50V, CK06 cap	C6, C7, C8, C14, C42	
5	2		M39014/02-1236		0.22 μ F, $\pm 10\%$, 50V, CK06 cap	C12, C34	
6	2		M39014/02-1225		0.047 μ F, $\pm 10\%$, 100V, CK06 cap	C17, C18	
7	1		M39014/02-1212		4700 μ F, $\pm 10\%$, 200V, CK06 cap	C19	
8	1		M39003/06-		TBD	C20	
9	3		M39014/02-1238		0.33 μ F, $\pm 10\%$, 50V, CK06 cap	C23, C24, C25	
10	3		M39014/02-		TBD	C28, C29, C30	
11	3		M39014/02-		TBD	C31, C32, C33	
12	3		M39014/02-		TBD	C35, C36, C37	
13	3		M39014/02-		TBD	C38, C39, C40	
14	1		M39014/01-1455		0.01 μ F, $\pm 10\%$, 100V, CK05 cap	C41	
15							
16							
18							
19							
20	1		JAN1N5565B		12V, $\pm 5\%$, 1W ZENER DIODE	CR1	
21	24		JAN1N4148-1		SILICON SIGNAL DIODE	CR2, CR3, CR4, CR5, CR6, CR7, CR8, CR9, CR10, CR11, CR12, CR13, CR14, CR15, CR16, CR17, CR18, CR19, CR20, CR21, CR22, CR23, CR24, CR25, CR26, CR27, CR28	
21							
21							
21							
21							

LAYOUT PARTS LIST

Title GP FREQUENCY CHANGER
CCAA1

Ship
DL-

Rev

AD-A056 302

GENERAL MOTORS CORP GOLETA CALIF DELCO ELECTRONICS DIV F/G 10/2
15KW GENERAL PURPOSE POWER CONDITIONER (FREQUENCY CHANGER). AC---ETC(U)
APR 78 DAAK70-77-C-0035

UNCLASSIFIED

R78-38

NL

2 of 2

AD
A056 302

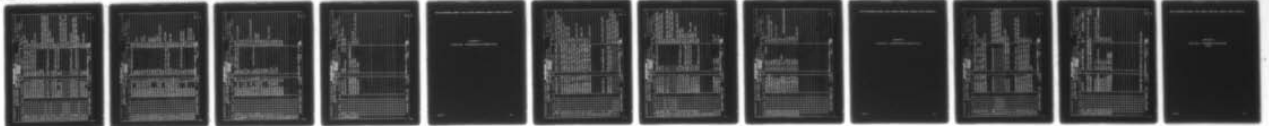

END
DATE
FILMED
8 -78
DDC

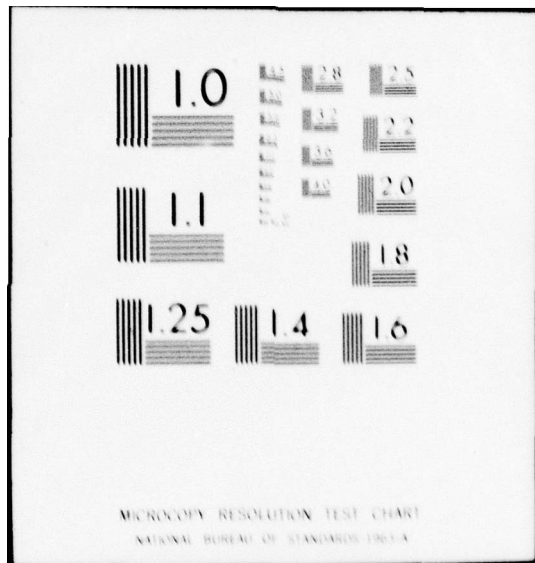

Drafting/Date: A.H.B. / 4/3/78
 Engineering/Date: A.H.B. / 4/3/78
 Delco Electronics
 GENERAL MOTORS CORPORATION
 SANTA BARBARA, CALIFORNIA
 CODE IDENT NO. 13160
 Code: S = New Standard Dwg. (SCD)
 P = Dwg. in Process
 C = Dwg. Completed
 N = New Dwg.
 W = Word Dwg.
 R = Rework Existing Dwg.

Item	Quantity	Code	Part Number	Rev	Part Name	Material	Remarks
22	3		RTR24DW103M		10K, ±5%, 0.75W, Trim pot	R1, R2, R5	
23	2		RJR24FW104M		100K, ±10%, 0.5W, Trim pot	R3, R4	
24	1		RCR20G101JS		100, ±5%, 0.5W, carb res.	R6	
25	2		RNC60H4993FM		499K, ±1%, 0.25W, prec. res.	R7, R8	
26	3		RNC55H1002FM		100K, ±1%, 0.125W, prec. res.	R9, R10, R114	
27	1		RNC55H1001FM		1.00K	R11	
28	1		RNC55H4641FM		4.64R	R12	
29	13		RNC55H2002FM		20.01K	R13, R14, R15, R16, R20, R21, R27,	
29						R28, R29, R75, R76, R77, R78	
30	9		RCR07G203JS		20K, ±5%, 0.25W, carb res.	R17, R36, R53, R71, R72, R90	
30						R91, R113, R145	
31	2		RCR07G474JS		470K	R18, R42	
32	1		RNC55H4992FM		499K, ±1%, 0.125W, prec. res.	R19	
33	1		RCR07G JS		TBD, ±5%, 0.25W, carb res.	R22	
34	17		RCR07G-103JS		10K	R23, R40, R50, R51, R52, R54,	
34						R55, R56, R69, R111, R112,	
34						R116, R118, R125, R132, R133,	
34						R134	
35	3		RNC55H1582FM		15.8K, ±1%, 0.125W, prec. res.	R24, R25, R26	
36	6		RNC55H7872FM		78.7K	R30, R31, R32, R87, R88, R89	
37	8		RCR07G332JS		3.3K, ±5%, 0.25W, carb res.	R33, R34, R35, R65, R83, R149,	
37						R150, R151	
38	1		RCR07G433JS		43K	R37	
39	3		RCR07G393JS		39K	R38, R46, R101	
40	1		RCR07G JS		TBD	R39	

LAYOUT PARTS LIST
 Title GP FREQUENCY CHANGER
 CCAA1
 Sh2P CONV
 DL-
 Rev

Drafting/Date: **AHB. / 4/3/78** Engineering/Date: **4/3/78**

Delco Electronics
 GENERAL MOTORS CORPORATION
 SANTA BARBARA, CALIFORNIA

Code: S = New Standard Dwg. (SCD)
 P = Dwg. in Process
 C = Dwg. Completed

Code: S = New Standard Dwg. (SCD)
 P = Dwg. in Process
 C = Dwg. Completed

Code: S = New Standard Dwg. (SCD)
 P = Dwg. in Process
 C = Dwg. Completed

Code: S = New Standard Dwg. (SCD)
 P = Dwg. in Process
 C = Dwg. Completed

Item	Quantity	Code	Part Number	Rev	Part Name	Material	Remarks
41	1		RCR07G473JS		47K, ±5%, 0.25W, carb res	R41	
42	1		RCR07G		TBD	R43	
43	2		RCR07G394JS		390K	R44, R45	
44	1		RCR07G823JS		82K	R47	
45	2		RCR07G333JS		33K	R48, R49	
46	1		RCR07G155JS		1.5M	R57, R153	
47	1		RCR07G154JS		150K	R58	
48	2		RCR07G272JS		2.7K	R59, R60	
49	2		RCR07G		TBD	R61, R62	
50	2		RCR07G		TBD	R63, R64	
51	2		RCR07G222JS		2.2K	R66, R147	
52	4		RCR07G104JS		100K	R67, R68, R73, R74	
53	1		RCR07G		TBD	R70	
54	3		RNC60H2263FM		226K, ±1%, 0.25W, prec res	R79, R80, R81	
55	1		RNC55H6811FM		6.81K, ±1%, 0.125W, prec res	R82	
56	3		RNC55H3572FM		35.7K	R84, R85, R86	
57	1		RNC55H56R2FM		56.2	R92	
58	1		RNC55H2261FM		2260	R93	
59	1		RNC55H1101FM		1100	R94	
60	3		RCR07G		TBD, ±5%, 0.25W, carb res	R95, R96, R97	
61	3		RCR07G		TBD	R98, R99, R100	
62	1		RCR07G223JS		22K	R102	
63	3		RCR07G		TBD	R103, R104, R105	
64	3		RCR07G		TBD	R106, R107, R108	
65	2		RCR07G		TBD	R109, R110	

LAYOUT PARTS LIST

Title: **GP FREQUENCY CHANGER** Sh3P
 CCAA1 CONV

DL-

Rev

Drafting/Date: **A.H.B. / 4/3/78** Engineering/Date: **Delco Electronics**
GENERAL MOTORS CORPORATION
SANTA BARBARA, CALIFORNIA
CODE IDENT NO. 13160

Item	Quantity	Code	Part Number	Rev	Part Name	Material	Remarks
66	1		RNC55H	FM	TBD ±1%, 0.125W, prec res	R115	
67	3		RCR07G 334J5		330K, ±5%, 0.125W, carb res	R117, R122, R126	
68	1		RCR07G	J5	TBD	R119	
69	1		RCR07G 911J5		910	R120	
70	1		RCR07G 912J5		9.1K	R121	
71	1		RCR07G	J5	TBD	R123	
72	4		RCR07G 102J5		1K	R124, R135, R136, R137	
73	1		RNC55H	FM	TBD, ±1%, 0.125W, prec res	R127	
74	2		RNC55H 1241FM		1240	R128, R129	
75	2		RNC55H 3241FM		3240	R130, R131	
76	1		RCR07G 273J5		27K	R138	
77	1		RCR07G	J5	TBD	R139	
78	1		RCR07G	J5	TBD	R140	
79	3		RCR07G 105J5		1M	R141, R142, R143	
80	1		RCR07G 124J5		120K	R144	
81	1		RCR07G 3R3J5		3.3	R146	
82	1		RCR07G 204J5		200K	R148	
83	1		RCR07G	J5		R152	
84	1		RCR07G	J5		R154	
85							
86							
87							
88							
89							
90							

LAYOUT PARTS LIST
 Title: **GP FREQUENCY CHARGER**
 CCAAL
 Sh-4P
DL-
 Rev

DELCO ELECTRONICS DIVISION • SANTA BARBARA OPERATIONS • GENERAL MOTORS CORPORATION

APPENDIX C
PARTS LIST -- CONVERTER GATE CONTROL CCAA2

Delco Electronics
 GENERAL MOTORS CORPORATION
 SANTA BARBARA, CALIFORNIA
 CODE IDENT NO. **13160**
 Engineering/Date: **A.H.B. / 4/3/78**
 Code: S = New Standard Dwg. (SCD)
 P = Dwg. in Process
 C = Dwg. Completed
 N = New Dwg.
 W = Word Dwg.
 R = Rework Existing Dwg.

Item	Quantity	Code	Part Number	Rev	Part Name	Material	Remarks
1	15		CCR05CG471JM		470pF, ±5%, 100V, CK05 cap	C1, C2, C3, C4, C5, C6, C7, C8, C9	
2	6		CCR05CG470JM		47pF, ±5%, 200V, CK05 cap	C10, C11, C12, C25, C26, C27	
3	4		CCR06CG102GM		1000pF, ±2%, 200V, CK06 cap	C13, C14, C15, C16, C17, C18	
4	3		CCR05CG200JM		20pF, ±5%, 200V, CK05 cap	C19, C20, C21, C31	
5	3		M8342101-2171M		0.1μF, ±1%, 50V, polycarb	C22, C23, C24	
6	1		M39014/01-1236		820pF, ±10%, 200V, CK05 cap	C28, C29, C30	
7	1		M39014/01-1218		82pF, ±10%, 200V, CK05 cap	C32	
8	4		M39003/01-0166		10μF, ±10%, 35V, tant cap	C33	
9	1		M39014/01-1228		330pF, ±10%, 200V, CK05 cap	C34, C36, C45, C46	
10	3		M39014/02-1236		0.22μF, ±10%, 50V, CK06 cap	C35	
11	1		M39014/02-1230		0.10μF, ±10%, 100V, CK06 cap	C37, C38, C39	
12	1		M39003/06-0147		3.3μF, ±10%, 20V, tant cap	C40	
13	3		M39003/06-0155		68μF, ±10%, 20V, tant cap	C41	
14						C42, C43, C44	
15							
16							
17							
18	5		JAN1N4148-1		SILICON SIGNAL DIODE	CRI, CR2, CR3, CR4, CR5	
19							
20	6		RCR20G201J5		200, ±5%, 0.5W, carb res	R1, R2, R3, R4, R5, R6	
21	24		RCR07G242J5		2.4K, ±5%, 0.25W, carb res	R7, R8, R9, R10, R11, R12, R13, R14, R15, R16, R17, R18, R19, R20, R21, R22, R23, R24, R25, R26, R27, R28, R29, R30	
21							
21							
21							

LAYOUT PARTS LIST
 Title: GP FREQUENCY CHANGER
 CCAA 2
 Ship CONV
DL-
 Rev

Code
 S = New Standard Dwg. (SC11)
 P = Dwg. in Process
 Dwg. C = Dwg. Completed

Delco Electronics
 GENERAL MOTORS CORPORATION
 SANTA BARBARA, CALIFORNIA
 CODE IDENT NO. **13160**
 W = New Dwg.
 W = Word Dwg.
 R = Rework Existing

Drafting/Date
A.H.B. / 4/3/78

Item	Quantity	Code	Part Number	Rev	Part Name	Material	Remarks
22	6		RCR07G 134 JS		130K, ±5%, 0.25W, carb res	R31, R32, R33, R34, R35, R36	
23	6		RCR07G 224 JS		220K	R37, R38, R39, R40, R41, R42	
24	6		RCR07G 472 JS		4.7K	R43, R44, R45, R46, R47, R48, R49	
25	20		RCR07G 103 JS		10K	R49, R50, R51, R61, R62, R63, R64, R65, R66, R74, R75, R76, R77, R78, R79, R80, R81, R82, R83, R84	
26	6		RCR07G 203 JS		20K	R52, R53, R54, R55, R56, R57	
27	3		RNC55H 1002 FM		10.0K, ±1%, 0.125W, prec res	R58, R59, R60	
28	3		RNC55H 1003 FM		100K	R67, R68, R69	
29	2		RTR24DW 103 M		10K, ±5%, 0.75W, trim pot	R70, R71	
30	2		RNC55H 4991 FM		4990, ±1%, 0.25W, prec res	R72, R73	
31	4		RCR07G 101 JS		100, ±5%, 0.25W, carb res	R85, R86, R87, R88	
32	2		RCR07G 474 JS		470K	R89, R90	
33	3		RCR07G 104 JS		100K	R91, R92, R93	
34	1		RCR20G 471 JS		470, ±5%, 0.5W, carb res	R94	
35							
36							
37							
38							
39							
40	2		LM139D/883B		IC, COMP	U1, U2	
41	1		CD4093BD/3		IC, CMOS	U3	
42	2		CD4071BP/3		IC, CMOS	U4, U5	

LAYOUT PARTS LIST
 TITLE GP FREQUENCY CHANGER
 CCAA2
 SLIP
 DL
 Rev

DELCO ELECTRONICS DIVISION • SANTA BARBARA OPERATIONS • GENERAL MOTORS CORPORATION

APPENDIX D
PARTS LIST — CONVERTER GATE DRIVERS CCAA3

Code
 S = New Standard Dwg. (SCD)
 P = Dwg. in Process

Material
 C = Dwg. Completed

Part Name
 W = Word Dwg.
 R = Rework Existing Dwg.

Remarks
 C1, C2, C3, C4, C5, C6, C7, C8
 C9, C10
 C11
 C12
 C13, C14
 CR1, CR2, CR3, CR4, CR5, CR6,
 CR7, CR8, CR9, CR10, CR11, CR12,
 CR13, CR14, CR15, CR16, CR17, CR18,
 CR19, CR20, CR21, CR22, CR23,
 CR24
 CR25, CR26
 CR27
 R1, R2, R3, R4, R5, R6
 R7, R8, R9, R10, R11, R12
 R13
 R14
 R15
 R16
 R17

DL-
 Rev

Delco Electronics
 GENERAL MOTORS CORPORATION
 SANTA BARBARA, CALIFORNIA

CODE IDENT NO. **13160**

Part Number
 M39014/01-1455
 M39018/01-0707
 M39018/01-0723
 M39014/01-1486
 M39003/06-0076

Rev
 —
 —
 —
 —
 —

Quantity
 8
 2
 1
 1
 2
 6
 7
 8
 8
 8
 8
 2
 1
 1
 12
 6
 6
 1
 1
 1
 1
 1
 20
 21

Code
 JAN1N4148-1
 —
 —
 —
 —
 JAN1N4973
 JAN1N746A
 RWR889N4R99FP
 RCR20G430JS
 RCR07G151JS
 RCR20G821JS
 RCR07G271JS
 RNC60H2370FM
 RNC60H3161FM

Part Name
 SILICON SIGNAL DIODE
 —
 —
 —
 —
 43V, ±5%, 5W, ZENER DIODE
 3.3V, ±5%, 0.4W, ZENER DIODE
 —
 —
 —
 4.99, ±1%, 3W, W/W res
 43, ±5%, 0.5W, carb res
 150, ±5%, 0.25W, carb res
 820, ±5%, 0.5W, carb res
 270, ±5%, 0.25W, carb res
 237, ±1%, 0.25W, prec res
 3160

Rev
 —
 —
 —
 —
 —
 —
 —
 —
 —
 —
 —
 —
 —
 —
 —
 —
 —
 —
 —
 —
 —

Quantity
 —
 —
 —
 —
 —
 —
 —
 —
 —
 —
 —
 —
 —
 —
 —
 —
 —
 —
 —
 —
 —

Code
 —
 —
 —
 —
 —
 —
 —
 —
 —
 —
 —
 —
 —
 —
 —
 —
 —
 —
 —
 —
 —

Part Name
 FREQUENCY CHANGER
 CONV

Rev
 —
 —
 —
 —
 —
 —
 —
 —
 —
 —
 —
 —
 —
 —
 —
 —
 —
 —
 —
 —
 —

Quantity
 —
 —
 —
 —
 —
 —
 —
 —
 —
 —
 —
 —
 —
 —
 —
 —
 —
 —
 —
 —
 —

Code
 CCAA3

Rev
 —

Quantity
 —

Code
 —

Part Name
 —

Rev
 —

Quantity
 —

Code
 —

Part Name
 —

Rev
 —

Quantity
 —

Code
 —

Part Name
 —

Rev
 —

Quantity
 —

Code
 —

Part Name
 —

Rev
 —

Quantity
 —

Code
 —

Part Name
 —

Rev
 —

Quantity
 —

Code
 —

Part Name
 —

Rev
 —

Quantity
 —

Code
 —

Part Name
 —

Rev
 —

Quantity
 —

Code
 —

Part Name
 —

Rev
 —

Quantity
 —

Code
 —

Part Name
 —

Rev
 —

Quantity
 —

Code
 —

Part Name
 —

Rev
 —

Quantity
 —

Code
 —

Part Name
 —

Rev
 —

Quantity
 —

Code
 —

Part Name
 —

Rev
 —

Quantity
 —

Code
 —

Part Name
 —

Rev
 —

Quantity
 —

Code
 —

Part Name
 —

Rev
 —

Quantity
 —

Code
 —

Part Name
 —

Rev
 —

Quantity
 —

Code
 —

Part Name
 —

Rev
 —

Quantity
 —

Code
 —

Part Name
 —

Rev
 —

Quantity
 —

Code
 —

Part Name
 —

Rev
 —

Quantity
 —

Code
 —

Part Name
 —

Rev
 —

Quantity
 —

Code
 —

Part Name
 —

Rev
 —

Quantity
 —

Code
 —

Part Name
 —

Rev
 —

Quantity
 —

Code
 —

Part Name
 —

Rev
 —

Quantity
 —

Code
 —

Part Name
 —

Rev
 —

Quantity
 —

Code
 —

Part Name
 —

Rev
 —

Quantity
 —

Code
 —

Part Name
 —

Rev
 —

Quantity
 —

Code
 —

Part Name
 —

Rev
 —

Quantity
 —

Code
 —

Part Name
 —

Rev
 —

Quantity
 —

Code
 —

Part Name
 —

Rev
 —

Quantity
 —

Code
 —

Part Name
 —

Rev
 —

Quantity
 —

Code
 —

Part Name
 —

Rev
 —

Quantity
 —

Code
 —

Part Name
 —

Rev
 —

Quantity
 —

Code
 —

Part Name
 —

Rev
 —

Quantity
 —

Code
 —

Part Name
 —

Rev
 —

Quantity
 —

Code
 —

Part Name
 —

Rev
 —

Quantity
 —

Code
 —

Part Name
 —

Rev
 —

Quantity
 —

Code
 —

Part Name
 —

Rev
 —

Quantity
 —

Code
 —

Part Name
 —

Rev
 —

Quantity
 —

Code
 —

Part Name
 —

Rev
 —

Quantity
 —

Code
 —

Part Name
 —

Rev
 —

Quantity
 —

Code
 —

Part Name
 —

Rev
 —

Quantity
 —

Code
 —

Part Name
 —

Rev
 —

Quantity
 —

Code
 —

Part Name
 —

Rev
 —

Quantity
 —

Code
 —

Part Name
 —

Rev
 —

Quantity
 —

Code
 —

Part Name
 —

Rev
 —

Quantity
 —

Code
 —

Part Name
 —

Rev
 —

Quantity
 —

Code
 —

Part Name
 —

Rev
 —

Quantity
 —

Code
 —

Part Name
 —

Rev
 —

Quantity
 —

Code
 —

Part Name
 —

Rev
 —

Quantity
 —

Code
 —

Part Name
 —

Rev
 —

Quantity
 —

Code
 —

Part Name
 —

Rev
 —

Quantity
 —

Code
 —

Part Name
 —

Rev
 —

Quantity
 —

Code
 —

Part Name
 —

Rev
 —

Quantity
 —

Code
 —

Part Name
 —

Rev
 —

Quantity
 —

Code
 —

Part Name
 —

Rev
 —

Quantity
 —

Code
 —

Part Name
 —

Rev
 —

Quantity
 —

Code
 —

Part Name
 —

Rev
 —

Quantity
 —

Code
 —

Part Name
 —

Rev
 —

Quantity
 —

Code
 —

APPENDIX E
PARTS LIST — CONVERTER SCR ISOLATORS
CCAA4

APPENDIX F
PARTS LIST — INPUT/OUTPUT SENSE CIRCUITS
CCAA5

Code
 S = New Standard Dwg. (SCD)
 P = Dwg. in Process
 C = Dwg. Completed

New Dwg.
 W = Word Dwg.
 R = Rework Existing Dwg.

Delco Electronics
 GENERAL MOTORS CORPORATION
 SANTA BARBARA, CALIFORNIA
 CODE IDENT NO. **13160**

Engineering/Date
A.H.B. / 4/3/78

Item	Quantity	Code	Part Number	Rev	Part Name	Material	Remarks
1							
2							
3							
4	12		JAN1N5619		SILICON RECTIFIER	CR1, CR2, CR3, CR4, CR5, CR6, CR35, CR36, CR37, CR38, CR39, CR40	
4							
4							
5	34		JAN1N4148-1		SILICON SIGNAL DIODE	CR7, CR8, CR9, CR10, CR11, CR12, CR13, CR14, CR15, CR16, CR17, CR18, CR19, CR20, CR21, CR22, CR23, CR24, CR25, CR26, CR27, CR28, CR29, CR30, CR31, CR32, CR33, CR34, CR41, CR42, CR43, CR44, CR45, CR46	
5							
5							
5							
5							
5							
5							
6							
7							
8	6		RNC60H2002FM		20.0K, ±1%, 0.25W, prec res	R1, R2, R3, R20, R21, R22	
9	6		RWR7451002FM		10.0K, ±1%, 5W, WW res	R4, R5, R6, R23, R24, R25	
10	3		RCR20G102JS		1K, ±5%, 0.5W, carb res	R7, R8, R9	
11	1		RNC60H7502FM		75.0K, ±1%, 0.25W, prec res	R10	
12	1		RNC60H1273FM		127K	R11	
13	1		RNC60H7872FM		78.7K	R12	
14	1		RCR42G101JS		100, ±5%, 2W, carb res	R13	
15	6		RNC60H2000FM		200, ±1%, 0.25W, prec res	R14, R15, R16, R17, R18, R19	
16	3		RNC60H28R7FM		28.7	R26, R27, R28	

LAYOUT PARTS LIST

CCAA5

FREQUENCY CHANGER

CONV/INV

DL-

Rev