

AD-A056 576

DAVID W TAYLOR NAVAL SHIP RESEARCH AND DEVELOPMENT CE--ETC F/6 13/10
HEAVE AND PITCH REGULAR WAVE EXCITING FORCES AND MOMENTS ACTING--ETC(U)
APR 78 R STAHL

UNCLASSIFIED

DTNSRDC/SPD-0396-16

NL

[OF]
AD
A056576

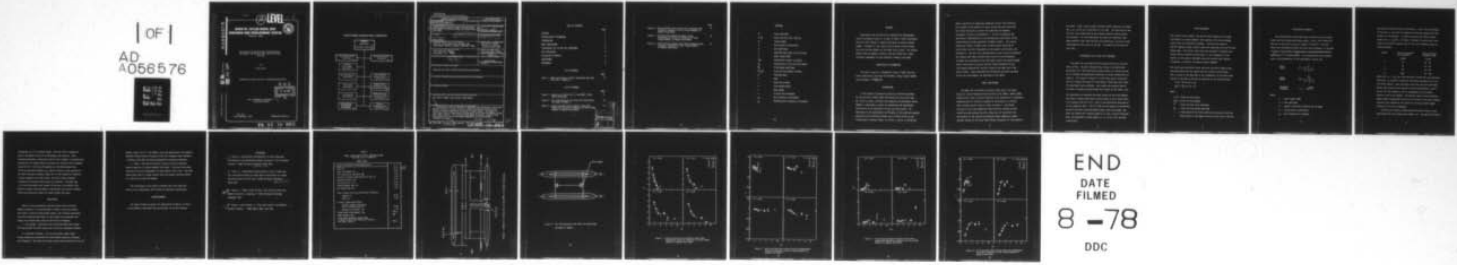

END
DATE
FILMED
8 -78
DDC

AD A 056576

AD No.
DDC FILE COPY

HEAVE AND PITCH REGULAR

(12) LEVEL II k

DAVID W. TAYLOR NAVAL SHIP RESEARCH AND DEVELOPMENT CENTER



Bethesda, Md. 20084

HEAVE AND PITCH REGULAR WAVE EXCITING FORCES
AND MOMENTS ACTING ON A SMALL WATERPLANE AREA
TWIN HULL

by

Ralph Stahl

APPROVED FOR PUBLIC RELEASE: DISTRIBUTION UNLIMITED

DDC
RECEIVED
JUL 24 1978
B

SHIP PERFORMANCE DEPARTMENT
EVALUATION REPORT

May 1973
(Reissued) April 1978

DTNSRDC/SPD-0396-16

78 07 10 063

MAJOR DTNSRDC ORGANIZATIONAL COMPONENTS

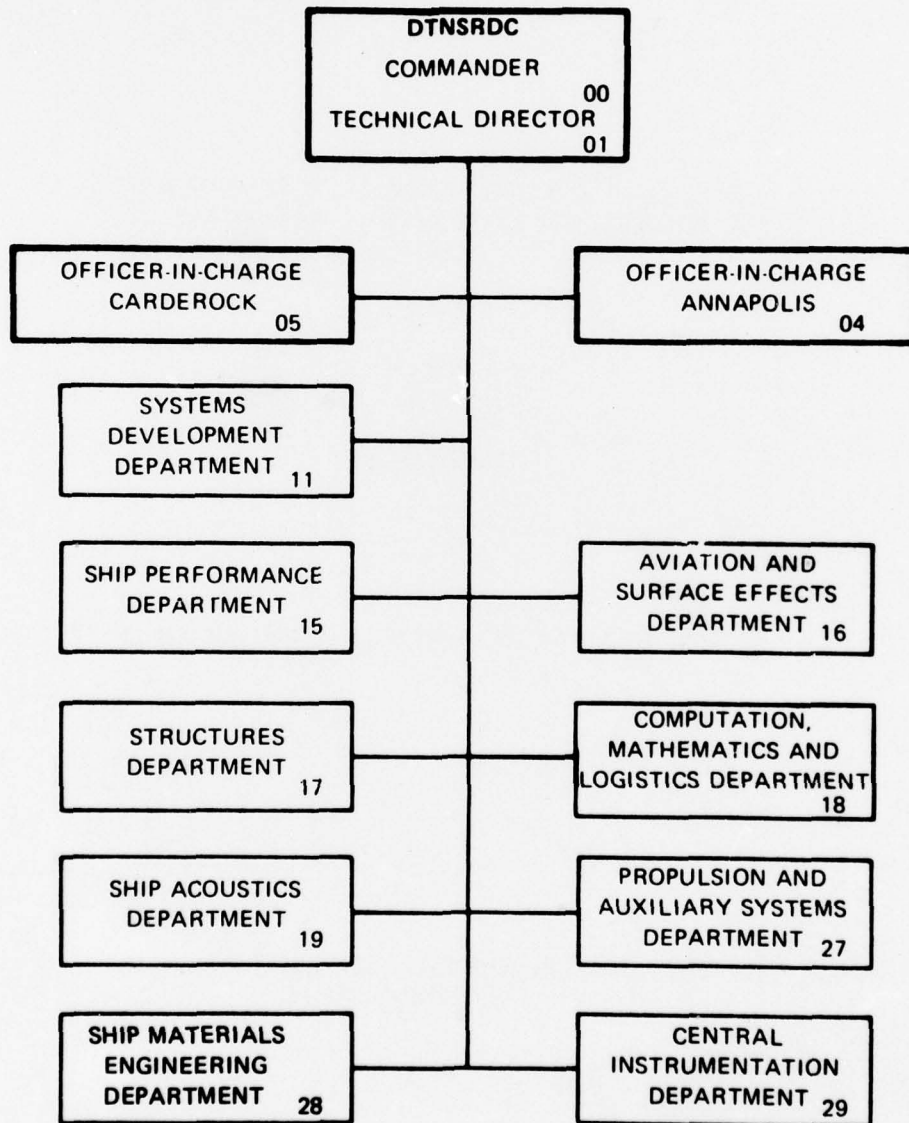

UNCLASSIFIED

SECURITY CLASSIFICATION OF THIS PAGE (When Data Entered)

REPORT DOCUMENTATION PAGE		READ INSTRUCTIONS BEFORE COMPLETING FORM
1. REPORT NUMBER 14 DTNSRDC/SPD-0396-16	2. GOVT ACCESSION NO.	3. RECIPIENT'S CATALOG NUMBER
4. TITLE (and Subtitle) 6 HEAVE AND PITCH REGULAR WAVE EXCITING FORCES AND MOMENTS ACTING ON A SMALL WATERPLANE AREA TWIN HULL	5. TYPE OF REPORT & PERIOD COVERED 9 Interim rept.	
7. AUTHOR(s) 10 RALPH STAHL	17 ZF43422001	8. CONTRACT OR GRANT NUMBER(s) 16 F43422
9. PERFORMING ORGANIZATION NAME AND ADDRESS DAVID W. TAYLOR NAVAL SHIP RESEARCH AND DEVELOPMENT CENTER, BETHESDA, MARYLAND 20084	10. PROGRAM ELEMENT, PROJECT, TASK AREA & WORK UNIT NUMBERS Element No. 62754 N Task Area ZF434 22001	
11. CONTROLLING OFFICE NAME AND ADDRESS Naval Material Command Washington, D.C. 20360	12. REPORT DATE May 1973 (Reissued April 1978)	
14. MONITORING AGENCY NAME & ADDRESS (if different from Controlling Office) 12 21p	13. NUMBER OF PAGES 16 Apr 78	
	15. SECURITY CLASS. (of this report) Unclassified	
16. DISTRIBUTION STATEMENT (of this Report) Approved for Public Release-Distribution Unlimited		
17. DISTRIBUTION STATEMENT (of the abstract entered in Block 20, if different from Report)		
18. SUPPLEMENTARY NOTES		
19. KEY WORDS (Continue on reverse side if necessary and identify by block number) Twin Hulls, SWATH, Wave Forces, Experiments		
20. ABSTRACT (Continue on reverse side if necessary and identify by block number) Experiments were carried out to determine the hydrodynamic forces and moments acting on a model of SWATH I (Small Waterplane Area Twin Hull) design in regular head waves at several forward speeds. Presented in this report are the heave exciting forces and pitch exciting moments on the model due to waves. The results showed force and moment linearity with wave height and a force and moment dependency on wave encounter frequency and speed.		

DD FORM 1473 1 JAN 73

EDITION OF 1 NOV 65 IS OBSOLETE
S/N 0102-014-6601

78 UNCLASSIFIED

SECURITY CLASSIFICATION OF THIS PAGE (When Data Entered) 389 694 10 063

TABLE OF CONTENTS

	Page
ABSTRACT	1
ADMINISTRATIVE INFORMATION	1
INTRODUCTION	1
MODEL PARTICULARS	2
EXPERIMENTAL SET UP AND TEST PROCEDURES	3
DATA EVALUATION	4
DISCUSSION OF RESULTS	5
CONCLUSIONS	7
REFERENCES	9

LIST OF TABLES

	Page
Table 1 - Model Particulars of Small Waterplane Area Twin Hull Ship I (SWATH I)	10

LIST OF FIGURES

	Page
Figure 1 - Sketch of a Single Hull of the SWATH I with Model Dimensions	11
Figure 2 - Test Configuration (Top View) for Restraining the Model of SWATH I	12
Figure 3 - Heave Exciting Force Parameter versus Non-dimensional Encounter Frequency for Four Froude Numbers in Regular Head Waves	13

Justification	<input checked="" type="checkbox"/> Section <input type="checkbox"/> Section <input type="checkbox"/>
BY	
DISTRIBUTION/AVAILABILITY CODES	
Dist.	AVAIL and/or SPECIAL
A	-

	Page
Figure 4 - Heave Exciting Force Phase versus Nondimensional Encounter Frequency for Four Froude Numbers in Regular Head Waves	14
Figure 5 - Pitch Exciting Moment Parameter versus Nondimensional Encounter Frequency for Four Froude Numbers in Regular Head Waves	15
Figure 6 - Pitch Exciting Moment Phase versus Nondimensional Encounter Frequency for Four Froude Numbers in Regular Head Waves	16

NOTATION

\bar{F}	Force amplitude
$F'(t)$	Heave exciting force function
Fr	Froude number
g	Gravitational acceleration
h	Wave amplitude
H	Nondimensional heave exciting force
L	Model length (LBP)
LCG	Longitudinal center of gravity
M_{ψ}	Nondimensional pitch exciting moment
\bar{M}_{ψ}	Pitch moment amplitude
$M'_{\psi}(t)$	Pitch exciting moment function
m	Displaced mass
t	Time
ϵ	Heave force phase
δ	Pitch moment phase
λ	Wave length
ω	Circular wave frequency
ω_e	Wave frequency of encounter
μ_e	Nondimensional frequency of encounter

ABSTRACT

Experiments were carried out to determine the hydrodynamic forces and moments acting on a model of SWATH I (Small Waterplane Area Twin Hull) design in regular head waves at several forward speeds. Presented in this report are the heave exciting forces and pitch exciting moments on the model due to waves. The results showed force and moment linearity with wave height and a force and moment dependency on wave encounter frequency and speed.

ADMINISTRATIVE INFORMATION

This work is part of a fundamental study of SWATH type hull forms authorized in Task Area ZF 434-22001, Element Number 62754N and Job Number 1-1170-026-55.

INTRODUCTION

In the process of developing analytical prediction methods for the motions of SWATH (Small Waterplane Area Twin Hull) type hull forms in waves, the Naval Ship Research and Development Center (NSRDC) is developing a theory for determining the hydrodynamic coefficients in the equations of heave and pitch motion. Of importance is the experimental verification of the prediction methods especially since nonlinear effects can be present which are not incorporated in present theory. Initially, a series of cylindrical

models consisting of completely submerged circular and elliptical hull mounted to the bottom of a water surface piercing strut were oscillated vertically to obtain the added mass and damping parameters in heave, see Reference 1. This was followed by the experimental determination of the hydrodynamic coefficients of the coupled heave and pitch equations of SWATH I models. The results showed the effects of model scale, forward speed, amplitude of oscillation, and hull interaction on the dynamic coefficients, see Reference 2. The twin hull configuration was then tested to determine the regular wave heave excited forces and pitch excited moments. The model was restrained at the free water surface and passed through regular head waves at several distinct forward speeds while two force gauges measured the vertical forces on the model due to the passing waves. These experimentally determined wave exciting heave forces and pitch moments are presented in the report.

MODEL PARTICULARS

The model was an existent 10.74-foot (LBP) model of an early design of a Small Waterplane Area Twin Hull Ship, SWATH I (Model 5226). Geometrically, each of the two identical hulls consisted of a completely submerged body of revolution attached to the bottom of a vertical water surface piercing strut as shown in Figure 1. The faired cylindrical strut was symmetrical about both the amidship and the centerline plane whereas the hull, whose axis of revolution lies horizontally in the centerline plane, was nearly symmetrical about amidship except for the stern where design allowances for the propeller

were made. Table 1 gives further essential model dimensions including the $\frac{1}{2}$ to $\frac{1}{2}$ twin hull separation of 3.37 feet. The separation of the twin hull was accomplished by two aluminum channels equally spaced from amidship. For the experiments the model was rudderless, had dummy propeller hubs replacing the stock propellers, and had no turbulence inducing sand strips at the bow. The model was ballasted for zero trim.

EXPERIMENTAL SET UP AND TEST PROCEDURE

The model was restrained with the design waterline at the free water surface. The wave induced forces acting on the model were measured by two \pm 500 pound block gauges placed, one forward and one aft of amidship and equidistant therefrom, as shown schematically in Figure 2. Also shown in Figure 2, is the frame used to attach the twin hull beneath Carriage II of the Center's Deep Water Basin where the experiments were conducted. Wave height was measured with an ultrasonic transducer mounted 24.86 feet forward of the model's LCG.

The experiments to determine the heave forces and the pitch moments were made in regular head waves in wave length to ship length ratios (λ/L) ranging from 0.5 to 4.7. Most of the experiments were made at a wave steepness, $2h/\lambda = 1/37$ to $1/100$ for the purpose of determining possible nonlinear force and moment effects with wave height. The model was towed with a forward speed of 0, 2.20, 4.40 and 6.60 knots, which corresponded to Froude numbers $Fr = 0, 0.20, 0.40,$ and 0.60 respectively.

DATA EVALUATION

The vertical force signals from the two block gauges were recorded individually on analog magnetic tape together with the wave height signal from the ultrasonic transducer. Utilizing the Center's SDS 910 computer system, digital tapes were generated from the filtered analog tape. The digital tapes were then analyzed to determine the complex Fourier transform coefficients of the fundamental of the signals on the Center's CDC 6400 using the standard Power Spectra, Histograms, and Fourier Transforms Program (PSHAFT).

The total heave excitation forces and pitch excitation moments were then determined from the complex Fourier transform coefficients. Each is given as the amplitude of the fundamental and the phase with respect to the wave at the LCG as expressed in the following form:

$$F'(t) = \bar{F} \sin(\omega t + \epsilon)$$
$$M'_{\psi}(t) = \bar{M}_{\psi} \sin(\omega t + \delta)$$

where

$F'(t)$ = heave exciting force

$M'_{\psi}(t)$ = pitch exciting moment

\bar{F} = heave exciting force amplitude

\bar{M}_{ψ} = pitch exciting moment amplitude

ϵ = phase angle of the force relative to the wave at the LCG

δ = phase angle of the moment relative to the wave at the LCG

DISCUSSION OF RESULTS

The experimentally determined heave excitation force and pitch moment and the corresponding phase angles, ϵ and δ , with respect to the wave at the LCG are given in Figures 3 through 6. The parameters were nondimensionalized using the same techniques as indicated in similar experimental investigations on catamarans (Reference 3) and Program YF 17 (Reference 4). The nondimensionalized parameters used in the presentation of the experimental results are:

$$\begin{array}{l} \text{heave} \\ \text{force} \end{array} \quad H = \frac{L \cdot \bar{F}}{h \cdot m \cdot g}$$

$$\begin{array}{l} \text{pitch} \\ \text{moment} \end{array} \quad M_{\psi} = \frac{\bar{M}_{\psi}}{h \cdot m \cdot g}$$

$$\begin{array}{l} \text{encounter} \\ \text{frequency} \end{array} \quad \omega_e = \sqrt{L/g}$$

where

L = model length (LBP)

h = wave amplitude

m = weight of the water displaced by the model

g = gravitational acceleration

ω_e = wave frequency of encounter

The phase of the heave force to the wave, ϵ , and of the pitch moment to the wave, δ , are given in degrees with the span ranging from +90 degrees to -270 degrees. In order to present the effect of wave height on H , ϵ , M_{ψ} , and δ in Figures 3 through 6, respectively, four symbols were used to signify each of four wave steepness groups as indicated below:

Symbol	Nominal Reciprocal Wave Steepness ($\lambda/2h$)	Reciprocal Wave Steepness Range ($\lambda/2h$)
◇	37	34 - 44
○	50	44 - 62
▽	75	62 - 87
□	100	87 - 103

Generally, H , ϵ , M_{ψ} , and δ had consistent trends with wave encounter frequency, ω_e (Figures 3 through 6) with good repeatability for all four model speeds. Heave excitation force (H) and pitch excitation moment (M_{ψ}) linearity with respect to wave height (Figures 3 and 5) as well as their phases' (ϵ and δ) independence to wave height (Figures 4 and 6) are evident. The general trend of curves shifting toward higher frequencies as well as an increase in the wave encounter frequency span bounded by the curves for increasing model speeds (Figures 3 to 6) was as expected.

Referring to Figure 3, maximum heave excitation forces H , were experienced with the longest wave length, i.e. the smallest encounter

frequencies at all four model speeds. Here the force H lagged the wave at the model's LCG by 0 to 20 degrees, see Figure 4. With increasing encounter frequencies (shorter wave lengths), H progressively decreased at all speeds whereas the phase lag remained fairly constant, except for FR = 0.60 where 80 degrees was the maximum phase lag. The pitch excitation moments, M_{ψ} , shown in Figure 5, were constant in the small encounter frequency range for all four speeds but tended to increase somewhat with model speed. With both higher encounter frequencies and greater model speeds M_{ψ} increased. The phase lag, δ , of the pitch moment with respect to the wave at the model's LCG generally ranged from 220 degrees to 90 degrees with several distinct minima and consistent trends for speeds greater than zero.

CONCLUSIONS

Based on the experimentally obtained heave forces and pitch moments exerted on a restrained model of SWATH I design by regular head waves at several forward model speeds, the following conclusions were made concerning the effect of wave height, wave encounter frequency, and forward model speed on the forces and moments;

1. Wave Height - Both heave force and pitch moment were linear with wave height and their phases were relatively independent thereof.
2. Encounter Frequency - For any given model speed, heave forces progressively decreased and pitch moments generally increased with frequency. The heave force phase lag was nearly constant at 0 to 20

degrees except for $FR = 0.60$ whereas the pitch moment phase lag tended to decrease with increasing frequency in the low frequency range, becoming a minimum around 90° , and then increased with increasing frequency.

3. Speed - Both heave excitation forces and pitch excitation moments generally increased somewhat with speed. The heave force phase lags were relatively independent of speed except at $FR = 0.60$. The pitch moment phase lags for speeds greater than zero showed inflection points at a phase lag of about 90 degrees.

The consistency of the results indicates their very good reliability as an experimental verification of theoretical predictions.

ACKNOWLEDGMENTS

The author wishes to express his appreciation to Messrs. M. Davis, J. Bonilla-Norat, and R. Duerr who participated in the test program.

REFERENCES

✓ 1. Stahl, R., "Experimental Determination of Heave Added Mass and Damping of Two-Dimensional Bulbous Cylinders at the Free Water Surface," NSRDC T&E Report ~~516-H-01~~, March 1973

396H-14

✓ 2. Stahl, R., "Experimental Determination of Scale, Speed, and Hull Interaction Effects on Heave Motion Coefficients of a Small Waterplane Area Twin Hull Ship," NSRDC T&E Report ~~516-H-02~~,

March 1973

396-H-15

delete Jones, H., "Heave, Pitch and Roll, Wave Exciting Forces and Moments Acting on a Catamaran," NSRDC T&E Report 348-H-05, September 1970

✓ ~~A.~~ Frank, W. and Salvesen, N., "The Frank Close-Fit Ship-Motion

3 Computer Program, " NSRDC Report 3289, June 1970

TABLE I

MODEL PARTICULARS OF SMALL WATERPLANE AREA
TWIN HULL SHIP I (SWATH I)

- MODEL 5226 -

Static and Geometric Characteristics	
	12.7'
^{12.4} LBP, ft.	10.74
Beam at Midship, ft.	3.79
Hull Separation from C to C	3.37
Vertical distance from baseline to WL, ft.	1.39
Waterplane Area, ft. ²	8.10
LCG aft of F.P., ft.	5.21
Forward Moment Arm, ft.	2.68
Aft Moment Arm, ft.	3.07
Water Surface Piercing Cylindrical Struts(s):	
Length, ft.	10.74
Beam, ft.	0.42
Circular Submerged Hull(s):	
Overall length from bow to end of propeller hub, ft.	12.85
Diameter at Midship, ft.	0.75
Fresh Water Displacement, lbs.	958.2
Model Weight, lbs.	947
Fresh Water Restoring Coefficient in Heave (within the limits of ± 0.63 ft. from DWL), lbs/ft.	505.0

Handwritten:
Strut
Length

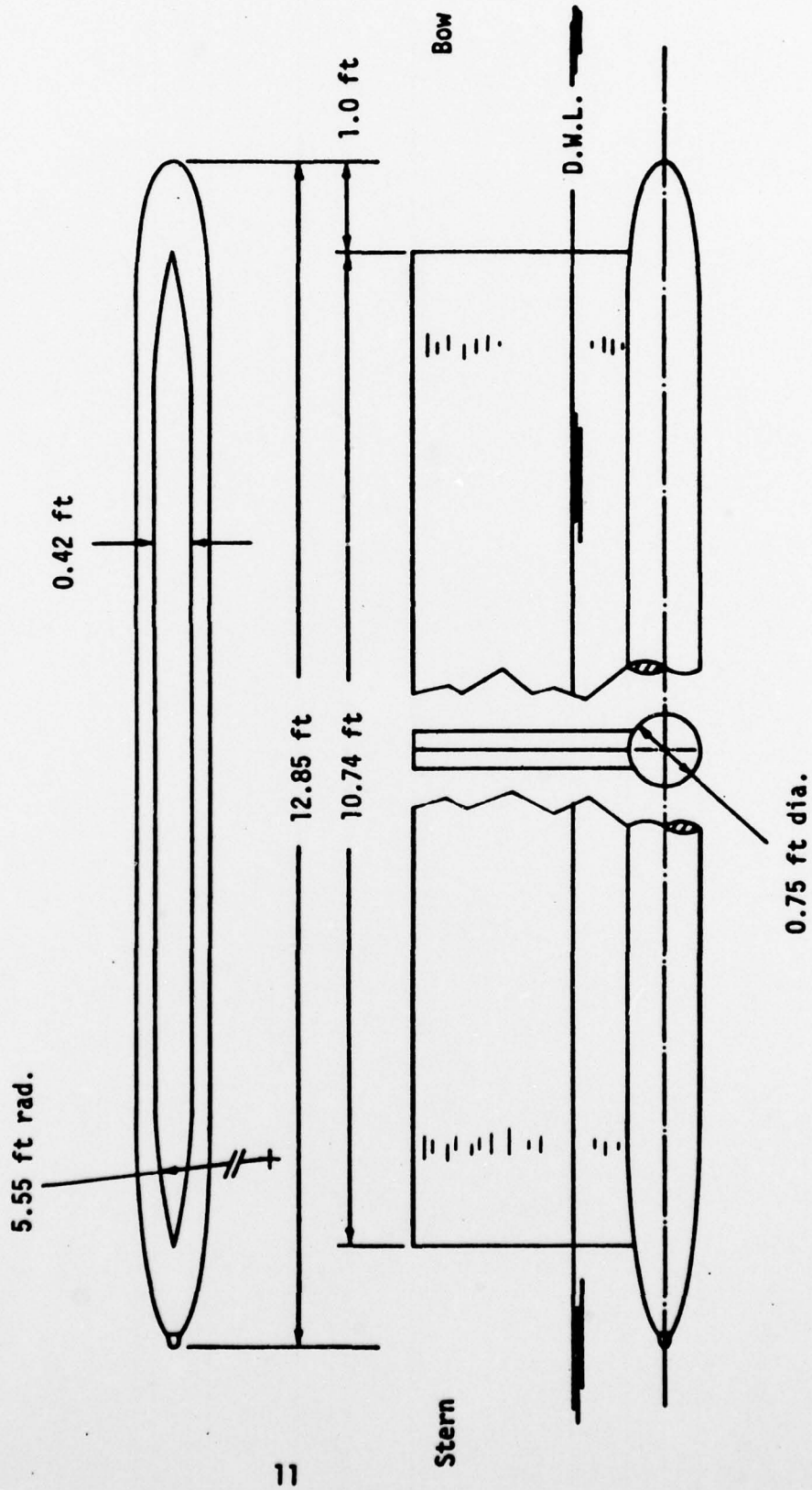

Figure 1 - Sketch of a Single Hull of the SMATH I with Model Dimensions

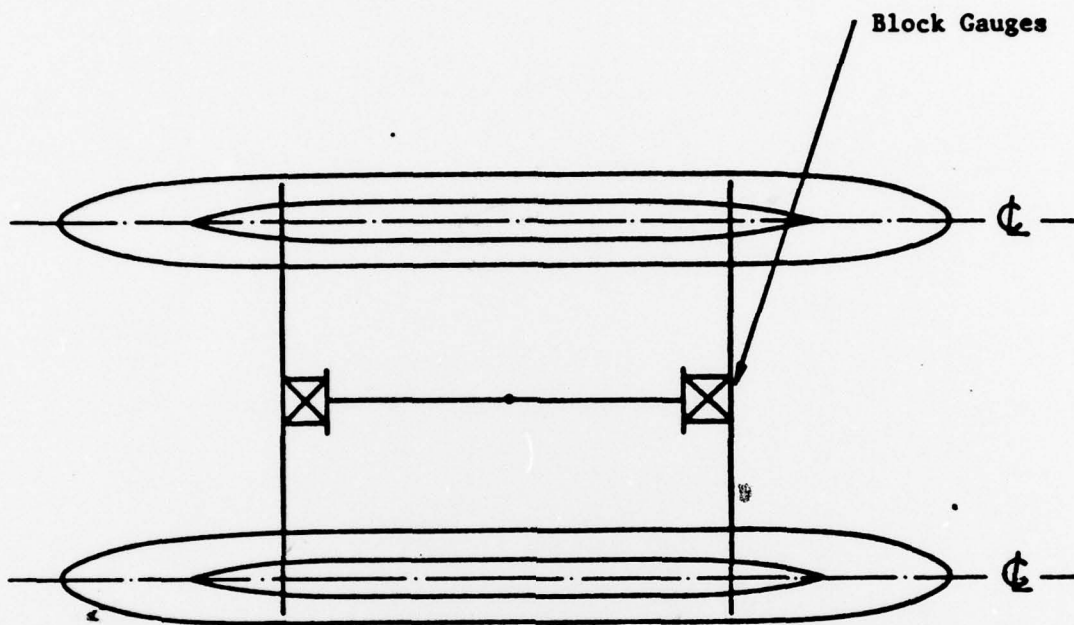

Figure 2 - Test Configuration (Top View) for Restraining
the Model of SWATH I

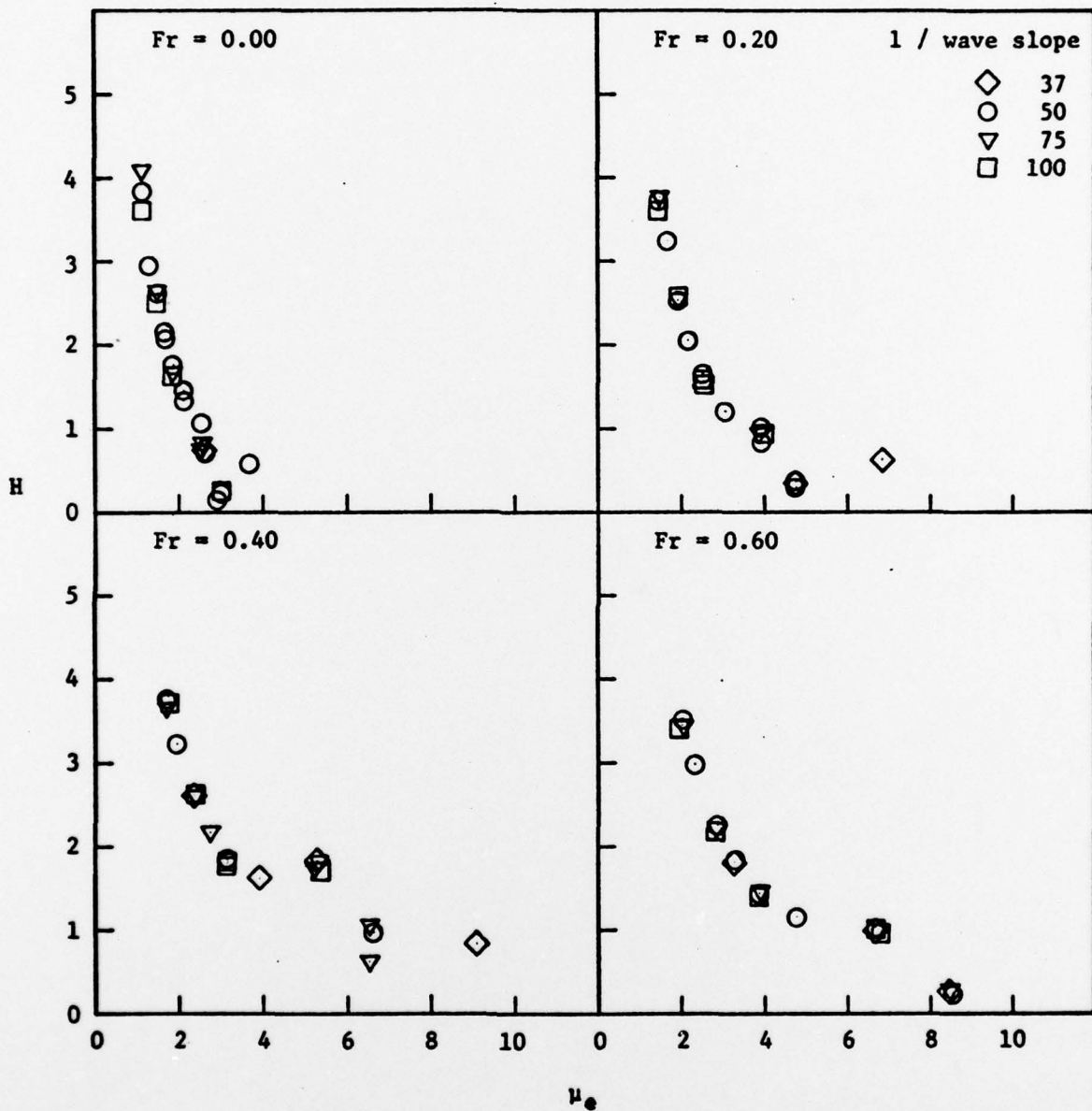

Figure 3 - Heave Exciting Force Parameter Versus Non-Dimensional Encounter Frequency for Four Froude Numbers in Regular Head Waves

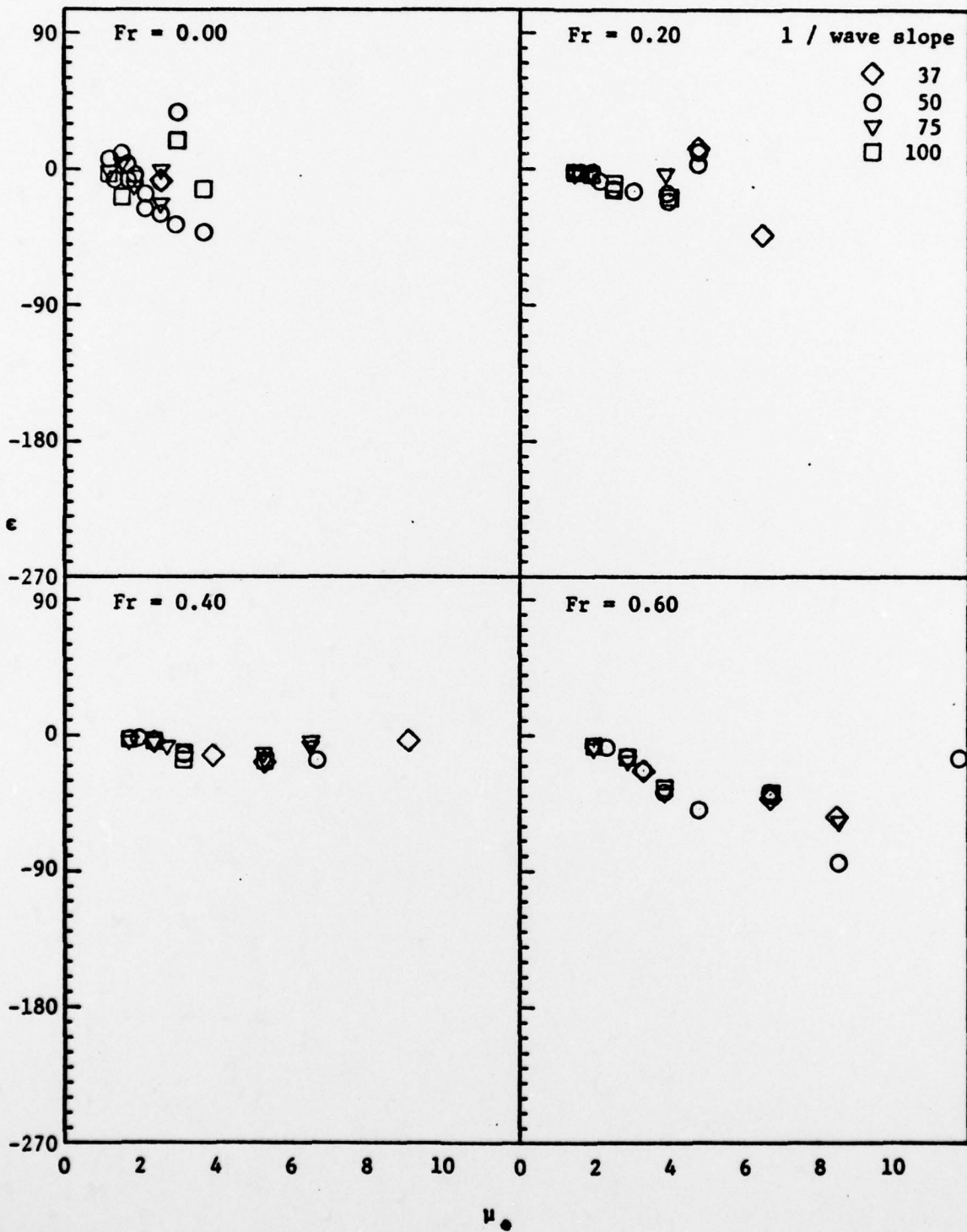

Figure 4 - Heave Exciting Force Phase Versus Non-Dimensional Encounter Frequency for Four Froude Numbers in Regular Head Waves

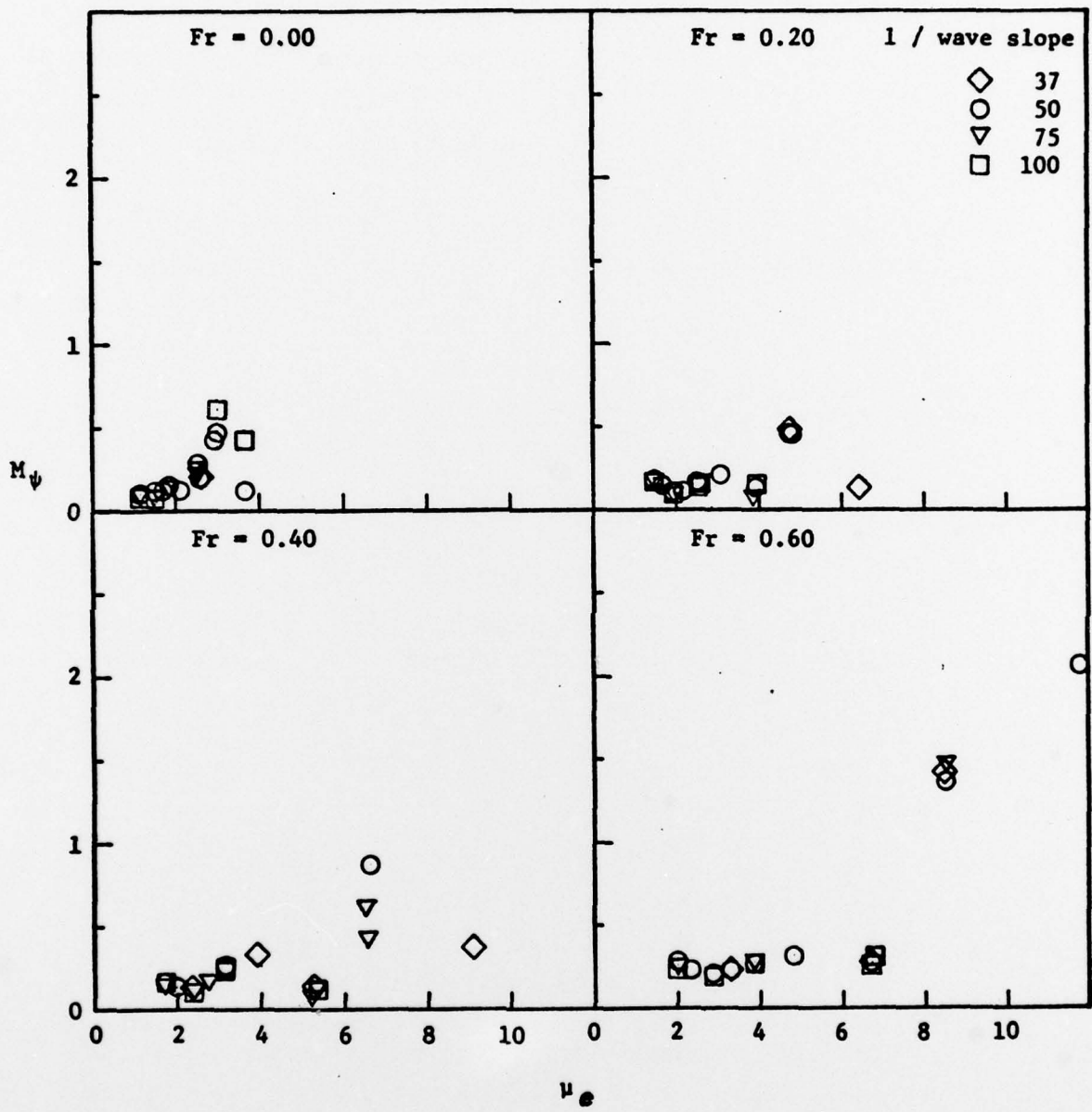

Figure 5 - Pitch Exciting Moment Parameter Versus Non-Dimensional Encounter Frequency for Four Froude Numbers in Regular Head Waves

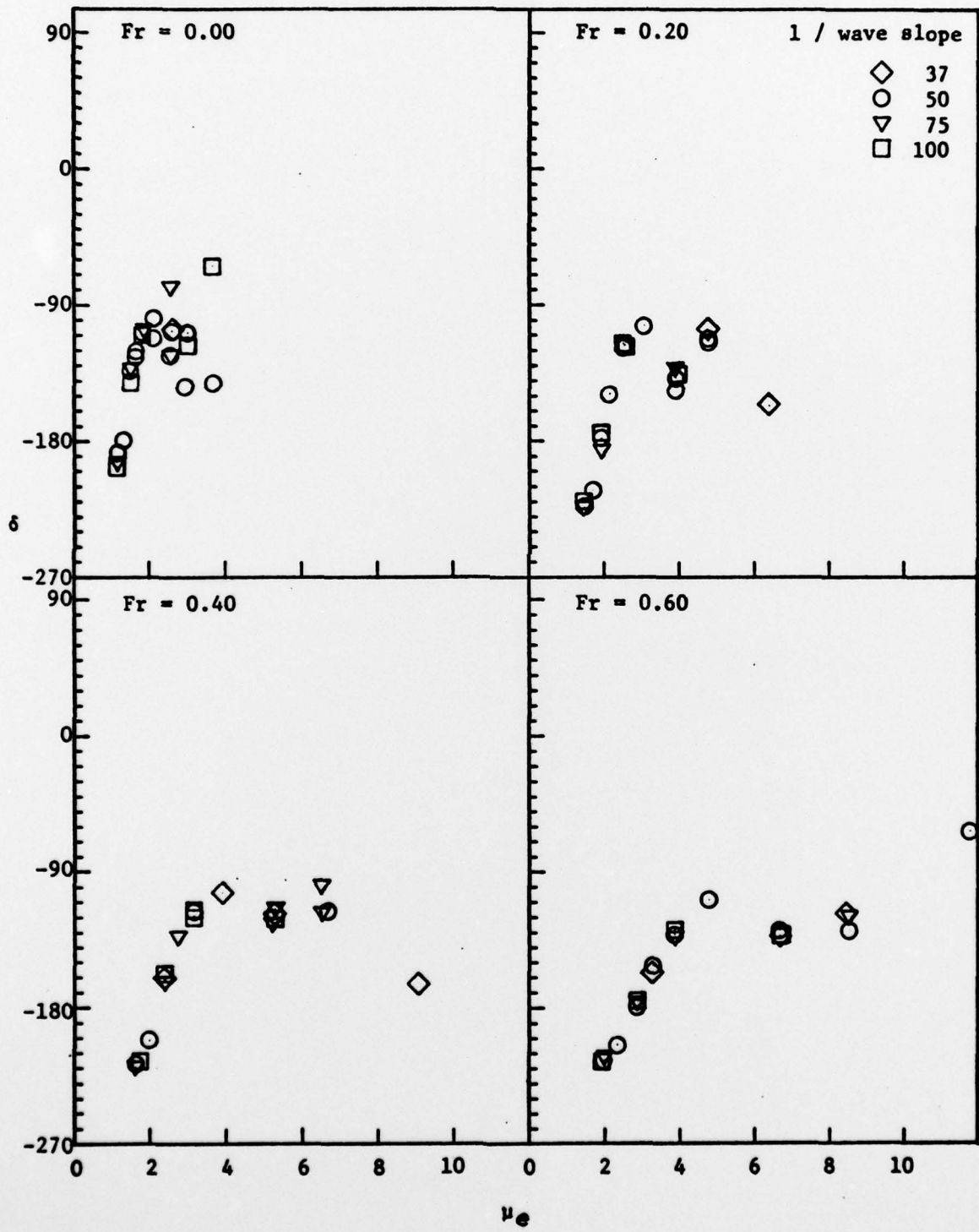

Figure 6 - Pitch Exciting Moment Phase Versus Non-Dimensional Encounter Frequency for Four Froude Numbers in Regular Head Waves