

AD-A056 638

AIR FORCE OCCUPATIONAL MEASUREMENT CENTER LACKLAND A--ETC F/G 5/9  
LGM-25 (TITAN) MISSILE MECHANIC CAREER LADDER AFSCS 44330E, 443--ETC(U)  
JUN 78 L J TAUSCHER

UNCLASSIFIED

AFPT-90-443-289

NL

| OF |  
AD  
A056 638



END  
DATE  
FILMED  
9-78  
DDC

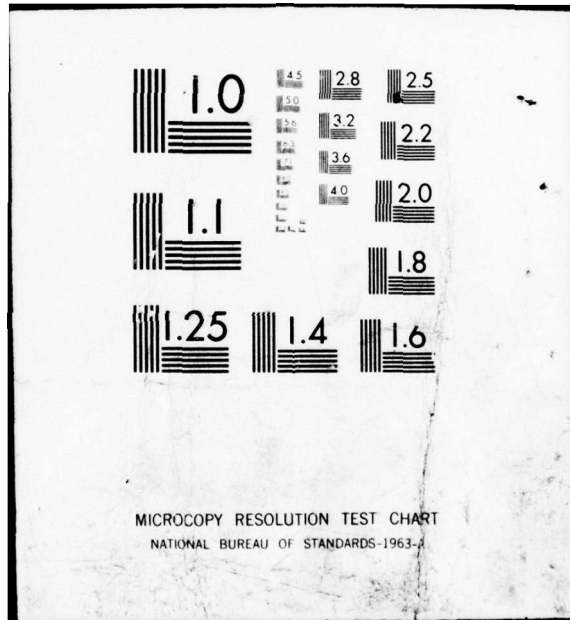

AD A 056638

AD No.   
 DDC FILE COPY

**LEVEL II**  
**OCCUPATIONAL SURVEY REPORT**



DDC  
JUL 19 1978  
F

Lern J. / Tauscher

LGM-25 (TITAN) MISSILE MECHANIC CAREER LADDER ✓

AFSCs 44330E, 44350E, and 44370E .

AFPT-90-443-289

JUNE 1978

55p.

OCCUPATIONAL SURVEY BRANCH  
USAF OCCUPATIONAL MEASUREMENT CENTER  
LACKLAND AFB TEXAS 78236

APPROVED FOR PUBLIC RELEASE; DISTRIBUTION UNLIMITED

78 07 10 112

408 889

act

TABLE OF CONTENTS

	PAGE NUMBER
PREFACE -----	3
SUMMARY OF RESULTS -----	4
INTRODUCTION -----	6
INVENTORY DEVELOPMENT AND ADMINISTRATION -----	6
CAREER LADDER STRUCTURE -----	9
JOB DIFFERENCES ASSOCIATED WITH SKILL LEVELS -----	14
JOB DIFFERENCES ASSOCIATED WITH EXPERIENCE LEVEL --	18
ANALYSIS OF TASK DIFFICULTY -----	22
ANALYSIS OF AFR 39-1 SPECIALTY DESCRIPTIONS -----	28
COMPARISON OF SPECIALTY TRAINING STANDARD (STS) TO SURVEY DATA -----	29
DISCUSSION -----	30
APPENDIX A -----	32
APPENDIX B -----	33
APPENDIX C -----	34

ACCESSION for	
NTIS	Wide Section <input checked="" type="checkbox"/>
DOC	Buff Section <input type="checkbox"/>
UNANNOUNCED	<input type="checkbox"/>
JUSTIFICATION _____	
BY _____	
DISTRIBUTION/AVAILABILITY CODES	
Dist.	SPECIAL
A	

78 07 10 112

## PREFACE

This report presents the results of an Air Force Occupational Survey of the LGM-25 (TITAN) Missile Mechanic career ladder (AFSCs 44330E, 44350E, and 44370E). This project was directed by USAF Program Technical Training, Volume 2, dated October 1976. Authority for conducting specialty surveys is contained in AFR 35-2. Computer outputs from which this report was produced are available for use by operating and training officials.

The survey instrument was developed by Captain Alan Trask, Inventory Development Specialist. Captain Leon J. Tauscher analyzed the survey data and wrote the final report. This report has been reviewed and approved by Major Walter F. Kasper, Chief, Airman Career Ladders Analysis Section, Occupational Survey Branch, USAF Occupational Measurement Center, Lackland AFB, Texas, 78236.

Computer programs for analyzing the occupational data were designed by Dr. Raymond E. Christal, Occupational and Manpower Research Division, Air Force Human Resources Laboratory (AFHRL), and were written by the Project Analysis and Programming Branch, Computational Sciences Division, AFHRL.

Copies of this report are available to air staff sections, major commands, and other interested training and management personnel upon request to the USAF Occupational Measurement Center, attention of the Chief, Occupational Survey Branch (OMY), Lackland AFB, Texas 78236.

This report has been reviewed and is approved.

JAMES A. TURNER, JR., Col, USAF  
Commander  
USAF Occupational Measurement  
Center

WALTER E. DRISKILL, Ph.D.  
Chief, Occupational Survey Branch  
USAF Occupational Measurement  
Center

## SUMMARY OF RESULTS

1. Survey Coverage. The LGM-25 (TITAN) Missile Mechanic job inventory analysis was completed during June 1978. Survey results are based on responses from 183 of the 223 incumbents assigned to the 443X0E career ladder (82 percent of all assigned personnel). Superintendents (AFSC 44399) are not included specifically in this analysis due to the very small number of 9-level personnel in the sample.
2. Career Ladder Structure. Ninety percent of the survey respondents comprised two major clusters and one independent job-type. One cluster specialized in work planning and scheduling functions while the other cluster concentrated specifically on overall TITAN missile maintenance and handling functions. A small group of senior, experienced personnel specialized in quality control functions. The career ladder structure seen in this study tends to validate the existing Air Force classification structure and is characterized to a great extent by specialization of major job function.
3. DAFSC and Experience Differences. In general, both 5- and 7-skill level personnel perform primarily technical job functions related to either work planning and scheduling or hands-on missile maintenance (but not both at the same time). However, where 5-skill level personnel perform only one or the other of these technical functions, 7-skill level personnel also perform supervisory and managerial functions. Similar trends were noted in the analysis by experience levels (TAFMS groups). However, first enlistment personnel were found to perform the full range of hands-on missile maintenance functions but very little work planning and scheduling functions. Second and successive enlistment personnel perform technical functions as well as supervisory and management tasks.
4. Task and Job Difficulty. The most difficult tasks are those associated with propulsion system maintenance, and those related with high level management and supervision functions. Overall, hands-on maintenance jobs are substantially more difficult than work planning and scheduling jobs.
5. AFR 39-1 Evaluation. The current AFR 39-1 specialty descriptions exclude training functions performed by 3- and 5-skill level personnel and work planning and scheduling functions performed by 5- and 7-skill level personnel. Otherwise, they appear to provide a thorough and accurate picture of the career ladder duties and responsibilities of AFS 443X0E personnel.
6. STS Analysis. With the exception of three minor tasks, all tasks specified in the current STS are being performed in the field. In addition, 48 survey tasks are being performed in the field that are not directly listed in the current STS. These tasks relate to such areas as planning status boards, maintaining bench stock inventories, transporting various trailers, and servicing various hydraulic reservoirs.

**7. Job Satisfaction.** Most members within each major job group, DAFSC group, and AFMS group find their jobs slightly less interesting and utilizing their talents and training slightly less than members of other USAF career fields. Despite this, however, the reenlistment intentions of most groups of AFS 443X0E personnel are slightly better than for comparable groups in other USAF career fields.

OCCUPATIONAL SURVEY REPORT  
LGM-25 (TITAN) MISSILE MECHANIC CAREER LADDER  
(AFSC 443X0E)

INTRODUCTION

This is a report of the results of an occupational survey of the LGM-25 (TITAN) Missile Mechanic career ladder (AFSC 443X0E) completed by the Occupational Survey Branch, USAF Occupational Measurement Center, during June 1978. This is the initial occupational survey of this career ladder.

The TITAN Missile Mechanic career ladder is relatively small, consisting of only 223 assigned airmen as of December 1977. This career ladder appears to have been highly stable over the last five years, and has experienced no significant classification or assignment changes during this time. The basic school for this specialty is a Category A school conducted at Sheppard AFB and is 79 academic days in length.

INVENTORY DEVELOPMENT AND ADMINISTRATION

The data collection instrument for this occupational survey was USAF Job Inventory AFPT 90-443-289. Thorough research of career field publications and directives, personal interviews with nine subject matter specialists at Sheppard Technical Training Center and Davis Monthan AFB, and written reviews from 38 experienced TITAN missile mechanics from five bases led to the final development of the survey instrument. The current survey instrument consists of 246 tasks grouped under 10 duty headings.

During the period October 1977 through January 1978, consolidated base personnel offices in all TITAN missile operational units administered the inventory booklets to airmen holding DAFSCs 443X0E or 44399. Table 1 reflects the percentage distribution, by major command, of assigned personnel in the career ladder as of December 1977. Also reflected is the distribution by major command of airmen making up the final survey sample. The 183 respondents making up this final sample represent 82 percent of the 223 assigned personnel in the career ladder and is considered to be an adequate and representative sample of the DAFSC 443X0E population.

APPROVED FOR PUBLIC RELEASE; DISTRIBUTION UNLIMITED

Tables 2 and 3 reflect distribution of the survey sample in terms of DAFSC and TAFMS groups. As shown, over 90 percent of the 3- and 7-skill level personnel were sampled, and 69 percent of the larger 5-skill level group was sampled. Regarding TAFMS groups, the largest number of personnel were in their second and third enlistment periods; only 19 percent of the sample were in their first enlistment.

TABLE 1

COMMAND REPRESENTATION OF THE SURVEY SAMPLE

COMMAND	AFSC 44330E/50E/70E *	
	PERCENT ASSIGNED	PERCENT SAMPLE
ATC	5	5
SAC	95	95
TOTAL	100	100

TOTAL 443XOE PERSONNEL ASSIGNED - 223  
 TOTAL 443XOE PERSONNEL SAMPLED - 183  
 PERCENT OF 443XOE AIRMEN SAMPLED - 82%

\* NOTE: SURVEY BOOKLETS WERE MAILED TO 17 9-SKILL LEVEL PERSONNEL. ONLY THREE SUPERINTENDENTS RESPONDED, WHICH IS AN INSUFFICIENT NUMBER TO BE A REPRESENTATIVE SAMPLE. THUS, SUPERINTENDENTS ARE NOT ANALYZED SEPARATELY IN THIS REPORT.

TABLE 2

DAFSC DISTRIBUTION OF SURVEY SAMPLE

DAFSC	NUMBER ASSIGNED	NUMBER IN SURVEY SAMPLE	PERCENT OF ASSIGNED SAMPLED
44330E	22	20	91
44350E	123	85	69
44370E	78	76	97

TABLE 3

TAFMS DISTRIBUTION OF SURVEY SAMPLE

	MONTHS TIME IN SERVICE					
	1-48	49-96	97-144	145-192	193-240	
NUMBER IN FINAL SAMPLE	35	59	53	16	14	7
PERCENT OF SAMPLE	19%	32%	29%	9%	8%	4%

## CAREER LADDER STRUCTURE

An essential part of the USAF Occupational Analysis program is the examination of career ladder personnel in terms of the actual structure of the jobs they perform rather than the career field structure outlined in official documents. This examination of actual structure is made possible by the Comprehensive Occupational Data Analysis Programs (CODAP) which generate a hierarchical clustering of all jobs performed in the field based upon the similarity of tasks performed and the relative time spent on these tasks. Background factors such as DAFSC, job title, grade, position, etc. have no bearing on the job clustering process. Rather, these factors are used only to help describe the members of job groups that the CODAP process has identified.

The basic identifying group used in the hierarchical job structuring analysis is the Job Type. A job type is a group of individuals who perform many of the same tasks and who also spend similar amounts of time performing them. When there is a substantial degree of similarity between different job types, they are grouped together and labeled as Clusters. In most cases, a cluster will contain more personnel than the total number of members within its job type groups, since it also contains respondents whose pattern of tasks performed is too different to meet job type criteria, but which is similar enough to meet cluster criteria. Finally, there are often cases of specialized job types that are too dissimilar to be grouped into any cluster. These fairly unique groups are labeled Independent Job Types.

Based on task and relative time spent similarities, the jobs performed in the 443X0E career ladder are as illustrated in Figure 1. The two clusters, their related job types, and the one independent job type which constitute this career ladder structure are listed below. (A more detailed description of representative duties, distinguishing tasks, and common background characteristics for each of these groups is presented in Appendix A, and should be viewed in relationship to the diagram in Figure 1).

- I. Work Planning, Supervision, and Scheduling Personnel Cluster  
(GRP007, N=50)
  - a. NCOIC, Work Planning and Scheduling (GRP032, N=7)
  - b. Missile Maintenance Supervisor (GRP041, N=9)
  - c. Maintenance Planning and Scheduling Specialist  
(GRP040, N=7)
  - d. Job Control Specialist (GRP035, N=15)

FIGURE 1

LGM-25 (TITAN) MISSILE MAINTENANCE MECHANIC CAREER LADDER STRUCTURE

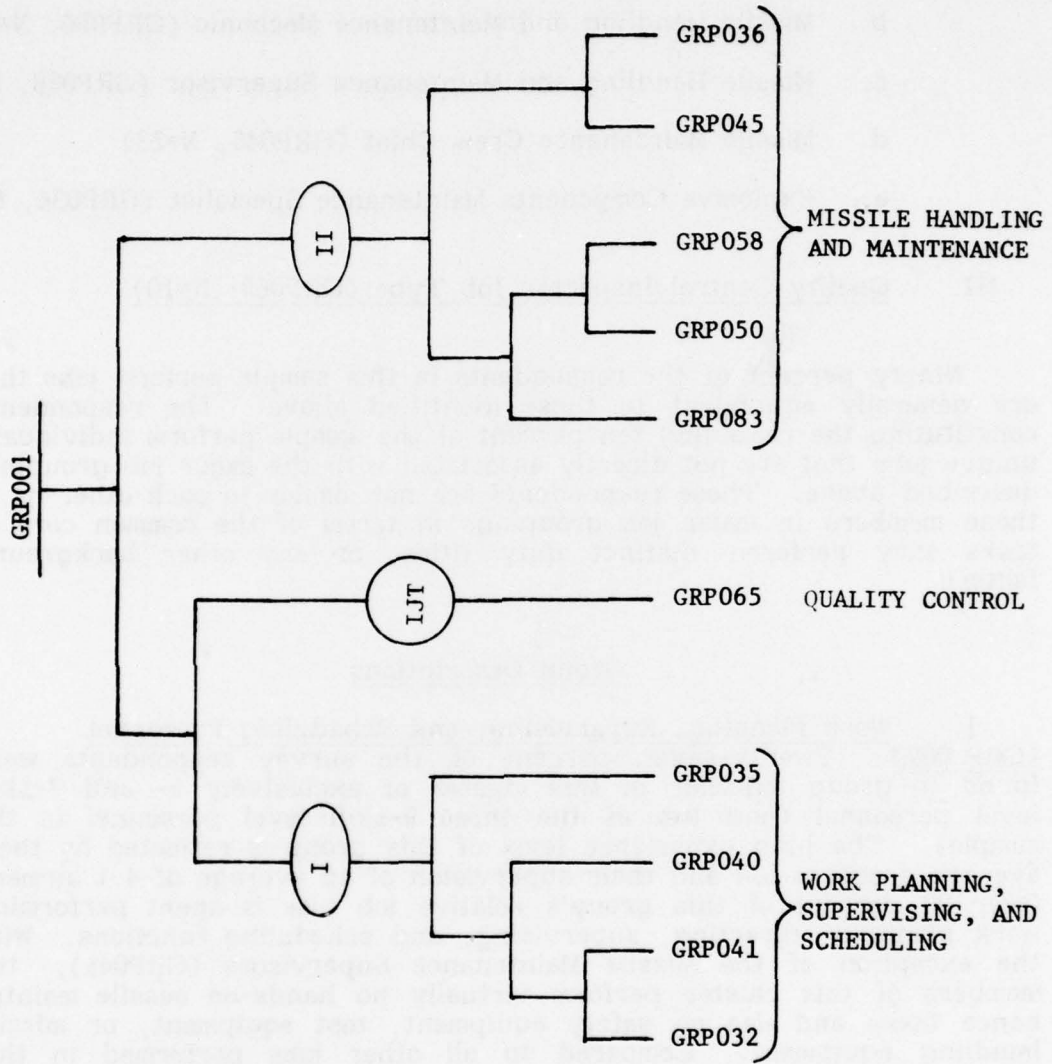

II. Missile Handling and Maintenance Personnel Cluster  
(GRP015, N=106)

- a. Propulsion Maintenance Technician (GRP083, N=32)
- b. Missile Handling and Maintenance Mechanic (GRP050, N=27)
- c. Missile Handling and Maintenance Supervisor (GRP058, N=8)
- d. Missile Maintenance Crew Chief (GRP045, N=22)
- e. Explosive Components Maintenance Specialist (GRP036, N=8)

III. Quality Control Inspector Job Type (GRP065, N=10)

Ninety percent of the respondents in this sample perform jobs that are generally equivalent to those identified above. The respondents constituting the remaining ten percent of the sample perform individually unique jobs that are not directly associated with the major job groupings described above. These respondents are not similar to each other or to those members in major job groupings in terms of the common core of tasks they perform, distinct duty titles, or any other background factors.

Group Descriptions

I. Work Planning, Supervising, and Scheduling Personnel (GRP 007). Twenty-seven percent of the survey respondents were found to group together in this cluster of exclusively 5- and 7-skill level personnel (and two of the three 9-skill level personnel in the sample). The high experience level of this group is reflected by their average grade of 5.4 and their supervision of an average of 4.1 airmen. Over 90 percent of this group's relative job time is spent performing work planning, directing, supervising, and scheduling functions. With the exception of the Missile Maintenance Supervisors (GRP041), the members of this cluster perform virtually no hands-on missile maintenance tasks and use no safety equipment, test equipment, or missile handling equipment. Compared to all other jobs performed in this career ladder, these personnel perform the least difficult job, although there is considerable variance in the job difficulty levels for the job types within this cluster. (For a more thorough description and discussion of job difficulty, see the TASK DIFFICULTY section of this report.) Also characteristic of this cluster is the very low average number of tasks performed (26). Maintenance Planning and Scheduling Specialists (GRP040), for example, spend over 80 percent of their relative job time performing only 11 tasks. Overall, the group members are well satisfied with their jobs and feel their talents are used very well. Thirty-four percent of the group, however, feel their training is not being utilized well.

II. Missile Handling and Maintenance Personnel (GRP015). This is the larger of the two clusters in this analysis, and consists of 57 percent of the survey respondents. Eighty-six percent of all first enlistment personnel are contained in this group, with the remaining group members being primarily 5- and 7-skill level personnel in their second or third enlistment period. As a whole, this group spends over 74 percent of its relative job time performing the total spectrum of TITAN missile maintenance functions. The five job types within the cluster are clearly distinguishable in terms of specialized maintenance or maintenance supervision tasks performed. One job type tends to perform general missile maintenance and handling functions while two others tend to specialize in propulsion or explosive components maintenance functions, respectively. Supervision is performed by crew chiefs and by the higher level, general maintenance supervisors. It must be noted, however, that despite the distinct job differences among the job types in this cluster, there is a high degree of task overlap among members of all groups in this cluster. No job type performed any specialized tasks exclusively. Rather, the members in this cluster appear to perform a general "team" maintenance function, with some members of the team applying noticeably more emphasis to general maintenance, propulsion, or explosive components maintenance functions. Substantial percentages of all members use every item of test equipment, safety equipment, and missile handling equipment available in the field. With the exception of crew chiefs (GRP045) and explosive components specialists (GRP036), job types in this group are above or well above average in difficulty. While over 70 percent of the group members find their jobs very interesting, there is considerable variance among job types regarding their perceived use of talents and training in their job. Over 80 percent of the propulsion technicians (GRP083) and general maintenance mechanics (GRP050) feel their talents and training are being utilized well; however, 50 percent of the maintenance supervisors (GRP036) feel that both their talents and training are being used little or not at all.

III. Quality Control Inspectors (GRP065). As depicted in Figure 1, Quality Control Inspectors emerged as an independent job type. Consisting of five percent of the survey respondents, this highly specialized group is comprised of primarily 7-skill level personnel and contains no first enlistment personnel. Group members have an average grade of 5.1, an average of 9.2 years in the career field, and an average of 9.6 years TAFMS. Fifty-seven percent of this group's relative job time is spent performing inspecting and evaluating functions. The group members perform virtually no hands-on maintenance functions and use little if any safety, test, or missile handling equipment. Their job is about average in difficulty, consists of a relatively low average number of tasks, and includes a considerable amount of supervisory duties. All members feel their job is very interesting, and over 90 percent feel their talents and training are utilized very well.

## General Discussion

The picture of the career field structure that emerged from this analysis of job similarity tends to validate the existing Air Force classification structure for this specialty. With respect to the career ladder as a whole, there appears to be three highly distinct job functions performed: Work Planning and Scheduling, Hands-on Missile Maintenance, and Quality Control. Supervisory functions are performed by readily distinguishable groups within each cluster, and also to some extent by quality control personnel.

While each of the three basic job functions performed tends to be quite homogeneous within itself and there tends to be very little task overlap between functions, the primary factor which differentiates the jobs performed is experience level. Work planning and scheduling personnel have the highest average time in service; those in quality control have the highest average time in the career field; and those in hands-on missile maintenance have lower average times both in the career field and in service.

An interesting finding in this analysis is the fact that no apparent distinction was found between personnel in this career field performing shop and those performing on-site maintenance functions. It is quite normal in the analysis of maintenance career fields to find personnel who specialize in shop maintenance versus on-site (flight-line) maintenance functions. This finding suggests that technical missile maintenance personnel can function as a "team" when working on the missiles themselves, and can also function interchangeably with respect to where they perform the maintenance functions. Considering the small number of airmen assigned to this ladder, this versatility should be a tremendous help to operational managers.

Another noteworthy finding is that technical training instructors were not separately distinguishable from their operational counterparts with respect to the tasks they perform. Technical school supervisors showed up as members of the supervisory job types of clusters I and II, and technical school instructors were members of the various missile maintenance job types of cluster II. In most occupational surveys, instructors and training supervisors typically form a separate job type.

As a whole, the members of this career ladder are well satisfied with their respective jobs. High percentages of airmen in each of the two clusters and the independent job type report their job as interesting and most feel their talents are being well utilized. In addition, while considerable percentages of work planners and schedulers feel their training is used little or not at all, those personnel performing missile maintenance or quality control functions feel their training is being utilized quite well. Thus, there does not appear to be any serious job dissatisfaction among members of this career field. In fact, 72 percent of the Work Planning, Supervision and Scheduling cluster and 65 percent of the Missile Handling and Maintenance cluster personnel intend to reenlist for another term.

## JOB DIFFERENCES ASSOCIATED WITH SKILL LEVELS

In conjunction with the job structure of the career ladder, it is important from a personnel management viewpoint to examine general skill level differences in jobs performed and to examine such differences in the light of the career ladder structure identified in this analysis. As a whole, members of this career ladder spend 40 percent of their job time performing managerial, supervisory, and training duties, 14 percent performing maintenance administrative functions, and the remaining 46 percent performing hands-on maintenance functions. As shown in Table 4, however, this overall distribution of job time across duties does not reflect the relative job time spent by 5- and 7-skill level personnel when they are analyzed as individual groups. The majority of 5-skill level job time is spent on technical maintenance functions, whereas the majority of 7-skill level job time is spent on managerial, supervisory and training functions. Thus from a management standpoint, it is not realistic to discuss only functions that career ladder members do "in general". Rather, a much clearer picture of the actual job functions performed by different skill level groups results from an analysis of each skill level group (as is done in AFR 39-1), by distribution of skill level of jobs within the career ladder job clusters, and by contrasting the tasks performed by skill level of incumbents.

When 5-skill level personnel are combined as a whole, they perform the total spectrum of tasks contained in this job inventory. However, as shown in Table 4, 5-skill level personnel in the Work Planning, Supervision, and Scheduling cluster spend 97 percent of their job time performing job control functions, and perform virtually no hands-on missile maintenance tasks. In contrast, those personnel in the Missile Handling and Maintenance cluster spend 76 percent of their job time performing the complete spectrum of hands-on missile maintenance tasks and only 24 percent performing managerial, supervisory, training, and administrative tasks. In addition, those 5-skill level personnel in the Missile Handling and Maintenance cluster perform an average of almost three times as many tasks, and their job is well above average in difficulty compared to the below average difficulty job performed by Work Planning and Scheduling personnel. Substantial percentages of the maintenance personnel use every piece of test, safety, and missile handling equipment in the field where work planners and schedulers use virtually none. Thus, for all practical purposes, 5-skill level personnel perform either one or the other of these two distinct jobs, but not both at the same time. (See Tables II, III, and IV in Appendix B for an illustration of the differences in tasks between 5-skill level personnel.) Interestingly enough, however, both functional groups of 5-skill level personnel find their jobs equally interesting and are equally favorable with regards to the use of their talents and training on the job.

Similar to the findings noted above, 7-skill level personnel as a whole also perform the complete spectrum of tasks contained in this job inventory. Like the 5-skill level personnel, 7-skill level personnel perform one or the other of two almost completely different job functions

depending on whether they focus on work planning, supervision, and scheduling functions or hands-on maintenance functions. As shown in Table 4, those 7-skill level personnel in Cluster I spend 93 percent of their job time performing management, supervision, training, and administrative functions and perform virtually no hands-on missile maintenance functions. In sharp contrast, those personnel in Cluster II spend 61 percent of their job time performing the complete range of missile maintenance functions. (See Tables V, VI, and VII in Appendix B for an illustration of task differences between 7-skill level personnel.) In addition, hands-on maintenance personnel perform a much more difficult job that consists of over three times the average number of tasks compared to the average job of work planning, supervision, and scheduling personnel. Another job that is primarily a 7-skill level function is that of quality control. Eighty percent of the members performing this above-average difficulty job are 7-skill level personnel.

One thing that all 7-skill level personnel have in common that 5-skill level personnel generally do not is the supervisory and managerial functions they perform. Many high time-consuming tasks performed by 7-level personnel as a whole (Table V, Appendix B) are supervisory and managerial. This commonality among 7-skill level personnel is further highlighted in Table 5 which contains representative task data concerning major differences between 5- and 7-skill level personnel as a whole. While 7-skill level personnel carry this supervisory commonality across all their jobs, 5-skill level personnel as a whole have little if any commonality in any tasks across jobs.

Another important finding surfaces when 7-skill level personnel are looked at within their respective job clusters. Whether these personnel perform work scheduling functions (Cluster I), hands-on maintenance functions (Cluster II), or quality control functions (independent job type), they are primarily technicians; supervisory and managerial duties are secondary. This is clearly shown in Tables VI and VII of Appendix B. While 7-skill level quality control inspectors are highly satisfied with their jobs all the way around, those 7-skill level personnel performing hands-on maintenance feel their jobs are somewhat less interesting and that their talents and training are not being utilized as well as those personnel performing work planning, supervision, and scheduling functions.

In summary, most 5- and 7-skill level personnel perform one or the other of two distinct technical jobs: work planning and scheduling (job control) or hands-on maintenance. In addition, primarily 7-skill level personnel perform the function of quality control inspectors. While the 5-skill level jobs are almost exclusively technical (that is, non-supervisory) in nature, 7-skill level technical jobs carry with them a substantially large common thread of supervisory and managerial duties in addition to the technical duties. From a standpoint of technical functions performed, however, there is virtually no difference between 5- and 7-skill level jobs.

TABLE 4

## PERCENT TIME SPENT ON DUTIES BY DAFSC GROUPS

DUTIES	DAFSC 443X0E					
	5-SKILL LEVEL		7-SKILL LEVEL		7-SKILL LEVEL	
	TOTAL (N=85)	I* (N=20)	TOTAL (N=76)	I* (N=28)	TOTAL (N=76)	II** (N=31)
<u>MANAGEMENT, SUPERVISION AND TRAINING</u>						
A ORGANIZING AND PLANNING	10	36	2	13	26	4
B DIRECTING AND IMPLEMENTING	10	27	5	16	24	7
C INSPECTING AND EVALUATING	7	8	5	14	12	7
D TRAINING	4	5	3	11	16	8
TOTAL	31	76	15	54	78	26
<u>ADMINISTRATION</u>						
E PREPARING AND MAINTAINING FORMS, RECORDS, AND REPORTS	15	21	9	14	15	13
<u>MISSILE HANDLING AND MAINTENANCE</u>						
F HANDLING AND TRANSPORTING MISSILES	23	1	32	10	5	17
G MAINTAINING PROPULSION SYSTEMS	9	-	13	6	1	14
H MAINTAINING MISSILE AIR FRAMES	4	-	5	1	-	2
I MAINTAINING ORDNANCE ITEMS	3	-	5	2	-	4
J PERFORMING GENERAL TITAN MAINTENANCE	15	2	21	13	1	24
TOTAL	54	3	76	32	7	61

\* SKILL LEVEL MEMBERS WITHIN WORK PLANNING, SUPERVISION, AND SCHEDULING CLUSTER

\*\* SKILL LEVEL MEMBERS WITHIN MISSILE HANDLING AND MAINTENANCE CLUSTER

TABLE 5

TASKS WHICH MOST CLEARLY DISTINGUISH BETWEEN DAFSC 44350E AND 44370E PERSONNEL  
(PERCENT MEMBERS PERFORMING)

TASKS	DAFSC 44350E	DAFSC 44370E	DIFFERENCE
F38 REMOVE OR INSTALL MISSILE DOORS OR FASTENERS	61	25	36
F39 REMOVE OR INSTALL MISSILE PROTECTIVE COVERS	46	14	32
F40 REMOVE OR INSTALL MISSILE TRAILER COMPONENTS	42	12	30
H4 REMOVE OR INSTALL COOLING AIR DUCTS FROM OR ON STAGE I ENGINES	44	16	28
H1 REMOVE OR INSTALL AIR SCOOPS	34	8	26
J10 PERFORM COMMUNICATION CHECKS WITH COMBAT CREW COMMANDERS	61	36	25
F26 POSITION MISSILE HANDLING EQUIPMENT AT LAUNCH SITES	42	17	25
F4 CHARGE THRUST MOUNT DAMPER PNEUMATIC SYSTEM SUBASSEMBLIES	58	33	25
C22 REVIEW CORRESPONDENCE OR REPORTS	21	54	-33
A15 SCHEDULE LEAVES OR PASSES	6	36	-30
C23 VALIDATE NEW MAINTENANCE PROCEDURES	8	33	-25
D16 MAINTAIN TRAINING RECORDS	27	51	-24
C2 ANALYZE MAINTENANCE OR INSPECTION REPORTS	17	37	-20
C25 WRITE RECOMMENDATIONS OF INDIVIDUALS FOR PERSONNEL ACTIONS	6	25	-19
B2 COUNSEL SUBORDINATES ON JOB PROGRESSION OR CAREER DEVELOPMENT	27	45	-18

TOTAL NUMBER OF TASKS EXCEEDING 10% DIFFERENCES: 135  
 NUMBER TASKS PERFORMED BY MORE 44350E PERSONNEL: 89  
 NUMBER TASKS PERFORMED BY MORE 44370E PERSONNEL: 46

## JOB DIFFERENCES ASSOCIATED WITH EXPERIENCE LEVEL

Important management information is gained by comparing groups of personnel on the basis of total active federal military service (TAFMS) in conjunction with the career structure identified in this analysis. TAFMS groups are used to reflect variations in tasks performed as a function of different levels of experience in the career ladder. Table 6 lists the percent time spent on the 10 duty categories by personnel within each enlistment (or AFMS) group. In general, the picture created by the job differences between experience level groups is quite different from that for DAFSC groups. Recall that the differences in technical tasks performed by 5- and 7-skill level groups were found to be small overall, but were large and virtually exclusive within each skill level (depending on the job cluster the respective skill-level members were in). In contrast, the job differences between enlistment groups are generally more moderate and reflect a greater degree of gradual blending between technical, supervisory, and managerial functions as experience increases. This trend is clearly reflected by Table 6. Job time spent performing managerial, supervisory, and training duties increases progressively from 15 percent for the 1-48 months AFMS group to 69 percent for the 241+ months AFMS group. Conversely, the job time spent for missile handling and maintenance duties decreases from 76 percent to 23 percent for the same two AFMS groups.

The largest difference in tasks performed occurs between first enlistment and second and successive enlistment groups. Recall that the work planning, supervision, and scheduling group (Cluster I) contained virtually no first enlistment personnel (1-48 months AFMS). Rather, the vast majority of first enlistment airmen group in the missile handling and maintenance cluster. Analysis of the actual tasks performed by first enlistment personnel indicates that their job covers the complete range of hands-on missile maintenance functions. Every technical maintenance task listed in this task inventory is performed by considerable percentages of these personnel. Further, substantial percentages of these airmen use every piece of test, safety, and missile handling equipment in the field. The average numbers of tasks performed (65) is on par with that for other enlistment groups, and the same holds true for their job difficulty which is about average. With the exception of supervisory functions, which are picked up from second enlistment on, the technical job performed by first enlistment personnel is very similar to the technical job performed by more experienced personnel.

An interesting finding related to experience level groups is that, as shown in Table 7, all AFMS groups of 443X0E personnel are to varying degrees less satisfied with their jobs and the use of their talents and training than comparable groups of all other USAF career fields surveyed in 1977. Interestingly enough, however, with the exception of second enlistment personnel (49-96 months AFMS), the degree of dissatisfaction present among AFS 443X0E personnel does not

seem to adversely affect their reenlistment intentions, which for both first enlistment and career airmen groups are more favorable than comparable groups in other USAF career fields.

In summary, the changes that occur as a function of increasing experience in the AFS 443X0E career field reflect a definite change in the actual nature of the job performed by first versus second and successive enlistment groups. The job changes that occur from the second enlistment on reflect more of shift in emphasis from technical/supervisory to supervisory/technical functions as experience increases. All 443X0E personnel up through the 7-skill level continue to perform the full range of hands-on maintenance tasks despite their years experience in the field. Even though job interest and perceived utilization of talents and training are somewhat less favorable for 443X0E AFMS groups compared to other USAF career fields, reenlistment intentions are in most cases more favorable than for other USAF career fields.

TABLE 6

## PERCENT TIME SPENT ON DUTIES BY AFMS GROUPS

DUTIES	MONTHS AFMS (DAFSC 443XOE)					
	1-48 (N=35)	49-96 (N=59)	97-144 (N=53)	145-192 (N=16)	193-240 (N=14)	241+ (N=7)
<b>MANAGEMENT, SUPERVISION AND TRAINING</b>						
A ORGANIZING AND PLANNING	4	9	14	18	10	16
B DIRECTING AND IMPLEMENTING	5	10	12	21	21	19
C INSPECTING AND EVALUATING	4	8	13	14	8	18
D TRAINING	2	4	7	7	24	16
TOTAL	15	31	46	60	63	69
<b>ADMINISTRATION</b>						
E PREPARING AND MAINTAINING FORMS, RECORDS, AND REPORTS	9	15	16	11	16	8
<b>MISSILE HANDLING AND MAINTENANCE</b>						
F HANDLING AND TRANSPORTING MISSILES	30	22	11	7	8	12
G MAINTAINING PROPULSION SYSTEMS	12	8	7	12	7	3
H MAINTAINING MISSILE AIR FRAMES	4	3	2	1	-	1
I MAINTAINING ORDNANCE ITEMS	6	4	2	4	2	1
J PERFORMING GENERAL TITAN MAINTENANCE	24	17	16	5	4	6
TOTAL	76	54	38	29	21	23

TABLE 7

EXPRESSION OF JOB INTEREST, PERCEIVED UTILIZATION OF TALENTS AND TRAINING AND REENLISTMENT INTENTIONS  
FOR FIRST ENLISTMENT, SECOND ENLISTMENT AND CAREER AFMS GROUPS  
(PERCENT MEMBERS RESPONDING)

	FIRST ENLISTMENT (1-48 MONTHS AFMS)		SECOND ENLISTMENT (49-96 MONTHS AFMS)		CAREER AIRMEN (49-241+ MONTHS AFMS)	
	443X0E (N=35)	OTHER USAF FIELDS	443X0E (N=59)	OTHER USAF FIELDS	443X0E (N=90)	OTHER USAF FIELDS
I FIND MY JOB:						
DULL	20	16	16	13	25	9
SO-SO	34	19	30	16	10	10
INTERESTING	46	65	54	71	65	81
MY JOB UTILIZES MY TALENTS:						
NOT AT ALL OR VERY LITTLE	40	31	31	23	23	15
FAIRLY WELL OR BETTER	60	69	69	77	77	85
MY JOB UTILIZES MY TRAINING:						
NOT AT ALL OR VERY LITTLE	25	26	42	24	31	19
FAIRLY WELL OR BETTER	75	74	58	76	69	81
I PLAN TO REENLIST:						
NO OR PROBABLY NO	57	59	39	35	20	27
YES OR PROBABLY YES	43	41	61	65	80	73

## ANALYSIS OF TASK DIFFICULTY

From a listing of airmen identified for this Occupational Survey, career ladder incumbents performing 7-skill level duty at various operational locations were selected to rate task difficulty. Tasks were rated on a nine-point scale from extremely low to extremely high difficulty, with difficulty defined as the length of time it takes an average member to learn to do the task. Interrater reliability (as assessed by components of variance of mean ratings) among the 75 raters was .92. Ratings were adjusted so that tasks of average difficulty have ratings of 5.00.

The most difficult tasks in this career field are those associated with maintaining propulsion systems. Forty-one of the 45 tasks listed under this duty category in the task inventory were rated above average in difficulty. Nine of the top 20 most difficult tasks in the career field are propulsion system maintenance tasks such as remove and install turbopump assemblies, stage I and II engines, and thrust chamber fuel valves, assemblies, and pressure sequencing valves. However, generally less than 30 percent of all AFS 443X0E personnel perform these tasks. There was one job type in Cluster II that specialized in propulsion system maintenance (GRP083), and this group was rated as having the most difficult job in the career field.

The next most difficult group of tasks in the career field are managerial and supervisory in nature, such as develop, improve, or validate work methods and procedures; write airman performance, quality control, and routine or special reports; and perform various quality control inspections and analyses. Generally less than 20 percent of AFS 443X0E personnel perform these tasks, and those personnel who do perform them do so primarily in conjunction with less difficult tasks.

In general, of the 123 tasks rated above average in difficulty, only 24 are performed by 30 percent or more of all AFS 443X0E personnel, as shown in Table 8. These tasks relate relatively equally to technical and managerial/supervisory functions, and are not performed specifically by any one group of AFS 443X0E personnel. Rather, they appear to be performed mostly in conjunction with less difficult tasks for any given group of AFS 443X0E personnel. The only exception is that the highly difficult managerial and supervisory tasks are not performed to any extent by personnel in their first enlistment. The highly difficult technical tasks, however, are performed to some extent by first-enlistment personnel.

Table 9 contains 21 tasks that are below average in difficulty and which are performed by 40 percent or more of all AFS 443X0E personnel. These tasks relate primarily to general TITAN maintenance and handling functions such as operating personnel or equipment elevators, intrasite communication equipment, blast door systems and work platform systems; locking, unlocking, or adjusting thrust mount damper assemblies; locating information in and maintaining technical order files; and

initiating maintenance data collection forms. Other less difficult tasks are characteristically performed by less than 40 percent of all AFS 443X0E personnel and also relate primarily to general TITAN maintenance, handling, and transportation functions.

### Job Difficulty Index (JDI)

Based on the difficulty ratings of tasks, the amount of time spent on various tasks performed, and the number of tasks performed by the job incumbents, job difficulty values were calculated for the overall jobs performed by major groups of AFS 443X0E personnel described throughout this report. This data is shown in Table 10. Of the primary career ladder structure groups, missile handling and maintenance personnel have the most difficult job overall. The difficulty levels of job types within this cluster vary considerably, however, from a low of 7.9 for crew chiefs to a high of 18.8 for propulsion maintenance technicians. Similarly, while the job difficulty level for work planning and scheduling personnel as a whole is somewhat below average, there is considerable variance among the job types. In this cluster, job difficulty ranges from a low of 10.1 for planning and scheduling specialists to a high of 15.1 for maintenance supervisors. The last primary work group, quality control inspectors, perform a job slightly above average in difficulty.

Considering the other primary groups of 443X0E personnel shown in Table 10, 5- and 7-skill level groups as a whole perform average difficulty jobs. However, for both skill level groups, those members in the work planning and scheduling cluster perform a below average difficulty job while those members in the missile handling and maintenance cluster perform an above average difficulty job. Also noteworthy is that the 7-skill level members in Cluster I have a considerably more difficult job than 5-skill level members in the same cluster. This is due to the fact that these 7-skill level members perform a higher average number of tasks, some of which are supervisory and managerial in nature.

Unlike most other USAF career fields, however, AFMS groups in this career field have no ascending job difficulty as experience increases. Rather, with the exception of fourth and sixth enlistment groups, who have very difficult jobs, all enlistment groups have a below average difficulty job. Both the fourth and sixth enlistment groups perform a high average number of tasks, and their respective jobs consist of both supervisory/managerial and technical tasks combined.

In summary, the two types of tasks rated as most difficult relate to propulsion maintenance and managerial duties. With the exception of the propulsion maintenance job-type groups, many of the most difficult tasks in the career field are generally not being performed by substantial percentages of any given group of AFS 443X0E personnel. Rather, they appear to be performed by small percentages of personnel in conjunction with a broader spectrum of less difficult tasks. Those

personnel performing hands-on maintenance functions in conjunction with supervisory functions generally have the most difficult jobs as a whole. This is most readily apparent in the supervisory job types such as maintenance supervisors (GRP041) and missile handling and maintenance supervisors (GRP058), and in the fourth and sixth enlistment groups of personnel.

TABLE 8

TASKS RATED ABOVE AVERAGE IN DIFFICULTY WHICH ARE PERFORMED BY 30 PERCENT  
OR MORE OF DAFSC 443XOE PERSONNEL

TASK	DIFFICULTY INDEX	PERCENT MEMBERS PERFORMING
C20 PREPARE AIRMAN PERFORMANCE REPORTS (APR)	6.96	31
A5 DEVELOP OR IMPROVE WORK METHODS OR PROCEDURES	6.93	43
B18 WORK TECHNICAL PROBLEMS	6.36	33
F44 REMOVE OR INSTALL STAGES I OR II IN OR FROM SILOS	6.16	31
A4 CONDUCT THE ACTIVITIES OF MAINTENANCE SPECIALISTS WITH OTHER AGENCIES	6.02	32
A8 PLAN OR SCHEDULE WORK ASSIGNMENTS	5.92	36
B3 COUNSEL SUBORDINATES ON PERSONAL OR MILITARY-RELATED PROBLEMS	5.86	39
F31 PREPARE STAGES I OR II FOR INSTALLATION OR REMOVAL IN OR FROM SILOS	5.74	32
I4 PERFORM STRAY VOLTAGE CHECKS ON MISSILE ORDNANCE CIRCUITS	5.73	32
F12 LOAD OR UNLOAD STAGES I OR II ON OR OFF MISSILE TRAILERS	5.60	32
F10 LEVEL THRUST MOUNTS	5.58	36
D7 CONDUCT ON-THE-JOB TRAINING (OJT)	5.57	34
B12 SUPERVISE APPRENTICE MISSILE MECHANICS (AFSC 44330E)	5.51	30
J16 PERFORM PERIODIC INSPECTIONS OF MISSILES	5.51	39
I1 CONNECT OR DISCONNECT ORDNANCE CIRCUITS	5.50	34
D16 MAINTAIN TRAINING RECORDS	5.41	36
B2 COUNSEL SUBORDINATES ON JOB PROGRESSION OR CAREER DEVELOPMENT	5.27	34
A3 CONDUCT OR PARTICIPATE IN STAFF MEETINGS OR CONFERENCES	5.17	35
I5 REMOVE OR INSTALL ENGINE START CARTRIDGES	5.16	31
B14 SUPERVISE MISSILE MECHANICS (AFSC 44350E)	5.13	34
H8 REMOVE OR INSTALL MANHOLE COVERS OR SEALS	5.08	36
C22 REVIEW CORRESPONDENCE OR REPORTS	5.05	34
I7 REMOVE OR INSTALL IGNITORS OR INITIATORS	5.05	31
D15 EXPLAIN POLICIES OR DIRECTIVES TO SUBORDINATES	5.01	30

TABLE 9

TASKS RATED BELOW AVERAGE IN DIFFICULTY WHICH ARE PERFORMED BY  
40 PERCENT OR MORE OF DAFSC 443XOE PERSONNEL

TASK	DIFFICULTY INDEX	PERCENT MEMBERS PERFORMING
B4 DIRECT CARE OR USE OF EQUIPMENT, SUPPLIES, OR WORK SPACE	4.71	42
E11 MAINTAIN TECHNICAL ORDER FILES	4.67	40
E2 INITIATE MAINTNANCE DATA COLLECTION FORMS	4.61	40
B10 ORIENT NEWLY-ASSIGNED PERSONNEL	4.58	41
J11 PERFORM DEW POINT MEASUREMENTS OF MISSILE TANKS OR ENGINES	4.57	41
E7 LOCATE INFORMATION IN TECHNICAL PUBLICATIONS	4.40	64
F13 LOCK OR UNLOCK THRUST MOUNT DAMPER ASSEMBLIES	4.34	51
J3 IDENTIFY OR TREAT CORROSION	4.26	53
E3 INITIATE USAF HAZARD REPORTS	4.21	40
F2 ADJUST THRUST MOUNT DAMPER ASSEMBLIES	4.15	41
F8 INSPECT THRUST MOUNT SUSPENSION SPRING ASSEMBLIES	3.98	43
F4 CHARGE THRUST MOUNT DAMPER PNEUMATIC SYSTEM SUBASSEMBLIES	3.79	46
F45 REMOVE OR INSTALL STAGE II ENGINE MAINTENANCE PLATFORMS OR SAFETY NETS	3.79	46
J9 OPERATE WORK PLATFORM SYSTEMS	3.52	58
J5 INTERPRET COLOR CODING OF FLUID LINES	3.49	41
F38 REMOVE OR INSTALL MISSILE DOORS OR FASTENERS	3.16	47
J6 OPERATE BLAST DOOR SYSTEMS	2.61	58
E16 SIGN FOR OR SECURE CODE SLIPS	2.54	51
J7 OPERATE INTRASITE COMMUNICATION EQUIPMENT	2.43	56
J10 PERFORM COMMUNICATION CHECKS WITH COMBAT CREW COMMANDERS	2.28	51
J8 OPERATE PERSONNEL OR EQUIPMENT ELEVATORS	2.08	59

TABLE 10  
 JOB DIFFICULTY INDEX (JDI)\* FOR MAJOR GROUPS OF  
 AFS 443XOE PERSONNEL

<u>MAJOR GROUPS</u>	<u>JDI</u>
<b>CAREER LADDER STRUCTURE GROUPS:</b>	
I. WORK PLANNING, SUPERVISION, AND SCHEDULING PERSONNEL	11.8
NCOIC, WORK PLANNING AND SCHEDULING	11.5
MISSILE MAINTENANCE SUPERVISOR	15.1
MAINTENANCE PLANNING AND SCHEDULING SPECIALIST	10.1
JOB CONTROL SPECIALIST	12.0
II. MISSILE HANDLING AND MAINTENANCE PERSONNEL	14.5
PROPULSION MAINTENANCE TECHNICIAN	18.8
MISSILE HANDLING AND MAINTENANCE MECHANIC	15.5
MISSILE HANDLING AND MAINTENANCE SUPERVISOR	18.6
MISSILE MAINTENANCE CREW CHIEF	7.9
EXPLOSIVE COMPONENTS SPECIALIST	10.8
IJT. QUALITY CONTROL INSPECTORS	13.4
<b>DAFSC GROUPS:</b>	
44350E PERSONNEL	13.1
44350E PERSONNEL IN CLUSTER I	10.9
44350E PERSONNEL IN CLUSTER II	14.9
44370E PERSONNEL	13.0
44370E PERSONNEL IN CLUSTER I	12.5
44370E PERSONNEL IN CLUSTER II	14.3
<b>AFMS GROUPS:</b>	
1-48 MONTHS AFMS	12.8
49-96 MONTHS AFMS	12.6
97-144 MONTHS AFMS	12.5
145-192 MONTHS AFMS	15.1
193-240 MONTHS AFMS	12.2
241+ MONTHS AFMS	16.6

\* AVERAGE JDI FOR TOTAL SAMPLE IS 13.0

## ANALYSIS OF AFR 39-1 SPECIALTY DESCRIPTIONS

In conjunction with the analysis of DAFSC groups, a comparison was made between the AFSC job descriptions in AFR 39-1 and the survey data for the 3-, 5-, and 7-skill levels in the AFS 443X0E career field.

Regarding the hands-on maintenance and supervisory functions, the AFR 39-1 specialty descriptions give a relatively thorough and accurate picture of what 3-, 5-, and 7-skill level personnel are actually doing in the field. However, one minor exception is the exclusion in the 3- and 5-skill level AFR 39-1 description of training functions performed by these personnel. Task D7, Conduct On-The-Job Training (OJT), is performed by 20 percent of 3-skill level and 33 percent of 5-skill level personnel. Similar percentages of respective 3- and 5-skill level personnel also conduct team training (D8), maintain training records (D16), and review training progress of individuals (D18).

One major exclusion in both the 3- and 5-skill level job description and the 7-skill level job description relates to the non-supervisory job functions associated with work planning and scheduling (or job control). One entire job group (Cluster I) in this analysis was comprised of primarily 5- and 7-skill level personnel performing mostly these job functions. Both the 5- and the 7-skill level specialty descriptions should reflect those work planning and scheduling duties that are currently excluded.

## COMPARISON OF SPECIALTY TRAINING STANDARD (STS) TO SURVEY DATA

This section of the analysis focuses primarily on two areas of concern: 1) those tasks cross-referenced to the STS but not performed to any extent by AFS 443X0E personnel, and 2) those tasks not directly cross-referenced to the STS but which are performed by substantial percentages of 3- and 5-skill level personnel.

During March and April 1978, Sheppard Technical Training School personnel cross-referenced 16 of the 19 paragraphs of STS 443X0E to the current inventory tasks. STS paragraphs 5 (Mechanical Fundamentals), 9 (Electricity), and 19 (Operations Security) were not directly cross-referenced to any of the current survey tasks. Those 16 paragraphs of the STS that were cross-referenced related to survey tasks which are being performed by substantial percentages of first enlistment, 5-, or 7-skill level personnel. Furthermore, all primary jobs or functions identified in this analysis are contained either in whole or in part in the current STS. Only three of 191 tasks referenced to the STS are performed by less than 10 percent of first enlistment, 5-, or 7-skill level personnel: conducting first aid training (D6), removing or installing coded switch components (G27), and crating or uncrating missiles (J2). These findings indicate that the job functions specified in the current STS are indeed being performed by substantial numbers of personnel in the field.

Table I in Appendix C contains 48 survey tasks that were not cross-referenced to the current STS but which are being performed by 10 percent or more of first enlistment, 5-, or 7-skill level personnel. While some of these tasks may be indirectly related to more general paragraphs of the STS, in the judgment of the Technical School personnel who performed the STS cross-referencing, they are not related to specific functions contained in the current STS. These tasks cover such areas as: planning status boards, directing the use of equipment and supplies, inspecting work areas, maintaining bench stock inventories, transporting fuel, missile, oxidizer, and conditioning trailers, removing or installing fuel pre-valves, and servicing HS-1, HS-3, and HS-4 hydraulic reservoirs. These tasks should be evaluated by appropriate field managers to determine if the current STS should be expanded or modified to account for these tasks.

In summary, the current STS does appear to cover all the major job functions identified in this analysis. There are, however, some tasks performed in the field but not directly related to the current STS which warrant evaluation for possible inclusion in the STS.

## DISCUSSION

Because this is the original survey analysis of the AFS 443X0E career ladder, it is not possible to determine whether or not the jobs performed in this career area have changed substantially over the past few years. There were no major problems or difficulties associated with this current analysis, and all findings appear straight-forward and quite clear. There are, however, several implications associated with the findings of this analysis that may require the attention and action of current career field managers.

One of the major findings is that the career area structure that emerged from this analysis tends to validate the existing classification structure for AFS 443X0E personnel. The three primary job functions performed in the field (work planning, supervising, and scheduling; missile handling and maintenance; and quality control) all focus directly on the single job responsibility of TITAN maintenance. While the largest number of AFS 443X0E personnel spend the major portion of their job time working as hands-on maintenance team members, 27 percent of the sample respondents perform virtually no hands-on maintenance tasks but spend the majority of their job time performing work planning and scheduling (or job control) functions. The current AFR 39-1 Specialty Descriptions for respective 5- and 7-skill level personnel do not reflect these work planning and scheduling functions, and thus should be evaluated or modified to reflect these responsibilities. In a somewhat similar vein, over 40 survey tasks were found to be performed by substantial percentages of AFS 443X0E personnel but are not directly specified in the current STS. Thus it appears the STS should also be reviewed.

There appears to be very little difference in the technical (i.e., non-supervisory) job functions performed by 5- and 7-skill level personnel, whether the jobs they perform be related to missile maintenance or to work planning and scheduling. However, personnel with a 7-skill level, and some of the more experienced 5-skill level personnel, also perform supervisory functions in addition to their technical functions. Whether a person is a 5-skill level or a 7-skill level, that member performs either a work planning and scheduling job or a maintenance and handling job, but not both at the same time. This fact should be taken into account by operational managers, supervisors or trainers when assigning personnel from one of these major job functions to another to insure that transferring personnel have proper job proficiency.

From the results of this analysis, there do not appear to be any major career field management problems related to morale or job satisfaction. Career area job groups, DAFSC groups, and AFMS groups all appear to be fairly well or better satisfied with their jobs and the use

of their talents and training, although some of these groups tend to be slightly lower than commensurate groups in other USAF fields. Interestingly enough, however, reenlistment intentions for first-term and for most career personnel tend to be somewhat more favorable than for comparable groups in other USAF career fields.

Training of entry level personnel may need to be reviewed, evaluated, or modified due to several findings of this analysis. From a missile maintenance and handling standpoint, first-term airmen were found to do it all. As a whole, they perform the complete range of TITAN missile maintenance and handling functions currently outlined in their AFR 39-1 specialty description. Every technical maintenance task listed in this task survey is being performed by substantial percentages of first-enlistment personnel. However, very few of these airmen perform work planning and scheduling functions. Thus, it appears that entry-level training consideration should focus entirely on the full range of TITAN maintenance and handling functions and not at all on work planning and scheduling functions.

Based on the overall structure and functional operation of the AFS 443X0E career field that has emerged from this analysis, it is suggested that the next occupational survey be initiated on an "as needed" basis. Significant changes to the TITAN system or to the current manpower management and utilization pattern of AFS 443X0E personnel could warrant such a new analysis.

APPENDIX A

<u>Group Index</u>	<u>Page</u>
Work Planning, Supervision, and Scheduling Personnel (GRP007) --	A1
Missile Handling and Maintenance Personnel (GRP015) -----	A6
Quality Control Inspectors (GRP065) -----	A12

CLUSTER I - WORK PLANNING, SUPERVISION, AND SCHEDULING PERSONNEL (GRP007)

GENERAL DESCRIPTION

NUMBER IN GROUP: 50 PERCENT OF SAMPLE: 27%

DAFSC DISTRIBUTION: 44330E (2%), 44350E (40%), 44370E (56%), 44399 (2%)

AVERAGE GRADE: 5.4 JOB DIFFICULTY INDEX: 11.8

AVERAGE TIME IN CAREER FIELD: 6.1 YEARS

AVERAGE TIME IN SERVICE: 11.4 YEARS

PERCENT MEMBERS IN FIRST ENLISTMENT: 6%

AMOUNT OF SUPERVISION: 4.1

EXPRESSED JOB INTEREST: DULL (10%), SO-SO (14%), INTERESTING (76%)

PERCEIVED UTILIZATION OF TALENTS: LITTLE OR NOT AT ALL 16%  
FAIRLY WELL OR BETTER 84%

PERCEIVED UTILIZATION OF TRAINING: LITTLE OR NOT AT ALL 34%  
FAIRLY WELL OR BETTER 66%

AVERAGE NUMBER OF TASKS PERFORMED: 26

GROUP DIFFERENTIATING TASKS:

TASKS

A1 ASSIGN PERSONNEL TO DUTY POSITIONS  
A4 CONDUCT THE ACTIVITIES OF MAINTENANCE SPECIALISTS WITH OTHER AGENCIES  
A5 DEVELOP OR IMPROVE WORK METHODS OR PROCEDURES  
A8 PLAN OR SCHEDULE WORK ASSIGNMENTS  
A11 PLAN STATUS BOARDS  
A16 SCHEDULE MISSILE MAINTENANCE INSPECTIONS  
B1 COMPILE INFORMATION FOR REPORTS OR STAFF STUDIES  
B4 DIRECT CARE OR USE OF EQUIPMENT, SUPPLIES, OR WORK SPACE  
B5 DIRECT MISSILE MAINTENANCE EVALUATION PROCEDURES OR FUNCTIONS  
B6 DISPATCH MAINTENANCE TEAMS  
B18 WORK TECHNICAL PROBLEMS  
C22 REVIEW CORRESPONDENCE OR REPORTS  
E6 KEYPUNCH MAINTENANCE DATA  
E7 LOCATE INFORMATION IN TECHNICAL PUBLICATIONS

TIME SPENT ON DUTIES:

<u>DUTY</u>	<u>AVERAGE TIME SPENT BY ALL MEMBERS</u>
A ORGANIZING AND PLANNING	30
B DIRECTING AND IMPLEMENTING	26
E PREPARING AND MAINTAINING FORMS, RECORDS, AND REPORTS	17
D TRAINING	11
C INSPECTING AND EVALUATING	10

GROUP ID NUMBER AND TITLE: GRP032 - NCOIC, WORK PLANNING AND SCHEDULING

NUMBER IN GROUP: 7 PERCENT OF SAMPLE: 4%

DAFSC DISTRIBUTION: 44350E (43%), 44370E (43%), 44399 (14%)

AVERAGE GRADE: 5.7 JOB DIFFICULTY INDEX: 11.5

AVERAGE TIME IN CAREER FIELD: 3.8 YEARS

AVERAGE TIME IN SERVICE: 13.2 YEARS

PERCENT MEMBERS IN FIRST ENLISTMENT: 14%

AMOUNT OF SUPERVISION: 3.0

EXPRESSED JOB INTEREST: DULL (14%), SO-SO (14%), INTERESTING (72%)

PERCEIVED UTILIZATION OF TALENTS: LITTLE OR NOT AT ALL 0%  
FAIRLY WELL OR BETTER 100%

PERCEIVED UTILIZATION OF TRAINING: LITTLE OR NOT AT ALL 29%  
FAIRLY WELL OR BETTER 71%

AVERAGE NUMBER OF TASKS PERFORMED: 17

GROUP DIFFERENTIATING TASKS:

TASKS

- A4 CONDUCT THE ACTIVITIES OF MAINTENANCE SPECIALISTS WITH OTHER AGENCIES
- A5 DEVELOP OR IMPROVE WORK METHODS OR PROCEDURES
- A6 ESTABLISH ORGANIZATIONAL POLICIES
- B1 COMPILE INFORMATION FOR REPORTS OR STAFF STUDIES
- B2 COUNSEL SUBORDINATES ON JOB PROGRESSION OR CAREER DEVELOPMENT
- B3 COUNSEL SUBORDINATES ON PERSONAL OR MILITARY-RELATED PROBLEMS
- B4 DIRECT CARE OR USE OF EQUIPMENT, SUPPLIES, OR WORK SPACE
- C22 REVIEW CORRESPONDENCE OR REPORTS
- D5 CONDUCT EMERGENCY WAR ORDER (EWO) BRIEFINGS

TIME SPENT ON DUTIES:

<u>DUTY</u>	<u>AVERAGE TIME SPENT BY ALL MEMBERS</u>
B DIRECTING AND IMPLEMENTING	33
A ORGANIZING AND PLANNING	30
C INSPECTING AND EVALUATING	17
D TRAINING	11

GROUP ID NUMBER AND TITLE: GRP041 - MISSILE MAINTENANCE SUPERVISOR  
NUMBER IN GROUP: 9 PERCENT OF SAMPLE: 5%  
DAFSC DISTRIBUTION: 44350E (22%), 44370E (78%)  
AVERAGE GRADE: 6.0 JOB DIFFICULTY INDEX: 15.1  
AVERAGE TIME IN CAREER FIELD: 7.3 YEARS  
AVERAGE TIME IN SERVICE: 14.2 YEARS  
PERCENT MEMBERS IN FIRST ENLISTMENT: 0%  
AMOUNT OF SUPERVISION: 6.9  
EXPRESSED JOB INTEREST: DULL (22%), SO-SO (0%), INTERESTING (78%)  
PERCEIVED UTILIZATION OF TALENTS: LITTLE OR NOT AT ALL 11%  
FAIRLY WELL OR BETTER 89%  
PERCEIVED UTILIZATION OF TRAINING: LITTLE OR NOT AT ALL 33%  
FAIRLY WELL OR BETTER 67%  
AVERAGE NUMBER OF TASKS PERFORMED: 58

GROUP DIFFERENTIATING TASKS:

TASKS

- A1 ASSIGN PERSONNEL TO DUTY POSITIONS
- A13 PROJECT TRAINING REQUIREMENTS
- A15 SCHEDULE LEAVES OR PASSES
- B2 COUNSEL SUBORDINATES ON JOB PROGRESSION OR CAREER DEVELOPMENT
- B3 COUNSEL SUBORDINATES ON PERSONAL OR MILITARY-RELATED PROBLEMS
- B10 ORIENT NEWLY-ASSIGNED PERSONNEL
- B14 SUPERVISE MISSILE MECHANICS (AFSC 44350E)
- C6 EVALUATE SUGGESTIONS
- C7 EVALUATE TRAINING PROGRAMS
- C11 INSPECT WORK AREAS
- C20 PREPARE AIRMAN PERFORMANCE REPORTS (APR)
- D3 ASSIGN INSTRUCTORS OR TRAINEES
- D18 REVIEW TRAINING PROGRESS OF INDIVIDUALS

TIME SPENT ON DUTIES:

<u>DUTY</u>	<u>AVERAGE TIME SPENT BY ALL MEMBERS</u>
C INSPECTING AND EVALUATING	22
B DIRECTING AND IMPLEMENTING	20
D TRAINING	19
A ORGANIZING AND PLANNING	17

GROUP ID NUMBER AND TITLE: GRP040 - MAINTENANCE PLANNING AND SCHEDULING  
SPECIALIST

NUMBER IN GROUP: 7

PERCENT OF SAMPLE: 4%

DAFSC DISTRIBUTION: 44350E (71%), 44370E (29%)

AVERAGE GRADE: 4.6

JOB DIFFICULTY INDEX: 10.1

AVERAGE TIME IN CAREER FIELD: 5.0 YEARS

AVERAGE TIME IN SERVICE: 8.6 YEARS

PERCENT MEMBERS IN FIRST ENLISTMENT: 14%

AMOUNT OF SUPERVISION: 0

EXPRESSED JOB INTEREST: DULL (0%), SO-SO (0%), INTERESTING (100%)

PERCEIVED UTILIZATION OF TALENTS: LITTLE OR NOT AT ALL 14%  
FAIRLY WELL OR BETTER 86%

PERCEIVED UTILIZATION OF TRAINING: LITTLE OR NOT AT ALL 29%  
FAIRLY WELL OR BETTER 71%

AVERAGE NUMBER OF TASKS PERFORMED: 9

GROUP DIFFERENTIATING TASKS:

TASKS

- A3 CONDUCT OR PARTICIPATE IN STAFF MEETINGS OR CONFERENCES
- A4 CONDUCT THE ACTIVITIES OF MAINTENANCE SPECIALISTS WITH OTHER AGENCIES
- A7 PLAN OR DESIGN FUNCTIONAL CHARTS
- A8 PLAN OR SCHEDULE WORK ASSIGNMENTS
- A11 PLAN STATUS BOARDS
- A14 REVIEW PERSONNEL REQUIREMENTS
- A16 SCHEDULE MISSILE MAINTENANCE INSPECTIONS

TIME SPENT ON DUTIES:

<u>DUTY</u>	<u>AVERAGE TIME SPENT BY ALL MEMBERS</u>
A ORGANIZING AND PLANNING	70
E PREPARING AND MAINTAINING FORMS, RECORDS, AND REPORTS	15
B DIRECTING AND IMPLEMENTING	11

GROUP ID NUMBER AND TITLE: GRP035 - JOB CONTROL SPECIALIST

NUMBER IN GROUP: 15

PERCENT OF SAMPLE: 8%

DAFSC DISTRIBUTION: 44350E (27%), 44370E (67%)

AVERAGE GRADE: 5.3

JOB DIFFICULTY INDEX: 12.0

AVERAGE TIME IN CAREER FIELD: 7.7 YEARS

AVERAGE TIME IN SERVICE: 10.7 YEARS

PERCENT MEMBERS IN FIRST ENLISTMENT: 0%

AMOUNT OF SUPERVISION: 2.7

EXPRESSED JOB INTEREST: DULL (0%), SO-SO (13%), INTERESTING (87%)

PERCEIVED UTILIZATION OF TALENTS: LITTLE OR NOT AT ALL 7%  
FAIRLY WELL OR BETTER 93%

PERCEIVED UTILIZATION OF TRAINING: LITTLE OR NOT AT ALL 27%  
FAIRLY WELL OR BETTER 73%

AVERAGE NUMBER OF TASKS PERFORMED: 27

GROUP DIFFERENTIATING TASKS:

TASKS

A4 CONDUCT THE ACTIVITIES OF MAINTENANCE SPECIALISTS WITH OTHER AGENCIES  
A8 PLAN OR SCHEDULE WORK ASSIGNMENTS  
A12 PROJECT EQUIPMENT OR SUPPLIES REQUIREMENTS  
B6 DISPATCH MAINTENANCE TEAMS  
C22 REVIEW CORRESPONDENCE OR REPORTS  
E1 EDIT MAINTENANCE DATA COLLECTION FORMS  
E2 INITIATE MAINTENANCE DATA COLLECTION FORMS  
E6 KEYPUNCH MAINTENANCE DATA  
E7 LOCATE INFORMATION IN TECHNICAL PUBLICATIONS

TIME SPENT ON DUTIES:

<u>DUTY</u>	<u>AVERAGE TIME SPENT BY ALL MEMBERS</u>
A ORGANIZING AND PLANNING	32
E PREPARING AND MAINTAINING FORMS, RECORDS, AND REPORTS	25
B DIRECTING AND IMPLEMENTING	23

CLUSTER II - MISSILE HANDLING AND MAINTENANCE PERSONNEL (GRP015)

GENERAL DESCRIPTION

NUMBER IN GROUP: 106 PERCENT OF SAMPLE: 57%

DAFSC DISTRIBUTION: 44330E (17%), 44350E (52%), 44370E (29%) 44399 (2%)

AVERAGE GRADE: 4.5 JOB DIFFICULTY INDEX: 14.5

AVERAGE TIME IN CAREER FIELD: 3.8 YEARS

AVERAGE TIME IN SERVICE: 7.2 YEARS

PERCENT MEMBERS IN FIRST ENLISTMENT: 28%

AMOUNT OF SUPERVISION: 3.2

EXPRESSED JOB INTEREST: DULL (18%), SO-SO (9%), INTERESTING (73%)

PERCEIVED UTILIZATION OF TALENTS: LITTLE OR NOT AT ALL 35%  
FAIRLY WELL OR BETTER 65%

PERCEIVED UTILIZATION OF TRAINING: LITTLE OR NOT AT ALL 32%  
FAIRLY WELL OR BETTER 68%

AVERAGE NUMBER OF TASKS PERFORMED: 88

GROUP DIFFERENTIATING TASKS:

TASKS

- J9 OPERATE WORK PLATFORM SYSTEMS
- J7 OPERATE INTRASITE COMMUNICATION EQUIPMENT
- J10 PERFORM COMMUNICATION CHECKS WITH COMBAT CREW COMMANDERS
- F13 LOCK OR UNLOCK THRUST MOUNT DAMPER ASSEMBLIES
- F38 REMOVE OR INSTALL MISSILE DOORS OR FASTENERS
- F4 CHARGE THRUST MOUNT DAMPER PNEUMATIC SYSTEM SUBASSEMBLIES
- F2 ADJUST THRUST MOUNT DAMPER ASSEMBLIES
- J5 INTERPRET COLOR CODING OF FLUID LINES
- E14 PERFORM BENCH STOCK INVENTORIES
- I1 CONNECT OR DISCONNECT ORDNANCE CIRCUITS
- J11 PERFORM DEW POINT MEASUREMENTS OF MISSILE TANKS OR ENGINES
- I3 INSPECT ORDNANCE ITEMS PRIOR TO INSTALLATION
- H8 REMOVE OR INSTALL MANHOLE COVERS OR SEALS
- F9 INSPECT VERTICAL OR HORIZONTAL DAMPER LOCKING MECHANISM SIGNALING DEVICES
- I5 REMOVE OR INSTALL ENGINE START CARTRIDGES
- F35 REMOVE OR INSTALL FORWARD LIFTING ADAPTERS
- G4 DRAIN OR FILL TURBOPUMP ASSEMBLY LUBRICATION RESERVOIRS
- G19 PERFORM TURBOPUMP ASSEMBLY GEARBOX OR GEARBOX SEAL LEAK CHECKS
- G40 REMOVE OR INSTALL THRUST CHAMBER OXIDIZER VALVES

TIME SPENT ON DUTIES:

<u>DUTY</u>	<u>AVERAGE TIME SPENT BY ALL MEMBERS</u>
F HANDLING AND TRANSPORTING MISSILES	27
J PERFORMING GENERAL TITAN MAINTENANCE	23
G MAINTAINING PROPULSION SYSTEMS	14
E PREPARING AND MAINTAINING FORMS, RECORDS, AND REPORTS	9
I MAINTAINING ORDNANCE ITEMS	6

GROUP ID NUMBER AND TITLE: GRP083 - PROPULSION MAINTENANCE TECHNICIAN

NUMBER IN GROUP: 32

PERCENT OF SAMPLE: 17%

DAFSC DISTRIBUTION: 44330E (13%), 44350E (53%), 44370E (31%), 44399 (3%)

AVERAGE GRADE: 4.8

JOB DIFFICULTY INDEX: 18.8

AVERAGE TIME IN CAREER FIELD: 3.5 YEARS

AVERAGE TIME IN SERVICE: 8.4 YEARS

PERCENT MEMBERS IN FIRST ENLISTMENT: 22%

AMOUNT OF SUPERVISION: 3.2

EXPRESSED JOB INTEREST: DULL (25%), SO-SO (0%), INTERESTING (75%)

PERCEIVED UTILIZATION OF TALENTS: LITTLE OR NOT AT ALL 19%  
FAIRLY WELL OR BETTER 81%

PERCEIVED UTILIZATION OF TRAINING: LITTLE OR NOT AT ALL 19%  
FAIRLY WELL OR BETTER 81%

AVERAGE NUMBER OF TASKS PERFORMED: 128

GROUP DIFFERENTIATING TASKS:

TASKS

- G8 PERFORM ENGINE ELECTRICAL SYSTEM CONTINUITY CHECKS
- G19 PERFORM TURBOPUMP ASSEMBLY GEARBOX OR GEARBOX SEAL LEAK CHECKS
- G20 PERFORM TURBOPUMP ASSEMBLY TURBINE SEAL OR GAS GENERATOR LEAK CHECKS
- G24 PERFORM THRUST CHAMBER VALVE FUNCTIONAL CHECKS
- G25 PERFORM TURBOPUMP ASSEMBLY TORQUE CHECKS
- G39 REMOVE OR INSTALL THRUST CHAMBER FUEL VALVES
- I7 REMOVE OR INSTALL IGNITORS OR INITIATORS
- I8 REMOVE OR INSTALL PITCH ROCKETS
- I10 REMOVE OR INSTALL VERNIER ROCKETS
- J13 PERFORM INITIAL OR FINAL INSPECTIONS OF PROPULSION SYSTEMS
- J17 PERFORM PERIODIC INSPECTIONS OF PROPULSION SYSTEMS

TIME SPENT ON DUTIES:

<u>DUTY</u>	<u>AVERAGE TIME SPENT BY ALL MEMBERS</u>
G MAINTAINING PROPULSION SYSTEMS	34
F HANDLING AND TRANSPORTING MISSILES	20
J PERFORMING GENERAL TITAN MAINTENANCE	14
I MAINTAINING ORDNANCE ITEMS	10

GROUP ID NUMBER AND TITLE: GRP050 - MISSILE HANDLING AND MAINTENANCE MECHANIC

NUMBER IN GROUP: 27

PERCENT OF SAMPLE: 15%

DAFSC DISTRIBUTION: 44330E (22%), 44350E (70%), 44370E (8%)

AVERAGE GRADE: 4.2

JOB DIFFICULTY INDEX: 15.5

AVERAGE TIME IN CAREER FIELD: 3.7 YEARS

AVERAGE TIME IN SERVICE: 5.3 YEARS

PERCENT MEMBERS IN FIRST ENLISTMENT: 41%

AMOUNT OF SUPERVISION: 3.6

EXPRESSED JOB INTEREST: DULL (8%), SO-SO (11%), INTERESTING (81%)

PERCEIVED UTILIZATION OF TALENTS: LITTLE OR NOT AT ALL 26%  
FAIRLY WELL OR BETTER 74%

PERCEIVED UTILIZATION OF TRAINING: LITTLE OR NOT AT ALL 19%  
FAIRLY WELL OR BETTER 81%

AVERAGE NUMBER OF TASKS PERFORMED: 91

GROUP DIFFERENTIATING TASKS:

TASKS

F12 LOAD OR UNLOAD STAGES I OR II ON OR OFF MISSILE TRAILERS  
F16 OPERATE BALL SCREW JACK ASSEMBLIES  
F24 PERFORM MISSILE VERTICAL ALIGNMENTS  
F26 POSITION MISSILE HANDLING EQUIPMENT AT LAUNCH SITES  
F32 PREPARE THRUST MOUNT AND DAMPERS FOR MISSILE INSTALLATION OR REMOVAL  
F33 REMOVE OR INSTALL BREATHER SETS  
F35 REMOVE OR INSTALL FORWARD LIFTING ADAPTERS  
F36 REMOVE OR INSTALL HANDLING RINGS  
F37 REMOVE OR INSTALL LONGERON LIFTING ADAPTERS  
F44 REMOVE OR INSTALL STAGES I OR II IN OR FROM SILOS  
H5 REMOVE OR INSTALL FILL, VENT, OR DRAIN LINES ON STAGE II  
H9 REMOVE OR INSTALL OXIDIZER PRESSURE SWITCHES  
J12 PERFORM INITIAL OR FINAL INSPECTIONS OF MISSILES

TIME SPENT ON DUTIES:

DUTY

AVERAGE TIME SPENT  
BY ALL MEMBERS

F	HANDLING AND TRANSPORTING MISSILES	47
J	PERFORMING GENERAL TITAN MAINTENANCE	18
H	MAINTAINING MISSILE AIR FRAMES	9
C	INSPECTING AND EVALUATING	6

GROUP ID NUMBER AND TITLE: GRP050 - MISSILE HANDLING AND MAINTENANCE SUPERVISOR

NUMBER IN GROUP: 8

PERCENT OF SAMPLE: 4%

DAFSC DISTRIBUTION: 44350E (38%), 44370E (50%), 44399 (12%)

AVERAGE GRADE: 5.6

JOB DIFFICULTY INDEX: 18.6

AVERAGE TIME IN CAREER FIELD: 9.0 YEARS

AVERAGE TIME IN SERVICE: 13.3 YEARS

PERCENT MEMBERS IN FIRST ENLISTMENT: 0%

AMOUNT OF SUPERVISION: 3.8

EXPRESSED JOB INTEREST: DULL (13%), SO-SO (25%), INTERESTING (62%)

PERCEIVED UTILIZATION OF TALENTS: LITTLE OR NOT AT ALL 50%  
FAIRLY WELL OR BETTER 50%

PERCEIVED UTILIZATION OF TRAINING: LITTLE OR NOT AT ALL 63%  
FAIRLY WELL OR BETTER 37%

AVERAGE NUMBER OF TASKS PERFORMED: 160

GROUP DIFFERENTIATING TASKS:

TASKS

A3 CONDUCT OR PARTICIPATE IN STAFF MEETINGS OR CONFERENCES  
A4 CONDUCT THE ACTIVITIES OF MAINTENANCE SPECIALISTS WITH OTHER AGENCIES  
A8 PLAN OR SCHEDULE WORK ASSIGNMENTS  
B7 DRAFT CHANGES TO JOB DESCRIPTIONS  
B8 IMPLEMENT SAFETY PROCEDURES  
B17 SUPERVISE MILITARY PERSONNEL OTHER THAN AFSC 443XOE  
C23 VALIDATE NEW MAINTENANCE PROCEDURES  
C24 WRITE QUALITY CONTROL INSPECTION REPORTS  
C25 WRITE RECOMMENDATIONS OF INDIVIDUALS FOR PERSONNEL ACTIONS  
D15 EXPLAIN POLICIES OR DIRECTIVES TO SUBORDINATES  
D18 REVIEW TRAINING PROGRESS OF INDIVIDUALS

TIME SPENT ON DUTIES:

<u>DUTY</u>	<u>AVERAGE TIME SPENT BY ALL MEMBERS</u>
F HANDLING AND TRANSPORTING MISSILES	23
J PERFORMING GENERAL TITAN MAINTENANCE	14
C INSPECTING AND EVALUATING	13
A ORGANIZING AND PLANNING	11
B DIRECTING AND IMPLEMENTING	11

A9

GROUP ID NUMBER AND TITLE: GRP045 - MISSILE MAINTENANCE CREW CHIEF

NUMBER IN GROUP: 22 PERCENT OF SAMPLE: 12%

DAFSC DISTRIBUTION: 44330E (4%), 44350E (46%), 44370E (50%)

AVERAGE GRADE: 4.6 JOB DIFFICULTY INDEX: 7.9

AVERAGE TIME IN CAREER FIELD: 2.4 YEARS

AVERAGE TIME IN SERVICE: 7.0 YEARS

PERCENT MEMBERS IN FIRST ENLISTMENT: 23%

AMOUNT OF SUPERVISION: 2.0

EXPRESSED JOB INTEREST: DULL (32%), SO-SO (14%), INTERESTING (54%)

PERCEIVED UTILIZATION OF TALENTS: LITTLE OR NOT AT ALL 54%  
FAIRLY WELL OR BETTER 46%

PERCEIVED UTILIZATION OF TRAINING: LITTLE OR NOT AT ALL 55%  
FAIRLY WELL OR BETTER 45%

AVERAGE NUMBER OF TASKS PERFORMED: 33

GROUP DIFFERENTIATING TASKS:

TASKS

C11 INSPECT WORK AREAS  
E8 MAINTAIN BENCH STOCK RECORDS  
E11 MAINTAIN TECHNICAL ORDER FILES  
E14 MAKE ENTRIES IN MISSILE HISTORICAL RECORDS  
F13 LOCK OR UNLOCK THRUST MOUNT DAMPER ASSEMBLIES  
J3 IDENTIFY OR TREAT CORROSION  
J6 OPERATE BLAST DOOR SYSTEMS  
J7 OPERATE INTRASITE COMMUNICATION EQUIPMENT  
J8 OPERATE PERSONNEL OR EQUIPMENT ELEVATORS  
J10 PERFORM COMMUNICATION CHECKS WITH COMBAT CREW COMMANDERS  
J22 REMOVE OR INSTALL WORK PLATFORM SEGMENTS  
J23 SERVICE COMPLEX NITROGEN STORAGE TANKS (TK-4 SYSTEM)

TIME SPENT ON DUTIES:

<u>DUTY</u>	<u>AVERAGE TIME SPENT BY ALL MEMBERS</u>
J PERFORMING GENERAL TITAN MAINTENANCE	40
E PREPARING AND MAINTAINING FORMS, RECORDS, AND REPORTS	27
F HANDLING AND TRANSPORTING MISSILES	17
C INSPECTING AND EVALUATING	6

GROUP ID NUMBER AND TITLE: GRP036 - EXPLOSIVE COMPONENTS MAINTENANCE  
SPECIALIST

NUMBER IN GROUP: 8

PERCENT OF SAMPLE: 4%

DAFSC DISTRIBUTION: 44330E (63%), 44350E (12%), 44370E (25%)

AVERAGE GRADE: 3.4

JOB DIFFICULTY INDEX: 10.8

AVERAGE TIME IN CAREER FIELD: 3.6 YEARS

AVERAGE TIME IN SERVICE: 5.1 YEARS

PERCENT MEMBERS IN FIRST ENLISTMENT: 50%

AMOUNT OF SUPERVISION: 2.5

EXPRESSED JOB INTEREST: DULL (0%), SO-SO (13%), INTERESTING (87%)

PERCEIVED UTILIZATION OF TALENTS: LITTLE OR NOT AT ALL 50%  
FAIRLY WELL OR BETTER 50%

PERCEIVED UTILIZATION OF TRAINING: LITTLE OR NOT AT ALL 25%  
FAIRLY WELL OR BETTER 75%

AVERAGE NUMBER OF TASKS PERFORMED: 40

GROUP DIFFERENTIATING TASKS:

TASKS

F45 REMOVE OR INSTALL STAGE II ENGINE MAINTENANCE PLATFORMS OR SAFETY NETS  
I1 CONNECT OR DISCONNECT ORDNANCE CIRCUITS  
I3 INSPECT ORDNANCE ITEMS PRIOR TO INSTALLATION  
I4 PERFORM STRAY VOLTAGE CHECKS ON MISSILE ORDNANCE CIRCUITS  
I5 REMOVE OR INSTALL ENGINE START CARTRIDGES  
I6 REMOVE OR INSTALL GAS PRESSURE CARTRIDGES  
I7 REMOVE OR INSTALL IGNITORS OR INITIATORS  
J6 OPERATE BLAST DOOR SYSTEMS  
J8 OPERATE PERSONNEL OR EQUIPMENT ELEVATORS  
J9 OPERATE WORK PLATFORM SYSTEMS  
J10 PERFORM COMMUNICATION CHECKS WITH COMBAT CREW COMMANDERS

TIME SPENT ON DUTIES:

<u>DUTY</u>	<u>AVERAGE TIME SPENT BY ALL MEMBERS</u>
J PERFORMING GENERAL TITAN MAINTENANCE	35
I MAINTAINING ORDNANCE ITEMS	21
G MAINTAINING PROPULSION SYSTEMS	18
F HANDLING AND TRANSPORTING MISSILES	15

INDEPENDENT JOB TYPE - QUALITY CONTROL INSPECTORS (GRP065)

GENERAL DESCRIPTION

NUMBER IN GROUP: 10   PERCENT OF SAMPLE: 5%

DAFSC DISTRIBUTION: 44350E (20%), 44370E (80%)

AVERAGE GRADE: 5.1   JOB DIFFICULTY INDEX: 13.4

AVERAGE TIME IN CAREER FIELD: 9.2 YEARS

AVERAGE TIME IN SERVICE: 9.6 YEARS

PERCENT MEMBERS IN FIRST ENLISTMENT: 0%

AMOUNT OF SUPERVISION: 3.0

EXPRESSED JOB INTEREST: DULL (0%), SO-SO (0%), INTERESTING (100%)

PERCEIVED UTILIZATION OF TALENTS: LITTLE OR NOT AT ALL 0%  
   FAIRLY WELL OR BETTER 100%

PERCEIVED UTILIZATION OF TRAINING: LITTLE OR NOT AT ALL 10%  
   FAIRLY WELL OR BETTER 90%

AVERAGE NUMBER OF TASKS PERFORMED: 44

GROUP DIFFERENTIATING TASKS:

TASKS

- C1 ACCOMPLISH IN-PROGRESS AND END-ITEM INSPECTIONS
- C2 ANALYZE MAINTENANCE OR INSPECTION REPORTS
- C3 EVALUATE CORROSION CONTROL PROCEDURES
- C4 EVALUATE SAFETY PROCEDURES
- C10 INSPECT PROTECTIVE EQUIPMENT
- C11 INSPECT WORK AREAS
- C14 PERFORM QUALITY CONTROL INSPECTIONS OF AEROSPACE GROUND EQUIPMENT (AGE)  
       OR SUPPORT EQUIPMENT
- C15 PERFORM QUALITY CONTROL INSPECTIONS OF MECHANICAL MAINTENANCE SHOPS
- C17 PERFORM QUALITY CONTROL INSPECTIONS OF MISSILE MAINTENANCE TEAMS (MMT)
- C18 PERFORM QUALITY CONTROL INSPECTIONS OF MISSILES IN STORAGE
- C24 WRITE QUALITY CONTROL INSPECTION REPORTS

TIME SPENT ON DUTIES:

<u>DUTY</u>	<u>AVERAGE TIME SPENT BY ALL MEMBERS</u>
C INSPECTING AND EVALUATING	57
E PREPARING AND MAINTAINING FORMS, RECORDS AND REPORTS	13
J PERFORMING GENERAL TITAN MAINTENANCE	9

APPENDIX B

30  
31  
32  
33  
34  
35  
36  
37  
38  
39  
40  
41  
42  
43  
44  
45  
46  
47  
48  
49  
50

1975  
1976  
1977  
1978  
1979  
1980  
1981  
1982  
1983  
1984  
1985  
1986  
1987  
1988  
1989  
1990  
1991  
1992  
1993  
1994  
1995

100  
101  
102  
103  
104  
105  
106  
107  
108  
109  
110  
111  
112  
113  
114  
115  
116  
117  
118  
119  
120  
121  
122  
123  
124  
125  
126  
127  
128  
129  
130  
131  
132  
133  
134  
135  
136  
137  
138  
139  
140  
141  
142  
143  
144  
145  
146  
147  
148  
149  
150  
151  
152  
153  
154  
155  
156  
157  
158  
159  
160  
161  
162  
163  
164  
165  
166  
167  
168  
169  
170  
171  
172  
173  
174  
175  
176  
177  
178  
179  
180  
181  
182  
183  
184  
185  
186  
187  
188  
189  
190  
191  
192  
193  
194  
195  
196  
197  
198  
199  
200

TABLE I

TASKS PERFORMED BY 35 PERCENT OR MORE OF DAFSC 443X0E  
5- AND 7-SKILL LEVEL PERSONNEL

TASKS	PERCENT PERFORMING	
	DAFSC 44350E	DAFSC 44370E
A5 DEVELOP OR IMPROVE WORK METHODS OR PROCEDURES	40	50
B4 DIRECT CARE OR USE OF EQUIPMENT, SUPPLIES, OR WORK SPACE	38	46
C11 INSPECT WORK AREAS	40	50
E2 INITIATE MAINTENANCE DATA COLLECTION FORMS	44	38
E3 INITIATE USAF HAZARD REPORTS	36	45
E7 LOCATE INFORMATION IN TECHNICAL PUBLICATIONS	58	70
E11 MAINTAIN TECHNICAL ORDER FILES	39	43
E16 SIGN FOR OR SECURE CODE SLIPS	54	51
J6 OPERATE BLAST DOOR SYSTEMS	62	47
J7 OPERATE INTRASITE COMMUNICATION EQUIPMENT	60	43
J8 OPERATE PERSONNEL OR EQUIPMENT ELEVATORS	65	46
J9 OPERATE WORK PLATFORM SYSTEMS	65	46
J10 PERFORM COMMUNICATION CHECKS WITH COMBAT CREW COMMANDERS	61	36

TABLE II

## THE 20 MOST TIME-CONSUMING TASKS PERFORMED BY ALL DAFSC 44350E PERSONNEL

TASKS	PERCENT MEMBERS PERFORMING*	PERCENT TIME SPENT ON TASK
E11 MAINTAIN TECHNICAL ORDER FILES	38.82	2.63
E7 LOCATE INFORMATION IN TECHNICAL PUBLICATIONS	57.65	2.55
E2 INITIATE MAINTENANCE DATA COLLECTION FORMS	43.53	1.95
B6 DISPATCH MAINTENANCE TEAMS	28.24	1.89
J9 OPERATE WORK PLATFORM SYSTEMS	64.71	1.59
J8 OPERATE PERSONNEL OR EQUIPMENT ELEVATORS	64.71	1.57
E16 SIGN FOR OR SECURE CODE SLIPS	54.12	1.56
J6 OPERATE BLAST DOOR SYSTEMS	62.35	1.47
A4 CONDUCT THE ACTIVITIES OF MAINTENANCE SPECIALISTS WITH OTHER AGENCIES	27.06	1.45
F38 REMOVE OR INSTALL MISSILE DOORS OR FASTENERS	61.18	1.42
J7 OPERATE INTRASITE COMMUNICATION EQUIPMENT	60.00	1.42
A8 PLAN OR SCHEDULE WORK ASSIGNMENTS	29.41	1.41
F13 LOCK OR UNLOCK THRUST MOUNT DAMPER ASSEMBLIES	58.82	1.35
A11 PLAN STATUS BOARDS	23.53	1.32
C11 INSPECT WORK AREAS	40.00	1.26
J10 PERFORM COMMUNICATION CHECKS WITH COMBAT CREW COMMANDERS	61.18	1.26
J3 IDENTIFY OR TREAT CORROSION	57.65	1.23
E14 PERFORM BENCH STOCK INVENTORIES	24.71	1.12
B4 DIRECT CARE OR USE OF EQUIPMENT, SUPPLIES, OR WORK SPACE	37.65	1.11

\* OF ALL 44350E PERSONNEL

TABLE III

THE 20 MOST TIME-CONSUMING TASKS PERFORMED BY DAFSC 44350E PERSONNEL IN THE  
WORK PLANNING, SUPERVISION, AND SCHEDULING JOB CLUSTER

TASKS	PERCENT MEMBERS PERFORMING*	PERCENT TIME SPENT ON TASKS
B6 DISPATCH MAINTENANCE TEAMS	55.00	7.43
A4 CONDUCT THE ACTIVITIES OF MAINTENANCE SPECIALISTS WITH OTHER AGENCIES	65.00	5.68
A11 PLAN STATUS BOARDS	60.00	5.35
A8 PLAN OR SCHEDULE WORK ASSIGNMENTS	55.00	5.34
E2 INITIATE MAINTENANCE DATA COLLECTION FORMS	50.00	4.09
E6 KEYPUNCH MAINTENANCE DATA	40.00	3.80
A16 SCHEDULE MISSILE MAINTENANCE INSPECTIONS	35.00	3.56
B18 WORK TECHNICAL PROBLEMS	30.00	3.37
E7 LOCATE INFORMATION IN TECHNICAL PUBLICATIONS	50.00	3.15
B4 DIRECT CARE OR USE OF EQUIPMENT, SUPPLIES, OR WORK SPACE	45.00	3.00
B5 DIRECT MISSILE MAINTENANCE EVALUATION PROCEDURES OR FUNCTIONS	20.00	2.99
A3 CONDUCT OR PARTICIPATE IN STAFF MEETINGS OR CONFERENCES	55.00	2.89
E10 MAINTAIN STANDARD PUBLICATIONS FILES	35.00	2.87
A5 DEVELOP OR IMPROVE WORK METHODS OR PROCEDURES	55.00	2.82
B1 COMPILE INFORMATION FOR REPORTS OR STAFF STUDIES	50.00	2.65
C22 REVIEW CORRESPONDENCE OR REPORTS	45.00	2.63
A7 PLAN OR DESIGN FUNCTIONAL CHARTS	30.00	2.56
E16 SIGN FOR OR SECURE CODE SLIPS	35.00	2.23
E11 MAINTAIN TECHNICAL ORDER FILES	30.00	1.89
D5 CONDUCT EMERGENCY WAR ORDER (EWO) BRIEFINGS	25.00	1.51

\* OF 5-LEVEL PERSONNEL IN CLUSTER I

TABLE IV

THE 20 MOST TIME-CONSUMING TASKS PERFORMED BY DAFSC 44350E PERSONNEL IN THE  
MISSILE HANDLING AND MAINTENANCE JOB CLUSTER

TASKS	PERCENT MEMBERS PERFORMING*	PERCENT TIME SPENT ON TASKS
J8 OPERATE PERSONNEL OR EQUIPMENT ELEVATORS	94.55	2.11
J9 OPERATE WORK PLATFORM SYSTEMS	94.55	1.99
J6 OPERATE BLAST DOOR SYSTEMS	89.09	1.91
J7 OPERATE INTRASITE COMMUNICATION EQUIPMENT	87.27	1.88
J10 PERFORM COMMUNICATION CHECKS WITH COMBAT CREW COMMANDERS	90.91	1.84
J3 IDENTIFY OR TREAT CORROSION	83.64	1.62
F38 REMOVE OR INSTALL MISSILE DOORS OR FASTENERS	89.09	1.51
F4 CHARGE THRUST MOUNT DAMPER PNEUMATIC SYSTEM SUBASSEMBLIES	85.45	1.45
E16 SIGN FOR OR SECURE CODE SLIPS	67.27	1.35
E7 LOCATE INFORMATION IN TECHNICAL PUBLICATIONS	61.82	1.31
F13 LOCK OR UNLOCK THRUST MOUNT DAMPER ASSEMBLIES	85.45	1.28
E11 MAINTAIN TECHNICAL ORDER FILES	41.82	1.22
J16 PERFORM PERIODIC INSPECTIONS OF MISSILES	67.27	1.14
F2 ADJUST THRUST MOUNT DAMPER ASSEMBLIES	76.36	1.07
F45 REMOVE OR INSTALL STAGE II ENGINE MAINTENANCE PLATFORMS OR SAFETY NETS	78.18	1.03
F10 LEVEL THRUST MOUNTS	58.18	.93
C11 INSPECT WORK AREAS	49.09	.91
F47 REMOVE OR INSTALL THRUST MOUNT DAMPER PNEUMATIC SYSTEM SUBASSEMBLIES	65.45	.90
J22 REMOVE OR INSTALL WORK PLATFORM SEGMENTS	47.27	.90
J5 INTERPRET COLOR CODING OF FLUID LINES	72.73	.89

\* OF 5-LEVEL PERSONNEL IN CLUSTER II

TABLE V

THE 20 MOST TIME-CONSUMING TASKS PERFORMED BY ALL DAFSC 44370E PERSONNEL

TASKS	PERCENT MEMBERS PERFORMING*	PERCENT TIME SPENT ON TASKS
E7 LOCATE INFORMATION IN TECHNICAL PUBLICATIONS	69.74	2.34
A4 CONDUCT THE ACTIVITIES OF MAINTENANCE SPECIALISTS WITH OTHER AGENCIES	43.42	2.28
A8 PLAN OR SCHEDULE WORK ASSIGNMENTS	47.37	2.12
B6 DISPATCH MAINTENANCE TEAMS	34.21	2.04
B3 COUNSEL SUBORDINATES ON PERSONAL OR MILITARY-RELATED PROBLEMS	51.32	1.98
E11 MAINTAIN TECHNICAL ORDER FILES	43.42	1.89
C22 REVIEW CORRESPONDENCE OR REPORTS	53.95	1.84
B2 COUNSEL SUBORDINATES ON JOB PROGRESSION OR CAREER DEVELOPMENT	44.74	1.74
B14 SUPERVISE MISSILE MECHANICS (AFSC 44350E)	40.79	1.73
E16 SIGN FOR OR SECURE CODE SLIPS	51.32	1.44
J6 OPERATE BLAST DOOR SYSTEMS	47.37	1.40
J8 OPERATE PERSONNEL OR EQUIPMENT ELEVATORS	46.05	1.40
J9 OPERATE WORK PLATFORM SYSTEMS	46.05	1.38
B1 COMPLETE INFORMATION FOR REPORTS OR STAFF STUDIES	34.21	1.38
D16 MAINTAIN TRAINING RECORDS	51.32	1.29
A3 CONDUCT OR PARTICIPATE IN STAFF MEETINGS OR CONFERENCES	48.68	1.27
D15 EXPLAIN POLICIES OR DIRECTIVES TO SUBORDINATES	44.74	1.26
J7 OPERATE INTRASITE COMMUNICATION EQUIPMENT	43.42	1.24
B4 DIRECT CARE OR USE OF EQUIPMENT, SUPPLIES, OR WORK SPACE	46.05	1.19
C11 INSPECT WORK AREAS	50.00	1.18

\* OF ALL 44370E PERSONNEL

TABLE VI

THE 20 MOST TIME-CONSUMING TASKS PERFORMED BY DAFSC 44370E PERSONNEL IN THE  
WORK PLANNING, SUPERVISION, AND SCHEDULING JOB CLUSTER

TASKS	PERCENT MEMBERS PERFORMING*	PERCENT TIME SPENT ON TASK
A4 CONDUCT THE ACTIVITIES OF MAINTENANCE SPECIALISTS WITH OTHER AGENCIES	67.86	5.19
A8 PLAN OR SCHEDULE WORK ASSIGNMENTS	78.57	5.14
B6 DISPATCH MAINTENANCE TEAMS	57.14	5.14
E7 LOCATE INFORMATION IN TECHNICAL PUBLICATIONS	78.57	3.64
D15 EXPLAIN POLICIES OR DIRECTIVES TO SUBORDINATES	57.14	2.56
C22 REVIEW CORRESPONDENCE OR REPORTS	64.29	2.52
B4 DIRECT CARE OR USE OF EQUIPMENT, SUPPLIES, OR WORK SPACE	64.29	2.51
C20 PREPARE AIRMAN PERFORMANCE REPORTS (APR)	71.43	2.36
A1 ASSIGN PERSONNEL TO DUTY POSITIONS	53.57	2.33
A5 DEVELOP OR IMPROVE WORK METHODS OR PROCEDURES	57.14	2.32
B14 SUPERVISE MISSILE MECHANICS (AFSC 443350E)	42.86	2.32
B10 ORIENT NEWLY-ASSIGNED PERSONNEL	71.43	2.23
B17 SUPERVISE MILITARY PERSONNEL OTHER THAN AFSC 443X0E	42.86	2.19
D16 MAINTAIN TRAINING RECORDS	60.71	2.11
E2 INITIATE MAINTENANCE DATA COLLECTION FORMS	39.29	1.98
B3 COUNSEL SUBORDINATES ON PERSONAL OR MILITARY-RELATED PROBLEMS	67.86	1.90
E6 KEYPUNCH MAINTENANCE DATA	28.57	1.78
B1 COMPILE INFORMATION FOR REPORTS OR STAFF STUDIES	35.71	1.63
A14 REVIEW PERSONNEL REQUIREMENTS	35.71	1.58
A3 CONDUCT OR PARTICIPATE IN STAFF MEETINGS OR CONFERENCES	46.43	1.56

\* OF 7-LEVEL PERSONNEL IN CLUSTER I

TABLE VII

THE 20 MOST TIME-CONSUMING TASKS PERFORMED BY DAFSC 44370E PERSONNEL IN THE  
MISSILE HANDLING AND MAINTENANCE JOB CLUSTER

TASKS	PERCENT MEMBERS PERFORMING*	PERCENT TIME SPENT ON TASK
J9 OPERATE WORK PLATFORM SYSTEMS	93.55	2.42
J8 OPERATE PERSONNEL OR EQUIPMENT ELEVATORS	87.10	2.31
J6 OPERATE BLAST DOOR SYSTEMS	90.32	2.20
E11 MAINTAIN TECHNICAL ORDER FILES	58.06	1.87
J3 IDENTIFY OR TREAT CORROSION	87.10	1.75
J7 OPERATE INTRASITE COMMUNICATION EQUIPMENT	80.65	1.75
E7 LOCATE INFORMATION IN TECHNICAL PUBLICATIONS	74.19	1.63
E16 SIGN FOR OR SECURE CODE SLIPS	77.42	1.63
E14 PERFORM BENCH STOCK INVENTORIES	64.52	1.58
J10 PERFORM COMMUNICATION CHECKS WITH COMBAT CREW COMMANDERS	70.97	1.43
F4 CHARGE THRUST MOUNT DAMPER PNEUMATIC SYSTEM SUBASSEMBLIES	61.29	1.40
E10 MAINTAIN STANDARD PUBLICATIONS FILES	51.61	1.37
F13 LOCK OR UNLOCK THRUST MOUNT DAMPER ASSEMBLIES	64.52	1.34
E8 MAINTAIN BENCH STOCK RECORDS	51.61	1.29
F2 ADJUST THRUST MOUNT DAMPER ASSEMBLIES	64.52	1.28
J22 REMOVE OR INSTALL WORK PLATFORM SEGMENTS	45.16	1.26
C11 INSPECT WORK AREAS	67.74	1.24
J21 REMOVE OR INSTALL GUARD RAILS AT COMPLEXES	58.06	1.15
J20 REMOVE OR INSTALL BUTTERFLY VALVE LOCK (BVL) COVERS	54.84	.99
D16 MAINTAIN TRAINING RECORDS	58.06	.99

\* OF 7-LEVEL PERSONNEL IN CLUSTER II

APPENDIX C

TABLE I

TASKS NOT REFERENCED TO THE STS BUT WHICH ARE PERFORMED BY 10 PERCENT OR MORE OF FIRST ENLISTMENT 5-, OR 7-SKILL LEVEL DAFSC 443XOE PERSONNEL

TASK	PERCENT PERFORMING		
	FIRST ENLISTMENT	DAFSC 44350E	DAFSC 44370E
A3	14	27	49
A6	11	14	20
A7	9	14	21
A11	11	24	21
A14	6	14	30
A15	3	6	36
A16	6	14	18
B4	34	38	46
B10	23	34	51
B11	6	9	17
C1	11	24	28
C6	0	12	29
C8	6	17	24
C11	34	40	50
C12	0	7	15
C15	3	6	21
C17	3	9	18
C19	3	5	15
C24	0	9	22
D1	6	11	21
D5	9	11	8
D14	3	9	24
E5	3	8	22
E6	0	12	17

CONDUCT OR PARTICIPATE IN STAFF MEETINGS OR CONFERENCES

ESTABLISH ORGANIZATIONAL POLICIES

PLAN OR DESIGN FUNCTIONAL CHARTS

PLAN STATUS BOARDS

REVIEW PERSONNEL REQUIREMENTS

SCHEDULE LEAVES OR PASSES

SCHEDULE MISSILE MAINTENANCE INSPECTIONS

DIRECT CARE OR USE OF EQUIPMENT, SUPPLIES, OR WORK SPACE

ORIENT NEWLY-ASSIGNED PERSONNEL

PREPARE WRITTEN JUSTIFICATIONS FOR CHANGES TO AUTHORIZATION

LISTS

ACCOMPLISH IN-PROGRESS AND END-ITEM INSPECTIONS

EVALUATE SUGGESTIONS

EVALUATE WORK SPACE, EQUIPMENT OR SUPPLIES

INSPECT WORK AREAS

INVESTIGATE ACCIDENTS AS A TEAM MEMBER

PERFORM QUALITY CONTROL INSPECTIONS OF MECHANICAL MAINTENANCE

SHOPS

PERFORM QUALITY CONTROL INSPECTIONS OF MISSILE MAINTENANCE

TEAMS (MMT)

PERFORM QUALITY CONTROL INSPECTIONS OF REAL PROPERTY INSTALLED

EQUIPMENT

WRITE QUALITY CONTROL INSPECTION REPORTS

ADMINISTER OR SCORE ORAL, WRITTEN, OR PERFORMANCE TESTS

CONDUCT EMERGENCY WAR ORDER (EWO) BRIEFINGS

EVALUATE SPECIALTY TRAINING STANDARDS (STS)

INITIATE UNSATISFACTORY REPORTS (URS)

KEYPUNCH DATA

TABLE I (CONTINUED)

TASKS NOT REFERENCED TO THE STS BUT WHICH ARE PERFORMED BY 10 PERCENT OR MORE OF FIRST ENLISTMENT 5-, OR 7-SKILL LEVEL DAFSC 443XOE PERSONNEL

TASK	PERCENT PERFORMING		
	FIRST ENLISTMENT	DAFSC 44350E	DAFSC 44370E
E8	17	20	28
E9	3	6	12
E10	20	24	33
E12	20	17	18
E13	9	11	17
E14	25	25	30
E15	14	17	22
E16	43	54	51
F53	26	28	11
F54	31	27	12
F55	46	31	15
F56	31	29	13
F57	34	27	12
G3	26	25	13
I2	14	20	18
J1	9	14	16
J4	17	11	18
J19	9	14	12
J20	46	37	24
J21	54	41	24
J22	49	32	22
J24	9	13	12
J26	14	14	15
J27	14	14	13

ED  
78