

AD-A056 849

MASSACHUSETTS INST OF TECH CAMBRIDGE ELECTRONIC SYST--ETC F/G 12/1  
ADAPTIVE STOCHASTIC CONTROL OF LINEAR SYSTEMS WITH RANDOM PARAM--ETC(U)  
MAY 78 R T KU

AFOSR-77-3281

UNCLASSIFIED

ESI -TH-820

AFOSR-TR-78-1188

NL

1 of 3  
AD  
A056849



18 AFOSR TR

19 78-1188

# LEVEL II

11 May 1978

14 ESL-TH-820

2

12 235p.

Research Supported by:

NSF Grant NSF/SOC-76-05827

15 AFOSR-77-3281

NSF-SOC 76-

05827

AD A 056849

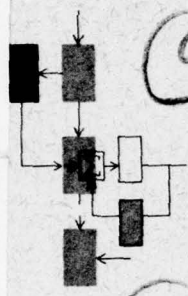

9 Doctoral thesis,

6 ADAPTIVE STOCHASTIC CONTROL OF LINEAR SYSTEMS WITH RANDOM PARAMETERS .

10 Richard Tse-min/Ku

16 2344

17 A7

DDC  
RECEIVED  
JUL 31 1978

E

Electronic Systems Laboratory

MASSACHUSETTS INSTITUTE OF TECHNOLOGY, CAMBRIDGE, MASSACHUSETTS 02139

AD No. \_\_\_\_\_  
DDC FILE COPY

78 07 26 098

Approved for public release; distribution unlimited.

127 200

SM

AIR FORCE OFFICE OF SCIENTIFIC RESEARCH (AFSC)  
NOTICE OF TRANSMITTAL TO DDC

This technical report has been reviewed and is  
approved for public release IAW AFR 190-12 (7b).  
Distribution is unlimited.

A. D. BLOSE  
Technical Information Officer

REPORT DOCUMENTATION PAGE		READ INSTRUCTIONS BEFORE COMPLETING FORM
1. REPORT NUMBER AFOSR-TR- 78-1188	2. GOVT ACCESSION NO.	3. RECIPIENT'S CATALOG NUMBER
4. TITLE (and Subtitle) ADAPTIVE STOCHASTIC CONTROL OF LINEAR SYSTEMS WITH RANDOM PARAMETERS	5. TYPE OF REPORT & PERIOD COVERED Interim	
7. AUTHOR(s) Richard Tse-min Ku	6. PERFORMING ORG. REPORT NUMBER ESL-TH-820	
9. PERFORMING ORGANIZATION NAME AND ADDRESS Massachusetts Institute of Technology Electronic Systems Laboratory Cambridge, MA 02139	8. CONTRACT OR GRANT NUMBER(s) AFOSR-77-3281	
11. CONTROLLING OFFICE NAME AND ADDRESS Air Force Office of Scientific Research/NM Bolling AFB, Washington, DC 20332	10. PROGRAM ELEMENT, PROJECT, TASK AREA & WORK UNIT NUMBERS 61102F 2304/A1	
14. MONITORING AGENCY NAME & ADDRESS (if different from Controlling Office)	12. REPORT DATE May 1978	
	13. NUMBER OF PAGES 234	
	15. SECURITY CLASS. (of this report) UNCLASSIFIED	
	15a. DECLASSIFICATION/DOWNGRADING SCHEDULE	
16. DISTRIBUTION STATEMENT (of this Report)  Approved for public release; distribution unlimited.		
17. DISTRIBUTION STATEMENT (of the abstract entered in Block 20, if different from Report)		
18. SUPPLEMENTARY NOTES		
19. KEY WORDS (Continue on reverse side if necessary and identify by block number)		
20. ABSTRACT (Continue on reverse side if necessary and identify by block number)  In this thesis, <del>we will</del> investigate the adaptive stochastic control of linear dynamic systems with purely random parameters. Hence there is no posterior learning about the system parameters. The control law is non-dual; still it has the qualitative properties of an adaptive control law. In the perfect measurement case, the control law is modulated by the priori level of uncertainty of the system parameters. The Certainty-Equivalence Principle does not hold. <i>→ next page</i>		

## 20. Abstract

This thesis shows that the optimal stochastic control of dynamic systems with uncertain parameters has certain limitations. For the linear-quadratic optimal problem, ~~it is shown that~~ the infinite horizon solution does not exist if the parameter uncertainty exceeds a certain quantifiable threshold. By considering the discounted cost problem, we have obtained some results on optimality versus stability for this class of stochastic control problems.

For the noisy sensor measurement case, ~~we obtained~~ the optimal fixed structure estimator-controller. The control law requires the solution of a coupled nonlinear two-point boundary value problem. Computer simulations of the forward and backward difference equations provided some insight into the uncertainty threshold for the closed-loop system. Stochastic stability analysis further results in a sufficient condition for the mean square stability of the fixed structure dynamic compensator.

\* is obtained

May, 1978

ESL-TH-820

ADAPTIVE STOCHASTIC CONTROL OF LINEAR SYSTEMS  
WITH RANDOM PARAMETERS

by

Richard Tse-min Ku

This report is based on the unaltered thesis of Richard Tse-min Ku submitted in partial fulfillment of the requirements for the degree of Doctor of Philosophy at the Massachusetts Institute of Technology in May, 1978. The research was carried out at the M.I.T. Electronic Systems Laboratory with the partial support provided by the National Science Foundation under Grant NSF/SOC-76-05827 and by the Air Force Office of Scientific Research under Grant AFOSR-77-3281.

ACCESSION for	
NTIS	White Section <input checked="" type="checkbox"/>
DDC	Buff Section <input type="checkbox"/>
UNANNOUNCED	<input type="checkbox"/>
JUSTIFICATION.....	
BY.....	
DISTRIBUTION/AVAILABILITY CODES	
Dist.	AvAIL. and/or SPECIAL
A	

Electronic Systems Laboratory  
Massachusetts Institute of Technology  
Cambridge, Massachusetts 02139

78 07 26 098

ADAPTIVE STOCHASTIC CONTROL OF LINEAR SYSTEMS  
WITH RANDOM PARAMETERS

by

Richard Tse-min Ku

B.S., Massachusetts Institute of Technology  
(1970)

S.M., Massachusetts Institute of Technology  
(1972)

E.E., Massachusetts Institute of Technology  
(1972)

SUBMITTED IN PARTIAL FULFILLMENT  
OF THE REQUIREMENTS FOR THE  
DEGREE OF

DOCTOR OF PHILOSOPHY

at the

MASSACHUSETTS INSTITUTE OF TECHNOLOGY

May, 1978

Signature of Author.....*Richard T. Ku*.....  
Department of Electrical Engineering and  
Computer Science, May 24, 1978

Certified by.....*Michael Athans*.....  
Thesis Supervisor

Accepted by.....  
Chairman, Departmental Committee on Graduate Students

ADAPTIVE STOCHASTIC CONTROL OF LINEAR SYSTEMS

WITH RANDOM PARAMETERS

by

Richard Tse-min Ku

Submitted to the Department of Electrical Engineering and Computer Science on May 24, 1978 in partial fulfillment of the requirements for the Degree of Doctor of Philosophy.

ABSTRACT

In this thesis, we will investigate the adaptive stochastic control of linear dynamic systems with purely random parameters. Hence there is no posterior learning about the system parameters. The control law is non-dual; still it has the qualitative properties of an adaptive control law. In the perfect measurement case, the control law is modulated by the a priori level of uncertainty of the system parameters. The Certainty-Equivalence Principle does not hold.

This thesis shows that the optimal stochastic control of dynamic systems with uncertain parameters has certain limitations. For the linear-quadratic optimal control problem, it is shown that the infinite horizon solution does not exist if the parameter uncertainty exceeds a certain quantifiable threshold. By considering the discounted cost problem, we have obtained some results on optimality versus stability for this class of stochastic control problems.

For the noisy sensor measurement case, we obtained the optimal fixed structure estimator-controller. The control law requires the solution of a coupled nonlinear two-point boundary value problem. Computer simulations of the forward and backward difference equations provided some insight into the uncertainty threshold for the closed-loop system. Stochastic stability analysis further resulted in a sufficient condition for the mean square stability of the fixed structure dynamic compensator.

THESIS SUPERVISOR: Michael Athans

TITLE: Professor of Electrical Engineering and Computer Science

### ACKNOWLEDGEMENTS

I want to thank my thesis supervisor Professor Michael Athans for his continued interest, guidance, and support for my research. Professor Athans always had a coherent sense of the on-going research direction and a tremendous insight of the analytical results. He has made a significant contribution to my doctoral education experience.

I would like to thank my thesis readers Professor Timothy Johnson and Dr. David Castanon. Professor Johnson provided many useful comments and in general helped to improve the technical content of the thesis. Dr. Castanon helped out with some mathematical details in the thesis. I want to thank my Graduate Counselor Professor Sanjoy Mitter for his concern for my graduate program. I like to thank Professors Edwin Kuh and Robert Pindyck of the Sloan School for their part in enriching my total doctoral research program.

I thank Professor Dimitri Bertsekas, Dr. Stanley Gershwin, and Demos Teneketzis for many valuable discussions on my thesis research. Technical comments contributed by Professors P. Varaiya, Y.C. Ho, J.C. Willems, and R. Gallager are acknowledged. I am deeply grateful to Jamie Eng for her timely assistance with the preparation of the thesis draft.

Thanks are due to the Technical Publications Department of The Analytic Sciences Corporation. Lillian Tibbetts typed superbly the thesis and James Powers created the art work. The computer work was done at the M.I.T. Information Processing Services on IBM 370/168.

This research was carried out at the M.I.T. Electronic Systems Laboratory with the partial support provided by the National Science Foundation under Grant NSF/SOC-76-05827 and by the Air Force Office of Scientific Research under Grant AFOSR-77-3281.

-4-

To My Parents

Yun Chang Ku

and

Sau Chun Ku

TABLE OF CONTENTS

	PAGE
ABSTRACT	2
ACKNOWLEDGEMENT	3
LIST OF FIGURES	8
CHAPTER 1 INTRODUCTION	10
1.1 A Historical Survey of Adaptive Stochastic Control	10
1.2 Structure of the Thesis	17
1.3 Contributions of the Thesis	20
CHAPTER 2 OPTIMAL STOCHASTIC CONTROL FOR THE PERFECT MEASUREMENT SYSTEM	24
2.1 Introduction	24
2.2 Problem Statement	25
2.3 Problem Solution	27
2.4 Asymptotic Behavior	35
2.5 Stochastic Stability Results	52
2.6 The Discounted Cost Problem	60
2.7 Control of Linear Systems With Correlated Multiplicative and Additive Noises	70
2.8 Conclusions	73
CHAPTER 3 OPTIMAL LINEAR ESTIMATION OF STOCHASTIC SYSTEMS WITH RANDOM PARAMETERS	75
3.1 Introduction	75
3.2 Problem Statement	77
3.3 Derivation of the Linear Minimum Variance Filter	79

	PAGE
3.4 Linear Filter With Uncorrelated Parameters	83
3.5 Mutually Correlated Random Parameters	88
3.6 Conclusions	91
CHAPTER 4 OPTIMUM CONTROL OF RANDOM PARAMETER SYSTEM WITH NOISY MEASUREMENTS	92
4.1 Introduction	92
4.2 Problem Statement	94
4.3 Optimum Solution of the Stochastic Control Problem	97
4.4 Formulation of the Deterministic Control Problem	106
4.5 Solution of the Deterministic Control Problem	116
4.6 Discussion of the Optimal Linear Controller	129
4.7 Optimum Stationary Linear Control	136
4.8 Stability of Stochastic Dynamical Systems	160
4.9 Conclusions	171
CHAPTER 5 ON LINEAR MULTIVARIABLE CONTROL SYSTEMS	174
5.1 Introduction	174
5.2 Optimal Control of Systems With Exact Measurements	175
5.3 Linear Multivariable Control for Systems With Scalar Random Parameters	179
5.4 Optimal Control for Systems With Inexact Measurements	186
5.5 Conclusions	196

	PAGE
CHAPTER 6	
SUMMARY AND CONCLUSIONS	197
6.1 Summary of the Main Results	197
6.2 Conclusions	200
6.3 Suggestions for Future Research	202
APPENDIX A	
DERIVATION OF THE OPTIMAL LINEAR CONTROL USING THE MATRIX MINIMUM PRINCIPLE	205
APPENDIX B	
DERIVATION OF THE OPTIMAL LINEAR CONTROL USING DYNAMIC PROGRAMMING	211
REFERENCES	223
BIOGRAPHICAL NOTE	231

LIST OF FIGURES

	PAGE
Figure 1.1 Stochastic control structure	14
Figure 2.1 Optimal controller for system equation (2.2.1)	33
Figure 2.2 Solution of the Riccati-like equation (2.4.1) for $N=50$ and known $a(t)=\bar{a}=1.1$	37
Figure 2.3 Solution of the Riccati-like equation (2.4.1) for $N=50$ and known $b(t)=\bar{b}=1.0$	38
Figure 2.4 Solution of the Riccati-like equation (2.4.1) for $N=50$ when both $a(t)$ and $b(t)$ are random	39
Figure 2.5 Behavior of the optimal cost $J^*$ vs planning horizon $N$	41
Figure 2.6 Stability region defined by equation (2.4.3) for system (2.2.1)	45
Figure 2.7 Stability regions defined by equation (2.4.3) for system (2.2.1) with known $a(t) = \bar{a}$	47
Figure 2.8 Stability region defined by equation (2.4.3) for system (2.2.1) when $\bar{b} = 0.0$	50
Figure 2.9 Behavior of solution as a function of threshold parameter $m$	66
Figure 2.10 Optimality and stability regions for system equation (2.2.1)	69
Figure 3.1 Linear minimum variance unbiased estimator for stochastic system (3.2.1) and (3.2.2)	85
Figure 4.1 Fixed structure linear controller and estimator	108
Figure 4.2 Optimal fixed structure controller	119
Figure 4.3 Computed stability region for system given by equations (4.4.1) and (4.4.14)	144

	PAGE
Figure 4.4 Lower bound on the stability region defined by equation (4.7.26) for system given by equations (4.4.1) and (4.4.14)	146
Figure 4.5 Stability region defined by equation (4.7.27) for system given by equations (4.4.1) and (4.4.14)	147
Figure 4.6 Behavior of the states and costates given by equations (4.7.6) to (4.7.12)	148
Figure 4.7 Behavior of the optimal control and filter gain sequences $G(t)$ and $H(t)$	149
Figure 4.8 Behavior of the divergent states and costates given by equations (4.7.6) to (4.7.12)	151
Figure 4.9 Solution of costate equation (4.7.18) for known $a(t)=\bar{a}=1.1$ and $b(t)=\bar{b}=1.0$	152
Figure 4.10 Solution of the costate equation (4.7.23) for known $a(t)=\bar{a}=1.1$	153
Figure 4.11 Solution of the costate equation (4.7.22) for known gain $b(t)=\bar{b}=1.0$	154

CHAPTER 1  
INTRODUCTION

1.1 A Historical Survey of Adaptive Stochastic Control

The theory of optimal closed-loop control of stochastic linear dynamic systems has progressed since the original contributions in [1], [2]. For discrete-time linear dynamic systems with known system parameters and known additive gaussian noise statistics with quadratic cost, the optimum solution to the stochastic control problem is given by the Separation Theorem [3], [4]. These stochastic control-theoretic results have been reconciled with the statistical decision-theoretic results given by the Certainty-Equivalence Principle for multi-stage decision processes [5], [6].

For linear dynamic systems with uncertain parameters or unknown noise statistics, there does not exist at present a general computationally feasible theory of optimum stochastic control. Bellman first presented a mathematical theory of adaptive control processes in [7]. He introduced the concepts of "information pattern" and a control device that can "learn". Feldbaum expanded on the concept and algorithms of adaptive control in his four-part theory of dual control [8], so-called because the optimum controller must actively try to identify the unknown parameters as well as simultaneously control the system. He showed that in dual control systems, there may

exist inherent conflict between applying the inputs for learning and for effective control purposes. The dual control law is then to reflect the optimum interaction of caution and probing in the closed-loop control system. Feldbaum then distinguished between two kinds of loss, one due to the deviation of the state and the other due to the nonoptimal learning control law [9].

The concepts of separation, certainty-equivalence, neutrality, and related dual control effects have been further clarified and discussed in [10]-[16]. The present dual control action may influence future learning. In the so-called neutral control systems described in [17], [18], learning is independent of the control law. The neutral control law accounts for present uncertainty, but neglect the possibility that the present control action may influence future uncertainty resulting thus in a one-way separation.

Optimal solutions to the adaptive stochastic control of a class of linear dynamic systems with constant or time-varying unknown parameters can be obtained, in principle, using the stochastic dynamic programming method. The optimization algorithm is constructive and the solution is obtained by solving a recursive functional equation involving alternating minimizations and expectations, [8]. However, due to the "curse of dimensionality" the solution in general cannot be obtained analytically in closed form. The dynamic

programming algorithm encounters the problem of infinite dimensionality of the probability distribution function in the general case.

Since we cannot solve analytically the adaptive control problem except for very special cases [19], [20], in practice we resort to approximation methods. The degradation in performance of the suboptimal adaptive control law can be measured by comparing the average performance of the proposed suboptimal control algorithm obtained from Monte Carlo simulations with the optimal but unattainable performance for the same control system in which the parameters are known with certainty.

There are two approaches to the approximation of the optimal adaptive control law. First, we may approximate the optimal solution to the adaptive stochastic control problem. This approach is taken in [7], [8], [11], [21-23]. The second approach is to approximate the linear system as one with random parameters and derive the optimal adaptive stochastic control for the approximate control system. This can be done by relaxing certain mathematical assumptions and information structure of the optimal adaptive control law. In doing so, we may be able to obtain the suboptimal control law analytically. One such method is the enforced separation as in [24]. Another is the open-loop feedback technique [25]-[30].

Literature surveys and reviews of the state-of-the-art of adaptive control concepts and methods are found in [31]-[33]. An extensive bibliography on the theory and application of the various suboptimal adaptive estimation and control techniques is given in [34].

In this thesis, we will investigate a class of stochastic optimal control problems with purely random (white) parameters whose mathematical solutions reflect some of the aspects of adaptive stochastic control laws, Fig. 1.1. The use of multiplicative white noise parameters explicitly tells the mathematics that the system dynamics are not known exactly and can vary in an unpredictable way. This is an important class of problems because it represents a worst case design and analysis. The results provide some insights and help to evaluate whether the use of very sophisticated identification and control algorithms may represent an "overkill".

Optimum control of linear systems with statistically independent random parameters is considered in [35]. For a constant linear system with multiplicative input noise, the effect of the random parameters was found to show the convergence of the feedback coefficients [2]. Necessary and sufficient conditions for a class of stationary linear system with random parameter to be controllable in mean-square sense was examined in [36]. Solution to the optimal stochastic

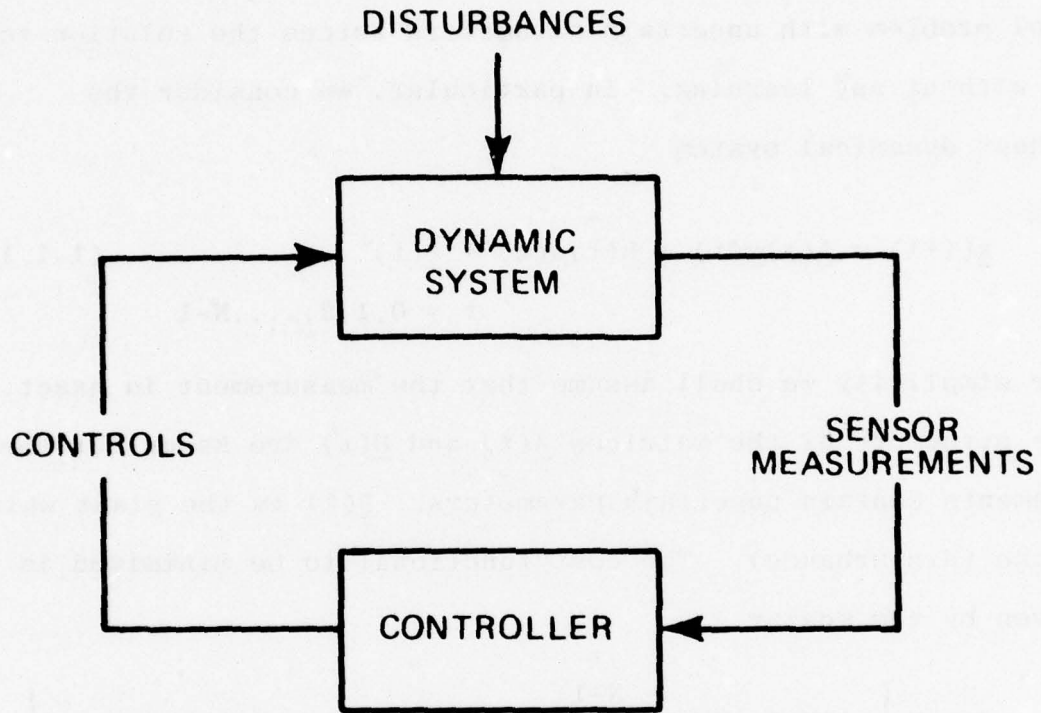

Figure 1.1 Stochastic control structure

control problem with independent random parameter has been derived in [37], [38], and [39].

The mathematical formulation of the stochastic control problem with uncertain parameters forces the solution to be without any learning. In particular, we consider the linear dynamical system

$$\begin{aligned} \underline{x}(t+1) &= \underline{A}(t)\underline{x}(t) + \underline{B}(t)\underline{u}(t) + \underline{\xi}(t) & (1.1.1) \\ t &= 0, 1, 2, \dots, N-1 \end{aligned}$$

For simplicity we shall assume that the measurement is exact. The structure of the matrices  $\underline{A}(t)$  and  $\underline{B}(t)$  are known but the elements contain uncertain parameters.  $\underline{\xi}(t)$  is the plant white noise (disturbance). The cost functional to be minimized is given by the scalar

$$J = E \left\{ \underline{x}'(N)\underline{F}\underline{x}(N) + \sum_{t=0}^{N-1} \underline{x}'(t)\underline{Q}(t)\underline{x}(t) + \underline{u}'(t)\underline{R}(t)\underline{u}(t) \right\} \quad (1.1.2)$$

where  $\underline{F}$ ,  $\underline{Q}(\cdot)$ , and  $\underline{R}(\cdot)$  are at least positive semi-definite.

The uncertain parameters in  $\underline{A}(\cdot)$  and  $\underline{B}(\cdot)$  change randomly with time. At each instant of time, "nature" selects the value of the system parameters from some a priori given distribution. The way "nature" selects the particular numerical value of system parameters at each instant of time represent a chance event in time. That is, the time-varying parameters represent a white process. Hence, the mathematics

tells the compensator that it cannot use the measurement data to improve the a priori mean or reduce the level of uncertainty of parameters anymore than the a priori variance. The optimal solution cannot involve any learning about the system parameters.

Although the mathematical formulation of the problem precludes identification, the solution of the optimal stochastic control problem in the sense of minimizing a cost functional shows the effects of parameter uncertainty in the performance of the control system. The control gain of an optimal stochastic system with randomly varying parameters will depend upon the unconditional means and covariances of the uncertain parameters. The Separation Theorem does not hold. Randomness in the system parameters has strong influence on the gain of the control system, even in the absence of any learning.

The minimum value of the expected quadratic cost depends not only upon the means but also upon the variance of the randomly varying parameters. In the worst case sense, one has then an upper bound upon the performance deterioration of the control system due to uncertain parameters. The difference between this worst case cost and the Separation Theorem cost is the so-called value of model information for stochastic adaptive control problems.

This class of stochastic control problems is closely related to the state-dependent and control-dependent noise problem considered in continuous-time for perfect measurement

[40] to [45] and in discrete-time for noisy measurement, [46] to [49]. The specific class of stochastic models given in Eq. 1.1.1 are also known as the multiplicative noise or random coefficient (multiplier) models. In [20] it is shown that if the only uncertainty parameter in Eq. 1.1.1 is in the matrix  $\underline{B}$  then the nonlinear stochastic control system is essentially a bilinear system. Hence the results for the class of adaptive control problems are readily applicable to the class of stochastic bilinear systems.

## 1.2 Structure of the Thesis

In this thesis, we will obtain the results almost entirely for the scalar systems. In the very simple first-order dynamical systems, we have no problem with system controllability or observability. The optimized stochastic control problem is well-posed and well-defined to give existence and uniqueness results. The analytical results in the subsequent chapters for the scalar linear-quadratic-Gaussian systems must be true for multivariable-nonlinear-non-Gaussian systems since the LQG problem is a special case of the more general formulation. The extension of these results to the multivariable case is conceptually straightforward, although notationally cumbersome.

The optimal stochastic control problem with perfect state measurement is considered in Chapter 2. The mathematical

formulation of the problem is given in Section 2.2. The solution to the "white noise parameters" optimization is obtained using the stochastic dynamic programming algorithm in Section 2.3. The important features of the control solution are discussed. In Section 2.4, we examine the steady-state solution of the optimal stochastic control problem. In particular, we derive the inequality condition for the existence of a finite solution to the Riccati-like equation for infinite horizon problem. In Section 2.5, the stochastic optimization problem is treated as a stochastic stability problem. We give the necessary and sufficient conditions for the almost sure and mean square stability of the stochastic system under linear feedback. The concepts of optimality versus stability is further brought out in Section 2.6 when we consider the discounted cost problem. We extend the results in Section 2.3 to the case where the multiplicative noises are correlated with the additive noise in Section 2.7.

In Chapter 3, we treat the problem of optimum linear minimum variance estimation for the random parameter system. The estimation problem is stated in Section 3.1. The linear minimum variance filter is derived in Section 3.2. It is found that the parameter means and variances have to satisfy a necessary and sufficient condition for the asymptotic variance of the uncontrolled linear system to be finite (and this turns out to be sufficient to ensure stochastic stability as

well). In Section 3.4, we discuss the case where the uncertain parameters are uncorrelated. In Section 3.5, the analysis is given to include mutually correlated randomly varying parameters.

In Chapter 4, we consider the closed-loop (feedback) control of randomly varying parameters system with noisy measurements. The mathematical problem is formulated in Section 4.2. In Section 4.3 we examine the optimal solution to the control problem using stochastic dynamic programming. In Section 4.4, we fix the structure of the class of dynamic compensates to be considered. We obtain the optimal parameters (filter gains and control gains) first using the Matrix Minimum Principle and then dynamic programming algorithm. The important point is that we transformed the original stochastic control problem in Section 4.2 into a deterministic parameter optimization problem in Section 4.4. Section 4.5 shows that we have to solve a complex coupled nonlinear two-point boundary value problem in order to compute the optimal gains. We discuss the various aspects of the fixed structure estimate-controller in Section 4.6. We consider the asymptotic behavior of the stochastic control law derived in Section 4.7. Numerical simulations of the stochastic equations provide the needed insights into the existence of steady-state control laws. Stochastic ability analysis analogous to that in Section 2.5 based on output feedback is given in Section 4.8. A sufficient

condition for the stochastic system to be mean-square stabilizable under feedback is presented.

In Chapter 5, we extend the results in Chapter 2 to a special class of linear multivariable systems. We give the mathematical formulation of the optimal stochastic control problem in Section 5.2. The solution via dynamic programming algorithm is given. In Section 5.3, we consider the optimal stochastic control of a multivariable linear system with a specific structure with respect to a quadratic performance index. The system dynamics are described by a linear vector difference equation with white, possibly mutually correlated, scalar random parameters. In Section 5.4 we summarize the results on the adaptive stochastic control of linear multivariable systems with imperfect measurements.

We summarize the results on the optimum stochastic control of linear dynamic systems with purely random parameters in Section 6.1. We make conclusions about optimality and stochastic stability in Section 6.2. We discuss the existence, finiteness, and convergence of the derived optimal control law. In Section 6.3, we recommend the directions for future research in this area.

### 1.3 Contributions of the Thesis

The optimal stochastic control results for the exact state measurements problem have been known for some time in

[37]. However, their potential importance and their implications in adaptive control has not yet been fully realized. This thesis reports on the research of the optimal stochastic control of white noise parameter systems. The objective is to gain deeper insights and clearer understanding of the issues and philosophy of the adaptive control. Even in the absence of learning, the degree of dynamic uncertainty (as quantified by the variances of the multiplicative white noise parameters) influences both the optimal control gains and the optimal value of the performance index.

In this thesis research we shall analyze stochastic systems with white parameters as a worst case to provide a systematic analysis and design approach to adaptive stochastic control. We derive the upper bound on the average cost for the exact measurement and the noise-corrupted measurement cases. We analyze the dual nature of stochastic control for systems with uncertain parameters in a most transparent mathematical framework. The mathematical formulation precludes any learning about the parameters, however.

We derive the necessary and sufficient condition for the optimal control law for the perfect measurement case. We then derive the necessary and sufficient condition for the stochastic stability in the almost sure and mean-square sense for the class of stochastic systems under consideration. The Uncertainty Threshold Principle then says there exists a

threshold of dynamic uncertainty, if exceeded then optimal strategies cannot exist. We have derived the optimality condition for the discounted cost problem. The problem provides an interesting and important case study of optimality versus stability problem in stochastic control theory. We were also able to extend the analysis on control to the case where the multiplicative noises are correlated with additive noises.

In deterministic linear quadratic control problem the duality principle holds, that is, the linear stochastic estimation problem is related through duality to the optimal deterministic control problem. The dual of the control problem with the pair  $(\underline{C}, \underline{B})$  is the estimation problem pair  $(\underline{B}, \underline{C})$ . For linear discrete-time systems, duality principle says that the various matrices that occur in the optimal regulator problem and the optimal state reconstruction problem are related and have symmetry property, [50]. We show that this duality property does not hold for the optimal regulator and optimum linear minimum variance estimation problems for the class of adaptive stochastic control problems. In particular, the stability condition for the asymptotic behavior of the optimum linear minimum variance filter problem cannot be obtained by "dualizing" the stability condition for the optimum regulator problem given in Section 2.4.

We have obtained the linear minimum variance unbiased filter with deterministic control input. Results are generalized to the case where all the random parameters may be correlated. The necessary and sufficient condition for the asymptotic stability of the state second moment turns out to be only a sufficient condition for the stochastic stability of the fixed structure overall closed-loop system.

For the noisy sensor measurement case, we derived the fixed structure dynamic compensator using dynamic programming algorithm. We determined the average cost expression (in a worst case sense). The use of direct output feedback is shown to give only a sufficient condition for the mean-square stability for the overall control system.

CHAPTER 2  
OPTIMAL STOCHASTIC CONTROL FOR THE  
PERFECT MEASUREMENT SYSTEM

2.1 Introduction

In this chapter, the optimal control problem for purely random parameters will be formulated and solved for the perfect observation case. We present the mathematical model of a class of stochastic linear systems in Section 2.2 and give the technical assumptions about the statistical laws for the random processes. The optimal stochastic control problem is then formulated assuming perfect measurements. In Section 2.3, we give the solution to the optimal control problem via dynamic programming. In Section 2.4, we examine the stability properties of a stationary system. The Uncertainty Threshold Principle is given in Theorem 2.1. We examine the stochastic stability of a linear system under linear feedback in Section 2.5. In Section 2.6, we discuss the discounted cost problem and give a modified threshold for the particular cost functional chosen. We discuss some important new issues in stochastic controllability and stability. In Section 2.7, we extend the results of Sections 2.2 and 2.4 to linear systems where the random parameters and the additive noise are correlated.

## 2.2 Problem Statement

In this section, we will state the problem. Consider a first-order stochastic linear dynamical system with state  $x(t)$  and control  $u(t)$  described by the difference equation

$$x(t+1) = a(t)x(t) + b(t)u(t) + \xi(t) \quad (2.2.1)$$

$$t = 0, 1, 2, \dots, N-1$$

$x(0)$  given.

We assume that the additive noise  $\xi(t)$  driving the system dynamics is a zero-mean Gaussian white noise with known variance

$$E\{\xi(t)\xi(\tau)\} = \Xi(t)\delta(t, \tau) \quad (2.2.2)$$

We assume that the purely random parameters  $a(t)$  and  $b(t)$  are Gaussian and white (uncorrelated in time) with known means  $\bar{a}(t)$  and  $\bar{b}(t)$ , and covariances  $\Sigma_{aa}(t)$  and  $\Sigma_{bb}(t)$ , respectively and cross-covariance given by  $\Sigma_{ab}(t)$ . More precisely, we assume that

$$E\{a(t)\} = \bar{a}(t) \quad , \quad E\{b(t)\} = \bar{b}(t) \quad \forall t \quad (2.2.3)$$

and

$$E\left\{(a(t) - \bar{a}(t))(a(\tau) - \bar{a}(\tau))\right\} = \Sigma_{aa}(t)\delta(t, \tau) \quad (2.2.4)$$

$$E\left\{(b(t) - \bar{b}(t))(b(\tau) - \bar{b}(\tau))\right\} = \Sigma_{bb}(t)\delta(t, \tau) \quad (2.2.5)$$

$$E\left\{(a(t) - \bar{a}(t))(b(\tau) - \bar{b}(\tau))\right\} = \Sigma_{ab}(t)\delta(t, \tau) \quad (2.2.6)$$

where  $\delta(t, \tau)$  is the Kronecker delta and

$$\Sigma_{aa}(t)\Sigma_{bb}(t) - \Sigma_{ab}^2(t) \geq 0 \quad (2.2.7)$$

since the correlation coefficient  $|\rho| \leq 1$ .

It is assumed that the additive white noise  $\xi(t)$  is statistically independent of the random parameters  $a(t)$  and  $b(t)$ . The case where  $a(t)$ ,  $b(t)$ , and  $\xi(t)$  are correlated is discussed later in Section 2.7.

For the stochastic control problem it is very important to specify the information available for control. In this chapter, we assume that the state  $x(t)$  can be measured exactly. Hence we assume that  $x(0)$  is given.

We assume that the admissible controls are real-valued and of state feedback type  $u(t) = \gamma(x(t), t)$ . The control can only depend on the given a priori information and measurements up to time  $t$ . The control  $u(t)$  at time  $t$  can only influence the state  $x(\tau)$  at  $\tau \geq t+1$  and not before. This is the important notion of causal inputs - past and present output values do not depend on future input values.

The optimal control problem is to determine the control law  $u(t) = \gamma(x(t), t)$  ( $t = 0, 1, \dots, N-1$ ) such that the expected value of a quadratic cost functional is minimized. The quadratic cost functional is the standard regulator type.

$$J(0) = E_{\substack{a(\cdot), b(\cdot), \\ \xi(\cdot)}} \left\{ F x^2(N) + \sum_{t=0}^{N-1} x^2(t)Q(t) + u^2(t)R(t) \right\} \quad (2.2.8)$$

$F, Q \geq 0, \quad R > 0$

The expectation is taken with respect to the probability distribution of the underlying random variables  $a(t)$ ,  $b(t)$ , and  $\xi(t)$ .

Based upon the application of the Bellman's Principle of Optimality and functional equations, dynamic programming is used to solve the optimal control problem formulated in Eqs. (2.2.1) and (2.2.8).

### 2.3 Problem Solution

The solution to the optimal control problem given in Eqs. (2.2.1) and (2.2.8) can be obtained by applying the standard dynamic programming method. The cost-to-go at the final time is given by

$$V(x(N), N) = F x^2(N) \quad (2.3.1)$$

By the Principle of Optimality

$$\begin{aligned} V(x(N-1), N-1) &= \min_{u(N-1)} E \left\{ Q(N-1)x^2(N-1) + R(N-1)u^2(N-1) \right. \\ &\quad \left. + V(x(N), N) | x^{N-1} \right\} \\ &= \min_{u(N-1)} \left\{ \left[ Q(N-1) + F(\bar{a}^2(N-1) + \Sigma_{aa}(N-1)) \right] x^2(N-1) \right. \\ &\quad \left. + \left[ R(N-1) + F(\bar{b}^2(N-1) + \Sigma_{bb}(N-1)) \right] u^2(N-1) \right. \\ &\quad \left. + 2F(\bar{a}(N-1)\bar{b}(N-1) + \Sigma_{ab}(N-1))x(N-1)u(N-1) \right\} \\ &\quad + F \bar{\epsilon}(N-1) \quad (2.3.2) \end{aligned}$$

since  $\xi(N-1)$  is independent of  $u(N-1)$  and  $x(N-1)$  and the random parameters  $a(N-1)$  and  $b(N-1)$ .

We minimize the algebraic expression in Eq. (2.3.2) by taking the derivative with respect to  $u(N-1)$  and setting it to zero, we obtain as a result

$$u^*(N-1) = - \frac{F(\bar{a}(N-1)\bar{b}(N-1) + \Sigma_{ab}(N-1))}{(\bar{b}^2(N-1) + \Sigma_{bb}(N-1))F + R(N-1)} x(N-1) \quad (2.3.3)$$

Substituting this optimal control at  $N-1$  into cost Eq. (2.3.2) the optimum cost-to-go becomes

$$V(x(N-1), N-1) = x^2(N-1)K(N-1) + F \xi(N-1) \quad (2.3.4)$$

where

$$K(N-1) = F(\Sigma_{aa}(N-1) + \bar{a}^2(N-1)) + Q(N-1) - G^2(N-1) \left[ R(N-1) + F(\bar{b}^2(N-1) + \Sigma_{bb}(N-1)) \right] \quad (2.3.5)$$

$$G(N-1) = \frac{F \left[ \bar{a}(N-1)\bar{b}(N-1) + \Sigma_{ab}(N-1) \right]}{R(N-1) + F(\bar{b}^2(N-1) + \Sigma_{bb}(N-1))} \quad (2.3.6)$$

We note that the optimum cost-to-go at time  $N-1$  is of the same form as Eq. (2.3.1). The second term is due to the additive noise driving the system. The first term includes the cost of control and implicitly the added cost due to the randomness of the parameters  $a(N-1)$  and  $b(N-1)$ .

At time  $N-2$ , the cost-to-go is given by the equation

$$\begin{aligned}
 V(x(N-2), N-2) &= \min_{u(N-2)} E \left\{ Q(N-2)x^2(N-2) + R(N-2)u^2(N-2) \right. \\
 &\quad \left. + V(x(N-1), N-1) | x^{N-2} \right\} \\
 &= \min_{u(N-2)} E \left\{ Q(N-2)x^2(N-2) + R(N-2)u^2(N-2) \right. \\
 &\quad \left. + K(N-1)x^2(N-1) | x^{N-2} \right\} + F E(N-1)
 \end{aligned} \tag{2.3.7}$$

This expression for the cost-to-go is identical to that in Eq. (2.3.2) except for the time indexes. Therefore, the optimal control  $u^*(N-2)$  is given by

$$u^*(N-2) = - \frac{K(N-1)(\bar{a}(N-2)\bar{b}(N-2) + \Sigma_{ab}(N-2))}{(\bar{b}^2(N-2) + \Sigma_{bb}(N-2))K(N-1) + R(N-2)} x(N-2) \tag{2.3.8}$$

and the optimal cost-to-go is given by

$$\begin{aligned}
 V^*(N-2, x(N-2)) &= K(N-2)x^2(N-2) + K(N-1) E(N-2) \\
 &\quad + F E(N-1)
 \end{aligned} \tag{2.3.9}$$

where

$$\begin{aligned}
 K(N-2) &= K(N-1)(\bar{a}^2(N-1) + \Sigma_{aa}(N-1)) + Q(N-2) \\
 &\quad - \frac{K^2(N-1)(\bar{a}(N-2)\bar{b}(N-2) + \Sigma_{ab}(N-2))^2}{R(N-2) + K(N-1)(\bar{b}^2(N-2) + \Sigma_{bb}(N-2))}
 \end{aligned} \tag{2.3.10}$$

By induction on  $t$ , we obtain the solution to the stochastic state regulator problem. Given the linear stochastic

system Eq. (2.2.1) and the cost functional Eq. (2.2.8), where  $u(t)$  is not constrained, the optimal feedback control at each instant of time is given by a linear transformation of the state,

$$u^*(t) = -G(t)x(t) \quad (2.3.11)$$

where

$$G(t) = \frac{K(t+1)(\Sigma_{ab}(t) + \bar{a}(t)\bar{b}(t))}{R(t) + (\Sigma_{bb}(t) + \bar{b}^2(t))K(t+1)} \quad (2.3.12)$$

and  $K(t)$  is the solution of the Riccati-like equation

$$K(t) = (\bar{a}^2(t) + \Sigma_{aa}(t))K(t+1) + Q(t) - G^2(t) \left[ R(t) + K(t+1)(\Sigma_{bb}(t) + \bar{b}^2(t)) \right] \quad (2.3.13)$$

satisfying the boundary condition

$$K(N) = F \quad (2.3.14)$$

The state of the optimal system is then the solution of the linear difference equation

$$x(t+1) = \left[ a(t) - b(t) \frac{K(t+1)(\Sigma_{ab}(t) + \bar{a}(t)\bar{b}(t))}{R(t) + K(t+1)(\Sigma_{bb}(t) + \bar{b}^2(t))} \right] x(t) \quad (2.3.15)$$

$$x(0) = x_0$$

The optimal control given by Eq. (2.3.11) is a random variable since  $x(t)$  is a random variable. It is linear in the completely measurable state. The uncertainty

in the parameters  $a(t)$  and  $b(t)$  introduces equivalent state and control weightings,  $\Sigma_{aa}(t)K(t+1)$  and  $\Sigma_{bb}(t)K(t+1)$ , respectively in a very natural way into the control problem.

In order for the extremal control to be the unique optimal control, we need to show that the second partial derivative of  $T$  with respect to  $u$ ,

$$R(t) + (\Sigma_{bb}(t) + \bar{b}^2(t))K(t+1) > 0 \quad (2.3.16)$$

The solution to the Riccati-like Eq. (2.3.13) is non-negative definite. This can be seen from the fact that for any  $x$ .

$$\begin{aligned} x^2 K(t) = \min_u E \left[ x^2 Q(t) + u^2 R(t) \right. \\ \left. + (a(t)x + b(t)u)^2 K(t+1) \right], \\ K(N) = F \geq 0 \end{aligned} \quad (2.3.17)$$

Since  $F, Q(t) \geq 0$  and  $R(t) > 0$ , the expression within the bracket is non-negative. Since the minimization over  $u$  preserves non-negativity, it follows that  $x^2 K(t) \geq 0$  for all  $x$ . Hence,  $K(t)$  is non-negative definite. Since  $R(t)$  is positive definite, we conclude that  $[R(t) + (\Sigma_{bb}(t) + \bar{b}^2(t))K(t+1)] > 0$ .

The Riccati-like Eq. (2.3.13) is a first-order non-linear time-varying ordinary difference equation, the solution  $K(t)$  exists and is unique. The external control given by Eq. (2.3.11) is, therefore, the unique optimal control.

The optimal cost-to-go is obtained by substituting the expression for the optimal control Eqs. (2.3.11) and (2.3.12) into Eq. (2.2.8) to get

$$J^*(x(t), t) = K(t)x^2(t) + \sum_{\tau=t}^{N-1} K(\tau+1) \Xi(\tau) \quad (2.3.18)$$

If the optimal control  $u(t) \neq 0$  for all states then  $K(t) > 0$  for all  $0 \leq t < N$ . This follows from the fact if  $u(t) \neq 0$ , then the cost  $T$  must be positive. We shall say that an optimal control exists, when  $J^*$  is defined for all  $x(t)$  and  $t$ .

Figure 2.1 shows the structure of the optimal feedback system. Since the optimal control is  $u(t) = -G(t)x(t)$ , the state  $x(t)$  is multiplied by the linear gain  $G(t)$  to generate the control. The optimal feedback system is, thus, linear and time-varying in the finite horizon problem. This will be the case even if the system is stationary and the cost functional is time-invariant. Note that the optimal control given by Eqs. (2.3.11) to (2.3.13) is modulated by the covariances of the purely random (white) parameters. The optimal controller is cautious when the parameter  $b(t)$  is uncertain. The gain  $G(t)$  is smaller in magnitude, *ceteris paribus*, than the linear-quadratic gain. The controller is more vigorous when the parameter  $a(t)$  is uncertain, since the controller must be more active to regulate the system. The gain  $G(t)$  are larger in magnitude, *ceteris paribus*, with larger variance  $\Sigma_{aa}(t)$ .

Since the gain  $G(t)$  is a function of  $K(t)$ , the solution  $K(t)$  to the Riccati-like Eq. (2.3.13) governs the behavior of the optimal feedback system. The Eq. (2.3.13)

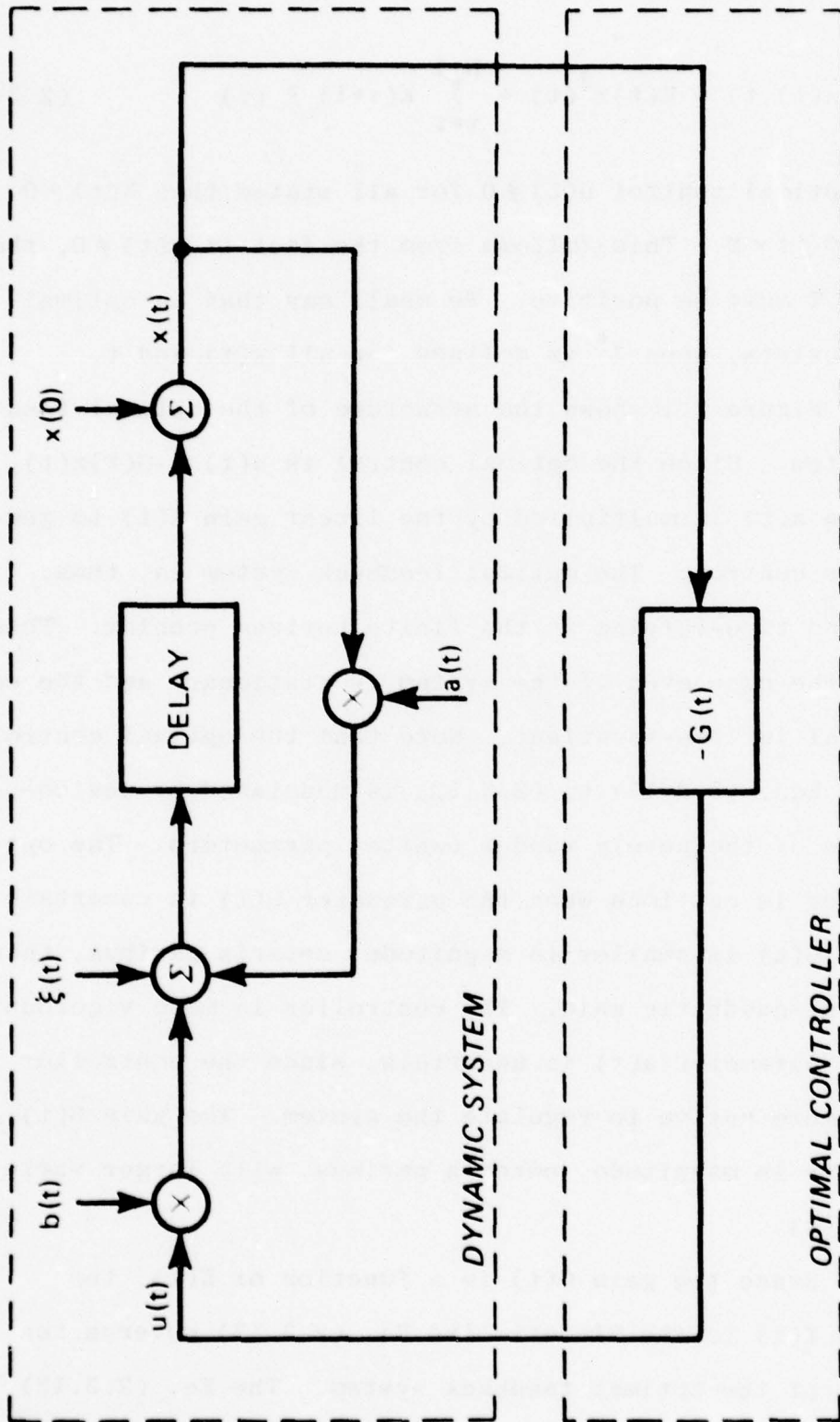

Figure 2.1 Optimal controller for system equation (2.2.1)

is nonlinear and, in general, we cannot obtain closed-form solutions. We shall discuss in the next section the solution  $K(t)$  to Eq. (2.3.13) as  $N \rightarrow \infty$  to obtain a steady-state controller for the stationary system and cost functional with constant weightings.

We remark that the optimal control law given by Eqs. (2.3.11) to (2.3.13) is not the Certainty-Equivalent control, since the control gain depends on the parameter variances. The Certainty-Equivalent control law is

$$u^{C.E.}(t) = - \frac{\bar{b}(t)K(t+1)\bar{a}(t)}{\bar{b}^2(t)K(t+1) + R(t)} x(t) \quad (2.3.19)$$

where

$$K(t) = \bar{a}^2(t)K(t+1) + Q(t) - \frac{\bar{b}^2(t)K^2(t+1)\bar{a}^2(t)}{\bar{b}^2(t)K(t+1) + R(t)} \quad (2.3.20)$$

This can be obtained from Eqs. (2.3.11) to (2.3.13) by setting arbitrarily  $\Sigma_{aa}(t) = \Sigma_{bb}(t) = \Sigma_{ab}(t) = 0$ . The Certainty-Equivalence control law does not account for the uncertainty in the system parameters.

The optimal stochastic control is without posterior learning. The parameters  $a(t)$  and  $b(t)$  cannot be identified, because by assumption they are white. Nature/chance picks the parameters and the controller must adapt to the structural change. This is a worst-case control system design, as compared to assuming the parameters are unknown but constant or

slowly time-varying. However, the assumption of purely random parameters is unrealistic from a physical point of view. The assumption that the parameters are unknown but constant leads to the well-known dual control problem whose exact solution cannot be easily computed analytically. The white parameter assumption leads to a very simple stochastic control law Eq. (2.3.11) that can be easily implemented. Economists, and in particular Chow [38] have argued that in economic systems, treatment of unknown parameters as being purely random is desirable to obtain the inherent caution in the control especially when  $b(t)$  is not known accurately. In [32], Athans and Varaiya have argued that the control of systems with white parameters represents a worst-case situation in which the ratio

$$\frac{K(0 | \Sigma_{aa} \neq 0, \Sigma_{bb} \neq 0, \Sigma_{ab} \neq 0)}{K(0 | \Sigma_{aa} = 0, \Sigma_{bb} = 0, \Sigma_{ab} = 0)} \geq 1 \quad (2.3.21)$$

provides a measure of the deterioration in performance due to the unknown parameters, which can provide a guide as to whether sophisticated parameter estimation and adaptive control algorithms are warranted.

#### 2.4 Asymptotic Behavior

We assume in this section that the stochastic linear system given by Eq. (2.2.1) has wide-sense stationary statistics.

The state and control weightings  $Q(t)$  and  $R(t)$  are assumed to be constant.

The Riccati-like Eq. (2.3.13) is then given by

$$K(t) = Q + K(t+1)(\bar{a}^2 + \Sigma_{aa}) - \frac{K^2(t+1)(\bar{a}\bar{b} + \Sigma_{ab})^2}{(\bar{b}^2 + \Sigma_{bb})K(t+1) + R} \quad (2.4.1)$$

$$K(N) = 0$$

Since the nonlinear difference Eq. (2.4.1) has constant parameters, one may well think that it will attain a steady-state solution "backward in time" as it certainly does for the ordinary linear-quadratic problem with known parameters, so that one can then calculate the infinite horizon (constant) gain. This is, however, not the case for Eq. (2.4.1).

Figures 2.2, 2.3, and 2.4 show the numerical solution of Eq. (2.4.1) for  $N = 50$  for different values of means and covariances of the parameters. Note the logarithmic scale used. A close examination of Eq. (2.4.1) shows what can happen to the solution  $K(t)$  of the Riccati equation.

Consider then Eq. (2.4.1) and assume that  $K(t+1)$  is "large". Then the "backward in time" evolution of  $K(t)$  is given approximately by

$$K(t) \approx K(t+1)m \quad (2.4.2)$$

where the threshold parameter  $m$  is given by

$$m = \Sigma_{aa} + \bar{a}^2 - \frac{(\Sigma_{ab} + \bar{a}\bar{b})^2}{\Sigma_{bb} + \bar{b}^2} \quad (2.4.3)$$

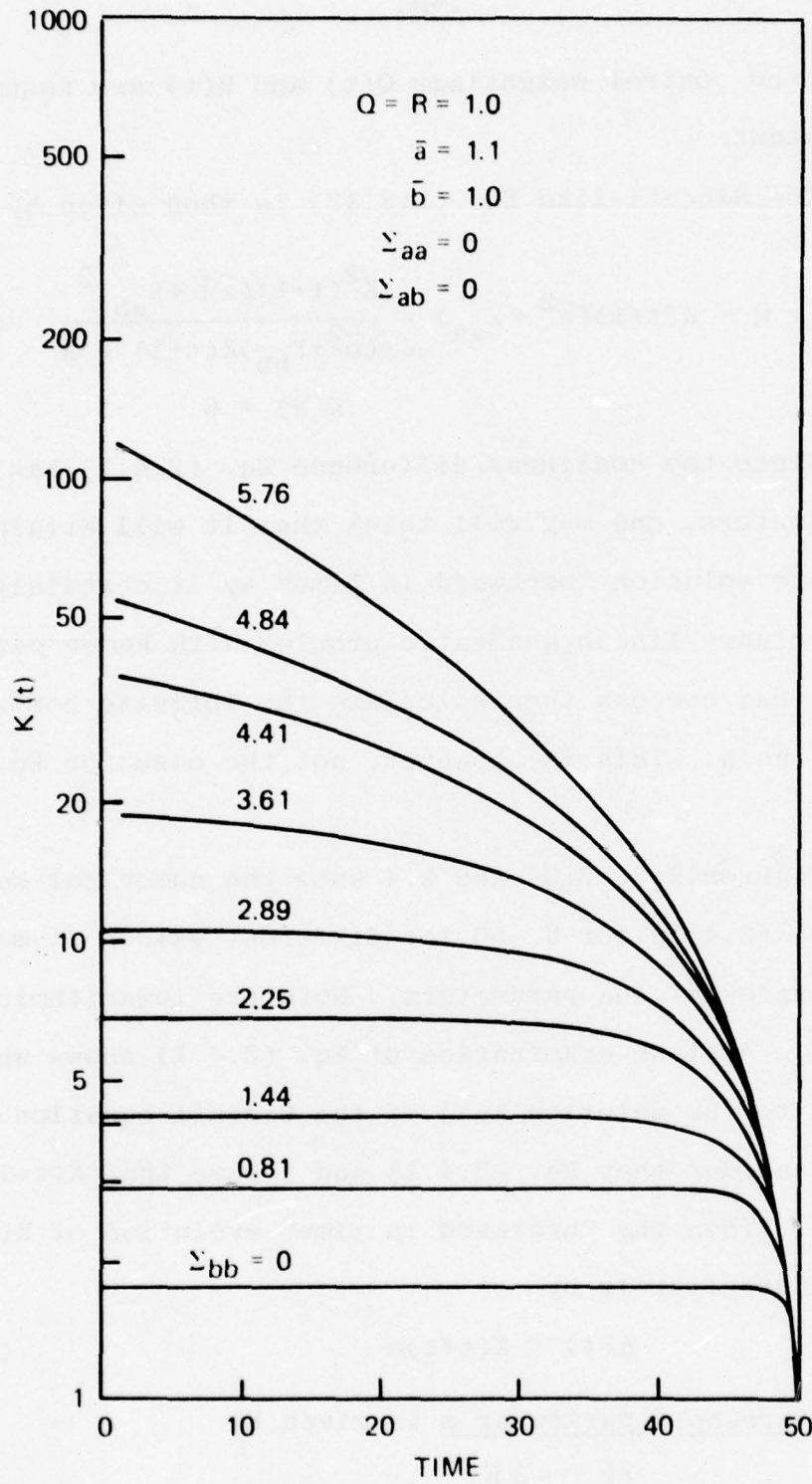

Figure 2.2 Solution of the Riccati-like equation (2.4.1) for  $N=50$  and known  $a(t)=\bar{a}=1.1$

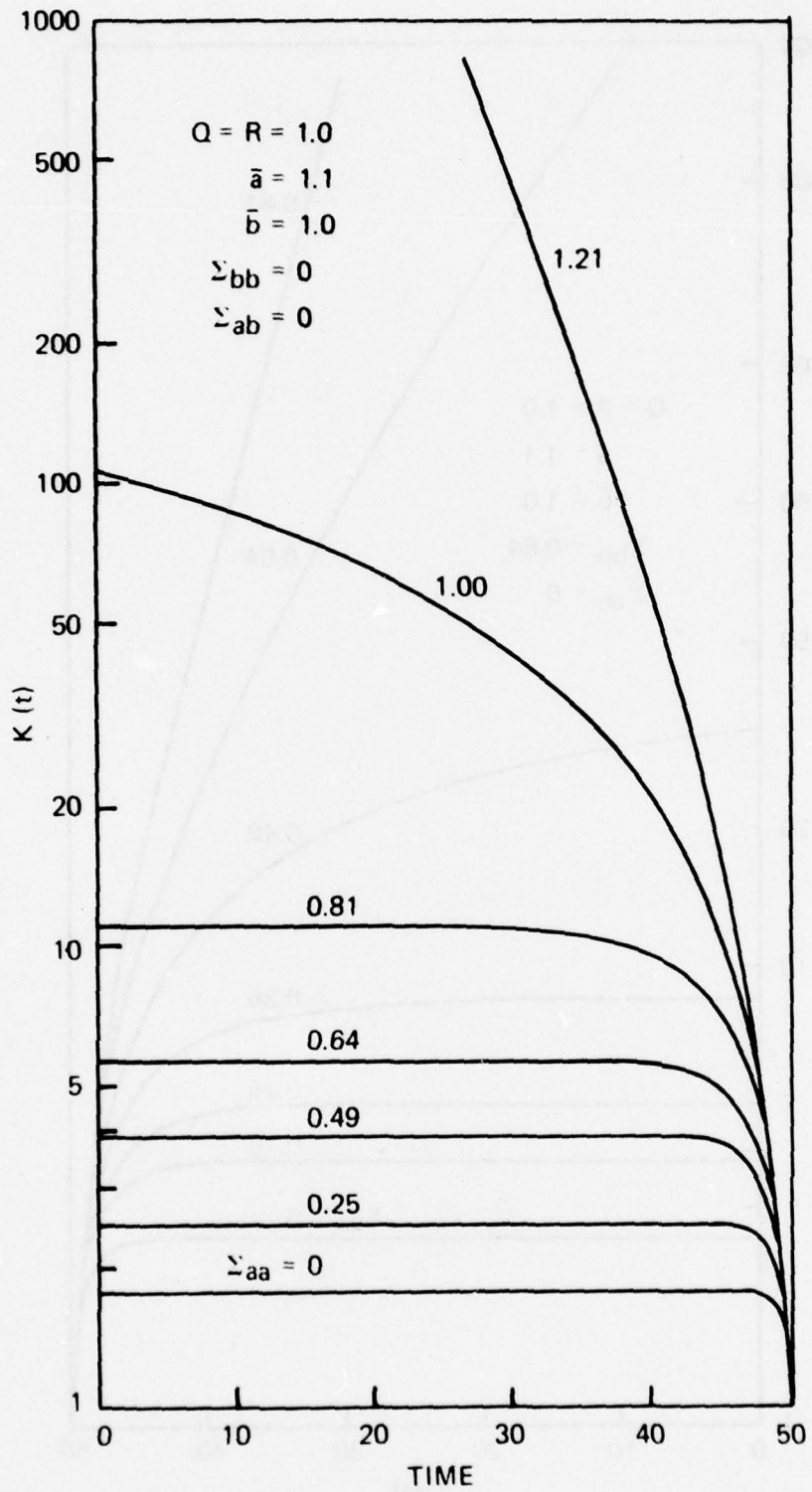

Figure 2.3 Solution of the Riccati-like equation (2.4.1) for  $N=50$  and known  $b(t)=\bar{b}=1.0$

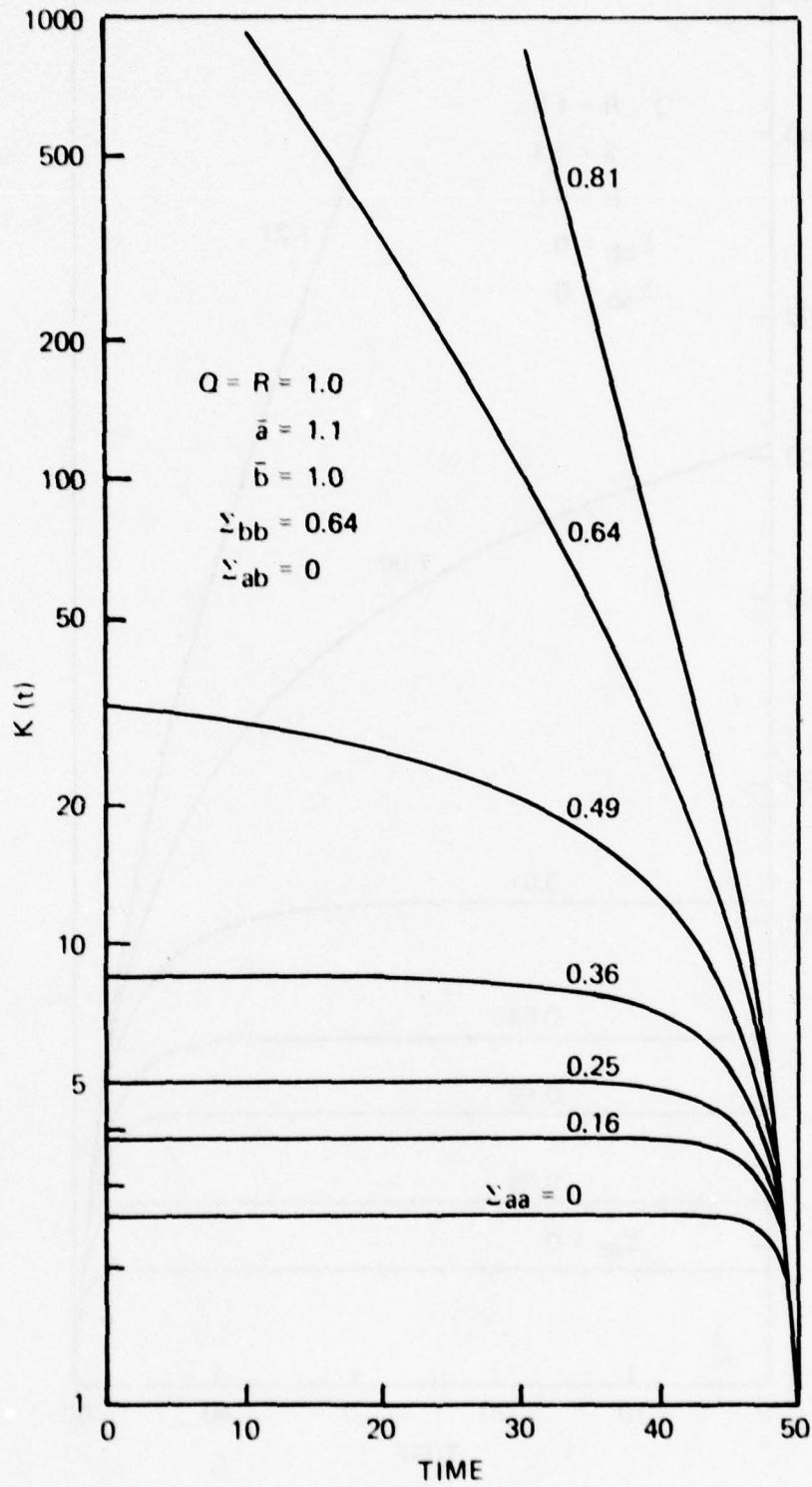

Figure 2.4 Solution of the Riccati-like equation (2.4.1) for  $N=50$  when both  $a(t)$  and  $b(t)$  are random

or

$$m = \frac{\Sigma_{aa} \Sigma_{bb} + \Sigma_{aa} \bar{b}^2 + \Sigma_{bb} \bar{a}^2 - \Sigma_{ab}^2 - 2\Sigma_{ab} \bar{a} \bar{b}}{\Sigma_{bb} + \bar{b}^2} \quad (2.4.4)$$

Clearly, from Eq. (2.4.2)  $K(t)$  will undergo exponential growth "backward in time" if

$$m > 1 \quad (2.4.5)$$

From the expression in Eq. (2.4.3) or (2.4.4) one can see that there are certain combinations of the parameter means and covariances that will yield the inequality condition in Eq. (2.4.5). Hence, we can immediately arrive at the conclusion that in the case of optimal stochastic control with purely random (white) parameters, a well-behaved solution to the infinite horizon problem may not exist.

A different insight can be provided by examining the dependence of the optimal cost upon the planning horizon. Figure 2.5 shows the behavior of the optimal cost versus time  $N$ . Note that if the threshold parameter  $m > 1$  then the optimal cost grows exponentially,

$$J^*(N) \cong x^2(0) e^{mN}, \quad m > 1 \quad (2.4.6)$$

Otherwise ( $m < 1$ ) the optimal cost remains bounded and finite.

Now, suppose that Eq. (2.4.1) has a steady-state solution given by  $\hat{K}$  satisfying the algebraic equation

$$\hat{K} = \hat{K}(\bar{a}^2 + \Sigma_{aa}) + Q - \frac{\hat{K}^2(\Sigma_{ab} + \bar{a} \bar{b})^2}{R + \hat{K}(\Sigma_{bb} + \bar{b}^2)} \quad (2.4.7)$$

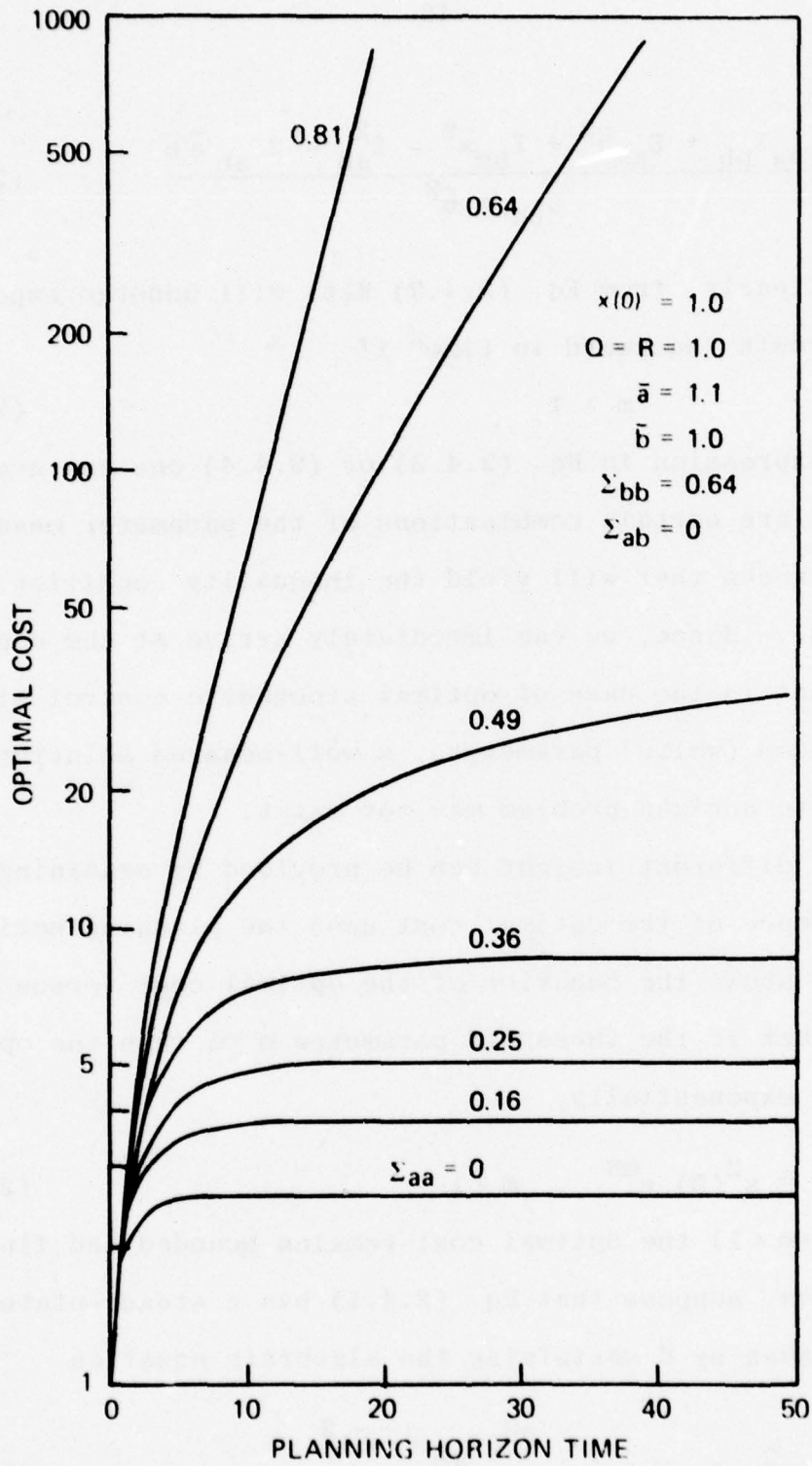

Figure 2.5 Behavior of the optimal cost  $J^*$  vs. planning horizon  $N$

Note that  $\hat{K}$  must be positive definite. The solution to the quadratic equation is then given by

$$\hat{K} = \left\{ - (R(\Sigma_{aa} + \bar{a}^2 - 1) + Q(\Sigma_{bb} + \bar{b}^2)) - \left[ (R(\Sigma_{aa} + \bar{a}^2 - 1) - Q(\Sigma_{bb} + \bar{b}^2))^2 + 4QR(\Sigma_{ab} + \bar{a}\bar{b})^2 \right]^{1/2} \right\} \cdot \left[ 2((\Sigma_{aa} + \bar{a}^2 - 1)(\Sigma_{bb} + \bar{b}^2) - (\Sigma_{ab} + \bar{a}\bar{b})^2) \right]^{-1} \quad (2.4.8)$$

The limiting solution  $\hat{K}$  is positive if

$$\Sigma_{aa} + \bar{a}^2 - \frac{(\Sigma_{ab} + \bar{a}\bar{b})^2}{\Sigma_{bb} + \bar{b}^2} < 1 \quad (2.4.9)$$

or

$$m < 1 \quad (2.4.10)$$

We state the following result.

Theorem 2.1

The unique positive solution to the infinite horizon problem given by Eqs. (2.2.1)-(2.2.7) exists if and only if  $m < 1$ .

Proof: ( $\Rightarrow$ ) we rewrite the Riccati-like Eq. (2.3.13), reversing the time index; as

$$K(t+1) = Q + K(t) \left[ (\Sigma_{aa} + \bar{a}^2) - \frac{(\Sigma_{ab} + \bar{a}\bar{b})^2}{\Sigma_{bb} + \bar{b}^2} \right] + \frac{(\Sigma_{ab} + \bar{a}\bar{b})^2}{\Sigma_{bb} + \bar{b}^2} \left[ K(t) - \frac{K^2(t)}{\left( \frac{R}{\Sigma_{bb} + \bar{b}^2} \right) + K(t)} \right] \quad (2.4.11)$$

Since the third term is non-negative definite ( $R > 0$ ),

$$\begin{aligned} K(t+1) &\geq Q + K(t)m \\ &\geq \sum_{\ell=0}^t Q m^{\ell} \end{aligned} \quad (2.4.12)$$

It follows immediately that if  $m > 1$ , then  $K(t)$  diverges as  $t \rightarrow \infty$ .

Since the third term is monotone increasing in  $K(t)$ , it follows that  $K(t)$  is monotone increasing for  $K(0) = Q$ . Let

$$M(t) = K(t) - \frac{K^2(t)}{\left(\frac{R}{\Sigma_{bb} + \bar{b}^2}\right) + K(t)} \quad (2.4.13)$$

Note that  $M(t)$  is also monotone for positive  $R$ . Thus there exists an  $\alpha > 0$  such that

$$M^{-1}(t) = \frac{1}{K(t)} + \frac{\Sigma_{bb} + \bar{b}^2}{R} \geq \alpha^{-1} \quad (2.4.14)$$

from which we have that  $M(t)$  is uniformly bounded in  $K(t)$ , that is,

$$M(t) \leq \alpha, \quad \alpha > 0 \quad (2.4.15)$$

It follows from Eqs. (2.4.11) and (2.4.15)

$$\begin{aligned}
 K(t+1) &\leq Q + \left[ (\Sigma_{aa} + \bar{a}^2) - \frac{(\Sigma_{ab} + \bar{a}\bar{b})^2}{\Sigma_{bb} + \bar{b}^2} \right] K(t) \\
 &\quad + \alpha \frac{(\Sigma_{ab} + \bar{a}\bar{b})^2}{\Sigma_{bb} + \bar{b}^2} \\
 &\leq \sum_{\ell=0}^t \left( Q + \alpha \frac{(\Sigma_{ab} + \bar{a}\bar{b})^2}{\Sigma_{bb} + \bar{b}^2} \right) m^\ell \tag{2.4.16}
 \end{aligned}$$

so that  $K(t)$  is bounded as  $t \rightarrow \infty$  because  $m < 1$ .

Since there is a sharp dividing line, quantified by the means and covariances of the random parameters, between the cases that the optimal stochastic control exists or does not exist for the infinite horizon case (see Fig. 2.6) it is obvious that there is a fundamental limitation to optimal infinite time quadratic control problem. We call this phenomenon, the Uncertainty Threshold Principle. This result has several implications in engineering and socioeconomic systems, since it points out there is a clear quantifiable boundary between our ability of making optimal decisions or not (in the sense that the optimal cost is bounded) as a function of the parameter modeling uncertainty.

Katayama [51] has pointed out this instability problem when  $b(t)$  is random in a multivariable system. For continuous-time systems the existence of solutions has been investigated by Bismut [45], but only for finite horizon

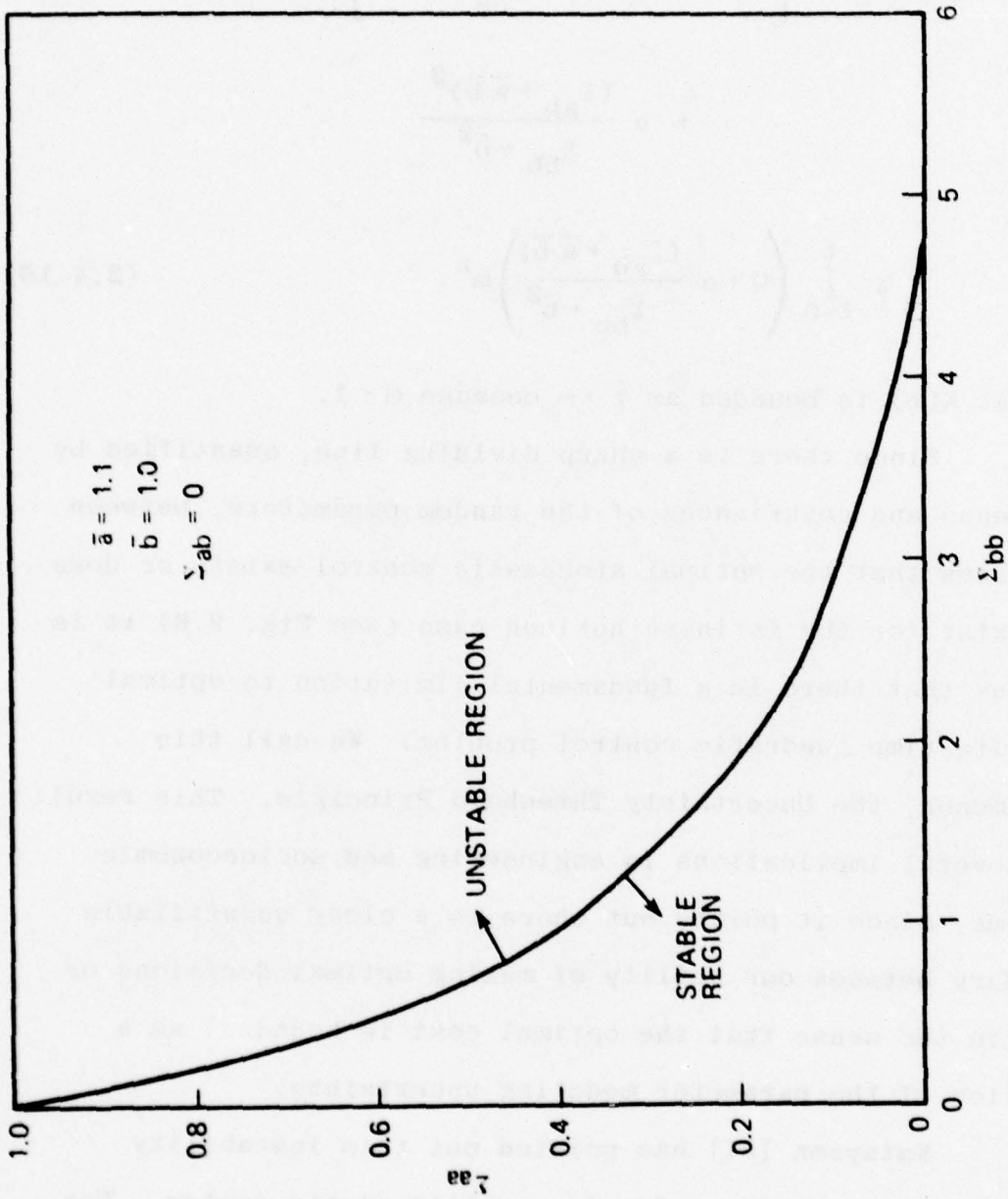

Figure 2.6 Stability region defined by equation (2.4.3) for system (2.2.1)

problems. In related problems involving control-dependent noise, Kleinman [41] assumed the existence of a solution.

In the case of known parameters ( $\Sigma_{aa} = \Sigma_{bb} = \Sigma_{ab} = 0$ ) Eq. (2.4.4) yields  $m = 0$ . This is the reason why there is no problem with the stationary solution for standard linear quadratic problem.

In the case where  $a(t) = \bar{a}$  ( $\Sigma_{aa} = 0 = \Sigma_{ab}$ ), Eq. (2.4.4) yields

$$m = \frac{\Sigma_{bb} + \bar{a}^{-2}}{\Sigma_{bb} + \bar{b}^{-2}} \quad (2.4.17)$$

so that as long as  $\bar{a}^{-2}$  is less than or approximately equal to one, then  $m < 1$  and there is no convergence problem for the solution  $K(t)$  to the Riccati-like Eq. (2.4.1), (see Fig. 2.7). This may possibly explain Kleinman's results [41] on control-dependent noise problems and their application for pilot models controlling stable aircraft. This is also the same stability condition derived by Katayama for random gains [51].

In the case where  $b(t) = \bar{b}$  ( $\Sigma_{bb} = 0 = \Sigma_{ab}$ ), Eq. (2.4.4) yields  $m = \Sigma_{aa}$ . This implies that independent of the average values of  $\bar{a}$  and  $\bar{b}$ , as long as the variance  $\Sigma_{aa}$  of the "time constant"  $\bar{a}$  of the system exceeds unity, then one is in trouble for long horizon planning problems, even for systems that are stable on the average ( $|\bar{a}| < 1$ ). This result seems to state that when the standard deviation of the parameter

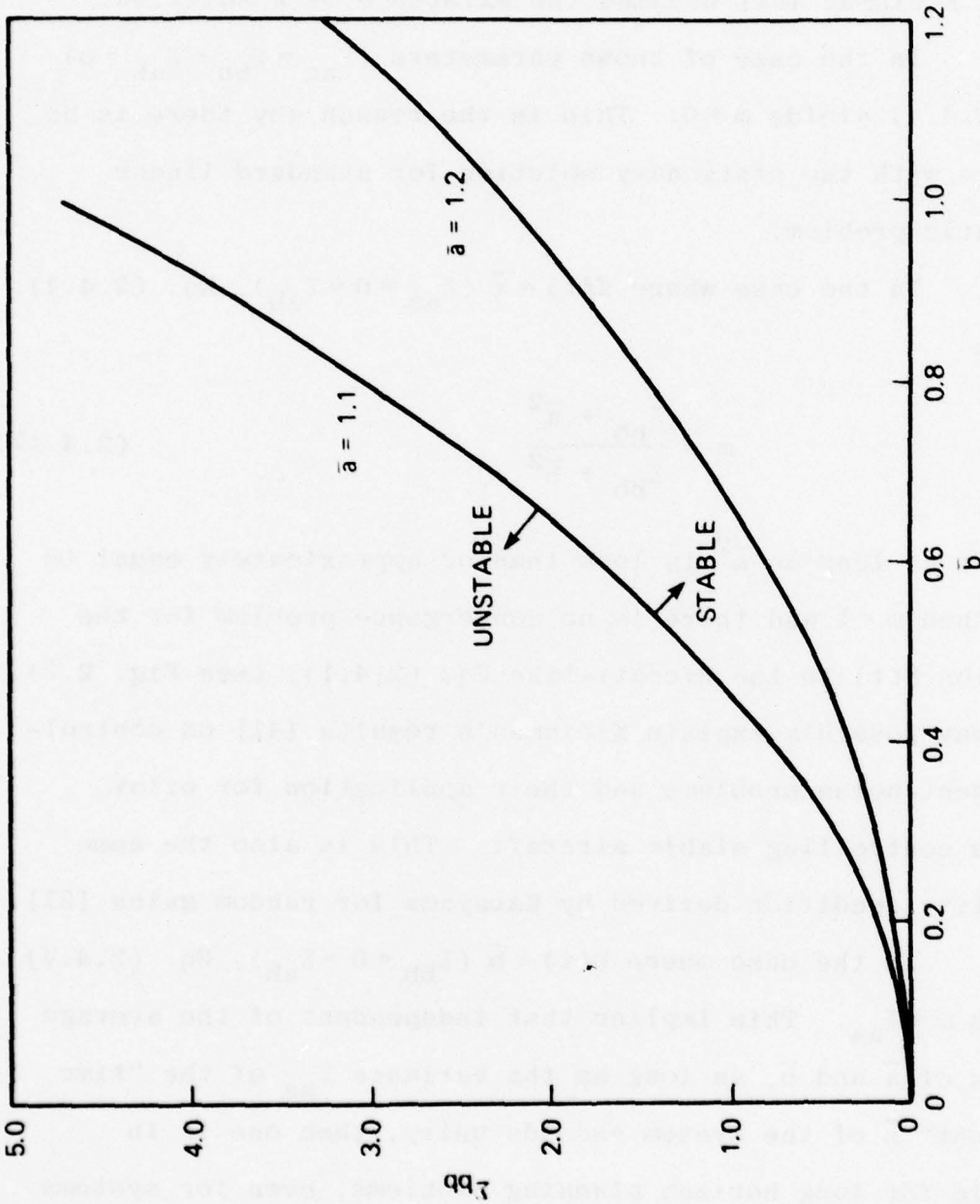

Figure 2.7 Stability regions defined by equation (2.4.3) for system (2.2.1) with known  $a(t)=\bar{a}$

$a(t)$  is greater than unity, then the system is statistically mean-square unstable, and under these conditions, one cannot stabilize the system. This provides a tie with the literature on stochastic stability with state-dependent noises ([52], [53]).

From Eq. (2.4.3), it is evident that a non-zero parameter correlation ( $\Sigma_{ab} > 0$ ) always reduces the value of  $m$ , and hence it helps prevent (up to a point) the divergence of  $K(t)$ . From a modeling viewpoint, this implies that a careful modeling of the relationship of the joint statistics in the coefficients that multiply the state variables and those that multiply the control variables can only help.

Suppose that the threshold parameter  $m < 1$  so that a steady-state  $\hat{K}$  exists, then the steady-state control gain given by

$$\bar{G} = \lim_{N \rightarrow \infty} G(t) = \frac{\hat{K} [\Sigma_{ab} + \bar{a} \bar{b}]}{R + \hat{K} (\Sigma_{bb} + \bar{b}^2)} \quad (2.4.18)$$

is well-defined. Since the gain  $G(t)$  is constant, the resulting optimal system will be linear and constant; from engineering point of view, such an optimal controller would be very simple to construct for stationary systems.

Next, suppose that  $\bar{b} = 0$ , so that the system (2.2.1) is "most uncontrollable on the average". Note that  $\bar{G} \neq 0$  and  $u(t) \neq 0$  provided that the correlation  $\Sigma_{ab} \neq 0$ . This means heuristically that the random time constant system is

controllable in a stochastic sense; the nonzero covariance  $\Sigma_{ab}$  means that  $a(t)$  and  $b(t)$  "swing together" and this implies that we can still control a system which is "most uncontrollable on the average". This observation seems to suggest a new concept of "stochastic controllability".

Note that in the case  $\bar{b} = 0$ , the uncertainty threshold parameter  $m$  is given by

$$m = \frac{\Sigma_{aa}\Sigma_{bb} - \Sigma_{ab}^2}{\Sigma_{bb}} + \bar{a}^{-2} \quad (2.4.19)$$

In view of the fact (2.2.7), this "stochastic controllability" is possible only for systems that are stable on the average ( $|\bar{a}| < 1$ ), otherwise  $m > 1$  (see Fig. 2.8).

Suppose now that the threshold parameter  $m > 1$ , so that the optimal cost given by Eq. (2.3.14) grows exponentially with the time horizon  $N$ . The control gain remains, however, a well-defined quantity, and is given by the constant value

$$\hat{G} = \frac{\Sigma_{ab} + \bar{a}\bar{b}}{\Sigma_{bb} + \bar{b}^2} \quad (2.4.20)$$

which is obtained by letting  $K(t+1) \rightarrow \infty$  in Eq. (2.3.13). One could argue that there is an optimal limiting gain in the sense that one is still trying to do his best so as to minimize the rate of the exponential growth of the optimal cost  $J$  with increasing horizon  $N$  (see Fig. 2.5).

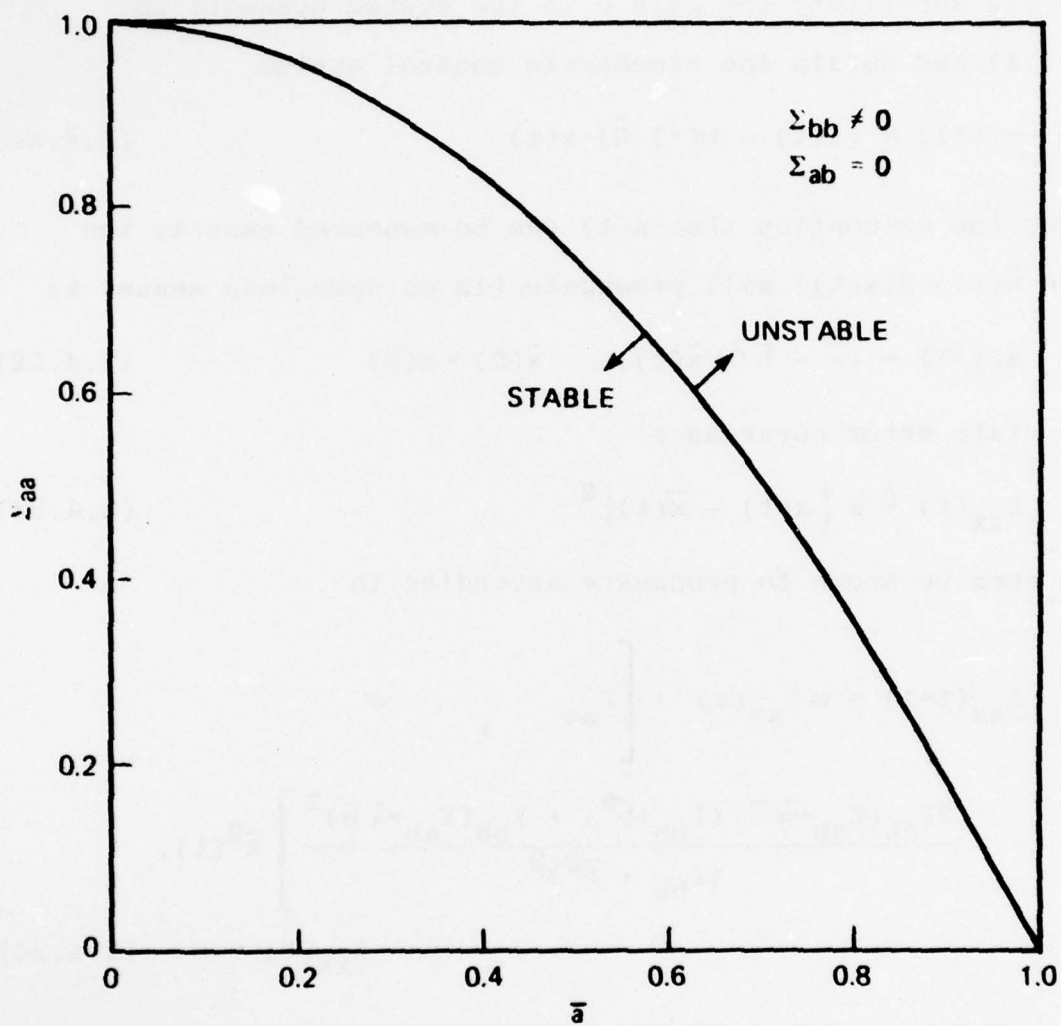

Figure 2.8 Stability region defined by equation (2.4.3) for system (2.2.1) when  $\bar{b}=0.0$

To see further the implication of this philosophy one can substitute the gain  $\hat{G}$  in the system dynamics Eq. (2.2.1) and obtain the stochastic control system

$$x(t+1) = (a(t) - b(t) \hat{G}) x(t) \quad (2.4.21)$$

Under the assumption that  $x(t)$  can be measured exactly the mean  $\bar{x}(t) = E\{x(t)\}$  will propagate (in an open-loop sense) as

$$\bar{x}(t+1) = (\bar{a} - \bar{b} \hat{G}) \bar{x}(t), \quad \bar{x}(0) = x(0) \quad (2.4.22)$$

The state error covariance

$$\Sigma_{xx}(t) \triangleq E \left\{ x(t) - \bar{x}(t) \right\}^2 \quad (2.4.23)$$

can then be shown to propagate according to

$$\Sigma_{xx}(t+1) = m \Sigma_{xx}(t) + \left[ \Sigma_{aa} - \frac{2\Sigma_{ab}(\Sigma_{ab} + \bar{a}\bar{b})(\Sigma_{bb} + \bar{b}^2) + \Sigma_{bb}(\Sigma_{ab} + \bar{a}\bar{b})^2}{(\Sigma_{bb} + \bar{b}^2)^2} \right] \bar{x}^2(t), \quad \Sigma_{xx}(0) = 0 \quad (2.4.24)$$

where  $m$  is the threshold parameter given by Eq. (2.4.13).

It is clear that if  $m > 1$  in Eq. (2.4.24) then the open-loop propagation of the variance of the state  $\Sigma_{xx}(t)$  is unstable. Essentially, this says that although the steady-state control is well-defined by a constant gain Eq. (2.4.20), and the closed-loop system of Eq. (2.4.21) can be implemented,

the variability of the state as measured by its variance "blows up" as  $t$  becomes large.

A sufficient condition that will ensure that the inequality (2.4.10) will be met is

$$\sum_{aa} + \frac{-2}{a} < 1 \quad (2.4.25)$$

This condition is both a necessary and sufficient condition for the asymptotic variance of the uncontrolled linear system

$$x(t+1) = a(t) x(t) \quad (2.4.26)$$

to be finite, and thus turns out to be sufficient to ensure that an optimal control exists as well.

## 2.5 Stochastic Stability Results

We want to now analyze the optimal control problem posed in Section 2.2 from an alternative point of view and arrive at exactly the same conclusions. The approach treats the stochastic control problem as essentially a mathematical problem, that is, stochastic difference equation and we will consider the stochastic stability of such system under feedback. Asymptotic stability of linear stochastic systems with random coefficients have been considered in [52] to [57].

Consider the first-order linear dynamical system

$$x(t+1) = a(t) x(t) + b(t) u(t) \quad (2.5.1)$$

One can include additive white noise driving the system dynamics, but the stability result is unchanged from the deterministic case. The question we want to deal with is

whether or not the system Eq. (2.5.1) is stabilizable under feedback when  $a(t)$  and  $b(t)$  are assumed to be random coefficients.

Let

$$u(t) = g(t) x(t) \quad (2.5.2)$$

Thus the closed-loop system will propagate according to the stochastic equation.

$$x(t+1) = \left[ a(t) + g(t) b(t) \right] x(t) \triangleq c(t) \quad (2.5.3)$$

If  $a(t)$  and  $b(t)$  are uncorrelated in time, one can calculate the ratio

$$\frac{E\{x^2(t+1)\}}{E\{x^2(1)\}} = E\{c^2(1)\}E\{c^2(2)\}\dots E\{c^2(t)\} \triangleq S(t) \quad (2.5.4)$$

The value of  $S(t)$  is a measure of how the second moment of the state propagates in time. The larger the value of  $S(t)$ , the more variable the state is. In particular if

$$\lim_{t \rightarrow \infty} S(t) \rightarrow \infty \quad (2.5.5)$$

the system (2.5.3) is unstable in the mean square sense.

The value of  $S(t)$  will be influenced in part by the value of the feedback gain  $g(t)$  in Eq. (2.5.2). So one can seek the value of  $g(t)$  which will minimize the ratio  $S(t)$  in Eq. (2.5.4).

The product  $S(t)$  is minimized if each element of the product

$$E\{c^2(t)\} = E\{[a(t) + g(t) b(t)]^2\} \quad (2.5.6)$$

is minimized by  $g(t)$ . Since

$$E\{c^2(t)\} = E\{a^2(t)\} + g^2(t) E\{b^2(t)\} + 2g(t) E\{a(t)b(t)\} \quad (2.5.7)$$

therefore, the best value of  $g(t)$  is obtained by algebraic minimization which yields

$$g^* = g^*(t) = - \frac{\Sigma_{ab} + \bar{a}\bar{b}}{\Sigma_{bb} + \bar{b}^2} = \text{constant} \quad (2.5.8)$$

Hence the minimum value of  $E\{c^2(t)\}$  is given by

$$\begin{aligned} E\{c^{2*}(t)\} &= E\{[a(t) + g^* b(t)]^2\} \\ &= \Sigma_{aa} + \bar{a}^2 - \frac{(\Sigma_{ab} + \bar{a}\bar{b})^2}{\Sigma_{bb} + \bar{b}^2} = m \end{aligned} \quad (2.5.9)$$

where  $m$  is the undiscounted threshold parameter given by Eq. (2.4.3).

It follows that

$$S^*(t) = m^t \quad (2.5.10)$$

and hence that

$$\lim_{t \rightarrow \infty} S^*(t) < \infty \quad \text{if } m < 1. \quad (2.5.11)$$

We state the results in the following theorem.

Theorem 2.2

The stochastic system in Eq. (2.5.1) is stabilizable by linear feedback in a mean-square sense if and only if the uncertainty threshold parameter  $m$ , defined by Eq. (2.4.3) is less than unity.

We note that the minimum variance gain  $g^*$  in Eq. (2.5.9) is the same as  $\hat{G}$  in Eq. (2.4.20) where we concluded that the limiting control gain is a constant and the feedback system can be implemented. The feedback system may or may not be stabilizable under feedback depending on whether or not the threshold parameter  $m < 1$  is satisfied.

The stochastic stability analysis resulted in an optimal gain  $g(t)$  given by Eq. (2.5.8) which is identical to Eq. (2.4.20). It yields the sufficient condition for optimal control to exist. Since we are considering mean-square stability, we could have obtained the same gain by setting  $R = 0$  in the cost functional Eq. (2.2.8); and then Eq. (2.4.18) becomes Eq. (2.5.8). The stochastic stability condition is thus independent of the numerical solution  $\hat{K}$ .

Following Kozin [58], we consider now the "almost sure stability" analysis (sample path stability) of the stochastic linear system Eq. (2.5.1) under feedback Eq. (2.5.2).

Definition 2.5.1. The equilibrium solution  $x(t) = 0$  of the system

$$\begin{aligned}x(t+1) &= (a(t) + b(t)g(t))x(t) \\ &= c(t)x(t)\end{aligned}\tag{2.5.12}$$

where

$$x(0) = x_0 \text{ is a random variable}$$

is almost surely stable if

$$\lim_{\delta \rightarrow 0} P \left\{ \sup_{|x_0| < \delta} \sup_{t \geq 0} |x(t, \omega)| > \epsilon \right\} = 0 \quad (2.5.13)$$

for any given  $\epsilon > 0$  and  $\delta(\epsilon, 0) > 0$ .

For discrete-time systems, an equivalent condition is given in [59].

Definition 2.5.2. The equilibrium solution  $x(t) = 0$  of the system Eq. (2.5.12) is almost surely stable if for  $\epsilon > 0$

$$\lim_{|x_0| \rightarrow 0} P \left\{ \sup_{t \geq 0} |x(t)| > \epsilon \right\} = 0 \quad (2.5.14)$$

Accordingly, Konstantinov in [59] proved the following:

Theorem 2.3

The solution  $x(t) = 0$  of the system (2.5.12) is almost surely stable for  $t \geq 0$  if there exists a function  $V(t, x) \in D_L$  (domain of definition) which for  $t \geq 0$  satisfies the conditions

- (i)  $V(t, x)$  is continuous at  $x = 0$  and  $V(t, 0) = 0$
- (ii)  $\inf_{|x| > \delta} V(t, x) > \alpha(\delta) > 0$  for any  $\delta > 0$
- (iii)  $L[V(t, x)] \leq 0$  in some neighborhood of  $x = 0$ .

A suitable Lyapunov function to use is

$$V(t, x) = x^2(t) \quad (2.5.15)$$

Then condition (iii) in Theorem 2.3 says that

$$E\{V(t+1, x) - V(t, x)\} \leq 0 \quad (2.5.16)$$

and using Eq. (2.5.12)

$$\bar{a}^2 + 2\bar{a}\bar{b}g(t) + \bar{b}^2 g^2(t) \leq 1 \quad (2.5.17)$$

We now show that for  $|\bar{a} + \bar{b}g(t)| < 1$ , then almost every sample sequence  $\{x(t)\}$  would approach zero. Following [54], we have

Theorem 2.4

The equilibrium solution of Eq. (2.5.12) is almost surely stable if  $|\bar{a} + \bar{b}g| < 1$ .

Proof: We must show that

$$\lim_{\delta \rightarrow 0} P \left\{ \sup_{|x_0| < \delta} \sup_{t \geq 0} |x(t, \omega)| > \epsilon \right\} = 0 \quad (2.5.18)$$

but,

$$\begin{aligned} & \lim_{\delta \rightarrow 0} P \left\{ \sup_{|x_0| < \delta} \sup_{t \geq 0} |x(t, \omega)| > \epsilon \right\} \\ &= \lim_{\delta \rightarrow 0} P \left\{ \sup_{|x_0| < \delta} \sup_{t \geq 0} |\phi(t, 0)| |x_0| > \epsilon \right\} \end{aligned} \quad (2.5.19)$$

where  $\phi(t, 0)$  is the solution of the difference equation

$$\phi(t+1, 0) = c(t) \phi(t, 0) \quad (2.5.20)$$

Hence, Eq. (2.5.19) becomes

$$\lim_{\delta \rightarrow 0} P \left\{ \sup_{t \geq 0} |\phi(t, 0)| > \frac{\epsilon}{\delta} \right\} \leq \quad (2.5.21)$$

$$\lim_{\delta \rightarrow 0} \left[ P \left\{ \sup_{0 \leq t \leq T(\omega)} |\phi(t, 0)| > \frac{\epsilon}{\delta} \right\} + P \left\{ \sup_{t > T(\omega)} |\phi(t, 0)| > \frac{\epsilon}{\delta} \right\} \right]$$

We note that

$$\phi(t, 0) = \prod_{\tau=0}^{t-1} (a(\tau) + b(\tau)g) \quad (2.5.22)$$

Therefore, the first term in Eq. (2.5.21) is given by

$$\begin{aligned}
 & \lim_{\delta \rightarrow 0} P \left\{ \sup_{0 \leq t \leq T(\omega)} |\phi(t, 0)| > \frac{\epsilon}{\delta} \right\} \\
 &= \lim_{n \rightarrow \infty} P \left\{ \sup_{0 \leq t \leq T(\omega)} |\phi(t, 0)| > n \epsilon \right\} \\
 &= P \left[ \bigcap_{n=1}^{\infty} \left\{ \omega : \sup_{0 \leq t \leq T(\omega)} |\phi(t, 0)| > n \epsilon \right\} \right] \\
 &= 0 \tag{2.5.23}
 \end{aligned}$$

since  $|\bar{a} + \bar{b}g| < 1$ .

For ergodic process in the parameters,

$$\lim_{t \rightarrow \infty} \frac{1}{t} \phi(t, \omega) = E\{\phi(t, \omega)\} \tag{2.5.24}$$

Given  $\beta > 0$ , there exists then a random time  $T_{\beta}(\omega)$

such that

$$\left| \frac{1}{t} \phi(t, \omega) - E\{\phi(t, \omega)\} \right| < \beta \quad \text{a.s.} \tag{2.5.25}$$

for all  $t > T_{\beta}(\omega)$ .

Since

$$E\{\phi(t, \omega)\} = \bar{c}^t \tag{2.5.26}$$

then

$$\left| \frac{1}{t} \phi(t, \omega) \right| < \bar{c}^t + \beta \quad \text{a.s.} \tag{2.5.27}$$

for all  $t > T_{\beta}(\omega)$  and

$$\phi(t, \omega) < t(\bar{c}^t + \beta) \quad \text{almost surely} \tag{2.5.28}$$

The second term in Eq. (2.5.21) is, therefore, given

by

$$\lim_{\delta \rightarrow 0} P \left\{ \sup_{t > T(\omega)} |\phi(t, 0)| > \frac{\epsilon}{\delta} \right\} \leq \lim_{\delta \rightarrow 0} P \left\{ \sup_{t > T(\omega)} |(\bar{c}^t + \beta)t| > \frac{\epsilon}{\delta} \right\} \quad (2.5.29)$$

Now for arbitrarily small  $\beta \rightarrow 0$  for  $T(\omega) \rightarrow \infty$  in Eqs.

(2.5.24) and (2.5.25), we have in the limit

$$T_{\beta}(\omega) \bar{c}^{T_{\beta}(\omega)} = (\bar{c}^t + \beta)t$$

so that Eq. (2.5.29) becomes

$$\lim_{\delta \rightarrow 0} P \left\{ |T(\omega) \bar{c}^{T(\omega)}| > \frac{\epsilon}{\delta} \right\} = 0 \quad (2.5.30)$$

since  $|\bar{c}| < 1$  and  $T(\omega)$  belongs to the positive integers set.

Combining Eqs. (2.5.21), (2.5.23), and (2.5.30) we complete the proof.

We demonstrate that the mean-square stability condition is stronger than the almost sure stability criterion.

From Eq. (2.5.8),

$$g = - \frac{\bar{a}\bar{b}}{\Sigma_{bb} + \bar{b}^2} \quad (\Sigma_{ab} = 0) \quad (2.5.31)$$

Substitute this into Eq. (2.5.32)

$$|\bar{a} + \bar{b}g| < 1 \quad (2.5.32)$$

we get

$$\left| \frac{\bar{a} \Sigma_{bb}}{\Sigma_{bb} + \bar{b}^2} \right| < 1 \quad (2.5.33)$$

which does not hold for the general case ( $|\bar{a}| > 1$ ).

Since almost sure stability requires  $|\bar{a} + \bar{b}g| < 1$ ,

this implies that

$$\bar{a}^2 + 2\bar{a}\bar{b}g + \bar{b}^2g^2 < 1$$

Note that this is less restrictive than the mean-square stability condition given by Eq. (2.5.8). Almost sure stability (pointwise stability) states that for the stochastic system under linear feedback Eq. (2.5.12), the equilibrium solution  $x(t) = 0$  is stochastic stabilizable. It ensures the existence of a control that will drive the system towards zero (except for random fluctuations). It is different from the mean-square stability in that it deals with the ensemble of sample paths and says that the variance of  $x(t)$  is finite and bounded if and only if  $m \leq 1$ .

## 2.6 The Discounted Cost Problem

In this section we will consider the effects of including a discount factor in the objective function. Traditionally, discount factors have been used in economic problems to emphasize the near-term worth of the utility function as compared to the long-term worth [60]. One may then suspect that the inclusion of the discount factor in the objective function may increase the threshold at which the optimal control for the infinite horizon problem is well-defined. That this is indeed the case will be shown in the development below.

In control systems, the discount factor has been used for infinite-time control problem. Since the cost is infinite in the infinite horizon problem, it is usually

normalized by the planning horizon  $N$ , that is, one considers

$$\lim_{N \rightarrow \infty} \frac{1}{N} E \left\{ \sum_{t=1}^N Q x^2(t) + R u^2(t) \right\} \quad (2.6.1)$$

Kushner ([61], pp. 152-153) shows that this can be closely approximated by

$$E \sum_{t=0}^{\infty} \alpha^t [Q x^2(t) + R u^2(t)] \quad 0 < \alpha < 1 \quad (2.6.2)$$

The use of the discount factor  $\alpha$  guarantees that all costs are finite and prevents  $J$  from "blowing up" as  $N \rightarrow \infty$ .

We are given that the system is described by Eqs. (2.2.1)-(2.2.6). We consider the minimization of the discounted quadratic cost given by

$$J = E \left\{ \sum_{t=0}^N \alpha^t (Q x^2(t) + R u^2(t)) \right\} \quad (2.6.3)$$

where  $N$  is the planning horizon and  $Q > 0$ ,  $R > 0$ . The case  $\alpha = 1$  is the undiscounted cost problem we have considered in Sections 2.2-2.4. The state  $x(t)$  can be measured exactly.

The solution to the optimal control problem is obtained by the method of dynamic programming. The derivation follows closely that given in Section 2.3 for the undiscounted problem and, hence is not repeated. We note that in the discounted cost problem, the dynamic programming algorithm can be modified for the cost functional of the form

$$E \left\{ \alpha^N K(x(N)) + \sum_{t=0}^{N-1} \alpha^t L(t, x(t), u(t), \xi(t)) \right\} \quad (2.6.4)$$

$0 < \alpha < 1$

to be

$$V(x(N)) = K(x(N))$$

$$V(x(t)) = \inf_{u(t)} E \left\{ L(t, x(t), u(t), \xi(t)) + \alpha V(x(t+1)) \right\} \quad (2.6.5)$$

Theorem 2.5

Given a linear stochastic system described by Eqs. (2.2.1) to (2.2.6) and the cost functional (2.6.3), the optimal feedback control at each instant of time is given by a linear transformation of the measured state, that is,

$$u(t) = - G(t) x(t) \quad (2.6.6)$$

$$G(t) = \frac{\alpha K(t+1)(\Sigma_{ab} + \bar{a}\bar{b})}{R + \alpha K(t+1)(\Sigma_{bb} + \bar{b}^2)} \quad (2.6.7)$$

The  $K(t)$ 's satisfies a Riccati-like recursive equation

$$K(t) = Q + \alpha K(t+1)(\Sigma_{aa} + \bar{a}^2) - \frac{\alpha^2 K^2(t+1)(\Sigma_{ab} + \bar{a}\bar{b})^2}{R + \alpha K(t+1)(\Sigma_{bb} + \bar{b}^2)}, \quad K(N) = Q \quad (2.6.8)$$

The optimal average cost is given by

$$J^* = K(0) x^2(0) + \sum_{t=0}^{N-1} \alpha^{t+1} K(t+1) \Xi(t) \quad (2.6.9)$$

Proof: Use dynamic programming as in Section 2.3.

The optimal solution given in Theorem 2.5 exists for all finite horizon  $N$ . However, the solution to the optimal control problem may fail to exist (in the sense that the

optimum cost is infinite) for the infinite horizon case.

The precise result is stated as follows.

Theorem 2.6

Let the horizon time  $N$  go to  $\infty$ . Define the undiscounted threshold parameter by Eq. (2.4.3).

$$m = (\Sigma_{aa} + \bar{a}^2) - \frac{(\Sigma_{ab} + \bar{a}\bar{b})^2}{\Sigma_{bb} + \bar{b}^2} \quad (2.6.10)$$

Then the optimal solution to the infinite horizon problem exists if and only if  $m \leq \frac{1}{\alpha}$ .

Proof: Let  $\tilde{a} \triangleq \sqrt{\alpha} a(t)$  and  $\tilde{R} = R/\alpha$ ,  $\tilde{\Sigma}_{aa} = \alpha \Sigma_{aa}$ ,  $\tilde{\Sigma}_{ab} = \sqrt{\alpha} \Sigma_{ab}$ .

Then after some algebra, Eq. (2.6.8) becomes

$$K(t) = Q + K(t+1)(\tilde{\Sigma}_{aa} + \bar{a}^2) - \frac{K^2(t+1)(\tilde{\Sigma}_{ab} + \bar{a}\bar{b})^2}{\tilde{R} + K(t+1)(\Sigma_{bb} + \bar{b}^2)} \quad (2.6.11)$$

The form of the nonlinear difference equation is identical to that of Eq. (2.4.1). Hence the results follow from Theorem 2.1.

The above results imply that if the stability condition  $m \leq \frac{1}{\alpha}$  holds, then the limiting solution of Eq. (2.6.8) exists, is bounded, and approaches a constant value  $K$ .

$$\lim_{N \rightarrow \infty} K(t) = K \quad (2.6.12)$$

and it is the positive solution to the algebraic equation

$$K = Q + \alpha(\Sigma_{aa} + \bar{a}^2) K - \frac{\alpha^2 K^2 (\Sigma_{ab} + \bar{a}\bar{b})^2}{R + \alpha K(\Sigma_{bb} + \bar{b}^2)} \quad (2.6.13)$$

and, consequently, the linear gain  $G(t)$  in Eq. (2.6.7) also approaches a constant value

$$G = \lim_{N \rightarrow \infty} G(t) = \frac{\alpha K(\Sigma_{ab} + \bar{a}\bar{b})}{R + \alpha K(\Sigma_{bb} + \bar{b}^2)} \quad (2.6.14)$$

Otherwise,  $\lim_{N \rightarrow \infty} K(t)$  is not bounded, and,  $K(t)$  grows exponentially as

$$\lim_{N \rightarrow \infty} K(t) \approx e^{\alpha m N} \quad (2.6.15)$$

We remark that in the discounted problem, the more the future cost is discounted ( $\alpha \rightarrow 0$ ) the more uncertainty can be tolerated in the randomness of the parameters and still have an optimal solution for the infinite horizon problem.

Thus in the case that the solution exists ( $m \leq \frac{1}{\alpha}$ ) the use of the optimal control laws Eq. (2.6.6) where  $G(t)$  is the constant gain given by Eq. (2.6.14) will result in the following optimum evolution of the state  $x(t)$ ,

$$x(t+1) = \left[ a(t) - \frac{\alpha K(\Sigma_{ab} + \bar{a}\bar{b})}{R + \alpha K(\Sigma_{bb} + \bar{b}^2)} b(t) \right] x(t) \quad (2.6.16)$$

One may suspect that the existence of an optimal control in the case  $m \leq \frac{1}{\alpha}$  results in the feedback stabilization according to Eq. (2.6.16). This is not true. We will now show that the optimal closed-loop system (2.6.16) is unstable

in a mean-square sense in the region  $1 \leq m \leq \frac{1}{\alpha}$  in spite of the existence of an optimum control in the region specified above.

Recall that the stochastic system Eq. (2.2.1) is stabilizable if and only if the undiscounted threshold parameter  $m$  defined in Eq. (2.4.3) is less than unity. This holds for any stochastic linear system and any linear feedback control law. Applying the Theorem 2.2, the optimal closed-loop system of Eq. (2.6.16) is not stable in a mean-square sense in the region  $1 \leq m \leq \frac{1}{\alpha}$ , where  $\alpha$  is the discount factor.

This is a very interesting and important result. The implications of the above results are best understood by referring to Fig. 2.9a. The undiscounted threshold parameter  $m$  can be thought as a measure of the system parameter uncertainty, since for any given mean values  $\bar{a}$  and  $\bar{b}$  of the random parameters  $a(t)$  and  $b(t)$ ,  $m$  increases monotonically with both parameter variances  $\Sigma_{aa}$  and  $\Sigma_{bb}$ . Note that  $m$  is uniquely characterized by the stochastic system itself and is independent of the performance criterion  $J$  used. For any given discount factor  $\alpha$ , if the system uncertainty is large enough (Region C in Fig. 2.9a), no stabilizing optimal control exists for the infinite horizon problem. If the system uncertainty is sufficiently small (Region A in Fig. 2.9a) then the optimal and stabilizing feedback control exists for the infinite-time problem.

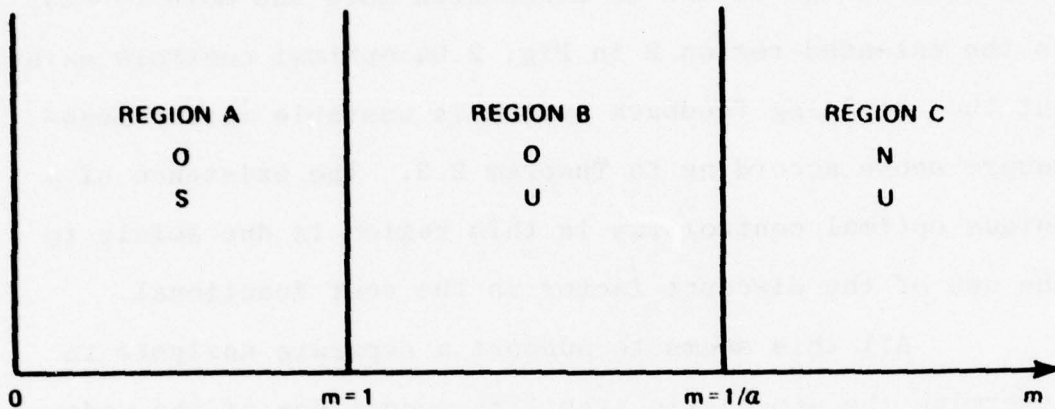

$0 < a < 1$ : DISCOUNT FACTOR

(a)

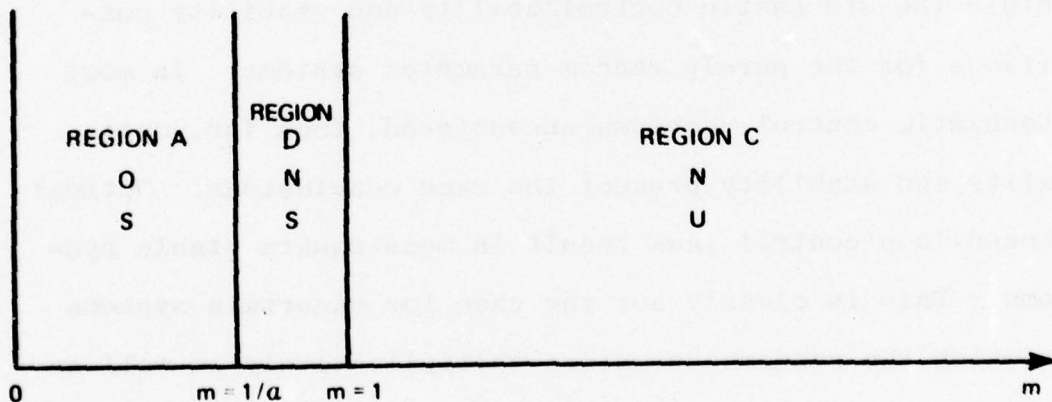

$1 < a < \infty$

(b)

Figure 2.9 Behavior of solution as a function of threshold parameter  $m$ . Legend:

- O: Optimal infinite horizon controls exist
- N: Optimal infinite horizon controls do not exist
- S: Closed loop system stochastically mean square stable
- U: Closed loop system stochastically mean square unstable

The interesting phenomenon occurs on the extended existence region B. Note that the size of this region increases as the future is discounted more and more ( $\alpha \rightarrow 0$ ). In the extended region B in Fig. 2.9a optimal controls exist, but the resulting feedback system is unstable in the mean-square sense according to Theorem 2.2. The existence of a unique optimal control law in this region is due solely to the use of the discount factor in the cost functional.

All this seems to support a separate analysis to determine the stochastic stability conditions of the underlying systems as has considered. A careful analysis of the stochastic optimization problem from the optimal control theory and stability theory are needed simultaneously to obtain the stochastic controllability and stability conditions for the purely random parameter systems. In most stochastic control problems encountered, thus far, optimality and stability present the same conclusions. Optimal closed-loop control laws result in mean-square stable systems. This is clearly not the case for uncertain systems in which the randomness enters multiplicatively as well as additively into the stochastic system in a significant way.

Following Magill [62] and Ramsey [63] where the discount rate  $\delta = r - \rho$  is allowed to vary from  $-\infty$  to  $+\infty$  with appropriate economic interpretations, we shall now consider the discrete-time problem where the discount factor  $\alpha$  can take on values  $1 < \alpha < \infty$ . We can argue heuristically that in

order for the cost functional Eq. (2.6.3) to remain finite for larger  $N$ , the terms in the cost functional must decrease faster than the growth in  $\alpha^t$  factor. Specifically, we have the cost functional

$$T = E \left\{ \sum_{t=0}^N \alpha^t (Q x^2(t) + R u^2(t)) \right\} \quad (2.6.3)$$

Using Eq. (2.6.5), we obtain the optimal stochastic control law for the discounted cost problem,

$$u(t) = - \frac{K(t+1) \bar{a} \bar{b}}{R + \alpha K(t+1) (\bar{b}^2 + \Sigma_{bb})} x(t) \quad (2.6.17)$$

where

$$K(t) = Q + \alpha K(t+1) \bar{a}^2 - \frac{\alpha^2 K^2(t+1) \bar{a}^2 \bar{b}^2}{R + \alpha K(t+1) (\bar{b}^2 + \Sigma_{bb})} \quad (2.6.18)$$

The previous results for  $0 < \alpha < 1$  can be extended to  $1 < \alpha < \infty$ .

In Fig. 2.9(b), we have plotted the regions of mean-square stability and optimality for  $1 < \alpha < \infty$ . Region A is shortened to the interval  $0 < m < \frac{1}{\alpha}$ . The use of the factor  $1 < \alpha$  gives rise to a new region D to where the optimal solution to the infinite horizon problem does not exist, but the system is mean-square stabilizable under linear feedback. The interpretation of this result is that the redefined cost functional grows as powers of  $\alpha$  so fast, that no optimal control  $u(t)$  exists to keep the cost bounded. Region C for  $m > 1$  has the same interpretation as in Fig. 2.9(a). In Fig. 2.10, we show the region of existence of optimal controls for  $0 \leq \alpha < \infty$ .

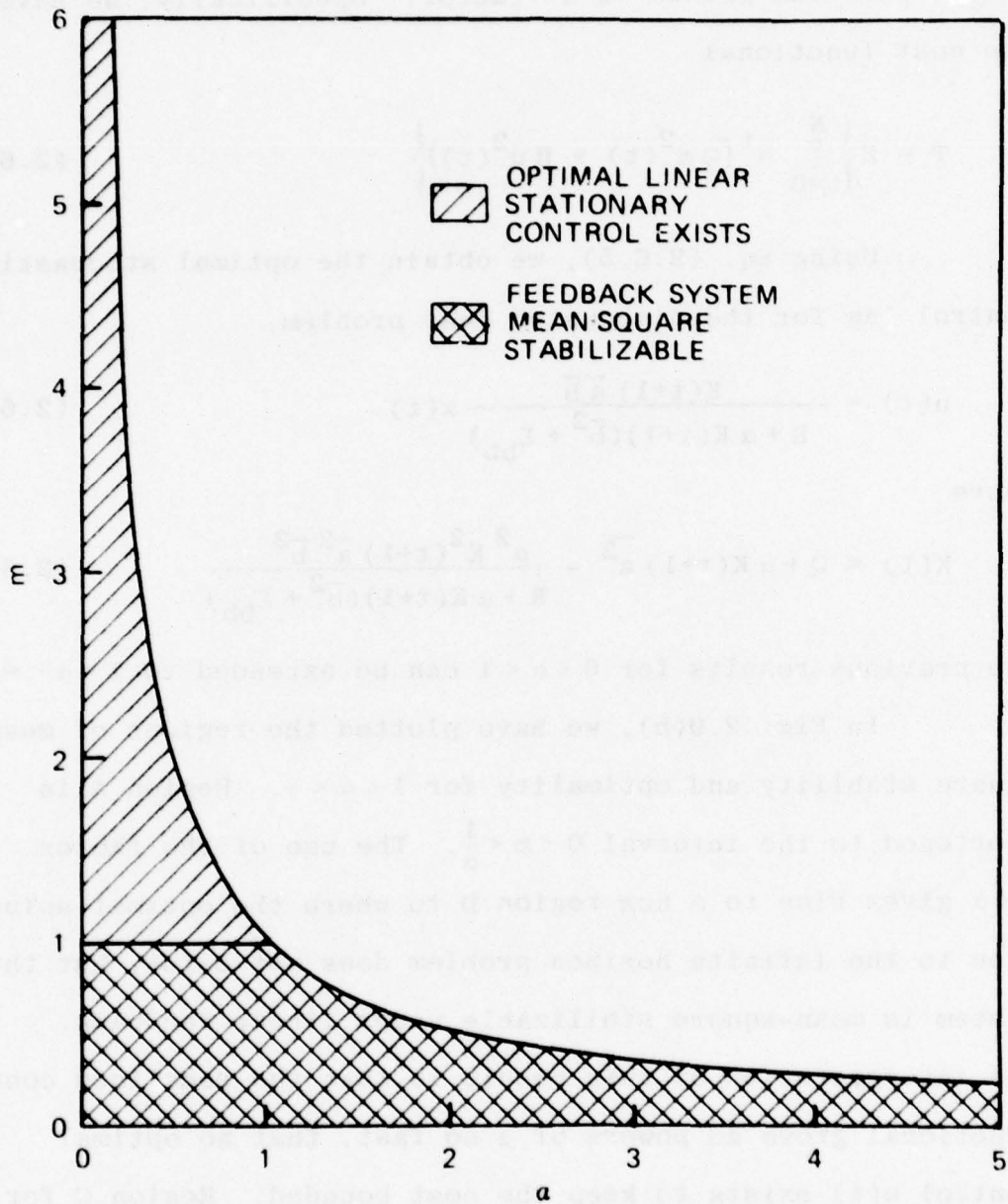

Figure 2.10 Optimality and stability regions for system equation (2.2.1)

## 2.7 Control of Linear Systems With Correlated Multiplicative and Additive Noises

The results we have obtained for the purely random (white) parameter stochastic control problem can be extended to allow for correlations between the system additive noise  $\xi(t)$  and random parameters  $a(t)$  and  $b(t)$ . We define the correlations by

$$E \left\{ (a(t) - \bar{a}(t)) \xi(s) \right\} = \Sigma_{a\xi}(t) \delta(t, s) \quad (2.7.1)$$

$$E \left\{ (b(t) - \bar{b}(t)) \xi(s) \right\} = \Sigma_{b\xi}(t) \delta(t, s) \quad (2.7.2)$$

The control problem is to minimize the average quadratic cost functional,

$$T = E_{\xi, a, b} \left\{ Q x^2(N) + \sum_{t=0}^{N-1} Q x^2(t) + R u^2(t) \right\} \quad (2.7.3)$$

subject to the same dynamical system Eq. (2.2.1).

$$x(t+1) = a(t) x(t) + b(t) u(t) + \xi(t) \quad (2.7.4)$$

We have that

$$V(N) = Q x^2(N) \quad (2.7.5)$$

$$\begin{aligned} V(N-1) = E \left\{ (Q a^2(N-1) + Q) x^2(N-1) + (Q b^2(N-1) + R) u^2(N-1) \right. \\ \left. + 2Q (a(N-1) b(N-1) x(N-1) + b(N-1) \xi(N-1)) u(N-1) \right. \\ \left. + 2Q a(N-1) \xi(N-1) x(N-1) \mid x^{N-1} \right\} + Q E \quad (2.7.6) \end{aligned}$$

Now the noise  $\xi(t)$  is correlated with  $a(t)$  and  $b(t)$ .

The cost-to-go is minimized when

$$u(N-1) = - G(N-1) x(N-1) - p(N-1) \quad (2.7.7)$$

$$G(N-1) = \frac{Q(\Sigma_{ab} + \bar{a}\bar{b})}{R + Q(\Sigma_{bb} + \bar{b}^2)} \quad (2.7.8)$$

$$p(N-1) = \frac{Q \Sigma_{b\xi}}{R + Q(\Sigma_{bb} + \bar{b}^2)} \quad (2.7.9)$$

Substituting this optimal solution into Eq. (2.7.6), we obtain for the optimal cost-to-go that

$$\begin{aligned} V^*(x(N-1), N-1) &= \left[ Q + Q(\bar{a}^2 + \Sigma_{aa}) \right. \\ &\quad \left. - \frac{Q^2(\Sigma_{ab} + \bar{a}\bar{b})^2}{R + Q(\bar{b}^2 + \Sigma_{bb})} \right] x^2(N-1) \\ &\quad + 2 \left[ Q \Sigma_{a\xi} - Q^2 \frac{(\Sigma_{ab} + \bar{a}\bar{b})}{R + Q(\Sigma_{bb} + \bar{b}^2)} \Sigma_{b\xi} \right] \\ &\quad x(N-1) + \text{constants} \\ &= K(N-1) x^2(N-1) + 2 k(N-1) x(N-1) + \text{const.} \end{aligned} \quad (2.7.10)$$

where

$$K(N-1) \triangleq Q + Q(\bar{a}^2 + \Sigma_{aa}) - \frac{Q^2(\Sigma_{ab} + \bar{a}\bar{b})^2}{R + Q(\Sigma_{bb} + \bar{b}^2)} \quad (2.7.11)$$

and

$$k(N-1) \triangleq Q \Sigma_{a\xi} - Q^2 \frac{(\Sigma_{ab} + \bar{a}\bar{b})}{R + Q(\Sigma_{bb} + \bar{b}^2)} \Sigma_{b\xi} \quad (2.7.12)$$

Going back one more step to N-2, we see that the structure of the minimization problem is the same. By

indulation on  $t$ , we then obtain the following result.

Theorem 2.7

Under the assumptions in Section 2.2, but allowing  $\xi(t)$  to be correlated with both  $a(t)$  and  $b(t)$ , the solution to the optimal control problem specified by Eqs. (2.7.3) and (2.7.4) exists and is of the form

$$u(t) = - G(t) x(t) - p(t) \quad (2.7.13)$$

$$G(t) = \frac{K(t+1)(\Sigma_{ab} + \bar{a}\bar{b})}{R + K(t+1)(\Sigma_{bb} + \bar{b}^2)} \quad (2.7.14)$$

$$p(t) = \frac{\bar{b} k(t+1) + K(t+1) \Sigma_{b\xi}}{R + K(t+1)(\Sigma_{bb} + \bar{b}^2)} \quad (2.7.15)$$

$$K(t) = Q + (\bar{a}^2 + \Sigma_{aa}) K(t+1) - \frac{K^2(t+1)(\Sigma_{ab} + \bar{a}\bar{b})^2}{R + K(t+1)(\Sigma_{bb} + \bar{b}^2)} \quad (2.7.16)$$

$$k(t) = (\bar{a} - \bar{b} G(t)) k(t+1) + K(t+1) (\Sigma_{a\xi} - G(t) \Sigma_{b\xi}) \quad (2.7.17)$$

with the boundary conditions

$$\left. \begin{aligned} K(N) &= Q \\ k(N) &= 0 \end{aligned} \right\} \quad (2.7.18)$$

The optimal policy is seen to consist of a feedback component  $G(t)$ , together with a fixed component  $p(t)$ . It is interesting to note that the expression for  $G(t)$  is identical to that given in Section 2.3, Eq. (2.3.12), so that feedback regulation of the state is independent of any correlation between the additive and multiplicative noise. The optimal feedback control law is still linear in the state. On the

other hand, the correction term  $p(t)$  depends crucially on the cross-covariances; if they are zero this term vanishes and leaves us with the feedback component alone and reduces to the results given in Section 2.3.

## 2.8 Conclusions

This chapter shows that the optimal control of dynamic systems with known structure, but with randomly varying parameters (modeled as white noise) has some limitations. In particular, by means of a simple scalar linear - quadratic control problem, it is shown in Section 2.4 that the infinite horizon solution does not exist if the parameter uncertainty exceeds a certain quantifiable threshold. We call this the Uncertainty Threshold Principle. This result has major engineering implications in the modeling accuracy required in terms of the variance of the parameters of a dynamical system before any stochastic optimal control scheme makes sense.

In Sections 2.5 and 2.6, it is demonstrated that the uncertainty threshold parameter is uniquely characterized by the stochastic system itself and is independent of the performance criterion used. Optimal controls may still be defined, due to the inclusion of a discount factor in the performance index, in region where the closed-loop system is unstable in a mean-square sense. The engineering implication is that a stochastic stability analysis should be carried independent of the stochastic optimization results. In most

stochastic optimization problems solved to-date optimality and stability are not in conflict; optimal controls result in stable systems. This is clearly not the case for systems in which the randomness enters multiplicatively as well as additively.

CHAPTER 3  
OPTIMAL LINEAR ESTIMATION OF STOCHASTIC SYSTEMS  
WITH RANDOM PARAMETERS

3.1 Introduction

In Chapter 2 we have considered the optimal stochastic control of a scalar linear stochastic dynamical system with purely random parameters. We would like to extend the analysis to scalar systems with noisy measurements. Before doing that we will examine the estimation problem.

It is well-known that for the standard linear-quadratic-Gaussian problem, the optimal stochastic control problem separates into the optimal deterministic control problem and optimal estimation problem with no control. That the two optimization problems are not completely unrelated is embodied in the Duality Theorem which says that one problem is the dual of the other. We will show that the optimal linear estimation results are not completely the formal dual of the optimal control problem. For the optimal stochastic control derived in Chapter 2 to be truly optimal, the optimal estimation algorithm derived in this chapter will be only optimal in the class of linear estimators. The technical assumptions we make to derive the linear unbiased estimators have excluded the filter from being the truly optimal estimator. We present the results for the linear minimum variance filter since the optimal filter would have to be nonlinear and infinite dimensional.

We will state the problem of state estimation with purely random parameters in the next section. The mathematical model developed in here can be related to the state-dependent and control-dependent noise models. In Section 3, we derive the optimal linear unbiased estimator in the minimum variance sense. The estimator is to operate in the open-loop sense. We will consider feedback control in the next chapter. In Section 4, the asymptotic behavior of the linear unbiased filter is examined, first for the case where the random parameters are all mutually uncorrelated at all times and next for the case where the random parameters may be correlated at each instant of time with each other. A stability analysis for the stochastic estimation problem in which the purely random (white) parameters are correlated has not been found in the literature. We note that the results in this chapter were obtained before the related references [64] and [65] were found.

Linear optimal filtering for a continuous-time linear dynamical system, in which the process and observation have state-dependent noise was considered in [66]. For the time-invariant problems, it was shown that the second moment of the state must be asymptotically stable for the uniqueness of the filtering solution. Necessary and sufficient conditions for the second moment to be asymptotically stable is given in [67]. The discrete-time filtering problem was considered in [68] for the case where only the measurement

equation contains state-dependent noise and no input is applied.

### 3.2 Problem Statement

Suppose that the scalar linear stochastic dynamical system is described by the difference equation

$$x(t+1) = a(t)x(t) + b(t)u(t) + \xi(t) \quad (3.2.1)$$

We include the second term in the estimation problem since this will be of importance in the case to be discussed when  $a(t)$  and  $b(t)$  are correlated random parameters. More importantly, this just represents the open-loop optimal estimation. But when we allow  $u(t)$  to be a function of the measurement, then the control system is closed-loop.

Let us assume that the measurement equation is given by

$$z(t) = c(t)x(t) + \theta(t) \quad (3.2.2)$$

Assume that the initial state  $x(0)$  is a random variable, with given a priori statistics.

$$E\{x(0)\} = \bar{x}_0, \quad E\{(x(0) - \bar{x}_0)^2\} = \Sigma_{x0} \quad (3.2.3)$$

The initial state variable is assumed to be uncorrelated with any other random variables in the system. The input  $u(t)$  is assumed to be a deterministic quantity in the estimation problem.

The additive noises  $\xi(t)$  and  $\theta(t)$  are assumed to be zero-mean Gaussian white noises, uncorrelated with each other at all times, and to have known a priori statistics.

$$E\{\xi(t) \xi(\tau)\} = \Xi(t) \delta(t, \tau) \quad (3.2.4)$$

$$E\{\theta(t) \theta(\tau)\} = \Theta(t) \delta(t, \tau) \quad (3.2.5)$$

What distinguishes our problem from the standard linear Gaussian estimation problem is that the parameters  $a(t)$  and  $b(t)$  and  $c(t)$  are assumed to be random parameters uncorrelated in time, with known means and covariances.

$$E\{a(t)\} = \bar{a}(t) , \quad E\{(a(t) - \bar{a}(t)) (a(\tau) - \bar{a}(\tau))\} \\ = \Sigma_{aa}(t) \delta(t, \tau) \quad (3.2.6)$$

$$E\{b(t)\} = \bar{b}(t) , \quad E\{(b(t) - \bar{b}(t)) (b(\tau) - \bar{b}(\tau))\} \\ = \Sigma_{bb}(t) \delta(t, \tau) \quad (3.2.7)$$

$$E\{c(t)\} = \bar{c}(t) , \quad E\{(c(t) - \bar{c}(t)) (c(\tau) - \bar{c}(\tau))\} \\ = \Sigma_{cc}(t) \delta(t, \tau) \quad (3.2.8)$$

The random parameters may be correlated with each other at each instant of time, so that

$$E\{(a(t) - \bar{a}(t)) (b(\tau) - \bar{b}(\tau))\} = \Sigma_{ab}(t) \delta(t, \tau) \quad (3.2.9)$$

Moreover the random parameter  $c(t)$  may be correlated with  $a(t)$  and  $b(t)$ , that is

$$E\{(a(t) - \bar{a}(t)) (c(\tau) - \bar{c}(\tau))\} = \Sigma_{ac}(\tau) \delta(t, \tau) \quad (3.2.10)$$

$$E\{(b(t) - \bar{b}(t)) (c(\tau) - \bar{c}(\tau))\} = \Sigma_{bc}(\tau) \delta(t, \tau) \quad (3.2.11)$$

We assume that the random parameters are independent of the additive white noise  $\xi(t)$  in the system dynamics and  $\theta(t)$  in the measurement. Note that in Eq. (3.2.1) if  $b(t)$  is

uncorrelated with  $a(t)$  and  $c(t)$  for all  $t$ , then the second product term essentially affects the system dynamics as an additional driving noise that can be combined with  $\xi(t)$  in the solution to the filtering problem as we will see.

The stochastic linear system given by the difference Eq. (3.2.1) is a Gaussian-Markov process, since the random parameters are assumed to be Gaussian white. However, the a posteriori conditional density function is non-Gaussian due to the random system parameter  $a(t)$ . The conditional probability density cannot in general be computed exactly since an infinite number of conditional moments are needed. In practice then, one would approximate the nonlinear filter or fix a priori the structure of the estimator to be linear and unbiased. We will constrain the filter in this chapter to be linear in both the state and the measurements, although it can be shown that the linear filter is not optimal in the class of all possible filters for the system Eqs. (3.2.1) and (3.2.2) [65].

We shall denote the post measurements by

$$z^t \triangleq \{z(1), z(2), \dots, z(t)\}$$

### 3.3 Derivation of the Linear Minimum Variance Filter

We consider now the Kalman-type linear filter of the following recursive form [69], the conditional mean being given by

$$\hat{x}(t+1|t) = F(t) \hat{x}(t|t-1) + G(t) u(t) + \psi(t) z(t) \quad (3.3.1)$$

Substitute Eq. (3.2.2) into this equation, we get

$$\begin{aligned} \hat{x}(t+1|t) = F(t) \hat{x}(t|t-1) + G(t) u(t) + \psi(t) c(t) x(t) \\ + \psi(t) \theta(t) \end{aligned} \quad (3.3.2)$$

Subtracting this equation from Eq. (3.2.1) we get the estimation error

$$\begin{aligned} x(t+1) - \hat{x}(t+1|t) = F(t) (x(t) - \hat{x}(t|t-1)) \\ + [a(t) - \psi(t) c(t) - F(t)] x(t) \\ + (b(t) - G(t)) u(t) - \psi(t) \theta(t) + \xi(t) \end{aligned} \quad (3.3.3)$$

We require that the estimate be unbiased, so that

$$E\{x(t+1) - \hat{x}(t+1|t)\} = 0 \quad \forall t \quad (3.3.4)$$

Taking the expectation of Eq. (3.3.3) we obtain that

$$F(t) = \bar{a}(t) - \psi(t) \bar{c}(t) \quad (3.3.5)$$

$$G(t) = \bar{b}(t) \quad (3.3.6)$$

The estimation error then satisfies the recursive equation

$$\begin{aligned} e(t+1|t) = (\bar{a}(t) - \psi(t) \bar{c}(t)) e(t|t-1) + (b(t) - \bar{b}(t)) u(t) \\ + \left[ (a(t) - \bar{a}(t)) + \psi(t) (\bar{c}(t) - c(t)) \right] x(t) \\ - \psi(t) \theta(t) + \xi(t) \end{aligned} \quad (3.3.7)$$

and the state estimate evolves as

$$\hat{x}(t+1|t) = \left[ \bar{a}(t) - \psi(t) \bar{c}(t) \right] \hat{x}(t|t-1) + \bar{b}(t) u(t) + \psi(t) z(t) \quad (3.3.8)$$

Define the conditional error covariance to be

$$\Sigma_{xx}(t+1|t) \triangleq F \{ e^2(t+1|t) | z^t \} \quad (3.3.9)$$

It is evident from Eq. (3.3.7) that the predicted error covariance  $\Sigma_{xx}(t+1|t)$  will involve terms requiring the computation of the second conditional moment of the state.

We note here that the measurement update is unbiased, since if we define

$$\bar{a}(t) \hat{x}(t|t) \triangleq \left[ \bar{a}(t) - \psi(t) \bar{c}(t) \right] \hat{x}(t|t-1) + \psi(t) z(t) \quad (3.3.10)$$

then

$$\begin{aligned} \bar{a}(t) E\{x(t) - \hat{x}(t|t) | z^t\} &= \bar{a}(t) E\{x(t) - \hat{x}(t|t-1) | z^{t-1}\} \\ &+ \psi(t) E\{c(t) x(t) - \bar{c}(t) \hat{x}(t|t-1) | z^{t-1}\} \\ &= 0 \end{aligned} \quad (3.3.11)$$

Now, the estimation error covariance is given by

$$\begin{aligned} \Sigma_{xx}(t+1|t) &= \left[ \bar{a}^2(t) + \psi^2(t) \bar{c}^2(t) - 2\bar{a}(t) \bar{c}(t) \psi(t) \right] \Sigma_{xx}(t|t-1) \\ &+ \left[ \Sigma_{aa}(t) + \psi^2(t) \Sigma_{cc}(t) - 2\Sigma_{ac}(t) \psi(t) \right] E\{x^2(t)\} \\ &+ \Sigma_{bb}(t) u^2(t) + \Xi(t) + \psi^2(t) \Theta(t) \\ &+ 2 \left[ \Sigma_{ab}(t) - \psi(t) \Sigma_{bc}(t) \right] u(t) E\{x(t)\} \end{aligned} \quad (3.3.12)$$

where the second moment of the state is given by

$$\begin{aligned} E\{x^2(t+1)\} &= (\bar{a}^2(t) + \Sigma_{aa}(t)) E\{x^2(t)\} + (\bar{b}^2(t) + \Sigma_{bb}(t)) u^2(t) \\ &+ \Xi(t) + 2(\bar{a}(t) \bar{b}(t) + \Sigma_{ab}(t)) u(t) E\{x(t)\} \end{aligned} \quad (3.3.13)$$

If we define,

$$X(t+1) \triangleq E\{x^2(t+1)\}$$

We can write Eq. (3.3.13) as

$$\begin{aligned} X(t+1) = & (\bar{a}^2(t) + \Sigma_{aa}(t)) X(t) + (\bar{b}^2(t) + \Sigma_{bb}(t)) u^2(t) + \Xi(t) \\ & + 2(\bar{a}(t)\bar{b}(t) + \Sigma_{ab}(t)) u(t)\hat{x}(t|t) \end{aligned} \quad (3.3.14)$$

and the mean is given by definition

$$\bar{a}(t)\hat{x}(t|t) = [\bar{a}(t) - \psi(t)\bar{c}(t)]\hat{x}(t|t-1) + \psi(t)z(t) \quad (3.3.15)$$

with initial conditions.

$$\hat{x}(0|-1) = E\{x(0)\} = \bar{x}_0 \quad (3.3.16)$$

$$\Sigma_{xx}(0|-1) = \Sigma_{x0} \quad (3.3.17)$$

$$X(0) = \Sigma_{x0} + \bar{x}_0^2 \quad (3.3.18)$$

We now want to determine the filter gain  $\psi(t)$  such that the error covariance in Eq. (3.3.12) is minimized. We have a deterministic optimization problem. Taking the derivative with respect to  $\psi(t)$  and setting the necessary condition to zero, we get

$$\psi^*(t) = \frac{\bar{a}(t)\bar{c}(t)\Sigma_{xx}(t|t-1) + \Sigma_{ac}(t)X(t) + \Sigma_{bc}(t)u(t)}{\bar{c}^2(t)\Sigma_{xx}(t|t-1) + \theta(t) + \Sigma_{cc}(t)X(t)} \quad (3.3.19)$$

Substituting this result into Eq. (3.3.12) the minimum estimation error covariance is

$$\begin{aligned} \Sigma_{xx}(t+1|t) = & \bar{a}^2(t)\Sigma_{xx}(t|t-1) + \Sigma_{bb}(t)u^2(t) + \Sigma_{aa}(t)X(t) \\ & + 2\Sigma_{ab}(t)u(t)E\{x(t)\} + \Xi(t) \\ & - \psi^2(t)\left[\bar{c}^2(t)\Sigma_{xx}(t|t-1) + \Sigma_{cc}(t)X(t) + \theta(t)\right] \end{aligned} \quad (3.3.20)$$

It can be shown that the optimal filter gain  $\psi^*(t)$  in Eq. (3.3.19) minimizes the error covariance at any time. The filter gains may be pre-computed since they are independent of the measurement.

### 3.4 Linear Filter With Uncorrelated Parameters

In this section we will present the results on the asymptotic behavior of the linear minimum variance filter when the random parameters are mutually independent at all times. This assumption is made to simplify the algebra and notations, but do not change the conclusions.

The optimal linear filter is given by the recursive equations.

Prediction: (Update Cycle)

$$\begin{aligned} \hat{x}(t+1|t) = & (\bar{a}(t) - \psi(t) \bar{c}(t)) \hat{x}(t|t-1) + \bar{b}(t) u(t) \\ & + \psi(t) z(t) \end{aligned} \quad (3.4.1)$$

The estimate has to be computed on-line since it is dependent on the current observations. The filter gain computation is given by

$$\psi(t) = \frac{\bar{a}(t) \bar{c}(t) \Sigma_{xx}(t|t-1)}{\bar{c}^2(t) \Sigma_{xx}(t|t-1) + \Sigma_{cc}(t) X(t) + \theta(t)} \quad (3.4.2)$$

The estimation error covariance is given by

$$\begin{aligned} \Sigma_{xx}(t+1|t) = & \bar{a}^2(t) \Sigma_{xx}(t|t-1) - \bar{a}(t) \bar{c}(t) \Sigma_{xx}(t|t-1) \psi(t) \\ & + \Sigma_{bb}(t) u^2(t) + \Sigma_{aa}(t) X(t) + \Xi(t) \end{aligned}$$

$$\begin{aligned}
 &= \bar{a}^2(t) \Sigma_{xx}(t|t-1) \\
 &\quad - \psi^2(t) \left[ \bar{c}^2(t) \Sigma_{xx}(t|t-1) + \Sigma_{cc}(t) X(t) + \theta(t) \right] \\
 &\quad + \Sigma_{bb}(t) u^2(t) + \Sigma_{aa}(t) X(t) + \Xi(t) \quad (3.4.3)
 \end{aligned}$$

and can be computed off-line.

We can also rewrite the filtering equations in terms of the mixed equations as follows.

Filtering: (Measurement Update Cycle)

From Eq. (3.4.1) we have

$$\hat{x}(t|t) = (1 - H(t)\bar{c}(t)) \hat{x}(t|t-1) + H(t) z(t) \quad (3.4.4)$$

We redefine the filter gain in terms of  $H(t)$ , the standard filter gain, using

$$\psi(t) \triangleq \bar{a}(t)H(t) \quad (3.4.5)$$

From Eq. (3.4.2), we write the update estimation error covariance as

$$\Sigma_{xx}(t|t) = (1 - H(t)\bar{c}(t)) \Sigma_{xx}(t|t-1) \quad (3.4.6)$$

It can be seen that the estimation error covariance depend on the input  $u(t-1)$ .

It can be shown that for the uncorrelated parameter case that [64]

$$E\{(x(t) - \hat{x}(t|t)) \hat{x}(t|t)\} = 0 \quad \forall t > 0$$

if  $E\{(x(0) - \hat{x}(0|0))\hat{x}(0|0)\} = 0$ . The estimation error is thus orthogonal to the state estimate.

The optimal linear filter given by Eqs. (3.4.1) to (3.4.6) resembles the standard Kalman filter for linear

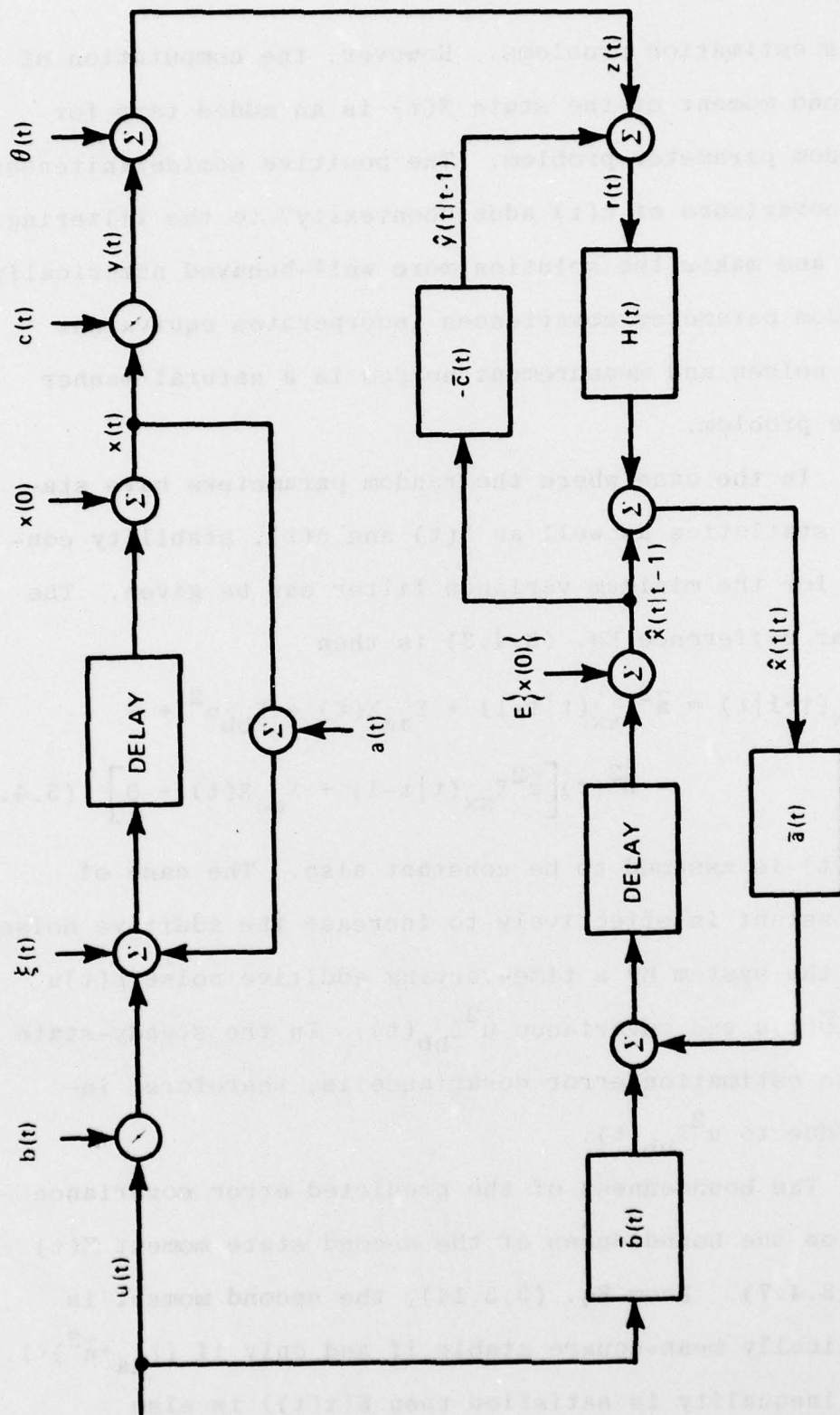

Figure 3.1 Linear minimum variance unbiased estimator for stochastic system (3.2.1) and (3.2.2)

Gaussian estimation problems. However, the computation of the second moment of the state  $X(t)$  is an added term for the random parameter problem. The positive semidefiniteness of the covariance of  $c(t)$  adds "convexity" to the filtering problem and makes the solution more well-behaved numerically. The random parameter covariances incorporates equivalent driving noises and measurement noises in a natural manner into the problem.

In the case where the random parameters have stationary statistics as well as  $\xi(t)$  and  $\theta(t)$ , stability conditions for the minimum variance filter can be given. The nonlinear difference Eq. (3.4.3) is then

$$\begin{aligned} \Sigma_{xx}(t+1|t) = & \bar{a}^2 \Sigma_{xx}(t|t-1) + \Sigma_{aa} X(t) + \Sigma_{bb} u^2 + \Xi \\ & - H^2(t) \left[ \bar{c}^2 \Sigma_{xx}(t|t-1) + \Sigma_{cc} X(t) + \Theta \right] \end{aligned} \quad (3.4.7)$$

where  $u(t)$  is assumed to be constant also. The case of  $u(t) = \text{constant}$  is effectively to increase the additive noise  $\xi(t)$  in the system by a time-varying additive noise  $b(t)u$  of mean  $\bar{b}(t)u$  and covariance  $u^2 \Sigma_{bb}(t)$ . In the steady-state the state estimation error covariance is, therefore, increased due to  $u^2 \Sigma_{bb}(t)$ .

The boundedness of the predicted error covariance depends on the boundedness of the second state moment  $X(t)$  in Eq. (3.4.7). From Eq. (3.3.14), the second moment is asymptotically mean-square stable if and only if  $(\Sigma_{aa} + \bar{a}^2) < 1$ . If this inequality is satisfied then  $E\{x(t)\}$  is also

asymptotically mean-square stable. For stationary systems, the asymptotic stability of the second moment of the state  $X(t)$  is a sufficient condition for the stability of the estimator. If  $(\Sigma_{aa} + \bar{a}^2) < 1$  then the predicted error covariance will be bounded. The filter is effectively a Kalman filter with time-varying noise statistics given by  $\Sigma_{aa} X(t)$ .

We summarize the results above in the following theorem

Theorem 3.1

The solution to the Riccati-like Eq. (3.4.7)

$$\Sigma_{xx}(t+1|t) = \bar{a}^2 \Sigma_{xx}(t|t-1) - \frac{\bar{a}^2 \bar{c}^2 \Sigma_{xx}^2(t|t-1)}{\bar{c}^2 \Sigma_{xx}(t|t-1) + \theta + \Sigma_{cc} X(t)} + \Xi + \Sigma_{aa} X(t) + \Sigma_{bb} u^2 \quad (3.4.8)$$

exists and is unique if the condition

$$\Sigma_{aa} + \bar{a}^2 < 1$$

is satisfied for  $u(t) = \text{constant}$ .

The steady-state  $\Sigma_{xx}$  satisfies the algebraic equation

$$\Sigma_{xx} = \bar{a}^2 \Sigma_{xx} - \frac{\bar{a}^2 \bar{c}^2 \Sigma_{xx}^2}{\bar{c}^2 \Sigma_{xx} + \Sigma_{cc} X + \theta} + \Sigma_{aa} X + \Sigma_{bb} u + \Xi \quad (3.4.9)$$

For  $(\Sigma_{aa} + \bar{a}^2) > 1$ , the predicted error covariance diverges, but the filter gain computation is still given by

$$H = \frac{\bar{c}}{\bar{c}^2 + \Sigma_{cc}} \quad (3.4.10)$$

since

$$X \equiv \Sigma_{xx} + E\{\hat{x}^2\} \quad (3.4.11)$$

In the special case where the parameter  $a(t)$  is known, then the necessary and sufficient condition for the asymptotic stability of the second moment of the state is  $|a| < 1$ .

An approximate analysis of Eq. (3.4.7) shows that for  $\Sigma_{xx}(t+1|t)$  large

$$\begin{aligned} \Sigma_{xx}(t+1|t) &\approx a^2 \Sigma_{xx}(t|t-1) + \Sigma_{aa} \Sigma_{xx}(t|t-1) - \frac{a^2 c^2 \Sigma_{xx}(t|t-1)}{c^2 + \Sigma_{cc}} \\ &\approx m \Sigma_{xx}(t|t-1) \end{aligned} \quad (3.4.12)$$

where

$$m \triangleq a^2 + \Sigma_{aa} - \frac{a^2 c^2}{c^2 + \Sigma_{cc}} \quad (3.4.13)$$

then  $m > 1$ . However, this inequality is weaker than the threshold condition given in Theorem 3.1 and would include points which did not give rise to mean-square stable filters. This simple analysis shows that the expression in (3.4.13) which can be obtained by equating  $\bar{b}$  with  $\bar{c}$  is only a sufficient stability condition in the filtering problem.

### 3.5 Mutually Correlated Random Parameters

In this section we will consider the asymptotic behavior of Eq. (3.3.20). When the random parameters  $a(t)$ ,  $b(t)$ , and  $c(t)$  may be mutually correlated at each instant of time. For the scalar stochastic system with wide-sense stationary statistics,

$$\begin{aligned} \Sigma_{xx}(t+1|t) &= \bar{a}^2 \Sigma_{xx}(t|t-1) \\ &\quad - \frac{[\bar{a} \bar{c} \Sigma_{xx}(t|t-1) + \Sigma_{ac} X(t) + \Sigma_{bc} u E\{x(t)\}]^2}{\bar{c}^2 \Sigma_{xx}(t|t-1) + \Sigma_{cc} X(t) + \theta} \\ &\quad + \Xi + \Sigma_{aa} X(t) + 2\Sigma_{ab} u E\{x(t)\} + \Sigma_{bb} u^2 \end{aligned} \quad (3.5.1)$$

In case the random parameter  $b(t)$  is not correlated with any other white noise parameter, we have a simplification. The predicted error covariance is given by

$$\begin{aligned} \Sigma_{xx}(t+1|t) &= \bar{a}^2 \Sigma_{xx}(t|t-1) - \frac{[\bar{a} \bar{c} \Sigma_{xx}(t|t-1) + \Sigma_{ac} X(t)]^2}{\bar{c}^2 \Sigma_{xx}(t|t-1) + \Sigma_{cc} X(t) + \theta} \\ &\quad + \Sigma_{aa} X(t) + \Sigma_{bb} u^2 + \Xi \end{aligned} \quad (3.5.2)$$

We recall from the asymptotic stability analysis of Section 3.4, that the solution to the above Riccati-like equation will remain bounded as  $t \rightarrow \infty$  if the second moment of  $x(t)$  is asymptotically stable. A sufficient condition for  $X(t)$  to be asymptotically stable is that  $(\Sigma_{aa} + \bar{a}^2) < 1$ .

For  $t \rightarrow \infty$ , and if the solution to the Eq. (3.5.2) diverges then we can write

$$\begin{aligned} \Sigma_{xx}(t+1|t) &\approx \bar{a}^2 \Sigma_{xx}(t|t-1) - \frac{(\bar{a} \bar{c} + \Sigma_{ac})^2}{\bar{c}^2 + \Sigma_{cc}} \Sigma_{xx}(t|t-1) \\ &\quad + \Sigma_{aa} \Sigma_{xx}(t|t-1) \end{aligned} \quad (3.5.3)$$

since

$$X(t) = \Sigma_{xx}(t|t-1) + E\{\hat{x}^2(t|t-1)\} \quad (3.5.4)$$

Thus,

$$\Sigma_{xx}(t+1|t) \approx m \Sigma_{xx}(t|t-1) \quad (3.5.5)$$

and  $m > 1$ .

Where

$$m = \frac{-2}{a} + \Sigma_{aa} - \frac{(\bar{a}\bar{c} + \Sigma_{ac})^2}{\bar{c}^2 + \Sigma_{cc}} \quad (3.5.6)$$

However, this is only a sufficient condition for Eq. (3.5.2) to diverge.

The case in which the random parameter  $b(t)$  is correlated with  $a(t)$  but not with  $c(t)$ , does not change the asymptotic stability condition since  $|\bar{a}| > 1$  implies  $\Sigma_{aa} + \bar{a}^2 > 1$ . The case in which  $b(t)$  is correlated with both  $a(t)$  and  $c(t)$  as given in Eq. (3.5.1) will also not change the asymptotic stability results given in Eq. (3.5.5).

If  $u(t) = 0$ , then the deterministic input is effectively eliminated from the plant Eq. (3.2.1). This allows us to deal with only the pure estimation problem. It does not simplify the problem any greater than if we assumed that the random parameter  $b(t)$  is uncorrelated with  $a(t)$  and  $c(t)$ , since then the input  $u(t)$  multiplied by  $b(t)$  affects Eq. (2.2.1) as an additional driving noise. The analysis was presented in Section 3.4. The effective additive noise covariance is increased by  $\Sigma_{bb} u^2$  as in Eq. (3.4.7).

### 3.6 Conclusions

This chapter considered the linear minimum-variance estimation for stochastic systems with purely random (white) parameters. Because of the random parameters multiplying the state, the conditional density is non-Gaussian even if all the random processes are Gaussian. We extend previous results on the linear minimum variance estimation for such a class of stochastic systems to include state- and control-dependent noises in both the plant and measurement equations.

The linear filter determined in this chapter is similar in form to the Kalman filter, except that the second moment of the state must be propagated. Conditions for stability of the linear minimum-variance estimator are presented. We allow for the correlations of the uncertain parameters in the general estimation problem. For the stochastic system with purely random (white) parameters, we have shown that the solution to the Riccati-like forward difference equation may become divergent as  $t \rightarrow \infty$  for some quantifiable threshold depending on the means and variances of the randomly varying parameters. This result is analogous to the linear quadratic control problem, but does not arise in the standard linear-gaussian estimation problem.

AD-A056 849

MASSACHUSETTS INST OF TECH CAMBRIDGE ELECTRONIC SYST--ETC F/G 12/1  
ADAPTIVE STOCHASTIC CONTROL OF LINEAR SYSTEMS WITH RANDOM PARAM--ETC(U)  
MAY 78 R T KU

AFOSR-77-3281

UNCLASSIFIED

FSI -TH-820

AFOSR-TR-78-1188

NL

2 of 3  
AD  
A056849

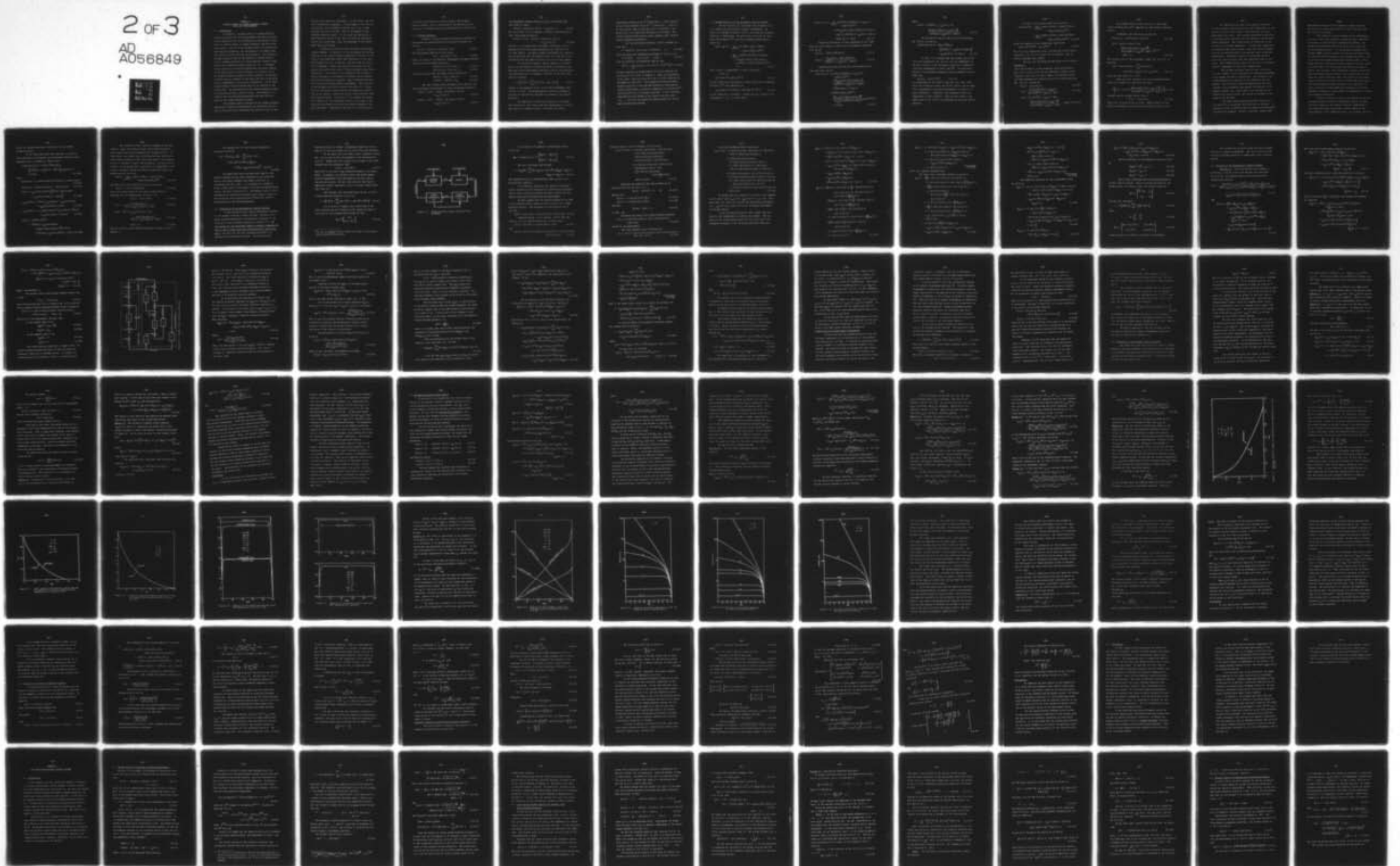

CHAPTER 4  
OPTIMUM CONTROL OF RANDOM PARAMETER SYSTEMS  
WITH NOISY MEASUREMENTS

4.1 Introduction

In Chapter 2, optimum control of random parameter system with noise-free state measurements has been discussed. In this chapter we will be concerned with the optimum control laws for systems subject to random parameters and with noisy observations. Just as in the optimum control of systems with deterministic parameters, the determination of random parameter control systems involves two problems (1) the problem of optimum estimation and (2) the problem of optimum control. In the standard deterministic linear-quadratic-Gaussian (LQG) problem the separation theorem holds [3], [4]. A stronger result stated as the Certainty-Equivalence Principle applies to the LQG stochastic control problem. As we shall see in the random parameter stochastic control problem, the optimum solution does not separate in the sense that the filter gains are not independent of the control computation. In the white noise parameter control problem there is no learning in the control law. The covariances for the random parameters cannot be reduced below their a priori values. From Chapter 2, it follows that the Certainty-Equivalence Principle does not apply in the random parameter problem.

The optimum control strategy for the random parameter system has to perform simultaneously the estimation and control of the state while minimizing the expected value of some

scalar real-valued cost functional. In this sense, the control law derived is adaptive. It must adapt to the level of uncertainty in the parameters and the state, yet it must regulate the control system. This is an example of non-learning adaptive control. If we accept the definition of dual control as given in [8], [9], and [70] our stochastic control law is non dual, since our knowledge of the system model does not increase.

In Section 4.2 we will state precisely the optimal control problem. In Section 4.3, we investigate the optimum solution to the control problem formulated in Section 4.2 in terms of the conditional means and covariances of the state. The optimum filter is, in general, nonlinear and not practical to implement. Hence, we proceed to determine the sub-optimal solution in the class of linear estimators and linear controllers. In Section 4.4 we reformulate the stochastic control problem as a deterministic optimum control problem. Two solution methods are possible - Matrix Minimum Principle [71] and non-stationary dynamic programming. The structure of the optimum controller is given in Section 4.5. In Section 4.6, we discuss in more detail the qualitative properties of the optimal control law for the fixed structure feedback control system. In Section 4.7, we examine the asymptotic behavior of the stationary control for stochastic systems with stationary statistics and constant weights in the cost functional. Analogous to Section 2.5, in Section 4.8,

we analyze the stability of the stochastic system under output feedback. We are interested in the question of the existence of optimum controls in steady-state for finite cost.

#### 4.2 Problem Statement

Consider a linear stochastic system with purely random parameters characterized by the scalar difference Eq.

(2.2.1)

$$x(t+1) = a(t)x(t) + b(t)u(t) + \xi(t) \quad (4.2.1)$$

The measurement equation is also scalar

$$z(t) = c(t)x(t) + \theta(t) \quad (4.2.2)$$

where  $\xi(t)$  and  $\theta(t)$  are mutually independent zero-mean Gaussian white noises with known statistics,

$$E\{\xi(t)\xi(\tau)\} = \Xi(t)\delta(t,\tau) \quad (4.2.3)$$

$$E\{\theta(\tau)\theta(\tau)\} = \Theta(t)\delta(t,\tau) \quad (4.2.4)$$

The initial state  $x(0)$  has known a priori statistics

$$E\{x(0)\} = \bar{x}(0) = \hat{x}(0|-1) \quad (4.2.5)$$

$$E\{(x(0) - \bar{x}(0))^2\} = \Sigma_{x0} \quad (4.2.6)$$

The time varying system parameters  $a(t)$  and  $b(t)$  are white processes, uncorrelated in time, with known statistics,

$$\begin{aligned} E\{a(t)\} &= \bar{a}(t), \quad E\{(a(t) - \bar{a}(t))(a(\tau) - \bar{a}(\tau))\} \\ &= \Sigma_{aa}(t)\delta(t,\tau) \end{aligned} \quad (4.2.7)$$

$$\begin{aligned} E\{b(t)\} &= \bar{b}(t), \quad E\{(b(t) - \bar{b}(t))(b(\tau) - \bar{b}(\tau))\} \\ &= \Sigma_{bb}(t)\delta(t,\tau) \end{aligned} \quad (4.2.8)$$

The independent random parameters may be correlated with each other at time  $t$ ,

$$E\{(a(t) - \bar{a}(t))(b(\tau) - \bar{b}(\tau))\} = \Sigma_{ab}(t) \delta(t, \tau) \quad (4.2.9)$$

The coefficient  $c(t)$  is assumed to be white, uncorrelated in time, with known statistics,

$$\begin{aligned} E\{c(t)\} &= \bar{c}(t) , \quad E\{(c(t) - \bar{c}(t))(c(\tau) - \bar{c}(\tau))\} \\ &= \Sigma_{cc}(t) \delta(t, \tau) \end{aligned} \quad (4.2.10)$$

Finally, it is assumed that the output coefficient  $c(t)$  is uncorrelated with the system parameters  $a(t)$  and  $b(t)$  for all time indexes. The white random coefficients  $a(t)$  and  $b(t)$  are uncorrelated with the additive noise  $\xi(t)$  and  $c(t)$  is uncorrelated with the additive noise  $\theta(t)$  for all time indexes.

The optimum stochastic control problem is to determine a non-anticipative closed-loop control law based on the past and current measurements and past controls that minimizes the expected value of a quadratic function of the state and control variables,

$$J = E \left\{ F x^2(N) + \sum_{t=0}^{N-1} Q(t) x^2(t) + R(t) u^2(t) \right\} \quad (4.2.11)$$

subject to the dynamics of Eq. (4.2.1) and measurement function Eq. (4.2.2). The weightings  $Q(t)$  and  $F$  are assumed to be positive semi-definite and  $R(t)$  is assumed to be positive definite.

The admissible controls are required to be measurable functions of the current and past measurements to assure that they are a random variable. We denote the entire

measurement history to be  $z^t \triangleq \{z(0), z(1), \dots, z(t)\}$  and the entire control history to be  $u^{t-1} = \{u(0), u(1), \dots, u(t-1)\}$ . We seek control laws of the type  $u(t) = \gamma(t, \hat{x}(t|t))$ ,  $u \in U$ , where  $\hat{x}(t|t)$  is a sufficient statistic of the state. The control specified has perfect recall (memory) and a totally nested information structure.

For the multistage stochastic control problem, we have that

$$J = E\{L(u(t), \xi(t), x(t)) + L(x(t+1))\} \quad \xi \in \Omega \quad (4.2.12)$$

Where we define the information available to  $u(t)$  at  $t$  as

$$z^t \triangleq \{u(0), \dots, u(t-1), y(1), \dots, y(t)\} \quad (4.2.13)$$

then the Principle of Optimality implies that

$$J^*(z^t) = \min_{u(t)} E\{L(u(t), \xi(t), x(t)) + J^*(z^{t+1}) \mid z^t\} \quad (4.2.14)$$

We have examined the problem where  $z(t) = x(t)$  (perfect observation of the state) in Chapter 2. When the measurement is not exact, then the solution of Eq. (4.2.14) requires the knowledge of  $p(x(t)|z^t)$ . The assumption of perfect memory renders  $p(x(t)|z^t)$  a well-defined probability distribution function and permits a recursive computation of  $p(x(t+1)|z^{t+1})$  from  $p(x(t)|z^t)$  by a filtering algorithm. If the filtering algorithm does not depend on the control functions  $\gamma(0)$ ,  $\gamma(1), \dots, \gamma(t)$  then the Separation Theorem holds for the dynamic optimization problem.

### 4.3 Optimum Solution of the Stochastic Control Problem

In this section, we investigate the stochastic control problem via the method of dynamic programming. We derive the optimum stochastic control law using the Bellman's Principle of Optimality. We define the cost-to-go at  $t=N-1$ , given measurements  $z^{N-1}$  and using optimum systems control  $u(N-1)$  by

$$\begin{aligned}
 V(N-1, x(N-1)) &= \min_{u(N-1)} E\{F x^2(N) + Q(N-1) x^2(N-1) \\
 &\quad + R(N-1) u^2(N-1) | z^{N-1}\} \\
 &= \min_{u(N-1)} E\{x^2(N-1)(F a^2(N-1) + Q(N-1)) \\
 &\quad + 2 F a(N-1) b(N-1) x(N-1) u(N-1) \\
 &\quad + (F b^2(N-1) + R(N-1) u^2(N-1)) | z^{N-1}\} \\
 &\quad + F \xi \quad (4.3.1)
 \end{aligned}$$

since  $\xi(N-1)$  is independent of  $u(N-1)$  and  $x(N-1)$ .

If we let

$$\hat{x}(N-1|N-1) \triangleq E\{x(N-1) | z^{N-1}\} \quad (4.3.2)$$

be the conditional expectation of  $x(N-1)$  given the information statistic  $z^{N-1}$  and similarly let

$$\Sigma_{xx}(N-1|N-1) \triangleq E\{(x(N-1) - \hat{x}(N-1|N-1))^2 | z^{N-1}\} \quad (4.3.3)$$

be the conditional covariance. Assume that  $a(t)$  and  $b(t)$  are independent of  $x(t)$ , we then obtain

$$\begin{aligned}
 V(x(N-1), N-1) = \min_{u(N-1)} & \left\{ E\{x^2(N-1)(F(\bar{a}^2(N-1) + \Sigma_{aa}(N-1)) \right. \\
 & \left. + Q(N-1)) | z^{N-1}\} \\
 & + 2F(\Sigma_{ab}(N-1) + \bar{a}(N-1)\bar{b}(N-1)) \hat{x}(N-1|N-1) \\
 & \cdot u(N-1) + (F(\bar{b}^2(N-1) + \Sigma_{bb}(N-1)) + R(N-1)) \\
 & \cdot u^2(N-1) \left. \right\} + F \Xi(N-1) \quad (4.3.4)
 \end{aligned}$$

Taking the derivative of this expression on the right hand side with respect to  $u(N-1)$  for the algebraic minimization, we get

$$u^*(N-1) = - G(N-1) \hat{x}(N-1|N-1) \quad (4.3.5)$$

$$G(N-1) = \frac{F(\Sigma_{ab}(N-1) + \bar{a}(N-1)\bar{b}(N-1))}{F(\bar{b}^2(N-1) + \Sigma_{bb}(N-1)) + R(N-1)} \quad (4.3.6)$$

Substituting these results into the expression for the cost-to-go, we get

$$\begin{aligned}
 V(x(N-1), N-1) &= E\{x^2(N-1)(F(\bar{a}^2(N-1) + \Sigma_{aa}(N-1)) \\
 & \quad + Q(N-1)) | z^{N-1}\} \\
 & \quad - \frac{F^2(\Sigma_{ab}(N-1) + \bar{a}(N-1)\bar{b}(N-1))^2}{F(\bar{b}^2(N-1) + \Sigma_{bb}(N-1)) + R(N-1)} \\
 & \quad \cdot \hat{x}^2(N-1|N-1) + F \Xi(N-1) \\
 &= E\{x^2(N-1) K(N-1) | z^{N-1}\} \\
 & \quad + \frac{[F(\Sigma_{ab}(N-1) + \bar{a}(N-1)\bar{b}(N-1))]^2}{F(\Sigma_{bb}(N-1) + \bar{b}^2(N-1)) + R(N-1)} \Sigma_{xx}(N-1|N-1) \\
 & \quad + F \Xi(N-1) \quad (4.3.7)
 \end{aligned}$$

where

$$K(N-1) = F(\bar{a}^2(N-1) + \Sigma_{aa}(N-1)) + Q - \frac{[F(\bar{a}(N-1)\bar{b}(N-1) + \Sigma_{ab}(N-1))]^2}{F(\bar{b}^2(N-1) + \Sigma_{bb}(N-1)) + R(N-1)} \quad (4.3.8)$$

An alternative form for the cost-to-go expression Eq. (4.3.7) is given by

$$V(\hat{x}(N-1|N-1), N-1) = K(N-1) \hat{x}^2(N-1) + [F(\bar{a}^2(N-1) + \Sigma_{aa}(N-1)) + Q(N-1)] \cdot \Sigma_{xx}(N-1|N-1) + F \Xi(N-1) \quad (4.3.9)$$

In [37], it is claimed that the second term in the cost-to-go expression, Eq. (4.3.7), will be independent of the past controls if the estimation error has a conditional covariance independent of  $x(N-1)$  and  $z^{N-1}$ . In the deterministic linear-quadratic-gaussian control problem it can be shown that

$E\{(x(t) - \hat{x}(t|t))^2 | z^t\} \quad 0 \leq t \leq N$   
are independent of  $x(t)$  and  $z^t$  (see [3], [4], [72], [73]) since the estimation errors  $e(t) \triangleq x(t) - \hat{x}(t|t)$  can be shown to be independent of the past measurements or functions of these measurement. Therefore, the estimation errors are independent of past controls. Only the first term in the expectation of Eq. (4.3.7) is influenced by previous control policies.

At time  $t = N-2$ , we have then the cost-to-go

$$\begin{aligned} V(N-2, x(N-2)) &= \min_{u(N-2)} E\{V(N-1, x(N-1)) + Q(N-2) x^2(N-2) \\ &\quad + R(N-2) u^2(N-2) | z^{N-2}\} \\ &= \min_{u(N-2)} E\{K(N-1) x^2(N-1) + Q(N-2) x^2(N-2) \\ &\quad + R(N-2) u^2(N-2) | z^{N-2}\} \quad (4.3.10) \end{aligned}$$

using the property of the conditional expectation

$$E\{E\{\cdot | z^{N-1}\} | z^{N-2}\} = E\{\cdot | z^{N-2}\} \quad (4.3.11)$$

The cost-to-go expression in Eq. (4.3.10) has a form exactly identical to Eq. (4.3.1) except for the indexes. The inductive procedure now repeats.

We state the following theorem based on our results,

Theorem 4.1

Given the stochastic linear dynamical system described by Eqs. (4.2.1) and (4.2.2) and the admissible control law belonging to the class of causal inputs, the optimum control law that minimizes the expected value of the cost functional Eq. (4.2.11) is given by

$$u^*(t) = -G(t) \hat{x}(t|t) \quad (4.3.12)$$

$$G(t) = \frac{K(t+1)(\bar{a}(t) \bar{b}(t) + \Sigma_{ab}(t))}{K(t+1)(\bar{b}^2(t) + \Sigma_{bb}(t)) + R(t)} \quad (4.3.13)$$

$$\begin{aligned} K(t) &= K(t+1)(\bar{a}^2(t) + \Sigma_{aa}(t)) + Q(t) \\ &\quad - \frac{[K(t+1)(\bar{a}(t) \bar{b}(t) + \Sigma_{ab}(t))]^2}{K(t+1)(\bar{b}^2(t) + \Sigma_{bb}(t)) + R(t)}, \quad K(N) = F \quad (4.3.14) \end{aligned}$$

The estimate  $\hat{x}(t|t)$  in Eq. (4.3.12) is the conditional estimate  $E\{x(t)|z^t\}$  computed via some optimal nonlinear filter.

In general, the cost-to-go is given by

$$V^*(x(t), t) = E\{x^2(t) K(t) + p(t) | z^t\} \quad (4.3.15)$$

$$p(t) = p(t+1) + K(t+1) \Xi(t) + \frac{[K(t+1)(\bar{a}(t) \bar{b}(t) + \Sigma_{ab}(t))]^2}{K(t+1)(\bar{b}^2(t) + \Sigma_{bb}(t)) + R(t)} \Sigma_{xx}(t|t)$$

$$p(N) = 0 \quad (4.3.16)$$

The average value of the performance index, Eq. (4.2.11), is given by

$$J(0) = K(0) E\{x^2(0)\} + \sum_{t=0}^{N-1} K(t+1) (\Xi(t) + (\bar{a}(t) \bar{b}(t) + \Sigma_{ab}(t)) G(t) \Sigma_{xx}(t|t)) \quad (4.3.17)$$

using the fact  $E\{E\{\cdot|z\}\} = E\{\cdot\}$ .

When the state variable  $x(t)$  can be measured exactly  $E\{x(t)|z^t\}$  becomes  $x(t)$  and hence the term

$$E \left\{ (x(t) - \hat{x}(t|t))^2 \frac{[K(t+1)(\bar{a}(t) \bar{b}(t) + \Sigma_{ab}(t))]^2}{K(t+1)(\bar{b}^2(t) + \Sigma_{bb}(t)) + R(t)} \Big| z^t \right\} \quad (4.3.18)$$

vanishes and the optimal control law is

$$u^*(t) = -G(t) x(t) \quad (4.3.19)$$

where  $G(t)$  is given by Eq. (4.3.13). These results for the perfect measurement case have been presented in Section 2.3.

We remark that the gain in the optimal controller for the stochastic system with noisy state measurement is the same as the gain in the optimal controller when the state measurements are exact. The certainty-equivalence controller is not the optimal controller for the stochastic system with random parameters. The control gains are functions of the variances of the white parameters. In this case, separation of estimation and control exists, since the control depends only on the expected value of the current state, given past measurements. Separation occurs in the optimum solution since the control affects only the conditional mean of the state. The feedback gains in Eq. (4.3.13) can be calculated a priori independent of the filter computations.

The optimum controller given by Eqs. (4.3.12) to (4.3.14) "hedges" or acts cautiously or vigorously depending on the amount and type of uncertainty. No learning of the system parameters is involved in the estimation process, however. The controller gains are modulated by the uncertainties of the parameters and exhibit the behavior of an adaptive control law. Since there is no learning in the closed-loop control system, the control is non-dual in the sense of [8] and [22].

The conditional probability density function of  $x(t)$  given  $z^t$  is in general very difficult to evaluate. A nonlinear filter is required which is usually not realizable for practical purposes. We will, therefore, examine some

approximate solutions to the stochastic control posed in Section 4.2 by fixing the structure of the controller and the filter to be linear.

The stochastic control problem can be reformulated in terms of the state estimate, estimation error, and error covariance as a deterministic optimization problem. The parameter optimization problem is solved first using the matrix minimum principle. A true two-point boundary value problem (TPBVP) results because the control now affects both the mean and error covariance of the estimation process. We do not have the standard separation theorem results. This fixed structure controller-estimator exhibits the dual nature of control where the filter gains and control are used to improve the estimates. This suboptimal solution is different from the optimal solution given in the previous Section 4.3, where the control does not affect the variance of the conditional estimator as contrast with a control that does affect the linear minimum variance estimator. For simplicity of filter structure, we have added the complexity of a policy dependent estimator, a true tradeoff in implementing a closed-loop estimator-controller.

Before we proceed to present the results on the constrained estimator-controller suboptimal control, we shall elaborate further on the concept of policy independence of the conditional mean and discuss a control based on the approximation to the conditional mean. As a result, we will

derive an enforced separation controller for the random parameter system.

If the conditional mean and covariance in the cost  $V(N-1, \hat{x}(N-1|N-1))$  is computed via the minimum variance linear unbiased filter of Chapter 3, then we have

$$\begin{aligned} V(\hat{x}(N-1|N-1), N-1) &= K(N-1) \hat{x}^2(N-1|N-1) \\ &+ \left[ F(\bar{a}^2(N-1) + \Sigma_{aa}(N-1)) + Q(n-1) \right] \Sigma_{xx}(N-1|N-1) \\ &+ F \Xi(N-1) \end{aligned} \quad (4.3.20)$$

where

$$\hat{x}(N-1|N-1) = (1 - H(N-1) \bar{c}(N-1)) \hat{x}(N-1|N-2) + H(N-1) z(N-1) \quad (4.3.21)$$

$$\hat{x}(N-1|N-2) = \bar{a}(N-2) \hat{x}(N-2|N-2) + \bar{b}(N-2) u(N-2) \quad (4.3.22)$$

$$\begin{aligned} H(N-1) &= \Sigma_{xx}(N-1|N-2) \bar{c}(N-1) \left[ \bar{c}^2(N-1) \Sigma_{xx}(N-1|N-2) \right. \\ &\quad \left. + \Sigma_{cc}(N-1|N-1) X(N-1) + \Theta(N-1) \right]^{-1} \end{aligned} \quad (4.3.23)$$

$$\begin{aligned} \Sigma_{xx}(N-1|N-2) &= \bar{a}^2(N-2) \Sigma_{xx}(N-2|N-2) + \Sigma_{aa}(N-2) X(N-2) \\ &\quad + \Sigma_{bb}(N-2) u^2(N-2) + \Xi(N-2) \end{aligned} \quad (4.3.24)$$

$$\begin{aligned} \Sigma_{xx}(N-1|N-1) &= (1 - H(N-1) \bar{c}(N-1))^2 \Sigma_{xx}(N-1|N-2) + H^2(N-1) \\ &\quad \cdot (\Sigma_{cc}(N-1) X(N-1) + \Theta(N-1)) \end{aligned} \quad (4.3.25)$$

$$\begin{aligned} X(N-1) &= E\{x^2(N-1) | z^{N-1}\} \\ &= (\bar{a}^2(N-2) + \Sigma_{aa}(N-2)) X(N-2) \\ &\quad + 2\bar{a}(N-2) \bar{b}(N-2) u(N-2) \hat{x}^2(N-1|N-1) \\ &\quad + (\bar{b}^2(N-2) + \Sigma_{bb}(N-2)) u^2(N-2) + \Xi(N-2) \end{aligned} \quad (4.3.26)$$

The estimation error covariance depends on the past control. Hence the optimal control  $u(N-1)$  which minimizes  $V(N-2)$  would also seek to minimize the estimation error. In other words, the control has to perform the dual function of control and estimation of the state and leads to the inseparability of stochastic control and estimation. To obtain ad hoc control, we can assume that  $\Sigma_{xx}(N-1|N-1)$  is independent of the control, and hence obtain the enforced separation control by minimizing the cost-to-go

$$V(N-1) = \min_{u(N-2)} E\{K(N-1) x^2(N-1) + Q(N-2) x^2(N-2) + R(N-2) u^2(N-2) | z^{N-2}\} \quad (4.3.27)$$

and obtain that the suboptimal control is given by

$$u(N-2) = - G(N-2) \hat{x}(N-2|N-2) \quad (4.3.28)$$

where the control gains are the same as those given by assuming that the measurements are exact. So,

$$u(t) = - G(t) \hat{x}(t|t) \quad (4.3.29)$$

$$G(t) = - \frac{\bar{a}(t) \bar{b}(t) K(t+1)}{(\bar{b}^2(t) + \Sigma_{bb}(t)) K(t+1) + R(t)} \quad (4.3.30)$$

$$K(t) = (\bar{a}^2(t) + \Sigma_{aa}(t)) K(t+1) + Q(t) - \frac{(\bar{a}(t) \bar{b}(t) K(t+1))^2}{(\bar{b}^2(t) + \Sigma_{bb}(t)) K(t+1) + R(t)} \quad (4.3.31)$$

$$K(N) = F \quad (4.3.32)$$

and the estimate is the minimum mean-square estimate given in Chapter 3.

The average cost for this enforced separation solution is given by

$$\begin{aligned}
 J(0) = & K(0)(\Sigma_{x0} + \bar{x}_0^2) + \sum_{t=0}^{N-1} K(t+1) \Xi(t) \\
 & + \bar{a}^2(t) K^2(t+1) \bar{b}^2(t+1) \left[ R(t) \right. \\
 & \left. + (\bar{b}^2(t) + \Sigma_{bb}(t)) K(t+1) \right]^{-1} \cdot \Sigma_{xx}(t|t)
 \end{aligned}
 \tag{4.3.33}$$

We remark that there has been other types of sub-optimal feedback control laws considered in the literature such as the output feedback zero memory controller in continuous-time [41], [43]. It is possible to cascade an ad hoc scheme based on the Kalman filter and the deterministic control law given in Section 2.3. The Kalman filter is to be implemented by arbitrarily setting  $\Sigma_{aa}(t) = \Sigma_{bb}(t) = \Sigma_{cc}(t) = 0$ . The resulting filter gains would not reflect the level of uncertainties in the system parameters.

#### 4.4 Formulation of the Deterministic Control Problem

In this section we will find an approximate solution to the optimal stochastic control problem. The goal is to apply standard deterministic optimization techniques to the stochastic control problem formulated in Section 4.2. We will assume for the suboptimal adaptive feedback compensation that it has a linear controller cascaded with a linear estimator. We shall see that the reformulated problem is a deterministic optimization problem. The discrete-time

minimum principle or dynamic programming method can then be applied to find the optimal control and filter gain sequences.

We are given the first-order linear stochastic system Eqs. (4.2.1) and (4.2.2) with quadratic cost functional Eq. (4.2.11). Assume that the control law is linear in the state estimate and time-varying so that\*

$$u(t) = - G(t) \hat{x}(t) \quad (4.4.1)$$

where  $\hat{x}(t)$  is the best linear unbiased estimate to be determined. In general, the optimal control law would require infinite dimensional state estimators as we have seen in the previous section. We will thus restrict the class of admissible control functions to be of a certain linear structure, Fig. 4.1.

The original cost functional given by Eq. (4.2.11) is then rewritten using Eq. (4.4.1) as

$$J = E \left\{ F x^2(N) + \sum_{t=0}^{N-1} Q(t) x^2(t) + R(t) G^2(t) \hat{x}^2(t) \right\} \quad (4.4.2)$$

Let us define a random vector consisting of the state variable and the estimation error (which are dual of each other in the standard LQG problem) by [74].

$$\underline{m}(t) \triangleq \begin{bmatrix} x(t) \\ x(t) - \hat{x}(t) \end{bmatrix} \quad (4.4.3)$$

---

\*The use of constant linear controller leads to a different, static minimization problem.

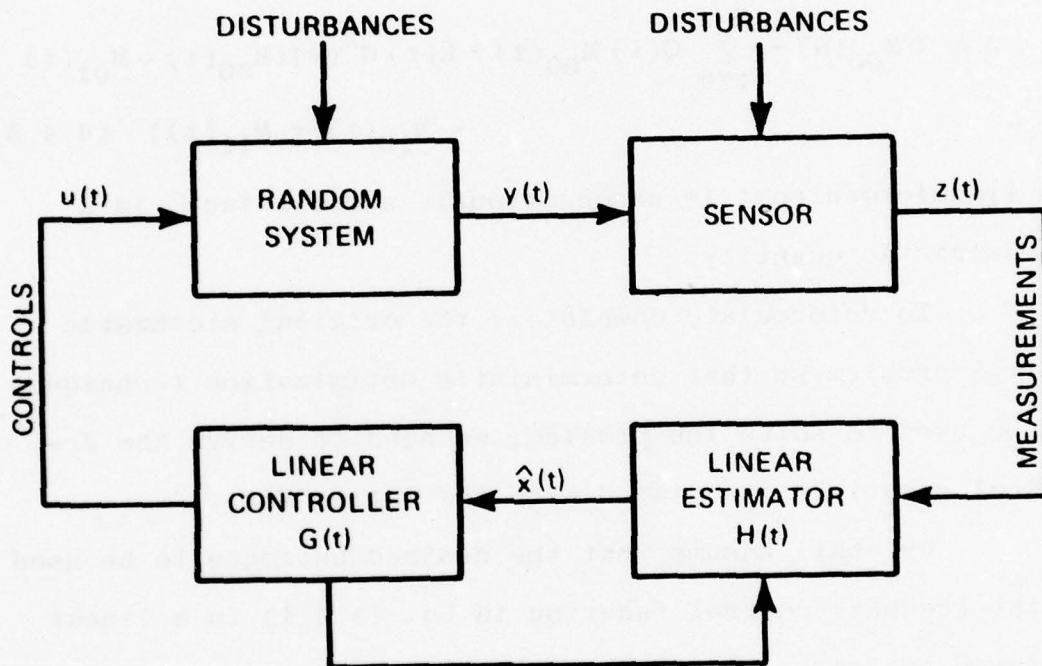

Figure 4.1 Fixed structure linear controller and estimator

Let us denote the symmetric second moment matrix of  $\underline{m}(t)$  as

$$\underline{M}(t) \triangleq E\{\underline{m}(t) \underline{m}'(t)\} \triangleq \begin{bmatrix} M_{00}(t) & M_{01}(t) \\ M_{10}(t) & M_{11}(t) \end{bmatrix} \quad (4.4.4)$$

The cost functional then becomes

$$J = F M_{00}(N) + \sum_{t=0}^{N-1} Q(t) M_{00}(t) + R(t) G^2(t) (M_{00}(t) - M_{01}(t) - M_{10}(t) + M_{11}(t)) \quad (4.4.5)$$

The transformed cost is unconditional, and, in fact, is a deterministic quantity.

To reformulate completely the original stochastic control problem so that deterministic optimization techniques can be used to solve the problem, we need to derive the dynamical equations associated with the matrix  $\underline{M}(t)$ .

We shall assume that the desired estimate to be used in the feedback control function in Eq. (4.4.1) is a linear unbiased estimate. The estimator is constrained to be of the form,

$$\hat{x}(t+1) = D(t+1) \hat{x}(t) + H(t+1) z(t+1) + L(t+1) u(t) \quad (4.4.6)$$

Substituting Eq. (4.4.1) and Eq. (4.2.2) into the state Eq. (4.2.1) and the filter Eq. (4.4.6) we get

$$x(t+1) = a(t) x(t) - b(t) G(t) \hat{x}(t) + \xi(t) \quad (4.4.7)$$

and

$$\begin{aligned} \hat{x}(t+1) = D(t+1) \hat{x}(t) + H(t+1) c(t+1) x(t+1) - L(t+1) G(t) \hat{x}(t) \\ + H(t+1) \theta(t+1) \end{aligned} \quad (4.4.8)$$

Subtracting Eq. (4.4.8) from Eq. (4.4.7) we get

$$\begin{aligned}
 x(t+1) - \hat{x}(t+1) &= a(t) x(t) - D(t+1) \hat{x}(t) - b(t) G(t) \hat{x}(t) \\
 &+ \xi(t) - H(t+1) c(t+1) a(t) x(t) \\
 &+ H(t+1) c(t+1) b(t) G(t) \hat{x}(t) \\
 &+ L(t+1) G(t) \hat{x}(t) - H(t+1) \theta(t+1) \\
 &= ((1 - H(t+1) c(t+1)) a(t) - D(t+1)) x(t) \\
 &+ D(t+1)(x(t) - \hat{x}(t)) + \xi(t) \\
 &- \left[ (1 - H(t+1) c(t+1)) b(t) \right. \\
 &\quad \left. - L(t+1) \right] G(t) \hat{x}(t) \\
 &- H(t+1) \theta(t+1) \tag{4.4.9}
 \end{aligned}$$

Improving the condition that the estimate be unbiased of  $x(t)$  for all  $u(t)$ , i.e.,

$$E\{x(t) - \hat{x}(t) | z^t\} = 0 \quad \forall t \tag{4.4.10}$$

implies that

$$D(t+1) = (1 - H(t+1) \bar{c}(t+1)) \bar{a}(t) \tag{4.4.11}$$

$$L(t+1) = (1 - H(t+1) \bar{c}(t+1)) \bar{b}(t) \tag{4.4.12}$$

and that

$$E\{x(0) - \hat{x}(0)\} = 0 \tag{4.4.13}$$

or  $\hat{x}(0) = \bar{x}_0$ .

We obtain the form of the linear unbiased estimator

$$\begin{aligned}
 \hat{x}(t) &= (1 - H(t) \bar{c}(t)) (\bar{a}(t-1) - \bar{b}(t-1) G(t-1)) \hat{x}(t-1) \\
 &+ H(t) z(t) \tag{4.4.14}
 \end{aligned}$$

driven by the measurements.

The state dynamics can be rewritten as

$$\begin{aligned}
 x(t) &= (a(t-1) - b(t-1) G(t-1)) x(t-1) + b(t-1) G(t-1) (x(t-1) \\
 &- \hat{x}(t-1)) + \xi(t-1) \tag{4.4.15}
 \end{aligned}$$

The state estimation error is given by

$$\begin{aligned}
 x(t) - \hat{x}(t) &= (1 - H(t) c(t)) x(t) - H(t) \theta(t) - (1 - H(t) \bar{c}(t)) \\
 &\quad \cdot (\bar{a}(t-1) - \bar{b}(t-1) G(t-1)) \hat{x}(t-1) \\
 &= (1 - H(t) c(t)) a(t-1) x(t-1) \\
 &\quad - (1 - H(t) c(t)) b(t-1) G(t-1) \cdot \hat{x}(t-1) \\
 &\quad + (1 - H(t) c(t)) \xi(t-1) - (1 - H(t) \bar{c}(t)) \\
 &\quad \cdot (\bar{a}(t-1) - \bar{b}(t-1) G(t-1)) \hat{x}(t-1) - H(t) \theta(t) \\
 &= (1 - H(t) c(t)) (a(t-1) - b(t-1) G(t-1)) x(t-1) \\
 &\quad + (1 - H(t) c(t)) b(t-1) G(t-1) (x(t-1) - \hat{x}(t-1)) \\
 &\quad + (1 - H(t) c(t)) \xi(t-1) + (1 - H(t) \bar{c}(t)) (\bar{a}(t-1) \\
 &\quad \quad - \bar{b}(t-1) G(t-1)) (x(t-1) - \hat{x}(t-1)) \\
 &\quad - (1 - H(t) \bar{c}(t)) (\bar{a}(t-1) - \bar{b}(t-1) G(t-1)) x(t-1) \\
 &\quad - H(t) \theta(t) \tag{4.4.16}
 \end{aligned}$$

We remark that the estimation error  $x(t) - \hat{x}(t)$  depends on  $x(t)$  and  $z^t$  when  $\Sigma_{aa}(t) \neq 0$ ,  $\Sigma_{bb}(t) \neq 0$ , or  $\Sigma_{cc}(t) \neq 0$ . This means that the control will affect the estimation performance, i.e.,  $\Sigma_{xx}(t|t)$  as we shall see in the following development of the  $\underline{M}(t)$  matrix.

In the derivations below we shall assume that  $a(t)$  and  $b(t)$  are independent to simplify the algebra. The elements of the second moment matrix for the vector  $\underline{m}(t)$  then propagate according to the following difference equations,

$$\begin{aligned}
 M_{00}(t) &= E \left\{ (a(t-1) - b(t-1)G(t-1))^2 \right\} M_{00}(t-1) \\
 &+ 2E \left\{ (a(t-1) - b(t-1)G(t-1)) b(t-1) G(t-1) \right\} M_{01}(t-1) \\
 &+ E \left\{ b^2(t-1) \right\} G^2(t-1) M_{11}(t-1) + \Xi(t-1) \\
 &= (\bar{a}(t-1) - \bar{b}(t-1)G(t-1))^2 M_{00}(t-1) + \Sigma_{aa}(t-1) M_{00}(t-1) \\
 &+ \Sigma_{bb}(t-1)G^2(t-1)M_{00}(t-1) + 2\bar{b}(t-1) G(t-1) (\bar{a}(t-1) \\
 &\quad - \bar{b}(t-1) G(t-1)) M_{01}(t-1) \\
 &- 2\Sigma_{bb}(t-1)G^2(t-1)M_{01}(t-1) \\
 &+ \Sigma_{bb}(t-1) G^2(t-1) M_{11}(t-1) \\
 &+ \bar{b}^2(t-1) G^2(t-1) M_{11}(t-1) + \Xi(t-1) \quad (4.4.17)
 \end{aligned}$$

$$\begin{aligned}
 M_{01}(t) &= E \left\{ (a(t-1) - b(t-1)G(t-1)) \left[ (1 - H(t)c(t))(a(t-1) \right. \right. \\
 &\quad \left. \left. - b(t-1) G(t-1)) - (1 - H(t) \bar{c}(t)) (\bar{a}(t-1) \right. \right. \\
 &\quad \left. \left. - \bar{b}(t-1) G(t-1)) \right] \right\} M_{00}(t-1) \\
 &+ E \left\{ (a(t-1) - b(t-1)G(t-1)) \left[ 1 - H(t)\bar{c}(t) (\bar{a}(t-1) \right. \right. \\
 &\quad \left. \left. - \bar{b}(t-1) G(t-1)) \right] \right\} M_{01}(t-1) \\
 &+ E \left\{ b(t-1)G(t-1) \left[ (1 - H(t) c(t))(a(t-1) \right. \right. \\
 &\quad \left. \left. - b(t-1) G(t-1)) \right. \right. \\
 &\quad \left. \left. - (1 - H(t) \bar{c}(t)) (\bar{a}(t-1) - \bar{b}(t-1) G(t-1)) \right] \right\} M_{10}(t-1) \\
 &+ E \left\{ b(t-1)G(t-1) \left[ (1 - H(t) \bar{c}(t)) (\bar{a}(t-1) \right. \right. \\
 &\quad \left. \left. - \bar{b}(t-1) G(t-1)) \right. \right. \\
 &\quad \left. \left. + (1 - H(t) c(t)) b(t-1) G(t-1) \right] \right\} M_{11}(t-1) \\
 &+ (1 - H(t) \bar{c}(t)) \Xi(t-1) \quad (4.4.18)
 \end{aligned}$$

$$\begin{aligned}
 M_{01}(t) = & (1 - H(t) \bar{c}(t)) (\Sigma_{aa}(t-1) + \Sigma_{bb}(t-1) G^2(t-1)) M_{00}(t-1) \\
 & + (1 - H(t) \bar{c}(t)) (\bar{a}^2(t-1) - 2\Sigma_{bb}(t-1) G^2(t-1) \\
 & \quad - \bar{a}(t-1) \bar{b}(t-1) G(t-1)) (M_{01}(t-1) + M_{10}(t-1)) \\
 & + (1 - H(t) \bar{c}(t)) (\bar{a}(t-1) \bar{b}(t-1) G(t-1) \\
 & \quad + \Sigma_{bb}(t-1) G^2(t-1)) M_{11}(t-1) \\
 & + (1 - H(t) \bar{c}(t)) \Xi(t-1) \qquad \qquad \qquad \text{(Concluded)} \\
 & \qquad \qquad \qquad \qquad \qquad \qquad \qquad \qquad \qquad \qquad \qquad \qquad \qquad \text{(4.4.18)}
 \end{aligned}$$

after some algebraic manipulations.

The state error covariance equation is given by

$$\begin{aligned}
 M_{11}(t) = & E \left\{ \left[ (1 - H(t) c(t)) (a(t-1) - b(t-1) G(t-1)) \right. \right. \\
 & \left. \left. - (1 - H(t) \bar{c}(t)) (\bar{a}(t-1) - \bar{b}(t-1) G(t-1)) \right]^2 \right\} M_{00}(t-1) \\
 & + 2E \left\{ \left[ (1 - H(t) c(t)) (a(t-1) - b(t-1) G(t-1)) \right. \right. \\
 & \left. \left. - (1 - H(t) \bar{c}(t)) (\bar{a}(t-1) \right. \right. \\
 & \quad \left. \left. - \bar{b}(t-1) G(t-1)) \right] \left[ (1 - H(t) \bar{c}(t)) (\bar{a}(t-1) \right. \right. \\
 & \quad \left. \left. - \bar{b}(t-1) G(t-1)) \right] \right\} M_{01}(t-1) \\
 & + E \left\{ \left[ (1 - H(t) \bar{c}(t)) (\bar{a}(t-1) - \bar{b}(t-1) G(t-1)) \right. \right. \\
 & \left. \left. + (1 - H(t) c(t)) b(t-1) G(t-1) \right]^2 \right\} M_{11}(t-1) \\
 & + ((1 - H(t) \bar{c}(t))^2 + \Sigma_{cc}(t) H^2(t)) \Xi(t-1) \\
 & + H^2(t) \Theta(t) \\
 = & (1 - H(t) \bar{c}(t))^2 \left[ \bar{a}^2(t-1) M_{11}(t-1) \right. \\
 & \left. + \Sigma_{bb}(t-1) G^2(t-1) M_{11}(t-1) + \Sigma_{aa}(t-1) M_{00}(t-1) \right. \\
 & \left. + \Sigma_{bb}(t-1) G^2(t-1) M_{00}(t-1) \right] \qquad \qquad \qquad \text{(4.4.19)}
 \end{aligned}$$

$$\begin{aligned}
 & + 2\Sigma_{bb}(t-1) G^2(t-1) M_{01}(t-1) + \Xi(t-1) \Big] \\
 & + H^2(t) \Sigma_{cc}(t) \left[ (\bar{a}^2(t-1) + \Sigma_{aa}(t-1) \right. \\
 & \quad - 2\bar{a}(t-1) \bar{b}(t-1) G(t-1) \\
 & \quad + (\bar{b}^2(t-1) + \Sigma_{bb}(t-1)) G^2(t-1)) M_{00}(t-1) \\
 & + \Xi(t-1) + 2G(t-1)(\bar{a}(t-1) \bar{b}(t-1) \\
 & \quad - (\bar{b}^2(t-1) + \Sigma_{bb}(t-1)) G(t-1)) M_{01}(t-1) \\
 & + (\bar{b}^2(t-1) + \Sigma_{bb}(t-1)) G^2(t-1) M_{11}(t-1) \Big] \\
 & + H^2(t) \theta(t) \qquad \qquad \qquad \text{(Concluded)} \\
 & \qquad \qquad \qquad \qquad \qquad \qquad \qquad \qquad \qquad \qquad \qquad \qquad \qquad \text{(4.4.19)}
 \end{aligned}$$

The dynamical equations for the transformed system are given by

$$\begin{aligned}
 M_{00}(t) = & (\bar{a}(t-1) - \bar{b}(t-1) G(t-1))^2 M_{00}(t-1) + 2\bar{b}(t-1) G(t-1) \\
 & \cdot (\bar{a}(t-1) - \bar{b}(t-1) G(t-1)) M_{01}(t-1) + \Xi(t-1) \\
 & + \bar{b}^2(t-1) G^2(t-1) M_{11}(t-1) + \Sigma_{aa}(t-1) M_{00}(t-1) \\
 & + \Sigma_{bb}(t-1) G^2(t-1) (M_{00}(t-1) - 2M_{01}(t-1) \\
 & \quad + M_{11}(t-1)) \qquad \qquad \qquad \text{(4.4.20)}
 \end{aligned}$$

$$\begin{aligned}
 M_{01}(t) = & (1 - H(t) \bar{c}(t)) \left[ \bar{a}(t-1) ((\bar{a}(t-1) \right. \\
 & \quad - \bar{b}(t-1) G(t-1)) M_{01}(t-1) \\
 & + \bar{b}(t-1) G(t-1) M_{11}(t-1)) + \Sigma_{aa}(t-1) M_{00}(t-1) \\
 & + \Sigma_{bb}(t-1) G^2(t-1) (M_{00}(t-1) - 2M_{01}(t-1) + M_{11}(t-1)) \\
 & \left. + \Xi(t-1) \right] \qquad \qquad \qquad \text{(4.4.21)}
 \end{aligned}$$

$$\begin{aligned}
 M_{11}(t) = & (1 - H(t) \bar{c}(t))^2 \hat{M}_{11}(t) \\
 & + H^2(t) \left[ \Sigma_{cc}(t) M_{00}(t) + \theta(t) \right] \qquad \qquad \qquad \text{(4.4.22)}
 \end{aligned}$$

$$\begin{aligned} \hat{M}_{11}(t) \triangleq & \bar{a}^2(t-1) M_{11}(t-1) + \Sigma_{aa}(t-1) M_{00}(t-1) \\ & + \Sigma_{bb}(t-1) G^2(t-1) \cdot (M_{00}(t-1) - 2M_{01}(t-1) \\ & + M_{11}(t-1)) + \Xi(t-1) \end{aligned} \quad (4.4.23)$$

Initial conditions for the dynamical system is given

by

$$M_{00}(0) = \bar{x}_0^2 + \Sigma_{x0} \geq 0 \quad (4.4.24)$$

$$M_{01}(0) = \Sigma_{x0} \geq 0 \quad (4.4.25)$$

$$M_{11}(0) = \Sigma_{x0} \geq 0 \quad (4.4.26)$$

Thus we have formulated the following deterministic optimal control problem. Given the system described by the dynamical Eqs. (4.4.20)-(4.4.23), the initial condition

$$\underline{M}(0) = \begin{bmatrix} \bar{x}_0^2 + \Sigma_{x0} & \Sigma_{x0} \\ \Sigma_{x0} & \Sigma_{x0} \end{bmatrix} \quad (4.4.27)$$

and the cost functional

$$J = \text{tr} \left[ \hat{F} \underline{M}(N) \right] + \sum_{t=0}^{N-1} \text{tr} \left[ \hat{Q}(t) \underline{M}(t) \right] \quad (4.4.28)$$

where

$$\hat{F} = \begin{bmatrix} F & 0 \\ 0 & 0 \end{bmatrix} \quad (4.4.29)$$

$$\hat{Q}(t) = \begin{bmatrix} Q(t) + R(t) G^2(t) & -R(t) G^2(t) \\ -R(t) G^2(t) & R(t) G^2(t) \end{bmatrix} \quad (4.4.30)$$

find the gains  $G(t)$  and  $H(t)$  such that  $J$  is minimized.



where the state second moment equation is given by

$$\begin{aligned}
 M_{00}^*(t+1) &= (\bar{a}(t) - \bar{b}(t) G^*(t))^2 M_{00}^*(t) \\
 &+ 2\bar{b}(t) G^*(t) (\bar{a}(t) - \bar{b}(t) G^*(t)) M_{11}^*(t) + \Xi(t) \\
 &+ \bar{b}^2(t) G^{*2}(t) M_{11}^*(t) + \Sigma_{aa}(t) M_{00}^*(t) \\
 &+ \Sigma_{bb}(t) G^{*2}(t) (M_{00}^*(t) - M_{11}^*(t)) , \\
 M_{00}^*(0) &= \Sigma_{x0} + \bar{x}_0^2 \quad (4.5.3)
 \end{aligned}$$

The state estimation error covariance equation is given by

$$\begin{aligned}
 M_{11}^*(t+1) &= (1 - H^*(t+1) \bar{c}(t+1))^2 \left[ \bar{a}^2(t) M_{11}^*(t) + \Sigma_{aa}(t) M_{00}^*(t) \right. \\
 &+ \left. \Sigma_{bb}(t) G^{*2}(t) (M_{00}^*(t) - M_{11}^*(t)) + \Xi(t) \right] \\
 &+ H^{*2}(t+1) \left[ \Sigma_{cc}(t+1) M_{00}^*(t+1) + \Theta(t+1) \right] , \\
 M_{11}^*(0) &= \Sigma_{x0} \quad (4.5.4)
 \end{aligned}$$

and the co-states  $P_{00}^*(t)$  and  $P_{11}^*(t)$  are propagated backwards by equations

$$\begin{aligned}
 P_{00}^*(t) &= (\bar{a}^2(t) + \Sigma_{aa}(t)) (\Sigma_{cc}(t+1) H^{*2}(t+1) P_{11}^*(t+1) \\
 &+ P_{00}^*(t+1)) + Q(t) \\
 &- G^{*2}(t) \left[ (\bar{b}^2(t) + \Sigma_{bb}(t)) (\Sigma_{cc}(t+1) H^{*2}(t+1) \right. \\
 &+ P_{11}^*(t+1) + P_{00}^*(t+1)) + R(t) \\
 &+ \left. \Sigma_{bb}(t) (1 - H^*(t+1) \bar{c}(t+1))^2 P_{11}^*(t+1) \right] \\
 &+ \Sigma_{aa}(t) (1 - H^*(t+1) \bar{c}(t+1))^2 P_{11}^*(t+1) \\
 P_{00}^*(N) &= F \quad (4.5.5)
 \end{aligned}$$

$$\begin{aligned}
 P_{11}^*(t) = & \bar{a}^2(t)(1 - H^*(t+1) \bar{c}(t+1))^2 P_{11}^*(t+1) \\
 & + G^{*2}(t) \left[ (\bar{b}^2(t) + \Sigma_{bb}(t)) (\Sigma_{cc}(t+1) H^2(t+1) P_{11}^*(t+1) \right. \\
 & \left. + P_{00}^*(t+1)) + \Sigma_{bb}(t)(1 - H(t+1) \bar{c}(t+1))^2 \right. \\
 & \left. \times P_{11}^*(t+1) + R(t) \right] \\
 P_{11}^*(N) = & 0 \quad (4.5.6)
 \end{aligned}$$

Proof: See Appendix A.

The optimal linear time-varying feedback control law is thus

$$u^*(t) = -G^*(t) \hat{x}(t) \quad (4.5.7)$$

where time-varying gain  $G^*(t)$  is given by Eq. (4.5.1) and the linear minimum variance unbiased estimate  $\hat{x}(t|t)$  is given by

$$\begin{aligned}
 \hat{x}(t+1) = & (1 - H^*(t+1) \bar{c}(t+1)) (\bar{a}(t) - \bar{b}(t) G^*(t)) \hat{x}(t) \\
 & + H^*(t+1) z(t+1) \quad , \quad \hat{x}(0) = \bar{x}_0 \quad (4.5.8)
 \end{aligned}$$

and  $z(t+1)$  is the measurement "driving" term

At the initial time ( $t=0$ )

$$M_{00}(0) = \Sigma_{x0} + \bar{x}_0^2 \quad (4.5.9)$$

$$M_{11}(0) = \Sigma_{x0} \quad (4.5.10)$$

At the terminal time ( $t=N$ )

$$P_{00}(N) = F \quad (4.5.11)$$

$$P_{11}(N) = 0 \quad (4.5.12)$$

The fixed structure controller is shown in Fig. 4.2.

Using the Matrix Minimum Principle, we have obtained the necessary conditions for optimum control. To compute the optimum control gain sequence at time  $t$ , we need  $P_{11}(t+1)$ ,

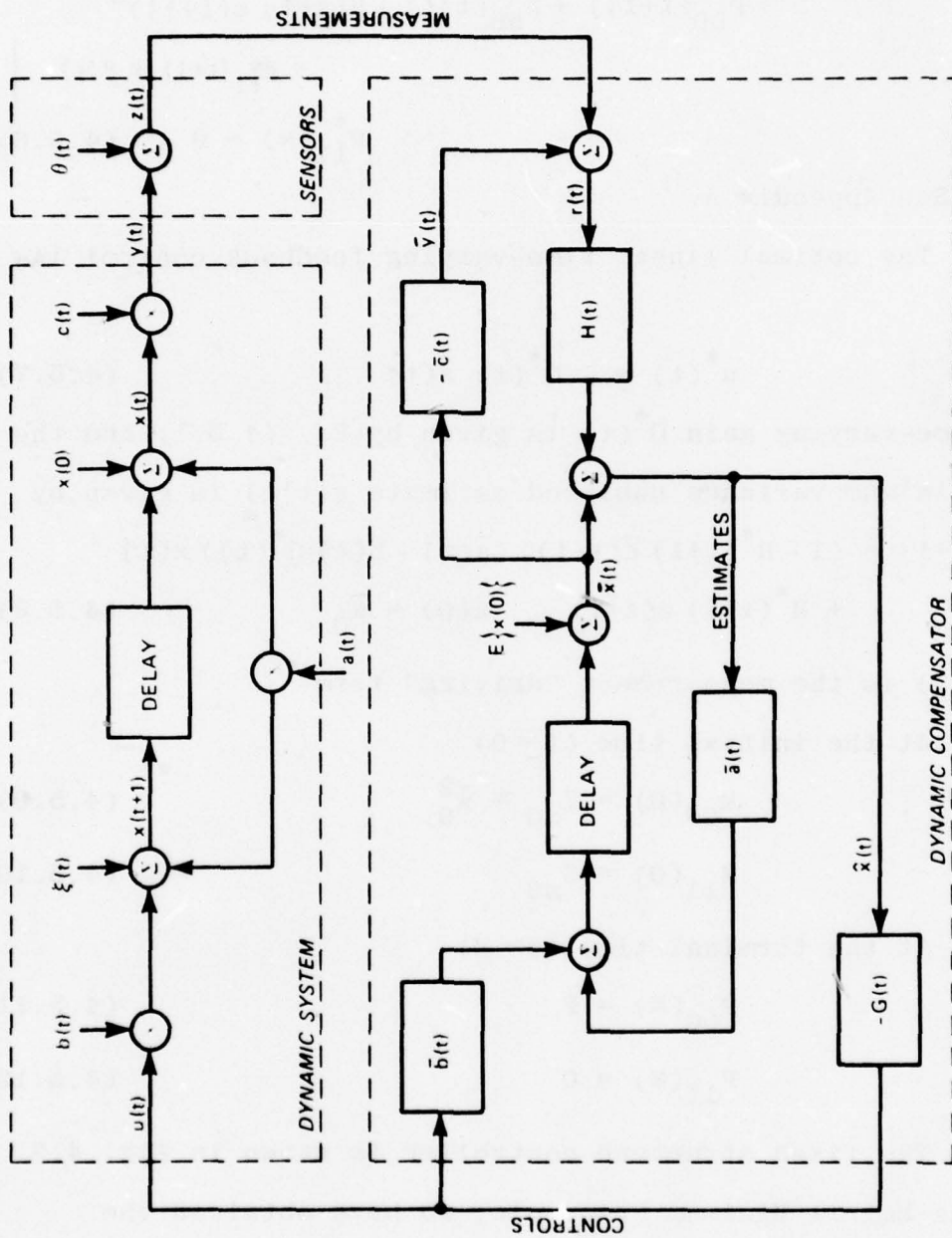

Figure 4.2 Optimal fixed structure controller

$P_{00}(t+1)$ , and  $H(t+1)$ . Since  $P_{00}(t)$  and  $P_{11}(t)$  are given at the terminal time  $N$ , they have to be propagated backwards from time  $N$ . The filter gains  $H(t+1)$  depends on  $M_{00}(t)$ ,  $M_{11}(t)$ , and  $G(t)$ . Since  $M_{00}(t)$  and  $M_{11}(t)$  are given at the initial time, they have to be propagated forward in time. The solution using the Matrix Minimum Principle is a true nonlinear two-point boundary value problem (TPBVP) that has to be solved by iterative methods.

If we substitute the expression for  $H(t+1)$  into the forward difference equations for  $M_{00}(t+1)$  and  $M_{11}(t+1)$  we see that they are coupled nonlinear difference equations in general. In the special case where  $\Sigma_{aa}(t) = \Sigma_{bb}(t) = \Sigma_{cc}(t) = 0$ , as is assumed in the standard linear-quadratic-Gaussian problem, the  $M_{00}(t)$  and  $M_{11}(\cdot)$  equations becomes decoupled. More precisely,

$$\begin{aligned} M_{00}(t+1) = & \bar{a}^2(t) M_{00}(t) - 2\bar{a}(t) \bar{b}(t) G(t) (M_{00}(t) \\ & - M_{11}(t)) b^2(t) G^2(t) (M_{00}(t) - M_{11}(t)) \\ & + \Xi(t) \end{aligned} \quad (4.5.13)$$

where

$$G(t) = \frac{\bar{b}(t) P_{00}(t+1) \bar{a}(t)}{\bar{b}^2(t) P_{00}(t+1) + R(t)} \quad (4.5.14)$$

Thus, the mean-square of the state  $M_{00}(t) = E\{x^2(t)\}$  depends on the error covariance quantities  $M_{11}(t)$ . But, the covariance is completely decoupled from the second moment of the state since

$$M_{11}(t+1) = (1 - H(t+1) \bar{c}(t+1))^2 (\bar{a}^2(t) M_{11}(t) + \Xi(t)) + H^2(t+1) \Theta(t+1) \quad (4.5.15)$$

This is just the measurement update covariance equation in the Kalman filter.

Equation (4.5.13) for  $M_{00}(t)$  is the mean square history of the state variable  $x(t)$ .

$$M_{00}(t+1) = (\bar{a}(t) - \bar{b}(t) G(t))^2 (M_{00}(t) - M_{11}(t)) + \Xi(t) + \bar{a}^2(t) M_{11}(t) \quad (4.5.16)$$

This is the same result obtained in ([75], Eq. 4.7.30).

Let us now analyze the co-state equations  $P_{00}(t)$ , and  $P_{11}(t)$ . If we let  $\Sigma_{aa}(t) = \Sigma_{bb}(t) = \Sigma_{cc}(t) = 0$ , we obtain

$$P_{00}(t) = \bar{a}^2(t) P_{00}(t+1) + Q(t) - \frac{\bar{a}^2 \bar{b}^2 P_{00}^2(t+1)}{\bar{b}^2 P_{00}(t+1) + R(t)} \quad (4.5.17)$$

This is just the nonlinear Riccati difference equation encountered in discrete-time deterministic optimal control problem. We know that the solution exists and is unique and finite if the system is controllable.

The deterministic co-state equation for  $P_{11}(t)$  is given by

$$P_{11}(t) = \bar{a}^2(t) (1 - H(t+1) \bar{c}(t+1))^2 P_{11}(t+1) + \frac{\bar{b}^2(t) \bar{a}^2(t) P_{00}^2(t+1)}{\bar{b}^2(t) P_{00}(t+1) + R(t)} \quad (4.5.18)$$

Since in the case where the parameters are known

$$H(t+1) = M_{11}(t+1) \bar{c}(t+1) \Theta^{-1}(t+1) \quad (4.5.19)$$

$P_{11}(t)$  is still coupled to the  $M_{11}(t)$  equation, but is uncoupled from the  $P_{00}(\cdot)$  equation.

In the linear-quadratic-Gaussian problem  $M_{11}(t)$  and  $P_{00}(t)$  are used to compute the optimal filter gains and control gains, respectively. The  $P_{00}$  forward and backward difference equations are completely uncoupled from each other. This is a very fortunate situation. The two-point boundary value problem can be solved as two single-point boundary value problems.

The fact that the co-state  $P_{00}(t)$  is the solution of the Riccati equation when the system parameters are known perfectly suggest that it has some physical interpretation. If we think of the co-states  $P(t)$  as the gradient of the cost with respect to the state variables as in the Hamilton-Jacobs'-Bellman approach, i.e.,

$$\underline{P}(t) = \frac{\partial J}{\partial \underline{M}(t)} \quad (4.5.20)$$

then it is evident that the co-state equation defines the evolution of the partial derivatives  $\partial J / \partial M_{00}(t)$  and  $\partial J / \partial M_{11}(t)$  for  $t \in [0, N]$ .

From the expression for the average value of the quadratic cost functional, Eq. (4.4.28)

$$J = F M_{00}(N) + \sum_{t=0}^{N-1} Q(t) M_{00}(t) + R(t) G^2(t) (M_{00}(t) - M_{11}(t)) \quad (4.5.21)$$

If we now add  $P_{00}(0) M_{00}(0)$  and  $P_{11}(0) M_{11}(0)$  outside the summation and compensate this by adding the terms

$P_{00}(t+1)M_{00}(t+1) - P_{00}(t)M_{00}(t)$  and  $P_{11}(t+1)M_{11}(t+1) - P_{11}(t)M_{11}(t)$  inside the summation, the expression is not changed. We get

$$\begin{aligned}
 J = & P_{00}(0)M_{00}(0) + P_{11}(0)M_{11}(0) + \sum_{t=0}^{N-1} Q(t)M_{00}(t) \\
 & + R(t)G^2(t)(M_{00}(t) - M_{11}(t)) + P_{00}(t+1)M_{00}(t+1) \\
 & - P_{00}(t)M_{00}(t) + P_{11}(t+1)M_{11}(t+1) - P_{11}(t)M_{11}(t)
 \end{aligned} \tag{4.5.22}$$

Now we substitute into the above equation, the expressions for  $M_{00}(t+1)$ ,  $P_{00}(t)$ ,  $M_{11}(t+1)$ , and  $P_{11}(t)$

$$\begin{aligned}
 M_{00}(t+1) = & (\bar{a}(t) - \bar{b}(t)G(t))^2(M_{00}(t) - M_{11}(t)) \\
 & + \bar{a}^2(t)M_{11}(t) + \Xi(t) + \Sigma_{aa}(t)M_{00}(t) \\
 & + \Sigma_{bb}(t)G^2(t)(M_{00}(t) - M_{11}(t))
 \end{aligned} \tag{4.5.23}$$

Equations (4.5.4), (4.5.5), and (4.5.6) respectively, we obtain that

$$\begin{aligned}
 J = & P_{00}(0)M_{00}(0) + P_{11}(0)M_{11}(0) + \sum_{t=0}^{N-1} P_{00}(t+1)\Xi(t) \\
 & + M_{11}(t) \left[ 2\bar{a}(t)\bar{b}(t)G(t)P_{00}(t+1) - ((\bar{b}^2(t) \right. \\
 & \quad \left. + \Sigma_{bb}(t))P_{00}(t+1) + R(t)G^2(t) \right] \\
 & - M_{00}(t) \left[ (\bar{a}(t) - \bar{b}(t)G(t))^2 \Sigma_{cc}(t+1)H^2(t+1) \right. \\
 & \quad \left. + (\Sigma_{aa}(t) + G^2(t)\Sigma_{bb}(t))(\Sigma_{cc}(t+1)H^2(t+1) \right. \\
 & \quad \left. + (1 - H(t+1)\bar{c}(t+1))^2) \right] P_{11}(t+1) \\
 & + P_{11}(t+1) \left\{ (1 - H(t+1)\bar{c}(t+1))^2 (\bar{a}^2(t)M_{11}(t) \right. \\
 & \quad \left. + \Sigma_{aa}(t)M_{00}(t) + \Sigma_{bb}(t)G^2(t)(M_{00}(t) - M_{11}(t)) \right\}
 \end{aligned} \tag{4.5.24}$$



then

$$\begin{aligned}
 J = & P_{00}(0) M_{00}(0) + P_{11}(0) M_{11}(0) + \sum_{t=0}^{N-1} P_{00}(t+1) \Xi(t) \\
 & + P_{11}(t+1) \left[ (1 - H(t+1) \bar{c}(t+1))^2 \Xi(t) \right. \\
 & \left. + H^2(t+1) \theta(t+1) \right]
 \end{aligned} \tag{4.5.29}$$

where

$$H(t+1) = M_{11}(t+1) \bar{c}(t+1) \theta^{-1}(t+1) \tag{4.5.30}$$

The average cost in the stochastic control problem is composed of terms due to the initial state uncertainty and due to the plant noise  $\xi(t)$  and measurement noise  $\theta(t)$ .

We remark that the form of the optimal cost obtained here is the discrete-time equivalent of that obtained in the solution to the two-controller team problem in [74].

Sufficiency conditions for optimality may be obtained from the second partial derivatives of  $J$  with respect to  $G$  and  $H$ . Taking the derivatives of  $\partial J/\partial G$  and  $\partial J/\partial H$  we then obtain that the sufficient conditions for a strong minimum are

$$\begin{aligned}
 (i) \quad & (\bar{b}^2(t) + \Sigma_{bb}(t)) (P_{00}(t+1) + \Sigma_{cc}(t+1) H^2(t+1) P_{11}(t+1)) \\
 & + \Sigma_{bb}(t) (1 - H(t+1) \bar{c}(t+1))^2 P_{11}(t+1) + R(t) > 0
 \end{aligned} \tag{4.5.31}$$

$$(ii) \quad M_{00}(t) - M_{11}(t) > 0 \tag{4.5.32}$$

$$(iii) \quad \bar{c}^2(t) \hat{M}_{11}(t) + \theta(t) + \Sigma_{cc}(t) M_{00}(t) > 0 \tag{4.5.33}$$

We remark that in condition (i), the randomness in the parameter  $\bar{b}(t)$  introduces mathematically equivalent

control penalties into the control problem. Hence if  $R(t)$  is selected wrong, then  $\Sigma_{bb}(t)$  can be used to account for the error. In condition (iii)  $\Sigma_{cc}(t)M_{00}(t)$  is positive semidefinite if  $M_{00}(t)$  is positive semidefinite. The product will increase the effective weighting  $[\theta(t) + \Sigma_{cc}(t)M_{00}(t)]$  that needs to be inverted in Eq. (4.5.2). So the randomness in the parameters  $b(t)$  and  $c(t)$  effectively make the solution more stable numerically.

We note that if  $Q(t) = 0$ , then  $P_{00}(t) = 0$  if  $\Sigma_{aa}(t) = \Sigma_{cc}(t) = 0$ , but  $P_{00}(t) \neq 0$  if  $\Sigma_{aa}(t)$  or  $\Sigma_{cc}(t)$  is nonzero. In the case  $P_{00}(t) = 0$  and  $R(t) = 0$ , the control gain  $G(t)$  in Eq. (4.5.1) may still be a well-defined quantity due to the uncertainty in  $c(t)$ , ( $\Sigma_{cc}(t) \neq 0$ ).

In the special case when the measurements are exact so that  $\theta(t)$  and  $\Sigma_{cc}(t) = 0$ , then the equations for the optimal stochastic control problem Eqs. (4.5.1) to (4.5.6) reduces to the same results obtained in Chapter 2.

#### Problem Solution Using Dynamic Programming

We have seen that the minimum principle gives the necessary conditions for the minimization of the quadratic cost function Eq. (4.4.28). It reduced the optimum systems control problem to a nonlinear two-point boundary value problem. The solution yields an optimum open-loop control. For the standard linear-quadratic (regular) problem, the two-point boundary value problem can be replaced by solving a Riccati difference equation to obtain the gains of the

closed-loop system. In general, the set of difference equations may not be solved in a straightforward manner and this remark applies to Eqs. (4.5.1) to (4.5.12).

A direct method to solve the optimization problem is the dynamic programming algorithm [7]. Discrete dynamic programming is essentially the repeated sequential (stage by stage) application of the Hamilton-Jacobi equation (continuous dynamic programming) or the Bellmans' Principle of Optimality [7]. From the solution of dynamic programming we immediately know the cost-to-go function as well as the closed-loop control and optimum trajectory. Dynamic programming method minimizes directly the given cost functional and thus a Riccati equation without introducing a two-point boundary value problem. However, it generally requires guessing the form of the solution to the functional equation.

We give now an useful alternative method of solution to the optimum control problem. The objective of the closed-loop optimal stochastic control system is to minimize the average cost functional,

$$J = E \left\{ x^2(T)F + \sum_{t=0}^{T-1} Q(t) x^2(t) + R(t) u^2(t) \right\} \quad (4.5.34)$$

where both  $x(t)$  and  $u(t)$  are random sequences subject to the system dynamics

$$x(t+1) = a(t) x(t) + b(t) u(t) + \xi(t) \quad (4.5.35)$$

The state is measured imperfectly according to equation

$$z(t) = c(t) x(t) + \theta(t) \quad (4.5.36)$$

The expectation in Eq. (4.5.36) is taken with respect to random variables  $x(0)$ ,  $\xi(t)$ ,  $\theta(t)$ ,  $a(t)$ ,  $b(t)$ , and  $c(t)$ .

In the suboptimal design of the stochastic control system, we will restrict our attention to linear controllers and linear filters. Using this approach necessary optimality conditions are derived using the dynamic programming method. We are interested in control laws having the form

$$u(t) = - G(t) \hat{x}(t) \quad (4.5.37)$$

where  $G(t)$  as before is a time-varying linear control gain to be determined. The best estimate  $\hat{x}(t)$  is a priori specified to be given by the recursive equation

$$\begin{aligned} \hat{x}(t+1) = & \bar{a}(t) \hat{x}(t) + \bar{b}(t) u(t) \\ & + H(t+1) \left[ z(t+1) - \bar{c}(t+1) \bar{x}(t+1) \right] \end{aligned} \quad (4.5.38)$$

$$\bar{x}(t+1) = \bar{a}(t) \hat{x}(t) + \bar{b}(t) u(t) \quad (4.5.39)$$

where  $H(t+1)$  is the time-varying filter gain to be determined. Notice that we restrict ourselves to considerations of a specific controller-estimator structure and optimize the choice of "control" sequences  $G(t)$  and  $H(t)$  over the parameter space.

Equation (4.5.37) specifies that the admissible class of control that will be allowed in the optimization explicitly. The structure of Eq. (4.5.37) is a mathematically realizable control. The control  $u(t)$  at any time  $t$  depends on all information available up to time  $t$ . The information set is  $\{z^t, u^{t-1}\} = \{z(1), z(2), \dots, z(t), u(0), \dots, u(t-1)\}$ . Mathematically, the  $u(t)$  is a linear map of all

past measurements and controls, and, perhaps, of time  $t$ . We expect to make future observations (from time  $t$  on) and that the future controls will be functions of these measurements.

The stochastic control problem will be stated formally now. Given the dynamic system Eq. (4.2.1) and the observation Eq. (4.2.1), the information set  $\{z^t, u^{t-1}\}$  find the control law in the class specified by Eq. (4.4.1) such that the "average cost-to-go" given by

$$J_0(\tau) = E \left\{ F x^2(N) + \sum_{t=\tau}^{N-1} Q(t) x^2(t) + R(t) u^2(t) \middle| z^\tau, u^{\tau+1} \right\} \quad (4.5.40)$$

is minimum. The weightings are  $Q(t) \geq 0$ ,  $F \geq 0$ , and  $R(t) > 0$ . The statistical properties of the additive noises  $\xi(t)$  and  $\theta(t)$  and purely random (white) parameters  $a(t)$ ,  $b(t)$ , and  $c(t)$  are the same as those assumed in Section 4.2.

We show in Appendix B, that the optimum solution obtained by applying the dynamic programming algorithm is the same as that given in Theorem 4.3.

#### 4.6 Discussion of the Optimal Linear Controller

We remark here that the solution in terms of coupled nonlinear two-point boundary value problem was also obtained in [74] which considered the decentralized control of linear systems with different information sets. It was also pointed out that in the general case

$$M_{01}(t) \neq M_{11}(t) \quad (4.6.1)$$

The filter derived in [74] is not the Kalman filter, although it is linear and unbiased. In our problem solution, the orthogonality condition assumption allowed the solution to be solved analytically. This same conclusion was made by [76].

It can be seen from Eqs. (4.5.1) and (4.5.2) for the gains  $G(t)$  and  $H(t)$  that the product of the state and co-state  $P_{11}(t) M_{11}(t)$  play an important role. Note that  $H(t)$  depends mainly on  $\underline{M}(t)$ , while  $G(t)$  depends mainly on  $\underline{P}(t)$ . In the deterministic case,  $G(t)$  depends only on  $P_{00}(t)$  and  $H(t)$  depends only on  $M_{11}(t)$ . The uncertainty in the parameters reflected by  $\Sigma_{aa}(t) \neq 0$ ,  $\Sigma_{bb} \neq 0$ , and  $\Sigma_{cc}(t) \neq 0$  has coupled the state and co-states together.

The gain  $G(t)$  resembles the filter gain  $G(t)$  for the deterministic LQG problem except that  $\theta(t)$  is replaced by  $[\theta(t) + \Sigma_{cc}(t) M_{00}(t)]$ . The co-state  $M_{00}(t)$  now plays an important part in the filter gain computation. Even with perfect (noise-free) measurement, the measurement will be weighed accordingly because of the multiplicative noise in the measurement equation. In the deterministic LQG case,  $H(t)$  depends only on  $\theta(t)$  the measurement error covariance. Futhermore,  $M_{11}(t)$  depends on  $\underline{P}(t)$  through the control gains  $G(t)$ .

The control gains  $G(t)$  are similar to the  $G(t)$  given in Eq. (4.5.27) except that  $P_{00}(t)$ , the solution to the Riccati equation, has been replaced by expressions

involving both  $\underline{P}(t)$  and  $\underline{M}(t)$ , i.e.,  $[P_{00}(t) + \Sigma_{cc}(t)H^2(t)P_{11}(t)]$ . They are no longer the deterministic optimal control gains, but depend on the error covariances of the state estimates.

The equations for  $G(t)$  and  $H(t)$  are complicated expressions, so we shall consider some of the special cases.

Remark 4.1. If  $\Sigma_{cc}(t) = 0$ ,  $\Sigma_{bb}(t) \neq 0$ , and  $\Sigma_{aa}(t) \neq 0$ , then we have essentially the results of Chapter 2, control of linear stochastic systems with perfect measurements ( $\theta(t) = 0$ ).

Remark 4.2. If  $\Sigma_{bb}(t) = 0$ , then this says that the control input has a deterministic multiplier. To reduce Eq. (4.5.1) to the pure estimation problem ( $\Sigma_{aa}(t) \neq 0$ ,  $\Sigma_{cc}(t) \neq 0$ ), set  $R(t) = 0$ , so that

$$G(t) = \frac{\bar{a}(t)}{\bar{b}(t)} \quad (4.6.2)$$

and the closed-loop system parameter

$$\bar{a}(t) - \bar{b}(t)G(t) = 0 \quad (4.6.3)$$

The Eqs. (4.5.3) and (4.5.4) for the error covariance then evolves as

$$M_{00}(t+1) = \Sigma_{aa}(t)M_{00}(t) + \Xi(t) + \bar{a}^2(t)M_{11}(t) \quad (4.6.4)$$

$$\hat{M}_{11}(t+1) = \bar{a}^2(t)M_{11}(t) + \Sigma_{aa}(t)M_{00}(t) + \Xi(t) \quad (4.6.5)$$

$$\begin{aligned} M_{11}(t+1) &= (1 - H(t+1)\bar{c}(t+1))^2 \left[ \bar{a}^2(t)M_{11}(t) + \Sigma_{aa}(t)M_{00}(t) \right. \\ &\quad \left. + \Xi(t) \right] + H^2(t+1) \left[ \Sigma_{cc}(t+1)M_{00}(t+1) + \theta(t+1) \right] \\ &= (1 - H(t+1)\bar{c}(t+1))\hat{M}_{11}(t+1) \end{aligned} \quad (4.6.6)$$

The perfect control

$$u(t) = - \frac{\bar{a}(t)}{\bar{b}(t)} \hat{x}(t) \quad (4.6.7)$$

drives the estimated state to zero just prior to measurement update, i.e.,

$$\bar{x}(t+1) = \bar{a}(t) \hat{x}(t) - \bar{b}(t) G(t) \hat{x}(t) = 0 \quad (4.6.8)$$

and the state estimate evolves as

$$\hat{x}(t) = H(t) z(t) \quad (4.6.9)$$

since the predicted state estimate  $\bar{x}(t) = 0$ .

Note that in this case, the optimal gains are independent of the state weightings  $Q(t)$  used in the original cost functional. Only a single-point boundary value problem need to be solved to compute the optimal filter gain sequence since the filter equations have been uncoupled from the co-state equations  $P(t)$ . Since the optimal gains are independent of the data, they may be pre-computed off-line given the noise statistics.

We remark that since the control in this case may be written as

$$u(t) = - \frac{\bar{a}(t)}{\bar{b}(t)} H(t) z(t) \quad (4.6.10)$$

it is a linear function of the measurement  $z(t)$  and  $H(t)$ . This is an example of the nonclassical information pattern, Wittsenhausen [4]. The controller is a zero-memory controller without perfect recall.

Remark 4.3. The presence of the uncertainty  $\Sigma_{aa}(t)$  and  $\Sigma_{cc}(t)$  in the parameters  $a(t)$  and  $b(t)$  multiplying the

state  $x(t)$  tends to destabilize the system. This is readily seen from Eqs. (4.6.5) and (4.6.6) since the variance can be destabilized by large  $\Sigma_{aa}$  and high gain  $H(t)$ .

$$\begin{aligned} \hat{M}_{11}(t+1) = & \bar{a}^2(t) (1 - H(t) \bar{c}(t))^2 \hat{M}_{11}(t) + \Sigma_{aa}(t) \hat{M}_{11}(t) \\ & + \Xi(t) + H^2(t) \left[ \Sigma_{cc}(t) \hat{M}_{11}(t) + \Theta(t) \right] \bar{a}^2(t) \end{aligned} \quad (4.6.11)$$

This result is very intuitive and cautions one against using arbitrarily high gains in the closed-loop system.

Remark 4.4. The stochastic singular control problem

( $\Sigma_{bb}(t) = 0$ ,  $R(t) = 0$ ), represents the formal dual to the optimal stochastic control with perfect estimation discussed in Chapter 2. To see this, we write for the optimal filter gain

$$H(t) = \hat{M}_{11}(t) \bar{c}(t) \left[ \bar{c}^2(t) \hat{M}_{11}(t) + \Sigma_{cc}(t) M_{00}(t) + \Theta(t) \right]^{-1} \quad (4.6.12)$$

where

$$\hat{M}_{11}(t) = \bar{a}^2(t-1) M_{11}(t-1) + \Sigma_{aa}(t-1) \hat{M}_{11}(t-1) + \Xi(t-1) \quad (4.6.13)$$

since  $\hat{M}_{11}(t) = M_{00}(t)$ .

The predicted error covariance then satisfies the equation

$$\begin{aligned} \hat{M}_{11}(t+1) = & \bar{a}^2(t) \hat{M}_{11}(t) - \bar{a}^2(t) H(t) \bar{c}(t) \hat{M}_{11}(t) \\ & + \Sigma_{aa}(t) \hat{M}_{11}(t) + \Xi(t) \end{aligned} \quad (4.6.14)$$

using Eq. (4.6.12)

$$\hat{M}_{11}(t+1) = (\bar{a}^2(t) + \Sigma_{aa}(t)) \hat{M}_{11}(t) + \Xi(t) - \frac{\bar{a}^2(t) \bar{c}^2(t) \hat{M}_{11}^2(t)}{(\bar{c}^2(t) + \Sigma_{cc}(t)) \hat{M}_{11}(t) + \Theta(t)} \quad (4.6.15)$$

and

$$H(t) = \frac{\bar{c}(t) \hat{M}_{11}(t)}{(\bar{c}^2(t) + \Sigma_{cc}(t)) \hat{M}_{11}(t) + \Theta(t)} \quad (4.6.16)$$

The equations are the formal duals to the Eqs. (2.3.12) and (2.3.13) for the optimal stochastic control with perfect measurements. Note that the linear feedback control given by Eq. (2.3.11) is the optimal solution whereas the linear unbiased filter structure given by Eqs. (4.6.12) and (4.6.13) is not the optimal solution to the original stochastic control problem. Hence, the duality relationship between the perfect estimation problem and the perfect control problem is only formal.

Recalling the result of Chapter 3, we see that the results for the linear unbiased minimum variance estimator did not represent a dual to the optimal stochastic control problem with perfect measurement considered in Chapter 2. For the optimal linear estimation problem, it was found that the dual problem is a control problem with constraints on the states. The similarity in the solutions are presented in Sankaran and Srinath [77].

### Conclusions

In this section we have discussed the optimum control of independent parameter systems using a fixed structure

dynamic compensator. The structure of the linear estimator-controller is given in Fig. 4.2. We discussed in more detail the solution to this problem, i.e., coupled Riccati-type equations. We note from Eq. (4.5.5) that  $P_{11}(t)$  is uncoupled from the  $P_{00}(t)$  equation if  $\Sigma_{cc}(t) = 0, \forall t$ , and the measurement data is noise free. In the noisy sensor measurement case,  $P_{11}(t)$  is uncoupled from the  $P_{00}(t)$  equation if the covariances  $\Sigma_{aa}(t) = \Sigma_{bb}(t) = 0$ ; and this is the standard linear-quadratic-Gaussian problem. The assumption of randomly varying parameters in the dynamic system has coupled the "state"  $\underline{M}$  and "co-state"  $\underline{P}$  together. The solution of a matrix two-point boundary value problem will yield the optimal gains of the dynamic compensator. The optimal controls are not given by the separation theorem.

We then considered several special cases for the dynamic system with purely random (white) parameters. We discussed a case of deadbeat control problem in discrete-time systems. The optimal control gains is independent of  $Q$  in the cost function. They may be computed a priori given the noise statistics. The solution is applicable to the "stochastic" singular control problem; and only a single point boundary value problem needs to be solved. The stochastic singular control problem is the dual of the control problem with exact measurements considered in Chapter 2; hence one can replace in the solution equations given in Section 2.3 the symbols  $(\bar{a}, \Sigma_{aa})$  by  $(\bar{c}, \Sigma_{cc})$ ,  $K$  by  $\hat{M}_{11}$ , and  $G$  by  $H$ .

#### 4.7 Optimum Stationary Linear Control

In Section 2.4, we showed that the infinite horizon solution to the optimal control of dynamic systems with uncertain parameters and exact measurements, does not exist if the parameter uncertainty exceeds a certain quantifiable threshold. We call this the uncertainty threshold. For dynamic systems with randomly varying parameters and noisy sensor measurements, we seek the threshold parameter associated with the infinite horizon problem.

In this section we will investigate the question of the existence of steady state linear optimal stochastic controls for the random parameter problem. We assume that the system has stationary statistics so that for the random parameters

$$E\{a(t)\} = \bar{a} \quad \text{cov}\{a(t), a(\tau)\} = \Sigma_{aa} \delta(t, \tau) \quad (4.7.1)$$

$$E\{b(t)\} = \bar{b} \quad \text{cov}\{b(t), b(\tau)\} = \Sigma_{bb} \delta(t, \tau) \quad (4.7.2)$$

$$E\{c(t)\} = \bar{c} \quad \text{cov}\{c(t), c(\tau)\} = \Sigma_{cc} \delta(t, \tau) \quad (4.7.3)$$

and additive noises

$$\text{cov}\{\xi(t), \xi(\tau)\} = \Xi \delta(t, \tau) \quad (4.7.4)$$

$$\text{cov}\{\theta(t), \theta(\tau)\} = \Theta \delta(t, \tau) \quad (4.7.5)$$

We will examine the existence and finiteness of steady-state control for the infinite-time stochastic control problem by analyzing the solutions to the forward difference equations,

$$\begin{aligned}
 M_{00}(t+1) &= (\bar{a} - \bar{b} G(t))^2 M_{00}(t) + 2\bar{b} G(t) (\bar{a} - \bar{b} G(t)) M_{11}(t) \\
 &+ \bar{\varepsilon} + \bar{b}^2 G^2(t) M_{11}(t) + \Sigma_{aa} M_{00}(t) + \Sigma_{bb} G^2(t) \\
 &\times (M_{00}(t) - M_{11}(t)) \quad (4.7.6)
 \end{aligned}$$

$$M_{00}(0) = \Sigma_{x0} + \bar{x}_0^2$$

$$\begin{aligned}
 \hat{M}_{11}(t+1) &= \bar{a}^2 M_{11}(t) + \Sigma_{aa} M_{00}(t) \\
 &+ \Sigma_{bb} G^2(t) (M_{00}(t) - M_{11}(t)) + \bar{\varepsilon} \quad (4.7.7)
 \end{aligned}$$

$$H(t+1) = \hat{M}_{11}(t+1) \bar{c} \left[ \bar{c}^2 \hat{M}_{11}(t+1) + \Sigma_{cc} M_{00}(t+1) + \theta \right]^{-1} \quad (4.7.8)$$

$$\begin{aligned}
 M_{11}(t+1) &= (1 - H(t+1) \bar{c}(t+1))^2 \hat{M}_{11}(t+1) \\
 &+ H^2(t+1) (\Sigma_{cc} M_{00}(t+1) + \theta) \quad (4.7.9)
 \end{aligned}$$

$$M_{11}(0) = \Sigma_{x0}$$

and backward difference equations.

$$\begin{aligned}
 P_{00}(t) &= (\bar{a}^2 + \Sigma_{aa}) (\Sigma_{cc} H^2(t+1) P_{11}(t+1) + P_{00}(t+1)) + Q \\
 &- G^2(t) \left[ (\bar{b}^2 + \Sigma_{bb}) (\Sigma_{cc} H^2(t+1) P_{11}(t+1) + P_{00}(t+1)) \right. \\
 &\left. + R + (1 - H(t+1) \bar{c})^2 P_{11}(t+1) \Sigma_{bb} \right] \quad (4.7.10)
 \end{aligned}$$

$$P_{00}(N) = Q$$

$$\begin{aligned}
 P_{11}(t) &= \bar{a}^2 (1 - H(t+1) \bar{c})^2 P_{11}(t+1) \\
 &+ G^2(t) \left[ R + (\Sigma_{bb} + \bar{b}^2) (\Sigma_{cc} H^2(t+1) P_{11}(t+1) \right. \\
 &\quad \left. + P_{00}(t+1)) \right. \\
 &\left. + \Sigma_{bb} (1 - H(t+1) \bar{c})^2 P_{11}(t+1) \right] \quad (4.7.11)
 \end{aligned}$$

$$P_{11}(N) = 0$$

where

$$G(t) = \frac{\bar{a} \bar{b} (\Sigma_{cc} H^2(t+1) P_{11}(t+1) + P_{00}(t+1))}{(\bar{b}^2 + \Sigma_{bb}) (\Sigma_{cc} H^2(t+1) P_{11}(t+1) + P_{00}(t+1)) + R} + \frac{\Sigma_{bb} (1 - H(t+1) \bar{c})^2 P_{11}(t+1)}{\quad} \quad (4.7.12)$$

We can obtain the necessary conditions for the existence of the steady-state solution to the difference equations by assuming that as time extends to infinity in both directions (that is  $(t_0 \rightarrow -\infty, N \rightarrow +\infty)$ ) that  $\bar{P}_{00}$ ,  $\bar{P}_{11}$ ,  $\bar{M}_{00}$ , and  $\bar{M}_{11}$  are the steady-state values.

$\bar{G}$  and  $\bar{H}$  can be eliminated from  $\bar{M}_{00}$ ,  $\bar{M}_{11}$ , and  $\bar{P}_{00}$  and  $\bar{P}_{11}$  equations to obtain a system of quadratic equations in  $\bar{M}_{00}$  and  $\bar{M}_{11}$  and  $\bar{P}_{00}$  and  $\bar{P}_{11}$  separately. Simultaneous solutions of two quadratic equations requires solving a quartic equation. Hence, the algebraic solution to the linear stationary system is intractable mathematically in closed functional form except by numerical methods.

An alternative approach to the algebraic solution of the quartic equation resulting from a system of quadratic equations is the solution method of successive approximation. In particular, we propose to solve the coupled nonlinear difference equations using the control iteration method. This essentially means that we start with an initial guess of the solution  $G(t)$  gain sequence to be used in computing the forward difference equations  $M_{00}(t)$  and  $M_{11}(t)$ . The

computed solution  $H(t)$  sequence is stored on the forward pass. On the backward pass the stored  $H(t)$  are used to solve the backward difference equations  $P_{00}(t)$  and  $P_{11}(t)$ ; the control gains  $G(t)$  are stored on the backward pass. These forward-backward steps are iterated until the solutions converge to some convergence criterion chosen (0.001 in our case) and the average cost stops to change significantly.

The simulation results are used to guide the analysis of the coupled nonlinear difference equations  $M_{00}(t)$ ,  $M_{11}(t)$ ,  $P_{00}(t)$ , and  $P_{11}(t)$  that have to be solved to obtain the optimal control gains and filter gains. If the measurements are exact and  $\Sigma_{cc} = 0$ , the stability results of Section 2.4 apply to the optimal stochastic control problem since all equations reduce to the perfect measurement case.

We now give the following theorem.

Theorem 4.4. For the linear stationary system, if the quantity

$$\bar{a}^2 + \Sigma_{aa} - \frac{\bar{a}^2 \bar{b}^2}{\bar{b}^2 + \Sigma_{bb}} > 1 \quad (4.7.13)$$

then the Riccati-type equation  $P_{00}(t)$  diverges as  $N$  becomes  $+\infty$ . The resultant closed-loop control system is unstable in mean-square sense.

Proof: From Eq. (4.5.5)

$$P_{00}(t) = (\bar{a}^2 + \Sigma_{aa})(\Sigma_{cc} H^2(t+1) P_{11}(t+1) + P_{00}(t+1) + Q) \quad (4.7.14)$$

$$P_{00}(t) = - \frac{\bar{a}^2 \bar{b}^2 (\Sigma_{cc} H^2(t+1) P_{11}(t+1) + P_{00}(t+1))^2}{(\bar{b}^2 + \Sigma_{bb})(\Sigma_{cc} H^2(t+1) P_{11}(t+1) + P_{00}(t+1)) + R}$$

$$+ \Sigma_{bb} (1 - H(t+1) \bar{c})^2 P_{11}(t+1)$$

$$+ \Sigma_{aa} (1 - H(t+1) \bar{c})^2 P_{11}(t+1) \quad \text{(Concluded)} \quad (4.7.14)$$

Adding  $\Sigma_{cc} H^2(t) P_{11}^2(t)$  to both sides, and define  $\hat{P} = P_{00} + \Sigma_{cc} H^2 P_{11}$  we obtain that

$$\hat{P}(t) = (\bar{a}^2 + \Sigma_{aa}) \hat{P}(t+1) + Q$$

$$- \frac{\bar{a}^2 \bar{b}^2 \hat{P}_{11}^2(t+1)}{(\bar{b}^2 + \Sigma_{bb}) \hat{P}(t+1) + R + \Sigma_{bb} (1 - H(t+1) \bar{c})^2 P_{11}(t+1)}$$

$$+ (\Sigma_{aa} (1 - H(t+1) \bar{c})^2 + \Sigma_{cc} H^2(t)) P_{11}(t) \quad (4.7.15)$$

$$\hat{P}(t) > (\bar{a}^2 + \Sigma_{aa}) \hat{P}(t+1) - \frac{\bar{a}^2 \bar{b}^2 \hat{P}_{11}^2(t+1)}{(\bar{b}^2 + \Sigma_{bb}) \hat{P}(t+1) + R} + Q \quad (4.7.16)$$

We have proved in Section 2.4 for the perfect measurement a Riccati equation of the form above has a finite solution if and only if the means and covariances of the random parameters satisfy the condition

$$\bar{a}^2 + \Sigma_{aa} - \frac{\bar{a}^2 \bar{b}^2}{\bar{b}^2 + \Sigma_{bb}} < 1 \quad (4.7.17)$$

We have obtained, therefore, a sufficient condition for the Riccati-type equation for  $\hat{P}(t)$  to diverge for the infinite-horizon stochastic control problem.

If  $\hat{P}(t)$  diverges, we may have the case that only  $P_{00}(t)$  diverges while  $P_{11}(t)$  converge. But this is not possible from Eq. (4.7.11). We can also have the case that  $P_{00}(t)$  converges and  $P_{11}(t)$  diverges. Again this is not possible from Eq. (4.7.10). Hence we can only conclude that both  $P_{00}(t)$  and  $P_{11}(t)$  diverge together.

Remark 4.5. Consider the special case  $\Sigma_{aa} = \Sigma_{bb} = 0$ , then the co-state equations simplify to

$$P_{00}(t) = \bar{a}^{-2}(\Sigma_{cc} H^2(t+1) P_{11}(t+1) + P_{00}(t+1)) + Q - \frac{\bar{a}^{-2} \bar{b}^{-2} (\Sigma_{cc} H^2(t+1) P_{11}(t+1) + P_{00}(t+1))^2}{\bar{b}^{-2} (\Sigma_{cc} H^2(t+1) P_{11}(t+1) + P_{00}(t+1)) + R} \quad (4.7.18)$$

$$P_{11}(t) = \bar{a}^{-2}(1 - H(t+1) \bar{c})^2 P_{11}(t+1) + \frac{\bar{a}^{-2} \bar{b}^{-2} (\Sigma_{cc} H^2 P_{11}(t+1) + P_{00}(t+1))^2}{\bar{b}^{-2} (\Sigma_{cc} H^2 P_{11}(t+1) + P_{00}(t+1)) + R} \quad (4.7.19)$$

Note that Eq. (4.7.18) is just the standard Riccati equation for the linear quadratic control problem,  $P_{00}(t)$  does not diverge independent of what  $P_{11}(t)$  does. If  $P_{11}(t)$  diverges, then  $P_{00}(t)$  approaches  $(\bar{a}^{-2}/\bar{b}^{-2} R + Q)$  as  $N \rightarrow \infty$ . In other words, the Riccati equation  $P_{00}(t)$  converges for any value of  $\Sigma_{cc}$ .

If the co-state  $P_{11}(t)$  diverges, then

$$P_{11}(t) = \bar{a}^{-2}(1 - H(t+1) \bar{c})^2 P_{11}(t+1) + \bar{a}^{-2} \Sigma_{cc} H^2(t+1) P_{11}(t+1) \geq \bar{a}^{-2} \frac{\Sigma_{cc}}{\bar{c}^{-2} + \Sigma_{cc}} P_{11}(t+1) \quad (4.7.20)$$

A sufficient condition is that  $(\bar{a}^2 \Sigma_{cc}/\bar{c}^2 + \Sigma_{cc}) > 1$  for  $P_{11}(t)$  to diverge. In deriving the inequality above we have claimed that the minimum variance filter gain is given by  $\Sigma_{cc}/(\bar{c}^2 + \Sigma_{cc})$ . This can be readily deduced from the filter equations. Note that Eq. (4.7.20) is the same condition we derived for the linear minimum variance estimator in Eq. (3.4.12).

Remark 4.6. In the special case that  $\Sigma_{bb} = 0$ , then we have that

$$P_{11}(t) = \bar{a}^2(1 - H(t+1)\bar{c})^2 P_{11}(t+1) + \frac{\bar{a}^2 \bar{b}^2 (\Sigma_{cc} H^2(t+1) P_{11}(t+1) + P_{00}(t+1))^2}{\bar{b}^2 (\Sigma_{cc} H^2(t+1) P_{11}(t+1) + P_{00}(t+1)) + R} \quad (4.7.21)$$

If the homogeneous part of  $P_{11}(t)$  diverges then  $\bar{a}^2 (\Sigma_{cc}/\bar{c}^2 + \Sigma_{cc}) > 1$ . The co-state equation is given by

$$P_{00}(t) = (\bar{a}^2 + \Sigma_{aa})(\Sigma_{cc} H^2(t+1) P_{11}(t+1) + P_{00}(t+1)) + Q - \frac{\bar{a}^2 \bar{b}^2 (\Sigma_{cc} H^2(t+1) P_{11}(t+1) + P_{00}(t+1))^2}{\bar{b}^2 (\Sigma_{cc} H^2(t+1) P_{11}(t+1) + P_{00}(t+1)) + R} + \Sigma_{aa} (1 - H(t+1)\bar{c})^2 P_{11}(t+1) \quad (4.7.22)$$

This is not in the form of the standard Riccati equation. The inequality condition of Eq. (4.7.12) is still a sufficient condition for divergence, however.

Remark 4.7. In the case that  $\Sigma_{aa} = 0$ , we have then the co-state

$$P_{00}(t) = \bar{a}^2 (\Sigma_{cc} H^2(t+1) P_{11}(t+1) + P_{00}(t)) + Q - \frac{\bar{a}^2 \bar{b}^2 (\Sigma_{cc} H^2(t+1) P_{11}(t+1) + P_{00}(t+1))^2}{(\bar{b}^2 + \Sigma_{bb})(\Sigma_{cc} H^2(t+1) P_{11}(t+1) + P_{00}(t+1)) + R} + \Sigma_{bb} (1 - H(t+1)\bar{c})^2 P_{11}(t+1) \quad (4.7.23)$$

and

$$\begin{aligned}
 P_{11}(t) = & \bar{a}^2(1 - H(t+1) \bar{c})^2 P_{11}(t+1) \\
 & + \frac{\bar{a}^{-2} \bar{b}^{-2} (\Sigma_{cc} H^2(t+1) P_{11}(t+1) + P_{00}(t+1))^2}{(\bar{b}^2 + \Sigma_{bb})(\Sigma_{cc} H^2(t+1) P_{11}(t+1) + P_{00}(t+1))} \\
 & \frac{+ R + \Sigma_{bb} (1 - H(t+1) \bar{c})^2 P_{11}(t+1)}{\quad} \quad (4.7.24)
 \end{aligned}$$

The sufficient condition for divergence as given by the inequality Eq. (4.7.13) holds in this case ( $\Sigma_{aa} = 0$ ).

Remark 4.8. For the lack of an analytical result on the asymptotic stability of closed-loop stochastic control system, we turned to simulations to guide the analysis. Solutions to the state and co-state equations were obtained by the method of successive approximation. Solution values for  $P_{00}(t)$ ,  $P_{11}(t)$ ,  $M_{00}(t)$ , and  $M_{11}(t)$  are recorded to determine the limiting solution value in case they converge. For a particular system ( $\Sigma_{cc} = 1.0$ ,  $\bar{c} = 1.0$ ,  $\bar{a} = 1.1$ ,  $\bar{b} = 1.0$ ), Fig. 4.3 gives the stability and instability regions for the random parameter system. We see that for certain combinations ( $\Sigma_{aa}$ ,  $\Sigma_{bb}$ ) the steady-state solution to  $P_{00}(t)$  and  $P_{11}(t)$  does not exist because the uncertainties are larger than some threshold for the closed-loop system.

If we draw in the curve for

$$\bar{a}^{-2} + \Sigma_{aa} - \frac{\bar{a}^{-2} \bar{b}^{-2}}{\bar{b}^2 + \Sigma_{bb}} = 1 \quad (4.7.25)$$

it will be much above the computed stability curve in Fig. 4.3 since it is only a sufficient condition. Now if we

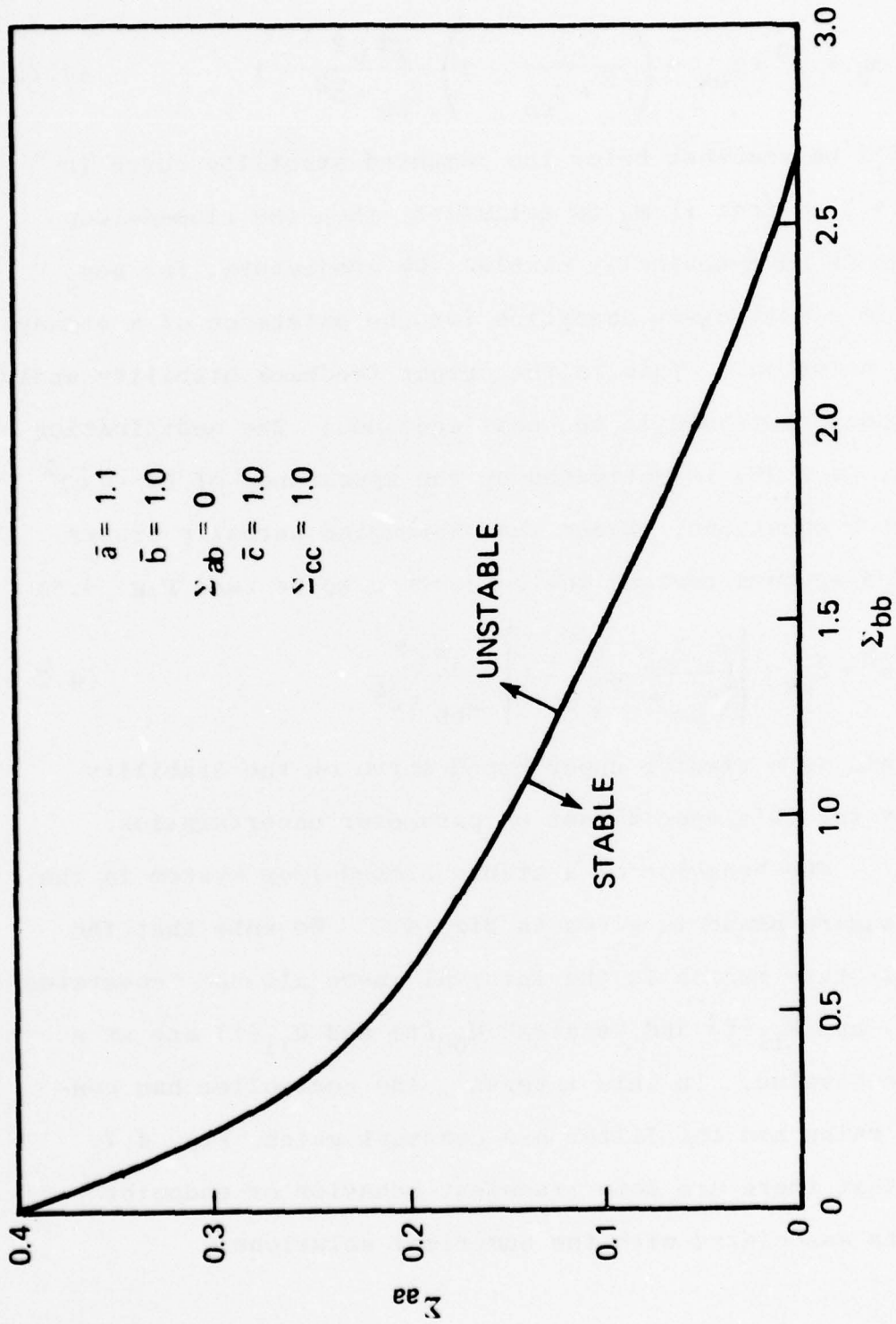

Figure 4.3 Computed stability region for system given by equations (4.4.1) and (4.4.14)

draw in the curve (see Fig. 4.4)

$$m_2 = \bar{a}^{-2} + \Sigma_{aa} + \left( \frac{\Sigma_{cc}}{\bar{c}^{-2} + \Sigma_{cc}} - 1 \right) \frac{\bar{a}^{-2} \bar{b}^{-2}}{\Sigma_{bb} + \bar{b}^{-2}} = 1 \quad (4.7.26)$$

it will be somewhat below the computed stability curve in Fig. 4.3 so that if  $m_2$  is satisfied, then the closed-loop system is asymptotically stable. We conjecture, for now, this is a sufficient condition for the existence of a steady-state solution. (This is the output feedback stability analysis result obtained in the next section.) The modification in Eq. (4.7.26) is motivated by the appearance of  $(1 - H\bar{c})^2$  in the P equations. Since the expression actually occurs squared we then revised the conjecture to be (see Fig. 4.5)

$$\bar{a}^{-2} + \Sigma_{aa} + \left[ \left( \frac{\Sigma_{cc}}{\Sigma_{cc} + \Sigma^2} \right)^2 - 1 \right] \frac{\bar{a}^{-2} \bar{b}^{-2}}{\Sigma_{bb} + \bar{b}^{-2}} \quad (4.7.27)$$

and this is a tighter upper bound curve on the stability region for this special set of parameter uncertainties.

The behavior of a stable closed-loop system in the mean-square sense is given in Fig. 4.6. We note that the steady-state region is the interval where all the "co-states"  $P_{00}(t)$  and  $P_{11}(t)$  and "states"  $M_{00}(t)$  and  $M_{11}(t)$  are at a constant value. In this interval, the controller has constant gains and the filter has constant gains, Fig. 4.7. Note that there are some transient behavior or endpoint effects associated with the numerical solutions.

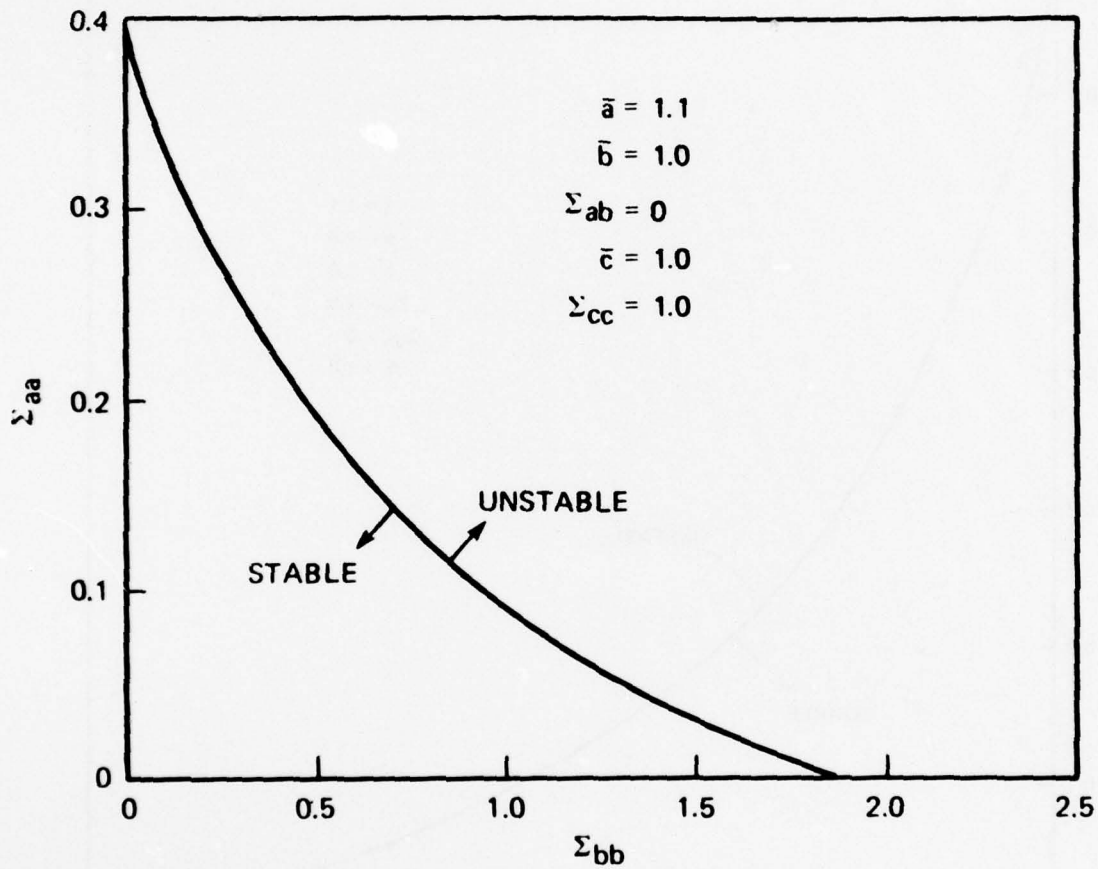

Figure 4.4 Lower bound on the stability region defined by equation (4.7.26) for system given by equations (4.4.1) and (4.4.14)

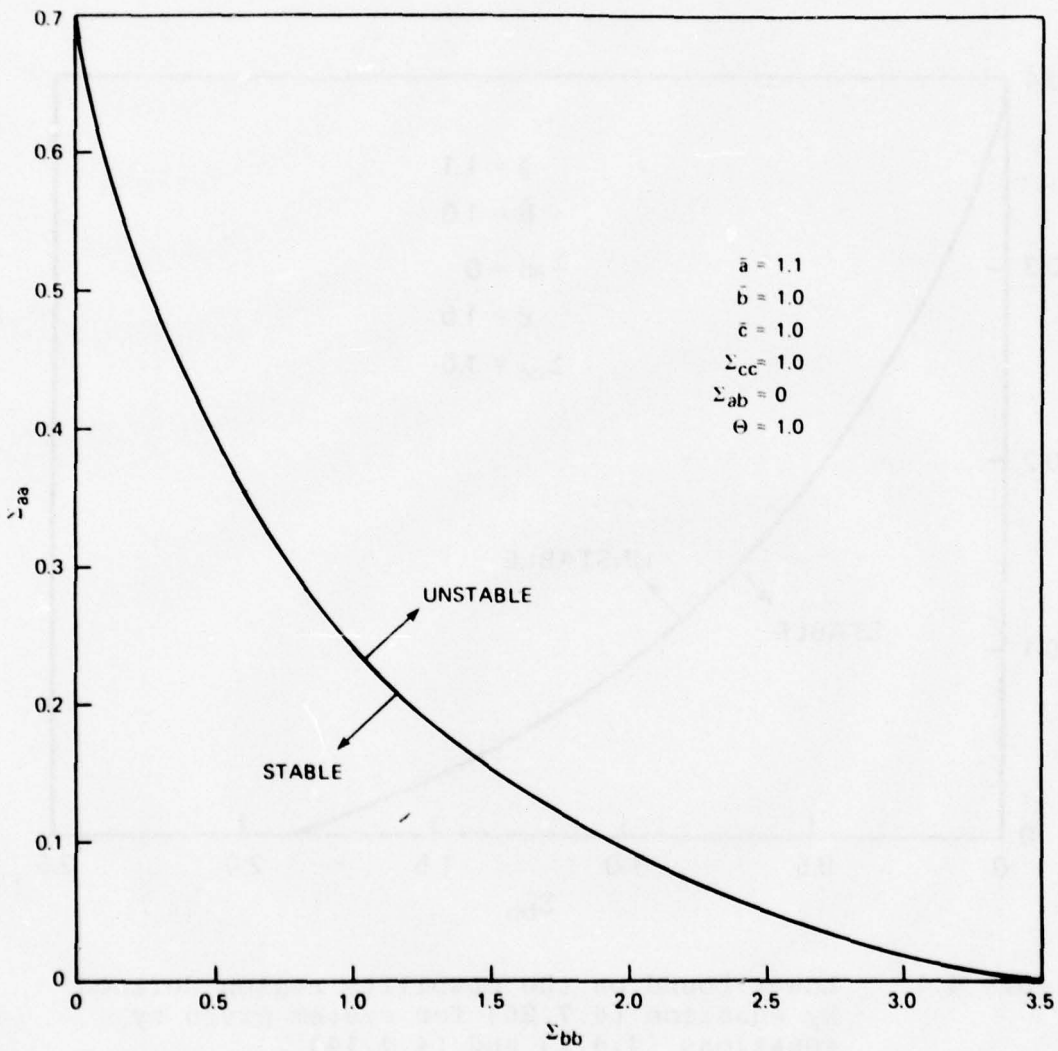

Figure 4.5 Stability region defined by equation (4.7.27) for system given by equations (4.4.1) and (4.4.14)

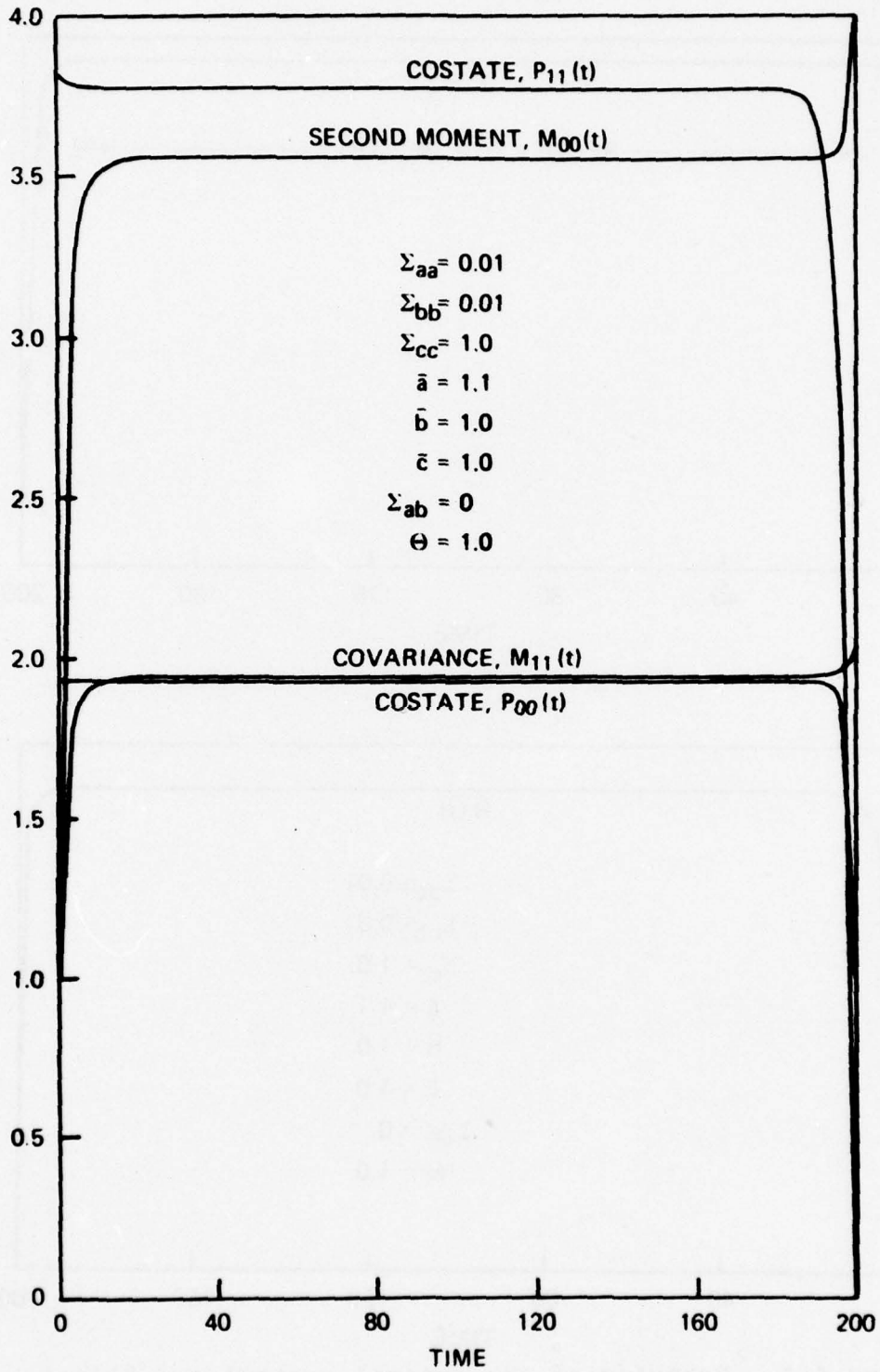

Figure 4.6 Behavior of the states and costates given by equations (4.7.6) to (4.7.12)

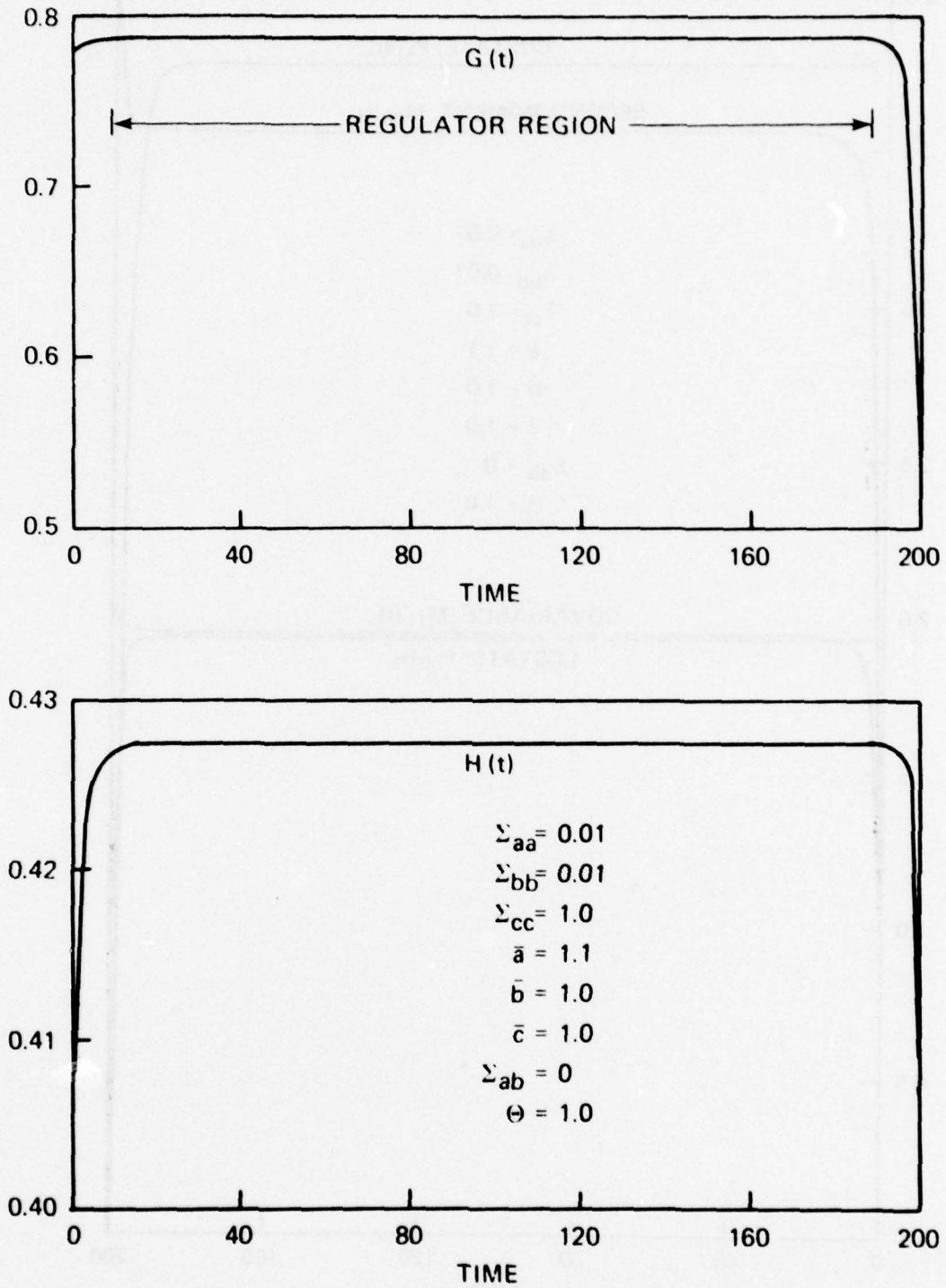

Figure 4.7 Behavior of the optimal control and filter gain sequences  $G(t)$  and  $H(t)$

In Fig. 4.8 we show what happens to the solution values of  $P_{00}(t)$ ,  $P_{11}(t)$ ,  $M_{00}(t)$ , and  $M_{11}(t)$  in an unstable closed-loop system. The solution values for all four variables increases monotonically and for all practical purposes diverge.

Remark 4.9. The effect of uncertainty in the parameter  $c$  is investigated in Fig. 4.9. For  $\Sigma_{aa} = \Sigma_{bb} = 0$ , the covariance of  $c$  contributes to the destabilization of the closed-loop system when the parameters are known with certainty. In the case illustrated  $\bar{a} = 1.1$ ,  $\bar{b} = 1.0$ , and  $\bar{c} = 1.0$ , the co-state  $P_{11}(t)$  becomes exponentially large when  $\Sigma_{cc}$  exceeds the value 5.0.

In Fig. 4.10 we show the effect of  $\Sigma_{cc} > 0$ ,  $\Sigma_{aa} = 0$  on the uncertainty threshold developed in Chapter 2.

$$m = \frac{1}{\bar{a}^2 + \Sigma_{aa}} - \frac{\frac{1}{\bar{a}^2} \frac{1}{\bar{b}^2}}{\frac{1}{\bar{b}^2} + \Sigma_{bb}} \quad (4.7.28)$$

It is intuitively obvious that the effective threshold is higher, that is, there is less tolerance for the uncertainty in the parameters  $b$  in order for the closed-loop system to be asymptotically stable. We show similarly in Fig. 4.11, for  $\Sigma_{bb} = 0$ , the level of uncertainty  $\Sigma_{aa}$  the closed-loop system will tolerate is smaller than the perfect observation case. Figures 4.10 and 4.11 can be compared with those of Figs. 2.2 and 2.3.

The larger the covariance of  $b$ , ceteris paribus, the smaller the magnitude of the control gain and the larger

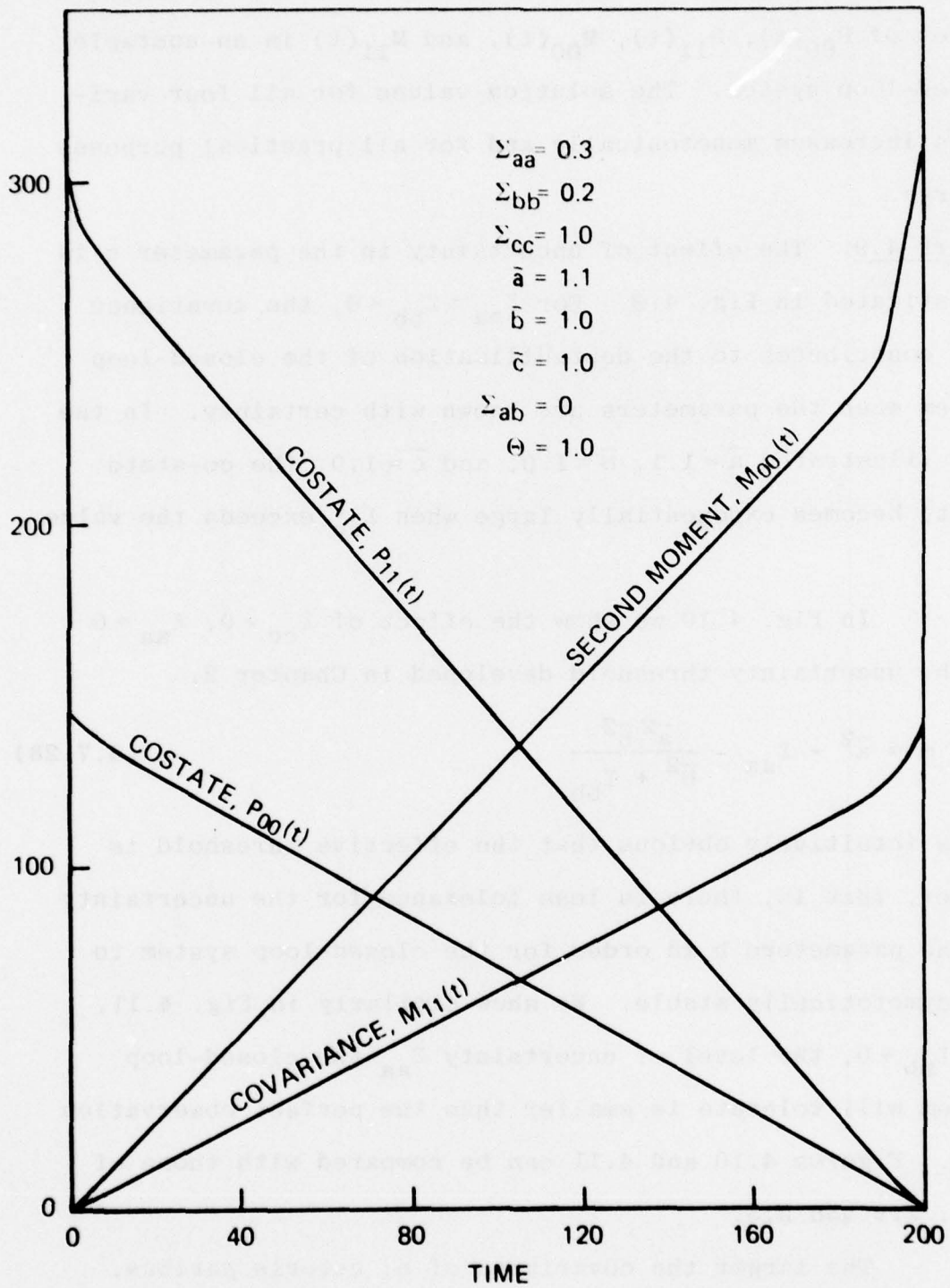

Figure 4.8 Behavior of the divergent states and costates given by equations (4.7.6) to (4.7.12)

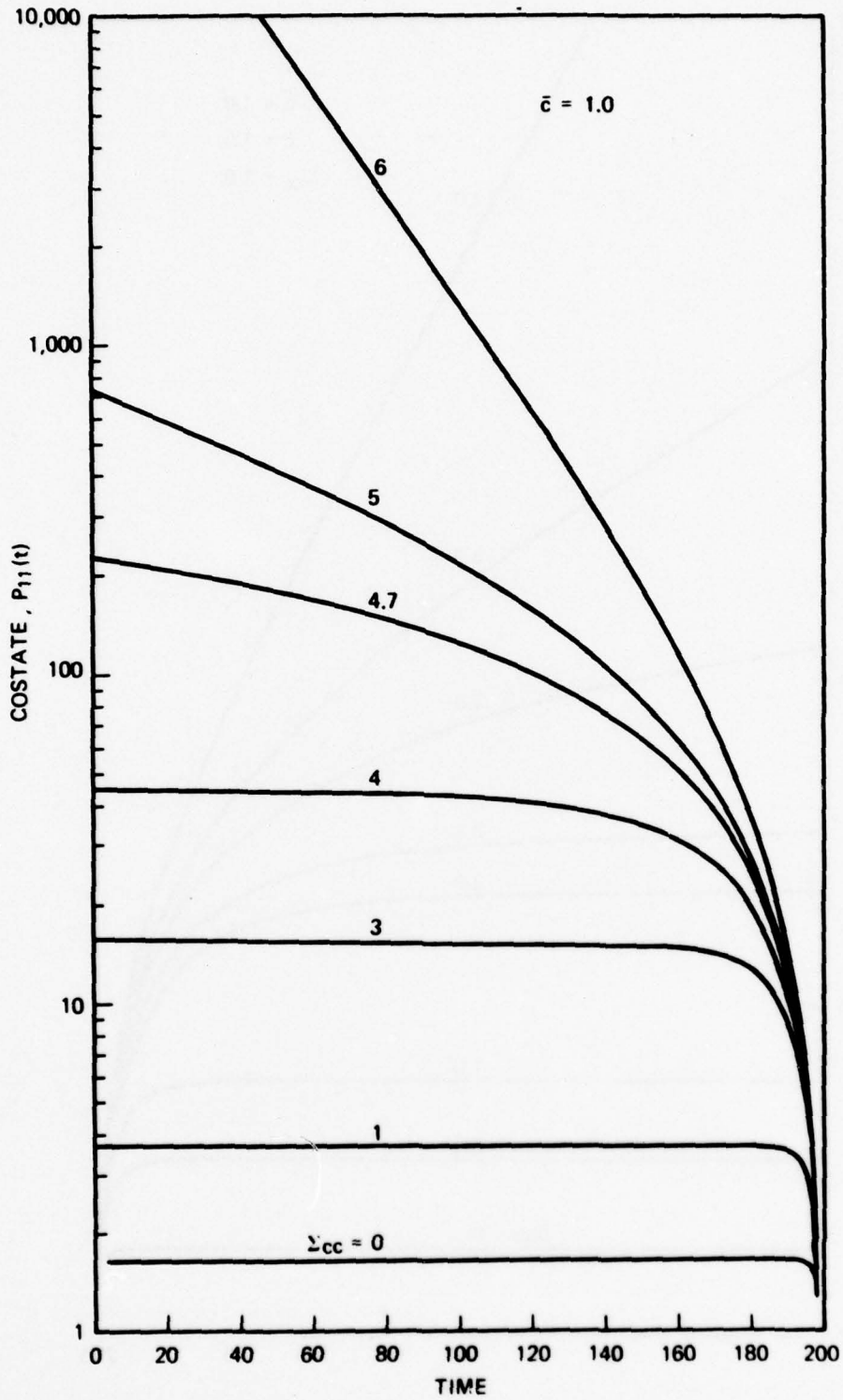

Figure 4.9 Solution of costate equation (4.7.18) for known  $a(t)=\bar{a}=1.1$  and  $b(t)=\bar{b}=1.0$

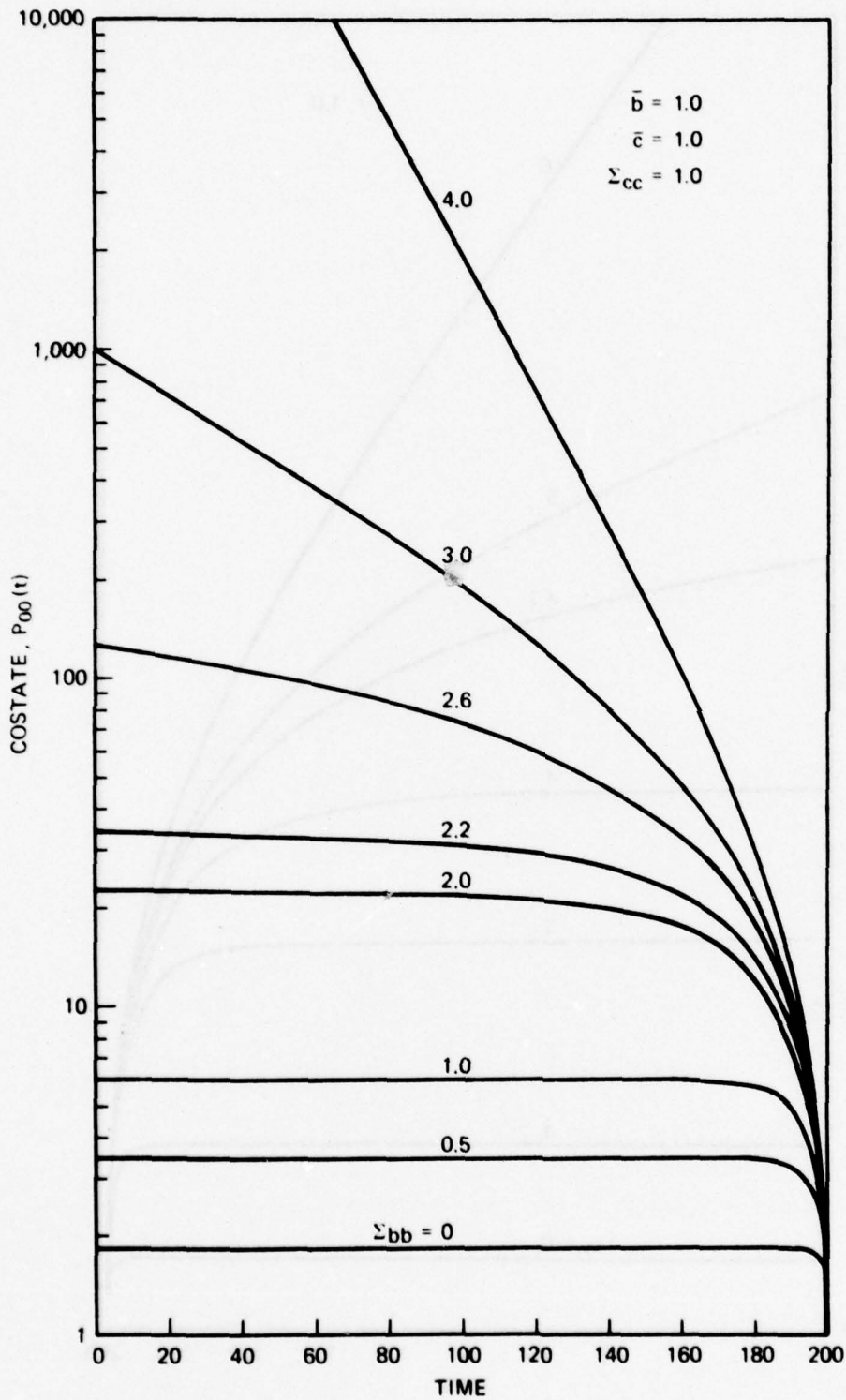

Figure 4.10 Solution of the costate equation (4.7.23) for known  $a(t)=a=1.1$

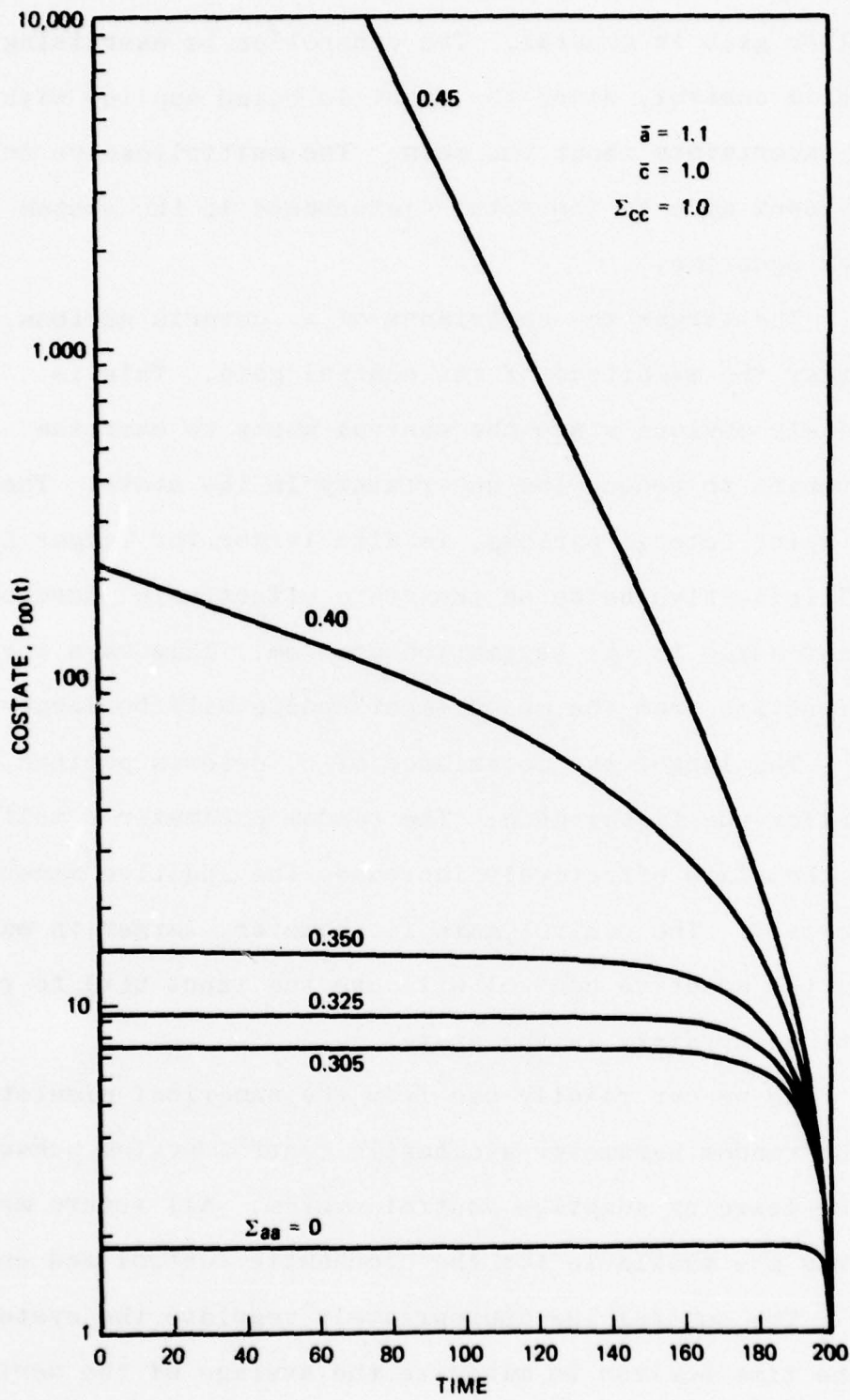

Figure 4.11 Solution of the costate equation (4.7.22) for known gain  $b(t)=\bar{b}=1.0$

the filter gain in general. The controller is exercising caution in control, since the input is being applied with larger uncertainty about the mean. The multiplicative noise on the input adds to the total disturbance in the system dynamics equation.

The larger the covariance of  $a$ , ceteris paribus, the larger the magnitude of the control gain. This is intuitively obvious since the control wants to exercise more probing to reduce the uncertainty in the state. The filter gain, ceteris paribus, is also larger for larger  $\Sigma_{aa}$ . The multiplicative noise on the state effectively increases the plant noise in the estimation problem. This says that the correction from the measurement update will be larger.

The larger the covariance of  $c$ , ceteris paribus, the smaller the filter gain. The random parameter  $c$  multiplying the state effectively increases the additive measurement noise  $\theta$ . The control gain is, however, larger in magnitude as the adaptive control will use the input  $u(t)$  to reduce the uncertainty in the state.

As we can readily see from the numerical simulation that the random parameter stochastic control system behaves as a non-learning adaptive control system. All future measurements are available for the stochastic control and estimation. The control law appropriately regulate the system over the time horizon to minimize the average of the deviation of the state from zero and control effort; and this control involves no parameter identification.

The control input  $u(t)$  affects the estimation process and the estimation performance affects the amount of control action necessary to regulate the system. The system is not neutral. Caution and probing is an important functional part of the controller. The control gains are modulated by the covariances, which are in turn affected by the control action.

The value of information for the stochastic control problem in general is defined as the difference between the expected cost  $J_1$ , the best we can do with the information and  $J_2$ , the best the controller can do without the information. This value of information provides a measure of how the performance of a random parameter system is degraded when we assume that nature specifies the system parameters at all times.

To obtain a comparison of the cost among the several control schemes, the constrained controller-estimator of Section 4.4, the certainty-equivalent controller, the enforced separation controller, and Kalman filter-perfect estimation controller, one could proceed with a Monte Carlo simulation of the closed-loop system.

Remark 4.10. For stable systems where  $|\bar{a}| < 1$ , it is observed from the simulation results that if

$$\left( \frac{\bar{a}^2}{\sigma^2} + \Sigma_{aa} \right) < 1 \quad (4.7.29)$$

the closed-loop system converges for any values of means and covariances.

If  $(\bar{a}^{-2} + \Sigma_{aa}) > 1$ , then the solution values of  $P_{00}(t)$  and  $P_{11}(t)$  diverges for certain combinations of the means and variances of the parameters. In general, the sufficient condition Eq. (4.7.13) holds for the original stable as well as unstable systems.

If  $\Sigma_{aa} = \Sigma_{bb} = 0$ , then there is no possibility of divergence since the stability region is above the curve

$$\frac{\Sigma_{cc}}{\bar{c}^{-2} + \Sigma_{cc}} \bar{a}^{-2} = 1 \quad (4.7.30)$$

For the stationary system, we consider the perfect control problem presented in Section 4.6. The existence of a solution to the stochastic singular control problem depends on the existence of positive-definite solution of the algebraic Riccati-type equation.

$$\hat{M}_{11}(t+1) = (\bar{a}^{-2} + \Sigma_{aa}) \hat{M}_{11}(t) + \Xi - \frac{\bar{a}^{-2} \bar{c}^{-2} \hat{M}^2(t)}{(\bar{c}^{-2} + \Sigma_{cc}) \hat{M}(t) + \Theta} \quad (4.7.31)$$

The critical points of this type of algebraic equation was discussed in Section 2.4. By identifying  $\hat{M}_{11}$  with  $K$  in Eq. (2.4.1) the following result can be stated.

Theorem 4.5

If the means and covariances of the random parameters are such that

$$\bar{a}^{-2} + \Sigma_{aa} - \frac{\bar{a}^{-2} \bar{c}^{-2}}{\bar{c}^{-2} + \Sigma_{cc}} < 1 \quad (4.7.32)$$

then a non-negative definite solution of Eq. (4.7.31) exists.

Proof: The proof is similar to that given in Section 2.4.

This inequality condition can be analyzed in the same manner as for the perfect estimation case. The stochastic singular control system is stable if and only if the inequality in Eq. (4.7.32) is satisfied.

The covariance may be written as,

$$\begin{aligned} \hat{M}_{11}(t+1) = & (1 - H(t) \bar{c})^2 \hat{M}_{11}(t) + \Sigma_{aa} \hat{M}_{11}(t) + \Xi \\ & + \bar{a}^2 H^2(t) \left[ \Sigma_{cc} \hat{M}_{11}(t) + \theta \right] \end{aligned} \quad (4.7.33)$$

where  $[(1 - H(t) \bar{c}) \bar{a}]$  is the closed-loop system parameter and

$$H(t) = \hat{M}_{11}(t) \bar{c} \left[ (\bar{c}^2 + \Sigma_{cc}) \hat{M}_{11}(t) + \theta(t) \right]^{-1} \quad (4.7.34)$$

When  $\Sigma_{aa} = \Sigma_{cc} = 0$ , the sufficient condition for stability is that  $\hat{M}_{11}(t)$  be stable. It is well-known that in general if the system is observable, then the propagation of the covariances will converge to some steady-state value; and this is true for a scalar system.

When  $\Sigma_{aa} \neq 0$  and  $\Sigma_{cc} \neq 0$ , then stability of the covariance equation depends on the level of uncertainty in the parameters  $a(t)$  and  $c(t)$ . Note that both uncertainties destabilize the covariance propagation equation. The destabilizing effect due to  $\Sigma_{cc}$  will be greater since it is multiplied by the square of the filter gain.

### Conclusions

In this subsection we summarize the key results obtained in Section 4.7. We are interested in seeking a

threshold condition for the infinite horizon problem; and, hence, the existence of steady-state control law. Since the coupled nonlinear Riccati-type matrix difference equation is computationally complex to solve analytically, we used the control iteration method to simulate the system of equations in the two-point boundary problem. We were able to immediately obtain a sufficient condition for the solution to the coupled Riccati-type equations to diverge for infinite-horizon problem.

Next we proceeded to investigate some special cases.

1)  $\Sigma_{aa} = \Sigma_{bb} = 0$ , the Riccati-like equation for  $P_{00}(t)$  always has a limiting solution, 2)  $\Sigma_{aa} \neq 0$ ,  $\Sigma_{bb} = 0$ ,  $P_{00}(t)$  may diverge as  $N \rightarrow \infty$ , and 3)  $\Sigma_{aa} = 0$ ,  $\Sigma_{bb} \neq 0$ ,  $P_{00}(t)$  may diverge as  $N \rightarrow \infty$ . The computed (simulated) stability region curve is then presented in Fig. 4.3. Some conjectures on the sufficient conditions for mean-square stability are given in Figs. 4.4 and 4.5. The uncertainties in the random parameters have a destability effect on the dynamic system, in moving the effective poles outside the unit disk. This is argued as follows. The uncertainty in  $a$  increases the magnitude of the control gain. The uncertainty in  $b$  increases the magnitude of the filter gains. The uncertainty in  $c$  reduces the filter gains, but it increases the control gains since the variance  $\Sigma_{cc} \neq 0$  is effectively additional control weight in the co-state equations.

If the random system is originally stable, we can say something more about the mean-square stability of the linear control system. The feedback system is stable if  $(a^{-2} + \Sigma_{aa}) < 1$ . If  $\Sigma_{aa} = \Sigma_{bb} = 0$ , then the fixed structure control system is always stable.

For the stochastic singular control system, we obtained the sufficient condition for mean-square stability under feedback; which is the dual to the case with exact measurements ( $\Sigma_{cc} = 0, \theta = 0$ ). If this threshold condition is violated, then the optimal solution to the infinite horizon problem does not exist.

#### 4.8 Stability of Stochastic Dynamical Systems

In this section we will follow by analogy with the method of analysis in Section 2.5 and derive the conditions for the asymptotic stability of the closed-loop system. In particular, we shall deal with the stochastic difference equation

$$y(t+1) = a(t)x(t) + b(t)u(t) \quad (4.8.1)$$

where the linear output feedback law

$$u(t) = g(t)y(t) \quad (4.8.2)$$

and output

$$y(t) = c(t)x(t) \quad (4.8.3)$$

then

$$y(t+1) = [a(t) + b(t)g(t)c(t)]x(t) = \phi(t)x(t) \quad (4.8.4)$$

The propagation of the second moment of  $x$  is given by

$$\begin{aligned} E\{x^2(t+1)\} &= E\{a^2(t) + b^2(t) g^2(t) c^2(t) \\ &\quad + 2a(t) b(t) g(t) c(t)\} E\{x^2(t)\} \\ &= E\{a^2(t)\} + g^2(t) E\{b^2(t) c^2(t)\} \\ &\quad + 2g(t) E\{a(t) b(t) c(t)\} E\{x^2(t)\} \end{aligned} \quad (4.8.5)$$

$$\frac{E\{x^2(t+1)\}}{E\{x^2(1)\}} = E\{\phi^2(1)\} E\{\phi^2(2)\} \dots E\{\phi^2(t)\} = S(t) \quad (4.8.6)$$

The minimum of  $S(t)$  is obtained if each term is minimized for all  $t$ . Thus, taking the algebraic minimization we get that

$$g^*(t) = - \frac{E\{a(t) b(t) c(t)\}}{E\{b^2(t) c^2(t)\}} \quad (4.8.7)$$

Substitute this result into Eq. (4.8.6) we get the minimum value of  $\delta(t)$  is

$$S(t) = \left[ \overline{a^2(t)} - \frac{\overline{a(t) b(t) c(t)}^2}{\overline{b^2(t) c^2(t)}} \right] t \quad (4.8.8)$$

In the case where the system parameters  $a(t)$  and  $b(t)$  are uncorrelated with the measurement parameter  $c(t)$  as has been assumed in Section 4.3, we then have

$$g^*(t) = - \frac{\overline{a(t) b(t) c(t)}}{\overline{b^2(t) c^2(t)}} \quad (4.8.9)$$

The minimum value of  $S(t)$  is then, assuming the random parameters are wide sense stationary,

$$S(t) = \left[ \bar{a}^2 + \Sigma_{aa} - \frac{(\bar{a}\bar{b} + \Sigma_{ab})^2 \bar{c}^2}{(\Sigma_{bb} + \bar{b}^2)(\Sigma_{cc} + \bar{c}^2)} \right] t \triangleq \tilde{m}t \quad (4.8.10)$$

The variance of  $x(t)$  is bounded if and only if

$$\tilde{m} < 1 \quad (4.8.11)$$

If we rewrite this result as

$$\tilde{m} = \bar{a}^2 + \Sigma_{aa} + \left( \frac{\Sigma_{cc}}{\Sigma_{cc} + \bar{c}^2} - 1 \right) \frac{(\Sigma_{ab} + \bar{a}\bar{b})^2}{(\Sigma_{bb} + \bar{b}^2)} < 1 \quad (4.8.12)$$

We find that this threshold  $\tilde{m}$  differs from the  $m$  in Eq. (2.4.3) in the expression  $((\Sigma_{cc}/\bar{c}^2 + \Sigma_{cc}) - 1)$ . We note that if  $\Sigma_{cc} = 0$ , then  $\tilde{m}$  reduces to  $m$ . Effectively, driving the system in Eq. (4.8.1) using direct output feedback represents a worst-case analysis.

In other words, we can improve on this sufficient condition for mean square stability by using any reasonable control law. This is verified when we use the linear unbiased estimator of a fixed structure given by Eqs. (4.5.2) to (4.4.4). In principle, we have then derived the lower bound on the actual stability curve for the closed-loop system given by Eq. (4.8.12).

We remark that from Eq. (4.8.12) if  $\bar{a}^2 + \Sigma_{aa} \leq 1$  and  $\Sigma_{ab} \geq 0$ , then the stable system (4.8.1) is again stabilizable under feedback. Mathematically, this says that for the combination of means and covariances that satisfy inequality (4.8.12) also satisfies the true threshold condition. The converse is not true. The inequality condition in Eq. (4.8.12)

is only a sufficient condition. This is illustrated in Fig. 4.4. Superimposing Fig. 4.4 on Fig. 4.3 would show that the stability region curve given by Eq. (4.8.12) is below the computed mean-square stability region curve in Fig. 4.3. Hence, it is not surprising to see from that the stability curve of Eq. (4.8.12) in Fig. 4.4 is lower than the experimental curve in Fig. 4.3 obtained from simulations.

Consider now the case  $\Sigma_{bb} = 0$ , then the threshold  $\tilde{m}$  becomes

$$\tilde{m} = \Sigma_{aa} + \frac{\Sigma_{cc}}{\Sigma_{cc} + \bar{c}^2} \bar{a}^2 = \bar{a}^2 + \Sigma_{aa} - \frac{\bar{a}^2 \bar{c}^2}{\Sigma_{cc} + \bar{c}^2} \quad (4.8.13)$$

and from Eq. (4.6.9)

$$g^* = - \frac{\bar{a} \bar{c}}{\bar{b}(\Sigma_{cc} + \bar{c}^2)} \quad (4.8.14)$$

If  $\Sigma_{cc} = 0$ , we have the stability condition  $\Sigma_{aa} < 1$ . In the case  $\Sigma_{cc} \neq 0$ , if  $\bar{a}^2 + \Sigma_{aa} < 1$ , then the system is stabilizable under linear feedback for all levels of parameter uncertainty.

We have stated that the inequality condition in Eq. (4.8.11) is only a sufficient condition for mean-square stability, the gain in Eq. (4.8.14) does not correspond to the limiting control gain obtained from the TPBVP, i.e.,

$$\lim_{N \rightarrow \infty} G(t) = - \frac{\bar{a}}{\bar{b}} \quad (4.8.15)$$

which is independent of  $\Sigma_{cc}$  and  $\bar{c}$ . This is obvious since the  $g^*$  here is based on output feedback. So that when  $\Sigma_{cc} = 0$ ,

$$g^* = - \frac{\bar{a}}{\bar{b} \bar{c}} \quad (4.8.16)$$

If in addition  $\Sigma_{aa} = 0$ , then

$$\tilde{m} = \frac{\Sigma_{cc}}{\bar{c}^2 + \Sigma_{cc}} \bar{a}^{-2} \quad (4.8.17)$$

Hence, the closed-loop system is mean-square stable for all  $|\bar{a}| < 1$ . In the perfect estimation problem  $m = 0$ , of course.

If  $\Sigma_{aa} = 0$ , but  $\Sigma_{bb} > 0$ , then the sufficient condition for mean-square stability becomes

$$\tilde{m} = \bar{a}^{-2} + \left( \frac{\Sigma_{cc}}{\Sigma_{cc} + \bar{c}^2} - 1 \right) \frac{\bar{a}^{-2} \bar{b}^{-2}}{\Sigma_{bb} + \bar{b}^2} \quad (4.8.18)$$

and

$$g^* = - \frac{\bar{a} \bar{c}}{(\Sigma_{bb} + \bar{b}^2)(\Sigma_{cc} + \bar{c}^2)} \quad (4.8.19)$$

For  $|\bar{a}| < 1$ , the system is stabilizable under linear feedback.

We conclude that the really interesting cases to study are systems with  $(\bar{a}^{-2} + \Sigma_{aa}) > 1$  and  $m < 1$ . The destabilizing effect of the variance of  $c(t)$  is manifested in this range of values.

#### Stochastic Stability Using Fixed Structure Controller

The next problem to examine at this point is if the parameter uncertainties are such that

$$\bar{a}^2 + \Sigma_{aa} - \frac{(\bar{a}\bar{b} + \Sigma_{ab})^2 \bar{c}^2}{(\Sigma_{bb} + \bar{b}^2)(\Sigma_{cc} + \bar{c}^2)} > 1 \quad (4.8.20)$$

can the stochastic system with random parameters still be mean-square stabilizable under linear feedback ( $u(t) = g \hat{x}(t)$ ).

We will attempt to formulate this problem in the subsequent analysis. We propose to use a linear unbiased estimator for the state in the closed-loop controller, i.e.,

$$\hat{x}(t) = (1 - h\bar{c}) \hat{x}(t-1)(\bar{a} + \bar{b}g) + h y(t) \quad (4.8.21)$$

where

$$y(t) = c(t) x(t) \quad (4.8.22)$$

and the closed-loop system is

$$x(t+1) = a(t) x(t) + b(t) g(t) \hat{x}(t) \quad (4.8.23)$$

The naive estimate of the form

$$x(t) = \frac{1}{c} y(t) = \frac{c}{c} x(t) \quad (4.8.24)$$

Therefore,

$$u(t) = g(t) \frac{c}{c} x(t) \quad (4.8.25)$$

Substituting this into Eq. (4.8.1) we get that

$$x(t+1) = \left[ a(t) + b(t) g(t) \frac{c(t)}{c} \right] x(t) \quad (4.8.26)$$

Minimizing the variance of  $x(t)$ , we obtain that

$$\frac{\partial}{\partial g} \left\{ a^2(t) + b^2(t) g^2(t) \left( \frac{c(t)}{c} \right)^2 + 2a(t) b(t) g(t) \frac{c(t)}{c} \right\} = 0$$

$$g = - \frac{\bar{a}\bar{b} \bar{c}^2}{b^2 \bar{c}^2} \quad (4.8.27)$$

The resulting control law is given by

$$u(t) = - \frac{\overline{ab} \overline{c}}{\overline{b}^2 \overline{c}^2} x(t) \quad (4.8.28)$$

We note that this is the same control law as using the direct output feedback. Hence, all the previous results follow (Eq. (4.8.11)). It is obvious from Eq. (4.8.21) that if

$$h = \frac{1}{\overline{c}} \quad (4.8.29)$$

then Eq. (4.8.24) follows. Therefore, the output feedback control is equivalent (identical) to  $h = 1/\overline{c}$ .

In the linear-quadratic-Gaussian problem we are able to examine the necessary and sufficient conditions for the existence of stabilizing gains. In the time-invariant case, the characteristic values of the closed-loop system comprise the characteristic values of  $[a - bg]$  (the regulator poles) and the characteristic values of  $[a - hc]$  (the estimator poles). Overall system stability then requires the poles to be inside the unit circle. For the random parameter system, the cascaded system poles do not comprise of those of the deterministic optimal control problem and those of the optimal estimation problem since the Separation Principle no longer is true. Hence, we need a separate analysis and a measure of stochastic stability to consider.

We want to analyze the stability of the fixed structure control system and obtain a tighter lower bound on the stability region curve. We have that

$$x(t+1) = a(t)x(t) + b(t)g(t)\hat{x}(t) \quad (4.8.30)$$

where

$$\hat{x}(t) = (1 - h(t)\bar{c})\hat{x}(t|t-1) + h(t)c(t)x(t) \quad (4.8.31)$$

From Eq. (4.8.30) we have that

$$\hat{x}(t+1|t) = \bar{a}\hat{x}(t) + \bar{b}g(t)\hat{x}(t) = (\bar{a} + \bar{b}g)\hat{x}(t) \quad (4.8.32)$$

We can then write for the closed-loop control system a second-order difference equation in  $[x(t+1), \hat{x}(t+1|t)] \triangleq \underline{\tilde{x}}(t+1)$ .

We remark that this "state" representation is equivalent to a  $[\hat{x}(t+1|t), e(t+1|t)]$  representation if we define

$$e(t+1|t) \triangleq \hat{x}(t+1|t) - x(t+1) \quad (4.8.33)$$

Then we have

$$\begin{bmatrix} x(t+1) \\ \hat{x}(t+1|t) \end{bmatrix} = \begin{bmatrix} a(t) + b(t)g(t)h(t)c(t) & b(t)g(t)(1 - h(t)\bar{c}) \\ (\bar{a} + \bar{b}g(t))h(t)c(t) & (\bar{a} + \bar{b}g(t))(1 - h(t)\bar{c}) \end{bmatrix} \times \begin{bmatrix} x(t) \\ \hat{x}(t|t-1) \end{bmatrix} \quad (4.8.34)$$

We write the above as

$$\underline{\tilde{x}}(t+1) \triangleq \underline{A}(t)\underline{\tilde{x}}(t) \quad (4.8.35)$$

We analyze the mean-square stability of such a second-order system by examining the Lyapunov function

$$V(\underline{\tilde{x}}(t)) = \underline{\tilde{x}}'(t)\underline{\tilde{x}}(t) \quad (4.8.36)$$

Then we compute

$$E\{V(\underline{\tilde{x}}(t+1)) - V(\underline{\tilde{x}}(t))\} = \underline{\tilde{x}}'(t)(\underline{A}'(t)\underline{A}(t) - I)\underline{\tilde{x}}(t) \quad (4.8.37)$$

Theorem 4.6. The solution of the system given by the second-order difference equation is mean-square stable if and only if

$$E\{\underline{A}'(t)\underline{A}(t)\} - \underline{I} \leq \underline{0} \quad (4.8.38)$$

or that the maximum eigenvalue of the matrix  $E\{\underline{A}'(t)\underline{A}(t)\}$  has to be less than unity in magnitude, i.e.,  $\max|\lambda_1, \lambda_2| < 1$ .

Proof: See [58].

Applying this fact to our system, then

$$E\{\underline{A}'(t)\underline{A}(t)\} = \begin{bmatrix} \overline{a^2} + 2\overline{ab}gh\overline{c} + \overline{b^2}g^2h^2\overline{c^2} & (\overline{ab} + \overline{b^2}gh\overline{c})g(1-h\overline{c}) \\ + (\overline{a} + \overline{b}g)^2h^2\overline{c^2} & + (\overline{a} + \overline{b}g)^2h\overline{c}(1-h\overline{c}) \\ g(1-h\overline{c})(\overline{ab} + \overline{b^2}gh\overline{c}) & \overline{b^2}g^2(1-h\overline{c})^2 \\ + (\overline{a} + \overline{b}g)^2(1-h\overline{c})h\overline{c} & + (\overline{a} + \overline{b}g)^2(1-h\overline{c})^2 \end{bmatrix} \quad (4.8.39)$$

The eigenvalues of this symmetric matrix is obtained by solving  $\det(\underline{A} - \lambda \underline{I}) = 0$ . We are free to choose  $g$  and  $h$ . After some algebraic manipulations, we obtain that the roots of the characteristic equation are given by

$$\lambda_{1,2} = \frac{-\beta \pm \sqrt{\beta^2 - 4\alpha}}{2} \quad (4.8.40)$$

If we define

$$\beta \triangleq - \left[ \overline{a^2} + 2\overline{ab}gh\overline{c} + \overline{b^2}g^2h^2\overline{c^2} + (\overline{a} + \overline{b}g)^2h^2\overline{c^2} + (1-h\overline{c})^2(\overline{b^2}g^2 + (\overline{a} + \overline{b}g)^2) \right] \quad (4.8.41)$$

and

$$\alpha \triangleq \left[ \overline{a^2} + 2\overline{ab}gh\overline{c} + \overline{b^2}g^2h^2\overline{c^2} + (\overline{a} + \overline{b}g)^2h^2\overline{c^2} \right] \left[ \overline{b^2}g^2 + (\overline{a} + \overline{b}g)^2 \right] (1-h\overline{c})^2 - \left[ (\overline{ab} + \overline{b^2}gh\overline{c})g + (\overline{a} + \overline{b}g)^2h\overline{c} \right]^2 (1-h\overline{c})^2 \quad (4.8.42)$$

Thus,

$$\beta^2 - 4\alpha = \left[ \bar{a}^2 + 2\bar{a}\bar{b}gh\bar{c} + \bar{b}^2g^2h^2\bar{c}^2 + (\bar{a} + \bar{b}g)^2h^2\bar{c}^2 - (1 - h\bar{c})^2(\bar{b}^2g^2 + (\bar{a} + \bar{b}g)^2) \right]^2 + 4 \left[ (\bar{a}\bar{b} + \bar{b}^2gh\bar{c})g + (\bar{a} + \bar{b}g)^2h\bar{c} \right]^2 (1 - h\bar{c})^2 > 0 \quad (4.8.43)$$

The problem is to choose  $g$  and  $h$  such that the  $\max(|\lambda_1|, |\lambda_2|) < 1$ . This involves the solution of a system of quartic equations in  $g$  and  $h$ , resulting from the necessary conditions.

$$\frac{\partial}{\partial g} \left[ -\beta + \sqrt{\beta^2 - 4\alpha} \right] = 0 \quad (4.8.44)$$

and

$$\frac{\partial}{\partial h} \left[ -\beta + \sqrt{\beta^2 - 4\alpha} \right] = 0$$

The computation is algebraically cumbersome.

In the case of output feedback the above equations simplify since we have

$$h = \frac{1}{\bar{c}}, \quad g = -\frac{\bar{a}\bar{b}\bar{c}^{-2}}{\bar{b}^2\bar{c}^2} \quad (4.8.45)$$

so that Eq. (4.8.47) becomes

$$E\{\underline{A}'(t)\underline{A}(t)\} = \begin{bmatrix} \bar{a}^2 - 2\bar{a}\bar{b}\frac{\bar{a}\bar{b}\bar{c}^{-2}}{\bar{b}^2\bar{c}^2} + \bar{b}^2\left(\frac{\bar{a}\bar{b}\bar{c}^{-2}}{\bar{b}^2\bar{c}^2}\right)^2\frac{\bar{c}^2}{\bar{c}^2} & 0 \\ + \left(\bar{a} - \bar{b}\frac{\bar{a}\bar{b}\bar{c}^{-2}}{\bar{b}^2\bar{c}^2}\right)^2\frac{\bar{c}^2}{\bar{c}^2} & \\ 0 & 0 \end{bmatrix} \quad (4.8.46)$$

The nonzero eigenvalue is thus given by

$$\lambda_1 = \left( \overline{a^2} - \frac{\overline{ab^2} \overline{c^2}}{\overline{b^2} \overline{c^2}} \right) + \overline{a^2} \frac{\overline{c^2}}{\overline{c^2}} - 2\overline{ab} \frac{\overline{ab}}{\overline{b^2}} + \overline{b^2} \frac{\overline{ab^2} \overline{c^2}}{\overline{b^2} \overline{b^2} \overline{c^2}} \quad (4.8.47)$$

Hence, the condition that

$$\overline{a^2} - \frac{\overline{ab^2} \overline{c^2}}{\overline{b^2} \overline{c^2}} < 1$$

does not satisfy the necessary conditions in Eq. (4.8.38).

It is, therefore, not the optimal values of  $g$  and  $h$ .

### Conclusions

We summarize the main results in this subsection. It is shown that the feedback linear control using output directly gives a sufficient condition for the mean-square stability of the randomly-varying dynamic system. By analogy with the reasoning in Section 2.5, the optimum gain using output feedback obtained from the stability analysis is the true limiting gain for the truly optimal stochastic control law in the unstable region (in the mean-square sense).

For the fixed structure feedback control system, we then give the necessary conditions for the optimal gains and implicitly the necessary conditions for mean-square stability. It is then shown that the optimum gains derived for the output feedback do not satisfy the necessary conditions for the mean-square stability of the fixed structure control system.

#### 4.9 Conclusions

In this chapter we have presented the results for the adaptive stochastic control of linear systems with purely random (white) parameters. The system state cannot be measured exactly. The measurement data is computed by additive white noise. We first gave the optimum control law in terms of the conditional means. We know that for this class of non-linear-quadratic-gaussian stochastic control problem, the optimum estimator is nonlinear and requires computation of all the moments. Hence, we seek adaptive controllers with a given fixed structure. The class of admissible controllers are thus restricted to be linear feedback regulator type. The original stochastic system is then transformed into a deterministic system. We solved the dynamic deterministic optimization problem first using the Matrix Minimum Principle and then the dynamic programming. With the structure of the dynamic compensator fixed, we subsequently optimize the free parameters of the compensators. The free parameters are the linear control and estimator gains.

In the resulting time-varying feedback controller the off-line computational requirements seem more severe than the case of optimal stochastic controller. To obtain the optimal gains we have to solve a coupled nonlinear two-point boundary value problem involving difference equations. This is not a trivial computation even compared to solve the non-linear filtering problem.

In the fixed structure dynamic compensator, the control now affects both the mean and variance of the estimation error. This is an example of cautious control. This is contrasted with the optimum solution obtain by stochastic dynamic programming where the minimum variance of the state estimate is independent of the control. In the linear minimum variance filter, the control does affect the estimation accuracy.

For the first time in the literature, the asymptotic behavior of the linear controller for stationary system is examined. Taking an approach analogous to that in Section 2.5, we derived a sufficient condition for the existence of optimum linear feedback controller. We also derived a sufficient condition for the system to be mean-square unstabilizable under linear feedback.

In Chapter 3, we obtained the result that the linear discrete filter is stable if the second moment is bounded. The necessary and sufficient condition for asymptotic stability of the second moment is that the  $\bar{a}^2 + \Sigma_{aa} < 1$ . This is only a sufficient condition in the fixed structure optimal control problem. As indicated by the stability region (boundary) curve derived from computer simulations, the true stability curve is somewhere between that given by the output feedback stability analysis in Section 4.8 and the uncertainty threshold for the exact measurement case in Section 2.5.

We have shown that for the linear dynamic systems with fixed structure feedback controller, there exists a threshold determined by the means and covariances of the randomly varying parameters such that optimum linear control laws for the infinite horizon problem exist if and only if that inequality condition is satisfied.

CHAPTER 5

ON LINEAR MULTIVARIABLE CONTROL SYSTEMS

5.1 Introduction

In this chapter, we shall extend the analysis in Chapter 2 to linear multivariable control systems. We will consider the exact measurement case in Section 5.2. We state the optimal stochastic control problem with purely random parameters; the results have been presented in [35] and [37]. In Section 5.3, we consider a special case of the problem stated in Section 5.2. In particular, we present the optimality and stability results when the matrices  $\underline{A}$  and  $\underline{B}$  are multiplied by some scalars, sequentially uncorrelated in time. The results have appeared in [51] and [79].

In Section 5.4, we consider the inexact measurement case, where the observations are corrupted by white noise. The solution to the fixed structure estimator-controller is given. The primary motivation for this chapter is to indicate where the previous results apply and can be extended readily, and to indicate the mathematical notational complexity and computational burden required. Basically, no new theoretical results are presented in the analysis.

## 5.2 Optimal Control of Systems with Exact Measurements

Consider a first-order linear dynamical system with state vector  $\underline{x}(t)$  and control  $\underline{u}(t)$  described by the difference equation

$$\underline{x}(t+1) = \underline{A}(t)\underline{x}(t) + \underline{B}(t)\underline{u}(t) + \underline{\xi}(t) \quad (5.2.1)$$
$$t = 0, 1, 2, \dots$$

where  $\underline{x}(t)$  is an  $n$ -dimensional vector,  $\underline{A}(t)$  is an  $n \times n$  matrix,  $\underline{B}(t)$  is an  $n \times m$  matrix,  $\underline{u}(t)$  is an  $m$ -dimensional vector, and  $\underline{\xi}(t)$  is an  $n$ -dimensional white noise vector. The initial state vector  $\underline{x}(0)$  is given.

It is assumed that we have exact measurement of the state,

$$\underline{y}(t) = \underline{x}(t) \quad (5.2.2)$$

In Eq. (5.2.1), it is assumed that the system parameters  $\underline{A}(t)$  and  $\underline{B}(t)$  contain purely random parameters as elements which may be grouped into a random parameter vector  $\underline{p}(t)$ . It is assumed that the random vector  $\underline{p}(t)$  is statistically independent and identically distributed in time. The random vectors selected at each time may have correlated elements, so that the off-diagonal elements of the covariance matrix of  $\underline{p}(t)$  are non-zero. To be more precise, we assume that for wide-sense stationary parameters in  $\underline{A}(t)$  and  $\underline{B}(t)$ ,

$$\mathbf{E}\{\underline{p}(t)\} = \bar{\underline{p}} \quad (5.2.3)$$

$$\mathbf{E}\{(\underline{p}(t) - \bar{\underline{p}})(\underline{p}(\tau) - \bar{\underline{p}})'\} = \underline{\Sigma}_p \delta(t, \tau) \quad (5.2.4)$$

where  $\delta(t, \tau)$  is the Kronecker delta function.

However, to be able to write down mathematically the ensuing results for the multivariable system, we will soon need some machinery from tensor analysis, since the covariance of  $\underline{A}(t)$  is a fourth-order tensor of  $n^4$  components. Alternatively, because of our particular formulation of the white parameter problem, the notational complexity is lessened. We will need the relationship following [80]

$$E\{\underline{x}'(t+1)\underline{Q}\underline{x}(t+1)\} \triangleq \underline{\bar{x}}'(t+1)\underline{Q}\underline{\bar{x}}(t+1) + \text{tr } \underline{Q} \underline{\Sigma}^{\underline{x}(t+1)} \quad (5.2.5)$$

where the  $ij^{\text{th}}$  element of the matrix  $\underline{\Sigma}^{\underline{x}(t+1)}$  is given by using Eq. (5.2.1)

$$\begin{aligned} \underline{\Sigma}_{ij}^{\underline{x}(t+1)} = & \underline{x}'(t) \underline{\Sigma}^{A_i A_j} \underline{x}(t) + 2\underline{x}'(t) \underline{\Sigma}^{A_i B_j} \underline{u}(t) \\ & + \underline{u}'(t) \underline{\Sigma}^{B_i B_j} \underline{u}(t) + \underline{\Sigma}^{\xi_i \xi_j} \end{aligned} \quad (5.2.6)$$

where  $\underline{\Sigma}^{A_i B_j}$  is the covariance matrix of the  $i^{\text{th}}$  row of  $\underline{A}$  with the  $j^{\text{th}}$  row of  $\underline{B}$ .

Finally, we remark that the additive noise  $\underline{\xi}(t)$  is assumed to be zero-mean Gaussian white, and independent of  $\{\underline{A}(t)\}$  and  $\{\underline{B}(t)\}^*$ .

The control problem is the stochastic regulator type optimization problem with the expected cost function given by

---

\* If  $\underline{\xi}(t)$  is a colored noise, then we can always generate it with a pre-whitening filter. If  $\underline{\xi}(t)$  is correlated with  $\underline{A}(t)$  and  $\underline{B}(t)$ , then expressions in Eq. (5.2.6) are appropriately changed.

$$J = E\{\underline{x}'(N)\underline{F} \underline{x}(N) + \sum_{t=0}^{N-1} \underline{x}'(t) \underline{Q}(t) \underline{x}(t) + \underline{u}'(t)\underline{R}(t)\underline{u}(t)\} \quad (5.2.7)$$

where  $\underline{Q}(t)$ ,  $\underline{R}(t)$ , and  $\underline{F}$  are symmetric positive semi-definite matrices. The quadratic cost functional in Eq. (5.2.7) assigns a real member to the pair vector  $\underline{x}(t)$  and  $\underline{u}(t)$ .

The set of admissible controls  $\underline{u}(t) \in U(t)$  where  $U(t)$  is a subset of the  $m$ -dimensional Euclidean space. Since we are interested in closed-loop controls, the admissible controls  $\underline{u}(t)$  are assumed to depend only on the a priori given information and

$$Y^t = \{\underline{y}(0), \underline{y}(1), \dots, \underline{y}(t)\} \quad \text{and} \quad U^{t-1} = \{\underline{u}(0), \underline{u}(1), \dots, \underline{u}(t-1)\}$$

The stochastic control problem is to find a control sequence  $\{\underline{u}(0), \underline{u}(1), \dots, \underline{u}(N-1)\}$  such that it minimizes the expression in Eq. (5.2.7). The solution is given by the stochastic dynamic programming algorithm.

The optimal control law is given by<sup>†</sup>

$$\underline{u}^*(t) = -\underline{G}^*(t)\underline{x}^*(t) \quad (5.2.8)$$

<sup>†</sup>If both  $\underline{B}$  and  $\underline{Q}$  matrices are  $2 \times 2$ , then  $\text{tr } \underline{Q} \underline{B} \underline{B}^T = q_{11} \underline{B}_1 \underline{B}_1 + q_{12} \underline{B}_1 \underline{B}_2 + q_{21} \underline{B}_2 \underline{B}_1 + q_{22} \underline{B}_2 \underline{B}_2$ .

$$\underline{G}^*(t) = - \left[ \underline{R}(t) + \underline{\bar{B}}' \underline{K}^*(t+1) \underline{\bar{B}} + \overline{\text{tr } \underline{K}^*(t+1) \underline{\Sigma}^{\text{BB}}} \right]^{-1} \{ \underline{\bar{B}}' \underline{K}^*(t+1) \underline{\bar{A}} + \overline{(\text{tr } \underline{K}^*(t+1) \underline{\Sigma}^{\text{AB}})' } \} \quad (5.2.9)$$

where the Riccati-like matrix difference equation is

$$\underline{K}^*(t) = \underline{Q}(t) + \underline{\bar{A}}' \underline{K}^*(t+1) \underline{\bar{A}} + \overline{\text{tr } \underline{K}^*(t+1) \underline{\Sigma}^{\text{AA}}} - \underline{S}^*(t) \left( \underline{\bar{B}}' \underline{K}^*(t+1) \underline{\bar{B}} + \overline{(\text{tr } \underline{K}^*(t+1) \underline{\Sigma}^{\text{AB}})' } \right) \quad (5.2.10)$$

$$\underline{K}^*(N) = \underline{F}$$

and

$$\underline{S}^*(t) \triangleq \left( \underline{\bar{A}}' \underline{K}^*(t+1) \underline{\bar{B}} + \overline{(\text{tr } \underline{K}^*(t+1) \underline{\Sigma}^{\text{AB}})} \right) \left[ \underline{R}(t) + \underline{\bar{B}}' \underline{K}^*(t+1) \underline{\bar{B}} + \overline{\text{tr } \underline{K}^*(t+1) \underline{\Sigma}^{\text{BB}}} \right]^{-1} \quad (5.2.11)$$

The recursive functional equation is thus

$$V(N) = \underline{x}'^*(N) \underline{F} \underline{x}^*(N) \quad (5.2.12)$$

$$V(t, \underline{x}^*(t)) = \underline{x}^{*'}(t) \underline{K}(t) \underline{x}^*(t) + \sum_{\tau=t}^{N-1} \underline{K}^*(\tau+1) \underline{\Xi} \quad (5.2.13)$$

From the results for scalar system analyzed in Chapter 2, we know that the convergence of the sequence of  $\{\underline{K}(t)\}$  generated by the Riccati-like equations (5.2.10) and (5.2.11) must satisfy some inequality condition on the a priori means and covariances of the randomly varying parameters. The steady-state solution  $\underline{K}$  then satisfies the so-called algebraic Riccati equation, and the control law has linear constant gains in the

steady-state interval.

The limiting gain for the closed-loop control system exists even if the Riccati solutions diverge, as shown in the scalar system examined in Chapter 2. The gain in the limit is obtained from Eq. (5.2.9). Alternatively, the gain can be derived by considering the mean-square stability of a stochastic system Eq. (5.2.1), under linear feedback as demonstrated in Section 2.5. In any case, the analysis will give the stability condition for the closed-loop stochastic control system.

### 5.3 Linear Multivariable Control for Systems with Scalar Random Parameters

In this section, we will consider a special case of the linear multivariable system formulated in Eq. (5.2.1). In particular, instead of the random matrices we have to deal with in Eqs. (5.2.1) and (5.2.2), we replace the randomness by a random scalar multiplying the matrices  $\underline{A}(t)$  and  $\underline{B}(t)$ . So the notations and symbols involved in the solutions are that much less cumbersome. The results given in this section are also found in [51] and generalized in [79].

Consider then the linear discrete-time stochastic system whose dynamics are described by the vector difference equation

$$\underline{x}(t+1) = \gamma(t)\underline{A} \underline{x}(t) + \delta(t) \underline{B} \underline{u}(t) + \underline{\xi}(t) \quad (5.3.1)$$

Both the system matrix  $\underline{A}$  and the control matrix  $\underline{B}$  are multiplied by white, possibly correlated, scalar random sequences. We

assume that  $\underline{A}$  and  $\underline{B}$  are constant matrices of appropriate dimensions without loss of generality, since the product  $(\gamma(t)\underline{A})$  is time-varying. The additive noise  $\underline{\xi}(t)$  is a zero-mean Gaussian white noise. Assume that  $[\underline{A}, \underline{B}]$  is a controllable pair and that  $\underline{B}$  is  $n \times n$  and of full rank.

We further assume that the scalars  $\gamma(t)$  and  $\delta(t)$  are Gaussian white random sequences with known stationary statistics. More precisely, we have:

$$E\{\gamma(t)\} = \bar{\gamma}, \quad E\{(\gamma(t) - \bar{\gamma})(\gamma(\tau) - \bar{\gamma})\} = \Gamma \delta(t, \tau) \quad (5.3.2)$$

$$E\{\delta(t)\} = \bar{\delta}, \quad E\{(\delta(t) - \bar{\delta})(\delta(\tau) - \bar{\delta})\} = \Delta \delta(t, \tau) \quad (5.3.3)$$

$$E\{(\gamma(t) - \bar{\gamma})(\delta(\tau) - \bar{\delta})\} = \Lambda \delta(t, \tau) \quad (5.3.4)$$

$$E\{\underline{\xi}(t)\} = \underline{0}, \quad E\{\underline{\xi}(t)\underline{\xi}'(\tau)\} = \Xi \delta(t, \tau) \quad (5.3.5)$$

where  $\delta(t, \tau)$  is the Kronecker delta. Furthermore, we assume that the plant noise  $\underline{\xi}(t)$  is mutually independent of the scalar random sequences  $\gamma(t)$  and  $\delta(t)$ .

We have the standard quadratic cost function (5.2.7) we want to minimize. Assume that  $[\underline{A}, \underline{Q}^{\frac{1}{2}}]$  is an observable pair. Under the assumption that we can measure the entire state vector  $\underline{x}(t)$  exactly, at each instant of time, we wish then to find the feedback optimal control sequence  $\underline{u}(0), \underline{u}(1), \underline{u}(2), \dots$  such that the quadratic cost (5.2.7) is minimized.

The problem can be readily solved using the dynamic programming algorithm as in Section 5.2. The optimal control is

in linear state variable feedback form,

$$\underline{u}^*(t) = - \underline{G}^*(t) \underline{x}^*(t) \quad (5.3.7)$$

where the optimal feedback gain is given by

$$\underline{G}(t) = [\underline{R} + (\bar{\delta}^2 + \Delta)\underline{B}'\underline{K}(t+1)\underline{B}]^{-1} (\bar{\gamma}\bar{\delta} + \Lambda)\underline{B}'\underline{K}(t+1)\underline{A} \quad (5.3.8)$$

The  $n \times n$  matrix  $\underline{K}(t)$  satisfies a recursive matrix equation of the form

$$\begin{aligned} \underline{K}(t) = & (\bar{\gamma}^2 + \Gamma)\underline{A}'\underline{K}(t+1)\underline{A} + \underline{Q} - \\ & (\bar{\gamma}\bar{\delta} + \Lambda)^2 \underline{A}'\underline{K}(t+1)\underline{B}[\underline{R} + (\bar{\delta}^2 + \Delta)\underline{B}'\underline{K}(t+1)\underline{B}]^{-1} \underline{B}'\underline{K}(t+1)\underline{A} \end{aligned} \quad (5.3.9)$$

$$\underline{K}(N) = \underline{0}$$

We remark that the matrix Riccati-like equation (5.3.9) cannot be related to a coupled set of linear equations, however.

Therefore, it will be referred to as the "UTP matrix" equation.

Under our assumptions, the solution to the UTP matrix equation (5.3.9) exists and is positive definite and bounded for all

finite planning horizon times,  $N$ . The average optimal cost is given by

$$J^*(\underline{x}(0), N) = \underline{x}'(0) \underline{K}(0)\underline{x}(0) + \text{tr} \int_{t=0}^N \underline{K}(t) \underline{\Xi} \quad (5.3.10)$$

For the infinite horizon case as  $N \rightarrow \infty$ , we are interested in examining the existence of an optimal solution and the stabilization of the stochastic system Eq. (5.2.1). We prove the following theorem.

Theorem 5.1 (Uncertainly Threshold Principle)

An optimal solution exists for the problem given by Eqs. (5.3.1) to (5.3.6), as  $N \rightarrow \infty$  if and only if

$$\max_i |\lambda_i(\underline{A})| < \frac{1}{\beta} \quad i = 1, 2, \dots, n \quad (5.3.11)$$

where  $\beta$  is defined by

$$\beta = \bar{\gamma}^2 + \Gamma - \frac{(\bar{\gamma}\delta + \Lambda)^2}{\delta^2 + \Delta} \geq 0 \quad (5.3.12)$$

and  $\max_i |\lambda_i(\underline{A})|$  denotes the magnitude of the maximum eigenvalue of the constant system matrix  $\underline{A}$  in Eq. (5.3.1).

Before we present the proof of the theorem, it is important to make some remarks.

Remark 1. In the case of non-random parameters ( $\Gamma = \Delta = \Lambda = 0$ ),  $\beta = 0$ , this means that given our assumptions of the pairs  $[\underline{A}, \underline{B}]$  controllability and  $[\underline{A}, \underline{Q}^{\frac{1}{2}}]$  observability, one can always solve the infinite horizon optimal control problem independent of the (open-loop) eigenvalues of  $\underline{A}$ . On the other hand, as the variances  $\Gamma$  and  $\Delta$  of the random parameters increase, then  $\beta$  increases and the value of  $1/\beta$  defines the radius of a shrinking disc which must contain all the open-loop eigenvalues of  $\underline{A}$  in order for the problem to have a solution.

Remark 2. If the condition in Eq. (5.3.11) is violated, i.e., if

$$\max_i |\lambda_i(\underline{A})| \geq \frac{1}{\beta} \quad (5.3.13)$$

then there is no solution to the optimal control problem, and one cannot stabilize (in the mean-square sense) the system of Eq. (5.2.1). Under these conditions, (5.3.13), the optimal cost in (5.3.10), undergoes exponential growth as  $N$  increases, so that

$$J^*(N) \geq c e^{\max_i |\lambda_i(\beta A)| N}, \quad c = \text{constant} \quad (5.3.14)$$

Because of the explosive growth of the optimal cost in (5.3.14) then only the short-term (small  $N$ ) control makes sense; see also Section 2.4.

As in the scalar system in Section 2.4, even if condition Eq. (5.3.12) holds, the control gain matrix  $\underline{G}(t)$  in (5.3.8) remains well-behaved and is bounded, so the limiting gain

$$\underline{G} = \lim_{N \rightarrow \infty} \frac{(\bar{\gamma} \bar{\delta} + \Lambda)}{\bar{\delta}^2 + \Delta} [\underline{B}' \underline{K}(t+1) \underline{B}]^{-1} \underline{B}' \underline{K}(t+1) \underline{A} \quad (5.3.15)$$

Next, we present the details of proving Theorem 5.1. We remark that the proof essentially uses algebraic manipulations and well known properties of the discrete Lyapunov and Riccati matrix equations. The main idea of the proof is to examine the behavior of  $\lim_{N \rightarrow \infty} \underline{K}(t)$  or the behavior "backward in time" of the UTP matrix equation (5.3.9). The arguments are similar to that used in [51].

Proof: For the sake of notational convenience, define the scalars

$$\alpha_1 \triangleq \bar{\gamma}^2 + \Gamma, \quad \alpha_2 \triangleq (\bar{\gamma} \bar{\delta} + \Lambda)^2, \quad \alpha_3 \triangleq \frac{1}{\bar{\delta}^2 + \Delta} \quad (5.3.16)$$

The UTP matrix equation (5.3.9) can then be written as

$$\underline{K}(t) = \alpha_1 \underline{A}' \underline{K}(t+1) \underline{A} + \underline{Q} - \alpha_2 \underline{A}' \underline{K}(t+1) \underline{B} \left[ \underline{R} + \frac{1}{\alpha_3} \underline{B}' \underline{K}(t+1) \underline{B} \right]^{-1} \underline{B}' \underline{K}(t+1) \underline{A} \quad (5.3.17)$$

From Eqs. (5.3.12) and (5.3.16), we obtain that

$$\beta^2 = \alpha_1 - \alpha_2 \alpha_3 \quad (5.3.18)$$

By adding and subtracting  $\alpha_2 \alpha_3 \underline{A}' \underline{K}(t+1) \underline{A}$  to the right-hand side of (5.3.17), and after some algebraic manipulations, Eq. (5.3.17) reduces to

$$\underline{K}(t) = \beta^2 \underline{A}' \underline{K}(t+1) \underline{A} + \underline{Q} + \alpha_2 \alpha_3 \underline{A}' \{ \underline{K}(t+1) - \underline{K}(t+1) \underline{B} [\alpha_3 \underline{R} + \underline{B}' \underline{K}(t+1) \underline{B}]^{-1} \underline{B}' \underline{K}(t+1) \} \underline{A} \quad (5.3.19)$$

Attention is focused on the matrix we now define:

$$\underline{M}(t+1) \triangleq \underline{K}(t+1) - \underline{K}(t+1) \underline{B} [\alpha_3 \underline{R} + \underline{B}' \underline{K}(t+1) \underline{B}]^{-1} \underline{B}' \underline{K}(t+1) \quad (5.3.20)$$

Such matrices arise naturally in the matrix Riccati equation of standard linear-quadratic problems where the control weighting matrix is  $\alpha_3 \underline{R}$  [81]. Under the given assumptions of  $[\underline{A}, \underline{B}]$  controllability and  $[\underline{A}, \underline{Q}^{\frac{1}{2}}]$  observability, it is well known

[81], [82] that

$$\underline{M}(t+1) = \underline{M}'(t+1) > \underline{0} \quad (5.3.21)$$

and there exists a bound

$$\underline{L} \geq \underline{M}(t) \quad , \text{ for all } t \quad (5.3.22)$$

Since  $\underline{M}(t+1)$  is positive definite, so is  $\alpha_2 \alpha_3 \underline{A}' \underline{M}(t+1) \underline{A}$ .

Hence, we readily obtain

$$\underline{K}(t) \geq \beta^2 \underline{A}' \underline{K}(t+1) \underline{A} + \underline{Q} \quad (5.3.23)$$

From Eq. (5.3.23) it is obvious that if any eigenvalue of  $(\beta \underline{A})$  is greater than unity, then  $\underline{K}(t)$  grows without any bound backward in time,  $\lim_{N \rightarrow \infty} \underline{K}(t)$  does not exist, and the optimal cost undergoes exponential growth as given by Eq. (5.3.14).

On the other hand, from (5.3.22) and (5.3.23), we obtain that

$$\underline{K}(t) \leq \beta^2 \underline{A}' \underline{K}(t+1) \underline{A} + \underline{Q} + \alpha_2 \alpha_3 \underline{A}' \underline{L} \underline{A} \quad (5.3.24)$$

Hence, if all the eigenvalues of  $(\beta \underline{A})$  are less than unity, the right-hand side of the recursion Eq. (5.3.24) will approach a bounded constant solution matrix, and so will  $\underline{K}(t)$ . The limiting solution  $\lim_{N \rightarrow \infty} \underline{K}(t)$  is well defined.

We make an important remark that the proof requires that  $\underline{B}$  matrix is  $n \times n$  and nonsingular, as required in the corollary

of [51] . However, we believe that this is a sufficient, but by no means a necessary, condition.

#### 5.4 Optimal Control for Systems with Inexact Measurements

In this section, we shall consider the optimal stochastic control of linear dynamical systems with purely random parameters and imperfect measurements. More precisely, we have the same linear dynamical system as in Eq. (5.2.1), but the measurement data are now assumed to be corrupted by additive white noise, i.e.,

$$\underline{z}(t) = \underline{C}(t) \underline{x}(t) + \underline{\theta}(t) \quad (5.4.1)$$

where  $\underline{\theta}(t)$  is the zero-mean Gaussian white noise vector, and  $\underline{C}(t)$  is assumed to contain elements that are randomly varying.

This general case has been considered in [37]. The cost functional we want to minimize is that given by Eq.(5.2.7). Using dynamic programming algorithm , the optimal control at  $t = N-1$  is given by

$$\underline{u}^*(N-1) = - \underline{G}(N-1) \hat{\underline{x}}(N-1/N-1) \quad (5.4.2)$$

where  $\hat{\underline{x}}(N-1/N-1)$  is the conditional mean of  $x(N-1)$  given the past measurements up to time  $N-1$  under controls up to  $N-2$ , and

$$\underline{G}(N-1) = \left[ \underline{R}(N-1) + \underline{B}'(N-1) \underline{F} \underline{B}(N-1) \right]^{-1} \underline{B}(N-1) \underline{F} \underline{A}(N-1) \quad (5.4.3)$$

We note that in computing the optimal control at  $t = N-2$ ,

it is important to have the estimation error have a conditional covariance matrix  $\underline{\Sigma}_{xx}(N-1/N-1)$  be independent of  $\underline{x}(N-1)$  and  $\underline{z}^{N-1} = \{ \underline{z}(0), \dots, \underline{z}(N-1) \}$ . If this is true, then the covariance will be independent of the past controls. In linear-quadratic-Gaussian problems, the linearity of both the system and measurement equations is sufficient for the conditional covariance to be independent of past controls. Under these assumptions, then the optimal control at time  $t$  is given by

$$\underline{u}^*(t) = - \underline{G}(t) \hat{\underline{x}}(t/t) \quad (5.4.4)$$

where

$$\underline{G}(t) = \left[ \underline{R}(t) + \underline{B}'(t) \underline{K}(t+1) \underline{B}(t) \right]^{-1} \underline{B}'(t) \underline{K}(t+1) \underline{A}(t) \quad (5.4.5)$$

and the Riccati-like matrix difference equation is given by

$$\underline{K}(t) = \underline{A}'(t) \underline{K}(t+1) \underline{A}(t) + \underline{Q}(t) - \frac{\underline{A}'(t) \underline{K}(t) \underline{B}(t) \left[ \underline{R}(t) + \underline{B}'(t) \underline{K}(t+1) \underline{B}(t) \right]^{-1} \underline{B}'(t) \underline{K}(t+1) \underline{A}(t)}{\underline{B}'(t) \underline{K}(t+1) \underline{A}(t)}, \quad \underline{K}(N) = \underline{F} \quad (5.4.6)$$

Note that the optimal gain  $\underline{G}(t)$  in Eq. (5.4.5) is not random.

The optimal cost-to-go expression is then given by

AD-A056 849

MASSACHUSETTS INST OF TECH CAMBRIDGE ELECTRONIC SYST--ETC F/G 12/1  
ADAPTIVE STOCHASTIC CONTROL OF LINEAR SYSTEMS WITH RANDOM PARAM--ETC(U)  
MAY 78 R T KU AFOSR-77-3281

UNCLASSIFIED

FSI -TH-820

AFOSR-TR-78-1188

NL

3 of 3

AD  
A056849



END  
DATE  
FILMED  
9-78

DDC

$$\begin{aligned}
 J(t) = & \hat{\underline{x}}'(t) \underline{K}(t) \hat{\underline{x}}(t) + \text{tr } \underline{K}(t) \underline{\Sigma}(t/t) \\
 & + \sum_{\tau=t}^{N-1} \text{tr } \underline{K}(\tau+1) \left( \underline{\Xi} + \underline{B}(\tau) \underline{G}(\tau) \underline{\Sigma}(\tau/\tau) \underline{A}'(\tau) \right)
 \end{aligned}
 \tag{5.4.7}$$

The conditional mean is not computable in closed form, since the truly optimum filter is infinite-dimensional.\* However, analogous to the development in Section 4.3, we can restrict our attention to a fixed structure dynamic compensator, where we cascade a linear filter with a linear controller. And we reformulate the original stochastic control problem into a deterministic parameter optimization problem, using only the first and second unconditional moments.

#### Fixed-Structure Linear Controller

Suppose the linear multivariable dynamic system is described by the vector difference equation

$$\underline{x}(t+1) = \underline{A}(t)\underline{x}(t) + \underline{B}(t)\underline{u}(t) + \underline{\xi}(t) \tag{5.4.8}$$

$$t = 0, 1, 2, \dots$$

where  $\underline{x}(t)$  is the  $n$ -dimensional state vector in  $R^n$ ,  
 $\underline{u}(t)$  is the  $m$ -dimensional control vector in  $R^m$   
 $\underline{\xi}(t)$  is the zero-mean white Gaussian noise vector,  
 with covariance matrix  $\underline{\Xi}$ ,

\* Aoki's book contains an error in using the Kalman filter.

$\underline{x}(0)$  is a random vector with mean  $\bar{\underline{x}}_0$  and covariance  $\underline{\Sigma}_{x_0}$ .

The measurement data are given by

$$\underline{z}(t) = \underline{C}(t)\underline{x}(t) + \underline{\theta}(t) \quad (5.4.9)$$

$\underline{z}(t)$  is the actual  $r$ -dimensional sensor measurement  
vector in  $R^n$

$\underline{\theta}(t)$  is the  $r$ -dimensional zero-mean white Gaussian noise  
vector with covariance matrix  $\underline{\theta}$ .

The matrices  $\underline{A}(t)$ ,  $\underline{B}(t)$  and  $\underline{C}(t)$  in Eqs. (5.4.8) and (5.4.9) contain elements that are uncertain. We assume that the unknown parameters are purely random processes. We also assume that their structure is known.

In the case of stochastic regulators, we define the scalar index of performance by a quadratic cost functional of the form

$$J = E\{\underline{x}'(N)\underline{F}\underline{x}(N) + \sum_{t=0}^{N-1} \underline{x}'(t)\underline{Q}\underline{x}(t) + \underline{u}'(t)\underline{R}\underline{u}(t)\} \quad (5.4.10)$$

where  $\underline{F}$ ,  $\underline{Q}$ ,  $\underline{R} \geq \underline{0}$ . The optimal stochastic control problem is to minimize the cost functional in Eq. (5.4.10) subject to the dynamic system constraints Eqs. (5.4.8) and (5.4.9).

We fix the structure of the optimal stochastic controller or compensator to be considered. The optimal stochastic control at each constant of time is to be generated by time-varying control,

$$\underline{u}(t) = - \underline{G}(t) \hat{\underline{x}}(t) \quad , \quad (5.4.11)$$

$\hat{\underline{x}}(t) \in \mathbb{R}^{\hat{n}}$  ( $\hat{n}$  arbitrary, but finite).

The quantity  $\hat{\underline{x}}(t)$  is the state estimate of the true state vector  $\underline{x}(t)$  and is to be generated by the linear unbiased estimator

$$\hat{\underline{x}}(t) = \left( \underline{I} - \underline{H}(t) \underline{C}(t) \right) \left( \underline{A}(t-1) - \underline{B}(t-1)\underline{G}(t-1) \right) \hat{\underline{x}}(t-1) + \underline{H}(t) \underline{z}(t) \quad (5.4.12)$$

$$\hat{\underline{x}}(0) = \hat{\underline{x}}_0$$

From the results presented in Section 4.4, we can write down the recursive equations for the propagation of the second moment matrices. †

$$\begin{aligned} \underline{M}_{00}(t) = & \left( \underline{A} - \underline{B} \underline{G}(t-1) \right) \underline{M}_{00}(t-1) \left( \underline{A} - \underline{B} \underline{G}(t-1) \right)' + \underline{B} \underline{G}(t-1) \underline{M}_{01}(t-1) \\ & \left( \underline{A} - \underline{B} \underline{G}(t-1) \right)' + \left( \underline{A} - \underline{B} \underline{G}(t-1) \right) \underline{M}_{01}'(t-1) \underline{G}'(t-1) \underline{B}' \\ & + \underline{\Xi} + \underline{B} \underline{G}(t-1) \underline{M}_{11}(t-1) \underline{G}'(t-1) \underline{B}' + \\ & \frac{\text{tr} \sum^{AA} \underline{M}_{00}(t-1) + \text{tr} \sum^{BB} \left( \underline{G}(t-1) \left( \underline{M}_{00}(t-1) - \right. \right. \\ & \left. \left. \underline{M}_{01}(t-1) - \underline{M}_{01}'(t-1) + \underline{M}_{11}(t-1) \right) \underline{G}'(t-1) \right)}{\quad} \end{aligned} \quad (5.4.13)$$

---

†  $\text{tr} \sum^{AA} \underline{\Xi} \equiv \xi_{11} \sum^{A_1 A_1} + \xi_{12} \sum^{A_1 A_2} + \xi_{21} \sum^{A_2 A_1} + \xi_{22} \sum^{A_2 A_2}$  where  
 $\sum^{A_i A_j} =$  covariance of the  $i^{\text{th}}$  column of  $\underline{A}$  and  $j^{\text{th}}$  column of  $\underline{A}$ .

$$\begin{aligned}
 \underline{M}_{01}(t) = & - \left( \underline{I} - \underline{H}(t)\underline{C}(t) \right) \left[ \underline{A} - \left( \underline{M}_{01}(t-1) \left( \underline{A} - \underline{B} \underline{G}(t-1) \right)' + \underline{M}_{11}(t-1) \right. \right. \\
 & \left. \left. \times \underline{G}'(t-1) \underline{B}' \right) - \overline{\text{tr} \sum^{AA} \underline{M}_{00}(t-1) - \underline{\Xi} - \text{tr} \sum^{BB}} \right. \\
 & \left. \overline{\underline{G}(t-1) \left( \underline{M}_{00}(t-1) - \underline{M}_{01}(t-1) - \underline{M}'_{01}(t-1) + \underline{M}_{11}(t-1) \right)} \right. \\
 & \left. \overline{\underline{G}'(t-1)} \right]
 \end{aligned}
 \tag{5.4.14}$$

$$\begin{aligned}
 \underline{M}_{11}(t) = & \left( \underline{I} - \underline{H}(t)\underline{C}(t) \right) \left[ \underline{A} \underline{M}_{11}(t-1) \underline{A}' + \overline{\text{tr} \sum^{AA} \underline{M}_{00}(t-1) + \underline{\Xi}} \right. \\
 & \left. + \overline{\text{tr} \sum^{BB} \underline{G}(t-1) \left( \underline{M}_{00}(t-1) - \underline{M}_{01}(t-1) - \underline{M}'_{01}(t-1) \right.} \right. \\
 & \left. \left. + \underline{M}_{11}(t-1) \right) \underline{G}'(t-1)} \right] \\
 & \left( \underline{I} - \underline{H}(t)\underline{C}(t) \right)' + \underline{H}(t) \left( \overline{\text{tr} \sum^{CC} \underline{M}_{00}(t) + \underline{\Theta}} \right) \underline{H}'(t)
 \end{aligned}
 \tag{5.4.15}$$

The cost function to be minimized becomes:

$$\begin{aligned}
 J = & \text{tr} \left[ \underline{F} \underline{M}_{00}(N) \right] + \sum_{t=0}^{N-1} \text{tr} \left[ \underline{Q} \underline{M}_{00}(t) \right] + \\
 & \text{tr} \left[ \underline{G}'(t) \underline{R} \underline{G}(t) \left( \underline{M}_{00}(t) - \underline{M}_{01}(t) - \underline{M}'_{01}(t) + \underline{M}_{11}(t) \right) \right]
 \end{aligned}
 \tag{5.4.16}$$

The original problem has now been reformulated as a minimization over the elements of the controller matrices  $\underline{G}(t)$  and  $\underline{H}(t)$ .

The deterministic optimization problem is then given the constraint equations (5.4.13) to (5.4.15) and initial conditions

$$\underline{M}(0) = \begin{bmatrix} \underline{\bar{x}}_0 & \underline{\bar{x}}_0' + \underline{\Sigma}_{x_0} & \underline{\Sigma}_{x_0} \\ \underline{\Sigma}_{x_0} & \underline{\Sigma}_{x_0} \end{bmatrix} \quad (5.4.17)$$

and the cost functional, Eq. (5.4.16), find the controller matrices  $\underline{G}^*(t)$  and  $\underline{H}^*(t)$  such that  $J$  is minimized.

The optimization problem can be solved using the Matrix Minimum Principle or Dynamic Programming algorithm. The results are summarized in the following theorem. The proof is similar to that given for the scalar system, and hence will not be repeated.

Theorem 5.2

The optimal gain matrices to the deterministic optimization problem formulated in Eqs. (5.4.13) to (5.4.17) are given by

$$\underline{H}^*(t) = \underline{\Sigma}_{xx}(t/t-1) \underline{\bar{C}}' \left[ \underline{\bar{C}} \underline{\Sigma}_{xx}(t/t-1) \underline{\bar{C}}' + \frac{\text{tr } \underline{\Sigma}^{CC} \underline{X}(t) + \underline{\varrho}}{\quad} \right]^{-1} \quad (5.4.18)$$

$$\begin{aligned}
 \underline{G}^*(t-1) = & \left[ \underline{\bar{B}}' \left( \overline{\text{tr } \underline{H}'(t) \underline{P}(t) \underline{H}(t) \underline{\Sigma}^{\text{CC}} + \underline{K}(t)} \right) \underline{\bar{B}} \right. \\
 & + \underline{R} + \text{tr} \left( \overline{\text{tr } \underline{H}'(t) \underline{P}(t) \underline{H}(t) \underline{\Sigma}^{\text{CC}} + (\underline{I} - \underline{H}(t) \underline{C})} \right) \\
 & \left. \underline{P}(t) \left( \underline{I} - \underline{H}(t) \underline{C} \right) + \underline{K}(t) \right] \underline{\Sigma}^{\text{BB}} \Big]^{-1} \underline{\bar{B}}' \\
 & \left( \overline{\text{tr } \underline{H}'(t) \underline{P}(t) \underline{H}(t) \underline{\Sigma}^{\text{CC}} + \underline{K}(t)} \right) \underline{\bar{A}} \quad (5.4.19)
 \end{aligned}$$

where

$$\begin{aligned}
 \underline{K}(t) = & \underline{\bar{A}}' \left( \overline{\text{tr } \underline{H}'(t+1) \underline{P}(t+1) \underline{H}(t+1) \underline{\Sigma}^{\text{CC}} + \underline{K}(t+1)} \right) \underline{\bar{A}} \\
 & + \underline{Q} - \underline{\bar{A}}' \left( \overline{\text{tr } \underline{H}'(t+1) \underline{P}(t+1) \underline{H}(t+1) \underline{\Sigma}^{\text{CC}} + \underline{K}(t+1)} \right) \\
 & \underline{\bar{B}} \left[ \underline{\bar{B}}' \left( \overline{\text{tr } \underline{H}'(t+1) \underline{P}(t+1) \underline{H}(t+1) \underline{\Sigma}^{\text{CC}} + \underline{K}(t+1)} \right) \underline{\bar{B}} + \underline{R} \right. \\
 & \left. + \text{tr} \left( \overline{\text{tr } \underline{H}'(t+1) \underline{P}(t+1) \underline{H}(t+1) \underline{\Sigma}^{\text{CC}} + (\underline{I} - \underline{H}(t+1) \underline{C})} \right) \right. \\
 & \left. \underline{P}(t+1) \left( \underline{I} - \underline{H}(t+1) \underline{C} \right) + \underline{K}(t+1) \right] \underline{\Sigma}^{\text{BB}} \Big]^{-1} \underline{\bar{B}}' \\
 & \left( \overline{\text{tr } \underline{H}'(t+1) \underline{P}(t+1) \underline{H}(t+1) \underline{\Sigma}^{\text{CC}} + \underline{K}(t+1)} \right) \underline{\bar{A}} + \\
 & \text{tr} \left( \overline{\text{tr } \underline{H}'(t+1) \underline{P}(t+1) \underline{H}(t+1) \underline{\Sigma}^{\text{CC}} + \underline{K}(t+1)} + \right. \\
 & \left. \left( \underline{I} - \underline{H}(t+1) \underline{C} \right)' \underline{P}(t+1) \left( \underline{I} - \underline{H}(t+1) \underline{C} \right) \right) \underline{\Sigma}^{\text{AA}}
 \end{aligned}$$

$$\underline{K}(N) = \underline{F} \quad (5.4.20)$$

$$\begin{aligned}
 \underline{P}(t) = & \underline{\bar{A}}' \left( \underline{I} - \underline{H}(t+1)\underline{\bar{C}} \right)' \underline{P}(t+1) \left( \underline{I} - \underline{H}(t+1) \underline{\bar{C}} \right) \underline{\bar{A}} \\
 & + \underline{\bar{A}}' \left( \overline{\text{tr } \underline{H}'(t+1)\underline{P}(t+1)\underline{H}(t+1) \underline{\Sigma}^{\text{CC}} + \underline{K}(t+1)} \right) \underline{\bar{B}} \\
 & \left[ \underline{\bar{B}}' \left( \overline{\text{tr } \underline{H}'(t+1)\underline{P}(t+1)\underline{H}(t+1) \underline{\Sigma}^{\text{CC}} + \underline{K}(t+1)} \right) \underline{\bar{B}} + \underline{R} \right. \\
 & \left. + \text{tr} \left( \overline{\text{tr } \underline{H}'(t+1)\underline{P}(t+1)\underline{H}(t+1) \underline{\Sigma}^{\text{CC}} + \left( \underline{I} - \underline{H}(t+1) \underline{\bar{C}} \right)'} \right. \right. \\
 & \left. \left. \underline{P}(t+1) \left( \underline{I} - \underline{H}(t+1) \underline{\bar{C}} \right) + \underline{K}(t+1) \right) \underline{\Sigma}^{\text{BB}} \right]^{-1} \underline{\bar{B}}' \\
 & \left( \overline{\text{tr } \underline{H}'(t+1)\underline{P}(t+1)\underline{H}(t+1) \underline{\Sigma}^{\text{CC}} + \underline{K}(t+1)} \right) \underline{\bar{A}} \\
 \underline{P}(N) = & \underline{0} \tag{5.4.21}
 \end{aligned}$$

where we also identify  $\underline{X}(t) \equiv \underline{M}_{00}(t)$  and  $\underline{\Sigma}_{\text{xx}}(t/t) \equiv \underline{M}_{11}(t)$ .

It can be shown that  $\underline{M}_{11}(t) = \underline{M}_{01}(t)$ , hence the state second moment is given by

$$\begin{aligned}
 \underline{X}(t) = & \left( \underline{\bar{A}} - \underline{\bar{B}} \underline{G}(t-1) \right) \underline{X}(t-1) \left( \underline{\bar{A}} - \underline{\bar{B}} \underline{G}(t-1) \right)' + \underline{\bar{B}} \underline{G}(t-1) \\
 & \underline{M}_{11}(t-1) \left( \underline{\bar{A}} - \underline{\bar{B}} \underline{G}(t+1) \right)' + \left( \underline{\bar{A}} - \underline{\bar{B}} \underline{G}(t+1) \right) \underline{M}_{11}(t-1) \\
 & \times \underline{G}'(t-1) \underline{\bar{B}}' + \underline{\Xi} + \underline{\bar{B}} \underline{G}(t-1) \underline{M}_{11}(t-1) \underline{G}'(t-1) \underline{\bar{B}}' + \\
 & \overline{\text{tr } \underline{\Sigma}^{\text{AA}} \underline{X}(t-1)} + \overline{\text{tr } \underline{\Sigma}^{\text{BB}} \underline{G}(t-1) \left[ \underline{M}_{00}(t-1) - \right.} \\
 & \left. \underline{M}_{11}(t-1) \right] \underline{G}'(t-1)} \tag{5.4.22}
 \end{aligned}$$

The optimal cost is given by

$$\begin{aligned}
 J = & \text{tr} \left[ \underline{K}(0)\underline{X}(0) + \underline{P}(0) \sum_{\underline{xx}}(0/0) \right] + \\
 & \text{tr} \left[ \sum_{t=0}^{N-1} \underline{K}(t+1) \underline{\Xi} + \underline{P}(t+1) \left( \underline{I} - \underline{H}(t+1)\underline{C} \right) \underline{\Xi} \left( \underline{I} - \underline{H}(t+1)\underline{C} \right)' \right. \\
 & + \underline{P}(t+1)\underline{H}(t+1) \overline{\text{tr} \underline{\Xi} \sum^{CC} \underline{H}'(t+1)} + \\
 & \left. \underline{P}(t+1) \underline{H}(t+1) \underline{\Theta} \underline{H}'(t+1) \right] \quad (5.4.23)
 \end{aligned}$$

To obtain the optimal gain matrices, we have to solve a coupled nonlinear two-point boundary value problem which involves matrix difference equations (5.4.20) - (5.4.22) and (5.4.15). Hence, there is no separation between control and filter equations. Numerical solutions to the TPBVP can be obtained by using the successive approximation method.

### 5.5 Conclusions

For algebraic simplicity, we have thus far restricted our consideration to the case of scalar linear control systems only. An extension to the linear multivariable systems with purely random parameters can be made in a straightforward manner. The results of Sections 2.2 and 2.3 are extended in Sections 5.2 and 5.3 for a particular class of problems in which the random parameters are scalar variables. The results of Sections 4.2 and 4.3 to 4.4 are extended in Section 5.4 to linear multivariable control systems.

For the special case of a multivariable linear system, we derived a threshold condition involving the maximum eigenvalue of the system matrix  $\underline{A}$  and the means, variances, and cross-correlations of the purely random parameters. If the threshold condition is violated, then there does not exist an optimal solution to the infinite horizon problem. The linear multivariable system is then not mean-square stabilizable under linear feedback.

In Section 5.4, we presented the form of solutions to the linear multivariable control systems with fixed structure feedback regulator to control the dynamical system. The specific notation used readily degenerates to the standard linear-quadratic-Gaussian solutions. Other possible notations involve tensors and Kronecker products (direct products). The complexity of the matrix difference equations would even make the computer simulations a nontrivial problem.

CHAPTER 6

SUMMARY AND CONCLUSIONS

6.1 Summary of the Main Results

In this research, our objective has been to investigate the optimal stochastic control of linear dynamical systems with purely (white) parameters. The uncertain parameters are thus uncorrelated in time. The white parameter approach to adaptive stochastic control is important because it shows (in a worst case sense) the fact that the control gains of an optimal stochastic system with purely random parameters depend not only upon the mean values, but also upon the variances of the random parameters. The solution of this class of problems illustrates how the effects of model parameter uncertainty, as quantified by the parameter variances, modulate the control gains, thus introducing the notion of "hedging" in the presence of dynamic uncertainty.

In Chapter 2 we analyzed the adaptive stochastic control of uncertain systems with exact measurements of the state. We obtained the time-varying linear feedback control law. We then investigated the existence of optimal control law for the infinite horizon problem. The result is known as the Uncertainty Threshold Principle. The solution to the discounted cost problem further emphasizes the issue of optimality versus stability in adaptive stochastic control problem. Optimality is based on Bellman's Principle of

Optimality or Pontryagin's Maximum Principle. Stability of stochastic systems under feedback is an extension of the Lyapunov stability concept for deterministic systems. Both the almost sure (pointwise) stability and mean-square stability criteria are obtained for the perfect measurement system.

In Chapter 3 we analyzed the optimal stochastic estimation of linear systems with randomly varying parameters. Since the optimal estimator is nonlinear and infinite dimensional, we derived the optimal linear minimum variance unbiased filter. The optimal linear estimator turns out not to be the dual of the optimal control problem considered in Chapter 2. We note that the optimal solution derived in Chapter 2 is the truly optimal control law, whereas the optimal state reconstructor in Chapter 3 is only the linear minimum variance estimator.

In Chapter 4 we considered the optimal control of linear systems with purely random parameters and noisy sensor measurement data. Hence, we need to solve simultaneously the optimal stochastic estimation and the optimal stochastic control problems. The optimal controller must reduce the uncertainty in the state and regulate the process. In the case of stochastic systems with uncertain parameters, "good" knowledge of the future values of the state is not available. Our approach is to let the mathematical formulation of the problem handle the complex tradeoff between good identifica-

tion and good control, and provide the optimal solution containing the appropriate strategy for optimizing a performance index as a function of time. Since the problem is a non-linear stochastic control problem, we then consider the design of the control structure composed of a linear controller and a linear estimator. We thus transform the original stochastic control problem into a deterministic parameter optimization problem. We jointly optimize the control and filter gains to minimize the expected value of the quadratic performance index.

The solution to the deterministic optimization problem can be obtained using the Matrix Minimum Principle or the dynamic programming method. We then considered the infinite horizon problem, and found the stability region for a particular set of parameter means and variances through the computer simulations of the two-point boundary value problem. We carried out the mean-square stability analysis using the direct output feedback, and obtained the sufficient condition for stability.

In Chapter 5 the results obtained for the scalar systems are then generalized to linear multivariable systems. The notations quickly become cumbersome. We then considered a special class of linear multivariable control systems where the constant system matrices are multiplied by scalar random variables, and derived stability criteria for such a system. We also indicated the form of solution to the optimal control

problem of systems with noisy sensor measurements employing the design based upon the decomposition of the control structure into a linear control and linear estimator of fixed finite dimension.

## 6.2 Conclusions

We have shown in this thesis that for dynamic systems with known structure, but randomly varying parameters (modelled as white noise), the Uncertainty Threshold Principle states that optimal infinite horizon control exists if and only if the dynamic uncertainty (as quantified by the means and variances of the uncertain parameters) satisfies a certain threshold condition. If this threshold is exceeded, then the optimal stationary control does not exist.

Further, the results obtained for the discounted cost problem seem to imply that one has to be careful in interpreting the stochastic optimization results, and that an independent stochastic stability analysis should be performed. In most stochastic optimization problems solved to date, optimality and stability are not in conflict; optimal feedback controllers result in stable systems. (The system may be inherently unstable in the absence of control.) This is clearly not the case for uncertain systems in which the randomness enters in multiplicatively as well as additively (such as in the standard linear-quadratic-Gaussian problems).

The results on the optimal linear state reconstruct-

ion for systems with randomly varying parameters give a sufficient condition for the stability of the linear estimator. The condition turns out to be sufficient to ensure that the uncertainty threshold condition in Chapter 2 will be met. It is also the necessary and sufficient condition for the asymptotic variance of the uncontrolled linear system to be finite.

In the fixed structure linear control and estimator design for systems with noisy sensor data, the filter stability condition dominates the control stability condition. If the filter stability condition is satisfied then the specific structure dynamic compensator has steady-state solution. The linear controller is mean-square stabilizable under feedback for all system parameter means and variances that satisfy the linear estimator stability criteria. If the linear dynamic compensator is stabilizable, then the uncertainty threshold for the exact measurement case is satisfied. The true stability criteria for the case with randomness in the measurement equation lies between the above two stability conditions. The stability region for linear systems with random measurement parameters is much reduced from the exact measurement case, but it is larger than that for the linear minimum variance filter problem.

6.3 Suggestions for Future Research

(A) It would be desirable to derive the uncertainty threshold condition for the linear multivariable systems both for the exact measurement and the noisy sensor measurement cases. It is obvious that the uncertainty threshold condition will involve the means and covariances of the purely random (white) parameters. In the perfect measurement case, the analog of Eq. (2.4.13) appears to be a matrix recursion of the form

$$\underline{K}(t) \approx \underline{M} \underline{K}(t+1) \underline{M}'$$

where the matrix  $\underline{M}$  contains all the mean values of the vector parameters and their covariance matrices. Non-existence of a stationary solution for the infinite horizon problem would result if an eigenvalue of the matrix  $\underline{M}$  is greater than unity.

(B) The results given in this thesis can be used to analyze the performance of aggregated small models versus the large model. The approach is to treat certain coefficients in the aggregated model as being purely random. The variance of the coefficients should be such that the forecasts of the state variables generated by the more complex model would fall within the three standard deviations of the forecasts generated by the aggregated model. To accomplish this may require some of the uncertain parameters of the aggregated model to be time-varying, and analytical methods will have to

be developed to determine how the variances are to be chosen. It is conjectured that the optimum determination of the parameter covariance matrix can be formulated and solved as a deterministic optimal control problem using the minimum principle.

We remark that the use of random coefficient models in economic policy analysis is very common. The benefits to economic stabilization policy analysis is apparent if we are able to devise methods for evaluating aggregation costs in a well-defined manner.

(C) An important aspect in designing optimal stochastic control law concerns the sensitivity of the resultant system to large parameter variations. The analysis of stochastic systems with randomly varying parameters can further develop and aid the design of optimal stochastic controller. The dependence of the random parameter system control law on the parameter covariances can systematically indicate which system parameters are more important in the design of the closed-loop system controls. An extension and application of the theory in this thesis to the socio-economic models in [83] would demonstrate the importance of an understanding of the random parameter systems.

(D) The analytical results from the adaptive stochastic control of linear systems with white parameters are applicable to the Multiple Model Adaptive Control systems design [84] since in the MMAC design, we hypothesize a set

of possible models that the actual operating system we are trying to control may belong to. Additional quantitative measure can be introduced into the analysis by assigning the parameters with a priori variances to reflect the uncertainty in our knowledge of the random system parameters.

(E) The results in this thesis research can be directed toward the further understanding of the dual control methods. Since most dual adaptive control algorithms are computationally iterative in nature, the assumption of purely random parameters in the future can reduce the analysis required to generate an approximate optimal nonlinear stochastic control law. We have seen that the control gains of the optimal stochastic control system are strongly modulated by the uncertainty level of the random parameters. These results can be used to refine the suboptimal dual control methods so as to preserve the planned learning concept, but reduce the real-time computational requirements.

APPENDIX A

DERIVATION OF THE OPTIMAL LINEAR CONTROL USING  
THE MATRIX MINIMUM PRINCIPLE

The system defined by difference equations (4.4.12) - (4.4.18) and the scalar cost functional Eq. (4.4.5) are in the form required to use the matrix minimum principle [71]. So, let  $\underline{P}(t)$  be the co-state matrix associated with  $\underline{M}(t)$ . The Hamiltonian function  $\mathcal{H}(\underline{M}(t), \underline{P}(t+1), G(t), H(t+1), t)$  for our problem is then

$$\mathcal{H}(\underline{M}(t), \underline{P}(t+1), G(t), H(t+1), t) = \text{tr}[\hat{Q}(t)\underline{M}(t)] + \text{tr}[(\underline{M}(t+1) - \underline{M}(t))\underline{P}'(t+1)] \quad (\text{A.1})$$

If  $\{G^*(t), t=0,1,\dots, N-1\}$  and  $\{H^*(t+1), t=0,1,\dots, N-1\}$  are optimal gains and  $\{\underline{M}^*(t), t=0,1,\dots, N\}$  is the optimal state, then the discrete minimum principle states that there exists a co-state  $\{P^*(t), t=0,1,\dots, N\}$  such that the following hold:

The canonical equations are given by

$$\underline{M}^*(t+1) - \underline{M}^*(t) = \left. \frac{\partial \mathcal{H}}{\partial \underline{P}(t+1)} \right|_* \quad (\text{A.2})$$

$$\underline{P}^*(t+1) - \underline{P}^*(t) = - \left. \frac{\partial \mathcal{H}}{\partial \underline{M}(t)} \right|_* \quad (\text{A.3})$$

The boundary conditions are given by

$$\underline{M}^*(0) = \underline{M}(0) \quad (\text{A.4})$$

$$\underline{P}^*(N) = \hat{\underline{F}} \quad (\text{A.5})$$

First, we expand the terms in the Hamiltonian to obtain

$$\begin{aligned}
 \mathcal{H} [\underline{M}(t), \underline{P}(t+1), G(t), H(t+1), \bar{t}] = & [Q(t)+R(t)G^2(t)]M_{00}(t) \\
 & - G^2(t)R(t)M_{10}(t) - G^2(t)R(t)M_{01}(t) + \\
 & G^2(t)R(t)M_{11}(t) + (M_{00}(t+1) - M_{00}(t))P_{00}(t+1) \\
 & + (M_{01}(t+1) - M_{01}(t))P_{01}(t+1) + (M_{10}(t+1) - M_{10}(t)) \\
 & P_{10}(t+1) + (M_{11}(t+1) - M_{11}(t))P_{11}(t+1) \quad (A.6)
 \end{aligned}$$

From Eq. (A.3), the components of the co-state matrix  $\underline{P}$  are given by

$$\begin{aligned}
 P_{00}^*(t) = & Q(t) + G^2(t)R(t) + [(\bar{a}(t) - \bar{b}(t)G(t))^2 + \sum_{aa}(t) + \\
 & \sum_{bb}(t)G^2(t)]P_{00}^*(t+1) + [1-H(t+1)\bar{c}(t+1)] \\
 & [\sum_{aa}(t) + \sum_{bb}(t)G^2(t)] [P_{01}^*(t+1) + P_{10}^*(t+1)] \\
 & + [(1-H(t+1)\bar{c}(t+1))^2 (\sum_{aa}(t) + \sum_{bb}(t)G^2(t)) \\
 & + \sum_{cc}(t+1)H^2(t+1) ((\bar{a}(t) - \bar{b}(t)G(t))^2 + \sum_{aa}(t) \\
 & + \sum_{bb}(t)G^2(t))] P_{11}^*(t+1) \quad (A.7)
 \end{aligned}$$

$$\begin{aligned}
 P_{01}^*(t) = & - G^2(t)R(t) + P_{00}^*(t+1) [\bar{b}(t)G(t) (\bar{a}(t) - \bar{b}(t)G(t)) - \\
 & \sum_{bb}(t)G^2(t)] + [(1-H(t+1)\bar{c}(t+1)) (\bar{a}^2(t) - \\
 & \sum_{bb}(t)G^2(t) - \bar{a}(t)\bar{b}(t)G(t))] P_{01}^*(t+1) + P_{11}^*(t+1) \\
 & \left[ - (1-H(t+1)\bar{c}(t+1))^2 \sum_{bb}(t)G^2(t) + \sum_{cc}(t+1)H^2(t+1) \right. \\
 & \left. (\bar{a}(t)\bar{b}(t) - (\bar{b}^2(t) + \sum_{bb}(t)G^2(t))G(t)) \right] \quad (A.8)
 \end{aligned}$$

$$\begin{aligned}
 P_{11}^*(t) = & G^2(t)R(t) + \left[ (\Sigma_{bb}(t) + \bar{b}^2(t)) G^2(t) \right] P_{00}^*(t+1) \\
 & + \left[ (1-H(t-1)\bar{c}(t+1)) (\bar{a}(t)\bar{b}(t)G(t) + \Sigma_{bb}(t)G^2(t)) \right] \\
 & (P_{10}^*(t+1) + P_{01}^*(t+1)) + P_{11}^*(t+1) \left[ (1-H(t+1)\bar{c}(t+1))^2 \right. \\
 & \left. (\bar{a}^2(t) + \Sigma_{bb}(t)G^2(t)) + \Sigma_{cc}(t+1)H^2(t+1) \right. \\
 & \left. (\bar{b}^2(t) + \Sigma_{bb}(t)) G^2(t) \right] \quad (A.9)
 \end{aligned}$$

For every  $G(t)$  and  $H(t)$ ,  $t = 0, 1, 2, \dots, N-1$ ,

$$\mathcal{H}[\underline{M}^*(t), \underline{P}^*(t+1), G^*(t), H^*(t+1)] \leq \mathcal{H}[\underline{M}^*(t), \underline{P}^*(t+1), G(t), H(t+1)] \quad (A.10)$$

Since the "controls"  $G(t)$  and  $H(t)$  are unconstrained in this problem, the necessary conditions for the minimization of the Hamiltonian function are:

$$\left. \frac{\partial \mathcal{H}}{\partial G(t)} \right|_* = 0, \quad \left. \frac{\partial \mathcal{H}}{\partial H(t+1)} \right|_* = 0 \quad (A.11)$$

We obtain from the necessary conditions  $\partial \mathcal{H} / \partial G$  that

$$\begin{aligned}
 0 = & \bar{b}(t) \left( \Sigma_{cc}(t+1)H^2(t+1)P_{11}(t+1) + P_{00}(t+1) \right) \bar{a}(t) [M_{00}(t) - \\
 & M_{01}(t)] + \bar{b}(t)P_{01}(t+1) \left( 1-H(t+1)\bar{c}(t+1) \right) \bar{a}(t) [M_{01}(t) - M_{11}(t)] \\
 & - \left[ \bar{b}^2(t) \left( \Sigma_{cc}(t+1)H^2(t+1)P_{11}(t+1) + P_{00}(t+1) \right) + R(t) + \right. \\
 & \left. \Sigma_{bb}(t) \left( \Sigma_{cc}(t+1)H^2(t+1)P_{11}(t+1) + P_{00}(t+1) \right) + \right. \\
 & \left. \left[ 1-H(t+1)\bar{c}(t+1) \right]^2 P_{11}(t+1) + \left[ 1-H(t+1)\bar{c}(t+1) \right] P_{01}(t+1) \right]
 \end{aligned}$$

$$\times G(t) \left[ M_{00}(t) - 2M_{01}(t) + M_{11}(t) \right] \quad (\text{A.12})$$

and from  $\partial \mathcal{H} / \partial H$  that

$$\begin{aligned} 0 = & P_{11}(t+1) \left[ H(t+1) \bar{c}^2(t+1) \left( \bar{a}^2(t) M_{11}(t) + \Xi(t) + \Sigma_{bb}(t) G^2(t) \right. \right. \\ & \left. \left. (M_{00}(t) - 2M_{01}(t) + M_{11}(t)) + \Sigma_{aa}(t) M_{00}(t) \right) + H(t+1) \Sigma_{cc}(t+1) \right. \\ & \left[ \left( M_{00}(t) \left( \bar{a}(t) - \bar{b}(t) G(t) \right)^2 + M_{00}(t) \Sigma_{aa}(t) + \Sigma_{bb}(t) G^2(t) \right. \right. \\ & \left. \left. (M_{00}(t) - 2M_{01}(t) + M_{11}(t)) - 2M_{01}(t) \left( -\bar{a}(t) \bar{b}(t) G(t) \right. \right. \right. \\ & \left. \left. + \bar{b}^2(t) G^2(t) \right) + M_{11}(t) \bar{b}^2(t) G^2(t) \right] + H(t+1) \Theta(t+1) - \\ & \bar{c}(t+1) \left( \bar{a}^2(t) M_{11}(t) + \Xi(t) + \Sigma_{aa}(t) M_{00}(t) + \right. \\ & \left. \Sigma_{bb}(t) G^2(t) (M_{00}(t) - 2M_{01}(t) + M_{11}(t)) \right) \left. \right] - \\ & P_{01}(t+1) \bar{c}(t+1) \left[ \left( \bar{b}(t) G(t) M_{11}(t) + (\bar{a}(t) - \bar{b}(t) G(t)) \right. \right. \\ & \left. \left. M_{01}(t) \right) \bar{a}(t) + \Sigma_{aa}(t) M_{00}(t) + \Sigma_{bb}(t) G^2(t) \right. \\ & \left. (M_{00}(t) - 2M_{01}(t) + M_{11}(t)) + \Xi(t) \right] \quad (\text{A.13}) \\ & t = 0, 1, \dots, N-1 \end{aligned}$$

If we assume that the orthogonality condition holds,

$$E \{ \left[ \mathbf{x}(t) - \hat{\mathbf{x}}(t) \right] \hat{\mathbf{x}}(t) \} = 0 \quad (\text{A.14})$$

so that  $M_{01}(t) = M_{11}(t)$  and assume  $P_{01}(t+1) = 0$ , the Eq.

(A.12) is satisfied if the optimal control gain is given by

$$\begin{aligned} G(t) = & \left[ \bar{b}(t) \left( \Sigma_{cc}(t+1) H^2(t+1) P_{11}(t+1) + P_{00}(t) \right) \bar{a}(t) \right] \sqrt{\left[ \bar{b}^2(t) + \right.} \\ & \left. \Sigma_{bb}(t) \right] \Sigma_{cc}(t+1) H^2(t+1) P_{11}(t+1) + P_{00}(t) + R(t)} \\ & + \Sigma_{bb}(t) \left[ 1 - H(t+1) \bar{c}(t+1) \right]^2 P_{11}(t+1) \quad (\text{A.15}) \end{aligned}$$

and we conclude immediately from Eq. (A.13) that

$$H(t+1) = \hat{M}_{11}(t+1)\bar{c}(t+1) \left[ \bar{c}^{-2}(t+1)\hat{M}_{11}(t+1) + \Sigma_{cc}(t+1)M_{00}(t+1) + \Theta(t+1) \right]^{-1} \quad (A.16)$$

where

$$\hat{M}_{11}(t+1) = \bar{a}^2(t)M_{11}(t) + \Xi(t) + \Sigma_{bb}(t)G^2(t)[M_{00}(t) - M_{11}(t)] \quad (A.17)$$

Substituting the optimum gain Eq. (A.15) into (A.8), we obtain that  $P_{01}(t) = 0$ . Since we choose  $P_{01}(N) = 0$ , we conclude that  $P_{01}(t) = P_{10}(t) = 0$  for all  $t \in [0, N]$ .

The difference equation for the correlation between state estimate and the estimation error is given by

$$E\{(x(t) - \hat{x}(t)) \hat{x}(t)\} = M_{01}(t) - M_{11}(t) \quad (A.18)$$

It can be shown that if  $M_{01}(t) = M_{11}(t)$  and the filter gain given by (A.16) then  $M_{01}(t+1) = M_{11}(t+1)$ . Since by choice of initial condition, Eq. (4.4.19),  $M_{11}(0) = M_{01}(0)$ , we conclude that  $M_{11}(t) = M_{01}(t)$  for all  $t \in [0, N]$ .

The filter and control gains for the deterministic optimization problem are given by Eqs. (A.15) and (A.16). The costates propagate backwards according to

$$\begin{aligned}
 P_{00}(t) = & \left( \bar{a}(t) - \bar{b}(t)G(t) \right)^2 \left( \Sigma_{cc}(t+1)H^2(t+1)P_{11}(t+1)P_{00}(t+1) \right) \\
 & + Q(t) + \Sigma_{aa}(t) \left( \Sigma_{cc}(t+1)H^2(t+1)P_{11}(t+1) + P_{00}(t+1) \right) \\
 & + G^2(t) \left[ R(t) + \Sigma_{bb}(t) \left( \Sigma_{cc}(t+1)H^2(t+1)P_{11}(t+1) + P_{00}(t+1) \right) \right. \\
 & \left. + \left( 1-H(t+1) \bar{c}(t+1) \right)^2 P_{11}(t+1) \right]
 \end{aligned}$$

$$P_{00}(N) = F \quad (A.19)$$

$$\begin{aligned}
 P_{11}(t) = & \bar{a}^2(t) \left( 1-H(t+1)\bar{c}(t+1) \right)^2 P_{11}(t+1) + G^2(t) \left[ \left( \bar{b}^2(t) \right. \right. \\
 & \left. \left. + \Sigma_{bb}(t) \right) \Sigma_{cc}(t+1)H^2(t+1)P_{11}(t+1) + P_{00}(t+1) \right] \\
 & + R(t) + \Sigma_{bb}(t) \left( 1-H(t+1)\bar{c}(t+1) \right)^2 P_{11}(t+1)
 \end{aligned}$$

$$P_{11}(N) = 0 \quad (A.20)$$

Note that the co-state equations are coupled nonlinear difference equations.

The closed-loop system transition parameter is given by

$$\begin{aligned}
 \phi(t) = & \bar{a}(t) \left\{ 1 - \bar{b}^2(t) \left( \Sigma_{cc}(t+1)H^2(t+1)P_{11}(t+1) + P_{00}(t+1) \right) \right. \\
 & \left[ \left( \bar{b}^2(t) + \Sigma_{bb}(t) \right) \left( \Sigma_{cc}(t+1)H^2(t+1)P_{11}(t+1) + P_{00}(t+1) \right) \right. \\
 & \left. \left. + R(t) + \Sigma_{bb}(t) \left( 1-H(t+1)\bar{c}(t+1) \right)^2 P_{11}(t+1) \right]^{-1} \right\}
 \end{aligned}$$

$$(A.21)$$

APPENDIX B  
 DERIVATION OF THE OPTIMAL LINEAR CONTROL  
 USING DYNAMIC PROGRAMMING

The optimal control problem stated in Eqs. (4.5.34) to (4.5.36) is solved in this appendix using the dynamic programming method. At time  $t = T-1$ , the expected cost-to-go is given by

$$J(T-1, \hat{x}(T-1)) = E \left\{ F x^2(T) + Q(T-1) x^2(T-1) + R(T-1) u^2(T-1) \middle| z^{T-1}, u^{T-2} \right\} \quad (B.1)$$

Imposing the constraint that the control  $u(t)$  be given by the linear time-varying feedback law of the form

$$u(t) = - G(t) \hat{x}(t) \quad (B.2)$$

we get

$$\begin{aligned} J(\hat{x}(T-1), T-1) &= \min_{\substack{G(T-1) \\ H(T-1)}} E \left\{ Q(T-1) x^2(T-1) + R(T-1) G^2(T-1) \right. \\ &\quad \cdot \hat{x}^2(T-1) + F [a^2(T-1) x^2(T-1) \\ &\quad + b^2(T-1) G^2(T-1) \hat{x}^2(T-1) \\ &\quad - 2a(T-1) b(T-1) x(T-1) G(T-1) \hat{x}(T-1) \\ &\quad \left. + \xi^2(T-1) \right] \middle| z^{T-1} \left\{ \right. \\ &= \min_{\substack{G(T-1) \\ H(T-1)}} E \left\{ [Q(T-1) + F a^2(T-1)] x^2(T-1) \middle| z^{T-1} \right\} \\ &\quad + E \left\{ (R(T-1) + F b^2(T-1)) G^2(T-1) \hat{x}^2(T-1) \right. \\ &\quad \left. - 2Fa(T-1) b(T-1) G(T-1) x(T-1) \hat{x}(T-1) \middle| z^{T-1} \right\} \\ &\quad + F E(T-1) \end{aligned} \quad (B.3)$$

To compute the cost-to-go expression we need to evaluate  $E\{x(t) \hat{x}(t) | z^t\}$  and  $E\{\hat{x}^2(t) | z^t\}$  and obtain their dynamical equations.

The state of the constrained linear controller-estimator system are given by

$$x(t+1) = a(t) x(t) - b(t) G(t) \hat{x}(t) + \xi(t) \quad (B.4)$$

Denote the predicted estimate by  $\bar{x}(\cdot)$  then

$$\hat{x}(t+1) = (1 - H(t+1) \bar{c}(t+1)) \bar{x}(t+1) + H(t+1) z(t+1) \quad (B.5)$$

The estimate  $\hat{x}(t+1)$  is a random process since it depends on  $z(t+1)$ , the measurement process.

The predicted state estimate is given by

$$\bar{x}(t+1) = (\bar{a}(t) - \bar{b}(t) G(t)) \hat{x}(t) \quad (B.6)$$

Using Eq. (B.4) we calculate the quantities

$$\begin{aligned} E\{x(t) \hat{x}(t) | z^t\} &= E\left\{ \left[ (1 - H(t) \bar{c}(t)) \bar{x}(t) + H(t) z(t) \right] x(t) \middle| z^t \right\} \\ &= E\{ \bar{x}(t) \bar{e}(t) \} \\ &\quad + H(t) \bar{c}(t) \Sigma_{xx}(t|t-1) + E\{\bar{x}^2(t)\} \\ &\quad + H(t) \bar{c}(t) E\{\bar{e}(t) \bar{x}(t)\} \end{aligned} \quad (B.7)$$

where  $\bar{e}(t) = x(t) - \bar{x}(t)$ .

From the derivation of the optimal solution to the deterministic problem in which the control is constrained to be linear mapping of the outputs of linear filter driven by measurement, it was shown with the assumption of

$$E\{\hat{e}(0) \hat{x}(0)\} = 0, \quad \hat{e}(0) = x(0) - \hat{x}(0) \quad (B.8)$$

the filter and control gains given by Eq. (4.5.1) and

Eq. (4.5.2) jointly satisfy the necessary conditions for optimality. In addition, the orthogonality condition  $E\{\hat{x}(t) e(t|t)\} = 0$  for all  $t \in [0, N]$ , so that the estimate and the error are uncorrelated.

Then we have

$$E\{x(t) \hat{x}(t) | z^t\} = \bar{X}(t) + H(t) \bar{c}(t) \Sigma_{xx}(t|t-1) \quad (\text{B.9})$$

where

$$\bar{X}(t) \triangleq E\{\bar{x}^2(t)\} \quad (\text{B.10})$$

$$\begin{aligned} E\{\hat{x}^2(t) | z^t\} &= E\{(1 - H(t) \bar{c}(t))^2 \bar{x}^2(t) + H^2(t) z^2(t) \\ &\quad + 2(1 - H(t) \bar{c}(t)) \bar{x}(t) H(t) z(t) | z^t\} \\ &= \bar{X}(t) + H^2(t) (\theta(t) + \bar{c}^2(t) \bar{\Sigma}_{xx}(t) \\ &\quad + \Sigma_{cc}(t) X(t)) = \hat{X}(t) \end{aligned} \quad (\text{B.11})$$

where the orthogonality conditions was used, and we define

$$X(t) \triangleq E\{x^2(t)\} = \Sigma_{xx}(t) + \hat{X}(t) \quad (\text{B.12})$$

Substitute these results for  $E\{\hat{x}(T-1) x(T-1) | z^{T-1}\}$  and  $E\{\hat{x}^2(T-1) | z^{T-1}\}$  into the cost-to-go we obtain

$$\begin{aligned} J(T-1) &= E\left\{ \left[ Q(T-1) + F a^2(T-1) \right] x^2(T-1) | z^{T-1} \right\} + E\left\{ \left[ R(T-1) \right. \right. \\ &\quad \left. \left. + F b^2(T-1) \right] \right\} G^2(T-1) (\bar{X}(T-1) \\ &\quad + H^2(T-1) (\bar{c}^2(T-1) \bar{\Sigma}_{xx}(T-1) + \theta(T-1)) \\ &\quad + H^2(T-1) \Sigma_{cc}(T-1) X(T-1)) \\ &\quad - 2F \bar{a}(T-1) \bar{b}(T-1) G(T-1) (\bar{X}(T-1) \\ &\quad + H(T-1) \bar{c}(T-1) \bar{\Sigma}_{xx}(T-1)) + F \bar{\epsilon}(T-1) \end{aligned} \quad (\text{B.13})$$

We want to minimize the cost-to-go with the  $G(T-1)$  and  $H(T-1)$ . The necessary conditions for optimality are

obtained by setting the partial derivatives  $\partial J/\partial G(T-1)$  and  $\partial J/\partial H(T-1)$  to zero, respectively. Therefore,

$$\begin{aligned} \left. \frac{\partial J}{\partial G(T-1)} \right|_* = 0 &= \left[ R(T-1) + F(\bar{b}^2(T-1) + \Sigma_{bb}(T-1)) \right] G(T-1) \\ &\cdot \left( \bar{X}(T-1) + H^2(T-1)(\bar{c}^2(T-1) \bar{\Sigma}_{xx}(T-1) \right. \\ &+ \Theta(T-1) + \Sigma_{cc}(T-1) X(T-1)) \left. \right) \\ &- F \bar{a}(T-1) \bar{b}(T-1) (\bar{X}(T-1) \\ &+ H(T-1) \bar{c}(T-1) \bar{\Sigma}_{xx}(T-1)) \end{aligned} \quad (B.14)$$

$$\begin{aligned} \left. \frac{\partial J}{\partial H(T-1)} \right|_* = 0 &= \left[ R(T-1) + F(\bar{b}^2(T-1) + \Sigma_{bb}(T-1)) \right] G^2(T-1) \\ &\cdot H(T-1)(\bar{c}^2(T-1) \bar{\Sigma}_{xx}(T-1) + \Theta(T-1) \\ &+ \Sigma_{cc}(T-1) X(T-1)) \\ &- F \bar{a}(T-1) \bar{b}(T-1) G(T-1) \bar{c}(T-1) \bar{\Sigma}_{xx}(T-1) \end{aligned} \quad (B.15)$$

Multiply the first Eq. (B.14) by  $G(T-1)$  and the second Eq. (B.15) by  $H(T-1)$ , then subtract Eq. (B.15) from Eq. (B.14) we obtain that

$$G^*(T-1) = \frac{F \bar{a}(T-1) \bar{b}(T-1)}{R(T-1) + F(\bar{b}^2(T-1) + \Sigma_{bb}(T-1))} \quad (B.16)$$

Substitute this optimal control in Eq. (4.4.75) we get then

$$H^*(T-1) = \frac{\bar{\Sigma}_{xx}(T-1) \bar{c}(T-1)}{\bar{c}^2(T-1) \bar{\Sigma}_{xx}(T-1) + \Theta(T-1) + \Sigma_{cc}(T-1) X(T-1)} \quad (B.17)$$

where

$$\begin{aligned} \bar{\Sigma}_{xx}(T-1) = & \bar{a}^2(T-2) \Sigma_{xx}(T-2) + \Sigma_{aa}(T-2) X(T-2) \\ & + \Sigma_{bb}(T-2) G^2(T-2) \hat{X}(T-2) + \Xi(T-2) \end{aligned} \quad (B.18)$$

To evaluate the cost-to-go at  $t = T-1$ , we substitute the optimal linear control gain  $G^*(T-1)$  and filter gain  $H^*(T-1)$  into the cost-functional Eq. (B.13) to get

$$\begin{aligned} J(\hat{x}(T-1), T-1) = & \left[ F(\bar{a}^2(T-1) + \Sigma_{aa}(T-1)) + Q(T-1) \right] \\ & \cdot E\{x^2(T-1) | z^{T-1}\} \\ & + \frac{[F \bar{b}(T-1) \bar{a}(T-1)]^2}{[R(T-1) + F(\bar{b}^2(T-1) + \Sigma_{bb}(T-1))]} \\ & \cdot E\{\hat{x}^2(T-1) | z^{T-1}\} \\ & - 2 \frac{[F \bar{a}(T-1) \bar{b}(T-1)]^2}{[R(T-1) + F(\bar{b}^2(T-1) + \Sigma_{bb}(T-1))]} \\ & \cdot E\{x(T-1) \hat{x}(T-1) | z^{T-1}\} \\ & + F \Xi(T-1) \\ = & E\left\{ K(T-1) x^2(T-1) | z^{T-1} \right\} + G^2(T-1) \left[ R(T-1) \right. \\ & \left. + F(\bar{b}^2(T-1) + \Sigma_{bb}(T-1)) \right] \Sigma_{xx}(T-1) \\ & + F \Xi(T-1) \end{aligned} \quad (B.19)$$

where we define the variable

$$\begin{aligned} K(T-1) = & F(\bar{a}^2(T-1) + \Sigma_{aa}(T-1)) + Q(T-1) - G^2(T-1) \\ & \cdot [R(T-1) + F(\bar{b}^2(T-1) + \Sigma_{bb}(T-1))] \end{aligned} \quad (B.20)$$

and

$$k(T-1) = G^2(T-1) [R(T-1) + F(\bar{b}^2(T-1) + \Sigma_{bb}(T-1))] \quad (B.21)$$

Now we will proceed to find the optimal  $G(T-2)$  and  $H(T-2)$ , using the Principle of Optimality, we have

$$\begin{aligned} J(\hat{x}(T-2), T-2) = E \left\{ K(T-1) x^2(T-1) + k(T-1) \Sigma_{xx}(T-1) \right. \\ \left. + F \Xi(T-1) + Q(T-2) x^2(T-2) \right. \\ \left. + R(T-2) G^2(T-2) \hat{x}^2(T-2) | z^{T-2} \right\} \quad (B.22) \end{aligned}$$

Since the covariance of the estimation error is not independent of the past controls, we have to include it in the recurrence functional equation. The dependence on  $x(t)$  and  $z^t$  is evident in the covariance propagation equation for  $\Sigma_{xx}(t)$ , Eq. (B.14). The problem of estimation is no longer separable from that of the control.

Hence the cost-to-go becomes

$$\begin{aligned} J(\hat{x}(T-2), T-1) = E \left\{ (a^2(T-2) K(T-1) + Q(T-2)) x^2(T-2) | z^{T-2} \right\} \\ + E \left\{ \left[ R(T-2) + K(T-1) b^2(T-2) \right] \right. \\ \left. G^2(T-2) \hat{x}^2(T-2) | z^{T-2} \right\} \\ - 2K(T-1) E \{ a(T-2) b(T-2) \} G(T-2) \\ \cdot E \left\{ x(T-2) \hat{x}(T-2) | z^{T-2} \right\} \\ + K(T-1) \Xi(T-2) + k(T-1) \Sigma_{xx}(T-1) \\ + F \Xi(T-1) \quad (B.23) \end{aligned}$$

We need to expand the expression for the error covariance  $\Sigma_{xx}(T-1|T-1)$  from Eq. (B.14)

$$\begin{aligned} \Sigma_{xx}(T-1) = (1 - H(T-1) \bar{c}(T-1))^2 \bar{\Sigma}_{xx}(T-1) \\ + H^2(T-1) \left[ \Sigma_{cc}(T-1) X(T-1) + \Theta(T-1) \right] \quad (B.24) \end{aligned}$$

and the predicted covariance is given by

$$\begin{aligned} \bar{\Sigma}_{xx}(T-1) = & \bar{a}^2(T-2) \Sigma_{xx}(T-2) + \Sigma_{aa}(T-2) x(T-2) \\ & + \Sigma_{bb}(T-2) G^2(T-2) E\{\hat{x}^2(T-2) | z^{T-2}\} + \Xi(T-2) \end{aligned} \quad (B.25)$$

The cost-to-go is, therefore,

$$\begin{aligned} J(T-2) = & \left[ (\bar{a}^2(T-2) + \Sigma_{aa}(T-2)) K(T-1) + Q(T-2) \right. \\ & \left. + k(T-1)(1-H(T-1)\bar{c}(T-1))^2 \Sigma_{aa}(T-2) \right] \\ & \cdot E\{x^2(T-2) | z^{T-2}\} \\ & + \left[ R(T-2) + K(T-1)(\bar{b}^2(T-2) + \Sigma_{bb}(T-2)) \right. \\ & \left. + (1-H(T-1)\bar{c}(T-1))^2 \Sigma_{bb}(T-2) k(T-1) \right] G^2(T-2) \\ & \cdot E\{\hat{x}^2(T-2) | z^{T-2}\} \\ & - 2K(T-1) \bar{a}(T-2) \bar{b}(T-2) G(T-2) \\ & \cdot E\{x(T-2) \hat{x}(T-2) | z^{T-2}\} \\ & + k(T-1) \left[ \bar{a}^2(T-2) \Sigma_{xx}(T-2) \right. \\ & \left. + \Xi(T-2) \right] (1-H(T-1)\bar{c}(T-1))^2 \\ & + k(T-1) H^2(T-1) \left[ \Sigma_{cc}(T-1) X(T-1) + \Theta(T-1) \right] \\ & + K(T-1) \Xi(T-2) + F \Xi(T-1) \end{aligned} \quad (B.26)$$

Substituting the expressions for  $E\{\hat{x}(T-2) x(T-2)\}$

$E\{\hat{x}^2(T-2)\}$ ,  $\Sigma_{xx}(T-2)$ , and  $X(T-1)$  yields

$$\begin{aligned} X(T-1) = & (\bar{a}(T-2) - \bar{b}(T-2) G(T-2))^2 X(T-2) \\ & + 2\bar{b}(T-2) G(T-2) (\bar{a}(T-2) - \bar{b}(T-2) G(T-2)) S(T-2) \\ & + \Xi(T-2) + \bar{b}^2(T-2) G^2(T-2) \Sigma_{xx}(T-2) \\ & + \Sigma_{aa}(T-2) X(T-2) + \Sigma_{bb}(T-2) \hat{X}(T-2) G^2(T-2) \end{aligned} \quad (B.27)$$

where we identify  $S(t) = M_{01}(t)$ , Eq. (4.4.18).

$$\begin{aligned}
 J(T-2) = & \left[ (\bar{a}^2(T-2) + \Sigma_{aa}(T-2)) K(T-1) + Q(T-2) \right. \\
 & + k(T-1)(1 - H(T-1) \bar{c}(T-1))^2 \Sigma_{aa}(T-2) \\
 & + k(T-1) H^2(T-1) \Sigma_{cc}(T-1) (\bar{a}^2(T-2) \\
 & \quad \left. + \Sigma_{aa}(T-2)) \right] E \left\{ x^2(T-2) \mid z^{T-2} \right\} \\
 & + \left[ R(T-2) + K(T-1)(\bar{b}^2(T-2) + \Sigma_{bb}(T-2)) \right. \\
 & + \Sigma_{bb}(T-2)(1 - H(T-1) \bar{c}(T-1))^2 k(T-1) \\
 & + k(T-1) H^2(T-1) \Sigma_{cc}(T-1) (\bar{b}^2(T-2) \\
 & \quad \left. + \Sigma_{bb}(T-2)) \right] G^2(T-2) \left\{ \bar{x}(T-2) \right. \\
 & + H^2(T-2)(\bar{c}^2(T-2) \bar{\Sigma}_{xx}(T-2) + \theta(T-2) \\
 & \quad \left. + \Sigma_{cc}(T-2) X(T-2)) \right\} \\
 & - \left[ 2K(T-1) \bar{a}(T-2) \bar{b}(T-2) G(T-2) \right. \\
 & + 2\bar{a}(T-2) \bar{b}(T-2) G(T-2) k(T-1) H^2(T-1) \Sigma_{cc}(T-1) \left. \right] \\
 & \quad \cdot \left[ \bar{x}(T-2) + H(T-2) \bar{c}(T-2) \bar{\Sigma}_{xx}(T-2) \right] \\
 & + k(T-1)(1 - H(T-1) \bar{c}(T-1))^2 \left[ \bar{a}^2(T-2) \Sigma_{xx}(T-2) \right. \\
 & + \Xi(T-2) \left. \right] + k(T-1) H^2(T-1) \theta(T-1) \\
 & + k(T-1) H^2(T-1) \Sigma_{cc}(T-1) \Xi(T-2) \\
 & + K(T-1) \Xi(T-2) + F \Xi(T-1) \tag{B.28}
 \end{aligned}$$

Carrying out the algebraic minimization, we get

$$\begin{aligned}
 \frac{\partial J}{\partial G(T-2)} \Big|_* = 0 = & \left[ R(T-2) + K(T-1)(\bar{b}^2(T-2) + \Sigma_{bb}(T-2)) \right. \\
 & \left. + \Sigma_{bb}(T-2)(1 - H(T-1) \bar{c}(T-1))^2 k(T-1) \right]
 \end{aligned}$$

$$\begin{aligned}
 & + (\bar{b}^2(T-2) + \Sigma_{bb}(T-2)) H^2(T-1) \Sigma_{cc}(T-1) \\
 & \quad \cdot k(T-1) \Big] G(T-2) \left[ \bar{X}(T-2) \right. \\
 & + H^2(T-2) (\bar{c}^2(T-2) \bar{\Sigma}_{xx}(T-2) \\
 & + \Theta(T-2) + \Sigma_{cc}(T-2) X(T-2)) \Big] \\
 & - \left[ \bar{a}(T-2) \bar{b}(T-2) k(T-1) H^2(T-1) \Sigma_{cc}(T-1) \right. \\
 & + K(T-1) \bar{a}(T-2) \bar{b}(T-2) \Big] \left[ \bar{X}(T-2) \right. \\
 & \left. + H(T-2) \bar{c}(T-2) \bar{\Sigma}_{xx}(T-2) \right] \tag{B.29}
 \end{aligned}$$

and

$$\begin{aligned}
 \frac{\partial J}{\partial H(T-2)} \Big|_* = 0 = & \left[ R(T-2) + K(T-1) (\bar{b}^2(T-2) + \Sigma_{bb}(T-2)) \right. \\
 & + \Sigma_{bb}(T-2) (1 - H(T-1) \bar{c}(T-1))^2 k(T-1) \\
 & + k(T-1) (\bar{b}^2(T-2) + \Sigma_{bb}(T-2)) H^2(T-1) \Sigma_{cc}(T-1) \Big] \\
 & \quad \cdot G^2(T-2) H(T-2) (\bar{c}^2(T-2) \bar{\Sigma}_{xx}(T-2) \\
 & + \Theta(T-2) + \Sigma_{cc}(T-2) X(T-2)) \\
 & - \left[ K(T-1) + H^2(T-1) \Sigma_{cc}(T-1) k(T-1) \right] \\
 & \quad \cdot \bar{a}(T-2) \bar{b}(T-2) G(T-2) \bar{c}(T-2) \bar{\Sigma}_{xx}(T-2) \tag{B.30}
 \end{aligned}$$

Multiplying the first equation by  $G(T-2)$  and the second equation by  $H(T-2)$  we get that the solution is given by

$$\begin{aligned}
 G^*(T-2) = & \frac{\bar{b}(T-2) \bar{a}(T-2) (K(T-1) + H^2(T-1) \Sigma_{cc}(T-1) k(T-1))}{R(T-2) + (\bar{b}^2(T-2) + \Sigma_{bb}(T-2)) (K(T-1) + H^2(T-1) \Sigma_{cc}(T-1) k(T-1))} \\
 & + \Sigma_{bb}(T-2) (1 - H(T-1) \bar{c}(T-1))^2 k(T-1) \tag{B.31}
 \end{aligned}$$

$$H^*(T-2) = \frac{\bar{c}(T-2) \bar{\Sigma}_{xx}(T-2)}{\bar{c}^2(T-2) \bar{\Sigma}_{xx}(T-2) + \theta(T-2) + \Sigma_{cc}(T-2) X(T-2)} \quad (B.32)$$

The cost-to-go when evaluated at  $t = T-2$  is given by

$$\begin{aligned} J(T-2) = & \left[ (\bar{a}^2(T-2) + \Sigma_{aa}(T-2))(K(T-1) + k(T-1) H^2(T-1) \Sigma_{cc}(T-1)) \right. \\ & + Q(T-2) k(T-1) (1 - H(T-1) \bar{c}(T-1))^2 \Sigma_{aa}(T-2) \\ & - G^2(T-2) (R(T-2) + (\bar{b}^2(T-2) + \Sigma_{bb}(T-2))) \\ & \quad \cdot (K(T-1) + k(T-1) H^2(T-1) \Sigma_{cc}(T-1)) \\ & \left. + \Sigma_{bb}(T-2) (1 - H(T-1) \bar{c}(T-1))^2 k(T-1) \right] X(T-2) \\ & + G^2(T-2) \left[ R(T-2) + (\bar{b}^2(T-2) + \Sigma_{bb}(T-2))(K(T-1) \right. \\ & + k(T-1) H^2(T-1) \Sigma_{cc}(T-1)) \\ & \left. + \Sigma_{bb}(T-2) (1 - H(T-1) \bar{c}(T-1))^2 k(T-1) \right] \Sigma_{xx}(T-2) \\ & + k(T-1) (1 - H(T-1) \bar{c}(T-1))^2 \bar{a}^2(T-2) \Sigma_{xx}(T-2) \\ & + k(T-1) \left[ (1 - H(T-1) \bar{c}(T-1))^2 \Xi(T-2) \right. \\ & \left. + \Sigma_{cc}(T-1) H^2(T-1) \Xi(T-2) + \Sigma_{cc}(T-1) \theta(T-1) \right] \\ & + K(T-1) \Xi(T-2) + F \Xi(T-1) \\ = & E \left\{ K(T-2) x^2(T-2 | z^{N-2}) + k(T-2) \Sigma_{xx}(T-2) + \sum_{t=2}^{T-1} K(t+1) \Xi(t) \right. \\ & + k(t+1) \left[ (1 - H(t+1) \bar{c}(t+1))^2 \Xi(t) \right. \\ & \left. \left. + H^2(t+1) \Sigma_{cc}(t+1) \Xi(t) + H^2(t+1) \theta(t+1) \right] \right\} \quad (B.33) \end{aligned}$$

where we define

$$\begin{aligned} K(T-2) = & (\bar{a}^2(T-2) + \Sigma_{aa}(T-2))(K(T-1) + \Sigma_{cc}(T-1) H^2(T-1) k(T-1)) \\ & + Q(T-2) + \Sigma_{aa}(T-2) (1 - H(T-1) \bar{c}(T-1))^2 k(T-1) \quad (B.34) \end{aligned}$$

$$\begin{aligned}
 & - G^2(T-2) \left[ R(T-2) + (\bar{b}^2(T-2) + \Sigma_{bb}(T-2))(K(T-1)) \right. \\
 & \quad \left. + H^2(T-1) \Sigma_{cc}(T-1) k(T-1) \right. \\
 & \quad \left. + \Sigma_{bb}(T-2)(1 - H(T-1) \bar{c}(T-1))^2 k(T-1) \right] \quad \text{(Concluded)} \\
 & \hspace{15em} \text{(B.34)}
 \end{aligned}$$

$$\begin{aligned}
 k(T-2) = & \bar{a}^2(T-2)(1 - H(T-1) \bar{c}(T-1))^2 + G^2(T-2) \left[ R(T-2) \right. \\
 & \quad \left. + (\bar{b}^2(T-2) + \Sigma_{bb}(T-2))(K(T-1) + H^2(T-1) \right. \\
 & \hspace{15em} \Sigma_{cc}(T-1) k(T-1)) \\
 & \quad \left. + \Sigma_{bb}(T-2)(1 - H(T-1) \bar{c}(T-1))^2 k(T-1) \right] \quad \text{(B.35)}
 \end{aligned}$$

Using the Principle of Optimality we have that

$$\begin{aligned}
 J(\hat{x}(T-3), (T-3)) & = \min_{\substack{G(T-3) \\ H(T-3)}} E \left\{ J(T-2) + Q(T-3) x^2(T-3) \right. \\
 & \quad \left. + R(T-3) G^2(T-3) \hat{x}^2(T-3) | z^{T-3} \right\} \\
 & = \min_{\substack{G(T-3) \\ H(T-3)}} E \left\{ K(T-2) x^2(T-2) \right. \\
 & \quad \left. + k(T-2) \Sigma_{xx}(T-2|T-2) + Q(T-3) x^2(T-3) \right. \\
 & \quad \left. + R(T-3) G^2(T-3) \hat{x}^2(T-3) | z^{T-3} \right\} \quad \text{(B.36)}
 \end{aligned}$$

This is exactly identical to the form of cost-to-go expression in Eq. (B.22) except for the indices. By induction on  $t$ , we obtain the solution to the optimum constrained linear estimator-controller system problem,

$$u(t) = - G(t) \hat{x}(t) \quad \text{(B.37)}$$

where

$$\begin{aligned}
 G(t) = & \left[ R(t) + (\bar{b}^2(t) + \Sigma_{bb}(t))(K(t+1) + H^2(t+1) \right. \\
 & \left. \cdot \Sigma_{cc}(t+1) k(t+1)) \right. \\
 & \left. + \Sigma_{bb}(t)(1 - H(t+1) \bar{c}(t+1))^2 k(t+1) \right]^{-1} \bar{b}(t) \bar{a}(t) \\
 & \cdot \left[ K(t+1) + H^2(t+1) \Sigma_{cc}(t+1) k(t+1) \right] \quad (B.38)
 \end{aligned}$$

$$\begin{aligned}
 K(t) = & (\bar{a}^2(t) + \Sigma_{aa}(t))(K(t+1) + H^2(t+1) \Sigma_{cc}(t+1) k(t+1)) + Q(t) \\
 & - \frac{\bar{b}^2(t) \bar{a}^2(t)(K(t+1) + H^2(t+1) \Sigma_{cc}(t+1) k(t+1))^2}{\left[ R(t) + (\Sigma_{bb}(t) + \bar{b}^2(t))(K(t+1) + H^2(t+1) \Sigma_{cc}(t+1) \right. \\
 & \left. \cdot k(t+1) + \Sigma_{bb}(t)(1 - H(t+1) \bar{c}(t+1))^2 k(t+1)) \right]} \quad (B.39)
 \end{aligned}$$

$$\begin{aligned}
 k(t) = & \bar{a}^2(t)(1 - H(t+1) \bar{c}(t+1))^2 \\
 & + \frac{\bar{b}^2(t) \bar{a}^2(t)(K(t+1) + H^2(t+1) \Sigma_{cc}(t+1) k(t+1))^2}{\left[ R(t) + (\Sigma_{bb}(t) + \bar{b}^2(t))(K(t+1) + H^2(t+1) \Sigma_{cc}(t+1) \right. \\
 & \left. \cdot k(t+1)) + \Sigma_{bb}(t)(1 - H(t+1) \bar{c}(t+1))^2 k(t+1) \right]} \quad (B.40)
 \end{aligned}$$

$$H(t) = \frac{\bar{c}(t) \bar{\Sigma}_{xx}(t)}{\bar{c}^2(t) \bar{\Sigma}_{xx}(t) + \theta(t) + \Sigma_{cc}(t) X(t)} \quad (B.41)$$

and

$$\begin{aligned}
 \hat{x}(t) = & (1 - H(t) \bar{c}(t)) (\bar{a}(t-1) - \bar{b}(t-1) G(t-1)) \hat{x}(t-1) \\
 & + H(t) z(t) \quad (B.42)
 \end{aligned}$$

where  $\bar{\Sigma}_{xx}(t)$  is given by Eq. (4.4.15) and Eqs. (4.4.12) to (4.4.15) if we identify  $\bar{\Sigma}_{xx}(t) = \hat{M}_{11}(t)$  and  $\Sigma_{xx}(t) = M_{11}(t)$ , and  $X(t) = M_{00}(t)$ .

REFERENCES

- [1] P.D. Joseph and J.T. Tou, "On linear Control Theory," AIEE Trans. (Appl. and Ind.) Pt. II, Vol. 80, pp.193-196, Sept. 1961.
- [2] T.L. Gunckel and G.F. Franklin, "A General Solution for Linear, Sampled-Data Control," Trans. of the ASME, Journ. of Basic Engineering, pp. 197-203, June 1963.
- [3] C. Striebel, "Sufficient Statistics in the Optimum Control of Stochastic Systems," Journ. of Mathematical Analysis and Applications, Vol. 12, pp. 576-592, 1965.
- [4] H.S. Witsenhausen, "Separation of Estimation and Control for Discrete Time Systems," Proc. of the IEEE, Vol. 59, pp. 1557-1566, Nov. 1971.
- [5] H.A. Simon, "Dynamic Programming under Uncertainty with a Quadratic Criterion Function," Econometrica, Vol. 24, pp. 74-81, Jan. 1956.
- [6] H. Theil, "A Note on Certainty Equivalence in Dynamic Planning," Econometrica, Vol. 25, pp. 346-349, Apr. 1957.
- [7] R. Bellman, Adaptive Control Processes, Princeton, N.J., Princeton University Press, 1961.
- [8] A.A. Feldbaum, "Dual Control Theory," Automation and Remote Control, Pt. I, Vol. 21, pp. 874-880, Apr., 1961, Pt. II, Vol. 21, pp. 1033-1039, May, 1961, Pt. III, Vol. 22, pp. 1-12, Aug., 1961, Pt. IV, Vol. 22, pp. 109-121, Sept. 1961.
- [9] A.A. Feldbaum, Optimal Control Systems, N.Y. ,Academic Press, 1965.
- [10] J.W. Patchell and O.L.R. Jacobs, "Separability, Neutrality and Certainty Equivalence," Int. J. Control, Vol. 13, pp. 337-342, 1971.
- [11] J.J. Florentin, "Optimal, Probing, Adaptive Control of a Simple Bayesian System," J. of Electronics and Control, Vol. 13, pp. 165-177, Aug. 1962.

- [12] O.L.R. Jacobs and J.W. Patchell, "Caution and Probing in Stochastic Control," Int. J. Control, Vol. 16, pp. 189-199, 1972.
- [13] Y. Bar-Shalom and E. Tse, "Dual Effect, Certainty Equivalence, and Separation in Stochastic Control," IEEE Trans. on Automatic Control, Vol. AC-19, pp. 494-500, Oct. 1974.
- [14] Y. Bar-Shalom and E. Tse, "Caution, Probing and Value of Information in the Control of Uncertain Systems," Annals of Economic and Social Measurement, Vol. 5, No. 3, pp. 323-337, 1976.
- [15] E. Tse and Y. Bar-Shalom, "Generalized Certainty Equivalence and Dual Effect in Stochastic Control," IEEE Trans. on Automatic Control, Vol. AC-20, pp. 817-819, Dec. 1975.
- [16] Y. Bar-Shalom and E. Tse, "Value of Information in the Control of Stochastic Systems," Proc. of the 1975 IEEE Conf. on Decision and Control, Houston, Tx., pp. 504-506, Dec. 1975.
- [17] D.J. Hughes and O.L.R. Jacobs, "Turnoff, Escape, and Probing in Nonlinear Stochastic Control," IFAC Symp. on Stochastic Control, Budapest, Hungary, pp. 343-352, Sept. 1974.
- [18] O.L.R. Jacobs and D.J. Hughes, "Simultaneous Identification and Control Using a Neutral Control Law," Proc. of the IFAC Sixth Triennial World Congress, Pt. I, Paper No. 30.2, Cambridge, Mass., Aug. 1975.
- [19] J Sternby, "A Simple Dual Control Problem with an Analytical Solution," IEEE Trans. on Automatic Control, Vol. AC-21, pp. 840-844, Dec. 1976.
- [20] O.L.R. Jacobs and R.V. Potter, "Optimal Control of a Stochastic Bilinear System," University of Oxford, Dept. of Eng. Science Report, OUEL Report No. 1156/76, June 1976.
- [21] W.J. Murphy, "Optimal Stochastic Control of Discrete Linear Systems with Unknown Gain," IEEE Trans. on Automatic Control, Vol. AC-13, pp. 338-344, Aug. 1968.
- [22] E. Tse and Y. Bar-Shalom, "An Actively Adaptive Control for Linear Systems with Random Parameters via the Dual Control Approach," IEEE Trans. on Automatic Control, Vol. AC-18, pp. 109-117, Apr. 1973.

- [23] G.C. Chow, "A Solution to Optimal Control of Linear Systems with Unknown Parameters." Econometric Research Program, Research Memo. No. 157, Princeton University, Dec. 1973.
- [24] K. Astrom and B. Wittenmark, "On Self-Tuning Regulators," Automatica, Vol. 9, pp. 185-199, March 1973.
- [25] H.A. Spang, "Optimal Control of an Unknown Linear Plant Using Bayesian Estimation of the Error," IEEE Trans. on Automatic Control, Vol. AC-10, pp. 80-83, Jan. 1965.
- [26] J.B. Farison, R.E. Graham, and R.C. Shelton, "Identification and Control of Linear Discrete Systems," IEEE Trans. on Automatic Control, Vol. AC-12, pp. 438-442, Aug. 1967.
- [27] E. Tse and M. Athans, "Adaptive Stochastic Control for a Class of Linear Systems," IEEE Trans. on Automatic Control, Vol. AC-17, pp. 38-52, Feb. 1972.
- [28] Y. Bar-Shalom and R. Sivan, "On the Optimal Control of Discrete-Time Linear Systems with Random Parameters," IEEE Trans. on Automatic Control, Vol. AC-14, pp. 3-8, Feb. 1969.
- [29] R. Ku and M. Athans, "On the Adaptive Control of Linear Systems Using the Open-Loop-Feedback-Optimal Approach," IEEE Trans. on Automatic Control, Vol. AC-18, pp. 489-493, Oct. 1973.
- [30] E.C. MacRae, "Linear Decision with Experimentation," Annals of Economic and Social Measurement, Vol. 1, No. 4, pp. 437-447, Oct. 1972.
- [31] B. Wittenmark, "Stochastic Adaptive Control Methods: A Survey," Int. J. Control, pp. 705-730, 1975.
- [32] M. Athans and P. Varaiya, "A Survey of Adaptive Stochastic Control Methods," in ERDA Report, Systems Engineering for Power: Status and Prospect, (L.H. Fink and K Carlsen, Eds.) pp. 356-366, Oct. 1975.
- [33] A. Sarris and M. Athans, "Optimal Adaptive Control Methods for Structurally Varying Systems," Computer Research Center for Economics and Management Science, Working Paper No. 24, Dec. 1973.
- [34] R. Asher, D. Andrisani, and P. Dorato, "Bibliography on Adaptive Control Systems," Proc. of the IEEE, Vol. 64, pp. 1226-1240, Aug. 1976.

- [35] J.T. Tou, Optimum Design of Digital Control Systems, N.Y., Academic Press, 1963.
- [36] R.F. Drenick and L. Shaw, "Optimal Control of Linear Plants with Random Parameters," IEEE Trans. on Automatic Control, Vol. AC-9, pp. 236-244, July 1964.
- [37] M. Aoki, Optimization of Stochastic Systems, N.Y., Academic Press, 1967.
- [38] G.C. Chow, Analysis and Control of Dynamic Economic Systems, N.Y., John Wiley and Sons, 1975.
- [39] G.C. Chow, "Effect of Uncertainty on Optimal Control Policies," Int. Economic Review, Vol. 14, pp. 632-645, Oct. 1973.
- [40] W.M. Wonham, "Optimal Stationary Control of a Linear System with State-Dependent Noise," SIAM J. Control, Vol. 51, pp. 486-500, 1967.
- [41] D.L. Kleinman, "Optimal Stationary Control of Linear Systems with Control-Dependent Noise," IEEE Trans. on Automatic Control, Vol. AC-14, pp. 673-677, Dec. 1969.
- [42] W.M. Wonham, "Random Differential Equations in Control Theory," in Probabilistic Methods in Applied Mathematics, Vol. 2, A.T. Bharucha-Reid Ed., N.Y., Academic Press, 1970.
- [43] P.J. McLane, "Optimal Stochastic Control of Linear Systems with State- and Control-Dependent Disturbances," IEEE Trans. on Automatic Control, Vol. AC-16, pp. 793-798, Dec. 1971.
- [44] U.G. Haussmann, "Optimal Stationary Control with State and Control Dependent Noise," SIAM J. Control, Vol. 9, No. 2, pp. 184-198, May 1971.
- [45] J.J. Bismut, "Linear Quadratic Optimal Stochastic Control with Random Coefficients," SIAM J. Control and Optimization, Vol. 14, No. 3, pp. 419-444, May 1976.
- [46] D.L. Alspach, "A Dual Control for Linear Systems with Control Dependent Plant and Measurement Noise," Proc. of the 1973 IEEE Conf. on Decision and Control, San Diego, Ca., pp. 681-689, Dec. 1973.

- [47] M. Aoki, "Control of Linear Discrete-Time Stochastic Dynamic Systems with Multiplicative Disturbances," IEEE Trans. on Automatic Control, Vol. AC-20, pp. 388-391, June 1975.
- [48] S.M. Joshi, "On Optimal Control of Linear Systems in the Presence of Multiplicative Noise," IEEE Trans. on Aerospace and Electronic Systems, Vol. AES-12, pp. 81-85, Jan. 1976.
- [49] H. Kwakernaak and R. Sivan, Linear Optimal Control Systems, N.Y., Wiley-Interscience, 1972.
- [50] M. Athans, R. Ku, and S.B. Gershwin, "The Uncertainty Threshold Principle: Some Fundamental Limitations of Optimal Decision Making under Dynamic Uncertainty," IEEE Trans. on Automatic Control, Vol. AC-22, pp. 491-495, June 1977.
- [51] T. Katayama, "On the Matrix Riccati Equation for Linear Systems with a Random Gain," IEEE Trans. on Automatic Control, Vol. AC-21, pp. 770-771, Oct. 1976.
- [52] S. Niwa, M. Hayase, and I. Sugiura, "Stability of Linear Time-Varying Systems with State Dependent Noise," IEEE Trans. on Automatic Control, Vol. AC-21, pp. 775-776, Oct. 1976.
- [53] D.N. Martin and T.L. Johnson, "Stability Criteria for Discrete-Time Systems with Colored Multiplicative Noise," Proc. of the 1975 IEEE Conf. on Decision and Control, Houston, Tx., pp. 169-175, Dec. 1975.
- [54] D.N. Martin, Stability Criteria for Systems with Colored Multiplicative Noise, ESL-R-567, Ph. D. Thesis, Dept. of Electrical Eng. and Computer Sci., M.I.T., Cambridge, Mass., Sept. 1974.
- [55] J. Conlisk, "Stability in a Random Coefficient Model," Int. Economic Review, Vol. 15, pp. 529-533, June 1974.
- [56] J. Conlisk, "A Further Note on Stability in a Random Coefficient Model," Int. Economic Review, Vol. 17, pp. 759-764, Oct. 1976.
- [57] J.L. Willems and J.C. Willems, "Feedback Stabilization for Stochastic Systems with State and Control Dependent Noises," Automatica, Vol. 12, pp. 277-283, May 1976.

- [58] F. Kozin, "A Survey of Stability of Stochastic Systems," Automatica, Vol. 5, pp. 95-112, Jan. 1969.
- [59] V.M. Konstantinov, "The stability of Stochastic Difference Equations," Problems of Information Transmission, Vol. 6, pp. 70-75, Jan.-Mar. 1970.
- [60] R.Ku, M. Athans, and P. Varaiya, "The Effects of Discounted Cost on the Uncertainty Threshold Principle," ESL-P-749, M.I.T. Electronic Systems Laboratory, May 1977. Paper presented at the NBER Conf. on Stochastic Control, New Haven, Conn., May 1977.
- [61] H. Kushner, Introduction to Stochastic Control, N.Y., Holt, Rinehart, and Winston, 1971.
- [62] M. Magill, "Some New Results on the Local Stability of the Process of Capital Accumulation," J. of Economic Theory, Vol. 15, pp. 174-210, June 1977.
- [63] F.P. Ramsey, "A Mathematical Theory of Saving," The Economic Journal, Vol. 38, pp. 543-559, Dec. 1928.
- [64] D.E. Gustafson and J.L. Speyer, "Linear Minimum Variance Estimation in Systems with State Dependent Noise," Proc. of the Second Symp. on Nonlinear Estimation Theory and Its Applications, San Diego, Ca., pp. 143-146, Sept. 1971.
- [65] D.E. Gustafson, On Optimal Estimation and Control of Linear Systems with State-Dependent and Control-Dependent Noise, Ph.D. Thesis, Dept. of Aero. and Astro., M.I.T., Cambridge, Mass., June 1972.
- [66] P.J. McLane, "Optimum Linear Filtering for Linear Systems with State-Dependent Noise," Int. J. Control, Vol. 10, pp. 41-51, July 1969.
- [67] P.J. McLane, "Asymptotic Stability of Linear Autonomous Systems with State-Dependent Noise," IEEE Trans. on Automatic Control, Vol. AC-14, pp. 754-755, Dec. 1969.
- [68] P.K. Rajasekaran et al., "Optimum Linear Estimation of Stochastic Signals in the Presence of Multiplicative Noise," IEEE Trans. on Aerospace and Electronic Systems, Vol. AES-7, pp. 462-468, May 1971.
- [69] M. Athans and E. Tse, "A Direct Derivation of the Optimal Linear Filter Using the Maximum Principle," IEEE Trans. on Automatic Control, Vol. AC-12, pp. 690-698, Dec. 1967.

- [70] E. Tse, Y. Bar-Shalom, and L. Meier, "Wide-Sense Adaptive Dual Control for Nonlinear Stochastic Control Systems," IEEE Trans. on Automatic Control, Vol. AC-18, pp. 98-109, Apr. 1973.
- [71] M. Athans, "The Matrix Minimum Principle," Information and Control, Vol. 11, pp. 592-606, Nov.-Dec. 1967.
- [72] H.S. Witsenhausen, "On Policy Independence of Conditional Expectations," Information and Control, Vol. 28, pp. 65-75, May 1975.
- [73] D.P. Bertsekas, Dynamic Programming and Stochastic Control, N.Y., Academic Press, 1976.
- [74] C.Y. Chong and M. Athans, "On the Stochastic Control of Linear Systems with Different Information Sets," IEEE Trans. on Automatic Control, Vol. AC-16, pp. 423-430, Oct. 1971.
- [75] A.E. Bryson and Y.C. Ho, Applied Optimal Control, Waltham, Mass., Ginn and Company, 1969.
- [76] I.B. Rhodes and D.G. Luenberger, "Stochastic Differential Games with Constrained State Estimators," IEEE Trans. on Automatic Control, Vol. AC-14, pp. 476-481, Oct. 1969.
- [77] V. Sankaran and M.D. Srinath, "Duality of Linear Estimation and Control with Constraints," J. of Optimization Theory and Applications, Vol. 10, pp. 41-50, July 1972.
- [78] H.S. Witsenhausen, "A Standard Form for Sequential Stochastic Control," Mathematical Systems Theory, Vol. 7, pp. 5-11, 1973.
- [79] R.Ku and M. Athans, "Further Results on the Uncertainty Threshold Principle," IEEE Trans. on Automatic Control, Vol. AC-22, pp. 866-868, Oct. 1977.
- [80] F.R. Shupp, "Uncertainty and Optimal Policy Intensity in Fiscal and Income Policies," Annals of Economic and Social Measurement, Vol.5, pp. 225-237, Spring 1976.
- [81] G.A. Hewer, "Analysis of a Discrete Matrix Riccati Equation of Linear Control and Kalman Filtering," J. of Mathematical Analysis and Applications, Vol. 42, pp. 226-236, 1973.

- [82] A.H. Levis, On the Optimal Sampled-Data Control of Linear Processes, Sc. D. Thesis, Dept. of Mech. Eng., M.I.T., Cambridge, Ma., 1968.
- [83] P.J. Vermeulen and D.C.J. De Jongh, "Growth in a Finite World- A Comprehensive Sensitivity Analysis," Automatica, Vol. 13, pp. 77-84, Jan. 1977.
- [84] M. Athans et al., "The Stochastic Control of the F-8C Aircraft Using a MMAC Method," IEEE Trans. on Automatic Control, Vol. AC-22, pp. 768-780, Oct. 1977.

BIOGRAPHICAL NOTE

Richard T. Ku received the B.S., M.S., and E.E. degrees in Electrical Engineering from the Massachusetts Institute of Technology, Cambridge, Mass. in 1970, 1972, and 1972 respectively.

He was employed by IBM, New York, N.Y. in the summer of 1969 and was appointed as a corporate summer engineer intern by RCA, Moorestown, New Jersey in 1970 and 1971. From 1972 to 1974, he was a Staff Engineer with the consulting firm Intermetrics, Inc., Cambridge, Massachusetts. At M.I.T. he has been a Teaching Assistant in the Department of Electrical Engineering from 1970 to 1972, Research Assistant in the Electronic Systems Laboratory from 1974 to 1977, and Technical Assistant in the Sloan School of Management in the Summer of 1975. In Spring 1978, he joined the Technical Staff of The Analytic Sciences Corporation, Reading, Mass. He is the co-author of several articles on the theory and applications of modern control.

Mr. Ku is a member of Tau Beta Pi, Eta Kappa Nu, and Sigma Xi.