

AD-A056 927 ARMY MOBILITY EQUIPMENT RESEARCH AND DEVELOPMENT COMM--ETC F/G 13/6
BASELINE TESTS OF THE EVA METRO ELECTRIC PASSENGER VEHICLE.(U)
MAY 78 E J DOWGIALLO, C E BAILEY EC-77-A-31-1042
UNCLASSIFIED MERADCOM-2244 DOF-CONS/0421-1 NL

1 of 2
AD
A056 927



LEVEL

11

821 16 20 82

AD

AD A056927

DDC FILE COPY

Report 2244

**BASELINE TESTS OF THE EVA METRO ELECTRIC PASSENGER VEHICLE
(DOE Report No. CONS/0421-1)**

by
Edward J. Dowgiallo, Jr.
Cornelius E. Bailey Jr.
Ivan R. Snellings
William H. Blake
Donald Sherwood

DDC
AUG 3 1978
F

May 1978

Approved for public release; distribution unlimited.

Prepared For:

DEPARTMENT OF ENERGY
Electric and Hybrid Highway Vehicle Systems Program,
Division of Transportation Energy Conservation



**U.S. ARMY MOBILITY EQUIPMENT
RESEARCH AND DEVELOPMENT COMMAND
FORT BELVOIR, VIRGINIA**

78 07 31 178

**Destroy this report when it is no longer needed.
Do not return it to the originator.**

The citation in this report of trade names of commercially available products does not constitute official endorsement or approval of the use of such products.

This report was prepared to document work sponsored by the United States Government. Neither the United States nor its agent, the United States Energy Research and Development Administration, nor any Federal employees, nor any of their contractors, subcontractors, or their employees, makes any warranty, express or implied, or assumes any legal liability or responsibility for the accuracy, completeness, or usefulness of any information, apparatus, product, or process disclosed, or represents that its use would not infringe privately owned rights.

(18) DOE (19) CONS/0421-1

UNCLASSIFIED

SECURITY CLASSIFICATION OF THIS PAGE (When Data Entered)

REPORT DOCUMENTATION PAGE		READ INSTRUCTIONS BEFORE COMPLETING FORM
1. REPORT NUMBER 2244	2. GOVT ACCESSION NO. (14) MERADCOM-2244	3. RECIPIENT'S CATALOG NUMBER
4. TITLE (6) BASELINE TESTS OF THE EVA METRO ELECTRIC PASSENGER VEHICLE.	5. TYPE OF REPORT & PERIOD COVERED (9) Final Technical Memorandum	6. PERFORMING ORG. REPORT NUMBER CONS/0421-1
7. AUTHOR(s) (10) Edward J. Dowgiallo, Jr., Cornelius E. Bailey, Jr., Ivan R. Snellings, William H. Blake Donald Sherwood	8. CONTRACT OR GRANT NUMBER(s) (15) Interagency Agreement EC-77-A-31-1042	9. PROGRAM ELEMENT PROJECT TASK AREA & WORK UNIT NUMBERS (12) I23P1
9. PERFORMING ORGANIZATION NAME AND ADDRESS U.S. Army Mobility Equipment Research and Development Command Fort Belvoir, Virginia 22060	10. REPORT DATE (11) May 78	11. NUMBER OF PAGES 133
11. CONTROLLING OFFICE NAME AND ADDRESS Department of Energy Division of Transportation Energy Conservation Washington, DC 20545	12. SECURITY CLASS. (of this report) Unclassified	13. DECLASSIFICATION/DOWNGRADING SCHEDULE
14. MONITORING AGENCY NAME & ADDRESS (if different from Controlling Office)	16. DISTRIBUTION STATEMENT (of this Report) Approved for public release; distribution unlimited.	
17. DISTRIBUTION STATEMENT (of the abstract entered in Block 20, if different from Report)	18. SUPPLEMENTARY NOTES	
19. KEY WORDS (Continue on reverse side if necessary and identify by block number) Electric Vehicle Traction Battery Charger	19. KEY WORDS (Continue on reverse side if necessary and identify by block number)	
20. ABSTRACT (Continue on reverse side if necessary and identify by block number) The EVA Metro is a four-passenger Renault 12 Sedan that has been converted to an electric vehicle. It was tested by the U.S. Army Mobility Equipment Research and Development Command (MERADCOM), Fort Belvoir, Virginia, as part of a Department of Energy (DOE) project to characterize the state-of-the-art of electric vehicles. The EVA Metro Sedan vehicle performance test results are presented in this report. The EVA Metro is powered by sixteen, 6-volt traction batteries through a silicon-controlled rectifier (SCR) controller actuated by a		

DDC
PROCESSED
AUG 3 1978
MOBILE
F

(Continued)

443169 Jan 31 1978

UNCLASSIFIED

SECURITY CLASSIFICATION OF THIS PAGE(When Data Entered)

(Block 20 Cont'd)

foot throttle to change the voltage applied to a 10-kW motor. The braking system is a power-assist, hydraulic braking system with front-wheel disk and rear drum. Regenerative braking is not provided.

UNCLASSIFIED

SECURITY CLASSIFICATION OF THIS PAGE(When Data Entered)

CONTENTS

Section	Title	Page
	ILLUSTRATIONS	v
	TABLES	viii
I	SUMMARY	1
II	INTRODUCTION	3
III	OBJECTIVES	3
IV	TEST VEHICLE DESCRIPTION	4
V	INSTRUMENTATION	4
VI	TEST PROCEDURES	
	1. Vehicle Test Speed	10
	2. Range Tests – Constant Speed	10
	3. Range Tests – Driving Schedules	10
	4. Acceleration and Coast-Down Tests	10
	5. Braking Tests	10
	6. Tractive Force Tests	11
	7. Charger Efficiency Tests	11
VII	TEST RESULTS AND DISCUSSION	
	1. Maximum Speed	11
	2. Range	11
	3. Maximum Acceleration	11
	4. Gradeability	16
	5. Gradeability Limit	16
	6. Road Energy Consumption	22
	7. Road Power Requirements	23
	8. Indicated Energy Consumption	29
	9. Braking Capability	30
VIII	COMPONENT PERFORMANCE AND EFFICIENCY	
	1. Battery Charger	32
	2. Battery Characteristics	32
	3. Constant Vehicle Speed Battery Performance	34
	4. Battery Performance – Driving Cycle	39

Approved by _____

EIS Write Section

DDC B. II Section

UNANNOUNCED

JUSTIFICATION _____

BY _____

DISTRIBUTION/AVAILABILITY CODES

Dist. _____ or SPECIAL

A

	5. Battery Performance – Maximum Acceleration	39
	6. General Battery Performance	39
	7. Charging and Battery Efficiency	39
	8. Controller	39
	9. Motor and Drive Train	52
IX	VEHICLE RELIABILITY	52
X	DRIVER REACTION AND SERVICEABILITY	52
	APPENDICES	
	A. ERDA Electric and Hybrid Vehicle Test and Evaluation Procedure	53
	B. Vehicle Summary Data Sheet	82
	C. EVA Corporation "Battery Marshall" Battery Charger	85
	D. Data Acquisition Systems	103
	E. Description of Vehicle Test Track	107
	F. Vehicle Preparation and Test Procedure	113

ILLUSTRATIONS

Figure	Title	Page
1	Side View of EVA Metro Sedan at MERADCOM	5
2	View of Front Showing SCR Controller and One Set of Batteries	6
3	View of Rear Showing Charger Rear Set of Propulsion Batteries, Auxiliary Battery, and Gasoline-Fueled Heater	7
4	Schematic Diagram of Vehicle Electric Propulsion System Showing Instrumentation Monitors	9
5a	Vehicle Acceleration (English Units)	13
5b	Vehicle Acceleration (Metric Units)	14
6a	Acceleration as a Function of Speed (English Units)	17
6b	Acceleration as a Function of Speed (Metric Units)	18
7a	Gradeability as a Function of Speed (English Units)	19
7b	Gradeability as a Function of Speed (Metric Units)	20
8a	Road Energy as a Function of Speed (English Units)	24
8b	Road Energy as a Function of Speed (Metric Units)	25
8c	Road Energy as a Function of Speed (Metric Units)	26
9a	Road Power as a Function of Speed (Metric Units)	27
9b	Road Power as a Function of Speed (English Units)	28
10	Battery Discharge Characteristics	35
11	Battery Energy/Power Relationship	36
12	Battery Capacity Check	37
13a	Constant Speed Battery Performance – First 25% of Range	38
13b	Constant Speed Battery Performance – Last 25% of Range	38
14	Typical Voltage vs Time Curve at 80°F and Various Discharge Rates – EV-106 Battery	41

ILLUSTRATIONS (Cont'd)

Figure	Title	Page
15a	Average Battery Current	42
15b	Average Battery Voltage	43
15c	Average Battery Power	44
15d	Speed as a Function of Time	45
16a	Average Battery Current	46
16b	Average Battery Voltage	47
16c	Average Battery Power	48
16d	Speed as a Function of Time	49
A1	Vehicle Test Cycle, SAE-J227a	65
A2	Acceleration Characteristics	68
A3	Vehicle Speed versus Time During Acceleration	70
A4	Vehicle Maximum Acceleration versus Vehicle Speed	71
A5	Vehicle Speed versus Time during Coasting	73
A6	Road Power versus Vehicle Speed	75
A7	Road Energy Consumption versus Vehicle Speed	75
C1	Main Input-Output Circuit	86
C2	Ground Detector Circuit	87
C3	± 15 -Volt DC Supply	88
C4	Battery Charger Control Circuit	89
C5	Connector and Component Wiring Diagram	90
C6	Instrumentation Setup to Determine Charge-Rate Curves	93
C7	EVA Corporation Battery Charger: Input Voltage – 115 VAC	94

ILLUSTRATIONS (Cont'd)

Figure	Title	Page
C8	EVA Corporation Battery Charger, 115-V Connection, Voltage vs Current	95
C9	EVA Corporation Battery Charger: Input Voltage – 120 VAC	96
C10	EVA Corporation Battery Charger; 120-V Connection, Voltage vs Current	97
C11	EVA Corporation Battery Charger: Input Voltage – 230 VAC	98
C12	EVA Corporation Battery Charger; 230-V Connection, Voltage vs Current	99
C13	Broadband Radiated Emissions	100
C14	Audio Sound Level: Input – 120 VAC; Output – 10A	101
D1	Data Acquisition System Block Diagram	104
D2	Vehicle-Mounted Signal Conditioning Instrumentation Package	105
E1	Half Plan and Section of Fording Basin	108
E2	Tractor in Fording Basin	108
E3	Plan View of Slopes	109
E4	Eight of the Standard Gradeability Slopes	109
E5	Aerial View of Mile Loop	110
E6	Aerial View of Perryman Test Area	111
E7	Dynamometer Course	112

TABLES

Table	Title	Page
1	Range Test of EVA Metro	1
2	Parameters, Symbols, Units, and Unit Abbreviations	2
3a	Summary of Test Results for EVA Metro (Metric Units)	12
3b	Summary of Test Results for EVA Metro (English Units)	12
4	Acceleration Test for EVA Metro	15
5	Acceleration Characteristics for EVA Metro	21
6	Gradeability of EVA Metro	21
7	Road Energy Consumption of EVA Metro	23
8	Road Power Requirements of EVA Metro	29
9	Indicated Energy Consumption for EVA Metro Sedan	29
10	Straight-Line Braking Test Results	31
11	Braking in a Turn Test Results	31
12	Wet Brake Recovery Test Results	32
13	Speed Versus Time During Coasting for EVA Metro	33
14	Battery Specifications	33
15	EVA Metro Constant Speed Battery and Motor Data	40
16	Driving Cycle Performance of EVA Metro	50
17	EVA Metro Maximum Acceleration – Battery Performance	50
18	EVA Metro Sedan Battery Test Data	51
19	EVA Metro Sedan Traction Motor Ratings	52
A1	Test Schedule for Repeatable Driving Pattern, SAE-J227a	65
A2	Lateral (g) Forces as a Function of Vehicle Velocity and Turning Radius	81
A3	Stopping Distances	81
D1	Signal Conditioning Instrumentation Accuracy	106

BASELINE TESTS OF THE EVA ELECTRIC PASSENGER VEHICLE

I. SUMMARY

The EVA Metro Sedan, an electric vehicle manufactured by Electric Vehicle Associates, Valley View, Ohio, was tested under the direction of the U.S. Army Mobility Equipment Research and Development Command (MERADCOM) Fort Belvoir, Virginia, at the Aberdeen Proving Ground, Aberdeen, Maryland, between April 21 and September 2, 1977. The tests are part of a Department of Energy (DOE) project to assess the state-of-the-art of electric vehicles. This report presents the performance test results on the EVA Metro vehicle.

The EVA Metro is a converted, four-passenger Renault 12 Sedan. It is powered by sixteen, 6-volt traction batteries through an SCR Cableform controller actuated by a foot throttle to change the voltage applied to the 10-kW motor. The braking system is a power-assist, hydraulic braking system with front-wheel disk and rear drum. Regenerative braking is not provided.

The results of the tests are shown in Table 1, and a list of parameters, symbols, units, and unit abbreviations is shown in Table 2.

Table 1. Range Test of EVA Metro

Road								
Range Test		Range		Power	Road Energy		Energy Economy	
(km/h)	(mi/h)	(km)	(mi)	(kW)	(MJ/km)	(kWh/mi)	(MJ/km)	(kWh/mi)
40	25	60.7	37.7	3.51	0.318	0.142	1.07	0.48
55	34.3	43.8	27.2	6.66	0.416	0.186	1.18	0.53
77	48	36.7	22.8	12.8	0.602	0.269	1.48	0.66
"B" Cycle		32.6	20.3				1.03	0.46
"C" Cycle		34.2	21.2				1.00	0.44
Acceleration								
0 to 32 km/h (20 mi/h) in 10.7 seconds.								
0 to 48 km/h (30 mi/h) in 20 seconds.								
Gradeability Limit								
34.5%								
Charger Efficiency								
68%								

Table 2. Parameters, Symbols, Units, and Unit Abbreviations

Parameter	Symbol	SI Units		US Customary Units	
		Unit	Abbreviation	Unit	Abbreviation
Acceleration	a	meter per second squared	m/s ²	mile per hour per second	mi/h/s
Area	-	square meter	m ²	square foot: square inch	ft ² : in ²
Energy	-	megajoule	MJ	kilowatt hour	kWh
Energy consumption	e	megajoule per kilometer	MJ/km	kilowatt hour per mile	kWh/mi
Energy Economy	-	megajoule per kilometer	MJ/km	kilowatt hour per mile	kWh/mi
Force	p	newton	N	pound force	lbf
Integrated current	-	ampere hour	Ah	ampere hour	Ah
Length	-	meter	m	inch: foot: mile	in.: ft: mi
Mass: weight	w	kilogram	kg	pound mass	lbm
Power	p	kilowatt	kW	horsepower	hp
Pressure	-	kilopascal	kPa	pound force per square inch	lbf/in ²
Range	-	kilometer	km	mile	mi
Specific energy	-	megajoule per kilogram	MJ/kg	watt hour per pound mass	Wh/lbm
Specific power	-	kilowatt per kilogram	kW/kg	kilowatt per pound mass	kW/lbm
Speed	v	kilometer per hour	km/h	mile per hour	mi/h
Volume	-	cubic meter	m ³	cubic inch: cubic foot	in. ³ : ft ³

II. INTRODUCTION

The vehicle tested and the data presented in this report are in support of Public Law 94-413 enacted by Congress on September 17, 1976. The law requires the Department of Energy (DOE) to develop data characterizing the state-of-the-art with respect to electric and hybrid vehicles. The data so developed are to serve as a baseline to (1) compare improvements in electric- and hybrid-vehicle technologies, (2) assist in establishing performance standards for electric and hybrid vehicles, and (3) help guide future research and development activities.

The U.S. Army Mobility Equipment Research and Development Command (MERADCOM) under the direction of the Electric and Hybrid Research, Development, and Demonstration Office, Division of Transportation Energy Conservation, DOE, has conducted track tests of electric vehicles to measure their performance characteristics. The tests were conducted using a DOE test procedure "ERDA-EHV-TEP" (Appendix A). This procedure is a modification of the SAE "Electric Vehicle Test Procedure SAE J227a," revised February 1976. Seventeen vehicles have been tested under this phase of the program - twelve by NASA-Lewis Research Center, four by MERADCOM, and one by the Canadian Government. U.S. Customary units were used in the collection and reduction of data. The units were converted to the International System of Units for presentation in this report. U.S. Customary units are presented in parentheses.

The assistance and cooperation of the vehicle manufacturer were greatly appreciated. The Department of Energy supplied funding support and guidance during this project.

III. OBJECTIVES

The objectives of this track test were to determine vehicle and component performance characteristics and vehicle component efficiencies. The characteristics of interest are:

- Vehicle Speed
- Range at Constant Speed
- Range Over Stop-and-Go Driving Schedules
- Maximum Acceleration
- Gradeability
- Gradeability Limit
- Road Energy Consumption
- Road Power
- Indicated Energy Consumption

Braking Capability
Battery Charger Efficiency
Battery Characteristics
Controller Efficiency
Motor Efficiency

IV. TEST VEHICLE DESCRIPTION

The EVA Metro #1 Sedan is a converted Renault 12 Sedan powered by sixteen, 6-volt batteries. An SCR Cableform controller, actuated by a foot throttle, changes the voltage applied to the 10-kW motor. An automatic transmission with torque converter is provided for forward and reverse. The vehicle is accelerated by depressing the accelerator which sends a programmed voltage to the SCR controller which provides a variable-pulse-width voltage to the 10-kW motor to control its r/min. The motor, in turn, drives the torque converter to the transmission which has three forward positions and one reverse. A complete description of the vehicle is given in Appendix B. The vehicle is shown in Figure 1. A 120/220-volt ac, on-board battery charger is provided to charge both the traction batteries and the accessory battery. An evaluation of the charger is given in Appendix C. The vehicle manufacturer specifies 12 hours to completely recharge fully discharged batteries. No regenerative braking is provided on this vehicle. The controller and front battery pack are shown in Figure 2, and the charger and rear battery pack are shown in Figure 3.

V. INSTRUMENTATION

The EVA Metro Sedan was instrumented to measure vehicle speed and range, battery voltage, current, "instantaneous" power and averaged power, motor voltage, (motor current was assumed equal to battery current), the temperature of the motor frame, and the battery charger power. Battery electrolyte temperatures were measured with thermometers. A brief description of the instrumentation system is given in the following paragraphs. Details of the recorder are given in Appendix D.

Instrumentation consisted of signal-conditioning circuits and a magnetic tape recorder for recording analog signals of electrical parameters. The magnetic tape recorder was operated in the frequency modulation mode at 4.763 cm (1.875 inches) per second. The signal-conditioning circuitry to the recorder consisted of a main battery voltage divider, a shunt-voltage amplifier for current monitor, an analog multiplier, and averager circuits for averaging power and current because the recorder response was less than 0.3 dB down at 500 hertz (Hz). A voltage proportional to power was produced by the instantaneous multiplication of voltage and current. Current and power were recorded both raw and electronically averaged. The raw values include the rapid switching transients associated with the solid-state controller.

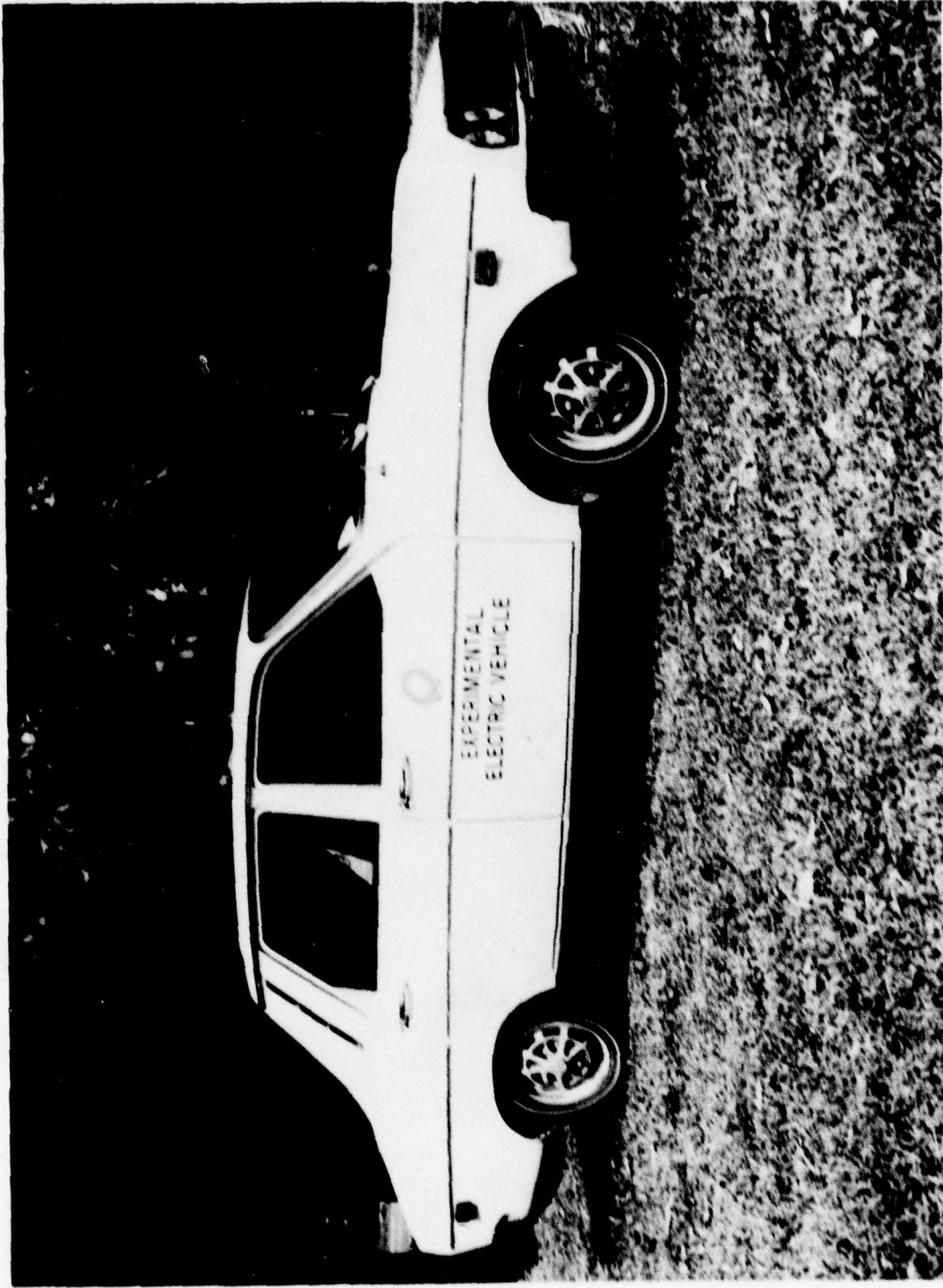

Figure 1. Side view of EVA metro sedan at MERADCOM.

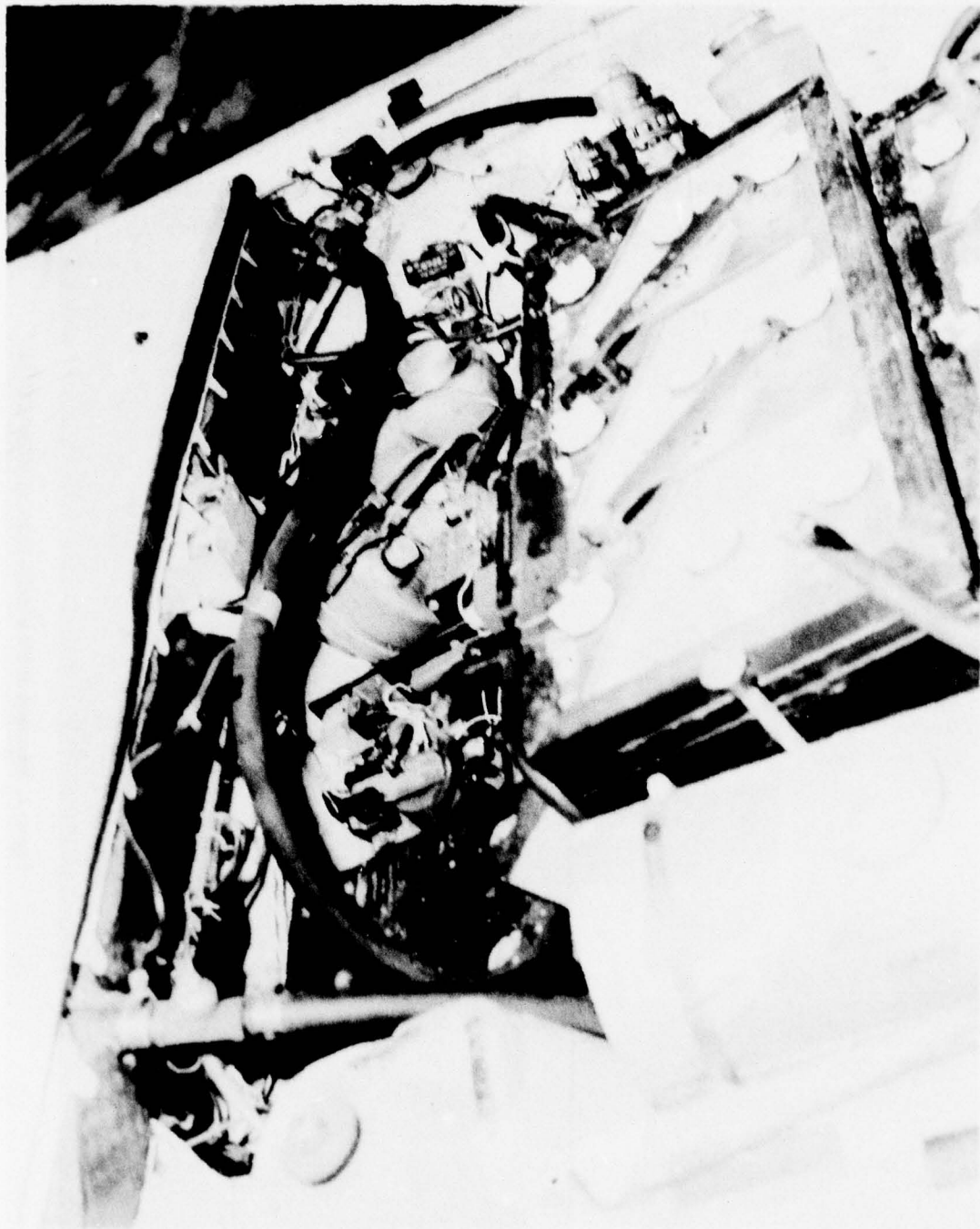

Figure 2. View of front showing SCR controller and one set of batteries.

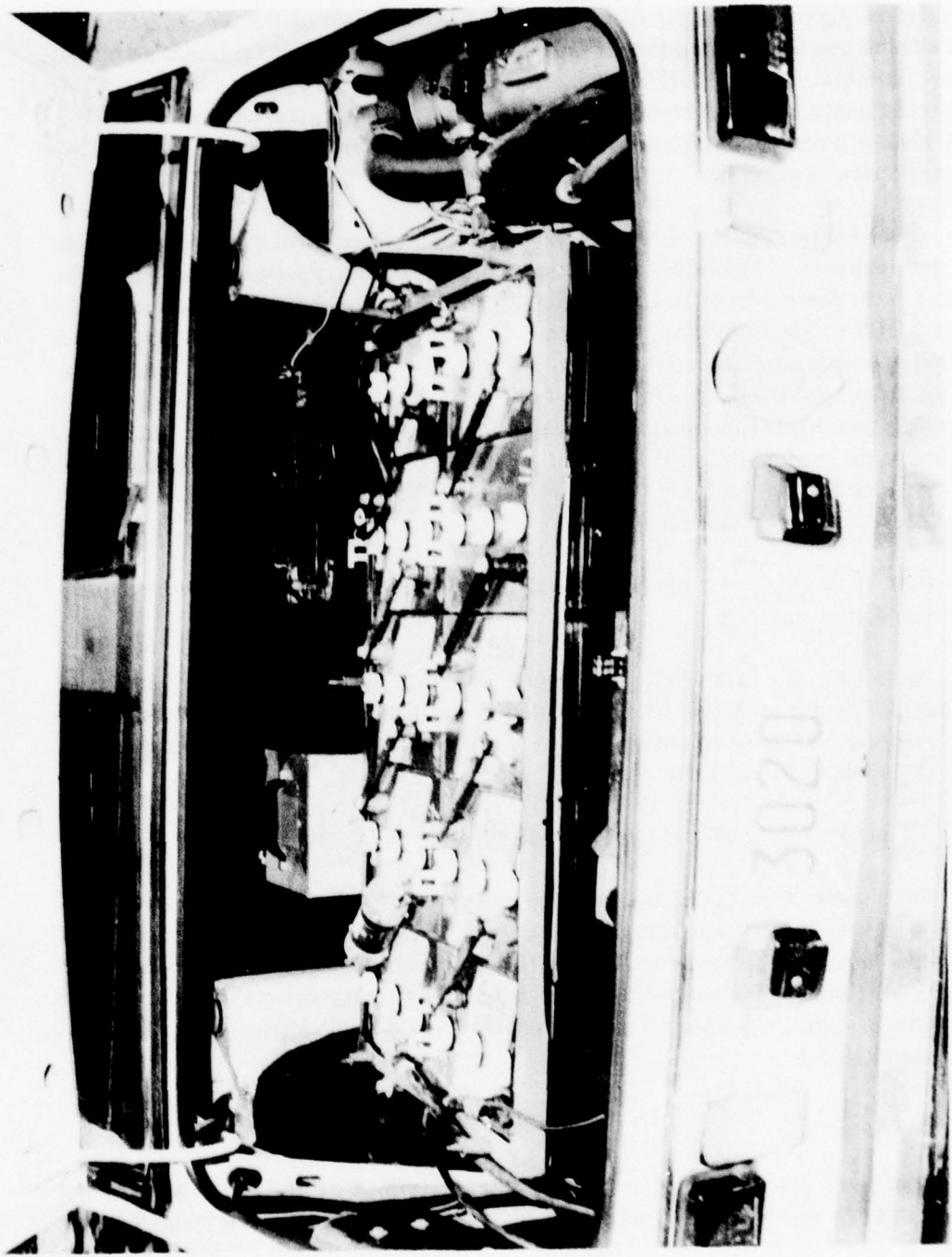

Figure 3. View of rear showing charger, rear set of propulsion batteries, auxiliary battery, and gasoline-fueled heater.

The estimated overall dc measurement error is less than $\pm 1.8\%$ for power. This includes digitization from the field-recorded analog magnetic tape to a computer-compatible digitized magnetic tape. The measurement error of the various conditioning circuits can be broken down as follows: current shunt $\pm 0.25\%$; current amplifier: $\pm 1\%$; multiplier: $\pm 0.25\%$ (Phase deterioration starts to be significant above 3 kHz when the multiplier is combined with an averager: $\pm 1\%$); magnetic tape recorder: $\pm 1\%$. The analog-to-digital converter at 16 bits and 100 conversions per second did not introduce any significant error.

A schematic diagram of the electric propulsion system with the instrumentation sensors is shown in Figure 4. A Laboratory Equipment Corporation, Tracktest Fifth Wheel, with the model DD1.1, Electronics Digital Speed and Distance Meter and the model DD2.1, Electronic Digital Distance Meter, was used during the track tests. A tachometer generator was connected to the fifth wheel to record velocity and to calculate distance traveled. The fifth wheel and auxiliaries weighed about 18.6 kg (41 lb). The fifth wheel was calibrated by rotating the wheel on a constant-speed, fifth-wheel calibrator drum mounted on the shaft of a synchronous ac motor. The accuracy of the velocity readings was within $\pm \frac{1}{2}\%$ of the reading. Velocity was recorded on a Lockheed Store 7 magnetic tape recorder.

Battery electrolyte temperatures and specific gravities were measured manually before and after the tests.

Power for the fifth-wheel instruments was provided by two vehicle, auxiliary, 12-volt SLI batteries which were connected in parallel. The power for the magnetic tape recorder and signal-conditioning instrument package was supplied from a battery pack described in Appendix D.

All instruments were calibrated periodically with checks before each test.

The current into the battery and the energy into the battery charger were measured while the battery was recharged after each test. The current to the battery was recorded on a Hewlett Packard 7100 B strip chart recorder. The current was measured using a 100 ampere/100 millivolt current shunt. The energy delivered to the charger was measured with a Sangamo Electric Type J4S 30TA single-phase, residential, watt-hour meter.

VI. TEST PROCEDURES

The tests described in this report were performed at the Aberdeen Proving Ground (APG) test facilities at Aberdeen, Maryland. Five different test locations were used. A complete description of the track is given in Appendix E. When the vehicle was delivered to MERADCOM, Fort Belvoir, Virginia, the pretest checks described in

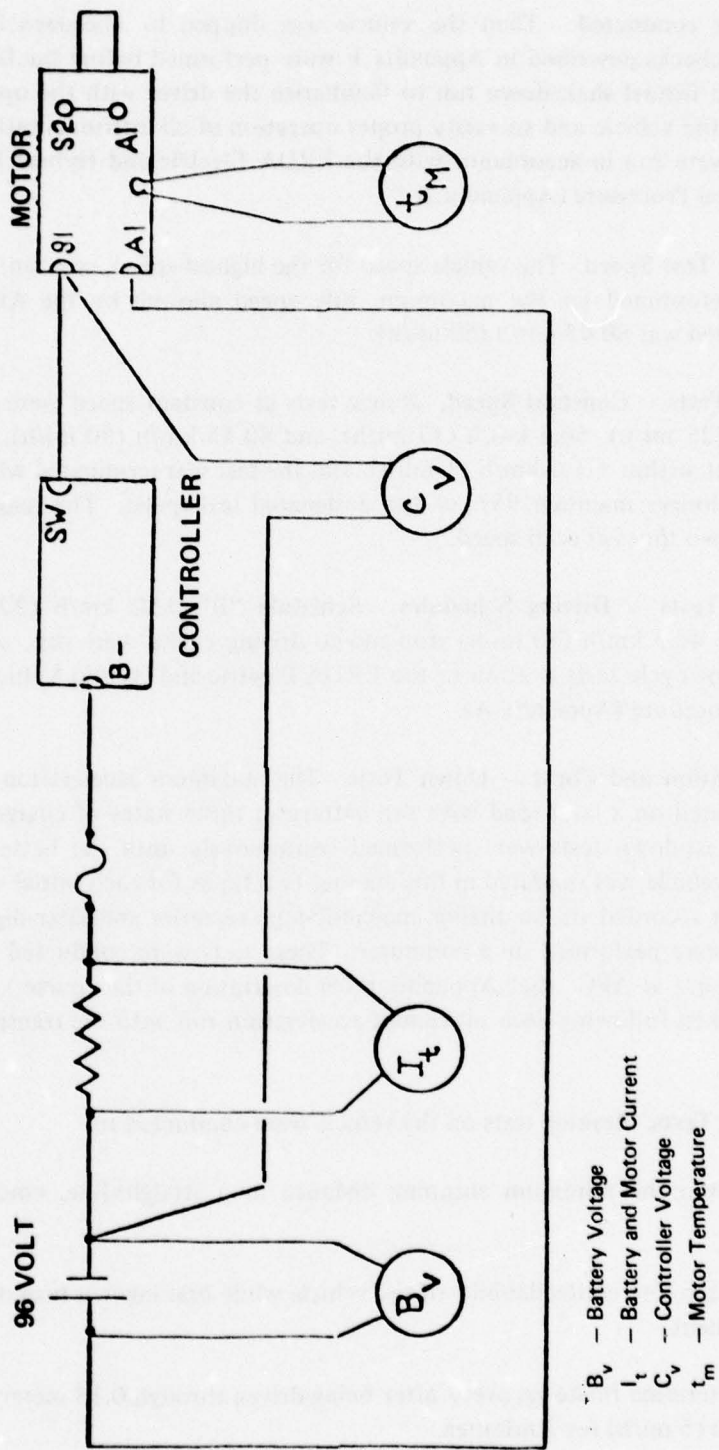

Figure 4. Schematic diagram of vehicle electric propulsion system showing instrumentation monitors.

Appendix F were conducted. Then the vehicle was shipped to Aberdeen Proving Ground, and the checks described in Appendix F were performed before the first test runs. There was a formal shakedown run to familiarize the driver with the operating characteristics of the vehicle and to verify proper operation of all instrumentation systems. All tests were run in accordance with the ERDA Electric and Hybrid Vehicle Test and Evaluation Procedure (Appendix A).

1. **Vehicle Test Speed.** The vehicle speed for the highest-speed, constant-speed-range test was determined by the maximum, safe speed allowed by the APG test facilities. This speed was 80.45 km/h (50 mi/h).

2. **Range Tests – Constant Speed.** Range tests at constant speed were carried out at 40 km/h (25 mi/h), 56.3 km/h (35 mi/h), and 80.45 km/h (50 mi/h); speeds were held constant within ± 1.6 km/h (1 mi/h), and the test was terminated when the vehicle could no longer maintain 95% of the designated test speed. The range tests were run at least two times at each speed.

3. **Range Tests – Driving Schedules.** Schedule "B" 32.2 km/h (20 mi/h) and Schedule "C" 48.3 km/h (30 mi/h) stop-and-go driving cycles were run. A complete description of cycle tests is given in the ERDA Electric and Hybrid Vehicle Test and Evaluation Procedure (Appendix A).

4. **Acceleration and Coast – Down Tests.** The maximum acceleration of the vehicle was measured on a level road with the battery at three states of charge. The acceleration – coast-down tests were performed continuously until the battery was discharged. The vehicle was operated in this manner two times for each initial state of charge. Data was recorded on an analog, magnetic-tape recorder and later digitized, and calculations were performed on a computer. These tests were conducted on the Dynamometer Course at APG. (See Appendix E for description of the course.) Coast-down data was taken following each maximum-acceleration run with the transmission in neutral.

5. **Braking Tests.** Braking tests on the vehicle were conducted to:

- a. Determine minimum stopping distance in a straight-line, emergency stop.
- b. Determine controllability of the vehicle while braking in a turn on both wet and dry pavement.
- c. Determine brake recovery after being driven through 0.15 meter (6 in.) of water at 8 km/h (5 mi/h) for 2 minutes.

d. Determine parking brake effectiveness on an incline.

6. Tractive Force Tests. The maximum-grade capability of the test vehicle was determined from tractive force tests by towing an M8 light, field dynamometer at 1.6 km/h (1 mi/h) while the test vehicle was being driven with wide-open throttle. The force was measured by the dynamometer instrumentation from the load cell attached between the vehicles. The test was run with the batteries 0%, 40%, and 80% discharged.

7. Charger Efficiency Tests. The on-board charger supplied by EVA was not used in the field tests because it did not charge the cells above the required specific gravity of 1.265 overnight on 115 Vac. The efficiency of the EVA charger was calculated based on a charge from a 118-Vac line. A residential kilowatt-hour meter was used to measure input power to the charger. The charger output power was measured with a Hall-effect-device, watt-hour meter which responds to inputs from dc to considerably higher than 5 kHz. The efficiency was 68%.

VII. TEST RESULTS AND DISCUSSION

The data collected from all the range tests are summarized in Tables 3a and 3b. Shown in the tables are the test data, type of test, environmental conditions, the range test results, the ampere-hours into and out of the battery, and the energy into the charger. These data are used to determine vehicle range, battery efficiency, and energy economy.

1. Maximum Speed. The maximum speed of the vehicle was measured during the checkout tests. It is defined as the average speed that could be maintained on the track under full power. The measured maximum speed was 77 km/h (48 mi/h) for this vehicle.

2. Range. Two 40-km/h (25 mi/h), two 55-km/h (35 mi/h), two 77-km/h (48 mi/h), two B-cycle, and two C-cycle range tests were run. All the test results are shown in Tables 3a and 3b.

3. Maximum Acceleration. The maximum acceleration of the vehicle was measured with the batteries fully charged, 40% discharged, and 80% discharged. The results of the tests are shown in Figures 5a and 5b and are tabulated in Table 4. The average acceleration, \bar{a}_n , was calculated for the time period, t_{n-1} to t_n , where the vehicle speed increased from V_{n-1} to V_n from the equation:

$$\bar{a}_n = \frac{V_n - V_{n-1}}{t_n - t_{n-1}}$$

Table 3a. Summary of Test Results for EVA Metro
(Metric Units)

Date	Test	Wind (km/h)	Temp (C°)	Range (km)	Cycles	Ah Out of Batteries	Ah Into Batteries	Energy * Economy (MJ/km)
5-16-77	55 km/h	11.3	19.0	45.4	-	119	140.0	1.14
5-17-77	55 km/h	8	18.5	45.4	-	118	139.6	1.18
5-18-77	40 km/h	0	23.6	58.4	-	145	149.5	1.10
5-19-77	40 km/h	8	23.3	61.2	-	143	154.7	1.06
5-23-77	77 km/h	4.8	22.8	37.0	-	101	123.3	1.56
5-24-77	77 km/h	0-3.2	21.0	37.0	-	103	115.5	1.45
5-25-77	"B" Cycle	3.2-5	19.8	38.8	87	113	129.6	1.54
5-26-77	"B" Cycle	6.4-14	22.0	30.7	81	107	129.0	1.75
5-27-77	"C" Cycle	8.9	19.3	33.8	53	117	138.0	1.69
5-31-77	"C" Cycle	8.9	21.8	35.4	54	124	130.5	1.59

* A MERADCOM Power Supply was used for charging because of the inability of the EVA Charger to fully charge the Traction Battery overnight on 115 Vac.

PROBLEMS ENCOUNTERED

Date	Type of Problem	Remarks
4-08-77	Low battery capacity.	Replaced 3 batteries.
4-28-77	Low battery capacity.	Replaced all batteries with different make.
5-06-77	One battery with low capacity.	Replaced one battery.
5-11-77	Battery charge terminated prematurely.	Manufacturer's representative replaced control in charger and readjusted.

Table 3b. Summary of Test Results for EVA Metro
(English Units)

Date	Test	Wind (mi/h)	Temp (F°)	Range (mi)	Cycles	Ah Out of Batteries	Ah Into Batteries	Energy * Economy (kWh/mi)
5-16-77	35 mi/h	7	66.0	28.2	-	119	140.0	0.51
5-17-77	35 mi/h	5	65.2	28.2	-	118	139.6	0.52
5-18-77	25 mi/h	0	74.4	36.3	-	145	183.0	0.49
5-19-77	25 mi/h	5-10	74.4	38.0	-	143	128.0	0.47
5-23-77	48 mi/h	3	73.0	23.0	-	101	123.3	0.69
5-24-77	48 mi/h	0-2	69.8	23.0	-	103	115.5	0.65
5-25-77	"B" Cycle	2-3	67.6	24.1	87	113	129.6	0.68
5-27-77	"B" Cycle	4-9	71.7	19.1	81	107	129.0	0.79
5-27-77	"C" Cycle	3-8	66.8	21.0	53	117	138.0	0.76
5-31-77	"C" Cycle	5-6	71.3	22.0	54	124	130.5	0.70

* A MERADCOM Power Supply was used for charging because of the inability of the EVA Charger to fully charge the Traction Battery overnight on 115 Vac.

PROBLEMS ENCOUNTERED

Date	Type of Problem	Remarks
4-08-77	Low battery capacity.	Replaced 3 batteries.
4-28-77	Low battery capacity.	Replaced all batteries with different make.
5-06-77	One battery with low capacity.	Replaced one battery.
5-11-77	Battery charge terminated prematurely.	Manufacturer's representative replaced control in charger and readjusted.

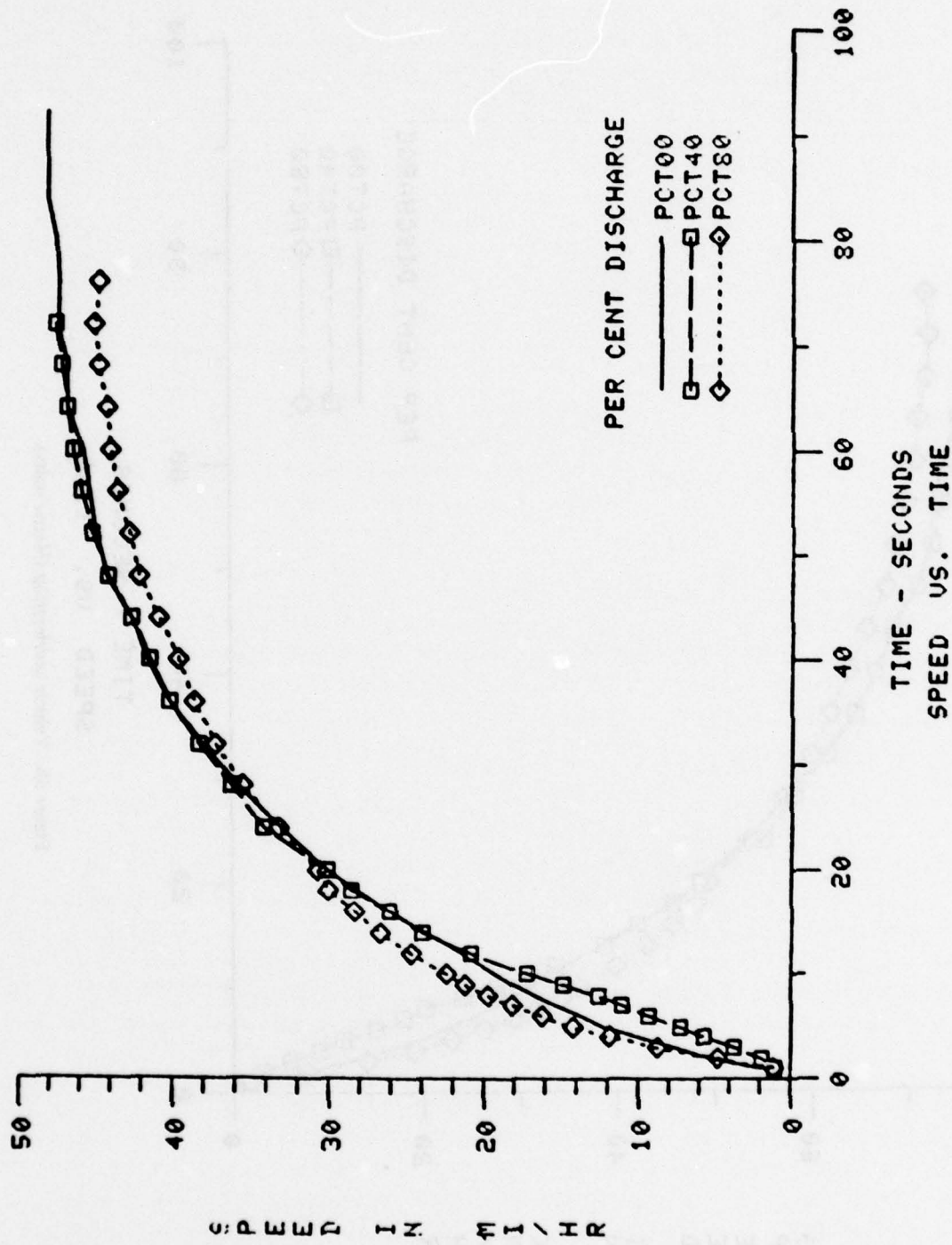

Figure 5a. Vehicle acceleration (English units).

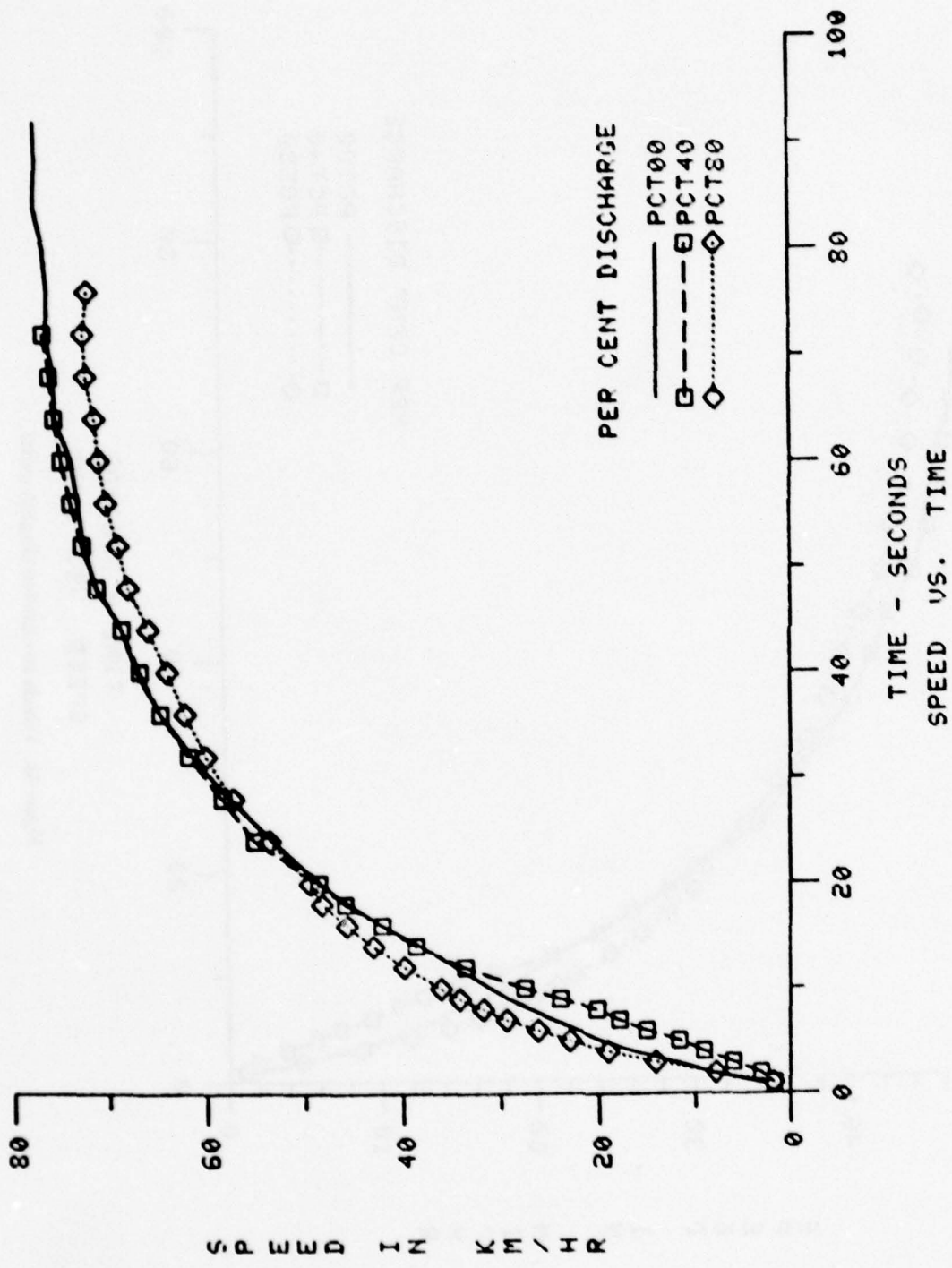

Figure 5b. Vehicle acceleration (Metric units).

Table 4. Acceleration Test for EVA Metro

Time (s)	Vehicle Speed km/h (mi/h)					
	0% Discharged		40% Discharged		80% Discharged	
1	3.03	(1.9)	1.7	(1.06)	1.8	(1.13)
2	8.38	(5.21)	3.1	(1.93)	7.8	(4.8)
3	12.17	(7.56)	6.0	(3.73)	14.2	(8.8)
4	16.4	(10.2)	9.1	(5.7)	19.1	(11.9)
5	19.78	(12.3)	11.7	(7.3)	23.0	(14.3)
6	22.1	(13.7)	15.1	(9.4)	26.2	(16.3)
7	24.7	(15.35)	17.9	(11.1)	29.4	(18.2)
8	26.9	(16.7)	20.2	(12.6)	31.8	(19.7)
9	29.2	(18.1)	24.0	(14.9)	34.2	(21.2)
10	31.0	(19.3)	27.6	(17.2)	36.1	(22.4)
12	34.5	(21.4)	33.6	(20.9)	39.8	(24.7)
14	38.1	(23.7)	38.6	(24.0)	42.9	(26.7)
16	42.0	(26.1)	42.0	(26.1)	45.6	(28.33)
18	45.4	(28.2)	45.8	(28.5)	48.2	(30.0)
20	48.4	(30.1)	48.5	(30.1)	49.4	(30.7)
24	53.13	(33)	55.0	(34.2)	53.5	(33.2)
28	57.4	(35.7)	58.2	(36.2)	57.1	(35.5)
32	61.2	(38.0)	61.6	(38.3)	59.9	(37.2)
36	64.5	(40.1)	64.5	(40.1)	62.0	(38.5)
40	66.9	(41.6)	66.6	(41.4)	63.8	(39.6)
44	68.4	(42.5)	68.4	(42.5)	65.7	(40.8)
48	71.1	(41.2)	71.0	(44.1)	67.8	(42.1)
52	72.3	(44.9)	72.5	(45.1)	68.8	(42.7)
56	72.9	(45.3)	73.6	(45.8)	70.0	(43.5)
60	73.6	(45.7)	74.7	(46.4)	70.8	(44.0)
64	75.3	(46.8)	75.4	(46.8)	71.2	(44.2)
68	75.4	(46.85)	75.9	(47.2)	72.1	(44.8)
72	76.3	(47.4)	76.6	(47.6)	72.4	(45.0)
76	76.2	(47.4)	-	-	72.0	(44.8)
80	76.6	(47.6)	-	-	-	-
84	77.6	(48.2)	-	-	-	-
88	77.5	(48.2)	-	-	-	-
92	77.6	(48.2)	-	-	-	-

and the average speed of the vehicle, \bar{V} , from the equation:

$$\bar{V} = \frac{V_n + V_{n-1}}{2}$$

Average acceleration as a function of speed is shown in Figures 6a and 6b and Table 5.

4. **Gradeability.** The maximum vehicle speed on a specific grade is determined from maximum acceleration tests by using the equations:

Gradeability, G, at a speed, \bar{V} , in km/h:

$$G = 100 \tan (\sin^{-1} 0.1026 \bar{a}_n) \%$$

or in English units at a speed, \bar{V} , in mi/h:

$$G = 100 \tan (\sin^{-1} 0.0455 a_n) \%$$

where:

\bar{a}_n = acceleration in meters per second squared (miles per hour per second)

The resulting maximum grade that the EVA Metro can negotiate as a function of speed is shown in Figures 7a and 7b and Table 6.

5. **Gradeability Limit.** Gradeability limit is defined by the SAE J227a procedure as the maximum grade on which the vehicle can just move forward. The limit is determined by measuring the tractive force with a load cell while towing a second vehicle at about 1.6 km/h (1 mi/h). It is calculated from:

$$\text{Gradeability limit in percent} = 100 \tan \left(\sin^{-1} \frac{P}{9.8W} \right),$$

or, in English units:

$$\text{Gradeability limit in percent} = 100 \tan \left(\sin^{-1} \frac{P}{W} \right),$$

where:

P = tractive force in newtons, N (lbf).

W = gross vehicle weight in kg (lb).

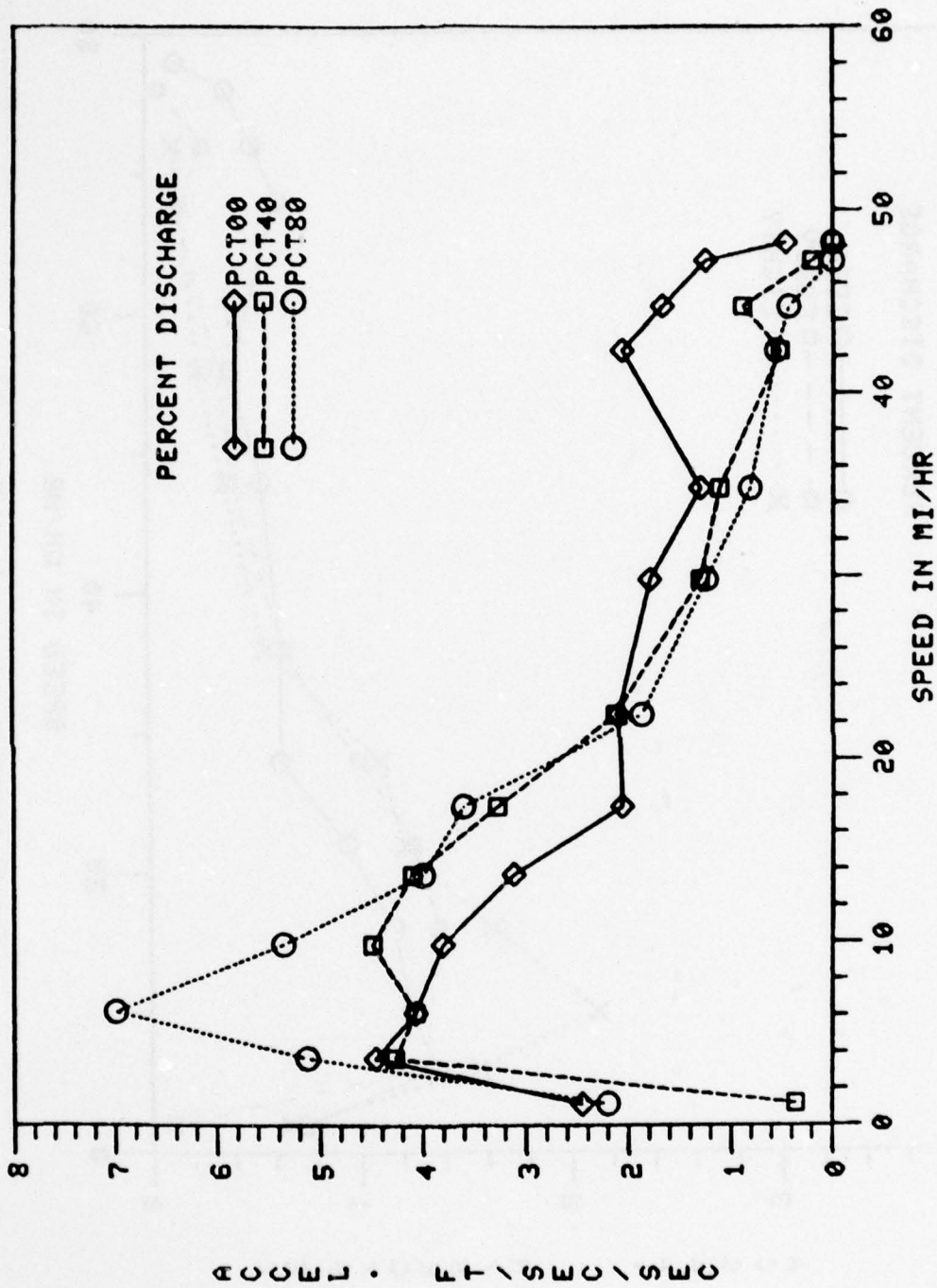

Figure 6a. Acceleration as a function of speed (English units).

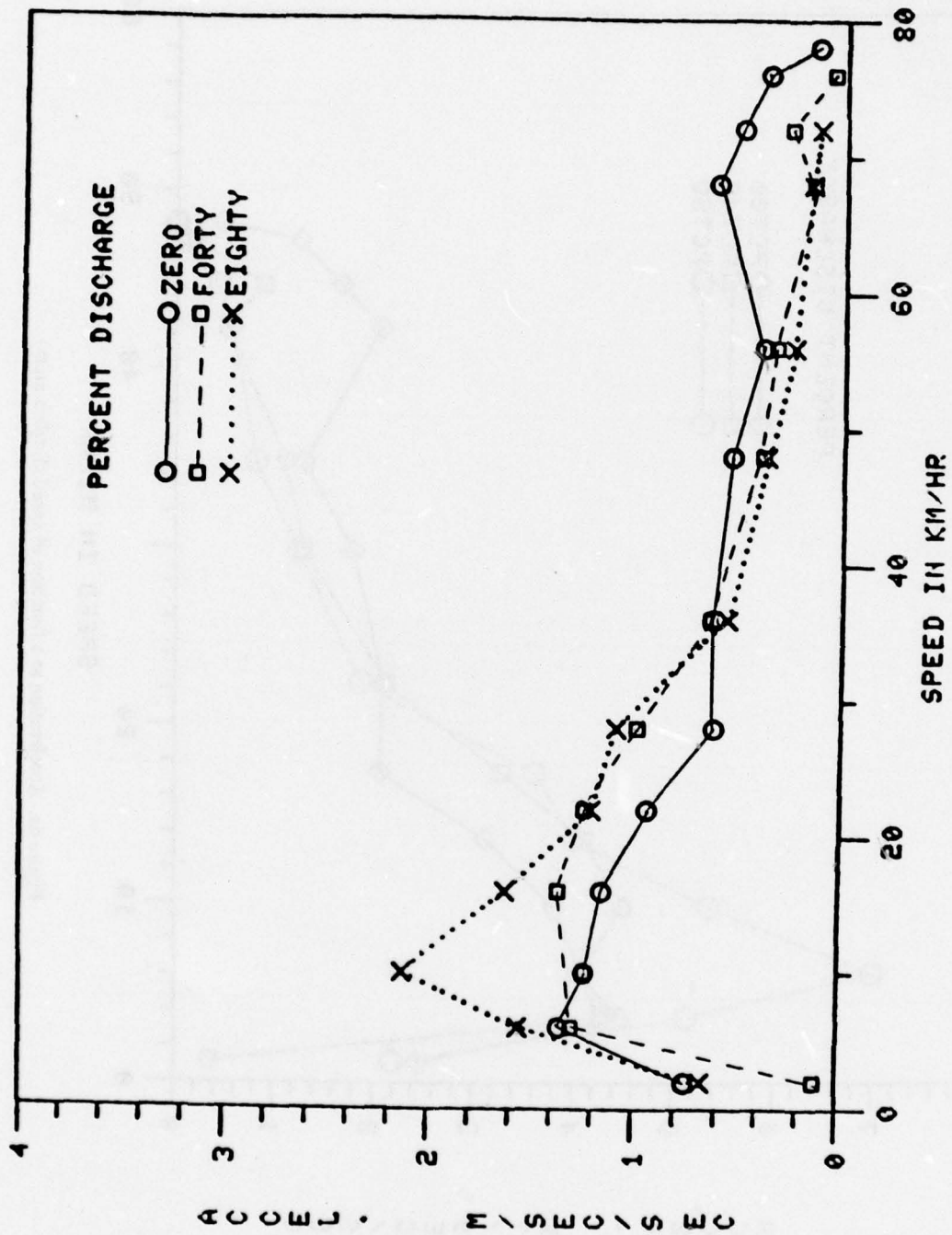

Figure 6b. Acceleration as a function of speed (Metric units).

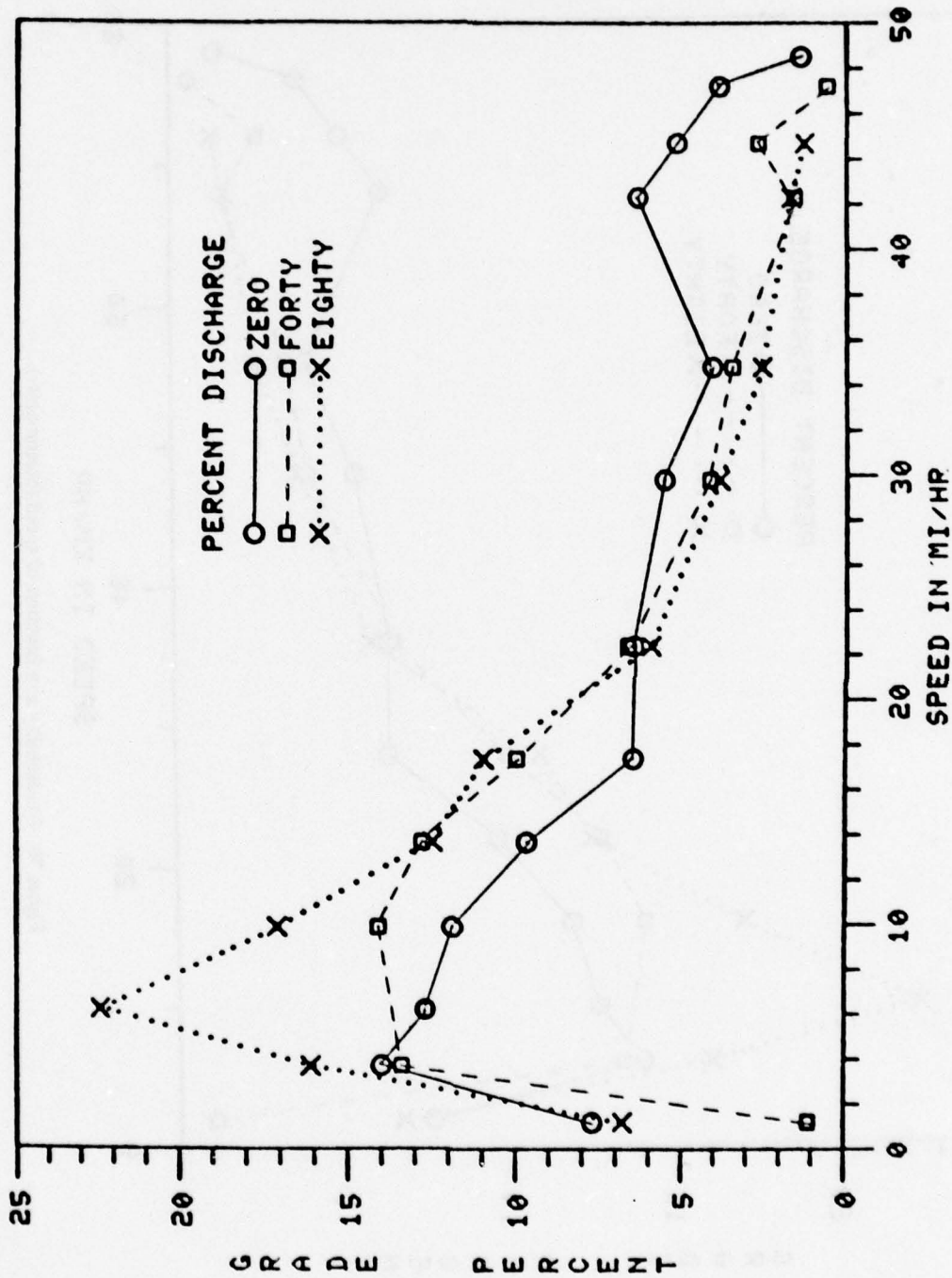

Figure 7a. Gradeability as a function of speed (English units).

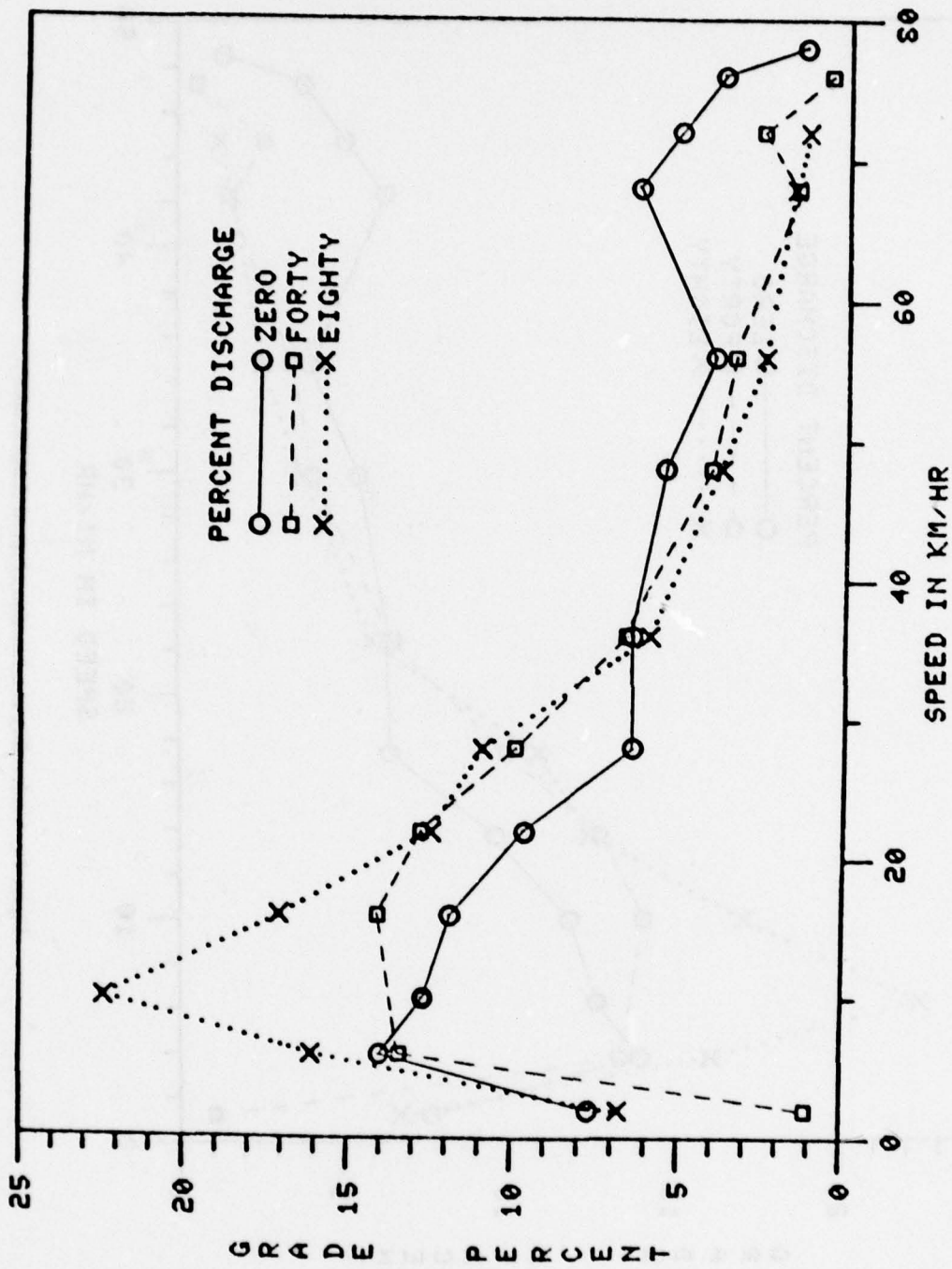

Figure 7b. Gradeability as a function of speed (Metric units).

Table 5. Acceleration Characteristics for EVA Metro

Vehicle Speed		0% Discharged		40% Discharged		80% Discharged	
km/h	mi/h	m/s ²	ft/s ²	m/s ²	ft/s ²	m/s ²	ft/s ²
2	1.2	.75	2.46	.11	.36	.67	2.20
6	3.7	1.36	4.46	1.3	4.27	1.56	5.12
10	6.2	1.24	4.07	1.24	4.07	2.13	6.99
16	9.9	1.16	3.81	1.37	4.49	1.63	5.35
22	13.7	.95	3.12	1.25	4.10	1.22	4.00
28	17.4	.63	2.07	1.0	3.28	1.1	3.61
36	22.4	.64	2.10	.65	2.13	.57	1.87
48	29.8	.55	1.8	.4	1.31	.38	1.25
56	34.8	.40	1.31	.34	1.12	.25	.82
68	42.3	.63	2.07	.16	.52	.17	.56
72	44.7	.51	1.67	.27	.89	.13	.43
76	47.2	.38	1.25	.06	.20	0	0
78	48.5	.14	.46	0	0	0	0

Table 6. Gradeability of EVA Metro

Vehicle Speed		Gradeability (%)		
km/h	mi/h	0% Discharged	40% Discharged	80% Discharged
2	1.2	7.7	1.1	1.8
6	3.7	14.0	13.4	16.1
10	6.2	12.7	12.7	22.4
16	9.9	11.9	14.1	17.1
22	13.7	9.7	12.8	12.5
28	17.4	6.5	10.0	11.0
36	22.4	6.52	6.7	6.0
48	29.8	5.6	4.2	3.9
56	34.8	4.11	3.5	2.6
68	42.3	6.4	1.6	1.7
72	44.7	5.2	2.7	1.3
76	47.2	3.9	0.6	-
78	48.5	1.4	-	-

The tractive forces that the EVA Metro Sedan was capable of exerting for three states of battery discharge were:

- 0% Discharged – 5250 N (1180 lbf).
- 40% Discharged – 5470 N (1230 lbf).
- 80% Discharged – 4405 N (990 lbf).

All tests were performed in first gear. At a vehicle test weight of 1642 kg (3620 lb), the resulting gradeability limits were:

- 0% Discharged – 34.5% (range: 33 to 36%).
- 40% Discharged – 36.0% (range: 35 to 37%).
- 80% Discharged – 28.5% (range: 27 to 30%).

The values at the 40% discharged state were greater than at the 0% discharged state for the tractive force and the gradeability limits. The cause could have been the increase in battery temperature which would decrease the battery internal resistance. This is possible because the battery was discharged at 75 amperes between measurements to attain the states of discharge. The percent discharged was determined by measuring the ampere-hours taken out.

During actual longitudinal slope operations, a 20% slope was negotiated in forward and reverse gears; a 30% slope was negotiated in forward gear, but the vehicle stalled in reverse. The vehicle was stopped and started from a stationary position on each grade.

6. Road Energy Consumption. Road energy is a measure of the energy consumed in overcoming the vehicle's aerodynamic and rolling resistance plus the energy consumed in the differential drive shaft and the portion of the transmission rotating when in neutral. Road energy is obtained during coast-down with the differential being driven only by the wheels.

The road energy consumed for the vehicle at various speeds and the losses in the differential were determined from coast-down tests. Road energy consumption, E_n , is calculated as megajoules per kilometer from the following equation:

$$E_n = 2.78 \times 10^{-4} W \frac{V_{n-1} - V_n}{t_n - t_{n-1}}, \frac{\text{MJ}}{\text{km}}$$

or, in English units:

$$E_n = 9.07 \times 10^{-5} W \frac{V_{n-1} - V_n}{t_n - t_{n-1}}, \frac{\text{kWh}}{\text{mi}}$$

where:

V = vehicle speed in km/h (mi/h)

t = time, s.

The results for the road energy determination are shown in Figures 8a, 8b, and 8c and Table 7.

Table 7. Road Energy Consumption of EVA Metro

Vehicle Speed		Road Energy		
km/h	(mi/h)	MJ/km	kWh/km	(kWh/mi)
65.33	40.6	.49	.14	.22
42.64	26.5	.34	.09	.15
26.71	16.6	.29	.08	.13
15.77	9.8	.20	.06	.09
6.92	4.3	.19	.05	.085

7. Road Power Requirements. The road power is a measure of vehicle aerodynamic and rolling resistance plus the differential, drive shaft, and a portion of the transmission's power loss.

The road power, P_n , required to propel a vehicle at various speeds is also determined from the coast-down tests. The following equations are used:

$$P_n = 3.86 \times 10^{-5} W \frac{V_{n-1}^2 - V_n^2}{t_n - t_{n-1}}, \text{ kW,}$$

or, in English units:

$$P_n = 6.08 \times 10^{-5} W \frac{V_{n-1}^2 - V_n^2}{t_n - t_{n-1}}, \text{ hp.}$$

The results of road power calculations are shown in Figures 9a and 9b and Table 8.

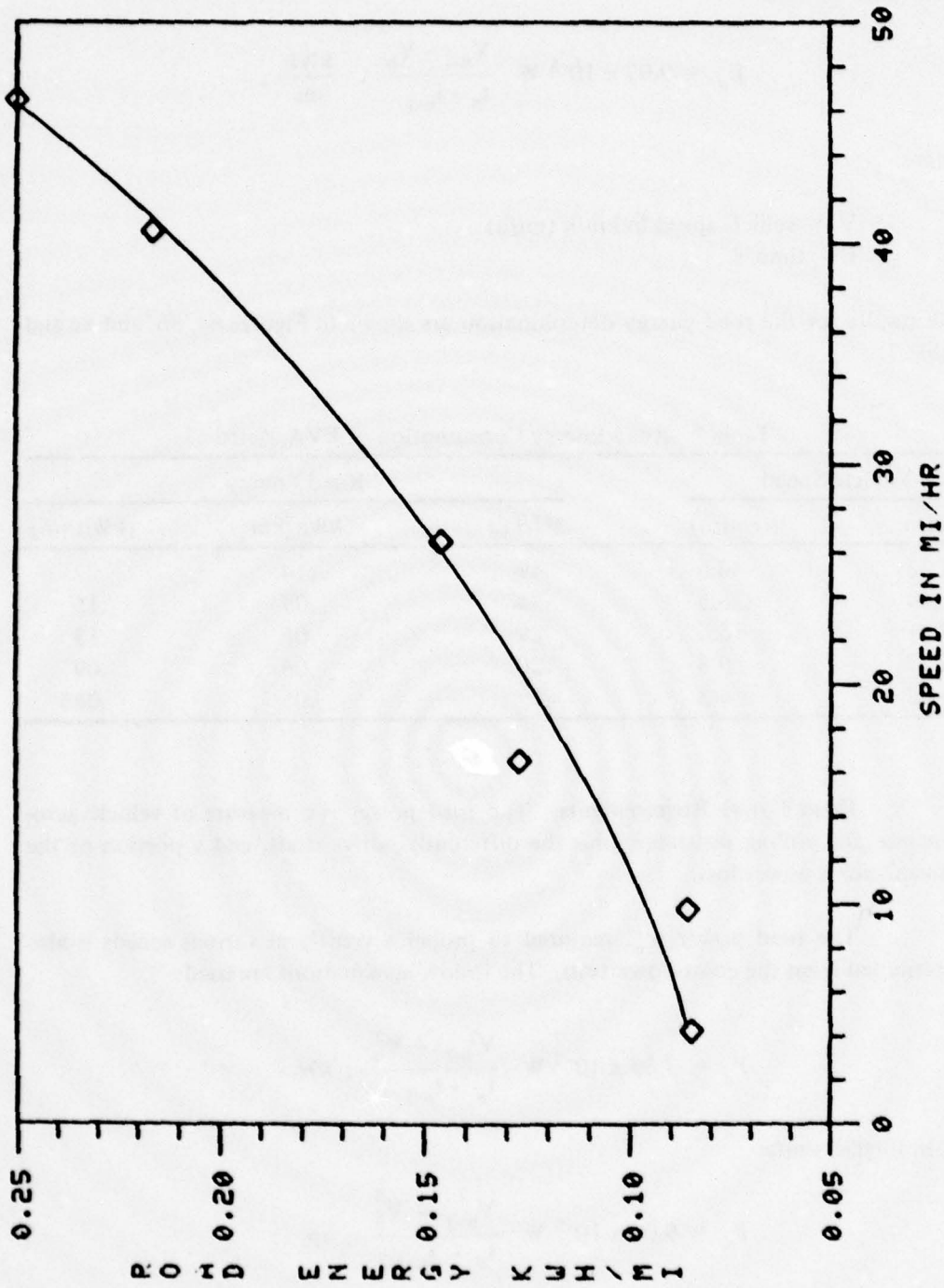

Figure 8a. Road energy as a function of speed (English units).

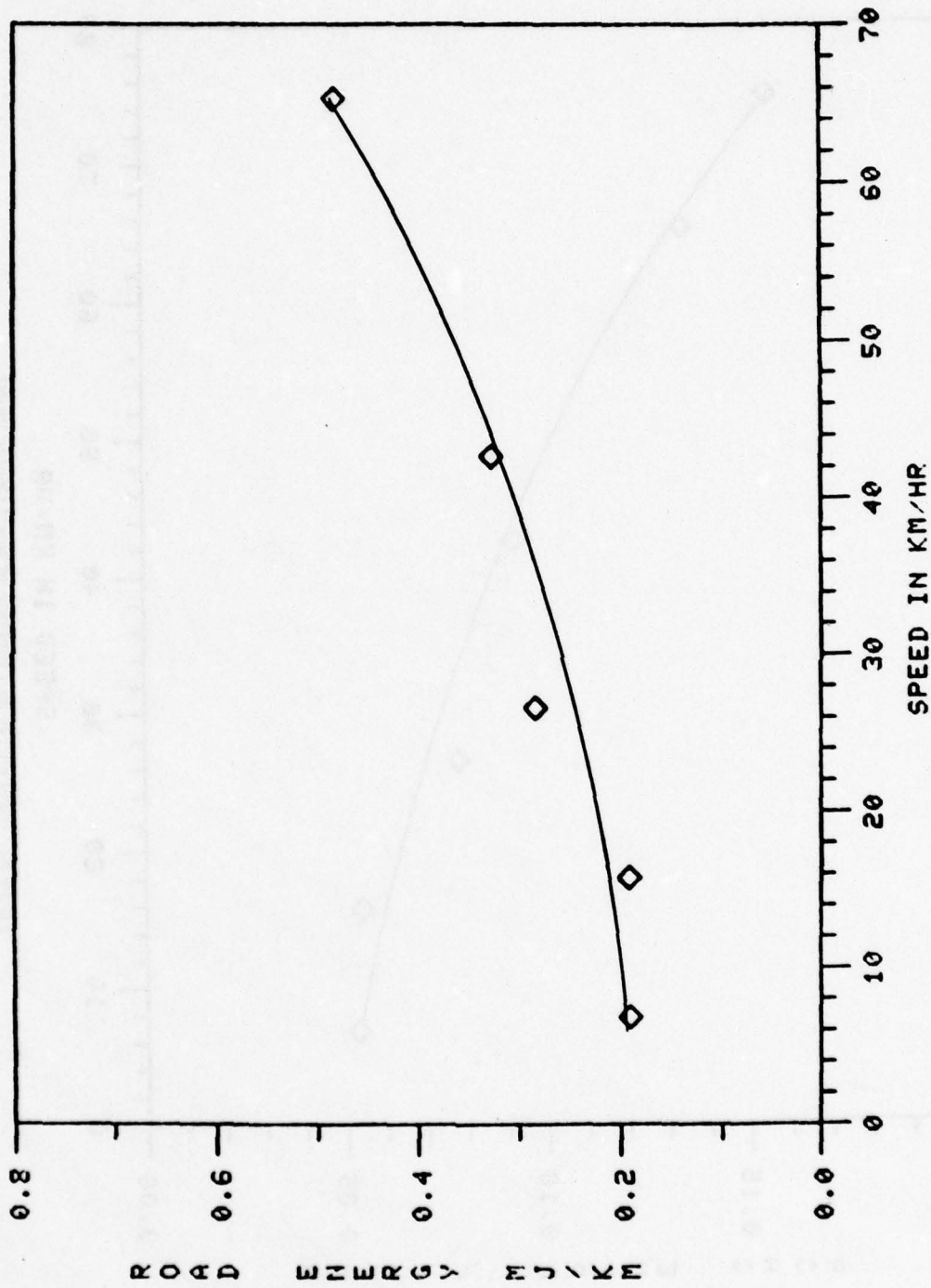

Figure 8b. Road energy as a function of speed (Metric units).

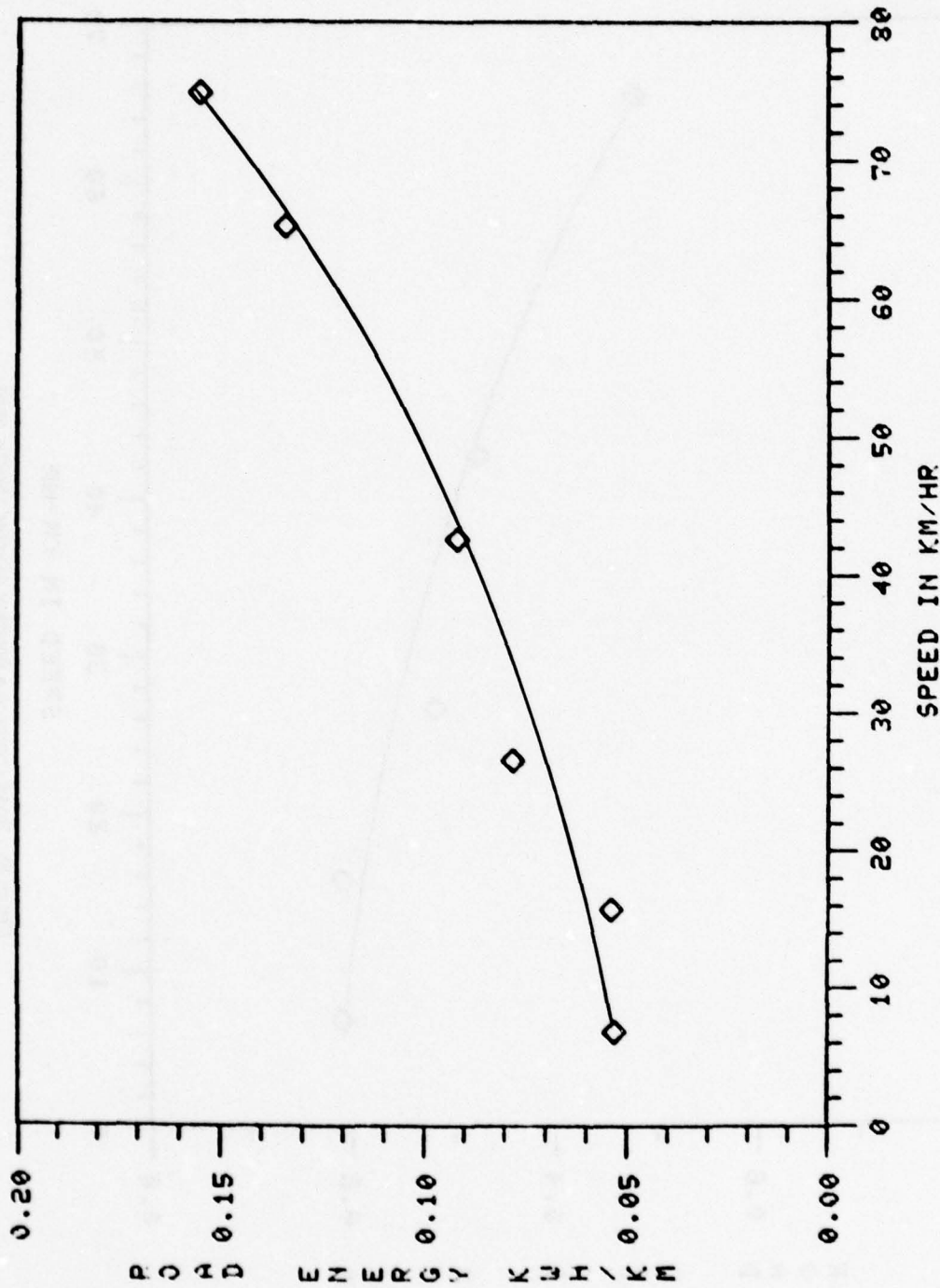

Figure 8c. Road energy as a function of speed (Metric units).

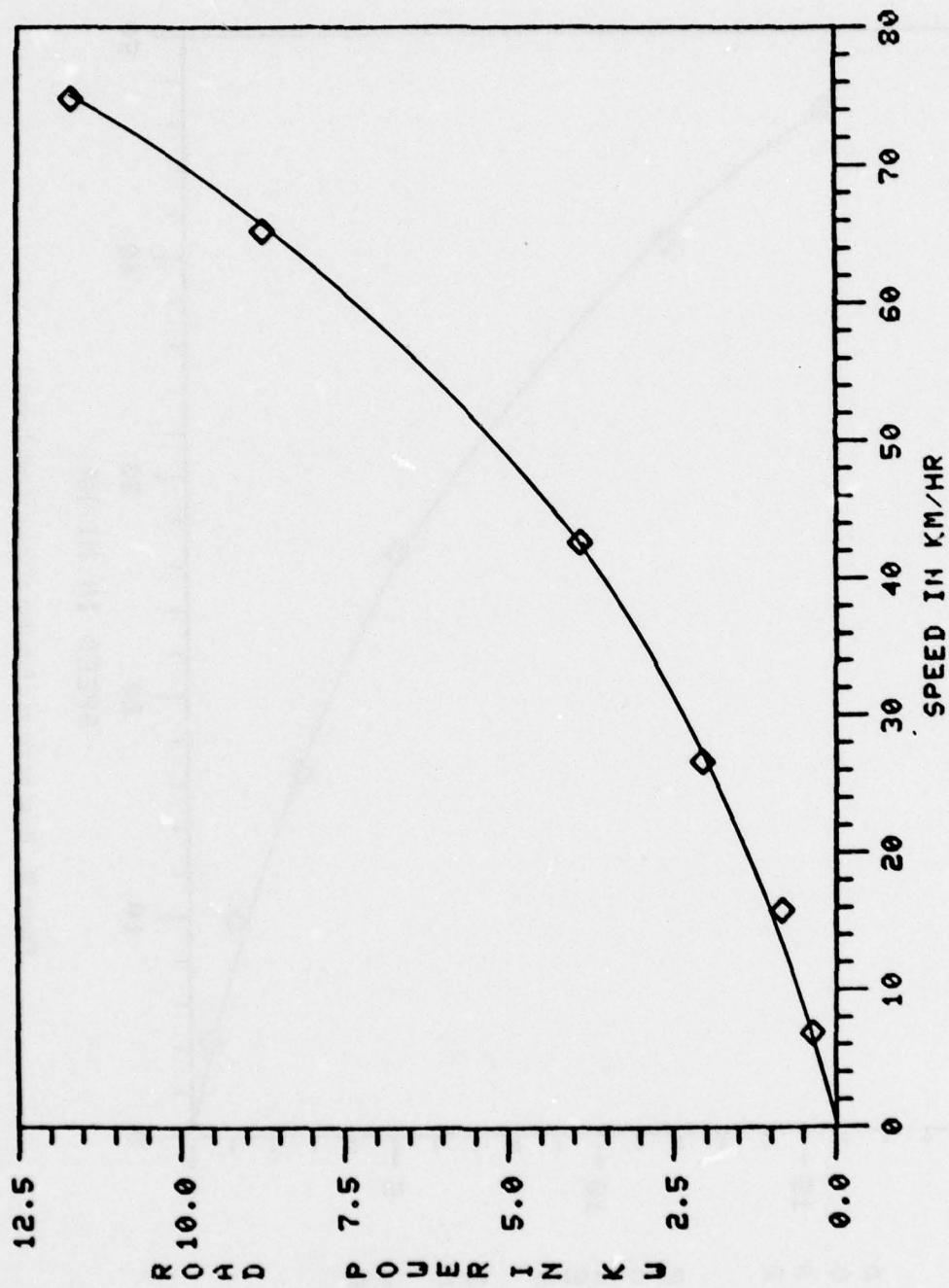

Figure 9a. Road power as a function of speed (Metric units).

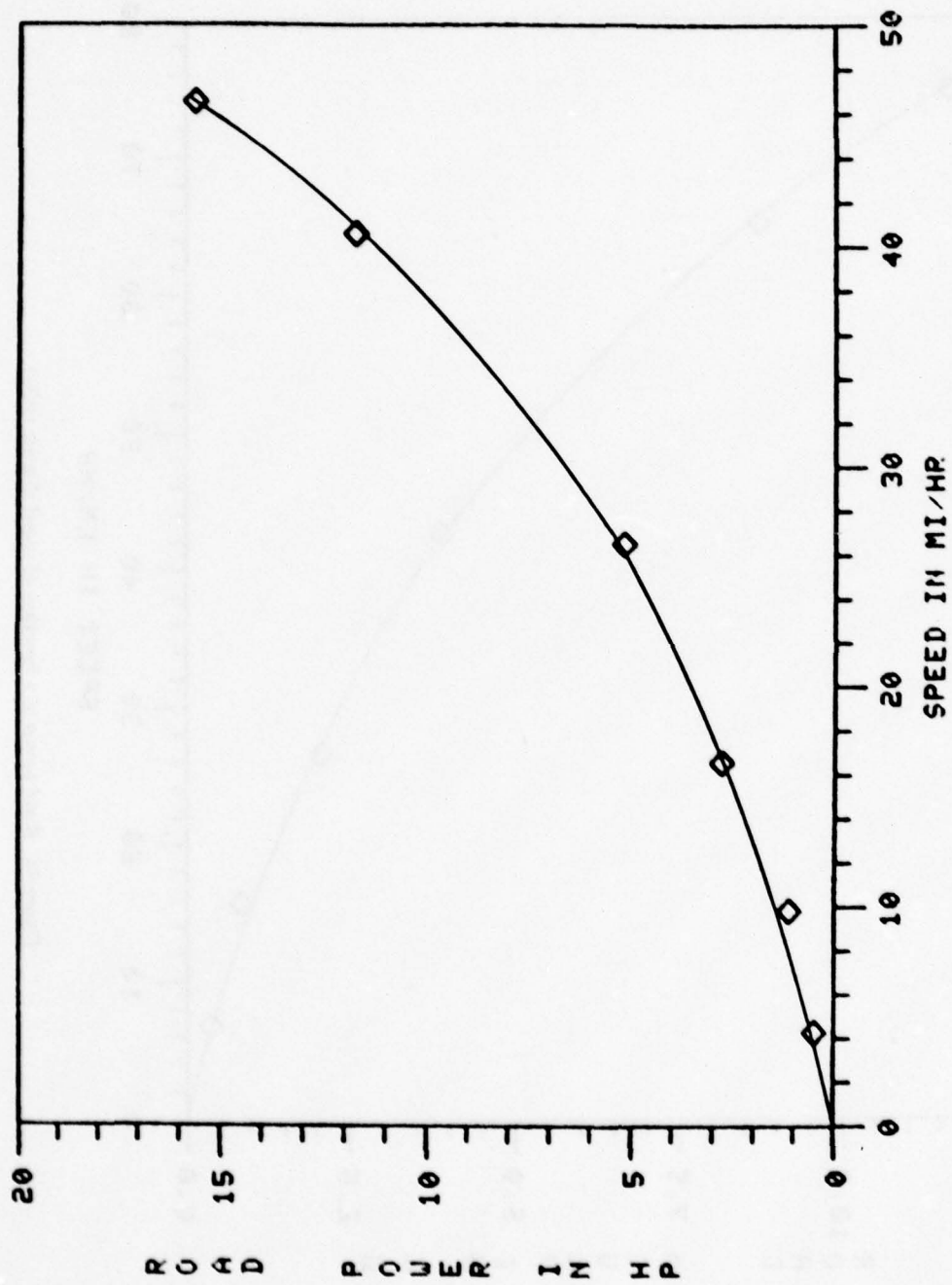

Figure 9b. Road power as a function of speed (English units).

Table 8. Road Power Requirements of EVA Metro

Vehicle Speed		Road Power Required	
km/h	(mi/h)	kW	(hp)
65.33	40.6	8.73	11.7
42.64	26.5	3.88	5.2
26.71	16.6	2.09	2.8
15.77	9.8	.82	1.1
6.92	4.3	.37	.5

8. **Indicated Energy Consumption.** The vehicle indicated energy consumption is defined as the energy required to recharge the battery after a test divided by the vehicle range achieved during the test where the energy is measured as the input to the battery charger.

The energy input to the battery charger was measured with a residential kilowatt-hour meter following each range test. Some overcharge of the batteries was usually required in order to assure that all cells of the battery were fully charged and the pack was equalized. The energy usage reported in Table 9 was based on field data acquired with a MERADCOM power supply used as a charger to charge the battery faster than the EVA Charger and to bring all cells above a specific gravity of 1.265.

Table 9. Indicated Energy Consumption for EVA Metro Sedan

Vehicle Speed		kWh* Into Charger	Indicated Energy Economy*	
km/h	mi/h		MJ/km	kWh/mi
40	25	17.8	1.1	0.49
		18.0	1.05	0.47
55	35	14.3	1.14	0.51
		14.8	1.16	0.52
77	48	16.0	1.57	0.70
		15.0	1.45	0.65
"B" Schedule		16.5	1.52	0.68
		15.0	1.74	0.78
"C" Schedule		16.0	1.70	0.76
		15.5	1.57	0.70

* A MERADCOM Power Supply was used for charging because of the inability of the EVA Charger to fully charge the Traction Battery overnight on 115 Vac.

9. Braking Capability. Simplified braking capability tests were conducted, as per the procedure outlined in Appendix A, to provide a preliminary evaluation of the vehicle's braking capabilities. The procedure also calls for handling tests but they were not conducted on this vehicle.

a. Straight-Line Braking. Braking capability and performance were determined in accordance with Section 2.8.8 of the test procedure in Appendix A. Maximum-effort brake applications were made from road speeds of 48.3 km/h (30 mi/h) and 80.5 km/h (50 mi/h) on a level, bituminous concrete road that has a 70 dry skid number. The results of these tests are presented in Table 10. The stopping distance requirement that at least one stop be within 17.4 m (57 ft) from 48.3 km/h (30 mi/h) and 45.7 m (150 ft) from 80.5 km/h (50 mi/h) was met.

b. Braking in a Turn. Braking in a turn on dry and wet pavement was limited to a speed of 48.3 km/h (30 mi/h) because the level, paved areas available to perform these tests were dimensionally inadequate to accommodate the large turning circles required to develop 0.2g and 0.3g lateral accelerations. The area used has a skid number of 40 when dry and 29 when wet. Turning radii of 60.7 m (199 ft) and 90.8 m (298 ft) were measured and a 3.7-m (12-ft)-wide lane was identified by means of pylons. Three brake stops were made in each left- and right-turn configuration with the road surface dry at the 60.7 m (199 ft) turn radius; the tests were repeated with the road wet at the 90.8 m (298 ft) turn radius. Brake performance from 48.3 km/h (30 mi/h) is presented in Table 11. Stability and controllability of the vehicle within the 3.7-m (12-ft)-lane width were satisfactory during both dry- and wet-road brake tests. Wheel lockup occurred at the inside front wheel and momentarily at the inside rear wheel during all dry-road turns. Both inside wheels locked during all wet-road turns and in one instance during a left turn both front wheels locked; however, the vehicle remained within the 3.7-m (12-ft) lane.

c. Wet Brake Recovery. Service brake water recovery tests were accomplished by making three 48.3 km/h (30 mi/h), 3 m/s² (6.8 mi/h/s) baseline stops prior to wetting down the brakes. The vehicle had insufficient front-end ground clearance to drive the vehicle in a 15-cm (6-in.) water depth; the drive motor is highly susceptible to damage by water or road obstacles because of its proximity to the road surface. Wetting was accomplished with a hose on the front brakes and by backing into a water facility until the rear brakes were immersed. Five recovery brake stops were made with wet brakes. The results of the recovery tests are presented in Table 12. Service-brake recovery after water immersion was satisfactory.

Table 10. Straight-Line Braking Test Results

Road Speed		Stopping Distance		Avg Deceleration		Max Brake Temp °C (°F)	
(km/h)	(mi/h)	(m)	(ft)	(m/s ²)	(ft/s ²)	(Front)	(Rear)
48.3	30	15.6	51.2	5.8	18.9	129 (264)	72 (169)
		18.2	59.8	4.9	16.2	122 (251)	77 (170)
		14.4	47.3	6.2	20.5	111 (231)	72 (169)
80.5	50	56.1	184.0	4.5	14.6	77 (171)	49 (120)
		46.9	154.0	5.3	17.5	110 (230)	64 (147)
		44.9	146.0	5.6	18.4	133 (271)	76 (168)

Table 11. Braking in a Turn Test Results

Test Conditions	Stopping Distance		Max Hydraulic Line Pressure		Max Brake Temp °C (°F)	
	(m)	(ft)	(kPa)	(lbf/in ²)	(Front)	(Rear)
Dry Surface						
Left Turn	22.9	75.2	10,600	1540	33 (91)	27 (81)
	20.9	68.6	10,600	1540	—	—
	15.1	49.4	11,200	1620	89 (192)	56 (133)
Right Turn	16.6	54.5	11,900	1720	—	—
	16.0	52.6	10,900	1580	—	—
	19.1	62.8	11,600	1680	106 (223)	67 (153)
Wet Surface						
Left Turn	17.8	58.4	10,800	1560	34 (93)	28 (83)
	19.4	63.5	11,200	1620	—	—
	17.2	56.5	10,500	1520	95 (203)	58 (137)
Right Turn	20.8	68.1	10,100	1460	—	—
	16.5	54.2	11,900	1720	—	—
	21.6	70.8	11,200	1620	117 (242)	71 (160)

Table 12. Wet Brake Recovery Test Results

Condition 48.3 km/h (30.0 mi/h) at 3 m/s ² (6.8 mi/h/s)	Stopping Distance		Brake Hydraulic Press. (max.)		Pedal Effort	
	(m)	(ft)	(kPa)	(lbf/in ²)	(N)	(lbf)
Baseline	31.4	103	4270	620	290	65
	35.1	115	4000	580	270	60
	33.2	109	4140	600	280	62
Recovery	43.0	141	4340	630	290	66
	41.8	137	4140	600	280	62
	35.7	117	5380	780	380	85
	32.6	107	5240	760	370	83
	32.6	107	4270	620	290	65

d. **Parking Brake Tests.** Parking brake tests were performed on 20- and 30-percent longitudinal slopes. A force of 380 to 400 N (85 to 90 lbf) applied to the parking-brake handle was sufficient to hold the vehicle stationary in an upgrade or downgrade attitude on a 20% slope with the transmission in neutral; a handle force of 560 N (125 lbf) was necessary on a 30% slope. If the transmission is placed in "park," the 400-N (90-lbf) handle force is sufficient on the 30% slope. The parking brake is satisfactory.

e. **Coast-Down Tests.** Coast-down data was taken with the transmission in neutral following each maximum-acceleration run. The averaged results of two coast-down tests are given in Table 13.

VIII. COMPONENT PERFORMANCE AND EFFICIENCY

1. **Battery Charger.** The EVA "Battery Marshall" traction battery charger operates from single-phase power from either a 120-volt or 240-volt ac outlet. The charger incorporates line input monitoring that selects the appropriate charge rate. The charger test report is in Appendix C. A 120-volt ac outlet is provided on the charger for the 12-volt auxiliary battery charger. The auxiliary charger consists of a step-down transformer and two diodes to produce half-wave rectification and is equipped with a circuit breaker, ammeter, and battery clips.

2. Battery Characteristics.

a. **Manufacturer's Data.** The batteries supplied with the EVA Metre Sedan vehicle were Electric Storage Battery (ESB) Exide EV106 Electric Vehicle Batteries. The EV106 is a 6-volt, 3-cell module rated at 106 minutes discharge at a current of 75 amperes (132.5 Ah) to a voltage cutoff of 1.75 volts per cell at a

temperature of 25°C (77°F). Dimensional specifications as supplied by battery manufacturers are shown in Table 14.

Table 13. Speed Versus Time During Coasting for EVA Metro

Time (s)	Vehicle Speed	
	km/h	(mi/h)
0	77.7	48.3
5	71.9	44.7
10	65.3	40.6
15	61.6	38.3
20	55.8	34.7
25	52.8	32.8
30	47.8	29.7
35	45.2	28.1
40	41.5	25.8
45	38.3	23.8
50	35.1	21.9
55	32.3	20.2
60	30.2	18.9
65	25.9	16.2
70	22.8	14.2
75	20.7	12.9
80	18.9	11.8
85	17.8	11.1
90	15.9	9.9
95	13.3	8.3
100	10.7	6.7
105	8.6	5.3
110	6.8	4.2
115	4.7	3.0
120	2.9	1.8

Table 14. Battery Specifications

Length	0.26 m (10.375 in.)
Width	0.18 m (7.188 in.)
Height	0.28 m (11.219 in.)
Weight	
Dry	21.4 kg (47.2 lb)
Wet	29.5 kg (65.1 lb)
Electrolyte	6.2 L (6.6 qt)
Life Cycles (lab)	400-450
Fully Charged Specific Gravity	1.280
Plates Per Cell	19

Battery manufacturer's discharge data are presented in Figures 10 and 11. Figure 10 gives the relationship of discharge current and voltage to the length of time the battery is able to deliver this current. As can be seen, the battery is able to deliver 10 amperes for 20 hours or 200 ampere-hours, but at 250 amperes the battery will only operate 0.37 hour or deliver 92.5 ampere-hours at a discharge rate of 10 amperes, the mean cell voltage is 2.0 volts while at 250 amperes the mean cell voltage drops to 1.5 volts during the discharge period. The rated capacity of the battery is actually about 15% lower than the capacity shown in Figure 10, and this rated capacity is actually used to evaluate the battery.

Figure 11 gives the relationship of specific power to specific energy available from a single EV106 battery.

b. Battery Acceptance. Prior to initiation of road tests, the batteries supplied by the vehicle manufacturer were tested for battery capacity and terminal integrity as specified in Appendix A. The capacity check was performed on the batteries using a thyristor-controlled discharge unit. Since the measured capacity was 132.5 ampere-hours at a discharge rate of 75 amperes to 1.75 volts per cell (100% of the manufacturer's rated capacity), the battery was acceptable. As shown in Figure 12, the battery voltage at the initiation of discharge was 95.7 volts and decayed gradually to 84.10 volts at the end of the test.

The 300-ampere discharge test was run with a thyristor-controlled discharge unit. At the end of the 5-minute test, the highest battery-terminal temperature was 57°C (135°F). As this was less than 60°C above ambient, the battery system was within specifications.

3. Constant Vehicle Speed Battery Performance. During the road tests, battery current and motor voltage were constantly monitored. Since the battery, controller, and the motor unit (with its free-wheel diode, forward and reverse contactors, and braking diode) made up a high-current closed loop and the motor unit was constructed so as to make inserting a shunt for current monitor difficult, battery current was monitored and was assumed to be equal to motor (or more accurately to motor unit) current.

Presented in Figures 13a and 13b are the battery characteristics during the 40 km/h (25-mi/h) range test 17 May 1977, the 55-km/h (34.3-mi/h) range test run on 16 May 1977, and the 77-km/h (48-mi/h) range test run on 23 May 1977. The average battery current, voltage, and power during the first 25% of the vehicle's range are shown in Figure 13a. Similar battery performance data during the last 25% of the vehicle's range is shown in Figure 13b. Battery power decreases toward the end of the

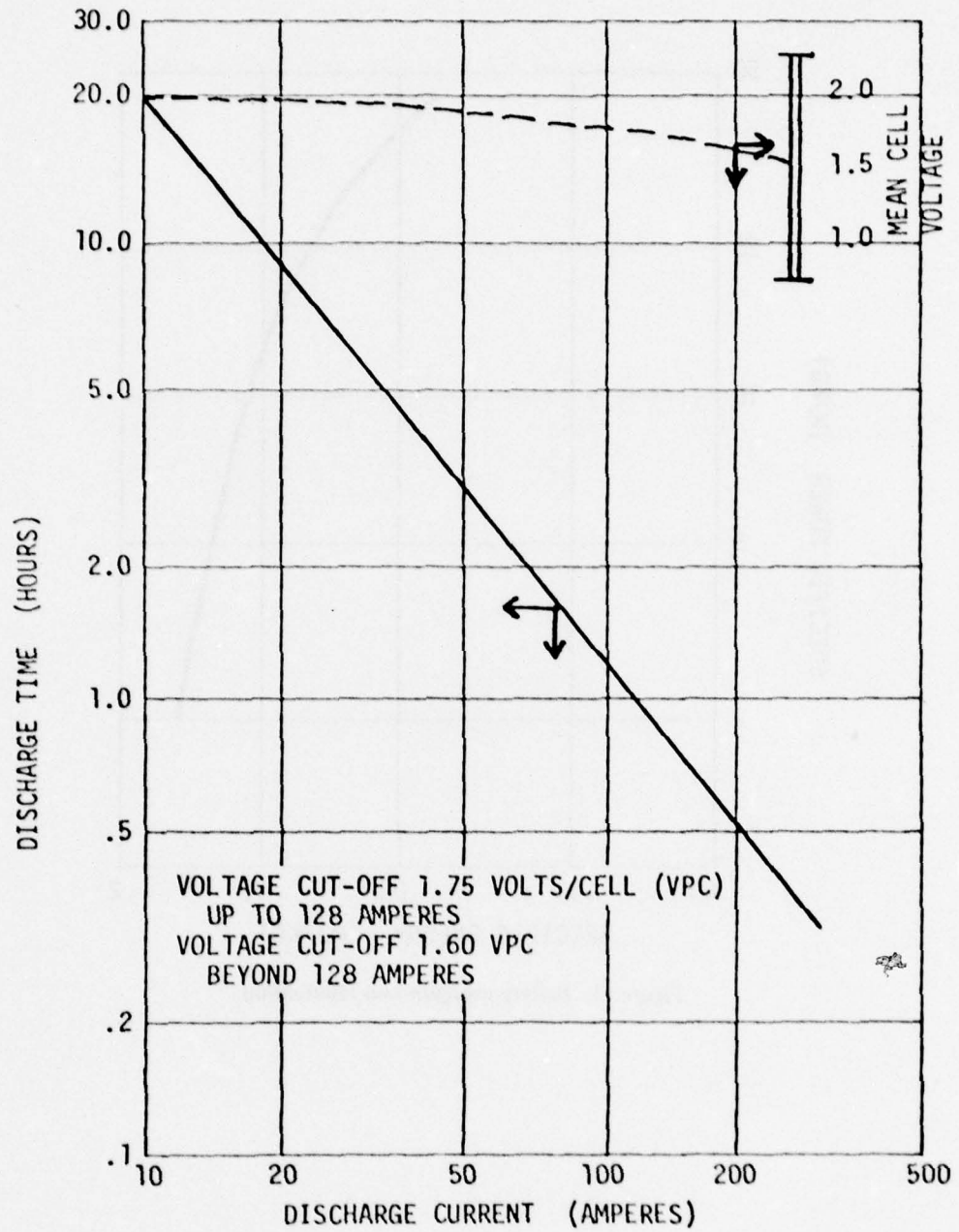

Figure 10. Battery discharge characteristics.

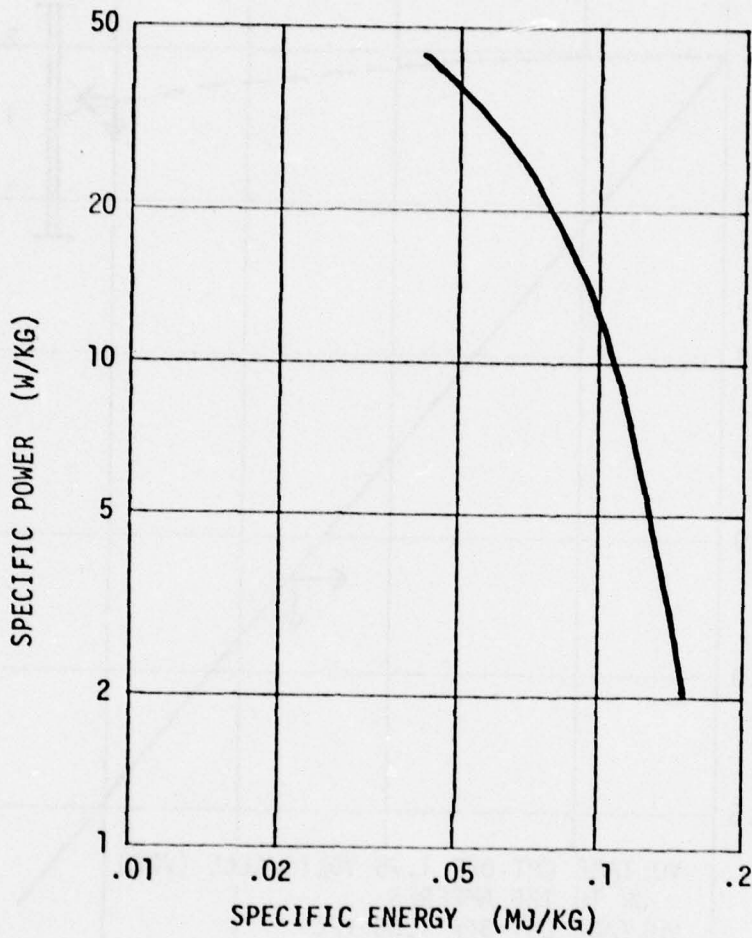
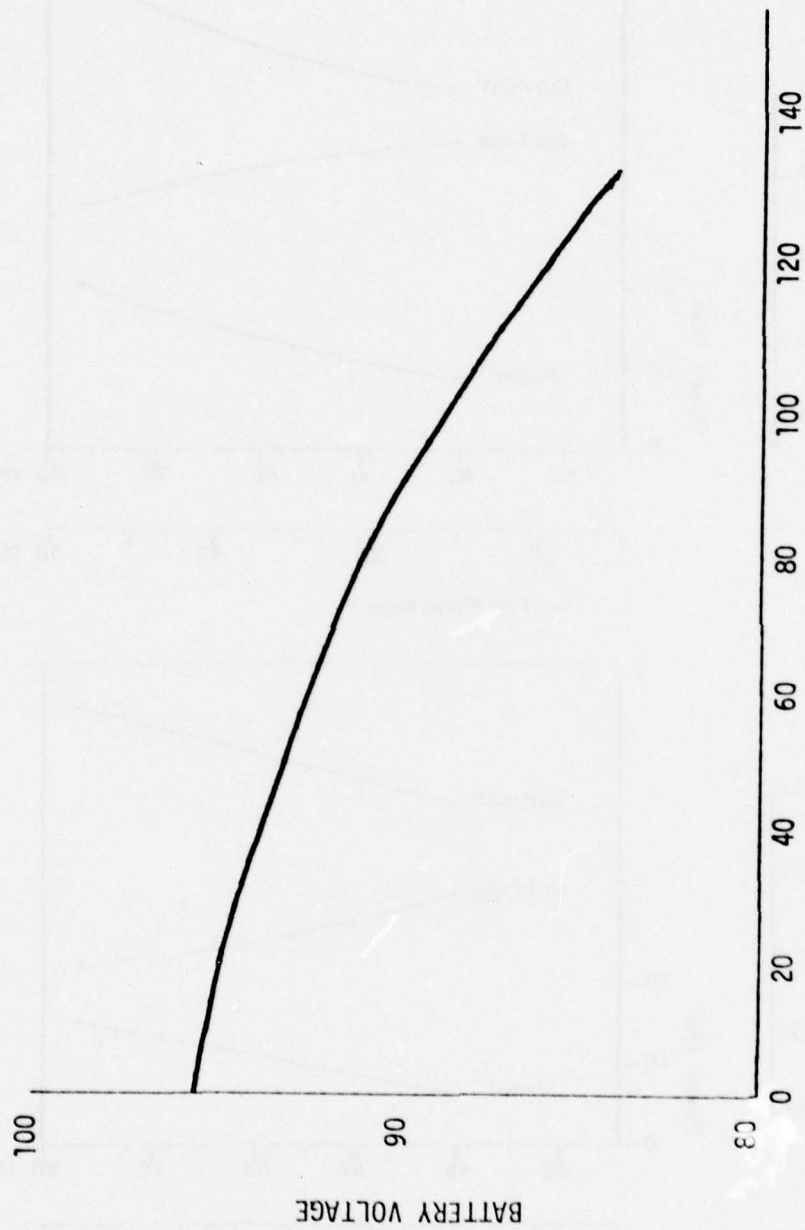
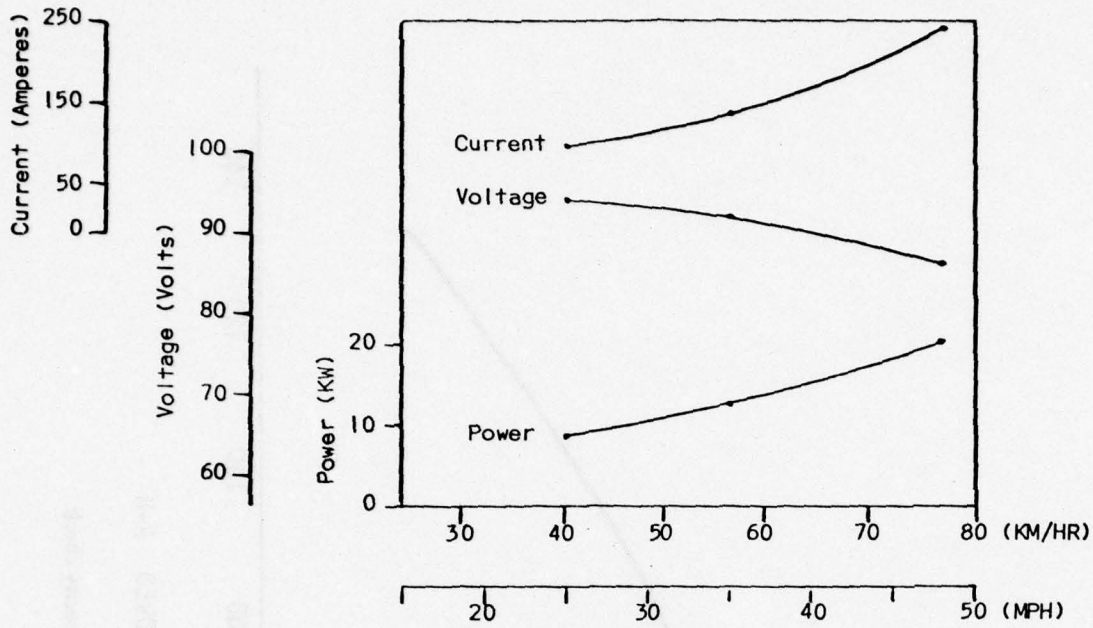

Figure 11. Battery energy/power relationship.



CAPACITY REMOVED A-H

Figure 12. Battery capacity check.



a. First 25% of Range

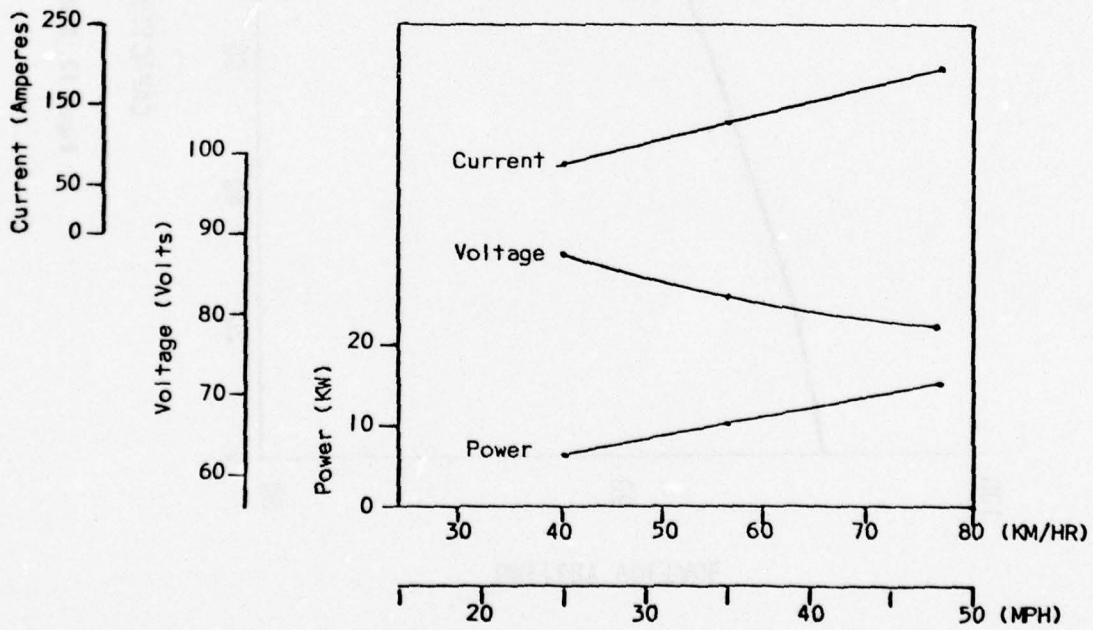

b. Last 25% of Range

Figure 13. Constant speed battery performance.

test. The decrease is probably due to the reduced power requirements as the temperature of the mechanical drive train components and associated lubricants increases during the test.

Table 15 contains battery performance data for the three speeds in Figure 13a and 13b. The total energy removed from the battery decreases as the speed increases in the manner characteristic of lead acid batteries. Figure 14 is a set of curves showing the "knees" at which the capacity of the EV106 battery starts to fall rapidly for various rates of discharge.

4. Battery Performance – Driving Cycle. The average battery current, voltage, and power and the vehicle speed for the third and next to last cycle of a "B" schedule (20 mi/h start/stop run) and of a "C" schedule (30 mi/h start/stop run) are shown in Figures 15a-d and 16a-d respectively. The total number of start/stops, distance traveled, and other data on the battery and drive cycles are given in Table 16.

5. Battery Performance – Maximum Acceleration. Battery performance data at selected times during the maximum acceleration test for three depths of battery discharge are presented in Table 17.

6. General Battery Performance. Shown in Table 18 are battery data for the driving tests. The fully charged battery electrolyte specific gravities range from 1.254 to 1.270 and the fully discharged specific gravities, from 1.127 to 1.170. The ampere-hour overcharge varies from 6% to 35%. To assure that all cells in the battery were equalized, it was necessary to overcharge beyond the desired overcharge of 10% in most cases. Even then, the average specific gravities, at times, stayed below the desired minimum of 1.260. The battery temperature had a tendency to increase from ambient at the start of the test to about 14°C (25°F) above ambient at the end of test.

7. Charging and Battery Efficiency. See Appendix C for an evaluation of the EVA "Battery Marshall" solid state battery charger supplied with the vehicle.

8. Controller. The controller for the EVA Metro Sedan is a commutation system in which a voltage is applied to silicon-controlled-rectifier (SCR) gates causing conduction. The frequency and pulse width of these gates are varied by a potentiometer-controlled voltage varied by the accelerator displacement.

Power being delivered to the motor is continually monitored and is automatically controlled so that a maximum, pre-determined level is not exceeded.

Table 15. EVA Metro Constant Speed Battery and Motor Data

Parameter	40.2 km/h (25 mi/h) Test		55.2 km/h (34.3 mi/h) Test		77.2 km/h (48 mi/h) Test	
	First 25%	Last 25%	First 25%	Last 25%	First 25%	Last 25%
I_M Average Motor Current (A)	92.7	75.7	135.3	126.0	240.7	194.9
I_B Average Battery Current (A)	92.7	75.7	135.3	126.0	240.7	194.9
V_M Average Motor Voltage (V)	42.0	36.8	51.5	50.2	83.9	75.7
V_B Average Battery Voltage (V)	93.5	87.0	91.6	81.6	86.0	78.3
P_M Average Motor Power (kW)	3.9	2.8	7.0	6.3	20.2	14.8
P_B Average Battery Power (kW)	8.7	6.4	12.4	10.3	20.7	15.3
Total Energy Removed from Battery	11.9 kWh		9.6 kWh		8.3 kWh	

EV-106 BATTERY

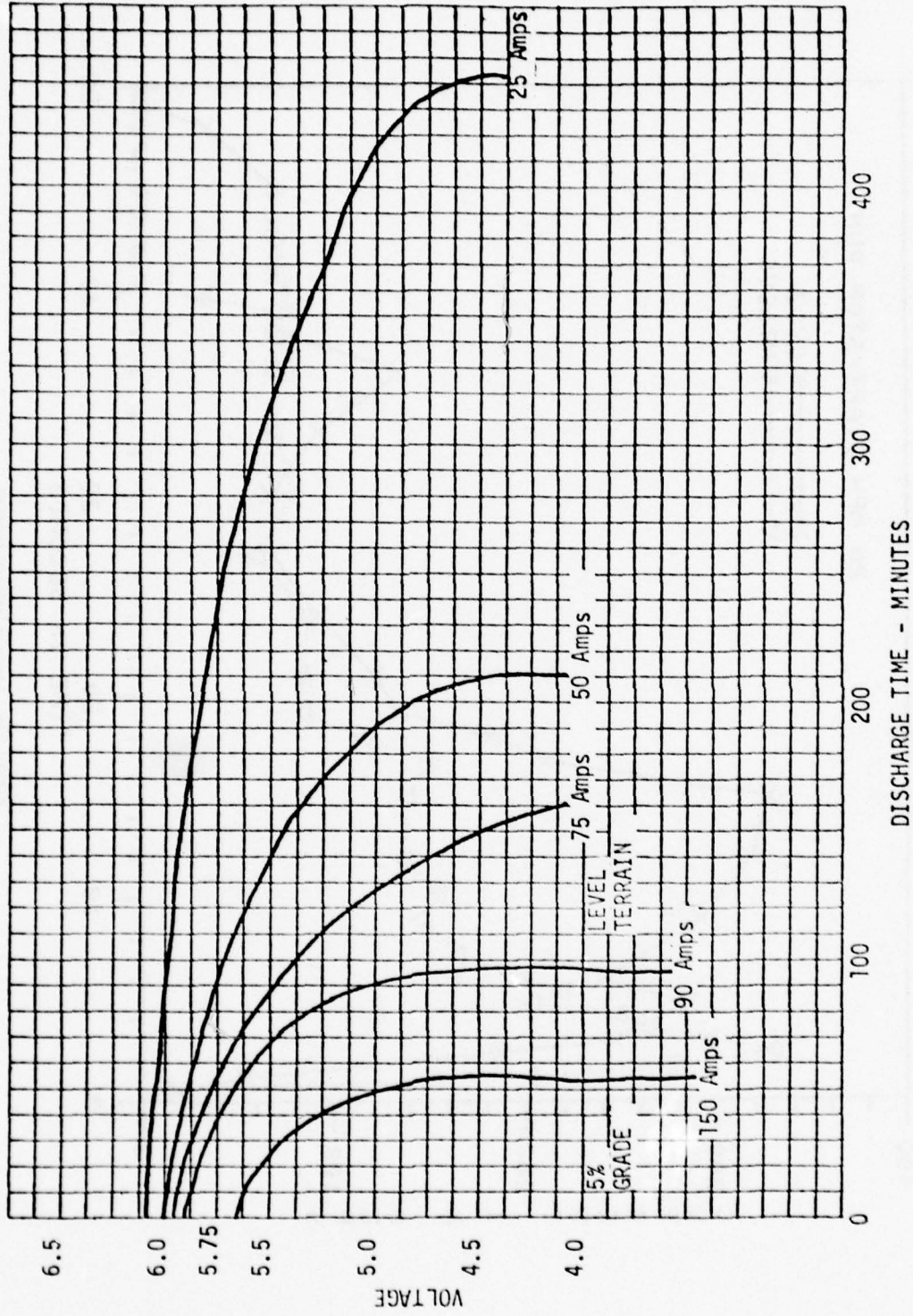

Figure 14. Typical voltage vs time curve at 80°F and various discharge rates.

VEHICLE PERFORMANCE OF E.V.A. METRO

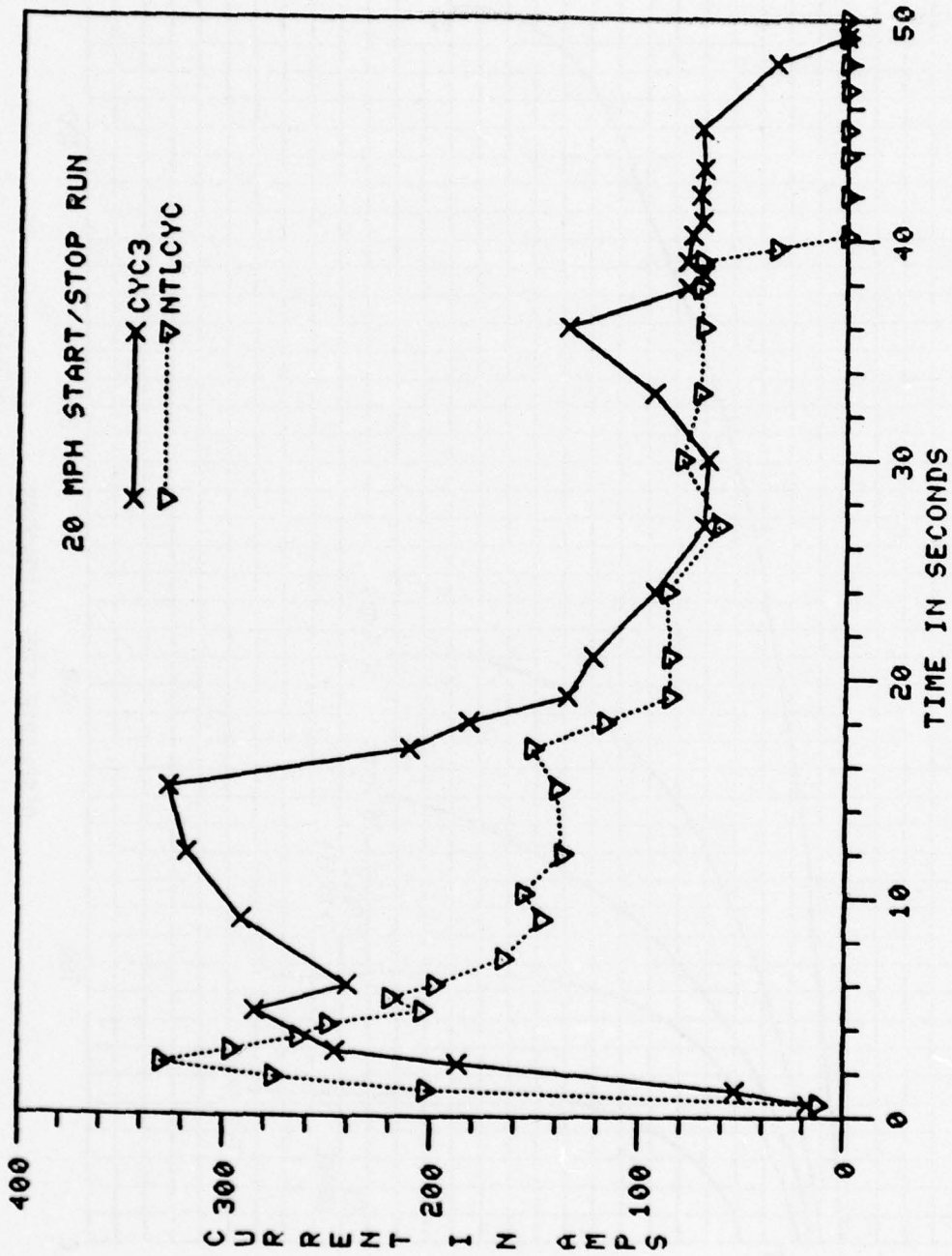

Figure 15a. Average battery current.

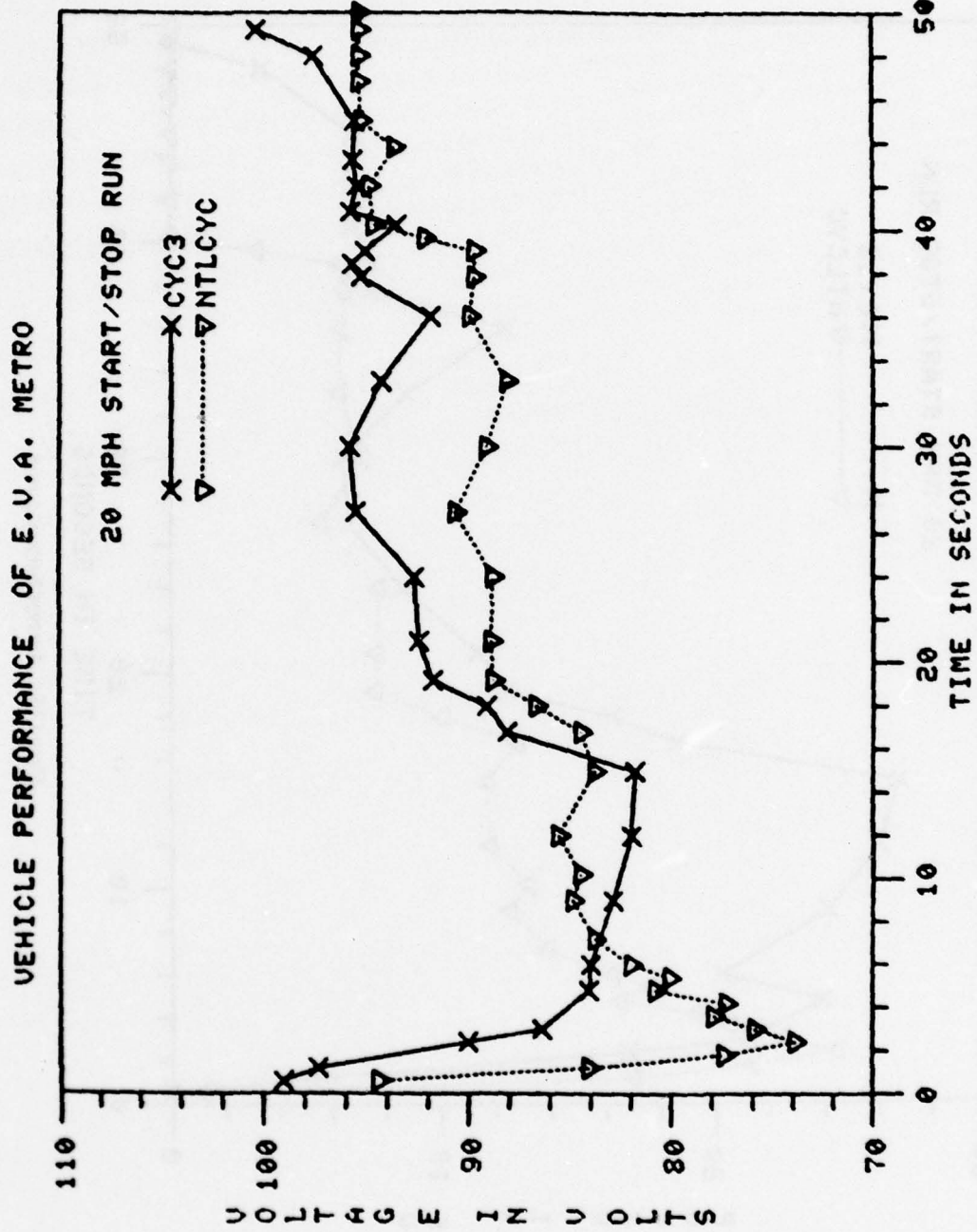

Figure 15b. Average battery voltage.

VEHICLE PERFORMANCE OF E.U.A. METRO

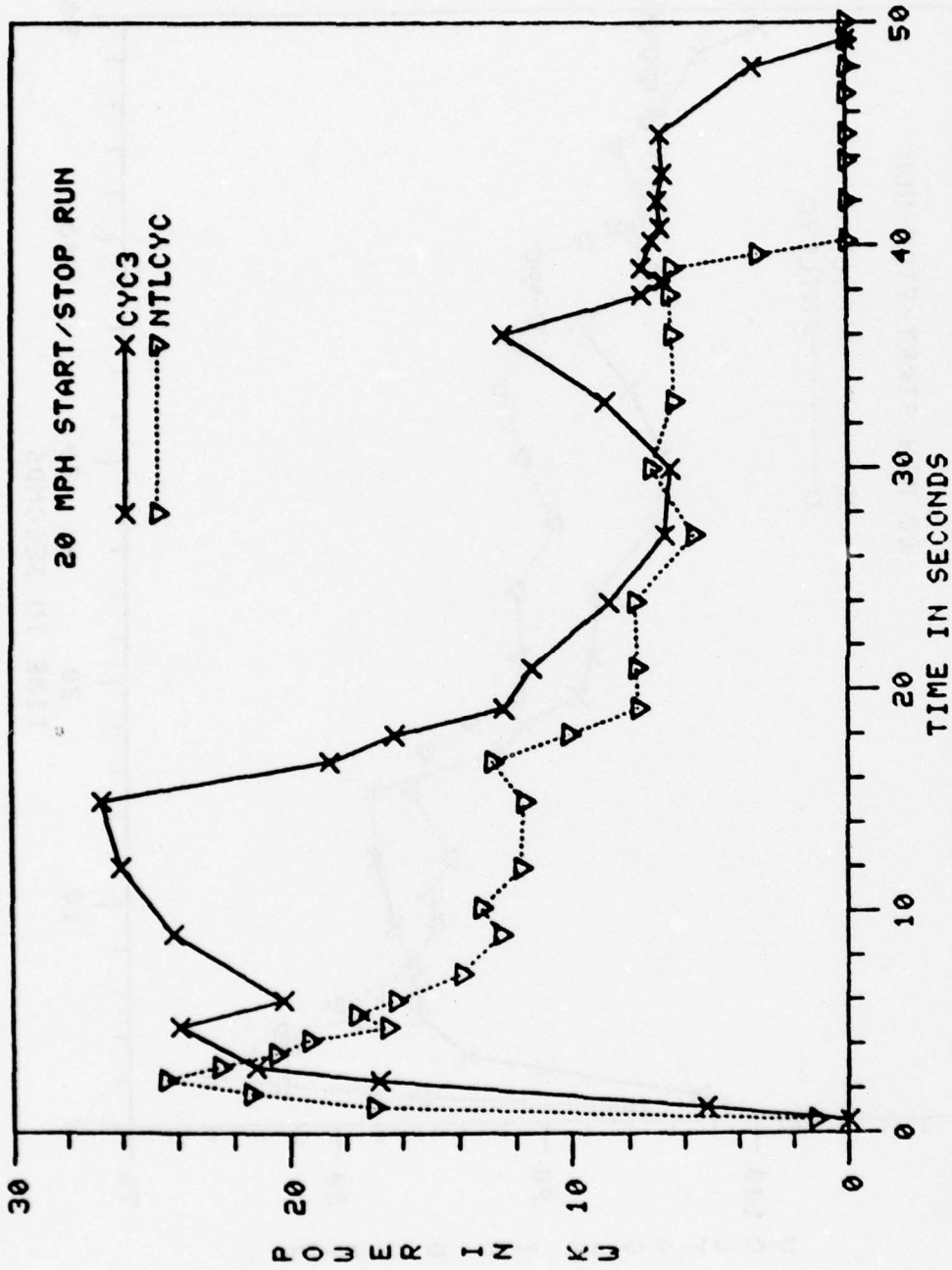

Figure 15c. Average battery power.

VEHICLE PERFORMANCE OF E.V.A. METRO

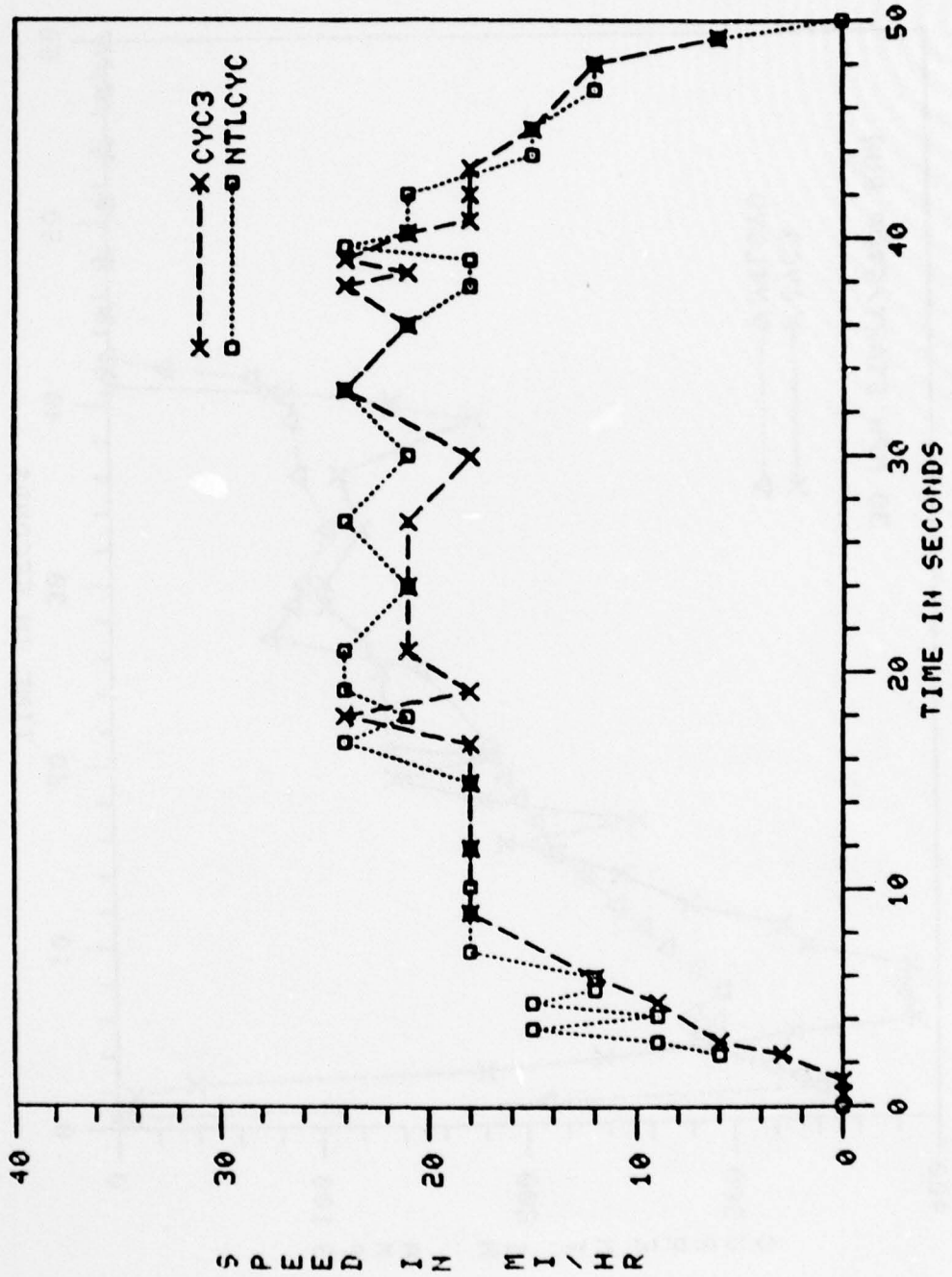

Figure 15d. Speed as a function of time.

VEHICLE PERFORMANCE OF E.V.A. METRO

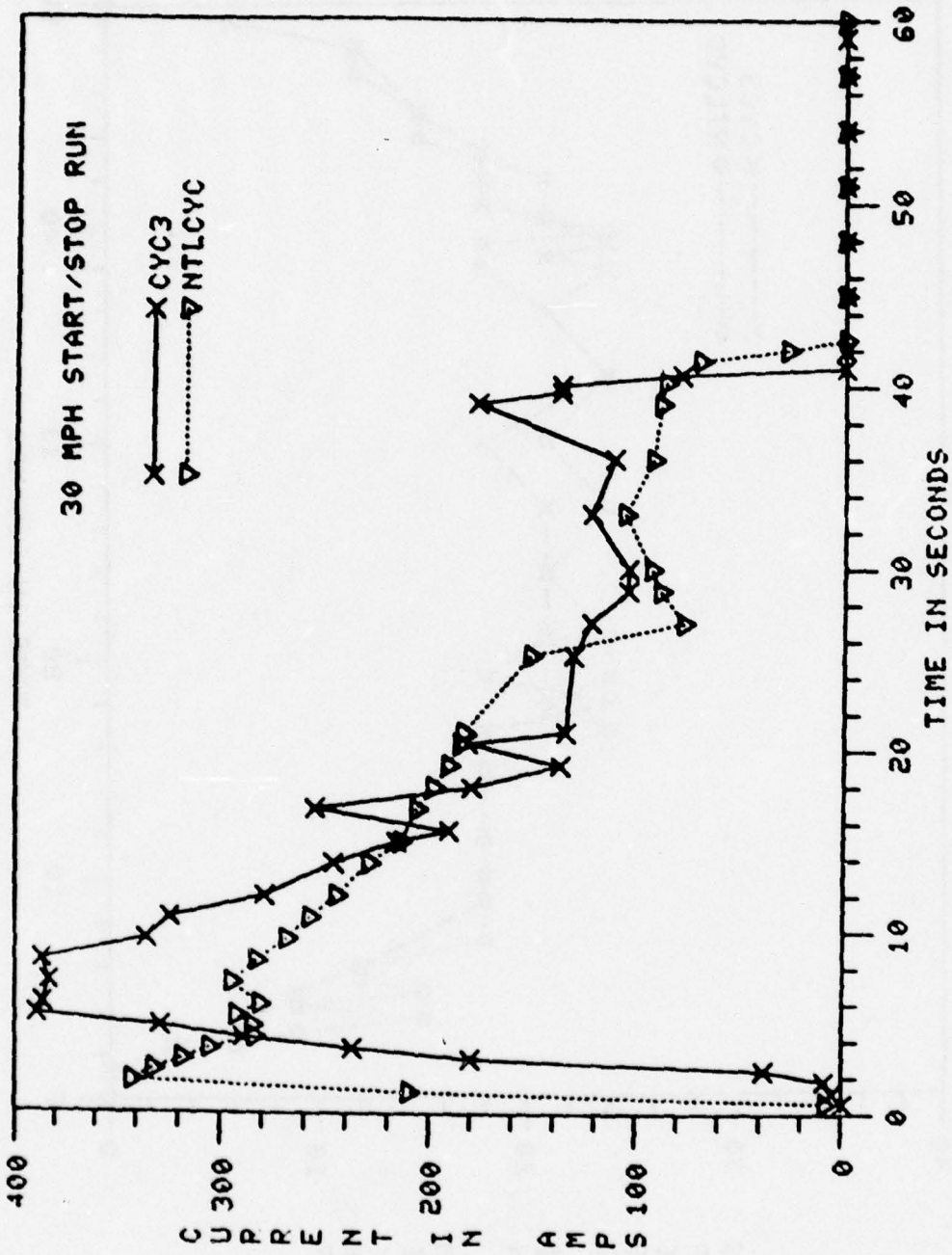

Figure 16a. Average battery current.

VEHICLE PERFORMANCE OF E.V.A. METRO

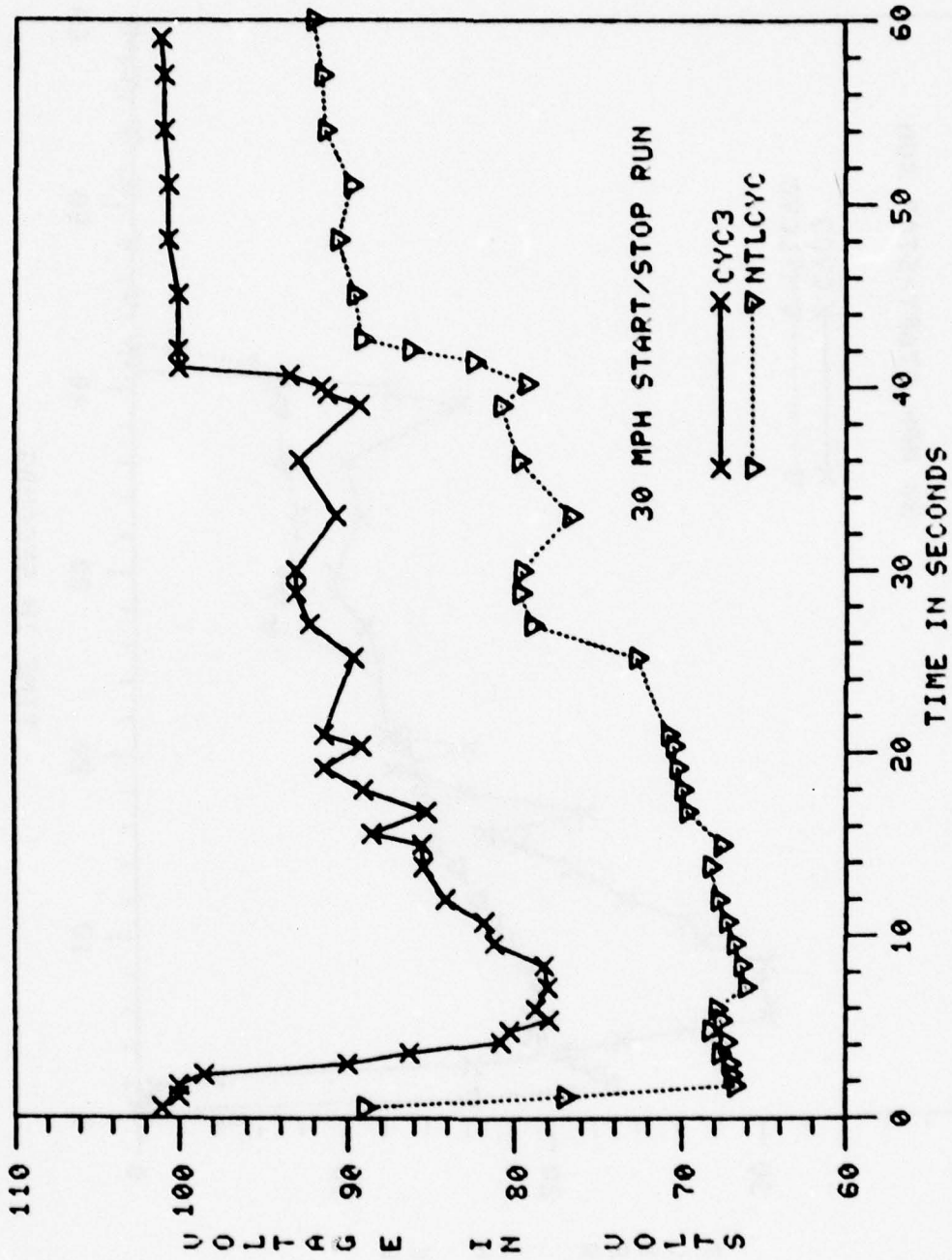

Figure 16b. Average battery voltage.

VEHICLE PERFORMANCE OF E.U.A. METRO

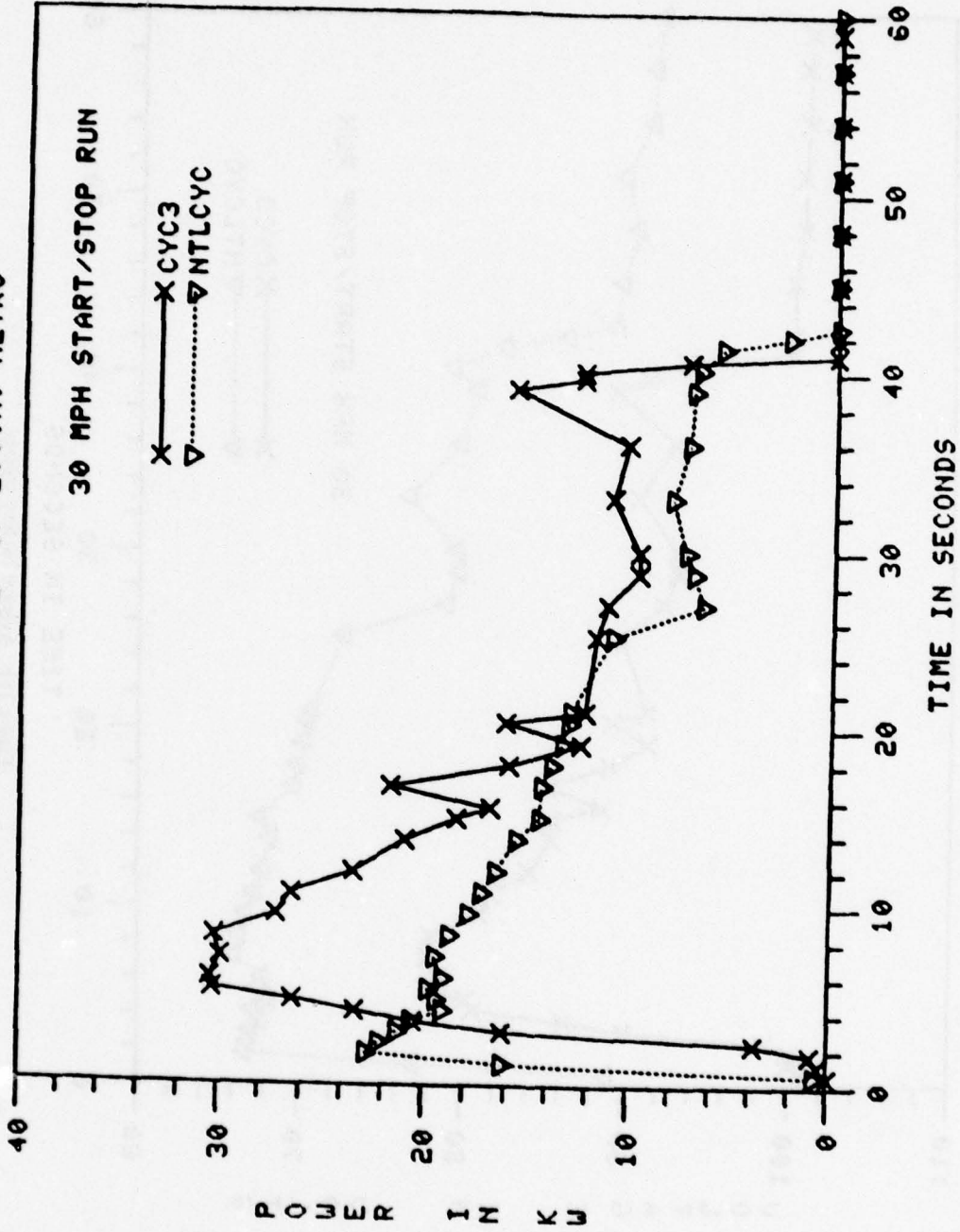

Figure 16c. Average battery power.

VEHICLE PERFORMANCE OF E.U.A. METRO

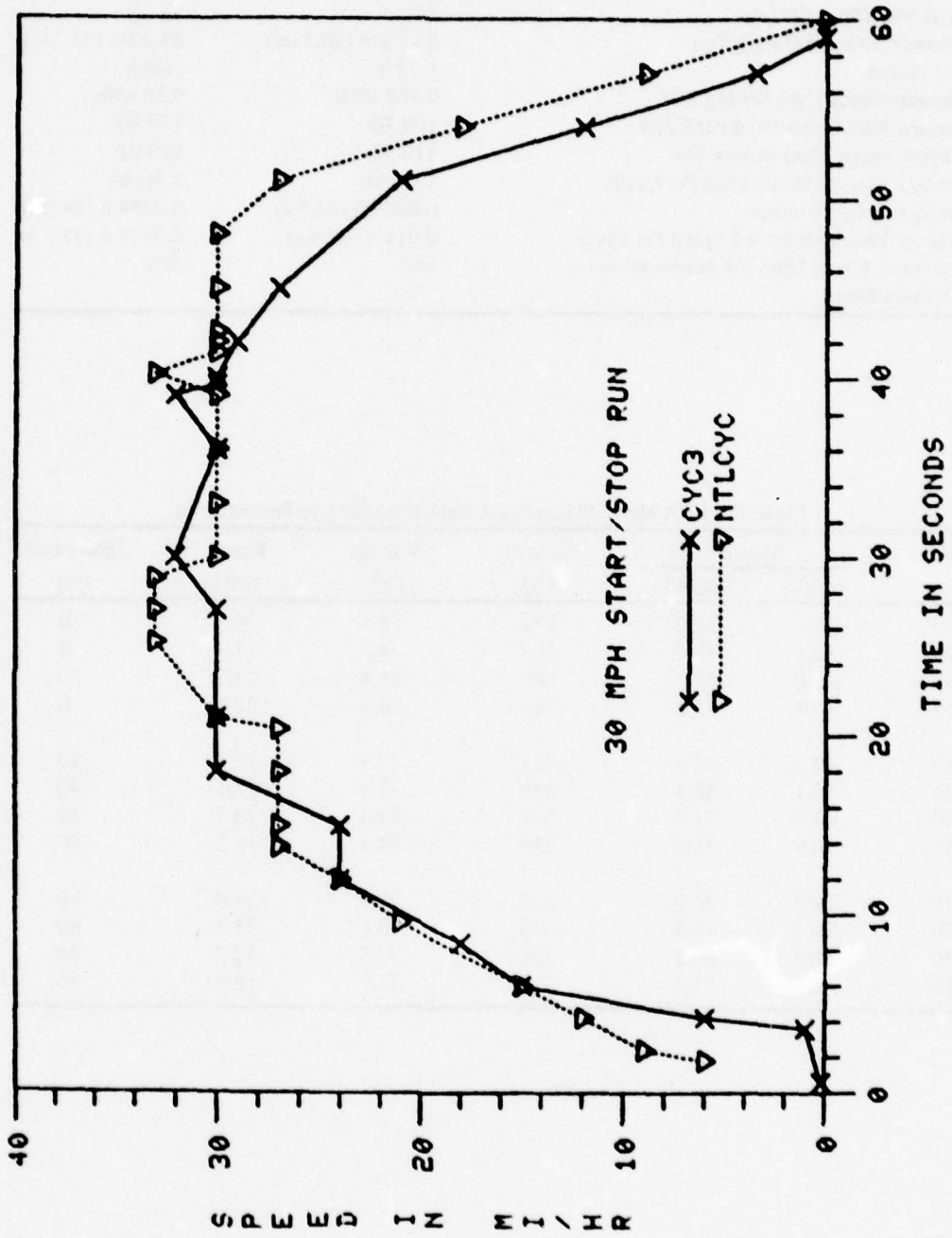

Figure 16d. Speed as a function of time.

Table 16. Driving Cycle Performance of EVA Metro

Parameter	Schedule B	Schedule C
Total Start/Stop Cycles	84	53
Distance Traveled During Test	32.7 km (20.3 mi)	34.2 km (21.2 mi)
Test Period	1.72 h	1.24 h
Kilowatt-Hours Used During Test	9.164 kWh	9.38 kWh
Average Watt-Hours Used Per Cycle	109 Wh	177 Wh
Ampere-Hours Used During Test	110 Ah	120 Ah
Average Ampere-Hours Used Per Cycle	1.31 Ah	2.26 Ah
Average Cycle Duration	0.0205 h (73.8 s)	0.0234 h (84.2 s)
Average Time Battery is Loaded Per Cycle	0.011 h (39.6 s)	0.0117 h (42.1 s)
Percent of Power Used for Acceleration to Cruising Speed	56%	59%

Table 17. EVA Metro Maximum Acceleration Battery Performance

Time (s)	Speed		Current (A)	Voltage (V)	Power (kW)	Discharged (%)
	(mi/h)	(km/h)				
10	19.3	31.0	372	78.5	29.2	0
20	30.1	48.4	380	78.6	29.9	0
50	43.0	69.2	280	84.4	23.5	0
65	46.8	75.3	260	84.8	22.0	0
10	17.2	27.6	353	77.9	27.5	40
20	30.1	48.4	349	77.6	27.1	40
50	44.6	71.8	249	82.4	20.5	40
65	46.9	75.5	230	83.4	19.2	40
10	22.4	36.0	325	73.9	24.0	80
20	30.7	49.4	319	73.6	23.5	80
50	42.4	68.2	235	77.5	18.2	80
65	44.3	71.3	217	77.7	16.9	80

Table 18. EVA Metro Sedan Battery Test Data

Test	Data	Cell Capacity		Battery Overcharge (%)	Electrolyte Specific Gravity		Battery Temperature	
		Ah In	Ah Out		Before	After	Before (°C)	After (°C)
55 km/h	5-16-77	-	119	-	1.270	1.159	17.8	35.5
55 km/h	5-17-77	140	118	19	1.256	1.156	26	41
40 km/h	5-18-77	149	110	35	1.254	1.143	26	37
40 km/h	5-19-77	147	113	30	1.254	1.140	25	39
77 km/h	5-23-77	123	101	22	1.267	1.170	24	37
77 km/h	5-24-77	120	103	17	1.259	1.165	33.6	47.2
"B" Cycle	5-25-77	130	113	15	1.261	1.127	31	44
"B" Cycle	5-26-77	129	107	21	1.258	1.154	31	39.4
"C" Cycle	5-27-77	138	117	18	1.255	1.131	33.3	45.5
"C" Cycle	5-31-77	131	124	6	1.262	1.154	20.8	38.3

9. **Motor and Drive Train.** The EVA Metro traction motor is 10-kW continuous dc series compensated designed for a voltage range of 72 to 96 volts. A data sheet supplied by EVA gives the weight as 150 lb w/o base. The resistance is given as 0.0315 ohm. Other ratings are given in Table 19.

Table 19. EVA Metro Sedan Traction Motor Ratings

Rate	Current (A)	Voltage (V)	Velocity (r/min)	Torque (ft-lb)
Maximum, Intermittent Duty	300	120	4500	39
Continuous Duty	130	96	3500	17

The motor is limited to 4500 r/min by an overspeed-compensated winding. The motor has extensive convective and conductive cooling and uses laminated pole pieces for cooling. The SCR controller acts as a current limiter. The electric motor drives a torque converter which, in turn, drives an automatic transaxle. The shifting of the transaxle is controlled through comparison of motor speed and motor current. Final drive ratio in third gear is 3.65:1 while in 1st, 2nd, and 3rd transmission ratios are 2.33:1, 1.44:1, and 1.00:1, respectively. The rolling radius of the tires is given by EVA as 0.92 foot. Further evaluation of the drive-train components is now in progress at MERADCOM and will be reported separately.

IX. VEHICLE RELIABILITY

No major problems were encountered to prevent completion of the tests, but several problems occurred that delayed the tests. These problems were related to the propulsion batteries and battery charger. Three sets of batteries were tested for capacity before a set met ampere-hour capacity specifications; this set was composed of sixteen, series-connected EV106 Exide batteries that were removed from the EVA Metro #2 Sedan at ERDA. An external power supply was used for charging because the onboard charger took too long (typically more than 16 hours) and did not bring the specific gravity above the required 1.265 for each cell.

X. DRIVER REACTION AND SERVICEABILITY

The vehicle was comfortable and handled well at constant speeds. However, acceleration was very slow. This was caused by the automatic transmission design which required the converter to be at speed before the vehicle would move. The batteries were relatively easy to service (water addition and terminal accessibility) except for the last row of cells in the battery pack in the trunk of the vehicle rear compartment. It was very difficult to make specific gravity readings in this area.

APPENDIX A

ENERGY RESEARCH AND DEVELOPMENT ADMINISTRATION ELECTRIC AND HYBRID VEHICLE TEST AND EVALUATION PROCEDURE (ERDA-EHV-TEP)

TABLE OF CONTENTS

- 1.0 Objective and Purpose
- 1.1 Objective and Purpose of the Project
- 1.2 Objective and Purpose of the Test Procedure and Data
- 2.0 Test Procedure
- 2.1 Scope and Itemized Tests
- 2.2 Terminology
- 2.3 Vehicle Condition
- 2.4 Battery Condition
- 2.5 Environmental Conditions
- 2.6 Instrumentation
- 2.7 Data to be Recorded
- 2.8 Tests
- 2.8.1 Range at Steady Speed
- 2.8.2 Range on a Driving Cycle
- 2.8.3 Acceleration on a Level Road
- 2.8.4 Gradeability Limit
- 2.8.5 Gradeability at Speed
- 2.8.6 Road Energy Consumption
- 2.8.7 Vehicle Energy Economy
- 2.8.8 Braking
- 2.8.9 Handling (OMITTED BY MERADCOM)

NOTE: This procedure has been modified as agreed upon by ERDA for MERADCOM testing.

**ENERGY RESEARCH AND DEVELOPMENT ADMINISTRATION
ELECTRIC AND HYBRID VEHICLE TEST AND EVALUATION PROCEDURE
(ERDA-EHV-TEP)**

1.0 Objective and Purpose

1.1 Objective and Purpose of the Project

The test project objective is to continually evaluate representative state-of-the-art electric and hybrid vehicles, subsystems, and components. The test results should:

- Verify, correct, and add to the vehicle manufacturer's data sheets
- Provide a common basis for cross comparison of vehicle:
 - design specifications
 - purchase specifications
 - technical papers
 - engineering decisions

In addition, the analyzed data and reports will be used for ERDA research and development program planning toward acceleration of component and vehicle technology.

1.2 Objective and Purpose of the Test Procedure and Data

The test procedure objective is to provide a standard approach for testing which will allow performance characteristics of vehicles and in situ components to be measured on a common basis for cross comparison. Vehicle comparison is derived from the gross vehicle performance characteristics reduced to unitized form, such as performance per cycle, per ton mile or seat mile. Powertrain performance projections are derived from the gross vehicle performance and the associated component and subsystem efficiency results. The total results measure the vehicle state-of-the-art and develop a component, powertrain, and subsystem information base from which to plan electric and hybrid vehicle research and development programs.

2.0 Test Procedure

This ERDA test procedure uses and references the Society of Automotive Engineers Recommended Practice, Electric Vehicle Test Procedure (SAE J227a), as a base to build a more detailed test procedure. The ERDA Electric and Hybrid Vehicle Test and Evaluation Procedure (ERDA-EHV-TEP) includes instrumentation and procedures to collect powertrain, powertrain component, and braking data. The SAE J227a con-

concentrates on the attributes of the gross vehicle system reserving subsystem and component testing to separate procedures.

2.1 Scope and Itemized Tests

The objective, purpose, and scope of this test procedure are detailed in Section 1.2 of this procedure. The specific tests covered by this document are:

- Range at Steady Speed (Section 2.8.1)
- Range on a Driving Cycle (Section 2.8.2)
- Acceleration on a Level Road (Section 2.8.3)
- Gradeability Limit (Section 2.8.4)
- Gradeability at Speed (Section 2.8.5)
- Road Energy Consumption (Section 2.8.6)
- Vehicle Energy Economy (Section 2.8.7)
- Braking (Section 2.8.8)
- Handling (Section 2.8.9) (optional – not performed by MERADCOM)

2.2 Terminology

2.2.1 Curb Weight. The total weight of the vehicle including batteries, lubricants, and other expendable supplies but excluding the driver, passengers, and other payloads.

2.2.2 Drive Line Ratio. The motor shaft rpm divided by the rpm of the traction wheels of the vehicle. (OMITTED BY MERADCOM)

2.2.3 Gradeability. The maximum percent grade which the vehicle can traverse at a specified speed. The gradeability limit is the grade upon which the vehicle can just move forward.

2.2.4 Initial State of Charge (of Battery). The amount of energy stored in the battery. When practical, the initial state of charge should be expressed as a percent of the capacity obtainable from a fully charged battery when discharged at a rate equivalent to the vehicle maximum cruise speed discharge rate.

2.2.5 Projected Frontal Area. The total frontal area of the vehicle obtained by projecting its image on a vertical plane normal to its direction of travel.

2.2.6 Tractive Force. The force available from the driving wheels at the driving wheel ground interface.

2.2.7 Tire Rolling Radius. The effective radius of a tire when it is deformed by the weight of the vehicle ballasted to its rated gross vehicle weight (SAE J670c), OMITTED BY MERADCOM.

2.2.8 Maximum Cruise Speed. The highest vehicle speed sustainable for at least 1 hour under specified environmental road test conditions starting with a fully charged battery or such other maximum cruise speed as may be recommended by the vehicle manufacturer.

2.2.9 Powertrain. The energy storage components (batteries, etc), power conditioning controls, and propulsion unit (electric rotor, etc).

2.2.10 Gross Vehicle Weight. The total weight of the vehicle including batteries, lubricants, expendable supplies, driver, passengers, and other payload.

2.2.11 Vehicle Test Weight. The vehicle test weight is the vehicle weight during testing, including batteries, lubricants, expendable supplies, driver, passengers, and other payload.

2.3 Vehicle Condition.

Upon receipt of a vehicle, it is to be inspected for visible damage. Damage is to be photographed and reported immediately to the shipping company, to the manufacturer, and to the ERDA program manager. If the vehicle appears to be in good condition, it is to be driven by test personnel for familiarization with its handling and performance characteristics. Wiring diagrams are to be studied, and the propulsion system is to be inspected to determine the appropriate locations for test instrument and sensor locations.

2.3.1 The vehicle shall be tested in its normal configuration with all normal appendages, mirrors, bumpers, hubcaps, etc. The vehicle shall be tested at the manufacturer's rated gross vehicle weight.

2.3.2 Ensure that the front-wheel alignment is set to the manufacturer's specifications.

2.3.3 Manufacturer's recommended tires shall be used. Tire pressures shall equal the vehicle manufacturer's recommended values or pressures. Tire tread shall not be worn to the point where the tread wear indicators are exposed.

2.3.4 Normal manufacturer's recommended lubricants shall be employed.

2.3.5 Vehicle checks preliminary to test:

2.3.5.1 Ability to fully charge and equalize battery cells.

2.3.5.2 Draw the maximum vehicle manufacturer allowed load current but not greater than 300 amperes from the fully charged batteries into a load at battery terminals for 5 minutes while monitoring battery terminal interconnection temperatures. Measurements can be made with a hand-held temperature monitor for the last 2 minutes or with temperature-sensitive labels. If any terminal or interconnect should exceed 60 degrees Celsius above ambient or if any terminal temperature rises rapidly above the average of the others, the test shall be terminated and the terminal shall be checked and repaired.

2.3.5.3 Tire pressure for possible air leaks.

2.3.5.4 All lights for proper function.

2.3.5.5 All brakes for drag, air in hydraulic lines, etc.

2.3.5.6 All safety equipment for proper function.

2.3.5.7 Weight of the vehicle without driver and test equipment.

2.3.5.8 Weight of the vehicle with the driver, all the test equipment, and ballast weight* to meet the manufacturer's payload specifications. The fifth wheel shall be up so it is included as part of the test equipment weight.

2.3.5.9 Calibration of the instrumentation package and recorder(s) installed.

2.3.5.10 Operation of the vehicle on short sample road tests simulating all probable test conditions. Check out all channels of the instrumentation package and recorder(s).

2.3.6 The vehicle shall be stored at an ambient temperature in the range of (5 to 32 degrees Celsius) 40 to 90 degrees Fahrenheit during the charge cycle. Battery electrolyte temperature must be below 90°F when the tests begin.

2.3.7 The vehicle track tests will be terminated when a vehicle failure occurs that requires either (1) more than 24 hours to repair or (2) the repair results in modifications to the vehicle that significantly change the performance of the vehicle.

* GVW (test weight) may vary ± 2 percent from manufacturer's specifications. Distribution of the test load shall be such that actual vehicle weight distribution (percent front versus percent rear) is also within 2 percent of the manufacturer's specifications.

2.4 Battery Condition

2.4.1 If batteries are new or have been subject to extended storage, the batteries shall be cycled per the manufacturer's recommendation before starting tests.

2.4.2 Full charge is to be established using manufacturer's recommended charging procedure and equipment.

2.4.3 For tests (for example, gradeability tests) requiring an X percent discharged battery at the start, the required initial state-of-charge will be established as follows: A Range at Steady State test shall be performed at recommended maximum cruise speed, the end-point of range shall be determined as defined in Section 2.8.1.2.2, and the amp hours taken from the battery shall be measured. To achieve X percent discharge of a fully charged battery, the battery will be discharged by driving the vehicle at recommended maximum cruise speed or by discharging the battery through a load at an equivalent constant power until X percent of the amp hours as determined above are removed from battery. Tests conducted with the battery partially discharged at the start must be initiated no longer than 10 minutes after the desired initial state-of-discharge is reached.

2.4.4 For tests in which the effects of battery initial state-of-charge are to be investigated, tests should be conducted with the propulsion batteries at 0 percent, 40 percent, and 80 percent discharged.

2.4.5 Capacity and Quality Verification. The battery shall be discharged at the 3-hour or other manufacturer's published rate (to 1.7 volts/cell specific gravity 1.160 + .01 for lead acid). The capacity shall be within 20 percent of the manufacturer's capacity at the published rate to pass this test. A second cycle shall be run to verify the battery's quality.

2.4.6 Before each vehicle test cycle (unless otherwise specified), lead/acid batteries shall be fully charged and equalized. If the specific gravity of any cell is 10 points below the battery manufacturer's specification for full charge, the cell shall be checked and replaced if necessary.

2.5 Environmental Conditions

2.5.1 Ambient temperature during road testing shall be in the range of 5 degrees to 32 degrees C (40 degrees to 90 degrees F), except short tests may be conducted wherein the average temperature of the vehicle chassis and powertrain does not exceed the prescribed temperature limits.

2.5.2 Road tests are to be performed on a road which is level to within ± 1 percent and has a hard, dry surface. Tests shall be run in opposite directions when they are performed on a road test route. The direction of travel need not be reversed when operating on a closed test track.

2.5.3 The recorded wind speed at the test site during test shall not exceed 16 km/h (10 mph); gusts shall not exceed 24 km/h (15 mph).

2.6 Instrumentation

2.6.1 Test Instrumentation. This section provides a list of instrumentation required to perform the tests specified in this procedure. The overall error in recording or indicating instruments shall be no worse than ± 2 percent of the maximum value of the variable to be measured (not including reading errors). Periodic calibration shall be performed and documented to insure compliance with this requirement.

2.6.2 General Instrumentation. The following classes of instruments are required for the purpose of tests outlined in this procedure:

- A.C. watt-hour meter or watt-time recorder
- D.C. watt-hour meter or watt-time recorder
- Distance-versus-time recorder
- Tire pressure gauge
- Periodic ambient temperature measurements during tests
- D.C. watt meter (calculation is option)
- Battery temperature indicator
- Battery voltage versus time
- Battery current versus time
- Motor shaft speed versus time or vehicle speed (OMITTED)
- Motor input current versus time
- Motor input voltage versus time
- Stopwatch
- A suitable multichannel recording system
- A fifth wheel

2.7 Data to be Recorded

2.7.1 General

2.7.1.1 Manufacturer's specification sheet data.

2.7.1.2 Vehicle identification.

2.7.1.3 Overall maximum dimension (including projected frontal area).

2.7.1.4 Weight: curb weight and test weight to within ± 2 percent.

2.7.1.5 Battery:

- Manufacturer
- Type and normal rating at specified discharge rate
- Previous history of the battery including chronological age, number, and nature of charge-discharge cycles, serial numbers.
- State of initial charge using the definition of percent charge presented in Sections 2.4.3 and 2.4.4. Where meaningful, other parameters such as open circuit voltage and electrolyte specific gravity shall also be stated.
- Watt-hours consumed during test
- Power consumed during test
- Temperature at the start and the end of the test (either within the electrolyte or at the cell terminal, as appropriate).
- Recharge energy
- Recharge amp-hours
- Recharge time

2.7.1.6 Motor type and rating.

2.7.1.7 Overall drive train ratio(s) available and those used during test, plus vehicle manufacturer's recommended shift points of manual transmission.

2.7.1.8 Tires: manufacturer, design, size, rolling radius measured at GVW, and the pressure at the start and the end of the test.

2.7.1.9 Power consumption of individual accessories, either measured or as specified by vehicle manufacturer, and times when each accessory was on during the test.
(OMITTED)

2.7.1.10 Environmental conditions:

- Range of the ambient temperature during test
- Range of the wind velocities during test
- Range of the wind direction during test
- Presence of any precipitation during test
- Mean test site altitude relative to sea level

2.7.1.11 Running surface.

2.7.1.12 Description of test route: road class, road surface type, and condition (Table 9 of SAE J688) and the lengths and grades of the test route.

2.7.1.13 Date and the starting and ending times of test.

2.7.1.14 List of all instruments used in the test (manufacturer, model number, serial number) and their last calibration date.

2.7.1.15 Any deviation from the test procedure and the reason for the deviation.

2.7.2 Road Tests

2.7.2.1 Data shall be recorded and averaged for tests in opposite directions when tests are run on a road test route. The data reported shall be the average of at least two test runs – one in each direction. The range of the test results and the number of test runs also shall be reported.

2.7.2.2 Data shall be recorded and averaged and reported from two test runs in opposite directions on the test route for power and energy transferred through the powertrain and through each of the components of the powertrain.

2.7.2.3 Recharge energy into the battery charger and into the battery shall be recorded, averaged, and reported for the two tests per cycle described in 2.7.2.2.

2.7.2.4 Battery voltage and current (power and energy) and the motor voltage and current shall be recorded and repeat test runs averaged and reported as specified under the respective tests.

2.7.2.5 Perform the following checks prior to each day of testing:

2.7.2.5.1 Ensure that all fluid levels are as specified in the vehicle manufacturer's log book: Battery _____, Brake _____, Automatic Transmission _____, Power Steering _____, Other _____.

2.7.2.5.2 Check all electrical power connections for physical tightness and evidence of running hot.

2.7.2.5.3 Inspect tires for damage and wear.

2.7.2.5.4 Torque all wheel lug nuts to vehicle manufacturer's recommended values.

2.7.2.5.5 Set tire pressures and record pressures on data sheets.

2.7.2.5.6 Ensure that the fifth-wheel tire pressure meets manufacturer's recommendations.

2.7.2.5.7 Install tape in recorder and record reel number and tracks used on data sheet.

2.7.2.5.8 Record instrumentation channel identities.

2.7.2.5.9 Record driver and observer identities. Weigh the test vehicle and record weight.

2.7.2.5.10 Record wind direction, wind speed, and ambient temperature. (Do not undertake testing if wind speeds are greater than 10 mph or if gusts exceed 15 mph.) Record wind direction, velocity, and ambient temperature midway through the test period and at the end of the test period.

2.7.2.5.11 Warm up and stabilize the electronics before beginning tests.

2.7.2.5.12 Obtain pretest zeros and electrical step calibrations. Repeat at the completion of a series of tests or at the end of a test day.

2.7.2.6 Perform the following checks prior to each test:

2.7.2.6.1 Ensure that the proper or sufficient amount of charge is in the battery.

2.7.2.6.2 Ensure that there is sufficient tape in the recorder.

2.7.2.6.3 Record run to be made, direction, and course on the data sheet.

2.7.2.6.4 Other pertinent checks and facts about the test.

2.8 Tests

2.8.1 Range at Steady Speed

2.8.1.1 Purpose of Test. The purpose of this test is to determine the maximum range an electric road vehicle can achieve on a level road at a steady speed.

2.8.1.2 Test Procedure. These road tests are to be conducted subject to the test conditions and data requirements described in Sections 2.3 through 2.7. Individual tests shall be started with the vehicle propulsion battery in a full state of charge.

2.8.1.2.1 Road Tests. The vehicle shall be operated in a normal manner and be accelerated under its own power to the preselected test speed. The range tests shall be continued without interruption at the preselected speed which is to be maintained to within ± 5 percent until the vehicle reaches its end of range as defined in Section 2.8.1.2.3. The vehicle range shall be determined as the average of two tests made around a closed test track or in opposite directions over a road test route. The steady speed reported is to be the average speed maintained over the distance traveled.

2.8.1.2.2 Selection of Test Speeds. The test speed selection depends on the top speed capability of the vehicle. The test speeds to be used are specified below in charted form. The 25 mph (40 km/h) base speed agrees with a commonly used foreign reference speed while 45 and 55 mph correlate with expressway speed limits. In addition, the range at the manufacturer's recommended top speed is to be determined. If a manufacturer's recommendation is not available, the top speed will be defined as 95 percent of the minimum speed of the vehicle when driven around the test track at wide-open throttle.

Vehicle Test Speeds for Selection		Vehicle Top-Speed Capability (mph)			
mph	(km/h)	0-39	40-49	50-59	60 & Over
25	(40)	X	X	X	X
35	(56)		X	X	
45	(72)				X
55	(88)				X
Manufacturer's Recommended Top Speed or Top Speed as determined in 2.8.1.2.2		X	X	X	X

2.8.1.2.3 Definition of End of Range. The end of the driving range is reached when the vehicle speed falls below 95 percent of the initially programmed steady speed or when such other vehicle performance limitation is reached as may be specified by the vehicle manufacturer. For example, if continuing the range test might result in deleterious operation of the battery, the vehicle manufacturer may relate the end of driving to some characteristic of the battery such as terminal voltage under load.

2.8.1.3 Special Data Recording. In addition to recording the data specified in Section 2.7, the following special data shall be reported.

2.8.1.3.1 The test data shall be tabulated and also plotted as a curve showing range as a function of vehicle speed. The actual test points shall be indicated on this curve.

2.8.1.3.2 The battery voltage and current (power and energy) and the motor voltage and current shall be tabulated at the first half-mile point and at a point one-half mile from the end of range.

2.8.1.3.3 The factor(s) involved in determining the end of range as defined in Section 2.8.1.2.3 shall be reported.

2.8.2 Range on a Driving Cycle

2.8.2.1 Purpose of Test. The purpose of this test is to determine the maximum range traveled and the energy consumed by a test vehicle when operated on a level surface in a definite, repeatable driving cycle. The driving cycles defined in this procedure are not necessarily intended to simulate a particular vehicle use pattern. Rather, it is the intent of this section to provide standard procedures for testing electric road vehicles so that their performance can be cross compared when operated over a fixed driving pattern.

2.8.2.2 Definition of Test Cycles. Three test cycles are defined and shown to allow the vehicle to be tested under conditions which best match its intended use. The three test cycles all have the characteristics shown in Figure A1

where: V = vehicle cruise speed – km/h (mph)
 t_a = acceleration time – s.
 t_{cr} = cruise time at speed V – s.
 t_{co} = coast time – s.
 t_b = braking time to zero speed – s.
 t_i = idle time at zero speed – s.
 T = total cycle time – s.

Values for the parameters of the three test cycles are presented in Table A1.

2.8.2.2.1 Driving Schedule B. Schedule B is characterized by a cruise speed of 32 km/h (20 mph) and is intended for use in testing a vehicle designed for use on a fixed

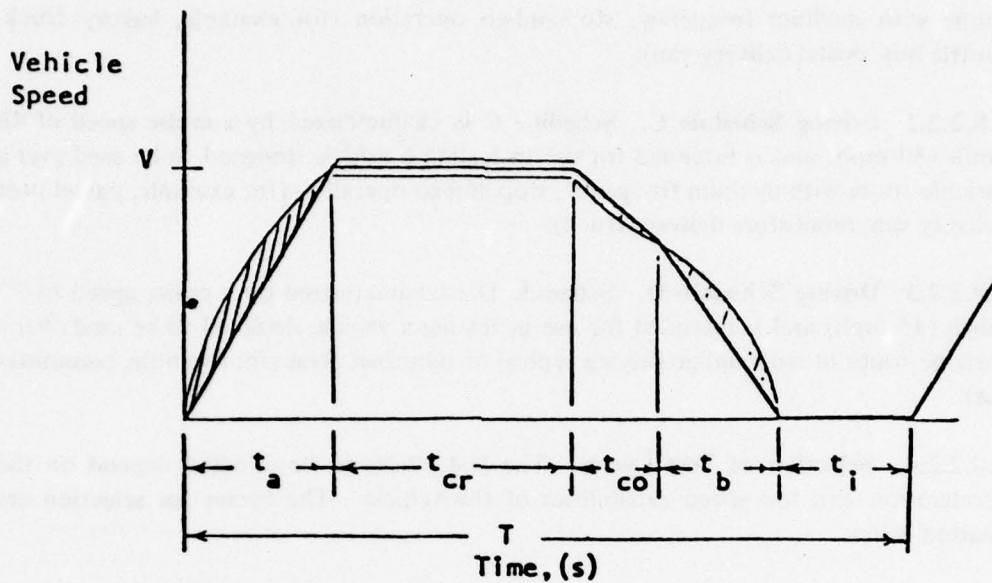

NOTE: The shaded band paths indicate that the velocity profile is tolerant but the time base is carefully stated as shown in Table A1.

Figure A1. Vehicle Test Cycle, SAE-J227a.

Table A1. Test Schedule for Repeatable Driving Pattern, SAE-J227a

Schedule	B	C	D
V	32 ± 1.5 km/h (20 ± 1 mph)	48 ± 1.5 km/h (30 ± 1 mph)	72 ± 1.5 km/h (45 ± 1 mph)
t_a	19 ± 1	18 ± 2	28 ± 2
t_{cr}	19 ± 1	20 ± 1	50 ± 2
t_{co}	4 ± 1	8 ± 1	10 ± 1
t_b	5 ± 1	9 ± 1	9 ± 1
t_i	25 ± 2	25 ± 2	25 ± 2
T	72 ± 3	80 ± 3	122 ± 4

NOTE: All times shown are in seconds.

route with medium frequency, stop-and-go operation (for example, bakery truck, shuttle bus, postal delivery van).

2.8.2.2.2 Driving Schedule C. Schedule C is characterized by a cruise speed of 48 km/h (30 mph) and is intended for use in testing a vehicle designed to be used over a variable route with medium frequency, stop-and-go operation (for example, parcel post delivery van, retail store delivery truck).

2.8.2.2.3 Driving Schedule D. Schedule D is characterized by a cruise speed of 72 km/h (45 mph) and is intended for use in testing a vehicle designed to be used over a variable route in stop-and-go driving typical of suburban areas (for example, commuter car).

2.8.2.2.4 Selection of Test Cycles. The test cycles to be selected depend on the acceleration and top speed capabilities of the vehicle. The cycles for selection are charted below:

SAE, J277 a Test Schedules	Vehicle Top Speed (mph)			
	0-39	40-49	50-59	60 & Over
B (20 mph)	X	X	X	X
C (30 mph)	X	X	(X)**	(X)**
D (45 mph)*			X	X

2.8.2.3 Test Procedures. The road tests defined in this procedure are to be conducted subject to the test conditions and data requirements of Sections 2.3 through 2.7. The tests are to be started with the battery fully charged using the vehicle manufacturer's standard procedures.

2.8.2.3.1 Road Tests. The test vehicle shall be operated repeatedly and without interruption over the selected driving schedule on a legal road or test track until it reaches its end of range as defined in Section 2.8.2.3.2. The vehicle range shall be determined as the average of at least two tests made around a closed test track or in opposite directions over a road test route. The steady speed reported is to be the distance traveled divided by the total elapsed time.

* All delivery-type vehicles will be tested to the "C" cycle even though the top speed exceeds 50 m.ph.

** To be tested to "D" schedule if vehicle meets acceleration requirements; if not, the vehicle will be tested to "C" schedule.

2.8.2.3.2 End of Range. The end of the driving range is defined as the end of the driving cycle immediately preceding the cycle in which the vehicle either ceases to meet the requirements of the selected driving schedule or reaches some other vehicle performance limitation specified by the vehicle manufacturer. For example, if continuing the test might result in deleterious operation of the battery, the vehicle manufacturer may relate the end of range to some battery characteristic such as its voltage under load.

2.8.2.4 Special Data Recording. In addition to recording the data specified in Section 2.7, the following special data shall be reported:

2.8.2.4.1 The range achieved, the number of test cycles successfully completed, and the test schedule used shall be recorded for each range achieved over at least two tests. The number of tests and the spread of the data also shall be reported.

2.8.2.4.2 The battery voltage and current (power and energy) and the motor voltage and current shall be tabulated and also plotted as a function of time and speed for the third cycle and the last complete cycle of these tests.

2.8.2.4.3 The factor(s) used to define the end of range in Section 2.8.2.3.2 shall be identified and reported.

2.8.3 Acceleration on a Level Road

2.8.3.1 Purpose of Test. The purpose of this test is to determine the maximum acceleration the vehicle can achieve on a level road with the propulsion battery at various initial states-of-charge.

2.8.3.2 Test Procedure. The road tests defined in this section are to be conducted subject to the test conditions, instrumentation, and data recording requirements of Sections 2.3 through 2.7.

2.8.3.3 Road Test Procedure

2.8.3.3.1 A suitable, straight, paved test route shall be selected upon which the vehicle can be safely accelerated to speeds near its peak speed.

2.8.3.3.2 The test vehicle is to be accelerated from a standing start at its maximum attainable, or permissible, acceleration rate until either the vehicle's peak speed is reached or until a safe-limit speed is attained.

2.8.3.3.3 At least two successive runs shall be made in opposite directions over the test course to establish the vehicle's maximum acceleration characteristics at each of the three battery states-of-charge specified in Section 2.4. The time interval from the end of one acceleration run to the beginning of the next successive acceleration run at each battery state-of-charge shall not exceed 5 minutes.

2.8.3.3.4 **Special Data Recording.** In addition to recording the data specified in Section 2.7, the following special data shall be reported:

2.8.3.3.4.1 The vehicle's acceleration characteristics shall be tabulated and also plotted as speed versus time for each of the initial states-of-charge. The data to be tabulated and plotted shall be the average results of two runs for that initial state-of-charge (Figure A2).

2.8.3.3.4.2 The battery current and the motor current shall be tabulated and also plotted as a function of time and of speed for the acceleration characteristics.

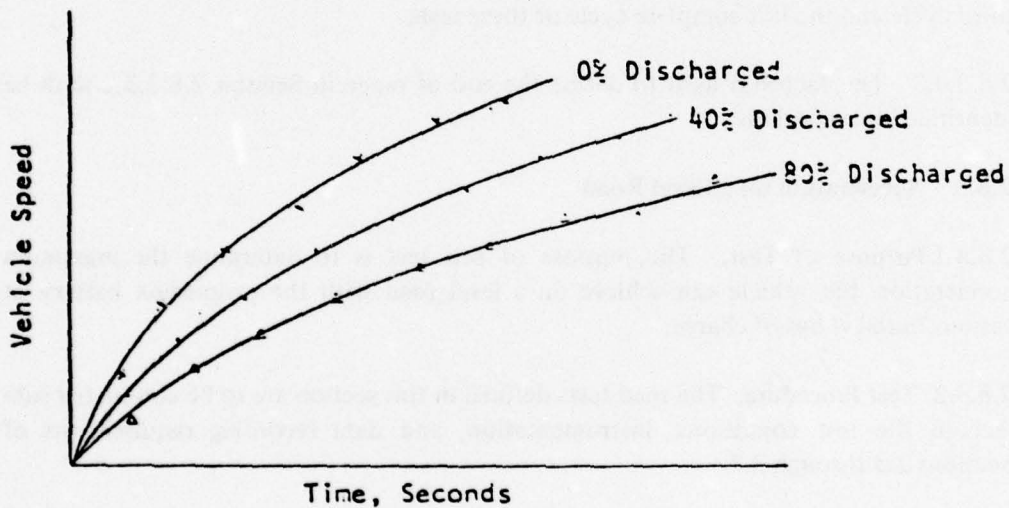

Figure A2. Acceleration characteristics.

2.8.4 Gradeability Limit

2.8.4.1 **Purpose of Test.** The purpose of this test is to determine the maximum grade on which the test vehicle can just move forward.

2.8.4.2 **Test Procedure.** Direct measurement of the gradeability limit on steep test grades generally is impractical. Therefore, the gradeability limit is to be calculated

from the gross vehicle test weight and the measured tractive force delivered by the vehicle at a speed near zero.

2.8.4.2.1 The tractive force shall be measured on a suitable horizontal surface and is the maximum force which can be maintained by the vehicle propulsion system for a period of 20 s while moving the vehicle at a minimum speed of 1.6 km/h (1 mph).

2.8.4.2.2 The tractive force shall be determined for various battery states-of-charge where the latter are defined in Section 2.4 and at selected transmission gear ratio.

2.8.4.2.3 Because the high-rate discharge capability of batteries is time dependent, two tractive-force tests are to be made for each battery state-of-charge. The lower of the two tractive-force measurements shall be used to determine the gradeability limit.

2.8.4.3 Calculation of Gradeability Limit. The percent gradeability limit is to be determined using the following relationship:

$$\text{Percent Gradeability Limit} = 100 \tan^{-1} \left(\frac{P}{W} \right)$$

where: P = measured traction force – kg (lb)

W = manufacturer's rated gross vehicle weight – kg (lb)

2.8.4.4 Special Data Requirements. The procedures just defined establish the gradeability limit of the test vehicle as a function of the battery state-of-charge. If the traction force is limited by slippage between the vehicle's drive wheels and the road surface, this fact should be recorded.

2.8.4.5 The battery voltage and current (power) and the motor voltage and current shall be tabulated with the gradeability limit.

2.8.5 Gradeability at Speed

2.8.5.1 Purpose of Test. The purpose of this test is to determine the maximum vehicle speed which can be maintained on roads having different grades. The effect of battery state-of-charge on the vehicle capability is to be brought out in these tests. An analytical method using data collected in Section 2.8.3, "Acceleration on a Level Road," is described.

2.8.5.2 Analytical Method. Using the speed-time data from the road tests of Section 2.8.3.3, the vehicle's acceleration characteristics shall be plotted as in Figure A3 for each state-of-charge. Data for successive time intervals then are to be used to determine the vehicle's average acceleration during the nth time interval:

$$a_n = \frac{V_n - V_{n-1}}{t_n - t_{n-1}}$$

when the vehicle has reached the average speed:

$$V = \frac{V_n + V_{n-1}}{2}$$

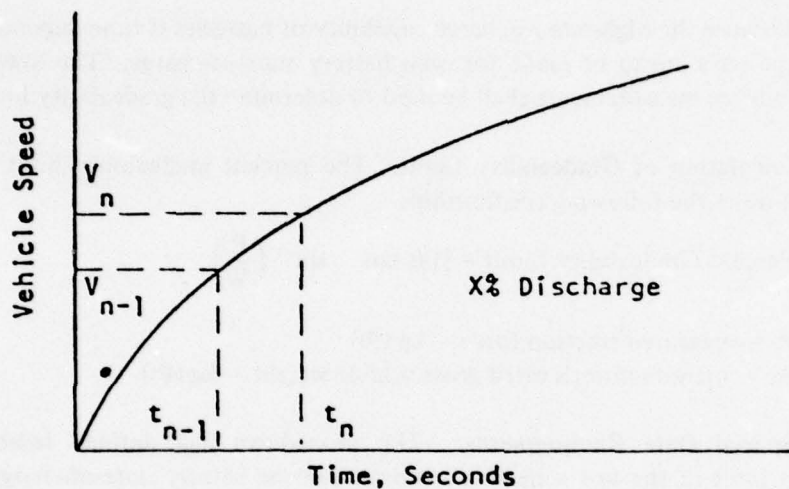

Figure A3. Vehicle speed versus time during acceleration.

The data derived from these calculations shall be tabulated and also plotted as average acceleration versus vehicle speed, and a smooth curve shall be drawn through the calculated points for each state-of-charge as shown in Figure A4. If the test vehicle is equipped with a recording accelerometer as well as speedometer during the test of Section 2.8.3.3, the information of Figure A4 is obtained directly and can be plotted as illustrated. The percent grade the vehicle is able to traverse at any selected speed is now to be calculated using the following relationship:

$$\text{Percent Gradeability at Speed} = 100 \tan (\sin^{-1} 0.0285a)$$

where a = vehicle acceleration at the selected speed – km/h.s (mph/s).

The constant 0.0285 in this equation becomes 0.0455 when the vehicle's acceleration is determined in English units of mph/s.

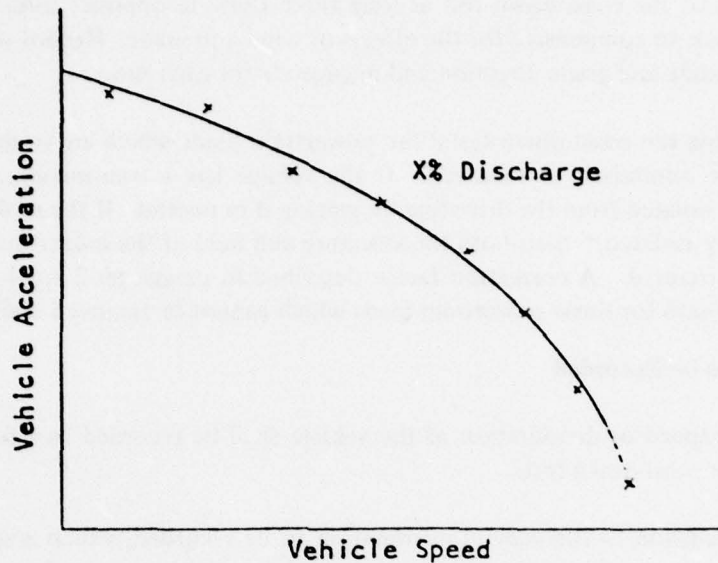

Figure A4. Vehicle maximum acceleration versus vehicle speed.

2.8.5.3 Special Data Recording

2.8.5.3.1 The calculated percent gradeability of the vehicle shall be recorded for each test speed and for the three battery initial states-of-charge specified in Section 2.4.4.

2.8.5.3.2 The battery voltage and current (power) and the motor voltage and current shall be tabulated and also plotted in correspondence with the gradeability at speed.

2.8.6 Road Energy Consumption

2.8.6.1 Purpose of Test. The purpose of this procedure is to determine the power and energy consumed at varying vehicle speeds to overcome aerodynamic drag and rolling resistance.

2.8.6.2 Test Procedure. Vehicle road power and energy consumption at various steady speeds are to be determined from a coast-down test which shall be performed in the following way:

2.8.6.2.1 Accelerate the test vehicle under its own power on a level road or test track to its maximum safe speed.

2.8.6.2.2 Disconnect the drive motor(s) where possible and allow the vehicle to coast freely to zero speed while recording vehicle speed versus time.

2.8.6.2.3 Repeat the coast-down test at least three times in opposite directions over the road or track to compensate for the effects of wind and grade. Record wind direction and magnitude and grade direction and magnitude for each run.

2.8.6.2.4 During the coast-down tests, the powertrain loads which are coupled to the wheels shall be minimized or removed. If the vehicle has a transmission, then the motor shall be isolated from the drive line by placing it in neutral. If the motor cannot be mechanically isolated,* then both the armature and field of the motor shall be electrically open circuited. A correction factor described in paragraph 2.8.6.4.1 shall be used to compensate for those powertrain loads which cannot be removed easily.

2.8.6.3 Data to be Recorded

2.8.6.3.1 The speed or deceleration of the vehicle shall be recorded as a function of time during the coast-down tests.

2.8.6.3.2 In addition to the general information to be recorded, which is specified in Section 2.7, any special modifications to the vehicle which were made to minimize powertrain loads during the coast-down tests as described in the previous paragraph shall be recorded.

2.8.6.4 Data Reduction. The vehicle speed versus time data obtained during the coast-down tests shall be processed to establish an average coast-down characteristic for the test vehicle. This characteristic data shall be tabulated and also plotted as shown in Figure A5.

2.8.6.4.1 Vehicle Road Load Power. The vehicle propulsion power required to overcome aerodynamic and rolling resistance is to be determined from Figure A5. From this curve, determine the vehicle speed, V_n , which occurs at successive intervals of time, t_n . The power required, P_n , to propel the vehicle at the average speed

$$V_n = \frac{V_n + V_{n-1}}{2}$$

then shall be determined from the following relationship:

$$P_n = 3.86 \times 10^{-5} W \frac{(V_n^2 - V_{n-1}^2)}{(t_n - t_{n-1})} \text{ KW}$$

* Motor windage, bearing losses, etc. are to be determined with the help of the vehicle manufacturer.

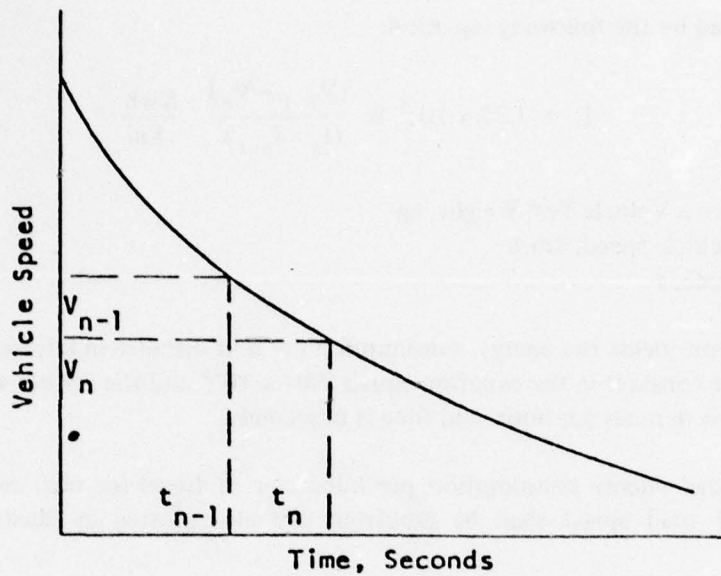

Figure A5. Vehicle speed versus time during coasting.

where: W = Gross Vehicle Test Weight, kg
 V = Vehicle Speed, km/h
 t = Time, s

The above equation yields the road load power in horsepower when the constant in the equation equals 6.08×10^{-5} and vehicle weight is in pounds, speed is in miles per hour, and time is in seconds.

The calculated power dissipated at each calculated average value of road speed shall be plotted as illustrated in Figure A6.

2.8.6.4.2 Vehicle Road Energy. The road energy consumed per kilometer in propelling the vehicle at steady speed also can be determined from the coast-down characteristics previously plotted as Figure A5.

Again, using the vehicle speed, V_n , at successive time intervals, t_n , the road energy consumed at the average speed

$$V_n = \frac{V_n + V_{n-1}}{2}$$

shall be determined by the following equation:

$$E = 7.72 \times 10^{-5} W \frac{(V_{n-1} - V_n)}{(t_n - t_{n-1})} \frac{\text{Kwh}}{\text{km}}$$

where: W = Gross Vehicle Test Weight, kg
V = Vehicle speed, km/h
t = Time, s

The above equation yields the energy consumption per unit distance in kilowatt hours per mile when the constant in the equation equals 9.07×10^{-5} and the vehicle weight is in pounds, speed is in miles per hour, and time is in seconds.

The calculated road energy consumption per kilometer of travel for each calculated average value of road speed shall be tabulated and also plotted as illustrated in Figure A7.

2.8.6.4.3 Alternate Procedures. The equations of paragraphs 2.8.6.4.1 and 2.8.6.4.2 use speed changes over fixed time intervals to determine an average deceleration rate. The calculations, therefore, yield the average values of energy and power dissipated during each selected time interval. The average dissipated energy and power, therefore, were plotted in Figure A6 and Figure A7 against the average speed for each successive time interval. If instantaneous values of vehicle acceleration are available from instruments which record acceleration directly, then instantaneous values of dissipated energy and power can be determined using appropriate equations to produce the relationships illustrated in these figures.

2.8.6.4.4 Corrections for Powertrain Loads. The values determined using this procedure are to be the energy and power dissipated external to the vehicle by aerodynamic drag and rolling losses. Corrections, therefore, must be made to the values of energy and power determined in paragraphs 2.8.6.4.1 and 2.8.6.4.2 to compensate for those powertrain loads which could not be eliminated during the coast-down tests. Specifically, the windage and friction losses in the motor and driveline may be significant if they cannot be decoupled. In this case, data describing the windage and friction losses of each component are to be obtained from the component manufacturer. Gear ratios in the driveline then are to be used to relate component speeds to vehicle speed and the energy and power dissipated in the driveline established as a function of vehicle speed. These data can be used to correct values of road energy and power previously obtained, and the corrected energy and power curves can be plotted in a manner similar to Figures A6 and A7.

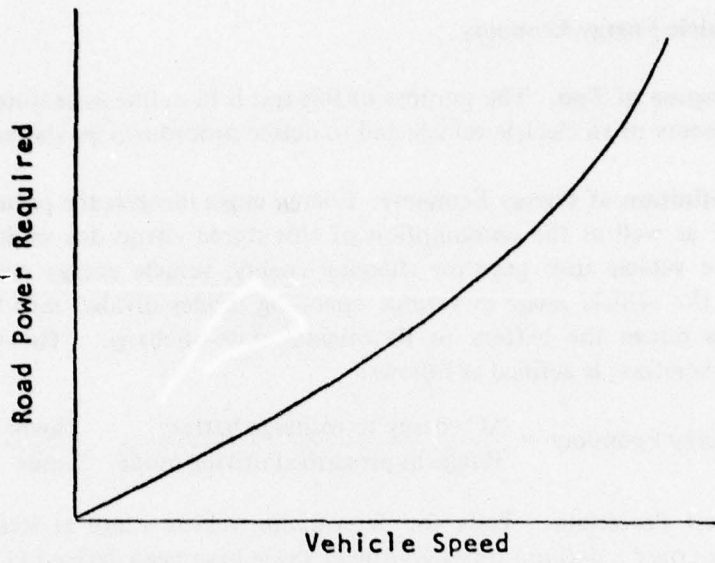

Figure A6. Road power versus vehicle speed.

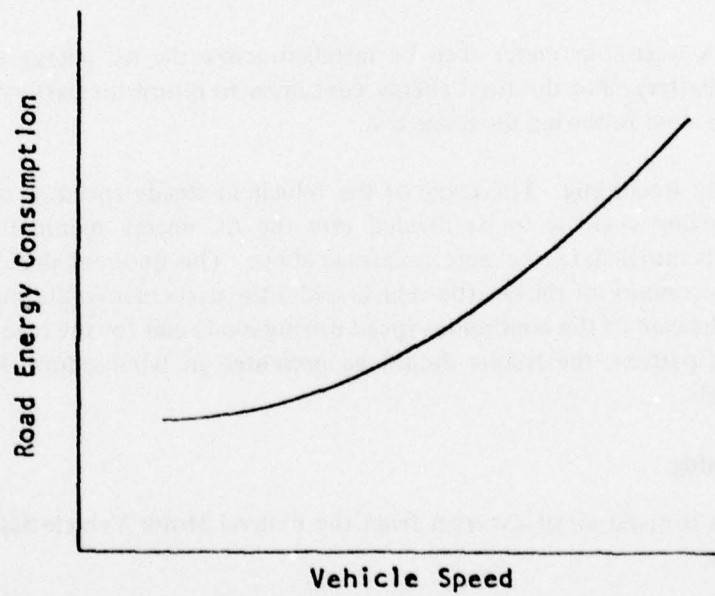

Figure A7. Road energy consumption versus vehicle speed.

2.8.7 Vehicle Energy Economy.

2.8.7.1 Purpose of Test. The purpose of this test is to define a measure of the overall energy economy of an electric vehicle and to define procedures for its evaluation.

2.8.7.2 Definition of Energy Economy. Energy usage involves the process of charging the battery as well as the consumption of this stored energy for vehicle propulsion. Because the vehicle user pays for charging energy, vehicle energy economy is here defined as the vehicle range in various operating modes divided into the AC energy required to return the battery to its original state-of-charge. The vehicle energy economy, therefore, is defined as follows:

$$\text{Vehicle Energy Economy} = \frac{\text{AC energy to recharge battery}}{\text{Range in prescribed driving mode}} \left(\frac{\text{kwhr}}{\text{mile}} \right)$$

2.8.7.3 Test Procedure. Tests for determining vehicle range at steady speed and vehicle range over a definite repeated driving cycle have been defined in Sections 2.8.1 and 2.8.2, respectively. Both of these range tests are to be used to establish values for vehicle energy economy.

2.8.7.3.1 Vehicle manufacturer's recommended procedures shall be used to charge the battery to full capacity both before and after the selected range tests.

2.8.7.3.2 A watt-hour meter shall be installed across the AC energy source used to charge the battery, and the total energy consumed to return the battery to full charge shall be measured following the range test.

2.8.7.4 Data Recording. The range of the vehicle at steady speed or its range over a repeated driving cycle is to be divided into the AC energy required to return the battery to its initial state-of-charge as defined above. This quotient shall be reported as the energy economy of the electric vehicle under the particular conditions of the range test. For the case of the continuous-speed driving mode and for the case of the repeatable driving pattern, the results should be presented in tabular form for the driving modes tested.

2.8.8 Braking

This section is made up of excerpts from the Federal Motor Vehicle Safety Standards No. 105-75.

2.8.8.1 Purpose of the Tests. The purpose of these tests is to determine the vehicle's braking capability and performance under normal and emergency conditions. This includes stopping distance on dry pavement and also vehicle safety while braking in turns on wet and dry pavement.

2.8.8.2 Test Procedure. Each vehicle shall be capable of meeting all the requirements of the stopping distance when tested according to the procedures and in the sequence set forth below without replacing any brake system part or making any adjustments to the brake system other than as permitted in burnish and reburnish procedures. Automatic adjusters may be locked out, according to the manufacturer's recommendation, when the vehicle is prepared for testing. If this option is selected, adjusters must remain locked out for entire sequence of tests. A vehicle shall be deemed to comply with the stopping distance requirements if at least one of the stops at each speed and load specified is made within a stopping distance that does not exceed the corresponding distance specified in the table shown in Section 2.8.8.4.

2.8.8.3 Road Test Procedure

2.8.8.3.1 Pretest Instrumentation Check. Conduct a general check of instrumentation by making not more than 10 stops from a speed of not more than 30 mph or 10 snubs from a speed of not more than 40 to 10 mph at a deceleration of not more than 10 fpsps. If instrument repair, replacement, or adjustment is necessary, make not more than 10 additional stops or snubs after such repair, replacement, or adjustment.

2.8.8.3.2 Service Brake Systems Test. This is a preburnish brake effectiveness test. It is intended that this test be conducted after the required "B," "C," and/or "D" cycle tests. Also, it is intended that these tests be conducted after a number of snubs equivalent to Section 2.8.8.3.1. The tests are: Make six stops from 30 mph, then make six stops from the manufacturer's recommended maximum speed but no greater than 60 mph.

2.8.8.3.3 Braking in a Turn Test

2.8.8.3.3.1 Braking in a Turn on Dry Pavement. Drive the vehicle in a circle that will produce a lateral acceleration (2.8.8.3.6) of .3g using the top speed as determined in 2.8.1.2.2 but no greater than 60 mph. Apply maximum braking but make sure that lockup does not occur on more than one wheel per axle. Under these conditions, the vehicle should continue to negotiate the same circular path and be controllable within a 12-foot-wide lane. This test is to be repeated three times for right turning and left turning.

2.8.8.3.3.2 Braking in a Turn on Wet Pavement. Drive the vehicle in a circle that will produce a lateral acceleration (2.8.8.3.6) of .2g using the top speed as determined in 2.8.1.2.2 but no greater than 60 mph. Apply maximum braking but make sure that lockup does not occur on more than one wheel per axle. Under these conditions, the vehicle should continue to negotiate the same circular path and be controllable within a 12-foot-wide lane. This test is to be repeated three times for right turning and left turning.

2.8.8.3.4 Service Brake Water Recovery Test. The service brakes shall be capable of stopping each vehicle in a water recovery test as specified below. Preceding brake water recovery test, three baseline check stops shall be made from 30 mph at 10 fpsps. The speed, stopping distance, and control force shall be documented. The control force used for the baseline check stops shall be not less than 10 pounds nor more than 60 pounds, except that the control force for a vehicle with a GVW of 10,000 pounds or more may be between 10 and 90 pounds.

After being driven for 2 minutes at a speed of 5 mph in any combination of forward and reverse directions through a trough having a water depth of 6 inches, each vehicle with a GVW of 10,000 pounds or less shall be capable of making five recovery stops from 30 mph at 10 fpsps for each stop with a control force application that falls within the following maximum and minimum limits:

(1) A maximum for the first four recovery stops of 150 pounds, and for the fifth stop, of 45 pounds more than the average control force for the baseline check (but in no case more than 90 pounds) except that the maximum control force for the fifth stop in the case of a vehicle manufactured before September 1, 1976 shall be not more than plus 60 pounds of the average control force for the baseline check (but in no case more than 110 pounds).

(2) A minimum of the average control force for the baseline check minus 10 pounds or the average control force for the baseline check times 0.60 whichever is lower (but in no case lower than 5 pounds).

2.8.8.3.5 Parking Brake Test. The parking brake tests for any vehicle on different grades, in different directions, and for different loads may be conducted in any order. The force required for actuation of a hand-operated brake system shall be measured at the center of the hand-grip area or at a distance of 1½ inches from the end of the actuation lever.

2.8.8.3.5.1 Test procedure for requirements in 2.8.8.3.5.3.

2.8.8.3.5.1.1 Condition the parking brake friction elements so that the temperature at the beginning of the test is at any level not more than 150°F (when the temperature of components on both ends of an axle is averaged).

2.8.8.3.5.1.2 Drive the vehicle, loaded to GVW, onto a 30 percent grade (2.8.8.3.5.3) with the longitudinal axis of the vehicle in the direction of the slope of the grade, stop the vehicle, hold it stationary by application of the service brake control, and place the transmission in neutral.

2.8.8.3.5.1.3 With the vehicle held stationary by means of the service brake control, apply the parking brake by a single application of the force specified in (a) or (b), except that a series of applications to achieve the specified force may be made in the case of a parking brake system design that does not allow the application of the specified force in a single application:

(a) In the case of a passenger car, not more than 125 pounds for a foot-operated system and not more than 90 pounds for a hand-operated system.

(b) In the case of a school bus, not more than 150 pounds for a foot-operated system and not more than 125 pounds for a hand-operated system.

Following the application of the parking brake, release all force on the service brake control and commence the measurement of time if the vehicle remains stationary. If the vehicle does not remain stationary, reapplication of the service brake to hold the vehicle stationary with reapplication of a force to the parking brake control at the level specified in (a) or (b) as appropriate for the vehicle being tested (without release of the ratcheting or other holding mechanism of the parking brake) may be used twice to attain a stationary position.

2.8.8.3.5.1.4 Following observation of the vehicle in a stationary condition for the specified time in one direction, repeat the same test procedure with the vehicle orientation in the opposite direction on the specified 30 percent grade.

2.8.8.3.5.2 Alternate test procedure for requirements of 2.8.8.3.5.3.

(a) Check that the transmission must be placed in park position to release key.

(b) Test as in 2.8.8.3.5.1 except in addition place the transmission control to engage the parking mechanism.

(c) Test as in 2.8.8.3.5.1 except on a 20-percent grade with the parking mechanism not engaged.

2.8.8.3.5.3 Parking Brake System Requirements. Each vehicle shall be manufactured with a parking brake system of a friction type with a solely mechanical means to retain engagement when tested according to the procedures specified in 2.8.8.3.4(1) and (2) and meet the requirements specified below as appropriate with the system engaged:

(a) In the case of a passenger car, with a force applied to the control not to exceed 125 pounds for a foot-operated system and 90 pounds for a hand-operated system.

(b) In the case of a school bus, with a force applied to the control not to exceed 150 pounds for a foot-operated system and 125 pounds for a hand-operated system.

2.8.8.3.5.3.1 Except as provided in the parking brake system on a vehicle with a GVW of 10,000 pounds or less shall be capable of holding the vehicle stationary (to the limit of traction on the braked wheels) for 5 minutes in both a forward and reverse direction on a 30-percent grade.

2.8.8.3.5.3.2 A vehicle of a type described in previous paragraph at the option of the manufacturer may meet the requirements below instead of the requirements of the previous paragraph if:

(a) The vehicle has a transmission or transmission control which incorporates a parking mechanism.

(b) The parking mechanism must be engaged before the ignition key can be removed. The vehicle's parking brake and parking mechanism, when both are engaged, shall be capable of holding the vehicle stationary (to the limit of traction of the braked wheels) for 5 minutes in both forward and reverse directions on a 30-percent grade.

The vehicle's parking brake, with the parking mechanism not engaged, shall be capable of holding the vehicle stationary for 5 minutes in both forward and reverse directions on a 20-percent grade.

2.8.8.3.5.3.3 The parking brake system on a vehicle with a GVW greater than 10,000 pounds shall be capable of holding the vehicle stationary for 5 minutes, in both forward and reverse directions, on a 20-percent grade.

2.8.8.3.6 Lateral Acceleration (see Table A2).

Table A2. Lateral (g) Forces as a Function of Vehicle Velocity and Turning Radius

Vehicle Velocity			Lateral (g) Acceleration			
(mph)	ft/sec	(ft/sec) ²	Radius for Turning Vehicle			
			.2	.3	.4	.6
20	29.32	860	132	88	66	44
25	36.65	1343	207	138	104	69
30	43.98	1934	298	199	149	100
37.5	54.97	3022	470	314	235	157
45	65.97	4352	672	466	336	233
Manufacturer's Maximum Recommended Speed			V^2	V^2	V^2	V^2
			.2G	.3G	.4G	.6G
55	80.63	6501	1003	669	502	334
60	87.96	7737	1194	796	597	398

G = 32.4 ft/sec²

2.8.8.4 Stopping Distances (see Table A3)

Table A3. Stopping Distances

Vehicle Test Speed (mph)	Stopping Distance in Feet Pre-Burnish Effectiveness Tests and Spike Effectiveness Tests		
	(a)	(b)	(c)
30	57	69	88
35	74	110	132
40	96	144	173
45	121	182	218
50	150	225	264
55	181	272	326
60	216	323	388

Note: (a) Passenger cars.
 (b) Vehicles other than passenger cars with GVW of 10,000 pounds or less.
 (c) Vehicles other than passenger cars with GVW greater than 10,000 pounds.

APPENDIX B

VEHICLE SUMMARY DATA SHEET

1. Vehicle Manufacturer: Name and Address

Electric Vehicle Associates
Valley View, Ohio

2. Vehicle Description

Name: Renault 12

Model: EVA-ELECTRIC #1

Availability: 5-10 days

Price: \$9500

3. Vehicle Weight

Curb Wt: 1525.44 kg

Passengers Wt: 84.44 kg

Driver Wt: 88.98 kg

Payload Wt: 44.49 kg

Gross Wt: 1743.36 kg

4. Vehicle Size

Wheelbase: 2.44 m Length: 4.42 m Width: 1.64 m

Headroom: .851 m Legroom: .66 m

5. Auxiliaries & Options

No. Lights: 14

Type and Function: N/A

- a. Four head lamps, sealed beam
- b. Two stop and turn signals rear
- c. Two backup lights rear
- d. Four side turn signal lights
- e. Two front turn signal lights

Windshield Wipers: Yes

Windshield Washers: Yes

Defroster: Yes

Heater: Yes

Radio: Yes

Fuel Gage: No

Ampmeter: Yes

Tachometer: No

Speedometer: Yes

Odometer: Yes

No. Mirrors: 3

Power Steering: No

Power Brakes: Yes

Transmission Type: Automatic with
torque converter

6. Propulsion Batteries

Type: EV 106
No. of Modules: 16-6 volts
No. Cells: 48
AH Capacity: 132.5
Battery Wt: 472 kg
Battery Rate: 106 min, 75A rate

Manufacturer: Exide Corporation
S/N: None
Battery Voltage: 96
Battery Size: .184 m³
Battery Age: unknown
Battery Cycles: unknown

7. Auxiliary Battery

Type: SL1 (2)

No. Cells: 6 ea
AH Capacity: 72 ah
Battery Rate: 20 hr

Manufacturer: 1. unknown
2. J. C. Penney
Battery Voltage: 12
Battery Size: (2) .0116 m³
Battery Wt: 45 kg

8. Controller

Type: SCR Manufacturer: Cableform
Voltage Rating: 96
Size: N/A Weight: 11.35 kg

Current Rating: 340 Amps

9. Propulsion Motor

Type: Series DC
Insulation Class: Field 8 ARM 8/A
Current Rating: 300 Amp
Max. 5 Min. Rating: N/A
Weight: 73 kg
Max. Speed: 4500 rpm

Manufacturer: Proprietary
Voltage Rating: 72-96 V
HP Rating: 10 KW
Size: N/A
Rated Speed: 4500

10. Body

Type: Unibody
No. Doors: 4
No. Windows: 6
No. Seats: 3
Cargo Volume: N/A

Manufacturer: Renault
Type: Standard
Type: Safety Glass
Type: Standard
Cargo Dimensions: None

11. Chassis

Type Frame:
Type Material: Steel
Type Springs: Coil
Axle Type Front: Dual Beam
Axle Manufacturer: Renault
Type Brakes Front: Disk

Manufacturer:
Modifications: N/A
Type Shocks: Tube
Axle Type Rear: Dual Beam
Drive Line Ratio: 3.65:1
Type Brakes Rear: Drum

Regenerative Brakes: No
Manufacturer: Michelin
Pressure: 220 kpa

Tire Type: Radial
Size: 155 R-13
Rolling Radius: .28 m

12. Battery Charger

Type: SS
On or Off Board: on
Peak Current: 30 A
Size: .305 m X .152 m X .178 m
Automatic Turn Off: Yes

Manufacturer: EVA
Input Voltage: 110/220 V 1 Ph
Recharger Timer: None
Weight: 10.55 Kg

APPENDIX C

EVA CORPORATION* "BATTERY MARSHALL" BATTERY CHARGER

General Description. The EVA "Battery Marshall" is a solid state battery charger that provides automatic control of the output charging current as well as automatic switching of input line voltages. The charger is primarily designed to recharge a 48-cell lead acid battery pack (Sixteen EV-106 batteries) from fully discharged to fully charged in eight to ten hours. The unit is designed to provide a high rate of safe charging current to a discharged battery pack, then automatically switching to a low maintenance current as the battery pack becomes charged. When adjusted properly, the charger will not overcharge the batteries, will slowly reduce the charge current to prevent excessive gassing, and will terminate the charge when the batteries reach 2.5 volts per cell. With total solid state construction of the control components, the charger should provide good reliability and long service if adequate preventive maintenance is performed periodically. The charger efficiency of input current versus output current is approximately 85% on the 115-VAC connection and 75% on the 230-VAC connection. The power required for the charger is approximately one kilowatt with 0.73 power factor on the 115-VAC connection and 3.6 kilowatts with 0.46 power factor on the 230-VAC connection.

Electrical Characteristics. The battery charger schematic diagrams are illustrated in Figures C1 through C5. The charger operates directly from a single-phase power source with voltages from 110 to 240 VAC, 60 Hertz. A sensing circuit on the input determines the input voltage range and automatically provides the switching to obtain the proper operating voltage. The input also senses the power ground circuit and interlock features to disable the charger should a fault occur.

The input-output circuit is overcurrent protected by 30-ampere circuit breakers with additional fuse protection for the cooling fan, accessory receptacle, and regulator circuits.

The output of the charger is obtained directly from the input power line through relay contacts to a full-wave bridge rectifier circuit with silicon-controlled rectifiers (SCR) in two legs of the bridge. The output current control is obtained by a "pulse-width modulation" technique that controls the conduction time of the SCRs. As the "on" time of the SCRs increases, the average DC output current also increases.

* The charger evaluation, Appendix C, was financed by the Division of Transportation, Office for Electric and Hybrid Vehicle Systems, Hybrid Systems Branch.

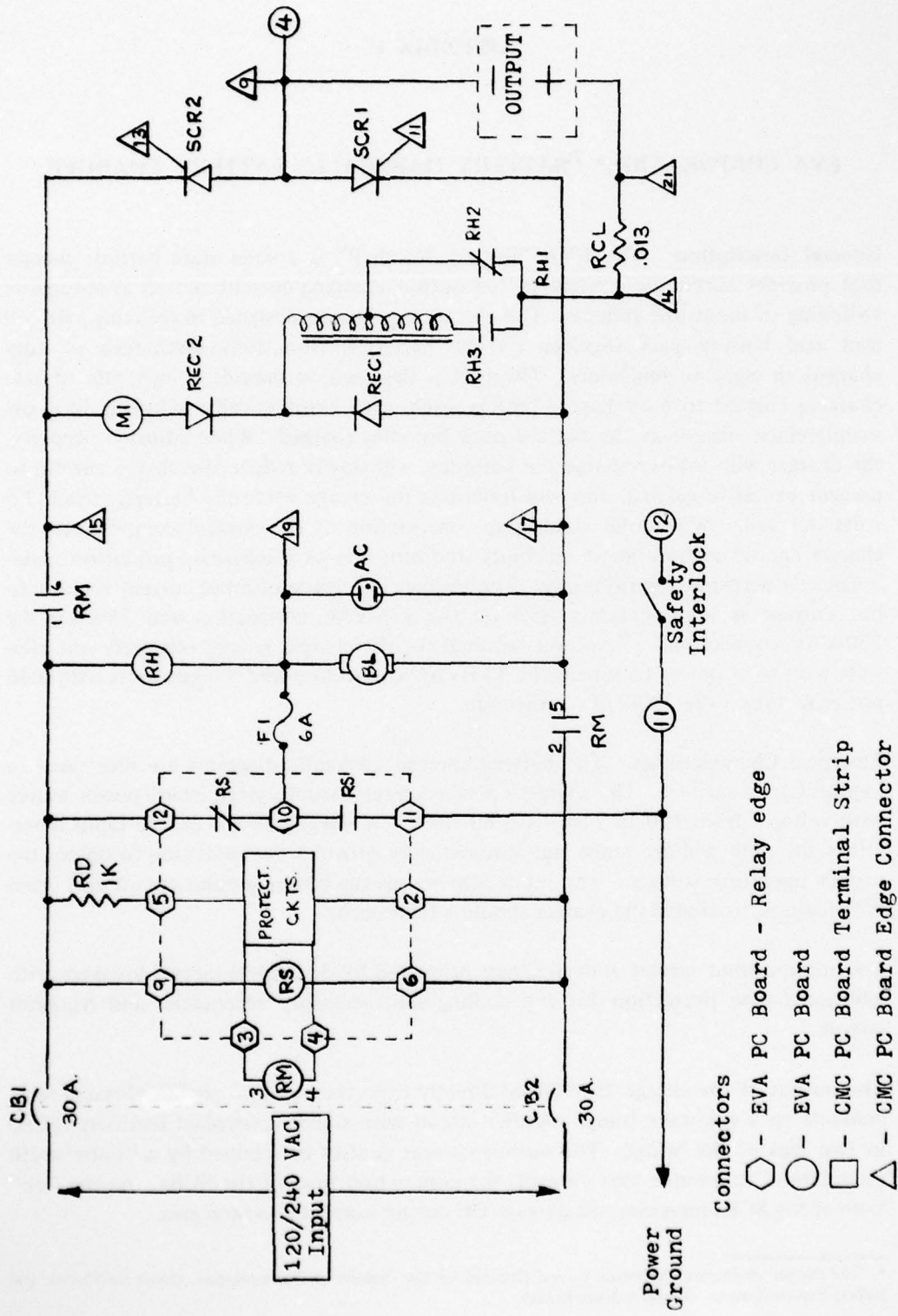

Figure C1. Main Input-Output Circuit (Components not on PC Boards).

AD-A056 927 ARMY MOBILITY EQUIPMENT RESEARCH AND DEVELOPMENT COMM--ETC F/G 13/6
BASELINE TESTS OF THE EVA METRO ELECTRIC PASSENGER VEHICLE. (U)
MAY 78 E J DOWGIALLO, C E BAILEY EC-77-A-31-1042

UNCLASSIFIED

MERADCOM-2244

DOF-CONS/0421-1

NL

2 of 2
AD
A056 927



END
DATE
FILMED
9-78
DDC

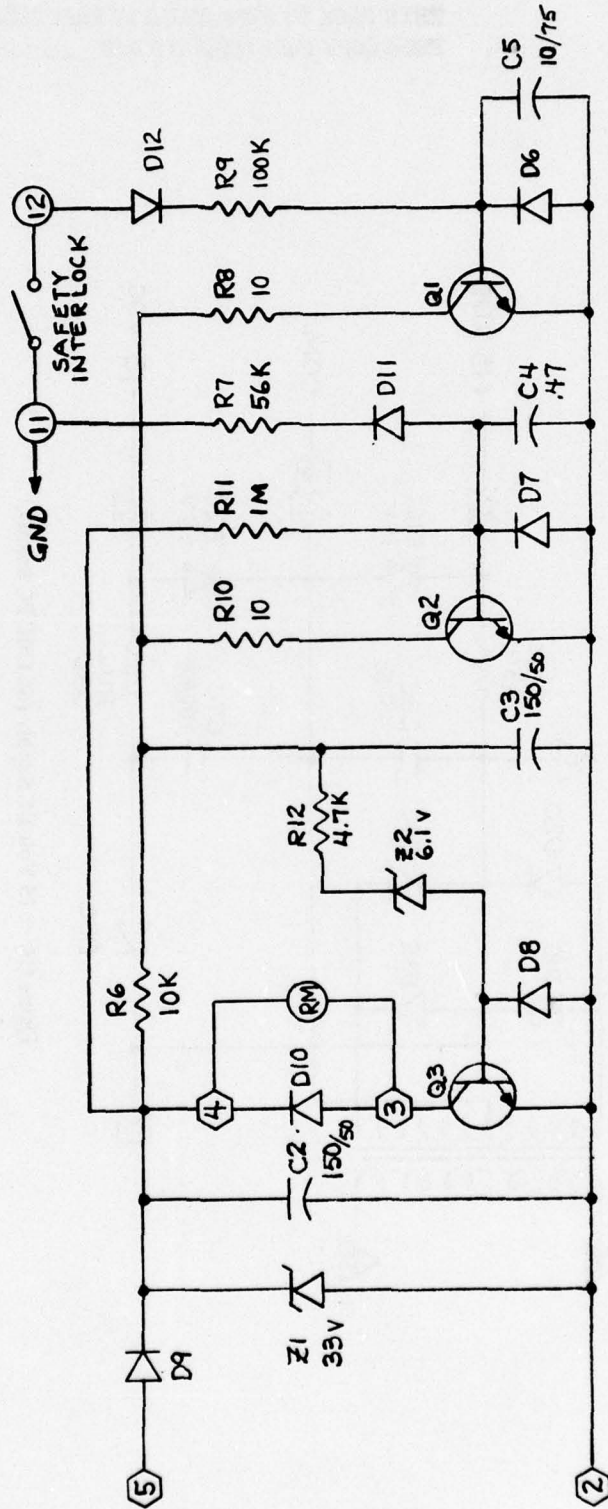

Figure C2. Ground detector circuit (on EVA PC Board)

THIS PAGE IS BEST QUALITY PRACTICABLE
FROM COPY FURNISHED TO BDC

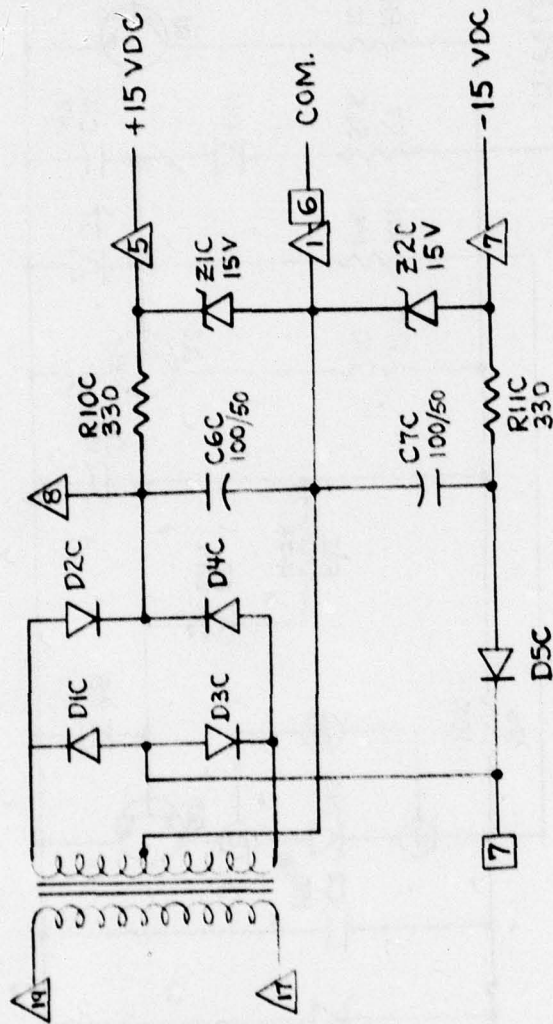

Figure C3. ± 15 Volt DC Supply (on CMC PC Board).

THIS PAGE IS BEST QUALITY PRACTICABLE
FROM COPY FURNISHED TO DDC

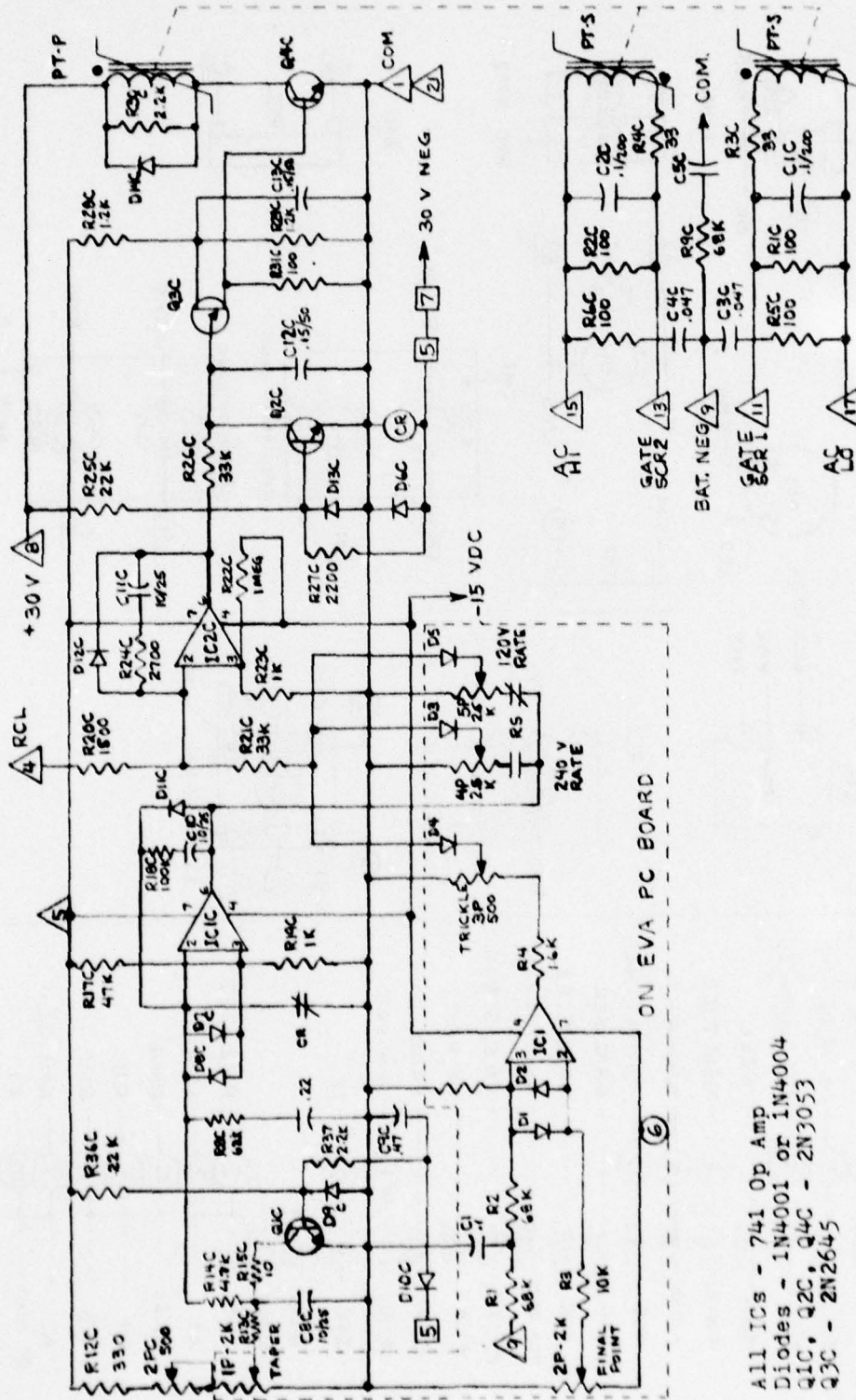

Figure C4. Battery Charger Control Circuit.

All ICs - 741 Op Amp
Diodes - 1N4001 or 1N4004
Q1C, Q2C, Q4C - 2N3053
Q3C - 2N2645

THIS PAGE IS BEST QUALITY PRACTICABLE
FROM COPY FURNISHED TO DDC

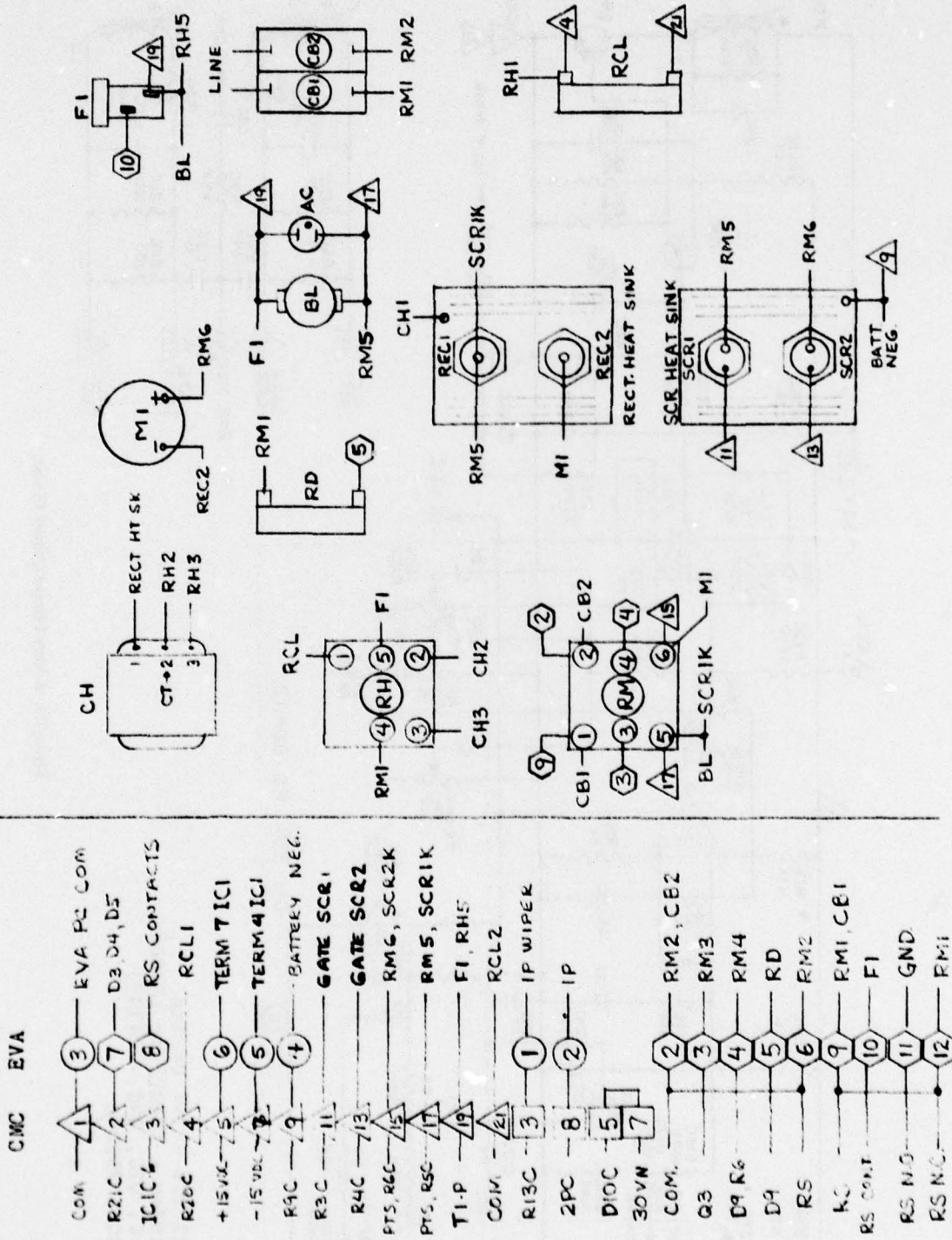

Figure C5. Connector and Component Wiring Diagram.

The "on" time of the SCRs is controlled by the "gate" pulses that are provided by a voltage-regulator circuit. The regulator senses the output current and voltage to provide the proper rate of pulses to the SCR gates. The regulator circuits are error-detection circuits constructed of integrated circuit operational amplifiers and other solid state components on two printed circuit boards. The regulator circuits incorporate five external adjustments that control the output parameters of the charger. The adjustable parameters are trickle current, taper point voltage, 120-volt maximum current, 240-volt maximum current, and final point voltage (cutoff).

The output of the SCR-rectifier bridge is direct coupled from the input line; therefore, the output voltage and current is a "chopped," pulsating DC because of the SCR conduction. With this output, there is no isolation of the output from the supply line. This creates a grounding problem and a possible hazard if personnel or single-ended test equipment become exposed to the output lines of the charger. Differential or "floating-type" instrumentation must be used to measure the parameters at the output of the charger.

The variation of the input line voltage has little effect on the output characteristics of the charger on the 230/240 volt connection – less than 2% variation. On the lower voltage inputs, 115/120 volts, the output current may vary as much as 40% with a ten-volt deviation of the input line voltage.

The reverse current flow from the battery through the charger, in case of power line failure, is approximately 1.5 milliamperes with a battery pack voltage of 105 volts. Test indicated a reverse impedance at the charger output to be approximately 70K ohms.

The only instrumentation on the charger is a small 0–30 A ammeter. The accuracy of this meter varied from within 1% at 3 amperes to 12% at 25 amperes. The meter error was on the low side throughout the meter range. This meter should not be used to adjust the charge current rates. During one test, the 240-volt maximum current was adjusted to indicate 25 amperes by the charger meter. Because of the meter error, the charger would only operate a few seconds before the charger would shut off on a high current termination.

The five charger adjustments – trickle, taper, 120-volt rate, 240-volt rate, and final point – are screwdriver adjustments that are accessible through grommets in the top of the charger case. External instrumentation should be used to make the adjustments in order to maintain proper operation of the charger.

Slope Characteristics. To determine the charge characteristics of the battery charging system, a battery pack consisting of sixteen EV-106 batteries was used as a load. Attempts were made to obtain the parameters of the charger with only a resistive load; however, the output characteristics were too unstable to obtain meaningful data. The circuit indicated in Figure C6 was used to obtain the input-output characteristics of the charger. The input source for the 115/120 voltage connection was a 30-ampere auto-transformer across a 120-VAC line. The input for the 230-volt connection was obtained from a 15-kW Engine Generator. The 5-kW variable load was used to discharge the battery pack from full charge to 1.7 volts per cell following each charge cycle. Prior to the charge rate tests, the charger adjustments were made as follows:

- a. Trickle current – 3 amperes
- b. Taper-point voltage – 110 volts
- c. 120-volt maximum current – 15 amperes
- d. 240-volt maximum current – 25 amperes
- e. Final-point voltage – 120 volts

The battery pack was cycled from discharge to charge several times at the different voltage connections to obtain the input-output parameters as a function of time. The slope characteristics including voltage and current versus time and voltage versus current for the charger at three different input voltages are illustrated in Figures C7 through C12.

The tests on the charger were performed only at ambient temperatures of 72-75°F and 85-92°F. The output of the charger appeared to be stable and comparable at these ranges. Temperature extreme tests were not performed.

Environmental Emanations. The Electromagnetic Interference (EMI) tests were performed on the battery charger utilizing the procedures outlined in MIL-STD-461A. The tests were conducted with the charger installed in an EVA Corporation Electric Vehicle. The radiated EMI was measured with the trunk lid in both the open and closed positions. The tests were performed using the 120-volt connection and a charger output of 10 amperes. The tests indicated that the charger radiates EMI in excess of the limits specified in MIL-STD-461A (RE02, Figure 13) in the entire frequency range below 8 Megahertz. Figure C13, shows the radiated EMI from the charger as compared to the MIL-STD-461A limits. Two additional limits, used for engine-generators, are also indicated on the graph.

The audio sound levels emanating from the charger are relatively low as indicated on Figure C14. The tests were performed in a sound chamber with the sensing microphone at a distance of 40 inches from the charger and 4 inches above the charger. Measurements were made on all four sides of the charger while the unit was operated on the 120-volt connection with an output of 10 amperes. The "db" values indicated on Figure C14, are the average of the four readings taken in each octave band.

THIS PAGE IS BEST QUALITY PRACTICABLE
FROM COPY FURNISHED TO DDG

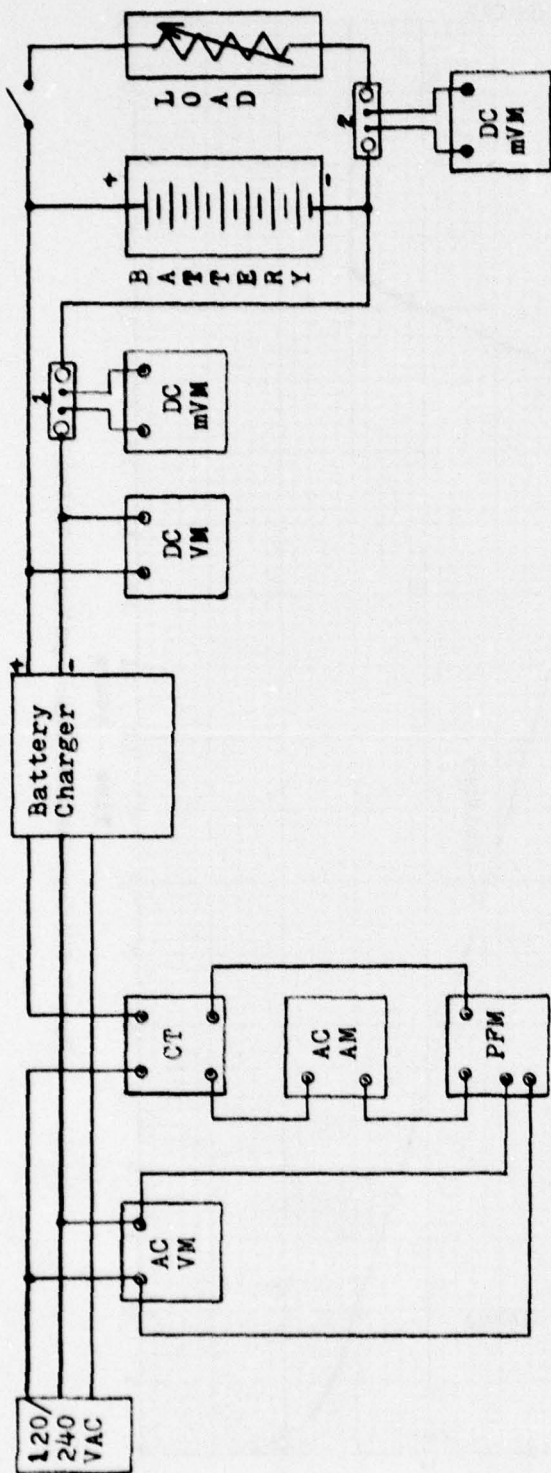

Instruments:

- ACVM - A C Voltmeter, Weston 904, ID #1208
- ACAM - A C Ammeter, Weston 904, ID # 0654
- CT - Current Transformer, Weston 461, S/N 22167
- PPM - Power Factor Meter, Weston 338, ID # 0168
- DCVM - D C Voltmeter, Weston 901, ID # 0308
- DCmVM - D C Millivoltmeter, Weston 931, ID # 0541 & 1246
- Shunt #1 - 20 Amp/50 mv, ID # 16591
- Shunt #2 - 100 Amp/50 mv, ID #16592
- Battery - Sixteen EV106 Batteries in series
- Load - 5KW resistive load, variable

Other instruments:

- Digital Multimeter, Keithley 167, ID # 18374
- Digital Multimeter, Keithley 168, ID # 22509
- Storage Oscilloscope, Tektronix 549, ID #9686

Figure C6. Instrumentation set-up to determine charge rate curves.

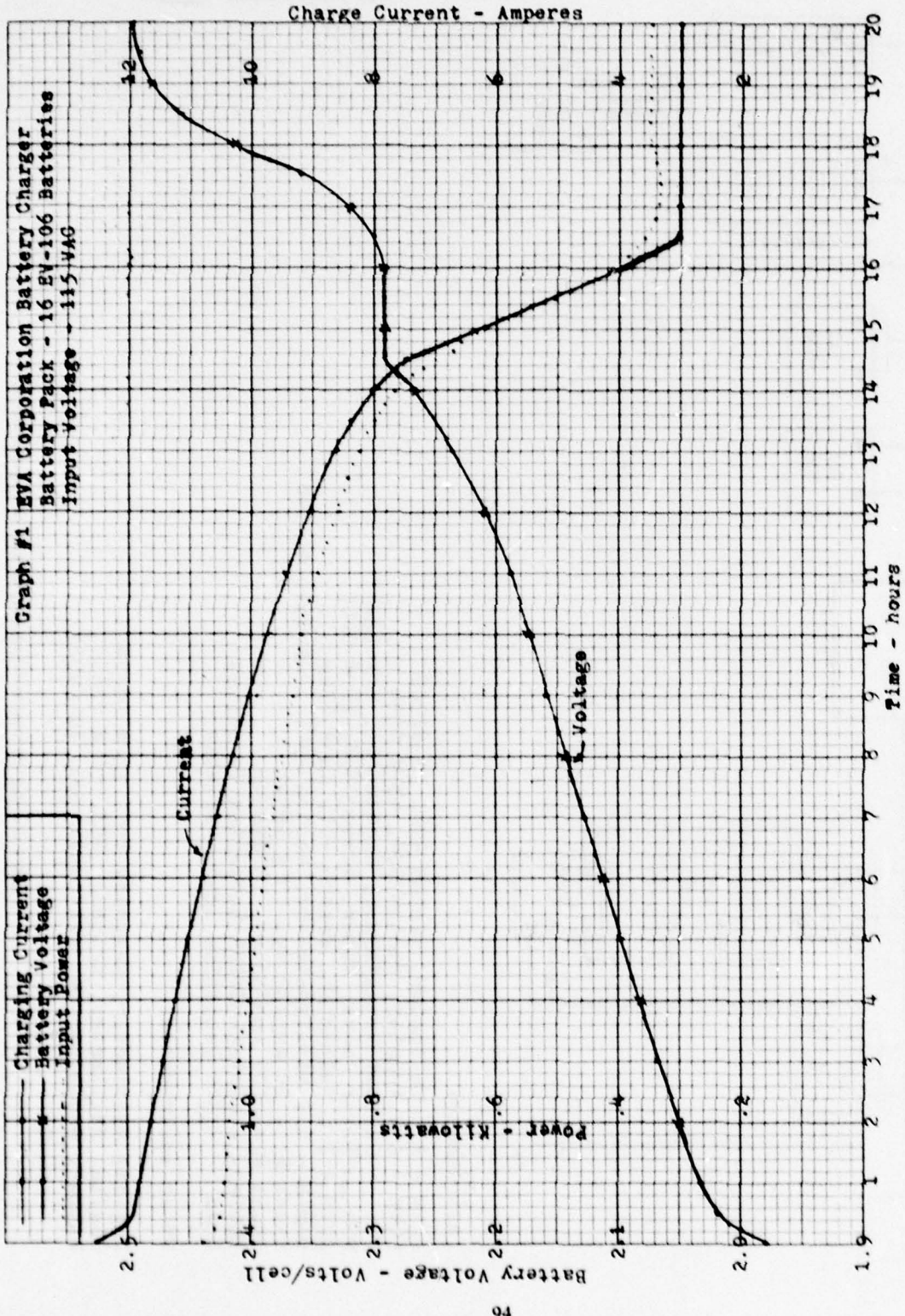

Figure C7. EVA Corporation Battery Charger: Input Voltage - 115 VAC.

EVA CORP. Battery Charger ** 115 Volt Conn. ** Voltage vs Current
Graph #2

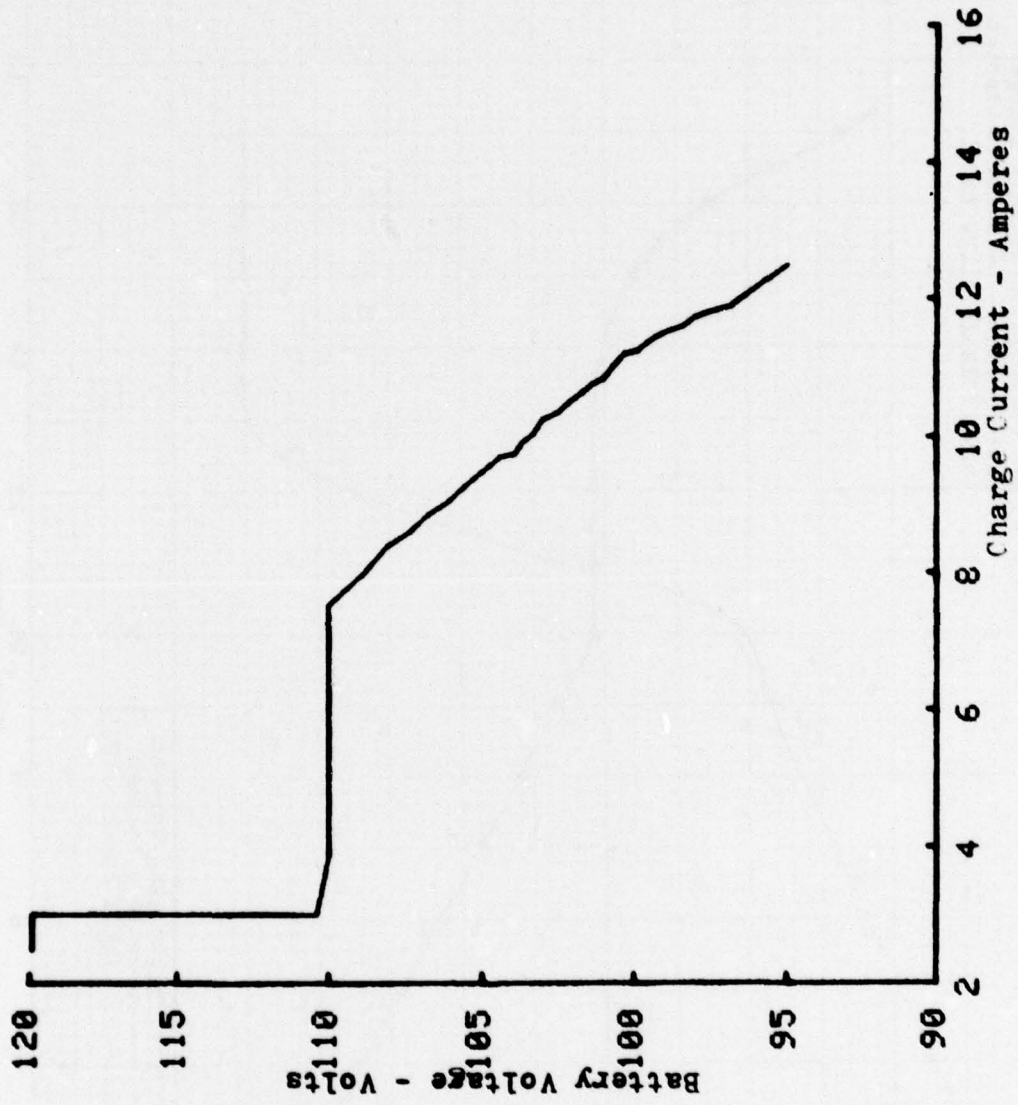

Figure C8. EVA Corporation Battery Charger, 115-V Connection, Voltage vs Current.

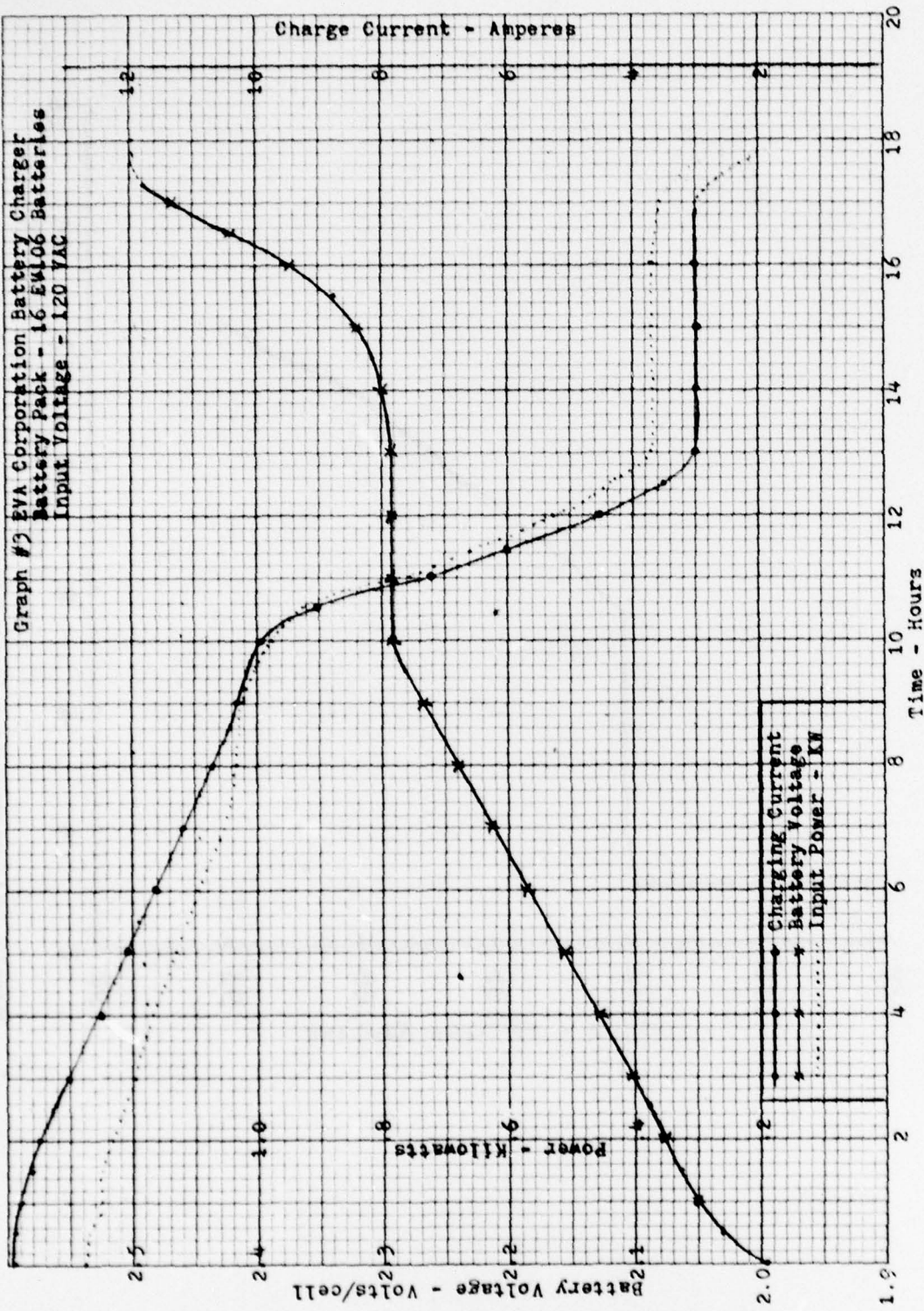

Figure C9. EVA Corporation Battery Charger. Input Voltage - 120 VAC.

EVA CORP > Battery Charger ** 120 Volt Conn. ** Voltage vs Current
Graph #4

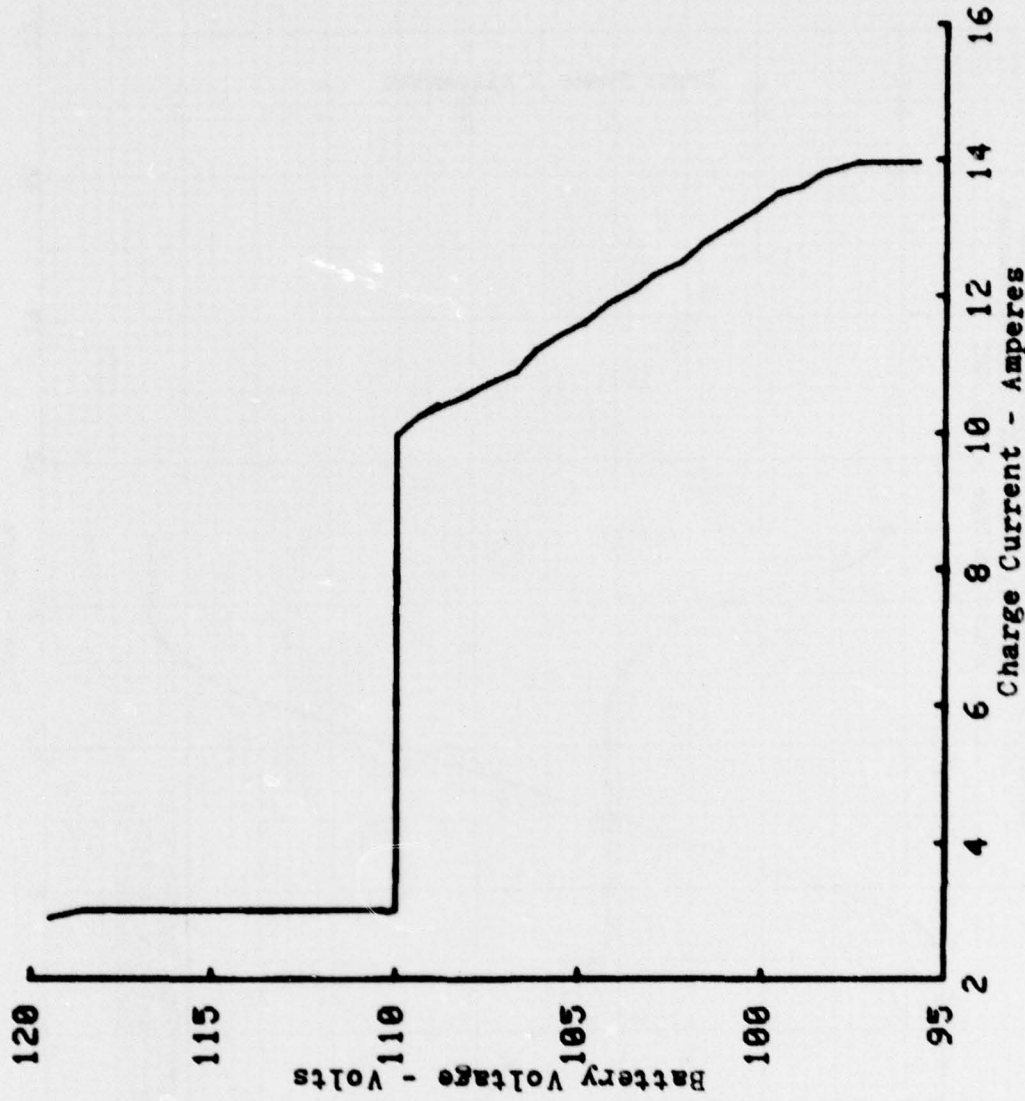

Figure C10. EVA Corporation Battery Charger; 120-V Connection, Voltage vs Current.

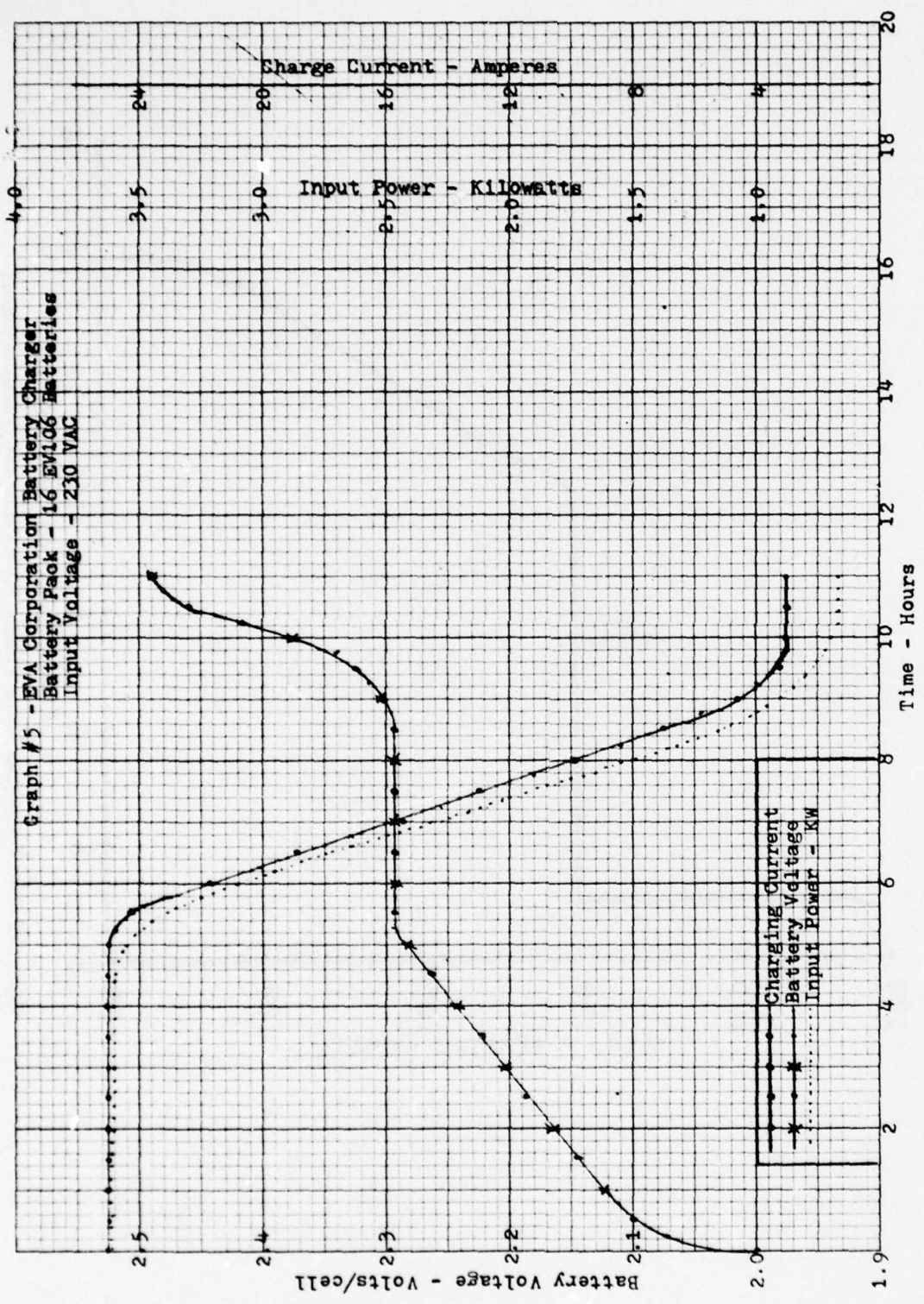

Figure C11. EVA Corporation Battery Charger: Input Voltage - 230 VAC.

EVA CORP. Battery Charger ** 230 Volt Conn. ** Voltage vs. Current
Graph #6

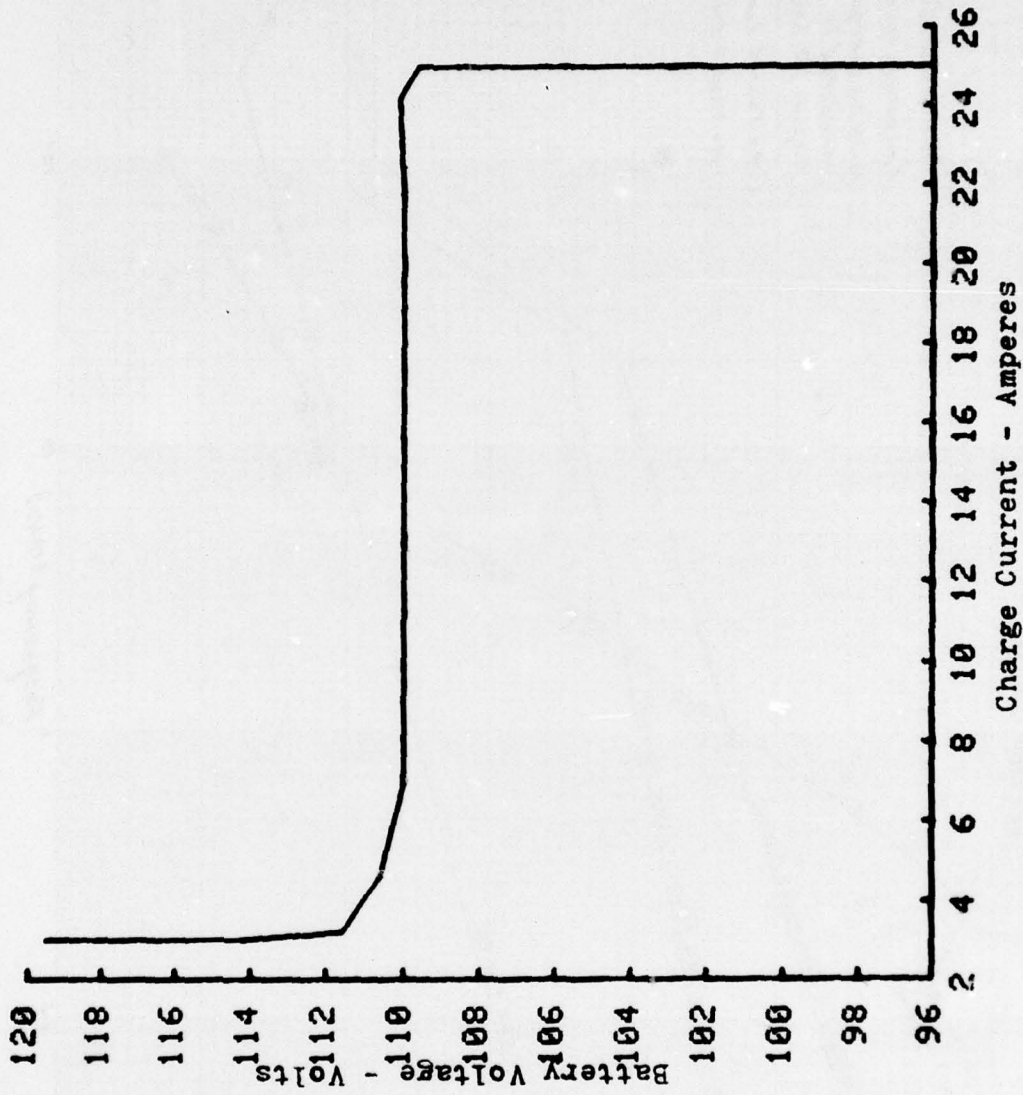

Figure C12. EVA Corporation Battery Charger; 230-V. Connection, Voltage vs Current.

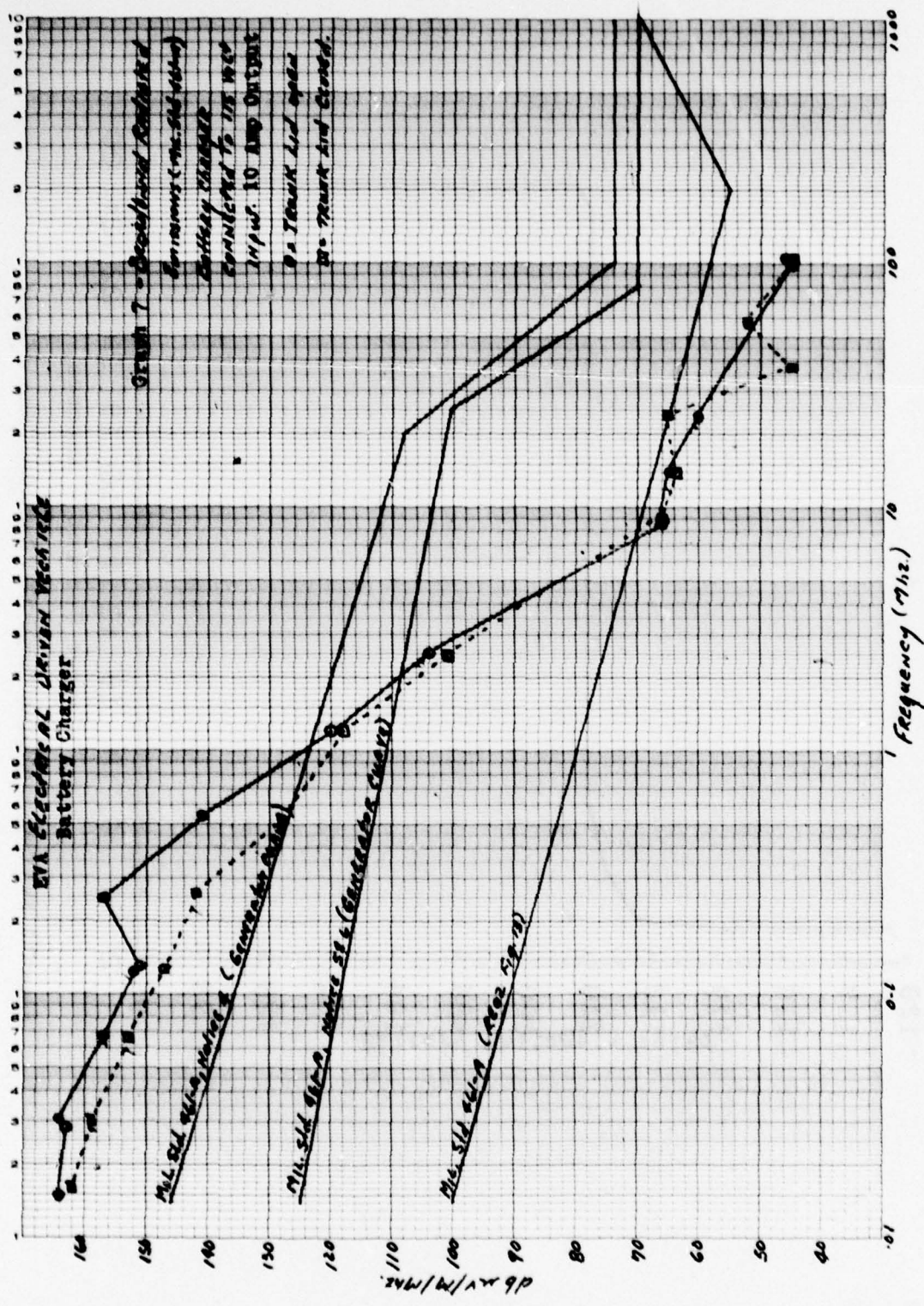

Figure C13. Broadband Radiated Emissions.

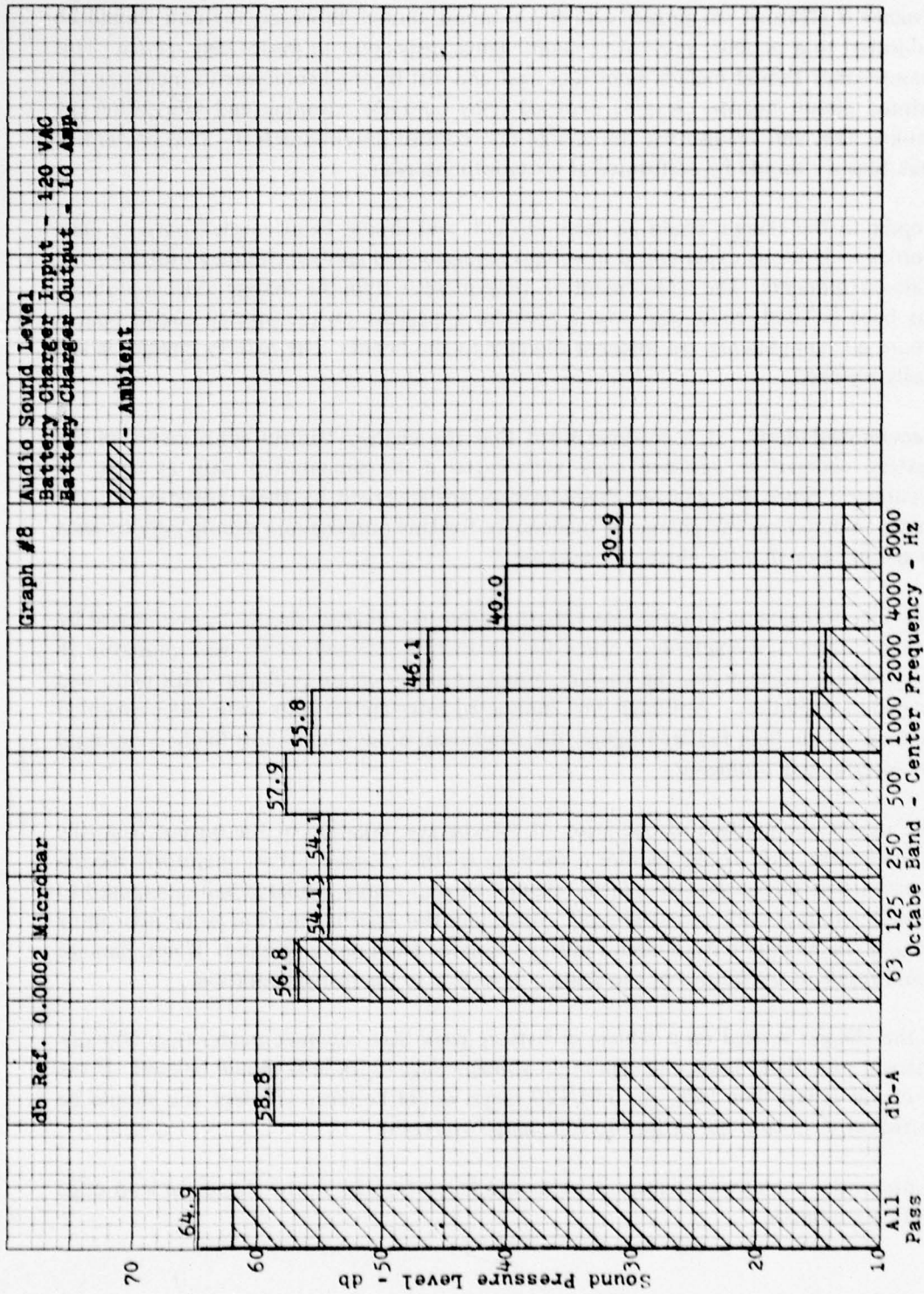

Figure C14. Audio Sound Level: Input - 120 VAC; Output - 10 A.

Maintenance. The EVA Corporation Battery Charger should require very little maintenance if afforded the proper care and it is not abused; however, the unit should be subjected to a periodic preventive maintenance inspection to insure long service. This maintenance should include removing dust and dirt from all components including the printed circuit boards, cleaning exposed relay contacts, cleaning and lubricating the cooling fan, and readjusting the charge rate control potentiometers. This preventive maintenance should be performed at six-month intervals.

Repair to the charger could be quite difficult and should be attempted only by electronics technicians experienced in voltage regulator and control circuitry utilizing solid state components. The replacement of components within the charger, once a problem has been isolated, could also pose a problem, especially on the printed circuit boards where all components are soldered directly to the board. The battery charger is not easily repaired.

Recommendations. It is recommended that the charger control adjustments of the battery charger be adjusted only with external instrumentation with at least 1% accuracy. Since the charger characteristics are governed by these adjustments, the single ammeter on the charger is inadequate for this purpose and should only be used as an indicator that the charger is working.

The Electromagnetic Interference radiation from the charger should be suppressed by either filtering or shielding. Since the charger is designed to be used primarily in residential environments, the charger would probably create problems with radio and television reception. Although the conducted interference tests were not performed because of the high radiated figure, the conducted noise would most likely compound the interference problems.

Because of the method of operation of the charger, isolation of the output from the input power line would require a redesign of the charger. It is, therefore, recommended that the output lines of the charger be thoroughly insulated and unexposed to possible contact with power ground. Also, any test instrumentation to be used in or around the charger output circuit must be isolated from power ground. If not, damage could result to the output of the charger as well as to the instrumentation.

If the charger is used on a vehicle or battery pack that becomes greater than 50% discharged on a daily basis, the high input voltage range (230/240) should be used. If the discharge is less than 50%, the 114/120 range would be more efficient and should be sufficient to restore the battery to full charge overnight.

A preventive maintenance inspection should be performed on the charger at least once every six months.

APPENDIX D

DATA ACQUISITION SYSTEMS

Data acquired from the test vehicle are conditioned with an instrumentation package and recorded on magnetic tape aboard the vehicle. The data are then reproduced off-board, and the analog signals are converted to digital and recorded on magnetic tape. This tape is then analyzed at the MERADCOM computer center. See Figure D-1 for a block diagram of the system. A description of the system components follows.

Vehicle Instrumentation Package. The vehicle instrumentation package consists of voltage attenuators, a current shunt output voltage amplifier, a multiplier, and averaging circuits. A 24-volt battery is used to power a DC to DC converter for power to the sub-components and the magnetic tape recorder. See Figure D-2 for a block diagram of the package. The current shunt voltage amplifier is a differential instrumentation type with a gain of 18.66 and can be operated up to 15 volts above ground. A calibration voltage was supplied separately for each channel before a test sequence.

Tape Recorder. The tape recorder has seven channels operated with FM signal electronics at 1-7/8 in/s. Tape speed accuracy is $\pm 0.2\%$, and the signal-to-noise ratio is 46 db. Time-base error and interchannel-time-displacement error are ± 12 and ± 25 microseconds, respectively.

Analog to Digital Converter. All seven outputs are converted to a digital format with a high-speed, 15 bit A/D converter. All input channels were sampled at rates of about 100 samples per channel per second and written onto magnetic tape for computer processing.

Data Reduction and Display. The digital magnetic tape is processed on the CDC 6600 computer. The data are smoothed by averaging sixty points. The data are then plotted and printed on a line printer.

System Accuracy. Table D1 contains the signal conditioning instrumentation errors. The values are taken from the component specifications. The overall error can be calculated based on the component paths shown in Figure D2. The fifth wheel-tachometer generator calibration is given in Table D-1.

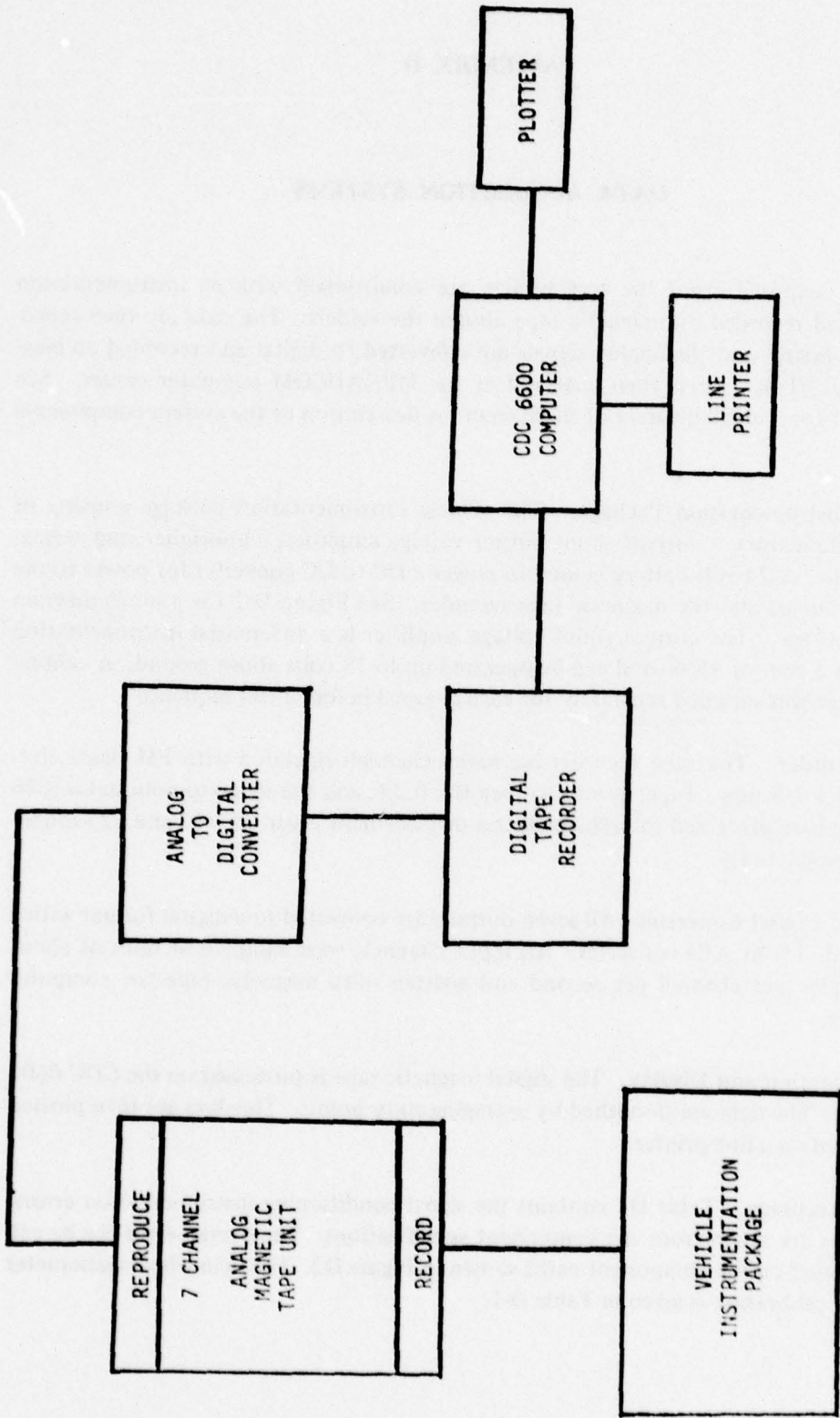

Figure D-1. Data Acquisition System Block Diagram.

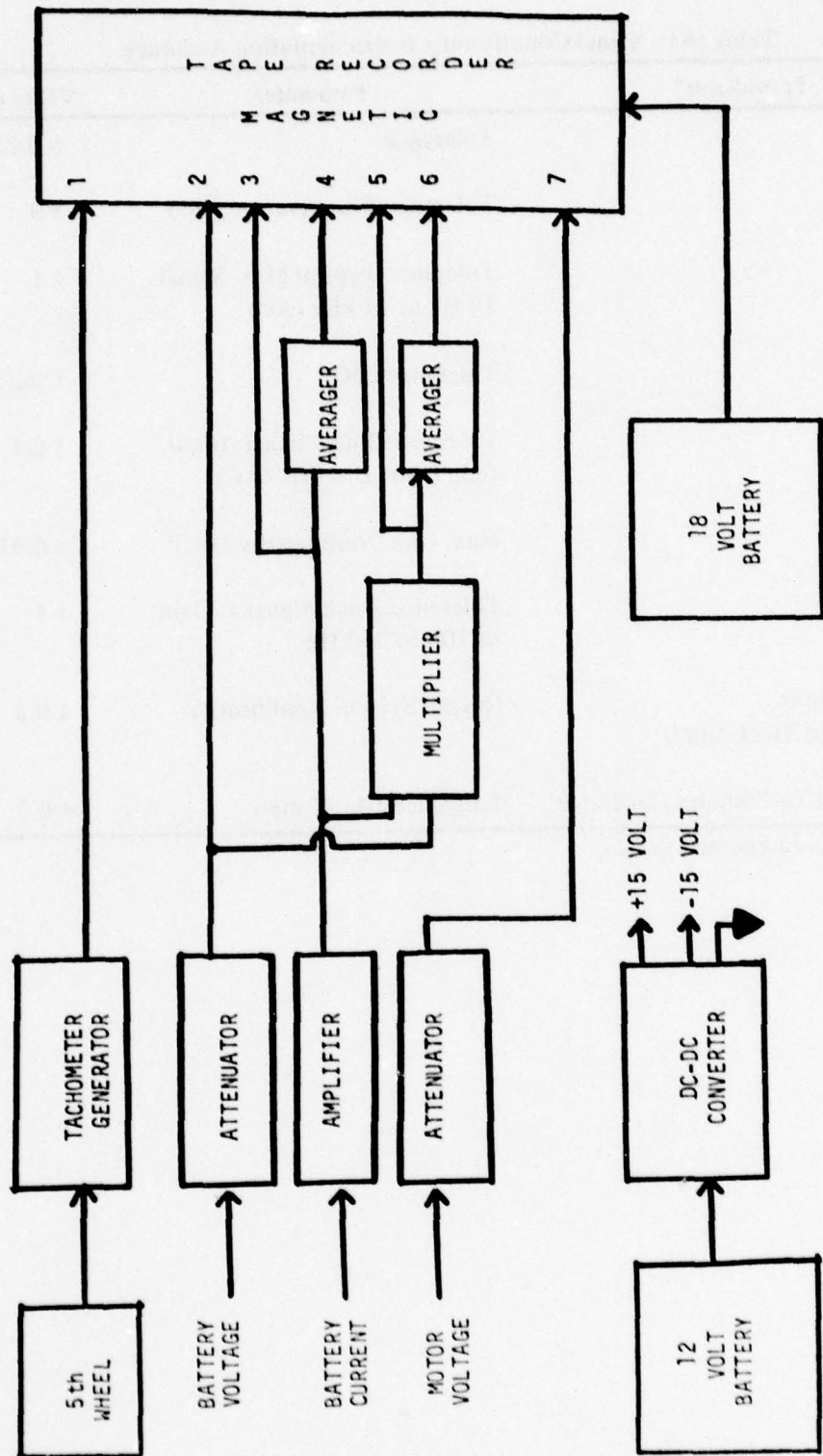

Figure D-2. Vehicle-mounted signal conditioning instrumentation package.

Table D-1. Signal Conditioning Instrumentation Accuracy

Transducer*	Parameter	Value (%)
Shunt	Tolerance	± 0.25
Averager	Tolerance-True Average (DC)	± 3
	Tolerance-Typical Max. Signal 10 Hz to 15 kHz (AC)	± 1
Multiplier	Tolerance (DC)	± 0.25
	Tolerance-Small Signal Amplitude Error at 4 kHz (AC)	± 0.1
Amplifier	Max. Gain Nonlinearity (DC)	± 0.01
	Tolerance-Small Signal at Gain of 100 to 25 kHz	± 1
Tape Recorder (F. M. Signal Electronics)	Overall System Nonlinearity	± 0.3
Fifth Wheel-Tachometer Generator	Tolerance 10-55 mph	± 0.7

* Refer to Figure D-2 for Block Diagram.

APPENDIX E

DESCRIPTION OF VEHICLE TEST TRACK

The test site used to conduct the tests described in this report is located at Aberdeen Proving Ground, Aberdeen, Maryland. The track is owned and operated by the US Army. Five test sites were used.

1. **Fording Basin.** The Fording Basin, or "Bathtub" (Figures E1 and E2), was designed to provide still water at controlled depths up to 6 feet. Ramps at both ends permit gradual immersion if desired. Length and width of the basin are sufficient for running preliminary flotation tests on some amphibious vehicles. The principal uses for the basin are for determining the fording characteristics of nonfloating vehicles and for studying the effects of water on running-gear components such as brakes, seals, and universal joints.

2. **Gradeability Slopes.** Gradeability of vehicles is a basic characteristic usually given in design specifications of military vehicles. The Munson gradeability slopes (Figures E3 and E4) cover a range of 5 to 60 percent. They are used to determine optimum drive ratios and maximum attainable speeds on each slope as well as brake-holding ability and adequacy of angles of approach and departure. With the test vehicle in both ascending and descending attitudes, functions such as lubrication, fuel flow, and carburetion are investigated. The effect of unbalance on turret traversing efforts and functioning of turret drive systems may also be studied on the slopes. The 5, 10, 15, and 20 percent slopes, approximately 14 feet wide, are paved with asphalt; the 30, 40, 45, 50, and 60 percent slopes, with concrete.

3. **Mile Loop.** The Mile Loop (Figure E5) was originally constructed in 1933 as a level, concrete course of oval shape for continuous, high-speed operating tests of vehicles. Near the headquarters area of the post, the course consists essentially of two straight sections, each one-quarter-mile long, joined at each end by quarter-mile sections of regular curvature to form an oval of 1 mile total circumference.

The course has been modified by covering and maintaining the surface with hot-mixed bituminous concrete and by the addition of a gravel surface parallel to and outside the oval. Several facilities also have been added in the area: a winch test facility, a "pothole-crosstie" course for forklift truck testing, and a 1-inch bump course for mobility testing of towed vehicles.

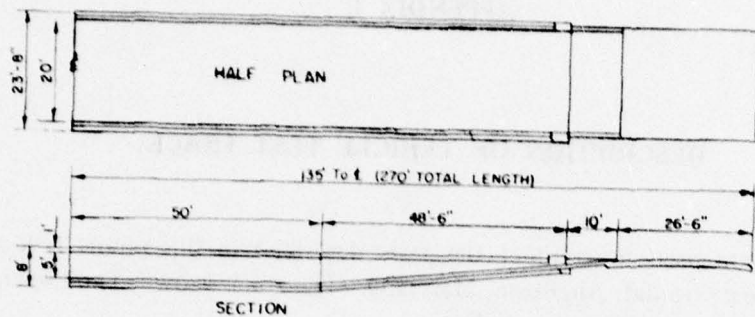

NOTE: DEPTH CAN BE INCREASED TO 6 FT. BY BLOCKING OVERFLOWS.

Figure E1. Half Plan and Section of Fording Basin.

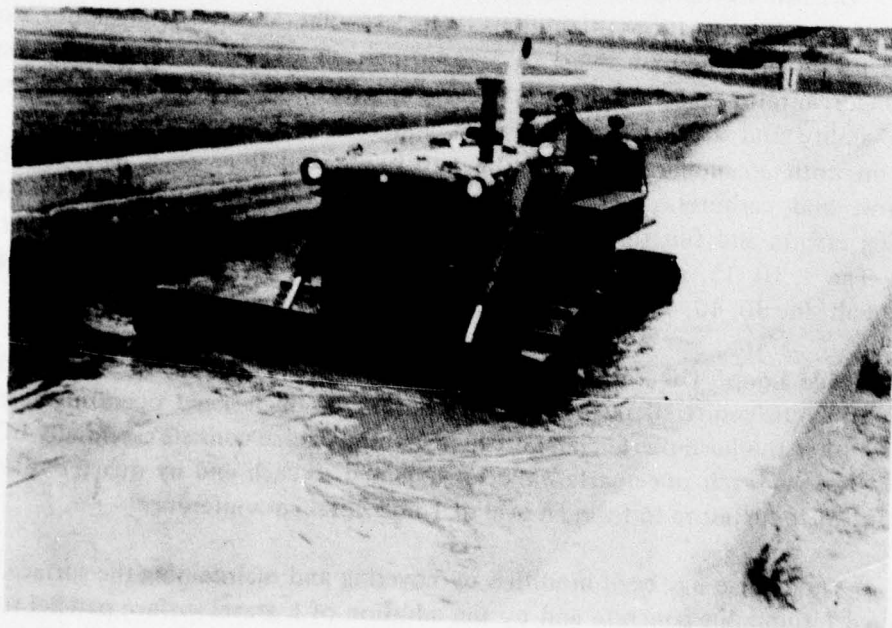

Figure E2. Tractor in Fording Basin.

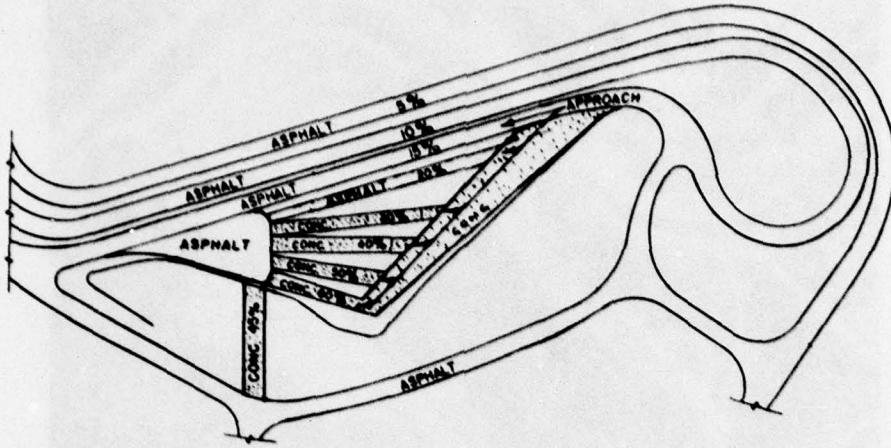

Figure E3. Plan View of Slopes.

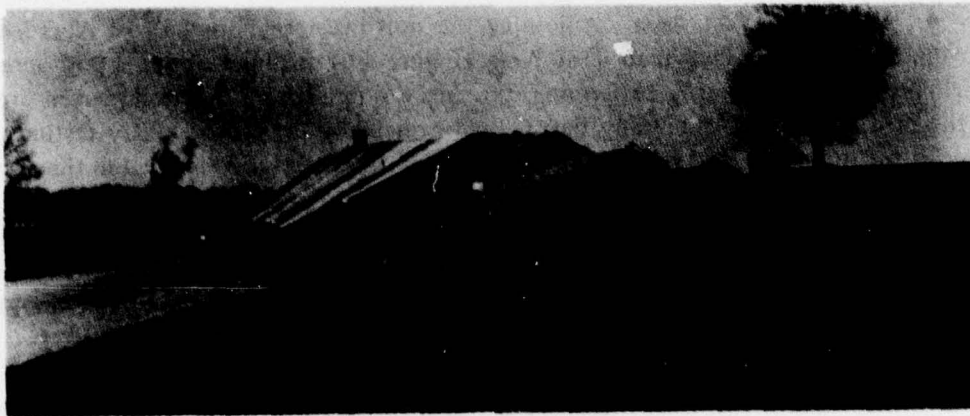

Figure E4. Eight of the Standard Gradeability Slopes.



Figure E5. Aerial View of Mile Loop.

4. **Perryman Test Area.** Adjoining the northwestern boundary of Aberdeen Proving Ground, the Perryman Test Area (Figure E6) includes about 2,000 acres. Originally devoted primarily to farming, the area is 5 miles from the headquarters area of the post. The land, essentially flat, is used principally for cross-country testing of vehicles for durability and reliability. Facilities for other tests are included in the area.

5. **Dynamometer Course.** The Dynamometer Course (Figure E7) is located in the Michaelsville section of the proving ground, 4 miles from the headquarters area. Constructed of reinforced concrete with a hot-mixed bituminous surface, it is suitable for the operation of the heaviest tracklaying vehicles.

The course has a total gradient of less than 0.1 percent in its 1-mile length, and turnarounds are provided at each end. It is used for closely controlled engineering tests such as drawbar pull and tractive resistance measurements, acceleration and braking tests, and fuel consumption measurements.



- | | |
|-----------------------------|----------------------------------|
| 1 - No. 1 Cross-Country | 8 - Mud Bypass Course |
| 2 - No. 2 Cross-Country | 9 - Mud Mobility Course |
| 3 - No. 3 Cross-Country | 10 - Mobile Bridge Test Facility |
| 4 - No. 4 Cross-Country | 11 - Deep Water Fording Facility |
| 5 - Secondary Road A | 12 - Swamp Quarter Mobility Area |
| 6 - Secondary Road B | 13 - Crash Barrier |
| 7 - 3-Mile, High Speed Road | 14 - Shop Area |

Figure E6. Aerial View of Perryman Test Area.

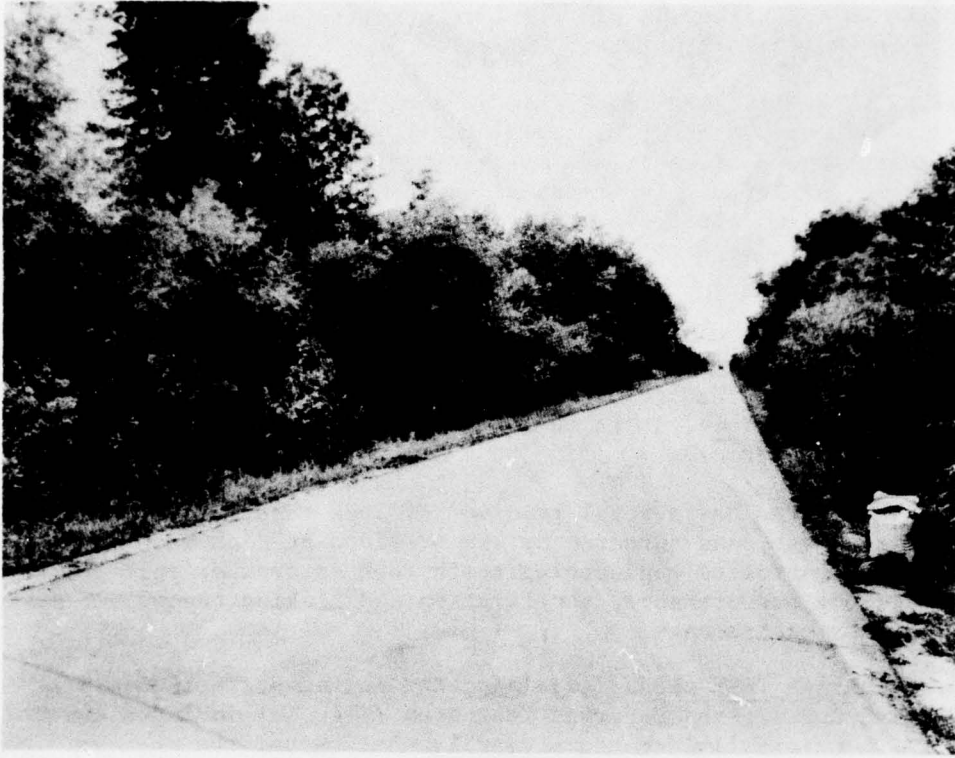

Figure E7. Dynamometer Course.

APPENDIX F

VEHICLE PREPARATION AND TEST PROCEDURE

When a vehicle was first received at Fort Belvoir, MERADCOM, a number of checks were made to assure that it was ready for performance tests. These checks were recorded on a vehicle preparation check sheet. The vehicle was examined for physical damage upon arrival. Before the vehicle was operated, a complete visual check was made of the entire vehicle. The battery was charged, and specific gravities were taken to determine if the batteries were equalized. If not, an equalizing charge was applied to the batteries. The integrity of the internal interconnections and the battery terminals was checked by drawing 300 amps or the vehicle manufacturer's maximum allowed current from the battery for five minutes. If the battery terminals or interconnections temperature rose more than 60°C above ambient, the test was terminated and the terminals were cleaned or the battery was replaced. The batteries were recharged, and a battery-capacity check was made. This test was made in accordance with the battery manufacturer's recommendations. To pass this test, the capacity had to be within 20% of manufacturer's published capacity at the published rate.

When a vehicle arrived at a test site (APG), a number of checks were performed to assure that it was ready for performance testing. The wheel alignment was checked, compared, and corrected to the manufacturer's recommended alignment values. The vehicle was weighed and compared with the manufacturer's specified curb weight. The gross vehicle weight was determined by manufacturer's rated pay load.

TEST PROCEDURE

Each day, before a test, a number of pre-test checks were made and entered on the vehicle data sheet. This data included:

- (1) Average specific gravity before and after test
- (2) Tire pressures
- (3) Fifth-wheel tire pressures
- (4) Weather information
- (5) Battery temperatures
- (6) Test start time
- (7) Test termination time
- (8) Amp hours out of the battery
- (9) Fifth wheel distance count
- (10) Odometer reading before and after each test
- (11) AC Kw used for recharge
- (12) DC Amp hours into battery on recharge

To prepare for a test, the specific gravities are first measured and recorded. The tire pressures are measured. The instrumentation is connected, and power from the instrumentation battery is applied. All instruments are turned on and warmed up, and all data channels are calibrated. The vehicle is towed to the starting point on the track. Weather data is recorded; odometer reading is taken. The test is started and is carried out in accordance with the DOE test and evaluation procedure. When the test is terminated, the test team makes all the proper checks and records all data on data test sheet for the day's test. After all checks are made, vehicle is towed back to the charge station and placed on charge for next day's test.

WEATHER DATA

Measurements of wind velocity and direction and ambient temperatures were taken at the beginning and at the end of each day's testing. The APG Airport weather station was used for all weather data.

DISTRIBUTION FOR MERADCOM REPORT 2244

No. Copies	Addressee	No. Copies	Addressee
	Department of Defense		
1	Director, Technical Information Defense Advanced Research Projects Agency 1400 Wilson Blvd Arlington, VA 22209	1	Technical Library Chemical Systems Lab Aberdeen Proving Ground, MD 21010
12	Defense Documentation Center Cameron Station Alexandria, VA 22314	1	Commander US Army Aberdeen Proving Ground ATTN: STEAP-MT-U (GE Branch) Aberdeen Proving Ground, MD 21005
	Department of the Army		
1	Commander, HQ TRADOC ATTN: ATEN-ME Fort Monroe, VA 23651	1	Director US Army Materiel Systems Analysis Agency ATTN: DRXSY-CM Aberdeen Proving Ground, MD 21005
1	HQDA (DAMA-AOA-M) Washington, DC 20310	1	Director US Army Ballistic Research Lab ATTN: DRDAR-TSB-S (STINFO) Aberdeen Proving Ground, MD 21005
1	HQDA (DALO-TS M-P) Washington, DC 20310	1	Director US Army Engineer Waterways Experiment Station ATTN: Chief, Library Branch Technical Info Ctr Vicksburg, MS 39180
1	HQDA (DAEN-RDL) Washington, DC 20314	1	Commander US Army Troop Support & Aviation Materiel Readiness Command ATTN: DRSTS-KTE 4300 Goodfellow Blvd St Louis, MO 63120
1	HQDA (DAEN-MCE-D) Washington, DC 20314	2	Director Petrol & Fld Svc Dept US Army Quartermaster School Fort Lee, VA 23801
1	Commander US Army Missile Research and Development Command ATTN: DRSMI-BR Redstone Arsenal, AL 35809	1	Commander US Army Electronics Research & Development Command ATTN: DRSEL-GG-TD Fort Monmouth, NJ 07703
1	Chief, Engineer Division DCSLOG ATTN: AFKC-LG-E HQ Sixth US Army Presidio of San Francisco, CA 94129		
1	Director Army Materials and Mechanics Research Center ATTN: DRXMR-STL Technical Library Watertown, MA 02172		
1	US Army Ballistic Research Labs Technical Library DRXBR-LB (Bldg 305) Aberdeen Proving Ground, MD 21005		

No. Copies	Addressee	No. Copies	Addressee
1	President US Army Aviation Test Board ATTN: STEBG-PO Fort Rucker, AL 36360	1	Commander 2nd Engineer Group ATTN: S4 APO San Francisco 96301
1	US Army Aviation School Library P.O. Drawer 0 Fort Rucker, AL 36360	1	Commander and Director USAFESA ATTN: FESA-RTD Fort Belvoir, VA 22060
1	HQ, 193D Infantry Brigade (CZ) Directorate of Facilities Engineering Fort Amador, Canal Zone	1	Director US Army TRADOC Systems Analysis Activity ATTN: ATAA-SL (Tech Lib) White Sands Missile Range, NM 88002
1	Commander Special Forces Detachment (Airborne), Europe APO New York 09050		MERADCOM
1	HQ, USAREUR & Seventh Army DCSENGR, ATTN: AEAEN-MO ATTN: Mil Ops Div APO New York 09403	1	Commander, DRDME-Z Technical Director, DRDME-ZT Assoc Tech Dir/R&D, DRDME-ZN Assoc Tech Dir/Engrg & Acq, DRDME-ZE Spec Asst/Matl Asmt, DRDME-ZG Spec Asst/Tech Asmt, DRDME-ZK CIRCULATE
2	Engineer Representative US Army Standardization Group, UK Box 65, FPO New York 09510		
1	Commander Rock Island Arsenal ATTN: SARRI-LPL Rock Island, IL 61201	1	C, Ctrmine Lab, DRDME-N C, Engy & Wtr Res Lab, DRDME-G C, Cam & Topo Lab, DRDME-R C, Mar & Br Lab, DRDME-M C, Mech & Constr Eqpt Lab, DRDME-H C, Ctr Intrus Lab, DRDME-X C, Matl Tech Lab, DRDME-V Director, Product A&T Directorate, DRDME-T CIRCULATE
1	Commander Frankford Arsenal ATTN: Library, K2400, B1 51-2 Philadelphia, PA 19137	10	Elec Pwr Lab, DRDME-E
1	Learning Resources Center US Army Engineer School Bldg 270 Fort Belvoir, VA 22060	200	Electrochem Div, DRDME-EC
1	President US Army Airborne, Communications and Electronics ATTN: STEBF-ABTD Fort Bragg, NC 28307	3	Tech Reports Ofc, DRDME-WP
1	Commander Headquarters, 39th Engineer Battalion (Cbt) Fort Devens, MA 01433	3	Security Ofc (for liaison officers) DRDME-S
1	President US Army Armor and Engineer Board ATTN: ATZK-AE-TD-E Fort Knox, KY 40121	2	Tech Library, DRDME-WC
		1	Plans, Programs & Ops Ofc, DRDME-U
		1	Pub Affairs, Ofc, DRDME-I
		1	Ofc of Chief Counsel, DRDME-L
			Department of the Navy
		1	Director Naval Research Laboratory ATTN: Code 2627 Washington, DC 20375

No. Copies	Addressee	No. Copies	Addressee
1	Commander, Naval Facilities Engineering Command Department of the Navy ATTN: Code 032-A 200 Stovall St Alexandria, VA 22332	1	Advanced Ground Systems Eng ATTN: Dr. George Gelb 3270 E. 70th Street Long Beach, CA 90805
1	US Naval Oceanographic Office Library (Code 1600) Washington, DC 20373	1	Airesearch Manufacturing Co ATTN: Bob Rowlett Program Manager 2525 W. 190th Street Torrance, CA 90509
1	Officer-in-Charge (Code L31) Civil Engineering Lab Naval Construction Battalion Ctr Port Huene, CA 93043	1	AM General Corporation ATTN: H. H. Crist, Sales Manager 32500 Van Born Road Wayne, MI 48184
1	Naval Training Equipment Ctr ATTN: Technical Library Orlando, FL 32813	1	Amectran ATTN: Mr. Ed Ramirez President 1545 West Mockingbird Suite 4020 Dallas, TX 75235
	Department of the Air Force		
1	HQ USAF/RDPS (Mr. Allan Eaffy) Washington, DC 20330	1	Argonne National Labs ATTN: Al Chilenskas 9700 South Cass Avenue Argonne, IL 60439
1	Mr. William J. Engle Chief, Utilities Branch HQ USAF/PREEU Washington, DC 20332	1	B&Z Electric Car Robert McCoy 1418 West 17th Street Long Beach, CA 90813
1	AFSC/INJ Andrews AFB, MD 20334	1	Batronic Truck Corporation ATTN: Mr. Harry Yoder President 3rd and Walnut Streets Boyetown, PA 19512
1	AFCEC/XR/21 Tyndall AFB, FL 32401	1	Billings Energy Corporation ATTN: Mr. Hadden P.O. Box 555 Provo, UT 84601
1	HQ USAF/PREES ATTN: Mr. Edwin B. Mixon Bolling AFB-Bldg 626 Washington, DC 20332	1	Booz, Allen & Hamilton Inc. John F. Wing Transportation Consulting Div 4330 East West Highway Bethesda, MD 20014
1	AFAPL/SFL Wright-Patterson AFB, OH 45433	1	Borisoff Engineering Co 7726 Burnet Ave Van Nuys, CA 91405
1	Department of Transportation Library, FOB 10A, TAD-494.6 800 Independence Ave., SW Washington, DC 20591		
	Others		
1	A. D. Little ATTN: Brad Underhill 15 Acorn Park Cambridge, MA 02140		

No. Copies	Addressee	No. Copies	Addressee
1	C. H. Waterman Industries ATTN: C. H. Waterman President White Pond Road Athol, MA 01331	1	Department of Energy ATTN: Walter J. Dippold Electric & Hybrid Vehicle Systems 20 Massachusetts Avenue NW Washington, DC 20545
1	Chloride America James A. Gilchrist, President 5200 W. Kennedy Blvd P.O. Box 24598 Tampa, FL 33623	1	Department of Industry, Trade, & Commerce Fred Johnson, Special Vehicle Div Transportation Industries Branch Ottawa, Canada, KIA 085
1	Compass Industries, Inc. Richard J. Barkley 715 15th Street Hermosa Beach, CA 90254	1	Department of Transportation Transportation Systems Center ATTN: Dr. Norman Rosenberg Cambridge, MA 02142
1	Cooper Development Association ATTN: Donald K. Miner, Manager 430 N. Woodward Ave Birmingham, MI 48011	1	Derl Manufacturing Company ATTN: Mr. Erwin Meeks 2730 N. Slater Avenue Compton, CA 90222
1	Cornell University Joe Rosson, Associate Director School of Engineering Phillips Hall Ithaca, NY 14853	1	Die Mesh Corporation ATTN: Mr. Domenic Borello President 629 Fifth Avenue Pelham, NY 10803
1	Creative Automotive Research ATTN: Erwin A. Ulbrich Chief Engineer 8136 Byron Road, Suite G Whittier, CA 90606	1	Dimension V. Inc. James H. Muir, President 598 Sea Breeze Drive Indialantic, FL 32903
1	Creative Research Corp ATTN: Larry Nalley, President P.O. Box 186 Roebuck, SC 29376	1	Douglas Dow Consulting Engineer P.O. Box 14078 Detroit, MI 48214
1	Daihatsu Motor Co., Ltd ATTN: Shoji Honda General Manager Electric Vehicle Department 1-1 Daihatsu - Cho Ikeda City, Osaka Prefecture, Japan	1	Dynamic Science ATTN: Mr. B. Enserik 1850 W. Pinnacle Peak Rd Phoenix, AZ 85027
50	Department of Energy ATTN: Dr. Robert S. Kirk Transportation Energy Conservation 20 Massachusetts Avenue NW Washington, DC 20545	1	Edward Harding & Co. c/o W. W. Craig 1411 North State Parkway Chicago, IL 60610
		1	Elcar Corporation ATTN: Leon Shahnasarian President 2118 Bypass Road P.O. Box 937 Elkhart, IN 46514

No. Copies	Addressee	No. Copies	Addressee
1	Electraction Limited ATTN: R. D. Haynes Heybridge Basin Maldon Essex, England	1	Fiat ATTN: Dennis Hanify, Manager IIT Research Institute 10 West 35th Street Chicago, IL 60616
1	Electric Dynamics Corp James C. Boylan, President 607 North Main Street Plainwell, MI 49080	1	Fluid Drive Engineering Co. ATTN: Joseph Seliber 313 Hibbard Road Wilmette, IL 60091
1	Electric Fuel Propulsion Corp ATTN: Robert Aronson President 2237 Elliott Avenue Troy, MI 48084	1	General Electric Corporate Research & Development ATTN: Gene Rowland Program Manager P.O. Box 8 Schenectady, NY 12301
1	Electric Passenger Cars, Inc. ATTN: P. H. Rubie, President 5127 Galt Way San Diego, CA 92117	1	General Research Corporation ATTN: John Brennand 5383 Hollister Avenue Santa Barbara, CA 93105
1	Electric Power Research Institute ATTN: Dr. Fritz R. Kalhammer 3412 Hillview Avenue P.O. Box 10412 Palo Alto, CA 94304	1	General Services Administration Federal Supply Service ATTN: Mel Globerman Washington, DC 20406
1	Electric Vehicle Associates ATTN: Warren Harhay President 9100 Bank Street Cleveland, OH 44125	1	General Services Administration Federal Supply Service ATTN: R. L. Ullrich Washington, DC 20406
1	Electric Vehicle Council ATTN: Mr. Edward Campbell 90 Park Avenue New York, NY 10016	1	Jet Industries, Inc. ATTN: William Bales, President 4201 South Congress Austin, TX 78745
1	Electric Vehicle Engineering Wayne Goldman, President P.O. Box 1 Lexington, MA 02173	1	Jet Propulsion Laboratory ATTN: T. Barber 4800 Oak Grove Drive Pasadena, CA 91103
1	Energy Research and Development Corp ATTN: R. Childs, President 9135 Fernwood Drive Olmsted Falls, OH 44138	3	Jet Propulsion Laboratory ATTN: Donald W. Ritchie 198-220 4800 Oak Grove Drive Pasadena, CA 91103
1	ESB, Inc. ATTN: Jim Norberg 5 Penn Center Plaza Philadelphia, PA 19103	1	Kaylor Energy Products ATTN: Roy Kaylor, President 1918 Menalto Avenue Menlo Park, CA 94025
1	EVE Electric Motor Car, Inc. ATTN: Alan D. Brown 723 Forest Street East Lansing, MI 48823	1	Kinergy Research & Development ATTN: Laura Omohundro P.O. Box 1124 Wake Forest, NC 27587

No. Copies	Addressee	No. Copies	Addressee
1	Lavelle Aircraft Co ATTN: R. Wilks Sterling Street Newtown, PA 18940	1	Meteor Research Limited ATTN: W. H. Fengler, President 29440 Calahan Avenue Roseville, MI 48066
1	Lawrence Livermore Laboratory ATTN: Douglas Davis-MS-L-216 P.O. Box 808 Livermore, CA 94550	1	Minicars, Inc. ATTN: Mr. Donald Friedman 35 La Patera Lane Goleta, CA 93017
1	Lectran ATTN: Ray L. Boeger 5452 Business Drive Huntington Beach, CA 92649	1	NASA - Lewis Research Center ATTN: J. S. Fordyce MS: 309-1 21000 Brookpark Road Cleveland, OH 44135
1	Linear Alpha, Inc. ATTN: Dr. E. H. Wakefield 1927 Sherman Avenue Evanston, IL 60201	1	NASA - Lewis Research Center ATTN: Mort Krasner MS: 500-210 21000 Brookpark Road Cleveland, OH 44135
1	Los Alamos Scientific Labs Byron McCormick P.O. Box 1663 Los Alamos, New Mexico 87545	20	NASA - Lewis Research Center ATTN: H. J. Schwartz MS: 500-215 21000 Brookpark Road Cleveland, OH 44135
1	Joseph Lucas, Ltd. ATTN: Dr. Brian Phillips Special Projects 17 Evelyn Road Sparkhill, Birmingham B 11 3JR England	1	NASA ATTN: NE/E. E. VanLandingham Washington, DC 20546
1	Lucas Industries N.A. Inc. ATTN: Tony Burgess Two Northfield Plaza Troy, MI 48098	1	National Motors Corporation ATTN: Barryl Kane, President P.O. Box 1523 Lancaster, PA 17604
1	Marathon Electric Vehicles, Limited ATTN: Howard Candlish 8305 LeCreusot Street Ville St. Leonard, P.Q. Montreal, Quebec, H1P 2A2 Canada	1	Newton Engineering Co. ATTN: John S. Newton, President 22 W. 450 Ahlstrand Drive Glen Ellyn, IL 60137
1	Maxon Industries, Inc. ATTN: Murray Lugash 1960 E. Slavson Avenue Huntington Park, CA 90255	1	Northwestern University ATTN: Dr. Gordon Murphy Electric Engineering Dept 2145 Sheridan Road Evanston, IL 60201
1	McKee Engineering Corporation ATTN: Robert McKee, President 411 West Colfax Street Palatine, IL 60067	1	Onan Corporation ATTN: David Burns 1400 73rd Avenue NE Minneapolis, MN 55432
		1	Packaged Promotions, Inc. ATTN: Al Masters 549 W. Randolph Chicago, IL 60606

No. Copies	Addressee	No. Copies	Addressee
1	Petro-Electric Motors, Ltd ATTN: Victor Wouk, Consultant 342 Madison Avenue, Suite 831 New York, NY 10017	1	Triad Services, Inc. ATTN: Michael Pocabello, President 10611 Haggerty Street Dearborn, MI 48126
1	Powertrain, Inc ATTN: Mr. Alfred Blackerby 3665 S. 300 West Salt Lake City, UT 84115	1	TurElec, Inc. ATTN: Harry Grepke, President 1915 29th Avenue, West Bradenton, FL 33505
1	Purdue University IIES A. A. Potter Engineering Center ATTN: Dr. R. E. Goodson W. Lafayette, IN 47907	1	Unique Mobility, Inc. ATTN: John Gould 3730 South Jason Englewood, CO 80110
1	REI ATTN: E. Papandreas 1209 Lake Avenue Lake Worth, FL 33460	1	United States Postal Service ATTN: Dick Bowman Office of Fleet Mgmt Delivery Services Dept Washington, DC 20260
1	Sandia Laboratories Richard Bassett Division 2354 P.O. Box 5800 Kirkland Base East Albuquerque, New Mexico 87115	1	United States Postal Service ATTN: Donn Crane, Director Office of Fleet Mgmt Delivery Services, Dept Washington, DC 20260
1	Sebring-Vanguard, Inc. ATTN: Robert Beaumont President 9130 Red Branch Road Columbia, MD 21045	1	United States Postal Service Research & Development Lab ATTN: Lewis J. Gerlach Program Manager 11711 Park Lawn Drive Rockville, MD 20852
1	Society of Automotive Engineers, Inc. William Toth, Staff Engineer 400 Commonwealth Warrendale, PA 15096	1	United States Postal Service ATTN: Thomas W. Martin, Manager Vehicle Services Branch Western Region San Bruno, CA 94099
1	Solargen Electronics, Ltd. Steven J. Romer 562 Fifth Avenue New York, NY 10036	1	University of California Jack Bolger Lawrence Berkeley Labs Berkeley, CA 94720
1	South Coast Technology, Inc. ATTN: Robert Schwarz P.O. Box 3265 Santa Barbara, CA 93105	1	Volkswagen of America, Inc. ATTN: Tom Turnure Englewood Cliffs, NJ 07632
1	Structural Plastics, Inc. ATTN: William Gillespie, President 1133 S. 120th East Avenue Tulsa, OK 74128	1	Volkswagen of America, Inc. ATTN: Rudy Schmidt c/o Tom Turnure Englewood Cliffs, NJ 07632
1	Transportation Research Center of Ohio ATTN: Mr. C. Glassburn East Liberty, OH 43319		

No. Copies	Addressee
1	Western Research Industries ATTN: G. Hayes Turney 3013 West Sahara Avenue Las Vegas, NV 89102
1	Westinghouse R&D Center ATTN: G. Frank Pittman, Jr. 1310 Beulah Road Pittsburgh, PA 15235
1	Wolverine Diesel Power Co. ATTN: J. F. Corcoran, President 2880 Aero Park Drive Traverse City, MI 49684
1	Wood-Ivey Systems Corporation ATTN: Mr. Ivey P.O. Box 4609 Winterpark, FL 32793
1	Paul Zaroni 820 Tenth Street Boulder, CO 80302
1	Zeonics Corporation ATTN: Mr. Ai Long 4085 Chain Bridge Road Fairfax, VA 22030