

SECURITY CLASSIFICATION OF THIS PAGE (When Data Entered)

11

AD A 057221

AD No. —
DDC FILE COPY

REPORT DOCUMENTATION NUMBER		READ INSTRUCTIONS BEFORE COMPLETING FORM
1. REPORT NUMBER Volume 2	2. CONTROLLING OFFICE SYMBOL AND NUMBER	3. RECIPIENT'S CATALOG NUMBER
4. TITLE (and Subtitle) ⑥ PRODUCTION BASELINE MK83 BOMB BODY ASSEMBLY, Volume II. ENGINEERING ASSESSMENT OF PLANT EQUIPMENT PACKAGE (PEP) MODERNIZATION PROGRAM.		5. TYPE OF REPORT & PERIOD COVERED Final 11/77 - 7/78
7. AUTHOR(s) Kaiser Engineers in Association with Stetter Associates, Inc.		6. PERFORMING ORG. REPORT NUMBER ⑭ 78-13-R-2
9. PERFORMING ORGANIZATION NAME AND ADDRESS Kaiser Engineers 300 Lakeside Drive, P. O. Box 23210 Oakland, CA 94623		8. CONTRACT OR GRANT NUMBER(s) ⑮ DAAK10-78-C-0020 ✓
11. CONTROLLING OFFICE NAME AND ADDRESS Department of the Army Project Manager, Munitions Production Base Modernization & Expansion, Dover, NJ 07801		10. PROGRAM ELEMENT, PROJECT, TASK AREA & WORK UNIT NUMBERS DD Form 1423
14. MONITORING AGENCY NAME & ADDRESS (if different from Controlling Office) ⑨ Final rept. Nov 77 - Jul 78.		12. REPORT DATE ⑪ Jul 1978
		13. NUMBER OF PAGES 50 ⑫ 110p
		15. SECURITY CLASS. (of this report) Unclassified
		15a. DECLASSIFICATION/DOWNGRADING SCHEDULE
16. DISTRIBUTION STATEMENT (of this Report) Approved for public release; distribution unlimited		
17. DISTRIBUTION STATEMENT (of the abstract entered in Block 20, if different from Report)		
18. SUPPLEMENTARY NOTES The production baseline was designed as a standard for evaluating existing MK83 bomb production facilities.		
19. KEY WORDS (Continue on reverse side if necessary and identify by block number) Plant Equipment Package Model Line PEP Bomb PEP Modernization MK83 Metal Parts Production Line		
20. ABSTRACT (Continue on reverse side if necessary and identify by block number) A production baseline is a theoretical production line based on technical data package configurations and specifications. This report describes alternative methods and provides a recommended method for the production of metal part components and the assembly of the MK83 bomb body.		

LEVEL III

DDC
RECEIVED
AUG 8 1978
ALBUQUERQUE

58 08 07 030

DD FORM 1 JAN 73 1473

EDITION OF 1 NOV 65 IS OBSOLETE

Unclassified

SECURITY CLASSIFICATION OF THIS PAGE (When Data Entered)

194 625

PRODUCTION BASELINE
MK83 BOMB BODY ASSEMBLY

REPORT NO. 78-13-R-2

Volume 2

ACCESSION for	
NTIS	Write Section <input checked="" type="checkbox"/>
DDC	Buff. Section <input type="checkbox"/>
UNANNOUNCED	<input type="checkbox"/>
JUSTIFICATION	
BY	
DISTRIBUTION/AVAILABILITY CODES	
Disc.	SPECIAL
A	

ENGINEERING ASSESSMENT OF
PLANT EQUIPMENT PACKAGE (PEP) MODERNIZATION PROGRAM

Prepared for Project Manager
Munitions Production Base Modernization and Expansion

Administered by U.S. Army Armament Research and Development Command
Contract No. DAAK10-78-C-0020

July 1978

KAISER ENGINEERS
In Association with Stetter Associates, Inc.

TABLE OF CONTENTS

<u>Section</u>	<u>Page</u>
I. Introduction	I-1
II. Process Description Summary	II-1
III. Analysis of Operations	III-1
A. Casing, Bomb, MK83 Mod 4 (1380266)	III-1
B. Ring, Adapter, Bomb Body (1252606)	III-17
C. Plug, Base, Bomb Body (4902488)	III-22
D. Insert, Suspension Lug (1253008)	III-27
E. Insert, Forward (1380267)	III-31
F. Retainer, Fuze Liner (4902493)	III-35
G. Fuze Liner, Aft (4902490)	III-37
H. Canister - Item 1	III-38
I. Collar - Item 2, Part of (4902490)	III-39
J. Sleeve, Fuze Liner (4902492)	III-40
K. Fuze Liner, Aft (4902490)	III-41
L. Fuze Liner Assembly (4902494) Aft	III-43
M. Fuze Liner, Forward (1239593)	III-44
N. Canister - Item 1, Part of (1239593)	III-45
O. Collar - Item 2, Part of (1239593)	III-46
P. Sleeve, Fuze Liner (4902492)	III-47
Q. Fuze Liner, Fwd (1239593)	III-48
R. Fuze Liner Assembly (4902495), Fwd	III-50
S. Body Assembly, Bomb, General Purpose (2841464)	III-51
IV. Recommended Production Baseline for the MK83 Mod 4, 1,000-lb Bomb Body Assembly	IV-1
A. Casing, Bomb, MK83 Mod 4 (1380266)	IV-4
B. Ring, Adapter, Bomb Body (1381204)	IV-9
C. Plug, Base, Bomb Body (4902488)	IV-11
D. Insert Suspension Lug (1253008)	IV-13
E. Insert, Forward (1380267)	IV-15

LIST OF FIGURES

<u>Figures</u>		<u>Follows</u> <u>Page</u>
III-1	Casing, Bomb, General Purpose 1,000 Pound MK83 Mod 4, Empty, Part No. 2841466	III-1
III-2	Flow Chart, MK83 Bomb Body (Tube) Sub-Assembly (1380266)	III-1
III-3	Flow Chart, MK83 Bomb, Ring Adapter (1381204); Base Plug (4902488); Insert, Suspension Lug (1253008); Insert, Forward (1380267)	III-17
III-4	Body Assembly, Bomb, General Purpose, 1,000 Pound, MK83 Mod 4, Empty, Part No. 2841464	III-51
III-5	Flow Chart, MK83 Bomb Body Assembly (2841464)	III-51

LIST OF TABLES

<u>Tables</u>	<u>Page</u>
II-1 Process Description Summary for Bomb Casing (1380266)	II-3
II-2 Process Description Summary for Adapter Ring (1381204)	II-10
II-3 Process Description Summary for Base Plug (4902488)	II-12
II-4 Process Description Summary for Insert, Suspension Lug (1253008)	II-14
II-5 Process Description Summary for Forward Insert (1380267)	II-16
IV-1 Recommended Sequence of Manufacture Tube Method for Casing (1380266)	IV-17
IV-2 Recommended Sequence of Manufacture Hot Cup Method for Adapter Ring (1381204)	IV-20
IV-3 Recommended Sequence of Manufacture Hot Cup Forging Method for Base Plug (4902488)	IV-22
IV-4 Recommended Sequence of Manufacture Hot Cup Method for Insert, Suspension Lug (1253008)	IV-24
IV-5 Recommended Sequence of Manufacture Hot Cup Method for Insert, Forward (1380267)	IV-25
IV-6 Estimated Equipment Cost Summary for Recommended Production Baseline	IV-26

I. INTRODUCTION

The production baseline described is a theoretical munitions production line developed from technical data package configuration and specifications applicable to the manufacture of the MK83 bomb body assembly. This baseline reflects the best elements of current methods of manufacture utilized by existing producers and is limited to proven state-of-the-art production technology.

The production baseline includes industrial production equipment and critical support equipment only. Discussion of all other contributory factors is restricted to general comments.

When possible, examples of recommended equipment are included in the general discussions of each operation. An example cited should be considered neither as the only choice nor as an indication of any exclusion. The type of tooling used in the operations is included only when it affects equipment choice. Without specific costs and design data, any detailed discussion of tooling is of doubtful value.

The MK83 production baseline is designed to produce the following metal parts and assemblies:

1265394	Charging-tube fitting
1381204	Bomb-body adapter
1380266	Bomb casing
1380267	Forward insert
1253008	Suspension
1239593	Forward fuze-liner assembly
4902493	Fuze-liner retainer
4902490	Aft fuze-liner assembly
4902487	Base plug

The remaining parts of the MK83 bomb body assembly are purchased from vendors specializing in the process required to produce the part. For example, Part No. 2519634, a fuze insert shipping plug made from plastic material, would be produced by a vendor with plastic molding capabilities.

II. PROCESS DESCRIPTION SUMMARY

Following this page are process description summaries that show the sequence of operations required to manufacture the components of the MK83 bomb body assembly. Equipment used to perform each operation, including any applicable alternate equipment, is also listed. Only industrial plant equipment (IPE) is specifically identified. Other plant equipment (OPE) is discussed only where necessary to identify the process requirements.

The operation numbers are four digit characters indicating the numerical sequence of operations. Across from the operation number is a description of the operation, with the equipment listed below.

Under the operation sequence, a path shown by X's indicate steps of manufacture. If an alternate method of manufacture is available, it is shown as an alternate on the flow charts, Figure III-2 and Figure III-3.

For a detailed description of each operation, see Section III, Analysis of Operations.

Gross capacities, production capabilities of the equipment designated for the operation, are shown in pieces per hour. These figures are not factored for downtime or delays. As an example, a press capable of cycling in 10 seconds (i.e., 6 cycles per minute) will have a gross capacity of 360 pieces per hour.

The drawing/specification of the MK83 bomb casing shows a hot-forge option to the seamless and seam-welded tubing. The MK83 production baseline report addresses both the forging and the tubing processes, although the forging process appears not to be economical. The forging demands presses of both high tonnage and extra stroke lengths. These presses neither are readily available nor can they be specially manufactured within a reasonable lead time.

The following process description summaries are provided:

<u>Table</u>	<u>Title</u>
II-1	Casing (1380266)
II-2	Adapter Ring (1381204)
II-3	Base Plug (4902488)
II-4	Suspension Lug Insert (1253008)
II-5	Forward Insert (1380267)

TABLE II-1
 PROCESS DESCRIPTION SUMMARY
 MK83 MOD 4, 1,000-LB BOMB, CASING (1380266)
 PEP MODERNIZATION PROGRAM

Oper No.	No. of Equip Alt's	Operation Description <u>Equipment Description</u>	Gross Capacity Pieces/h	Operation Sequence	
				Hot Forge	Tube
1110	1	Handle Received Material Material handling equipment	30	X	X
1120	4	Separate Lengths, Tube Saw, carbide tipped, 25 hp Saw, band, 15 hp Flame-cutting equipment Cutoff machine, rotary 60 hp	60 36 50 200		X
1130	5	Separate Mults Press, 2,200 ton (cold shearing) Saw, carbide tipped, 30 hp Saw, band, 25 hp Press, hydraulic, 100 ton (nick and break) Flame-cutting equipment	180 40 20 180 50	X	
1140	3	Heat Mults Heater, induction, 800 kW, 180 Hz, 2200 F Rotary-earth furnace, 2200 F	180 180		X

TABLE II-1 (cont)

Oper No.	No. of Equip Alt's	Operation Description Equipment Description	Gross Capacity Pieces/h	Operation Sequence Hot Forge Tube
		Continuous tunnel furnace, 2200 F	180	
1150	1	Descale Mults Cabinet, water jet	180	X
1160	1	Cabbage Press, hydraulic, 1,500 ton	120	X
1170	1	Pierce Press, hydraulic, 1,250 ton	120	X
1180	1	First Draw Press, hydraulic, 600 ton	120	X
1190	1	Draw and Pierce Base Press, hydraulic, 600 ton	120	X
1200	1	Cool Tunnel	200	X
1210	1	Descale ID Cabinet, abrasive cleaning	120	X
1220	1	Descale OD Cabinet, abrasive cleaning	120	X

TABLE II-1 (cont)

Oper No.	No. of Equip Alt's	Operation Description		Gross Capacity Pieces/h	Operation Sequence	
		Equipment Description			Hot Forge	Tube
1230	1	Trim Nose and Base Ends		60	X	
		Lathe, chucking, automatic, 50 hp				
1240	1	Preform Nose		180	X	X
		Press, hydraulic, 600 ton				
1250	1	Preform Nose and Base Ends		180		X
		Press, hydraulic, 600 ton				
1260	1	Heat Nose End		180	X	X
		Heater, induction, 500 kW, 180 Hz, 1400 F				
1270	1	Form Nose		180	X	X
		Press, hydraulic, 600 ton				
1280	1	Reheat Nose End		180		X
		Heater, induction, 800 kW, 180 Hz, 2200 F				
1290	1	Final Form Nose		180		X
		Press, hydraulic, 600 ton				

TABLE II-1 (cont)

Oper No.	No. of Equip Alt's	Operation Description Equipment Description	Gross Capacity Pieces/h	Operation Sequence Hot Forge Tube
1300	1	Heat Base End Heater, induction, 500 kW, 180 Hz, 1400 F	180	X
1310	1	Form Base Press, hydraulic, 600 ton	180	X
1320	1	Machine Nose Lathe, chucking, automatic, 30 hp	60	X
1330	1	Machine Base Lathe, chucking, automatic, 30 hp	60	X
1340	1	Machine, Nose and Base Way type, 40 hp, dual head (Alternate to Operation Nos. 1300 and 1310)	60	X
1350	1	Machine Base Lathe, chucking, automatic, 30 hp	60	X
1360	1	Cut Lug and Charging Holes Cutting machine, flame	30	X

TABLE II-1 (cont)

Oper No.	No. of Equip Alt's	Operation Description <u>Equipment Description</u>	Gross Capacity Pieces/h	Operation Sequence	
				Hot Forge	Tube
1370	1	Weld Lug and Charging Adapter Welding machine, arc, automatic	50	X	X
1380	1	Weld Adapter Ring Welding machine, arc, automatic	60		X
1390	1	Heat Treat and Temper Heater, induction, 3,000 kW, 180 Hz, 1650 F Furnace, gas, 1600 F	180 180	X	X
1400	1	Blast Clean Roto-blast unit	120	X	X
1410	1	Check Hardness Hardness tester	180	X	X
1420	1	Bore, Face, Thread Nose Lathe, turret, automatic, 30 hp	25	X	X
1430	1	Bore, Face, Thread Base Lathe, turret, automatic, 30 hp	25	X	X

TABLE II-1 (cont)

Oper No.	No. of Equip Alt's	Operation Description <u>Equipment Description</u>	Gross Capacity Pieces/h	Operation Sequence Hot Forge Tube
1440	1	Drill & Tap Lifting & Charging Holes Drill press, multistation	65	X X
1450	1	Drill 16 Holes, Base End Drill, press, multispindle	100	X X
1460	1	Drill and Tap Nose Hole Drill press	200	X X
1470	1	Drill 16 Holes, Base End, and Drill Nose End Drill press, multispindle (alternate to Operation Nos. 1430 and 1440)	100	X X
1480	1	Test Lifting Lug Adapter Special test equipment	150	X X
1490	1	Pressure Test Body Special testing equipment	150	X X
1500	1	Stamp Identification Marking machine	200	X X

TABLE II-1 (cont)

Oper No.	No. of Equip Alt's	Operation Description Equipment Description	Gross Capacity Pieces/h	Operation Sequence Hot Forge Tube
1510	1	Phospate Treat Paint exterior	200	X X

TABLE II-2
 PROCESS DESCRIPTION SUMMARY
 ADAPTER RING (1381204)
 MK83 MOD 4, 1,000-LB BOMB
 PEP MODERNIZATION PROGRAM

Oper No.	No. of Equip Alt's	Operation Description <u>Equipment Description</u>	Gross Capacity Pieces/h	Operation Sequence	
					<u>Hot Cup</u>
2110	1	Handle Received Material Material handling equipment		X	
2120	3	Separate Mults Press, shear, 1,000 ton Saw, carbide tipped, 30 hp Saw, band, 25 hp	180 120 60	X	
2130	3	Heat Mult Heater, induction, 700 kW, 180 Hz, 2200 F Furnace, rotary hearth, gas, 2200 F Furnace, tunnel, continuous, 2200 F	200 250 300	X	
2140	1	Descale Tumbler, squirrel cage	250	X	
2150	1	Forge Complete Press, mechanical, 2,200 ton, 12-inch stroke	225	X	

TABLE II-2 (cont)

Oper No.	No. of Equip Alt's	Operation Description <u>Equipment Description</u>	Gross Capacity Pieces/h	Operation Sequence <u>Hot Cup</u>
2160	1	Descale Blast-cleaning equipment	250	X
2170	1	Ring Roll Machine, special, rolling	60	X
2180	1	Machine Inside and Outside Diameters Lathe, six spindle, automatic, chucking, 30 hp	200	X
2190	1	Clean Degreaser, vapor	700	X

TABLE II-3
 PROCESS DESCRIPTION SUMMARY
 BASE PLUG (4902488)
 MK83 MOD 4, 1,000-LB BOMB
 PEP MODERNIZATION PROGRAM

Oper No.	No. of Equip Alt's	Operation Description <u>Equipment Description</u>	Gross Capacity Pieces/h	Operation Sequence <u>Hot Cup</u>
3110	1	Handle Received Material Material handling equipment		X
3120	3	Separate Mults Press, shear, 1,000 ton Saw, carbide tipped, 30 hp Saw, band, 25 hp	180 120 60	X
3130	3	Heat Mult Heater, induction, 600 kW, 180 Hz, 2200 F Furnace, rotary hearth, gas, 2200 F Furnace, tunnel, continuous, 2200 F	200 250 300	X
3140	1	Descale Tumbler, squirrel cage	250	X
3150	1	Forge Complete Press, mechanical, 2,000 ton 12-inch stroke	225	

TABLE II-3 (cont)

Oper No.	No. of Equip Alt's	Operation Description <u>Equipment Description</u>	Gross Capacity <u>Pieces/h</u>	Operation Sequence <u>Hot Cup</u>
3160	1	Descale Blast-cleaning equipment	250	X
3170	1	Ring Roll Machine, special, rolling	60	X
3175	1	Machine Inside and Outside Diameters Lathe, six spindle, automatic, chucking, 30 hp	200	X
3180	1	Undercut, Thread and Face Lathe, six spindle, automatic, chucking, 30 hp	200	X
3190	1	Drill and Tap Six Holes Multiple drill head and shuttle fixture	180	X
3200	1	Stamp Identification Marking machine	350	X
3210	1	Clean Degreaser, vapor	2,000	X

TABLE II-4
 PROCESS DESCRIPTION SUMMARY
 SUSPENSION LUG (1253008)
 MK83 MOD 4, 1,000-LB BOMB
 PEP MODERNIZATION PROGRAM

Oper No.	No. of Equip Alt's	Operation Description <u>Equipment Description</u>	Gross Capacity Pieces/h	Operation Sequence <u>Hot Cup</u>
4110	1	Handle Received Material Material handling equipment		X
4120	3	Separate Mults Press, shear, 350 ton Saw, carbide tipped, 25 hp Saw, band, 15 hp	270 180 90	X
4130	3	Heat Mult Heater, induction 50 kW, 180 Hz, 2200 F Furnace, rotary hearth, gas, 2200 F Furnace, tunnel, continuous, 2200 F	200 250 300	X
4140	1	Descale Tumbler, squirrel cage	400	X
4150	1	Preform and Restrike Press, mechanical, 500 ton, 6-inch stroke	250	X

TABLE II-4 (cont)

Oper No.	No. of Equip Alt's	Operation Description <u>Equipment Description</u>	Gross Capacity <u>Pieces/h</u>	Operation Sequence <u>Hot Cup</u>
4160	1	Descale Blast-cleaning equipment	400	X
4170	1	Clean Degreaser, vapor	2,000	X

TABLE II-5
 PROCESS DESCRIPTION SUMMARY
 FORWARD INSERT (1380267)
 MK83 MOD 4, 1,000-LB BOMB
 PEP MODERNIZATION PROGRAM

Oper No.	No. of Equip Alt's	Operation Description Equipment Description	Gross Capacity Pieces/h	Operation Sequence Hot_Curr
5110	1	Handle Received Material Material handling equipment		X
5120	3	Separate Mults Press, shear, 350 ton Saw, carbide tipped, 25 hp Saw, band, 15 hp	180 120 50	X
5130	3	Heat Mult Heater, induction 250 kW, 180 Hz, 2000 F Furnace, rotary hearth, gas, 2200 F Furnace, tunnel, continuous, 2200 F	200 250 300	X
5140	1	Descale Tumbler, squirrel cage	250	X
5150	1	Preform and Restrike Press, mechanical, 500 ton, 6-inch stroke	250	X

TABLE II-5 (cont)

Oper No.	No. of Equip Alt's	Operation Description Equipment Description	Gross Capacity Pieces/h	Operation Sequence Hot Cup
5160	1	Descale Blast-cleaning equipment	250	X
5170	1	Clean Degreaser, vapor	2,000	X

III. ANALYSIS OF OPERATIONS

A. CASING, BOMB, MK83 MOD 4 (1380266 without weldments)

This section provides an analysis of operations for the production of the casing for the 1,000-pound MK83 Mod 4 bomb. Details of the body assembly (part No. 2841466 with weldments) shown in Figure III-1. The flow chart depicting the sequence of operations is shown in Figure III-2.

Material - Carbon steel, seamless extruded tube/seam-welded plate
- Carbon steel, forging quality

1. Operation 1110 - Handle Billets/Tubes

Equipment - Standard cranes, hoists, and transfer equipment

The handling of steel billets/tubes is not a step in the production process, but the materials handling problem must be anticipated in any line designed for high-tonnage consumption of steel billets/tubes. The operations that must be considered, are discussed below.

a. Receiving Bulk Stock

This operation includes moving rolling stock and trailers and stacking material in the storage areas. Overhead cranes, forklifts, and jib cranes, are used to unload the stock. The stacking is arranged to assure material traceability.

Receiving inspection is completed before a lot becomes available for processing. If the material's supplier certification is acceptable, a verification of quantity, either by weight or length, is accomplished without extra handling.

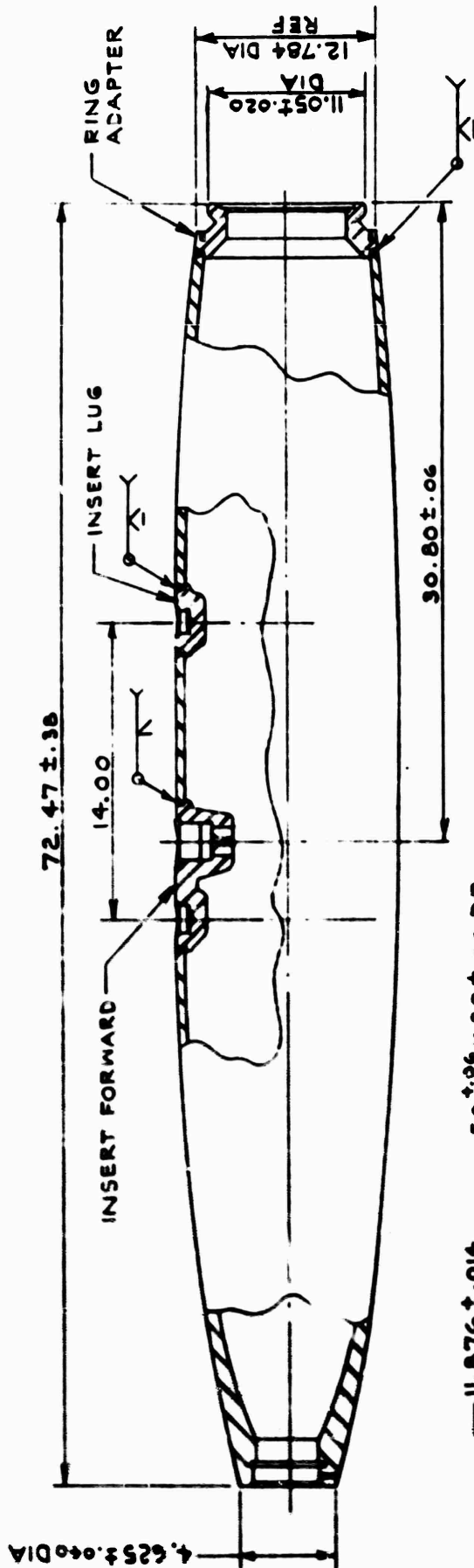

.50 ± .06 X .38 ± .06 DP
 16 HOLES EQUALLY SPACED
 CSK. 30° X .62 DIA
 HOLES TO BE BURR FREE

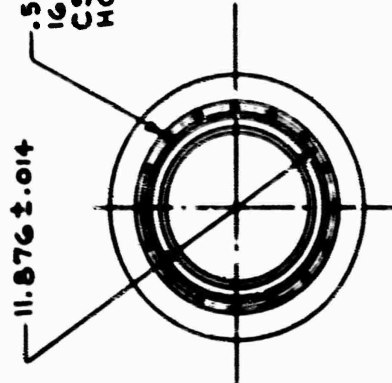

END VIEW

FIGURE III-1
 CASING, BOMB, GENERAL
 PURPOSE, 1000 POUND,
 MK 83 MOD 4, EMPTY,
 PART No. 2341466

FIGURE D-2
FLOW CHART

MK 83 BOMB BODY (TUBE)
SUB-ASSEMBLY (1380268)
PRODUCTION BASELINE

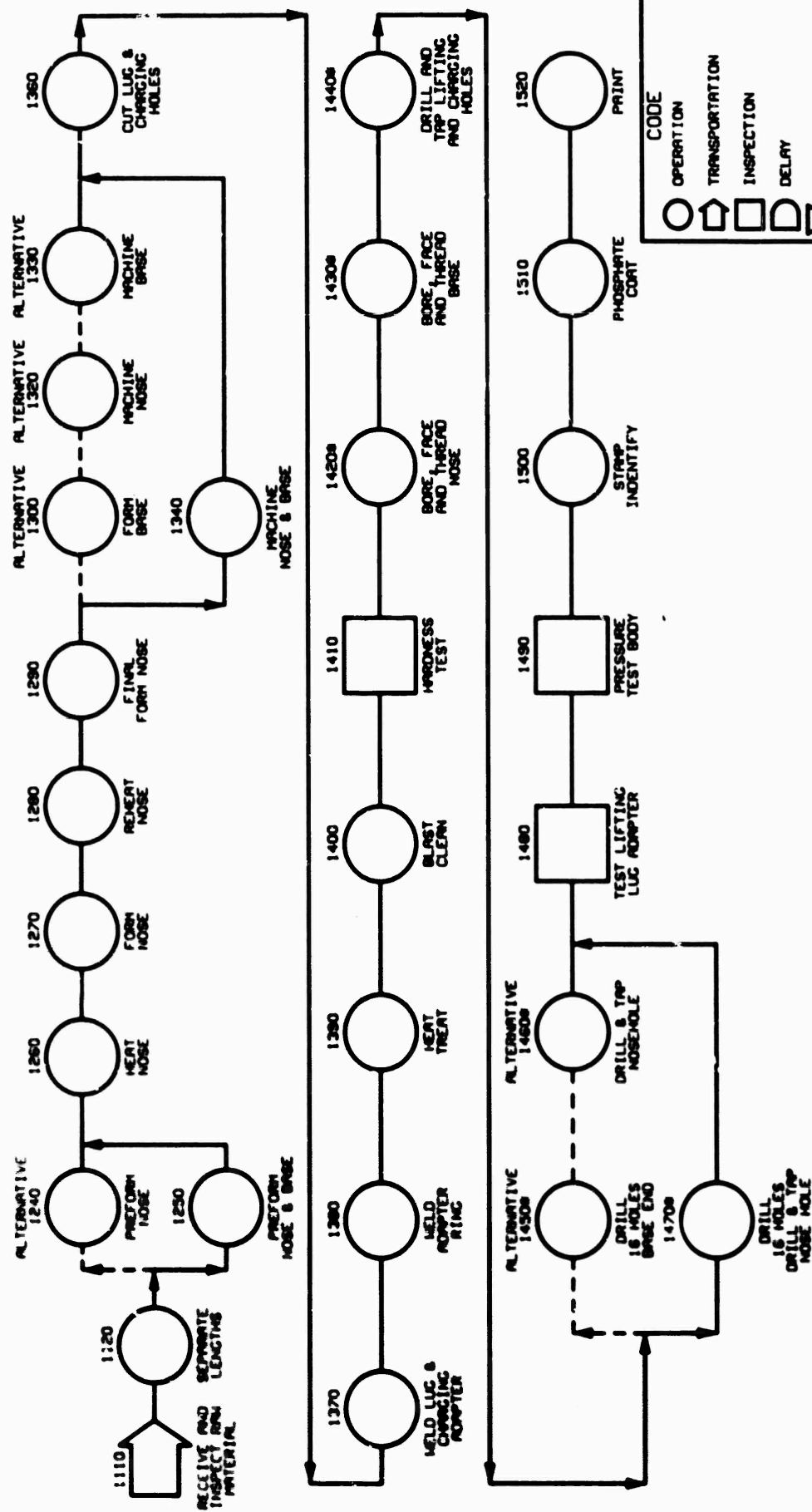

CODE

- OPERATION
- ◻ TRANSPORTATION
- ◻ INSPECTION
- ◻ DELAY
- ◻ STORAGE

8 ALTERNATIVE OPERATION---1475, MACHINE COMPLETE

- b. Movement of Billets/Tubes from Bulk Storage to First Process Station, 11-Inch RCS, 8,200 lb Each/14-Inch OD, .475-Inch Wall, 2,600 lb

This operation includes:

- o Separating stock into single billets/lengths. Special handling equipment such as magnets, hooks, grapples, slings, and hoists are needed.
- o Continuously processing individual billets/lengths through weighing devices, metallurgical scanning, and physical measuring devices. This activity is required to develop the correct mult/length weight to be generated at the billet/tube separation operation. A computerized system to scan weight and length is the preferred control system. Although the system does not increase the yield per billet/tube, it assures the cutting of mults to the required weight/length.
- o Moving billet/length through separation operation. This activity involves controlling the alignment and progression of the billet/length and handling the rejects. Included are any additional functions, such as multiple-racking saw-trim requirement and a possible laydown or holding requirements.

An example of the proper equipment to use is a Shepard-Niles 25-ton bridge crane.

2. Operation 1120 - Separate Lengths, Tube

Equipment alternatives:

- Saw, carbide tipped, 40 inch, 25 hp (sawing)
- Saw, band, 16 inch, 15 hp (sawing)
- Flame cutting equipment
- Cut-off machine, rotary, 60 hp

a. Circular Saw

Carbide-tipped circular saws produce precision lengths.

An example of the proper equipment to use is a Heller Gebrueder SSH 630, circular saw, 25 hp.

b. Band Saw

The band saw, although less accurate, is less expensive than a circular saw. The band sawing process is slow, compared with the forging rate; therefore, materials handling provisions must be developed for multiple machines.

An example of the proper equipment to use is a Do-All Automatic P16A, band saw, 15 hp.

c. Flame Cutting

Flame cutting equipment can be used with an automated rotating device and materials handling equipment.

An example of the proper equipment to use is a H&M Pipe Cutting & Beveling #2, with a machine torch adapted for synthetic fuel.

d. Rotary Cutting

The tube is cut off to the required length, while burrs are generated on the outside diameter. This method eliminates end deburring.

An example of the proper equipment to use is a Stamet Co. S024450, lathe, automatic, 95-r/min spindle, 60 hp.

3. Operation 1130 - Separate Mults. Forging

Equipment alternatives:

- Press, 3,600 ton (cold shearing)
- Saw, carbide tipped, 32 inch, 30 hp (sawing)
- Saw, band, 16 inch, 25 hp (sawing)
- Press, 1,500 ton, and torch (nick and break)
- Flame cutting equipment

The weighing of each mult is an integral part of this operation.

a. Cold Shear

The 3,600-ton shear press requires automatic feed, clamp, and eject attachments. The press may be in the production line to minimize materials handling and traceability problems, but the press can be off-line if facilities dictate.

An example of the proper equipment to use is a Buffalo Billet Shear, 3,600 ton.

b. Circular Saw

Carbide-tipped circular saws produce precision mult.

Abrasive cutting, even done wet, is not approved. Experience has shown that trapped abrasive causes excessive tool wear during forging.

An example of the proper equipment to use is a Heller Gebrueder SSH 630, circular saw, 25 hp.

c. Band Saw

The band saw, although less accurate, is less expensive than a circular saw. The band-sawing process is slow, compared with the forging rate; therefore, materials handling provisions must be developed for multiple machines.

An example of the proper equipment to use is a Do-All Automatic C70, band saw, 15 hp.

d. Nick and Break

This process is based on the concentration of a stress called the nick in the cold billet, followed by a cold-breaking operation.

An example of the proper equipment to use is a Production Machinery Division U.S. Industry Press, Mechanical, Vertical, Straight Sided F11500-48, 1,500 ton and Arcair 62-001, Electrode 1/4 - 3/4.

e. Flame Cutting

Flame cutting is not recommended because it is slow, and wasteful of material. It may also affect the metallurgy of the mult.

4. Operation 1140 - Heat Mult. Forging

Equipment alternatives:

- Heater, induction, 2200 F, 5000 kW, 180 Hz
- Rotary-hearth furnace, gas, 2200 F
- Continuous-tunnel furnace, gas, 2200 F
11-inch RCS

This step is required for the hot-cup, hot-draw process. Time at temperature should be long enough to assure uniform heating, but excessive soak time should be avoided, because of the high degree of scaling that occurs in gas furnaces with natural atmosphere.

Examples of the proper equipment to use are:

- a. Tocco induction heating in-line system with multicoil stations for sequential heating, 2200 F.
- b. Flinn and Drefflein Inc., rotary hearth, gas fired, 2200 F.

- c. Lindburg Div. of Sola Basic Industries slot furnaces, open flame, gas fired, 2200 F.

5. Operation 1150 - Descale Mult, Forging

Equipment - Cabinet, water-jet automatic feed

The removal of scale from hot mults prior to forging is accomplished by water jets. Water pressures of 1,200 to 2,200 lbf/in² and flow rates of 1/2 to 2 gal/s normally are used. Power feeding of the hot mults is done by chain conveyor or pusher.

This equipment is normally custom-made to incorporate handling as well as descaling equipment.

An example of the proper equipment to use is a Pangborn Div. of Carborundum Co. ES421, descaling machine, 7-1/2 hp.

6. Operation 1160 - Cabbage, Forging

Equipment - Press, hydraulic, 1,500 ton, 48-inch stroke

In the cabbage step, the heated square mult is shaped into a round die. Once the mult is sized, the pierce operation accomplishes the first major movement of metal, with or without reheating.

An example of the proper equipment to use is a Verson Allsteel Press 1500HDI-76T, 1,500 ton, 48-inch stroke.

7. Operation 1170 - Pierce, Forging

Equipment - Press, hydraulic, 1,250 ton, 60-inch stroke

The pierce step is a hot-working process that uses a backward extrusion technique to form the sized mult to an intermediate hollow length. The uniformity of metal flow determines the effectiveness of the succeeding forging operations in attaining overall dimensional accuracy and a high level of quality.

An example of the proper equipment to use is a Verson Allsteel Press 1250 HD1-84T 60-inch stroke.

8. Operation 1180 - First Draw, Forging

Equipment - Press, hydraulic, 600 ton, 175-inch stroke

The casing is hot drawn, and the wall thickness is reduced as the casing is extended through rings and over a mandrel.

An example of the proper equipment to use is a Bliss Co., press, horizontal, special, 600 ton, 175-inch stroke.

9. Operation 1190 - Draw and Pierce Base, Forging

Equipment - Press, hydraulic, 600 ton, 175-inch stroke

The bomb casing is open at both ends. It is now hot-drawn to length, and during the same stroke, the end is pierced.

An example of the proper equipment to use is a Bliss Co., press, horizontal, special, 600 ton, 175-inch stroke.

10. Operation 1200 - Cool

Equipment - Tunnel, cooling

High carbon steels have mechanical properties sensitive to the rates at which the steel is cooled from forging temperatures. To produce the best possible metallurgical structure for subsequent machining operations, cooling must be slow. Slower cooling introduces fewer thermal stresses and less warpage.

An example of the proper equipment to use is a Selas Corp. tunnel, four stage, special.

11. Operation 1210 - Descale Inside Surface, Forging

Equipment - Cabinet, abrasive cleaning, 75 hp

The descaling by abrasive cleaning is necessary prior to subsequent machining and forming operations.

An example of the proper equipment to use is a Wheelabrator-Frye, 42D393, blast cleaning machine.

12. Operation 1220 - Descale Outer Surface, Forging

Equipment - Cabinet, shot blast, automatic feed, 75 hp

The removal of scale from the forging is accomplished by propelling steel shot at high velocity against the surface while the forging is conveyed on skewed and tapered rolls. This exposes all of the surface to the scaling media.

An example of the proper equipment to use is a Wheelabrator-Frye, 42D393, blast-cleaning machine.

13. Operation 1230 - Trim & Turn Nose and Base Ends, Forging

Equipment - Way-type machine, single station, double ended horizontal, boring, 50 hp

This operation prepares the forging for the nosing operations.

An example of the proper equipment to use is a machine made by Heald Machine Co., 442A, 80-inch-long table, 50 hp.

14. Operation 1240 - Preform Nose End

Equipment - Press, hydraulic, 600 ton, 48-inch stroke

Preforming the nose is a combination of reducing the diameter of the nose end and upsetting the tube end to increase the wall thickness.

An example of the proper equipment to use is a Verson Allsteel Press 60GHDI-66T, 600 ton, 48-inch stroke.

15. Operation 1250 - Preform Nose and Base End, Tube

Equipment - Press, hydraulic, 600 ton, 48-inch stroke

The preforming of the nose and the forming of the base may be combined when using tubing.

An example of the proper equipment to use is a Verson Allsteel Press 600HDI-66T, 600 ton, 48-inch stroke.

16. Operation 1260 - Heat Nose End

Equipment - Heater, induction, 1400 F, 500 kW, 180 Hz

The nose end of the casing requires heating prior to the nosing operation. A convenient heating method is induction heating to ranging from 1200 F to 1400 F.

An example of the proper equipment to use is a Westinghouse Electric induction heater, 500 kW, 180 Hz.

17. Operation 1270 - Form Nose

Equipment - Press, hydraulic, 600 ton, 48-inch stroke

Forming the nose is a combination of reducing the diameter of the nose and upsetting the end to increase the wall thickness to meet the required length for the fuze liner wall.

An example of the proper equipment to use is a Verson Allsteel Press 600HDI-48 ton, 48-inch stroke.

18. Operation 1280 - Reheat Nose End

Equipment - Heater, induction 2200 F, 800 kW, 180 Hz

The nose is heated to forging temperatures in order to attain its final form.

An example of the proper equipment to use is a Westinghouse Electric induction heater, 800 kW, 180 Hz.

19. Operation 1290 - Final-Form Nose

Equipment - Press, hydraulic, 600 ton, 48-inch stroke

The heated nose end is final-formed to meet design requirements.

An example of the proper equipment to use is a Verson All Steel Press 600HDI-66T, 600 ton, 48-inch stroke.

20. Operation 1300 - Heat Base End, Forging

Equipment - Heater, induction, 1400 F, 500 kW, 180 Hz

To form base end of the casing from a forging requires prior heating. This operation may not be required for casing made from tubing.

An example of the proper equipment to use is a General Electric Co. induction heater, 500 kW, 180 Hz.

21. Operation 1310 - Form Base End

Equipment - Press, hydraulic, 600 ton, 48-inch stroke

The diameter of the base end is reduced when it is formed. The wall is to be thickened only slightly. With the forged casing, the ring adapter No. 1381204 is to be formed in this operation.

An example of the proper equipment to use is a Verson Allsteel Press 500HDI-48T, 500 ton, 36-inch stroke.

22. Operation 1320 - Rough Machine Nose End

Equipment - Lathe, automatic, chucking, 16-inch swing,
73-inch centers, 30 hp

The nose end of the casing is rough-bored, counter-bored and faced.

An example of the proper equipment to use is a Jones and Lamson, model 20, lathe, automatic, chucking, 16-inch swing, 73-inch centers, 30 hp.

23. Operation 1330 - Machine Base End, Tube

Equipment - Lathe, automatic, chucking, 18-inch swing, 96-inch centers, 30 hp

The base end is cut off, a bore is made for the ring adapter, chamfer outside, and inside of end for welding.

An example of the proper equipment to use is a Warner-Swasey automatic lathe, 12-inch swing, 72-inch centers, 30 hp.

24. Operation 1340 - Machine Nose and Base End, Tube (Alternate)

Equipment - Way type machine, single station, double ended, horizontal, boring, 50 hp

Operations 1300 and 1310 are combined on one double end machine, where the nose and base ends are machined simultaneously.

An example of the proper equipment to use is a machine made by Heald Machine Co., 442A, 80-inch-long table, 50 hp.

25. Operation 1350 - Rough-Machine Base - Adapter Ring, Forging

Equipment - Lathe, automatic chucking, 12-inch swing, 72-inch centers, 30 hp

This operation is used for an adapter ring as forged with the casing. The base is bored, faced, cut with a relief groove, and turned.

An example of the proper equipment to use is a Jones and Lamson Co. model 20, lathe, automatic, chucking, 16-inch swing, 73-inch centers, 30 hp.

26. Operation 1360 - Flame-Cut Lug and Charging-Tube Adapter Holes

Equipment - Two automatic machine torches
- Two 500 to 600 A power supplies
- Special cradling and fixturing machine base

The bomb body is conveyed into the special flame-cutting machine. The body is aligned and positioned. The two torches can be either mechanically guided by templates or through a numerically controlled device in order to follow the required cutting pattern.

An example of the proper equipment to use is a Linde Division, Union Carbide Co., CM-55 with CW-45 cutting torches.

27. Operation 1370 - Weld Lug and Charging Adapters

Equipment - Two automatic machine torches, gas shielded with flux-cored wire
- Two 500 to 600 A 100 percent duty-cycle power supply
- Special cradling and fixturing machine base

The bomb-body subassembly is conveyed into the special welding machine. The lug and the adapter are then installed face up. The body is aligned and positioned. The two torches can be guided either mechanically by templates or numerically by a controlled device to follow the required weld pattern.

An example of the proper equipment to use is a Linde Division of Union Carbide Co., VI600 welding power supply, SWM-23 wire feeder, ST-5 water-cooled machine torch.

28. Operation 1380 - Weld Ring, Adapter, Tubing

Equipment - Automatic machine torch with arc-length sensor, gas shielded with flux-cored welding wire
- 500 to 600 A 100 percent duty-cycle power supply
- Special cradling and fixturing machine base

The bomb body subassembly is conveyed into the special welding machine. The bomb body is then affixed in place. The arc is then started, while the bomb body rotates 360 degrees for a one pass weld.

An example of the proper equipment to use is a Linde Division of Union Carbide Co. VI-600 welding power supply, SWM-23 wire feeder, ST-5 water-cooled machine torch.

29. Operation 1390 - Heat Treat and Temper

Equipment alternatives:

- Heater, induction 1550 F to 1650 F, 800 kW, 180 Hz or
- Furnace, gas 1550 F to 1650 F; hardening
- Furnace, gas, 750 F to 950 F; tempering

The strength of the case is achieved by heating and quenching. Furnace or induction heating is used to heat at 1550 F to 1650 F. Quenching should be by immersion in an agitated bath. The case is tempered at 950 F in an atmosphere-controlled draw furnace.

An example of the proper equipment to use is a special heat-treat and temper system made by Flinn & Drefflein Engineering Co., special.

30. Operation 1400 - Blast Clean ID and OD

Equipment - Roto-blast unit

All scale is blast-cleaned from inside and outside surfaces.

An example of the proper equipment to use is a Wheelabrator & Frye Co., 42D393, blast-cleaning machine.

31. Operation 1410 - Check Hardness

Equipment - Hardness tester, brinell, automatic

The hardness required by specifications is checked.

An example of the proper equipment to use is a Rockwell Corp., 5JR, hardness tester.

32. Operation 1420 - Bore, Face, Thread Nose End

Equipment - Lathe, turret, automatic 16-inch swing, 7 1/2 inch centers, 30 hp

Standard machining operations.

An example of the proper equipment to use is a Jones and Lamson Co. model 20, lathe, automatic, chucking, 16-inch swing, 73-inch centers, 30 hp.

33. Operation 1430 - Bore, Face, Thread, Machine Base End

Equipment - Lathe, turret, automatic 16-inch swing, 73-inch centers, 30 hp

These are standard machining operations.

An example of the proper equipment to use is a Jones and Lamson Co. model 20, lathe, automatic, chucking, 16-inch swing, 73-inch centers, 30 hp.

34. Operation 1440 - Step Drill and Tap Lifting Holes and Charging Hole

Equipment - Drill press, tapping multistation, 2-1/4-inch capacity

This is a standard machining operation.

An example of the proper equipment to use is a Barnes multispindle drill press, special.

35. Operation 1450 - Drill and Countersink 16 Holes Base End

Equipment - Drill press, multispindle, 3/8 capacity

This is a standard machining operation.

An example of the proper equipment to use is a Barnes multispindle, horizontal drill press, special.

36. Operation 1460 - Drill Countersink & Tap Nose Hole

Equipment - Drill press, tapping, 3/8 capacity

This is a standard machining operation.

An example of the proper equipment to use is a Zagar, Inc., Special.

37. Operation 1470 - Drill 16 Holes, Base End and Drill and Tap Nose End

Equipment - Drill press, multispindle, 2 units, horizontal

This operation finish-machines the casing in one setup. Operations 33 and 34, on the other hand, require two setups.

An example of the proper equipment to use is a Barnes multispindle horizontal drill press, 15 hp.

38. Operation 1475 - Machine Complete

Equipment - Special transfer-and-shuttle type with turning, boring, drilling and threading heads, and attachments

This alternate operation reduces the part handling and extensive setups (outlined in the preceding steps, starting with Operation 1400 to Operation 1450) which relate to conventional equipment and processes.

An example of the proper equipment to use is a specially designed and built transfer-and-shuttle turning machine.

39. Operation 1480 - Test Lifting Lug Adapter

Equipment - Special test machine

The push-and-pull test required in the drawing is conducted.

An example of the proper equipment to use is special test equipment manufactured to dictated parameters.

40. Operation 1490 - Pressure Test Bomb Body

Equipment - Special test equipment

The pressure test drawing is conducted.

An example of the proper equipment to use is special test equipment manufactured to dictated parameters.

41. Operation 1500 - Stamp Identification

Equipment - Machine, stamping, rotary, 5 hp

The stamping is performed on a horizontal rotating fixture. At this time, the nomenclature, date of manufacture, lot number, and contractor's identification are imprinted.

An example of the proper equipment to use is the James H. Matthews Co. Marking Machine N2201.

42. Operation 1510 - Phosphate Treat

Equipment - Chemical line (multistage spray/dip system)

Foreign particles are removed, and the surface is prepared for subsequent painting.

An example of the proper equipment to use is the five-stage phosphatizer made by Litton Unit Handling Systems.

43. Operation 1520 - Paint

Equipment - Paint spraying machine, automatic,
electrostatic

Except for the threads, both inside and outside surfaces are painted.

An example of the proper equipment to use is the special unit made by Binks Manufacturing Co.

B. RING, ADAPTER, BOMB BODY (1252606)

This section contains an analysis of the operations required for the production of the adapter ring. The flow chart depicting the sequence of operations is shown in Figure III-3.

Material - Carbon steel with yield strength 40,000 lbf/in² and tensile strength 70,000 lbf/in², forging quality

1. Operation 2110 - Handle Billet

Equipment - Standard cranes, hoists, and forklift trucks

The handling of steel billets is not a step in the production process, but the materials handling problem must be anticipated in any line designed for high-tonnage consumption of steel billets. How these operations must be considered, is discussed below.

a. Receiving Billets

This operation includes moving both rolling stock and trailers and stacking material in the storage areas. Overhead cranes, forklifts, and jib cranes are used to unload the stock. The stacking is arranged to assure material traceability.

Receiving inspection must be completed before a lot becomes available for processing. If the material certification from the supplier is acceptable, a verification of quantity, either by weight or by length, is accomplished without extra handling.

b. Movement of Billets From Storage to First Process Station
5-inch RCS, 1.700 lb Each Billet

This operation includes the movement of stock to the sawing or shearing operation of the billet, preceding the first processing step.

FIGURE III-3
FLOWCHART

MK 83 BOMB
RING ADAPTER (1381204)
PRODUCTION BASELINE

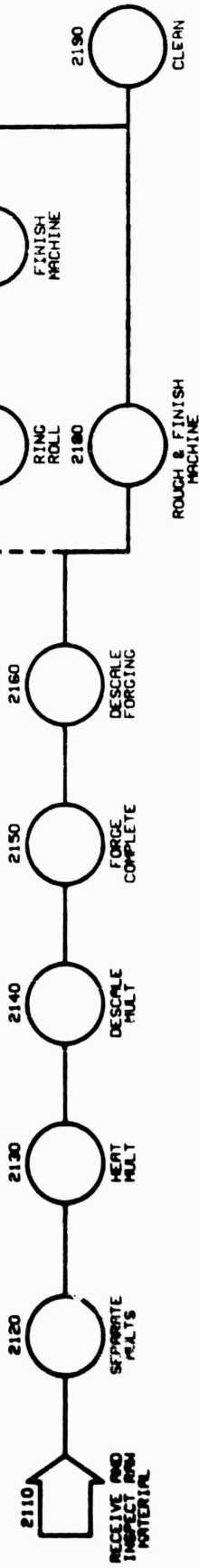

MK 83 BOMB
BASEPLUG (4902488)
PRODUCTION BASELINE

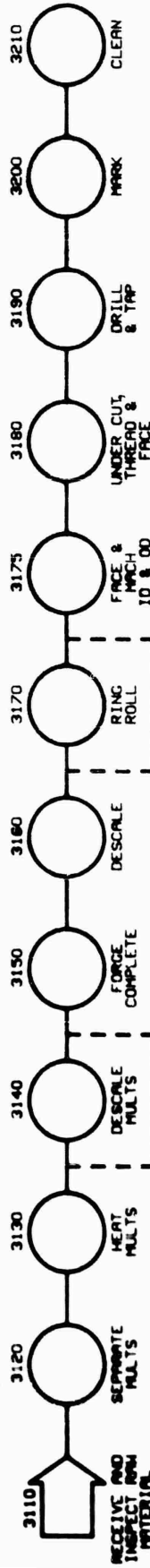

MK 83 BOMB
INSERT, SUSPENSION LUG (1253008)
PRODUCTION BASELINE

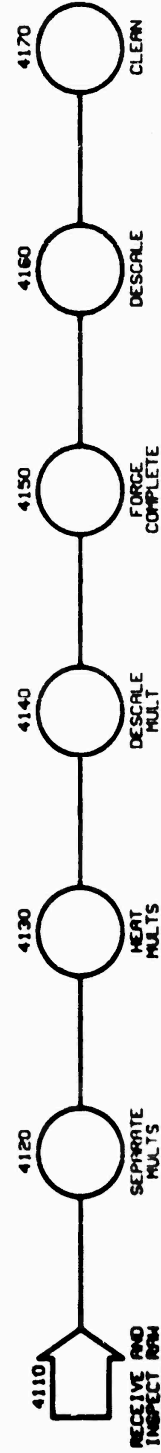

MK 83 BOMB
INSERT, FORWARD (1380267)
PRODUCTION BASELINE

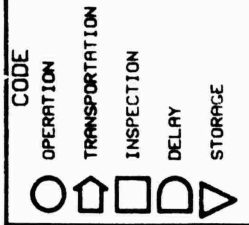
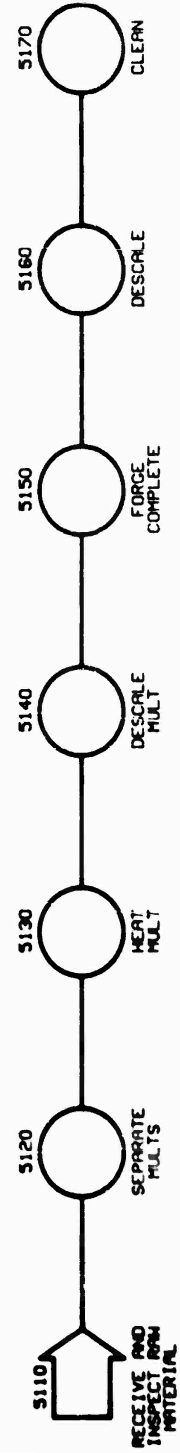

Examples of the proper equipment to use are a Shepard-Niles 25-ton bridge crane and a Clark 2-ton forklift truck.

2. Operation 2120 - Separate Mults

Equipment alternatives

- Shearing machine, 1,000 ton (cold shearing)
- Saw, carbide tipped, 24 inch, 30 hp (sawing)
- Saw, band, 16 inch, 25 hp (sawing)

a. Cold Shear

The 1,000 ton shearing machine requires automatic feed, clamp, and eject attachments. The press can either be in the production line to minimize material handling and traceability problems, but the press can be off line if facilities dictate.

An example of the proper equipment to use is a Buffalo Forge Co., shearing machine, 5-5/8-inch bar, model 13.

b. Circular Saw

Carbide-tipped circular saws produce precision mult.

Abrasive cutting, even done wet, is not approved. Experience has shown that trapped abrasive causes excessive tool wear during forging.

An example of the proper equipment to use is a Heller Gebrueder cut off machine, circular saw blade, manual, model No. SSH630.

c. Band Saw

Although the band saw is less accurate, it is less expensive than a circular saw. The band-sawing process is slow, compared with the forging rate; therefore, materials handling provisions must be developed for multiple machines.

An example of the proper equipment to use is a Do-All cut off machine, automatic feed, horizontal, model No. P16M.

3. Operation 2130 - Heat Mult

Equipment alternatives:

- Heater, induction, 2200 F, 700 kW, 180 Hz
- Rotary hearth furnace, 2200 F
- Continuous tunnel furnace, 2200 F

Induction heating is the preferable method, since the heating normally is fast enough to prevent scaling of the mult. If furnace heating is used, the furnaces should have dual-fuel burners.

Examples of the proper equipment to use are:

- a. Tocco induction-heating in-line system with multicoil stations for sequential heating, 2200 F.
- b. Flinn and Drefflein Inc., rotary hearth gas fired, 2200 F.
- c. Lindberg Div. Sola Basic Industries, slot furnace open Flame, gas fired, 2200 F.

4. Operation 2140 - Descale

Equipment - Squirrel-cage tumbler

The mults are placed in a squirrel-cage tumbler to remove the scale formed by exposure to the atmosphere. This operation normally is not necessary, if induction heating is used.

Typically, the squirrel-cage tumbler is custom designed and made for the part being tumbled.

5. Operation 2150 - Pancake, Preform, Punch, and Restrike

Equipment - Press, mechanical, 2,000 ton, 10-inch stroke

The part is forged in a three-stage die with one part in each stage at a time.

An example of the proper equipment to use is a National Machinery Co. Maxipress 2000, mechanical.

6. Operation 2160 - Descale

Equipment - Blast-clean and finishing machine, horizontal

During this operation, forging scale is removed by tumble blasting.

An example of the proper equipment to use is a Pangborn Corporation blast-cleaning machine, endless-belt barrel type, model 15GN3.

7. Operation 2170 - Ring Roll

Equipment - Ring rolling-machine, 10-inch diameter x 3-inch capacity

This operation enlarges and rough-rolls the adapter ring outer and inner contour to expedite machining and conserve material. This operation may be eliminated if the ring adapter was forged to rough size at Operation No. 2150.

An example of the proper equipment to use is a Wagner-Dortmund, KFRWT-630, four-mandrel-ring rolling mill.

8. Operation 2175 - Rough-and-Finish Machine

Equipment - Lathe, six-spindle, automatic chucking
10-inch capacity

The forging is rough-and-finish machined without being ring-rolled.

An example of the proper equipment to use is a National Acme Co. RPA6 automatic chucker, 30 hp.

9. Operation 2180 - Machine Ends and Outside

Equipment - Lathe, six-spindle, automatic chucking,
10-inch capacity

The inside surface is forged to size. Machining is required on the ends and the outside contour.

An example of the proper equipment to use is a National Acme Co. automatic chucker, 30 hp, model RPA6.

10. Operation 2190 - Clean

Equipment - Vapor degreaser

This is the standard cleaning process to prepare for welding.

This equipment is classified as "other production equipment."

An example of the proper equipment to use is a Baron-Blakeslee, model 1019.

C. PLUG, BASE, BOMB BODY (4902488)

This section contains an analysis of operations required for the production of the base plug. A flow chart depicting a sequence of operations is shown in Figure III-3.

Material - Carbon steel with yield strength 40,000 lbf/in² and tensile strength 70,000 lbf/in², forging quality
- Carbon steel with yield strength 40,000 lbf/in² and tensile strength 70,000 lbf/in², bar stock

1. Operation 3110 - Handle Bar/Billet

Equipment - Standard cranes, hoists, and forklift trucks

The handling of steel bar/billet is not a step in the production process, but the materials handling problem must be anticipated in any line designed for high-tonnage consumption of steel bar/billets. The operations to be considered are discussed below.

a. Receiving Bulk Stock

This operation includes moving rolling stock and trailers and stacking material in the storage areas. Overhead cranes, forklifts, and jib cranes will be used to unload the stock. The stacking is arranged to assure material traceability.

Receiving inspection must be completed before a lot becomes available for processing. If the material's supplier certification is acceptable, a verification of the quantity, either by weight or by length, can be accomplished without extra handling.

b. Movement of Bar/Billets From Storage to First Process Station, 4-inch, 1,100 lb Each Billet and 6-1/2-inch, 2,200-lb-Each Bar

This operation includes the movement of stock to the sawing or shearing operation to produce forgings for the first machining operation.

Examples of the proper equipment to use are a Shepard-Niles 25-ton bridge crane and a Clark 2-ton forklift truck.

2. Operation 3120 - Separate Mults

Equipment alternatives:

- Shearing machine, 1,000 ton (cold shearing)
- Saw, carbide tipped, 24 inch, 30 hp (sawing)
- Saw, band, 16 inch, 25 hp (sawing)

a. Cold Shear

The 1,000-ton shearing machine requires automatic feed, clamp, and eject attachments. The press can either be in the production line to minimize materials handling and traceability problems or be off-line if facilities dictate.

An example of the proper equipment to use is a Buffalo Forge Co., shearing machine, bar, model 13.

b. Circular Saw

Carbide-tipped circular saws are used to produce a precision mult.

Abrasive cutting, even done wet, is not approved. Experience has shown that trapped abrasive causes excessive tool wear during forging.

An example of the proper equipment to use is a Heller Gebrueder cut off machine, circular-saw blade, manual, model No. SSH630.

c. Band Saw

The band saw, although less accurate, is less expensive than a circular saw. The band sawing process is slow, compared with the forging rate; therefore, materials handling provisions must be developed for multiple machines.

An example of the proper equipment to use is a Do-All cut-off machine, automatic feed, horizontal, model No. P16M.

3. Operation 3130 - Heat Mult

Equipment alternatives:

- Heater, induction, 2200 F, 600 kW, 180 Hz
- Rotary hearth furnace, 2200 F
- Continuous-tunnel furnace, 2200 F, 3,000 lb/h

Induction heating is the preferable method, since the heating is normally fast enough to prevent scaling of the mult. If furnace heating is used, the furnaces should have dual-fuel burners.

Examples of the proper equipment to use

- a. Tocco induction heating in-line system with multicoll stations for sequential heating, 2200 F.
- b. Flinn and Drefflein Inc., rotary hearth, gas fired, 2200 F
- c. Lindburg Bros. Co. T-slot oven, open flame, gas fired, 2200 F

4. Operation 3140 - Descale, Mult

Equipment - Squirrel-cage tumbler

The mults are placed in a squirrel-cage tumbler to remove the scale formed by exposure to the atmosphere. This operation normally is not necessary, if induction heating is used.

Typically, the squirrel cage tumbler is custom designed and made for the part being tumbled.

5. Operation 3150 - Pancake, Preform, Punch and Restrike

Equipment - Press, mechanical, 2,000 ton, 12-inch stroke

The part is forged in a three-stage die, with one part in each stage at a time.

An example of the proper equipment to use is a National Machinery Co. Maxipress 2000.

6. Operation 3160 - Descale

Equipment - Blast-clean and finish machine, horizontal

During this operation, forging scale is removed by tumble blasting.

An example of the proper equipment to use is a Pangborn Corporation blast-cleaning machine, endless endless-belt barrel type, model 15GN3.

7. Operation 3170 - Ring Roll

Equipment - Ring rolling machine, 10 inch diameter x 2 inch capacity

This operation enlarges and rough-rolls the adapter ring outer and inner contour to expedite machining and conserve scrap. This operation can be eliminated, if the ring adapter was forged to rough size at Operation No. 3150.

An example of the proper equipment to use is a Wagner-Dortmund, KFRWT-630, four-mandrel, ring rolling mill.

8. Operation 3175 - Machine Inside and Outside Diameters, Forging

Equipment - Lathe, six-spindle, automatic chucking, 10-inch capacity

Machining is required on the the inside and the outside diameter of the forging.

An example of the proper equipment to use is a National Acme Co. 30 hp, model RPA6, automatic chucking lathe.

9. Operation 3180 - Under Cut, Thread and Face

Equipment - Lathe, six-spindle, automatic, chucking

To complete turning operations, chuck part and face; turn the outside diameter, under cut and thread.

An example of the proper equipment to use is a National Acme Co. 30 hp, model RPA6, automatic chucking lathe.

10. Operation 3190 - Drill and Tap Holes

Equipment - Drill press, 2 spindle, 3/4 capacity

Six holes are drilled and tapped with the index fixture and multiple-drill head.

An example of the proper equipment to use is a Leland Gifford Co., drilling machine, manual, model 2LMS-26.

11. Operation 3200 - Mark

Equipment - Marking machine, reciprocating die, semiautomatic feed, mechanical power

The required part number is marked.

An example of the proper equipment to use is a Noble and Westbrook marking machine, model 245.

12. Operation 3210 - Clean

Equipment - Vapor degreaser

This is a standard cleaning process.

This equipment is classified as "other production equipment."

An example of the proper equipment to use is a Baron-Blakeslee, model 1019.

D. INSERT, SUSPENSION LUG (1253008)

This section contains an analysis of operations required for the production of the suspension-lug insert. The flow chart depicting the sequence of operations is shown in Figure III-3.

Material - Carbon steel with yield strength 40,000 lbf/in² and tensile strength 70,000 lbf/in², forging quality

1. Operation 4110 - Handle Bar/Forgings

Equipment - Standard cranes, hoists, and forklift trucks

Although the handling of steel bar/forgings is not a step in the production process, the materials handling problem must be anticipated in any line designed for high-tonnage consumption of steel bar/forgings. The operations to be considered are discussed below.

a. Receiving Bar Stock/Forgings

This operation includes moving rolling stock, trailers and stacking material in the storage areas. The unloading activity utilizes overhead cranes, forklifts, and jib cranes. The stacking is arranged to assure material traceability.

Receiving inspection must be completed before a lot becomes available for processing. If a material's supplier certification is acceptable, a verification of quantity, either by weight or by length, can be accomplished without extra handling.

b. Movement of Bar/Forgings from Storage to First Process Station

This operation includes the movement of raw material to the sawing or shearing operation for forgings to the first machining operation.

Examples of the proper equipment to use are a Shepard-Niles 25-ton bridge crane and a Clark 2-ton forklift truck.

2. Operation 4120 .. Separate Mults

Equipment alternatives:

- Press, shear, 350 ton (cold shearing)
- Saw, carbide tipped, 24 inch, 30 hp (sawing)
- Saw, band, 16 inch, 25 hp (sawing)

a. Cold Shear

The 350-ton shear press requires automatic feed, clamp, and eject attachments. The press can either be in the production line to minimize materials handling and traceability problems or be off-line if facilities dictate.

An example of the proper equipment to use is a Buffalo Forge Co., shearing machine, 5-inch bar, model 12.

b. Circular Saw

Carbide-tipped circular saws are used to produce a precision mult.

Abrasive cutting, even done wet, is not approved. Experience has shown that trapped abrasive causes excessive tool wear during forging.

An example of the proper equipment to use is be a Heller Gebrueder cut-off machine, circular-saw blade, manual, model No. SSH630.

c. Band Saw

The band saw, although less accurate, is less expensive than a circular saw. The band-sawing process is slow, compared to the forging rate; therefore, materials handling provisions must be developed for multiple machines.

An example of the proper equipment to use is a Do-All cut-off machine, automatic feed, horizontal, model No. C70.

3. Operation 4130 - Heat Mult

Equipment alternatives:

- Heater, induction, 2200 F, 50 kW, 180 Hz
- Rotary-hearth furnace, 2200 F, 3,000 lb/h
- Continuous-tunnel furnace, 2200 F, 3,000 lb/h

Induction heating is the preferable method, since the heating is normally fast enough to prevent scaling of the mult. If furnace heating is used, the furnaces should have dual-fuel burners.

Examples of the proper equipment to use are:

- a. Tocco induction heating in-line system with multicoil stations for sequential capacity, 2200 F
- b. Flinn and Drefflein Inc. rotary hearth, gas fired,, 2200 F
- c. Lindburg Bros. Co. T-Slot Oven, open flame, gas fired, 2200 F

4. Operation 4140 - Descale

Equipment - Squirrel cage tumbler

Heated mults are placed in a squirrel-cage tumbler to remove scale. This operation normally is not necessary, if induction heating is used.

Typically, the squirrel cage tumbler is custom designed and made for the part being tumbled.

5. Operation 4150 - Preform and Restrike

Equipment - Press, mechanical, vertical, straight sided, single crank, 500 ton, 6-inch stroke

The part is forged in a three-stage die, with one part in each stage at a time.

An example of the proper equipment to use is a National Machinery Co. Maxipress 2000 mechanical press, model No. 500.

6. Operation 4160 - Descale

Equipment - Blast-clean and finish machine, horizontal endless belt barrel type

The forging scale is removed by tumble blasting.

An example of the proper equipment to use is a Pangborn Corporation 15GN3 Blast Cleaning Machine.

7. Operation 4170 - Clean

Equipment - Vapor degreaser

This is a standard cleaning process to prepare for welding.

This equipment is classified as "other production equipment."

E. INSERT, FORWARD (1380267)

This section contains an analysis of operations required for the production of the forward insert. The flow chart depicting the sequence of operations is shown in Figure III-3.

1. Operation 5110 - Handle Bar/Forgings

Equipment - Standard cranes, hoists, and forklift trucks

The handling of steel bar/forgings is not a step in the production process, but the material handling problem must be anticipated in any line designed for high-tonnage consumption of steel bar/forgings. The operations to be considered are discussed below.

a. Receiving Bar Stock/Forgings

This operation includes moving rolling stock and trailers and stacking material in the storage areas. The unloading activity utilizes overhead cranes, forklifts, and jib cranes. The stacking is arranged to assure material traceability.

Receiving inspection is completed before a lot becomes available for processing. If a material's supplier certification is acceptable, a verification of quantity, either by weight or by length, can be accomplished without extra handling.

b. Movement of Bar/Forgings from Storage to First Process Station

This operation includes the movement of raw material to the sawing or shearing operation to produce forgings for the first machining operation.

Examples of the proper equipment to use are a Shepard-Niles 15 ton bridge crane and a Clark 2-ton forklift truck.

2. Operation 5120 - Separate Mults

Equipment alternatives:

- Press, shear, 300 ton (cold shearing)
- Saw, carbide tipped, 24 inch, 30 hp (sawing)
- Saw, band, 16 inch, 25 hp (sawing)

a. Cold Shear

The 350 ton shear press requires automatic feed, clamp, and eject attachments. The press may either be in the production line to minimize material handling and traceability problems or be off-line if facilities dictate.

An example of the proper equipment to use is a Buffalo Forge Co., Shearing Machine, 5-inch bar, model 12.

b. Circular Saw

Carbide tipped circular saws produce precision mult.

Abrasive cutting, even done wet, is not approved. Experience has shown that trapped abrasive causes excessive tool wear during forging.

An example of the proper equipment to use is a Heller Gebrueder cut-off machine, circular-saw blade, manual, model No. SSH630.

c. Band Saw

The band saw, although less accurate, is less expensive than a circular saw. The band sawing process is slow, compared with the forging rate; therefore, materials handling provisions must be developed for multiple machines.

An example of the proper equipment to use is a Do-All cut-off machine, automatic feed, horizontal, model No. C70.

3. Operation 5130 - Heat Mult

Equipment alternatives:

- Heater, induction, 2200 F, 250 kW, 180 Hz
- Rotary-hearth furnace, 2200 F
- Continuous-tunnel furnace, 2200 F

Induction heating is the preferable method, since the heating is normally fast enough to prevent scaling of the mult. If furnace heating is used, the furnaces should have dual-fuel burners.

Examples of the proper equipment to use are:

- a. Tocco induction heating in-line system with multicoil stations for sequential heating, 2200 F
- b. Flinn and Dreffein Inc. Rotary Hearth, gas fired, 2200 F
- c. Lindberg Bros. T-Slot Oven, open flame, gas fired, 2200 F

4. Operation 5140 - Descale

Equipment - Squirrel cage tumbler

Heated mults are placed in a squirrel-cage tumbler to remove scale. This operation normally is not necessary, if induction heating is used.

Typically, the squirrel-cage tumbler is custom-designed and made for the part being tumbled.

5. Operation 5150 - Preform and Restrike

Equipment - Press, mechanical, vertical, straight sided, single crank, 500 ton, 6-inch stroke

The part is forged in a three-stage die with one part in each stage at a time.

An example of the proper equipment to use is a National Machinery Co. Mechanical Press, model No. 500.

6. Operation 5160 - Descale

Equipment - Blast-clean and finish machine, horizontal,
endless-belt barrel type

The forging scale is removed by tumble blasting.

An example of the proper equipment to use is a Pangborn
Corporation 15GN3.

7. Operation 5170 - Clean

Equipment - Vapor degreaser

This is a standard cleaning process to prepare for welding.

This equipment is classified as "other production equipment."

F. RETAINER, FUZE LINER (4902493)

The following section contains a detailed analysis of operations for the production of the fuze-liner piece parts and assembly.

Material - Carbon-steel tube, 5-inch OD x 3-1/4-inch ID, MIL-T-16343

1. Operation 5110 - Handle Tube

Equipment - Standard cranes, hoists, and forklift trucks

The handling of steel bar is not a step in the production process, but the materials handling problem must be anticipated in any line designed for high-tonnage consumption of steel bar. The operations to be considered are discussed below.

a. Receiving Tube Stock

This operation includes moving rolling stock, trailer and stacking material in the storage areas. The unloading activity utilizes overhead cranes, forklifts, and jib cranes. The stacking is arranged to assure material traceability.

Receiving inspection is completed before a lot becomes available for processing. If the material's supplier certification is acceptable, a verification of the quantity, either by weight or by length, can be accomplished without extra handling.

b. Movement of Tube from Storage to First Process Station

This operation includes the movement of stock to the first machining operation.

Examples of the proper equipment to use are Shepard-Niles 25 ton bridge crane and a Clark 2-ton forklift truck.

2. Operation 6120 - Machine Complete and Cut Off

Equipment - Lathe, bar, horizontal, four spindle, automatic
5-inch dia bar

The machining is complete except for drilled holes in the face.

An example of the proper equipment to use is a National Acme Co. automatic bar lathe, four spindle, model RB4, 5-1/8-inch dia bar.

3. Operation 6130 - Drill Two Holes

Equipment - Drill press, 2 spindle

The index fixture is used to drill two holes.

An example of the proper equipment to use is be a Leland Gifford Drilling Machine model 2LMS-26.

4. Operation 6140 - Drill and Tap Hole

Equipment - Drill press, two spindle

This is a standard machining operation.

An example of the proper equipment to use is a Leland Gifford Drilling Machine, model 2LMS-26.

5. Operation 6150 - Clean

Equipment - Vapor degreaser

This is a standard cleaning process.

The equipment is classified as "other production equipment."

G. FUZE LINER, AFT (4902490)

1. Operation 7110 - Receive Raw Material

Equipment - Forklift and hoist

This standard operation, which is used in all processes, requires standard materials handling equipment.

2. Operation 7120 - Handle Coil Strip, Bar & Tube

Equipment - Standard cranes, hoists and transfer equipment

Handling of material is not a step in the production process but materials handling must be anticipated in a line designed for high utilization of coil strip and bar. Handling of the material is accomplished by standard equipment such as overhead hoists, conveyors, hooks, slings, and lift trucks. No example of specific equipment or manufacturer is required, because the equipment used is standard in the metal-working industry.

H. CANISTER - ITEM 1

Material - Steel, (CRDQ) QQ-S-698 (.072 thick)

1. Operation 7130 - Blank and Form

Equipment - Press, straight sided, mechanical, 230 ton,
15-inch stroke, coil-stock reel, straightener,
lubricator, and scrap chopper

The stock is pulled from the reel, through the straightener and lubricator into a five-station die. The die stations include blanking, three draws and a punch at the last draw station, and trim to length. The unused strip is chopped to facilitate scrap removal from the press area.

An example of the proper equipment to use is a Bliss 5S, mechanical, vertical, straight sided, double-action press.

2. Operation 7140 - Degrease

Equipment - Degreaser, conveyORIZED

Parts are received from the previous operation, loaded onto racks with the large open end down, and conveyed through the degreaser unit to remove all contaminants.

An example of the proper equipment to use is a Baron-Blakeslee Degreaser, 1019, type TH-LL-V.

I. COLLAR - ITEM 2, PART OF (4902490)

Material - Steel tubing, type 1, MIL-T-16343

1. Operation 8110 - Turn Complete

Equipment - Lathe, horizontal, six-spindle automatic,
4-inch diameter bar, 30 hp

Parts are produced by from lengths of tubing by a standard machining operation. All parts are complete except for the inside diameter, which must be .12 inches smaller on each part. This material is removed after welding in Operation 4010. The machine production rate is based on double-tooling the machine, thus two finished parts are produced with each cycle of the machine.

An example of the proper equipment to use is a Cone-Blanchard Machine Co., automatic screw machine, model SZ, six-spindle.

2. Operation 8120 - Deburr

Equipment - Finishing machine, vibratory type, circular bowl,
20-cubic-ft capacity with automatic washer and
unloader

All burrs and sharp edges are removed by the abrasive media and the vibratory motion.

An example of the proper equipment to use is a Sweco Inc., model FM20, finishing machine.

3. Operation 8130 - Degrease

Equipment - Degreaser, conveyORIZED

Parts are loaded into racks and then conveyed through the degreaser unit to remove all contaminants.

A typical example of the proper types of equipment to use is a Baron-Blakeslee Degreaser, type TH-LL-V, model 1019.

J. SLEEVE, FUZE LINER (4902492)

Material - Steel, AISI 1025, 1024, or 1022

1. Operation 9110 - Machine Complete

Equipment - Lathe, bar, horizontal, six-spindle automatic,
1-5/8-inch dia bar, 30 hp

Standard machining practices are used to produce a finished part with each cycle of the machine

An example of the proper equipment to use is a Cone-Blanchard Machine Co. automatic screw machine SW, 30 hp.

2. Operation 9120 - Degrease

Equipment - Degreaser, conveyORIZED

Parts are loaded on racks and conveyed through the cleaning cycle to remove contaminants.

An example of the proper equipment to use is a Baron-Blakeslee, Type TH-LL-V, model 1019.

K. FUZE LINER, AFT (4902490)

1. Operation 10110 - Friction Weld (Inertia Weld)
Collar to Canister

Equipment - Friction-welding machine, special with automatic load and unload

Parts are automatically loaded in the machine and joined by the friction weld process, which consists of one part rotated at a controlled r/min, while the other part, restrained from turning, is forced against the rotating part. The heat generated by the rotation and the force, or forging action, creates a weld without filler materials, fluxes, or shielding gases. Only a narrow heat zone is required.

An example of the proper equipment to use is a Manufacturing Technology Inc., 180-B Inertia Welding Machine.

2. Operation 10120 - Machine Weld Flash

Equipment - Lathe, automatic chucking, 3-inch dia bar, 10 hp

This is a standard machining operation which includes back-boring the flash on the inside diameter of the collar and plunge-cutting the external flash from the part.

An example of the proper equipment to use is a Warner & Swasey OAC, 4410 Automatic Turret Lathe, 3-inch bar, 10 hp.

3. Operation 10130 - Degrease

Equipment - Degreaser, conveyORIZED

Parts with flange down are loaded on racks and conveyed through the degreaser unit to remove all contaminants.

An example of the proper equipment to use is a Baron-Blakeslee, type TH-LL-V, model 1019

4. Operation 10140 - Magnetic-Particle Inspection

Equipment - Magnetic-particle inspection, magnaflux

To determine imperfections, parts are inspected by a standard procedure.

An example of the proper equipment to use is a Magnaflux Corporation model H720 with a No. SB1416 demagnetizer.

L. FUZE LINER ASSEMBLY (4902494) AFT

1. Operation 11110 - Friction-Weld (Inertia Weld) Sleeve to
Canister Sub-Assembly

Equipment - Friction welding machine, special with automatic
load and unload

Parts are automatically loaded in the machine and joined by the friction-weld process. One part is rotated at a controlled r/min, then the other part, restrained from turning, is forced against the rotating part. The heat generated by the rotation and the force or forging action creates a weld without filler materials, fluxes, or shielding gases. Only a narrow heat zone is required.

An example of the proper equipment to use is a Manufacturing Technology Inc. model 90-B Inertia Welder.

2. Operation 11120 - Zinc Plate

Equipment - Zinc plating machine, automatic, return type,
continuous 12

Parts are racked and automatically processed through the plating machine. Loading and unloading is manual.

An example of the proper equipment to use is a Udylite Co., Division of OXY Finishing Corp., Custom Zinc Plating Machine.

M. FUZE LINER, FORWARD (1239593)

1. Operation 12110 - Receive Raw Material

Equipment - Forklift and hoist

This standard operation is used in all processes and requires standard materials handling equipment.

2. Operation 12120 - Handle Coil Strip, Bar, and Tube

Equipment - Standard cranes, hoists, and transfer equipment

Although it is not a step in the production process, but materials handling must be anticipated in a line designed for high utilization of coil strip and bar. The handling is accomplished by standard handling equipment, such as overhead hoists, conveyors, hooks, slings, and lift trucks.

No specific equipment or manufacturer is required, because the equipment used is standard to the metal-working industry.

N. CANISTER - ITEM 1, PART OF (1239593)

Material - Steel (CRDQ) QQ-S-598 (072 THK)

1. Operation 12130 - Blank and Form

Equipment - Press, straight sided, mechanical, 230 ton,
15-inch stroke, with coil-stock reel, straight-
ener, lubricator, and scrap chopper

The stock is pulled from the reel through the straightener and the lubricator into a five-station die. The die stations include blanking, three draws (with a punch at the last draw station), and trim to length. The unused strip is chopped to facilitate scrap removal from the press area.

An example of the proper equipment to use is a Bliss 5S, mechanical, vertical, straight-sided, double-action press.

2. Operation 12140 - Degrease

Equipment - Degreaser, conveyORIZED

Parts received from the previous operation are loaded with large open end down onto racks and conveyed through the degreaser unit to remove all contaminants.

An example of the proper equipment to use is a Baron-Blakeslee Degreaser, 1019, type TH-LL-V.

0. COLLAR - ITEM 2, PART OF (1239593)

Material - Steel tubing, type 1 MIL-T-16343

1. Operation 13110 - Turn Complete

Equipment - Lathe, horizontal, six-spindle automatic,
4-inch dia bar, 30 hp

Parts are produced from lengths of tubing by standard machining operations. All parts are complete except for the inside diameter, which must be .12 inches smaller on each part. This material is removed after welding Operation 4010. The machine production rate is based on double-tooling the machine, thus two finished parts are produced with each cycle of the machine.

An example of the proper equipment to use is a Cone-Blanchard Machine Co., automatic screw machine, model SZ, six-spindle.

2. Operation 13120 - Deburr

Equipment - Finishing machine, vibratory type, circular bowl,
20 cubic ft capacity with automatic washer and
unloader

All burrs and sharp edges are removed by the abrasive media and the vibratory motion.

An example of the proper equipment to use is a Sweco Inc., model FM20, finishing machine.

3. Operation 13130 - Degrease

Equipment - Degreaser, conveyORIZED

Parts are loaded into racks and conveyed through the degreaser unit to remove all contaminants.

An example of the proper equipment to use is a Baron-Blakeslee degreaser, type TH-LL-V, model 1019.

P. SLEEVE, FUZE LINER (4902492)

Material - Steel, AISI 1025, 1024, or 1022

1. Operation 14110 - Machine Complete

Equipment - Lathe, bar, horizontal, six-spindle automatic,
1-5/8-inch dia bar, 30 hp

Standard machining practices are used to produce a finished part with each cycle of the machine.

An example of the proper equipment to use is be a Cone-Blanchard Machine Co. automatic screw machine, SW, 30 hp.

2. Operation 14120 - Degrease

Equipment - Degreaser, conveyORIZED

Parts are loaded on racks and conveyed through the cleaning cycle for removal of contaminants.

An example of the proper equipment to use is a Baron-Blakeslee, type TH-LL-V, model 1019.

Q. FUZE LINER, FWD (1239593)

1. Operation 15110 - Friction-Weld (Inertia-Weld)
Collar to Canister

Equipment - Friction-welding machine, custom built with automatic load and unload

Parts are automatically loaded into the machine and joined by the friction weld process. One part is rotated at a controlled r/min, and the other part, restrained from turning, is forced against the rotating part. The heat generated by the rotation and the force or forging action creates a weld without filler materials, fluxes, or shielding gases. Only a narrow heat zone is required.

An example of the proper equipment to use is a Manufacturing Technology Inc., 180-B Inertial Welding Machine.

2. Operation 15120 - Machine Weld Flash

Equipment - Lathe, automatic chucking, 3-inch dia bar, 10 hp

This is a standard machining operation which includes back boring the flash on the inside diameter of the collar and then plunge cutting the external flash from the part.

An example of the proper equipment to use is a Warner & Swasey OAC, 4410 automatic turret lathe, 3-inch bar, 10 hp.

3. Operation 15130 - Degrease

Equipment - Degreaser, conveyorized, liquid-vapor-liquid type

Parts are loaded with flange down on racks, then conveyed through the degreaser unit to remove all contaminants.

An example of the proper equipment to use is a Baron-Blakeslee, type TH-LL-V, model 1019.

4. Operation 15140 - Magnetic Particle Inspect

Equipment - Magnetic-particle inspection, magnaflux

Parts are inspected to determine imperfections. A standard procedure is used.

An example of the proper equipment to use is be a Magnaflux Corporation machine, model H720 with a No. SB1416 de-magnetizer.

R. FUZE LINER ASSEMBLY (4902495) FWD

1. Operation 16110 - Friction-Weld (Inertia-Weld)
Sleeve to Canister Subassembly

Equipment - Friction-welding machine, custom built with automatic load and unload

Parts are automatically loaded in the machine and joined by the friction weld process. One part is rotated at a controlled r/min, and the other part, restrained from turning, is forced against the rotating part. The heat generated by the rotation and the force or forging action creates a weld without filler materials, fluxes, or shielding gases. Only a narrow heat zone is required.

An example of the proper equipment to use is a Manufacturing Technology Inc. model 90-B Inertia Welder.

2. Operation 16120 - Zinc Plate

Equipment - Zinc plating machine, automatic, return type, continuous 12

Parts are racked and automatically processed through the plating machine. Loading and unloading is manual.

An example of the proper equipment to use is a Udylite Co., Division of OXY Finishing Corp., Custom Zinc Plating Machine.

S. BODY ASSEMBLY, BOMB, GENERAL PURPOSE (2841464)

This section contains an analysis of operations required for the production of the body assembly shown in Figure III-4. The flow chart depicting the assembly of the bomb is shown in Figure III-5.

1. Operation 17110 - Assemble Complete

- Equipment - Special tube expander, air activated
- Special air-activated assembly holding fixture
- 100-candle-power light source

The bomb body is secured in the special air-activated assembly holding fixture. The body is held in a fixed position to facilitate the assembly of charging tubes, fuze liners, plugs and rings. The fixture should be designed to allow vertical, horizontal, and rotary movement of the body for the assembly operations. The operator can manipulate the body without leaving the assembly station. Tools and parts to be assembled should be located for easy access in the assembly work station. The expansion tools should also be located for efficient use. The use of balance suspension equipment is recommended.

The assembly station must have a light source capable of providing 100 candle power of light inside the bomb body cavity without impairing the vision of the operator looking into the interior of the body.

The light is required to adequately view the holes in the charge inserts for ease of installation of the charge tubes, and to inspect the interior of the cavity for possible damage to the bituminous protective coating.

The bomb body will be processed into the assembly station by conveyor and moved out to the next operation the same way.

Detailed assembly steps are performed as follows:

a. Install Forward and Aft Charging Tubes

The forward charge tube is manually inserted into the boss on the forward insert. (Care is to be taken to assure

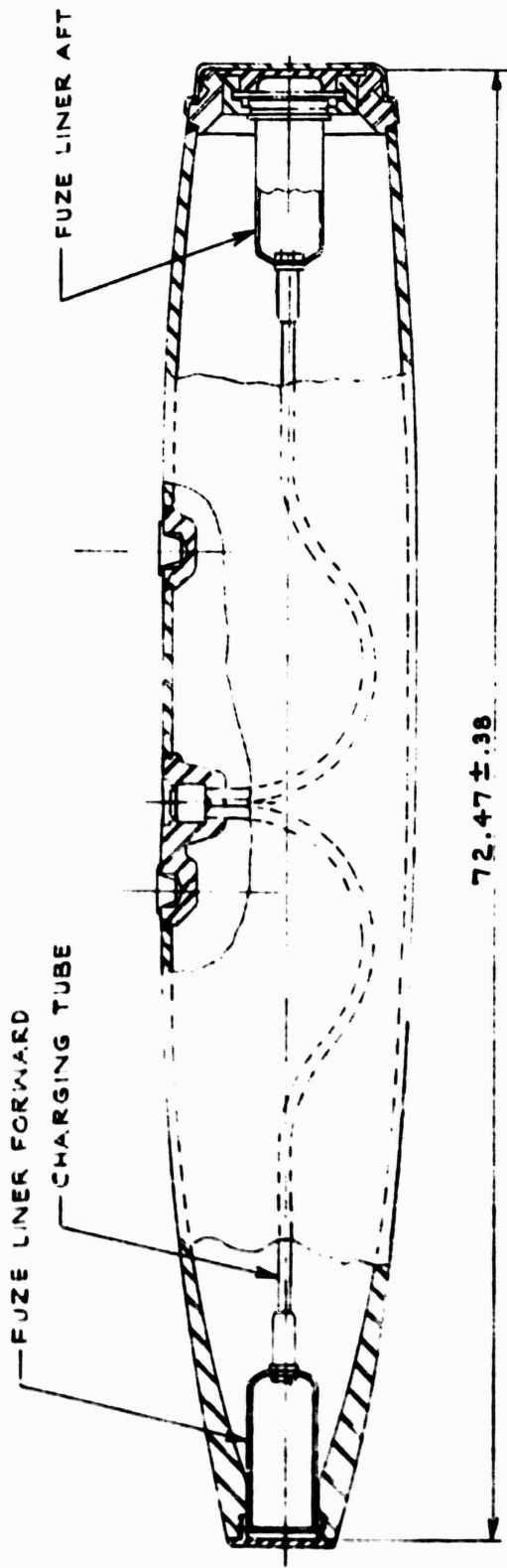
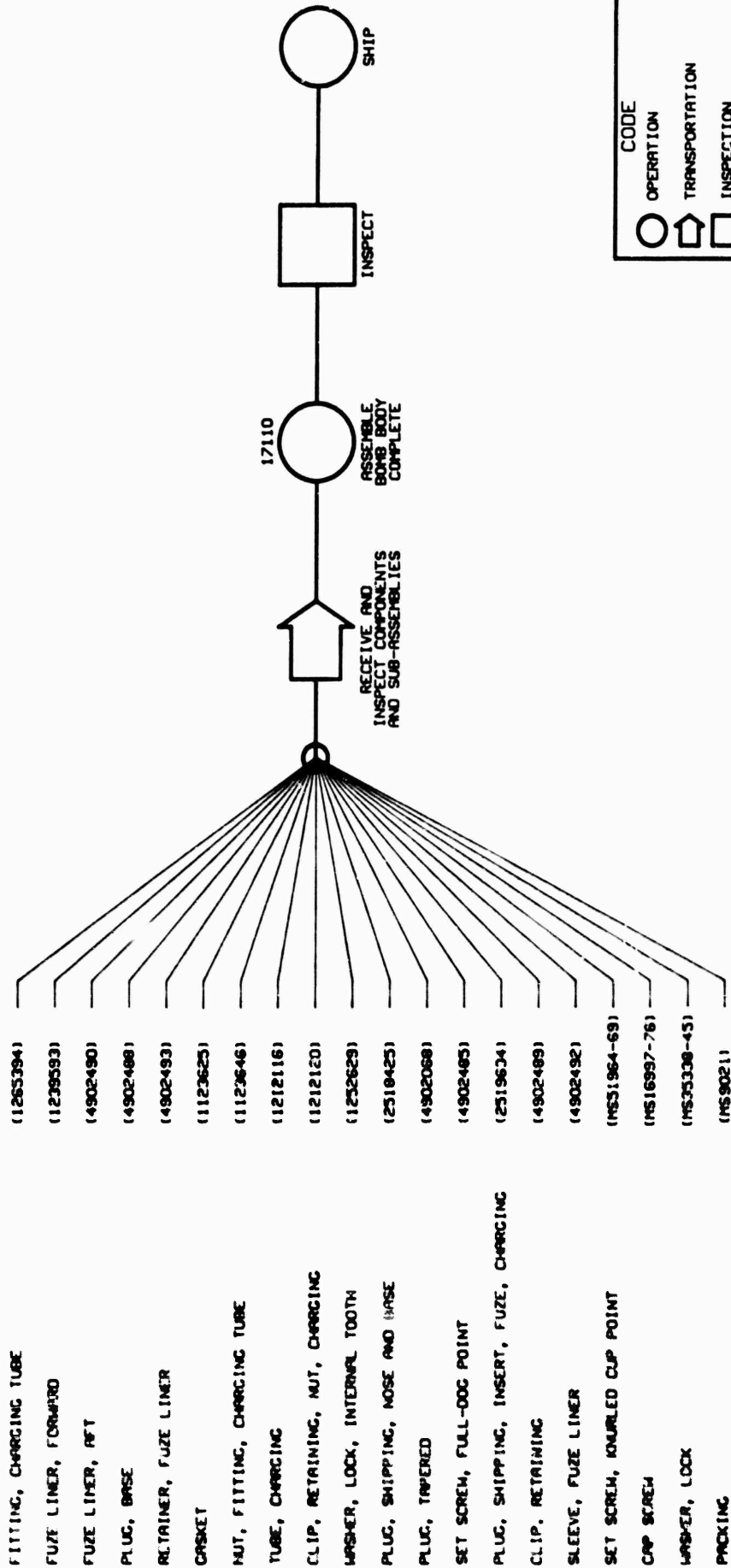

FIGURE II-4
BODY ASSY, BOMB, GENERAL
PURPOSE, 1000 POUND
MK 83 MOD 4, EMPTY
PART No. 2841464

FIGURE III-5

FLOW CHART

MK 83 BOMB BODY ASSEMBLY (2841464)
PRODUCTION BASELINE



CODE

○	OPERATION
◡	TRANSPORTATION
◻	INSPECTION
◩	DELAY
◪	STORAGE

that the forward most boss is used, the rear one is used to receive the aft charging tube.) Align the tube in the proper position to mate with the forward and aft fuze-wells, which are installed in the next operation. The position of the tubes in relation to the bosses is critical. Care must be taken to assure that the tubes are fully inserted into the bosses. The tubes must bottom-out against the flanges at the bottom of the holes.

The joint must be pressure tight after expansion. A seal compound is suggested if needed to assure proper sealing of the joints.

Should the compound be used, it must be applied just prior to the insertion of the tubes into the bosses.

b. Form Joints of Forward and Aft Charging Tubes

To form an air tight joint an air-activated expansion tool is used to expand the steel tubing into the coupling.

The inside diameter of the tube must remain open throughout the entire length of the tube.

Both ends of the forward charging tube are expanded in this operation. The depth of insertion of the expansion tool into the charge tube varies at each end. The operator must take care to insert the tool to the proper depth before expanding the joints. Improper use of special expansion tool could cause permanent damage to all parts (bomb body, charging tube, and fuze-well assembly).

c. Assemble Forward Fuze Liner in Bomb Body

The fuze liner is threaded and must be carefully screwed into place. The threads are coated with an antiseize compound before the fuze liner is inserted into the bomb body.

Care must also be taken to assure the proper alignment of the forward charge tube with the coupling that is at the rear of the fuze liner. The two parts must slip together

as the fuze-well is screwed into position. The flange on the fuze-well is later coated with a bituminous coating compound, MIL-C-450.

The thin coating ensures proper sealing of the two parts and prevents leakage and exposure of the explosives used in the bomb.

The fuze liner should be torqued to 200 ft-lb.

The depth of penetration of the charging tube into the fuze liner flange must be inspected. Care is required to make the tubes conform to the drawing specifications.

d. Install Aft Fuze Liner

Slip the aft fuze-well flange onto the aft charging tube. The position of the aft fuze-well is critical and the relationship of the base plug must be properly maintained prior to expanding the joints of the charge tube.

Care must also be taken to assure the proper alignment of the aft charge tube and the coupling at the rear of the fuze liner. The two parts must slip together as the fuze-well is screwed into position.

The flange on the fuze-well is to be coated with a thin layer of a coating compound MIL-C-450 to ensure the proper sealing of the two parts to prevent leakage and exposure of the explosives used in the bomb.

The depth of penetration of the charging tube into the fuze liner flange must be inspected.

e. Form Joints of Forward and Aft Charging Tube

An air-activated expansion tool is used to expand the steel tubing into the coupling to form an air tight joint and withstand the mechanical force associated with the application.

The inside diameter of the tube must remain open throughout the length of the tube.

f. Inspect Cavity

The entire interior surface of the body cavity, the charging tubes, and the fuze-wells are visually inspected for any damage to the coating compound.

Special attention is given to the fuze-well coupling/charge-tube joints and the charge-tube insert and tubes.

Any exposed surface is coated with the bituminous coating compound MIL-C-450. In addition, any other foreign material trapped in the cavity is removed.

g. Install Base Plug

The threads of the base plug are coated with an antiseize compound according to MIL-A-907.

The base plug is screwed into the bomb-body ring adapter. Care is required to properly align the aft fuze-well with the base plug.

The base plug is then torqued to 200 ft-lb.

The seat of the fuze-well that mates with the base plug is applied with a thin coating of bituminous compound MIL-C-450.

i. Install Aft Fuze Liner Retainer

The aft fuze-well retainer is attached to the aft fuze-well assembly and screwed into place.

Prior to assembly, the threads are coated with an antiseize compound, as specified in MIL-A-907.

Torque to 200 ft-lb/min.

The screw is not installed in this procedure. The set screw is shipped separately with each finished bomb body assembly. It is clearly identified and packaged.

j. Move Completed Assembly to Next Operation

The completed bomb assembly is released from the assembly fixture and taken away on a conveyor. The assembly station is now clear for the next unit.

IV. RECOMMENDED PRODUCTION BASELINE FOR THE MK83 MOD 4,
1,000-LB BOMB BODY ASSEMBLY

The recommended production baseline for the MK83 bomb body assembly is summarized in Tables IV-1, 2, 3, 4, and 5 by operation number. The recommended process and equipment are based on the findings of the PEP modernization study. The rationale and assumptions used in preparing the baseline are discussed below.

The lack of an assigned production rate required the arbitrary establishment of a gross capacity production rate as a basis for quantifying the equipment requirements. Capacity can be altered by adding and deleting equipment for each operation.

The technical data package indicates the casing may be formed by the hot forging process or by hot forming seamless or welded-seam tubing. The MK83 production baseline analysis addresses both the forging and tubing processes. The forging process does not appear to be economical in that the forging process will require presses of high tonnage with exceptionally long strokes. Presses of this type are not available in existing equipment inventories, nor are they of the design and size that can be manufactured within a reasonable leadtime. Therefore, the baseline processes and equipment are planned and designed to use steel tubing to produce the bomb casing.

The initial evaluation of the manufacturing requirements considered all feasible methods for producing the MK83 piece parts. In some instances, this evaluation led to the identification and evaluation of the alternate production equipment/methods discussed earlier in this report.

Operations for which alternate methods were discussed are listed below along with the rationale for selecting the process shown in the recommended baseline.

- o Table IV-1, Bomb Casing, Operation 1120 - (Separate Lengths of Tube). The four methods investigated for this operation were band sawing, circle sawing, flame cutting, and rotary cutting. Rotary cutting is the most efficient means of performing this operation. This method, which produces a clean, accurate parting of the tube section at a gross rate of 200 pieces/h is much faster than the other methods and does not result in any

material loss to saw or torch kerf. Moreover, the roll cutters generate a chamfer on the outside diameter of the tube ends and thereby eliminate the need for deburring.

- o Table IV-2, Adapter Ring, Operation No. 2120 - (Separate Mults). Three methods were considered for this operation. They included cold shearing and types of metal sawing (circle and band). Cold shearing is the most productive and accurate method. Moreover, this method generates appreciable material savings by eliminating saw kerf.
- o Table IV-2, Adapter Ring, Operation 2130 - (Heat Mult). The induction heater was chosen over the rotary hearth or through-feed furnace processes. Although the productivity of the induction heater is less than the continuous furnaces, there is a tremendous energy savings due to the localized heat control and startup/shutdown response. This method also minimizes soak time and consequently produces less surface scale and related material loss.
- o Table IV-3, Base Plug, Operation No. 3120 - (Separate Mults). Three methods were considered for this operation. They included cold shearing and two types of metal sawing (circle and band). Cold shearing is the most productive and accurate method. Moreover, this method generates appreciable material savings by eliminating saw kerf.
- o Table IV-3, Base Plug, Operation No. 3130 - (Heat Mult). The induction heating method was selected over the rotary hearth or through-feed furnace processes. Although the productivity of the induction heating method is not as great as that of the through-feed systems, the reduced energy consumption justifies the choice. Also, the localized heat and soak control minimizes material loss from surface scale formation.
- o Table IV-4, Insert Suspension Lug, Operation No. 4120 - (Separate Mults). Three methods were considered for this operation. They included cold shearing and two types of metal sawing (circle and band). Cold shearing is the most productive and accurate method. Moreover, this method generates appreciable material savings by eliminating saw kerf.

- o Table IV-5, Forward Insert, Operation No. 5130 - (Heat Mult). Induction heating was selected over the rotary hearth and tunnel furnaces. This choice was based on energy savings resulting from the startup/shutdown response time, localized heat zone control, material savings from reduced surface scaling, and elimination of subsequent descaling operations.

RECOMMENDED MANUFACTURING PROCESS: ANALYSIS OF OPERATIONS

A. CASING, BOMB, MK83 MOD 4 (1380266)

The recommended sequence of manufacture is summarized in Table IV-1. The operation numbers are the same as those shown in Section III.

1. Operation 1110 - Handle Tubes

Equipment - Standard cranes, hoists, and transfer equipment

An example of the proper equipment to use is a Shepard-Niles 25-ton bridge crane,

2. Operation 1120 - Separate Lengths, Tube

Equipment - Cut-off machine, rotary, 60 hp

d. Rotary Cutting

The tube is cut to the required length while chamfers are generated on the outside diameter. This method eliminates end deburring.

A typical example of the proper equipment to use is a Stamet Co. S024450, lathe, automatic, 95-r/min spindle, 60 hp.

3. Operation 1250 - Preform Nose and Base End, Tube

Equipment - Press, hydraulic, 600 ton, 48-inch stroke

An example of the proper equipment to use is a Verson Allsteel Press model 600HDI-66T, 600 ton, 48-inch stroke.

4. Operation 1260 - Heat Nose End

Equipment - Heater, induction, 1400 F, 500 kW, 180 Hz

An example of the proper equipment to use is a Westinghouse Electric induction heater.

5. Operation 1270 - Form Nose

Equipment - Press, hydraulic, 600 ton, 48-inch stroke

An example of the proper equipment to use is a Verson Allsteel Press model 600HDI-48T, 600 ton, 48-inch stroke.

6. Operation 1280 - Reheat Nose End

Equipment - Heater, induction 2200 F, 800 kW, 180 Hz

An example of the proper equipment to use is a Westinghouse Electric induction heater, 800 kW, 180 Hz.

7. Operation 1290 - Final Form Nose

Equipment - Press, hydraulic, 600 ton, 48-inch stroke

An example of the proper equipment to use is a Verson All Steel Press model 600HDI-66T, 600 ton, 48-inch stroke.

8. Operation 1340 - Machine Nose and Base End, Tube (Alternate)

Equipment - Way-type machine, single station, double ended horizontal, boring, 50 hp

An example of the proper equipment to use is a machine made by Heald Machine Co., 442A, 80-inch-long table, 50 hp.

9. Operation 1360 - Flame-Cut Lug and Charging Tube Adapter Holes

Equipment - Two automatic machine torches
- Two 500 to 600 A power supplies
- Special cradling and fixturing machine base

An example of the proper equipment to use is a Linde Division, Union Carbide Co., model CM-56 with CW-45 cutting torches.

10. Operation 1370 - Weld Lug and Charging Adapters

- Equipment - Two automatic machine torches, gas shielded with flux cored wire
- Two 500 to 600 A 100 percent duty-cycle power supply
 - Special cradling and fixturing machine base

An example of the proper equipment to use is a Linde Division of Union Carbide Co., VI600 welding power supply, SWM-23 wire feeder, ST-5 water-cooled machine torch.

11. Operation 1380 - Weld Ring, Adapter, Tubing

- Equipment - Automatic machine torch with arc length sensor, gas shielded with flux-cored welding wire
- 500 to 600 A 100 percent duty-cycle power supply
 - Special cradling and fixturing machine base

An example of the proper equipment to use is a Linde Division of Union Carbide Co. VI-600 welding power supply, SWM-23 wire feeder, ST-5 water-cooled machine torch.

12. Operation 1390 - Heat Treat and Temper

Equipment alternatives:

- Heater, induction 1550 F to 1650 F, 800 kW, 180 Hz or
- Furnace, gas, 1550 F to 1650 F and
- Furnace, gas, 750 F to 950 F

An example of the proper equipment to use is a special heat-treat and temper system made by Flinn & Drefflein Engineering Co., special.

13. Operation 1400 - Blast Clean ID and OD

Equipment - Roto-blast unit

An example of the proper equipment to use is a Wheelabrator & Frye Co., 42D393, blast cleaning machine.

14. Operation 1410 - Check Hardness

Equipment - Hardness tester, brinell, automatic

An example of the proper equipment to use is a Rockwell Corp., model 5JR, hardness tester.

15. Operation 1420 - Bore, Face, Thread Nose End

Equipment - Lathe, turret, automatic 16-inch swing, 73 inch centers, 30 hp

An example of the proper equipment to use is a Jones and Lamson Co. model 20, lathe, automatic, chucking, 16-inch swing, 73-inch centers, 30 hp.

16. Operation 1430 - Bore, Face, Thread, Machine Base End

Equipment - Lathe, turret, automatic 16-inch swing, 73-inch centers, 30 hp

An example of the proper equipment to use is a Jones & Lamson Co. model 20, lathe, automatic, chucking, 16-inch swing, 73-inch centers, 30 hp.

17. Operation 1440 - Step Drill and Tap Lifting Holes and Charging Hole

Equipment - Drill press, tapping, multistation, 2-1/4-inch capacity

An example of the proper equipment to use is a Barnes multispindle drill press, special.

18. Operation 1470 - Drill 16 Holes, Base End and Drill and Tap Nose End

Equipment - Drill press, multispindle, two units, horizontal

An example of the proper equipment to use is a Barnes multispindle horizontal drill press, 15 hp.

19. Operation 1480 - Test Lifting Lug Adapter

Equipment - Special test machine

An example of the proper equipment to use is special test equipment manufactured to dictated parameters.

20. Operation 1490 - Pressure Test Bomb Body

Equipment - Special test equipment

An example of the proper equipment to use is special test equipment manufactured to dictated parameters.

21. Operation 1500 - Stamp Identification

Equipment - Machine, stamping, rotary, 5 hp

An example of the proper equipment to use is a James H. Matthews Co. Marking Machine model N2201.

22. Operation 1510 - Phosphate Treat

Equipment - Chemical line (multistage spray/dip system)

An example of the proper equipment to use is a five-stage phosphatizer made by Litton Unit Handling Systems.

23. Operation 1520 - Paint

Equipment - Paint-spraying machine, automatic, electrostatic

An example of the proper equipment to use is a special unit made by Binks Manufacturing Co.

B. RING, ADAPTER, BOMB BODY (1381204)

Material - Carbon steel with yield strength 40,000 lbf/in² and tensile strength 70,000 lbf/in², forging quality

1. Operation 2110 - Handle Billet

Equipment - Standard cranes, hoists, and forklift trucks

An example of the proper equipment to use is a Shepard-Niles 25-ton bridge crane and a Clark 2-ton forklift truck.

2. Operation 2120 - Separate Mults

Equipment - Press, shear, 1,000 ton

An example of the proper equipment to use is a Buffalo Forge Co., shearing machine, 5-5/8 inch bar, model 13.

3. Operation 2130 - Heat Mult

Equipment - Heater, induction, 700 kW, 180 Hz, 2200 F

An example of the proper type of equipment to use is a Tocco induction heating in-line system with multicoll stations for sequential heating, 2200 F.

4. Operation 2150 - Forge Complete

Equipment - Press, mechanical, 2,000 ton, 10-inch stroke

An example of the proper type of equipment to use is a National Machinery Co., Maxipress 2000, mechanical.

5. Operation 2160 - Descale

Equipment - Blast-clean and finishing machine

An example of the proper type of equipment to use is a Pangborn Corporation blast-cleaning machine, endless-belt barrel type, model 15GN3.

6. Operation 2180 - Rough and Finish Machine

Equipment - Lathe, six-spindle, automatic chucking, 10-inch capacity

An example of the proper equipment to use is a National Acme Co., model RPA6 automatic chucker, 30 hp.

7. Operation 2190 - Clean

Equipment - Vapor degreaser

An example of the proper equipment to use is a Baron Blakeslee, model 1019.

C. PLUG, BASE, BOMB BODY (4902488)

Material - Carbon steel with yield strength 40,000 lbf/in² and tensile strength 70,000 lbf/in², bar stock

1. Operation 3110 - Handle Billet

Equipment - Standard cranes, hoists, and forklift trucks

Examples of the proper equipment to use is a Shepard-Niles 25-ton bridge crane and a Clark 2-ton forklift truck.

2. Operation 3120 - Separate Mults

Equipment - Press, shear, 350 ton

An example of the proper equipment to use is a Buffalo Forge, Co., shearing machine, bar, Model 13.

3. Operation 3130 - Heat Mult

Equipment - Heater, induction 2200 F, 600 kW, 180 Hz

An example of the proper equipment to use is a Tocco induction heating in-line system with multicoil stations for sequential capacity, 2200 F.

4. Operation 3150 - Forge Complete

Equipment - Press, mechanical, vertical, straight-sided, crank, 1,000 ton, 12-inch stroke

An example of the proper equipment to use is a National Machinery Co. Maxipress 2000.

5. Operation 3160 - Descale

Equipment - Blast-clean and finish machine

An example of the proper equipment to use is a Fangborn Corporation 15GN3 blast cleaning machine.

6. Operation 3175 - Face and Machine Inside and Outside Diameters

Equipment - Lathe, six-spindle, automatic, chucking

An example of the proper equipment to use is a National Acme chucking lathe, six-spindle, automatic, 30 hp, model RPA6.

7. Operation 3180 - Under Cut Thread and Face

Equipment - Lathe, six-spindle, automatic, chucking

An example of the proper equipment to use is a National Acme Co., automatic chucker, 30 hp, model RPA6.

8. Operation 3190 - Drill and Tap Six Holes

Equipment - Drill press, 2-spindle, 3/8-inch capacity

An example of the proper equipment to use is a Leland Gifford Co., drilling machine, manual, model 2LMS-26

9. Operation 3200 - Mark

Equipment - Marking machine, reciprocating die, semiautomatic feed, mechanical power

An example of the proper equipment to use is a Noble and Westbrook marking machine, model 245.

10. Operation 3210 - Clean

Equipment - Vapor degreaser

An example of the proper equipment to use is a Baron Blakeslee, model 1019.

D. INSERT, SUSPENSION LUG (1253008)

Material - Carbon steel with yield strength 40,000 lbf/in² and tensile strength 70,000 lbf/in², forging quality

1. Operation 4110 - Handle Bar

Equipment - Standard cranes, hoists, and forklift trucks

Examples of the proper equipment to use is a Shepard-Niles 25-ton bridge crane and a Clark 2-ton forklift truck.

2. Operation 4120 - Separate Mults

Equipment - Shear press, 350 ton

An example of the proper equipment to use is a Buffalo Forge Co., shearing machine, 5-inch bar, model 12.

3. Operation 4130 - Heat Mult

Equipment - Heater, induction, 2200 F, 50 kW, 180 Hz

An example of the proper equipment to use is a Tocco induction heating in-line system with multicoil stations for sequential capacity, 2200 F.

4. Operation 4150 - Pre-form and Restrike

Equipment - Press, mechanical, vertical, straight-sided, single crank, 500 ton, 6-inch stroke

An example of the proper equipment to use is a National Machinery Co., Maxipress 2000 mechanical press, model No. 500.

5. Operation 4160 - Descale

Equipment - Blast-clean and finish machine

An example of the proper equipment to use is a Pangborn Corporation model 15GN3 blast-cleaning machine

6. Operation 4170 - Clean

Equipment - Vapor degreaser

This equipment is classified as "other production equipment."

E. INSERT, FORWARD (1380267)

Material - Carbon steel with yield strength 40,000 lbf/in² and tensile strength 70,000 lbf/in² forging quality

1. Operation 5110 - Handle Bar Stock

Equipment - Standard cranes, hoists, and forklift trucks

Examples of the proper equipment to use is a Shepard-Niles 15-ton bridge crane and a Clark 2-ton forklift truck.

2. Operation 5120 - Separate Mults

Equipment - Press, shear, 350 ton

An example of the proper equipment to use is a Buffalo Forge Co., shearing machine, 5-inch bar, model 12.

3. Operation 5130 - Heat Mult

Equipment - Heater, induction, 2200 F, 250 kW, 180 Hz

An example of the proper equipment to use is a Tocco induction heating in-line system with multicoil stations for sequential heating, 2200 F.

4. Operation 5150 - Pre-form and Restrike

Equipment - Press, mechanical, vertical, straight-sided, single crank, 500 ton, 6-inch stroke

An example of the proper equipment to use is a National Machinery Co., mechanical press, model No. 500.

5. Operation 5160 - Descale

Equipment - Blast-clean and finish machine

An example of the proper equipment to use is a Pangborn Corporation model 15GN3.

6. Operation 5170 - Clean

Equipment - Vapor degreaser

This equipment is classified as "other production equipment."

TABLE IV-1
 RECOMMENDED SEQUENCE OF MANUFACTURE
 PROCESS DESCRIPTION SUMMARY
 MK83 MOD 4, 1,000-LB BOMB, CASING (1380266)
 TUBE METHOD

BASIS, 50 PIECES/H ASSIGNED OUTPUT RATE

Oper No.	Equipment Required	Operation Description --- Equipment Description	Gross Capacity Pieces/h	Equipment Est. Cost, \$
1110	As Required	Handle Received Material Materials handling equipment	50	N/A
1120	1	Separate Lengths, Tube Cutoff machine, rotary, 60 hp	200	241,000
1250	1	Pre-form Nose and Base Ends Press, hydraulic, 500 ton	180	300,000
1260	1	Heat Nose End Heater, induction, 500 kW, 180 Hz, 1400 F	180	175,000
1270	1	Form Nose Press, hydraulic, 500 ton	180	300,000
1280	1	Reheat Nose End Heater, induction, 2200 F, 800 kW, 180 Hz	180	200,000
1290	1	Final Form Nose Press, hydraulic, 600 ton	180	740,000

TABLE IV-1 (Cont)

<u>Oper No.</u>	<u>Equipment Required</u>	<u>Operation Description</u> <u>Equipment Description</u>	<u>Gross Capacity</u> <u>Pieces/h</u>	<u>Equipment Est. Cost, \$</u>
1340	1	Machine Nose and Base End, Tube Way-type, 50 hp, dual head	60	300,000
1360	2	Cut Lug and Charging Holes Flame cutting machine	60	68,000
1370	1	Weld Lug and Charging Adapter Welding machine, arc, automatic	50	60,000
1380	1	Weld Adapter Ring, Tubing Welding machine, arc, automatic	60	36,000
1390	1	Heat Treat and Temper Furnace, gas, 1600 F	170	674,000
1400	1	Blast-Clean ID and OD Roto-blast unit	120	82,000
1410	1	Check Hardness Hardness tester	180	2,000
1420	2	Bore, Face, Thread Nose End Lathe, turret, automatic, 30 hp	50	220,000

TABLE IV-1 (Cont)

Oper No.	Equipment Required	Operation Description <u>Equipment Description</u>	Gross Capacity Pieces/h	Equipment Est. Cost., \$
1430	1	Bore, Face, Thread Base Lathe, turret, automatic, 30 hp	50	220,000
1440	1	Drill and Tap Lifting & Charging Holes Drill press, multi-station	65	300,000
1470	1	Drill 16 Holes Base End & Drill & Tap Nose End Drill press, multispindle	100	250,000
1480	1 1	Test Lifting Lug Adapter Special test equipment	150	30,000
1490	1	Pressure-Test Body Special test equipment	150	25,000
1500	1	Stamp Identification Marking machine	300	30,000
1510	1	Phosphate Treat Chemical line	200	240,000
1520	1	Paint Paint Equipment	200	31,000
SUBTOTAL				<u>4,744,000</u>

TABLE IV-2
 RECOMMENDED SEQUENCE OF MANUFACTURE
 PROCESS DESCRIPTION SUMMARY
 ADAPTER RING (1381204)
 MK83, MOD 4, 1,000-LB BOMB
 HOT CUP METHOD
 BASIS, 50 PIECES/H ASSIGNED OUTPUT RATE

Oper No.	Equipment Required	Operation Description <u>Equipment Description</u>	Gross Capacity Pieces/h	Equipment Est. Cost, \$
2110	As Required	Handle Received Material Materials handling equipment	50	N/A
2120	1	Separate Mults Press, shear, 1,000 ton	180	430,000
2130	1	Heat Mult Heater, induction, 700 kW, 180 Hz, 2200 F	200	240,000
2150	1	Forge Complete Press, mechanical, 2,000 ton, 12-inch stroke	225	700,000
2160	1	Descale Blast cleaning equipment	250	60,000
2180	1	Machine Inside and Outside Diameters Bore and Face Lathe, six-spindle, automatic, chucking, 30 hp	200	76,000

TABLE IV-2 (Continued)

Oper No.	Equipment Required	Operation Description Equipment Description	Gross Capacity Pieces/h	Equipment Est. Cost, \$
2190	1	Clean Degreaser, vapor	700	27,000
SUBTOTAL			<u>1,533,000</u>	

TABLE IV-3
 RECOMMENDED SEQUENCE OF MANUFACTURE
 PROCESS DESCRIPTION SUMMARY
 BASE PLUG (4902488)
 MK83 MOD 4, 1,000-L3 BOMB
 HOT CUP FORGING METHOD
 BASIS, 50 PIECES/H ASSIGNED OUTPUT RATE

<u>Oper No.</u>	<u>Equipment Required</u>	<u>Operation Description</u> <u>Equipment Description</u>	<u>Gross Capacity</u> <u>Pieces/h</u>	<u>Equipment Est. Cost., \$</u>
3110	As Required	Handle Received Material, Bar Stock Materials handling equipment	50	N/A
3120	1	Separate Mults Cold Shear 1,000 ton	180	430,000
3130	1	Heat Mult Heater, induction 600 kw, 180 Hz, 2200 F	200	150,000
3150	1 1	Forge Complete Press, mechanical 2,000 ton, 12-inch stroke	225	700,000
3160	1	Descale Blast clean equipment	250	60,000
3175	1	Machine Inside and Outside Diameters Lathe, automatic, chucking, six-spindle	200	178,000
3180	1	Under Cut, Thread and Face Lathe, automatic, chucking, six-spindle,	200	178,000

TABLE IV-3 (Continued)

<u>Oper No.</u>	<u>Equipment Required</u>	<u>Operation Description</u> <u>Equipment Description</u>	<u>Gross Capacity</u> <u>Pieces/h</u>	<u>Equipment</u> <u>Est. Cost., \$</u>
3190	1	Drill and Tap Six Holes Multiple drill head and shuttle fixture	180	75,000
3200	1	Stamp Identification Marking machine	350	12,000
3210	1	Clean Degreaser, vapor	2,000	27,000
			<u>SUBTOTAL</u>	<u>1,810,000</u>

TABLE IV-4
 RECOMMENDED SEQUENCE OF MANUFACTURE
 PROCESS DESCRIPTION SUMMARY
 INSERT, SUSPENSION LUG (1253008)
 MK83 MOD 4, 1,000-LB BOMB

HOT CUP METHOD
 BASIS, 50 PIECES/H ASSIGNED OUTPUT RATE

Oper No.	Equipment Required	Operation Description <u>Equipment Description</u>	Gross Capacity Pieces/h	Equipment Est. Cost, \$
4110	As Required	Handle Received Material Materials handling equipment	50	N/A
4120	1	Separate Mults Press, shear, 350 ton	270	430,000
4130	1	Heat Mult Heater, induction 50 kW, 180 Hz, 2500 F	200	60,000
4150	1	Preform and Restrike Press, mechanical, 500 ton, 6-inch stroke	250	250,000
4160	1	Descale Blast-cleaning equipment	400	59,000
4170	1	Clean Degreaser, vapor	2,000	27,000
		SUBTOTAL		826,000

TABLE IV-5
 RECOMMENDED SEQUENCE OF MANUFACTURE
 PROCESS DESCRIPTION SUMMARY
 INSERT, FORWARD (1380267)
 MK83 MOD 4, 1,000-LB BOMB
 HOT CUP METHOD
 BASIS, 50 PIECES/H ASSIGNED OUTPUT RATE

Oper No.	Equipment Required	Operation Description <u>Equipment Description</u>	Gross Capacity Pieces/h	Equipment Est. Cost. \$
5110	As Required	Handle Received Material Materials handling equipment	50	N/A
5120	1	Separate Mults Press, shear, 350 ton	180	430,000
5130	1	Heat Mult Heater, induction, 250 kW, 180 Hz, 2200 F	200	150,000
5150	1	Perform and Restrike Press, mechanical, 500 ton, 6-1ch stroke	250	250,000
5160	1	Descale Blast-cleaning equipment	250	59,000
5170	1	Clean Degreaser, vapor	2,000	27,000
SUBTOTAL				<u>916,000</u>

TABLE IV-6
 RECOMMENDED PRODUCTION BASELINE FOR
 MK83 MOD 4, 1,000-LB BOMB BODY ASSEMBLY
 ESTIMATED EQUIPMENT COST SUMMARY

<u>Reference Table</u>	<u>Component</u>	<u>Part No.</u>	<u>Qty of IPE</u>	<u>Estimated Cost.\$</u>
IV-1	Casing	1380236	24	4,744,000
IV-2	Adapter Ring	1381204	6	1,533,000
IV-3	Base Plug	4902488	5	1,810,000
IV-4	Insert, Suspension Lug	1253008	5	826,000
IV-5	Insert, Forward	1380267	5	916,000
			TOTAL	9,829,000