

AD-A057 339

NAVAL POSTGRADUATE SCHOOL MONTEREY CALIF
USE OF INTELLIGENT TERMINALS AT THE BATTALION/SQUADRON LEVEL FO--ETC(U)
JUN 78 L D RANNALS

F/G 5/9

UNCLASSIFIED

NL

1 of 2

AD A057339

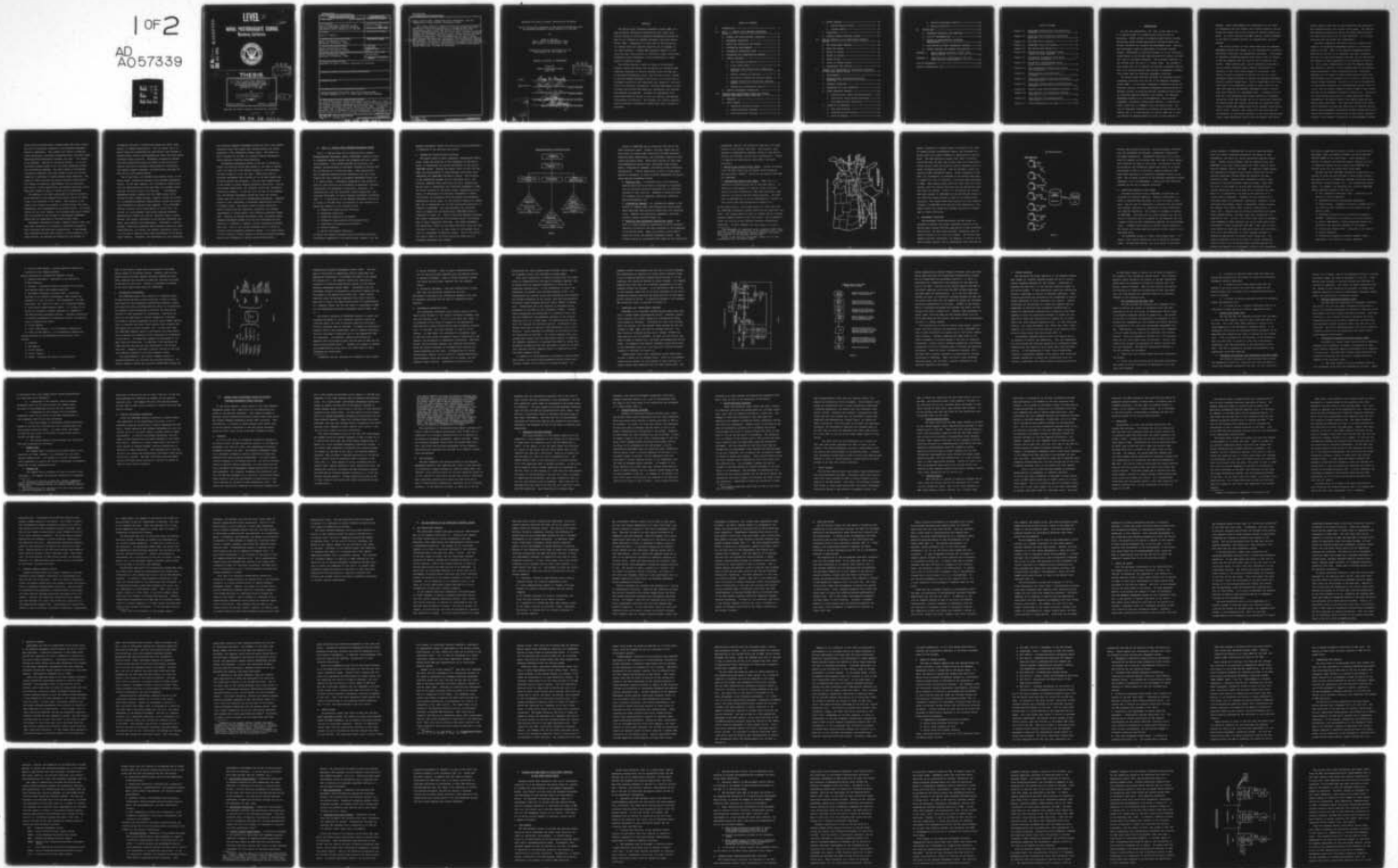

LEVEL II

2
NW

AD A057339

NAVAL POSTGRADUATE SCHOOL

Monterey, California

AD No. _____
DDC FILE COPY



DDC
RECEIVED
AUG 10 1978
D

① Master's **THESIS**

⑥ USE OF INTELLIGENT TERMINALS
AT THE BATTALION/SQUADRON LEVEL
FOR MANPOWER MANAGEMENT SYSTEM
REPORTING IN THE EMF.

by

⑩ Larry D. Rannals

⑪ Jun 1978

Thesis Advisor: Ronald J. Roland

⑫ 167p

Approved for public release; distribution unlimited.

251 450

78 08 09 081 Jan

UNCLASSIFIED

SECURITY CLASSIFICATION OF THIS PAGE (When Data Entered)

REPORT DOCUMENTATION PAGE		READ INSTRUCTIONS BEFORE COMPLETING FORM
1. REPORT NUMBER	2. GOVT ACCESSION NO.	3. RECIPIENT'S CATALOG NUMBER
4. TITLE (and Subtitle) Use of Intelligent Terminals at the Battalion/Squadron Level for Manpower Management System Reporting in the FMF		5. TYPE OF REPORT & PERIOD COVERED Master's Thesis; June 1978
		6. PERFORMING ORG. REPORT NUMBER
7. AUTHOR(s) Larry D. Rannals		8. CONTRACT OR GRANT NUMBER(s)
9. PERFORMING ORGANIZATION NAME AND ADDRESS Naval Postgraduate School Monterey, California 93940		10. PROGRAM ELEMENT, PROJECT, TASK AREA & WORK UNIT NUMBERS
11. CONTROLLING OFFICE NAME AND ADDRESS Naval Postgraduate School Monterey, California 93940		12. REPORT DATE June 1978
		13. NUMBER OF PAGES 167
14. MONITORING AGENCY NAME & ADDRESS (if different from Controlling Office) Naval Postgraduate School Monterey, California 93940		15. SECURITY CLASS. (of this report) Unclassified
		15a. DECLASSIFICATION/DOWNGRADING SCHEDULE
16. DISTRIBUTION STATEMENT (of this Report) Approved for public release; distribution unlimited.		
17. DISTRIBUTION STATEMENT (of the abstract entered in Block 20, if different from Report)		
18. SUPPLEMENTARY NOTES		
19. KEY WORDS (Continue on reverse side if necessary and identify by block number) Manpower Management System (MMS), Source Data Automation (SDA), Personnel Management in the U. S. Marine Corps, Intelligent Terminals		
20. ABSTRACT (Continue on reverse side if necessary and identify by block number) The Marine Corps' Manpower Management System (MMS) is a semi-automated information system which uses inputs from several sources to provide personnel-management-oriented outputs to all echelons of command throughout the Fleet Marine Forces (FMF). Preparation of input data is done primarily in a manual mode and requires extensive use of manpower at the lower echelons. Present MMS automated support for FMF units has been characterized as inflexible, (over)		

UNCLASSIFIED

SECURITY CLASSIFICATION OF THIS PAGE(When Data Entered)

↳ highly centralized, inadequate during deployment, and non-responsive to lower echelon information needs.

This study explores a means of using an intelligent-terminal system and source data automation to accomplish MMS reporting functions at various echelons within the FMF down to the Battalion/Squadron level; and the use of such a system to provide command and management functions at all levels with an increased flexibility and timeliness with respect to the availability of personnel information. Benefits/advantages of such a system over current MMS reporting, processing, and distribution methods are examined. Concepts for employment of an intelligent-terminal system in both the garrison and deployed environments are explored. The prospect for reducing administrative personnel requirements needed under such a system is discussed.

procedure

Approved for public release; distribution unlimited.

Use of Intelligent Terminals at the Battalion/Squadron Level
for Manpower Management System Reporting in the FMF

by

Larry D. Rannals
Major, United States Marine Corps
BBA, Texas A & M University, 1965

Submitted in partial fulfillment of the
requirements for the degree of

MASTER OF SCIENCE IN MANAGEMENT

from the
NAVAL POSTGRADUATE SCHOOL
June 1978

DDC
RECEIVED
AUG 10 1978
RECEIVED
D

Author

Larry D. Rannals

Approved by:

Ronald J. [Signature]

Thesis Advisor

James D. Buttinger

Second Reader

[Signature]
Chairman, Department of Administrative Sciences

[Signature]
Dean of Information and Policy Sciences

SESSION NO.	
DATE	White Section <input checked="" type="checkbox"/>
NO.	Blue Section <input type="checkbox"/>
CLASSIFICATION	<input type="checkbox"/>
APPROVAL	<input type="checkbox"/>
CONTINUING AVAILABILITY CODES	
PUBL. RES./OR SPECIAL	
A	

ABSTRACT

The Marine Corps' Manpower Management System (MMS) is a semi-automated information system which uses inputs from several sources to provide personnel-management-oriented outputs to all echelons of command throughout the Fleet Marine Forces (FMF). Preparation of input data is done primarily in a manual mode and requires extensive use of manpower at the lower echelons. Present MMS automated support for FMF units has been characterized as inflexible, highly centralized, inadequate during deployment, and non-responsive to lower echelon information needs.

This study explores a means of using an intelligent-terminal system and source data automation to accomplish MMS reporting functions at various echelons within the FMF down to the Battalion/Squadron level; and the use of such a system to provide command management functions at all levels with an increased flexibility and timeliness with respect to the availability of personnel information. Benefits/advantages of such a system over current MMS reporting, processing, and distribution methods are examined. Concepts for employment of an intelligent-terminal system in both the garrison and deployed environments are explored. The prospect for reducing administrative personnel requirements needed under such a system is discussed.

TABLE OF CONTENTS

I.	INTRODUCTION -----	9
II.	THE U. S. MARINE CORPS MANPOWER MANAGEMENT SYSTEM -----	15
	A. COMMAND AND ORGANIZATIONAL STRUCTURE -----	16
	B. MANAGEMENT OBJECTIVES -----	21
	C. INPUTS AND OUTPUTS OF THE SYSTEM -----	23
	D. INFORMATION REQUIREMENTS -----	27
	E. INFORMATION PROCESSING CYCLE -----	30
	F. INTERFACES AND COMMUNICATION NETWORKS -----	32
	G. CONTROL MEASURES -----	36
	1. Unit Transaction Register -----	37
	2. Visual Audit Sheet -----	38
	3. Personnel Verification Unit Transaction Register -----	38
	4. Pending Transaction Register -----	39
	5. Statistical Transaction Analysis Report ---	39
	6. Command Statistical Transaction Analysis Report -----	40
	7. Command Unit Transaction Register -----	40
	H. HOSTILE ENVIRONMENT OPERATIONS -----	41
III.	PROBLEM AREAS ENCOUNTERED WITHIN THE PRESENT MANPOWER MANAGEMENT SYSTEM STRUCTURE -----	42
	A. OVERVIEW -----	42
	B. INPUT RELATED -----	44
	1. Typewriter Related Problems -----	45
	2. Format/Procedure Problems -----	46
	3. Non-controllable Problems -----	47

C.	OUTPUT RELATED -----	48
1.	Limited Responsiveness -----	49
2.	Limited Support -----	49
D.	TIMELINESS -----	51
E.	GARRISON VERSUS DEPLOYED SUPPORT -----	54
IV.	USE AND BENEFITS OF AN INTELLIGENT TERMINAL SYSTEM -----	58
A.	THE INTELLIGENT TERMINAL -----	58
B.	MINIS AND MICROS -----	62
C.	EFFECT ON INPUTS -----	65
D.	EFFECT ON OUTPUTS -----	68
E.	OTHER SAVINGS -----	71
F.	IMPACT OF RECENT STUDIES -----	77
G.	OPERATIONAL TEST RESULTS -----	81
V.	CONCEPTS FOR EMPLOYMENT OF INTELLIGENT TERMINALS IN THE FLEET MARINE FORCES -----	87
A.	REQUIREMENTS -----	87
B.	ORGANIZATIONAL STRUCTURE/OPERATIONAL FUNCTIONS -----	89
C.	GARRISON OPERATIONS -----	97
D.	AMPHIBIOUS OR FIELD OPERATIONS -----	104
E.	OTHER OPERATING CONCEPTS -----	109
1.	Centralization versus Decentralization ----	110
2.	Stand-alone versus Shared Processors -----	113
3.	Telecommunications Technology -----	114
F.	ISSUES TO BE RESOLVED -----	119
1.	Data Base Security -----	120
2.	Hardware/Facility Security -----	121
3.	Audit Procedures -----	121

4.	Hostile Environment Security -----	122
5.	Backup Procedures -----	124
VI.	CONCLUSIONS -----	126
A.	INCREASED CAPABILITY AND READINESS -----	127
B.	COST OF IMPLEMENTATION -----	129
C.	CHANGE IN ADMINISTRATIVE PERSONNEL REQUIREMENTS -----	139
D.	APPLICATION TO OTHER INFORMATION SYSTEMS -----	145
E.	FUTURE CONCEPTS AND RELATED APPLICATIONS -----	149
APPENDIX A	Data Elements Contained in SDPI Field Master Record -----	154
APPENDIX B	Reporting Unit Classification and Unit Diary Delivery Requirements -----	163
	LIST OF REFERENCES -----	165
	INITIAL DISTRIBUTION LIST -----	167

LIST OF FIGURES

Figure 1-1	JUMPS/MMS Organizational and Operational Structure -----	17
Figure 1-2	Satellite Data Processing Installation Locations -----	20
Figure 1-3	Data Base File Locations -----	22
Figure 1-4	JUMPS/MMS Inputs and Outputs -----	28
Figure 1-5	MMS Abbreviated System Flow -----	33
Figure 1-6	Processing Cycle Interface Points (Marine Aircraft Squadron) -----	34
Figure 5-1	Information Processing Cycle Using Source Data Automation -----	94
Figure 5-2	Hierarchy of ADP Equipment Using Source Data Automation -----	96
Figure 5-3	Data Transmission Network with Source Data Automation -----	98
Figure 6-1	Characteristics and Evolution of Processors -----	131
Figure 6-2	Auxiliary Storage Technology Performance Characteristics -----	132
Figure 6-3	Auxiliary Storage Module Cost/Performance Forecasts -----	133
Figure 6-4	Magnetic Tape Cost/Performance Forecast -----	134
Figure 6-5	Cost Forecast for Transaction Terminal Stations -----	134
Figure 6-6	Cost Forecast for Communications Controllers -----	135
Figure 6-7	Data Transmission Line Costs -----	136

I. INTRODUCTION

As with any organization, the name of the game in the U. S. Marine Corps is to promote more efficient use of resources. Better utility of resources means dollar savings; and dollars saved through operational efficiency means more dollars available for research and development uses. Research and development leads to improvement in existing systems. Finally, improvement in existing systems, be it the individual combat Marine or the highly sophisticated F-18 fighter aircraft, will lead to increased readiness. And increased readiness is the "bottom line" for the U. S. Marine Corps. The purpose of this thesis will be to research and discuss a proposed improvement to an existing Marine Corps system--a management information system used for personnel management functions.

The Marine Corps currently performs its personnel-related management functions with the aid of the Manpower Management System (MMS). As the Corps' management information system for personnel matters, the Manpower Management System provides an enormous variety of personnel-related information which helps to facilitate decision making at all levels. The Manpower Management System is an all-encompassing, semi-automated management information system which affects, in some manner, every single unit or command within the Marine Corps. Not only is personnel information collected and processed by this system, but it is also returned in various forms and in varying degrees of responsiveness to units at every echelon of

command. Some units/commands are responsible for the input of information into the system, while others primarily tap the system for output data to be utilized for decision making purposes. All units involved with MMS, however, receive feedback in one form or another--usually via standardized, cyclical reports.

The initial portion of this thesis describes the Manpower Management System with respect to its organizational structure, functional objectives, and operational processes. A discussion of currently recognized problem areas found within all phases of MMS and stemming from the lack of total automation will follow. These problem areas involve drawbacks attributed to certain manual processes whose presence contributes to a reduction in the total effectiveness of the system. This thesis is going to propose and discuss the use of a fully-automated, modern-day means to upgrade the Manpower Management System's present capabilities. Such an improvement will eliminate most of the weaknesses alluded to above, while at the same time enabling the Manpower Management System to become much more effective as a management tool. A proposal will be made as to the advantages and overall benefits of increased automation within MMS through the use of intelligent terminals. The Marine Corps has recently recognized this need and taken steps to advance MMS capabilities within non-FMF (Fleet Marine Force) units. However, this thesis will deal with the use and benefits of intelligent terminals in the Fleet Marine Force units--those operational units within the Marine Corps whose

mission require that they be fully deployable and operationally effective within all corners of the globe. The need for more advanced capabilities within the present MMS structure for these units has not as yet been satisfied. It is within this area that the thesis will concentrate.

The first chapter of the thesis will be a complete description of the Manpower Management System as it functions today in the FMF. What is the Manpower Management System; what does it do; how is it organized; who does it benefit; what are its inputs and outputs; and what are its objectives? The answers to these questions will be addressed in Section II. With a basic understanding of what the Manpower Management System is, Section III will address many of the problem areas encountered in this information system. Particular emphasis will be placed on those problem areas arising from the outdated manual procedures still in use as a part of the overall system processes. Section IV will be an introduction to intelligent terminals and microcomputers; and how they can tie-in with the present computer system of MMS to help alleviate most of the problems discussed in Section III. Section IV will also discuss the results of recent operational tests, evaluations, and studies made by both Marine Corps and non-Marine Corps activities. Such tests and studies were conducted to determine the need and feasibility of updating various Marine Corps management information systems through the use of source data automation devices such as intelligent terminals. Section V will present a discussion on the employment concept

which would be desired and/or needed within FMF units, should the use of intelligent terminals in the Manpower Management System be undertaken. This chapter will focus on organizational structures, functional responsibilities, garrison versus amphibious/field employment concepts, and significant issues to be resolved. Section VI, the final section, will be the concluding chapter based on all the facts presented throughout the previous chapters. The total effect of introducing intelligent terminals into such systems as MMS will be discussed as it pertains to overall Marine Corps readiness. The effect of costs incurred and savings realized (particularly with regard to personnel requirements) will be discussed. And finally, future applications and benefits which may accrue from this system and apply to others will be addressed.

The purpose of the above paragraphs has been to present a brief overview of the proposed scope and an outline of objectives to be discussed in the thesis. Each chapter of the thesis that follows will present in greater detail the ideas, assumptions, and recommendations as outlined above. But before turning to the first chapter, the following additional information is provided on the history of the Manpower Management System and its importance to the Marine Corps today.

Management information systems, commonly known as MIS, have long been recognized as a foundation cornerstone supporting many successful and efficient organizations. A good management information system, particularly a fully-automated, computerized MIS, can provide the flexibility and breadth of

information required to efficiently manage any large, wide-spread, or complex organization. Over the years, the U. S. Marine Corps has established and used several such systems to provide better control and manageability within the many facets of Marine Corps activities. Management information systems have been established within the Corps to facilitate such varying functions as personnel administration, maintenance and logistic support programs, and operational readiness for both the air and ground elements.

One of the first, and probably most broadly based, of the Marine Corps' information systems is the Manpower Management System. As the name suggests, this information system deals with the administration of the most basic and highest valued resource the Marine Corps owns--manpower. The Manpower Management System, together with the JUMPS system (Joint Uniform Military Payment System), combine to form the nucleus of a standardized personnel administration system used worldwide throughout all Marine Corps commands. Since JUMPS/MMS affects virtually every single Marine on active duty, the virtues of a well-managed, efficiently operated personnel administration system can lead to a positive sense of satisfaction, well being, and morale in all Marines throughout the Corps, thus enhancing job performance. Conversely, a poorly-managed, inefficient personnel administration system can cause dissatisfaction, low morale, and general discontent, which in turn can have a negative effect upon performance of the Marine Corps' mission. Therefore, the advantages of a well-organized

and efficient Manpower Management System can have a far greater reflected value than simply that realized within the inborn processes of the information system itself. The effect of such a system will be felt in a positive manner throughout a whole spectrum of Marine Corps functions.

The Manpower Management System is not new to the Marine Corps, the function having been around in one form or another since 1775 when the first Marines signed on in Philadelphia, and were joined to a unit for duty. These early days of personnel management were carried out in the most simple mode of using pencils and notebooks. Over the next hundred years little change in record keeping procedures took place. Pencils soon became typewriters, and notebooks turned into voluminous records and reports. It was not until the age of the computer that the Manpower Management System was given its current formal name and a new set of standardized procedures. Computers brought a vast improvement to personnel administration within the Marine Corps. Data bases, record storage capability, speed of processing and reporting, automation--all brought improvements to create better, more effective personnel management. However, up through the present time, the Marine Corps' Manpower Management System still has not manifested the full potential it requires to become a totally satisfactory management tool. Even in its current advanced state it cannot be called a fully-automated information system. To a large extent it still retains a certain degree of manually-oriented processes which create drawbacks to overall system effectiveness.

II. THE U. S. MARINE CORPS MANPOWER MANAGEMENT SYSTEM

The U. S. Marine Corps Joint Uniform Military Payment System/Manpower Management System (JUMPS/MMS) combine to form an integrated system of manual and automated personnel reporting procedures. This system provides for recording, processing, and maintaining of personnel information and pay data for all Marines on a continuing basis. More specifically, this integrated system provides information for use in performing the total function of manpower management within the U. S. Marine Corps. Information produced by this system is used for such functions as procurement of personnel, training, distribution and assignment of personnel, promotion, job classification, pay and allowances, budget preparation, and continued development of better manpower management procedures [Ref. 1]. A description of the Manpower Management System as it exists in the FMF today is presented in this chapter, with particular emphasis on the following areas:

- Command and Organizational Structure
- Management Objectives
- Inputs and Outputs of the System
- Information Requirements and Processing Cycle
- Interfaces and Communication Networks
- Control Measures
- Hostile Environment Operations

A similar and separate personnel reporting system exists for the Reserve components of the Marine Corps, however, only the

Manpower Management System for active duty military personnel is presented in the sections that follow.

A. COMMAND AND ORGANIZATIONAL STRUCTURE

The Deputy Chief of Staff (Manpower), Headquarters Marine Corps, under the direction of the Commandant of the Marine Corps, is responsible for policy development of the overall JUMPS/MMS system. Beneath the Deputy Chief of Staff for Manpower are the directors of three separate functional areas comprising the JUMPS/MMS information system. Each director is the responsible manager for his individual area. The Director, Manpower Plans and Policy Division, Headquarters Marine Corps is responsible for functional management of MMS. The Fiscal Director of the Marine Corps, Headquarters Marine Corps, is responsible for functional management of JUMPS. The Director of Information Services Support and Management, Headquarters Marine Corps, is the technical manager for JUMPS/MMS; and is responsible for all data processing operations in support of JUMPS/MMS. The organizational and functional chain of command for the Marine Corps JUMPS/MMS system is displayed in Figure 1-1. Each of the three separate directors has overall responsibility for strategic policy and development of their respective functions. The middle management and operational levels for the three functional areas are also pictured in Figure 1-1, as they relate to the pyramid structure of a management information system. Each of the different levels, shown in all three functional areas will be discussed throughout this chapter.

JUMPS/MMS ORGANIZATIONAL AND OPERATIONAL STRUCTURE

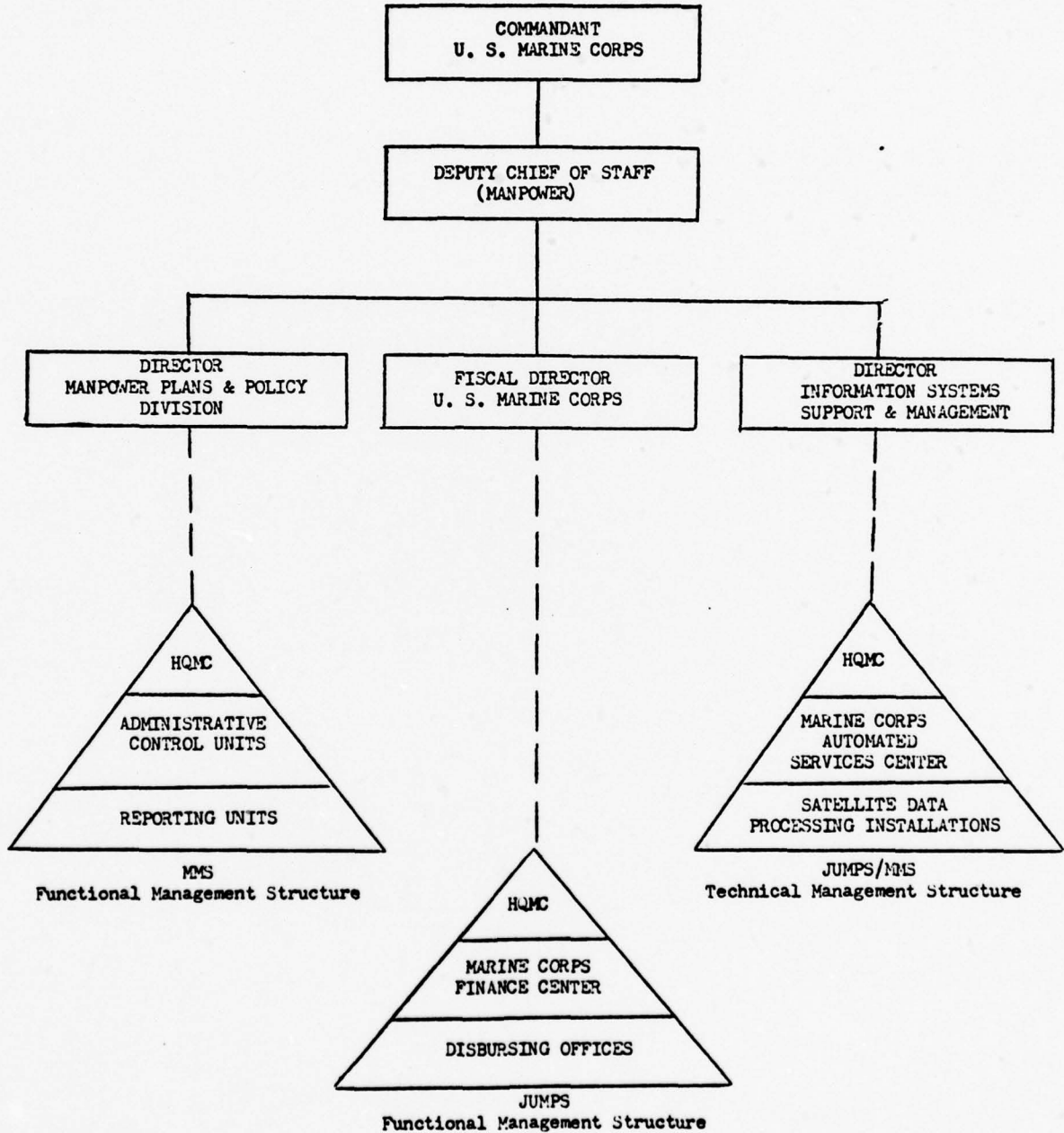

FIGURE 1-1

Inputs to JUMPS/MMS can be originated from any of the three functional areas. However, the most common and primary source of inputs comes from within the MMS functional structure--more specifically, the individual reporting units within the Marine Corps. Other basic sources of input come from Headquarters Marine Corps, the Marine Corps Finance Center, Intermediate Commands, and Satellite Data Processing Installations. A brief description of each of these input sources is necessary in order to better understand the Marine Corps Manpower Management System.

- Reporting Unit - A reporting unit is an individual administrative activity which is required to accomplish certain personnel reporting functions for all personnel assigned to that activity. Examples of reporting units are commands such as Companies, Batteries, Squadrons, Marine Detachments, etc.
- Intermediate Command - An intermediate command is any echelon of command other than Headquarters Marine Corps which exercises administrative supervision over reporting units. Examples are Battalions, Regiments, Divisions, Aircraft Groups, Aircraft Wings, etc.
- Satellite Data Processing Installation (SDPI) - The SDPI is a data processing installation to which personnel reporting jurisdiction has been delegated by the Commandant of the Marine Corps. There are currently seven SDPI's operating within the Manpower Management System. They function mainly as distributed data bases for the collection,

processing, editing, and storage of data prior to transmission to the central data base. Additionally, they maintain a comprehensive computer record on each Marine, officer and enlisted, within their jurisdiction.¹ Figure 1-2 depicts the seven Marine Corps SDPI's and their locations.

- Marine Corps Finance Center (MCFC) - Located at Kansas City, the MCFC along with the Marine Corps Automated Services Center (MCASC),² serves as the central data base for JUMPS/MMS.

- Headquarters Marine Corps (HQMC) - HQMC acts in a capacity of functioning as one of the seven SDPI's. In addition to maintenance of computer files on Marines within its SDPI jurisdiction, HQMC also maintains a data base for all active duty and reserve Marines. The data base at Headquarters is not as comprehensive, however, as the central data base maintained at Kansas City.

As mentioned earlier, the primary source of input data into the JUMPS/MMS information system comes from the reporting unit level. The primary means of input is through use of a source document commonly known as the "unit diary"; and is produced within the unit by an OCR (optical character recognition) typewriter. In most commands the "unit diary" is a daily

¹The assignment of reporting units to specific SDPI jurisdictions is based upon proximity of the reporting unit to the SDPI, the ability to maintain command integrity, and equal apportionment of the workload for each SDPI.

²MCASC is the technical management center for all data processing within the Marine Corps.

SATELLITE DATA PROCESSING INSTALLATION LOCATIONS

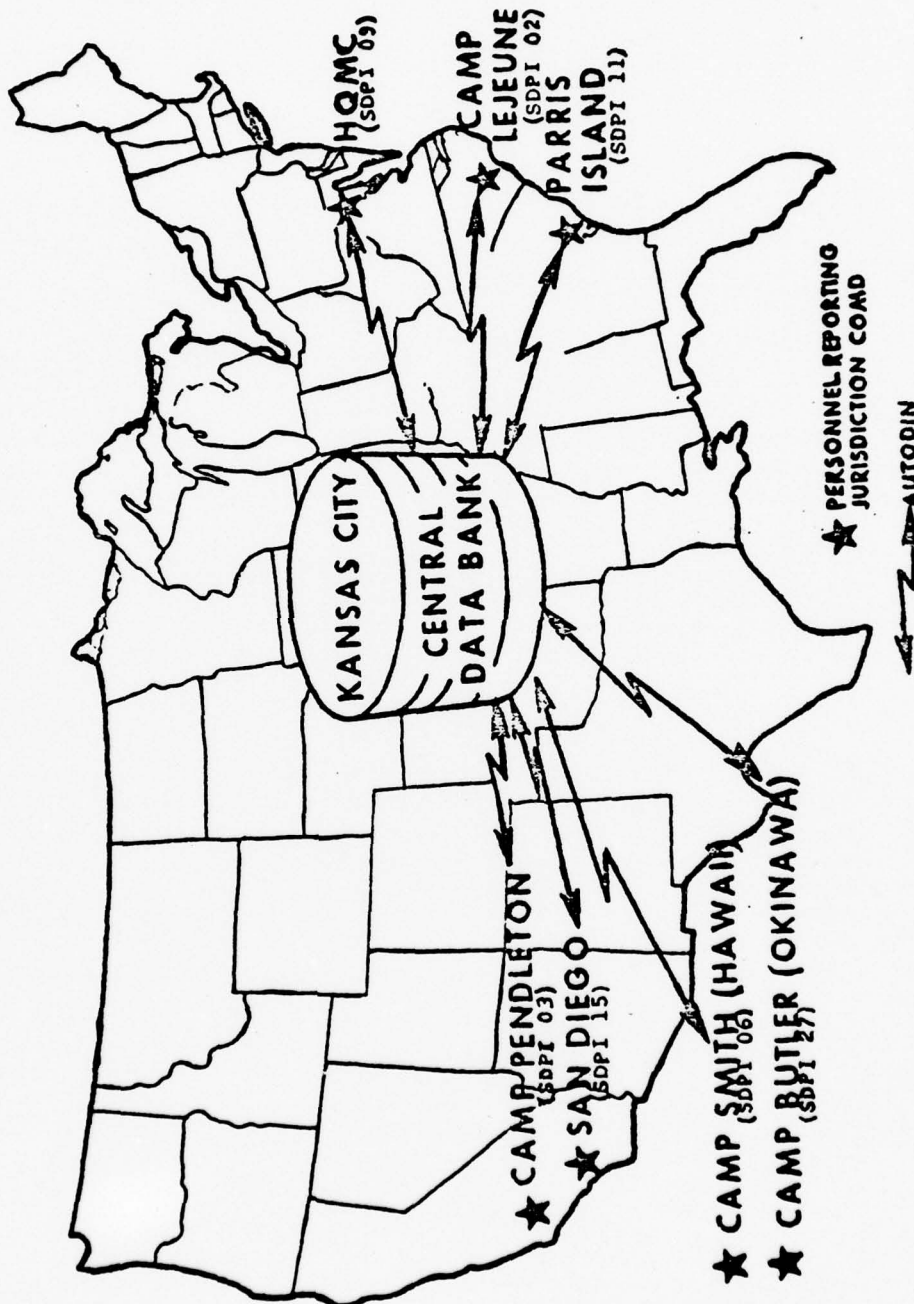

FIGURE 1-2

report, required on a regular basis, forwarded up the chain of command through intermediate levels, and collected at a single point for further transfer to Administrative Control Units. The Administrative Control Unit (ACU) is usually collocated with the SDPI and its main task is to administratively control input and output of source documents prior to actual automated processing. Once at the SDPI, actual processing of MMS information begins. After processing at the SDPI, the information is forwarded to the central data base at Kansas City and, if required, to the data base maintained at HQMC. When system inputs come from other than unit level sources, both the central data base and the appropriate SDPI data base are updated. Figure 1-3 illustrates the central data base concept of JUMPS/MMS and the distributed aspect of the field data bases located at each of the separate SDPI locations. The central data base contains all data elements resident in JUMPS/MMS while the field and Headquarters data bases contain only those data elements required for management at those activities.

B. MANAGEMENT OBJECTIVES

The management objectives within the MMS system are designed to enhance the overall personnel position of the Marine Corps through efficient application of MMS procedures. Specifically, the MMS system provides information used for decision making at all levels of command. The Marine Corps depends upon MMS information, for example, to provide up-to-date strength reports; and to substantiate such functions as

DATA BASE FILE LOCATIONS

FIELD MASTER FILES

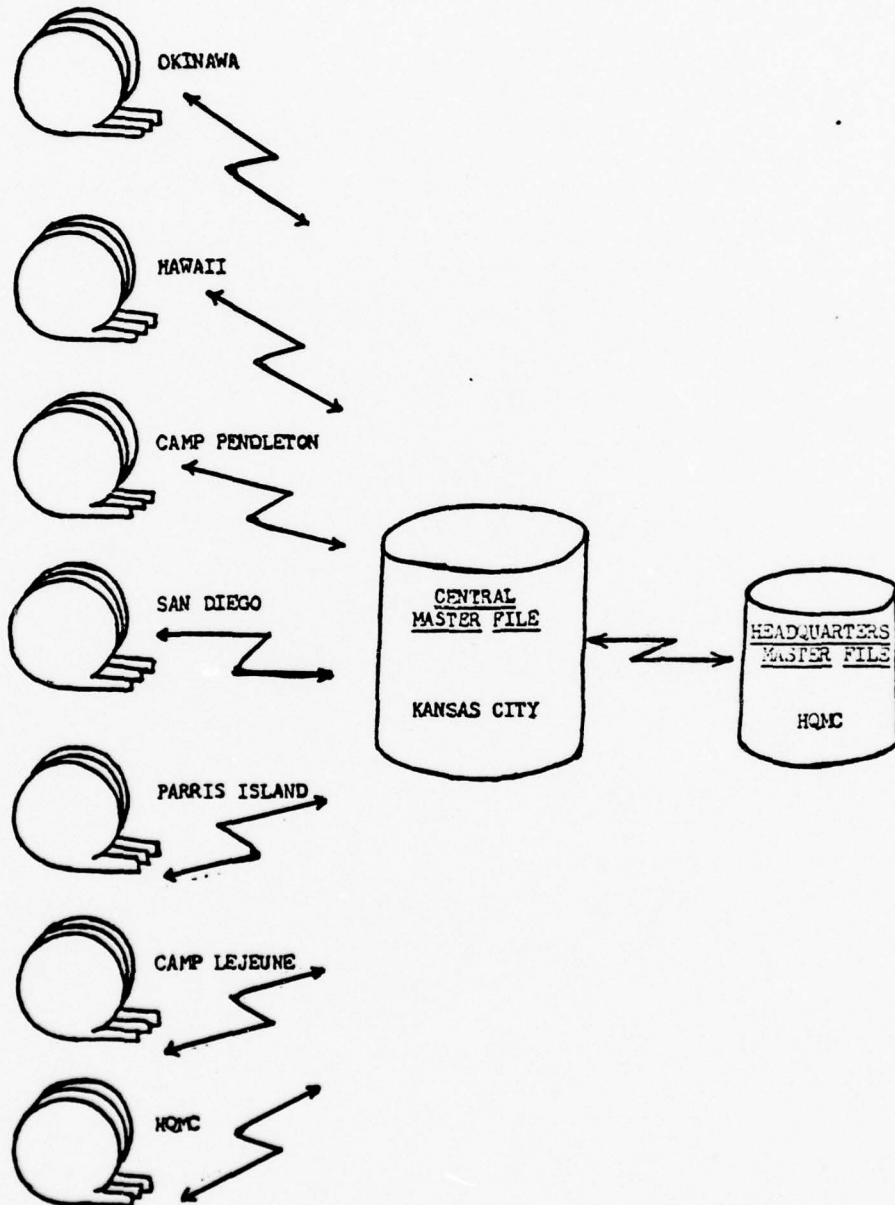

FIGURE 1-3

officer and enlisted recruiting, training programs, distribution and assignment of personnel, promotions, separations, and budget preparation. Management objectives vary at each level of command, but no matter what the level or what management decisions are made at that level, the decision can only be as good as the information system upon which it is based. The purpose of MMS is to provide a strong foundation from which good decisions of a personnel management nature can be made. The ultimate objective of the Manpower Management System, therefore, is to aid management in making the best decisions possible on the use of manpower resources.

C. INPUTS AND OUTPUTS OF THE SYSTEM

The data collection within JUMPS/MMS is based upon the principle of singular reporting. Whenever practicable, an event is reported when and where it occurs to ensure timeliness. Once an item of information is entered into the system, only changes, deletions, or corrections to this information are reported thereafter. The concept of feedback is central to JUMPS/MMS. The status of all inputs entered into the system by a reporting unit is returned to the reporting unit via a report called the Unit Transaction Register (to be discussed later). Feedback also occurs via certain output products of the system and through specified quality control reports to be discussed later.

The JUMPS/MMS system is a basic input-output model. Primarily, input occurs through the use of optically scannable forms. As mentioned earlier, the "unit diary" is the basic

source document of JUMPS/MMS and is used to report personnel gains and losses, establish information and change to that information, and delete or correct previously reported information. Another source document used for reporting data into JUMPS/MMS is the Data Transcription Form (DTF)--used by intermediate commands, SDPI's, and HQMC. In addition, JUMPS uniques are reported by the Marine Corps Finance Center and its subordinate Disbursing Offices using the Transcript of Data Extraction (TODE). Typical input information covers a wide spectrum of required personnel reporting needs. Input data can refer to any number of various type occurrences which require reporting; and can be made on an individual (by name) basis or, if appropriate, the same action reported for an entire group of personnel. Examples of data reported on an individual basis are promotions, reductions, transfers, joins, individual pay changes, number of dependents, depent location, MOS changes, duty status (AWOL, missing, hospitalized, on leave, etc.), judicial and non-judicial proceedings and punishments awarded therein, and many, many more occurrences, too numerous to list. In fact, all of the items listed in Appendix A are examples of data reported; and can be found within each individual's record maintained under MMS. Each item is initially entered as input data at some point during the individual's first tour; and thereafter is either updated, changed, or deleted as appropriate via another input transaction. Any legally reportable item can be input on a group transaction basis as long as the occurrence being reported applies completely and equally to all personnel listed in the transaction.

All inputs, regardless of source or mode, are entered using LAST NAME, FIRST and MIDDLE INITIALS, and SOCIAL SECURITY ACCOUNT NUMBER as the record keys. Cross references, a variety of indexes, and numerous subject listings are used in producing outputs, but all inputs into JUMPS/MMS are entered using only the record keys listed above.

Outputs from the JUMPS/MMS information system occur in a variety of forms and are provided to three primary levels-- the reporting unit, intermediate commands (Divisions, Wings, Battalions, Aircraft Groups, etc.), and Headquarters Marine Corps. For example, the reporting unit receives JUMPS/MMS system generated outputs in the form of:

- Unit Transaction Registers (UTR) - explained in the section on Control Measures.
- Paychecks and Leave and Earnings Statements.
- Alpha Rosters - alphabetic listings of members of the unit with as much information as practicable on each Marine listed.
- Personnel Verification Unit Transaction Registers (PVUTR) - explained in the section on Control Measures.
- Class I MMS Reports - system generated reports controlled by the functional manager of the system.
- Visual Audit Sheets (VAS) - explained in the section on Control Measures.
- Statistical Transaction Analysis Reports (STAR) - explained in the section on Control Measures.

- Class III MMS Reports - system generated reports controlled by local command managers.

Outputs produced for intermediate commands include:

- Command STAR Report - explained in the section on Control Measures.
- Locators - microfiche location listings of all active duty Marines within the command specified.
- Enlistment Assignment Listings (EAL) - microfiche listings of all onboard "chargeables" (MOS trained and assigned to a unit for duty), "non-chargeables" (not MOS qualified), and "due-ins" by MOS, for a specified command.
- Quota Serial Number Reports (QSN's) - a listing of all quotas for personnel transfer assigned to a command by the HQMC Enlisted Assignment Section. (Normally consisting of overseas assignments and specialty billets; and applies only to Corporals and below.)
- AD HOC Reports
- Class I MMS Reports - for intermediate command use.
- Class III MMS Reports - for intermediate command use.

Outputs produced for the Headquarters Marine Corps level include:

- Locators
- QSN Reports
- AD HOC Reports
- Class I Reports
- Models - planning and decision aiding models.

Most of the outputs listed above are produced in printed-report format or microfiche listing. However, some on-line, direct access retrieval systems utilizing Cathode Ray Tube (CRT) terminals are available at HQMC for retrieval and query of MMS data at that level. Figure 1-4 provides an overview of the total input-output model for JUMPS/MMS.

D. INFORMATION REQUIREMENTS

The JUMPS/MMS master files consist of a complete record of each Marine serving on active duty for 31 days or longer. Each Satellite Data Processing Installation contains a computer record for every individual Marine within its jurisdiction. The computer record maintained at the SDPI for each Marine consists of 1200 characters of information. Some data elements are not applicable to certain categories of Marines. For example, overseas assignment by Quota Serial Number applies only to Corporals and below, while certain other elements are applicable only to Naval Aviators, etc. On the other hand, the JUMPS/MMS computer record in the central data base master file at Kansas City consists of 2400 characters of information on each Marine. The same data elements as maintained in the SDPI files are found here. In addition, 1200 characters of JUMPS peculiar pay data are also maintained in the central data base. Appendix A provides a partial listing of the type data elements contained in the SDPI computer record.

The establishment of the initial computer record is handled differently for officers and enlisted personnel. All officer computer records are initially established through the

JUMPS / MMS INPUTS AND OUTPUTS

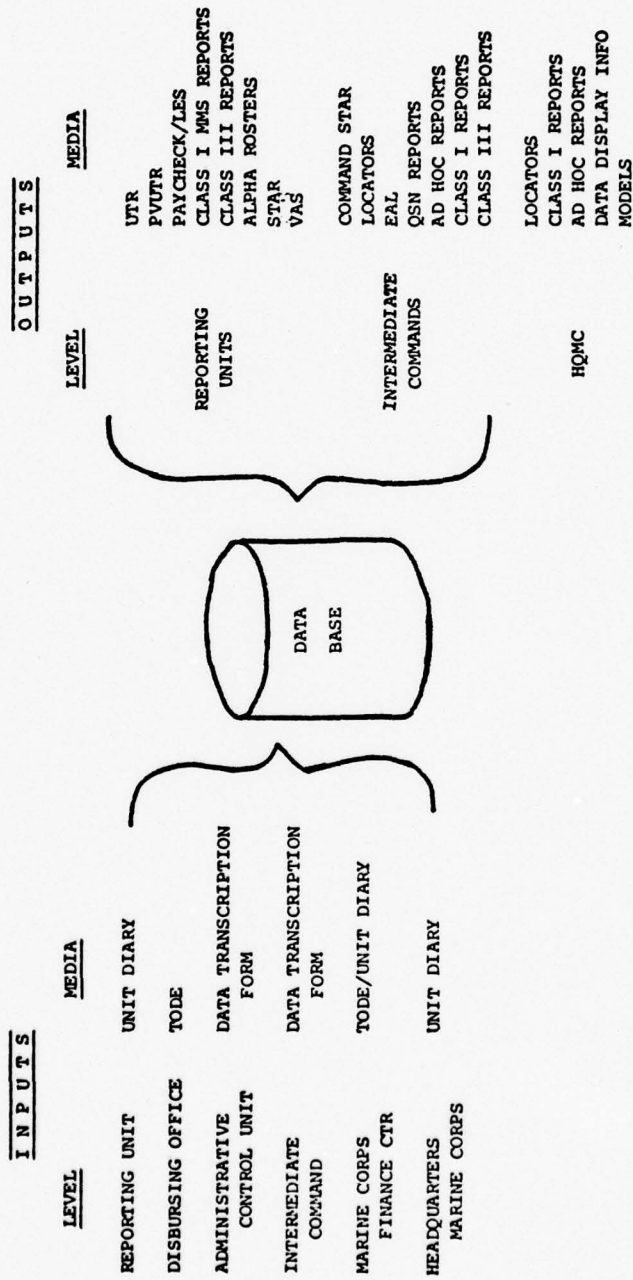

FIGURE 1-4

Commissioning Accession Management System (CAMS). This process is controlled at Headquarters Marine Corps where the appropriate information is processed and added to the Kansas City master file. All computer records for recruits are accessed at the Marine Corps Recruit Depots via the Recruit Accession Management System (RAMS). Information from the enlistment contract is processed at the Recruit Depots and the data added to the Kansas City master file. When a Marine reenlists after having been separated from active duty for more than 24 hours, the same process occurs for establishment of a computer record, but the new record is reaccessed at HQMC via the Headquarters Accession Management System (HAMS) [Ref. 2].

The overall operation of JUMPS/MMS consists of manual and automated processes to first establish computer records as indicated above; and then to maintain them with up-to-date military personnel data as required. To update an individual's computer record, once established, data is normally submitted from the individual's reporting unit to the appropriate SDPI for processing. On occasions, updates and changes are reported into the system by other sources such as HQMC and the Marine Corps Finance Center.³ Updates and changes to records are accomplished by using one of the three types of input statements as listed below:

³Promotions and pay increases are examples of such inputs.

- Action Statement - used to report information which has not been previously reported into the computer record.
- Deletion Statement - used to delete erroneous information which was previously reported into the computer record.
- Correction Statement - used when resubmitting a statement that was previously rejected as an error.

The method of processing the information depends on the type of statement submitted and the type of transaction being reported.

E. INFORMATION PROCESSING CYCLE

The information processing cycle normally begins with an input source document in OCR (optical character readable) form from the reporting unit. If it's a unit diary (UD) input, it is forwarded via the chain of command to the appropriate Administrative Control Unit/Satellite Data Processing Installation. At the SDPI, the input document is read by an OCR scanner. In some cases, the characters or statements typed on the unit diary cannot be properly read or identified by the scanner, and processing is temporarily interrupted. When this occurs, the OCR scanner operator can intervene and manually enter the correct character or statement which permits continued processing of the diary. Processing may be totally discontinued, however, due to invalid or unauthorized characters/statements which the scanner will not accept, and the operator cannot identify. Processing of diaries can be

discontinued for other reasons such as format errors, character alignment errors, and wrinkled or stained paper.

Each input transaction is edited to ensure that the transaction is compatible with the type of statement reported; and to ensure that the reported information is valid for the individual reported upon. If the transaction is valid, the information is entered into the SDPI computer record. All transactions not rejected during SDPI processing are forwarded for further processing at the central data base maintained by the Marine Corps Automated Services Center (MCASC) in Kansas City. Transactions which are rejected as erroneous during processing at the SDPI are not forwarded to MCASC. Instead, these transactions are maintained in a "pending" error file; and the information simultaneously returned to the original reporting unit (or in some cases, the Administrative Control Unit) for analysis and corrective action. Processing at the central data base is similar to SDPI processing, but is more detailed. Errors detected are returned to the reporting unit for correction via the SDPI. For errors detected which have already been entered into the SDPI master record, an appropriate computer transaction is returned from MCASC to remove the erroneous information from the individual's record at the SDPI. This restores the SDPI computer record to compatibility with the MCASC computer record.

In addition to the processing of information received from SDPI inputs, the Marine Corps Automated Services Center periodically reviews its own files on a recurring basis. All

computer records are examined with the use of utility programs. This examination of records will check certain selected items to see if machine generated changes should be made or if the reporting unit should be alerted to submit changes. For example, Rotation Tour Date (RTD) on an overseas assignment is an item examined during this process. If an individual's RTD is found to have expired, there will be an entry generated on his unit's Transaction Register advising the reporting unit to take appropriate corrective action. A simplified diagram of the complete MMS processing cycle is pictured in Figure 1-5.

F. INTERFACES AND COMMUNICATION NETWORKS

JUMPS/MMS is an integrated system sharing common input and using a common master personnel/pay record. Personnel information reported into either system will automatically update both systems as necessary. Interfaces not only occur between these two systems, but also between these systems and the subsystems of CAMS, RAMS, and HAMS as discussed earlier. The most recurring interface points occur, however, between the reporting unit and the ACU/SDPI, the SDPI and the central data base at MCASC in Kansas City, the MCASC and Headquarters Marine Corps. An example of the typical interface points which occur in the processing cycle of a unit diary for a Marine aircraft squadron is depicted in Figure 1-6.

Communication within this information system takes place on both a formal and an informal basis. There is no automated communication network for the transfer of data currently in effect between FMF reporting units and their parent SDPI. The

MMS ABBREVIATED SYSTEM FLOW

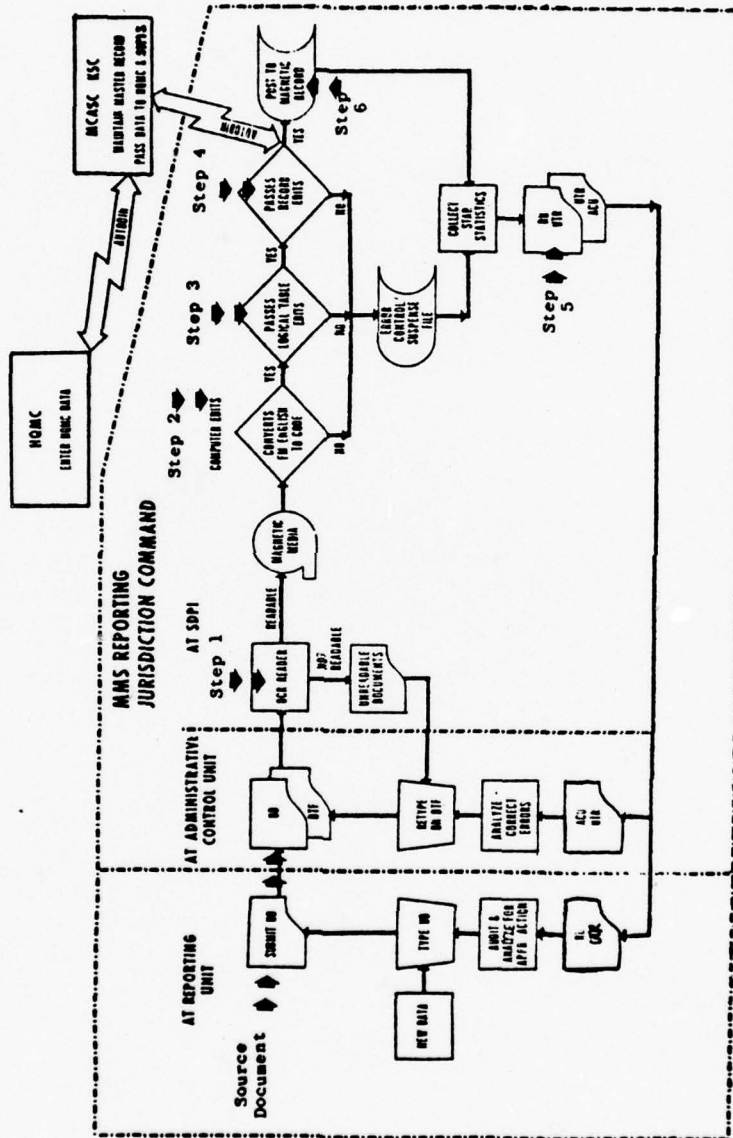

FIGURE 1-5

PROCESSING CYCLE INTERFACE POINTS
(MARINE AIRCRAFT SQUADRON)

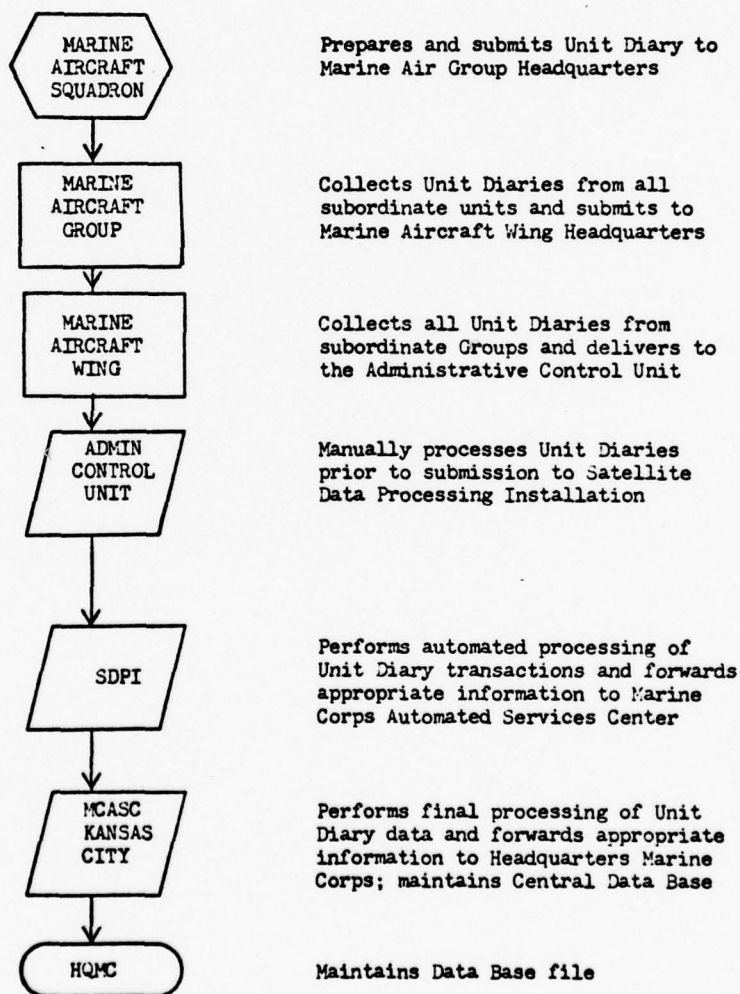

FIGURE 1-6

formal communication network between individual units and their parent SDPI parallels the established transportation network; and is accomplished via government vehicle, U. S. Mail, or government air, depending on the proximity of the reporting unit to the SDPI. Delivery of all output reports returned to individual reporting units from the SDPI follows these same available means of communication. It is not until MMS data reaches the level of interactive exchange between the SDPI and the central data base that the capability exists for automated electronic communication of the data. AUTODIN is the primary means of exchanging processed data between the SDPI's and the central data base in Kansas City. However, some exchanging of master tapes involving HQMC and the Finance Center with the field data bases and the central data base is also accomplished via the U. S. postal system.

The distribution of official Marine Corps orders, publications, and SOP's dealing with operation of the JUMPS/MMS systems is also considered an integral part of the formal communication network. Informal communication takes place at all levels throughout the entire system in the form of telephone interaction, liaison visits, courtesy inspections, and working conferences to iron out problem areas or discuss new operating procedures. Reporting units, intermediate commands, ACU's, and HQMC often interact informally on administrative matters pertaining to JUMPS/MMS. HQMC, the Marine Corps Automated Services Center, and the SDPI's interact informally on the technical aspects of the system.

G. CONTROL MEASURES

The efficient and proper operation of the Manpower Management System is currently assured through the use of certain control measures designed for that purpose. Timeliness is probably the most basic, if not the most important aspect of the entire system. In both submitting inputs and distributing outputs, timeliness is the key to efficient operation. Time-limiting guidelines are provided to unit commanders to ensure timely submission of their individual unit diaries. Similar guidelines for the delivery of outputs are imposed upon the commanders of Satellite Data Processing Installations to ensure the same prompt distribution of products to the users. Appendix B gives the guidelines currently in effect for submission of inputs and distribution of outputs for all seven SDPI's and their assigned reporting units. So that timeliness prevails, all output documents (UTR, PVUTR, VAS, STAR, Class I Reports, etc.) must be on distribution to the reporting units within 24 hours after they are printed [Ref. 1].

Intermediate commands operate within the overall system as agencies of control and supervision. They are responsible for the accurate and efficient execution of information system directives by the reporting units under their administrative control. In the performance of their control/supervisory function, intermediate commands often conduct both formal and informal inspections to ensure that subordinate units are acting in compliance with current system directives and SOP's.

An additional means of control can be found in several of the outputs of the information system itself. The following specific report documents are outputs of the MMS information system which are primarily utilized for internal audit and quality control purposes. They not only reflect the quality and efficiency of reporting accomplished by each individual unit, but also perform the important function of providing feedback to the reporting unit.

1. Unit Transaction Register (UTR)

The UTR provides the reporting unit commander with a means to monitor the status of information which has been reported by his own unit diary, by Headquarters Marine Corps, or by machine generated entries at Kansas City. The purpose of the UTR is to assist the reporting unit commander in discharging his responsibility for accurate and timely reporting of information by his unit into the Manpower Management System. Additionally, it provides the reporting unit commander a list of those entries made on his personnel from outside sources. UTR's are prepared by the SDPI on an "as required" basis for all units under their jurisdiction. Usually this occurs after receipt and processing of several diaries from the unit concerned. The specific information reported in the UTR includes the following:

a. Those unit diary entries which have been accepted by the system.

b. Those unit diary entries which have been rejected by the system as errors (along with an explanation of why the entry was rejected).

c. A listing of previous errors that have been corrected and accepted into the system as a result of correction statements recently submitted.

d. A listing of unit diary entries that were not posted to the field record, but were still passed to the central master file in Kansas City for approval/verification prior to posting.

e. A listing of machine generated entries on personnel within the reporting unit.

f. A listing of any illogical conditions found on an individual's record during an internal computerized audit.

2. Visual Audit Sheet (VAS)

The VAS provides the commanding officer with the means to audit the MMS computer record on each individual Marine in his unit. The Visual Audit Sheet contains a listing of all items appearing on the individual's computer record. It is personally verified by the individual Marine concerned; and by administrative personnel who check it against his unit record book. A VAS is produced for an individual on two occasions--when the individual is joined to a new unit, and annually thereafter, upon the anniversary of the individual's birth-date. The VAS is produced at the SDPI and forwarded to the appropriate units when required.

3. Personnel Verification Unit Transaction Register (PVUTR)

The PVUTR is produced on a monthly basis and provides the commanding officer of a reporting unit with the means to verify the personnel assigned to his unit. It is an "electronic

muster," so to speak, used by the commanding officer to certify the actual number and names of personnel in his unit. Total Marine Corps strength is verified through the PVUTR and its accuracy is important. Its totals can affect everything from the number of new recruits to be enlisted, to higher headquarters decisions on training requirements, personnel assignments, and distribution of personnel assets.

4. Pending Transaction Register (PTR)

The PTR gives the reporting unit commander visibility and control over his unit diary transactions which were in error, are currently delinquent in resolution, have not as yet been posted, and still require continued attention. More specifically, it is a concise listing of erroneous unit diary transactions which are currently unresolved; and which have been previously listed on earlier UTR's, but have yet to be corrected. The PTR is generated monthly and can be viewed as a quality control tool for grading the unit diary clerk's error-response effectiveness.

5. Statistical Transaction Analysis Report (STAR)

The STAR is a monthly report which provides commanding officers with information to assist in evaluation of their unit's overall personnel reporting performance as it compares to other units. The STAR gives current month statistics and cumulative statistics for the current calendar year with respect to the following areas:

a. The total number of action statements (from the unit concerned) which have been processed by the SDPI. Based

on historical data, this number should average approximately 2.5 times the unit's strength.⁴

b. A comparison of the average "action statement acceptance rate" for all units within the command (Wing, Division) to the acceptance rate for the unit concerned.

c. A comparison of the average "action statement acceptance rate" for all units in the SDPI jurisdiction to the acceptance rate for the unit concerned.

d. The total number of discrepancy notices previously passed to the unit by a UTR and still not corrected after two such notices during the month. (In other words, the number of times the unit had to be notified at least three times to correct the same error).

e. The average number of days between unit diary date and diary processing at the SDPI.⁵

6. Command STAR

The Command STAR is essentially the same report as the reporting unit STAR, however, it is produced for the intermediate command level. Its purpose is to allow intermediate level commanders to monitor the overall performance of personnel reporting in their subordinate units.

7. Command UTR

The Command UTR is produced for Wing or Division level commanders. The Command UTR contains transactions or messages

⁴If the unit is failing to meet this average, commanders should investigate their internal unit diary procedures to ensure that all reportable events are actually getting reported on the diary.

⁵The average delay for reporting units will vary according to the unit's proximity to the SDPI.

pertaining to Marines who are en route ("due-in") to the command addressed and therefore not members of any specific reporting unit. The Command UTR also lists Marines overdue by more than 45 days during a period of transfer from one command to another.

H. HOSTILE ENVIRONMENT OPERATIONS

Since the JUMPS/MMS system is basically a manual system (OCR typewriter) at the operational unit level, it is a personnel reporting system which is easily deployable for FMF units. Normal operation and standard procedures can still be carried out on an "as usual" basis in either field or combat environments. In hostile environment operations, the only aspect of the system which may become degraded is the timeliness factor. Reduction in timely inputs and/or the lack of quick receipt of outputs becomes a definite possibility in deployed or combat operations. Such degradations in the system will only affect the operationally deployable Fleet Marine Force units, however. The SDPI field data bases and MCASC central data base should continue to function as normal because of their secure locations.

III. PROBLEM AREAS ENCOUNTERED WITHIN THE PRESENT MANPOWER MANAGEMENT SYSTEM STRUCTURE

In the first chapter, a brief review of the total Manpower Management System and a description of its operational processes in the FMF were presented. This chapter attempts to describe certain operational-related problem areas found within the present Manpower Management System (MMS) structure. More specifically, it focuses on those problems which result from or can be directly attributed to the many manual processes which are still a part of the total MMS information system.

A. OVERVIEW

As is the case with all automated information systems in the Marine Corps, the MMS information system is a far superior management tool than the older, less comprehensive personnel management systems once used. The Manpower Management System is an automated information system, supported by modern day computers and data processing methodology. Yet there remain certain drawbacks to the system which can, not only be directly linked to specific manual procedures, but also arise from the early conceptual and development stages through which the system progressed. For instance, automated data processing support for MMS was developed in an intuitive, evolutionary manner based primarily upon the requirements of administrative functional managers at the Marine Corps headquarters level. The system has historically supported the functional managers well,

but in the process has provided little support to the FMF unit commander at the lower echelons such as Squadron and Battalion level. To a large extent, the Manpower Management System has become an upward, one-way flow of information reported to higher command levels, with little in the way of "user benefits" returned to the source units. No real-time or on-line accessibility to updated management information files exists for the lower echelon commands. Other than informal means previously mentioned, the only real reverse flow of information from headquarters level commands to lower echelon units occurs in the form of cyclic reports and error advisories.

This whole discussion points to the fact that improvements are needed within the present framework of MMS in order for it to realize the efficiency and effectiveness capabilities inherent in a fully automated management information system. In its recent study conducted on automated data system concepts for support of the FMF in the 1980's, the Stanford Research Institute (SRI) provided a thorough description of the Marine Corps' current state of automation used in support of FMF units [Ref. 3]. With respect to actual automated data processing (ADP) support provided to lower echelon FMF units, the present ADP structure (including the MMS information system) was described by Stanford Research Institute as a "rigid and narrowly focused system." Further observations made by SRI in their study of the current ADP system included the following description.

"The system supports the Wing and Division echelons well in garrison, but it has little flexibility to accommodate the afloat or deployed-ashore environments; and it does not support MAB's, MAU's (Marine Amphibious Brigades, Units), or lower echelon units responsively, if at all. It is designed to support the flow of administrative information from FMF units to higher headquarters. This is accomplished by transcribing the manual input data from the lower echelons to computer cards or OCR media, organizing the data, and forwarding the data to higher establishments (SDPI's and Kansas City in the case of MMS data) for processing. Generalized reports on a strictly scheduled basis flow back to the lower echelons from the higher supporting ADP computers. To a large extent, it is a computer card and paper-oriented operation. The flow of information is conducted primarily through the physical transportation of paper."

This description of automated system support currently provided to FMF units applies particularly well to MMS; and is indicative of its present characteristics as it pertains to the degree of personnel management, support provided. There are certainly drawbacks found within the present MMS structure; and within the following paragraphs of this chapter a more definitive appraisal will be made as to specific problem areas encountered.

B. INPUT RELATED

The most immediate and imposing problem of the Manpower Management System at the reporting unit level is the fact that it is strictly a manual process for input of source data. Furthermore, this situation begins at the most immediate source for initial capture of input data--the OCR font electric typewriter. Each individual reporting unit within the FMF rates one or more of these electric typewriters, depending on unit personnel strength. In the majority of cases, it turns out to be one.

Although they are electrically operated, and at the time of their initial use were considered a true advancement, the OCR font typewriter cannot today be considered an up-to-date means of automation. Too many typewriter-related problems affecting input of data into MMS are associated with their usage. Cost was once a justifiable reason to advocate continued usage of such input instruments. But with the cost of more-advanced techniques of source data capture and automation continuously decreasing, the argument for use of OCR media is becoming less supportable.

1. Typewriter Related Problems

The first derogation to the system caused by the OCR typewriter is the consequence of not having one to begin with. In cases where the reporting unit's own OCR typewriter is "down," in for repair, or for any other reason not available for typing of the diary, the unit diary simply does not get submitted for that day's activities. There is no backup system available for input of a unit's reportable data. The remedy normally used in this situation is to borrow another unit's OCR typewriter when it becomes available. Or the diary can be typed by using a normal typewriter and forwarded to the ACU, which in turn retypes it in OCR form when time permits. The result of either method is that the unit diary is delayed in submission for processing, and input information does not get into the system as soon as possible. Then there are the problems which can result even when the unit does have a workable OCR typewriter. Such infractions as improper paper

alignment, poor quality/unreadable characters, dirty keys, improper character spacing, etc., are all occurrences which can cause a unit diary entry to be rejected and not processed in a timely manner [Ref. 1].

2. Format/Procedure Problems

Assuming no typewriter-related problems occur, there are certain other errors associated with unit diary submission which can cause entire diaries or certain portions of them to be rejected. Of course any time this occurs, the processing of new input data is delayed; and the result is old or untimely information still maintained in the system. Examples of such causes for input rejection are the following: failure to number a page of the unit diary, missing pages to the unit diary, heavy smudges/coffee stains/mutilated paper causing the diary to be unreadable by the OCR scanner, invalid/unauthorized statements used for reporting input information, editing errors found in initial screening of the diary (i.e., statement format is correct, but not compatible with the individual's current computer record, or not compatible with the type of statement being reported). An example of this first instance is an entry that says, Private Jones was promoted to Lance Corporal, but his computer record shows he has not been promoted to PFC yet. An example of the second is an entry which says, Private Smith was promoted to PFC meritoriously and his date of rank is 780101. Such an entry would be

rejected as an error because all meritorious promotions must have a date of rank of the second day of the month.⁶

3. Non-Controllable Problems

Other time-consuming input errors can occur in which the reporting unit does not become aware of, nor have control over, until they are reported via UTR at a later date. One example of this type occurrence is the case where the reporting unit submits a perfectly normal, completely correct unit diary for processing. However, prior to arriving at the SDPI for processing, portions of, or possibly the entire diary become lost--lost in transit through the chain of command or lost by the ACU prior to processing. The reporting unit is unaware of the problem until a UTR arrives some days later reporting that the applicable diary was missing/not processed. The data reported by that diary must then be resubmitted and reprocessed, which reduces the effectiveness of the unit concerned (not to mention the irritability caused by having to repeat the process). Other uncontrollable errors can occur through inputs submitted by activities other than the reporting unit. As an example, suppose the optical scanner at the SDPI detects an invalid statement in the unit diary it is processing. The statement is rejected for processing and the scanner operator has the option of making the appropriate correction himself or returning the diary to ACU for correction. Regardless of where the correction is made,

⁶All regular promotions carry date of rank of the first day of the month.

when accomplished by other than the original source, the chance for inaccuracy of data increases. The correction could become an unintentional bit of wrong information, based upon a mistaken assumption, and entered into the concerned individual's record. Although less frequent, unintentional input errors may also get entered into an individual's record when submitted from Headquarters, Finance Center, or Disbursing Office activities. And once again in the above two mentioned instances, the individual's reporting unit becomes aware of the fact that an error was committed only when a UTR arrives at a later date or via one of the other output reports of the system.

The whole point of this discussion is to stress the fact that such minute problems with input of data, as discussed in the above paragraphs, can have a large bearing upon the quality and effectiveness of the MMS data base. A management information system which cannot be easily and expeditiously updated is really a "misinformation" system causing the whole process to be less than totally effective.

C. OUTPUT RELATED

The previous section dealt with certain input-related problem areas associated with MMS. Discussion within this section deals with those problems related to output products and procedures of the MMS system. Once again, the problems discussed here center on those areas which render the present Management Information System a less effective management control tool

than it should be, especially for the lower echelon units of the FMF. As previously noted, "user benefits" available to the reporting unit do not currently match the degree of input toils exerted by those units under present MMS concepts. To be said another way--the user works for the system more than the system works for the user.

1. Limited Responsiveness

The basic fault with the MMS output concept in general is the limited support and/or responsiveness provided to lower echelon units in the FMF. These units have limited access to both a data processing capability and the data base itself--both of which are available to headquarters level managers. Instead, lower echelon units must utilize computer listings which are provided on a scheduled basis from SDPI's and other supporting establishments where ADP capability exists. Reporting units are able to submit requests for "ad hoc" information requirements by going through the proper higher echelon channels, but such requests are on a "last priority" basis to other application programs. Control of lower level user participation rests solely with the ADP center; and results of such requests usually bring either untimely information to the requesting unit or none at all.

2. Limited Support

What results is a system of manually produced and updated files and records used by the reporting unit to meet its own information needs. Many of the output products of MMS (Alpha Rosters, Class I reports, etc.) provide large

quantities of information in the form of personnel-related data pertaining to the members of the unit receiving such reports. But no means is available to query the data base as to specialized data or unique bits of information which the unit commander may need in making timely decisions. Most information the unit commander requires for effective decision making is available somewhere, in some form, and in at least one of the MMS printed outputs available to the reporting unit. But to dig out this information requires first of all, an individual knowledge of the total MMS report structure, and secondly, the manual process of searching through the sources available to find the required information. For example, suppose the unit commander wants to know how many Marines, and by what rank, his unit will lose in the next six months because of normal enlistment expiration. Or for example, the Regimental Commander wants to know which Sergeants in his command have been assigned to the Regiment for more than two years. Such questions as these can be answered using presently provided MMS data, but only through use of the time-consuming technique known as the "search and list" method.

This is not the most efficient method of personnel administration or management of manpower resources. It can be said that information is provided to lower echelon units via MMS outputs generated at higher levels in an automated manner. But this information may not be useful information, nor in the right format, nor at the right time-frames to satisfy individual needs for individual units. Even more

important, the MMS Information upon which decision making for personnel-related matters is being made, is produced from an outdated data base. The data base is outdated because it, itself, is not updated in a timely manner. As is discussed in the next section, untimeliness is probably the most far-reaching problem of the current MMS structure.

D. TIMELINESS

Untimeliness is a very real problem found within the present MMS structure. Its effects are felt by practically each and every unit operating under the current system; and its presence stems from both input and output factors of the system, itself. Untimeliness can be said to begin with the input phase of MMS. Disregarding the earlier mentioned means by which input errors may occur, there are certain other problems which have an effect on the timely input of data into MMS. For example, the system basically depends upon the human element--those administrative personnel charged with the responsibility of collecting and reporting appropriate MMS data. The initial input of error-free and timely reported data can only be as good as the unit diary clerk making the initial entries. Units have always had to contend with this human element, and even in future systems, human-related data entry errors will always be a factor. But a disadvantage associated with the present system is that such errors are not normally detected until initial processing of the data is begun at the SDPI.

The current means of communication and transportation of data is also a problem affecting timeliness of inputs. The present reporting system is primarily one of paper flow, physically transported from the reporting unit, via the chain of command, to the SDPI where initial processing begins. In some cases the data may have to flow through as many as four separate collection points prior to reaching the SDPI.⁷ Not only is this process time consuming, but it increases the occurrences of lost or missing portions of the diary. Only at the SDPI does the potential finally exist for the information to be communicated electronically.

The output phase of MMS also fosters lag time with respect to maintenance of a current data base. Some of the MMS output products themselves create lags within the system even though conforming with standard operating procedures. For example, the Unit Transaction Register (UTR), which is used to inform the reporting unit of initial entry errors not accepted for processing, may not reach the reporting unit for some days after the original error was made. The length of time it takes for a unit to receive feedback via the UTR is a function of the unit's proximity to the SDPI, the efficiency of the input and output distribution systems, and the processing workload of the SDPI. By the time a UTR error report is received at the reporting unit, one or more additional entries may have been made with respect to the first, thus compounding the original problem.

⁷Company to Battalion to Regiment to Division to ACU.

Then there is the problem of the original error not being corrected in a timely manner by the reporting unit, once alerted to the fact that an error has been made. (Or a correction is applied, but is an inappropriate one.) The unit is given two such notifications to make the required correction, and if still not accomplished in the required time, the unit will receive a Higher Authority UTR. The Higher Authority UTR informs the reporting unit that it is being notified for the third time to correct the same error. Rather than going directly to the unit, the Higher Authority UTR goes via the chain of command so that each level may see that the unit concerned has "dropped the ball," so to speak. In this way the intermediate commands can exercise their supervisory and control functions by individual endorsement. By the time that the Higher Authority UTR arrives at the reporting unit with all of its imposing endorsements, the time factor has become significant--usually a matter of weeks since the original erroneous entry. In some cases the Higher Authority UTR becomes an after-the-fact document in that the required correction does in fact get made by the reporting unit prior to receipt of the Higher Authority UTR. In other instances, the individual concerned in the original entry may have been transferred out of the unit; and the entire process would have been for naught.

The whole point to be made in the above discussion on error detection and control measures used in the present system is the fact that "timeliness" is not a dominant

characteristic. Long update and validation intervals have become a common feature of the system. This leads to persistent discrepancies between information stored at one node of the process and the same information stored at another node. This in turn leads to significantly large volumes of activity in all error correction channels. The whole process becomes duplicative and redundant in effort required, especially at the reporting unit level. Administrative personnel presently spend too many manhours on validation and correction of MMS data. Reconciliation of the UTR alone requires many manhours which could be devoted to other important areas. More important, the final product of this entire process, as presently operated, is a MMS data base which cannot truly be considered an up-to-date, reliable data base.

E. GARRISON VERSUS DEPLOYED SUPPORT

Support provided within the present framework of the MMS structure occurs somewhat differently for the deployed unit than for the unit in garrison. There are certain constraints within the present system which are imposed on both situations-- such as inadequate teleprocessing facilities, limited access to centralized data processing, limited access to data bases, and other familiar problems previously discussed within this chapter. However, the additional constraints often imposed upon the deployed unit leave such forces with practically no ADP supported MIS capabilities. The deployed unit should have access to just as reliable, up-to-date information, communicated

on a timely basis, and capable of satisfying unit needs, as that provided to the unit established in garrison. But such is not normally the case. Often the deployed unit's interactive capability with respect to either input or output of information is drastically reduced.

The individual FMF unit, as functions within the present structure of MMS, encounters no problem with deployment of its internal system capability. It need only to pack up its OCR typewriter, the appropriate OPNAV forms, and ensure that the appropriate administrative personnel are available to perform the required functions.⁸ However, the problem is encountered, not in the ability of the unit to deploy its MMS assets, but in the automated support available and/or effectively provided to the unit, once deployed.

Untimeliness associated with interactions between FMF units and higher level supporting establishments has already been identified as a key problem area tied to current MMS operating concepts. In addition, other weaknesses attributed to the input and output phases of the system have been discussed. In the deployed situation these same problems still occur, but are compounded to a much greater extent. When a unit is deployed, afloat or in the field, it can still conduct normal operations with respect to internal MMS functions. However, communication/transportation of MMS data with external organizations is usually hampered to a larger extent than when operating in the garrison environment. In the deployed tactical

⁸That's one of the benefits of the present system.

situation, the inherent time lags and error rates common to garrison operations are further intensified. While in a deployed status, a unit's ability to report MMS information into or receive processed outputs from rear area ADP systems is restricted to hand-carried, mail-serviced, or air-delivered means. Furthermore, when deployed, the degree of availability or exposure to these methods in comparison to garrison operations is usually lessened, thus making the timeliness problem more acute. Teleprocessing support in garrison can be facilitated by the use of commercial telephone lines. No such direct counterpart is yet available in the area of tactical communications for deployed units. Until communications capabilities are developed that provide a more timely data transmission media via electronic automation, deployed units will be constrained to use of the self-supporting manual procedures presently in effect.

This lack of an effective communication network for reporting of inputs/receiving of outputs while in the deployed situation is a major problem related to today's Manpower Management System. However, the answer for the most efficient and technically feasible means for electronic communication of MMS data when in a deployed status is beyond the scope of this thesis. Such a problem is considered to be a communications engineering study beyond the technical expertise of this writer. Some reference will be made in the latter portion of the next chapter, however, to results noted in recent testing of source data automation devices with field

communication lines. And some discussion will be presented in Section V in reference to certain theoretical applications with regard to communication networks.

The recent Stanford Research Institute study referred to earlier in this chapter pointed out certain limitations on the Marine Corps' ability to adequately provide ADP support to deployed units. As the size of the unit increases, the degree of ADP support needed, but not available, also tends to increase. According to the Stanford study, the capability for adequate ADP support of a deployed MAB or MAU (Marine Amphibious Brigade, Unit) is presently lacking. This includes all automated support (in addition to MMS) required for the effective use of various management information systems available to assist the commander of such units. An organic data processing capability should be available to such units when deployed for both maintaining a reporting interface with existing ADP systems, and for performing information processing to satisfy internal requirements.

IV. USE AND BENEFITS OF AN INTELLIGENT TERMINAL SYSTEM

A. THE INTELLIGENT TERMINAL

The intelligent terminal has been called the "Renaissance Man" of the computer field [Ref. 4]. Versatile and capable of either stand-alone or on-line performance, the term describes a data input/output and communications terminal with a programming capability. The concept of the intelligent terminal is not new; it was being discussed in the technical literature quite a few years ago [Refs. 5 and 6]. But only in the past couple of years, has the intelligent terminal achieved the general interest and increased attention it currently receives. Much of the future potential it holds for various applications and users has yet to be developed. By definition, an intelligent terminal is a device that can be programmed to perform certain functions that would otherwise require the services of the central processor to which it is attached. But by operating in an interactive role, it becomes an on-line input/output device designed for two-way transmission of data with a central computer.

In its simplest form this interactive, non-intelligent, or "dumb" terminal is used as a keyboard data-entry device, with the central computer performing control, edit, verify, and storing functions, in addition to acknowledging that the data has been successfully entered. The data so stored, for example, in disk storage, can later be processed by a specific user application program. On a more sophisticated level, these

same data entry control functions are performed, not by the central computer receiving the data, but by an internal processor within the terminal itself. The functions of control, editing, verifying, accepting, storing, and processing of entered data can be accomplished through the use of software programming of the internal processor. In addition, these truly "intelligent" terminals, unlike earlier hardwired models, can be reprogrammed to change functions if desired. Because of the tremendous price drops in memory and integrated circuitry storage over the past few years, the cost of these new programmable terminals is competitive with that of older, hardwired terminals. In fact, often times, such older rented terminals can be replaced with an intelligent terminal at a lower monthly rate [Ref. 6]. The concept of using the intelligent terminal as a data entry device involves four distinct system elements:

- A keyboard, located at some distance from a central computer system, for entering alphanumeric data.
- A data communications network to transmit this data between the remotely located terminal and the central computer.
- An internal processor to receive, pre-process, and store the data entered at the remote location.
- A typewriter or Cathode Ray Tube (CRT) display screen at the remote location to print/emit inputs, responses, directions, or outputs from the internal processor or the central computer.

The intelligent terminal cannot only be used to enter data, but can also receive immediately or in near "real-time," the central computer's response in the form of meaningful output data. This may include an on-line inquiry followed by an immediate real-time response. Take for example, the airline reservations agent who can inquire as to the status of open seats remaining on Flight X, scheduled to depart airport Y, on specified date Z. A replying response can be received within seconds via the intelligent terminal system used in that application. Such an inquiry and response usage can be used in any application requiring an immediate response to a "status" query. These type applications are plentiful among the many Marine Corps management information systems currently in use. The ability to query a system as to "status" (for any number of possible inquiry situations), and receive a near real-time response, would be a vast improvement over the present capabilities found within the Manpower Management System information structure.

Today's terminals are available and marketed for a variety of technological functions. There are CRT terminals and hard-copy printer terminals with limited capabilities; and there are various functional terminals with overlapping characteristics. For example, there are CRT terminals which are primarily alphanumeric-oriented, but which may possess some graphics capability. On the other hand, there are other CRT terminals which are primarily graphic and picture oriented (more commonly known as "graphic display systems" rather than

alphanumeric terminals), but contain some alphanumeric capabilities. All CRT's, whether graphic or alphanumeric oriented, may additionally be procured with an add-on hard-copy print capability. Alphanumeric terminals have proven to be much easier to work with, cost less money, come in more available models, and have fewer software interface problems than graphic display systems [Ref. 7]. The best equipped specific device to serve as an interactive, remote intelligent terminal for data entry is the alphanumeric CRT display unit, coupled with a keyboard. With the addition of a hard-copy printing unit for transaction record purposes, a highly capable, state-of-the-art means to accomplish input/output functions for large amounts of data is provided. Such a system permits the operator to key in required data elements much as would be done when using an OCR (Optical Character Recognition) typewriter. The CRT's operation in this function would be faster, however, than that of the typewriter, since its action is largely electronic rather than mechanical. Also of significance is the fact that multiple CRT devices can be scattered about in different facilities, and used simultaneously in entering related data or non-related data to the same central computer system for temporary storage/eventual processing. In doing so, the relatively high costs of the central computer facility can, thus, be shared by a number of different users both at the remote locations and the central location.

B. MINIS AND MICROS

One of the main reasons for the growth in popularity and versatility of the intelligent terminal has been the increased association and adaptability these devices have incurred with the minicomputer. In recent years, minicomputers have been attracting just as much attention in the fast-moving data processing field as the intelligent terminal [Ref. 8]. These compact, yet surprisingly powerful computers are being delivered at an ever-increasing rate for use in a broadening spectrum of applications.

The capabilities of the minicomputer have been increasing over the last decade while, at the same time, their costs have been decreasing in an equally rapid fashion [Ref. 8]. Over seventy companies are now manufacturing minicomputers. The increased competition in this segment of the data processing industry, coupled with the recent innovations in design and manufacturing technology, have combined to provide a high-capability computer with a low price tag. Two other factors have caused the minicomputer to become more popular in recent years. First, economic pressures have forced computer users to strive for achieving maximum performance at minimum cost. And in many cases, minicomputers represent the best answer to this situation. Secondly, increased emphasis is being placed upon distributed processing; and once again, the minicomputer is specifically designed to handle this task.

Today's typical minicomputer is considered one in which the mainframe purchase price remains below the \$100,000 range--many sell for less than \$20,000. They are available with a large range of characteristics and capabilities. However, the below listed description is a reasonably representative characterization of most minicomputers on the market today [Ref. 8]. The typical minicomputer is a parallel, binary processor with a 16-bit word length (although 8, 12, 18, 24, and 32-bit word lengths are also available). It uses integrated circuitry and is housed in a compact cabinet suitable for either tabletop use or mounting in a standard 19-inch rack. It weighs less than 50 pounds, consumes less than 500 watts of standard 115-volt electric power, and requires no special air-conditioning. It offers from 4,096 to 65,536 words of magnetic core or semiconductor storage with a cycle time of 0.6 to 1.2 microseconds. By all previous standards of value in the computer field, it's a truly impressive little package of computer power for the price.

Along with the increased interest in minicomputers there has been a proliferation of new peripheral equipment designed specifically for use with the "mini." In addition to the line of products offered by most of the major minicomputer manufacturers, literally hundreds of independent firms are now offering an incredible variety of peripheral products. The competition within this market has produced a variety of disk drives, floppy disk units, cassette tape units, printers,

card readers, CRT display units, and other peripherals whose capabilities and prices are well suited to the needs and budget of the minicomputer buyer. Even the developers of software systems are increasingly designing their wares around the minicomputer.

The minicomputer can be said to have established a solid position as a cheaper alternative to the larger general-purpose computers for many applications. However, the minicomputer is, in turn, being threatened by a newer and still cheaper class of computers called "microprocessors." A microprocessor can be defined as a single large-scale integrated chip or set of chips that performs the basic arithmetic and logical functions of a computer central processing unit. When equipped with memory and input/output circuitry, the microprocessor becomes a "microcomputer," which can offer capabilities quite similar to those of the smaller minicomputers [Ref. 8].

The microprocessor concept was pioneered in 1971 by Intel Corporation, but like "minis," microprocessors received such rapid acceptance that numerous other companies quickly jumped into the field with competitive products. The microcomputer can be expected to open up vast new application areas where even the cheapest minicomputers have been uneconomically justifiable. For example, one can look at the recent strides made in the pocket calculator industry with respect to programmability, memory storage space, and functions available in these devices. Along with the increased

capability of pocket calculators has been a concurrent decrease in costs--the entire evolution having resulted from the increased development of large-scale-integrated chip technology in this industry. With continued development of new innovations and increasing competition within the "micro" field, the feasibility of putting a computer at the disposal of every Battalion/Squadron may not be far away. In conjunction with development of the microcomputer is the increasing trend toward use of microprogrammed logic, which can make it comparatively easy for the end user to tailor the computer's capabilities to fit his particular needs.

C. EFFECT ON INPUTS

With the preceding introduction on the characteristics and capabilities of intelligent terminals, "minis," and "micros" as background, the remainder of this chapter will discuss specific areas to which these concepts can be applied in order to bring about improvements to those problem areas disclosed in the previous chapter. The first to be discussed will be the input phase of the system. The most immediate benefit to be gained with respect to input of information into the Manpower Management System via the intelligent terminal, is the ability to capture input data at its source. This aspect alone--capturing input data at its source in an accurate, acceptable form--is a tremendous advantage to MMS (as it would be with any information system). Secondly, intelligent terminals would provide a more accurate, efficient

and automated means of data input (or "source data automation" as the term most often used). Furthermore, the vast volume of activity currently found within the system's error-correction channels could be either greatly reduced or practically eliminated as a result of accurate data capture at its source. The entire processing cycle for MMS data could be readily shortened, thus leading to a more realistic, reliable data base for this information system.

To be more specific, assume that a reporting unit (Battalion/Squadron) has been given a source data automation capability. In the same manner and amount of time that it would take for the unit diary clerk to type the diary by the traditional means, he could enter this information via the intelligent terminal. The entered data would be simultaneously stored in the terminal's buffer memory and displayed on the face of the CRT screen. This would permit the clerk to visually verify the correctness of the data before submitting it to the microprocessor for further edit checks. The microprocessor could then perform more detailed accuracy and edit checks. If an error is detected, the operator would be notified at once and solicited for an immediate re-entry of the erroneous data.

The error-correction cycle is thus compressed to a logical minimum (a real-time basis) and required corrections can be entered at the data source, not somewhere downstream in the processing cycle. What has just been accomplished by this procedure is the elimination of certain

recognized problems common to the error-correction cycle as discussed in the previous section. These were problems which had the capability to either delay or completely stop processing of input data. The unit diary clerk can be expected to continue to make the same type of routine entry errors as experienced under the present system, but such things as invalid/unauthorized statements, illogical statements, and just plain typing errors will be immediately detected and corrected. And there will be no processing rejections under this system due to smudged, mutilated, or stained paper, improper character spacing, missing diary pages, improper paper alignment, or unreadable characters caused by dirty keys. These types of problem sources will be completely eliminated.

By using intelligent terminals, input data could be pre-processed at the reporting unit; and all input data which has been edited and verified as acceptable would be immediately ready for entry/update to the data base. Because of data verification and acceptance at the initial entry point, updates and changes to the data base could be accomplished on the first attempt to do so. Presently such changes sometimes take weeks to accomplish because of the error detection and correction cycle which must be followed. Finally, of significant value is the fact that input data, once entered, would in most cases be transferred electronically throughout the whole spectrum of required processing. Thus, the transfer of information from its source to the central data base would in fact be a fully automated process.

D. EFFECT ON OUTPUTS

Improvement can also be accomplished to the output cycle of the Manpower Management System through the use of intelligent terminals. Intelligent terminals in this phase would provide the reporting unit with a capability to receive current and reliable information. Intelligent terminals would provide the lower echelon units more flexibility with respect to individual information requirements than that presently available through the current system of recurring, routinized reports. Some specific examples will be cited.

Recall the questions asked in the last chapter concerning unique information requirements needed for decision making purposes. One commander wanted to know how many of his Marines, and by what rank, he would be losing within the next six months as a result of normal enlistment expirations. Another commander wanted to know the names of those Sergeants in his command who had been assigned to the command for more than two years. In both cases, intelligent terminals and the proper software-programming could provide the answers to such questions in a timely manner. In both cases, only an exact listing of personnel who met the parameters specified would be provided for the commander's review. And the listing provided would be as near "real-time" or up-to-date as possible because it would have come from a data base which had been recently updated with accurate, timely inputs from the same intelligent terminals. If this example were compared to the present means of providing answers to such theoretical

cases, the following would be noted. Under the present system, a list of individuals meeting the conditions asked for, could also be provided. But the list would have been manually written-up, only after manually searching through appropriate MMS reports/listings where the information could be found. Those individuals meeting the requested criteria would have had to have been individually screened from a list of all personnel within the command. Furthermore, the list of reports from which they would have been screened may not have been the most current, nor have presented a true picture of the current situation. And when such a fact is realized, it usually leads to further screening of backup or secondary sources to verify accuracy. This timely procedure and need to verify/consult secondary sources could be eliminated by the use of terminals.

Another potential improvement stemming from use of the intelligent terminal relates to its value to the Visual Audit Sheet process. Recall, as discussed in Section II, that the Visual Audit Sheet (VAS) is forwarded to a reporting unit each time a new Marine checks into the unit, and yearly thereafter on the Marine's birthdate. The VAS is a computer printout, for a specified individual, of all information currently contained within that individual's computer record at the SDPI. Upon receipt, the printout is personally verified for accuracy by the Marine concerned; required changes are entered into his unit record book; and changes are entered into the MMS records via unit diary inputs. This individual

record audit could be a much improved process with the aid of intelligent terminals. For example, at the time a new Marine checks into the unit and upon the occasion of his birthdate, his computer record could be merely called out of the data base, displayed on the CRT for his personal verification, and appropriate changes thereto immediately entered, edited, and accepted. In fact, the intelligent terminal could be used for providing a complete listing of all unit personnel who require a VAS audit each month.

In addition to the above examples, there are numerous other applications in which the individual unit could use the intelligent terminal to tap the MMS data base. And in so doing, many of the routine problems, which often arise in the course of performing personnel administration/management functions within a unit, can be solved in a more efficient manner. Intelligent terminals, together with general purpose software programs (designed to meet the general needs of a unit), have the potential for solving many of the output-related drawbacks associated with the present system. Moreover, output information can be more efficiently generated and produced from a more up-to-date data base.⁹ Utilization of reports from a reliable and up-to-date MMS data base

⁹Compared to the present system, reliable data base information could be produced by one iteration of the processing cycle, and provided within a more compact, efficient cycle than under the present system. Therefore, output information, whether received routinely or in response to a direct query, could be counted on as being both current and efficiently produced by the data processing cycle.

could facilitate more effective management at the lower unit levels. Information received for management decision making purposes--being more reliable--can also be considered to be more useful to management. In addition, less management time would be required for auditing, reconciling, or error-correction activities.

Local file management could also be facilitated because of an increased ability to both query for and retrieve individual information needs. Certain Class I reports may continue to be generated and distributed via normal chains, but the reporting unit would no longer be dependent upon such reports as the sole source or latest update of MMS data. With the intelligent terminal the unit commander would have at his finger tips, a current data base from which to tap the most current personnel information contained on members of his unit. Such a new found capability would enhance the overall effectiveness of his personnel-related decisions and, in turn, the effectiveness of the unit itself.

E. OTHER SAVINGS

As previously argued, the input of data into the Manpower Management System, and receipt of output data produced within the MMS framework, can be greatly facilitated through the use of intelligent terminals. However, an additional factor other than the input/output functions of the total system can also be potentially improved through the effect of such devices. The timeliness factor alone (a basic "given"

with respect to intelligent terminal benefits), represents an immeasurable degree of improvement to the present system. Unfortunately, no real, definitive value can be placed on the timeliness factor. Yet, it must be considered as a highly significant aspect of the total improvement package to be gained within MMS upon implementation of an intelligent terminal system.

Assume, as in utility theory,¹⁰ that each unit commander has exact and full knowledge of all information relevant to his needs in performing the necessary personnel management functions within his unit; and that he also has full knowledge of the means available and their technical capacity to satisfy those needs. Although not quantitatively measurable, each of the means available could be ranked on an ordinal basis in comparison to the others. The commander would choose that method of meeting his needs which provided him the greatest maximization of satisfaction (or utility) in comparison to all other choices. This same theory can be applied to the benefits received from use of intelligent terminals to perform MMS functions. What value can be placed on the ability to immediately enter, edit, error-check, correct, and verify acceptance of input data at the reporting unit? What value can be placed on the query, retrieve, and report generation functions which would be available to lower

¹⁰Ferguson, C. E., and Gould, J. P., Microeconomic Theory, 4th ed., p. 11-16, Richard D. Irwin, Inc., 1975.

echelon units? What value can be placed upon the decision making capabilities afforded to reporting unit commanders because of easy access to updated data bases? It is difficult to quantify such values as these yet, on an ordinal basis, they would be ranked higher than those capabilities presently afforded within the current system.

There are other, more easily identifiable areas, however, in which improvements can be readily seen. Certain output products of the present system, for example, could either be eliminated or at least drastically reduced. For instance, there would be no real need for most of the MMS generated quality control reports. The Unit Transaction Register would no longer have to advise each unit as to which of their latest entries were accepted, which were rejected due to errors, and which "re-entries" were accepted on the re-submission of previously erroneous data. The Pending Transaction Register would no longer be needed to advise the reporting unit commander at the end of each month, of those entry errors for the month still currently unresolved. The Higher Authority UTR would no longer be needed to advise the reporting unit commander that one of his entry errors is still not corrected after the issue of two previous notices on the same referenced error. Such reports as the STAR (Statistical Transaction Analysis Report), the Command UTR, and the PVUTR (Personnel Verification Unit Transaction Register) would no longer have to be generated in their entirety. The information which they

report would either no longer be required or, if still applicable, could be accessed by the unit concerned via the intelligent terminal.

Understandably, other quality-control/audit-trail measures applicable to the operation of a more-automated, terminal-to-central processor, interactive type system must be included in the formulation of concepts for such a system. Additional discussion of this subject, however, will be deferred until the next chapter and presented in more detail. More importantly, what must be noted in relation to the savings discussed in the above paragraphs is the implied potential to reduce manhours presently devoted to support of MMS functions (through an elimination of unnecessary paperwork and administrative processing time). Current operation of the Manpower Management System requires significant personnel assets at the low echelon levels for input preparation and audit, error correction functions, and routine performance of the duplicative, manual functions required at these levels to overcome the lack of sufficient ADP responsiveness. These personnel are often diverted from their intended duties within their organizations to support the required input/output processing procedures. Because of their characteristics (as discussed earlier within this chapter), the introduction of intelligent terminals into the FMF can potentially reduce the manpower assets currently required to support MMS operations at low echelon levels. Similar experience within non-FMF supporting establishments confirmed that certain

administrative billets could be eliminated under a source data automation concept. Such an accomplishment was recently demonstrated at the non-FMF activities of MCRD, Parris Island and MCRD, San Diego. These two commands were able to identify a total of forty-one billets to be dropped from their Table of Organization after institution of source data automation within their commands [Ref. 9].

Not only does the potential exist to reduce manhours in the preparation/input phase of data capture, but a potential reduction in manhours can also be effected in the output phase of the system, the information distribution process, and the other administrative processes currently needed to reconcile, validate, or rectify outputs produced by the system. The simple fact of the matter as discussed in the above paragraphs is the following presumption: If a reduction in the data capture/entry process, information processing cycle, and output product/distribution system can be accomplished, then quite possibly a similar reduction in the number of personnel required to perform these functions can also be effected. What may be seen as a more appropriate advantage to the FMF, however, is the fact that many of the non-administrative personnel currently working in the "admin field" could be reassigned to their primary skills. Such a move would certainly improve the overall readiness posture within the FMF. An evaluation of possible personnel reductions which could be effected upon implementation of source data automation within FMF establishments will be made in Section VI.

Whether it be a reduction to unit Table of Organization requirements or an increased ability to assign personnel to billets commensurate with their MOS (Military Occupational Specialty) qualifications, the performance of either measure should greatly enhance utilization of Marine Corps resources and lead to increased efficiency. Increased efficiency, as stated in the Introduction to this thesis, leads to further improvement in future systems. In the decade ahead, it must be expected that manpower costs will continue to rise as they have historically done in the past. On the other hand, it can be expected that costs for computer hardware/software systems and their associated data communication networks will continue to drop as recent trends have shown. From a performance standpoint, substantial reductions in operating costs can be realized through installation of an intelligent terminal system to perform the variety of tasks (at the local level) that were previously performed by the host CPU (Central Processing Unit). The ability to perform data capture, edit, validation, format, and other data entry functions at the local level (independent of the host computer, or prior to transmission to the host computer) reduces data transmission costs as well as host computer processing overhead [Ref. 10]. Furthermore, it can be expected that reliability standards for modern data entry/retrieval systems will continue to improve due to the increased development and technological advances associated with such devices. Therefore, based upon

the above assumptions, it will soon become operationally feasible and economically desirable to encourage increased usage of such systems.

F. IMPACT OF RECENT STUDIES

The need to improve capabilities and responsiveness currently provided to lower echelon units by the Manpower Management System is recognized by the Marine Corps. In fact, the desire to upgrade ADP capabilities within all Marine Corps automated information systems is a continuous, ongoing program which is reflected by the existence of external study and evaluation projects. The strategic goals and objectives, general operational requirements, and procedural guidance in relation to development and procurement of future Marine Corps ADP needs are provided through the DOD Planning, Programming, and Budgeting System [Ref. 2]. Fundamental guidance for development of Marine Corps ADP programs is provided through certain DOD and JCS major planning documents. Further guidance for both ongoing and future ADP programs is additionally expressed in the following Marine Corps planning documents:

- Commandants Programming and Fiscal Guidance
- Marine Corps Mid-Range Objectives Plan
- Marine Corps Capabilities Plan
- Marine Corps Field Budget Guidance

Other references which have a bearing in MIS planning within the Marine Corps include:

- DOD INST. 5010.27 - Management of the ADP Program
- SECNAVINST. 5230.4 - Department of Navy ADP Program
- MCO P5000.10 - Systems Acquisition Management Manual
- MCO 5000.XX - Standardized Guidelines for Computer Resources Used in Automated Tactical Command and Control Systems, Communications Equipment, Sensors, and Ruggedized or Stand-Alone ADP Devices
- MCO P5200.15A - Automated Data Systems Manual
- MCO 5320.2C - Central Design and Programming Activities
- MCO 5230.8 - Maintenance and Modification of ADP Application Software
- MCO 5230.9 - Standard Procedures for the Control of Centrally Managed Automated Data Processing Systems.

All of the above planning and guidance documents impact upon how the Marine Corps must plan for future MIS and ADP systems. In addition to the above sources, future MIS and ADP planning efforts are influenced by the knowledge obtained through ongoing studies in this area. Most of these study efforts deal in a broad spectrum of ADP supported MIS programs. Yet, even though they reflect a variety of problems presently experienced, and explore various avenues of corrective action, they are relevant to the present MMS structure within the FMF. They are relevant in that they relate to problem areas currently associated with the Manpower Management System and the improvements needed therein to reduce such problems. The below listed major studies have all been completed within the last year, supporting the

proposition that MMS can be improved through increased automation. These studies will undoubtedly influence the future of automation within the Manpower Management System.

- "Management Information Systems Doctrine Development" - Conducted by the Marine Corps Command and Staff College. Its purpose was to provide a developmental bulletin on MIS doctrine for the operating forces.
- "Automated Data Systems Management Methodology" - Conducted by Stanford Research Institute, Naval Warfare Research Center. Its purpose was to operationally define and document a methodology for the development of useful measures of effectiveness and cost for automated data systems.
- "Alternative Automated Data Systems (ADS) Concepts for Support of the FMF (1980-1990)" - Conducted by Stanford Research Institute, Naval Warfare Research Center. Its purpose was to develop and evaluate alternative concepts for FMF automated data systems in the 1980's.
- "Feasibility for Replacement of Marine Corps ADP Equipment" - Conducted by Auerbach Associates, Inc. Its purpose was to provide projections of ADP resource requirements for the period 1980-1990, currently available technical alternatives to replace ADP resources in order to meet requirements, and anticipated changes in available technical alternatives.
- "Data Base Management System Study" - Conducted by Auerbach Associates, Inc. Its purpose was to analyze

USMC data systems to determine which ones might benefit from a Data Base Management System (DBMS), identify capabilities desired in an ideal BBMS for the USMC, and present DBMS alternatives available to the USMC.

More studies will continue to be made and new concepts will continue to be evaluated by Headquarters Marine Corps with regard to future MIS and ADP capabilities. One of the latest concepts presented for staffing and study is the Real Time Finance and Manpower Management Information System (REAL FAMMIS) [Refs. 2 and 11]. REAL FAMMIS is a concept suggesting a completely centralized, automated pay and manpower management information system in which on-line, real-time, interactive update and retrieval capabilities exist between every echelon of command and one central data base. Several of its objectives are similar to those presented in this thesis, yet its concepts are quite different--stressing a fully-centralized operation rather than a distributed processing operation; and combining the separate functions of personnel reporting and financial record maintenance into a single function performed by one individual at each reporting activity.

These studies all point to the fact that the Marine Corps is constantly searching for new techniques and improved methods for dealing with (and providing improvements to) its many-faceted management information systems. Not only are studies being made, but recent operational testing has been conducted within the FMF to determine the degree of utility

that increased automation would bring to FMF units. The results of these tests and their relation to MMS are discussed below.

G. OPERATIONAL TEST RESULTS

The final topic to be discussed within this chapter concerns the data generated in a recently completed operational test and evaluation by FMF units on the use of source data automation (SDA) devices in a variety of environments. A broad overview will be presented on both the nature of the tests and the results observed by the test evaluation report. Although the operational test and evaluation involved the use of SDA equipment in support of several, separately-related management information systems, it did prove SDA devices to be reliable, efficient, and compatible with respect to MMS operations.

The period of testing conducted by the Fleet Marine Forces occurred from 1 December 1975 to 30 June 1976. The main objectives to the test were to evaluate the military utility, operational effectiveness, and suitability of source data automation for FMF use in garrison and in amphibious operations. In the process, reliability, maintainability, availability, and interoperability of the equipment itself were to be evaluated; concepts of employment and logistic support required in amphibious operations were to be determined; and the capability of SDA equipment to interface with present Marine Corps computer support systems was to be

analyzed. Finally, the capability of non-technically trained Marines to operate SDA terminals/equipment was to be observed. Specific applications that were evaluated included source data entry, inquiry, and retrieval functions; plus limited data manipulation for local file management purposes [Ref. 12].

Two types of commercially available SDA devices were tested--shared processor systems and stand-alone terminals. More specifically, the EXTREX System 580 and SYCOR 340-B and 340-D Systems were tested by FMFLANT; the IBM SYSTEM 32/IBM 3740 Data Entry System was tested by FMFPAC. The test was designed to provide FMF units with the opportunity to examine the usefulness of source data entry for a number of information systems; and to provide local commanders at all echelons with ADP support to assist in the decision making process. Software applications were developed and validated for support of all information systems evaluated in the test. A partial listing of the type information systems evaluated during the testing period includes:

- MMS - Manpower Management System
- JUMPS - Joint Uniform Military Payment System
- FREDS - Flight Readiness Evaluation Data System
- MEDS - Mechanized Embarkation Data System
- MIMMS - Marine Corps Integrated Maintenance Management System
- 3M - Navy Maintenance and Material Management System
- MARES - Marine Automated Readiness Evaluation System
- SASSY - Supported Activities Supply System

Without going into full details of procedures used or observations made, the following factors pertaining to use of SDA within the FMF were evaluated during the test period:

- Operational Effectiveness (garrison and amphibious/field operations)
- Operational Suitability (availability, reliability, maintainability, transportability, environmental requirements, power supply requirements, and logistic support requirements)
- Personnel Factors (SDA operator skills/training requirements, SDA maintenance skills/training requirements, SDA programmability, and human engineering factors)
- Data Transmission (direct wire transmission, field telephone transmission, field radio transmission, and interface with AUTODIN)

Analysis and evaluation of the data collected during the testing period led to the following general conclusions with respect to the factors listed below:

- Military Utility - Commercial off-the-shelf SDA equipment can be used by Marine Corps personnel to support a variety of applications, both in garrison and in the field. It can be operated and programmed by Marine Corps personnel requiring minimal training and no restrictive backgrounds or occupational specialties. It can be transported, powered, and sheltered by standard Marine Corps means in amphibious/field operations. Data

transmission requirements can be met in both garrison and field environments. It can be easily interfaced with other systems (IBM 360, AUTODIN, etc.).

- Operational Effectiveness - Significant reductions in manhours required for data preparation and input, reduction or elimination of errors in entered transactions, and more efficient management of information at the local unit level can be realized through the use of SDA equipment. All test units involved reported advantages in speed and efficiency through the use of SDA equipment for data input.

- Operational Suitability - Commercial off-the-shelf SDA equipment exhibits high performance characteristics, in garrison and in the deployed environment. From the available data, reliability, availability, and maintainability parameters indicated that the SDA equipment performed very well with respect to frequency of failures and total operational time.¹¹

- Logistic Support Requirements - A definitive statement of the quantity of spare parts and consumable supplies required to support an amphibious/field operation of any duration cannot be made from the available data. Available data does indicate that few parts were required throughout the test period for garrison operations,

¹¹ However, with the majority of the devices tested being new, a smaller number of failures would be expected than might occur if the equipment were older. Only by increasing the observation period for recording failures, can a high degree of confidence be achieved in measuring the true failure rate.

however, the quantities and types of parts were machine dependent--IBM equipment having different characteristics than ENTREX equipment, and so on. Definitive spare parts requirements cannot be determined until a specific system is acquired and undergoes acceptance testing in a Marine Corps environment.

- Data Transmission - Commercial off-the-shelf SDA equipment, when provided with appropriate interface devices, can exchange data over existing tactical communications media. Commercial telephone systems, field telephone systems, and several field radio systems were tested with generally good results; and in most cases, distance was not a factor.

- Interface with Other Systems - Commercial off-the-shelf SDA equipment can interface with other information and communication systems. Transactions initiated on deployed SDA equipment were transmitted to an IBM 360 via magnetic tape, paper tape, and AUTODIN.

During the course of the testing period there were some major and several minor deficiencies noted in various areas of evaluation. Some deficiencies were perceived to have arisen from the testing and data collection procedures themselves, while others were attributed to equipment, software, and vendor support. Many of the observed discrepancies can be overcome through further modifications and testing/evaluation. Of primary importance, however, is the fact that

source data automation is feasible, as seen in the final conclusions reached in this evaluation [Ref. 12]. Based upon the above results, it appears that SDA could be readily integrated into FMF units, and in so doing, would lead to increased efficiency in performance in their MMS functions. Although MMS was only one, among a full spectrum of information systems evaluated, and did not receive a thorough testing of its entire system structure, those aspects of the system which were tested proved to be fully-enhanced through the use of SDA terminals and related equipment.

V. CONCEPTS FOR EMPLOYMENT OF INTELLIGENT TERMINALS
IN THE FLEET MARINE FORCES

Assuming source data automation (the use of intelligent terminals) is to be adopted by the Marine Corps as a method to increase the effectiveness of the Manpower Management System, this chapter will deal with the concepts associated with employment of such devices within the Fleet Marine Forces. As discussed in previous chapters, there is a requirement (need for) to provide the Fleet Marine Forces with an increased capability to facilitate the input of MMS data into the system, and to provide improved automated support for FMF management actions at all levels. This capability should provide support in garrison, afloat, and in a combat environment.

A. REQUIREMENTS

The ADP equipment chosen to provide the required support should be easily deployable and permit easy transition between all operational environments. It should require little or no modification to existing Marine Corps ADP equipment and/or telecommunications media. Furthermore, this expanded capability must be achieved at low cost, be capable of operation by non-technical personnel, and provide no restrictions on tactical operations. Economically, it should create a reduction in the FMF manpower resources currently dedicated to the support of existing MMS operations.

Source data automation (SDA) is a widely-used, modern-technology concept which can be implemented within the FMF through the use of commercially available, off-the-shelf devices that possess the required capabilities, and which have been properly packaged to operate in a tactical environment. However, the following specific requirements must be met if the use of source data automation within the FMF is to be successfully implemented:

1. Operators for SDA equipment must be the same non-data-processing personnel who now provide the input preparation, validation, and other manual administrative functions currently required before data processing begins within the present system. In the case of MMS, for example, SDA equipment must be capable of operation by the unit diary clerk at the reporting unit level; and by comparable administrative personnel at each succeeding echelon who now currently deal with MMS data.

2. Training for operators of SDA equipment should require no more effort than that required to operate an electric typewriter or key-punch machine (approximately eight hours of hands-on classroom training).

3. SDA equipment must be packaged to function within a semi-controlled environment such as tentage or mobile field vans. It must offer maximum resistance to vibration, dust, humidity, temperature variations, and other environmental constraints which would be imposed by combat conditions.

4. SDA devices must utilize, and be compatible with, existing or planned telecommunications equipment and electrical power generators.

5. Technical support of SDA equipment should require no increase in the number of data processing personnel in the FMF, or in the Marine Corps.

6. SDA equipment must seek to minimize the potential for compromising emanations if a classification requirement should arise (it should be capable of providing TEMPEST integrity when operating in a hostile environment).

7. Basic organizational maintenance of SDA equipment must be limited to fault isolation, accomplished through self-diagnostic software; and repair limited to the replacement of circuit boards and other major modules. Any maintenance above the basic level would be accomplished by one of the following methods:

- Specialized maintenance performed by Marine Corps Computer Repair Technicians at the Intermediate Maintenance Activity Level.
- On-site maintenance provided by the equipment vendor.
- Major rehabilitation accomplished by evacuation of defective equipment to the manufacturer's designated service facility/factory.

8. In the event of nuclear attack, the equipment should be survivable to the best extent possible within reason.

B. ORGANIZATIONAL STRUCTURE/OPERATIONAL FUNCTIONS

The organizational structure for operation of the Manpower Management System, after incorporation of an enhanced

input/output data processing capability, would remain basically equivalent to the present organizational structure. Functional management of MMS would still be under the control and direction of Headquarters Marine Corps through the Director of Manpower Plans and Policy. One phase of the organization which might be potentially reduced/eliminated, however, would be the requirement for the Administrative Control Unit (ACU), as the need for their functional responsibilities would be greatly reduced. Because of the internal processing capabilities of proposed technology and communication interfaces which intermediate commands and reporting units would enjoy under the new system, the administrative control functions of the ACU would no longer be necessary. More on this point will be discussed later within the next chapter as it relates to personnel reductions.

Possibly substituted in place of the ACU would be a control element whose function would be to provide supervision and control over software development for use within the FMF. With the switch to intelligent terminals, and the resulting increase in individual processing power, will come an increased emphasis on software and its ability to satisfy individual requirements at the intermediate and reporting unit levels. There will be certain input/output processes with respect to MMS functions which will be standardized and directed from HQMC and FMF levels as is currently done. Other processes, as a result of increased computer power, will be individualized functions, desired

by individual commands within the FMF, to support their own particular needs. Somewhere within the functional chain, there must be an organization to control, coordinate, and develop software programs which will meet the particular needs of intermediate commanders without affecting or interfering with high-level requirements. Perhaps this role can be provided by the Central Design and Programming Activity (CDPA) located at the Marine Corps Automated Services Center in Kansas City. The CDPA is the activity currently responsible for designing, developing, programming, testing, and implementing software programs pertaining to MMS. On the other hand, perhaps a new organization, more closely aligned to the local level, would best be suited to handle these functions. However, it must be pointed out that the use of only one organization to direct and control all software development and implementation within the FMF would probably be the most cost effective method; and therefore, the CDPA is recommended by this writer to continue its function within this regard.

With respect to the technical management structure, Headquarters Marine Corps would still direct and control the requirement for, procurement of, capabilities allowed in, and technical operation/maintenance of all Marine Corps ADP equipment. The Marine Corps Automated Services Center at Kansas City would still retain its function as the central data base for the Manpower Management System. The functions of the Satellite Data Processing Installation would be

somewhat modified, however, because of the increased processing capability available to reporting units in the proposed system. The present SDPI functions of editing, error detection/reporting, and information feedback on data accepted into the system would no longer be required. There would be no need for most of the quality control reports (UTR, PTR, STAR) now generated by the SDPI. In effect, reports generated by the SDPI would basically be reduced to just those Class I reports still considered necessary (MOS Rosters, Location Rosters, Alpha Rosters, and so on) after introduction of intelligent terminals into MMS. The SDPI would keep its own computer files updated using inputs provided from the reporting units, the central data base, HQMC, and other normal sources of MMS input data. Under the new improved system, the SDPI's main responsibilities would include receiving processed data from the reporting units, telecommunicating this processed data (when appropriate) to the central data base, interacting with intermediate commands and reporting units within their jurisdiction to provide responses to MMS information requested, and providing backup processing capability for information, reports, and so on, too large to be handled by lower echelons.

With the possible exception of the ACU requirements as discussed above, the organizational structure of a Manpower Management System incorporating source data automation would be identical with that presented in Section Two by Figure 2-1. The operational processing cycle, however, would be

somewhat changed; with the primary difference resulting from the new capability gained at the reporting unit level to immediately accept, edit, and process input data to a machine-readable form. Another significant change within the processing cycle would result from the use of a direct communications network to pass the processed inputs directly to appropriate data bases versus the current manual means of forwarding input data. This improved information processing cycle using source data automation (intelligent terminals and minicomputers) is pictured in Figure 5-1. In comparison to the processing cycle as shown by Figure 2-5 in Section Two, it can be seen that several steps that would normally be accomplished by the SDPI, would now be completed at the reporting unit level. In addition, because of direct transmission of processed data, several of the interface points as depicted in Figure 2-6 of Section Two would be eliminated. The net result of such a new system is that the manual preparation and transportation processes now occurring for MMS input data would be eliminated, thus realizing a high degree of time-factor benefits. A further impact of such a processing cycle would be seen in the re-location of error-control procedures now in effect. No longer would the time-consuming, error-detection/correction problems, as discussed in Section Three, be such a disruptive factor to MMS. Furthermore, the elimination of certain error-control reports would enable more manhours to be available for application to other necessary areas.

INFORMATION PROCESSING CYCLE
USING SOURCE DATA AUTOMATION

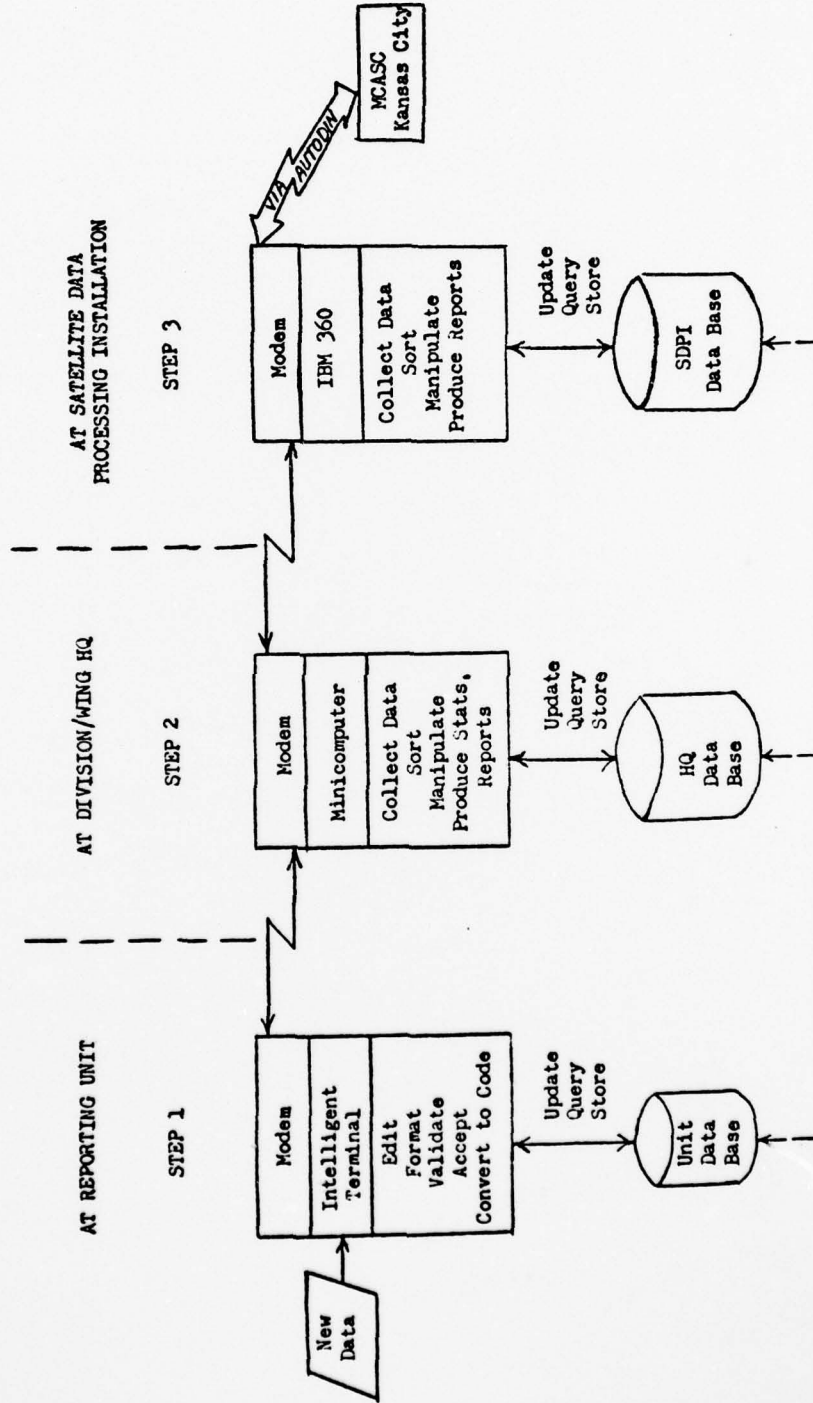

FIGURE 5-1

The reverse flow of MMS information (the output phase) from the SDPI and headquarters-level establishments down to the lower echelon units should also improve significantly. To begin with, each reporting unit would have its own self-contained, unit-oriented MMS data base from which to draw specific information to help the commander effectively manage his personnel. Secondly, through an increased "ad hoc" query capability, lower echelon units would enjoy a greater degree of flexibility with respect to their accessibility to information. More importantly, responsiveness to their information needs (from both in-house and external sources) would be vastly improved; data received could be assured of being as close to near real-time information as feasibly possible; and MMS would finally have achieved the dual capacity to satisfy reporting unit needs, while still supporting higher command level requirements.

Under the proposed system, Fleet Marine Forces would have organic automated data processing equipment available to each echelon of command down to the Battalion/Squadron level. The equipment would be of varying computer power, determined by the level of functions engaged in, and would be upwardly compatible with the next higher echelon. Figure 5-2 depicts the proposed hierarchy of ADP equipment for use within the FMF organizational structure of a Manpower Management System with source data automation capability. The ADP equipment at the Battalion/Squadron level, for example, would have a stand-alone capability with all of the

AD-A057 339

NAVAL POSTGRADUATE SCHOOL MONTEREY CALIF
USE OF INTELLIGENT TERMINALS AT THE BATTALION/SQUADRON LEVEL FO--ETC(U)
JUN 78 L D RANNALS

F/G 5/9

UNCLASSIFIED

NL

2 OF 2

AD
A057339



A microfiche card containing a grid of frames. The frames contain various types of content, including text, diagrams, and tables. The text is mostly illegible due to the small size of the frames. There are several diagrams, including one that appears to be a schematic of a terminal or control panel. The frames are arranged in a grid that is approximately 6 frames wide and 10 frames high, with some frames missing or blank.

END
DATE
FILMED
9 - 78
DDC

HIERARCHY OF ADP EQUIPMENT
USING SOURCE DATA AUTOMATION

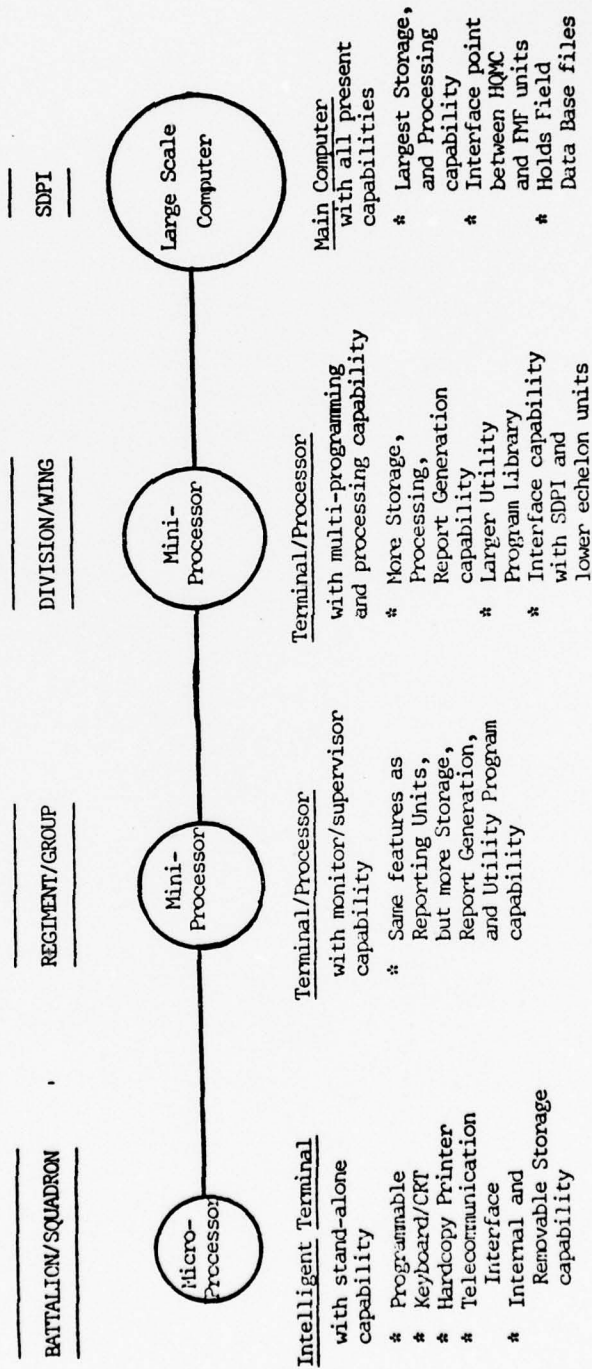

FIGURE 5-2

required features to edit, format, change, store, and verify acceptance of input data; query for, manipulate, retrieve, and print output data. Capabilities at higher levels would be increased only to the degree required at those levels. Transmissions of data, once entered, would be conducted electronically to higher levels until it reached all appropriate data bases for change, update, or storage purposes (see Figure 5-3). Receipt of output data from higher level sources would also come via direct electronic transmission. The operational features and functional requirements associated with source data automation and its relation to MMS, in both the garrison and deployed environments, are discussed below.

C. GARRISON OPERATIONS

This section presents a proposed concept for the use of source data automation (SDA) in carrying out the functions required by the Manpower Management System when operating within the garrison environment. Beginning at the reporting unit level (Battalion/Squadron), the SDA system will consist of a stand-alone, programmable (intelligent) terminal--incorporating a Cathode Ray Tube, a typewriter keyboard, a magnetic storage medium (cassette or "floppy disk"), and a terminal printer. The intelligent terminal would use Marine Corps or vendor provided software to support the following capabilities:

DATA TRANSMISSION NETWORK
WITH SOURCE DATA AUTOMATION

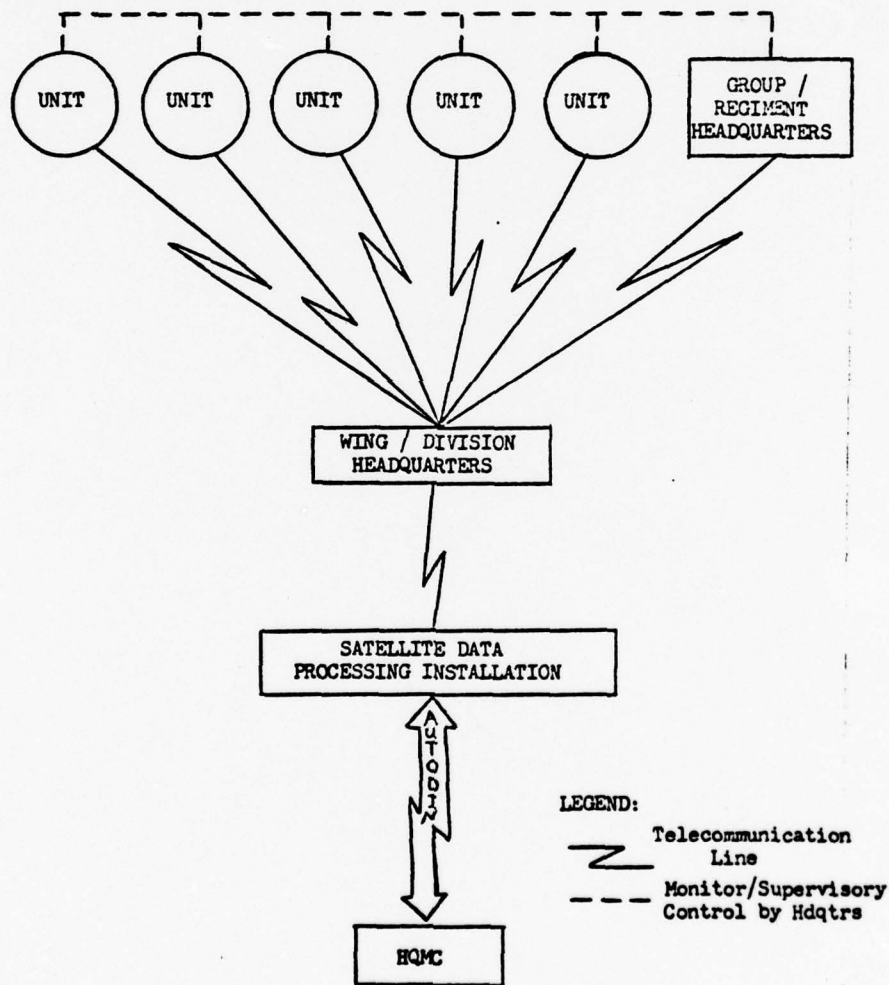

FIGURE 5-3

- Interactive editing of input data.
- Verification and validation of input data prior to acceptance.
- Formatting of input data and storage on magnetic media for future machine reading.
- Inquiry and retrieval capability of data from small local files.
- Local report generation from small local files or input data sources.
- Ability to receive and utilize data from external sources such as higher level ADP equipment.
- Ability to communicate over unconditioned, switched telephone lines in garrison, and over field radio/field wire when deployed.
- Ability to prevent unauthorized access to the data base.
- Ability to produce multi-copy output in hardcopy form when required.

The following specific benefits would be gained through the use of source data automation at the reporting unit level to carry out normal MMS functions:

- A more efficient, one-step process for data input would be achieved via the intelligent terminal--immediate error detection and correction would occur, thus eliminating error detection by downstream checks (which may or may not be able to apply satisfactory corrective action).

- An immediate update to the unit data base is accomplished at the same time that inputs are entered, rather than days later when command-level output reports are received.
- Daily update to higher-headquarters data bases is accomplished by accurate/error-free data.
- Electronic transmission of MMS data to higher headquarters via commercial telephone lines, thus increasing timeliness of throughput and reducing the chances for lost/missing data while enroute.
- The availability of a unit data base--containing MMS data on unit personnel, in accurate and "current status" form.
- An increased flexibility and faster response time provided to lower echelon units with respect to their authorized accessibility to external data bases.
- A faster, more direct means to submit updates/changes to such MMS audit documents as the VAS and PVUTR.
- An elimination of the requirement to manually process such MMS quality control reports as the UTR, PTR, and STAR, thus reducing the manhours needed to accomplish these required administrative tasks.
- An elimination of the multiple-reporting requirements due to losses, errors, and so on, for the same MMS input data, thus eliminating the manhours needed to accomplish these unnecessary administrative tasks.

- A smooth flow of information, not clogged with excessive raw data and containing a low percentage of error traffic relative to the general flow, would be facilitated.

Applications which would be used at the reporting unit level would be either for source data entry purposes or for data manipulation, inquiry, or retrieval purposes.

For source data entry purposes, all data presently input into the system via the unit diary would now be entered through the intelligent terminal. Input, editing, error correction, and data acceptance would all take place at the entry source and immediately upon entry. Once entered and accepted, two modes of data communication are possible in garrison operations. First, direct, on-line communication of data to the Division/Wing level could be accomplished at the time initial entries are input and accepted. Or, if system workload does not permit such "real-time" (or near real-time) transmission, the data could be stored upon entry and transmitted to higher headquarters at a later specified time--either on a "called" basis or by regularly scheduled transmission periods.

For manipulation, query, and retrieval purposes, an internally-held, unit-oriented data base of MMS information could be maintained in storage on cassettes or disks. With the aid of appropriate software applications, the unit data base could be manipulated, queried, and so on, to provide useful and timely information to the unit commander. Other

retrieval applications may involve the request for current information from higher level sources to support local unit needs. Such requests may take the form of direct inquiries and return responses via the intelligent terminal; or the inquiry may be made directly via the intelligent terminal, with the response following later in printed-report format.

Applications which would be used at the intermediate command levels (Regiment, Group, Division, Wing Headquarters) would mainly consist of query and data manipulation applications rather than input reporting applications. The MMS area of interest at these levels would mostly be directed toward:

- Personnel "availability and status" inquiries with respect to such varied items as qualified MOS's, rank structure, projected losses, and so on, within subordinate commands.
- Data manipulation and generation of reports for their own respective commanding officers/generals.
- The monitoring/control of input reporting and output distribution for MMS information from/to their subordinate reporting units.

With respect to the communication of processed MMS data from the reporting unit to the SDPI, it would be suggested that this data be transmitted directly from the reporting unit to its supporting Wing or Division headquarters. Data received from all reporting units within the Wing or Division would be used to update the data base at this echelon (for future

inquiry/manipulation purposes), and be transmitted at specified time periods to the appropriate SDPI for its own files. As depicted in Figure 5-3, data transmission would occur in all cases via commercial telephone lines until reaching the SDPI, and via AUTODIN from the SDPI to the central data base at Kansas City. As verified by recent testing, commercial telephone lines do have the capability to transmit computerized data--and distance is not a limiting factor [Ref. 12].

The intermediate Regimental and Air Group headquarters would not be included as a node in the transmission process. Instead, they would have terminals connected in parallel with, and capable of monitor/supervisory control over the terminals at subordinate units as shown in Figure 5-3. The Regimental and Group headquarters would have a storage library and a processing capability large enough to accommodate the necessary personnel data used at their levels. With respect to the communication network, they would have a direct access capability to their respective Division or Wing headquarters. They would also have the ability to access any of the individual unit data bases within their command. This would give the Regiments and Groups a query capability in both directions, and a means to receive direct outputs from Division/Wing level terminals.

With respect to routine input reporting procedures, daily operation within this functional framework would occur as follows:

1. Each reporting Battalion/Squadron would enter its MMS data using the intelligent terminal for immediate processing; and at the specified time, transmit the data to its respective Division/Wing headquarters.

2. The Division/Wing would collect all processed data from its subordinate units; and at the specified time, transmit the data to the appropriate Satellite Data Processing Installation (SDPI).

3. The SDPI would collect all MMS data from units within its jurisdiction and forward the required data to the central data base via AUTODIN.

Under this process, only purified, error-free MMS data would be passed to the next higher level; and each data base would in turn be updated with the latest, edited, and verified MMS inputs. (Figures 5-1 and 5-3 refer.) Since each echelon level is provided with the capability to manipulate and access MMS data through locally available ADP equipment, there is no need for locally useful information to be forwarded to a central location to be processed and returned. Not only would all data bases be more current under this concept, but there would also be a larger degree of relevancy between headquarters-level information and the "realistic" situation at the reporting unit level.

D. AMPHIBIOUS OR FIELD OPERATIONS

In the deployed environment (aboard ship or in the field) the functional routines associated with Manpower Management System requirements must continue. Under the present operating

concepts these functions are often reduced in scope or performed with such tardiness that they might as well be ruled as non-productive. Contained within this section will be a discussion of concepts for using source data automation in the deployed environment to carry out required MMS functions in a timely, effectual manner.

It must first be emphasized that organic SDA equipment used in garrison would be the same equipment used when transitioning from that environment to the afloat or field environments. One of the basic parameters required of SDA equipment for FMF use is that it be small enough in weight and cube to be easily packaged and transported from one operational environment to another (a fundamental requirement of all organic FMF equipment). Additionally, it must be capable of operation within a full range of environmental conditions which could reasonably be expected to be encountered in a deployed situation. Assuming that these basic conditional parameters are met, SDA systems can be carried onboard ships as troops embark, operated aboard ship according to the needs of the unit, and debarked for use by the unit after deployment ashore. The ease of mobility and modular design associated with current minicomputer/intelligent-terminal systems would cause no special preparation or handling requirements to be entailed for the deployment of such systems to amphibious or field sites. Modularity and compactness would permit easy breakdown and setup of unit SDA equipment for mobility purposes. No SDA devices would

be placed, however, where they would adversely affect the mobility and/or operational capability of combat or minimum-equipment units (i.e., an infantry battalion would not take a SDA device anyplace it would not normally take a typewriter for preparing unit diaries).

Because SDA equipment would be organically assigned down to the Battalion/Squadron level, deploying units would take their own ADP assets when leaving the garrison environment. Those units remaining in garrison would still retain their SDA equipment and the full range of associated capabilities, thereby not affecting their performance of normal MMS functions. Regardless of the deploying unit size, be it a single, reinforced unit or a complete MAU, MAB, or MAF (Marine Amphibious Unit/Brigade/Force), the stand-alone, individual processing capabilities inherent to the organic ADP equipment utilized by such units would enable them to be fully self-supporting. The deployed unit, therefore, could comply with external MMS requirements, and at the same time be responsive to its own internal needs.

The primary concern/constraint to be resolved in the deployed phase concerns the information transmission process which would be utilized under deployment circumstances. Although deployed, the initial data capture and editing processes for MMS information would be conducted by the reporting unit exactly as performed while in garrison. Use of the same equipment and approximately the same procedures as in the garrison environment would improve the chances for

successful operation in the deployed environment. The deployed unit would still benefit from the ability to update, query, and manipulate its own internal, unit-oriented data base. However, transmission of reportable data and/or receipt of externally provided data (MMS updates, reports, query responses, and so on) would be subject to possible communication/transportation constraints. It was verified, however, by recent evaluation testing, that MMS data could be successfully transmitted in field environments via field radio/field wire communication methods [Ref. 12]. To be fully acceptable for FMF use in the deployed environment, SDA systems must also interface and be readily compatible [as specified in Ref. 13] with such devices as:

- AN/TYC-5A Mobile AUTODIN Terminal and the Naval Communications System.
- Shipboard computers such as the AN/UYK-20 aboard the LCC-Class ships and the AN/UYK-7 aboard the LHA-Class ships.
- Naval Communications Systems that provide an AUTODIN entry point.

It would be through the above systems and the Marine Corps' own field communication systems that most direct transmission of MMS data would occur while in a deployed status. There is also the possibility for increased usage of satellite communications as a medium for data transfer in future systems. Such a concept would be an excellent means to guarantee worldwide coverage to deployed units. Assuming, however,

that no satellite communication capability is currently available on a routine basis to deployed Marine Corps units, performance of the MMS functions while in a deployed status would occur as follows:

1. Each reporting unit would enter its own reportable MMS data using the SDA devices collocated at the deployment site.

2. Using the most feasible and direct means of communication, processed MMS data would be transmitted to the next higher supporting echelon (MAU, MAB, MAF headquarters, or parent Division/Wing headquarters), and from that point to the appropriate SDPI via the most appropriate transmission means--most likely via AUTODIN.

3. Use of available telecommunications media would be the primary method of input and receipt of output data in the deployed environment when such methods are feasible.

4. When such a transmission process is not feasible (and as a backup means for information transfer), communication of MMS data would be effected through physical transportation¹² of magnetic storage media (i.e., cassettes or "floppy disks").

The effects of source data automation in the deployed environment would be very similar to those previously listed

¹²Physical transportation of data by cassette or floppy disk is analogous to the present system of MMS paper flow within the FMF. However, a distinct advantage which would be afforded over the present system is the fact that data being transferred would already have been pre-processed and rendered acceptable for system entry. Additionally, in the event of loss/damage during physical transfer, the affected data could be easily duplicated and re-transmitted by the reporting unit.

for garrison operations. The fact that a unit goes into a deployed status does not change the overall capabilities and benefits it would derive from the use of source data automation in performing its MMS functions. And to further emphasize the usefulness of SDA in the deployed environment, it must be restated that SDA devices were proven to be capable of easy transition to, and satisfactory operation within such environments [Ref. 12].

E. OTHER OPERATING CONCEPTS

The previous information within this chapter dealt with the broad spectrum of requirements which source data automation devices must satisfy in order to adequately serve the needs of Fleet Marine Force units within the Marine Corps. Guidelines and operating concepts were proposed for use of source data automation within the FMF to accomplish the principal operating functions required within the Manpower Management System. Operating concepts were presented for both the garrison and deployed environments. Use of SDA to accomplish routine input reporting while in both environments, and the associated advantages/output-benefits to both the garrison and deployed units were examined. This section will focus upon and briefly discuss certain principles of operation to be encountered when bringing source data automation into the Manpower Management System. Advantages, disadvantages, or special relevancy to MMS which these particular concepts may entail will be discussed.

1. Centralization vs. Decentralization

The first principle to be discussed is the question of centralization/decentralization. Which would be the most appropriate method of operation for the proposed SDA concept of MMS operations within the FMF? The present system clearly appears to be a purely-centralized system--with inputs centrally collected, data centrally processed, outputs centrally produced and distributed, and the entire MMS information system centrally controlled. As previously stated, such a system works fine for upper echelon management, but provides little responsiveness/user-information to the reporting unit level.

At one time centralization was largely stressed because of high data processing costs and use of such a procedure gave the advantages of economies of scale, ease of control, and the need for fewer qualified data processing personnel [Ref. 14]. Reduced processing costs, the trend toward distributed processing, and the increased ability for non-data-processing personnel to easily operate remote, intelligent terminal equipment have led toward more use of decentralized operations. The centralized system does not lend itself particularly well to meeting the small, ad hoc, spontaneous, individual computing needs of individual users. From the procedural point of view, centralization has the advantage of efficiency in the processing of large numbers of applications whose schedule is fairly regular and in which the user does not demand fast response. It has the

disadvantage of comparative rigidity in meeting unique, spontaneous needs of small users.

Decentralization, from the point of view of procedures, offers the advantage of more immediate response to user needs, an extension in the applications of computing, and direct user control that promotes interest and motivation. Disadvantages include the potential for duplication of facilities and activities, possible lack of uniformity within the organization and possible increased total data system cost [Ref. 15]. Furthermore, distributing the processing among multiple locations can add greatly to the problems of administrative control of operations. But the rewards of providing a local processing capability at remote sites can more than justify the extra trouble. At first glance, this may seem like a backward step. The economies of scale (the same ideas that led to the development of the super computers) seem to indicate that it would be better to let a central computer do all the processing rather than using distributed processing power around a network. While there may be some truth in this viewpoint about processing power, the question of communication costs begins to enter the picture; and here is where decentralization comes into play.

Reducing the amount of data to be transmitted reduces connect time when a public network is used or increases the number of terminals that can share a line when leased lines are used. Intelligent terminals can potentially reduce transmission volume in two ways which in turn reduces transmission

costs. Editing operations performed by intelligent terminals can streamline the data format. And on-site processing power makes it possible to perform simple tasks locally, thus eliminating the need for transmissions to the computer and back. Furthermore, some of the required data manipulation can be performed by the terminal prior to transmission further lightening the processing load of the central computer [Ref. 16].

A final word on decentralization is a quote from an article concerning the banking business [Ref. 17], but one which also points out strong reasons for some use of decentralization in an automated MMS information system.

"Decentralizing inputs limits errors and puts error correction where it belongs. Decentralizing outputs places information squarely in the hands of the user."

Even though decentralization is strongly implied in the use of intelligent terminals/source data automation to upgrade MMS and make it a more-responsive system within the FMF, neither a pure-decentralized nor pure-centralized system is suggested. Instead, a combination of the two principles is recommended. In order to meet the objectives of high echelon management, centralization should be stressed in the appropriate places such as system development, program/software development, file organization, and personnel training procedures. Decentralization should be used to provide individualized processing in order to reduce data transmission costs, to support local command needs, and to meet the unique demands of reporting units.

2. Stand-alone vs. Shared Processors

Certain benefits are available under either type of system--stand-alone or shared processor--and the degree of adaptability to either system would depend upon the operating environment or constraints under which MMS functions would be performed. Stand-alone devices offer the full capability to perform all data entry and editing functions, in addition to limited data manipulation, inquiry, and retrieval functions. Their main limiting factor is the degree of size-tradeoff found to be acceptable. In other words, the larger the software package, storage area, or functional capability desired, the larger the stand-alone device must be to provide these capabilities.

Shared processor systems offer the advantage of greater computer power--which can support multiple CRT terminals linked to a central control unit via software-supported telecommunications media. Greater processing power and larger software-support provide increased functional capabilities to individual terminals when compared to the stand-alone systems. Such systems would offer distinct advantages while in the garrison environment, but may not be practicable for units in hostile environments where mobility is desired and/or communication lines are lacking.

Like the centralization/decentralization issue, the optimum solution for this issue would probably be to use a mixture of stand-alone devices and shared processor systems. Stand-alone devices would enable a unit deployed to forward

areas to perform necessary data entry and information processing functions, and yet be small enough so as not to hamper the unit's mobility in the field. Such devices could be used by lower echelon units in forward combat areas, with data transfer being accomplished by manual passing of cassette, diskette, or other similar type storage medium. Once communication lines could be established, the device should then be capable of data transfer via field telephone, field radio, or direct wire to a central processing site.

In the garrison environment, the shared processor system has particular advantages over stand-alone devices due to its greater processing capability, and ability to accept data from numerous sources. Functional users of this type system have the ability to interact with a larger data base to satisfy their individual information requirements. Additionally, the central control unit of a shared processor system can be used at higher command levels to collect MMS data from subordinate units and perform large-scale processing functions relating to information needs pertaining to the entire command. Given the appropriate communications interfaces and input/output devices, the shared processor system would additionally be capable of accepting inputs from remote stand-alone terminals on either a demand access basis or via cassette, "floppy disk," or other appropriate medium.

3. Telecommunications Technology

Assuming that the questions on information requirements within MMS--what type of information, how much

information, when is it required, from where does it come, and to whom does it go--have been aired and resolved, the next characteristic of importance to establish is data flow--or more specifically, how to achieve faster data flow. If an intelligent terminal system is to provide a greater responsiveness and higher degree of individualized service to the lower echelons within the FMF (with respect to MMS support), then one of the keys to success for such an improvement lies in the telecommunications media to be utilized. The ability to provide accurate, timely, and uninterrupted quantities of data flow over established communication networks will give an intelligent terminal system the impact it needs to become a powerful management tool within MMS. Only through timely data communications can the effective interchange of information between an ADP system and its users be facilitated.

Currently, the electronic communication of MMS data is restricted to telephone networks (which weren't designed for data transmission in the first place) and AUTODIN. Even then it only occurs between the SDPI and higher level commands. The introduction of the AN/TYC-5A Data Communications Terminal in FY-77 was the first significant improvement in the area of data communications within the FMF. This equipment provides a medium speed (1200-2400 bps), multimode, mobile AUTODIN terminal capability to each major headquarters in the FMF [Ref. 2]. For FMF purposes, the ability to support mobile activity is of primary importance for all functions (including MMS); and as such, the use of radio transmission

(vice wire) has proved particularly attractive as a means for data transfer. For this reason, a wide variety of mobile radio equipment is already in use within the FMF and additional equipment is being developed or planned. Improved man-packable, team-packable, and truck-mobile units are being developed for future operational use. Development of these improved communication systems should be interfaced with concurrent development of source data automation systems within the FMF to provide for an increased flexibility and capability for information transfer.

For future planning purposes when ADP systems may become available to all commands as low as the Battalion/Squadron level, the development of a responsive telecommunications system to support such ADP systems requires early identification of potential users and system communications requirements. Such requirements should include consideration of such items as system capacity, terminal locations, speed of service, area of coverage, communities of interest, and security requirements (where applicable).

Some telecommunications technologies in use today could be applied to the scheme of an intelligent terminal system for MMS functions within the FMF, and provide the means of effective data transfer. One such system is the Advanced Research Projects Agency Network (ARPANET) operated by the Defense Communications Agency. The ARPANET provides a capability for geographically separated computers, called Hosts, to communicate with each other. The Host computers

typically differ from one another in type, speed, word length, operating system, and so on. Each Host computer is connected into the network through a small local computer called an Interface Message Processor (IMP). The complete network is formed by interconnecting these IMPs, all of which are virtually identical, through wideband communications lines supplied by the telephone company. Each IMP is programmed to store and forward messages to the neighboring IMPs in the network. During a typical operation, a Host passes a message to its local IMP; the first few bits of this message include the "network address" of a destination Host. The message is passed from IMP to IMP until it finally arrives at the destination IMP, which in turn passes it along to the destination Host [Ref. 18]. A similar technique or slightly modified method could be used for transfer of MMS data between geographically separated units/commands. In fact, a system to accommodate Marine Corps needs would probably require a less complicated system of interface IMPs than the present ARPA-NET system.

Other telecommunications technology programs are being designed and developed within the Department of Defense for operational use in the 1980's. Their advancements, once fully developed, may also impact upon or be applied to future data transfer concepts to be used in Marine Corps information systems. One such system being developed by the Defense Communications Agency to provide a worldwide, general purpose, data communications network is AUTODIN II. AUTODIN II is

designed to provide economical and reliable data communications service both for interactive timesharing and transaction-oriented systems requiring rapid response between terminals and computers; and for remote job entry and computer-to-computer data transfers requiring high transmission capacity. AUTODIN II is based on the technology of packet-switching. Packet-switching is rapidly gaining world-wide recognition as the most effective means of providing switching data service to computer users. Public packet-switching networks are already operating or under implementation in several major countries, including the U.S., Canada, Britain, and France [Ref. 2].

The principal motive underlying the development of AUTODIN II was to provide a convenient and economic method for making ADP resources more responsive to user needs. A similar requirement (of making ADP resources more responsive to FMF user needs) exists within the current MMS framework as discussed throughout this thesis. Therefore, the approaching availability of AUTODIN II will certainly help to meet this requirement.

A final note concerns Marine Corps development of telecommunications media to be used in support of deployed FMF units. In order to provide this capability for support of deployed ADP systems, the Landing Force Integrated Communications System (LFICS) is being developed in coordination with the Joint Tactical Communications Office and the Navy Communications system. LFICS is a basic systems communications

plan for the integrated Marine Air-Ground Task Force; and is meant to guide the future development of interoperable tactical data systems and communications equipment over the next fifteen years [Ref. 19]. As such, LFICS will have an impact upon data transfer technology for MMS or any other information systems which continue to operate in the deployed environment.

The main point to be made with regard to telecommunications is the fact that new, improved data transfer methods are either in current development or on the horizon. And as such, they should help to facilitate the Marine Corps' ability to convert present manually-oriented, non-user-related information systems, such as MMS, into updated, fully-automated, user-oriented systems.

F. ISSUES TO BE RESOLVED

The use of source data automation equipment within the FMF will not bring a complete panacea to the current inadequacies of the Manpower Management System. There still remain certain prominent issues to be resolved before the use of source data automation can be viewed as an optimized system, fully capable of meeting all the requirements desired of a model system. Although not discussed at great length, some of those areas which require further investigation and refinement prior to complete implementation of an optimum input/output reporting system are examined below. Each area could potentially be the subject of further investigation and more extensive discussion in future research projects.

1. Data Base Security

The first issue of concern is the area of security-- data base security and physical hardware security. Because of the increased query and data manipulation capabilities which would become available to more organizations under the SDA concept, protective measures against sabotage of the contents of data bases (whether advertently or inadvertently) must be designed into the system. Additionally, the data base will be subject to legal requirements, such as those required by the Privacy Act, concerning how certain information should be protected and released to users. The ways and means of meeting the security requirements imposed by the Privacy Act, and those measures needed to protect the data base against accidental or intentional destruction are certainly significant issues to be dealt with.

While some of this control may be implemented through hardware and software procedures, a significant portion of the security should be provided by procedures having to do with authorization of access, identification of users, documentation of information use, and so on. For example, a basic start for providing data base security begins with proper operator identification. This may be accomplished through the use of such measures as using a validity check of an identification number, or using a password before a terminal operator can gain access to specific programs and/or data base files. These are only two, from a number of possible procedural methods, which can be devised to promote adequate data base security.

2. Hardware Security

In addition to data base security, procedures must also be devised to provide for the protection of (and unauthorized access to) the physical system hardware, data files, programs, and so on, contained within each unit. Due to the value of ADP assets (in comparison to MMS assets presently found at the reporting unit level), appropriate security measures for their physical protection must be emphasized. System and data security is not just a conceptual issue--it is a practical problem because the consequences of inadequate security can be serious. The following measures have been suggested as minimum requirements for establishing security of computer-based information systems [Ref. 20].

- Terminal access security
- Data access security
- Special fire and theft provisions
- Off-premises backup for files and programs
- Provision for backup processing
- Internal and external audit capability

These same procedures would apply to the Manpower Management System with respect to security requirements needed to protect this information system in an automated environment.

3. Audit Procedures

With respect to internal and external audit capability, the provision of adequate audit-trail procedures is another issue requiring further definition/refinement. Internal auditing controls and system evaluation by external

auditors is especially difficult in the case of on-line or "real-time" ADP systems since the amount of hardcopy input and output source documentation is substantially reduced [Ref. 21]. However, an adequate audit trail is necessary to enable management to effectively direct and control operations, to permit file reconstruction in the event of processing errors, and to accommodate the requirements laid down by governmental agencies with overseeing powers.

One particular auditing factor within the Manpower Management System which must be resolved concerns the present requirement that an authorizing signature be affixed to input data submitted for the purpose of changing an individual's pay. Under the present system, either the unit commander or an officer designated by him, must sign the unit diary (as an authorizing officer) if it contains any input entries affecting pay data for a member of his unit. The means by which this authorizing signature can be established electronically via intelligent terminal inputs is a matter of importance to be resolved.

4. Hostile Environment Security

Another data security issue to be resolved concerns the possible requirement for encryption of data at its source prior to transmission and decoding of it upon receipt at its end point. Although MMS data is not normally of a classified nature, operations within a hostile environment may dictate that such procedures be used. Therefore, the capability to pass or receive MMS data in a classified format via various

telecommunications media is a desirable feature. Yet no specific tests as to the capability to exercise this option were conducted in the previous evaluation of SDA equipment by FMF units. The security (where required) of data being transmitted in hostile environments will be an issue to be resolved, as well as the security of the interfaces themselves. Relative to this issue is the fact that DOD is moving toward a totally secure ADP/communications environment [Ref. 9]. Should the Marine Corps field a non-TEMPEST-approved deployable ADP system to be used in all environments, the possibility exists that the National Security Agency could ban non-TEMPEST configured systems from combat zones.

A further issue requiring additional investigation concerns the development of procedures related to the possible capture of ADP equipment by enemy forces while in a combat environment. Such capture would provide the enemy with valuable data files or with access to the FMF ADP system. Future automated system design should include procedures for minimizing the vulnerability of files and equipment while operating in an objective area, as well as procedures that would deny the enemy use of ADP resources should they fall into his hands. This is a new problem because only recently has the ADP technology provided equipment that could follow troops into the field. There appears to be no easy solution to this issue.

5. Backup Procedures

A final issue to be resolved with respect to SDA implementation within the FMF concerns the requirement for backup capability. Providing a backup capability to an automated system could be a costly process--depending on whether automated or manual backup is used. Among such procedures should be provisions for shifting loads to alternative processors/computers; creating, storing, and protecting redundant copies of data storage media; initiation of checkpoint-restart operations; and so on.

Since units will continue to have typewriters, it is reasonable to assume that in the case of system failure or "downtimes" of long duration, records/transactions could be typed and sent by courier to another unit or echelon still possessing automated support.¹³ There is a natural trend today, however, toward shifting the burden of backup from non-automated to automated means [Ref. 15]. As systems become more highly organized, the system itself can often handle backup activities more efficiently than can a human through manual intervention. However, in any given situation there are usually some types of backup provisions that are best implemented by manual procedures. Fully-automated backup may be a possibility, but if so, the associated costs for redundancy of processing and/or duplication of data bases

¹³The backup capability using this procedure would be much the same as the primary method for passing MMS data within the sub-SDPI environment under the current system.

must be considered. Regardless of the method chosen, provision for a backup capability should be established prior to beginning total automation of MMS functions.

VI. CONCLUSION

As discussed throughout the preceding chapters, source data automation (SDA) is an approach to making management information systems more accurate, more timely, and more responsive to the information system user. In addition, source data automation offers a substantial potential to reduce the amount of current recordkeeping, redundant data entry, and data maintenance requirements associated with the Manpower Management System (MMS). Source data automation also provides a potential for reducing the number of administrative and technical personnel presently required to accomplish the manual MMS recordkeeping functions. Finally, by providing the reporting echelon with the capability to capture information at its source, SDA makes it possible to reduce the present burden of data input requirements imposed by higher headquarters; and at the same time provide reporting units with the means for retrieving information in a timely fashion to meet their local needs. This final chapter will summarize and discuss these and other benefits which source data automation should bring to Fleet Marine Force (FMF) units. Particular emphasis in this final chapter will be directed toward the following areas:

- Increased capability and readiness within the FMF through SDA.
- Cost of SDA implementation.
- Change in administrative personnel requirements.

- Application of SDA to other information systems.
- Future technological concepts and related applications.

A. INCREASED CAPABILITY AND READINESS

There appear to be no major technical obstacles to the introduction of an intelligent terminal input/output reporting system within the FMF to upgrade the Manpower Management System. The capabilities needed to meet present Manpower Management System requirements are available within the current state-of-the-art. Present technology is producing equipment having increased computer power on one hand, and decreased size, weight, and volume on the other. Such advancements lend themselves to meeting the requirements of today's FMF information needs--maximum information processing provided by minimum physical equipment is certainly compatible with the mission and mobility requirements of FMF units.

Developing technology emphasizes modularity of design, where computer automation devices can be specifically tailored to the needs of the organizational element to which they belong [Ref. 15] -- once again, a well-suited design for meeting FMF requirements. It is presently possible to procure off-the-shelf, an intelligent terminal with stand-alone microcomputer capability that weighs less than thirty pounds. Additional memory can be added in the form of portable cassette recorders weighing less than ten pounds. If hard-copy output is a requirement, matrix printers approximately the size of portable electric typewriters, producing 125 lines per minute, and weighing less than twenty pounds are

available. Solid state technology, non-rotating and non-volatile memories, non-impact printers, and modems on a chip are all part of the developing technology which should offer substantial improvements in reliability, availability, and communications coupling of intelligent terminal systems. These developments should also help to reduce the cost and compatibility problems of SDA equipment which may eventually be used by FMF units in both garrison and deployed modes.

What does all this mean to the FMF and its related capabilities with respect to the Marine Corps' Manpower Management System? Source data automation (or the use of intelligent terminals for input/output functions) could provide individual units within the FMF with an improved means of system support and reference data--which in turn, could increase the unit commander's ability to make timely, accurate and productive decisions with respect to management of personnel within his unit. At the same time, an accurate presentation of the "big picture" with respect to the current status of FMF manpower resources would be projected to higher headquarters at all command echelons for their review/evaluation. This would provide the opportunity at the appropriate levels to undertake timely corrective action (when needed) to improve "weak links" in the manpower portion of the FMF readiness posture. More importantly, because of the near "real-time" flow of information within such a system, redundancy and unnecessary personnel management actions would be reduced and/or eliminated. Only those actions deemed necessary and/or productive

would need to be taken. Thus, increased efficiency and an increased overall readiness posture within the FMF (and the Marine Corps) can be effected as a result of upgrading MMS with source data automation.

B. COST OF IMPLEMENTATION

An automated management information system is justified to the degree that it can provide more accurate and timely information (hopefully at a lower cost) than the alternative of a manual or semi-automated system. Such a system must be economically justified, yet no mention has been made thus far on costs incurred when implementing an automated MMS. Perhaps the most important question for the Marine Corps to ask with regard to the introduction of source data automation into the FMF is: How much is such a system going to cost? Such a question is not easy to answer within the scope of this thesis--a complete estimate of costs is difficult for several reasons. First, there is the everchanging price spectrum (mostly in a downward direction) common to the ADP field. According to professional computer system reference guides,¹⁴ there is currently a large number of vendors in both hardware and software products; a vast number of dealers specializing in just peripherals; and a variety of lease, purchase, maintenance, and discount plans available in the ADP market. Furthermore, with increased competition, new innovations, and more data processing products on the horizon, costs will probably continue their downward trend--making the use of

¹⁴Auerbach and Datapro.

intelligent terminal systems and distributed processing even more economically attractive as a means of information processing and transfer.

Illustrating the above noted trends are Figures 6-1 through 6-6 which provide a comparison of mid-1970 prices and performance characteristics for various ADP systems/technologies to the projected costs and performance factors for similar systems in mid-1980. Reference 22 provides the source for the trends projected in Figures 6-1 through 6-6; and all figures are based on constant dollars with no allowance made for inflation. Yet, as can be seen in the data projections, costs will be declining in this period while performance levels will be increasing--causing price-to-performance ratios to continually decrease through the mid-1980's. A rather simplistic inference from the entire forecast is that, by 1985, the same performance levels available in mid-1970 will cost about one-tenth the price required in that era to achieve those performance levels. Not only will performance levels increase relative to prices, but by 1985, ADP data transmission traffic is expected to increase by twenty times the 1975 rate, along with a similar cost reduction. Figure 6-7, also from reference 22, depicts the overall trend forecast for data transmission line costs through 1985 at three standard speeds. An average reduction of 50% is expected for line costs projected through that period.

Those same patterns of projected cost decreases may not necessarily apply in equal proportion, however, with respect

CHARACTERISTICS AND EVOLUTION OF PROCESSORS

	1977	1985
<u>Microcomputer</u>		
Main memory capacity	4-8 KB	32-64 KB
Auxiliary storage	300 KB	500 KB
Processor cost	\$1,000 - 2,000	\$ 300 - 500
<u>Minicomputer</u>		
Main memory capacity	32-156 KB	500-1,000 KB
Auxiliary storage	1-8 MB	4-30 MB
Processor cost	\$10,000 - 20,000	\$10,000 - 25,000
<u>General Purpose Computer</u>		
Main memory capacity	0.5-16 MB	2-64 MB
Auxiliary storage	10-200 MB	30-500 MB
Processor cost	\$150,000 - 2,500,000	\$75,000 - 2,000,000

KB - Thousand Bytes
MB - Million Bytes

Source: DATAMATION, January 1975

FIGURE 6-1

AUXILIARY STORAGE TECHNOLOGY PERFORMANCE CHARACTERISTICS

	Storage Capacity (bits/unit)	Access Time (sec)	Cost/Bit (cents)
<u>1974 Technologies</u>			
High Speed/Low Capacity	$10^7 - 10^8$	$10^{-5} - 10^{-2}$	0.1 - 2.0
Moderate Speed/Moderate Capacity	$10^8 - 10^9$	$10^{-1} - 10^{-2}$	$10^{-3} - 10^{-2}$
Low Speed/High Capacity	$10^{11} - 10^{12}$	1.0 - 10	$10^{-5} - 10^{-4}$
<u>1985 Technologies</u>			
High Speed/Moderate Capacity	$10^8 - 10^9$	$10^{-7} - 10^{-5}$	0.01 - 0.1
Moderate Speed/Very High Capacity	$10^9 - 10^{14}$	$10^{-5} - 10^{-1}$	10^{-6}

Source: DATAMATION, January 1975

FIGURE 6-2

AUXILIARY STORAGE MODULE COST/PERFORMANCE FORECASTS

	1974	1985
<u>Microprocessor Auxiliary Storage</u>		
Capacity	1 million bytes	5 million bytes
Medium	small fixed disk	semiconductor, CCD
Access Time	10 msec	10 usec
Cost	\$ 2,500 - 3,500	\$ 1,500 - 2,500
<u>Minicomputer Auxiliary Storage</u>		
Capacity	20 million bytes	50 million bytes
Medium	small removable disk	bubble memory
Access Time	30 msec	100 usec
Cost	\$ 25,000 - 35,000	\$ 15,000 - 25,000
<u>Multiprocessor Auxiliary Storage</u>		
Capacity	2 billion bytes	5 billion bytes
Medium	multiple disk unit	multiple disks
Access Time	25 msec	20 msec
Cost	\$180,000 - 220,000	\$ 90,000 - 130,000

Source: DATAMATION,
January 1975

msec - millisecond
usec - microsecond
CCD - charged-coupled
device

FIGURE 6-3

MAGNETIC TAPE COST/PERFORMANCE FORECAST

	1974	1985
<u>Low Performance</u>		
Data Rate	40,000 bytes/sec	40,000 bytes/sec
Cost	\$ 10,000	\$ 6,500 - 7,500
<u>Medium Performance</u>		
Data Rate	600,000 bytes/sec	1.2 million bytes/sec
Cost	\$ 75,000	\$ 25,000 - 40,000
<u>High Performance</u>		
Data Rate	7.5 million bytes/sec	15 million bytes/sec
Cost	\$ 220,000	\$ 80,000 - 120,000

FIGURE 6-4

COST FORECAST FOR TRANSACTION TERMINAL STATIONS

	1977	1985
<u>Basic Terminal</u>		
Keyboard/Teleprinter	\$ 700 - 2,500	\$ 600 - 2,000
Keyboard/CRT Display	\$ 900 - 3,000	\$ 700 - 1,500
<u>Intelligent Terminal</u>		
Keyboard/Teletinter	\$ 4,000 - 9,000	\$ 2,000 - 2,500
Keyboard/CRT Display	\$ 4,000 - 8,000	\$ 2,000 - 2,500

FIGURE 6-5

Source: DATAMATION, January 1975

COST FORECAST FOR COMMUNICATIONS CONTROLLERS

	1974	1985
<u>Large Systems</u>		
2 CPU's* & 128K memory	\$ 80,000	\$ 15,000
100 megabyte disk	55,000	10,000
Line adapters (100)	45,000	10,000
Host interface	<u>12,000</u>	<u>2,500</u>
Total	\$192,000	\$ 37,500
<u>Intermediate Systems</u>		
*CPU & 16K memory	\$ 12,000	\$ 3,000
2 megabyte disk	5,000	100
Line adapters (20)	6,000	1,500
Host interface	<u>8,000</u>	<u>2,000</u>
Total	\$ 31,000	\$ 6,600

* Processors include teleprinter control, power supply system, power fail/auto restart, memory protection, and similiar features.

Source: DATAMATION, January 1975

FIGURE 6-6

DATA TRANSMISSION LINE COSTS

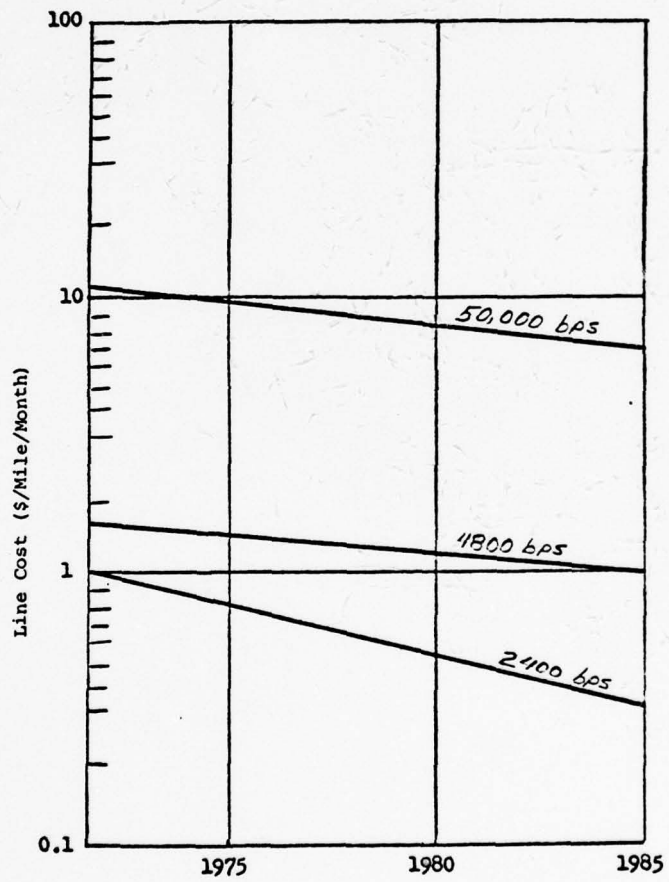

Source: DATAMATION, January 1975

FIGURE 6-7

to software-support costs. Even though software-support costs have historically paralleled hardware development with respect to cost reductions over the long run, software costs are the hardest to estimate and tend to grow out of proportion unless very well managed. In fact with the introduction of a new system, software costs often tend to rise over the short run. The need for increased software support may become a necessary reality upon implementation of source data automation down to the Battalion/Squadron level within the FMF. An increase in the required software support may very well become a costing factor in future FMF intelligent terminal systems, and may downplay the benefits acquired through increased performance levels gained as a result of such systems. For example, increased production capability resulting from increased automation, is often accompanied by an increase in system software support required to sustain that automation. The same may hold true for certain personnel support requirements. While low-echelon personnel requirements may be lessened to a large degree because of SDA, certain mid or high-level supporting-echelon personnel requirements may actually be increased in order to provide the extra software or maintenance support needed to operate the overall system. This is not to say, however, that support costs (software and personnel) will outweigh the benefits gained through the use of SDA concepts--only that the incurrence of such extra support costs as these may be needed to properly sustain a SDA system, and that they would most likely reduce the scope of maximum benefits possible.

Another problem associated with ADP implementation costs is the unpredictability of certain new start-up costs involved with SDA. For example, consider the requirements of the recent 1974 Privacy Act as it applies to ADP systems. The Privacy Act imposes stringent demands upon all Federal agencies with respect to the acquisition, management, and utilization of ADP systems. As a consequence, the process of selecting system design options through cost-benefit analyses will take on added significance for Marine Corps planners. Because certain system performance parameters have been prescribed by the Privacy Act, the future development or acquisition of heretofore commonplace or relatively inexpensive ADP applications may be restricted to just those systems which meet compliance standards. Within this regulation (Public Law 93-579) can be seen the first sign of ADP system performance specifications prescribed, albeit indirectly, by law. Although the exact means of implementing and administering these laws has not yet been determined, inasmuch as a large amount of personal data is currently, and will continue to be, maintained in automated systems (especially true of MMS), the impact of such laws on ADP systems will be significant.

The main point to be stressed in the above discussion is that costs such as those involved for ensuring conformance to Privacy Act procedures or any other similar regulatory constraints, must be taken into account in determining total implementation costs for a new Marine Corps ADP system. Such

costs are not always easily identifiable. Another example of an unpredictable cost that may eventually enter into the ADP system procurement picture, is the imminent possibility of a Defense Communications Agency directive--requiring that all future ADP data transmission media be capable of handling data in an encrypted format. Other varied implementation costs will be a function of such things as the hierarchy of ADP equipment purchased (or leased); the total number of terminals/printers/minicomputers, and so on, placed within major commands of the FMF; the capabilities of the systems chosen; and of course, the price levels and maintenance/support agreements accepted at the time of contract negotiation. While a determination of total implementation costs is not pursued further within this chapter, an area of possible savings that might be realized as a result of SDA implementation within the FMF will be discussed in the following section. This savings applies to the future potential to cut back certain administrative personnel requirements.

C. CHANGE IN ADMINISTRATIVE PERSONNEL REQUIREMENTS

One of the primary benefits of source data automation discussed in Section IV is the ability, under such a system, to reduce or eliminate the amount of manhours needed to accomplish certain areas of administrative paperwork and redundant information processing. One of the main problems with the current MMS information system is the number of personnel needed to perform comparatively low-level data manipulation functions, and the many manhours used by both

data-processing and non-data-processing personnel to accomplish these activities. Such excessive administrative processing involves procedures dealing with input data preparation, data transfer processes, feedback and reconciliation processes, error-control measures, and so on, as discussed in Section III. Thus, it could be theorized that if this excessive MMS administrative workload could be reduced/eliminated, then so could the administrative personnel manhours and manpower assets that are currently devoted to pursuing it. In other words, a reduction in the present administrative personnel manpower requirements would be a direct benefit accruing from the introduction of intelligent terminals and source data automation into MMS. An exact amount of annual dollar savings realized from such a benefit would basically depend upon what grades, and how many, Occupational Field 01 (Administrative Personnel specialists) billets could be eliminated from the Table of Organization (T/O) allowances for FMF units and supporting organizations. Although no specific dollar amount is forecast, the following paragraphs will provide an idea, however, of the most likely areas and magnitude of reductions that could be possible if SDA were to be adopted within the FMF.

First and most likely choices for personnel cutbacks, are the Administrative Control Units (ACU's). They currently perform the same functions at their activity that would be accomplished at the reporting unit level under the SDA concept. As the name implies, this organization's principal responsibility

is to receive unit diaries from reporting units, screen and control all input data prior to its automated processing at the SDPI, and then perform the same functions in reverse for processed output data. Upon implementation of source data automation, no such requirements would exist, or at most, would be minimal compared to the present system. Since all input data received at the SDPI under the proposed system would have been screened and preprocessed at the reporting unit and/or its parent headquarters; and since all data transfer both up and down the reporting chain would be controlled electronically (Section V), current ACU responsibilities would disappear.

ACU T/O billets could therefore be dropped, or if required, their personnel reassigned to other commands. An illustration of the number of possible billet reductions involved can be seen using the Administrative Control Unit located at Camp Pendleton, California. This ACU has a Table of Organization calling for twelve Occupational Field 01 (OF-01) personnel.¹⁵ They range in rank and quantity as shown below:

<u>Rank</u>	<u>MOS</u>	<u>Qty</u>	<u>Rank</u>	<u>MOS</u>	<u>Qty</u>
O-3	0170	1	E-5	0182	2
E-8	0193	1	E-4	0131	2
E-7	0193	1	E-3	0131	2
E-6	0182	2	E-2	0131	1

Assuming that all seven of the Marine Corps' ACU's (Section II) are comparatively equal with respect to personnel

¹⁵ Marine Corps T/O No. 2630.

requirements, and that all seven could equally afford to reduce their OF-01 billets, such a reduction would add up to quite a large annual savings in salaries, operations, and maintenance costs. (Salary savings, of course, would actually be a function of "time-in grade and rank" pay rates in effect for those personnel filling ACU billets at the time of billet elimination.)

The above personnel reductions would actually come from within the supporting establishment rather than from among FMF manpower assets. There are additional administrative personnel within the FMF who would also fall within the category of "potential personnel reductions" as a result of SDA. Take, for example, the Third Marine Aircraft Wing located at MCAS El Toro, California. This Aircraft Wing is composed of fixed-wing fighter, attack, and transport squadrons; attack and transport helicopter squadrons; HAWK missile battalions; and other units performing various training and support roles. Each of the individual units within this Wing rate a specified number of administrative personnel to carry out the administrative responsibilities required of the unit--including all unit-related MMS functions. The Wing is provided a "personnel staffing goal" from Headquarters Marine Corps for each occupational specialty required within the Wing--the staffing goal authorizing the Wing its fair share of total Marine Corps assets in those occupational fields. Personnel are then assigned to the Wing by Headquarters Marine Corps to meet the given staffing goals. Based

on the given staffing goal, Wing headquarters assigns (on a fair share basis) Occupational Field 01 personnel to each of the individual units and supporting staffs within the Wing to meet the T/O requirements for 01's in these activities. As of 1 March 1978, for instance, the Third Marine Aircraft Wing's staffing goal [Ref. 23] and rank structure for enlisted administrative personnel (OF-01) existed as follows:

<u>Rank</u>	<u>Total Authorized</u>
E-1 to E-4	265
E-5	56
E-6 to E-9	59
	<hr/>
	380 Total

The above figures provide a basic perception of the magnitude of administrative personnel assets belonging to just one Marine Aircraft Wing. With this background in mind, and coupled with the discussion presented in Section IV on the potential ability of SDA concepts to significantly reduce current workload requirements associated with MMS, the following assessment is made concerning personnel reductions. Based on a conservative estimate, this writer proposes that, upon implementation of SDA, at least a 10% Wing-wide reduction in administrative manpower requirements could be accomplished. Furthermore, because of SDA-related improvements/benefits, such a reduction could be effected without decreasing the Wing's capacity to fully execute or comply with all MMS functional requirements.

The potential manhours saved, for instance, with regard to just the present efforts required for reconciliation of Unit Transaction Registers alone (or the error/correction/resubmission procedures involved in this process) would amount to at least a ten percent work reduction. However, to be conservative, assume that a ten percent reduction with respect to administrative personnel requirements within the Third Marine Aircraft Wing could be effected, and that thirty-eight billets could be eliminated. Only thirty-eight personnel may seem to be an insignificant reduction for one Marine Aircraft Wing, but aggregated over the entire FMF (composed of three Aircraft Wings and three Divisions), such a personnel reduction would be substantial. Within the air element alone, over 100 T/O billets for administrative personnel could be eliminated. The ground components within the FMF (the Divisions) have an even larger manpower size and consequently offer an even greater opportunity for personnel cuts within the administrative field.

Thus, assuming a conservative ten percent manpower reduction in administrative billets, aggregated over the magnitude as discussed above, the potential annual savings that could be realized Marine Corps wide would be significant. Since manpower costs have traditionally consumed a large portion of the total Defense budget, and can be expected to continue their historical growth pattern, the proper use of feasible personnel reductions (or other similar measures which can reduce growing expenses) can provide a positive means to

ensure maximum utility of available resources. In addition, consider what further personnel reductions and dollar savings might eventually be realized in the event that SDA concepts were to be applied to various other management information systems used within the FMF. This added potential to reduce manhours and personnel requirements currently used in producing MIS's for other functional areas within the FMF is certainly a realistic one.

D. APPLICATION TO OTHER INFORMATION SYSTEMS

Not only would the Manpower Management System benefit from the use of SDA, but other common Marine Corps information systems providing data in the areas of operations/training, logistics, maintenance, intelligence, and so on, could probably be improved upon using SDA concepts. Source data automation applied to information systems within these other areas would offer the same attractive advantages in the way of responsiveness, accuracy, timeliness, and so on, as previously discussed for MMS. Assuming that such common Marine Corps information systems as FREDS (Flight Readiness Evaluation Data System), MEDS (Mechanized Embarkation Data System), MIMMS (Marine Corps Integrated Maintenance Management System), MARES (Marine Automated Readiness Evaluation System), and others such as those previously evaluated for SDA compatibility (Section IV) could equally benefit from intelligent terminal applications, then undoubtedly SDA concepts would eventually be applied to all. Such an application would raise some unanswered questions, however, dealing with such issues as how

much terminal/processing/storage capacity would various echelons require; would timesharing of the same system be feasible and which management information systems would have usage priority in a timesharing system; could a common data base be developed for all systems or would a separate data base be required for each MIS? Additional questions such as how accountable costs would be allocated between different functional areas/MIS's--by processing time used, by storage area required, etc.--would also be raised. The problems and solutions involved with each of the above issues would provide suitable subject matter for further research in the area of SDA applications to multiple or integrated information systems. Regardless of the conceptual issues to be resolved, the important point to make is that source data automation offers an improved means by which to upgrade any MIS, whether within the personnel management business, the operational readiness business, or the maintenance support business. If successfully implemented in one area of the FMF, SDA should be considered for implementation in other appropriately receptive systems.

There is another area of importance with respect to the Manpower Management System and its integration with other management information systems. In some functions, information is extracted from the MMS data base to support certain personnel-related information systems used exclusively at the Headquarters Marine Corps (HQMC) level. Data used in support of these headquarters-level management control systems is taken

from the MMS data base on a recurring basis. For instance, the following management control systems/models used at the HQMC level are currently using information extracted from the MMS data base as input data for their own needs.

- Enlisted Staffing Goal Model - The Enlisted Staffing Goal Model is a computer-based system which provides numerical staffing goals for HQMC manpower managers to place people-to-fill-jobs into jobs-to-be-filled. The Staffing Goal Model is run monthly using latest MMS data on the distribution, grades, and skills of the inventory of Marines.
- Enlisted Assignment Model - The Enlisted Assignment Model is a computer-based model designed to identify billet vacancies on a world-wide basis and to determine the "best" Marine to fill the vacancy. Indirectly, the model identifies billets which cannot be filled because of shortages in grades and skills, or because of various policies which result in rendering personnel ineligible for transfer. The model is applied only to the careerist structure (Sergeant and above). The Enlisted Assignment Model runs twice monthly and is based upon personnel data provided from the MMS central data base. The first cycle run during the month is the "Overseas" cycle and recommends personnel for assignment to all overseas commands. The second cycle, known as the "CONUS" cycle, recommends assignments to CONUS for overseas personnel who are about to have expiring Rotation-Tour-Dates. This cycle also includes CONUS to CONUS assignments.

● Recruit Distribution Model - The Recruit Distribution Model is a computer based model designed to optimize utilization of Marines upon graduation from recruit training. During the first week of each month, information essential to the assignment process is extracted on each recruit scheduled to graduate during the following month and forwarded to HQMC.¹⁶ The Recruit Distribution Model matches the assignment data from the recruit depots with the prerequisites for each job category (formal school) for which training quotas have been established. This model attempts to fill all quotas by assigning the highest quality recruit to each quota, assigning each recruit to the job category for which he is best qualified, and equally distributing minorities among all quotas for which they are qualified.

In addition to the above management control systems, an Officer Staffing Goal Model is currently in the developmental stage, and an Officer Assignment Model is in the conceptual phase of development [Refs. 2 and 15]. These models applying to the officer structure of the Marine Corps will also be using as input data, information extracted from the MMS data base. As can be seen from this discussion, MMS is not a totally independent information system, but integrated to some extent with other personnel-oriented management/control systems.

¹⁶Information is extracted from the MMS subsystem of RAMS--Recruit Accession Management System (see Section III).

Therefore , the importance of accuracy within the MMS data base and the use of systematic, timely update procedures, add to the emphasis placed by this thesis on the advantages and value of source data automation. Inputs and updates from the field must be accurate and must be timely so that decisions made by managers at the headquarters level are based upon realistic data base information. The use of such a system leads to both efficient and effective manpower management. Once again, it is source data automation which provides the means to better achieve this goal.

E. FUTURE CONCEPTS AND APPLICATIONS

As presented in Section IV, the present state of technology with respect to display terminals is fast undergoing a complete transition with respect to transaction processing capabilities. No longer does the remote CRT terminal require access to a large computer for updating, no longer does it require a controller with buffer memory for refreshing the display at rates up to thirty times a second. Instead, display terminals, with internal microprocessors and stand-alone capability, are emerging to provide improved display versatility and resolution at reduced costs [Ref. 15]. In fact, all areas of ADP system technology are continuing to undergo refinements with respect to reduced costs, increased reliability, improved ruggedness, and decreased maintenance requirements.

This final section will review the extent of research and development efforts that are currently being made in the ADP

field. Such developments may eventually be applied to present MMS requirements, or quite possibly even change the current MMS concepts altogether. For instance, in the early 1980's, CRT displays are expected to be strongly challenged by some form of flat display surfaces employing solid state technologies. Such surfaces may include plasma displays, liquid-crystal displays, and ferro-electric displays. These technologies, which are now in the laboratory and in limited production, offer the long awaited breakthrough in flat-panel television and data display terminals. They promise to be smaller, weigh less, and be more rugged and reliable than today's CRT displays--all desirable qualities needed in FMF ADP systems.

Current keyboards are electromechanical in nature and have relatively low reliability in comparison to solid state technology. Solid state keyboards without moving parts are undergoing development and becoming available; these promise improved reliability. It is projected that solid state keyboards will be in use in the 1980's. They will reduce maintenance and be relatively insensitive to the adverse environments associated with FMF operations.

Non-impact printing techniques such as ink-jet, thermal, electrostatic, xerographic, and electro-optical offer increased speed, and decreased weight, volume, and cost for hard copy printing. Their reliability is improved over that of impact printers because of less mechanical actions; however, they usually require special paper.

Few dramatic changes are anticipated for current storage devices. A steady improvement in performance, reliability, and reduction in cost is expected. Disk or diskette type storage systems will continue to be used in a variety of capacities. Improvement will come in bit-packing density (leading to higher transfer rates), track-packing density (leading to reduced access time), and in "head" technology (leading to greater use of head-per-track disks, and further reductions in access time).

One evolving aspect of current storage technologies is the improved capability for data transportability through such media as cassettes, diskettes, and floppy disks. The FMF operational environment is such that it is extremely attractive to have a means of transporting machine-readable data by physical means as well as by electronic telecommunication--this is especially true for operations in the deployed environment. The trends in the technology of transportable media suggest that a doubling of storage density in this area will follow in the near future. This means that such media will be smaller and have more capacity, making them well suited to FMF operational needs.

Memory technology developments will affect all levels of the memory hierarchy. A most significant development will be the advances in electro-optical random-access memory using holographic storage and laser read/write techniques. With this technique, 10^8 to 10^{12} bits of data can be stored in memory and be accessible in 0.1 to 10 microseconds. More

important to the FMF, however, will be advances in magnetic domain-wall motion technology--"bubble memories" and charged-coupled devices (CCD's). Such memory technologies can provide non-rotating cyclic storage in place of the storage currently provided by mechanically actuated drums and disks. The absence of mechanical components will increase the operational applicability of such memory devices to FMF usage. An additional aspect of bubble memories and CCD's which is important to the FMF is the fact that these devices should provide a "better and cheaper" memory than the magnetic disk and drum technology. The cost of computer memory has decreased several orders of magnitude with the introduction of memory systems using bulk-material properties for storage rather than individual circuit elements. As the technology of these devices is advanced, their costs are expected to further decrease at a rapid rate [Ref. 15].

With respect to new developments in the ADP field which may soon become applicable to FMF needs, the following considerations must be kept in mind. First, effective performance and reliability are the two key parameters which must be met by ADP systems used in support of FMF units. Secondly, new or advanced computer technology for the FMF must be directed at simplifying the tasks/missions of the user instead of complicating them. With these factors in mind, and in light of the major strides underway with respect to advancing technology and diminishing costs, the value of source

data automation to such major Marine Corps information systems as MMS is more than apparent. Faced with a continuing rise in manpower costs, the choice should be a simple one--daily MMS reporting requirements should be performed using an advanced means of technology which can provide a wider range of capabilities at a lower cost, while simultaneously requiring fewer personnel resources.

APPENDIX A

Data Elements Contained in SDPI Field Master Record

Source: Marine Corps Order P1080.35B

<u>DATA ELEMENT NAME</u>	<u>DESCRIPTION</u>
ACTIVE DUTY AVIATION SERVICE BASE DATE	The date an officer first reports to the aviation facility having aircraft in which the Marine will receive flight training.
ACTIVE DUTY OFFICER BASE DATE	The date of acceptance of appointment as an officer.
ACTIVE NAVAL SERVICE BASE DATE	A constructive date computed from active service performed in the Navy and Marine Corps as modified by time lost or periods not creditable as naval service.
ADVANCE MONITORED COMMAND CODE AND EDA	The projected MCC and EDA to which an individual may be assigned beyond the FMCC.
AERONAUTICALLY DESIGNATED CATEGORIES	Describes the attainment of age and years designated as NA and NFO.
ARMED FORCES ACTIVE DUTY BASE DATE	A constructive date computed from active service performed in any branch of the Armed Forces as modified by time lost or periods not creditable as active federal service.
BASIC ALLOWANCE FOR QUARTERS	Type of entitlement and the reason.
BASIC ALLOWANCE FOR SUBSISTENCE	Entitlement and the reason. Always ZERO for officers.
CAREERIST FLAG	Indicates an individual is beyond the 1st entitlement.

CATEGORY (COMPONENT/CLASS)

Identifies an individual as Regular, Reserve, Retired, or member of Other Services.

CITIZENSHIP

Indicates whether an individual is a US citizen, naturalized citizen (and country of origin) or an alien.

CIVILIAN EDUCATION

Indicates the highest level of creditable schooling attained by the individual. Major subject is included if attended college or trade, business, specialized or vocational school.

CLASSIFICATION TESTS

1. Aptitude-Area Classification Test - A battery of 11 tests administered to recruits, or a battery of 8 tests administered upon retest, given to enlisted Marines. Test scores are used for classification and assignment.

2. Armed Services Vocational Aptitude Battery (ASVAB) - A battery of 16 tests administered to enlisted Marines for the purposes of classification and assignment. ASVAB will replace the A-A Classification Test in October 1976.

COMBAT SERVICE

Denotes participation in combat and in which theater and/or war.

COMMAND DPI CODE

A data processing installation having computer capability to provide JUMPS payroll-related services to reporting units located off-the-SDPI's base.

COMPOSITE SCORE

The 3-digit composite score in accordance with MCO P1400.29.

COMPUTED GCT (OFFICERS ONLY)

The computed GCT score is developed for officers who were enlisted Marines prior to commissioning. It is derived from the classification test.

CONTRACT EXTENSION DATA

Number of extension, length of extension in months; termination date and effective date.

CONTRACT LEGAL AGREEMENT

Type of contract or legal agreement under which the officer is serving, such as LDO, SWAG, Reserve Program, etc.

CURRENT SOURCE OF ENTRY CODE

Denotes previous Armed Service status or affiliation and the means by which a member entered the Marine Corps.

DATE ARRIVED U.S. DEPENDENTS NOT RESTRICTED

Date an individual returns from an overseas assignment where dependents were authorized.

DATE ARRIVED U.S. DEPENDENTS RESTRICTED

Date an individual returns from an overseas assignment where dependents were not authorized.

DATE CURRENT ACTIVE DUTY BEGAN

Date individual's current active duty began.

DATE CURRENT TOUR BEGAN

Denotes the date the individual commences the current tour at the present MCC.

DATE DETACHED LAST COMMAND

Denotes the date an individual is reported transferred from the last reporting unit.

DATE JOINED PRESENT UNIT

The date an individual joined his present RUC.

DATE LAST TOUR COMBAT

Indicates when an individual served in an unaccompanied status in a combat area.

DATE OF BIRTH - (DOB)

Self explanatory.

DATE OF ENLISTMENT/ACCEPTANCE

The date current enlistment contract or induction was effected, or officer acceptance was signed.

DATE OF ORIGINAL ENTRY ARMED FORCES

Date of initial entry into any branch of the Armed Forces. Never modified.

DAYS LOST CURRENT CONTRACT

Accumulated number of days current enlistment or extension thereof.

DEPENDENTS INFORMATION

Contains the relationship, date of birth and location of dependents, and date dependents location began. Total of 14 may be listed.

DEPLOYMENT MONITORED COMMAND CODE

A code representing a unit, battalion, squadron, BLT, etc., that has been designated as a specific deployment unit with HQMC controlled personnel input.

DUTY LIMITATION

Limitations imposed by law, policy and/or physical limitations such as Conscientious Objector; Sole Survivors, Physical Remedial, etc.

DUTY STATUS

Contains the Strength Category, Duty Status, Casualty Status and Type Current Duty information.

ELECTRONIC DATA PROCESSING TEST SCORE

Contains the score attained on the test.

ESTIMATED DATE OF ARRIVAL

Estimated date the member is due to arrive at the next MCC.

ESTIMATED DATE OF DEPARTURE

Estimated date the member is due to depart from the current MCC.

ETST (ENLISTED ONLY)

A test given to certain members based upon the results of the AA Test.

ETHNIC GROUP

Contains a one-character DOD standard code indicating the individual's ethnic group.

EX-POW

Indicates whether a member was ever classified as a prisoner-of-war and the geographic area in which held.

EXPIRATION OF ACTIVE SERVICE - (EAS)

Reflects the contractual active service, as adjusted as a result of an extension of enlistment, periods of time lost, etc., which is in effect.

EXPIRATION OF OBLIGATED SERVICE - (EOS)

Contains the year, month and date of termination of the obligation under the terms of the Military Service Act (MSA).

FORMER UNIT IDENTIFICATION

Indicates the RUC/MCC SDPI from which the individual was transferred.

FUTURE TOUR CONTROL FACTOR

Represents the number of months authorized as a normal tour of duty for an individual at his Future Monitored Command Code.

FUTURE UNIT IDENTIFICATION

Consists of the intermediate MCC, intermediate SDPI code, final MCC and final SDPI code.

GMST RESULTS

Not utilized.

GRADE FOR WHICH SELECTED

The grade for which member has been selected for promotion.

HOME OF RECORD

The county and state code or geopolitical code (if other than U.S.), which identifies the member's declared home of record at time of entry into the Marine Corps.

HOSTILE FIRE PAY

Describes the award and type duty entitling member to Hostile Fire Pay.

INCENTIVE PAY

Contains the identity of incentive pay for hazardous duty, such as demolition duty, flying duty, stress duty, parachute jumping duty, etc., which the individual is drawing.

INDIVIDUAL LOCATION

Contains the 3-digit county and 2-digit state/country code of member's current location. If location is in foreign country, the county code will be 3 zeros.

INITIALS

Contains Marine's initials in sequence of: last, first and middle.

INTERMEDIATE MCC-EDA

Contains the Intermediate Monitored Command Code Estimated Date of Arrival.

LANGUAGE APTITUDE TEST

Contains the test score achieved in the language aptitude test.

LANGUAGE APTITUDE TEST DATE

Contains the date the member was tested for language aptitude, i.e., year, month and date.

LANGUAGE PROFICIENCY

Means of evaluation and date of evaluation is maintained or the two most proficient languages. Additionally contains a code to indicate further (more) language qualifications.

LAST PROCESSING CYCLE AUTHORITY

Contains the computer assigned transaction code and date of authority to change a record status indicating a member is separated, in transit, awaiting INIT join, etc.

LENGTH OF ACTIVE SERVICE

Length of time expressed in months a member is serving on active duty.

LENGTH OF CURRENT ENLISTMENT

Length of time expressed in years for which a member enlists, is inducted or reenlists.

MARITAL STATUS

Contains a one-character code indicating the individual's marital status.

MEMBER ID

Contains the social security number as the member's personnel identifier.

MOS'S

Contains the billet MOS and the member's primary, 1st and 2nd additional (if any) MOS's.

NAME

Contains the information in the following sequence:
last name and suffix; first name and middle initial.

PAY ENTRY BASE DATE

The basic date used to determine when a member is
entitled to increased basic pay.

PAYMENT INFORMATION

JUMPS oriented data regarding an individual's pay
record. It is a summary record.

PERMANENT GRADE AND DATE OF RANK

A grade code and date of permanent grade.

PREFERENCE FOR DUTY

Contains the 3 choices of next assignment indicated
on fitness reports of individuals on whom fitness
reports are submitted. Corporals and below may
indicate preference for duty by unit diary entry.

PRESENT GRADE

Grade; date of rank and effective date of promotion
to this grade.

PRESENT TOUR CONTROL FACTOR

Represents the number of months authorized as a normal
tour of duty for an individual at his present MCC.

PRESENT UNIT IDENTIFICATION

Consists of MCC, RUC and SDPI codes of the member's
present unit.

PRIOR KEY

Contains the member's previous ID numbers and initials.

PROFICIENCY PAY

Contains a code denoting the type of award, rate of
award and the MOS for which awarded.

PROGRAM ELEMENT NUMBER

Contains a six-character code denoting Fiscal Guidance
Category and used for manpower budgeting by HQMC. PEN
is automatically generated upon a join or change of MCC.

PROGRAM ENLISTED FOR

Indicates the type duty the individual enlisted for, i.e., Aviation, Band, Ground, etc. For enlisted only. Officer's record contains zeros.

PROJECTED DUTY STATUS (QUOTA TRANSFER ORDERS)

The quota serial the individual is assigned; julian date and consecutive numbering of quotas; the final MCC, whether chargeable and the Basic Syllabus Training quote information.

RACE

Contains a one-character DOD standard code indicating the individual's race.

REASON FOR TRANSFER CODE

A code indicating the reason an individual was given a PCS transfer.

RELIGION

Denotes the member's religious preference.

RESPONSIBILITY CENTER NUMBER

Contains a six-digit number identifying organizations which are suboperational budget holders. PEN and RCN are both interrelated and automatically generated.

ROTATION TOUR DATE

Year, month and day an individual is scheduled to return to CONUS from overseas.

SEA OR FOREIGN DUTY

Contains a code to indicate entitlement to Sea or Foreign Duty Pay, or the suspension of the entitlement.

SECURITY INVESTIGATION

Denotes the type of investigation conducted; level of security authorized and date the investigation was completed.

SEPARATION DOCUMENT TYPE

A one-character code indicating the type of separation document.

SERVICE SCHOOLS

Contains up to a maximum of 8 formal schools or courses which are identified by a service school code which have been completed by the member.

SEX

Contains the identity of member's sex.

SPECIAL PAY

Contains the identity of CMC; SgtMaj of the Marine Corps and officers with 4 years active enlisted service. Also denotes members drawing Diving Duty Pay.

TEMPORARY REPORTING UNIT CODE

Denotes the RUC of a member that is "attached" by unit while on TAD.

TIME LOST

The accumulated number of days lost in current enlistment or extension of enlistment which may affect PEBD EAS EOS and rotation tour date.

FAP RUC

The reporting unit code of the unit to which the Marine is assigned for FAP.

FAP MCC

The monitored command code of the command to which the Marine is assigned for FAP.

SPOUSE

Contains a code to denote the branch of service in which an active duty Marine's wife is serving on active duty and/or a code of "C" to identify a married woman Marine.

APPENDIX B

Reporting Unit Classification and Unit Diary
Delivery Requirements

Source: Marine Corps Order P1080.35B

A. Delivery Classifications

(1) Class 1. Commanding officers of reporting units assigned to this class must ensure that the unit diary is delivered by direct courier to the servicing ACU not later than 0800 of the next working day following the day of preparation.

(2) Class 2. Commanding officers of reporting units assigned to this class must ensure that the unit diary is deposited with the U.S. Postal Service not later than 2400 the day of preparation. Airmail will be utilized at geographic areas where that service provides the most rapid delivery means.

(3) Class 3. Commanding officers of reporting units assigned to this class must ensure delivery of the unit diary by the fastest available means to include direct courier when appropriate, government aircraft or the U.S. Postal Service.

B. Unit Classifications within SDPI Jurisdictions

<u>SDPI JURISDICTION</u>	<u>UNITS</u>	<u>CLASS</u>
MCB CAMLEJ (SDPI 02)	1. ALL RU'S AT CAMLEJ COMPLEX	1
	2. ALL RU'S AT MCAS, CHER PT	1
	3. ALL RU'S AT MCAS (H) NEW RIVER	1
	4. DEPLOYED UNITS	3
	5. ALL OTHERS	2
MCB CAMPEN (SDPI 03)	1. ALL RU'S AT CAMPEN	1
	2. ALL RU'S AT EL TORO/ SANTA ANA COMPLEX	1
	3. FALLBROOK RU'S	1
	4. DEPLOYED RU'S	3
	5. ALL OTHER RU'S	2

HQ FMFPAC (SDPI 06)	1. ALL OAHU BASED RU'S	1
	2. ALL OTHER RU'S	2

HQMC (SDPI 09)	1. ALL RU'S IN WASHINGTON , D.C. METROPOLITAN AREA	1
	2. ALL RU'S MCDEC, QUANTICO COMPLEX	1
	3. ALL OTHER RU'S	2

MCRDEP, PISC (SDPI 11)	1. ALL RU'S IN PARRIS ISLAND-BEAUFORT S.C. AREA	1
	2. DEPLOYED RU'S	3
	3. ALL OTHER RU'S	2

MCRDEP SDIEGO (SDPI 15)	1. ALL RU'S IN SAN DIEGO COUNTY	1
	2. DEPLOYED RU'S	3
	3. ALL OTHER RU'S	2

MCB CAMP BUTLER (SDPI 27)	1. ALL OKINAWA BASED RU'S	1
	2. ALL JAPAN BASED RU'S	3
	3. DEPLOYED RU'S	3
	4. ALL OTHER RU'S	2

C. Centralized Collection Stations. When developing unit diary control systems, local commanders should consider establishing central collection stations/substations with courier service to all reporting units at a single geographic location. Commanders of deployed units should investigate the most rapid means of delivering diaries to the servicing ACU consistent with operational commitments. The same system should be used for rapid dissemination of JUMPS/MMS output documents such as the Unit Transaction Register (UTR), Personnel Verification UTR (PVUTR), Visual Audit Sheet (VAS), Pending Transaction Register (PTR), Leave and Earnings Statement (LES), Statistical Transaction Analysis Report (STAR), and local MMS management reports.

LIST OF REFERENCES

1. Marine Corps Order P1080.35B, with Ch. 1-4, Personal Reporting Instructions Manual (PRIM), 13 November 1973.
2. Marine Corps Bulletin 5200, Marine Corps Management Information Systems Plan, FY 78-83, 3 March 1978.
3. Naval Warfare Research Center, Stanford Research Institute, SRI Project 4950, Alternative Automated Data System Concepts for Support of the FMF (1980-1990), Interim Report: Phase III, Peters, L. S., and others, March 1977.
4. Auerbach Guide to Intelligent Terminals, Spring ed., p. 1., Auerbach Publishers, Inc., 1977.
5. Auerbach Datacomm 80, Auerbach Computer Technology Reports, v. 819, "Regnecentralen R C 3600 Support System," and "Olivetti T C 380 Programmable Terminal," 1972, 1973.
6. Datapro 70 the EDP buyer's bible, v. 2, "How to Select and Use Data Entry Devices," February 1978.
7. "Terminals: CRT, Graphic Display and Printing," Digital Design, p. 55-75, January 1978.
8. Datapro 70 the EDP buyer's bible, v. 1, "All About Minicomputers," December 1977.
9. "Mid-Range Automated Data Processing Support Plan FY78-FY85 (Draft)," Headquarters Marine Corps, 1977.
10. Auerbach Datacomm 80, Auerbach Computer Technology Reports, v. 819, "Auerbach on . . . Intelligent Alphanumeric Display Terminals," 1977.
11. "Concept Statement for the Real Time Finance and Manpower Management Information System (REAL FAMMIS)," Headquarters Marine Corps, Code MPI-40, 21 September 1977.
12. Naval Electronics Laboratory Center, TN 3295, Source Data Automation (SDA) Test Evaluation Report, 10 January 1977.
13. "Required Operational Capability for SDA Implementation in the FMF," Marine Corps Distributed Systems Activity, Quantico, Virginia, p. 6, 1977.

14. Glaser, George, "The Centralization vs. Decentralization Issue: Arguments, Alternatives, and Guidelines," Data Base (2:3), p. 1-7, 1970 Fall/Winter.
15. Naval Warfare Research Center, Stanford Research Institute, SRI Project 4950, Alternative Automated Data Processing System Concepts for Support of the FMF (1980-1990), Final Report, Peters, L.S., and others, June 1977.
16. Datapro 70 the EDP buyer's bible, v. 1, "How to Analyze Your Data Communications Needs," November 1977.
17. Jensen, F. J., "Centralization or Decentralization in Banking," Datamation, July 1976.
18. Defense Communications Agency, ARPANET Protocol Handbook, p. 1, Rev. January 1978.
19. "Landing Force Integrated Communications System Architecture 1976-1990," Marine Corps Development and Education Command, Quantico, Virginia, April 1976.
20. Davis, G. B., Management Information Systems: Conceptual Foundations, Structure, and Development, McGraw-Hill, 1974.
21. Meigs, W. B., Larsen, E. J., and Meigs, R. F., Principles of Auditing, 6th ed., p. 181-206, Richard D. Irwin, 1977.
22. Withington, F. G., "Beyond 1984: A Technology Forecast," Datamation, p. 54-73, January 1975.
23. Headquarters Marine Corps, "Staffing Goal Requirements for Monitored Command Code 143," Third Marine Aircraft Wing, Occupational Field 01, 28 February 1978.
24. Headquarters Marine Corps, "Precise Personnel Assignment System," MMEA letter, WER:plk/1300, 22 July 1977.

INITIAL DISTRIBUTION LIST

	No. Copies
1. Defense Documentation Center Cameron Station Alexandria, Virginia 22314	2
2. Library, Code 0142 Naval Postgraduate School Monterey, California 93940	2
3. Department Chairman, Code 36 Department of Administrative Sciences Naval Postgraduate School Monterey, California 93940	1
4. Asst Professor R. J. Roland, Code 52 RI Department of Computer Science Naval Postgraduate School Monterey, California 93940	1
5. Major Bob Sullivan, USMC Headquarters, U. S. Marine Corps Code MPI-40 Washington, DC 20380	1
6. First Lieutenant J. R. Lloyd, USMC Director, Marine Corps Reserve Forces 1500 East 9th St. Kansas City, Missouri 64131	1
7. Major Larry D. Rannals, USMC SMC 1558 Naval Postgraduate School Monterey, California 93940	1