

AD-A057 351

FRANK J SEILER RESEARCH LAB UNITED STATES AIR FORCE --ETC F/G 20/5
STUDIES OF O2((1) DELTA SUB G) PRODUCTION AND DEACTIVATION.(U)
MAY 78 L P DAVIS, C J DYMEK

UNCLASSIFIED

FJSRL-TR-78-0001

NL

| OF |
AD
A057351



END
DATE
FILMED
9-78
DDC

AD A057351



AD No. _____
DDC FILE COPY



LEVEL II

11

5C

FRANK J. SEILER RESEARCH LABORATORY

FJSRL TECHNICAL REPORT-78-0001

MAY 1978

STUDIES OF $O_2(^1\Delta_g)$ PRODUCTION
AND DEACTIVATION

DDC
AUG 10 1978
F

CAPT LARRY P. DAVIS
MAJ CHESTER J. DYMEK

PROJECT 2303

APPROVED FOR PUBLIC RELEASE;
DISTRIBUTION UNLIMITED.

AIR FORCE SYSTEMS COMMAND
UNITED STATES AIR FORCE

78 08 07 148

FJSRL-TR-78-0001

This document was prepared by the Molecular Dynamics Division, Directorate of Chemical Sciences, Frank J. Seiler Research Laboratory, United States Air Force Academy, Colorado. The research was conducted under Project Work Unit Number 2303-F4-01, Chemiluminescent Gas Phase Reactions. Captain Larry P. Davis was the Project Scientist in charge of the work.

When US Government drawings, specifications or other data are used for any purpose other than a definitely related Government procurement operation, the Government thereby incurs no responsibility nor any obligation whatsoever, and the fact that the Government may have formulated, furnished or in any way supplied the said drawings, specifications or other data is not to be regarded by implication or otherwise, as in any manner licensing the holder or any other person or corporation or conveying any rights or permission to manufacture, use or sell any patented invention that may in any way be related thereto.

Inquiries concerning the technical content of this document should be addressed to the Frank J. Seiler Research Laboratory (AFSC) FJSRL/NC, USAF Academy, Colorado 80840. Phone AC 303, 472-2655.

This report has been reviewed by the Chief Scientist and is releasable to the National Technical Information Service (NTIS). At NTIS it will be available to the general public, including foreign nations.

This technical report has been reviewed and is approved for publication.

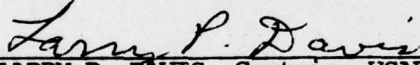
LARRY P. DAVIS, Captain, USAF
Project Scientist

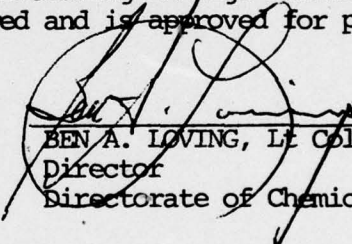
BEN A. LOVING, Lt Colonel, USAF
Director
Directorate of Chemical Sciences

FOR THE COMMANDER

CHARLES E. SIMON, Lt Colonel, USAF
Chief Scientist

Copies of this report should not be returned unless return is required by security considerations, contractual obligations, or notice on a specific document.

Printed in the United States of America. Qualified requestors may obtain additional copies from the Defense Documentation Center. All others should apply to: National Technical Information Service
5285 Port Royal Road
Springfield, Virginia 22161

UNCLASSIFIED

SECURITY CLASSIFICATION OF THIS PAGE (When Data Entered)

REPORT DOCUMENTATION PAGE		READ INSTRUCTIONS BEFORE COMPLETING FORM
1. REPORT NUMBER 14 FJSRL-TR-78-0001	2. GOVT ACCESSION NO. ADA	3. RECIPIENT'S CATALOG NUMBER 9
4. TITLE (and Subtitle) Studies of O ₂ ^(1Δg) Production and Deactivation.	5. TYPE OF REPORT & PERIOD COVERED Rept. for 1 Nov 76 - 31 Nov 77	
7. AUTHOR Capt/Larry P./Davis Maj/Chester J./Dymek	8. CONTRACT OR GRANT NUMBER(s)	
9. PERFORMING ORGANIZATION NAME AND ADDRESS Frank J. Seiler Research Laboratory U. S. Air Force Academy, Colorado 80840	10. PROGRAM ELEMENT, PROJECT, TASK AREA & WORK UNIT NUMBERS 2303-F4-01	17 F4
11. CONTROLLING OFFICE NAME AND ADDRESS Frank J. Seiler Research Laboratory U. S. Air Force Academy, Colorado 80840	12. REPORT DATE May 1978	13. NUMBER OF PAGES 22
14. MONITORING AGENCY NAME & ADDRESS (if different from Controlling Office) 12 25p.	15. SECURITY CLASS. (of this report) UNCLASSIFIED	
15a. DECLASSIFICATION/DOWNGRADING SCHEDULE		
16. DISTRIBUTION STATEMENT (of this Report) Approved for public release; distribution unlimited.		
17. DISTRIBUTION STATEMENT (of the abstract entered in Block 20, if different from Report)		
18. SUPPLEMENTARY NOTES		
19. KEY WORDS (Continue on reverse side if necessary and identify by block number) Oxygen Deactivation Electronic Transition Lasers Oxygen Production Electron Spin Resonance Chemical Lasers		
20. ABSTRACT (Continue on reverse side if necessary and identify by block number) Production and deactivation of singlet delta oxygen has been measured with electron spin resonance spectroscopy. Microwave discharge and chemical reactions were used to produce the excited oxygen. Deactivation rate measurements of the excited oxygen by self- and wall collisions as well as with gaseous chlorine have been accomplished. Results indicate insignificant deactivation by chlorine.		

219 920

LB

FJSRL-TR-78-0001

STUDIES OF $O_2(^1\Delta_g)$ PRODUCTION
AND DEACTIVATION

By

Capt Larry P. Davis
Maj Chester J. Dymek

TECHNICAL REPORT FJSRL-TR-78-0001

May 1978

Approved for public release; distribution unlimited.

Directorate of Chemical Sciences
Frank J. Seiler Research Laboratory
Air Force Systems Command
US Air Force Academy, Colorado 80840

PREFACE

This interim report documents work done under Work Unit 2303-F4-01, Chemiluminescent Gas Phase Reactions, between 1 November 1976 and 30 November 1977. Work is continuing and will be documented in future interim reports and/or a final report as events warrant. The authors wish to acknowledge the contribution of M. J. DeLong, who worked for a short time on this work unit, and J. L. Pflug, who assisted with the mass spectrometric and IR spectrometric analyses. In addition, thanks are due to D. G. Reynolds and B. J. Darcy for typing the manuscript.

ACCESSION for	
NTIS	White Section <input checked="" type="checkbox"/>
DDC	Buff Section <input type="checkbox"/>
UNANNOUNCED	<input type="checkbox"/>
JUSTIFICATION	
BY	
DISTRIBUTION/AVAILABILITY CODES	
SP. CIAL	
A	

TABLE OF CONTENTS

<u>SECTION</u>	<u>PAGE</u>
List of Figures	iii
Introduction	1
Experimental	3
Self-Deactivation of $O_2(^1\Delta_g)$	3
Deactivation of $O_2(^1\Delta_g)$ by Cl_2	4
Determination of HCl Content from a Chemical Generator	6
Results and Discussion	10
Self-Deactivation of $O_2(^1\Delta_g)$	10
Deactivation of $O_2(^1\Delta_g)$ by Cl_2	14
Determination of HCl Content from a Chemical Generator	15
Conclusions and Recommendations	17
References	18

LIST OF FIGURES

Figure 1. Experimental set-up for self-deactivation of $O_2(^1\Delta_g)$. . . 5

Figure 2. Experimental set-up for Cl_2 deactivation of $O_2(^1\Delta_g)$. . . 7

Figure 3. Experimental set-up for detection of HCl as a
product from the Cl_2/H_2O_2 reaction 9

Figure 4. Fraction of $O_2(^1\Delta_g)$ as a function of downstream
distances at 1.00 torr 12

I. Introduction

One of the more promising electronic transition laser systems is the $O_2(^1\Delta_g)/I$ chemical laser. The basis for this potential new laser system is energy transfer from $O_2(^1\Delta_g)$ to I:

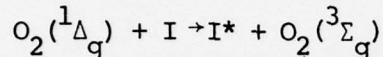

followed by lasing on I^* . One of the key requirements for successful lasing is a substantial ratio of $O_2(^1\Delta_g)$ to ground state oxygen $O_2(^3\Sigma_g)$.

Two potential methods for producing suitable concentrations of $O_2(^1\Delta_g)$ are via microwave discharge of O_2 and via chemical reactions. Microwave discharge of O_2 has been thoroughly investigated at AFWL and here at the USAF Academy¹, and it appears the maximum percentage of $O_2(^1\Delta_g)$ that can be produced is about 15%, considerably short of what is required for successful lasing. Chemical generators have been employed both at FJSRL under previous work units^{2,3} and at various AFWL contractor's installations⁴ to attain promising yields of $O_2(^1\Delta_g)$. Attempts to observe lasing with systems utilizing chemical generators are currently underway at AFWL. The first demonstration of this laser was recently reported by AFWL personnel as having occurred on 1 December 1977 at their facility⁵.

The chemical generator systems which have been successful to date have employed reaction of halogens or halogen-containing compounds with basic hydrogen peroxide solutions to produce the $O_2(^1\Delta_g)$. The initial goal for this work unit was to chemically engineer a Cl_2/H_2O_2 generator developed under a previous work unit^{2,3} to optimize the production of $O_2(^1\Delta_g)$. Due to success of other chemical generator systems, this goal was abandoned in favor of other objectives. These included studies of

self-deactivation of $O_2(^1\Delta_g)$, deactivation of $O_2(^1\Delta_g)$ and I^* by Cl_2 , and determination of HCl content of the exhaust from the Cl_2/H_2O_2 chemical generator system. This report documents progress to date on these three goals.

Self-deactivation of $O_2(^1\Delta_g)$ was studied by measuring $O_2(^1\Delta_g)$ concentrations at various distances downstream from the production point. The excited O_2 was produced via microwave generation and both $O_2(^1\Delta_g)$ and $O_2(^3\Sigma_g)$ were measured with ESR. The results of this study provided a rough estimate of how much $O_2(^1\Delta_g)$ was lost via self- and wall deactivation for various downstream distances. No attempt was made to separate the two effects.

Preliminary estimates of the deactivation of Cl_2 on $O_2(^1\Delta_g)$ were made by comparison with Ar deactivation. More reliable equipment is on order to establish a quantitative result for the deactivation rate.

Attempts to measure HCl in the exhaust of a Cl_2/H_2O_2 generator with mass spectrometry and IR spectrometry have been made. Problems have arisen with both methods, but work is continuing.

II. Experimental

Self-Deactivation of $O_2(^1\Delta_g)$

The $O_2(^1\Delta_g)$ was produced via microwave discharge. Nominal operating conditions for the microwave unit were seventy watts total power with less than two watts reflected power. Flow rates were varied from about 15 STDCC/min to 85 STDCC/min and pressures from about .5 to 2 torr. Flow rate was measured with a Matheson thermal conductivity type flowmeter and pressures with a Baratron capacitance-type pressure gauge with a 10 torr head.

$O_2(^1\Delta_g)$ and $O_2(^3\Sigma_g)$ concentrations were measured via ESR. A Varian 4502 spectrometer utilizing 100 Kc modulation monitored the $K=3, J=4, M=3 \rightarrow 4$ transition of $O_2(^3\Sigma_g)^6$ (the so-called "A-line") and one of the center quadruplets of the $O_2(^1\Delta_g)$ spectrum. Using these lines, the ratio of the concentration can be given in terms of the ratio of the intensities by

$$(1) \quad \frac{C(^1\Delta_g)}{C(^3\Sigma_g)} = .624 \times \frac{I(^1\Delta_g)}{I(^3\Sigma_g)}$$

in which

$C(^1\Delta_g)$ = concentration of $O_2(^1\Delta_g)$

$C(^3\Sigma_g)$ = concentration of $O_2(^3\Sigma_g)$

$I(^1\Delta_g)$ = intensity of $O_2(^1\Delta_g)$ ESR peak

$I(^3\Sigma_g)$ = intensity of $O_2(^3\Sigma_g)$ ESR peak

The factor of .624 relates the theoretical intensities of the two lines measured. The intensities were estimated from the ESR peaks by taking

the peak-to-peak height of the derivative spectrum and multiplying by the square of the peak-to-peak width ($H \times W^2$). This approximation saves considerable effort in replacing the double integration which would have to be done in order to get the area under the absorption curve otherwise and is estimated to be accurate to within a few percent. The fraction of $O_2(^1\Delta_g)$ of the total O_2 can be obtained from the concentration ratio.

$$(2) \quad f(^1\Delta_g) = \frac{C(^1\Delta_g)}{C(^3\Sigma_g)} \left(1 + \frac{C(^1\Delta_g)}{C(^3\Sigma_g)} \right)^{-1}$$

in which $f(^1\Delta_g)$ is the fraction of the total O_2 flow which is $O_2(^1\Delta_g)$.

Oxygen atoms were also detected in the flow via ESR. There is a strong oxygen atom line near 3500 G which was used to detect the O atoms.

The distance between the microwave production of $O_2(^1\Delta_g)$ and the ESR measurements was varied between 80 and 211 cm under the variety of flow rate and pressure conditions mentioned previously. A schematic of the experimental apparatus is shown in Figure 1. The glass and tygon tubing between the microwave and ESR was 3/8" I.D.

Deactivation of $O_2(^1\Delta_g)$ by Cl_2

Production of the $O_2(^1\Delta_g)$ was accomplished with the microwave discharge unit as described in the previous section. Measurement of $O_2(^1\Delta_g)$ and $O_2(^3\Sigma_g)$ was made with the ESR, also as described in the previous section. Varying amounts of Cl_2 or Ar were introduced into the O_2 flow downstream of the $O_2(^1\Delta_g)$ production. Argon was used to insure

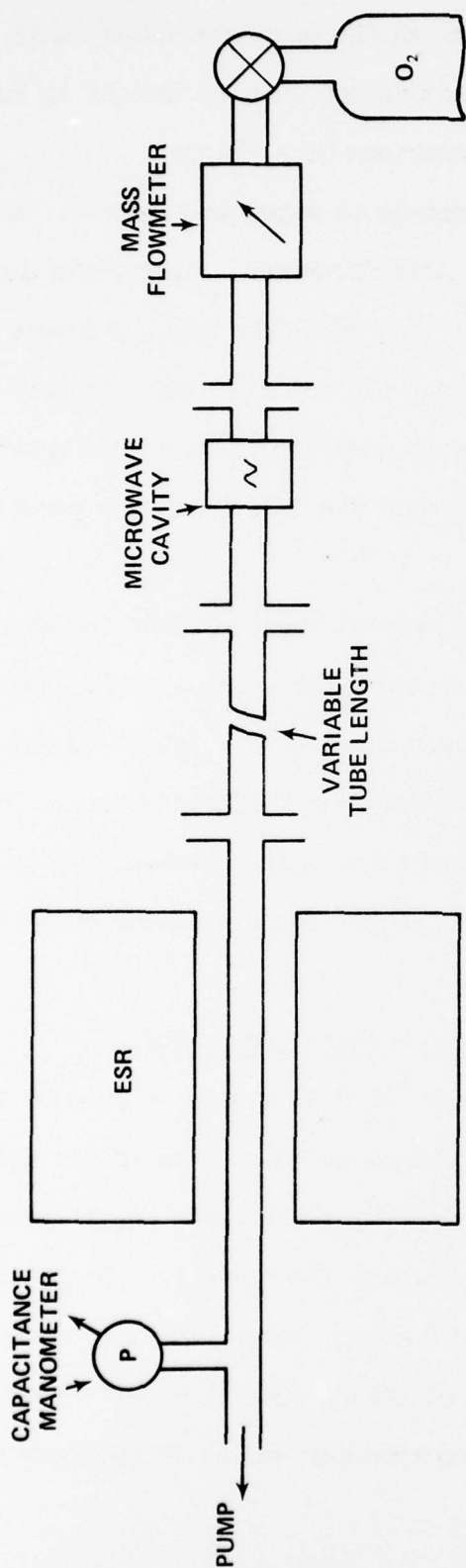

FIGURE 1. EXPERIMENTAL SET-UP FOR SELF-DEACTIVATION OF O_2 (Δg).

the same pressure-flow rate conditions in the microwave cavity with the Cl_2 as without. The Ar - $\text{O}_2(^1\Delta_g)$ deactivation rate is thought to be quite small, affording a point of comparison with the Cl

A schematic of the experimental set-up is shown in Figure 2. Either Cl_2 or O_2 can be shunted through the mass flowmeter. During the experiments the O_2 pressure was kept near 1 torr while the total pressure ($\text{Ar} + \text{O}_2$ or $\text{Cl}_2 + \text{O}_2$) was varied between 1.3 and 2.0 torr. It must be recognized that because of the different pumping speeds of the various gases the total pressure is not the sum of the individual gas pressures measured by themselves.

The conditions which were matched between the Ar/ O_2 and the Cl_2/O_2 experiments were total system pressure and O_2 flow rate. This assured the same $\text{O}_2(^1\Delta_g)$ production rate in each case. The O_2 pressure and flow rate were first set with only O_2 being pumped through the system. Then enough Ar or Cl_2 was added to bring the total system pressure up to the desired value. This procedure required different flow rates of Ar or Cl_2 to achieve the desired match.

Determination of HCl Content from a Chemical Generator

The chemical generator utilized the $\text{Cl}_2/\text{H}_2\text{O}_2$ system to produce the $\text{O}_2(^1\Delta_g)$. NaOH in the amount of 12% by weight was dissolved in 90% H_2O_2 . About 20 ml of this solution was poured over glass beads in the reactor. Cl_2 was bubbled through the solution forming the $\text{O}_2(^1\Delta_g)$. The total system pressure was maintained around 2 torr. The effluent from the reaction was frozen out in a sample collection tube with LN_2 . The sample was then analyzed on a mass spectrometer and an IR spectrometer

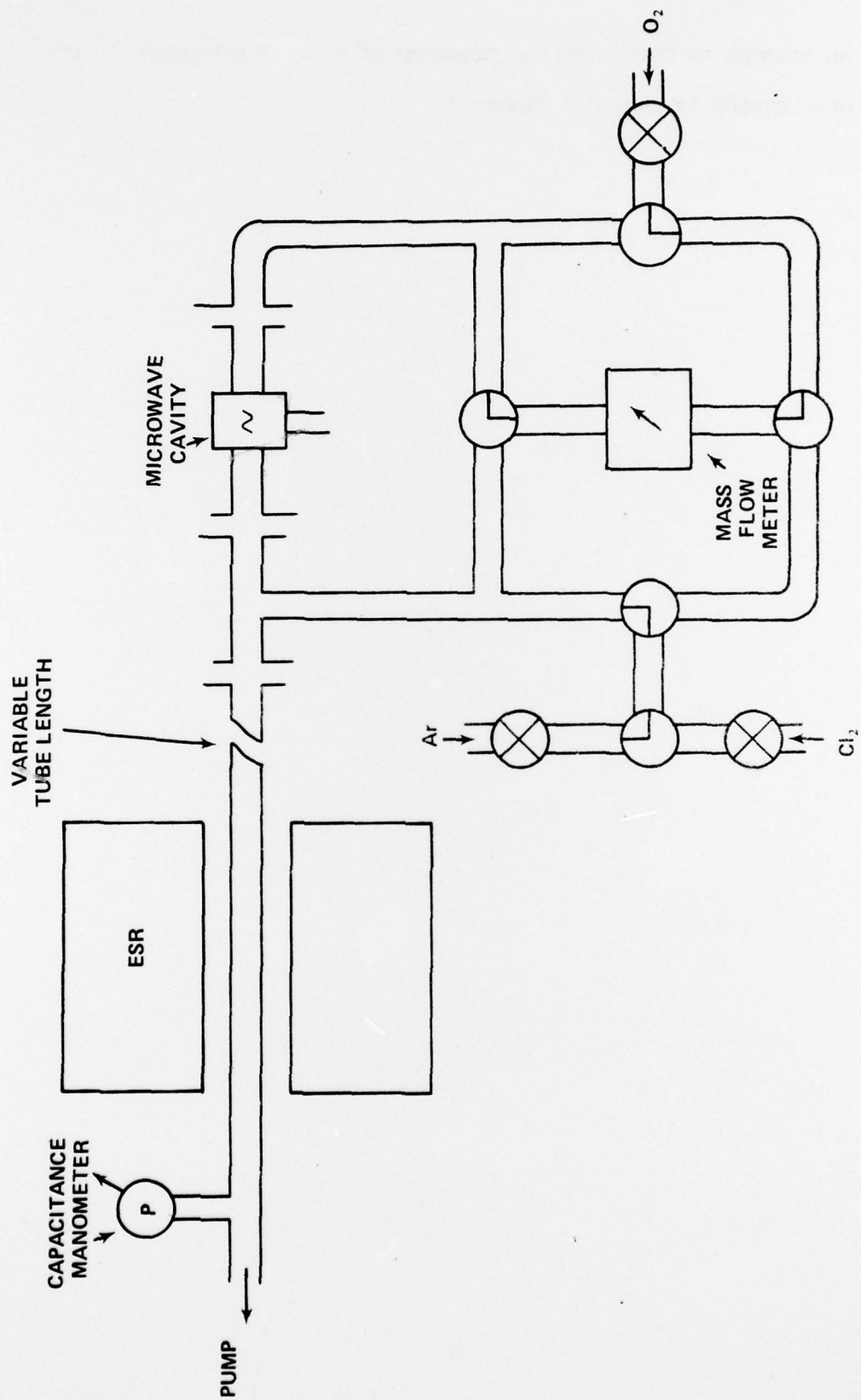

FIGURE 2. EXPERIMENTAL SET-UP FOR Cl_2 DEACTIVATION OF O_2 (Δ_g)

in an attempt to determine the presence of HCl. A schematic of the reactor system is shown in Figure 3.

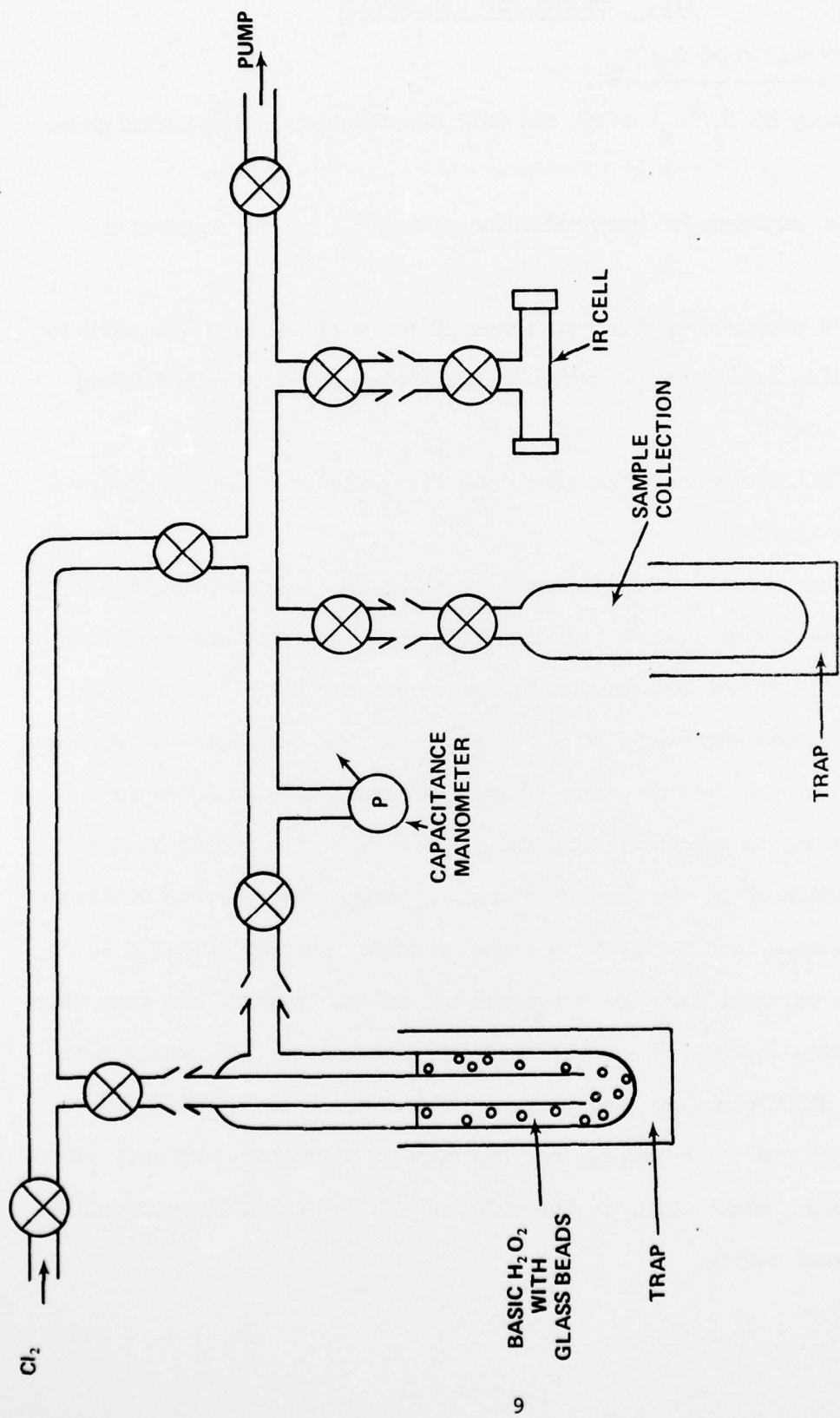

FIGURE 3. EXPERIMENTAL SET-UP FOR DETECTION OF HCl AS A PRODUCT FROM THE $\text{Cl}_2/\text{H}_2\text{O}_2$ REACTION.

III. RESULTS AND DISCUSSION

Self-Deactivation of $O_2(^1\Delta_g)$

The study of $O_2(^1\Delta_g)$ self- and wall deactivation accomplished three goals:

- (1) An estimate of the production of $O_2(^1\Delta_g)$ at the microwave cavity.
- (2) An estimate of the importance of the wall and self-deactivation under similar conditions to those utilized with the previous chemical generator work^{2,3}.
- (3) The dependence of pressure and flow rate on the $O_2(^1\Delta_g)$ microwave production.

In order to obtain the production rate at the microwave and the self- and wall deactivation, the fraction of $O_2(^1\Delta_g)$ was measured as a fraction of distance between the microwave and the ESR. The pressure for all of these data was $1.00 \pm .05$ torr, and the flow rate varied from 15.5 STDCC/min to 51 STDCC/min. These data are tabulated in Table 1. Figure 4 shows in graphical form the data in Table 1. There is considerable scatter in the data, but it is apparent that the two different flow rates have little effect upon the measured fraction of $O_2(^1\Delta_g)$. In fact, a straight line least squares fit of the 16 STDCC/min flow rate points yields a slope of $-.000212$ and an intercept of $.125$, while that of the 50 STDCC/min flow rate points yields a slope of $-.000192$ and an intercept of $.127$. Obviously, the two sets of parameters are very close. The intercept, about $.126$, is the value of $O_2(^1\Delta_g)$ actually produced at the microwave cavity.

TABLE I

Fraction of O₂(¹Δ_g) at One Torr Pressure

<u>Distance (cm)</u>	<u>Flow Rate (STDCC/min)</u>	<u>Fraction (¹Δ_g)</u>
80	16	.110
80	16	.108
80	50	.110
80	50	.120
80	51	.105
122	16	.0958
122	50	.102
150	50	.102
150	50	.0926
150	50	.102
211	15.5	.0853
211	15.5	.0859
211	15.5	.0881
211	16	.0707
211	16	.0715
211	50	.0909
211	50	.0814

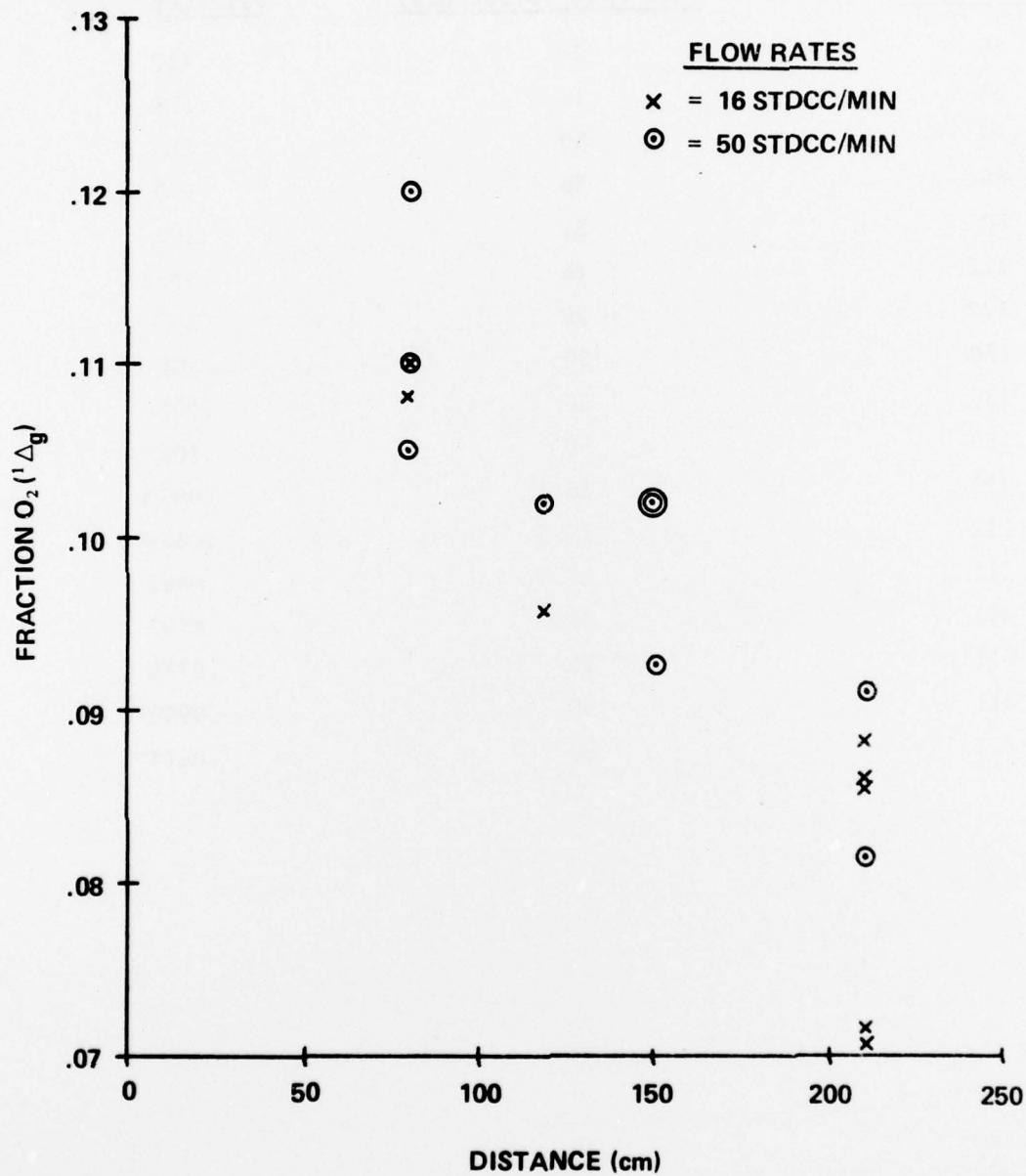

FIGURE 4. FRACTION OF O_2 (Δg) AS A FUNCTION OF DOWNSTREAM DISTANCE AT 1.00 TORR.

The data shows that self- and/or wall deactivation of $O_2(^1\Delta_g)$ under these conditions can be substantial over a few hundred centimeters of flow distance. No attempt was made to separate the wall from the self-deactivation or to calculate a rate constant for the deactivation.

The pressure of the system was varied from .5 to 2.0 torr. There is an obvious dropoff in $O_2(^1\Delta_g)$ production at pressures above 1.5 torr. Below 1.5 torr, there seems to be only a small increase in $O_2(^1\Delta_g)$ production as the pressure is decreased.

Deactivation of $O_2(^1\Delta_g)$ by Cl_2

Two sets of experiments were run. In the first, the total distance from the microwave cavity to the ESR was 75 cm. The Cl_2 or Ar injection port was 20 cm downstream from the microwave unit. The O_2 pressure alone was 1.11 torr, with the total pressure being 1.33 torr. With Ar as the deactivant, the average fraction of $O_2(^1\Delta_g)$ over six measurements was $.116 \pm .011$. The average over six runs with Cl_2 as the deactivant was $.115 \pm .011$. Thus there appears to be no deactivation over and above that caused by Ar.

In the second set of experiments, the deactivant injection port was moved to a distance of 155 cm to give time for more deactivation. Under these same pressure conditions stated above, the Ar-deactivated fraction of $O_2(^1\Delta_g)$ was .062, while the Cl_2 -deactivated fraction was .077. These values are based on only two measurements each, so their accuracy is questionable. Once again, however, Cl_2 certainly appears to no more effectively deactivate $O_2(^1\Delta_g)$ than Ar. When the total system pressure was raised to 1.9 torr, the Cl_2 -deactivated fraction was .057 while the Ar-deactivated fraction was .067, this time based on only one data point each.

Based on the results of the first set of experimental conditions an estimate of the upper limit of the deactivation rate constant of Cl_2 on $O_2(^1\Delta_g)$ has been made. It was estimated that, at most, the Cl_2 deactivated the $O_2(^1\Delta_g)$ by 10% more than the Ar. Based on this, a second order deactivation of $O_2(^1\Delta_g)$ by Cl_2 , the Cl_2 pressure, and the

distance and flow rate, an upper limit for the second order rate constant of 10^{-16} CC/moles-sec has been estimated.

The fact that no deactivation could be conclusively shown with Cl_2 underscores the need for more accurate measurements. These measurements are planned for the near future.

Determination of HCl Content from a Chemical Generator

The reaction of Cl_2 with the basic hydrogen peroxide clearly produced the $\text{O}_2(^1\Delta_g)$ as determined by the red glow of the $[\text{O}_2(^1\Delta_g)]_2$ dimol radiation above the solution. The gaseous products trapped were inserted into the mass spectrometer. No other species except an apparent increase in the O_2 peaks over that of the background air spectrum appeared. However, insertion of pure Cl_2 into the mass spectrometer showed that very high pressures of Cl_2 (on the order of atmospheric pressure) were needed before any chlorine species could be observed. Furthermore, the Cl_2 was apparently reacted in the mass spectrometer with contaminants such as H_2O vapor to produce HCl. Therefore, it appears any Cl_2 in the reactor effluent may show up as HCl on the mass spectrometer. Further research into the possibility of detecting HCl with this instrument, including contact with the manufacturer, produced discouraging forecasts⁷.

Infrared spectrometry was selected as a possible alternative for observing HCl. Experiments with gas samples of HCl showed that the instrument lacked sensitivity to detect HCl partial pressures in the range of those present in the chemical generator system. However, it was sensitive enough to detect HCl in the 10-20 torr pressure range. Freezing out of the reaction gaseous products with LN_2 and subsequent

introduction into the IR cell could allow enough HCl to be detected in the gas phase. This approach will be attempted in the near future.

IV. CONCLUSIONS AND RECOMMENDATIONS

The maximum $O_2(^1\Delta_g)$ fraction which can be produced from one microwave cavity is about .125 at 1 torr O_2 pressure. Self-deactivation and wall deactivation can be substantial over several hundred centimeters of tubing.

Deactivation of $O_2(^1\Delta_g)$ by Cl_2 appears to be of the same order of magnitude as that of Ar. More detailed experiments are needed to obtain a quantitative rate constant. Measurements of the deactivation of I^* by Cl_2 are also needed.

Infrared spectrometry appears to be feasible in the determination of whether appreciable HCl is produced with the Cl_2/H_2O_2 chemical generator. Mass spectrometry with our current system seems to be fraught with insurmountable problems in this determination.

REFERENCES

- (1) D. M. Thomas, A Parametric Study of the Production of $O_2^1\Delta$ By Microwave Excitation, FJSRL-TM-06, 30 June 1976.
- (2) W. E. McDermott and J. T. Viola, Efficient Chemical Production of Singlet Delta Oxygen, FJSRL-TR-76-0005, January 1976.
- (3) W. E. McDermott, R. E. Lotz, M. L. DeLong, and D. M. Thomas, New Gas Lasers, FJSRL-TR-76-0011, August 1976.
- (4) P. H. Lee and W. D. Slafer, Chemical Generation of Gaseous Excited Oxygen, AFWL-TR-76-90, August, 1977.
- (5) W. E. McDermott, private communication.
- (6) M. Tinkham and W. P. Strandberg, Physical Review, 97, 951 (1955).
- (7) J. L. Pflug, private communication.