

AD-A057 369 NATIONAL AVIATION FACILITIES EXPERIMENTAL CENTER ATL--ETC F/G 4/1  
TWO LIGHTNING-FLASH COUNTER SYSTEMS.(U)  
JUL 78 L W EINBINDER, N MERCADO

UNCLASSIFIED

FAA-NA-77-18

FAA-RD-78-39

NL

| of |  
AD  
A057 369



Report No. FAA-RD-78-39

**LEVEL** <sup>H</sup>

12  
H

AD A 057369

**TWO LIGHTNING-FLASH COUNTER SYSTEMS**

L. William Einbinder  
Nicholas Mercado  
Robert C. Greenwood

AD No. \_\_\_\_\_  
DDC FILE COPY



JULY 1978

FINAL REPORT

Document is available to the U.S. public through  
the National Technical Information Service,  
Springfield, Virginia 22161.

DDC  
RECEIVED  
AUG 14 1978  
A

Prepared for

**U.S. DEPARTMENT OF TRANSPORTATION**  
**FEDERAL AVIATION ADMINISTRATION**  
Systems Research & Development Service  
Washington, D.C. 20590

78 08 04 030

**NOTICE**

The United States Government does not endorse products or manufacturers. Trade or manufacturer's names appear herein solely because they are considered essential to the object of this report.

<p>18. Report No. <b>FAA-RD-78-39</b></p>	<p>2. Government Accession No.</p>	<p>3. Recipient's Catalog No. <b>12 / 43p.</b></p>	
<p>4. Title and Subtitle <b>TWO LIGHTNING-FLASH COUNTER SYSTEMS.</b></p>		<p>5. Report Date <b>11 Jul 1978</b></p>	<p>6. Performing Organization Code</p>
<p>7. Author(s) <b>L. William Einbinder, Nicholas Mercado, Robert C. Greenwood</b></p>		<p>8. Performing Organization Report No. <b>14 FAA-NA-77-18</b></p>	
<p>9. Performing Organization Name and Address <b>Federal Aviation Administration National Aviation Facilities Experimental Center Atlantic City, New Jersey 08405</b></p>		<p>10. Work Order No. (TKAS)</p>	<p>11. Contract or Grant No. <b>975-140-003</b></p>
<p>12. Sponsoring Agency Name and Address <b>U.S. Department of Transportation Federal Aviation Administration Systems Research and Development Service Washington, D.C. 20590</b></p>		<p>13. Type of Report and Period Covered <b>9 Final rept. 7 December 1975-December 1976</b></p>	
<p>15. Supplementary Notes</p>			
<p>16. Abstract  Two lightning-flash counter systems were fabricated at the National Aviation Facilities Experimental Center (NAFEC) to determine local ambient lightning-flash activity and to consider the usefulness of these devices to air traffic control. These two devices were designed by members of two international groups. The first device, CIGRE, is an acronym for "Conference Internationale des Grande Reseaux Electrique." The second device, RSA-10, is an acronym for "Republic of South Africa," a National Electrical Engineering Research Institute and Council for Scientific and Industrial Research." Data were collected for about 1 year, and the resultant information indicated that the RSA-10 and the CIGRE lightning-flash counters are effective devices for determining the presence of lightning usually associated with cumulonimbus clouds.</p>			
<p>17. Key Words  <b>Lightning-Flash Counter</b></p>		<p>18. Distribution Statement  Document is available to the U.S. public through the National Technical Information Service, Springfield, Virginia 22151</p>	
<p>19. Security Classif. (of this report)  <b>Unclassified</b></p>	<p>20. Security Classif. (of this page)  <b>Unclassified</b></p>	<p>21. No. of Pages  <b>62</b></p>	<p>22. Price</p>

240 550

Heu

# METRIC CONVERSION FACTORS

## Approximate Conversions to Metric Measures

Symbol	When You Know	Multiply by	To Find	Symbol
<b>LENGTH</b>				
in	inches	2.5	centimeters	cm
ft	feet	30	centimeters	cm
yd	yards	0.9	meters	m
mi	miles	1.6	kilometers	km
<b>AREA</b>				
sq in	square inches	6.5	square centimeters	cm <sup>2</sup>
sq ft	square feet	0.09	square meters	m <sup>2</sup>
sq yd	square yards	0.8	square meters	m <sup>2</sup>
sq mi	square miles	2.6	square kilometers	km <sup>2</sup>
	acres	0.4	hectares	ha
<b>MASS (weight)</b>				
oz	ounces	28	grams	g
lb	pounds	0.45	kilograms	kg
	short tons (2000 lb)	0.9	tonnes	t
<b>VOLUME</b>				
tblsp	tablespoons	5	milliliters	ml
fl oz	fluid ounces	30	milliliters	ml
c	cup	0.24	liters	l
pt	pint	0.47	liters	l
qt	quart	0.96	liters	l
gal	gallon	3.8	liters	l
ft <sup>3</sup>	cubic feet	0.03	cubic meters	m <sup>3</sup>
yd <sup>3</sup>	cubic yards	0.76	cubic meters	m <sup>3</sup>
<b>TEMPERATURE (exact)</b>				
°F	Fahrenheit temperature	5/9 (after subtracting 32)	Celsius temperature	°C

\*1 in = 2.54 (exactly). For other exact conversions and more detailed tables, see NBS Misc. Publ. 286, Units of Weights and Measures, Price \$2.25, SD Catalog No. C13.10.286.

## Approximate Conversions from Metric Measures

Symbol	When You Know	Multiply by	To Find	Symbol
<b>LENGTH</b>				
mm	millimeters	0.04	inches	in
cm	centimeters	0.4	inches	in
m	meters	3.3	feet	ft
km	kilometers	1.1	yards	yd
		0.6	miles	mi
<b>AREA</b>				
cm <sup>2</sup>	square centimeters	0.16	square inches	sq in
m <sup>2</sup>	square meters	1.2	square yards	sq yd
km <sup>2</sup>	square kilometers	0.4	square miles	sq mi
ha	hectares (10,000 m <sup>2</sup> )	2.5	acres	ac
<b>MASS (weight)</b>				
g	grams	0.035	ounces	oz
kg	kilograms	2.2	pounds	lb
t	tonnes (1000 kg)	1.1	short tons	st
<b>VOLUME</b>				
ml	milliliters	0.03	fluid ounces	fl oz
l	liters	2.1	pints	pt
l	liters	1.06	quarts	qt
l	liters	0.26	gallons	gal
m <sup>3</sup>	cubic meters	35	cubic feet	ft <sup>3</sup>
m <sup>3</sup>	cubic meters	1.3	cubic yards	yd <sup>3</sup>
<b>TEMPERATURE (exact)</b>				
°C	Celsius temperature	9/5 (then add 32)	Fahrenheit temperature	°F

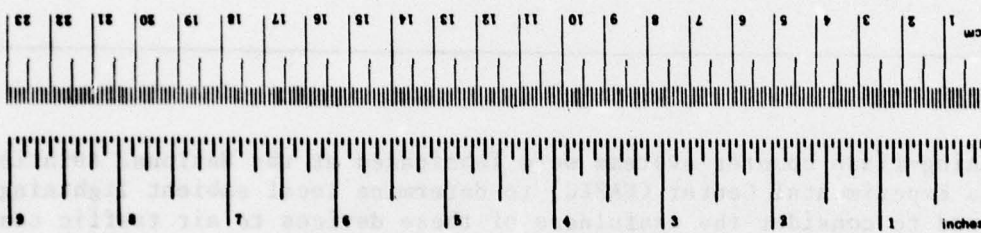
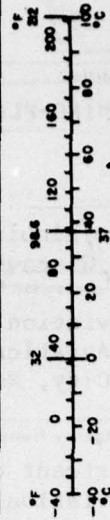

PREFACE

Acknowledgement is given the contributions of Mr. William J. Mayer, Mr. H. Regal, and Mr. I. Taylor, all of the National Aviation Facilities Experimental Center model shop, for their extensive work in fabricating the required antenna parts, sheet metal enclosures, and related components.

In addition, thanks and appreciation are conveyed to Mr. Paul O'Brien, Mr. George C. Apostolakis, and Mr. Ted Turnock (ANA-140) and Dr. Robert Lefferts (ANA-220) for their review and critique of the draft of this report.

CHECKED BY		
CVS	12/10/60 <input checked="" type="checkbox"/>	
JSB	12/10/60 <input type="checkbox"/>	
CHALLENGED	<input type="checkbox"/>	
JUSTIFIED	<input type="checkbox"/>	
BY		
DETROIT/ST. LOUIS/CHICAGO		
OR		
DETROIT/ST. LOUIS/CHICAGO		
A		

TABLE OF CONTENTS

	Page
INTRODUCTION	1
Purpose	1
Background	1
Summary	1
DISCUSSION	1
Theory of Operation	1
Fabrication	3
Calibration	4
Test	5
RESULTS	6
CONCLUSIONS	9
RECOMMENDATIONS	10
REFERENCES	11
APPENDIX - Lightning Theory	

PRECEDING PAGE BLANK

## LIST OF ILLUSTRATIONS

Figure		Page
1	RSA-10 Circuit Diagram	13
2	CIGRE Circuit Diagram	14
3	Display Unit Circuit Diagram	15
4	Lightning-Flash Counter Sensor Unit	17
5	Lightning-Flash Counter Sensor Unit, Interior View	18
6	Lightning-Flash Counter Display Unit	19
7	Lightning-Flash Counter Display Unit, Interior View	20
8	RSA-10 Antenna Assembly Drawing	21
9	RSA-10 Antenna Site	23
10	CIGRE Antenna Assembly Drawing	25
11	CIGRE Antenna Site	27
12	Lightning-Flash Counter Sensor Unit Calibration Drawing	28
13	RSA-10 Lightning-Flash Counts per Week during 1-Year Cycle, 1976	29
14	CIGRE Lightning-Flash Counts per Week during 43-Week Period, 1976	30
15	Mean Number of Days with Thunderstorms, Annual	31

## INTRODUCTION

### PURPOSE.

The purpose of this report is to provide a detailed description of and to evaluate two lightning-flash counter systems.

### BACKGROUND.

Two lightning detection devices were designed by members of two international groups. One of the two devices, CIGRE (reference 1), is an acronym for "Conference Internationale des Grande Reseaux Electrique." The other device, RSA-10 (reference 2), is an acronym for "Republic of South Africa," a National Electrical Engineering Research Institute and Council for Scientific and Industrial Research. Both units are described within. A more detailed description of lightning theory is contained in the appendix.

### SUMMARY.

The two lightning-flash counters, as specified, were evaluated for effectiveness in the National Aviation Facilities Experimental Center (NAFEC) area. Local ambient lightning-flash activity was assessed, and the presence of lightning associated with cumulonimbus clouds was detected. A cumulonimbus cloud is a "rain-mountain," a mountainous cloudy mass of condensed vapor discharging showers of rain, associated with thunderstorms.

General observation of the counters' performance showed that the CIGRE detection system had greater sensitivity than the RSA-10 detection system. However, the antenna used with the CIGRE system is large and difficult to mount; whereas, the RSA-10 antenna is simple and inexpensive by comparison.

Both detection systems were fabricated in accordance with the specifications received. Therefore, frequency response, detection sensitivity, and related circuit functions remained constant throughout the testing period.

## DISCUSSION

### THEORY OF OPERATION.

GENERAL. The RSA-10 and CIGRE lightning-flash counter systems are battery-operated instruments used for automatic registration of the number of lightning flashes from a surrounding area. The range of the system is defined by the antenna and input circuit characteristics which are sensitive to the rapid changes in the electrostatic field produced by the lightning discharge. The circuit is essentially responsive to positive field changes, cloud-to-ground and intracloud flashes.

SENSOR UNITS. The RSA-10 and CIGRE sensor circuits differ primarily in their respective input impedances. Other differences exist, but they are relatively insignificant. The input impedance of the RSA-10 provides maximum sensitivity at 10 kilohertz (kHz) and CIGRE at 500 hertz (Hz). The circuit diagram of the RSA-10 is shown in figure 1; the circuit diagram of CIGRE is shown in figure 2. Antennas are shown connected to the input circuits which provide the desired frequency response. The three transistors, T1, T2, and T3, and their associated components form a monostable multivibrator which draws only a very small leakage current from the battery in the relaxed state. A lightning flash picked up by the antenna applies a voltage to the base of T1, causing the multivibrator circuit of T1, T2, and T3 to conduct, which energizes the relay. The operation of the relay closes a first set of contacts, which enables the sensor counter for a count of one. A second set of contacts, which enables a mechanical counter in a remote display unit, also for a count of one. This operation continues, and the mechanical counters provide a record of the total number of lightning flashes up to a maximum of 9,999. The total number of lightning flashes counted in a given period can be reset to zero at any time.

The additional function of the sensor circuits include positive feedback via capacitor C3, which keeps T2 and T3 in the conductive state until C3 is charged through resistor R8 sufficiently to switch T2 off. During the period of "hold-off" time (1 second for RSA-10, 50 milliseconds (ms) for CIGRE), the base of T1 is inhibited through diode D1 to the collector of transistor T3. Upon expiration of hold-off time, the circuit switches back to the relaxed state, whereupon capacitor C3 discharges through resistor R9, and the counter is enabled.

DISPLAY UNIT. The display units used for data readout and lightning-flash indication for both systems were the same. The basic unit, with its "receive" circuitry (and readout panel), was designed by Mr. N. Mercado, ANA-140, of NAFEC. It receives lightning-flash counts from a relay in the lightning-flash counter sensor unit. The counts are transmitted several miles over telephone lines from the test site to an office building where lightning activity records are maintained. The display unit counts are verified by periodic comparison with counts received at the sensor unit.

Lightning strikes are counted during a 2.7-minute period. The number of strikes are categorized into four ranges: 1, 2 to 4, 5 to 8, and greater than 9. Once the 2.7-minute period has expired, the counts are shifted out of storage and displayed. Simultaneously, a new 2.7-minute count period starts.

Referring to figure 3, the operation of the display unit is as follows: the relay contact closures from the sensor unit relay applies a voltage ( $\geq 2.1$  V) to the A1B1 SN74121 multivibrator (single shot). This input voltage triggers a 200-ms output pulse from A1B1, which is fed to the A1C1 SN74193 four-bit up/down counter which is connected as an up counter. Hence, for every lightning flash detected during a 2.7-minute period, a 200-ms pulse is fed to the up counter where the count is stored.

The 2.7-minute period is derived from a 60-Hz nominal 120-V waveform. A pulse every cycle (16.6 ms) for 2.7 minutes is approximately 10,000 pulses. The 10,000 pulses are provided by the timing generator, consisting of the A3B3 SN7414 Schmitt-Trigger Inverter and four SN74190 decade counters (A3C3, A3D3, A3E3, and A2D2). The positive-going transition through zero of the alternating current (a.c.) input provides the Schmitt-Trigger input to A3D3, which, in turn, provides an output pulse to A3C3. The tenth pulse to A3C3 provides the first pulse to A3D3 and so on, until the last (10,000) pulse to A2D2 is completed and all counters are automatically reset to zero.

The output from A2D2 is fed to the A2C2 SN74121 single shot. The single shot provides the 20-microsecond ( $\mu$ s) load pulse to the A1D1 SN74193 four-bit shift register. The load pulse causes data being stored in the A1C1 four-bit counter to be unloaded into the shift register. Also, the load pulse is fed to the A2A2 SN74121 single shot, which clears the A1C1 counter for the next 2.7-minute count period.

The A1D1 shift register output data are applied to A1E1 and A2E2 SN74155 decoders. The output of the decoders is fed to Darlington Transistor Modules A1G1, A2G2, A3G3, and A3G4, which supply the required current to set their respective alarm light indicators.

It is to be noted that the intent of counting the number of lightning discharges in a given time period was not only to indicate storm intensity but also the probability of occurrence of related lightning-caused faults on powerlines (based on data resulting from Japanese research in this field). Therefore, the alarm lights indicated thunderstorm activity according to the following classes:

**White Light:** A count of one lightning discharge in 2.7 minutes indicates a thunderstorm is occurring in an area outside the effective area of the system and that there is a possibility of a thunderstorm.

**Green Light:** A count of two to four lightning discharges in 2.7 minutes indicates a weak thunderstorm in the effective area of the system, and the probability of the occurrence of a fault is about 10 percent.

**Amber Light:** A count of five to eight lightning discharges in 2.7 minutes indicates a medium thunderstorm in the effective area of the system, and the probability of the occurrence of a fault is about 20 percent.

**Red Light:** A count of nine or more lightning discharges in 2.7 minutes indicates an intense thunderstorm in the area of the system, and the probability of the occurrence of a fault is about 50 percent.

#### FABRICATION.

SENSOR UNIT. Cabinets used to house the components for RSA-10 and CIGRE sensors were identical. The RSA-10 cabinet is shown in figure 4. Both units utilized printed circuit boards for component mounting. The printed circuit boards, batteries, relays, etc., are shown typically for the RSA-10 in

figure 5. The metal cabinet measures 8-inches deep, 5 1/2-inches wide, and 8-inches high. The mechanical counter and test button are front-panel mounted; test jacks are also brought out to the front panel for antenna connection and test voltage measurements. The relay shown in figure 5 has a plug-in base to facilitate replacement; the unused set of contacts are brought out to the rear of the cabinet for remoting data.

DISPLAY UNIT. Cabinets used to house the components for RSA-10 and CIGRE display units are identical. The RSA-10 display unit is shown in figure 6. The unit measures 8 1/2-inches wide, 11-inches deep, and 4 1/2-inches high. The white, green, amber, and red lights showing the storm category are front-panel mounted. Also shown is the ON/OFF switch with volume control for the speaker (which alerts the operator of an approaching storm) appearing above the switch. An ON/OFF light is shown to the right of the switch. An interior view showing component and integrated circuit locations is shown in figure 7.

ANTENNA ASSEMBLY, RSA-10. The RSA-10 antenna assembly consists of aluminum antenna sections, weather-proof sensor unit housing, ground post, ground rod, and miscellaneous mounting hardware. Three aluminum tubular sections are press-fit together to comprise the antenna as shown in construction details of figure 8. A copper ball is fixed at the highest point to minimize ionization. A 600 millimeter (mm) long polyvinylchloride (PVC) pipe is fastened to the lower section of the antenna and secured to the ground post with two Bakelite stand-offs. A weather-proof housing containing the lightning-flash counter sensor unit is also mounted to the ground post. The housing measures 11 3/4-inches deep, 12-inches wide, and 18-inches high. A field site installation is shown in figure 9.

ANTENNA ASSEMBLY, CIGRE. The CIGRE antenna assembly consists of a horizontal aerial system, downlead, weather-proof housing, ground rod, and miscellaneous hardware. Construction details of this assembly are shown in figure 10; the CIGRE antenna site is shown in figure 11. The antenna system requires reasonably flat terrain, clear of trees, buildings, or other structures for a radius of about 100 feet and located as far as possible from high-voltage transmission lines.

The horizontal antenna is comprised of six spans of uninsulated No. 8 American wire gauge (AWG) stranded wire suspended approximately 16 feet off the ground between utility poles. The wires are bonded at each end and fastened to an insulated No. 8 AWG stranded downlead and terminated at the input circuit of the sensor unit.

The weather-proof housing used for the CIGRE sensor is identical to the RSA-10 housing. The ground rod was installed at an earth resistance of 5 ohms.

#### CALIBRATION.

A calibration test is required to check the frequency response of the sensor units. A sine wave oscillator and electronic voltmeter are used for calibration purposes as shown in the drawing of figure 12. The voltage and frequen-

cies should conform to the values indicated on the drawing. The connecting leads should be short, and the capacitor shown should be as close as possible to the sensor antenna terminals. At each frequency, the voltage is slowly raised until the counter operates. The capacitor values are chosen to allow operation of the counter within the voltage tolerances shown.

#### TEST.

SENSOR UNIT. The sensor unit has been provided with a sample test function. The test function consists of a test button which, when depressed, closes a circuit between the internal 9-volt battery and the mechanical counter. This function allows the local and remote counters to be tested periodically.

DISPLAY UNIT. The display unit has been provided with a test function to determine the operating status of the category light indicators. An auxiliary single-pole double-throw (SPDT) relay is used to close a circuit to the light indicators. Depressing the relay button once should light the white light for 2.7 minutes; depressing the button 2 to 4 times, the green light should light for 2.7 minutes; depressing the button 5 to 8 times, the amber light goes ON; and 9 to 15 times should cause the red light to go ON. Failure of these lights to function properly indicates the need for maintenance.

## RESULTS

The performance of both lightning-flash counter systems at the NAYEC field site, was monitored over the period of data collection. Also, the calibration test of both counters as previously described was run through on the bench to check the frequency response of the sensor units.

The calibration test showed that the RSA-10 and CIGRE counters operated in agreement with design specifications (figure 12). The electrostatic field generated by the lightning discharges and the related field strength of each were the major triggering variables to the sensor circuits.

The data collection, as discussed in the following paragraphs, illustrated that the field strength (FS) (and FS variations) comprised the actual test parameter for proving the effectiveness of each lightning-flash counter system. In addition, the variations in the field strength of the lightning discharges and the corresponding sensor detection enabled "comparison" of the two lightning-flash counter systems. Also, the collected data showed the "relative" gains of the associated antenna rigs of each counter system.

Results of data collection are shown graphically in figures 13 and 14. Figure 13 shows RSA-10 lightning-flash counts over a period of 1 year in weekly increments from December 21, 1975, to December 19, 1976. No lightning flashes were received for 20 weeks of the year from December 21, 1975, through February 29, 1976, and October 10, 1976, through December 19, 1976.

During the peak of the lightning season, from May 30 through August 22, 1976, 1,641 flashes were recorded during the 12-week period, or 137 flashes per week. During the remaining 20 weeks of the year, 141 flashes were recorded, approximately 7 flashes per week.

Figure 14 shows CIGRE lightning-flash counts for a period less than 1 year. CIGRE was the second lightning-flash counter to be built, and the program was ended before completion of a 1-year data cycle. Data were collected from a 43-week period from February 22, 1976, through December 19, 1976. No lightning flashes were received by CIGRE during a 10-week period from February 22 to February 29, 1976, and October 17 through December 19, 1976. During the peak of the lightning season from May 30 through August 22, 1976, 6,625 flashes were recorded over the 12-week period, approximately 550 per week. During the remaining 23 weeks, 1,053 flashes were recorded, approximately 46 per week.

It is evident from the data collected that during the period of peak lightning activity, the CIGRE system was registering very nearly four times as many lightning flashes as the RSA-10 system.

Similarly, during the period of low lightning activity (when data were collected), the CIGRE system was registering in the range of six to seven times as many lightning flashes as the RSA-10 system.

These data tend to indicate that the CIGRE system tested has a greater range and is more sensitive than the RSA-10 system tested. However, the RSA-10 antenna is simple and inexpensive in comparison to CIGRE and would be more practical to select in a situation not requiring optimum range and sensitivity. The RSA-10 antenna can be easily mounted to a tower cab; whereas, CIGRE requires a 100-foot clearing for its antenna.

The collected data listed in table 1 show the comparative lightning counts for given dates during 1976, as registered by both the RSA-10 and CIGRE counter systems.

The number of counts shown illustrate the lightning activity for the months listed, and represent the basic data from which the graphs in figures 13 and 14 were constructed.

Extensive data are compiled by weather observers regarding the annual incidence of thunderstorm days. Such data are plotted in the form of maps which are available through governmental weather bureaus. This type map is shown in figure 15 for the United States.

It can be seen in figure 15 that the mean number of thunderstorm days (annual) for southern New Jersey is approximately 30, as taken from weather bureau data.

In general, this agrees with the lightning activity count registered for the NAFEC area as shown in table 1.

This correlation tends to show that the RSA-10 and CIGRE lightning-flash counter systems were registering valid data.

It is important to note that the two sets of lightning-flash counter system specifications received were followed to the letter in construction of the counter circuits and assembly of the associated antennas used with each system. No specification adjustments nor changes were made to either system.

The true threshold voltage  $V$  or voltage input, that comes from an antenna to trigger a given counter can be described by the expression,

$$V_i = - h_e E_z$$

where  $h_e$  is defined as the effective height of the antenna, and  $E_z$  is defined as the vertical electric field strength, including the electrostatic, inductive, and radiation components.

Then, for  $V_i = - h_e E_z$ ,

in the case of a monopole antenna,  $h_e$  is considered  $= \frac{\ell}{2}$ , where  $\ell$  is the true physical length of the antenna.

The CIGRE antenna, therefore, will transmit  $V_i$  values several times (approximately 3.5) greater than the ones from an RSA-10 antenna, when both are located in approximately the same place. This is true because of the differences in their physical construction (figures 8 and 10).

TABLE 1. LIGHTNING ACTIVITY COUNT FOR 1976 AT NAFEC AREA

<u>DATES</u>	<u>UNIT NO. 1, RSA-10</u>	<u>UNIT NO. 2, CIGRE</u>
Feb. 7	0	0
14	0	0
21	0	0
28	0	0
March 3	3	13
13	13	64
20	0	0
27	0	0
April 1	0	26
4	12	29
20	0	2
22	17	49
28	1	1
May 1	0	3
15	3	23
20	5	7
21	42	361
29	13	68
June 1	474	1441
8	1	2
12	1	102
19	28	100
26	0	7
29	21	560
July 6	34	600
12	280	850
23	4	46
29	40	560
Aug. 13	550	1800
15	220	750
29	7	75
Sep. 11	1	20
26	18	260
Oct. 9	10	50

It can be stated that both systems tested gave test results that did correspond with the system physical parameters, and at the same time showed differences between these parameters.

While both counter systems consistently registered significant differences in the number of lightning flashes counted, they did show that each system had reasonable merit of it's own in detecting and counting lightning flashes within system limits.

Based on the design features of each, both systems could be used to count lightning flashes and indicate storm intensity categories. But as to their application for air traffic control, a separate utilization study would have to be made.

#### CONCLUSIONS

From the results, it is concluded that:

1. The RSA-10 and CIGRE lightning-flash counters are effective devices for determining the presence of lightning usually associated with cumulonimbus clouds.
2. As described in the RESULTS section, the collection of data during the testing period showed that both lightning-flash counter systems can be used to detect and relay the number and, within relative range, the rate of lightning discharges for a given location. These data also indicated the intensity of thunderstorm activity for a given time.
3. The detection range from a given point can be extended to any distance by locating a sensor at the desired reporting area and relaying the collected data back to that point, via land lines or some other type data link.

## RECOMMENDATIONS

From the conclusions, it is recommended that:

1. A network of outlying sensor locations could be established surrounding a central reporting point to provide directional as well as distance-type information regarding approaching thunderstorms. Thus, a storm "warning" system could be realized with "correlated approach time" and "relative intensity" as continuously updated data. These data could be analyzed and relayed to pilots, air traffic controllers, and associated personnel to help with air traffic control functions.
2. Other thunderstorm detection systems could be compared with the lightning-flash counter systems. An operational evaluation of the lightning-flash counters could also be completed so that (1) radar location of cumulonimbus clouds can be correlated with the activity of the lightning-flash counters, and (2) the usefulness of the devices to air traffic control can be determined. This could be done at NAFEC or in a region where thunderstorm activity is known to be high.

## REFERENCES

1. Prentice, S. A. (Australia), Conference Internationale des Grande Reseaux Electrique (CIGRE) Lightning-Flash Counter, Electra 1972 (22) pp 149-171.
2. Anderson, R. B., Van Niekerk, H. R., and Gertennbach, J. J., Improved Lightning-Earth Flash Counter, Electronics Letters, Vol. 9, No. 17, 23 Aug. 1973, pp 394-395 Republic of South Africa (RSA).
3. Van Niekerk, H. R., General Description and Specification of the RSA-10 Lightning-Flash Counter, Republic of South Africa (RSA), 1973.
4. Prentice, S. A., (Australia), CIGRE, Lightning-Flash Counter, 1973.
5. Lightning, The Encyclopedia Americana, Book 17, page 398, current issue.
6. Lightning Position and Tracking System, Atlantic Science Corp., P.O. Box 3201, Indialantic, Fl. 32903, Pamphlet, 1976.
7. Sensor-Minicomputer Network Tells When Lightning Will Strike, Electronic Design, News, Dec. 20, 1975.
8. American Institute of Electrical Engineers (AIEE) Lightning Reference Book, 1918-1935 (New York 1937), AIEE Lightning Reference Bibliography, 1936-1949 (New York, 1950).
9. American Meteorological Society, Compendium of Meteorology (Boston 1951).
10. American Institute of Electrical Engineers, 8, 242 (1962) Thunderstorms.
11. National Bureau of Standards, Code for Protection Against Lightning, Handbook 46 (Washington 1952).
12. Shielding Factors for Electrostatic Aerials, Proceedings of IEE Vol. 114, No. 10, Oct. 1967.
13. Hays, J. B., Electrical Protection of Tactical Communications Systems, Bell Telephone Laboratories, Inc. New York, New York.
14. FAA Lightning Protection Study, Final Report, FAA Report No. RD74-71, Jan. 1974.

15. Margolies, S., The Striking Thing About Lightning is it Can be Predicted, Wall Street Journal, Aug. 1975.

16. Lightning, Dept. of Commerce, NOAA, 1972.

17. Thunderstorms, Dept. of Commerce, NOAA, 1974.

18. Golde, R. H., A Lightning-Flash Counter, Electronic Engineering, March 1966.

18. Prentice, S. A., Recording Range of a Lightning-Flash Counter, Proceedings, IEEE Vol. 116, Feb. 1969.

VERTICAL ANTENNA

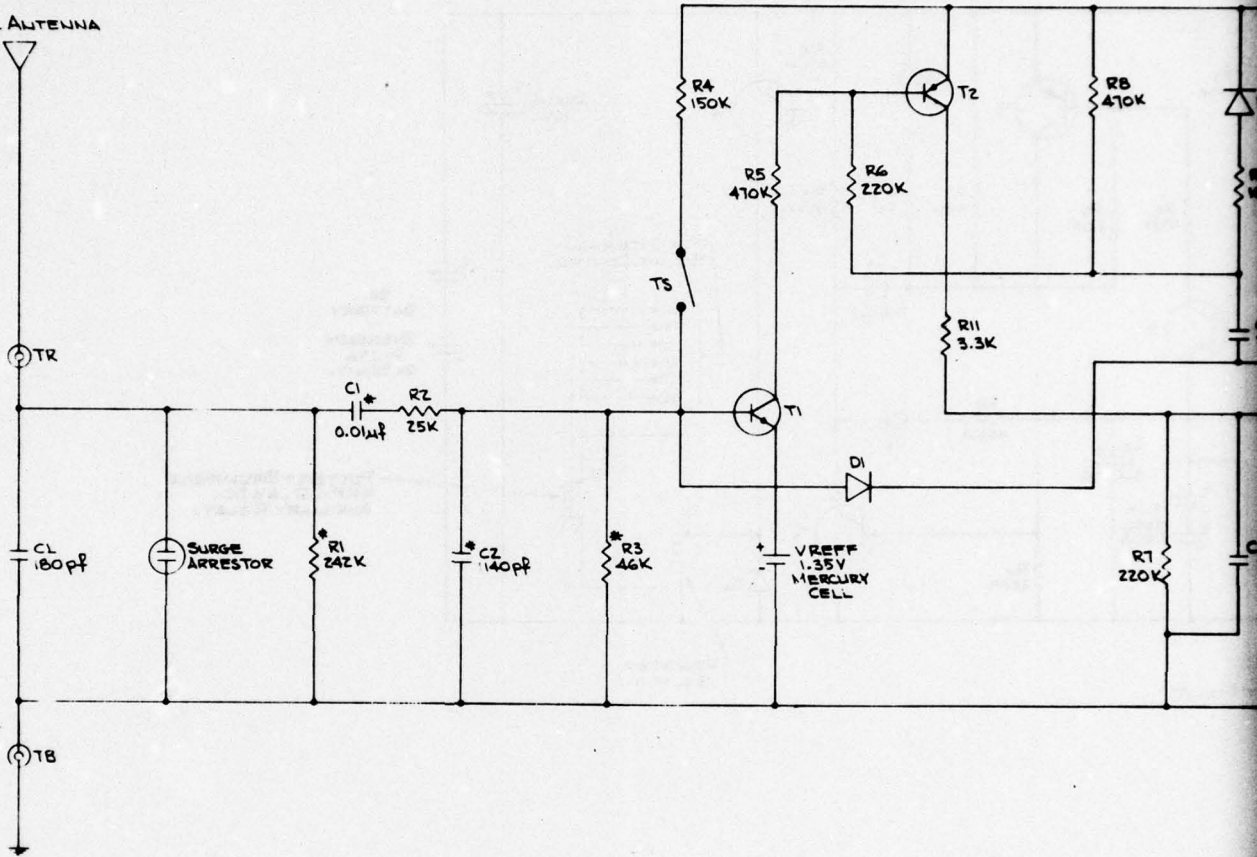

\* = 1% ACCURACY.

FIGURE 1. RSA-10 CIRCUIT DIAGRAM

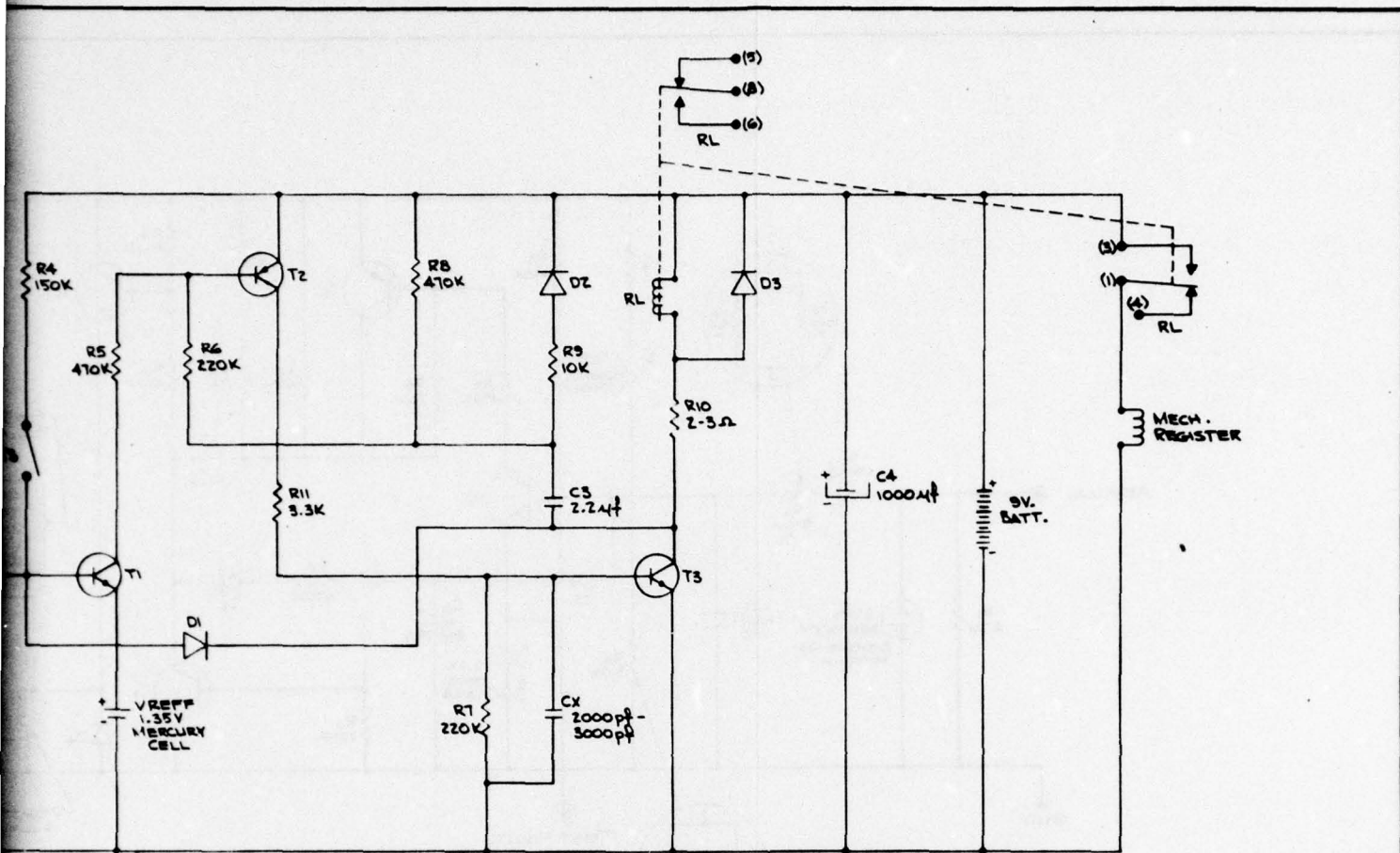

REVISED BY	DATE	DESCRIPTION	DESIGNED BY	APPROVED
<b>FEDERAL AVIATION ADMINISTRATION</b> NATIONAL AVIATION FACILITIES EXPERIMENTAL CENTER      ATLANTA CITY, GA				
<b>RSA-10 LIGHTNING FLASH SENSOR .</b> <b>CIRCUIT DIAGRAM .</b> MODEL - 1				
DESIGNED BY	N. MERCADO ANA-140		APPROVED BY	<i>[Signature]</i>
REVISED BY	DATE	DESCRIPTION	REVISED BY	DATE
REVISED BY		ANA-522	REVISED BY	10-31-75
				XD-2757

77-18-1

2/2

FIGURE 1. RSA-10 CIRCUIT DIAGRAM

2



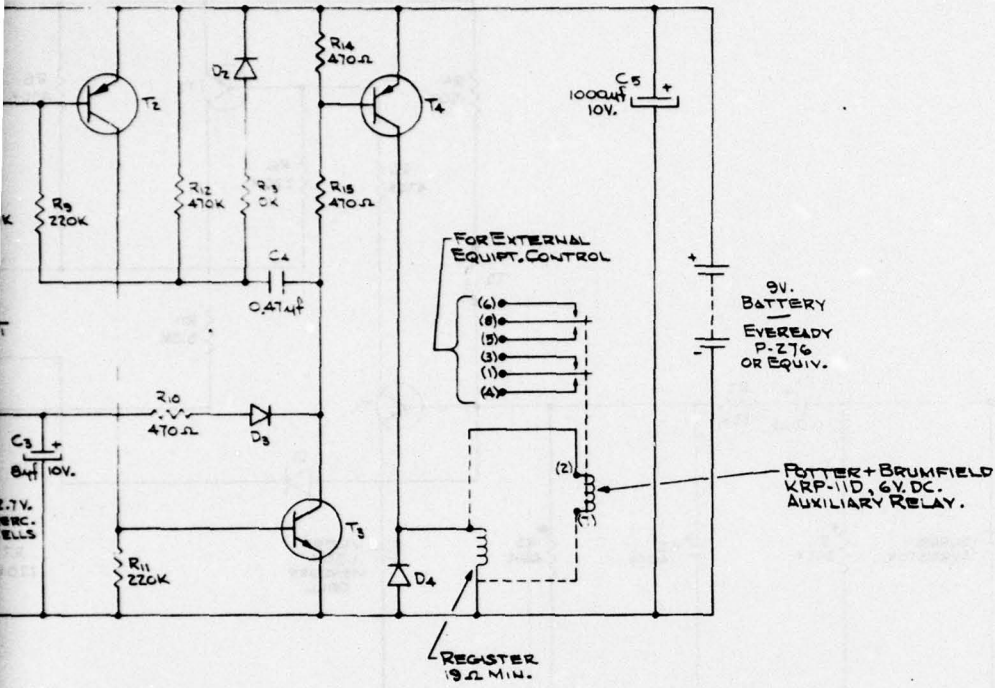

Δ	4/76	Changed "R3-10" to "CIGRE"	BY	RWF
REVISION	DATE	DESCRIPTION	BY	APPROVED
<b>FEDERAL AVIATION ADMINISTRATION</b> NATIONAL AVIATION FACILITIES EXPERIMENTAL CENTER ATLANTA CITY, GA				
<b>CIGRE LIGHTNING FLASH-SENSOR</b> SCHEMATIC. MODEL #2 - ELECTRA.				
DESIGNED BY	REVIEWED BY	DATE	BY	
	N. MERCADO ANA-140	3-22-76	N. Mercado	
FILE NO.	AWA-522	XD-2784	SHEET # 2	

CIGRE CIRCUIT DIAGRAM







77-18-4

FIGURE 4. LIGHTNING-FLASH COUNTER SENSOR UNIT

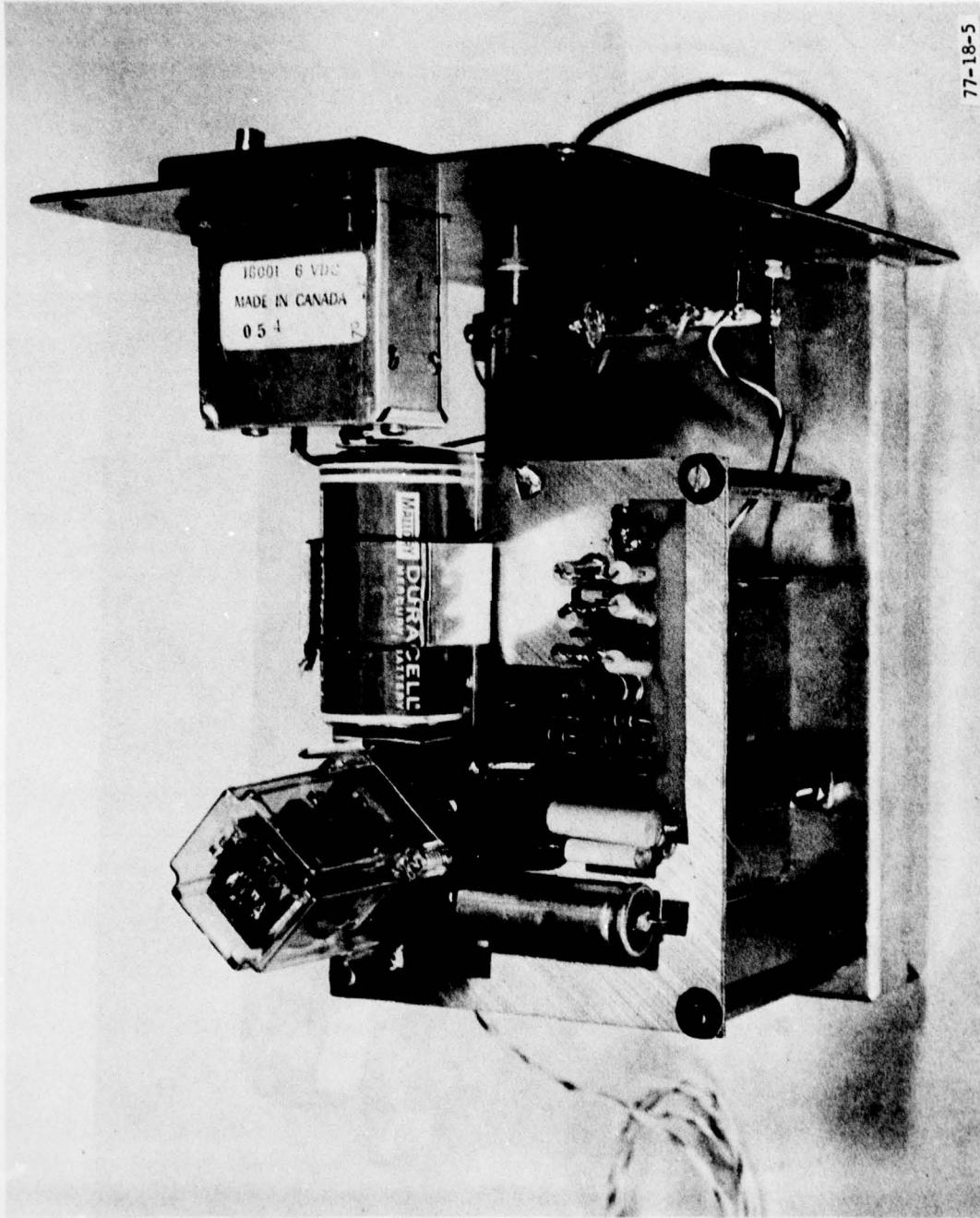

77-18-5

FIGURE 5. LIGHTNING-FLASH COUNTER SENSOR UNIT, INTERIOR VIEW

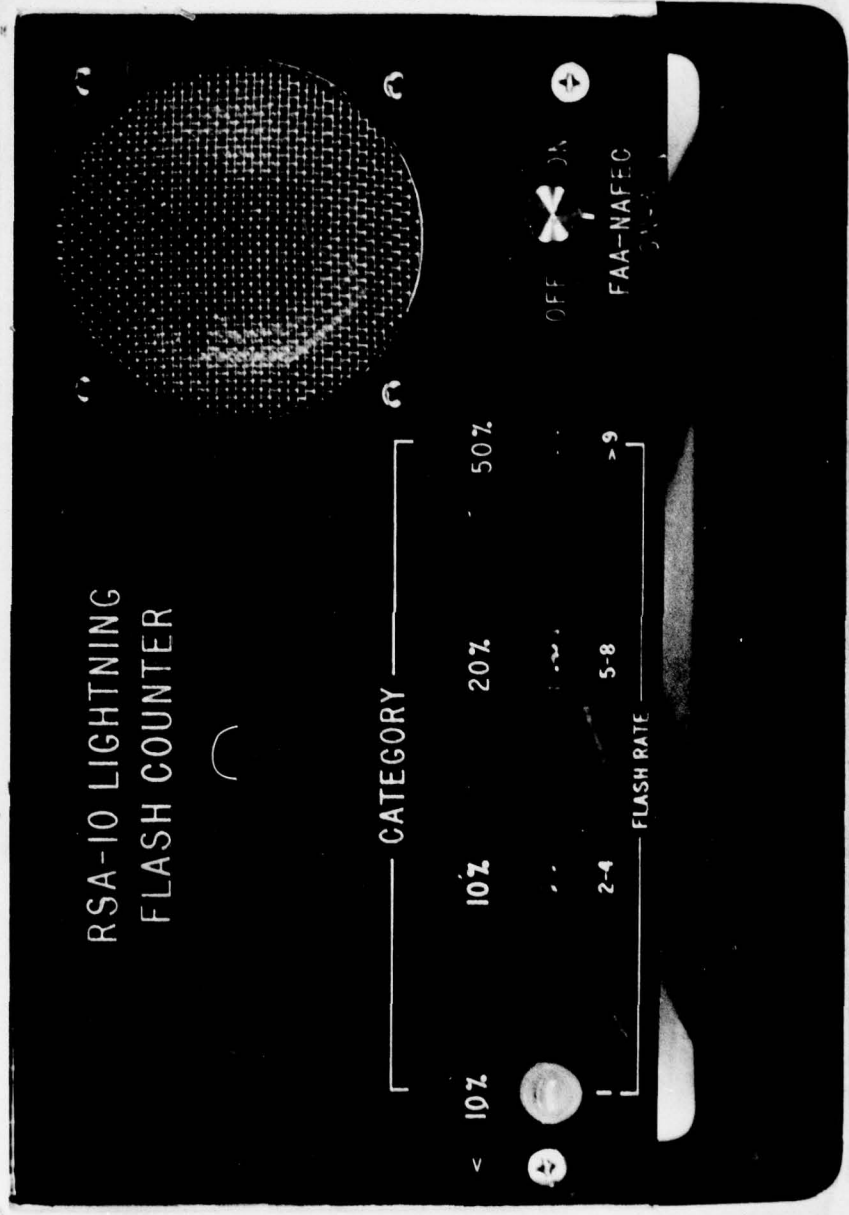

77-18-6

FIGURE 6. LIGHTNING-FLASH COUNTER DISPLAY UNIT

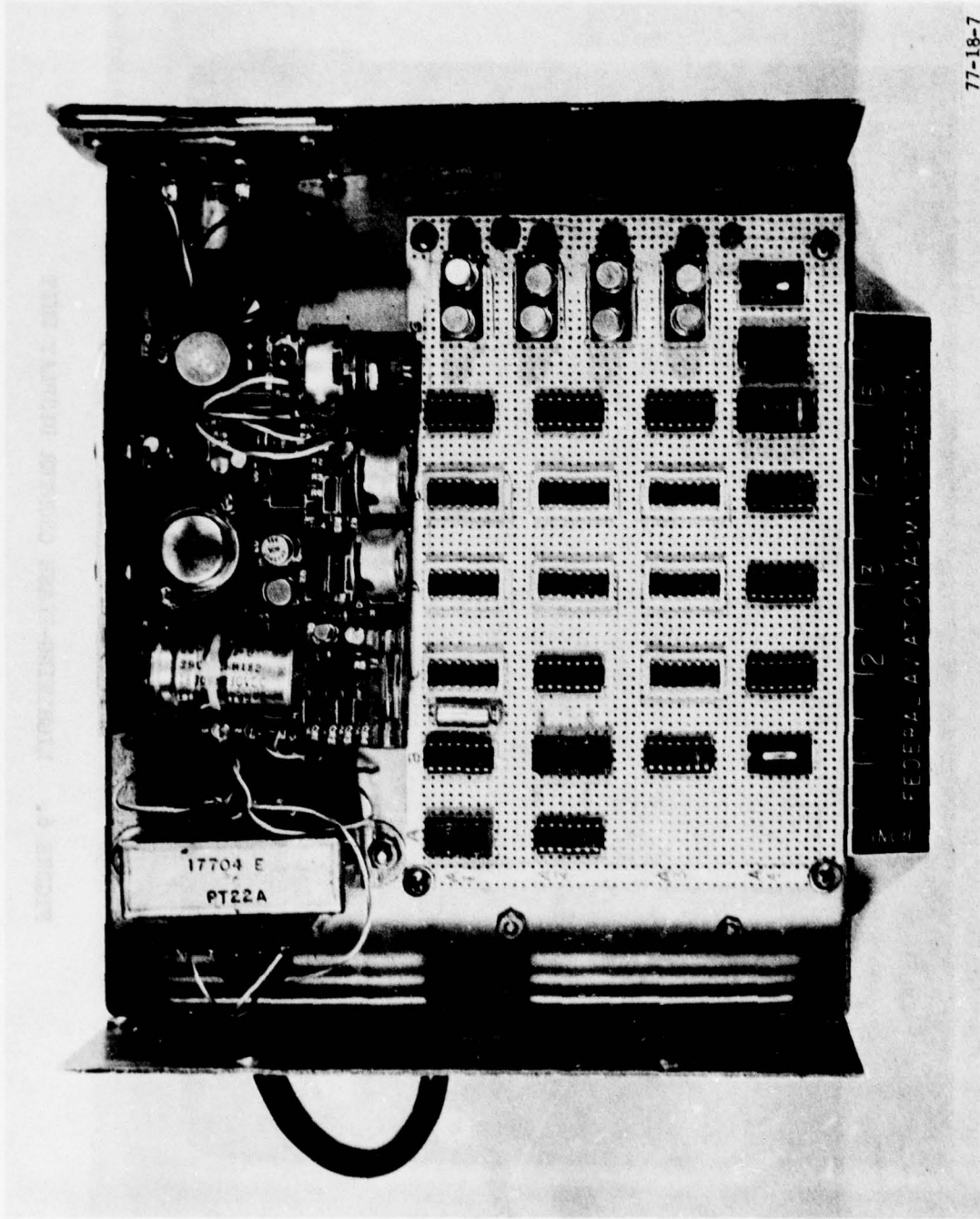

77-18-7

FIGURE 7. LIGHTNING-FLASH COUNTER DISPLAY UNIT, INTERIOR VIEW

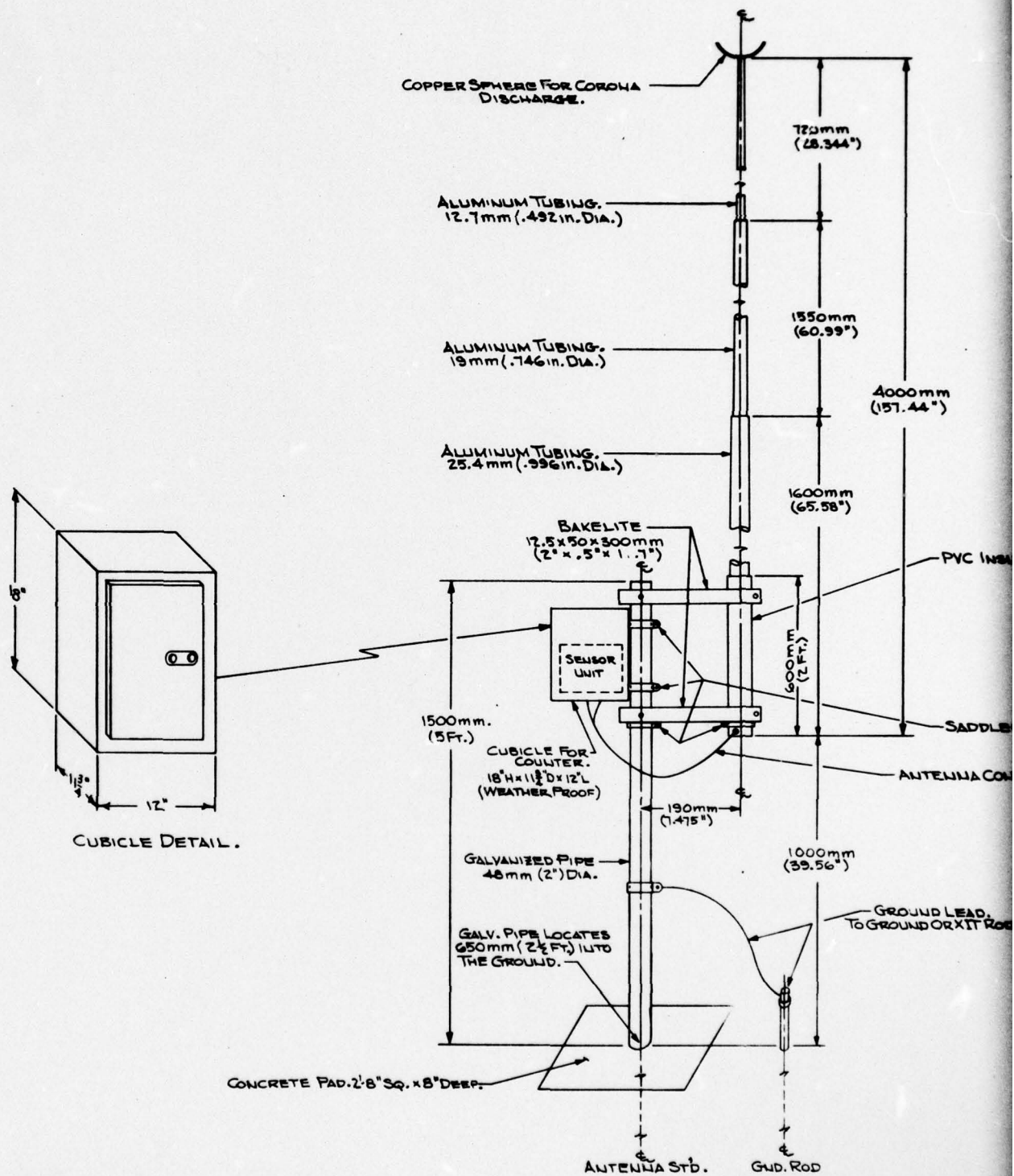
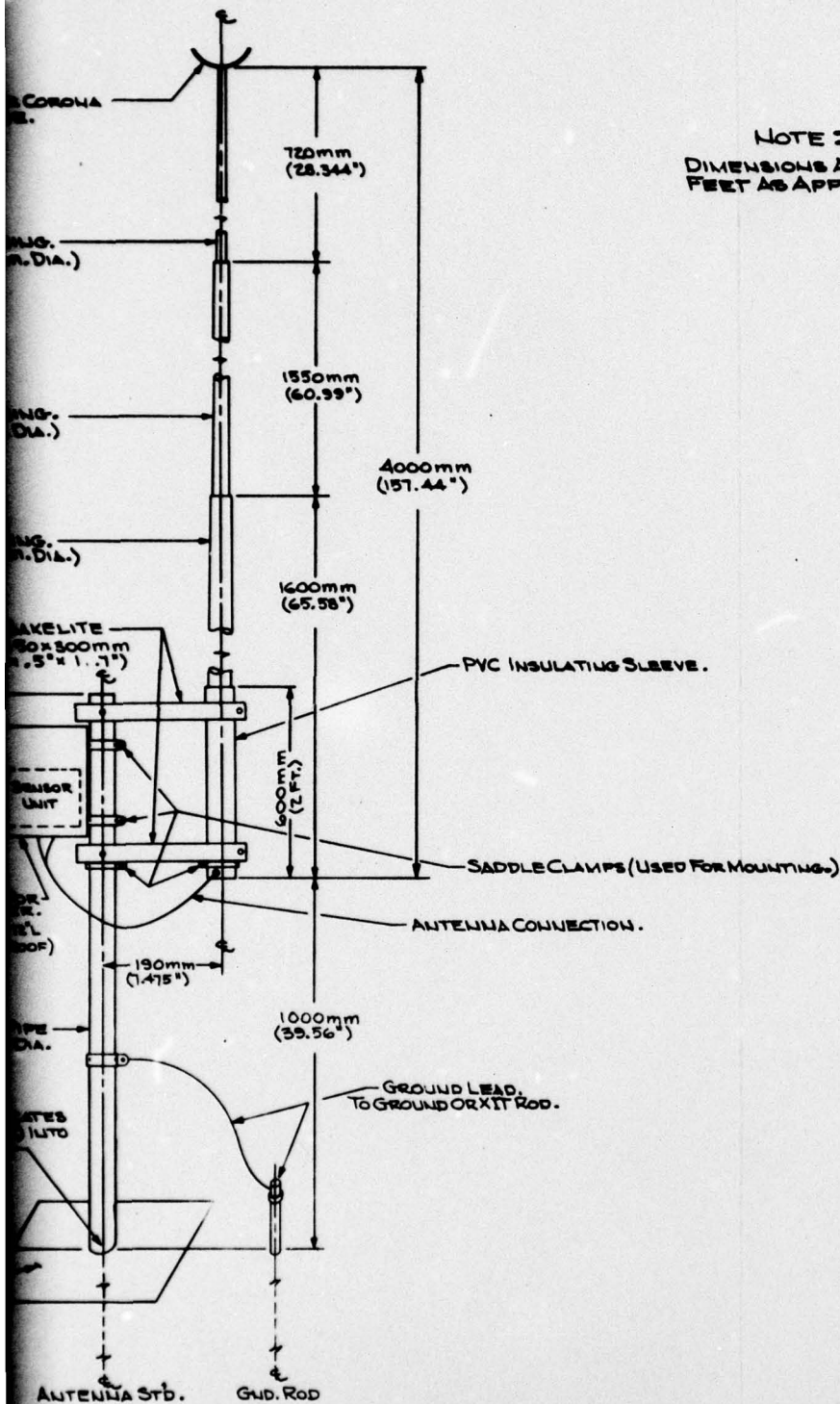

FIGURE 8. RSA-10 ANTENNA ASSEMBLY DRAWING



NOTE:  
DIMENSIONS ARE IN MILLIMETERS, CONVERTED TO INCHES OR FEET AS APPLICABLE.

FEDERAL AVIATION ADMINISTRATION	
NATIONAL AVIATION FACILITIES EXPERIMENTAL CENTER ATLANTA CITY, GA	
RSA-10 LIGHTNING FLASH ANTENNA. MODEL #1 - ELEK-50.	
DESIGNED BY	N. MERCADO ANA-140 <i>[Signature]</i>
DATE	5-22-76
APP'D BY	ANA-522
PROJECT NO.	XD-2784
REV.	1

77-18-8

F78

2/5

8. RSA-10 ANTENNA ASSEMBLY DRAWING

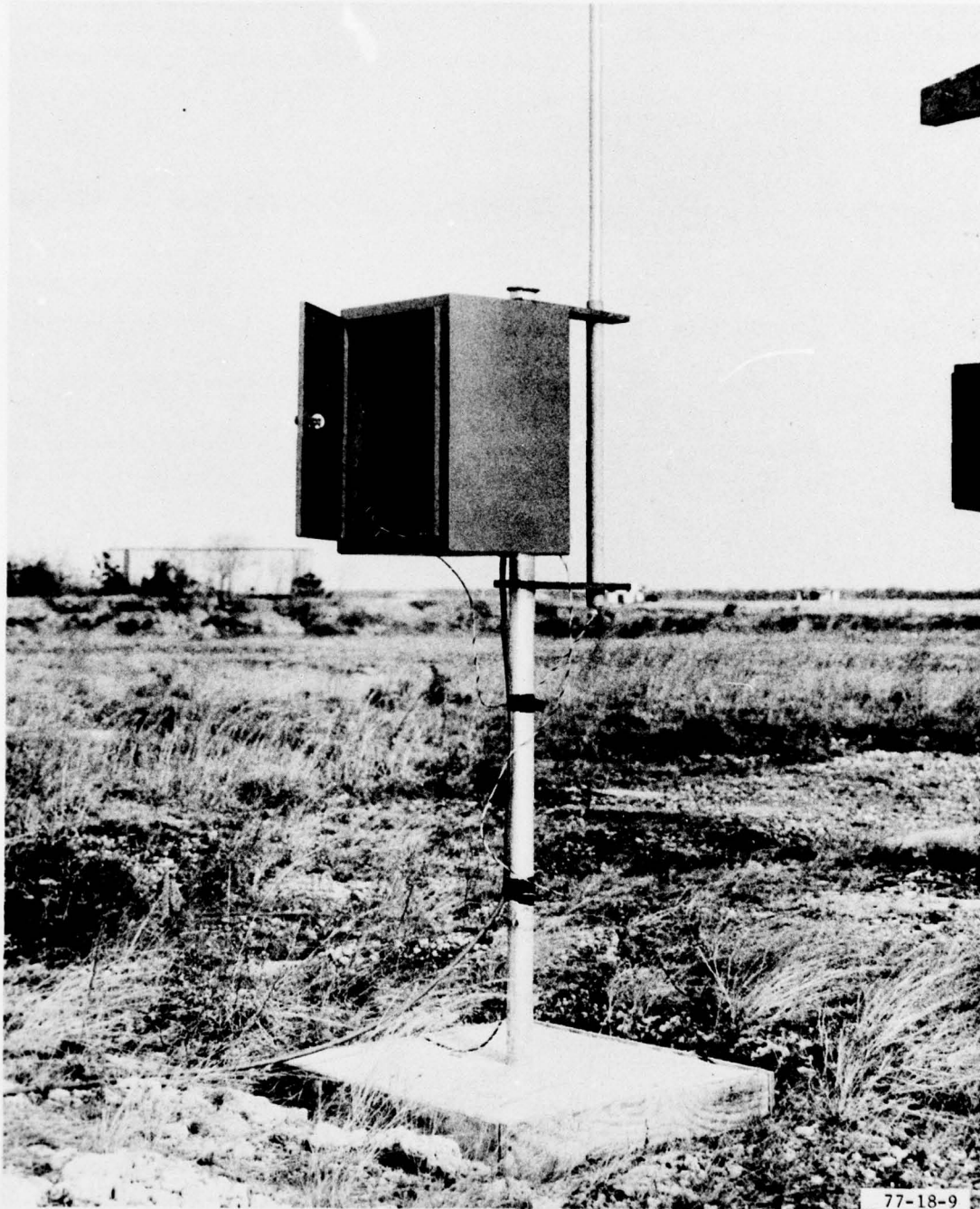

FIGURE 9. RSA-10 ANTENNA SITE

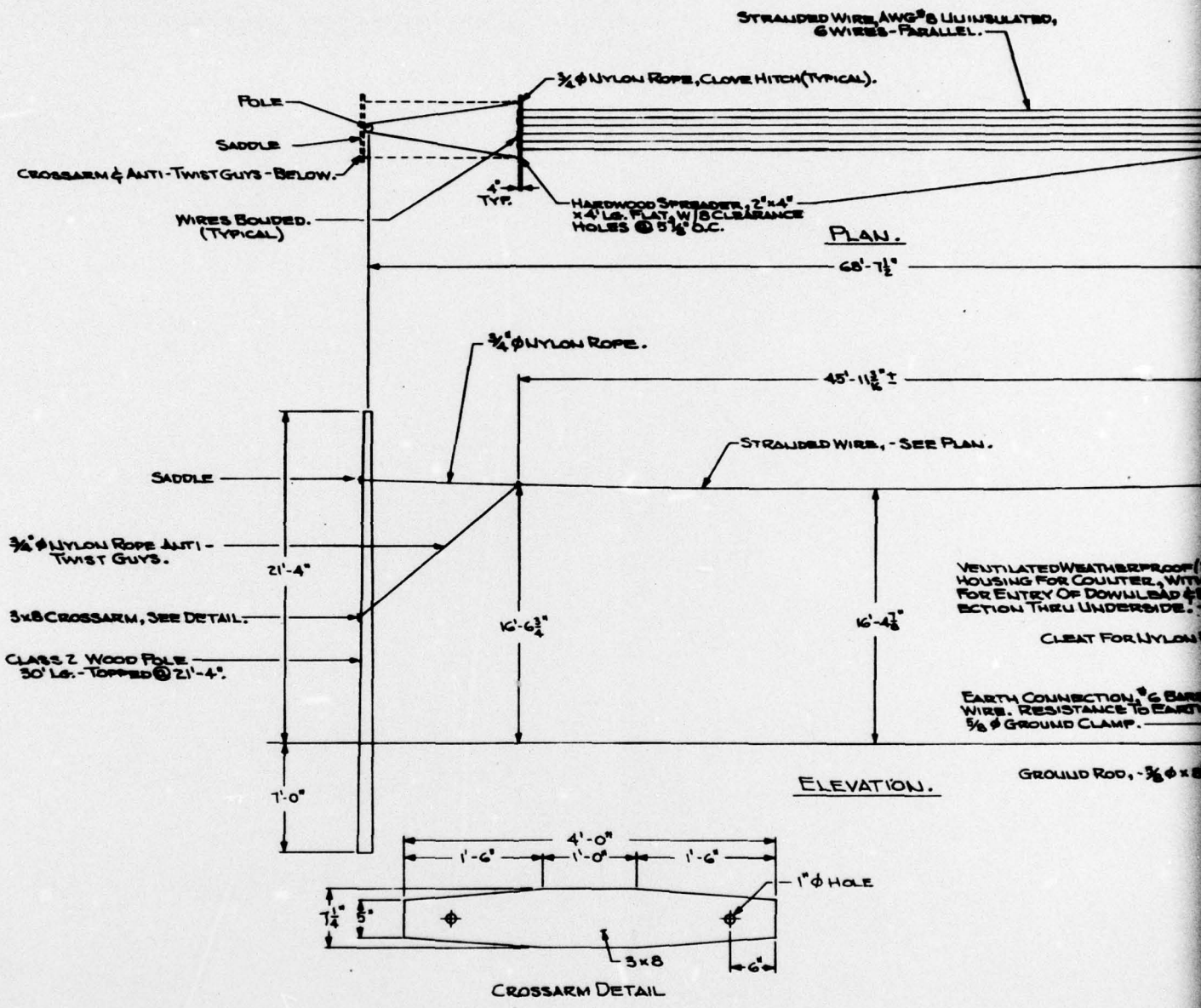
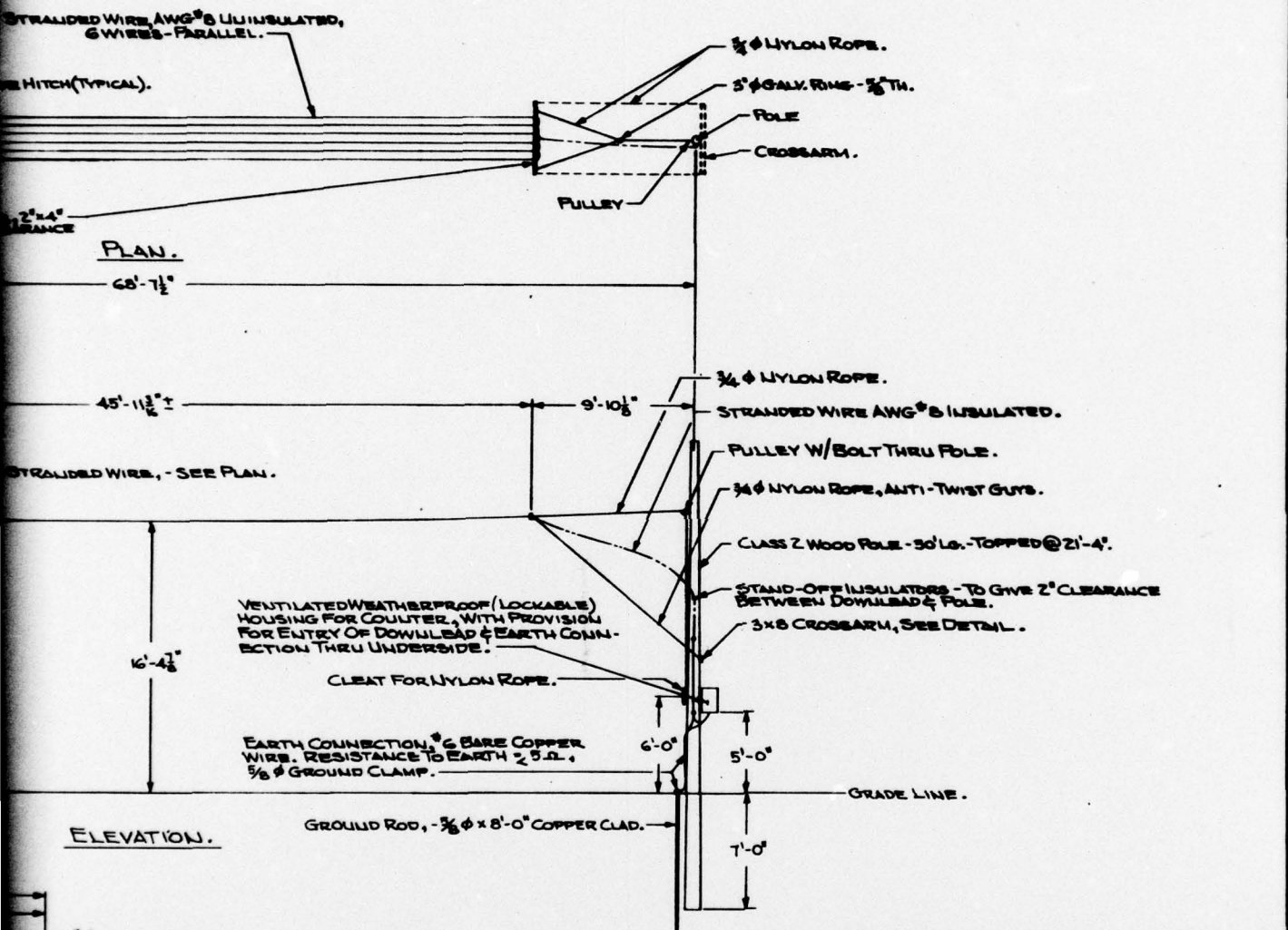

FIGURE 10. CIGRE Antenna Assembly Drawing



77-18-10

FEDERAL AVIATION ADMINISTRATION			
NATIONAL AVIATION FACILITIES EXPERIMENTAL CENTER ATLANTA CITY, GA			
CONSTRUCTION DETAILS FOR LIGHTNING FLASH COUNTER.			
ANTENNA. MODEL-2			
N. MERCADO ANA-140			
ANA-522		4-7-76	
		XD-2789	

2/3

25/26

2

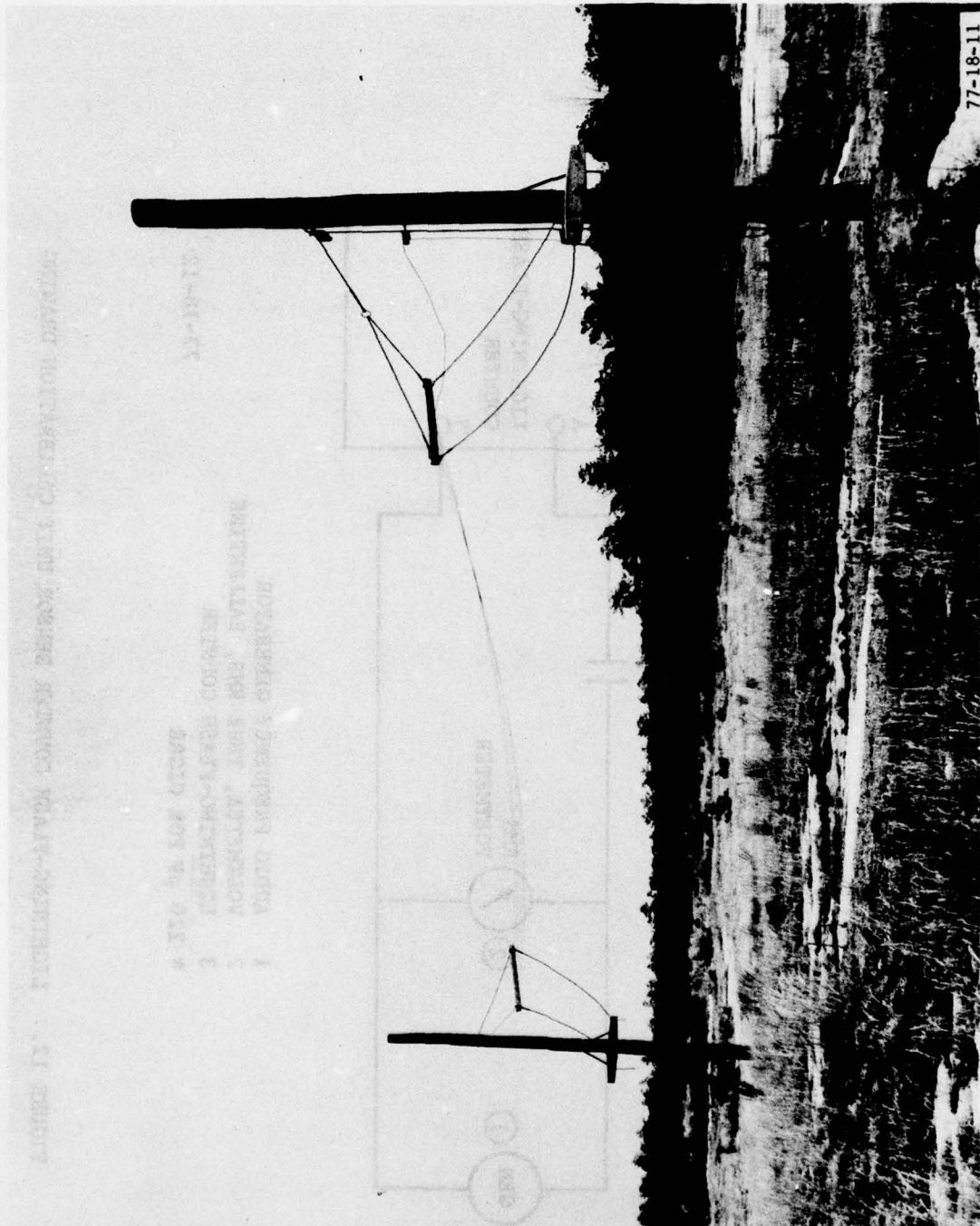

77-18-11

FIGURE 11. CIGRE ANTENNA SITE

FREQUENCY IN Hz

	ROOT MEAN SQUARE (RMS) VOLTAGE
RSA-10	67.5 ± 6.5
	41.5 ± 2.0
	67.5 ± 6.5

	ROOT MEAN SQUARE (RMS) VOLTAGE
CIGRE	42.5 ± 5.0
	25.0 ± 1.0
	42.5 ± 5.0

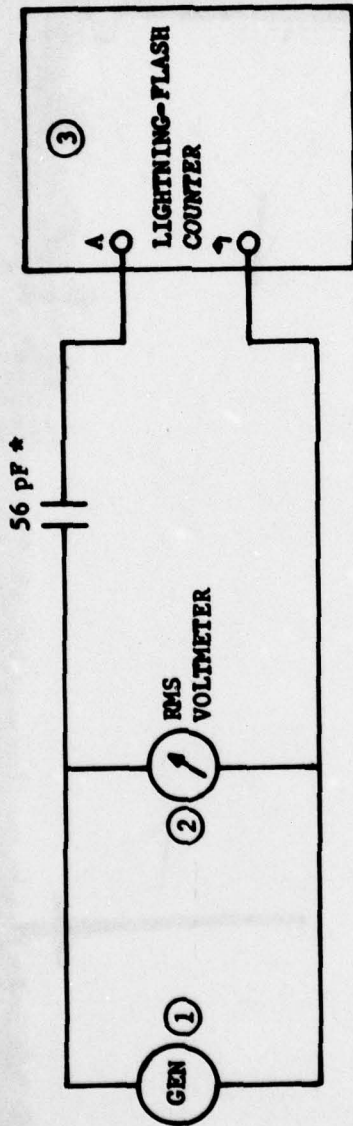

- 1 AUDIO FREQUENCY GENERATOR
- 2 VOLTMETER, TRUE RMS, BALLENTINE
- 3 LIGHTNING-FLASH COUNTER
- \* 220 PF FOR CIGRE

77-18-12

FIGURE 12. LIGHTNING-FLASH COUNTER SENSOR UNIT CALIBRATION DRAWING

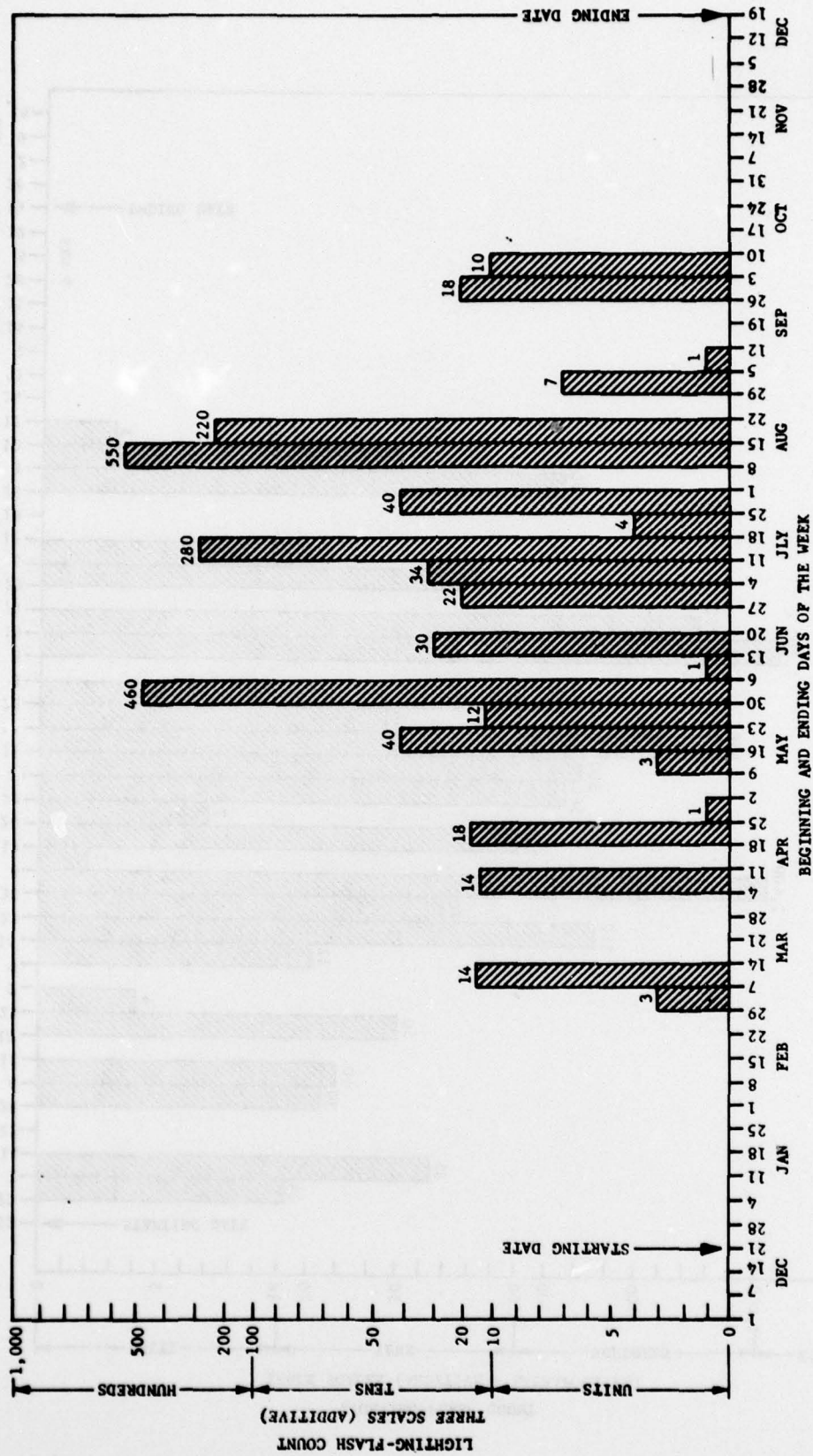

77-18-13

FIGURE 13. RSA-10 LIGHTNING-FLASH COUNTS PER WEEK DURING 1-YEAR CYCLE, 1976

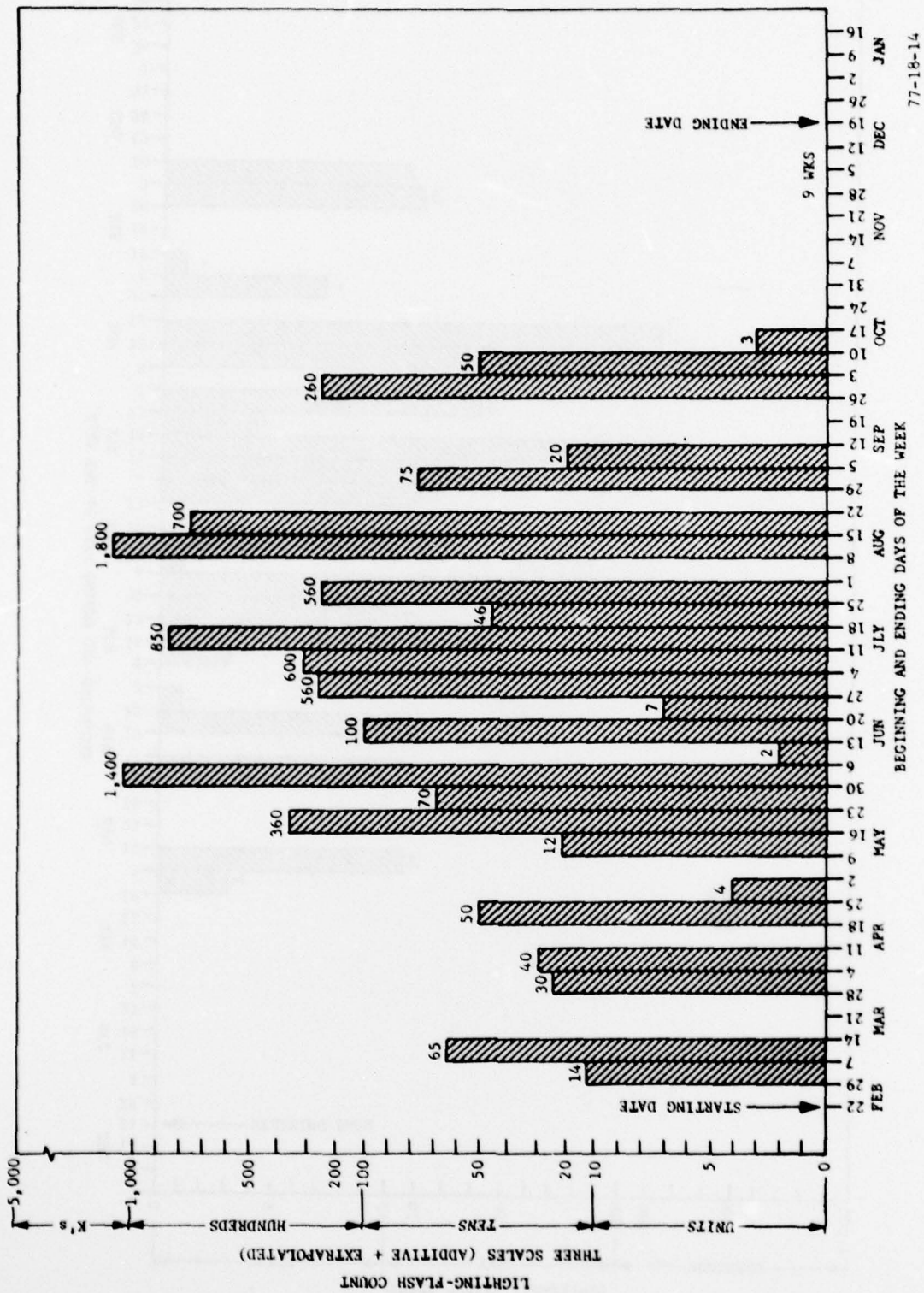
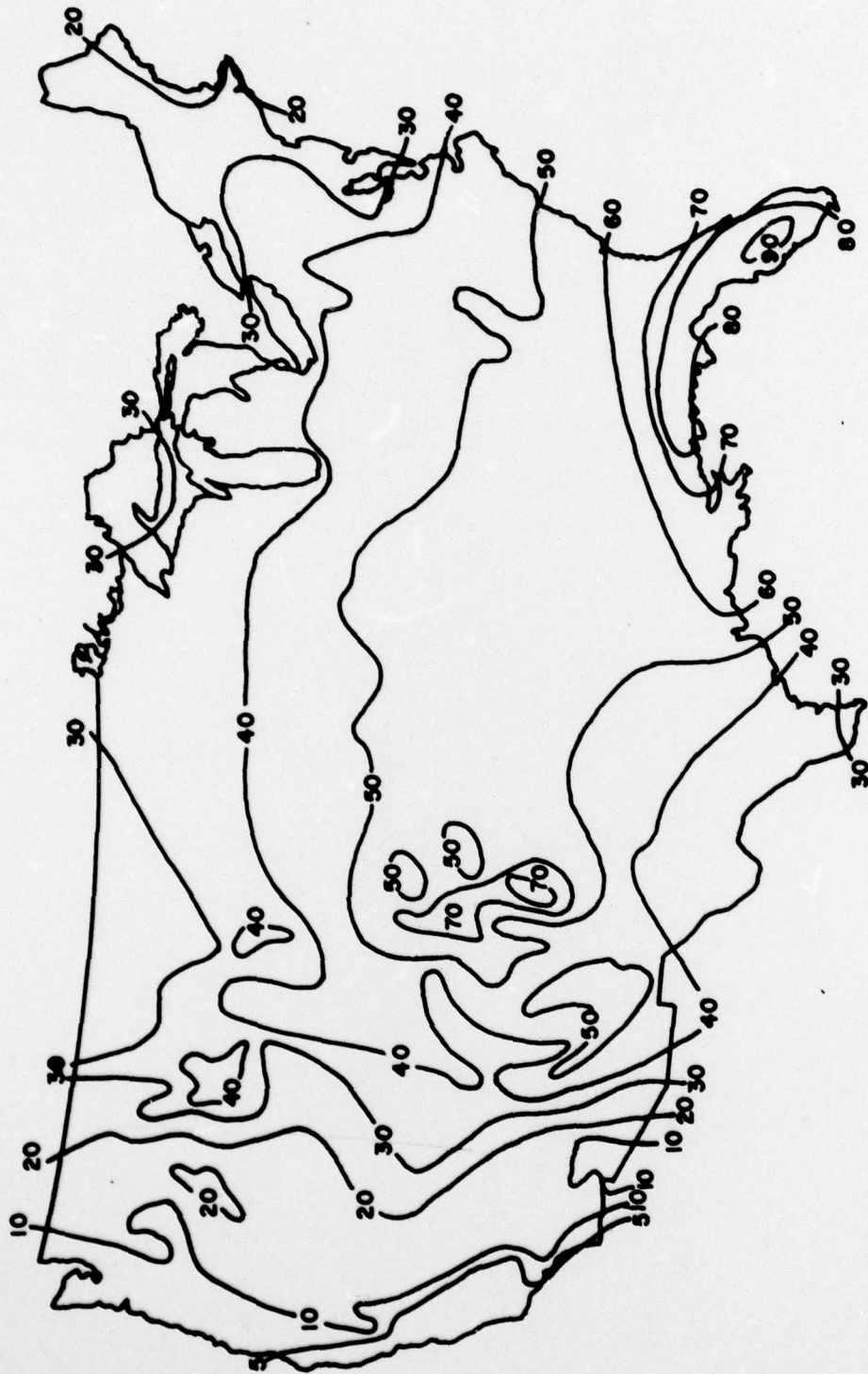

FIGURE 14. CIGRE LIGHTNING-FLASH COUNTS PER WEEK DURING 43 WEEK PERIOD, 1976



77-18-16

FIGURE 15. MEAN NUMBER OF DAYS WITH THUNDERSTORMS, ANNUAL

APPENDIX  
LIGHTNING THEORY

ATMOSPHERIC.

Experiments have shown that there is always free electricity in the atmosphere, which is sometimes negative and sometimes positive, but most generally positive, and the intensity of this free electricity is greater in the middle of the day than at morning or night and is greater in summer than in winter. In fine weather, the potential increases with altitude at the rate, according to some writers, of about 30 volts per foot. To detect the presence of free electricity in the air, a pointed metal rod projecting into the air several feet and connected at its lower end to a gold-leaf electroscope may be used. When this rod is projected into the air a few feet, the leaves diverge. Kites and ballons have also been used to detect and, so to speak, draw down the free electricity of the air.

The origin of atmospheric electricity is still unknown. Some physicists have ascribed it to the friction of the air upon the ground, others to the gradual oxidation of plant and animal life, others again, to evaporation to induction from the sun, and to differences of temperature. Most authorities are agreed, however, that whatever may be the origin of free electricity in the atmosphere, the electricity of enormous voltages that disrupts the air and produces the phenomena of lightning is due to the condensation of the watery vapor forming the clouds; each minute vapor drop as it moves through the air collecting upon its surface a certain amount of free electricity. Then, as these drops of vapor coalesce into larger drops with a corresponding decrease in the total surface exposed, the electric potential rises until it overcomes the resisting power of the air. This remark will be more clearly understood when it is considered that with a given charge of electricity, its potential rises as the electrical capacity of the object holding the charge is decreased, which is the case when the minute vapor drops coalesce into larger drops. The similarity of lightning to the electricity developed by an electrical machine was demonstrated by Benjamin Franklin in his memorable kite experiments.

Lightning is a giant electrical spark seen mostly in thunderstorms, while discharges of this type may also occur over active volcanos, in dust clouds over desert sand atomic explosions, or any places where there are rapid changes in wind and temperature. Lightning is the big daddy of any other electrical spark, as in autos and TV sets. The principle used in precaution must be used in both cases.

THE PRINCIPAL OPERATION OF A THUNDERSTORM.

The cumulonimbus cloud is the source of electrical charges needed to produce lightning strokes. In local convection thunderstorms from local heating of the air adjacent to the ground, only a few of these clouds are present. In frontal storms, the cold air masses move over masses of warm, moist air, and

cumulus clouds are formed which may extend over many miles. The cumulous clouds always are formed by violent updrafts which carry the cloud tops to 40,000 feet and even higher. In later stages, violent downdrafts are observed. Electrification of the cloud masses is closely related to these rapid movements of large air masses and the moisture carried along.

The formation and concentration of sufficient electrical charges to produce lightning strokes appear to involve free ions, the breaking up of raindrops under the influence of gravity and wind, and probably the generation of electrical charges by freezing of rain in regions of the clouds extending beyond 20,000 feet in height at temperatures below 10° C. From balloon observations and airplane flights, it is well established that the lower part of the cloud carries negative charges, while a positive charge is principally located in the upper regions and in the ground underneath the cloud. In some cases, small charge pockets of positive polarity may exist in and under the cloud bottom.

It has been estimated that over the whole surface of the earth, 16 million thunderstorms occur in one year. Java has thunderstorms during 222 days out of a whole year. In the United States, a number of storm days varies between 4 or less for the California Coast and 90 for Florida.

The lightning stroke equalizes the potential difference between the clouds' charges toward the earth, and neutralizes these charges with those of opposite polarity in the ground. It is the same phenomenon similar to, but greatly magnified, experienced when a person walks on a thick carpet, thereby accumulating the charge. This charge is released upon contact with a metallic object, such as a light switch, or a radiator, by means of a small spark. The same thing can happen when a lady with a fur coat slides across the seat of a car. (The charge that has built up when a person walks across a carpet is between the carpet and the body with the leather shoes acting as an insulator. Try it without shoes and the experiment is voided. Again the problem of the electrical shock can be eliminated by increasing the amount of humidity in the room. The idea behind this is to reduce the insulation resistance.)

The lightning strike is a huge spark, which may have a length in excess of 3 miles. The formation of such long discharges does not occur all at once, but occurs in steps, the so-called "stepped leader." When the charges in the cloud have resulted in a gradient or voltage difference with neighboring parts of the cloud in excess of 5,000 volts per centimeter, a local electrical breakdown results. Due to various processes, the field condition, the impedance of the breakdown path, and the limited supply of charges, the breakdown streamer cannot progress very far (on the average of about 150 feet). It appears to stop and a period of inactivity is indicated for about 0.00005 second or 50 microseconds. This is followed by an extension of the step leader by another 150 feet. This process is repeated until the leader has reached the ground.

On its way, branches may develop away from the original channel but in the same general downward direction and utilizing the same mechanism of the stepped leader. The total time involved to complete the travel from the cloud to ground is in the order of  $1/1000$  to  $1/100$  of a second. The eye cannot perceive this phenomenon because the illumination is relatively weak and the reaction of the eye is not fast enough. The data which are available were obtained with high-speed Boys Cameras. In these cameras, either the lens or the film is rotated at a speed of 200,000 feet per hour. As the leader approaches the earth, charges of opposite polarity to those in the leader makes contact with the ground. This results in an immediate exchange between the ground charges and the leader charges and in a large increase in current. These lightning stroke currents are of the order of 12,000 amperes (amps) and may be as high as 200,000 amps. They are called current peak or return strokes and are usually of negative polarity and decay to half their peak value in about 0.00004 seconds (40 microseconds). In spite of their short duration, these peaks of current may be extremely destructive, supplying the explosive force of the lightning stroke.

From the photographic evidence, these currents appear to travel upward toward the clouds at a speed about 100 times as great as the velocity of the downward stepped leader, approaching one half the speed of light or 90,000 mps. At least one-half of the lightning discharges observed produce a second leader. It progresses continuously--the so-called continuous or dart leader--with 10 times the velocity of the stepped leader. Again, on reaching earth, a return stroke results, with a tremendous increase in current. This may be repeated many times, a maximum of 42 current peaks having been recorded. These are multiple strokes and can be detected with the eye by the flickering illumination of the stroke channel. In the intervals between the current peaks current of much lower amplitude (500 amps or less) are flowing. These usually carry the bulk of the charges, since they persist for a long time. They are called continuous currents and are primarily responsible for fires resulting from lightning stroke. They also burn holes in metal roofs and the metal skin of airplanes.

For strokes to high buildings, for instance the Empire State Building and the 110 story Sears Building in Chicago, the process described for strokes to the ground is reversed. In most cases, the stroke starts at the building and progresses upward toward the cloud in the form of a stepped leader. However, when it reaches the cloud, a return stroke is not observed. Instead, a continuous current of a few hundred amperes flows for a fraction of a second and the discharge then may stop, or it may be followed by one or more continuous leaders starting at the cloud and progressing toward the tall building, where a return stroke will result, just as with cloud-to-ground strokes in ordinary terrain.

The continuous current portions of these strokes are particularly large, carrying charges as high as 150 coulombs. The average total duration of a stroke is  $1/500$  of a second. The longest duration recorded was 1.65 seconds.

The light produced by the current peaks is so intense that for close strokes, the retina of the eye is saturated. The image of the stroke is then retained for several seconds. For very close strokes, such as to aircraft during flight, the observer can be completely blinded for a period of minutes.

Frequently, the branches developed during the step leader process also reach the ground, sometimes simultaneously with the original leader, at other times during the progress of one of the subsequent continuous leaders. The ground terminal of the branch may be within a few hundred feet or miles away. Thus, two widely separated points may be struck during the same strokes. The wind during the storm has a lot to do with distance between strokes.

Although cloud-to-cloud strokes are more numerous than cloud-to-ground strokes, less data are available. They indicate that these strokes start with a stepped leader and do not usually result in return strokes. When return strokes were recorded they were of minor current amplitude. These strokes are of no importance for objects on the ground except for the static produced in radio receivers and minor damage to aircraft skins. It is estimated that the number of cloud-to-ground strokes per square mile is approximately equal to half the thunderstorm days in that area. Estimates also indicate that about 100 lightning discharges occur every second in some part of the earth.

There are various visual forms of lightning strokes. All are believed to have the described characteristics.

1. Streak lightning is the normally observed type.
2. Bead lightning may be caused by variation in the luminosity of the channel, perhaps caused by brush discharges.
3. Ribbon lightning probably is a multiple stroke where the channel is blown along by the wind.
4. Fork lightning is the term used for strokes with several apparently simultaneous paths to ground.
5. Heat lightning is a form of streak lightning at great distances so that thunder is not heard.
6. Sheet lightning usually occurs in clouds between the lower and upper atmosphere over a considerable area.
7. Ball lightning is described as a luminous ball of reddish color with an average diameter of 20 centimeters and a relatively low speed of travel. Usually the ball explodes after 3 to 5 seconds. This is a very controversial form of lightning. It is believed to be an optical illusion caused by saturation of the retina from a nearby lightning stroke. This image is carried along as the observer shifts his eyes. The testimony of a few apparently well qualified observers seem to indicate that such phenomena may exist. Ball lightning also may be confused with St. Elmo's fire, which is a corona discharge occurring in strong electric fields and has been observed on masts of ships, treetops, and propellers of aircraft.

Thunder is the sound effect of the lightning stroke and results from the sudden expansion of the channel and increase in pressure due to heating, ionization, and disassociation along the path of a lightning stroke. Evidence of the pressure developed is found by windows and clapboards blown outward in houses struck by lightning. Thunder apparently is produced only by current peaks where the rate of change of current is rapid. Thunder may not be heard when a lightning discharge consists only of continuing currents, as is the case at times for strokes to tall buildings. Since sound travels at a rate of approximately 1,100 feet per second (1,087 at 0° C), while the light reaches the eye almost instantaneously; an observer can judge the distance of a lightning flash by counting the seconds elapsing between the flash and the arrival of the sound wave. Each second equals therefore, 1,000 feet or approximately 5 seconds = 1 mile. Thundering can be heard for a distance of about 15 miles.