

AD-A057 376

DAYTON UNIV OHIO RESEARCH INST
QUICK REACTION EVALUATION OF MATERIALS AND PROCESSES. (U)
FEB 78 D R ASKINS, G J PETRAK

F/G 11/6

UNCLASSIFIED

UDR-TR-77-66

AFML-TR-78-6

F33615-76-C-5034

NL

1 of 3
AD
A057 376

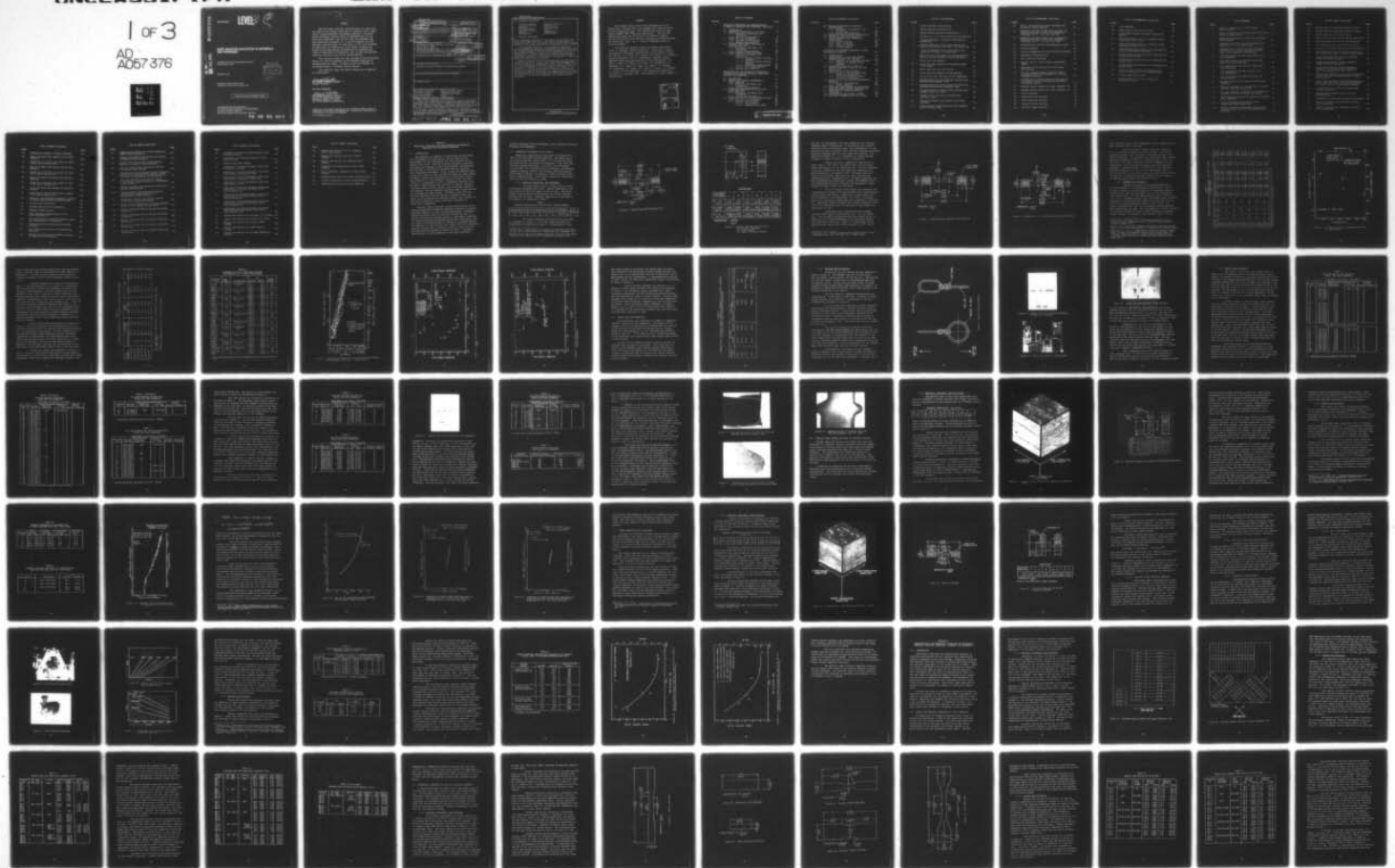

AD A 0 5 7 3 7 6

AFML-TR-78-6

LEVEL



②
SF

**QUICK REACTION EVALUATION OF MATERIALS
AND PROCESSES**

*UNIVERSITY OF DAYTON RESEARCH INSTITUTE
DAYTON, OHIO 45469*

FEBRUARY 1978

TECHNICAL REPORT AFML-TR-78-6
Final Report - January 1976 - December 1977

DDC
RECEIVED
AUG 11 1978
RECEIVED

Q7 F

Approved for public release; distribution unlimited.

AIR FORCE MATERIALS LABORATORY
AIR FORCE WRIGHT AERONAUTICAL LABORATORIES
AIR FORCE SYSTEMS COMMAND
WRIGHT-PATTERSON AIR FORCE BASE, OHIO 45433

78 08 02 03 9

AU NU.
DDC FILE COPY

NOTICE

When Government drawings, specifications, or other data are used for any purpose other than in connection with a definitely related Government procurement operation, the United States Government thereby incurs no responsibility nor any obligation whatsoever; and the fact that the government may have formulated, furnished, or in any way supplied the said drawings, specifications, or other data, is not to be regarded by implication or otherwise as in any manner licensing the holder or any other person or corporation, or conveying any rights or permission to manufacture, use, or sell any patented invention that may in any way be related thereto.

This technical report has been reviewed by the Information Office (OI) and is releasable to the National Technical Information Service (NTIS). At NTIS, it will be available to the general public, including foreign nations.

This technical report has been reviewed and is approved for publication.

MR. ALBERT OLEVITCH, Chief
Project Engineer

FOR THE COMMANDER:

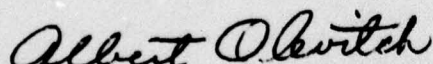
MR. ALBERT OLEVITCH, Chief
Materials Engineering Branch
Materials Support Division
Air Force Materials Laboratory

Copies of this report should not be returned unless return is required by security considerations, contractual obligations, or notice on a specific document.

UNCLASSIFIED

SECURITY CLASSIFICATION OF THIS PAGE (When Data Entered)

19 REPORT DOCUMENTATION PAGE		READ INSTRUCTIONS BEFORE COMPLETING FORM	
1. REPORT NUMBER 18 AFML-TR-78-6	2. GOVT ACCESSION NO.	3. RECIPIENT'S CATALOG NUMBER	
4. TITLE (and Subtitle) 6 QUICK REACTION EVALUATION OF MATERIALS AND PROCESSES.		5. TYPE OF REPORT & PERIOD COVERED 9 Final Report 1 Jan 76 - 31 Dec 77.	
7. AUTHOR(s) 10 D.R. Askins G.J. Petrak		14. PERFORMING ORG. REPORT NUMBER 14 UDR-TR-77-66	8. CONTRACT OR GRANT NUMBER(s) 15 F33615-76-C-5034
9. PERFORMING ORGANIZATION NAME AND ADDRESS University of Dayton Research Institute University of Dayton Dayton, Ohio 45469		10. PROGRAM ELEMENT, PROJECT, TASK AREA & WORK UNIT NUMBERS 16 73810678 17 06	
11. CONTROLLING OFFICE NAME AND ADDRESS Air Force Materials Laboratory (AFML/MXE) Wright-Patterson Air Force Base, Ohio 45433		11. REPORT DATE 11 Feb 1978 12. NUMBER OF PAGES 216	
14. MONITORING AGENCY NAME & ADDRESS (if different from Controlling Office)		15. SECURITY CLASS. (of this report) Unclassified 12 217p. 15a. DECLASSIFICATION DOWNGRADING SCHEDULE	
16. DISTRIBUTION STATEMENT (of this Report) Approved for public release; distribution unlimited			
17. DISTRIBUTION STATEMENT (of the abstract entered in Block 20, if different from Report)			
18. SUPPLEMENTARY NOTES			
19. KEY WORDS (Continue on reverse side if necessary and identify by block number) Mechanical Properties Swivel and Link Assembly 7475-T7651 Aluminum Composite Materials 2124-T851 Aluminum Polyphenylene Sulfide Crack Growth Rate Nylon Stress Corrosion Cracking Polypropylene			
20. ABSTRACT (Continue on reverse side if necessary and identify by block number) This report summarizes the results of a variety of materials evaluation and related materials engineering studies which were completed under contract with the Materials Support Division of the Air Force Materials Laboratory. The report is divided into three sections according to the general class of material involved. The first section describes studies of the mechanical properties of metal alloys and structural components. Included are data			

DD FORM 1 JAN 73 1473

EDITION OF 1 NOV 65 IS OBSOLETE

UNCLASSIFIED

SECURITY CLASSIFICATION OF THIS PAGE (When Data Entered)

105 400 808 08 02 039

UNCLASSIFIED

SECURITY CLASSIFICATION OF THIS PAGE(When Data Entered)

19. Key Words (Concluded)

Potting Compounds	Thawing Techniques
Durability Testing	Compatibility
Adhesives	High Sulfur Fuel
Portable Shelters	Shale Oil Fuel
Fuel Tank Sealants	O-rings
Adhesion	Compression Set
Contamination	Polycarbonate

20. Abstract (Concluded)

on the mechanical properties of aluminum alloy 7475-T7651, complete crack growth rate data on 2124-T851, and the results of tests on a swivel and link assembly from an operational AF system. A discussion of stress corrosion test techniques is also included.

In the second section the test programs involving non-metallic composites, plastics, and adhesives are discussed. Data are included for the tensile and flexural properties of E741D and NR 150 B2/S composites, and the tensile properties of nylon and polypropylene. Results of durability tests of adhesives and an investigation of potting compounds are presented and discussed along with a summary of a comprehensive investigation of adhesive bonding for use in portable shelters.

The last section of this report deals with the evaluation of elastomeric sealants, O-rings, and related materials. Included are the results of an investigation of fuel tank sealants for the F-111, the evaluation of PR-1755, class B-2 sealant, a study of the effect of thawing of fuel tank sealants, the effect of JP-4 and JP-8 on a variety of non-metallic materials, material compatibility in high sulfur and shale oil fuels, and an evaluation of Fairchild-Republic rigid foam. Two programs involving O-rings are discussed; one is the evaluation of MIL-P-83461 O-rings and the other is the long-term compression set of various O-ring materials.

UNCLASSIFIED

SECURITY CLASSIFICATION OF THIS PAGE(When Data Entered)

PREFACE

This summary report covers work performed during the period from 1 January 1976 to 31 December 1977 under Air Force Contract F33615-76-C-5034. The contract was initiated under Project Number 7381, "Materials Application". The work was administered under the direction of the Materials Support Division of the Air Force Materials Laboratory, Wright-Patterson Air Force Base, Ohio. Mr. A. Olevitch (AFML/MXE) acted as Project Engineer.

This work was conducted under the general supervision of Mr. D. Gerdeman, Project Supervisor. University of Dayton personnel who made major contributions to the program include: W.E. Berner, G.J. Petrak, D.R. Askins, R.R. Cervay, J.J. Ruschau, Research Engineers; and J.A. Ziegenhagen, Research Chemist. Research Technicians participating in this program were J.N. Dues, T. Dusz, J.H. Eblin, R.B. Glett, P.D. Klosterman, R.J. Kuhbänder, A.L. Logue, S.C. Macy, R.J. Marton, D.C. Maxwell, J.C. McKiernan, D.S. Opela, L.D. Pike, G.E. Price, P.L. Proshek, E. Soltis, and D.W. Wolesslagle. This report was submitted by the authors in December 1977. The contractor's report number is UDR-TR-77-66.

ACCESSION for	
NTIS	White Section <input checked="" type="checkbox"/>
DDC	Buff Section <input type="checkbox"/>
UNANNOUNCED	<input type="checkbox"/>
JUSTIFICATION	
BY	
DISTRIBUTION/AVAILABILITY CODES	
DI	SPECIAL
A	

TABLE OF CONTENTS

SECTION		PAGE
1	MECHANICAL PROPERTIES AND CHARACTERISTICS OF METALLIC MATERIALS AND STRUCTURAL COMPONENTS	1
1.1	INTRODUCTION	1
1.2	MECHANICAL PROPERTIES OF 7475-T7651	2
1.2.1	Materials, Specimens, and Procedures	2
1.2.2	Results and Discussion	8
1.3	SWIVEL AND LINK ASSEMBLIES	17
1.3.1	Specimen and Procedures	19
1.3.2	Results and Discussion	23
1.4	COMPLETE CRACK GROWTH RATE DATA ON ALUMINUM 2124-T851	33
1.4.1	Materials, Specimens, and Procedures	34
1.4.2	Results and Discussion	38
1.5	STRESS CORROSION TEST TECHNIQUES	45
1.5.1	Material, Specimens, and Procedures	46
1.5.1.1	Vertical Loaded, Constant Immersion	50
1.5.1.2	Vertical Loaded Alternate Exposure	51
1.5.1.3	Horizontal Loaded Method	51
1.5.1.4	Bolt Loaded Method	52
1.5.2	Results and Discussion	55
2	CHARACTERISTICS AND MECHANICAL PROPERTIES OF NON-METALLIC MATERIALS INCLUDING COMPOSITES, PLASTICS, AND ADHESIVES	62
2.1	INTRODUCTION	62
2.2	TENSILE AND FLEXURAL PROPERTIES OF E741D COMPOSITE	62
2.2.1	Material, Specimens, and Procedures	63
2.2.2	Results and Discussion	66
2.3	MECHANICAL PROPERTIES OF NR 150 B2/S-GLASS COMPOSITE	71
2.3.1	Materials, Specimens, and Procedures	71
2.3.2	Results and Discussion	77
2.4	CANDIDATE PLASTICS FOR BOMB SENSING UNITS	82
2.4.1	Materials and Specimens	86
2.4.2	Results and Discussion	87
2.4.2.1	Coupon Tests	87
2.4.2.2	Component Part Tests	99

TABLE OF CONTENTS (Concluded)

SECTION	PAGE
2.5 TENSILE PROPERTIES OF NYLON AND POLYPROPYLENE	99
2.5.1 Specimens, Environments, and Procedures	103
2.5.2 Results and Discussion	105
2.6 SHELTER POTTING COMPOUND INVESTIGATION	113
2.7 DURABILITY TESTING OF ADHESIVES	118
2.8 SHELTER ADHESIVE BOND DURABILITY INVESTIGATION	119
2.8.1 Phase I Testing	128
2.8.2 Phase II Testing	131
2.8.3 Phase III Testing	131
2.8.4 Program Summary	133
 3 EVALUATION OF ELASTOMERIC SEALANTS, O-RINGS AND RELATED MATERIALS	 135
3.1 INTRODUCTION	135
3.2 INVESTIGATION OF FUEL TANK SEALANT SYSTEMS FOR THE F-111 AIRCRAFT	136
3.2.1 Adhesion to Contaminated Surfaces	136
3.2.2 Adhesion to Cadmium Plated Surfaces	141
3.3 EVALUATION OF PR-1755, CLASS B-2 SEALANT ACCORDING TO MIL-S-83313 AND MIL-S-83430	148
3.4 THAWING OF FUEL TANK SEALANTS	154
3.4.1 Effect of Frozen Storage Time on Sealant Properties	158
3.4.2 Effect of Microwave Thawing on Sealant Properties	164
3.5 EFFECT OF JP-4 AND JP-8 ON NON-METALLIC MATERIALS	167
3.5.1 Phase 1 Investigation	167
3.5.2 Phase 2 Testing	169
3.6 MATERIALS COMPATIBILITY IN HIGH SULFUR FUELS AND FUELS DERIVED FROM SHALE OIL	170
3.7 EVALUATION OF FAIRCHILD-REPUBLIC RIGID FOAM	170
3.8 EVALUATION OF MIL-P-83461 O-RINGS	173
3.9 LONG-TERM COMPRESSION SET OF O-RINGS	190

LIST OF ILLUSTRATIONS

FIGURE		PAGE
1	Tensile Specimen Configuration	3
2	Compact Specimen Configuration	4
3	Smooth Fatigue Specimen Configuration	6
4	Notched ($K_t = 3.0$) Fatigue Specimen Configuration	7
5	Ultimate Strength of Aluminum 7475-T7651 vs. Temperature	10
6	Constant Amplitude Cyclic Crack Growth Test Results for Aluminum 7475-T7651, 1.5-Inch Plate	14
7	Smooth and Notched Fatigue Test Results for Aluminum 7475-T7651, 1.5-Inch Plate	15
8	Smooth Fatigue Test Results of the As-Received Material and the Thermally Cycled Specimens	16
9	Swivel and Link Assembly	20
10	Swivel and Link Assemblies Furnished by ADTC (five groups)	21
11	Swivel and Link Pull Test Set-Up	21
12	Swivel and Link Assembly in Test Machine	22
13	Typical Pull Test Failures for S&L Assemblies	29
14	Photomicrograph of Failed Brazed Junction From MAU-166/B S&L Assembly (50X)	32
15	Photomicrograph of Failed Brazed Junction From 4030-00-764-1284 MN S&L Assembly (50X)	32
16	Photomicrograph of Pressure Weld From MAU-78/B Assembly, Spec #11 (40X)	33
17	Aluminum Alloy 2124-T851 Microstructure Composite (100X)	35
18	Fracture Toughness and Fatigue Crack Growth Specimens	36
19	Complete Crack Growth Rate Curve for Aluminum Alloy 2124-T851 Plate	40

LIST OF ILLUSTRATIONS (Continued)

FIGURE		PAGE
20	COD vs. a/W Calibration Curve Developed For Elongated Compact Specimen	42
21	Comparison of Crack Growth Data Developed For Aluminum 2124-T851 via Two Crack Measuring Techniques for B = 1.50 inch (38.1 mm)	43
22	Comparison of Crack Growth Data Developed For Aluminum 2124-T851 via Two Crack Measuring Techniques for B = 0.75 inch (19.1 mm)	44
23	Aluminum Alloy 7075-T651 Microstructure (150X)	47
24	Tensile Specimen	48
25	Fracture Toughness and Stress Corrosion Specimen	49
26	Horizontal Stressing Frame	53
27	Bolt Loaded WOL Specimen	53
28	Typical Load vs. Crack Opening Displacement Traces	54
29	Compliance Curve Obtained For Bolt Loaded WOL Specimen	54
30	Vertical Loading Constant Immersion Stress Corrosion Cracking Test Results for Chloride-Dichromate Solution	59
31	A Comparison of Stress Corrosion Test Results For Various Loading Conditions in Chloride-Dichromate Solution	60
32	Specimen Layout Drawing for Panel (Exhibit) "A"	64
33	Specimen Layout Drawing for Panel (Exhibit) "B"	65
34	Tensile Specimen	73
35	Three-Point Flex Specimen	74
36	Short Beam Shear Specimen	74
37	Flexural Fatigue Specimen	75
38	Ballistic Impact Specimen	75

LIST OF ILLUSTRATIONS (Concluded)

FIGURE		PAGE
39	Creep Specimen	76
40	Creep Data For NR 150 B2/S-Glass	84
41	Guided Bomb Candidate Plastics Fatigue Test Results	98
42	Load Displacement Trace for Component Tests Conducted at 72°F (22°C)	101
43	Load Displacement Trace for Component Tests Conducted at 225°F (107°C)	102
44	Stress/Strain Characteristics of Unexposed and Exposed Polypropylene Specimens	108
45	Stress/Strain Characteristics of Unexposed and Exposed Polypropylene	109
46	Stress/Strain Characteristics of Unexposed and Exposed Nylon	110
47	Stress/Strain Characteristics of Unexposed and Exposed Nylon	111
48	Effect on Data of Using Original Area for Computing Stresses vs. Using Exposed Area	112
49	Typical Compression Curves	116
50	Testing Matrix For JP-4/JP-8 Materials Evaluation Program	171

(Continued) LIST OF TABLES

TABLE		PAGE
1	Chemical Composition of Al7475-T7651, Weight Percent	2
2	Tensile Properties of Aluminum Alloy 7475-T7651 Plate (1.5-Inch Thick)	9
3	Mechanical Properties of 7000-Series Aluminum Alloys/Temper	12
4	Aluminum 7475-T7651 Fracture Toughness Test Results for 1.5-Inch Thick Plate	13
5	Aluminum Alloy 7475-T7651 Stress Corrosion Cracking in a 3.5% NaCl Solution (1.5-Inch Plate, Short-Transverse Orientation)	18
6	Pull Test Results For MAU-166/B Swivel and Link Assemblies	24
7	Pull Test Results For 4030-00-764-1284 MN Swivel and Link Assemblies	26
8	Pull Test Results for FMU-54/B Swivel and Link Assemblies	28
9	Pull Test Results For FMU-56 Swivel and Link Assemblies	28
10	Pull Test Results for MAU-78/B Swivel and Link Assemblies	30
11	Hardness Values of End Link For Various S&L Assemblies	30
12	Tensile Properties of Aluminum Alloy 2124-T851 Two-Inch (50.8-mm) Thick Plate	39
13	Fracture Toughness Properties of Aluminum Alloy 2124-T851 Two-Inch (50.8-mm) Thick Plate	39
14	Room Temperature Tensile Properties of Aluminum Alloy 7075-T651	56
15	Fracture Toughness Test Results (S-T) Orientation, Room Temperature	56
16	Stress Corrosion Cracking Test Results For a Strongly Acidic (pH=1.3) Chloride-Dichromate Solution	58

LIST OF TABLES (Continued)

TABLE		PAGE
17	Tensile Data For Glass-Epoxy Material E741D	67
18	Flexural Data For Glass-Epoxy Material E741D	69
19	Tensile Data For NR 150 B2/S-Glass	78
20	Three-Point Flexural Data For NR 150 B2/S-Glass	79
21	Short Beam Shear Data For NR 150 B2/S-Glass	81
22	Flex Fatigue Results For NR 150 B2/S-Glass	83
23	Results of Ballistic Impact on NR 150 B2/S-Glass	83
24	'Room Temperature Residual Tensile Results For NR 150 B2/S-Glass After 1000-Hour Creep Testing	85
25	Guided Bomb Candidate Plastics As-Molded Condition Tensile Strength	88
26	Guided Bomb Candidate Plastics Annealed Condition Tensile Properties	89
27	Guided Bomb Candidate Plastics Humidity Exposure Conditioning Tensile Properties [All Tests Conducted at 72°F (22°C)]	91
28	Guided Bomb Candidate Plastics Room Temperature Tensile Strength Following Boiling in Water For Two Hours	95
29	Guided Bomb Candidate Plastics Room Temperature Tensile Strength After a 200-Hour Submersion in a 165°F (74°C) 5 Percent NaCl Solution	96
30	Fatigue Cycles to Failure For Guided Bomb Candidate Plastics	97
31	Guided Bomb Candidate Plastics Retained Strength Tests	100
32	Dimensions of Nylon and Polypropylene Specimens	104
33	Effect of Solvents and Lubricants on Nylon and Polypropylene	106
34	Effect of Solvents and Lubricants on Nylon and Polypropylene	107

LIST OF TABLES (Continued)

TABLE		PAGE
35	Compressive Strength - Potting Compounds	115
36	Static Lap Shear Test Results For PL-729-3 Adhesive	120
37	Durability of PL-729-3 Lap Joints in 140°F (60°C) and 95 Percent R.H.	121
38	Static Lap Shear Test Results For AF-143-2 Adhesive	122
39	Durability of AF-143-2 Lap Joints in 140°F (60°C) and 95 Percent R.H.	123
40	Static Lap Shear Test Results For FM-123-2 Adhesive	124
41	Durability of FM-123-2 Lap Joints in 140°F (60°C) and 95 Percent R.H.	125
42	Static Lap Shear Test Results for FM-123-2 Adhesive	126
43	Durability of FM-123-2 Lap Joints in 120°F (49°C) and 95 Percent R.H.	127
44	Materials and Processing Parameters Included in Shelter Adhesive Bond Corrosion Study	129
45	Lap Shear Test Conditions	132
46	Climbing Drum Peel Test Conditions	132
47	Summary of Total Program	134
48	Glass Transition Temperatures of F-111 Fuel Tank Materials	138
49	Peel Test Results of Sealants Bonded to Clean and Contaminated C-130 Surfaces	140
50	Alternative Barrier Materials and Primers Evaluated	142
51	Fuel Exposure Test Results on AFML Barrier Materials	143
52	Adhesion Test Results For PS-899 B-2 Sealant on Cadmium Plated Fasteners	145

LIST OF TABLES (Continued)

TABLE		PAGE
53	Adhesion Test Results For PR-611J Topcoat on Cadmium Plated Fasteners	146
54	Adhesion Test Results For PR-1422 B-2 Sealant on Cadmium Plated Fasteners	147
55	Adhesion Test Results For EC-2216 Barrier Material on Cadmium Plated Fasteners	147
56	Physical Property Test Results For PR-1755 B-2 Sealant (First Batch)	149
57	Repairability and Accelerated Storage Properties of PR-1755 B-2 Sealant (First Batch), Tested According to Requirements of MIL-S-83318, I	150
58	Peel Test Results For PR-1755 B-2 Sealant (First Batch), Tested According to Requirements of MIL-S-83318, I	151
59	Physical Property Test Results For PR-1755 B-2 Sealant (Second Batch)	155
60	Peel Test Results For PR-1755 B-2 Sealant (Second Batch), Tested According to Requirements of MIL-S-83318, I	156
61	Properties of PR-1755 B-2 Sealant (Second Batch) After Accelerated Storage	157
62	Effect of Cure Temperature on Curing Properties of PR-1755 B-2 Sealant (Second Batch)	157
63	Effect of Freezing Time on Sealant Properties; PR-1422 B-2	159
64	Effect of Freezing Time on Sealant Properties; PR-1440 B-2	160
65	Effect of Freezing Time on Sealant Properties; PR-1422 A-2	161
66	Effect of Freezing Time on Sealant Properties; PR-1440 A-2	162
67	Effect of Freezing Time on Sealant Properties; PR-1750 A-2	163

LIST OF TABLES (Continued)

TABLE		PAGE
68	Properties of Class B-2 Type Sealants After Microwave Thawing	166
69	Volume Swell of Materials Exposed to JP-4 and JP-8 Fuels	168
70	Materials and Test Methods	172
71	Properties of Fairchild-Republic Rigid Foam After Aging in Water	174
72	Properties of Fairchild-Republic Rigid Foam After Aging in MIL-H-5606 Fluid	175
73	Properties of Fairchild-Republic Rigid Foam After Aging in Stauffer's 7700 Fluid	176
74	Properties of Fairchild-Republic Rigid Foam After Aging in JP-4	177
75	Properties of Fairchild-Republic Rigid Foam After Aging For 30 Days at 160°F (71°C) and 95 Percent R.H.	178
76	Properties of Fairchild-Republic Rigid Foam After Aging For 60 Days at 160°F (71°C) and 95 Percent R.H.	179
77	Properties of Fairchild-Republic Rigid Foam After Aging For 120 Days at 160°F (71°C) and 95 Percent R.H.	180
78	Properties of Fairchild-Republic Rigid Foam After Aging For 180 Days at 160°F (71°C) and 95 Percent R.H.	181
79	Dynamic Test Results For Precision 7757 O-Rings	182
80	Dynamic Test Results For Goshen 2249 O-Rings	183
81	Dynamic Test Results For National A5568 O-Rings	184
82	Dynamic Test Results For Parker N756-75 O-Rings	185
83	Dynamic Test Results For Stillman SR-8014-75 O-Rings	186

LIST OF TABLES (Concluded)

TABLE		PAGE
84	Dynamic Test Results For E.F. Houghton 10V 75-440 O-Rings	187
85	Dynamic Test Results for Parco 4367-70 O-Rings	188
86	Dynamic Test Results for Acushnet H14379 O-Rings	189
87	Compression Set Properties of MIL-P-83461 O-Rings	191
88	Static Mechanical Properties of MIL-P-83461 O-Rings	192
89	Compression Set Data For Parco O-Ring Materials	193
90	Physical Properties of Parco O-Ring Materials	197
91	Compression Set Data For O-Ring Compounds	198

SECTION 1

MECHANICAL PROPERTIES AND CHARACTERISTICS OF METALLIC MATERIALS AND STRUCTURAL COMPONENTS

1.1 INTRODUCTION

The response of a material to externally applied forces and environments is significant to the Air Force and the requirements for such information can occur anytime during a system's life cycle. From the earliest conceptual stage when the mission of a system is first being defined, consideration must be given to the type of materials that can withstand the anticipated environment. Later, during the system's operational life, there is often the need to define the exact amount of damage a system has experienced due to the actual service. The University of Dayton Research Institute (UDRI) has been involved in aiding the Air Force in addressing questions such as these. These efforts have involved all types of materials from those used in static systems, such as portable shelters and antennas, to high technology materials used in state-of-the-art airframes and power plants. Included in this list are metallic components made of aluminum, titanium, steel, and super alloys; fasteners and fastener systems; and a variety of structural composites ranging from simple fiberglass to metal matrix composites.

Specific types of programs include investigating the mechanical properties of emerging aerospace materials, evaluating candidate materials in their intended environment, developing engineering design data for materials selected for use in a system, investigating possible repair or replacement technology for systems experiencing problems during their operational life, and aiding in failure analysis of damaged or destroyed systems. The magnitude of these projects has ranged from small evaluations requiring no more than a few days of work to large long-term programs involving several man-years of effort. Included in this section is a brief summation of the more significant

projects conducted during the course of this contract on metallic materials and components.

1.2 MECHANICAL PROPERTIES OF 7475-T7651

Mechanical properties were developed on aluminum alloy 7475 in the T7651 heat treated condition. The effort was a follow-on to previous efforts (Ref. 1, 2) in which the alloy was evaluated for its mechanical properties in the T7351 and T651 heat treated conditions. Alloy 7475 is a refinement of alloy 7075, and is presented by its producer, the Aluminum Company of America (ALCOA), as possessing improved strength and fracture toughness, as compared to other in-service 7000-series aluminum alloys. Test results reported in References 1 and 2 confirm the producer's claims.

1.2.1 Material, Specimens, and Procedures

The test material was a 1.5-inch (38.1-mm) thick rolled plate purchased from ALCOA. Nominal dimensions of the test piece were 36 by 24 inches (914 by 610 mm). The longitudinal grain direction coincides with the 36-inch (914-mm) dimension of the plate. Chemical composition, as provided by the producer, is presented in Table 1.

TABLE 1
CHEMICAL COMPOSITION OF AL7475-T7651, WEIGHT PERCENT

Zn	Mg	Cu	Cr	Mn	Fe	Si	Ti	Others	Al
5.89	2.10	1.58	0.18	0.01	0.07	0.05	0.02	0.05 ea. 0.15 tot.	Balance

The tensile specimen configuration that was used is reproduced in Figure 1. All three compact specimen configurations are depicted in Figure 2. Configuration "a" was

¹Cervay, R.R., "Engineering Design Data for Aluminum Alloy 7475 in the T761 and T61 Condition," AFML-TR-72-173, September 1972.

²Cervay, R.R., "Static and Dynamic Fracture Properties for Aluminum Alloy 7475-T651 and T7351," AFML-TR-75-20, April 1975.

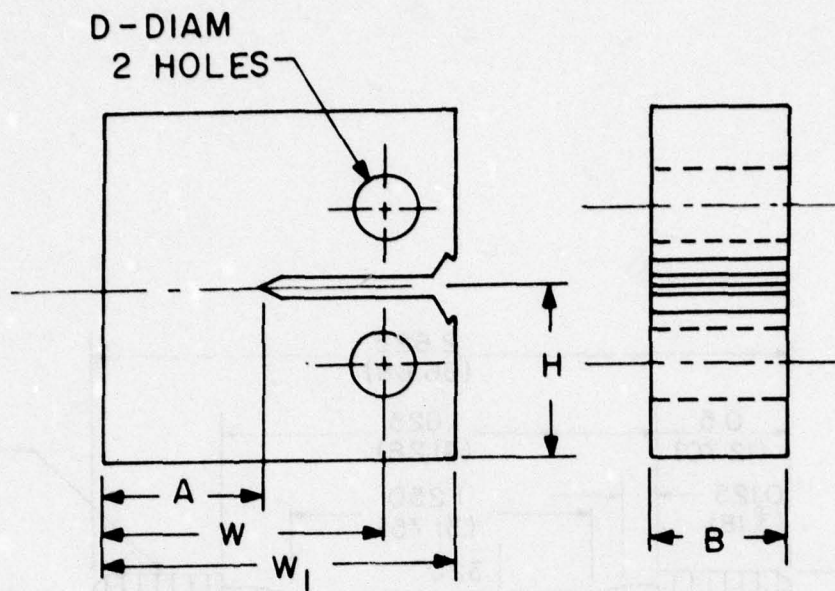

DIMENSIONS

SPECIMEN THICKNESS	A	B	W	W_1	H	D
(a) $1\frac{1}{2}$ (38.1)	1.65 (41.9)	1.50 (38.1)	3.0 (76.2)	3.35 (95.3)	1.80 (45.7)	0.625 (15.9)
(b) 0.650 (16.51)	0.835 (21.21)	0.650 (16.51)	1.500 (38.10)	1.875 (47.63)	0.900 (22.86)	0.375 (9.53)
(c) $\frac{1}{2}$ (12.70)	0.550 (1.397)	0.500 (12.70)	1.000 (25.40)	1.250 (3.175)	0.600 (15.24)	0.250 (0.635)

DIMENSIONS : INCHES
(mm)

Figure 2. Compact Specimen Configuration.

- * (a) Fracture Toughness
- (b) Crack Growth
- (c) Stress Corrosion Cracking

used for the longitudinal (L-T) and transverse (T-L) fracture toughness tests, configuration "b" was used for the constant amplitude cyclic crack growth tests, and configuration "c" was used for the short transverse (S-L) fracture toughness and stress corrosion cracking tests in a salt water test solution. The smooth and notched ($K_t = 3.0$) (Reference 3) fatigue specimen drawings are shown in Figures 3 and 4, respectively.

Tensile tests were conducted at temperatures of -65°F (-54°C), 72°F (22°C), and 200°F (94°C) in two orientations, longitudinal (L) and transverse (T). Fracture toughness tests were conducted at the same three test temperatures as those employed for the tensile tests. Toughness tests were repeated at each test temperature for three orientations: longitudinal (L-T), transverse (T-L), and short transverse (S-L). The longitudinal room temperature tensile and toughness tests were duplicated following a specimen time-temperature furnace exposure, at 250°F (121°C) for 1000 hours.

All of the cyclic crack growth test specimens were longitudinally oriented (L-T) and the tests were conducted using constant-amplitude loading. These cyclic crack growth tests were performed at room temperature, 72°F (22°C), in environments of 3.5 percent by weight salt water solution or laboratory air. Additional compact specimens were furnace-exposed to 250°F (121°C) for 1000 hours prior to undergoing a room temperature laboratory air test.

Longitudinal and transverse oriented fatigue specimens were tested in both notched ($K_t = 3.0$) and smooth ($K_t = 1.0$) specimen configurations with the loading ratio, R , equal to 0.1, a loading frequency of 110 cycles per second, and a sinusoidal wave form. Additional longitudinal smooth specimens were prepared and furnace-exposed to 250°F (121°C)

³Peterson, R.E., "Stress Concentration Design Factors," John Wiley and Sons, Inc., New York, N.Y., August 1966.

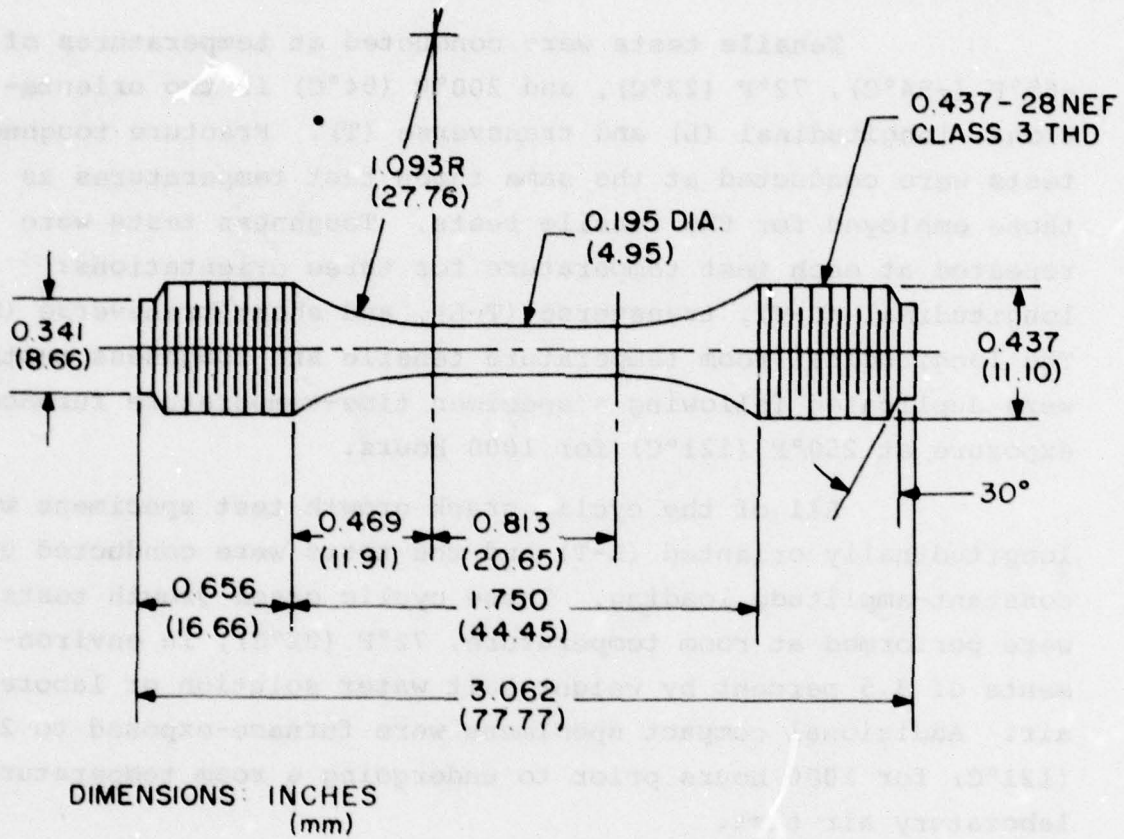
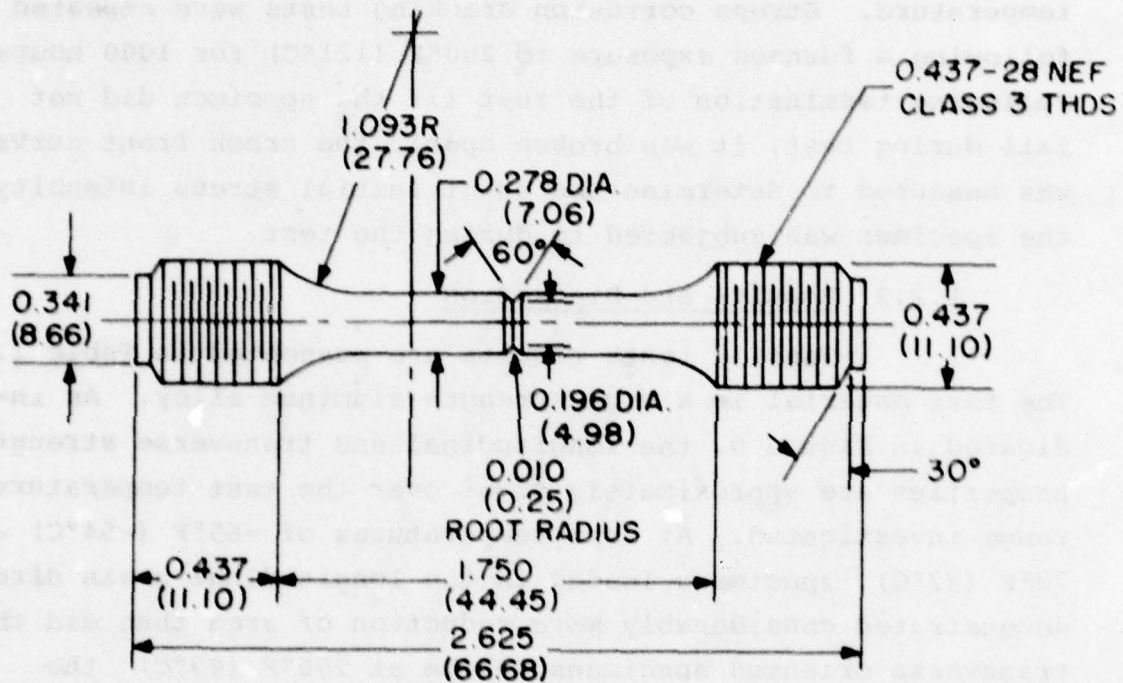

Figure 3. Smooth Fatigue Specimen Configuration.



DIMENSIONS: INCHES
(mm)

Figure 4. Notched ($K_t = 3.0$) Fatigue Specimen Configuration.

for 1000 hours prior to room temperature test in laboratory air, under the above test conditions.

Stress corrosion cracking tests were completed in a 3.5 percent by weight salt water solution. All stress corrosion cracking tests used short transverse oriented (S-L) compact specimens. The specimens were precracked under constant-amplitude sinusoidal loading at a stress intensity level less than half of the short-transverse fracture toughness at room temperature. Stress corrosion cracking tests were repeated following a furnace exposure to 250°F (121°C) for 1000 hours. Following termination of the test (if the specimen did not fail during test, it was broken open), the crack front curvature was measured to determine the exact initial stress intensity the specimen was subjected to during the test.

1.2.2 Results and Discussion

Tensile tests results are presented in Table 2. The test material is a high-strength aluminum alloy. As indicated in Figure 5, the longitudinal and transverse strength properties are approximately equal over the test temperature range investigated. At test temperatures of -65°F (-54°C) and 72°F (22°C), specimens loaded in the longitudinal grain direction demonstrated considerably more reduction of area than did the transverse oriented specimens, while at 200°F (93°C) the plastic deformation for the two differently oriented specimens was approximately the same. The test material's strength capabilities compare directly to those of other 7000-series aluminum alloys currently of interest to the Air Force (Ref. 4, 5, 6).

⁴Jones, R.E. and Fudge, K.A., "Engineering Design Data for Aluminum Alloy 7050-T73651 Plate," Technical Report AFML-TR-73-269, November 1973.

⁵Petrak, G.J., "Fracture Toughness and Stress Corrosion Properties of 7175-T736," Data Report No. UDRI-TR-69-01, January 1969.

⁶Babilon, C.F., et al., "Mechanical Properties, Fracture Toughness, Fatigue, Environmental Fatigue Crack Growth Rate, and Corrosion Characteristics of High-Toughness Aluminum Alloy Forgings, Sheet, and Plate," Technical Report AFML-TR-73-83, April 1973.

TABLE 2
TENSILE PROPERTIES OF ALUMINUM ALLOY 7475-T7651 PLATE
(1.5-INCH THICK)

Specimen No.	Test °F	Temp. °C	Orientation	Ultimate Strength		Yield Strength	Elongation %**	Red. of Area %
				KSI	(MPa)			
76L1	-65	(-54)	Long.	81.1	(559)	74.3	(512)	35.0
76L2				82.1	(566)	74.3	(512)	36.0
76L3				82.1	(566)	74.1	(511)	34.0
Avg.				81.4	(561)	74.2	(512)	35.0
76T1	-65	(-54)	Trans.	83.6	(576)	73.5	(506)	21.0
76T3				82.1	(566)	73.3	(505)	27.0
76T101				80.7	(566)	71.5	(492)	22.7
Avg.				82.1	(566)	72.8	(502)	23.6
76L4	72	(22)	Long.	78.4	(540)	71.3	(491)	50.2
76L5				78.7	(542)	71.8	(495)	49.8
76L6				78.3	(539)	71.5	(493)	45.8
Avg.				78.4	(540)	71.5	(493)	48.6
76T4	72	(22)	Trans.	79.3	(546)	70.1	(483)	41.3
RT5				79.1	(545)	69.8	(481)	38.8
76T6				79.5	(548)	69.8	(481)	34.8
Avg.				79.3	(546)	69.9	(481)	38.3
76L7	200	(93)	Long.	67.4	(464)	65.2	(450)	55.0
76L8				69.9	(481)	66.1	(455)	53.0
RL5				69.1	(476)	65.3	(450)	43.0
Avg.				68.8	(474)	65.5	(451)	50.0
76T7	200	(93)	Trans.	69.4	(478)	65.1	(448)	53.0
76T8				71.2	(490)	65.3	(450)	51.0
76T9				69.4	(478)	65.2	(450)	54.0
Avg.				70.0	(482)	65.2	(450)	53.0
76L10*	72	(22)	Long.	72.2	(498)	63.8	(440)	49.0
76L11*				73.0	(503)	64.7	(446)	48.0
Avg.				72.6	(500)	64.3	(443)	48.5

*Specimen exposed to 250°F (121°C) for 1000 hrs. prior to a 72°F (22°C) test.
**Percent elongation in a 1 inch (25.4 mm) gage length.

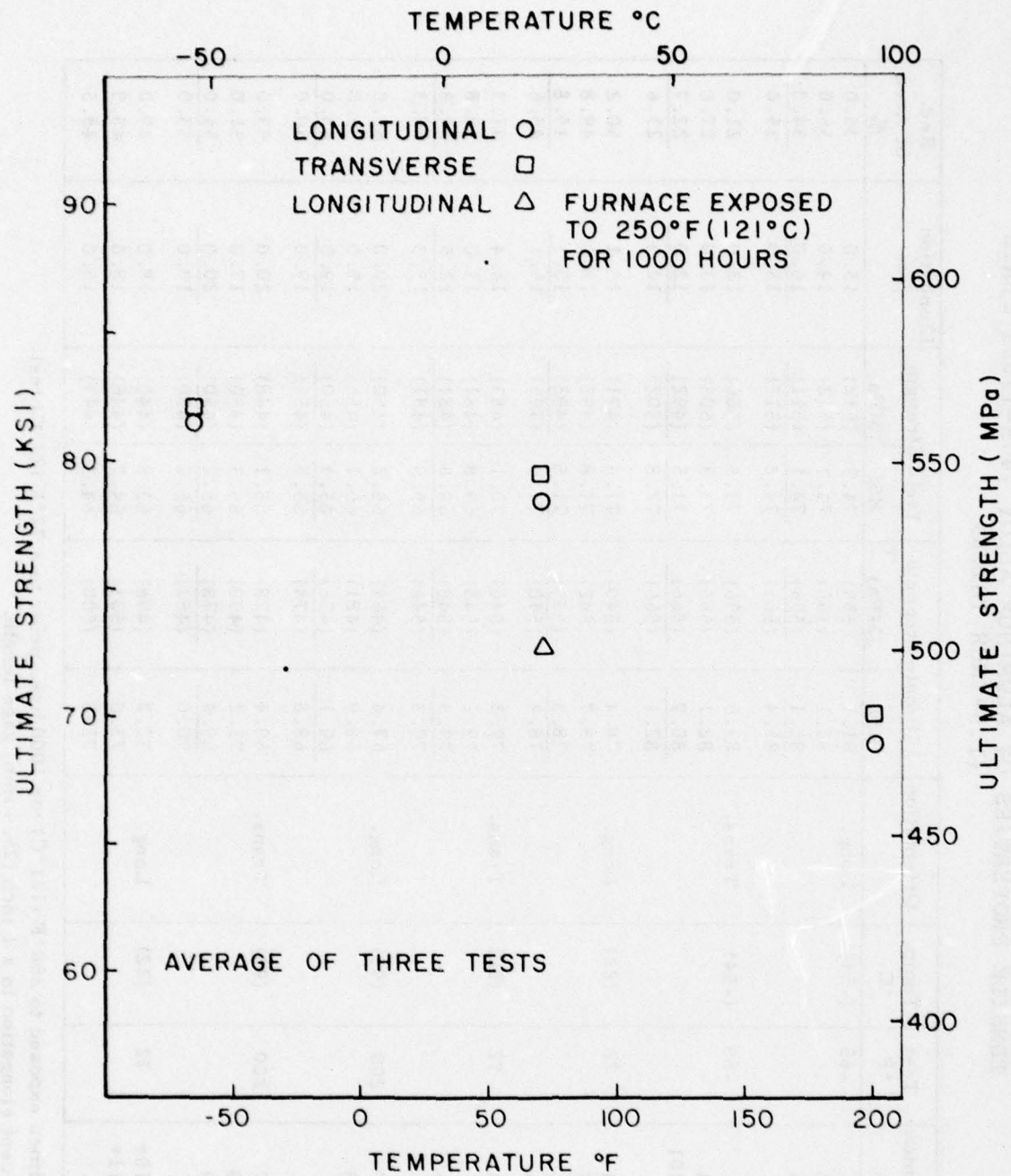

Figure 5. Ultimate Strength of Aluminum 7475-T7651 vs. Temperature.

Table 3 shows that the tensile properties of the test material closely parallel those of alloy-temper 7475-T651 reported in Reference 2. The load-carrying capability was reduced by 7 percent following a 250°F (121°C)/1000-hour thermal cycling in air.

Fracture toughness test results are presented in Table 4. The room temperature test results for longitudinal and long-transverse oriented test specimens are valid test results by ASTM standards; the tests indicate that the test material is very tough. Although the short-transverse (S-L) oriented specimen test results are invalid due to insufficient thickness, the conditional test results, K_Q , are lower than the other two specimen orientations that underwent test. Also, for the short-transverse oriented toughness tests there is less variation in test results (K_Q) over the test temperature range of -65°F (-54°C) to 200°F (93°C) than was encountered for the longitudinal and long-transverse oriented toughness specimens. Longitudinal oriented fracture toughness is improved by 12 percent following a 250°F (121°C)/1000-hour furnace time-temperature exposure.

Cyclic crack growth test results are presented in Figure 6. The cyclic loading crack propagation for the as-received material and that for furnace-preconditioned specimens plot in overlapping scatter bands. The tests conducted in a 3.5 percent by weight sodium chloride solution environment demonstrated a crack growth rate approximately three times faster than the data derived from tests conducted in a laboratory air environment. The crack growth data presented in Reference 2 for the same alloy with two different heat treatments fall in the same scatter band as that of the test plate.

Fatigue test results are presented in Figures 7 and 8. There is a data scatter band similar to that reported in Reference 2 for alloy 7475 in the T7351 and T651 heat treated conditions. There was a problem with specimens failing in the

TABLE 3
MECHANICAL PROPERTIES OF 7000-SERIES ALUMINUM ALLOYS/TEMPER

Alloy/ Temper	Reference	Ultimate* Strength KSI (MPa)	Yield Strength KSI (MPa)	KSI/in	K _Q (MPa√m)
7475-T7651		78.4 (540)	71.5 (493)	49.2	(54.0)
7475-T651	(2)	78.7 (542)	70.9 (488)	48.6**	(53.4)
7475-T7351	(2)	71.6 (493)	59.5 (410)	63.5**	(69.3)
7050-T73651	(3)	80.5 (550)	70.0 (482)	36.6	(40.2)
7175-T736	(5)	82.6 (570)	75.4 (520)	33.1	(36.3)
7049-T73	(6)	75.0 (517)	65.5 (452)	33.8	(37.1)

*All specimens are longitudinally oriented and underwent test at 72°F (22°C).

**Fracture toughness test invalid by ASTM test method.

TABLE 4
ALUMINUM 7475-T7651 FRACTURE TOUGHNESS
TEST RESULTS FOR 1.5-INCH THICK PLATE

Specimen No.	Test Temp.	Orientation	K_Q		ASTM Valid?
			KSI $\sqrt{\text{in}}$	MPa $\sqrt{\text{m}}$	
76LT4	72°F	Longitudinal	50.5	55.5	yes
76LT5	22°C	L-T	49.4	54.3	yes
76LT6			47.6	52.3	yes
Avg.			49.2	54.0	
76TL4	72°F	Long Trans.	43.9	48.2	yes
76TL5	22°C	T-L	44.8	49.2	yes
76TL6			44.0	48.3	yes
Avg.			44.2	48.6	
76S4	72°F	Short Trans.	39.1	43.0	no
76S5	22°C	S-L	38.7	42.5	no
76S6			37.1	40.7	no
Avg.			38.3	42.0	
76LT1	-65°F	Longitudinal	42.3	46.4	no
76LT2	-54°C	L-T	41.5	45.6	no
76LT3			41.1	45.1	no
Avg.			41.6	45.7	
76TL1	-65°F	Long Transverse	37.8	41.5	yes
76TL2	-54°C	T-L	38.4	42.1	yes
76TL3			38.1	41.8	yes
Avg.			38.1	41.8	
76S2	-65°F	Short Transverse	38.5	42.2	no
76S3	-54°C	S-L	36.9	40.5	no
Avg.			37.7	41.4	
76LT7	200°F	Longitudinal	64.9	72.3	yes
76LT8	93°C	L-T	61.5	67.5	yes
76LT9			57.9	63.6	yes
Avg.			61.4	67.8	
76TL7	200°F	Long. Trans.	50.6	55.6	no
76TL8	93°C	T-L	50.1	55.0	no
76TL9			49.8	54.7	yes
Avg.			50.2	55.1	
76S9	200°F	Short Trans.	36.8	40.4	no
76S10	93°C	S-L	44.2	48.5	no
Avg.			40.5	44.5	
76TL10*	72°F	Longitudinal	54.2	59.5	yes
76TL11*	22°C	L-T	54.3	59.6	yes
76TL12*			56.2	61.7	yes
Avg.			54.9	60.3	

*Furnace exposed to 250°F (121°C) for 1000 hours prior to room temperature test.

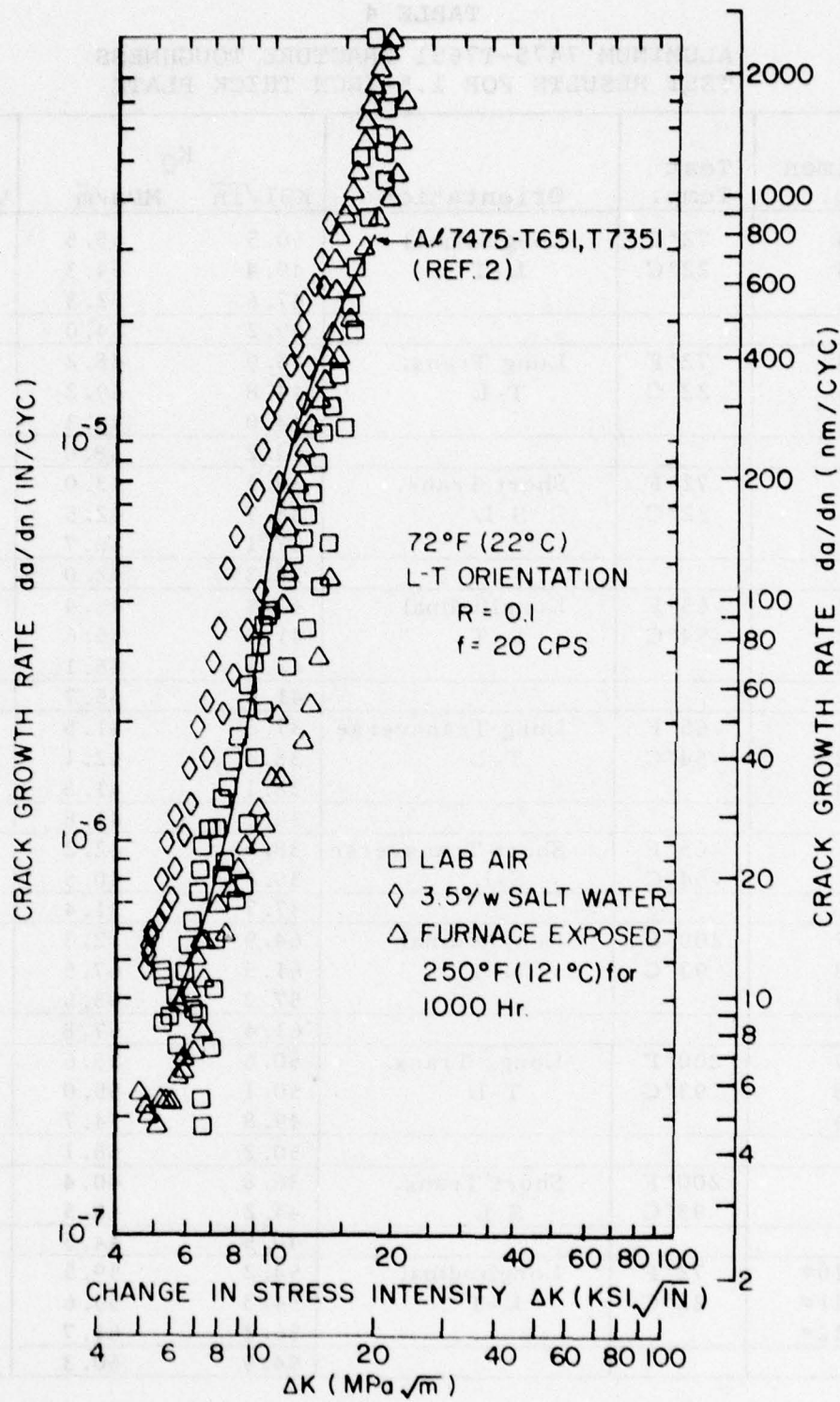

Figure 6. Constant Amplitude Cyclic Crack Growth Test Results for Aluminum 7475-T7651, 1.5-Inch Plate.

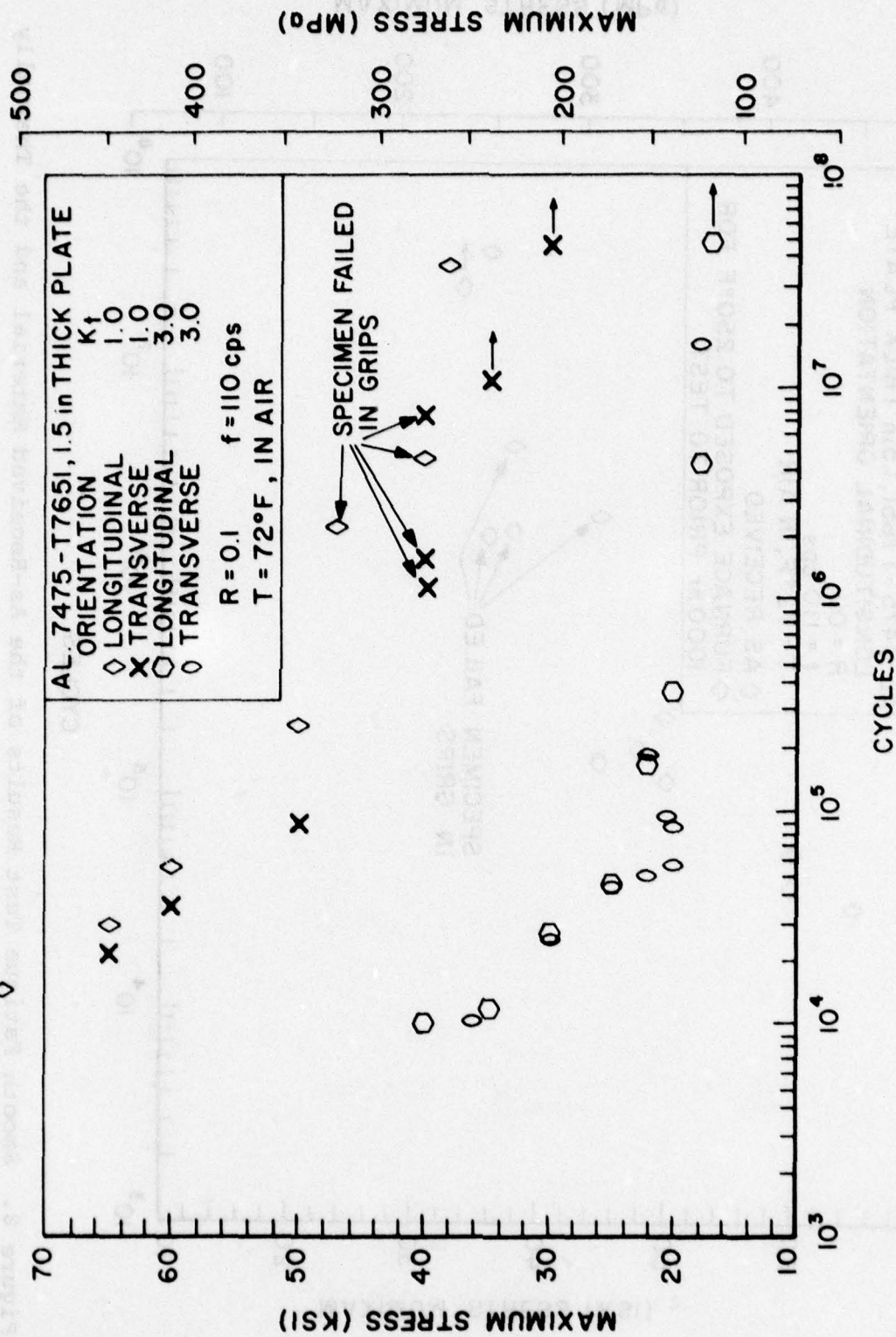

Figure 7. Smooth and Notched Fatigue Test Results for Aluminum 7475-T7651, 1.5-Inch Plate.

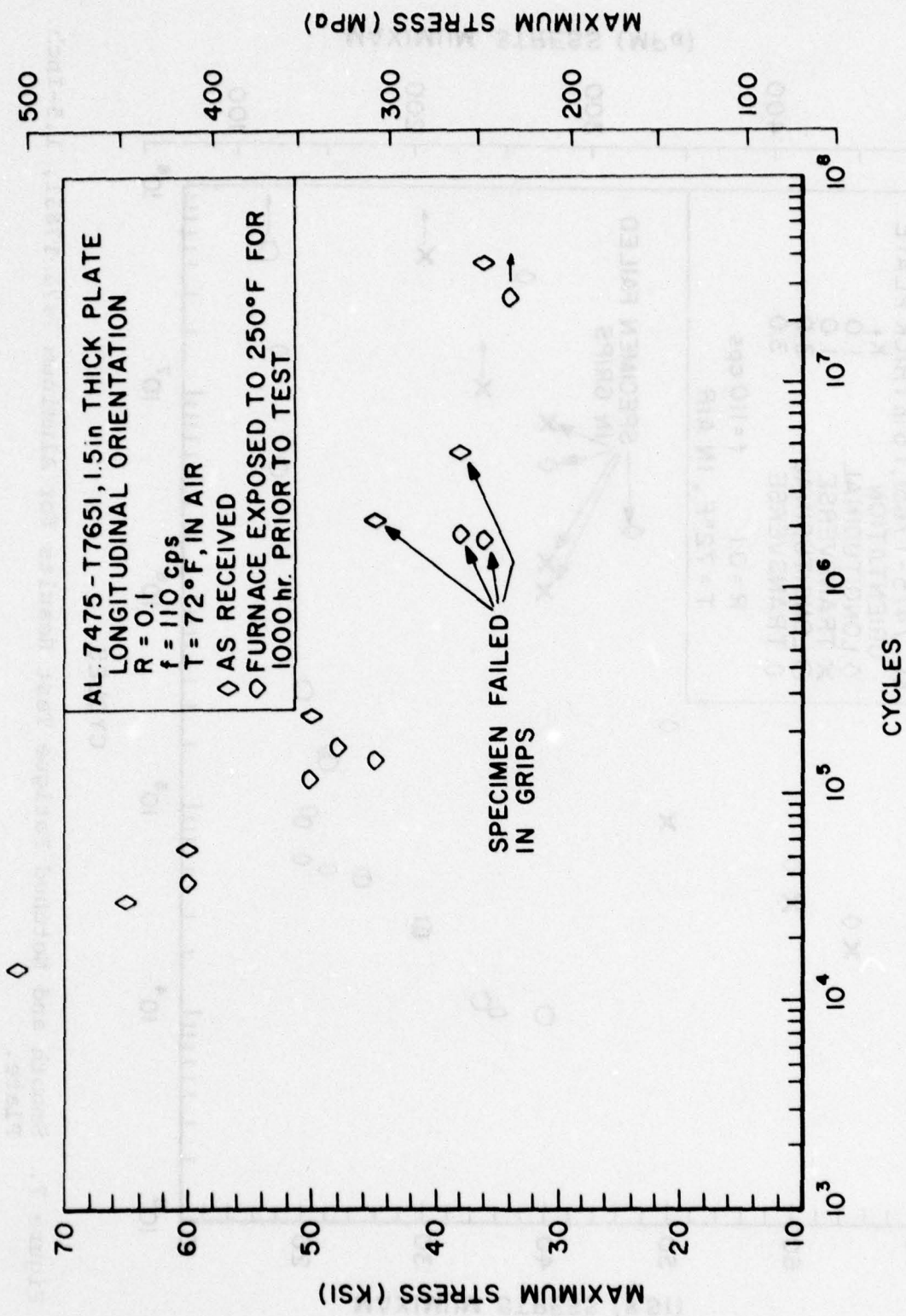

Figure 8. Smooth Fatigue Test Results of the As-Received Material and the Thermally Cycled Specimens.

test grips caused by the thread root radius being too sharp. The longitudinal and transverse oriented fatigue specimen test results fall in one wide scatter band and no distinction can be made between the two orientations. A time-temperature exposure of 250°F (121°C) for 1000 hours reduced the fatigue life slightly as shown in Figure 8.

Stress corrosion cracking test results in a 3.5 percent by weight sodium chloride test solution are presented in Table 5. All corrosion cracking specimens had a short-transverse orientation; the short-transverse orientation being the most sensitive to stress corrosion cracking. The precracked specimens were loaded up to 87 percent of the room temperature conditional short-transverse toughness, K_Q , that was previously determined. Short-transverse compact specimens, following a thermal cycle of 250°F (121°C) for 1000 hours, were loaded up to 83 percent of the conditional toughness, K_Q , and no failures occurred after 1000 hours in test.

1.3 SWIVEL AND LINK ASSEMBLIES

An investigation was conducted on a number of components labeled as Swivel and Link Assemblies. The purpose of this assembly is to arm a bomb during its release from the aircraft. During jettison of this bomb, the assembly pulls a lanyard attached to the bomb which, in turn, activates the detonation system of the unit. It is suspected that a significant number of the assemblies are breaking during bomb release, thus failing to arm the bomb.

A total of five different groups of Swivel and Link Assemblies were provided for evaluation. Pull tests were conducted on each assembly under various loading conditions in order to evaluate the maximum pull strengths of each system. A number of specimens were also sent to the Failure Analysis Branch of AFML in an attempt to identify the cause for the premature failures.

TABLE 5
ALUMINUM ALLOY 7475-T7651 STRESS CORROSION CRACKING IN A 3.5% NaCl SOLUTION
(1.5-inch Plate, Short-Transverse Orientation)

Specimen No.	K _I (initial)		Test Time		Exposure Prior to Test
	KSI√IN	MPa√m	Failure(Hr.)	No Failure (Hr.)	
S11	27.76	30.48	1000.0	1000.0	none
S12	33.14	36.38	1000.0	1000.0	none
S16	30.30	33.27	1000.0	1000.0	250°F (121°C) for 1000 hr.
S17	31.70	34.80	1000.0	1000.0	250°F (121°C) for 1000 hr.

1.3.1 Specimen and Procedures

A sketch of the basic Swivel and Link Assembly is shown in Figure 9. The assembly consists of three parts: the link swivel, the eye swivel, and the end link. The material for all test groups is steel which is protected by some form of cadmium plating. The end link is either brazed or welded together to form a solid ring. The assemblies are required to withstand a minimum load of 220 lbs (978 N) when applied in the direction specified in the figure.

The five groups of assemblies investigated were identified as: a) MAU-166/B, b) MAU-78/B, c) FMU-56, d) 4030-00-764-1284 MN, and e) FMU-54/B. A photograph of the five assemblies is presented in Figure 10.

All pull tests were performed on an MTS hydraulic servo-controlled testing machine. Maximum load was recorded using an MTS peak detector. A dual-trace storage oscilloscope was used to record both load and hydraulic ram position as functions of time. A Honeywell Visicorder was also used in conjunction with the oscilloscope to record both load and ram position as functions of time. The entire test set-up is shown in Figure 11.

The original loading pin diameters which were specified for the MAU-166/B assembly pull tests were 0.110 inch (2.79 mm) for the link swivel and 0.187 inch (4.75 mm) for the link end. Because it was suspected that the diameter of the lower loading pin (link end) might have an effect on the maximum pull strength, smaller diameters were subsequently used for the other four groups for a closer approximation of the lanyard which would normally apply the load in actual service.

A photograph of the Swivel and Link Assembly properly gripped in the testing machine is shown in Figure 12. The orientation of the specimen (link swivel at the top) was consistent for all the pull tests conducted. A loading rate of

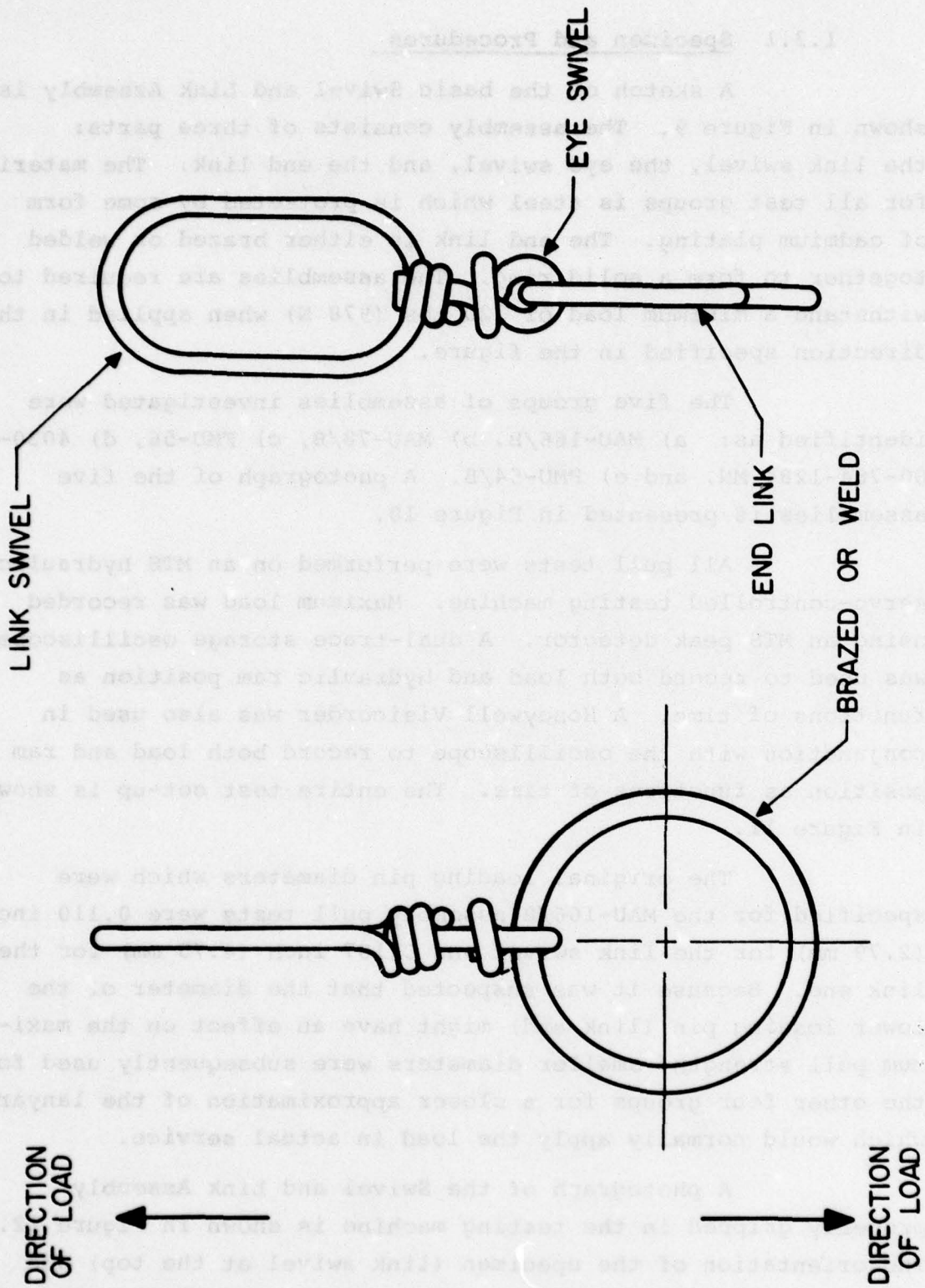

Figure 9. Swivel and Link Assembly.

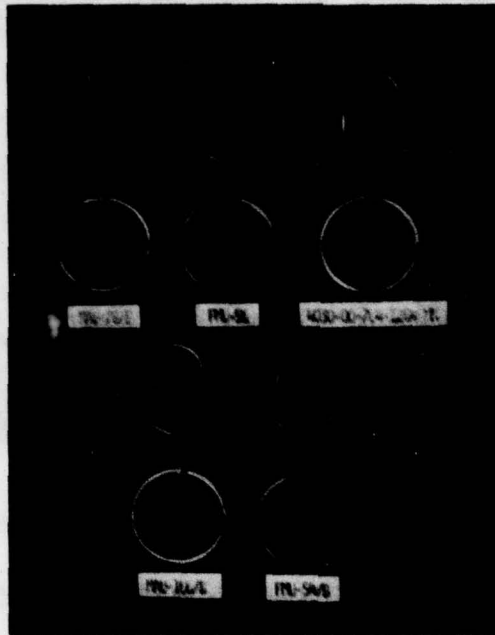

Figure 10. Swivel and Link Assemblies Furnished by ADTC (five groups).

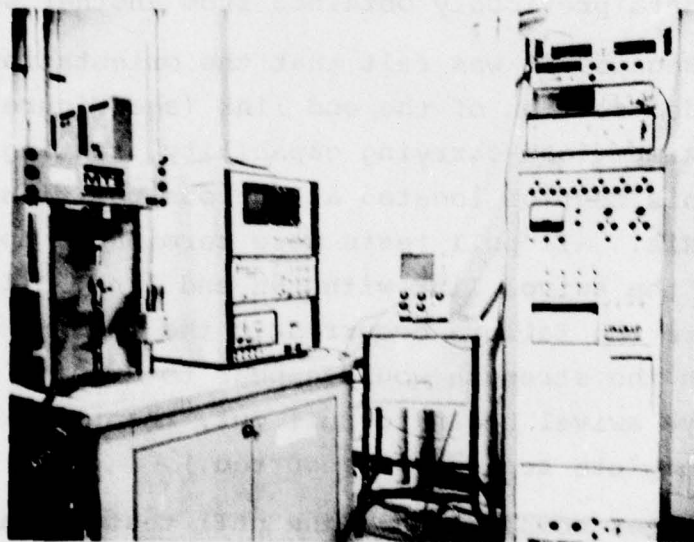

Figure 11. Swivel and Link Pull Test Set-Up.

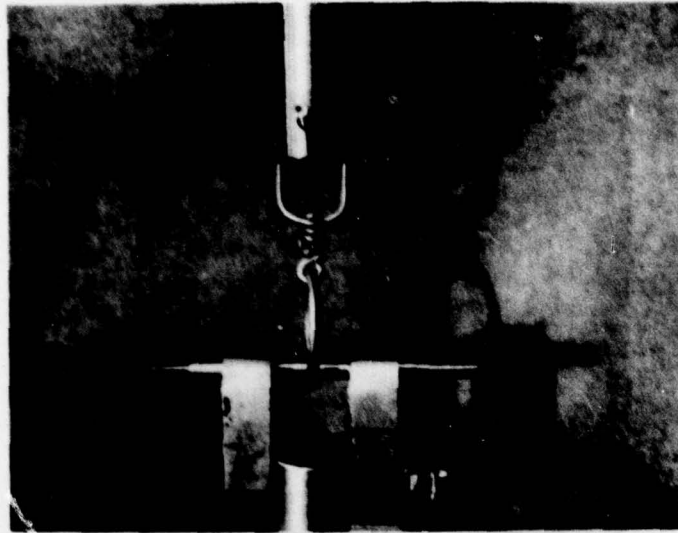

Figure 12. Swivel and Link Assembly in Test Machine.

30 in/s (762 mm/s) was used for the majority of the testing although speeds of 10 in/s (254 mm/s) and 0.33 in/s (8.5 mm/s) were also employed during initial test set-up. The speed of 0.33 in/s (8.5 mm/s), which corresponds to 20 in/min (508 mm/min), was used for the MAU-166/B assemblies so that a comparison could be made with data previously obtained from another source.

Because it was felt that the orientation of the brazed or welded section of the end link (see Figure 9) could affect the maximum load-carrying capability, testing was conducted with this section located at various positions relative to the load axis. All pull tests were terminated upon complete separation of the swivel link with the end link. (In many instances where the failure occurred in the winding of the link swivel portion the strength would appear to drop as the nail head of the eye swivel began to pull out, then rise to a greater value until complete separation occurred.)

After completion of the pull tests, a number of those specimens which failed below the minimum requirement of 220 lbs (978 N) were sent to the Failure Analysis Branch of AFML to determine a possible explanation for the premature failure.

1.3.2 Results and Discussion

The results of pull tests for the MAU-166/B assemblies are presented in Table 6 for three different loading speeds. The fastest loading rate originally obtained was 10 in/s (254 mm/s), but through some modifications in the testing machine a maximum loading rate of 30 in/s (762 mm/s) was obtained. Also noted in this table is the location of the brazed section of the end link relative to the face of a clock, as well as the failure location. All specimens for all the different groups failed either as a break in the brazed or welded junction of the end link or as a "pull-out" of the eye swivel (nail) from the winding of the link swivel.

From the amount of data available, there appears to be no effect of testing speed on the maximum load-carrying capability of the MAU-166/B assembly. It was discovered, however, that the location of the brazed joint of the end link had a significant effect on the strength values. For those specimens which failed below the 220 lbs (978 N) requirement, 53 percent failed when the brazed joint was located in the 12:00 position (in the eye of the eye swivel) and 26 percent failed when the braze was at the 6:00 position (beneath the lower loading pin). Only three specimens failed away from the 6:00 and 12:00 positions, and those still maintained loads in excess of 200 lbs (890 N). Finally, all MAU-166/B assemblies which failed below the minimum requirement failed in the brazed joint of the end link. For all five groups tested, those specimens which did not meet the 220 lbs (978 N) minimum requirement all failed at the brazed or welded joint.

Pull test results for the 4030-00-764-1284 MN assemblies are presented in Table 7. Forty percent of those specimens tested with the braze in the 12:00 position failed below the 220 lbs (978 N) requirement, while 18 percent of those tested in the 6:00 position failed prematurely. The loading pin diameter did not appear to have any effect on the maximum

TABLE 6

PULL TEST RESULTS FOR MAU-166/B
SWIVEL AND LINK ASSEMBLIES

Head Speed = 10 in/sec. (254 mm/s)

Specimen No.	Max. Load Lbs. (N)	Braze Orientation (Relative to Clock Face)	Loading Pin Diameter In. (mm)	Failure Location (N-Nail, B-Braze)
1	296 (1317)	-	0.187 (4.75)	B
2	389 (1730)	-	" "	N
3	244 (1085)	-	" "	B
5	388 (1726)	5:00	" "	N
6	377 (1677)	6:00	" "	N
7	456 (2028)	7:00	" "	N
8	222 (987)	9:00	" "	B
9	-	9:00	" "	B
10*	206 (916)	10:00	" "	B
11	407 (1810)	11:00	" "	N
4	264 (1174)	11:00	" "	B
12*	161 (716)	12:00	" "	B
13	376 (1672)	12:00	" "	N
14	332 (1477)	1:00	" "	B
15	342 (1521)	2:00	" "	B
16	232 (1032)	3:00	" "	B
17	250 (1112)	4:00	" "	B
18	358 (1592)	5:00	" "	N
19	363 (1615)	6:00	" "	N
20	356 (1583)	7:00	" "	N

HEAD SPEED = 20 in./min. (8.47 mm/s)

21	350 (1557)	1:00	0.187 (4.75)	B
22	252 (1121)	2:00	" "	B
23	262 (1165)	3:00	" "	B
24	362 (1610)	4:00	" "	N
25	358 (1592)	5:00	" "	N
26	366 (1628)	6:00	" "	N
27	359 (1597)	7:00	" "	N
28	251 (1116)	8:00	" "	B
29*	212 (943)	9:00	" "	B
30	310 (1379)	10:00	" "	B
31	390 (1735)	11:00	" "	N
32*	176 (783)	12:00	" "	B
33*	125 (556)	12:00	" "	B

* Failed below minimum requirement of 220 lbs (978 N)

TABLE 6 (Continued)
 PULL TEST RESULTS FOR MAU-166/B
 SWIVEL AND LINK ASSEMBLIES
 Head Speed = 30 in/sec. (762 mm/s)

Specimen No.	Max. Load Lbs. (N)	Braze Orientation (Relative to Clock Face)	Loading Pin Diameter In. (mm)	Failure Location (N-Nail, B-Braze)
34	238 (1059)	12:00	0.187 (4.75)	B
35	380 (1690)	"	" "	N
36	280 (1245)	"	" "	B
37	355 (1579)	"	" "	B
38*	175 (778)	"	" "	B
39	361 (1606)	"	" "	N
40*	168 (747)	"	" "	B
41*	156 (694)	"	" "	B
42	368 (1637)	"	" "	B
43*	215 (956)	"	" "	B
44*	172 (765)	"	" "	B
45	272 (1210)	"	" "	B
46	363 (1615)	1-2:00	" "	N
47	350 (1557)	"	" "	B
48	368 (1637)	"	" "	B
49	373 (1659)	"	" "	N
50	304 (1352)	"	" "	B
51	270 (1201)	"	" "	B
52	375 (1668)	"	" "	B
53	328 (1459)	"	" "	B
54	272 (1210)	"	" "	B
55	266 (1183)	3:00	" "	B
56	225 (1001)	"	" "	B
57	228 (1014)	"	" "	B
58	284 (1263)	"	" "	B
59	236 (1050)	"	" "	B
60	222 (987)	"	" "	B
61*	207 (921)	"	" "	B
62	260 (1156)	"	" "	B
63	265 (1179)	4-5:00	" "	N
64	357 (1588)	"	" "	B
65	356 (1584)	"	" "	B
66	335 (1490)	"	" "	B
67	316 (1405)	"	" "	B
68	350 (1557)	"	" "	N
69	242 (1076)	"	" "	B
70	374 (1664)	"	" "	N
71	376 (1672)	6:00	" "	N
72	296 (1317)	"	" "	B
73	282 (1254)	"	" "	B
74	320 (1423)	"	" "	B
75*	177 (787)	"	" "	B
76*	208 (925)	"	" "	B
77*	153 (680)	"	" "	B
78	401 (1784)	"	" "	N
79*	214 (952)	"	" "	B

* Failed below minimum requirement of 220 lbs (978 N)

TABLE 6 (Concluded)

PULL TEST RESULTS FOR MAU-166/B
SWIVEL AND LINK ASSEMBLIES

Specimen No.	Max.Load Lbs. (N)	Braze Orientation (Relative to Clock Face)	Loading Pin Diameter In. (mm)	Failure Location (N-Nail, B-Braze)
80	378 (1681)	6:00	0.187 (4.75)	N
81	371 (1650)	"	" "	N
82	262 (1165)	"	" "	B

* Failed below minimum requirement of 220 lbs (978 N)

TABLE 7

PULL TEST RESULTS FOR 4030-00-764-1284 MN
SWIVEL AND LINK ASSEMBLIES

Head Speed = 30 in/sec. (762 mm/s)

Specimen No.	Max.Load Lbs. (N)	Braze Orientation (Relative to Clock Face)	Loading Pin Diameter In. (mm)	Failure Location (N-Nail, B-Braze)
1	380 (1690)	12:00	0.187 (4.75)	N
2*	204 (907)	"	" "	B
3	313 (1392)	"	" "	B
4*	185 (823)	"	" "	B
5	226 (1005)	"	" "	B
6	268 (1192)	3:00	" "	B
7	272 (1210)	"	" "	B
8	292 (1299)	"	" "	B
9	241 (1072)	6:00	" "	N
10	399 (1775)	"	" "	B
11*	175 (778)	"	" "	B
12	358 (1592)	"	" "	B
13	256 (1139)	"	0.061 (1.55)	B
14*	184 (818)	"	" "	B
15	438 (1948)	"	" "	N
16	254 (1130)	"	0.100 (2.54)	B
17	346 (1539)	"	" "	N
18	364 (1619)	"	" "	N
19	296 (1317)	"	" "	N

* Failed below minimum requirement of 220 lbs (978 N)

load-carrying capability. The results for this assembly are quite similar to those for the MAU-166/B assemblies.

Pull test results for the FMU-54/B assemblies are presented in Table 8. All specimens tested greatly exceed 220 lbs (978 N) although the link assembly suffered severe deformation in the link end. No failures occurred at the weld junction of the link end. The weld orientation and the variation of link end loading pin had no noticeable effect on the maximum load-carrying capability of the assembly.

The pull test results for the FMU-56 assemblies are presented in Table 9. As with the FMU-54/B assemblies, there was no effect of weld location or loading pin diameter on the maximum pull strength. Like the FMU-54/B assemblies, none of the failures originated at the weld junction, but there was severe deformation of the end link. All assemblies tested greatly exceeded the 220 lbs (978 N) minimum requirement.

Pull test results for the MAU-78/B assemblies are presented in Table 10. Almost every specimen tested with the weld oriented in either the 12:00 or the 6:00 position failed well below the 220 lbs (978 N) limit, the lowest being 57.5 lbs (256 N). For those specimens tested at the 3:00 position, the minimum requirement was greatly exceeded. The orientation of this welded section prior to loading will definitely determine whether this assembly functions correctly or fails prematurely.

Upon completion of tensile testing, a number of specimens were analyzed to determine a possible cause for the premature failures. For all assemblies the link end was the only part analyzed, since it was this link, more accurately the braze or weld in this link, which was responsible for all premature failures.

Typical failures for each type of assembly were photographed and presented in Figure 13. Note the severe deformation experienced with both the FMU-56 and the FMU-54/B

TABLE 8

PULL TEST RESULTS FOR FMU-54/B
SWIVEL AND LINK ASSEMBLIES

Head Speed = 30 in/sec. (762 mm/s)

Specimen No.	Max. Load Lbs. (N)	Weld Orientation (Relative to Clock Face)	Loading Pin Diameter In. (mm)	Failure Location (W-Weld, N-Nail)
1	348 (1548)	6:00	0.061 (1.55)	N
2	337 (1499)	6:00	0.100 (2.54)	N
7	360 (1601)	6:00	0.100 (2.54)	N
8	330 (1468)	6:00	0.100 (2.54)	N
3	324 (1441)	12:00	0.100 (2.54)	N
4	346 (1539)	12:00	0.100 (2.54)	N
5	412 (1832)	12:00	0.100 (2.54)	N
6	342 (1521)	12:00	0.100 (2.54)	N

TABLE 9

PULL TEST RESULTS FOR FMU-56
SWIVEL AND LINK ASSEMBLIES

Head Speed = 30 in/sec. (762 mm/s)

Specimen No.	Max. Load Lbs. (N)	Weld Orientation (Relative to Clock Face)	Loading Pin Diameter In. (mm)	Failure Location (W-Weld, N-Nail)
1	381 (1695)	12:00	0.187 (4.75)	N
2	344 (1530)	12:00	0.187 (4.75)	N
3	308 (1370)	12:00	0.187 (4.75)	N
4	372 (1655)	12:00	0.187 (4.75)	N
5	340 (1512)	12:00	0.187 (4.75)	N
6	354 (1574)	3:00	0.187 (4.75)	N
7	286 (1272)	3:00	0.187 (4.75)	N
8	342 (1521)	12:00	0.113 (2.87)	N
9	285 (1268)	6:00	0.100 (2.54)	N
10	386 (1717)	6:00	0.100 (2.54)	N
11	362 (1610)	6:00	0.100 (2.54)	N

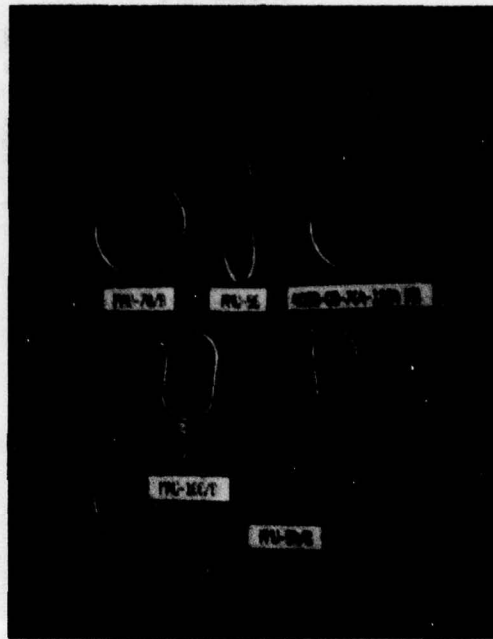

Figure 13. Typical Pull Test Failures for S&L Assemblies.

assemblies. For those link assemblies employed in actual service, it was at times found that for both the FMU-54/B and the FMU-56 assembly there was a deep groove cut in the link end apparently caused by the action of the lanyard pulling through during bomb release. If enough material was eroded away during this action, the link could be weakened (enough to cause failure upon loading) thus resulting in an unarmed drop. Microhardness measurements were obtained for each of the assemblies for the link end component. Results are tabulated in Table 11, along with representative tensile strengths obtained from conversion charts furnished by Wilson Instrument Division. Links from the FMU-54/B and the FMU-56 assemblies are much softer than for the other assemblies which explains the severe deformation experienced by these two assemblies. The other three links are a very high-strength steel, particularly the links from MAU-166/B and the 4030-00-764-1284 MN assemblies. For some specimens from these last three assemblies

TABLE 10
PULL TEST RESULTS FOR MAU-78/B
SWIVEL AND LINK ASSEMBLIES

Head Speed = 30 in/sec. (762 mm/s)

Specimen No.	Max. Load Lbs. (N)	Weld Orientation (Relative to Clock Face)	Loading Pin Diameter In. (mm)	Failure Location (N-Nail, W-Weld)
1*	57.5 (256)	6:00	0.100 (2.54)	W
2*	120 (534)	"	" "	W
3*	139 (618)	"	" "	W
4*	170 (756)	"	" "	W
5*	160 (712)	"	" "	W
6	384 (1708)	12:00	" "	N
7*	122 (543)	"	" "	W
8*	98 (436)	"	" "	W
9*	70.5 (314)	"	" "	W
10	355 (1579)	3:00	" "	N
11	294 (1308)	"	" "	N

* Failed below minimum requirement of 220 lbs (978 N)

TABLE 11
HARDNESS VALUES OF END LINK
FOR VARIOUS S&L ASSEMBLIES

Assembly Identification	Average Hardness (500g Vickers Hardness)	Representative Tensile Str. KSI	(MPa)
MAU-166/B	566	284	(1958)
4030-00-764-1284 MN	565	284	(1958)
MAU-78/B	450	216	(1489)
FMU-56	177	85	(586)
FMU-54/B	149	71	(490)

which failed at low loads in the brazed or welded section, it took a significant load [i.e., 75 to 100 lbs (334 to 445 N)] just to bend the link straight as it pulled through the eye swivel.

Because it was discovered that the brazed or welded junction of the link end was the "weakest link" in the entire assembly (at least for the MAU-166/B, the 4030-00-764-1284 MN, and the MAU-78/B assemblies) an investigation was made at this junction. The investigation revealed that for the MAU-166/B and the 4030-00-764-1284 MN assemblies, the end loop was joined by a brazing process. Since the braze material is much weaker than the end link material, the link will fail when the tensile strength of the braze material is exceeded. This, coupled with a poor quality braze caused by brazing after the ring is plated, as is the case of the MAU-166/B links, creates a weak member, despite the mechanical properties of the end link material. Cross sections of links from the MAU-166/B and the 4030-00-764-1284 MN assemblies showing the failed brazed junction are presented in Figures 14 and 15, respectively.

End links from the failed MAU-78/B assembly were cross-sectioned, etched with a Nital solution, and analyzed under low magnification ($\sim 40X$). Photomicrographs indicate the end link loop is joined by some type of pressure-weld. A photomicrograph, using interference contrast techniques, of a good weld taken from a specimen which failed as a result of nail pull-out is presented in Figure 16. The diamond-shaped marks on this photomicrograph are the results from the hardness tests. This weld forms a continuous ring of material, with no disjunction or gap at the interface. The pull test results for the MAU-78/B assemblies indicate a poor quality weld exists in most cases for this assembly, since this welded junction broke at very low loads. Test results for the FMU-54 and FMU-56 assemblies, however, indicate a good quality weld (Figure 16) exists for these particular assemblies, since no failures were experienced at the welded junction.

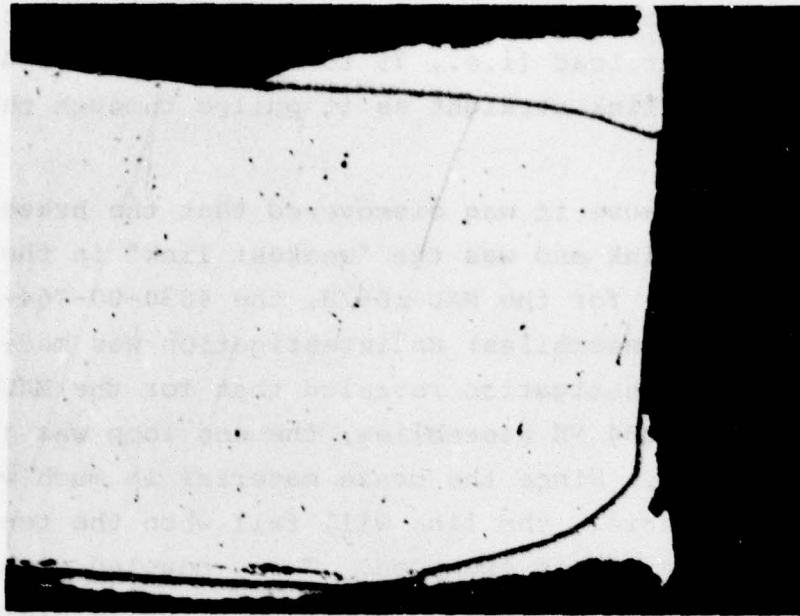

Figure 14. Photomicrograph of Failed Brazed Junction
From MAU-166/B S&L Assembly (50X).

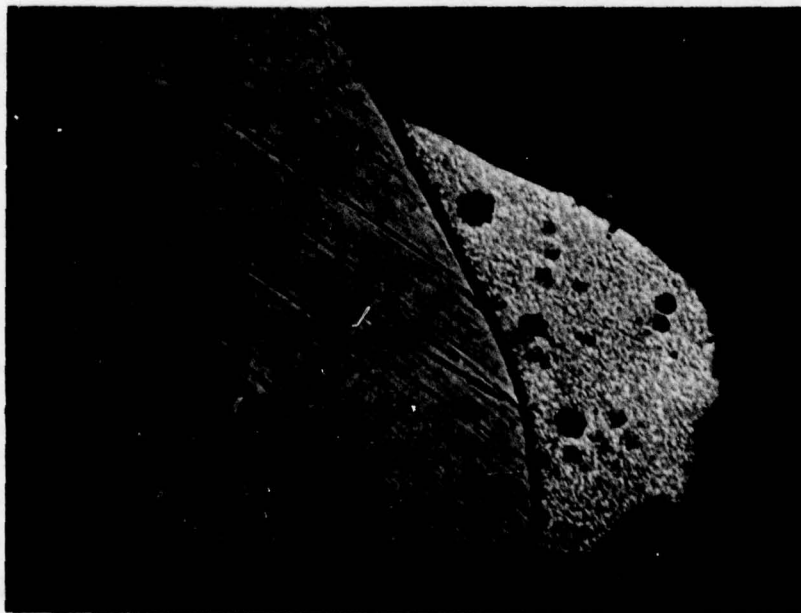

Figure 15. Photomicrograph of Failed Brazed Junction
From 4030-00-764-1284 MN S&L Assembly (50X).

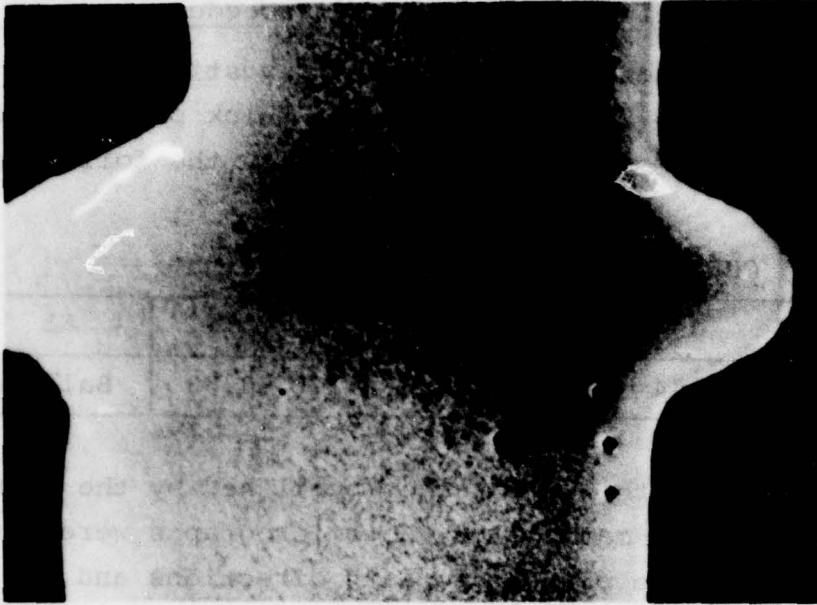

Figure 16. Photomicrograph of Pressure Weld From MAU-78/B Assembly, Spec #11 (40X).

1.4 COMPLETE CRACK GROWTH RATE DATA ON ALUMINUM 2124-T851

Constant amplitude fatigue crack growth rate data were generated for a material from the threshold region for fatigue crack growth to the high growth rate region where the maximum stress intensity approaches the material's critical stress intensity. The investigation was undertaken because of a lack of such a complete data set for any one material. The material investigated in this program was aluminum alloy 2124-T851 which is used extensively on the Air Force's F-15 and F-16 aircraft.

In addition to developing the data set, a technique to determine crack length measurements via a compliance method was perfected. The latter has the distinct possibility of being incorporated into an automated crack growth data generating system.

1.4.1 Materials, Specimens, and Procedures

The material used in this investigation was aluminum alloy 2124-T851, 2.0-inch (50.8-mm) thick plate. A chemical analysis was performed on the material with the following results obtained:

CHEMICAL COMPOSITION, % by weight

Cu	Mg	Mn	Si	Fe	Ti	Al
3.9	1.3	0.54	0.08	0.14	<0.03	Balance

These results are within the ranges published by the Aluminum Association for this material. Photomicrographs were also obtained from the three principal plate directions and are illustrated in Figure 17.

Tensile specimens were removed from the longitudinal orientation of the plate. Two-inch (50.8-mm) thick compact fracture toughness specimens were removed from the longitudinal (L-T) orientation of the test plate and machined in accord with Figure 18. Elongated compact specimens for crack growth investigations were likewise removed from the plate in the same orientation and machined to the dimensions shown in Figure 18. The crack growth specimens were machined in three thicknesses so that the effect of specimen thickness on fatigue crack growth rates could be examined.

Tensile testing was performed on a Baldwin-Wiedemann tensile testing machine. Strain was monitored with a 1.0-inch (25.4-mm) Instron extensometer. Fracture toughness testing was accomplished using a Tinius-Olsen tensile testing machine following the guidelines set forth in ASTM E399-74. Crack-opening-displacement (COD) was monitored with a clip-on gage as described in the test standard.

All fatigue crack growth rate testing was carried out with a 2.5 KIP (11.1 KN) MTS electro-hydraulic servo-controlled

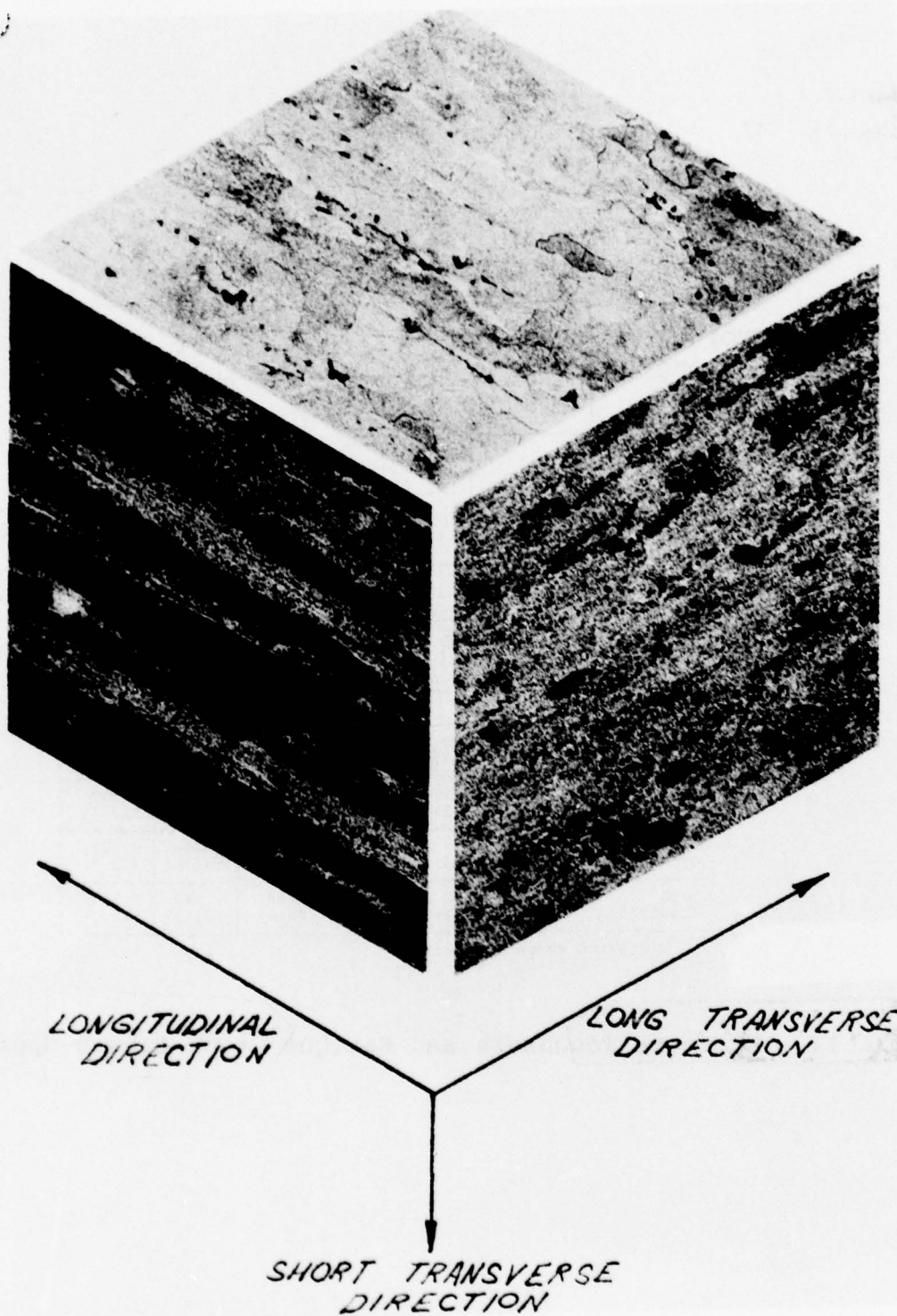
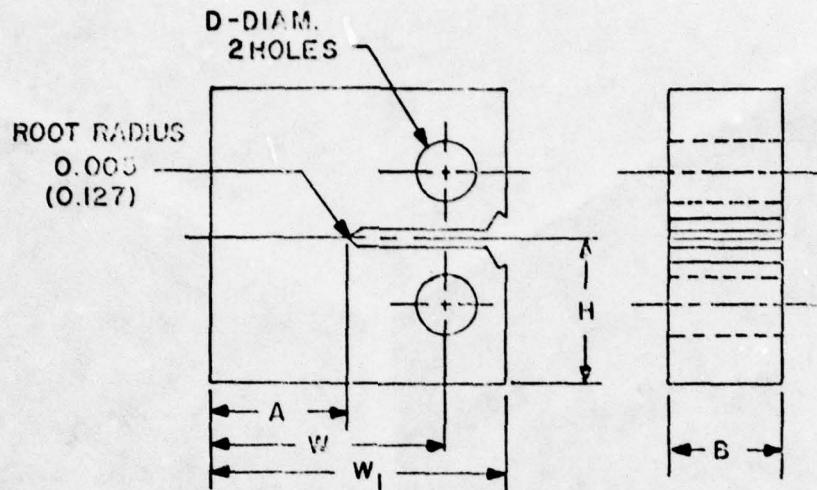

Figure 17. Aluminum Alloy 2124-T851 Microstructure Composite (100X).



DIMENSIONS: INCHES (mm)

SPECIMEN TYPE	A	B	W	W ₁	H	D
Fracture Toughness	2.250 (57.15)	2.000 (50.80)	4.000 (101.60)	4.625 (117.48)	2.400 (60.96)	0.625 (15.87)
Crack* Growth	1.785 (45.3)	0.375 (9.52)	2.550 (64.8)	3.188 (80.9)	1.240 (31.5)	0.500 (12.7)
Crack* Growth	1.785 (45.3)	0.750 (19.05)	2.550 (64.8)	3.188 (80.9)	1.240 (31.5)	0.500 (12.7)
Crack* Growth	1.785 (45.3)	1.500 (38.1)	2.550 (64.8)	3.188 (80.9)	1.240 (31.5)	0.500 (12.7)

*Elongated compact specimen

Figure 18. Fracture Toughness and Fatigue Crack Growth Specimens.

fatigue testing machine operating at 20-30 Hz. Crack length measurements were made with a 30X Gaertner traveling microscope. A stress ratio (minimum stress divided by maximum stress) of $R = +0.1$ was employed in this program. Temperature and humidity were both carefully monitored. Temperature was maintained at 68-72°F (20-22.2°C). Humidity chambers were fashioned from plexiglass, with humidity limited to less than 10 percent. All fatigue precracking was also done at these test conditions.

Raw crack growth data were reduced to the standard accepted form (crack growth rate, da/dN , as a function of change in stress intensity, ΔK) in the manner prescribed in the current proposed ASTM test standard. This method fits a second order polynomial to a seven point data subset, and in turn calculates the slope at the midpoint of the subset. The midpoint crack length is used to calculate the ΔK value, while the slope is the corresponding da/dN value. This procedure is applied throughout the entire raw data set to generate the complete da/dN vs. ΔK curve.

In addition to generating the complete crack growth rate curve for aluminum 2124-T851 at $R = +0.1$, an investigation was also performed to develop techniques for determining crack growth rates via a compliance technique. A compliance curve was generated using two specimen thicknesses, 0.375 inch (9.52 mm) and 0.75 inch (19.0 mm). The procedure involved precracking to a certain crack length, an elongated compact specimen instrumented with a clip-on gage. Load was then applied slowly and a trace of load vs. COD was obtained with an X-Y recorder. Care was taken so this load never exceeded 90 percent of the maximum precracking load, in order to avoid any retardation effects. The specimen was then further precracked to a different crack length and the same technique repeated. A series of curves was obtained for the a/W (crack length/specimen width) range of 0.35 to 0.65. Normalized values of crack opening displacement and crack length were then plotted and an expression

developed relating the specimen COD to crack length. Crack growth rates for two specimen thicknesses, 0.75 inch (19.0 mm) and 1.5 inch (38.1 mm) were then determined using both the optical and compliance methods and the results compared.

1.4.2 Results and Discussion

The tensile test results for specimens tested in the longitudinal orientation are presented in Table 12 and are in good agreement with published data^[7,8]. Fracture toughness test results for longitudinal-transverse (L-T) oriented specimens are listed in Table 13 and are also in agreement with References 7 and 8.

The fatigue crack growth rate curve for aluminum alloy 2124-T851 for an R-ratio of +0.1 is presented in Figure 19. The curve presented in this figure represents the data obtained from 16 specimens. A threshold value of stress intensity range, ΔK , below which cracks will not grow by fatigue, for these testing conditions is approximately $2.4 \text{ KSI}\sqrt{\text{in}}$ ($2.63 \text{ MPa}\sqrt{\text{m}}$).

The thickness effect on fatigue crack growth was examined only at the growth rate portion of the curve above 10^{-6} in/cyc. (25.4 nm/cyc.) since it was felt that any thickness effect would manifest itself to a greater extent at higher values of stress intensities. For the three thicknesses investigated there does not appear to be any thickness effect for crack growth rates below 10^{-4} in/cyc. ($2.5 \times 10^3 \text{ nm/cyc.}$).

Normalized values of crack length with corresponding normalized values of crack-opening-displacement were obtained for a number of elongated compact specimens of various thicknesses. A third degree polynomial was fitted to this data yielding the expression:

⁷Fudge, K.A. and Jones, R.E., Engineering Design Data for Aluminum Alloy 2124-T851 Thick Plate, January 1974.

⁸Cervay, R.R., Temperature Effects on the Mechanical Properties of Aluminum Alloy 2124-T851, December 1975.

TABLE 12
TENSILE PROPERTIES OF ALUMINUM ALLOY
2124-T851 TWO-INCH (50.8-mm) THICK PLATE

Specimen No.	Yield Strength		Ultimate Strength		% Elongation 1.0-inch (25.4-mm) G.L.	Reduction in Area (%)
	KSI	(MPa)	KSI	(MPa)		
X1	65.6	(452)	71.9	(496)	9.0	21.5
X2	67.0	(462)	72.5	(500)	9.1	22.6
X3	<u>66.7</u>	<u>(460)</u>	<u>71.9</u>	<u>(496)</u>	<u>9.0</u>	<u>21.2</u>
Avg.	66.4	(458)	72.1	(497)	9.0	21.7

TABLE 13
FRACTURE TOUGHNESS PROPERTIES OF ALUMINUM ALLOY
2124-T851 TWO-INCH (50.8-mm) THICK PLATE

Specimen No.	Orientation	K_{IC}	
		KSI \sqrt{in}	(MPa \sqrt{m})
1C	Long.-Transverse	30.1	(33.1)
2C	Long.-Transverse	30.9	(34.0)
3C	Long.-Transverse	<u>30.4</u>	<u>(33.4)</u>
Avg.		30.5	(33.5)

(MEGAPASCAL SQR(METERS))
 5 6 7 8 9 10¹ 2 3 4 5

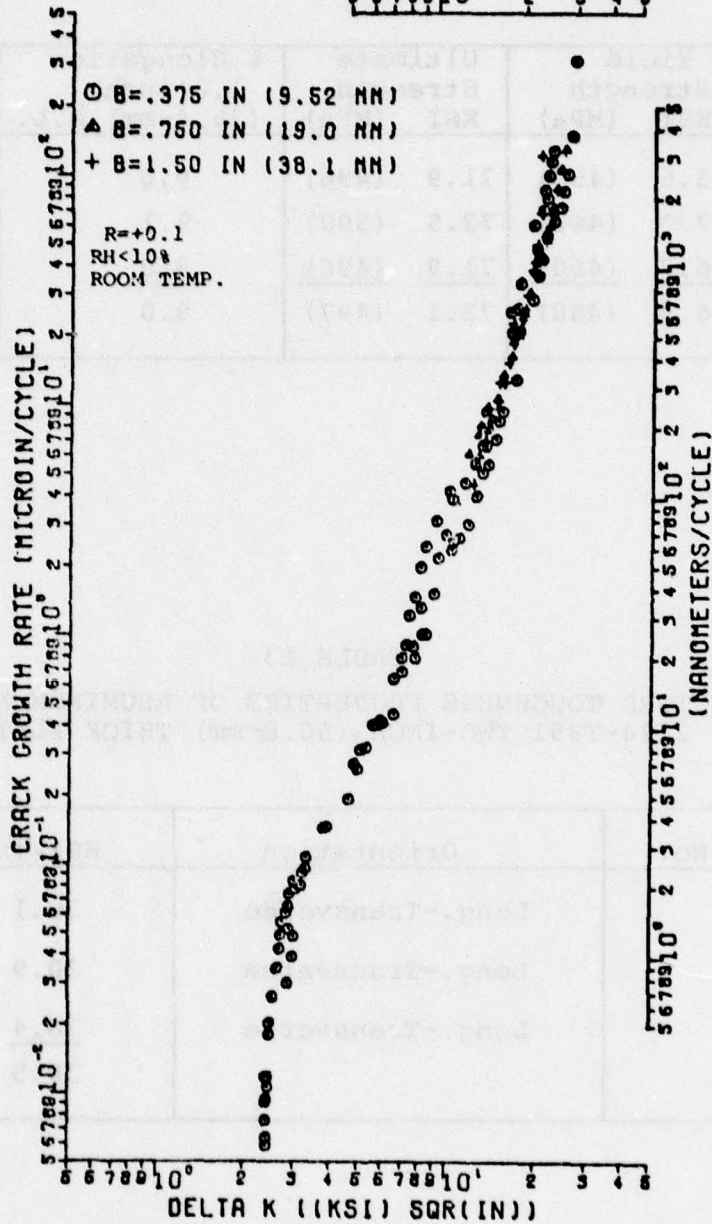

Figure 19. Complete Crack Growth Rate Curve for Aluminum Alloy 2124-T851 Plate.

$$\frac{E \cdot B \cdot \text{COD}}{P} = -348.6 + 2492 \left(\frac{a}{W}\right) - 5512 \left(\frac{a}{W}\right)^2 + 4431 \left(\frac{a}{W}\right)^3$$

or

$$\begin{aligned} \frac{a}{W} = & 0.0677 + 0.00894 \left(\frac{E \cdot B \cdot \text{COD}}{P}\right) - 0.000049 \left(\frac{E \cdot B \cdot \text{COD}}{P}\right)^2 \\ & + 0.000000101 \left(\frac{E \cdot B \cdot \text{COD}}{P}\right)^3 \end{aligned}$$

where E is the material's modulus of elasticity, B is the specimen thickness, COD is the displacement as measured by the clip gage, and P is the applied load.

The first equation is illustrated in the computer-prepared curve shown in Figure 20 along with a similar curve^[9] developed for compact specimens machined from aluminum alloys 7075-T6 and 2024-T351, titanium 6Al-4V, and 4340 steel. Deviation between the two curves is small over the range of $\frac{a}{W}$ from 0.35 to 0.60. For crack length/width ratios above this, differences between the two curves become greater with increasing values of $\frac{a}{W}$.

Crack growth rate tests were then performed on elongated compact specimens with a clip-on gage attached. Crack length measurements, obtained via visual measurements, and specimen COD were both recorded as functions of elapsed cycles. The COD measurements were converted to crack lengths, utilizing the previously determined expressions, and crack growth rates determined. Results of this procedure are presented in Figures 21 and 22 in the form of crack growth rate curves. Also presented are the data obtained via visual measurements. The results are nearly identical over the range investigated.

The advantages of this procedure are many. By indirectly measuring the crack length via an electronic signal from a clip gage, operator error is virtually non-existent. With the availability of a crack length to crack-opening-displacement

⁹Sullivan, A.M., Crack Length Determination for the Compact Tension Specimen Using a Crack-Opening-Displacement Calibration, NRL Report No. 7888, June 1975.

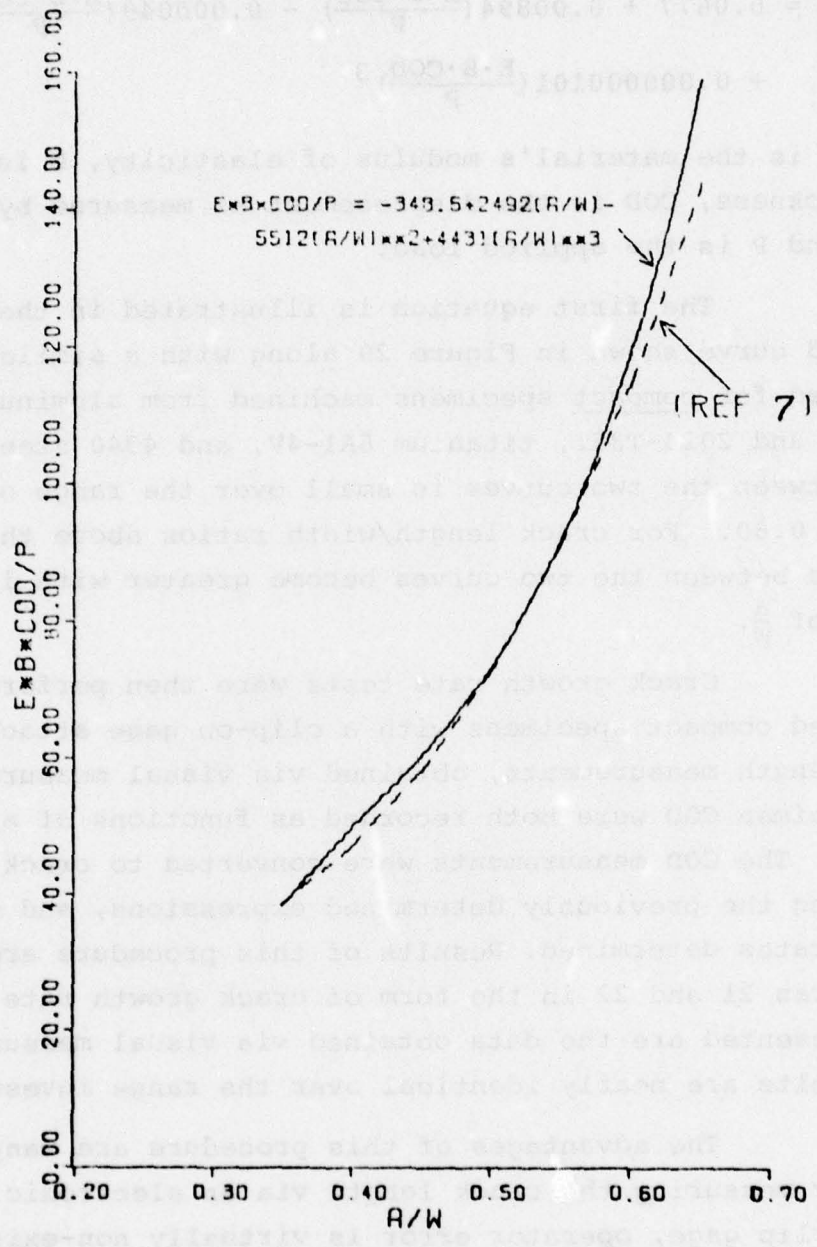

Figure 20. COD vs. a/W Calibration Curve Developed For Elongated Compact Specimen.

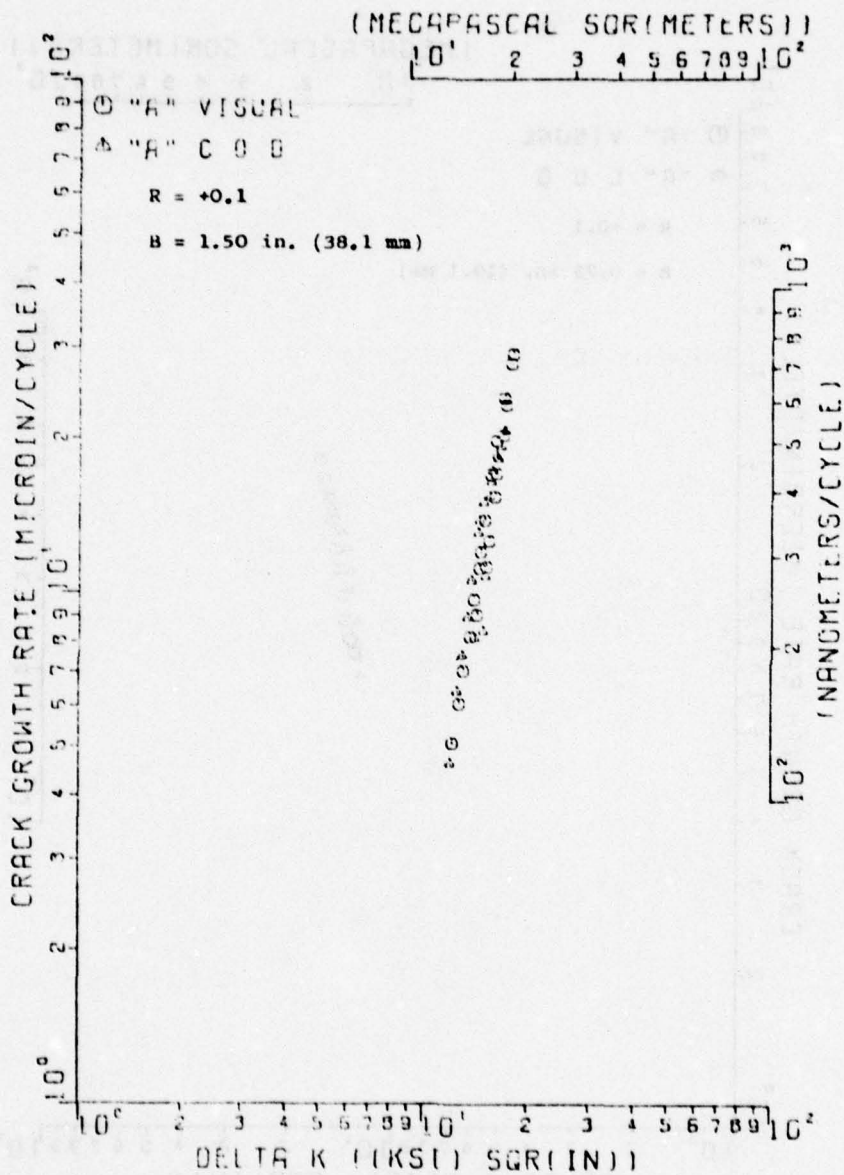

Figure 21. Comparison of Crack Growth Data Developed For Aluminum 2124-T851 via Two Crack Measuring Techniques for B = 1.50 inch (38.1 mm).

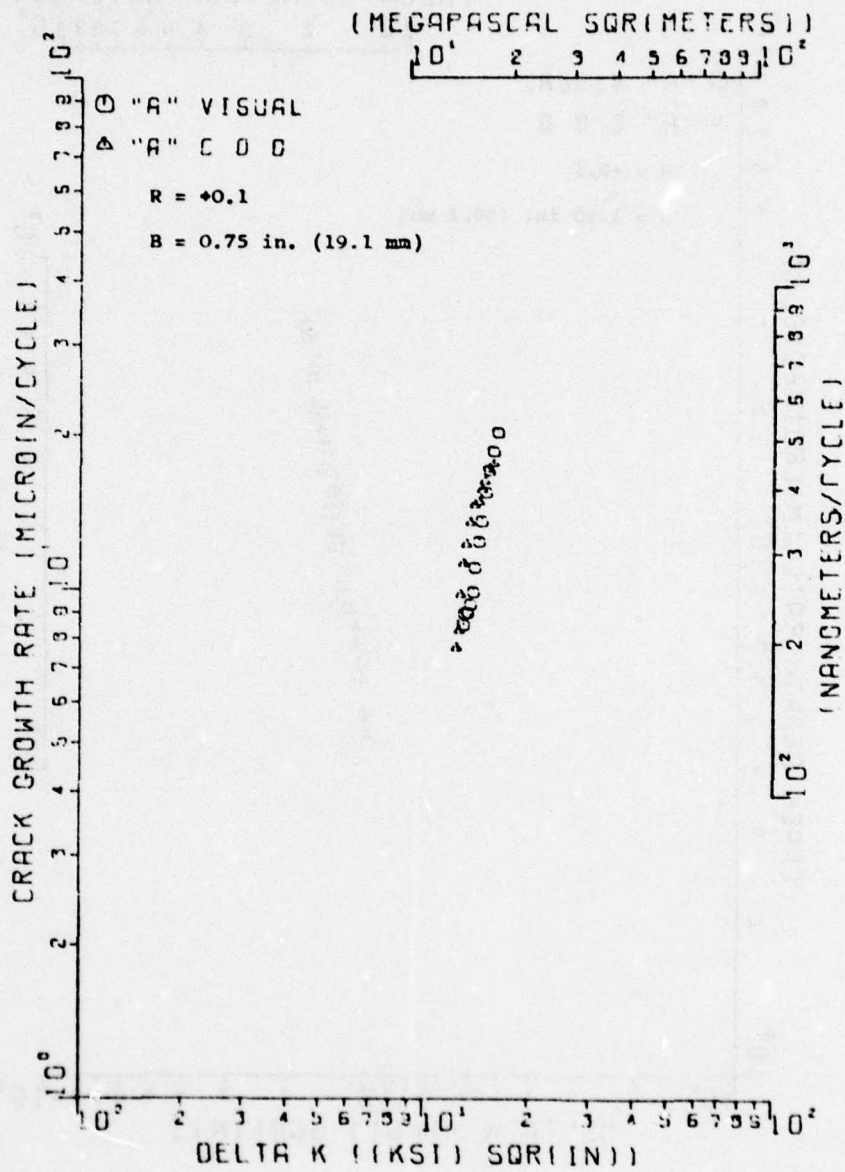

Figure 22. Comparison of Crack Growth Data Developed For Aluminum 2124-T851 via Two Crack Measuring Techniques for B = 0.75 inch (19.1 mm).

relationship, the possibility exists for a completely automated system to determine constant amplitude fatigue crack growth rates, while the test is being conducted, thus reducing any chance for error during the time-consuming data reduction process.

1.5 STRESS CORROSION TEST TECHNIQUES

A program was conducted to study stress corrosion cracking test methodology. The effort was not to investigate nor explain the stress corrosion cracking phenomenon of the test material for the test solution employed, but rather to study the influence of various testing techniques and methods on the material's threshold for stress corrosion cracking in a corrosive medium.

The material employed for the tests was aluminum alloy 7075-T651. Alloy 7075 was selected because it is readily available and its properties are well documented in the literature. Heat treatment T651 was used because of its known susceptibility to stress corrosion cracking.

There were four variations of the test set-ups for loading an ASTM standard 3/4-inch (19-mm) compact specimen. "Baseline" data were generated using a constant immersion vertical loaded creep frame; this test set-up was subsequently altered to perform vertical loaded alternate immersion tests. A horizontal loaded constant immersion test frame was incorporated into the test program, while the fourth test method used a constant immersion, bolt-loaded, (wedge-opening-loading) compact specimen immersed in a bath of the test solution. The solution was a strongly acidic chloride-dichromate solution which is reported to cause rapid stress corrosion crack growth in a precracked 7000-series aluminum specimen^[10].

¹⁰Sprowls, D.O., et al., "Evaluation of Stress-Corrosion Cracking Susceptibility Using Fracture Mechanics Techniques," May 1973.

1.5.1 Material, Specimens, and Procedures

A single rolled plate of aluminum alloy 7075-T651, 2.0-inch (50.8-mm) thick, was procured with nominal dimensions of 12 by 12 inch (305 by 305 mm). A chemical analysis was performed on the as-received material which yielded the following composition:

CHEMICAL COMPOSITION OF TEST PLATE OF 7075-T651
(Weight %)

Zn	Mg	Cu	Cr	Si	Mg	Fe	Ti	Al
5.5	2.5	1.4	0.2	0.05	0.11	0.26	0.03	Balance

The chemical composition of the test plate is well within the ranges specified by the Aluminum Standards and Data Handbook^[11] with such elements as iron and silicon existing in very small proportions. This would indicate this material is a "clean" plate of aluminum 7075, closely resembling the chemical composition of aluminum alloy 7175. Electro-conductivity measurements were taken to insure a T651 temper. Electro-conductivity readings of ~32 percent of the International Annealed Copper Standard verified the correct heat treatment.

Photomicrographs of the alloy illustrating the grain orientation with respect to the rolling direction of the plate are shown in Figure 23.

Tensile coupons were removed from the short transverse direction of the plate and machined to the configuration shown in Figure 24. Fracture toughness and stress corrosion specimens were machined to the dimensions illustrated in Figure 25. For the bolt-loaded specimens, a hole was drilled and tapped in one arm of the specimen to accommodate a 0.375-16 UNC aluminum bolt used to stress the specimen. All fracture toughness and

¹¹Aluminum Standards and Data, the Aluminum Association, 3rd Edition, January 1972.

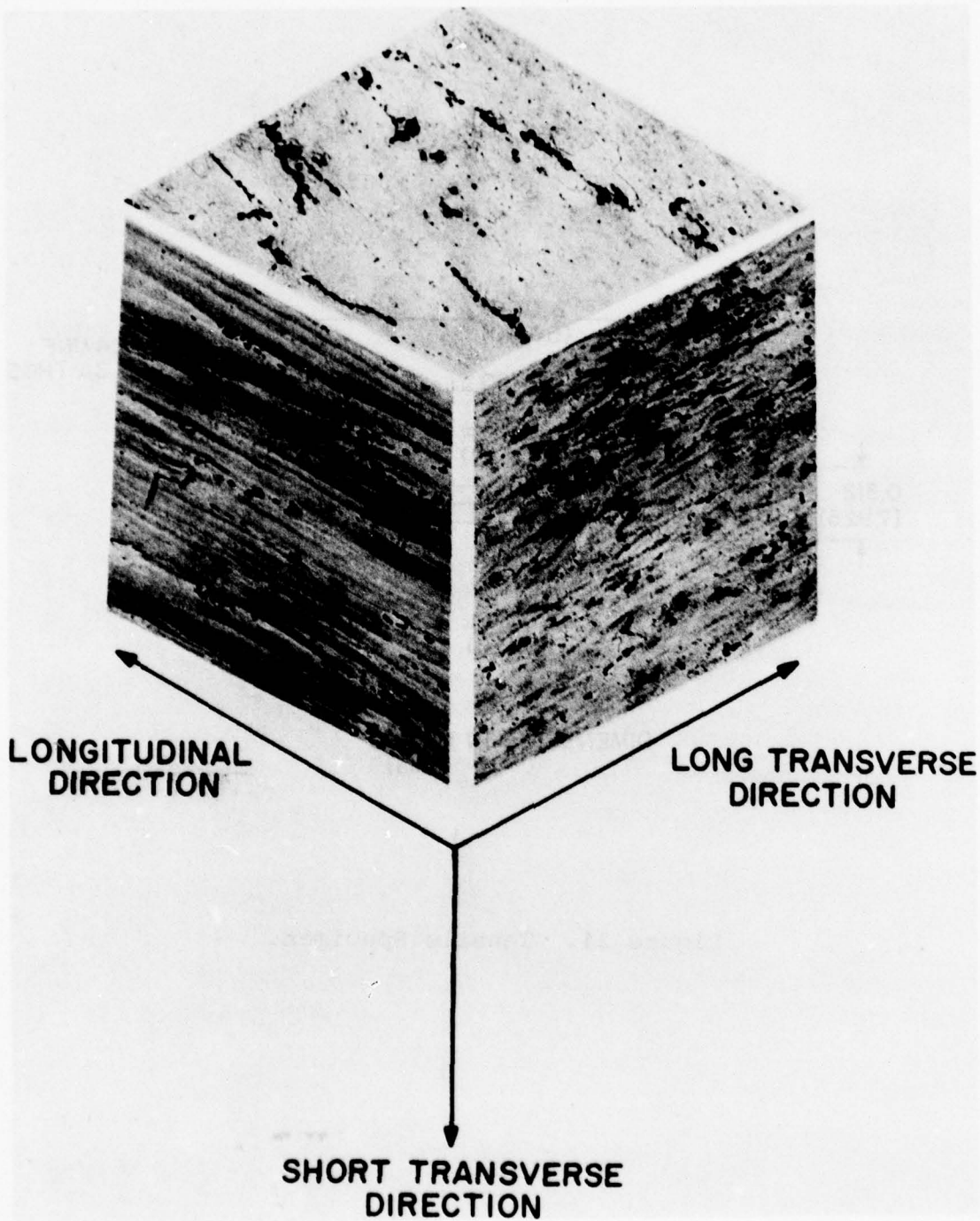

Figure 23. Aluminum Alloy 7075-T651 Microstructure (150X).

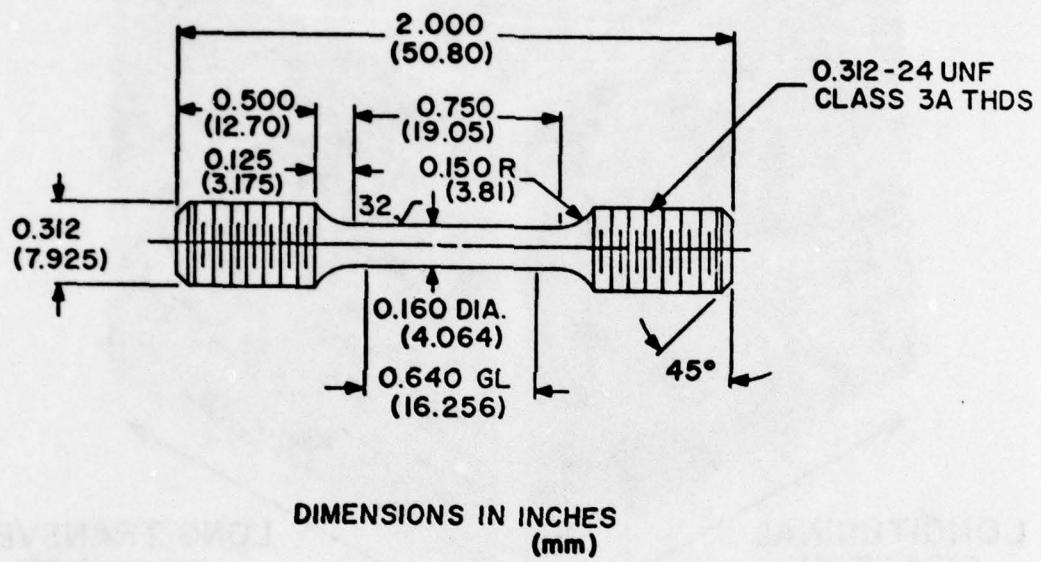
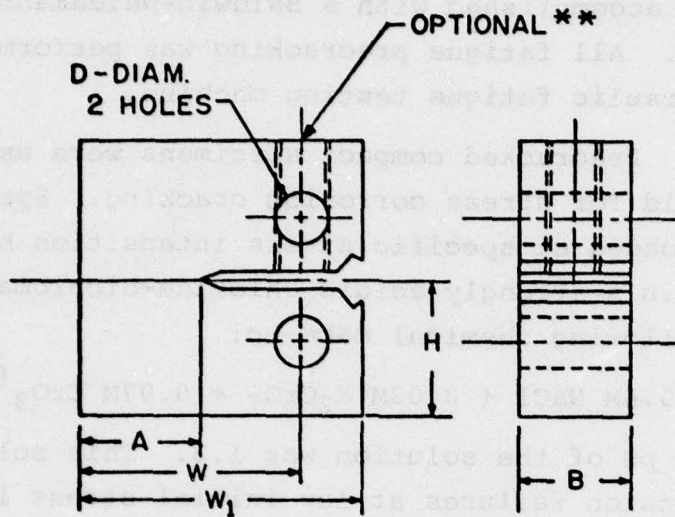

Figure 24. Tensile Specimen.



DIMENSIONS *

SPECIMEN THICKNESS	A	B	W	W ₁	H	D
3/4 (19.05)	0.915 (23.2)	.750 (19.05)	1.500 (38.10)	1.875 (47.63)	0.900 (22.86)	0.375 (9.53)

* DIMENSIONS IN INCHES
(mm)

** 0.375 -16 UNC THD. FOR BOLT - LOADED SPECIMENS.

Figure 25. Fracture Toughness and Stress Corrosion Specimen.

stress corrosion specimens were machined in the short-transverse (S-T) orientation.

Tensile testing was performed at room temperature using an Instron tensile testing machine. Fracture toughness testing was accomplished with a Baldwin-Weidemann tensile testing machine. All fatigue precracking was performed on an MTS electro-hydraulic fatigue testing machine.

Precracked compact specimens were used to determine the threshold for stress corrosion cracking. Specimens were initially loaded at specific stress intensities by a variety of methods in a strongly acidic chloride-dichromate solution with the following chemical make-up:

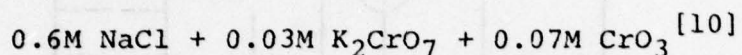

The initial pH of the solution was 1.3. This solution provided stress-corrosion failures at low initial stress intensities for reasonable time durations (<2000 hrs.).

Specimens loaded by various methods were subjected either to a constant immersion in the test solution or to an alternate immersion, defined as 10 minutes totally submerged and 50 minutes air exposure for each hour of the test duration. The various methods for loading the specimens are described in the following sections.

1.5.1.1 Vertical Loaded, Constant Immersion

Precracked compact specimens were loaded via a clevis and pin-type arrangement, as described in E399 for Fracture Toughness Testing, in a vertical loaded Satec stress-rupture testing machine. Clevises and pins were fashioned from aluminum to minimize any galvanic coupling effects. Load was applied with dead weights acting through a lever arm. An environmental chamber was fashioned from a one-gallon plastic container which enclosed the specimen. The specimen was then completely submerged in the test solution and the test load applied. Lab air was bubbled through the solution for the

duration of the test to prevent any solute from precipitating out, as well as to supply oxygen to the corrosive medium.

Upon failure, defined as complete separation of the specimen, the specimen was removed, examined, and the initial stress-intensity calculated and recorded along with time to failure. If no failure was experienced, the test was terminated, the specimen broken apart, the fracture face examined for crack growth, and the initial stress intensity accurately determined.

1.5.1.2 Vertical Loaded Alternate Exposure

Specimens were tested in the manner described previously for vertical loaded constant immersion with the exception of the type of solution exposure. Instead of a constant total immersion the specimens were subjected to an alternating immersion environment of 10 minutes totally immersed and 50 minutes in lab air. As in the case of the vertical loaded constant immersion, specimens were initially loaded while totally submerged in the test solution to draw the corrosive medium into the crack tip. Initial stress intensities were likewise calculated as previously described and recorded along with time to failure. Again, if no failure occurred after the allotted test period, the test was terminated.

1.5.1.3 Horizontal Loaded Method

Specimens were loaded at various initial stress intensities in a constant total immersion environment but in these tests the specimens were loaded in a horizontal stressing frame as opposed to the previously mentioned vertical loading frames. A photograph of the horizontal stressing frame with a specimen in place, minus the environmental chamber, is presented in Figure 26. A vertical load stress rupture frame is still utilized to transmit load to the horizontal frame and in turn to the specimen. The advantage of this type of arrangement is that it allows for instrumentation of the specimen to

monitor crack-opening-displacement, thereby crack length, continuously without interrupting the test. Like the previous two methods, the specimen was initially loaded with the crack completely submerged. Air was likewise bubbled through the test solution, and the test terminated either upon failure (complete separation) or after the allotted time period elapsed.

1.5.1.4 Bolt Loaded Method

The bolt loaded test method employs a bolt (of the same material as the test specimen to avoid any galvanic corrosion effects) to apply an initial stress intensity (see Figure 27). After initial stressing the specimen is exposed in the desired test environment for a specified time duration. Upon completion of the exposure period the specimen is removed and the final stress intensity (after crack extension) is computed. Since this is a crack arrest method, the final stress intensity computed is the threshold value for stress corrosion cracking.

Before the specimens were preloaded, the necessary compliance data were obtained. A fatigue crack was grown to various lengths and at each length a trace of specimen crack-opening-displacement (COD) vs. load was obtained. Typical traces of load vs. COD obtained from a single specimen are presented in Figure 28. The data derived in this matter can easily be rearranged in the form of a series of curves as illustrated in Figure 29. Utilizing these compliance data, an initial stress intensity was applied by wedging open the crack with the bolt.

A precracked compact specimen, with a standard clip-on gage in place, was initially loaded to a stress intensity higher than the anticipated threshold for stress-corrosion cracking by applying torque to the bolt until the desired COD, corresponding to the desired pre-stress condition, was reached. The bolt tip was machined to a gentle radius to achieve point loading. Before and during torqueing, a few drops of the test solution were placed at the crack tip so that the

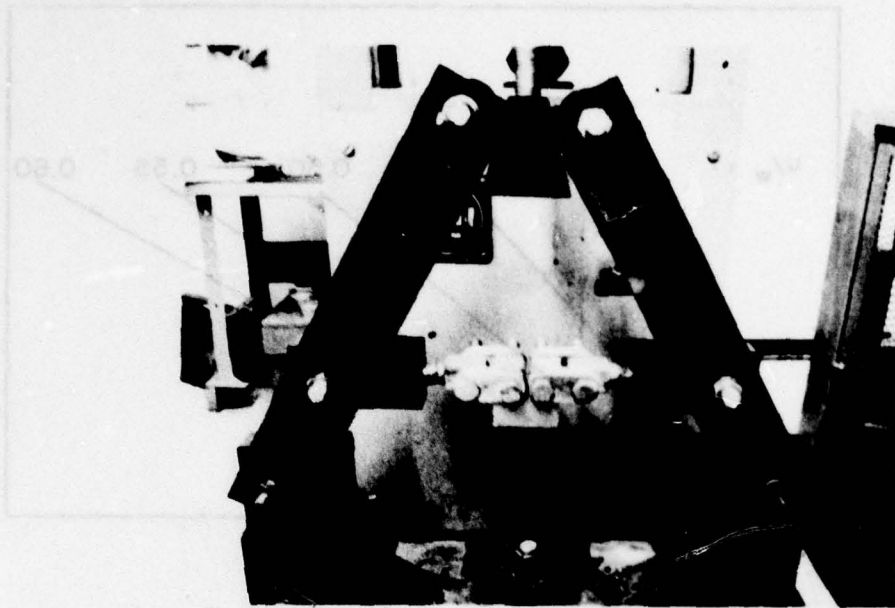

Figure 26. Horizontal Stressing Frame.

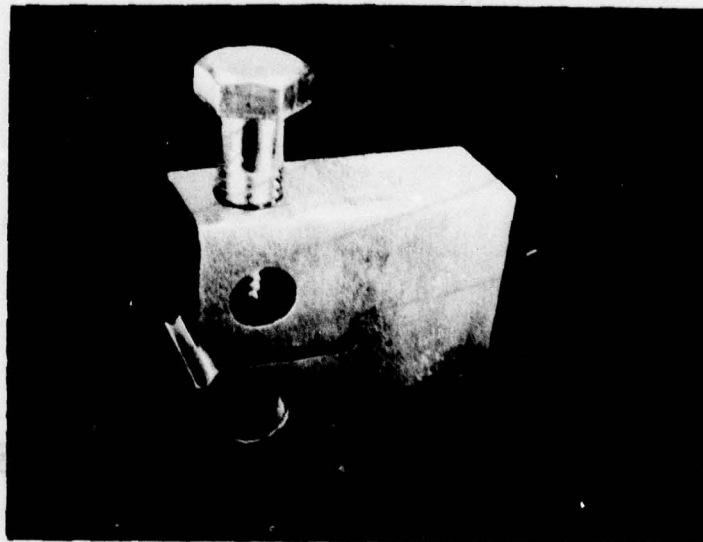

Figure 27. Bolt Loaded WOL Specimen.

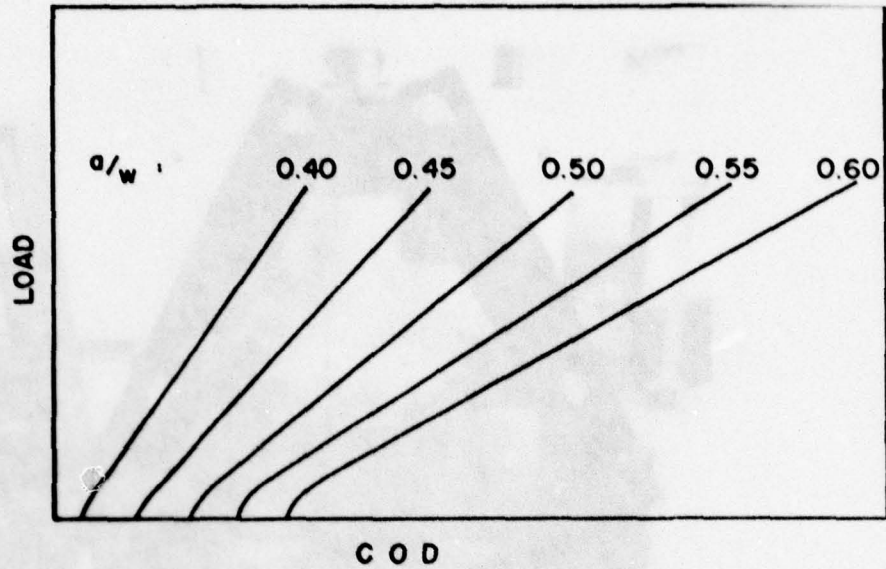

Figure 28. Typical Load vs. Crack Opening Displacement Traces.

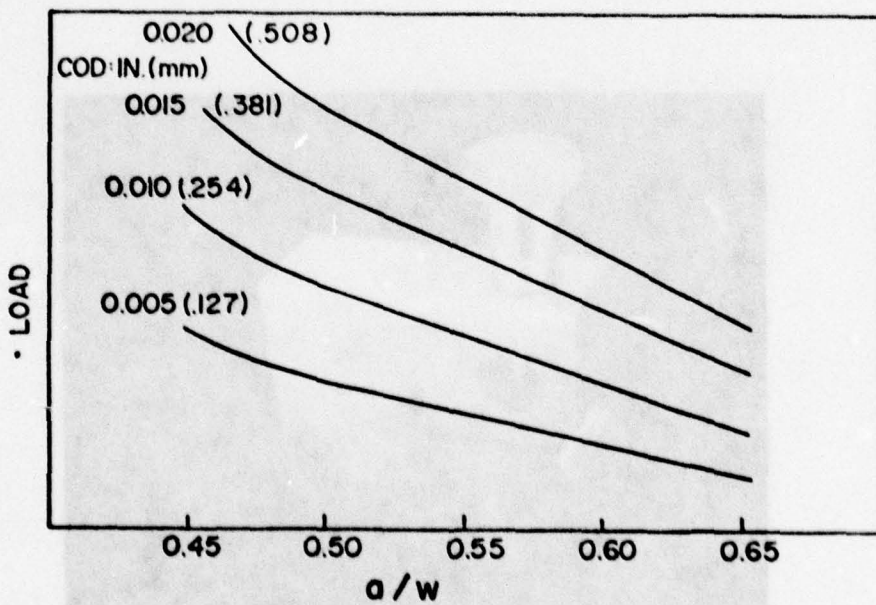

Figure 29. Compliance Curve Obtained For Bolt Loaded WOL Specimen.

solution would be drawn into the crack. After the proper COD was reached, as indicated by the clip gage, the gage was removed and COD verified with a toolmaker's microscope. The specimen was then placed in an environmental chamber. Care was taken to avoid any contact of the bolt tip with the solution as any corrosion build-up at the bolt tip could possibly wedge the specimen open further than desired. As with the other previously mentioned constant immersion exposures, air was bubbled through the solution.

After the exposure period, the specimens were removed and the COD again verified. The bolt was then carefully removed and the specimen was loaded in a Tinius-Olsen tensile test machine with the clip gage in place. A trace of load vs. COD was obtained until complete specimen fracture, quite similar to the test procedure for fracture toughness testing. Afterwards, the load corresponding to the COD value applied by the bolt during the corrosion test and the final crack length were determined and used to calculate the final stress intensity at crack arrest. This value for stress intensity is defined as the threshold for stress corrosion cracking in a decreasing stress intensity field.

1.5.2 Results and Discussion

Tensile test results are presented in Table 14 and are identical to those reported in Reference 12, but lower in strength and ductility than the material reported in Reference 13; this behavior is probably attributable to the slightly lower copper content of the test material.

Fracture toughness test results are presented in Table 15. These test results are valid by ASTM test standards and are equal to those reported in References 12 and 13.

¹²Staley, J.T., "Investigation to Develop a High Strength Stress-Corrosion Resistance Naval Aircraft Aluminum Alloy," November 1970.

¹³Terrell, J., "Time Exposure Studies on Stress Corrosion Cracking of Aluminum 2014-T6, 2219-T87, 2014-T651, 7075-T651, and Titanium 6Al-4V," June 1973.

TABLE 14
ROOM TEMPERATURE TENSILE PROPERTIES OF
ALUMINUM ALLOY 7075-T651

Specimen No.	Orientation	Ultimate Strength		Yield Strength		Elongation (%) in 3/4-inch (25.4-mm) G.L.	Reduction of Area* (%)
		KSI	(MPa)	KSI	(MPa)		
S1	Short Transverse	73.8	(509)	64.5	(450)	1.5	4.0
S2		74.4	(513)	66.2	(456)	1.6	3.5
S3		73.4	(506)	65.4	(451)	1.2	2.5
S4		72.7	(501)	63.7	(439)	1.9	2.6
		73.6	(507)	65.2	(450)	1.6	3.2

*Gage section 0.160-inch (4.06-mm) diameter.

TABLE 15
FRACTURE TOUGHNESS TEST RESULTS
(S-T) Orientation, Room Temperature

Specimen No.	K_{IC}		$2.5 \left(\frac{K_Q}{Y.S.} \right)^2$	ASTM Valid?
	KSI \sqrt{in}	MPa \sqrt{m}		
SP2	17.6	19.3	0.18	Yes
SP6	18.6	20.4	0.20	Yes
SC6	<u>18.1</u>	<u>19.9</u>	0.19	Yes
Avg.	18.1	19.9		

Results for stress corrosion tests using the chloride-dichromate solution are presented in Table 16. There was little pitting, corrosion product build-up, or staining of the machined surfaces. However, there was considerable exfoliation of the machined notch surfaces where the longitudinal grains of the central plate region were exposed. To a much lesser extent there was some evidence of exfoliation on the top and bottom surfaces, which are the rolled surfaces of the parent test plate.

Of the four methods of loading the greatest number of tests were performed in the vertical loaded constant immersion test stand. Due to the greater degree of confidence in these data they were used as baseline data. The results of this method are presented graphically in Figure 30. The line represents the best least squares fit to the test data, a second degree polynomial.

For the baseline tests (vertical loaded constant immersion method), the test material proved to be very sensitive to stress corrosion cracking in the acidic chloride dichromate test solution (Figure 30). The threshold for stress corrosion cracking as determined by this method is less than $4 \text{ KSI}\sqrt{\text{in}}$ ($4.4 \text{ MPa}\sqrt{\text{m}}$), 22 percent of the room temperature fracture toughness value. The crack grew considerably further along the free surfaces than it did in the central region of the test specimen; this phenomena occurred for all four loading methods.

The vertical loaded alternate immersion, horizontally loaded constant immersion, and bolt loaded constant immersion loading conditions test results are presented in Figure 31 along with the curve from Figure 30 that represents the baseline data (vertical loaded constant immersion loading condition). For the horizontally loaded constant immersion method of loading, a loading condition of $3.5 \text{ KSI}\sqrt{\text{in}}$ ($3.8 \text{ MPa}\sqrt{\text{m}}$), which is 19 percent of the material's fracture toughness, produced failure after 1801 hours. Data obtained for the horizontal loaded and vertical

TABLE 16
STRESS CORROSION CRACKING TEST RESULTS FOR A STRONGLY
ACIDIC (pH=1.3) CHLORIDE-DICHROMATE SOLUTION

Loading Method	KSI \sqrt{IN}	MPa \sqrt{m}	Duration of Test (Hours)
Vertical Loaded Constant Immersion	15.0	16.4	333
	11.7	12.7	240
	11.8	12.9	306
	5.8	6.3	706
	7.9	8.6	721
	5.0	5.4	1215
	3.6	3.9	1605
	4.1	4.5	1710
Vertical Loaded Alternate Immersion	9.6	10.5	456
	7.7	8.4	672
	6.4	6.9	1118
	5.3	5.8	2500*
	3.8	4.2	2154*
Horizontal Loaded Constant Immersion	7.0	7.6	572
	4.2	4.6	1340
	3.5	3.8	1801
Bolt-Loaded WOL Constant Immersion	9.0	9.8	2000
	9.2	10.0	2000

*No failure, test terminated.

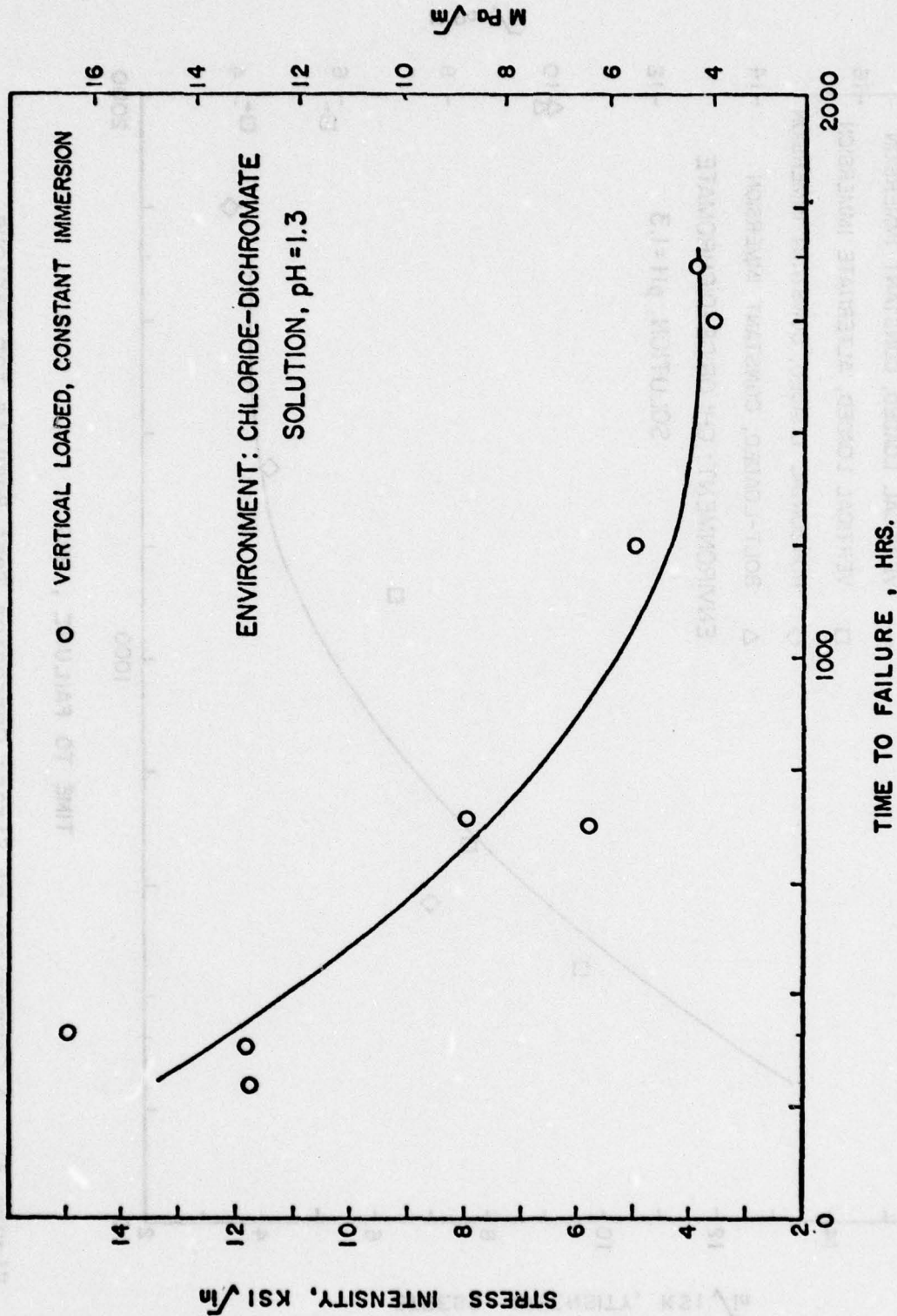

Figure 30. Vertical Loading Constant Immersion Stress Corrosion Cracking Test Results for Chloride-Dichromate Solution.

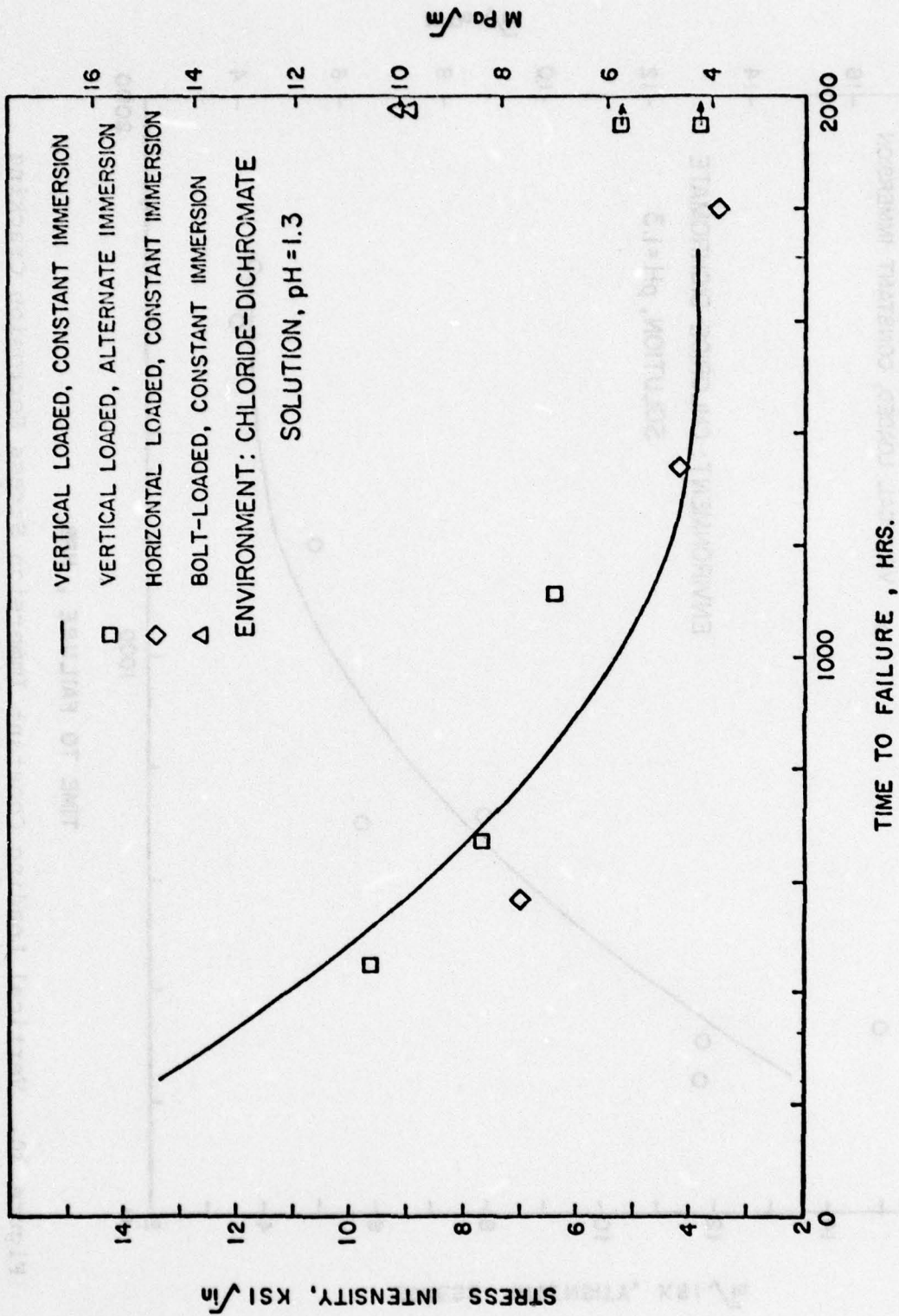

Figure 31. A Comparison of Stress Corrosion Test Results for Various Loading Conditions in Chloride-Dichromate Solution.

loaded constant immersion test conditions are nearly identical both yielding a threshold stress intensity value in the range 3.0 to 4.0 KSI $\sqrt{\text{in}}$ (3.3 to 4.4 MPa $\sqrt{\text{m}}$).

The bolt loaded WOL test specimens produced the highest magnitude threshold for stress corrosion cracking; the cracks grew in a decreasing stress intensity field to an average value of 9.10 KSI $\sqrt{\text{in}}$ (9.91 MPa $\sqrt{\text{m}}$). This result is considerably higher than results obtained from both the vertical and horizontal loaded constant immersion techniques.

The vertical loaded alternate immersion condition was less severe than either of the constant immersion constant loading techniques. The threshold value for stress corrosion cracking for this technique is estimated to be between 5.5 and 6.5 KSI $\sqrt{\text{in}}$ (6.0 and 7.1 MPa $\sqrt{\text{m}}$).

SECTION 2

CHARACTERISTICS AND MECHANICAL PROPERTIES OF NON-METALLIC MATERIALS INCLUDING COMPOSITES, PLASTICS, AND ADHESIVES

2.1 INTRODUCTION

Non-metallic materials are becoming more important in structural applications and are replacing many traditionally metallic components on Air Force systems. Composites, plastics, and adhesives offer the advantage of significant weight savings with possible improvement in the reliability of a system. There are similar requirements for qualifying non-metallic materials for a particular usage as there are for metallic materials. Also, throughout the life-cycle of these materials there are the same needs for determining damage incurred in use, evaluating potentially degrading environments, and determining the applicability of substituting such technology for more traditional materials and methods. Quite often these materials are proposed for replacements for damaged or potentially damaged parts.

Although the types of information required on non-metallic materials are similar to these for their metal counterparts, the types of environments that can compromise the integrity of non-metallic components are somewhat more extensive and often require a more in-depth investigation. A discussion of some of the major efforts on non-metallic materials that have been undertaken during this contract are presented in this section.

2.2 TENSILE AND FLEXURAL PROPERTIES OF E741D COMPOSITE

The application of composite materials have in many instances been successful in reducing the weight and increasing the service life of many systems. One such system where composites have been proven more successful than their metal counterparts is the supersonic wind tunnel located at the Arnold Engineering and Development Center (AEDC). Because

the blades of the C1 and C2 stages of the AEDC wind tunnel have successfully been replaced with fiberglass-epoxy composites, the decision was made to convert the C3 stage blades to composite blades. One of the candidate materials for reblading the C3 compressor, a glass-epoxy composite, was evaluated.

2.2.1 Material, Specimens, and Procedures

Two panels, 18 inches (457 mm) by 18 inches (457 mm), of glass-epoxy composite material, identified as E741D-1543-A1100, Exhibit "A", and E741D-7811-A1100, Exhibit "B" were obtained for testing. Tensile and flex specimens were machined from the panels as indicated in the layout drawings illustrated in Figures 32 and 33. The first letter of the specimen I.D. indicates from which panel it was taken, while the second letter refers to tensile or flex specimen. The number in the specimen I.D. indicates the specimen location in the panel. The arrows next to the figures indicate the warp directions of each panel.

Tensile specimens were machined to the dimensions specified in ASTM Standard D638-72, Type I, while the flex specimens conformed to the dimensions specified in ASTM Standard D790-71, Method I.

All tensile and flexural testing was performed in an Instron testing machine equipped with an environmental test chamber for the elevated temperature testing. Tensile testing was carried out in accordance with ASTM Standard D638-72. The specimens were secured in the test machine using self-tightening wedge grips, and specimen extension was monitored with a two-inch, high-temperature Instron extensometer. The speed of the testing machine cross-head was held constant at 0.05 in/min (0.021 mm/s) for all tests. Tensile specimens undergoing high-temperature testing were allowed to "soak" at the desired test temperature for approximately 1/2-hour before testing.

Flexural testing was carried out in accordance with ASTM Standard D790-71, Method I, Procedure A for three-point flexing. Since a 16:1 span-to-depth ratio was desired,

	AF-1	AT-1
	AF-2	AT-2
	AF-3	AT-3
	AF-4	AT-4
	AF-5	AT-5
	AF-6	AT-6
	AF-7	AT-7
	AF-8	AT-8
	AF-9	AT-9
	AF-10	AT-10
	AF-11	AT-11
	AF-12	AT-12
	AF-13	AT-13
	AF-14	AT-14
	AF-15	AT-15
AF-1X		
AF-2X		
AF-3X		
AF-4X		
AF-5X		



 WARP DIRECTION

Figure 32. Specimen Layout Drawing for Panel (Exhibit) "A".

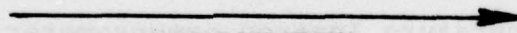
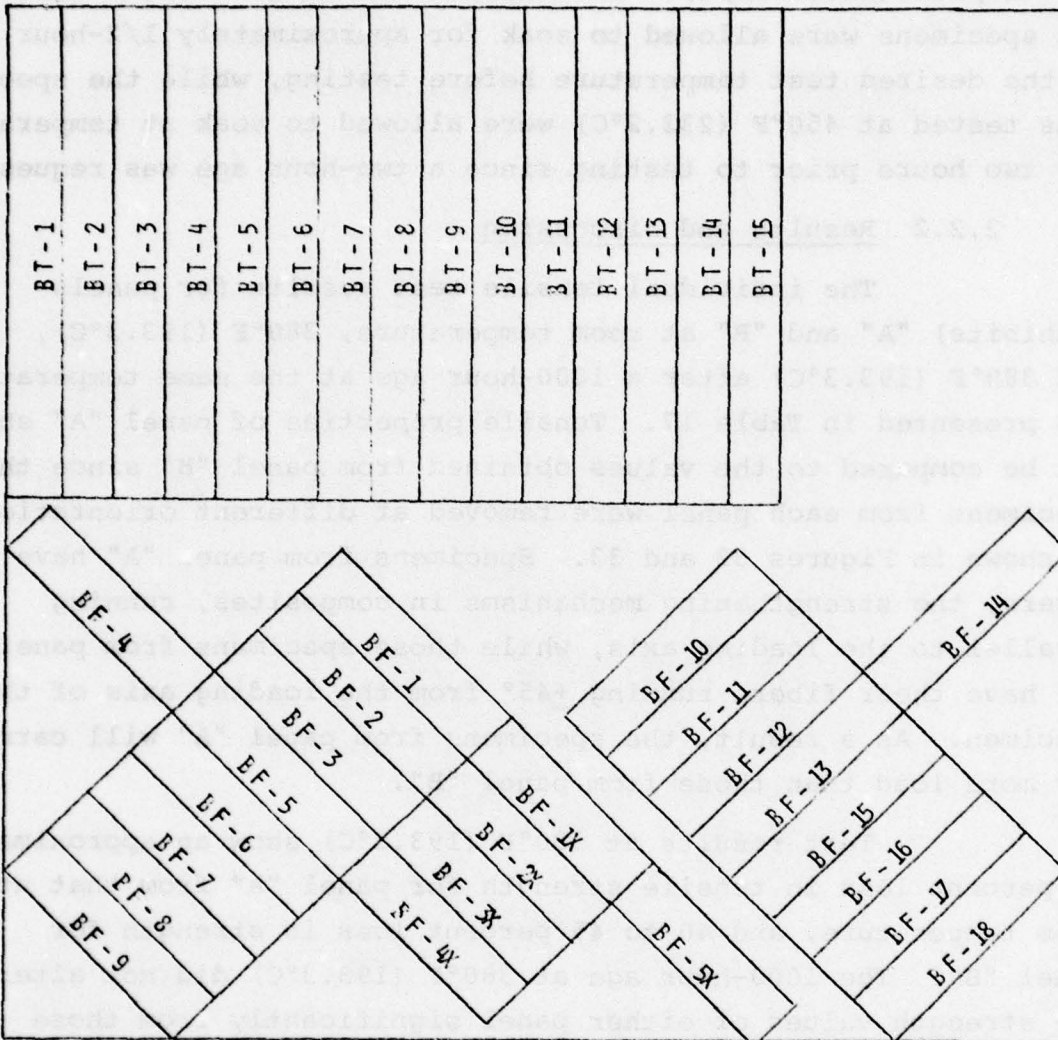

Figure 33. Specimen Layout Drawing for Panel (Exhibit) "B".

the span was set at 2.00 inches (50.8 mm) for all flex tests. The cross-head speed of the testing machine was maintained at 0.05 in/min (0.021 mm/s). For flexural testing at 380°F (193.3°C), the specimens were allowed to soak for approximately 1/2-hour at the desired test temperature before testing, while the specimens tested at 450°F (232.2°C) were allowed to soak at temperature for two hours prior to testing since a two-hour age was requested.

2.2.2 Results and Discussion

The individual tensile test results for panels (Exhibits) "A" and "B" at room temperature, 380°F (193.3°C), and 380°F (193.3°C) after a 1000-hour age at the same temperature are presented in Table 17. Tensile properties of panel "A" should not be compared to the values obtained from panel "B" since the specimens from each panel were removed at different orientations, as shown in Figures 32 and 33. Specimens from panel "A" have the fibers, the strengthening mechanisms in composites, running parallel to the loading axis, while those specimens from panel "B" have their fibers running +45° from the loading axis of the specimen. As a result, the specimens from panel "A" will carry far more load than those from panel "B".

Test results at 380°F (193.3°C) show an approximate 10 percent loss in tensile strength for panel "A" from that at room temperature, and 40 to 45 percent loss in strength for panel "B". The 1000-hour age at 380°F (193.3°C) did not alter the strength values of either panel significantly from those at 380°F (193.3°C) unaged; however, the appearance change was drastic. Specimens from both panels after 1000-hour aging appeared black in comparison to the original as-supplied light color, while those specimens from panel "B" became warped due to the exposure.

The modulus values of panel "A", while decreasing with increasing temperature, showed an improvement after the 1000-hour age when compared to the unaged results at 380°F (193.3°C). This phenomenon might be explained by the specimens

TABLE 17
TENSILE DATA FOR GLASS-EPOXY MATERIAL E741D

Specimen No.	Test Temp. °F (°C)	Exposure	Ultimate Strength		Modulus	
			KSI	(MPa)	MSI	(TPa)
AT-1	70 (21)	NONE	69.4	(478)	5.24	(36.1)
AT-2			71.3	(492)	4.65	(32.1)
AT-3			71.9	(496)	4.76	(32.8)
AT-4			73.1	(504)	4.77	(32.9)
AT-5			70.9	(489)	4.82	(33.2)
BT-1	70 (21)	NONE	20.9	(144)	-	-
BT-2			20.3	(140)	-	-
BT-3			20.2	(139)	-	-
BT-4			20.0	(138)	-	-
BT-5			20.0	(138)	-	-
AT-6	380 (193.3)	NONE	63.4	(437)	4.50	(31.0)
AT-7			66.8	(460)	4.19	(28.9)
AT-8			-	-	4.36	(30.1)
AT-9			-	-	4.36	(30.1)
AT-10			63.6	(438)	4.40	(30.3)
BT-6	380 (193.3)	NONE	12.4	(85.5)	-	-
BT-7			9.7	(66.9)	-	-
BT-8			12.6	(86.9)	-	-
BT-9			12.1	(83.4)	-	-
BT-10			11.8	(81.4)	-	-
AT-11	380 (193.3)	1000 hr, 380°F (193.3°C)	61.3	(423)	4.80	(33.1)
AT-12			58.8	(405)	4.76	(32.8)
AT-13			79.0	(545)	5.07	(35.0)
AT-14			61.8	(426)	4.65	(32.1)
AT-15			57.5	(396)	4.84	(33.4)
BT-11	380 (193.3)	1000 hr, 380°F (193.3°C)	11.2	(77.2)	-	-
BT-12			11.5	(79.3)	-	-
BT-13			11.6	(80.0)	-	-
BT-14			11.8	(81.4)	-	-
BT-15			12.3	(84.8)	-	-

undergoing a post-cure during this exposure period. Modulus values for panel "B" were not recorded since the glass fibers ran $\pm 45^\circ$ with respect to the loading axis and any strain measured would probably be that of the resin and not the cloth. Likewise, there was no separation or fracture when these specimens failed. Instead, the specimens appeared necked down at the failed area.

The tensile specimens from panel "A" experienced a much different type of failure. All specimens from this panel failed either in the grips or at the radius of the specimen gage section, or some combination of the two. This might be explained by the fact that a high localized stress was caused by the radius or by a nick induced by the teeth of the grips resulting in failure at those locations before the stress in the gage section reached the ultimate strength of the material. In an attempt to reduce the grip area failures, the grip faces were lined with emery paper to minimize the change of the teeth digging into the material. However, the success was minimal. It is probably for this reason that more scatter appears in the results for panel "A" material.

The individual results from the three-point flex tests at room temperature, 380°F (193.3°C), and 380°F (193.3°C) and 450°F (232.2°C), both after aging, are presented in Table 18. In general, the flexural strength and modulus of panel "A" are higher than those of panel "B" over all temperature conditions investigated. The flexural strength values of both panels at 380°F (193.3°C) decreased to approximately a half of the room temperature values. The addition of a 1000-hour age did not appear to significantly change the mechanical properties of either panel at 380°F (193.3°C). Flexural properties determined after a two-hour age and test at 450°F (232.2°C) showed an approximate 70 percent loss in strength and a 50 to 60 percent decrease in modulus from those tested at room temperature.

Specimens from both panels experienced basically the same types of failures: a normal flex failure at room

TABLE 18
 FLEXURAL DATA FOR GLASS-EPOXY MATERIAL E741D

Specimen No.	Test Temp.		Exposure	Flex. Strength		Flex. Modulus	
	°F	(°C)		KSI	(MPa)	MSI	(TPa)
AF-1	70	(21)	NONE	83.8	(578)	3.58	(24.7)
AF-2				81.0	(558)	3.84	(26.5)
AF-3				85.5	(590)	3.88	(26.8)
AF-4				84.8	(585)	3.80	(26.2)
AF-5				86.3	(595)	3.84	(26.5)
BF-1	70	(21)	NONE	69.9	(482)	3.01	(20.8)
BF-2				66.7	(460)	3.04	(21.0)
BF-3				67.7	(467)	3.03	(20.9)
BF-10				67.3	(464)	2.98	(20.5)
BF-11				65.8	(454)	2.76	(19.0)
BF-12				67.4	(465)	2.90	(20.0)
AF-6	380	(193.3)	NONE	38.0	(262)	2.22	(15.3)
AF-7				39.2	(270)	2.78	(19.2)
AF-8				34.5	(238)	2.58	(17.8)
AF-9				30.9	(213)	2.08	(14.3)
AF-10				34.3	(236)	2.04	(14.1)
BF-4	380	(193.3)	NONE	34.0	(234)	2.30	(15.8)
BF-5				34.0	(234)	2.30	(15.8)
BF-6				31.0	(214)	2.22	(15.3)
BF-13				32.5	(224)	2.17	(15.0)
BF-14				32.4	(223)	2.15	(14.8)
BF-15				31.0	(214)	2.18	(15.0)
AF-11	380	(193.3)	1000 hr, 380°F (193.3°C)	40.0	(276)	2.65	(18.3)
AF-12				41.2	(284)	2.64	(18.2)
AF-13				41.6	(287)	2.70	(18.6)
AF-14				39.0	(269)	2.60	(17.9)
AF-15				41.3	(285)	2.65	(18.3)
BF-7	380	(193.3)	1000 hr, 380°F (193.3°C)	33.8	(233)	1.94	(13.4)
BF-8				35.7	(246)	1.90	(13.1)
BF-9				34.9	(241)	1.88	(13.0)
BF-16				32.9	(227)	1.88	(13.0)
BF-17				33.1	(228)	2.00	(13.8)
BF-18				35.3	(243)	1.94	(13.4)

TABLE 18 (Concluded)
 FLEXURAL DATA FOR GLASS-EPOXY MATERIAL E741D

Specimen No.	Test Temp.		Exposure	Flex. Strength		Flex. Modulus	
	°F	(°C)		KSI	(MPa)	MSI	(TPa)
AF-1X	450	(232.2)	2 hr, 450°F (232.2°C)	22.8	(157)	1.42	(9.79)
AF-2X				23.4	(161)	1.35	(9.31)
AF-3X				24.1	(166)	1.42	(9.79)
AF-4X				22.8	(157)	1.35	(9.31)
AF-5X				23.4	(161)	1.59	(11.0)
BF-1X	450	(232.2)	2 hr, 450°F (232.2°C)	20.9	(144)	1.34	(9.24)
BF-2X				20.1	(138)	1.44	(9.93)
BF-3X				21.0	(145)	1.38	(9.51)
BF-4X				21.9	(151)	1.50	(10.3)
BF-5X				19.4	(134)	1.48	(10.2)

temperature, a compression failure in the top plies for test at 380°F (193.3°C), and a simple shear failure for those specimens that underwent a 1000-hour age before test at 380°F (193.3°C). Likewise, the specimens undergoing a two-hour age prior to test at 450°F (232.2°C) experienced a similar shear failure in most cases.

2.3 MECHANICAL PROPERTIES OF NR 150 B2/S-GLASS COMPOSITE

A decision was made to reblade the C4 compressor stage of the supersonic wind tunnel located at AEDC with composite material. As discussed in Section 2.2, the blades of the C1 and C2 compressor stages had previously been replaced with composite structures. The composite system NR 150 B2/S-Glass had been designated as a candidate material for the reblading program. Since only limited data were available on this material, a program was initiated to generate a variety of mechanical property data for this composite system.

2.3.1 Materials, Specimens, and Procedures

Four panels, approximately 12 inches (305 mm) by 12 inches (305 mm) by 0.125-inch (3.18-mm) thick, of the composite system NR 150 B2/S-Glass were received for testing. The material, produced by Hamilton Standard, consisted of 14 plies of S-Glass, style 6581 with an I589 finish, laid-up 0° to 90° in alternate layers. The resin system was NR 150 B2 Polyimide. Tensile, flex, short beam shear, flexural fatigue, creep, and extra wide tensile coupons used for ballistic impact studies were removed from each panel. Because of the poorer quality in certain portions of panels identified as Panels No. 1 and No. 2, they were combined and treated as one representative sample of this material. An equal number of specimens were removed from each of these three samples: Panels No. 1 and 2, Panel No. 3, and Panel No. 4. The first number of the specimen I.D. indicates from which panel it was taken. The following letter, or letters, indicate the type of specimen, i.e., T-tensile, F-flex, FF-flex

fatigue, etc. The final number indicates the specimen location in each panel.

Tensile specimens were machined to the configuration shown in Figure 34. Flex and short beam shear specimens were machined to the configurations shown in Figures 35 and 36, respectively. The flex fatigue, ballistic impact, and creep specimen dimensions conform to those illustrated in Figures 37, 38, and 39, respectively. Specimens were not machined in the thickness direction, leaving the as-manufactured surfaces on the samples.

Tensile testing was carried out in accordance with ASTM Standard D638-72. Strain was monitored with a two-inch Instron extensometer for the room temperature tests and strain gages for the elevated temperature tests. Tensile specimens, as well as all other specimens undergoing high-temperature testing, were allowed to "soak" at the desired test temperature for approximately 1/2-hour before testing.

Flexural testing was carried out in accordance with ASTM Standard D790-71, Method I, Procedure A for three-point flexing. Since a 16:1 span-to-depth ratio was desired, the span was set at 2.00 inches (50.8 mm) for all flex tests. The cross-head speed of the testing machine was maintained at 0.05 in/min (0.021 mm/s). Apparent horizontal shear stress data were obtained in a similar manner. The cross-head speed was the same, while the span was set at 0.50 inch (12.7 mm).

Flexural fatigue was performed on a Krause fatigue machine, which operates on a constant displacement principal. A stress ratio, R , equal to 0.0 was used. The specimens were first mounted to a strain-gaged flexural load transducer which, in turn, was mounted to the machine base. A dead weight was applied at the tip of the specimen to give the desired stress at the gage section of the sample. The strain from the transducer was recorded, the load removed, and the crank of the machine attached. By adjusting the eccentricity of the crank

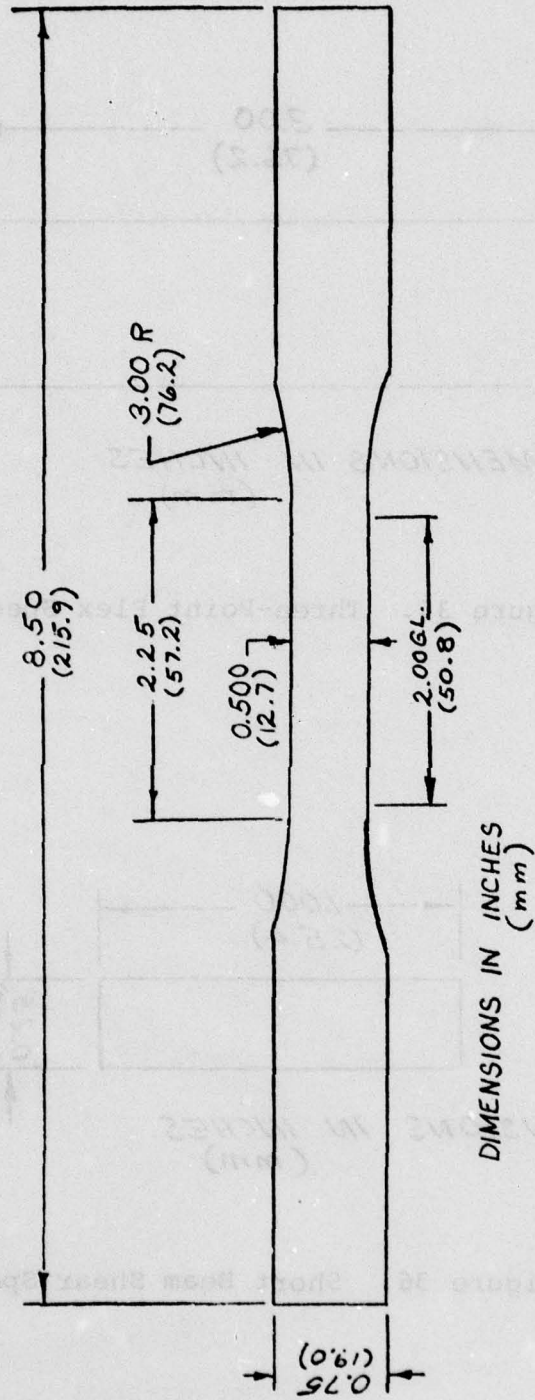
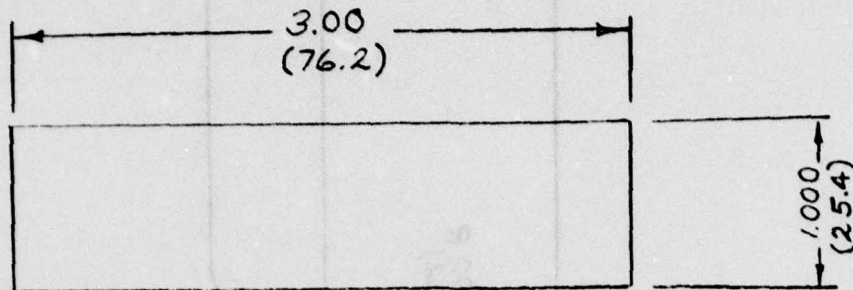
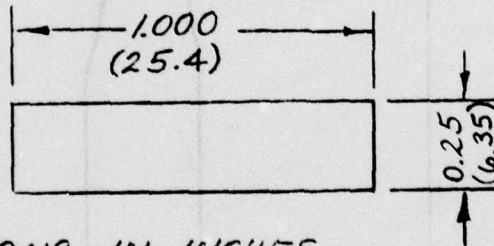

Figure 34. Tensile Specimen.



DIMENSIONS IN INCHES
(mm)

Figure 35. Three-Point Flex Specimen.



DIMENSIONS IN INCHES
(mm)

Figure 36. Short Beam Shear Specimen.

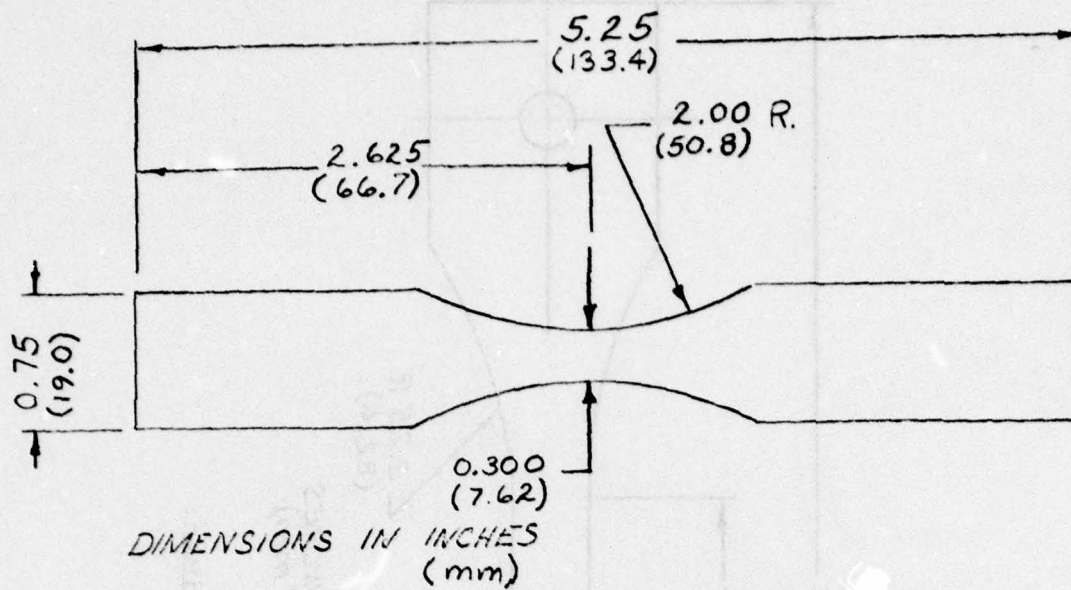

Figure 37. Flexural Fatigue Specimen.

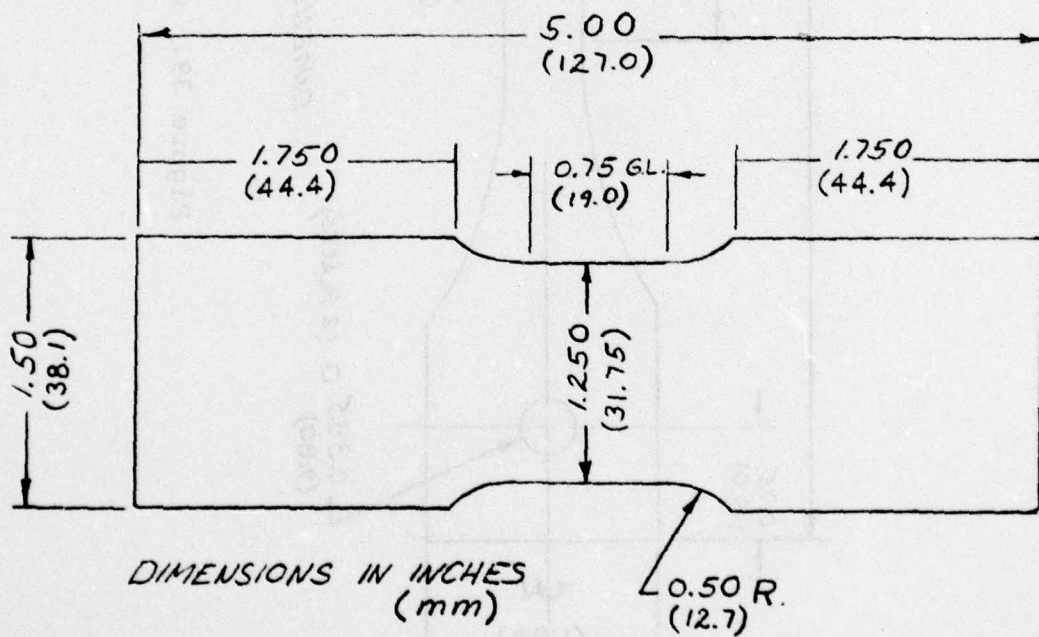

Figure 38. Ballistic Impact Specimen.

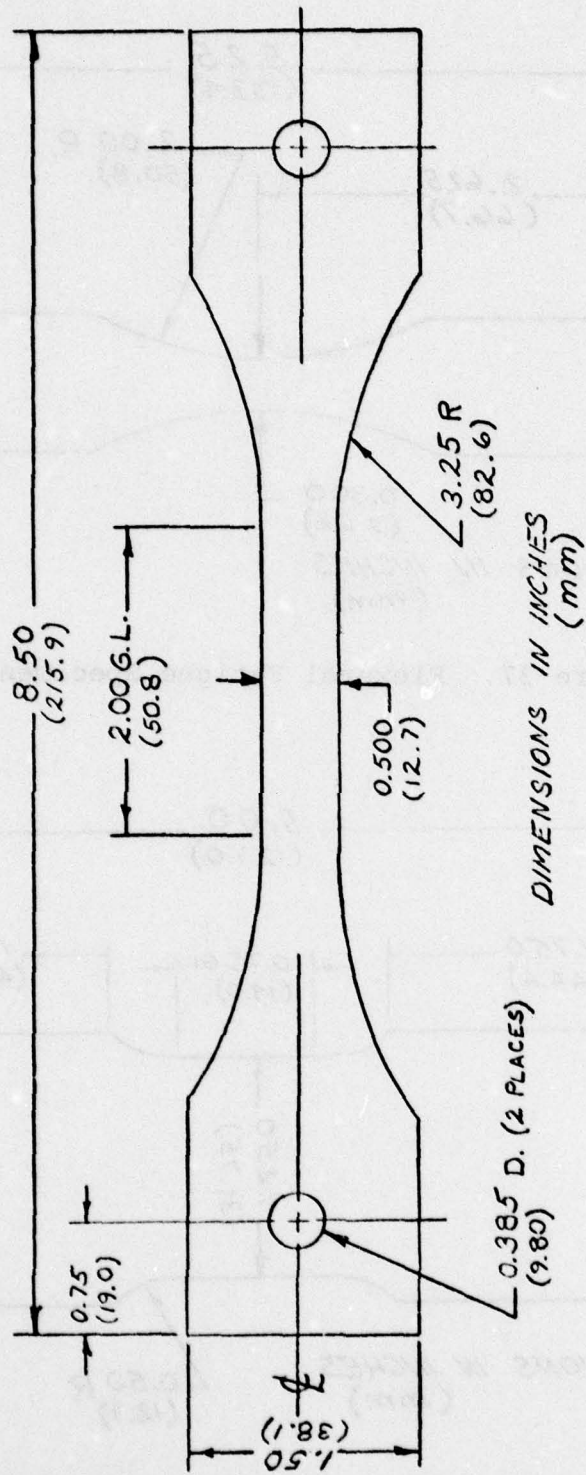

Figure 39. Creep Specimen.

mechanism on the machine, a deflection was set to give the same transducer strain reading as the dead weight produced and the test started.

Creep testing was carried out in accordance with ASTM Standard D674-56 using Satec creep frames. Extension was measured using a linear variable differential transformer with the output signal fed back to a central data acquisition system. Elongation was recorded as a function of time for each specimen at each condition. At the conclusion of the test, the specimens were removed and tensile tested at room temperature to determine their residual strength.

2.3.2 Results and Discussion

Tensile data for NR 150 B2/S-Glass for room and elevated temperatures are presented in Table 19, as well as the results for those specimens undergoing long-term aging at elevated temperatures. Although there is much scatter in the data, the results for the unexposed specimens indicated a slight decrease in strength with increasing temperature. The increase in apparent modulus at high temperatures might be a result of driving off some trapped solvent in the material which was used during the processing of this system. The presence of this solvent would undoubtedly create some softening of the material. Also, some post-curing might be occurring. Tensile specimens undergoing long-term aging at elevated temperatures show a significant loss in strength values from the unaged specimens tested at the same temperature.

The three-point flex test results are presented in Table 20. Almost all the specimens failed as a result of compression in the top plies, rather than the desired tensile failures in the lower ply which is indicative of a good flex test. In general, however, the apparent flex strengths decreased with increasing temperature for the unexposed specimens. The time-temperature exposures appeared to improve the strength values. This phenomenon might again be explained as a post-cure for this material.

TABLE 19
TENSILE DATA FOR NR 150 B2/S-GLASS

Specimen No.	Exposure Conditions Hrs/°F(°C)	Test Temp. °F(°C)	Ultimate Strength		Apparent Modulus	
			KSI	(MPa)	MSI	(GPa)
4T-1	None	RT	69.5	(479)	3.29	(22.7)
3T-1			69.6	(480)	3.62	(25.0)
2T-1			44.1	(304)	3.29	(22.7)
4T-2	None	550 (288)	64.8	(447)	4.08	(28.1)
3T-2			70.9	(489)	4.10	(28.3)
2T-2			59.0	(407)	4.31	(30.0)
1T-1	None	600 (316)	60.4	(416)	4.2	(29.0)
2T-3			61.8	(426)	4.6	(31.7)
3T-3			59.8	(412)	4.2	(29.0)
2T-4	500/550 (288)	550 (288)	55.6	(383)	3.30	(22.8)
3T-4			43.7	(301)	3.42	(23.6)
4T-3			51.9	(358)	3.44	(23.7)
2T-5	500/600 (316)	600 (316)	48.4	(334)	3.50	(24.1)
3T-5			37.0	(255)	3.27	(22.5)
4T-4			44.1	(304)	3.17	(21.8)
1T-2	1000/600 (316)	600 (316)	47.0	(324)	3.33	(23.0)
2T-6			46.3	(319)	3.57	(24.6)
3T-6			37.6	(259)	3.27	(22.5)
2T-7	1500/600 (316)	600 (316)	34.3	(236)	3.22	(22.2)
3T-7			36.0	(248)	3.56	(24.5)
4T-5			33.7	(232)	3.45	(23.8)

TABLE 20
THREE-POINT FLEXURAL DATA FOR NR 150 B2/S-GLASS

Specimen No.	Exposure Conditions Hrs/°F(°C)	Test Temp. °F(°C)	Flexural Strength		Apparent Modulus	
			KSI	(MPa)	MSI	(GPa)
2F-1	None	RT	58.2	(401)	2.72	(18.8)
3F-1			78.0	(538)	3.13	(21.6)
4F-1			90.3	(623)	3.16	(21.8)
2F-2	None	550 (288)	47.5	(328)	2.51	(17.3)
3F-2			47.4	(327)	2.74	(18.9)
4F-2			43.0	(296)	2.59	(17.9)
2F-3	None	600 (316)	33.0	(228)	2.59	(17.9)
3F-3			35.2	(243)	2.62	(18.1)
4F-3			36.2	(250)	2.46	(17.0)
1F-4	500/550 (288)	550 (288)	48.2	(332)	3.45	(23.8)
3F-4			49.6	(342)	3.87	(26.7)
4F-4			51.0	(352)	3.43	(23.6)
1F-5	500/600 (316)	600 (316)	37.6	(259)	3.68	(25.4)
2F-5			34.0	(234)	3.14	(21.6)
4F-5			40.3	(278)	3.40	(23.4)
1F-6	1000/600 (316)	600 (316)	39.0	(269)	3.06	(21.1)
3F-6			39.7	(274)	3.04	(21.0)
4F-6			36.2	(250)	3.06	(21.1)
1F-7	1500/600 (316)	600 (316)	27.2	(188)	2.23	(15.4)
3F-7			32.0	(221)	2.43	(16.8)
4F-7			25.2	(174)	2.28	(15.8)
1F-8	2000/600 (316)	600 (316)	34.4	(237)	2.53	(17.4)
3F-8			35.8	(247)	2.73	(18.8)
4F-8			32.2	(222)	2.54	(17.5)

Short beam shear data were obtained for similar test conditions. The apparent shear strengths are reported in Table 21. As with the flex specimens, the mode of failure is a compression in the top plies rather than the desired shear failure between plies. The results at 550°F (288°C) and 600°F (316°C) demonstrate a drastic loss in strength, about 50 to 60 percent from those tested at room temperature. The 500-hour exposure lowered the strength values noticeably from those tested at the same temperature without an exposure. Results for those specimens undergoing 1000, 1500, and 2000-hour exposures at 600°F (316°C) do not differ greatly from those which underwent the 500-hour exposure at 600°F (316°C).

The flex fatigue results are presented in Table 22 for an "R" ratio of 0.0. Criterion for failure was defined as a 10 percent loss in stiffness. It was difficult to determine the exact number of load cycles to failure for those specimens which did not endure the run out life of 10^7 cycles. This was caused by the fact that the loss of load-carrying capability of the specimen did not correlate exactly with specimen separation, and the cycle count is terminated only when complete separation occurs. In an attempt to determine the specimen life as established by the foregoing criterion, the specimens were periodically inspected during test to establish when failure (10 percent loss of stiffness) occurred. The ranges presented in Table 22 represent the scheduled inspections between which failure occurred.

In addition to the more standardized tests (i.e., tensile, flexural, etc.) a ballistic impact test was improvised to determine residual tensile strength after impact by a projectile. A number of wide tensile specimens, as shown in Figure 38, were exposed to various temperature conditions and struck by a pellet, weighing 0.350 gr. with a diameter of 0.177 inch (4.5 mm), traveling at approximately 750 f/s (229 m/s). The temperatures used during exposure and impacting were room

AD-A057 376

DAYTON UNIV OHIO RESEARCH INST
QUICK REACTION EVALUATION OF MATERIALS AND PROCESSES. (U)
FEB 78 D R ASKINS, G J PETRAK

F/G 11/6

F33615-76-C-5034

UNCLASSIFIED

UDR-TR-77-66

AFML-TR-78-6

NL

2 of 3

AD
A057 376

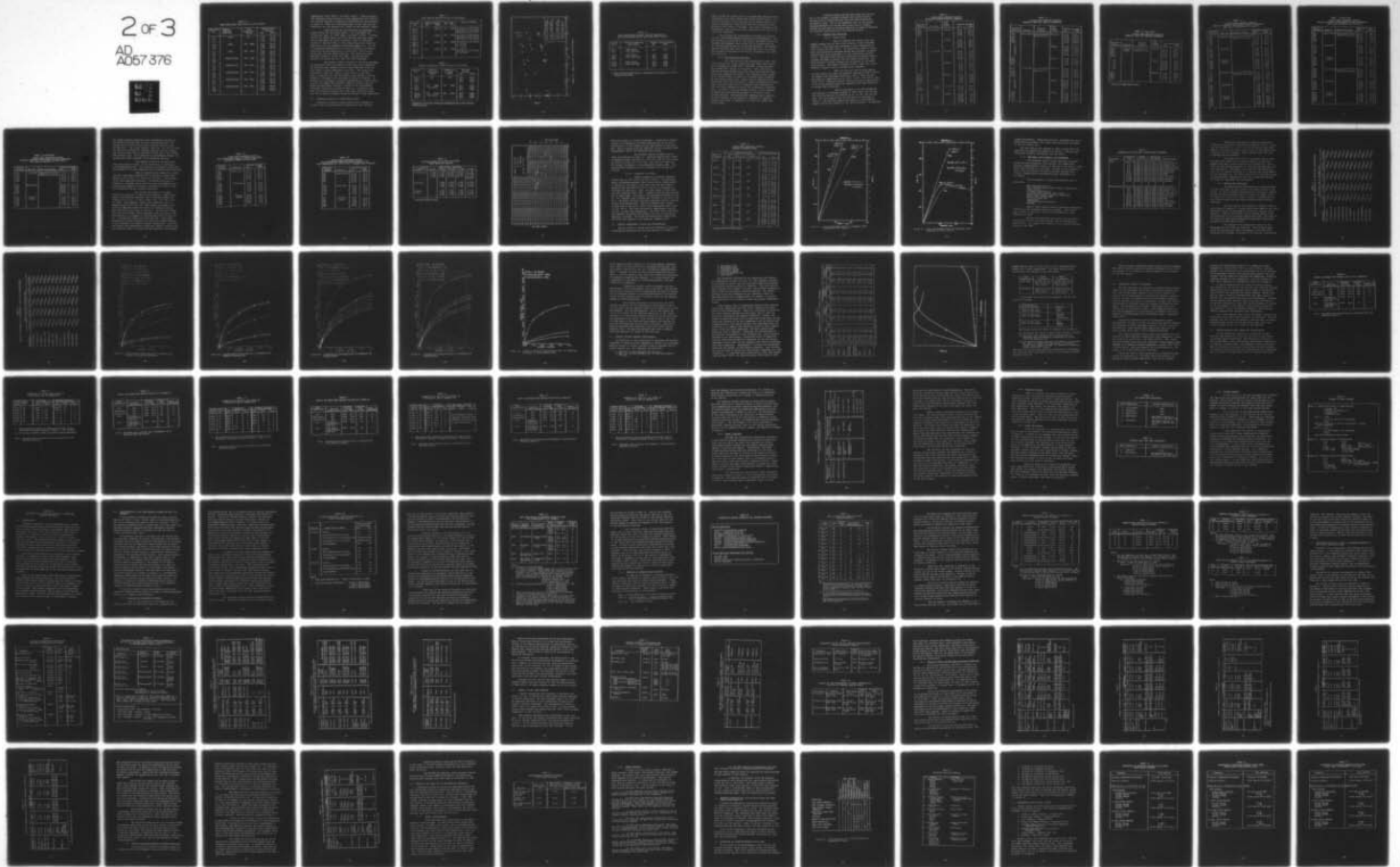

TABLE 21

SHORT BEAM SHEAR DATA FOR NR 150 B2/S-GLASS

Specimen No.	Exposure Conditions Hrs/°F(°C)	Test Temperature °F(°C)	Apparent Shear Strength	
			KSI	(MPa)
1-1	None	RT	7.52	(51.8)
3-1			7.71	(53.2)
4-1			7.90	(54.5)
1-2	None	550 (288)	3.53	(24.3)
3-2			3.69	(25.4)
4-2			3.48	(24.0)
1-3	None	600 (316)	3.04	(21.0)
3-3			3.09	(21.3)
4-3			2.91	(20.1)
1-4	500/550 (288)	550 (288)	2.86	(19.7)
3-4			3.08	(21.2)
4-4			2.98	(20.5)
1-5	500/600 (316)	600 (316)	2.37	(16.3)
3-5			1.98	(13.7)
4-5			2.11	(14.6)
1-6	1000/600 (316)	600 (316)	2.49	(17.2)
3-6			2.41	(16.6)
4-6			2.27	(15.6)
1-7	1500/600 (316)	600 (316)	2.36	(16.3)
3-7			2.02	(13.9)
4-7			2.02	(13.9)
1-8	2000/600 (316)	600 (316)	2.61	(18.0)
3-8			2.50	(17.2)
4-8			2.70	(18.6)

temperature, 550°F (288°C), and 600°F (316°C). These specimens then underwent tensile loading at room temperature until failure. The residual tensile strengths were determined and are presented in Table 23. There is a significant drop in the load-carrying capability for this material as a result of the ballistic impact.

Creep data for NR 150 B2/S-Glass are presented in Figure 40 for the two stress levels, 7 KSI (48.3 MPa) and 14 KSI (96.5 MPa), at 550°F (288°C) and 600°F (316°C). Although the initial strain varies with each specimen the creep rates for all specimens are nearly identical. Data for specimens loaded at 7 KSI (48.3 MPa) at both temperatures fall along the same curve with the exception of specimen number 4C-3. Due to an instrument malfunction this test was terminated 15 minutes after start-up and restarted at a later date. Data are presented only for this second start-up. The curves for those specimens tested at 14 KSI (96.5 MPa), although shifted, parallel the curves for the 7 KSI (48.3 MPa) specimens.

The residual tensile strength of the creep specimens was determined after the 1000-hour creep tests were completed. The specimens were removed from the creep test set-up and tensile tested at room temperature to failure. The results are presented in Table 24. There is much scatter in the data. This is caused by the fact that during creep testing an extensometer is attached to the specimens to monitor extension. In securing this instrument, surface deformations are created which, in turn, can weaken the specimen's apparent tensile strength. Those specimens where fracture occurred at the extensometer knife-edge locations are noted in Table 24. In general, however, the tensile strengths after the creep testing are about half of the tensile strength values determined at room temperature.

2.4 CANDIDATE PLASTICS FOR BOMB SENSING UNITS

A mechanical property testing program was conducted to evaluate three glass-reinforced thermoplastics that could be

TABLE 22
FLEX FATIGUE RESULTS FOR NR 150 B2/S-GLASS

Specimen No.	Maximum Stress		Test Temp.		Cycles to Failure
	KSI	(MPa)	°F	(°C)	
1FF-1 3FF-1 4FF-1	7	(48.3)	550	(288)	No Failure at 10 ⁷ Cycles No Failure at 10 ⁷ Cycles No Failure at 10 ⁷ Cycles
1FF-3 3FF-3 4FF-3	7	(48.3)	600	(316)	No Failure at 10 ⁷ Cycles No Failure at 10 ⁷ Cycles No Failure at 10 ⁷ Cycles
1FF-2 4FF-2 3FF-2	14	(96.6)	550	(288)	No Failure at 10 ⁷ Cycles 5 - 7 x 10 ⁶ 3 - 7 x 10 ⁶
1FF-4 3FF-4 4FF-4	14	(96.6)	600	(316)	4 - 5 x 10 ⁶ No Failure at 10 ⁷ Cycles 8 - 10 x 10 ⁶

TABLE 23
RESULTS OF BALLISTIC IMPACT ON NR 150 B2/S-GLASS

Specimen No.	Exposure Temperature °F(°C)	Temperature at Impact °F(°C)	Residual Strength	
			KSI	(MPa)
1B-3 3B-2 4B-2	RT	RT	44.0 54.2 50.6	(303) (374) (349)
1B-1 2B-1 4B-1	550 (288) for 1/2 hr	550 (288)	36.5 45.6 50.3	(252) (314) (347)
1B-2* 2B-2** 4B-1	600 (318) for 1/2 hr	600 (318)	34.8 30.5 50.6	(240) (210) (349)

*Failed due to improper loading (not aligned properly in test machine)

**Failed in grips.

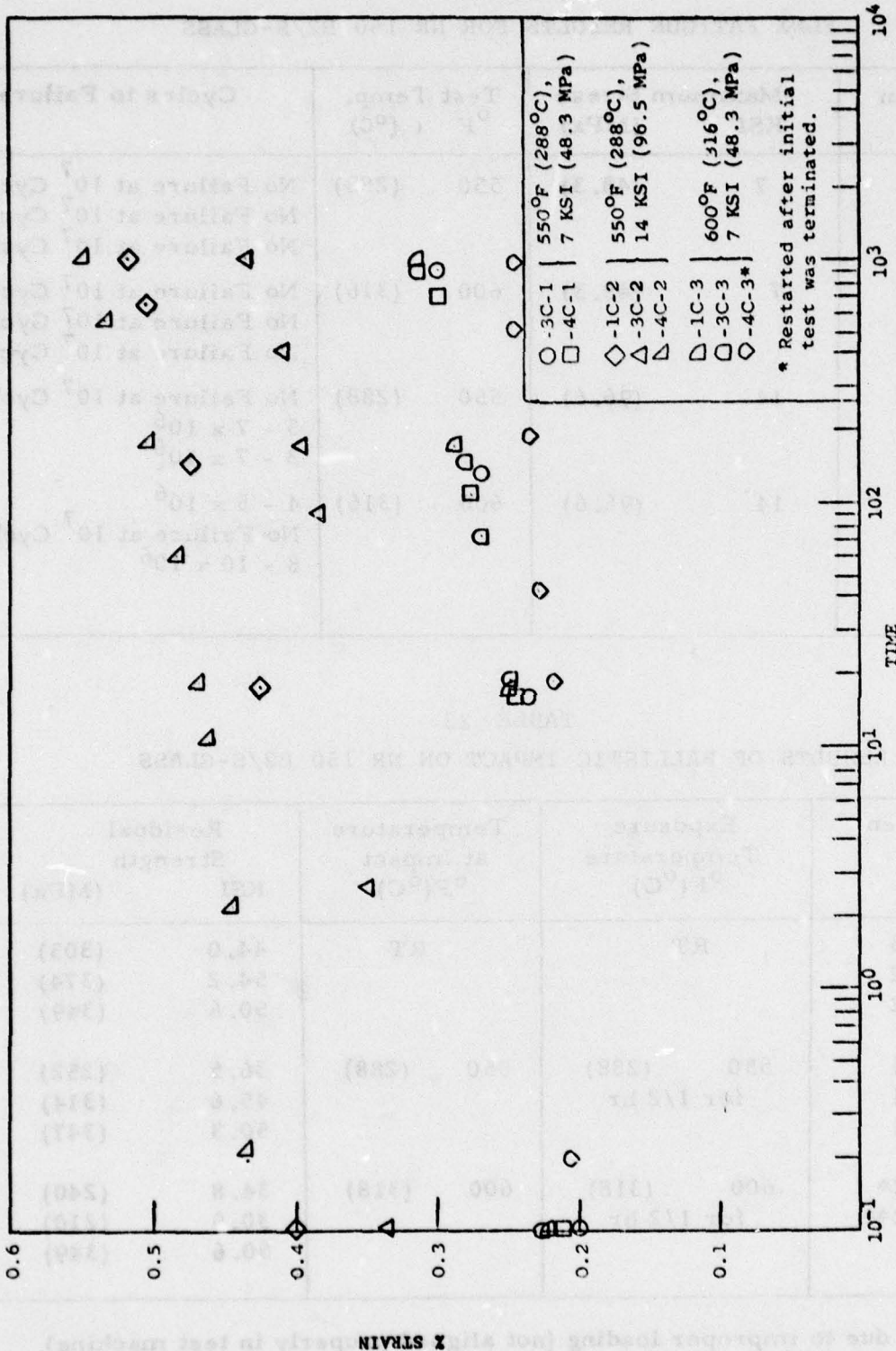

Figure 40. Creep Data for NR 150 B2/S-Glass.

used to house the testing unit of a guided beam which was being developed by the East Guided Beam System Project Office. In service the beam is hung vertically on an elevator and is exposed to aerodynamic loads during aircraft operation as well as during free flight of the bomb. The stress vibration could potentially cause fatigue failure resulting in the loss of an in-service component.

TABLE 24
 ROOM TEMPERATURE RESIDUAL TENSILE RESULTS FOR
 NR 150 B2/S-GLASS AFTER 1000-HOUR CREEP TESTING

Specimen No.	Creep Test Conditions Temp, Stress	Residual Tensile Strength	
		KSI	(MPa)
3C-1	550°F (288°C)	35.2	(243)
4C-1	7 KSI (48.3 MPa)	-	-
1C-2	550°F (288°C),	45.8	(316)
3C-2*	14 KSI (96.5 MPa)	36.4	(251)
4C-2		43.1	(297)
1C-3*	600°F (316°C),	26.0	(179)
3C-3*	7 KSI (48.3 MPa)	15.4	(106)
4C-3		25.8	(178)

* These specimens failed where the extensometer knife-edges were located during creep testing.

used to house the sensing unit of a guided bomb which was being developed by the Laser Guided Bomb System Project Office. In service the bomb is hung externally on an aircraft and is exposed to aerodynamic loads during aircraft operation as well as during free flight of the bomb. The stream vibration could potentially cause fatigue failures emanating in the fins of an in-service component.

A test program was inaugurated to evaluate the tensile, fatigue, and fatigue damaged properties of the materials. Tensile tests were conducted on both dogbone specimens prepared by the AFML and component parts molded to the configuration of the housing produced by the system subcontractor. The dogbone tensile specimens were used to evaluate the effect of various environmental conditions on the tensile strength of the candidate materials.

2.4.1 Materials and Specimens

The three glass-filled thermoplastics under consideration for use in the guided bomb were Noryl GFN-2, which is a polyphenylene oxide (PPO), Lexan 500, a polycarbonate, and Eastman 6F91, which is a polyester. Both conventional dogbone specimens molded from these three materials and components were prepared for testing. The component parts consist of two molded plastic cylinders of different radii connected by thin walled radial fins. Actual service component parts fabricated from a fourth material, a Ryton polyphenylene sulfide (PPS), were delivered with the component parts manufactured from the other candidate materials and subsequently underwent test. In order to grip the component parts, it was necessary to adhesively bond reinforcing bands to the parts in non-critical regions. The Eastman 6F91 component parts could not be tested because of the material's resistance to adhesive bonding, which made it impossible to attach the needed reinforcing bands.

A dogbone-shaped flat specimen blank was used for all of the tensile, retained strength, and fatigue testing. Ultimate load at failure were the only test data recorded for the tensile tests. All of the specimens used for the tensile, retained strength, and fatigue tests were made in a single molding run for each of the three materials in order to eliminate any variation encountered with the material process.

2.4.2 Results and Discussion

2.4.2.1 Coupon Tests

Table 25 presents the tensile data from dogbone coupons for the three test materials in the as-molded condition. Five tests were performed at test temperatures of -65°F (-54°C) and 72°F (22°C). An insufficient number of Noryl GFN-2 and Eastman 6F91 specimen blanks were available to permit tensile tests to be performed at a test temperature of 165°F (74°C). The Noryl GFN-2 material possessed the highest tensile strength followed by Eastman 6F91 and finally Lexan 500. The Noryl material's higher strength was attributed to its higher glass content. The lowest strength material, Lexan 500, is the material currently used for producing the component.

Table 26 lists the tensile test results for Noryl GFN-2 and Lexan 500 specimens annealed at 295°F (146°C) and Eastman 6F91 specimens annealed at 305°F (152°C) for one hour prior to undergoing test at -65°F (-54°C), 72°F (22°C), and 165°F (74°C). Annealing caused a minute increase in the strength of all three materials which was expected since these materials are glass fiber reinforced.

Tensile specimens of the three materials were exposed in a humidity chamber at 120°F (84°C) and 100 percent relative humidity for periods of 14, 28, 60, 120, and 180 days. The test results from the specimens are presented in Table 27. The elevated temperature exposure in the humidity chamber reduced the strength of all three materials. As expected,

TABLE 25
 GUIDED BOMB CANDIDATE PLASTICS
 AS-MOLDED CONDITION TENSILE STRENGTH

Specimen Number	Material	Test Temp. °F (°C)	Ultimate Strength	
			Ksi	MPa
NT11	Noryl GFN-2	-65(-54)	18.24	125.7
NT12			18.35	126.4
NT13			16.85	116.1
NT14			17.22	118.6
1			72(22)	12.61
2			12.53	86.3
3			12.50	86.1
4			12.56	86.5
5			12.50	86.1
LT11			Lexan 500	-65(-54)
LT12	13.72	94.5		
LT13	13.71	94.5		
LT14	13.90	95.8		
LT15	13.63	93.4		
6		72(22)	9.74	67.1
7			9.71	66.9
8			9.68	66.7
9			9.51	65.5
10			9.67	66.6
LT16		165(74)	7.17	49.4
LT17			7.23	49.8
LT18			7.17	49.4
LT19			7.37	50.8
LT20			7.27	50.1
ET11	Eastman 6FN91	-65(-54)	16.55	114.0
ET12			16.69	115.0
ET13			17.23	118.7
11		72(22)	11.02	75.9
12			11.02	75.9
13			11.01	75.9
14			11.09	76.4
15			11.85	81.6

TABLE 26
 GUIDED BOMB CANDIDATE PLASTICS
 ANNEALED CONDITION TENSILE PROPERTIES

Specimen Number	Material	Material Condition	Test Temp. °F (°C)	Ultimate Strength	
				Ksi	MPa
NT6	Noryl GFN-2	Annealed @ 295° F (146° C) for 1 hr.	-65 (-54)	18.41	128.5
NT7				15.46	107.9
NT8				17.36	121.2
NT9				17.88	124.8
NT10				17.25	120.4
21			72 (22)	12.87	89.8
22				12.80	89.3
23				12.87	89.8
24				12.77	89.1
25				12.80	89.3
NT1	165 (74)	9.54	66.5		
NT2		9.62	67.1		
NT4		9.40	65.6		
NT5		9.62	67.1		
LT6	Lexan 500	Annealed @ 295° F (146° C) for 1 hr.	-65 (-54)	14.09	98.3
LT7				14.14	98.7
LT8				14.20	99.1
LT9				14.19	99.0
LT10				14.14	98.7
26			72 (22)	10.38	72.5
27				10.29	71.8
28				10.35	71.3
29				10.45	72.0
30				10.35	71.3
LT1	165 (74)	8.19	56.4		
LT2		8.41	57.9		
LT3		8.20	56.5		
LT4		8.20	56.5		
LT5		8.29	57.1		

TABLE 26 (Concluded)
 GUIDED BOMB CANDIDATE PLASTICS
 ANNEALED CONDITION TENSILE PROPERTIES

Specimen Number	Material	Material Condition	Test Temp. °F(°C)	Ultimate Strength	
				Ksi	MPa
ET6	Eastman 6FN91	Annealed @ 305° F (152° C) for 1 hr.	-65 (-54)	18.78	129.4
ET7				16.78	115.6
ET8				17.79	122.6
ET9				17.61	121.3
ET10				17.53	120.8
16			72(22)	13.42	92.5
17				11.48	79.1
18				11.47	99.0
19				11.60	79.9
20				11.54	79.5
ET2	165(74)	6.33	43.6		
ET3		6.33	43.6		
ET4		6.34	43.7		
ET5		6.26	43.1		

* Test at too high of head speed.

TABLE 27
 GUIDED BOMB CANDIDATE PLASTICS
 HUMIDITY EXPOSURE CONDITIONING TENSILE PROPERTIES
 [All Tests Conducted at 72°F(22°C)]

Specimen Number	Material	Material Condition	Ultimate Strength	
			Ksi	MPa
NR1	Noryl GFN-2	Exposed @ 120°F (49°C) +100% R. H. for 4 days	11.29	77.8
NR2			11.20	77.2
NR3			9.71	66.9
NR4			11.66	80.3
NR5			11.60	79.9
LR1	Lexan 500		9.22	63.5
LR2		9.33	64.3	
LR3		9.16	63.1	
LR4		9.28	63.9	
LR5		9.23	63.9	
ER1	Eastman 6FN91		8.54	58.8
ER2		8.85	61.0	
ER3		8.70	61.0	
ER4		8.78	60.5	
ER5		8.64	59.5	
N1	Noryl GFN-2	Exposed @ 120°F (49°C) +100% R. H. for 28 days	11.25	77.5
N2			11.15	76.8
N3			11.38	78.4
N4			11.28	77.7
N5			11.41	79.9
L1	Lexan 500		9.18	63.3
L2		9.12	62.8	
L3		9.21	63.5	
L4		9.18	63.3	
L5		9.15	63.0	
E1	Eastman 6FN91		7.85	54.1
E2		7.78	53.6	
E3		7.91	54.5	
E4		8.14	56.1	
E5		8.10	55.8	

TABLE 27 (Continued)
 GUIDED BOMB CANDIDATE PLASTICS
 HUMIDITY EXPOSURE CONDITIONING TENSILE PROPERTIES
 [All tests Conducted at 72°F(22°C)]

Specimen Number	Material	Material Condition	Ultimate Strength	
			Ksi	MPa
N31	Noryl GFN-2	Exposed @120°F(49°C) +100% R. H. for 60 days	11.33	78.1
N32			11.39	78.5
N33			11.29	77.8
N34			11.15	76.8
N35			11.46	79.0
L31	Lexan 500		9.21	63.5
L32		9.18	63.3	
L33		9.10	62.7	
L34		8.98	61.9	
L35		9.18	63.3	
E31	Eastman 6FN91		7.78	53.6
E32		7.72	53.2	
E33		7.77	53.5	
E34		7.87	54.2	
E35		7.86	54.2	
N36	Noryl GFN-2	Exposed @120°F(49°C) +100% R. H. for 120 days	10.54	72.6
N37			10.70	73.7
N38			10.63	73.2
N39			10.73	73.9
N40			10.50	72.3
L36	Lexan 500		8.75	60.3
L37		8.84	60.9	
L38		9.06	62.4	
L39		9.07	62.5	
L40		8.65	59.6	
E36	Eastman 6FN91		7.53	51.9
E37		7.60	52.4	
E38		7.60	52.4	
E39		7.63	52.6	
E40		7.46	51.4	

TABLE 27 (Concluded)
GUIDED BOMB CANDIDATE PLASTICS
HUMIDITY EXPOSURE CONDITIONING TENSILE PROPERTIES
[All Tests Conducted at 72°F(22°C)]

Specimen Number	Material	Material Condition	Ultimate Strength	
			Ksi	MPa
L41	Lexan 500	Exposed @120°F (49°C) +100% R.H. for 180 days	9.25	63.8
L42			9.18	63.3
L43			9.21	63.5
L44			9.34	64.4
L45			9.25	63.8
N41	Noryl GFN-2		10.89	75.1
N42			10.82	74.6
N43			10.91	75.2
N44			10.88	75.0
N45			10.85	74.8
E41	Eastman 6FN91		7.59	52.3
E42			7.66	52.8
E43			7.69	52.8
E44			7.65	52.7
E45			7.57	52.2

the longer exposure times had a more detrimental influence on the ultimate strength than the short exposure periods. The Eastman 6F91 was more significantly affected than the other two materials. The longer exposure times (60, 120, and 180 days) are the only environmental exposures employed in this program that cause serious loss of strength and that was to the Eastman 6F91 material only. After 180 days in the humidity chamber, the Eastman 6F91 lost 31 percent of its as-molded strength.

Test samples of each of the three materials were boiled in water for two hours prior to undergoing a room temperature test. The results are presented in Table 28. The strength of all three materials was not significantly affected.

Table 29 presents room temperature tensile test data from samples exposed to a 5 percent by weight NaCl spray at 165°F (74°C) for a period of 200 hours. The strength of all three materials decreased. The Eastman 6F91 was influenced to a greater extent than the other two materials; the load-carrying capability dropped to 88 percent of what it was for the material in the as-molded condition.

The fatigue test results for sample coupons are presented in Table 30 and Figure 41. Three specimens of each material underwent test at maximum loading conditions of 8.5, 8.0, 7.0, and 6.0 KSI (58.6, 55.2, 48.3, and 41.1 MPa). Only samples of Noryl GFN-2 underwent test at a maximum stress of 9.0 KSI (62.1 MPa) because specimens of the other two materials would fail before the loading condition had stabilized at the start of the test. For both the fatigue tests and the residual tensile strength tests the cyclic loads were applied at a frequency of 2900 CPM and with an R ratio of 0.1. A sinusoidal loading wave form was used. Noryl GFN-2 demonstrated the best fatigue life, which was expected because it also possessed the highest strength capabilities. Lexan 500 and Eastman 6F91 demonstrated considerably shorter fatigue lives than the Noryl GFN-2; the Lexan 500 was superior to the Eastman

TABLE 28

GUIDED BOMB CANDIDATE PLASTICS
ROOM TEMPERATURE TENSILE STRENGTH FOLLOWING
BOILING IN WATER FOR TWO HOURS

Specimen Number	Material	Ultimate Strength	
		Ksi	MPa
NB1	Noryl GFN-2	12.44	85.7
NB2		12.53	86.3
NB3		12.34	85.0
NB4		12.34	85.0
NB5		12.44	85.7
LB1	Lexan 500	9.67	66.6
LB2		9.52	65.6
LB3		9.55	65.8
LB4		9.58	66.0
LB5		9.61	66.2
EB1	Eastman 6FN91	10.43	71.9
EB2		10.01	69.0
EB3		10.39	71.6
EB4		10.43	71.9
EB5		10.33	71.2

TABLE 29
 GUIDED BOMB CANDIDATE PLASTICS
 ROOM TEMPERATURE TENSILE STRENGTH AFTER A 200-
 HOUR SUBMERSION IN A 165°F(74°C) 5 PERCENT NaCl SOLUTION

Specimen Number	Material	Ultimate Strength	
		Ksi	MPa
N1	Noryl GFN-2	11.93	82.2
N2		11.85	81.6
N3		11.95	82.3
N4		11.99	82.6
N5		11.87	81.8
L11	Lexan 500	9.31	64.1
L12		9.34	64.4
L13		9.40	64.8
L14		9.31	64.1
L15		9.40	64.8
E6	Eastman 6FN91	9.58	66.0
E7		9.81	67.6
E8		9.60	66.1
E9		9.66	66.6
E10		9.97	68.7

TABLE 30
 FATIGUE CYCLES TO FAILURE FOR GUIDED
 BOMB CANDIDATE PLASTICS

Material	Stress	Max. Stress Ksi(MPa)			
		9.0(62)	8.5(58)	8.0(155)	7.0(48)
Noryl GFN-2	7,000	17,100	24,400	78,800	233,300
	6,300	17,800	20,700	91,400	259,000*
	6,900	15,700	47,400	181,000	365,000
					290,000
Lexan 500		3,000	4,900	6,300	45,300
		1,900	3,300	17,700	46,800
		800	3,800	5,900	54,600
Eastman 6FN91		2,200	3,600	7,800	11,100
		1,800	3,800	7,100	11,400
		2,200	3,200	15,900	10,400

* Specimen Failed in Grip

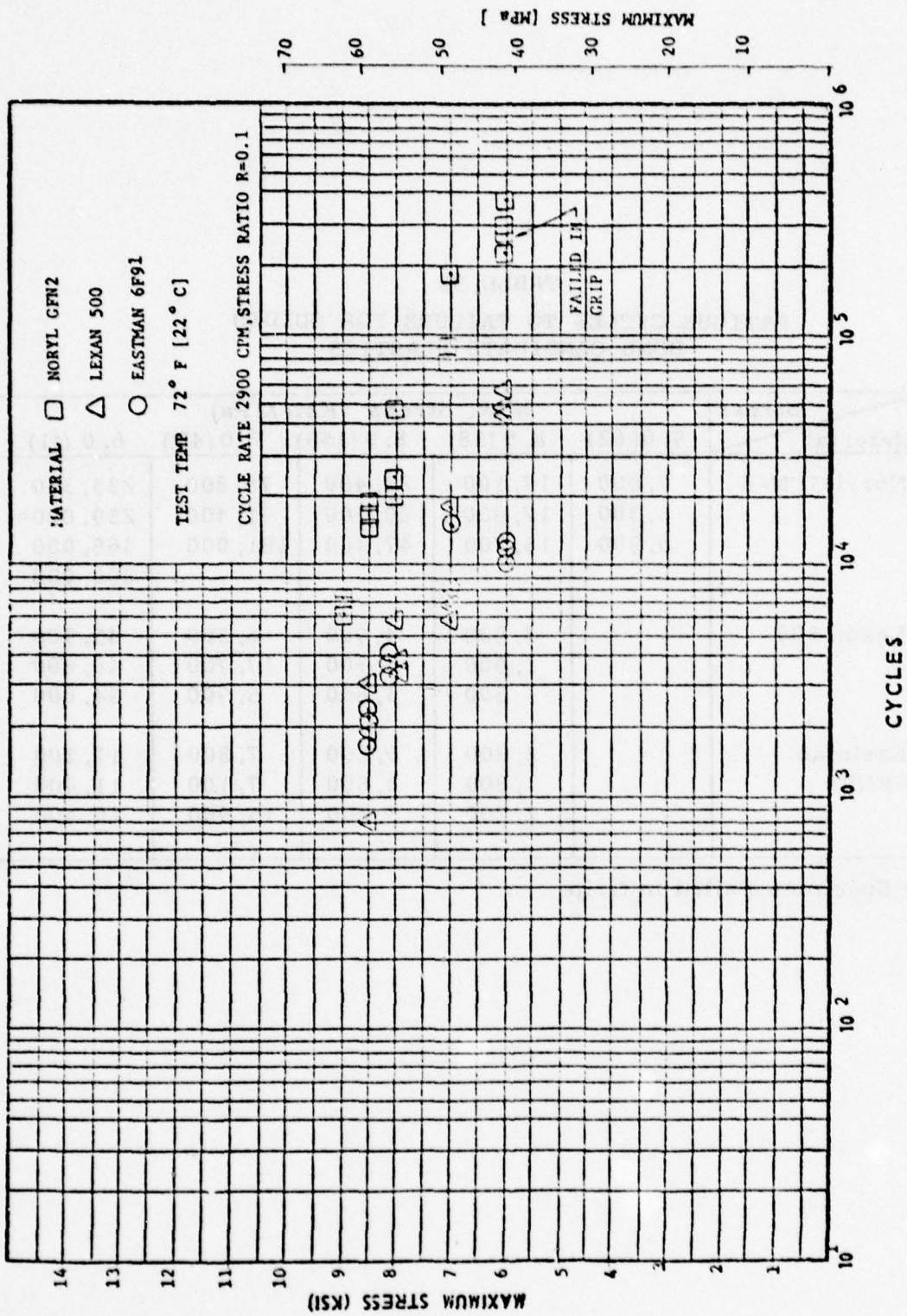

Figure 41. Guided Bomb Candidate Plastics Fatigue Test Results.

6F91 with respect to fatigue performance. Formation of fatigue cracks could frequently be visibly detected due to the gross discoloration of the surfaces of the gage section of the specimen. Once a fatigue crack was observed, failure occurred within approximately 300 to 700 additional load cycles.

The residual tensile strength test results are presented in Table 31. Duplicate samples were loaded at maximum stress conditions of 8 KSI (55.2 MPa) for 10^3 cycles, at 6 KSI (41.2 MPa) for 10^4 cycles, and 4 KSI (27.6 MPa) for 10^5 cycles, followed by a room temperature tensile test. The load-carrying capability was not reduced by the fatigue pre-cycling.

2.4.2.2 Component Part Tests

Molded components of hardware underwent tensile test at 72°F (22°C) and 225°F (107°C). As previously noted, the Eastman component parts could not be tested because of difficulty in bonding to the parts and also the humidity exposure data had indicated that it was not as acceptable as the other two materials. Also, for these tests a fourth material was supplied, Ryton (PPS). Overall elongation was recorded during these tests. The results are presented in Figures 42 and 43. All component test failures were located in the area of the fins. The Ryton and Noryl materials sustained brittle fractures at both test temperatures. The Ryton material had a higher failure load at the 225°F (107°C) test temperature than it did at 72°F (22°C). The Lexan 500 material experienced a ductile failure at both test temperatures. At 225°F (107°C) the Lexan 500 component stretched approximately 1/2-inch (13 mm) before separation occurred. The Lexan 500 material was tougher than the other test materials that underwent component test.

2.5 TENSILE PROPERTIES OF NYLON AND POLYPROPYLENE

Tensile stress vs. strain data were obtained on nylon and polypropylene specimens that had been exposed to a number of

TABLE 31
 GUIDED BOMB CANDIDATE PLASTICS
 RETAINED STRENGTH TESTS

Specimen Number	Fatigue Condition			Residual Strength	
	Max. Stress Ksi	MPa	No. of Cycles R=.1, f=2900 cpm	Ksi	MPa
Noryl 1	8	55.16	10^3	12.84	88.53
				12.64	87.15
				12.54	86.46
Lexan 1	8	55.16	10^3	9.72	67.02
				9.75	67.22
				9.75	67.22
Eastman 1	8	55.16	10^3	10.92	75.29
				10.92	75.29
				10.98	75.70
Noryl 4	6	41.37	10^4	12.78	88.12
				12.68	87.43
				11.51	79.36
Lexan 4	6	41.37	10^4	9.47	65.30
				9.43	65.02
				9.72	67.02
Eastman 4 *	6	41.37	10^4	9.69	66.81
				*	
				10.97	75.64
				10.99	75.78
Noryl 7	4	27.58	10^5	12.93	89.15
				12.91	89.01
				12.72	87.70
Lexan 7	4	27.58	10^5	9.59	66.12
				9.44	65.09
				9.60	66.19
Eastman 7	4	27.58	10^5	11.01	75.91
				11.07	76.33
				11.11	76.60

* Fatigue Failure at 9100 Cycles

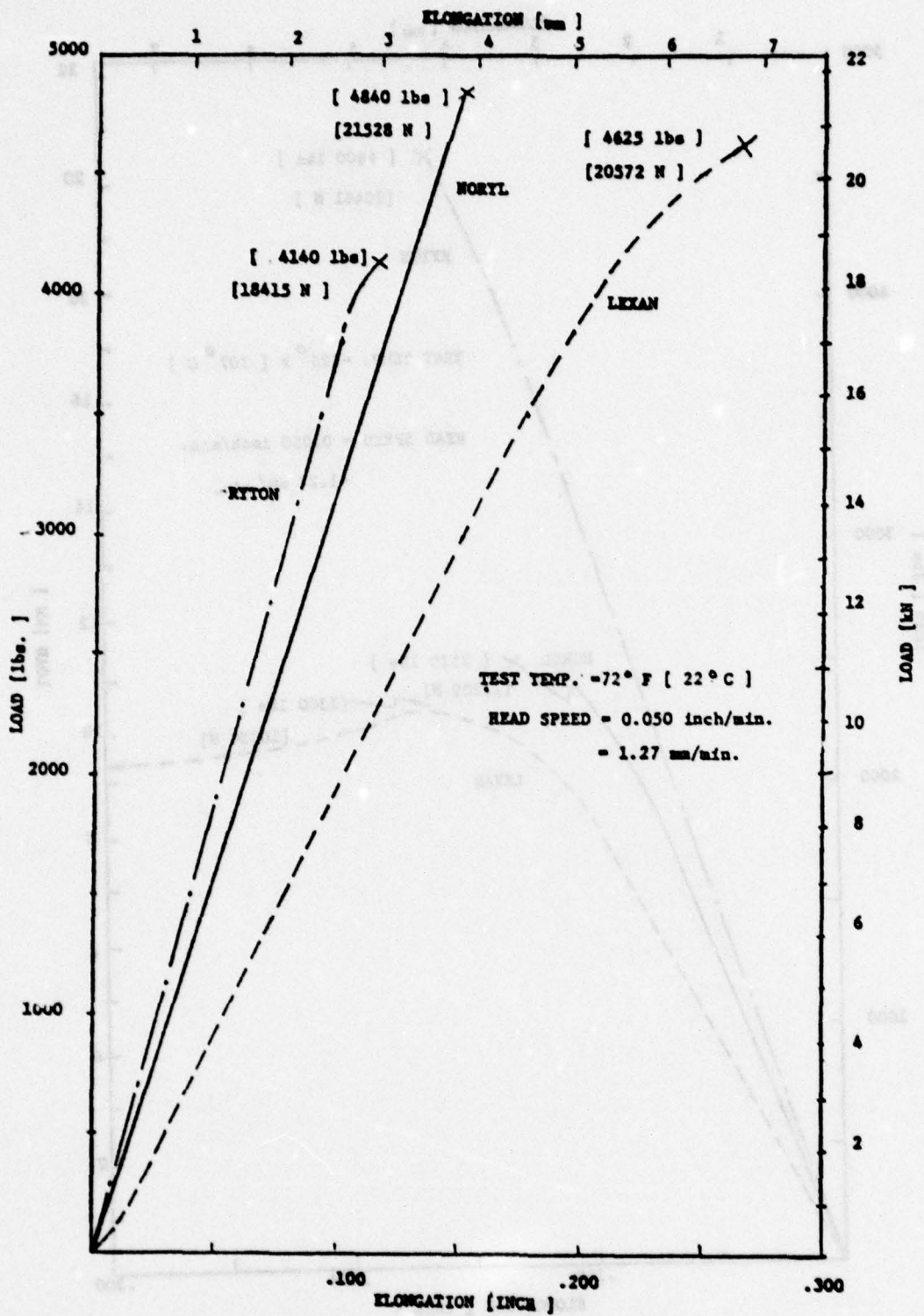

Figure 42. Load Displacement Trace For Component Tests Conducted at 72°F (22°C).

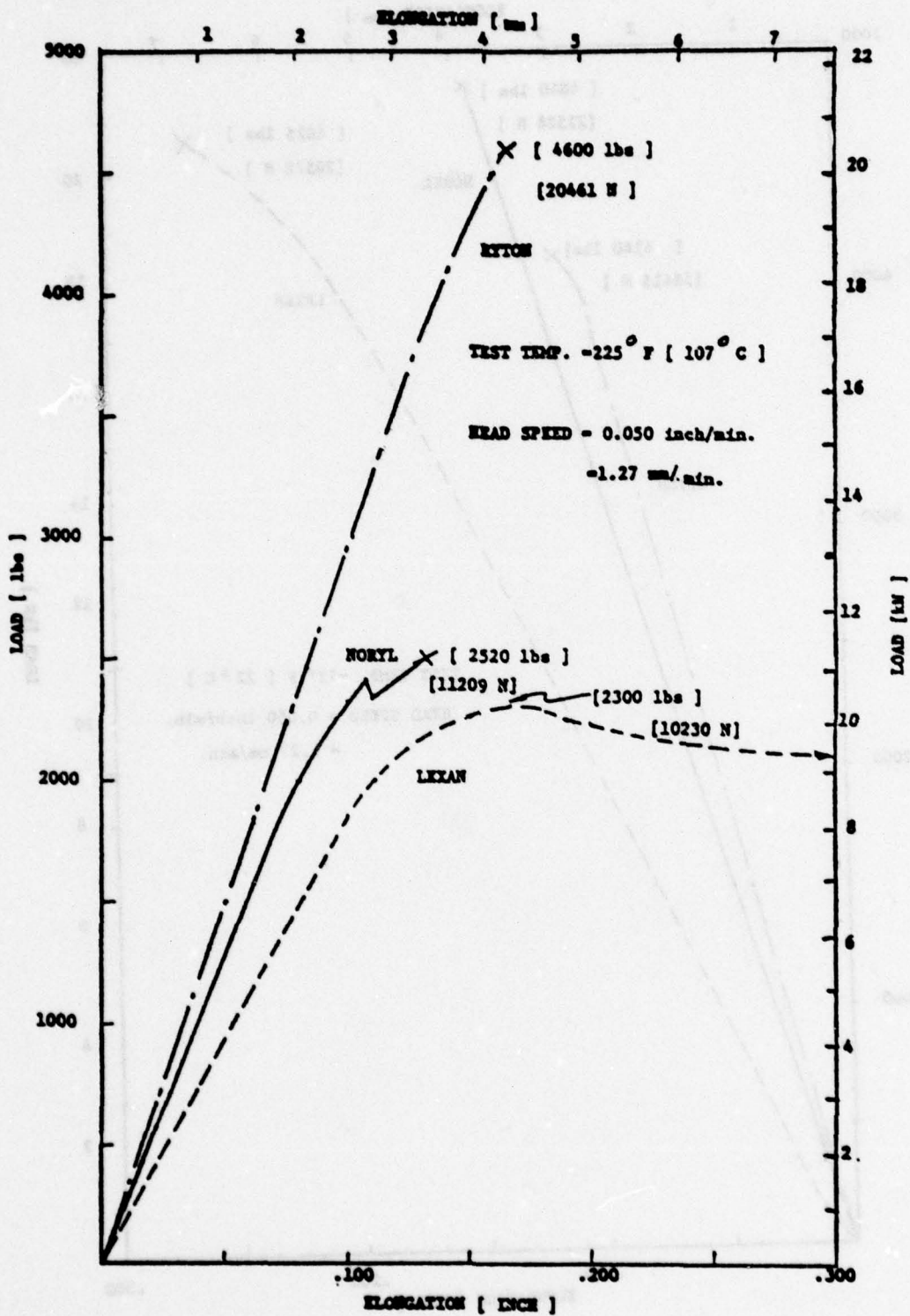

Figure 43. Load Displacement Trace For Component Tests Conducted at 225°F (107°C).

liquid environments. These materials were candidates for use in manufacturing emergency radio cases which were being developed by the Life Support SPO.

The test samples were exposed to those liquids which the radios may be expected to encounter in service. They include lubricants, solvents, detergents, and salt water.

2.5.1 Specimens, Environments, and Procedures

The specimens used in these tests were injection molded and had rectangular cross-sections (no reduced gage section), approximately 5 inches (13 cm) long, 0.12-inch (0.3-cm) thick, and 0.49-inch (1.2-cm) wide. Because of the configuration it was not possible to develop ultimate strength data. Instead, stress/strain characteristics were developed up to 0.1 strain.

The environments to which the materials were exposed were:

- MIL-5606 Hydraulic Oil
- MIL-L-7808 Di-2-Ethyl Hexyl Adipate (Engine Lub.)
- Ethyl acetate
- Factopure Magnaflux Oil
- 5 percent NaCl solution (Salt water)
- MIL-C-25789 Detergent Solution (Detergent)
- Methyl Ethyl Ketone (MEK)
- JP-4 Jet Engine Fuel
- Isopropanol
- Trichloroethylene (Trichlor)
- Toluene

Some of these liquids caused significant dimensional increases in the specimens during the exposure. This can be seen in Table 32 where the cross-section dimensions of the samples are listed.

The two test materials were nylon, with the designation Zytel ST 801, and polypropylene, with the designation Exxon CD-391. All samples were prepared in an injection molding machine at the AFML.

TABLE 32
DIMENSIONS OF NYLON AND POLYPROPYLENE SPECIMENS

Material	Specimen No.	Width		Thickness		Environment
		(in.)	(cm)	(in.)	(cm)	
Nylon	Baseline	0.483	1.227	0.121	0.307	As Molded
	1-1	0.485	1.232	0.121	0.307	Hydraulic Oil
	3-4	0.487	1.237	0.122	0.310	Engine Lub.
	5-6	0.488	1.240	0.123	0.312	Ethyl Acetate
	7-7	0.484	1.229	0.122	0.310	Magnaflux Oil
	9-9	0.487	1.237	0.123	0.312	Salt Water
	11-12	0.490	1.245	0.122	0.310	Detergent
	13-13	0.488	1.240	0.122	0.310	MEK
	15-16	0.487	1.237	0.121	0.307	JP-4 Fuel
	17-18	0.483	1.227	0.120	0.305	Isopropanol
	19-20	0.494	1.255	0.126	0.320	Trichlor.
	22-22	0.489	1.242	0.122	0.310	Toluene
	Polypropylene	Baseline	0.494	1.255	0.125	0.318
2-1		0.526	1.336	0.160	0.406	Hydraulic Oil
4-3		0.493	1.260	0.127	0.323	Engine Lub.
6-5		0.500	1.270	0.130	0.330	Ethyl Acetate
8-7		0.523	1.328	0.158	0.401	Magnaflux Oil
10-10		0.494	1.255	0.125	0.318	Salt Water
12-11		0.493	1.260	0.127	0.323	Detergent
14-14		0.500	1.270	0.129	0.328	MEK
16-16		0.531	1.349	0.158	0.401	JP-4 Fuel
18-17		0.500	1.270	0.127	0.323	Isopropanol
20-21		0.530	1.346	0.158	0.401	Toluene
21-19		0.538	1.367	0.162	0.411	Trichlor.

Testing was performed in an MTS servohydraulic closed-loop test machine equipped with hydraulic grips. Elongation was measured by a 1 inch (2.54 cm) MTS strain gage extensometer. The load and strain signals from the MTS console were recorded on an X-Y recorder. These graphical data were used to develop the test results.

To develop the baseline (as-molded) curves, three specimens were tested and the average values for the three samples were used in data reduction and presentation. The results for the exposed specimens are from one test specimen from each environment. Throughout this report the identification code for the exposed specimens is as follows; the first numbers are the specimen I.D., the single letter N or P designates nylon or polypropylene, respectively, and the information following the slash (/) represents the environment.

2.5.2 Results and Discussion

The stress/strain characteristics of the materials are such that there is very little or no linear portion to the curves. To give a graphical presentation to the data a computer program was written which plotted the stress at strain values of 0.005, 0.02, 0.04, 0.07, and 0.1 strain. A smooth line was then fitted through the data using a modified spline fitting technique.

The test results are presented in Tables 33 and 34 and Figures 44 through 47. Stress values were based on the cross-sectional area of the specimens at the time of testing (after exposure). Some of the curves could be shifted upward if the cross-sections of the as-molded samples were used. See Table 32 for those specimens that experienced considerable dimensional change during the exposure cycle.

The effects of the dimensional changes on the polypropylene can be seen in Figure 48. The top curve represents the baseline data (POLY, AS MOLDED), the middle curve represents the stresses calculated on the original cross-section

TABLE 33

EFFECT OF SOLVENTS AND LUBRICANTS ON NYLON AND POLYPROPYLENE

SPEC/EXPOSURE	STRESS IN PSI (MPA) AT INDICATED STRAIN				
	0.005 IN/IN	0.02 IN/IN	0.04 IN/IN	0.07 IN/IN	0.10 IN/IN
POLY, AS MOULDED	838.7 (5.8)	1983.9 (13.7)	2568.5 (17.7)	3048.4 (21.0)	3258.1 (22.5)
2-1 P/HYDRAULIC OIL	45.2 (.7)	285.7 (2.0)	500.0 (3.4)	750.0 (5.2)	892.9 (6.2)
4-3 P/ENGINE LUB.	761.9 (5.3)	1793.7 (12.4)	2428.6 (16.7)	2936.5 (20.2)	3208.3 (22.1)
6-5 P/ETHYL ACETATE	353.8 (2.4)	969.2 (6.7)	1415.4 (9.8)	1861.5 (12.8)	2153.8 (14.8)
8-7 P/MAGNAFLUX OIL	161.3 (1.1)	358.8 (2.4)	505.4 (3.5)	645.2 (4.4)	778.2 (5.3)
10-10 P/SALT WATER	838.7 (5.8)	1951.6 (13.5)	2564.5 (17.7)	3032.3 (20.9)	3258.1 (22.5)
12-11 P/DETERGENT	761.9 (5.3)	1793.7 (12.4)	2396.8 (16.5)	2984.1 (20.6)	3182.9 (21.7)
14-14 P/M E K	430.8 (3.0)	1046.2 (7.2)	1507.7 (10.4)	1969.2 (13.6)	2288.2 (15.5)
16-16 P/IP-4 FUEL	158.8 (1.1)	345.2 (2.4)	511.9 (3.5)	666.7 (4.6)	797.6 (5.5)
18-17 P/ISOPROPANOL	734.4 (5.1)	1687.5 (11.6)	2250.0 (15.5)	2734.4 (18.9)	3000.0 (20.7)
20-21 P/TOLUENE	131.0 (.9)	345.2 (2.4)	523.8 (3.6)	690.5 (4.8)	833.3 (5.7)
21-19 P/TRICHLOR.	82.5 (.6)	216.5 (1.5)	371.1 (2.6)	586.8 (3.8)	618.6 (4.3)

TABLE 34
EFFECT OF SOLVENTS AND LUBRICANTS ON NYLON AND POLYPROPYLENE

SPEC/EXPOSURE	STRESS IN PSI (MPa) AT INDICATED STRAIN					
	0.005 IN/IN	0.02 IN/IN	0.04 IN/IN	0.07 IN/IN	0.10 IN/IN	
NYLON, AS MOULDED	1241.4 (8.6)	3362.1 (23.2)	4444.3 (30.7)	5017.2 (34.6)	5293.1 (36.5)	
1-1 M/HYDRAULIC OIL	644.1 (4.4)	1779.7 (12.3)	2474.0 (17.5)	3423.7 (23.6)	3464.4 (26.6)	
3-4 M/ENGINE LUB.	474.6 (3.3)	1491.5 (10.3)	2339.0 (16.1)	3135.6 (21.6)	3559.3 (24.5)	
5-6 M/ETHYL ACETATE	414.7 (2.9)	1283.3 (8.8)	1943.3 (13.7)	2416.7 (17.0)	2903.3 (20.6)	
7-7 M/MAGNAFLUX OIL	694.9 (4.8)	1430.5 (12.6)	2674.0 (18.5)	3457.6 (23.8)	3932.2 (27.1)	
9-9 M/SALT WATER	500.0 (3.4)	1383.3 (9.5)	2100.0 (14.5)	2733.3 (18.8)	3083.3 (21.3)	
11-12 M/DETERGENT	383.3 (2.6)	1250.0 (8.6)	1950.0 (13.4)	2533.3 (17.5)	2883.3 (19.9)	
13-13 M/M F K	550.0 (3.8)	1564.7 (10.8)	2343.3 (16.4)	3100.0 (21.4)	3516.7 (24.2)	
15-16 M/IP-4 FUEL	427.1 (3.3)	1410.2 (11.1)	2057.4 (14.9)	3220.3 (22.2)	3474.0 (25.4)	
17-18 M/ISOPROPANOL	431.0 (3.0)	1241.4 (8.6)	1844.6 (13.1)	2465.5 (17.0)	2827.6 (19.5)	
22-22 M/TOLUENE	614.7 (4.3)	1733.3 (11.9)	2483.3 (17.5)	3366.7 (23.2)	3766.7 (26.0)	
19-20 M/TRICHLOR.	443.9 (3.3)	1419.4 (9.8)	2193.5 (15.1)	2834.7 (19.6)	3225.0 (22.2)	

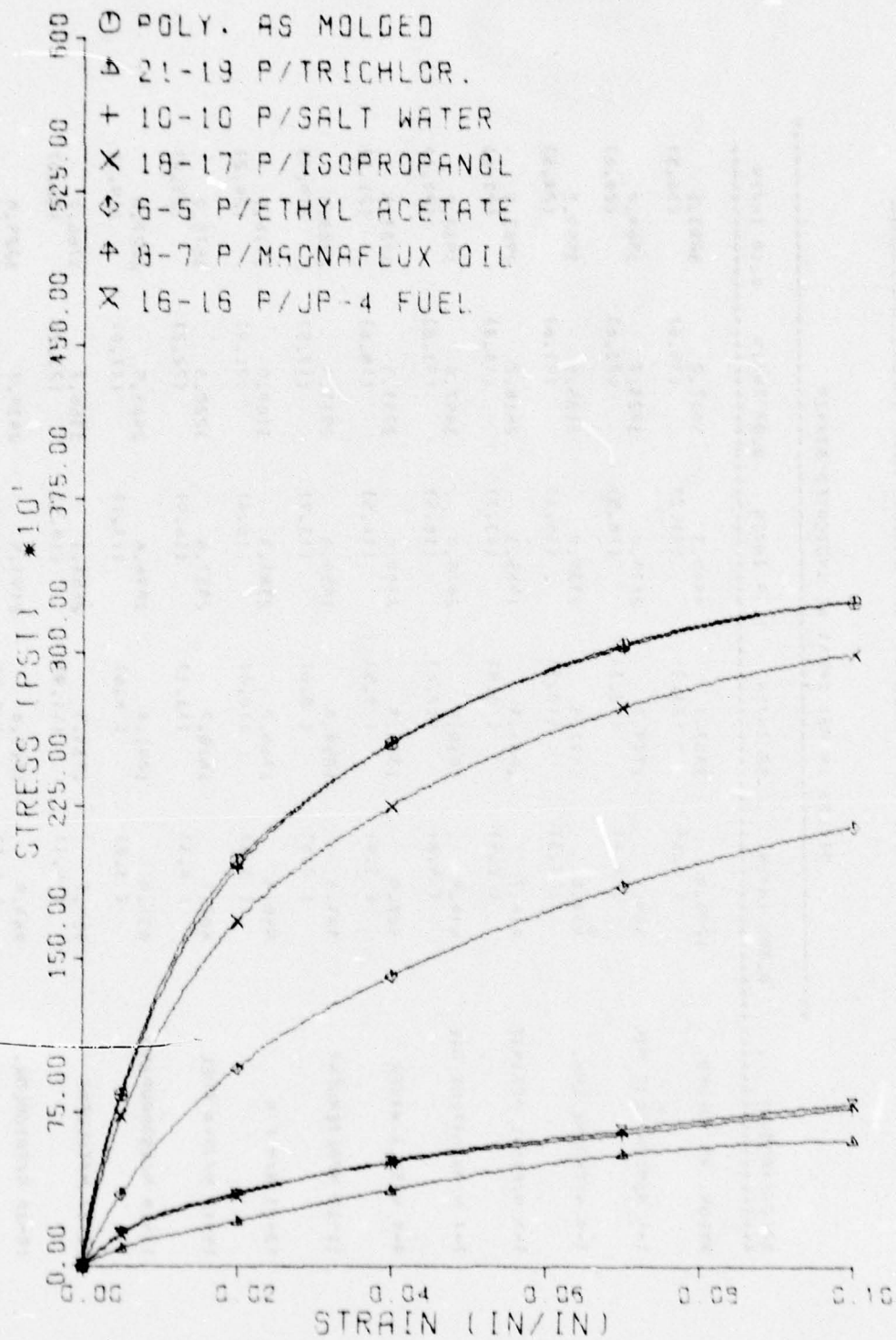

Figure 44. Stress/Strain Characteristics of Unexposed and Exposed Polypropylene Specimens.

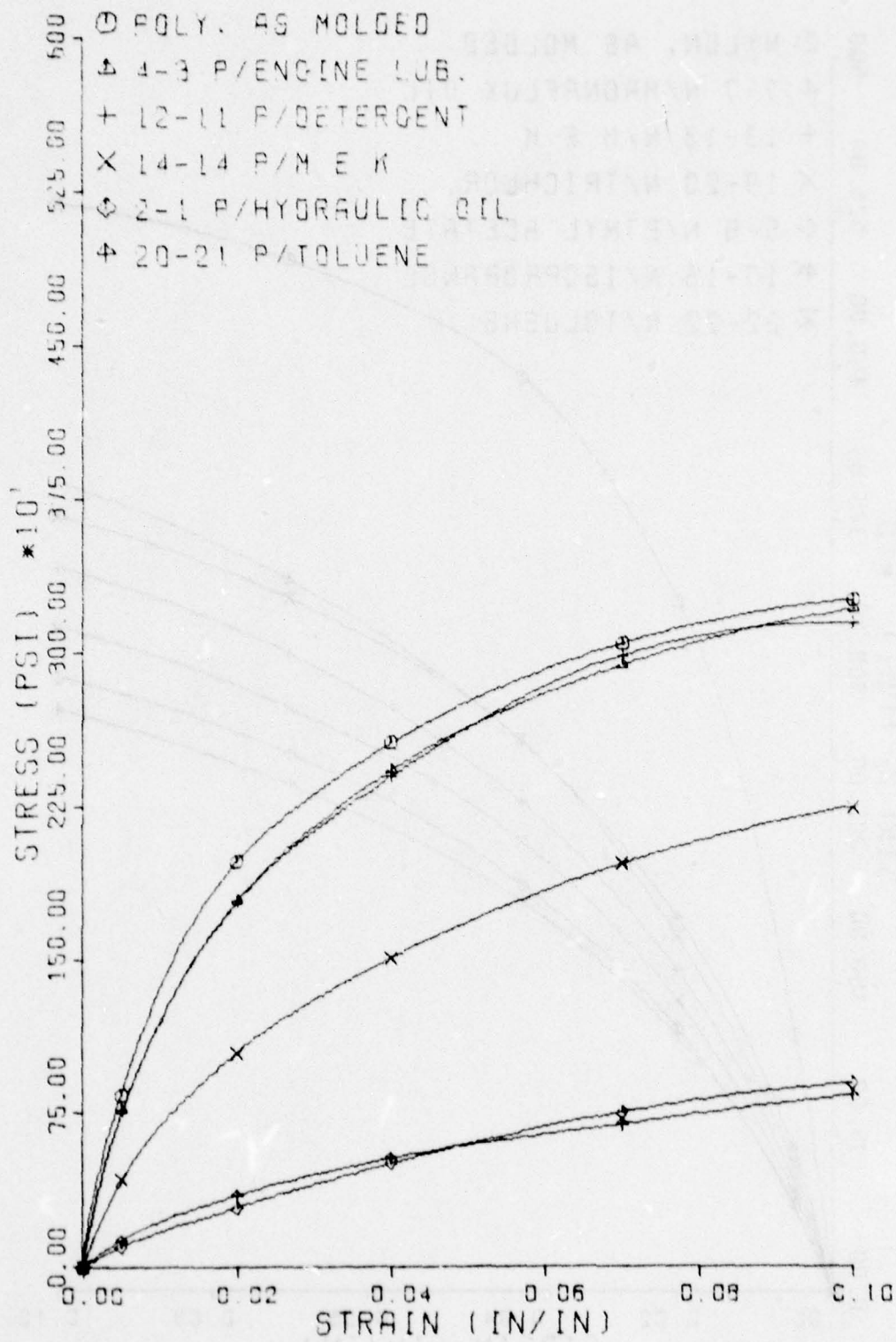

Figure 45. Stress/Strain Characteristics of Unexposed and Exposed Polypropylene.

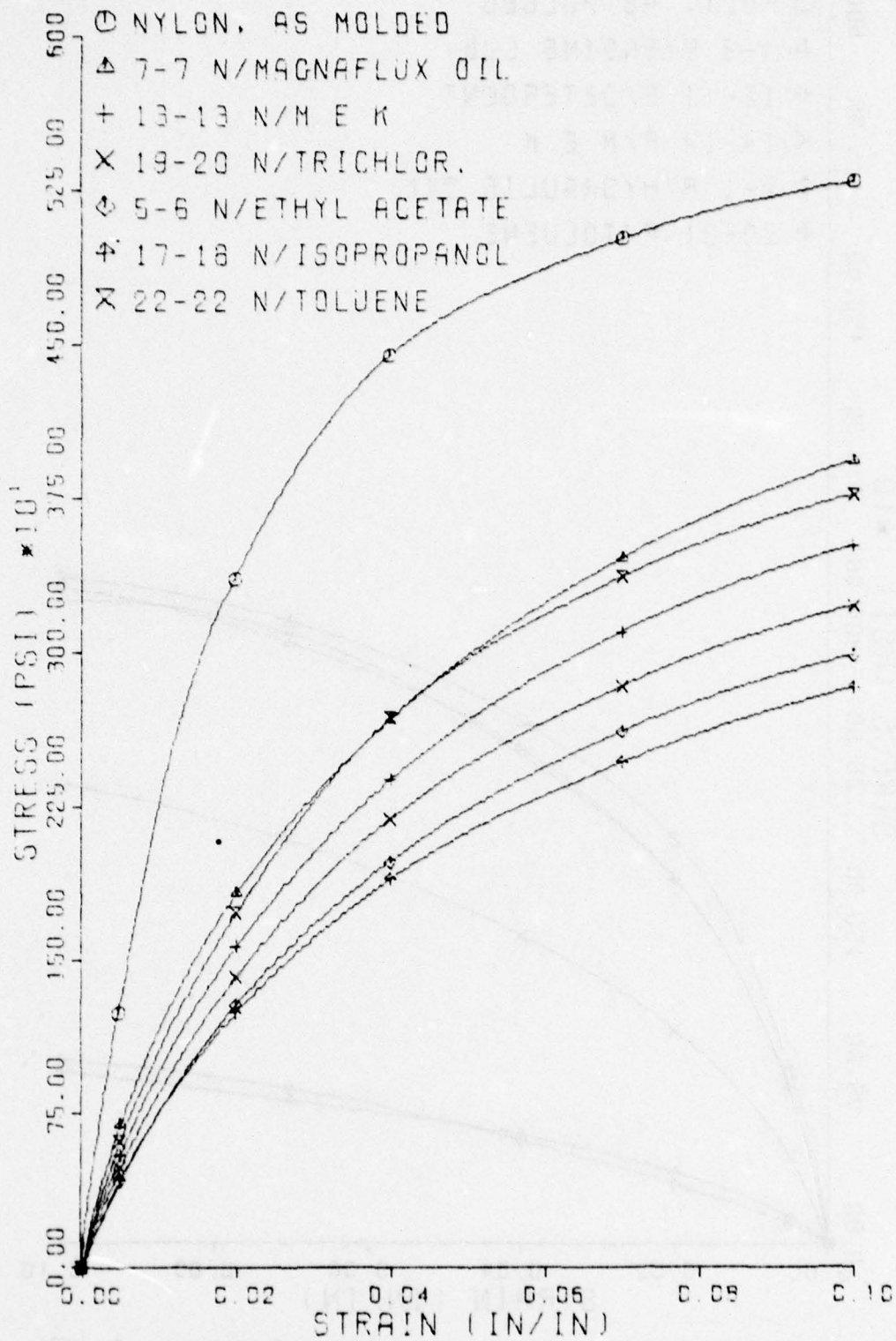

Figure 46. Stress/Strain Characteristics of Unexposed and Exposed Nylon.

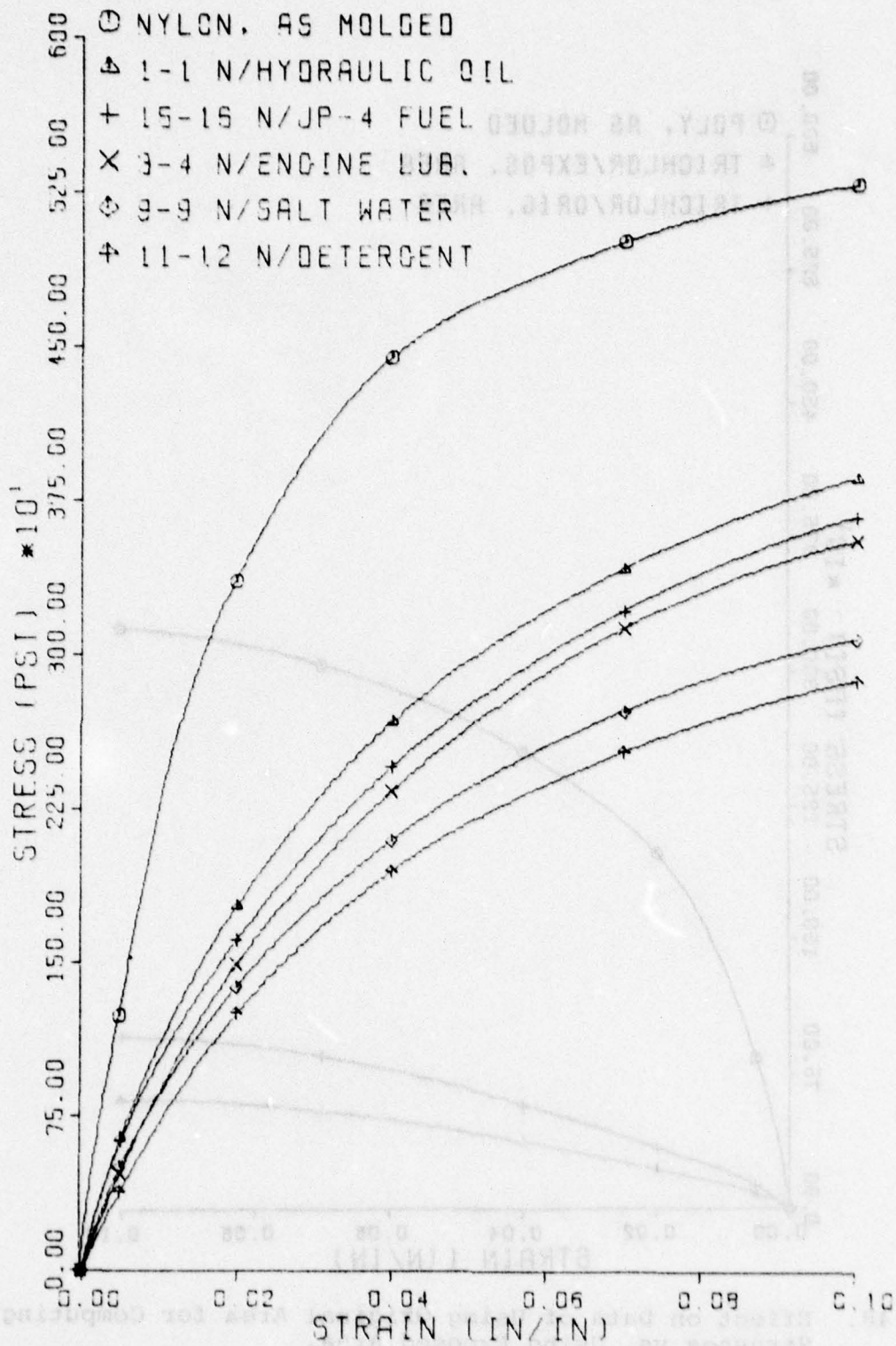

Figure 47. Stress/Strain Characteristics of Unexposed and Exposed Nylon.

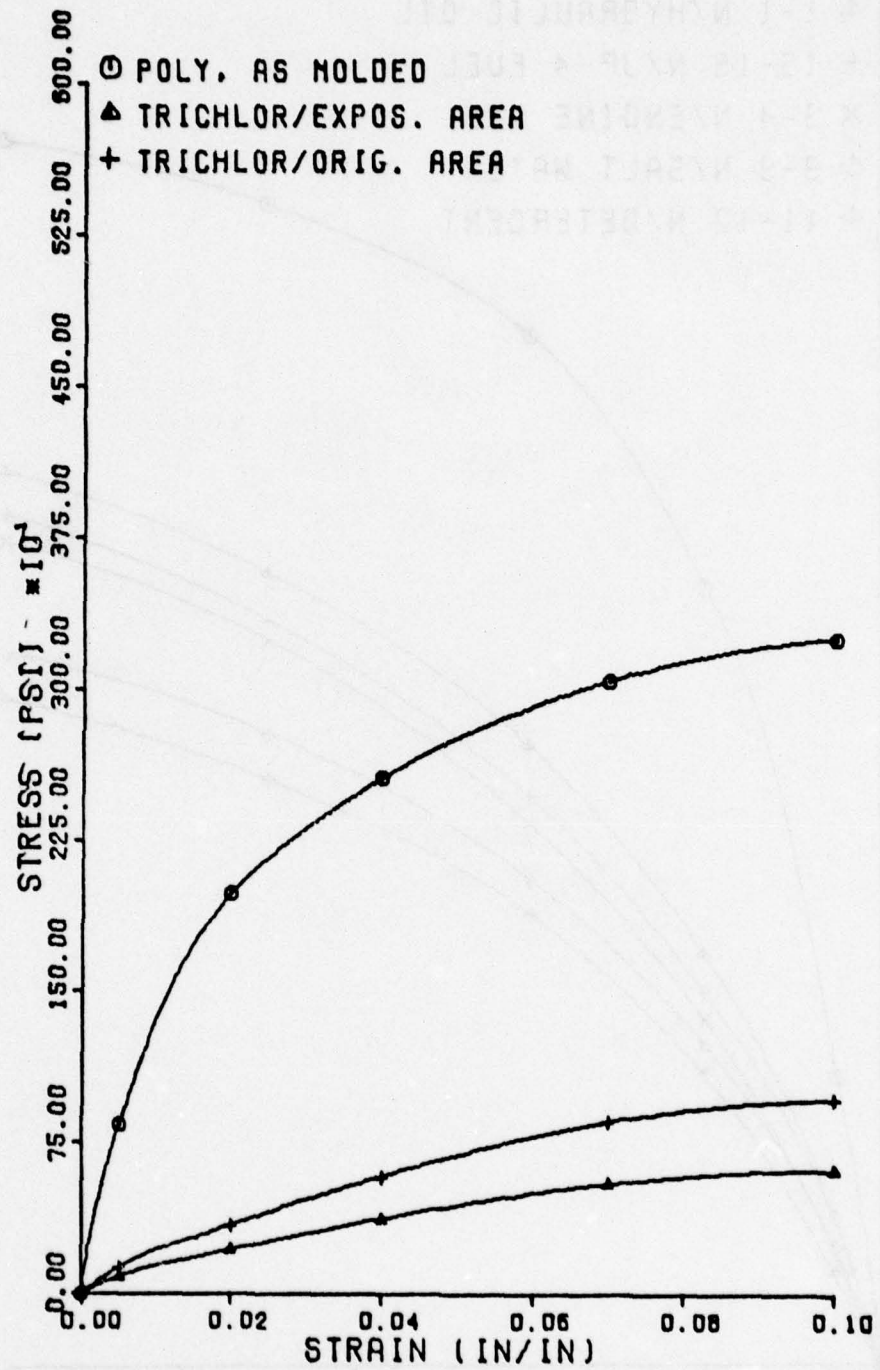

Figure 48. Effect on Data of Using Original Area for Computing Stresses vs. Using Exposed Area.

of the specimen before exposure to trichloroethylene (TRICHLOR/ORIG. AREA), and the bottom curve represents the stresses using the exposed cross-section area for calculations (TRICHLOR/EXPOS. AREA). Although the curve is moved up when using the original area, it is still apparent that there was significant degradation of properties caused by the exposure. It is then obvious that irrespective of the method of calculating stresses, the same trends will be observed.

Dimensional changes caused by exposure were more significant in the polypropylene than in the nylon. The maximum cross-section increase for the polypropylene was about 50 percent for the specimen exposed to trichloroethylene while the maximum change for the nylon was about 5 percent, again for the specimen exposed to trichloroethylene.

One obvious difference in the two sets of curves (Figures 44 and 45 for the polypropylene and Figures 46 and 47 for the nylon) was the apparent attack of the nylon by all of the environments. For the polypropylene, four of the liquids had little or no effect on the material whereas all of the liquids appeared to at least cause moderate reductions in the load-carrying capability of the nylon. This was due in part to the lack of conditioning of the baseline nylon samples with moisture so that the nylon baseline was practically bone dry. None of the baseline specimens were subjected to any 120°F (49°C)/30-day exposure cycle. The baseline specimens were held at ambient conditions and were all tested at the same time.

2.6 SHELTER POTTING COMPOUND INVESTIGATION

The objective of this program was to determine the moisture resistance of several potting compounds in current use in portable shelters as well as several candidate potting compounds for potential shelter use. The compounds evaluated were:

1. Epon 828 (70 pts)/Versamid 140 (30 pts),
2. Epon 815 (70 pts)/Versamid 140 (30 pts)/HTS graphite (15 pts),

3. Reliabond R-371,
4. Reliabond R-380,
5. Scotchcast XR5236,
6. Scotchcast XR5240,
7. Shur-Lok SLE3009, and
8. Hysol EA934.

The evaluation consisted of the preparation and testing (in compression) of short 1/2-inch (12.7-mm) diameter cylinders of each material before and after elevated temperature/humidity environmental agings according to ASTM D695. The environmental aging consisted of two-week, four-week, and six-week exposures to 180°F (82°C) and 100 percent relative humidity. The results obtained during the investigation are reported in Table 35. Some explanation must accompany Table 35, however, to clarify the significance of the reported stress and percent compression values.

Three general types of compression behavior were observed during room temperature and 180°F (82°C) testing of the materials in this investigation. These are illustrated in Figure 49. Not every material followed one particular type of curve for every test temperature and exposure condition. Further, the points at which the peaks occur or where the curves begin turning upward are affected by the test temperature and the analysis and interpretation of the results becomes very cumbersome since the objective is to compare eight materials tested at three temperatures, after four aging conditions, and which produce three different types of behavior. Based upon our understanding of the material requirements it was concluded that, since excessive deformation was undesirable, a simplified basis of comparison would be useful and suitable for comparing the various potting compounds to each other and for assessing the effects of moisture upon their properties. Consequently, a criteria was established based upon the unaged, as-cast material behavior. This criteria was then utilized to divide the eight potting compounds into three categories: (a) materials which looked good at both room temperature and 180°F (82°C); (b) materials which looked good at room

TABLE 35
 COMPRESSIVE STRENGTH - POTTING COMPOUNDS

Potting Material	Test Temp.	As Cast		Aging Conditions								
		Stress (psi)	Stress (MPa)	2 weeks @ 180° F/100% R. H.		4 weeks @ 180° F/100% R. H.		6 weeks @ 180° F/100% R. H.				
				Com- pression (%)	Stress (psi)	Stress (MPa)	Com- pression (%)	Stress (psi)	Stress (MPa)	Com- pression (%)		
Scotchcast XR5236	-65° F	18,500	127.5	9	14,200	97.9	10	14,500	100.0	17,200	118.6	9
	R. T.	5,400	37.2	40	1,600	11.0	40	2,000	13.8	4,700	32.4	40
	180° F	400	2.8	25	400	2.8	25	500	3.4	700	4.8	25
Scotchcast XR5240	-65° F	19,900	137.2	7	14,900	102.7	13	13,600	93.8	14,300	98.6	12
	R. T.	8,500	58.6	40	2,800	19.3	40	2,600	17.9	2,900	20.0	40
	180° F	1,300	9.0	25	1,100	7.6	25	900	6.2	800	5.5	25
Shur-Lok SLE3009	-65° F	22,000	151.7	9	15,700	108.2	15	17,200	118.6	14,100	97.2	10
	R. T.	11,600	80.0	5	6,700	46.2	15	6,700	46.2	6,300	43.4	15
	180° F	500	3.4	15	800	5.5	15	1,000	6.9	600	4.1	15
Epon 828(70 pts) Ver. 140(30 pts)	-65° F	22,800	157.2	9	21,400	147.5	15	22,600	155.8	22,600	155.8	15
	R. T.	12,200	84.1	5	10,600	73.1	9	9,700	66.9	9,800	67.6	15
	180° F	400	2.8	15	3,000	20.7	15	2,200	15.2	1,300	9.0	15
Epon 815(70 pts) Ver. 140(30 pts) HTS (15 pts)	-65° F	23,400	161.3	10	19,800	136.5	12	21,700	149.6	21,900	151.0	13
	R. T.	11,800	81.3	5	8,200	56.5	15	7,600	52.4	7,000	48.3	7
	180° F	400	2.8	15	800	5.5	15	700	4.8	700	4.8	15
Hysol EA934	-65° F	21,900	151.0	13	23,300	160.6	24	23,400	161.3	24,000	165.5	24
	R. T.	11,000	75.8	6	13,400	92.4	24	12,600	86.9	10,900	75.1	23
	180° F	7,600	52.4	25	7,400	51.0	24	7,300	50.3	5,600	38.6	20
Reliabond R-371	-65° F	10,800	74.5	8	9,600	66.2	11	10,500	72.4	9,900	68.3	11
	R. T.	4,200	29.0	40	3,200	22.1	40	3,800	26.2	3,200	22.1	40
	180° F	700	4.8	25	600	4.1	25	500	3.4	600	4.1	25
Reliabond R-380	-65° F	19,300	133.1	8	23,300	160.6	19	25,300	174.4	23,200	159.9	18
	R. T.	10,900	75.1	5	11,700	80.7	18	11,500	79.3	11,400	78.6	22
	180° F	7,400	51.0	25	5,800	40.0	20	6,400	44.1	6,600	45.5	21

NOTE: Results are an average of three tests.

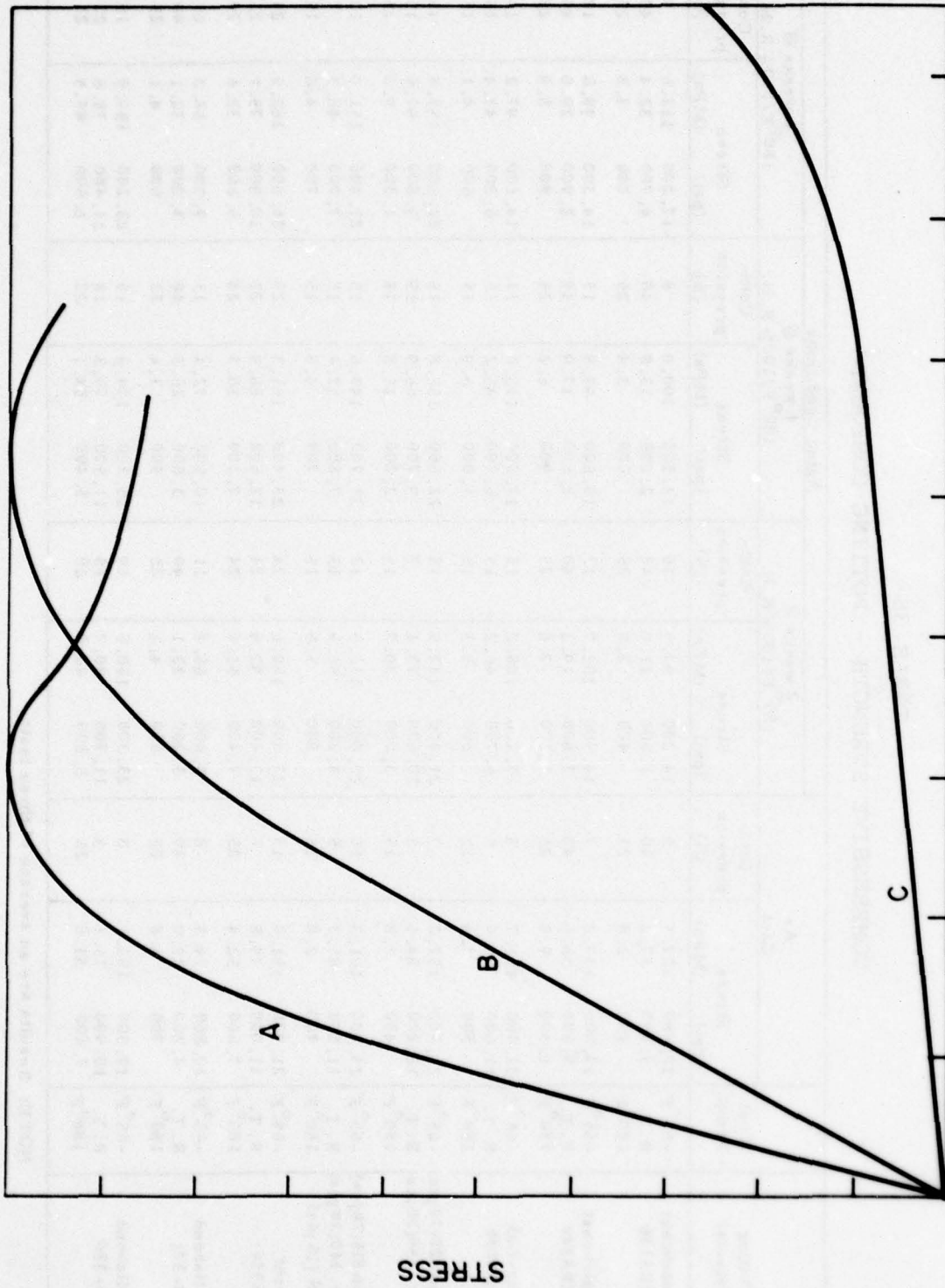

% COMPRESSION

Figure 49. Typical Compression Curves.

temperature but poor at 180°F (82°C); and (c) materials which looked poor at both temperatures. The terms good and poor, as used here, are defined in the table below.

Test Temperature	"Good" Performance	"Poor" Performance
Room Temp.	>10,000 psi (68.9 MPa) at 10% or less strain	<10,000 psi (68.9 MPa) at 10% or less strain
180°F(82°C)	>5,000 psi (34.4 MPa) at 25% or less strain	<5,000 psi (34.4 MPa) at 25% or less strain

On this basis the eight potting compounds, can be categorized as follows:

Performance of As-Cast Material	Material
good at R.T. and good at 180°F(82°C)	EA934 R380
good at R.T. but poor at 180°F(82°C)	SLE3009 828/140 815/140/HTS
poor at R.T. and poor at 180°F(82°C)	R371 XR5236 XR5240

The values reported in Table 35 represent the greater of:

- (a) the stress and strain at which gross fracture occurred;
- (b) the peak stress exhibited by the material if it displayed the type behavior illustrated by curves A or B in Figure 49; or
- (c) for materials which displayed the behavior illustrated by curve C in Figure 49, the stress at 40 percent strain (R.T. tests) or either 15 percent or 25 percent strain (180°F/82°C tests).

Thus far, only as-cast data have been considered in establishing the "good" or "poor" performance levels of the potting compounds listed in Table 35.

Since the exact requirements which shelter potting compounds must meet in order to assure acceptable performance in the field are unknown, it is difficult to proceed further in the analysis of the test results.

2.7 DURABILITY TESTING OF ADHESIVES

The last few years have witnessed a widespread and dramatic growth in R&D activities pertaining to structural adhesive bonding. One of the primary aspects of this recent adhesive R&D activity which distinguishes it from earlier adhesive investigations is the use of stressed rather than unstressed durability tests to evaluate the ability of adhesives, primers, and surface preparations to withstand long-term exposure to adverse environments. The University has designed, constructed, and had in service for the past several years, a test apparatus which permits the determination of the durability of bonded joints while exposed to elevated temperature and humidity under a controlled stress level.

During this contractual period, blister-shear panels with machined 1/2-inch (12.7 mm) lap joints were used to evaluate the durability of three different adhesives; PL-729-3, AF-143-2, and FM-123-2. These blister-shear panels were made with 1/4-inch (6.3-mm) thick, bare, 7075-T6 aluminum adherends.

Dry, static lap shear control tests were conducted on each adhesive at three different temperatures [room temperature, either 120°F (49°C) or 140°F (60°C), and 250°F (121°C)]. Wet, static lap shear control tests were also conducted on each adhesive after exposure to a combined elevated temperature, [either 120°F (49°C) or 140°F (60°C)], and high humidity (95 to 98 percent R.H.) for either 28 or 30 days and also for 100 days.

Durability tests on these materials were conducted by subjecting the adhesives to a lap shear stress of from 20 to 80 percent of their elevated temperature, dry, static ultimate

strength and simultaneous exposure to a combined elevated temperature, [either 120°F (49°C) or 140°F (60°C)], and high humidity (95 to 98 percent R.H.) environment for up to 100 days. If the specimens survived this 100-day aging period, they were removed from the durability apparatus and immediately tested for residual strength at room temperature. The test results for these three adhesives are presented in Tables 36 through 43.

It can be observed from the tables of static strength data (Tables 36, 38, 40, and 42) that the only interface attacked during humid aging of unstressed joints seemed to be that between FM-123-2 and optimized FPL etched aluminum. Wedge crack quality control tests on specimens made with these joints indicated that the surface preparation was satisfactory. Strength losses observed after humidity aging of AF-143-2 and FM-123-2 on anodized surfaces are slight and can be attributed to effects of the environment on the adhesive itself since the failures were cohesive. All of the adhesives exhibit a decreasing dry cohesive strength with increasing test temperature.

All of the adhesives also exhibit decreasing lifetime with increasing stress level during exposure (as expected). Residual strength data for all of the adhesives indicate that, for those specimens which survive the 100-day aging, under load, very little strength is lost as a result of the exposure.

2.8 SHELTER ADHESIVE BOND DURABILITY INVESTIGATION

A large program was conducted to investigate durable adhesive bond systems for use by the Air Force in the bonding of portable shelter structures. The University's efforts in this program were aimed at determining more durable combinations of adhesive, surface primer, and substrate surface preparation than are currently being used to manufacture portable shelters. The original program plan was very comprehensive and consequently much too large to be completed within the required time frame

TABLE 36
 STATIC LAP SHEAR TEST RESULTS FOR PL-729-3 ADHESIVE

Test Temperature	Specimen Conditioning	Ultimate Strength (psi) (MPa)		Failure Mode (% Coh)	Number of Specimens
R.T.	Dry	6370	43.9	100	10
140°F (60°C)	Dry	5780	39.8	100	5
250°F (121°C)	Dry	4770	32.9	100	5
R.T.	28 days @ 140°F (60°C) + 95% R.H.	6560	45.2	---	5
R.T.	100 days @ 140°F (60°C) + 95% R.H.	6350	43.8	95	3

Note: Specimens were prepared with an optimized FPL etch adherend surface.

TABLE 37
 DURABILITY OF PL-729-3 LAP JOINTS IN
 140°F(60°C) AND 95 PERCENT R.H.

Stress Level During Aging ¹ (psi) (%)		Lifetime ²		Residual Strength		
		Avg. (hrs)	Std.Dev. (hrs)	Avg. (psi)	Std.Dev. (psi)	No. of Spec.
1160	20	2400	0	6660	40	3
2310	40	1860	935	5630	127	2
3470	60	638	377	--	--	0
3760	65	821	374	--	--	0
4050	70	470	430	--	--	0
4630	80	15.7	7.0	--	--	0

1. The percentages listed are based upon the dry, static 140°F(60°C) ultimate strength (5780 psi = 100 percent).
2. All of the lifetime values are based on three specimens.

Note: Specimens were prepared with an optimized FPL etch adherend surface.

TABLE 38

STATIC LAP SHEAR TEST RESULTS FOR AF-143-2 ADHESIVE

Test Temperature	Specimen Conditioning	Ultimate Strength (psi) (MPa)		Failure Mode (% Coh)	Number of Specimens
R.T.	Dry	6330	43.6	90	6
140°F(60°C)	Dry	5180	35.7	95	10
250°F(121°C)	Dry	4360	30.0	99	6
R.T.	30 days @ 140°F(60°C)+ 95% R.H.	5970	41.2	100	6
R.T.	100 days @ 140°F(60°C)+ 95% R.H.	5780	39.8	100	5

Note: Specimens were prepared with a phosphoric acid anodized adherend surface.

TABLE 39

DURABILITY OF AF-143-2 LAP JOINTS IN
140°F(60°C) AND 95 PERCENT R.H.

Stress Level During Aging ¹ (psi) (%)		Lifetime			Residual Strength		
		Avg. (hrs)	Std.Dev. (hrs)	No. of Spec.	Avg. (psi)	Std.Dev. (psi)	No. of Spec.
1040	20	2400	0	3	5840	110	3
1550	30	2400	0	3	5760	90	3
2070	40	2400	0	3	5900	80	3
2590	50	2400	0	2	5645	--	2
3110	60	1530	910	3	--	--	0
3630	70	480	170	3	--	--	0

1. The percentages listed are based upon the dry, static 140°F(60°C) ultimate strength (5180 psi = 100 percent).

Note: Specimens prepared with a phosphoric acid anodized adherend surface.

TABLE 40
 STATIC LAP SHEAR TEST RESULTS FOR FM-123-2 ADHESIVE

Test Temperature	Specimen Conditioning	Ultimate Strength (psi) (MPa)		Failure Mode (% Coh)	Number of Specimens
R.T.	Dry	5850	40.3	100	6
140°F(60°C)	Dry	5020	34.6	100	12
250°F(121°C)	Dry	3770	26.0	90	6
R.T.	28 days @ 140°F(60°C) + 95% R.H.	4500	31.0	98	6
R.T.	100 days @ 140°F(60°C) + 95% R.H.	4170	28.7	80	6

Note: Specimens were prepared with an optimized FPL etch adherend surface.

TABLE 41
 DURABILITY OF FM-123-2 LAP JOINTS IN
 140°F(60°C) AND 95 PERCENT R.H.

Stress Level During Aging ¹ (psi) (%)		Lifetime			Residual Strength		
		Avg. (hrs)	Std.Dev. (hrs)	No. of Spec.	Avg. (psi)	Std.Dev. (psi)	No. of Spec.
1000	20	1893	687	3	No specimens of this adhesive survived for residual strength tests at any stress level.		
1510	30	658	533	5			
2010	40	487	390	4			
2510	50	99.7	74.8	4			
3010	60	57.9	38.9	4			
3510	70	17.9	14.8	4			
4020	80	0	--	3			

1. The percentages listed are based upon the dry, static 140°F(60°C) ultimate strength (5020 psi = 100 percent).

Note: Specimens were prepared with an optimized FPL etch adherend surface.

TABLE 42
 STATIC LAP SHEAR TEST RESULTS FOR FM-123-2 ADHESIVE

Test Temperature	Specimen Conditioning	Ultimate Strength (psi) (MPa)		Failure Mode (% Coh)	Number of Specimens
R.T.	Dry	5770	39.8	100	6
120°F (49°C)	Dry	5010	34.5	100	9
250°F (121°C)	Dry	2495	17.2	75	6
R.T.	30 days @ 120°F (49°C) + 95% R.H.	5520	38.0	100	6
R.T.	100 days @ 120°F (49°C) + 95% R.H.	5530	38.1	100	6

Note: Specimens were prepared with phosphoric acid anodized adherend surfaces.

TABLE 43

DURABILITY OF FM-123-2 LAP JOINTS IN
120°F(49°C) AND 95 PERCENT R.H.

Stress Level During Aging ¹		Lifetime			Residual Strength		
(psi)	(%)	Avg. (hrs)	Std.Dev. (hrs)	No. of Spec.	Avg. (psi)	Std.Dev. (psi)	No. of Spec.
1000	20	2400	0	3	5040	144	3
1500	30	2400	0	3	5090	121	3
2000	40	2147	438	3	5700	---	2
2510	50	811	542	5	--	---	0
3010	60	111	31	3	--	---	0
3510	70	4.0	2.0	3	--	---	0
4010	80	0.06	0.12	3	--	---	0

1. The percentages listed are based upon the dry, static 120°F(49°C) ultimate strength (5010 psi = 100 percent).

Note: Specimens were prepared with phosphoric acid anodized adherend surfaces.

with the manpower and facilities available. As a result, an approach was adopted which reduced the effort to a manageable level without sacrificing the validity or comprehensiveness of the results.

The approach pursued consisted of three testing phases. The first phase was a screening process to define the most promising combinations of surface preparation/primer/adhesive, and to eliminate those other less promising combinations from subsequent consideration in Phases II and III. The second phase of the effort consisted of the generation of metal-to-metal lap shear data for all of the combinations of substrate alloy, surface preparation, primer, and adhesive which looked promising after Phase I. The third phase of the effort consisted of generating climbing drum peel data for one surface preparation with all of the substrate alloys, primers, and adhesives evaluated in Phase II.

2.8.1 Phase I Testing

The AFML has conclusively established, through extensive testing programs concerned with aircraft bonding problems, that the use of the wedge crack specimen can readily discriminate between durable and non-durable adhesive bonds exposed to hostile environments. Specifically, the wedge cracked specimen permits both the measurement of the rate of crack growth and the mode of failure in the adhesive bondline. A durable bondline is one which exhibits both cohesive failure and a low rate of crack growth, while a non-durable bondline exhibits either rapid crack growth or adhesive failure. Hence, Phase I utilized the wedge crack specimen to permit the elimination of some of the surface prep/primer/adhesive combinations from further consideration.

The materials and the processing (M&P) parameters which were included in Phase I of the investigation are listed in Table 44. The adherend substrate materials were 0.125-inch (0.32-cm) thick and were used to fabricate 6-inch (15.2-cm)

TABLE 44
 MATERIALS AND PROCESSING PARAMETERS INCLUDED IN SHELTER
 ADHESIVE BOND CORROSION STUDY

Adherend Alloy Materials	Surface Preparations	Corrosion Resistant Adhesive Primers	Adhesives
1. 6061-T6 Aluminum	1. None	1. None	1. Epic JS 794-1/ Versamide 140 (R.T.)
2. 5052-H34 Aluminum	2. Non-optimized FPL etch	2. BR-127	2. TAME 200/c (R.T.)
3. 2024-T3 Aluminum	3. Optimized FPL etch	3. 3M; XC3950	3. DA 561-2 (R.T.)
	4. Phosphoric acid anodization	4. Hysol; ADX 238.2	4. 100-172 (200°F)
			5. Reliabond 7114 (250°F)
			6. EA 9601 (250°F)
			7. XA 180 (250°F)

by 6-inch (15.2-cm) panels of each combination. The 2024-T3 alloy was included to provide baseline data, since this is the alloy upon which most current AFML data exists and without which the data obtained from the 6061 and 5052 alloys would be difficult to assess. All wedge crack testing consisted of exposure to 140°F (60°C) and condensing (100 percent) humidity, and crack lengths were measured at one hour, four hours, 24 hours, one week, and 30 days.

Phase I testing proceeded according to the following scheme. The first available alloy, in this case 5052 H34, was used to prepare wedge crack specimens with all of the combinations of surface prep/primer/adhesive listed in Table 44. This required 112 panels (four surfaces, four primers, and seven adhesives). The wedge crack results for these 560 specimens (five from each panel) were used to eliminate two surface treatments, one primer, and three adhesives from further consideration. Wedge crack specimens were then prepared with the remaining two alloys (2024-T3 and 6061-T6) and those surface preps, primers, and adhesives which were not eliminated. This required an additional 48 panels (two alloys, two surfaces, three primers, and four adhesives) or 240 specimens. At the conclusion of these tests, one additional primer was eliminated.

The rationale for the elimination of the less-durable surface preps, primers, and adhesives as a result of the wedge crack tests from only one alloy, was based on the established fact from previous work that durability, as demonstrated by wedge crack results, is not nearly so dependent upon the nature of the aluminum alloy used as a substrate as it is upon the surface preparation, the primer, and the adhesive. Data attesting to this fact currently exist for both 2024-T3 and 7075-T6 aluminum alloys. Hence, the surfaces, primers, and adhesives which were eliminated on the basis of the 5052 alloy data could not be expected to look significantly better on the other alloys.

2.8.2 Phase II Testing

Phase II consisted of a metal-to-metal lap shear evaluation of the alloy/surface treatment/primer/adhesive combinations which survived the Phase I screening process. The test consisted of single lap shear specimens prepared with 0.064-inch (0.16-cm) thick adherends. For this phase, there were 32 M&P combinations (two alloys, two surfaces, two primers, and four adhesives). Each of these combinations was subjected to five test conditions with five replications resulting in a total of 800 lap shear tests. Table 45 lists the test conditions for the lap shear tests. The results for Phase II were not used to eliminate any further materials or process conditions from consideration in Phase III.

2.8.3 Phase III Testing

Phase III consisted of a climbing peel drum evaluation of some of the material and processing combinations tested in Phase II. Although it was expected that the anodized surface treatment would prove the most durable, it was felt that because of cost considerations it would be more likely that the next best surface treatment (the optimized FPL etch) would be more likely to be adopted by the manufacturers of these portable shelters. It was, therefore, decided that because of the considerably greater cost and time requirements to conduct climbing drum peel tests, relative to lap shear tests, only optimized FPL etch surface treatment would be utilized for the peel tests. This reduced the number of tests to half of what would have been required for both surface treatments.

Since two types of core (foam and honeycomb) were used, there were still 32 materials combinations to be tested (two alloys, two primers, four adhesives, and two core types). Two test conditions (listed in Table 46) were employed resulting in a total of 192 climbing drum peel tests (32 materials combinations), two test conditions, and three replications).

TABLE 45
LAP SHEAR TEST CONDITIONS

Test Temperature	Pretest Conditioning
1. -65°F(-54°C)	none
2. 72°F(22°C)	none
3. 200°F(93°C)	none
4. 200°F(93°C)	two weeks exposure to 200°F(93°C) and 100% R.H.
5. 72°F(22°C)	two weeks exposure to 95°F(35°C) and 5% salt spray

TABLE 46
CLIMBING DRUM PEEL TEST CONDITIONS

Test Temperature	Pretest Conditioning
1. 72°F(22°C)	none
2. 200°F(93°C)	two weeks exposure to 200°F(93°C) and 100% R.H.

2.8.4 Program Summary

A grand total of 1,792 test specimens were scheduled for fabrication and testing during the three phases of this program. During Phase I testing, however, the standard or non-optimum FPL surface condition was dropped so that the actual number of tests conducted was somewhat less than this figure. Table 47 presents an outline of the total testing program.

All of the work on this program was completed on schedule, with the exception of the data for one of the four adhesives used in Phases II and III. These were not completed on schedule because of a five-month delay in shipment of this material by the supplier. All of the results of this program have been compiled, summarized, and presented to the project monitor in the form of a technical memorandum.

It was hoped that the results of this program would clearly define one or more combinations of adhesive/primer/surface preparations which would meet the desired performance requirements for portable shelter structures. Unfortunately, no combination investigated met all of the desired requirements. It may be that these requirements are more stringent than necessary and that one of the combinations studied may, in fact, perform suitably. It is generally conceded that the fabrication procedures used to manufacture full-sized structures are not as rigidly controlled as those used in the fabrication of laboratory samples. As a result, the failures observed in the field with some of the materials combinations studied here may have resulted from bonds which were inferior to those tested in this program.

TABLE 47
SUMMARY OF TOTAL PROGRAM

Phase I. Wedge Crack Tests (5 replications)

- 3 alloys (Al)
- 4 surface treatments (S)
- 4 primers (P)
- 7 adhesives (Ad)

Part A. 1 Al }
 4 S } 112 panels, 560 specimens
 4 P }
 7 Ad }

this will eliminate 2 surface treatments, 1 primer,
and 3 adhesives

Part B. 2 Al }
 2 S } 48 panels, 240 specimens
 3 P }
 4 Ad }

this will eliminate 1 more primer

Phase II. Lap Shear Tests (5 replications)

2 Al	-65°F	} 25 spec. per mtl. comb. 800 specimens
2 S	72°F	
2 P	200°F, dry	
4 Ad	200°F, wet	
	72°F, salt spray	
32 mtl. comb.	5 test cond.	

Phase III. Drum Peel Tests (3 replications)

2 Al	72°F	} 32 panels 6 spec. per mtl. comb. 192 specimens
1 S	200°F, wet	
2 P	2 test cond.	
4 Ad		
2 C (cores)		
32 mtl. comb.		

SECTION 3

EVALUATION OF ELASTOMERIC SEALANTS, O-RINGS AND RELATED MATERIALS

3.1 INTRODUCTION

Elastomeric materials are in widespread use in current aircraft and missile weapons systems and their usage will continue to grow in future systems as performance and payload requirements increase. With each passing year, these types of materials are required to withstand higher temperatures, harsher environments, and higher stress levels for longer periods of time. The investigations discussed in this section have provided both the quick-response solutions to technical problems involving these materials in operational aircraft and missile systems and the engineering support necessary for the development of improved materials for future aerospace systems.

Eight major investigations are reported in the following sections. In addition to these eight major programs, many smaller scale studies and tasks have been conducted. These smaller efforts are not reported here but each of them has been reported in one or more of the bimonthly letter reports submitted during the contractual period and the results of each of them have also been submitted to the appropriate AFML project engineer.

Three of the eight major tasks involved the investigation and evaluation of sealant materials. Two others involved compatibility studies aimed at determining the effect of various types of fuel on all of the different types of elastomeric, adhesive, and plastic materials which these fuels would contact in an aircraft. Two efforts consisted of O-ring evaluations, one a dynamic testing program, and the other a long-term compression set study. The last involved the evaluation of a rigid foam material after various types of environmental exposure.

3.2 INVESTIGATION OF FUEL TANK SEALANT SYSTEMS FOR THE F-111 AIRCRAFT

A large materials evaluation program has been conducted during the course of this contract aimed at evaluating materials for use in resealing fuel tanks on the F-111 aircraft. One of the sealants originally used in sealing the F-111 fuel tanks, the polyester material designated EC-5106, developed a moisture reversion problem, making it necessary for the Air Force to deseal and reseal these tanks.

The procedure consists of stripping the old sealant from the fuel tank, cleaning the surface, and applying a new sealant. A problem existed in that reverted EC-5106 material in the faying surfaces could not be completely removed during the stripping and cleaning process, and before a new sealant material could be applied some of this material would seep from the faying surface onto the freshly cleaned surfaces, contaminating them with by-products of the reverted EC-5106 sealant. Since these reversion by-products, if permitted to come into contact with the new sealant, cause it to debond from the substrate surfaces, a barrier material was employed. The purpose of the barrier material was to restrict the EC-5106 seepage to as small an area as possible and to prevent it from coming into contact with the replacement sealant. This obviously will work only if the barrier material is capable of bonding to a contaminated substrate surface while at the same time retaining sufficient flexibility to resist cracking during in-flight service. In addition to adhering to surfaces contaminated with reverted EC-5106 material, this barrier material had to be capable of adhering to cadmium plated fasteners as well.

A variety of materials have been evaluated during this program to establish their ability to adhere to both contaminated as well as to cadmium plated surfaces.

3.2.1 Adhesion to Contaminated Surfaces.

Prior to the University's involvement in this effort, McClellan Air Force Base reported a successful fix to

this problem by the use of a polyester barrier material designated EC-2216, a modified epoxy material, overcoated with PR-899 B-2 sealant. Testing at General Dynamics, however, had indicated that this barrier material was not sufficiently flexible at low temperatures to resist cracking. To confirm this, the University conducted glass transition temperature determinations both before and after heat and fuel aging on this barrier material as well as on two sealants, PR-899 B-2 and PR-1750 B-2. These test results are presented in Table 48 and indicate that the EC-2216 material chosen as a barrier has a considerably higher glass transition temperature than either of the two fuel tank sealant materials and that while it was capable of withstanding the strenuous MIL-S-83430 heat cycle without a fuel soak and a fuel soak without a heat aging, it cracked severely following a combined fuel soaking and heat aging.

In addition to these glass transition temperature tests, peel panels were prepared on MIL-C-27725 polyurethane coated panels to verify the results reported by McClellan Air Force Base. The panels were contaminated with reverted EC-5106 by manually wiping a thin layer of this material onto the panels followed by wiping with a dry towel. The panels were then primed with PR-148. Nine contaminated panels were then coated with PS-899 B-2 sealant and nine with PRC-1422 B-2 sealant. Nine additional non-contaminated panels were primed with PR-148 and coated with a 40 mil thick layer of EC-2216 barrier coating. Another layer of PR-148 primer was applied over this barrier coating before an overcoat of PS-899 B-2 sealant was applied. Each of these three sets of panels were then subdivided into three groups of three specimens each. Three specimens of each set were tested immediately after curing, three were tested after fuel soaks, and three after the fuel soaks plus MIL-S-83430 heat cycle.

All the panels tested exhibited predominantly adhesive failures. Inasmuch as McClellan Air Force Base reported

TABLE 48

GLASS TRANSITION TEMPERATURES OF F-111
FUEL TANK MATERIALS

Material	Aging Prior to Test	Glass Transition Temperature	
		(°F)	(°C)
EC-2216	Control	63	17
	MIL-S-83430 Heat Cycle Only	95	35
	Fuel Soak ¹ + MIL-S-83430 Heat Cycle	Sample Cracked	
	Fuel Soak ¹ + F-111 Heat Cycle ²	Sample Cracked	
	Fuel Soak ¹ Only	104	40
PS 899	Control	-49	-45
	MIL-S-83430 Heat Cycle Only	-30	-34
	Fuel Soak ¹ + F-111 Heat Cycle ²	-31	-35
	Fuel Soak ¹ Only	-49	-45
PR-1750	Control	-29	-34
	MIL-S-83430 Heat Cycle Only	-34	-37
	Fuel Soak ¹ + MIL-S-83430 Heat Cycle	-47	-44
	Fuel Soak ¹ Only	-34	-37

Notes:

- Fuel soak consisted of: 7 days @ 140°F (60°C) in JRF.
- F-111 heat cycle consisted of:
 - 66 hrs @ 200°F (93°C)
 - 5 hrs @ 255°F (124°C)
 - 4 hrs @ 280°F (138°C)
 - 72 min @ 300°F (149°C)

that the EC-2216 material did not fail adhesively when bonded to contaminated panels, and our results did indicate adhesive failures when bonded to clean, uncontaminated, and contaminated panels, it was necessary to contact McClellan and determine if any differences existed between the two test techniques. It was learned from this contact that both preparation and testing differences did in fact exist.

While the University had applied the pure, reverted EC-5106 sealant directly to the panel surfaces, McClellan had dipped their panels in a 10 percent solution of the EC-5106 in a MIL-C-38736 solvent. In addition, it was learned that in conducting the peel tests, McClellan had not cut completely through both the sealant topcoat and the EC-2216 barrier to the substrate surface, but only through the topcoat, while UDRI had cut completely through to the substrate surface. This latter method is the standard and accepted practice in conducting peel tests. As a result, it was concluded by AFML that the fix adopted by McClellan Air Force Base would not, in fact, solve the problem of adhesion to a surface contaminated with reverted EC-5106 and that the EC-2216 barrier material would not provide sufficient protection of the new sealant from the reverted EC-5106.

Since the EC-2216 material at this point did not appear very promising as a successful barrier material, it was decided to investigate several sealant materials by themselves without an intermediate barrier material on contaminated EC-5106 panels. As can be noted from Table 49 none of the sealant materials evaluated exhibited good adhesion properties to contaminated C-130 surfaces.

Since none of the materials evaluated to this point looked suitable for solving the resealing problem on the F-111, a search was initiated for new types of barrier materials to substitute for the EC-2216 material and also for different primers to try to improve the adhesion of EC-2216 to contaminated MIL-C-27725 surfaces. The materials examined in this phase of

TABLE 49

PEEL TEST RESULTS OF SEALANTS BONDED TO CLEAN
AND CONTAMINATED C-130 SURFACES

Barrier Material	Sealant System	Panel Surface Condition	Aging Prior to Test	Failure Load ¹ (PIW) (N/cm)	Failure Mode ¹ (% Coh)
EC-2216	PS-899/B-2	Clean-C130 ²	None Fuel ³ Fuel/ Heat ⁴	6.3 11.0 7.3 12.8 11.1 19.4	2 85 8
None	PS-899/B-2	Contaminated ⁶ -C130	None Fuel ³ Fuel/ Heat ⁴	3.3 5.8 fell apart 11.2 ⁷ 19.6 ⁷	0 0 22 ⁷
None	PR-1422/ B-2	Contaminated ⁶ -C130	None Fuel ³ Fuel/ Heat ⁴	8.2 14.4 3.5 6.1 14.7 25.7	7 2 85
None	EC-7765R/ PS-899 B-2	Clean-C130	None	3.4 6.0	0
None	EC-7765R/ PS-899 B-2	Contaminated ⁶ -C130	None	5.4 9.5	0

Notes:

1. Average of three specimens.
2. C-130 panels indicate panels taken from a C-130 aircraft which has been in service. These panels are identical to the surfaces in an F-111 and have the MIL-C-27725 polyurethane coating. All of these surfaces were primed with PR-148 prior to application of the barrier or sealant material.
3. Fuel aging consisted of: 120 hrs @ 140°F(60°C) in Jet Reference Fluid (JRF)
60 hrs @ 160°F(71°C) in JRF
6 hrs @ 180°F(82°C) in JRF.
4. Fuel/Heat aging consisted of: 7 days @ 140°F(60°C) in JRF
66 hrs @ 200°F(93°C)
5 hrs @ 255°F(124°C)
4 hrs @ 280°F(138°C)
72 min @ 300°F(149°C).
5. These failures were half at the PS-899/EC-2216 interface and half at the EC-2216/panel interface.
6. Contaminated surface condition means that the panels were dipped in a 10 percent solution of reverted EC-5106 in MIL-C-38736 solvent after application of the PR-148 primer.
7. One of the three specimens fell apart while the other two gave one average failure level of 16.9 lb and a 33 percent cohesive failure mode.

the program are listed in Table 50. None of the candidate barrier materials exhibited any better adhesion to the contaminated surfaces than the EC-2216 or the sealant materials previously tested. Also, none of the primers used with the EC-2216 seemed to improve the adhesion of the 2216 material to the contaminated surfaces.

As a corollary effort to those tests described above, the Air Force Materials Laboratory had developed some materials which were felt to possess the required properties for the solution of the F-111 resealing problem. UDRI exposed 14 of these materials to a seven-day elevated temperature soak in JRF and/or JP-4, and measured hardness change and volume swell. If these results indicated a satisfactory resistance to the elevated temperature fuel soak, peel panels were to be prepared. Unfortunately, the results presented in Table 51 indicate that all of these materials had volume swells in excess of 70 percent and all of the materials experienced some loss of hardness, in some cases a very significant loss. In summary, after testing a great many materials, very little success has been achieved in finding a material which holds substantial promise for adhering to a surface contaminated with reverted EC-5106 material.

3.2.2 Adhesion to Cadmium Plated Surfaces

In addition to bonding to a contaminated MIL-C-27725 coating, the barrier or sealant material used in the F-111 fuel tank must also bond to cadmium plated fasteners. Simultaneous, therefore, with the testing discussed above, a number of materials were being evaluated for their ability to adhere to cadmium plated fasteners. Three types of fasteners were utilized in this testing, as listed below:

- Type I. Silver-MS21043-4, an as-plated cadmium surface,
- Type II. Gold-C2950-8K067, a cadmium plated surface with a supplementary chromate surface, and
- Type III. Grey-14S21042L4, K068.

TABLE 50

ALTERNATIVE BARRIER MATERIALS AND PRIMERS EVALUATED

Barrier Materials

3J-8572X (polyurethane tape-3M)
EC-91 (modified epoxy-3M)
EC-9309.2 (modified epoxy-3M)
XB-3594B/A (experimental material-3M)
EC-3529 (experimental material-3M)
PR-611 (polysulfide-Products Research)
PR-611J (polysulfide-Products Research)
PR-1561 (2-part polyurethane-Products Research)
94-002 (silicone-Dow Corning)
FPS (hot-melt polyimide-TRW)
GC-414 B2 (MIL-S-8802D sealant-Grow)

Primer Materials Evaluated with EC-2216

EC-3901 (3M)
EC-2333 (3M)
Thixon AB-1153/66 (Dayton Coatings & Chemicals)
AP-131 (Chemlok)

TABLE 51
FUEL EXPOSURE TEST RESULTS ON AFML
BARRIER MATERIALS

Sample Designation ¹	Aging Fluid ²	Original Shore-A Hardness (pts)	Shore-A Hardness After Aging (pts)		Volume Swell (%)
			Instantaneous	Final ³	
#1-As cured	JRF	75	38	36	121
-Aged	JRF	65	34	33	128
#2-As cured	JRF	28	3	3	278
-Aged	JRF	32	4	4	261
#3-As cured	JRF	59	26	26	146
-Aged	JRF	57	19	19	156
#4-As cured	JRF	78	36	32	130
-Aged	JRF	75	21	20	155
#5-As cured	JRF	85	37	34	122
-Aged	JRF	88	34	31	130
#9-As cured	JRF	52	25	--	133
-Aged	JP-4	41	31	--	81
#10-As cured	JRF	82	83	--	73
-Aged	JP-4	80	85	--	29
#11-As cured	JRF	80	74	73	77
-Aged	JP-4	80	74	71	34
#12-As cured	JRF	84	76	76	75
-Aged	JP-4	86	85	84	31
#13-As cured	JRF	94	86 ⁴	84 ⁴	187
-Aged	JP-4	90	88 ⁴	86 ⁴	137
#20-As cured	JRF	89	71	69	63.8
-Aged	JP-4	92	73	71	25.2
#21-As cured	JRF	83	57	50	70.1
-Aged	JP-4	81	69	72	23.7
#22-As cured	JRF	87	64	57	75.0
-Aged	JP-4	91	77	72	20.4
#23-As cured	JRF	73	26	21	83.7
-Aged	JP-4	65	44	30	21.5

Notes:

1. These designations were assigned by AFML. The As-cured designation indicates freshly prepared material. The Aged designation does not pertain to the fuel aging indicated in the second column. Rather, it indicates that the material was subjected to some sort of aging at AFML prior to delivery to UDRI. The nature of this aging is unknown.
2. All of the fuel agings were for 7 days at 140°F(60°C).
3. The final hardness value represents that value indicated one minute after the instantaneous value was obtained, the pressure on the indenter point being maintained throughout this one-minute period.
4. These values were not obtained until after the specimens had been exposed to ambient conditions for about one hour after removal from the aging fluid.

Specimens were prepared with four different materials on these three types of fasteners. The four materials evaluated were PS-899 B-2 sealant, EC-2216 polyester barrier coating material, PR-1422 B-2 sealant, and PR-611J topcoat. Tables 52 through 55 present the results of these tests.

The PS-899 B-2 sealant was tested on contaminated and uncontaminated cadmium plated surfaces of all three types, both with the without fuel and heat soaks. On the Type I and Type III non-contaminated surfaces, this sealant exhibited 100 percent cohesive failure after nearly all of the aging environments. On the contaminated surfaces all the failures with the sealant were adhesive except after the F-111 heat cycle, where some degree of cohesive failure occurred.

The PR-611J topcoat material was tested only on clean Type II surface materials in the as-cured condition and following fuel aging. All of these specimens failed largely in an adhesive mode and the use of PR-148 primer did not improve adhesion. In addition it was observed that the PR-148 softened the PR-611J material.

Tests were also conducted to determine if the PS-899 B-2 sealant would adhere to the PR-611J topcoat material without the use of the PR-148 primer. No bond failures at the PR-611J/PS-899 interface were observed. Because of the adhesive failure mode of the PR-611J to the cadmium surface, however, these loads were all relatively low.

PR-1422 B-2 sealant was also tested for adhesion to cadmium plated surfaces. Both Type I and Type II uncontaminated surfaces were used with this sealant. In the as-fabricated condition, 100 percent adhesive failures were noted between the PR-1422 sealant and the cadmium plated surfaces. Fuel agings further weakened this bond and also resulted in complete adhesive failures.

The last material evaluated for adhesion to cadmium plated surfaces, EC-2216, was tested only on clean Type II

TABLE 52

ADHESION TEST RESULTS FOR PS-899 B-2 SEALANT ON
CADMIUM PLATED FASTENERS

Type Surface	Surface Preparation ¹	Specimen Aging ²	Failure Load		Failure Mode
			(lb)	(N)	(% Coh)
I	Clean	Fuel	25.6	113.9	80
I	Clean	Fuel/Heat	60.4	268.7	100
I	Contaminated	None	15.6	69.4	0
I	Contaminated	Fuel	4.6	20.5	2
I	Contaminated	Fuel/Heat	54.5	242.4	80
II	Contaminated	None	19.7	87.6	8
II	Contaminated	Fuel	4.0	17.8	0
II	Contaminated	Fuel/Heat	29.8	132.6	50
III	Clean	None	59.1	262.9	100
III	Clean	Fuel	37.9	168.6	100
III	Clean	Fuel/Heat	70+	311+	100
III	Contaminated	None	16.7	74.3	0
III	Contaminated	Fuel	1.9	8.5	0
III	Contaminated	Fuel/Heat	19.8	88.1	15

Notes:

- All the substrate surfaces were primed with PR-148. The contaminated surfaces were dipped in a 10 percent solution of reverted EC-5106 in MIL-C-38736 solvent after priming.
- Specimen aging conditions were as follows:
 - Fuel - 7 days at 140°F(60°C) in JRF
 - Fuel/Heat - 7 days at 140°F(60°C) in JRF followed by the F-111 heat cycle, which consists of
 - 66 hrs at 200°F(93°C)
 - 5 hrs at 255°F(124°C)
 - 4 hrs at 280°F(130°C)
 - 72 min at 300°F(149°C)

TABLE 53

ADHESION TEST RESULTS FOR PR-611J TOPCOAT ON
CADMIUM PLATED FASTENERS

Type Surface	Panel Construction ³	Surface Preparation ¹	Specimen Aging ²	Failure Load (lb) (N)	Failure Mode (% Coh)
II	A	Clean	None	34 151.2	0
II	B	Clean	None	25 111.2	0
II	A	Clean	Fuel	17.1 76.1	5
II	B	Clean	Fuel	21.8 97.0	10

Notes:

- All the substrate surfaces were primed with PR-148. The contaminated surfaces were dipped in a 10 percent solution of reverted EC-5106 in MIL-C-38736 solvent after priming.
- Specimen aging conditions were as follows:
 - Fuel - 7 days at 140°F(60°C) in JRF
 - Fuel/Heat - 7 days at 140°F(60°C) in JRF followed by the F-111 heat cycle, which consists of
 - 66 hrs at 200°F(93°C)
 - 5 hrs at 255°F(124°C)
 - 4 hrs at 280°F(130°C)
 - 72 min at 300°F(149°C)
- The panels used for the PR-611J topcoat tests were prepared as follows:
 - A - clean Type II surface
 - primed with PR-148
 - coated with PR-611J
 - overcoated with PS-899 B-2
 - B - clean Type II surface
 - primed with PR-148
 - coated with PR-611J
 - primed with PR-148
 - overcoated with PS-899 B-2

TABLE 54

ADHESION TEST RESULTS FOR PR-1422 B-2 SEALANT ON
CADMIUM PLATED FASTENERS

Type Surface	Surface Preparation ¹	Specimen Aging ²	Failure Load		Failure Mode
			(lb)	(N)	(% Coh)
I	Clean	None	53.1	236.2	20
II	Clean	None	56	249.1	10
II	Clean	Fuel	10.1	44.9	0

Notes:

- All the substrate surfaces were primed with PR-148. The contaminated surfaces were dipped in a 10 percent solution of reverted EC-5106 in MIL-C-38736 solvent after priming.
- Specimen aging conditions were as follows:
 - Fuel - 7 days at 140°F(60°C) in JRF
 - Fuel/Heat - 7 days at 140°F(60°C) in JRF followed by the F-111 heat cycle, which consists of
 - 66 hrs at 200°F(93°C)
 - 5 hrs at 255°F(124°C)
 - 4 hrs at 280°F(130°C)
 - 72 min at 300°F(149°C).

TABLE 55

ADHESION TEST RESULTS FOR EC-2216 BARRIER MATERIAL ON
CADMIUM PLATED FASTENERS³

Type Surface	Surface Preparation ¹	Specimen Aging ²	Failure Load		Failure Mode
			(lb)	(N)	(% Coh)
II	Clean	None	---	---	---
II	Clean	Fuel	6.4	28.5	0

Notes:

- Same as Note #1 above.
- Same as Note #2 above.
- The panels used for the EC-2216 barrier material tests consisted of - clean Type II surface
 - primed with PR-148
 - coated with EC-2216
 - primed with PR-148
 - overcoated with PS-899 B-2.
- Test invalid (see text).

surfaces. This material exhibited poor adhesion after fuel agings and produced 100 percent adhesive failures. The tests on non-fuel aged panels were found to be invalid because the EC-2216 was bonded to a washer used in the preparation of the test sample which became an influential factor in the adhesion tests. A post-test examination of the retainer following removal of the washer showed the EC-2216 could be easily peeled from the cadmium surface, thereby indicating that even in the as-fabricated condition the EC-2216 did not bond well to this surface.

3.3 EVALUATION OF PR-1755, CLASS B-2 SEALANT ACCORDING TO MIL-S-83313 AND MIL-S-83430

PR-1755 B-2 is a fast-curing, high-temperature fuel tank repair sealant. It was tested for tack-free time, application, standard cure, fluid immersed curing time, fluid rupture, specific gravity, adhesion and corrosion, hydraulic stability, accelerated storage, repairability, and peel strength according to the requirements of MIL-S-83318, Amendment 1. Its tensile strength, elongation, thermal rupture, and low-temperature flexure properties were determined according to the requirements of MIL-S-83430.

The PR-1755 B-2 sealant was supplied in a Semkit form. During mixing of the sealant, it was observed that some of the Semkits did not mix well even after mixing for the maximum time. These had a lumpy appearance and were not used.

The results of these tests are presented in Tables 56 through 58. The PR-1755 B-2 material did not meet the requirements of MIL-S-83313 by failing tack-free time, standard cure, accelerated storage, fluid immersed curing rate, and fluid rupture. It also failed to meet the as-cured ultimate tensile strength and thermal rupture requirement of MIL-S-83430. The sealant did adhere well to most of the peel test panels but it did show a tendency to fail adhesively from the C-130 panels, although these peel strengths were relatively high.

TABLE 56

 PHYSICAL PROPERTY TEST RESULTS FOR
 PR-1755 B-2 SEALANT (First Batch)

Property	Mil.Spec. Reqmt. Mil-S-	Pass/ Fail	Test Value
Application Life	83318,I	Pass	94 gm/min @ 10 min.
Tack-Free Time	83318,I	Failed	Passed @ 7 hrs
Standard Cure, 8 hrs.	83318,I	Failed	18 pts
24 hrs.	98318,I	Pass	43 pts
Fluid Imm. Curing Time, 8 hrs.	83318,I	Failed	5 pts
24 hrs.	83318,I	Pass	40 pts
Fluid Rupture Resistance	83318,I	Failed	---
Specific Gravity	83318,I	Pass	1.57
Wt. Loss and Flexibility	83318,I	Pass	---
Adhesion & Corrosion, JRF	83318,I	Pass	---
[20 days in JRF/SW] SW	83318,I	Pass	---
[at 140°F(60°C)] JRF&SW	83318,I	Pass	---
Hydrolytic Stability	83318,I	Pass	---
Thermal Rupture	83430		
unaged control { Tested @		Failed	---
aged { 360°F(182°C)		Pass	---
Low Temp. Flexibility	83430	Pass	---
Ultimate Tensile Strength	83430		
Controls		Pass	285.8 psi
8 hrs. @ 360°F(182°C)		Pass	239 psi
Std. heat cycle, 7 days @ 140°F(60°C)/JRF		Pass	121.2 psi
Ultimate Elongation	83430		
Controls		Failed	342 psi
8 hrs. @ 360°F(182°C)		Pass	80 psi
Std. heat cycle, 7 days @ 140°F(60°C)/JRF		Pass	63.3 psi
Hardness, Shore _A	83430		
Controls		---	47 psi
8 hrs. @ 360°F(182°C)		---	61 psi
Std. heat cycle, 7 days @ 140°F(60°C)/JRF		---	54 psi

TABLE 57

REPAIRABILITY AND ACCELERATED STORAGE PROPERTIES OF
PR-1755 B-2 SEALANT (FIRST BATCH), TESTED ACCORDING
TO REQUIREMENTS OF MIL-S-83318, I

Repairability			
Material	Aging Condition	Load (lbs)	Failure Mode (%)
PR-1755 B-2 on PS-899 B-2	Control	7.2-Fail	AP-90 C-10
PR-1755 B-2 on PR-1755 B-2	Control	14.6-Pass	AP-75 C-25
PR-1755 B-2 on PR-1750 B-2	Control	7.3-Fail	AP-85 C-15
PR-1755 B-2 on PR-1755 B-2	*Conditioned ²	35.0-Pass	AS-100
PR-1755 B-2 on PR-1750 B-2	*Conditioned ²	24.0-Pass	AP-30 AS-60 C-10
PR-1755 B-2 on PS-899 B-2	*Conditioned ²	22.9-Pass	AS-90 C-10

¹Failure modes were C-cohesive
AP-adhesive at primer surface
AS-adhesive at substrate surface

²Prior to last layer of sealant, the panels were aged for 3 days at 140°F(60°C) in JRF, air dried at 120°F(49°C) for 3 days, then 7 days at 250°F(121°C) in air. They were aged after curing for 14 days at Std. Cond.

Accelerated Storage

Application Life - 83.2 gms/min. @ 10 min.
Tack-Free Time - Failed - 8 hrs.
Std. Cure Rate - Failed - 11 pts (Passed at 24 hrs.)
Peel Strength - Failed - 7.2 lbs. with adhesive to panel failures.

TABLE 58

PEEL TEST RESULTS FOR PR-1755 B-2 SEALANT (FIRST BATCH),
TESTED ACCORDING TO REQUIREMENTS OF MIL-S-83318, I

Substrate Metal*	Aging Condition	Coating	Pass/ Fail	Failing Load (PIW)	Failure Mode
7075 Clad	8 days @ 140°F (60°C) in JRF/SW	MIL-A-8625	Pass	20.77/JRF	Sealant to Screen-
7075 Clad		MIL-A-8625	Pass	27.23/SW	100% JRF + SW
7075 Clad		MIL-A-8625	Pass	17.63/JRF	Sealant to Screen-
7075 Clad		MIL-A-8625	Pass	17.2	100% JRF + SW
7075 Clad	8 days @ 140°F (60°C) in JRF	MIL-A-8625	Pass	17.2	Sealant to Screen-100%
7075 Clad		MIL-A-8625	Pass	19.5	Sealant to Screen-100%
7075 Clad	8 days @ 140°F (60°C) in JRF	MIL-C-5541	Pass	19.52	Sealant to Screen-100%
7075 Clad		MIL-C-5541	Pass	19.90	Sealant to Screen-100%
7075 Clad	8 days @ 140°F (60°C) in JRF/SW	MIL-C-5541	Pass	23.3/JRF	Sealant to Screen-
7075 Clad		MIL-C-5541	Pass	34.5/SW	100% JRF + SW
7075 Clad		MIL-C-5541	Pass	19.05/JRF	Sealant to Screen-
7075 Clad		MIL-C-5541	Pass	30.8/SW	100% JRF + SW
C-130	8 days @ 140°F (60°C) in JRF	---	Fail	8.0	Sealant to Panel-90%
C-130		---	Pass	19.32	Sealant to Screen-100%
C-130	8 days @ 140°F (60°C) in JRF/SW	---	Fail	13.50/JRF	Sealant to Panel-90%/JRF
C-130		---	Fail	25.27/SW	Sealant to Panel-50%/SW
C-130		---	Fail	21.3/JRF	Sealant to Panel-100%/JRF
C-130		---	Fail	23.95/SW	Sealant to Panel-50%/SW

*All panels primed with PR-148.

TABLE 58 (Continued)

PEEL TEST RESULTS FOR PR-1755 B-2 SEALANT (FIRST BATCH),
TESTED ACCORDING TO REQUIREMENTS OF MIL-S-83318, I

Substrate Metal*	Aging Condition	Coating	Pass/ Fail	Failing Load (PIW)	Failure Mode
Titanium	8 days @ 140°F (60°C) in JRF	None	Pass	15.9	Sealant to Screen-100%
Titanium	8 days @ 140°F (60°C) in JRF	None	Pass	15.82	Sealant to Screen-100%
Titanium	8 days @ 140°F (60°C) in JRF/SW	None	Pass	23.07/JRF	Sealant to Screen-100% in JRF + SW
Titanium	8 days @ 140°F (60°C) in JRF/SW	None	Pass	30.8/SW	Sealant to Screen-100% in JRF + SW
Titanium	8 days @ 140°F (60°C) in JRF/SW	None	Pass	20.0/JRF	Sealant to Screen-100% in JRF + SW
Titanium	8 days @ 140°F (60°C) in JRF/SW	None	Pass	30.6/SW	Sealant to Screen-100% in JRF + SW
7075 Clad	8 days @ 140°F (60°C) in JRF	None	Pass	18.84	Sealant to Screen-100%
7075 Clad	8 days @ 140°F (60°C) in JRF	None	Pass	17.42	Sealant to Screen-100%
7075 Clad	8 days @ 140°F (60°C) in JRF/SW	None	Pass	22.97/JRF	Sealant to Screen-100% in JRF + SW
7075 Clad	8 days @ 140°F (60°C) in JRF/SW	None	Pass	29.27/SW	Sealant to Screen-100% in JRF + SW
7075 Clad	8 days @ 140°F (60°C) in JRF/SW	None	Pass	16.43/JRF	Sealant to Screen-100% in JRF + SW
7075 Clad	8 days @ 140°F (60°C) in JRF/SW	None	Pass	25.63/SW	Sealant to Screen-100% in JRF + SW
Stainless Steel	8 days @ 140°F (60°C) in JRF	None	Pass	19.42	Sealant to Screen-100%
Stainless Steel	8 days @ 140°F (60°C) in JRF	None	Pass	18.68	Sealant to Screen-100%
Stainless Steel	8 days @ 140°F (60°C) in JRF/SW	None	Pass	16.8/JRF	Sealant to Screen-100% in JRF + SW
Stainless Steel	8 days @ 140°F (60°C) in JRF/SW	None	Pass	26.73/SW	Sealant to Screen-100% in JRF + SW
Stainless Steel	8 days @ 140°F (60°C) in JRF/SW	None	Pass	20.27/JRF	Sealant to Screen-100% in JRF + SW
Stainless Steel	8 days @ 140°F (60°C) in JRF/SW	None	Pass	31.03/SW	Sealant to Screen-100% in JRF + SW

*All panels primed with PR-148.

TABLE 58 (Concluded)
 PEEL TEST RESULTS FOR PR-1755 B-2 SEALANT (FIRST BATCH),
 TESTED ACCORDING TO REQUIREMENTS OF MIL-S-83318, I

Substrate Metal*	Aging Condition	Coating	Pass/ Fail	Failing Load (PIW)	Failure Mode
7075 Clad	70 days @ 140°F (60°C) in JRF/SW	None	Pass Pass	20.4/JRF 17.8/SW	Sealant to Screen Sealant to Screen
7075 Clad	70 days @ 140°F (60°C) in JRF/SW	None	Fail Fail	18.9/JRF 23.3/SW	Adhesive to Panel-50% Adhesive to Panel-50%
7075 Clad	70 days @ 140°F (60°C) in JRF	None	Pass	11.6	Sealant to Screen
7075 Clad	70 days @ 140°F (60°C) in JRF	None	Pass	21.6	Sealant to Screen

*All panels primed with PR-148.

While the sealant failed many of the test requirements, most of these were related to the curing rate and because several of the Semkits supplied were of questionable quality, as indicated by the mixing problems, additional samples of this sealant were requested and received and several of the tests were repeated. The results of these tests are presented in Tables 59 through 62.

At standard curing conditions, the second batch of the PR-1755 B-2 sealant met specification requirements for standard cure. However, it failed to meet the tack-free requirement and at 40°F (4.4°C) and 20°F (-6.7°C) it failed to meet either the tack-free or the standard cure requirements of MIL-S-83318. After accelerated storage, this material also failed to meet tack-free and standard cure requirements, although it did pass application rate and peel strength requirements.

Although the cure rate for this sealant appears to be somewhat slower than that required to meet the specifications of MIL-S-83313, its other properties appear to be fairly good.

3.4 THAWING OF FUEL TANK SEALANTS

A testing program has been conducted to determine the effect, if any, of various fuel tank sealant thawing techniques on sealant properties. Fuel tank sealants used in the field are generally pre-mixed in large quantities and then quick-frozen in plastic cartridges. The cartridges are stored at -40°F (-40°C) and thawed just prior to use. In this program, thawing means warming the sealant from its -40°F (-40°C) storage temperature to 60°F (15.6°C).

Three thawing techniques were investigated in this program. In the first, the sealant cartridges were simply permitted to sit at ambient conditions until the sealant reached 60°F (15.6°C). In the second technique, sealants were thawed by blowing 80 psig compressed air over the cartridge. In the

TABLE 59
 PHYSICAL PROPERTY TEST RESULTS FOR
 PR-1755 B-2 SEALANT (SECOND BATCH)

Property	Mil. Spec. Reqmt. MIL-S-	Pass/ Fail	Test Value
Application Life	83318, I	Pass	83.2 gm/min @ 10 min.
Tack-Free Time	83318, I	Fail	6 hrs.
Standard Cure	83318, I	Pass	35 pts
		---	44 pts @ 23 hrs.
		---	48 pts @ 47 hrs.
		---	50 pts @ 55 hrs.
		---	50 pts @ 72 hrs.
Fluid Imm. Curing Time	83318, I	Fail	5 pts @ 6 hrs.
		Pass	40 pts @ 15 hrs.
Thermal Rupture	83430	Fail	---
		Pass	---
Ultimate Tensile Strength Control	83430	Pass	245 psi
Hardness	83430	---	50 pts

TABLE 60
 PEEL TEST RESULTS FOR PR-1755 B-2 SEALANT (SECOND BATCH),
 TESTED ACCORDING TO REQUIREMENTS OF MIL-S-83318, I

Substrate	Aging Condition	Cleaning Procedure	Pass/ Fail	Failing Load	Failure Mode
C-130	7 days @ 140°F (60°C) in JRF	MIL-C-38736 PR-130 PR-148	Pass	21.4 lbs (95.2)	Cohesive
C-130	7 days @ 140°F (60°C) in JRF/SW	MIL-C-38736 PR-130 PR-148	Pass	24.2 lbs (107.6) -JRF 31.5 lbs (140.1) -SW	Cohesive Cohesive
MIL-C-27725	7 days @ 140°F (60°C) in JRF	MIL-C-38736 PR-148	Pass	24.5 lbs (109.0)	Cohesive
MIL-C-27725	7 days @ 140°F (60°C) in JRF/SW	MIL-C-38736 PR-148	Pass	25.7 lbs (114.3) -JRF 33.2 lbs (147.7) -SW	Cohesive Cohesive

TABLE 61
 PROPERTIES OF PR-1755 B-2 SEALANT (SECOND BATCH)
 AFTER ACCELERATED STORAGE

Property	Test Value	Pass/ Fail	MIL-S-83313 Rqmt.
Application Rate	97.2 gms/min	Pass	<100 gms/min after 10 minutes
Tack-Free Time	27.5 hrs.	Fail	3 hours or less
Standard Cure	33 pts after 27 hrs.	Fail	30 pts or more after 8 hrs.
Peel Strength on QQ-A-250/13	22.0 PIW & 100% Coh.	Pass	10 PIW - 100% Coh.

TABLE 62
 EFFECT OF CURE TEMPERATURE ON CURING PROPERTIES OF
 PR-1755 B-2 SEALANT (SECOND BATCH)

Cure Temp.	Property	Test Value	Pass/ Fail	MIL-S-83313 Rqmt.
77°F (25°C)	Tack-Free Time	6 hrs.	Fail	3 hrs. or less
	Std. Cure	30 pts @ 8 hrs.	Pass	>30 pts @ 8 hrs.
40°F (4.4°C)	Tack-Free Time	23 hrs.	Fail	12 hrs. or less
	Std. Cure	39 pts @ 168 hrs.	Fail	>30 pts @ 24 hrs.
20°F (-6.7°C)	Tack-Free Time	49 hrs.	Fail	48 hrs. or less
	Std. Cure	36 pts @ 264 hrs.	Fail	>30 pts @ 96 hrs.

third technique, sealants were thawed by heating the frozen cartridges in a microwave oven. After determining the thawing time using these various techniques, a two-phase investigative program was adopted. The first phase dealt with an investigation of the effects of storage time at $-40^{\circ}\text{F}(-40^{\circ}\text{C})$ upon the properties of the sealant, while in the second phase of the program, the specific effects of microwave thawing on various sealant materials was investigated.

3.4.1 Effect of Frozen Storage Time on Sealant Properties

Five sealant materials, PR-1422 B-2, PR-1422 A-2, PR-1440 B-2, PR-1440 A-2, and PR-1750 A-2, were utilized to determine the effect of frozen storage time on sealant properties. Each of these sealants were mixed, quick-frozen, and stored for 10, 20, 30, 60, and 90 days at $-40^{\circ}\text{F}(-40^{\circ}\text{C})$. After each of these storage time periods, the sealants were thawed and used to prepare specimens for the determination of: (1) application life, (2) tack-free time, (3) curing rate, (4) flow, (5) peel strength on MIL-C-27725 panels, (6) weight loss, (7) hardness, and (8) low temperature flexibility.

Each of the materials investigated in this phase of the program was mixed on a Semco mixer and 15 cartridges of each material were frozen in a dry ice/acetone bath and stored at $-40^{\circ}\text{F}(-40^{\circ}\text{C})$. After the intervals stated above, three cartridges of each material were thawed by exposure to ambient conditions for periods of from 50 to 60 minutes until the sealant temperature in the cartridges reached $60^{\circ}\text{F}(15.6^{\circ}\text{C})$. The specimens required for the determination of the properties listed above were then prepared. Tables 63 through 67 present the test results obtained from these specimens.

The PR-1422 B-2 sealant material met all of the MIL-S-8802D specification requirements except application rate, which it failed for all freezing periods.

The PR-1440 B-2 material also had difficulty in meeting the MIL-S-8802D requirements for application rate. The

TABLE 63
EFFECT OF FREEZING TIME ON SEALANT PROPERTIES; PR-1422 B-2

Test/Property	Condition	Freezing Time						MIL-S-8802D Requirement
		Fresh	10 days	21 days	28 days	50 days	90 days	
Application	Original	12.67 gms/min	6.69 gms/min	8.0 gms/min	8.4 gms/min	---	3.1 gms/min	>15 gms/min
Tack-Free Time	Original	24 hours	33 hours*	18 hours	18 hours	17 hours	24 hours	40 hrs, max.
Std. Curing Rate	Original	40 pts (Shore A ₂) @ 66 hours	40 pts (Shore A ₂) @ 66 hours	37 pts (Shore A ₂) @ 43 hours	37 pts (Shore A ₂) @ 50 hours	36 pts (Shore A ₂) @ 40 hours	37 pts (Shore A ₂) @ 72 hours	35 pts, min. @ 72 hours
14-day Hardness	Original	56 pts (Shore A ₂)	58 pts (Shore A ₂)	58 pts (Shore A ₂)	56 pts (Shore A ₂)	57 pts (Shore A ₂)	55 pts (Shore A ₂)	14 pts, min.
Flow	Original	0.02" (0.05 cm)	0.38" (0.97 cm)	0.10" (0.25 cm)	0.10" (0.25 cm)	0.19" (0.48 cm)	0.32" (0.81 cm)	0.10" - 0.75" →
	-Initial:	0.07" (0.18 cm)	0.05" (0.13 cm)	0.01" (0.03 cm)	0.08" (0.20 cm)	0.21" (0.53 cm)	0.15" (0.38 cm)	
	-50 min:	0.02" (0.05 cm)	0.03" (0.08 cm)	0.01" (0.03 cm)	0.01" (0.03 cm)	---	0.08" (0.20 cm)	
Low Temp. Flex.	Original	Passed	Passed	Passed	Passed	Passed	Passed	No cracking, checking, or loss of adhesion
	7 days @ 250°F (121°C)	Passed	Passed	Passed	Passed	Passed	Passed	
Peel Strength	Original	27.2 PIW(48.0 N/cm) 100% Coh.	26.2 PIW (46.2 N/cm) 95% Coh.	29.1 PIW (51.3 N/cm) 100% Coh.	23.9 PIW (42.2 N/cm) 100% Coh.	21.5 PIW (37.9 N/cm) 100% Coh.	36.4 PIW (64.0 N/cm) 100% Coh.	20 PIW, min. & 100% Coh. →
	7 days @ 140°F (60°C) /JRF	20.5 PIW(36.2 N/cm) 100% Coh.	18.8 PIW (33.2 N/cm) 90% Coh.	26.7 PIW (47.1 N/cm) 100% Coh.	20.0 PIW (35.3 N/cm) 100% Coh.	17.4 PIW (30.7 N/cm) 100% Coh.	41.4 PIW (72.9 N/cm) 100% Coh.	
Weight Loss	7 days @ 140°F (60°C) /JRF+3 days @ 120°F (49°C)/Air	10.5%	9.6%	6.2%	7.5%	8.8%		8%, max.

*When taken, may have been earlier.

TABLE 64
EFFECT OF FREEZING TIME ON SEALANT PROPERTIES; PR-1440 B-2

Test/Property	Condition	Freezing Time					MIL-S-8802D Requirement
		Fresh	14 days	20 days	40 days	60 days	
Application	Original	30.4 gm/min	13.97 gm/min	11.93 gm/min	8.45 gm/min	11.0 gm/min	>15 gms/min
Tack-Free Time	Original	40 hours	40 hours	40 hours	40 hours	40 hours	40 hrs, max.
Std. Curing Rate	Original	37 pts	30 pts*	38 pts*	37 pts	38 pts	35 pts, min. @ 72 hours
14-Day Hardness	Original	56 pts	37 pts	51 pts	54 pts	52 pts	14 pts, min.
Low Temp. Flex.	Original	Passed	Passed	Passed	Passed	Passed	No cracking, checking, or loss of adhesion
	7 days @ 250°F (121°C)	Passed	Passed	Passed	Passed	Passed	
Peel Strength	Original	29.4 PIW (51.48 N/cm) 100% Coh.	19.3 PIW (33.79 N/cm) 100% Coh.	18.3 PIW (32.04 N/cm) 100% Coh.	24.9 PIW (43.60 N/cm) 100% Coh.	34.9 PIW (61.11 N/cm) 100% Coh.	20 PIW, min. & 100% Coh.
	7 days @ 140°F (60°C) /JRF	20.8 PIW (36.42 N/cm) 100% Coh.	16.5 PIW (28.89 N/cm) 100% Coh.	12.5 PIW (21.89 N/cm) 100% Coh.	23.6 PIW (41.32 N/cm) 85% Coh.	17.6 PIW (30.82 N/cm) 100% Coh.	↓
Flow	Original	0.22" (0.56 cm)	0.15" (0.38 cm)	0.22" (0.56 cm)	0.25" (0.64 cm)	0.25" (0.64 cm)	0.10" - 0.75"
	-Initial:	0.19" (0.48 cm)	0.15" (0.38 cm)	0.15" (0.38 cm)	0.18" (0.46 cm)	0.25" (0.64 cm)	↓
	-50 min:	0.10" (0.25 cm)	0.15" (0.38 cm)	0.18" (0.46 cm)	0.15" (0.38 cm)	0.31" (0.79 cm)	
	-90 min:						

*Voidy

TABLE 65
EFFECT OF FREEZING TIME ON SEALANT PROPERTIES; PR-1422 A-2

Test/Property	Condition	Freezing Time*					R.T. Thaw	80 psi	MIL-S-8802D Requirements
		Fresh	10 days	30 days	60 days	80 days			
Application	Original	1180 poise	---	---	---	---	620	2500 poise, max.	
Tack-Free Time	Original	24 hrs	17 hrs	15 hrs	24 hrs	24 hrs	Failed	40 hrs, max.	
Std. Curing Rate	Original	36 pts @ 132 hrs. ¹	35 pts	43 pts @ 168 hrs. ¹	36 pts	36 pts	35 pts @ 216 hrs. ¹	35 pts, min. @ 72 hours	
14-Day Hardness	Original	42 pts	44 pts	44 pts	44 pts	44 pts	35 pts	14 pts, min.	
Low Temp. Flex.	Original	Passed	Passed	Passed	Passed	Passed	---	No cracking, checking, or loss of adhesion	
	7 days @ 250°F (121°C)	Passed	Passed	Passed	Passed	Passed	---		
Feel Strength	Original	30.6 PIW(53.58 N/cm) 100% Coh.	20.3 PIW (35.5 N/cm) 100% Coh.	18.4 PIW (32.22 N/cm) 100% Coh.	19.7 ³ PIW (34.5 N/cm) 100% Coh.	19.7 ³ PIW (34.5 N/cm) 100% Coh.	---	20 PIW, min. & 100% Coh.	
	7 days @ 140°F (60°C) / JRF	28.3 PIW(49.55 N/cm) 100% Coh.	15.1 PIW (26.44 N/cm) 100% Coh.	21.1 PIW (36.9 N/cm) 100% Coh.	17.8 ³ PIW (31.2 N/cm) 100% Coh.	17.8 ³ PIW (31.2 N/cm) 100% Coh.	---		
Weight Loss	7 days @ 140°F (60°C) / JRF+3 days @ 120°F (49°C)/Air	9.72%	---	---	---	---	---	8%, max.	

¹Did not reach 35 pts @ 72 hours.

²Could not take viscosity, sealant had skinned over.

³Voidy.

*The material frozen for 90 days was too viscous to work with.

TABLE 66
EFFECT OF FREEZING TIME ON SEALANT PROPERTIES; PR-1440 A-2

Test/Property	Condition	Freezing Time					MIL-S-8802D Requirement
		Fresh	10 days	30 days	60 days	90 days	
Application	Original		660 poise	620 poise	820 poise	1100 poise	2500 poise, max.
Tack-Free Time	Original	19 hrs	22 hrs	40 hrs ¹	24 hrs	18 hrs	40 hrs, max.
Std. Curing Rate	Original	38 pts	38 pts	38 pts	36 pts	42 pts	35 pts, min. @ 72 hours
14-Day Hardness	Original	41 pts	42 pts	42 pts	44 pts	47 pts	14 pts, min.
Low Temp. Flex.	Original	Passed	Passed	Passed	Passed	Passed	No cracking, checking, or loss of adhesion
	7 days @ 250°F (121°C)	Passed	Passed	Passed	Passed	Passed	
Peel Strength	Original	45.3 PIW (79.3 N/cm) 100% Coh.	18.3 PIW (32.0 N/cm) 100% Coh.	59.6 PIW (104.4 N/cm) 100% Coh.	18.3 ² PIW (32.0 N/cm) 100% Coh.	57.2 PIW (100 N/cm) 100% Coh.	20 PIW, min. % 100% Coh.
	7 days @ 140°F (60°C) / JRF	42.6 PIW (74.6 N/cm) 100% Coh.	15.4 PIW (27.0 N/cm) 100% Coh.	48.2 PIW (84.4 N/cm) 100% Coh.	17.7 ² PIW (31.0 N/cm) 100% Coh.	52.4 PIW (91.8 N/cm) 100% Coh.	
Weight Loss	7 days @ 140°F (60°C) / JRF + 3 days @ 120°F (49°C) / Air	5.7%	---	---	---	---	8%, max.

¹May have reached Tack-Free Time before 40 hours, but not checked.

²Extremely voidy.

TABLE 67
EFFECT OF FREEZING TIME ON SEALANT PROPERTIES; PR-1750 A-2

Test/Property	Condition	Freezing Time*				MIL-S-8802D Requirement
		Fresh	10 days	30 days	60 days	
Application	Original	1200 poise	1200 poise			2500 poise, max.
Tack-Free Time	Original	24 hrs	24 hrs	26 hrs	24 hrs	40 hrs, max.
Std. Curing Rate	Original	35 pts	36 pts	35 pts	42 pts @ 65 hrs	35 pts, min. @ 72 hours
14-Day Hardness	Original	35 pts	37 pts	41 pts	51 pts	14 pts, min.
Low Temp. Flex.	Original	Passed	Passed	Passed	Passed	No cracking, checking, or loss of adhesion
	7 days @ 250°F (121°C)	Passed	Passed	Passed	Passed	
Peel Strength	Original	19.3 PIW(33.8 N/cm) 100% Coh.	48.0 PIW(89.0 N/cm) 100% Coh.	44.4 PIW(77.7 N/cm) 100% Coh.	21.0 PIW(36.8 N/cm) 100% Coh.	20 PIW, min. & 100% Coh.
	7 days @ 140°F (60°C) / JRF	19.0 PIW(33.3 N/cm) 100% Coh.	53.9 PIW(94.4 N/cm) 100% Coh.	38.1 PIW(67.7 N/cm) 100% Coh.	18.5 PIW(32.4 N/cm) 100% Coh.	
Weight Loss	7 days @ 140°F (60°C) / JRF + 3 days @ 120°F (49°C) / Air	6.5%	---	---	---	8%, max.

*Did not have enough 90-day material to run.

peel strength values for this material were also low but failure of the sealant along the screen was considered to be the cause of these low values. In addition, after a 10-day frozen storage, the sealant did not meet the standard cure or the flow after 90 minutes requirements. These were only isolated shortcomings, however, and were not repeated in the 20-, 30-, 60-, or 90-day test results.

The PR-1422 A-2 sealant did not meet the MIL-S-8802D specifications for application time or peel strength after frozen storage for 10- and 30-day periods, although the peel panels did have a high void content. These voids may have been introduced during mixing or entrapped during fabrication as a result of the high viscosity of this sealant. The PR-1422 A-2 sealant was also tested for application after being frozen for only four hours. A viscosity of 620 poise was obtained for this case after thawing by both an 80 psig compressed air stream and by warming at ambient conditions. These values contrast with the 1180 poise value obtained for fresh, unfrozen sealant.

The PR-1440 A-2 sealant met all the MIL-S-8802D requirements after being frozen for up to 30 days except for peel strength after a 10-day freeze. This also may be attributable to the high void contents of these specimens rather than to the material itself.

The PR-1750 A-2 material met all of the MIL-S-8802D requirements after being frozen for up to 30 days. The PR-1750 A-2 sealant was also tested for its application after being frozen for four hours. The sealant was then thawed by setting at ambient temperature or blowing 80 psig air over it. The viscosities obtained were 1080 poise and 1140 poise, respectively, which were very close to the value of 1200 obtained for fresh, unfrozen material.

3.4.2 Effect of Microwave Thawing on Sealant Properties

In this phase of the work, a thawing schedule developed and used at the Rockwell International B-1 division for

thawing sealants was utilized to thaw frozen sealant material. After thawing, these sealants were tested for: (1) application life, (2) tack-free time, (3) curing rate, (4) flow, (5) peel strength on MIL-C-27725 panels, (6) weight loss, and (7) hardness. The materials used in this portion of the program were PR-1422 B-2, PR-1440 B-2, PS-899 B-2, PR-1422 A-2, PR-1440 A-2, and PR-1750 A-2. Each of these materials was mixed on a Semco sealant mixer and the cartridges were quick-frozen and stored at $-40^{\circ}\text{F}(-40^{\circ}\text{C})$ for short periods of time, not exceeding five days. The sealants were thawed in a microwave oven with the thawing schedule used at the Rockwell International B-1 division.

The thawing schedule involved placing the cartridges in a microwave oven and the oven then being turned on for 50 seconds, followed by one minute off, followed by 25 seconds on, followed by 30 seconds off, and finally followed by 15 seconds on. This thaw schedule is supposed to warm the sealant material to at least $60^{\circ}\text{F}(15.6^{\circ}\text{C})$. After this thaw-out period in the microwave oven, the cartridges were removed and used for making specimens for determination of the properties listed above. Testing on the three class B-2 sealants after microwave thawing has been completed. These results are presented in Table 68.

It will be noted in Table 68 that the requirements of MIL-S-8802D are presented, even though one of three materials, PS-899 B-2, is designed to meet the stricter requirements of MIL-S-83430. This material, however, was tested according to the low-temperature flexibility tests specified in MIL-S-8802D rather than the MIL-S-83430 requirements. The standard curing rate, on the other hand, was determined after 48 hours as required by the MIL-S-83430 specification.

The PS-899 B-2 sealant material met all of the specification requirements after microwave thawing with the exception of standard curing rate. It exhibited a hardness of only 32 rather than the required 35 points. This test was performed after 48 hours as required by the MIL-S-83430 specification, rather than after the 72 hours required in the MIL-S-8802D specification.

TABLE 68
 PROPERTIES OF CLASS B-2 TYPE SEALANTS AFTER MICROWAVE THAWING

Test/Property	Condition	Sealant			MIL-S-8802D Requirement
		PR-1472 B-2	PR-1470 B-2	PS-899 B-2	
Application	Original	1.82 gms/min	13.89 gms/min	35.31 gms/min	>15 gms/min
Tack-Free Time	Original	18 hrs	40 hrs	24 hrs	40 hrs, max.
Std. Curing Rate	Original	42 pts	36 pts	32 pts @ 48 hours	35 pts, min. @ 72 hours
Flow	Original -Initial	0.45 in. (1.14 cm)	0.15 in. (0.38 cm)	0.11 in. (0.28 cm)	0.10"-0.75" ↓
	-50 min.	0.19 in. (0.48 cm)	0.19 in. (0.48 cm)	0.11 in. (0.28 cm)	
	-90 min.	0.05 in. (0.45 cm)	0.21 in. (0.53 cm)	0.12 in. (0.30 cm)	
Low Temp. Flex.	Original	Passed	Passed	Passed	No cracking, checking, or loss of adhesion
	7 days @ 250°F (121°C) / Air	Passed	Passed	Passed	
Peel Strength	Original	32.3 PIW (56.6 N/cm) 100% Coh.	22.4 PIW (39.2 N/cm) 100% Coh.	32.1 PIW (56.6 N/cm) 100% Coh.	20 PIW, min. & 100% Coh. ↓
	7 days @ 140°F (60°C) / JRF	29.2 PIW (51.1 N/cm) 95% Coh.	14.0 PIW (24.5 N/cm) 100% Coh.	20.4 PIW (36.0 N/cm) 100% Coh.	
Weight Loss	7 days @ 140°F (60°C) / JRF + 3 days @ 120°F (49°C) / Air	6.94%	---	4.72%	8%, max.
14-Day Hardness	Original	51 pts	43 pts	---	14 pts, min.

↑Voidy and 80% failure occurred at screen.

Microwave thawing caused the PR-1422 B-2 material to fall short of the MIL-S-8802D requirements in three different areas; application rate, tack-free time, and flow properties after 90 minutes.

The PR-1440 B-2 material, after microwave thawing, failed to meet the MIL-S-8802D requirements for application rate and peel strength after seven days at 140°F(60°C) in JRF.

3.5 EFFECT OF JP-4 AND JP-8 ON NON-METALLIC MATERIALS

A materials evaluation program was undertaken during the past contractual period to investigate compatibilities of non-metallic materials with JP-8 fuel. The Air Force is considering switching from JP-4 to JP-8 fuel, and fuel test reports have indicated that in the F-15 aircraft, an increase in fuel tank leakage problems occurred after JP-8 was introduced into the fuel system. A two-phase materials investigation program was adopted. Phase 1 was aimed at investigating the F-15 leakage problem, while Phase 2 was aimed at investigating the effects of JP-8 on additional non-metallic aircraft materials that could possibly come into contact with the JP-8 fuel.

3.5.1 Phase 1 Investigation

Three materials were investigated in the Phase 1 portion of this program: (1) Dow Corning 94-031 groove fuel tank sealant, (2) PARCO 1393 O-rings, and (3) Stillman TM-1057 O-rings. The volume swell on these three materials was measured after exposure for seven days at room temperature to JP-4 and also after exposure to JP-8 for an additional seven days at room temperature. The results obtained from these volume swell tests are presented in Table 69. For both the two O-ring materials as well as the groove sealant, the data in Table 69 indicate that the effects of JP-8 tends to cause a shrinkage of the materials. These materials are used in applications which depend on some degree of volume swell to affect a good seal. The shrinkage caused by contact with JP-8 fuel could indeed lead to leakage problems.

TABLE 69
 VOLUME SWELL OF MATERIALS EXPOSED
 TO JP-4 AND JP-8 FUELS

Material	Swell After JP-4 Aging (%)	Swell After Combined JP-4 and JP-8 Aging (%)	Change in Swell Between End of JP-4 Aging and End of JP-8 Aging (%)
Dow Corning 94-031 groove sealant	2.12	-0.64	-2.71
PARCO 1393 O-rings	14.53	10.21	-3.76
Stillman TM 1057 O-rings	12.50	10.39	-1.87

3.5.2 Phase 2 Testing

In Phase 2 of this testing program, adhesives, O-rings, sealants, sheet goods, fuel bladder materials, fuel bladder adhesives, and internal fuel cell foam materials were evaluated after exposure to JP-4 and JP-8 environments. Two exposure conditions were utilized: (1) seven days at 140°F(60°C) in JP-8, and (2) 14 days at 140°F(60°C) in JP-4, followed by seven days at 140°F(60°C) in JP-8. A brief synopsis of the types of tests and the materials evaluated follows:

(1) Five adhesive systems (FM-47, AF-126, AF-143, 828-DTA, and EC-2216) were tested for lap shear strength in a double lap-shear configuration at room temperature.

(2) Four fuel tank sealants (Product Research's PR-1440 B-2, PR-1221 B-2, PR-1422 B-2, and Pro Seal's PS-899 B-2) were tested for peel strength on MIL-C-27725 coated panels, and for volume swell. Two of the sealants, PR-1221 B-2 and PR-1440 B-2, exhibited a negative volume swell in the JP-4 and JP-8 fuel systems. These tests will be repeated to verify the results.

(3) Two groove sealants (Product Research's PR-703 and Dow Corning's 94-031) were tested for their volume swell and pressure rupture characteristics.

(4) Four fuel tank coatings (MIL-S-4383, MIL-C-27725, BMS 10-20 anodized, and BMS 10-20 alodined) were evaluated for their pencil hardness.

(5) Four O-ring compounds (Precision's 7866 [Buna-N], 11647 [fluorosilicone], 19357 [fluoroelastomer], and Parker's V747-75 [fluoroelastomer]) were tested for their tensile strength, percent elongation, hardness, and volume swell.

(6) Four marmon clamp materials (CL-IGR-60, 17466 Kirkill, AMS-3227 PMP, and 82021-1-60) were tested for the same properties as the O-rings.

(7) Six bladder materials (Buna-N 51956, Goodyear's 80C29, Buna-N innerliner, Pliocel BTC-69, and BTC-17-4) were tested for their tensile strength, percent elongation, hardness, volume swell, and permeability characteristics.

(8) Two foams (Red-a polyurethane, and blue-a hybrid polyether) were evaluated for their tensile strength, percent elongation, and volume swell.

(9) Two sheet materials (polyethylene and nylon) were evaluated for tensile strength and percent elongation.

The test matrix shown in Figure 50 indicates the tests performed on each material in this program.

In general, the strength of all the materials investigated in this program were not significantly affected by either the JP-4 or JP-8 fuels. The volume swells, however, were generally lower after exposure to JP-8 than after exposure to JP-4. Since a considerable amount of data was generated on this program and since these data are being reported in a separate Technical Report, they are omitted here for brevity.

3.6 MATERIALS COMPATIBILITY IN HIGH SULFUR FUELS AND FUELS DERIVED FROM SHALE OIL

A materials compatibility program was conducted in which all classes of non-metallic aircraft materials were evaluated for their relative compatibility to fuels. Ten different fuels were used in the program including two that were derived from shale oil deposits. The remaining eight fuels were JP-4 based, with two different aromatic additives to obtain fuel compositions of 25 percent, 35 percent, and 45 percent aromatics, total sulfur of 0.1 and 1.0 percent, and mercaptan sulfur contents of 0.001 and 0.003 percent. Table 70 contains a listing of the materials used and the type of tests that were conducted on them.

Since a very large body of data was generated in this program and since an AFML Technical Report is being published describing the work and results obtained, these data are likewise not repeated here.

3.7 EVALUATION OF FAIRCHILD-REPUBLIC RIGID FOAM

An evaluation of Fairchild-Republic rigid foam for compressive strength, volume change, weight change, and density has been conducted. The effort consisted of determining these properties after exposure to the following different environments:

Test Methods

	Lap Shear	Peel Strength	Seam Adhesion	Pressure Rupture	Permeability	Tensile Strength	Elongation	Hardness	Swell	Volume Change	Pencil Hardness
Adhesives	X										
Fuel Tank Sealants		X								X	
Fuel Bladder Materials			X		X	X	X	X		X	
Fuel Bladder Repair Adhesive		X									
Non-Curing Fuel Tank Sealants				X						X	
O-Rings						X	X	X	X		
Marmon Clamp Materials						X	X	X	X		
Sheet Materials						X	X				
Fuel Cell Coatings											X
Fuel Cell Foams						X	X			X	

Figure 50. Testing Matrix For JP-4/JP-8 Materials Evaluation Program.

TABLE 70
MATERIALS AND TEST METHODS

	Material	Test Method
1.	Structural Adhesives -EC-2216 FM-47 PL-729-3 AF-126 828/DTA	Blister specimens tested in shear
2.	Fuel Tank Sealants PS 890 B-2 PS 899 B-2 PR-1422 B-2 PR-1221 B-2	Adhesion test - 180° peel test
3.	Fuel Bladder Materials -Buna-N Innerliner -Buna-N Bladder -Urethane Bladder -Pliocel	Ultimate tensile strength, elongation, hardness, swell, permeability
4.	Bladder Adhesive EC-678	Overlap shear
5.	Groove Injection Sealants PR-703 94-031	Pressure rupture
6.	Marmon Clamp Seals CL-1GR-60 503-162 KK-125 17466	Ultimate tensile strength, elongation
7.	Sheet Materials Polyethylene Nylon 101	Ultimate tensile strength, elongation
8.	Fuel Tank Coatings MIL-C-27725 MIL-S-4383	Pencil hardness
9.	Fuel Cell Foams Blue Foam Red Foam	Ultimate tensile strength, elongation, swell
10.	O-Ring Packings Precision 7866 Precision 19357 Parker V747 Precision 11647	Ultimate tensile strength, elongation, hardness

1. 48 hours at 72°F(25°C) in water,
2. 48 hours at 72°F(25°C) in JP-4,
3. 48 hours at 72°F(25°C) in Stauffer's 7700,
4. 48 hours at 72°F(25°C) in MIL-H-5606,
5. 30 days at 160°F(71°C) and 95 percent R.H.,
6. 60 days at 160°F(71°C) and 95 percent R.H.,
7. 120 days at 160°F(71°C) and 95 percent R.H., and
8. 180 days at 160°F(71°C) and 95 percent R.H.

The four properties mentioned above were determined immediately after removal from the aging environment and the density, weight change, and volume change were also measured one hour, 24 hours, and 30 days after removal. These data are presented in Tables 71 through 78.

3.8 EVALUATION OF MIL-P-83461 O-RINGS

Dynamic cycling and 60-day compression set tests were conducted on MIL-P-83461 O-rings. The following compounds were involved in this evaluation:

1. Precision Rubber Products - Compound 7757,
2. Parker Seal Company - Compound N756-75,
3. E.F. Houghton - Compound 10V75,
4. Plastic and Rubber Products - Compound 4367-70,
5. Stillman Rubber Division of Sargent Industries -
Compound SR8014-75,
6. Federal Mogul-National Seal Division -
Compound A5568,
7. Goshen Rubber - Compound 2249, and
8. Acushnet - Compound H-14379.

Dynamic cycling test conditions were 275°F(133°C), 1500 psi (10.3 MPa) pressure, and 4-inch (102 mm) stroke at 30 cycles per minute with MIL-H-5606C hydraulic fluid. Three compounds (Precision 7757, Goshen 2249, and Federal Mogul-National Seal A5568) appeared to produce consistently longer lifetimes than the other five. All of the dynamic cycling results are presented in Tables 79 through 86.

TABLE 71
PROPERTIES OF FAIRCHILD-REPUBLIC RIGID FOAM
AFTER AGING IN WATER

Property	Test Results
Original Compressive Strength	28.9 psi (0.20 MPa)
Original Density	0.039 gms/cc (2.43 pcf)
After 48 hrs. @ 77°F(25°C) in H₂O	
UPON REMOVAL	
Compressive Strength	25.6 psi (0.18 MPa)
Weight Change	39.3%
Volume Change	2.7%
Density	0.053 gms/cc (3.31 pcf)
1 HOUR AFTER REMOVAL	
Weight Change	4.4%
Volume Change	3.2%
Density	0.039 gms/cc (2.43 pcf)
24 HOURS AFTER REMOVAL	
Weight Change	0.06%
Volume Change	3.9%
Density	0.037 gms/cc (2.31 pcf)
30 DAYS AFTER REMOVAL	
Weight Change	0.007%
Volume Change	4.3%
Density	0.037 gms/cc (2.31 pcf)

TABLE 72
PROPERTIES OF FAIRCHILD-REPUBLIC RIGID FOAM
AFTER AGING IN MIL-H-5606 FLUID

Property	Test Results
Original Compressive Strength	28.9 psi (0.20 MPa)
Original Density	0.041 gms/cc (2.56 pcf)
After 48 hrs. @ 77°F(25°C) in MIL-H-5606	
UPON REMOVAL	
Compressive Strength	31.2 psi (0.22 MPa)
Weight Change	112.3%
Volume Change	1.1%
Density	0.082 gms/cc (5.12 pcf)
1 HOUR AFTER REMOVAL	
Weight Change	93.8%
Volume Change	1.3%
Density	0.078 gms/cc (4.87 pcf)
24 HOURS AFTER REMOVAL	
Weight Change	66.8%
Volume Change	2.4%
Density	0.066 gms/cc (4.12 pcf)
30 DAYS AFTER REMOVAL	
Weight Change	24.4%
Volume Change	3.60%
Density	0.049 gms/cc (3.06 pcf)

TABLE 73

PROPERTIES OF FAIRCHILD-REPUBLIC RIGID FOAM
AFTER AGING IN STAUFFER'S 7700 FLUID

Property	Test Results
Original Compressive Strength	28.9 psi (0.20 MPa)
Original Density	0.041 gms/cc (2.56 pcf)
<u>After 48 hrs. @ 77°F(25°C) in Stauffer's 7700</u>	
UPON REMOVAL	
Compressive Strength	28.6 psi (0.20 MPa)
Weight Change	123.4%
Volume Change	2.0%
Density	0.090 gms/cc (5.62 pcf)
1 HOUR AFTER REMOVAL	
Weight Change	106.0%
Volume Change	2.3%
Density	0.083 gms/cc (5.18 pcf)
24 HOURS AFTER REMOVAL	
Weight Change	82.4%
Volume Change	2.8%
Density	0.073 gms/cc (4.56 pcf)
30 DAYS AFTER REMOVAL	
Weight Change	59.0%
Volume Change	4.1%
Density	0.063 gms/cc (3.93 pcf)

AD-A057 376

DAYTON UNIV OHIO RESEARCH INST
QUICK REACTION EVALUATION OF MATERIALS AND PROCESSES. (U)
FEB 78 D R ASKINS, G J PETRAK

F/G 11/6

F33615-76-C-5034

UNCLASSIFIED

UDR-TR-77-66

AFML-TR-78-6

NL

3 OF 3
AD
A057 376



END
DATE
FILMED
9-78
DDC

TABLE 74

PROPERTIES OF FAIRCHILD-REPUBLIC RIGID FOAM
AFTER AGING IN JP-4

Property	Test Results
Original Compressive Strength	28.9 psi (0.20 MPa)
Original Density	0.040 gms/cc (2.50 pcf)
After 48 hrs. @ 77°F(25°C) in JP-4	
UPON REMOVAL	
Compressive Strength	26.0 psi (0.18 MPa)
Weight Change	80.1%
Volume Change	1.8%
Density	0.077 gms/cc (4.81 pcf)
1 HOUR AFTER REMOVAL	
Weight Change	35.0%
Volume Change	5.4%
Density	0.055 gms/cc (3.43 pcf)
24 HOURS AFTER REMOVAL	
Weight Change	7.9%
Volume Change	3.1%
Density	0.043 gms/cc (2.68 pcf)
30 DAYS AFTER REMOVAL	
Weight Change	0.42%
Volume Change	4.4%
Density	0.040 gms/cc (2.50 pcf)

TABLE 75

PROPERTIES OF FAIRCHILD-REPUBLIC RIGID FOAM AFTER AGING
FOR 30 DAYS AT 160°F (71°C) AND 95 PERCENT R.H.

Property	Test Results
Original Compressive Strength	28.9 psi (0.20 MPa)
Original Density	0.040 gms/cc (2.50 pcf)
UPON REMOVAL	
Compressive Strength	22.6 psi (0.16 MPa)
Weight Change	-7.25%
Volume Change	8.16%
Density	0.035 gms/cc (2.19 pcf)
1 HOUR AFTER REMOVAL	
Weight Change	-9.06%
Volume Change	6.80%
Density	0.035 gms/cc (2.19 pcf)
24 HOURS AFTER REMOVAL	
Weight Change	-9.16%
Volume Change	6.13%
Density	0.035 gms/cc (2.19 pcf)
30 DAYS AFTER REMOVAL	
Weight Change	-8.28%
Volume Change	6.48%
Density	0.035 gms/cc (2.19 pcf)

TABLE 76

PROPERTIES OF FAIRCHILD-REPUBLIC RIGID FOAM AFTER AGING
FOR 60 DAYS AT 160°F(71°C) AND 95 PERCENT R.H.

Property	Test Results
Original Compressive Strength	28.9 psi (0.20 MPa)
Original Density	0.041 gms/cc (2.56 pcf)
UPON REMOVAL	
Compressive Strength	21.9 psi (0.15 MPa)
Weight Change	-6.92%
Volume Change	2.95%
Density	0.037 gms/cc (2.31 pcf)
1 HOUR AFTER REMOVAL	
Weight Change	-9.19%
Volume Change	1.57%
Density	0.037 gms/cc (2.31 pcf)
24 HOURS AFTER REMOVAL	
Weight Change	-8.78%
Volume Change	0.67%
Density	0.037 gms/cc (2.31 pcf)
30 DAYS AFTER REMOVAL	
Weight Change	-7.65%
Volume Change	2.41%
Density	0.037 gms/cc (2.31 pcf)

TABLE 77

PROPERTIES OF FAIRCHILD-REPUBLIC RIGID FOAM AFTER AGING
FOR 120 DAYS AT 160°F(71°C) AND 95 PERCENT R.H.

Property	Test Results
Original Compressive Strength	28.9 psi (0.20 MPa)
Original Density	0.043 gms/cc (2.68 pcf)
UPON REMOVAL	
Compressive Strength	17.3 psi (0.12 MPa)
Weight Change	-5.33%
Volume Change	1.41%
Density	0.040 gms/cc (2.50 pcf)
1 HOUR AFTER REMOVAL	
Weight Change	-7.57%
Volume Change	0.43%
Density	0.039 gms/cc (2.43 pcf)
24 HOURS AFTER REMOVAL	
Weight Change	-8.48%
Volume Change	1.76%
Density	0.038 gms/cc (2.37 pcf)
30 DAYS AFTER REMOVAL	
Weight Change	-8.19%
Volume Change	1.52%
Density	0.038 gms/cc (2.37 pcf)

TABLE 78

PROPERTIES OF FAIRCHILD-REPUBLIC RIGID FOAM AFTER AGING
FOR 180 DAYS AT 160°F(71°C) AND 95 PERCENT R.H.

Property	Test Results
Original Compressive Strength	28.9 psi (0.20 MPa)
Original Density	0.042 gms/cc (2.62 pcf)
UPON REMOVAL	
Compressive Strength	19.0 psi (0.13 MPa)
Weight Change	-3.19%
Volume Change	4.06%
Density	0.039 gms/cc (2.43 pcf)
1 HOUR AFTER REMOVAL	
Weight Change	-6.80%
Volume Change	3.26%
Density	0.038 gms/cc (2.37 pcf)
24 HOURS AFTER REMOVAL	
Weight Change	-8.27%
Volume Change	1.35%
Density	0.038 gms/cc (2.37 pcf)
30 DAYS AFTER REMOVAL	
Weight Change	-8.75%
Volume Change	0.00%
Density	0.038 gms/cc (2.37 pcf)

TABLE 79
DYNAMIC TEST RESULTS FOR PRECISION 7757 O-RINGS

Run	Sta.	Block	Position	Cycles to Failure	Leakage Rate	Total Leakage
17	1	4	Left	111,903	4.84 cc/min	70 cc
			Right	---	.006 cc/min	20 cc
	2	1	Left	---		
			Right	101,643	.016 cc/min	70 cc
18*	1	4	Left			
			Right			
	2	1	Left			
			Right			
19	1	4	Left	136,377	.015 cc/min	70 cc
			Right	---		
	2	1	Left	---		
			Right	4,500	2.33 cc/min	70 cc
20	1	4	Left	139,190	Blowout	70 cc
			Right	---		
	2	1	Left	---	.005 cc/min	25 cc
			Right	161,690	Blowout	70 cc
21	2	1	Left	---		
			Right	122,390	.018 cc/min	70 cc

* Machine shut down @ 72,600 cycles due to lack of hydraulic fluid - no ring had more than 25 cc leakage.

TABLE 80
DYNAMIC TEST RESULTS FOR GOSHEN 2249 O-RINGS

Run	Sta.	Block	Position	Cycles to Failure	Leakage Rate	Total Leakage
40	1	4	Left*	120,083	0.023 cc/min	70 cc
			Right			
	2	1	Left	126,383	0.023 cc/min	70 cc
			Right			
41	1	4	Left	88,650	0.035 cc/min	70 cc
			Right		0.014 cc/min	10 cc
	2	1	Left	112,500	>4 cc/min	70 cc
			Right		0.026 cc/min	65 cc
42	1	4	Left	113,400	0.024 cc/min	70 cc
			Right			
	2	1	Left	3,150	>4 cc/min	70 cc
			Right			
43	1	4	Left	124,600	0.022 cc/min	70 cc
			Right			
	2	1	Left	120,600	>4 cc/min	70 cc
			Right			

* >4 cc/min after 50 cc leakage

Test Conditions: Rate - 30 cycles/min
 Pressure - 1,500 psi
 Temperature - 275°F (135°C)
 Stroke - 4 inches
 Test Fluid - MIL-H-5606C

TABLE 81
 DYNAMIC TEST RESULTS FOR NATIONAL A5568 O-RINGS

Run	Sta.	Block	Position	Cycles to Failure	Leakage Rate	Total Leakage
37	1	4	Left	106,912	0.019 cc/min	70 cc
			Right			
	2	1	Left*	79,960	0.013 cc/min	70 cc
			Right			
38	1	4	Left	110,881	0.012 cc/min	50 cc
			Right		> 4 cc/min	70 cc
	2	1	Left	142,561	0.018 cc/min	50 cc
			Right		> 4 cc/min	70 cc
39	1	4	Left**	93,940	0.014 cc/min	70 cc
			Right			
	2	1	Left	141,100	0.014 cc/min	28 cc
			Right		0.018 cc/min	70 cc

*Had 0.013 cc/min leakage rate until 37 cc leakage, then had > 4 cc/min

**Had 0.014 cc/min leakage rate until 40 cc leakage, then had > 4 cc/min

Test Conditions: Rate - 30 cycles/min
 Pressure - 1,500 psi
 Temperature - 275°F (135°C)
 Stroke - 4 inches
 Test Fluid - MIL-H-5606C

TABLE 82
 DYNAMIC TEST RESULTS FOR PARKER N756-75 O-RINGS

Run	Sta.	Block	Position	Cycles to Failure	Leakage Rate	Total Leakage
23	1	4	Left	123,456	.018 cc/min	70 cc
			Right	---		
	2	1	Left	---	.027 cc/min	70 cc
			Right	88,200		
24	1	4	Left	111,060	.035 cc/min	70 cc
			Right	---		
	2	1	Left	---		
			Right	42,700	.060 cc/min	70 cc
25	1	4	Left	85,980	.037 cc/min	70 cc
			Right	---		
	2	1	Left	48,150	.058 cc/min	70 cc
			Right	---		
26	1	4	Left	78,597	.035 cc/min	70 cc
			Right	---		
	2	1	Left	---	.006 cc/min	10 cc
			Right	80,397	.027 cc/min	70 cc

Test Conditions: Rate - 30 cycles/min
 Pressure - 1,500 psi
 Temperature - 275°F (135°C)
 Stroke - 4 inches
 Test Fluid - MIL-H-5606C

TABLE 83

DYNAMIC TEST RESULTS FOR STILLMAN SR-8014-75 O-RINGS

Run	Sta.	Block	Position	Cycles to Failure	Leakage Rate	Total Leakage
46	1	4	Left	86,593	0.079 cc/min	70 cc
			Right			
	2	1	Left	81,325	0.033 cc/min	70 cc
			Right			
47	1	4	Left	53,550	> 4 cc/min	70 cc
			Right	54,900	> 4 cc/min	70 cc
	2	1	Left	61,650	> 4 cc/min	70 cc
			Right	62,100	> 4 cc/min	70 cc
48	1	4	Left		0.066 cc/min	50 cc
			Right	68,850	> 4 cc/min	70 cc
	2	1	Left*	78,750	0.019 cc/min	70 cc
			Right	78,750	> 4 cc/min	70 cc

* > 4 cc/min after 30 cc leakage

Test Conditions: Rate - 30 cycles/min
 Pressure - 1,500 psi
 Temperature - 275° F (135° C)
 Stroke - 4 inches
 Test Fluid - MIL-H-5606C

TABLE 84

DYNAMIC TEST RESULTS FOR E.F. HOUGHTON 10V 75-440 O-RINGS

Run	Sta.	Block	Position	Cycles to Failure	Leakage Rate	Total Leakage
27	1	4	Left	9,000	2.33 cc/min	70 cc
			Right			
	2	1	Left	99,450	0.08 cc/min	70 cc
			Right			
28	1	4	Left	5,344	1.17 cc/min	70 cc
			Right			
	2	1	Left	5,344	2.33 cc/min	70 cc
			Right			
29	1	4	Left	82,550	1.0 cc/min	70 cc
			Right			
	2	1	Left	102,973	0.023 cc/min	70 cc
			Right			
30	1	4	Left	6,370	0.67 cc/min	70 cc
			Right			
	2	1	Left	6,370	1.17 cc/min	70 cc
			Right			
44	1	4	Left	3,300	>4 cc/min	70 cc
			Right			
	2	1	Left	1,700	>4 cc/min	70 cc
			Right			

Test Conditions: Rate - 30 cycles/min
 Pressure - 1,500 psi
 Temperature - 275°F (135°C)
 Stroke - 4 inches
 Test Fluid - MIL-H-5606C

TABLE 85

DYNAMIC TEST RESULTS FOR PARCO 4367-70 O-RINGS

Run	Sta.	Block	Position	Cycles to Failure	Leakage Rate	Total Leakage
31	1	4	Left*		0.02 cc/min	20 cc
			Right*	96,594	> 4 cc/min	70 cc
	2	1	Left*	14,400	2.33 cc/min	70 cc
			Right*			
32	1	4	Left	3,376	> 4 cc/min	70 cc
			Right*			
	2	1	Left*			
			Right	1,230	> 4 cc/min	70 cc
33	1	4	Left*	2,880	2.33 cc/min	70 cc
			Right*	2,880	> 4 cc/min	70 cc
	2	1	Left*	84,848	0.036 cc/min	70 cc
			Right*			
34	1	4	Left			
			Right	3,600	> 4 cc/min	70 cc
	2	1	Left*	71,600	1.17 cc/min	70 cc
			Right*		0.023 cc/min	40 cc
35	1	4	Left*	94,400	0.020 cc/min	70 cc
			Right	96,178	> 4 cc/min	70 cc
	2	1	Left	31,500	> 4 cc/min	70 cc
			Right	2,700	2.33 cc/min	70 cc
36	1	4	Left*			
			Right*	9,900	1.56 cc/min	70 cc
	2	1	Left	3,000	1.16 cc/min	70 cc
			Right			
45	1	4	Left			
			Right	4,500	> 4 cc/min	70 cc
	2	1	Left			
			Right	3,600	> 4 cc/min	70 cc

*Rings were too thin

Test Conditions: Rate - 30 cycles/min
 Pressure - 1,500 psi
 Temperature - 275°F (135°C)
 Stroke - 4 inches
 Test Fluid - MIL-H-5606C

The 50-day compression test data, which are presented in Table 87, do not appear to provide a suitable indication as to which compounds exhibited the best dynamic properties (long lifetime).

TABLE 86

DYNAMIC TEST RESULTS FOR ACUSHNET H14379 O-RINGS

Run	Sta.	Block	Position	Cycles to Failure	Leakage Rate	Total Leakage
1	1	4	Left	928	>4 cc/min	70 cc
			Right	---	---	---
	2	1	Left	---	---	---
			Right	928	>4 cc/min	70 cc
2	1	4	Left	---	---	---
			Right	3547	>4 cc/min	70 cc
	2	1	Left	---	---	---
			Right	2100	>4 cc/min	70 cc
3	1	4	Left	1950	>4 cc/min	70 cc
			Right	1950	>4 cc/min	23 cc
	2	1	Left	---	---	---
			Right	2670	>4 cc/min	70 cc

Test Conditions: Rate - 30 cycles/min
 Pressure - 1,500 psi
 Temperature - 275°F (135°C)
 Stroke - 4 inches
 Test Fluid - MIL-H-5606C

These 13 O-ring materials were also tested for tensile strength, elongation, and hardness. These data are presented in Table 88. A second set of nine O-ring compounds was also tested for long-term compression set at ambient conditions in the same fashion as those discussed above. The results of these tests are presented in Table 89. Two rings of each material

The 60-day compression set data, which are presented in Table 87, do not appear to provide a suitable indication as to which compounds would exhibit the best dynamic properties (long lifetimes).

These compounds were also tested for tensile strength, 50 percent modulus, 100 percent modulus, and elongation, in an effort to establish a correlation between some static property and dynamic performance. It has not been possible thus far, however, to ascertain whether such a relationship between static and dynamic properties exists. The static property data are presented in Table 88.

3.9 LONG-TERM COMPRESSION SET OF O-RINGS

Long-term compression set tests were conducted over a 12-month period on 13 PARCO O-ring compounds. These O-rings were tested according to ASTM-D-395, Method B, for compression set and recovery. The rings were compressed 25 percent for periods of one week, three months, six months, and 12 months at ambient conditions. At the end of each of these periods, the O-rings were removed from the test fixture and measured for initial recovery as well as recovery after 30 minutes, 24 hours, 48 hours, and 168 hours.

As would be expected, the materials, in general, exhibited a tendency to undergo greater compression set the longer they were under compression. For all of the compression times, the materials in general seemed to reach their approximate equilibrium recovery point after 24 hours out of the fixture. These data are presented in Table 89.

These 13 O-ring materials were also tested for tensile strength, elongation, and hardness. These data are presented in Table 90. A second set of nine O-ring compounds was also tested for long-term compression set at ambient conditions in the same fashion as those discussed above. The results of these tests are presented in Table 91. Two rings of each material

TABLE 87
COMPRESSION SET PROPERTIES OF MIL-P-83461 O-RINGS

Material	Exposure Condition	Compression Set as per ASTM D395				
		Initial	30 Min.	24 Hrs.	48 Hrs.	168 Hrs.
Precision 7757	60 days @ R.T.	20.6	17.6	11.8	8.8	5.9
		20.6	17.6	11.8	8.8	5.9
	60 days @ R.T. in 5606C	14.7	11.8	8.8	8.8	8.8
		14.7	11.8	8.8	8.8	8.8
Parker N756-75	60 days @ R.T.	20.6	14.7	8.8	8.8	5.9
		20.6	14.7	8.8	8.8	5.9
	60 days @ R.T. in 5606C	14.7	14.7	8.8	8.8	8.8
		14.7	11.8	8.8	8.8	8.8
Houghton 10V 75-440	60 days @ R.T.	28.6	20.0	11.4	11.4	8.6
		25.7	20.0	14.3	14.3	8.6
	60 days @ R.T. in 5606C	20.6	17.6	8.8	8.8	8.8
		22.9	17.1	11.4	11.4	11.4
Parco 4367-70	60 days @ R.T.	23.5	17.6	11.8	11.8	8.8
		17.6	17.6	8.8	8.8	5.9
	60 days @ R.T. in 5606C	17.6	14.7	5.9	5.9	5.9
		17.6	14.7	11.8	11.8	11.8
Stillman SR-8014-75	60 days @ R.T.	17.6	14.3	8.6	8.6	5.7
		17.6	11.4	8.6	8.6	5.7
	60 days @ R.T. in 5606C	14.3	11.4	8.6	8.6	8.6
		11.4	11.4	5.7	5.7	5.7
National A5568	60 days @ R.T.	20.0	11.4	8.6	8.6	5.7
		20.0	14.3	11.4	8.6	5.7
	60 days @ R.T. in 5606C	14.3	11.4	8.6	8.6	8.6
		11.4	11.4	5.7	5.7	5.7
Goshen 2249	60 days @ R.T.	17.6	11.8	8.8	5.9	5.9
		14.7	11.8	8.8	5.9	2.9
	60 days @ R.T. in 5606C	8.8	2.9	2.9	2.9	5.9
		11.8	5.9	2.9	2.9	8.8
Acushnet	60 days @ R.T.	29.4	11.8	8.8	8.8	8.8
		23.5	11.8	5.9	5.9	5.9
	60 days @ R.T. in 5606C	14.7	8.8	2.9	5.9	8.8
		14.7	8.8	5.9	5.9	8.8

TABLE 88
 STATIC MECHANICAL PROPERTIES OF MIL-P-83461 O-RINGS

Material	Spec.	50% Mod (psi)	100% Mod (psi)	Ult. Str. (psi)	Elong. (%)
Precision 7757	1	458.1	1116.5	1703.6	138
	2	366.5	1102.9	1835.9	148
	3	393.7	1031.7	1900.4	149
	Avg.	406.1	1083.7	1813.3	145
Stillman SR- 8014-75	1	398.9	1348.3	1826.3	109
	2	386.7	1264.1	1829.6	128
	3	441.7	1467.0	1671.4	112
	Avg.	409.1	1359.8	1775.8	116
National A5568	1	317.7	943.2	1712.4	144
	2	301.0	936.5	1665.6	141
	3	254.2	1040.2	1488.3	130
	Avg.	291.0	973.3	1622.1	138
Acushnet H-14379	1	234.2	475.2	1904.4	254
	2	241.1	482.3	1401.4	202
	3	155.0	244.5	1263.8	364
	4	234.2	437.8	1357.4	211
	5	217.0	378.8	1880.2	317
	Avg.	216.3	403.7	1561.4	270
Houghton M83461/1	1	390.3	926.4	1401.6	139
	2	339.4	722.8	1618.7	181
	3	387.5	727.5	1630.4	177
	4	441.2	1085.9	1703.6	166
	5	356.3	655.0	1574.6	188
	6	397.0	845.0	1520.3	155
	7	363.1	709.3	1421.9	168
	8	451.3	923.1	1398.2	139
	9	380.1	851.8	1632.3	165
	Avg.	389.6	827.4	1544.6	164
Goshen 2249	1	520.7	1146.3	1146.3	100
	2	509.0	1510.1	1595.0	126
	3	520.0	1215.6	1215.6	100
	Avg.	516.6	1290.7	1319.0	109
Parco 4367-70	1	340.9	895.4	1739.1	159
	2	340.9	823.0	1787.3	174
	3	349.5	807.7	1723.9	159
	4	356.5	831.8	1831.5	167
	5	375.4	860.9	1876.8	168
	Avg.	352.6	843.8	1791.7	165
Parker N756- 75	1	451.5	1100.4	1668.9	135
	2	398.0	959.9	1411.4	126
	3	448.2	1013.4	1568.6	137
	4	468.1	959.3	1671.4	135
	5	435.2	989.0	1500.0	126
	Avg.	440.2	1004.4	1564.1	132

TABLE 89
 COMPRESSION SET DATA FOR
 PARCO O-RING MATERIALS

Material	Time in Compression	Time out of Fixture (% Compression Set)					
		Initial	30 min.	24 hrs.	48 hrs.	168 hrs.	
MIL-P-5516 479-70	1 week	15.15	9.09	6.06	6.06	6.06	
		15.15	12.12	9.09	9.09	9.09	
	3 months	23.5	20.6	14.7	11.8	11.8	
		20.0	17.1	14.3	11.4	11.4	
	6 months	32.4	20.6	14.7	14.7	11.8	
		31.4	22.9	14.3	14.3	14.3	
	12 months	37.1	25.7	25.7	25.7	17.1	
		34.3	25.7	25.7	25.7	22.9	
	AMS 3238 Butyl-Sulfur Cure 805-70	1 week	13.89	11.11	8.33	8.33	5.56
			13.89	11.11	8.33	8.33	8.33
3 months		29.4	23.5	20.6	17.6	17.6	
		28.6	22.9	20.0	20.0	17.1	
6 months		36.1	27.8	22.2	22.2	22.2	
		30.3	24.2	21.2	21.2	21.2	
12 months		37.1	31.4	28.6	28.6	25.7	
		37.1	31.4	28.6	28.6	25.7	
Chlorobutyl 823-70		1 week	26.47	14.71	8.82	8.82	5.88
			23.53	14.71	8.82	8.82	5.88
	3 months	29.4	23.5	20.6	14.7	14.7	
		32.3	26.4	20.6	17.6	14.7	
	6 months	32.6	23.5	17.6	17.6	14.7	
		32.6	23.5	17.6	17.6	17.6	
	12 months	44.1	32.4	29.4	26.5	20.6	
		41.1	29.4	23.5	23.5	20.6	
	MIL-R-25988 Type 1, Class 1 Gr. 70 1903-70	1 week	6.06	3.03	3.03	3.03	0
			14.29	11.43	11.43	11.43	11.43
3 months		11.8	11.8	11.8	11.8	11.8	
		12.1	12.1	12.1	12.1	12.1	
6 months		24.2	18.2	15.2	15.2	15.2	
		23.5	20.6	14.7	14.7	14.7	
12 months		32.4	26.5	23.5	20.6	17.6	
		30.3	24.2	18.2	18.2	15.2	

TABLE 89 (Continued)
 COMPRESSION SET DATA FOR
 PARCO O-RING MATERIALS

Material	Time in Compression	Time out of Fixture (% Compression Set)				
		Initial	30 min.	24 hrs.	48 hrs.	168 hrs.
AMS 3304 No Postcure 1235-70	1 week	6.25	6.25	6.25	6.25	6.25
		9.38	9.38	6.25	6.25	6.25
	3 months	11.4	11.4	11.4	11.4	11.4
		12.1	12.1	9.1	9.1	9.1
	6 months	15.2	12.1	12.1	12.1	9.1
		17.6	14.7	14.7	11.8	11.8
	12 months	20.6	17.6	14.7	14.7	11.8
		20.6	14.7	14.7	14.7	8.9
AMS 7267 Postcured 1373-70	1 week	9.09	9.09	6.06	6.06	6.06
		6.06	6.06	6.06	6.06	6.06
	3 months	12.1	12.1	9.1	9.1	9.1
		9.1	9.1	9.1	9.1	9.1
	6 months	14.7	14.7	11.8	8.8	8.8
		15.6	12.5	9.4	9.4	9.4
	12 months	15.2	12.1	12.1	9.1	6.1
		14.7	11.8	11.8	8.8	8.8
Polyacrylate 2930-70	1 week	15.63	9.38	6.25	6.25	6.25
		16.13	9.68	6.45	3.23	3.23
	3 months	15.2	9.1	3.0	3.0	3.0
		12.1	6.1	3.0	3.0	3.0
	6 months	21.2	12.1	9.1	9.1	9.1
		21.2	12.1	6.1	6.1	6.1
	12 months	21.2	12.1	12.1	12.1	6.1
		21.2	12.1	12.1	12.1	6.1

TABLE 89 (Continued)
 COMPRESSION SET DATA FOR
 PARCO O-RING MATERIALS

Material	Time in Compression	Time out of Fixture (% Compression Set)				
		Initial	30 min	24 hrs.	48 hrs.	168 hrs.
MIL-R-25732 4067-70	1 week	12.12	9.09	6.06	6.06	3.03
		12.50	9.38	6.25	3.13	3.13
	3 months	17.1	17.1	8.6	8.6	8.6
		20.6	14.7	11.8	11.8	8.8
	6 months	25.7	20.0	14.3	11.4	8.6
		23.5	17.6	11.8	11.8	11.8
	12 months	26.5	20.6	14.7	14.7	11.8
		26.5	20.6	14.7	11.8	8.8
MIL-P-83461 4367-70	1 week	14.71	8.82	8.82	8.82	5.88
		14.71	11.76	5.88	5.88	5.88
	3 months	18.2	15.2	12.1	9.1	9.1
		20.0	20.0	14.3	11.4	11.4
	6 months	26.5	20.6	14.7	14.7	8.8
		20.6	17.6	11.8	11.8	5.9
	12 months	26.5	20.6	17.6	14.7	11.8
		28.6	22.9	20.0	17.1	14.3
MIL-P-5315 457-60	1 week	12.50	9.38	6.25	3.13	3.13
		11.76	8.82	8.82	5.88	5.88
	3 months	11.4	11.4	8.6	5.7	5.7
		14.7	11.8	8.8	2.9	2.9
	6 months	20.6	14.7	14.7	11.8	8.8
		23.5	17.6	14.7	11.8	11.8
	12 months	22.9	20.0	14.3	14.3	11.4
		20.0	20.0	14.3	14.3	11.4

TABLE 89 (Concluded)
 COMPRESSION SET DATA FOR
 PARCO O-RING MATERIALS

Material	Compression	Time out of Fixture (% Compression Set)					
		Initial	30 min.	24 hrs.	48 hrs.	168 hrs.	
EPT Peroxide Cure 5657-60	1 week	20.59	14.71	14.71	11.76	11.76	
		18.92	13.51	10.81	10.81	5.41	
	3 months	35.3	29.4	20.6	17.6	17.6	
		34.3	22.9	17.1	14.3	14.3	
	6 months	39.4	30.3	21.2	21.2	18.2	
		33.3	25.0	19.4	16.7	13.9	
	12 months	36.4	27.3	21.2	18.2	18.2	
		37.1	31.4	17.1	17.1	11.4	
	SBR 161-70	1 week	25.00	12.50	9.38	9.38	6.25
			27.23	21.21	15.15	12.12	12.12
		3 months	34.3	25.7	20.0	17.1	17.1
			32.3	20.6	14.7	14.7	11.8
6 months		35.3	26.5	17.6	17.6	14.7	
		35.3	26.5	17.6	14.7	14.7	
12 months		41.2	29.4	20.6	17.6	14.7	
		35.3	23.5	17.6	14.7	11.8	
MIL-R-6855 Class 2 Gr. 70 376-70		1 week	11.76	11.76	3.32	8.82	5.88
			9.09	9.09	6.06	6.06	3.03
		3 months	14.7	11.8	8.8	8.8	8.8
			11.8	11.8	8.8	8.8	5.9
	6 months	17.6	14.7	11.8	11.8	8.8	
		17.1	14.3	11.4	11.4	8.6	
	12 months	25.0	19.4	16.7	16.7	11.1	
		21.2	18.2	18.2	15.2	12.1	

TABLE 90
 PHYSICAL PROPERTIES OF PARCO O-RING MATERIALS

Material	Tensile Strength		Elong. (%)	Hardness (Shore A ₂)
	(psi)	(MPa)		
MIL-P-5516 479-70	913	6.3	162	70
AMS 3238 Butyl-Sulfur Cure 805-70	1070	7.4	148	77
Chlorobutyl 823-70	1430	9.9	276	66
MIL-R-25988 Type 1, Class 1 1903-70 Gr. 70	688	4.7	257	65
AMS 3304 Postcured 1235-70	634	4.4	246	66
AMS 7267 Postcured 1373-70	461	3.2	125	68
Polyacrylate 2930-70	1520	10.5	199	67
MIL-R-25732 4067-70	1240	8.5	191	72
MIL-P-83461 4367-70	1060	7.3	129	72
MIL-P-5315 457-60	755	5.2	221	64
EPT Peroxide Cure 5657-60	1960	13.5	502	64
SBR 161-70	1620	11.2	279	73
MIL-R-6855 Class 2 Gr. 70 376-70	1260	8.7	186	72

TABLE 91
 COMPRESSION SET DATA FOR O-RING COMPOUNDS

Material	Time in Compression	Time Out of Fixture (% Compression Set)				
		Initial	30 min	24 hrs	48 hrs	168 hrs
V747-75 Parker O-rings	1 week	30.3	15.2	6.1	3.6	3.0
		29.4	14.7	5.9	4.7	2.9
	3 months	36.4	18.2	9.1	9.1	9.1
		41.2	23.5	11.8	11.2	8.8
	6 months	34.3	20.0	14.3	13.6	8.6
		32.4	17.6	11.8	11.1	8.8
	12 months	41.2	23.5	11.8	10.8	8.8
		38.2	23.5	11.8	10.8	8.8
AFE-124D	1 week	63.2	50.0	23.7	21.5	13.2
		68.4	50.0	23.7	23.7	15.8
	3 months	78.9	68.4	57.9	52.1	50.0
		78.9	71.1	57.9	56.9	52.6
	6 months	78.4	67.6	59.5	57.5	51.4
		77.8	69.4	58.3	56.9	50.0
	12 months	81.1	75.7	62.2	60.4	56.8
		81.1	73.0	62.2	60.4	56.8
KEL-F-5500 Peroxide cured	1 week	63.9	44.4	19.4	17.2	11.1
		61.1	44.4	19.4	17.2	11.1
	3 months	75.7	67.6	45.9	39.5	35.1
		73.0	67.6	48.6	41.1	36.8
	6 months	78.9	68.4	52.6	50.6	42.1
		81.1	70.3	51.4	49.4	40.5
	12 months	80.6	72.2	55.6	52.8	41.7
		80.6	72.2	55.6	52.8	44.4
9022-70 Acid resistant E-60 PARCO O-rings	1 week	19.6	9.7	3.2	3.2	3.2
		22.6	12.9	3.2	3.2	3.2
	3 months	22.6	12.9	6.5	3.2	3.2
		25.8	16.1	6.5	5.9	3.2
	6 months	31.6	15.6	12.5	11.0	6.3
		28.1	18.8	9.4	9.4	9.4
	12 months	31.3	18.8	9.4	9.4	9.4
		25.8	16.1	6.5	6.5	6.5

TABLE 91 (Continued)
 COMPRESSION SET DATA FOR O-RING COMPOUNDS

Material	Time in Compression	Time Out of Fixture (% Compression Set)					
		Initial	30 min	24 hrs	48 hrs	168 hrs	
846-70 Resin-Cured Butyl PARCO O-rings	1 week	6.1	6.1	3.0	3.0	3.0	
		6.1	6.1	3.0	3.0	3.0	
	3 months	9.1	3.0	3.0	0	0	
		6.1	6.1	3.0	0	0	
	6 months	14.7	11.8	5.9	5.9	5.9	
		14.7	8.8	5.9	5.9	5.9	
	12 months	14.7	11.8	5.9	5.9	5.9	
		15.2	12.1	6.1	6.1	6.1	
	4120-70 Unplasticized Buna-N PARCO O-rings	1 week	17.7	8.8	0	0	0
			20.6	8.8	2.9	2.9	2.9
		3 months	27.2	18.2	12.1	11.5	9.1
			25.0	15.6	9.4	8.8	6.3
6 months		36.4	27.3	21.2	21.2	21.2	
		38.4	26.5	23.5	22.8	20.6	
12 months		33.3	21.2	18.2	17.2	15.2	
		34.4	21.9	15.6	15.6	15.6	
5502-70 KEL-F-5500 Elastomer PARCO O-rings		1 week	41.2	26.5	11.8	11.8	8.8
			41.2	26.5	11.8	11.8	8.8
		3 months	38.2	26.5	11.8	11.8	11.8
			33.3	24.2	11.8	9.1	6.1
	6 months	50.0	35.3	20.6	19.9	14.7	
		54.3	40.0	28.6	27.2	22.9	
	12 months	50.0	35.3	20.6	18.6	14.7	
		50.0	38.2	20.6	19.6	14.7	

TABLE 91 (Concluded)

COMPRESSION SET DATA FOR O-RING COMPOUNDS

Material	Time in Compression	Time Out of Fixture (% Compression Set)					
		Initial	30 min	24 hrs	48 hrs	168 hrs	
5649-70 Unplasticized EPR PARCO O-rings	1 week	32.4	20.6	14.7	12.3	11.8	
		32.4	23.5	14.7	12.3	11.8	
	3 months	37.5	28.1	18.8	15.6	15.6	
		42.4	30.3	18.2	18.2	18.2	
	6 months	41.2	35.3	26.5	25.0	20.6	
		39.4	35.3	24.2	23.5	20.6	
	12 months	44.1	35.3	26.5	25.5	23.5	
		42.4	35.3	24.2	24.2	24.2	
	V494-70 Parker O-rings	1 week	45.5	27.3	6.1	6.1	3.0
			45.5	24.2	6.1	6.1	3.0
		3 months	51.5	33.3	15.2	11.5	9.1
			54.5	33.3	15.2	14.0	9.1
6 months		61.8	38.2	20.6	19.1	14.7	
		55.9	38.2	20.6	19.1	14.7	
12 months		60.6	39.4	21.2	19.2	15.2	
		54.5	36.4	18.2	16.2	12.1	

were tested in compression set, both with the original 13 materials discussed in this section, as well as the second set of nine materials. For this reason, two sets of data appear in the compression set tables for each test condition.