

AD-A057 493

BOEING VERTOL CO PHILADELPHIA PA
RELIABILITY AND MAINTAINABILITY BLOCK DIAGRAMS AND MATHEMATICAL--ETC(U)
MAR 77 E W KING
D210-11187-1

F/G 6/7

N62269-76-C-0341

NL

UNCLASSIFIED

1 OF 1
ADA
057493

11

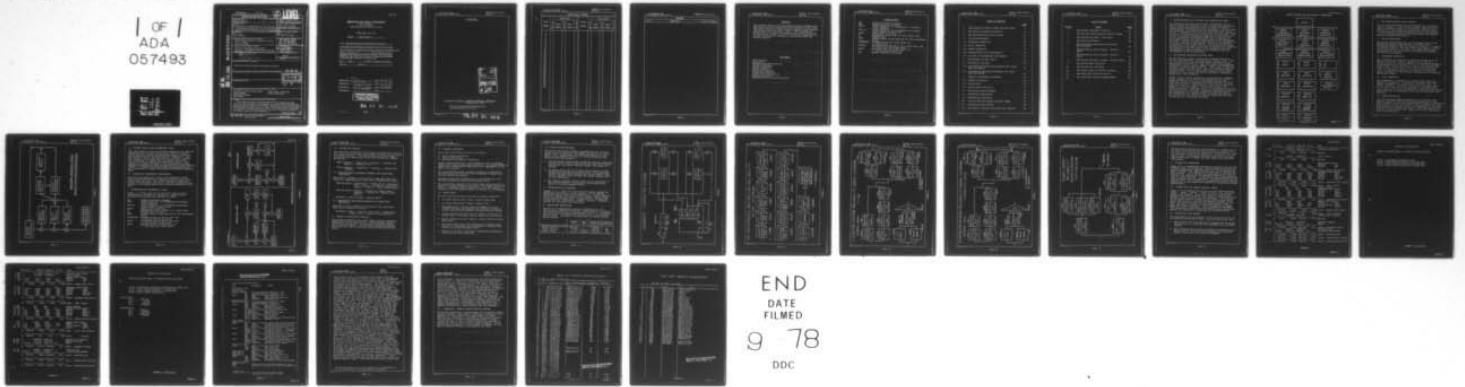

END
DATE
FILMED
9 78
DDC

UNCLASSIFIED

SECURITY CLASSIFICATION OF THIS PAGE (When Data Entered)

② LEVEL II

REPORT DOCUMENTATION PAGE

1. REPORT NUMBER ⑭ D210-11187-1		2. GOVT ACCESSION NO.	3. REPORT'S CATALOG NUMBER ⑨ Rept. no. 13 (Final), Jun 76 - Mar 77
4. TITLE (and Subtitle) ① Reliability and Maintainability Block Diagrams and Mathematical Models for the Sink Rate Delay/ Improved In-Water Stability System for Helicopters.		5. TYPE OF REPORT & PERIOD COVERED Final ((13) of (14)) June 1976 - Mar 1977	
6. AUTHOR(S) ⑩ E. W./King		7. CONTRACT OR GRANT NUMBER(s) ⑮ N62269-76-C0341	
9. PERFORMING ORGANIZATION NAME AND ADDRESS Boeing Vertol Company, Survivability Section P.O. Box 16858 Phila., PA 19142		10. PROGRAM ELEMENT, PROJECT, TASK AREA & WORK UNIT NUMBERS Prog. Element 63216N Proj. No. W0584001 Task Area No. W4567001 W. U. No. DS-903 (Form DD1498)	
11. CONTROLLING OFFICE NAME AND ADDRESS Naval Air Development Center (6033) Aircraft & Crew Systems Technology Directorate Warminster, PA 18974		12. REPORT DATE ⑪ 21 Mar 77	
14. MONITORING AGENCY NAME & ADDRESS (if different from Controlling Office) ⑬ W0584 ⑰ W0584001		13. NUMBER OF PAGES ⑫ 32 p.	
16. DISTRIBUTION STATEMENT (of this Report) Approved for Public Release; Distribution unlimited		15. SECURITY CLASS. (of this report) UNCLAS	
17. DISTRIBUTION STATEMENT (of the abstract entered in Block 20, if different from Report)		15a. DECLASSIFICATION/DOWNGRADING SCHEDULE	
18. SUPPLEMENTARY NOTES			
19. KEY WORDS (Continue on reverse side if necessary and identify by block number) Helicopter Flotation System (HFS) Flight Safety Reliability Block Diagrams Mission Reliability Planned Maintenance Math Models			
20. ABSTRACT (Continue on reverse side if necessary and identify by block number) This document defines the maintainability block diagrams and math models and the reliability block diagrams for the sink rate delay/improved in-water stability system for helicopters (Helicopter Flotation System (HFS)). These diagrams and models serve as a basis for estimating the effectiveness of the HFS as a survival system and will be used in allocation, prediction, and failures modes and effects analysis. ↑			

AD No. DDC FILE COPY AD A 057493

DDC
RECEIVED
AUG 16 1978
B

403682

BOEING VERTOL COMPANY

A DIVISION OF THE BOEING COMPANY

P.O. BOX 16858
PHILADELPHIA, PENNSYLVANIA 19142

CODE IDENT. NO. 77272

NUMBER D210-11187-1

TITLE Reliability and Maintainability Block
Diagrams and Mathematical Models for the Sink Rate
Delay/Improved In-Water Stability System for Helicopters

ORIGINAL RELEASE DATE _____ . FOR THE RELEASE DATE OF
SUBSEQUENT REVISIONS, SEE THE REVISION SHEET. FOR LIMITATIONS
IMPOSED ON THE DISTRIBUTION AND USE OF INFORMATION CONTAINED
IN THIS DOCUMENT, SEE THE LIMITATIONS SHEET.

MODEL H-46 CONTRACT NG2269-76-C-0341

ISSUE NO. _____ ISSUED TO: _____

PREPARED BY	<u><i>E. W. King</i></u>	DATE	<u>3-21-77</u>
APPROVED BY	<u><i>E. W. King</i></u> FOR E. W. King	DATE	<u>3-21-77</u>
APPROVED BY	<u><i>E. Quinn</i></u>	DATE	<u>3-21-77</u>
APPROVED BY	<u><i>G. W. Windolph</i></u>	DATE	<u>3-21-77</u>
APPROVED BY	_____	DATE	_____

DISTRIBUTION STATEMENT A
Approved for public release
Distribution Unlimited

78 07 31 03 6

LIMITATIONS

ACCESSION FOR	
NTIS	White Section <input checked="" type="checkbox"/>
DOC	Blue Section <input type="checkbox"/>
UNANNOUNCED	<input type="checkbox"/>
JUSTIFICATION _____	
BY _____	
DISTRIBUTION/AVAILABILITY CODES	
Dist.	AVAIL. RING or SPECIAL
A	23

This document is controlled by Product Assurance Department
Organization 7930

All revisions to this document shall be approved by the
above noted organization prior to release.

ACTIVE SHEET RECORD

SHEET NUMBER	REV LTR	ADDED SHEETS				SHEET NUMBER	REV LTR	ADDED SHEETS			
		SHEET NUMBER	REV LTR	SHEET NUMBER	REV LTR			SHEET NUMBER	REV LTR	SHEET NUMBER	REV LTR
1											
2											
3											
4											
5											
6											
7											
8											
9											
10											
11											
12											
13											
14											
15											
16											
17											
18											
19											
20											
21											
22											
23											
24											
25											
26											
27											
28											
29											
30											
31											
32											

ABSTRACT

This document defines the maintainability block diagrams and math models and the reliability block diagrams for the "Sink Rate Delay/Improved In-Water Stability System for Helicopters" (Helicopter Flotation System) (HFS). These diagrams and models serve as a basis for estimating the effectiveness of the Helicopter Flotation System as a survival system and will be used in allocation, prediction, and failure modes and effects analysis.

KEY WORDS

Block Diagram
Math Model
Hardware Breakdown Structure
Planned Maintenance
Special Inspection
Phased Inspection
Maintenance Downtime
Turnaround Inspection
Flight Safety Reliability
Mission Reliability
Maintenance Malfunction Reliability

ABBREVIATIONS

HFS	Helicopter Flotation System
WRA	Weapon Replaceable Assembly
BCM-9	Beyond Capability of Intermediate Maintenance (Item condemned)
BCM 1-8	Beyond Capability of Intermediate Maintenance (Item shipped to depot level)
MH/FH	Manhour per flight hour
λ	Maintenance action rate per 1000 flight hours
ET	Elapsed Time
CREW	Average number of men required for the maintenance action
TURNAROUND	Performed every two flight hours and $\lambda = 500/1000$ FH
SPECIAL	Performed every 28 days or 38.4 flight hours and $\lambda = 26.042$ per 1000 flight hours
PHASE	Performed every 400 flight hours and $\lambda = 2.5$ per 1000 flight hours
HBS	Hardware Breakdown Structure

TABLE OF CONTENTS

	<u>Page</u>
1. Maintainability Block Diagram and Math Model	9
2. HFS Hardware Breakdown Structure	9
3. HFS Maintainability Block Diagram	11
4. Planned Maintenance	11
4.1 Turnaround Inspection	11
4.2 Daily Inspection	11
4.3 Phased Inspection	11
4.4 Standard Depot Level Maintenance	13
4.5 Corrective (Unscheduled) Maintenance	13
5. Maintainability Math Model	13
5.1 Maintenance Downtime	15
5.2 Organizational Maintenance Manhours Per Flight Hour (Org MH/FH)	15
5.3 Intermediate Maintenance Manhours Per Flight Hour (Int MH/FH)	15
6. Summary of Reliability Analysis	15
6.1 General Discussion	16
6.2 Ground Rules	16
6.3 Design Change Rationale	17
7. Reliability Block Diagrams	17
8. Reliability Predictions	17
9. Reliability Allocations	23
10. Failure Mode and Effects Analysis (FMEA)	23
11. Reliability Test Program	23
11.1 Development (Problem Identification) Testing	30

LIST OF FIGURES

<u>Figure</u>	<u>Title</u>	<u>Page</u>
1	HFS Hardware Breakdown Structure	10
2	HFS Top Level Maintainability Block Diagram	12
3	Maintainability Model - Flow Chart	14
4	HFS Revised Schematic	18
5	HFS Maintenance Malfunction Reliability Block Diagram	19
6	HFS Reliability Block Diagram - Mission - Bench	20
7	HFS Reliability Block Diagram - Mission - Field	21
8	HFS Reliability Block Diagram - Flight Safety	22
9	HFS Failure Rate Prediction	24
10	HFS Reliability Allocation	26
11	HFS Failure Mode and Effects Analysis	28
12	HFS Bench Test Trade-Off Factors	31
13	HFS Field Test Trade-Off Requirements	32

1. MAINTAINABILITY BLOCK DIAGRAM AND MATHEMATICAL MODEL

The Helicopter Flotation System (HFS) installation, by its nature as survival equipment, is not normally exercised during routine flight operations and hence its impact on overall system operational readiness may be considered as insignificant. This parameter, considered herein as synonymous with availability, is assessed by the following model and later quantified as a part of maintainability allocations and predictions. Preventive or scheduled maintenance comprises the major portion of the installation maintenance burden and is addressed at both organizational and intermediate levels of maintenance by the model. However, preventive maintenance at the intermediate level is not presently anticipated. Corrective maintenance is treated in a like manner and as a result the block diagram and maintainability model can be used to determine the character and magnitude of the HFS installation maintenance downtimes and maintenance support demands at the organizational and intermediate levels of maintenance.

2. HFS HARDWARE BREAKDOWN STRUCTURE (HBS)

The HBS affords a graphic display and interrelationship of the end item subdivided into successively smaller units. Each unit is identified with a summary number conforming to the requirements of MIL-STD-780, "Work Unit Codes and Maintenance Engineering Analysis Control Numbers (MEACNS) for Aeronautical Equipment; Uniform Numbering System". This number is used for Logistic Support Analysis (LSA) identification during design and development, and for maintenance reporting during operational use, thus closing the loop of Allocation, Prediction, Demonstration and Evaluation.

Figure 1 shows the HFS installation interfaced with a segment of the existing HBS of the H-46 helicopter as contained in NAVAIR 01-250HD-8, "Work Unit Code Manual H-46 Aircraft". As indicated, the HFS as presently envisioned consists of three major installations: Nose Flotation, Stub Wing Flotation and Controls. With the exception of the access panels, the Weapon Replaceable Assemblies (WRA's) of the flotation installation are identical. The added electrical components and wiring are considered in this model, recognizing that operational maintenance would be reported under the Electrical Work Unit Code of 42,000. Any of the HFS summary numbers may be used to exercise the maintainability model.

HFS HARDWARE BREAKDOWN STRUCTURE

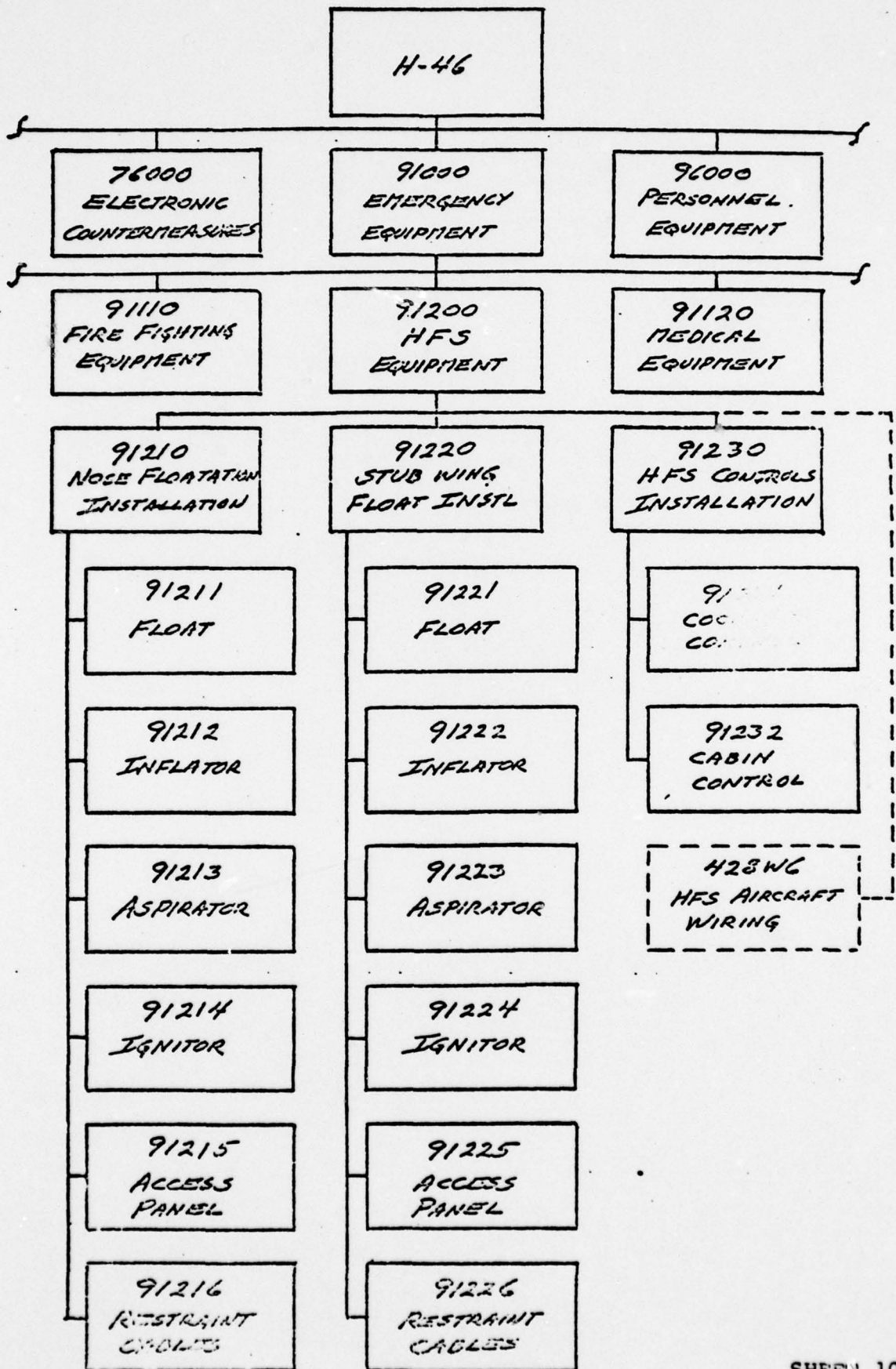

FIGURE 1

3. HFS MAINTAINABILITY BLOCK DIAGRAM

The top level maintainability block diagram for the HFS is shown in Figure 2. This diagram indicates what maintenance must be performed and why it is performed. Applying this rationale to lower levels of installation indenture results in the definition of maintainability analysis work packages, i.e. how can maintainability techniques reduce the support burden of required maintenance?

4. PLANNED MAINTENANCE

The planned maintenance block of the diagram refers to the planned maintenance requirements of the Naval Aviation Maintenance Program (NAMP) as defined in Chapter 11, Volume II of OPNAVINST 4790.2A. The HFS installation support is based on the requirements of the NAMP. The planned maintenance requirements of the HFS with their rationale are defined in the following paragraphs.

4.1 TURNAROUND INSPECTION

This inspection is conducted to ensure the integrity of the HFS for flight and to detect degradation that may have occurred during the previous flight. The turnaround inspection is performed prior to the first flight of each day and after every flight. Since the HFS has a built in test capability which is exercised as part of the pilot's preflight check list, the turnaround inspection is limited to an external visual inspection of the flotation installations for security and obvious damage.

4.2 DAILY INSPECTION

This inspection is conducted to a greater depth than the turnaround inspection. In addition to security and obvious damage, components are inspected for corrosion, wear, and overall condition. The daily inspection is performed prior to the first flight of the day and may be considered valid for a period of 72 hours, provided that no flight occurs during this period and no maintenance other than servicing has been performed.

4.3 PHASED INSPECTION

The H-46 helicopter phased inspection is a series of four related inspections that are performed sequentially at 100 hour intervals. One of these phases shall include a comprehensive inspection of the HFS installation. This inspection will check the condition and operation of all HFS components to the extent allowed without inflating the floats. The floats shall be so designed and constructed that inspection will not be required for 24 month periods.

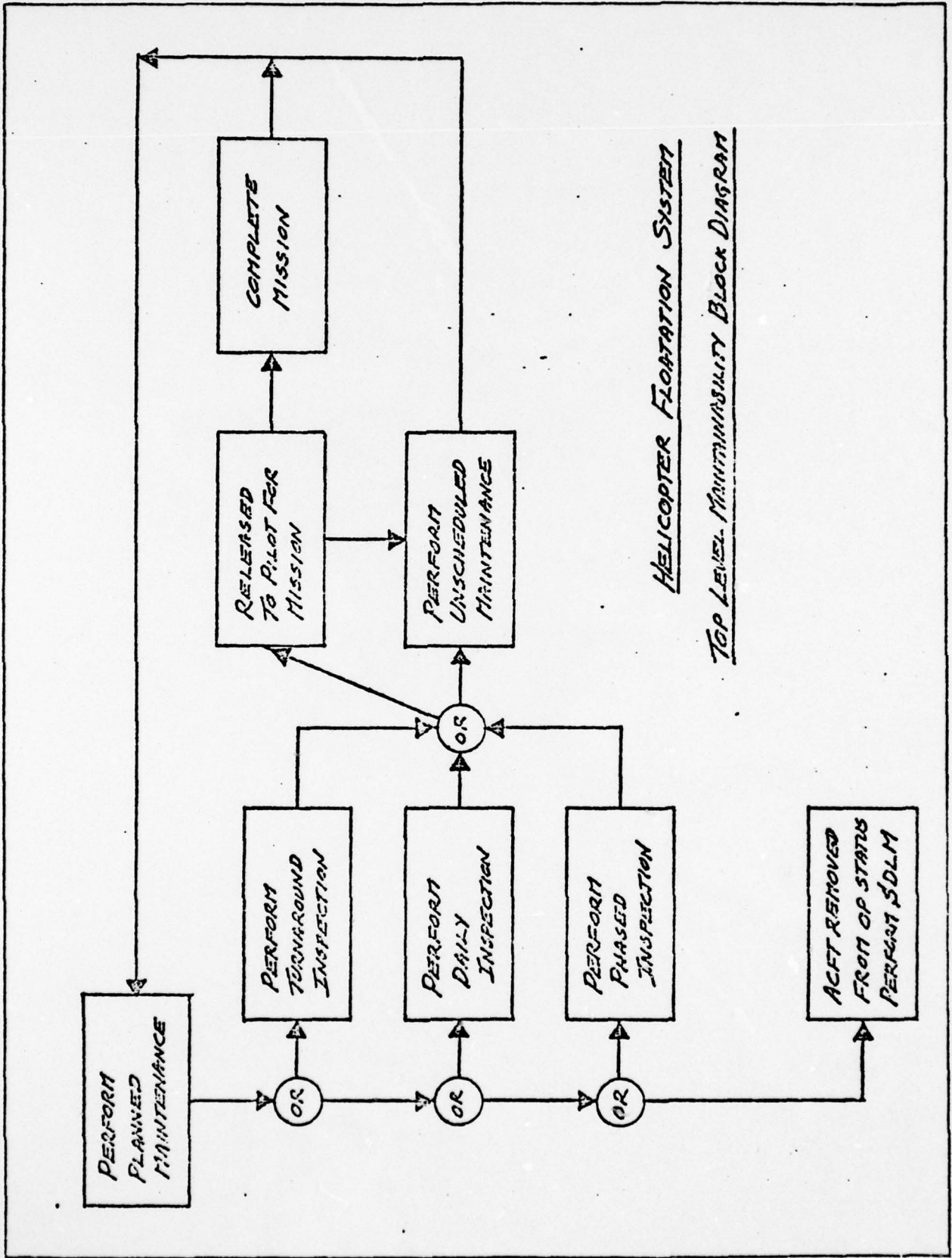

HELICOPTER FLOATATION SYSTEM
TOP LEVEL MAINTAINABILITY BLOCK DIAGRAM

4.4 STANDARD DEPOT LEVEL MAINTENANCE (SDLM)

SDLM requirements provide for in-depth inspections for material degradation that may have occurred since the last SDLM and include essential preventive maintenance beyond the scope of that performed during the normal periodic inspections. The SDLM interval for the H-46 helicopter is 24 months. During this inspection the floats shall be inflated and tested, and the aircraft is removed from operational status. This inspection is beyond the scope of the maintainability block diagram and mathematical model as specified by MIL-STD-1304A (AS) "Reports: Reliability and Maintainability Engineering Data" but is mentioned to complete the planned maintenance inspection cycle.

4.5 CORRECTIVE (UNSCHEDULED) MAINTENANCE

Corrective maintenance is a result of discrepancies noted during planned maintenance or reported by pilots after unsuccessful preflight test. The latter represent an impact on overall H-46 helicopter availability and hence maintainability features of HFS design shall receive special attention in this area.

5. MAINTAINABILITY MATHEMATICAL MODEL

Figure 3 is a flow chart of the math model used to derive maintainability quantitative parameters. Abbreviations, constants and variables are defined as follows:

WRA	Weapons Replaceable Assembly
BCM 9	Beyond Capability of Intermediate Maintenance (Item condemned)
BCM 1-8	Beyond Capability of Intermediate Maintenance (Item shipped to depot level)
MH/FH	Manhours per Flight Hour
λ	Maintenance action rate per 1000 flight hours
ET	Elapsed time in minutes
CREW	Average number of men required for the maintenance action
TURNAROUND	Performed every two flight hours and $\lambda = 500$ per 1000 flight hours
PHASE	Performed every 400 flight hours and $\lambda = 2.5$ per 1000 flight hours
DAILY	Performed every 3 flight hours and $\lambda = 333.3$ per 1000 flight hours

NUMBER
REV LTR

THE BOEING COMPANY

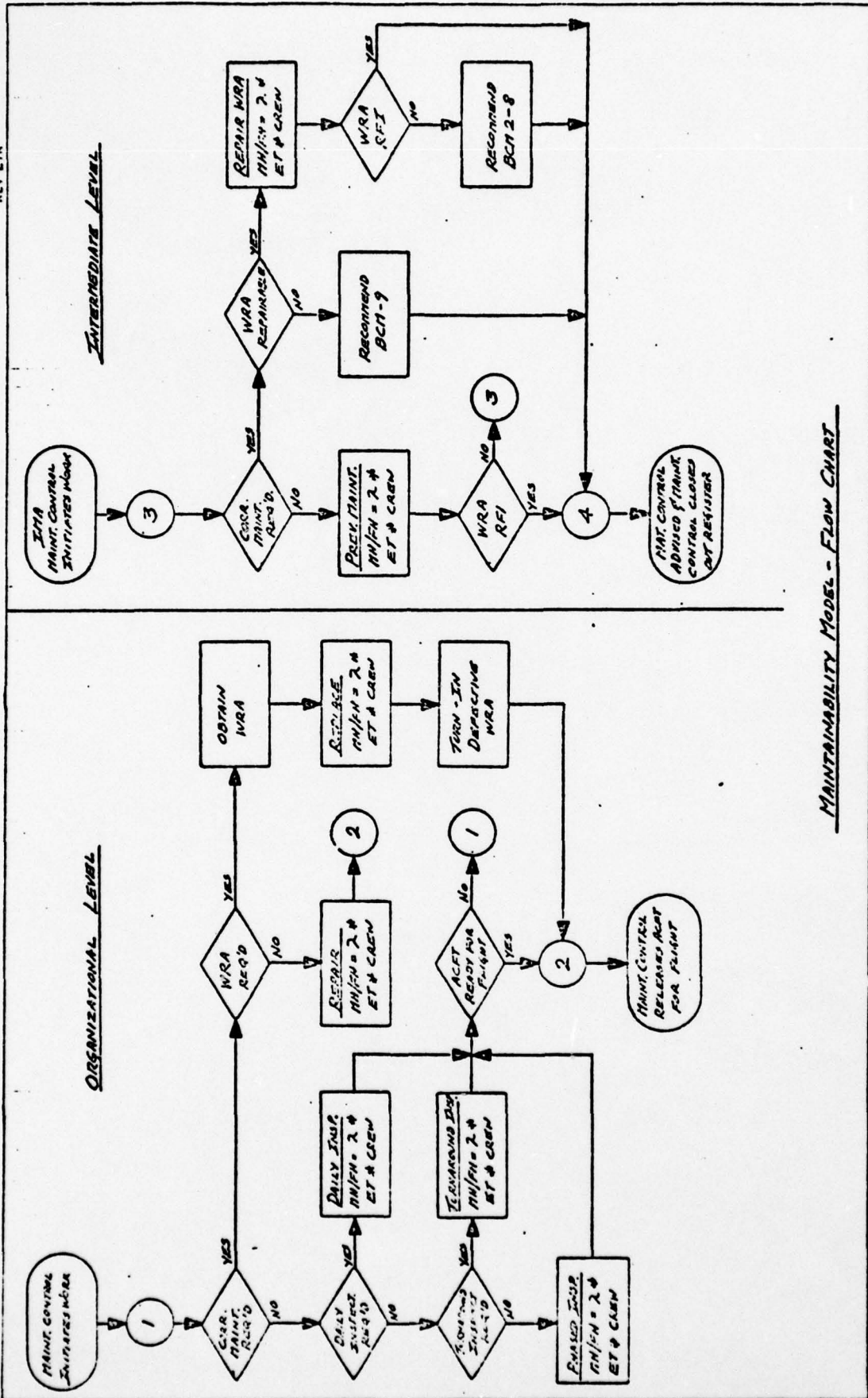

MAINTAINABILITY MODEL - FLOW CHART

FIGURE 3

5.1 MAINTENANCE DOWNTIME

HFS preventive maintenance is performed concurrent with existing H-46 preventive maintenance requirements and hence has no effect on aircraft downtime. HFS Mean Maintenance Downtime (MMDT) and Maintenance Downtime per Flight Hour (DT/FH) are computed as follows:

$$\text{MMDT} = ((\text{Repair } \lambda * \text{Repair ET}) + (\text{Replace } \lambda * \text{Replace ET})) / ((\text{Repair } \lambda + \text{Replace } \lambda) * 60)$$

$$\text{DT/FH} = ((\text{Repair } \lambda * \text{Repair ET}) + (\text{Replace } \lambda * \text{Replace ET})) / (1000 * 60)$$

5.2 ORGANIZATIONAL MAINTENANCE MANHOURS PER FLIGHT HOUR
(ORG MH/FH)

ORG MH/FH is a summation of preventive (PREV ORG MH/FH) and corrective (CORR ORG MH/FH) times, and is computed as follows:

$$\text{PREV ORG MH/FH} = ((\text{Turnaround } \lambda * \text{Turnaround ET} * \text{Turnaround Crew}) + (\text{Daily } \lambda * \text{Daily ET} * \text{Daily Crew}) + (\text{Phase } \lambda * \text{Phase ET} * \text{Phase Crew})) / (1000 * 60)$$

$$\text{CORR ORG MH/FH} = ((\text{Repair } \lambda * \text{Repair ET} * \text{Repair Crew}) + (\text{Replace } \lambda * \text{Replace ET} * \text{Replace Crew})) / (1000 * 60)$$

$$\text{ORG MH/FH} = \text{PREV ORG MH/FH} + \text{CORR ORG MH/FH}$$

5.3 INTERMEDIATE MAINTENANCE MANHOURS PER FLIGHT HOUR
(INT MH/FH)

INT MH/FH is also a summation of preventive and corrective time, and is computed as follows:

$$\text{INT MH/FH} = ((\text{Prev } \lambda * \text{Prev ET} * \text{Prev Crew}) + (\text{Repair WRA } \lambda * \text{Repair WRA ET} * \text{Repair WRA Crew})) / (1000 * 60)$$

6. SUMMARY OF RELIABILITY ANALYSIS

The system was analyzed for flight safety, mission, and maintenance malfunction reliabilities. This analysis included predictions, allocations, Failure Mode and Effects Analysis, and test program design. All numerical reliability requirements were met, and no verifiable single failure points were found.

6.1 GENERAL DISCUSSION

Three types of Reliability have been analyzed:

- a. Flight Safety Reliability
- b. Mission Reliability
- c. Maintenance Malfunction Reliability

Flight Safety Reliability is the probability that no hardware failure will cause a catastrophic accident. For the HFS stability system this is essentially equivalent to the deployment of the bag(s) while flying.

For this stability system, Mission Reliability is defined as the probability that the bags would successfully deploy whenever the system was activated.

Maintenance Malfunction Reliability is the probability of no hardware malfunction requiring maintenance action.

The simultaneous analysis of all three types of Reliability is essential to truly optimize the system. For example, additional levels of redundancy tend to improve the first two types of Reliability, but Maintenance Malfunction Reliability is degraded.

6.2 GROUND RULES

The following ground rules were used for design evaluation:

- a. No single failure shall cause a flight safety loss.
- b. No single failure shall cause a mission loss.
- c. The probability of flight safety loss shall be in the "remote" category (Rfs greater than .9999999 or about 10 million hours between hardware failures affecting safety).
- d. Mission Reliability shall equal or exceed .90 for 439.65 flight hours (18 calendar months) under field conditions.
- e. Mission Reliability shall equal or exceed .98 for one hour bench tests.
- f. The system shall have a 90% probability of passing tests designed to demonstrate the requirements of ground rules 4 and 5 at the 90% confidence level.
- g. Subject to the above constraints, Maintenance Malfunction Reliability shall be maximized.

6.3 DESIGN CHANGE RATIONALE

Preliminary reliability analysis indicated that the system as defined in D210-11003-1 was not capable of meeting the above ground rules. Accordingly, the design was modified to that shown in the schematic of Figure 4. The following are the rationale for these changes:

- a. The preliminary Failure Mode and Effects Analysis identified several wiring single failure points for both flight safety and mission (e.g. opens, shorts to power, and shorts to ground).
- b. The deploy relay (K1) was a single failure point for both flight safety and mission reliabilities. The preliminary reliability prediction indicated that single squibs - even "Hi-rel" squibs - could not meet the "bench" mission reliability requirement.
- c. The control circuitry prior to relay K1 was vulnerable to EMI (electro-magnetic interference) thus defeating the intent of the high amperage squibs.

7. RELIABILITY BLOCK DIAGRAMS

Figures 5, 6, 7, and 8 are the Reliability Block Diagrams for Maintenance Malfunction, "bench" Mission, "field" Mission, and Flight Safety Reliabilities respectively. Unless otherwise noted, all numbers are "effective" or "average" failure rates in failures per million hours. Numbers such as .0(8)123 are a short form for .0000000123 (likewise .9(5)123 = .99999123). MIL-STD-756 conventions are applicable.

8. RELIABILITY PREDICTIONS

Figure 9 is a computerized reliability prediction for the four different types of reliability. These predictions utilize the logical relationships (redundancies) shown in the Reliability Block Diagrams. All numbers are failure rates in failures per million hours. Converted to reliabilities, the system values are as follows:

	Failure Rate	Time (Hrs)	Predicted Reliability	Required Reliability
Maintenance Malfunction	1533.100	1	.9(2)846	
"bench" Mission	426.913	1	.9(3)573	.98
"field" Mission	.977	439.65	.9(3)570	.90
Flight Safety	.0(8)175	439.65	.9(12)226	.9(7)

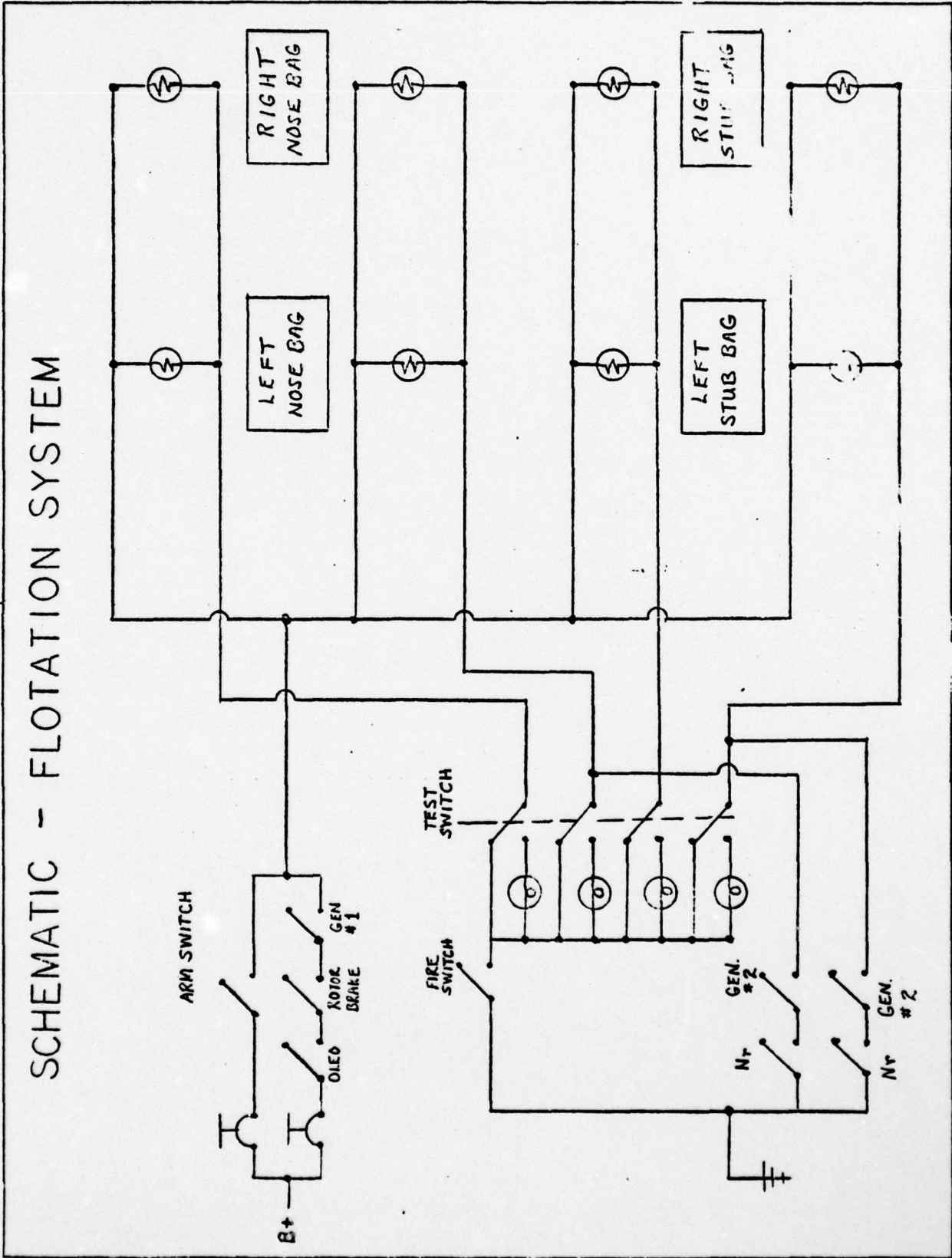

FORM 48294 (11/66)

FIGURE 4

HFS MAINTENANCE MALFUNCTION RELIABILITY BLOCK DIAGRAM

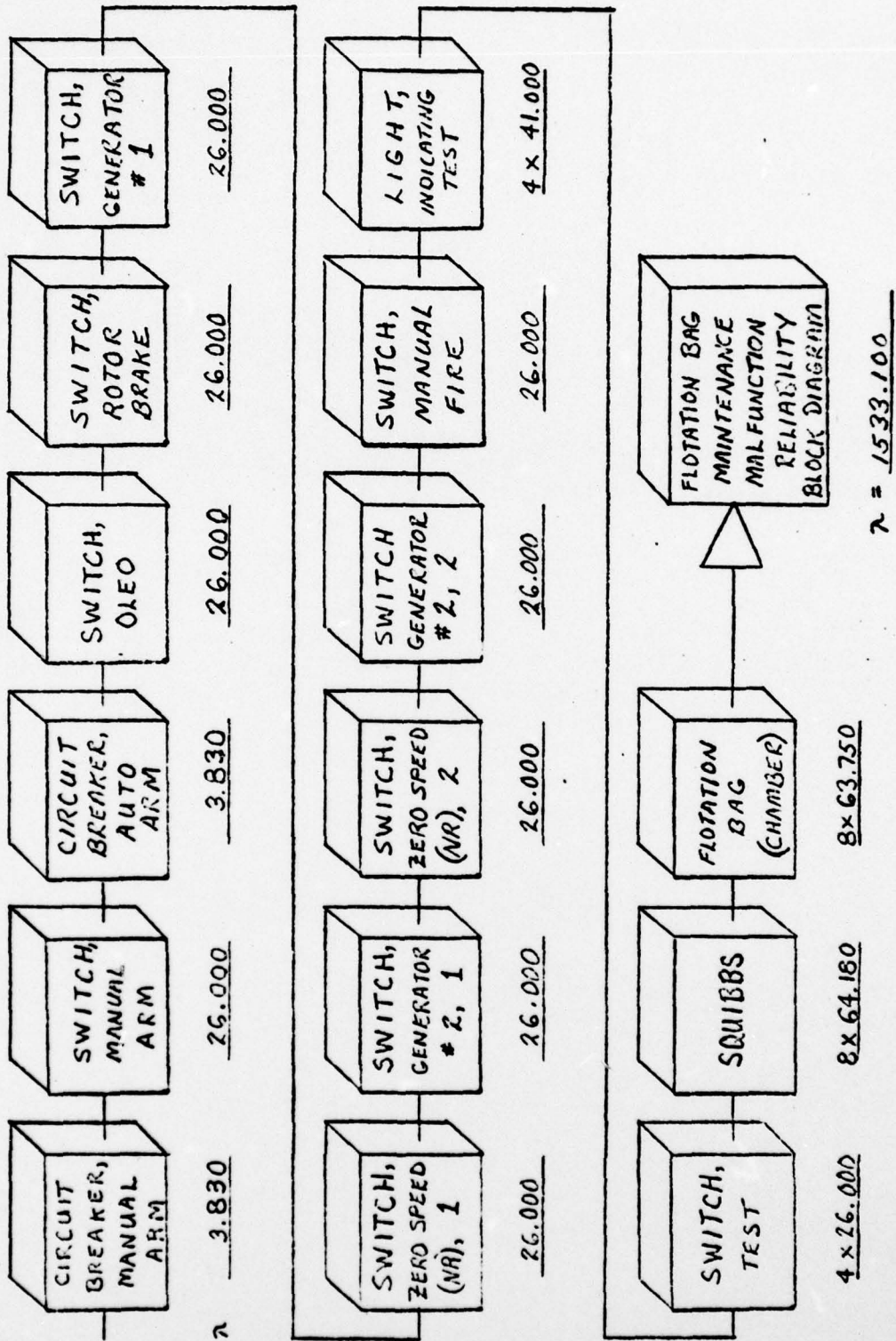
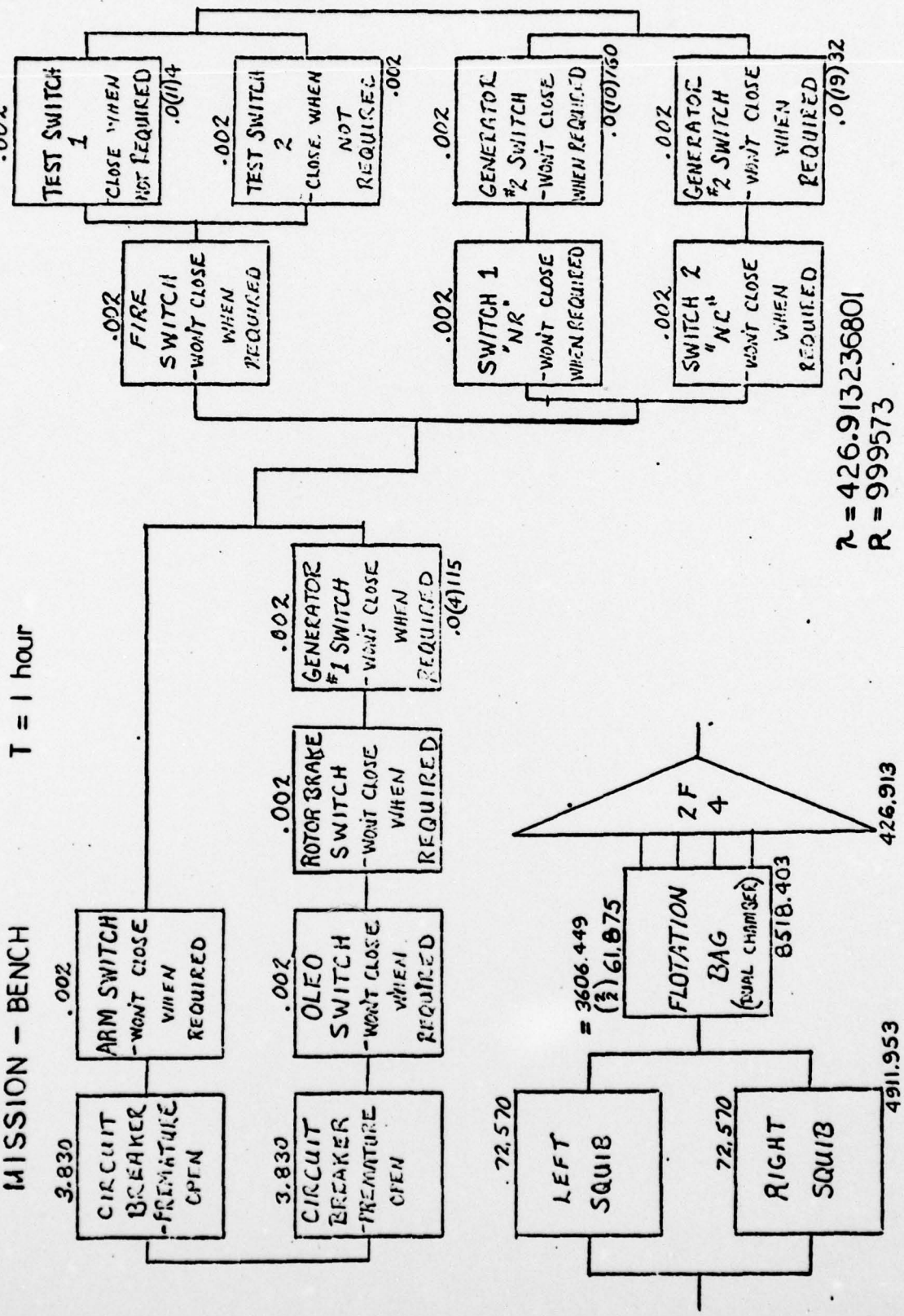

FIGURE 5

FLOTATION SYSTEM RELIABILITY BLOCK DIAGRAM

MISSION - BENCH
T = 1 hour



$\lambda = 426.913236801$
 $R = 999573$

FIGURE 6

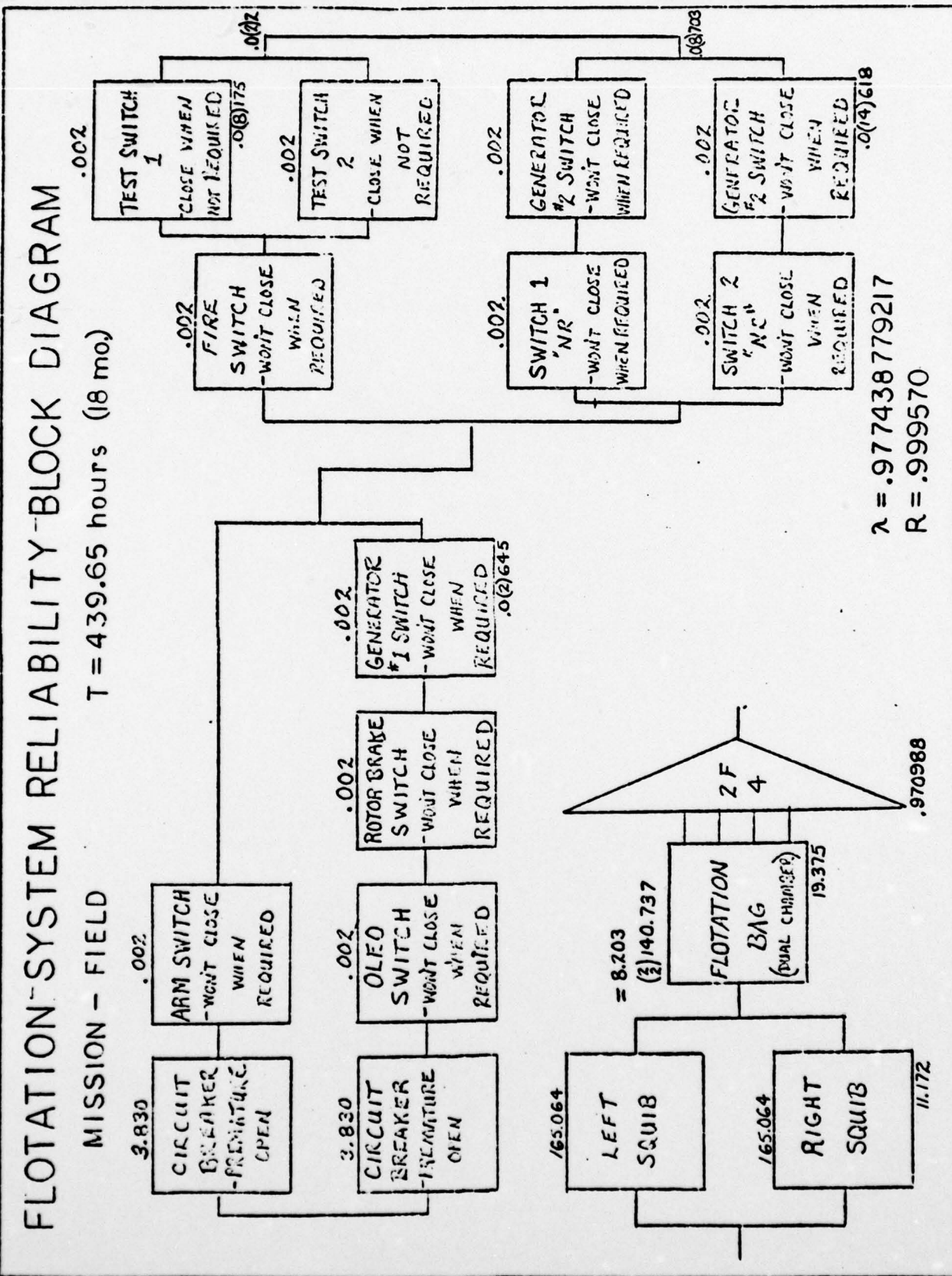

FIGURE 7

FLIGHT SAFETY
RELIABILITY
BLOCK DIAGRAM
FLOTATION SYSTEM

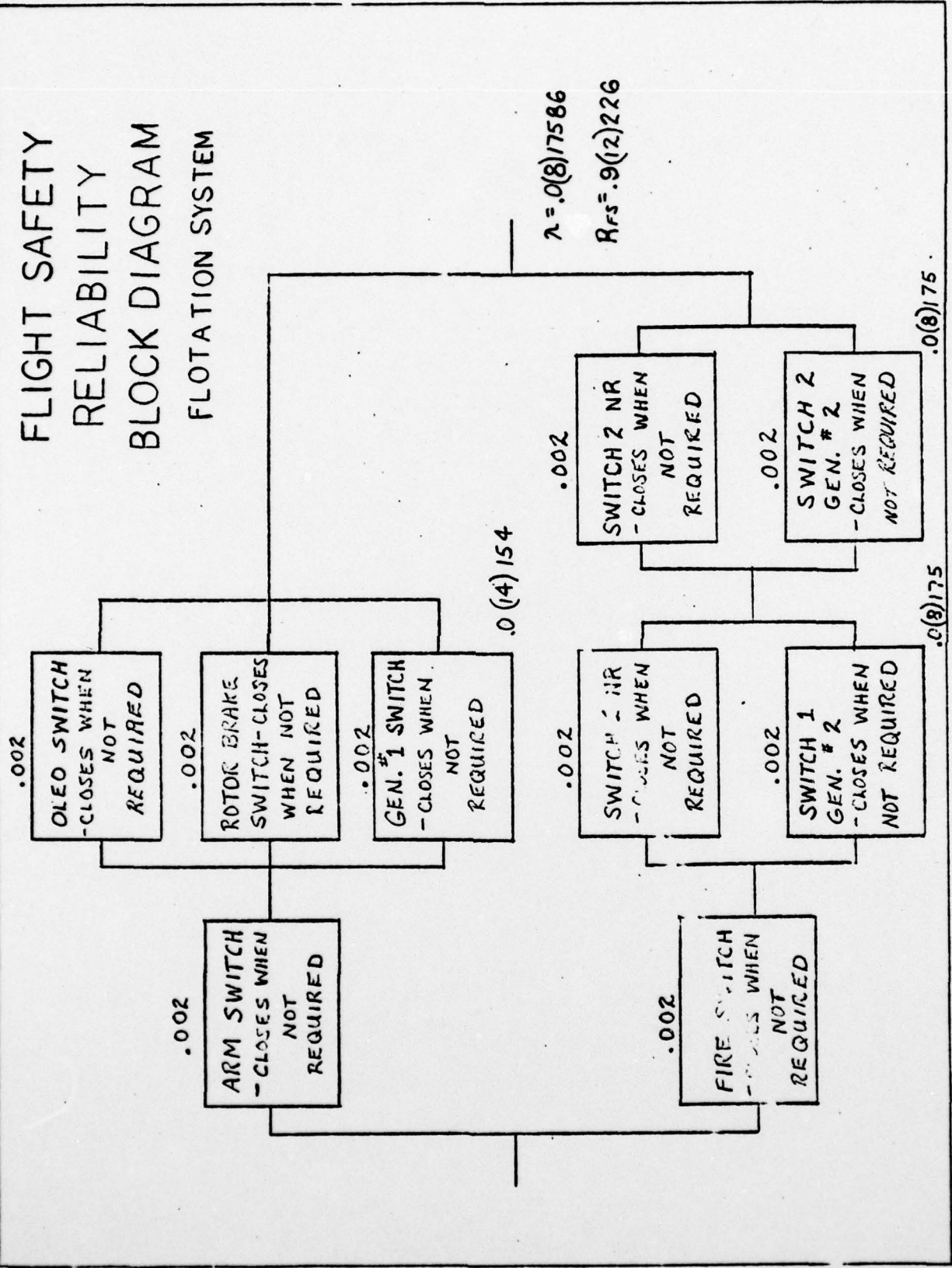

FIGURE 8

The Maintenance Malfunction value indicates an average time of 652 flight hours between maintenance-requiring malfunctions. The remaining reliabilities exceed their requirements by a margin big enough to assure 90% probability of passing a 90% confidence test. These margins are also large enough to assure that a worst case (-3 sigma) deviation would still meet the requirements.

9. RELIABILITY ALLOCATIONS

Figure 10 is a computerized reliability allocation for the four different types of reliability. These allocations utilize the logical relationships (redundancies) shown in the Reliability Block Diagrams. All numbers are failure rates in failures per million hours. If the system level predicted failure rate is less than the requirement, the program allocates the predicted values to the components. If the system level predicted failure rate is greater than the requirement, the program allocates the required value to the components in proportion to their relative contribution to the system level prediction (proportioned burden apportionment).

10. FAILURE MODE AND EFFECTS ANALYSIS (FMEA)

Figure 11 is a computerized Failure Mode and Effects Analysis (FMEA). "Opens", "shorts", "shorts to power", and "shorts to ground" were analyzed. Since both inputs and outputs were analyzed, wiring failures are also covered. After redesign, no mission single failure points were identified. Auto-ignition of the squibs would be a flight safety single failure point, but we were unable to identify any recorded instance of this mode. The basic technique for protection against shorts to power and shorts to ground is switch disconnection of both power and ground connections. This technique-in conjunction with twisted pair power/ground wiring-gives better protection against EMI firing than is possible with shielded wiring.

11. RELIABILITY TEST PROGRAM

The requirements for this program do not specifically call for a Reliability Demonstration Test. However, they do say that:

- a. Each system shall be designed for a probability of success (reliability) of .98 at the 90% confidence level for bench testing.
- b. Each helicopter system shall be capable of demonstrating a reliability of .90 at the 90% confidence level when completely installed in the subject helicopter.

QTY	MM	FR	FIELD FR	BENCH FR	FS FR	NAME
1	999	1	R.97743E	R426.913	RC.	FLOTATION BAG SYSTEM
1X		0.0	C.977	426.913	0.0	SUBTOTAL
2	998	1	R.00645	R.C0C0115		'ARM' CIRCUIT
1X		C.0	C.C06	0.000	0.0	SUBTOTAL
3	997	1				MANUAL ARM CIRCUIT
4	69	1	3.830	3.830	,0.	BREAKER ARM
5	75	1	26.	.002	.002	SWITCH ARM
1X		29.830	3.832	3.832	0.002	TOTAL: MANUAL ARM CIRCUIT
6	997	1			RC.	AUTOMATIC ARM CIRCUIT
7	69	1	3.830	3.830	3.830	BREAKER AUTO
8	75	1	26.	.002	.002	SWITCH OLEO
9	75	1	26.	.002	.002	SWITCH RTR BRAK
10	75	1	26.	.002	.002	SWITCH GEN #1
1X		81.330	3.836	3.836	0.0	TOTAL: AUTOMATIC ARM CIRCUIT
1X		111.660	0.006	0.000	0.002	TOTAL: 'ARM' CIRCUIT
11	998	1	RO.	RO.		'FIRE' CIRCUIT
12	997	1	RC.	RO.	RO.	AUTOMATIC FIRE CIRCUIT
13	75	1	26.	.002	.002	SWITCH NR,1
14	75	1	26.	.002	.002	SWITCH GEN#2,1
15	75	1	26.	.002	.002	SWITCH NR,2
16	75	1	26.	.002	.002	SWITCH GEN#2,2
1X		104.000	C.0	0.0	0.0	TOTAL: AUTOMATIC FIRE CIRCUIT
17	997	1	R.002	R.002		MANUAL FIRE CIRCUIT
18	75	1	26.	.002	.002	SWITCH FIRE
19	79	4	41.	40.986	40.986	LIGHT,INDICATE RIGHT
20	75	4	26.	.002	.002	SWITCH TEST,R
1X		294.000	C.002	0.002	0.002	TOTAL: MANUAL FIRE CIRCUIT
1X		398.000	J.0	0.0	0.002	TOTAL: 'FIRE' CIRCUIT
21	998	4	R.97098E	R426.913		'DEPLOY BAG' CIRCUITS
1X		C.0	C.971	426.913	0.0	SUBTOTAL
22	997	1	R11.172	R4911.953		REDUNDANT SQUIBS
23	145	2	64.180	,165.064	,72570.	SQUIB
1X		128.360	11.172	4911.953	0.0	TOTAL: REDUNDANT SQUIBS
24	997	1	R8.203	R3606.449		FLOTATION BAG
25	0	2	,63.75	,140.737	,61875.	FLOTATION BAG CHAMBER
1X		127.500	8.203	3606.449	0.0	TOTAL: FLOTATION BAG
4X		255.860	C.971	426.913	0.0	TOTAL: 'DEPLOY BAG' CIRCUITS
1X		1523.100	0.977	426.913	0.0	TOTAL: FLOTATION BAG SYSTEM

FIGURE 9

FAILURE RATE PREDICTION

NOTE: ALL FAILURE RATES = FAILURES PER MILLION HOURS

MM FR : MAINTENANCE MALFUNCTION RATE
M1 FR : FIELD MISSION RELIABILITY FAILURE RATE
M2 FR : BENCH MISSION RELIABILITY FAILURE RATE
FS FR : FLIGHT SAFETY RELIABILITY FAILURE RATE

FIGURE 9 (Continued)

	QTY	MM FR	FIELD FR	BENCH FR	FS FR	NAME
1	999	1	R.177438	R426.913	RO.	FLOTATION BAG SYSTEM
2	998	1	R.00645	R.0000115		'ARM' CIRCUIT
3	997	1				MANUAL ARM CIRCUIT
4	69	1	3.830	3.830	.0.	BREAKER ARM
5	75	1	26.	.002	.002	SWITCH ARM
	1X	29.830	3.832	3.832	0.002	TOTAL: MANUAL ARM CIRCUIT
6	997	1			RO.	AUTOMATIC ARM CIRCUIT
7	69	1	3.830	3.830	3.830	BREAKER AUTO
8	75	1	26.	.002	.002	SWITCH OLEO
9	75	1	26.	.002	.002	SWITCH RTR BRAK
10	75	1	26.	.002	.002	SWITCH GEN #1
	1X	81.830	3.836	3.836	0.0	TOTAL: AUTOMATIC ARM CIRCUIT
	1X	111.660	0.006	0.000	0.002	TOTAL: 'ARM' CIRCUIT
11	998	1	RO.	RO.		'FIRE' CIRCUIT
12	997	1	RO.	RO.	RO.	AUTOMATIC FIRE CIRCUIT
13	75	1	26.	.002	.002	SWITCH NR,1
14	75	1	26.	.002	.002	SWITCH GEN#2,1
15	75	1	26.	.002	.002	SWITCH NR,2
16	75	1	26.	.002	.002	SWITCH GEN#2,2
	1X	104.000	0.0	0.0	0.0	TOTAL: AUTOMATIC FIRE CIRCUIT
17	997	1	R.002	R.002		MANUAL FIRE CIRCUIT
18	75	1	26.	.002	.002	SWITCH FIRE
19	79	4	41.	40.986	0.0	LIGHT, INDICATE RIGHT
20	75	4	26.	.002	.002	SWITCH TEST, R
	1X	294.000	0.002	0.002	0.002	TOTAL: MANUAL FIRE CIRCUIT
	1X	398.000	0.0	0.0	0.002	TOTAL: 'FIRE' CIRCUIT
21	998	4	R.970988	R426.913		'DEPLOY BAG' CIRCUITS
22	997	1	R11.172	R4911.953		REDUNDANT SQUIBS
23	145	2	64.180	,165.064	,72570.	SQUIB
	1X	128.360	11.172	4911.953	0.0	TOTAL: REDUNDANT SQUIBS
24	997	1	R8.203	R3606.449		FLOTATION BAG
25	0	2	,63.75	,140.737	,61875.	FLOTATION BAG CHAMBER
	1X	127.500	8.203	3606.449	0.0	TOTAL: FLOTATION BAG
	4X	255.860	0.971	426.913	0.0	TOTAL: 'DEPLOY BAG' CIRCUITS
	1X	1532.100	0.977	426.913	0.0	TOTAL: FLOTATION BAG SYSTEM

FIGURE 10

FAILURE RATE ALLOCATION

NOTE: ALL FAILURE RATES = FAILURES PER MILLION HOURS

MM FR : MAINTENANCE MALFUNCTION RELIABILITY FAILURE RATE
M1 FR : FIELD MISSION RELIABILITY FAILURE RATE
M2 FR : BENCH MISSION RELIABILITY FAILURE RATE
FS FR : FLIGHT SAFETY FAILURE RATE

PREDICTIONS:

MM = 1533.100
M1 = 0.977
M2 = 426.913
FS = 0.000000

REQUIREMENTS:

MM = 1533.100
M1 = 239.646
M2 = 20202.707
FS = 0.000227

FIGURE 10 (Continued)

THIS PAGE IS BEST QUALITY PRACTICAL
FROM COPY FURNISHED TO DDC

FAILURE MODE AND EFFECTS ANALYSIS

NAME	FAILURE MODE	EFFECT
FLOTATION BAG SYSTEM		
'ARM' CIRCUIT		
MANUAL ARM CIRCUIT		
BREAKER, CIRCUIT	ARM	-NO OP. WHEN REQD-WON'T DISCONNECT A SHORT
	ARM	-OP. WHEN NOT REQD-WON'T MANUAL ARM
SWITCH	ARM	-SHORT, IN TO OUT-MANUAL ERRONEOUSLY ARMED
	ARM	-OPEN -WON'T MANUAL ARM
	ARM	-GROUNDED -WON'T ARM (BOTH BREAKERS POP)
	ARM	-SHORT TO B+ -ERRONEOUSLY ARMED
AUTOMATIC ARM CIRCUIT		
BREAKER, CIRCUIT	AUTO	-NO OP. WHEN REQD-WON'T DISCONNECT A SHORT
	AUTO	-OP. WHEN NOT REQD-WON'T AUTO ARM
SWITCH	OLED	-SHORT, IN TO OUT-WILL ARM ON LANDING
	OLED	-OPEN -WON'T AUTO ARM
	OLED	-GROUNDED -BREAKER POPS ON LANDING
	OLED	-SHORT TO B+ -WILL ARM ON LANDING
SWITCH	RTR BRAK	-SHORT, IN TO OUT-WILL FIRE ON WATER SHUTDOWN
	RTR BRAK	-OPEN -WON'T AUTO ARM
	RTR BRAK	-GROUNDED -BREAKER POPS ON LANDING
	RTR BRAK	-SHORT TO B+ -ARMS ON SHUTDOWN
SWITCH	GEN #1	-SHORT, IN TO OUT-PARTIAL AUTO ARM
	GEN #1	-OPEN -WON'T AUTO ARM
	GEN #1	-GROUNDED -POPS BREAKER ON WATER LANDING OR TEST
	GEN #1	-SHORT TO B+ -ERRONEOUSLY ARMED
'FIRE' CIRCUIT		
AUTOMATIC FIRE CIRCUIT		
SWITCH	NR, 1	-SHORT, IN TO OUT-PART. CLOSURE, NOSE BAG AUTO FIRE CIRCUIT
	NR, 1	-OPEN -1/2 NOSE BAG SQUIBS WON'T AUTO FIRE
	NR, 1	-GROUNDED -1/2 NOSE BAG SQUIBS FIRE ON SHUTDOWN
	NR, 1	-SHORT TO B+ -ELECTRICAL SHORT ON SHUTDOWN
SWITCH	GEN#2, 1	-SHORT, IN TO OUT-PART. CLOSURE, NOSE BAG AUTO FIRE CIRCUIT
	GEN#2, 1	-OPEN -1/2 NOSE BAG SQUIBS WON'T AUTO FIRE
	GEN#2, 1	-GROUNDED -1/2 NOSE BAG SQUIBS FIRE ON SHUTDOWN
	GEN#2, 1	-SHORT TO B+ -ELECTRICAL SHORT ON SHUTDOWN
SWITCH	NR, 2	-SHORT, IN TO OUT-PART. CLOSURE, NOSE BAG AUTO FIRE CIRCUIT
	NR, 2	-OPEN -1/2 NOSE BAG SQUIBS WON'T AUTO FIRE
	NR, 2	-GROUNDED -1/2 NOSE BAG SQUIBS FIRE ON SHUTDOWN
	NR, 2	-SHORT TO B+ -ELECTRICAL SHORT ON SHUTDOWN
SWITCH	GEN#2, 2	-SHORT, IN TO OUT-PART. CLOSURE, STUB BAG AUTO FIRE CIRCUIT
	GEN#2, 2	-OPEN -1/2 STUB BAG SQUIBS WON'T FIRE
	GEN#2, 2	-GROUNDED -1/2 STUB BAG SQUIBS FIRE ON SHUTDOWN
	GEN#2, 2	-SHORT TO B+ -ELECTRICAL SHORT ON SHUTDOWN
MANUAL FIRE CIRCUIT		
SWITCH	FIRE	-SHORT, IN TO OUT-WILL FIRE IF ARMED
	FIRE	-OPEN -WON'T MANUAL FIRE
	FIRE	-GROUNDED -WON'T MANUAL FIRE
	FIRE	-SHORT TO B+ -WILL FIRE IF ARMED
LIGHT, INDICATE		-SHORT, IN TO OUT-WILL FIRE SQUIBS IN TEST
LIGHT, INDICATE		-OPEN -WON'T INDICATE ON TEST
LIGHT, INDICATE		-GROUNDED -WON'T INDICATE ON TEST
LIGHT, INDICATE		-SHORT TO B+ -ERRONEOUS INDICATION ON TEST
SWITCH	TEST	-SHORT, IN TO OUT-WON'T TEST SQUIBS
	TEST	-OPEN -WON'T MANUAL FIRE/TEST SQUIBS
	TEST	-GROUNDED -WILL FIRE IF ARMED
	TEST	-SHORT TO B+ -1/2 SQUIBS WON'T FIRE WHEN COMMANDED
'DEPLOY BAG' CIRCUITS		
REDUNDANT SQUIBS		
SQUIB		-NO OP. WHEN REQD-NO EFFECT (OTHER SQUIBS WILL FIRE)
SQUIB		-OP. WHEN NOT REQD-SINGLE FAILURE POINT (NO RECORDED OCCUR.)

SHEET

FLOTATION BAGS
FLOTATION BAG CHAMBER

-NO OP. WHEN REQD-1/2 BAG REDUNDANCY LOST
-OP. WHEN NOT REQD-CAN'T OCCUR BY ITSELF

FIGURE 11

These require that a test program be designed so that the system would be capable of passing such a test if it were run. MIL-STD-781 gives test plans which demonstrate at 90% (and other) levels of confidence, but this, by itself, is insufficient to respond to the above requirements! The reason is that high confidence tests (such as MIL-STD-781) are so powerful in rejecting bad equipment (less than the requirement) that it also has a high probability of rejecting good equipment! For example take requirement a. above (R of .98 at 90% confidence). Figure 9 shows that if you were to conduct a test of 114 components (or systems) with no failures, you would demonstrate a reliability of .98 at the 90% confidence level. Now suppose you entered this test with 114 components with a true reliability of exactly .98? You would find that you have only a 10% chance of passing the test.* In other words, if you repeated this test a number of times, an average of 9 out of 10 tests would "flunk" (have one or more failures). It turns out that just to have a 50-50 chance of passing the test, you must go into the test with a true reliability of .99394, even though the requirement was only .98. In fact, in order to have a good (e.g. 90%) probability of passing the test, you must go into the test with a true reliability of .999076! In order to better understand what this means, consider the "mean time between failure" or MTBF. A reliability of .98 for a one hour mission is equivalent to an MTBF of 50 hours. A reliability of .99394 is equivalent to an MTBF of 164 hours! A reliability of .999076 is equivalent to an MTBF of 1,081 hours! Thus, the true MTBF must be 22 times greater than the required-just to have a reasonably good probability of passing the test! The probability of not passing the test is usually referred to as "producer's risk" (although it should be realized that in the long run, the consumer actually pays for it). Thus, producer's risk is the probability of rejecting good equipment. One minus the confidence (as a decimal) is equivalent to "consumer's risk" (risk of accepting bad equipment). The convention is to set up a "fair" testing program (consumer's risk equals producer's risk or probability of passing equals confidence), and Figure 12 shows the results for requirement a. Note that by increasing the number of allowable failures (and the number of tests!) the "true" or designed reliability can be lowered. Obviously there is a practical limit to this approach. Even if we were to increase the number of allowable failures to 52, the design reliability would still have to be .9859 or an MTBF of 70 hours which is still 142% of the required MTBF of 50 hours. Furthermore, the destructive testing of 3,121 systems is probably impractical from both the time and cost standpoint. Thus a balance must be struck between the designed (true) reliability and the number of tests. If we use the reliability prediction

* The theoretical error in this statement is recognized but is not significant to the conclusions developed.

as an estimate of the true reliability, the bench mission prediction of $R = .999573$ allows selection of the "zero failure in 114 tests" test program. If we allow for an "order of magnitude" error in the prediction: $R = .99573$, the test program must become "3 or less failures in 333 tests" because this is the smallest program with a 90% probability of passing. It should be noted that this is the primary reason why the design was not frozen when the prediction first reached $R = .98$. Figure 13 is an equivalent table for the "field" mission and the predicted value of $R = .999570$ allows the selection of the "zero failure in 22 tests" test program. The time value of 439.65 flight hours was based on 18 months on each of 275 aircraft—the test being an actual firing of the system just prior to refurbishment. This approach would assure testing under field conditions and avoid the cost of special purchases and flights strictly for test purposes.

11.1 DEVELOPMENT (PROBLEM IDENTIFICATION) TESTING

The primary reliability testing program will be problem identification testing. The purpose of this type of testing is confirmation of failure effects as identified by the FMEA. Specifically, each FMEA failure mode is artificially induced into the system and the resulting system effect is noted. In addition, system level interface failures are induced to confirm the logic of the Reliability Block Diagrams. Due to the artificial creation of failure modes, no attempt will be made to calculate failure rates based on this data.

BENCH TEST TRADEOFF FACTORS (T=1 hour)

R = .98 at 90% CONFIDENCE

F	N	CONE	Rt for 90% PA	Qt for 90% PA	Qt/Qt REQ.
0	114	.900052340	.999076211913	1081	21.857
1	194	.901537749	.997255382153	363	7.35
2	265	.902767174	.995854125743	239	4.83
3	333	.904013472	.994750522908	189	3.83
4	398	.905376362	.993875867736	162	3.28
5	462	.906845362	.993163775676	145	2.94
6	525	.908423558	.992566446051	134	2.70
7	587	.910120515	.992052023213	125	2.50
8	648	.911912301	.991599865926	118	2.39
9	708	.913807402	.991195511927	113	2.28
10	768	.915806168	.990840577415	108	2.19
11	828	.917914377	.990526071941	105	2.122
12	887	.9201355707	.990234073642	101	2.058
13	945	.922472198	.989960478216	99	2.002
14	1004	.924958008	.989722410523	96	1.95
15	1062	.927595702	.989495604861	95	1.91
16	1120	.9303971098	.989287717493	93	1.87
17	1177	.933368799	.9890987059036	91	1.84
18	1235	.9365093622	.9889210475147	90	1.81
19	1292	.9398226420	.9887537763352	88	1.78
20	1349	.9433184588	.988577331437	87	1.75
21	1406	.94699252322	.988427320314	86	1.73
22	1463	.950846012	.988286846707	85	1.71
23	1519	.9548747861	.988147162327	84	1.69
24	1576	.95908381400	.988023277275	83	1.68
25	1632	.9634786043	.987897031559	82	1.65
26	1688	.968067815	.987781583449	81	1.64
27	1744	.9728619697	.987670356208	81	1.63
28	1800	.9778734980	.987564838074	80	1.61
29	1856	.9830107666	.987464573150	79	1.60
30	1912	.988282379	.987369157216	79	1.59
31	1968	.9937044286	.987278215991	78	1.58
32	2023	.999282296			
33	2079	.9950344009			
34	2134	.991117755			
35	2190	.98745458	.986941227070	76	1.54
36	2245	.98410661			
37	2300	.980205978	.986787361413	75	1.52
38	2355	.976137880			
39	2410	.972103852			
40	2465	.968101572			
41	2520	.964124893			
42	2575	.960183829			
43	2630	.956264573			
44	2685	.95247319			
45	2739	.948832677			
46	2794	.94535911			
47	2847	.941951712			
48	2903	.93869700			
49	2958	.935511977			
50	3012	.93241045	.9860	71	1.43
51	3067	.929394479			
52	3121	.926475281	.9859	70	1.42

THIS PAGE IS BEST QUALITY PRACTICABLE FROM COPY FURNISHED TO DDG

FIGURE 12

FIELD TEST TRADE-OFF REQUIREMENTS

R = .90 at 90% CONFIDENCE

F	N	CONF	R _T for = RISK
0	22	.901522909	.99522233518
1	38	.904704869	.98591697
2	52	.903366714	.978619
3	65	.900447174	.97289
4	78	.900605676	.9684915
5	91	.902424110	.96563287417
6	104	.905164016	.96216118
7	116	.903612658	.959444555
8	128	.902872620	.957121541
9	140	.902736185	.955108963191
10	150	.903054246	.953345633172
11	164	.903717433	.951785804859
12	175	.900568851	.950107901560
13	187	.901858866	.948863900485
14	199	.903294126	.947743429032
15	210	.901107564	.945473106936
16	222	.902876028	.945550814046
17	233	.901140383	.944464711760
18	245	.903125862	.943691216365
19	256	.901737086	.942750787225
20	267	.90509799	.941874571825
21	279	.902743287	.941269036307
22	290	.901757058	.940476630841
23	301	.900887839	.939771191198
24	312	.902130924	.939088324846
25	324	.902557997	.938635792233
26	335	.901953607	.938022525676
27	346	.901430670	.937441789598
28	357	.900783576	.936890900223
29	368	.900605570	
30	379	.900291681	.935869528855
31	390	.900036657	.935394969669

THIS PAGE IS BEST QUALITY PRACTICABLE
FROM COPY FURNISHED TO DDG

FIGURE 13