

AD-A057 644

ILLINOIS UNIV AT URBANA-CHAMPAIGN DECISION AND CONTROL LAB F/G 12/1
SINGULAR PERTURBATION OF NONLINEAR REGULATORS AND SYSTEMS WITH --ETC(U)
DEC 77 J H CHOW
DC-8

DAAB07-72-C-0259

NL

UNCLASSIFIED

1 OF 2

AD
A057644



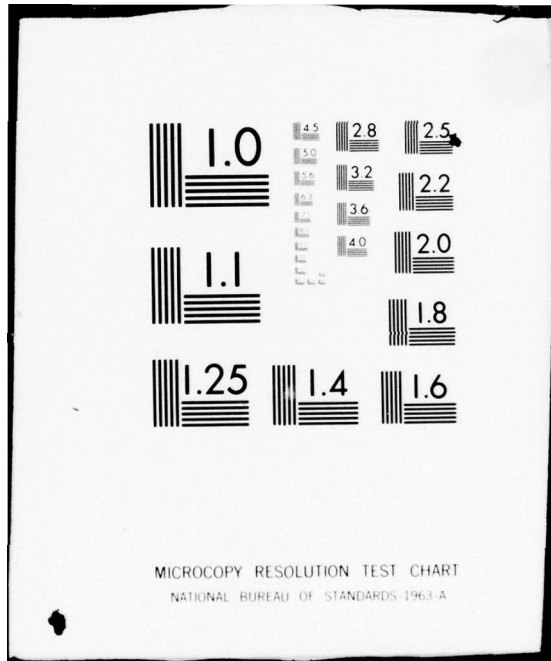

1.0

1.1

1.25

4.5
5.0
5.6
6.3
7.1
8.0
9.0
10

2.8

3.2

3.6

4.0

2.5

2.2

2.0

1.8

1.4

1.6

MICROCOPY RESOLUTION TEST CHART
NATIONAL BUREAU OF STANDARDS-1963-A

LEVEL II

12
NU

REPORT DC-8

DECEMBER, 1977

AD A 057644

CSL COORDINATED SCIENCE LABORATORY

DECISION AND CONTROL LABORATORY

**SINGULAR PERTURBATION
OF NONLINEAR REGULATORS
AND SYSTEMS WITH
OSCILLATORY MODES**

JOE HONG CHOW

DDC FILE COPY

DDC
RECEIVED
AUG 18 1978
[Signature]

APPROVED FOR PUBLIC RELEASE. DISTRIBUTION UNLIMITED.

78 08 15 082

REPORT R-801

UILU-ENG 77-2248

UNIVERSITY OF ILLINOIS - URBANA, ILLINOIS

UNCLASSIFIED

SECURITY CLASSIFICATION OF THIS PAGE (When Data Entered)

REPORT DOCUMENTATION PAGE		READ INSTRUCTIONS BEFORE COMPLETING FORM
1. REPORT NUMBER	2. GOVT ACCESSION NO.	3. RECIPIENT'S CATALOG NUMBER 14
4. TITLE (and Subtitle) SINGULAR PERTURBATION OF NONLINEAR REGULATORS AND SYSTEMS WITH OSCILLATORY MODES.		5. TYPE OF REPORT & PERIOD COVERED Technical Report DC-8,
7. AUTHOR(s) Joe Hong/Chow		6. PERFORMING ORG. REPORT NUMBER R-801/ULLU-ENG-77-2248
9. PERFORMING ORGANIZATION NAME AND ADDRESS Coordinated Science Laboratory University of Illinois at Urbana-Champaign Urbana, Illinois 61801		8. CONTRACT OR GRANT NUMBER(s) DAAB-07-72-C-0259; US ERDA EX-76-C-01-2088; NSF-ENG-74-20091; AFOSR 73-2570
11. CONTROLLING OFFICE NAME AND ADDRESS Joint Services Electronics Program		10. PROGRAM ELEMENT, PROJECT, TASK AREA & WORK UNIT NUMBERS
14. MONITORING AGENCY NAME & ADDRESS (if different from Controlling Office) Doctoral Thesis,		12. REPORT DATE December, 1977
		13. NUMBER OF PAGES 114
		15. SECURITY CLASS. (of this report) UNCLASSIFIED
16. DISTRIBUTION STATEMENT (of this Report) Approved for public release; distribution unlimited. DAAB 07-72-C-0259, AFOSR-73-2570		15a. DECLASSIFICATION/DOWNGRADING SCHEDULE
17. DISTRIBUTION STATEMENT (of the abstract entered in Block 20, if different from Report)		
18. SUPPLEMENTARY NOTES		
19. KEY WORDS (Continue on reverse side if necessary and identify by block number) Two Time Scales Nonlinear Regulators Separation of Designs Systems with Fast Frequency Oscillations		
20. ABSTRACT (Continue on reverse side if necessary and identify by block number) This report applies singular perturbation techniques to nonlinear optimal control problems and systems with high frequency oscillatory behavior. For a class of nonlinear regulator problems we solve for the Hamilton-Jacobi equation as a power series expansion whose coefficients are solved from equations involving the slow variables only. Consequently we obtain near-optimal feedback controls. Through the construction of a composite Lyapunov function, we show that these controls can stabilize large disturbances of the fast variables. A fixed endpoint nonlinear control problem is decomposed,		

DD FORM 1473

1 JAN 73

EDITION OF 1 NOV 65 IS OBSOLETE

UNCLASSIFIED

SECURITY CLASSIFICATION OF THIS PAGE (When Data Entered)

410 775

LB to next page

UNCLASSIFIED

SECURITY CLASSIFICATION OF THIS PAGE(When Data Entered)

20. ABSTRACT (continued)

into three lower order problems, namely, the nonlinear reduced order problem and the linear quadratic left and right boundary layer problems. For systems with high frequency oscillatory behavior, ~~we decompose~~ the original system ^{is decomposed} into a slowly varying system and a fast oscillatory system. This procedure provides physical interpretations for the high frequency oscillations occurring in a mass-spring-damper system and an interconnected power system.

UNCLASSIFIED

SECURITY CLASSIFICATION OF THIS PAGE(When Data Entered)

ACCESSION FOR	
NTIS	White Section <input checked="" type="checkbox"/>
DDC	Outf Section <input type="checkbox"/>
UNANNOUNCED	<input type="checkbox"/>
JUSTIFICATION	
BY	
DISTRIBUTION/AVAILABILITY CODES	
Dist.	AVAIL. and/or SPECIAL
A	

LEVEL II

12

UILU-ENG 77-2248

SINGULAR PERTURBATION OF NONLINEAR
REGULATORS AND SYSTEMS WITH OSCILLATORY MODES

by

Joe Hong Chow

This work was supported in part by the Joint Services Electronics Program (U.S. Army, U.S. Navy and U.S. Air Force) under Contract DAAB-07-72-C-0259; by the Energy Research and Development Administration under Contract US ERDA EX-76-C-01-2088; by the National Science Foundation under Grant NSF-ENG-74-20091; and by the Air Force Office of Scientific Research under Contract AFOSR 73-2570.

Reproduction in whole or in part is permitted for any purpose of the United States Government.

Approved for public release. Distribution unlimited.

DDC
RECEIVED
AUG 18 1978
D

28 08 10 072

SINGULAR PERTURBATION OF
NONLINEAR REGULATORS AND SYSTEMS WITH OSCILLATORY MODES

BY

JOE HONG CHOW

B.E.E., University of Minnesota, 1974
B.Math., University of Minnesota, 1974
M.S., University of Illinois, 1975

THESIS

Submitted in partial fulfillment of the requirements
for the degree of Doctor of Philosophy in Electrical Engineering
in the Graduate College of the
University of Illinois at Urbana-Champaign, 1978

Thesis Advisor: Professor Petar V. Kokotovic

Urbana, Illinois

SINGULAR PERTURBATION OF
NONLINEAR REGULATORS AND SYSTEMS WITH OSCILLATORY MODES

Joe Hong Chow, Ph.D.
Department of Electrical Engineering
University of Illinois at Urbana-Champaign, 1978

This thesis applies singular perturbation techniques to nonlinear optimal control problems and systems with high frequency oscillatory behavior. For a class of nonlinear regulator problems we solve for the Hamilton-Jacobi equation as a power series expansion whose coefficients are solved from equations involving the slow variables only. Consequently we obtain near-optimal feedback controls. Through the construction of a composite Lyapunov function, we show that these controls can stabilize large disturbances of the fast variables. A fixed endpoint nonlinear control problem is decomposed into three lower order problems, namely, the nonlinear reduced order problem and the linear quadratic left and right boundary layer problems. For systems with high frequency oscillatory behavior, we decompose the original system into a slowly varying system and a fast oscillatory system. This procedure provides physical interpretations for the high frequency oscillations occurring in a mass-spring-damper system and an interconnected power system.

ACKNOWLEDGMENT

The author would like to thank his advisor Professor P. V. Kokotovic for his invaluable help and encouragement during the preparation of this thesis. He would also like to thank Professors J. B. Cruz, Jr., W. R. Perkins, and J. Medanic for serving on his dissertation committee, and Mr. John Allemong for his helpful discussions on the power system examples. Finally, he would like to thank Mrs. Hazel Corray and Mrs. Trudy Williams for their excellent typing.

TABLE OF CONTENTS

	Page
1. INTRODUCTION	1
1.1 Singular Perturbation Methods	1
1.2 Stability Results	2
1.3 Optimal Control Problems	3
1.4 Systems with High Frequency Oscillatory Modes	4
1.5 Chapter Preview	5
2. STABILITY RESULTS	7
2.1 Introduction	7
2.2 A Synchronous Machine Model	9
2.3 A Composite Lyapunov Function	12
2.4 Example	19
2.5 A Stabilizing Feedback Control	22
2.6 Discussion	24
3. SINGULARLY PERTURBED NONLINEAR REGULATOR	25
3.1 Introduction	25
3.2 A Speed Control Example	27
3.3 The Reduced Control	28
3.4 The Composite Control	31
3.5 An Optimal Speed Control Example	35
3.6 The Formal Expansion	40
3.7 Coefficients of Higher Order Expansions	44
3.8 Approximations of the Performance Value Function	48
3.9 Discussion	53
4. NONLINEAR FIXED ENDPOINT PROBLEM	54
4.1 Introduction	54
4.2 Lower Order Problems	56
4.3 Main Theorem	60
4.4 Example	61
4.5 Asymptotic Expansions	65
4.6 Discussion	76
5. SYSTEMS WITH HIGH FREQUENCY OSCILLATORY MODES	77
5.1 Introduction	77
5.2 Modeling	78
5.3 Averaging of Oscillatory States	82
5.4 Eigenvalue and State Approximations	86

	Page
5.5 Nonlinear Systems	91
5.6 A Power System Example	94
5.7 Discussion	101
6. CONCLUSIONS	102
APPENDIX A: DC MOTOR PARAMETERS	104
APPENDIX B: EQUIVALENCE OF \bar{V}_0 AND L	105
APPENDIX C: EQUIVALENCE OF \bar{x} , \bar{p} and x_0 , p_0	107
APPENDIX D: NOTATIONS USED IN THE POWER SYSTEM EXAMPLE	109
REFERENCES	110
VITA	113

1. INTRODUCTION

1.1 Singular Perturbation Methods

The main theme of this thesis is the study of the regulator problem for a class of singularly perturbed nonlinear systems. Closely related to this topic, we also derive some stability results for these nonlinear systems. Finally, singular perturbation techniques are extended to analyze systems containing high frequency oscillatory modes.

Singular perturbation methods [1] have been recognized in recent years as a powerful tool for analyzing high dimensional systems. These methods not only reduce the order of the system but also remove the stiffness due to the fast phenomena. The full order system

$$\begin{aligned}\dot{x} &= \varphi(x, z, u, t, \mu) \\ \mu \dot{z} &= \psi(x, z, u, t, \mu)\end{aligned}\tag{1.1}$$

where the states are $x \in R^n$ and $z \in R^m$, the input is $u \in R^r$ and μ is the singular perturbation parameter, is interpreted as a perturbation of the lower order system

$$\begin{aligned}\dot{\bar{x}} &= \varphi(\bar{x}, \bar{z}, \bar{u}, t, 0) \\ 0 &= \psi(\bar{x}, \bar{z}, \bar{u}, t, 0)\end{aligned}\tag{1.2}$$

obtained from (1.1) by setting $\mu = 0$. The accuracy of the approximation is improved by reintroducing the fast phenomena as a boundary layer. Higher order approximations are possible by using asymptotic expansion methods.

For linear time-invariant systems

$$\begin{aligned}\dot{x} &= A_{11}x + A_{12}z + B_1u \\ \mu \dot{z} &= A_{21}x + A_{22}z + B_2u\end{aligned}\tag{1.3}$$

initial value problems [2,3] and optimal control problems [4-8] are well documented. One of the tasks of singular perturbation analysis is to establish whether the full problem (1.3) is well posed in the sense that its solution tends to the solution of the reduced problem

$$\begin{aligned}\dot{\bar{x}} &= A_{11}\bar{x} + A_{12}\bar{z} + B_1\bar{u} \\ 0 &= A_{21}\bar{x} + A_{22}\bar{z} + B_2\bar{u}\end{aligned}\tag{1.4}$$

as $\mu \rightarrow 0^+$. We have shown in [8,9] that the regulator problem of minimizing system (1.3) with respect to the performance index

$$J = \int_0^{\infty} (x'Q_1x + 2x'Q_2z + z'Q_3z + u'Ru) dt\tag{1.5}$$

can be solved approximately from two separate reduced order regulator problems for the reduced system and the boundary layer system. Based on these independent reduced order designs, we propose a composite control u_c such that the performance of system (1.3) controlled by u_c is an $O(\mu^2)$ approximation of the optimal performance.

1.2 Stability Results

Stability properties of the nonlinear system (1.1) have been investigated previously in [10-13]. In this thesis we analyze a special class of system (1.1) in the form

$$\begin{aligned}\dot{x} &= a_1(x) + A_1(x)z \\ \mu\dot{z} &= a_2(x) + A_2(x)z\end{aligned}\tag{1.6}$$

which is nonlinear in x and linear in z . By assuming that the equilibrium of the reduced system of (1.6) possesses a domain of stability D and that the real parts of the eigenvalues of $A_2(x)$ are negative for all $x \in D$,

we construct a composite Lyapunov function for (1.6) to examine some stability properties. The main accomplishment here is that our predicted domain of stability is larger than those obtained in previous works [10-13]. An estimate of the singular perturbation parameter μ is also given. The stability results are applied to the design of the control for the system

$$\begin{aligned}\dot{x} &= a_1(x) + A_1(x)z + B_1(x)u \\ \mu\dot{z} &= a_2(x) + A_2(x)z + B_2(x)u.\end{aligned}\tag{1.7}$$

It is shown that by considering separately the designs of the controls for the reduced system and the boundary layer system, we construct a stabilizing composite control for the full system (1.7).

1.3 Optimal Control Problems

The stability results are utilized in the design of the optimal control for system (1.7) with respect to the performance index

$$J = \int_0^{\infty} [p(x) + s'(x)z + z'Q(x)z + u'R(x)u]dt.\tag{1.8}$$

Finite time trajectory optimization problems for the same class of systems have been treated in [14-16] via two point boundary value problems originating from necessary optimality conditions. For the infinite time regulator problem (1.7), (1.8), the Hamilton-Jacobi-Bellman sufficiency condition is more suitable since it readily incorporates stability requirements and leads to feedback solutions. The solution to the Hamilton-Jacobi equation is shown to possess a power series expansion in the components of z and in μ , similar to the results in [17,18,5,8]. A major advantage of the series solution is that the coefficients in the expansion can be solved from

equations involving the slow variable x only. In particular, the coefficients of the leading terms are solved from the reduced order problem and an algebraic Riccati equation. Then similar to our approach of the linear regulator in [8], we construct a composite control for the full system (1.7). With this approach we avoid the explicit treatment of boundary layer phenomena as they are optimized by the z -dependent part of the composite control which uses the variable x as a gain parameter.

For the fixed endpoint problem of minimizing the performance

$$J = \int_0^T [V_1(x, t, \mu) + V_2^T(x, t, \mu)z + z^T V_3(x, t, \mu)z + u^T R(x, t, \mu)u] dt \quad (1.9)$$

of the system (1.7) with initial and end conditions

$$\begin{aligned} x(0, \mu) &= x_0(\mu), \quad z(0, \mu) = z_0(\mu) \\ x(T, \mu) &= x_T(\mu), \quad z(T, \mu) = z_T(\mu) \end{aligned} \quad (1.10)$$

our approach is to decompose the full order problem into three lower order problems, namely, the reduced problem and the left and the right boundary layer problems. Thus the technique in [7] for linear quadratic problems is now extended to nonlinear problems. The boundary layer problems are linear quadratic and contrary to previous singular perturbation works, the reduced problem has a simple formulation. For system (1.7) where A_2 is unstable, a partially closed-loop control is proposed.

1.4 System with High Frequency Oscillatory Modes

Singular perturbation techniques are primarily developed for systems of the type (1.3)

$$\begin{aligned} \dot{x} &= Ax + Bz \\ \mu \dot{z} &= Cx + Dz \end{aligned} \quad (1.11)$$

where D is a stable matrix. Then after the transients in z have decayed, the states of (1.11) are approximated by the reduced system where $\mu = 0$. In this thesis, we extend singular perturbation techniques to systems with high frequency oscillatory modes characterized by (1.11) with D a $2m \times 2m$ matrix in the form

$$D = \begin{bmatrix} \mu D_1 & D_2 \\ D_3 & \mu D_4 \end{bmatrix} \Bigg\}^m \quad (1.12)$$

where the eigenvalues of $D_2 D_3$ are negative real and simple. It is shown that the state x is primarily a slow variable while the state z consists of both the slow modes and the high frequency oscillatory modes. Letting $\mu = 0$ is equivalent to neglecting the high frequency components of z and retaining its averaged value [19,20]. The Chang's transformation [21,22] can be used to decompose system (1.11) into a slowly varying system and a fast oscillatory system. A similar transformation is applied to nonlinear systems with high frequency oscillatory behavior. This decomposition technique is used to show the high frequency oscillations in a mass-spring-damper system and an interconnected power system.

1.5 Chapter Preview

Chapter 2 derives sufficient conditions to guarantee the stability of the singularly perturbed nonlinear system (1.6). A procedure of constructing a Lyapunov function for such a class of systems is given and a clearly defined domain of attraction of the equilibrium is obtained. A stabilizing feedback control for such systems is also proposed.

Chapter 3 develops a new series expansion method for the regulator problem (1.7), (1.8). The feedback design is simplified by the fact that the

coefficients of the series are determined from equations involving only the slow variable x . An estimate of the degree of near-optimality of the feedback control is given and illustrated by a speed control example.

Chapter 4 decomposes the fixed endpoint problem (1.7), (1.9), (1.10) into three lower order problems and combines the solutions to these problems to yield an approximate solution. An asymptotic series solution is also discussed.

Chapter 5 proposes a subsystem decomposition for systems containing high frequency oscillatory modes. Eigenvalues and state approximations achieved by the subsystems are given. Nonlinear systems are decomposed in a similar manner. A mass-spring-damper example shows that a stiff spring can be regarded as a perturbation of a rigid rod and an interconnected power system example illustrates the occurrence of coherency and intermachine oscillations.

2. STABILITY RESULTS

2.1 Introduction

Stability properties of the nonlinear system

$$\begin{aligned}\dot{x} &= \varphi(t, x, z, \mu), \quad x(0) = x_0 \\ \mu \dot{z} &= \psi(t, x, z, \mu), \quad z(0) = z_0\end{aligned}\tag{2.1}$$

where μ is a small positive parameter, $x, \varphi \in R^n$ and $z, \psi \in R^m$, have been investigated previously in [2,10-13]. In this chapter we analyze a special class of system (2.1) in the form

$$\dot{x} = a_1(x) + A_1(x)z, \quad x(0) = x_0\tag{2.2a}$$

$$\mu \dot{z} = a_2(x) + A_2(x)z, \quad z(0) = z_0\tag{2.2b}$$

which is nonlinear in x and linear in z .

Letting $\mu = 0$, system (2.2) becomes

$$\frac{d\bar{x}}{dt} = a_1(\bar{x}) + A_1(\bar{x})\bar{z}, \quad \bar{x}(0) = x_0\tag{2.3a}$$

$$0 = a_2(\bar{x}) + A_2(\bar{x})\bar{z}.\tag{2.3b}$$

Assuming that $A_2(\bar{x})$ is nonsingular, \bar{z} is solved from (2.3b) as

$$\bar{z} = -A_2^{-1}(\bar{x})a_2(\bar{x})\tag{2.4}$$

and its elimination from (2.3a) results in the reduced system

$$\dot{\bar{x}} = a_1 - A_1 A_2^{-1} a_2 \equiv a_0(\bar{x}), \quad \bar{x}(0) = x_0.\tag{2.5}$$

To derive the fast subsystem or the boundary layer system, we assume that the slow variables are constant in the boundary layer, that is $\dot{\bar{z}} = 0$ and $x = x_0 = \text{constant}$. Subtracting (2.4) from (2.2b) at $t = 0$, we obtain

$$\mu(\dot{z} - \dot{\bar{z}}) = A_2(x_0)(z - \bar{z}).\tag{2.6}$$

Redefining $\hat{z} = z - \bar{z}$, we formulate the fast subsystem of (2.2) as

$$\mu \dot{\hat{z}} = A_2(x_0) \hat{z}, \quad \hat{z}(0) = z_0 - \bar{z}(0) \quad (2.7)$$

that is,

$$\frac{d\hat{z}}{d\tau} = A_2(x_0) \hat{z} \quad (2.8)$$

where $\tau = t/\mu$ is the fast time scale.

Under the assumptions specified later, the response of system (2.2) can be approximated by

$$\begin{aligned} x(t) &= \bar{x}(t) + O(\mu) \\ z(t) &= \bar{z}(t) + \hat{z}(t) + O(\mu). \end{aligned} \quad (2.9)$$

We assume that systems (2.2), (2.5) and (2.7) satisfy the following assumptions for all $x \in D$ where D is a closed set in R^n containing the origin:

(A2.1) The vectors a_1 , a_2 and matrices A_1 , A_2 are bounded and differentiable with respect to x , and $a_1(x) = 0$, $a_2(x) = 0$ only at $x = 0$.

(A2.2) The real parts of the eigenvalues of A_2 are strictly negative, that is, there exists a fixed $\sigma < 0$ such that $\text{Re}\{\lambda(A_2)\} \leq \sigma$.

Thus A_2 is nonsingular.

(A2.3) There exists a Lyapunov function $L(\bar{x})$ for the reduced system (2.5) where $\dot{L}(\bar{x})$ is negative definite, guaranteeing that $\bar{x} = 0$ is an asymptotically stable equilibrium. Furthermore, the level surface $L(\bar{x}) = c$ where c is a positive constant is taken to be the boundary of D . Hence D belongs to the domain of attraction of $\bar{x} = 0$.

Assumption (A2.2) guarantees that there exists a positive definite matrix $P(x)$ such that

$$P(x)A_2(x) + A_2'(x)P(x) = -I_m \quad (2.10)$$

where I_i denotes the $i \times i$ identity matrix. Then based on $L(x)$ and $P(x)$, we formulate a Lyapunov function for system (2.2). Since the structure of system (2.2) is simpler than system (2.1), we relax the condition used in [2,11] that the linearized reduced system (2.5) be asymptotically stable. Furthermore, by introducing a small parameter ϵ into our Lyapunov function for system (2.2), the domain of stability of $x=0$, $z=0$ includes z of $O(1/\sqrt{\epsilon})$.

2.2 A Synchronous Machine Model

As an example of system (2.2), we consider a well known fifth order model of a synchronous machine [23]. Neglecting the damper windings and saturation, the equations for the direct and quadrature axis voltages v_d and v_q , and the field flux linkage ψ_f are

$$\frac{v_d}{r_a} = -i_d - \frac{(L_d L_f - M_{df}^2)}{r_a L_f} \frac{di_d}{d\tau} + \frac{M_{df}}{r_a L_f} \frac{d\psi_f}{d\tau} + \frac{L_q \Omega i_q}{r_a} \quad (2.11)$$

$$\frac{v_q}{r_a} = -i_q - \frac{L_q}{r_a} \frac{di_q}{d\tau} - \frac{(L_d L_f - M_{df}^2) \Omega i_d}{r_a L_f} + \frac{M_{df} \Omega \psi_f}{r_a L_f} \quad (2.12)$$

$$\frac{L_f}{r_f} \frac{d\psi_f}{d\tau} = -\psi_f - M_{df} i_d + \frac{L_f v_f}{r_f} \quad (2.13)$$

where i_d , L_d , i_q , L_q are the currents and reactances of the d- and q-axes, respectively, r_a is the armature resistance, v_f , L_f , r_f are the field voltage, reactance and resistance, respectively, M_{df} is the mutual reactance between the d-axis and field circuit, Ω is the instantaneous per unit angular velocity of the rotor and τ is the per unit time. The swing equation is

$$\frac{d\gamma}{d\tau} = \Omega - \Omega_0, \quad \gamma = \theta - \Omega_0 \tau \quad (2.14)$$

$$2\omega_0 H \frac{d\Omega}{d\tau} = T_{in} - \frac{M_{df} \psi_f i_q}{L_f} \quad (2.15)$$

where θ is the rotor angle, Ω_0 the nominal value of Ω , ω_0 the rated frequency in rad/sec., H the inertia constant and T_{in} the input torque. Note that the torque $(L_d - L_q - M_{df}^2/L_f) i_d i_q$ due to saliency has been neglected in (2.15).

From experience it is known that the mechanical and field circuit transients primarily described by (2.13), (2.14), (2.15) are much slower than the transients in the d- and q-axes (2.11), (2.12). To exhibit this two-time-scale behavior we introduce a slow time variable

$$\tau' = \frac{r_f \tau}{L_f} = \frac{\tau}{T'_{do}} \quad (2.16)$$

normalized with respect to the d-axis open-circuit time constant T'_{do} .

Defining the singular perturbation parameter μ as the ratio of a small and a large time constant

$$\mu = \frac{r_f (L_d L_f - M_{df}^2)}{r_a L_f^2} \quad (2.17)$$

we rewrite (2.11), (2.12) in the slow time scale as

$$\frac{v_d}{r_a} = -i_d - \mu \frac{di_d}{d\tau'} + \alpha_1 \mu \frac{d\psi_f}{d\tau'} + \frac{L_q \Omega i_q}{r_a} \quad (2.18)$$

$$\frac{v_q}{r_a} = -i_q - \alpha_2 \mu \frac{di_q}{d\tau'} - \frac{(L_f L_d - M_{df}^2) \Omega i_d}{r_a L_f} + \frac{M_{df} \Omega \psi_f}{r_a L_f} \quad (2.19)$$

where

$$\alpha_1 = \frac{M_{df}}{(L_d L_f - M_{df}^2)}, \quad \alpha_2 = \frac{L_q L_f}{(L_d L_f - M_{df}^2)}. \quad (2.20)$$

Similarly we rewrite (2.13), (2.14), (2.15) in the slow time scale. The resulting system has the form (2.2) in which the slow variables are $\bar{\gamma}$, $\bar{\Omega}$ and $\bar{\Psi}_f$ and the fast variables i_d and i_q whose derivatives are multiplied by μ , appear linearly in these equations.

Letting $\mu = 0$, the slow subsystem of (2.11)-(2.15) is

$$\begin{aligned} \frac{d\bar{\gamma}}{d\tau'} &= \frac{L_f}{r_f} (\bar{\Omega} - \Omega_0) \\ \frac{d\bar{\Omega}}{d\tau'} &= \frac{L_f}{2\omega_0 H r_f} (T_{in} - \frac{M_{df} \bar{\Psi}_f \bar{i}_q}{L_f}) \\ \frac{d\bar{\Psi}_f}{d\tau'} &= -\bar{\Psi}_f - M_{df} \bar{i}_d + \frac{L_f v_f}{r_f} \end{aligned} \quad (2.21)$$

where the slow parts of i_d and i_q satisfy the algebraic equations

$$\begin{aligned} \frac{v_d}{r_a} &= -\bar{i}_d + \frac{L_q \bar{\Omega} \bar{i}_q}{r_a} \\ \frac{v_q}{r_a} &= -\bar{i}_q - \frac{(L_f L_d - M_{df}^2) \bar{\Omega} \bar{i}_d}{r_a L_f} + \frac{M_{df} \bar{\Omega} \bar{\Psi}_f}{r_a L_f}. \end{aligned} \quad (2.22)$$

The fast subsystem is

$$\begin{aligned} \frac{d\hat{i}_d}{d\tau''} &= -\hat{i}_d + \frac{L_q \bar{\Omega} \hat{i}_q}{r_a} \\ \frac{d\hat{i}_q}{d\tau''} &= -\frac{(L_f L_d - M_{df}^2) \bar{\Omega} \hat{i}_d}{\alpha_2 r_a L_f} - \frac{\hat{i}_q}{\alpha_2} \end{aligned} \quad (2.23)$$

where $\tau'' = \tau'/\mu$. It is crucial that in (2.23) the slow part $\bar{\Omega}$ is regarded as a constant.

The slow subsystem (2.21) is analogous to Kimbark's third order model [24]. Instead of neglecting $di_d/d\tau$, $di_q/d\tau$ as it was in [24], we set $\mu = 0$ to obtain the slow subsystem. We also obtain the fast subsystem (2.23) governing the transient behavior of i_d and i_q . Since this order reduction is caused by a parameter perturbation from $\mu > 0$ to $\mu = 0$, we are able to use approximations of the type $\gamma \simeq \bar{\gamma}$, $\Omega \simeq \bar{\Omega}$, $\Psi_f \simeq \bar{\Psi}_f$, $i_d \simeq \bar{I}_d + \hat{i}_d$ and $i_q \simeq \bar{i}_q + \hat{i}_q$.

2.3 A Composite Lyapunov Function

With the change of variables

$$\eta = z + A_2^{-1} a_2 \quad (2.24)$$

exhibiting η as the fast part of z , system (2.2) becomes

$$\dot{x} = a_0 + A_1 \eta, \quad x(0) = x_0 \quad (2.25a)$$

$$\begin{aligned} \mu \dot{\eta} &= \mu (A_2^{-1} a_2)_x a_0 + [A_2 + \mu (A_2^{-1} a_2)_x A_1] \eta \\ &\equiv \mu f(x) + [A_2(x) + \mu F(x)] \eta, \quad \eta(0) = z_0 + A_2^{-1}(x_0) a_2(x_0) \end{aligned} \quad (2.25b)$$

where the subscript x denotes partial differentiation with respect to x . Since the right-hand side of (2.25b) is an $O(\mu)$ perturbation of $A_2(x)\eta$ and $\text{Re}\{\lambda(A_2)\} < 0$ in D , we expect that η will rapidly decay to an $O(\mu)$ quantity. This motivates the introduction of

$$U(x, \eta, \mathcal{E}) = L(x) + \mathcal{E} \eta' P(x) \eta \quad (2.26)$$

as a tentative Lyapunov function for system (2.25). Here \mathcal{E} is a small positive scalar to be determined. From Assumption (A2.3) and (2.10), $L(x)$ and $P(x)$ are positive definite in D . Hence U is positive definite for all $x \in D$ and $\eta \in \mathbb{R}^m$. Furthermore, since $L(x) = c > 0$ for all x on the boundary of D , the surface

$$S(x, \eta, \varepsilon) = \{x, \eta : U(x, \eta, \varepsilon) = c\} \quad (2.27)$$

is closed in the $(n+m)$ -dimensional domain $x \in D$, $\eta \in R^m$. We define S_{in} to be the domain in the interior of S .

Let D_1 be a set strictly in the interior of D , that is, the boundary of D_1 does not intersect the boundary of D , and let E be a bounded set in R^m . The presence of ε in U extends S to encompass (x, η) for all $x \in D_1$ and for η in any prescribed set E . This crucial result is stated as follows.

Lemma 2.3.1

If Assumptions (A2.2) and (A2.3) are satisfied, then there exists an $\varepsilon > 0$ such that the domain S_{in} contains all $x \in D_1, \eta \in E$.

Proof: At each point $\hat{x} \in D_1$, the projection of S onto the η subspace is the ellipsoid

$$\eta' P(\hat{x}) \eta = (c - L(\hat{x})) / \varepsilon \quad (2.28)$$

implying that η extends to $O(1/\sqrt{\varepsilon})$. Hence for every \hat{x} , there exists an $\varepsilon(\hat{x})$ sufficiently small such that the ellipsoid (2.28) includes all $\eta \in E$. (Note that we must exclude the boundary of D because from (2.28) the projection of S at any point on the boundary of D is a single point $\eta = 0$.) Hence choosing ε^* to be the smallest of such $\varepsilon(\hat{x})$, the domain S_{in} contains all $x \in D_1, \eta \in E$ for any $\varepsilon \in (0, \varepsilon^*]$.

By virtue of Lemma 2.3.1, the initial condition $\eta(0)$ of (2.25b), and hence $z(0)$ of (2.2), can be as far away from zero as $O(1/\sqrt{\varepsilon})$ and still be enclosed by S . We now examine the relationship between ε and μ .

The time derivative of U with respect to (2.25) is

$$\dot{U} = -g(x, \varepsilon, \mu) - \frac{\varepsilon}{2\mu} \xi' \xi - \frac{\varepsilon}{\mu} \eta' M(x, \eta, \mu) \eta \quad (2.29)$$

where

$$\begin{aligned}
 g &= g_1 - \frac{\mu}{2\mathcal{E}} y'y \\
 g_1 &= -L_x a_0 \\
 y &= A_1' L_x' + 2\mathcal{E}PF \\
 \xi &= \eta - \frac{\mu}{\mathcal{E}} y \\
 M &= I_m/2 - \mu(PF + F'P) - \mu\dot{P}.
 \end{aligned} \tag{2.30}$$

Since $PF + F'P$ and \dot{P} are bounded for all x, η in S_{in} , it follows that there exists a $\mu_1^* > 0$ such that $M > 0$ for all x, η in S_{in} and for $\mu \in (0, \mu_1^*]$. Thus the last two terms in \dot{U} are positive definite. To ensure that $g(x, \mathcal{E}, \mu)$ is positive definite, we assume that the reduced system also satisfies

(A2.4) The limit

$$\lim_{|x| \rightarrow 0} \frac{y'y}{g_1} = k(\mathcal{E}) < \infty \tag{2.31}$$

exists for all fixed $\mathcal{E} > 0$.

Note that $k \geq 0$ because $y'y$ is positive definite and from Assumption (A2.3), g_1 is also positive definite. The limit (2.31) implies that there exists a domain \tilde{D} about $x = 0$ such that

$$y'y \leq (1+k)g_1. \tag{2.32}$$

Then for $\mu < 2\mathcal{E}/(1+k)$, g is positive definite in \tilde{D} , see (2.30). Let $\bar{k}(\mathcal{E}) > 0$ be the minimum value of g_1 on the boundary of \tilde{D} . Hence in the domain

$$\tilde{D}_1(x) = \{x : g_1(x) < \bar{k}\} \tag{2.33}$$

g is positive definite. On the other hand, since D is bounded, there exists a $k_1(\mathcal{E}) > 0$ such that $y'y < k_1$ for all $x \in D$. Thus g is positive definite when x is not in the domain

$$\bar{D}(x) = \{x : g_1(x) < \mu k_1 / 2\mathcal{E}\} \quad (2.34)$$

about the origin. But for $\mu < 2\mathcal{E}\bar{k}/k_1$, $\bar{D} \subset \tilde{D}_1$, implying that g is positive definite in D . Thus \dot{U} is negative definite for all x, η contained in S_{in} . We now conclude that U is a Lyapunov function for (2.25) guaranteeing that $x = 0, \eta = 0$ is asymptotically stable for all $x \in D_1, \eta \in E$ and for $\mu \in (0, \mu^*]$, where

$$\mu^* = \min\left(\frac{2\mathcal{E}}{1+k}, \frac{2\mathcal{E}\bar{k}}{k_1}, \mu_1^*\right). \quad (2.35)$$

Returning from the η variable to the z variable via $z = \eta - \bar{A}_2^{-1} \frac{1}{a_2}$, we obtain for all $x \in D_1, \eta \in E$ a corresponding bounded domain E_1 for z . We summarize the above discussions as follows.

Theorem 2.3.1

If Assumptions (A2.1)-(A2.4) are satisfied, then there exists a $\mu^* > 0$ that for all $\mu \in (0, \mu^*]$ and for all $x \in D_1$ and z in any prescribed bounded set E_1 , the origin $x = 0, z = 0$ of system (2.2) is asymptotically stable.

Theorem 2.3.1 can be applied in two different directions. As outlined above, for any given D_1 and E_1 , we first find \mathcal{E}^* such that S_{in} of (2.27) contains all $x \in D_1, z \in E_1$. Then we find μ^* from (2.35). This direction is suitable when μ is a parameter at the designer's disposal, such as a gain factor [25]. In the other direction, if μ represents some given physical parameters, such as time constants, we use its value to determine the smallest \mathcal{E} such that \dot{U} of (2.29) is negative definite, that is we find the largest D_1 and E_1 .

A sufficient condition for the reduced system (2.5) to satisfy Assumption (A2.4) is the following:

(A2.5) There exists a positive definite matrix $Q(x)$ satisfying the x -dependent algebraic Lyapunov equation

$$Q(x)a_{ox}(x) + a'_{ox}(x)Q(x) = -C(x) \quad (2.36)$$

for some differentiable positive definite matrix $C(x)$ and for all $x \in D$. Let the matrices $G(x)$ and $N(x)$ be

$$G(x) = 2Q(x)a_{ox}(x) + K(x) \quad (2.37a)$$

$$N(x) = Qa_{ox} + a'_{ox}Q + \sum_{j=1}^n Q_{x_j} a_{oj} = -C + \sum_{j=1}^n Q_{x_j} a_{oj} \quad (2.37b)$$

where K is a matrix whose j th column is $(Q_{x_j} a_o)$ and x_j, a_{oj} are the j th components of the vectors x, a_o , respectively. It is assumed that G bounded and $\lambda(N(x)) \leq \sigma_1$ for a fixed $\sigma_1 < 0$.

The meaning of Assumption (A2.5) is that the reduced system (2.5) possesses a Lyapunov function $L(\bar{x})$ of Krasovskii's type [26], [27, p. 38], that is,

$$L(\bar{x}) = a'_o(\bar{x})Q(\bar{x})a_o(\bar{x}) > 0, \quad L(0) = 0 \quad (2.38)$$

such that $L_{\bar{x}}(\bar{x}) = a'_o(\bar{x})G(\bar{x})$ and

$$\dot{L}(\bar{x}) = a'_o(\bar{x})N(\bar{x})a_o(\bar{x}) < 0, \quad \dot{L}(0) = 0. \quad (2.39)$$

Thus the origin $\bar{x} = 0$ of (2.5) is an asymptotically stable equilibrium. Without loss of generality, D is chosen such that $L(\bar{x}) = c$ for a fixed $c > 0$ and all \bar{x} on the boundary of D .

From (2.30) and (2.25b), we obtain

$$y = [A'_1 G' + 2\mathcal{E}P(A_2^{-1} a_2)_{x'}] a_o \equiv Y a_o \quad (2.40)$$

and the limit (2.31) is bounded by

$$\begin{aligned} \lim_{|x| \rightarrow 0} \frac{y'y}{g_1} &= \lim_{|x| \rightarrow 0} \frac{a_o' Y' Y a_o}{-a_o' N a_o} \\ &\leq \lim_{|x| \rightarrow 0} \frac{\alpha_1 a_o' a_o}{\alpha_2 a_o' a_o} = \frac{\alpha_1}{\alpha_2} \end{aligned} \quad (2.41)$$

where α_1 is the largest eigenvalue of $Y'Y$ and α_2 is the smallest eigenvalue of $-N$ for all $x \in D$. We summarize this result as follows.

Corollary 2.3.1

If Assumptions (A2.1), (A2.2) and (A2.5) are satisfied, then the conclusion of Theorem 2.3.1 holds.

As a special case of Assumption (A2.5), consider when the origin $\bar{x} = 0$ of the reduced system (2.5) is exponentially stable. Then near the origin, $|a_o(\bar{x})|$ grows as $|\bar{x}|$ and we can find $L(\bar{x})$ such that $L(\bar{x})$ grows as $|\bar{x}|^2$ and $|L_{\bar{x}}(\bar{x})|$ grows as $|\bar{x}|$. Hence there exist positive constants k_2, \dots, k_9 and δ such that

$$\begin{aligned} k_2 |x|^2 &\leq L(x) \leq k_3 |x|^2 \\ k_4 |x|^2 &\leq -L_{\bar{x}} a_o(x) \leq k_5 |x|^2 \\ k_6 |x| &\leq |L_{\bar{x}}(x)| \leq k_7 |x| \\ k_8 |x| &\leq |a_o(x)| \leq k_9 |x| \end{aligned} \quad (2.42)$$

for all $|x| < \delta$. It follows from (2.42) that there exists a fixed $k_{10}(\mathcal{E}) > 0$ such that

$$y'y \leq k_{10} |x|^2 \quad (2.43)$$

and the limit (2.31) is bound by

$$\lim_{|x| \rightarrow 0} \frac{y'}{g_1} \leq \lim_{|x| \rightarrow 0} \frac{k_{10}|x|^2}{k_4|x|^2} = \frac{k_{10}}{k_4} \quad (2.44)$$

satisfying Assumption (A2.4).

In this case a claim stronger than Theorem 2.3.1 can be made.

Corollary 2.3.2

If Assumptions (A2.1)-(A2.3) are satisfied and the origin $\bar{x} = 0$ of the reduced system is exponentially stable, then the conclusion of Theorem 2.3.1 holds and moreover the origin $x = 0, z = 0$ of (2.2) is exponentially stable.

Proof: The first part of the corollary follows from Theorem 2.3.1. The second part follows from the linearization of (2.2) at the origin

$$\frac{d}{dt} \begin{bmatrix} \delta x \\ \delta z \end{bmatrix} = \begin{bmatrix} \frac{\partial a_1(0)}{\partial x} & A_1(0) \\ \frac{1}{\mu} \frac{\partial a_2(0)}{\partial x} & \frac{1}{\mu} A_2(0) \end{bmatrix} \begin{bmatrix} \delta x \\ \delta z \end{bmatrix}. \quad (2.45)$$

The system matrix of (2.45) has one group of n small eigenvalues $O(\mu)$ close to those of $\left(\frac{\partial a_1}{\partial x} - A_1 A_2^{-1} \frac{\partial a_2}{\partial x} \right) \Big|_{x=0}$ and another group of m large eigenvalues $O(1)$ close to those of $\frac{1}{\mu} A_2(0)$ [22]. But $a_1 - A_1 A_2^{-1} a_2 = a_0$ and $\frac{\partial a_0}{\partial x} \Big|_{x=0} = \left(\frac{\partial a_1}{\partial x} - A_1 A_2^{-1} \frac{\partial a_2}{\partial x} \right) \Big|_{x=0}$ as $a_2(0) = 0$. Thus the real parts of the eigenvalues of the system matrix of (2.45) are all negative and $x = 0, z = 0$ is exponentially stable.

If the origin $\bar{x} = 0$ of the reduced system is asymptotically stable but does not satisfy Assumption (A2.4), then in general g need not be positive definite for all $x \in D$. For this situation the system is now shown to possess

a weaker stability property, that is, its trajectories tend to a small sphere around the origin. Define the domain in \mathbb{R}^n

$$\rho(x) = \{x : g(x, \epsilon, \mu) \leq 0\} \quad (2.46)$$

which is contained in the domain \bar{D} of (2.34). Due to the presence of μ in (2.29), \dot{U} may be positive only if $x \in \rho(x)$ and $\eta = 0(\mu)$. Otherwise, \dot{U} is negative. Defining the surface

$$\pi(x, z) = \{x, z : x \in \rho(x), z = -A_2^{-1}(x)a_2(x)\} \quad (2.47)$$

about the origin in \mathbb{R}^{m+n} , this stability result is formulated in the following theorem.

Theorem 2.3.2

If Assumptions (A2.1)-(A2.3) are satisfied, then there exists a $\mu^* > 0$ such that for all $\mu \in (0, \mu^*]$ and for all $x \in D_1$, $z \in E_1$, the states of the full system (2.2) converge $0(\mu)$ close to the surface $\pi(x, z)$.

Proof: Since $U > 0$ and $\dot{U} < 0$ except for $x \in \rho(x)$ and $\eta = 0(\mu)$, x converges to $\rho(x)$ and η decays to an $0(\mu)$ quantity. Thus in the x, z variables, (x, z) converges to an $0(\mu)$ neighborhood of the surface $\pi(x, z)$.

2.4 Example

We now demonstrate the construction of the Lyapunov function U of (2.26) for the system

$$\begin{aligned} \dot{x} &= xz \\ \mu \dot{z} &= -x^2 - z. \end{aligned} \quad (2.48)$$

Letting $\mu = 0$, we obtain $\bar{z} = -x^2$ and the reduced system

$$\frac{\dot{x}}{x} = -x^3. \quad (2.49)$$

Then the origin $\bar{x} = 0$ is the unique asymptotic stable equilibrium but the linearization of the reduced system at $\bar{x} = 0$ fails to provide any stability information. For system (2.49), $Q(x) = 1/(4\bar{x}^2)$ satisfies Assumption (A2.5) and a Krasovskii's type of Lyapunov function is

$$L(\bar{x}) = \frac{1}{4} \bar{x}^4, \quad \dot{L}(\bar{x}) = -\bar{x}^6. \quad (2.50)$$

Let D be the interval $[-1,1]$, that is, $L = c = \frac{1}{4}$ at $x = \pm 1$.

Using the change of variables $\eta = z + x^2$, system (2.48) becomes

$$\begin{aligned} \dot{x} &= -x^3 + x\eta \\ \mu \dot{\eta} &= -2\mu x^4 + (-1 + 2\mu x^2)\eta. \end{aligned} \quad (2.51)$$

Since we require $|x| \leq 1$, μ is restricted to be less than $1/2$. The tentative Lyapunov function (2.26) for (2.51) is

$$U(x, \eta, \mathcal{E}) = \frac{1}{4} x^4 + \frac{\mathcal{E}}{2} \eta^2. \quad (2.52)$$

If we require that the initial conditions of (2.52) be in $|x| \leq .8$, $|\eta| \leq 4$, then we must set \mathcal{E} to be less than .01845 in order for the ellipse

$$S(x, \eta, \mathcal{E}) = \left\{ x, \eta : U = \frac{1}{4} x^4 + \frac{\mathcal{E}}{2} \eta^2 = \frac{1}{4} \right\} \quad (2.53)$$

to enclose these initial conditions. Plots of S in the x, η coordinates and the x, z coordinates for $\mathcal{E} = .018$ are shown in Figure 2.1.

The time derivative of U with respect to (2.51) is

$$\dot{U} = -(g_1 - \frac{\mu}{\mathcal{E}} y^2) - \frac{\mathcal{E}}{2\mu} \xi^2 - \frac{\mathcal{E}}{\mu} M\eta^2 \quad (2.54)$$

where

$$\begin{aligned} g_1 &= x^6, \quad y = (1-2\mathcal{E})x^4 \\ \xi &= \eta - \frac{2\mu}{\mathcal{E}} y, \quad M = \frac{1}{2} - 2\mu x^2. \end{aligned} \quad (2.55)$$

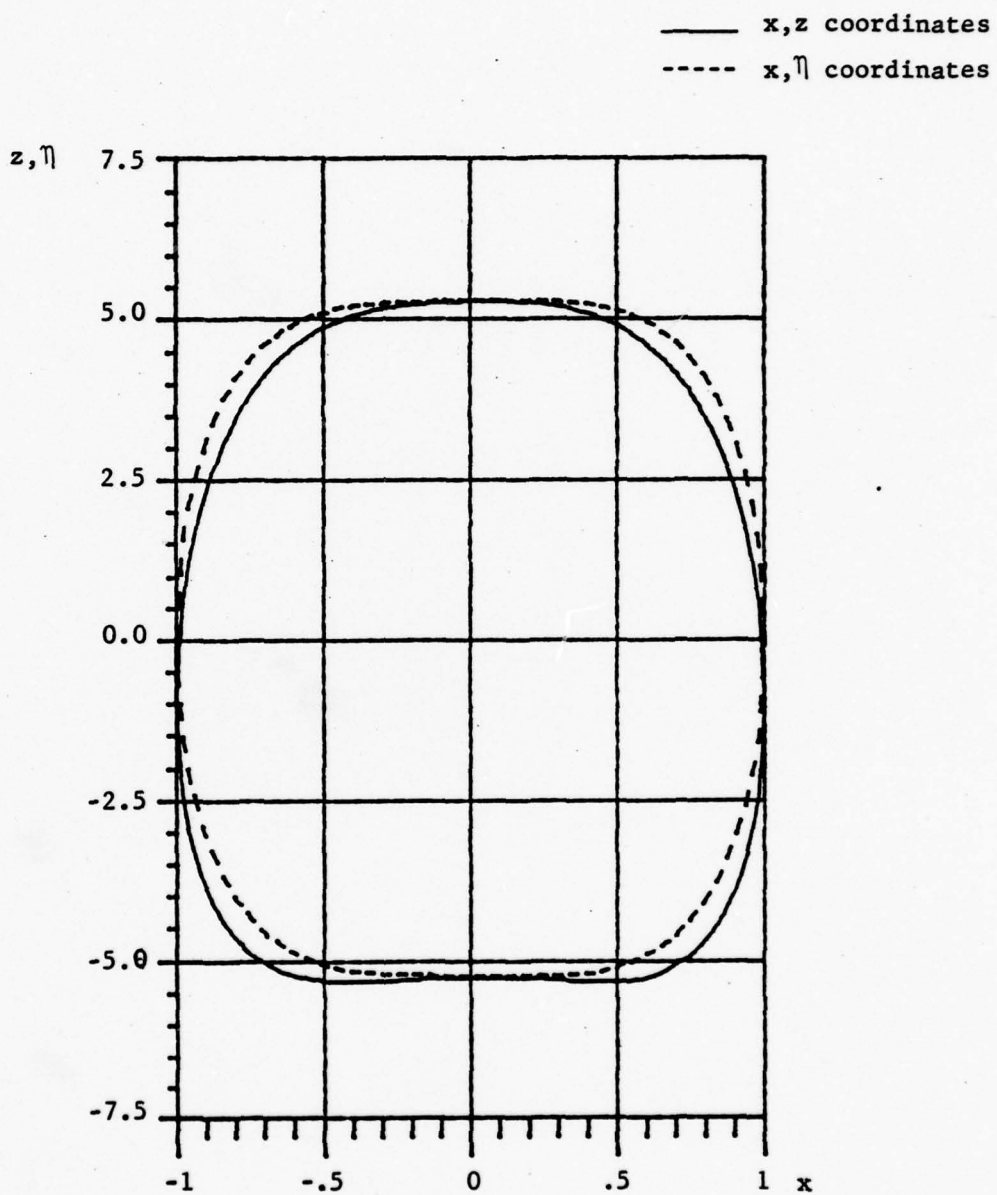
Figure 2.1 Plot of S in (2.53).

Since $\lim_{x \rightarrow 0} y^2/g_1 = 0$, Assumption (A2.4) is satisfied. For all x, η in the interior of S and $\mathcal{E} = .018$, \dot{U} is negative definite for all $\mu \in (0, .018]$. Hence $x=0, z=0$ is asymptotically stable for all $|x| \leq .8, |z + x^2| \leq 4$ and $\mu \in (0, .018]$.

2.5 A Stabilizing Feedback Control

The results in Section 2.3 are now applied to the design of a stabilizing control $u \in R^r$ for the system

$$\begin{aligned}\dot{x} &= a_1(x) + A_1(x)z + B_1(x)u \\ \mu \dot{z} &= a_2(x) + A_2(x)z + B_2(x)u.\end{aligned}\tag{2.56}$$

Formally letting $\mu = 0$, the reduced system of (2.56) is

$$\dot{\bar{x}} = (a_1 - A_1 A_2^{-1} a_2) + (B_1 - A_1 A_2^{-1} B_2) \bar{u} \equiv a_0(\bar{x}) + B_0(\bar{x}) \bar{u}.\tag{2.57}$$

Systems (2.56) and (2.57) are assumed to satisfy the following conditions for $x \in D$:

(A2.6) In addition to Assumption (A2.1), the matrices B_1 and B_2 are bounded and differentiable with respect to x .

(A2.7) A_2 is nonsingular and

$$\text{rank}[B_2, A_2 B_2, \dots, A_2^{m-1} B_2] = m.\tag{2.58}$$

(A2.8) There exists a vector $h(\bar{x}) \in R^r$ with $h(0) = 0$ such that the system

$$\dot{\bar{x}} = a_0(\bar{x}) + B_0(\bar{x})h(\bar{x})\tag{2.59}$$

satisfies Assumption (A2.3).

By Assumption (A2.7), we can find $H(x)$ such that

$$\text{Re}\{\lambda(A_2 + B_2 H)\} \leq \sigma_2\tag{2.60}$$

for a fixed $\sigma_2 < 0$ and for all $x \in D$. Assumption (A2.8) implies that there exists a stabilizing feedback control for system (2.57)

$$\bar{u}(\bar{x}) = h(\bar{x}) \quad (2.61)$$

such that the reduced system (2.59) possesses a Lyapunov function guaranteeing that the equilibrium $\bar{x} = 0$ is asymptotically stable. From the reduced control (2.61) and the inequality (2.60), we formulate a stabilizing feedback control for (2.56).

Theorem 2.5.1

If Assumptions (A2.6)-(A2.8) are satisfied, then there exists a $\mu^* > 0$ such that for all $\mu \in (0, \mu^*]$, the control

$$u(x, z) = (I_n + H(x)A_2^{-1}(x)B_2(x))h(x) + H(x)A_2^{-1}(x)a_2(x) + H(x)z \quad (2.62)$$

where $H(x)$ satisfies (2.60), steers all $x \in D_1$, $z \in E_1$ of system (2.56) $0(\mu)$ close to a surface near the equilibrium $x = 0$, $z = 0$. Furthermore, if the reduced system also satisfies Assumption (A2.4), then the equilibrium $x = 0$, $z = 0$ of system (2.56) controlled by (2.62) is asymptotically stable.

Proof: System (2.56) controlled by (2.62) becomes

$$\begin{aligned} \dot{x} &= a_1 + B_1(I_n + HA_2^{-1}B_2)h + B_1HA_2^{-1}a_2 + (A_1 + B_1H)z \\ \mu \dot{z} &= a_2 + B_2(I_n + HA_2^{-1}B_2)h + B_2HA_2^{-1}a_2 + (A_2 + B_2H)z. \end{aligned} \quad (2.63)$$

Letting $\mu = 0$, the reduced system of (2.63) is

$$\begin{aligned} \dot{\bar{x}} &= (a_1 + B_1HA_2^{-1}a_2) - (A_1 + B_1H)(A_2 + B_2H)^{-1}(a_2 + B_2HA_2^{-1}a_2) \\ &\quad + (B_1 - (A_1 + B_1H)(A_2 + B_2H)^{-1}B_2)(I_n + HA_2^{-1}B_2)h \\ &= a_0(\bar{x}) + B_0(\bar{x})h(\bar{x}) \end{aligned} \quad (2.64)$$

by using simple algebraic manipulation. Hence we can construct a Lyapunov function (2.26) for system (2.63). Then the conclusions of this theorem follow from Theorems 2.3.1 and 2.3.2.

Theorem 2.5.1 outlines a low order design where the reduced system and the boundary layer system are considered separately. In addition, the parameter μ is not required to be known exactly provided that it is sufficiently small. The result here is a generalization of our design for linear time-invariant singularly perturbed systems [28].

2.6 Discussion

In this chapter we have formulated some stability results for the nonlinear system (2.2). Based on the stability properties of the reduced system (2.5) and the fast transients in z , a composite Lyapunov function (2.26) is constructed to show stability properties of the full system (2.2). Since the structure of system (2.2) is simpler than (2.1), the conditions we derived are easier to apply to (2.2) than the conditions derived in [10-13] for (2.1). We also relax the condition used in [2,11] that the linearized reduced system (2.5) be asymptotically stable. Furthermore, the introduction of the small parameter ϵ in (2.26) enables us to substantially enlarge our predicted domain of stability. This feature is lacking in previous works. These results are readily incorporated in the design of a stabilizing control for system (2.56) and in the design of nonlinear regulators which is treated in Chapter 3.

3. SINGULARLY PERTURBED NONLINEAR REGULATOR

3.1 Introduction

Compared with the rich literature on linear regulator theory, publications dealing with feedback design of nonlinear systems are a small minority. Realistic approaches to the difficult nonlinear feedback control problem usually exploit properties of special classes of systems to develop approximate methods [17,18,29]. The approach in this paper exploits multiple time scale properties of a class of nonlinear singularly perturbed systems [14-16] to achieve stabilization and near-optimality. Due to a separation of time scales, the proposed design procedure is applicable to higher order systems.

The problem considered is to optimally control the nonlinear system

$$\dot{x} = a_1(x) + A_1(x)z + B_1(x)u, \quad x(0) = x_0 \quad (3.1a)$$

$$\mu \dot{z} = a_2(x) + A_2(x)z + B_2(x)u, \quad z(0) = z_0 \quad (3.1b)$$

with respect to the performance index

$$J = \int_0^{\infty} [p(x) + s'(x)z + z'Q(x)z + u'R(x)u]dt \quad (3.2)$$

where $\mu > 0$ is the small singular perturbation parameter, x , z are n -, m -dimensional states, respectively, and u is an r -dimensional control. It is assumed that there exists a domain $D \subset R^n$ containing the origin such that for all $x \in D$ and $z \in R^m$ the problem satisfies the following assumptions:

- (A3.1) The functions a_1 , a_2 , A_1 , A_2 , B_1 , B_2 , p , s , Q and R are differentiable with respect to x a sufficient number of times and a_1 , a_2 , p and s are all zero only at $x = 0$.

(A3.2) The matrices $Q(x)$ and $R(x)$ are positive definite, that is $Q(x) > 0$, $R(x) > 0$. Furthermore, the scalar function $p + s'z + z'Qz$ of x and z is positive definite in both x and z .

(A3.3) For every fixed $x \in D$

$$\text{rank}[B_2, A_2 B_2, \dots, A_2^{m-1} B_2] = m \quad (3.3)$$

and hence $A_2(x)$ is assumed to be nonsingular. (If not, then using $u = \hat{u} + K(x)z$ such that $A_2 + B_2 K$ is nonsingular we redefine the problem.)

Assumptions (A3.1) and (A3.2) establish that the origin is the desired equilibrium of (3.1). Assumption (A3.3) and $Q(x) > 0$ simplify the derivations. Alternatively a less restrictive stabilizability-detectability condition can be used.

Finite time trajectory optimization problems for the same class of systems have been treated in [14-16] via singularly perturbed two point boundary value problems originating from necessary optimality conditions. The resulting controls are open-loop and require boundary layer correction terms at both ends of the interval. For the infinite time regulator problem considered here the Hamilton-Jacobi-Bellman sufficiency condition is more suitable since it readily incorporates stability requirements and leads to feedback solutions. Using this condition we obtain near-optimal stabilizing controls in feedback form and avoid explicit treatment of boundary layer phenomena.

Our procedure is based on a nested power series expansion of the optimal value function in z and μ . An advantage of this procedure is that it uses lower order equations involving only the slow variable x . In applications truncated series are of interest. Based on the results in

Chapter 2, stabilizing properties of various truncated designs are discussed. Furthermore, near-optimality of these truncated designs is established in terms of $O(\mu)$, $O(\mu^2)$, etc. The proposed design is illustrated by a speed control example.

3.2 A Speed Control Example

To illustrate a physical system whose dynamics are represented by (3.1), we consider a DC motor model

$$\begin{aligned} L_f \frac{di_f}{dt} &= -R_f i_f + V_f \\ L_a \frac{di_a}{dt} &= -R_a i_a - c_1 i_f \omega + V_a \\ J \frac{d\omega}{dt} &= -c_2 \omega + c_3 i_f i_a \end{aligned} \quad (3.4)$$

where i_f , R_f , L_f , V_f , i_a , R_a , L_a , V_a are the currents, resistances, inductances, voltages of the field and armature circuits, respectively, J is the inertia of the rotor, c_1 the back emf constant, c_2 the viscous damping and c_3 the torque constant. It is desired to maintain the speed ω constant at $\omega = \omega^*$, while the other equilibrium values are i_f^* , i_a^* , V_f^* , V_a^* .

Since the field time constant $T_f = L_f/R_f$ is much larger than either the armature time constant $T_a = L_a/R_a$ or the mechanical time constant $T_m = J/(c_2 + c_1 c_3 i_f^{*2}/R_a)$, we identify i_f as slow variable and i_a and ω as the fast variables, and let $\mu = T_a/T_f$. For the DC motor whose specifications are given in Appendix A, this relationship is satisfied as $T_a = .0170$ sec., $T_m = .0966$ sec., $T_f = 2.71$ sec. and $\mu = .00625$.

Defining the variables

$$\begin{aligned} x &= i_f - i_f^*, z_1 = i_a - i_a^*, z_2 = \omega - \omega^* \\ u_1 &= V_f - V_f^*, u_2 = V_a - V_a^* \end{aligned} \quad (3.5)$$

the system equation (3.4) for this DC motor can be expressed in the form (3.1) with

$$\begin{aligned} a_1(x) &= -.369 x \\ a_2(x) &= \begin{bmatrix} -5.25 \\ 3.80 \times 10^{-4} \end{bmatrix} x \\ A_1(x) &= \begin{bmatrix} 0 & 0 \end{bmatrix} \\ A_2(x) &= \begin{bmatrix} -.369 & -10.5(128.5 + x) \\ 1.33 \times 10^{-7} (128.5 + x) & -2.33 \times 10^{-3} \end{bmatrix} \\ B_1(x) &= \begin{bmatrix} .388 & 0 \end{bmatrix} \\ B_2(x) &= \begin{bmatrix} 0 & 41.7 \\ 0 & 0 \end{bmatrix} \end{aligned} \quad (3.6)$$

3.3 The Reduced Control

In singular perturbation techniques, a problem for the full order system (3.1) where $\mu > 0$ is interpreted as a perturbation of a reduced problem

$$\dot{\bar{x}} = a_1(\bar{x}) + A_1(\bar{x})\bar{z} + B_1(\bar{x})\bar{u}, \quad \bar{x}(0) = x_0 \quad (3.7a)$$

$$0 = a_2(\bar{x}) + A_2(\bar{x})\bar{z} + B_2(\bar{x})\bar{u} \quad (3.7b)$$

in which $\mu = 0$. Due to Assumption (A3.3), \bar{z} can be solved from (3.7b) and eliminated from (3.7a) and (3.2). Then the reduced problem is to optimally control the system

$$\dot{\bar{x}} = a_o(\bar{x}) + B_o(\bar{x})\bar{u}, \quad \bar{x}(0) = x_o \quad (3.8)$$

with respect to

$$J_o = \int_0^{\infty} [p_o(\bar{x}) + 2s_o'(\bar{x})\bar{u} + \bar{u}'R_o(\bar{x})\bar{u}] dt \quad (3.9)$$

where

$$\begin{aligned} a_o &= a_1 - A_1 A_2^{-1} a_2 \\ B_o &= B_1 - A_1 A_2^{-1} B_2 \\ p_o &= p - s' A_2^{-1} a_2 + a_2' A_2^{-1} Q A_2^{-1} a_2 \\ s_o &= B_2' A_2^{-1} (Q A_2^{-1} a_2 - \frac{1}{2} s) \\ R_o &= R + B_2' A_2^{-1} Q A_2^{-1} B_2 \end{aligned} \quad (3.10)$$

The origin $\bar{x} = 0$ is the desired equilibrium of the optimally controlled reduced system (3.8) for all $\bar{x} \in D$, since, in view of Assumption (A3.2), $a_o(0) = 0$ and

$$p_o(\bar{x}) + 2s_o'(\bar{x})\bar{u} + \bar{u}'R_o(\bar{x})\bar{u} \quad (3.11)$$

is positive definite in \bar{x} and \bar{u} .

The reduced problem (3.8), (3.9) is considerably simpler than the original problem (3.1), (3.2) because of the elimination of the fast variables and the reduction of the system order. One of the tasks of the singular perturbation analysis is to establish whether the full problem is well posed in the sense that its solution tends to the solution of the reduced problem as $\mu \rightarrow 0$. If so, then the next task is to deduce the properties of the original problem from the properties of the reduced problem. Finally these properties are to serve as a basis for a simplified design procedure.

To formulate our basic assumption about the properties of the solution of the reduced problem we use the optimality principle

$$0 = \min_{\bar{u}} [p_0(\bar{x}) + 2s_0'(\bar{x})\bar{u} + \bar{u}'R_0(\bar{x})\bar{u} + L_{\bar{x}}(a_0(\bar{x}) + B_0(\bar{x})\bar{u})] \quad (3.12)$$

where $L(\bar{x})$ is the optimal value function and $L_{\bar{x}}$ is its partial derivative with respect to \bar{x} . This yields the minimizing control

$$u_0(\bar{x}) = -R_0^{-1}(s_0 + \frac{1}{2} B_0' L_{\bar{x}}') \quad (3.13)$$

whose elimination from (3.12) results in the Hamilton-Jacobi equation

$$0 = (p_0 - s_0' R_0^{-1} s_0) + L_{\bar{x}}(a_0 - B_0 R_0^{-1} s_0) - \frac{1}{4} L_{\bar{x}} B_0 R_0^{-1} B_0' L_{\bar{x}}', \quad L(0) = 0. \quad (3.14)$$

Note that, due to (3.11), $p_0 - s_0' R_0^{-1} s_0$ is positive definite in D . Our crucial assumption is then stated as follows.

(A3.4) The unique positive definite solution $L(\bar{x})$ of (3.14) exists in D and is differentiable with respect to \bar{x} a sufficient number of times. Furthermore the level surface $L = c = \text{constant}$ is taken to be the boundary of the set D .

In the special case considered in [17], where the linearization of (3.8) at $\bar{x} = 0$ is stabilizable and its states are observable in the quadratic approximation of J_0 , our Assumption (A3.4) is automatically satisfied for all \bar{x} near the origin. It follows from Assumption (A3.4) that u_0 is the unique optimal feedback control for the reduced problem and L is a Lyapunov function of the optimally controlled reduced system

$$\dot{\bar{x}} = a_0 - B_0 R_0^{-1} (s_0 + \frac{1}{2} B_0' L_{\bar{x}}') = \bar{a}_0(\bar{x}) \quad (3.15)$$

establishing that the origin is asymptotically stable and the set D belongs to its domain of attraction.

3.4 The Composite Control

The optimal value function $V(x, z, \mu)$ of the full problem (3.1), (3.2) satisfies the equation

$$0 = \min_u [p + s'z + z'Qz + u'Ru + V_x(a_1 + A_1z + B_1u) + \frac{1}{\mu} V_z(a_2 + A_2z + B_2u)] \quad (3.16)$$

where V_x, V_z denote the partial derivatives of V with respect to the variables x, z , respectively. The minimizing control of (3.16) is

$$u = -\frac{1}{2} R^{-1} (B_1' V_x' + \frac{1}{\mu} B_2' V_z') \quad (3.17)$$

and its substitution into (3.16) yields the Hamilton-Jacobi equation

$$0 = p + s'z + z'Qz + V_x(a_1 + A_1z) + \frac{1}{\mu} V_z(a_2 + A_2z) - \frac{1}{4} (V_x B_1 + \frac{1}{\mu} V_z B_2) R^{-1} (B_1' V_x' + \frac{1}{\mu} B_2' V_z'), \quad V(0, 0, \mu) = 0. \quad (3.18)$$

Since system (3.1) is linear in z and J in (3.2) is quadratic in z , and since \dot{z} is multiplied by μ , we seek a solution of (3.18) in the form

$$\begin{aligned} V(x, z, \mu) &= \bar{V}_0(x) + \mu \bar{V}_1'(x)z + \mu z' \bar{V}_2(x)z + \mu q(x, z, \mu) \\ &\equiv \nabla(x, z, \mu) + \mu q(x, z, \mu), \quad \bar{V}_0(0) = 0 \end{aligned} \quad (3.19)$$

where

$$\partial q / \partial x = 0(1), \quad \partial q / \partial z = 0(\mu). \quad (3.20)$$

We shall investigate the expansion of q in a later section. The partial derivatives of V with respect to x, z are

$$\begin{aligned} v_x &= \bar{v}_{0x} + o(\mu) \\ v_z &= \mu \bar{v}'_1 + 2\mu z' \bar{v}'_2 + o(\mu^2). \end{aligned} \quad (3.21)$$

Substituting (3.21) into (3.18) and neglecting the μ dependent terms, we obtain the equation

$$\begin{aligned} 0 &= p + \bar{v}_{0x} a_1 + \bar{v}'_1 a_2 - \frac{1}{4} (\bar{v}_{0x} B_1 + \bar{v}'_1 B_2) R^{-1} (B_1 \bar{v}'_{0x} + B_2 \bar{v}'_1) \\ &+ [s' + 2a_2 \bar{v}'_2 + \bar{v}_{0x} (A_1 - B_1 R^{-1} B_2 \bar{v}'_2) + \bar{v}'_1 (A_2 - B_2 R^{-1} B_2 \bar{v}'_2)] z \\ &+ z' (Q + \bar{v}_2 A_2 + A_2 \bar{v}'_2 - \bar{v}_2 B_2 R^{-1} B_2 \bar{v}'_2) z. \end{aligned} \quad (3.22)$$

In order to satisfy (3.22) identically for all z , we require that

$$0 = p + \bar{v}_{0x} a_1 + \bar{v}'_1 a_2 - \frac{1}{4} (\bar{v}_{0x} B_1 + \bar{v}'_1 B_2) R^{-1} (B_1 \bar{v}'_{0x} + B_2 \bar{v}'_1), \quad \bar{v}_0(0) = 0 \quad (3.23)$$

$$0 = s' + 2a_2 \bar{v}'_2 + \bar{v}_{0x} (A_1 - B_1 R^{-1} B_2 \bar{v}'_2) + \bar{v}'_1 (A_2 - B_2 R^{-1} B_2 \bar{v}'_2) \quad (3.24)$$

$$0 = Q + \bar{v}_2 A_2 + A_2 \bar{v}'_2 - \bar{v}_2 B_2 R^{-1} B_2 \bar{v}'_2. \quad (3.25)$$

At each fixed value of x , (3.25) is an algebraic Riccati equation for \bar{v}_2 .

In view of (3.3) and $Q(x) > 0$, the unique positive definite solution \bar{v}_2 exists such that for all $x \in D$, the real parts of the eigenvalues of $\bar{A}_2 = A_2 - B_2 R^{-1} B_2 \bar{v}'_2$ are less than a negative constant. Thus \bar{A}_2 is nonsingular and \bar{v}'_1 can be expressed in terms of \bar{v}_{0x} and \bar{v}_2 as

$$\bar{v}'_1 = -[s' + 2a_2 \bar{v}'_2 + \bar{v}_{0x} (A_1 - B_1 R^{-1} B_2 \bar{v}'_2)] \bar{A}_2^{-1}. \quad (3.26)$$

It is of crucial importance that the elimination of \bar{v}'_1 from (3.23) results in an equation involving only \bar{v}_{0x} . For the well posedness of the full problem it is necessary that the leading term \bar{v}_0 of (3.19) be identical to the solution L of the reduced problem.

Lemma 3.4.1

If Assumptions (A3.3) and (A3.4) are satisfied, then the unique positive definite solution $\bar{V}_0(x)$ of (3.23)-(3.25) exists in D and is identical to the solution $L(x)$ of the reduced problem (3.8), (3.9).

Proof: It is shown in Appendix B that eliminating \bar{V}_1 from (3.23), we obtain the Hamilton-Jacobi equation (3.14) with \bar{V}_{0x} in place of L_x , and hence $\bar{V}_0(x) \equiv L(x)$ with properties as in Assumption (A.34).

By virtue of Lemma 3.4.1, \bar{V}_0 and \bar{V}_2 are solved independently from (3.14) and (3.25). This is the separation of time scales in the design of nonlinear regulators, analogous to our linear time-invariant design in [8].

Using \bar{V} , we derive the control

$$\begin{aligned} u &= -\frac{1}{2} R^{-1} (B_1' \bar{V}'_x + \frac{1}{\mu} B_2' \bar{V}'_z) \\ &= -\frac{1}{2} R^{-1} [B_1' \bar{V}'_{0x} + B_2' (\bar{V}_1 + 2\bar{V}_2 z)] + 0(\mu) \\ &\equiv u_c + 0(\mu) \end{aligned} \quad (3.27)$$

whose main part u_c is defined as the composite control. Eliminating \bar{V}_1 from (3.27) using (3.26) and following our derivation in [8], u_c can be written as

$$\begin{aligned} u_c &= -R_o^{-1} (s_o + \frac{1}{2} B_o' \bar{V}'_{0x}) - R^{-1} B_2' \bar{V}_2 [z + A_2^{-1} (a_2 - B_o R_o^{-1} (s_o + \frac{1}{2} B_o' \bar{V}'_{0x}))] \\ &= u_o(x) - R^{-1} B_2' \bar{V}_2 (z + \bar{A}_2^{-1} \bar{a}_2) \end{aligned} \quad (3.28)$$

where

$$\begin{aligned} \bar{A}_2(x) &= A_2 - B_2 R^{-1} B_2' \bar{V}_2 \\ \bar{a}_2(x) &= a_2 - \frac{1}{2} B_2 R^{-1} (B_1' \bar{V}'_{0x} + B_2' \bar{V}'_1), \quad \bar{a}_2(0) = 0. \end{aligned} \quad (3.29)$$

Hence the composite control u_c consists of a slow control u_0 which optimizes the reduced system (3.8) and a fast control $-R^{-1}B_2'\bar{V}_2(z + \bar{A}^{-1}\bar{a}_2)$ which optimizes the fast part $(z + \bar{A}^{-1}\bar{a}_2)$ of z in the sense that \bar{V}_2 satisfies (3.25). Note that when z is not penalized in (3.2), that is when $Q(x) = 0$, but $\text{Re}\{\lambda(A_2)\} < 0$, then \bar{V}_2 is identically zero and u_c reduces to u_0 of (3.13).

We now apply the results of Chapter 2 to investigate the stabilizing properties of u_c . System (3.1) controlled by u_c is

$$\begin{aligned}\dot{x} &= a_1 + A_1z + B_1u_c \equiv \bar{a}_1(x) + \bar{A}_1(x)z, & x(0) &= x_0 \\ \mu\dot{z} &= a_2 + A_2z + B_2u_c \equiv \bar{a}_2(x) + \bar{A}_2(x)z, & z(0) &= z_0\end{aligned}\tag{3.30}$$

where

$$\begin{aligned}\bar{a}_1 &= a_1 - \frac{1}{2} B_1 R^{-1} (B_1' \bar{V}'_{0x} + B_2' \bar{V}'_1), & \bar{a}_1(0) &= 0 \\ \bar{A}_1 &= A_1 - B_1 R^{-1} B_2' \bar{V}_2.\end{aligned}\tag{3.31}$$

After applying the algebraic manipulation (2.64) to (3.30), the resulting reduced system of (3.30) is identical to the optimally controlled reduced system (3.15). Hence by Assumption (A3.4), L is a Lyapunov function for the reduced system of (3.30) satisfying Assumption (A2.3), and Theorem 2.3.2 is applicable to the full system (3.30). If Assumption (A2.4) is also satisfied, then from Theorem 2.3.1, the equilibrium $x = 0$, $z = 0$ of (3.30) is asymptotically stable.

In the case where the fast transients of z in (3.1) are exponentially stable, that is, $A_2(x)$ is stable for all $x \in D$, and we are only concerned with the optimality of the reduced system (3.8), then the z -independent reduced control u_0 of (3.13) stabilizes the full system (3.1) with essentially the same stabilizing properties as u_c of (3.27). We shall not repeat the argument.

An attractive feature of the controls u_c and u_o is that they do not require the knowledge of the actual value of μ provided that it is sufficiently small. When appropriately implemented, these controls stabilize the full system (3.1) and achieve optimality of the reduced system, and in the case of u_c , also optimality of the fast part of z . The above results also answer the question of well posedness by giving the conditions under which the same optimal reduced order system is obtained with μ set equal to zero either when system (3.1) is uncontrolled or when it is controlled by u_c or u_o . In contrast to many other singular perturbation results which require μ to be sufficiently small, we can also estimate the allowable values of μ given a stability domain or vice versa.

3.5 An Optimal Speed Control Example

The design procedure based on solving the lower order equations (3.23), (3.24), and (3.25) for \bar{V}_0 , \bar{V}_1 , and \bar{V}_2 is now applied to the optimal control of the DC motor (3.1), (3.6) with performance index

$$J = \int_0^{\infty} (\bar{x}^2 + z_1^2 + 18000z_2^2 + 5u_1^2 + u_2^2) dt. \quad (3.32)$$

The reduced system of (3.1), (3.6) is

$$\begin{aligned} \dot{\bar{x}} &= .369\bar{x} + .388\bar{u}_1 \\ \bar{z} &= -A_2^{-1}(\bar{x})(a_2(\bar{x}) + B_2 \bar{u}) = H(\bar{x})\bar{x} + G(\bar{x})\bar{u}_2 \end{aligned} \quad (3.33)$$

and the reduced performance index is

$$J_o = \int_0^{\infty} [(1 + H'QH)\bar{x}^2 + 2\bar{x}H'QG\bar{u}_2 + 5\bar{u}_1^2 + (1 + G'QG)\bar{u}_2^2] dt \quad (3.34)$$

where $Q = \text{diag}(1, 18000)$. The optimal control for this reduced problem is

$$\begin{aligned} u_{10} &= -.0388 \bar{V}_{0x}(\bar{x}) = -.0388 \hat{V}_{0x}(\bar{x})\bar{x} \\ u_{20} &= -(1 + G'QG)^{-1}G'QH\bar{x} \end{aligned} \quad (3.35)$$

where the function $\hat{V}_{0x}(x)$ is plotted in Figure 3.1a for $-50A \leq x \leq 50A$.

Note that u_{10} , u_{20} are nonlinear as J_0 is not quadratic. Since the pair $(A_2(x), B_2)$ of (3.6) is controllable for all x except at $x = -128.5$,

Assumption (A3.2) is satisfied in a domain about $x=0$. As $A_2(x)$ of (3.6) is x -dependent, the solution \bar{V}_2 of (3.25) is also x -dependent and is plotted in Figure 3.1d-f for $-50A \leq x \leq 50A$, where

$$\bar{V}_2(x) = \begin{bmatrix} 1\bar{V}_2(x) & 2\bar{V}_2(x) \\ 3\bar{V}_2(x) & 4\bar{V}_2(x) \end{bmatrix}. \quad (3.36)$$

$\bar{V}_1(x)$ is computed from (3.26) and $\hat{V}_1(x) = \bar{V}_1(x)/x$ is plotted in Figures 3.1b, 3.1c for $-50A \leq x \leq 50A$ where

$$\hat{V}_1(x) = \begin{bmatrix} 1\hat{V}_1(x) \\ 2\hat{V}_1(x) \end{bmatrix}. \quad (3.37)$$

The nonlinear composite feedback control u_c in (3.27) is

$$\begin{aligned} u_{1c} &= -.0388 \hat{V}_{0x}(x)x \\ u_{2c} &= -20.8 \hat{V}_1(x)x - 41.7 \bar{V}_2(x)z_1 - 41.7 \bar{V}_2(x)z_2. \end{aligned} \quad (3.38)$$

A block diagram of this controller is given in Figure 3.2. Applying our technique in [8], the linear quadratic design of the DC motor (3.1), (3.6) at $x=0$ results in the same controllers u_{1c}, u_{2c} of (3.38) except \hat{V}_{0x} , $1\hat{V}_1$, $1\bar{V}_2$, $2\bar{V}_2$ are now fixed at $\hat{V}_{0x}(0)$, $1\hat{V}_1(0)$, $1\bar{V}_2(0)$, $2\bar{V}_2(0)$. It follows

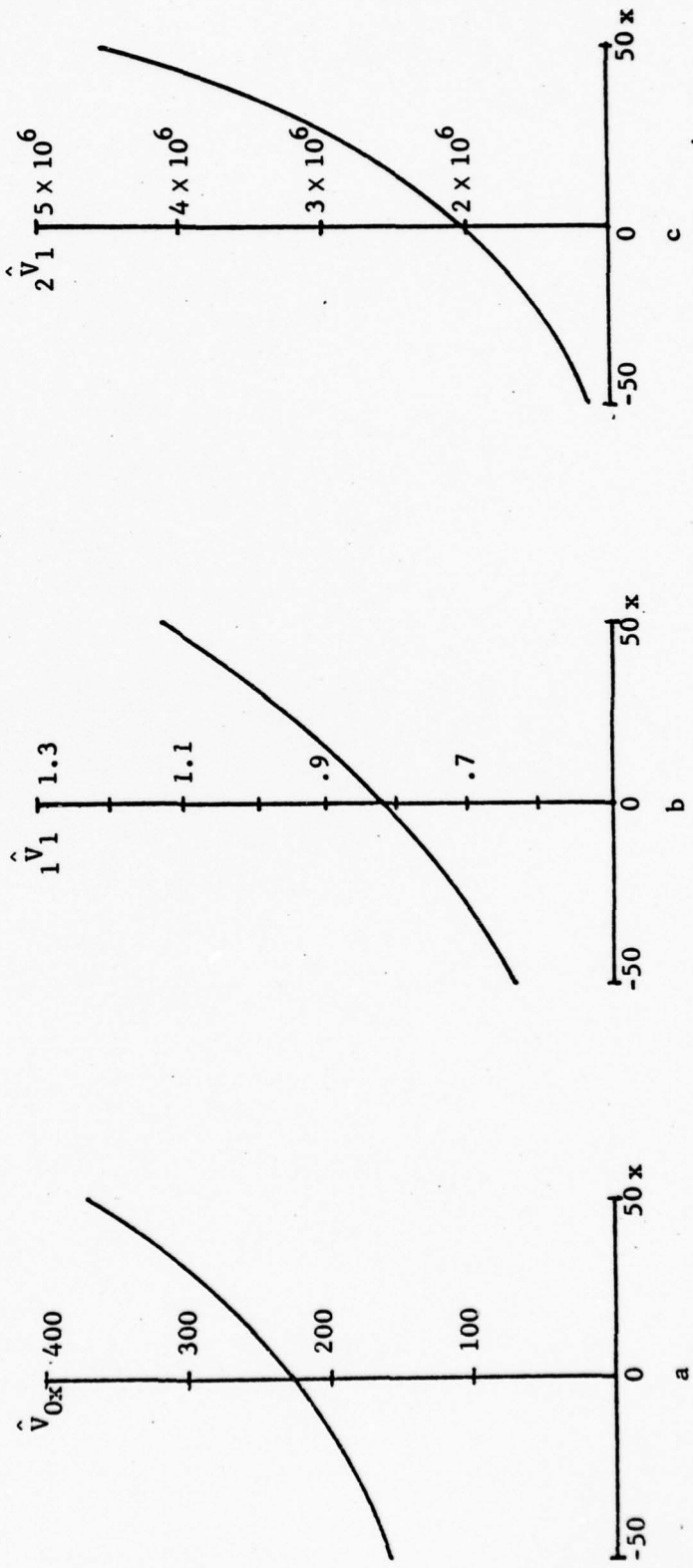

Figure 3.1 Plots of Feedback Gains for Speed Control Example (3.6), (3.32).

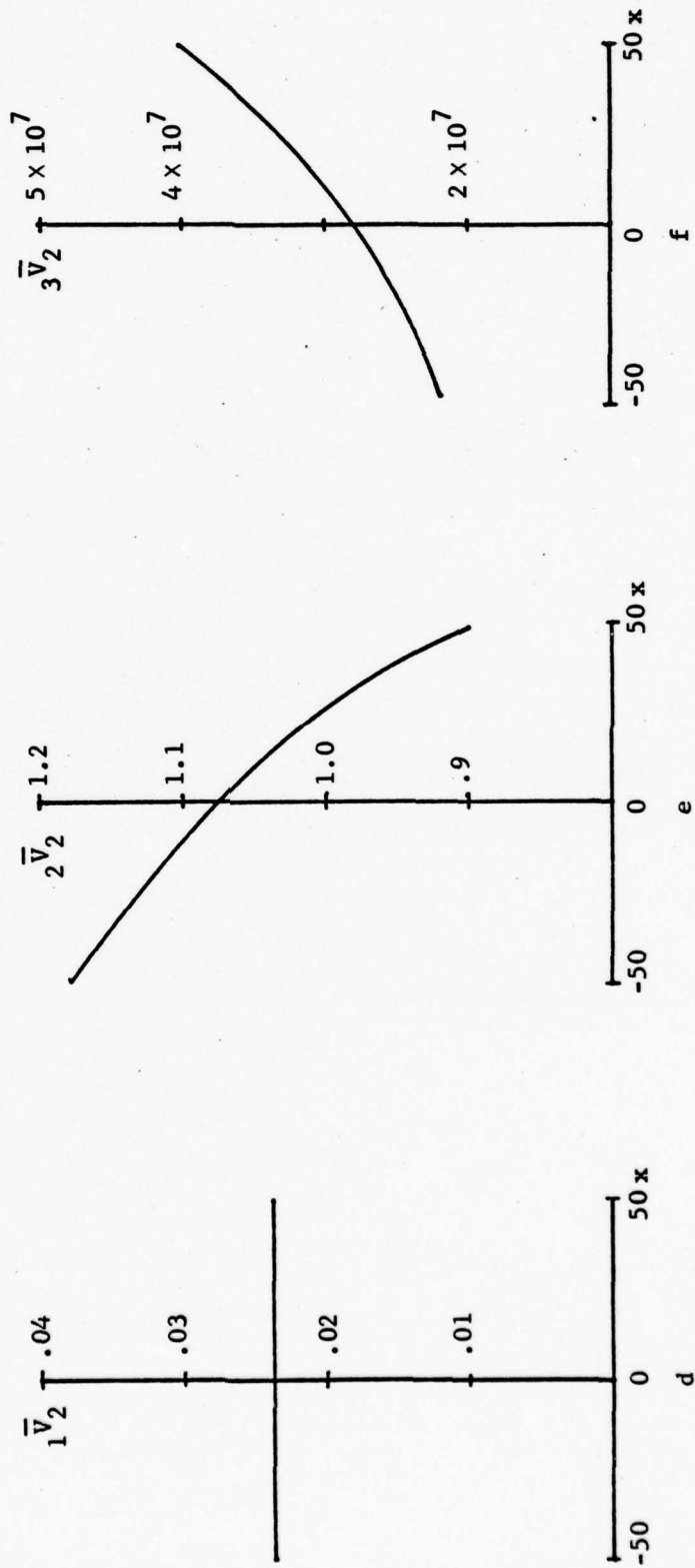

Figure 3.1 Plots of Feedback Gains for Speed Control Example (3.6), (3.32).

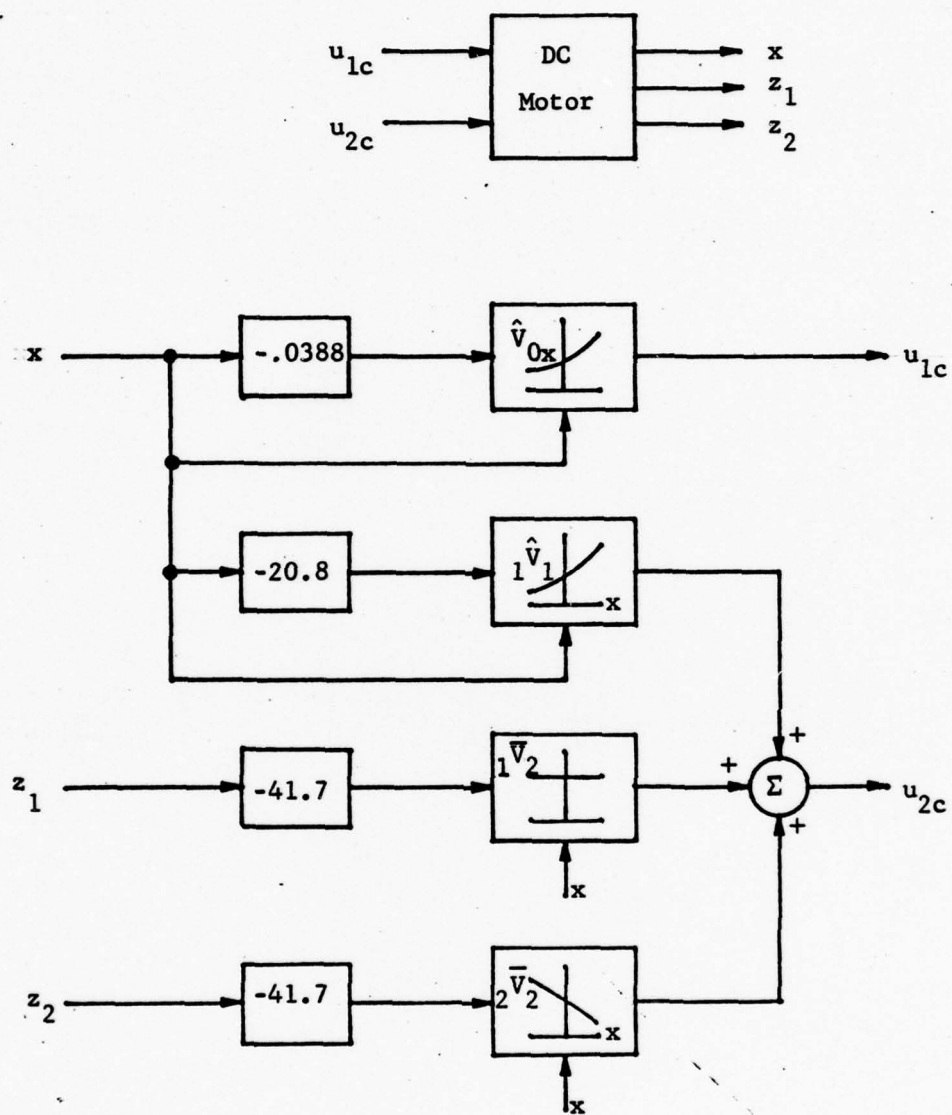

Figure 3.2 Controllers u_{1c} and u_{2c} (3.38).

from Corollary 2.3.2 that $x=0, z=0$ of the DC motor (3.1), (3.6) controlled by (3.38) is an asymptotically (exponentially) stable equilibrium.

3.6 The Formal Expansion

The expansion (3.19) only satisfies the Hamilton-Jacobi equation (3.18) to $O(\mu)$ order. We now propose to solve (3.18) by expanding V formally as a nested infinite power series. If this power series is convergent, then the optimal solution V of (3.18) exists. For x, z near the origin, it has been shown in [17] that the optimal solution exists and possesses a power series expansion when system (3.1) after linearization at the origin is stabilizable and the state in the quadratic approximation of J is observable. Here we are interested in a power series of V which satisfies (3.18) to any order of μ .

Since system (3.1) is linear in z and J is quadratic in z , the optimal value function can be expanded as a power series in the components of z [18]. In addition, since z is the fast variable, the z terms in the optimal value function are multiplied by appropriate powers of μ [5,8]. In view of these two characteristics, we seek a solution of (3.18) in the form

$$\begin{aligned}
 V(x, z, \mu) = & V_0(x, \mu) + \mu \sum_{j=1}^m V_{1j}(x, \mu) z_j + \mu \sum_{j=1}^m \sum_{k=1}^m V_{2jk}(x, \mu) z_j z_k \\
 & + \mu^2 \sum_{j=1}^m \sum_{k=1}^m \sum_{q=1}^m V_{3jkq}(x, \mu) z_j z_k z_q + \dots \\
 & + \mu^{i-1} \sum_{j_1=1}^m \sum_{j_2=1}^m \dots \sum_{j_i=1}^m V_{i j_1 j_2 \dots j_i}(x, \mu) z_{j_1} z_{j_2} \dots z_{j_i} + \dots, \\
 & V_0(0, \mu) = 0 \quad (3.39)
 \end{aligned}$$

where $V_{ij_1j_2\dots j_i}$ is the (j_1, j_2, \dots, j_i) element of the completely symmetric generalized matrix¹ V_i of dimension m^i and z_j is the j th component of z . The summation signs in (3.39) and in other equations will be omitted when there is no confusion as to which indices j_1, j_2, \dots, j_i are being summed. The partial derivatives $V_x, V_{z_1}, \dots, V_{z_m}$ expressed in terms of the vector x and the scalars z_1, \dots, z_m are

$$\begin{aligned} V_x &= V_{0x} + \mu V_{1jx} z_j + \mu^2 V_{2jkx} z_j z_k + \dots \\ V_{z_i} &= \mu V_{1i} + 2\mu^2 V_{2ij} z_j + 3\mu^3 V_{3ijk} z_j z_k + \dots, \quad i=1,2,\dots,m \end{aligned} \quad (3.40)$$

where the summation signs over j, k are omitted.

For the series (3.39) to satisfy (3.18) as an identity, we first rewrite (3.18) in terms of the vector x and the scalars z_1, \dots, z_m ,

$$\begin{aligned} 0 &= p + s_i z_i + Q_{ij} z_i z_j + V_x (a_1 + A_{1i} z_i) + \frac{1}{\mu} V_{z_i} (a_{2i} + A_{2ij} z_j) \\ &\quad - \frac{1}{4} (V_x B_1 + \frac{1}{\mu} V_{z_i} B_{2i}) R^{-1} (B_1' V_x' + \frac{1}{\mu} B_{2i}' V_{z_i}') \end{aligned} \quad (3.41)$$

where s_i, a_{2i} are the i th components of the vectors s, a_2 , respectively, A_{1i} is the i th column of the matrix A_1 , B_{2i} is the i th row of B_2 , Q_{2ij}, A_{2ij} are the (i, j) elements of Q, A_2 , respectively, and the summation signs over the indices i, j are omitted. Then, upon substituting (3.40) into (3.41) and equating the coefficients of the like powers of z_i , we obtain

¹The (j_1, j_2, \dots, j_i) elements of V_i are identical for all permutations of the indices j_1, j_2, \dots, j_i [31].

$$0 = p + v_{0x} a_1 + v_{1i} a_{2i} - \frac{1}{4} (v_{0x} B_1 + v_{1i} B_{2i}) R^{-1} (B_1' v_{0x}' + B_{2i}' v_{1i}'),$$

$$v_0(0, \mu) = 0 \quad (3.42a)$$

$$0 = s_i + v_{0x} A_{1i} + \mu v_{1ix} a_1 + v_{1j} A_{2ji} + 2v_{2ij} a_{2j} - \frac{1}{2} (v_{0x} B_1 + v_{1j} B_j) R^{-1} (\mu B_1' v_{1ix}' + 2B_{2j}' v_{2ji}'), \quad i = 1, 2, \dots, m \quad (3.42b)$$

$$0 = Q_{ij} + \mu v_{2ijx} a_1 + \mu (v_{1ix} A_{1j})_s + 2(v_{2ik} A_{2kj})_s + 3\mu v_{3ijk} a_{2k} - \frac{1}{2} (v_{0x} B_1 + v_{1k} B_{2k}) R^{-1} (\mu B_1' v_{2ijx}' + 3\mu B_{2k}' v_{3kij}') - \frac{1}{4} (\mu v_{1ix} B_1 + 2v_{2ik} B_{2k}) R^{-1} (\mu B_1' v_{1jx}' + 2B_{2k}' v_{2kj}'), \quad i, j = 1, 2, \dots, m \quad (3.42c)$$

$$0 = \mu^2 v_{3ijkx} a_1 + \mu (v_{2ijx} A_{1k})_s + 4\mu^2 v_{4ijkq} a_{2q} + 3\mu (v_{3ijq} A_{2qk})_s - \frac{1}{2} (v_{0x} B_1 + v_{1q} B_{2q}) R^{-1} (\mu^2 B_1' v_{3ijkx}' + 4\mu^2 B_{2q}' v_{4ijkq}') - \frac{1}{2} (\mu v_{1ix} B_1 + 2v_{2iq} B_{2q}) R^{-1} (\mu B_1' v_{2jkx}' + 3\mu B_{2q}' v_{3qjk}')_s, \quad i, j, k = 1, 2, \dots, m \quad (3.42d)^2$$

⋮
⋮
⋮

²The subscript s denotes the symmetrization operation of generalized matrices [31]. For example,

$$(v_{2ik} A_{2kj})_s = \frac{1}{2} (v_{2ik} A_{2kj} + v_{2jk} A_{2ki})$$

$$(v_{3ijq} A_{2qk})_s = \frac{1}{6} (v_{3ijq} A_{2qk} + v_{3jiq} A_{2qk} + v_{3ikq} A_{2qj} + v_{3kiq} A_{2qj} + v_{3jkq} A_{2qi} + v_{3kjq} A_{2qi}).$$

where the right hand sides of (3.42a), (3.42b), (3.42c), (3.42d),..., are the coefficients of the z -independent terms and of the $z_i, z_i z_j, z_i z_j z_k, \dots$, terms, respectively. Because of symmetry, there are $m(m+1)/2$ equations in (3.42c), $m(m+1)(m+2)/6$ equations in (3.42d) and in general, $(\prod_{k=0}^{i-1} (m+k))/i!$ equations when the coefficients of $z_{j_1} z_{j_2} \dots z_{j_i}, j_1, j_2, \dots, j_i = 1, 2, \dots, m$, are equated.

For a simplified treatment of these equations we now exploit the presence of the small singular perturbation parameter μ . We expand each coefficient of (3.39) as a power series in μ

$$V_i(x, \mu) = \sum_{j=0}^{\infty} \mu^j V_i^j(x), \quad i = 0, 1, 2, \dots \quad (3.43)$$

where the boundary condition of V_0^j is $V_0^j(0) = 0, j = 0, 1, 2, \dots$. The expressions (3.43) substituted into equations (3.42) are to satisfy them as identities in μ . Equating the coefficients of the like powers in μ , we generate sets of equations for $V_i^j, i, j = 0, 1, 2, \dots$. The first set of equations obtained by equating the μ -independent parts in (3.42a), (3.42b), (3.42c), are precisely equations (3.23), (3.24), (3.25), respectively. Hence from the uniqueness of solutions to (3.23), (3.24), (3.25), we conclude that

$$V_0^0 = \bar{V}_0 = L, \quad V_1^0 = \bar{V}_1, \quad V_2^0 = \bar{V}_2 \quad (3.44)$$

and \bar{V} thus consists of the leading terms of V .

The second set of equations in matrix form

$$0 = V_{0x}^1 \bar{a}_1 + V_1^{1'} \bar{a}_2, \quad V_0^1(0) = 0 \quad (3.45a)$$

$$0 = V_{0x}^1 \bar{A}_1 + \bar{a}_1' V_{1x}^{0'} + V_1^{1'} \bar{A}_2 + 2\bar{a}_2' V_2^1 \quad (3.45b)$$

$$0 = (V_{2x}^0 \bar{a}_1) + \frac{1}{2} (V_{1x}^0 \bar{A}_1 + \bar{A}_1' V_{1x}^{0'}) + V_{2A}^1 + \bar{A}_2' V_2^1 + 3(V_3^0 \bar{a}_2) \quad (3.45c)$$

$$0 = 3(V_3^0 \bar{A}_2)_s + (V_{2x}^0 \bar{A}_1)_s \quad (3.45d)$$

obtained by equating the μ terms in (3.42a), (3.42b), (3.42c), (3.42d), respectively, involve only the unknown terms V_{0x}^1 , V_1^1 , V_2^1 and V_3^0 . In (3.45) the multiplication of an $n_1 \times n_2 \times n_3$ matrix by an $n_3 \times n_4$ matrix results in an $n_1 \times n_2 \times n_4$ matrix. For convenience we suppress the last dimension of the $m \times m \times 1$ matrices $(V_{2x}^0 \bar{a}_1)$ and $(V_3^0 \bar{a}_2)$ and regard them as $m \times m$ matrices.

In general, in equating the μ^i terms we obtain the $(i+1)$ st set of equations involving the terms V_{0x}^i , V_1^i , V_2^i , V_3^{i-1} , ..., V_{i+2}^0 . The main accomplishment of the nested expansions is that the first set of equations (3.23), (3.24), (3.25) can be solved independently for the first three zeroth order terms V_{0x}^0 , V_1^0 and V_2^0 . Similarly, (3.45) and the subsequent sets of equations can be solved independently for V_{0x}^i , V_1^i , ..., V_{i+2}^0 .

3.7 Coefficients of Higher Order Expansions

After V_{0x}^0 , V_1^0 and V_2^0 are obtained, we proceed to solve for V_{0x}^1 , V_1^1 , V_2^1 and V_3^0 in (3.45). The following result is needed.

Lemma 3.7.1: [18]

If $\text{Re}\{\lambda(\bar{A}_2)\} \leq \sigma$ for a fixed $\sigma < 0$ and X is a completely symmetric $m \times m \times \dots \times m = m^k$ matrix, then the unique m^k matrix solution Y of the equation

$$(Y\bar{A}_2)_s = X \quad (3.46)$$

exists and is completely symmetric.

Thus by Lemma 3.7.1, the unique completely symmetric $m \times m \times m$ matrix solution V_3^0 of (3.45d) exists. After obtaining V_3^0 , we solve for the unique symmetric $m \times m$ matrix solution V_2^1 of (3.45c). Since V_3^0 and V_2^1 are known,

V_1^1 in (3.45b) can be rewritten as

$$V_1^1 = - [(V_{0x}^1 \bar{A}_1 + \bar{a}_1' V_{1x}^{0'} + 2\bar{a}_2' V_2^1) \bar{A}_2^{-1}]' \quad (3.47)$$

Elimination of V_1^1 from (3.45a) yields

$$0 = V_{0x}^1 \bar{a}_o - \bar{a}_1' V_{1x}^{0'} \bar{A}_2^{-1} \bar{a}_2 - \bar{a}_2' (V_2^1 \bar{A}_2^{-1} + \bar{A}_2^{-1} V_2^1) \bar{a}_2 \quad (3.48)$$

by using the relation $\bar{a}_o = \bar{a}_1 - \bar{A}_1 \bar{A}_2^{-1} \bar{a}_2$. Premultiplying (3.45c) by $\bar{A}_2'^{-1}$ and postmultiplying by \bar{A}_2^{-1} , we obtain

$$\begin{aligned} \bar{A}_2'^{-1} (V_{2x}^0 \bar{a}_1) \bar{A}_2^{-1} + \frac{1}{2} \bar{A}_2'^{-1} (V_{1x}^0 \bar{A}_1 + \bar{A}_1' V_{1x}^{0'}) \bar{A}_2^{-1} \\ + 3 \bar{A}_2'^{-1} (V_3^0 \bar{a}_2) \bar{A}_2^{-1} = - (V_2^1 \bar{A}_2^{-1} + \bar{A}_2^{-1} V_2^1). \end{aligned} \quad (3.49)$$

Substituting (3.49) into (3.48) and rearranging, (3.48) becomes

$$0 = V_{0x}^1 \bar{a}_o - \bar{a}_2' \bar{A}_2'^{-1} V_{1x}^0 \bar{a}_o + \bar{a}_2' \bar{A}_2'^{-1} [(V_{2x}^0 \bar{a}_1) + 3(V_3^0 \bar{a}_2)] \bar{A}_2^{-1} \bar{a}_2. \quad (3.50)$$

We now rewrite (3.45d) in scalar form

$$\begin{aligned} V_{3ijq}^0 \bar{A}_{2qk} + V_{3iqk}^0 \bar{A}_{2qj} + V_{3qjk}^0 \bar{A}_{2qi} + \\ \frac{1}{3} (V_{2ijx}^0 \bar{A}_{lk} + V_{2ikx}^0 \bar{A}_{lj} + V_{2jkk}^0 \bar{A}_{li}) = 0. \end{aligned} \quad (3.51)$$

Then multiplying the expression (3.51) by $(\bar{A}_2^{-1} \bar{a}_2)_i$, $(\bar{A}_2^{-1} \bar{a}_2)_j$, $(\bar{A}_2^{-1} \bar{a}_2)_k$ and summing over the indices i, j, k , we obtain

$$\begin{aligned}
& [v_{3ijq}^0 \bar{A}_{2qk} + v_{3iqk}^0 \bar{A}_{2qj} + v_{3qjk}^0 \bar{A}_{2qi} + \\
& + \frac{1}{3}(v_{2ijx}^0 \bar{A}_{1k} + v_{2ikx}^0 \bar{A}_{1j} + v_{2jix}^0 \bar{A}_{1i})] (\bar{A}_2^{-1} \bar{a}_2)_i (\bar{A}_2^{-1} \bar{a}_2)_j (\bar{A}_2^{-1} \bar{a}_2)_k \\
& = [v_{3ijq}^0 \bar{a}_{2q} + \frac{1}{3} v_{2ijx}^0 \bar{A}_1 \bar{A}_2^{-1} \bar{a}_2] (\bar{A}_2^{-1} \bar{a}_2)_i (\bar{A}_2^{-1} \bar{a}_2)_j \\
& + [v_{3ikq}^0 \bar{a}_{2q} + \frac{1}{3} v_{2ikx}^0 \bar{A}_1 \bar{A}_2^{-1} \bar{a}_2] (\bar{A}_2^{-1} \bar{a}_2)_i (\bar{A}_2^{-1} \bar{a}_2)_k \\
& + [v_{3jqk}^0 \bar{a}_{2q} + \frac{1}{3} v_{2jix}^0 \bar{A}_1 \bar{A}_2^{-1} \bar{a}_2] (\bar{A}_2^{-1} \bar{a}_2)_j (\bar{A}_2^{-1} \bar{a}_2)_k = 0 \quad (3.52)
\end{aligned}$$

where the summation signs of the indices i , j , and k are omitted. Expression (3.52) in matrix form is

$$(\bar{A}_2^{-1} \bar{a}_2)' [3(v_{3a_2}^0) + (v_{2x}^0 \bar{A}_1 \bar{A}_2^{-1} \bar{a}_2)] (\bar{A}_2^{-1} \bar{a}_2) = 0. \quad (3.53)$$

Using (3.53) to eliminate the term $(v_{3a_2}^0)$ in (3.50), we obtain the first order linear partial differential equation

$$\begin{aligned}
& v_{0x}^1 \bar{a}_o - \bar{a}_2' \bar{A}_2^{-1} v_{1x}^0 \bar{a}_o + \bar{a}_2' \bar{A}_2^{-1} (v_{2x}^0 \bar{a}_o) \bar{A}_2^{-1} \bar{a}_2 \\
& \equiv v_{0x}^1 \bar{a}_o - f(\bar{a}_2, \bar{A}_2, v_{1x}^0, v_{2x}^0) \bar{a}_o = 0, \quad v_0^1(0) = 0. \quad (3.54)
\end{aligned}$$

To guarantee the existence of the solution v_0^1 of (3.54), the stability condition for the reduced system (3.15) is restated as:

(A3.5) The trajectories $\xi(t)$ of (3.15) for all $\xi(0) = x_o \in D$ satisfy

$$\int_{x_o}^{x^*} |d\xi| = \int_0^\infty |\dot{\xi}(t)| dt < \infty \quad (3.55)$$

that is, their lengths are finite.

One case in which Assumption (A3.5) is clearly satisfied is when $\bar{x} = 0$ is an exponentially stable equilibrium of the reduced system (3.15). Certain nonlinear systems whose equilibria are only asymptotically stable also satisfy this condition.

We now show the existence of the solution of V_0^1 of (3.54) in the following lemma.

Lemma 3.7.2

If Assumption (A3.5) is satisfied, then the unique bounded solution $V_0^1(x)$ with $V_0^1(0) = 0$ of (3.54) exists for all $x \in D$.

Proof: The partial differential equation (3.54) can be expressed as a set of ordinary differential equations [32]

$$\dot{x} = \bar{a}_0(x) \quad , \quad x(0) = x_0 \quad (3.56a)$$

$$\dot{V}_0^1 = f(\bar{a}_2(x), \bar{A}_2(x), V_{1x}^0(x), V_{2x}^0(x)) \bar{a}_0(x), V_0^1(0) = 0 \quad (3.56b)$$

Assumption (A3.4) implies that the trajectory $\xi(t)$ of (3.56a) with $\xi(0) = x_0 \in D$ is contained in D and $\xi(\infty) = 0$. Thus $V_0^1(x_0)$ is determined by

$$\begin{aligned} V_0^1(0) - V_0^1(x_0) &= \int_0^\infty f(\bar{a}_2(\xi(t)), \bar{A}_2(\xi(t)), V_{1x}^0(\xi(t)), V_{2x}^0(\xi(t))) \bar{a}_0(\xi(t)) dt \\ &= \int_\Gamma f(\bar{a}_2(\xi), \bar{A}_2(\xi), V_{1x}^0(\xi), V_{2x}^0(\xi)) d\xi \end{aligned} \quad (3.57)$$

where Γ is the trajectory of $\xi(t)$. Imposing the end condition $V_0^1(0) = 0$, (3.57) becomes

$$V_0^1(x_0) = - \int_\Gamma f(\bar{a}_2, \bar{A}_2, V_{1x}^0, V_{2x}^0) d\xi \quad (3.58)$$

Thus (3.58) is the unique solution to (3.54) as

$$|V_0^1(x_0)| \leq |f| \int_\Gamma |d\xi| < \infty \quad (3.59)$$

which follows from Assumption (A3.5) and the boundedness of f in D .

Similarly, the solution of the other coefficients of V in the k th set of equations can be obtained. Let V^k be the series solution of V to (3.39), (3.43) incorporating all the coefficients of V up to the k th set of equations of V , and let

$$u^k = -\frac{1}{2} R^{-1} (B_1' V_x^k + \frac{1}{\mu} B_2' V_z^k) . \quad (3.60)$$

We summarize the above discussion as follows.

Theorem 3.7.1

If Assumptions (A3.1)-(A3.5) are satisfied, then the unique series expansions of V^k and u^k exist for all finite k . Furthermore, V^k satisfies the Hamilton-Jacobi equation (3.18) to an $O(\mu^k)$ error.

Proof: Assumptions (A3.1)-(A3.5) imply that for all finite k , the coefficients of V up to the k th set of equations of V can be uniquely solved for as bounded functions of $x \in D$. Thus the unique series expansions of V^k and u^k exist. If V^k is substituted in (3.41), the Hamilton-Jacobi equation (3.41) is satisfied to $O(\mu^k)$, implying the second conclusion of the theorem.

Repeating the derivation in Section 2.3, we can show that u^k stabilizes the full system (3.1) with similar stabilizing properties as u_c of (3.27). We first introduce the $x, \eta = z + \bar{A}_2^{-1} a_2$ variables and consider U in (2.26) as a tentative Lyapunov function. The analysis is more cumbersome but results similar to Theorems 2.3.1 and 2.3.2 and Corollaries 2.3.1 and 2.3.2 can be established.

3.8 Approximations of the Performance Value Function

We now investigate the performance of the full system (3.1) controlled by a truncated series of the minimizing control u of (3.17). Consider the composite control u_c of (3.27) which is obtained from u of

(3.17) by neglecting all the $O(\mu)$ terms. System (3.1) controlled by u_c becomes

$$\begin{aligned}\dot{x} &= a_1 x + A_1 z + B_1 u_c = \bar{a}_1 x + \bar{A}_1 z \\ \mu \dot{z} &= a_2 x + A_2 z + B_2 u_c = \bar{a}_2 x + \bar{A}_2 z.\end{aligned}\quad (3.61)$$

The performance $U(x, z, \mu)$ of (3.61) satisfies the partial differential equation

$$\begin{aligned}p + s'z + z'Qz + u_c' R u_c + U_x (a_1 + A_1 z + B_1 u_c) + \frac{1}{\mu} U_z (a_2 + A_2 z + B_2 u_c) &= 0, \\ U(0, 0, \mu) &= 0,\end{aligned}\quad (3.62)$$

that is

$$\begin{aligned}p + s'z + z'Qz + \frac{1}{4} [V_{0x}^0 B_1 + (V_1^0 + 2V_2^0 z)' B_2] R^{-1} [B_1' V_{0x}^0 + B_2' (V_1^0 + 2V_2^0 z)] \\ + U_x (\bar{a}_1 + \bar{A}_1 z) + \frac{1}{\mu} U_z (\bar{a}_2 + \bar{A}_2 z) &= 0.\end{aligned}\quad (3.63)$$

Similar to V , U can be expanded as a nested power series of μ and z

$$\begin{aligned}U &= U_0(x, \mu) + \mu U_1'(x, \mu)z + \mu z' U_2(x, \mu)z + \mu^2 U_{3ijk}(x, \mu)z_i z_j z_k + \dots \\ U_q(x, \mu) &= \sum_{i=0}^{\infty} \mu^i U_q^i(x), \quad q=0, 1, 2, \dots\end{aligned}\quad (3.64)$$

subject to $U_0^i(0) = 0$, $i=0, 1, 2, \dots$. Following the procedure to find the coefficients of the series expansion V , we substitute (3.64) into (3.63) and equate the resulting μ -independent terms to obtain

$$\begin{aligned}p + \frac{1}{4} (V_{0x}^0 B_1 + V_1^0 B_2) R^{-1} (B_1' V_{0x}^0 + B_2' V_1^0) + U_{0x}^0 \bar{a}_1 + U_1^0 \bar{a}_2 &= 0, \quad U_0^0(0) = 0 \\ s' + (V_{0x}^0 B_1 + V_1^0 B_2) R^{-1} B_2' V_2^0 + U_{0x}^0 \bar{A}_1 + U_1^0 \bar{A}_2 + 2\bar{a}_2' U_2^0 &= 0 \\ Q + V_2^0 B_2 R^{-1} B_2' V_2^0 + U_2^0 \bar{A}_2 + \bar{A}_2' U_2^0 &= 0\end{aligned}\quad (3.65)$$

which are the coefficients of the z -independent, z_i , $z_i z_j$ terms, respectively.

However, equations (3.65) can be rearranged into the form of (3.23), (3.24),

(3.25) with U_{0x}^0 , U_1^0 , and U_2^0 replacing \bar{V}_{0x} , \bar{V}_1 , \bar{V}_2 , respectively. Then from the uniqueness of solution of (3.23), (3.24), (3.25), and from (3.44)

$$U_0^0 = V_0^0, U_1^0 = V_1^0, U_2^0 = V_2^0. \quad (3.66)$$

Equating the μ terms in (3.63), we obtain the equations

$$U_{0x}^1 \bar{a}_1 + U_1^{1'} \bar{a}_2 = 0, \quad U_0^1(0) = 0$$

$$\bar{a}_1' U_{1x}^{0'} + U_{0x}^0 \bar{A}_1 + U_1^{1'} \bar{A}_2 + 2\bar{a}_2 U_2^1 = 0$$

$$(U_{2x}^0 \bar{a}_1) + \frac{1}{2} (U_{1x}^0 \bar{A}_1 + \bar{A}_1' U_{1x}^{0'}) + (U_2^1 \bar{A}_2 + \bar{A}_2' U_2^1) + 3(U_2^0 \bar{a}_2) = 0 \quad (3.67)$$

$$(U_{2x}^0 \bar{A}_1)_s + 3(U_2^0 \bar{A}_2)_s = 0.$$

Comparing these equations to (3.45), it is obvious that

$$U_0^1 = V_0^1, U_1^1 = V_1^1, U_2^1 = V_2^1, U_3^0 = V_3^0. \quad (3.68)$$

The other coefficients in the expansion of U can also be obtained sequentially and the procedure is similar to that of solving for V . Let U^k be the performance of (3.61) incorporating the coefficients of U up to the k th set of equations of U .

Theorem 3.8.1

If Assumptions (A3.1)-(A3.5) are satisfied, then the unique series expansion of the performance U^k of the full system (3.1) controlled by u_c of (3.27) exists for all finite k and matches the expansion V^k to $O(\mu^2)$, that is,

$$U^k(x, z, \mu) - V^k(x, z, \mu) = O(\mu^2), \quad k \geq 2. \quad (3.69)$$

The proof of Theorem 3.8.1 follows immediately from (3.66), (3.68) and Lemma 3.72. Although u_c is independent of μ , it is an $O(\mu^2)$ near-optimal control in the sense of (3.69). It is also applicable when μ is small but uncertain.

In the special case where $\text{Re}\{\lambda(A_2(x))\} < 0$ for all $x \in D$, the optimal control u_o of the reduced problem (3.8), (3.9) can be applied to (3.1). Then the feedback system is

$$\begin{aligned}\dot{x} &= a_1 + A_1 z + B_1 u_o = a_1 - B_1 R_o^{-1} (s_o + \frac{1}{2} B_o' V_{0x}^0) + A_1 z \\ \mu \dot{z} &= a_2 + A_2 z + B_2 u_o = a_2 - B_2 R_o^{-1} (s_o + \frac{1}{2} B_o' V_{0x}^0) + A_2 z.\end{aligned}\tag{3.70}$$

The performance $Y(x, z, \mu)$ of (3.70) also possesses a series expansion of the form (3.64) and satisfies the partial differential equation

$$p + s'z + z'Qz + u_o' R u_o + Y_x (a_1 + A_1 z + B_1 u_o) + \frac{1}{\mu} Y_z (a_2 + A_2 z + B_2 u_o) = 0.\tag{3.71}$$

Following [8], we rewrite (3.13) as

$$u_o = -\frac{1}{2} R^{-1} (B_1' V_{0x}^0 + B_2' \tilde{V}_1)\tag{3.72}$$

where

$$\tilde{V}_1 = [I_m + V_2^0 (A_2 - B_2 R^{-1} B_2' V_2^0)^{-1} B_2 R^{-1} B_2'] [V_1^0 + 2V_2^0 A_2^{-1} (a_2 - B_2 R^{-1} B_1' V_{0x}^0)]\tag{3.73}$$

and obtain the difference between u_o and u_c as

$$u_c - u_o = -\frac{1}{2} R^{-1} B_2' (V_1^0 - \tilde{V}_1) + R^{-1} B_2' V_2^0 z.\tag{3.74}$$

Then subtracting (3.71) from (3.63) and expanding $W = Y - U$ as a series expansion in μ and z , we equate the μ -independent terms to obtain

$$W_{Ox}^0 [a_1 - \frac{1}{2} B_1 R^{-1} (B_1' V_{Ox}^{0'} + B_2' \tilde{V}_1)] + W_1^0 [a_2 - \frac{1}{2} B_2 R^{-1} (B_1' V_{Ox}^{0'} + B_2' \tilde{V}_1)] + \frac{1}{4} (V_1^0 - \tilde{V}_1)' B_2 R^{-1} B_2' (V_1^0 - \tilde{V}_1) = 0, \quad W_0^0(0) = 0 \quad (3.75a)$$

$$W_{Ox}^0 A_1 + W_1^0 A_2 + 2 [a_2 - \frac{1}{2} B_2 R^{-1} (B_1' V_{Ox}^{0'} + B_2' \tilde{V}_1)]' W_2^0 - (V_1^0 - \tilde{V}_1)' B_2 R^{-1} B_2' V_2^0 = 0 \quad (3.75b)$$

$$W_2^0 A_2 + A_2' W_2^0 + V_2^0 B_2 R^{-1} B_2' V_2^0 = 0 \quad (3.75c)$$

which are the coefficients of z -independent, z_i , $z_i z_j$ terms, respectively.

If $\text{Re}\{\lambda(A_2)\} < 0$, the positive semidefinite solution W_2^0 of (3.75c) exists. Solving for W_1^0 in terms of W_2^0 and W_{Ox}^0 from (3.75b) and substituting into (3.75a) yield

$$W_{Ox}^0 [a_o - B_o R_o^{-1} (s_o + \frac{1}{2} B_o' V_{Ox}^{0'})] = N B_2 R^{-1} B_2' N', \quad W_0^0(0) = 0 \quad (3.76)$$

where

$$N = \frac{1}{2} (V_1^0 - \tilde{V}_1)' - [a_2 - \frac{1}{2} B_2 R^{-1} (B_1' V_{Ox}^{0'} + B_2' \tilde{V}_1)]' A_2^{-1} V_2^0. \quad (3.77)$$

But $N \equiv 0$ due to (3.73), and hence $W_{Ox}^0 \equiv 0$ and $W_0^0 \equiv 0$. Thus

$$Y_0^0 = V_0^0. \quad (3.78)$$

The procedure of solving for other coefficients in the expansion Y is similar to that of solving for those in V . Let Y^k be the performance of (3.70) incorporating the coefficients of Y up to the k th set of equations of Y . The above results are summarized in the following theorem.

Theorem 3.8.2

If Assumptions (A3.1), (A3.2) and (A3.4) are satisfied and $\text{Re}\{\lambda(A_2)\} \leq 0$, then the unique series expansion of the performance Y^k of the full system (3.1) controlled by the reduced control u_o of (3.13) exists

for all finite k and matches V^k to $O(\mu)$, that is

$$Y^k(x, z, \mu) - V^k(x, z, \mu) = O(\mu), \quad k \geq 1. \quad (3.79)$$

From Theorem 3.8.2, u_0 is an $O(\mu)$ near-optimal control in the sense of (3.79). Since it is also independent of μ , it can be applied when μ is small but uncertain.

3.9 Discussion

The nonlinear composite feedback control proposed in this chapter is composed of a fast part optimizing and stabilizing the fast transients and a reduced control representing the solution of the reduced order optimization problem. Conditions under which this composite control exists and stabilizes the full system are simple to check. It is shown that this control is $O(\mu^2)$ near-optimal. The series expansion method for higher order expansions is outlined. A crucial property of the analytical relationship and design computations is that they all appear in separate time scales. Thus the proposed design procedure is applicable to large scale systems. The resulting feedback control also has the two-time-scale structure where the slow variables are used for the slow feedback part and appear as slowly adjusted parameters in the fast feedback part. As a simple illustration of this control scheme, a DC motor control by both armature and field voltages is designed. The field phenomenon being much slower than the mechanical and armature transients appears in the reduced problem, while the armature control obtained as a result of the fast problem involves the field variables as slowly varying parameters.

4. NONLINEAR FIXED ENDPOINT PROBLEM

4.1 Introduction

In Chapter 3 we have considered the regulator problem for the nonlinear system (3.1). In this chapter, we consider fixed endpoint problem of minimizing the performance index

$$\begin{aligned} J &= \int_0^T [V_1(x, t, \mu) + V_2'(x, t, \mu)z + z'V_3(x, t, \mu)z + u'R(x, t, \mu)u] dt \\ &\equiv \int_0^T [V(x, z, t, \mu) + u'R(x, t, \mu)u] dt \end{aligned} \quad (4.1)$$

subject to the nonlinear dynamics

$$\frac{dx}{dt} = a_1(x, t, \mu) + A_1(x, t, \mu)z + B_1(x, t, \mu)u, \quad x(0, \mu) = x_0(\mu), x(T, \mu) = x_T(\mu) \quad (4.2a)$$

$$\mu \frac{dz}{dt} = a_2(x, t, \mu) + A_2(x, t, \mu)z + B_2(x, t, \mu)u, \quad z(0, \mu) = z_0(\mu), z(T, \mu) = z_T(\mu) \quad (4.2b)$$

where the states are $x \in \mathbb{R}^n$ and $z \in \mathbb{R}^m$, the control is $u \in \mathbb{R}^r$, μ is a small parameter and the prime denotes transposition. We assume that the matrices V_3 and R are positive definite in x and V is a positive definite function of x and z . Furthermore, we assume that a_i , A_i , B_i , x_0 , x_T , z_0 , z_T , V and R have asymptotic power series expansions as $\mu \rightarrow 0$ with infinitely differentiable coefficients. In addition, A_2 is assumed to be nonsingular. The Hamiltonian for problem (4.1), (4.2) is

$$H(x, z, u, p, q, t, \mu) = V + p'(a_1 + A_1 z + B_1 u) + q'(a_2 + A_2 z + B_2 u) + u' R u \quad (4.3)$$

where the costates p and μq satisfy the equations

$$\frac{dp}{dt} = -\nabla_x H(x, z, u, p, q, t, \mu) \quad (4.4a)$$

$$\mu \frac{dq}{dt} = -\nabla_z H(x, z, u, p, q, t, \mu) . \quad (4.4b)$$

The control which solves

$$\frac{\partial H}{\partial u} = 2Ru + B_1'p + B_2'q = 0 \quad (4.5)$$

is the minimizing control

$$u = -\frac{1}{2} R^{-1} (B_1'p + B_2'q) . \quad (4.6)$$

The substitution of (4.6) into (4.2) and (4.4) yields a nonlinear two-point-boundary-value (TPBV) problem

$$\begin{aligned} dx/dt &= a_1 + A_1 z - \frac{1}{2} B_1 R^{-1} (B_1'p + B_2'q) \equiv g_1(x, p, z, q, \mu, t) \\ dp/dt &= -\nabla_x H(x, z, -\frac{1}{2} R^{-1} (B_1'p + B_2'q), p, q, t, \mu) \equiv g_2(x, p, z, q, \mu, t) \\ \mu dz/dt &= a_2 + A_2 z - \frac{1}{2} B_2 R^{-1} (B_1'p + B_2'q) \equiv g_3(x, p, z, q, \mu, t) \\ \mu dq/dt &= -V_2 - 2V_3 z - A_1'p - A_2'q \equiv g_4(x, p, z, q, \mu, t) \end{aligned} \quad (4.7a)$$

where the boundary conditions are

$$x(0, \mu) = x_0(\mu), \quad x(T, \mu) = x_T(\mu), \quad z(0, \mu) = z_0(\mu), \quad z(T, \mu) = z_T(\mu) . \quad (4.7b)$$

Optimal control problems of the type (4.1), (4.2) with free endpoints are treated in [14-16], while more general free endpoint problems are considered in [33-35]. Fixed endpoint problem has been treated in [7] where (4.1) is in quadratic form and (4.2) is linear. For the nonlinear fixed endpoint problem, our approach is to decompose the full problem (4.1), (4.2) into three separate lower order problems, an n -dimensional nonlinear

"reduced" problem and two m-dimensional linear quadratic "boundary layer" problems. Thus the technique in [7] for linear quadratic problems is now extended to nonlinear problems. A further result is that our formulation of the reduced problem is particularly simple. Then similar to the results in [14-16,35] a solution x, z, p, q, u to the full TPBV problem (7) is shown to possess an asymptotic series expansion in μ and is approximated to $O(\mu)$ by combining the solutions to the reduced problem and the boundary layer problems. For practical implementation, we propose a partially closed-loop control to achieve stability of the fast variable z .

4.2 Lower Order Problems

Due to the presence of μ , system (4.2) possesses a two-time-scale property, that is the variable x varies slowly while the variable z has a rapidly varying part. Letting $\mu = 0$ in (4.2), which is equivalent to neglecting the fast part in z , we obtain

$$\frac{d\bar{x}}{dt} = \bar{a}_1 + \bar{A}_1 \bar{z} + \bar{B}_1 \bar{u}, \quad \bar{x}(0) = x_0(0), \quad \bar{x}(T) = x_T(0) \quad (4.8a)$$

$$0 = \bar{a}_2 + \bar{A}_2 \bar{z} + \bar{B}_2 \bar{u}. \quad (4.8b)$$

Here and in the following, an overbar indicates that $\mu = 0$. Assuming that \bar{A}_2 is nonsingular, the slow part \bar{z} of z is solved from (4.8b) as

$$\bar{z} = -\bar{A}_2^{-1} (\bar{a}_2 + \bar{B}_2 \bar{u}). \quad (4.9)$$

Eliminating \bar{z} from (4.8a) and the performance function (4.1) evaluated at $\mu = 0$, we define the reduced problem as follows.

Reduced Problem: The reduced problem is to minimize the performance index

$$\bar{J} = \int_0^T [L_1(\bar{x}, t) + 2L_2'(\bar{x}, t)\bar{u} + \bar{u}'L_3(\bar{x}, t)\bar{u}] dt \quad (4.10)$$

subject to

$$d\bar{x}/dt = \bar{a}(\bar{x}, t) + \bar{B}(\bar{x}, t)\bar{u} \quad , \quad \bar{x}(0) = x_0(0), \quad \bar{x}(T) = x_T(0) \quad (4.11)$$

where

$$\begin{aligned} L_1 &= \bar{V}_1 - \bar{V}_2' \bar{A}_2^{-1} \bar{a}_2 + \bar{a}_2' \bar{A}_2^{-1} \bar{V}_3 \bar{A}_2^{-1} \bar{a}_2 \\ L_2 &= \bar{B}_2' \bar{A}_2^{-1} (\bar{V}_3 \bar{A}_2^{-1} \bar{a}_2 - \frac{1}{2} \bar{V}_1) \\ L_3 &= \bar{R} + \bar{B}_2' \bar{A}_2^{-1} \bar{V}_3 \bar{A}_2^{-1} \bar{B}_2 \\ \bar{a} &= \bar{a}_1 - \bar{A}_1 \bar{A}_2^{-1} \bar{a}_2 \\ \bar{B} &= \bar{B}_1 - \bar{A}_1 \bar{A}_2^{-1} \bar{B}_2 \end{aligned} \quad (4.12)$$

The Hamiltonian of the reduced problem is

$$\bar{H}(\bar{x}, \bar{p}, \bar{u}, t) = L_1 + 2L_2' \bar{u} + \bar{u}' L_3 \bar{u} + \bar{p}' (\bar{a} + \bar{B} \bar{u}) \quad (4.13)$$

where the costate \bar{p} satisfies

$$d\bar{p}/dt = -\nabla_{\bar{x}} \bar{H}(\bar{x}, \bar{p}, \bar{u}, t) \quad (4.14)$$

The control which solves

$$\partial \bar{H} / \partial \bar{u} = 2L_2 + 2L_3 \bar{u} + \bar{B}' \bar{p} = 0 \quad (4.15)$$

is the minimizing control

$$\bar{u} = -\frac{1}{2} L_3^{-1} (2L_2 + \bar{B}' \bar{p}) \quad (4.16)$$

Substitution of (4.16) into (4.11) and (4.14) results in the reduced TPBV problem

$$d\bar{x}/dt = \bar{a} - \bar{B} L_3^{-1} L_2 - \frac{1}{2} \bar{B} L_3^{-1} \bar{B}' \bar{p} = f_1(\bar{x}, \bar{p}, t), \quad \bar{x}(0) = x_0(0), \quad \bar{x}(T) = x_T(0) \quad (4.17a)$$

$$d\bar{p}/dt = -\nabla_{\bar{x}} \bar{H}(\bar{x}, \bar{p}, -\frac{1}{2} L_3^{-1} (2L_2 + \bar{B}' \bar{p}), t) = f_2(\bar{x}, \bar{p}, t) \quad (4.17b)$$

The following assumption is crucial.

(A4.1) The reduced TPBV problem (4.17) has a unique solution $\bar{x}^*(t), \bar{p}^*(t)$ and $\bar{u}^*(t)$ for all $t \in [0, T]$.

Linearizing (4.17) along \bar{x}^*, \bar{p}^* , we obtain the variational equation as

$$\frac{d}{dt} \begin{bmatrix} \delta \bar{x} \\ \delta \bar{p} \end{bmatrix} = \begin{bmatrix} f_{1\bar{x}} & f_{1\bar{p}} \\ f_{2\bar{x}} & f_{2\bar{p}} \end{bmatrix} \begin{bmatrix} \delta \bar{x} \\ \delta \bar{p} \end{bmatrix} \equiv \begin{bmatrix} C_1 & -C_2 \\ -C_3 & -C_1' \end{bmatrix} \begin{bmatrix} \delta \bar{x} \\ \delta \bar{p} \end{bmatrix}. \quad (4.18)$$

System (4.18) is assumed to satisfy the following assumption.

(A4.2) C_3 is positive semidefinite along \bar{x}^*, \bar{p}^* .

Assumption (A4.2) rules out the occurrence of conjugate points [36] and guarantees that \bar{x}^*, \bar{p}^* yield a local minimum. This assumption is also crucial for finding higher order terms in the asymptotic series expansions for x, z, p, q, u of (4.6), (4.7).

Since \bar{z}^* in general does not satisfy the end conditions (4.2b), we assume that the variable z contains an initial (left) boundary layer $\lambda(\tau)$ and an end (right) boundary layer $\rho(\sigma)$ such that

$$z(t) = \bar{z}^*(t) + \lambda(\tau) + \rho(\sigma) \quad (4.19)$$

where $\tau = t/\mu$ and $\sigma = (t-T)/\mu$ are the "stretched" time scales. Substituting (4.19) into (4.2b) and equating the layer terms, we obtain the boundary layer systems as

$$\frac{d\lambda(\tau)}{d\tau} = \bar{A}_2(0)\lambda(\tau) + \bar{B}_2(0)u_\lambda(\tau) \quad , \quad \lambda(0) = z_0(0) - \bar{z}^*(0) \quad (4.20)$$

$$\frac{d\rho(\sigma)}{d\sigma} = \bar{A}_2(T)\rho(\sigma) + \bar{B}_2(T)u_\rho(\sigma) \quad , \quad \rho(0) = z_T(0) - \bar{z}^*(T) \quad (4.21)$$

where u is also decomposed into

$$u(t) = \bar{u}^*(t) + u_\lambda(\tau) + u_\rho(\sigma) . \quad (4.22)$$

Substituting (4.19) and (4.22) into (4.1) and retaining only the quadratic terms in λ , ρ , u_λ , u_ρ , we define the boundary layer problems as follows.

Boundary Layer Problems: The left boundary layer problem (LBLP) is to minimize

$$J_\lambda = \int_0^\infty [\lambda' \bar{V}_3(0)\lambda + u_\lambda' \bar{R}(0)u_\lambda] d\tau \quad (4.23)$$

subject to the dynamics (4.20). The right boundary layer problem (RBLP) is to minimize

$$J_\rho = \int_{-\infty}^0 [\rho' \bar{V}_3(T)\rho + u_\rho' \bar{R}(T)u_\rho] d\sigma \quad (4.24)$$

subject to the dynamics (4.21).

We now make the following assumption.

(A4.3) For all $t \in [0, T]$ and along the trajectory \bar{x}^*

$$\text{rank}[\bar{B}_2, \bar{A}_2 \bar{B}_2, \dots, \bar{A}_2^{m-1} \bar{B}_2] = m$$

$$\text{rank}[\bar{H}_2', \bar{A}_2' \bar{H}_2', \dots, \bar{A}_2'^{m-1} \bar{H}_2'] = m$$

where \bar{H}_2 satisfies $\bar{H}_2' \bar{H}_2 = \bar{V}_3$.

Under Assumption (A4.3), the solutions to LBLP and RBLP exist and are given by

$$u_\lambda(\tau) = -\bar{R}^{-1}(0) \bar{B}_2'(0) K_\lambda(0) \lambda(\tau) \quad (4.25)$$

$$u_\rho(\sigma) = -\bar{R}^{-1}(T) \bar{B}_2'(T) K_\rho(T) \rho(\sigma) \quad (4.26)$$

where $K_\lambda(0)$ is the positive definite solution and $K_\rho(T)$ is the negative definite solution of

$$\bar{K} \bar{A}_2 + \bar{A}_2' \bar{K} - \bar{K} \bar{B}_2 \bar{R}^{-1} \bar{B}_2' \bar{K} + \bar{V}_3 = 0 \quad (4.27)$$

at $t = 0$ and $t = T$ respectively.

4.3 Main Theorem

The decomposition of the full problem (4.1), (4.2) into the reduced problem and two boundary layer problems is justified in the following theorem.

Theorem 4.3.1

If Assumptions (A4.1)-(A4.3) hold, then there exists a $\mu^* > 0$ such that for all $\mu \in (0, \mu^*]$, an asymptotic series solution x^* , z^* , p^* , q^* , u^* to (4.6), (4.7) exists and is approximated to $O(\mu)$ by the solution of the reduced problem and the boundary layer problems as

$$x^*(t, \mu) = \bar{x}^*(t) + O(\mu) \quad (4.28a)$$

$$z^*(t, \mu) = \bar{z}^*(t) + \lambda(\tau) + \rho(\sigma) + O(\mu) \quad (4.28b)$$

$$p^*(t, \mu) = \bar{p}^*(t) + O(\mu) \quad (4.28c)$$

$$q^*(t, \mu) = -\bar{A}_2'^{-1} (\bar{V}_2 + 2\bar{V}_3 \bar{z}^* + \bar{A}_1' \bar{p}^*) + 2K_\lambda(0)\lambda(\tau) + 2K_\rho(T)\rho(\sigma) + O(\mu) \quad (4.28d)$$

$$u^*(t, \mu) = \bar{u}^*(t) + u_\lambda(\tau) + u_\rho(\sigma) + O(\mu) \quad (4.28e)$$

The meaning of this theorem is that we can obtain an $O(\mu)$ approximate solution to the full TPBV problem (4.6), (4.7) by solving for the reduced problem, the LBLP and the RBLP. The reduced problem is of lower order and does not involve the small parameter μ . Thus we can use large stepsizes in the numerical computation of the reduced problem. The LBLP and the RBLP are linear quadratic problems and their computation is a small fraction of the time required to compute nonlinear problems of the same dimension. Thus solving for the lower dimension problems results in considerable savings of computation time.

In the actual implementation of the control (4.22) to the physical system (4.2), undesirable behavior will occur if A_2 is unstable. Since $u(t)$ of (4.22) is an open-loop control, it does not affect the stability of the

system (4.2). Hence if A_2 is unstable, the higher order μ terms in (4.28) which are not compensated will grow as $O(e^{1/\mu})$. Furthermore, the error increases as μ decreases. An example illustrating this behavior in linear time-varying system is given in [7]. This problem can be avoided by using a partially closed-loop control.

$$u = M(x(t), t)z + v \quad (4.29)$$

such that $(A_2 + B_2 M)$ is stable along the trajectory \bar{x}^* . Assumption (A4.3) guarantees that such an M exists and can be computed as

$$M = -\bar{R}^{-1} \bar{B}_2' K(t) \quad (4.30)$$

where $K(t)$ is the positive definite solution to (4.27) for $t \in [0, T]$. Then the open-loop control v is computed as

$$v = u - Mz . \quad (4.31)$$

4.4 Example

We consider the optimal control of the system

$$\begin{aligned} \dot{x} &= xz, & x(0) &= 1/\sqrt{2}, & x(1) &= .5 \\ \mu \dot{z} &= -z + u, & z(0) &= 0, & z(1) &= 0 \end{aligned} \quad (4.32)$$

with respect to the performance function

$$J = \int_0^1 (x^4 + \frac{1}{2} z^2 + \frac{1}{2} u^2) dt . \quad (4.33)$$

The Hamiltonian for (4.32), (4.33) is

$$H = x^4 + \frac{1}{2} z^2 + \frac{1}{2} u^2 + p(xz) + q(-z + u) \quad (4.34)$$

and the minimizing control is

$$u = -q \quad (4.35)$$

as $\partial H/\partial u = u + q = 0$. Thus the TPBV problem is

$$\begin{aligned} \dot{x} &= xz \\ \mu \dot{z} &= -z - q \\ \dot{p} &= -\partial H/\partial x = -4x^3 - pz \\ \mu \dot{q} &= -\partial H/\partial z = -px - z + q. \end{aligned} \quad (4.36)$$

We now apply the decomposition procedure to obtain $O(\mu)$ approximations of x, z, p, q, u .

The reduced problem of (4.32), (4.33) is to optimally control the reduced system

$$\dot{\bar{x}} = \bar{x}\bar{u}, \quad \bar{x}(0) = 1/\sqrt{2}, \quad \bar{x}(1) = .5 \quad (4.37)$$

with respect to

$$\bar{J} = \int_0^{\infty} (\bar{x}^4 + \bar{u}^2) dt. \quad (4.38)$$

The Hamiltonian for this reduced problem is

$$\bar{H} = \frac{\bar{x}^4}{4} + \frac{\bar{u}^2}{2} + \bar{p}\bar{x}\bar{u} \quad (4.39)$$

and the reduced control \bar{u} satisfies

$$\partial \bar{H}/\partial \bar{u} = 2\bar{u} + \bar{p}\bar{x} = 0 \quad (4.40)$$

that is,

$$\bar{u} = -\bar{p}\bar{x}/2. \quad (4.41)$$

The reduced TPBV problem becomes

$$\dot{\bar{x}} = -\bar{x}^2 \bar{p} / 2, \quad \bar{x}(0) = 1/\sqrt{2}, \quad \bar{x}(1) = .5 \quad (4.42)$$

$$\dot{\bar{p}} = -\partial \bar{H} / \partial \bar{x} = -4\bar{x}^3 - \bar{p} \bar{u} = -4\bar{x}^3 + \bar{x} \bar{p}^2 / 2.$$

The unique solution to (4.42) is found analytically to be

$$\begin{aligned} \bar{x}^*(t) &= 1/\sqrt{2(t+1)} \\ \bar{p}^*(t) &= 2\bar{x}^*(t) = \sqrt{2/(t+1)} \\ \bar{u}^*(t) &= -\bar{x}^{*2}(t) = -1/(2(t+1)) \\ \bar{z}^*(t) &= \bar{u}^*(t). \end{aligned} \quad (4.43)$$

Linearization of (4.43) along \bar{x}^*, \bar{p}^* reveals that $C_3 = \frac{5}{t+1}$ and hence (A4.2) is satisfied.

The LBLP is to optimally control

$$d\lambda/d\tau = -\lambda + u_\lambda, \quad \lambda(0) = 0 - (-1/2) = 1/2, \quad \tau = t/\mu \quad (4.44)$$

with respect to

$$J_\lambda = \frac{1}{2} \int_0^\infty (\lambda^2 + u_\lambda^2) d\tau. \quad (4.45)$$

The optimal control is

$$u_\lambda(\tau) = -k_\lambda \lambda(\tau) = -(\sqrt{2-1})\lambda(\tau) \quad (4.46)$$

where k_λ is the positive definite solution to the Riccati equation

$$0 = 2k + k^2 - 1. \quad (4.47)$$

Thus the optimally controlled LBL system is

$$d\lambda/d\tau = -\sqrt{2} \lambda \quad (4.48)$$

yielding

$$\lambda(\tau) = \lambda(0)e^{-\sqrt{2}\tau}, \quad 0 \leq \tau < \infty. \quad (4.49)$$

Similarly, the RBLP is to optimally control

$$d\rho/d\sigma = -\rho + u_\rho, \quad \rho(0) = 0 - (-1/4) = 1/4, \quad \sigma = (t-1)/\mu \quad (4.50)$$

with respect to

$$J_\rho = \frac{1}{2} \int_{-\infty}^0 (\rho^2 + u_\rho^2) d\sigma. \quad (4.51)$$

The optimal control is

$$u_\rho = -k_\rho \rho(\tau) = (1 + \sqrt{2})\rho(\tau) \quad (4.52)$$

where k_ρ is the negative definite solution to the Riccati equation (4.47), resulting in the feedback system

$$d\rho/d\sigma = \sqrt{2} \rho \quad (4.53)$$

such that

$$\rho(\sigma) = \rho(0)e^{\sqrt{2}\sigma}, \quad -\infty < \sigma \leq 0. \quad (4.54)$$

Thus an $O(\mu)$ approximation to the solution of the full order problem (4.36) is

$$\begin{aligned} \hat{x}(t) &= 1/\sqrt{2(t+1)} \\ \hat{z}(t) &= -1/(2(t+1)) + \frac{1}{2} e^{-\sqrt{2}t/\mu} + \frac{1}{4} e^{\sqrt{2}(t-1)/\mu} \\ \hat{p}(t) &= \sqrt{2/(t+1)} \\ \hat{q}(t) &= 1/(2(t+1)) + \frac{1}{2} (\sqrt{2}-1)e^{-\sqrt{2}t/\mu} - \frac{1}{4}(1+\sqrt{2})e^{\sqrt{2}(t-1)/\mu} \\ \hat{u}(t) &= -\hat{q}(t). \end{aligned} \quad (4.55)$$

For $\mu = .1$, the trajectories are shown by dashed lines in Figures 4.1-4.5. The Newton-Raphson algorithm in [37] is modified for fixed end-point problems by using the dichotomy transformation in [38] and is used to compute an optimal solution of (4.36) numerically. Using (4.55) as the initial guess, the computation converges in four iterations and the optimal trajectories are shown in solid lines in Figures 4.1-4.5. The closeness of (4.55) to the optimal trajectories are obvious.

4.5 Asymptotic Expansions

We now proceed to obtain asymptotic series expansions of x , z , p , q , u in μ . Then Theorem 4.3.1 follows from the fact that (4.28) consists of the leading terms in the expansions.

Lemma 4.5.1

Under Assumptions (A4.1)-(A4.3), the TPBV problem (4.7) possesses a solution of the form

$$\begin{aligned}
 x(t, \mu) &= X^N(t, \mu) + \mu m_1^N(\tau, \mu) + \mu n_1^N(\sigma, \mu) + \mu^N x^N(t, \mu) \\
 p(t, \mu) &= P^N(t, \mu) + \mu m_2^N(\tau, \mu) + \mu n_2^N(\sigma, \mu) + \mu^N p^N(t, \mu) \\
 z(t, \mu) &= Z^N(t, \mu) + m_3^N(\tau, \mu) + n_3^N(\sigma, \mu) + \mu^N z^N(t, \mu) \\
 q(t, \mu) &= Q^N(t, \mu) + m_4^N(\tau, \mu) + n_4^N(\sigma, \mu) + \mu^N q^N(t, \mu)
 \end{aligned} \tag{4.56}$$

for all $N \geq 0$ where

$$\begin{aligned}
 X^N &= \sum_{i=0}^N \mu^i X_i(t, \mu), & P^N &= \sum_{i=0}^N \mu^i P_i(t, \mu) \\
 Z^N &= \sum_{i=0}^N \mu^i Z_i(t, \mu), & Q^N &= \sum_{i=0}^N \mu^i Q_i(t, \mu)
 \end{aligned} \tag{4.57}$$

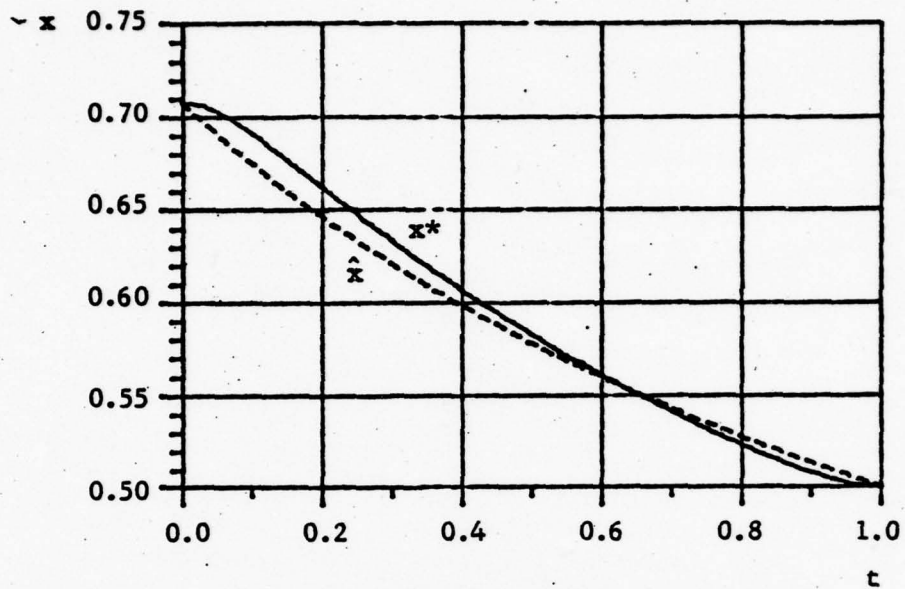

Figure 4.1 Plots of x^* and \hat{x} .

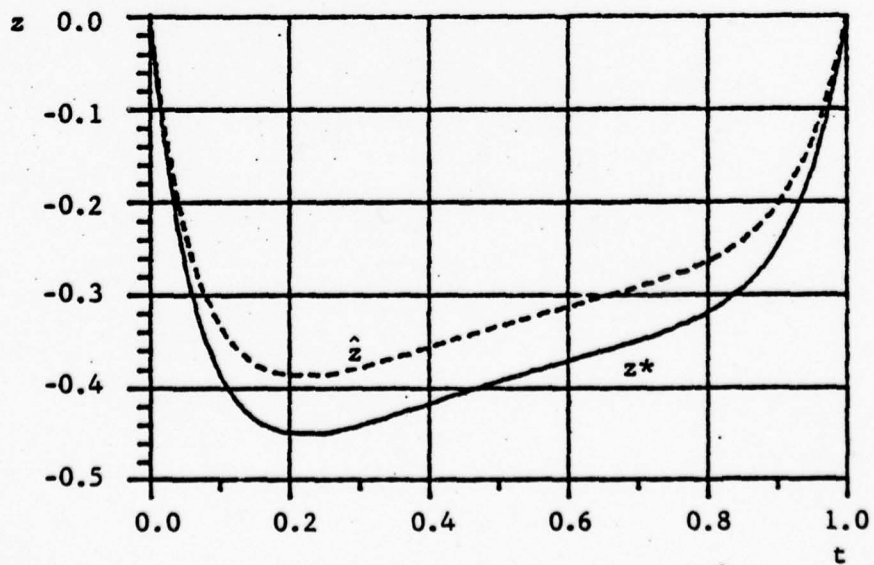
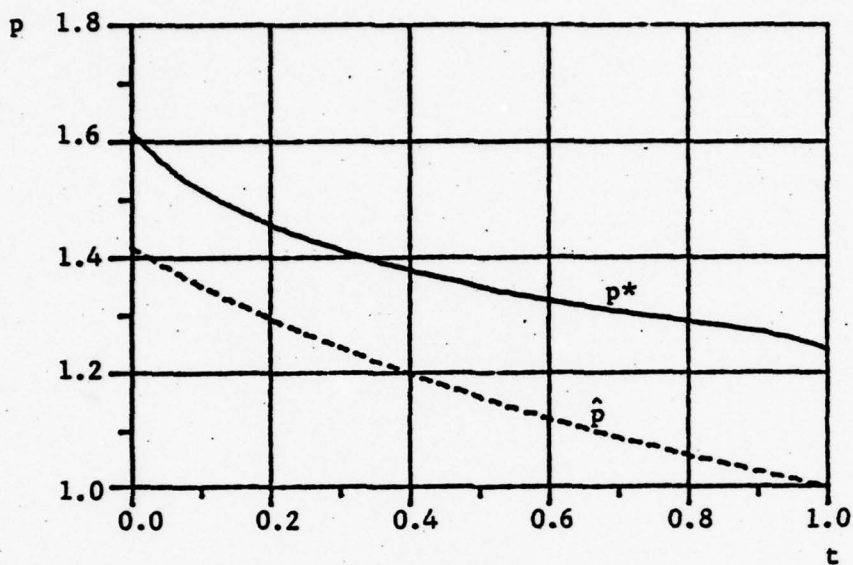
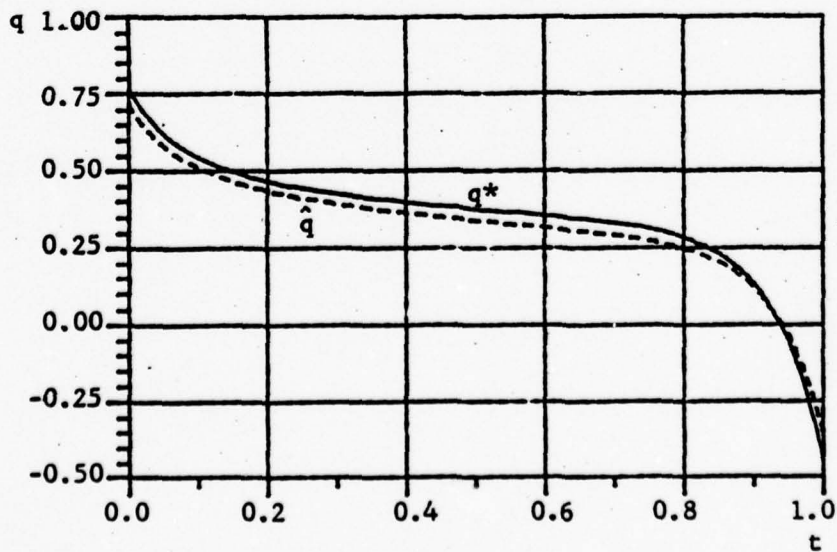

Figure 4.2 Plots of z^* and \hat{z} .

Figure 4.3 Plots of p^* and \hat{p} .Figure 4.4 Plots of q^* and \hat{q} .

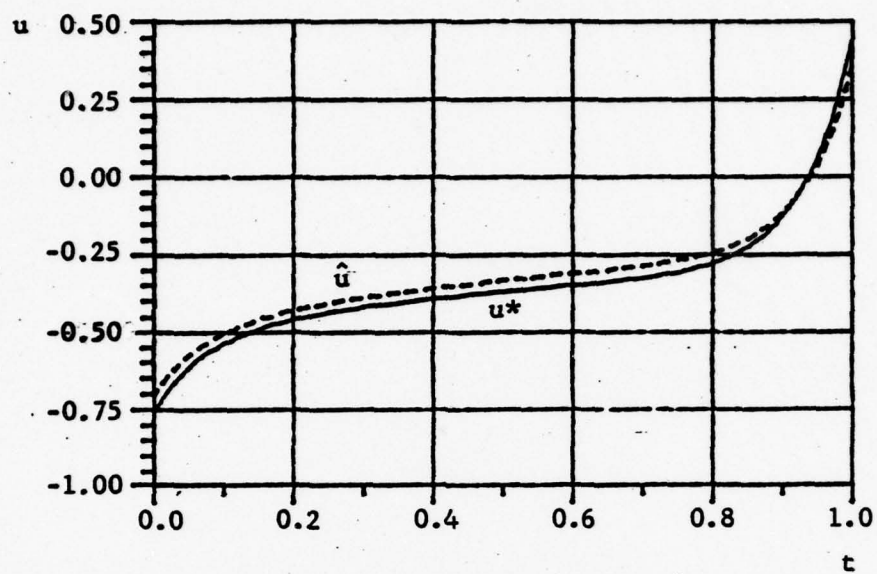

Figure 4.5 Plots of u^* and \hat{u} .

are the outer expansion,

$$m_k^N = \sum_{i=0}^{N-1} \mu^i m_{ki}^i(\tau, \mu), \quad k = 1, 2, \quad m_k^N = \sum_{i=0}^N \mu^i m_{ki}^i(\tau, \mu), \quad k = 3, 4 \quad (4.58)$$

$$n_k^N = \sum_{i=0}^{N-1} \mu^i n_{ki}^i(\sigma, \mu), \quad k = 1, 2, \quad n_k^N = \sum_{i=0}^N \mu^i n_{ki}^i(\sigma, \mu), \quad k = 3, 4$$

are the left and the right boundary layer expansions, respectively, and x^N, p^N, z^N, q^N are $O(\mu)$ uniformly in the interval $t \in [0, T]$ for μ sufficiently small.

Proof:

Outer Expansion. The outer expansion is obtained by substituting (X^N, P^N, Z^N, Q^N) into (4.7) and equating the coefficients of like power of μ^i , $0 \leq i \leq N$.

At $i=0$, (X_0, P_0, Z_0, Q_0) is the solution to

$$\left. \begin{aligned} dX_0/dt &= \bar{a}_1 + \bar{A}_1 Z_0 - \frac{1}{2} \bar{S}_1 P_0 - \frac{1}{2} \bar{S}_2 Q_0, \quad X_0(0) = x_0(0), \quad X_0(T) = x_T(0) \\ dP_0/dt &= -\nabla_x H(X_0, Z_0, -\frac{1}{2} \bar{R}^{-1}(\bar{B}_1' P_0 + \bar{B}_2' Q_0), P_0, Q_0, t, 0) \end{aligned} \right\} \quad (4.59a)$$

$$\left. \begin{aligned} 0 &= \bar{a}_2 + \bar{A}_2 Z_0 - \frac{1}{2} \bar{S}'_1 P_0 - \frac{1}{2} \bar{S}_2 Q_0 \\ 0 &= -\bar{V}_2 - 2\bar{V}_3 Z_0 - \bar{A}'_1 P_0 - \bar{A}'_2 Q_0 \end{aligned} \right\} \quad (4.59b)$$

where $\bar{a}_1, \bar{a}_2, \bar{A}_1, \bar{A}_2, \bar{B}_1, \bar{B}_2, \bar{S}_1 = \bar{B}_1 \bar{R}^{-1} \bar{B}_1', \bar{S}_2 = \bar{B}_2 \bar{R}^{-1} \bar{B}_2', \bar{S} = \bar{B}_1 \bar{R}^{-1} \bar{B}_2', \bar{V}_2$ and \bar{V}_3 are evaluated at X_0, P_0, Z_0, Q_0 and $\mu = 0$. In general for $1 \leq i \leq N$,

(X_i, P_i, Z_i, Q_i) is the solution to

$$\left. \begin{aligned} dX_i/dt &= g_{1x}(t) X_i - \frac{1}{2} \bar{S}_1(t) P_i + \bar{A}_1(t) Z_i - \frac{1}{2} \bar{S}(t) Q_i + \alpha_{1i}(t) \\ dP_i/dt &= g_{2x}(t) X_i + g_{2p}(t) P_i + g_{2z}(t) Z_i + g_{2q}(t) Q_i + \alpha_{2i}(t) \end{aligned} \right\} \quad (4.60a)$$

$$\left. \begin{aligned} 0 &= g_{3x}(t)X_i - \frac{1}{2} \bar{S}'(t)P_i + \bar{A}_2(t)Z_i - \frac{1}{2} \bar{S}_2(t)Q_i + \alpha_{3i}(t) \\ 0 &= g_{4x}(t)X_i - \bar{A}'_1(t)P_i - 2\bar{V}_3(t)Z_i - \bar{A}'_2(t)Q_i + \alpha_{4i}(t) \end{aligned} \right\} \quad (4.60b)$$

where the matrix coefficients of X_i , P_i , Z_i , Q_i are evaluated at X_0 , P_0 , Z_0 , Q_0 and $\mu = 0$, and $\alpha_{ki}(t)$, $k=1,2,3,4$, are known functions of X_r , P_r , Z_r , Q_r , $r \leq i-1$. From Assumption (A4.3) it follows that

$$\begin{bmatrix} \bar{A}_2(t) & -\frac{1}{2} \bar{S}_2(t) \\ -2\bar{V}_3(t) & -\bar{A}'_2(t) \end{bmatrix} \quad (4.61)$$

is nonsingular. Hence Z_i , Q_i can be solved uniquely from (4.60b) and eliminated from the equations for dX_i/dt , dP_i/dt . For $i=0$, it is shown in Appendix C that the elimination of Z_0 , Q_0 from (4.59a) yields the reduced TPBV problem (4.17) with X_0 , P_0 replacing \bar{x}, \bar{p} . Hence from Assumption (A4.1), the uniqueness of solution guarantees

$$X_0 = \bar{x}^*, \quad P_0 = \bar{p}^* \quad (4.62)$$

and Z_0 , Q_0 are given in (C1) of Appendix C.

It then follows immediately that for $1 \leq i \leq N$, the elimination of Z_i , Q_i from (4.60a) yields

$$\begin{aligned} dX_i/dt &= C_1(t)X_i - C_2(t)P_i + \hat{\alpha}_{1i}(t) \\ dP_i/dt &= -C_3(t)X_i - C'_1(t)P_i + \hat{\alpha}_{2i}(t) \end{aligned} \quad (4.63)$$

where C_1, C_2, C_3 are given in (4.18). The boundary conditions of (4.63) are $X_i(0) = a^i$ and $X_i(T) = b^i$ where a^i , b^i will be specified later. Since C_3 is positive semidefinite and R is positive definite, the solution $K_p(t)$ to

$$\dot{K} = -KC_1 - C'_1K + KC_2K - C_3 \quad (4.64)$$

with end condition

$$K(T) = \pi_1 \quad (4.65)$$

is positive definite in $t \in [0, T)$ for any π_1 positive semidefinite, and the solution $K_n(t)$ to (4.64) with end condition

$$K(0) = \pi_2 \quad (4.66)$$

is negative definite in $t \in (0, T]$ for any π_2 negative semidefinite [38].

Introducing the dichotomy transformation [38]

$$X_i = y_i + w_i, \quad P_i = K_p y_i + K_n w_i \quad (4.67)$$

and substituting into (4.63), we obtain the equations for y_i, w_i as

$$dy_i/dt = (C_1 - C_2 K_p) y_i + \alpha_{y_i} \quad (4.68a)$$

$$dw_i/dt = (C_1 - C_2 K_n) w_i + \alpha_{w_i} \quad (4.68b)$$

where

$$\begin{bmatrix} \alpha_{y_i} \\ \alpha_{w_i} \end{bmatrix} = \begin{bmatrix} I_n & I_n \\ K_p & K_n \end{bmatrix}^{-1} \begin{bmatrix} \hat{\alpha}_{1i} \\ \hat{\alpha}_{2i} \end{bmatrix}. \quad (4.69)$$

Let Φ_1, Φ_2 be the state transition matrices of (4.68a), (4.68b), respectively.

Then the solution to (4.68) is

$$y_i(t) = \Phi_1(t, 0) y_i(0) + \int_0^t \Phi_1(t, s) \alpha_{y_i}(s) ds \quad (4.70)$$

$$w_i(t) = \Phi_2(t, T) w_i(T) + \int_T^t \Phi_2(t, s) \alpha_{w_i}(s) ds .$$

To determine $y_i(0), w_i(T)$, we evaluate (4.70) at $t=0$ and $t=T$ and substitute into (4.67) to obtain the relationship

$$\begin{bmatrix} y_i(0) \\ w_i(T) \end{bmatrix} = \begin{bmatrix} I_n & \Phi_2(0,T) \\ \Phi_1(T,0) & I_n \end{bmatrix}^{-1} \begin{bmatrix} a^i - \int_0^T \Phi_2(0,s) \alpha_{w_i}(s) ds \\ b^i - \int_0^T \Phi_1(T,s) \alpha_{y_i}(s) ds \end{bmatrix}. \quad (4.71)$$

Thus given a^i, b^i , the unique solutions y_i, w_i to (4.68) and hence those of X_i, P_i to (4.63) can be computed.

Boundary Layer Expansions. Since $Z(0, \mu)$ does not in general satisfy the initial condition $z_0(\mu)$, it is necessary to account for this boundary layer by $m_k^N(\tau, \mu)$, $k=1,2,3,4$, which satisfy at $t=0$ the equations

$$\begin{aligned} \left[\frac{dm_1^N}{d\tau} \right] &= \left[\frac{dx}{dt} - \frac{dX^N}{dt} \right]_{t=\mu\tau}, & \left[\frac{dm_2^N}{d\tau} \right] &= \left[\frac{dp}{dt} - \frac{dP^N}{dt} \right]_{t=\mu\tau}, \\ \left[\frac{dm_3^N}{d\tau} \right] &= \left[\frac{dz}{dt} - \frac{dZ^N}{dt} \right]_{t=\mu\tau}, & \left[\frac{dm_4^N}{d\tau} \right] &= \left[\frac{dq}{dt} - \frac{dQ^N}{dt} \right]_{t=\mu\tau}. \end{aligned} \quad (4.72)$$

to $O(\mu^N)$. Hence we have

$$\begin{aligned} \frac{dm_k^N}{d\tau} &= \hat{g}_k(m_1^N, m_2^N, m_3^N, m_4^N, \mu, \tau) \\ &= g_k(X^N(\mu\tau) + \mu m_1^N(\tau), P^N(\mu\tau) + \mu m_2^N(\tau), Z^N(\mu\tau) + m_3^N(\tau), \\ &\quad Q^N(\mu\tau) + m_4^N(\tau), \mu, \mu\tau) - g_k(X^N(\mu\tau), P^N(\mu\tau), Z^N(\mu\tau), \\ &\quad Q^N(\mu\tau), \mu, \mu\tau), \quad k=1,2,3,4. \end{aligned} \quad (4.73)$$

Substituting (4.72) into (4.73) and equating the coefficients of like power of μ^i , $0 \leq i \leq N$, we obtain a system of equations for the left boundary layer. At $i=0$, the zeroth order terms of m_k^N satisfy

$$dm_{10}/d\tau = \bar{A}_1(0)m_{30} - \frac{1}{2}\bar{S}(0)m_{40}$$

$$\begin{aligned} dm_{20}/d\tau &= g_2(X_0(0), P_0(0), Z_0(0) + m_{30}(\tau), Q_0(0) + m_{40}(\tau), 0, 0) \\ &\quad - g_2(X_0(0), P_0(0), Z_0(0), Q_0(0), 0, 0) \end{aligned} \quad (4.74)$$

$$dm_{30}/d\tau = \bar{A}_2(0)m_{30} - \frac{1}{2}\bar{S}_2(0)m_{40}$$

$$dm_{40}/d\tau = -2\bar{V}_3(0)m_{30} - \bar{A}'_2(0)m_{40}$$

where the initial condition of m_{30} is $m_{30}(0) = z_0(0) - Z_0(0)$. Furthermore $m_{i0}(\tau)$ tends to zero as τ tends to infinity. Letting

$$m_{40}(\tau) = 2K_\lambda(0)m_{30}(\tau) \quad (4.75)$$

where $K_\lambda(0)$ is the positive definite solution of (4.27) at $t=0$, we obtain

$$dm_{30}/d\tau = [\bar{A}_2 - \bar{S}_2 K_\lambda]_{t=0} m_{30}, \quad m_{30}(0) = z_0(0) - Z_0(0). \quad (4.76)$$

Thus $\bar{A}_2 - \bar{S}_2 K_\lambda$ is stable and $m_{30}(\tau)$, and hence $m_{40}(\tau)$, decay exponentially to zero. Now comparing (4.76) to (4.20) controlled by (4.25) we obtain

$$m_{30}(\tau) = \lambda(\tau). \quad (4.77)$$

Furthermore, $m_{10}(\tau)$, $m_{20}(\tau)$ are given by

$$m_{10}(\tau) = [(\bar{A}_1 - \bar{S}K_\lambda)(\bar{A}_2 - \bar{S}_2 K_\lambda)^{-1}]_{t=0} m_{30}(\tau) \quad (4.78)$$

$$m_{20}(\tau) = \int_0^\tau \frac{dm_{20}(s)}{ds} ds.$$

Then the initial condition a^1 of X_1 in (4.63) is given by

$$\begin{aligned}
 a^1 &= X_1(0) = \frac{\partial}{\partial \mu} x_o \Big|_{\mu=0} - m_{10}(0) \\
 &= \frac{\partial}{\partial \mu} x_o(\mu) \Big|_{\mu=0} - [(\bar{A}_1 - \bar{S}K_\lambda)(\bar{A}_2 - \bar{S}_2 K_\lambda)^{-1}]_{t=0} (z_o(0) - Z_0(0)).
 \end{aligned} \tag{4.79}$$

In general $m_{ki}(\tau)$ satisfies the equations

$$\begin{aligned}
 dm_{1i}/d\tau &= \bar{A}_1(0)m_{3i} - \frac{1}{2} \bar{S}(0)m_{4i} + M_{1i}(\tau) \\
 dm_{2i}/d\tau &= g_{2z}(X_0(0), P_0(0), Z_0(0) + m_{30}(\tau), Q_0(0) + m_{40}(\tau), 0, 0)m_{3i} \\
 &\quad + g_{2q}(X_0(0), P_0(0), Z_0(0) + m_{30}(\tau), Q_0(0) + m_{40}(\tau), 0, 0)m_{4i} \\
 &\quad + M_{2i}(\tau) \\
 dm_{3i}/d\tau &= \bar{A}_2(0)m_{3i} - \frac{1}{2} \bar{S}_2(0)m_{4i} + M_{3i}(\tau) \\
 dm_{4i}/d\tau &= -2\bar{V}_3(0)m_{3i} - \bar{A}'_2(0)m_{4i} + M_{4i}(\tau)
 \end{aligned} \tag{4.80}$$

where the exponentially decaying terms $M_{ki}(\tau)$, $k=1,2,3,4$, are known successively. We solve for the last two equations of (4.80) by letting

$$m_{4i}(\tau) = 2K_\lambda(0)m_{3i}(\tau) + \beta_i(\tau) \tag{4.81}$$

where β_i satisfies the linear vector equation

$$d\beta_i/d\tau = -[\bar{A}_2 - \bar{S}_2 K_\lambda]_{t=0}' \beta_i - 2K_\lambda(0)M_{3i}(\tau) + M_{4i}(\tau). \tag{4.82}$$

In [15], it is shown that there exists a unique exponentially decaying solution β_i to (4.82). Then $m_{3i}(\tau)$ is given by

$$dm_{3i}/d\tau = [\bar{A}_2 - \bar{S}_2 K_\lambda]_{t=0} m_{3i} - \frac{1}{2} \bar{S}_2(0)\beta_i(\tau) + M_{3i}(\tau) \tag{4.83}$$

with initial condition $m_{3i}(0) = [\partial^i z_o(\mu)/\partial \mu^i]_{\mu=0} - Z_i(0)$. Hence the solutions $m_{ki}(\tau)$, $k=1,2,3,4$, to (4.80) are exponentially decaying. The initial condition a^1 of X_1 in (4.63) is given by

$$a^i = X_i(0) = [\partial^i x_o(\mu) / \partial \mu^i]_{\mu=0} - m_{1i}(0) . \quad (4.84)$$

In a similar manner, the right boundary layer correction terms $n_k^N(\sigma, \mu)$ satisfy the equations

$$\begin{aligned} dn_k/d\sigma &= \tilde{g}_k(n_1, n_2, n_3, n_4, \mu, \sigma) \\ &= g_k(X(\mu\sigma) + \mu n_1(\sigma), P(\mu\sigma) + \mu n_2(\sigma), Z(\mu\sigma) + n_3(\sigma), Q(\mu\sigma) + n_4(\sigma), \mu, \mu\sigma) \\ &\quad - g_k(X(\mu\sigma), P(\mu\sigma), Z(\mu\sigma), Q(\mu\sigma), \mu, \mu\sigma) , \quad k=1,2,3,4 . \end{aligned} \quad (4.85)$$

We shall not give the procedure of solving for n_{ki} , which is exactly the same as that of solving for m_{ki} , except that we are now solving in inverse time, that is, from $t=0$ to $t=-\infty$. We only examine the equations for n_{30}, n_{40} , which are

$$\begin{aligned} dn_{30}/d\sigma &= \bar{A}_2(T)n_{30} - \frac{1}{2} \bar{S}_2(T)n_{40} , \quad n_{30}(T) = z_T(0) - Z_0(T) \\ dn_{40}/d\sigma &= -2\bar{V}_3(T)n_{30} - \bar{A}'_2(T)n_{40} . \end{aligned} \quad (4.86)$$

Let

$$n_{40}(\sigma) = 2K_\rho(T)n_{30}(\sigma) \quad (4.87)$$

where $K_\rho(T)$ is the negative definite solution to (4.27) at $t=T$. Since $-\bar{A}_2 - \bar{S}_2 K_\rho$ at $t=T$ is stable, the system

$$dn_{30}/d\sigma = [\bar{A}_2 - \bar{S}_2 K_\rho]_{t=T} n_{30} \quad (4.88)$$

is stable in negative time and n_{30} decays to zero as $\sigma \rightarrow -\infty$. Comparing (4.88) to (4.21) controlled by (4.26), we obtain

$$n_{30}(\sigma) = \rho(\sigma) . \quad (4.89)$$

The end conditions for $n_{3i}(T)$, $X_i(T)$ are

$$\begin{aligned} n_{3i}(T) &= [\partial^i z_T(\mu)/\partial \mu^i]_{\mu=0} - Z_i(T) \\ X_i(T) &= [\partial^i x_T(\mu)/\partial \mu^i]_{\mu=0} - n_{1i}(T) = b^i. \end{aligned} \quad (4.90)$$

It remains to be shown that x^N , p^N , z^N , q^N are $O(\mu)$. However, this asymptotic property has been shown in detail in [14] for free endpoint problem which can be translated for fixed endpoint problem without major changes. Thus we shall omit this part of the proof.

From Lemma 4.5.1, we obtain the approximation (4.28) of Theorem 4.3.1 by observing that (4.28a) and (4.28c) follow from (4.62), (4.28b) follows from (C2), (4.77) and (4.89), (4.28d) follows from (C2), (4.75) and (4.87), and finally (4.28e) follows from (C1) and (4.6).

4.6 Discussion

A singularly perturbed nonlinear fixed endpoint problem is decomposed into three lower order problems, namely, the reduced problem and the left and the right boundary layer problems. Two special features are that the reduced problem does not involve the singular perturbation parameter and the boundary layer problems are linear quadratic. Combining the solutions to these lower order problems we obtain an $O(\mu)$ approximation (4.28) of a solution to the full TPBV problem corresponding to (4.1), (4.2). Based on the properties of the lower order problems, we obtain an asymptotic expansion for this solution of the full TPBV problem. An example illustrates the design procedure and the computation of a locally optimal solution using a Newton-Raphson algorithm and the $O(\mu)$ approximate solution as the initial guess. Finally, it is emphasized that if the fast variable z in (4.2) is unstable, the partially closed-loop control (4.29) which stabilizes the fast variable should be applied to (4.2).

5. SYSTEMS WITH HIGH FREQUENCY OSCILLATORY MODES

5.1 Introduction

Mechanical and electromechanical systems often have slightly damped modes oscillating at frequencies much higher than the rest of the system. Well known examples are spring-mass suspension systems and multi-machine power systems. In linearized models of such systems some eigenvalues have small real parts and large imaginary parts. Typically they are due to either strong coupling, or small masses and inertias, or both. Synchronous machines connected through a low impedance can serve as an illustration.

In properly designed systems the amplitudes of high frequency oscillations are small and their effect negligible. However, the analysis and design methods must take these potentially troublesome modes into account. This leads to numerically stiff problems requiring expensive integration routines. A way out of this difficulty is to treat systems with oscillatory modes as singularly perturbed systems and analyze their slow and fast parts in different time scales. Presently available singular perturbation methods assume that the fast modes decay in the fast time scale during a boundary layer interval. Thus they do not incorporate the case of slightly damped or purely oscillatory modes. This chapter extends the singular perturbation approach to systems with fast oscillatory modes.

Our approach is to decompose a system with high frequency oscillations into two separate subsystems, one containing the slowly varying dynamics and the other containing the oscillatory modes. We show that the decomposition in [21,22] is also applicable to systems whose slightly damped large eigenvalues result in sustained high frequency oscillations. The slowly varying dynamics can be approximately analyzed by averaging methods

[19,20]. However for the linear time-invariant case our algebraic decomposition is more direct and yields estimates of the eigenvalues and states of the original high frequency oscillatory system. This procedure requires only the verification of an assumption given in the next section and the computation of a matrix inverse. Furthermore our decomposition retains the meaning of the physical variables. Nonlinear systems with high frequency oscillations are also analyzed in a similar manner. An interconnected power system illustrates the decomposition procedure and the concept of coherency [39,40].

5.2 Modeling

Systems governed by physical laws such as Newton's law and Kirchhoff's law can be modeled as second order matrix differential equations

$$\ddot{s} + P\dot{s} + Qs = 0, \quad \dot{s}(t_0) = \dot{s}_0, \quad s(t_0) = s_0 \quad (5.1)$$

where $s \in \mathbb{R}^r$ and P, Q are $r \times r$ matrices. We assume that system (5.1) is in the form

$$s = \begin{bmatrix} s_1 \\ s_2 \end{bmatrix}, \quad P = \begin{bmatrix} P_1 & P_2 \\ P_3 & P_4 \end{bmatrix}, \quad Q = \begin{bmatrix} Q_1 & Q_2/\mu^2 \\ Q_3 & Q_4/\mu^2 \end{bmatrix} \quad (5.2)$$

where μ is a small positive parameter which arises due to the presence of stiff springs or small masses and is responsible for the high frequency oscillations in (5.1). Then (5.1), (5.2) can be rewritten as a singularly perturbed system of first order differential equations

$$\dot{x} = Ax + Bz, \quad x(0) = x_0 \quad (5.3a)$$

$$\mu \dot{z} = Cx + Dz, \quad z(0) = z_0 \quad (5.3b)$$

where

$$\begin{aligned} \mathbf{x} &= \begin{bmatrix} \mathbf{x}_1 \\ \mathbf{x}_2 \end{bmatrix} = \begin{bmatrix} \mathbf{s}_1 \\ \dot{\mathbf{s}}_1 \end{bmatrix}, & \mathbf{z} &= \begin{bmatrix} \mathbf{z}_1 \\ \mathbf{z}_2 \end{bmatrix} = \begin{bmatrix} \mathbf{s}_2/\mu^2 \\ \dot{\mathbf{s}}_2/\mu \end{bmatrix} \\ \mathbf{A} &= \begin{bmatrix} 0 & \mathbf{I} \\ -\mathbf{Q}_1 & -\mathbf{P}_1 \end{bmatrix}, & \mathbf{B} &= \begin{bmatrix} 0 & 0 \\ -\mathbf{Q}_2 & -\mu\mathbf{P}_2 \end{bmatrix} \\ \mathbf{C} &= \begin{bmatrix} 0 & 0 \\ -\mathbf{Q}_3 & -\mathbf{P}_3 \end{bmatrix}, & \mathbf{D} &= \begin{bmatrix} 0 & \mathbf{I} \\ -\mathbf{Q}_4 & -\mu\mathbf{P}_4 \end{bmatrix}. \end{aligned} \quad (5.4)^1$$

Our analysis of (5.3) does not require the matrices A, B, C, D to be in the special form (5.4). The only assumptions that system (5.3) has to satisfy are the following:

(A5.1) The norms of A, B, C, D are bounded about $\mu = 0$ and the state \mathbf{z} is of even dimension, that is, $\mathbf{z} \in \mathbb{R}^{2m}$.

(A5.2) The matrix D is in the form

$$\mathbf{D} = \begin{bmatrix} \mu\mathbf{D}_1 & \mathbf{D}_2 \\ \mathbf{D}_3 & \mu\mathbf{D}_4 \end{bmatrix} \quad (5.5)$$

where $\mathbf{D}_2, \mathbf{D}_3$ are $m \times m$ nonsingular matrices and the matrix $\mathbf{D}_2\mathbf{D}_3$ has simple and negative eigenvalues $-\omega_i^2$, $i = 1, 2, \dots, m$.

There is no restriction on the dimension n of the state $\mathbf{x} \in \mathbb{R}^n$. Assumption

(A5.2) guarantees that high frequency oscillations will occur in (5.3).

As an example of a system in the form of (5.3), we consider a mass-spring-damper system (Figure 5.1) where the spring k_2 is stiff. A set of

¹The matrix I denotes an identity matrix of an appropriate dimension.

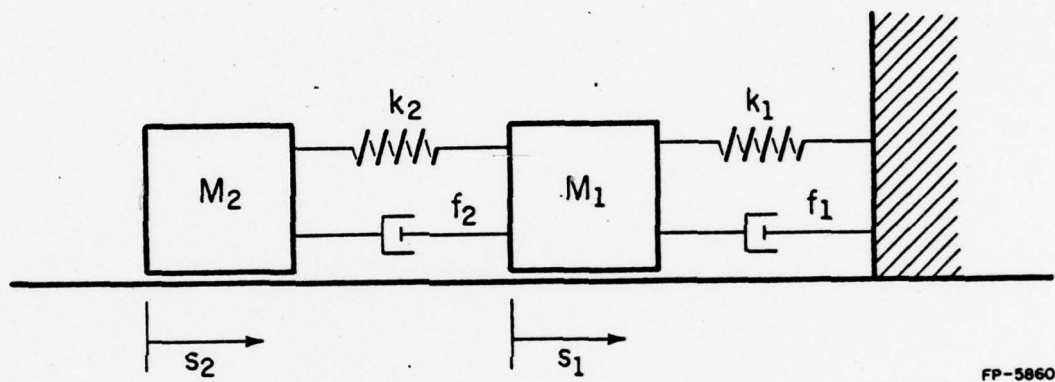

FP-5860

Figure 5.1 A mass-spring-damper system.

convenient state variables for this system is the position of the center of mass

$$s_c = (M_1 s_1 + M_2 s_2) / M, \quad M = M_1 + M_2 \quad (5.6)$$

and the relative displacement between the masses

$$s_d = s_1 - s_2 \quad (5.7)$$

where s_1, s_2 are the positions of the masses M_1, M_2 . The equation of motion for this system is

$$\begin{aligned} \ddot{s}_c + \frac{f_1}{M} \dot{s}_c + \frac{f_1 M_2}{M^2} \dot{s}_d + \frac{k_1}{M} s_c + \frac{f_1 M_2}{M^2} s_d &= 0 \\ s_c(0) = s_{c0}, \quad \dot{s}_c(0) = v_c(0) = v_{c0} \\ \ddot{s}_d + \frac{f_1}{M_1} \dot{s}_c + \left(\frac{f_1 M_2}{M_1 M} + \frac{f_2 M}{M_1 M_2} \right) \dot{s}_d + \frac{k_1}{M_1} s_c + \frac{k_2 M}{M_1 M_2} \left(1 + \frac{k_1 M_2^2}{k_2 M^2} \right) s_d &= 0 \\ s_d(0) = s_{d0}, \quad \dot{s}_d(0) = v_d(0) = v_{d0} \end{aligned} \quad (5.8)$$

Since the spring k_2 is stiff, we define

$$\frac{1}{\mu^2} = \frac{k_2 M}{M_1 M_2} \quad (5.9)$$

such that μ is small. In the state variables

$$x_1 = s_c, \quad x_2 = \dot{s}_c = v_c, \quad z_1 = s_d / \mu^2, \quad z_2 = \dot{s}_d / \mu = v_d / \mu \quad (5.10)$$

(5.8) becomes

$$\begin{aligned} \dot{x}_1 &= x_2 \\ \dot{x}_2 &= -\frac{k_1}{M} x_1 - \frac{f_1}{M} x_2 - \mu^2 \frac{k_1 M_2}{M^2} z_1 - \mu \frac{f_1 M_2}{M^2} z_2 \end{aligned}$$

$$\begin{aligned}\mu \dot{z}_1 &= z_2 \\ \mu \dot{z}_2 &= -\frac{k_1}{M_1} x_1 - \frac{f_1}{M_1} x_2 - \left(1 + \mu^2 \frac{k_1 M_2}{M M_1}\right) z_1 - \mu \left(\frac{f_1 M_2}{M_1 M} + \frac{f_2 M}{M_1 M_2}\right) z_2\end{aligned}\quad (5.11)$$

which is in the form (5.3) and satisfies Assumptions (A5.1) and (A5.2) with $\omega_1^2 = 1 + \mu^2 \frac{k_1 M_2}{M_1 M}$.

5.3 Averaging of Oscillatory States

Before analyzing (5.3), we investigate the behavior of the system

$$\mu \dot{w} = Dw + u, \quad w(0) = w_0 \quad (5.12)$$

where D satisfies Assumption (A5.2). The characteristic polynomial of D/u is

$$\begin{aligned}\varphi(\lambda) &= \det \begin{bmatrix} \lambda I - D_1 & -D_2/\mu \\ -D_3/\mu & \lambda I - D_4 \end{bmatrix} \\ &= \det \begin{bmatrix} 0 & -D_2/\mu + \mu(\lambda I - D_4)D_3^{-1}(\lambda I - D_1) \\ -D_3/\mu & \lambda I - D_4 \end{bmatrix} \\ &= -(-1)^m \det [\lambda^2 I - \lambda(D_4 + D_3^{-1}D_1D_3) - (D_2D_3 - \mu^2 D_4 D_3^{-1}D_1D_3)/\mu^2].\end{aligned}\quad (5.13)$$

Let T diagonalize D_2D_3 such that

$$\begin{aligned}TD_2D_3T^{-1} &= \Lambda \\ &= \text{diag}(-\omega_1^2, -\omega_2^2, \dots, -\omega_m^2)\end{aligned}\quad (5.14)$$

and rewrite the characteristic polynomial as

$$\varphi(\lambda) = -(-1)^m \det [\lambda^2 I - R_1 \lambda - (\Lambda + \mu^2 R_2)/\mu^2] \quad (5.15)$$

where $R_1 = T(D_4 + D_3^{-1}D_1D_3)T^{-1}$ and $R_2 = TD_4D_3^{-1}D_1D_3T^{-1}$. Neglecting $\mu^2 R_2$ and the off-diagonal elements of R_1 , (5.15) is approximated by

$$\tilde{\varphi}(\lambda) = -(-1)^m \prod_{i=1}^m (\lambda^2 - 2\sigma_i \lambda + \omega_i^2 / \mu^2) \quad (5.16)$$

where $2\sigma_i$ is the i th diagonal element of R_1 . Instead of (5.13), $\varphi(\lambda)$ can be expressed as

$$\varphi(\lambda) = -(-1)^m \det[\lambda^2 I - \lambda(D_1 + D_2^{-1}D_4D_2) - (D_3D_2 - \mu^2 D_1D_2^{-1}D_4D_2) / \mu^2]. \quad (5.17)$$

Letting $S = \Gamma TD_3^{-1}$ where Γ is any nonsingular diagonal matrix, we obtain $SD_3D_2S^{-1} = \Lambda$. Then the diagonal elements of $S(D_1 + D_2^{-1}D_4D_2)S^{-1}$ are identical to those of R_1 and (5.17) can also be approximated by (5.16). To analyze the roots of $\varphi(\lambda)$ we use the following lemma.

Lemma 5.3.1: If D satisfies Assumption (A5.2), then, as $\mu \rightarrow 0^+$, the eigenvalues of D/μ approach infinity as

$$\sigma_i \pm j\omega_i / \mu, \quad i = 1, 2, \dots, m. \quad (5.18)$$

By Lemma 5.3.1, as $\mu \rightarrow 0^+$, the eigenvalues of (5.12) approach infinity along asymptotes parallel to the imaginary axis. Note that the large imaginary parts of (5.18) are the consequence of solving for λ of the quadratic equations in (5.16). If some of the eigenvalues of D_2D_3 are either positive or not simple, then in general some of the eigenvalues of D/μ may be positive and $O(1/\mu)$. This case of fast instability is less realistic and will not be considered here.

Due to the eigenvalues with large imaginary parts, the response $w(t)$ of (5.12) contains high frequency oscillations. However, $w(t)$ also contains a slowly varying part because of the input $u(t)$.

Lemma 5.3.2: If D satisfies Assumption (A5.2) and if $u(t) = \bar{u}(t) + \tilde{u}(t)$ is an input where $\bar{u}(t)$ is a slowly varying part with $|\dot{\bar{u}}| \leq c_1$ and $|\ddot{\bar{u}}| \leq c_2$ for some fixed c_1 and c_2 , then there exists a finite $T(\mu)$ such that the slowly varying part $\bar{w}(t)$ of $w(t)$ of (5.12) for $0 \leq t \leq T$ is

$$\bar{w}(t) = - \begin{bmatrix} 0 & D_3^{-1} \\ D_2^{-1} & 0 \end{bmatrix} \bar{u}(t) + O(\mu). \quad (5.19)$$

Proof: Integrating the variations of constants formula

$$w(t) = \Phi(t,0)w_0 + \frac{1}{\mu} \int_0^t \Phi(t,\tau)u(\tau)d\tau \quad (5.20)$$

where $\Phi(t,\tau) = \exp\{D(t-\tau)/\mu\}$, by parts, we obtain

$$\begin{aligned} w(t) = & -D^{-1}\bar{u}(t) + \Phi(t,0)w_0 + D^{-1}\Phi(t,0)\bar{u}(0) \\ & + D^{-1} \int_0^t \Phi(t,\tau)\dot{\bar{u}}(\tau)d\tau + \frac{1}{\mu} \int_0^t \Phi(t,\tau)\tilde{u}(\tau)d\tau. \end{aligned} \quad (5.21)$$

But the first integral term in (5.21) is $O(\mu)$ since a further integration by parts reveals that

$$\left| \int_0^t \Phi(t,\tau)\dot{\bar{u}}(\tau)d\tau \right| \leq \mu |D^{-1}| \{c_1(1 + |\Phi(t,0)|) + c_2 \int_0^t |\Phi(t,\tau)|d\tau\}. \quad (5.22)$$

We also note that $\tilde{u}(\tau)$ generates high frequency terms and the terms contributed by $\Phi(t,0)$ are approximately of the type $\exp(\sigma_i t)\sin(\omega_i t/\mu)$ and $\exp(\sigma_i t)\cos(\omega_i t/\mu)$, $i = 1, 2, \dots, m$. Since

$$D^{-1} = \begin{bmatrix} \mu X_1 & D_3^{-1} + \mu^2 X_2 \\ D_2^{-1} + \mu^2 X_3 & \mu X_4 \end{bmatrix} \quad (5.23)$$

where

$$\begin{aligned} X_1 &= -(D_3 - \mu^2 D_4 D_2^{-1} D_1)^{-1} D_4 D_2^{-1} \\ X_2 &= -D_3^{-1} D_4 X_4 \\ X_3 &= -D_2^{-1} D_1 X_1 \\ X_4 &= -(D_2 - \mu^2 D_1 D_3^{-1} D_4)^{-1} D_1 D_3^{-1}, \end{aligned} \quad (5.24)$$

the only significant slowly varying part $-D^{-1}\bar{u}(t)$ of $w(t)$ in (5.12) is approximated to $O(\mu)$ by $-\bar{D}^{-1}\bar{u}(t)$, where

$$\bar{D} = \begin{bmatrix} 0 & D_2 \\ D_3 & 0 \end{bmatrix} \quad (5.25)$$

implying (5.19).

This analysis justifies a simple formal method to obtain $\bar{w}(t)$, that is, let $\mu = 0$ in (5.12), as is usually done in singular perturbations. However, the meaning of letting $\mu = 0$ here is different. Considering $u = \bar{u}$ as the input and w as the output, the input-output behavior of system (5.12) is that of a lowpass wideband filter. Then $\bar{w}(t)$ is the dominant part of the filter output which shows the relationship with the usual assumption in the technique of averaging [20]. Thus $\bar{w}(t)$ approximates $w(t)$ closely if the high frequency component of w is negligible or if $w(t)$ is used as an input to a slow filter.

5.4 Eigenvalue and State Approximations

Letting \bar{x} be the slowly varying part of x and either applying Lemma 5.3.2 to (5.3b) or setting $\mu = 0$, we obtain the slowly varying part \bar{z} of z as

$$\begin{aligned}\bar{z} &= -D^{-1}C\bar{x} + O(\mu) \\ &= \bar{D}^{-1}C\bar{x} + O(\mu) .\end{aligned}\tag{5.26}$$

To completely separate the slowly varying part \bar{z} from z , we introduce the change of variables

$$\eta = z + D^{-1}Cx + \mu Gx \equiv z + Lx\tag{5.27}$$

and determine G such that (5.3) is transformed into

$$\dot{x} = (A_0 - \mu BG)x + B\eta\tag{5.28a}$$

$$\mu \dot{\eta} = (D + \mu LB)\eta\tag{5.28b}$$

where

$$A_0 = A - BD^{-1}C.\tag{5.29}$$

Thus G is required to satisfy

$$-DG + (D^{-1}C + \mu G)(A_0 - \mu BG) = 0.\tag{5.30}$$

By the implicit function theorem, the solution of (5.30) is

$$\begin{aligned}G &= D^{-2}CA_0 + O(\mu) \\ &= \bar{D}^{-2}C\bar{A}_0 + O(\mu)\end{aligned}\tag{5.31}$$

where

$$\bar{A}_0 = A - \bar{B}\bar{D}^{-1}C.\tag{5.32}$$

Let

$$D + \mu LB = \begin{bmatrix} \mu D_1 & D_2 \\ D_3 & \mu D_4 \end{bmatrix} + \mu \begin{bmatrix} \mu D_1 & D_2 \\ D_3 & \mu D_4 \end{bmatrix}^{-1} CB + O(\mu^2)$$

$$\begin{aligned}
&= \begin{bmatrix} \mu(D_1 + D_3^{-1}C_2B_1) & D_2 + \mu D_3^{-1}C_2B_2 \\ D_3 + \mu D_2^{-1}C_1B_2 & \mu(D_4 + D_2^{-1}C_1B_2) \end{bmatrix} + o(\mu^2) \\
&\equiv \begin{bmatrix} \mu\tilde{D}_1 & \tilde{D}_2 \\ \tilde{D}_3 & \mu\tilde{D}_4 \end{bmatrix} + o(\mu^2) \equiv \tilde{D} + o(\mu^2)
\end{aligned} \tag{5.33}$$

where

$$B = [B_1 \ B_2] \ , \quad C = \begin{bmatrix} C_1 \\ C_2 \end{bmatrix} \ . \tag{5.34}$$

Then the upper block triangular form (5.28) exhibits the eigenvalues of (5.3).

Lemma 5.4.1: If Assumptions (A5.1) and (A5.2) are satisfied, then the eigenvalues of the original system (5.3) are $O(\mu)$ close to the eigenvalues of \bar{A}_0 and \tilde{D}/μ . Furthermore as $\mu \rightarrow 0^+$, the eigenvalues of \tilde{D}/μ approach infinity as

$$\rho_i \pm j\omega_i/\mu, \quad i=1,2,\dots,m \tag{5.35}$$

where $2\rho_i$ is the i th diagonal element of the matrix $T(\tilde{D}_4 + D_3^{-1}\tilde{D}_1D_3)T^{-1}$.

The second statement of Lemma 5.4.1 follows from Lemma 5.3.1.

The meaning of Lemma 5.4.1 is that n eigenvalues of system (5.3) are small. They are responsible for the slowly varying dynamics of the system. The other $2m$ eigenvalues have large imaginary parts and are responsible for the high frequency oscillations.

To separate the slowly varying part in x , we introduce

$$\xi = x - \mu(CD^{-1} + \mu N)\eta \equiv x - \mu H\eta \tag{5.36}$$

and choose N such that

$$B + \mu(A_0 - \mu BG)H - H(D + \mu LB) = 0 \ . \tag{5.37}$$

AD-A057 644

ILLINOIS UNIV AT URBANA-CHAMPAIGN DECISION AND CONTROL LAB F/G 12/1
SINGULAR PERTURBATION OF NONLINEAR REGULATORS AND SYSTEMS WITH --ETC(U)
DEC 77 J H CHOW DAAB07-72-C-0259

UNCLASSIFIED

DC-8

NL

2 OF 2

AD
A057644

END

END

DATE

FILMED

9-78

DDC

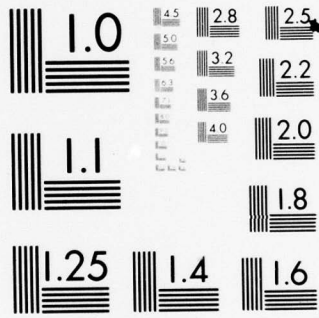

MICROCOPY RESOLUTION TEST CHART
NATIONAL BUREAU OF STANDARDS-1963-A

By the implicit function theorem,

$$\begin{aligned} N &= A_0 B D^{-2} - B D^{-2} C B D^{-1} + O(\mu) \\ &= \bar{A}_0 \bar{B} \bar{D}^{-2} - \bar{B} \bar{D}^{-2} \bar{C} \bar{B} \bar{D}^{-1} + O(\mu) . \end{aligned} \quad (5.38)$$

This completes the transformation (5.27), (5.36) which becomes

$$\begin{bmatrix} \xi \\ \eta \end{bmatrix} = \begin{bmatrix} I - \mu H L & -\mu H \\ L & I \end{bmatrix} \begin{bmatrix} x \\ z \end{bmatrix} \quad (5.39)$$

and its inverse is

$$\begin{bmatrix} x \\ z \end{bmatrix} = \begin{bmatrix} I & \mu H \\ -L & I - \mu L H \end{bmatrix} \begin{bmatrix} \xi \\ \eta \end{bmatrix} . \quad (5.40)$$

The original system (5.3) rewritten in the state variables ξ, η is completely decomposed into the fast and slow subsystems

$$\dot{\xi} = \mathcal{A} \xi \quad (5.41)$$

$$\mu \dot{\eta} = \mathcal{B} \eta \quad (5.42)$$

where $\mathcal{A} = A_0 - \mu B G$, $\mathcal{B} = D + \mu L B$.

The decomposition (5.39), (5.40) is an exact block diagonalization transformation. Neglecting the $O(\mu)$ term in (5.41), we define the slowly varying subsystem of (5.3) as

$$\dot{\bar{x}} = \bar{A}_0 \bar{x} \quad , \quad \bar{x}(0) = x_0 \quad (5.43a)$$

$$\bar{z} = -\bar{D}^{-1} C \bar{x} . \quad (5.43b)$$

The oscillatory subsystem

$$\mu \dot{\bar{z}} = \bar{D} \bar{z} \quad , \quad \bar{z}(0) = z_0 + \bar{D}^{-1} C x_0 \quad (5.44)$$

is obtained from (5.42) by neglecting the $O(\mu^2)$ terms in \mathcal{B} .

The state approximations achieved by the subsystems (5.43), (5.44) are stated as follows.

Theorem 5.4.1: If the original system (5.3) satisfies Assumptions (A5.1) and (A5.2), then the states of (5.3) are approximated to $O(\mu)$ by the subsystems (5.43), (5.44) for $0 \leq t \leq T(\mu)$, that is,

$$x(t) = \bar{x}(t) + O(\mu) \quad (5.45a)$$

$$z(t) = \bar{z}(t) + \tilde{z}(t) + O(\mu) . \quad (5.45b)$$

The result of Theorem 5.4.1 implies that if the initial condition $|\tilde{z}(0)|$ is much smaller than $|\bar{x}(0)|$, then the high frequency oscillation can be neglected and the original system (5.3) is adequately modeled by its lower order slowly varying subsystem (5.43). Furthermore the subsystems (5.43), (5.44) can be used to simulate approximately the actual response of (5.3). Due to the presence of μ , the ill-conditioned $(n+2m)$ -th order system (5.3) requires a prohibitively small integration stepsize. However, using the lower order subsystems, the small integration stepsize is necessary only for the $2m$ -th order fast oscillatory subsystem (5.44), while the integration of the slowly varying subsystem (5.43) can be computed with a much larger stepsize, resulting in savings of computing time. In the case when the high frequency oscillations are negligible, only the integration of the slowly varying subsystem is required.

We illustrate the subsystem decomposition procedure with the mass-spring-damper system (5.11). Neglecting the μ terms, the slowly varying subsystem (5.43) of (5.11) in the original state variables is

$$\begin{aligned}
 \dot{\bar{s}}_c &= \bar{v}_c & \bar{s}_c(0) &= s_{co} \\
 \dot{\bar{v}}_c &= -\frac{k_1}{M} \bar{s}_c - \frac{f_1}{M} \bar{v}_c, & \bar{v}_c(0) &= v_{co} \\
 \bar{s}_d &= 0 \\
 \bar{v}_d &= 0.
 \end{aligned}
 \tag{5.46}$$

Subsystem (5.46) represents the motion of the center of mass as if M_1 and M_2 are connected by a rigid rod and are moving together. Intuitively this is the limiting case as $\mu \rightarrow 0^+$, that is, as $k \rightarrow \infty$. The high frequency oscillation between the masses is modeled by the fast oscillatory subsystem (5.44)

$$\begin{aligned}
 \mu \dot{\bar{z}}_1 &= \bar{z}_2, & \bar{z}_1(0) &= s_{do}/\mu^2 \\
 \mu \dot{\bar{z}}_2 &= -\bar{z}_1 - \mu \left(\frac{f_1 M_2}{M_1 M} + \frac{f_2 M}{M_1 M_2} \right) \bar{z}_2, & \bar{z}_2(0) &= v_{do}/\mu.
 \end{aligned}
 \tag{5.47}$$

Subsystem (5.47) describes the motion of the masses M_1 and M_2 connected by a spring k_2 and a damper $f_2 + f_1 M_2^2/M^2$ as the equation for $\tilde{s}_d = \mu^2 \bar{z}_1$ is

$$\ddot{\tilde{s}}_d + \left(\frac{f_1 M_2}{M_1 M} + \frac{f_2 M}{M_1 M_2} \right) \dot{\tilde{s}}_d + \frac{1}{\mu} \tilde{s}_d = 0
 \tag{5.48}$$

that is,

$$\frac{M_1 M_2}{M} \ddot{\tilde{s}}_d + \left(f_2 + \frac{f_1 M_2^2}{M} \right) \dot{\tilde{s}}_d + k_2 \tilde{s}_d = 0.
 \tag{5.49}$$

Since the spring k_2 is stiff, the initial displacement s_{do} is small because a large amount of energy would be required to significantly change the length of the spring. Thus in systems with finite energy, $z_1 = s_d/\mu^2$ is not large and is actually properly scaled. The same property holds for $z_2 = v_d/\mu$ as $|s_d| = \mu |v_d|$ due to the high frequency oscillations in s_d .

Thus concluding from Theorem 5.4.1, if the initial conditions s_{do} and v_{do} are of $O(\mu)$, we obtain

$$\begin{aligned} s_c &= \bar{s}_c + O(\mu), & v_c &= \bar{v}_c + O(\mu) \\ s_d &= O(\mu), & v_d &= O(\mu). \end{aligned} \quad (5.50)$$

5.5 Nonlinear Systems

We now extend the analysis in Section 5.4 to nonlinear systems.

The system of second order differential equations

$$\begin{aligned} \ddot{s}_1 &= f_1(\dot{s}_1, \dot{s}_2, s_1, s_2, \mu) \\ &\equiv g_1(s_1, \dot{s}_1, s_2/\mu^2, \dot{s}_2/\mu) + \mu h_1(s_1, \dot{s}_1, s_2/\mu^2, \dot{s}_2/\mu, \mu) \\ \ddot{s}_2 &= f_2(\dot{s}_1, \dot{s}_2, s_1, s_2, \mu) \\ &\equiv G s_2/\mu^2 + g_2(s_1, \dot{s}_1) + \mu h_2(s_1, \dot{s}_1, s_2/\mu^2, \dot{s}_2/\mu) \\ &\quad + \mu^2 h_3(s_1, \dot{s}_1, s_2/\mu^2, \dot{s}_2/\mu, \mu) \end{aligned} \quad (5.51)$$

where the states are $s_1 \in \mathbb{R}^n$ and $s_2 \in \mathbb{R}^m$, is assumed to satisfy the following assumptions:

(A5.3) The limits

$$\lim_{\mu \rightarrow 0^+} |h_1(\alpha_1, \alpha_2, \alpha_3, \alpha_4, \mu)| < \infty \quad (5.52)$$

$$\lim_{\mu \rightarrow 0^+} |h_3(\alpha_1, \alpha_2, \alpha_3, \alpha_4, \mu)| < \infty \quad (5.53)$$

exist for all finite vectors $\alpha_1, \alpha_2, \alpha_3, \alpha_4$.

(A5.4) G is stable and its eigenvalues $-\omega_i^2$, $i = 1, 2, \dots, m$, are simple and real.

With the change of variables

$$x_1 = s_1, \quad x_2 = \dot{s}_1, \quad z_1 = s_2/\mu^2, \quad z_2 = \dot{s}_2/\mu \quad (5.54)$$

system (5.51) becomes

$$\begin{aligned} \dot{x}_1 &= x_2 \\ \dot{x}_2 &= f_1(x_2, \mu z_2, x_1, \mu^2 z_1, \mu) \\ \mu \dot{z}_1 &= z_2 \\ \mu \dot{z}_2 &= f_2(x_2, \mu z_2, x_1, \mu^2 z_1, \mu) . \end{aligned} \quad (5.55)$$

Formally letting $\mu \rightarrow 0^+$, system (5.55) becomes, under Assumption (A5.3)

$$\left. \begin{aligned} \dot{\bar{x}}_1 &= \bar{x}_2 \\ \dot{\bar{x}}_2 &= g_1(\bar{x}_1, \bar{x}_2, \bar{z}_1, \bar{z}_2) \end{aligned} \right\} (5.56a)$$

$$\left. \begin{aligned} 0 &= \bar{z}_2 \\ 0 &= G\bar{z}_1 + g_2(\bar{x}_1, \bar{x}_2) . \end{aligned} \right\} (5.56b)$$

From Assumption (A5.4), we eliminate

$$\begin{aligned} \bar{z}_1 &= -G^{-1}g_2(\bar{x}_1, \bar{x}_2) \\ \bar{z}_2 &= 0 \end{aligned} \quad (5.57)$$

from (5.56a) to obtain the nonlinear reduced system

$$\begin{aligned} \dot{\bar{x}}_1 &= \bar{x}_2 \\ \dot{\bar{x}}_2 &= g_1(\bar{x}_1, \bar{x}_2, -G^{-1}g_2(\bar{x}_1, \bar{x}_2), 0) \\ &\equiv g(\bar{x}_1, \bar{x}_2) . \end{aligned} \quad (5.58)$$

This system describes the motion of the slow parts of the states x and z .

To exhibit the fast oscillatory behavior, we introduce the change of variables

$$\begin{aligned}\eta_1 &= z_1 + G^{-1}g_2(x_1, x_2) \\ \eta_2 &= z_2.\end{aligned}\tag{5.59}$$

Then system (5.55) becomes

$$\left. \begin{aligned}\dot{x}_1 &= x_2 \\ \dot{x}_2 &= f_1(x_2, \mu\eta_2, x_1, \mu^2(\eta_1 - G^{-1}g_2(x_1, x_2)), \mu)\end{aligned}\right\}\tag{5.60a}$$

$$\left. \begin{aligned}\mu\dot{\eta}_1 &= \eta_2 + \mu G^{-1}g_{2x} \dot{x} \\ \mu\dot{\eta}_2 &= f_2(x_2, \mu\eta_2, x_1, \mu^2(\eta_1 - G^{-1}g_2(x_1, x_2)), \mu).\end{aligned}\right\}\tag{5.60b}$$

In (5.60b) we approximate x_1, x_2 by \bar{x}_1, \bar{x}_2 and neglect the higher order μ terms to obtain the fast oscillatory subsystem as

$$\begin{aligned}\mu\dot{\hat{z}}_1 &= \hat{z}_2 + \mu G^{-1} [g_{2x_1}(\bar{x}_1, \bar{x}_2)\bar{x}_2 + g_{2x_2}(\bar{x}_1, \bar{x}_2)g_1(\bar{x}_1, \bar{x}_2), \\ &\quad \hat{z}_1 - G^{-1}g_2(\bar{x}_1, \bar{x}_2), \hat{z}_2)] \equiv \hat{z}_2 + \mu k_1(\hat{z}_1, \hat{z}_2, t) \\ \mu\dot{\hat{z}}_2 &= G\hat{z}_1 + \mu h_2(\bar{x}_1, \bar{x}_2, \hat{z}_1 - G^{-1}g_2(\bar{x}_1, \bar{x}_2), \hat{z}_2) \\ &\equiv G\hat{z}_1 + \mu k_2(\hat{z}_1, \hat{z}_2, t)\end{aligned}\tag{5.61}$$

where \hat{z}_1, \hat{z}_2 approximate $\hat{\eta}_1, \hat{\eta}_2$, respectively, and \bar{x}_1, \bar{x}_2 are expressed as known functions of t . System (5.61) is poorly damped and high frequency oscillations are dominant in \hat{z}_1 and \hat{z}_2 . From (5.58) and (5.61), it follows that there exists a finite $T(\mu)$ such that for $0 \leq t \leq T$,

$$\left. \begin{aligned}x_i(t) &= \bar{x}_i(t) + o(\mu) \\ z_i(t) &= \bar{z}_i(t) + \hat{z}_i(t) + o(\mu)\end{aligned}\right\} i = 1, 2.\tag{5.62}$$

Higher order approximations of $x_i, z_i, i = 1, 2$, can be obtained by introducing a change of variables of the type (5.59) which is accurate to $O(\mu^k), k \geq 1$. Other less rigorous approaches such as linearizing the fast variable η_1, η_2 in (5.60b) and retaining μ in f_2 when solving for \bar{z}_1 , may also improve the approximation. These ideas are illustrated with a power system example.

5.6 A Power System Example

Consider the three machine system in Figure 5.2. The opening of one transmission line from bus 1 to bus 2 causes the system to oscillate. The following post-disturbance differential equations for the machine rotor angles may be written [24]

$$\begin{aligned} M_1 \ddot{\delta}_1 &= P_{in_1} - V_1'^2 Y_{11} \cos \theta_{11} - V_1' V_2' Y_{12} \cos(\theta_{12} + \delta_2 - \delta_1) - V_1' V_3' Y_{13} \cos(\theta_{13} + \delta_3 - \delta_1) \\ M_2 \ddot{\delta}_2 &= P_{in_2} - V_2'^2 Y_{22} \cos \theta_{22} - V_1' V_2' Y_{12} \cos(\theta_{12} + \delta_1 - \delta_2) - V_2' V_3' Y_{23} \cos(\theta_{23} + \delta_3 - \delta_2) \\ M_3 \ddot{\delta}_3 &= P_{in_3} - V_3'^2 Y_{33} \cos \theta_{33} - V_1' V_3' Y_{13} \cos(\theta_{13} + \delta_1 - \delta_3) - V_2' V_3' Y_{23} \cos(\theta_{23} + \delta_2 - \delta_3) . \end{aligned} \quad (5.63)$$

The notation for this and other equations of this example is given in Appendix D.

If Y_{23} is large compared to Y_{12} and Y_{13} , then machines 2 and 3 will be strongly coupled. In this case it is convenient to rewrite (5.63) in terms of the variables

$$\delta_{c1} = \frac{M_2 \delta_2 + M_3 \delta_3}{M_2 + M_3} - \delta_1, \quad \delta_{23} = \delta_2 - \delta_3 \quad (5.64)$$

as a fourth order system

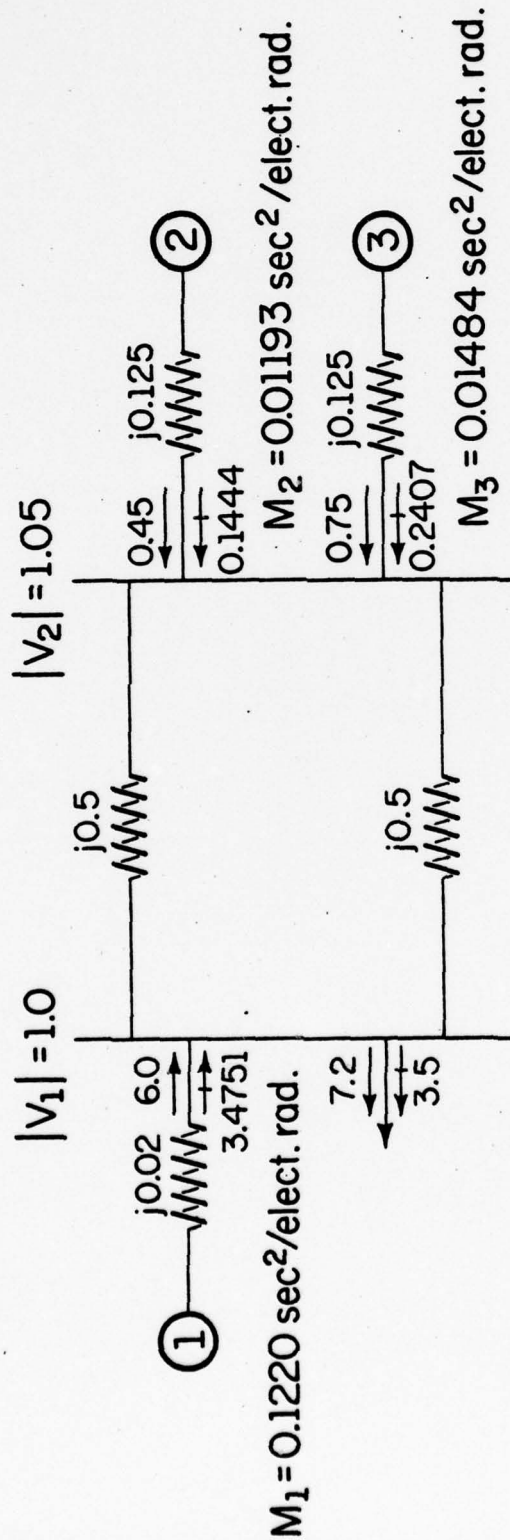

Note: All values given in per unit on 100 Mva base. Machine reactances include unit transformer and transient reactance.

FP-5861

Figure 5.2 Three machine power system.

$$\begin{aligned} \ddot{\delta}_{c1} = & F_1 - \frac{V_1' V_2' Y_{12}}{M_{12}} \cos(\psi_{12} - \frac{M_3}{M} \delta_{23} - \delta_{c1}) - \frac{V_1' V_3' Y_{13}}{M_{13}} \cos(\psi_{13} + \frac{M_2}{M} \delta_{23} - \delta_{c1}) \\ & - \frac{2V_2' V_3'}{M} Y_{23} \cos \theta_{23} \cos \delta_{23} \end{aligned} \quad (5.65)$$

$$\begin{aligned} \ddot{\delta}_{23} = & F_2 - \frac{V_1' V_2' Y_{12}}{M_2} \cos(\theta_{12} - \delta_{c1} - \frac{M_3}{M} \delta_{23}) + \frac{V_1' V_3' Y_{13}}{M_3} \cos(\theta_{13} - \delta_{c1} + \frac{M_2}{M} \delta_{23}) \\ & - \frac{V_2' V_3' Y_{23}}{M_{23}} \cos(\psi_{23} - \delta_{23}) \end{aligned}$$

where δ_1 is used as the reference and

$$\begin{aligned} F_1 = & \frac{P_{in_2} + P_{in_3} - V_2'^2 Y_{22} \cos \theta_{22} - V_3'^2 Y_{33} \cos \theta_{33}}{M} - \frac{P_{in_1} - V_1'^2 Y_{11} \cos \theta_{11}}{M_1} \\ F_2 = & \frac{P_{in_2} - V_2'^2 Y_{22} \cos \theta_{22}}{M_2} - \frac{P_{in_3} - V_3'^2 Y_{33} \cos \theta_{33}}{M_3} \end{aligned} \quad (5.66)$$

Since Y_{23} is large compared to Y_{12} and Y_{13} , we define μ as

$$\frac{1}{\mu^2} = \frac{V_2' V_3' Y_{23}}{M_{23}} \quad (5.67)$$

With the change of variables

$$x = \delta_{c1}, \quad z = \delta_{23} / \mu^2 \quad (5.68)$$

system (5.65) becomes

$$\begin{aligned} \ddot{x} = & F_1 - \frac{V_1' V_2' Y_{12}}{M_{12}} \cos(\psi_{12} - \mu^2 \frac{M_3}{M_1} z - x) \\ & - \frac{V_1' V_3' Y_{13}}{M_{13}} \cos(\psi_{13} + \mu^2 \frac{M_2}{M} z - x) - \frac{2V_2' V_3' Y_{23}}{M} \cos \theta_{23} \cos \mu^2 z \\ = & f_1(x, \mu^2 z) \end{aligned}$$

$$\begin{aligned}
\mu^2 \ddot{z} &= F_2 - \frac{V_1' V_2' Y_{12}}{M_2} \cos(\theta_{12} - \mu^2 \frac{M_3}{M} z - x) \\
&\quad + \frac{V_1' V_3' Y_{13}}{M_3} \cos(\theta_{13} + \mu^2 \frac{M_2}{M} z - x) - \frac{1}{\mu^2} \cos(\psi_{23} - \mu^2 z) \\
&= f_2(x, \mu^2 z, \mu) .
\end{aligned} \tag{5.69}$$

Note that

$$\lim_{\mu \rightarrow 0^+} \frac{1}{\mu^2} \cos(\psi_{23} - \mu^2 z) = \lim_{\mu \rightarrow 0^+} \frac{1}{\mu^2} \sin \mu^2 z = z \tag{5.70}$$

as $\psi_{23} = 90^\circ$. Thus system (5.65) satisfies Assumptions (A5.3) and (A5.4).

Letting $\mu \rightarrow 0^+$, the nonlinear reduced system of (5.69) is

$$\ddot{\bar{x}} = f_1(\bar{x}, 0) \tag{5.71}$$

$$\bar{z} = F_2 - \frac{V_1' V_2' Y_{12}}{M_2} \cos(\theta_{12} - \bar{x}) + \frac{V_1' V_3' Y_{13}}{M_3} \cos(\theta_{13} - \bar{x}) .$$

Equation (5.71) describes the oscillation of the center of inertia of machines 2 and 3 with respect to machine 1. Since machines 2 and 3 are relatively weakly tied to machine 1, this oscillation is of a relatively low frequency. The fast oscillatory subsystem of (5.69) is

$$\mu^2 \ddot{\hat{z}} = -\hat{z} \tag{5.72}$$

which is linear. Equation (5.72) describes the oscillation of machine 3 with respect to machine 2. Since the connection between machines 2 and 3 is relatively strong (compared to their respective connections to machine 1), this oscillation is of a higher frequency than the oscillation of the center of inertia of machines 2 and 3 with respect to machine 1.

The true states of (5.65) are then approximated by

$$\begin{aligned}\tilde{\delta}_{c1} &\approx \bar{x} \\ \tilde{\delta}_{23} &\approx \mu^2 \bar{z} + \mu^2 \hat{z}.\end{aligned}\quad (5.73)$$

For the initial conditions

$$\delta_{c1}(0) = 14.11^\circ, \quad \delta_{23}(0) = -1.86^\circ \quad (5.74)$$

δ_{c1} , $\tilde{\delta}_{c1}$, δ_{23} and $\tilde{\delta}_{23}$ are plotted in Figures 5.3 and 5.5 and $\mu^2 \bar{z}$ is plotted in Figure 5.4. The agreement between δ_{c1} and $\tilde{\delta}_{c1}$ is excellent. However, there are amplitude and frequency discrepancies between δ_{23} and $\tilde{\delta}_{23}$.

To correct for the amplitude discrepancy, we retain the μ terms in $f_2(x, \mu^2 z)$ and solve for the slow part of z from

$$0 = f_2(\bar{x}, \mu^2 \bar{z}). \quad (5.75)$$

The value of $\mu^2 \bar{z}$ is plotted against $\mu^2 \hat{z}$ in Figure 5.4 whose shows that including μ produces roughly a 20% shift in \bar{z} . Figure 5.6 shows that

$$\tilde{\delta}_{23} = \mu^2 \bar{z} + \mu^2 \hat{z} \quad (5.76).$$

approximates δ_{23} better than $\tilde{\delta}_{23}$ in amplitude.

To compensate for the frequency discrepancy, we linearize f_2 about $z=0$ to obtain

$$\begin{aligned}\mu^2 \ddot{\hat{z}} &= (-1 - \mu^2 \frac{V_1' V_2' Y_{12} M_3}{MM_2}) \sin(\theta_{12} - \bar{x}) \\ &\quad - \mu^2 \frac{V_1' V_3' Y_{13} M_2}{MM_3} \sin(\theta_{13} - \bar{x}) \hat{z}.\end{aligned}\quad (5.77)$$

Figure 5.7 shows that

$$\tilde{\delta}_{23}^{\hat{z}} = \mu^2 \bar{z} + \mu^2 \hat{z} \quad (5.78)$$

approximates δ_{23} very closely, both in frequency and amplitude.

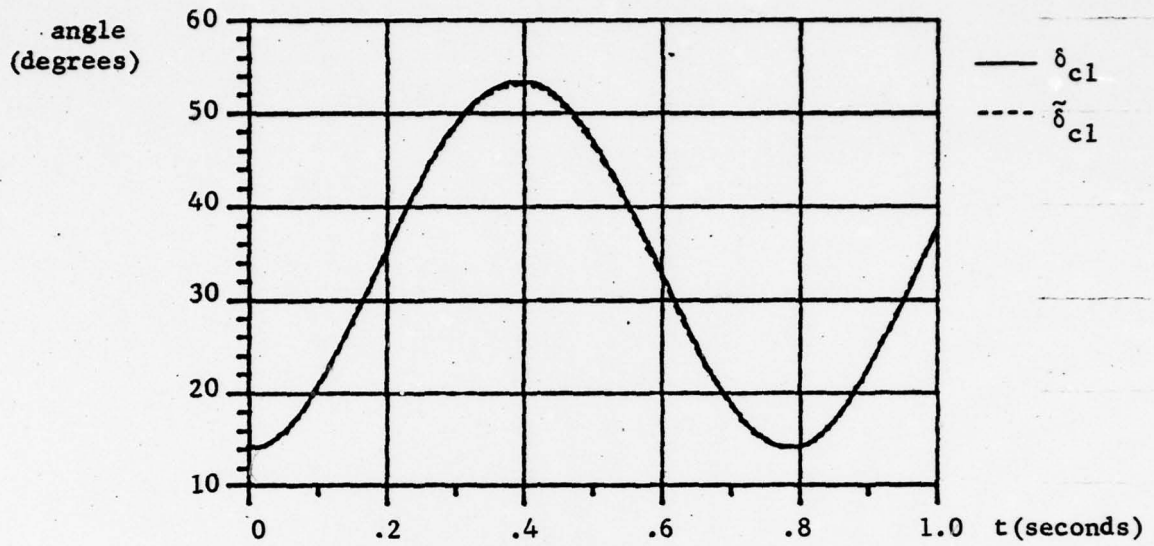

Figure 5.3 Plots of δ_{c1} and $\tilde{\delta}_{c1}$.

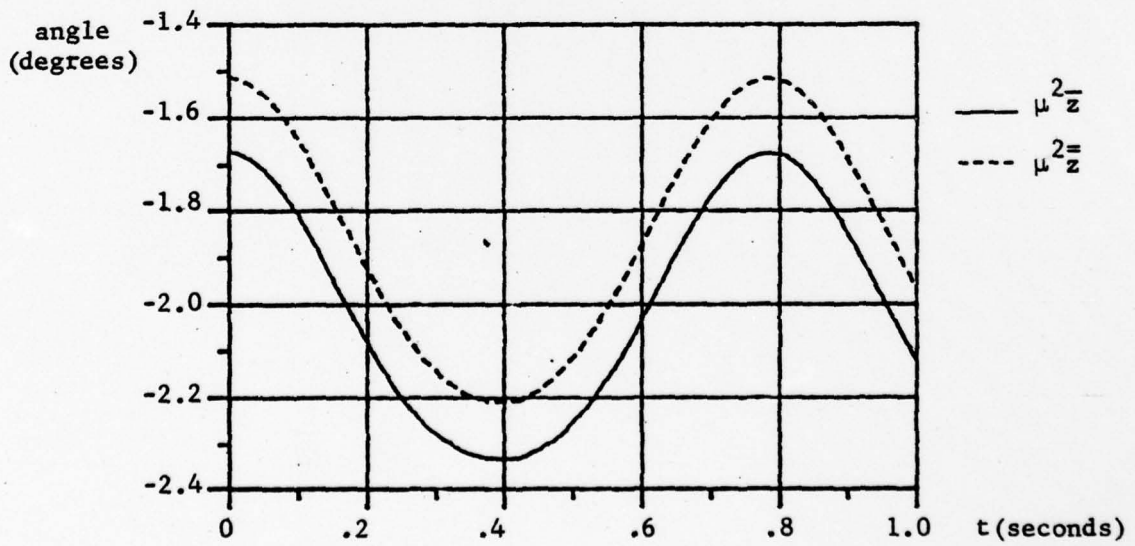
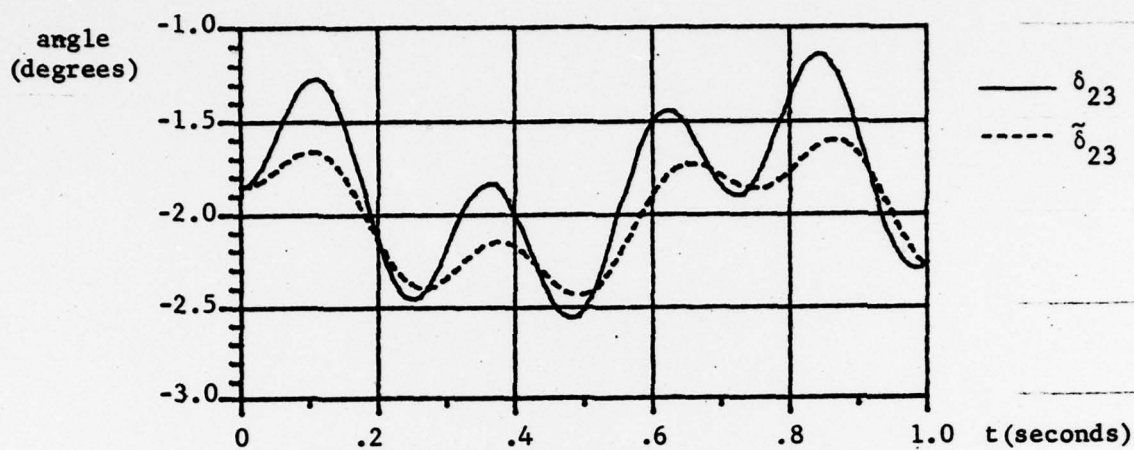
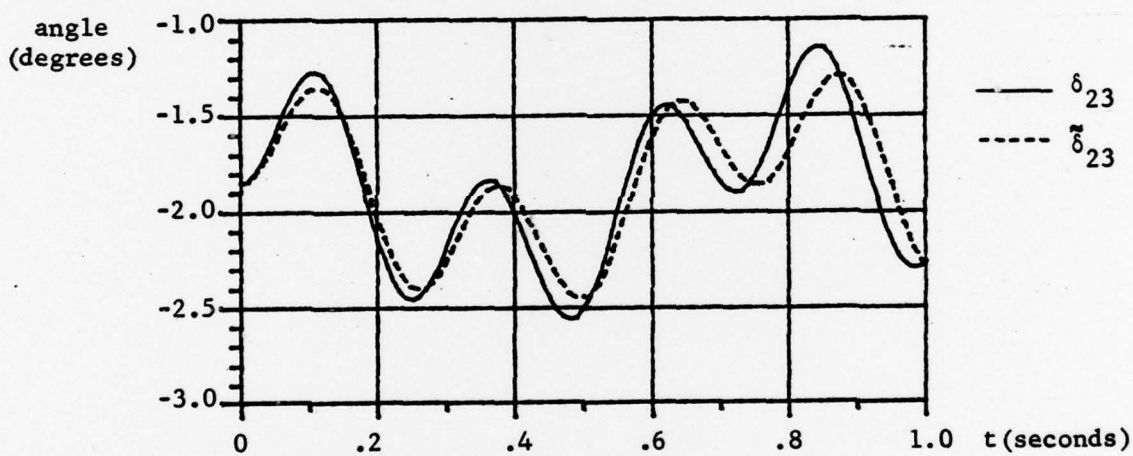
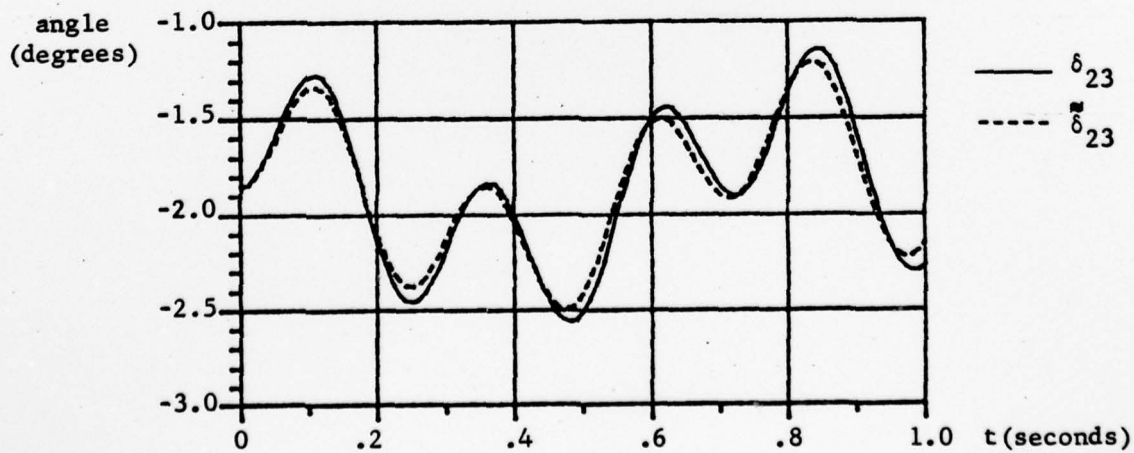

Figure 5.4 Plots of μ_z^2 and $\tilde{\mu}_z^2$.

Figure 5.5 Plots of δ_{23} and $\tilde{\delta}_{23}$.Figure 5.6 Plots of δ_{23} and $\tilde{\delta}_{23}$.Figure 5.7 Plots of δ_{23} and $\tilde{\delta}_{23}$.

In conclusion, the decomposition procedure applied to the power system (5.65) exhibits the coherent angular displacements of machines 2 and 3. In addition, the oscillations between machines 2 and 3 can be recovered from the fast oscillatory subsystem.

5.7 Discussion

It has been shown that singular perturbation techniques are applicable to systems which possess slightly damped modes oscillating at high frequencies. Our analysis procedures consist of first identifying the small parameter μ and expressing the system in the form (5.3). Then the original system is decomposed into a slowly varying subsystem and a fast oscillatory subsystem. Using these subsystems, we obtain $O(\mu)$ approximations of both the eigenvalues and the states of the original system (5.3). Beside the computational advantages of dealing with the lower order subsystems, the concept of subsystems contributes to the understanding of structural properties of physical systems. A mass-spring-damper example shows that a stiff spring can be regarded as a perturbation of a rigid rod, the imperfection resulting in high frequency oscillations between the masses. In an interconnected power system, neglecting the inter-machine oscillations, the power angles of the tightly connected machines are shown to be coherent.

6. CONCLUSIONS

This thesis applies the techniques of singular perturbation to the studies of nonlinear optimal control problems and systems with high frequency oscillatory behavior.

The stability properties of a class of singularly perturbed nonlinear systems are investigated through the construction of a composite Lyapunov function based on the stability properties of the reduced system and the boundary layer system. Beside relaxing the condition that the linearized reduced system be asymptotically stable, the introduction of a small parameter into the composite Lyapunov function enables us to obtain a predicted domain of stability which is substantially larger than those obtained in previous works.

In contrast to the open-loop solution obtained for finite time optimization problems, we propose a series expansion solution to the Hamilton-Jacobi equation for nonlinear regulator problems. As a result, near-optimal feedback controls are obtained which readily incorporates stability requirements.

For fixed endpoint nonlinear optimal control problems, we decompose the full order problem into three separate lower order optimal control problems. The advantages of this approach are that although the reduced problem is nonlinear, it is of lower order and that the boundary layer problems are linear quadratic. Hence the lower order problems are much easier to solve than the full problem.

For systems with high frequency oscillatory behavior, we propose a novel approach of applying singular perturbations to decompose the original system into a slowly varying subsystem and a fast oscillatory

subsystem. A mass-spring-damper system and an interconnected power system illustrate that the decomposition scheme is consistent with physical interpretation.

APPENDIX A. DC MOTOR PARAMETERS

Specifications of a DC motor used in [30].

$$\omega^* = 200 \text{ rpm}$$

$$R_a = .00885 \Omega$$

$$L_a = .00015 \text{ H}$$

$$i_a^* = 2850 \text{ A}$$

$$V_a^* = 700 \text{ V}$$

$$R_f = .951 \Omega$$

$$L_f = 2.58 \text{ H}$$

$$i_f^* = 128.5 \text{ A}$$

$$V_f^* = 122.2 \text{ V}$$

$$J = 2480 \text{ lb-ft-sec}$$

$$c_3 = .0529 \text{ lb-ft/A}^2.$$

APPENDIX B. EQUIVALENCE OF \bar{V}_0 AND L

Substituting (3.26) into (3.23) and rearranging yields

$$0 = X_1 + \bar{V}_{0x} X_2 - \frac{1}{4} \bar{V}_{0x} X_3 \bar{V}'_{0x}$$

where

$$X_1 = p - (s' + 2a_2' \bar{V}_2) \bar{A}_2^{-1} a_2 - (\frac{1}{2} s' + a_2' \bar{V}_2) \bar{A}_2^{-1} B_2 R^{-1} B_2' \bar{A}_2^{-1} (\frac{1}{2} s + \bar{V}_2 a_2)$$

$$X_2 = \tilde{a}_0 + \tilde{B}_0 R^{-1} B_2' \bar{A}_2^{-1} (\frac{1}{2} s + \bar{V}_2 a_2)$$

$$X_3 = \tilde{B}_0 R^{-1} \tilde{B}'_0$$

$$\tilde{a}_0 = a_1 - (A_1 - B_1 R^{-1} B_2' \bar{V}_2) \bar{A}_2^{-1} a_2$$

$$\tilde{B}_0 = B_1 - (A_1 - B_1 R^{-1} B_2' \bar{V}_2) \bar{A}_2^{-1} B_2$$

$$\bar{A}_2 = A_2 - B_2 R^{-1} B_2' \bar{V}_2.$$

Let $H = I_r + R^{-1} B_2' \bar{V}_2 \bar{A}_2^{-1} B_2$. Then $H^{-1} = I_r - R^{-1} B_2' \bar{V}_2 \bar{A}_2^{-1} B_2$ and $H^{-1} R H^{-1}$
 $= R + B_2' \bar{A}_2^{-1} Q A_2^{-1} B_2 = R_0$. Thus $\tilde{B}_0 = B_1 H - A_1 \bar{A}_2^{-1} B_2 = B_0 H$. Hence $X_3 = B_0 R_0^{-1} B_0'$.

Also,

$$\begin{aligned} X_2 &= a_0 + B_0 R_0^{-1} [(R + B_2' \bar{A}_2^{-1} Q A_2^{-1} B_2) R^{-1} B_2' \bar{V}_2 \bar{A}_2^{-1} + B_2' \bar{A}_2^{-1} \bar{V}_2] a_2 + \frac{1}{2} B_0 R_0^{-1} B_2' \bar{A}_2^{-1} s \\ &= a_0 + B_0 R_0^{-1} B_2' \bar{A}_2^{-1} (A_2' \bar{V}_2 + Q A_2^{-1} B_2 R^{-1} B_2' \bar{V}_2 + \bar{V}_2 A_2 - \bar{V}_2 B_2 R^{-1} B_2' \bar{V}_2) \bar{A}_2^{-1} \\ &\quad + \frac{1}{2} B_0 R_0^{-1} B_2' \bar{A}_2^{-1} s \\ &= a_0 - B_0 R_0^{-1} s_0. \end{aligned}$$

Furthermore, $\bar{A}_2^{-1} B_2 R^{-1} B_2' \bar{A}_2^{-1} = A_2^{-1} B_2 H R^{-1} H^{-1} B_2' \bar{A}_2^{-1} = A_2^{-1} B_2 R_0^{-1} B_2' \bar{A}_2^{-1}$ and

$$\begin{aligned}
\bar{A}_2^{-1} &= A_2^{-1} + A_2^{-1} B_2 R^{-1} B_2' \bar{V}_2 \bar{A}_2^{-1} \\
&= A_2^{-1} + A_2^{-1} B_2 R_0^{-1} B_2' (\bar{V}_2 + A_2'^{-1} Q A_2^{-1} B_2 R^{-1} B_2' \bar{V}_2) \bar{A}_2^{-1} \\
&= A_2^{-1} - A_2^{-1} B_2 R_0^{-1} B_2' A_2'^{-1} Q A_2^{-1} - A_2^{-1} B_2 R_0^{-1} B_2' A_2'^{-1} \bar{V}_2.
\end{aligned}$$

Thus X_1 becomes

$$\begin{aligned}
X_1 &= p - s' A_2^{-1} a_2 + s' A_2^{-1} B_2 R_0^{-1} B_2' A_2'^{-1} Q A_2^{-1} - \frac{1}{4} s' A_2^{-1} B_2 R_0^{-1} B_2' A_2'^{-1} s \\
&\quad + a_2' \bar{V}_2 A_2^{-1} B_2 R_0^{-1} B_2' A_2'^{-1} \bar{V}_2 a_2 - a_2' (\bar{V}_2 \bar{A}_2^{-1} + \bar{A}_2'^{-1} \bar{V}_2) a_2.
\end{aligned}$$

But

$$\begin{aligned}
\bar{V}_2 \bar{A}_2^{-1} + \bar{A}_2'^{-1} \bar{V}_2 &= -\bar{V}_2 A_2^{-1} - A_2'^{-1} \bar{V}_2 + \bar{V}_2 A_2^{-1} B_2 R_0^{-1} B_2' A_2'^{-1} Q A_2^{-1} + A_2'^{-1} Q A_2^{-1} B_2 R_0^{-1} B_2' A_2'^{-1} \bar{V}_2 \\
&\quad + 2\bar{V}_2 A_2^{-1} B_2 R_0^{-1} B_2' A_2'^{-1} \bar{V}_2 \\
&= A_2'^{-1} Q A_2^{-1} - A_2'^{-1} \bar{V}_2 B_2 R^{-1} B_2' \bar{V}_2 A_2^{-1} + (\bar{V}_2 + A_2'^{-1} Q) A_2^{-1} B_2 R_0^{-1} B_2' A_2'^{-1} (\bar{V}_2 + Q A_2^{-1}) \\
&\quad + \bar{V}_2 A_2^{-1} B_2 R_0^{-1} B_2' A_2'^{-1} \bar{V}_2 - A_2'^{-1} Q A_2^{-1} B_2 R_0^{-1} B_2' A_2'^{-1} Q A_2^{-1},
\end{aligned}$$

and

$$A_2'^{-1} \bar{V}_2 B_2 R^{-1} B_2' \bar{V}_2 A_2^{-1} = [-(\bar{V}_2 + A_2'^{-1} Q) A_2^{-1} + A_2'^{-1} \bar{V}_2 B_2 R^{-1} B_2' \bar{V}_2 A_2^{-1}] B_2 R^{-1} B_2' \bar{V}_2 A_2^{-1},$$

that is,

$$\begin{aligned}
A_2'^{-1} \bar{V}_2 B_2 R^{-1} B_2' \bar{V}_2 A_2^{-1} &= -(\bar{V}_2 + A_2'^{-1} Q) A_2^{-1} B_2 R^{-1} B_2' \bar{V}_2 \bar{A}_2^{-1} \\
&= (\bar{V}_2 + A_2'^{-1} Q) A_2^{-1} B_2 R^{-1} B_2' A_2'^{-1} (Q A_2^{-1} + \bar{V}_2),
\end{aligned}$$

implying $X_1 = p_0 - s_0' R_0^{-1} s_0$. Hence elimination of \bar{V}_1 from (3.23) yields the Hamilton-Jacobi equation (3.14) of the reduced problem.

APPENDIX C: EQUIVALENCE OF \bar{x}, \bar{p} AND x_0, p_0

Let

$$U_0 = -\frac{1}{2} \bar{R}^{-1} (\bar{B}'_1 P_0 + \bar{B}'_2 Q_0). \quad (C1)$$

From (4.59b)

$$\begin{aligned} z_0 &= -\bar{A}_2^{-1} (\bar{a}_2 + \bar{B}_2 U_0) \\ &= -(\bar{A}_2 + \bar{S}_2 \bar{A}'_2^{-1} \bar{V}_3)^{-1} (\bar{a}_2 + \frac{1}{2} \bar{S}_2 \bar{A}'_2^{-1} \bar{V}_2 - \frac{1}{2} \bar{B}_2 \bar{R}^{-1} \bar{B}'_1 P_0) \\ Q_0 &= -\bar{A}'_2^{-1} (\bar{V}_2 + 2\bar{V}_3 z_0 + \bar{A}'_1 P_0) \\ &= -(\bar{A}_2 + \bar{S}_2 \bar{A}'_2^{-1} \bar{V}_3)^{-1} [(\bar{V}_2 - 2\bar{V}_3 \bar{A}'_2^{-1} \bar{a}_2) + (\bar{A}'_1 + \bar{V}_3 \bar{A}'_2^{-1} \bar{S}'_1) P_0]. \end{aligned} \quad (C2)$$

Therefore

$$\begin{aligned} U_0 &= -\frac{1}{2} \bar{R}^{-1} [\bar{B}'_1 - \bar{B}'_2 (\bar{A}_2 + \bar{S}_2 \bar{A}'_2^{-1} \bar{V}_3)^{-1} (\bar{A}'_1 + \bar{V}_3 \bar{A}'_2^{-1} \bar{S}'_1)] P_0 \\ &\quad - \frac{1}{2} \bar{R}^{-1} \bar{B}'_2 (\bar{A}_2 + \bar{S}_2 \bar{A}'_2^{-1} \bar{V}_3)^{-1} (\bar{V}_2 - 2\bar{V}_3 \bar{A}'_2^{-1} \bar{a}_2) \\ &= -\frac{1}{2} L_3^{-1} [\bar{B}'_1 + \bar{B}'_2 \bar{A}'_2^{-1} \bar{V}_3 \bar{A}'_2^{-1} \bar{S}'_1 - \bar{B}'_2 \bar{A}'_2^{-1} (\bar{A}'_2 + \bar{V}_3 \bar{A}'_2^{-1} \bar{S}'_2) (\bar{A}_2 + \bar{S}_2 \bar{A}'_2^{-1} \bar{V}_3)^{-1} \\ &\quad \cdot (\bar{A}'_1 + \bar{V}_3 \bar{A}'_2^{-1} \bar{S}'_1)] P_0 - \frac{1}{2} L_3^{-1} \bar{B}'_2 \bar{A}'_2^{-1} (\bar{A}'_2 + \bar{V}_3 \bar{A}'_2^{-1} \bar{S}'_2) \\ &\quad \cdot (\bar{A}_2 + \bar{S}_2 \bar{A}'_2^{-1} \bar{V}_3)^{-1} (\bar{V}_2 - 2\bar{V}_3 \bar{A}'_2^{-1} \bar{a}_2) \\ &= -\frac{1}{2} L_3^{-1} [\bar{B}'_1 + \bar{B}'_2 \bar{A}'_2^{-1} \bar{V}_3 \bar{A}'_2^{-1} \bar{S}'_1 - \bar{B}'_2 \bar{A}'_2^{-1} (\bar{A}'_1 + \bar{V}_3 \bar{A}'_2^{-1} \bar{S}'_1)] P_0 \\ &\quad - \frac{1}{2} L_3^{-1} \bar{B}'_2 \bar{A}'_2^{-1} (\bar{V}_2 - 2\bar{V}_3 \bar{A}'_2^{-1} \bar{a}_2) \\ &= -L_3^{-1} (L_2 + \frac{1}{2} \bar{B}'_1 P_0). \end{aligned} \quad (C3)$$

Substituting (C3) into (4.59a) yields

$$\begin{aligned} dx_0/dt &= (\bar{a}_1 - \bar{A}_1 \bar{A}'_2^{-1} \bar{a}_2) + (\bar{B}_1 - \bar{A}_1 \bar{A}'_2^{-1} \bar{B}_2) U_0 \\ &\equiv \bar{a} + \bar{B} U_0 \end{aligned} \quad (C4)$$

$$\begin{aligned}
dP_0/dt &= -[\bar{V}_{1x} + Z_0' \bar{V}_{2x} + Z_0' \bar{V}_{3x} Z_0 + U_0' \bar{R}_x U_0 + P_0' (\bar{a}_{1x} + \bar{A}_{1x} Z_0 + \bar{B}_{1x} U_0) \\
&\quad + Q_0' (\bar{a}_{2x} + \bar{A}_{2x} Z_0 + \bar{B}_{2x} U_0)]' \\
&= -[\bar{V}_{1x} - \bar{a}_{2x}' \bar{A}_{2x}'^{-1} \bar{V}_{2x} + \bar{a}_{2x}' \bar{A}_{2x}'^{-1} \bar{V}_{3x} \bar{A}_{2x}'^{-1} \bar{a}_{2x} - (\bar{V}_{2x}' - 2\bar{a}_{2x}' \bar{A}_{2x}'^{-1}) \bar{A}_{2x}'^{-1} (\bar{a}_{2x} - \bar{A}_{2x}' \bar{A}_{2x}'^{-1} \bar{a}_{2x}) \\
&\quad + P_0' (\bar{a}_{1x} + \bar{A}_{1x}' \bar{A}_{2x}'^{-1} (-\bar{a}_{2x}' - \bar{B}_{2x}' U_0) + \bar{B}_{1x}' U_0 - \bar{A}_{1x}' \bar{A}_{2x}'^{-1} (\bar{a}_{2x}' - \bar{A}_{2x}' \bar{A}_{2x}'^{-1} (\bar{a}_{2x} + \bar{B}_{2x}' U_0 \\
&\quad + \bar{B}_{2x}' U_0))) + U_0' (-\bar{B}_{2x}' \bar{A}_{2x}'^{-1} \bar{V}_{2x} + 2\bar{B}_{2x}' \bar{A}_{2x}'^{-1} \bar{V}_{3x} \bar{A}_{2x}'^{-1} \bar{a}_{2x} \\
&\quad + 2\bar{B}_{2x}' \bar{A}_{2x}'^{-1} \bar{V}_{3x} \bar{A}_{2x}'^{-1} (\bar{a}_{2x}' + \bar{A}_{2x}' \bar{a}_{2x}) - \bar{B}_{2x}' \bar{A}_{2x}'^{-1} (\bar{V}_{2x}' - 2\bar{V}_{3x}' \bar{A}_{2x}'^{-1} \bar{a}_{2x}) \\
&\quad - \bar{B}_{2x}' \bar{A}_{2x}'^{-1} \bar{A}_{2x}' \bar{A}_{2x}'^{-1} (\bar{V}_{2x}' - 2\bar{V}_{3x}' \bar{A}_{2x}'^{-1} \bar{a}_{2x})] + U_0' (\bar{R}_x + \bar{B}_{2x}' \bar{A}_{2x}'^{-1} \bar{V}_{3x} \bar{A}_{2x}'^{-1} \bar{B}_{2x}' \\
&\quad + 2\bar{B}_{2x}' \bar{A}_{2x}'^{-1} \bar{V}_{3x} \bar{A}_{2x}'^{-1} (-\bar{A}_{2x}' \bar{A}_{2x}'^{-1} \bar{B}_{2x}' + \bar{B}_{2x}')) U_0]' \\
&= -[L_{1x} + 2U_0' L_{2x} + U_0' L_{3x} U_0 + P_0' (\bar{a}_x + \bar{B}_x U_0)]' \\
&= -\nabla_x H(x_0, p_0, u_0, t). \tag{C5}
\end{aligned}$$

In (C5), the partial derivative of an $n_1 \times n_2$ matrix G with respect to x results in an $n_1 \times n_2 \times n$ matrix G_x and its pre- and post-multiplication by an n_1 -vector h_1 and an n_2 -vector h_2 is defined as

$$h_1' G_x h_2 = \sum_{i=1}^{n_1} \sum_{j=1}^{n_2} h_{1i} h_{2j} G_{ijx} \tag{C6}$$

where h_{1i} is the i th component of h_1 , h_{2j} is the j th component of h_2 and G_{ij} is the (i,j) -th element of G . Thus the equations for x_0, p_0, u_0 are identical to the equations for $\bar{x}, \bar{p}, \bar{u}$. Hence from the uniqueness Assumption (A4.1)

$$x_0 = \bar{x}^*, \quad p_0 = \bar{p}^*, \quad u_0 = \bar{u}^*. \tag{C7}$$

APPENDIX D: NOTATIONS USED IN POWER SYSTEM EXAMPLE

Notation used in (5.63)

- δ_i : rotor angle of machine i in electrical radians.
- M_i : inertia constant of machine i in $\text{sec}^2/\text{elect. rad.}$
- P_{in_i} : input power to machine i in per unit.
- V'_i : voltage behind transient reactance of machine i in per unit.
- Y_{ij} : per unit magnitude of the ij^{th} element of the reduced network admittance matrix.
- θ_{ij} : angle in radians of the ij^{th} element of the reduced network admittance matrix.

Notation used in (5.65)

$$M = M_2 + M_3$$

$$\left(\frac{1}{M_{12}}\right)^2 = \left(\frac{1}{M} - \frac{1}{M_1}\right)^2 \cos^2 \theta_{12} + \left(\frac{1}{M} + \frac{1}{M_1}\right)^2 \sin^2 \theta_{12}, \tan \psi_{12} = \frac{\left(\frac{1}{M} + \frac{1}{M_1}\right)}{\left(\frac{1}{M} - \frac{1}{M_1}\right)} \tan \theta_{12}$$

$$\left(\frac{1}{M_{13}}\right)^2 = \left(\frac{1}{M} - \frac{1}{M_1}\right)^2 \cos^2 \theta_{13} + \left(\frac{1}{M} + \frac{1}{M_1}\right)^2 \sin^2 \theta_{13}, \tan \psi_{13} = \frac{\left(\frac{1}{M} + \frac{1}{M_1}\right)}{\left(\frac{1}{M} - \frac{1}{M_1}\right)} \tan \theta_{13}$$

$$\left(\frac{1}{M_{23}}\right)^2 = \left(\frac{1}{M_2} - \frac{1}{M_3}\right)^2 \cos^2 \theta_{23} + \left(\frac{1}{M_2} + \frac{1}{M_3}\right)^2 \sin^2 \theta_{23}, \tan \psi_{23} = \frac{\left(\frac{1}{M_2} + \frac{1}{M_3}\right)}{\left(\frac{1}{M_2} - \frac{1}{M_3}\right)} \tan \theta_{23}.$$

REFERENCES

1. P. V. Kokotovic, R. E. O'Malley, Jr., and P. Sannuti, "Singular Perturbations and Order Reduction in Control Theory - An Overview," Automatica, Vol. 12, 1976, pp. 123-132.
2. A. I. Klimushev and N. N. Krasovskii, "Uniform Asymptotic Stability of Systems of Differential Equations with a Small Parameter in the Derivative Terms," J. Appl. Math. Mech., Vol. 25, 1962, pp. 1011-1025.
3. R. R. Wilde and P. V. Kokotovic, "Stability of Singularly Perturbed Systems and Networks with Parasitics," IEEE Trans. Automatic Control, Vol. AC-17, 1972, pp. 245-246.
4. P. Sannuti and P. V. Kokotovic, "Near Optimum Design of Linear Systems by a Singular Perturbation Method," IEEE Trans. Automatic Control, Vol. AC-14, 1969, pp. 15-22.
5. P. V. Kokotovic and R. A. Yackel, "Singular Perturbation of Linear Regulators: Basic Theorems," IEEE Trans. Automatic Control, Vol. AC-17, 1972, pp. 29-37.
6. R. E. O'Malley, Jr., "Singular Perturbation of the Time Invariant Linear State Regulator Problem," J. Diff. Equations, Vol. 12, 1972, pp. 117-128.
7. R. R. Wilde and P. V. Kokotovic, "Optimal Open- and Closed-Loop Control of Singularly Perturbed Linear Systems," IEEE Trans. Automatic Control, Vol. AC-18, 1973, pp. 616-625.
8. J. H. Chow and P. V. Kokotovic, "A Decomposition of Near-Optimum Regulators for Systems with Slow and Fast Modes," IEEE Trans. Automatic Control, Vol. AC-21, 1976, pp. 701-705.
9. J. H. Chow, "Two Stage Design of Singularly Perturbed Linear Regulators," Proc. 13th Annual Allerton Conf. on Circuit and System Theory, Univ. of Illinois, 1975, pp. 48-57.
10. F. C. Hoppensteadt, "Singular Perturbations on the Infinite Interval," Trans. Amer. Math. Soc., Vol. 132, 1966, pp. 521-535.
11. F. C. Hoppensteadt, "Asymptotic Stability in Singular Perturbation Problems. II: Problems Having Matched Asymptotic Expansion Solutions," J. Diff. Equations, Vol. 15, 1974, pp. 510-521.
12. L. T. Grujic, "Vector Liapunov Functions and Singularly Perturbed Large-Scale Systems," Proc. 1976 JACC, Purdue University, pp. 409-416.
13. P. Habets, "Stabilite Asymptotique pour des Problemes de Perturbations Singulieres," in C.I.M.E. Stability Problems, Bressanone, Edizioni Cremonese, Roma, Italy, 1974, pp. 3-18.

14. P. Sannuti, "Asymptotic Expansion of Singularly Perturbed Quasi-Linear Optimal Systems," SIAM J. Control, Vol. 13, 1975, pp. 572-591.
15. P. Sannuti, "Asymptotic Series Solution of Singularly Perturbed Optimal Control Problems," Automatica, Vol. 10, 1974, pp. 183-194.
16. R. E. O'Malley, Jr., "Boundary Layer Methods for Certain Nonlinear Singularly Perturbed Optimal Control Problems," J. Math. Anal. Appl., Vol. 45, 1974, pp. 468-484.
17. D. L. Lukes, "Optimal Regulation of Nonlinear Dynamical Systems," SIAM J. Control, Vol. 7, 1969, pp. 75-100.
18. Y. Nishikawa, N. Sannomiya, and H. Itakura, "A Method for Suboptimal Design of Nonlinear Feedback Systems," Automatica, Vol. 7, 1971, pp. 703-712.
19. N. N. Bogoliubov and Yu. A. Mitropolskii, Asymptotic Methods in the Theory of Nonlinear Oscillations, Gordon and Breach, New York, 1961.
20. V. M. Volosov, "Averaging in Systems of Ordinary Differential Equations," Russ. Math. Surveys, Vol. 17, No. 6, 1962, pp. 1-126.
21. K. W. Chang, "Singular Perturbations of a General Boundary Value Problem," SIAM J. Math. Anal., Vol. 3, 1972, pp. 520-526.
22. P. V. Kokotovic and A. H. Haddad: Controllability and Time-Optimal Control of Systems with Slow and Fast Modes. IEEE Trans. Automatic Control, Vol. AC-20, 1975, pp. 111-113.
23. G. Shackshaft, "General-Purpose Turbo-Alternator Model," Proc. IEE, Vol. 110, 1963, pp. 703-713.
24. E. W. Kimbark, Power System Stability, Vol. 3, John Wiley, New York, 1956.
25. K.-K. D. Young, P. V. Kokotovic and V. I. Utkin, "A Singular Perturbation Analysis of High Gain Feedback Systems," IEEE Trans. Automatic Control, Vol. AC-22, 1977.
26. N. N. Krasovskii, "On Stability with Large Initial Perturbations," PPM, Vol. 21, 1957, pp. 309-319.
27. W. Hahn, Theory and Applications of Liapunov's Direct Method, Prentice-Hall, Englewood Cliffs, N.J., 1963.
28. J. H. Chow, "Preservation of Controllability in Linear Time-Invariant Perturbed Systems," Int. J. Control, Vol. 25, 1977, pp. 697-704.
29. W. L. Garrard, "Suboptimal Feedback Control for Nonlinear Systems," Automatia, Vol. 8, 1972, pp. 219-221.

30. M. Jamshidi, "An Integrated Near-Optimum Design of Cold Rolling Mills," Report R-499, Coordinated Science Lab., University of Illinois, 1971.
31. R. L. Bishop and S. I. Goldberg, Tensor Analysis on Manifolds, The Macmillan Company, 1968.
32. F. John, Partial Differential Equations, second edition, Springer-Verlag, New York, 1975.
33. C. R. Hadlock, "Existence and Dependence on a Parameter of Solutions of a Nonlinear Two Point Boundary Value Problem," J. Diff. Equations, Vol. 14, 1973, pp. 498-517.
34. M. I. Freedman and J. L. Kaplan, "Singular Perturbations of Two-Point Boundary Value Problems Arising in Optimal Control," SIAM J. Control and Optimization, Vol. 14, 1976, pp. 189-215.
35. M. I. Freedman and B. Granoff, "Formal Asymptotic Solution of a Singularly Perturbed Nonlinear Optimal Control Problem," JOTA, Vol. 19, 1976, pp. 301-325.
36. J. V. Breakwell and Y.-C. Ho, "On the Conjugate Point Condition for the Control Problem," Int. J. Engineering Science, Vol. 2, 1965, pp. 565-579.
37. C. H. Schley, Jr., and I. Lee, "Optimal Control Computation by the Newton-Raphson Method and the Riccati Transformation," IEEE Trans. Automatic Control, Vol. AC-12, 1967, pp. 139-144.
38. R. R. Wilde and P. V. Kokotovic, "A Dichotomy in Linear Control Theory," IEEE Trans. Automatic Control, Vol. AC-17, 1972, pp. 382-383.
39. K. N. Stanton, "Power System Dynamic Simulation Using Models with Reduced Dimensionality," Proc. JACC, 1972, pp. 415-419.
40. R. W. de Mello, R. Podmore, and K. N. Stanton, "Coherency-Based Dynamic Equivalents: Applications in Transient Stability Studies," Proc. 1975 PICA Conf., pp. 23-31.

VITA

Joe Hong Chow was born in Shanghai, China, on August 1, 1951. He received his Bachelor degrees in Electrical Engineering and Mathematics from the University of Minnesota in June, 1974 and his Master of Science degree in Electrical Engineering from the University of Illinois, Urbana in October, 1975.

Since August, 1974, he has been a research assistant for the Control System group at the Coordinated Science Laboratory, University of Illinois. His interests are in control systems and power systems.

Mr. Chow is a member of the Institute of Electrical and Electronic Engineers and the honor societies of Eta Kappa Nu and Phi Kappa Phi.

PUBLICATIONS

1. J. H. Chow, "Separation of Time Scales in Linear Time-Invariant System," M.S. Thesis, Report R-688, Coordinated Science Laboratory, University of Illinois, Urbana, Sept., 1975.
2. J. H. Chow, "Two Stage Design of Singularly Perturbed Linear Regulators," Proc. of 13th Annual Allerton Conf. on Circuit and System Theory, University of Illinois, 1975, pp. 48-57.
3. J. H. Chow and P. V. Kokotovic, "Eigenvalue Placement in Two-Time-Scale Systems," Proc. of IFAC Symposium on Large Scale Systems, Udine, Italy, June 1976, pp. 321-326.
4. J. H. Chow and P. V. Kokotovic, "A Decomposition of Near-Optimum Regulators for Systems with Slow and Fast Modes," IEEE Trans. on Automatic Control, Vol. AC-21, Oct., 1976, pp. 701-705; also in Proc. 1976 IEEE CDC, Clearwater, Florida, pp. 219-224.
5. J. H. Chow, "Preservation of Controllability in Linear Time-Invariant Perturbed Systems," Int. J. Control, Vol. 25, May 1977, pp. 697-704.
6. J. H. Chow, "Pole Placement Design of Multiple Controller Systems via Weak and Strong Controllability," Proc. of 14th Annual Allerton Conf. on Circuit and System Theory, University of Illinois, Urbana, Sept., 1976, pp. 132-139; also to appear in Int. J. System Science.
7. J. H. Chow and P. V. Kokotovic, "Two-Time-Scale Feedback Design of a Class of Nonlinear Systems," Proc. of 1977 JACC, San Francisco, pp. 556-561.
8. J. J. Allemong and J. H. Chow, "Multiple Time Scale for Power System Analysis," presented at Henniker Conf. on Systems Engineering for Power: Emergency Operating State Control, Henniker, N. H., 1977; also in Proc. of 15th Annual Allerton Conf. on Communication, Computer and Control, University of Illinois, Urbana, 1977.
9. J. H. Chow, J. J. Allemong and P. V. Kokotovic, "Singular Perturbation Analysis of Systems with Sustained High Frequency Oscillations," to appear in Automatica, 1978.