

AD-A057 904

NAVAL POSTGRADUATE SCHOOL MONTEREY CALIF  
MULTI STAGE Q-SWITCHED IODINE LASER.(U)  
JUN 78 J M PERIN

F/G 20/5

UNCLASSIFIED

NL

1 OF 1  
ADA  
057904

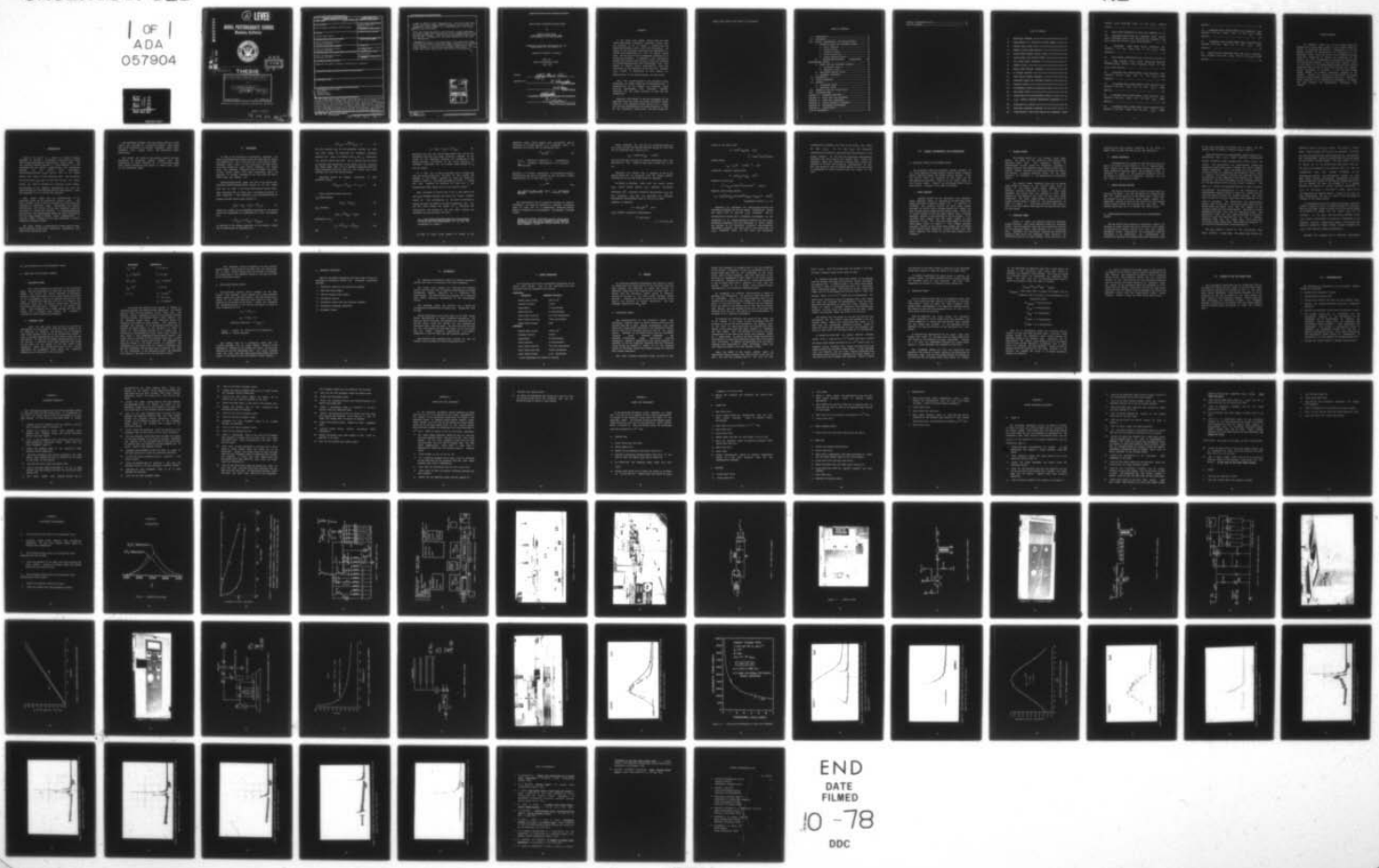

END  
DATE  
FILMED  
10-78  
DDC

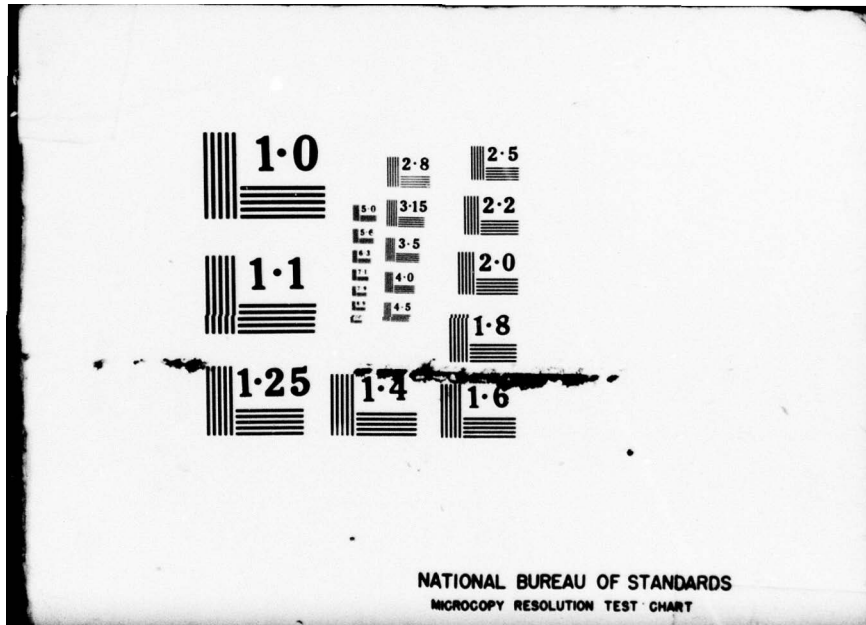

② SC

LEVEL II

ADA 057904

# NAVAL POSTGRADUATE SCHOOL Monterey, California



AD No. \_\_\_\_\_  
DDC FILE COPY

DDC  
RECEIVED  
AUG 24 1978  
B

⑨ Master's **THESIS**

⑥ Multi Stage Q-Switched Iodine Laser.

by

⑩ Jeffery Mark Perin

⑪ June 1978

⑫ 89p.

Thesis Advisor: F.R. Schwirzke

Approved for public release; distribution unlimited

251450  
78 08 23 03 8 mt

| REPORT DOCUMENTATION PAGE   |                       | READ INSTRUCTIONS<br>BEFORE COMPLETING FORM                         |
|---|-----------------------|---|
| 1. REPORT NUMBER  | 2. GOVT ACCESSION NO. | 3. RECIPIENT'S CATALOG NUMBER                                       |
| 4. TITLE (and Subtitle)<br>Multi Stage Q-Switched Iodine Laser  |                       | 5. TYPE OF REPORT & PERIOD COVERED<br>Master's Thesis:<br>June 1978 |
| 7. AUTHOR(s)<br>Jeffery Mark Perin  |                       | 6. PERFORMING ORG. REPORT NUMBER                                    |
| 9. PERFORMING ORGANIZATION NAME AND ADDRESS<br>Naval Postgraduate School<br>Monterey CA 93940   |                       | 8. CONTRACT OR GRANT NUMBER(s)                                      |
| 11. CONTROLLING OFFICE NAME AND ADDRESS<br>Naval Postgraduate School<br>Monterey CA 93940   |                       | 10. PROGRAM ELEMENT, PROJECT, TASK<br>AREA & WORK UNIT NUMBERS      |
| 14. MONITORING AGENCY NAME & ADDRESS (if different from Controlling Office)<br>Naval Postgraduate School<br>Monterey CA 93940   |                       | 12. REPORT DATE   |
|   |                       | 13. NUMBER OF PAGES<br>89   |
|   |                       | 15. SECURITY CLASS. (of this report)<br>Unclassified                |
|   |                       | 15a. DECLASSIFICATION/DOWNGRADING<br>SCHEDULE                       |
| 16. DISTRIBUTION STATEMENT (of this Report)<br>Approved for public release; distribution unlimited  |                       |   |
| 17. DISTRIBUTION STATEMENT (of the abstract entered in Block 20, if different from Report)  |                       |   |
| 18. SUPPLEMENTARY NOTES   |                       |   |
| 19. KEY WORDS (Continue on reverse side if necessary and identify by block number)<br>Photodissociation laser<br>Gas laser<br>Iodine laser<br>Chemical laser  |                       |   |
| 20. ABSTRACT (Continue on reverse side if necessary and identify by block number)<br>A two stage high energy Iodine Laser has been constructed using an existing oscillator stage that was modified so as to accept a Pockels cell and associated Brewster window stack for Q-switching. The output of the oscillator stage was then amplified by a second stage consisting of a 2.54 cm quartz lasing tube, 120 cm long and four flashlamps contained in an elliptical reflector. In addition a gas circulation system which removes the molecular iodine and replaces the perfluoropropyl iodide was incorporated into both |                       |   |

stages to improve output repeatability. With over 1000 shots on the oscillator stage using the original  $C_3F_7I$  liquid, no dependence on shot number, i.e. deterioration of the lasing medium, has been noted.

With 1180 Joules applied to the oscillator stage flashlamps, an output energy of 30 millijoules with a repeatability of two percent was achieved. Pulse duration measurements were detector limited. Estimates put the pulse duration at less than 100 nanoseconds.

Applying 3580 Joules to the flashlamps of the amplifier stage and using the stated oscillator output resulted in an estimated output energy of 8.2 Joules with similar repeatability and pulse duration to that of the oscillator stage alone. For both stages the output beam profile was found to be gaussian.

|                                |  |
|--------------------------------|--|
| ACCESSION NO.                  |  |
| NTIS                           | NTIS Section <input checked="" type="checkbox"/> |
| DDC                            | DDC Section <input type="checkbox"/>             |
| UNANNOUNCED                    | <input type="checkbox"/>                         |
| JUSTIFICATION                  |  |
| BY                             |  |
| RESTRICTION/AVAILABILITY CODES |  |
| Dist. AVAIL. and/or SPECIAL    |  |
| A                              |  |

Approved for public release; distribution unlimited

MULTI STAGE Q-SWITCHED IODINE LASER

by

Jeffery Mark Perin  
Lieutenant, United States Navy  
BA, University of South Florida

Submitted in partial fulfillment of the  
requirements for the degree of

MASTER OF SCIENCE IN PHYSICS

from the  
NAVAL POSTGRADUATE SCHOOL  
June 1978

Author:

*Jeffery Mark Perin*

Approved by:

*F. Schwirski*

THESIS ADVISOR

*a.w. booper*

Second Reader

*W. W. Walker*

Chairman, Department of Physics and Chemistry

*G. J. Haltiner*

Dean of Science and Engineering

## ABSTRACT

A two stage high energy Iodine Laser has been constructed using an existing oscillator stage that was modified so as to accept a Pockels cell and associated Brewster window stack for Q-Switching. The output of the oscillator stage was then amplified by a second stage consisting of a 2.54 cm quartz lasing tube, 120 cm long and four flashlamps contained in an elliptical reflector. In addition a gas circulation system which removes the molecular iodine and replaces the perfluoropropyl iodide was incorporated into both stages to improve output repeatability. With over 1000 shots on the oscillator stage using the original  $C_3F_7I$  liquid, no dependence on shot number, i.e. deterioration of the lasing medium, has been noted.

With 1180 Joules applied to the oscillator stage flashlamps, an output energy of 30 millijoules with a repeatability of two percent was achieved. Pulse duration measurements were detector limited. Estimates put the pulse duration at less than 100 nanoseconds.

Applying 3580 Joules to the the flashlamps of the amplifier stage and using the stated oscillator output resulted in an estimated output energy of 8.2 Joules with similar repeatability and pulse duration to that of the oscillator stage alone. For both stages the

output beam profile was found to be gaussian.

## TABLE OF CONTENTS

|  |    |
|--|----|
| I. INTRODUCTION.....   | 12 |
| II. BACKGROUND.....  | 14 |
| III. DESIGN, CONSTRUCTION, AND MODIFICATIONS.....                      | 21 |
| A. CAPACITOR CHARGE AND DISCHARGE SYSTEM.....                          | 21 |
| 1. Power Supplies.....   | 21 |
| 2. Trigger System .....  | 22 |
| 3. Capacitor Banks.....  | 22 |
| 4. Charge Indicators.....  | 23 |
| 5. Charge Warning Devices.....   | 23 |
| B. PERFLUOROPROPYLIODIDE PURIFICATION AND<br>REPLENISHMENT SYSTEM..... | 23 |
| C. LASER TUBE AND FLASHLAMP ASSEMBLY.....                              | 26 |
| 1. Oscillator Stage.....   | 26 |
| 2. Amplifier Stage.....  | 26 |
| D. OSCILLATOR OPTICAL CAVITY.....                                      | 28 |
| E. UNCHANGED COMPONENTS.....   | 29 |
| IV. DIAGNOSTICS.....   | 30 |
| V. SYSTEM PARAMETERS.....  | 31 |
| VI. RESULTS.....   | 32 |
| A. OSCILLATOR OUTPUT .....   | 32 |
| B. AMPLIFIER OUTPUT .....  | 35 |
| VII. SUMMARY OF THE NPS IODINE LASER.....                              | 38 |
| VIII. RECOMMENDATIONS .....  | 39 |
| Appendix A: ALIGNMENT PROCEDURE.....                                   | 40 |
| Appendix B: FLASH LAMP FILL PROCEDURE.....                             | 44 |
| Appendix C: LASER FILL PROCEDURES.....                                 | 46 |
| Appendix D: SYSTEM OPERATING PROCEDURES.....                           | 50 |
| Appendix E: MAINTENANCE REQUIRMENTS.....                               | 54 |
| Appendix F: ILLUSTRATIONS.....   | 55 |
| LIST OF REFERENCES.....  | 87 |

|                                |    |
|--------------------------------|----|
| INITIAL DISTRIBUTION LIST..... | 89 |
| LIST OF FIGURES.....           | 8  |

LIST OF FIGURES

|     |  |    |
|-----|--|----|
| 1.  | ABSORPTION SPECTRUM .....                                | 55 |
| 2.  | LASER ENERGY AS A FUNCTION OF PULSE NUMBER .....         | 56 |
| 3.  | CONTROL PANEL RELAY LOGIC .....                          | 57 |
| 4.  | GENERAL SYSTEM CONFIGURATION .....                       | 58 |
| 5.  | LASER SYSTEM WITHOUT SAFETY COVERS .....                 | 59 |
| 6.  | LASER SYSTEM WITH SAFETY COVERS .....                    | 60 |
| 7.  | 340V POWER SUPPLY SCHEMATIC .....                        | 61 |
| 8.  | CONTROL STAND .....                                      | 62 |
| 9.  | SECOND STAGE TRIGGER SCHEMATIC .....                     | 63 |
| 10. | HV TRIGGER CABINET .....                                 | 64 |
| 11. | THIRD STAGE TRIGGER SCHEMATIC .....                      | 65 |
| 12. | CAPACITOR CHARGE AND DISCHARGE SYSTEM .....              | 66 |
| 13. | CAPACITOR BOXES .....                                    | 67 |
| 14. | MICROAMMETER VOLTAGE CALIBRATION CHART .....             | 68 |
| 15. | MAIN POWER SUPPLY .....                                  | 69 |
| 16. | PURIFICATION AND REPLENISHMENT SYSTEM .....              | 70 |
| 17. | C F I PARTIAL PRESSURE TEMPERATURE DEPENDANCE ...<br>3 7 | 71 |
| 18. | FLASHLAMP FILL SYSTEM .....                              | 72 |
| 19. | AMPLIFIER FLASHLAMP REFLECTOR .....                      | 73 |
| 20. | "FREE RUNNING" OSCILLATOR OUTPUT AND FLASHLAMP PULSE     |    |

|   |    |
|---|----|
| (smooth curve flashlamp pulse, 60 torr $C_{37}F_{7}I$ , sweep $5\mu$<br>s/div.) .....   | 74 |
| 21. PULSE WIDTH DEPENDENCE ON TOTAL CELL PRESSURE .....   | 75 |
| 22. OSCILLATOR GIANT PULSE AND FLASHLAMP PULSE (smooth<br>curve flashlamp pulse, total oscillator cell pressure = 710<br>torr, argon with 60 torr $C_{37}F_{7}I$ , sweep $5\mu$ s/div.) ..... | 76 |
| 23. OSCILLATOR GIANT PULSE (total oscillator cell<br>pressure = 710 torr, argon with 60 torr $C_{37}F_{7}I$ , sweep<br>$500$ ns/div.) .....   | 77 |
| 24. PULSE ENERGY DISTRIBUTION PLOT .....  | 78 |
| 25. "FREE RUNNING" TOTAL SYSTEM OUTPUT AND AMPLIFIER<br>FLASHLAMP PULSE (smooth curve flashlamp pulse, 60 torr<br>$C_{37}F_{7}I$ , sweep $5\mu$ s/div.) .....                                 | 79 |
| 26. Q-SWITCHED TOTAL SYSTEM OUTPUT (total amplifier cell<br>pressure = 160 torr, argon with 60 torr $C_{37}F_{7}I$ , sweep<br>$10\mu$ s/div.) .....   | 80 |
| 27. Q-SWITCHED TOTAL SYSTEM OUTPUT (total amplifier cell<br>pressure = 260 torr, argon with 60 torr $C_{37}F_{7}I$ , sweep<br>$5\mu$ s/div.) .....  | 81 |
| 28. Q-SWITCHED TOTAL SYSTEM OUTPUT (total amplifier cell<br>pressure = 360 torr, argon with 60 torr $C_{37}F_{7}I$ , sweep<br>$5\mu$ s/div.) .....  | 82 |
| 29. Q-SWITCHED TOTAL SYSTEM OUTPUT (total amplifier cell<br>pressure = 460 torr, argon with 60 torr $C_{37}F_{7}I$ , sweep<br>$5\mu$ s/div.) .....  | 83 |

|  |    |
|--|----|
| 5 $\mu$ s/div.) .....  | 83 |
| 30. Q-SWITCHED TOTAL SYSTEM OUTPUT (total amplifier cell pressure = 560 torr, argon with 60 torr C <sub>3</sub> F <sub>7</sub> I, sweep 5 $\mu$ s/div.) .....      | 84 |
| 31. Q-SWITCHED TOTAL SYSTEM OUTPUT (total amplifier cell pressure = 660 torr, argon with 60 torr C <sub>3</sub> F <sub>7</sub> I, sweep 5 $\mu$ s/div.) .....      | 85 |
| 32. GIANT PULSE AT CALCULATED BEST TIME (total amplifier cell pressure = 660 torr, argon with 60 torr C <sub>3</sub> F <sub>7</sub> I, sweep 1 $\mu$ s/div.) ..... | 86 |

## ACKNOWLEDGEMENTS

My sincerest thanks go out to the many people who supported the Iodine Laser project. I give special thanks to Donald H. Strom MRCS and Michael J. Trumain MR-1 of the NPS Machine Facility who manufactured the components of the amplifier stage. These two men not only manufactured parts which were classified as beyond the capability of the school, but were instrumental in producing a working unit from theoretical designs. I also must give special notice to Tom Maris of the departmental machine shop and optics laboratory for his work on the cooling systems and general advice throughout the project. I can not thank enough Robert Sanders the leading technician assigned to the project. Without his guidance and assistance the project would not have reached a successful conclusion. Finally I thank Professor F. R. Schwirzke and Professor A. W. Cooper for their guidance and understanding throughout this project.

## I. INTRODUCTION

This is the third in a series of thesis projects designed to produce a multistage Q-Switched high energy short pulse photochemical dissociation Iodine Laser. The two previous reports, Marcell [ 1 ] and Halliday [ 2 ], are concerned with the design, construction, and preliminary testing of the Iodine Laser oscillator. Perfluoropropyl iodide ( $C_3F_7I$ ) gas was used as the lasing medium with argon as the buffering agent. The oscillator was filled with  $C_3F_7I$  gas for each test run and the output energy was found to decrease as a function of shot number. The accuracy of the pressure measurements for both the lasing medium and the flashlamp gas was questionable. First shot energies of up to 150 mJ were reported.

This report deals with the modifications to the oscillator stage and the associated control, power, and fill systems so as to make it suitable for Q-Switching and coupling to an amplifier stage. Furthermore the design, construction, and testing of the laser amplifier stage and the laser as a system are reported. A perfluoropropyl iodide purification and replenishment system has been incorporated into the laser system to produce output repeatability. A vigorous safety program has also been undertaken to insure laboratory personnel safety.

The laser system is envisioned as being used in laser fusion research, laser-target interaction experiments, and laser sound production work.

The appendices together with the results section of this report are intended as an operating manual. This manual will allow the operator to perform alignment, laser fill, flashlamp fill, system start and secure, and output predictions.

The format and style of the previous reports has been maintained and procedural phases changed only when differences in plant dictated so. It is therefore hoped that a smooth transition from report to report will occur for the interested reader.

## II. BACKGROUND

In 1964 at the University of California, Berkeley, the first photodissociation Iodine Laser was developed by Kasper and Pimentel [3]. Due to the need for a high energy (10kj), extremely short pulse (< 1ns), efficient, and high firing rate laser system for laser fusion research, the Iodine Laser has undergone intensive study throughout the world. To date Iodine Lasers have been constructed which are expected to produce energies in the 10kJ range and have a pulse width near 100psec. [3]

Perfluoroalkyl iodide gases are used as the parent gas. Currently perfluoropropyl iodide ( $C_3F_7I$ ) is the gas widely used and is used at the Naval Postgraduate School (NPS). When irradiated with UV light with a wavelength centered at 2700 angstroms  $\pm$  400 angstroms,  $C_3F_7I$  photodissociates to produce excited iodine atoms (figure 1).

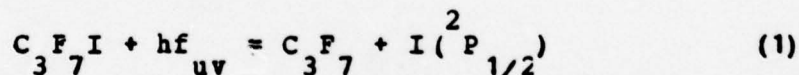

Lasing is a result of the forbidden transition to the ground state and corresponds to a wavelength of 1.3152 micrometers [3].

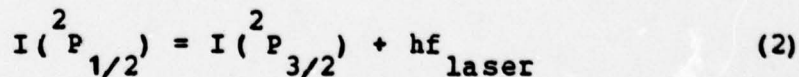

In addition to the lasing transition (2) the excited iodine may be deactivated by collisions [3].

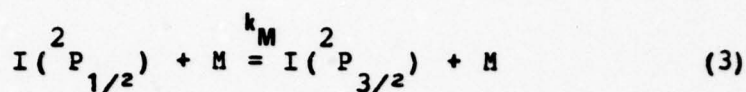

The rate constant ( $k_M$ ) for the quenching process can vary over many orders of magnitude for different collision partners "M". Hohla [3] reports that  $O_2$  and  $I_2$  deactivate the excited iodine very fast. The  $O_2$  problem can be solved by insuring good evacuation of the lasing cell and limiting the laser pump time so as to prevent impurities that are being evaporated from the wall of the lasing cell from reaching well into the lasing medium.

Unexcited iodine can undergo collisions to form molecular iodine.

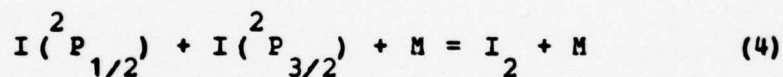

Other reactions which occur are:

$C_3F_7$  -dimerization:



$C_3F_7$  recovery:

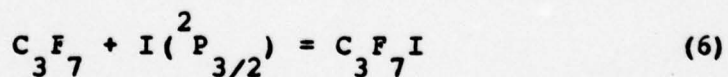

Photolysis of  $I_2$ :

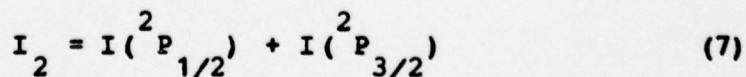

and

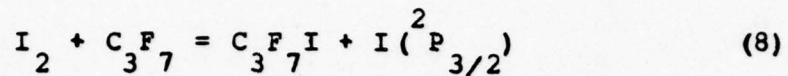

Reactions (1), (2), (6), and to some degree (7), and (8) are desirable since they are either directly involved in the lasing or the resulting products are beneficial to the lasing reaction. In addition to the above reaction, if pyrolysis conditions are not avoided, large amounts of  $I_2$  will be formed.

In a test run at NPS by Halliday [2] on a single gas fill the output energy as a function of shot number was similar to the output reported by Fuss and Hohla [4] (figure 2 curve 1). The Fuss and Hohla [4] curve 2 output was also reported by Halliday [2] when the  $I_2$  was precipitated using copper wire to form cuprous iodide.

Fuss and Hohla [4] found that if the  $I_2$  was removed and the  $C_3F_7I$  consumed replaced the output was nearly constant (curve 3). The nonlinearity of the rate of decrease in energy per shot was found to be due to equations (6), (7), and (8) which reduce the amount of  $I_2$  available for deactivation. The results of the NPS tests confirm the statement by Fuss and Hohla [4] that:

".....the energy decrease resulting from repeated shots with the same gas filling of an iodine laser is solely due to an accumulation of  $I_2$  and the consumption of iodide."

In order to store large amounts of energy in the

amplifier stage lasing medium self oscillation must be prevented or at least reduced to an acceptable level. An amplifier will behave like an oscillator when:

$$V_{TH}^2 R_1 R_2 T^2 = 1 \quad (9)$$

( $R_1, R_2$  - reflection coefficient,  $T$  - transmission,  
 $V_{TH}$  - threshold amplification for parasitic oscillations)

Therefore to prevent oscillation the stimulated emission cross-section ( $\sigma$ ) must be adjusted so that the small signal amplification ( $V$ ) is less than  $V_{TH}$  [4].

$$V = e^{\sigma n l} \quad (10)$$

( $l$  - length of the light path,  $\sigma$  - stimulated emission cross-section,  $n$  - inversion number density)

The cross-section may be reduced by pressure or magnetic broadening. As stated in Aldridge [5] pressure broadening using an inert gas is a homogeneous mechanism whereas magnetic broadening is inhomogeneous. Furthermore Aldridge states:

"Inert gas pressure broadening of the iodine laser emission line is thus as effective as magnetic broadening in reducing the emission cross section and increasing the energy storage capacity of this laser system.....[5]"

Using equations (9) and (10) the threshold energy per unit area and thus the maximum storable energy per unit area can be determined for a given  $\sigma$  [3].

$$e_{st} = (hf/\sigma) (\ln V_{TH}) \quad [J/cm^2]$$

The inert gas must provide the desired broadening with a low deactivation rate. Commonly used gases include CO<sub>2</sub>, Ar and He.

Reference [3] reports that a maximum of 66% of the stored energy can be extracted from the lasing medium. Efficiencies in the 50% range should be expected.

To design an amplifier stage once the output energy ( $E_0$ ), output energy density ( $e_0$ ), amplifier extraction efficiency ( $\eta^*$ ), tolerable threshold amplification ( $V_{TH}$ ) and the inversion rate ( $\alpha$ ), are specified the following approximate relationships given in ref [3] are used.

Diameter of amplifier

$$d = (4E_0/e_0\pi)^{1/2} \quad [cm]$$

C<sub>3</sub>F<sub>7</sub>I pressure (empirical relationship)

$$P = K/d \quad [torr]$$

$$K = 175 \quad [torr \text{ cm}]$$

Length of the lasing cell

$$L = (1/KK^*) (e_{st} d/\alpha) \quad [\text{cm}]$$

$$K^* = 5 \times 10^{-3} \quad [(\text{J/cm}^3) \text{ torr}]$$

Stored energy

$$e_{st} = e_0/\eta^* \quad [\text{J/cm}^2] \quad * \leq 0.66$$

Stimulated emission cross-section

$$\sigma = (hf/e_{st}) (\ln V_{TH}) \quad [\text{cm}^2]$$

Pressure of inert gas

$$P^* \geq (e_{st}^{-0.178 \times 10^{-2}} P) / 0.47 \times 10^{-2} \quad [\text{torr}]$$

Required input energy density

$$e_i = (e_0/\eta^* b \ln V_{TH}) \ln [(\exp(\eta^* b \ln V_{TH}) - 1) / V_{TH} + 1] \quad [\text{J/cm}^2]$$

b-degeneracy factor,  $b = 1.5$

Reference [6] discusses the relationship between the flashlamp configuration and the energy distribution within the lasing cell at specific  $C_{37}F_7$  pressures. The two configurations tested were a concentric arrangement of six flashlamps in an electropolished aluminum tube and a four flashlamp arrangement with the flashlamps in pairs behind one another in an elliptical reflector. The concentric arrangement produced a hot outer ring in the lasing cell at  $C_{37}F_7$  pressures above 20 torr while the elliptical

configuration produced a hot core in the lasing cell below 20 torr  $C_{37}F_{37}I$ . At 70 torr  $C_{37}F_{37}I$  the elliptical configuration produced a relatively even distribution of the energy density. At 100 torr the elliptical configuration produced a hot outer ring in the lasing cell. Since the amplifier stage was expected to operate with a parent gas pressure of 70 torr, the elliptical configuration of ref. [6] was chosen so that the energy density in the cell would be independent of radial distance from the center of the cell.

### III. DESIGN, CONSTRUCTION, AND MODIFICATIONS

#### A. CAPACITOR CHARGE AND DISCHARGE SYSTEM

The capacitor charge and discharge system consists of the power supplies, trigger system, control panel, charging meters, capacitor banks, and charge warning devices. From the control stand all functions of the laser can be controlled and monitored. Figure 3 is the relay logic of the control panel. Figure 4 is the general layout of the laser system. Figures 5 and 6 show the system.

##### 1. Power Supplies

Charging current for the oscillator and amplifier stage capacitor banks is provided by the 50KV main power supply described in Budzik's thesis [7]. In addition to providing the charging current the main power supply provides 115 VAC for the HV trigger cabinet and houses the high voltage vacuum relays of the control panel. Within the HV trigger cabinet is the 15KV power supply which provides charging current to both sections of the HV trigger. As is the 50KV power supply, the 15KV power supply is also described in ref. [7]. The final power supply is the 340V power supply shown in figure 7. This supply provides charging current to the second stage trigger and is located on the control stand (figure 8). Unlike the 50KV and 15KV power supplies the output of the 340V power supply is not variable.

## 2. Trigger System

The trigger system is a two channel, three stage system. The heart of the system is a ENC digital delay generator model 7010. This generator provides an instantaneous trigger pulse for diagnostic equipment, a primary pulse for the amplifier stage trigger channel and a delayed trigger pulse for the oscillator stage and Pockels cell channel. A complete operating manual for the pulse generator is contained in the manufacturer's instruction manual.

The digital delay generator along with the second stage trigger is located on the control stand shown in figure 8. The second stage trigger consists of two identical channels described in figure 9. This stage amplifies the pulses from the generator to 340V. These signals are then coupled to the grid of the third stage thyratrons. The third stage trigger is located in the HV trigger cabinet shown in figure 10. The stage schematic is shown in figure 11. This stage provides a 60KV pulse to each of the four element spark gap and the preionizing coils of both stages.

## 3. Capacitor Banks

Figure 12 shows the complete charge and discharge system circuitry. Both stage capacitor banks are identical except that the amplifier stage has four capacitors vice two for the oscillator stage. Each capacitor is a 7 microfarad unit. Therefore the oscillator capacitor can store 4375 Joules at 25KV, while the amplifier stage capacitor can store 8750 Joules at the same voltage. Since the age of the

capacitors and their internal condition is not known, a safety limit of 20KV has been set for the capacitors.

#### 4. Charge Indicators

Microammeters are located on each capacitor bank box and on the control stand (figures 13 and 8 respectively). These meters have been calibrated to read the voltage of their respective capacitor banks. The calibration chart is contained in figure 14. The resistance bridge for each of the meters is located in the respective capacitor box and has a value of approximately 300MΩ.

#### 5. Charge Warning Devices

The charge warning devices include an alarm bell and rotating red beacon. The bell and beacon are energized only when the control panel is in the charge mode. These units are located on top of the main power supply (figure 15). Additional warning is given by the circuit "8" red flashing lights located outside the building over each door. This warning system must be on to operate the control panel.

#### B. PERFLUOROPROPYLIODIDE PURIFICATION AND REPLENISHMENT SYSTEM

The NPS iodine laser reported in Halliday's thesis [2] produced an output energy that was a function of shot number as represented by figure 2 curve 1 [4]. With this rapidly decreasing output, construction of an amplifier stage was considered to be impractical. Two replenishment and purification systems were designed and built along the lines

of the units described in reference [4] to permit the NPS iodine laser to produce a constant output (curve 3).

Each purification and replenishment system consists of a purification tank,  $C_{37}F_{37}I$  liquid reservoir, refrigeration system, circulation pump, pressure gage, control valves and tubing. The purification and replenishment systems are connected to each laser stage through the stage Brewster window assemblies. Since the system was to be exposed to corrosive gases, all components are stainless steel, monel or plastic. The tubing is quarter inch stainless steel and is connected to each component of the system with Swagelok connectors. The valves and gages are all stainless steel as are the purification tank and  $C_{37}F_{37}I$  liquid reservoir. The pump is a three inch diaphragm pump and is made of plastic and neoprene. The configuration of the purification and replenishment system is shown in figure 16. Valves 9a,b and 10a,b are used to isolate the liquid reservoir for overnight storage of the  $C_{37}F_{37}I$  liquid and when evacuation of the laser is necessary. The purification and replenishment system ends at valve 6a,b. The vacuum lines leading to the vacuum system are copper since they are exposed to the corrosive gases for only brief periods. The Brewster window assemblies are monel and will be described later. The purification tanks are the same as described in Marcell's thesis [1] while the reservoirs are one inch in diameter stainless steel rods ten inches long, with a half inch center hole eight inches deep. Both tanks are connected to the system by Swagelok-pipe thread connectors.

The  $C_{37}F_{37}I$  liquid is placed in the purification tank which contains a copper mesh. The copper mesh removes the

molecular iodine in the  $C_3F_7I$  liquid. The liquid is frozen using liquid nitrogen and the tank is evacuated. With both the tank and purification system evacuated the purification and replenishment system is secured from the vacuum system and the liquid nitrogen removed. The  $C_3F_7I$  liquid can now be boiled out of the purification tank using a heat gun. The  $C_3F_7I$  will condense in the reservoir which is kept at temperatures below zero degrees centigrade by the refrigeration system. The refrigeration systems are home made using salvaged refrigerator compressors and parts. These systems are capable of maintaining temperatures as low as -40 degrees and with an accuracy of  $\pm 1$  degree. Reference [4] reports the partial pressure dependence of  $C_3F_7I$  as  $\log p(\text{mbar}) = -1515.2^\circ\text{K}/T + 7.8830$  (where "T" is the temperature in degrees kelvin). Figure 17 is a plot of this relationship and may be used to set the operating pressure of the lasing medium.

At temperatures below zero degrees centigrade, molecular iodine is reported to have a partial pressure of 4 mbar [4]. Thus the molecular iodine is frozen out of the lasing medium as the medium is pumped over the liquid  $C_3F_7I$  in the reservoir. At the same time the partial pressure of the  $C_3F_7I$  liquid is maintained by holding the temperature of the reservoir constant. Argon may be added to the purification system to buffer the lasing medium without changing the  $C_3F_7I$  liquid partial pressure significantly.

Appendix C is a complete set of operating instructions

for the purification and replenishment system.

## C. LASER TUBE AND FLASHLAMP ASSEMBLY

### 1. Oscillator Stage

Only minor changes have been made to the oscillator stage. The most significant of these was the flashlamp fill system. The valves and tubing described in Halliday's thesis [2] have been removed and the high voltage connection to the flashlamps is now on the opposite end from the fill lines. As before the flashlamp fill port is an eighth inch stainless steel tube. To insure a vacuum seal, the quarter inch lines have been silver soldered to the eighth inch lines. Both flashlamps use a common quarter inch fill line fitted with a pressure gage (figure 18). Appendix B contains the system operating procedures.

### 2. Amplifier Stage

Since the NPS laser will be used in a variety of experiments, it was decided to build the laser system to be as versatile as feasible. The ability to go to extremely short pulse lengths ( $\leq 1\text{ns}$ ) was to be included even though a need in present applications for this short a pulse was not anticipated. To this end the design characteristics of the IPP Asterix 2 (100J/1ns) first stage amplifier were chosen as the basis for the design of the NPS iodine laser amplifier. Using the scaling laws given in ref. (3) and specifying the parameters listed below, the remaining parameters are calculated to be as follows:

| <u>Specified:</u>  | <u>Calculated:</u>             |
|--------------------|--------------------------------|
| $E_0 = 10J$        | $d = 2.54 \text{ cm}$          |
| $e_0 = 1.97J/cm^2$ | $P = 69 \text{ torr}$          |
| $\eta^* = 0.50$    | $e_{st} = 3.95J/cm^2$          |
| $v_{TH} = 10^5$    | $l = 129 \text{ cm}$           |
| $\alpha = 0.1$     | $\sigma = 4.4 \times 10^{-19}$ |
|                    | $P^* = 814 \text{ torr}$       |
|                    | $e_i = 12.5mJ/cm^2$            |

The actual NPS amplifier was limited in design by available material and manufacturing capability. The lasing tube is 2.8cm, 1mm wall Suprasil tubing 120cm long. The Brewster window assemblies consist of the Brewster windows (1/8 inch quartz), the Brewster window mount (monel), and the Brewster window stand. The flashlamp mounts are plexiglass and double as light shields. The reflector is aluminum and consists of two ellipsoidal sections each at opposite 45 degree angles to the vertical, as shown in figure 19. Each reflector section is 21.5 inches long. By orienting the ellipsoids with their major axes normal to each other a more homogeneous lasing medium results. The lasing tube is centered in the ellipsoid which has a major axis of 5cm and a minor axis of 2cm. The flashlamps are located as close to the focal points as possible. The flashlamps are 29 inches long, 0.5 inches in diameter, have 2mm wall thickness, and the same type of tungsten end caps as the flashlamps in the oscillator stage. The flashlamp fill system is the same as for the oscillator stage.

The amplifier stage is mounted on its own two-part optical bench. This bench is six feet long, six inches wide and a total of four inches thick and is made of aluminum. All connections to the amplifier stage are the same as those on the oscillator stage.

#### D. OSCILLATOR OPTICAL CAVITY

The oscillator optical cavity consists of the rear mirror, rear Brewster stack, Pockels cell, front Brewster stack, lasing cell, and front mirror. The rear mirror has a radius of two meters while the front mirror is flat. The spacing of the mirrors is one meter. Using the resonator "g" parameters given in ref. [8] the oscillator is shown to have a stability of 0.5.

$$g_F = 1 - L/R_F = 1$$

$$g_R = 1 - L/R_R = 0.5$$

$$\text{Stability condition} - 0 < g_R g_F < 1$$

( $R_F, R_R$  - radius of curvature of the respective mirror,  $L$  - mirror spacing)

The Pockels cell is a Lasermetric model EOM- 817 Q-Switch equipped with an eight element Brewster stack permanently mounted to the Pockels cell case. The unit was operated in the half wavelength mode. The front Brewster stack was home made from eight microscope slides and wood shims. It was taped to the rear Brewster window assembly.

## E. UNCHANGED COMPONENTS

Many of the system components have been used as they are described in Halliday's thesis [2]. Unchanged components included:

1. oscillator capacitor and spark gap assembly
2. 50KV main power supply
3. 15KV HV trigger power supply
4. oscillator mirrors
5. oscillator lasing cell and mounting hardware
6. oscillator flashlamp reflectors
7. alignment lasers

#### IV. DIAGNOSTICS

As reported in Halliday's thesis [2] several diagnostic devices were used to investigate the laser discharge.

The output pulse shapes and durations were obtained using a photovoltaic InSb IR detector manufactured by Barnes Engineering Company connected to a Tektronix 7704 oscilloscope. The oscilloscope was equipped with a Polaroid Land Camera permitting photographs of the oscilloscope traces.

The flashlamp output was detected via a Model 330 Photodetector manufactured by Tropel Inc., terminated with 50 ohms.

Energy measurements were taken using two Rk 3230 Energy Meters manufactured by Laser Precision Corporation. The first as used by Halliday was equipped and calibrated with a RkP-335 probe, while the second unit was equipped and calibrated with a RkP-336 probe. The RkP-336 probe was used for the high energy and wide beam tests, due to its larger size and energy measuring capabilities (10 Joules). Comparison of the two units was made whenever possible.

Beam patterns were observed using surface #2 near IR display plates produced by Optical Engineering Inc.

## V. SYSTEM PARAMETERS

The following table lists the measured parameters of the Iodine Laser system. Some of the quantities have been extracted from the equipment label plates.

### Oscillator.

| <u>Parameter:</u>     | <u>Measured Quantity:</u> |
|-----------------------|---------------------------|
| Pumped Laser Volume   | 128.18 cm <sup>3</sup>    |
| Charging Voltage      | 0-25KV                    |
| Capacitance           | 14 microfarads            |
| Flash Duration        | 30 microseconds           |
| Laser Pulse Duration  | *0.5-500 nanoseconds      |
| Laser Pulse Rise Time | *<200 nanoseconds         |
| Laser Output Energy   | 30mJ                      |

### Amplifier.

|                       |                        |
|-----------------------|------------------------|
| Pumped Laser Volume   | 770.00 cm <sup>3</sup> |
| Charging Voltage      | 0-25KV                 |
| Capacitance           | 28 microfarads         |
| Flash Duration        | 45 microseconds        |
| Laser Pulse Duration  | *0.5-500 nanoseconds   |
| Laser Pulse Rise Time | *<200 nancseconds      |
| Laser Output Energy   | 8.2J (estimated)       |

\* Time measurement was detector limited.

## VI. RESULTS

All reported diagnostic measurements were made at a point ten meters from the output mirror of the oscillator with the beam expander and amplifier in place and aligned. In addition a glass plate was inserted into the beam path 9.5 meters from the oscillator output mirror to reflect a portion of the beam to the InSb liquid nitrogen cooled detector. Filters were used to reduce the intensity of the beam on the detector to prevent saturation. All burn patterns indicated the TEM<sub>00</sub> mode

### A. OSCILLATOR OUTPUT

The characteristics of the oscillator output were thoroughly studied, since the output energy varied only two percent from shot to shot. Energy measurements were made using both energy meters described in the diagnostic section and not only at the ten meter point but also at the output mirror. Readings at the output mirror were not considered reliable since detector - flashlamp and detector - preionizing pulse interaction occurred frequently. However a comparison of the output energies as detected at the two locations indicated that the oscillator output energy was reduced to almost 1/4 of the measured output at the output mirror when passed through the inactive down stream components.

The "free running" oscillator output was found to vary

widely from alignment to alignment due to the poor condition of the mirrors. Therefore to study the repeatability of the output energy each test run was normalized to the first stable shot on that alignment. With over 1000 shots on the oscillator no dependence on shot number of the output energy was observed. Energies as high as 0.6 Joules were measured at the ten meter point with a variance of less than two percent. Figure 20 is a typical "free running" output superimposed on the oscillator flashlamp pulse.

In attempting to Q-Switch the oscillator a number of problems were encountered. The Q-Switch itself was found to be unreliable. That is, it would frequently short to its outside case or internally when pulsed thus not completely going to the high "Q" mode. In addition the rear Brewster stack was fixed to the Pockels cell so that when the Pockels cell optical axis was aligned to the axis of the laser the Brewster stack was not. The result of this misalignment is believed to be a degraded performance.

To Q-Switch the oscillator the output of the stage had to be reduced to as close to zero as possible with the Q-Switch in the low "Q" mode throughout the pumping time. It was found in early tests that the Q-Switch had little effect on the output even when large amounts of buffering gas were added. This was believed to be due to the poor polarization of the beam by the single rear Brewster window on a single pass. In effect the laser simply shifted from horizontally to vertically polarized lasing when the Pockels cell was pulsed. To improve the polarization of the beam a Brewster stack consisting of eight microscope slides and wood shims was taped to the rear Brewster window.

Argon was added to the lasing medium until no significant lasing occurred with the Q-Switch in the low "Q" mode. The total cell pressure was 710 torr with 60 torr

being  $C_{37}F_{71}$ . When the Pockels cell was pulsed to the high "Q" mode a definite giant pulse could be seen.

To maximize the giant pulse with respect to the pumping time the Pockels cell high "Q" pulse was varied throughout the pumping time. A definite peak in the giant pulse energy was found to occur at 23 microseconds after the oscillator stage preionizing pulse. This pulse was steep, rising from almost zero at 18 microsecond and falling back to half the maximum value of  $30 \times 10^{-3}$  Joules by 24 microseconds. The giant pulse continued at half the maximum value well after the pump had concluded (45 microseconds). Once the giant pulse had been maximized in timing the total pressure was varied to insure a maximum desirable line broadening had occurred. The best total cell pressure for the giant pulse without any prepulse lasing was found to be 710 torr.

The Pockels cell was pulsed to the high "Q" mode for one microsecond and the output pulse was expected to be of a similar length. However the output pulse was found to be less than 500 nanoseconds (detector limited). Figure 21 shows the pulse width dependency on total cell pressure and sets the lower limit for the pulse width at 0.5 nanoseconds.

It should be noted that the energy detector readings varied from a high of  $50 \times 10^{-3}$  Joules when only a slight pre-giant pulse lasing occurred to  $30 \times 10^{-3}$  Joules when no prepulse lasing occurred even though the giant pulse was larger without the pre-giant pulse lasing. It was concluded that the detector can not self trigger accurately from nanosecond length pulses and therefore the output energy of the oscillator may be higher than reported. Figure 22 shows

the position of the giant pulse in relation to the flashlamp pulse while figure 23 shows the pulse on the 500ns scale.

To further investigate the output pulse a pinhole was scanned across the energy detector and the energy recorded for numerous shots at each position. The data were normalized and fitted to a gaussian curve (figure 24).

#### B. AMPLIFIER OUTPUT

Due to a broken lasing tube on the amplifier stage, less data than would have been desired is available on the total laser system. Figure 25 shows the "free running" total system output superimposed on the amplifier flashlamp pulse. The energy of this test was estimated to be in the 3 - 10 Joule range from burn patterns.

When the amplifier was fired without the oscillator firing, energies in the 0.5 Joule range were recorded. The output dropped to 0.1 Joules when the optical path between the two stages was blocked. It was concluded that the amplifier was using the mirrors of the oscillator as a rear mirror.

To maximize the amplification of the giant pulse both stages were fired at the same time and argon added until self lasing of the amplifier had been suppressed. Figures 26 - 31 show the progressive decrease to a single giant pulse at a total amplifier cell pressure of 660 torr.

The flashlamp pulses for both the oscillator and amplifier were similar in shape. Therefore the percentage of oscillator pump time that had passed before the pulsing of the Q-Switch for the maximum giant pulse should be similar

to the percentage of amplifier pump time to pass before the arrival of the oscillator giant pulse when trying to maximize the amplifier output energy. This time was chosen as a starting point for maximizing the amplified giant pulse. The best time for the oscillator giant pulse to enter the amplifier stage was found as follows:

$$(T_{g(osc)} / FD_{osc}) (FD_{amp}) = T_{g(amp)}$$

$T_{g(stage)}$  = best delay time to trigger the Pockels cell as measured from the firing of the flashlamps of the respective stage.

$$FD_{(stage)} = \text{flash duration}$$

$$FD_{osc} = 30 \text{ microseconds}$$

$$FD_{amp} = 45 \text{ microseconds}$$

$$T_{g(osc)} = 23 \text{ microseconds}$$

$$T_{g(amp)} = 34.5 \text{ microseconds}$$

With an 11 microsecond delay set in between the two stages the laser was fired and data taken. With this delay between stages the oscillator giant pulse entered the amplifier stage at the desired time. Initially, due to misalignment the energy meter readings did not correspond with the InSb cooled detector's indication that a giant pulse had occurred and been amplified. Using the near IR display plates the position of the beam relative to the detector was checked and found to be almost completely missing the detector.

In order to evaluate the energy output of the amplifier the effects of the filters used to prevent saturation of the InSb detector were evaluated and found to have a reduction factor of 240. This reduction factor and the calibrated voltage of the InSb detector for the oscillator stage was used to estimate the output energy of the amplifier stage. The energy of two successive shots was estimated to be 8.1 Joules and 8.45 Joules. These were the only two high energy shots made that the energy could be estimated for before the amplifier lasing tube was inadvertently broken during cleaning. Figure 32 shows the total system output pulse.

## VII. SUMMARY OF THE NPS IODINE LASER

Due to equipment limitations and the inadvertent loss of the amplifier lasing tube the output of the NPS Iodine Laser still must be maximized and verified as well as the exact pulse width determined. From the data available it can be concluded the the unit is capable of the high energy and short pulses it was intended to produce. The NPS laser has been Q-Switched and amplified; however the equipment problems involving the the Pockels cell and trigger misfire must be resolved before the system is ready for research work.

### VIII. RECOMMENDATIONS

The following are considered to be the minimum required changes to the system:

1. Replace both oscillator mirrors.
2. Repair/replace Pockels cell.
3. Separate the Pockels cell from the rear Brewster stack.
4. Replace the homemade Brewster stack with a commercial polarizer.
5. Replace the amplifier lasing tube and maintain a spare.
6. The trigger system may be simplified and its reliability improved if the preionizing of the flashlamps can be accomplished by charging the flashlamp coaxial cables with the capacitors and installing an inline inductor. When discharged this arrangement will provide a precapacitor pulse to preionize the flashlamps without the need for a separate preionizing circuit. This series injection of the preionizing pulse should be investigated to determine if it would improve the trigger system [10].
7. Upgrade the trigger system to prevent stage misfire.

## APPENDIX A

### ALIGNMENT PROCEDURE

The following procedure uses two He-Ne alignment lasers to correctly align the NPS Iodine Laser. It is possible to use only one laser; however this is considered to be less than optimum. For the following procedure refer to figure 4.

1. Install the rear alignment laser at position A and the front alignment laser at position B.
2. Remove the spherical mirror, beam expander lens, Pockels cell, Brewster stack, and top half reflector covers from both stages.
3. Turn on each alignment laser and adjust each so as to pass through the oscillator stage. Leave only the front alignment laser on.
4. Place the pinhole masks on the oscillator stage Brewster window assemblies.
5. The front alignment laser should silhouette the rear lasing tube opening so that the pinhole can be placed in the center of the opening.
6. Turn off the front laser and remove same.
7. Turn on the rear laser and adjust it so as to pass through the rear pinhole and down the oscillator stage lasing tube.
8. The front lasing tube opening should now be

silhouetted on the front pinhole mask. Place the pinhole in the center of the opening and adjust the rear laser so as to pass through both holes without reflecting inside the lasing tube. Turn off the rear laser.

9. Install the metal pinhole mask on the beam expander and amplifier stage. To install the masks on the amplifier stage, match up the corners of the mask with the scribe marks on the Brewster window assemblies.
10. Turn on the rear alignment laser and align the beam expander and amplifier stage so that the beam passes through all pinholes without reflecting inside the stages. Do not change the position of the alignment laser since it has already been aligned to the oscillator stage.
11. Align target and detectors. Mark the position of the alignment beam at the target end for later reference.
12. The beam expander lenses may steer the beam off target if the beam expander is not exactly aligned. Therefore the position of the alignment beam at the target must be checked when the lenses of the beam expander are in place. Install beam expander lenses.
13. Readjust beam expander so that the beam is again at the same position on target as previously observed.
14. Install the front alignment laser at position B and turn on laser.
15. Place the Pockels cell at position C and tape the Brewster stack to the rear oscillator Brewster window.
16. Readjust the rear alignment laser so as to pass through the pinholes.
17. Turn off the rear alignment laser.

18. Turn on the front alignment laser.
19. Adjust the front alignment laser so as to pass through all pinholes without reflecting.
20. Turn on the cell power supply and adjust the HV control so that 3.8KV is applied to the cell.
21. Place the power meter to the rear of the Pockels cell.
22. Adjust the Pockels cell so that a minimum in the transmitted beam is achieved.
23. Turn off the front alignment laser.
24. Turn on the rear alignment laser.
25. Readjust the rear alignment laser so as to pass through the pinholes.
26. Turn on the front alignment laser.
27. Turn off the Pockels cell HV.
28. Place a microscope slide to the rear of the Pockels cell aligned to reflect down the beam from the front alignment laser. Note the position of the spot. Turn off the laser.
29. This step is best performed in the dark with a white sheet of paper placed where the beams are to be reflected. Adjust the output mirror so that the beam from the rear alignment laser is reflected back through the pinholes. A faint spot will appear below the microscope slide near where the beam from the front laser was reflected to.
30. Turn on the front laser beam and adjust the laser so that the spot from the front beam coincides with the spot from the rear beam. To distinguish between spots interrupt the front beam since it is the brightest.

The alignment lasers are now parallel and co-axial.

31. Turn off the rear alignment laser and remove same.
32. Remove the microscope slide.
33. Place the spherical mirror just behind position C as marked and clamp down.
34. Place a microscope slide at position D so as to reflect down the reflected beam.
35. Adjust the spherical mirror to reflect the front beam back through the pinholes. As in step 28, a spct of light will appear when the mirror is aligned.
36. Remove the pinhole masks. Remove any other alignment aids.
37. Install safety covers without disturbing laser components.
38. Adjust the Pockels cell power supply so that 7.8KV is applied to the cell.
39. Turn off the Pockels cell power supply.

## APPENDIX B

### FLASH LAMP FILL PROCEDURE

In the following procedure, valves labelled a,b imply that the step is to be applied to each stage independently. "a" refers to the oscillator stage while "b" refers to the amplifier stage. To increase vacuum system pumping speed, close valves 6a,b and 3a,b on the system not being filled. Valve one is the high vacuum valve on the vacuum system. This procedure assumes the flashlamps have been evacuated to  $10^{-6}$  torr. Refer to figure 18 for the following procedure.

1. The xenon supply regulator should be set at 1 psi with the tank pressure above 1 psi and with the tank valve closed. If the tank pressure is zero with the tank valve secured, the line must be purged; open the tank valve momentarily; close valve 1; open valve 2 momentarily; rough down the system; close the roughing valve.
2. Close valves 3a, 3b, 4a, 4b 6a, 6b
3. If a positive pressure of at least 5 psi is indicated on the tank side of the regulator with the tank valve secured, open valve 2 momentarily.
4. Open valve 3a and adjust valve 4a for a slow fill.
5. Close valve 3a when the desired flashlamp pressure has been reached.
6. Repeat for the amplifier stage (valves labeled b).

7. Evacuate the vacuum lines.
8. To empty the flashlamps open valves 3a,b and 4a,b with the vacuum system set up for roughing, then use the diffusion pump to obtain a high vacuum.

## APPENDIX C

### LASER FILL PROCEDURES

In the following procedure, valves labelled a,b imply that the step is to be applied to each stage independently. "a" refers to the oscillator stage while "b" refers to the amplifier stage. To increase vacuum system pumping speed, close valves 6a,b and 3a,b on the system not being filled. Refer to figure 16. These procedures assume the flashlamps have been evacuated to  $10^{-6}$  torr.

#### A. INITIAL FILL

1. Close valves 6a,b and 8a,b.
2. Close valves 7a,b.
3. Remove the purification tank above valve 7a,b.
4. Install an enlarging coupling above valve 7a,b on the tank so that the liquid  $C_{37}F I$  may be poured in.
5. In a hood fill the coupling above valve 7a,b with  $C_{37}F I$ .
6. Slowly crack valve 7a,b to allow the liquid to be drawn in. Do not draw air. Repeat until one bottle of  $C_{37}F I$

( 28grams ) is in the tank.

7. Remove the coupling and reinstall the tank in the laser.

#### B. LASER FILL

1. Open valve 6a,b.
2. Place a dewar around the purification tank and fill with liquid nitrogen. Allow 15 minutes before proceeding.
3. Open valve 7a,b and evacuate to  $10^{-6}$  torr.
4. Open valve 8a,b.
5. Close valve 6a,b.
6. Remove dewar and heat the tank using a hot air gun.
7. When the pressure drops to operating pressure, close valves 8a,b and 7a,b.
8. Open valve 6a,b.
9. Start pump.
10. Adjust refrigeration system to desired temperature (there is a one hour settling time for the refrigeration systems).

#### C. SECURING

1. Close valve 10a,b.
2. Close valve 9a,b.

3. Stop pump.
4. Place a dewar around the purification tank and fill with liquid nitrogen. Allow 15 minutes before proceeding.
5. Open valves 8a,b and 7a,b. Wait for a pressure drop to less than one torr as read on the pressure gage mounted on each stage.
6. Open valve 6a,b and evacuate the system to  $10^{-6}$  torr.
7. Close valve 7a,b.

D. LASER INTERNAL REFILL

1. Close valve 8a,b and open valves 9a,b and 10a,b.

E. ARGON ADD

1. Secure the vacuum system valves.
2. Close valve 6a,b.
3. Open valve 5 momentarily (the same conditions as those for the xenon supply apply to the argon supply).
4. Close valve 7a,b and open valve 8a,b.
5. Bleed the argon into the laser using valve 6a,b.
6. Close valve 8a,b when the desired pressure has been reached.
7. Open valve 6a,b.
8. Evacuate the vacuum lines.

## F. PURIFICATION

1. When laser output shows degradation, place a dewar around the purification tank and fill with liquid nitrogen. Allow 15 minutes before proceeding.
2. Close valve 6a,b.
3. Open valves 7a,b and 8a,b.
4. When laser pressure drops to less than one torr as indicated on the pressure gage mounted on each stage, open valve 6a,b. and evacuate the system to  $10^{-6}$  torr.
5. Close valve 7a,b.

## APPENDIX D

### SYSTEM OPERATING PROCEDURES

#### A. START UP

The following procedures outline the steps to be taken to bring the laser up to firing ready, and the securing of the laser system. They assume that the high vacuum system is on and ready for use, the alignment is satisfactory, the flashlamps have been filled to the desired level, and the  $C_{F,I}$  is in the reservoir at the proper temperature with the  $C_{37}$  circulation pump on.

1. Check the local microammeter for charge. IF THE CAPACITORS ARE CHARGED A FATAL ELECTRIC SHOCK MAY OCCUR.
2. Open capacitor boxes and apply shorting bar to the capacitor being worked on.
3. Check for loose equipment and shorts along the discharge cables.
4. Turn on the nitrogen tank with the regulator set for 40 psi and allow the nitrogen flow through the spark gaps for one minute. Repeat every four hours of operation.
5. Turn on circuit breaker "10" located as in figure 4.

6. Turn on the auxiliary power circuit breaker located on the bottom panel of the main power supply.
7. Turn on the high voltage trigger power and filament switches located low on the HV trigger cabinet.
8. When the ready light indicates high voltage on, adjust the high voltage to 14 KV.
9. Turn on circuit breaker "8" located on the outside south end of the dark room.
10. Turn on the circuit "8" switch located as shown in figure 4.
11. Turn on control power and pulse generator.
12. Set the pulse generator period/delay switch to period and set the time selector controls to five seconds.
13. Observe the spark gap trigger for a clean sharp spark. THE HV TRIGGER USES A 5:1 STEP UP TRANSFORMER TO GENERATE THE SPARK GAP TRIGGER AND PREIONIZING PULSE. IF CONTACT IS MADE WITH EITHER OF THESE CIRCUITS, WITH THE HV TRIGGER TURNED ON A SERIOUS INJURY MAY RESULT. THEREFORE A TECHNICIAN MUST BE PRESENT WHILE WORK IS BEING PERFORMED ON THE TRIGGER SYSTEM.
14. Observe the preionizing of the flashlamps. (BEST PERFORMED IN THE DARK)
15. When all the above checks are satisfactory, remove the shorting bar and close capacitor boxes.
16. Turn on fan, rectifier, filament, and HV circuit breakers on the power supply. Set the HV limit to 25KV or less. THE CAPACITORS ARE 25KV UNITS; HOWEVER A SAFETY LIMIT OF 20KV HAS BEEN USED FOR THE CAPACITORS.
17. Press start button on the main power supply. WHEN MAIN POWER HIGH VOLTAGE IS ON THE LASER SAFETY COVERS

MUST BE IN PLACE AND CAPACITOR BOXES CLOSED. (THIS LASER CAN KILL.)

18. When the HV ready light comes on , press the HV on button and set the HV control for 20KV.
19. Turn on diagnostic equipment and set the pulse generator to delay.
20. Set the Pockels cell power supply to apply 7.8KV to the cell.
21. Set in an 11 microsecond delay on the oscillator channel of the delay generator and adjust the Pockels cell controller so that the sample pulse appears 23 microseconds after the oscillator preionizing pulse. SAFETY GLASSES MUST NOW BE WORN. AVOID LOOKING DIRECTLY IN TO THE LASER BEAM OR AT THE FLASHLAMPS. EYE DAMAGE MAY OCCUR.

\*\*\*\*\* THE LASER IS NOW READY TO FIRE. \*\*\*\*\*

22. Press the charge button. The laser charge voltage may be controlled by using the hold controls. The laser will fire in or out of hold.
23. Use a three number count down prior to firing and announce "FIRE" to lab personel. Then press the fire button. DO NOT LOOK AT THE LASER DURING FIRING.

B. SECURE

1. Turn all HV controls to zero.
2. Turn off trigger power and filament switches.

3. Turn off main power HV.
4. Press main power stop.
5. Turn off HV, fan, auxiliary, rectifier, and circuit "10" breakers.
6. Turn off diagnostics and Pockels cell power supply.
7. Turn off the control stand and pulse generator units.
8. Turn off circuit "8" switch and breaker.

## APPENDIX E

### MAINTENANCE REQUIREMENTS

- A. The following steps should be accomplished daily.
  - 1. Readjust trigger spark visually using screwdriver adjustment. DO NOT PUSH TRIGGER BUTTON WHILE IN CONTACT WITH SCREWDRIVER.
  
- B. The following steps should be accomplished after approximately 400 firings.
  - 1. Clean the elements of the spark gap using Kimwipes and ethyl alcohol. Ensure all alcohol vapors are removed from spark gap before firing.
  
- C. The following steps should be accomplished after approximately 1000 firings.
  - 1. Remove the Brewster windows and clean.
  - 2. Clean the lasing tube using Kimwipes as swabs.

APPENDIX F

ILLUSTRATIONS

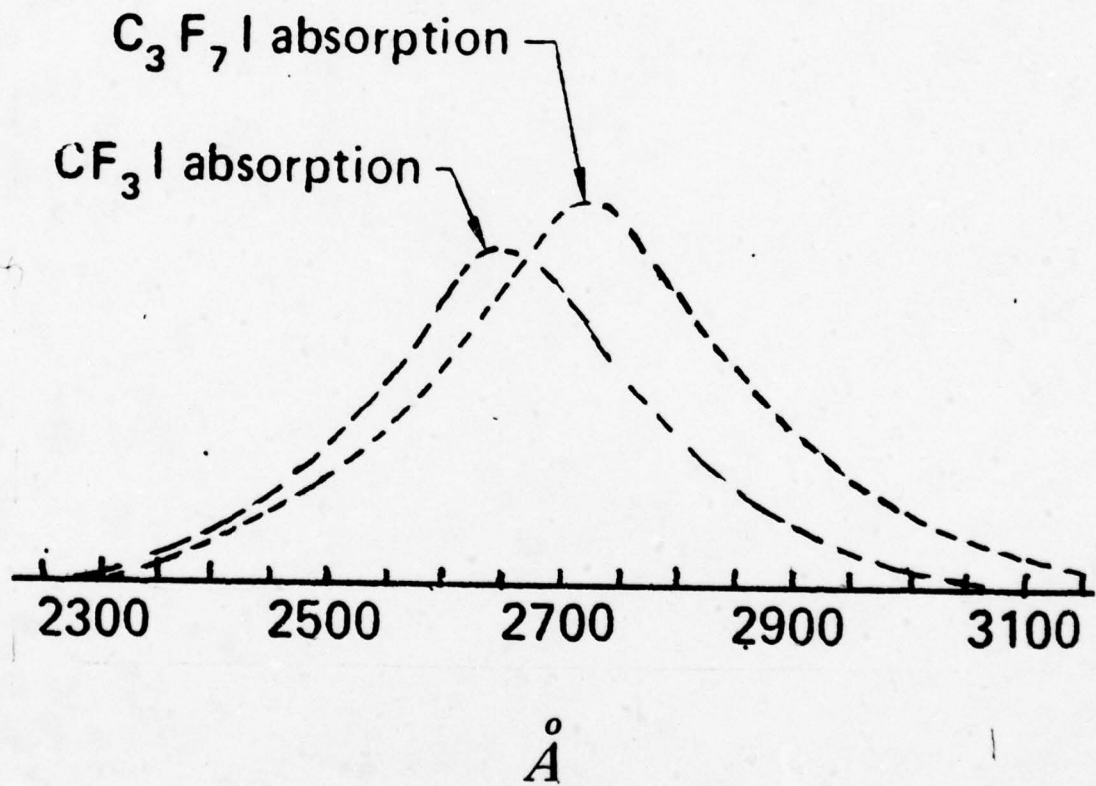

Figure 1 - ABSORPTION SPECTRUM

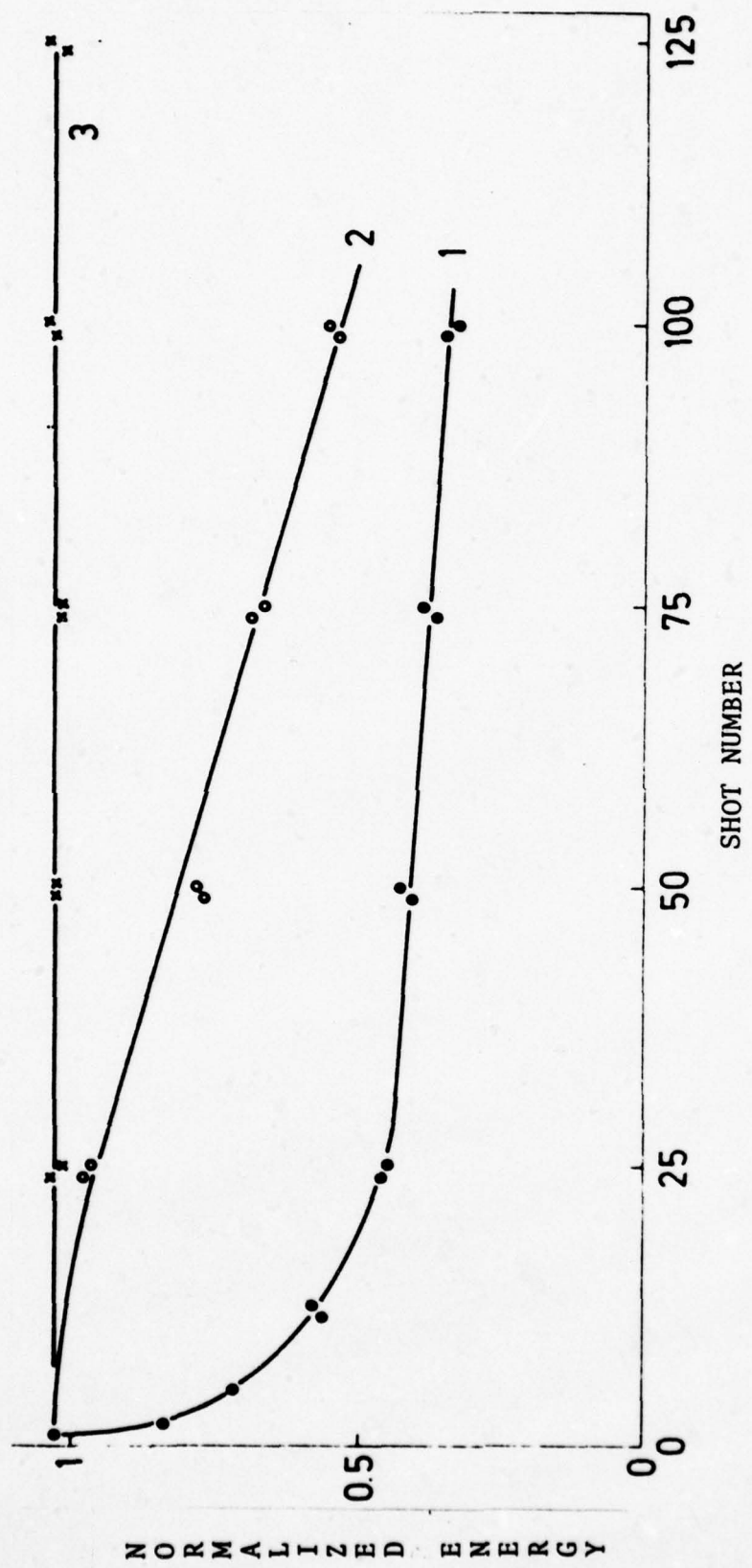

Figure 2 - LASER ENERGY AS A FUNCTION OF PULSE NUMBER; 1. WITHOUT I<sub>2</sub> PRECIPITATION, WITHOUT IODIDE REPLACEMENT; 2. WITH I<sub>2</sub> PRECIPITATION, WITHOUT IODIDE REPLACEMENT; 3. WITH I<sub>2</sub> PRECIPITATION, WITH IODIDE REPLACEMENT. [4]

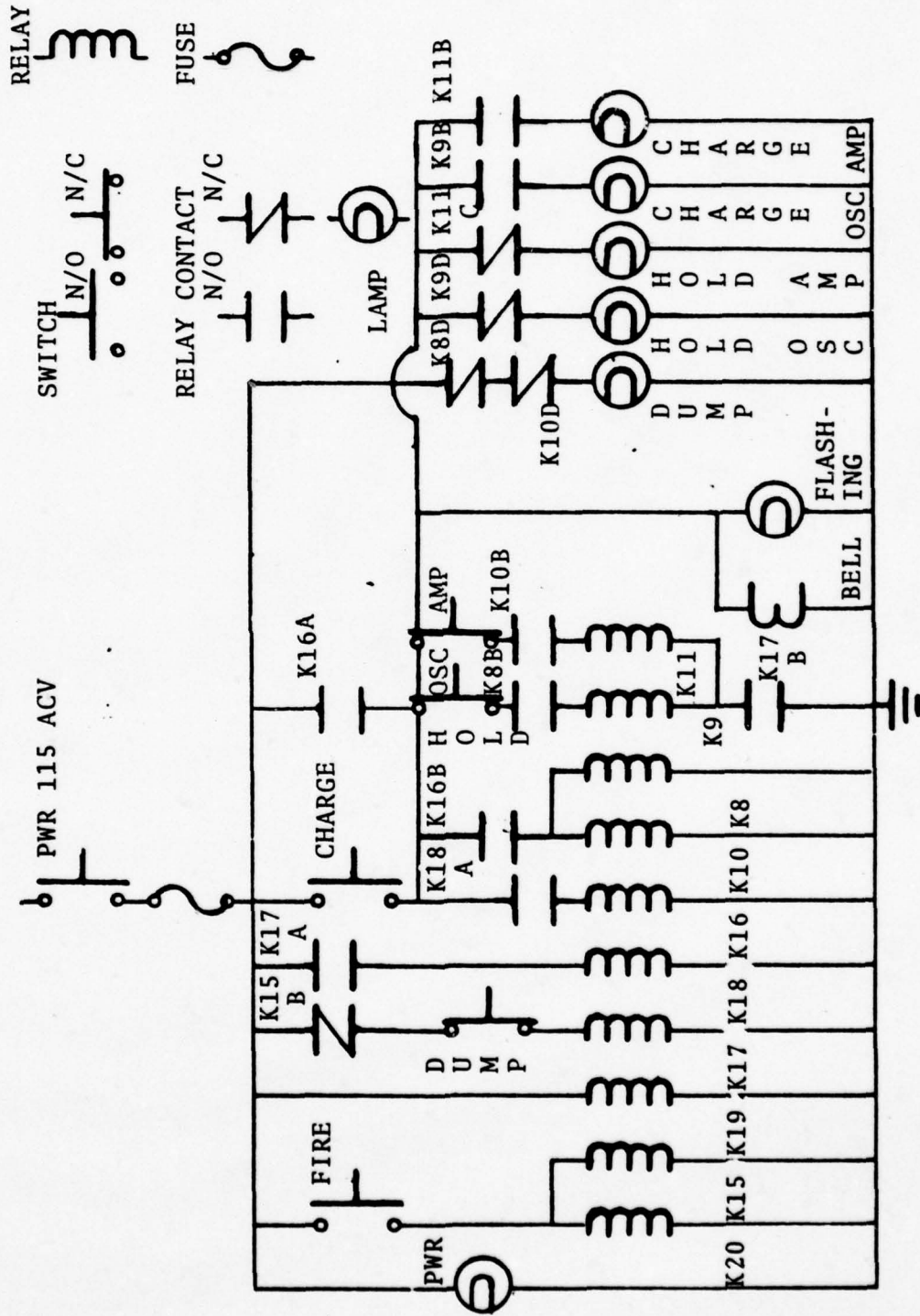

Figure 3 - CONTROL PANEL RELAY LOGIC

- 1. REFRIGERATION SYSTEM
- 2. PURIFICATION TANK
- 3. PUMP
- 4. POCCKELS CELL CONTROLLER
- 5. POCCKELS CELL
- 6. ALIGNMENT LASER
- 7. Xe SUPPLY
- 8. Ar SUPPLY
- 9. PULSE SHAPE SENSOR
- 10. ENERGY SENSOR
- 11. BEAM SPLITTER

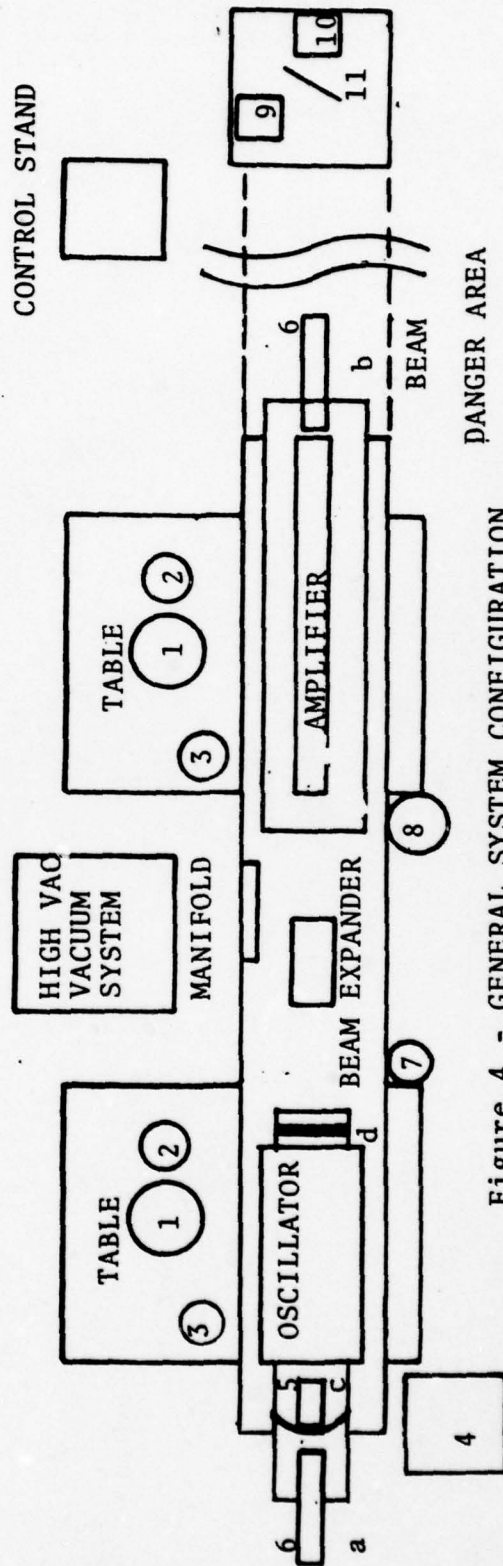
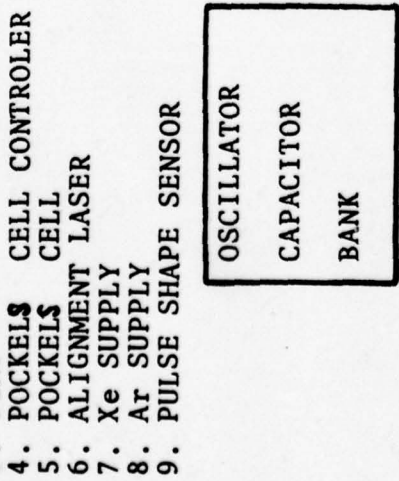
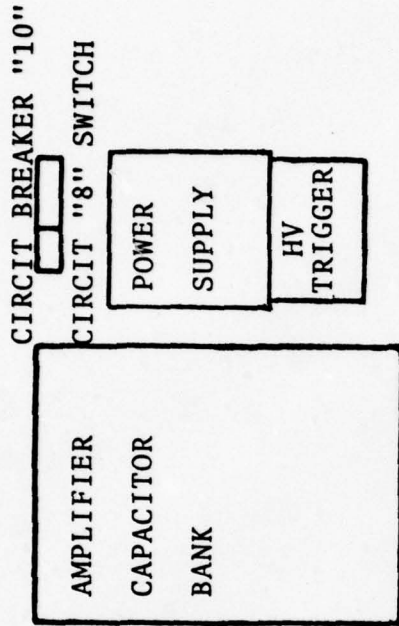

Figure 4 - GENERAL SYSTEM CONFIGURATION

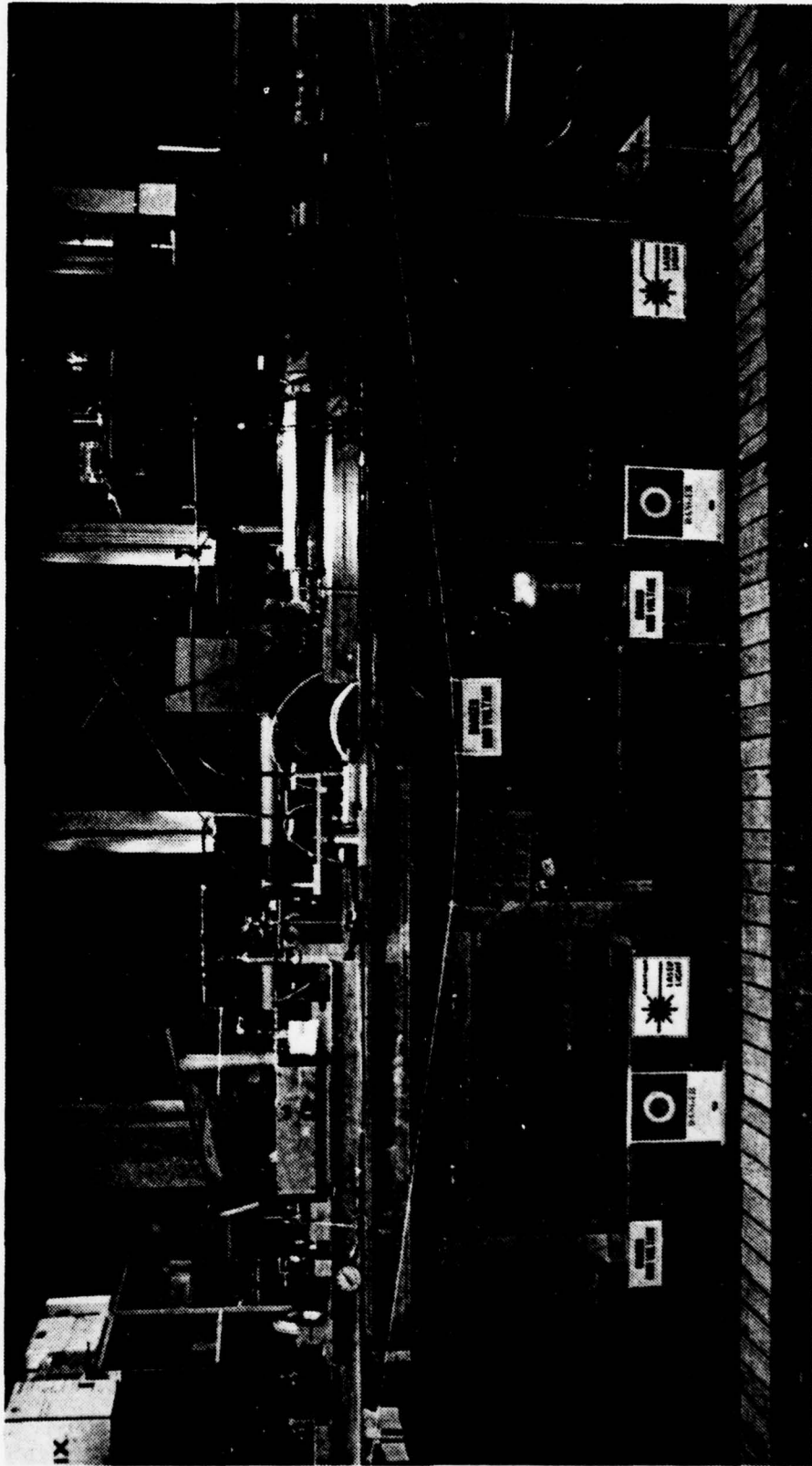

Figure 5 - LASER SYSTEM WITHOUT SAFETY COVERS

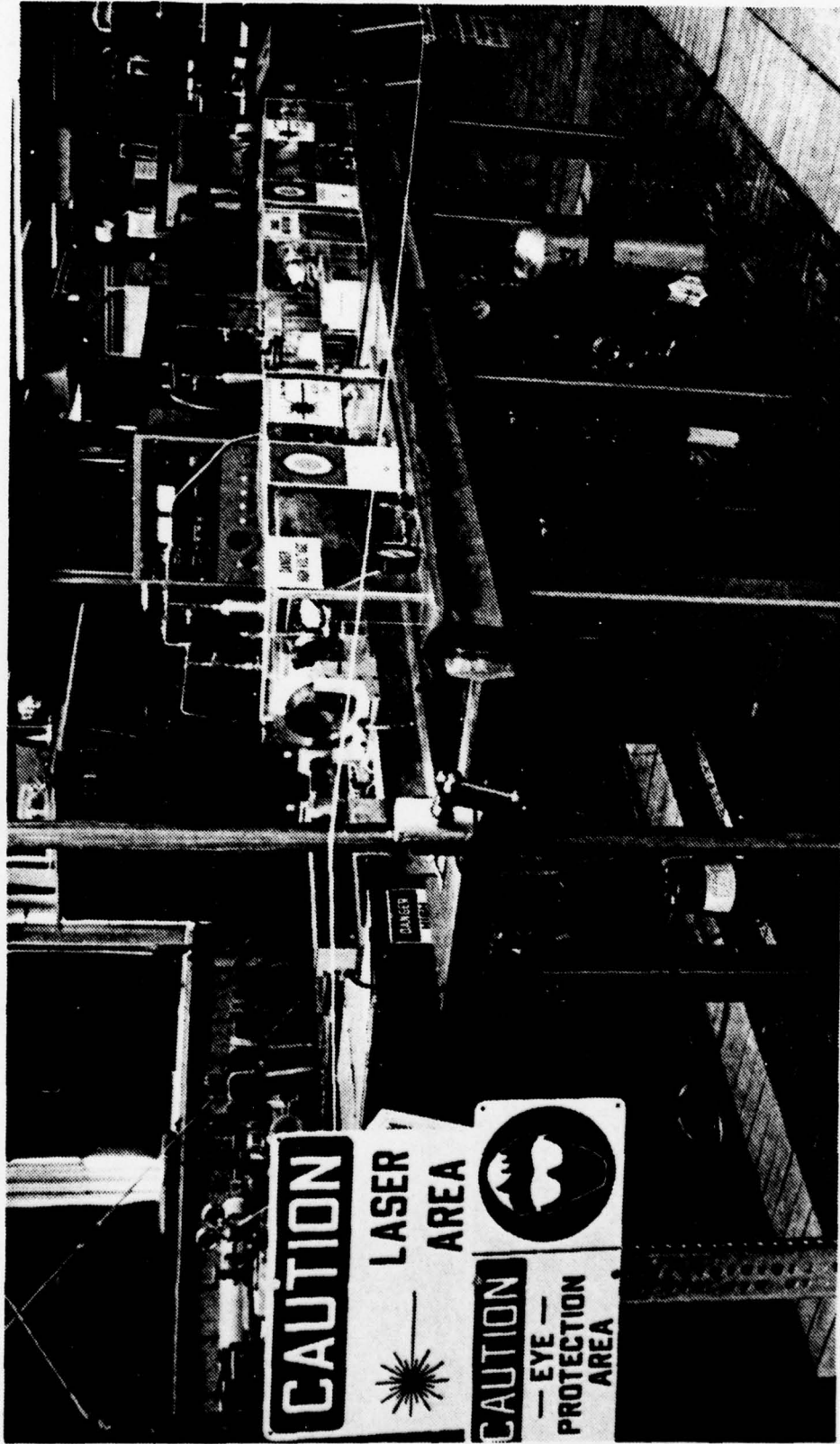

Figure 6 - LASER SYSTEM WITH SAFETY COVERS

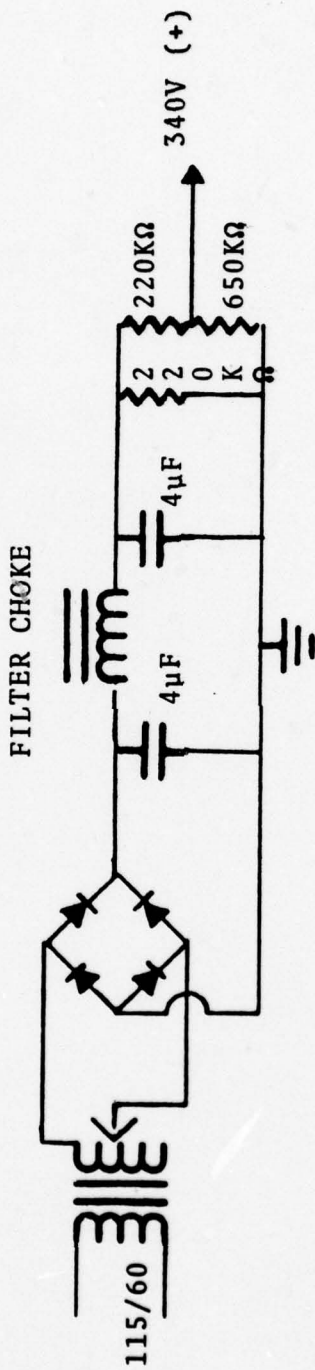

Figure 7 - 340V POWER SUPPLY SCHEMATIC



Figure 8 - CONTROL STAND

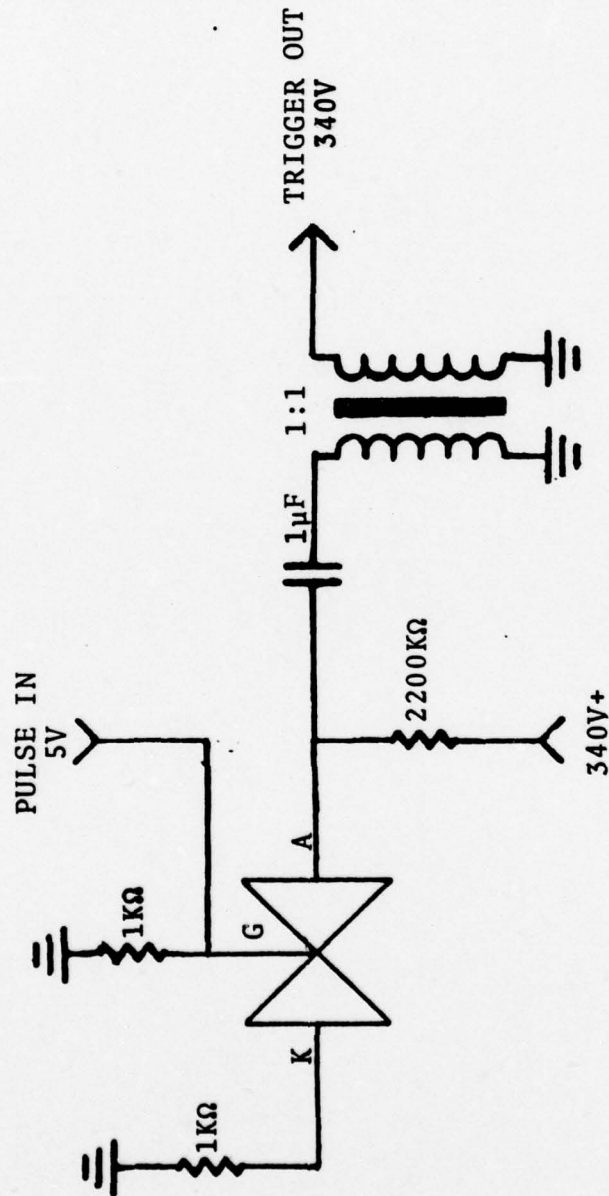

Figure 9 - SECOND STAGE TRIGGER SCHEMATIC

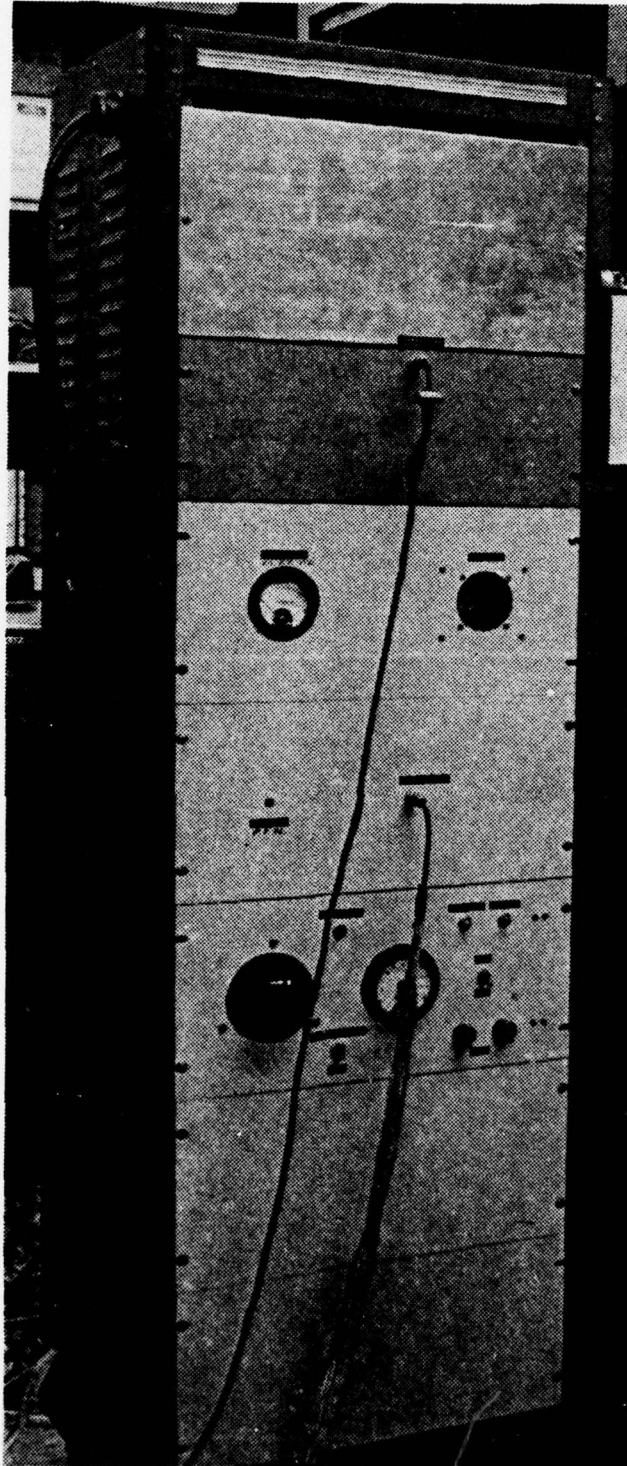

Figure 10 - HV TRIGGER CABINET

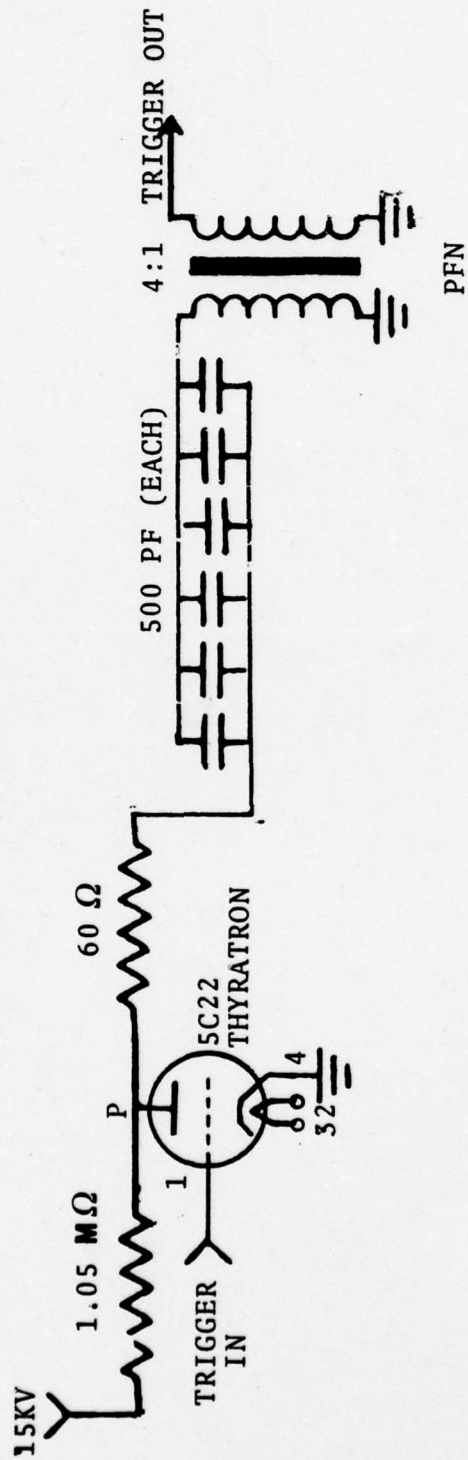

Figure 11 - THIRD STAGE TRIGGER SCHEMATIC

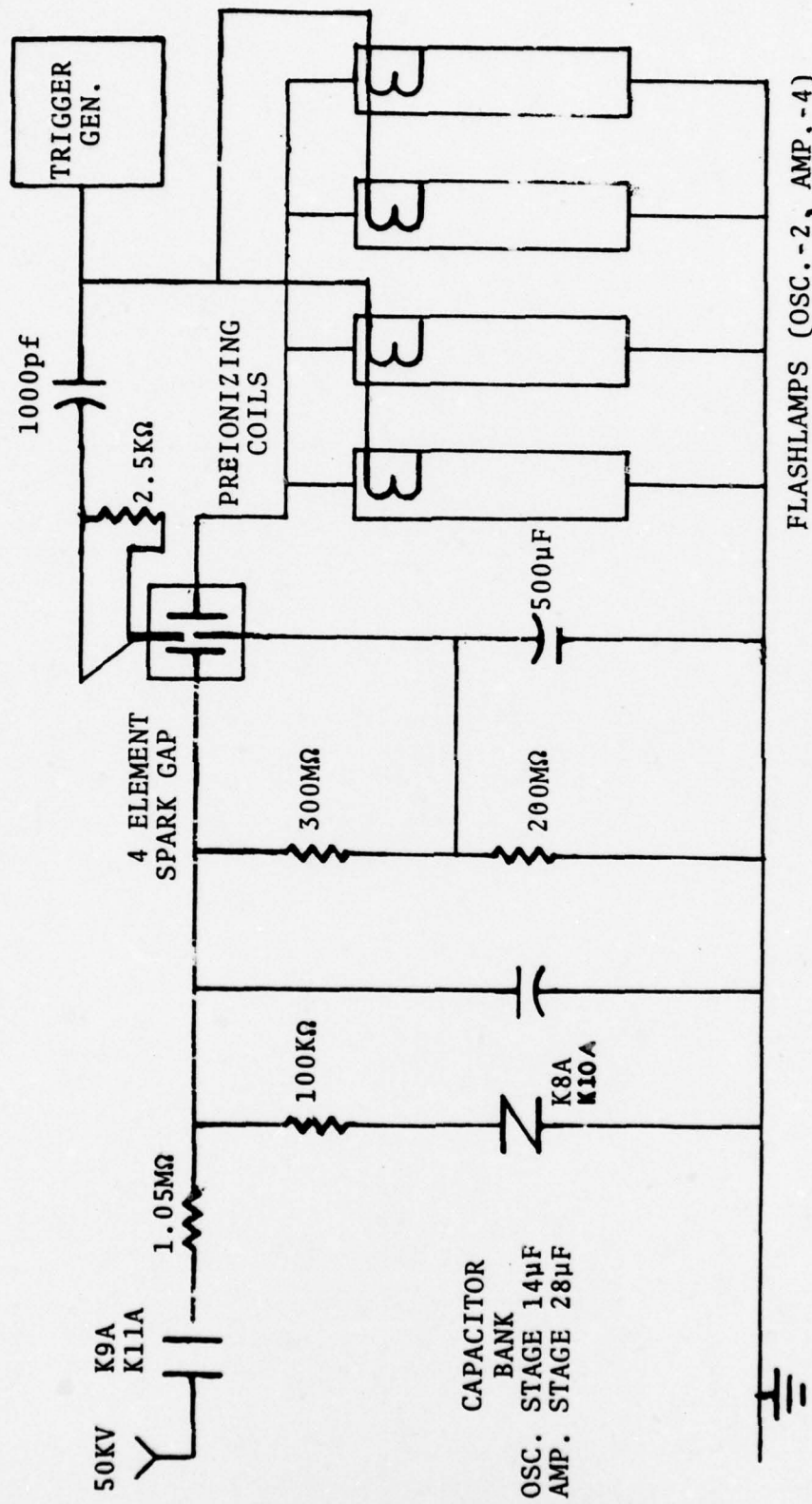

Figure 12 - CAPACITOR CHARGE AND DISCHARGE SYSTEM

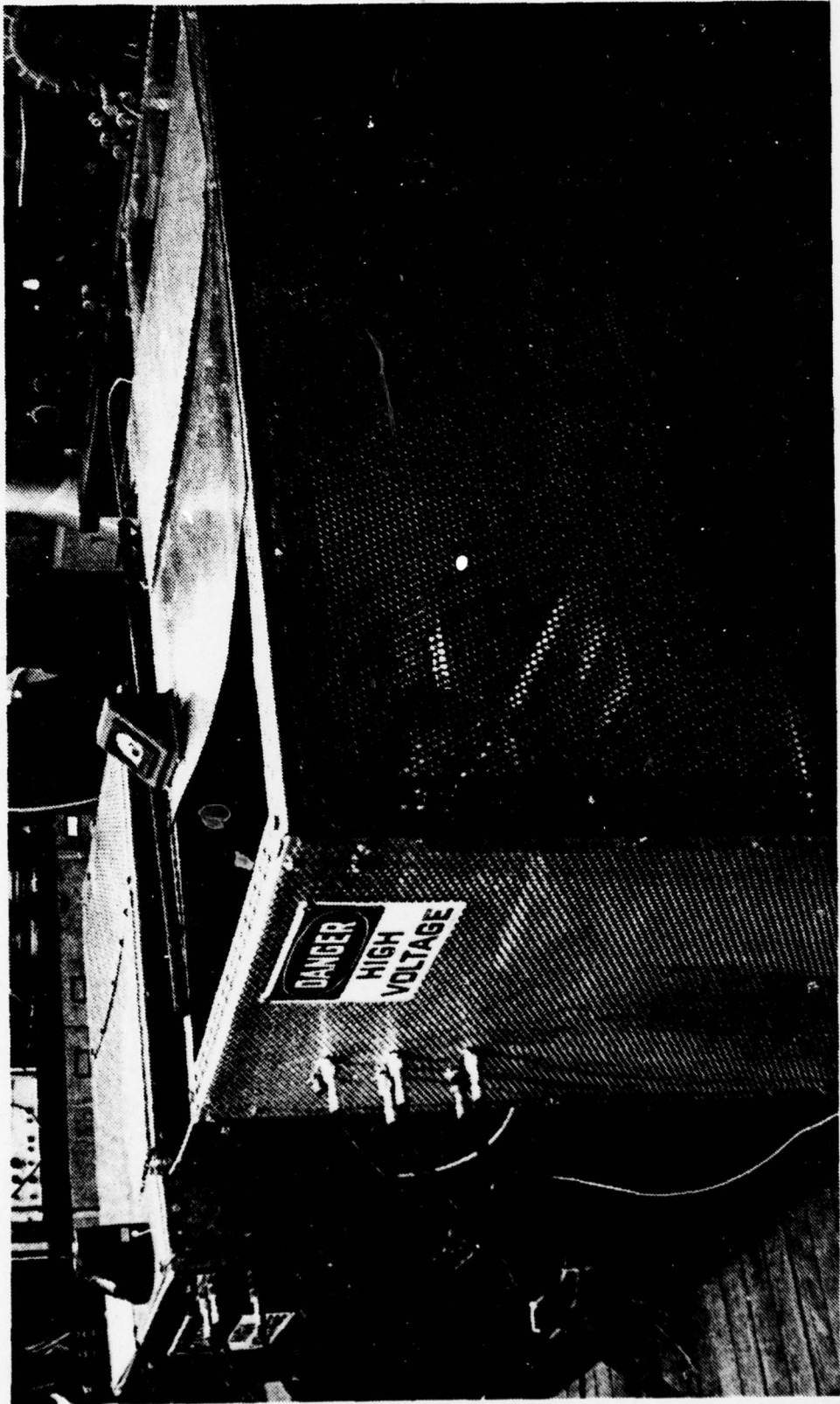

Figure 13 - CAPACITOR BOXES

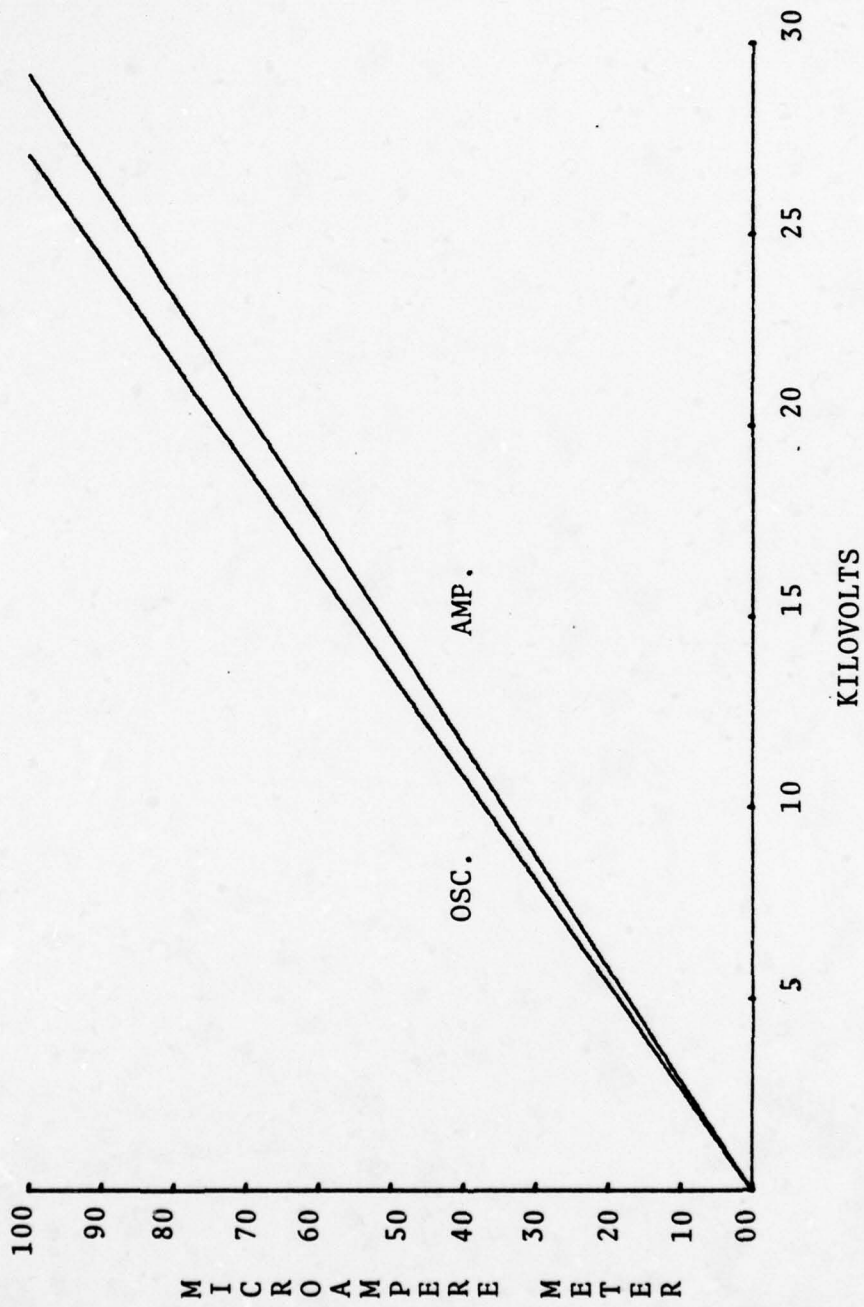

Figure 14 - MICROAMPERE METER VOLTAGE CALIBRATION CHART

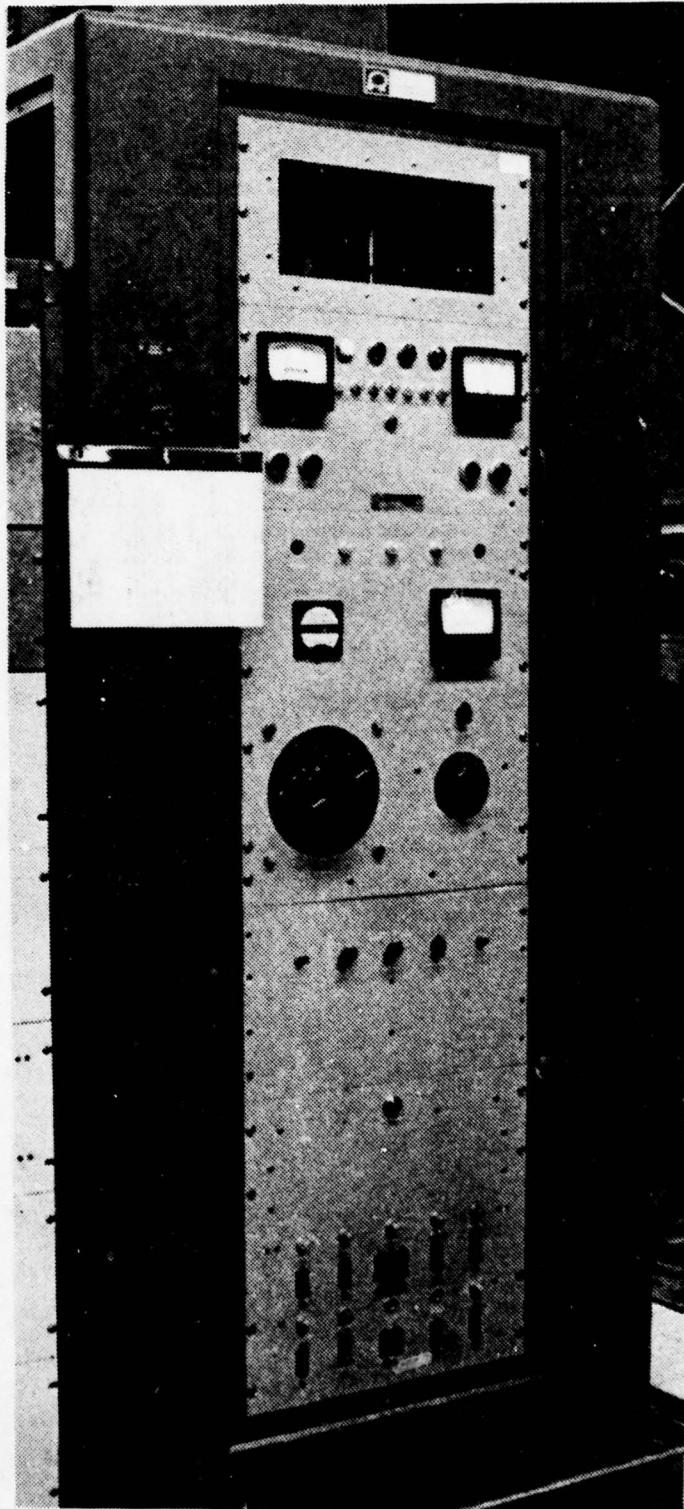

Figure 15 - MAIN POWER SUPPLY

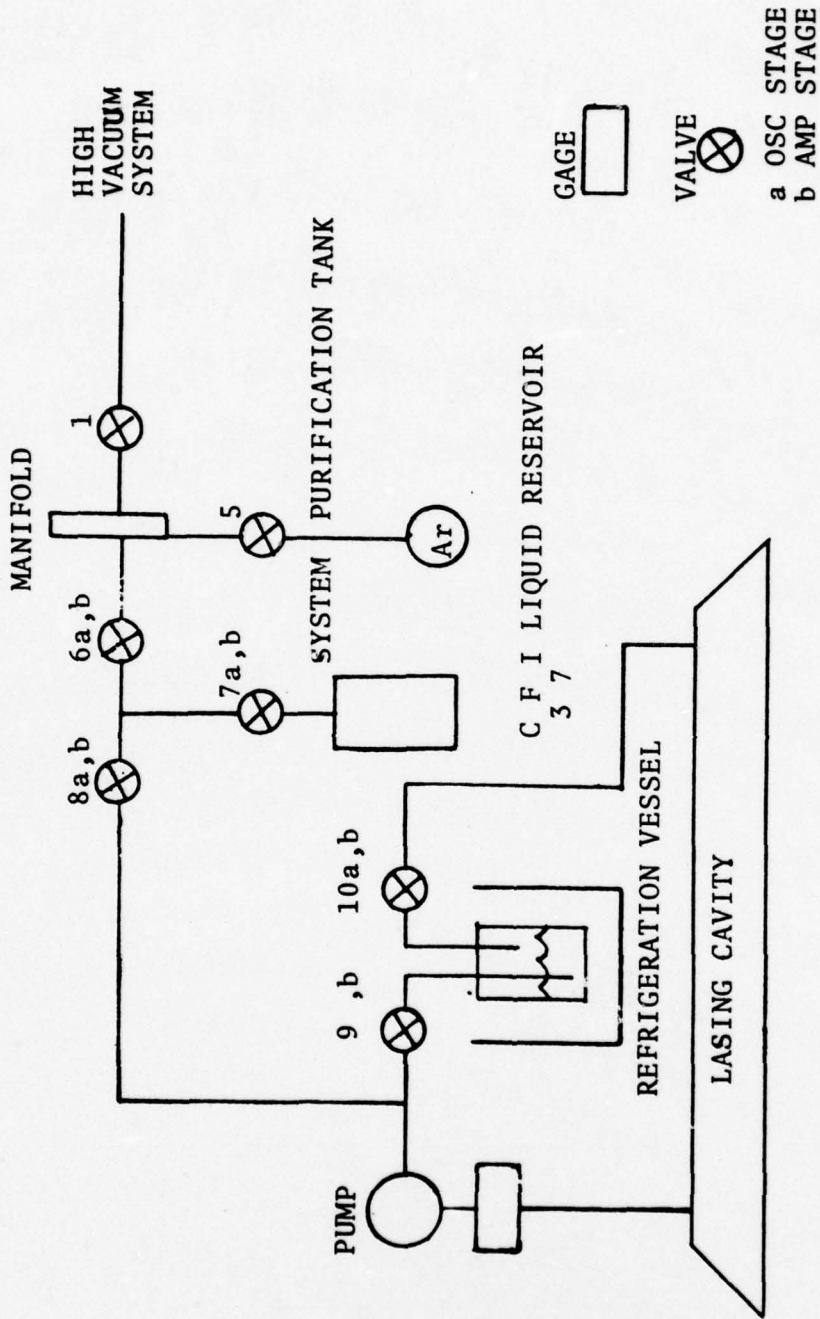

Figure 16 - PURIFICATION AND REPLENISHMENT SYSTEM

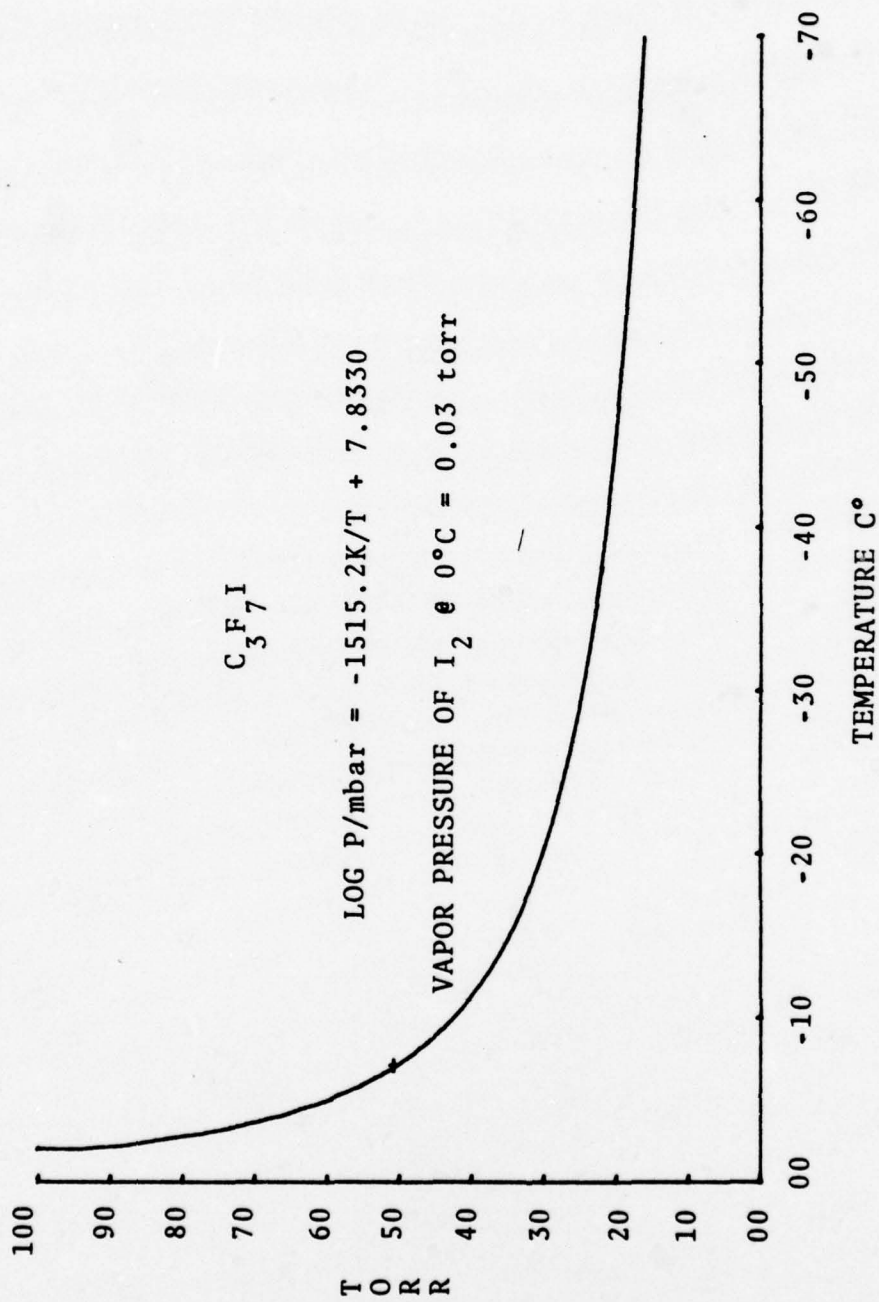

Figure 17 -  $C_3F_7I$  PARTIAL PRESSURE TEMPERATURE DEPENDANCE

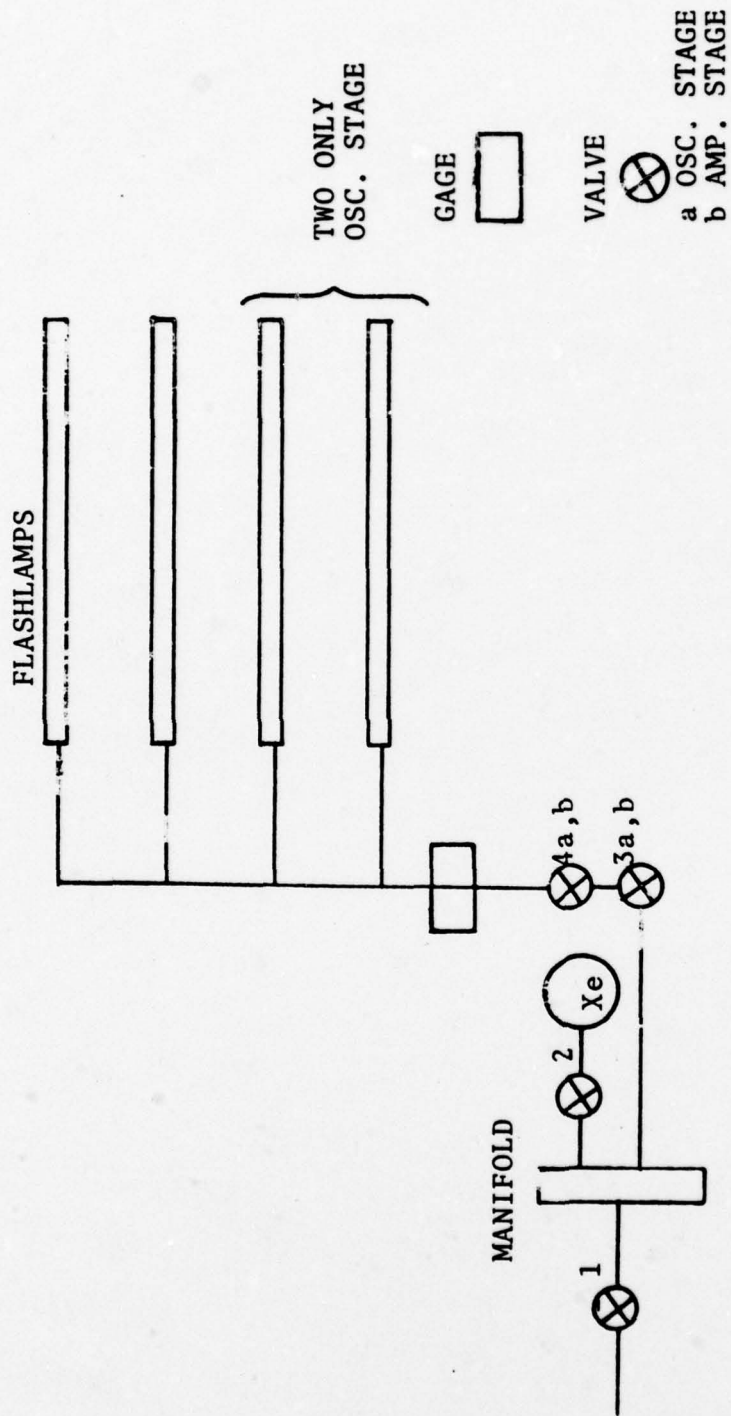

Figure 18 - FLASHLAMP FILL SYSTEM

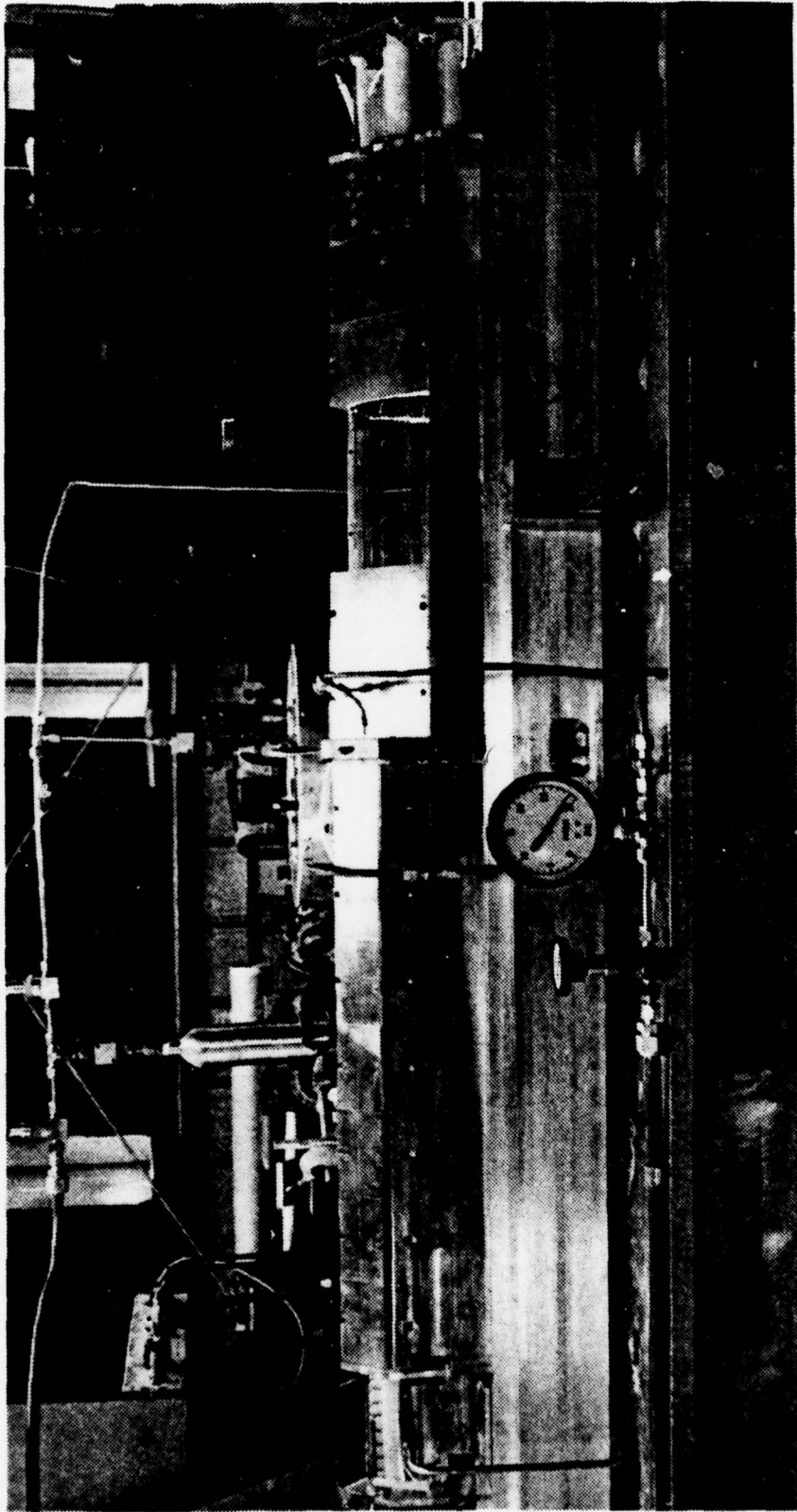

Figure 19 - AMPLIFIER FLASHLAMP REFLECTOR

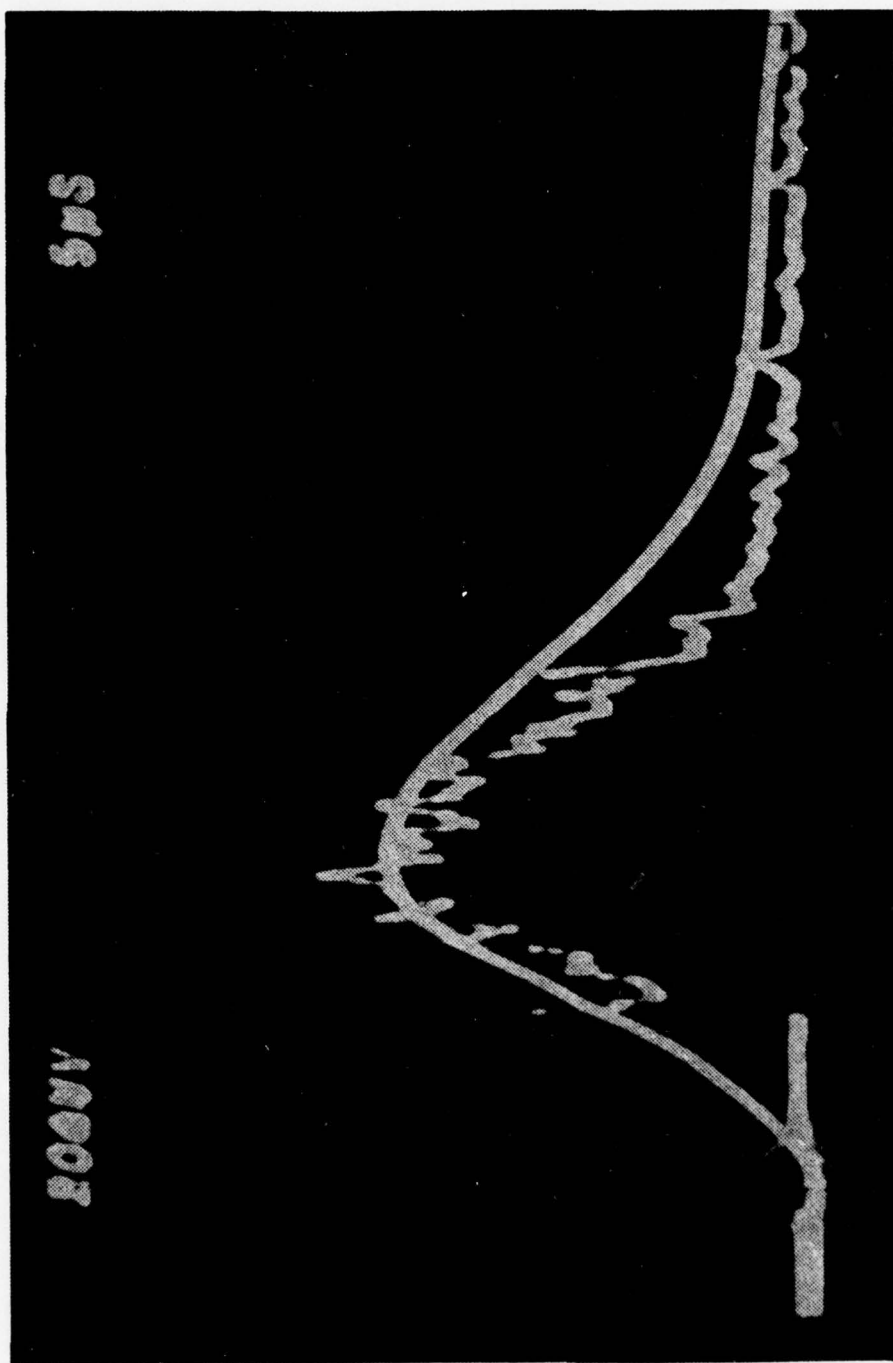

Figure 20 - "FREE RUNNING" OSCILLATOR AND FLASHLAMP PULSE (smooth curve flashlamp pulse, 60 torr  $C_3F_7I$ , sweep  $5\mu s/div.$ )

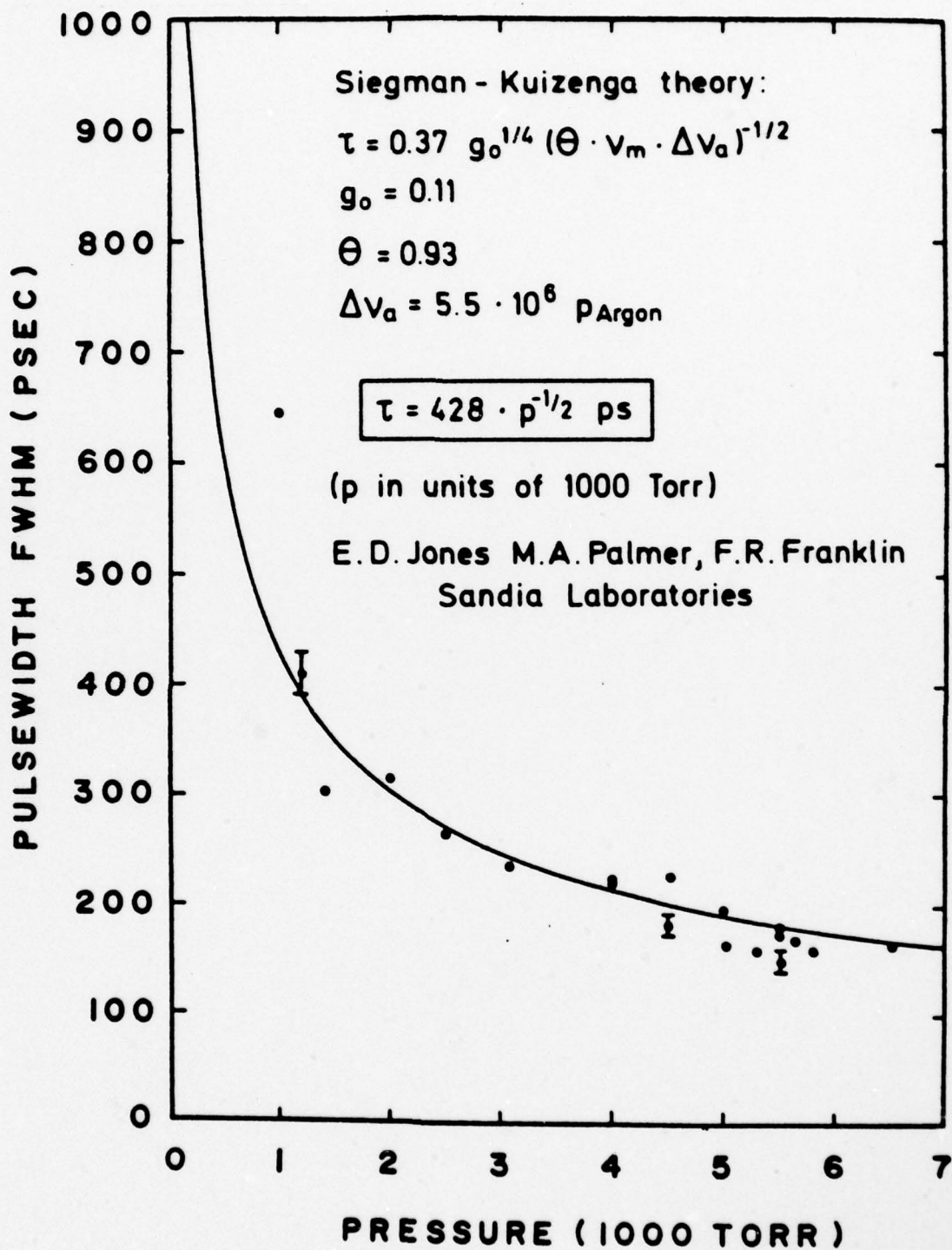

Figure 21 - PULSE WIDTH DEPENDENCE ON TOTAL CELL PRESSURE

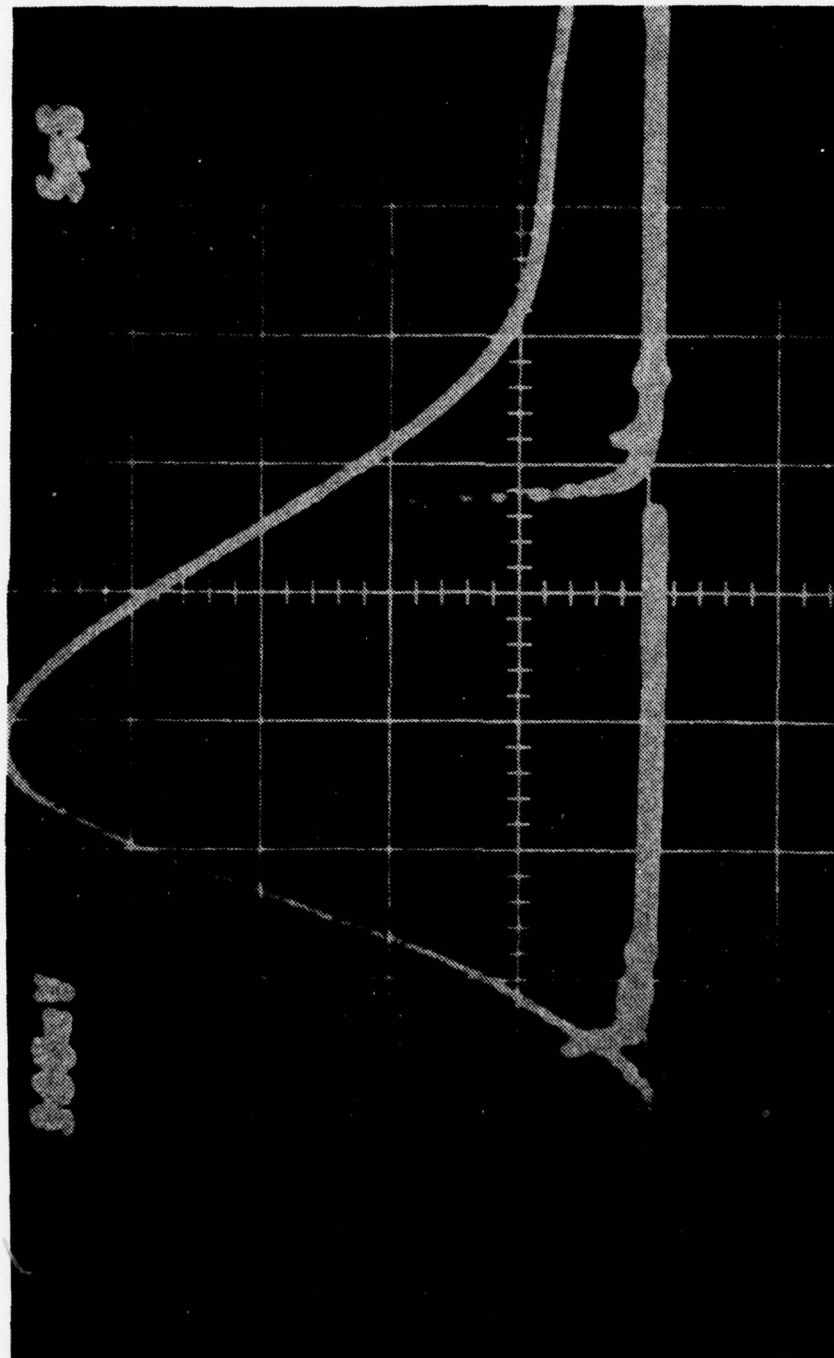

Figure 22 - OSCILLATOR GIANT PULSE AND FLASHLAMP PULSE (smooth curve flashlamp pulse, oscillator cell pressure = 710 torr, argon with 60 torr  $C_3F_7I$ , sweep  $5\mu s/div.$ )

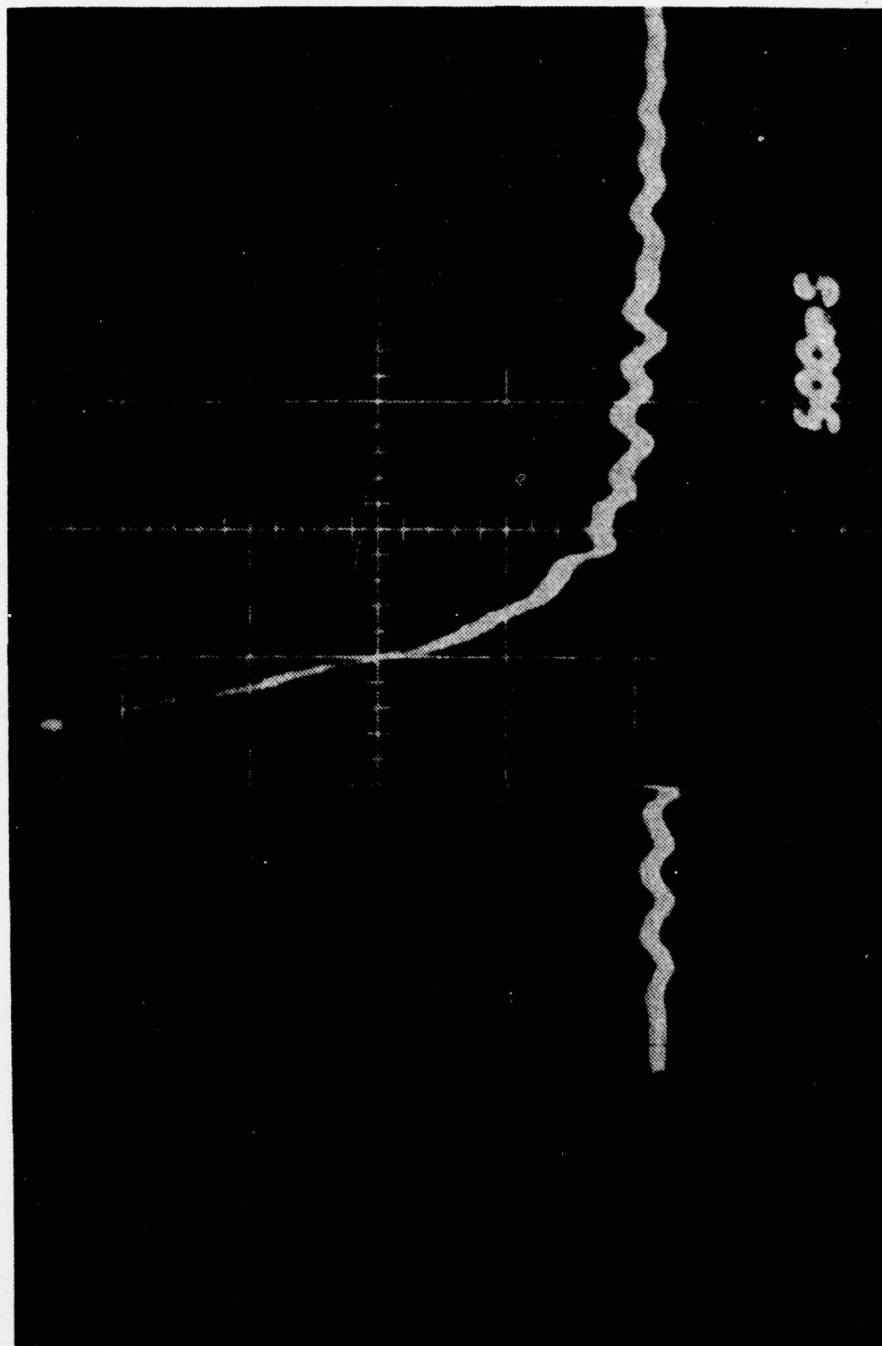
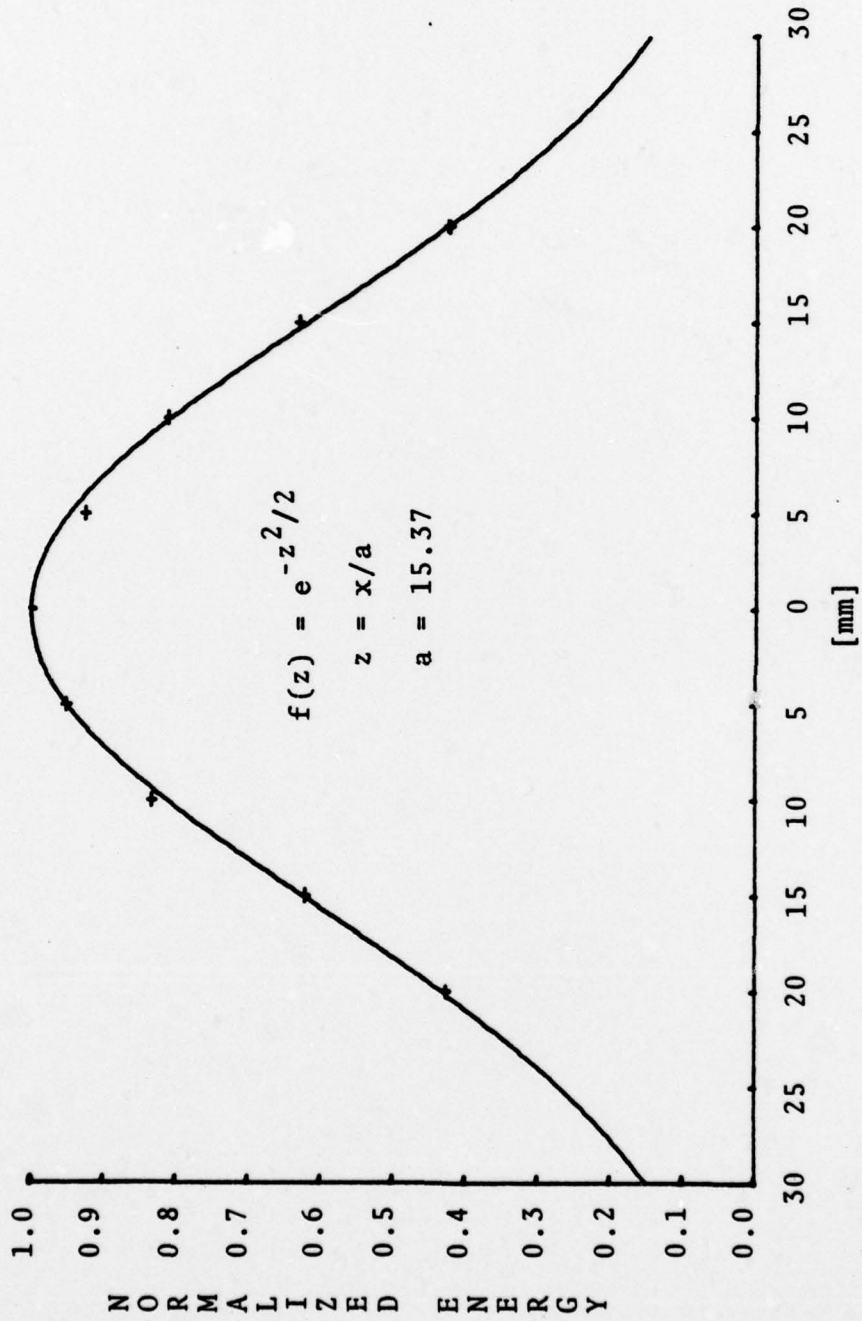

Figure 23 - OSCILLATOR GIANT PULSE (total oscillator cell pressure = 710 torr,  
argon with 60 torr  $C_3F_7I$ , sweep 500ns/div.)



RELATIVE POSITION IN THE LASING BEAM

Figure 24 - PULSE ENERGY DISTRIBUTION PLOT

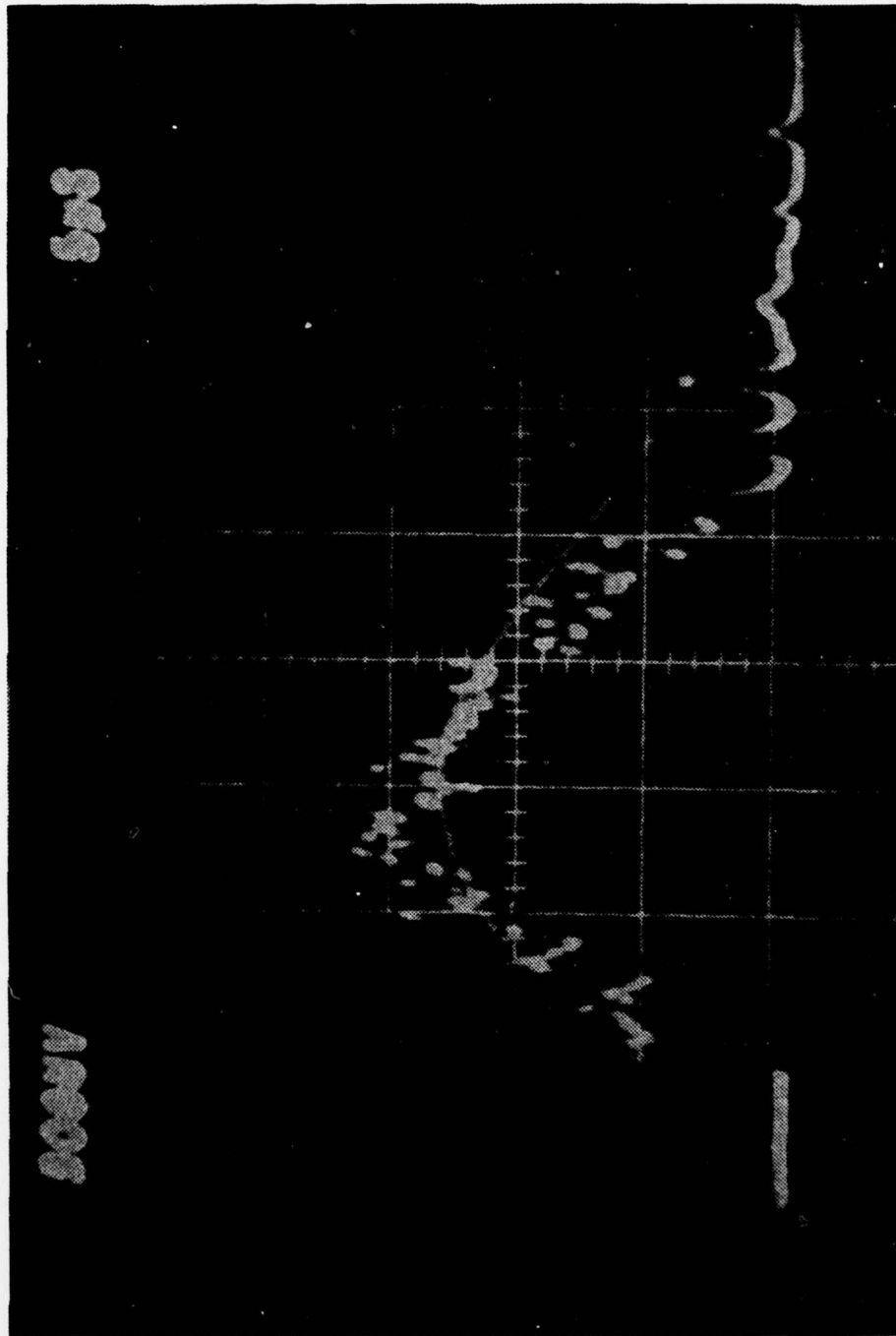

Figure 25 - "FREE RUNNING" TOTAL SYSTEM OUTPUT AND AMPLIFIER FLASHLAMP PULSE (smooth curve flashlamp pulse, 60 torr C<sub>3</sub>F<sub>7</sub>I, sweep 5 $\mu$ s/div.)

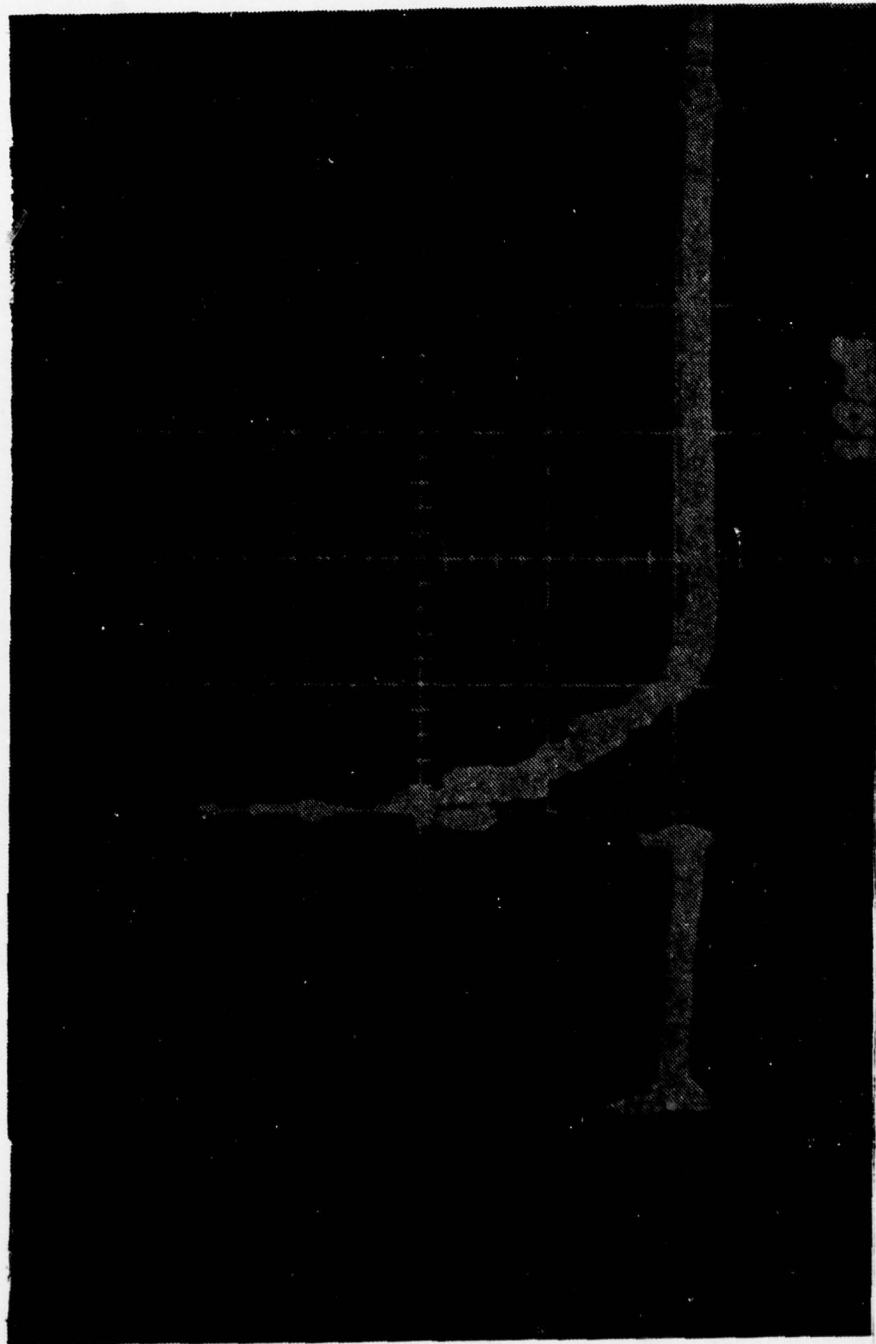

Figure 26 - Q-SWITCHED TOTAL SYSTEM OUTPUT (total amplifier cell pressure = 160 torr,  
argon with 60 torr C<sub>3</sub>F<sub>7</sub>I, sweep 10 $\mu$ s/div.)

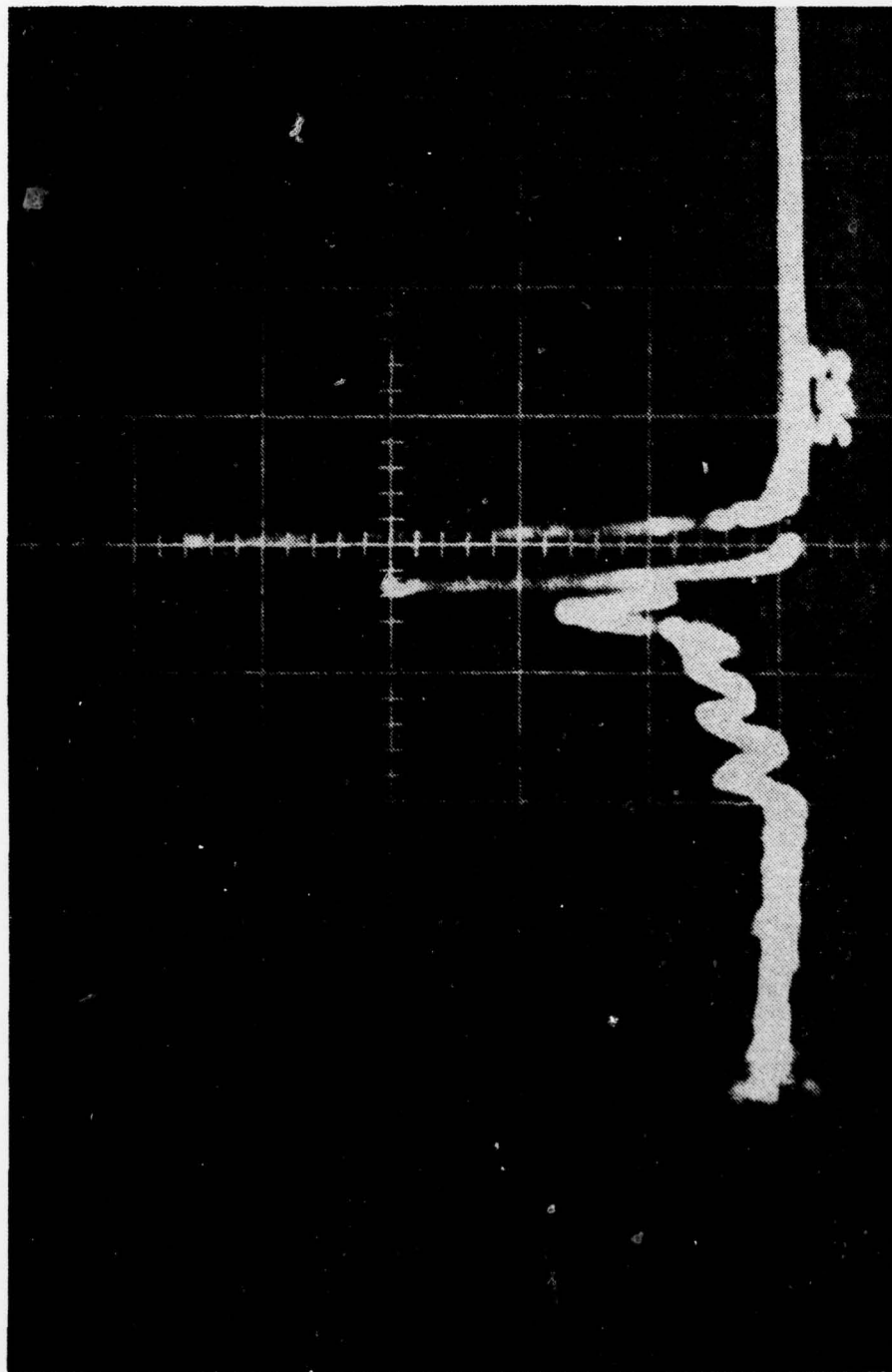

Figure 27 - Q-SWITCHED TOTAL SYSTEM OUTPUT (total amplifier cell pressure = 260 torr,  
argon with 60 torr C F I, sweep 5 $\mu$ s/div.)

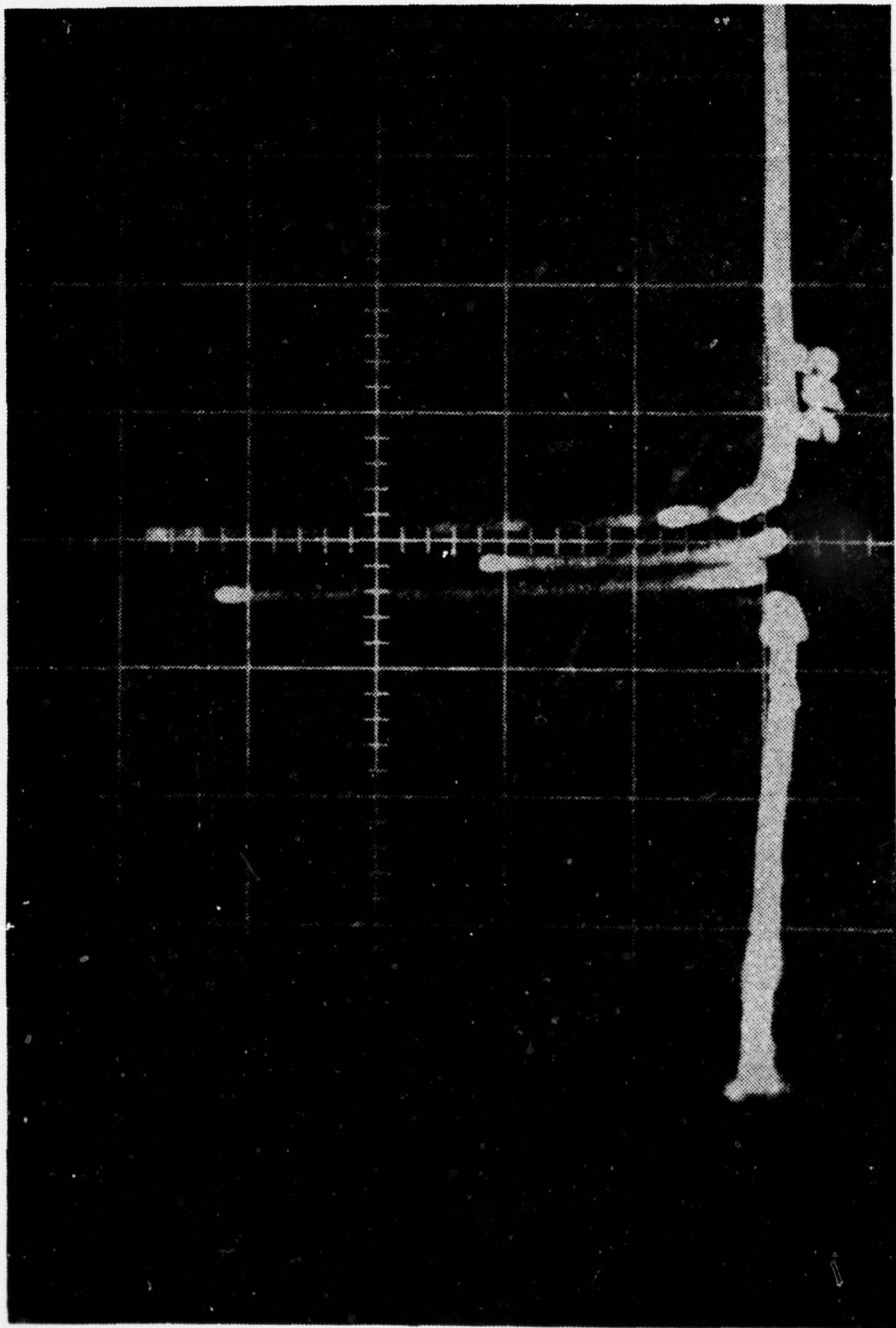

Figure 28 - Q-SWITCHED TOTAL SYSTEM OUTPUT (total amplifier cell pressure = 360 torr,  
argon with 60 torr C F I, sweep 5 $\mu$ s/div.)

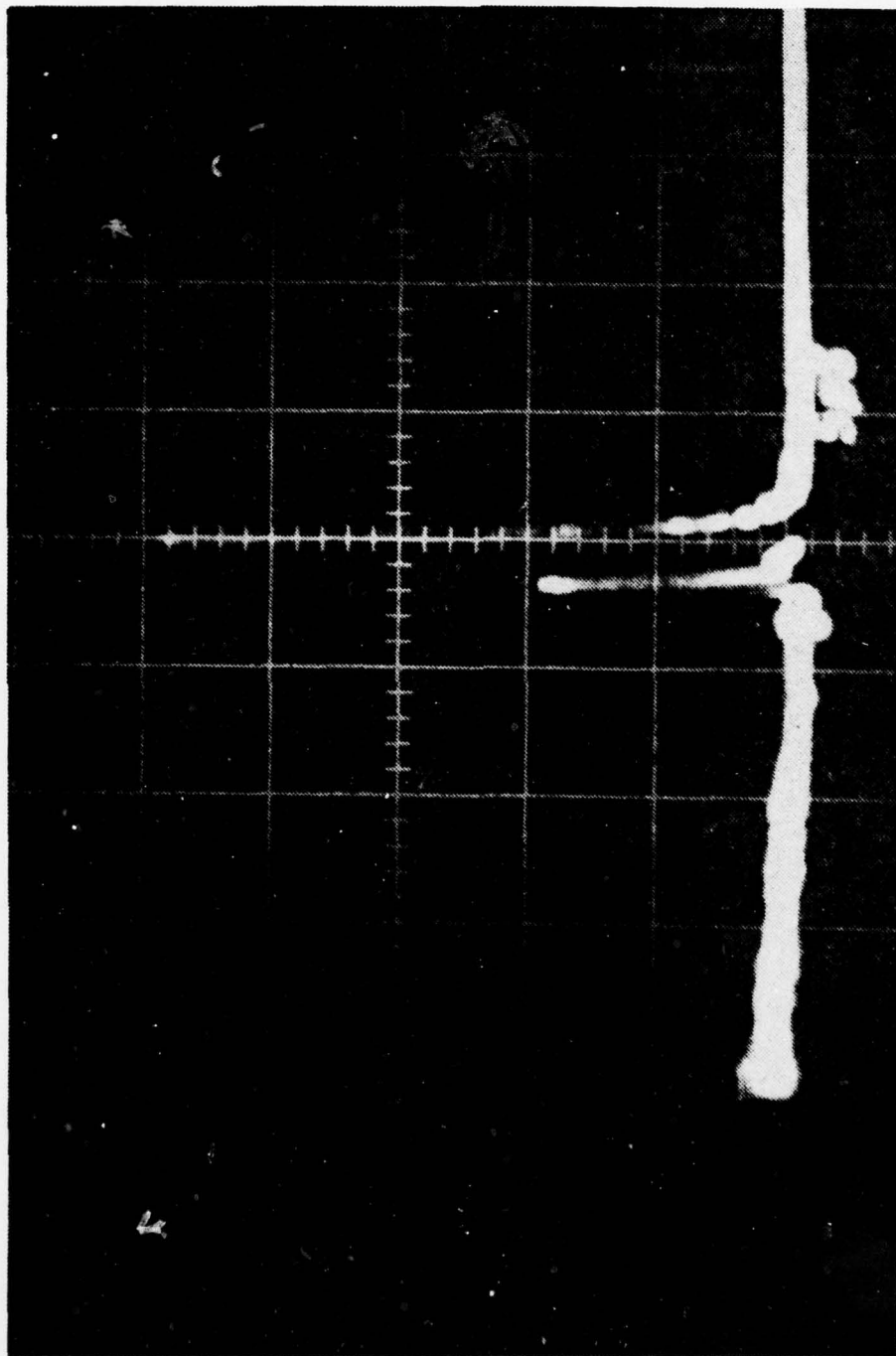

Figure 29 - Q-SWITCHED TOTAL SYSTEM OUTPUT (total amplifier cell pressure = 460 torr,  
argon with 60 torr C F I, sweep 5 $\mu$ s/div.)

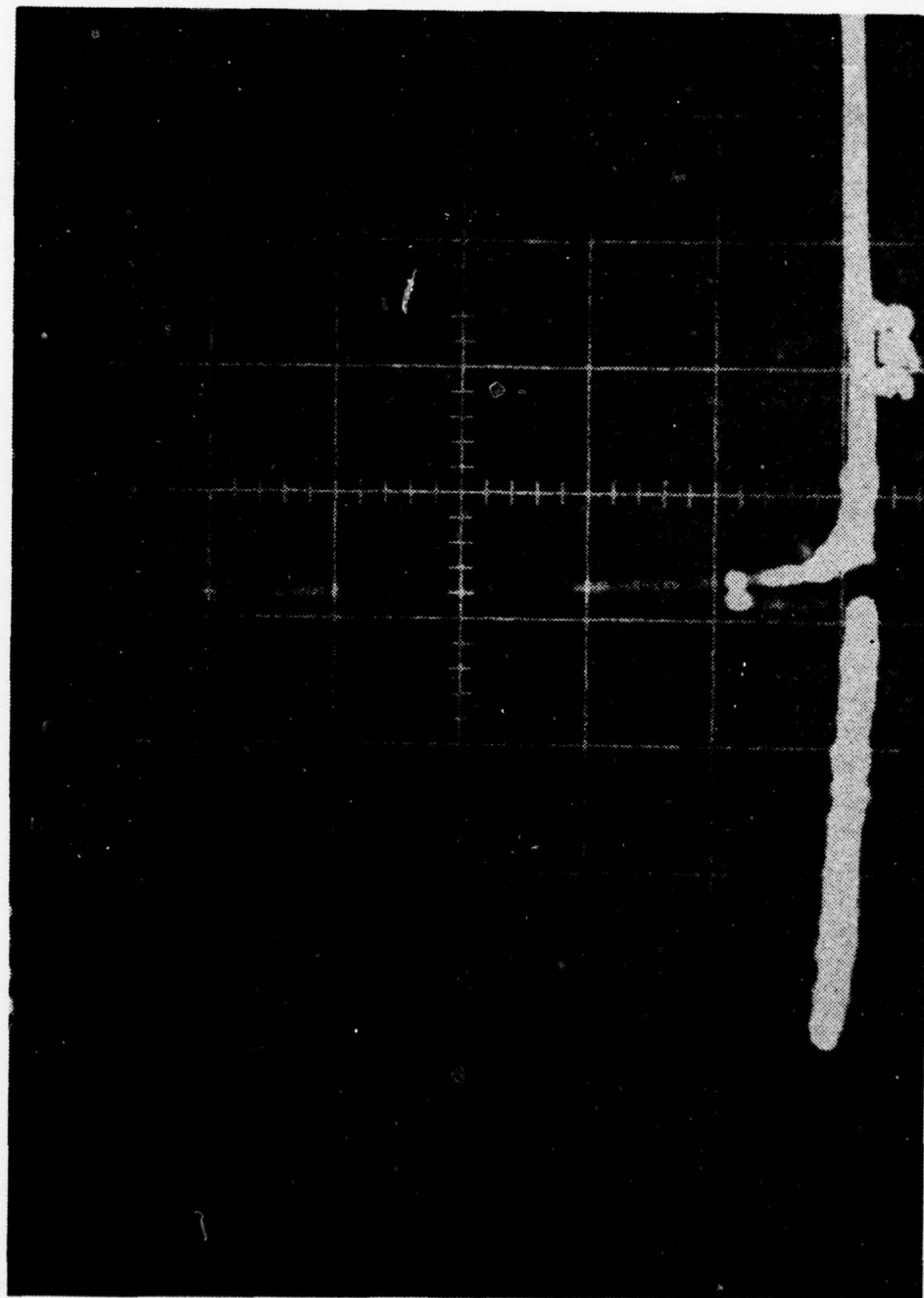

Figure 30 - Q-SWITCHED TOTAL SYSTEM OUTPUT (total amplifier cell pressure = 560 torr, argon with 60 torr C<sub>3</sub>F<sub>4</sub>I, sweep 5 $\mu$ s/div.)

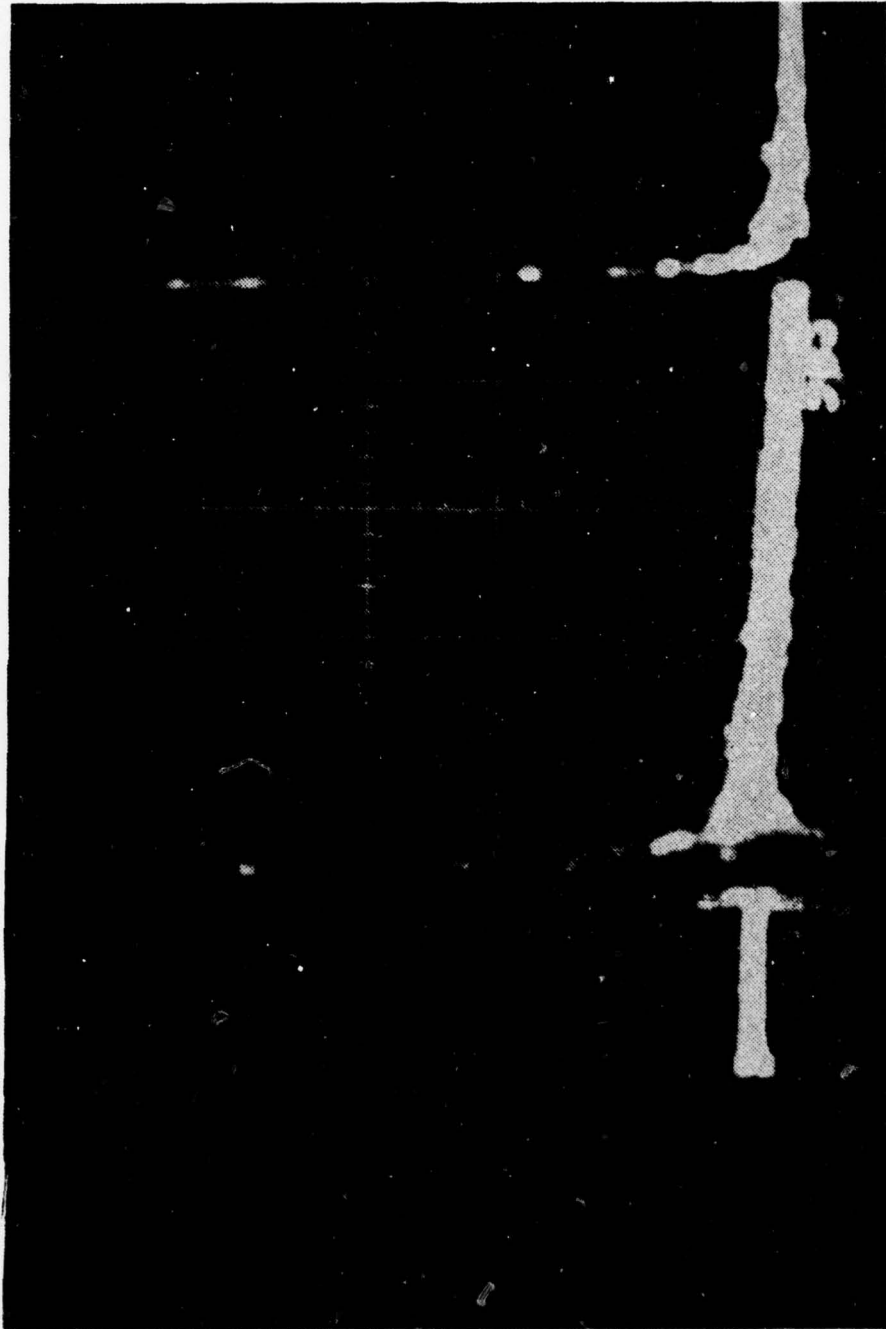

Figure 31 - Q-SWITCHED TOTAL SYSTEM OUTPUT (total amplifier cell pressure = 660 torr,  
argon with 60 torr  $C_3F_7I$ , sweep  $5\mu s/div.$ )

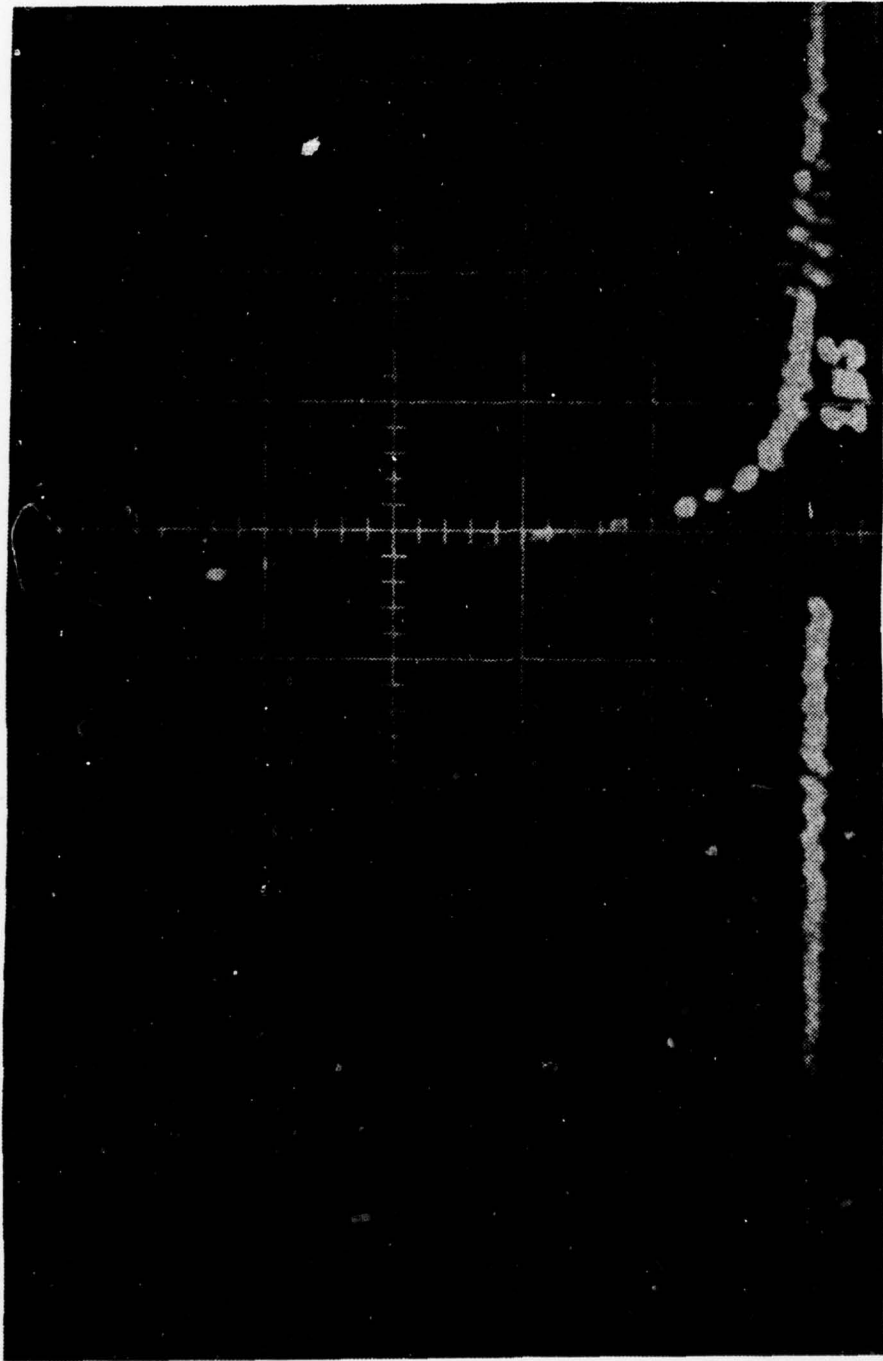

Figure 32 - GIANT PULSE AT CALCULATED BEST TIME (total amplifier cell pressure = 660 torr, argon with 60 torr C<sub>3</sub>F<sub>7</sub>I, sweep 1 $\mu$ s/div.)

LIST OF REFERENCES

1. F.C.Marcell Jr., "Design and Construction of an Iodine Laser Oscillator," M.S.Thesis, Naval Postgraduate School, 1976.
2. W. H. Halliday, "Iodine Laser", M.S. Thesis, Naval Postgraduate School, 1977.
3. K. Hohla, "The Iodine Laser, A High Power Gas Laser", A paper presented at the Third Workshop on "Laser Interactions and Related Plasma Phenomena," at Rensselaer Polytechnic Institute, Hartford Graduate Center August 13-17, 1973.
4. W. Fuss, K. Hohla , "A Closed Cycle Iodine Laser", Optics Communications, v. 18, No. 4, p. 427, 1976.
5. F.T.Aldridge , "High-Pressure Iodine Photodissociation Laser", Applied Physics Letters, v. 22 No. 4, p. 180, 15 Feb 1973.
6. W. Fuss, K. Hohla, R. Volk, K. Witte, "Parametric Studies of a 60J - 1 ns Iodine Laser", Paper presented at the 7th International Quantum Electronics Conference at San Francisco, CA, June 1974.
7. D. M. Budzik, Construction of a Theta-Pinch for the Generation of Shock Waves in a Nitrogen Plasma", M.S. Thesis, Naval Postgraduate School, 1970.
8. H. Weichel, L.S. Pedrotti, "A Summary of Useful Laser Equations", an LIA Report, p. 27, July 1976.
9. K. Hohla, G. Brederlow, E. Fill, R. Volk, K. J. Witte,

"Prospects of the High Power Iodine Laser ", A paper given at the Eleventh International Quantum Electronics Conference in Amsterdam, 1976.

10. Lawrence Livermore Laboratory, Laser Program Annual Report, report UCRL-500021-75, p. 170-186, 1975.

INITIAL DISTRIBUTION LIST

|   | No. Copies |
|---|------------|
| 1. Defence Documentation Centre<br>Cameron Station<br>Alexandria, Virginia 22314  | 2          |
| 2. Library, Code 0142<br>Naval Postgraduate School<br>Monterey, California 93940  | 2          |
| 3. Department Chairman, Code 61<br>Department of Physics And Chemistry<br>Naval Postgraduate School<br>Monterey, California 93940 | 2          |
| 4. Associate Professor F. R. Schwirzke, Code 61Sw<br>Naval Postgraduate School<br>Monterey, California 93940                      | 3          |
| 5. Professor A. W. Cooper, Code 61Cr<br>Naval Postgraduate School<br>Monterey, California 93940                                   | 1          |
| 6. Lieutenant J. M. Perin, USN<br>13244 Aubery<br>Poway, California, 92604  | 2          |