

AD-A057 938

STRATEGIC AIR COMMAND OFFUTT AFB NEBR AIRCRAFT ENGIN--ETC F/0 17/9  
GIANT IMAGE II RELIABILITY AND MAINTAINABILITY (B-52D). (U)

JUL 78 J H HARRINGTON  
SAC/LONE-ER-P-313

NL

UNCLASSIFIED

| OF |  
AD  
A057938

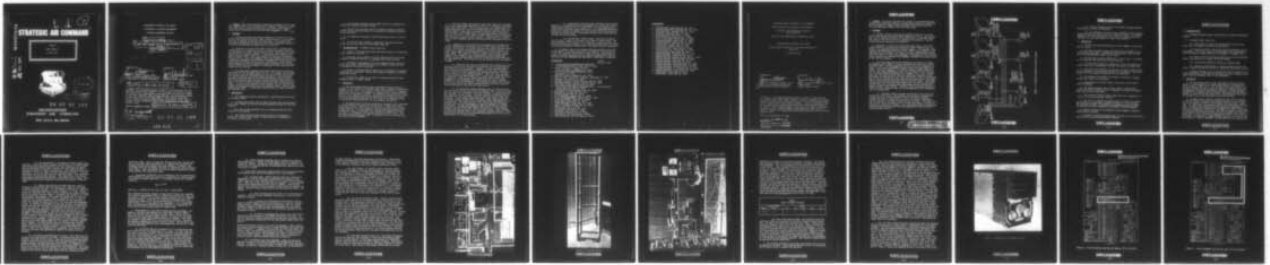

END  
DATE  
FILMED  
10-78  
DDC

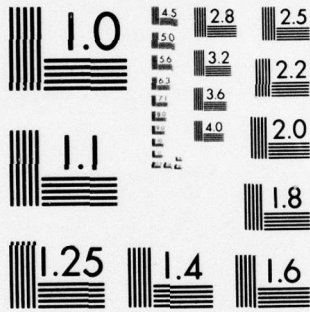

MICROCOPY RESOLUTION TEST CHART  
NATIONAL BUREAU OF STANDARDS-1963-A

ADA 057938

LEVEL #

(7)

# STRATEGIC AIR COMMAND

Annex A

Giant Image II

10 July 1978

AD No. ~~1~~  
JDC FILE COPY



D D C  
RECEIVED  
AUG 23 1978  
RECEIVED

DISTRIBUTION STATEMENT A  
Approved for public release;  
Distribution Unlimited

78 07 31 188

HEADQUARTERS  
STRATEGIC AIR COMMAND

Offutt Air Force Base, Nebraska

HEADQUARTERS STRATEGIC AIR COMMAND  
 DIRECTORATE OF AIRCRAFT MAINTENANCE  
 AIRCRAFT ENGINEERING DIVISION

9 ENGINEERING REPORT, NO. P-313 ✓  
 6 GIANT IMAGE II RELIABILITY AND MAINTAINABILITY  
 (B-52D)  
 11 10 July 1978

ACCESSION FOR	
NTIS	White Section <input checked="" type="checkbox"/>
DDC	Buff Section <input type="checkbox"/>
UNANNOUNCED	<input type="checkbox"/>
JUSTIFICATION	<i>little on file</i>
BY	
DISTRIBUTION/AVAILABILITY CODES	
Dist.	AVAIL. and/or SPECIAL
A	

A049 023

Submitted by:  
*James K. Street*  
 JAMES K. STREET, Colonel, USAF  
 Chief, Aircraft Engineering Division  
 Directorate of Aircraft Maintenance

Prepared by:  
*James H. Harrington*  
 JAMES H. HARRINGTON, Major, USAF  
 Project Officer  
 Avionics Systems Branch

14 SAC/LGME-ER-P-313      12 26 p.

APPROVED: This engineering report is Annex A to the Strategic Air Command Final Report "Giant Image II" (U), 15 January 1978, which contains the results of the Qualification Operational Test and Evaluation (QOT&E) of the B-52D AN/ALR-46A radar warning receiver. For operational aspects of the QOT&E, refer to the Giant Image II Final Report, classified Secret. Specific action by organizations or units will not be taken as a result of this engineering report unless requested by Hq SAC under separate cover.

FOR THE COMMANDER IN CHIEF 10 James H. Harrington

*T. W. Longworth*  
 T. W. LONGSWORTH, Colonel, USAF  
 Director of Aircraft Maintenance  
 SCS/Logistics

78 07 31 188

420 063      *elt*

1. PURPOSE: This report provides a subjective assessment of the logistics supportability of the AN/ALR-46(V)-3 (commonly referred to as ALR-46A) radar warning receiver during and following the Giant Image II Qualification Operational Test and Evaluation (QOT&E) in a B-52D. X

2. FOREWORD:

a. Limited frequency coverage and hardwired circuitry of the AN/APR-25 Radar Homing and Warning (RHAW) system resulted in a SAC requirement for an improved system for the B-52D fleet. The B-52G/H fleet received the AN/ALR-46 to replace the APR-25 and an improved version of the ALR-46 was selected for installation in the B-52D.

b. Objective 15 of the Giant Image II Test Plan, 15 August 1977, tasked SAC/LGM to subjectively assess the ALR-46A equipment reliability and maintainability (R&M), verify technical data, and evaluate the Integrated Logistics Support elements. In response to this tasking, SAC/LGME initiated Project P-313, Giant Image II Reliability and Maintainability (B-52D). Due to the proposed short test program (four missions), a subjective assessment was planned by evaluating the ALR-46A versus the normal ALR-46 installed on the B-52G/H. Specifically, those problem areas discovered during the ALR-46 Follow-on Operational Test and Evaluation (FOT&E) were to be examined to determine if those areas had been corrected in the ALR-46A.

c. The Giant Image II QOT&E test missions were flown on B-52D aircraft #56-606 from the 22BMW, March AFB, CA. Four formal test missions were flown, but the ALR-46A remained on the test aircraft until 4 April 1978 and R&M data were collected during this period. Data collected were taken from AFTO Forms 95 (Aircraft Significant Historical Data), AFM 66-1 Maintenance Data Collection System, and notes taken during on-site visits with maintenance technicians and Electronic Warfare Officers (EWOs). Analysis of the available data indicates that the ALR-46A R&M values are significantly better than the standard ALR-46. However, some problem areas remain. The principal problem areas are support equipment and technical data.

3. CONCLUSIONS:

a. The AN/ALR-46A logistic suitability is significantly better than the standard ALR-46.

b. The Mean Time Between Failure (MTBF) and Mean Time Between Maintenance Action (MTBMA) for the test ALR-46A exceeded 205 hours (no failures occurred).

c. The fuse problem identified with the standard ALR-46 has been corrected in the ALR-46A.

d. The ALR-46A technical data contains numerous discrepancies, errors, and omissions which should be resolved prior to deployment of the system to field units.

e. The Electronic Warfare Systems (EWS) shop has no capability to checkout the ALR-46A self-test circuits.

f. The lack of a suitable console or mounting racks for required ALR-46A signal generators results in a potentially hazardous situation on the test bench.

g. SAC experience indicates an R&M problem exists with the APM-379 cables.

h. The APM-327A Test Simulator (Squirt Box) variable attenuator cables are too short and are over stressed when used.

4. RECOMMENDATIONS: Recommend Warner Robins ALC:

a. Conduct a technical data review and rewrite prior to installation of the ALR-46A in the B-52D.

b. Authorize a shop standard to verify system self-test circuitry or modify the APM-379 test set to completely test these circuits.

c. Investigate replacement of the five required signal generators with a new, single, state-of-the-art unit or design a console or rack to accommodate the present generators.

d. Procure re-enforced APM-379 cables for the ALR-46A as is presently proposed for the ALR-46. Ensure cable length is adequate to prevent undue cable stress.

e. Increase the length of the APM-327A variable attenuator radio frequency cables to reduce stress.

5. DISCUSSION:

a. The increasingly hostile radio environment faced by the B-52 resulted in SAC requesting an improved RHAW system in Required Operational Capability (ROC) 14-71. The existing system, the AN/APR-25, is frequency limited and cannot easily be adapted to changing threat signal parameters because of its hardwired circuitry. The AN/ALR-46 was selected for installation in the B-52G/H fleet but the decision on the B-52Ds was delayed. The system subsequently selected for the B-52Ds was an improved version of the ALR-46, the AN/ALR-46(V)-3 or more commonly the ALR-46A.

b. SAC/LGME Project P-313 was initiated in September 1977 in response to SAC/DOO tasking to support the ALR-46A QOT&E. A March AFB B-52D, serial number 56-606, was selected as the test aircraft and the ALR-46A system installed. A limited number of test missions were planned thus a subjective logistics assessment was suggested by comparing the modified -46A to the standard -46 evaluated during the ALR-46 FOT&E. That evaluation, SAC/LGME Project P-286, is included as Atch 1 and forms the base line for this assessment.

c. Only four formal test missions were flown during the -46A QOT&E but the test system was retained and a total of 27 sorties--23 training plus 4 test--were flown. Over 205 flight hours were logged before the system was removed on 4 April 1978 terminating the logistics data collection effort. There were no confirmed failures during this period thus the MTBF and the MTBMA values for this one ALR-46A system were in excess of 205 hours. Actual MTBF and MTBMA values should be determined when operational systems become available. Conversations with technicians in other commands using the ALR-46A indicate such MTBF values are normal.

d. A comparison of the ALR-46A to the standard -46 revealed that several problems noted during the B-52G/H ALR-46 FOT&E have been corrected. Specifically, the CM-442A fuse and fuse holder have been changed and do not require any special equipment to change in-flight, the CM-442 Power Supply has been changed to enhance cooling and a cooling blower added. The changes to the power supply and the added cooling capability are thought to add significantly to system reliability. However, several problem areas identified during the ALR-46 FOT&E have not been addressed. The two major areas are technical data and support equipment.

(1) Technical data for the ALR-46A are much improved over that initially available for the ALR-46 but numerous errors, discrepancies, and omissions are still present. Example: a gross alignment procedure error was discovered for the CM-442A A-5 card, and a "Caution" note is needed to verify CM-442A blower operation and inlet and outlet areas clear prior to any shop maintenance. Other tech data problems as noted during the ALR-46 FOT&E [Atch 1, para 5g(1)] remain and should be corrected. Based on the limited experience gained during this assessment it is recommended that Warner Robins ALC host a complete ALR-46A tech data review/rewrite. The differences between the -46 and the -46A are minimal and ALR-46 experienced SAC technicians could and should participate in any such tech data review.

(2) One additional support equipment item is required to maintain the -46A versus the -46, a Test Set Adapter (TSA). The TSA is used with the APM-379 to interconnect with the CM-442A. A problem noted with this equipment was the cables. The cables connect the TSA and the CM-442A under test and their short length is such that under normal shop conditions, as was present during the QOT&E, undue stress is applied. Of special concern is cable W-5, a multi-wire cable terminated in a 155 pin connector. This cable and the others could pose maintainability problems since no repair procedures or special equipment, if needed, was provided. Similar cable problems exist for the APM-379 and were identified in the ALR-46 FOT&E report, para 5g(2)(d). Other support equipment problems include the need for a test console, lack of supply bit and piece hardware items, and a self-test circuitry checkout. These problems were identified in the ALR-46 FOT&E report and will not be discussed except for two observations.

(a) Commercially available signal generators have recently appeared on the market that have the capability to replace the five required signal generators with a single unit. With the problems associated with the present signal generators, it is recommended that Warner Robins ALC consider procurement of a new state-of-the-art generator to replace the existing units. Procurement of such a unit would eliminate the need for a test console.

(b) The APM-327A, "Squirt Boxes," used with the ALR-46 and -46A have a variable attenuator to be used on certain tests. The radio frequency cable used with this attenuator is short and when connected has undue stress applied. One such cable failed during the QOT&E during ground checkout of the ALR-46A. This cable should be lengthened.

e. In summary, many of the hardware problems identified with the ALR-46 appear to have been corrected in the ALR-46A. The reliability of the test system was significantly better than the standard ALR-46. However, problems associated with the support equipment and technical data have not been addressed and attention to these areas is required.

DISTRIBUTION:

1 Atch  
Engr Rpt P-286

- 12 - Hq SAC/LGMA/LGMT/HO/NR/XOR/DOOV/INED/XOKF/  
XPFA/XPHN/DOTTA/DOTTG, Offutt AFB, NE 68113
- 2 - DDC-TC, Building 5, Cameron Station,  
5010 Duke Street, Alexandria, VA 22314
- 6 - Hq USAF/LGYJ/RDRE/SAMI/PRPSB/RDQSA/XOODE,  
Washington DC 20330
- 3 - AFSC/INJ(2)/SDRW, Andrews AFB, MD 20334
- 1 - OJCS-J-3 (EW), Room 2D921G, Pentagon, Washington DC 20301
- 1 - AFEWC/SUR, San Antonio TX 78243
- 1 - AFAL/WRA (Library), Wright-Patterson AFB, OH 45433
- 3 - FTD/ETWD/PDJS/PDYF, Wright-Patterson AFB, OH 45433
- 1 - AFLC/LOAEW, Wright-Patterson AFB, OH 45433
- 11 - ASD/YYT/AEWS/AEWT/RNDA(5)/ENADD/ENCTH(Dr. D. Talcott)/SACSO,  
Wright-Patterson AFB, OH 45433
- 1 - 6570AMRL/HED, Wright-Patterson AFB, OH 45433
- 1 - AFTEC/TEFD, Kirtland AFB, NM 87115
- 1 - ESD/YWE, Hanscom AFB, MA 02173
- 2 - Hq TAC/DRW/DORE, Langley AFB, VA 23665
- 3 - OC-ALC/MMHM/MMSHM/MMSRH, Tinker AFB, OK 73145
- 1 - Ogden ALC/MMIRCPP, Hill AFB, UT 84406
- 1 - WR-ALC/MMRR, Robins AFB, GA 31098
- 3 - 19BMW/DO/MA/DONP, Robins AFB, GA 31098
- 1 - Keesler TTC/TTOXE, Keesler AFB, MS 39534
- 1 - SACPO, Eglin AFB, FL 32542
- 1 - USAFTAWC/TEW, Eglin AFB, FL 32542
- 1 - ADTC/DLOSL, Eglin AFB, FL 32542
- 1 - Hq ATC/DON, Randolph AFB, TX 78148
- 2 - 3AD/LGM/DOTP, APO San Francisco 96334
- 3 - 43SW/DO/LGM/DONP, APO San Francisco 96334

DISTRIBUTION:

2 - 8AF/LGMA/DOTTP, Barksdale AFB, LA 71110  
3 - 1CEVG/APY/EVBS/RBOX, Barksdale AFB, LA 71110  
3 - 2BMW/DO/MA/DONP, Barksdale AFB, LA 71110  
1 - 4201TESTS, Barksdale AFB, LA 71110  
2 - 15AF/LGMA/DOTTG, March AFB, CA 92508  
3 - 22BMW/DO/MA/DONP, March AFB, CA 92508  
1 - 323 Fly Tng Wg/EWT, Mather AFB, CA 95655  
3 - 320BMW/DO/MA/DONP, Mather AFB, CA 95655  
3 - 7BMW/DO/MA/DONP, Carswell AFB, TX 76127  
1 - 4018CCTS/TAE, Carswell AFB, TX 76127  
1 - 4235ISD/XPX, Carswell AFB, TX 76127  
3 - 93BMW/DO/MA/DONP, Castle AFB, CA 95342  
1 - 4017CCTS/TDQ (CCB), Castle AFB, CA 95342  
3 - 5BMW/DO/MA/DONP, Minot AFB, ND 58701  
3 - 28BMW/DO/MA/DONP, Ellsworth AFB, SD 57706  
3 - 42BMW/DO/MA/DONP, Loring AFB, ME 04751  
3 - 68BMW/DO/MA/DONP, Seymour Johnson AFB, NC 27530  
3 - 92BMW/DO/MA/DONP, Fairchild AFB, WA 99011  
3 - 96BMW/DO/MA/DONP, Dyess AFB, TX 79607  
3 - 97BMW/DO/MA/DONP, Blytheville AFB, AR 72315  
3 - 319BMW/DO/MA/DONP, Grand Forks AFB, ND 58201  
3 - 379BMW/DO/MA/DONP, Wurtsmith AFB, MI 48753  
3 - 410BMW/DO/MA/DONP, K. I. Sawyer AFB, MI 49843  
3 - 416BMW/DO/MA/DONP, Griffiss AFB, NY 13441  
1 - 544IESQ/RDET, Offutt AFB, NE 68113  
1 - 544IAS/IAAP, Offutt AFB, NE 68113

HEADQUARTERS STRATEGIC AIR COMMAND  
DIRECTORATE OF AIRCRAFT MAINTENANCE  
AIRCRAFT ENGINEERING DIVISION  
(HQ SAC/LGME)  
OFFUTT AIR FORCE BASE, NEBRASKA 68113

ENGINEERING REPORT NO. P-286  
GIANT IMAGE RELIABILITY AND MAINTAINABILITY  
(B-52G/H)

4 February 1977

Submitted by:

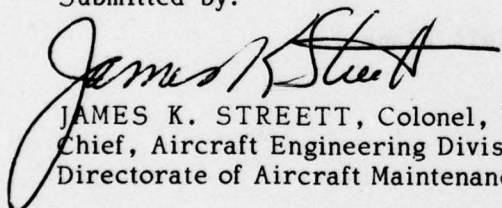
  
JAMES K. STREET, Colonel, USAF  
Chief, Aircraft Engineering Division  
Directorate of Aircraft Maintenance

Prepared by:

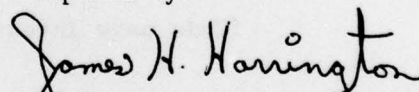
  
JAMES H. HARRINGTON, Major, USAF  
Project Officer  
Avionics Systems Branch

APPROVED: This engineering report appears as Annex A of the Strategic Air Command Final Report "Giant Image" (U), dated 31 December 1976, which contains the results of the Follow-on Operational Test and Evaluation (FOT&E) of the B-52G/H ALR-46 radar warning receiver. Annex A is reproduced here for the convenience of those primarily interested in the logistical aspects of the FOT&E. For operational aspects refer to the Giant Image Final Report, classified SECRET. Specific action by organizations or units will not be taken as a result of this engineering report unless requested by Hq SAC under separate cover.

FOR THE COMMANDER IN CHIEF

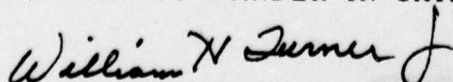
  
WILLIAM H. TURNER JR., Col, USAF  
Deputy Director of Aircraft Maintenance  
DCS/Logistics

6

# UNCLASSIFIED

1. PURPOSE: This report describes the results of an engineering evaluation of the AN/ALR-46 Electronic Warfare System (Figure 1) reliability and maintainability (R&M) during the AN/ALR-46 Follow-on Operational Test and Evaluation (FOT&E), code name Giant Image.

2. FOREWORD:

a. Limited frequency coverage and hardwired circuitry of the AN/APR-25 Radar Homing and Warning (RHAW) system resulted in a SAC requirement for an improved system for the B-52G/H fleet. An improved APR-25 was tested in the fall of 1972 and approved for production. This improved system was designated the AN/ALR-46.

b. Objective 17 of the Giant Image Test Plan, dated 1 June 1976, tasked SAC/LGM to determine the ALR-46 R&M, verify technical data, and evaluate the Integrated Logistics Support elements. In response to this tasking, SAC/LGME initiated Project P-286, "Giant Image Reliability and Maintainability (B-52G/H)," and formed a Logistic Supportability Evaluation Team (LSET) to conduct the assessment. SAC/LGME Test Plan P-286-T-1, dated 2 August 1976, outlined the assessment procedures and various tasks of the LSET participants.

c. The Giant Image operational evaluation was flown out of Minot and Barksdale AFBs; however, the R&M assessment was conducted at Minot and Mather AFBs. The R&M assessment was not conducted at Barksdale because of their heavy maintenance workload during the Giant Image time frame. Data were collected on all ALR-46 equipped B-52G/H aircraft at the two test bases commencing 1 August 1976 at Minot AFB and 10 August 1976 at Mather AFB and continuing to 15 November 1976. Data collected were taken from AFTO Forms 95 (Aircraft Significant Historical Data), AFTO Forms 349 (Maintenance Data Collection Record), AFM 66-1 Maintenance Data Collection System, and notes taken during on-site visits with maintenance technicians and Electronic Warfare Officers (EWOs). Data analysis indicates that the ALR-46 R&M values are not as good as anticipated. Problem areas were identified where system R&M could be improved and logistic support costs reduced. Principal areas include the Signal Processor (CM-442), technical data, and the intermediate level maintenance test set (AN/APM-379).

(1) The CM-442 Signal Processor reliability is well below the design goal of 300 hours. The processor was originally equipped with a 3-amp fuse which is insufficient to carry electrical transients. Although the fuse is located on the front of the CM-442, replacement requires removal of all CM-442 cables and the processor. The fuse structure is such that it requires a tool to remove and replace, thereby increasing the likelihood of damage. This replacement must be accomplished while wearing gloves because of the heat generated by the processor's integrated power supply.

# UNCLASSIFIED

UNCLASSIFIED

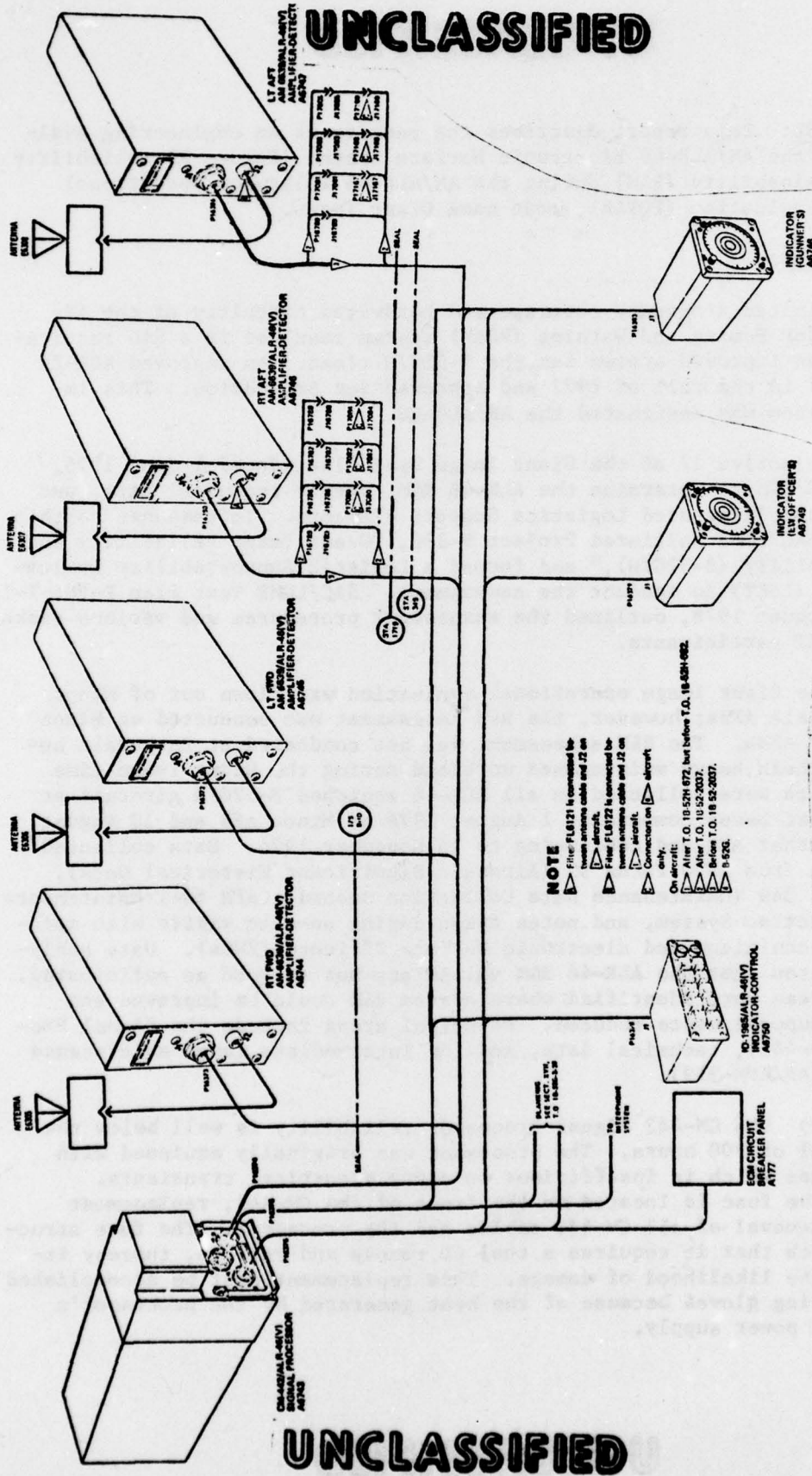

UNCLASSIFIED

Figure 1 - AN/ALR-46 Electronic Warfare System

# UNCLASSIFIED

(2) Technical manuals evaluated by SAC/LGMT contained numerous discrepancies, errors, and omissions.

(3) The AN/APM-379 test set is the intermediate level aerospace ground equipment for testing the CM-442 Signal Processor. In numerous instances, the ALR-46 system self-test indicated a malfunction on the aircraft, but the system passed all tests on the APM-379.

### 3. CONCLUSIONS:

a. The Mean Time Between Maintenance Actions (MTBMA) on the ALR-46 was 33.1 hours.

b. The ALR-46 achieved a Mean Time Between Failure (MTBF) of 56.7 hours during Giant Image. Disregarding fuse failures raises the MTBF to a more representative figure of 89.3 hours.

c. The Mean Time To Repair (MTTR) was 2.7 clock hours. An average of 6.7 man-hours was required per ALR-46 write-up.

d. The maintenance man-hours expended per flying hour (MH/FH) were 0.20, or one hour of maintenance for every five hours of flying time.

e. The 3-amp fuse originally installed in the ALR-46 signal processor is inadequate to handle existing electrical transients. Forty-four percent of all processor failures were of the 3-amp fuse.

f. The processor fuse holder is extremely susceptible to damage during fuse removal and replacement.

g. Discrepancies in aircraft wiring contributed to poor ALR-46 audio performance.

h. The ALR-46 technical data contains numerous discrepancies, errors, and omissions which render it inadequate to support the system with 5-skill level technicians.

i. The Electronic Warfare Systems (EWS) shop has no capability to check out the ALR-46 self-test circuits.

j. The lack of a console or mounting racks for ALR-46 test equipment results in a potentially hazardous situation on the test bench. The scattered placement of equipment and connecting cables increases the possibility of the technician and equipment becoming entangled.

k. Several failures of the AN/APM-379 cables suggest a potential maintainability problem.

l. Problems in obtaining numerous small peculiar bit and piece hardware items have impacted system maintainability.

# UNCLASSIFIED

# UNCLASSIFIED

## 4. RECOMMENDATIONS:

a. Recommend SAC/LGMA approve construction of an ALR-46 maintenance console.

b. Recommend Warner Robins ALC:

(1) Take action to replace the present CM-442 fuse and fuse holder with the standard type fuse and fuse holder.

(2) Expedite action to rewrite the ALR-46 intermediate technical manuals to the 5-skill level as outlined during the preliminary rewrite conference at Warner Robins ALC 30 November - 2 December 1976.

(3) Adopt a policy of procuring peculiar bit and piece hardware items as accessory kits to support future EW systems.

(4) Procure spare AN/APM-379 cables as insurance items.

(5) Authorize a shop standard to verify system self-test circuitry or modify the APM-379 test set to completely check these circuits.

c. Recommend Oklahoma City ALC relocate the CM-442 processor to improve accessibility to the fuse and eliminate the need to remove the processor from the equipment rack for fuse replacement.

## 5. DISCUSSION:

a. The increasingly hostile radar environment faced by the B-52 resulted in SAC requesting an improved RHAW system in Required Operational Capability (ROC) 14-71. The existing system, the AN/APR-25, is frequency limited and cannot easily be adapted to changing threat signal parameters because of its hardwired circuitry. During September-November 1972, an improved APR-25 prototype was tested and was found to satisfy the SAC ROC with some limitations. This system was designated the AN/ALR-46 and is being installed in the B-52G/H fleet.

b. SAC/LGME Project P-286 was initiated in June 1976 in response to SAC/DOO tasking to support the AN/ALR-46 Follow-on Test and Evaluation as outlined in the ALR-46 "Giant Image" Test Plan, dated 1 June 1976. Six operational test missions were flown from Barksdale and Minot AFBs. To conduct the reliability and maintainability assessment, a Logistics Supportability Evaluation Team (LSET) was formed to draw upon the various maintenance specialties. The LSET was chaired by Major James H. Harrington, SAC Aircraft Engineering Division (LGME); and included CMSgt John W. Carter, SAC Avionics Maintenance Division (LGMA); MSgt Roy W. Stewart, SAC Maintenance Standardization Evaluation Team (LGMT); and MSgt Wilfred F. Vandall, SAC/LGME. The R&M assessment was conducted at

# UNCLASSIFIED

# UNCLASSIFIED

Minot and Mather AFBs according to the SAC/LGME Test Plan P-286-T-1, dated 2 August 1976. Barksdale AFB was not selected for the R&M assessment due to their heavy maintenance workload during the Giant Image time frame. Data were collected on all ALR-46 equipped B-52G/H aircraft at the two test bases commencing 1 August 1976 at Minot AFB and 10 August 1976 at Mather AFB and continuing until test conclusion, 15 November 1976. Data collected were taken from AFTO Forms 95 (Aircraft Significant Historical Data), AFTO Forms 349 (Maintenance Data Collection Record), AFM 66-1 Maintenance Data Collection System, and notes taken during on-site visits with maintenance technicians and EWOs. The principal data sources were the AFTO Forms 95 and 349. Copies of these forms were forwarded to LGME for analysis and action. No maintenance was tracked past the shop level.

c. Data were collected on 17 H-model and 15 G-model ALR-46 equipped aircraft during the evaluation. Data collected covered 415 flights totaling 2946.0 flying hours. All recorded maintenance actions from these flights were analyzed to determine if a failure had occurred, which Line Replaceable Unit (LRU) had failed, and if possible, what component within the LRU caused the failure. In some instances, more than one LRU was defective or more than one failure occurred in an LRU. A "maintenance summary" of all ALR-46 maintenance actions during the R&M assessment is depicted in Table 1. To aid in understanding terminology the following definitions are offered:

(1) Maintenance Action (MA) - An apparent equipment discrepancy requiring expenditure of man-hours. For this project, an MA was considered for each LRU removal or servicing.

(2) Failure - Maintenance action requiring removal and repair/replacement of an LRU component. Minor adjustments or interconnecting cabling problems were not considered failures.

(3) Operate Time - Operate time was equated to flight time since the ALR-46 is placed in Operate soon after takeoff and remains in Operate, except for air refueling, until after landing. Code 5 (Inoperative Prior to Flight) sorties and sorties without an EWO on board were not included.

d. The data in Table 1 lead to the following conclusions:

(1) During the R&M assessment, the Mean Time Between Maintenance Actions (MTBMA) of the ALR-46 was 33.1 hours. This value was determined using the total system operate time and total system maintenance actions. For this assessment, no ground operate time (i.e., check out of the systems or shop operate time) was considered. This operate time should more than compensate for any discrepancy in the assumption that flight time equals operate time.

# UNCLASSIFIED

UNCLASSIFIED

TABLE 1

AN/ALR-46 MAINTENANCE SUMMARY														
	LRU NUMBER*													
	1	2	3	4	5	6	7	8	9	10	11	12	Gp A	System
MA	74**	1	4	1	2	2	2	2	0	1	0	0	4***	89
Failures	44**	1	2	0	2	1	0	1	0	1	0	0	2***	52
MTEMA	39.8	2946	736.5	2946	1473	—	—	—	>2946	2946	>2946	>2946	—	33.1
MTBF	67.0	2946	1473	>2946	1473	2946	>2946	2946	>2946	2946	>2946	>2946	—	56.7

\*See Figure 1 for pictorial view.

- LRU-1 CM-442 Signal Processor
- LRU-2 ID-1985 Indicator Control
- LRU-3 IP-957 EMO's Azimuth Indicator
- LRU-4 IP-957 Gunner's Azimuth Indicator
- LRU-5 AM-6639 Amplifier-Detector (RT FWD)
- LRU-6 AM-6639 Amplifier-Detector (LT FWD)

- LRU-7 AM-6639 Amplifier-Detector (RT AFT)
- LRU-8 AM-6639 Amplifier-Detector (LT AFT)
- LRU-9 Antenna (RT FWD)
- LRU-10 Antenna (LT FWD)
- LRU-11 Antenna (RT AFT)
- LRU-12 Antenna (LT AFT)

\*\*Includes 19 fuse malfunctions.

\*\*\*Group A (Interconnecting Cables and Filters) MA/Failures shown but not considered in calculations.

UNCLASSIFIED

# UNCLASSIFIED

(a) The distribution of maintenance actions by LRUs is as expected. The CM-442 Signal Processor is the heart of the ALR-46 system and contains the complex electronic circuitry; therefore, more maintenance is performed on this LRU. However, the total number of CM-442 maintenance actions is higher than expected. The 3-amp CM-442 fuse contributed to 31% of the signal processor maintenance actions. Of the 92 maintenance actions, 24 were Could Not Duplicate (CND). This represents 27% of the total maintenance actions. Thus almost half of all ALR-46 maintenance actions were attributable to the CM-442 fuse or CNDs. Erroneous system self-test indications constituted the majority of CND actions.

(b) Some of the self-test problems have been traced to rejection of the AM-6639 Amplifier-Detector test signal by the Signal Processor self-test circuitry. TO 12P3-2ALR46-12 directs the technician to set the Amplifier-Detector test gain voltage at 2.7 volts. Warner Robins ALC discovered that under certain conditions the Signal Processor may not recognize this test signal. Increasing the voltage to 4.0 volts helps correct this problem. This change was provided to the field as TO supplement 12P3-2ALR46-12S-1, dated 16 September 1976. It was received by field units approximately mid-October and was therefore in effect only during the latter portion of the Giant Image R&M assessment period. In addition to changing the test gain voltage, the supplement directs that the PRF switch on all Amplifier-Detectors be placed in the right rear position. The APR-25 required the PRF switch to be placed in the position corresponding to the position on the aircraft of its associated Amplifier-Detector. The ALR-46 does not have any such requirement. The ALR-46 does require the test signal pulse repetition interval (PRI) be within the Signal Processor parameter window to ensure a good self-test. Placing the PRF switch in the right rear position satisfies this requirement. Implementation of this supplement resolved some of the self-test CND problems but the problem of operator unfamiliarity remains. The ALR-46 system does not recognize most friendly radars; therefore, the operators' exposure to an operating system is limited during normal training missions. Engineering Change Proposal (ECP) 11, which has been submitted for evaluation, would correct this situation and would also significantly improve the system self-test software.

(2) The ALR-46 system MTBF was 56.7 hours. This figure was calculated in the same manner as the MTBMA. Disregarding the fuse failures increases this value to 89.3 hours. There was no system MTBF goal established or specified since the ALR-46 LRUs are manufactured by different vendors; however, LRU MTBF goals were established. The MTBF goal for the CM-442 Signal Processor was 300 hours; it achieved an MTBF of 67.0 hours, 117.8 hours if the fuse failures (19) are disregarded. This 3-amp fuse has been replaced with a 5-amp fuse to survive electrical transients present during initial system power application and changing aircraft

# UNCLASSIFIED

# UNCLASSIFIED

electrical loads. Since no 5-amp fuse failures have been reported from the two test units since installation, it appears that the electrical transient induced fuse failures have been resolved. Therefore, the 117.8 MTBF value for the Signal Processor is considered a more representative figure. Other system LRUs are from the APR-25 system and no individual analysis was conducted on them.

e. Operational reliability is the probability that an operationally ready system will perform as required to accomplish its intended mission or function as planned (AFR 80-5). The accepted formula for a mature system is:

$$R(t) = e^{-t/m}$$

Where  $R(t)$  = probability for time  $(t)$ , and  $m$  = system MTBF.

This exponential formula assumes a Poisson distribution over a denumerably infinite sample space; that is, failures are random over time, and the system is "mature" or has gone through a burn-in cycle to eliminate premature failures. Using the 89.3 hours MTBF discussed above, the operational reliability of the ALR-46 system was 0.92 for the average sortie length of 7.1 hours during this assessment. For a 12-hour mission, the operational reliability would thus be 0.87; meaning 87% of the sorties of this duration should be failure free.

f. Maintainability of the ALR-46 system was also evaluated. One measure of hardware maintainability is Mean Time To Repair (MTR). Data from the Base Level Information System (BLIS) from the two test bases were used to determine these figures. The data were correlated by job control number and incomplete data were rejected. Data analysis yielded a system MTR of 2.7 clock hours per write-up. The average man-hours expended per write-up were 6.7 hours. The man-hours lost in trouble-shooting CNDs were also investigated and found to be 3.1 man-hours per CND action.

(1) The CM-442 MTR was determined to be 2.3 hours which compared favorably with the design goal of 1.7 hours. The AFTO Forms 349 were used to determine "actual" versus "recorded" maintenance man-hours and clock hours expended and this information was cross-referenced to BLIS data. Each test base made an extra entry on the 349s reflecting actual maintenance man-hours expended. Actual clock hours were determined by dividing actual man-hours by crew size. This entry ignored such time inflating activities as awaiting parts, coffee breaks, time expended in locating tools, etc. In comparing the achieved MTR to the design goal, only shop maintenance was considered since the design goal was predicated only on shop conducted maintenance.

# UNCLASSIFIED

# UNCLASSIFIED

(2) Another measure sometimes used to indicate the relative maintainability of a system is the maintenance man-hours expended per flying hour (MH/FH). During the Giant Image project, the MH/FH of the ALR-46 was 0.20, meaning one hour of maintenance was required for every five hours of flying.

g. Some problem areas which significantly affected maintainability were technical data and the intermediate level test equipment.

(1) Technical Data - ALR-46 technical data were evaluated by two members of the SAC Maintenance Standardization Evaluation Team (LGMT), MSgt Roy Stewart and TSgt Walter Ide, at Minot AFB 3-8 October 1976. Assisting in this evaluation was Mr. Lawrence T. Long, Minot AFB ECM Air Force Engineering Technical Service (AFETS). They reviewed several key procedures from six technical orders needed to maintain the ALR-46. Numerous errors, discrepancies, and omissions were noted. For example:

(a) Eight discrepancies were noted in TO 12P3-2ALR46-12, Section 6, involving either ambiguous instructions or incorrect test equipment settings.

(b) A review of TO 12P3-2ALR46-32 (Maintenance Instructions for CM-442 Signal Processor) disclosed that it does not contain enough detailed information on theory of operation, does not contain schematic diagrams or point-to-point wiring diagrams for the chassis and circuit cards, and does not have any equivalence diagrams for the integrated circuits.

(c) Two major discrepancies were found in TO 33A1-8-723-1 (Maintenance Instructions for the AN/APM-379 Computer Test Set). It does not contain an adequate calibration section (and calibration interval) or maintenance instructions for the Tape Reader housed within the APM-379.

Similar problems were noted in the other TOs examined. These findings were passed to Warner Robins ALC and a Technical Manuals Review was convened 30 November - 2 December 1976 with SAC, TAC, ATC, MAC, PACAF, Air National Guard, and WR-ALC representatives present. Various discrepancies were discussed and it was determined that several manuals do require significant changes. Warner Robins ALC plans to accomplish an in-house rewrite using an existing WR-ALC data contractor.

(2) Intermediate Level Test Equipment - There are two major test sets required to maintain the ALR-46, the AN/APM-379 and the AN/APM-380. In addition, up to five radio frequency (RF) signal generators, a digital voltmeter, a frequency counter, a modulator, an oscilloscope,

# UNCLASSIFIED

# UNCLASSIFIED

DC power supply(s), and an RF power meter are required. Several maintainability problems exist with these equipments including the lack of a test console, numerous bit and piece hardware items, inadequate check of the self-test circuitry, and lack of spare interconnect cables.

(a) Test Console - To properly connect the many needed items of test equipment, even where the equipment is logically mounted in a console, is difficult. To make these equipment inter-connections when the equipment is scattered throughout the work area, stacked one on top of the other, or even neatly arranged, is exceedingly difficult and subjects the equipment to damage from falling, incorrect electrical connections, or over-heating from poor air circulation. Figure 2 depicts a typical ALR-46 work bench, this one at Barksdale AFB. Mather AFB technicians have successfully resolved many problems by placing the RF signal generators in an equipment rack obtained from an old communications van (Figure 3). This rack can hold the five required RF signal generators (the fifth was out for calibration) in a safe secure manner, freeing the work bench for other required test equipment (Figure 4). A Form 1000 (No. MAT 051-77) has been submitted on this ALR-46 console set-up.

(b) Bit and Piece Hardware Items - Another problem affecting system maintainability is the requirement for numerous bit and piece hardware items. This problem is especially evident in setting up test equipment for the Amplifier-Detector, when many special adapter-connectors, bandpass filters, coaxial attenuators, etc., are needed. Procurement of these items is the responsibility of the EWS shop. Each of the appropriate technical orders has a section listing needed equipment. In the case of common test equipment items there are no problems; however, serious problems arise attempting to procure the peculiar items. Normally, these items are not common to the EWS shop, are not stock listed, and are not generally available unless the supply agency goes to the vendor. For example, a survey of several shops revealed that they have been unable to get a Filtronics Low Pass Filter, stock number 5915-01-011-7102, which is required to properly check out the Amplifier-Detector. Until all the necessary hardware items are received, shop technicians must skip required checks, use work-around items which may affect test results, or ship the item(s) to depot for repair and check out. For future systems, peculiar bit and piece hardware items should be procured as accessory kits to the test equipment.

(c) Self-Test Circuitry Check Out - The present maintenance concept uses dedicated test equipment to test LRUs individually rather than as a complete system. A deficiency exists within the AN/APM-379 computer test set used to test the CM-442 Signal Processor. The APM-379 does not check the self-test circuitry on the Signal Processor A-5 printed circuit board. This creates a maintenance problem when an aircraft

# UNCLASSIFIED

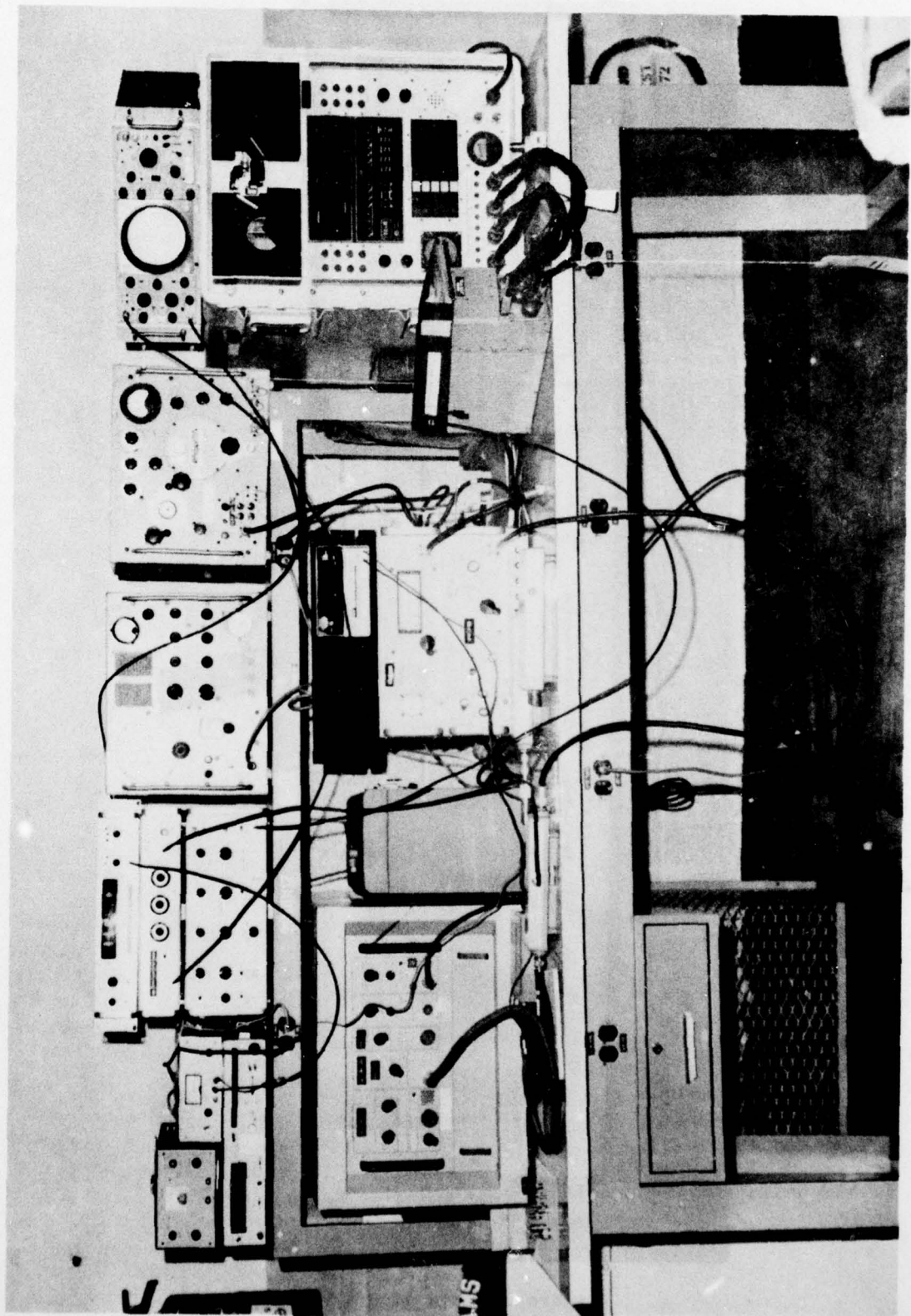

UNCLASSIFIED

17

**UNCLASSIFIED**

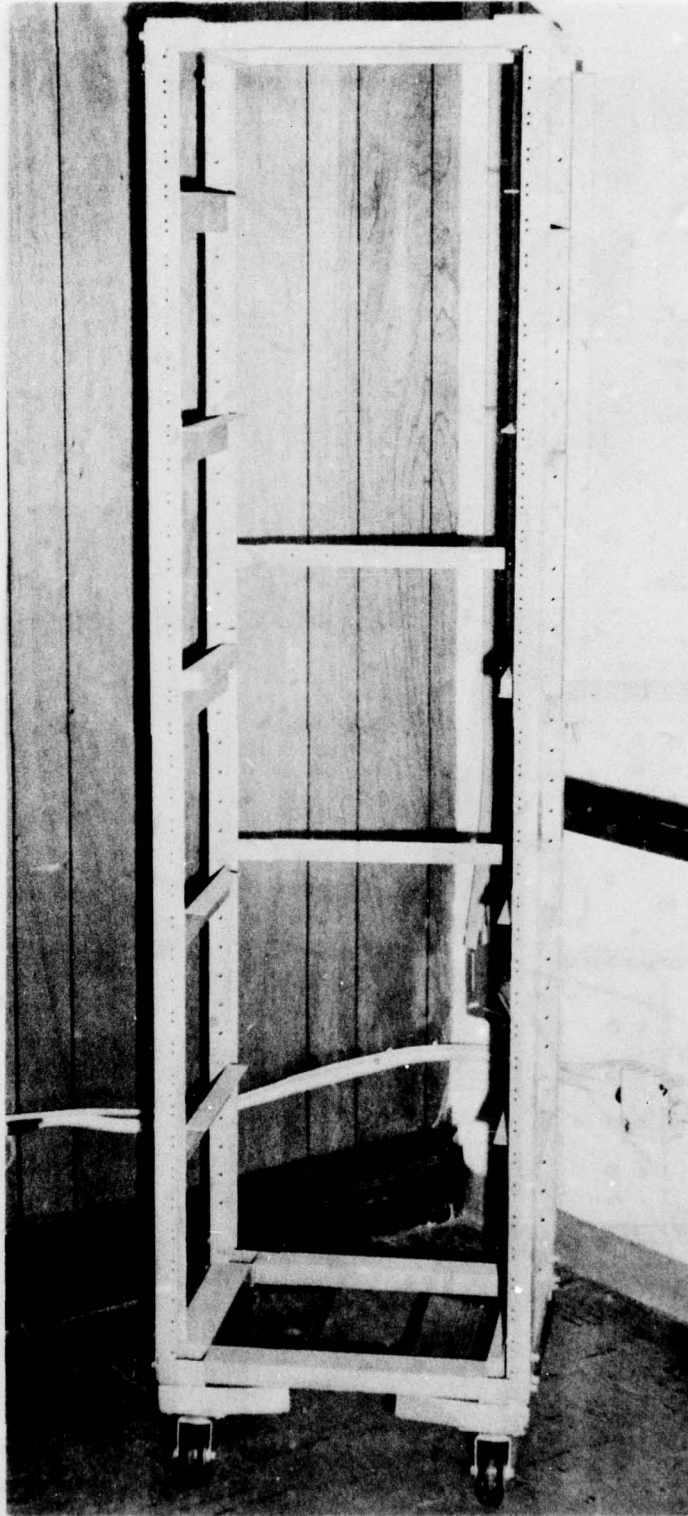

Figure 3 - Equipment Rack

**UNCLASSIFIED**

UNCLASSIFIED

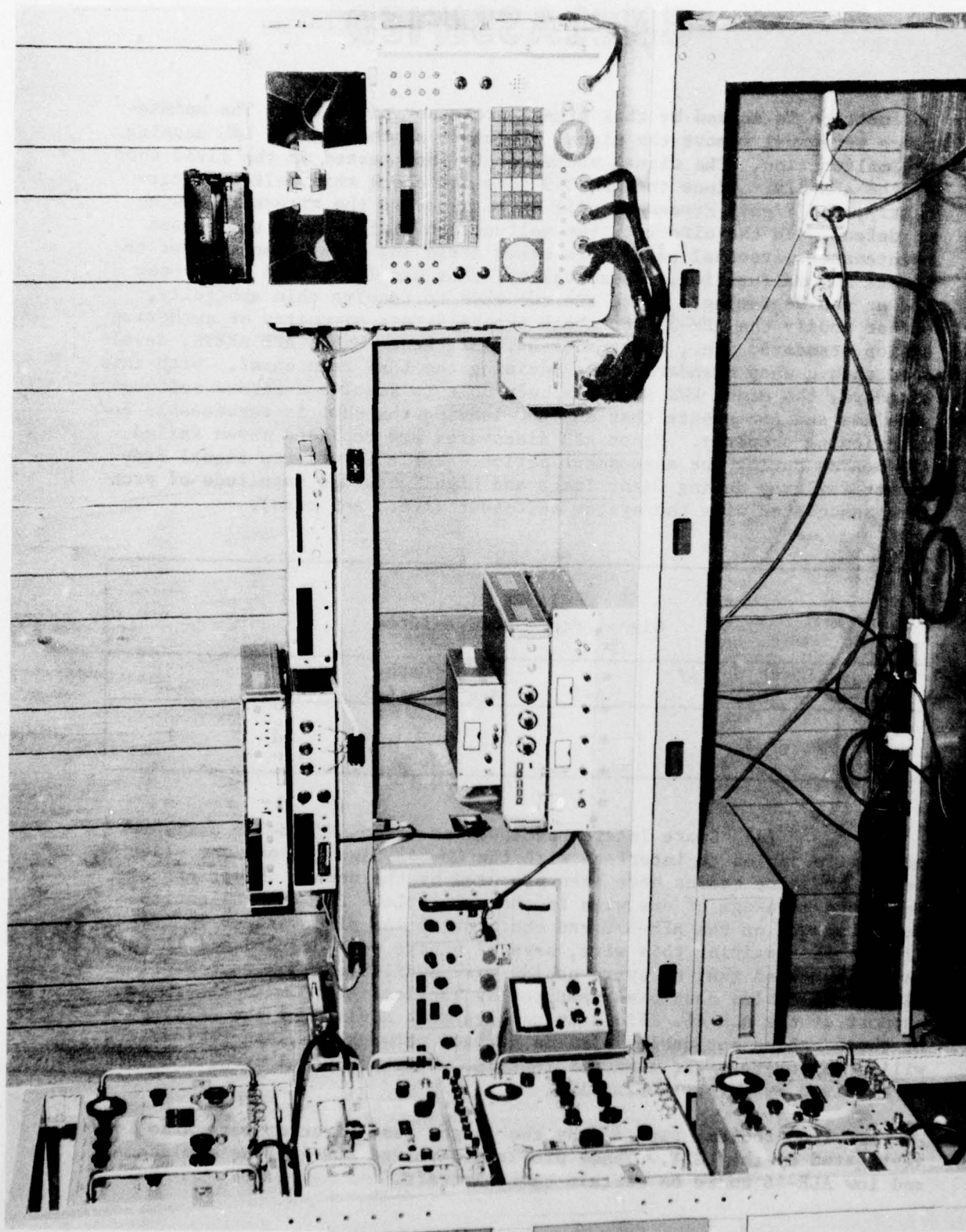

Figure 4 - Mather AFB AN/AIR-46 Work Area

UNCLASSIFIED

19

# UNCLASSIFIED

malfunction is caused by this signal processor circuitry. The maintenance personnel remove the signal processor as the logical LRU causing the malfunction. The signal processor is then tested in the field shop on the APM-379. Since the APM-379 does not check this self-test circuitry, the Signal Processor will be returned to the aircraft showing no defect. In the aircraft, the malfunction still exists and causes maintenance personnel to explore other areas and LRUs in an attempt to locate the malfunction. In actuality, they had identified the proper LRU at the beginning. There are two ways to resolve this ambiguity, either modify the APM-379 to check the self-test circuitry or authorize a shop standard; i.e., a hot mock-up. Mr. Long, Minot AFB AFETS, developed such a shop standard after advising the LSET team chief. With this standard, the Minot EWS shop has been able to resolve numerous self-test problems and can ensure that any LRU leaving the shop is serviceable and functioning properly. Minot AFB discovered and replaced seven failed A-5 boards during the assessment period. Table 2 reflects Signal Processor failures during Giant Image and highlights the magnitude of problems associated with the system self-test (i.e., A-5 card).

TABLE 2 Signal Processor Failures						
Fuse	Power Supply PS1	Cards				
		A-3	A-4	A-5	A-8	A-9
19	3	2	5	7	1	1

(d) Spare Interconnect Cables - The AN/APM-379 uses four multi-wire cables to interface with the CM-442 Signal Processor under test. No spare cables have been procured by the depot. Minot AFB experienced breakage of one wire in the W-2 cable. Erratic indications were observed on the APM-379 and the problem was discovered. In the process of repairing this wire, several others were damaged and it was then discovered that no spare cables were available. Numerous problems with these cables have been reported by Tactical Air Command in their support of the ALR-46. Field units have been advised of the delicacy of these cables but cables will be damaged through use, and performance will deteriorate after numerous repairs. This potential problem should be resolved by Warner Robins ALC.

h. Two problems reported by the flight test director were also investigated by the LSET. These problems involved ALR-46 fuse replacement and low ALR-46 audio on certain test aircraft.

# UNCLASSIFIED

# UNCLASSIFIED

(1) Fuse failures have been previously discussed and many of these problems have been resolved by increasing the fuse rating from 3-amps to 5-amps to handle electrical transients. However, the problem of removal and replacement of the fuse remains. The fuse and a spare are located on the lower front of the Signal Processor (Figure 5). The Signal Processor is mounted in an equipment rack on the floor to the left of the EWO as he is seated. Heat generated by the processor required a heat shield be added between the processor and the EWO. With the processor in its normal position, it is extremely difficult, if not impossible, to remove and replace the fuse. There is an equipment rack bulkhead approximately three inches (7.62 cm) to the front of the processor which obstructs access to the fuses. During the test flights several fuses failed and had to be replaced. The operator had to completely unstrap from his seat, disconnect the cables from the Signal Processor, remove it from the equipment rack, and then replace the fuse. The operator must wear gloves in handling the processor because of the heat generated by the integrated power supply. The fuse cap has a recessed slot requiring a tool (screwdriver or coin) to remove and replace. The cap material chips easily and with light force the slot edges become rounded. The cap must then be discarded. During this assessment, the Mather EWS shop had to drill out a fuse because an operator had stripped the slot edges and the shop was unable to remove the cap and fuse in any other manner. SrA Patricia Loegering, Mather AFB ALR-46 technician, investigated replacement of this fuse with the standard fuse and fuse holder, P/N FHN20G. The standard fuse holder does not require any tools for fuse replacement and will fit into the present fuse space. A Form 1000 has been submitted suggesting this change. This fuse and fuse holder would solve one operator problem but the signal processor location problem remains. Relocation of the signal processor is anticipated as part of the proposed AN/ALQ-155 Power Management System. If this system (ALQ-155) is not incorporated in the B-52G/H fleet, relocation of the Signal Processor should be considered.

(2) The other problem discovered during the flight test missions was weak ALR-46 audio on some aircraft. Investigation of this problem revealed a difference in configuration of the audio systems on several aircraft. When the AN/APR-25 system was installed in the B-52G, the AIC-10A interphone system would not provide an acceptable APR-25 audio level so an audio transformer, T6017, was added to boost the audio level. This transformer addition was completed as TCTO 1B-52-1894. With the addition of this transformer, resistor R6077 was to have been removed. During initial installation of the ALR-46 on the B-52H, a low audio condition also existed so the same transformer, T6017, was added to the B-52H as part of TCTO 1B-52H-682. Figure 6, taken from TO 1B-52G-2-23, depicts the interphone junction box (IJB) prior to the -682 modification. Resistor R6077 is properly in place across terminals 18 and 19. Figure 7 depicts the modified IJB with transformer T6017 across

# UNCLASSIFIED

UNCLASSIFIED

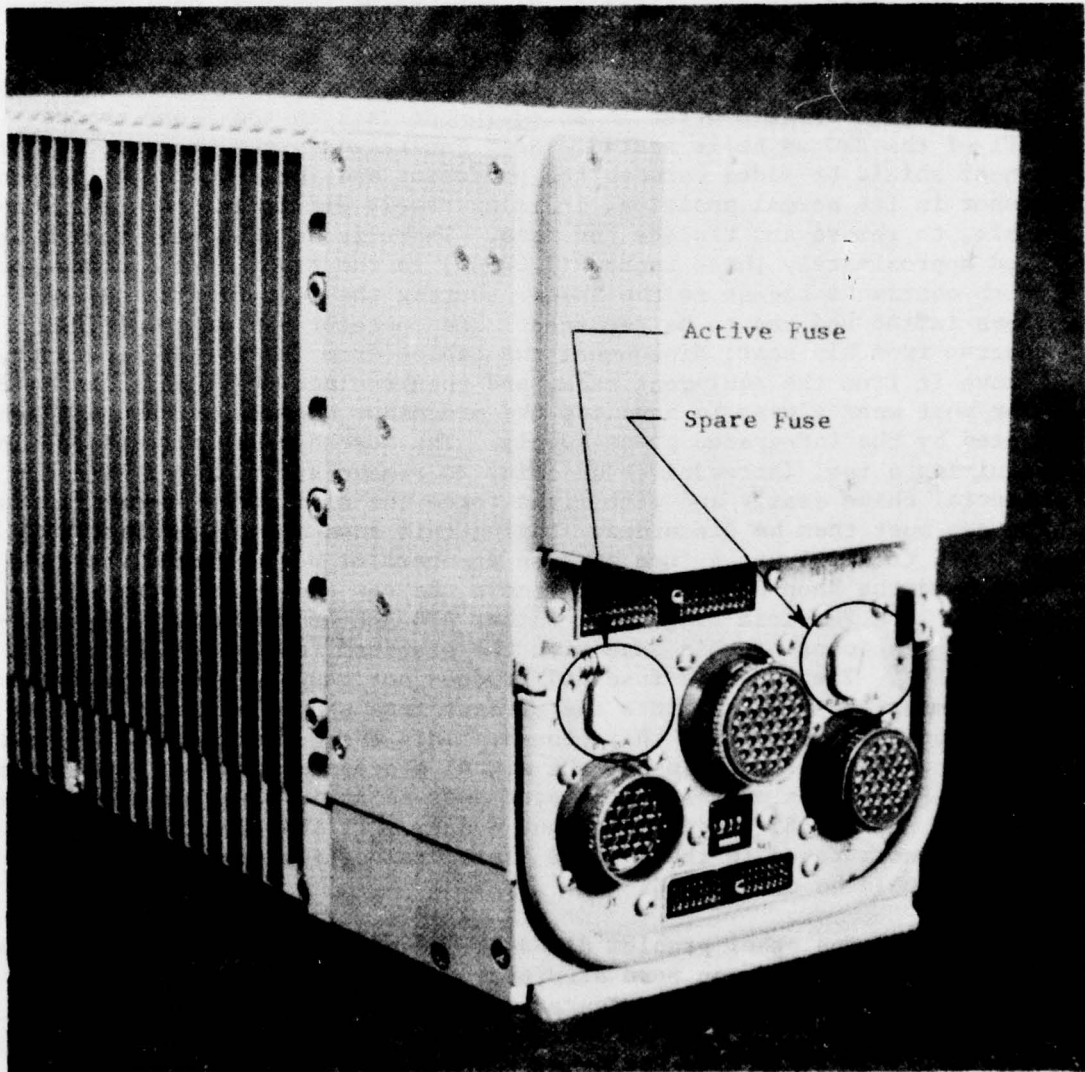

Figure 5 - AN/ALR-46 CM-442 Signal Processor

UNCLASSIFIED

UNCLASSIFIED

THIS PAGE IS BEST QUALITY PRACTICABLE  
FROM COPY FURNISHED TO DDC

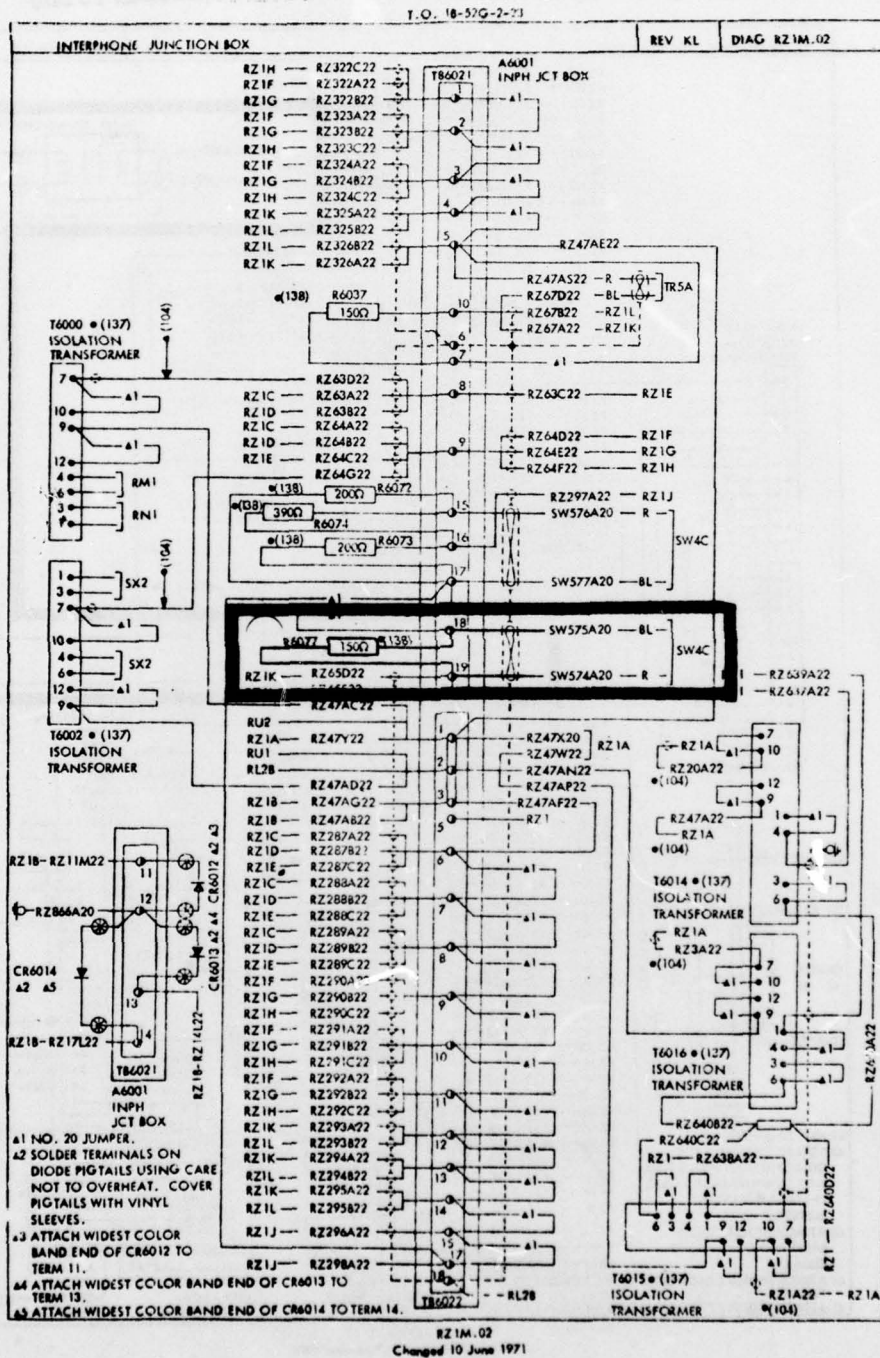

Figure 6 - B-52H Interphone Junction Box (Before TCTO 1B-52H-682)

UNCLASSIFIED

UNCLASSIFIED

THIS PAGE IS BEST QUALITY PRACTICABLE  
FROM COPY FURNISHED TO DDC

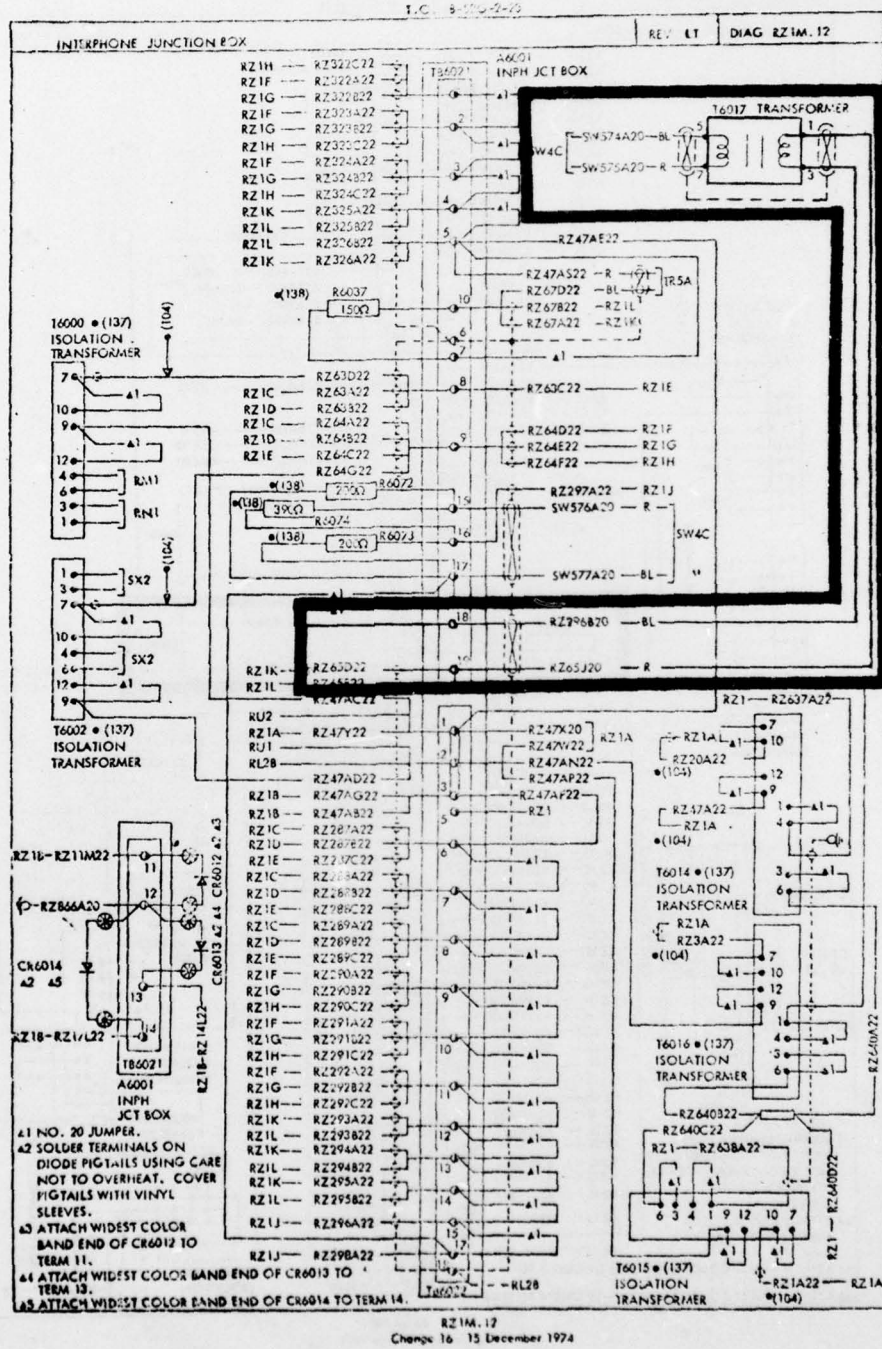

Figure 7 - B-52H Interphone Junction Box (After TCTO 1B-52H-682)

UNCLASSIFIED

# UNCLASSIFIED

terminals 18 and 19 (terminals 2 and 3 on TB6019 for B-52Gs) and resistor R6077 removed. Aircraft were found in three various configurations to include proper configuration with transformer installed and resistor removed, transformer installed and resistor not removed, and no transformer or resistor installed. These configurations were discovered at three bases after a telecon request for an inspection from the Giant Image LSET team chief. As a result, the SAC Deputy LGM requested all B-52G/H ALR-46 equipped units to conduct a one-time inspection to verify aircraft audio configurations and to bring them into compliance with applicable TCTOs. To date, six units have completed the inspection and have found seven aircraft improperly configured. The records of these seven aircraft reflected compliance with the applicable audio TCTOs. A significant improvement in ALR-46 audio was noted when the resistor R6077 was removed and the transformer installed.

UNCLASSIFIED