

AD-A058 236

HARRIS CORP MELBOURNE FLA ELECTRONIC SYSTEMS DIV
AN/TTC-38 FIBER-OPTIC VERIFICATION STUDY.(U)
AUG 77 J W BRUCE, W W COTTEN, C R PATISAUL

F/G 20/6

DAAB07-77-C-1777

UNCLASSIFIED

ECOM-77-1777-F

NL

1 OF 2

AD
A058236



ADA 058236



2
LEVEL

RESEARCH AND DEVELOPMENT TECHNICAL REPORT ECOM-77-1777-F

AN/TTC-38 FIBER-OPTIC VERIFICATION STUDY

AD No.
 DDC FILE COPY

J. W. Bruce
W. W. Cotten
C. R. Patisaul
J. C. Wyatt
Harris Corporation Electronic Systems Division
Melbourne, Florida 32901

August 1977

Final Report for Period 15 November 1976 through 30 June 1977

DISTRIBUTION STATEMENT
Approved for Public Release; Distribution Unlimited

DDC
RECEIVED
AUG 30 1978
A

Prepared for

ECOM

78 08 25 02 2



RESEARCH AND DEVELOPMENT TECHNICAL REPORT ECOM-77-1777-F

18

19

6

AN/TTC-38 FIBER-OPTIC VERIFICATION STUDY.

15

DAAB 7-77-C-1777

10

J. W. Bruce
W. W. Cotten
C. R. Patisaul
J. C. Wyatt

Harris Corporation Electronic Systems Division
Melbourne, Florida 32901

12 111p.

11

August 1977

9

Final Report for Period 15 November 1976 through 30 June 1977

DISTRIBUTION STATEMENT
Approved for Public Release; Distribution Unlimited

Prepared for

ECOM

U.S. ARMY ELECTRONICS COMMAND FORT MONMOUTH, NEW JERSEY 07703

408 972

LB

TABLE OF CONTENTS

<u>Paragraph</u>	<u>Title</u>	<u>Page</u>
1.0	INTRODUCTION.	1-1
2.0	PROGRAM SUMMARY	2-1
2.1	Configuration	2-1
2.2	Results and Conclusions.	2-4
2.3	Recommendations for Product Improvement.	2-16
3.0	BREADBOARD HARDWARE DESCRIPTION	3-1
3.1	General	3-1
3.2	Operating Instructions.	3-5
3.3	Theory of Operation.	3-10
3.4	Corrective Maintenance	3-22
4.0	DETAILED TEST RESULTS.	4-1
4.1	LED Burn-In Data.	4-1
4.2	Optical Driver/Receiver Test Data.	4-4
4.3	Test Plan	4-4
5.0	MECHANICAL AND CIRCUIT DIAGRAMS LIST	5-1
5.1	Mechanical Drawings	5-1
5.2	Electrical Circuit Drawings	5-1
6.0	PARTS LIST FOR BREADBOARD EQUIPMENT	6-1
Appendix A	TEST PROCEDURE FOR AN/TTC-38 FIBER OPTIC SYSTEM VERIFICATION STUDY.	A-1

ACCESSION No	White Section <input checked="" type="checkbox"/>	Soft Section <input type="checkbox"/>	DISTRIBUTION / AVAILABILITY CODES
DTIC	NSA	MARKS/QUOTES	Dist. Avail. and or SPECIAL
NSA	NSA	NSA	NSA
NSA	NSA	NSA	NSA

LIST OF ILLUSTRATIONS

<u>Figure</u>	<u>Title</u>	<u>Page</u>
2-1	AN/TTC-38 Fiber Optic System	2-2
2-2	System Diagram for Optical Loss Measurements	2-8
2-3	Fiber Pigtail - Photodetector Interface	2-11
3-1	AN/TTC-38 Simplified Functional Block Diagram	3-2
3-2	Installation and Setup of Breadboard with Interconnecting Cables	3-4
3-3	Equipment Front Panel	3-6
3-4	Equipment Rear Panel	3-7
3-5	AN/TTC-38 Simplified Functional Block Diagram	3-11
3-6	Schematic of Multiplex Transmitter	3-13
3-7	Schematic of Demultiplex Receiver	3-16
3-8	Schematic of Oscillator	3-18
3-9	Schematic of Motherboard	3-19
3-10	Schematic of Fiber Optic Transmitter	3-21
3-11	Schematic of Fiber Optic Receiver	3-23
4-1	LED Burn-in Data, Typical	4-3
4-2	Test Setup For Fiber Optics	4-5

LIST OF TABLES

<u>Table</u>	<u>Title</u>	<u>Page</u>
2-1	LED Optical Power Output Measurements	2-6
2-2	Optical Loss Measurements	2-10
2-3	Receiver Performance Measurements	2-14
3-1	Technical Characteristics	3-3
3-2	Controls, Indicators and Connectors	3-8
3-3	Test Equipment Required	3-24
4-1	System Fiber Channel Assignments	4-2
4-2	Test Data for Fiber Optics	4-4

SECTION 1.0
INTRODUCTION

1.0 INTRODUCTION

This document is a result of a 12 month verification study to determine the system performance of a 12 channel frequency division multiplex (FDM) fiber optic communication system proposed as a replacement for the CX-4566, 26 pair metallic cable in the AN/TTC-38 automatic telephone central office system. The investigation was conducted by Harris Corporation, Electronic Systems Division, for the Army Electronics Command, Fort Monmouth under Contract Number DAAB07-77-C-1777. In arriving at this specific approach, substantial performance and hardware trade-off analyses were performed for alternative multiplexing and modulation schemes, involving Time Division Multiplexing (TDM), Frequency Division Multiplexing (FDM), Space Division Multiplexing (SDM), and a hybrid combination of FDM and SDM. Results of those analyses are contained in a previously prepared report for ECOM⁽¹⁾.

As mentioned, this report is part of a verification study for the AN/TTC-38 Fiber Optic System. Harris ESD designed and fabricated a breadboard system compatible with interface requirements for the J-1077 field junction box and AN/TTC-38 telephone patching panel. Results of this effort are contained herein. Section 2 provides a system description and analysis of performance. Sections 3 and 4 contain an explanation of operation for the circuitry and test results, respectively. The mechanical and circuit diagrams list is provided in Section 5. Finally, the parts list is provided in Section 6.

(1) Patisaul, C.R., Slayton, I.B., Bruce, J.W., and Abrahamson, C.M., 26 - Pair Fiber Cable Study, ECOM-75-0363-F, Contract DAAB07-75-C-0367, January 1976.

SECTION 2.0

PROGRAM SUMMARY

2.0 PROGRAM SUMMARY

This study designed and implemented breadboard equipment for the AN/TTC-38 Fiber Optic System. The proposed system utilizes fiber optic communication technology as an interface between the J-1077 field telephone junction box and the AN/TCC-38 communications van. A system block diagram is shown in Figure 2-1. Simultaneous operation with both analog telephone and digital data sets (TA-341, TA-838, DSVT, DNVT) is possible, in any mix, up to a maximum of twelve sets. The complete link, from subscriber to subscriber is transparent in the sense that the fiber optics link will pass analog or digital information.

2.1 Configuration

The technical approach developed by Harris ESD for this breadboard equipment utilizes a unique combination of both Frequency Division Multiplexing (FDM) and Space Division Multiplexing (SDM). The hybrid FDM/SDM approach offers the best compromise between cost, performance, fault tolerance, and physical parameters. In depth analyses are provided in the previous study report⁽¹⁾.

This fiber optic link provides a 12 channel full duplex communication capability which can be integrated into the AN/TTC-38 Automatic Telephone Central Office System. The breadboard equipment is mechanically packaged to withstand normal bench handling. Electronic subsections provide multiplexing and demultiplexing and electro optic conversion. Each multiplex/demultiplex section will accommodate 4 channels of analog or digital information and also provide buffer circuitry compatible with the end equipments, i.e.,

(1) Patisaul, C.R., Slayton, I.B., Bruce, J.W., and Abrahamson, C.M., 26 - Pair Fiber Cable Study, ECOM-75-0363-F, Contract DAAB07-75-C-0367, January 1976.

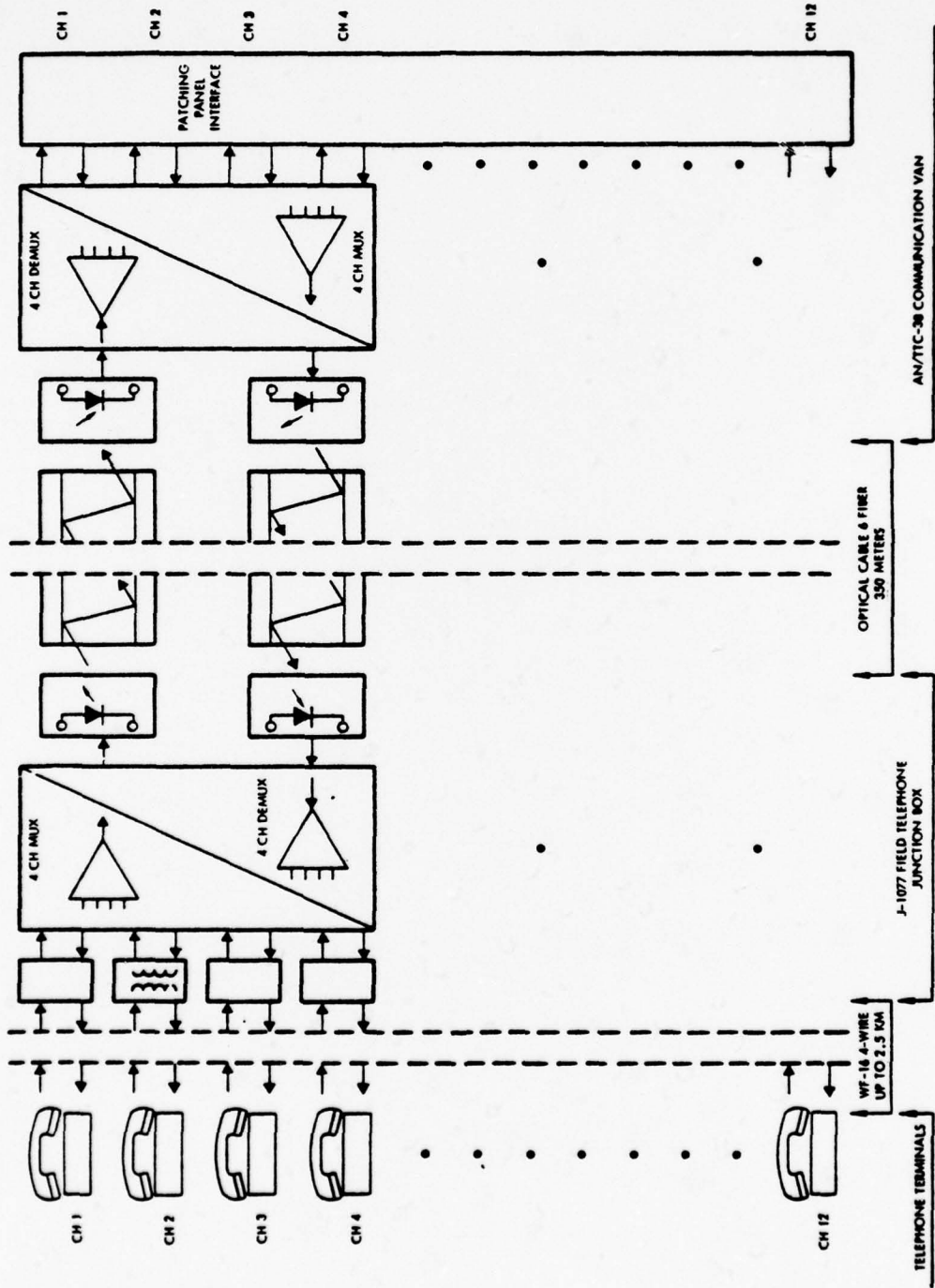

Figure 2-1. AN/TTC-38 Fiber Optic System

telephone terminal sets and AN/TTC-38 patching panel. Simply, individual baseband message channels are used to amplitude modulate specific RF subcarriers which are then frequency division multiplexed together for control of the electro optical circuitry.

The optical transmitter circuitry consists of a Light Emitting Diode (LED) and a Harris ESD developed driver. The composite 4-channel FDM signal intensity modulates the LED via the driver circuits. The optical power from the LED is coupled from this device into a 24" pigtail fiber which is permanently secured to the emitting surface of the LED.

These pigtail fibers are then individually connected to the G.F.E. 6-fiber cable connector assembly via Harris ESD single fiber connectors within the breadboard chassis. This additional connector was used in the breadboard since both the LED and in-board half of the 6-fiber connector contained pre-mounted pigtail fibers. The two breadboard chassis are connected through 350 meters of optical cable; each end preterminated with the outboard half of a 6-fiber bulkhead connector assembly. The cable and connectors were also G.F.E. by ECOM. To accommodate 12 full duplex channels, three fibers have been dedicated to each direction of transmission, 4 channels per fiber.

From the transmitter and through the fiber optic cable, the optical power is coupled to the receive circuitry of the second Harris ESD breadboard unit for the AN/TTC-38 fiber optic system. Again, this signal interfaces Harris ESD Electro-Optic circuitry via a 24" pigtail fiber. The optical receiver contains a PIN photodiode and preamp module and amplifier which detects the intensity modulated optical carrier and provides the composite 4-channel electrical signal to the demultiplexer circuitry. Recovery of the individual channels is accomplished within the appropriate filtering

networks of the demultiplexing circuitry. The two Harris ESD breadboard equipments, additionally contain necessary power conditioning circuitry for normal operation from a +28 Vdc battery. To facilitate lab testing, these units also have the capability for operating from 115 Vac.

In summary, the AN/TTC-38 fiber optic system is a technically feasible replacement for the present 26 pair field telephone system. Harris ESD has thoroughly examined all system interface criteria for existing telephone terminals and the AN/TTC-38 van equipment. The Harris ESD breadboard equipment is designed, electrically, to be fully compatible with these equipments.

2.2 Results And Conclusions

This section examines key performance parameters of the breadboard system developed during the course of the AN/TTC-38 Fiber Optic System Verification Study. The major goal of this study was to verify that a fiber optic communication system can provide good quality analog and digital voice communication over a distance of approximately 300 meters. A previous study resulted in a system design using a combination of frequency and spatial multiplexing to meet the desired performance goals⁽¹⁾. In the present study a breadboard system based on this design and configured as described in Section 2.1 was implemented to verify the system concept.

Signal-to-noise ratio (SNR) for the analog voice was found in the previous study to be the driving factor in system performance and it is the primary topic of discussion in

(1) Patisaul, C.R., Slayton, I.B., Bruce, J.W., and Abrahamson, C.M., 26 - Pair Fiber Cable Study, ECOM-75-0603-F, Contract DAAB07-75-C-0367, January 1976.

this section. SNR at the output of the system is determined by the noise performance of the optical receivers and the amount of optical power delivered to the receivers which, in turn, depends on the optical power output of the optical transmitters and the optical losses in the system. In the following three subparagraphs observations on three aspects of the breadboard system performance are reported, namely, optical transmitter output power, system optical losses and output SNR for analog signals. Where possible and appropriate, observed performance is compared to that predicted by theory.

2.2.1 Optical Transmitter Performance

The optical sources used in the breadboard system optical transmitters are Bell-Northern Research (BNR) 40-3-30-3 LED's. Permanently bonded to each LED is a fiber pigtail having a core diameter of 77 μm and an NA of 0.28. The pigtail fibers have a graded index profile. The optical power theoretically coupled to the fiber pigtail is given by

$$P_c = \frac{1}{2} I_o \pi (NA)^2 \quad (2.2.1-1)$$

where I_o is the on-axis radiant intensity of the LED. The factor of one-half accounts for the fact that the pigtail fiber has a graded index profile rather than a step profile⁽²⁾.

The best available information regarding radiant intensity of the LED is a typical value of

(2) DiVita, P. and Vanucci, R., "Multimode Optical Waveguides with Graded Refractive Index: Theory of Power Launching", Applied Optics, vol. 15, no. 11, pp. 2765-2772, November 1976.

2 mW/sr at a forward current of 100 mA. Using this value in (2.2.1-1) gives a typical theoretical coupled power level of 246 μ W.

Table 2-1 summarizes the measured optical power outputs from the fiber pigtailed of the LED's originally used in the breadboard system. If about 1 dB or so is allowed for fiber pigtail misalignment, Fresnel reflections, etc., then the measurements made by BNR are in excellent agreement with the predicted value. With the exception of LED #2 and perhaps #7, the power outputs measured by Harris ESD upon receipt of the LED's are in good agreement with theory. However, as indicated by the Harris ESD measurements made after approximately 40 hours of LED operation, there was noticeable degradation in the outputs of all the LED's, suggesting a lack of "burn-in" time before shipment by BNR. The subject of this initial degradation is treated in greater detail in section 4.1 of this report.

Table 2-1. LED Optical Power Output Measurements $I_F = 100$ mA

LED	BNR Measurement	Measurement #1	Measurement #2
2	235 μ W	134 μ W	117 μ W
3	325 μ W	301 μ W	207 μ W
4	215 μ W	194 μ W	145 μ W
5	240 μ W	208 μ W	144 μ W
6	250 μ W	234 μ W	182 μ W
7	210 μ W	178 μ W	132 μ W

Harris ESD Measurement #1 made upon receipt of LED's.

Harris ESD Measurement #2 made after approximately 40 hours of LED operation.

2.2.2 Optical Losses

The optical paths between the two terminals of the breadboard system are connected as shown in Figure 2-2. Pigtails from the multifiber bulkhead connector halves are connected to the LED pigtails through Harris ESD single-fiber connectors and to the photodetectors via Harris ESD-designed ferrules and alignment fixtures. The optical cable fibers and the pigtail fibers on the multifiber connectors are step-index fibers having a core diameter of 50 μm and an NA of 0.25.

The optical losses associated with the Harris ESD single-fiber connectors are due to Fresnel reflections, mechanical misalignments, and core area and NA mismatches between the BNR LED pigtail fiber and the pigtail fiber on the multifiber connector. Previous experience with this connector indicates that the loss contribution due to Fresnel reflections and mechanical misalignments should be no more than -2 dB. The maximum loss to be expected from core area and NA mismatch is

$$\begin{aligned} \text{Mismatch loss} &= 10 \log_{10} \left(\frac{50 \mu\text{m}}{77 \mu\text{m}} \right)^2 \left(\frac{0.25}{0.28} \right)^2 \quad (2.2.2-1) \\ &= 4.7 \text{ dB} \end{aligned}$$

so that the predicted maximum total Harris ESD connector loss is 6.7 dB. As measurement results show, however, the single fiber connector loss is typically -3 to -4 dB. At present it is hypothesized that the grading of the refractive index of the LED pigtail fiber causes optical energy propagating in that fiber to be concentrated near the core axis, thereby reducing the effective core area and, hence, the area mismatch loss.

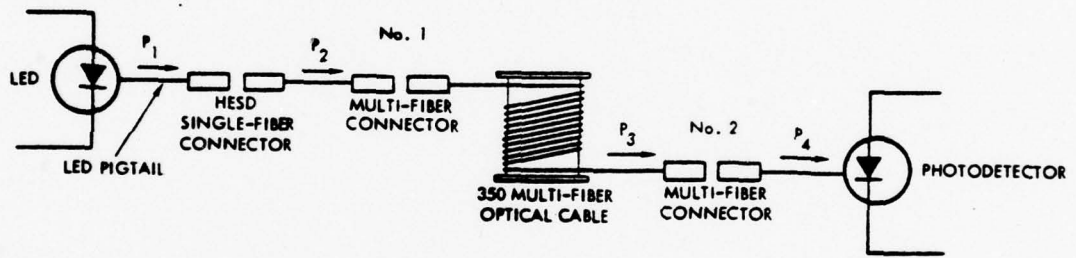

Figure 2-2. System Diagram for Optical Loss Measurement (one optical channel shown)

Table 2-2 lists the result of optical loss measurements on five of the fiber channels in the breadboard system. It is interesting to note that with the exception of optical channel A, all of the channels tested in the particular test reported here experienced on the order of -1 dB loss through multifiber connector #2. It has been observed, however, that by unmating and remating the multifiber connector or by merely "wiggling" the connector the optical loss could be made to vary over a 10 dB range.

In addition to the optical losses shown in Table 2-2, there is a loss encountered at the interface between the multifiber bulkhead connector pigtail and the photodiode sensitive surface. This interface is shown in simplified form in Figure 2-3. The output coupling loss for this interface is

$$\text{Output Coupling Loss} = 10 \log_{10} \frac{D_{\text{spot}}}{D_{\text{ss}}} + \text{Fresnel} \quad (2.2.2-2)$$

Simple trigonometry yields

$$D_{\text{spot}} = D_{\text{core}} + 2l \tan \theta_A \quad (2.2.2-3)$$

$$\theta_A = \sin^{-1} (\text{NA})$$

The Fresnel loss of three air-glass interfaces is about -0.6 dB and the loss due to mismatch of the projected spot area to the sensitive area is about -0.3 dB for a total predicted output coupling loss of -0.9 dB.

Table 2-2. Optical Loss Measurements

Optical Channel	Harris ESD Single-Fiber Connector Loss (P_2/P_1)	#2 Multifiber Connector Loss (P_4/P_3)	Multifiber Connectors + Cable Loss (P_4/P_2)	Total* Optical Loss (P_4/P_1)
A	-3.3 dB	-7.0 dB	-11.0 dB	-14.3 dB
B	-4.4 dB	-0.9 dB	-9.0 dB	-13.4 dB
C	-3.0 dB	-1.3 dB	-5.4 dB	-8.4 dB
D	-4.3 dB	-1.4 dB	-7.0 dB	-11.3 dB
F	-6.3 dB	-1.3 dB	-5.2 dB	-11.5 dB

*excluding output coupling loss at photodetector

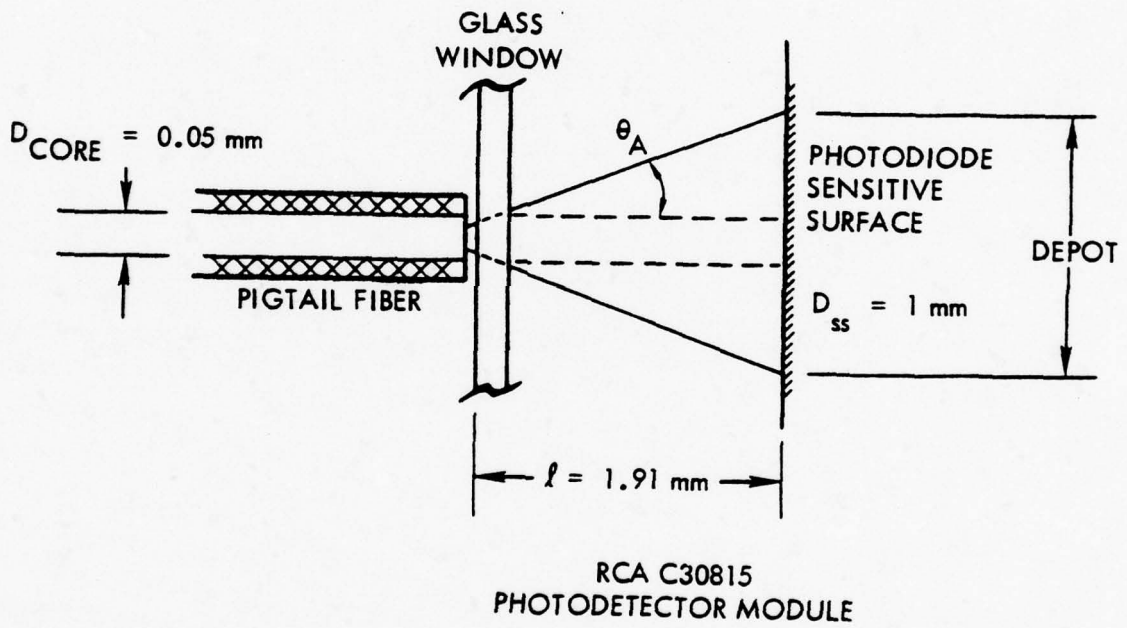

Figure 2-3. Fiber Pigtail - Photodetector Interface

2.2.3 Optical Receiver Performance

The theoretical value for the output SNR from an analog channel of the bread-board system is

$$\text{SNR} = \frac{(R P_R m_{sc} m_a)^2 \langle M^2 \rangle}{2b (2qrP_R K^2 + V_n^2)} \quad (2.2.3-1)$$

where

R = photodetector module responsivity (V/W)

r = photodiode responsivity (A/W)

K = photodetector preamp transimpedance (V/A)

V_n = photodetector module output noise voltage spectral density (V/ $\sqrt{\text{Hz}}$)

P_R = average optical carrier power incident on the photodiode (W)

m_a = amplitude modulation index of the AM carrier

m_{sc} = optical intensity modulation index to the unmodulated AM carrier

$\langle \dot{M}^2 \rangle$ = mean-square value of the modulating signal relative to $|M|_{\text{max}} = 1$

b = noise-equivalent bandwidth of the analog channel (Hz)

Equation (2.2.3-1) is a modified version of the previously derived result for envelope detector demodulation of an AM carrier signal delivered by an optical receiver⁽¹⁾.

(1) Patisaul, C.R., Slayton, I.B., Bruce, J.W., and Abrahamson, C.M., 26 - Pair Fiber Cable Study, ECOM-75-0363-F, Contract DAAB07-75-C-0367, January 1976.

The modification is the inclusion of the quantum noise term in the optical receiver output.

The RCA C30815 photodetector modules have the following typical characteristics in the 840 nm optical wavelength region:

$$R = 1 \times 10^4 \text{ V/W}$$

$$r = 0.6 \text{ A/W}$$

$$V_n = 3 \times 10^{-8} \sqrt{\text{V/Hz}}$$

$$K = 1.54 \times 10^{-4} \text{ V/A}$$

In an attempt to relate actual system performance to theory, laboratory measurements were performed on two arbitrarily selected analog channels. One of the channels was assigned to optical channel A while the other was assigned to optical channel E. The results of these measurements together with estimated measurement errors are summarized in Table 2-3. Using the photodetector parameters given above and the measured values of m_a , m_{sc} and P_R in (2.2.3-1) one computes a theoretical SNR of 47.7 dB for the test analog channel on optical channel A and 52.7 dB for the test channel on optical channel E compared to measured values of 52 dB and 47 dB respectively. Thus the measured SNF for the first test channel is 4.3 dB greater than the theoretical prediction based on measured parameters, while the second test channel falls 5.7 dB short of the theoretical value. The effects of measurement errors on the value of m_a , m_{sc} and P_R contribute to an uncertainty of ± 3.7 dB in the predicted value of SNR. Testing of the optical receivers indicates a ± 2 dB variation in noise performance from receiver to receiver, due in large measure to variations from typical in the performance of photodetector modules. Combining these effects with the estimated error in the measured

SNR value leads to the conclusion that the predicted and measured values of SNR are in agreement within the accuracy of measurement and component tolerance.

Performance of the 32 kb/s digital voice channels can be extrapolated from the above results. The fact that the performance with digital inputs is more than adequate is evident from the results of the System Test Procedure (see Section 4.3).

Table 2-3. Receiver Performance Measurements

Parameter	Channel A	Channel E	Est. Meas. Error
m_a	0.2	0.2	$\pm 20\%$
m_{sc}	0.07	0.13	$\pm 10\%$
P_R^*	7.4 μ W	7.1 μ W	± 0.5 dB
SNR^+	52 dB	47 dB	± 0.5 dB

*Including an estimated 1 dB output coupling loss

+1 kHz test tone, 3.7 kHz noise-equivalent bandwidth

2.2.4 Conclusions/Recommendations

The major conclusion of this breadboard study is that a fiber optic communication system using a combination of spatial multiplexing and frequency division multiplexing with AM carriers is a technically viable solution to the tactical, short haul voice communication problem. With some improvements in the optical transmission path the reach of the breadboard system could be extended well beyond the 350 m reported here. This is discussed further in subparagraph 2.2.4.1.

During the course of this study several points of potential improvement in the electronic portion of the breadboard system were noted. These are addressed in subparagraph 2.2.4.2.

2.2.4.1 Potential Reach Of The System With Optical Improvement

There were two sources of unnecessary optical loss in the breadboard system. The first of these was the use of a graded-index fiber pigtail on the LED. The use of a step-index pigtail of equivalent core diameter and NA would improve coupled power by approximately 3 dB, increasing the typical coupled power from the 150 μ W obtained here to 300 μ W.

The second source of unnecessary loss was the use of two fiber pigtails at the transmitter, one for the LED and one for the multifiber bulkhead connector, necessitating a single-fiber connector to join the two dissimilar fibers. If one pigtail were used a -3 to -4 dB loss could be eliminated.

Let us assume that the above mentioned improvements are made and that a multi-fiber cable made of fibers compatible in core diameter and NA with the pigtail fibers is available with a maximum loss of 10 dB/km. Furthermore assume the availability of multi-fiber connectors with insertion losses of -1.5 dB. Under these circumstances the Harris ESD breadboard system could provide a 40 dB analog voice SNR over a distance of 1.7 km. This distance limit was computed assuming -2 dB output coupling loss, an increase over the current -0.9 dB brought about by increasing the fiber core diameter and NA. Modulation indices assumed were $m_{sc} = 0.1$ and $m_a = 0.2$, typical of the breadboard system.

In an operational system the link distance would have to be reduced somewhat to provide optical power margin and to allow for additional connectors to join together standard lengths of cable. For instance, a reach of 1 km could be achieved using two 0.5 km cable sections with 5.5 dB optical power margin.

2.3 RECOMMENDATIONS FOR PRODUCT IMPROVEMENT

2.3.1 Receiver Power AGC

It is recommended on future development of this equipment that an Automatic Gain Control (AGC) circuit be provided to compensate for long-term signal level variations.

During the system testing, it was observed that the received optical power level varied over a 10 to 15 dB range, depending on random variations in the mating of the multi-way optical connector and in what position the connector was finally resting. Moving the connector slightly, either intentionally or accidentally from a bump or a jarring vibration, resulted in some channels' optical power increasing significantly, while others would decrease.

The effects of these random variations in received power on system operation are: variations in channel output power and variations in channel S/N ratio. In the laboratory tests however, these variations were not audibly noticeable to human observers talking on the voice link. This was probably due to the fact that the S/N of the equipment within a 4 kHz bandwidth was so high (49-53 dB) that a 10-15 dB change was not noticeable. With a longer link or a degraded S/N figure, the variations would become more apparent and objectionable.

2.3.2 Power And Cost Reduction

It is recommended that the next development model delete the fiber optic amplifier-driver and associated circuitry. The FO driver was included in the breadboard model because it was uncertain at the time of design whether sufficient power would be available to drive the LED, with sufficient margin to allow for a 6 dB variable power adjustment for setting the LED modulation index. Breadboard tests showed that sufficient RF drive power is available, and deletion of this circuit will have the following advantages:

- a. Reductions of Intermodulation Products - This advantage is not a major performance item taken by itself since the equipment already exceeds specification by a significant margin. It will nevertheless enable a noticeable technical improvement to be made with the added benefits of lower cost and lower power, as described below.
- b. Reduction of Cost - The deletion of the circuit components described in a above will reduce materials cost by over \$700 per system and enable smaller, less costly power supplies to be used by reducing power consumption as described below.
- c. Reduction of Power - The deletion of the circuit described in a above will also have the advantage of reducing power consumption by over 13 watts per box, or 26 watts per system. When operating from battery power, this is a very significant savings considering the negative cost associated with doing it.

2.3.3 Fiber Protection and Ruggedization

It is recommended that future development models of this equipment incorporate the fiber optics circuitry and pigtails in a completely enclosed metal box separate from (but packaged within) the mux/demux electronics chassis. In this way, the fiber optics equipment will be protected when technicians perform maintenance on peripheral electronics. For fiber optic servicing, the multi-way connector would be unplugged, RF coax and DC power connectors disconnected, and the entire FO assembly box would slide out of the chassis.

In system tests, several instances of fiber pigtail breakage were incurred as a result of wiring assemblers working on other portions of the mux/demux system having no relation to the fiber optics components. Fiber breakage is annoying and time-consuming to repair, and efforts should be made to adequately protect the fibers from accidental damage by field maintenance personnel.

Since the fiber optics interface is only a small portion of the total electronics package in this equipment, it is probable that most maintenance will occur on non-fiber optics circuit boards. The fiber optics portion should, therefore, be well-protected from damage when personnel are working in other areas of the equipment. Separate physical enclosures or partitions within the chassis drawer would satisfy this requirement.

SECTION 3.0

BREADBOARD HARDWARE DESCRIPTION

3.0 BREADBOARD HARDWARE DESCRIPTION

3.1 General

3.1.1 Purpose Of Equipment

The purpose of this breadboard equipment was to demonstrate the feasibility of multiplexing four (4) channels of data (Voice, 16 or 32 kilobit rate) onto a single fiber optic link and recovering this data by a demultiplexing method at the far end of the link with minimal interference from adjacent channels. The system has the capability of transmitting and receiving twelve (12) channels, in groups of four (4) each, in a full duplex operation over a fiber optic link whose length is a nominal 350 meters while maintaining the technical characteristics described below. A simplified functional block diagram is shown in Figure 3-1.

3.1.2 Technical Characteristics

Pertinent technical parameters for the AN/TTC-38 Fiber Optic System is given in Table 3-1.

3.1.3 Installation

The AN/TTC-38 Fiber Optic System will install in any flat surface whose horizontal clearances is 30 x 20 inches with routing areas for interconnecting cables and a vertical clearance of 7.5 inches. The breadboard system consists of two separate units with power cords provided for connection to an AC or DC line. Data and Fiber Optic interconnecting cables are provided by the ultimate user. Equipment setup is accomplished by connecting the units to a 115 Vac or 28 Vdc power and interconnecting the cables as specified in Figure 3-2.

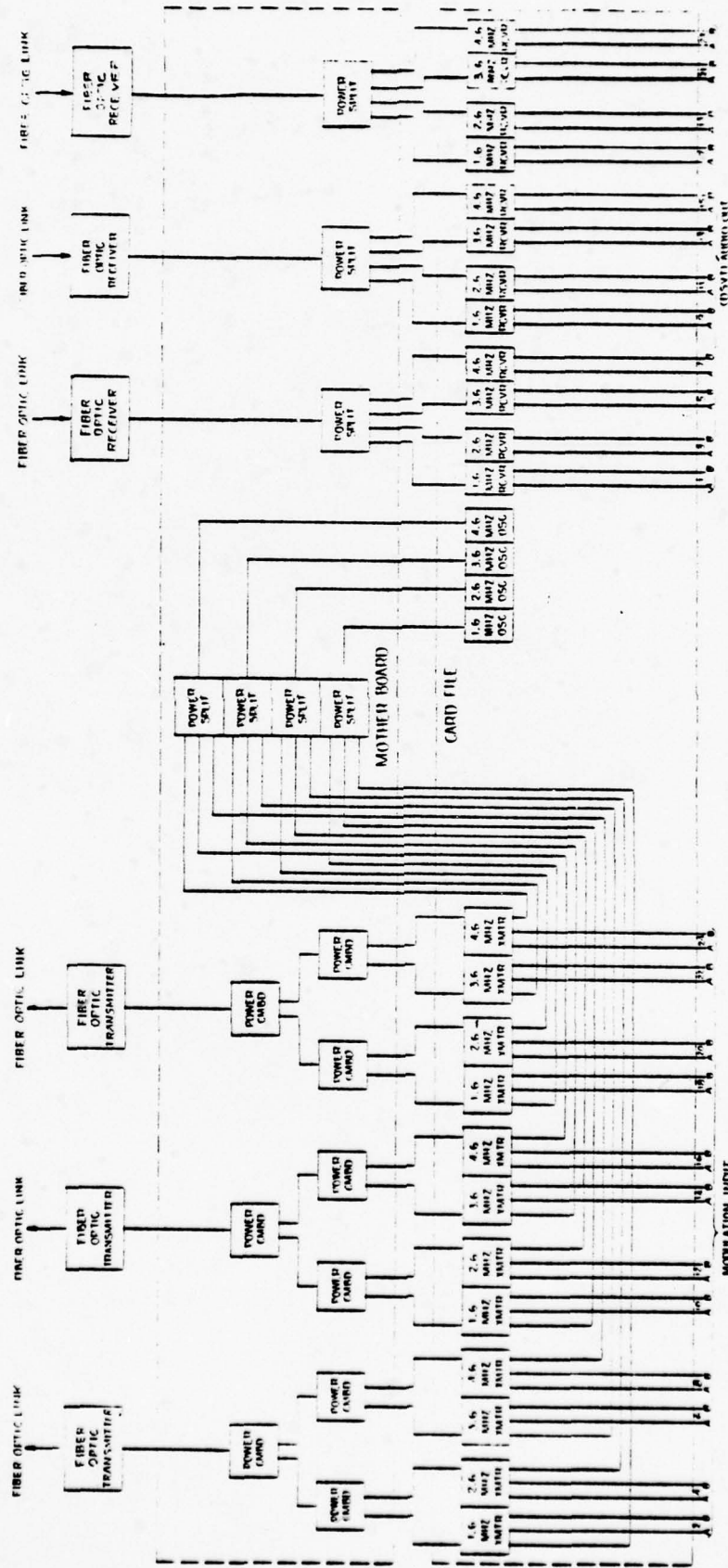

Figure 3-1. AN/TTC-38 Simplified Functional Block Diagram

Table 3-1. Technical Characteristics

Parameter	Specifications
Electrical	
AC Power	115 V single phase @ 1.5 amps
DC Power	28 V @ 3.2 amps
Carrier Frequencies	1.6 MHz 3 each 2.6 MHz 3 each 3.6 MHz 3 each 4.6 MHz 3 each
Data Inputs	12 channels of any mix of voice and 16 kilobit or 32 kilobit data rate.
S/N Each Channel	45 dB in 4 kHz Bandwidth
Cross Talk	40 dB Channel to Channel
Input Impedance	600 ohm balanced
Output Impedance	150 ohm balanced
Voice and Data Dynamic Signal level range	25 dB for ± 1.0 dB variation in output
Output Signal Level	1.2 V p-p nominal
Rise Time Through Link	5.0 μ s
Droop	5%
Mechanical	
Height	7.5 inches
Width	19.5 inches
Depth	25 inches
Weight	

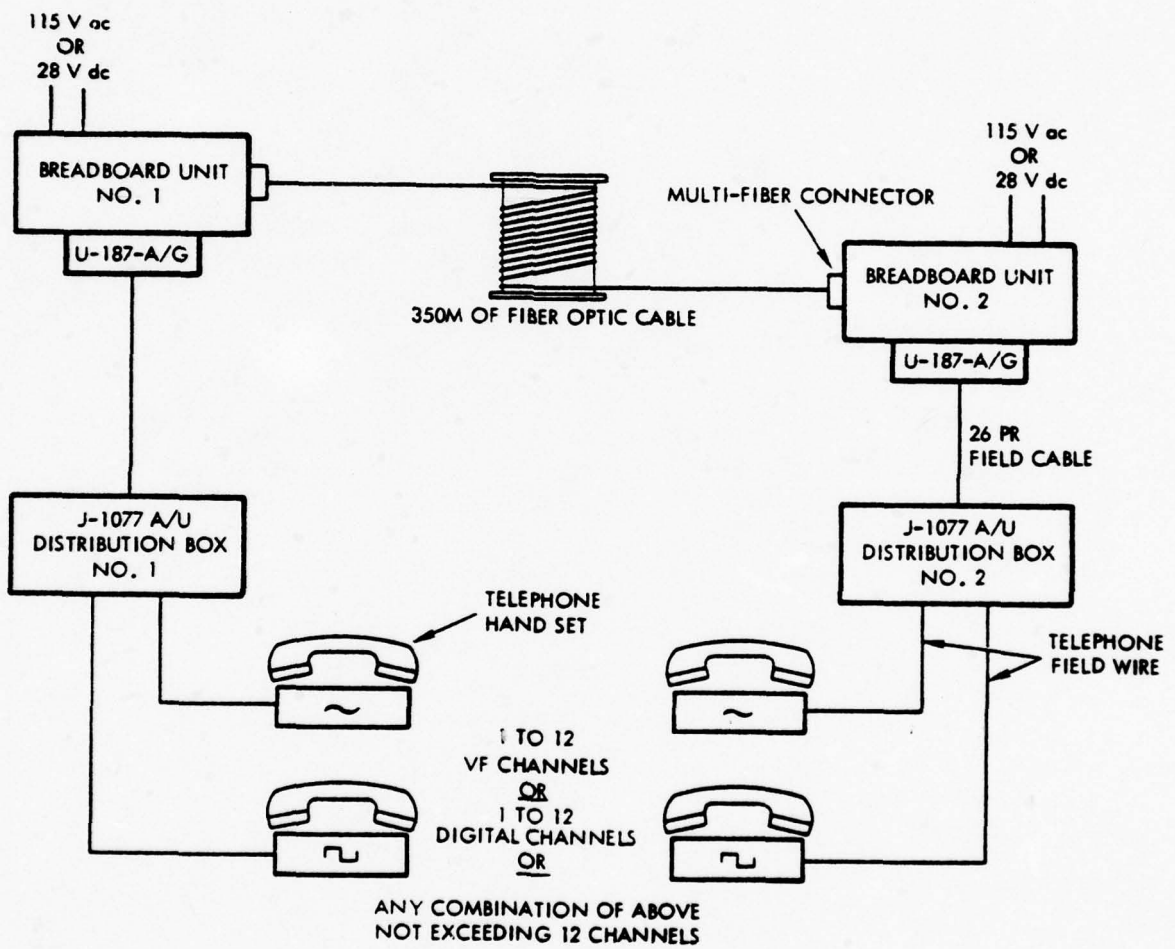

Figure 3-2. Installation And Setup Of Breadboard With Interconnecting Cables

After unpacking the optical cable reel, visually inspect the multi-way optical fiber connector for visual damage or dirt in the recessed holes. Optical fiber ends should be cleaned before installation by using a small cotton-tipped swab and lens cleaning solution.

The multi-way optical fiber connectors mounted on each mux/demux chassis should also be visually inspected for damage and carefully cleaned as described above.

The optical transmitter card contains 3 high radiance LEDs which are connected to the multi-way connector via three single-fiber optical bulkhead connectors. If these connectors are disconnected for any reason, they should be cleaned with lens cleaner before reassembly. The connectors must be carefully reassembled, making sure not to allow the fiber and body of the connector to twist or rotate while screwing on the mating cap.

3.2 Operating Instructions

This section contains information and location illustrations for the controls and connectors on the AN/TTC-38 Fiber Optic breadboard unit.

3.2.1 Controls, Indicators and Connectors

Operator controls and indicators are located on the equipment front and rear panels (Fig. 3-3 and 3-4). Reference designators and functions of each control and connector are listed in Table 3-2.

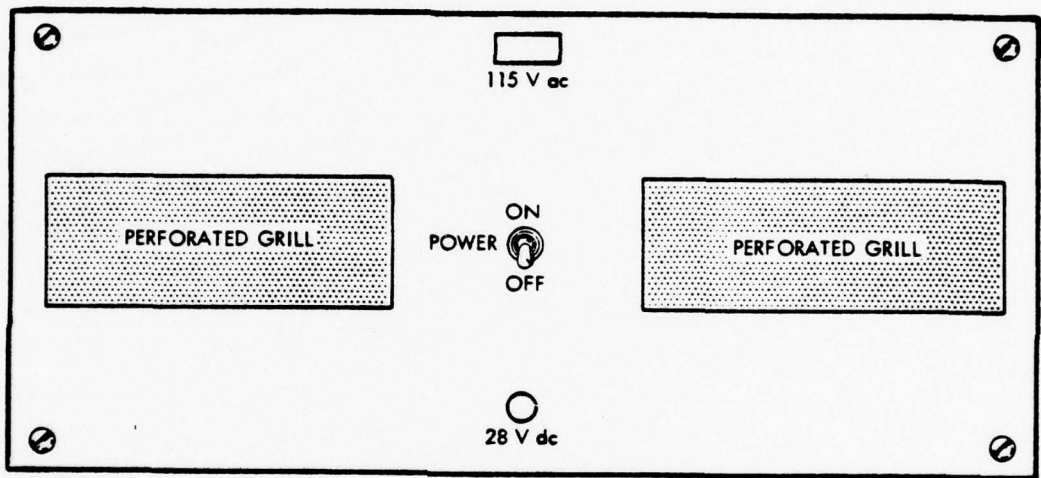

Figure 3-3. Front Panel Of Breadboard Equipment

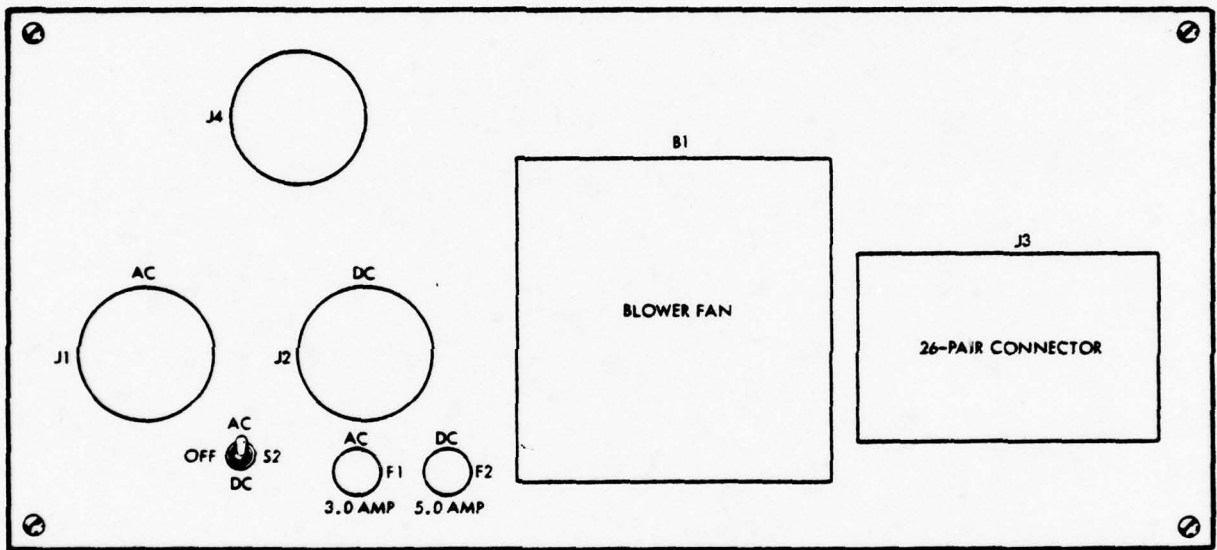

Figure 3-4. Equipment Rear Panel

Table 3-2. Controls, Indicators and Connectors

Control/Indicators/Connector	Reference Designation	Function
Power ON/OFF	S1	Applies input power (115 Vac or 28 Vdc) to power supplies and circuitry.
AC	L1	Indicates 115 Vac is applied to the system.
DC	L2	Indicates 28 Vdc is applied to the system.
Fiber Optic	J4	Fiber Optic Input/Output connector.
AC	J1	Supplies 115 Vac to system.
DC	J2	Supplies 28 Vdc to system.
DATA	J3	External interface for input and output signals.
AC/OFF/DC	S2	Selects either the AC or DC to be used to operate the system.
AC	F1	AC fuse
DC	F2	DC fuse
Fan	B1	Removes warm air from system.

3.2.2 Operating Procedures

The procedures outlined in the following paragraphs provide instructions for turn-on, operating checkout and shutdown of the AN/TTC-38 Fiber Optic System Equipment.

- a. Turn-On - Place AC/OFF/DC switch, S2 in the desired position to operate from either 115 Vac or 28 Vdc power.
Place ON/OFF, S1, into ON position. This completes the turn-on procedure for the breadboard equipment.
- b. Operation/Checkout - Operation/checkout is performed by speaking/-listening to a telephone pair which is connected to the system by an appropriate telephone terminal set.
- c. Shutdown - Place ON/OFF, S1, into the OFF position and place AC/OFF/-DC switch, S2, into the OFF position.

3.3 Theory Of Operation

3.3.1 Functional Theory

The AN/TTC-38 Fiber Optic System contains the necessary oscillators, filters, mixers, and amplifiers to multiplex and demultiplex up to 12 channels of information simultaneously. This information may be in the form of voice data such as that produced when telephones are employed or in the form of phase data whose bit rate is in the 16-32 kHz range. A block diagram of the Fiber Optic System is illustrated in Figure 3-5 for use in the following discussion.

- a. Oscillator Group - The oscillator group consists of four (4) crystal controlled oscillators tuned to 1.6, 2.6, 3.6, and 4.6 MHz. The output of each oscillator is applied to a motherboard where it is power split 3-ways. One output of each frequency is applied to each transmitter group where it serves as the carrier for the incoming data to each transmitter.
- b. Transmitter Group - There are three transmitter groups with four transmitters in each group. These transmitters accept their respective data and power level this data so as to achieve approximately 15% amplitude modulation on to the carriers received from the oscillators. This amplitude modulated signal is then band amplified and limited and applied to the Motherboard. The four transmitters of group #1 are combined onto a single coaxial cable and applied to a Fiber Optic Transmitter.
- c. Fiber Optic Transmitter - The Fiber Optic Transmitter accepts the input from the transmitter group and amplitude modulates an LED whose varying light intensity is applied to a fiber for transmission over the fiber optic link.

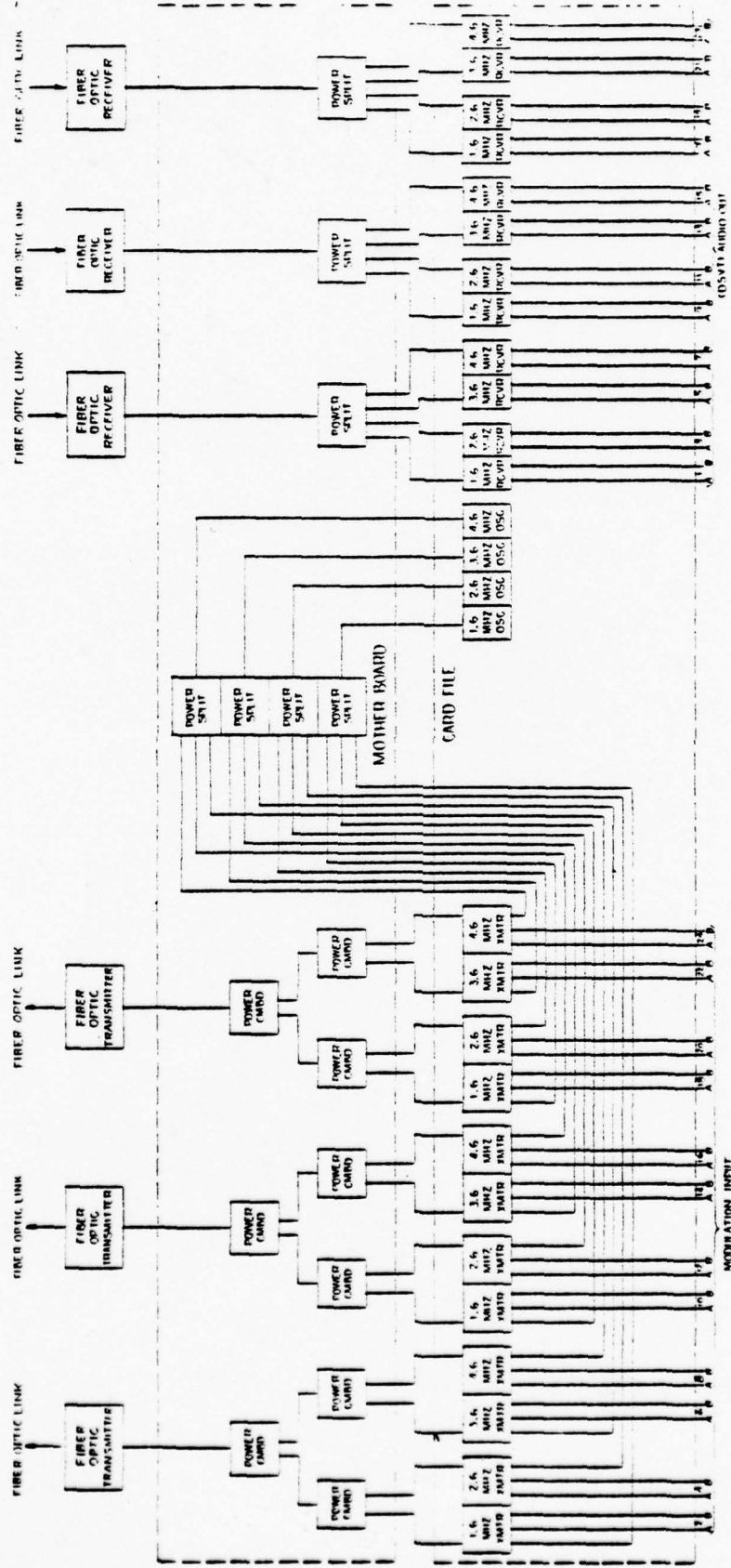

Figure 3-5. AN/HTC-38 Simplified Functional Block Diagram

- d. Fiber Optic Link - The fiber described above is one of six fibers contained in a single cable whose length is approximately 350 meters which runs between the fiber optic transmitter and the fiber optic receiver.
- e. Fiber Optic Receiver - The fiber optic receiver, in the receiving breadboard unit, converts the varying light intensity to voltage variations identical to those injected at the transmitting end of the fiber optic link. This signal is applied to the motherboard where it is power split into four signals, all of which contain the information sent by transmitter group #1 in the transmitting breadboard unit. These four signals are then applied to each receiver of receiver group #1.
- f. Receiver Group - Each receiver of the demultiplex receiver group is tuned to accept one of the four frequencies transmitted and to reject all others. Each receiver amplifies and detects its respective signal and supplies the demodulated signal to the proper telephone terminal.

3.3.2 Detailed Theory

3.3.2.1 Multiplexer Transmit Circuits

The transmitter circuit for the 1.6, 2.6, 3.6 and 4.6 MHz are very similar so only the analysis for the 1.6 MHz transmitter is presented here. Figure 3-6 is the schematic for the transmitters.

- a. Input Circuitry - The input to the transmitters for the modulating signal is balanced to ground. The signal is developed across R65 and may vary from $.35 V_{p-p}$ to $6.0 V_{p-p}$. Resistor, R65, along with Q12 and Q13, form a $600\Omega \pm 10\%$ input impedance to the transmitter. The output from Q12 is fed to the modulating leveling circuitry.

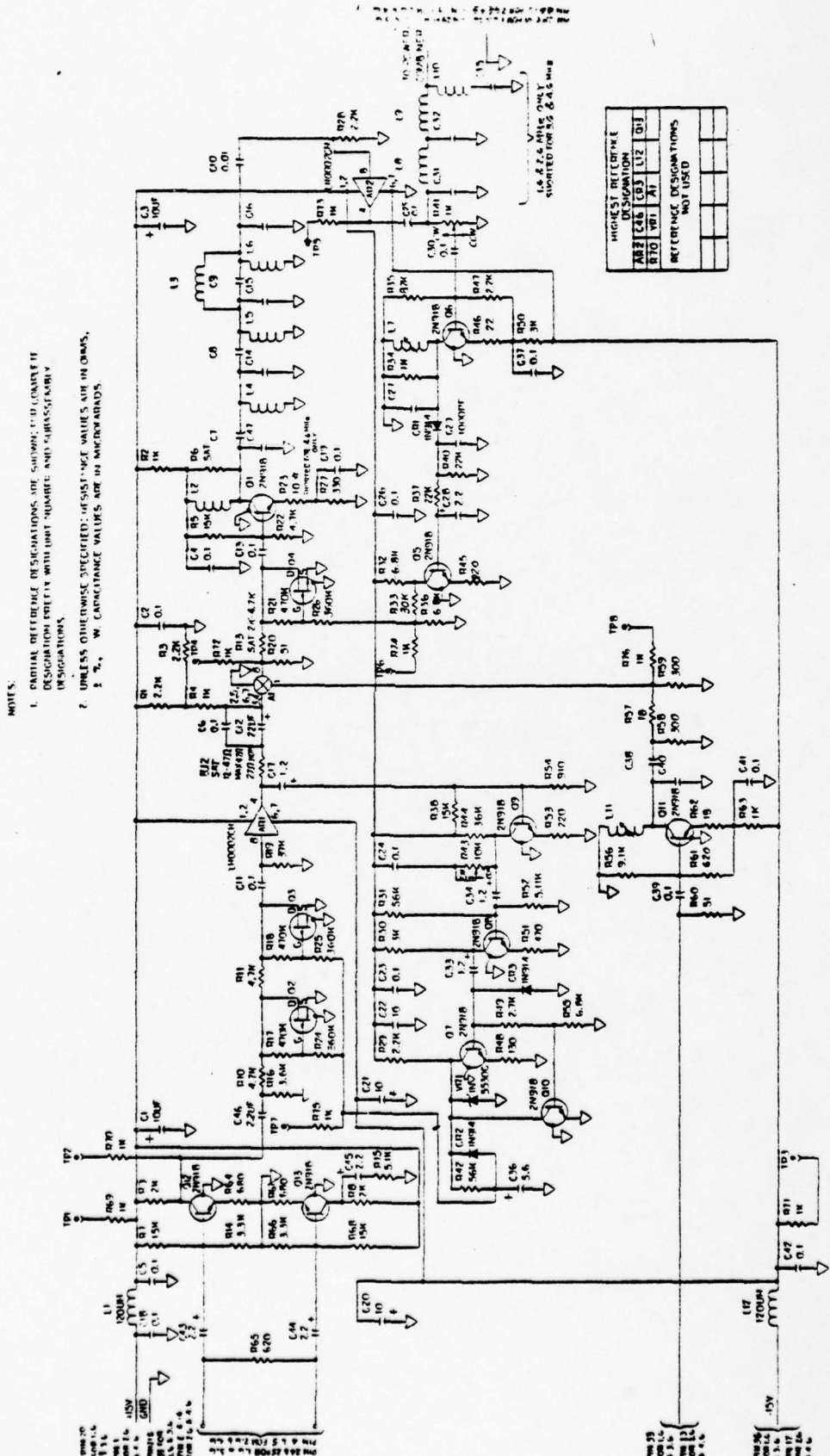

- NOTES:
1. PARTIAL REFERENCE DESIGNATIONS ARE SHOWN; FULL COMPLETE DESIGNATION PREFIX WITH UNIT NUMBER AND SUBASSEMBLY INDICATIONS.
 2. UNLESS OTHERWISE SPECIFIED: RESISTANCE VALUES ARE IN OHMS, $\% \pm$, W. CAPACITANCE VALUES ARE IN MICROFARADS.

HIGHEST REFERENCE DESIGNATION	DESIGNATION
AB2	C48
B70	V01
	A1
	L12
	O13
	REFERENCE DESIGNATIONS NOT USED

Figure 3-6. Schematic of Multiplex Transmitter

- b. Modulating Leveling Circuits - These circuits consist of Q2, Q3, AR1 and Q7-Q9. Any modulating signal fed to the transmitter is sensed and amplified by Q7-Q9. This signal is detected and produces a DC voltage on the gates of Q2-Q3 which is inversely proportional to the amplitude of the incoming signal. This DC voltage causes the resistance of Q2-Q3 to vary and in conjunction with R10 and R11, form a voltage variable attenuator which maintains a nearly constant average level at the output of the modulator driver AR1.
- c. Modulator - The modulator, A1, is a double balanced mixer biased to produce a DSB amplitude modulated waveform at its output when the carrier is present from the oscillator amplifier.
- d. Oscillator Amplifier - The oscillator amplifier, Q11, amplifies and filters the signal received from one of the four oscillators. This signal is amplitude modulated by the signal from AR1 and applied to Q1 via the power leveling circuits.
- e. Power Leveling Circuit - The power leveling circuit consists of Q4-Q6 and the associated circuitry. This circuitry operation is similar to the modulator leveling circuit except only one J-FET is used instead of two.
- f. Amplifier/Filter - The amplifier/filter circuitry bandwidth limits the signal to 500 kHz at an impedance level of $2K\Omega$ at the input of AR2, power amplifier.
- g. Power Amplifier - The power amplifier, AR2, transforms the impedance from $2K\Omega$ to 50Ω to drive a low pass filter (for 1.6 MHz and 2.6 MHz only) or the power combiners on the motherboard.

3.3.2.2 Demultiplexer Receive Circuits

All receiver circuits are identical except that they are each tuned to one of the four frequencies, 1.6 MHz, 2.6 MHz, 3.6 MHz or 4.6 MHz. Figure 3-7 is the schematic of the typical receiver.

- a. Input Filter - the input to each receiver is a multi-pole filter which selects the desired frequency and band limits this signal to approximately 500 kHz.
- b. Amplifier - Amplifier, Q4, is a conventional stage tuned to the same frequency as the input filter, which increases the signal level prior to it being applied to the amplifier/detector.
- c. Amplifier/Detector - The amplifier/detector, Q3, amplifies and applies the signal to CR1 which rectifies the signal and recovers the intelligence impressed onto the carrier. C16, R17, R14, L5 and C24 are designed to pass the data and filter the carrier from the signal path.
- d. Voltage Amplifier - The recovered signal is applied to the voltage amplifier stage, Q2, which amplifies the signal and along with C5, L4 and C17 further suppresses any residual carrier and 2nd harmonic of the carrier. This amplified signal is then applied to the phase splitter circuits.
- e. Phase Splitter - The phase splitter, Q1, produces two equal amplitude signals 180° apart for application to the driver stages. R7, C7 and R15 and C14 are used to further band limit the amplifier stages and suppress any remaining carrier and its harmonics.
- f. Line Drivers - The line drivers, AR1 and AR2, transform the high impedance of the phase splitter to a balanced output impedance of 150Ω . The output of the receiver is then connected to the Data Connector via a twisted shielded pair.

NOTES:

1. PARTIAL REFERENCE DESIGNATIONS ARE SHOWN FOR COMPLETE DESIGNATION DETAIL WITH UNIT NUMBER AND SUBASSEMBLY DESIGNATIONS.

2. UNLESS OTHERWISE SPECIFIED:

RESISTANCE VALUES ARE IN OHMS, $\%$, K , M .

CAPACITANCE VALUES ARE IN MICROFARADS.

3. L₁, C₂₄ USED ON 1.6, 2.6, AND 3.6 MHz.

L₄, C₁₇ USED ON 1.6, AND 2.6 MHz.

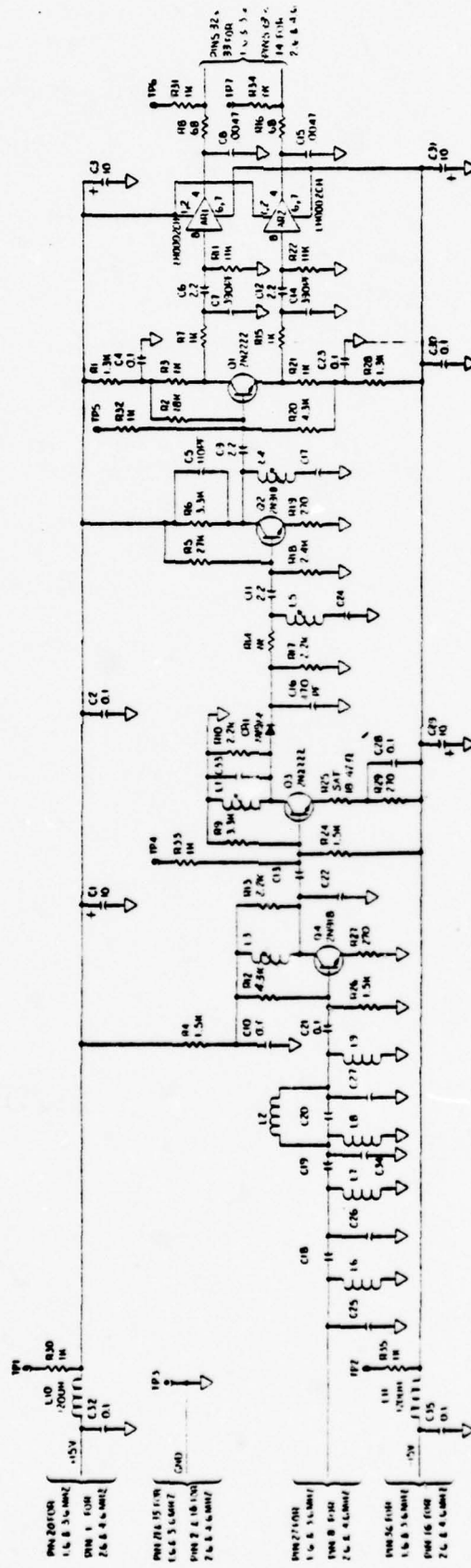

HIGHEST REFERENCE DESIGNATION	
RES	6/27
CAP	6/27
REFERENCE DESIGNATION NOT USED	

Figure 3-7. Schematic of Demultiplex Receiver

3.3.2.3 Oscillator Circuits

The oscillator circuits shown in Figure 3-8 are identical to each other except for some value changes to tune to the proper frequency. The circuits employed are crystal controlled colpitts oscillators with C23-C26 used to set each oscillator to its exact frequency. L2-L5 are used to tune the collector tanks to the exact frequency for maximum output. R9-R16 and R21-R24 are resistive pads which serves to insure a relatively constant impedance presented to the oscillators. The output of the oscillators are then fed to the motherboard.

3.3.2.4 Motherboard

The schematic of the motherboard is shown in Figure 3-9. It is on the motherboard that all required signal splitting and power combining is accomplished.

The inputs from Transmitter Group #1 are fed to power combiners 1 and 2 which in turn are fed to power combiner #7. The output from power combiner #7 is a composite signal consisting of the 1.6, 2.6, 3.6 and 4.6 MHz carrier each at a level of 2.5 mW along with their respective modulation if that particular transmitter is being modulated. The output of power combiner #7 is then fed to fiber optic transmitter via a coaxial cable. The outputs of power combiners #8 and #9 are the same as that from #7 described above.

The inputs to the motherboard from the oscillator group are power split in a resistive network and then coaxially coupled to its respective multiplex transmitter.

- NOTES:
1. PARTIAL REFERENCE DESIGNATIONS ARE SHOWN FOR COMPLETE DESIGNATION SHEET WITH UNIT NUMBER AND SUBASSEMBLY DESIGNATIONS.
 2. UNLESS OTHERWISE SPECIFIED:
RESISTANCE VALUES ARE IN OHMS, $\pm 5\%$, 1/4W.
CAPACITANCE VALUES ARE IN MICROFARADS.

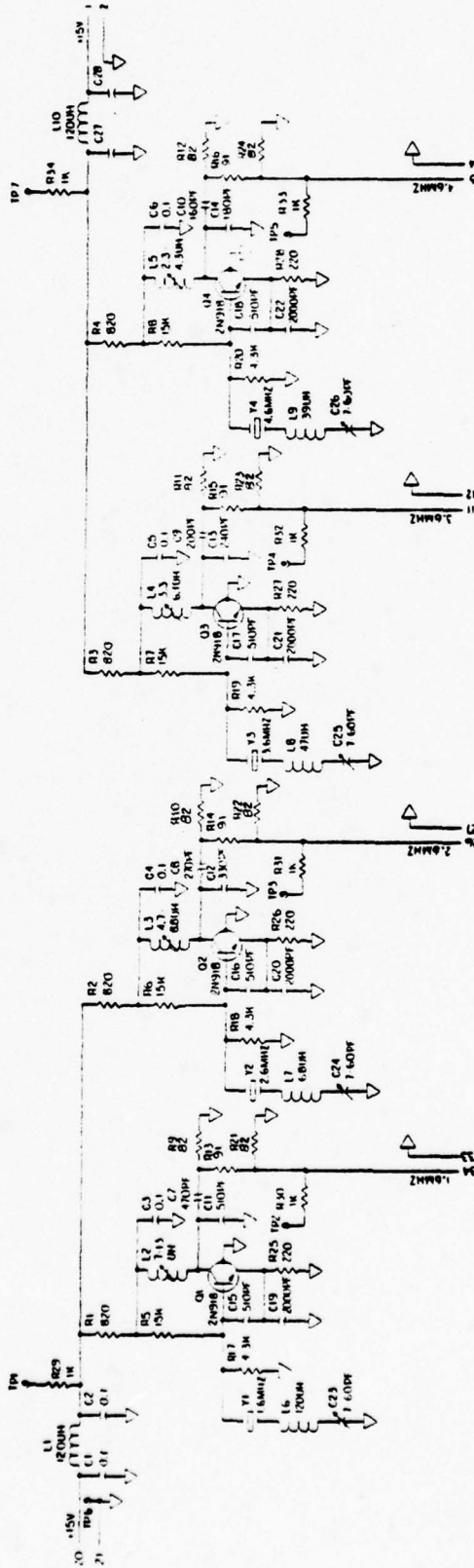

HIGHEST REFERENCE DESIGNATION	REFERENCE DESIGNATIONS NOT USED
C76	
R76	
L76	
C77	
R77	
L77	
C78	
R78	
L78	
C79	
R79	
L79	
C80	
R80	
L80	

Figure 3-8. Schematic of Oscillator

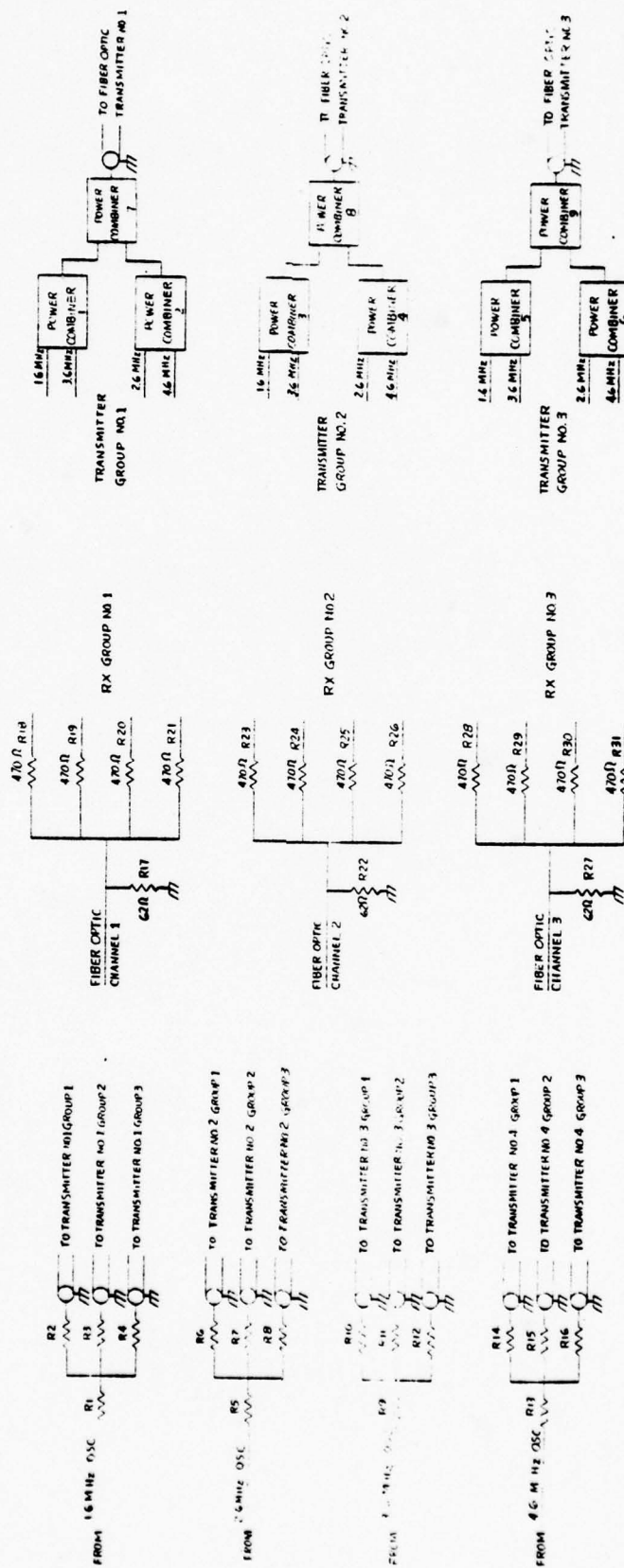

Figure 3-9. Schematic of Motherboard
3-19

3.3.2.5 Optical Transmit Circuits

The circuit diagram of the optical transmitter is shown in Figure 3-10.

The nominal input power level per carrier is +4 dBm, or +10 dBm total composite power for all four carriers as received from the multiplexer. This nominal power level can be adjusted by external in-line coaxial pads for correct operating levels in the end-to-end system, and fine adjustment (± 2 dB) is provided by variable resistor R6.

- a. Input Circuitry - The input signal is applied at RF connector J1 and is attenuated by a pi-pad for good VSWR interface performance. Transformer T1 provides impedance-matching from 50 ohms to 500 ohms. A Tee-attenuator is provided with variable resistor R6 for fine adjustment of signal level.
- b. Driver Circuitry - Amplifier AR1 is a MSK-750 power op amp with a 150 MHz f_t . It is operated in the inverting mode to drive the LED, and the output is DC offset by resistor network R8-R9-R10 to match the 1.9 Vdc drop across the LED.

AR1 drives the LED through R19 (47 ohms) to simulate a current source driver. The LED is a BNR type 40-3-30-3 High Radiance LED with a peak emission wavelength of 840 nm at a DC bias current to 100 ma for the particular diode used in the circuit.

- c. Compensation Circuitry - Also shown in Figure 3-10 (notes) are the Option A and B circuit configurations. Each of the two configurations are realizable by using jumper wires (JP1 - JP4) and the addition or deletion of circuit components. Option A is the configuration used in the breadboard cards. Option B was provided to enable testing of a compensation circuit to reduce the harmonic distortion content of the LED. (This circuit was tested and results are discussed in Section 4.0, Test Results.)

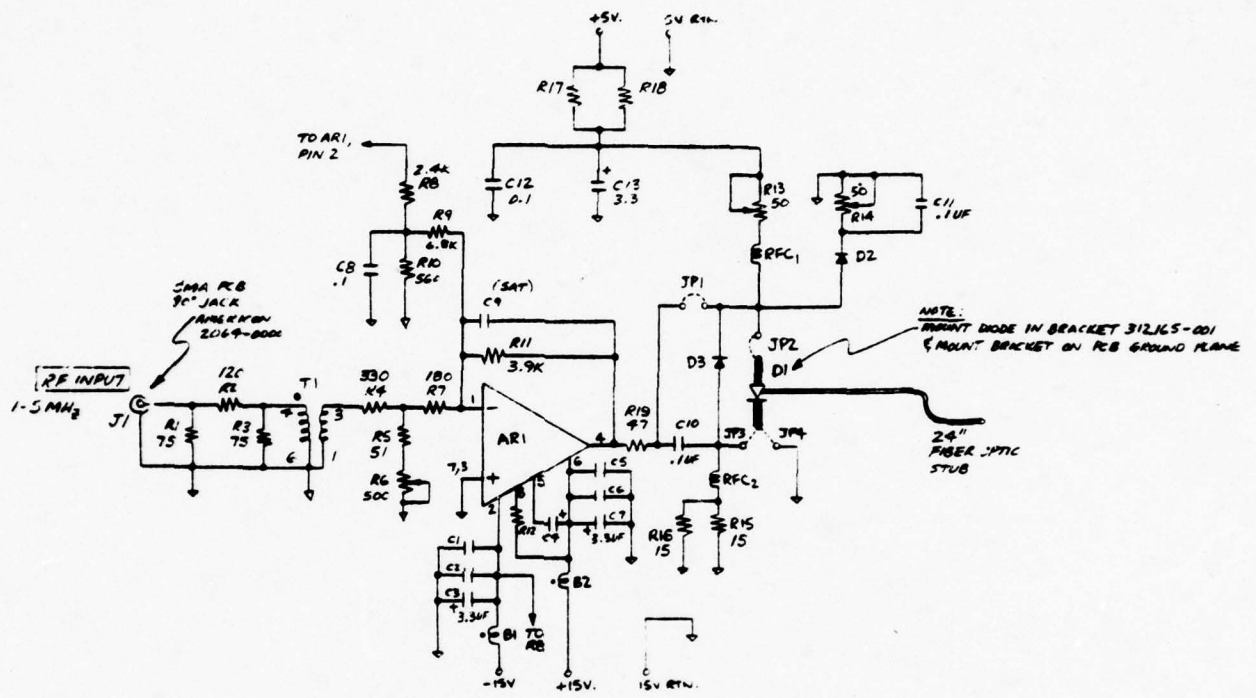

NOTES:

1. --- JUMPER WIRES
2. OPTION A CONFIGURATION: (UNCOMPENSATED MODE)

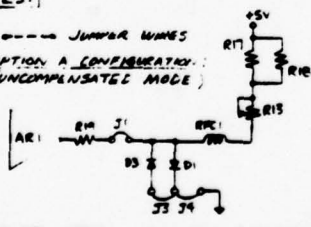

DELETE: R12, C1, C2, C3, C4, C5, C6, C7, C8, C9, C10, C11, C12, D1, D2
 Δ VALUES: R17 = R18 = 33Ω, 1/4W, RC20

3. OPTION B CONFIGURATION: (COMPENSATED MODE)

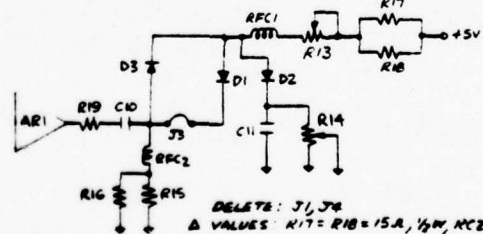

DELETE: J1, J4
 Δ VALUES: R17 = R18 = 15Ω, 1/4W, RC20

Figure 3-10. Schematic Of Fiber Optic Transmitter

3.3.2.6 Optical Receive Circuits

The circuit diagram of the Optical Receiver is shown in Figure 3-11.

- a. Input Circuitry - The optical input signal, nominally $10 \mu\text{W}$, is applied to the lens of photodetector - preamp AR1. AR1 is a RCA Type C30815 with a responsivity of $1 \times 10^4 \text{ V/W}$ at 900 nm. Variable resistor R4 permits the optical receiver gain to be adjusted from maximum to zero.
- b. Amplifier - Video amplifier AR2 is a Fairchild Type UA733 operating in the single ended mode with a gain of 35 dB. AR2 drives emitter follower Q1 which gives a final composite nominal power output of 0 dBm at 50 ohms for a $10 \mu\text{W}$ optical power input.
- c. Output Options - Jumpers JP1 and JP2 offer the option of selecting the inverting or non-inverting output of AR2. This option permits digital data to be reversed in phase if data reversals occurring in the end-to-end system do not have the desired phase relationship.

3.4 Corrective Maintenance

3.4.1 General

This section contains the information necessary to perform corrective maintenance on the AN/TTC-38 Fiber Optic System. Included are performance tests and adjustment procedures.

3.4.1.1 Test Equipment

Table 3-3 lists the test equipment necessary to perform any required maintenance. Test equipment with equivalent parameters may be substituted for the items listed.

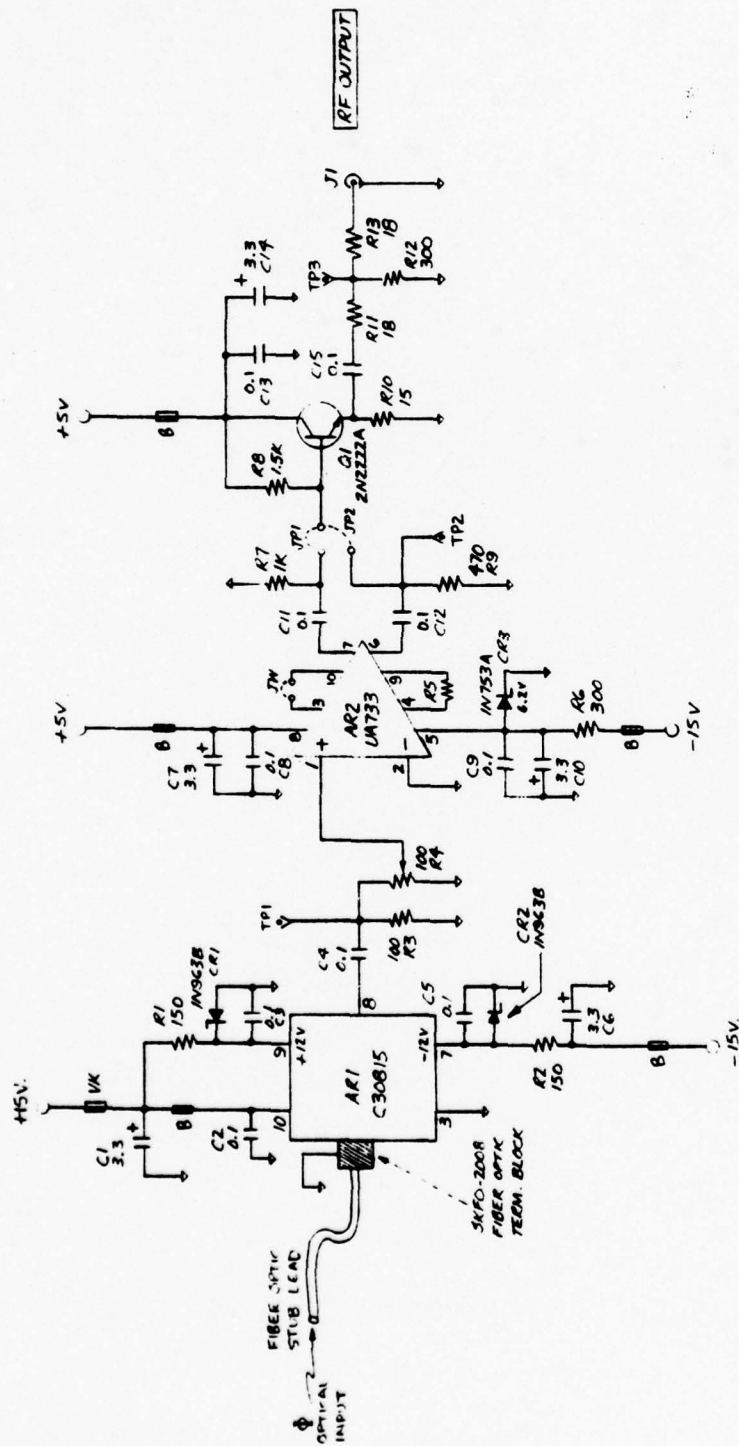

- NOTES:
 1. J1 OR J2: JUMPER OPTION
 2. J1: REMOVABLE JUMPER WIRE

Figure 3-11. Schematic Of Fiber Optic Receiver

Table 3-3. Test Equipment Required

<u>Model No.</u>	<u>Test Equipment</u>	<u>Manufacturer</u>
454	Oscilloscope	Tektronix
3450	Multi-function Meter	Hewlett-Packard
5245L	Electronic Counter	Hewlett-Packard
141T	Display Section Spectrum Analyzer	Hewlett-Packard
8552B	IF Section	Hewlett-Packard
8553B	RF Section	Hewlett-Packard
334A	Distortion Analyzer	Hewlett-Packard
8640B	Signal Generator	Hewlett-Packard

3.4.1.2 Performance Checks

The following tests can determine overall operation status very quickly:

a. Transmitter check procedure:

1. Remove power from the unit under test.
2. Disconnect coaxial cable labeled TX-1 from the fiber-optic transmitter.

Note: If a pad is present in this line disconnect between the pad and the multiplexer transmitter then insert a 10 dB pad at the input to the Spectrum Analyzer

3. Calibrate the spectrum analyzer so that the 0 dB reference line indicates 0 dBm.

4. Connect the multiplexer transmitter into the spectrum analyzer, restore input power and observe four equal level signals present on the display.
5. The indicated level on the spectrum analyzer for each signal should be a nominal -6 dBm.

Note: In some cases these amplitudes may be different (± 1.5 dB) to compensate for the frequency roll-off in the fiber-optic amplifiers. No attempt should be to adjust these levels until the test in Section 3.4.2.2 is completed.

6. Apply a 32 kHz sine wave to the multiplexer via the J-1077 junction box and adjust the spectrum analyzer. The sidebands should appear nominally 20 dB below the carrier.
7. Return the equipment to its normal operating condition.

b. Receiver Check Procedure

1. Remove power from the unit to be tested.
2. Disconnect receiver group #1 from the fiber optic interface.
3. Inject a 15% modulated carrier at 1 kHz and a power level of -15 dBm into the cable normally connected to the fiber optic receiver. The carrier frequency should be that of the particular receiver under test. Apply power to the unit.
4. Monitor TP-6 or TP-7 with the oscilloscope and observe the signal to be a 1 kHz sine wave at an amplitude of $1 V_{p-p}$.

5. Repeat for all channels within the group.
6. Return the equipment to its normal operating condition.

c. Oscillator Check Procedure

1. Remove the power from the equipment.
2. Remove oscillator card from the card cage and reinsert via the oscillator card extender.
3. Restore input power.
4. With an oscilloscope, measure the voltage at TP-2, 3, 4, or 5 depending on the oscillator to be tested. This voltage should be $0.9 V_{p-p} \pm 0.1 V$.
5. Return the AN/TTC-38 Fiber Optic System to its normal operating condition.

3.4.2 Alignment Procedures

All procedures here are referenced to Figures 3-6, 3-7 and 3-8.

3.4.2.1 Oscillator Alignment

1. Remove the oscillator card from the system and reinsert via the oscillator card extender.
2. With the oscilloscope, monitor TP-2, 3, 4 or 5 of Figure 3-8 depending on the oscillator to be aligned.
3. Adjust L2, 3, 4 or 5 for maximum signal amplitude at the respective test point.

Note: This signal is not a clean sine wave but this is not important since the transmitters will filter the signal prior to its being used.

4. To adjust the frequency of a given oscillator, remove any corresponding transmitter card and reinsert via its card extender.
5. Monitor TP-8 of that transmitter (Figure 3-6) with the frequency counter and adjust C23, 24, 25 or 26 corresponding to the oscillator being aligned.
6. Return the system to its normal operating configuration.

3.4.2.2 Multiplexer Transmit Alignment

1. Remove the transmitter card to be aligned and reinsert via the transmitter card extender.
2. Disconnect the coaxial cable between the transmitter group being aligned and the Fiber Optic transmitter.
3. Calibrate the spectrum analyzer so that $0 \text{ dB} = 0 \text{ dBm}$. Insert the coaxial cable above into the spectrum analyzer.

Note: Four signals should be present on the display.

4. Adjust L11 so that the signal of interest is maximized. Because the AGC circuit is operating here a point will be reached where turning this coil will have little or no effect. Rotate the slug until the signal begins to decrease. Reverse the direction until the signal maximizes and then decreases again. Set slug midway between these extremes.
5. Adjust R41 slightly to assure that the AGC circuit is working. If no effect is noticed turn R41 until the signal is seen to decrease.
6. Adjust L7 so that the signal is minimized.
7. Adjust R41 so that the output signal is +4 dBm.

8. Inject a 32 kHz sine wave into the transmitter being aligned via junction box, J-1077.
9. Adjust the sweep width on the spectrum analyzer so that the sidebands are indented.
10. Adjust R43 so that these sidebands are 20 dB \pm 1 dB below the carrier level.
11. Repeat steps 1-10 above until all cards have been aligned.
12. Return system to its normal configuration.

3.4.2.3 Demultiplexer Receive Alignment

1. Remove receiver card to be aligned from system and reinsert via the Receiver Extender Card.
2. Disconnect the coaxial cable between this receiver group and the fiber optic receiver.
3. Modulate the HP 8640B at 15% with the internal 1 kHz tone and inject this modulated carrier into the receiver card via the cable disconnected above. Set the power level of the HP 8640B to -15 dBm.
4. Connect the oscilloscope to TP-6 or TP-7 as shown in Figure
5. Set the HP 8640B to the frequency (\pm 1 kHz) of the receiver being aligned.
6. Adjust L1 and L3 to maximize the 1 kHz signal seen on the oscilloscope at a level of 1.5 V_{p-p}.
7. Adjust L5 and L4, if present in this particular receiver, for minimum "fuzziness" on the sine wave.

Note: It may be necessary to go to a very sensitive oscilloscope setting as this "fuzziness" can be >50 dB below the tone level.

8. Repeat the above process until all receiver channels have been aligned.
9. Return the system to its normal configuration.

3.4.2.4 Optical Transmitter Alignment

The optical transmitter has two pot adjustments. These are Gain Adjust (R6) and LED DC Bias Current (R13). R6 is located on the transmitter card on the same side as the SMA input jack, J1. R13 is located on the same side of the card as the optical fiber cable.

One test point is provided on the transmitter to monitor LED drive. This test point is connected to the amplifier output (AR1, Pin 4) and is located at the white teflon pin in the center area of the PC Board. This point is used for determining LED drive waveform and LED modulation index. Adjustments are as follows:

1. R13 is factory-set for a DC LED bias of 100 ma by monitoring the voltage across the R17-R18 parallel resistor pair, and adjusting R13 for 1.65 Vdc.
2. R6 is adjusted to give a nominal LED modulation index of 0.125, with final adjustments made on the system level.

3.4.2.5 Optical Receiver Alignment

The optical receiver card contains three RCA C30815 hybrid photodetector-preamplifiers, which receive optical signals from the optical fiber via the multi-way connector on the rear of the chassis. Three test points are provided on the fiber optic receiver. These are: Photodetector output, TP1, Video Amplifier (AR2) output, TP2, and Emitter Follower (Q1) output, TP3. Test points are located at the white teflon pins

on the receiver PC board and are used for troubleshooting and signal tracing. Adjustments are as follows:

1. The photodetectors are mounted in an aluminum block housing, and are adjustable in the X-Y plane to allow the fiber to be centered directly over the photodetector chip for optimum response. If it is necessary to replace the photodetector, the fiber centering adjustment must be performed. This is done by observing the receiver output with a 1 to 5 MHz signal driving the optical transmitter, and optimizing the X-Y position of the fiber for maximum output voltage. Tighten down holder cap screws carefully without disturbing position once the fiber has been optimally positioned.
2. The optical receiver card has one pot adjustment for receiver gain, R4. R4 is located on the side opposite from the fiber and photodetector assembly. R4 is factory set for maximum gain.

3.4.2.6 Optical-Connector Repair

Repair information on the ferrules and connectors was not included for several reasons.

The connector is a patented design of Harris ESD and presently is repairable only at the factory by specially trained personnel. ECOM was supplied with a spare LED with fiber and connector attached. In the event of a bad connector, the entire fiber-connector assembly should be returned to Harris ESD for repair.

The ferrule is simply a piece of precision stainless steel tubing over the glass fiber core, with heat shrink tubing support. The ferrule is polished on the end with a gem polishing machine. No printed procedure for repairing ferrules is available at this time, but complete fiber-ferrule assemblies should be returned to Harris ESD for factory repair if required.

SECTION 4.0
DETAILED TEST RESULTS

4.0 DETAILED TEST RESULTS

This section provides specific test results of the breadboard equipment as compiled by Harris ESD. To aid the ultimate user with proper identification and lifetime documentation, Table 4-1 shows physical location of different system components.

4.1 LED Burn-In Data

4.1.1 Test Results

The general decrease in light output from the LEDs as a function of operating time was discussed in Section 2.2.1 of this report. When the phenomenon was first noted, two of the units were selected from the lot and placed in a burn-in test fixture at a 27°C laboratory environment. The results of the burn-in are shown in Figure 4-1.

It can be seen from the graph that both units stabilized at a light power output of approximately 180 μ W (at the end of the fiber stub with Harris ESD connector attached) after 50 to 60 hours of operation at 100 ma DC bias. After 450 hours, no measurable change or additional degradation had taken place and the test was terminated.

4.1.2 Conclusions

While it could be argued that a sample of 2 units is not statistically adequate, we believe these data suggest a general trend for this lot of ten LEDs to show power output degradation for the first 40-60 hours of operation.

We believe that this lot of diodes was not burned in or tested adequately before shipment. It appears that, if one can weed out the infant mortalities past the 100-hour mark, the effective probability of failure beyond that point becomes much lower. The existing 6 LEDs that are used in the completed breadboard have over 1,000 hours of operation logged as of this writing, with no failures.

Table 4-1. System Fiber Channel Assignments

(1) Mux/Demux Box No.	(2) ITT Cable Fiber #	(3) Mux/Demux Xmtr Group #	(4) LED # 28477-	(5) FO Xmtr #	(6) FO Rcvr #
A	A	1	6	Bd 1, Ckt 3	Bd 2, Ckt 3
B	B	1	9	Bd 2, Ckt 3	Bd 1, Ckt 3
A	C	3	4	Bd 1, Ckt 1	Bd 2, Ckt 1
A	D	2	7	Bd 1, Ckt 2	Bd 2, Ckt 2
B	E	3	3	Bd 2, Ckt 1	Bd 1, Ckt 1
B	F	2	2	Bd 2, Ckt 2	Bd 1, Ckt

The table above shows physical locations of different system components.

Column (1) shows which Chassis Assembly the component is in, Box 1 or Box B.

Column (2) shows the assignment of particular Optical Fibers to given Mux/Demux Groups (Col. 3), LED's (Col 4, by serial number), Fiber Optic Transmitters (Col. 5) and Fiber Optic Receivers (Col. 6).

P_o AT FIBER END (μw)

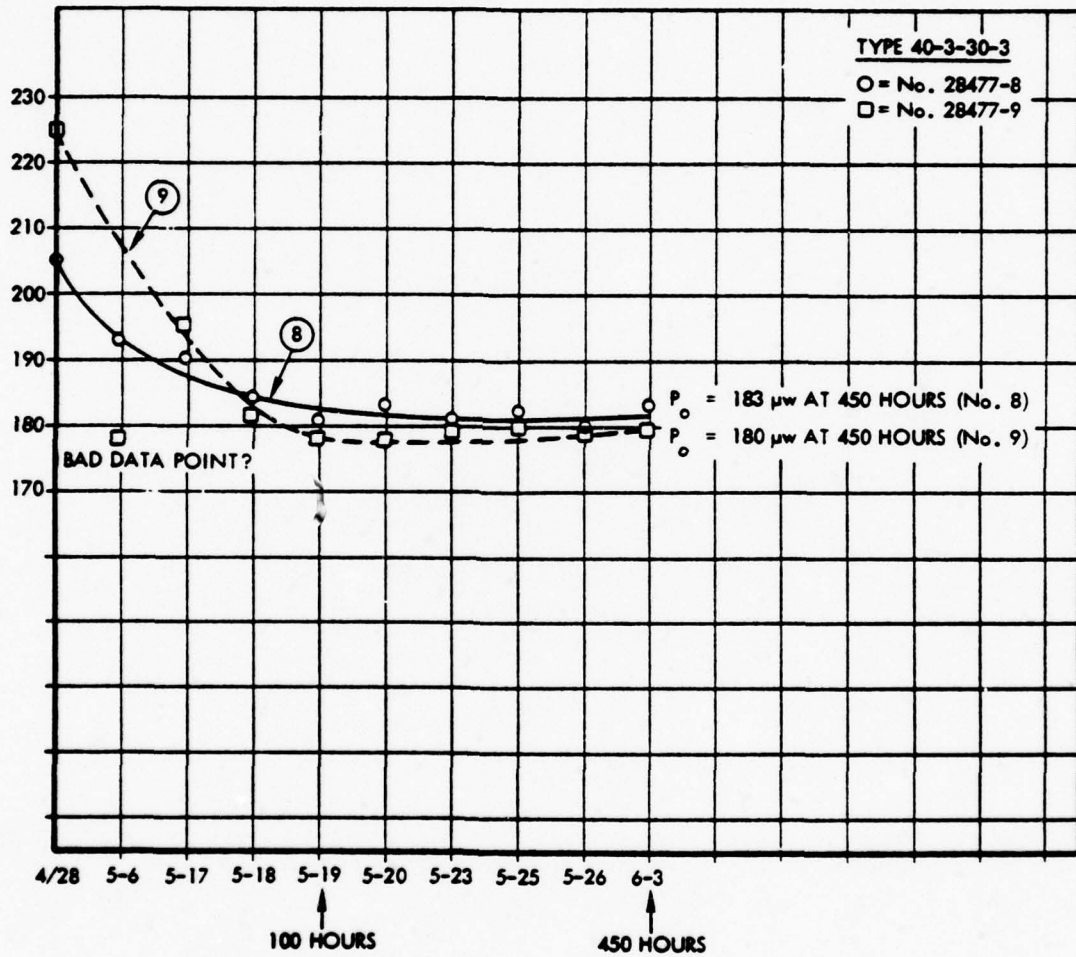

Figure 4-1. LED Burn-In Data

4.2 Optical Driver/Receiver Test Data

The test data in Table 4-2 is a summary of tests made on the optical transmitter and receiver through the 350 meters of G.F.E. optical cable. Figure 4-2 shows the test setup.

Table 4-2. Test Data For Fiber Optics

Fiber No.	Output	Harmonic Distortion ⁽⁵⁾			Bandwidth		Rise Time (2)
		2HD	3HD	Other	-1 dB	-3 dB	
A	-5 dBm	-40 dB	-58 dB	--	.41 to 4.1 MHz	.15 to 7.0 MHz	0.3 μ s
B	-4.5 dBm	-42	-49	-55(4)	.53 to 5.0 MHz	.12 to 6.7 MHz	0.3 μ s
C	-4.2 dBm	-42	-55	-60(3)	.36 to 3.5 MHz	.13 to 5.5 MHz	0.3 μ s
D	+1.0 dBm	-39	-48	-54(4)	.34 to 4.7 MHz	.16 to 6.7 MHz	0.3 μ s
E	-6.3 dBm	-48	-52	--	.42 to 3.0 MHz	.135 to 5.4 MHz	0.3 μ s
F	-4.6 dBm	-60	-54	-53(4)	.31 to 5.3 MHz	.135 to 6.6 MHz	0.3 μ s

NOTES:

- (1) Mod. Index on LEDs = 0.25, single tone @ 2.0 MHz.
- (2) Rise time measured with 10 μ sec pulse. 0 to + 1v, 30% duty cycle, t_r < 10 ns.
- (3) Third harmonic measurement.
- (4) Fourth harmonic measurement.
- (5) Harmonic Distortion tests made with AIL 727 Spectrum Analyzer

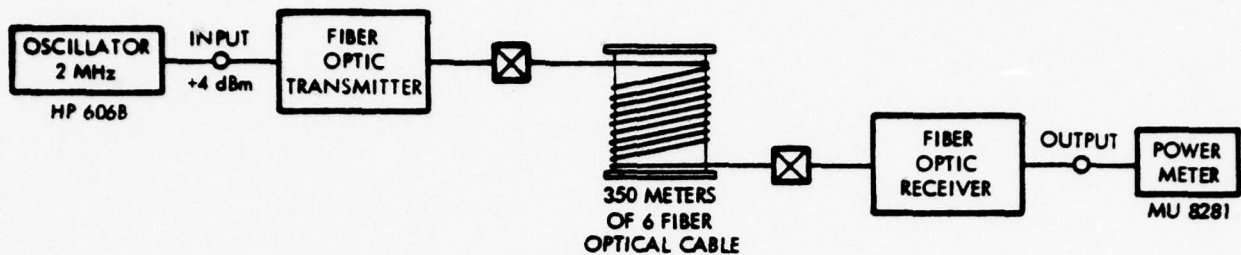

Figure 4-2. Test Setup for Fiber Optics

4.3 Compensation Circuitry Test

The compensation circuit referred to in the text was Option B as shown on the FO Transmitter Circuit diagram. The Option B circuit was built into the circuit board to allow a means by which the LED non-linearity could be reduced by the use of a balanced compensation technique.

This was a case where the circuit should have helped but didn't. We speculate that the most likely reason was because this particular batch of LED's had doping adjustments made by the vendor (BNR) in an attempt to pull the peak emission wavelength to 820 nm. They were not successful in this venture but instead turned out a batch of very good LED's with low non-linearity distortion products. We measured second and third-harmonic distortion products down from ~ 41 to -59 dB on these diodes using the Option A circuit, and the Option B compensating scheme simply did not improve the situation.

4.4 Test Plan

See Appendix A. Test procedure for AN/TCC-38 Fiber Optic System Verification Study.

SECTION 5.0

MECHANICAL AND CIRCUIT DIAGRAMS LIST

5.0 MECHANICAL AND CIRCUIT DIAGRAMS LIST

This section provides a list of those diagrams necessary to fabricate the AN/TTC-38 Fiber Optic breadboard unit.

5.1 MECHANICAL DRAWINGS

Title	Dwg. No.
Spacer	312759
Clip	312760
Handle	321773
Card Guide	432089
Trim Strip	432223
Divider	432245
Bracket, Terminal Board	432252
Cover, Top	548530
Angle, Mounting	548542
Panel, Rear	548553
Angle Mtg	548568
Panel Front	548956
Chassis	621343
PC Layout, Transmitter	549257
PC Layout, Receiver	549258
PC Layout, Oscillator	549259

5.2 ELECTRICAL CIRCUIT DRAWINGS

Schematic Diagram Electrical Transmitter	549037
Schematic Diagram, Electrical Receiver	549038
Schematic Diagram, Electrical Oscillator	549039
Power Wiring Diagram	549211
Motherboard, Power Split/Combiners	549212
AN/TTC-38 Simplified Block	549213
ECOM FO Transmitter	432835
ECOM Fiber Optic Receiver	432836

SECTION 6.0

PARTS LIST FOR BREADBOARD EQUIPMENT

6.0 PARTS LIST FOR BREADBOARD EQUIPMENT

This section provides the parts list for each major subassembly of the breadboard equipment units #1 and #2. Included are the Multiplex Transmitter, Demultiplex Receiver, Oscillator, Motherboard, Fiber Optic Transmitter, Fiber Optic Receiver and Chassis.

PARTS LIST		AGENCY (CONTRACTOR IDENT)		CONTRACT NO.		CODE IDENT		DOCUMENT NO.		REVISION LTR	
LIST TITLE		AUTHENTICATION		REV AUTH NO.		DATE		SHEET		NOTES	
ASSEMBLY NO.		DRAWING OR DOCUMENT NO.		PART OR IDENTIFYING NUMBER		NOMENCLATURE OR DESCRIPTION		SHEET		NOTES	
PL-594037						ASSEMBLY PART TITLE					
Transmitter											
ITEM NO.	QTY REQD	UM	CODE IDENT	DRAWING OR DOCUMENT NO.	PART OR IDENTIFYING NUMBER	NOMENCLATURE OR DESCRIPTION					
1	1				LH0002CN	NAT. SEM.	P C Card				
2	1				VCR5P	SILICONIX	Connector				
3	2				2N918		Integrated Circuit, AR ₁ , AR ₂				
4	3				IN5530C	MOTOROLA	JEET, Q ₂ , Q ₃ , Q ₄				
5	10				IN914		Transistor, Q ₁ , Q ₅ , Q ₆ , Q ₇ , Q ₈ , Q ₉ , Q ₁₀ , Q ₁₁ , Q ₁₂ , Q ₁₃				
6	1				RCR05G222J		10V Zener, VR ₁				
7	3				RCR05G102J		Diode, CR ₁ , CR ₂ , CR ₃				
8	5				RCR05G153J		Resistor, Carbon Comp. 2.2K, ±5%				
9	11				RCR05G202J		R ₁ , R ₃ , R ₂₈ , R ₂₉ , R ₄₇				
10	3				RCR05G472J		Resistor, Carbon Comp. 1.0K ±5%				
11	2				RCR05G272J		R ₂ , R ₄ , R ₃₄ , R ₆₉ - R ₇₆				
12	2				RCR05G332J		Resistor, Carbon Comp. 1.5K, ±5%				
13	2						R ₅ , R ₇ , R ₆₈				
14	3						Resistor, Carbon Comp. 2.0K, ±5%				
							R ₈ , R ₉				
							Resistor, Carbon Comp. 4.7K, ±5%				
							R ₁₀ , R ₁₁				
							Resistor, Carbon Comp. 2.7K, ±5%				
							R ₁₃ , R ₄₉				
							Resistor, Carbon Comp. 3.3K, R ₁₄ , R ₆₁ , R ₆₆				

PARTS LIST		AGENCY (CONTRACTOR IDENT)		CONTRACT NO.		CODE IDENT		DOCUMENT NO.		REVISION LTR	
LIST TITLE		AUTHENTICATION		REV AUTH NO.		DATE		SHEET		NOTES	
ASSEMBLY NO.		ASSEMBLY PART TITLE		NOMENCLATURE OR DESCRIPTION		PART OR IDENTIFYING NUMBER		DRAWING OR DOCUMENT NO.		CODE IDENT	
ITEM NO.	QTY REQD	UM	ASSEMBLY NO.	ASSEMBLY PART TITLE	NOMENCLATURE OR DESCRIPTION	PART OR IDENTIFYING NUMBER	DRAWING OR DOCUMENT NO.	CODE IDENT	ASSEMBLY NO.	REVISION LTR	DATE
15	1		PL-549037	Transmitter	Resistor, Carbon Comp. 5.1K, ±5%	RCR05G512J					
16	1				Resistor, Carbon Comp. 3.6K±5%	RCR05G362J					
17	6				Resistor, Carbon Comp. 470K, ±5%	RCR05G474J					
18	1				Resistor, Carbon Comp. 39K ±5%	RCR05G393J					
19	2				Resistor, Carbon Comp. 51Ω ±5%	RCR056510J					
20	1				Resistor, Carbon Comp. 4.7K ±5%	RCR05G472J					
21	1				Resistor, Carbon Comp. 10Ω ±5%	RCR05G100J					
22	1				Resistor, Carbon Comp. 330Ω ±5%	RCR05G331J					
23	2				Resistor, Carbon Comp. 3.0K ±5%	RCR05G302J					
24	2				Resistor, Carbon Comp. 56K, R31	RCR05G563J					
25	2				Resistor, Carbon Comp. 6.8K ±5%	RCR05G682J					
26	1				Resistor, Carbon Comp., 16K, ±5%	RCR056163J					

PARTS LIST		AGENCY (CONTRACTOR IDENT)		CONTRACT NO.		CODE IDENT		DOCUMENT NO.		REVISION LTR	
LIST TITLE		AUTHENTICATION		REV AUTH NO.		DATE		SHEET		NOTES	
Transmitter		ASSEMBLY PART TITLE		NOMENCLATURE OR DESCRIPTION		PART OR IDENTIFYING NUMBER		DRAWING OR DOCUMENT NO.		ITEM NO.	
ASSEMBLY NO.		CODE IDENT		DRAWING OR DOCUMENT NO.		PART OR IDENTIFYING NUMBER		DRAWING OR DOCUMENT NO.		ITEM NO.	
QTY REQD	UM	CODE IDENT	DRAWING OR DOCUMENT NO.	PART OR IDENTIFYING NUMBER	DRAWING OR DOCUMENT NO.	DRAWING OR DOCUMENT NO.	PART OR IDENTIFYING NUMBER	DRAWING OR DOCUMENT NO.	DRAWING OR DOCUMENT NO.	DRAWING OR DOCUMENT NO.	ITEM NO.
27	1			RCR05G683J			RCR05G683J				Resistor, Carbon Comp. 68K, ±5%, R ₃₆
28	2			RCR05G223J			RCR05G223J				Resistor, Carbon Comp. 22K, ±5%, R ₃₇ , R ₄₀
29	1			RCR05G273J			RCR05G273J				Resistor, Carbon Comp. 27K, ±5%, R ₃₉
30	1			RCR05G153J			RCR05G153J				Resistor, Carbon Comp., 15K, ±5%, R ₃₈
31	1			3299W-1-102			3299W-1-102				Bourns 1K Trim Pot, R ₄₁
32	1			3299W-1-103			3299W-1-103				Bourns 10K Trim Pot, R ₄₃
33	1			RCR05G363J			RCR05G363J				Resistor, Carbon Comp. 36K, ±5%, R ₄₄
34	1			RCR05G162J			RCR05G162J				Resistor, Carbon Comp, 1.6K, ±5%, R ₄₅
35	1			RCR05G121J			RCR05G121J				Resistor, Carbon Comp. 120Ω ±5%, R ₄₆
36	2			RCR05G131J			RCR05G131J				Resistor, Carbon Comp. 130Ω ±5%, R ₄₈ , R ₆₃
37	1			RCR05G471J			RCR05G471J				Resistor, Carbon Comp., 470Ω ±5%, R ₅₁
38	1			RCR05G512J			RCR05G512J				Resistor, Carbon Comp. 5.1K, ±5%, R ₅₂

114 ADM 586-2

PARTS LIST		AGENCY (CONTRACTOR IDENT)		CONTRACT NO.		CODE IDENT		DOCUMENT NO.		REVISION LTR	
LIST TITLE		AUTHENTICATION		REV AUTH NO.		DATE		SHEET		NOTES	
Transmitter		ASSEMBLY PART TITLE		NOMENCLATURE OR DESCRIPTION		PART OR IDENTIFYING NUMBER		DRAWING OR DOCUMENT NO.		CODE IDENT	
ITEM NO.	QTY REQD	UM	CODE IDENT	DRAWING OR DOCUMENT NO.	PART OR IDENTIFYING NUMBER	NOMENCLATURE OR DESCRIPTION	PART OR IDENTIFYING NUMBER	DRAWING OR DOCUMENT NO.	CODE IDENT	REVISION LTR	DATE
39	1				RCR05G221J	Resistor, Carbon Comp. 2200 ±5%	R ₅₃				
40	1				RCR05G911J	Resistor, Carbon Comp. 9100 ±5%	R ₅₄				
41	1				RCR05G912J	Resistor, Carbon Comp. 9.1K, ±5%	R ₅₆				
42	2				RCR05G180J	Resistor, Carbon Comp. 180 ±5%	R ₅₇ , R ₆₂				
43	2				RCR05G301J	Resistor, Carbon Comp. 3000 ±5%	R ₅₈ , R ₅₉				
44	2				RCR05G681J	Resistor, Carbon Comp. 6800 ±5%	R ₆₄ , R ₆₇				
45	1				RCR05G621J	Resistor, Carbon Comp. 6200 ±5%	R ₆₅				
46	1				RCR05G J (Sat)	Resistor, Carbon Comp. R ₆ (±2K-4K)					
47	1				RCR05G J (Sat)	Resistor, Carbon Comp. ±5%, R ₁₂ (±18-680)					
48	1				RCR05G J (Sat)	Resistor, Carbon Comp. ±5%, R ₃₃ (±30K-47K)					
49	5				CSR13E106KL	Capacitor, Tant., 10µF, ±10%, C ₁ , C ₃ , C ₂₀ , C ₂₁ , C ₂₂					

9-588 (REV 71)

PARTS LIST		AGENCY (CONTRACTOR IDENT)		CONTRACT NO.		CODE IDENT		DOCUMENT NO.		REVISION LTR	
LIST TITLE		AUTHENTICATION		REV AUTH NO.		DATE		SHEET		NOTES	
ASSEMBLY NO.		DRAWING OR DOCUMENT NO.		PART OR IDENTIFYING NUMBER		NOMENCLATURE OR DESCRIPTION		SHEET		NOTES	
PL-549037											
Transmitter											
50	1			CSRI3D226KL		Capacitor, Tant., 22µfd ±10%, C12					
51	3			CSRI3E125KL		Capacitor, Tant., 1.2µfd, ±10%, C17, C33, C34					
52	5			CSRI3E225KL		Capacitor, Tant. 2.2µfd ±10%, C28, C43, C44, C45, C46					
53	1			CSRI3F565KL		Capacitor, Tant., 5.6µfd ±10%, C36					
54	17			CK06BX104M		Capacitor, Ceramic, .1µfd ±20%, C2, C4, C5, C6, C11, C13, C18, C19, C23, C24, C25, C26, C30, C37, C39, C41, C42					
55	1			CK06BX103M		Capacitor, Ceramic, .01µf, ±20%, C10					
56	1			CM06FD102J03		Capacitor, Ceramic, 1000pf, ±20%, C29					
57	2			1537-80 (Delevan)		Inductor, Fixed, ±5%, L1, L12					
						The Following Parts Pertain to the 1.6 MHz Tx Only					
58	3			CM04ED510J03		Capacitor, mica, 51pf, ±5%, C7, C8, C9					
59	3			CM04FD181J03		Capacitor, mica, 180pf, ±5%, C14, C15, C27					

PARTS LIST		AGENCY (CONTRACTOR IDENT)		CONTRACT NO.		CODE IDENT		DOCUMENT NO.		REVISION LTR	
LIST TITLE		AUTHENTICATION		REV AUTH NO.		DATE		SHEET		NOTES	
ASSEMBLY NO.		DRAWING OR DOCUMENT NO.		PART OR IDENTIFYING NUMBER		NOMENCLATURE OR DESCRIPTION		SHEET		NOTES	
PL-549037											
Transmitter											
60	2			CM04FD910J03		Capacitor, mica, 91pf, ±5%, C16, C47					
61	1			CM06FD821J03		Capacitor, mica, 820pf, ±5%, C31					
62	1			CK06Bx272K		Capacitor, Ceramic, 2700pf ±10%, C32					
63	1			CM06FD681J03		Capacitor, mica 680pf, ±5%, C35					
64	1			CM04FC271J03		Capacitor, mica 270pf, ±5%, C38					
65	1			CM04FA331J03		Capacitor, mica, 330pf, ±5%, C40					
66	1			9405-32 DELEVAN		Inductor, Varib. 32.9-61.1µh, L7					
67	1			9405-26 DELEVAN		Inductor, Varib. 10.5-19.5, L11					
68	1			HESD		Inductor, 77.32µh on Micrometals T50-2					
69	1			HESD		Inductor, 92.48µh on Micro-metals T50-2					
70	1			HESD		Inductor, 38.64µh on Micro-metals T50-2					
71	1			HESD		Inductor, 52.69µh on Micro-metals T50-2					
72	1			HESD		Inductor, 65.4µh on Micro-metals T68-2					

PARTS LIST		AGENCY (CONTRACTOR IDENT)		CONTRACT NO.		CODE IDENT		DOCUMENT NO.		REVISION LTR	
LIST TITLE		AUTHENTICATION		REV AUTH NO.		DATE		SHEET		NOTES	
ASSEMBLY NO.		DRAWING OR DOCUMENT NO.		PART OR IDENTIFYING NUMBER		NOMENCLATURE OR DESCRIPTION		SHEET		NOTES	
PL-549037		Transmitter		ASSEMBLY PART TITLE							
73	1			HESD	Inductor, 165.4µh on Micro-metals T68-2						
74	2			HESD	Inductor, 5.53µh on Micro-metals T20-1						
75	1			HESD	Inductor, 3.85µh on Micro-metals T20-1						
				The Following Parts Pertain To The 2.6 MHz Tx Only							
76	2			CMO4ED300J03	Capacitor, mica, 30pf, ±5%, C ₇ , C ₈						
77	1			CMO4ED560J03	Capacitor, mica, 56pf, ±5%, C ₉						
78	1			CMO4FD221J03	Capacitor, mica, 220pf, ±5%, C ₁₄						
79	2			CMO4FD201J03	Capacitor, mica, 200pf, ±5%, C ₁₅ , C ₄₀						
80	1			CMO4FD910J03	Capacitor, mica 91pf, ±5%, C ₁₆						
81	1			CMO4FD181J03	Capacitor, mica 180pf, ±5%, C ₂₇						
82	1			CMO6FD511J03	Capacitor, mica 510pf, ±5%, C ₃₁						
83	1			CMO5FD431J03	Capacitor, mica 430pf, ±5%, C ₃₅						
84	1			CMO4FD161J03	Capacitor, mica 160pf, ±5%, C ₃₈						
85	1			CMO4FD101J03	Capacitor, mica 100pf, ±5%, C ₄₇						

PARTS LIST		AGENCY (CONTRACTOR IDENT)		CONTRACT NO.		CODE IDENT		DOCUMENT NO.		REVISION LTR	
LIST TITLE Transmitter		AUTHENTICATION		REV AUTH NO.		DATE		SHEET		NOTES	
ASSEMBLY NO. PL-549037		ASSEMBLY PART TITLE									
ITEM NO.	QTY REQD	UM	CODE IDENT	DRAWING OR DOCUMENT NO.	PART OR IDENTIFYING NUMBER	NOMENCLATURE OR DESCRIPTION					
86	1				CK06BX152K	Capacitor, ceramic, 1500pf, ±10%, C ₃₂					
87	1				9405-28 DELEVAN	Inductor, Varib. 15.4-28µh, L ₇					
88	1				9405-24 DELEVAN	Inductor, Varib. 7-13µh, L ₁₁					
89	1				HESD	Inductor, 20.65µh On Micro-metals T50-2					
90	1				HESD	Inductor, 41.96µh On Micro-metals T50-2					
91	1				HESD	Inductor, 14.32µh On Micro-metals T37-7					
92	1				HESD	Inductor, 18.25µh On Micro-metals T27-7					
93	1				HESD	Inductor, 54.25µh On Micro-metals T50-2					
94	2				HESD	Inductor, 3.44µh On Micro-metals T20-1					
95	1				HESD	Inductor, 2.35µh On Micro-metals T12-1					
						The Following Parts Pertain To 3.6MHz Tx Only					
96	2				CM04ED220J03	Capacitor, mica 22pf, ±5%, C ₇ , C ₈					

PARTS LIST		AGENCY (CONTRACTOR IDENT)		CONTRACT NO.		CODE IDENT		DOCUMENT NO.		REVISION LTR	
		LIST TITLE Transmitter		AUTHENTICATION				REV AUTH NO.		DATE	
ASSEMBLY NO.		ASSEMBLY PART TITLE									
PL-549037											
ITEM NO.	QTY RECD	UM	CODE IDENT	DRAWING OR DOCUMENT NO.	PART OR IDENTIFYING NUMBER	NOMENCLATURE OR DESCRIPTION	NOTES				
97	1				CMO4ED560J03	Capacitor, mica 56pf, ±5%, C ₉					
98	1				CMO4FD221J03	Capacitor, mica 220pf, ±5%, C ₁₄					
99	1				CMO4FD201J03	Capacitor, mica, 200pf, ±5%, C ₁₅					
100	1				CMO4FD910J03	Capacitor, mica, 91pf, ±5%, C ₁₆					
101	1				CMO4FD181J03	Capacitor, mica, 180pf, ±5%, C ₂₇					
102	1				CMO4FD151J03	Capacitor, mica, 150pf, ±5%, C ₄₀					
103	1				CMO4FD111J03	Capacitor, mica 110pf, ±5%, C ₄₇					
104	1				CMO4FD121J03	Capacitor, mica, 120pf, ±5%, C ₃₈					
105	1				9405-24 DELEVAN	Inductor, Varib. 7-13μh, L ₇					
106	1				9405-22 DELEVAN	Inductor, Varib. 4.76-8.84μh, L ₁₁					
107	1				HESD	Inductor, 14.84μh On Micro-metals T30-2					
108	1				HESD	Inductor, 23.84μh On Micro-metals T30-2					
109	1				HESD	Inductor, 7.40μh On Micro-metals T50-2					
110	1				HESD	Inductor, 9.52μh, On Micro-metals T50-2					
111	1				HESD	Inductor, 26.64μh On Micro-metals T30-2					

PARTS LIST		AGENCY (CONTRACTOR IDENT)		CONTRACT NO.		CODE IDENT		DOCUMENT NO.		REVISION LTR		
		LIST TITLE		AUTHENTICATION		REV AUTH NO.				DATE		
		Transmitter								SHEET		
ASSEMBLY NO.		ASSEMBLY PART TITLE										
PL-549037												
ITEM NO.	QTY REQD	UM	CODE IDENT	DRAWING OR DOCUMENT NO.	PART OR IDENTIFYING NUMBER	NOMENCLATURE OR DESCRIPTION						NOTES
						The Following Parts Pertain To 4.6MHz Tx Only						
112	2				CMO4CD180J03	Capacitor, mica, 18pf, ±5%, C ₇ , C ₈						
113	1				CMO4ED560J03	Capacitor, mica, 56pf, ±5%, C ₉						
114	1				CMO4FD221J03	Capacitor, mica, 220pf, ±5%, C ₁₄						
115	1				CMO4FD201J03	Capacitor, mica, 200pf, ±5%, C ₁₅						
116	2				CMO4FD910J03	Capacitor, mica 91pf, ±5%, C ₁₆ , C ₃₈						
117	1				CMO4FD181J03	Capacitor, mica, 180pf, ±5%, C ₂₇						
118	1				CMO4FD111J03	Capacitor, mica, 110pf, ±5%, C ₄₀						
119	1				CMO4FD121J03	Capacitor, mica, 120pf, ±5%, C ₄₇						
120	1				9405-22 DELEVAN	Inductor, Varib. 4.76-8.84μh, L ₇						
121	1				9405-20 DELEVAN	Inductor, Varib. 3.29-6.11μh, L ₁₁						
122	1				HESD	Inductor, 9.08μh, On Micro-metals T50-2						
123	1				HESD	Inductor, 15.84μh, On Micrometals T44-6						
124	1				HESD	Inductor, 4.45μh On Micrometals T50-2						

PARTS LIST		AGENCY (CONTRACTOR IDENT)		CONTRACT NO.		CODE IDENT		DOCUMENT NO.		REVISION LTR	
LIST TITLE		AUTHENTICATION		REV AUTH NO.		DATE		SHEET		NOTES	
ASSEMBLY NO.		DRAWING OR DOCUMENT NO.		PART OR IDENTIFYING NUMBER		NOMENCLATURE OR DESCRIPTION		SHEET		NOTES	
PL-549037											
ITEM NO.	QTY REQD	UM	CODE IDENT	DRAWING OR DOCUMENT NO.	PART OR IDENTIFYING NUMBER	NOMENCLATURE OR DESCRIPTION					
125	1				HESD	Inductor, 5.78µh On Micrometals T50-2					
126	1				HESD	Inductor 15.64µh On Micrometals T44-6					

PARTS LIST		AGENCY (CONTRACTOR IDENT)		CONTRACT NO.		CODE IDENT		DOCUMENT NO.		REVISION LTR	
LIST TITLE		Receiver		AUTHENTICATION				REV AUTH NO.		DATE	
ASSEMBLY NO.				ASSEMBLY PART TITLE						SHEET	
ITEM NO.	QTY REQD	UM	CODE IDENT	DRAWING OR DOCUMENT NO.	PART OR IDENTIFYING NUMBER	NOMENCLATURE OR DESCRIPTION				NOTES	
1	1				WESD	P C Card					
2	1					Connector					
3	2				LH0002CH	NAT. SEM. Integrated Circuit AR1, AR2					
4	1				IN914	Diode CR1					
5	1				2N2222	Transistor Q ₁					
6	3				2N918	Transistor Q ₂ -Q ₄					
7	3				RCR05G132J	Resistor, Carbon Comp. 1.3K ±5% R ₁ , R ₂₃ , R ₂₈					
8	1				RCR05G183J	Resistor, Carbon Comp. 18K R ₂					
9	5				RCR05G102K	Resistor, Carbon Comp. 10K, R ₃ R ₇ , R ₁₄ , R ₁₅ , R ₂₁ , R ₃₀₋₃₅					
10	3				RCR05G152J	Resistor, Carbon Comp. 1.5K, R ₄ , R ₂₄ , R ₂₆					
11	1				RCR05G273J	Resistor, Carbon Comp. 27K R ₅					
12	2				RCR05G332J	Resistor, Carbon Comp. 3.3K R ₆ R ₉					
13	2				RCR05G680J	Resistor, Carbon Comp. 68Ω R ₈ , R ₁₆					
14	3				RCR05G222J	Resistor, Carbon Comp. 2.2K ±5% R ₁₀ , R ₁₃ , R ₁₇					

PARTS LIST		AGENCY (CONTRACTOR IDENT)		CONTRACT NO.		CODE IDENT		DOCUMENT NO.		REVISION LTR	
LIST TITLE		AUTHENTICATION		REV AUTH NO.		DATE		SHEET		NOTES	
Receiver		ASSEMBLY NO.		ASSEMBLY PART TITLE		PART OR IDENTIFYING NUMBER		NOMENCLATURE OR DESCRIPTION		SHEET	
ITEM NO.	QTY RECD	UM	CODE IDENT	DRAWING OR DOCUMENT NO.	PART OR IDENTIFYING NUMBER	NOMENCLATURE OR DESCRIPTION	REVISION LTR	DATE	NOTES	SHEET	
15	2				RCR05G113J	Resistor, Carbon Comp. 11K R ₁₁ , R ₂₂					
16	1				RCR05C432J	Resistor, Carbon Comp. 4.3K, R ₁₂					
17	1				RCR05G242J	Resistor, Carbon Comp. 2.4K R ₁₈					
18	2				RCR05G271J	Resistor, Carbon Comp. 270Ω, R ₁₉ , R ₂₉					
19	1				RCR05G432J	Resistor, Carbon Comp. 4.9K R ₂₀					
20	1				RCR05G360J	Resistor, Carbon Comp. 36Ω R ₂₅					
21	1				RCR05G221J	Resistor, Carbon Comp. 220 R ₂₇					
22	4				CSR13E106KL	Capacitor, Tantalum 10 μfd ±10% C ₁ , C ₃ , C ₂₉ , C ₃₁					
23	9				CK06BX104KM	Capacitor, Ceramic .1μfd ±20% C ₂ , C ₄ , C ₁₀ , C ₂₁ , C ₂₃ , C ₂₈ , C ₃₀ , C ₃₂ , C ₃₅					
24	4				CSR13E225KL	Capacitor, Tantalum, 2.2μfd C ₆ , C ₉ , C ₁₁ , C ₁₂					
25	1				CMO4FD111J03	Capacitor, mica, 110pf ±5%, C ₅					
26	2				CMO4FA391J03	Capacitor, mica, 390pf, C ₇ , C ₁₄					
27	2				CK06BX472K	Capacitor, Ceramic, 4700pf ±10%, C ₈ , C ₁₅					

114 AGNI 888-2

PARTS LIST		AGENCY (CONTRACTOR IDENT)		CONTRACT NO.		CODE IDENT		DOCUMENT NO.		REVISION LTR	
LIST TITLE		AUTHENTICATION		REV AUTH NO.		DATE		SHEET		NOTES	
ASSEMBLY NO.		DRAWING OR DOCUMENT NO.		PART OR IDENTIFYING NUMBER		NOMENCLATURE OR DESCRIPTION		REVISION LTR		DATE	
PL-549038		The Following Parts Pertain to 1.6 MHz Rx Only		CMO4ED820J03		Capacitor, mica 82pf ±5%, C ₁₃		SHEET		NOTES	
28	1			CMO6FD471J03		Capacitor, mica 470pf, ±5% C ₁₆					
29	2			1537-80 DELEVAN		Inductor, Fixed, 120µh, ±5%, L ₁₀ , L ₁₁					
30	1					Capacitor, mica 82pf ±5%, C ₁₃					
31	1			CMO4ED240J03		Capacitor, mica 24pf ±5% C ₁₇					
32	3			CMO4FD201J03		Capacitor, mica 200pf ±5% C ₁₈ , C ₁₉ , C ₂₀					
33	2			CMO4FD101J03		Capacitor, mica, 100pf, ±5%, C ₂₂ , C ₂₄					
34	2			CMO4FA361J03		Capacitor, mica, 360pf ±5%, C ₂₅ , C ₂₇					
35	2			CMO6FD751J03		Capacitor, mica 750pf, ±5% C ₂₆ , C ₃₄					
36	1			CMO4FD181J03		Capacitor, mica, 180pf, ±5% C ₃₃					
37	2			9405-32 DELEVAN		Inductor, Tunable, 32.9-61.1µh, L ₁ , L ₃					
38	2			9405-36 DELEVAN		Inductor, Tunable, 70-130µh, L ₄ , L ₅					
39	1			HESD		23.12µh Inductor Wound On Micro-metals T37-2, L ₂					

PARTS LIST		AGENCY (CONTRACTOR IDENT)		CONTRACT NO.		CODE IDENT		DOCUMENT NO.		REVISION LTR	
LIST TITLE		AUTHENTICATION		REV AUTH NO.		DATE		SHEET		NOTES	
Receiver		ASSEMBLY PART TITLE		NOMENCLATURE OR DESCRIPTION		PART OR IDENTIFYING NUMBER		DRAWING OR DOCUMENT NO.		CODE IDENT	
ASSEMBLY NO. PL-549038		QTY REQ		UM		ITEM NO.		DRAWING OR DOCUMENT NO.		CODE IDENT	
40	1					HESD					
41	1					HESD					
42	1					HESD					
43	1					HESD					
The Following Parts Pertain To 2.6 MHz Rx Only											
44	1					CMO4ED510J03					
45	1					CMO4ED240J03					
46	2					CMO4FD121J03					
47	1					CMO4FD221J03					
48	1					CMO4FD131J03					
49	1					CMO4FD101J03					
50	1					CMO6FD431J03					
51	1					CMO6FD821J03					
52	1					CMO4FA361J03					
53	1					CMO4FD181J03					

FORM 10-72

PARTS LIST		AGENCY (CONTRACTOR IDENT)		CONTRACT NO.		CODE IDENT		DOCUMENT NO.		REVISION LTR	
LIST TITLE		AUTHENTICATION		REV AUTH NO.		DATE		SHEET		NOTES	
Receiver		ASSEMBLY PART TITLE									
ASSEMBLY NO. PL 549038											
ITEM NO.	QTY REQD	UM	CODE IDENT	DRAWING OR DOCUMENT NO.	PART OR IDENTIFYING NUMBER	NOMENCLATURE OR DESCRIPTION					
54	1				CMO6FD751J03	Capacitor, mica, 750pf, i5%, C ₃₄					
55	2				9405-28 DELEVAN	Inductor, Tunable, 15.4-28.6µh L ₁ , L ₃					
56	2				9405-30 DELEVAN	Inductor, Tunable, 23.1-42.9µh L ₄ , L ₅					
57	1				HESD	10.50µh Inductor Wound On Micro- metals T50-2, L ₂					
58	1				HESD	7.15µh Inductor Wound On Micro- metals T50-2, L ₆					
59	1				HESD	3.58µh Inductor Wound On Micro- metals T50-2, L ₇					
60	1				HESD	4.68µh Inductor Wound On Micro- metals T50-2, L ₈					
61	1				HESD	13.52µh Inductor Wound On Micro- metals T37-2, L ₉					
						The Following Parts Pertain to 3.6 MHz Rx Only					
62	1				CMO4ED360J03	Capacitor, mica, 36pf, i5%, C ₁₃					
63	1				CMO4ED240J03	Capacitor, mica, 24pf, i5%, C ₁₇					
64	2				CMO4FD910J03	Capacitor, mica, 91pf i5%, C ₁₈ , C ₁₉					

PARTS LIST		AGENCY (CONTRACTOR IDENT)		CONTRACT NO.		DOCUMENT NO.		REVISION LTR	
LIST TITLE		AUTHENTICATION		REV AUTH NO.		DATE		SHEET	
Receiver		ASSEMBLY PART TITLE		NOMENCLATURE OR DESCRIPTION		NOTES			
ASSEMBLY NO.		DRAWING OR DOCUMENT NO.		PART OR IDENTIFYING NUMBER					
ITEM NO.	QTY RECD	UIM	CODE IDENT						
65	1			CMO4FD221J03	Capacitor, mica, 220pf, ±5%, C20				
66	1			CMO4FD151J03	Capacitor, mica, 150pf, ±5%, C22				
67	1			CMO4FD101J03	Capacitor, mica, 100pf, ±5%, C24				
68	1			CMO6FD431J03	Capacitor, mica, 430pf, ±5%, C25				
69	1			CMO6FD911J03	Capacitor, mica, 910pf, ±5%, C26				
70	1			CMO4FA361J03	Capacitor, mica, 360pf, ±5%, C27				
71	1			CMO4FD181J03	Capacitor, mica, 180pf, ±5%, C33				
72	1			CMO6FD821J03	Capacitor, mica, 820pf, ±5%, C34				
73	2			9405-24 DELEVAN	Inductor, Tunable, 7-13µh, L1, L3				
74	2			9405-28 DELEVAN	Inductor, Tunable, 15.4-28.6, L4, L5				
75	1			HESD	5.96 µh Inductor Wound On Micro-metals T50-2, L2				
76	1			HESD	3.71µh Inductor Wound On Micro-metals T50-2, L6				
77	1			HESD	1.85µh Inductor Wound ON Micro-metals T50-2, L7				

PARTS LIST		AGENCY (CONTRACTOR IDENT)		CONTRACT NO.		CODE IDENT		DOCUMENT NO.		REVISION LTR	
LIST TITLE		AUTHENTICATION		REV AUTH NO.		DATE		SHEET		NOTES	
Receiver		ASSEMBLY PART TITLE		NOMENCLATURE OR DESCRIPTION		PART OR IDENTIFYING NUMBER		HESD		HESD	
ASSEMBLY NO.		DRAWING OR DOCUMENT NO.		PART OR IDENTIFYING NUMBER		HESD		HESD		HESD	
PL 549038		DRAWING OR DOCUMENT NO.		PART OR IDENTIFYING NUMBER		HESD		HESD		HESD	
ITEM NO.	QTY REQD	1/M	CODE IDENT	DRAWING OR DOCUMENT NO.		PART OR IDENTIFYING NUMBER		HESD		HESD	
78	1							2.38µh Inductor Wound On Micro-metals T50-2, L ₈			
79	1							6.66µh Inductor Wound On Micro-metals T50-2, L ₉			
								The Following Parts Pertain to 4.6 MHz Rx Only			
80	2					CMO4ED240J03		Capacitor, mica 24pf, ±5%, C ₁₃ , C ₁₇			
81	2					CMO4ED680J03		Capacitor, mica, 68pf, ±5%, C ₁₈ , C ₁₉			
82	1					CMO4FD221J03		Capacitor, mica 220pf, ±5%, C ₂₀			
83	1					CMO4FD161J03		Capacitor, mica 160pf, ±5%, C ₂₂			
84	1					CMO4FD101J03		Capacitor, mica 100pf ±5%, C ₂₄			
85	1					CMO6FD471J03		Capacitor, mica, 470pf, ±5%, C ₂₅			
86	1					CMO6FD911J03		Capacitor, mica, 910pf, ±5%, C ₂₆			
87	1					CMO4FA361J03		Capacitor, mica, 360pf, ±5%, C ₂₇			
88	1					CMO4FD181J03		Capacitor, mica, 180pf, ±5%, C ₃₁			
89	1					CMO6FD821J03		Capacitor, mica, 820pf, ±5%, C ₃₄			
90	2					9405-22 DELEVAN		Inductor, Tunable, 4.76-8.84µh, L ₁ , L ₃			

PARTS LIST		AGENCY (CONTRACTOR IDENT)		CONTRACT NO.		CODE IDENT		DOCUMENT NO.		REVISION LTR	
LIST TITLE		AUTHENTICATION		REV AUTH NO.		DATE		SHEET		NOTES	
Receiver											
ASSEMBLY NO.											
ASSEMBLY PART TITLE											
ITEM NO.	QTY REQD	UM	CODE IDENT	DRAWING OR DOCUMENT NO.	PART OR IDENTIFYING NUMBER	NOMENCLATURE OR DESCRIPTION					
91	2				9405-26 DELEVAN	Inductor, Tunable 10.5-19.5µh, L ₄ , L ₅					
92	1				HESD	3.96µh Inductor Wound on Micro-metals T50-2, L ₂					
93	1				HIESD	2.27µh Inductor Wound On Micro-metals T50-2, L ₆					
94	1				HESD	1.13µh Inductor Wound on Micro-metals T44-2, L ₇					
95	1				HESD	1.44 Inductor Wound On Micro-metals T44-2, L ₈					
96	1				HESD	3.91 Inductor Wound On Micro-metals T50-2, L ₉					

PARTS LIST		AGENCY (CONTRACTOR IDENT)		CONTRACT NO.		CODE IDENT		DOCUMENT NO.		REVISION LTR		
		LIST TITLE Oscillator		AUTHENTICATION		REV AUTH NO.				DATE		
ASSEMBLY NO. PL 549039		ASSEMBLY PART TITLE										
ITEM NO.	QTY REQD	UM	CODE IDENT	DRAWING OR DOCUMENT NO.	PART OR IDENTIFYING NUMBER	NOMENCLATURE OR DESCRIPTION						NOTES
1	1				1537-80 DELEVAN	Inductor, 120 μ h \pm 10% L ₁						
2	6				CKO6BX104KM	Capacitor, .1 μ fd \pm 20%, C ₁ , C ₂ , C ₃ , C ₄ , C ₅ , C ₆						
3	4				RCR05G821J	Resistor, Carbon 820 Ω \pm 5%, R ₁ , R ₂ , R ₃ , R ₄						
4	4				RCR05G153J	Resistor, Carbon 15K \pm 5%, R ₅ , R ₆ , R ₇ , R ₈						
5	4				RCR05G432J	Resistor, Carbon, 4.3K, \pm 5% R ₁₇ , R ₁₈ , R ₁₉ , R ₂₀						
6	4				RCR05G221J	Resistor, Carbon, 220 Ω \pm 5%, R ₂₅ , R ₂₆ , R ₂₇ , R ₂₈						
7	8				RCR05G820J	Resistor, Carbon \pm 5%, R ₉ , R ₁₀ , R ₁₁ , R ₁₂ , R ₂₁ , R ₂₂ , R ₂₃ , R ₂₄						
8	4				RCR05G 910J	Resistor, Carbon \pm 5%, R ₁₃ , R ₁₄ , R ₁₅ , R ₁₆						
9	1				CM06FD471J03	Capacitor, mica 470pf, \pm 5%, C ₇						
10	1				CM04FC271J03	Capacitor, mica 270pf, \pm 5%, C ₈						
11	1				CM04FD201J03	Capacitor, mica 200pf, \pm 5% C ₉						
12	1				CM04FD161J03	Capacitor, mica 160pf \pm 5%, C ₁₀						
13	5				CM06FD511J03	Capacitor, mica 510pf \pm 5%, C ₁₅ , C ₁₆ , C ₁₇ , C ₁₈ , C ₁₁						

PARTS LIST		AGENCY (CONTRACTOR IDENT)		CONTRACT NO.		CODE IDENT		DOCUMENT NO.		REVISION LTR	
LIST TITLE		AUTHENTICATION		REV AUTH NO.		DATE		SHEET		NOTES	
Oscillator		ASSEMBLY PART TITLE		NOMENCLATURE OR DESCRIPTION		PART OR IDENTIFYING NUMBER		DRAWING OR DOCUMENT NO.		DRAFTING OR DOCUMENT NO.	
ASSEMBLY NO.		PL 549039		CODE IDENT		ITEM NO.		QTY		RECD	
UIM		UIM		UIM		UIM		UIM		UIM	
14	4			CM06FD202J03							Capacitor, mica 2000pf, $\pm 5\%$, C ₁₉ C ₂₀ , C ₂₁ , C ₂₂
15	1			CM04FA331J03							Capacitor, mica 330pf $\pm 5\%$ C ₁₂
16	1			CM03FD241J03							Capacitor, mica 240pf $\pm 5\%$ C ₁₃
17	1			CM04FD181J03							Capacitor, mica 180pf $\pm 5\%$ C ₁₄
18	4			404 ARCO							Capacitor, Variable 7-60pf C ₂₃ , C ₂₄ , C ₂₅ , C ₂₆
19	1			9405-24 DELEVAN							Inductor, Variable L ₂ , 7-13 μ h
20	1			9405-22 DELEVAN							Inductor, Variable 4.7-8.8 μ h L ₃
21	1			9405-20 DELEVAN							Inductor, Variable 3.3-6.1 μ h L ₄
22	1			9405-18 DELEVAN							Inductor, Variable 2.3-4.3 μ h L ₅
23	1			Y1							Crystal, 1.6MHz International Crystal Mfg. Co.
24	1			Y2							Crystal 2.6 MHz International Crystal Mfg. Co.
25	1			Y3							Crystal 3.6MHz International Crystal Mfg. Co.
26	1			Y4							Crystal 4.6 Mfg. International Crystal Mfg. Co.

PARTS LIST		AGENCY (CONTRACTOR IDENT)		CONTRACT NO.		CODE IDENT		DOCUMENT NO.		REVISION LTR	
		LIST TITLE		AUTHENTICATION		REV AUTH NO.				DATE	
		Oscillator								SHEET	
ASSEMBLY NO.				PART OR IDENTIFYING NUMBER		NOMENCLATURE OR DESCRIPTION				NOTES	
PL 549039											
ITEM NO.	QTY REQD	UM	CODE IDENT	DRAWING OR DOCUMENT NO.	PART OR IDENTIFYING NUMBER	NOMENCLATURE OR DESCRIPTION					
27	4				2N918	Transistor Q ₁ -Q ₄					
28	1				1025-70	Inductor 120 μh ±10% L ₆					
29	1				1025-64	Inductor 68 μh ±10% L ₇					
30	1				1025-60	Inductor 47 μh ±10% L ₈					
31	1				1025-58	Inductor 39 μh ±10% L ₉					

PARTS LIST		AGENCY (CONTRACTOR IDENT)		CONTRACT NO.		CODE IDENT		DOCUMENT NO.		REVISION LTR	
LIST TITLE		AUTHENTICATION		REV AUTH NO.		DATE		SHEET		NOTES	
Mother Board		ASSEMBLY PART TITLE		NOMENCLATURE OR DESCRIPTION		PC Card Connectors		Resistor, Carbon Comp. 24Ω, ±5%		Resistor, Carbon Comp. 27Ω, ±5%	
ASSEMBLY NO.		DRAWING OR DOCUMENT NO.		PART OR IDENTIFYING NUMBER		HESD		Resistor, Carbon Comp. 62Ω, ±5%		Resistor, Carbon Comp. 470Ω, ±5%	
ITEM NO.	QTY REQD	UM	CODE IDENT	DRAWING OR DOCUMENT NO.	PART OR IDENTIFYING NUMBER	HESD		Resistor, Carbon Comp. 24Ω, ±5%		Resistor, Carbon Comp. 27Ω, ±5%	
1	1										
2	7										
3	4										
4	12										
5	3										
6	12										
7	6										
8	6										
9	6										
10	9										

PARTS LIST		AGENCY (CONTRACTOR IDENT)		CONTRACT NO.		FSCM NO.		DOCUMENT NO.		REVISION LTR	
LIST TITLE		AUTHENTICATION		REV AUTH NO.		DATE		SHEET		NOTES	
Fiber Optic Transmitter		ASSEMBLY PART TITLE		NOMENCLATURE OR DESCRIPTION		PART OR IDENTIFYING NUMBER		DRAWING OR DOCUMENT NO.		FSCM NO.	
ITEM NO.	QTY RECD	UM	FSCM NO.	ASSEMBLY NO.	QTY	UM	FSCM NO.	DESCRIPTION	PART OR IDENTIFYING NUMBER	DRAWING OR DOCUMENT NO.	FSCM NO.
1	2							Capacitor, Chip, 100 PF, C1, C5	C1006C101M5XAH, KEMET		
2	2							Capacitor, Chip, 0.01 μ F, C2, C6	C1808C104M5XAH, KEMET		
3	4							Capacitor, Chip, 3.3 μ F, C3, C4, C7, C13	T411E335M050AU, KEMET		
4	4							Capacitor, 0.1 μ F, C8, C10, C11, C12	CK058X104K		
5	0							NOT USED, C9	NOT USED		
6	2							Resistor, Carbon Comp., 75 ohm, 5%, R1, R3	RC07		
7	1							Resistor, Carbon Comp., 1200 ohm, 5%, R2	RC07		
8	1							Resistor, Carbon Comp., 330 ohm, 5%, R4	RC07		
9	1							Resistor, Carbon Comp., 51 ohm, 5%, R5	RC07		
10	1							Trim Pot, 500 ohm, R6	3299P-1-501, BOURNS		
11	1							Resistor, Carbon Comp., 180 ohm, 5%, R7	RC07		
12	1							Resistor, Carbon Comp., 2.4K ohm, 5%, R8	RC07		

R 955 (Feb. 77)

PARTS LIST		AGENCY (CONTRACTOR IDENT)		CONTRACT NO.		FSCM NO.		DOCUMENT NO.		REVISION LTR							
LIST TITLE		AUTHENTICATION		REV AUTH NO.		DATE		SHEET		NOTES							
Fiber Optic Transmitter ASSEMBLY NO.		ASSEMBLY PART TITLE															
ITEM NO.	QTY RECD	UIM	FSCM NO.	DRAWING OR DOCUMENT NO.	PART OR IDENTIFYING NUMBER	NOMENCLATURE OR DESCRIPTION	RC07	RC07	RC07	NOT USED, R12	333PW-1-500, BOURNS	RC20	RC20	RC20	VK-200-16-3B, FERROXCUBE	56-590-65-3B, FERROXCUBE	
13	1					Resistor, Carbon Comp., 6.8K ohm, 5%, R9											
14	1					Resistor, Carbon Comp., 560 ohm, 5%, R10											
15	1					Resistor, Carbon Comp., 3.9K ohm, 5%, R11											
16	0					NOT USED, R12											
17	2					Trim Pot, 50 ohm, R13, R14											
18	2					Resistor, Carbon Comp., 15 ohm, 5%, R15, R16											
19	2					Resistor, Carbon Comp, 33 ohm (15 ohm), 5%, R17, R18 Option A (B)											
20	1					Resistor, Carbon Comp., 47 ohm, 5%, R19											
21	2					RF Choke, (11555-9-103) RFC1, RFC2											
22	2					Bead, (115550-001) B1, B2											

F. 7. 9 (Rev. 7.1)

PARTS LIST		AGENCY (CONTRACTOR IDENT)		CONTRACT NO.		FSCM NO.		DOCUMENT NO.		REVISION LTR	
LIST TITLE		AUTHENTICATION		REV AUTH NO.		DATE		SHEET		NOTES	
Fiber Optic Transmitter		ASSEMBLY NO.		ASSEMBLY PART TITLE		PART OR IDENTIFYING NUMBER		NOMENCLATURE OR DESCRIPTION		NOTES	
ITEM NO.	QTY REQD	UM	FSCM NO.	DRAWING OR DOCUMENT NO.	PART OR IDENTIFYING NUMBER	NOMENCLATURE OR DESCRIPTION	NOTES	NOTES	NOTES	NOTES	NOTES
23	1				T9-1, Mini-Circuits Lab (MSK750)	RF XFMR, T1	Hybrid Amplifier, ARI				
24	1				BNR40-3-30-3		LED, D1 (Mount Diode in bracket 312165-001 on PC GND Plane)				
25	1				1N4001		Diode, D2				
26	1				1N4148		Diode, D3				
27	1						PC Board Jumper Pads with 0.1" LG Jumper Wires, JP1, JP2, JP3, JP4				
28	4						Input Jack, SMA PCB 90 DEG, J1				
29	1				2064-0000, AMERICON		Terminal Studs, (MS-17122-5)				
30	1				3653-2-05, CAMBION		Bracket for D1				
31					312165 MOD A						

19-5 (Feb. 77)

PARTS LIST		AGENCY (CONTRACTOR IDENT)		CONTRACT NO.		FSCM NO.		DOCUMENT NO.		REVISION LTR	
LIST TITLE		AUTHENTICATION		REV AUTH NO.		DATE		SHEET		NOTES	
Fiber Optic Receiver ASSEMBLY NO.		ASSEMBLY PART TITLE									
ITEM NO.	QTY RECD	UM	FSCM NO.	DRAWING OR DOCUMENT NO.	PART OR IDENTIFYING NUMBER	NOMENCLATURE OR DESCRIPTION	NOTES				
1	5				T411E335M050AU, KEMET	Capacitor, Chip, 3.3 μ F, C1, C6, C7, C10, C14					
2	10				CK05BX104-K	Capacitor, 0.1 μ F, 50V, C2, C3, C4, C5, C8, C9, C11, C12, C13, C15					
3	2				RC07	Resistor, Carbon Comp, 150 ohm, 5%, R1, R2					
4	1				RC07	Resistor, Carbon Comp, 100 Ω , 5%, R3					
5	1				3299P-1-101, BOURNS	Trim Pot, 100 ohm, R4					
6	0				NOT USED	NOT USED, R5					
7	1				RC07	Resistor, Carbon Comp., 300 ohm, 5%, R6					
8	1				RC07	Resistor, Carbon Comp., 1K ohm, 5%, R7					
9	1				RC07	Resistor, Carbon Comp., 1.5K ohm, 5%, R8					
10	1				RC07	Resistor, Carbon Comp., 470 ohm, 5%, R9					
11	1				RC07	Resistor, Carbon Comp., 15 ohm, 5%, R10					

11-5 (Feb. 77)

PARTS LIST		AGENCY (CONTRACTOR IDENT)		CONTRACT NO.		FSCM NO.		DOCUMENT NO.		REVISION LTR	
LIST TITLE		AUTHENTICATION		REV AUTH NO.		DATE		SHEET		NOTES	
Fiber Optic Receiver ASSEMBLY NO.		ASSEMBLY PART TITLE		PART OR IDENTIFYING NUMBER		NOMENCLATURE OR DESCRIPTION					
ITEM NO.	QTY RECD	UM	FSCM NO.	DRAWING OR DOCUMENT NO.	IDENTIFYING NUMBER	NOMENCLATURE OR DESCRIPTION					
12	1				RC07	Resistor, Carbon Comp., 18 ohm, 5%, R11, R13					
13	1				RC07	Resistor, Carbon Comp., 300 ohm, 5%, R12					
14	1				RCAC30815	IC Preamp, ARI					
15	1				UA733HC	IC RF Amplifier, AR2					
16	1				2N2222A	Transistor, Q1					
17	4				56-590-65-3B, FERROXCUBE	Bead (115550-001), B					
18	1				VK-200-10-3B, FERROXCUBE	RF Choke, VK					
19	1				2064-000, AMERICON	Output Jack, SMA PCB, 90 DEG, J1					
20						Jumper Wire, JW					
21	1				SKFO-2008, HESD	Fiber Alignment Fixture					
22	3				3653-2-05, CAMBION	Terminal Studs (MS-17122-5), TP1, TP2, TP3					
23	2				1N963B	Diode, CR1, CR2					
24	1				1N753A	Diode, CR3					

1-553 (Rev. 77)

AD-A058 236

HARRIS CORP MELBOURNE FLA ELECTRONIC SYSTEMS DIV
AN/TTC-38 FIBER-OPTIC VERIFICATION STUDY.(U)
AUG 77 J W BRUCE, W W COTTEN, C R PATISAUL

F/G 20/6

DAAB07-77-C-1777

UNCLASSIFIED

ECOM-77-1777-F

NL

2 OF 2

AD
A058236

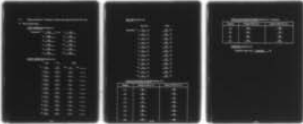

END
DATE
FILMED
10-78
DDC

PARTS LIST		AGENCY (CONTRACTOR IDENT)		CONTRACT NO.		FSCM NO.		DOCUMENT NO.		REVISION LTR	
LIST TITLE		AUTHENTICATION		REV AUTH NO.		DATE		SHEET		NOTES	
Chassis		ASSEMBLY NO.		ASSEMBLY PART TITLE		PART OR IDENTIFYING NUMBER		NOMENCLATURE OR DESCRIPTION		NOTES	
ITEM NO.	QTY	UM	FSCM NO.	DRAWING OR DOCUMENT NO.	ASSEMBLY PART TITLE	PART OR IDENTIFYING NUMBER	NOMENCLATURE OR DESCRIPTION	NOTES	REVISION LTR	DATE	SHEET
1	1				V12DS-24-7A	ABBOTT	AC-DC Power Supply				
2	1				CC14DH2.0	ABBOTT	DC-DC Converter, 28/±15V				
3	1				C5DH2.5	ABBOTT	DC-DC Converter, 28/5V				
4	1				7484/7486	HUBBEL	AC Connector				
5	1				7593/7595	HUBBEL	DC Connector				
6	2				HKP15A250V		Fuse Holder				
7	1				4110, PAMOTOR		DC Fan				
8	1				ALCO		Switch, 2P, ON/OFF/ON				
9	2				MST405N, ALCO		Switch, 4PDT				
10	1				U-187A/G, MX3227/G, ELCO		Connector, 26 PR				
11	1				GBPVX0188PNC, CANNON		Connector				
12	1				G35005184-15N, GLENAIR		Shell				
13	1						Terminal Strip				

PARTS LIST		AGENCY (CONTRACTOR IDENT)		CONTRACT NO.		FSCM NO.		DOCUMENT NO.		REVISION LTR	
LIST TITLE		AUTHENTICATION		REV AUTH NO.		DATE		SHEET		NOTES	
ASSEMBLY NO.		ASSEMBLY PART TITLE		PART OR IDENTIFYING NUMBER		NOMENCLATURE OR DESCRIPTION		NOTES			
ITEM NO.	QTY RECD	UM	FSCM NO.	DRAWING OR DOCUMENT NO.	PART OR IDENTIFYING NUMBER	NOMENCLATURE OR DESCRIPTION	NOTES				
14	1				DSFL-7005, BUCKEYE	Equipment Case					
15	1				508-8745-504, DIALCO	Lamp Holder					
16	1				SM-1A, SYLVANIA	Lamp Holder					
17	1				507-3918, DIALCO	Lamp 28 Vdc					
18	1				507-453822K, DIALCO	Lamp 115 Vac					

8 3-5 (Feb. 57)

APPENDIX A

**TEST PROCEDURE FOR AN/TTC-38 FIBER OPTIC
SYSTEM VERIFICATION STUDY**

TEST PROCEDURE FOR
AN/TTC-38 FIBER OPTIC
SYSTEM VERIFICATION STUDY
Specification DS-EN-0234A (A)

Engineer J.W. Bruce (9 June 1977)

C.O.T.R. Louis A. Coryell (9 June 1977)

Witness I.B. Slayton (9 June 1977)

Project 1033
1 June 1977

1.0 SCOPE

This document describes the tests to be performed on the AN/TTC-38 Fiber Optic System to ensure its compliance to specification numbers DS-EN-0234A (A).

2.0 APPLICABLE DOCUMENTS

2.1 Issues of Documents. The following documents of the issue in effect on date of invitation for bids or request for proposal, form a part of this specification to the extent specified herein:

SPECIFICATIONS

Military

MIL-P-11268	Parts, Materials and Processes Used in Electronics Equipment Connector, Plug, Electrical U-185 ()/G Connector Receptacle, Electrical U-186 ()/G Connector, Receptacle, Electrical U-187 ()/G Contact Assembly, Electrical MX-3227 ()/G
MIL-D-55456	Distribution Box, J-1077 ()/U, Distribution Box, J-2317 ()/U
MIL-C-55486	Cable Assembly Telephone CX-4566 ()/G and CX-4760 ()/U

Electronics Command

EL-CP0061-0001	Telephone Set TA-838 ()/TT
EL-CP0109-0001	Central Office, Telephone, Automatic AN/TTC-38 () (V)
SCL-1759	Telephone Set TA-341 ()/TT

3.0 TEST EQUIPMENT REQUIRED

The following test equipment or its equivalent shall be utilized in the performance of these tests.

MODEL	DESCRIPTION	MFG.	QTY
142	Signal Generator	Wavetek	1
721A	Power Supply	Hewlett-Packard	2
545A	Oscilloscope	Tektronix	1
Type-D	Plug-in Unit	Tektronix	1
334A	Distortion Analyzer	Hewlett-Packard	1
N/A	Test Fix. A	Harris ESD	1
N/A	150 ohm resistor 1/4W	N/A	1
N/A	300 ohm resistor 1/4W	N/A	2
315A	Variable Filter	KROHN-HITE	1

4.0 PROCEDURE

4.1 Input Impedance

4.1.1 Configure the system as shown in the Test Setup.

4.1.2 Insert the 300 ohm resistors into pins 1A and 1B of the distribution box J-1077A/U #1.

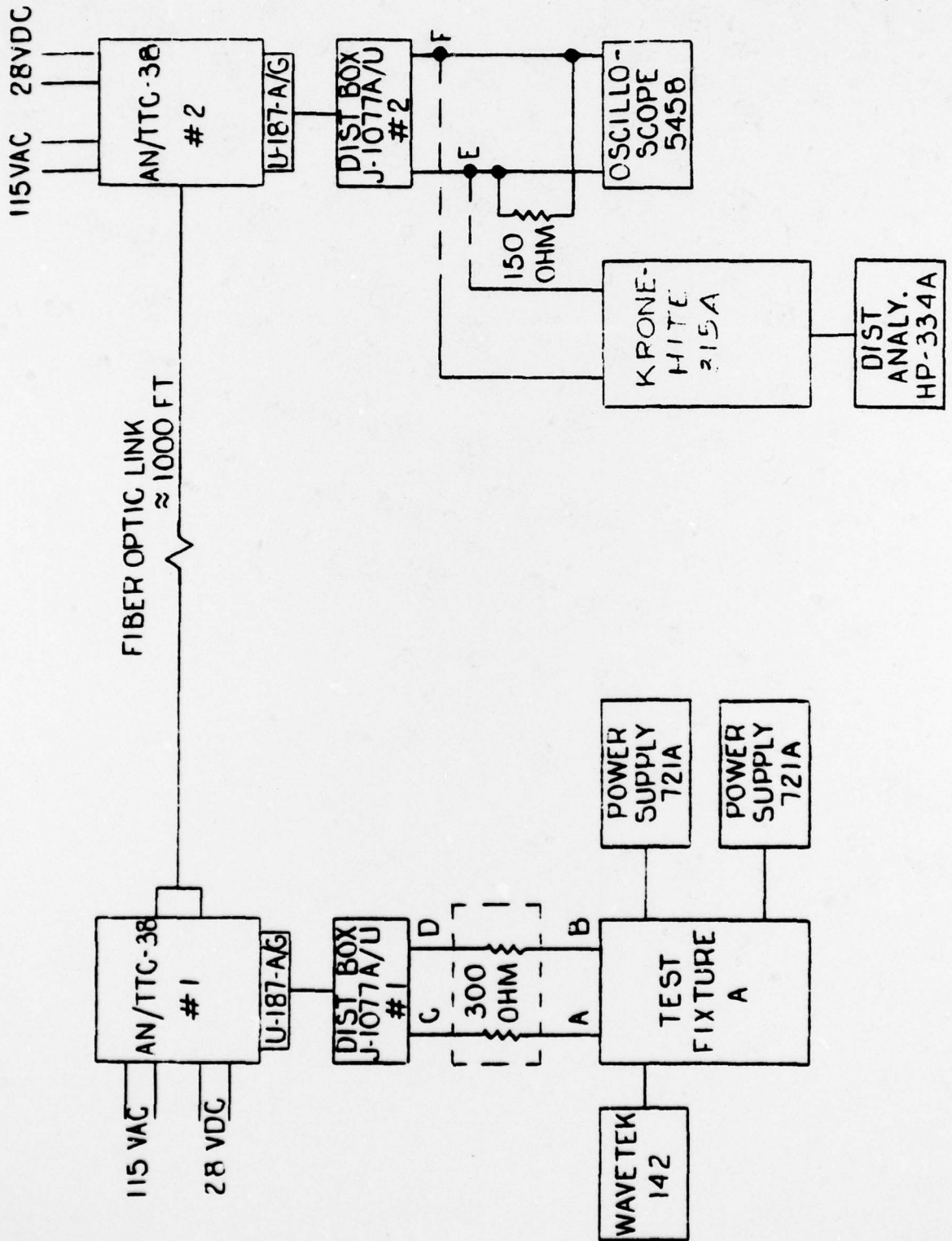

TEST SETUP

4.1.3 While monitoring points A and B with the oscilloscope, adjust the Wavetek for a 32 kHz square wave output at a voltage level of 4 V p-p.

4.1.4 Remove the oscilloscope from points A and B and monitor points C and D. The voltage here shall be between 1.8 V p-p and 2.2 V p-p indicating an input impedance of 600 ohms $\pm 10\%$

Voltage measured 1.9 V p-p

NOTE: This test may be repeated up to 12 times for each input to the transmitter if desired.

Transmitter # 2	<u>1.9</u>	8	<u>1.2*</u>
3	<u>1.9</u>	9	<u>1.9</u>
4	<u>1.9</u>	10	<u>1.9</u>
5	<u>1.9</u>	11	<u>1.9</u>
6	<u>1.9</u>	12	<u>1.9</u>
7	<u>1.9</u>		

4.2 Output Impedance

4.2.1 Configure the system as shown in the Test Setup such that the 300 ohm resistors shorted.

4.2.2 Monitor points E and F with the oscilloscope to determine the voltage with the 150 ohm resistor removed.

Volts p-p 1.6

*4.6 MHz, Hz Group

4.2.3 Tie the 150 ohm resistor across points E and F. Note that the voltage falls to a value one-half as large, $\pm 10\%$, as that noted in step 4.2.2.

Volts p-p 0.9 yes x no $\pm 10\%$

NOTE: Step 4.2.1 - 4.2.3 may be repeated until all channels have been measured.

4.2.4	V p-p	V p-p	Yes	$\pm 10\%$	No
#2	<u>3.2</u>	<u>1.5</u>	<u>x</u>		<u> </u>
3	<u>2.0</u>	<u>1.0</u>	<u>x</u>		<u> </u>
4	<u>2.4</u>	<u>1.2</u>	<u>x</u>		<u> </u>
5	<u>3.7</u>	<u>1.8</u>	<u>x</u>		<u> </u>
6	<u>3.7</u>	<u>1.8</u>	<u>x</u>		<u> </u>
7	<u>3.7</u>	<u>1.8</u>	<u>x</u>		<u> </u>
8	<u>4.8</u>	<u>2.4</u>	<u>x</u>		<u> </u>
9	<u>4.9</u>	<u>2.4</u>	<u>x</u>		<u> </u>
10	<u>5.2</u>	<u>2.5</u>	<u>x</u>		<u> </u>
11	<u>3.2</u>	<u>1.6</u>	<u>x</u>		<u> </u>
12	<u>3.4</u>	<u>1.6</u>	<u>x</u>		<u> </u>

4.3 RISE TIME

4.3.1 With the equipment configured as shown, set the Wavetek 142 to a square wave output at 32 kHz.

4.3.2 Utilizing the 545A oscilloscope monitor the input at points A & B and note the rise time and droop which may be present on the square wave.

Rise Time 10-90% _____ μs

Droop _____ %

4.3.3 Connect the oscilloscope to points E and F and note the rise time at the 10-90% points is less than 5 μs and that the droop is less than 5%.

Rise Time 2.9 μs

Droop OK %

Note this test may be repeated until all 12 channels have been tested.

	Rise Time	Droop	Rise Time	Droop
Trans # 2	<u>3.2</u> μs	<u>OK</u> %	7	<u>3.3</u> μs <u>OK</u> %
3	<u>2.5</u> μs	<u>OK</u> %	8	<u>4.7</u> μs <u>OK</u> %
4	<u>3.5</u> μs	<u>OK</u> %	9	<u>3.1</u> μs <u>OK</u> %
5	<u>3.5</u> μs	<u>OK</u> %	10	<u>2.7</u> μs <u>OK</u> %
6	<u>4.0</u> μs	<u>OK</u> %	11	<u>3.2</u> μs <u>OK</u> %
			12	<u>5.0</u> μs <u>OK</u> %

4.3.4 Change the frequency of the Wavetek 142 to a 16 kHz square wave and repeat steps 4.3.2 and 4.3.3.*

*Measurements for 16 kHz square wave were not taken. Satisfactory operation was indicated per results of para. 4.3.3

4.4 SIGNAL PLUS NOISE TO NOISE

4.4.1 Again with the equipment as shown in the test setup, monitor points E or F with the HP-334A instead of the oscilloscope at test fixture B via the Variable Filter. Set the filter for a HI Pass cutoff of 300 Hz and a Lo Pass cutoff of 4 kHz.

4.4.2 Set the Wavetek 142 to a 1 kHz sinewave and obtain a reference level on the HP-334A.

4.4.3 Remove the modulation input from the Wavetek 142 and determine the noise remaining in the channel to be greater than 40 dB below the reference obtained in step 4.4.2.

4.4.4 Repeat this process for all 12 channels and enter data below.

Unit #1 to Unit #2

Channel	Analog (4 kHz B.W.)	Digital (100 kHz B.W.)
<u>1</u>	<u>52 dB</u>	<u>34 dB</u>
<u>2</u>	<u>52</u>	<u>33</u>
<u>3</u>	<u>49</u>	<u>29</u>
<u>4</u>	<u>52</u>	<u>31</u>
<u>5</u>	<u>49</u>	<u>31</u>
<u>6</u>	<u>49</u>	<u>33</u>
<u>7</u>	<u>49</u>	<u>33</u>
<u>8</u>	<u>53</u>	<u>35</u>
<u>9</u>	<u>53</u>	<u>35</u>

Unit #1 to Unit #2 (Continued)

Channel	Analog (4 kHz B.W.)	Digital (100 kHz B.W.)
<u>10</u>	<u>53</u>	<u>35</u>
<u>11</u>	<u>50</u>	<u>32</u>
<u>12</u>	<u>50</u>	<u>35</u>

4.4.5 Change the Wavetek 152 to a 100 kHz square wave and remove the Krohn-Hite Filter from the test setup and repeat steps 4.4.1 through 4.4.4 and enter data above.

4.5 CROSSTALK

4.5.1 Configure the test setup as shown. Connect the 11 transmitters inputs in parallel utilizing jumper wires and set the Wavetek 142 to a 32 kHz square wave at a level of 1 volt p-p.

4.5.2 Monitor the receiver channel corresponding to a used transmitter channel with test fixture B in the wideband mode and the HP-334B and obtain a reference of 0 dB on the HP-334A.

4.5.3 Monitor the receiver channel corresponding to the unused transmitter channel and determine the noise to be greater than 40 dB below that obtained in step 4.5.2.

(Crosstalk) Noise Level Negligible dB

NOTE: If the reading obtained here is less than 40 dB below the signal level remove the modulation and determine that the high reading is caused by the residual noise of the system and is not caused by crosstalk in the system.

4.6 Repeat procedures 4.1 through 4.5 except inject signals from Unit #2 to Unit

#1. Record results below:

INPUT IMPEDANCE (Section 4.1)

Transmitter #	1	<u>1.85</u>	V p-p	7	<u>1.85</u>
	2	<u>1.85</u>		8	<u>1.85</u>
	3	<u>1.85</u>		9	<u>1.85</u>
	4	<u>1.85</u>		10	<u>1.85</u>
	5	<u>1.85</u>		11	<u>1.85</u>
	6	<u>1.85</u>		12	<u>1.88</u>

OUTPUT IMPEDANCE (Section 4.2)

	V p-p	V p-p	±10%	
#			Yes	No
1	<u>3.9</u>	<u>1.9</u>	<input checked="" type="checkbox"/>	<input type="checkbox"/>
2	<u>4.7</u>	<u>2.3</u>	<input checked="" type="checkbox"/>	<input type="checkbox"/>
3	<u>2.6</u>	<u>1.3</u>	<input checked="" type="checkbox"/>	<input type="checkbox"/>
4	<u>2.9</u>	<u>1.4</u>	<input checked="" type="checkbox"/>	<input type="checkbox"/>
5	<u>2.9</u>	<u>1.4</u>	<input checked="" type="checkbox"/>	<input type="checkbox"/>
6	<u>2.8</u>	<u>1.4</u>	<input checked="" type="checkbox"/>	<input type="checkbox"/>
7	<u>2.3</u>	<u>1.2</u>	<input checked="" type="checkbox"/>	<input type="checkbox"/>
8	<u>1.9</u>	<u>0.9</u>	<input checked="" type="checkbox"/>	<input type="checkbox"/>
9	<u>2.1</u>	<u>1.0</u>	<input checked="" type="checkbox"/>	<input type="checkbox"/>
10	<u>3.7</u>	<u>1.8</u>	<input checked="" type="checkbox"/>	<input type="checkbox"/>
11	<u>2.6</u>	<u>1.4</u>	<input checked="" type="checkbox"/>	<input type="checkbox"/>
12	<u>2.4</u>	<u>1.3</u>	<input checked="" type="checkbox"/>	<input type="checkbox"/>

RISE TIME (Section 4.3)

	Rise Time	Droop
Transmitter # 1	<u>2.8</u> μ s	<u>OK</u> %
2	<u>4.8</u> μ s	<u>OK</u> %
3	<u>2.7</u> μ s	<u>OK</u> %
4	<u>4.4</u> μ s	<u>OK</u> %
5	<u>3.5</u> μ s	<u>OK</u> %
6	<u>3.3</u> μ s	<u>OK</u> %
7	<u>4.0</u> μ s	<u>OK</u> %
8	<u>4.4</u> μ s	<u>OK</u> %
9	<u>3.0</u> μ s	<u>OK</u> %
10	<u>2.8</u> μ s	<u>OK</u> %
11	<u>3.1</u> μ s	<u>OK</u> %
12	<u>3.0</u> μ s	<u>OK</u> %

SIGNAL PLUS NOISE TO NOISE (Section 4.4)

Channel	Analog (4 kHz B.W.)	Digital (100 kHz B.W.)
<u>1</u>	<u>52</u>	<u>39</u>
<u>2</u>	<u>54</u>	<u>42</u>
<u>3</u>	<u>53</u>	<u>37</u>
<u>4</u>	<u>51</u>	<u>38</u>
<u>5</u>	<u>48</u>	<u>35</u>
<u>6</u>	<u>53</u>	<u>36</u>
<u>7</u>	<u>51</u>	<u>34</u>
<u>8</u>	<u>50</u>	<u>34</u>

SIGNAL PLUS NOISE TO NOISE (Section 4.4) - Continued

Channel	Analog (4 kHz B.W.)	Digital (100 kHz B.W.)
<u>9</u>	<u>56</u>	<u>38</u>
<u>10</u>	<u>45</u>	<u>37</u>
<u>11</u>	<u>48</u>	<u>36</u>
<u>12</u>	<u>49</u>	<u>36</u>

CROSSTALK (Section 4.5)

(Crosstalk) Noise Level Negligible dB