

AD-A058 359

NAVAL RESEARCH LAB WASHINGTON D C

F/G 17/2.1

FEASIBILITY OF A FIBER-OPTIC COMMUNICATIONS LINK BETWEEN A SUBM--ETC(U)

JAN 78 E L ALTHOUSE

UNCLASSIFIED

NRL-8182

SBIE-AD-E000 189

NL

1 of 1  
AD  
A058 359



END  
DATE  
FILMED  
11-78  
DDC

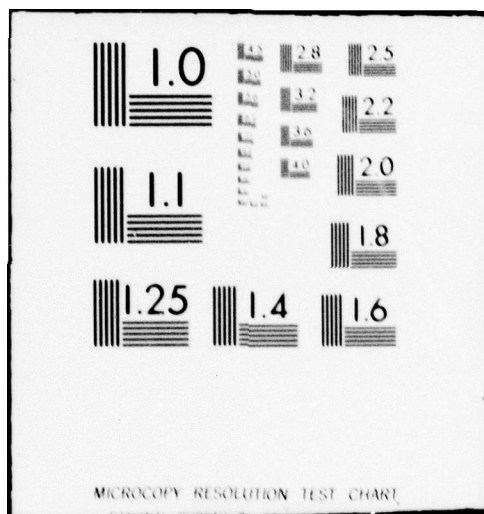

MICROCOPY RESOLUTION TEST CHART

ADA 058359

⑫ LEVEL II  
SC

ade 000189  
NRL Report 8182

# Feasibility of a Fiber-Optic Communications Link Between a Submarine and a Towed Buoy

E. L. ALTHOUSE

*Telecommunication Systems Technology Branch  
Communications Sciences Division*

January 27, 1978

AD No. \_\_\_\_\_  
DDC FILE COPY



DDC  
RECEIVED  
SEP 1 1978  
B

*[Handwritten signature]*

NAVAL RESEARCH LABORATORY  
Washington, D.C.

78 07 12 023

Approved for public release; distribution unlimited.

18 SBIE

19 AD-E000#189

14 NRL-8182

SECURITY CLASSIFICATION OF THIS PAGE (When Data Entered)

| REPORT DOCUMENTATION PAGE  |  | READ INSTRUCTIONS<br>BEFORE COMPLETING FORM                                 |
|--|--|---|
| 1. REPORT NUMBER<br>NRL Report 8182 ✓  | 2. GOVT ACCESSION NO.  | 3. RECIPIENT'S CATALOG NUMBER   |
| 4. TITLE (and Subtitle)<br>6 FEASIBILITY OF A FIBER-OPTIC COMMUNICATIONS LINK BETWEEN A SUBMARINE AND A TOWED BUOY.  |  | 5. TYPE OF REPORT & PERIOD COVERED<br>9 Interim report of continuing nature |
| 7. AUTHOR(s)<br>10 Edwin L. Althouse   | 16 F21222, D0004SB<br>17 XF21222092, D0004SB   | 6. PERFORMING ORG. REPORT NUMBER  |
| 9. PERFORMING ORGANIZATION NAME AND ADDRESS<br>Naval Research Laboratory<br>Washington, D. C. 20375  | 10. PROGRAM ELEMENT, PROJECT, TASK AREA & WORK UNIT NUMBERS<br>62721NXF-21-222-092 R01-96.201<br>64363N D-0004-SB R01-09.207<br>11402N X-0793-SB | 8. CONTRACT OR GRANT NUMBER(s)  |
| 11. CONTROLLING OFFICE NAME AND ADDRESS<br>Naval Electronic Systems Command<br>Washington, D. C. 20360   | 12. REPORT DATE<br>14 27 Jan 78  | 13. NUMBER OF PAGES<br>20 12 24p.   |
| 14. MONITORING AGENCY NAME & ADDRESS (if different from Controlling Office)  | 15. SECURITY CLASS. (of this report)<br>UNCLASSIFIED   |   |
| 15a. DECLASSIFICATION/DOWNGRADING SCHEDULE   |  |   |
| 16. DISTRIBUTION STATEMENT (of this Report)<br>Approved for public release; distribution unlimited.  |  |   |
| 17. DISTRIBUTION STATEMENT (of the abstract entered in Block 20, if different from Report)   |  |   |
| 18. SUPPLEMENTARY NOTES  |  |   |
| 19. KEY WORDS (Continue on reverse side if necessary; and identify by block number)<br>Fiber-optics<br>Towed communications buoys<br>Transmission lines  |  |   |
| 20. ABSTRACT (Continue on reverse side if necessary; and identify by block number)<br>The possibility of replacing the conventional conductive transmission line between a submarine and a towed communications buoy with a fiber-optic transmission line is explored. The general attributes of fiber-optic systems are put into proper perspective for this application. Specific emphasis is placed on the transfer to the submarine of the signals received at the buoy in the HF, VHF, and UHF bands. A system has been proposed that will permit wideband transfer of HF signals at RF and narrowband transfer of VHF/UHF signals at IFs of 70 MHz and below. The necessity of transferring VHF/UHF signals at a reduced frequency results from amplifier gain-stability considerations in the (Continued) |  |   |

DD FORM 1473 1 JAN 73

EDITION OF 1 NOV 65 IS OBSOLETE S/N 0102-LF-014-6601

SECURITY CLASSIFICATION OF THIS PAGE (When Data Entered)

78 07 12 023

251 950

Imc A

20. ABSTRACT (Continued)

buoy electronics. The major advantages of an optical information-transfer system are wide-bandwidth transfer at HF, simultaneous transfer of HF voice, NAVSAT, SATCOM, and UHF voice, a wideband nonresonant transmission line, less frequency jitter in the coherent-frequency conversions at VHF/UHF, the potential for support of additional buoy functions, and the removal of the presently required frequency synthesizer in the buoy. Possible disadvantages are technological difficulties in producing low-noise rotating-to-stationary optical interfaces or, alternatively, in producing nontwisting cable-spooling devices, the general vulnerability of silica fibers to physical stress and attack by moisture, and less radiation hardness than conventional systems. It was determined that the best optical source was the LED because of its reliability, temperature stability, and applicability to analog modulation. Because of the high attenuation of plastic fibers, silica fibers must be used. An avalanche photodetector is required for weak-reception areas, but in strong-reception areas a PIN photodetector is preferable because of better linearity at high signal levels and better temperature stability.

## CONTENTS

|    |  |    |
|----|--|----|
| 1. | INTRODUCTION .....   | 1  |
| 2. | REVIEW OF FIBER-OPTIC SYSTEM COMPONENTS .....                                  | 2  |
|    | Optical Sources .....  | 2  |
|    | Optical Fibers .....   | 4  |
|    | Photodetectors .....   | 5  |
|    | Summary and Proposed Components .....  | 6  |
| 3. | ADVANTAGES OF OPTICAL FIBER TRANSMISSION LINES .....                           | 7  |
|    | Attenuation and Bandwidth .....  | 7  |
|    | Absence of Reflections and Ground Loops .....                                  | 7  |
|    | Decrease in Crosstalk .....  | 8  |
|    | Reduction of Electromagnetic Interference (EMI) .....                          | 8  |
| 4. | DIGITAL VS ANALOG TRANSMISSION LINES .....                                     | 8  |
|    | Digital Transmission of RF signals .....                                       | 8  |
|    | Analog Transmission .....  | 10 |
| 5. | OPTICAL TRANSMISSION OF THE HF COMMUNICATIONS BAND .....                       | 10 |
| 6. | OPTICAL TRANSMISSION OF THE VHF/UHF BAND .....                                 | 12 |
| 7. | ELECTROMECHANICAL CONSIDERATIONS FOR FIBER-OPTIC<br>INFORMATION TRANSFER ..... | 14 |
| 8. | SUMMARY AND CONCLUSIONS .....  | 16 |
| 9. | REFERENCES .....   | 19 |

|                                   |              |                                     |
|-----------------------------------|--------------|-------------------------------------|
| QUESTION 10                       |              |                                     |
| N/A                               | Not Answered | <input checked="" type="checkbox"/> |
| DB                                | Not Answered | <input type="checkbox"/>            |
| BY                                |              |                                     |
| DISTRIBUTION/CLASSIFICATION CODES |              |                                     |
| Dist.                             | AVAIL        | and/or SPECIAL                      |
| A                                 |              |                                     |

## **FEASIBILITY OF A FIBER-OPTIC COMMUNICATIONS LINK BETWEEN A SUBMARINE AND A TOWED BUOY**

### **1. INTRODUCTION**

Because of the high attenuation that seawater presents to electromagnetic waves at frequencies above a few hundred hertz, severe constraints are imposed upon the ability of submarines to receive navigation and communication signals. Operating at periscope depth to allow an antenna mast to penetrate the seawater boundary severely compromises the security of the submarine. Towed buoys that allow the submarine to decrease its exposure and visibility while receiving navigation and command and control information have been developed. The submarine remains submerged at operational depth and maintains a moderate speed while towing a buoy that ideally travels just beneath the sea surface with an array of antennas that penetrate the air-sea interface. The buoy antennas and associated electronics serve a variety of purposes. Navigation satellite signals can be received at 400 and 150 MHz, short-range UHF voice communications from 225 to 400 MHz, satellite communications signals from 249 to 258 MHz, HF voice communications from 3 to 30 MHz, OMEGA navigation signals and naval shore-to-ship communications at VLF (10 to 20 kHz), and LORAN-C navigation signals at LF (100 kHz).

There are, however, several significant deficiencies and limitations in the existing towed-buoy system that are related to the limited electrical performance of the tow cable. The first problem is the large frequency dependence of the cable attenuation at frequencies within the HF band. For example, at a frequency of 30 MHz the cable presents an overall attenuation of 48 dB, while at 6 MHz the attenuation is only 18 dB. Frequency-dependent phase-shift characteristics are associated with this variation in attenuation and, consequently, dispersive effects would be evident in the HF band if broadband transfer were attempted. In the present system this problem is circumvented by transferring only a single narrowband channel at an IF near 500 kHz. A second and similar problem occurs for VHF-UHF transfer. These bands must be transferred at an IF of 15 MHz or less. The third problem involves the tuning of the tow-cable transmission line to prevent excessive reflections or standing waves at the particular frequency of interest. For simultaneous transfer of several bands of information the transmission line must be capable of supporting several IFs; in principle it is possible to tune a transmission line for this multifrequency performance, but in practice it may be difficult. A potential fourth problem stems from the reduced information bandwidths possible at the relatively low IFs required for transfer over the tow cable. A final problem in the existing tow cable is crosstalk between the various signal leads. The present 23 dB of crosstalk separation reduces the benefit of the multiconductor design.

The new technology of fiber optics shows promise of overcoming these deficiencies in the electrical performance of the tow cable. Fiber-optic transmission lines can support very

wide bandwidths (up to several hundred MHz), have a relatively low and constant attenuation rate within this bandwidth, show essentially no crosstalk, and eliminate problems with ground loops and resonant standing waves at high frequencies. In addition to the improvement that fiber-optic transmission lines could provide for the existing navigation and communication systems, there is also the possibility that the wide-bandwidth, low-crosstalk properties of these lines would allow additional functions, such as infrared surveillance, to be carried out by the buoy.

This report discusses the feasibility of using a fiber-optic data link between a communications buoy and a submarine. An introduction to the properties of fiber-optic systems is given in section 2. In section 3 the specific advantages of a fiber-optic information-transfer system relevant to the towed-buoy application are discussed.

The alternatives of digital and analog transmission of the received signals are pursued in section 4. In sections 5 and 6 the transmission of HF and VHF/UHF signals is considered, and simple candidate buoy receiving systems are proposed. Electromechanical problems encountered at the termination of the tow cable with the submarine are considered in section 7, and conclusions are given in section 8.

## 2. REVIEW OF FIBER-OPTIC SYSTEM COMPONENTS

A fiber-optic system used as a data link consists of three basic components: the optical source and modulator, the optical fiber, and the photodetector. Each of these three components will be reviewed briefly, with the emphasis being given to those properties which are important for the proposed application of fiber optics to towed buoys.

### Optical Sources

Sources include the light-emitting diode (LED), the superluminescent diode (SLD), the solid-state injection laser, and the neodymium-doped yttrium-aluminum-garnet laser (Nd:YAG). The LED is the most commonly used source at present because it is inexpensive and small, can be directly modulated, has the longest lifetime (projected to  $10^5$  hours continuous duty), and has the smallest temperature dependence. The transfer characteristic (optical power output versus drive current) is reasonably linear; deviation from linearity occurs at high currents, where heating effects decrease the optical efficiency. In analog modulation applications, where linearity is important, the LED is usually the optical source chosen.

The LED is an incoherent device because its luminescence is derived from a spontaneous emission process, as opposed to the coherent stimulated emission process that occurs in lasers. The spectral half-widths of typical LEDs range from 20 to 50 nanometers (nm). Infrared (IR) emitting GaAs and  $\text{Al}_x\text{Ga}_{1-x}\text{As}$  LEDs radiate in the 750-to-950-nm wavelength region, which fortunately corresponds to a low-attenuation band in optical fibers.

Moderately-priced LEDs can be modulated at rates up to 150 MHz, depending on the design compromises that were invoked (less bandwidth can often be traded for more optical power). Specially designed LEDs have been modulated at frequencies as high as 280 MHz.

In 150-MHz-bandwidth LEDs, continuous output optical power levels of about 500 to 1000  $\mu\text{W}$  can be obtained at drive currents of about 200 mA with a forward voltage drop of 1.5

to 2 volts. The dc resistance of the LED decreases with increasing bias current in an almost inverse relationship. The ac resistance is typically between 0.1 and 1.0 ohms over most of the bias range of interest. The modulation bandwidth obtainable with an LED increases with increasing bias current. For example, an RCA C30119 device (nominally rated at 150-MHz bandwidth) will support a bandwidth of only 70 MHz at a bias current of 20 mA; the rated bandwidth of 150 MHz is obtained by increasing the bias current to 100 mA. The significance of this point will be discussed later.

The temperature dependence of the radiation from  $\text{Al}_x\text{Ga}_{1-x}\text{As}$  LEDs is small. At constant drive current the radiation intensity decreases only by about 3 dB as the diode temperature increases from 20° to 100° C [1].

Superluminescent diodes achieve a higher intensity of radiance than do LEDs, because both spontaneous and stimulated emissions are excited in this device. The efficiency of this device is poor compared to the laser, and at present it is not used in fiber-optic systems.

The injection-laser source is still primarily a laboratory experimental device, although it is readily available commercially. The primary advantages of this source are: a spectral width that is an order of magnitude narrower than the LED spectral width, much higher radiated optical power, better coupling into small fibers because of narrower emission beamwidths, and the possibility of modulation rates up to a few GHz. AlGaAs lasers are available which can be operated continuously at an output optical power of 10 mW with a forward voltage of 2 V and a current of 300 mA. The dependence of ac and dc resistance and bandwidth on bias current must be known if one is to assess the application of injection-laser sources for analog applications. However, this information is not available in the literature, and the subject has not been pursued further in this report.

The transfer characteristic (optical power versus drive current) of the laser is much less linear overall than that of the LED because of the existence of a threshold current below which lasing action ceases. Above the threshold the transfer characteristic is quite linear but, unfortunately, is very temperature dependent. For RCA laser types C30127 and C30130 a  $\pm 10\%$  temperature change at 20° C results in approximately a  $\pm 67\%$  change in optical power output at a constant bias current of 270 mA. Because of this extreme temperature sensitivity, either the injection laser must be operated in a temperature-stabilized environment, or compensation schemes must be devised to adjust the bias current in a manner that will hold the quiescent operation point at constant-output optical power. Although in principle simple analog modulation could be used on the linear portion of the laser transfer characteristic, the extreme temperature dependence usually precludes this in practice. Normally, only digital or frequency-modulation techniques, for which linearity is unimportant, are used with laser sources.

Present injection-laser lifetimes are less than one tenth those for LEDs; consequently few permanent installations use these devices where reliability and longevity are important. The mechanisms for premature failure and degradation of these devices are being identified, and the necessary corrective innovations are being pursued. The lifetime problem may be solved within the next 5 years.

External modulation techniques must be used with the Nd:YAG laser because of the long fluorescence lifetime of the upper lasing level. External modulators can be designed by

E. L. ALTHOUSE

employing electrooptic, acoustooptic, and magneto optic effects. Many of these devices have been constructed and tested in the laboratory, but none are available commercially at present.

### Optical Fibers

Optical fibers that are used as light-transmission lines contain a propagating beam of light by total internal reflection. Total internal reflection occurs when light propagates from a medium of higher index of refraction toward a medium of lower index of refraction and the grazing angle of incidence with the boundary between the media is less than some critical value. The value of the critical angle is determined by the ratio of the two indices of refraction. The larger the ratio, the greater the angle that the light ray can make with the fiber wall and still be contained. Single fibers are usually designed with a central core with refractive index of approximately 1.4 to 1.5 and a concentric outer cladding with a refractive index that is a few percent lower. The transition in index of refraction from the core to the cladding may be abrupt, as in step-index fibers, or gradual, as in graded-index fibers. Typical core diameters vary from 60 to 250 micrometers ( $\mu\text{m}$ ). Since the wavelength of light in the IR region is approximately 1  $\mu\text{m}$ , the core is many wavelengths wide. As a consequence, thousands of modes of propagation can be supported in these fibers; hence they are termed *multimode fibers*. If the diameter of the fiber core approaches the wavelength of the light being guided, only a few modes can propagate. Fibers which will support one mode or possibly only a few modes of propagation are called *single mode fibers*. They are in the experimental stage and are not yet usable for practical applications because of the difficulty of coupling sufficient optical power into them.

The modes propagating within a fiber-waveguide core can be considered pictorially as rays of light propagating obliquely down the fiber while encountering multiple reflections at the core/cladding boundary. Each mode can be conceived of as being a ray which is incident upon and reflected by the core-cladding boundary at a particular angle. The lowest order mode travels axially down the core, and successively higher modes travel at larger angles with respect to the axis (or core/cladding boundary). For propagation over a given distance in the fiber, the higher order modes travel a longer distance, giving rise to so-called modal dispersion. A narrow pulse (short rise time) traveling down the fiber will experience spreading because of the modal dispersion. This phenomenon limits the modulation rate possible for optical fibers. Graded-index fibers that have an index-of-refraction profile that decreases nearly parabolically from the fiber axis exhibit significantly reduced modal dispersion. This reduction results from the increase in phase velocity as the ray travels outward toward the cladding, because of the concomitant decrease in the index of refraction. The increase in propagation speed for the higher order modes can be made to cancel exactly the effect of longer travel distance, so that all modes arrive in phase. Since production tolerances prohibit the exact attainment of a specified refractive-index profile over a reasonable length of fiber, some modal dispersion persists in the best of the graded-index fibers. Nevertheless, the use of graded-index fibers increases the usable bandwidth by a factor of at least 10. In addition to modal dispersion, material dispersion can also limit the usable bandwidth of a fiber, particularly for spectrally-broad sources such as LEDs.

The amount of optical power which can be coupled into a fiber depends on the cross-sectional area of the fiber relative to that of the source, the radiation pattern of the source, and the square of the numerical aperture (NA) of the fiber. The numerical aperture of a fiber is equal to the sine of the half-angle of the cone in which power can be coupled into the fiber (assuming the medium surrounding the fiber is air). Typical NA values for multimode step-

index and graded-index fibers range from 0.14 to 0.25. The coupling loss for a typical LED (RCA C30119) into a fiber with a numerical aperture of 0.20 is approximately 16 dB, provided the cross-sectional area of the fiber is not smaller than that of the source. Thus, starting with 500  $\mu\text{W}$  of power and assuming a 16-dB coupling loss, one is left with approximately 12.5  $\mu\text{W}$  in the fiber. The coupling loss for a typical injection laser (RCA C30127) would be only about 7.1 dB (97.5  $\mu\text{W}$  in the fiber) because of the inherently smaller radiation beamwidth. The larger the fiber diameter and numerical aperture, the better the coupling of optical power from the source. However, the number of modes that can propagate also increases (and therefore dispersion increases) as the fiber diameter and the numerical aperture increase. In practice the maximum modal dispersion tolerable for a given application will limit the maximum usable fiber diameter and numerical aperture.

Successful use has been made of microlenses to focus the radiation of the source for better capture by the fiber. These lenses have been formed by melting the end of the fiber under controlled conditions into a nearly spherical form [2]. An increase of about 4 dB in the coupled power has been obtained.

The materials most often used in production of optical fibers are high-silica glass, polystyrene, and methyl methacrylate plastic. The primary advantages claimed for the plastic fibers are that they are not fragile and that preparations for cable connections can be made with simple razor cuts. The major disadvantage is the high attenuation rate (470 dB/km), which makes these fibers useful for information transmission over short distances only. Silica fibers are available in many preparations and exhibit attenuation rates from hundreds of dB/km to just a few dB/km. The fragileness of early production silica fibers has been greatly reduced by new drawing techniques, increased cleanliness in the drawing process, and plastic cladding techniques. Bell Labs has reported tensile strengths of well over  $7 \times 10^5$  kPa ( $10^5$  psi) for silica fibers of 1-km length [3]. The maintenance of initial tensile-strength characteristics over the expected deployment lifetime of the cable is still of great concern. The initial strength degrades because microcracks on the fiber surface, that were unavoidably generated during manufacture, slowly propagate. They propagate faster at elevated temperatures and in the presence of moisture, especially when the fibers are subjected to tension. Polymer-plastic coatings over the fiber surfaces have helped significantly to isolate the vulnerable surfaces from moisture. However, over periods of many months to years small amounts of moisture can permeate these coatings when they are subjected to constant exposure. Plastic coatings have recently been developed that also exert small compressional forces on the fiber which tend to reduce crack-tip stresses.

The remaining area of concern is the radiation resistance of silica and plastic fibers. It has been found that nuclear ionizing radiation causes light-absorbing and light-emitting defect centers in the fiber material. Because of the length of the fibers that would be used in the tow cable, even low levels of nuclear radiation could lead to substantial increases in attenuation and consequent degradation in system performance. NRL tests of a fused-silica-core, polymer-clad fiber have shown unacceptable radiation damage at the 100-rad level [3]. The necessity for radiation resistance applies to all fiber-optic components, not just the fibers alone.

#### **Photodetectors**

Three types of photodetectors can be used in receiver circuits for fiber-optic systems: the PIN photodiode, the avalanche photodiode, and the dynode chain photomultiplier. These de-

E. L. ALTHOUSE

vices usually require the application of a reverse-bias voltage to establish conditions within the device that are favorable for efficient photocurrent production and response time.

The PIN diode normally operates with a 10-to-60-V reverse bias. The photocurrent produced is in one-to-one correspondence with electron production resulting from photon absorption. The device is linear in response to varying incident optical-power levels and can therefore be used in both analog and digital applications.

The avalanche photodiode operates with reverse-bias voltages between 100 and 500 V. The photocurrent developed has contributions from both the direct photoelectric effect and from secondary carriers created by the mechanism of collision ionization. The photocurrent amplification obtained from the secondary carriers increases (faster than linearly) as the reverse bias is increased. Because of the rather sensitive dependence of avalanche gain on bias voltage, the device is nonlinear for large signal variations, but it is linear over several orders of magnitude for very small signal variations. In addition to its possible nonlinearity, another drawback to the avalanche photodiode is its extreme temperature sensitivity; however, manufacturers are now providing matched photodiode/reference-diode pairs which make it possible to build a temperature-compensating bias circuit that will hold the avalanche gain constant over wide temperature variations.

Avalanche photodetectors are particularly suited for detection of low optical-signal powers in situations where the thermal noise of the photodetector amplifier is the dominant noise source (at unity avalanche gain). The optimum avalanche gain is obtained when the multiplied detector shot noise becomes comparable to the amplifier thermal noise. Shot noise is commonly attributed to the dark current flowing through the reverse-biased photodiode. However, the biasing of the light source produces a steady-state light component which induces a much larger shot-noise-generating current in the photodetector. For maximum signal-to-noise ratio (SNR) in the photodetector circuit, it is important to use the smallest biasing current on the light source consistent with other requirements (e.g. bandwidth). The detailed expression for the SNR in either PIN or avalanche photodiodes is given by Webb et al. [4].

The photomultiplier is a vacuum-tube device and can be used where space, temperature, and high voltages are not a problem. Recommended temperatures of operation are usually 20° C or below. Voltages of the order of 1000 volts are applied for typical operation. Photocurrent gain is obtained by secondary-electron production at the multiple dynode surfaces. Modern photomultipliers are claimed to be linear and very sensitive.

#### **Summary and Proposed Components**

In summary, the optical source most widely used is the LED. Where higher modulation rates and higher optical power coupled into the fiber are required than can be obtained with the LED, the injection laser would be the best source, provided the application is digital and long lifetime is not crucial. For the buoy-to-submarine link the LED is the more favorable source, because reliability is important, temperature extremes are not easily controllable, and analog modulation may be necessary.

Plastic fibers cannot be used because the attenuation rate is too high. The particular silica fiber chosen will depend on the intensity of the optical signal developed, the anticipated coupling losses, and the overall bandwidth of the multiplexed system.

For the receiving end of the system the choice of either a PIN or an avalanche photodiode will be dictated by the level of optical signal that can be transferred to the photodetector. For moderate to high levels, the PIN detector is favored for its linearity, but at low levels the avalanche detector is favored for its sensitivity. Photomultiplier detectors would be suitable for use only within the submarine where size and voltage and temperature requirements would not be a serious handicap.

The remainder of this study assumes that LEDs, low-loss fibers, and either PIN or avalanche photodetectors will be used.

### 3. ADVANTAGES OF OPTICAL FIBER TRANSMISSION LINES

#### Attenuation and Bandwidth

Optical fibers used as signal transmission lines can have dramatically lower attenuation rates and significantly higher bandwidths than are obtainable with relatively large coaxial cables. For example, Corning No. 1159 graded-index fiber has an attenuation of only 6 dB/km and will support a bandwidth of 400 MHz over a 1 km length. By comparison, RG-19 coaxial cable (2.84-cm o.d.) has an attenuation rate of 60.7 dB/km at 400 MHz. However, the advantage of the low attenuation rate of the fiber is offset somewhat by the high signal amplification required to drive the LED to establish a sufficient system SNR. Dispersion problems which plague ordinary transmission lines at high frequencies are essentially absent in wide-bandwidth fibers. The wide bandwidth of a fiber-optic system permits the following goals to be realized:

- Direct transmission of the entire HF band without downconversion,
- Transmission of VHF/UHF downconverted to an IF identical to the first IF of the shipboard receivers (15 - 70 MHz),
- Transmission of reference frequencies from the shipboard receiver to the buoy either unmodified or divided down only slightly in frequency.

At present the highest frequency transmitted over the tow cable is 15 MHz, the IF for the 400-MHz NAVSAT signal. Higher frequencies are not used because of the dispersive properties of the tow cable. The HF communications band is reduced to an IF of 455 kHz, and reception is limited to one IF band at a time.

#### Absence of Reflections and Ground Loops

When high-frequency signals are transmitted over the fiber-optic transmission line, there will be no problems with large standing-wave ratios. No effort will be required to stub or detune the transmission line to make it nonresonant, as would be the case with traditional conductive lines. Ground loops are also eliminated by the isolation provided by the optical transmission medium.

E. L. ALTHOUSE

#### **Decrease in Crosstalk**

The crosstalk between adjacent electrical conductors now used in the tow cable is  $-23$  dB at HF. By contrast, crosstalk between adjacent optical fibers can easily be kept to levels of  $-80$  to  $-100$  dB. The controlling factor is the opacity of the jacketing around the fiber cladding, which in principle can be made as large as is required. When simultaneous transmission of different signals in the same passband is required (via two different conductor or fiber pairs), the absence of crosstalk is a necessity.

#### **Reduction of Electromagnetic Interference (EMI)**

Immunity to EMI, a commonly claimed advantage of fiber-optic transmission lines, is gained, in the relatively noisy environment of the submarine, only if the transmission line is continuous through the hull to the final stages of the receiver. The receiver and (more importantly) the antenna are still subject to EMI. The existing conductor tow cable should be fairly well protected from EMI by the shielding effect of the surrounding water.

#### **4. DIGITAL VS ANALOG TRANSMISSION**

Although transmission of modulated RF or IF carriers (as opposed to the transmission of the baseband signal) on fiber-optic transmission lines represents inefficient use of the available bandwidth, the concept is potentially useful, because it would allow most of the receiver circuitry to be in the submarine. Advantages of a submarine-mounted receiver include easier repair or replacement of the receiver, elimination of receiver loss if the buoy is scuttled, and reduction of electronic hardware in the buoy. Analog and digital transmission of the RF or IF carriers is considered in this section.

#### **Digital Transmission of RF Signals**

The major limitation in bandwidth or bit rate for a fiber-optic communications link is the modulation rate achievable with available sources. It is instructive to consider for the moment the consequences of assuming that the sources can be modulated without limit, so that the maximum system bandwidth is limited only by fiber modal dispersion. If one assumes that 800 Mbits/s for a 500-meter link represents a practical present limit on fiber technology, one can compute the corresponding maximum bandwidth which could be supported by a pulse-code-modulation (PCM) system with 5 to 16 bits of resolution. This information is shown in Table 1. The bandwidth is computed from the requirement that the maximum frequency must be sampled at least twice per cycle, and this rate times the number of bits equals 800 Mbits/s. The dynamic range corresponding to the number of bits carried is also shown in Table 1. The dynamic range is specified differently for unipolar and bipolar signals, under the assumption that it is the maximum distortionless signal excursion above the noise baseline which is the determining factor. Table 1 points out rather dramatically that for a digitally encoded signal on a system which is limited in bit rate to 800 Mbits/s, the maximum bandwidth of the sampled signal is only 36 MHz if 11 bits resolution (approximately 60 dB bipolar dynamic range) is required. Even if only a minimal resolution of 5 bits is required, the maximum bandwidth is 80 MHz.

NRL REPORT 8182

Table 1 - Maximum Bandwidth and Dynamic Range for an Analog Signal Which is Digitally Encoded and Transmitted Over an 800-Mbit/S Optical Link

| Bandwidth (MHz) | Number of Bits (N) | Dynamic Range        |                     |
|-----------------|--------------------|----------------------|---------------------|
|                 |                    | Unipolar Signal (dB) | Bipolar Signal (dB) |
| 80.0            | 5                  | 29.8                 | 23.5                |
| 66.7            | 6                  | 36.0                 | 29.8                |
| 57.1            | 7                  | 42.1                 | 36.0                |
| 50.0            | 8                  | 48.1                 | 42.1                |
| 44.4            | 9                  | 54.2                 | 48.1                |
| 40.0            | 10                 | 60.2                 | 54.2                |
| 36.4            | 11                 | 66.2                 | 60.2                |
| 33.3            | 12                 | 72.2                 | 66.2                |
| 30.8            | 13                 | 78.3                 | 72.2                |
| 28.6            | 14                 | 84.3                 | 78.3                |
| 26.7            | 15                 | 90.3                 | 84.3                |
| 25.0            | 16                 | 96.3                 | 90.3                |

The numbers derived in Table 1, based on present fiber-optic technology, clearly make the concept of digitally encoding and transmitting RF signal carriers over the fiber-optic link possible only at HF or lower frequencies. However, even at HF, the most advanced A/D converters cannot have sufficiently fast conversion rates and high resolution simultaneously. The fastest A/D converter system known to the author is the Phoenix Model 1106-100, which has a maximum (Nyquist) bandwidth of 50 MHz and 6 bits resolution. Such other typical state-of-the-art A/D systems as the Datel model UH8B and Preston GMAD-01-8B have a maximum bandwidth of 5 MHz, with 8 and 9 bits resolution, respectively. With conventional packaging, these systems with power supply, control logic, sample-and-hold amplifiers, etc., are bulky and expensive (several thousand dollars) and are impractical for incorporation into buoy electronics. The point to be emphasized is that present A/D converter technology renders impractical the concept of digitally encoding RF carriers at HF. If PCM digital-encoding techniques are to be used for information transfer, the incoming signals must be downconverted to an IF significantly lower than 1 MHz.

Other types of digital encoding (such as pulse-position modulation (PPM) and delta modulation) exist which eliminate the need for high-speed A/D converters. However PPM requires a much larger bit rate for a given dynamic range than does PCM. Simple delta modulation also requires a wider bandwidth than does PCM, but modified methods, such as high-information delta modulation (HIDM) [5], require bandwidths of the same magnitude as for PCM. HIDM may therefore be of interest if digital encoding of the received signals is mandatory.

### Analog Transmission

The discussion in the previous section demonstrates that digital encoding and transmission of the RF carrier (HF) or the IF (VHF/UHF) is probably not practical because of limitations in fiber bandwidth and the conversion speed and resolution of A/D converters. Barring a dramatic improvement in these areas, it is necessary to consider analog transmission over the fiber-optic link.

The linear dynamic range of the fiber-optic system is the major item of concern for analog transmission. The presence of noise and of intermodulation products caused by the nonlinear transfer characteristic of the optical source limits the maximum analog dynamic range. Signal-to-noise ratios ranging from 55 to 60 dB (depending on frequency) have been obtained in a 100-kHz bandwidth with a system built by the Harris Corp. [6]. Experimental results from this system revealed that at modulation depths in the range of 20 to 30 percent of the bias, the nonlinear characteristics of the LED generated a second harmonic 40 dB below the carrier and a third harmonic 54 dB below the carrier without any compensation network for nonlinearity. With a compensation network, intermodulation products were -45 dB or lower with respect to the carrier at a -12-dBm input level. Lower input levels should produce lower level intermodulation products.

Because of the desirability of limiting the cost and volume of electronics in the buoy, *analog transmission of the HF band and the downconverted VHF/UHF band (15 to 70 MHz)* is the most favorable method of signal transfer. Information that is available from previously constructed analog systems indicates that acceptable system performance should be obtainable. The remainder of this study assumes that analog transmission over the fiber-optic cable will be used.

### 5. OPTICAL TRANSMISSION OF THE HF COMMUNICATIONS BAND

It is necessary that the fiber-optic system be able to transfer the received signal with negligible degradation in SNR. For computational purposes the SNR at the antenna was determined relative to atmospheric noise.\* To obtain a SNR of acceptable magnitude at the photodetector output, the amplifiers that provide the ac drive for the LED must have adequate gain. A satisfactory SNR is established in the photodetector when an adequate ratio of signal-induced current (which is proportional to driver gain) to noise-generated current (independent of driver gain†) is developed.

Preliminary calculations for reception of HF voice on the 2-meter BSQ-5 whip antenna [9] installed on the BIAS buoy indicate that a gain of 74 to 86 dB is required if a PIN photodetector is used and a gain of 36 to 48 dB is required if an avalanche photodetector is used. The lower gain value in each case applies when a transformer with a 16:1 impedance ratio is used to couple the drive amplifier to the low-impedance LED. The indicated gain values are independent of whether the modulation is simple AM or double or single sideband.

For wideband information transfer, some protective limiting must be built into the LED driver-amplification system to prevent the generation of excessive harmonic and intermodulation distortion products caused by driving the LED over the nonlinear portions of its transfer

\*Published data on HF atmospheric noise level can be found in Refs. 7 and 8.

†Photodetector noise is independent of the optical ac signal strength, provided the time average of the signal is zero.

curve. For information transfer over the HF band of 4 to 30 MHz, it is advantageous to subdivide into bands of somewhat less than octave widths. A possible way of accomplishing this is shown in Fig. 1. Here four bands are shown that overlap each other by 1 or 2 MHz to avoid performance degradation at the band boundaries. The first bandpass filter following the power divider defines the band. The following amplifier provides the additional RF gain to make the SNR of the fiber-optic system at least as large as the SNR at the antenna input. The limiter prevents overdriving of the LED by local noise. The harmonic-distortion products generated by the limiter are attenuated by the second bandpass filter. Since each of the bands is less than one octave wide, the second harmonic of the lowest in-band signal is rejected. However, intermodulation products are not eliminated, and the level at which they become intolerable defines the overload condition for the system.

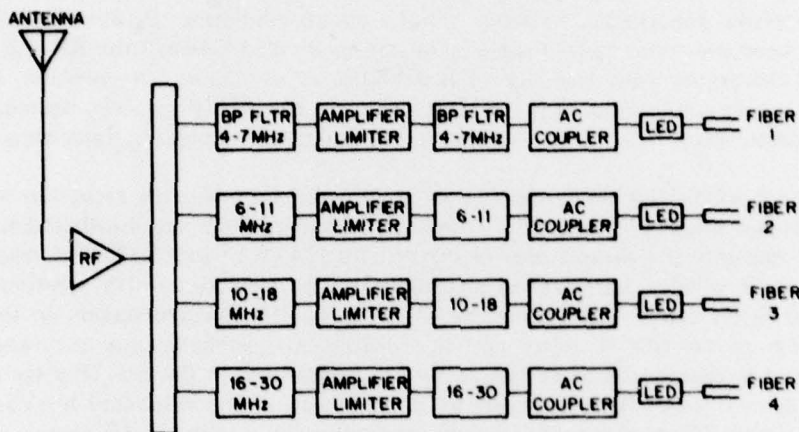

Fig. 1 - Subdivided HF broadband system for voice transmission

The effect of RF limiting of HF voice SSB transmissions has been reported [10], and this limiting has been used to advantage when the transmission path is noisy. Intelligibility improves because of an increase in the average-to-peak envelope power radiated when RF bandpass limiting is employed. Clip levels as high as 20 dB have been successfully used. Of importance here is that the intelligibility of speech is not significantly impaired because of the presence of intermodulation products created by moderate RF limiting. On the other hand, if data were being transmitted by some multilevel amplitude-modulation format, the consequences would be much less favorable.

In Fig. 1 the four bands are shown as being transmitted over four different fibers. It is possible to transmit the 4-to-7-MHz and 10-to-18-MHz bands on a single fiber, and the 6-to-11-MHz and 16-to-30-MHz bands on a second fiber. However harmonic distortion produced in the limiting process in the lower of the two bands transmitted on the fiber may appear as weak contaminants in the higher band because of the finite rolloff rate of the bandpass filter. Transmission of the 4-to-30-MHz band over a single fiber could be achieved by using nonoverlapping or even slightly separated passbands. Performance would be reduced, however, by remnant harmonic distortion products in the second and higher bands and by reduced

sensitivity at the band edges. This compromise is of interest if cable-connector designs (discussed later) are such that the allowable number of independent parallel fibers in the transmission line is limited.

## 6. OPTICAL TRANSMISSION OF THE VHF/UHF BAND

For the VHF/UHF reception of NAVSAT and SATCOM signals it is necessary to recover signals as low as  $-160$  dBW. Assuming that a minimum requirement is to receive a 75-bit/s frequency-shift-keyed (FSK) message at a  $10^{-3}$ -bit error rate, a carrier-to-noise ratio (CNR) of 31.8 dB in a unit bandwidth must be obtained at this level. Preliminary calculations with a BSQ-5 monopole antenna operating broadband into a  $50\text{-}\Omega$  resistive load indicate that a gain of 93 dB is required to drive the LED if a PIN photodetector is used, and a gain of 68 dB is required if an avalanche photodetector is used. Gains of this magnitude cannot be achieved with carriers in the VHF/UHF range because of instabilities that can occur from positive feedback caused by parasitic capacitance between various circuit elements. However, an IF-amplifier stage can be used, and the required signal gain can be divided between the RF and IF sections of the buoy electronics with less risk of instabilities or oscillation. In addition, if stepdown transformer coupling is feasible at these IF frequencies, the RF/IF gain can be reduced by the amount of current gain that can be obtained in the impedance-matching transformation.

A possible VHF/UHF buoy-electronics system for simultaneous reception at three frequencies is shown schematically in Fig. 2. After undergoing moderate broadband amplification, the signal is split into the three bands of interest for NAVSAT and SATCOM reception. Following the power divider, narrowband amplifiers can be used to furnish additional RF gain, and bandpass filters can be used to prepare the signals for downconversion in the following stage. Because an external IF entry port is available, it is advantageous to downconvert the SATCOM band to exactly the same frequency (70 MHz) used in the first IF stage of the shipboard receiver. Although there is presently no provision in the shipboard NAVSAT receiver for bypassing the RF section and entering an externally generated IF signal, we consider downconversion to the receiver first IFs (40 and 15 MHz), assuming that the appropriate receiver modifications could be made. If modification of the NAVSAT receiver is impractical, the transmitted IF must be upconverted to the original RF at the shipboard end of the fiber-optic transmission line. In this case the NAVSAT IF for transmission over the link can be chosen arbitrarily.

In Table 2 the VHF/UHF carriers of interest are listed, and they are associated with a possible choice of IF and of the corresponding local oscillator (LO) frequency that must be injected into the frequency converter. The 60-MHz alternate IF shown for the 150-MHz carrier is an option which is advantageous for data transfer on the fiber-optic system. This 60-MHz IF would be downconverted to 15 MHz at the output of the photodetector onboard the submarine. The intermediate 60-MHz IF for the 150-MHz NAVSAT channel keeps all the VHF/UHF IF carriers above the HF band, so that it is possible to transmit the HF band and the downconverted VHF/UHF bands over the same fiber. A second advantage of the alternate 60-MHz IF is that the IF carrier band of 15 to 70 MHz is narrowed to 40 to 70 MHz, which makes stepdown transformer coupling to the LED more feasible.

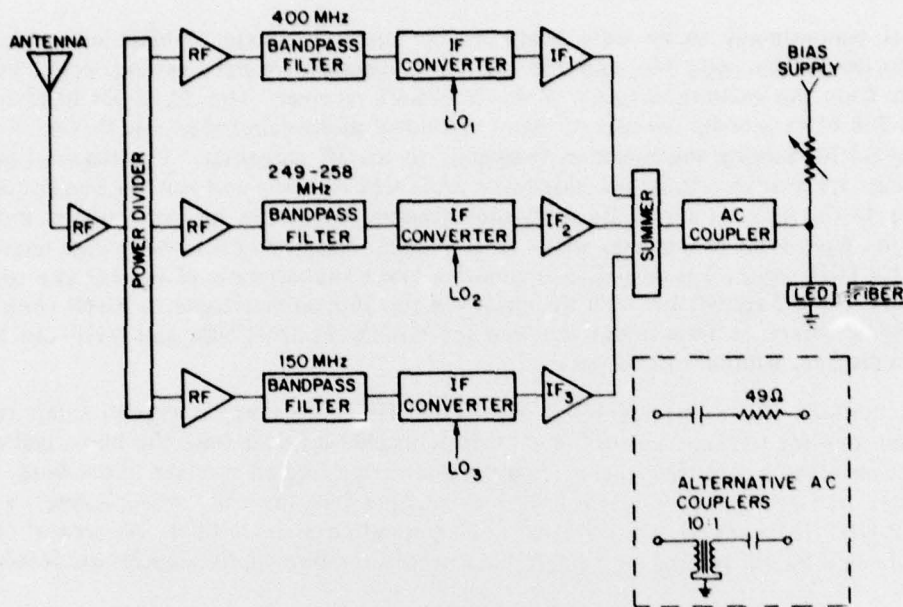

Fig. 2 - VHF/UHF buoy-system electronics

Table 2 - Possible RF-IF-LO Combinations for the VHF/UHF Fiber-Optic Buoy Electronics

| System      | RF (MHz) | IF (MHz) | LO Frequency (MHz) | Fiber Reference |                 |
|-------------|----------|----------|--------------------|-----------------|-----------------|
|             |          |          |                    | Subharmonic     | Frequency (MHz) |
| NAVSAT      | 400      | 40       | 360                | LO/8            | 45.000          |
| SATCOM      | 249-     | 70       | 319-               | LO/6            | 53.167-         |
|             | 258      | 70       | 328                | LO/6            | 54.667          |
| NAVSAT      | 150      | 60       | 90                 | LO/2            | 45.000          |
|             | 150      | 15       | 135                | LO/3            | 45.000          |
| UHF (VOICE) | 225-     | 70       | 295-               | LO/16           | 18.44-          |
|             | 400      | 70       | 470                | LO/16           | 29.38           |

To obtain IF carriers in the buoy at exactly the same frequencies as produced in the ship-board receiver, the LO frequencies must also be derived from the shipboard receiver. This can be accomplished by sending a subharmonic of the LO over a fiber-optic transmission line from the receiver to the buoy. The sending of reference frequencies to the buoy over an optical fiber eliminates the need for having an expensive frequency synthesizer located in the buoy as is presently required. The entries under "Fiber Reference" in Table 2 indicate a possible

E. L. ALTHOUSE

choice of subharmonic to be transmitted to the buoy. A single 45-MHz reference would suffice to derive the 360-, 90-, and 135-MHz LO injection frequencies and would be easily derivable from the existing circuitry of the NAVSAT receiver. The SATCOM band between 249 and 258 MHz actually consists of many individual narrowband channels that are individually selected by varying the injection frequency to the IF converter. The required injection frequencies are available from the shipboard SATCOM receiver and can be transmitted conveniently to the buoy at about the sixth subharmonic, which can be subsequently multiplied by 6 in the buoy prior to injection at the IF converter. Because of the wide range required for the LO for UHF voice, it is desirable to choose a lower subharmonic of the LO as a reference frequency. Table 2 shows that with the choice of the 16th subharmonic for UHF voice all the subharmonic reference frequencies required for NAVSAT, SATCOM, and VHF can be sent over a single fiber without interference.

As outlined above, the combined HF-VHF-UHF system would require a minimum of two fibers: one for transmission to the submarine-located receiver from the buoy, and one for transmission of reference frequencies from the submarine-located receiver to the buoy. When full duplex transmission on a single fiber becomes possible (by color multiplexing), a simple HF-VHF-UHF receiving system could be implemented on a single fiber. At present only the HF band could be transmitted on a single fiber, since no reference frequencies are required.

## **7. ELECTROMECHANICAL CONSIDERATIONS FOR FIBER-OPTIC INFORMATION TRANSFER**

The fiber-optic transmission line will be housed inside the tow cable that extends between the submarine and the buoy. The tow cable will be reeled in and out to retrieve the buoy and to control its operating depth. Consequently the mechanical design of the tow cable must protect the optical fiber from stretching and torsional strains developed by towing and from bending strains developed by winding over the driving and idler sheaves. The cable will also carry electrical conductors to supply power and control signals to the buoy. A detailed design study of the tow cable that addresses these and other considerations is needed before further conclusions can be drawn about potential problem areas. Such a detailed study is beyond the scope of this report.

One specific mechanical problem associated with the tow cable deserves further comment. With conventional cable-reeling techniques, the end of the transmission line which goes into the submarine must rotate when the takeup reel is in motion. At present a rotating-slip-ring electrical connector is used to maintain electrical continuity between the cable entering the submarine and the rotating cable end. When fiber-optic transmission lines are used, a suitable alternative method of handling the cable rotation must be devised. A few possible methods are discussed in the following paragraphs.

The most straightforward but probably least satisfactory method would be to convert all the optical signals to electrical signals in a module contained within the takeup reel, transfer the electrical signals through rotating-slip-ring connectors, and then reconvert the electrical signals to optical signals for transmission to the receivers. The basic problem with this technique is that of passing carriers with frequencies as high as 70 MHz through the rotating connectors without experiencing severe reflections.

A second possible technique is to use rotating optical connections. This connection could be between two well-aligned optical fibers, one rotating, the other stationary. However, the

alignment required for successful operation of this configuration for single-fiber joints is so critical that the method may not be practical. Alternatively an optical connection could be achieved between a rotating optical fiber and a stationary photodetector. Since the illumination acceptance cone for a photodetector is much broader than that for a fiber, alignment fluctuations during rotation are much less of a problem. The electrical signal from the photodetector would be reconverted to an optical signal to be carried by another fiber to the receiver onboard the submarine. An unfortunate limitation of this technique is that the total number of rotating joints configured in this manner is limited to two: one at each end of the axis of the takeup reel. If two-way transmission of information is required (as proposed above for the VHF/UHF system), all information from the buoy to the submarine must be sent on one fiber. The consequences are that the possibility of redundancy by simultaneous transmission over several fibers has been eliminated, that transmission of HF and VHF/UHF over the fiber would have to be carried out on an either/or basis instead of simultaneously to avoid performance degradation, or that the design of the system would have to be less than optimum to permit simultaneous transfer.

A third possible method would involve the development of a rotating optical connection between a fiber that is extended radially from the rotation axis and a cylindrical-concentric-shell photodetector (Fig. 3). This design allows an unlimited number of fibers to be coupled to the submarine via optical repeaters. The design problems are the higher noise level characteristic of larger area photodetectors and the present nonavailability of cylindrical-shell photodetectors.

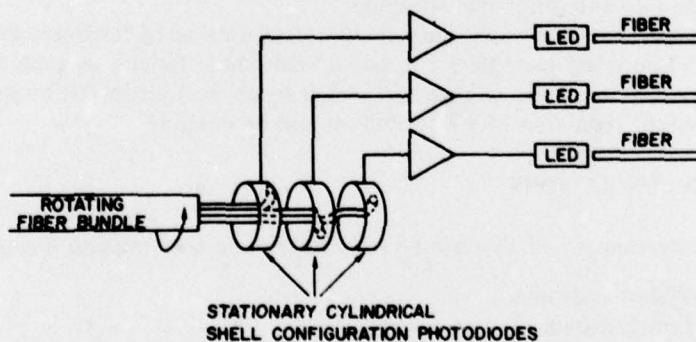

Fig. 3 - Rotating connection between radially extended optical fibers and cylindrical-shell photodetectors

An alternative configuration for a fiber-to-photodetector rotating connector is shown in Fig. 4. In this design the photodetectors are ring-disks mounted coaxially along a stationary shaft. The electrical output of all the photodetectors would again be converted to a light signal on another fiber. The device shown will allow bidirectional transfer (one fiber sends and three fibers receive). The design problems for this technique are the same as for the concentric-shell configuration of Fig. 3.

The last method to be considered is significant in that no rotating joints are involved and the number of fibers allowed is essentially unlimited. In this case the reeling technique (Fig. 5) is modified so that the inboard end of the cable is not twisted when the takeup reel is in

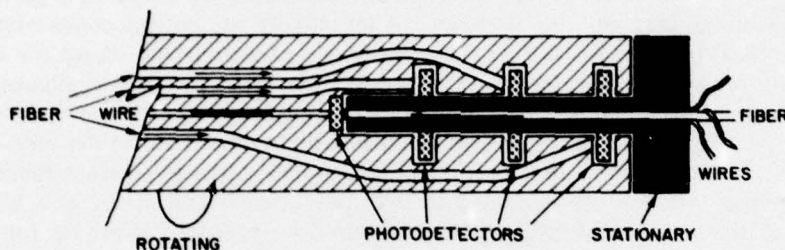

Fig. 4 - Rotating connection between optical fibers and ring-disk photodetectors

motion. Twisting is prevented by the inner concentric mechanism which transfers a reverse-wound loop from one end of the shaft to the other as the outer storage reel turns. This technique has been developed by the Morey Corporation, Downers Grove, Ill., to produce brushless cord reels. The devices produced are small; the largest model will handle approximately 10 m of cable. If a similar device were to be used for the submarine-buoy application, custom design and fabrication would be necessary. Some of the important design considerations are:

(a) The outer reel would have to hold at least 500 m of approximately 0.9-cm-diameter cable.

(b) Since the cable on the inner reels is not subject to severe longitudinal stress, it can be of much smaller diameter. This will allow more flexibility, a higher packing fraction, and a smaller turning radius on the inner-reel windings.

(c) The shaft and disk that carry the sheave rotate only once for every two turns of the cable-storage reel. Minimum diameters consistent with cable fatigue may be used internally, and the maximum diameter of the storage reel would result in the shortest total length of cable on the inside. A length reduction of 8:1 to 12:1 should be possible.

## 8. SUMMARY AND CONCLUSIONS

The general advantages usually claimed for a fiber-optic transmission line are:

- Wide bandwidth,
- Low crosstalk,
- Low attenuation and dispersion,
- Elimination of standing waves on the transmission line,
- Elimination of ground loops, and
- Elimination of electromagnetic interference.

For the present application of signal transfer from a buoy to a submarine the low attenuation characteristic of optical fibers is somewhat offset by the relatively large drive signal required to establish an acceptable SNR on the optical system. The minimum RF-amplifier gain for HF voice has been determined to be approximately 36 to 48 dB (depending upon the method of ac coupling to the LED source) for an avalanche photodetector and 74 to 86 dB for a PIN photodetector. For VHF/UHF information transfer the minimum gain is 56 to 68 dB for an avalanche photodetector and 81 to 93 dB for a PIN photodetector. Since it is unlikely that gains of these magnitudes can be achieved at VHF/UHF without accompanying problems of

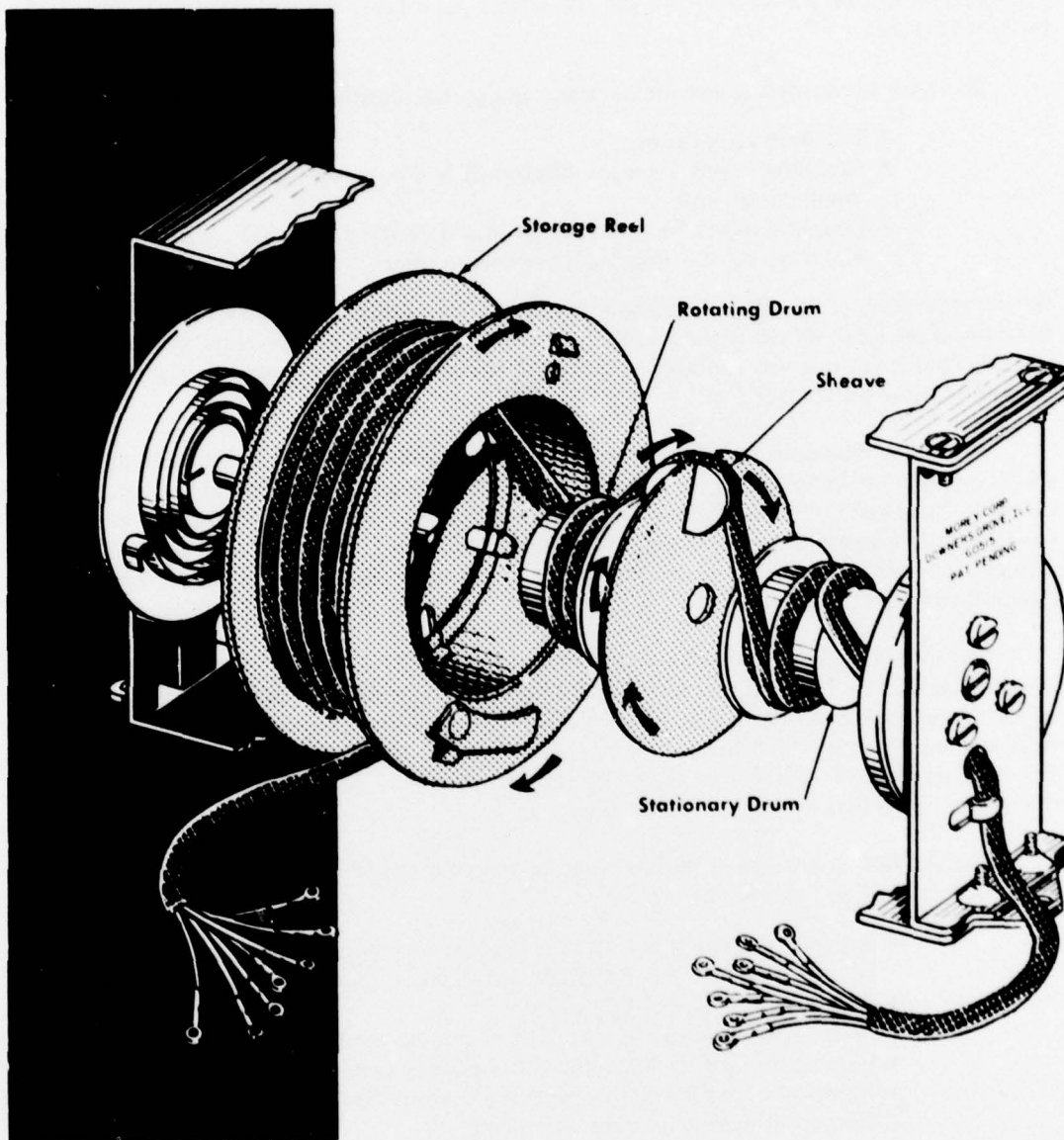

Fig. 5 - Nontwisting cable-reeling device. Figure reprinted with the permission of the Morey Corp.

E. L. ALTHOUSE

positive-feedback instability, frequency downconversion must be used. The required overall amplification can be shared between the RF and IF amplifiers. No downconversion is required for the HF band.

The total attenuation in the optical transmission line consists of the sum of:

- The fiber attenuation,
- Coupling losses for each fiber-to-fiber connection (a few tenths to 1 dB per connection), and
- Coupling losses between the fiber and optical source (15 to 20 dB for an LED and a typical low loss, high bandwidth fiber).

Hence, regardless of the fiber attenuation, there will be a minimum of about 16 to 21 dB of optical loss if an LED source is used. Although an injection laser can decrease this loss to 6 to 9 dB, this source is not given serious consideration because of its temperature sensitivity, reliability, and lifetime problems.

The claimed advantages of low dispersion, wide bandwidth, and low crosstalk do apply for the buoy application and result in the possibility of simultaneous support of a greater number of buoy functions at higher bandwidth than previously possible. The absence of standing waves on the fiber-optic transmission line makes possible the transfer of frequency-multiplexed signals at frequencies up to hundreds of megahertz without the need for complex transmission-line tuning.

The elimination of electromagnetic interference (EMI) is not a major advantage in the present application, because the antenna is still subject to external EMI and the shipboard receiver is vulnerable to internal sources of EMI. The existing conductive transmission line is relatively immune to EMI because of the shielding effect of the water. A fiber-optic transmission line would offer significant immunity only to internally generated sources of EMI along the transmission path within the submarine.

The specific advantages of transferring the received signals optically instead of electrically between the buoy and submarine are

- Support of many more parallel functions in the buoy, such as simultaneous reception of NAVSAT, SATCOM, UHF voice, and HF voice,
- Wideband transfer of HF voice,
- Wideband transmission line with no tuning required,
- Less phase jitter in the coherent frequency conversion at VHF/UHF,
- Removal of the frequency synthesizer from the buoy, and
- Support of additional buoy functions.

The disadvantage of optical transfer of the received signals are:

- The large amplifier gain required in the buoy,
- Possible technological difficulties in producing rotating optical connectors or in the adaptation of spooling techniques which do not twist either end of the tow cable,
- The general vulnerability of silica fibers to physical stress,

- The enhanced deterioration of fiber breaking strength if exposed to water or water vapor, and
- The smaller immunity to performance degradation after exposure to radiation than for conducting transmission lines.

The study has shown that the information transfer is best performed by direct analog modulation of the light source, since it is impractical to reduce the received signals at the buoy to baseband modulation form, for which digital transmission techniques are most suited. Consideration has been given to digitally encoding the signals after frequency translation (down-conversion), but when dynamic range, bandwidth, and equipment constraints were considered, analog modulation appeared to be preferable.

The preferred optical source for the buoy application presently is the LED, because of its better reliability, lower temperature sensitivity, and better applicability to analog modulation relative to an injection laser. However, as technological improvements are obtained in lifetime, reliability, and temperature effects, injection lasers might become the better source by allowing wider modulation bandwidth and less source-to-fiber coupling loss.

The best photodetector for the fiber-optic system depends on signal-reception conditions. Because of the superior temperature stability and linearity at high signal levels, the PIN photodetector offers an advantage in strong-reception areas. However in weak reception areas an avalanche photodetector must be used.

The best fiber design for the system is one that has the largest numerical aperture, largest core diameter, and lowest attenuation attainable at the required system bandwidth, which is anticipated to be about 70 MHz. The attenuation of presently available plastic fibers is far too high for their consideration in this application. Candidate silica fibers are:

- Corning 1152, 1158, 1153, and 1159;
- Valtec MG-05 and MG 10, and
- Bell Northern Research 7-2-A.

The next phase of this research effort will consist of procurement of a benchtop fiber-optic system that will be used to verify the concepts developed in this report.

## 9. REFERENCES

1. H. Kressel, "Electroluminescent Sources For Fiber Systems," pp. 109-153 in *Fundamentals of Optical Fiber Communications*, Michael K. Barnoski, editor, Academic Press, New York, 1976, p. 135.
2. J. P. Wittke, M. Ettenberg, and H. Kressel, "High Radiance LED for Single-Fiber Optical Links," *RCA Review*, 37, 159-183 (1976).
3. G. H. Sigel, Jr., "Fiber Optics for Naval Applications: An Assessment of Present and Near-Term Capabilities," NRL Report 8062, Sept. 1976, p. 14.
4. P. P. Webb, R. J. McIntyre, and J. Conradi, "Properties of Avalanche Photodiodes," Technical Report MNLD-74-TR-002, R&D Laboratories, RCA Limited, Ste. Anne de Bellevue, Quebec, Mar. 19. 1974.

E. L. ALTHOUSE

5. M. R. Winkler, "High Information Delta Modulation," IEEE International Convention Record, Vol. 11, part 8, Mar 1963, pp. 260-265.
6. J. J. Pan, G. A. Waschka, Jr., F. R. McDevitt, and C. H. Bell, "Wideband FDM Fiber-Optic Link," Harris Corporation, Electronic Systems Division, Melbourne, Fla.
7. W. E. Gustafson and W. M. Chase, "Shipboard HF Receiving System Design Criteria," Naval Electronics Center Technical Report 1712, June 1970.
8. K. Davies, *Ionospheric Radio Propagation*, National Bureau of Standards Monograph 80, U. S. Government Printing Office, Washington, D.C., 1965.
9. R. K. Royce, "Antenna Characteristics for the Buoy Integrated Antenna, Submarine (BIAS) System," NRL Memorandum Report 2995, March 1975.
10. H. G. Collins, "Ordinary and Processed Speech in SSB Application," QST, 53 (No. 1), 17-22, January 1969.