

AD-A058 400

AIR FORCE AVIONICS LAB WRIGHT-PATTERSON AFB OHIO
COMPUTER MODELING OF DIODE CIRCUITS AND ITS APPLICATIONS. (U)
MAR 78 Z I BOGAN, J B TSUI
AFAL-TR-77-266

F/G 9/4

UNCLASSIFIED

NL

1 OF 1
ADA
058400



END
DATE
FILMED
10 -78
DDC

AD A 058400

AFAL-TR-77-266

LEVEL II

2

17



COMPUTER MODELING OF DIODE CIRCUITS AND ITS APPLICATIONS

Dr. Zeev I. Bogan
and
Dr. James B. Y. Tsui

Passive ECM Branch
Electronic Warfare Division

March 1978

TECHNICAL REPORT AFAL-TR-77-266

Final Report for Period June 1976 to November 1977

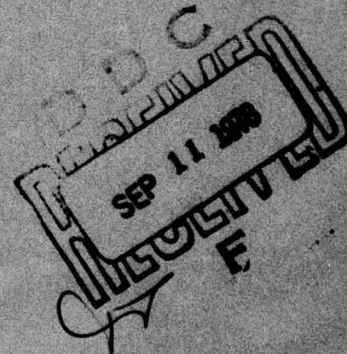

Approved for public release; distribution unlimited.

AIR FORCE AVIONICS LABORATORY
AIR FORCE WRIGHT AERONAUTICAL LABORATORIES
AIR FORCE SYSTEMS COMMAND
WRIGHT-PATTERSON AIR FORCE BASE, OHIO 45433

78 08 31 048

AD No. _____
DDC FILE COPY

NOTICE

When Government drawings, specifications, or other data are used for any purpose other than in connection with a definitely related Government procurement operation, the United States Government thereby incurs no responsibility nor any obligation whatsoever; and the fact that the government may have formulated, furnished, or in any way supplied the said drawings, specifications, or other data, is not to be regarded by implication or otherwise as in any manner licensing the holder or any other person or corporation, or conveying any rights or permission to manufacture, use, or sell any patented invention that may in any way be related thereto.

This report has been reviewed by the Information Office (OI) and is releasable to the National Technical Information Service (NTIS). At NTIS, it will be available to the general public, including foreign nations.

This technical report has been reviewed and is approved for publication.

James B. Y. Tsui
DR. JAMES B. Y. JTSUI
Project Engineer

William F. Bahret
WILLIAM F. BAHRET
Chief, Passive ECM Branch
Electronic Warfare Division

FOR THE COMMANDER

Joseph H. Jacobs
JOSEPH H. JACOBS, COL., USAF
Chief, Electronic Warfare Division

"If your address has changed, if you wish to be removed from our mailing list, or if the addressee is no longer employed by your organization please notify AFAL/WEP-1, W-PAFB, OR 45433 to help us maintain a current mailing list".

Copies of this report should not be returned unless return is required by security considerations, contractual obligations, or notice on a specific document.

UNCLASSIFIED

SECURITY CLASSIFICATION OF THIS PAGE (When Data Entered)

REPORT DOCUMENTATION PAGE

READ INSTRUCTIONS BEFORE COMPLETING FORM

14. 1. REPORT NUMBER AFAL-TR-77-266	2. GOVT ACCESSION NO.	3. RECIPIENT'S CATALOG NUMBER
9. 4. TITLE (and Subtitle) COMPUTER MODELING OF DIODE CIRCUITS AND ITS APPLICATIONS.		9. 5. TYPE OF REPORT & PERIOD COVERED Final Report, June 76 to Nov 77.
10. 3. AUTHOR(s) Zeev I. Bogan [redacted] James B. Y. Tsui, PhD		6. CONTRACT OR GRANT NUMBER(s)
9. PERFORMING ORGANIZATION NAME AND ADDRESS Air Force Avionics Laboratory (WRP) Wright-Patterson AFB OH 45433		10. PROGRAM ELEMENT, PROJECT, TASK AREA & WORK UNIT NUMBERS 62204F 7633 11 15
11. CONTROLLING OFFICE NAME AND ADDRESS Air Force Avionics Laboratory (WRP) Wright-Patterson AFB OH 45433		12. REPORT DATE March 1978
14. MONITORING AGENCY NAME & ADDRESS (if different from Controlling Office) 12 Eop.		13. NUMBER OF PAGES 66 15. SECURITY CLASS. (of this report) UNCLASSIFIED 15a. DECLASSIFICATION/DOWNGRADING SCHEDULE
16. DISTRIBUTION STATEMENT (of this Report) Approved for public release, distribution unlimited.		
17. DISTRIBUTION STATEMENT (of the abstract entered in Block 20, if different from Report)		
18. SUPPLEMENTARY NOTES		
19. KEY WORDS (Continue on reverse side if necessary and identify by block number) Diode Circuits Mixers Computer Modeling Spurious Response		
20. ABSTRACT (Continue on reverse side if necessary and identify by block number) This technical report presents a computer model for calculation of multiple diode circuits. The model solves iteratively a system of nonlinear equations in the time domain and obtains frequency domain information by means of a Fourier series expansion. Applications for this model include prediction of one and two tone intermodulation performance for single-ended, balanced and double balanced mixers, calculation of the multiple-signal capture range of back-to-back diode limiters, and prediction of the performance of a frequency		

DD FORM 1 JAN 73 1473

EDITION OF 1 NOV 65 IS OBSOLETE

UNCLASSIFIED

SECURITY CLASSIFICATION OF THIS PAGE (When Data Entered)

011670 78 08 31 048 LB

UNCLASSIFIED

SECURITY CLASSIFICATION OF THIS PAGE(When Data Entered)

20. Abstract (Continued)

doubling front-end for detection and identification of Pseudo-Noise BPSK modulated signals. Experimental data was collected for some diode circuits. This data agreed qualitatively with the calculated results.

ACCESSION for	
NTIS	White Section <input checked="" type="checkbox"/>
DDC	Buff Section <input type="checkbox"/>
UNANNOUNCED	<input type="checkbox"/>
JUSTIFICATION	
BY	
DISTRIBUTION/AVAILABILITY CODES	
Dist.	SPECIAL
A	

UNCLASSIFIED

SECURITY CLASSIFICATION OF THIS PAGE(When Data Entered)

FOREWORD

This report was written by Drs. Zeev Bogan and James Tsui. Dr. Bogan was a National Research Council Resident Research Associate at the Electronic Warfare Division (WR), Air Force Avionics Laboratory (AFAL) during the period of June 1976 to November 1977. During this period, Dr. James Tsui, acted as his scientific advisor. The work was accomplished under Project Number 7633, Task Number 763311, "Real Time Threat Warning, Identification, and Location", Work Unit 76331115 "Receiver Concepts, Analysis, and Evaluation." The authors would like to thank the National Research Council for providing support to this research. Special thanks to Dr. Charles H. Krueger, Jr. and Mr. W. T. Brumfield for their valuable advice, encouragement, and interest in this research effort.

TABLE OF CONTENTS

SECTION	PAGE
I INTRODUCTION	1
II SINGLE ENDED MIXER MODEL	3
1. Time Domain Solution	3
2. Frequency Domain Calculations	7
III MULTIPLE DIODE CIRCUIT SIMULATION	9
1. General Model	9
2. Back-To-Back Diode Limiter	11
3. Balanced Mixer	13
4. Double Balanced Mixer	15
IV COMPUTER EXPERIMENTS ON DIODE CIRCUITS	17
1. Calculations and Measurements on a Single-Ended Mixer	17
2. Back-To-Back Diode Limiter	22
3. 90° Hybrid Balanced Mixer	25
V CONCLUSIONS	28
APPENDIX A PSEUDO-NOISE BPSK SIGNAL DETECTION BY HETERODYNE MIXING	29
APPENDIX B COMPUTER PROGRAM USAGE	32
REFERENCES	59

LIST OF ILLUSTRATIONS

FIGURE	PAGE
1 Single Ended Mixer	4
2 Multiple Diode Circuit Model	10
3 Back-To-Back Diode Limiter	12
4 90° Hybrid Balanced Mixer	14
5 Double Balanced Mixer	16
6 Calculated Power Output (P_{out}) of (m,n) IMD Products as a Function of the Power Input (P_{in}). ($P_1=P_2=P_{in}$)	18
7 Measured Power Output (P_{out}) of (m,n) IMD Products as a Function of P_{in} . ($P_1= P_2= P_{in}$)	19
8 Experimental Setup for the Measurement of the Power Output of IMD Products Generated by the Mixer ($P_1= P_2$)	20
9 Simulation of a Limiter Fed by Two Signals at f_1 and f_2 : Power Output (P_{out_1}) vs. Power Input at f_1 (P_{in_1}) with the Power Input at f_2 (P_{in_2}) as a Parameter	23
10 Simulation of a Limiter Fed by Two Signals at f_1 and f_2 : P_{out} at f_1 and f_2 vs. P_{in_1} . $P_{in_2} = \text{const.}$	24
11 Calculated Insertion Loss and Two-Tone Third-Order IMD Intercept Point as a Function of the LO power, for a 90° Hybrid Balanced Mixer	26
12 Calculated Single-Tone IMD Response for a 90°-Hybrid Balanced Mixer	27

SECTION I

INTRODUCTION

Some of the key elements in superheterodyne receivers, such as mixers and limiters, include semiconductor diodes as their basic devices. The nonlinear characteristics of these diodes strongly impact receiver performance. For example, insertion loss in a mixer will affect sensitivity while harmonic intermodulation products generated in the mixer will affect the dynamic range of the receiver; a limiter response to multiple signals will determine the multiple signal handling capability of the receiver. For proper receiver design, it is essential to predict the performance of such nonlinear elements under varying conditions. At the present stage, the nonlinear performance of mixers and limiters, such as intermodulation distortion and multiple signal handling, are determined experimentally. The "spur table" furnished by mixer manufacturers is one example. This table provides information at the various harmonic frequencies for an "optimal" local oscillator (LO) drive level. However, the use of this spur table is quite limited because variations in the LO drive level will affect the output level of the intermodulation (IMD) products. An ideal solution to this problem would be to theoretically calculate the output levels of the IMD products as a function of the LO drive level.

In this report, a mathematical model is presented by means of which the nonlinear responses of various diode circuits can be calculated. A single diode circuit with multiple input sources was simulated to demonstrate the capabilities of the model (Section II). The solution to the circuit is obtained first in the time domain using iterative methods. The time domain solution is then Fourier analyzed to extract the frequency components which are of interest to us. For this single diode circuit, single and two-tone intermodulation distortion levels were calculated using this model. A single ended mixer was constructed to verify the calculated results.

In the course of this investigation, it was found that some harmonic products which adversely affect superheterodyne reception might in

some applications become an asset. Such is the case, for example, in a frequency doubling receiver for detection and identification of pseudo-noise biphas-shift-key (PN-BPSK) modulated signals (Appendix A). Another application where harmonic intermodulation products may be proven useful, is the detection of the presence of a nonlinear device within a given volume. The volume is irradiated with a known signal and a specified harmonic product generated by the nonlinear device is detected, if such a device is present within that volume.

The single diode circuit model was extended to account for multiple diodes. Using the multiple diode circuit general model, presented in Section III-1, we can simulate a variety of diode circuits such as limiters (Section III-2), balanced and double balanced mixers (Sections III-3 and III-4 respectively). Results of these simulations along with experimental data are presented in Section IV.

SECTION II

SINGLE ENDED MIXER MODEL

1. TIME DOMAIN SOLUTION

While various models for mixer analysis have been previously published in the literature (References 1 and 2), most of these models deal with the linear properties of mixers, such as conversion loss and noise figure, and base their analysis on a quasi-linear approach which assumes a small radio frequency (RF) signal and a sinusoidal local oscillator waveform on the mixer diode. These methods of analysis are quite suitable for predicting the linear performance of mixers under small signal conditions but fail to predict their nonlinear behavior under nonidealized conditions, such as a finite source impedance, large RF signals, and diode parasitics. In order to overcome these deficiencies, a more general model of a single ended mixer is presented in this section. This model can be applied to predict the nonlinear behavior of a mixer under large signal conditions, taking into account the finite source impedance and the diode losses.

The single ended mixer circuit to be modeled is shown in Figure 1a. The diode is fed by a voltage source $V_{in}(t)$ with 50Ω characteristic impedance, through a circulator. The reflected voltage from the diode appears across the load impedance Z_o at the output port of the circulator. This particular configuration was chosen in order to decouple the output from the input and ease the measurement procedure which will be later discussed. It has to be noted that this model does not include reactive elements which ought to be taken into account if proper representation of the diode and package parasitics is desired. Neglecting reactive elements in the model will obviously introduce discrepancies between the measured and calculated results. However, this model simplifies the numerical calculations by avoiding the solution of nonlinear differential equations which may include very large time constants to account for the d.c. blocking capacitors and RF chokes.

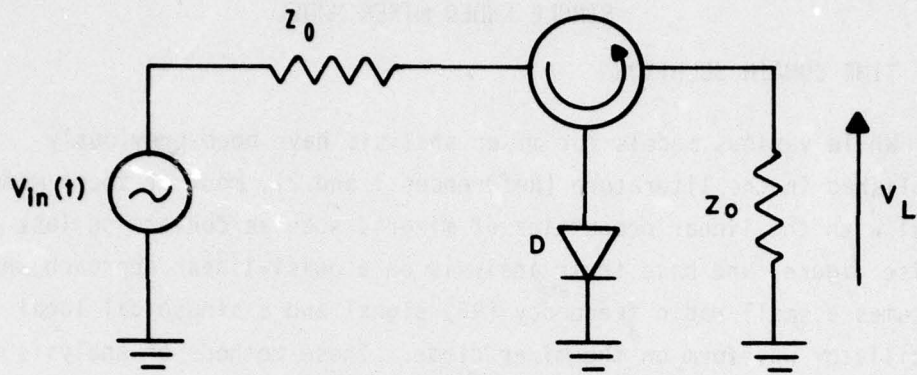

(a)

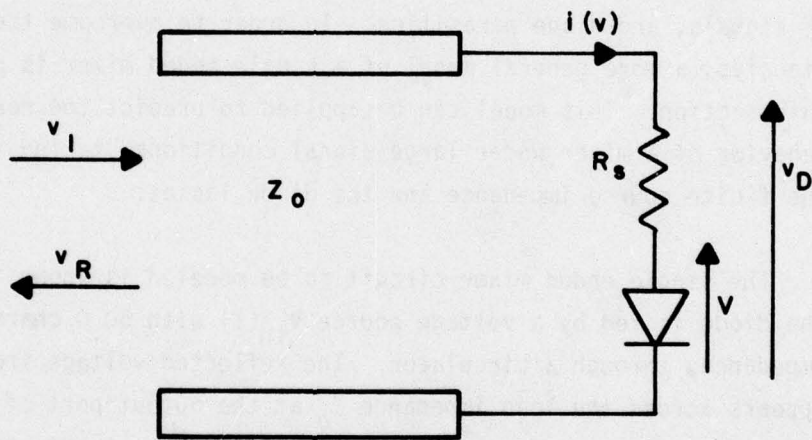

(b)

$$i(v) = I_s (e^{\alpha v} - 1)$$

$$v_D = v_I + v_R$$

$$i = (v_I - v_R) / Z_0$$

$$v_I = V_{in}(t) / 2 ;$$

$$v_L = v_R$$

Figure 1. Single Ended Mixer

The diode is modeled as a nonlinear conductance in series with a constant resistance (R_s). The current-voltage (I-V) characteristic of the diode is given by:

$$i = I_s [e^{\alpha(v_D - iR_s)} - 1] = I_s (e^{\alpha v} - 1) \quad (1)$$

where i is the current through the diode, I_s is the reverse saturation current, v_D is the voltage on its terminals, v is the voltage on the diode junction and $\alpha = \frac{q}{nKT}$ where q is the electronic charge, K is the Boltzmann constant and n is the quality factor of the junction ($1 \leq n \leq 2$) and T is the temperature in $^{\circ}K$. The voltage on the diode $v_D(t)$ and the current through it $i(t)$ are calculated from the boundary conditions on the diode plane:

$$v_D(t) = v_I + v_R \quad (2)$$

$$i(t) = (v_I - v_R)/Z_0 \quad (3)$$

v_I and v_R are the incident and reflected voltages respectively (Figure 1b). From the matched conditions at the input port of the circulator,

$$v_I = v_{in}(t)/2 \quad (4)$$

The relationship between the voltage on the diode v_D and the voltage on the junction v , is given by:

$$v_D = v + iR_s \quad (5)$$

and the current-voltage relationship of the junction itself is given by Equation 1.

From Equations 1 through 5 the following transcendental equation for the voltage on the diode junction is derived:

$$F(v) = v + (Z_0 + R_s) I_s (e^{\alpha v} - 1) - v_{in} = 0 \quad (6)$$

The diode parameters I_s , R_s and α are obtained for dc measurements on the diode, and Z_o is given.

The input voltage $V_{in}(t)$ is generally given as a sum of two sinusoidal waveforms at the LO and RF frequencies*:

$$V_{in}(t) = V_{LO} \sin \omega_{LO} t + V_{RF} \sin \omega_{RF} t \quad (7)$$

Equation (6) is now solved numerically at each point in time applying the Newton-Raphson method. Let v_n be the approximate solution of Equation 6 after n iterations, so that:

$$F(v_n) = v_n + (Z_o + R_s) I_s (e^{\alpha v_n} - 1) - V_{in} = \epsilon \neq 0 \quad (8)$$

The solution at the next iteration will be given by:

$$v_{n+1} = v_n - F(v_n)/F'(v_n) \quad (9)$$

$$\text{where } F'(v_n) = \left. \frac{dF(v)}{dv} \right|_{v=v_n} = 1 + I_s \alpha (Z_o + R_s) e^{\alpha v_n} \quad (10)$$

The computation stops when the difference between the solutions at two consecutive iterations falls within a predetermined error range. After the junction voltage $v(t)$ is obtained, the current through the diode $i(t)$ is calculated and subsequently the voltages $v_D(t)$ and $v_R(t)$. The load voltage is given by:

$$V_L = V_R = v_D - v_I = v_D - V_{in}/2 \quad (11)$$

*In case it is desired to calculate the two-tone third-order intermodulation (IMD) product, another term is added to $V_{in}(t)$:

$$V_{in}(t) = V_{LO} \sin \omega_{LO} t + V_{RF} (\sin \omega_{RF} t + \sin \omega'_{RF} t) \quad (7a)$$

where ω_{RF} and ω'_{RF} are the frequencies of the two tones.

Once the load voltage is known for an entire cycle, Fourier analysis is applied to obtain the output voltage at the various frequencies which are of interest to us.

2. FREQUENCY DOMAIN CALCULATIONS

The frequencies of the harmonic intermodulation products generated in a mixer are given by:

$$\omega_{mn} = |m\omega_{LO} + n\omega_{RF}| \quad (12)$$

where m and n are positive or negative integers. All (m,n) combinations other than $(1, -1)$ which is the intermediate frequency (IF), are considered to be detrimental to heterodyne reception, but might be beneficial in other applications. The output amplitude at a particular IMD product (ω_{mn}) is obtained by Fourier analysis of $v_L(t)$:

$$v_L(\omega_{mn}) = \frac{2}{T_0} \int_0^{T_0} v_L(t) e^{-j\omega_{mn}t} dt \quad (13)$$

where $T_0 = \frac{2\pi}{\omega_0}$ is the period of $v_L(t)$ and ω_0 is the largest common divisor of ω_{LO} and ω_{RF} .

For numerical purposes it is convenient to choose the set $(\omega_{LO}, \omega_{RF})$ so as to minimize T_0 in order to reduce computation time but at the same time care has to be taken in order to avoid overlapping of low order IMD products, meaning that $\omega_{n_1, m_1} \neq \omega_{n_2, m_2}$ for $m, n \leq 6$. The particular choice of the set $(\omega_{LO}, \omega_{RF})$ for calculation purposes is irrelevant to the actual performance of the mixer, since the circuit model described in the previous section does not include frequency dependent elements.

For calculations of two-tone intermodulation levels the choice of the frequency set $(\omega_{LO}, \omega_{RF}, \omega_{RF}')$ is guided by similar reasoning. The integration (Equation 13) is carried out numerically using the trapezoidal rule.

AFAL-TR-77-266

The computation of the output level at a given frequency ω_{mn} is now complete. From the given input voltage ($V_{in}(t)$) the voltage on the diode ($v(t)$) is calculated and subsequently the voltage on the load ($v_L(t)$) is obtained from circuit conditions. The desired frequency components of $v_L(t)$ are later calculated by a simple Fourier series expansion. Results of calculations using this model are presented in Section IV. These calculations are followed by experimental data taken on a similar circuit configuration.

In Section III, the single diode circuit model is expanded to multiple diode configurations.

SECTION III
MULTIPLE DIODE CIRCUIT SIMULATION

1. GENERAL MODEL

Consider the general circuit configuration shown in Figure 2. The circuit consists of a network of N interconnected diodes with M voltage inputs and a load impedance (Z_L). The diodes may or may not be identical and the parameters for each diode I_{sk} , R_{sk} and α_{sk} ($k=1,2,\dots,N$) are given. The voltage sources V_{in_j} ($j=1,2,\dots,M$) are given by:

$$V_{in_j} = c_j V_{LO} \sin(\omega_{LO} t + \theta_j) + d_j V_{RF} \sin(\omega_{RF} t + \theta_j) \quad (14)$$

where c_j and d_j are constants.

We now expand the single diode circuit model developed in Section II to solve for the voltage on each diode $v_k(t)$ and eventually for the voltage on the load $v_L(t)$.

The homogeneous loop equation will have the form:

$$\bar{F}(\bar{v}) = A \bar{v} + Z \bar{i} + B \bar{V}_{in} = 0 \quad (15)$$

where \bar{v} is the vector of the junction voltages, \bar{i} is the vector of the diode currents, \bar{V}_{in} is the input voltage vector, A and Z are $N \times N$ matrices, and B is an $N \times M$ matrix.

Similar to Equation 9 the approximate solution after $n+1$ iterations will be given by:

$$(\bar{v})_{n+1} = (\bar{v})_n - [J(\bar{v})_n]^{-1} [F(\bar{v})_n] \quad (16)$$

where $(\bar{v})_n$ is the solution at the previous iteration and $J(\bar{v})_n$ is the Jacobian of the system of Equation 15 evaluated at $\bar{v} = (\bar{v})_n$.

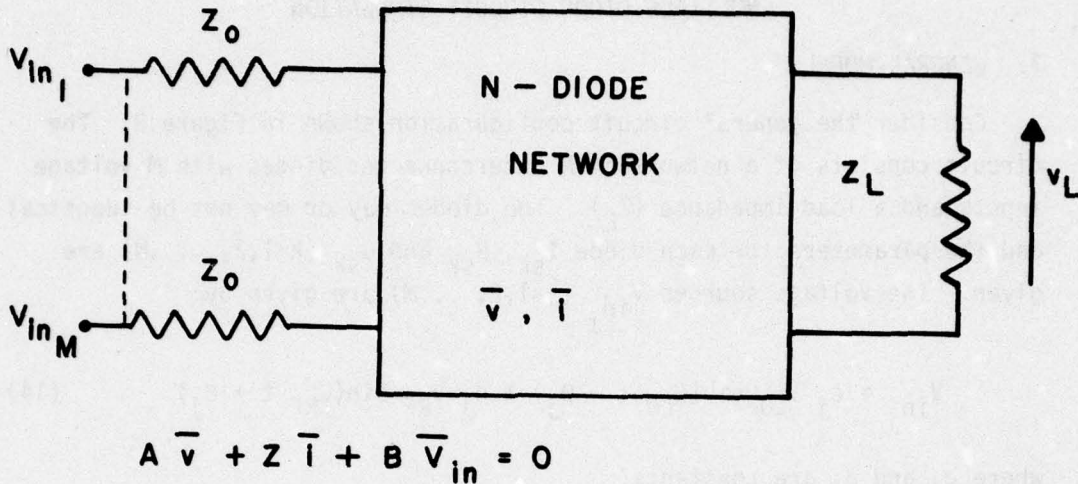

Figure 2. Multiple Diode Circuit Model

The elements of the Jacobian j_{ik} , are given by:

$$j_{ik} = \frac{\partial F_i(\bar{v})}{\partial v_k} = a_{ik} + a_{ik} i'_k \quad (17)$$

$$\text{where } i'_k = \frac{di_k}{dv_k} = \alpha_k I_{sk} e^{(\alpha_k v_k)} \quad (18)$$

In summary, once the matrices A, Z, B, and the input voltage vector \bar{V}_{in} are known from circuit conditions, the solution for the voltages on the diodes \bar{v} is straight-forward using Equation 16. As an example, the matrices for the single ended mixer case discussed in the previous section are given by:

$$A = 1 ; B = 1 ; Z = (R_s + Z_0); \quad (19)$$

$$J = 1 + (R_s + Z_0) \alpha I_s e^{\alpha v}$$

In the following sections the above matrices will be calculated for various circuits, namely, balanced and double balanced mixers and back-to-back diode limiters.

2. BACK-TO-BACK DIODE LIMITER

The multiple signal handling capability of a receiver is strongly affected by the performance of the limiter. The ideal input-output characteristic of a limiter is plotted in Figure 3a. Using the model developed in this section we can calculate the deviations from this ideal characteristic when two or more input signals are present at the limiter input.

The equivalent circuit of a back-to-back diode limiter is shown in Figure 3b. From loop analysis of this circuit we obtain the following system of equations:

$$F_1(v_1, v_2) = v_1 + (R_{s1} + Z_{eq}) i_1 - Z_{eq} i_2 - \frac{Z_{eq}}{Z_0} V_{in} = 0 \quad (20)$$

$$F_2(v_1, v_2) = v_1 + v_2 + R_{s1} i_1 + R_{s2} i_2 = 0 \quad (21)$$

where $Z_{eq} = Z_0 // Z_L$.

The circuit matrices for this case are given by:

$$A = \begin{bmatrix} 1 & 0 \\ 1 & 1 \end{bmatrix}; B = \begin{bmatrix} -Z_{eq}/Z_0 \\ 0 \end{bmatrix}; Z = \begin{bmatrix} R_{s1} + Z_{eq} & -Z_{eq} \\ R_{s1} & R_{s2} \end{bmatrix} \quad (22)$$

The voltage on the load, v_L , is given by:

$$v_L = v_1 + i_1 R_{s1} \quad (23)$$

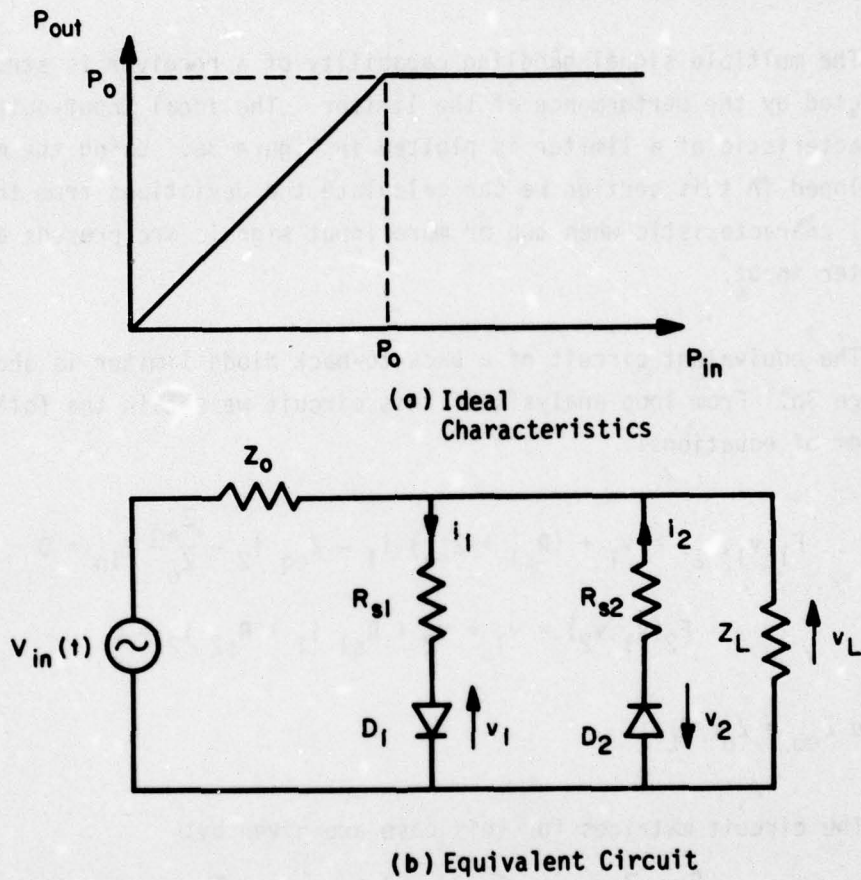

Figure 3. Back-To-Back Diode Limiter

3. BALANCED MIXER

A simplified circuit of a balanced mixer using a 90° hybrid is shown in Figure 4a. From loop analysis of the equivalent circuit (Figure 4b) we obtain the following circuit matrices:

$$A = \begin{bmatrix} 1 & 0 \\ 0 & 1 \end{bmatrix}; \quad B = \frac{\sqrt{2}}{2} \begin{bmatrix} -1 & -e^{-j\pi/2} \\ e^{-j\pi/2} & 1 \end{bmatrix}$$

$$Z = \begin{bmatrix} Z_0 + Z_L + R_{s1} & -Z_L \\ -Z_L & Z_0 + Z_L + R_{s2} \end{bmatrix} \quad (24)$$

$$\bar{V}_{in} = \begin{bmatrix} V_{RF} \cos \omega_{RF} t \\ V_{LO} \cos \omega_{LO} t \end{bmatrix}$$

The voltage on the load is given by:

$$v_L = (i_1 - i_2) Z_L \quad (25)$$

Note that the input voltage vector V_{in} is chosen in such a manner as to enable rapid convergence of the solution at $t=0$. Rapid convergence at $t=0$ is assured when the diodes are back biased or at a very low forward conduction state.

For a balanced mixer using a 180° hybrid, the A and Z matrices are the same as in the 90° hybrid case. The B matrix and the input voltage vector \bar{V}_{in} will be given in this case by:

$$B = \frac{\sqrt{2}}{2} \begin{bmatrix} -1 & -1 \\ -1 & -1 \end{bmatrix}; \quad \bar{V}_{in} = \begin{bmatrix} V_{LO} \sin \omega_{LO} t \\ V_{RF} \sin \omega_{RF} t \end{bmatrix} \quad (26)$$

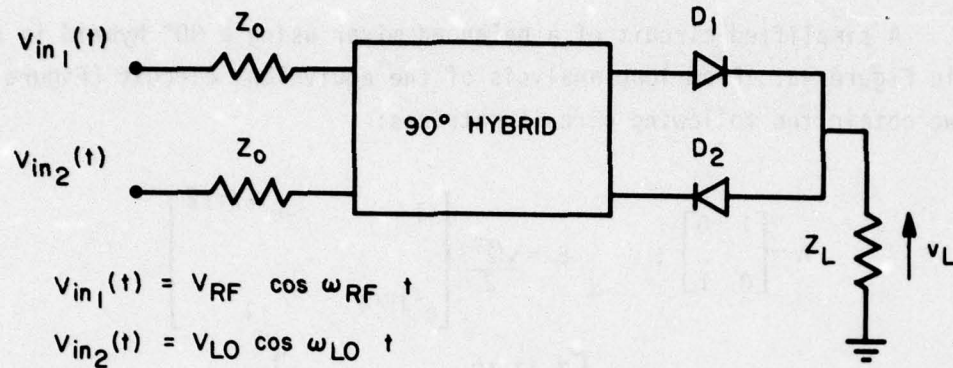

(a) Simplified Circuit

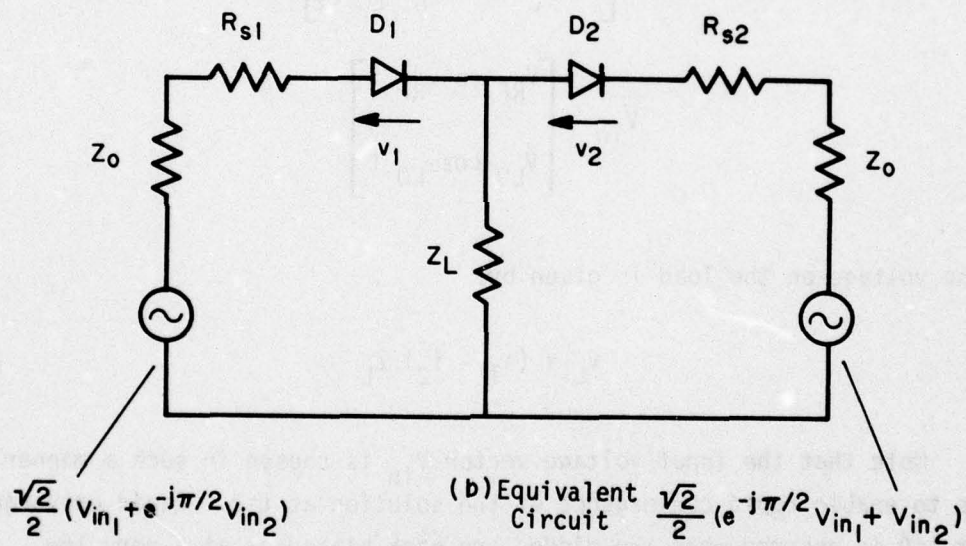

Figure 4. 90° Hybrid Balanced Mixer

4. DOUBLE BALANCED MIXER

The simplified circuit of a double balanced mixer is shown in Figure 5a. This mixer is analyzed using the equivalent circuit in Figure 5b. A and Z are in this case, 4 x 4 matrices and B is a 4 x 2 matrix.

$$A = \begin{bmatrix} 1 & 1 & 0 & 0 \\ 0 & 1 & 1 & 0 \\ 0 & 1 & 0 & 0 \\ 1 & 1 & 1 & 1 \end{bmatrix}; \quad B = \begin{bmatrix} -1 & 0 \\ 0 & -1 \\ -\frac{1}{2} & -\frac{1}{2} \\ 0 & 0 \end{bmatrix}$$

$$Z = \begin{bmatrix} R_{s1} + \frac{1}{2}Z_0 & R_{s2} + \frac{1}{2}Z_0 & -\frac{1}{2}Z_0 & -\frac{1}{2}Z_0 \\ -\frac{1}{2}Z_0 & R_{s2} + \frac{1}{2}Z_0 & R_{s3} + \frac{1}{2}Z_0 & -\frac{1}{2}Z_0 \\ -(\frac{1}{2}Z_0 + Z_L) & R_{s2} + Z_0 + Z_L & -(\frac{1}{2}Z_0 + Z_L) & Z_L \\ R_{s1} & R_{s2} & R_{s3} & R_{s4} \end{bmatrix}$$

(27)

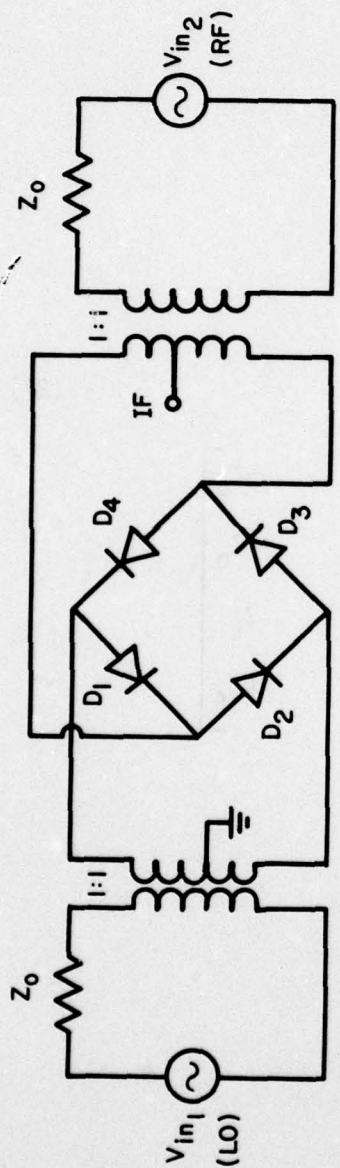

(a) Simplified Circuit

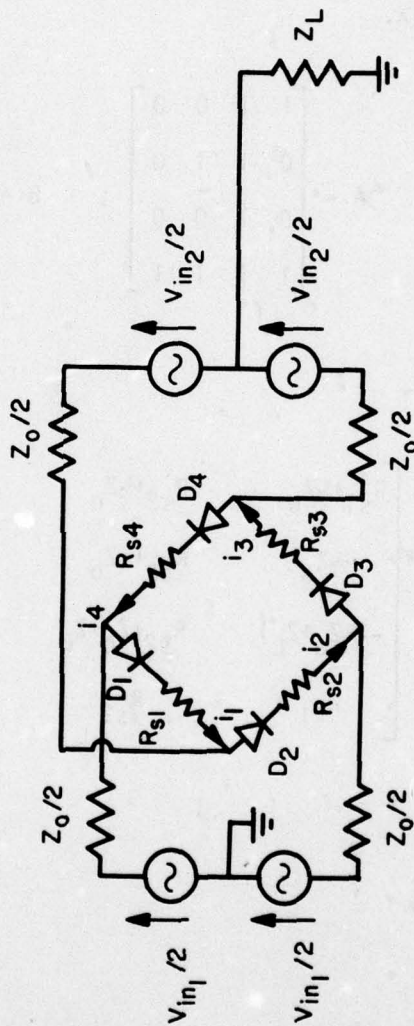

(b) Equivalent Circuit

Figure 5. Double Balanced Mixer

SECTION IV

COMPUTER EXPERIMENTS ON DIODE CIRCUITS

1. CALCULATIONS AND MEASUREMENTS ON A SINGLE ENDED MIXER

Two specific applications for the single ended mixer model were investigated in particular. The first case is the detection of the presence of a nonlinear device within a given volume by irradiating this volume with a known signal and detecting a specified harmonic product of the transmitted signal.

This method is widely applied in commercial antishoptlifting systems where a diode is attached to the protected merchandise and irradiated by a signal at f_0 . A receiver at the entrance to the store detects the second harmonic at $2f_0$ generated by the diode and activates an alarm. A variation of this method can be applied when it is preferred to have the harmonic product generated by the nonlinear device in the same frequency range as the transmitted signal. For this purpose, two equal amplitude signals at f_1 and f_2 are transmitted so that

$$V_{in}(t) = V_0 (\sin \omega_1 t + \sin \omega_2 t) \quad (28)$$

The product $|2f_1 - f_2|$ (or $|2f_2 - f_1|$) is then detected if a nonlinear device is present within the irradiated volume.

The model developed in Section II was applied to evaluate the efficacy of this method. The calculated and measured power output at various intermodulation products as a function of the power input (P_{in}) is shown in Figures 6 and 7 respectively.

The experimental results were taken on a homemade mixer constructed by mounting a detector diode in a shorted N-type connector without the benefit of any matching networks. The experimental setup used is shown in Figure 8. The static I-V characteristics of the diode were measured on a curve tracer and the diode parameters α , I_s , and R_s were matched to this curve and used in the computer simulation.

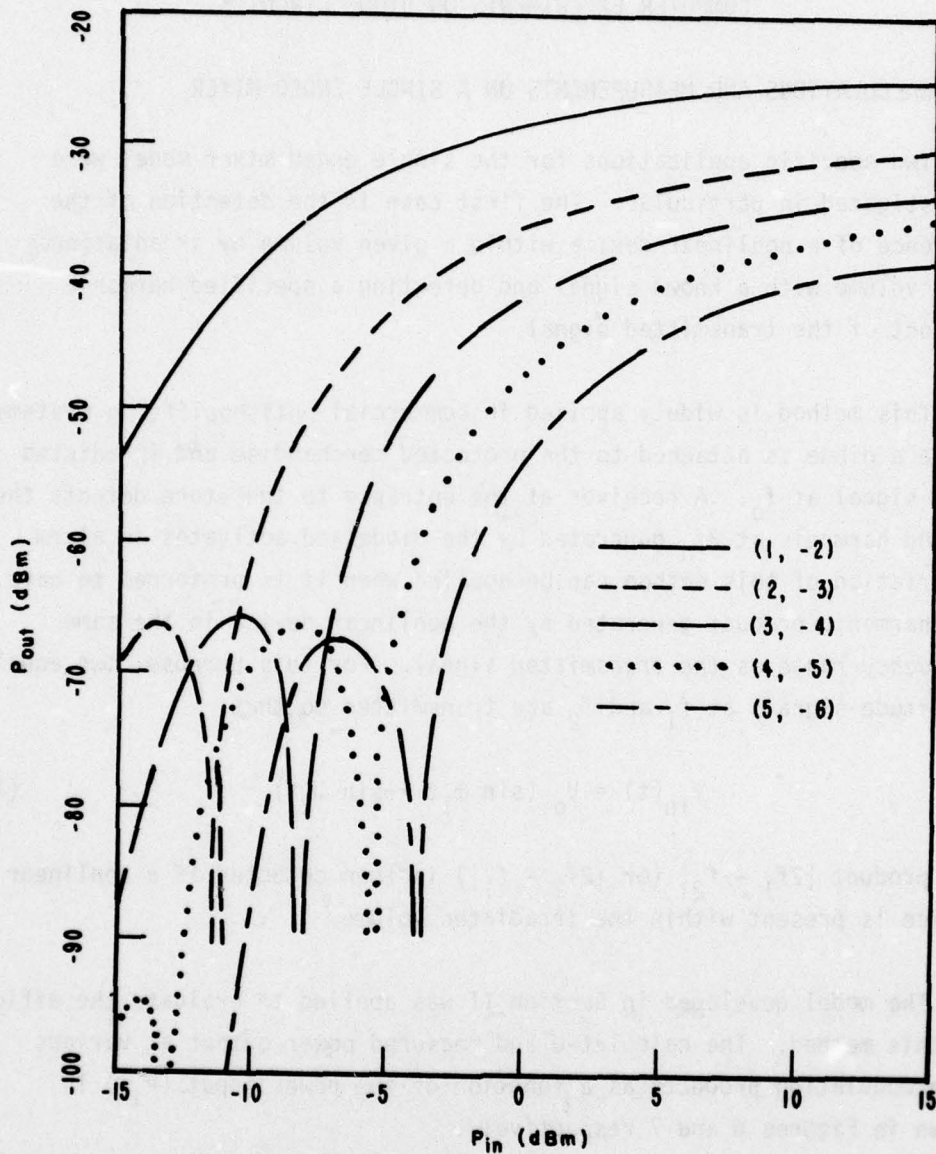

Figure 6. Calculated Power Output (P_{out}) of (m,n) IMD Products as a Function of the Power Input (P_{in}). ($P_1=P_2=P_{in}$)

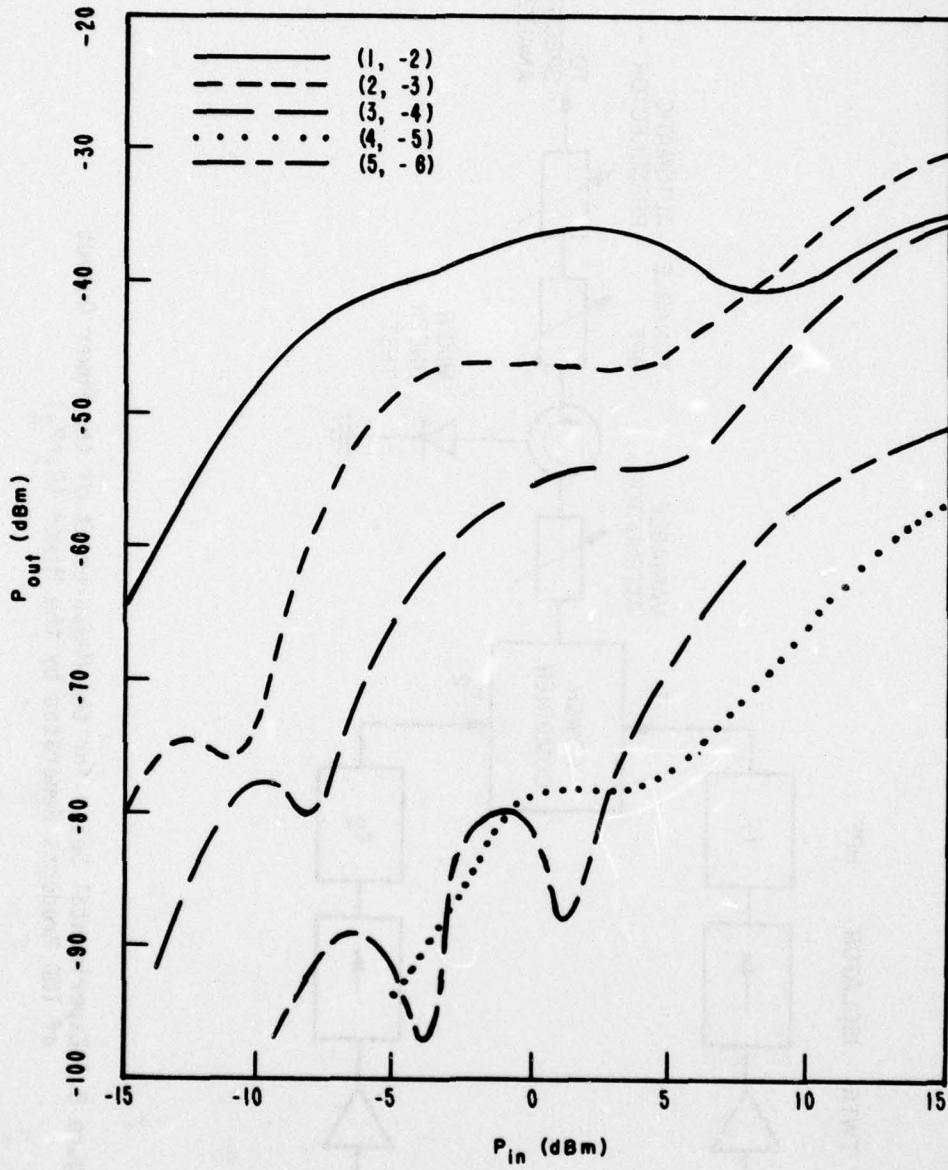

Figure 7. Measured Power Output (P_{out}) of (m,n) IMD Products as a Function of P_{in} . ($P_1=P_2=P_{in}$)

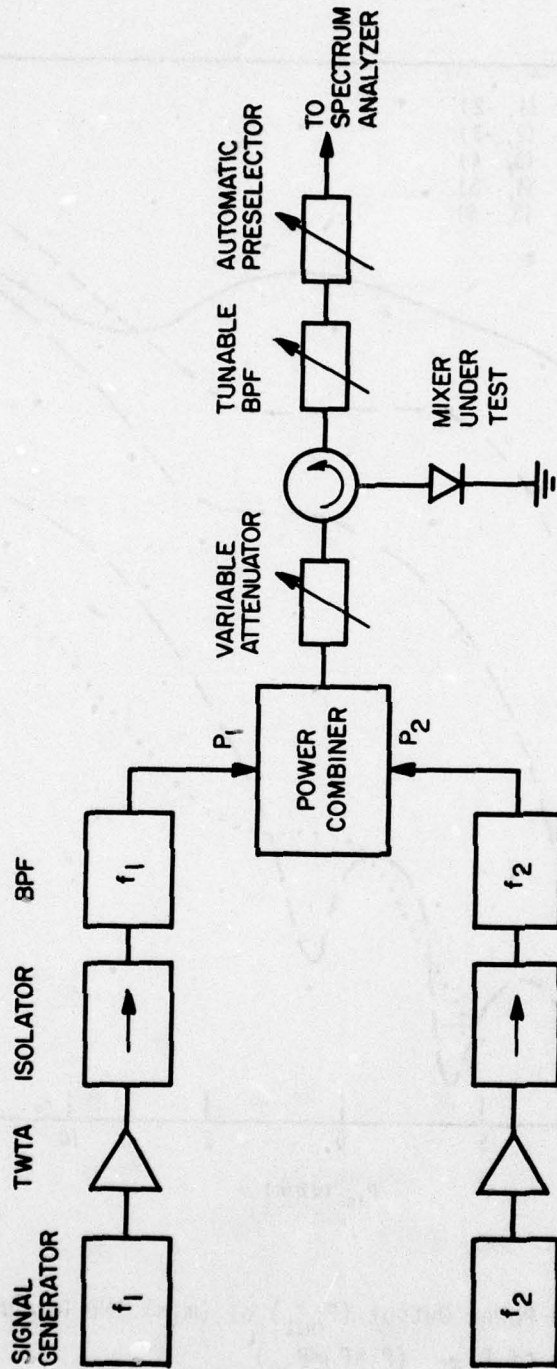

Figure 8. Experimental Setup for the Measurement of the Power Output of IMD Products Generated by the Mixer ($P_1=P_2$)

The results of this simulation (Figure 6) show that for some levels of input power, some of the IMD products completely disappear. A similar phenomenon was observed in the experimental data, as shown in Figure 7. Although in this case the output levels do not drop as drastically as in the simulated case, dips in the power output of the various IMD products were seen to occur for given input power levels. The numerical discrepancies between the calculated and measured results could be attributed to the fact that the computer model does not include frequency effects, while the experimental setup is frequency limited. In addition, the I-V diode characteristic is not strictly exponential as assumed in the computer model.

Another possible application for this model is to predict the level of the second harmonic generated in a diode in order to evaluate the feasibility of detection and identification of pseudo-noise BPSK modulated signals by a frequency doubling technique. The details of this investigation are presented in Appendix A.

The two-tone third-order intercept point in a mixer can be predicted as a function of the local oscillator drive level using the model presented here. For example, the intercept point for the single-ended mixer previously simulated was calculated for three values of LO drive level. The results, along with the RF to IF conversion loss at these LO levels, are shown in Table 1.

TABLE 1
TWO-TONE THIRD ORDER INTERCEPT POINT AND INSERTION LOSS AT
VARIOUS LO DRIVE LEVELS. (SINGLE-ENDED MIXER)

P_{LO} (dBm)	THIRD ORDER INTERCEPT (dBm)	INSERTION LOSS (dB)
3	11.1	11.3
6	14.5	10.9
9	17.7	10.7

It is seen that in this range, an increase of 3 dB in the LO drive level will increase the intercept point by more than 3 dB while slightly improving the insertion loss of the mixer. Thus, by using this model, an LO power can be calculated which would be optimal for our purposes, be it maximum linearity, minimum conversion loss, suppression or enhancement of a particular IMD product, etc.

2. BACK-TO-BACK DIODE LIMITER

The performance of a back-to-back diode limiter with an input consisting of two signals at f_1 and f_2 , was simulated using the formulation presented in Section III-2. The output power at f_1 (P_{out_1}) was calculated as a function of the input power at f_1 (P_{in_1}) with the input power at f_2 (P_{in_2}) as a parameter. Results of this calculation are shown in Figure 9. The simulated diodes were considered lossless ($R_s=0$), but for one case where a spurious series resistance was added ($R_s = 5\Omega$) in order to evaluate its effect on the performance of the limiter (dotted line).

As seen in Figure 9, the presence of a series resistance in the diode is detrimental to the limiting effect. The increase in current through the diodes due to increasing input power yields a higher voltage on the diode terminals, canceling the limiting effect of the junction itself.

Figure 9 also shows the effect of the presence of a second signal at the input of the limiter. The attenuation is linear with P_{in_1} for $P_{in_2} \geq P_{max}$, where P_{max} is the maximum output power. This is the "capture effect" of the limiter, where the stronger signal prevails and the weaker signal is further attenuated. This effect is clearly seen in Figure 10, where the output power of both signals is plotted.

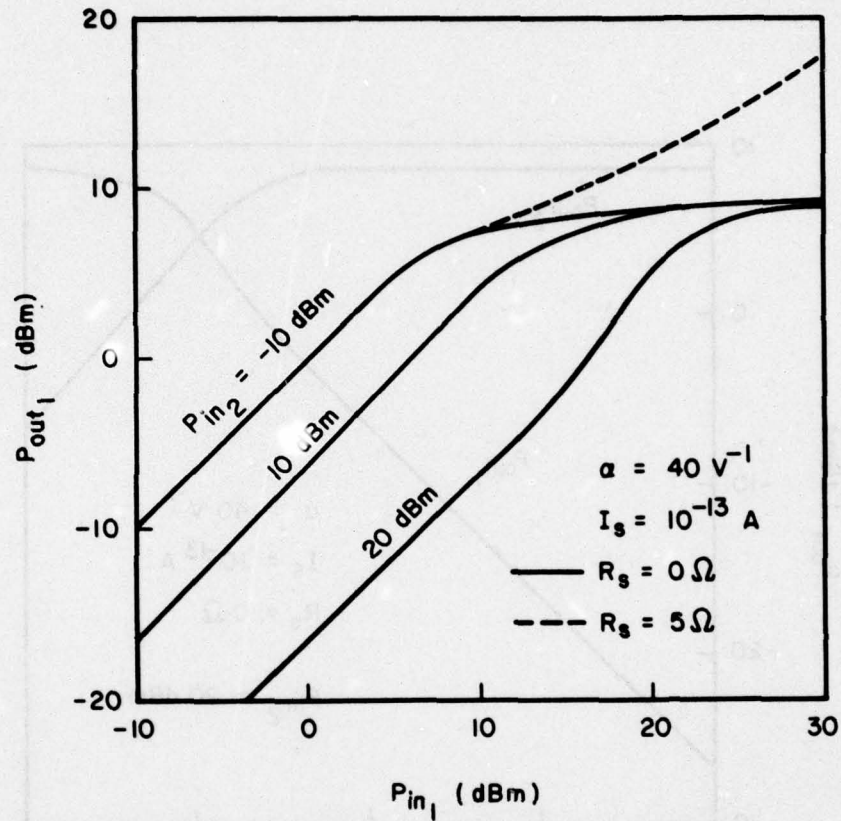

Figure 9. Simulation of a Limiter Fed by Two Signals at f_1 and f_2 : Power Output (P_{out_1}) Vs. Power Input at f_1 (P_{in_1}) With the Power Input at f_2 (P_{in_2}) as a Parameter

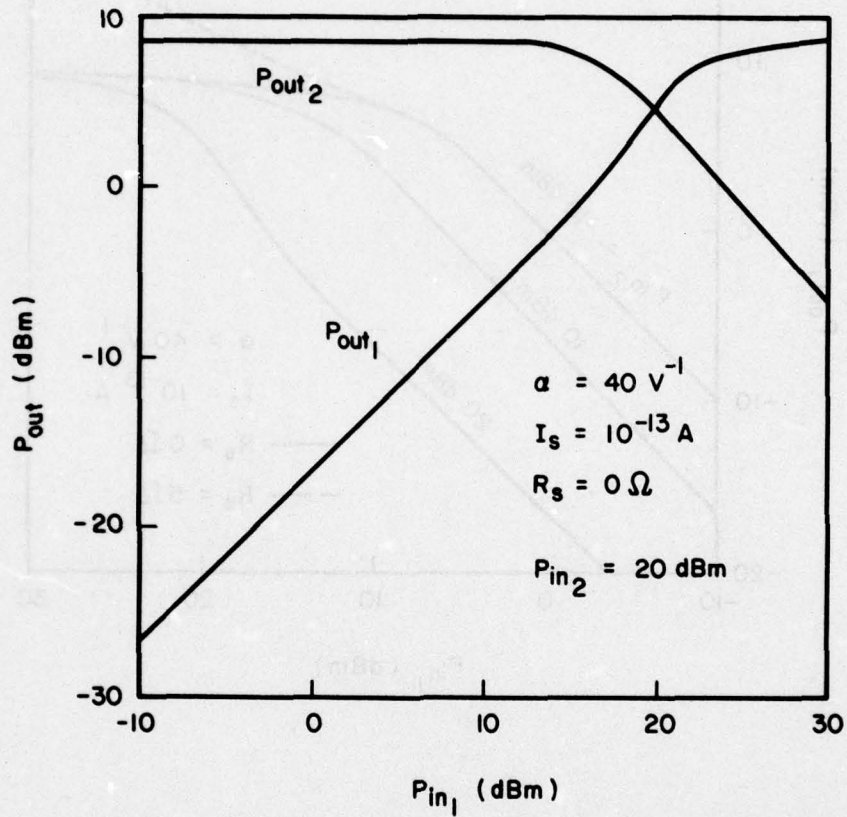

Figure 10. Simulation of a Limiter Fed by Two Signals at f_1 and f_2 :
 P_{out} at f_1 and f_2 Vs. P_{in_1} $P_{in_2} = \text{const.}$

3. 90° HYBRID BALANCED MIXER

A simulation of a 90° hybrid balanced mixer with identical diodes was carried on using the equations in Section III-3. Two cases were investigated:

- a. Insertion loss and two-tone third-order intercept as a function of the local oscillator power level (Figure 11).
- b. IF and single-tone IMD output levels as a function of RF input power (Figure 12).

As in the single-ended mixer case, increasing the LO power level will greatly improve linearity (higher intercept point) while slightly reducing insertion loss (Figure 11). The IF and IMD plots (Figure 12) are similar to those supplied by mixer manufacturers but for the "dips" in the output levels of the 2×2 and 1×2 products, ($m \times n \equiv |mf_{LO} - nf_{RF}|$). These dips appear in this simulation at high input power levels generally not measured by the manufacturers. No physical explanation for this phenomenon has been found by the authors. Mathematically, the load voltages at these products, which are calculated from a Fourier series expansion, change sign at these input RF levels.

Additional examples of applications of the model are presented in Appendix B, along with program usage instructions and the program listing.

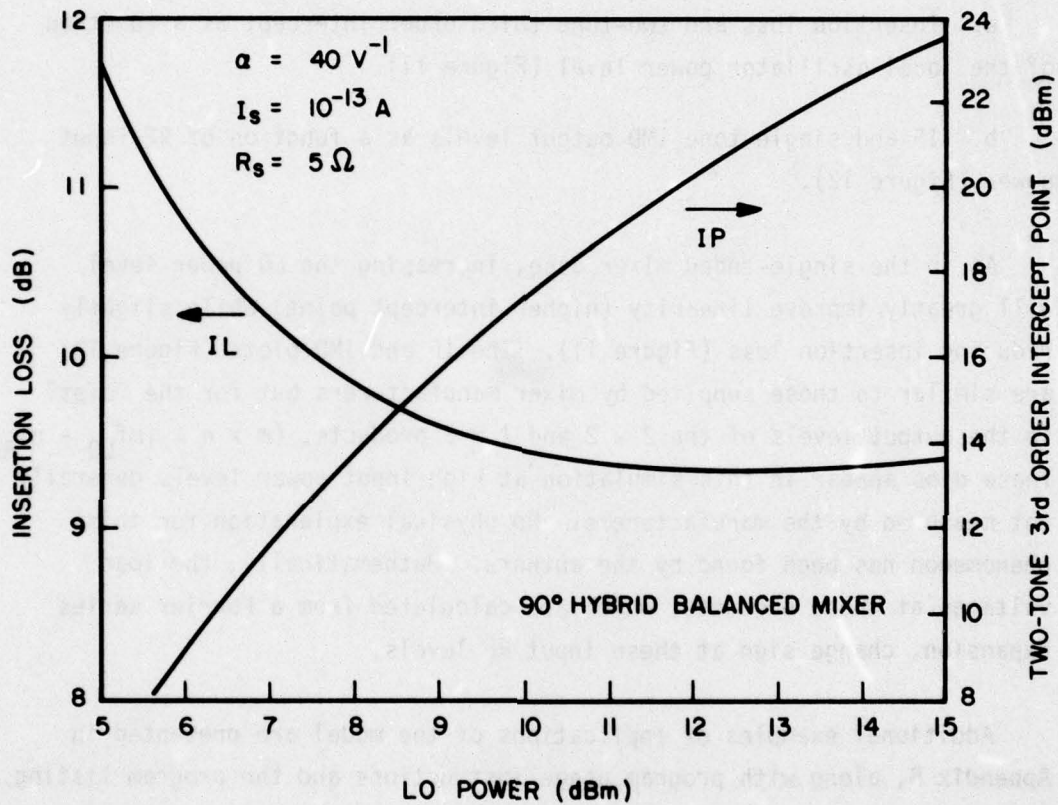

Figure 11. Calculated Insertion Loss and Two-Tone Third-Order IMD Intercept Point as a Function of the LO Power, for a 90° Hybrid Balanced Mixer

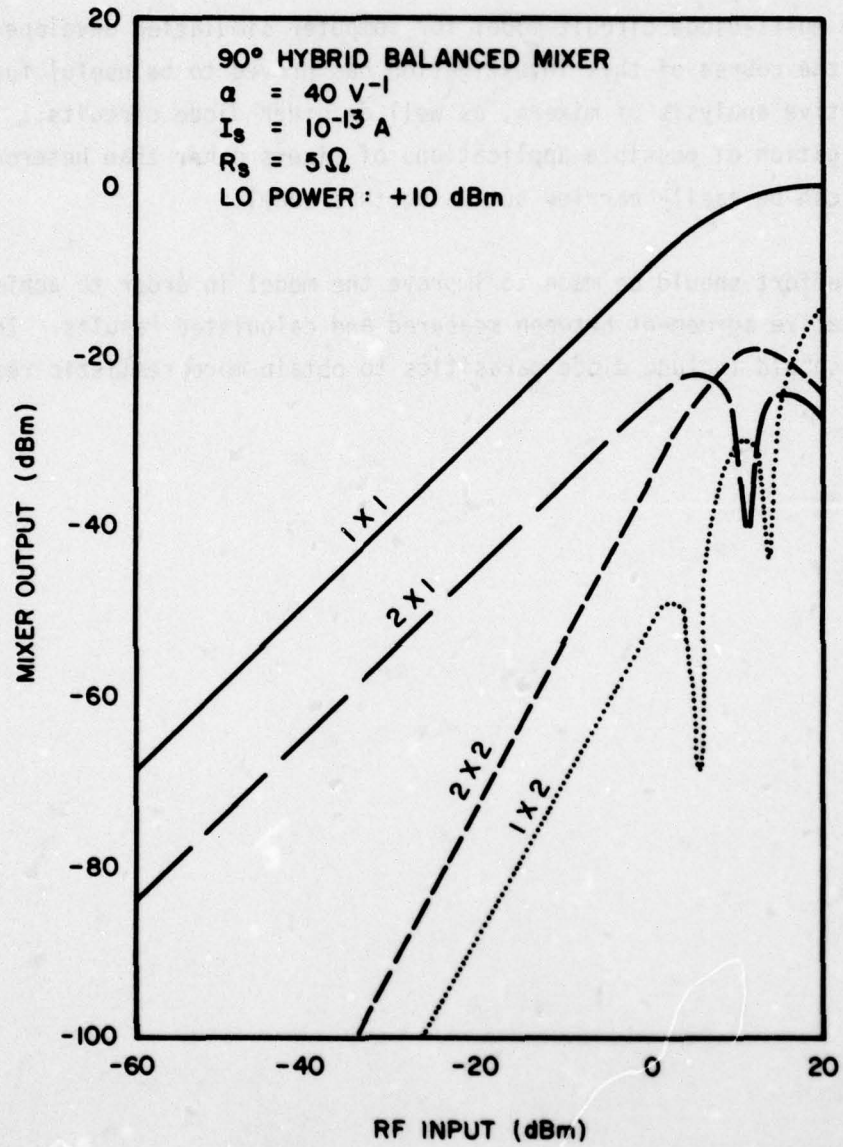

Figure 12. Calculated Single-Tone IMD Response for a 90° Hybrid Balanced Mixer

SECTION V
 CONCLUSIONS

The multi-diode circuit model for computer simulation developed during the course of this investigation has proved to be useful for qualitative analysis of mixers, as well as other diode circuits. Investigation of possible applications of mixers other than heterodyne mixing can be easily carried out using this model.

An effort should be made to improve the model in order to achieve quantitative agreement between measured and calculated results. This effort should include diode parasitics to obtain more realistic results.



APPENDIX A

PSEUDO-NOISE BPSK SIGNAL DETECTION BY HETERODYNE MIXING

Zeev Bogan and James B.Y. Tsui

Air Force Avionics Laboratory
Wright-Patterson AFB OH 45433

Detection of the presence of Pseudo-Noise Bi-Phase Shift Keyed signals from uncooperative sources is extremely difficult due to their noise like and suppressed carrier characteristics.

A method which facilitates detection of such signals is presented. The method consists of squaring the incoming signal by means of a non-linear device in the presence of a pumping signal. The squaring process eliminates the bi-phase modulation, thus obtaining a CW signal at the second harmonic of the carrier frequency. By pumping the non-linear device with a local oscillator signal, significant enhancement of the second harmonic output is obtained, with a distinctive peak in output power at a given pump level. Moreover, this method makes it possible to down-convert the second harmonic signal to a lower frequency without considerable loss, facilitating the post-processing.

The described method was tested successfully both by computer simulation and laboratory experiments.

INTRODUCTION

The non-linear properties of a heterodyne mixer, which adversely affect reception by generation of spurious signals, might in some applications become an asset. Such is the case presented here in which the mixer non-linearities are investigated as a means to the detection of the presence of Pseudo-Noise-BPSK signals from uncooperative sources.

The time function of a pseudo-noise-bi-phase modulated signal is given by:

$$V(t) = V_c \cos \{\omega_c t + \phi(t)\} \quad (1)$$

where ω_c is the carrier frequency and the phase $\phi(t)$ changes in a pseudo random fashion between 0 and π , controlled by a direct sequence modulator.

The power spectrum of such a signal which appears to be noise with a $(\sin x/x)^2$ distribution is shown in Fig 1(a).

This spectrum is obviously similar to that of a pulsed RF signal with a small duty cycle. An operator monitoring the spectrum and detecting a signal with such a power distribution on his display could not immediately decide if it is a PN or a pulse modulated signal. If time is no factor, however, a PN signal could be identified by its suppressed carrier characteristics, Fig 1(b).

An additional method for identification of a PN signal as such is suggested here. The method consists of obtaining a CW signal at the second harmonic of the carrier frequency by squaring the incoming signal in the presence of a pump (local oscillator). Applying this method, it is also possible to obtain a down-converted CW signal by heterodyne mixing of the pump frequency with the second harmonic of the carrier.

MATHEMATICAL FORMULATION

The squaring of the incoming signal is accomplished by means of a non-linear device, such as a semi-conductor diode. The output from such a device can be represented, for a small signal regime, as a power series of the form:

$$V_{out}(t) = \sum_{k=0}^{\infty} A_k V_{in}^k(t) \quad (2)$$

Expanding the quadratic term with $V_{in}(t)$ as given in (1), we get:

$$\begin{aligned} A_2 V_{in}^2(t) &= A_2 V_c^2 \cos^2 \{\omega_c t + \phi(t)\} = \\ &= \frac{A_2}{2} V_c^2 \{\cos [2\omega_c t + 2\phi(t)] + 1\} \end{aligned}$$

...but since $\phi(t)$ is either 0 or π , therefore

$$A_2 V_{in}^2(t) = \frac{A_2}{2} V_c^2 [\cos 2\omega_c t + 1] \quad (3)$$

Thus eliminating the phase modulation of the original signal and obtaining a CW signal at $2\omega_c$ with an amplitude of $A_2 V_c^2 / 2$; if we take into account the fourth order term also, the amplitude at the second harmonic will be

$$\frac{A_2 V_c^2}{2} \left(1 + \frac{A_4}{A_2} V_c^2 \right).$$

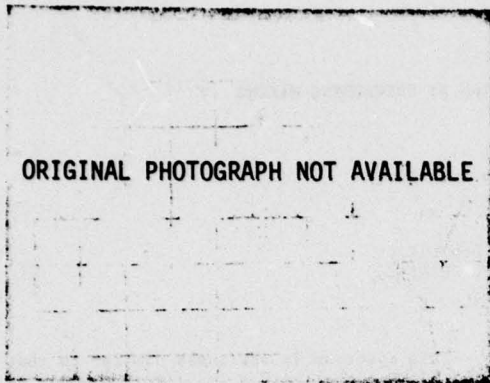

a) 3 kHz BW, 500 kHz/div

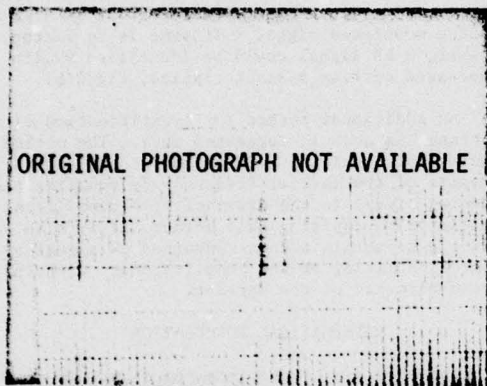

b) 1 kHz BW, 50 kHz/div

Fig 1: Power Spectrum of a PN-BPSK signal (10 dB/div). $f_c = 2200\text{MHz}$, 1 MHz clock, 127 bits sequence length.

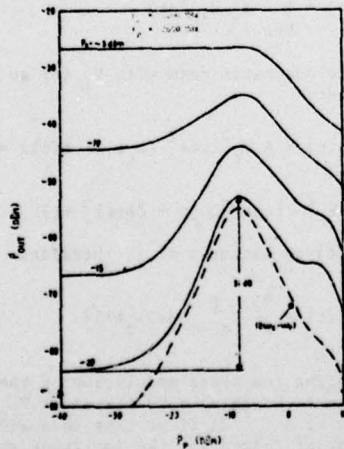

Fig 2: Calculated power output at $2\omega_c - \omega_p$ as a function of the pump power P_p , with the carrier power P_c as a parameter.

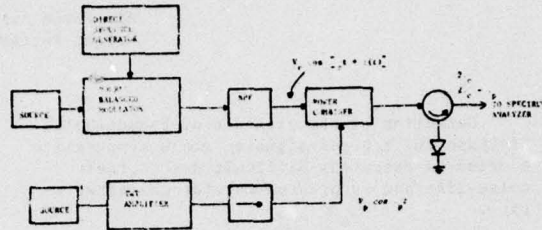

Fig 3: Experimental Set-Up

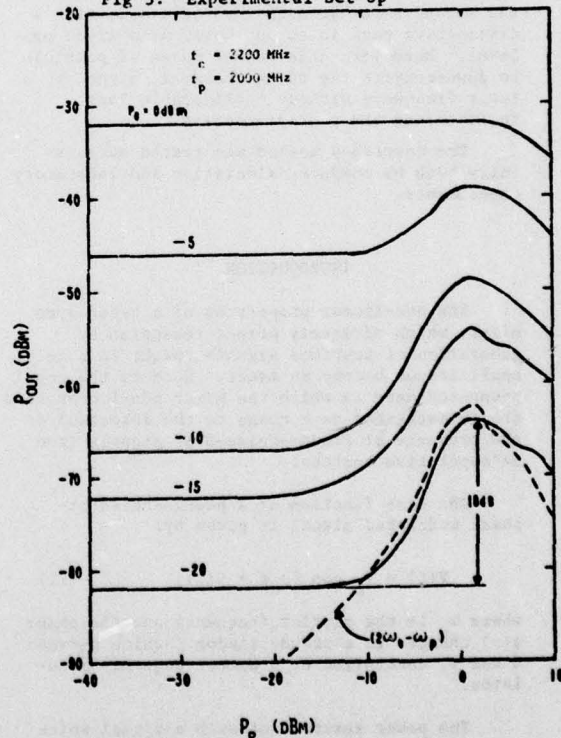

Fig 4: Measured power output at $2\omega_c - \omega_p$ as a function of the pump power P_p , with the carrier power P_c as a parameter.

AFAL-TR-77-266

This process is bound to be lossy due to its quadratic characteristic, especially at small signal levels, where this model applies. Some improvement can be obtained, however, by superimposing on the incoming signal a pump with an amplitude of V_p at a frequency of ω_p , so that the input voltage to the non-linear device will be now:

$$V_{in}(t) = V_c \cos[\omega_c t + \phi(t)] + V_p \cos \omega_p t \quad (4)$$

Let us now calculate the second and fourth order terms in (2) and extract the second harmonic component:

$$\begin{aligned} A_2 V_{in}^2 &= A_2 (V_c \cos[\omega_c t + \phi(t)] + V_p \cos \omega_p t)^2 = \\ &= \frac{A_2 V_c^2}{2} \cos 2\omega_c t + \dots \end{aligned} \quad (5)$$

$$A_4 V_{in}^4 = \left(\frac{A_4}{2} V_c^4 + \frac{3A_4}{2} V_c^2 V_p^2 \right) \cos 2\omega_c t + \dots \quad (6)$$

Adding (5) and (6) we get:

$$V_{out}(2\omega_c) = \frac{A_2}{2} V_c^2 \left(1 + \frac{A_4}{A_2} V_c^2 + \frac{3A_4}{A_2} V_p^2 \right) \quad (7)$$

Thus, an additional term is added to the amplitude of the pump signal V_c . If A_4 and A_2 have the same sign, the amplitude of the CW signal at $2\omega_c$ will increase with the pump level. Fortunately, as will be seen later, this is indeed the case up to some level of V_c where the small signal approximation collapses.

From the power series in (2), we can also obtain a down converted CW signal at a frequency $\omega_{1,2} = |\omega_p - 2\omega_c|$, by calculating the third order term in the series. The amplitude of this signal will be:

$$V_{out}(\omega_{1,2}) = \frac{3}{2} A_3 V_c^2 V_p \quad (8)$$

It has to be noted though, that a CW signal of amplitude V_c at the carrier frequency ω_c will generate a second harmonic of the same amplitude as a PN-BPSK signal, therefore, in order to positively identify such a signal, the carrier band has to be monitored simultaneously.

The above theoretical results, which indicate that an improvement in the second harmonic output can be achieved in the presence of a pumping signal were confirmed both by numerical calculations and by laboratory measurements.

NUMERICAL RESULTS

In order to confirm the above theoretical results, a computer simulation of a single-ended mixer was carried out. The model of the mixer consists of a semiconductor diode with an exponential I-V characteristic and a series resistance R_s representing the diode losses. The

diode is fed by a 500 signal source through a circulator in order to isolate the input from the output. The DC parameters of a detector diode, which was later used in our experiments, were obtained from the measured I-V curve. From this model a transcendental equation for the voltage on the load as a function of time, is obtained. This equation is solved using the Newton-Raphson method. After the time function is calculated, Fourier analysis is applied in order to calculate the various spectral components of interest.

In the case reported here, the power output at the second harmonic $2\omega_c$ and at the down converted frequency $\omega_{1,2} = |2\omega_c - \omega_p|$ was calculated as a function of P , the pump power level, with P_c , the carrier power level, as a parameter. The results are shown in Fig 2. It is observed that the outputs at the second harmonic and at the down converted product exhibit a peak at a certain pump power level, decreasing for higher pump levels, leading to the conclusion that the small signal power series model developed in the previous section is not valid anymore at these input levels. At the peak, the second harmonic output is about 34 dB over the non-pumped level in this particular simulation, a significant improvement.

EXPERIMENTAL RESULTS AND CONCLUSIONS

Using the experimental setup shown in Fig 3, measurements of the power output at the second harmonic and at the down converted product $\omega_{1,2}$ were carried on, as a function of the pump power level. These results are shown in Fig 4. These plots show a qualitative similarity to those obtained by computer simulation, alas, numerically they differ. Especially, the boost in second harmonic generation under optimal pump power is now only 18 dB above the non-pumped level. These differences might be attributed to the crudity of our computer model which does not take into account frequency effects; thus, such discrepancies might well be expected at microwave frequencies. However, the experimental results corroborated the computer calculations, at least qualitatively, showing the feasibility of this method for positive identification of PN-BPSK signals, provided that simultaneous monitoring is carried on at the carrier band.

ACKNOWLEDGMENTS

Dr. Zeev Bogan wishes to acknowledge the National Research Council for providing support for his associateship at the Air Force Avionics Laboratory.

APPENDIX B
COMPUTER PROGRAM USAGE

The computer program MIXER is written in FORTRAN IV and intended for interactive use.

Data is entered from the terminal as answers to queries by the program.

1. INPUT

MIXER accomodates the following options according to the specified number of diodes in the circuit, ND:

- ND=1 : Single ended mixer.
- ND=2 : Limiter or balanced mixer.
- ND=4 : Double balanced mixer.

If ND=2 the program asks whether the circuit to be analyzed is a balanced mixer or a limiter. If it is a mixer, the type of hybrid used (90 or 180) has to be specified.

For ND=2 the option exists to specify non-identical diodes in the circuit. This feature is useful to check for effects of unbalance on supposedly balanced configurations.

In case of trouble, it is desirable to obtain the output in the time domain in order to check for nonconvergence of the solutions. This option is available by answering YES to the "TIME DOMAIN ONLY?" query. In this case, the voltages on the diodes and the convergence error at each iteration could be obtained by answering YES to the "INTERMEDIATE ITERATION OUTPUT" query.

For frequency domain simulations the option is between calculation of the one-tone harmonic intermodulation products (SPURS) or the two-tone third-order intermodulation product (IMD). The levels of the

intermodulation products can be calculated as a function of the LO level (PLO) with the signal level (PSIG) as a parameter (1), or as a function of PSIG with PLO as a parameter (2), or as a function of PIN (3), where $PIN = PLO = PSIG$, for calculation of two-tone sideband levels.

After all the options for the run have been entered, the data is specified next in the following order:

Diode parameters: ALPHA (1/VOLTS), saturation current (IS) (AMPERES), series resistance (RS) (OHMS).

Input and output impedances (ZO and ZL) (OHMS).

LO and RF frequencies (FLO and FSIG) (HZ).

If IMD was specified, enter FSIG2 (second tone frequency).

Power Levels and power steps (dBm):

Option (1): PSIGMIN, PSIGMAX, STEPSIG, PLOMIN, PLOMAX, STEPLO.

Option (2): PLOMIN, PLOMAX, STEPLO, PSIGMIN, PSIGMAX, STEPSIG.

Option (3): PMIN, PMAX, PSTEP.

(Example: Calculate SPURS as a function of PSIG for $-30 \leq PSIG \leq -20$ dBm each 2 dB while PLO varies from 0 to 10 dBm in 5 dB steps: PLOMIN, PLOMAX, STEPLO, PSIGMIN, PSIGMAX, STEPSIG = 0, 10, 5, -30, -20, 2.)
For time domain only calculations only one set of power levels is specified: P10, PSIG.

If "SPURS" was specified the number of Spurs desired (NPRODS) is entered next. The order (m,n) of the spurs is entered as follows: m1, n1, m2, n2... m is the coefficient of FLO while n is the coefficient of FSIG. For example, the IF will be given by (1, -1); the LO feedthrough is given by (1,0) and the RF feedthrough is given by (0,1).

For time domain only simulation, the time limit of the calculation TMAX has to be specified in seconds. For frequency domain calculations TMAX is internally calculated.

Next, the integration step DELTAT is entered (seconds).

The maximum number of iterations and the maximum allowed convergence error are entered last.

2. INPUT CONSIDERATIONS

a. Choice of Frequencies

As explained in the text, the choice of the set (FLO, FSIG) does not affect the actual performance of the mixer but will affect the results of the simulation if not carefully chosen. The sampling window TMAX is internally calculated as: $TMAX = 1/|FLO-FSIG|$ for spur calculations. In order to avoid erroneous results $1/TMAX$ has to be a common divisor of FLO, FSIG and all their byproducts. A reasonable choice for the set (FLO, FSIG) would be (20, 19) so that $TMAX=1$. This set also assures that there will be no overlapping of low-order intermodulation products.

For two-tone third-order intermodulation calculations, the choice of the set (FLO, FSIG, FSIG2) is more critical yet since there are more intermodulation products to contend with and overlapping should be avoided. TMAX in this case is calculated as $1/|FSIG-FSIG2|$ and has to be a common divisor of FLO, FSIG, FSIG2 and all their byproducts. Again it is convenient to choose $TMAX=1$ as before. We have found that the set (30, 12, 11) works reasonably well.

b. Time Increment DELTAT

According to the Sampling theorem, the sampling rate has to be at least twice the maximum frequency present in the spectrum of the analyzed signal. It was found that for the above frequency choices, $DELTAT=10^{-3}s$ for spur calculations and $DELTAT=10^{-4}s$ for two-tone third-order IMD calculations give accurate results. It is advisable to check doubtful results by running the program again with the same data and a reduced DELTAT.

c. Number of Iterations and Maximum Error

Generally the solutions converge in less than five iterations with an error of less than 10^{-7} . It is advisable to specify the number of iterations as 10 or greater and the maximum allowable error as 10^{-7} or less.

AFAL-TR-77-266

3. OUTPUT

The frequency domain output (spur levels) is filed under TAPE1 while the time domain output is filed under TAPE2.

Up to six IMD products can be accomodated on an interactive terminal. If the number of spurs (NPRODS) is greater than six, the output has to be diverted to a line printer. Up to 10 spurs can be requested.

4. CONTROL

Mixer uses the matrix inversion subroutine LINVIF which is part of the IMSL library. To attach this library the following command is used: ATTACH, IMSL, ID=X654321, SN=AFIT.

To run the program: XEQ, LDSET, LIB=IMSL, LOAD-LFN where LFN is the file name under which the object deck of MIXER is filed. If immediate output on the terminal is desired use: DISCONT, TAPE1 (or TAPE2) before the XEQ command.

5. EXAMPLES

In the following pages various examples of the use of this program are presented.

EXAMPLE 1

CALCULATION OF TWO-TONE THIRD-ORDER IMD LEVELS

IN A SINGLE-ENDED MIXER

(a) Input

*** NON-LINEAR CIRCUIT SIMULATION ***

ENTER OPTIONS FOR THIS RUN:
 ENTER NUMBER OF DIODES FOR SIMULATED CIRCUIT.
 (TYPE 1,2, OR 4) ND=1

TIME DOMAIN ONLY? (YES OR NO): NO

CALCULATE SPURS OR 2-TONE 3RD ORDER IMD?
 TYPE SPURS OR IMD: IMD

DETERMINE WHAT KIND OF CALCULATION DESIRED.
 (1) POUT=F(PLO). (2) POUT=F(P SIG). (3) POUT=F(PIN), PIN=PLO=P SIG.
 TYPE 1, 2 OR 3.: 1

ENTER RUN DATA:
 ENTER DIODE #1: ALPHA, IS, RS= 40., 1.E-12, 10.

ENTER INPUT AND OUTPUT IMPEDANCES Z0, ZL= 50., 50.

ENTER FREQUENCIES FLO, F SIG (HZ): 30., 11.

ENTER 2ND TONE FREQUENCY F SIG2: 12.

ENTER POWER LEVELS (IN DBM):
 P SIG MIN, P SIG MAX, STEP SIG, P LO MIN, P LO MAX, STEP LO: -20, -10, 10, 3, 9, 3

ENTER SAMPLING INTERVAL DELTAT (SECS): 1.E-4

MAX, NUMBER OF ITERATIONS, MAX. ALLOWED ERROR=10, 1.E-7

*** END OF DATA INPUT, BEGIN EXECUTION. ***
 *** FIND FREQUENCY DOMAIN OUTPUT ON TAPE1. ***
 *** FIND TIME DOMAIN OUTPUT ON TAPE2. ***

EXAMPLE 1

(b) Output

SIMULATION OF A SINGLE ENDED MIXER
*CALCULATE THE POWER OUTPUT OF 2-TONE 3RD ORDER IMD PRODUCTS
AS A FUNCTION OF PLO

DIODE#1: ALPHA= 40.00 IS= 1.00E-12 RS= 10.00
FREQUENCIES: FLO= 3.00E+01 FSIG= 1.10E+01 FSIG2= 1.20E+01 HZ
SOURCE IMPEDANCE= 50.00 LOAD IMPEDANCE= 50.00
RUN PARAMETERS: DELTAT= 1.00E-04 NITER=10 ERMAX= 1.0E-07

PSIG= -20.00 DBM						
*	PLO	*	IMD	*	IF	*
*	3.00	*	-84.19	*	-28.27	*
*	6.00	*	-92.93	*	-26.86	*
*	9.00	*	-100.24	*	-26.22	*

PSIG= -10.00 DBM						
*	PLO	*	IMD	*	IF	*
*	3.00	*	-53.14	*	-18.69	*
*	6.00	*	-62.61	*	-16.98	*
*	9.00	*	-70.14	*	-16.27	*

EXAMPLE 2

CALCULATION OF SIDEBAND GENERATION

IN A SINGLE-ENDED MIXER

(a) Input

*** NON-LINEAR CIRCUIT SIMULATION ***

ENTER OPTIONS FOR THIS RUN:
ENTER NUMBER OF DIODES FOR SIMULATED CIRCUIT.
(TYPE 1, 2, OR 4) ND=1

TIME DOMAIN ONLY? (YES OR NO): NO

CALCULATE SPURS OR 2-TONE 3RD ORDER IMD?
TYPE SPURS OR IMD: SPURS

DETERMINE WHAT KIND OF CALCULATION DESIRED.
(1) POUT=F(PLO), (2) POUT=F(P SIG), (3) POUT=F(PIN), PIN=PLO=PSIG.
TYPE 1, 2 OR 3.: 3

ENTER RUN DATA:
ENTER DIODE #1: ALPHA, IS, RS= 40., 1.E-12, 10.

ENTER INPUT AND OUTPUT IMPEDANCES Z0, ZL= 50., 50.

ENTER FREQUENCIES FLO, F SIG (HZ): 20., 19

ENTER POWER LEVELS (IN DBM):
P MIN, P MAX, P STEP= -30, 0, 3

ENTER NUMBER OF SPURS DESIRED. (1 TO 10): 4

ENTER SPUR ORDER M, N. (M*FLO+N*F SIG): 1, -2 2, -3 3, -4 4, -5

ENTER SAMPLING INTERVAL DELTAT (SECS): 1.E-3

MAX, NUMBER OF ITERATIONS, MAX. ALLOWED ERROR= 10, 1.E-7

*** END OF DATA INPUT, BEGIN EXECUTION. ***
*** FIND FREQUENCY DOMAIN OUTPUT ON TAPE1. ***
*** FIND TIME DOMAIN OUTPUT ON TAPE2. ***

EXAMPLE 2

(b) Output

SIMULATION OF A SINGLE ENDED MIXER
*CALCULATE THE POWER OUTPUT OF SPURIOUS PRODUCTS
AS A FUNCTION OF PIN. PIN=PSIG=PLO.

DIODE#1: ALPHA= 40.00 IS= 1.00E-12 RS= 10.00
FREQUENCIES: FLO= 2.00E+01 FSIG= 1.90E+01 FSIG2= 0. HZ
SOURCE IMPEDANCE= 50.00 LOAD IMPEDANCE= 50.00
SPURIOUS:(1,-2)(2,-3)(3,-4)(4,-5)
RUN PARAMETERS: DELTAT= 1.00E-03 NITER=10 ERMAL= 1.0E-07

PIN=PLO=PSIG

* PIN	* (1,-2)	* (2,-3)	* (3,-4)	* (4,-5)
* -30.00	* -218.75	* -250.68	* -281.83	* -277.74
* -27.00	* -208.63	* -234.80	* -266.44	* -275.09
* -24.00	* -197.47	* -218.22	* -244.41	* -281.21
* -21.00	* -184.36	* -200.20	* -221.04	* -246.47
* -18.00	* -167.85	* -179.47	* -195.44	* -215.04
* -15.00	* -145.74	* -154.02	* -165.83	* -180.72
* -12.00	* -114.97	* -120.79	* -129.28	* -140.25
* -9.00	* -72.07	* -76.32	* -82.69	* -91.30
* -6.00	* -37.61	* -45.79	* -69.54	* -63.08
* -3.00	* -25.72	* -53.35	* -45.08	* -58.07
* 0.00	* -20.48	* -34.58	* -54.56	* -45.70

EXAMPLE 3CALCULATION OF ONE-TONE IMD LEVELS IN A 90°-HYBRID
BALANCED MIXER AS A FUNCTION OF PLO

(a) Input

*** NON-LINEAR CIRCUIT SIMULATION ***

ENTER OPTIONS FOR THIS RUN:
ENTER NUMBER OF DIODES FOR SIMULATED CIRCUIT.
(TYPE 1,2, OR 4) ND=2MIXER OR LIMITER? (TYPE M OR L): M90 OR 180 DEGREE HYBRID? TYPE 90 OR 180: 90IDENTICAL DIODES? (YES OR NO): YESTIME DOMAIN ONLY? (YES OR NO): NOCALCULATE SPURS OR 2-TONE 3RD ORDER IMD?
TYPE SPURS OR IMD: SPURSDETERMINE WHAT KIND OF CALCULATION DESIRED.
(1) POUT=F(PLO), (2) POUT=F(P SIG), (3) POUT=F(PIN), PIN=PLO=PSIG.
TYPE 1, 2 OR 3.: 1ENTER RUN DATA:
ENTER DIODE #1: ALPHA, IS, RS= 40, .1, E-12, 10.ENTER INPUT AND OUTPUT IMPEDANCES ZO, ZL= 50, 50.ENTER FREQUENCIES FLO, FSIG (HZ): 20, 19ENTER POWER LEVELS (IN DBM):
PSIGMIN, PSIGMAX, STEPSIG, PLOMIN, PLOMAX, STEPLO: -30, -20, 10, 5, 13, 1ENTER NUMBER OF SPURS DESIRED. (1 TO 10): 6ENTER SPUR ORDER M, N. (M*FLO+N*FSIG): 1, -1 1, -2 2, -1 2, -2 2, -3 3, -2ENTER SAMPLING INTERVAL DELTAT (SECS): 1.E-3MAX, NUMBER OF ITERATIONS, MAX. ALLOWED ERROR=10, 1.E-7*** END OF DATA INPUT, BEGIN EXECUTION. ***
*** FIND FREQUENCY DOMAIN OUTPUT ON TAPE1. ***
*** FIND TIME DOMAIN OUTPUT ON TAPE2 ***

THIS PAGE IS BEST QUALITY PRACTICABLE
FROM COPY FURNISHED TO DDC

EXAMPLE 3

(b) Output

SIMULATION OF A BALANCED MIXER WITH A 90. DEGREE HYBRID AND IDENTICAL DIODES

*CALCULATE THE POWER OUTPUT OF SPURIOUS PRODUCTS AS A FUNCTION OF PLO

DIODE#1: ALPHA= 40.00 IS= 1.00E-12 RS= 10.00
 FREQUENCIES: FLO= 2.00E+01 FSIG= 1.90E+01 FSIG2= 0. HZ
 SOURCE IMPEDANCE= 50.00 LOAD IMPEDANCE= 50.00
 SPURIOUS:(1,-1)(1,-2)(2,-1)(2,-2)(2,-3)(3,-2)
 RUN PARAMETERS: DELTAT= 1.00E-03 NITER=10 ERMAX= 1.0E-07

PSIG= -30.00 DBM

PLO	(1,-1)	(1,-2)	(2,-1)	(2,-2)	(2,-3)	(3,-2)
5.00	-41.24	-91.82	-48.56	-96.79	-139.51	-96.24
6.00	-40.62	-97.74	-49.32	-93.83	-131.53	-101.16
7.00	-40.24	-105.40	-50.60	-92.98	-143.00	-106.25
8.00	-40.00	-119.18	-52.34	-93.04	-141.11	-108.96
9.00	-39.85	-111.02	-54.56	-93.27	-128.60	-110.11
10.00	-39.76	-105.61	-57.42	-94.30	-126.21	-113.95
11.00	-39.71	-100.87	-61.43	-95.10	-126.14	-112.83
12.00	-39.69	-103.64	-67.96	-96.84	-146.27	-108.98
13.00	-39.69	-99.33	-89.58	-97.47	-140.91	-110.47

PSIG= -20.00 DBM

PLO	(1,-1)	(1,-2)	(2,-1)	(2,-2)	(2,-3)	(3,-2)
5.00	-31.25	-71.77	-38.59	-76.88	-113.75	-76.26
6.00	-30.63	-77.70	-39.34	-73.87	-108.55	-81.13
7.00	-30.24	-85.72	-40.62	-73.01	-127.74	-86.00
8.00	-30.00	-103.01	-42.35	-73.07	-113.70	-89.31
9.00	-29.85	-91.55	-44.56	-73.50	-104.31	-91.02
10.00	-29.76	-86.04	-47.43	-74.34	-97.69	-93.08
11.00	-29.71	-81.60	-51.43	-75.30	-99.12	-92.07
12.00	-29.69	-83.75	-58.04	-76.51	-121.20	-91.12
13.00	-29.69	-79.88	-81.03	-77.51	-120.39	-90.51

EXAMPLE 4CALCULATION OF ONE-TONE IMD LEVELS IN A 180° -HYBRID
BALANCED MIXER AS A FUNCTION OF PSIG

(a) Input

*** NON-LINEAR CIRCUIT SIMULATION ***

ENTER OPTIONS FOR THIS RUN:
ENTER NUMBER OF DIODES FOR SIMULATED CIRCUIT.
(TYPE 1,2, OR 4) ND=2MIXER OR LIMITER? (TYPE M OR L): M90 OR 180 DEGREE HYBRID? TYPE 90 OR 180: 180IDENTICAL DIODES? (YES OR NO): YESTIME DOMAIN ONLY? (YES OR NO): NOCALCULATE SPURS OR 2-TONE 3RD ORDER IMD?
TYPE SPURS OR IMD: SPURSDETERMINE WHAT KIND OF CALCULATION DESIRED.
(1) POUT=F(PLO). (2) POUT=F(PSIG). (3) POUT=F(PIN), PIN=PLO=PSIG.
TYPE 1, 2 OR 3.: 2

ENTER RUN DATA:

ENTER DIODE #1: ALPHA, IS, RS= 40., 1.E-12, 10.ENTER INPUT AND OUTPUT IMPEDANCES Z0, ZL= 50., 50.ENTER FREQUENCIES FLO, FSIG (HZ): 20., 19.

ENTER POWER LEVELS (IN DBM):

PLOMIN, PLOMAX, STEPLO, PSIGMIN, PSIGMAX, STEPSIG: 5, 10, 5, -30, -20, 2ENTER NUMBER OF SPURS DESIRED. (1 TO 10): 4ENTER SPUR ORDER M, N. (M*FLO+N*FSIG): 1, -1 1, -2 2, -1 2, -2 2, -3 3, -2ENTER SAMPLING INTERVAL DELTAT (SECS): 1.E-3MAX, NUMBER OF ITERATIONS, MAX. ALLOWED ERROR=10, 1.E-7*** END OF DATA INPUT, BEGIN EXECUTION. ***
*** FIND FREQUENCY DOMAIN OUTPUT ON TAPE1. ***
*** FIND TIME DOMAIN OUTPUT ON TAPE2. ***

EXAMPLE 4

(b) Output

SIMULATION OF A BALANCED MIXER WITH A180. DEGREE HYBRID AND IDENTICAL DIODES

*CALCULATE THE POWER OUTPUT OF SPURIOUS PRODUCTS AS A FUNCTION OF PSIG

DIODE#1: ALPHA= 40.00 IS= 1.00E-12 RS= 10.00
 FREQUENCIES: FLO= 2.00E+01 FSIG= 1.90E+01 FSIG2= 0. HZ
 SOURCE IMPEDANCE= 50.00 LOAD IMPEDANCE= 50.00
 SPURIOUS:(1,-1)(1,-2)(2,-1)(2,-2)(2,-3)(3,-2)
 RUN PARAMETERS: DELTAT= 1.00E-03 NITER=10 ERMAL= 1.0E-07

PLD= 5.00 DBM

* PSIG	* (1,-1)	* (1,-2)	* (2,-1)	* (2,-2)	* (2,-3)	* (3,-2)
* -30.00	* -43.54	* -280.09	* -47.89	* -281.68	* -128.52	* -281.57
* -28.00	* -41.53	* -277.56	* -45.90	* -278.85	* -122.52	* -279.85
* -26.00	* -39.53	* -275.30	* -43.90	* -276.83	* -116.40	* -278.43
* -24.00	* -37.53	* -273.82	* -41.90	* -275.08	* -110.40	* -276.70
* -22.00	* -35.53	* -271.88	* -39.91	* -272.97	* -104.46	* -276.30
* -20.00	* -33.52	* -269.81	* -37.92	* -270.94	* -98.52	* -275.17

PLD= 10.00 DBM

* PSIG	* (1,-1)	* (1,-2)	* (2,-1)	* (2,-2)	* (2,-3)	* (3,-2)
* -30.00	* -41.72	* -279.20	* -50.96	* -268.07	* -153.13	* -273.05
* -28.00	* -39.72	* -283.54	* -48.96	* -266.12	* -146.52	* -270.51
* -26.00	* -37.72	* -277.68	* -46.96	* -263.85	* -137.70	* -267.93
* -24.00	* -35.72	* -271.37	* -44.96	* -261.94	* -132.71	* -266.27
* -22.00	* -33.72	* -270.83	* -42.96	* -260.66	* -126.02	* -264.97
* -20.00	* -31.72	* -272.43	* -40.96	* -258.84	* -118.71	* -262.84

THIS PAGE IS BEST QUALITY PRACTICABLE
FROM COPY FURNISHED TO DDC

EXAMPLE 5

CALCULATION OF THE OUTPUT LEVELS OF A
LIMITER FED BY TWO SIGNALS

(a) Input

*** NON-LINEAR CIRCUIT SIMULATION ***

ENTER OPTIONS FOR THIS RUN:

ENTER NUMBER OF DIODES FOR SIMULATED CIRCUIT.
(TYPE 1,2, OR 4) ND=2

MIXER OR LIMITER? (TYPE M OR L): L

IDENTICAL DIODES? (YES OR NO): YES

TIME DOMAIN ONLY? (YES OR NO): NO

CALCULATE SPURS OR 2-TONE 3RD ORDER IMD?
TYPE SPURS OR IMD: SPURS

DETERMINE WHAT KIND OF CALCULATION DESIRED.

(1) POUT=F(PLO), (2) POUT=F(P SIG), (3) POUT=F(PIN), PIN=PLO=PSIG.
TYPE 1, 2 OR 3.: 1

ENTER RUN DATA:

ENTER DIODE #1: ALPHA, IS, RS= 40., 1.E-12, 10.

ENTER INPUT AND OUTPUT IMPEDANCES Z0, ZL= 50., 50.

ENTER FREQUENCIES FLO, FSIG (HZ): 20., 19.

ENTER POWER LEVELS (IN DBM):

PSIGMIN, PSIGMAX, STEPSIG, PLOMIN, PLOMAX, STEPLO: 5, 15, 10, 0, 20, 2

ENTER NUMBER OF SPURS DESIRED. (1 TO 10): 2

ENTER SPUR ORDER M, N. (M*FLO+N*FSIG): 1, 0, 0, 1

ENTER SAMPLING INTERVAL DELTAT (SECS): 1.E-3

MAX, NUMBER OF ITERATIONS, MAX. ALLOWED ERROR=10, 1.E-7

*** END OF DATA INPUT, BEGIN EXECUTION. ***

*** FIND FREQUENCY DOMAIN OUTPUT ON TAPE1. ***

*** FIND TIME DOMAIN OUTPUT ON TAPE2. ***

EXAMPLE 5

(b) Output

SIMULATION OF A LIMITER WITH
IDENTICAL DIODES

*CALCULATE THE POWER OUTPUT OF SPURIOUS PRODUCTS
AS A FUNCTION OF PLO

DIODE#1: ALPHA= 40.00 IS= 1.00E-12 RS= 10.00
 FREQUENCIES: FLO= 2.00E+01 FSIG= 1.90E+01 FSIG2= 0. HZ
 SOURCE IMPEDANCE= 50.00 LOAD IMPEDANCE= 50.00
 SPURIOUS:(1, 0)(0, 1)
 RUN PARAMETERS: DELTAT= 1.00E-03 NITER=10 ERMAX= 1.0E-07

PSIG= 5.00 DBM

* PLO *	* (1, 0) *	* (0, 1) *
* 0.00 *	* -1.52 *	* 4.07 *
* 2.00 *	* .33 *	* 3.75 *
* 4.00 *	* 2.13 *	* 3.30 *
* 6.00 *	* 3.87 *	* 2.66 *
* 8.00 *	* 5.55 *	* 1.77 *
* 10.00 *	* 7.11 *	* .60 *
* 12.00 *	* 8.44 *	* -.57 *
* 14.00 *	* 9.63 *	* -1.49 *
* 16.00 *	* 10.79 *	* -2.25 *
* 18.00 *	* 11.99 *	* -2.88 *
* 20.00 *	* 13.26 *	* -3.40 *

PSIG= 15.00 DBM

* PLO *	* (1, 0) *	* (0, 1) *
* 0.00 *	* -6.92 *	* 10.29 *
* 2.00 *	* -4.91 *	* 10.27 *
* 4.00 *	* -2.89 *	* 10.23 *
* 6.00 *	* -.88 *	* 10.17 *
* 8.00 *	* 1.16 *	* 10.07 *
* 10.00 *	* 3.23 *	* 9.90 *
* 12.00 *	* 5.35 *	* 9.60 *
* 14.00 *	* 7.56 *	* 9.02 *
* 16.00 *	* 9.65 *	* 8.19 *
* 18.00 *	* 11.46 *	* 7.31 *
* 20.00 *	* 12.99 *	* 6.68 *

EXAMPLE 6SIMULATION OF A DOUBLE BALANCED MIXER
WITH INTERMEDIATE ITERATION OUTPUT

(a) Input

*** NON-LINEAR CIRCUIT SIMULATION ***

ENTER OPTIONS FOR THIS RUN:

ENTER NUMBER OF DIODES FOR SIMULATED CIRCUIT.
(TYPE 1,2, OR 4) ND=4

IDENTICAL DIODES? (YES OR NO): YES

TIME DOMAIN ONLY? (YES OR NO): YES

PRINTOUT OPTIONS:

INTERMEDIATE ITERATION OUTPUT? (YES OR NO): YES

ENTER RUN DATA:

ENTER DIODE #1: ALPHA,IS,RS= 40.,1.E-12,10.

ENTER INPUT AND OUTPUT IMPEDANCES Z0,ZL= 50.,50.

ENTER FREQUENCIES FLO,FSIG (HZ): 20.,19.

ENTER POWER LEVELS (IN DBM):

FLO,PSIG= 10,-10

ENTER SAMPLING WINDOW TMAX (SECS)= 1.E-2

ENTER SAMPLING INTERVAL DELTAT (SECS): 2.E-3

MAX, NUMBER OF ITERATIONS, MAX. ALLOWED ERROR=10,1.E-7

*** END OF DATA INPUT,BEGIN EXECUTION. ***

*** FIND FREQUENCY DOMAIN OUTPUT ON TAPE1. ***

*** FIND TIME DOMAIN OUTPUT ON TAPE2. ***

THIS PAGE IS BEST QUALITY PRACTICABLE
FROM COPY FURNISHED TO DDC

EXAMPLE 6

(b) Output

SIMULATION OF A DOUBLE BALANCED MIXER WITH IDENTICAL DIODES

DIODE#1: ALPHA= 40.00 IS= 1.00E-12 RS= 10.00
 FREQUENCIES: FLO= 2.00E+01 FSIG= 1.90E+01 FSIG2= 0. HZ
 SOURCE IMPEDANCE= 50.00 LOAD IMPEDANCE= 50.00
 RUN PARAMETERS: DELTAT= 2.00E-03 NITER=10 ERMAT= 1.0E-07

T	PSIG= -10.00 DBM		PLO= 10.00 DBM		ERROR	ITER	IDT
	VD(1)	VD(2)	VD(3)	VD(4)			
0.	0.	0.	0.	0.	0.	1	1
0.	0.	0.	0.	0.	0.	2	1
2.000E-03	2.250E-01	2.723E-01	-2.250E-01	-2.723E-01	2.496E-01	1	1
2.000E-03	2.250E-01	2.723E-01	-2.250E-01	-2.723E-01	5.560E-11	2	1
4.000E-03	4.358E-01	5.277E-01	-4.358E-01	-5.277E-01	2.192E-01	1	1
4.000E-03	4.470E-01	5.066E-01	-4.213E-01	-5.351E-01	8.338E-04	2	1
4.000E-03	4.536E-01	4.952E-01	-4.136E-01	-5.395E-01	2.495E-04	3	1
4.000E-03	4.547E-01	4.932E-01	-4.122E-01	-5.402E-01	8.003E-06	4	1
4.000E-03	4.547E-01	4.931E-01	-4.121E-01	-5.402E-01	4.903E-09	5	1
6.000E-03	6.765E-01	5.981E-01	-5.143E-01	-7.873E-01	1.317E-01	1	1
6.000E-03	6.516E-01	5.758E-01	-4.983E-01	-7.696E-01	1.695E-03	2	1
6.000E-03	6.268E-01	5.586E-01	-4.859E-01	-7.520E-01	1.367E-03	3	1
6.000E-03	6.027E-01	5.512E-01	-4.803E-01	-7.351E-01	9.567E-04	4	1
6.000E-03	5.802E-01	5.516E-01	-4.801E-01	-7.195E-01	7.500E-04	5	1
6.000E-03	5.620E-01	5.528E-01	-4.806E-01	-7.068E-01	4.931E-04	6	1
6.000E-03	5.517E-01	5.535E-01	-4.809E-01	-6.997E-01	1.552E-04	7	1
6.000E-03	5.492E-01	5.536E-01	-4.809E-01	-6.980E-01	9.220E-06	8	1
6.000E-03	5.491E-01	5.536E-01	-4.809E-01	-6.979E-01	2.096E-08	9	1
8.000E-03	5.762E-01	5.774E-01	-5.168E-01	-7.896E-01	1.099E-02	1	1
8.000E-03	5.693E-01	5.716E-01	-5.127E-01	-7.847E-01	1.215E-04	2	1
8.000E-03	5.682E-01	5.709E-01	-5.122E-01	-7.839E-01	2.435E-06	3	1
8.000E-03	5.682E-01	5.709E-01	-5.122E-01	-7.839E-01	8.219E-10	4	1

6. PROGRAM LISTING

The comments on the enclosed listing make the program MIXER self explanatory. The equivalence between various symbols in the program and in the test follows:

<u>PROGRAM</u>	<u>TEXT</u>
AJ	J
AJINV	J^{-1}
FV	F
VD	v
ID	i
CVD	A
CE	Z
CVIN	B

```

PROGRAM MIXER(INPUT,OUTPUT,TAPE1,TAPE2)
C *****
C * THIS PROGRAM CALCULATES THE PERFORMANCE OF NON-LINEAR CIRCUITS *
C * CONTAINING SEMICONDUCTOR DIODES. (SINGLE ENDED,BALANCED, *
C * AND DOUBLE BALANCED MIXERS, AND BACK TO BACK DIODE LIMITERS). *
C * THE VARIOUS OPTIONS ARE: *
C * IDENTICAL OR NON-IDENTICAL DIODES. *
C * SOLUTION IN THE TIME DOMAIN ONLY. *
C * CALCULATION OF ONE TONE IMD'S OR TWO TONE THIRD ORDER IMD. *
C * ONE OF THE FOLLOWING POWER COMBINATIONS: *
C * A) CONSTANT SIGNAL POWER; POUT AS A FUNCTION OF LO POWER. *
C * B) CONSTANT LO POWER; POUT AS A FUNCTION OF SIGNAL POWER. *
C * C) SIGNAL POWER=LO POWER. *
C *****
C
IMPLICIT LOGICAL(L)
REAL IS(4),ALPHA(4),RS(4),E(4),E1(4),EP(4),VD(4),ID(4)
DIMENSION AJ(4,4),AJINV(4,4),WK(4),MPROD(10),NPROD(10),OMEG(10),
1POUT(10),VSIN(10),VCOS(10),CVD(4,4),CE(4,4),CVIN(4,4),
1VIN(4),VFINAL(4),FV(4)
COMMON/Z/ZO
PRINT 1
LSAME=LTDOM=LTHIRD=LITER=LIMIT=.FALSE.
C
C *****
C * BEGIN OPTIONS INPUT *
C *****
PRINT*, " ENTER OPTIONS FOR THIS RUN:"
PRINT*, " ENTER NUMBER OF DIODES FOR SIMULATED CIRCUIT."
PRINT*, " (TYPE 1,2, OR 4) ND="
READ*,ND
IF(ND.EQ.4)GO TO 90
LSAME=ND.EQ.1
IF(ND.EQ.1)GO TO 95
PRINT*, " MIXER OR LIMITER? (TYPE 'M' OR 'L'): "
READ 2,ANS
LIMIT=ANS.EQ.1HL
IF(.NOT.LIMIT)PRINT*, " 90 OR 180 DEGREE HYBRID? TYPE 90 OR 180:"
IF(.NOT.LIMIT)READ*,DEG
90 PRINT*, " IDENTICAL DIODES? (YES OR NO): "
READ 2,ANS
LSAME=ANS.EQ.1HY
95 PRINT*, " TIME DOMAIN ONLY? (YES OR NO): "
READ 2,ANS
LTDOM=ANS.EQ.1HY
IF(LTDOM)GO TO 100
PRINT*, " CALCULATE SPURS OR 2-TONE 3RD ORDER IMD? "
PRINT*, " TYPE SPURS OR IMD: "
READ 2,ANS
LTHIRD=ANS.EQ.1HI
PRINT*, " DETERMINE WHAT KIND OF CALCULATION DESIRED."

```

```

PRINT*, ' (1)POUT=F(PLO). (2)POUT=F(PSIG).',
1* (3)POUT=F(PIN),PIN=PLO=PSIG.'
PRINT*, ' TYPE 1 ,2 OR 3.!'
READ*,IFLAG
GO TO 110
100 PRINT*, ' PRINTOUT OPTIONS: '
PRINT*, ' INTERMEDIATE ITERATION OUTPUT? (YES OR NO): '
READ 2,ANS
LITER=ANS.EQ.1HY
IFLAG=1
C
C *****
C * BEGIN DATA INPUT *
C *****
110 PRINT*, ' ENTER RUN DATA:'
ND1=ND
IF(LSAME)ND1=1
DO 115 I=1,ND1
PRINT*, ' ENTER DIODE #, I, : ALPHA, IS, RS= '
115 READ*,ALPHA(I),IS(I),RS(I)
IF(.NOT.LSAME)GO TO 140
DO 120 I=2,4
ALPHA(I)=ALPHA(1)
IS(I)=IS(1)
120 RS(I)=RS(1)
140 PRINT*, ' ENTER INPUT AND OUTPUT IMPEDANCES ZO,ZL= '
READ*,ZO,ZL
PRINT*, ' ENTER FREQUENCIES FLO,FSIG (HZ): '
READ*,FLO,FSIG
IF(LTHIRD)PRINT*, ' ENTER 2ND TONE FREQUENCY FSIG2: '
IF(LTHIRD)READ*,FSIG2
PRINT*, ' ENTER POWER LEVELS (IN DBM):'
IF(LTDOM)GO TO 152
IF(IFLAG.EQ.3)GO TO 144
IF(IFLAG.EQ.1)PRINT*,
1* PSIGMIN,PSIGMAX,STEPSIG,PLOMIN,PLOMAX,STEPLO:'
IF(IFLAG.EQ.2)PRINT*,
1* PLOMIN,PLOMAX,STEPLO,PSIGMIN,PSIGMAX,STEPSIG:'
READ*,PCHIN,PCHAX,PCSTEP,PHIN,PHAX,PSTEP
GO TO 148
144 PRINT*, ' PHIN,PHAX,PSTEP= '
READ*,PHIN,PHAX,PSTEP
C
148 IF(LTHIRD)GO TO 156
PRINT*, ' ENTER NUMBER OF SPURS DESIRED. (1 TO 10): '
READ*,NPRODS
PRINT*, ' ENTER SPUR ORDER M,N. (M#FLO+N#FSIG): '
READ*,(MPROD(I),NPROD(I),I=1,NPRODS)
GO TO 156
152 PRINT*, ' PLO,PSIG= '

```

THIS PAGE IS BEST QUALITY PRACTICABLE
FROM COPY FURNISHED TO DDC

```

READ*,PMIN,PCMIN
PCMAX=PCMIN
PMAX=PCMIN
PCSTEP=PSTEP=0.
PRINT*, " ENTER SAMPLING WINDOW TMAX (SECS)= "
READ*,TMAX
156 PRINT*, " ENTER SAMPLING INTERVAL DELTAT (SECS): "
READ*,DELTAT
PRINT*, " MAX, NUMBER OF ITERATIONS, MAX. ALLOWED ERROR= "
READ*,NITER,ERMAX
PRINT*, " *** END OF DATA INPUT,BEGIN EXECUTION. ***"
PRINT*, " *** FIND FREQUENCY DOMAIN OUTPUT ON TAPE1. ***"
PRINT*, " *** FIND TIME DOMAIN OUTPUT ON TAPE2. ***"

C
C *****
C * BEGIN TITLE PRINTOUT *
C *****
ITAPE=1
IF(LTDOM)ITAPE=2
IF(ND.EQ.1)WRITE(ITAPE,8)
IF(ND.EQ.4)WRITE(ITAPE,10)
IF(LIMIT)WRITE(ITAPE,12)
IF(ND.EQ.2.AND..NOT.LIMIT)WRITE(ITAPE,14)DEG
IF(LSAME.AND.ND.NE.1)WRITE(ITAPE,16)
IF(.NOT.LSAME)WRITE(ITAPE,18)
IF(LTDOM)GO TO 168
IF(IFLAG.EQ.3)GO TO 166
PV=4H PLO
IF(IFLAG.EQ.2)PV=4HPSIG
IF(LTHIRD)GO TO 162
WRITE(1,24)PV
GO TO 168
162 WRITE(1,26)PV
GO TO 168
166 WRITE(1,28)
168 CONTINUE
DO 170 I=1,ND1
170 WRITE(ITAPE,30)I,ALPHA(I),IS(I),RS(I)
WRITE(ITAPE,32)FLO,FSIG,FSIG2
WRITE(ITAPE,33)ZO,ZL
IF(.NOT.(LTHIRD.OR.LTDOM))WRITE(1,34)NPRODS,
1(MPROD(I),NPROD(I),I=1,NPRODS)
WRITE(ITAPE,36)DELTAT,NITER,ERMAX

C
C *****
C * BEGIN INITIALIZATION *
C *****
IF(LTDOM)NPRODS=1
IF(LTHIRD)NPRODS=2
PI=ACOS(-1.)

```

```

RT2=SQRT(2.)
OMSIG=2*PI*FSIG
OMLO=2.*PI*FLO
NP=NPC=1
IF(PSTEP.NE.0.)NP=1+(PMAX-PMIN)/PSTEP
IF(PCSTEP.NE.0.)NPC=1+(PCMAX-PCHIN)/PCSTEP
IF(LTDOM)GO TO 230
TMAX=1./ABS(FLO-FSIG)
IF(LTHIRD)GO TO 200
DO 180 I=1,NPRODS
180 OMEG(I)=ABS(MPROD(I))*OMLO+NPROD(I)*OMSIG
GO TO 220
200 TMAX=AMAX1(TMAX,1./ABS(FSIG-FSIG2))
OMSIG2=2.*PI*FSIG2
OMEG(1)=ABS(2.*OMSIG-OMSIG2-OMLO)
OMEG(2)=ABS(OMLO-OMSIG)
220 IF(IFLAG.NE.3)GO TO 230
APV=4H PIN
WRITE(1,38)
IF(.NOT.LTHIRD)WRITE(1,40)APV,NPRODS,(MPROD(I),NPROD(I),
1I=1,NPRODS)
IF(LTHIRD)WRITE(1,42)APV
C
C *****
C * INITIALIZE CIRCUIT MATRICES *
C *****
230 DO 240 I=1,4
DO 235 J=1,4
235 CVD(I,J)=CE(I,J)=CVIN(I,J)=0.
240 CONTINUE
IF(ND.EQ.4)GO TO 250
IF(ND.EQ.2)GO TO 242
C *****
C * SINGLE ENDED MIXER *
C *****
C
CVD(1,1)=1.
CE(1,1)=RS(1)+Z0
CVIN(1,1)=-1.
GO TO 260
C *****
C * BALANCED MIXER *
C *****
C
242 CVD(1,1)=CVD(2,2)=1.
IF(LIMIT)GO TO 245
CE(1,1)=ZL+Z0+RS(1)
CE(2,2)=ZL+Z0+RS(2)
CE(1,2)=CE(2,1)=-ZL
CVIN(1,1)=-1.

```

```

CVIN(2,2)=1.
GO TO 260
C
C      *****
C      * LIMITER *
C      *****
245 DIV=ZL/(ZL+Z0)
    Z1=DIV*Z0
    CE(1,1)=RS(1)+Z1
    CE(2,2)=RS(2)+Z1
    CE(1,2)=CE(2,1)=-Z1
    CVIN(1,1)=-DIV
    CVIN(2,2)=DIV
    GO TO 260
C
C      *****
C      * DOUBLE BALANCED MIXER *
C      *****
250 CVD(1,1)=CVD(1,2)=CVD(2,2)=CVD(2,3)=CVD(3,2)=CVD(4,1)=
    1CVD(4,2)=CVD(4,3)=CVD(4,4)=1.
    CE(1,1)=RS(1)+Z0/2.
    CE(1,2)=CE(2,2)=RS(2)+Z0/2.
    CE(1,3)=CE(1,4)=CE(2,1)=CE(2,4)=-Z0/2.
    CE(2,3)=RS(3)+Z0/2.
    CE(3,1)=CE(3,3)=-Z0/2.+ZL
    CE(3,2)=RS(2)+Z0+ZL
    CE(3,4)=ZL
    DO 255 I=1,4
255 CE(4,I)=RS(I)
    CVIN(1,1)=-1.
    CVIN(2,2)=-1.
    CVIN(3,1)=CVIN(3,2)=-.5
260 CONTINUE
C
C      *****
C      * PARAMETER LOOP
C      *****
C
    DO 1000 KCSTEP=1,NPC
    PCONST=PCMIN+(KCSTEP-1)*PCSTEP
    VCONST=F(PCONST)
C
C      *****
C      * VARIABLE POWER LOOP *
C      *****
C
    DO 900 KSTEP=1,NP
    T=0.
    DO 280 I=1,NPRODS
280 VCOS(I)=VSIN(I)=0.

```

THIS PAGE IS BEST QUALITY PRACTICABLE
FROM COPY FURNISHED TO DDC

```

DO 290 I=1,ND
290 VIN(I)=VFINAL(I)-VD(I)=0.
   PVAR=PHIN+(KSTEP-1)*PSTEP
   VVAR=F(PVAR)
   IF(IFLAG.EQ.3)GO TO 320
   IF(IFLAG.EQ.2)GO TO 300
   VSIG=VCONST
   VLO=VVAR
   PSIG=PCONST
   PLO=PVAR
   APC=5HPSIG=
   APV=4H PLO
   GO TO 340
300 VSIG=VVAR
   VLO=VCONST
   PLO=PCONST
   PSIG=PVAR
   APC=5H PLO=
   APV=4HPSIG
   GO TO 340
320 VSIG=VVAR
   VLO=VSIG
   PSIG=PLO=PVAR
340 VSIG2=0.
   IF(LTHIRD)VSIG2=VSIG
   IF(LTDOM.OR.(KSTEP.GT.1).OR.(IFLAG.EQ.3))GO TO 345
   WRITE(1,44)APC,PCONST
   IF(.NOT.LTHIRD)WRITE(1,40)
   1APV,NPRODS,(MPROD(I),NPROD(I),I=1,NPRODS)
   IF(LTHIRD)WRITE(1,42)APV
345 IF(LTDOM)WRITE(2,46)PSIG,PLO
   IF(LTDOM.AND..NOT.LITER)WRITE(2,48)
   ITER=IDT=1
   IF(LITER)WRITE(2,49)
C
C *****
C * TIME STEP LOOP *
C *****
350 CONTINUE
C
C CALCULATE INPUT VOLTAGES AT T
C
C IF(ND.EQ.4)GO TO 370
C IF(LIMIT.OR.ND.EQ.1)GO TO 360
C
C BALANCED MIXER
C
C IF(DEG.EQ.180.)GO TO 354
C VIN(1)=RT2/2.*(VLO*SIN(OMLO*T)+VSIG*COS(OMSIG*T)+
C 1VSIG2*COS(OMSIG2*T))

```

```

      VIN(2)=RT2/2.*(VLO*COS(OMLO*T)+VSIQ*SIN(OMSIG*T)+
1VSIQ2*SIN(OMSIG2*T))
      IF(T.GT.0.)GOTO 380
C
C   INITIAL GUESS AT T=0
C
      VD(1)=VIN(1)
      VD(2)=-VIN(2)
      VMAX=1/ALPHA(1)*ALOG(ABS(VIN(1))/(CE(1,1)*IS(1)))
      IF(VD(1).LT.VMAX)GO TO380
      VD(1)=VMAX
      GO TO 380
354 VIN1=RT2/2.*VLO*SIN(OMLO*T)
      VIN2=RT2/2.*(VSIQ*SIN(OMSIG*T)+VSIQ2*SIN(OMSIG2*T))
      VIN(1)=-VIN1+VIN2
      VIN(2)=VIN1+VIN2
      GO TO 380
C
C   LIMITER AND SINGLE ENDED MIXER
C
360 VIN(1)=VIN(2)=VLO*SIN(OMLO*T)+VSIQ*SIN(OMSIG*T)+
1VSIQ2*SIN(OMSIG2*T)
      GO TO 380
C
C   DOUBLE BALANCED MIXER
C
370 VIN(1)=VLO*SIN(OMLO*T)
      VIN(2)=VSIQ*SIN(OMSIG*T)+VSIQ2*SIN(OMSIG2*T)
380 CONTINUE
C
C *****
C *   ITERATION LOOP   *
C *****
C
      DO 390 I=1,ND
      E1(I)=0.
      IF(ALPHA(I)*VD(I).GT.100.)GO TO 420
      IF(ALPHA(I)*VD(I).GT.-100.)E1(I)=EXP(ALPHA(I)*VD(I))
      E(I)=IS(I)*(E1(I)-1.)
390 EP(I)=IS(I)*ALPHA(I)*E1(I)
C
C   CALCULATE FV AND JACOBIAN
C
      DO 400 I=1,ND
      FV(I)=0.
      DO 395 J=1,ND
      FV(I)=FV(I)+CVD(I,J)*VD(J)+CE(I,J)*E(J)+CVIN(I,J)*VIN(J)
395 AJ(I,J)=CVD(I,J)+CE(I,J)*EP(J)
400 CONTINUE
C

```

THIS PAGE IS BEST QUALITY PRACTICABLE
FROM COPY FURNISHED TO DDC

```

C          CALCULATE INVERSE OF JACOBIAN
C
C          CALL LINV1F(AJ,ND,4,AJINV,0,WK,IER)
C          THE MATRIX AJ IS SINGULAR WHEN IER=129
C          IF(IER.EQ.129)GO TO 440
C          ERROR=0.
C
C          CALCULATE DIODE VOLTAGES
C
C          DO 410 I=1,ND
C          VDN=0.
C          DO 405 J=1,ND
C          405 VDN=VDN+AJINV(I,J)*FV(J)
C          ERROR=ERROR+VDN**2
C          VDN=VD(I)-VDN
C          410 VD(I)=VDN
C          IF(LITER)WRITE(2,60)T,VD,ERROR,ITER,IDT
C          IF(ERROR.LT.ERMAX.AND.ITER.GT.1)GO TO 460
C          ITER=ITER+1
C          IF(ITER.GT.NITER)GO TO 420
C          GO TO 380
C
C          IF SOLUTION DOES NOT CONVERGE REDUCE TIME STEP
C
C          420 ITER=1
C          IF(T.EQ.0.)GO TO 440
C          T=TLAST+DELTAT/(2**IDT)
C          IF(T.LE.T1)T=T1+DELTAT/(2**(IDT+1))
C          DO 430 I=1,ND
C          430 VD(I)=VFINAL(I)
C          IDT=IDT+1
C          IF(IDT.GT.4)GO TO 440
C          GO TO 350
C          440 WRITE(ITAPE,65)T
C          PRINT 65,T
C          STOP
C          460 IF(LITER)WRITE(2,50)
C
C          CALCULATE DIODE CURRENTS AND LOAD VOLTAGE
C
C          DO 480 I=1,ND
C          ID(I)=-IS(I)
C          480 IF(ALPHA(I)*VD(I).GT.-100.)
C          1ID(I)=IS(I)*(EXP(ALPHA(I)*VD(I))-1.)
C          VLOAD=(ID(1)-ID(2))*ZL
C          IF(ND.EQ.1)VLOAD=ID(1)*RS(1)+VD(1)-VIN(1)/2.
C          IF(LIMIT)VLOAD=VD(1)+ID(1)*RS(1)
C          IF(ND.EQ.4)VLOAD=ZL*(ID(4)+ID(2)-ID(1)-ID(3))
C          IF(LTDOM.AND..NOT.LITER)WRITE(2,60)T,VD,VLOAD,ITER,IDT
C          IF(IDT.GT.1)GO TO 520

```

```

      TLAST=T
      IF(LTDOM)GO TO 520
C
C      CALCULATE FOURIER COMPONENTS AND POWER OUTPUT
C
      DO 500 MN=1,NPRODS
      VCOS(MN)=VCOS(MN)+VLOAD*COS(OMEG(MN)*T)
500  VSIN(MN)=VSIN(MN)+VLOAD*SIN(OMEG(MN)*T)
520  T1=T
      DO 530 I=1,ND
530  VFINAL(I)=VD(I)
      T=TLAST+DELTAT
      ITER=IDT+1
      IF(T.LT.TMAX-DELTAT/10.)GO TO 350
      ADT=(2.*DELTAT/TMAX)**2
      DO 540 MN=1,NPRODS
      IF(LTDOM)GO TO 900
      POUT(MN)=10.*ALOG10(ADT*(VCOS(MN)**2+VSIN(MN)**2)/(2.*ZL)*1.E3)
      IF(OMEG(MN).EQ.0.)POUT(MN)=POUT(MN)+3.
540  CONTINUE
      WRITE(1,70)PVAR,NPRODS,(POUT(MN),MN=1,NPRODS)
900  CONTINUE
1000 CONTINUE
      WRITE(ITAPE,72)
      IF(.NOT.LTDOM)WRITE(1,74)
      STOP
C
C *****
C *   FORMAT STATEMENTS   *
C *****
      1  FORMAT(' *** NON-LINEAR CIRCUIT SIMULATION ***',/)
      2  FORMAT(A1)
      8  FORMAT(1H1,5X,'SIMULATION OF A SINGLE ENDED MIXER')
     10  FORMAT(1H1,5X,'SIMULATION OF A DOUBLE BALANCED MIXER WITH')
     12  FORMAT(1H1,5X,'SIMULATION OF A LIMITER WITH')
     14  FORMAT(1H1,5X,'SIMULATION OF A BALANCED MIXER WITH A',F4.0,
           1' DEGREE HYBRID AND')
     16  FORMAT(6X,'IDENTICAL DIODES',/)
     18  FORMAT(6X,'NON-IDENTICAL DIODES',/)
     24  FORMAT(5X,'*CALCULATE THE POWER OUTPUT OF SPURIOUS PRODUCTS',
           1/5X,' AS A FUNCTION OF ',A4,/)
     26  FORMAT(5X,'*CALCULATE THE POWER OUTPUT OF 2-TONE 3RD ORDER',
           1' IMD PRODUCTS',/6X,'AS A FUNCTION OF ',A4,/)
     28  FORMAT(5X,'*CALCULATE THE POWER OUTPUT OF SPURIOUS PRODUCTS',
           1/5X,' AS A FUNCTION OF PIN,PIN=PSIG=PLO.',/)
     30  FORMAT(5X,'DIODE#',I1,'; ALPHA=',F6.2,3X,'IS=',1PE9.2,
           13X,'RS=',OPF7.2)
     32  FORMAT(5X,'FREQUENCIES: FLO=',1PE9.2,2X,'FSIG=',1PE9.2,
           12X,'FSIG2=',1PE9.2,' HZ')
     33  FORMAT(5X,'SOURCE IMPEDANCE=',F6.2,10X,'LOAD IMPEDANCE=',

```

```

1F6.2)
34 FORMAT(5X,"SPURIOUS:",=((",I2,",",I2,")"))
36 FORMAT(5X,"RUN PARAMETERS: DELTAT=",1PE9.2,3X,"NITER=",
1I2,5X," ERMAX=",1PE8.1,/)
38 FORMAT(/,1X,120(" *")//5X,"PIN=PLO=PSIG")
40 FORMAT(" *",3X,A4,2X,"*",=(1X,(",I2,",",I2,") *"))
42 FORMAT(" *",3X,A4,2X,"* IMD * IF *")
44 FORMAT(/,1X,120(" *")//5X,A5,F7.2," DBM")
46 FORMAT(/,1X,120(" *")//10X,"PSIG=",F7.2," DBM",
15X,"PLO=",F7.2," DBM")
48 FORMAT(3X,"T",T12,"VD(1)",T22,"VD(2)",T32,"VD(3)",
1T42,"VD(4)",T52,"VLOAD",T62,"ITER",1X,"IDT")
49 FORMAT(3X,"T",T12,"VD(1)",T22,"VD(2)",T32,"VD(3)",
1T42,"VD(4)",T52,"ERROR",T62,"ITER",1X,"IDT")
50 FORMAT(/)
60 FORMAT(6(1PE10.3),2X,2I3)
65 FORMAT(" THE SOLUTION DOES NOT CONVERGE AT T=",1PE15.4)
70 FORMAT(" *",F7.2,2X,"*",=(1X,F7.2," *"))
72 FORMAT(/,1X,120(" *"))
74 FORMAT(1H1)
END

```

```

FUNCTION F(P)
COMMON/Z/ZO
F=10.**((P/ZO)*SQRT(8.*ZO/1000.))
RETURN
END

```

REFERENCES

1. M. R. Barber: "Noise Figure and Conversion Loss of the Schottky Barrier Mixer Diode", IEEE Trans. Microwave Theory Tech., vol. MTT-15, pp. 629-635, Nov 67.
2. E. M. Rutz-Phillips: "Power Conversion in Non-Linear Resistive Elements Related to Interference Phenomena", IBM Journal, Sep 67, pp. 544-552.