

AD-A058 642

SPERRY RAND CORP HUNTSVILLE AL SPERRY SUPPORT SERVICES
ARMOR TARGET SYSTEMS CONCEPTS. (U)
SEP 77

F/G 19/4

UNCLASSIFIED

210-5801-01

PM TRADE-TR-78-0001

N61339-76-D-0022
NL

1 of 3
AD
A058 642



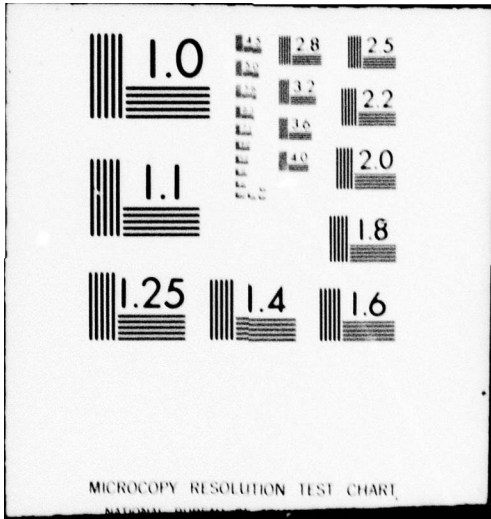

MICROCOPY RESOLUTION TEST CHART

NATIONAL BUREAU OF STANDARDS-1963-A

2
A

LEVEL II

AD A0 58642

ARMOR TARGET SYSTEMS CONCEPTS

DDC FILE COPY



DDC
 PREPARED
 SEP 14 1978
 HUNTSVILLE
 F

Prepared for:

US ARMY
 PROJECT MANAGER FOR TRAINING DEVICES
 NAVAL TRAINING EQUIPMENT CENTER
 ORLANDO, FLORIDA 32813

By:

SPERRY RAND CORPORATION
 SPERRY SUPPORT SERVICES
 HUNTSVILLE, ALABAMA 35801

This document has been approved
 for public release and sale; its
 distribution is unlimited.

16 SEPTEMBER 1977

78 09 07 029

Unclassified

SECURITY CLASSIFICATION OF THIS PAGE (When Data Entered)

REPORT DOCUMENTATION PAGE		READ INSTRUCTIONS BEFORE COMPLETING FORM	
1. REPORT NUMBER 18 PM TRADE TR-78-0001	2. GOVT ACCESSION NO.	3. RECIPIENT'S CATALOG NUMBER	
4. TITLE (and Subtitle) 6 Armor Target Systems Concepts	5. TYPE OF REPORT & PERIOD COVERED 9 Final Report Dec 76-Sep 77		6. PERFORMING ORG. REPORT NUMBER 14 218-5801-01
7. AUTHOR(s)	8. CONTRACT OR GRANT NUMBER(s) 15 N61339-76-D-0022/ew		9. REPORT DATE 11 16 September 77
9. PERFORMING ORGANIZATION NAME AND ADDRESS Sperry Rand Corporation Sperry Support Services ✓ Huntsville, Alabama 35801		10. PROGRAM ELEMENT, PROJECT, TASK AREA & WORK UNIT NUMBERS 12 232 p.	
11. CONTROLLING OFFICE NAME AND ADDRESS US Army Project Manager for Training Devices Naval Training Equipment Center Orlando, Florida 32813		13. NUMBER OF PAGES 218	
14. MONITORING AGENCY NAME & ADDRESS (if different from Controlling Office)		15. SECURITY CLASS. (of this report) Unclassified	
16. DISTRIBUTION STATEMENT (of this Report) Approved for public release, distribution is unlimited.			
17. DISTRIBUTION STATEMENT (of the abstract entered in Block 20, if different from Report)			
18. SUPPLEMENTARY NOTES			
19. KEY WORDS (Continue on reverse side if necessary and identify by block number) Armor, training devices, target systems, training device research, training device development			
20. ABSTRACT (Continue on reverse side if necessary and identify by block number) This report summarizes the results of the ARETS study program conducted by Sperry Support Services under Contract N61339-76-D-0022. The study recommendations are presented along with system cost data and a cost effectiveness analysis. Data pertaining to frangible ammunition and berm construction are included. Three subsystems makeup the moving target system: the moving target →			

DD FORM 1 JAN 73 1473

EDITION OF 1 NOV 68 IS OBSOLETE
S/N 0102-014-8601

Unclassified

SECURITY CLASSIFICATION OF THIS PAGE (When Data Entered)

393 443 78 09 07 029 Gu

carrier, the target, and auxiliary equipment. The moving target carrier constitutes the system prime mover and its associated protective scheme. The target element is made up of 3-D target and hit sensors while the auxiliary equipment comprises the guidance and communication, hostile fire simulators and visual hit simulator subsystems.

Three concepts for target carriers were investigated; no armor, a light armor and a heavy armor concept. In addition to the three concepts for carriers, an additional category, that of a carrier especially designed to Marine Corps requirements, is presented.

The various guidance, communication, hostile fire simulation and visual hit simulation schemes reviewed are presented along with the selection made by Sperry for incorporation into the MTS. The guidance and communication system selected is incorporated into a single element that would be specifically developed for an Armor Moving Target System.

Target materials that were investigated are discussed along with the selection of such materials considered most promising for three-dimensional (3-D) target construction. Also, a hit sensing system provided by PM TRADE was tested under actual live firing tests.

ACCESSION for

NTIS White Section
 DDC B.f.f Section

NAVY/NOPT
 JUSTIFICATION

BY

DISTRIBUTION/AVAILABILITY CODES

Dist.	Avail.	and/or	SPECIAL
A			

ARMOR TARGET SYSTEMS CONCEPTS

Prepared For

US ARMY

PROJECT MANAGER FOR TRAINING DEVICES

Naval Training Equipment Center

Orlando, Florida 32813

16 September 1977

Final Report for Period December 1976 - September 1977

Prepared by:

Sperry Rand Corporation
Sperry Support Services
Huntsville, Alabama 35801

TABLE OF CONTENTS

<u>SECTION</u>	<u>PAGE</u>
INTRODUCTION	1
I MOVING TARGET CARRIER	3
1.1 Introduction	3
1.2 Results and Discussion	4
a. General	4
b. Heavy Armor Concept	4
c. Light Armor Concept	15
d. No Armor Concept	25
e. Special Design Concept for ARETS	31
f. Comparison with Design 7002 Carrier to Murty, Inc. No Armor Carrier	47
II TARGET SYSTEM	49
2.1 Introduction	49
2.2 Targets	49
2.3 Target Materials	51
2.4 Target Realism	57
2.5 Thermal Image Enhancement	59
2.6 Hit Detection and Scoring System	66
2.7 Target Material Test Evaluation	71
a. Armor Plate	76
b. Polystyrene	84
c. Polyethylene	104
d. Fiberglass wool and chicken wire	124
e. Polypropylene	141
f. High Density Polyethylene	158
g. Hit Detector Performance Evaluation	168
h. IR Image Tests	176
III AUXILIARY EQUIPMENTS	182
3.1 Introduction	182
3.2 Hostile Fire Simulators and Visual Hit Indicators Indicators	182
3.3 MTC Automatic Guidance Systems	186
IV MOST FEASIBLE AND COST EFFECTIVE CONCEPT	195
4.1 Introduction	195
4.2 Moving Target System Cost Data	196
4.3 Cost Effectiveness Analysis	200
4.4 Effectiveness Analysis	201
APPENDIX A - BERM STUDY	207
APPENDIX B - FRANGIBLE AMMUNITION	216

TABLE OF CONTENTS (Continued)

<u>TABLE</u>		<u>PAGE</u>
1	Heavy Armor Carrier Companies Contacted	6
2	Heavy Armor Candidate Military Vehicles Evaluated	7
3	Murty, Inc. Carrier Characteristics	30
4	Chamberlain Manufacturing Corporation Specifications ...	34
5	Target Material Sources	52-53
6	Target Materials	56
7	IR/Thermal Simulation	63-64
8	Hit Detection and Scoring Systems	68-69
9	Hit Detection Test Data Summary	172
10	MTS Cost Data	197
11	Training Capabilities Listing	202
12	Effectiveness Analysis With Priority Weighting Factor ..	203
13	Effectiveness Analysis With Equal Weighting Factors	203
14	Effectiveness/Cost Comparison	204
15	Effectiveness/Cost Comparison Normalized to No Armor Case	205
16	Effectiveness/Cost Comparison	205
17	Effectiveness/Cost Comparison Normalized to No Armor Case	206

TABLE OF CONTENTS (Continued)

LIST OF ILLUSTRATIONS

<u>FIGURE</u>		<u>PAGE</u>
1	Projectile Kinetic Energy	8
2	Manned Evasive Target Tank	12
3	Thiokol IMP Modified for Light Armor Configuration (Less Armor)	17
4	Thiokol Model 1404 Military All-Terrain Vehicle	18
5	IMP Armor Scheme	22
6	V ₅₀ and V ₅ Penetration Curves	23
7	No Armor Carrier Murty, Inc.	26
8	Murty Vehicle Drive Components	28
9	Chamberlain Manufacturing Corporation Concept	32
10	Chamberlain Frame and Major Component Placement	37
11	Chamberlain Wheel Suspension	38
12	Chamberlain Hydraulic System Schematic	40
13	Chamberlain Control System and Interface Connections	45
14	Comparison of No Armor Concept with NTEC 7002 Concept	48
15	Potential ARETS Target Concepts	50
16	Target Realism Production Techniques	58
17	IR Wavelengths Considered in Study	60
18	Typical Heater Configuration	65
19	Main Gun Targets in Holding Fixtures	72
20	Sub-Caliber Targets in Holding Fixtures	72
21	Round Configuration	73
22	.50 Caliber on Mount	75

TABLE OF CONTENTS (Continued)

LIST OF ILLUSTRATIONS

<u>FIGURE</u>		<u>PAGE</u>
23	Front View Holding Fixture	76
24	Side View Holding Fixture	77
25	3/8" Plate - 50° Obliquity Angle	77
26	3/8" Plate - 45° Obliquity Angle	78
27	3/8" Plate - 30° Obliquity Angle	79
28	3/8" Plate - Rearview of Penetration Hole	79
29	3/8" Plate - 30° Obliquity - Ball Ammunition	80
30	1/2" Plate - 30° Obliquity - AP	81
31	1/2" Plate - 30° Obliquity - AP Second Hit	81
32	1/2" Plate - 20° Obliquity	82
33	3/8" Plate - 30° Obliquity - AP Hit from Soft Side	83
34	Polystyrene Target - 750M, 90 MM, M353	85
35	Polystyrene Target - 750M, 90MM, M353	85
36	Polystyrene Target - 750M, 105MM, M467.	86
37	Polystyrene Target - 750M, 105MM, M467	86
38	Polystyrene Target - 750M, 105MM, M724	87
39	Polystyrene Target - 750M, 105MM, M724	87
40	Polystyrene Target - 750M, 152MM, M411, 90MM, M353	88
41	Polystyrene Target - 750M, 152MM, M411, 90MM, M353	88
42	Polystyrene Target - 750M, 105MM, M467	89
43	Polystyrene Target - 750M, 105MM, M467	91
44	Polystyrene Target - 750M, 150MM, M411, 90MM, M353	91
45	Polystyrene Target - 1200M, 105MM, M467	92
46	Polystyrene Target - 1200M, 105MM, M467	92
47	Polystyrene Target - 1200M, 105MM, M467	93
48	Polystyrene Target - 1200M, 105MM, M490	93

TABLE OF CONTENTS (Continued)

LIST OF ILLUSTRATIONS

<u>FIGURE</u>		<u>PAGE</u>
49	Polystrene Target - 1200M, 105MM, M490 Effect of Wire . . .	94
50	Polystrene Target - 1200M, 105MM, M724	95
51	Polystrene Target - 1200M, 105MM, M724	95
52	Polystrene Target - 1200M, 152MM, M411	96
53	Polystrene Target - 1200M, 152MM, M411	96
54	Polystrene Target - 1200M, 152MM, M411	97
55	Polystrene Target - 2000M, 105M, M467.	98
56	Polystrene Target - 2000M, 105MM, M490	98
57	Polystrene Target - 2000M, 152MM, M411	99
58	Polystrene Target - 2000M, 152MM, M411	99
59	Polystrene Target - 1200M, 90MM, M353 Results of Near Miss	100
60	Polystrene Target - Damage due to Debris Striking Target .	100
61	Polystrene Target - 120M, .50 Caliber, 185 Rounds	102
62	Polystrene Target - 120M, .50 Caliber, 188 Rounds	102
63	Polystrene Target - 120M, 20MM, 19 Rounds	103
64	Polystrene Target - 120M, 20MM, 19 Rounds	103
65	Polyethylene Target - 750M, 90MM, M353	105
66	Polyethylene Target - 750M, 90MM, M353	105
67	Polyethylene Target - 750M, 105MM, M393	106
68	Polyethylene Target - 750M, 105MM, M393	106
69	Polyethylene Target - 750M, 105MM, M490	107
70	Polyethylene Target - 750M, 105MM, M490	107
71	Polyethylene Target - 750M, 105MM, M490	108
72	Polyethylene Target - 750M, 105MM, M724	109
73	Polyethylene Target - 750M, 105MM, M724	109
74	Polyethylene Target - 750M, 152MM, M411	110

TABLE OF CONTENTS (Continued)

LIST OF ILLUSTRATIONS

<u>FIGURE</u>		<u>PAGE</u>
75	Polyethylene Target - 750M, 152MM, M411	110
76	Polyethylene Target - 1000M, 105MM, M490	111
77	Polyethylene Target - 1000M, 105MM, M490	111
78	Polyethylene Target - 1200M, 90MM, M353	112
79	Polyethylene Target - 1200M, 90MM, M353	112
80	Polyethylene Target - 1200M, 105MM, M490	113
81	Polyethylene Target - 1200M, 105MM, M490	113
82	Polyethylene Target - 1200M, 105MM, M467	114
83	Polyethylene Target - 1200M, 105MM, M467	114
84	Polyethylene Target - 1200M, 105MM, M467	115
85	Polyethylene Target - 1200M, 105MM, M724	116
86	Polyethylene Target - 1200M, 105MM, M724	116
87	Polyethylene Target - 1200M, 152MM, M411	117
88	Polyethylene Target - 1200M, 152MM, M411	117
89	Polyethylene Target - 2000M, 90MM, M353	118
90	Polyethylene Target - 2000M, 90MM, M353	118
91	Polyethylene Target - 2000M, 105MM, M490	119
92	Polyethylene Target - 2000M, 105MM, M724	120
93	Polyethylene Target - 2000M, 105MM, M724	120
94	Polyethylene Target - 2000M, 105MM, M393	121
95	Polyethylene Target - 2000M, 105MM, M393	121
96	Polyethylene Target - 120M, .50 Caliber, 30 Rounds	122
97	Polyethylene Target - 120M, .50 Caliber, 30 Rounds	122
98	Polyethylene Target - 120M, 20MM, 19 Rounds	123
99	Polyethylene Target - 120M, 20MM, 19 Rounds	123
100	Fiberglass Wool Target - 750M, 90MM, M353	125

TABLE OF CONTENTS (Continued)

LIST OF ILLUSTRATIONS

<u>FIGURE</u>		<u>PAGE</u>
101	Fiberglass Wool Target - 750M, 90MM, M353	125
102	Fiberglass Wool Target - 750M, 105MM, M393	126
103	Fiberglass Wool Target - 750M, 105MM, M393	126
104	Fiberglass Wool Target - 750M, 105MM, M490	127
105	Fiberglass Wool Target - 750M, 105MM, M724	127
106	Fiberglass Wool Target - 750M, 152MM, M411	128
107	Fiberglass Wool Target - 750M, 152MM, M411, 90MM, M353 ..	128
108	Fiberglass Wool Target - 1200M, 90MM, M353	129
109	Fiberglass Wool Target - 1200M, 90MM, M353	129
110	Fiberglass Wool Target - 1200M, 105MM, M467	130
111	Fiberglass Wool Target - 1200M, 105MM, M467	130
112	Fiberglass Wool Target - 1200M, 105MM, M490	131
113	Fiberglass Wool Target - 1200M, 152MM, M411	132
114	Fiberglass Wool Target - 1200M, 152MM, M411	132
115	Fiberglass Wool Target - 1200M, 152MM, M411	133
116	Fiberglass Wool Target - 1200M, 152MM, M411	133
117	Fiberglass Wool Target - 2000M, 105MM, M393	134
118	Fiberglass Wool Target - 2000M, 105MM, M393	134
119	Fiberglass Wool Target - 2000M, 105M, M490	135
120	Fiberglass Wool Target - 2000M, 105MM, M724	136
121	Fiberglass Wool Target - 2000M, 105MM, M724	136
122	Fiberglass Wool Target - 2000M, 152MM, M411	137
123	Fiberglass Wool Target - 2000M, 152MM, M411	137
124	Fiberglass Wool Target - 120M, .50 Caliber	139
125	Fiberglass Wool Target - 120M, 20MM	139
126	Fiberglass Wool Target - 120M, 20MM	140

TABLE OF CONTENTS (Continued)
LIST OF ILLUSTRATIONS

<u>FIGURE</u>		<u>PAGE</u>
127	Polypropylene Target - 750M, 90MM, M353	142
128	Polypropylene Target - 750M, 90MM, M353	142
129	Polypropylene Target - 700M, 105MM, M393	143
130	Polypropylene Target - 750M, 105MM, M490	143
131	Polypropylene Target - 750M, 105MM, M724	144
132	Polypropylene Target - 750M, 105MM, M724	144
133	Polypropylene Target - 750M, 90MM, M393, 152MM, M411 . . .	145
134	Polypropylene Target - 750M, 90MM, M393, 152MM, M411 . . .	145
135	Polypropylene Target - 1000M, 105MM, M490	146
136	Polypropylene Target - 1200M, 90MM, M353	147
137	Polypropylene Target - 1200M, 90MM, M353	147
138	Polypropylene Target - 1200M, 105MM, M467	148
139	Polypropylene Target - 1200M, 105MM, M467	148
140	Polypropylene Target - 1200M, 105MM, M724	149
141	Polypropylene Target - 1200M, 105MM, M490	149
142	Polypropylene Target - 1200M, 152MM, M411	150
143	Polypropylene Target - 1200M, 152MM, M411	150
144	Polypropylene Target - 2000M, 105MM, M393	151
145	Polypropylene Target - 2000M, 105MM, M393	151
146	Polypropylene Target - 2000M, 105MM, M490	152
147	Polypropylene Target - 2000M, 105MM, M490	152
148	Polypropylene Target - 2000M, 105MM, M724	153
149	Polypropylene Target - 2000M, 105MM, M724	153
150	Polypropylene Target - 2000M, 152MM, M411	154
151	Polypropylene Target - 2000M, 152MM, M411	154
152	Polypropylene Target - 120M, .50 Caliber	156

TABLE OF CONTENTS (Continued)

LIST OF ILLUSTRATIONS

<u>FIGURE</u>		<u>PAGE</u>
153	Polypropylene Target - 120M, .50 Caliber	156
154	Polypropylene Target - 120M, 20MM	157
155	Polypropylene Target - 120M, 20MM	157
156	High Density Polyethylene Behind Fiberglass Wool	159
157	High Density Tarter - 750, 105MM, M490	160
158	High Density Target - 750M, 105MM, M490	160
159	High Density Target - 1200M, 90MM, M353	161
160	High Density Target - 1200M, 105MM, M724	161
161	High Density Target - 1200M, 105MM, M467	162
162	High Density Target - 1200M, 105MM, M467	162
163	High Density Target - 1200M, 105MM, M724, M490	163
164	High Density Target - 1200M, 105MM, M490	163
165	High Density Target - 1200M, 152MM, M411	164
166	High Density Target - 1200M, 152MM, M411	164
167	High Density Target - 120M, .50 Caliber	166
168	High Density Target - 120M, .50 Caliber	166
169	High Density Target - 120M, 20MM	167
170	Hit Sensor Equipment Mounted on Target	169
171	Close up of Hit Sensor Equipment	169
172	Polypropylene Target - 1200M, 152MM, M411	170
173	Polypropylene Target - 1200M, 152MM, M411	170
174	Polypropylene Target - 1200M, 90MM	171
175	I.R. Response Technit Paint vs. Conductive Glue 77x1430... . .	177
176	I.R. Response Conductive Glue 77x1429 vs. 60 ohm Tempsheet . .	179
177	I.R. Response Conductive Glue 77x1429 vs. 60 ohm Tempsheet (Scaled).	180
178	I.R. Response Conductive Glue 77x1430 vs 60 ohm Tempsheet (Scaled).	180

TABLE OF CONTENTS (Continued)

LIST OF ILLUSTRATIONS

<u>FIGURE</u>		<u>PAGE</u>
179	I.R. Response Conductive Glue 77x1203 vs 60 ohm Tempsheet (Scaled)	181
180	I.R. Response Conductive Glue 77x1203 vs 60 ohm Tempsheet (Scaled)	181

INTRODUCTION

The final report summarizes the results of the ARETS Study program conducted by Sperry Support Services under Contract N61339-76-D-0022, Task 6837A as revised in the January 5 work statement modification.

The study recommendations are presented along with system cost data and a cost effectiveness analysis to define the MTS concept recommended. Appendices relating to frangible ammo and berm construction, maintenance and implementation are included in this report.

The MTS is divided into three subsystems; the moving target carrier, target and auxiliary equipment. The moving target carrier constitutes the system prime mover and its associated protective scheme. The target element is made up of 3-D target and hit sensors while the auxiliary equipment comprises the guidance and communication, hostile fire simulators and visual hit simulator subsystems.

The report covers the three MTC configurations, guidance, communication, hostile fire simulation, visual hit simulation and target materials, testing and selection.

Three concepts for target carriers were investigated; no armor, a light armor and a heavy armor concept. In addition to the three concepts for carriers, an additional category, that of a carrier especially designed to meet ARETS requirements, is presented. The report discusses the various target

carriers selected for each category in some detail and provides information on the other carrier suppliers contacted.

The various guidance, communication, hostile fire simulation and visual hit simulation schemes reviewed are presented along with the selection made by Sperry for incorporation into the MTS. The guidance and communication system selected is incorporated into a single element that would be specifically developed for ARETS.

Target materials that were investigated are discussed along with the selection of such materials considered most promising for three dimensional (3-D) target construction. Also, a hit sensing system provided by NTEC was tested under actual live firing tests and the results are described.

SECTION I
MOVING TARGET CARRIER

1.1 INTRODUCTION

This study task evaluates the use of a remotely controlled vehicle as a 3-dimensional target carrier. Three different concepts (heavy armor, light armor, and no armor) were investigated and are individually discussed in this report. Also, this report makes a comparison of the carrier in the concept developed by the Naval Training Equipment Center in design approach number 7002, dated 20 December 1976, to the no armor concept.

The purpose of this study is to determine the technical feasibility of developing a cost effective remotely controlled three dimensional moving target carrier (MTC).

The study is directed towards the necessary analysis and evaluation to arrive at cost-effective designs for three different carrier concepts. The study has the following specific objective:

- o To determine the technical feasibility of a remotely controlled 3-D target carrier.

Due to the high cost and time involved in developing a carrier, Sperry initially concentrated on existing military and commercial carriers. However, as additional information was gathered, it became apparent that there were no such carriers in existence. Accordingly, emphasis was shifted to gathering information on those carriers which could conceivably be modified to meet our application or to a custom built carrier.

Only carriers which were deemed technically capable of meeting the requirements called out in the ARETS specification and determined cost-effective are included in this report.

1.2 RESULTS AND DISCUSSION

a. General

This section includes a technical discussion of the three carrier concepts. They are the heavy armor, light armor, and no armor. By definition, the heavy armor carrier can withstand repeated hits from 90 mm, 105 mm, and 152 mm inert service ammunition and tank TOW and DRAGON missiles. The light armor carrier can withstand repeated hits from .50 cal rounds, and the no armor carrier, as the name implies, offers no protection.

Also included in this section is the comparison of the NTEC design concept 7002 carrier to the no armor carrier.

b. Heavy Armor Concept

An extensive survey was made of vehicles currently in the Army inventory and those on the civilian market which could be used as a heavy armor carrier. No known existing vehicle could be found that would carry sufficient armor plate (20-25,000 lbs.) for protection, achieve the required mobility, and fit within the required envelope (small enough that Warsaw Pact tanks and armor personnel carrier targets would completely enclose carrier). Table 1 is a composite list of companies contacted and their comments on building a heavy armor carrier. Table 2 lists those military vehicles evaluated for a heavy armor carrier.

The heavy armor concept offers realism in that it allows free moving capability. This concept allows the carrier to use the natural terrain to appear, disappear, and reappear. However, the possibility of fielding a heavy armor carrier is not economically feasible. The kinetic energy, see Figure 1, generated by the inert training rounds would completely

destroy the carrier after a few direct hits. Also, the penetration by the training round, particularly the 105 mm TPDS-TM724 EI, would cause extensive damage to the external armor and internal onboard electronic systems.

The 105 mm TPDS-TM724 EI is a high velocity training round, and with its aluminum head, the projectile approximates the ballistics of the cartridge 105 mm APDS to about 2000 meters. The 105 mm TPDS-TM724 EI penetration is approximately one-third of the tactical round. It will easily penetrate 3 inches of homogenous armor plate at 2000 meters, and at zero obliquity at 500 meters, 5 inches of armor plate would be required for complete protection.

High obliquities, more than 45°, were studied as a way to protect the carrier. But even with a 45° fabrication, any tilt of the vehicle, plunging, or rising fire would reduce the impact obliquity. For an offensive tank this would be adequate, but for a target carrier required to survive repeated hits and continue to operate this would be uneconomical.

Table 1. Heavy Armor Carrier

Companies Contacted

Company	Comments
AIR LEC INDUSTRIES, INC.	NOT INTERESTED
ALLIS CHALMERS	NOTHING TO MEET SPECIFICATION
CADILLAC GAGE COMPANY	NOT INTERESTED
CASE TRACTORS	NOTHING TO MEET SPECIFICATION
CATERPILLAR	NOTHING TO MEET SPECIFICATION
CLARK EQUIPMENT COMPANY	COULD NOT HANDLE ARMOR WEIGHT
CRANE CARRIER COMPANY	NOT INTERESTED - NEED DEVELOPMENT MONEY
DODGE TRUCK	CAN NOT HANDLE ARMOR WEIGHT
FMC	REQUIRE DEVELOPMENT MONEY
FORD	NOT INTERESTED - NEED DEVELOPMENT MONEY
FWD	NOT INTERESTED
GENERAL MOTORS (GMC DIVISION)	REQUIRE DEVELOPMENT MONEY
HENDICKSON MFG. COMPANY	REQUIRE DEVELOPMENT MONEY
HYSTER	NOT INTERESTED
INTERNATIONAL HARVESTER	NOT INTERESTED
JOHN BLUE CO., INC.	TOO BUSY
JOHN DEERE	NOTHING TO MEET SPECIFICATION
KENWORTH TRUCK, INC.	NOTHING TO MEET SPECIFICATION
LULL ENGINEERING	WITHDREW - TOO BUSY
MASSEY-FERGUSON, INC.	NOTHING TO MEET SPECIFICATION
METZ ENGINEERING	REQUIRE DEVELOPMENT MONEY
OTTAWA TRUCK DIVISION (GULF AND WESTERN)	NOT INTERESTED
PETERBILT TRUCK CO.	NOTHING TO MEET SPECIFICATION
ROLLIGON CORPORATION	REQUIRE DEVELOPMENT MONEY
WALTER MOTOR TRUCK CO.	REQUIRE DEVELOPMENT MONEY

Table 2. Heavy Armor Candidate Military Vehicles Evaluated

M-60 TANK

M-47 TANK

M-48 TANK

M-103 TANK CHASSIS

M-114 COMMAND AND RECONNAISSANCE
ARMORED CARRIER

TRUCK 5 TON M55*

TRUCK 8 TON M520*

TRUCK 10 TON M-125*

*All series of these vehicles evaluated.

BY *D.S. Worden* DATE *14 Jan 77*
 CHKD BY _____ DATE _____

SUBJECT *105 mm
 Kinetic Energy*

SHEET NO. _____
 JOB NO. _____

AMMUNITION 105 mm. GUN M68

○ APDS-T M392, -A1 -A2	8.84 1/6
+ TPDS - TM724E1	4.67 1/6
△ HEAT-T M456, -E1	-22.4 1/6
○ HEP-T M393	24.8 1/6
○ APERS-T XM494E3	30.85 1/6
▽ DRAGON	11.8 1/6
◇ TOW	34.2 1/6
TP-T 490	
XM604	

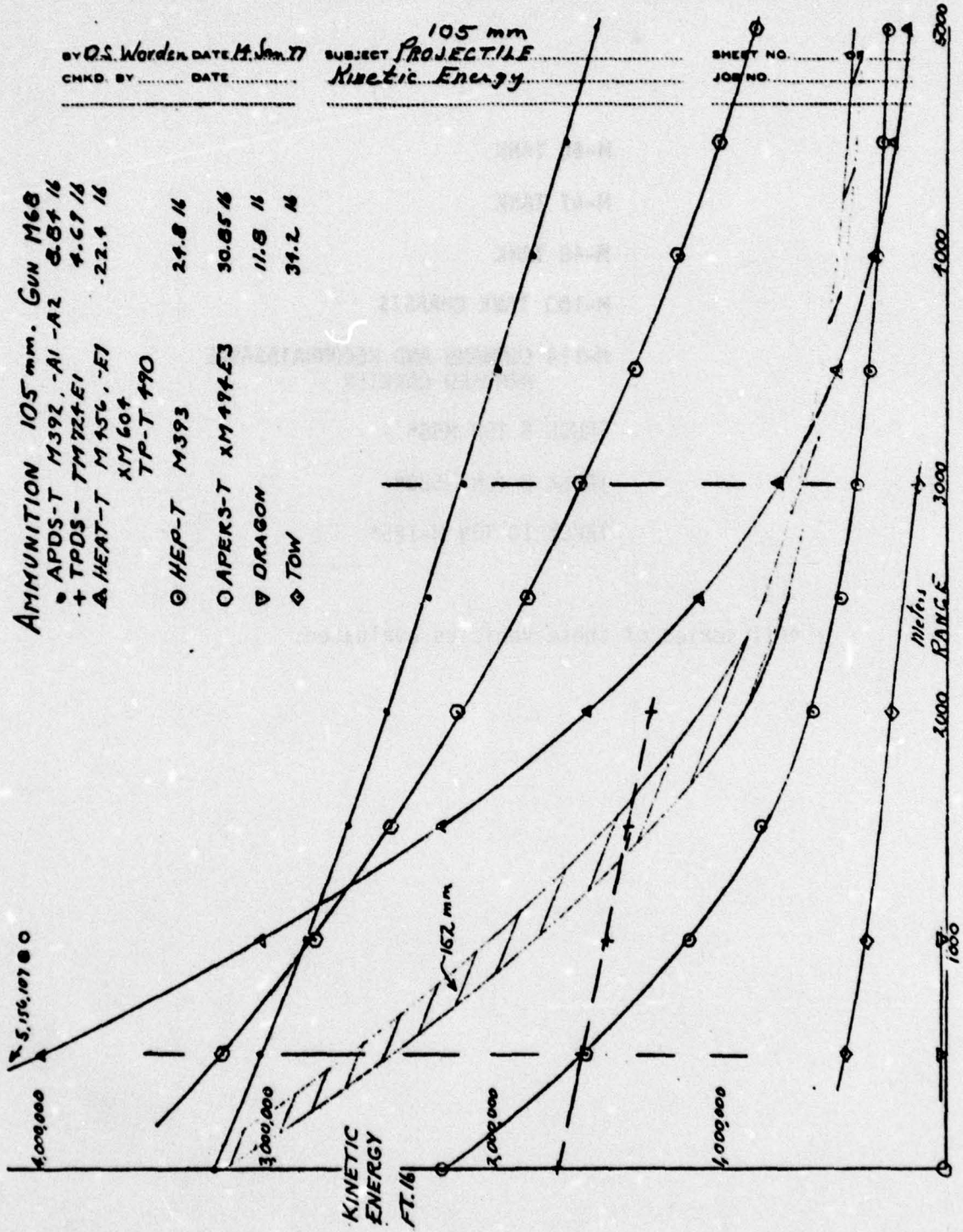

Figure 1. Projected Kinetic Energy

Other armor techniques, such as space and bar armor, were investigated as a means to protect the carrier. These techniques will prevent penetration of not only the training rounds but, with sufficient areal density, even the tactical rounds, one time. They will not sustain two hits in the same spot.

As we stated earlier, no known vehicle can carry 5 inches of armor plate required for protection, achieve the required mobility, and fit within the required envelope. Only the tank could qualify as a multi-hit target and only if it was equipped with additional armor plate. Even with the additional armor, the tank could only withstand repeated hits from TOW and DRAGON missiles. (See Figure 1. for the kinetic energy for TOW and DRAGON.)

Currently, two projects are under way by the U. S. Army utilizing tanks as moving targets. Both projects involve making use of surplus tanks, the M-47 tanks and the M-103 tank chassis.

The following data was provided to Sperry by USATARADCOM, Code DRATA-REA on the M-47 project.

(1) M-47 Project data

- All M-47 tanks located in the U. S. have been assigned (44 to White Sands, 22 to OTA). However, the tank command is trying to obtain additional tanks from the MAP countries. This effort has been underway for approximately one year, and they have not received any additional tanks.
- Surplus GFE was utilized to remote the vehicles. This surplus equipment is limited and will require purchasing on the civilian market if a large number of M47's are converted.

- The age and condition of the vehicles are such that no effort will be made to perform any scheduled maintenance. The vehicles will be refurbished to the point where they will run only.
- Once the vehicle becomes inoperative on a range, the salvageable hardware will be removed and the vehicle left on the range as a fixed target.
- The vehicle will defeat small arm fire such as the 20 mm and 50 cal and most of the inert practice rounds from low velocity weapons. However, systems that fire high KE rounds are expected to penetrate this target.
- Spare parts for the M-47 are limited as these vehicles have served their purpose and parts are no longer being produced. Approximately 170 power packs are available from the Anniston Army Depot.
- The tank command expects to recover two moving vehicles for every three returned, utilizing the third vehicle for spare parts.

(2) M-47 Project Cost

- The shipping cost to return the M-47 to the United States will be about \$6,000 per vehicle.
- The refurbishment of each vehicle including the remoted capability (using surplus GFE) is \$6,000. This cost will increase if the remoting equipment is purchased from the civilian market.
- Total cost for the return shipping, refurbishment, and remoting of the two M-47's that have been modified is \$24,000.

(3) M-47 Project Testing

- Testing was conducted at Warren Michigan only to ensure the vehicle was operative and would perform at 25 mph. This cost is reflected in the cost to refurbish.
- The vehicles were shipped to Hunter-Ligget, and 50 TOW rounds were fired at the two tanks. One tank was damaged and can only travel in a straight line direction.
- The cost for the Hunter-Ligget test is estimated to be around \$15,000. This includes shipping, labor, spare parts and all other cost.
- The tanks are expected to be shipped to Fort Carson for further testing.

(4) M-47 Operating Cost

- The cost to operate the M-47 tank for this application was estimated to be \$11.94 per mile. This is the current cost to operate the M-60A3.

The second on-going Army project is the Manned Evasive Target Tank (METT). See Figure 2. for METT configuration.

(1) METT Data

- The METT project utilizes surplus M-103A2 tank chassis heavily armored by the addition of approximately 40,000 pounds of steel plate. The original turret and tube have been removed and replaced by this steel plate. The plate used, varies in thickness from 1/2 inch to 2 1/2 inches. However, the weight has only been increased by 2,000 pounds. The GVW is now 129,000 pounds.

MANNED EVASIVE TARGET TANK

(DTA 168820)

FOR THE
OPERATIONAL TEST AND EVALUATION AGENCY
(OTEA)

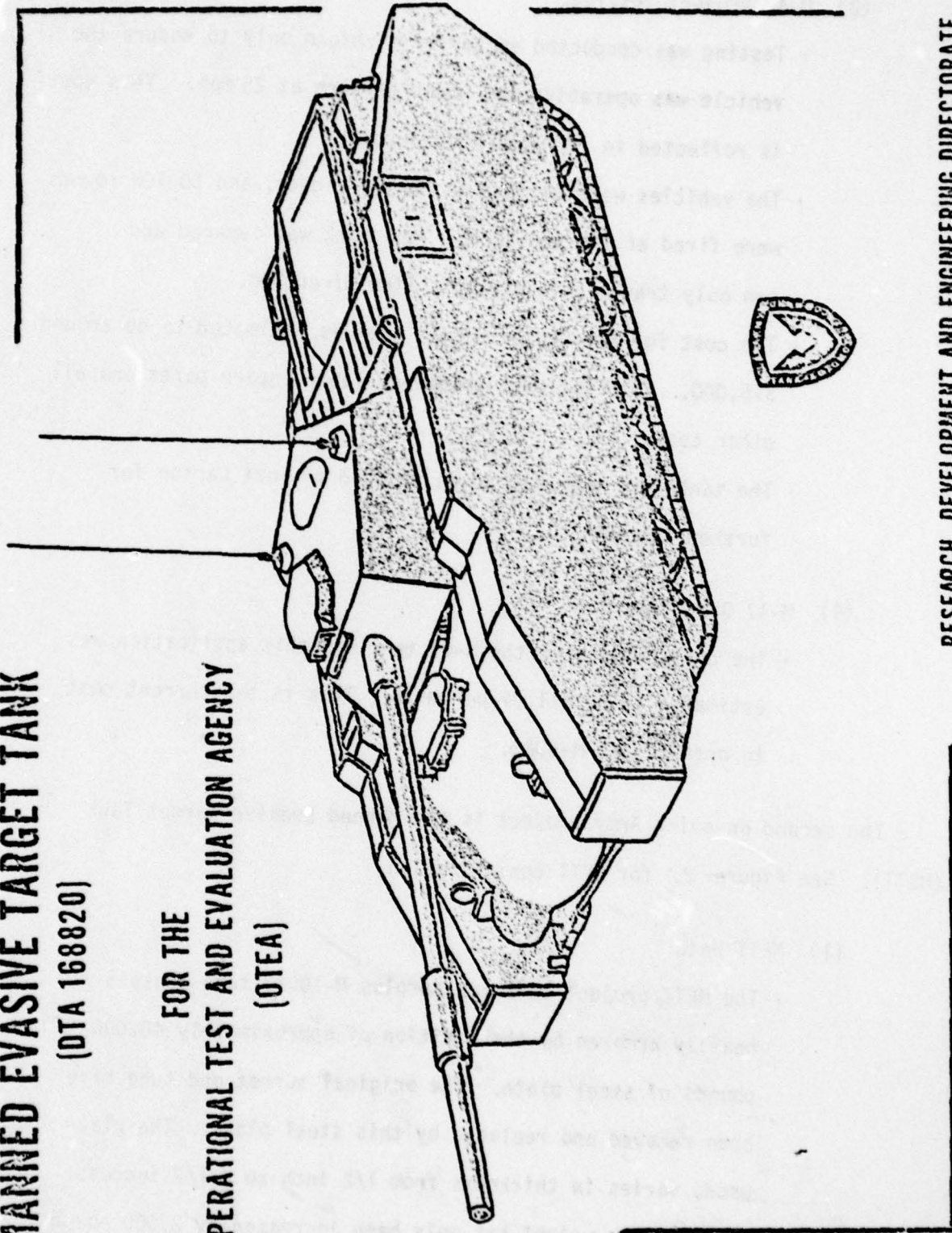

RESEARCH, DEVELOPMENT AND ENGINEERING DIRECTORATE

Figure 2. Manned Evasive Target Tank

- The vehicles have not been developed as remoted vehicles. They must be manually operated; however, the vehicle could be remotely controlled.
- The tank command does not recommend the firing of small arms such as the 50 cal or 20 mm at these manned vehicles because of the periscopes in the turret; however, this would not present a problem if the vehicle was remotely controlled.
- Three vehicles are currently under modification. One is approximately 95 percent complete and the other two are at various stages. A total of five vehicles were scheduled for conversion, but funds are only available for the three.
- One completed new turret has been shipped to Aberdeen for ballistics testing.
- The vehicles remain vulnerable in the engine area.
- The modified vehicle remains compatible with the M-60 tank in all areas except the suspension system and track. The track is similar to the track used on the M-88 tank carrier.

(2) METT Program Cost - (The following cost has been incurred by the program.)

- The METT program was allocated an appropriate 2.491 million dollars. As of this time, most of these dollars have been spent and it is estimated that the first of the vehicles delivered will have utilized 1.4 million of the total dollars.
- The cost for the steel plate required for each vehicle is \$40,000 to \$50,000. Any salvage after the cutting and fitting is not returned to the program.

- Presently, the average cost per completed vehicle without additional appropriations will be \$830,333.
- The estimated cost for hardware which includes the hanging and mounting of the steel is estimated to average \$600,000 per vehicle. This includes all labor.

(3) METT Vehicle Maintenance Cost

- Arrangements have been made for the vehicles to be maintained in accordance with current regulations. All maintenance access areas have been covered with steel plates that can be removed with special tools. The side skirts raise with the help of a crane to allow servicing of the track and suspension system. Routine maintenance cost is not expected to exceed the current cost for maintaining the M-60 tank family, \$13.38 per mile.

(4) METT Vehicle Operational Cost

- The cost to operate the METT vehicle will be the same as currently expended to operate the M-60 tanks, \$11.94 per mile.

(5) METT Vehicle Testing Cost

- One vehicle will be tested to verify the manned target concept only. Cost for this testing is expected to be about \$30,000.

(6) METT Vehicle Availability

- Anniston Army Depot currently has 181 M-103-A2 chassis on hand. The number of these that could be assigned and made serviceable is unknown.

An additional study was performed by Sperry to determine the cost to field a M-103 chassis with additional armor for use as a remoted moving target. The carrier could withstand repeated hits from TOW and DRAGON missiles only. Best estimates for this carrier is as follows:

Cost for prototype - \$700,000

Cost for production - \$300,000

c. Light Armor Concept

The carrier selected for the light armor concept is Thiokol's 1400 IMP series. Thiokol Corporation is one of the leading producers of a unique line of specialized off-highway tracked vehicles that are extensively used for transporting personnel, equipment, and machinery in rough, muddy, swampy, and snowy terrain. To date Thiokol has manufactured and sold approximately 1,000 of the 1400 IMP series vehicles.

With minor modification and the addition of armor plate, the IMP can withstand repeat hits by 50 caliber rounds and can meet the ARETS specification except as follows:

- Unable to achieve 24 mph in reverse
- Unable to meet 15 second transition time from full reverse to full forward

Since the IMP uses standard off-the-shelf components, development cost would be minimal, and the technical risk would be minimized. The general characteristics of the modified IMP are as follows:

Overall length	114 in.
Overall width	64 in.

Overall height	42 in.
Ground clearance	8 in.
Weight (w/o armor)	2100 lbs
Payload capacity	3400 lbs
Turning radius	10 ft
Maximum speed	25 MPH

The proposed modified IMP vehicle is shown in Figure 3, and the Thiokol Model 1404 Military all-terrain vehicle is shown in Figure 4.

Some rather basic, but important, design and operational features of the 1400 Series vehicle are as follows:

- The design provides a low profile and low center of gravity, making safe operation possible.
- The vehicle has excellent control, power, and a low center of gravity for climbing and traversing extremely steep slopes.
- The vehicle has a low ground bearing pressure. With such a low ground bearing pressure, mobility is excellent under the toughest and softest conditions.
- Standard components are used throughout the vehicle. Most basic components are high production items readily available at standard parts supply houses.
- The track system was specifically designed with environmental protection features and has been successfully used with extended life. The tire guides are designed to provide good track retention and eliminate the tire side-wall wear common in abrasive terrain conditions.

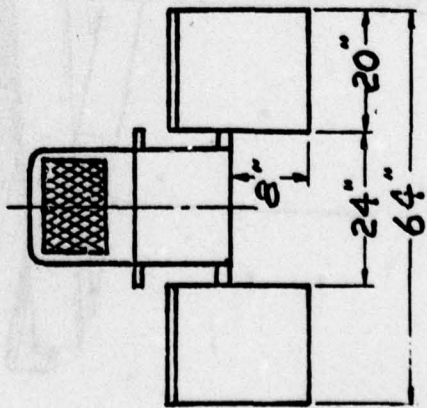
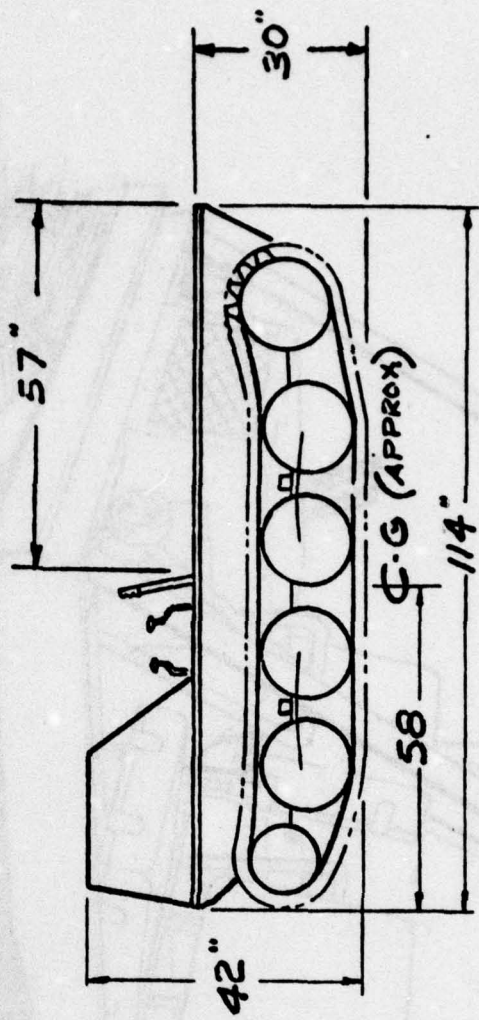
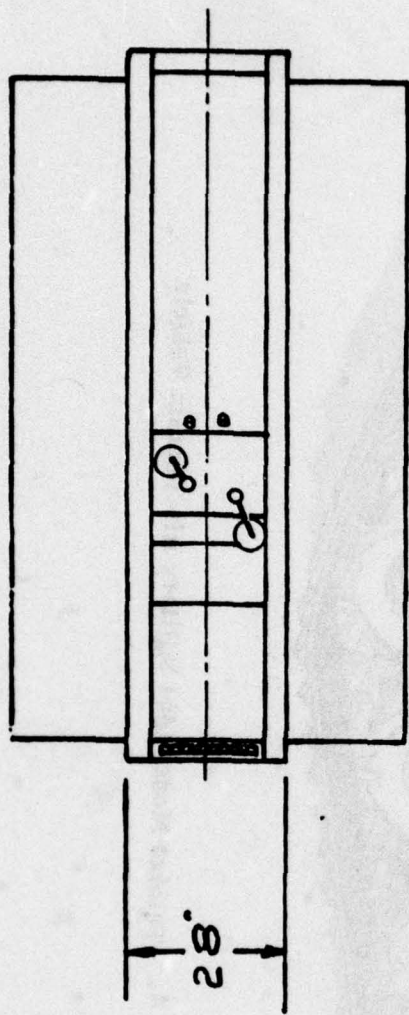

Figure 3. Thiokol IMP Modified for Light Armor Configuration (Less Armor)

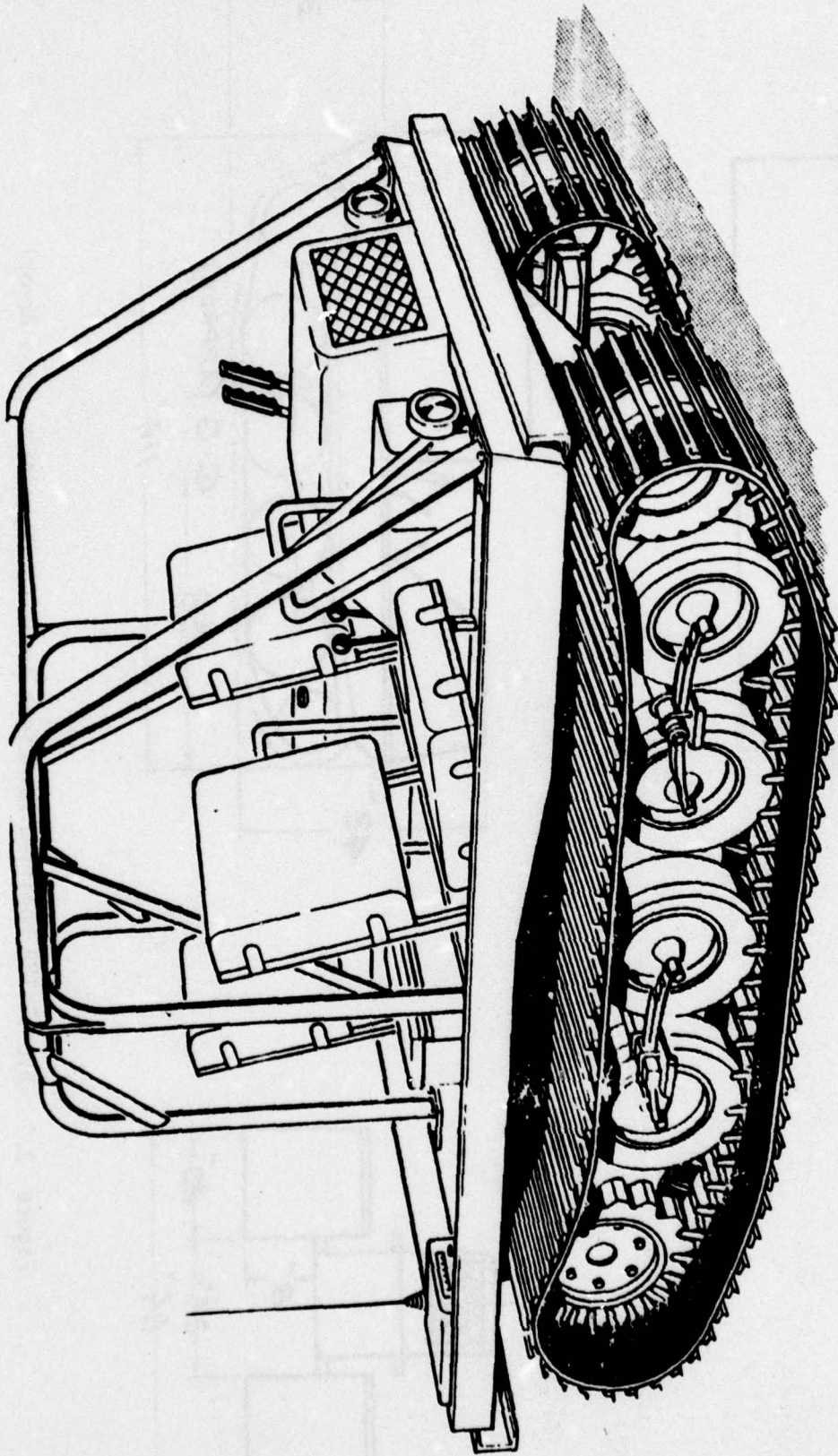

Figure 4. Thiokol Model 1404 Military All-Terrain Vehicle

- Transmission, steering differential, and final drive axles are all totally lubricated by an oil bath, requiring no daily maintenance other than periodic changes of lubricant.
- The vehicle has an excellent power-to-weight ratio, enabling it to perform adequately on highway or cross-country type operation and still have sufficient power for tough going in mud or swamp areas.
- The power train from the engine to the final drive sprockets is designed for high reliability and endurance.

(1) Carrier Description

(a) Engine and Power Train

The carrier uses an industrial Ford V-4, 104 CID gasoline engine capable of operation on 91 octane gasoline. The power train and engine have been proven in hundreds of applications in the United States and throughout the world. The engine is coupled to a Ford C-4 automatic transmission. A drive shaft will connect the automatic to a 4-speed Clark transaxle.

The carrier is designed to provide operation on slopes exceeding 100 percent. The engine is therefore equipped with an oil sump and pickup which will provide lubrication to the engine for unlimited periods. The engine is liquid cooled and is shipped with a 50/50 water, ethylene glycol mixture. The cooling system consists of a fin tube radiator with positive air flow through the radiator at idle from a shrouded fan.

(b) Suspension and Track System

The carrier is supported on eight wheels and pneumatic tires (filled with polyurethane to prevent the possibility of flat) suspended on semielliptical springs in pairs. The track is 20 inches wide and is

manufactured from 3 ply polyester reinforced rubber belting with heat treated steel cross links.

The grousers used on these tracks are hardened steel, and they were designed specifically to minimize terrain damage and provide good traction. The flat surface, 3/8 inch above the blade tip, reduces penetration and resultant damage. Those grousers which do not have side plates will have both ends tapered.

The tire guides used on the carrier to retain the tracks are also made of high strength hardened steel. The belts on the tracks are held together by lacings and a grade 5 bolt. These lacings will also be made of hardened steel.

(c) Chassis

The IMP chassis is a lightweight welded structure composed of an 11 gage steel skin reinforced with steel angles and tubes. Local reinforcement is provided in the carrier to accommodate the armor.

Skid plates will be installed under the carrier to protect the engine and differential.

(d) Electrical System

The electrical system for the carrier is a 12 volt dc negative ground system. A 12-volt commercial battery and belt driven alternator will be provided to supply electrical power for engine starting and operation. A 24 volt power source will provide power to operate the guidance and control system.

(e) Steering System

The steering system will be steering handles mounted behind the transmission operating a master cylinder which in turn activates steering actuators mounted on the differential. The differential is a planetary steered system which changes the relative track speed rather than skid steers.

(f) Armor Scheme

The design philosophy for the light armor carrier is to protect as much of the carrier as possible with the least amount of armor against 50 cal AP ammunition. The separate sections are bolted together with backup plates for individual replacement of damage sections or for clearance to repair or replace the track and suspension system. The light top plate is easily removed for manual vehicle operation. All armor plates are straight sections flame cut from dual hardness steel for ease of fabrication. Backup plates and angles are standard structural steel. High angles of obliquity of the side, front, and rear top plates (50° to 55°) ensure a high occurrence of ricochets resulting in less plate surface damage. See Figure 5 for the IMP armor scheme.

The spacing of the dual hardness armor from the carrier frame creates a spaced armor protective system. The steel frame and other sheet metal of the carrier acts as the internal armor to prevent full penetration from any low obliquity impacts that may result from terrain slopes. Most projectiles will be fragmented by penetration of the dual hardness armor resulting in little damage to the carrier steel.

Armor plate thickness required for V_{50} and V_5 protection is illustrated in Figure 6. This plot of thickness vs. obliquity shows the superiority of dual hardness steel over the high hardness steel at low

THIS PAGE IS BEST QUALITY PRACTICABLE
FROM COPY FURNISHED TO DDC

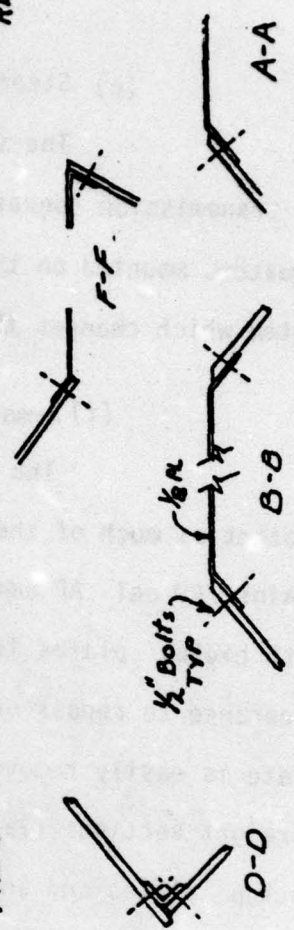
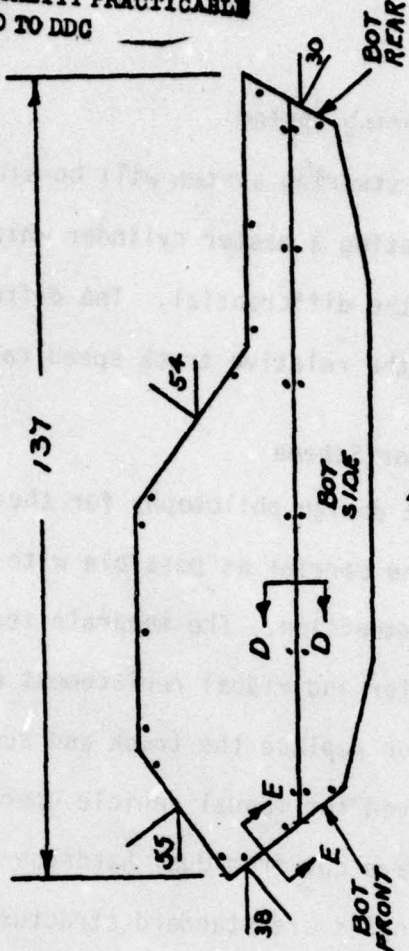
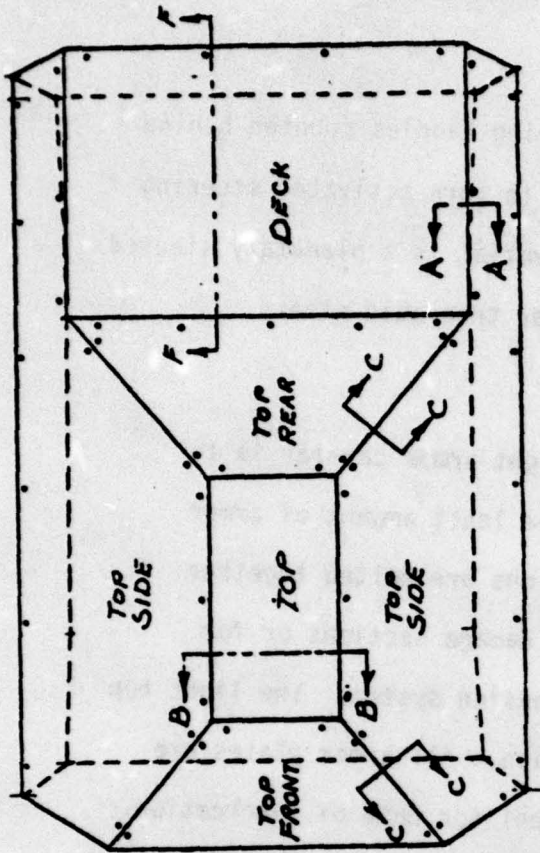

D.H. STEEL		WT
INCH	Sq FT	
1	.38	23.7
2		36.3
3		19.8
4		19.8
5		8.4
6		14.8
7		10.6
8		9.7
9		9.3
10		26.7
11		13.6
		23.1
		2105.4

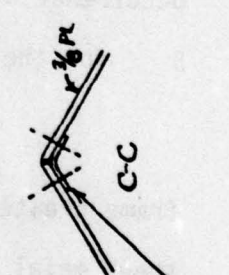
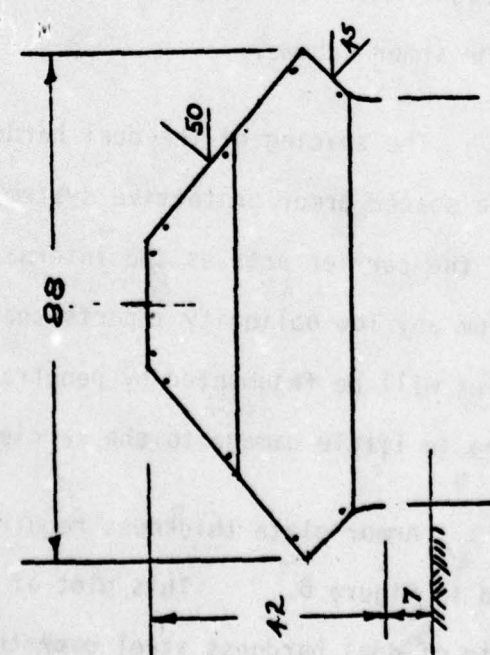

1/4 SPlice/BACK UP -
CONTINUOUS - TYP

D.H. STEEL ARMOR LIGHT WT TRACKED MTC
Figure 5. IMP Armor Scheme.

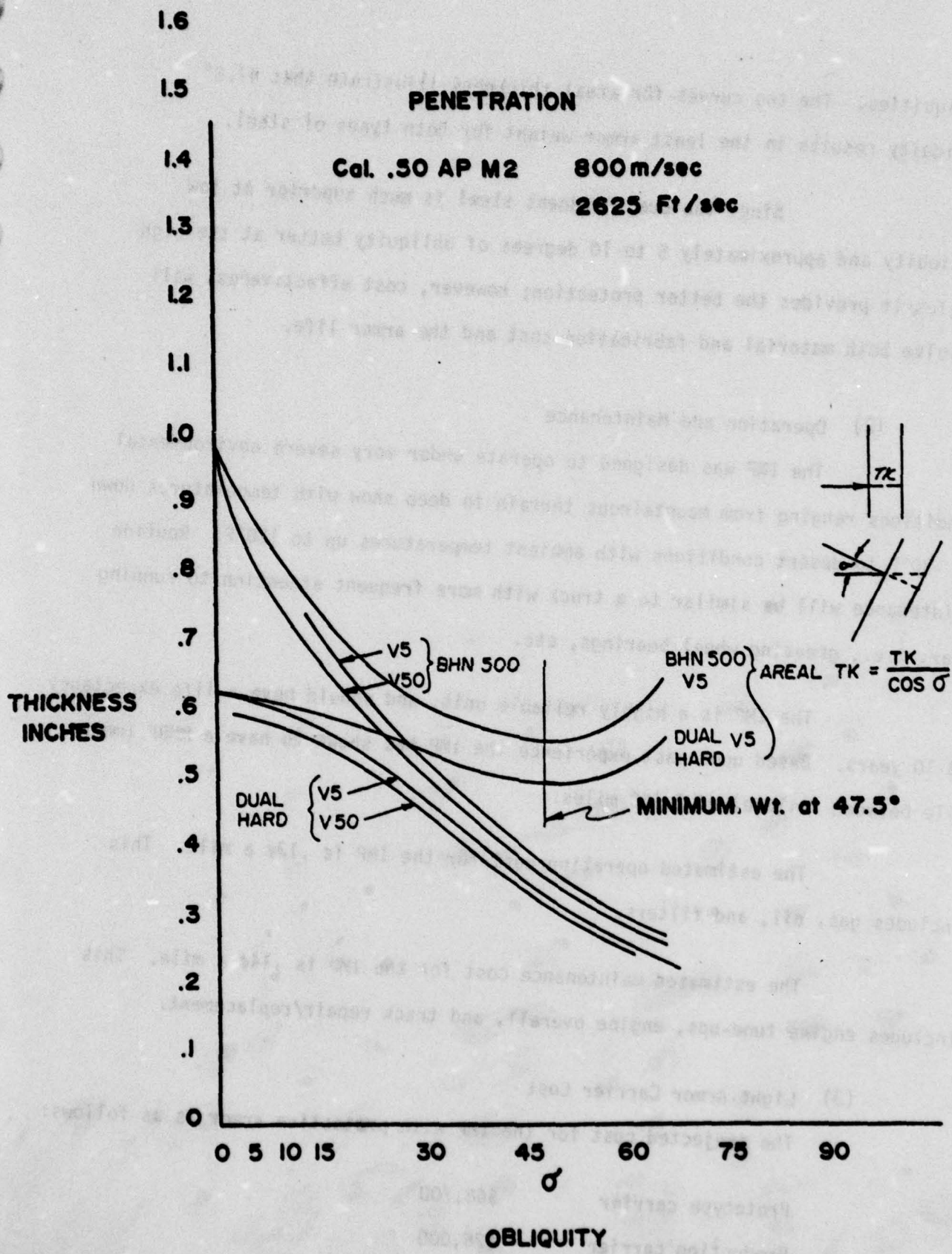

Figure I-6. V₅₀ and V₅ Penetration Curves.

obliquities. The two curves for areal thickness illustrate that 47.5° obliquity results in the least armor weight for both types of steel.

Since the dual hardness steel is much superior at low obliquity and approximately 5 to 10 degrees of obliquity better at the high angles, it provides the better protection; however, cost effectiveness will involve both material and fabrication cost and the armor life.

(2) Operation and Maintenance

The IMP was designed to operate under very severe environmental conditions ranging from mountainous terrain in deep snow with temperatures down to -30°F to desert conditions with ambient temperatures up to 120°F. Routine maintenance will be similar to a truck with more frequent attention to running gear, i.e., greasing wheel bearings, etc.

The IMP is a highly reliable unit, and should have a life expectancy of 10 years. Based upon past experience the IMP has shown to have a MMBF (mean mile between failure) of 2,160 miles.

The estimated operating cost for the IMP is .13¢ a mile. This includes gas, oil, and filters.

The estimated maintenance cost for the IMP is .14¢ a mile. This includes engine tune-ups, engine overall, and track repair/replacement.

(3) Light Armor Carrier Cost

The projected cost for the IMP with protective armor is as follows:

Prototype carrier	\$68,700
Production carrier	\$26,000

It is estimated that the cost to replace full armor would be \$10,000 or \$1,000 per section.

The above estimate for the IMP does not include the cost for berms.

d. No Armor Concept

The search for a no armor carrier entailed contact with over 35 companies. General Motors (Chevrolet Division), Ford Motor, AMC Jeep, etc., basic 4-wheel driven vehicles were the first to be evaluated as potential carriers. However, these vehicles were ruled out as they could not meet the ARETS specification without costly and major modifications. Next, the search was concentrated on the recreational all-terrain vehicles (ATV). The ATV's also could not meet the required specification, due to such things as limited payload capacity, speeds (forward and reverse), etc.

Concurrent with the search of the civilian market, several existing military vehicles were evaluated as candidate carriers. However, none were found that could meet the required specification. Since no existing carrier could be found on either the commercial market or in the Army inventory, the search for a no armor carrier progressed to custom builders. After a thorough search, two carriers were found and each would make an excellent no armor carrier. They are the concepts of Murty, Incorporated and Chamberlain Manufacturing Corporation and are discussed below.

(1) Murty Incorporated

The carrier proposed by Murty, Inc., Figure 7, uses proven components operating at low power levels. The engine is the White model G1600, which is basically the Army jeep engine except it has a displacement of 163

THIS PAGE IS BEST QUALITY PRACTICABLE
 FROM COPY FURNISHED TO DDG

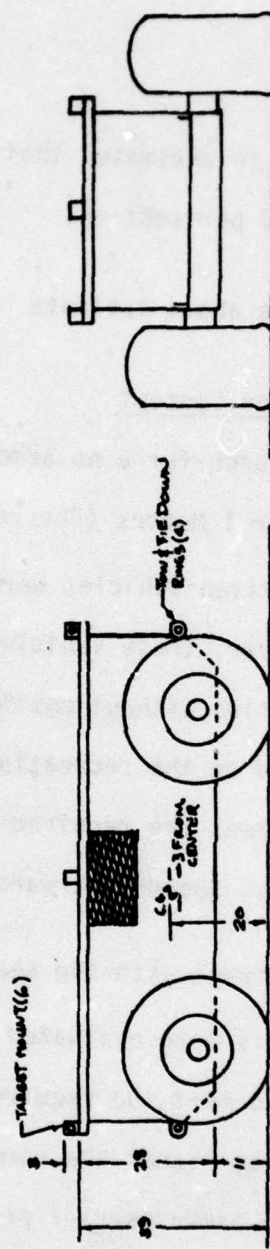
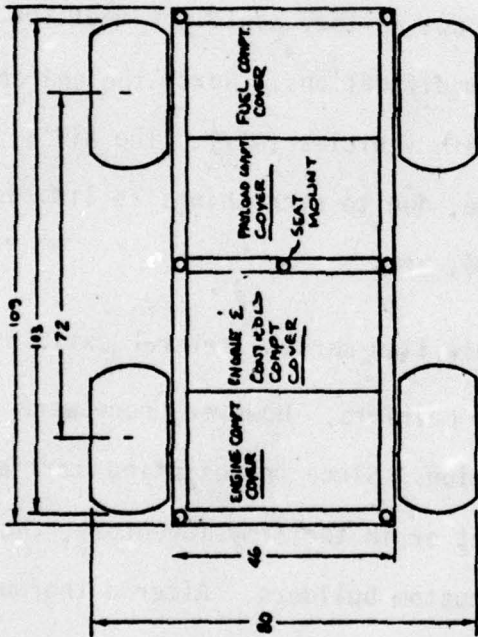

Figure 7. No Armor Carrier Murty, Inc.

METRIC DRIVE SYSTEM

cubic inches in stead of 141 cubic inches. The production carrier would use the jeep engine which has proven to be reliable, and the necessary documentation and spares are in the Army system. The maximum horsepower is 66 @ 3600 rpm, however, the carrier will be operated at a governed speed of 2800 rpm using less than 50 horsepower.

The engine is conected to two hydraulic pumps (see Figure 8). These pumps have the capability to operate at 150 horsepower and speed up to 3500 rpm and will drive four individual wheel motors.

The carrier will change from 24 mph forward to 24 mph reverse in 14 seconds. This performance can be attained with the largest target and 1500-pound payload when operating on flat, packed terrain. If the carrier accelerates into a 25 mph headwind, it will only reach a sustained speed of 20 mph. The carrier, when commanded, can come to complete stops (from 24 mph) in 5 to 7 seconds. For the carrier to operate 8 hours continuously, against zero headwind, 33 gallons of gasoline would be required. The fuel consumption was calculated using a payload of 1500 lbs and a target size equivalent to the M60 tank. However, the carrier fuel tank will hold 50 gallons giving well in excess of 8 hours run time.

The electrical system will have both 12 Vdc and 24 Vdc available. The engine will have a 24-volt, 30-amperer generator charging two 12-volt batteries in series. The engine electrical system and starter will use 12 volts.

The carrier has rigid axles and no suspension system. It uses low pressure tires to absorb the shock. However, large rocks and holes should not be hit at speeds in excess of 6 mph if the carrier is to achieve its useful

THIS PAGE IS BEST QUALITY PRACTICABLE
FROM COPY FURNISHED TO DDG

3 D MITC DRIVE SYSTEM

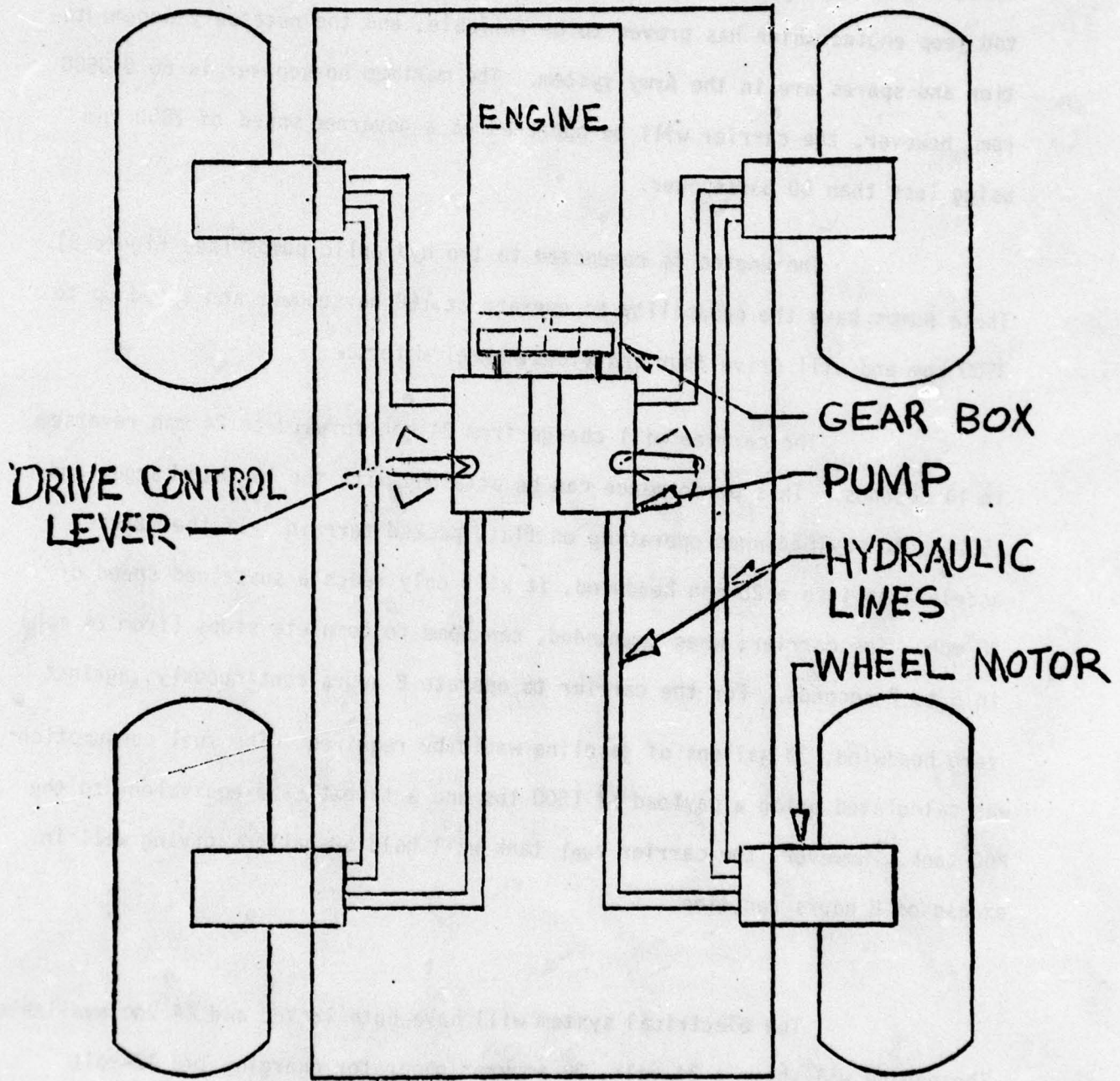

Figure 8. Murty Vehicle Drive Components.

life of 10 years. The body of the carrier will be enclosed to prevent water and mud from splashing on the internal components and enclosed payload. The carrier has provisions to carry targets representing the Warsaw Pact tanks and armored carriers. The payload compartment is 40 by 20 by 28-inches deep. To permit easy access to controls and carrier components, the entire top of the body may be opened by removing four covers.

For a complete list of carrier characteristics, see Table 3.

The Murty, Inc. carrier would have to take two exceptions to the ARETS specification. The first being tire chains to climb out of an 8 ft deep, 50 ft diameter parabolic crater. Secondly, the use of aggressive tire chains to climb a 30° slope covered with snow or mud would be required.

The predicted operating and maintenance cost is shown below.

Predicted Operating and Maintenance Cost

Assume average speed is 10 mph
50,000 miles = 5000 hours

Fuel - 7 mile/gal. @ .60/gal.	= \$.086/mile for gasoline
Oil & hydraulic oil - 1 qt./500 mile (each)	= <u>.0032/mile</u>
Fuel and oil - Total	= \$.089/mile
Oil, filter changes every 2000 miles	= .006/mile
Hydraulic oil service every 10,000 miles	= <u>.0018/mile</u>
Total operating costs	= \$.0968/mile

Table 3. Murty Inc. Carrier Characteristics

ANGLE OF APPROACH	70 Deg.
ANGLE OF DEPARTURE	70 Deg.
DIMENSIONS O/A	
Height	42 in.
Length	109 in.
Width	80 in.
Wheelbase	72 in.
TREAD	64 in.
GROUND CLEARANCE	11 in.
Center of Gravity W/O Payload	
Above Ground	20 in.
From Vehicle Center	3 in.
PAYLOAD	1500 lb.
PAYLOAD VOLUME	10 cu. ft.
SPEED (Max.) Forward and Reverse	30 mph
ACCELERATION TIME	
(Max. load, largest target, no headwind)	to 6 mph .7 sec.
	to 12 mph 1.7 sec.
	to 18 mph 3.3 sec.
	to 24 mph 6.5 sec.
FUEL CAPACITY - Regular gasoline	50 gal.

FUEL CONSUMPTION
(Max. load, largest target, no headwind)

Speed mph	Miles/ Gal.	Cruising Range-Miles
12	7	350
18	7	350
24	6.5	325

ENGINE: Four cylinder, liquid cooled,
valve-in-head, 67 hp at 3600 RPM,
163 cu. in. Same basic engine as
used in Jeep.

ELECTRICAL SYSTEM	12 and 24 VDC
BRAKES	
Dynamic	Hydrostatic braking
Static	automatic parking brake
TIRE SIZE	31 x 15.5-15 4 ply
SUSPENSION	Low pressure tire, Rigid Axle
STEERING	Proportional skid-steer remote and manual control
TURNING RADIUS	5.5 feet
DRIVE TRAIN	Two variable hydraulic pumps with four wheel motors

Service - Replace points, plugs, and condenser once between each engine overhaul (i.e., every 50,000 miles). \$30/50,000	= \$.006/mile
Assume another \$30 every 50,000 miles for miscellaneous items	= .006/mile
Complete vehicle overhaul every 50,000 miles	= .0637/mile
Replace 10% of structural parts every 50,000 miles	= <u>.00401/mile</u>
Total overhaul & service costs	= \$.0797/mile

The project cost for the Murty, Inc., no armor concept is as follows:

Prototype Carrier	\$60,000
Production Carrier	\$12,500

(2) Chamberlain Manufacturing Corporation (Refer to Paragraph e.)

e. Special Design Concept for ARETS (Chamberlain Manufacturing Corp.).

(1) General

Because of the rather unique requirements of the application, Chamberlain believes it is more logical to design a carrier specifically for the application rather than to attempt to modify an existing vehicle to meet the required specifications. The carrier described will meet the performance objectives at minimum cost. See Figure 9 for outline of Chamberlain no armor concept.

The carrier is a four-wheel drive design, with independent torsion bar suspension on each wheel. The prime mover is a Diesel engine, and two options are available: one liquid cooled and the other air cooled. A Diesel engine was selected over a gasoline engine primarily because of the reduced fire risk with Diesel fuel, although reduced maintenance and operating costs are also a consideration.

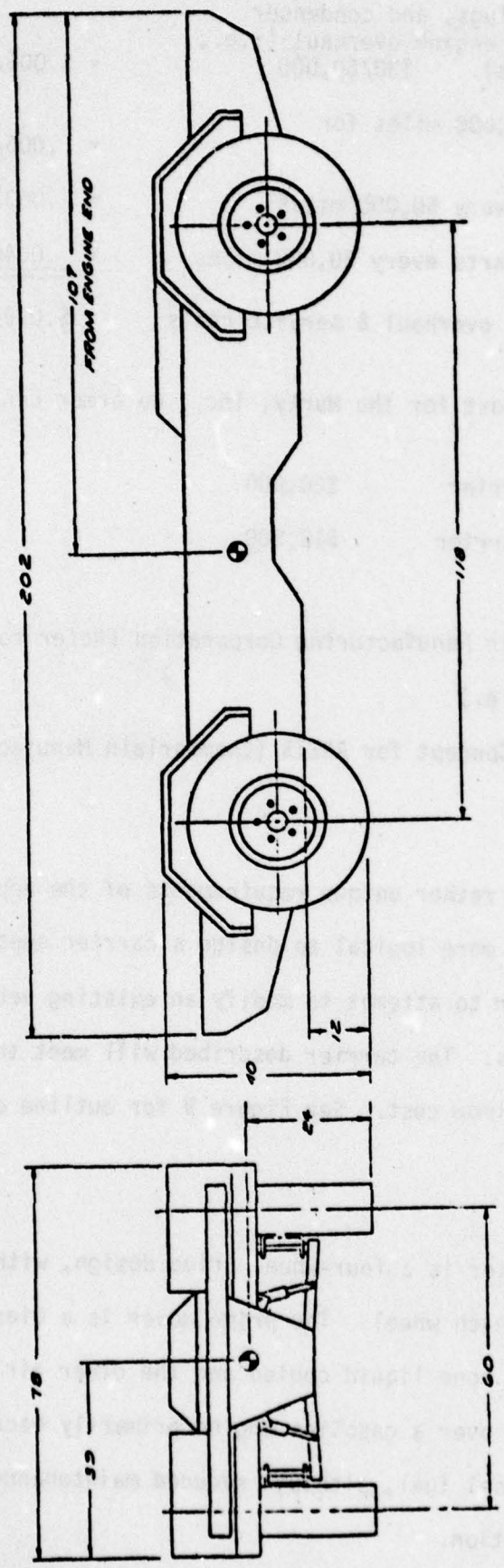

OUTLINE AND C.G. - ARETS VEHICLE

Figure 9. Chamberlain Manufacturing Corporation Concept

The drive system consists of a Sundstrand hydrostatic pump and an International Fluid Dynamics wheel motor on each wheel. This drive provides infinitely variable speed control from zero to maximum design speed in either direction. Hydrostatic braking is available, so a service brake system is not required. It also assures differential action for all wheels, and with appropriate flow dividers, it will provide a four-wheel positraction effect.

The carrier is capable of local or remote control. Provisions have also been made to supply electrical and hydraulic power to the target simulator. The proposed carrier is unarmored, but due to its relatively low profile, it could be operated behind berms. However, it would be a simple matter to add light armor to the chassis to protect vital components such as the engine, hydraulic pumps and reservoir, fuel tank, etc. The engine and chassis, hydraulic system, control system, and vehicle specifications are discussed in detail in the following sections.

See Table 4 for complete Chamberlain specifications.

(2) Engine and Chassis

In consideration of the carrier's main function and operational environment, it was our determination that a power plant using Diesel fuel would provide greater safety. Diesel fuel, having a higher ignition point than gasoline, will provide less fire hazard from stray hot particles which may occur from projectile impacts on the target.

The primary recommendation for a power plant is a Volkswagen water cooled Diesel. This engine, an in-line four cylinder, will power a

Table 4. Chamberlain Manufacturing Corporation Carrier Specifications

1. Engine Options	
A. Wisconsin	2 Cylinder, 4 Cycle Diesel, 38 hp at 2,600 rpm, Air Cooled
B. Volkswagen	4 Cylinder, 4 Cycle Diesel, 45 hp at 4,000 rpm, Water Cooled
2. Propulsion System	4-Wheel Hydrostatic Drive
3. Speed	Infinitely Variable from 0 to 24 mph in Either Direction (Local and Remote Controlled)
4. Acceleration	0 to 24 mph in 11 Seconds
5. Deceleration	Approximately .5 g
6. Tractive Force	680 Pounds per Wheel Maximum
7. Fuel Consumption	2.2 Gallons/Hour Maximum
8. Fuel Capacity	25 Gallons
9. Weight	3,650 Pounds
10. Length	202 Inches
11. Width	78 Inches
12. Height	40 Inches
13. Wheelbase	118 Inches
14. Wheel Track	60 Inches
15. Ground Clearance	12 Inches Minimum
16. Suspension	Independent "A" Frame with Torsion Bar
17. Steering	Full Power (Remote and Local Controls)
18. Tires	9.00 x 16-8 Ply Military Tread
19. Service Brakes	4-Wheel Hydrostatic
20. Parking Brakes	2-Wheel Multiple Disk (Failsafe Type)
21. Electrical System	24 Vdc, 50 Amp

Sundstrand Series 22 hydrostatic pump. It will run at 3,200 maximum rpm with 37 brake horsepower output. The weight of the engine pump package will be approximately 424 pounds.

The secondary power plant suggestion is a Wisconsin Model Z-108, 2 cylinder, air cooled, Diesel. It will power a Sundstrand Series 23 hydrostatic pump with an output of 38 brake horsepower at 2,600 rpm. The weight of this package is approximately 648 pounds.

The Volkswagen was the primary choice considering weight and cost. Either system should provide reliable performance in this application.

The chassis of the carrier will be of welded tubular steel. The main members of the frame will be two (2 by 4 inch) tubular members running the top length of the chassis. Additional members will be welded on below the main frame members for connection of the suspension, motor and pump, fuel and hydraulic reservoirs, and other chassis components. At both ends of the frame a bumper and obstacle skid frame have been added to provide low and high obstacle protection for suspension and main vehicle frame. Tubular steel used in this application provides for good strength to weight ratio and will provide for a strong rigid frame of optimum weight.

The frame has been designed to concentrate the engine and pump, fuel and hydraulic reservoirs, batteries, and control package within the main structure. This placement provides for the best hazard protection and ease of servicing of all components. The engine and pump assembly will be located

directly rear of the front suspension with the pump toward the center of the vehicle. The batteries will be located at the top center of the frame for ease of servicing. The fuel tank will be located forward of the wheels with oil cooler and filter below. The radiator for the engine will be located in the front suspension frame. Control package placement will be in an open area in center chassis for accessibility. This entire center frame section will be covered with sheet metal to protect from the environment and from falling target debris. Fenders cover the wheels for added protection, and prevent mud and dirt from being thrown on the target. See Figure 10 for frame and major components placement.

The carrier will be equipped with four wheel independent suspension using torsion bar springs and shock absorbers for damping. Wheels will be suspended on dual "A" frames to the side of the main frame. This suspension will provide superior traction from all wheels and minimal shock to frame and components on rough terrain. See Figure 11 for description of wheel suspension.

Steering will be achieved at the front suspension and wheel assembly using a King and Link pin arrangement with roller type bearings. A double acting hydraulic cylinder mounted on the main chassis will transfer motion to the wheels through a tie rod linkage to steer the wheels. Lubrication of steering rod ends and bearings will be achieved through grease fittings.

THIS PAGE IS BEST QUALITY PRACTICABLE
FROM COPY FURNISHED TO DDG

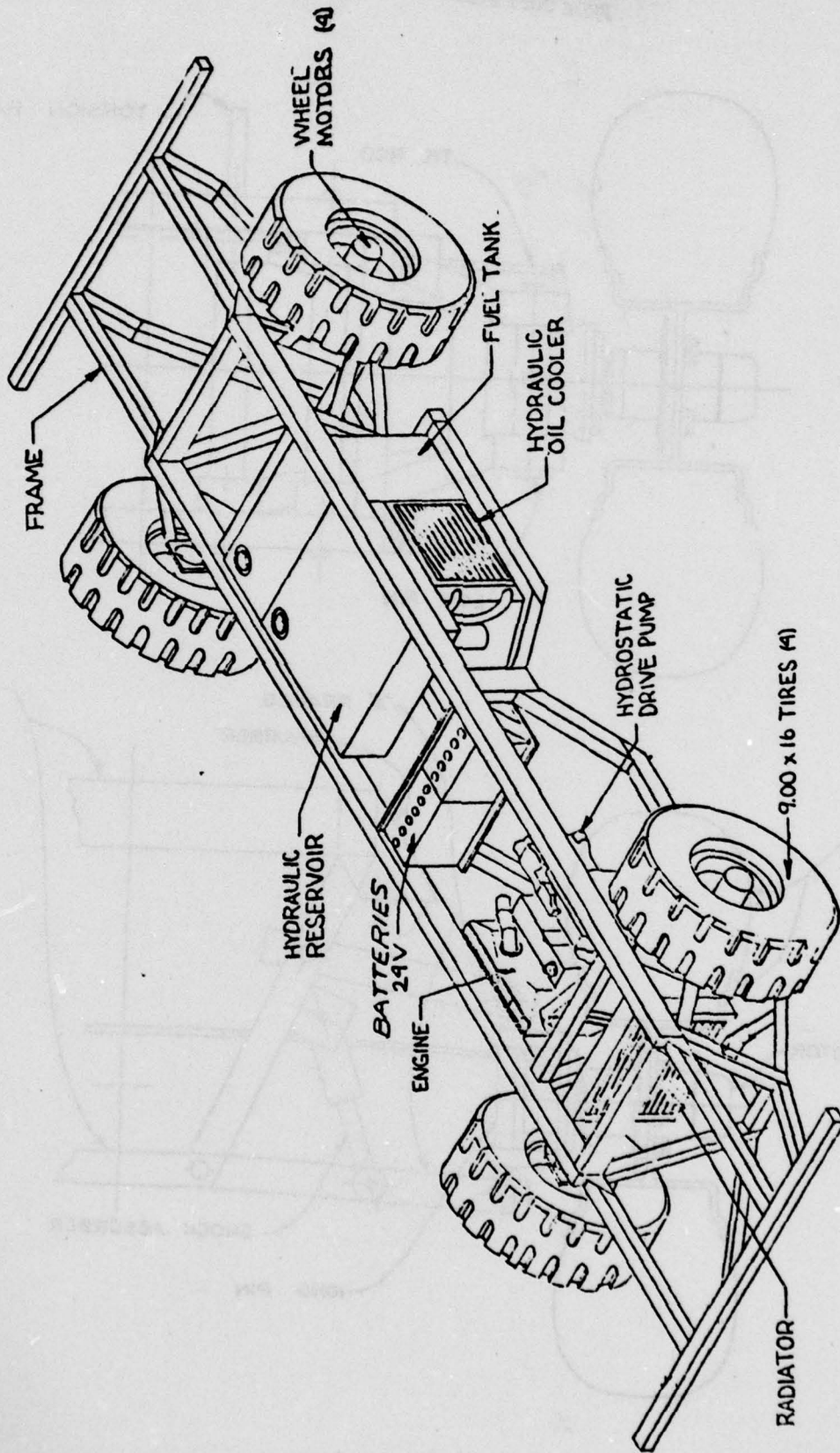

Figure 10. Chamberlain Frame and Major Component Placement

THIS PAGE IS BEST QUALITY PRACTICABLE
FROM COPY FURNISHED TO DDC

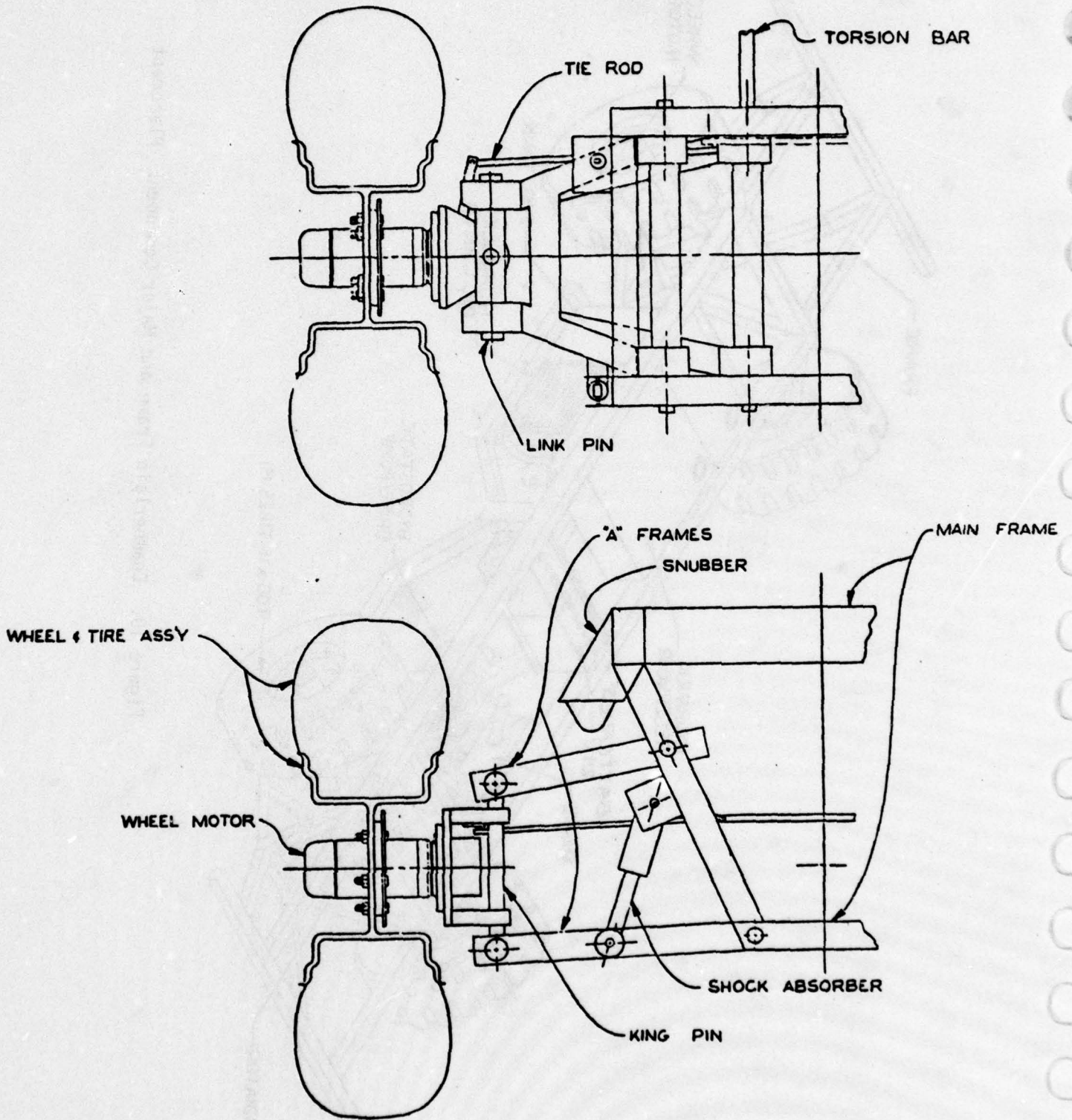

Figure 11. Chamberlain Wheel Suspension

(3) Hydraulic System

The hydraulic system consists of two basic circuits. One circuit provides carrier propulsion and braking and the other provides for power steering and target system auxiliary hydraulics. Both hydraulic systems are driven by the Diesel engine prime mover. A schematic of the hydraulic circuit is shown in Figure 12.

The propulsion system consists of a Sundstrand Series 22 or Series 23 (depending upon the engine selection) variable displacement, bidirectional pump and four International Fluid Dynamics Series 30 wheel motors with a displacement of 14.5 in.³ per revolution. These motors are capable of providing 680 pounds tractive force per wheel, which will be sufficient to drive the carrier over the specified terrain and produce the necessary forces for acceleration and deceleration to meet the requirements for changing from full speed forward to full speed backward in 15 seconds. The hydraulic system and chassis are completely bi-directional; the carrier will operate equally well in forward or reverse.

Operation of the system is as follows: The Sundstrand pump is a variable displacement, reversible flow unit with two pressure outlet ports. When one port is supplying pressure, the other port acts as return, and vice versa. The pump can be controlled to provide infinitely variable flow from zero to maximum output at either outlet port. This is accomplished by controlling the angle of the pump swashplate. If the swashplate angle is zero, pump output is zero. If the swashplate is tilted in the positive direction, the pump will supply a flow rate proportional to the swashplate angle that will drive the carrier in a forward direction. If the swashplate is tilted in the negative direction, the opposite will occur and the carrier will travel in reverse. Carrier speed is directly

THIS PAGE IS BEST QUALITY PRACTICABLE
FROM COPY FURNISHED TO DDG

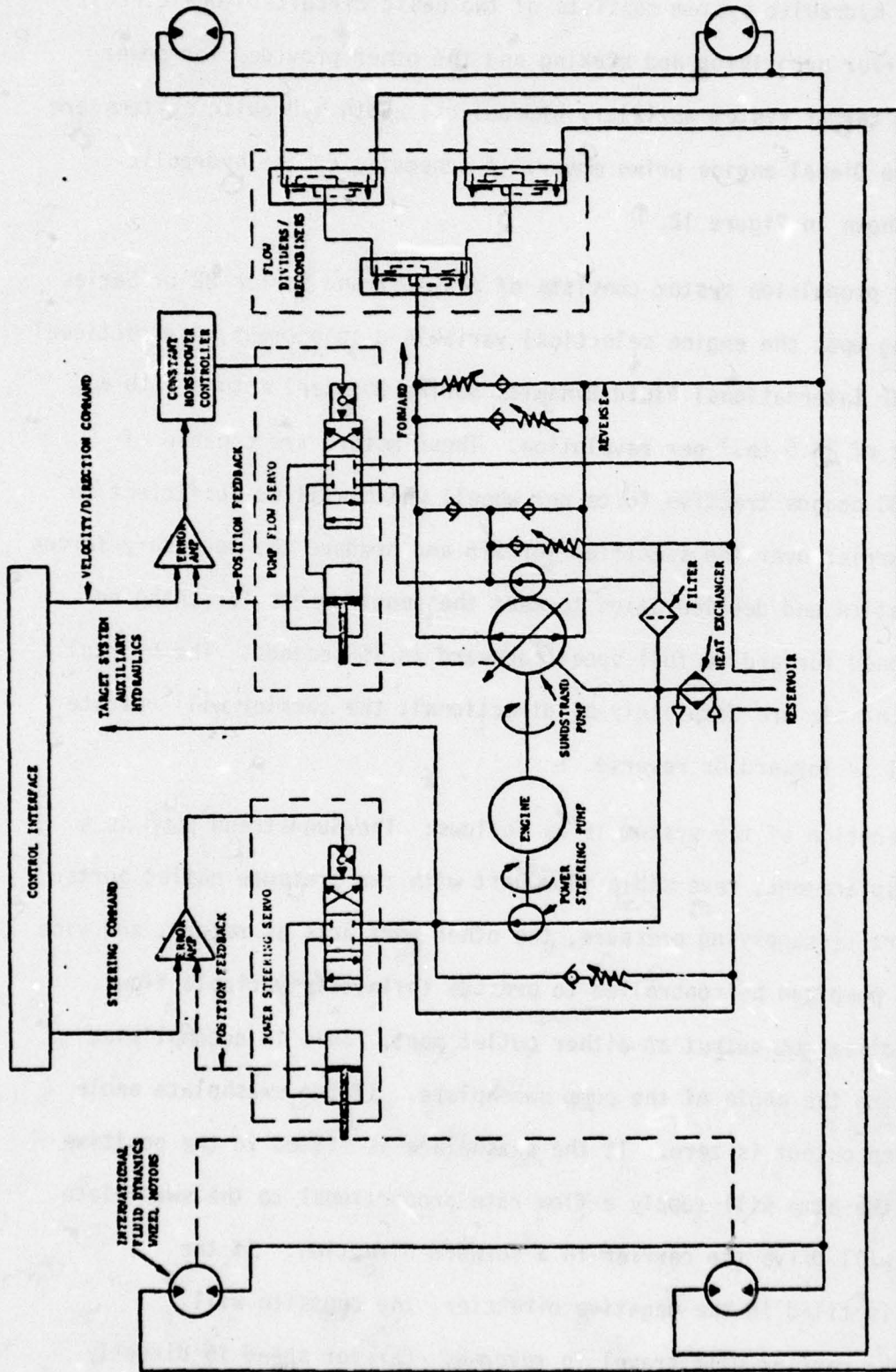

Figure 12. Chamberlain Hydraulic System Schematic

proportional to the swashplate angle, and acceleration is proportional to the rate of change of the swashplate angle.

If the pump is set to provide an output in the forward drive line, the flow enters the first flow divider valve in the flow divider/recombiner block. Here it is split into two streams, one of which drives the front wheels and the other the rear wheels. These streams are each divided again to provide a separate input to each wheel motor. This feature provides a positraction effect for all four wheels and will prevent immobilizing the carrier if one or more wheels are off the ground. Since the flow dividers are also recombiners (they will work in either direction) the same positraction effect will be obtained when operating in reverse. Limited differential action is still retained due to "slip" in the wheel motors and flow dividers. Once the flow exists, in the flow dividers, it passes through the wheel motors rotating them in the desired direction, and returns to the opposite side of the pump. The cycle is reversed when the opposite direction is selected.

The system is protected from excessive pressure with a crossover relief valve connected across the pump outputs. The hydraulic fluid is filtered with a 10 micron filter and is cooled with an oil to air heat exchanger.

The Sundstrand pump assembly also contains a small charge pump which supplies pressure to operate the main pump swashplate controller. The swashplate controller is basically a hydraulic ram that is controlled with a proportional servo valve. This is a closed loop servo system with position feedback to the error amplifier that also accepts velocity/direction commands. Also in the loop is a constant horsepower controller that senses the pump power output. It would be possible to apply commands to the system that would

exceed the engine capacity and cause the engine to stall since the pump can require more horsepower at maximum pressure and flow than the engine can deliver. The constant horsepower controller senses pump power output and maintains the pump swashplate angle so that engine capacity is not exceeded.

An additional hydraulic pump is mounted on the engine to provide hydraulic power for steering and also for auxiliary hydraulics to the target system if needed. This pump shares the same reservoir and fluid as the hydrostatic drive and will supply 3.8 gpm at 900 psi. The power steering system is controlled in the same manner as the pump swashplate is controlled except that it does not have the constant horsepower controller in the loop. In this case it is not needed since this pump only consumes about 2 horsepower.

Since the hydrostatic drive supplies horsepower to the carrier at a constant rate, it is possible to determine the time required to accelerate the vehicle to maximum velocity as follows. We will include the MA forces and rolling resistance in the calculation. The rolling resistance is given by

$$RR = \frac{GVW \times R}{1,000} \quad (1)$$

where

RR = rolling resistance in pounds

GVW = gross carrier weight

R = factor expressing rolling resistance in pounds per thousand pounds carrier weight.

For sandy dirt the factor R is 37 pounds, and the gross carrier weight, including the target, is 5,150 pounds. Therefore

$$RR = \frac{5,150 \times 37}{1,000} = 190 \text{ pounds}$$

For purposes of our calculations, we will assume the rolling resistance to be 200 pounds.

The horsepower required to accelerate the carrier is given by

$$Hp = \frac{V (Fa + Fr)}{550} \quad (2)$$

where

V = carrier velocity in ft/sec

Fa = force used to accelerate the carrier

Fr = force used to overcome rolling resistance

But $Fa = MA = M \frac{dv}{dt}$ and $Fr = 200$ pounds. There (2) becomes

$$HP = \frac{V (M \frac{dv}{dt} + 200)}{550} \quad (3)$$

This can be simplified to the form

$$\frac{V dv}{3.4375 Hp - 1.25 V} = dt \quad (4)$$

When this equation is integrated and the constant of integration determined, the following results:

$$t = 2.2 Hp \left[\ln \left(\frac{3.4375 Hp}{3.4375 Hp - 1.25 V} \right) \right] - .8 V \quad (5)$$

With this equation, one can determine the time required to reach a given velocity with a given horsepower input. The design velocity is 35.2 ft/sec. Assuming a 25 hp input, the carrier will reach this velocity in 11.3 seconds. A 30 hp input will develop design velocity in 8.6 seconds. The carrier can brake to a stop in approximately 3 seconds from maximum velocity since

maximum wheel force can be sustained throughout the braking phase. Therefore, with only 25 hp input, the carrier can change from full speed in one direction to full speed in the opposite direction within the 15 second limit. Assuming the hydraulic drive system is 75 percent efficient and an average of 4 hp is required to drive the power steering pump and alternator, a total engine Hp of 37.3 is required.

(4) Control System

Carrier control for both local and remote control will be achieved by using an error feedback system. System operation is as follows: For the steering, suppose a right turn is desired. A positive voltage is supplied to point (1), see Figure 13 on the steering error amplifier (note this voltage is supplied from either the remote or local controls). This positive voltage on point (1) will cause the voltage at point (3) to go negative which opens the hydraulic steering spool valve. The spool valve actuates the steering piston in the desired direction. A potentiometer which is mounted on the steering piston feeds a voltage back to the steering error amplifier. When the voltage at points (1) and (2) are of equal magnitude, the voltage at point (3) goes to zero, thus closing the spool valve, and the proportional turn selected is achieved. Reversing the voltage at point (1) will cause the carrier to turn in the opposite direction.

Speed and direction are obtained in the same manner except the hydraulic piston operates the flow control of the hydrostatic pump. Since both the steering and speed/direction controls are proportional, any speed in any direction is easily and precisely obtained.

The local control will be a "T" handle joystick controller, spring loaded to a neutral position. Rotation of the "T" handle controls steering;

THIS PAGE IS BEST QUALITY PRACTICABLE
FROM COPY FURNISHED TO DDC

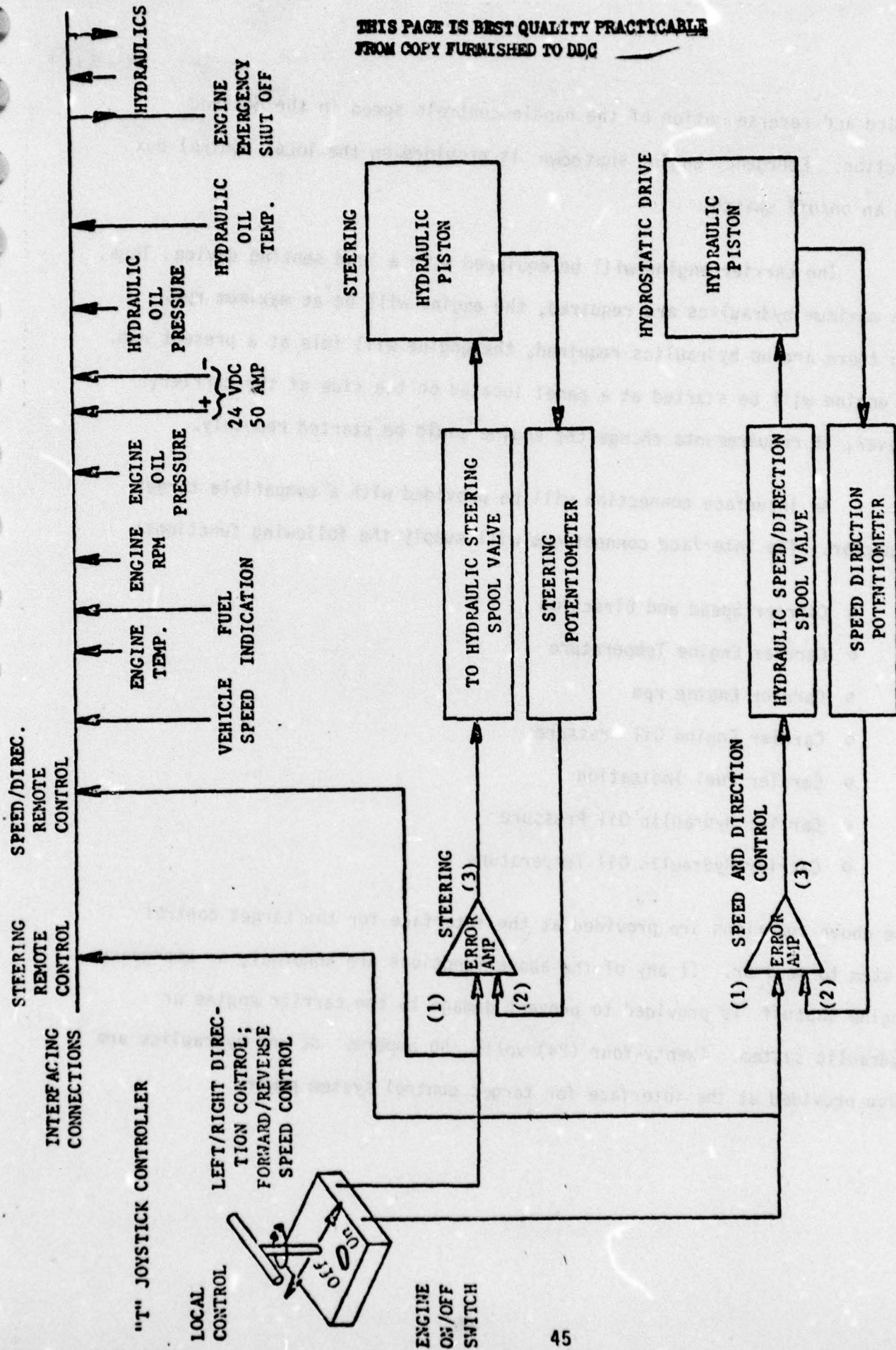

Figure 13. Chamberlain Vehicle Control System and Interface Connections

forward and reverse motion of the handle controls speed in the desired direction. Emergency engine shutdown is provided on the local control box with an on/off switch.

The carrier engine will be equipped with a load sensing device. Thus, when maximum hydraulics are required, the engine will be at maximum rpm. When there are no hydraulics required, the engine will idle at a present rpm. The engine will be started at a panel located on the side of the carrier; however, if requirements change the engine could be started remotely.

An interface connection will be provided with a compatible target connector. The interface connections will supply the following functions:

- o Carrier Speed and Direction
- o Carrier Engine Temperature
- o Carrier Engine rpm
- o Carrier Engine Oil Pressure
- o Carrier Fuel Indication
- o Carrier Hydraulic Oil Pressure
- o Carrier Hydraulic Oil Temperature

The above functions are provided at the interface for the target control system to monitor. If any of the above functions are abnormal, an emergency engine shutoff is provided to prevent damage to the carrier engine or hydraulic system. Twenty-four (24) volts, 50 amperes dc and hydraulics are also provided at the interface for target control system power.

(5) Carrier Cost

The estimated cost for the development and production for the carrier is as follows:

<u>Prototype Unit</u>		<u>Production Unit</u>	
<u>Liquid Cooled</u>	<u>Air Cooled</u>	<u>Liquid Cooled</u>	<u>Air Cooled</u>
\$67,630	\$67,813	\$10,574	\$10,947

f. Comparison of Design Approach 7002 Carrier To Murty, Inc. No Armor Carrier

Since the carrier discussed in NTEC's Design Approach Number 7002 and the Murty, Inc., no armor carrier are used in the same basic mode (that is the target is mounted on top of the carrier and each carrier must traverse behind a protective berm) a comparison was made of the two carriers. The results of this is shown in a matrix, Figure 14.

The carrier in design approach 7002 costs less than the Murty concept; however, it does not meet most of the requirements called out in the ARETS specification.

THIS PAGE IS BEST QUALITY PRACTICABLE
FROM COPY FURNISHED TO DDC

WTC	TEMPERATURE TOLERANCE METS. BY AMSIS	ANNUAL STEERING CAPABILITY	TURNING RADIUS	CARRIER SPECIFICATION							SPEEDS		TIME TO STOP (SPEED)	WTC WHEELS & TRACKS LIFE (MONTHS)	REMOTE CONTROL TO WAGON		
				WT.	LENGTH	WIDTH	HEIGHT	WHEEL BASE	GROUND CLEARANCE	ENGINE	TRANSMISSION	SUSPENSION				FORWARD	REVERSE
No Armor Martyr, Ltd.	For Exceptions 1. Requires tire chains on all 8 ft. deep 58 ft. diameter parabolic crest 2. Requires tire chains to climb a 30° slope covered with snow or mud	Yes	5.5 ft.	6000 lbs.	140 in.	80 in.	42 in.	72 in.	11 in.	Four Cylinder, 57 Limited Combed, 57 HP @ 3600 RPM, 163 cu in. Basic M151 Jeep Engine	Hydraulic	Right Side Low Pressure Tire	30 MPH 0-24 MPH 7 sec	30 MPH 0-24 MPH 7 sec	7 sec (25 MPH) Transition from 24 MPH to 24 MPH 15 Sec.	Yes	Yes
Design Approach Martyr, Ltd.	Unknown	Yes	17.5 ft.	1500 lbs.	165 in.	75 in.	60 in.	Unknown	0 in.	Air-cooled Wt. 40HP @ 4000 RPM	Automatic 3-speed	Unknown	65 MPH	Unknown	Unknown	No (Could Be Added)	Yes

WTC	PROTECTIVE TRENCH MATS & WEAR FINE SUBSTRATION	COMPATIBLE WITH IMAGE INTERFERIFICATION & THERMAL IMAGING	OPERATION IN WIND 25 MPH WITH DRIFTING TO 35 MPH	ELECTRICAL SYSTEM	REQUIRED WIND HEIGHT FOR PROTECTION	FUEL CONSUMPTION PER HOUR	ANGLE OF APPROACH ANGLE OF DEPARTURE	PAYLOAD CAPACITY	BRACES	TIRES	DRIVE TRAIN	STEERING SYS	REQUIRES A CLEARED ROAD PAIR
No Armor Martyr, Inc.	Yes	Yes	Yes	Batt 12 WBC & 24 WBC Engine Has 240V 30 Amp Generator Charging 2 12V Batteries Engine Electrical & Starter Has 12V	5.5 ft.	12 MPH 250 miles 18 MPH 250 miles 24 MPH 225 miles 58 Gal Fuel	70° 70°	2000 lbs.	Hydraulic Braking - Automatic Parking Brak	31 x 15.5 - 15 4 Ply	Hydraulic Drive Two Variable Hydraulic Pumps With Four Wheel Motors	Skid - Steering	No
Design Approach Martyr, Inc.	No (Could Be Added)	No (Could Be Added)	Yes	12/24V	0.25 ft.	25 WBC 200 Miles (Maximum)	Unknown	Unknown (Up to 1000 lbs)	Unknown	Unknown	Unknown	Actorman	Yes

Figure 14. Comparison of No Armor Concept with NTEC 7002 Concept.

SECTION II

TARGET SYSTEMS

2.1 INTRODUCTION

Present and future armor training concepts require the use and application of "live" firing of both subcaliber and main gun ammunition at fixed as well as at moving targets. Under optimum conditions, the targets should be realistic, cost effective, and deployable as simulated enemy forces. As effective targets they should also be capable of scoring multiple hits from any type of weapon and be adaptable to image intensification and thermal imaging systems and training devices such as Maglad II.

2.2 TARGETS

Targets can be classified as two dimensional (2-D) which are usually deployed as stationary targets and three dimensional (3-D) which are usually deployed on moving vehicles. Figure 15 depicts the types of target designs that can be manufactured.

View 1 - 2D self supporting target with simple highlight painting or silk screening for realism. Target can be cut to form or molded to form.

View 2 - 3D target design that has the potential of being very realistic at 500 meters or more. Conformation of the design effectiveness, however, would require deployment under typical target range conditions. The design is desirable because it minimizes material and simplifies logistics. This type of target can also be fabricated from a wide variety of materials. Realism can be achieved with highlight painting or silk screening.

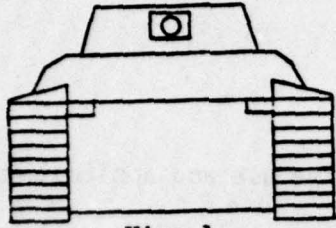

View 1

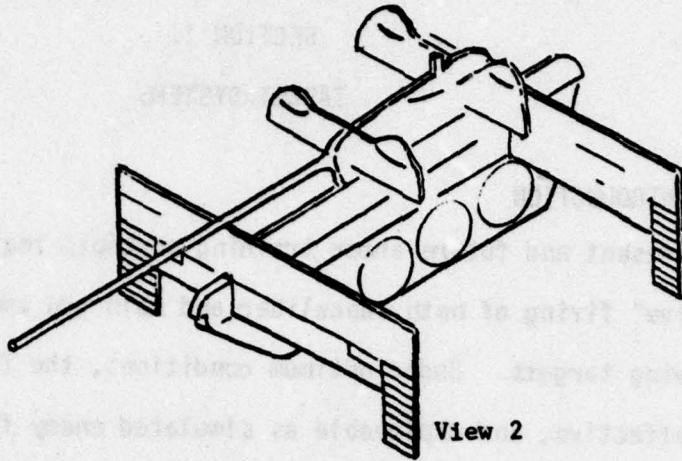

View 2

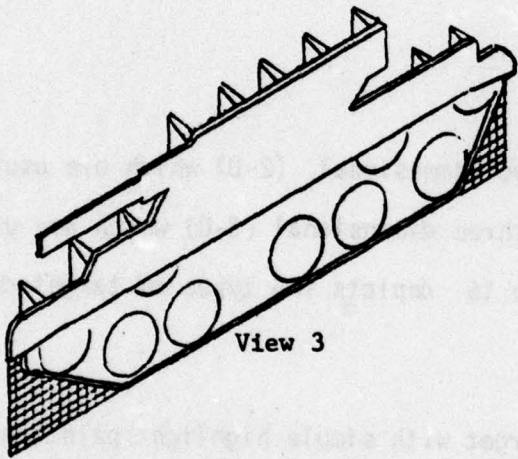

View 3

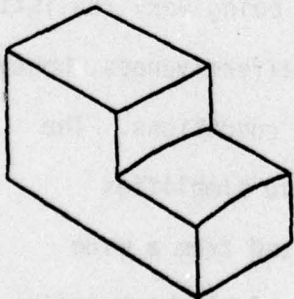

View 4

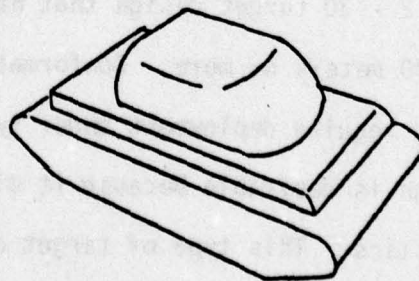

View 5

Figure 15. Potential ARETS Target Concepts

View 3 - 2-D stationary target that is supported with corrugated concrete reinforcement wire.

View 4 and 5 - Typical 3-D target designs that can be molded or fabricated from various plastics.

2.3 TARGET MATERIALS

Target materials can be classified as hard materials which oppose projectile penetration and soft material which offers little if any resistance to projectile penetration. The nature of hard target material implies weight and cost. Extra weight would present an excessive burden on the target support mechanism be it a moving target carrier or a stationary mount. Dissipation of the projectile impact energy would likewise require unusual engineering solutions. Soft targets, conversely, considerably reduce and in some cases eliminate the impact energy dissipation requirements. Their weight as well as their cost is much less than the hard target concept.

The materials that are applicable to the soft target concept are many and varied. A list of material references and manufacturers is noted in Table 5. A brief description of the most likely soft target materials is noted below:

- o Polyurethane Foam - Sponge like material often used in mattresses. It would need support as a 2-D target. It also degrades under ultra-violet exposure. Polyethylene foam is a preferred replacement.
- o Polyethylene - Is available in various densities, closed cell foams at various thicknesses, and in a high density form which is moldable into many different containers and forms. The foams with a thickness of two inches or greater are self supporting and can be used as 2-D and 3-D targets. The high density moldable polyethylene can likewise be used for 2-D and 3-D targets.

TABLE 5. Target Material Sources

MATERIAL REFERENCES

1. General

- A. Materials Standard Practice Instructions, Book I; metallic materials, aluminum, steel section - Sperry Rand.
Materials Standard Practice Instructions, Book II; nonmetallic materials, plastics - Sperry Rand.
- B. Machine Design Materials Reference Issue, March 4, 1976, Plastic Section.
- C. Machine Design, Fasteners, Adhesives, Assembly Hardware Issue, November 18, 1976.

2. Manufacturers

Wurzburg Brothers - Polypropylene, adhesives, expanded bead
Memphis, TN polystyrene

General Adhesives & Chemicals - Adhesives
Nashville, TN

Markel Products Co. - Polyurethane foam
Bronx, NY

Weber Systems Co. - Laminated corrugated paper
New Hope, AL

Exmet Corp. - Expanded plastic & metal
Bridgeport, CT

Morrison Molded Fiberglass - Structural fiberglass, shapes & sheets
Bristol, VA

Fablok Industrial Sales Corp. - Nylon fishnet
Murray Hill, NJ

Therodyne International Ltd. - Hi Density polyethylene (Phillips Martex
Hawthorne, CA or equivalent)

Bainbridges Sons - Foamcore board (feather weight)
Brooklyn, NY

Sloan Paper Co. - Foamcore board, Gator board
Huntsville, AL

TABLE 5. TARGET MATERIAL SOURCES (Continued)

2. Manufacturers (Continued)

Plasform Inc. - Plastic forming
Huntsville, AL

Mahoney Plastics Corp. - Expanded bead polystyrene
Decatur, AL

SGL Plastics - Polyethylene sheets; polypropylene sheets
Nazareth, PA

Engineered Plastics, Inc. - Molded plastic shapes
Huntsville, AL

Capitol Plastics of Ohio - Molded plastic shapes
Bowling Green, OH

United Molded Products - Rotational Molding
Port Washington, NY

Hexcel Products - Honeycomb paper
Michigan City, IN

Donray Products - Polyester urethan sheets; polyethylene foam sheets
Cleveland, OH

Packaging Corporation of America - Corrugated cardboard
Vincennes, IN

The Mearl Corporation - MEARLCRETE (foam concrete)
Roselle Park, NJ

Beridge Paper Co. - Laminated cardboard
Indianapolis, IN

Owens/Corning Co. - Fiberglass wool
Huntsville, AL

National Adhesives - Adhesives
Bridgewater, NJ

American Airfilter - Fiberglass wool
Louisville, KY

Modiglas Fiber - Fiberglass wool
Brimmen, OH

- o Polystyrene - An expandable bead foam that is manufactured in various densities in billet form (96 by 48 by 20 inches) which can be cut to the desired thickness. The material is self supporting in thickness greater than 1 inch and can be used in both 2-D and 3-D targets.
- o Polyvinyl - Is limited as a target material because the upper temperature limit is approximately 140°F.
- o Polypropylene and polyethylene - One, two, and three ply blankets. These materials would be used on 2-D and d-D targets over a support structure such as a wire frame.
- o Wire Frames - Concrete reinforcement wire with a 6-inch grid is a cost effective support structure for 2-D and 3-D targets. Chicken wire and flyscreen can be used to contain filler material such as fiber wool and plastic blankets.
- o Corrugated Aluminum, Steel, Fiberglass - Are heavy and expensive and they are not recommended as target materials.
- o Glasswool Filler - Is available in various densities from low density air filter to high density insulation. The low density wool can be used as a blanket and be held down with wire or nylon netting.
- o Hexcel Products - Are basically a lightweight honeycomb sandwich made of various materials. The most applicable, 2-D target, Hexcel product is made from craft paper that is coated to resist environmental conditions.
- o Papier-mache - Is a labor intensive material that does not weather well and therefore is not recommended for target material.

- o Concrete Foams - Are labor intensive, expensive, and tend to be brittle without reinforcement.
- o Plywood - Is useful as a 2-D target material but has limited use as a 3-D target because of the required support structure.

Many parameters must be taken into account to properly evaluate the usefulness of any target material. A prioritized group of target material parameters would include:

- o Survival of the target subjected to multiple hits
- o Support structure requirements
- o Logistics of material and labor
- o Applicability to 2-D and 3-D targets
- o Compatibility with realism requirements.

A degree of quantification is possible with the top three parameters by reformulating them into life cycle costs.

Table 6 is a tabulation of materials that would be most practical as targets. All the materials could be used with 2-D and 3-D targets. The material costs noted in the table are for production quantities; labor costs do not include a learning curve.

Since target material survival under live fire conditions is a fundamental evaluation criterion, a 2-D target material test program has been prepared and submitted. The program will evaluate under live fire conditions all the materials noted in Table 6.

Table 6. Target Materials

Type	Height/Ft ²	Cost/Ft ²	2D Target Approximately 140 Sq. Ft. Wt (lbs)	Cost	3D Target Approximately 700 Sq. Ft. Wt (lbs)	Cost
<u>Expanded Bead Styrofoam*</u>						
1.5 lb/cu. ft. density 4" thick	.50	\$.27	70	\$ 38.00	350	\$ 189.00
2.5 lb/cu. ft. density 4" thick	.84	.45	118	\$ 63.00	588	\$ 315.00
<u>Polyethylene Foam*</u>						
2" thick	.24	.85	34	\$ 119.00	168	\$ 595.00
4" thick	.48	\$ 1.70	68	238.00	336	1190.00
<u>Polypropylene Blanket *</u>						
3 Ply Blanket		.05	95	\$ 31.80	370	\$ 125.00
Reinforcement Wire (360 ft ² /2D; 1380 ft/3D)	.21	.033				
Chicken Wire (Restrainer)	.1	.05				
<u>Fiber Wool*</u>						
Wool (200 ft ² /2D)	.033	.075	102	\$ 36.80	397	\$ 145.00
Reinforcement Wire (360 ft ² /2D; 1380 ft/3D)	.21	.033				
Chicken Wire (Restrainer)	.1	.05				

Rotational Molding \$30,000 to \$50,000 Molding Cost (Approximately \$500 per mold, including labor)

* Estimated Labor @ \$10/Hr. - 2-D Target - 8 M/H = \$80 - 3-D Target - 24 M/H = \$240

Each test material will be subjected to various types of main gun and subcaliber ammunition. The amount of target damage and the structural integrity will be observed and recorded.

The program will also evaluate hit sensor systems and thermal image intensification techniques.

2.4 TARGET REALISM

Armor target realism is a highly desirable quality given a total armor training concept of recognition, identification, and first "hit" capability. A high skill level of armor personnel is possible with targets that resemble potential enemy forces. However, the degree of target realism that will achieve these training goals has not yet been established. Absolute target realism is expensive, therefore it becomes a matter of trade-off studies to determine what degree of realism will provide effective training in a cost effective manner.

Three target realism production techniques are applicable. The simplest of these requires the application of a single color paint, i.e., black, to highlight the vehicle features. The highlights could be applied in the field by untrained personnel working from an artists sketch. A much more expensive but effective method would be the application of silk screened images to the targets. These images would be in three colors and produce a high degree of realism. A pictorial view of these methods is shown in Figure 16. Both methods are usable with all the materials noted in Table 2-2 except the low density fiber wool.

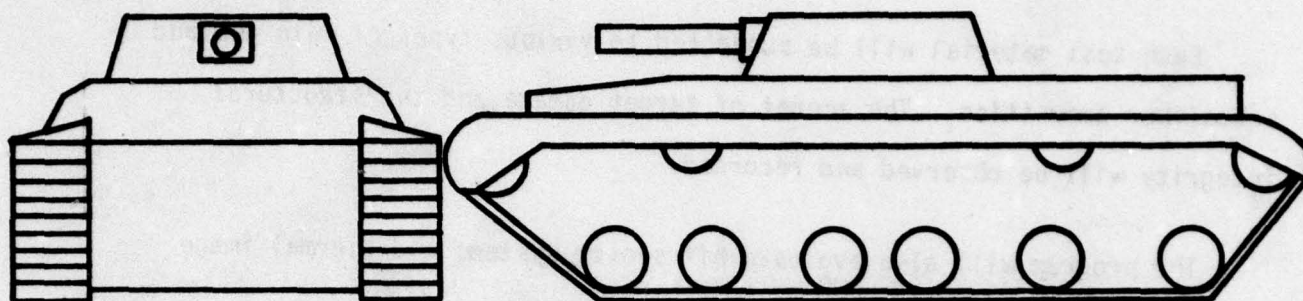

BLACK PAINT OUTLINE

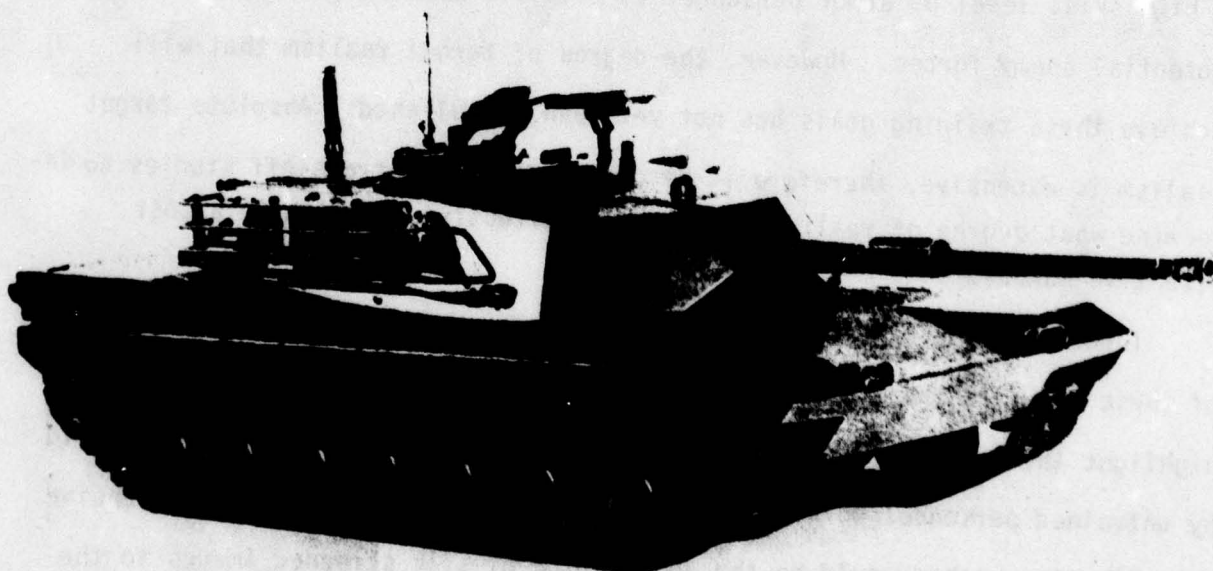

SILK SCREEN IMAGE

4.5' x 12' SILK SCREEN 2 color \$15

3 color \$20

SCREEN SET-UP \$1500

2D TANK APPROXIMATELY 3 SCREENS \$60

3D TANK APPROXIMATELY 8 SCREENS \$160

Figure 16. Target Realism Production Techniques.

The third method of achieving realism entails the use of polyethylene molded targets. For the 2-D target this can be vacuum formed and for the 3-D a rotational mold. Both methods can incorporate a high degree of detail and together with simple highlight painting or with silk screen image applications will provide the ultimate in target realism.

2.5 THERMAL IMAGE ENHANCEMENT

Complete training of armor personnel for present and future combat situations requires the inclusion of night engagement exercises. Effective night exercises require the use of presently available and projected night vision devices such as night vision scopes, xenon search lights, passive and active night vision systems, and various image intensification techniques. An evaluation study of night vision target enhancement and intensification techniques was initiated. No attempt was made to duplicate actual vehicle signatures during this test phase due to their classified nature.

The most important considerations in night vision imaging is that of target background contrast not just target radiation. The total radiance N of most surface targets is equal to the self-emission N_e (radiant energy from a body as a consequence of its temperature only) and the incident radiation N_r (energy reflected by a body). N_e for military

$$N = N_e + N_r$$

targets usually predominates at night and N_r may be neglected (except when xenon searchlight is used). Figure 17 shows the wavelengths that were considered during this study. For wavelengths greater than four or five microns N_e becomes unimportant except for very hot items, such as exhaust

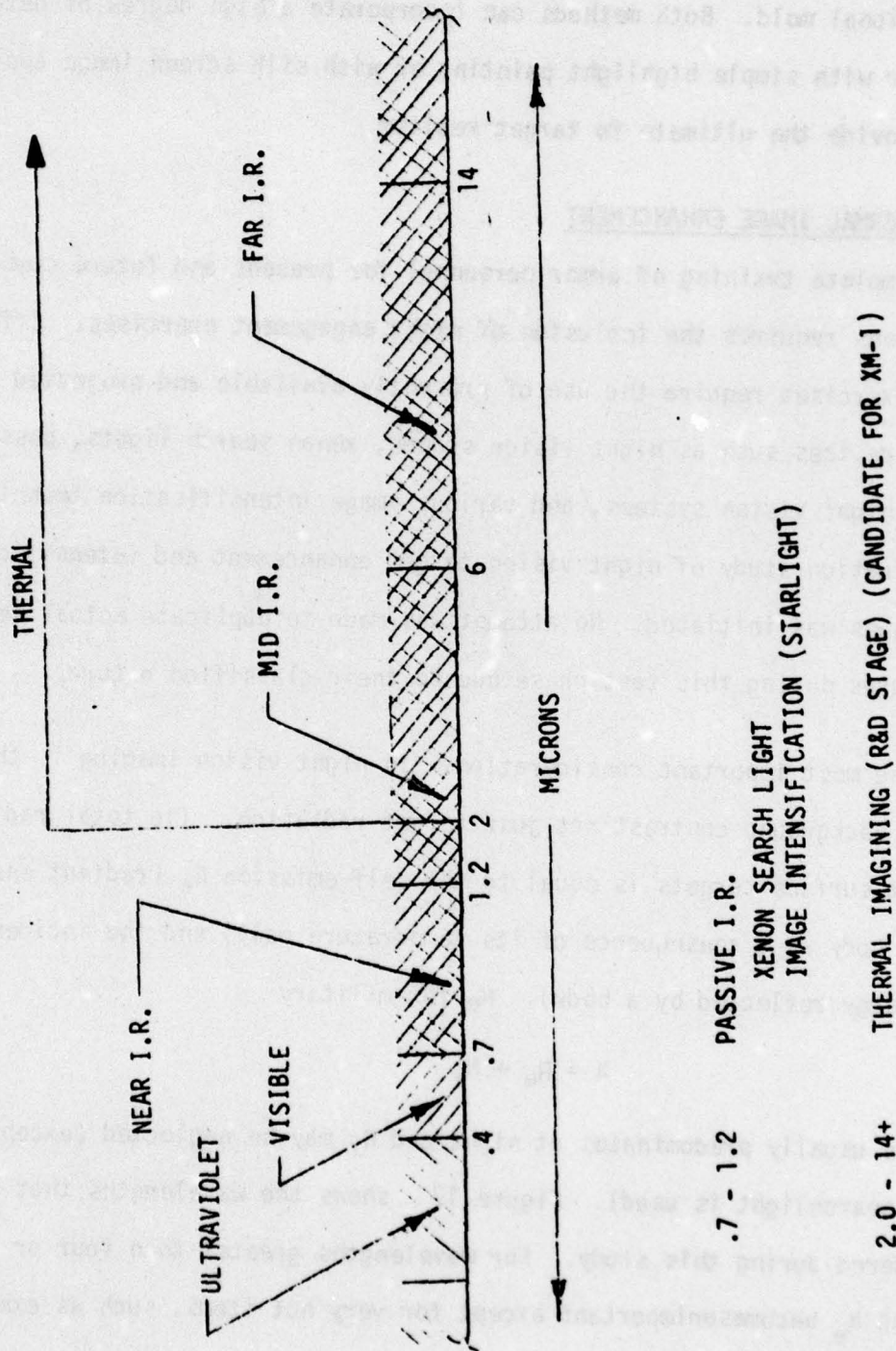

Figure 17. IR/Wavelengths Considered in Study

pipes. When wavelengths fall between one to five microns, N_e and N_r become important in calculating the total radiation of a surface.

Infrared radiation sources include a wide variety of objects such as: roads, railroads, airstrips, bridges, factories, vehicles and personnel. While some surface targets (e.g., the exhaust manifolds of tanks and other vehicles) can be distinguished by temperatures which are higher than ambient, many passive objects near ambient temperature must be recognized by characteristics, such as shape, size, position and contrast. It is an important phase of training for tank personnel to recognize the IR/thermal signature quickly as friend or foe.

There are many different methods by which the IR/thermal simulation can be accomplished. These different methods are listed in Table 7 along with the advantages and disadvantages of each. The main advantage of heater strips and thermal conductive tape, in the area of image intensification, is cost and the many thermal configurations that can be presented by changing the tape position on the target. One such outline is shown in Figure 18. The main object of the tape is to act as a heat sink for the heaters. The tape temperature should be higher than the surface of the target material giving a good outline of the target silhouette. The desired temperature of the tape and heaters and their configuration will be determined under actual target range conditions.

In the case of moving targets the simulation of IR sources is somewhat simplified because of the target construction. The target moves and the motive power required generates heat. This heat can then be used to

simulate an actual vehicle by the use of ducts and radiators. The fixed targets present another problem, the heat generating devices must be part of the target and must be simple enough to keep the target cost down. In the case of the fixed target, therefore, either reflective coatings, simple heat generators or target illumination could be used.

The target material itself will determine the IR material to some extent. Smooth surfaced devices using polyethylene, expanded bead polystyrenes or plywood lend themselves to the application of various conductive coatings. The chickenwire construction techniques seem to lend themselves to the use of heaters or direct IR illumination.

Table 7. IR/Thermal Simulation

Type	Mfr. or Device	Advantages	Disadvantages
o Cavity-type Blackbody Sources	Infrared Industries Nernst Glower	<ul style="list-style-type: none"> o Water cooling not req'd. o Usable to 30 microns o 200-1000 hours life o Elements easily replaced 	<ul style="list-style-type: none"> o Low mech. strength o Small size (point source) o Susceptibility to temp. variations caused by air currents. o AC power required o Cost \$1395.00
	Blackbody Radiation Source Mod. 414	<ul style="list-style-type: none"> o Fast warm-up o Closed loop control o 50°C - 250°C range o Accuracy 1°C o Self-contained 	<ul style="list-style-type: none"> o Cost \$1200.00 o AC power required o Use a field source
	Barnes	<ul style="list-style-type: none"> o Simple sheetmetal cone coated internally with silicon-black enamel. o Assumes amb. temp. quickly 	<ul style="list-style-type: none"> o No temp. control
o Low-temp. large-area source	Barnes	<ul style="list-style-type: none"> o 1 ft² flat metal surface covered with Zapon paint. o Temp. control by winding on back. 	<ul style="list-style-type: none"> o Max. temp = 250°C o Non-negligible gradients of temp. across the surface. o Cost \$2595.00

Table 7. IR/Thermal Simulation (Continued)

Type	Mfr. or Device	Advantages	Disadvantages
o Tungsten Filament Lamps	G.E. 30A/6V/T24	<ul style="list-style-type: none"> o Cost ~ \$60.00/lamp o DC power required 	<ul style="list-style-type: none"> o Must be in enclosure behind a suitable infrared window. Limited to about 3 microns if window not used.
o Combination of heater strips & silicon paint on targets		<ul style="list-style-type: none"> o Cost o Simplicity o Maintenance o Low weight o IR of target can be improved by painting target & use of heater strips. 	<ul style="list-style-type: none"> o High thermal temperature cannot be reached.

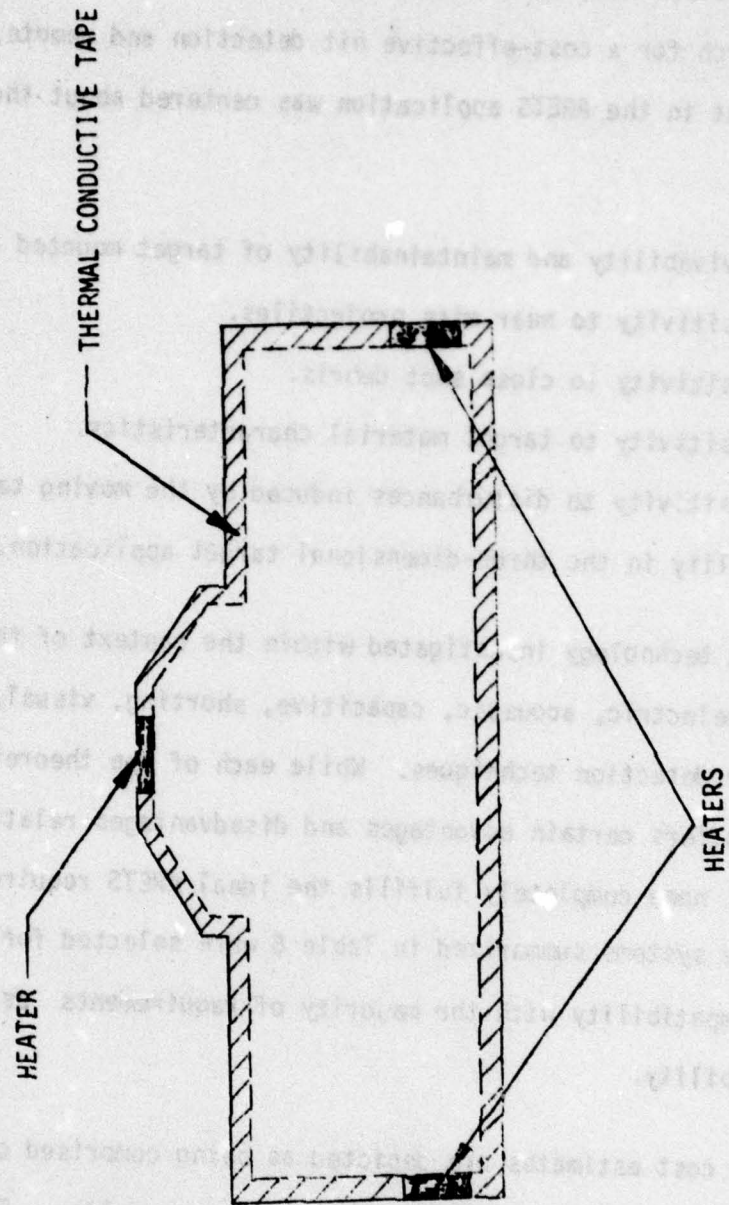

Figure 18. Typical Heater Configuration

2.6 HIT DETECTION AND SCORING SYSTEMS

The search for a cost-effective hit detection and remote scoring system for deployment in the ARETS application was centered about the following precepts:

- o Survivability and maintainability of target mounted components.
- o Sensitivity to near miss projectiles.
- o Sensitivity to close shot debris.
- o Sensitivity to target material characteristics.
- o Sensitivity to disturbances induced by the moving target carrier.
- o Utility in the three-dimensional target application.

Sensing technology investigated within the context of this study included laser, piezoelectric, acoustic, capacitive, shorting, visual, infrared, doppler, and intruder detection techniques. While each of the theoretical approaches considered offers certain advantages and disadvantages relative to a given application, none completely fulfills the ideal ARETS requirements. Consequently, the systems summarized in Table 8 were selected for consideration on the basis of compatibility with the majority of requirements as well as near term availability.

System cost estimates are depicted as being comprised of on-target and base station components, where so stated by the supplier. This affords an additional decision criterion relative to the expense of components that are potentially vulnerable to hit damage. Certain of these more expensive components, e.g., signal conditioning electronics, can be protected by appropriate buffering within the target carrier.

In view of the operational and environmental constraints stipulated in the ARETS specification and the variety of target materials to be considered, a

tandem combination of acoustical and vibration sensing elements is recommended for test and evaluation. The simultaneous sensing of impact generated vibration and the shock wave of a supersonic projectile appears to offer an effective solution to the problems of near miss and close shot debris sensitivity. To this end, the signal conditioning electronics should include such voting logic as to effectively utilize the inherent characteristics of the device, i.e., acoustic sensors will not score subsonic debris, and vibration sensors will not score a near miss.

As depicted in Table 8, three such systems are available from Del Mar Avionics of Irvine, California. Two of the systems are listed as being available through U.S. Army inventory, and with minor modification, can be rendered operational for tests.

Though listed as undesirable in the ARETS specification, near miss scoring, to include miss distance computation, could provide useful feedback in a given training situation. To this end, the Doppler system, soon to be available through U.S. Army inventory, appears to be the most highly developed and cost-effective.

Maglad II simulated fire detectors, when available, are not expected to pose an applications problem when deployed with targets considered in this study. Near miss scoring, a function of laser beam dispersion with range, can be reduced by proper sensor placement without reducing primary target coverage.

All the available off-the-shelf hit sensor systems noted in Table 8 have a minimum cost of \$20,000 where the sensing element cost is at least \$300. Most of these systems were developed for unique applications such as missile evaluation systems using stationary targets or small infantry targets

Table 8. Hit Detection and Scoring Systems

Type	Advantages	Disadvantages	Availability	Supplier	Cost	
					On Target	Base Station
Continuous Wave Doppler	<ul style="list-style-type: none"> One sensor/target Meets MIL-E-5400L Hard or soft target Will not score debris Telemetry compatible Laser Compatible 24 Vdc sensor 	<ul style="list-style-type: none"> Will score near miss Not radar compatible Non-metallic target required 	Sensor - April 1977 Gnd Station - June (RSA Contract)	Esterline	\$500	\$45,000
Acoustic (Bow Wave)	<ul style="list-style-type: none"> Hard or soft target Will not score subsonic debris Modem/computer compatible Can score, store & transmit 512 hits on 2 targets 	<ul style="list-style-type: none"> Sensor rod vulnerable to hits 110 Vac sensor system Will score near miss Will not score subsonic projectiles 	Off-the-shelf system Custom sensor (Eglin AFB)	Accubar	\$500 to \$4,000	\$26,500
Infrared Beam	<ul style="list-style-type: none"> Hard or soft target Will not score near miss 12 Vdc sensor system 	<ul style="list-style-type: none"> Will score debris Sensor mount vulnerable to hits Critical beam alignment 	Off-the-shelf data system Custom sensor & controller to be developed	Motorola Speer	\$1200 \$21/beam \$2000 controller	\$10,000
Ultrasonic (Acoustic)	<ul style="list-style-type: none"> Hermetic Wide bandwidth Hard or soft target Low vulnerability to hit damage Will not score subsonic debris 	<ul style="list-style-type: none"> Will score near miss Will not score subsonic projectiles 	Off-the-shelf sensor Signal conditioning to be developed	Dapco Sperry	\$300 (Estimate-sensor & circuitry)	TBD

Table 8. Hit Detection and Scoring Systems (Continued)

Type	Advantages	Disadvantages	Availability	Supplier	Cost.	
					On Target	Base Station
Accelerometer (impact vibration)	<ul style="list-style-type: none"> Will not score near miss Low vulnerability to hit damage 	<ul style="list-style-type: none"> Will score close shot debris 	Off-the-shelf sensor	Endevco	\$350 (Estimate-sensor & circuitry)	TBD
Acoustic	<ul style="list-style-type: none"> One sensor/target Will not score subsonic debris Hard or soft target Low vulnerability to hit damage Developed and operational 	<ul style="list-style-type: none"> Will score near miss Will not score subsonic projectiles 	Three systems developed & operational (Ft. Bragg, Knox, Rucker)	Del Mar Labs	\$350-450	\$25,000
Piezoelectric (impact vibration)	<ul style="list-style-type: none"> Will not score near miss Low vulnerability to hit damage Developed and operational 	<ul style="list-style-type: none"> Will score close shot debris Hard target required 		Del Mar Labs		
Piezoelectric (impact vibration)	<ul style="list-style-type: none"> Unable to obtain detailed data 		Off-the-shelf system	Saab Systems, Detroit Bullet	Unknown	Unknown

or air-to-surface target systems where area coverage is to be sensed and recorded.

Because of the wide variety of potential, although undeveloped, hit sensor devices on the market, the rapid technology changes and advances, and the somewhat unique ARETS target system requirements, it should be feasible to develop an effective ARETS target hit sensor system that in production quantities would be delivered for less than \$2,000 per system with the hit sensor costing less than \$100. This improvement in cost effectiveness would be achieved by using the latest sensing devices and engineering techniques and uniquely integrating them into the ARETS target system.

The development for such a system is estimated to be \$100,000.

2.7 TARGET MATERIAL TEST

A target material evaluation test program was conducted at Jefferson Proving Grounds, Madison, Indiana over a three week period. This test was conducted as a portion of task 6837A ARETS Study. The objectives of these tests were to ascertain the effect of live firings on various target materials and the ability of a piezo electric hit sensor to record hits on these targets.

The various target materials considered were reduced to five types of materials: Expanded bead polystyrene, polyethylene foam, fiberglass wool and chickenwire, polypropylene sheeting and chicken wire, and high density polyethylene. These materials were selected on a basis of cost, manufacturability, durability, and resistance to the normal environments encountered.

The first four materials were assembled into target panels approximately 8' x 16" and reinforced for a height of 6' with 10 gauge concrete reinforcing wire. The high density polyethylene targets were made of sections of a rotationally molded vat or tank.

The targets were to be held, where possible in fixture constructed from angle aluminum, Figure 19 and Figure 20. These fixtures were not considered to be part of the target, but were used to mount the hit sensor to reduce the possibility of damage to the sensing element and assure a firm mounting surface. In those cases where the fixtures were not used, due to terrain difficulties, sections of the holding fixtures were mounted to the target sections to maintain this firm mounting surface.

The targets were subjected to various types of main gun rounds and subcaliber rounds fired at various distances from the targets. The main gun rounds fired were: 90 mm TP-T M353 (AP), 105 mm TP-TM 490 (HEAT), M467 (HE) and M724 (APDS), and 152 mm TPT M411 (HEAT). The subcaliber rounds were the .50 caliber and 20 mm. Representative main gun rounds are shown in Figure 21 for reference only.

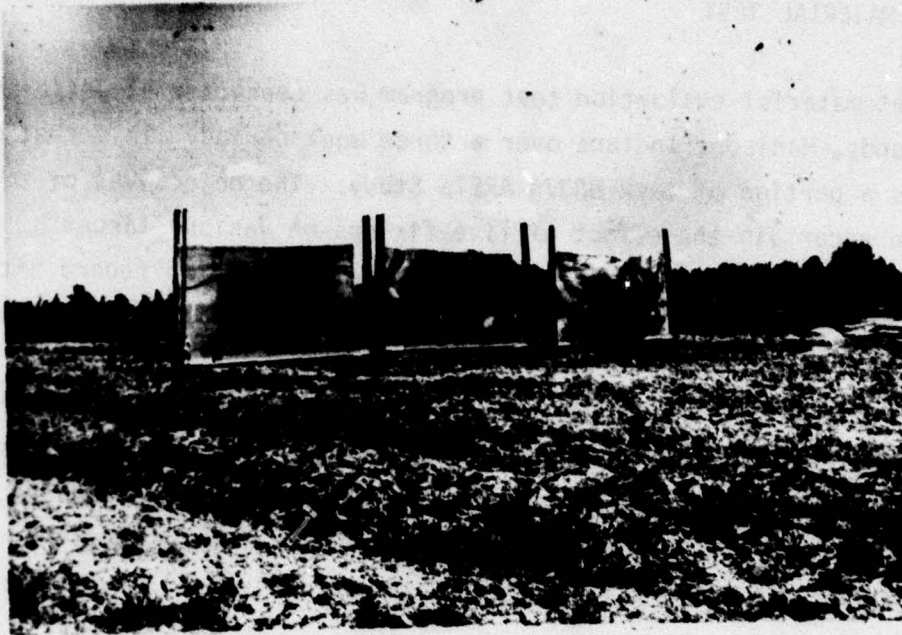

Figure 19. Main Gun Targets in Target Holding Fixtures.

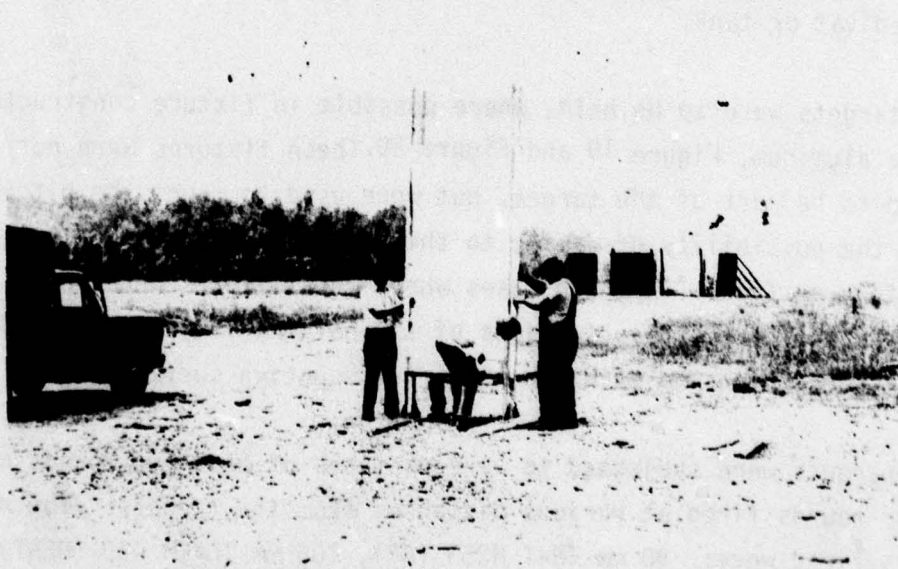
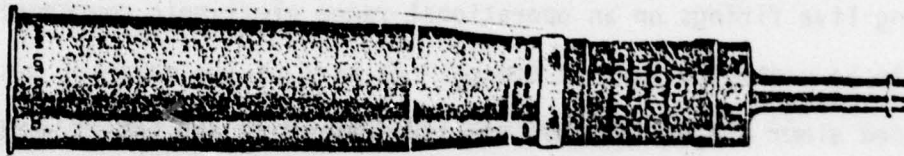
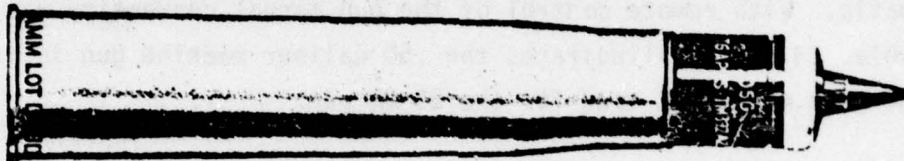
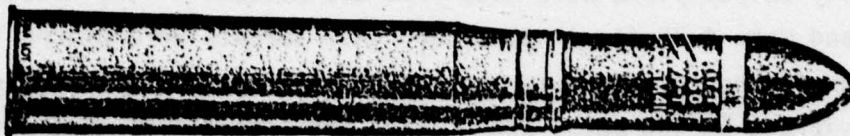

Figure 20. Sub-Caliber Targets in Target Holding Fixtures.



90 Millimeter



105 Millimeter



152 Millimeter

NOTE

While these rounds are not actual training rounds the configurations of the rounds as far as silhouettes are the same.

Figure 21 -Round Configuration

The main gun rounds were fired at the following ranges, 750 meters, 1200 meters and 2000 meters.

The sub-caliber tests were conducted using 4' x 8' targets for all the materials except high density polyethylene. The targets used for the high density polyethylene were made from the bottoms of the rotationally molded tanks and were 4.25 ft. in diameter. All targets were placed 120 meters from the firing point due to the tendency of the .50 caliber and 20 mm gun to vibrate on the mount and scatter the projectiles when fired full automatic. With remote control of the gun, manual correction was not available. Figure 22 illustrates the .50 caliber machine gun in its mount. The same mount was used for the 20 mm gun.

During live firings on an operational, range electronic components will have to be protected against damage. As part of the material testing face hardened armor plates 3/8 inch and 1/2 inch thick and set at various obliquities were subjected to .50 caliber machine gun fire at close range to evaluate the protection afforded by this type of armor.

A hit sensor, provided by NTEC, was used to determine the ability of various material to provide a hit indication for target scoring purposes.

The report is divided into a separate section for each type of material and will cover all ranges and types of projectiles fired at each type of target.

In addition to the required test samples two targets constructed of a cardboard honeycomb material in 2 inch and 4 inch thickness were tested on the 750 meter range using the 90 MM and 152 MM projectiles. The results were similar to the styrofoam tests.

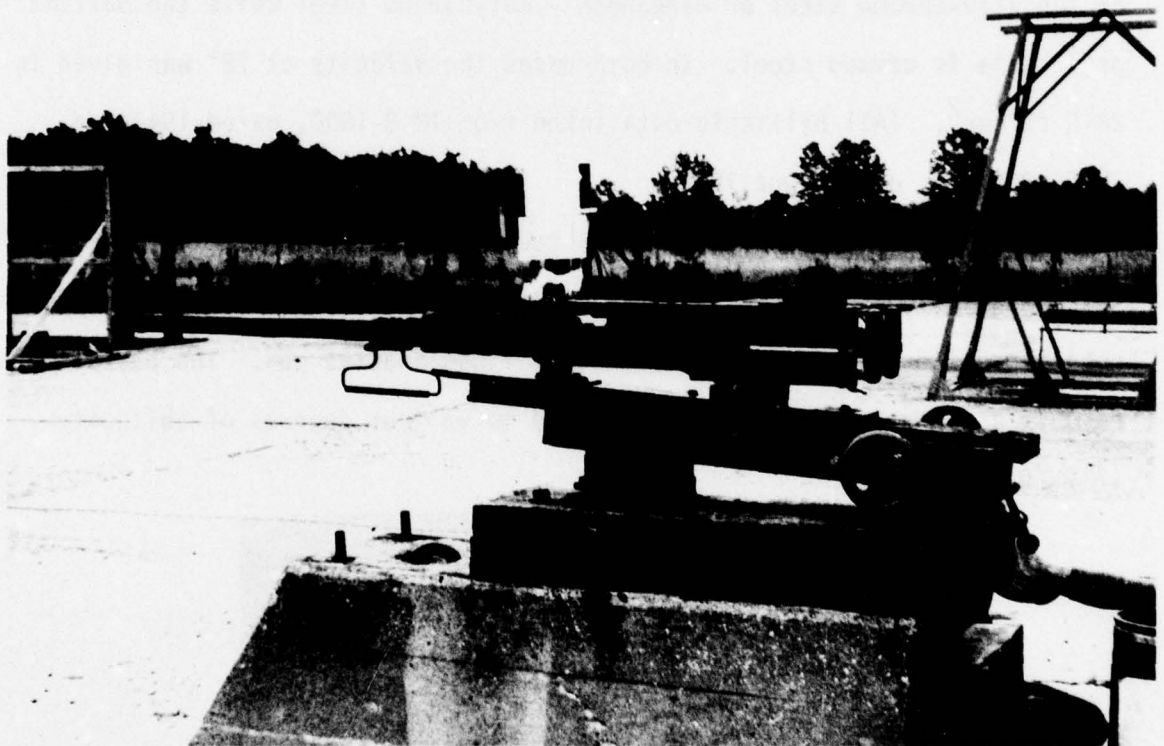

FIGURE 22. .50 CAL. ON MOUNT

a. Armor Plate

The purpose of this test was to determine the effects of .50 caliber ammunition on two thicknesses of face hardened armor plate positioned at several obliquities. Armor piercing .50 caliber ammunition was chosen as the most severe case to which the armor plate would be subjected. This ammunition has a muzzle velocity of 2840 ft/sec^2 for both the AP and ball variations. The projectile weights are within .5 grains of each other. The major difference is in the projectile core. The APM2 projectile has a core of Tungsten-chrome steel or Manganese - molybdenum steel while the ball M2 projectile is common steel. In both cases the velocity at 78' was given as 2810 ft/sec^2 . (All ballistic data taken from TM 9-1900, dated 1947 and TM 9-1305-200, dated June 1961).

The two armor plates used in the test were dual hardness steel plate (MIL-S-46099A), in thicknesses of 1/2 inch and 3/8. inch. These plates were positioned 156 feet from the muzzle of a fixed machine gun. The plates were held in a fixture that could be adjusted to various degrees of obliquity (figure 23 and 24).

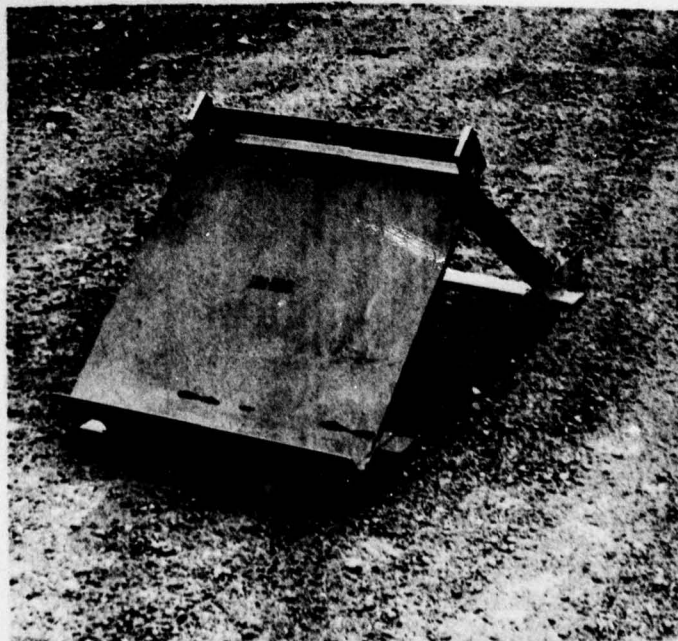

Figure 23. FRONT VIEW OF HOLDING FIXTURE

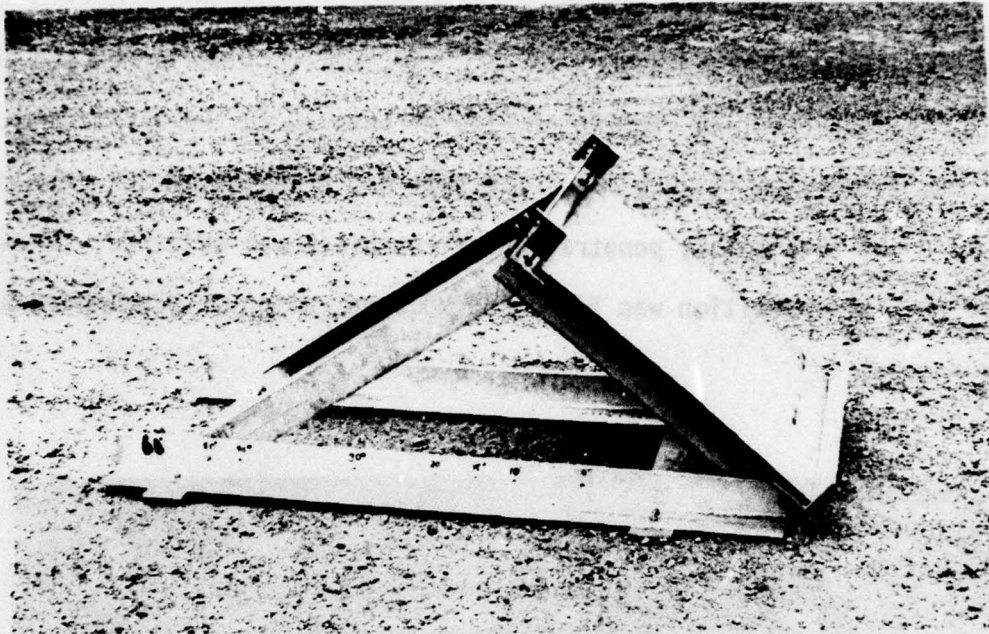

FIGURE 24. SIDE VIEW OF HOLDING FIXTURE

The 3/8 inch plate was mounted and set at 50° obliquity. The AP ammunition was fired and did not penetrate, although there was minor scoring of the surface approximately 1/32 inch deep (figure 25).

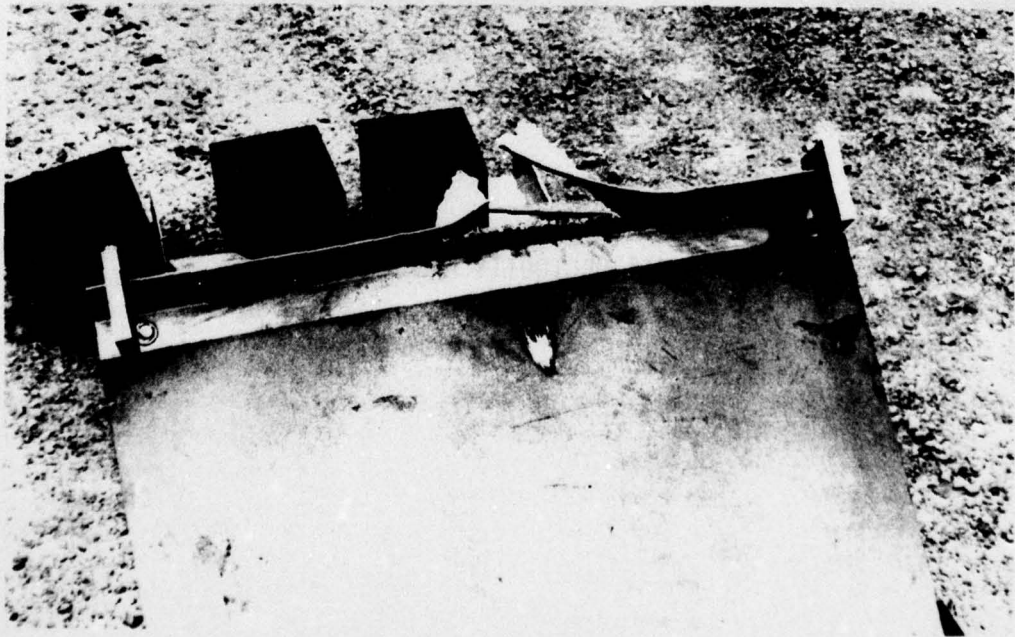

FIGURE 25. 3/8" PLATE - 50° OBLIQUITY ANGLE

With the obliquity changed to 45°, the same test was attempted again, with no penetration and similar scoring effects as in the first test using the same ammunition (figure 26). The test was repeated at 30° (figure 27) and 28. At this point, penetration of the plate was obtained. Then a round of ball ammunition was fired and no penetration or scoring occurred (figure 29).

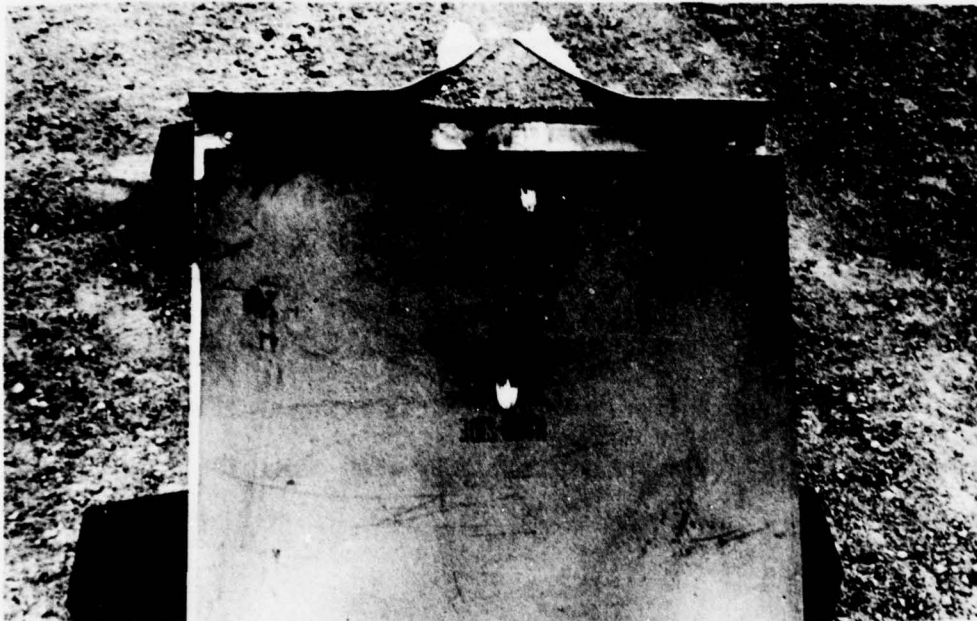

FIGURE 26. 3/8" PLATE
45° OBLIQUITY ANGLE

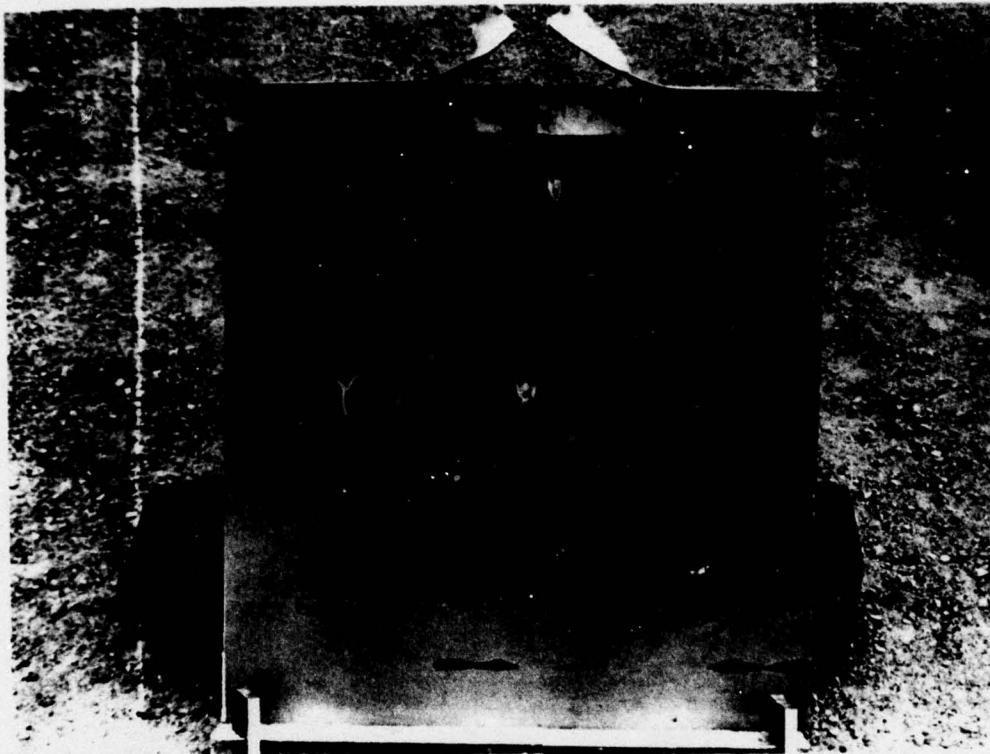

FIGURE 27. 3/8" PLATE
30° OBLIQUITY ANGLE

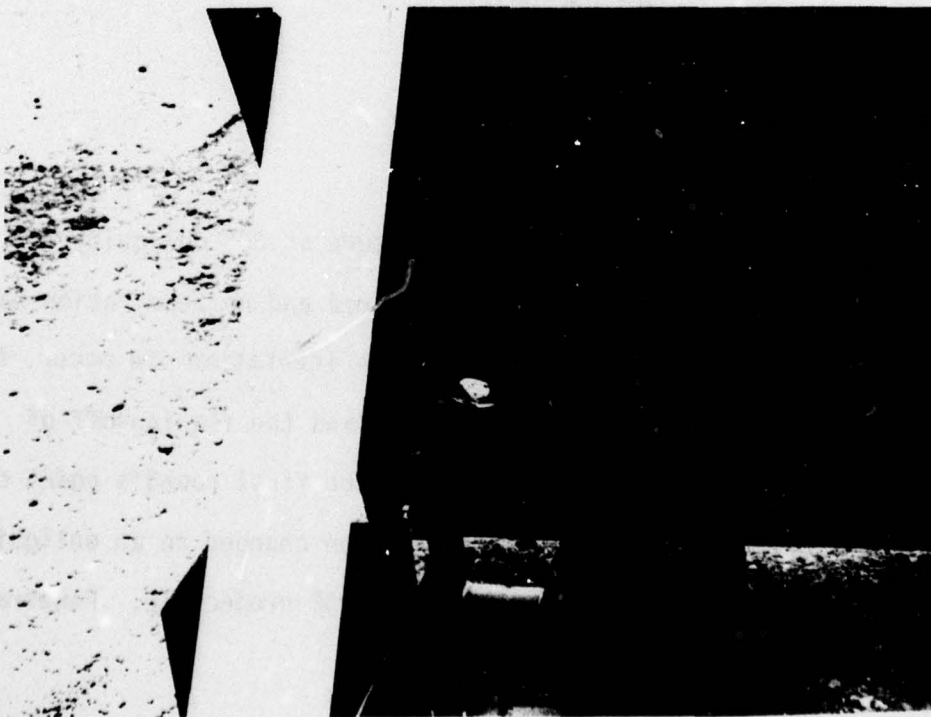

FIGURE 28. 3/8" PLATE
REAR VIEW OF PENETRATION HOLE

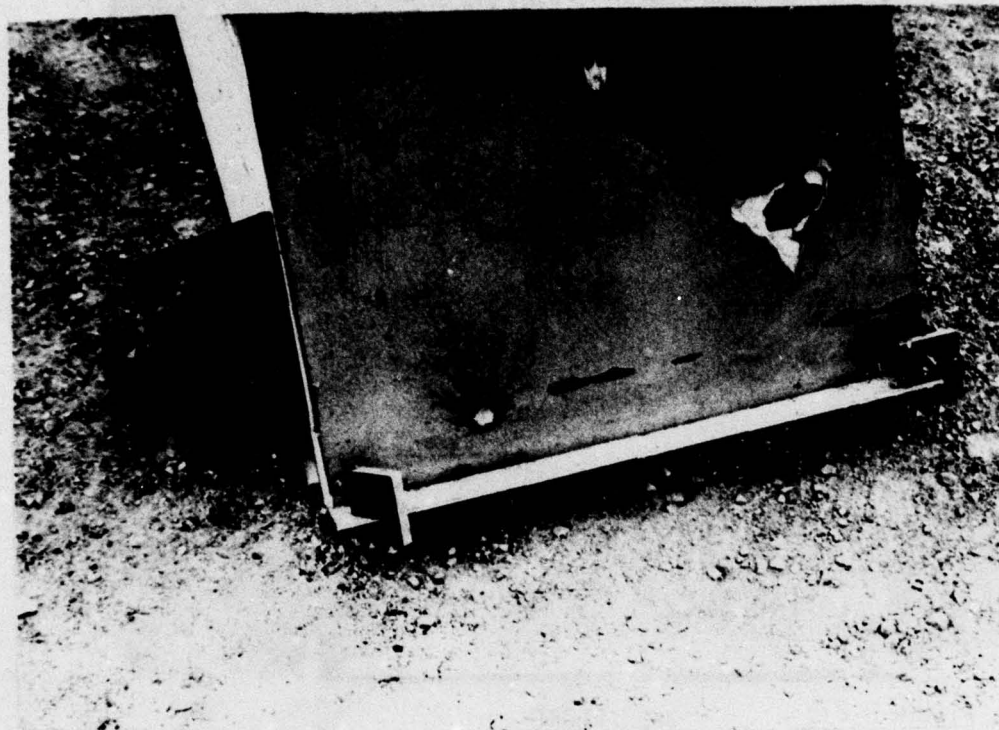

FIGURE 29. 3/8" PLATE
30° OBLIQUITY
BALL AMMUNITION

The 1/2 inch plate was placed on the fixture at 30° obliquity for testing (figure 30). A single AP round was fired and no penetration was achieved, although some cracking and a 1/8 inch indentation did occur. A second AP round resulted in a 1/16 inch crater and the flaking-off of some pieces of armor in the areas adjacent to the first round's point of impact (figure 31). The 1/2 inch plate was then changed to an obliquity of 20° and the test was repeated again with the AP projectile. Penetration was achieved at this point (figure 32).

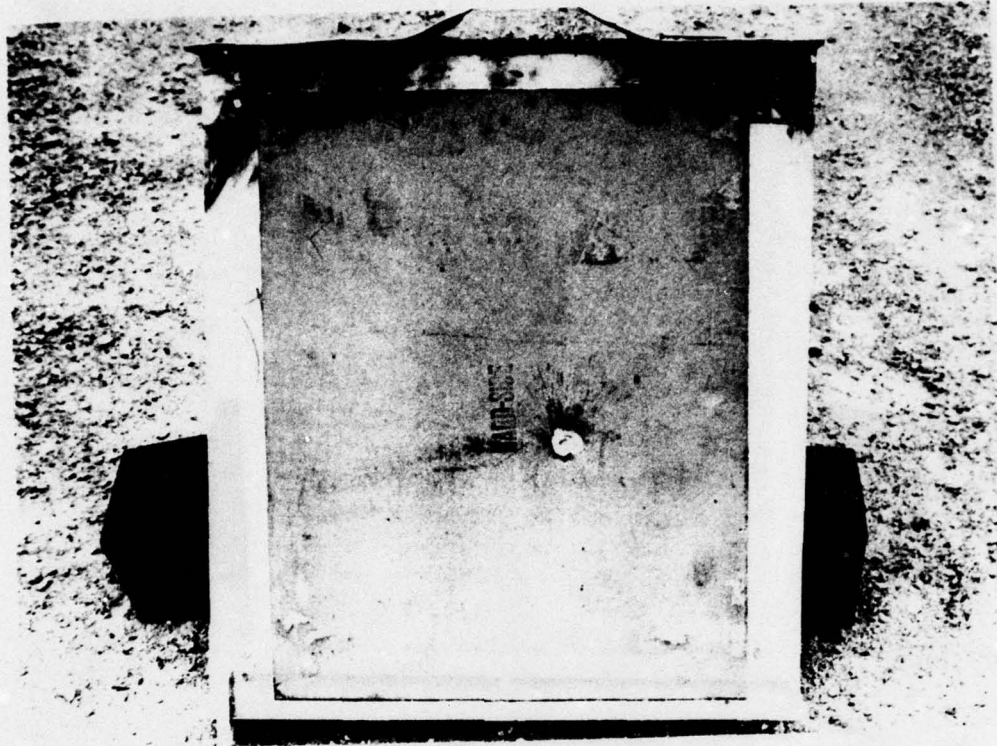

FIGURE 30. 1/2" PLATE
30° OBLIQUITY AP

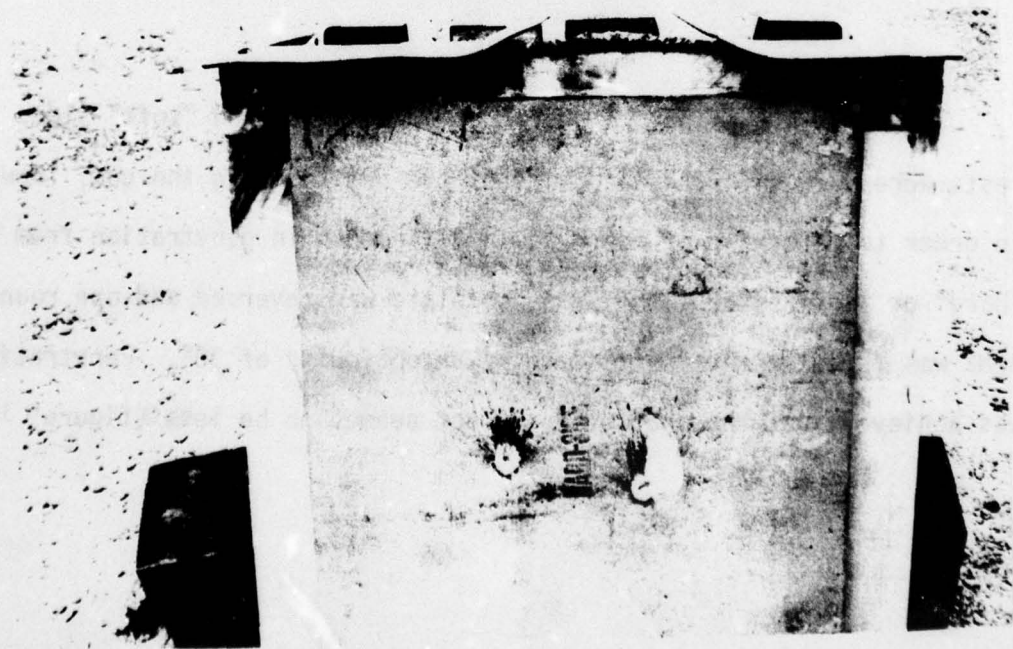

FIGURE 31. 1/2" PLATE
30 OBLIQUITY
AP SECOND HIT

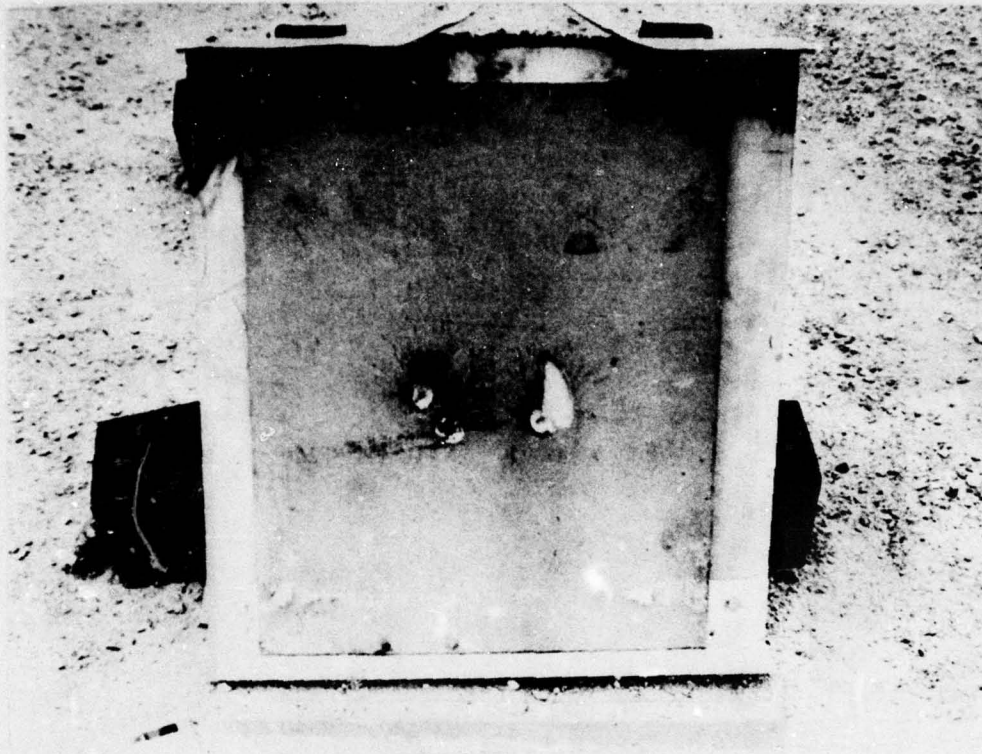

FIGURE 32. 1/2" PLATE
 20° OBLIQUITY

The armor plates have a characteristic "hard" and "soft" side. All tests were made with the hard side of the armor facing the gun. However, in order to determine if there was a difference in penetration from the "hard" or "soft" sides, the 3/8 inch plate was reversed and one round of APM2 was fired at the "soft" side at an obliquity of 30°. Penetration was achieved, but the shattering effect seemed to be less (figure 33).

AD-A058 642

SPERRY RAND CORP HUNTSVILLE AL SPERRY SUPPORT SERVICES
ARMOR TARGET SYSTEMS CONCEPTS. (U)
SEP 77

F/G 19/4

UNCLASSIFIED

210-5801-01

PM TRADE-TR-78-0001

N61339-76-D-0022
NL

2 of 3
AD
A058 642



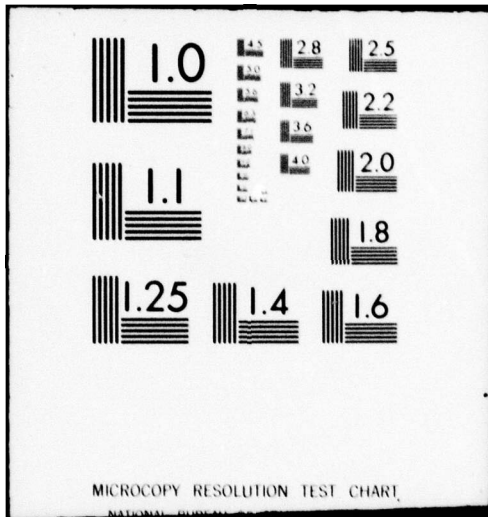

MICROCOPY RESOLUTION TEST CHART

NATIONAL BUREAU OF STANDARDS-1963-A

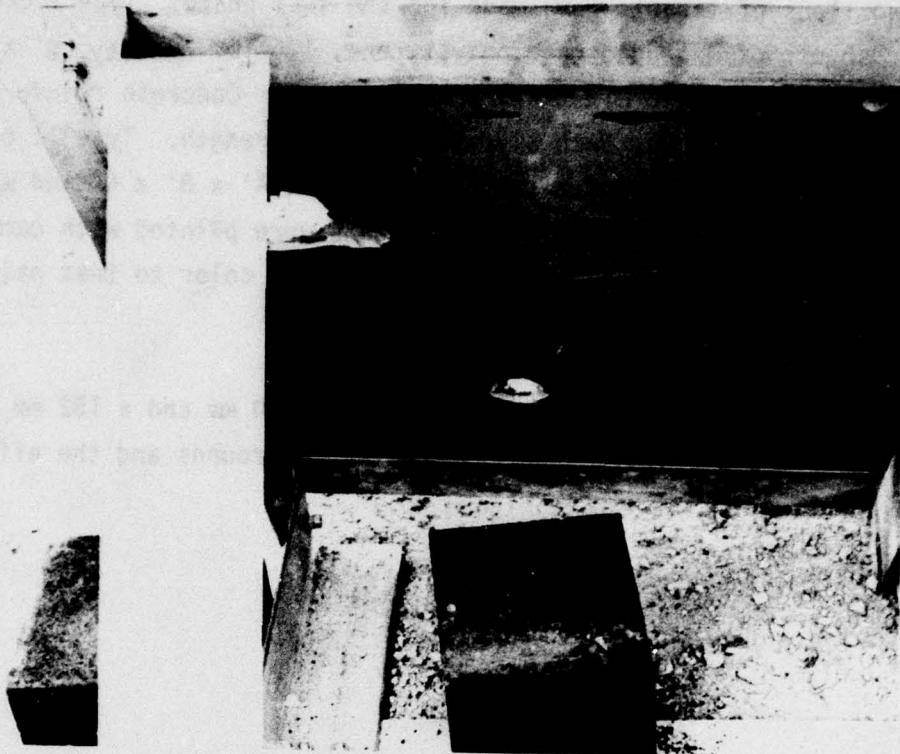

FIGURE 33. 3/8" PLATE
 30° OBLIQUITY
 AP HIT FROM SOFT SIDE

In conclusion, it appears that both 3/8 inch and 1/2 inch face-hardened plates will offer protection against .50 caliber ball ammunition when positioned at an obliquity of at least 30° and located farther than 150 feet from the firing point.

b. Polystyrene

Two types of targets were made for the test phase. Type I consisted of four sheets of expanded bead polystyrene, 1.5 lb. density, 8' x 4' x 4", fastened together to form a panel 8' x 16' x 4". Concrete reinforcing wire was fastened to the back side for added strength. Type II consisted of a single sheet of expanded bead polystyrene 4' x 8' x 4" and was used for the sub-caliber tests only. The targets were painted with commercial latex exterior paint approximately olive drab in color to test paint adherence and application.

It was possible to obtain an example of a 90 mm and a 152 mm hit to obtain a relative comparison between the two rounds and the effect on the target material. (See Figure 40.)

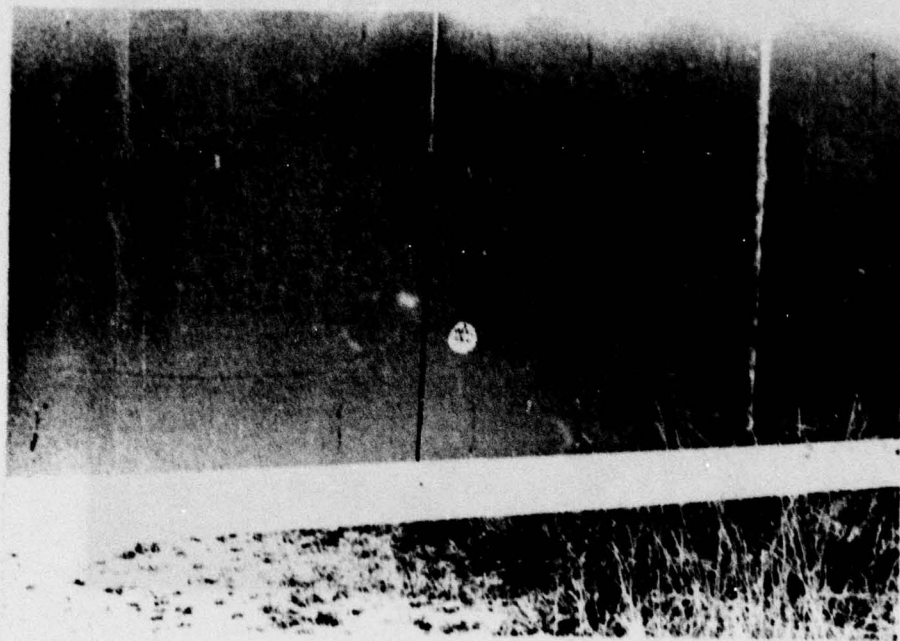

Figure 34. Polystyrene Target - 750 M. - 90MM M353

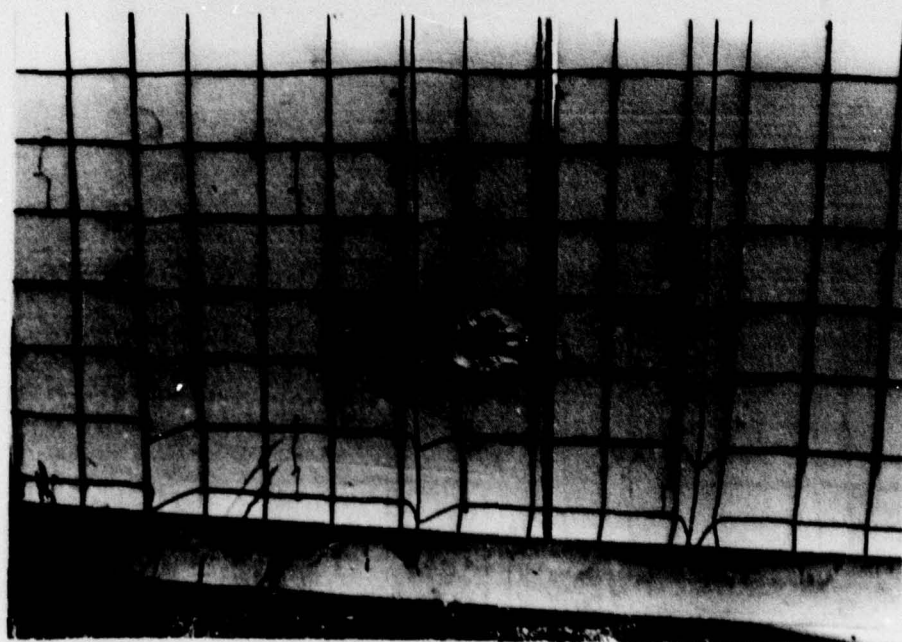

Figure 35. Polystyrene Target - 750 M - 90MM - M353.

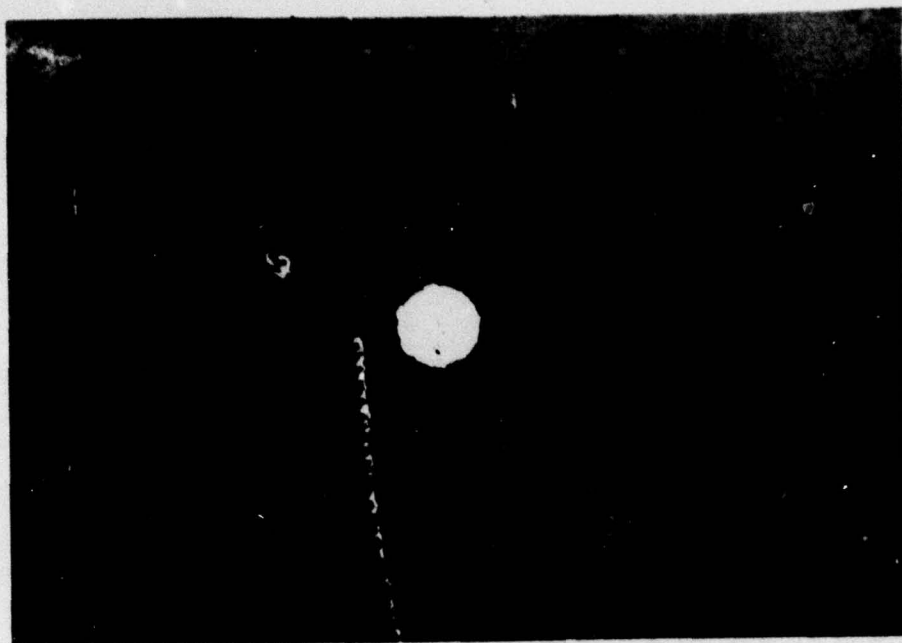

Figure 36. Polystyrene 750 M, 105 MM, M467



Figure 37. Polystyrene 750 M, 105 MM, M467

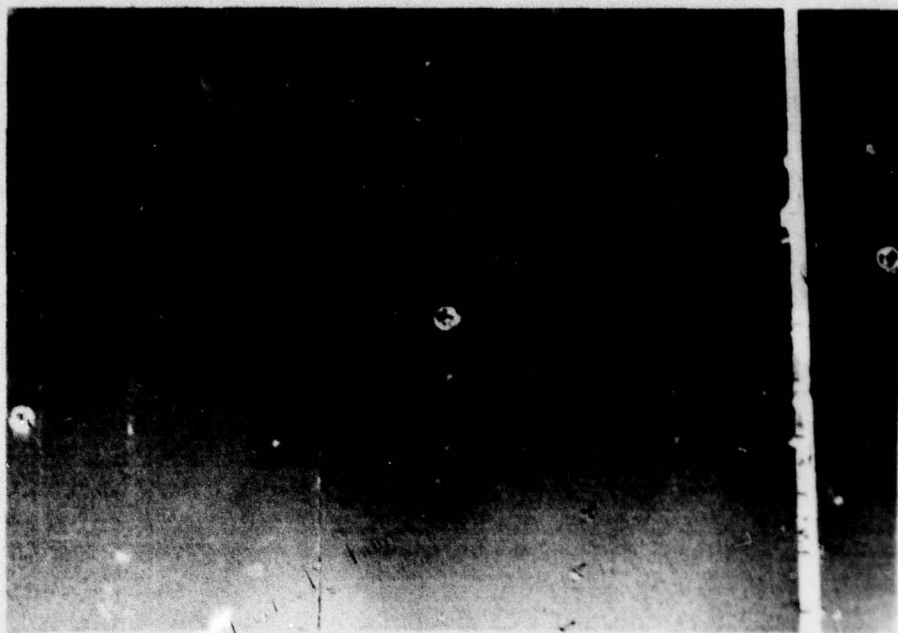

Figure 38. Polystyrene 750 M, 105 MM, M724.

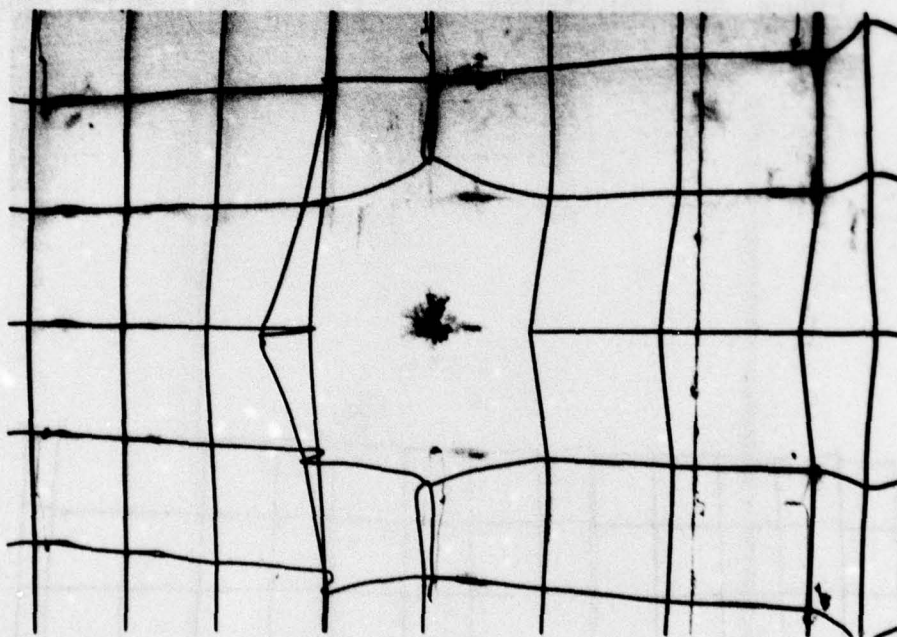

Figure 39. Polystyrene 750 M, 105 MM, M724.

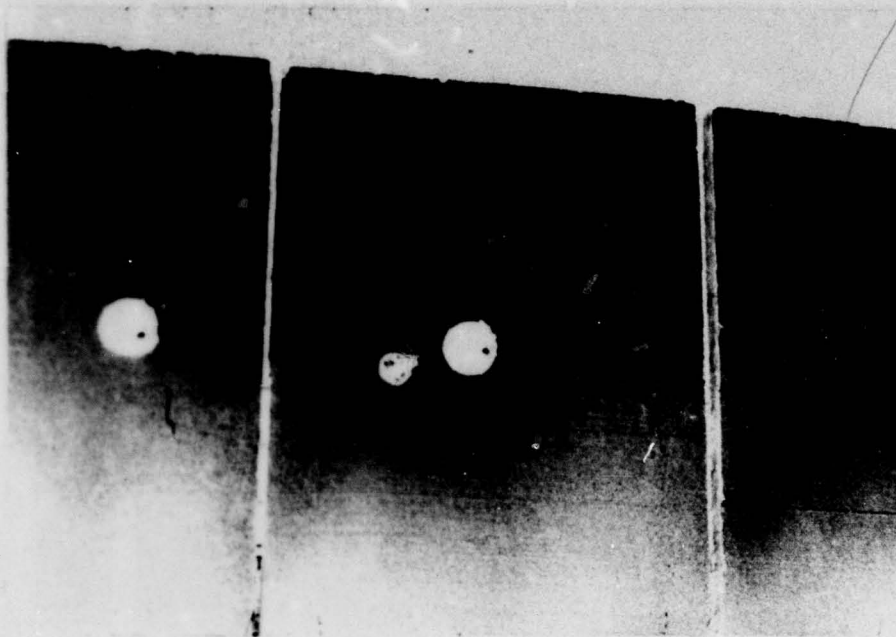

Figure 40. Polystyrene 750 M, 152 MM, M411, 90 MM, M353 Comparison.

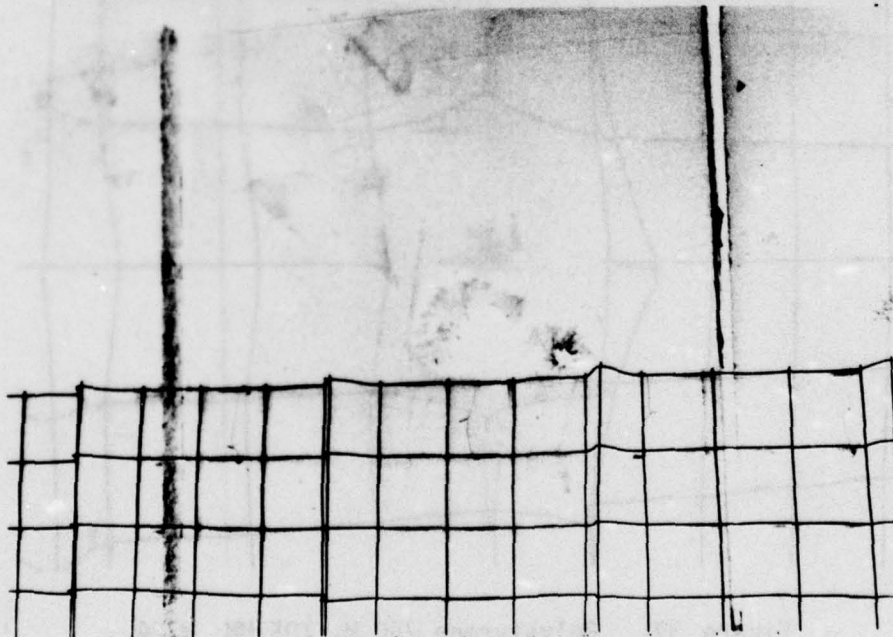

Figure 41. Polystyrene 750 M, 152 MM, M411, 90 MM, M353 Comparison.

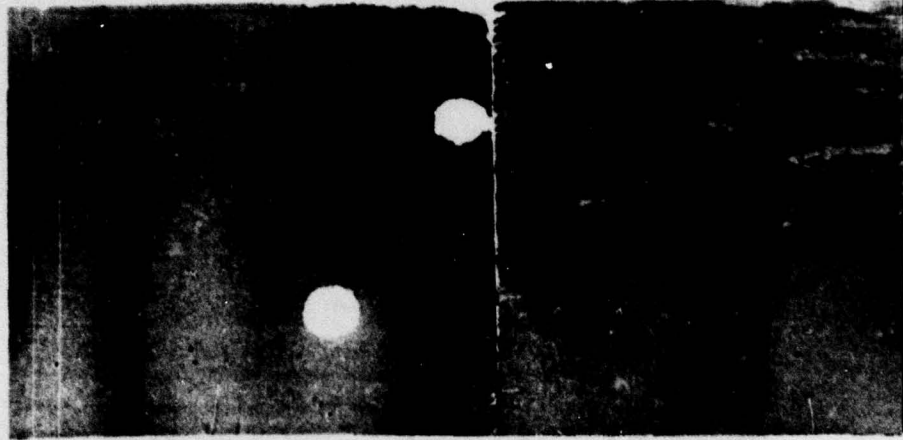

Figure 42. Polystyrene 750 M, 105 MM, M467 Multiple Hits.

This picture shows relatively close hits on the polyethylene target and the effect on the target. From this type of information it is possible to speculate the number of close hits a target can sustain and still be useable. The edge of upper hit is within approximately 1 inch of the edge of the target material and while a small portion is broken off the entire corner is still intact. The area covered is approximately 1 1/2 foot by 2 foot of a 4' x 8' sheet.

Theoretically a 8' x 16' target could therefore sustain approximately 48 evenly spaced hits and still maintain its integrity. This is a theoretical estimate but appears from the material and construction to be valid.

The damage estimate is further demonstrated by noting the damage on the reverse side.

Wire damage caused by close hits was not severe as shown in Figure 43.

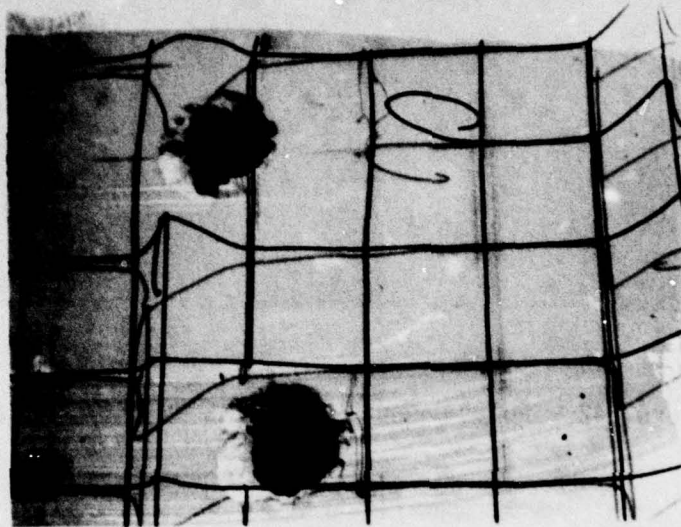

Figure 43. Polystyrene 750 Meters, 150mm, M467,
Reinforcing Wire Damage

Each square is 6" x 6" and damage has been confined to a maximum of one or two cross wires.

Target damage due to hits with large and small caliber projectile also indicates that the polystyrene material will withstand a fairly large number of hits without severe damage.

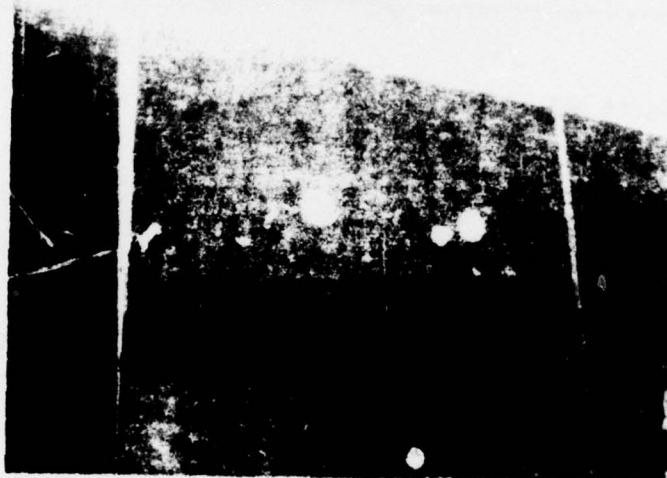

Figure 44. Polystyrene 750 Meters, 152mm, 90mm

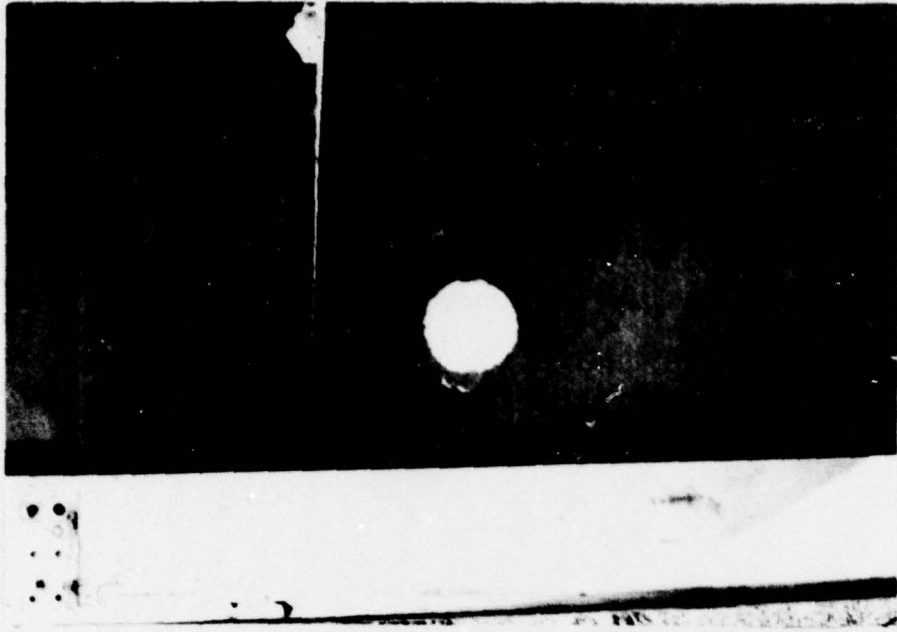

Figure 45. Polystyrene 1200M, 105 MM, M467.

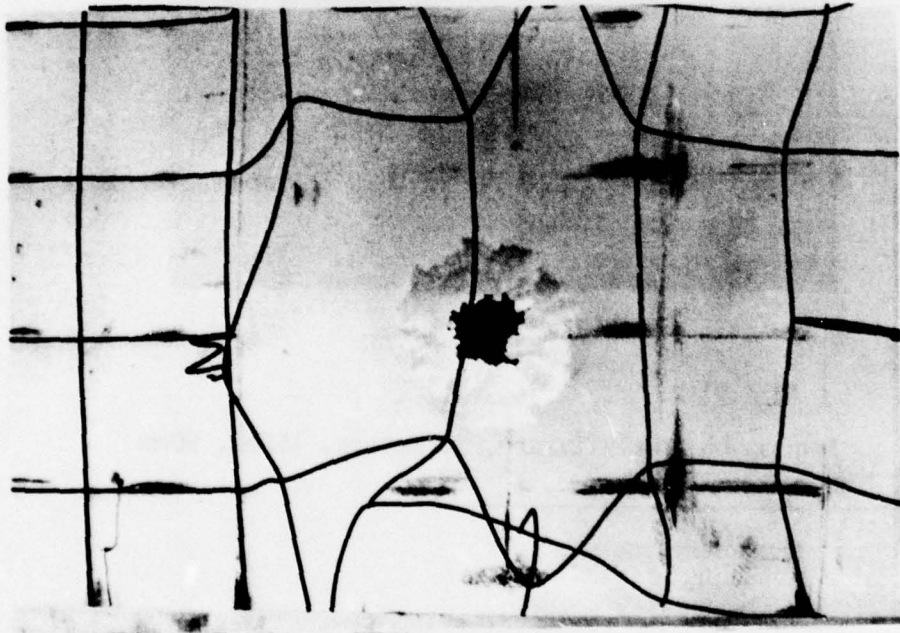

Figure 46. Polystyrene 1200M, 105 MM, M467.

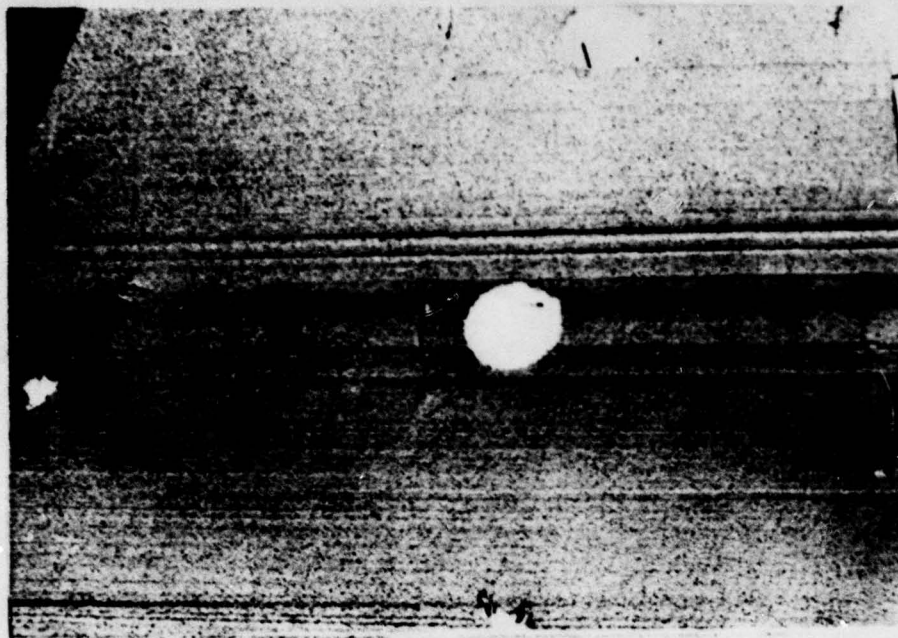

Figure 47. Polystyrene 1200 M 105 MM, M490.

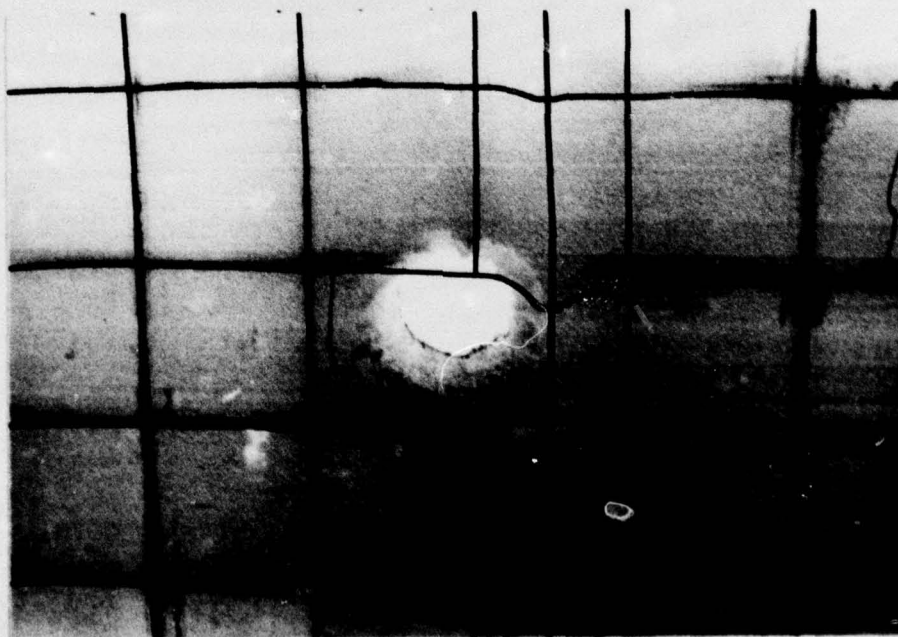

Figure 48. Polystyrene 1200 M 105 MM, M490.

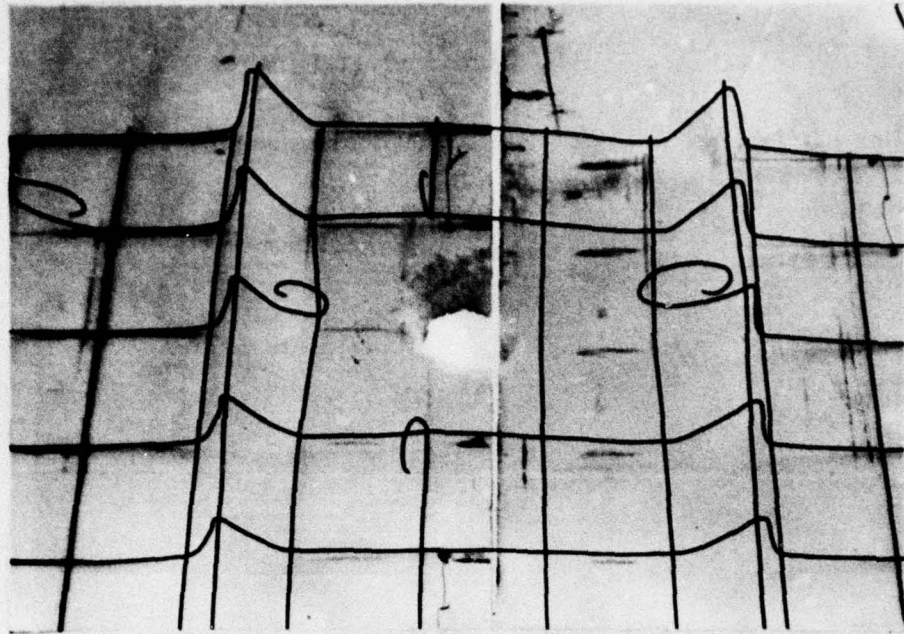

Figure 49. Polystyrene 1200 M. 105 MM, M490, Effect on Reinforcing Wire.

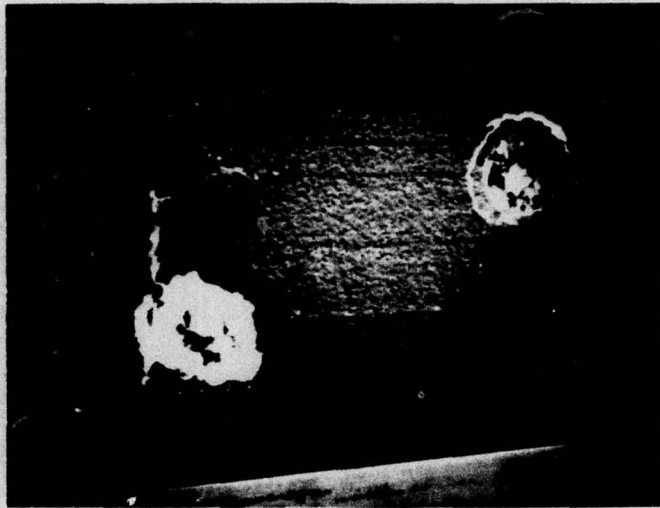

Figure 50. Polystyrene 1200 M, 105 MM M724.

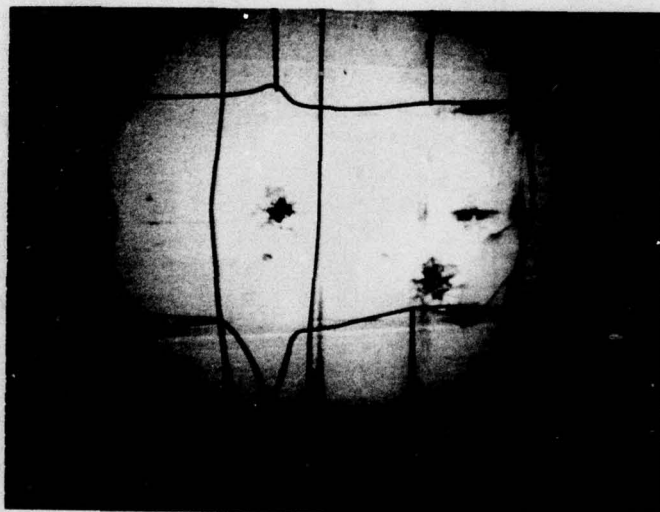

Figure 51. Polystyrene 1200 M, 105 MM M724.

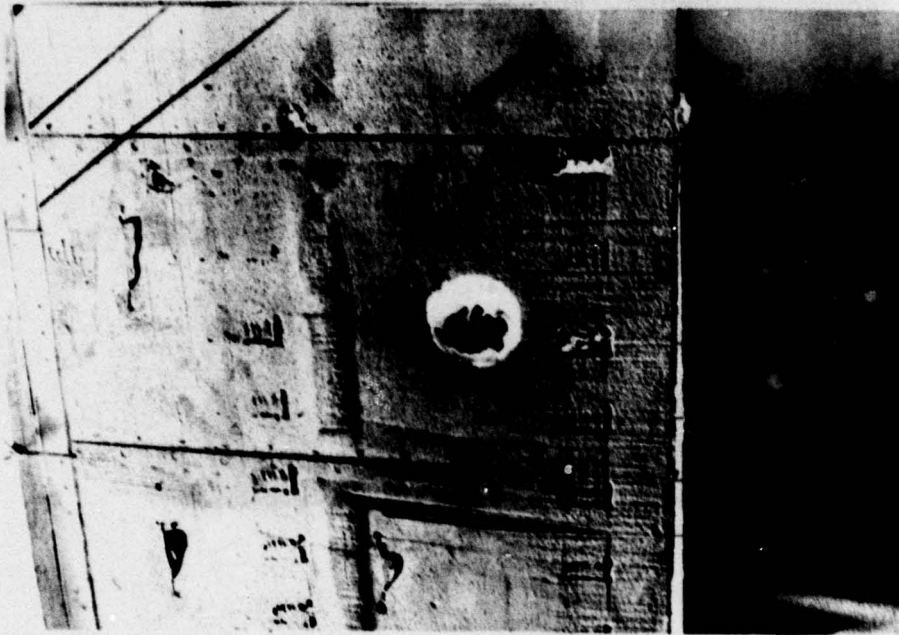

Figure 52. Polystyrene 1200 M 152 MM, M411.

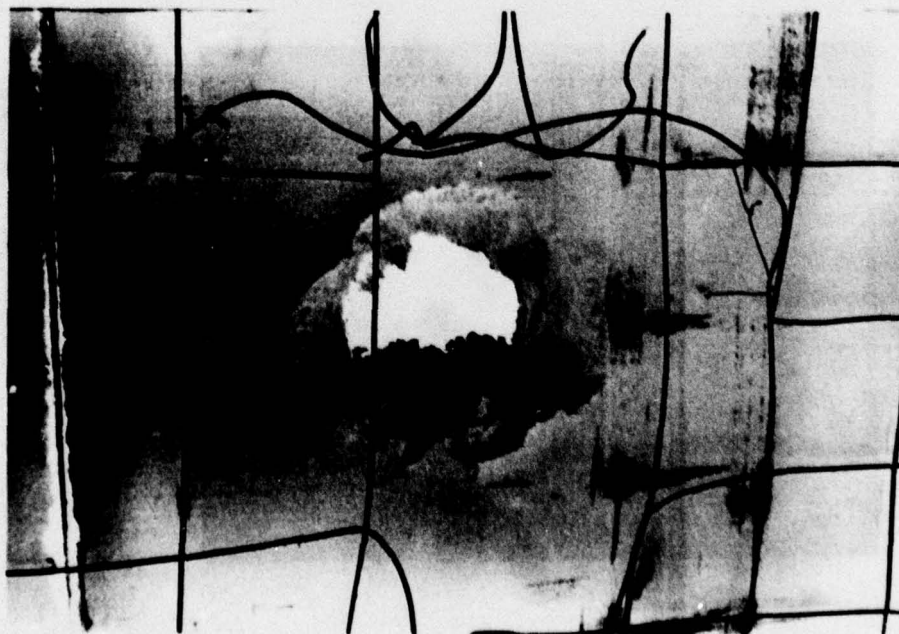

Figure 53. Polystyrene 1200 M 152 MM, M411.

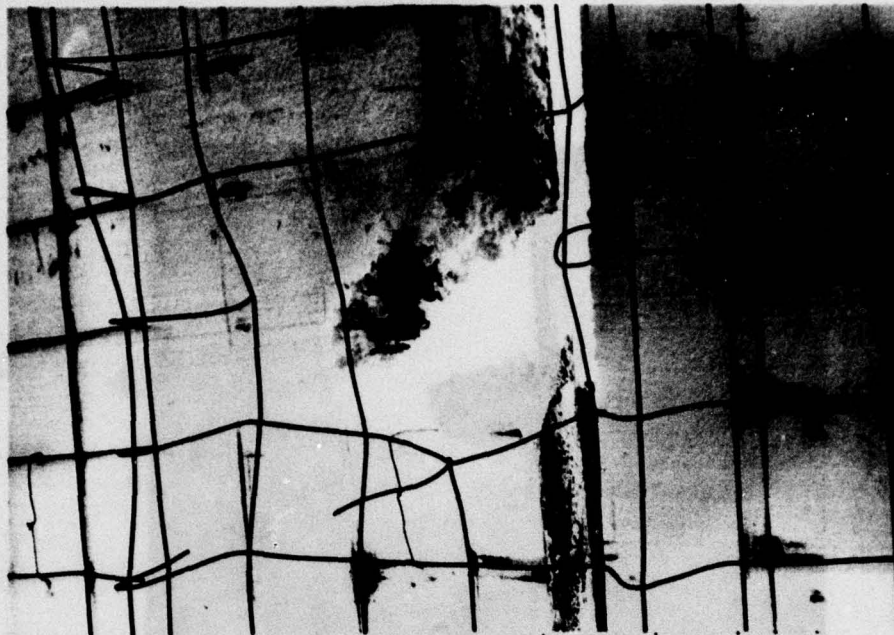

Figure 54. Polystyrene 1200 M 152 MM, M411.

Target damage due to breakaway of styrene on edge of hit.
Approximately 1 square foot of damage due to hit.



Figure 55. Polystyrene, 2000 M, 105 MM M467.



Figure 56. Polystyrene 2000 M, 105 MM M490.

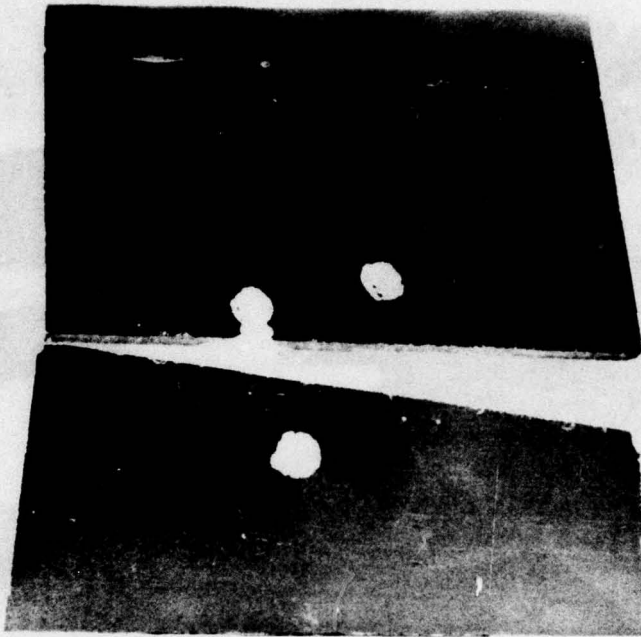

Figure 57. Polystyrene 2000 M 152 MM, M411.

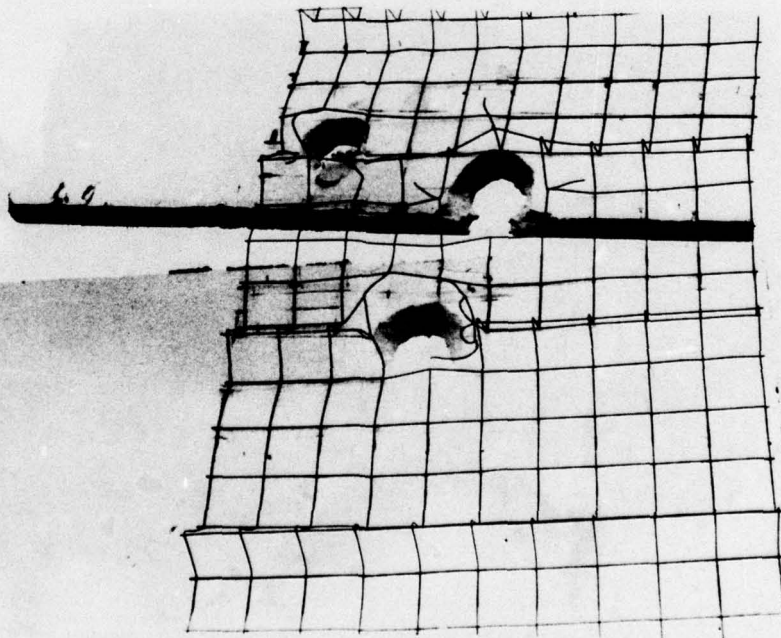

Figure 58. Polystyrene 2000 M 152 MM, M411.

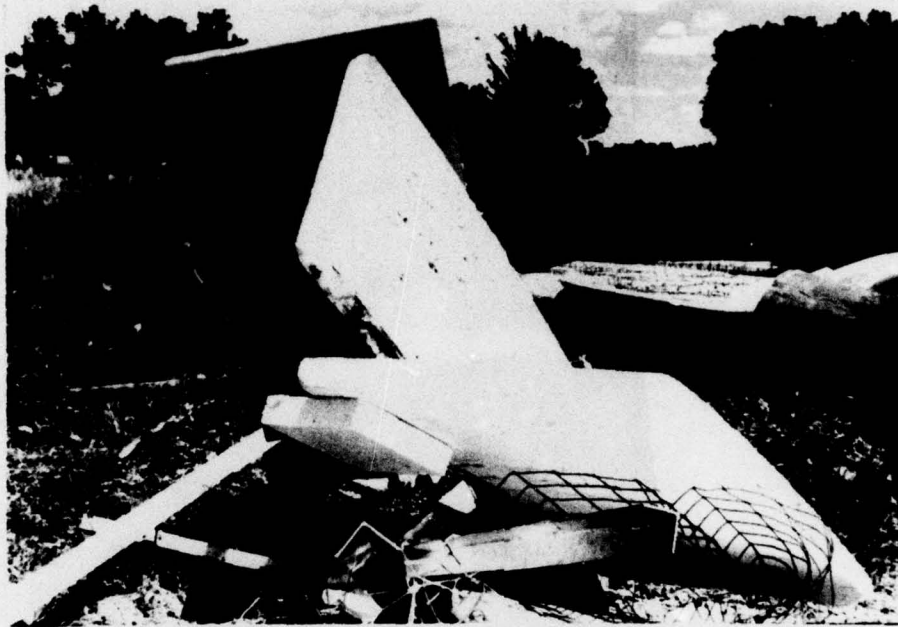

Figure 59. Result of near miss, 90 MM, M353 Round Fired at 1200 Meters, Struck Ground Under Target Frame.

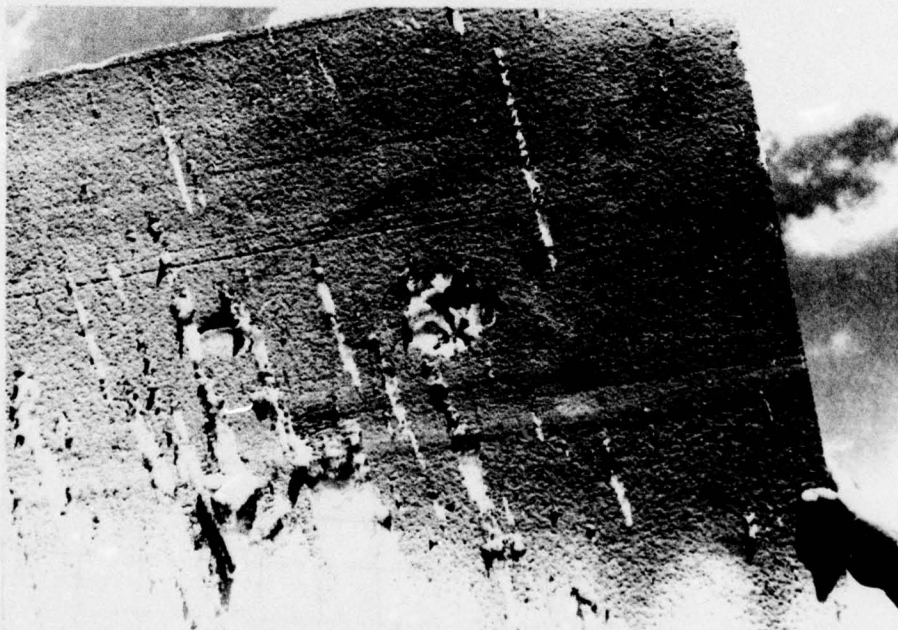

Figure 60. Damage Due to Debris Striking Target.

The effect of subcaliber rounds on polystyrene target material indicates that this material can absorb a large number of hits without severe damage. A section of the target material approximately one foot square was masked and the holes caused by the .50 caliber bullets were counted. With a density of over 100 holes per square foot, a 4' x 8' section could absorb at least 3200 round over its entire surface without severe damage (see Figures 61, 62). A concentrated fire well in excess of 100 rounds/square ft. would be required to produce a large hole in the target.

Using similar techniques and assuming even distribution of hits, a 4' x 8' target could absorb approximately 1500 hits from 20MM inert projectiles (see Figures 63, 64). It is realized that these values are theoretical but they are indicative of the effect on the target material.

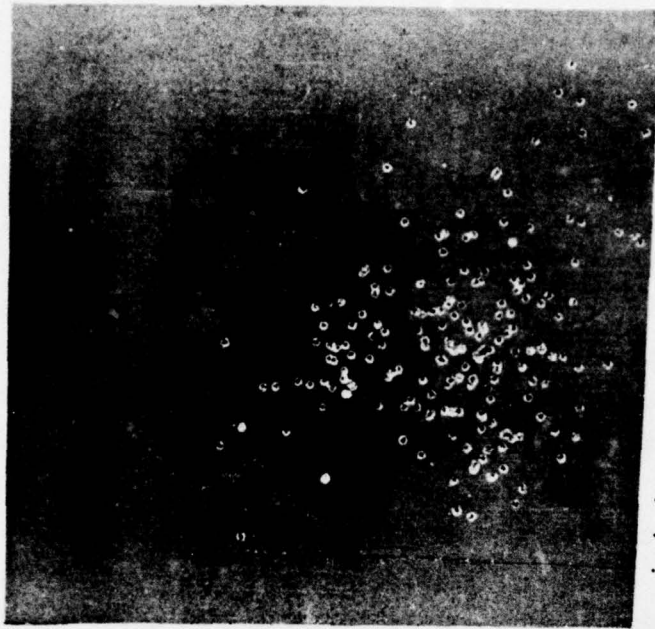

Figure 61. Polystyrene Target, 188 Rounds, .50 Caliber.
120M

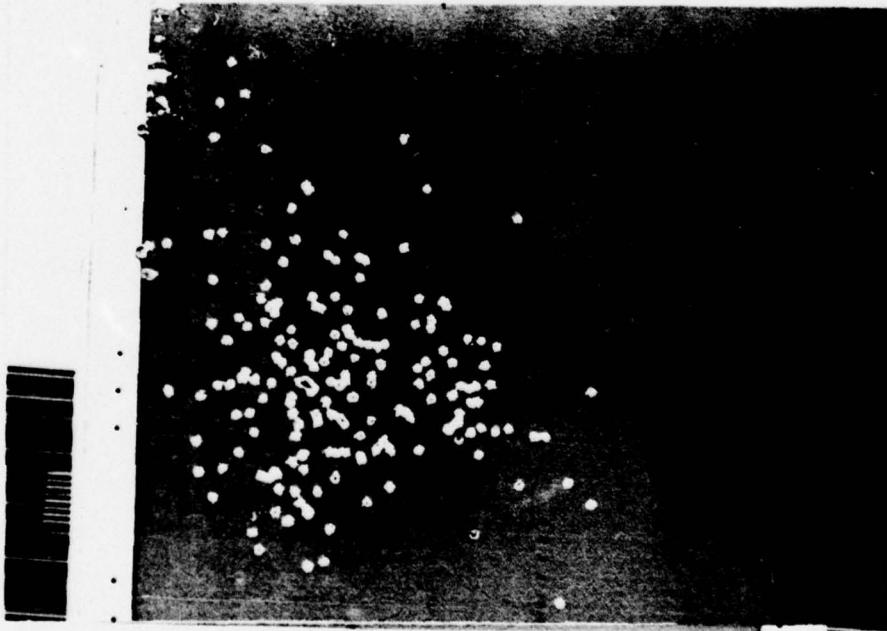

Figure 62. Polystyrene Target, 188 Rounds, .50 Caliber.
120M

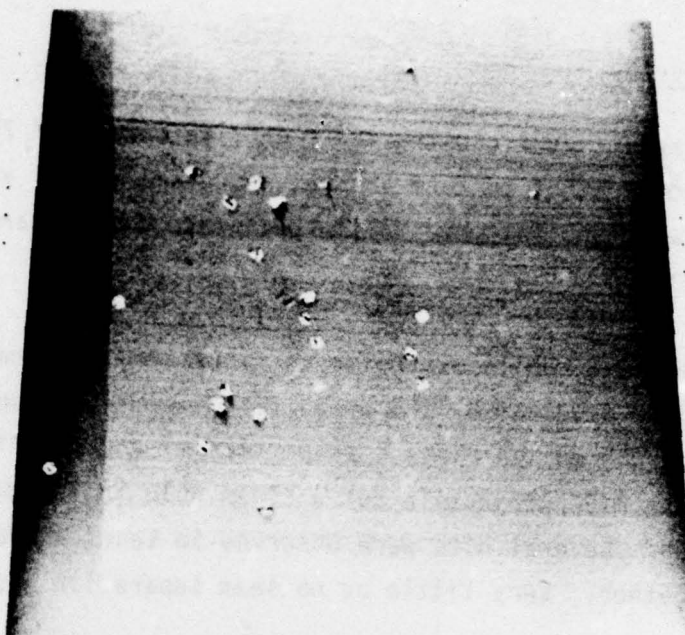

Figure 63. Polystyrene Target, 20 MM, -79 Rounds Automatic Fire.
120M



Figure 64. Polystyrene Target, 20 MM - 19 Rounds Automatic Fire.
120M

c. Polyethylene Foam

These targets were constructed from five panels of 2" thick polyethylene foam cemented together to form a panel approximately 8' x 15'. Concrete reinforcing wire was fastened to the back side of the target to add strength to the target.

This material, while expensive to fabricate, appeared to be the most durable. Holes produced by the projectile impacts produced the least visual damage due to the elastic properties of the material. It should be noted that the M490 projectile cut a clean hole in the material that did not close back up. Several hits were observed on seams where two sheets were fastened together. Very little or no seam separation was observed.

On a basis of 2 hits within an 18" square the 8' x 15' target could absorb at least 106 hits with 152 M411 projectiles and still maintain its identity.

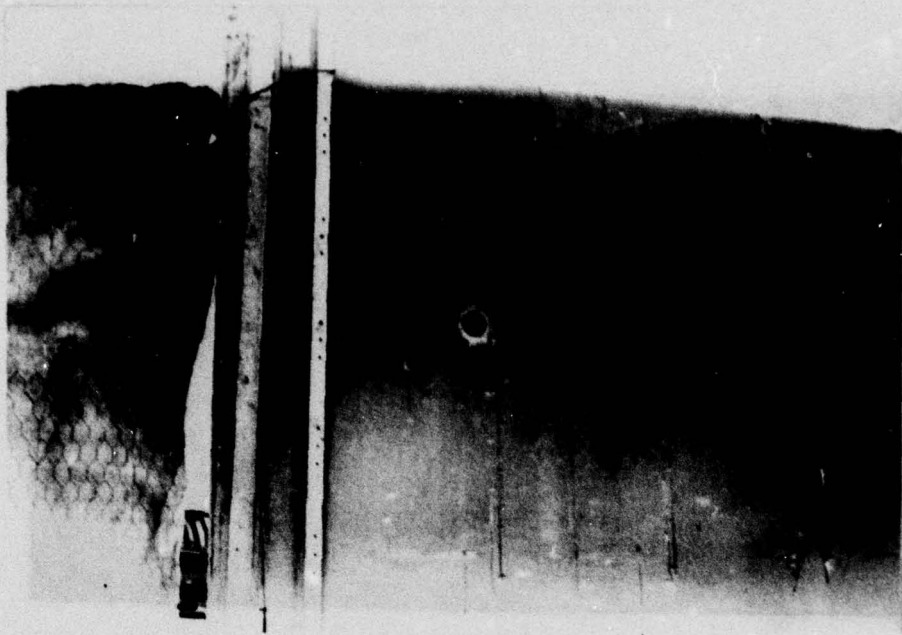

Figure 65. Polyethylene Foam, 750 M 90 MM, M353.

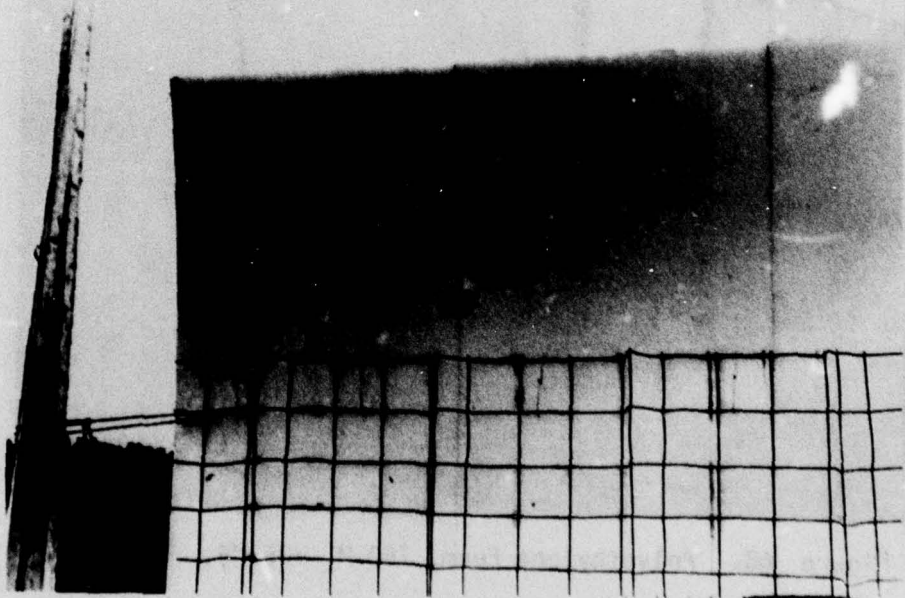

Figure 66. Polyethylene Foam, 750 M 90 MM, M353.

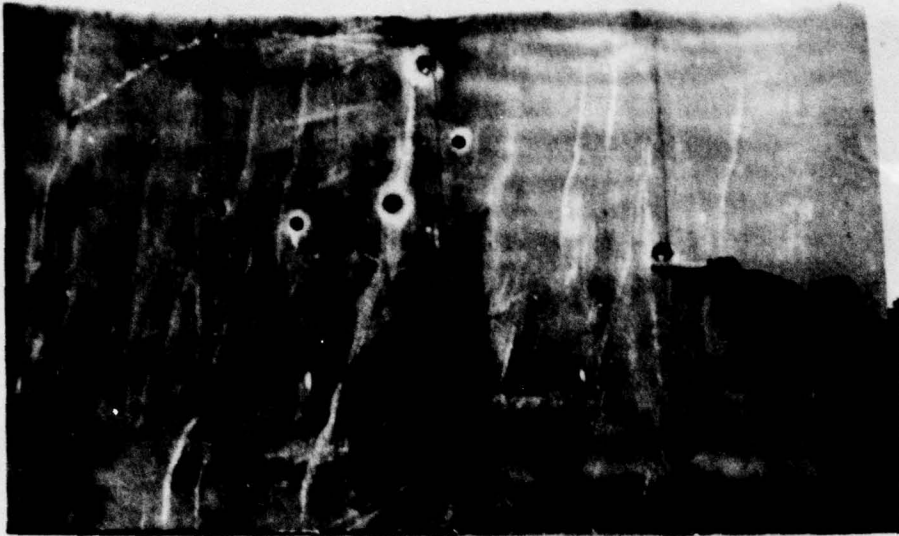

Figure 67. Polyethylene Foam, 750 M, 105 MM, M393.



Figure 68. Polyethylene Foam, 750 M, 105 MM, M393

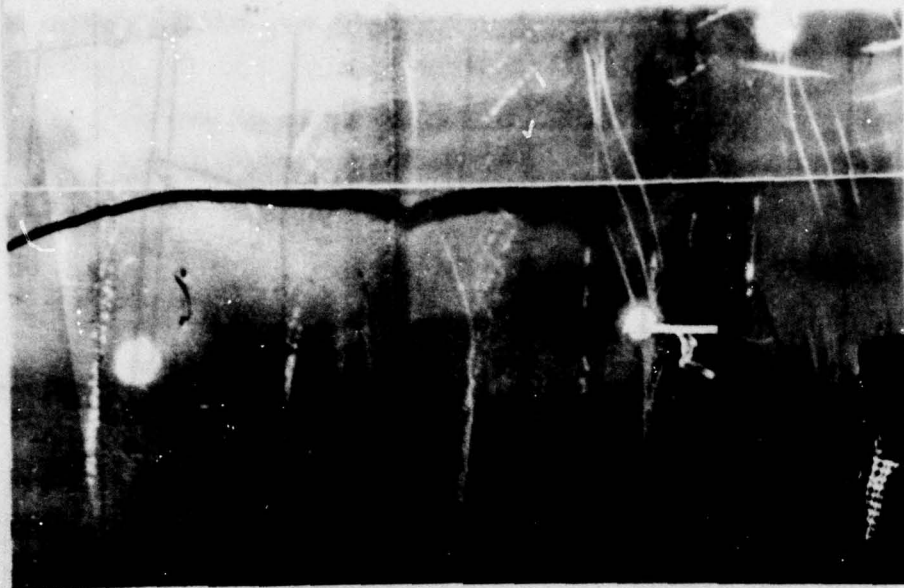

Figure 69. Polyethylene Foam, 750 M, 105MM, M490.

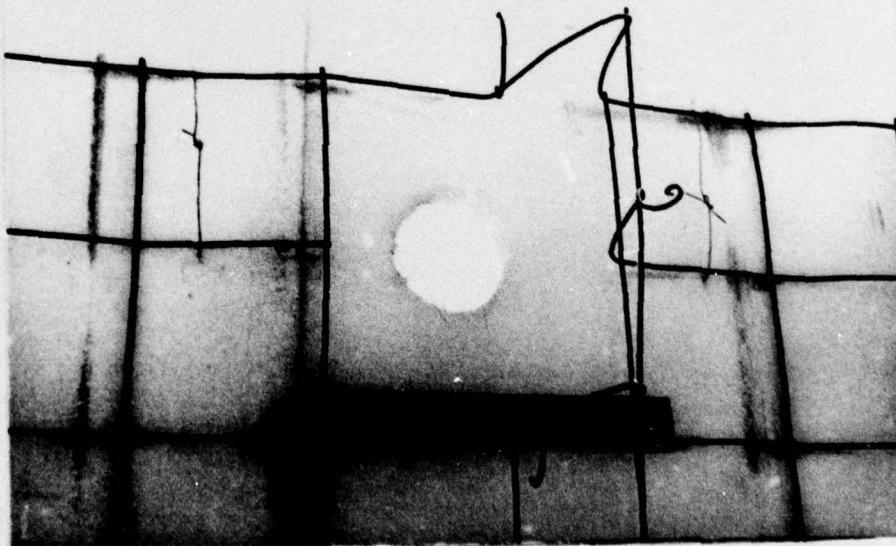

Figure 70. Polyethylene Foam, 750M, 105 MM, M490.

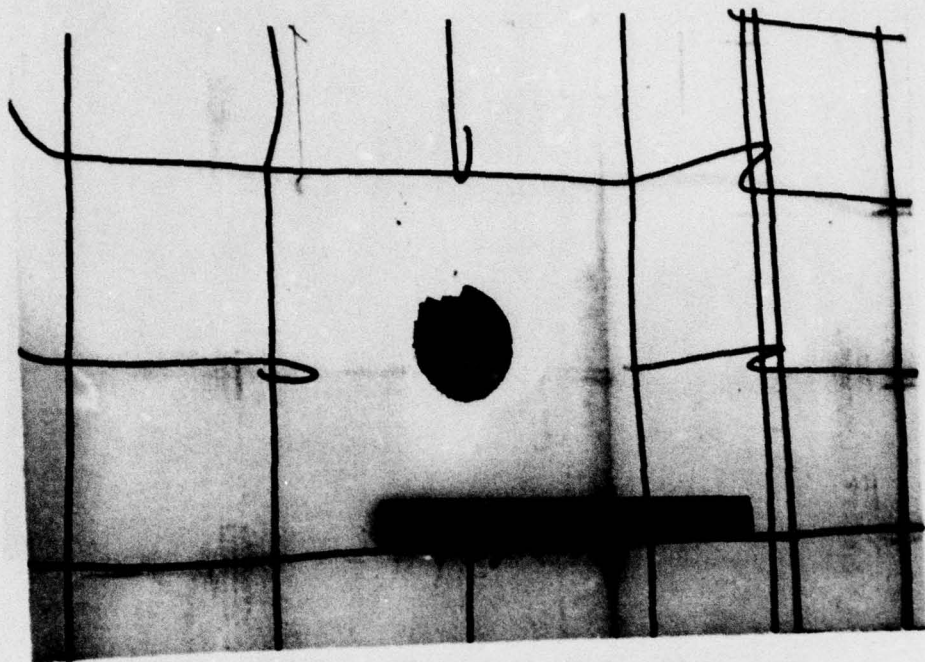

Figure 71. Polyethylene Foam, 750 M, 105 MM, M490



Figure 72. Polyethylene Foam, 750 M, 105 MM M724.

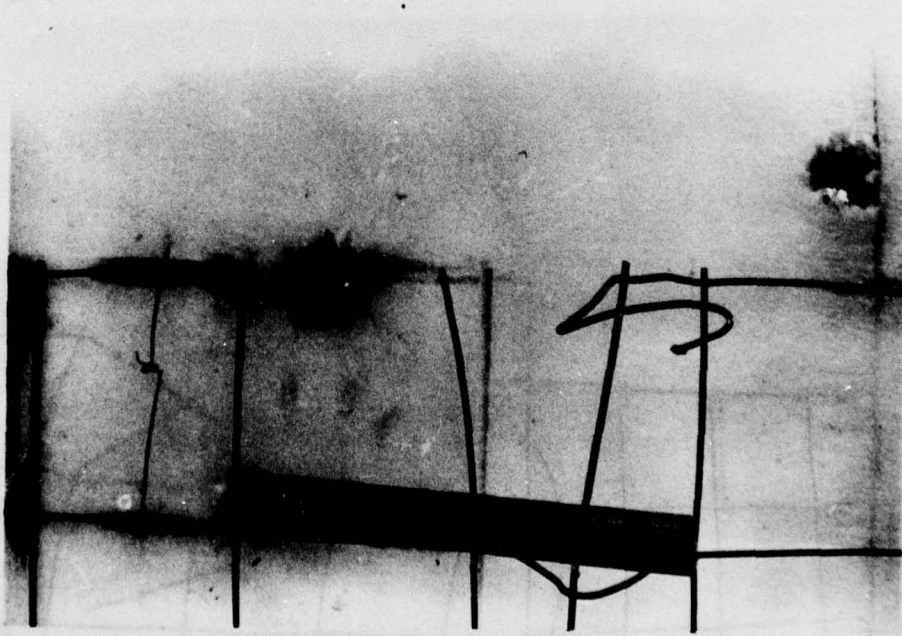

Figure 73. Polyethylene Foam, 750 M, 105 MM M724.

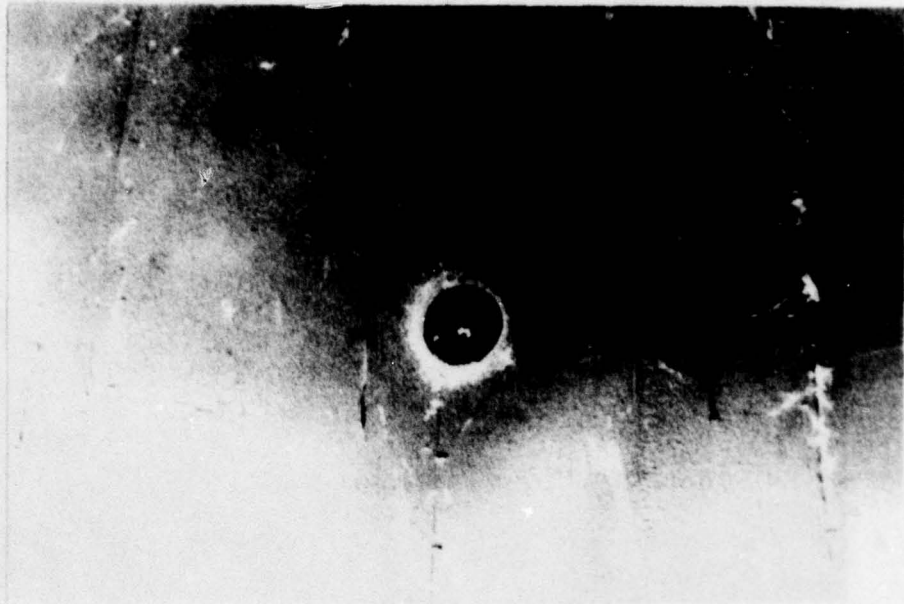

Figure 74. Polyethylene Foam, 750 M 152 MM, M411.

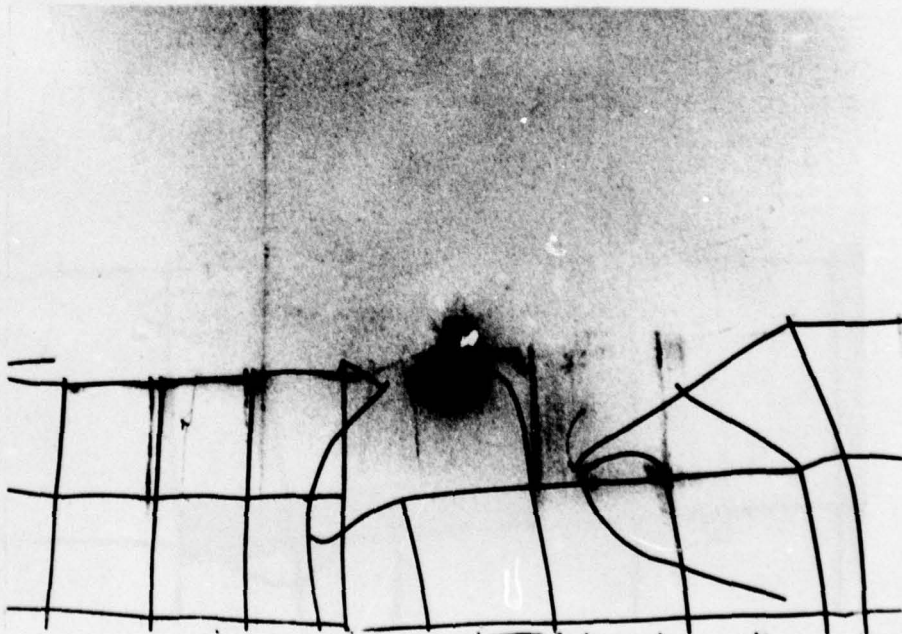

Figure 75. Polyethylene Foam, 750 M 152 MM, M411.

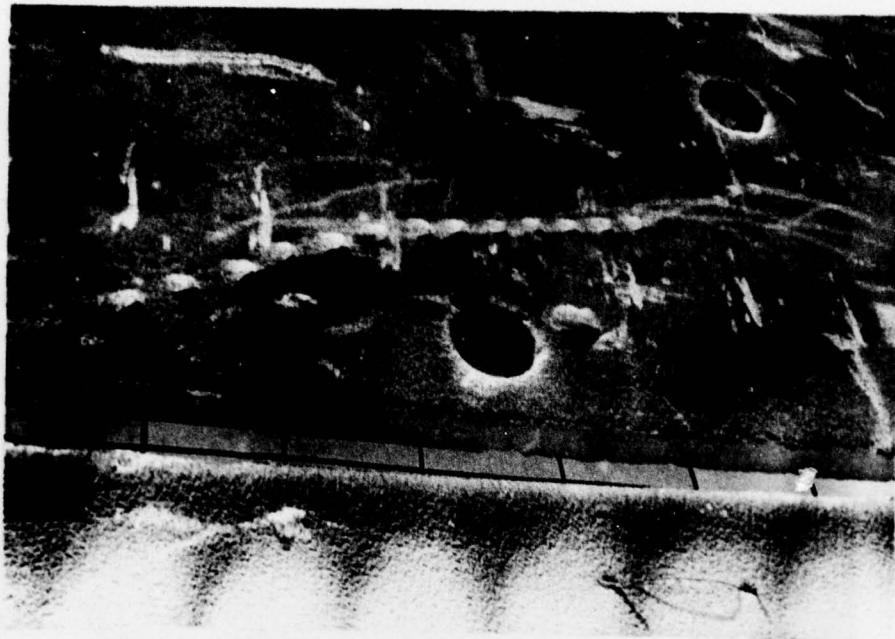

Figure 76. Polyethylene Foam, 1000 M, 105^MMM, M490.



Figure 77. Polyethylene Foam, 1000 M, 105 MM, M490.

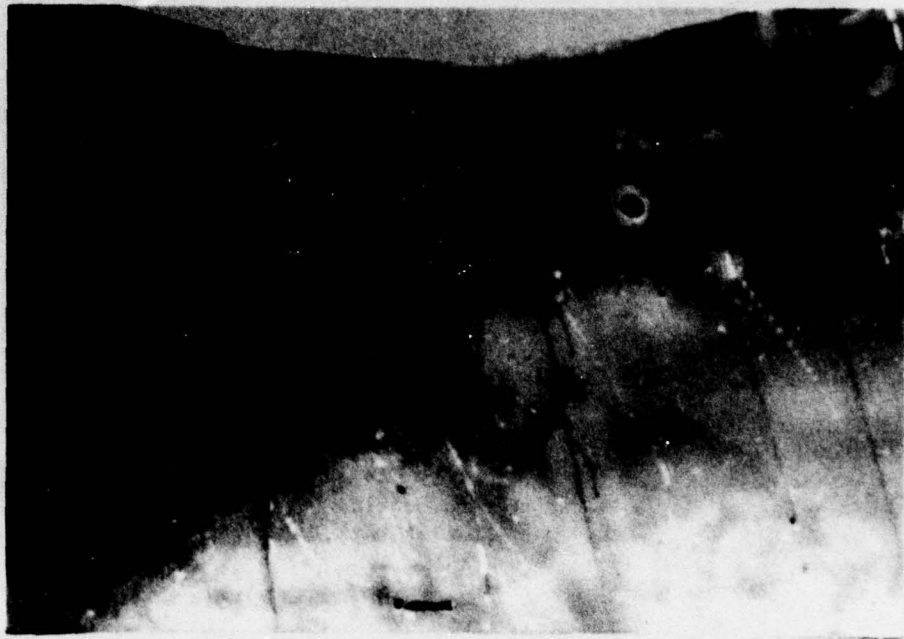

Figure 78. Polyethylene Foam, 1200 M, 90 MM, M353.

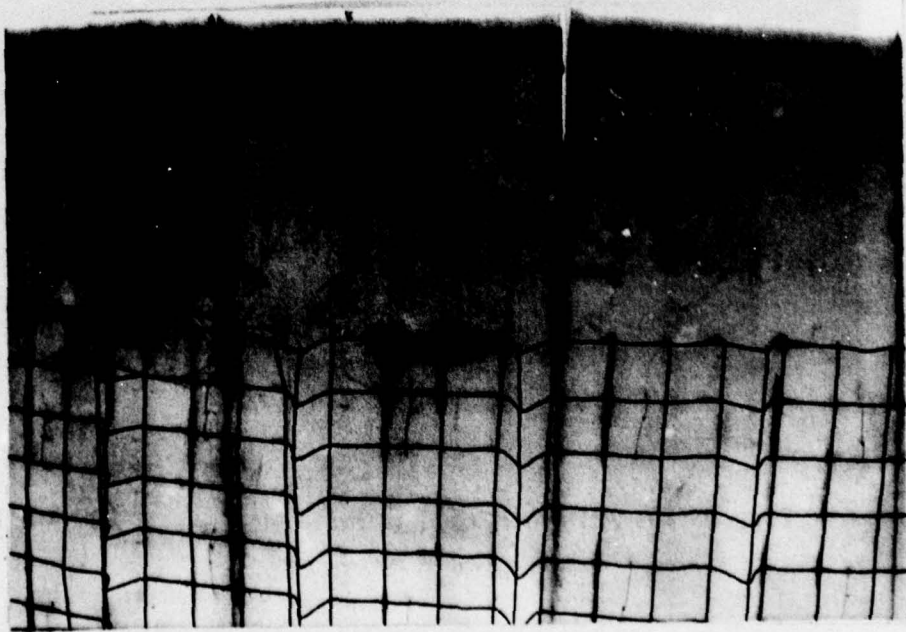

Figure 79. Polyethylene Foam, 1200 M, 90 MM, M353.

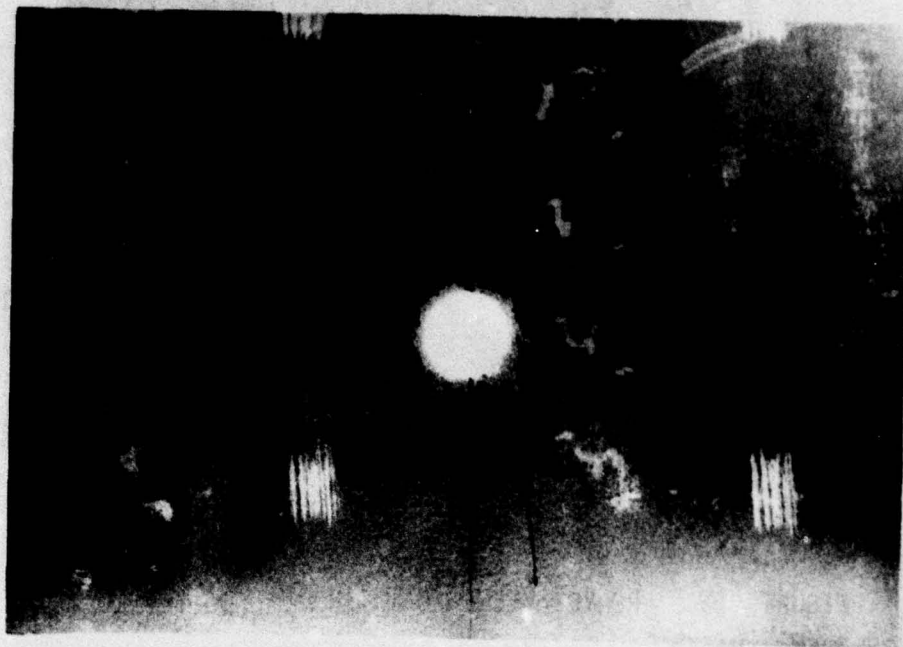

Figure 80. Polyethylene Foam, 1200 M, 105 MM, M490.

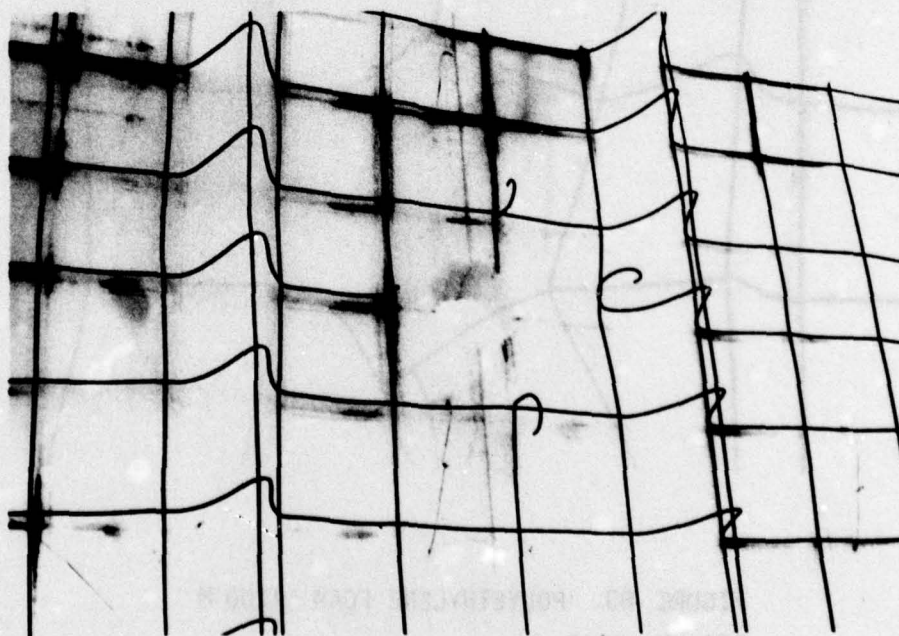

Figure 81. Polyethylene Foam, 1200 M, 105 MM, M490.



ENTRY

FIGURE 82. POLYETHYLENE FOAM 1200 M
105M , M467

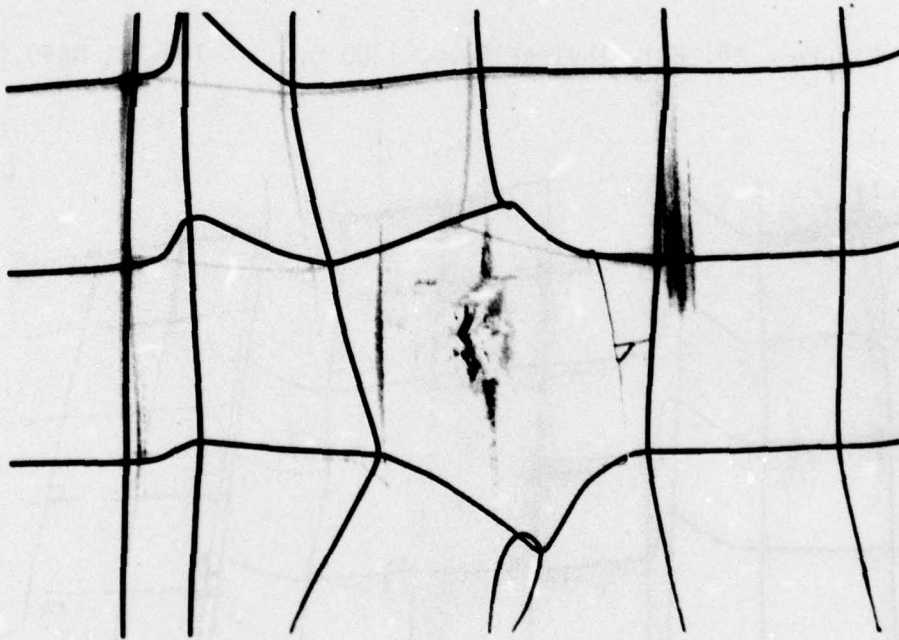

FIGURE 83. POLYETHYLENE FOAM 1200 M
105 MM, M467

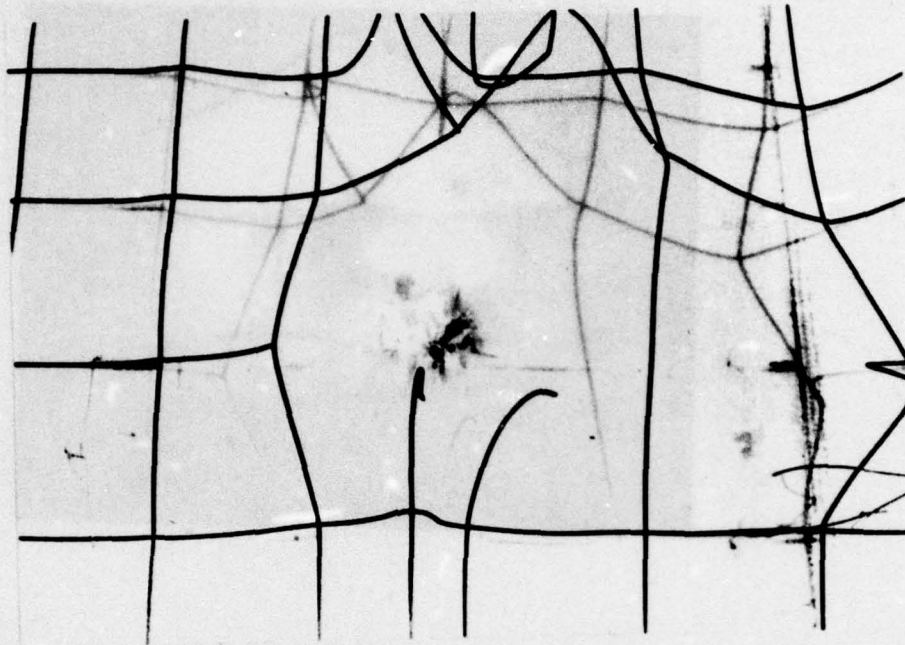

Figure 84. Polyethylene Foam, 1200 M. 105MM M467

Damage to reinforcing wire when direct hit scored on corregation.

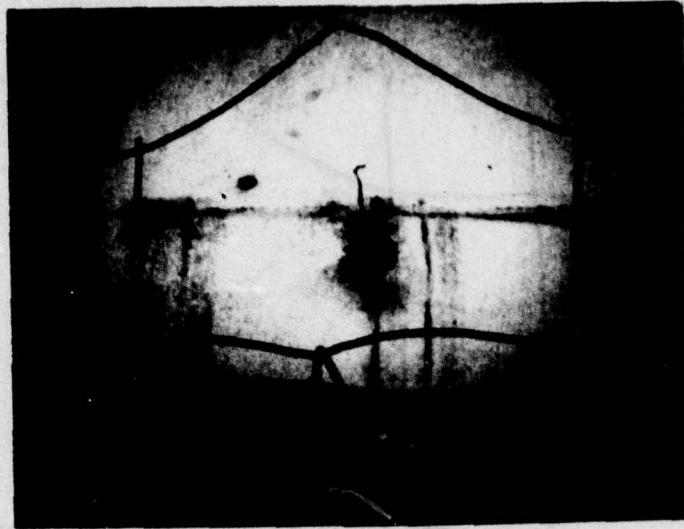

FIGURE 85. Polyethylene Foam 1200M, 105MM, M724



Figure 86. Polyethylene Foam 1200 M, 105MM, M724



Figure 87. Polyethylene Foam, 1200 M 152 MM, M411.

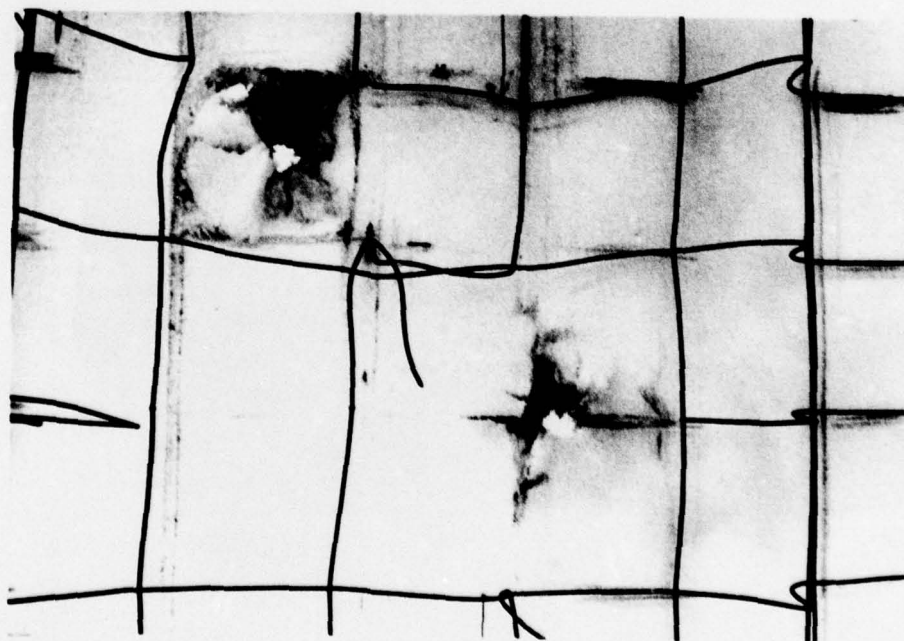

Figure 88. Polyethylene Foam, 1200 M 152 MM, M411.

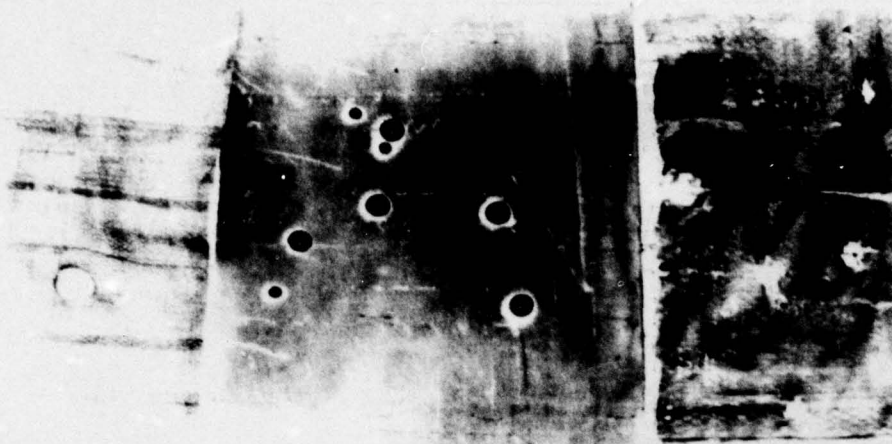

FIGURE 89. POLYETHYLENE FOAM 2000 M, 90MM, M353,
152MM, M411

EFFECT OF MULTIPLE HITS

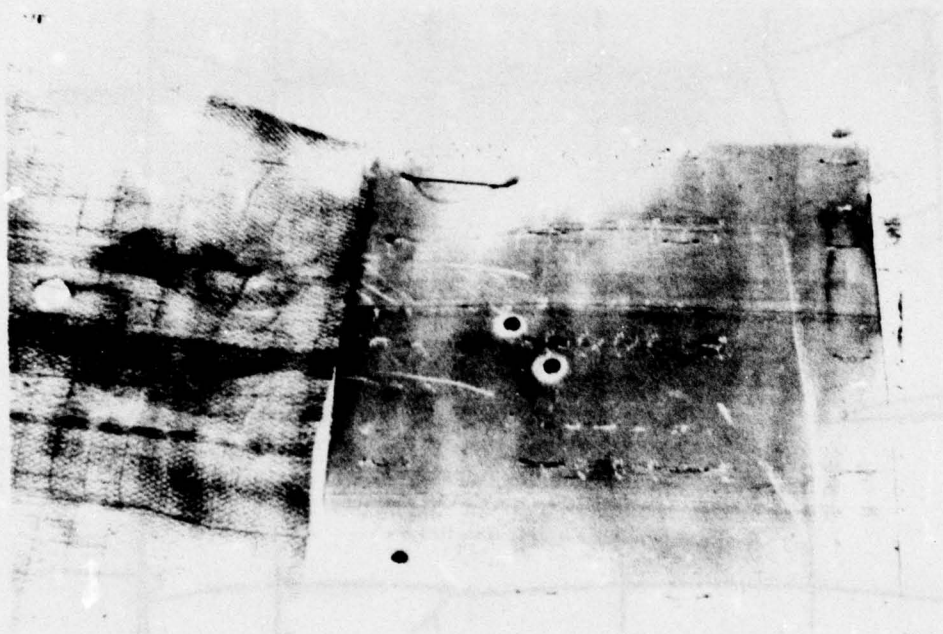

FIGURE 90. POLYETHYLENE FOAM 2000M , 90 MM, M353

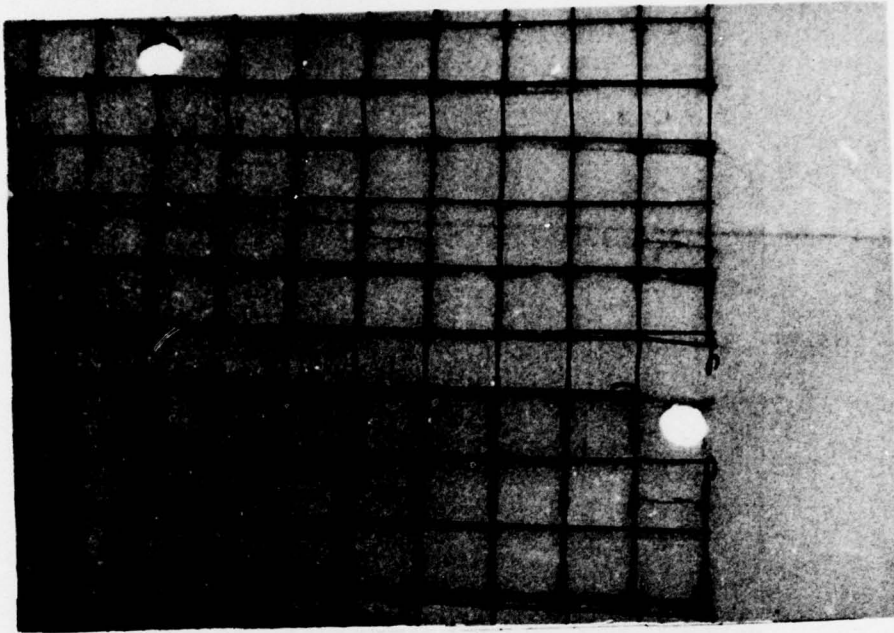

FIGURE 91. POLYETHYLENE FOAM 2000M, 105MM, M490

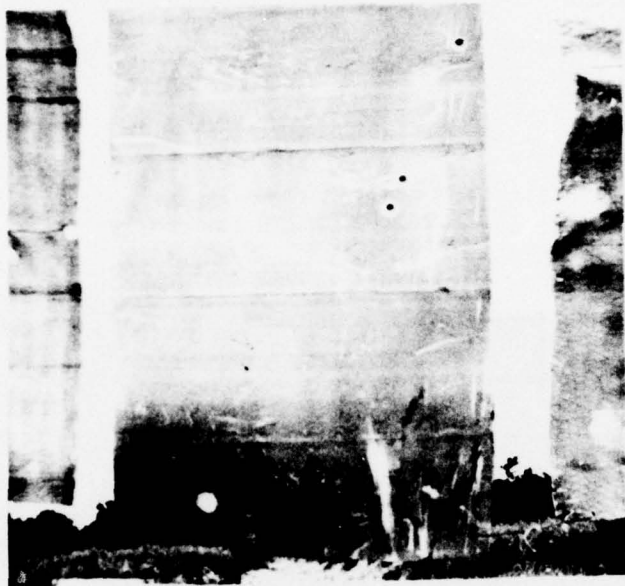

FIGURE 92. POLYETHYLENE FOAM 2000M, 105MM M724

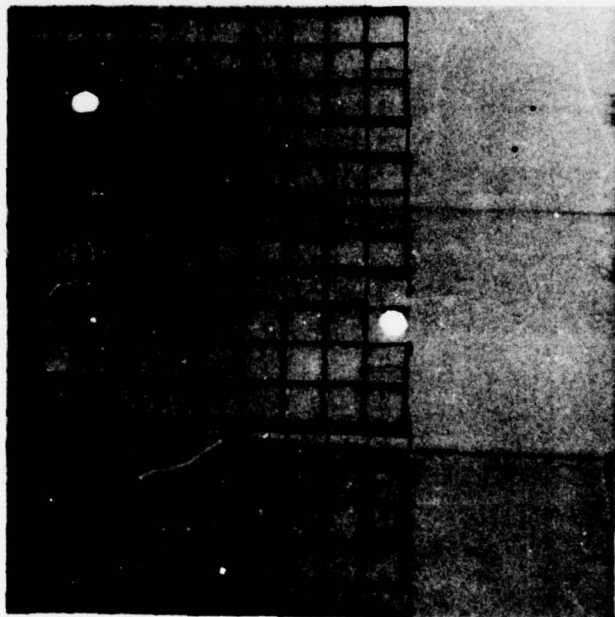

FIGURE 93. POLYETHYLENE FOAM 2000M, 105MM M724



FIGURE 94. POLYETHYLENE FOAM 2000M, 105M, M393



FIGURE 95. POLYETHYLENE FOAM 2000 M, 105MM, M393

Sub-caliber firings produced results similar to the main gun rounds. Caliber .50 bullets produced approximately .30 holes in the material and 20 MM projectile produced approximately .50 holes. This would indicate that the material could absorb hits in excess of those absorbed by the polystyrene targets.

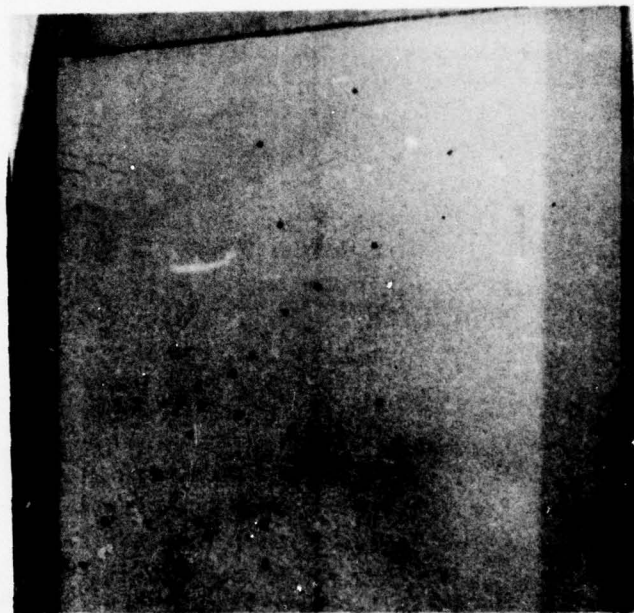

FIGURE 96. POLYETHYLENE 120 M .50 CAL, 30 ROUNDS



FIGURE 97. POLYETHYLENE 120 M .50 CAL, 30 ROUNDS

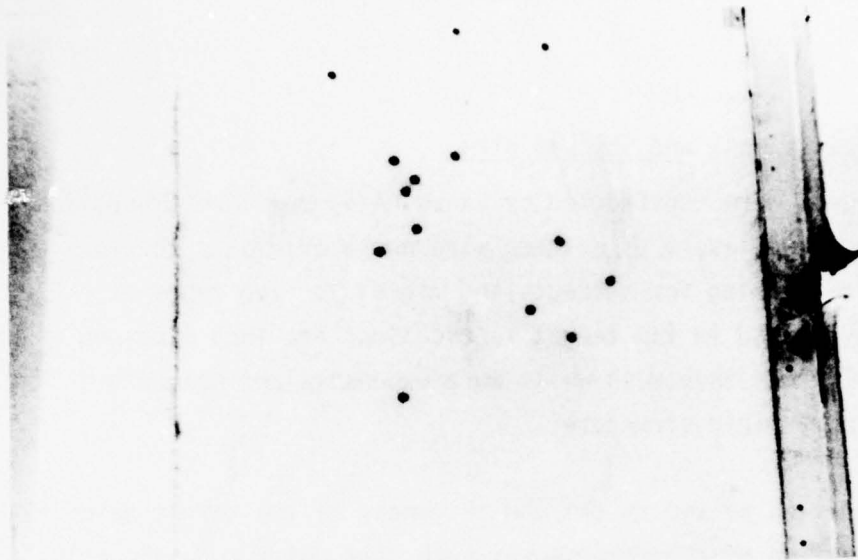

FIGURE 98. POLYETHYLENE FOAM 120 M 20MM,
19 ROUNDS AUTOMATIC FIRE



FIGURE 99. PLOYETHYLENE FOAM 120 M 20MM,
19 ROUNDS AUTOMATIC FIRE

d. Fiberglass Wool and Chicken Wire

These targets were constructed by sandwiching one inch fiberglass blankets between two layers of chicken wire and providing a concrete reinforcing wire backing for strength and rigidity. Two types of chicken wire were used in the target fabrication; one inch mesh and 2 inch mesh. The one inch mesh while more expensive and heavier, did provide a more rigid structure.

In this portion of the report the thickness of the target material and the construction of the targets was such that entry and exit holes were not significantly different. As a result, the exit hole only is used in most cases. This shows the effect on both the main material and the reinforcing wire material used in the target construction.

The effect of projectiles on the target material resulted in a clean hole regardless of the projectile. The hole size was approximately the diameter of the projectile with no elastic effect. The strength of the material was such that the capability of absorbing multiple hits is good.

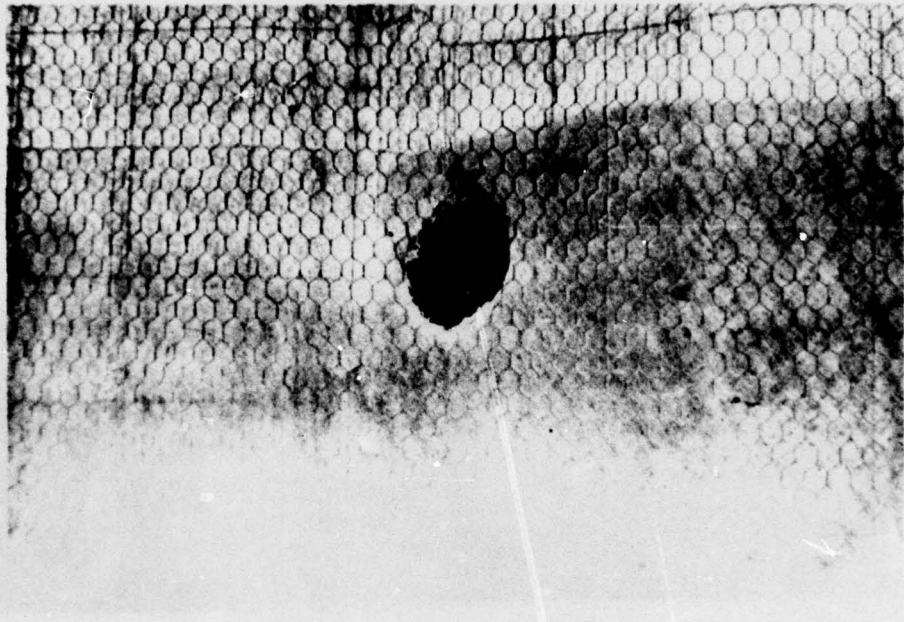

FIBERGLASS WOOL & CHICKEN WIRE 750 METERS
90MM M353
FIGURE 100.

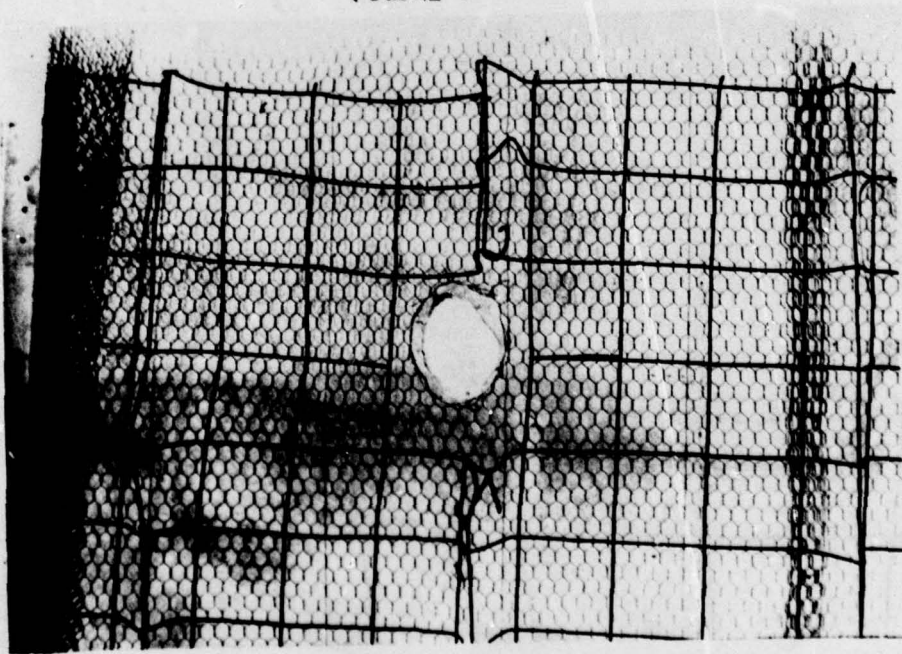

FIBERGLASS WOOL & CHICKEN WIRE 750 METERS
90MM M353
FIGURE 101.

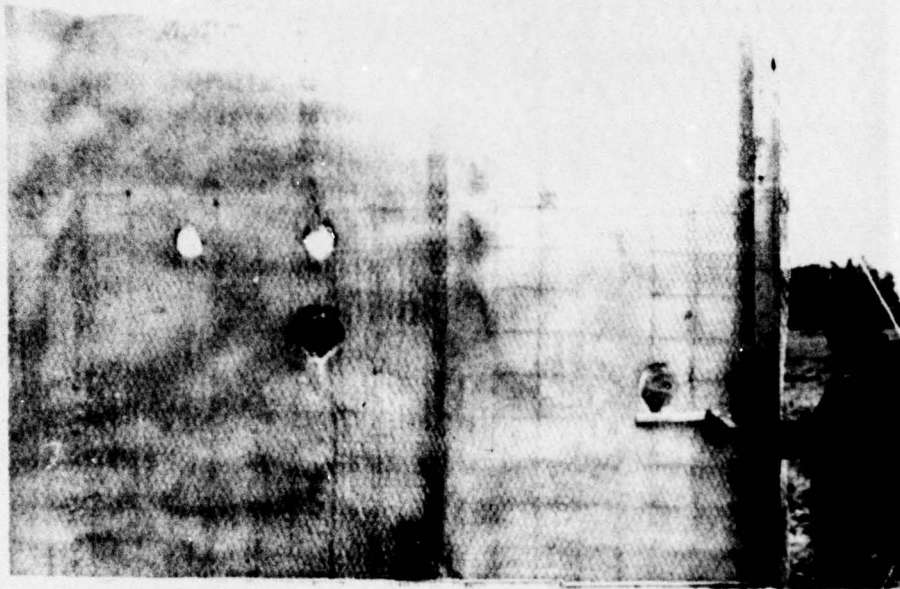

FIBERGLASS WOOL & CHICKEN WIRE 750 METERS
105MM M393

FIGURE 102.



FIBERGLASS WOOL & CHICKEN WIRE 750 METERS
105MM M393

FIGURE 103.
126



FIBERGLASS WOOL & CHICKEN WIRE 750 METERS

105MM 1:490

FIGURE 104.

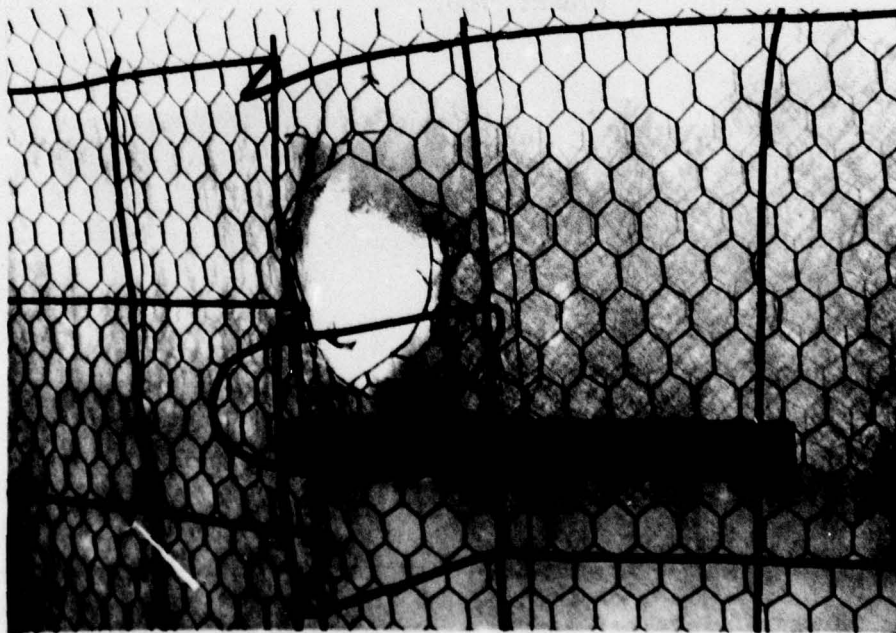

FIBERGLASS WOOL & CHICKEN WIRE 750 METERS

105MM 724

FIGURE 105.

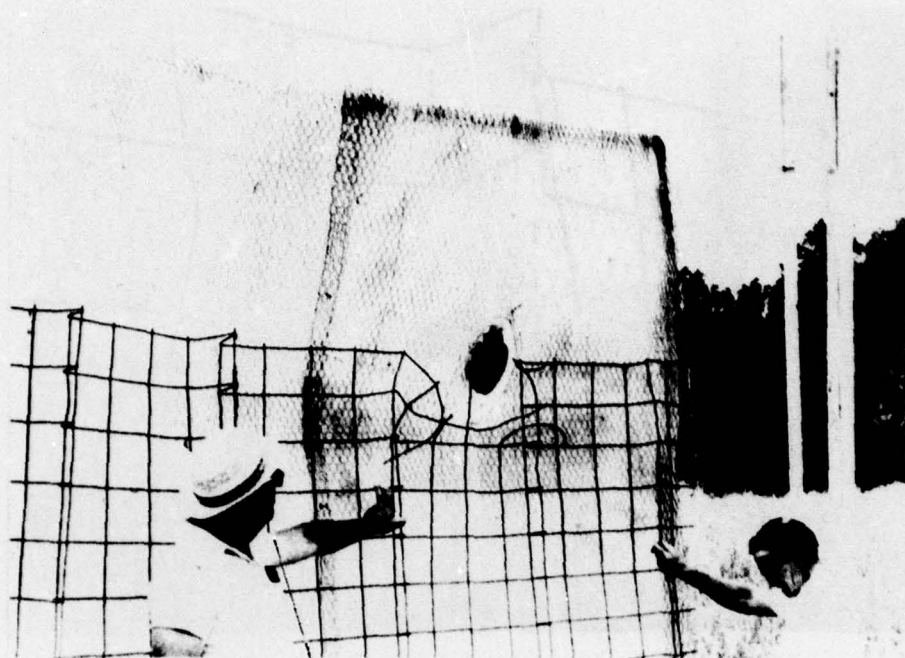

FIBERGLASS WOOL & CHICKEN WIRE 750 METERS
152MM M411
FIGURE 106.

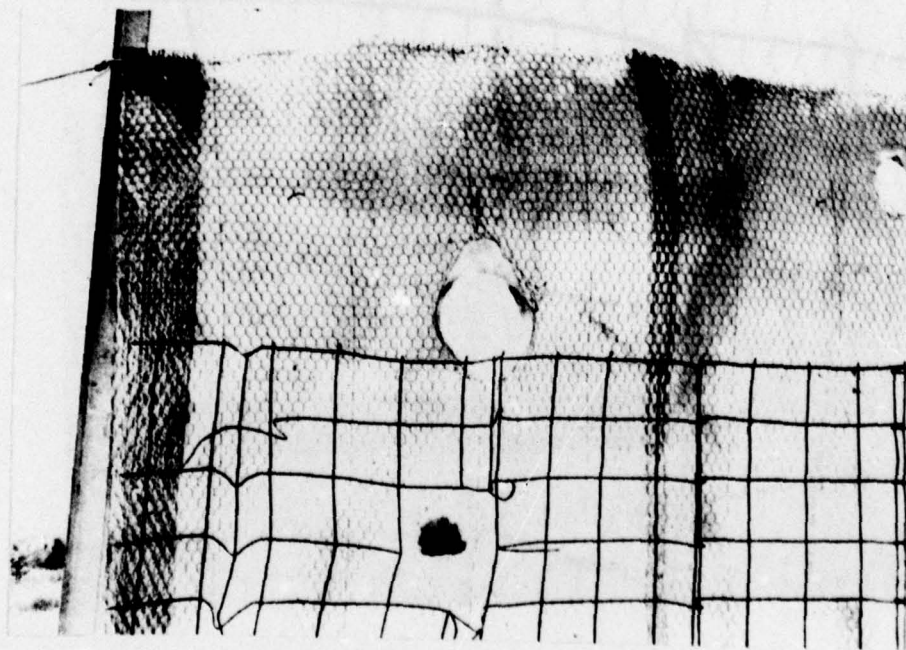

FIBERGLASS WOOL & CHICKEN WIRE 750 METERS
152MM, M411, 90MM, M353
FIGURE 107.
128

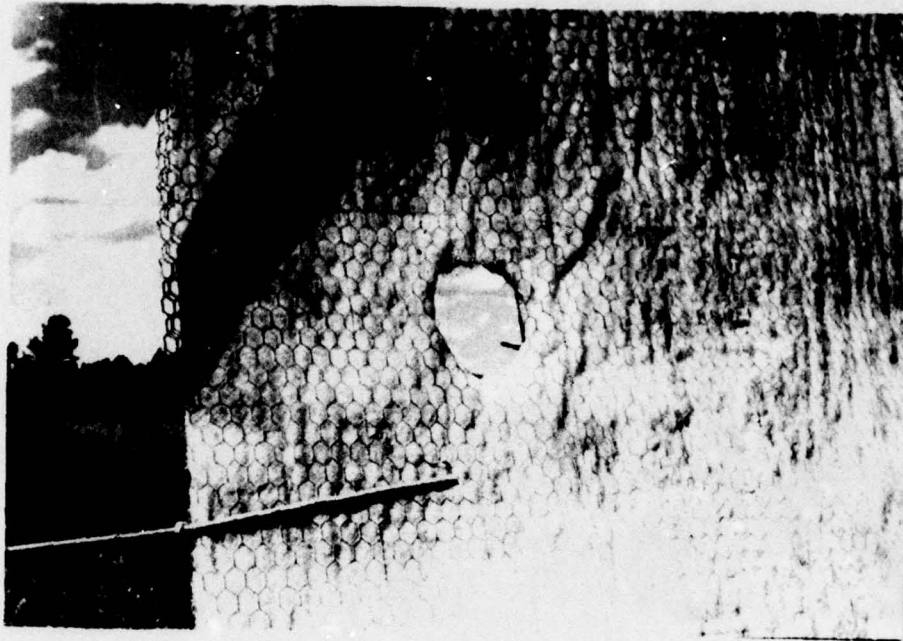

FIBERGLASS WOOL & CHICKEN WIRE 1200 METERS

90MM M353

FIGURE 108.



FIBERGLASS WOOL & CHICKEN WIRE 1200 METERS

90MM M353

FIGURE 109.

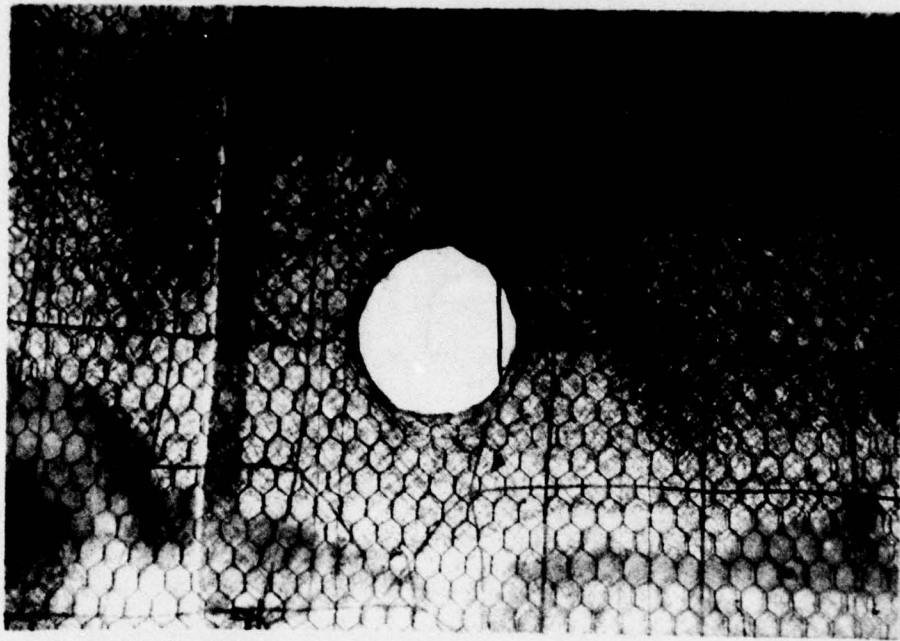

FIBERGLASS WOOL & CHICKEN WIRE 1200 METERS
105MM M467
FIGURE 110.

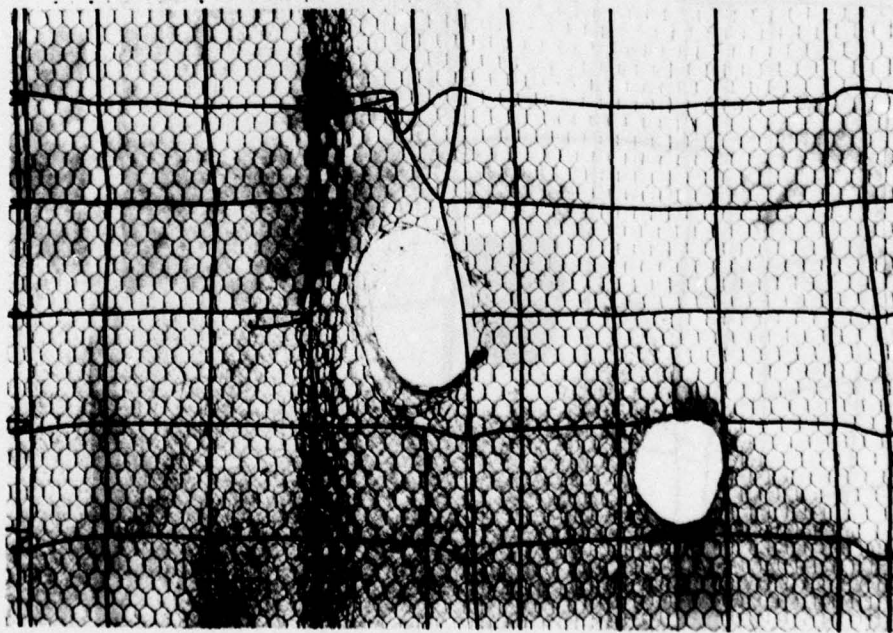

FIBERGLASS WOOL & CHICKEN WIRE 1200 METERS
105MM M467
FIGURE 111.



FIBERGLASS WOOL & CHICKEN WIRE 1200 METERS
105MM M490
FIGURE 112.

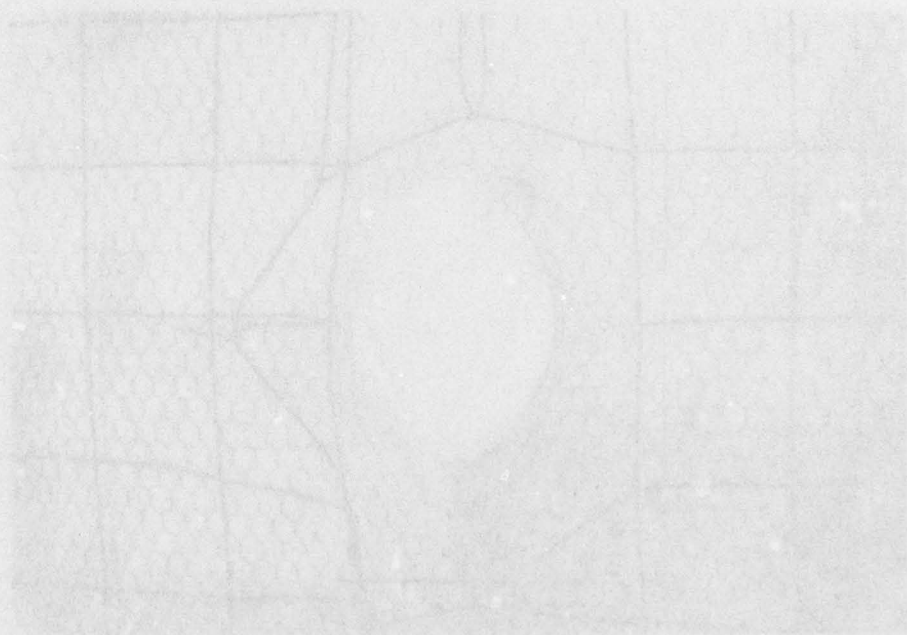

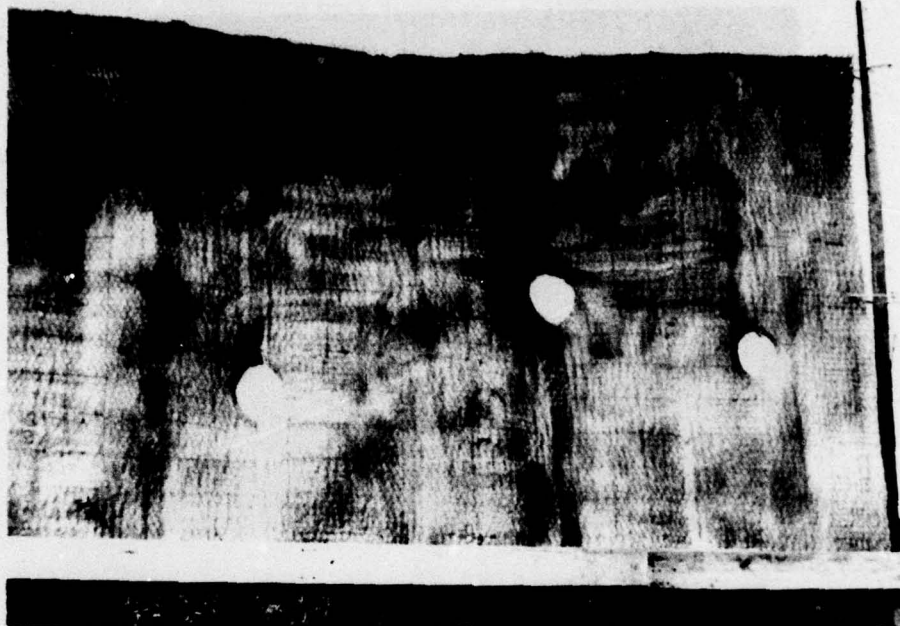

FIBERGLASS WOOL & CHICKEN WIRE 1200 METERS

152M M411

FIGURE 113.

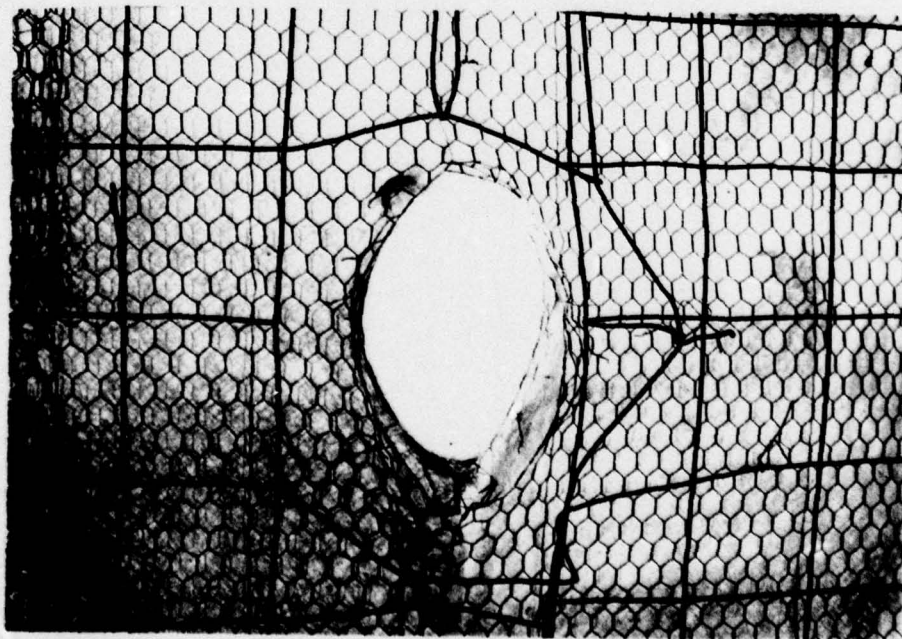

FIBERGLASS WOOL & CHICKEN WIRE 1200 METERS

152MM M411

FIGURE 114.

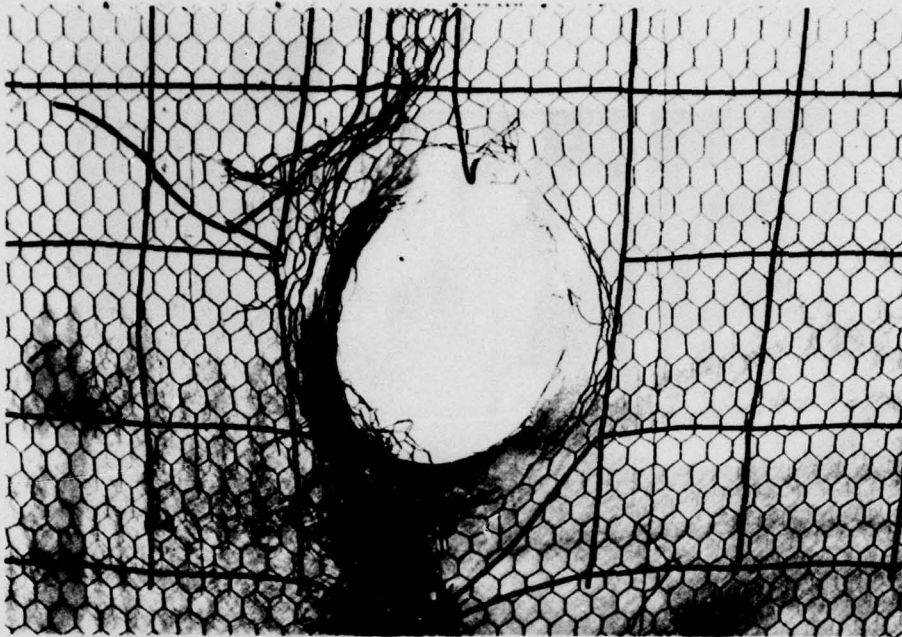

FIBERGLASS WOOL & CHICKEN WIRE 1200 METERS
152MM M411
FIGURE 115.

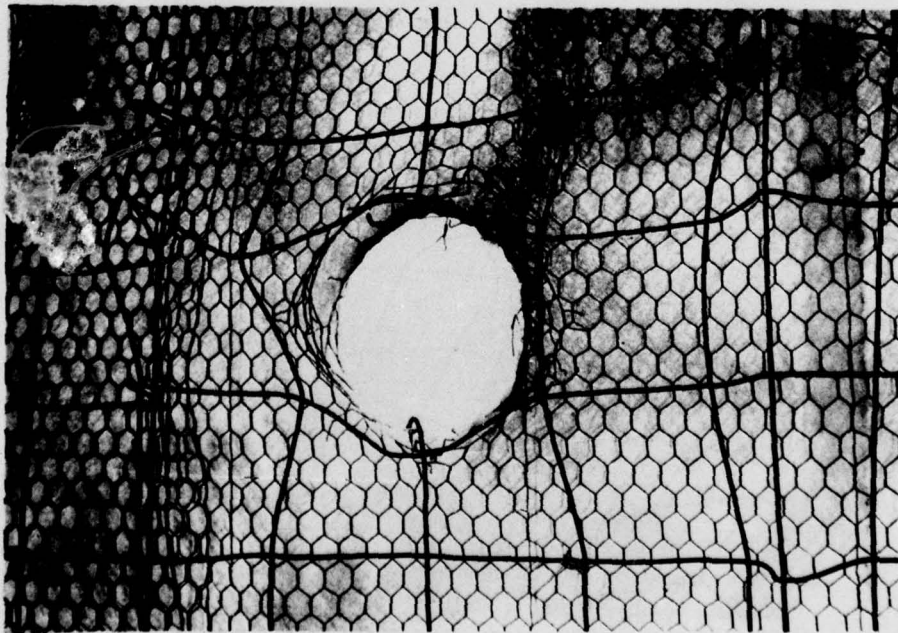

FIBERGLASS WOOL & CHICKEN WIRE 1200 METERS
152MM M411
FIGURE 116.



FIBERGLASS WOOL & CHICKEN WIRE 2000 METERS

105MM M393
FIGURE 117.

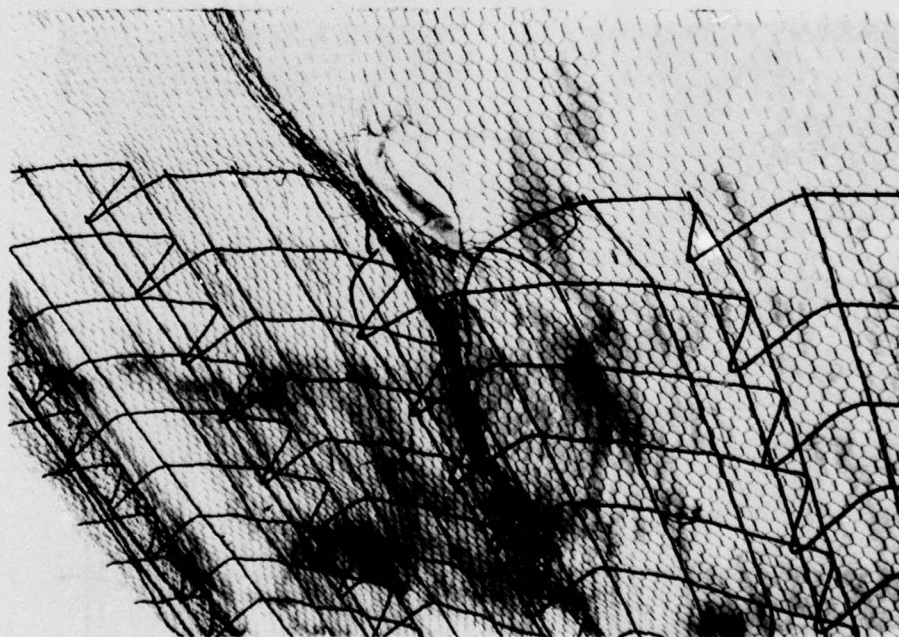

FIBERGLASS WOOL & CHICKEN WIRE 2000 METERS

105MM M393
FIGURE 118.

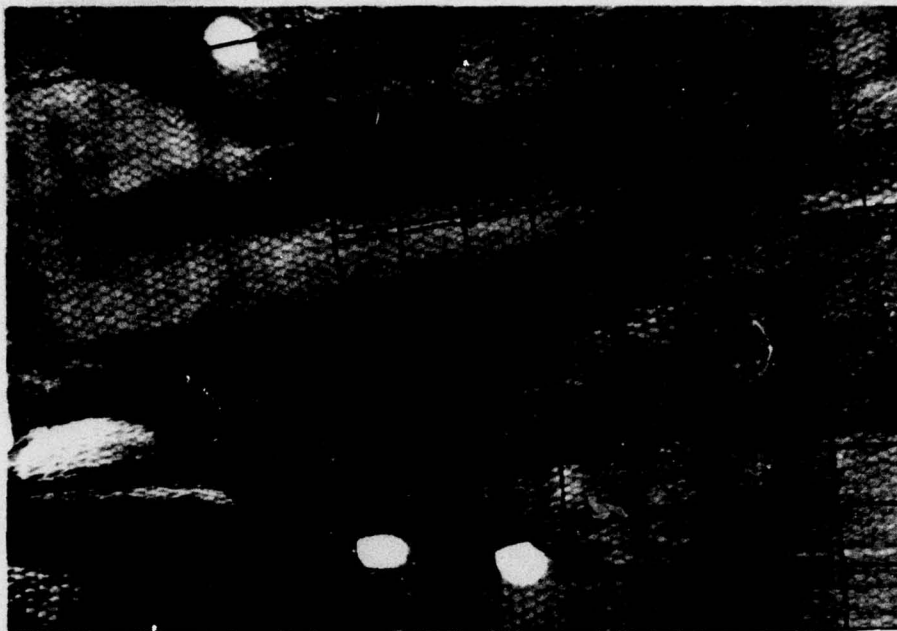

FIBERGLASS WOOL & CHICKEN WIRE 2000 METERS

105MM 490

FIGURE 119.

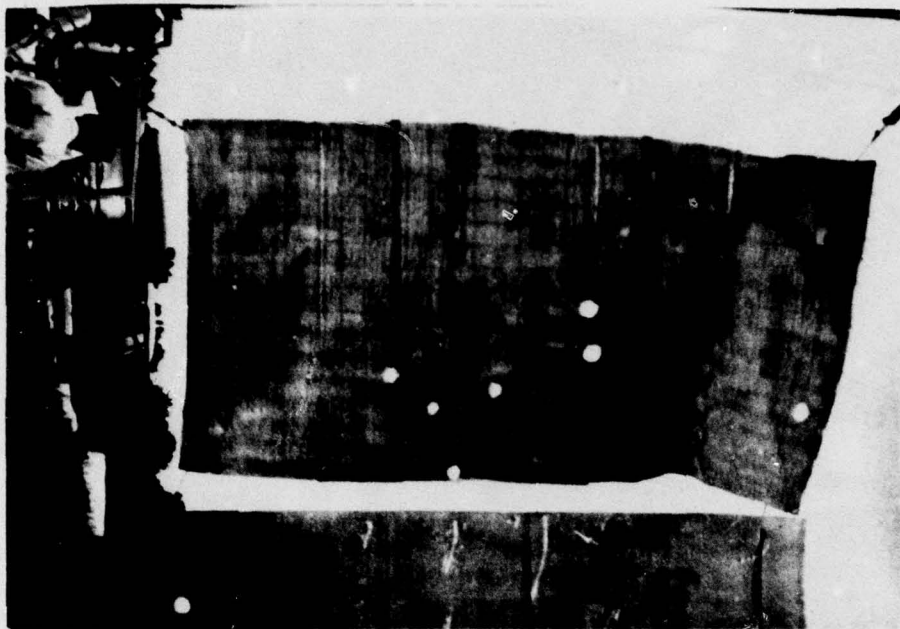

FIBERGLASS WOOL & CHICKEN WIRE 2000 METERS

105MM M724
FIGURE 120.

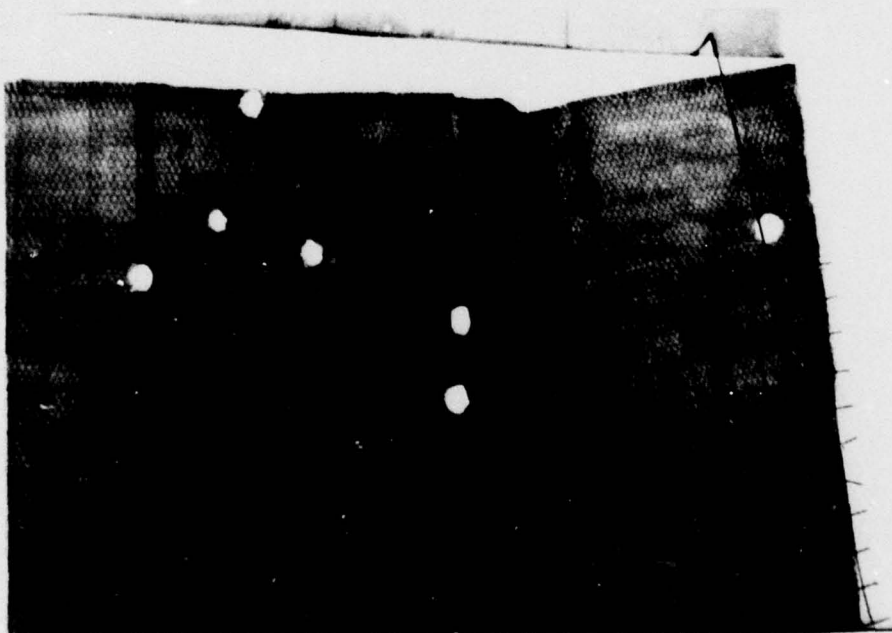

FIBERGLASS WOOL & CHICKEN WIRE 2000 METERS

105MM M 724
FIGURE 121.

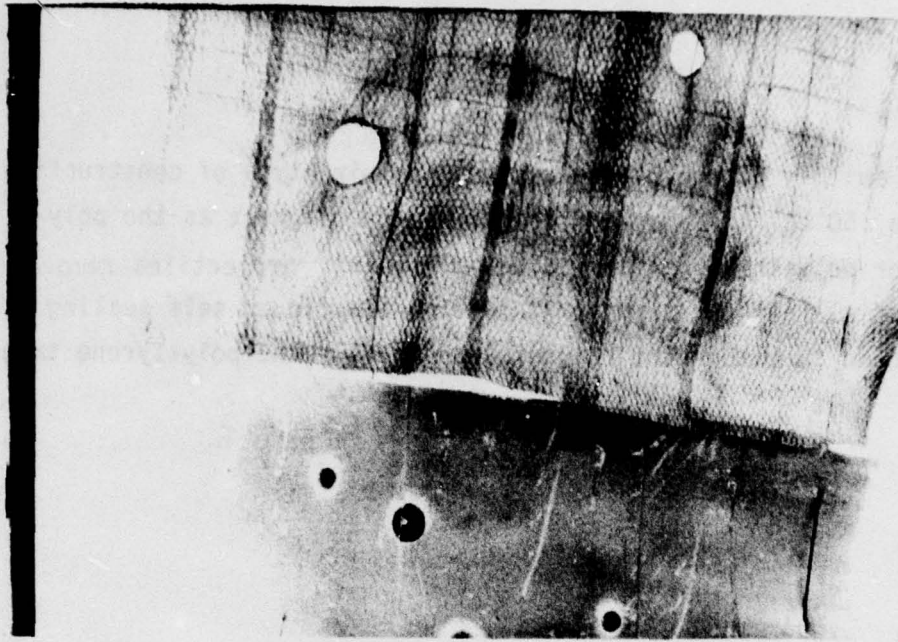

FIBERGLASS WOOL & CHICKEN WIRE 2000 . METERS

152MM 411
FIGURE 122.

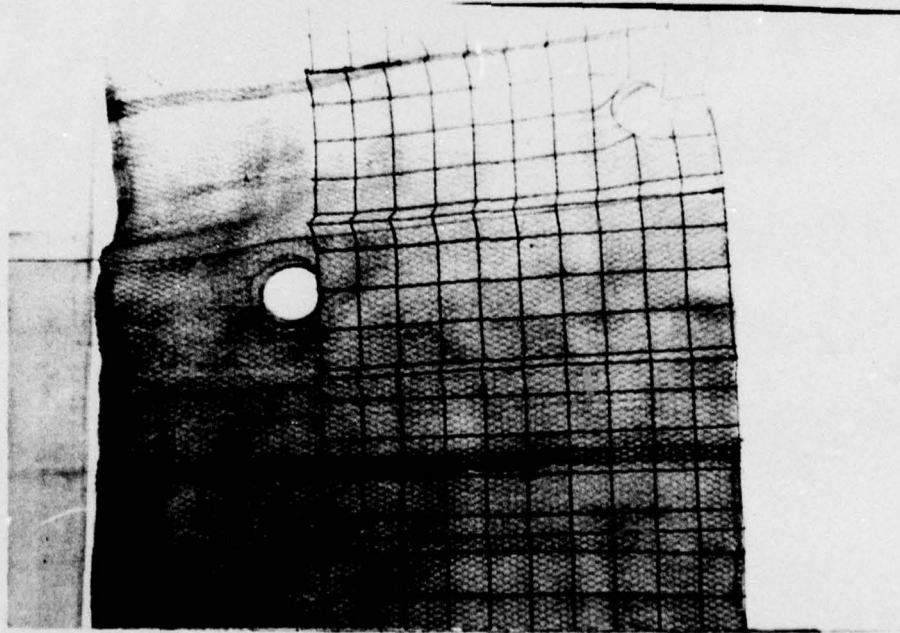

FIBERGLASS WOOL & CHICKEN WIRE 2000 METERS

152MM 411
FIGURE 123.

The ability of the fiberglass-chicken wire type of construction to absorb .50 caliber and 70MM rounds is not as great as the polystyrene or polyethylene foam. The sub caliber projectiles remove more material from the target without the elastic or self sealing effect found in either the polyethylene foam or the polystyrene targets.

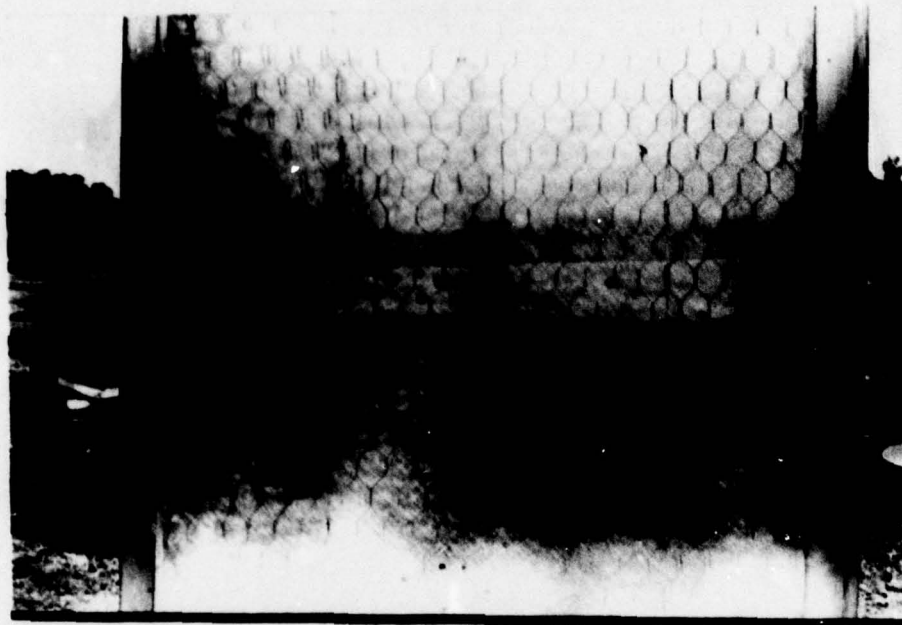

FIBERGLASS WOOL & CHICKEN WIRE 120 METERS
.50 Cal.

FIGURE 124.

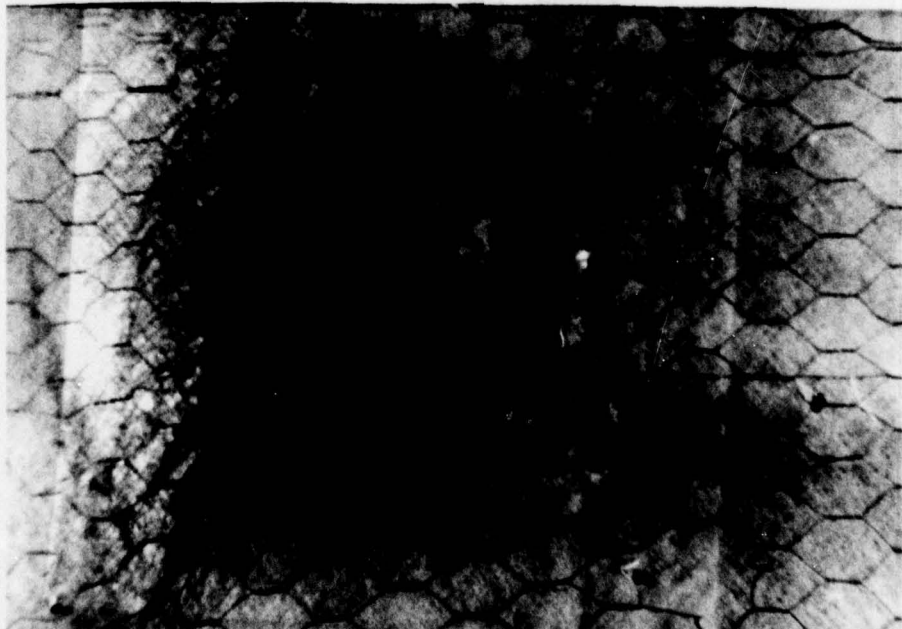

FIBERGLASS WOOL & CHICKEN WIRE 120 METERS
.50 Cal.

FIGURE 125.

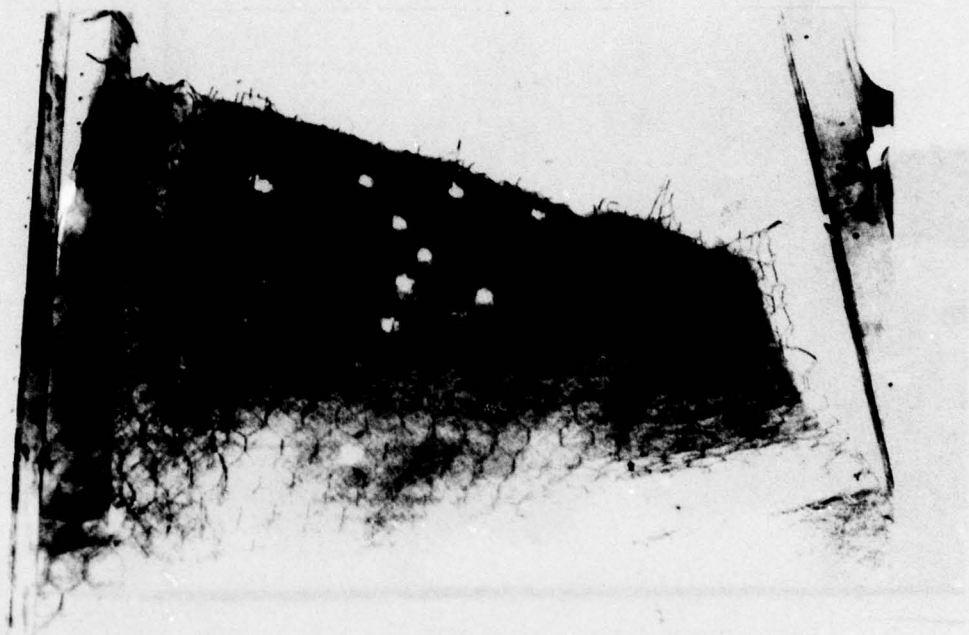

FIBERGLASS WOOL & CHICKEN WIRE 120 METERS

20MM

FIGURE 126.

e. Polypropylene Sheeting

The targets were constructed by sandwiching a three ply polypropylene sheet between two layers of chicken wire with concrete reinforcing wire for rigidity. The targets were a nominal 8' x 16'.

As in the case of the Fiberglass wool chicken wire construction it was decided that both entry and exit photographs were academic and are not shown for every case.

The polypropylene sheeting acted in a similar manner to the fiberglass wool but had a tendency to shred and tear under projectile impact leaving ragged hole in the target. There was a tendency by the hole to return to a smaller size after passage of the projectile. It appeared that the tearing tendencies would lead to progressive target damage under windy conditions.

Polypropylene chicken wire construction, while not as good as polystyrene or polyethylene foam, exhibited properties on a par with fiberglass wool chicken wire construction. It is easier to paint than the fiberglass wool and easier to handle during construction.

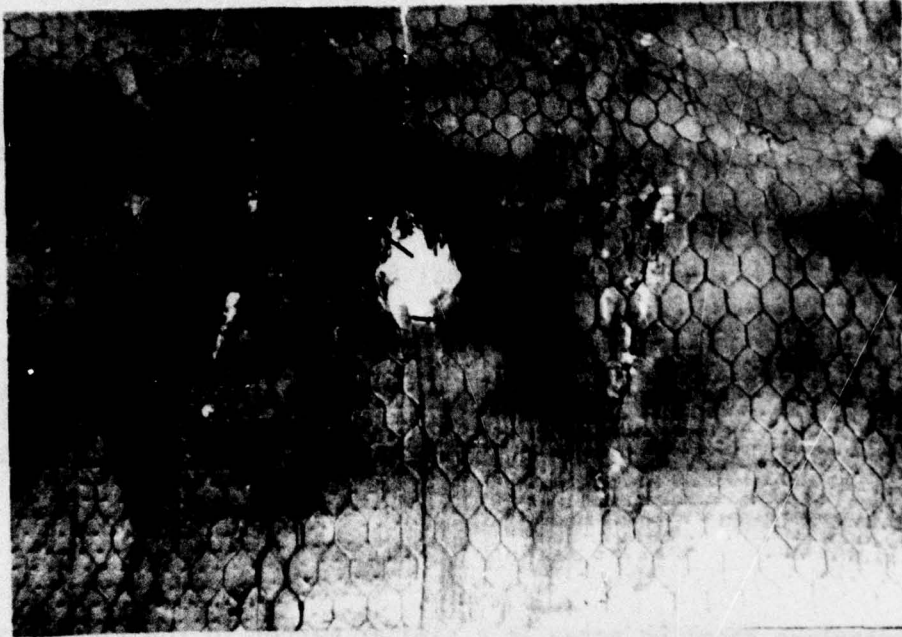

POLYPROPYLENE & CHICKEN WIRE 750 METERS
90MM M353

FIGURE 127.



POLYPROPYLENE & CHICKEN WIRE 750 METERS
90MM M353

FIGURE 128.



POLYPROPYLENE & CHICKEN WIRE 750 METERS

105MM M393

FIGURE 129.



POLYPROPYLENE & CHICKEN WIRE 750 METERS

105MM M490

FIGURE 130.

143

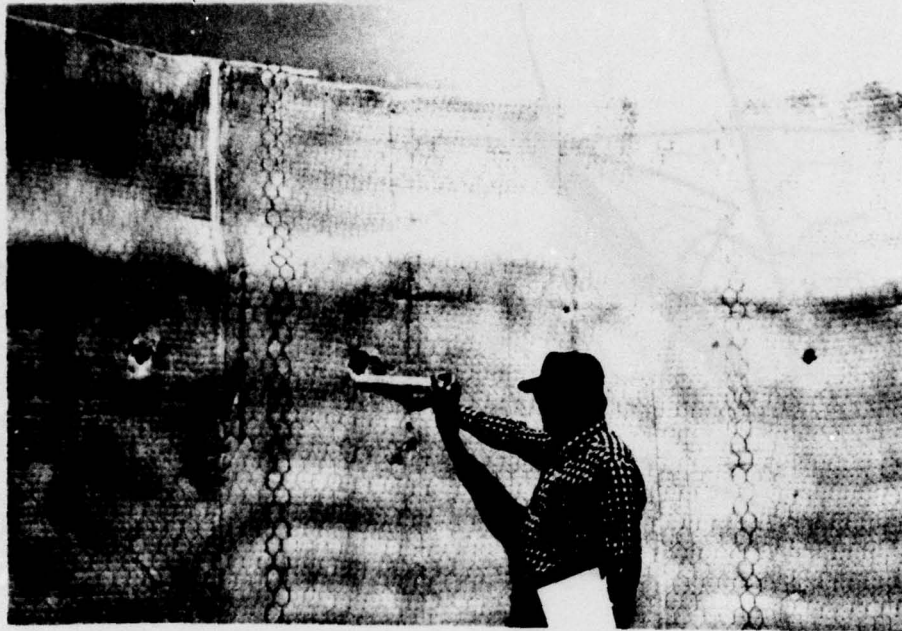

POLYPROPYLENE & CHICKEN WIRE 750 METERS

105MM M724

FIGURE 131.

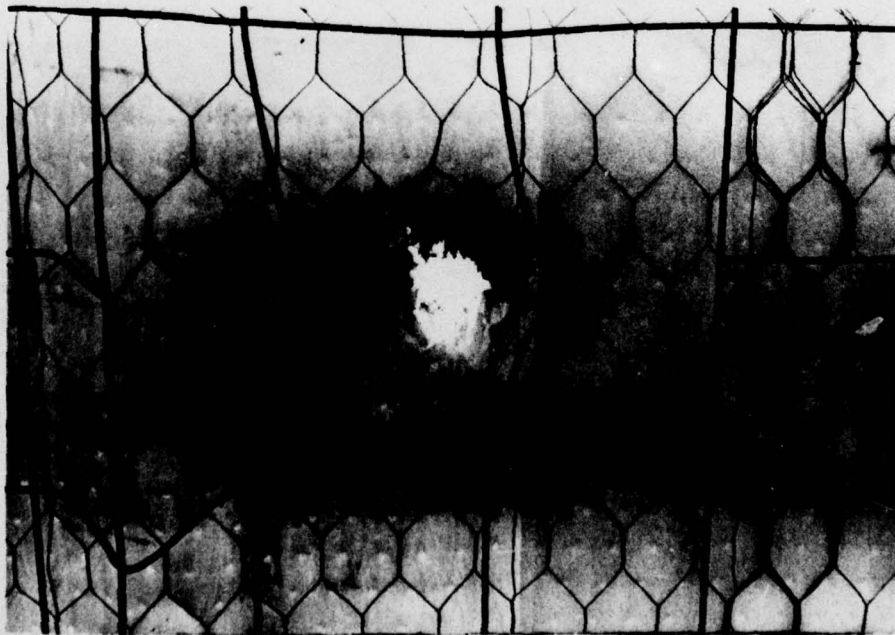

POLYPROPYLENE & CHICKEN WIRE 750 METERS

105MM M724

FIGURE 132.

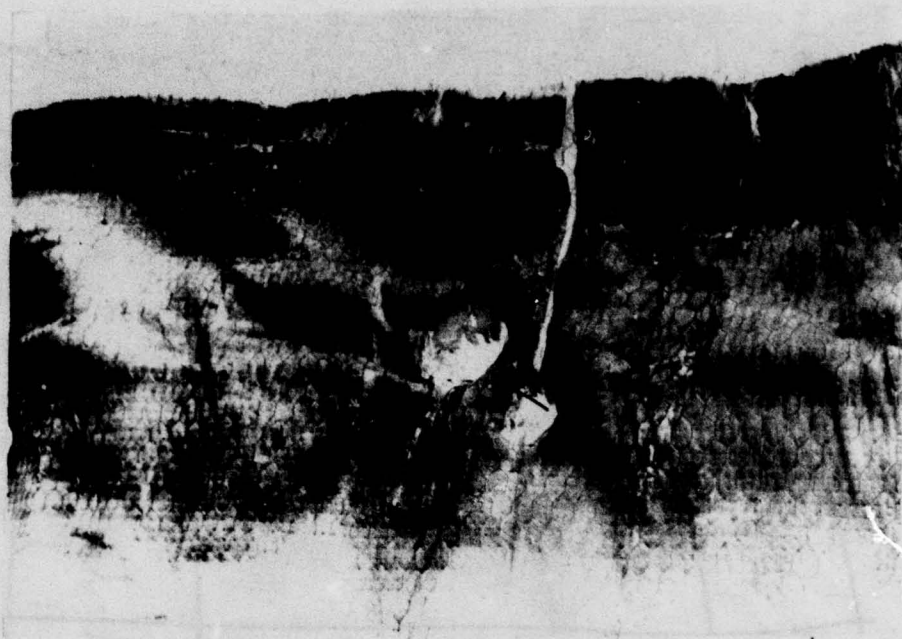

POLYPROPYLENE & CHICKEN WIRE 750 METERS

90MM 152MM

FIGURE 133.

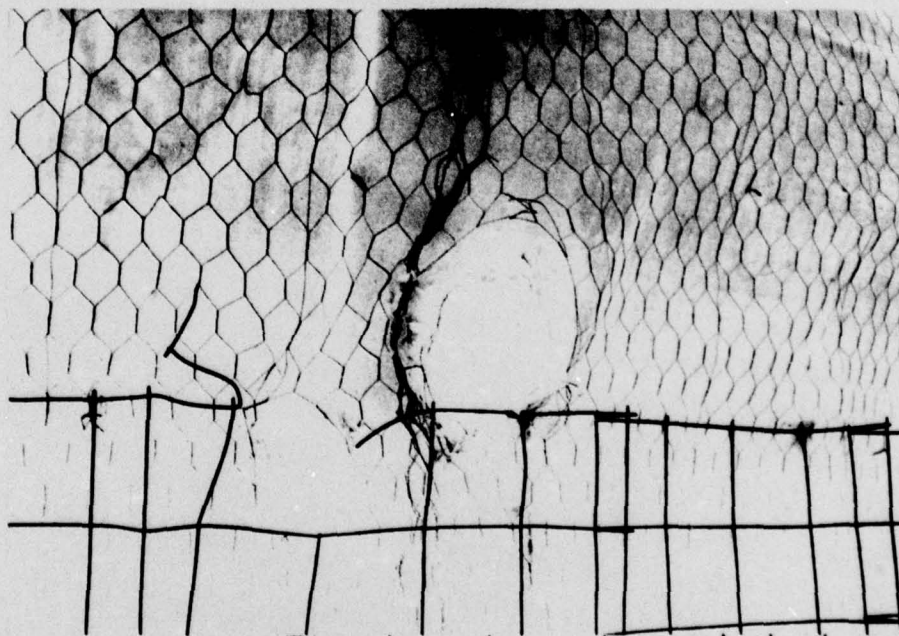

POLYPROPYLENE & CHICKEN WIRE 750 METERS

90MM 152MM

FIGURE 134.

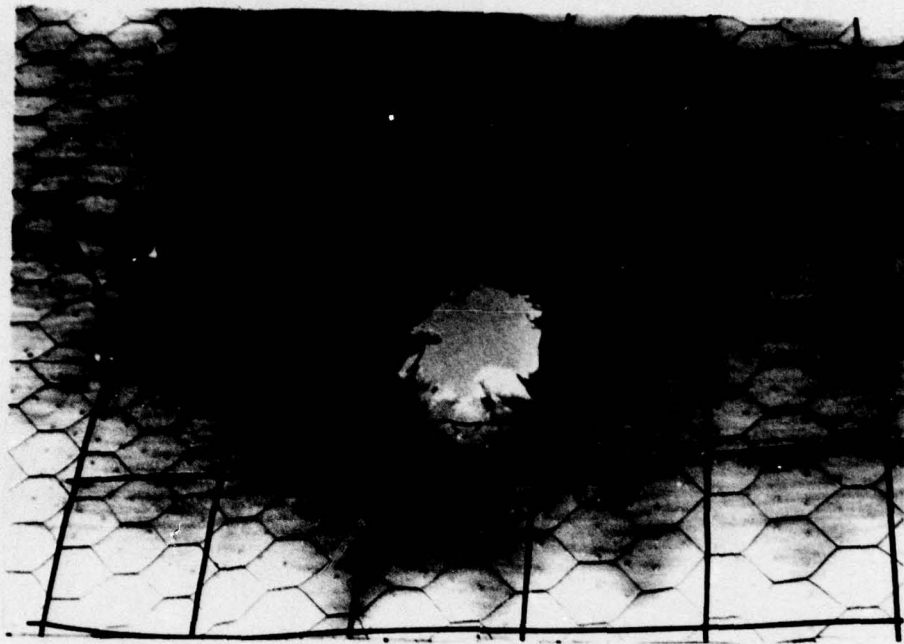

POLYPROPYLENE & CHICKEN WIRE 1000 METERS

105MM M490

FIGURE 135.

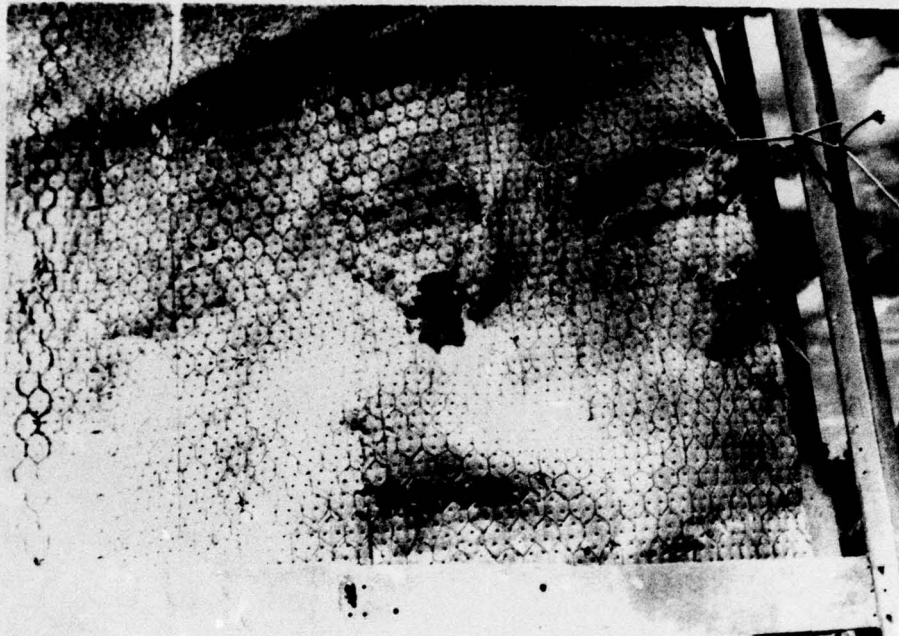

POLYPROPYLENE & CHICKEN WIRE 1200 METERS

90MM M353

FIGURE 136.



POLYPROPYLENE & CHICKEN WIRE 1200 METERS

90MM M353

FIGURE 137.

147



POLYPROPYLENE & CHICKEN WIRE 1200 METERS
105MM M467
FIGURE 138.

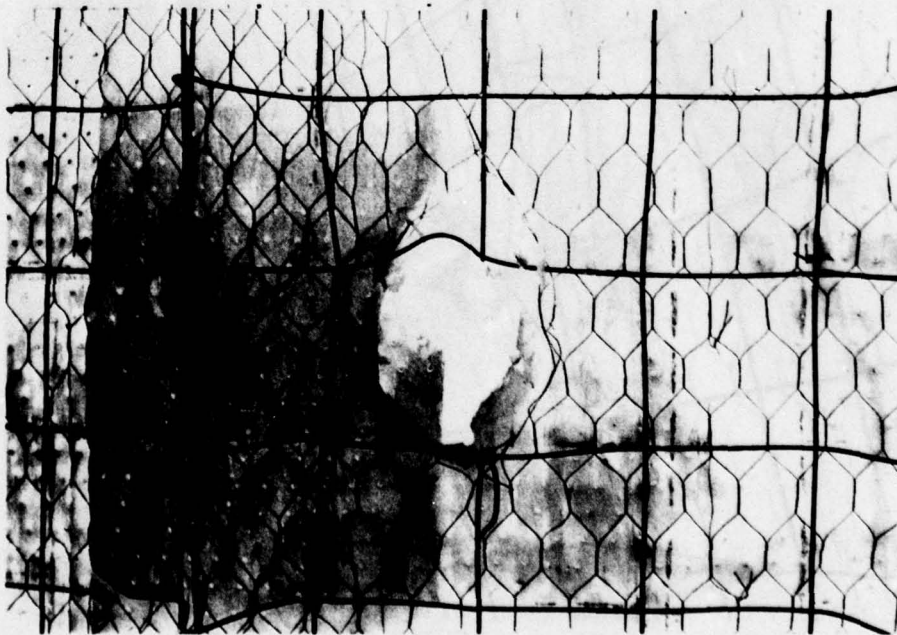

POLYPROPYLENE & CHICKEN WIRE 1200 METERS
105MM M467
FIGURE 139.



POLYPROPYLENE & CHICKEN WIRE 1200 METERS
105MM M724
FIGURE 140.



POLYPROPYLENE & CHICKEN WIRE 1200 METERS
105MM M490
FIGURE 141.

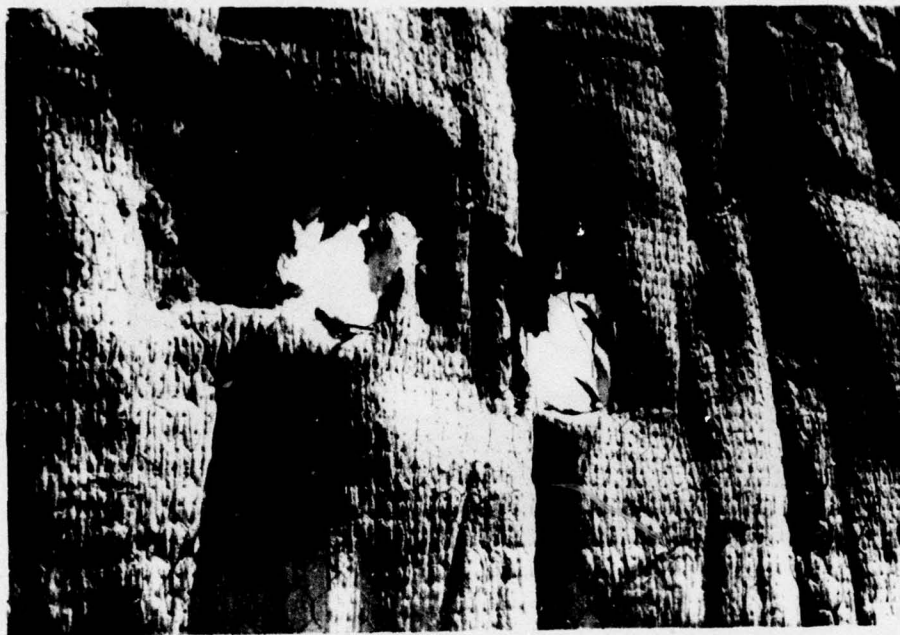

POLYPROPYLENE & CHICKEN WIRE 1200 METERS

152MM M411

FIGURE 142.

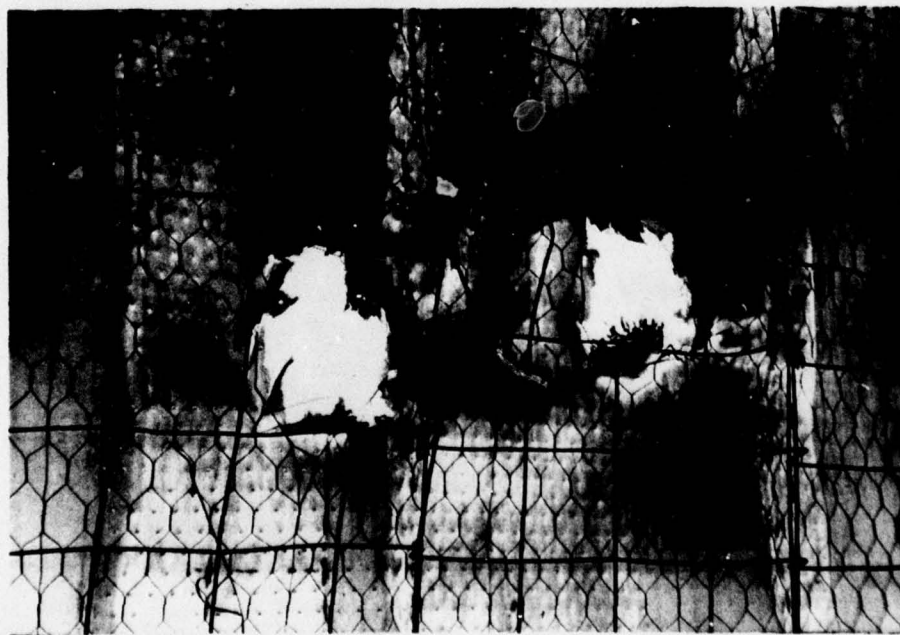

POLYPROPYLENE & CHICKEN WIRE 1200 METERS

152MM M411

FIGURE 143.

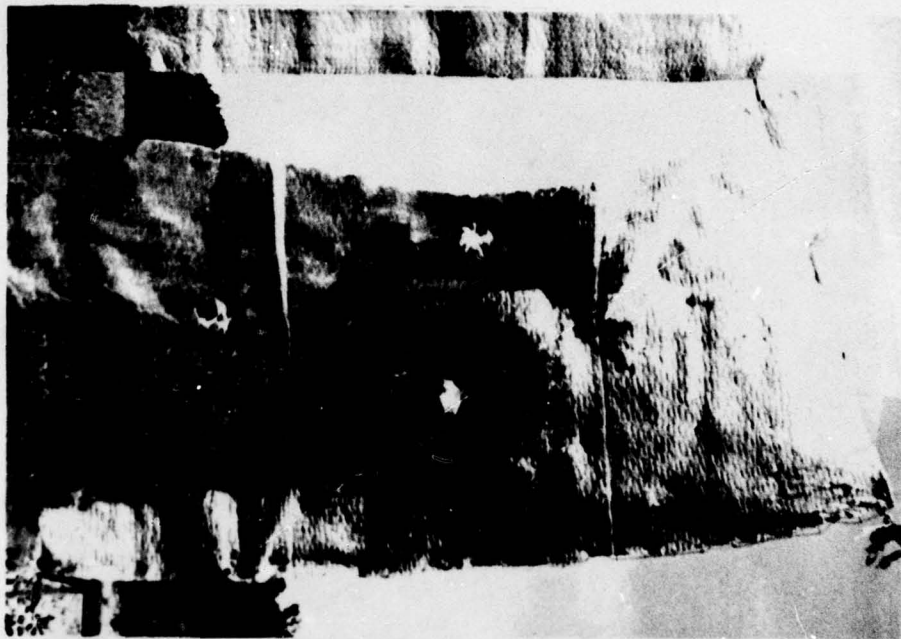

POLYPROPYLENE & CHICKEN WIRE 2000 METERS

105MM M393

FIGURE 144.



POLYPROPYLENE & CHICKEN WIRE 2000 METERS

105MM M393

FIGURE 145.

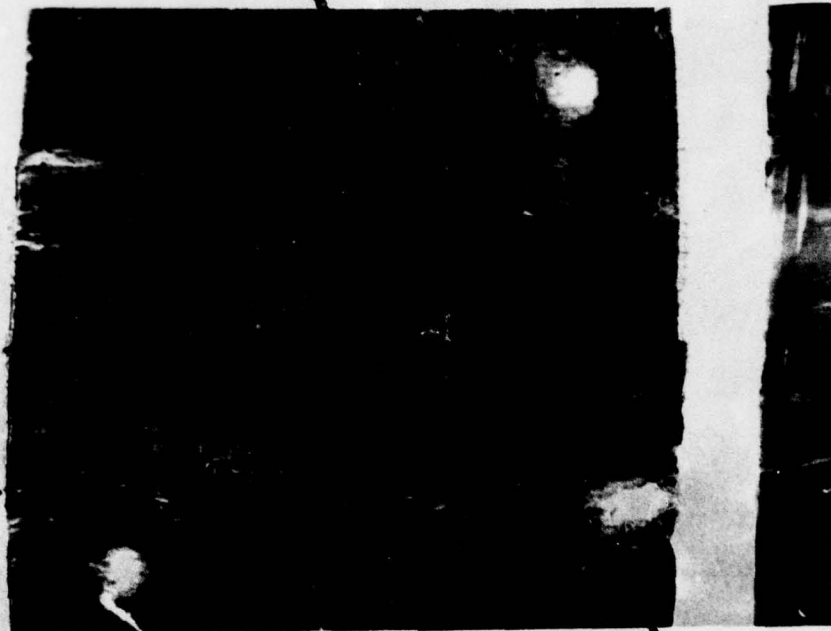

POLYPROPYLENE & CHICKEN WIRE 2000 METERS
105MM M490
FIGURE 146.



POLYPROPYLENE & CHICKEN WIRE 2000 METERS
105MM M490
FIGURE 147.

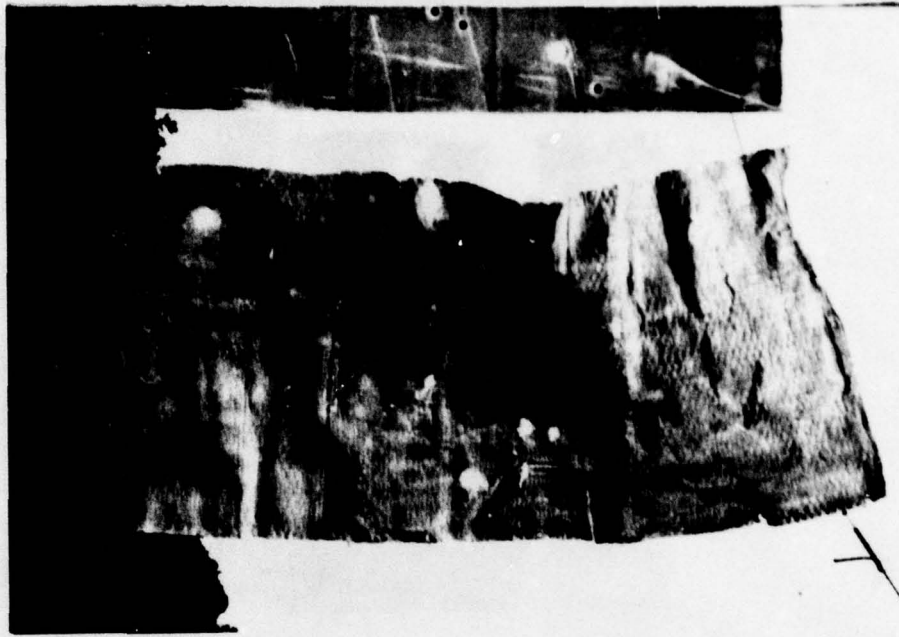

POLYPROPYLENE & CHICKEN WIRE 2000 METERS
105MM M724
FIGURE 148.



POLYPROPYLENE & CHICKEN WIRE 2000 METERS
105MM M724
FIGURE 149.

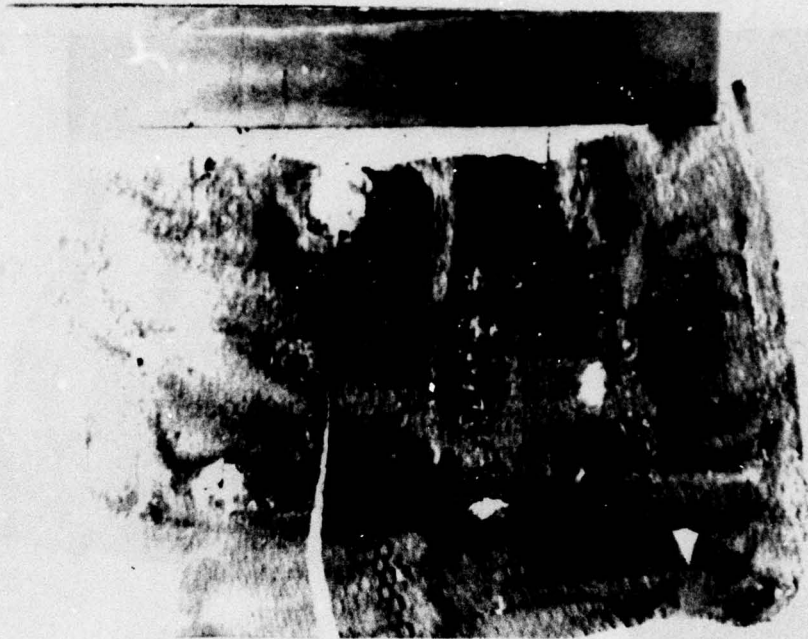

POLYPROPYLENE & CHICKEN WIRE 2000 METERS
152MM M411
FIGURE 150.

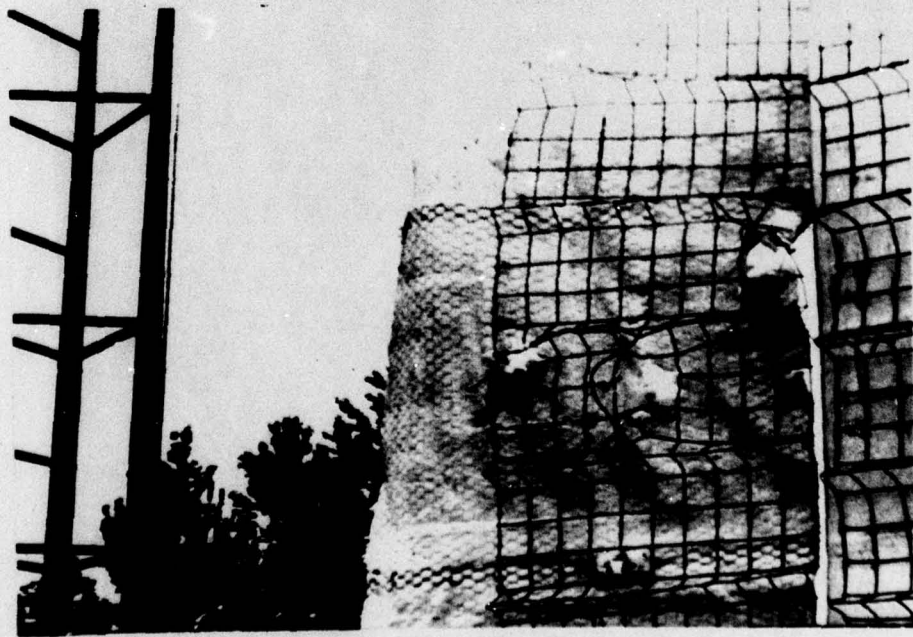

POLYPROPYLENE & CHICKEN WIRE 2000 METERS
152MM M411
FIGURE 151.

.50 caliber projectiles exhibited clean holes slightly smaller than the projectile diameter with a minimum of tearing. 20MM projectiles produced a more pronounced tearing effect and several close hits tore sections of material from the target.

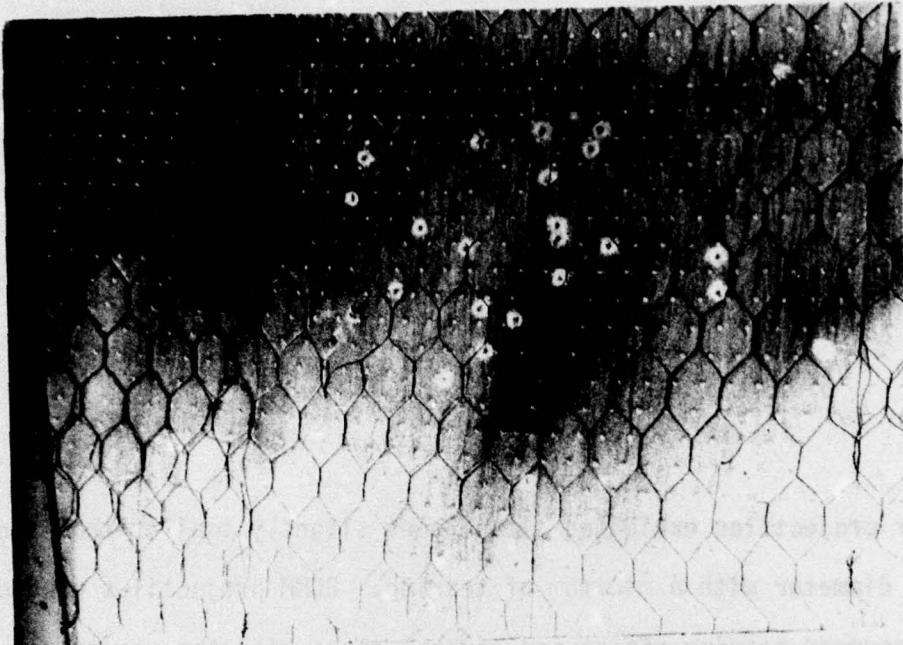

POLYPROPYLENE & CHICKEN WIRE 120 METERS
.50 CAL.

FIGURE 152.

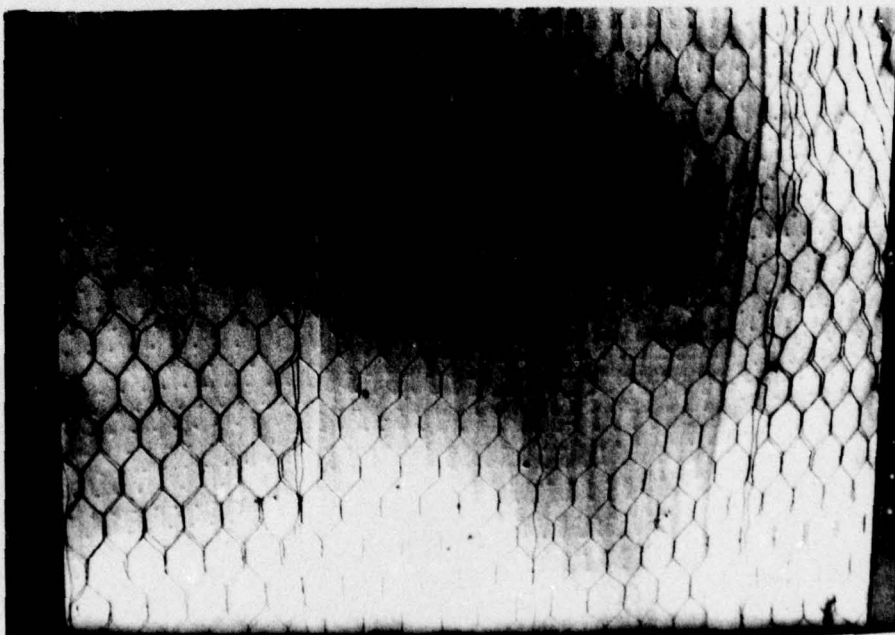

POLYPROPYLENE & CHICKEN WIRE 120 METERS
.50 CAL.

FIGURE 153.

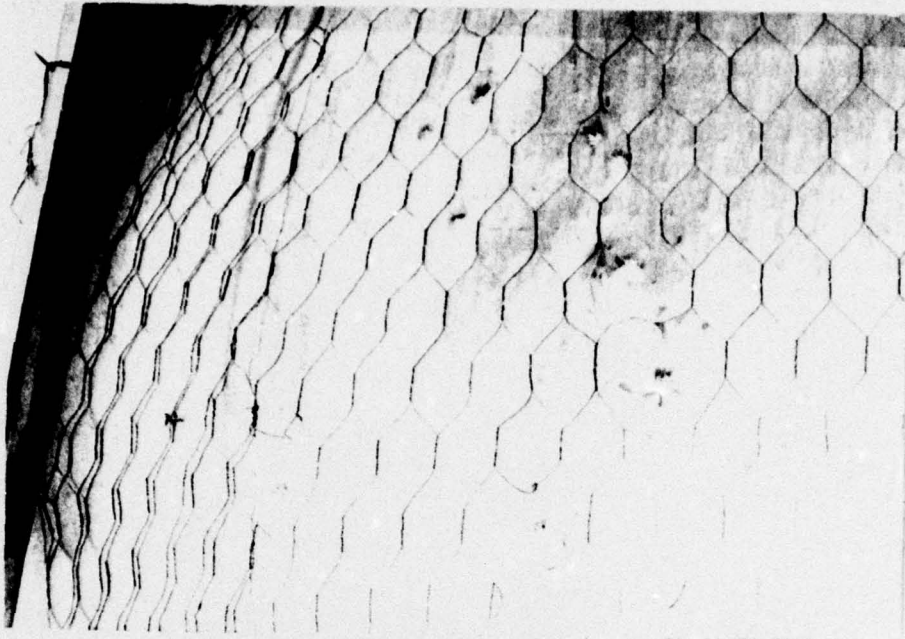

POLYPROPYLENE & CHICKEN WIRE 120 METERS
20MM

FIGURE 154.

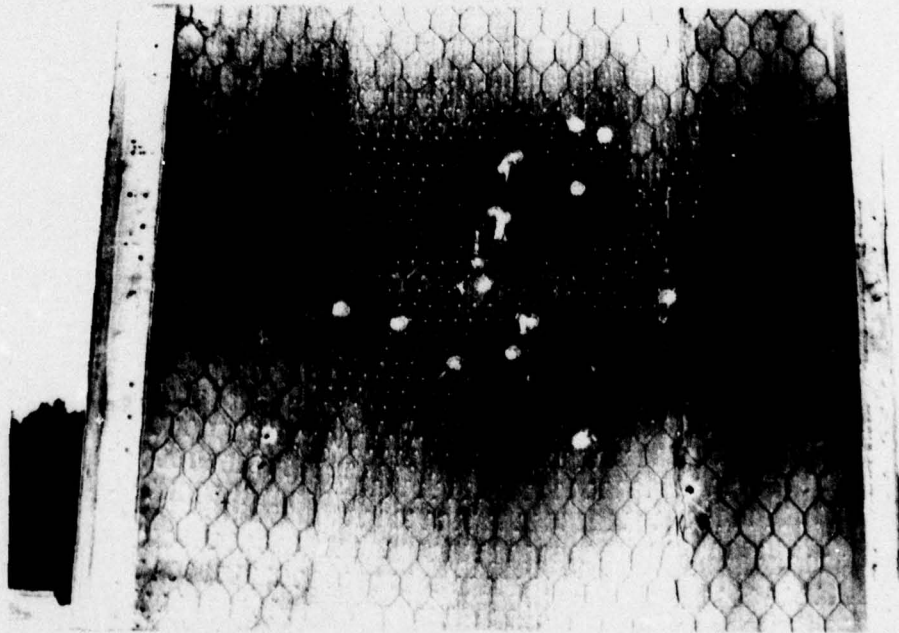

POLYPROPYLENE & CHICKEN WIRE 120 METERS
20MM

FIGURE 155.

The target section in some cases shared a portion of the same target holder used to hold other target material and resulted in at least one interesting result. Figure 156 is the exit hole after a 105MM M490 round passed through the polyethylene and the fiberglass wool and chicken wire target behind it. This may be an indication of the damage a three dimensional target made of the tested materials can sustain due to the debris from the entry hole.

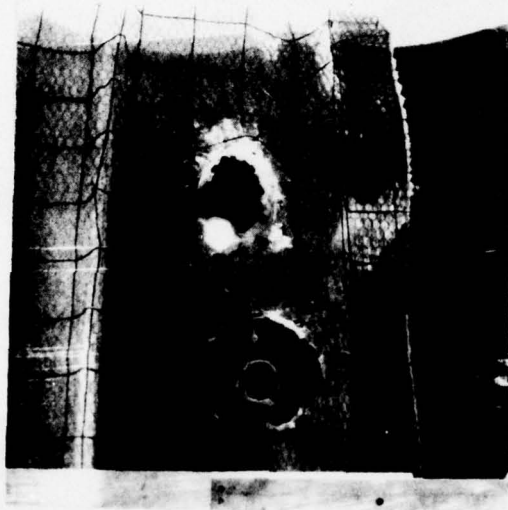
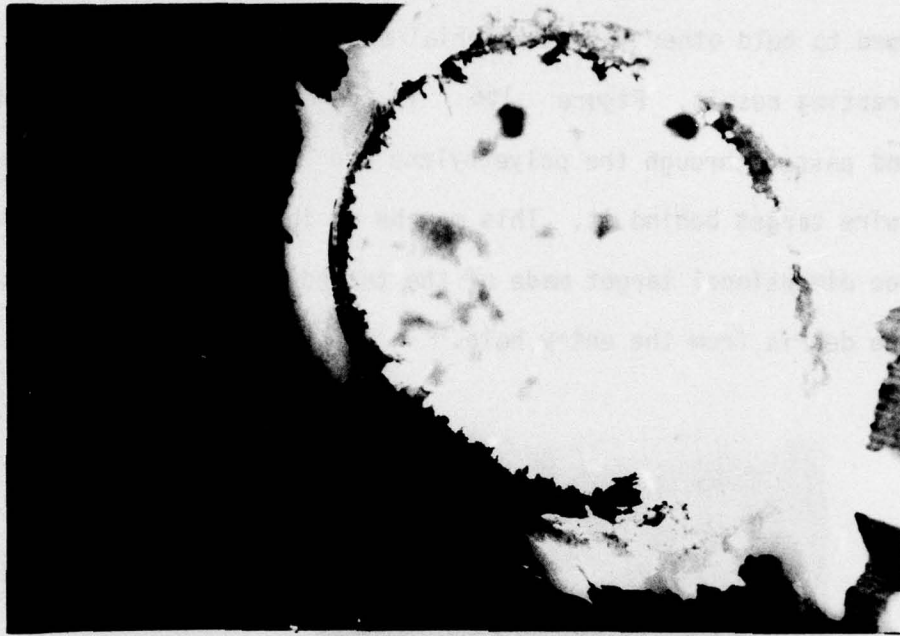
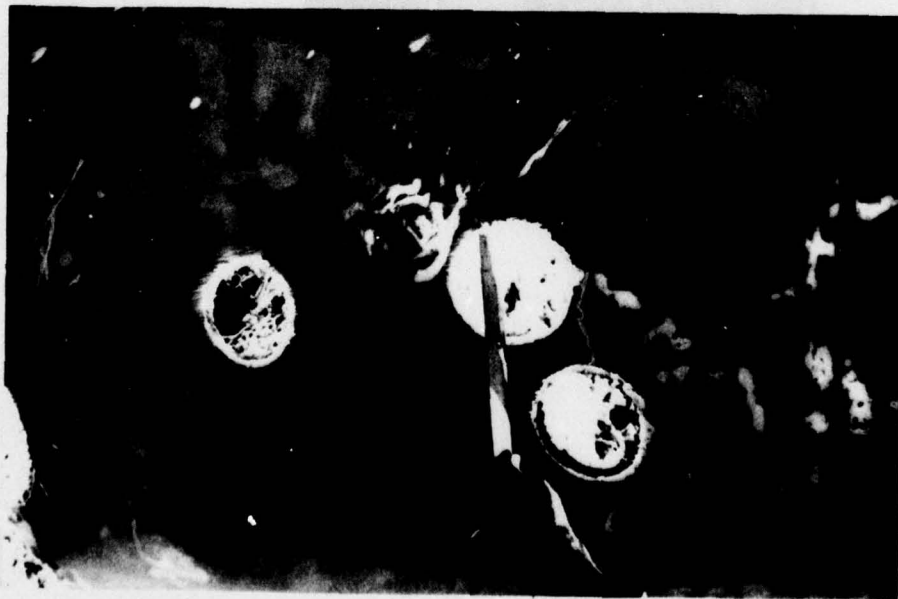

FIGURE 156.

PRECEDING PAGE BLANK



HIGH DENSITY POLYETHYLENE 750 METERS
105MM M 490
FIGURE 157.



HIGH DENSITY POLYETHYLENE 750 METERS
105MM M 490
FIGURE 158.

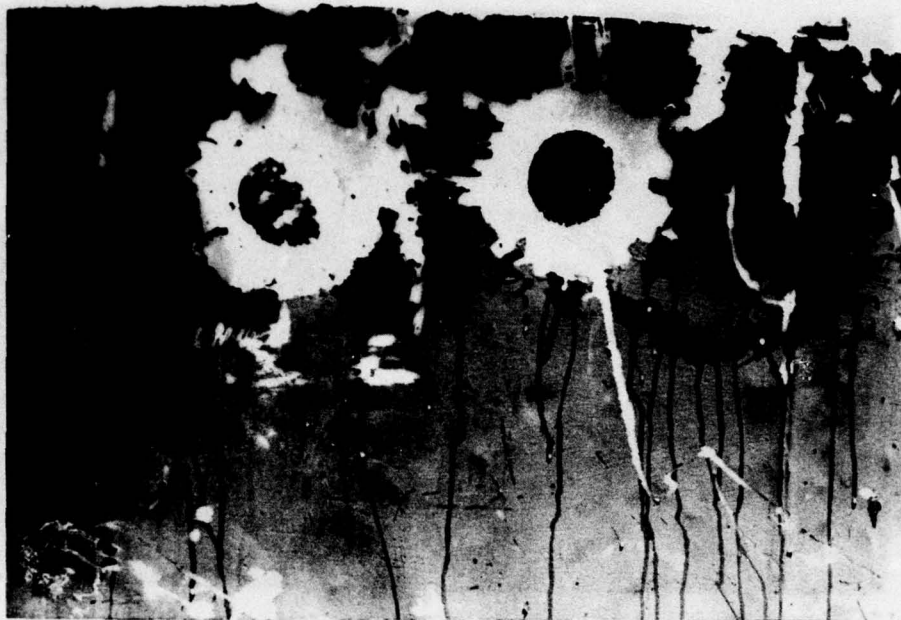

HIGH DENSITY POLYETHYLENE 1200 METERS
90MM M353
FIGURE 159.

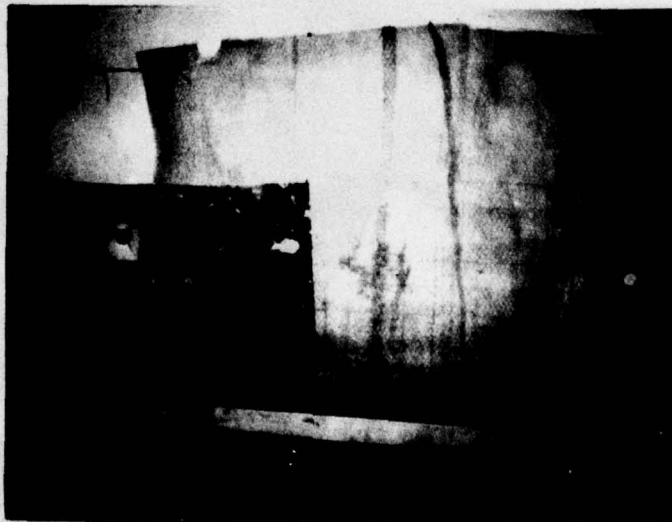

HIGH DENSITY POLYETHYLENE 1200 METERS
105MM M724
FIGURE 160.



HIGH DENSITY POLYETHYLENE 1200 METERS
105MM M467
FIGURE 161.



HIGH DENSITY POLYETHYLENE 1200 METERS
105MM M467
FIGURE 162.

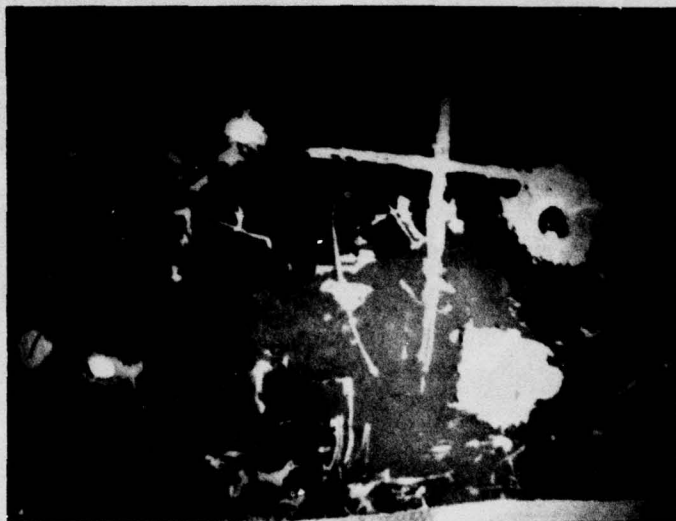

HIGH DENSITY POLYETHYLENE 1200 METERS
105MM M724 M490
FIGURE 163.

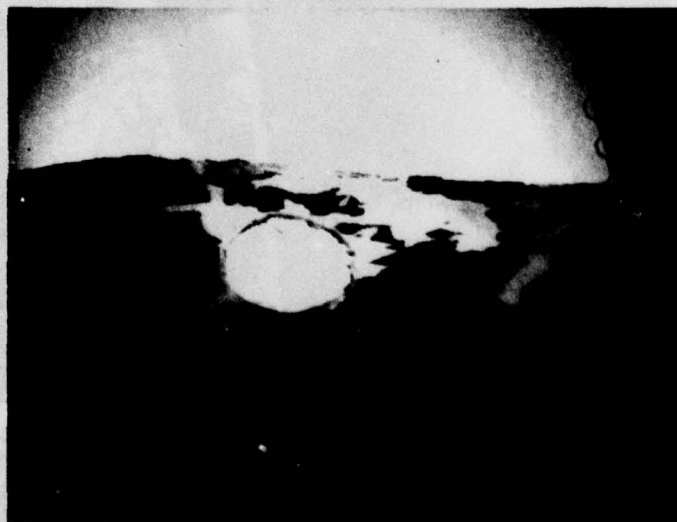

HIGH DENSITY POLYETHYLENE 1200 METERS
105MM M490
FIGURE 164.

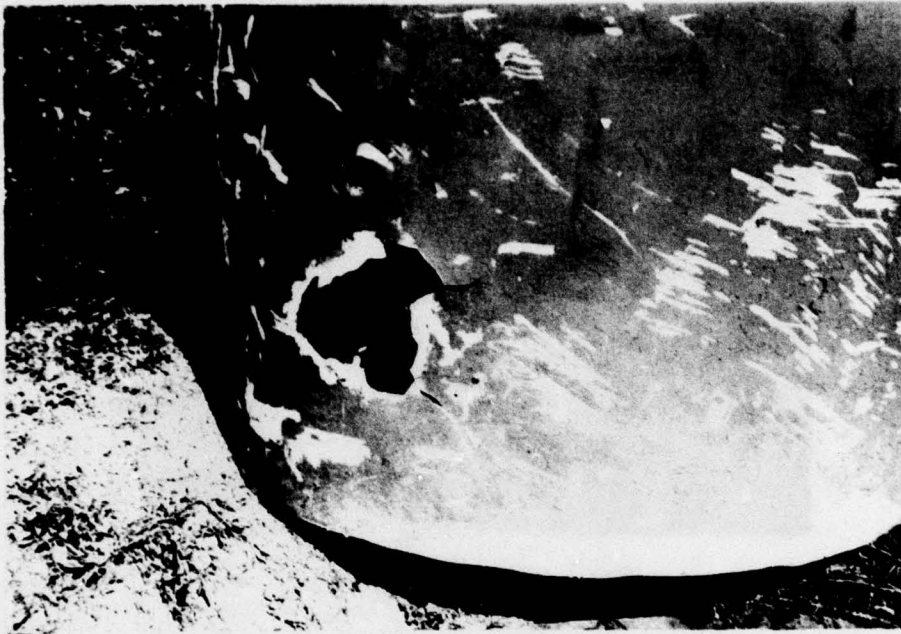

HIGH DENSITY POLYETHYLENE 1200 METERS

152MM M411
FIGURE 165.

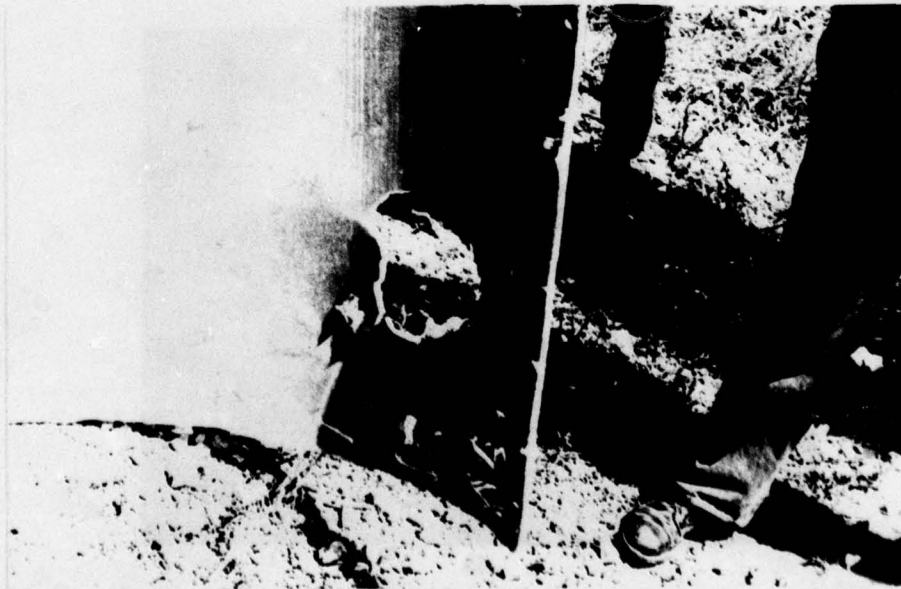

HIGH DENSITY POLYETHYLENE 1200 METERS

152MM M411
FIGURE 166.

The high density polyethylene material exhibited excellent properties for use as a subcaliber target. The projectiles left neat clean holes with very little damage to surrounding areas (see Figures 167, 168, 169). The target material was approximately one half inch thick, as a result of themolding techniques used, which is much thicker than required for actual targets. This thickness does, however, provide a quite rigid structure which would be necessary for a three dimensional target.



HIGH DENSITY POLYETHYLENE 120 METERS
.50 CAL.

FIGURE 167.

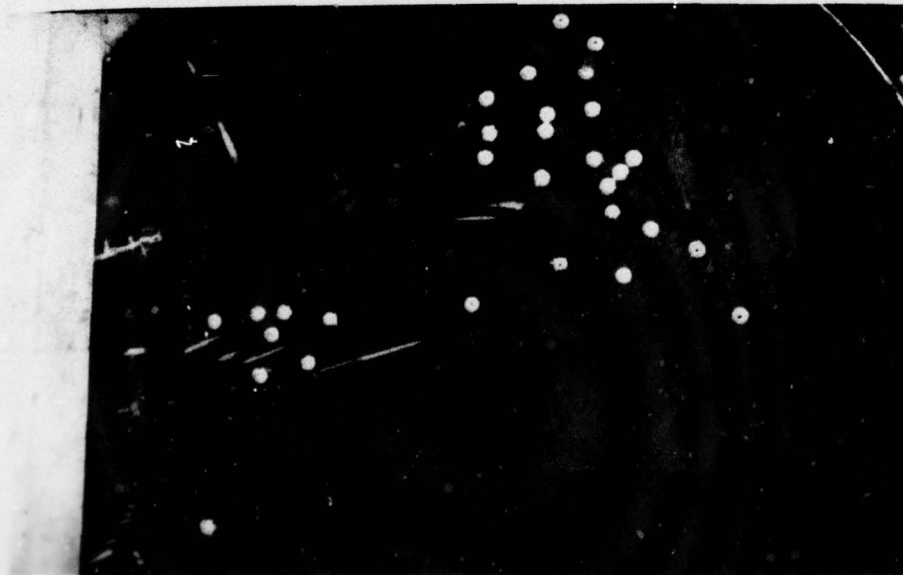

HIGH DENSITY POLYETHYLENE 120 METERS
.50 CAL.

FIGURE 168.

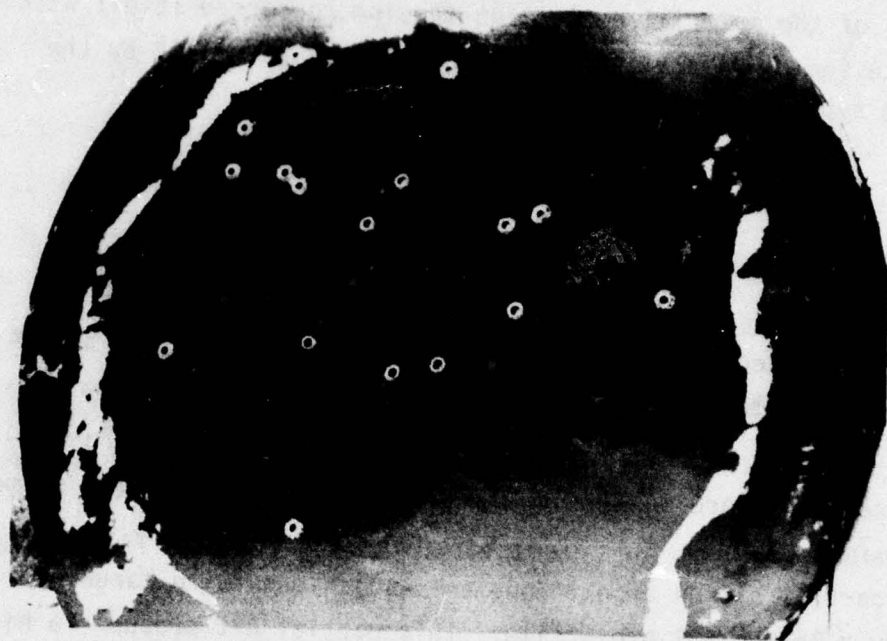

HIGH DENSITY POLYETHYLENE 120 METERS

20MM

FIGURE 169.

g. Hit Detector Performance Evaluation

A portion of the material evaluation testing concerned itself with the ability to sense projectile hits on the various materials by the different types of projectiles fired.

The equipment used was the hit detector device 3A109A/1, SN 500004 and piezoelectric detectors SN 14 and SN 002. This equipment was on loan from NTEC Orlando, Florida. Hit sensor mounting is shown in Figures 170 and 171.

The concrete reinforcing wire used in the target construction seemed to have a pronounced effect on the sensitivity of hit detector. Figure 172, 173 shows a partial hit on a polypropylene and chicken wire target at 1200 meters by a 152MM M411 projectile. This partial hit produced a hit indication even though very little target damage is evident.

The effect of debris on the hit detector could not be determined accurately from actual projectile impact. The one case where a short round occurred, the ground was impacted in front of and under the target holding fixture. The target and target holding fixture were demolished. The cable to the hit detector was severed and while a hit indication was received it is not known whether or not this was a result of the primary impact or debris. The hit detector sensitivity was such, however, that a 2" diameter rock thrown at the back of a target from about six feet resulted in a hit indication when the sensitivity was set on #1.

A summary of the total hit detection test data is tabulated in Table 9.

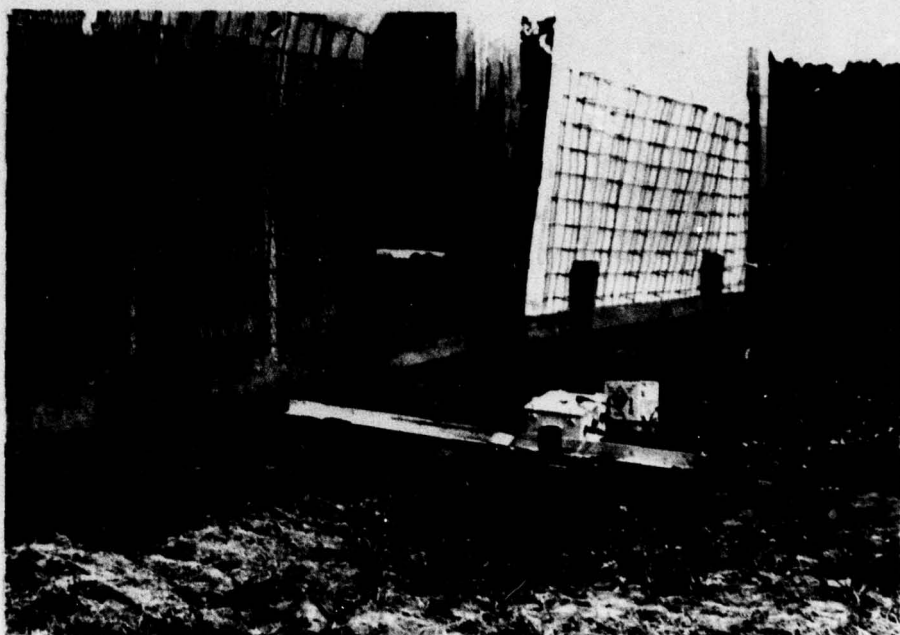

HIGH SENSOR EQUIPMENT
MOUNTED ON TARGET HOLDING FIXTURES
FIGURE 170.

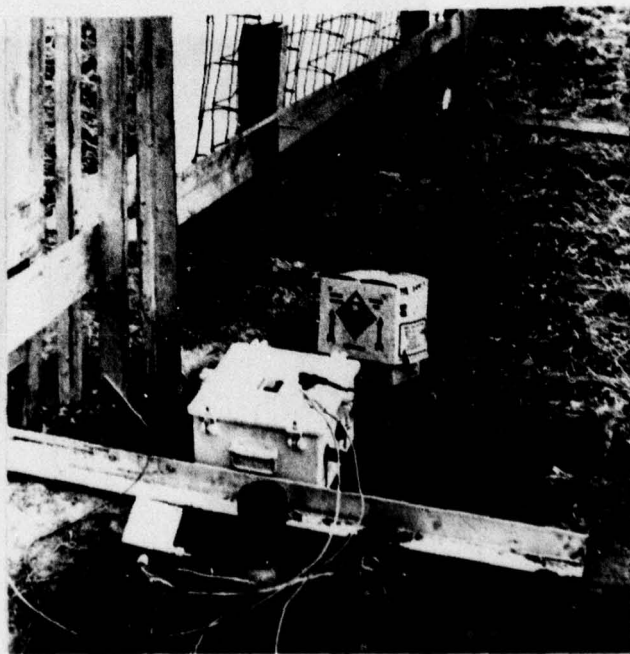

CLOSE UP OF HIT SENSOR EQUIPMENT
FIGURE 171.



POLYPROPYLENE & CHICKEN WIRE 1200 METERS

152MM M411

FIGURE 172.

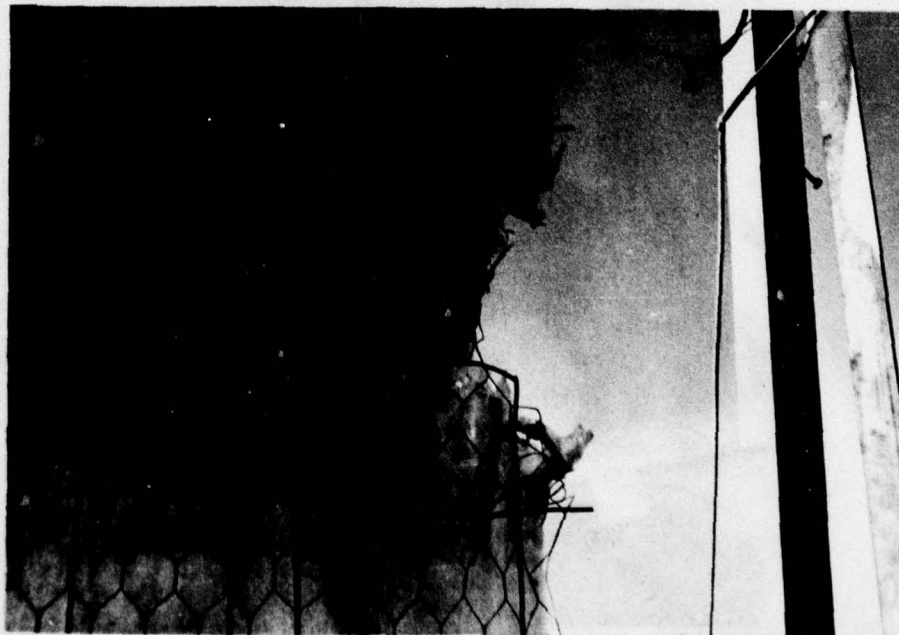

POLYPROPYLENE & CHICKEN WIRE 1200 METERS

152MM M411

FIGURE 173.

The impact of the 90MM M353 projectile resulting in the damage shown in Figure 174 did not indicate a hit. In this case the hit detector cable was cut approximately 8 inches from the detector and may have occurred just prior to or at the projectile impact precluding the actual hit indication.

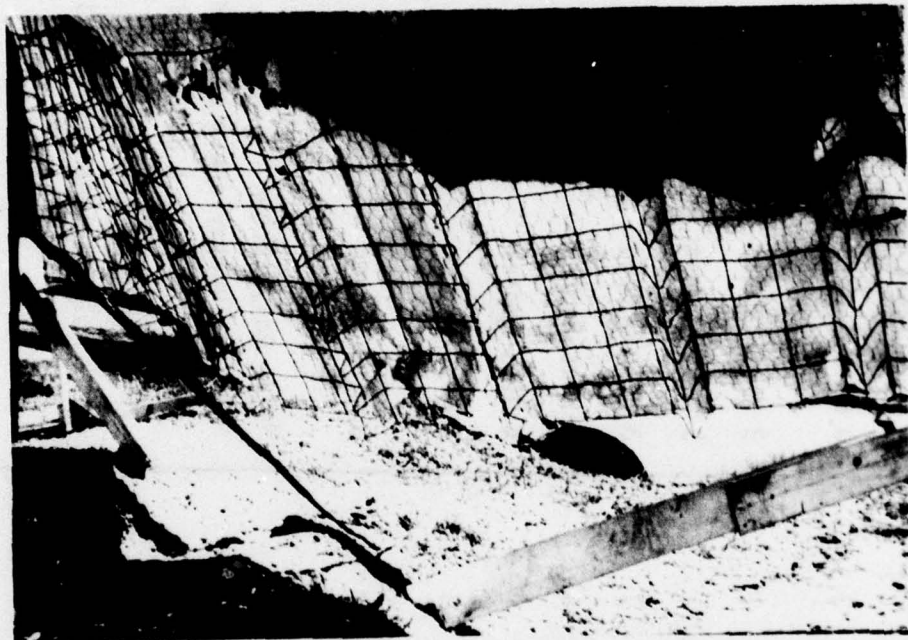

POLYPROPYLENE & CHICKEN WIRE 1200 METERS
Target Frame Damaged by 90MM Hit

Figure 174.

TABLE 9. HIT DETECTION TEST DATA SUMMARY

RANGE	PROJECTILE	MATERIAL	HIT SENSOR SETTING	COMMENTS	
750 Meters	105MM M467	ST*	1	3 Hits Scored	4 Actual Hits
		ST	3	0 Hits Scored	4 Actual Hits
	105MM M490	CP	1	3 Hits Scored	3 Actual Hits
		CF	1	3 Hits Scored	3 Actual Hits
	105MM M724	EF	1	3 Hits Scored	3 Actual Hits
		CP	1	3 Hits Scored	3 Actual Hits
	105MM 393	ST	2	4 Hits Scored	4 Actual Hits
		EF	1	3 Hits Scored	3 Actual Hits
		CP	1	3 Hits Scored	3 Actual Hits
	*ST - Polystyrene CP - Polypropylene & chicken wire CF - Fibre Wool & chicken wire EF - Polyethylene Foam PE - Polyethylene high density				

TABLE 9. HIT DETECTION TEST DATA SUMMARY (Cont.)

RANGE	PROJECTILE	MATERIAL	HIT SENSOR SETTING	COMMENTS	
1000 Meters	105MM M490	ST	3	No Hit Indication	3 Actual Hits
		CP	2	3 Hits Scored	3 Actual Hits
		CF	1	3 Hits Scored	3 Actual Hits
		EF	2	1 Hit Scored (loose wire could have caused trouble)	3 Actual Hits
1200 Meters	90MM M353	ST	1	1 Hit Scored Low round dismantled target holding fixture by striking ground under target. Hit detector cable broken but hit indication given.	1 Actual Hit 1 Near Miss
		CP	1	1 Hit Scored 2nd round hit target holding fixture cutting 6" x 6" angle beam and cutting hit detector cable. Due to erratic behavior tests using 90MM and hit detector stopped	2 Actual Hits

TABLE 9. HIT DETECTION TEST DATA SUMMARY (Cont.)

RANGE	PROJECTILE	MATERIAL	HIT SENSOR SETTING	COMMENTS			
1200 Meters	105MM M490	ST	1	2 Hits Scored	3 Actual Hits		
		EF	1	3 Hits Scored	3 Actual Hits		
		ST	1	3 Hits Scored	3 Actual Hits		
	105MM M467	EF	1	2 Hits Scored	2 Hits Scored	3 Actual Hits	
		CP	1	3 Hits Scored	3 Hits Scored	3 Actual Hits	
		CF	1	3 Hits Scored	3 Hits Scored	3 Actual Hits	
		PE	1	2 Hits Scored (CF Backing)	2 Hits Scored	2 Actual Hits	
		152MM M411	ST	2	1 Hit Scored	1 Hit Scored	3 Actual Hits
			CF	1	3 Hits Scored	3 Hits Scored	3 Actual Hits
	EF & PE		2	2 Hits Scored (1 on EF) (1 on PE)	2 Hits Scored	4 Actual Hits	
			CP	1	4 Hits Scored	4 Actual Hits	

TABLE 9. HIT DETECTION TEST DATA SUMMARY (Cont.)

RANGE	PROJECTILE	MATERIAL	HIT SENSOR SETTING	COMMENTS	
120 Meters	.50 Cal.	CF	1	No Hits Scored	1 Single Round 2 Round Burst
		CP	1	No Hits Scored	1 Single Round 2 Round Burst
		EF	1	No Hits Scored	1 Single Round 2 Round Burst
		ST	1	No Hits Scored	Total of 188 Rounds Single Shot and Automatic Fire

h. IR Image Testing

The following materials were tested by determining the change in the surface temperature of the material over a 2 hours period. In addition to the temperature test several of the materials were observed using an IR measuring device. The results obtained are as follows:

Tempsheet, 1100 ohm/Square - Armstrong Cork Co.

The only tempsheet sample available without purchasing a special order run of this material was 1100 ohm/Square resistance value. This material is a cardboard type material impregnated with conductive particles and can be obtained in various resistance values. The particular material obtained required the application of 110 volts to produce a 2.5 degree temperature change using a sample sheet approximately one foot square. NTEC is currently using a 60 ohm/square tempsheet that has produced excellent results. Based on the NTEC tests it has been concluded that this material will produce an excellent target when the proper resistance type is used.

Conductive Paint - Technit Co., Cranford, N.J.

The paint used for these tests was a 100 ohn/square acrylic type paint P/N 72-00085. This paint required a fairly smooth surface to provide an unbroken current path. Polyethylene foam was used for the initial tests but due to the nature of the polyethylene a good coating is difficult to achieve. Expanded bead polystyrene reacted with the paint unless a previous coating of laytex paint was applied. The Technit paint was then applied to a paper sheet with a spray gun and some information was obtained. The coating would generate some heat but the overall resistance was high and a relatively high voltage was required to produce a small temperature change. This material was

observed with an IR device and a visible image was obtained, however,
the image was not of good quality.

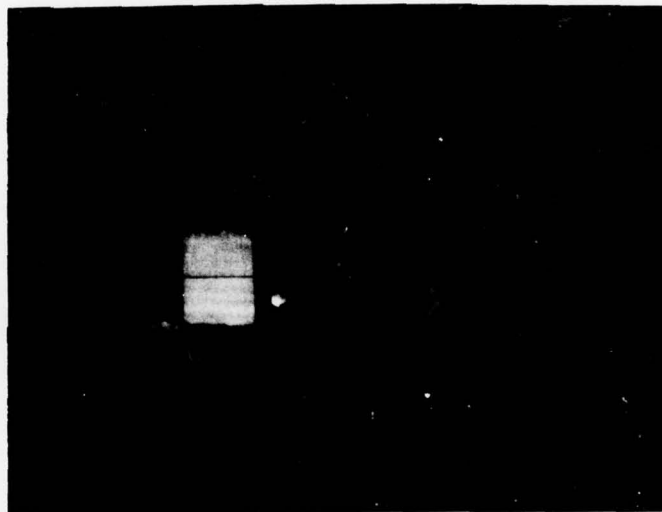

Figure 175

IR photo of Technit Paint sample compared to conductive glue 77X1430.
Technit sample is to right and shows only hot spots at electric connections.

Conductive Glues - General Adhesive & Glue, Nashville, Tennessee

These glues were obtained from General Adhesive in three configurations, 77X1203, 77X1429 and 77X1430. The 77X1203 glue is a General Adhesive glue developed for a commercial application and has a measured resistance of 52 ohms per square foot. Using the 77X1203 as a basic glue, 77X1429 and 77X1430 contain 50% and 100% more carbon black respectively. Temperature tests of the coatings were conducted using 12, 24 and 36 volts and produced spot temperature change in excess of 10 degrees. These temperature measurements were taken approximately half way between the electrodes.

As the applied voltage was increased, "hot" spots were cedernable to the touch and some melting of the underlying plastic was observed. This was attributed to the non-uniform coating of the glue and in some cases where a small electrode surface was used the "hot" spots were quire pronounced. These discontinuities are shown in some detail by the IR photo used to check IR emmission.

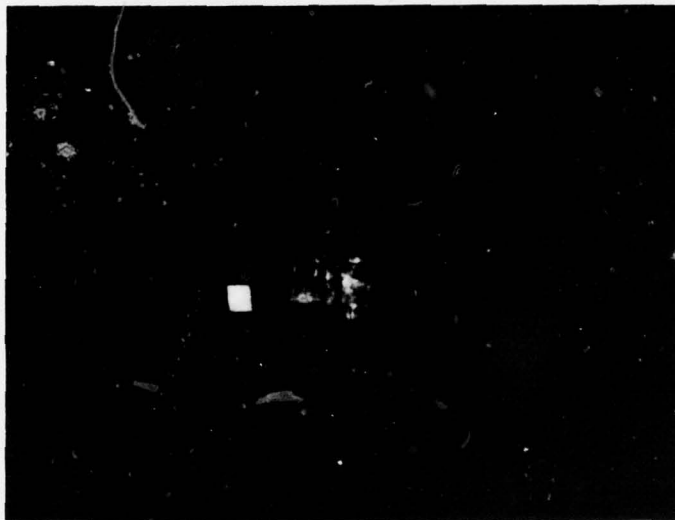

Figure 176

IR photo comparing conductive glue 77X1429 with small square of 60 ohm temp sheet. Conductive glue has not obtained a stable heat condition and "hot" spots caused in part by uneven coating are quite evident.

AD-A058 642 SPERRY RAND CORP HUNTSVILLE AL SPERRY SUPPORT SERVICES F/G 19/4
ARMOR TARGET SYSTEMS CONCEPTS. (U)
SEP 77

UNCLASSIFIED

210-5801-01

PM TRADE-TR-78-0001

N61339-76-D-0022
NL

3 of 3
AD
A068 642



END
DATE
FILMED
-11-78
DDC



MICROCOPY RESOLUTION TEST CHART

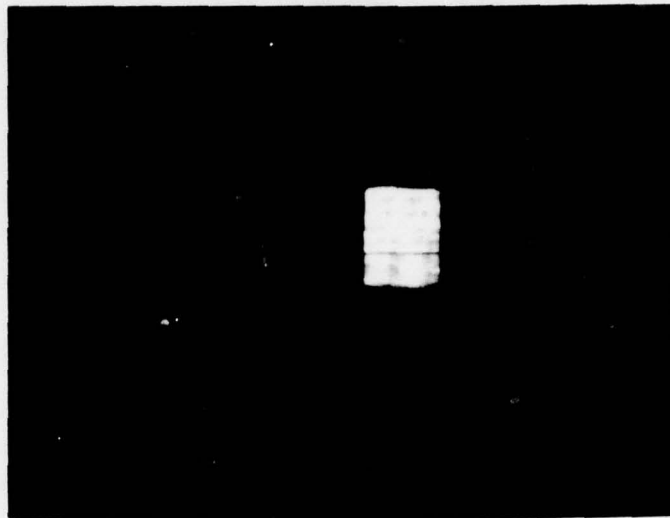

FIGURE 177

IR photo conductive glue 77X1429, at right, compared to Tepsheet sample.
Tepsheet is scaled to provide same power dissipation as glue.

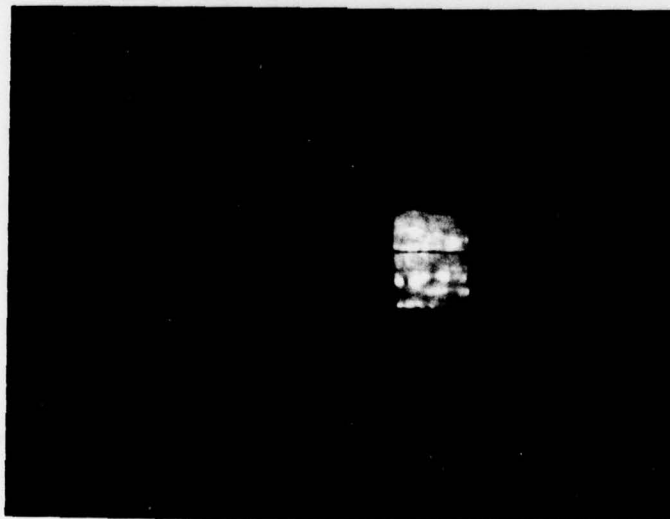

FIGURE 178

IR photo of conductive glue 77X1430, on right, compared to scaled Tepsheet sample. "Hot" spots are the result of uneven coating and handling cracks.

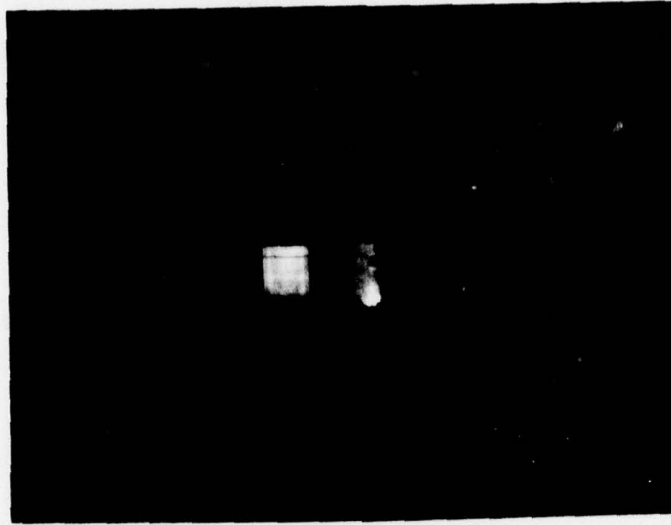

FIGURE 179

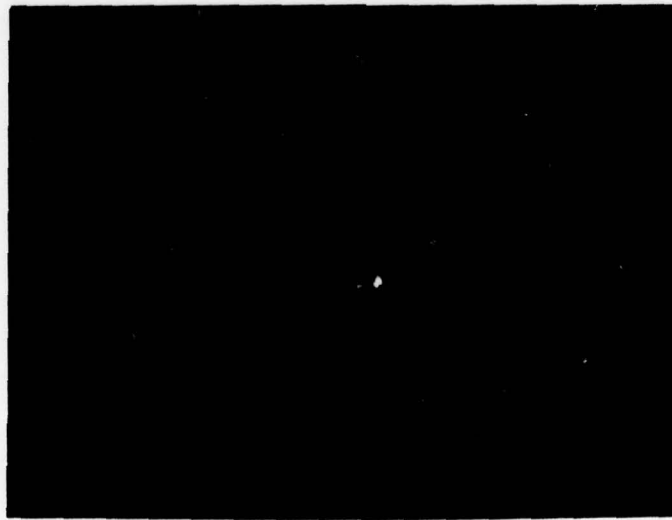

FIGURE 180

IR photos of conductive glue 77X1203 on right, compared to scaled sample of Tempsheet. Extreme "hot" spots at bottom of glue sample are the results of single electrode contacts. Electrode on top of sample extended completely across sample and did not produce "hot" spots.

SECTION III AUXILIARY EQUIPMENT

3.1 INTRODUCTION

The auxiliary MTS equipment consisting of Hostile Fire and Visual Hit simulators and the communication guidance systems are described in this section of the report. For each auxiliary equipment element there are sufficient existing systems that can be modified or developed to meet all of the ARETS specifications. There does not appear to be any real problem areas in assuring that a satisfactory auxiliary equipment subsystem package can not be purchased as individual components and integrated into a total subsystem for a moderate cost and no risk.

3.2 HOSTILE FIRE SIMULATORS AND VISUAL HIT INDICATORS

The following paragraphs describe the systems which are currently available to simulate main gun and machine gun firing and to provide the visual effects of a hit on the target. Several other systems considered during the investigation were determined to be unacceptable and do not appear in this report. Those that are listed are all very similar and are currently in production. Because of the similarities, no single device has been conclusively recommended. All are expected to perform well, but some units, as currently designed, will have minor variances to parts of the ARETS specifications. The most cost effective devices for which price data are available are the Hoffman devices. The primary factor in making this determination was the cost per round. The cost of the cartridges for the Hoffman main gun simulator and visual hit indicator is significantly lower than for the other devices. Hoffman is also the only manufacturer that has a multiple shot visual hit indicator. The Hoffman devices are

therefore Sperry's current recommendation for main gun simulator and visual hit indicator.

a. Main Gun Simulators

(1) SAAB

SAAB equipment is distributed in the U.S. by Detroit Bullet Trap Company, Schaumburg, Illinois. The SAAB BT 19A gun-fire simulator is a remotely controlled tank or anti-tank weapon simulator that provides a 1 to 2 meter muzzle flame. It uses a pyrotechnic cartridge that is loaded into a short barrel and fired with an electrical igniter. An operating voltage of 14.4 to 18 volts is required. The BT 19A is available with 15 or 30 cartridge magazine. Its dimensions are 610 mm by 520 mm by 200 mm and weighs approximately 27 kg.

Detroit Bullet Trap Corporation is currently revising their price list for SAAB equipment and would not provide data for this device.

(2) AAI Corporation

The AAI gunfire simulator consists of a frame, breechplate and control box assembly that will accept 24 cartridges. The cartridge uses a pyrotechnic mixture loaded into a 12 gauge shotgun shell with an electric primer. The device is designed to operate from vehicle nominal 24-volt power sources and is adaptable to a wide range of weapons. Sequential firing of the cartridges is controlled directly from the weapon control system. The assembly has a mounting bracket to adapt it to gun barrels having outside diameters up to 204 mm.

Cost of the simulator quoted by the manufacturer is \$3,000 each for two devices. Cartridges are \$2.50 each in quantities of 2000.

(3) Hoffman

Manufactured by Hoffman-Werke of Western Germany, the Hoffman

"simulation device for cannon bursts" consists of 9 short tubes that are loaded from the muzzle with pyrotechnic cartridges. The cartridges are ignited electrically. This is normally done from a switch box that has a pushbutton for each shot. Power is derived from the vehicle electrical system. A mounting bracket is used to attach the device to the gun tube. It may also be set up on the ground.

Hoffman was contacted by phone and telex in an effort to obtain a system description, operating characteristics and price data, but promised data were never received. The Hoffman simulator is being procured by PM TRADE. The unit cost is \$833 each, and the cartridge cost is approximately \$1.65 per round.

(4) Solartron

SIMFLASH is a main gun simulator manufactured by the Solartron Electronics Group. Ltd, in England and is used by British armed forces in training. The device is capable of holding 24 electrically detonated cartridges which are loaded from the muzzle end of the barrels. The device electronics controls the firing sequence and detonates one of the cartridges each time the weapon trigger is operated. A single pulse from the weapon system of 22 to 32 volts dc and 60 to 200 milliseconds duration is required. The device is mounted on the gun barrel. The dimensions of the device are 264 mm by 555 mm by 320 mm and weighs 48 kg, including mounting brackets.

Prices quoted by phone for the simulator are \$1600 for the unit and \$2.00 each for the cartridges.

b. Machine Gun Simulator

(1) SAAB

The SAAB BT 19 machine gun simulator is a self-contained, portable unit that uses compressed air for sound effects and an electronic

flash tube for muzzle flash and can be remotely controlled by wire or radio. Operating voltage is supplied by battery (12,1.5 volt cells or 12,1.2 volt cells). The rate of fire is specified at approximately 600 shots per minute. For the required 4 to 6 second sustained bursts, 40 to 60 shots would be expended. The capacity for one air charge is 1200 to 1500 rounds. This would meet the requirement for 20 bursts before reloading (800 to 1200 shots).

The U.S. distributor for SAAB, Detroit Bullet Trap Corporation, is currently revising their price list for SAAB equipment and will not quote prices for this device.

(2) Joanell

Joanell Laboratories manufactures a 50-caliber machine gun simulator which is a modified version of one that is in Army stock. This simulator uses a hydrocarbon fuel mixture (propane and oxygen) which is ignited inside the barrel by a spark plug. It can be fired remotely in single shots or bursts. Oxygen and propane cylinders are enclosed in a carrying case located near the simulator. Firing rate, shot capacity, and price data were not available. The device used 115/230 volts, single phase or 24 Vdc for power.

c. Visual Hit Indicator

(1) Hoffman

With a supplementary device, the Hoffman hostile fire simulator can be used as a hit indicator. The available data does not describe the supplementary device or indicate whether the same cartridge is used. No further price data were available.

(2) AAI Corporation

The AAI target kill simulator is a one-shot device which electrically fires a smoke producing kill simulator round. The device

operates from a vehicle nominal 24-volt power source. The cartridge supplies approximately 3-1/2 minutes of smoke. Price quotes from the manufacturer for two devices were \$330 each for the device and \$10 each for 1000 cartridges.

(3) Solartron

A smoke pyrotechnic and smoke pyrotechnic holder is used by Solartron as a visual hit indication. The holder is a bracket that houses the smoke pyrotechnic and provides the electrical interface for a detonation signal from a kill sensor. Smoke is emitted for about 30 seconds to simulate a kill. Price data for this device were not available.

(4) SAAB

The SAAB hit indicator is a smoke-flash generator that is not described in vendor literature. The smoke is apparently chemically generated and the flash appears to be generated by an electronic flash device. Further data, including costs, were not available.

3.3 MTC AUTOMATIC GUIDANCE SYSTEMS

The guidance systems included in this summary are those that showed promise in meeting the requirements for a MTC automatic guidance system.

Claims presented by each vendor are accepted as being design goals. Only one vendor had in production an off-the-shelf unit; however, this unit only meets the vehicle guidance requirements. Other designs are adaptations from other applications or they are in the concept state of development.

Sufficient development has been performed on vehicle guidance by remote control to find a vendor qualified to control moving target carriers. The most development activity has been in the area of wire guidance control.

a. Barrett Electronics

The Barrett wire guidance system is essentially off-the-shelf. The system includes a vehicle guidance package, a converter, interface equipment, and field wire. This system does not include a data link (communications) between the vehicle and a control console where commands and status lights for miscellaneous functions are maintained.

The guidance package consists of the guidance sensors, steering and control boards and interconnecting cables between the sensors and boards.

The converter operates from 117 volts, 60 Hz and includes a power supply, oscillator and regulator. The model quoted is capable of driving a line up to approximately 6 miles in length.

The interface equipment consists of hardware necessary to tie the guidance system into the vehicle controls (servos, actuators, piping, etc.).

The guide wire is laid in a closed loop around the course. The converter, fed by a 117-volt, 60-Hz line, drives approximately 150 MA of current in the kHz frequency range through the loop developing a magnetic field sensed by the guidance sensors. Deviations to either side of the wire, whether in forward or reverse vehicle direction, develop an error signal through the system resulting in a guidance correction. A few inches off course deviation will command an emergency stop. Specific locations are noted by the presence of beacons connected to the wire and placed around the closed loop path.

A movie demonstrating this guidance system was provided by Barrett. A heavy earth-moving machine was instrumented with this system in addition to automobiles, a bus, and a warehouse tractor.

With the addition of a communication link, this system is capable of meeting ARETS specifications. The communications link give the carrier capability to receive commands for speed control, activating the hostile fire simulator, and returning vehicle position data and hit sensor data. However, addition of the communications capability forces the total cost of the two prototype systems to \$70,000 per vehicle in addition to the one-time engineering fee of \$50,000.

A wire guidance system provides the most accurate vehicle positioning control of all systems reviewed. A potential problem of damaging the wire exists when using a track-type vehicle. If the wire is crossed or if the tracked vehicle turns on top of the wire, the track could catch the wire and cut it. Precaution must be taken to track the wire from the side of a tracked vehicle.

Sensor placement is not critical. The sensor can be placed as much as 36 inches above the wire, and under these conditions, will allow the vehicle to deviate with slightly more error in tracking. The wire will need to be laid as straight as possible to avoid oscillations in steering when the vehicle tries to follow minor deviations in wire directions. A recommendation is made to stake the wire to the ground about every 200 meters.

b. Beech Aircraft Company

This guidance system concept requires a gyroscope for directional control and an odometer for measuring distance. The course can be pre-programmed for direction, speed, required turns, etc. and inputs to the control systems from a microprocessor controller.

This basic system would have approximately 3 percent error in location which could be reduced somewhat by the addition of a fifth wheel

for use as a odometer input device.

Error sources are gyro drift in heading and drive slippage on odometer or distance measuring device. Gyro drift is 4° per hour which yields an error of 593 feet in 31 minutes at 12 mph. More accurate gyros are available which may reduce the error to approximately 2° heading error.

Odometer error is approximately 2 to 3 percent which could be reduced by 50 percent by adding a fifth or trailing wheel which would eliminate the slippage factor in the distance measurement.

Maximum error for the proposed Beech system could be 3.08 percent or 1012 feet over a 32,808 foot (10 km) route. Considering inclusion of the fifth wheel, the error could be reduced to 656 feet for the 32,808 foot route or 1.99 percent. This projected error is still out-of-spec based on location to ± 10 meters or ± 32.8 feet. Firm price estimates have not been developed for this system.

The Beech Aircraft guidance system was not considered in the final evaluation because of the excessive guidance error.

c. Brunswick, Celesco

A guidance system utilizing an azimuth encoder and an odometer provide control for a free roving vehicle. Such a device is under development by Brunswick, Celesco. They switched from a wire guidance system to the new principle about January 1, 1977. The system was reviewed with Brunswick engineering at the Sperry facility on February 3, 1977. At the time of this meeting, the engineering staff did not feel that system accuracy was sufficient to approach the specification requirements. The specification requirements on guidance accuracy do appear to be realistic

and would be mandatory if the guided vehicle must position itself behind berms. Based on the meeting with two company representatives, we ruled this unit as unacceptable because of system inaccuracies.

The guidance system includes a preprogrammed course system which controls the basic azimuth and distance coordinates for the vehicle's course around the range. A radio control system provides the functions for commanding vehicle functions of start/stop, forward/reverse, speed, and automatic shut off for loss of guidance. A central processing unit "learns" the desired vehicle path while the vehicle is manually driven over the desired path, the resultant data is stored on cassette tape for replay and decoding of the program as that path is used.

The system accuracy is undetermined. The azimuth encoder used for heading is accurate to 1° in a 360° turn but actual system operational accuracy is not predicted. The trailing wheel with a magnetic pickup inputs to a solid-state, bi-directional distance counter to control the distance travelled by the vehicle.

In addition, a two-way radio data link is required to provide commands for start/stop, forward/reverse, speed, target hit counting, and vehicle faults.

Cost of the guidance system is \$61K for single units, \$46K each in quantities of two, and \$14K each in quantities of 100.

d. General Dynamics

The Range Measurement System (RMS)/Simulated Combat Operations Range Equipment (SCORE) is a position location system for modern military weapons testing, training, and tactics evaluation.

The RMS/SCORE system consists of tracking instrumentation, a real-time display system, a computational system, and an airborne instrumentation system. This provides for the collection and evaluation of position and event data from multiple ground and air participants during simultaneous tests of offensive and defensive systems. It is a developed and proven system funded by the Department of Defense.

Elements of the system include:

- o At least three fixed (or mobile) towers at known locations used to measure and report target range between the tower and vehicles to an accuracy of 1.7 to 5 meters
- o A transponder placed on each target vehicle
- o A central subsystem housed in a van to control ranging and communication with the vehicle and send position/event data to the computer control center
- o A mobile van to house the computer control center which accepts, updates, and transmits the event and position location data to the display van
- o A display van to provide real-time display and monitoring of events and vehicle locations
- o A mobile maintenance site for electronic test and checkout of system equipment.

For carrier vehicle guidance this system would provide for real-time position location of multiple carrier vehicles, automatic event recording, two-way digital data communications, and permanent recording of training results for later analysis.

The design of this system was not intended to command vehicle control functions but it could be modified to do so by issuing a guidance correction as vehicle deviates from programmed direction. The vehicle will require guidance control and interface equipment to accept update data.

This equipment was not chosen for the final evaluation because the existing equipment for one installation will exceed \$1,000,000.

e. Martin/Orlando

This system is designed to guide a vehicle toward an IR light source(s) using an IR sensitive vidicon and special purpose tracking circuits mounted on the vehicle. The remainder of the system consists of a GFE transceiver on the vehicle, a GFE transceiver and electronics package at a remoted control station, and approximately 30 IR light sources located around the range. Command capability and status of the vehicle, i.e. location, mode of operation, direction of travel, speed, can be monitored at the remote control station in addition to hostile fire simulation activation and hit count for each vehicle. The system can be operated manually or automatically by programming the lights in a specific sequence. Variations of light sequences is possible with terrain permitting line of sight without obstructions.

The accuracy expected for this system is +2 meters

The costing of this system is:

- o Development cost \$150,000 for two units
- o Production cost \$15,000 per unit.

f. MB Associates

According to information supplied by personnel at Eglin AFB, MB Associates has tested a vehicle guidance system at Eglin Air Force Base which may meet the specification. Two telephone calls were made to this company but the responsible people were not available and never returned the calls.

The sources of information reported that the MB Associates system is a wire guidance system that requires no radio transceiver data link to the controller. It is assumed that two-way communication was handled over the wire guidance system.

No cost data is available.

g. Sperry Rand

In the development of radio control equipment for target ranges, Sperry has developed command and control equipment that is applicable to controlling moving target carriers. Since the moving target carriers do not remain within view of the controller, a radio link will not suffice in guiding and operating the moving target carrier. Therefore, of the concepts studied and perfected to date, the wire guidance technique shows the most promise as a method to guide moving target carriers.

Sperry proposes to adapt the command and control equipment proposed for target ranges to the command and control of moving target carriers. Instead of transmitting by radio, all command and control data will be transmitted on the guidance wire. A radio link will be unnecessary as the MTC is completely controlled by wire guidance by having a pickup device on the vehicle to receive guidance and command data.

The vehicle can also transmit data back onto the wire for controlling functions required at the control center.

With the proposed wire guidance system, all of the functions such as start, stop, forward, reverse, changes in speed, steering, firing of simulators, vehicle locator, hit counting, and equipment off

The control operator will have the capability to address a vehicle and receive a response from the vehicle when the command is acknowledged. Indicators on the control panel will identify the vehicle location on the course and indicate hits taken by targets on the vehicle. Each controller operator will be able to control up to five vehicles at one time. Any vehicle becoming disabled will be readily recognized by the operator who can arrange for removal of equipment.

The same precautions are required for laying a wire guidance line as outlined with the Barrett System.

Cost estimates for developing prototype system to operate one vehicle is \$55,000. Development costs for one prototype system to operate two vehicles is \$70,000. Production cost per vehicle is estimated at \$9,000.

SECTION IV

MOST FEASIBLE AND COST EFFECTIVE CONCEPT

4.1 INTRODUCTION

Based on the study results, Sperry recommends that a light armor concept be adopted and initially fielded with either full or 1/2 scale targets, and that only subcaliber (50 cal ammo) be used against these MTS. In parallel with fielding the light armor MTS a development program should be initiated to develop reliable and economical main gun frangible ammo. This frangible ammo, when fully developed, could be used to engage a "beefed up" light armor MTS, roaming in the open without berm protection.

This approach provides the maximum degree of realism at the least cost. No berms would be required when using either the subcaliber or frangible main gun ammo. The light armor carrier approach provides the maximum ability for maneuverability, thereby accommodating platoon and company battle run training strategy projected for the early 1980 time frame.

A carrier meeting all of the ARETS requirements is achievable in the light armor concept. In fact a variety of carriers approaching the ARETS specifications are obtainable off-the-shelf. There is sufficient vendor interest, that a light armor vehicle can be procured for a reasonable price which would meet the full ARETS specification.

The decisions made by Sperry in recommending the light armor concept are based on the cost effectiveness analysis presented herein. The recommendations for use of subcaliber ammo initially, while developing frangible main gun rounds are based on the armor center gunnery training device strategy 1976-19

4.2 MOVING TARGET SYSTEM COST DATA

The estimated cost for the three concept configurations selected as most suitable and which met the greatest number of ARETS technical performance requirements, are presented in Table 9. These cost estimates are based on the following data, some of which is hard while others remain somewhat soft. All assumptions used are applied universally to the three concepts, when such application is practical.

The MTS life cycle for each concept was set at 5 years. damage maintenance was assessed differently for each concept. The no armor system damage maintenance was assessed in terms of during the 5 year life cycle the

Table 10. MTS Cost Data

<u>Item</u>	<u>No Armor</u>	<u>Light Armor</u>	<u>Heavy Armor</u>
TARGET CARRIER	12.5K	26K	300K
DAMAGE MAINTENANCE	25 K	39K	288K
O&M	12 K	17K	317K
TARGETS	76 K	76K	--
BERMS	40 K	20K	--
BERM MAINTENANCE	15 K	7K	--
HIT SENSORS	8 K	8K	8K
HIT SENSOR MAINTENANCE	2 K	2K	2K
GUIDANCE EQUIPMENT	9 K	9K	9K
HFS/VFS	24 K	24K	24K
SYSTEMS INTEGRATION	10 K	15K	20K
	<u>221.5K</u>	<u>243K</u>	<u>968K</u>

carrier would be accidentally hit a sufficient number of times by sub-caliber and main gun rounds to have the two complete carrier replacements. The light armor damage maintenance would not be as severe because of its defense against subcaliber rounds. It was therefore estimated that replacement parts equivalent to 1 1/2 times the total vehicle cost would be required over the 5 year period.

In the case of the heavy armor concept, the assessment of damage was based on \$10.00 per hit taken. This figure is extrapolated from data received from OTEA relating to damage repair cost per hit for the M-47 chassis used as moving targets against TOW and Dragon missiles. The total cost of damage repair for this concept is based on data relating to main gun rounds fired at moving targets per month at Fort Hood and Fort Carson. With this data showing 4000 rounds per month fired and the probability of hitting the moving target between 500 and 3000 meters set at 60 percent and assuming 5 MTS per range (ARETS Specifications), the total damage maintenance cost is computed.

Operation and normal maintenance costs for the no and light armor configurations are based on data received from the respective supplier of these carriers. In the case of the heavy armor concept, the O&M costs are extrapolated from U.S. Army cost data for the M-60 tank. The extrapolation takes into consideration that only maintenance of the basic vehicle is priced, it does not take into consideration the numerous complex subsystem maintenance costs.

The cost of targets for the no and light armor systems is identical. These are based on an assumption that 100 hits on a target will render it unusable. The validity of this assumption will be examined as part of the

2-D target test program planned for Phase III of Task 6837A. The number of hits taken by targets over the 5-year life cycle is obtained in the same manner as the damage maintenance data for the heavy armor concept. Cost per target is presently estimated at \$400, each but based on the volume of targets required, it is lowered to \$260.00 each through the use of 95 percent learning curves for both material and labor. The heavy armor system does not require any targets.

The requirement of berms for the no armor and the light armor configurations are based on estimated costs for similar type berms to be constructed this year at Fort Polk. The total berm lengths are 2000 meters for the no armor concept and 1000 meters for the light armor. The cost of the berms are amortized over 5 MTS per range (ARETS Specifications). The survey of the berm costs are discussed in Appendix A of this report.

No hard data is available on berm maintenance cost. Due to the book-keeping methods used, such costs are included in total range maintenance costs and cannot be separated. Therefore, the best estimate for such costs for the 5-year life cycle is 40 percent of the total berm costs.

Hit sensor systems are identical for the three concepts. They are based on having to replace six sensors per MTS over the 5 year life cycle at \$500.00 per sensor. The \$25,000 control ground station required with these sensors is amortized over the 5 MTS per the ARETS Specifications.

Guidance like hit sensing is identical for all three MTS. It's cost is based on Sperry's estimate to produce a wire guidance and communication system for \$9K. The selected Hostile fire simulator is a Hoffman device similar to one contracted by PM-TRADE. It's cost is \$800 each due to the requirement of placing this device in proximity to the simulated main gun

location, it is estimated that six of these devices will be destroyed over the 5-year period. The visual hit simulator like the HFS is a Hoffman device and is not as vulnerable to damage as the HFS. It can be located low on the vehicle and a funnel arrangement used to direct the smoke. Therefore, it is estimated that only two replacements will be required during the 5-year life cycle. Identical HFS and VHS are used on all three concepts. In addition to the equipment for simulating visual hits and hostile fire it is estimated that 10,000 cartridges will be used per MTS at a cost of \$1.65 each.

The system integration costs are Sperry engineering estimates, which include the attachment of armor to the basic vehicle and the installation of the various subsystems into the MTS. The cost differences observed between the three concepts are due to the armor installation requirements.

For the purpose of developing a cost effective analysis it becomes convenient to convert the cost of each MTS concept to a cost per round fired. This provides the following:

- o No Armor - \$ 4.60/round
- o Light Armor - \$ 5.01/round
- o Heavy Armor - \$20.17/round

A significant cost element for the selected light armor concept is the target replacement costs. It is also the cost that can, with some effort, be most simply reduced. A small reduction in cost per unit will provide significant reduction in this line item total cost per range.

4.3 COST EFFECTIVENESS ANALYSIS

The three concept configurations discussed in this report and priced in Table 10 were subjected to a cost effectiveness analysis to establish

the optimum choice. The technique employed in performing the analysis was a cost benefit comparison.

The cost-benefit comparison technique for determining the cost effectiveness of a system consists of the following steps:

- o Determining the parameters which define the objectives of the system
- o Arranging the parameters in order of their relative importance and assigning weighting factors
- o Determining the capability of the various alternatives to satisfy the system objectives and computing an effectiveness figure-of-merit for each alternative
- o Developing a cost estimate for each alternative
- o Making a cost vs. effectiveness comparison for each of the alternatives to reveal the most cost-effective option.

4.4 EFFECTIVENESS ANALYSIS

The parameters which define the ARETS system are listed in order of priority in Table 11. and weighting factors are assigned with the most important parameter having a weighting of 1 and the least important carrying a weighting of .2.

Table 11. Training Capabilities Listing

Priority	Parameter	Alternatives			Weight Factor	Equal Weight Factors
		No Armor	Light Armor	Heavy Armor		
1	Target Motion	2	6	9	1	.2
2	Target Appearance	6	7	2	.8	.2
3	Versatility	3	5	7	.6	.2
4	Commonality	6	4	4	.4	.2
5	Deployment on Future Ranges	4	7	6	.2	.2

The last column indicates that each system parameter has a weighting of 0.2 if equal weighting factors are assumed. The three center columns contain rating factors representing the effectiveness of the various options with respect to the listed parameters. The subjectively determined rating factors are established on a scale from 0 to 9 where 9 represents maximum possible efficiency and 0 represents the least.

Next, the relative effectiveness of each alternative is calculated. Table 12 shows the effectiveness of each alternative with priority weighting factors included whereas Table 13 considers equal weights on the parameters. The numerical values in the columns under the three options in these two tables represent the product of each rating factor and the appropriate weighting

factor listed in Table 11. The figures in each column are totaled and then compared to the potential maximum total to compute a percentage effectiveness for each alternative.

Table 12. Effectiveness Analysis with Priority Weighting Factors

Priority	No. Armor	Lt. Armor	Hy. Armor	Potential Maximum
1	2.0	6.0	9.0	9.0
2	4.8	5.6	1.6	7.2
3	1.8	3.6	4.2	5.4
4	2.4	1.6	1.6	3.6
5	<u>0.8</u>	<u>1.4</u>	<u>1.2</u>	<u>1.8</u>
TOTAL	11.8	18.2	17.6	27.0
% EFFECTIVENESS	.44	.67	.65	

Table 13. Effectiveness Analysis with Equal Weighting Factors

Priority	No. Armor	Lt. Armor	Hy. Armor	Potential Maximum
1	0.4	1.2	1.8	1.8
2	1.2	1.4	0.4	1.8
3	0.6	1.2	1.4	1.8
4	1.2	0.8	0.8	1.8
5	<u>0.8</u>	<u>1.4</u>	<u>1.2</u>	<u>1.8</u>
TOTAL	4.2	6.0	5.6	9.0
% EFFECTIVENESS	.47	.67	.62	

Now, the comparison between cost and effectiveness can be made by constructing Table 14 which shows the effectiveness range (using both priority and equal weighting factors) and the cost per round estimate* for each of the three options.

Table 14. Effectiveness/Cost Comparison

Option	Effectiveness	Cost/Round
NO ARMOR	44% - 47%	\$ 4.60
LIGHT ARMOR	67%	5.01
HEAVY ARMOR	62% - 65%	20.17

Normalizing with respect to the no armor case**, the increase in effectiveness as a function of additional investment for the light and heavy armor options can be constructed. (See Table 15.)

*Cost per round estimates are derived by dividing the MTS cost by the expected number for rounds fired at the MTS over its 5 year life cycle.

Example

No armor MTS cost = \$222K.
 Number of rounds fired/MTS = 48,000
 Cost/round = $\frac{222K}{48K} = \$4.60/\text{round}$

** Effectiveness increase calculations

Example

$(67\% - 44\%) / 44\% = 52.3\%$
 $(\$5.01 - \$4.6) / \$4.60 = 8.9\%$

Table 15. Effectiveness/Cost Comparison
Normalized to No Armor Case

Option	Δ Effectiveness	Δ Cost
LIGHT ARMOR	42.6% - 52.3%	8.9%
HEAVY ARMOR	31.9% - 43.2%	338.5%

From Table 15, it is apparent that the light armor is more cost-effective than the no armor since a 8.9percent cost increase yields a 42.6 to 52.3 percent increase in effectiveness. Also, the heavy armor option is clearly not cost-effective since a 338.5 percent increase in cost yields only a 31.9 to 43.2 percent increase in effectiveness over the no armor option.

A similar but separate study was performed, and the effectiveness of the three options was determined based on the following defining parameters: (1) Realism, (2) Versatility, (3) Commonality, (4) Adaptation to future ranges, and (5) Automation of the range. The results of this effectiveness analysis are contained in Tables 16 and 17. As evidenced by Table 17, this analysis also indicates that the light armor option is the most cost-effective alternative.

Table 16. Effectiveness/Cost Comparison

Option	Effectiveness	Cost/Round
NO ARMOR	70.3% - 80.0%	\$ 4.60
LIGHT ARMOR	79.3% - 82.2%	5.01
HEAVY ARMOR	73.3% - 77.8%	20.17

Table 17. Effectiveness/Cost Comparison
Normalized to No Armor Case

Option	Δ Effectiveness	Δ Cost
LIGHT ARMOR	-0.9% - 17.4%	8.9%
HEAVY ARMOR	-8.4% - 9.6%	338.5%

Although both Tables 15 and 17 show the optimal cost benefit of the light armored MTC, these data were developed from subjectively determined weighting factors noted in Table 11. Also the estimated absolute costs of each vehicle as shown in Table 9 must also be considered in the overall evaluation of the three candidate MTC systems.

APPENDIX A
BERM STUDY

FORWARD

This study was made as part of the main study task funded under Phase I of Task 6837A. The purpose for this study on berms was two-fold: (1) to assist in providing realistic data to evaluate the effectiveness of berms as a protection for light and no armor moving target concepts, and (2) to assist in evaluating the NTEC 7002 concept.

1.0 INTRODUCTION

PM-TRADE requested an evaluation of earthen berms as a means of protecting a moving target carrier. Such berms would be arranged in a manner to allow protected free movement of a vehicle to be selected by PM TRADE.

2.0 PURPOSE

The purpose of this evaluation was to determine the feasibility of constructing earthen berms as a means of protection for a target-carrying vehicle.

3.0 SCOPE

The evaluation had the following specific objectives:

- a. To determine the current use of berms on moving target ranges.
- b. To determine the effectiveness of berms as a protection method.
- c. To determine an estimated cost figure for berm construction maintenance.
- d. To determine an estimated construction time for berms.
- e. To evaluate the specifications used to construct berms.
- f. To determine what equipment would be required to construct additional berms.
- g. To determine training problems associated with berms.

4.0 PROCEDURES

The first step undertaken in the evaluation was the development of a list specifying the data that would be necessary for the berm study. Step two was the selection of installations reflecting a cross-section of terrain types that could be encountered when constructing berms. A total of 13 installations, supporting 51 moving target tank gunnery ranges, were surveyed. These installations are located in the United States along the East coast, in the South and Midsouth, in the Midwest, and on the West coast.

The Facility Range Office of each installation was queried. The response was excellent, and all information gathered is considered to be factual. Two facilities were able to provide some cost figures, and a civil engineering and consulting firm located in Huntsville, Alabama, provided additional estimates of time and cost.

5.0 RESULTS AND DISCUSSION

a. Current Berm Utilization - The majority of installations contacted are utilizing berms at the present time. These berms vary in size, length, and arrangement. The longest berm, located at Fort Campbell, Kentucky, is 800 meters long and is constructed with a slight curve to the overall length of the berm. Several of the installations use a series of short berms 50 to 80 meters in length, arranged to protect the moving target only when it is behind these short berms.

One new berm has been constructed in the past year, and one facility is planning to begin construction of additional berms in the near future. All other berms have been in use for an undetermined period (estimates varied from 5 to 40 years at the different installations).

There is no standard berm currently in use. The thickness at the top of the berms used at this time ranged from a maximum of 16 feet to a minimum of 3 feet. The slope also varied, with the average slope being 1 to 1.5 feet for each foot of height.

The Department of the Army, Office of the Chief of Engineering, Military Construction-Engineering Division, Washington, D.C., was contacted to determine if specifications existed for the construction of berms. Personnel within this office were unable to reference or provide detailed specifications. However, the following rule of thumb used in the construction of berms to protect ammunition bunkers was given: "Construct the berm 2 feet higher than the structure to be protected, with a slope of 2 feet for each 1 foot of height."

Further discussion with this office established that the facility engineer has the overall responsibility for the design and construction of berms at a particular facility and usually designs a structure that meets his specific needs.

b. Berm Maintenance - All facilities utilizing berms agreed that maintenance of berms is relatively inexpensive, with some of the work being done by engineering units assigned to the post or with periodic repairs contracted to civilian construction companies. The actual cost for berm maintenance could not be determined with available data, as each facility requests maintenance dollars for the entire range complex, and these dollars are included in the construction repair cost. Since this cost also includes such items as road repair, firing line maintenance and observation tower maintenance, these cost figures are useless for calculating the cost of berm maintenance.

One factor affecting maintenance cost is the amount of firing conducted on each range with a berm. Fort Hood, Texas, Fort Knox, Kentucky, Fort Polk, Louisiana, China Lake, California, and Camp LeJeune, North Carolina, reported extremely heavy scheduling of their ranges, which necessitates more maintenance.

The training of individual tank crews also affects the cost. Crews that are experienced and advanced in training have fewer short rounds, resulting in less damage.

Another cost factor is the removal of dud rounds prior to any maintenance activities. This problem would also impact any new construction if located on acreage now used as impact areas.

c. Inclement Weather Damage - All range offices agreed that the following weather elements had some effects on berms now in use.

- (1) Wind - 5 range offices reported that wind did create some erosion. These ranges are located on soil whose composition is primarily sand.

(2) Rain - All ranges reported that heavy rains caused damage to berms unless grass was well grown in. The area damaged by short rounds is particularly vulnerable and erosion occurs in all types of soil.

(3) Snow - One range reported some damage from snow.

d. Training Problems Associated with Berms - All range offices agreed that during actual training operations the use of berms causes the following problems:

- (1) Restricts maneuvering by the attacking vehicles. Vehicles cannot traverse the berms without causing damage.
- (2) Restricts firing techniques. The crews can only fire from specific positions where the target is visible and protected.
- (3) Restricts realism. The berms force a "canned" type exercise, allowing crews to anticipate and ambush the target.

e. New Berm Construction - The survey revealed that ten of the offices contacted have ranges located on flat or rolling terrain. The remaining three offices reported ranges where the terrain was extremely rough. All offices agreed that any new construction could be accomplished by using bulldozers and road graders.

Demolition work would be required at sites with rough terrain. However, the actual amount was not determined, as this factor could not be calculated without the proper land survey. This problem could also occur at other ranges once construction started. Other problems involved included the following:

- (1) Dud Removal. Seven range offices reported the need for dud removal prior to any construction work on existing ranges. All others currently clear duds as they are found. All agree that some work in this area would be required.

(2) Timber Removal. Four range offices reported that new construction would require extensive timber removal.

(3) Area Available for New Range. Three range offices reported that the area for a complete new range could be made available. All others, however, felt they were cramped for space now.

(4) Impact of New Construction. Only one range office reported there would be no problem with new construction (this range had only been utilized for about 4 days in one year). Twelve range offices felt that construction on existing ranges would impact current training missions.

Two range offices indicated a problem could exist if military personnel were used for construction. Past construction at these locations utilizing such personnel have resulted in hard feelings with local civilian contractors.

(5) Environmental Impact Studies. All construction would require an environmental impact study. This could be a very simple analysis or can get to be a major problem if new ranges are constructed. The study is required by the Corps of Engineers for any major construction.

f. Berm Construction Cost - Estimates were gathered for the construction of berms utilizing a civilian construction company and a military TO&E engineering unit. The civilian construction company provided the estimate for a new range with 2,000 meters of berm, but stressed the point that they were only making educated guesses because the actual terrain could not be evaluated. Their estimate is for an entire range and is based upon the following specifications and conditions:

(1) Area size to work in - 2000 meters by 4000 meters (approximately 2,000 acres). Does not include impact area.

(2) Berm height - 2.5 meters.

(3) Berm width at top - 5 meters.

- (4) Berm slope - 2 feet for each 1 foot height, with proper drainage.
- (5) Berm length - 2,000 meters.
- (6) Timber removed - Approximately 50 acres.
- (7) Terrain - Rolling to rough.
- (8) Soil composition - Sand and clay with some rock.
- (9) Berm must be visible from all points on the firing side of the range with no berm signature.
- (10) Longest haul for any load is not to exceed 4,000 meters.

The estimate based upon these factors was:

<u>Time to site and complete construction</u>	- 30 months
<u>Cost for complete project</u>	- \$2,300,000

Fort Campbell, Kentucky

The following actual cost for construction done entirely by government equipment and personnel was obtained from the Facility Engineering, Fort Campbell, Kentucky. This berm was completed within the past year. It should be noted that this is a curved berm 800 meters long and presents to the firing unit a total berm signature.

Fort Campbell also provided a set of specifications dated August 1952, titled, Range, Moving Target, Tank or Anti-Aircraft (for guns to include 120 mm). The berm at Fort Campbell was not constructed to these specifications, they were used as a guide only with the berm built to meet local requirements.

The work was accomplished by a TO&E engineering section as identified in an air mobile division. The total volume of earth moved was 4,700 cubic yards and the cost was computed as outlined in Army Regulation 415-35.

EQUIPMENT UTILIZED

<u>NOMENCLATURE</u>	<u>HOURS USED</u>
Tractor, Full Tracked - M450	50 hours
Tractor, Full Tracked, Airtransportable - D5	150 hours
Tractor, Wheeled, Industrial w/Bulldozer - MRS100	186 hours
Loader, Scoop Type 2 1/2 cu yard capacity	18 hours
Loader, Scoop Type - M-450	50 hours
Truck, Dump 2 1/2 Ton - M-59	76 hours
Truck, Utility 1/4 Ton - M-151	24 hours
Roller, Sheeps Foot, 2 Drum Size	72 hours
Roller, 9 Wheel Pneumatic Tire	24 hours
	<u>650 Total</u>
	Equipment
	Hours

Total Equipment Cost - \$2,129.42

Total Manhours for
Section - 901 Hours

Unfunded Cost for
Labor - \$3,717.94

TOTAL BERM COST - \$2,129.42 + \$3,717.94 = \$5,847.36

Fort Polk Louisiana

The following costs are expected to be incurred by the installation for the construction of new berms.

o Cost for 3.05 meter high (10 feet) berm - \$30.00 per line foot

o Cost for 1.3 meter high (4 feet) berm - \$10.00 per line foot

A berm 2000 meters long (6,562 feet) at these quotes will cost:

3.05 meter high - \$196,860.00

1.3 meter high - \$ 65,620.00

o Construction time - 3.05 meter berm - No estimate available

1.3 meter berm - No estimate available.

g. Berm Effectiveness - All range offices agreed that berms are effective in the protection of moving target carriers. However, the majority felt that as weapons are improved, the maintenance of berms will become a greater problem and any new berm should be constructed with future weapons development in mind.

APPENDIX B
FRANGIBLE AMMUNITION

This appendix on frangible ammunition is added to this report in the interest of providing information on the present status of such training ammunition. The investigation of this ammunition was not part of the study directed by Task 6837A.

Frangible ammunition is defined, for the purpose of this report, as a projectile which upon impact will break into small fragments with little or no velocity. The breakup of the projectile upon impact and the low velocity of the resulting fragments should not cause excessive damage to the target or injury to personnel protected by relatively light armor. Ammunition of this type has been used by military forces for longer than forty years.

Frangible rounds, in general, have a lower velocity than service rounds and would require slightly different elevation adjustments when used on long range targets. This would have to be considered during the design of a training type round. Several programs conducted by industry under government contracts have produced qualified frangible or plastic rounds in a range up to the 40 mm grenade launcher. The largest round known to be qualified for use in a cannon is a 30 mm aircraft round. The larger type rounds, 20 mm - 30 mm, are constructed using steel washers encased in a frangible plastic and may be used against armored vehicles where in the personnel are protected against the possibility of hits from the washer fragments which could cause injury.

No studies or programs aimed at the development of larger caliber rounds, i.e., 90 mm to 155 mm, have been uncovered to date. However, it should be noted that several industry sources contacted agreed that a large caliber round

could be developed. It was anticipated that the time required to develop such a round in the 90 mm to 155 mm range would be at least one year for the development phase and a longer period of time before it could be qualified and put into production. The time periods are rough estimates and would depend on the ballistic requirements desired for each type round. The possible cost of such a program for development, test and production was estimated by several sources and due the lack of exact requirements as far as ballistics, range and caliber resulted in an extremely wide variation in cost estimates. Most sources agreed that the task could be accomplished with a 90 percent probability that a useful product could be developed.

References: TM-9-1900, Ammunition General , June 1956

TM-9-1990, Small Arms Ammunition, May 1942

TM 9-1990, Small Arms Ammunition, September 1947

TM 9-1300-203, Artillery Ammunition, April 1967

Plastic Manoeuvre - Ammunition (a presentation made in 1965 by
Dynamit-Nobel Genschow GMBH, West Germany)

FSTC-HT-23-136-72 - Special Purpose Ammunition, Caliber 90 mm
and 105 mm, for Primary Weapons of Tanks, etc. - Rheinmetall
GmbH - Tech. Translation, January 1972.

AFATL-TR-74-70, Plastic Frangible Projectile Gun Function Test
March 1974, Air Force Armament Laboratory, Eglin AFB

APG-MT-3626, August 1970, Product Improvement Test of Cartridge
40 mm, Practice, M385E3, Aberdeen Proving Ground, Maryland.

AFATL-TR-75-137, Development of a 30 mm Plastic Frangible Projectile
Airforce Armament Laboratory, Eglin AFB, October 1975

Memorandum Report #2358, Interior Ballistic Test of Frangible Rounds
for M139 Gun, March 1974, U. S. Army Ballistic Research Laboratories,
Aberdeen Proving Ground, Maryland.

AAI Reports, Cockeysville, Maryland

AAI-ER-7736, Report on 20 mm Frangible, February 1974

AAI-ER-8342, Report on 40 mm Training Ammo., June 1975

Discussions with:

AAI - Mr. Bill Davis, November 1976 and February 1977

Debell & Richardson - Mr. Fred Wiley, November 1976 and February 1977.

Rock Island Arsenal - Mr. Craighead, November 1976

Space Research Corp. - Mr. Dennis Jenkins, November 1976 & February 1977.

Bermite Co. - Mr. Bill Sanford, October 1976