

AD-A058 775

HENRY (J J) CO INC MOORESTOWN N J  
ABOVE HATCH VERTICAL MATERIAL HANDLING SUBSYSTEMS.(U)  
SEP 76

F/G 15/5

UNCLASSIFIED

1737-11-1

N00600-75-D-0814

NL

| of |  
40  
A058 775



END  
DATE  
FILMED  
-11-78  
DDC

**DDC FILE COPY**

**AD AO 58775**

ABSTRACT

**DISTRIBUTION STATEMENT A**  
Approved for public release  
Distribution Unlimited

TABLE OF CONTENTS:

Subject	Page
1-1. → BREAK BULK CAPABILITY CONCEPT FOR CONTAINER SHIPS;	1-1
1-2. ABOVE HATCH VERTICAL MATERIAL HANDLING SUBSYSTEM CONCEPT	1-1
1-3. UNIVERSAL PONTOON HATCH COVER SUBSYSTEM CONCEPT	1-1
1-4. BELOW HATCH VERTICAL MATERIAL HANDLING SUBSYSTEM CONCEPT	1-2
1-5. REPLENISHMENT SUBSYSTEM CONCEPT	1-2
1-6. COMMERCIAL APPLICATIONS	1-2
2-1. → ABOVE HATCH VERTICAL MATERIAL HANDLING SUBSYSTEMS;	2-1
3-1. → CONCEPT <sup>1</sup> - TOWER GUIDED PINION LIFTED PLATFORM SUBSYSTEM ;	3-1
3-2. Standard Boxed Channel and Rack Assembly	3-1
3-3. Special Boxed Channel and Rack Assembly	3-2
3-4. Pinion Lifted Boxed Platform Assembly	3-2
3-5. Medium Lift Industrial Truck	3-3
3-6. Subsystem Erection	3-4
3-7. Subsystem Operation	3-4
4-1. → CONCEPT <sup>2</sup> - TOWER GUIDED ROPE LIFTED PLATFORM SUBSYSTEM ;	4-1
4-2. Boxed Channel and Pulley Assembly	4-1
4-3. Standard Boxed Channel Assembly	4-2
4-4. Special Boxed Channel Assembly	4-2
4-5. Rope Lifted Platform Assembly	4-2
4-6. Wire Rope Winch Assembly	4-3
4-7. Medium Lift Industrial Truck	4-3
4-8. Subsystem Erection	4-4
4-9. Subsystem Operation	4-4

CONT

TABLE OF CONTENTS (Continued)

Subject	Page
<i>CONT</i> 5-1. → <sup>3</sup> <u>CONCEPT III - TOWER GUIDED TRUCK LIFTED PLATFORM SUBSYSTEM ;</u>	5-1
5-2. Boxed Channel Extender Assembly	5-1
5-3. Standard Boxed Channel Assembly	5-1
5-4. Special Boxed Channel Assembly	5-2
5-5. Truck Lifted Platform Assembly	5-2
5-6. Extra High Lift Industrial Truck	5-2
5-7. Subsystem Erection	5-3
5-8. Subsystem Operation	5-4
6-1. → <sup>4</sup> <u>CONCEPT IV - PARALLEL CHANNEL GUIDED TRUCK LIFTED PLATFORM SUBSYSTEM ;</u>	6-1
6-2. Channel Assembly	6-1
6-3. Truck Lifted Platform Assembly	6-1
6-4. Extra High Lift Industrial Truck	6-2
6-5. Subsystem Erection	6-3
6-6. Subsystem Operation	6-3
7-1. → <sup>5</sup> <u>CONCEPT V - PARALLEL CHANNEL GUIDED ROPE LIFTED PLATFORM SUBSYSTEM ;</u>	7-1 <i>CONT</i> →
7-2. Parallel Channel and Pulley Holder Assembly	7-1
7-3. Sectional Channel Assembly	7-1
7-4. Rope Lifted Cantilever Platform Assembly	7-2
7-5. Wire Rope Winch Assembly	7-3
7-6. Medium Lift Industrial Truck	7-3
7-7. Subsystem Erection	7-3
7-8. Subsystem Operation	7-5

ACCESSION for	
NTIS	Write Section <input checked="" type="checkbox"/>
DDC	Buff Section <input type="checkbox"/>
UNANNOUNCED	<input type="checkbox"/>
JUSTIFICATION	
BY	
DISTRIBUTION/AVAILABILITY CODES	
Dist.	SPECIAL
A	

TABLE OF CONTENTS (Continued)

Subject	Page
<u>CONT</u> 8-1. → ABOVE HATCH VERTICAL MATERIAL HANDLING SUBSYSTEM DETAILED CHARACTERISTICS ; and	8-1
8-2. Tower Guided Pinion Lifted Platform Subsystem	8-6
8-3. Tower Guided Rope Lifted Platform Subsystem	8-6
8-4. Tower Guided Truck Lifted Platform Subsystem	8-7
8-5. Parallel Channel Guided Truck Lifted Platform Subsystem	8-8
8-6. Parallel Channel Guide Rope Lifted Platform Subsystem	8-8
8-7. ABOVE HATCH VERTICAL MATERIAL HANDLING SUBSYSTEMS COSTS	8-9
8-8. ABOVE HATCH VERTICAL MATERIAL HANDLING SUBSYSTEMS WEIGHTED CHARACTERISTICS MATRIX	8-11
8-9. → RECOMMENDATIONS	8-13

ABSTRACT

## LIST OF ILLUSTRATIONS

Figure	Title	Page
3-1	Concept I - Tower Guided Pinion Lifted Platform Subsystem	3-6
4 1	Concept II - Tower Guided Rope Lifted Platform Subsystem	4-7
5-1	Concept III - Tower Guided Truck Lifted Platform Subsystem	5-6
6-1	Concept IV - Parallel Channel Guided Truck Lifted Platform Subsystem	6-5
7-1	Concept V - Parallel Channel Guided Rope Lifted Platform Subsystem	7-7

## LIST OF TABLES

Table	Title	Page
3-1	Concept I - Tower Guided Pinion Lifted Platform Subsystem	3-5
4-1	Concept II - Tower Guided Rope Lifted Platform Subsystem	4-6
5-1	Concept III - Tower Guided Truck Lifted Platform Subsystem	5-5
6-1	Concept IV - Parallel Channel Guided Truck Lifted Platform Subsystem	6-4
7-1	Concept V - Parallel Channel Guided Rope Lifted Platform Subsystem	7-6
8-1	Above Hatch Vertical Material Handling Subsystems Characteristics Matrix	8-3
8-2	Above Hatch Vertical Material Handling Subsystems Costs	8-10
8-3	Above Hatch Vertical Material Handling Subsystems Weighted Characteristics Matrix	8-12

### 1-1. BREAK BULK CAPABILITY CONCEPT FOR CONTAINER SHIPS

This concept would provide non-self sustaining container ships with the capability of being self sustaining palletized load ships. The capability would allow the removing of palletized loads from cargo containers stowed above or below pontoon hatch covers.

The system concept would consist of:

- (a) an Above Hatch Vertical Material Handling Subsystem,
- (b) a Universal Pontoon Hatch Cover Subsystem,
- (c) a Below Hatch Vertical Material Handling Subsystem, and
- (d) a Replenishment Subsystem.

### 1-2. ABOVE HATCH VERTICAL MATERIAL HANDLING SUBSYSTEM CONCEPT

The subsystem would be stowed in containers, located on a hatch cover. The subsystem would be removed from the containers and erected by an industrial truck. The subsystem would have the capability of removing palletized loads from containers located on the hatch cover and stacked up to four high. The palletized load would be transferred to the replenishment subsystem by an industrial truck.

### 1-3. UNIVERSAL PONTOON HATCH COVER SUBSYSTEM CONCEPT

The subsystem would fit any 20' container hold configuration. The subsystem would be penetrated by the below hatch vertical material handling subsystem. The subsystem would allow palletized loads to be moved from a below hatch container through the hatch cover and on to the hatch cover top plate by the below hatch vertical material handling subsystem.

#### 1-4. BELOW HATCH VERTICAL MATERIAL HANDLING SUBSYSTEM CONCEPT

The subsystem would be contained in a volume of 8' wide by 20' long and a height equal to the distance from the lowest below deck container to one container above the hatch cover. The subsystem would have the capability of removing palletized loads from below hatch containers stacked up to 2 deep, 8 wide, and 6 high. The subsystem would lift the palletized load through a penetration in the universal hatch cover up to the hatch cover top plate. The palletized load would be moved to the replenishment system by an industrial truck.

#### 1-5. REPLENISHMENT SUBSYSTEM CONCEPT

The subsystem would consist of a sending assembly and a receiving assembly. The subsystem would permit horizontal off-loading of palletized loads from the hatch cover of a sending ship to a receiving ship or a receiving land facility up to a distance of 150'.

#### 1-6. COMMERCIAL APPLICATIONS

The break bulk capability system would allow off-loading of palletized cargo in those areas where a full facilities port exist and also, in those places where the following conditions exist;

- (a) No hatch cover and container removal facilities,
- (b) No dock facilities, or
- (c) No anchoring facilities.

In those ports without hatch cover and container handling facilities, but with docking facilities, the sending ship would off-load the palletized cargo to

a receiving land station using a replenishment subsystem. The subsystem would consist of a sending and receiving replenishment assembly, or a railway receiving crane, or a motorized receiving crane.

In those harbors without docking facilities, but with anchoring areas, the sending ship would off-load the palletized cargo to a smaller break bulk receiving boat or a land receiving station using a replenishment subsystem. The subsystem would consist of either a sending and a receiving replenishment assembly or a floating receiver crane.

In the open sea, without anchoring areas, the sending ship would off-load the palletized cargo to a smaller break bulk ship using the sending and receiving assemblies of the replenishment subsystem. The off-loading would be accomplished, while both ships were underway.

## 2-1. ABOVE HATCH VERTICAL MATERIAL HANDLING SUBSYSTEMS

Five subsystems were developed for removing palletized loads from cargo ship containers. These subsystems would have the capability of handling palletized loads, measuring up to 4' long by 4' wide by 7' high and weighing up to 3200 pounds.

All assemblies of the subsystem, except the extra high lift truck, would be stored in one or two 20' cargo containers. The subsystem containers would be located in either the port or starboard outboard position of the first level row of cargo containers.

The figures for all subsystems are purposely drawn OVERSIZE in DEPTH and WIDTH to clearly illustrate the details.

The weights of the subsystems and assemblies are approximate and calculated on a safety factor of four.

The concepts envision removal of the container doors, in order to gain access to the palletized loads.

### 3-1. CONCEPT I - TOWER GUIDED PINION LIFTED PLATFORM SUBSYSTEM

This subsystem, Table 3-1 and Figure 3-1, would feature the following:

- (a) three standard boxed channel and rack assemblies,
- (b) a special boxed channel and rack assembly,
- (c) a pinion lifted platform assembly, and
- (d) a medium lift industrial truck.

Three standard boxed channel and rack assemblies, one with the boxed platform assembly inside, would be stowed in one container. The special boxed channel and rack assembly and the medium lift industrial truck would be stowed in another container.

#### 3-2. Standard Boxed Channel and Rack Assembly

The assembly would be 5'6" deep by 5'6" wide by 8'6" high and weigh about 675 pounds. The three assemblies would be locked together and to the special boxed channel and rack assembly by quick acting fasteners. The assemblies would guide the boxed platform at the second, third, and fourth container levels. Each assembly would have two vertical racks, one on the port side and one on the starboard side. The racks would be attached to the horizontal cross members of the boxed channels. The topmost assembly would weigh about 775 pounds and incorporate a horizontal trolley subassembly which would engage 8' guide rails. The rails would be attached horizontally across the bottom of the fourth level containers by quick acting fasteners. The trolley and rail subassembly together with the special boxed channel and rack assembly would permit the subsystem to be moved horizontally across the face of the container rows.

### 3-3. Special Boxed Channel and Rack Assembly

The assembly would be 5'6" deep by 5'6" wide by 8'6" high and weigh about 705 pounds. The assembly would be installed at the base of the subsystem and would be locked to the lower standard boxed channel and rack assembly by fast acting devices. The assembly would guide the boxed platform at first container level. The assembly would have two vertical racks, one on the port side and one on the starboard side. The racks would be attached to the horizontal cross members of the boxed channels. The assembly would have rollers in the base. The rollers together with the trolley and guide rail subassembly of the topmost standard boxed channel and rack assembly would permit the subsystem to be moved horizontally across the face of the container rows.

### 3-4. Pinion Lifted Boxed Platform Assembly

The assembly would be 5'6" deep by 5'6" wide by 8'6" high and weigh about 1500 pounds. The assembly would consist of a horizontal platform attached to an open box-like structure. The assembly would have rollers which contact the boxed channel assemblies to avoid binding, while lifting. Also, the assembly would have quick acting locks which would connect to the boxed channel assembly and permit lifting and moving of the assemblies by the medium lift industrial truck.

The pallet landing area of the assembly would be 5' deep by 5' wide by 1'6" high. The area would support a palletized load, 4' deep by 4' long by 7' high, weighing up to 3200 pounds.

A pallet extracting subassembly would be mounted in and controlled from the platform. The subassembly would consist of:

- (a) a safety hook,

(b) a 60' length of wire rope, and

(c) an electrically powered winch.

The assembly would be raised and lowered by a set of ganged pinions which would engage the vertical racks. The ganged pinions would be driven by an electrical motor. Another set of ganged pinions which would engage the vertical racks and would be connected to a safety device. The device would sense overspeed and bring the platform to a safe stop. The pinions, gearing, motors and safety device would be mounted in the overhead of the assembly.

### 3-5. Medium Lift Industrial Truck

The truck would be 12' deep by 4' wide by 6' high (lift retracted) or 11' high (lift extended) and weigh 9000 pounds. The truck would be able to lift 5000 pounds to a height of 9'.

The truck would perform the following:

- (a) remove subsystem components from containers;
- (b) erect subsystem;
- (c) remove palletized load from platform;
- (d) transfer palletized load to off-loading staging area;
- (e) dismantle subsystem; and
- (f) stow subsystem components in containers.

### 3-6. Subsystem Erection

The assemblies would be removed from the containers by the truck and then temporarily stowed on the hatch cover. One standard boxed channel and rack assembly would be lifted on to the second standard boxed channel and rack assembly. The lift would be performed by the truck using the boxed platform as a lifting point. In turn, the two previously stacked assemblies would be lifted on the third standard boxed channel and rack assemblies. Next, the three previously stacked assemblies would be lifted on to the special boxed channel and rack assembly. Finally, the assemblies would be locked together and to the stack of containers to be unstuffed.

### 3-7. Subsystem Operation

The selection and removal of a palletized load from any container in the stack would be permitted by:

- (a) the horizontal movement of the subsystem across the face of the container rows;
- (b) the vertical movement of the platform up and down a stack of containers; and
- (c) the fore and aft movement of the pallet extracting hook.

TABLE 3-1. CONCEPT I - TOWER GUIDED PINION LIFTED PLATFORM SUBSYSTEM

Index No.	Assembly Name
1	Standard Boxed Channel and Rack
2	Palletized Load
3	Pinion Lifted Platform
4	Pallet Extracting Device
5	Special Boxed Channel and Rack
6	Medium Lift Industrial Truck

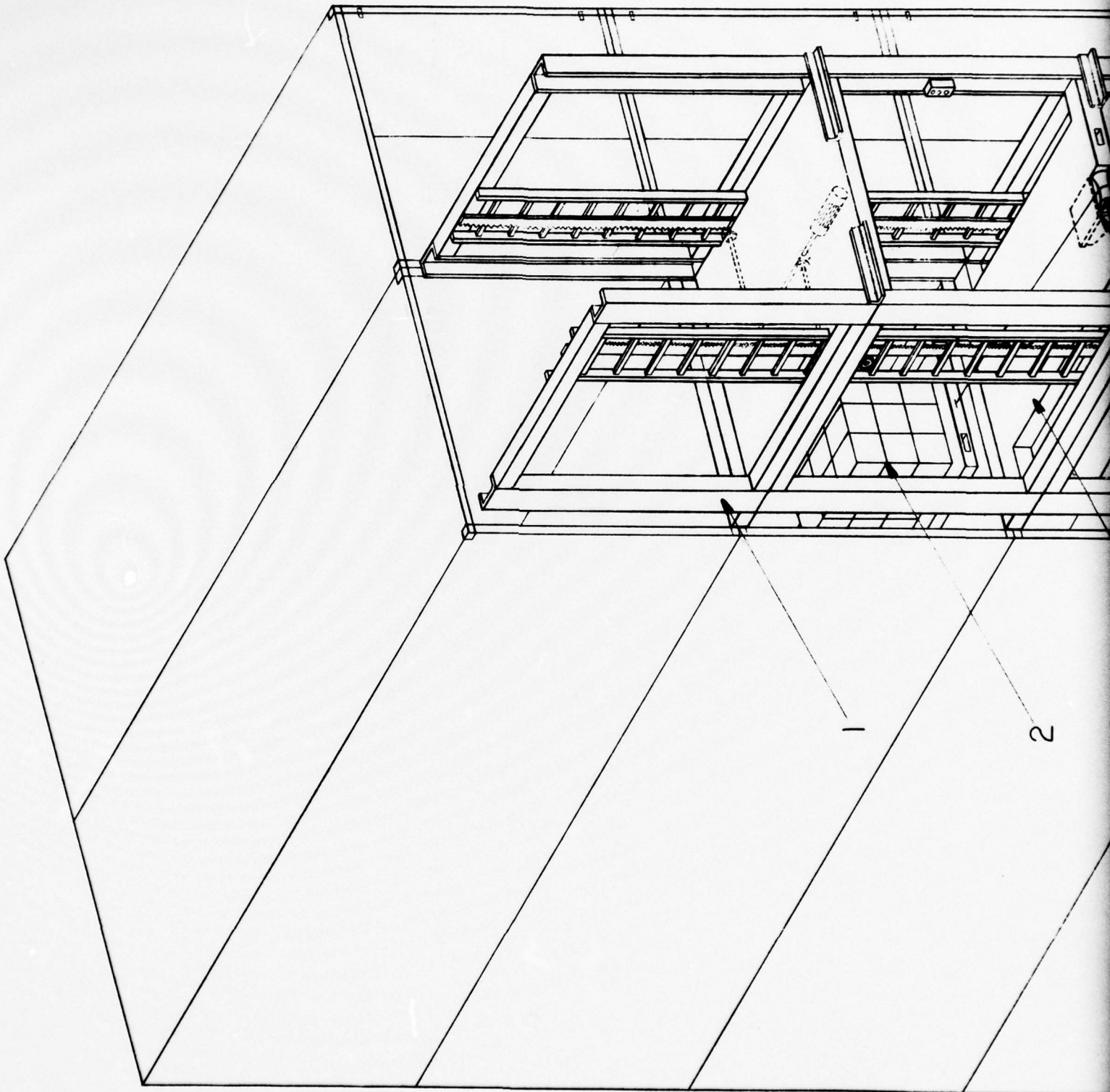

1

2

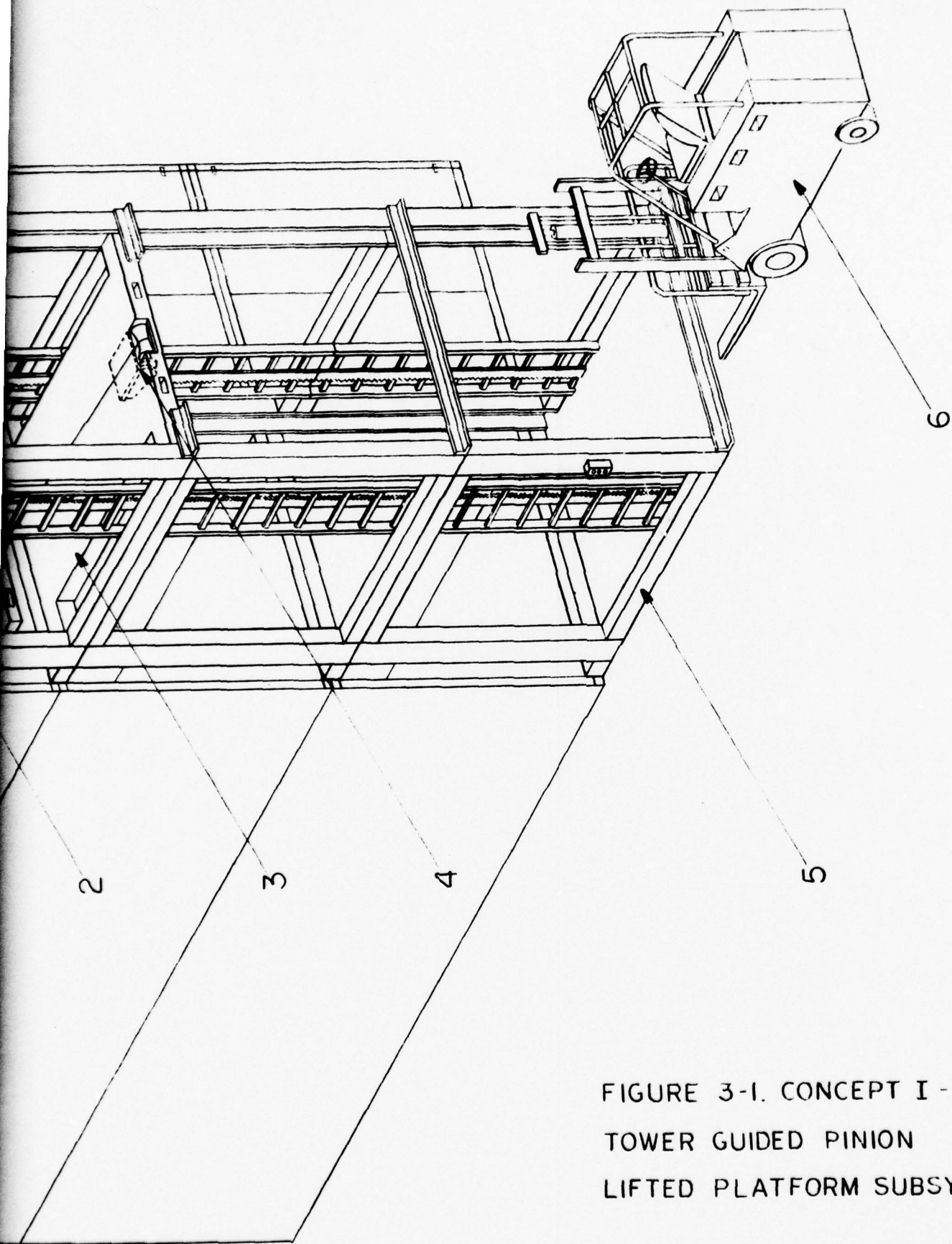

FIGURE 3-1. CONCEPT I -  
TOWER GUIDED PINION  
LIFTED PLATFORM SUBSYSTEM

#### 4-1. CONCEPT II - TOWER GUIDED ROPE LIFTED PLATFORM SUBSYSTEM

This subsystem, Table 4-1 and Figure 4-1, would feature the following;

- (a) a boxed channel and pulley holder assembly,
- (b) two standard boxed channel assemblies,
- (c) a special boxed channel assembly,
- (d) a rope lifted platform assembly,
- (e) a wire rope winch assembly, and
- (f) a medium lift industrial truck.

The boxed channel-pulley holder assembly, with the boxed platform assembly inside, one boxed standard channel assembly, and the wire rope winch assembly would be stowed in one container. The other boxed standard channel assembly, the special boxed channel assembly and the medium lift industrial truck would be stored in another container.

#### 4-2. Boxed Channel and Pulley Assembly

The assembly would be 5'6" deep by 5'6" wide by 9' high and weight about 800 pounds.

The boxed channel and pulley assembly would be installed at the top of the subsystem and would be affixed to the standard boxed channel assembly by quick acting fasteners. The assembly would guide the boxed platform at the fourth container level. The assembly would have a pulley system which would guide the wire ropes between the winches and the boxed platform assembly. A ladder and grided catwalk would permit the installation of the wire ropes and pulley system to the

boxed platform assembly. The assembly would incorporate a horizontal trolley subassembly which would engage 8' guide rails. The rails would be attached horizontally to the bottom of the fourth level containers by quick acting fasteners. The trolley and rails together with the special boxed channel assembly would permit the subsystem to be moved horizontally across the face of the container rows.

#### 4-3. Standard Boxed Channel Assembly

An assembly would be 5'6" deep by 5'6" wide by 8'6" high and weigh about 625 pounds. Two assemblies would be locked between and to the boxed channel-pulley assembly and the special boxed channel assembly by quick operating fasteners. The assemblies would guide the boxed platform at the second and third container levels.

#### 4-4. Special Boxed Channel Assembly

The assembly would be 5'6" deep by 5'6" wide by 8'6" high and weigh about 655 pounds. The assembly would be installed at the bottom of the subsystem and would be locked to the lower standard boxed channel assembly by quick acting fasteners. The assembly would guide the boxed platform at the first container level. The assembly would have rollers in the base. The rollers together with the trolley and rail subassembly of the boxed channel and pulley assembly would allow the system to move horizontally across the face of the container rows.

#### 4-5. Rope Lifted Platform Assembly

The assembly would be 5'6" deep by 5'6" wide by 8'6" high and weigh about 1200 pounds. The assembly would consist of a horizontal platform attached to an open box-like structure. The assembly would have rollers which contact the boxed channel assemblies to avoid binding. Also the assembly would have locks which

connect to the boxed channel assemblies to permit lifting and moving of the assemblies by a medium lift industrial truck.

The pallet landing area of the assembly would be 5' deep by 5' wide by 1'6" high. The area would support a palletized load, weighing up to 3200 pounds. A pallet extracting subassembly would be mounted in and controlled from the platform. The subassembly would consist of:

- (a) a safety hook;
- (b) a 60' length of wire rope; and
- (c) an electrically powered winch.

#### 4-6. Wire Rope Winch Assembly

The assembly would be 5'6" deep by 2' wide by 3' high and weigh 300 pounds. The electrically-powered wire-rope winch would be attached to a foundation. The foundation would be able to be attached to the special boxed channel assembly. The winch would be regulated from either the deck or the boxed platform, as so desired. The winch would incorporate an automatic holding brake which would energize after a power failure.

#### 4-7. Medium Lift Industrial Truck

The truck would be 12' deep by 4' wide by 6' high (lift retracted) or 13' high (lift extended) and weigh 8000 pounds. The truck would be able to lift a 4000 pound load to the height of 9'.

The truck would perform the following:

- (a) remove subsystem assemblies from containers;

- (b) erect subsystem;
- (c) remove palletized load from platform;
- (d) transfer palletized load to off-load staging area;
- (e) dismantle subsystem; and
- (f) stow subsystem assemblies in containers.

#### 4-8. Subsystem Erection

The boxed channel-pulley assembly, two standard boxed channel assemblies, the special boxed channel assembly, the boxed platform assembly, and the wire rope winch assembly would be removed from the containers by the medium lift industrial truck and would be temporarily stowed on the hatch cover. Using the platform as a lift point, the truck would raise the boxed channel and pulley assembly so that a boxed standard channel assembly could be placed beneath. Then, the two assemblies would be locked together. This up stacking action would continue until the subsystem was erected. The boxed channel and pulley assembly would be attached to the top of the fourth level container. Next, the wire rope winch assembly would be attached to the special boxed channel assembly. Finally, the wire rope and pulley assembly would be connected to the boxed platform assembly.

#### 4-9. Subsystem Operation

The subsystem would be operated in the following manner:

- (a) Unlock subsystem from existing container stack.
- (b) Roll subsystem to desired container stack.

- (c) Lock subsystem to container stack.
- (d) Raise platform to desired container level.
- (e) Slide palletized load from container onto platform landing area using pallet extracting subassembly.
- (f) Lower platform together with palletized load to hatch cover.
- (g) Remove palletized load from platform using medium lift industrial truck.
- (h) Move palletized load to off-loading staging area using medium lift industrial truck.

TABLE 4-1. CONCEPT II - TOWER GUIDED ROPE LIFTED PLATFORM SUBSYSTEM

Index No.	Assembly Name
1	Catwalk
2	Boxed Channel and Pulley
3	Palletized Load
4	Wire Rope Lifted Platform
5	Pallet Extractor
6	Standard Boxed channel
7	Special Boxed Channel
8	Ladder
9	Wire Rope Winch
10	Medium Lift Industrial Truck

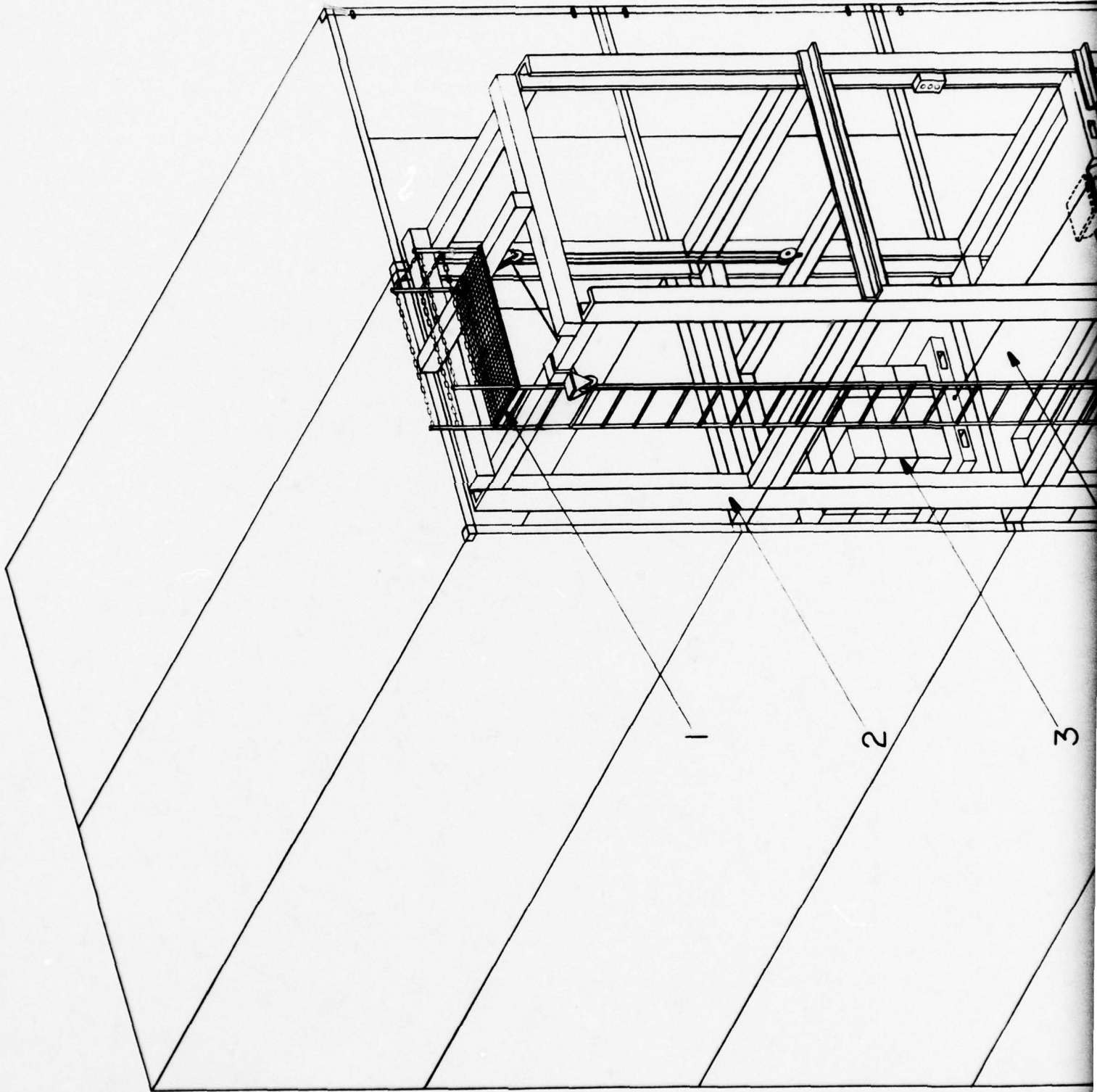

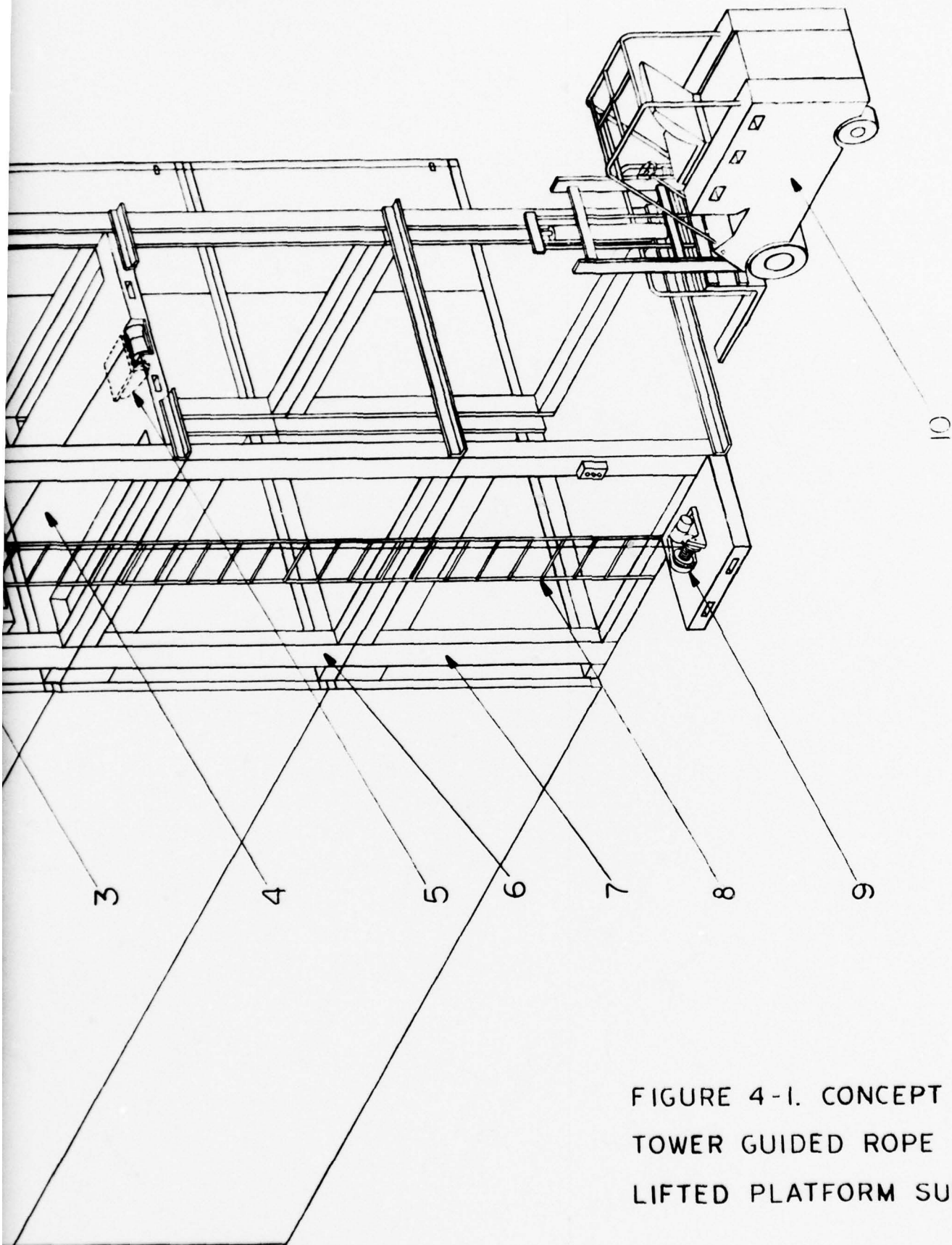

FIGURE 4-1. CONCEPT II -  
TOWER GUIDED ROPE  
LIFTED PLATFORM SUBSYSTEM

### 5-1. CONCEPT III - TOWER GUIDED TRUCK LIFTED PLATFORM SUBSYSTEM

This subsystem, Table 5-1 and Figure 5-1, would feature the following assemblies;

- (a) a boxed channel extender assembly,
- (b) two standard boxed channel assemblies,
- (c) a special boxed channel assembly,
- (d) a platform assembly, and
- (e) an extra high lift industrial truck.

All the assemblies, except the truck, would be stowed in one container. The truck would be stowed on the hatch cover.

#### 5-2. Boxed Channel Extender Assembly

The assembly would be 5'6" deep by 5'6" wide by 4' high and weigh about 320 pounds. The extender would be locked to the topmost standard boxed channel assembly by means of fasteners. The assembly would guide the platform at the fourth container level. The extender would incorporate a horizontal trolley subassembly which would engage 8' long guide rails. The rails would be attached horizontally to the bottom of the fourth level container row by quick acting fasteners. The trolley and rails together with the special boxed channel subassembly would allow the subsystem to move horizontally across the face of the container rows.

#### 5-3. Standard Boxed Channel Assembly

An assembly would be 5'6" deep by 5'6" wide by 8'6" high and weigh about 420 pounds. Two assemblies would be locked between and to the extender and the

special boxed channel assemblies by means of fasteners. The assembly would guide the platform at the second and third container levels.

#### 5-4. Special Boxed Channel Assembly

The assembly would be 5'6" deep by 5'6" wide by 8'6" high and weigh about 450 pounds. The assembly would be installed at the bottom of the subsystem and would be locked to the lower standard boxed channel assembly by means of quick acting fasteners. The assembly would guide the platform at first container level. The assembly would incorporate rollers in the base of the assembly. The rollers together with the trolley and guide rail subassembly of the channel boxed extender assembly would allow the subsystem to move horizontally across the face of the container rows.

#### 5-5. Truck Lifted Platform Assembly

The assembly would be 5'6" wide by 5'6" deep by 1'6" high and weigh about 900 pounds. The assembly would have rollers which contact the boxed channel assemblies to avoid binding. Also, the assembly would have locks which connect to the boxed channel assemblies to permit lifting and moving of the assemblies by the extra high lift industrial truck. In addition, the assembly would incorporate a wide roller. The roller would guide the wire rope of the pallet extracting subassembly.

The pallet landing area of the assembly would be 5' deep by 5' wide by 1'6" high and support a palletized load weighing 3200 pounds.

#### 5-6. Extra High Lift Industrial Truck

The truck would be 12' deep by 7' wide by 10' high (lift retracted) or 32' high (lift extended) and weigh about 16000 pounds. The truck would be able to

lift 4000 pounds to a height of 28'

A pallet extracting subassembly would be mounted on and controlled from the truck. The subassembly would consist of the following components;

- (a) a safety hook,
- (b) a 60' length of wire rope, and
- (c) a hydraulically powered winch.

The truck would perform the following:

- (a) remove subsystem assemblies from container;
- (b) erect subsystem;
- (c) raise platform to container level;
- (d) slide palletized load from container onto platform;
- (e) lower platform to hatch cover;
- (f) remove palletized load from platform;
- (g) transfer palletized load to off-loading staging area;
- (h) dismantle subsystem; and
- (i) stow subsystem assemblies in containers.

#### 5-7. Subsystem Erection

The special boxed channel assembly, two standard boxed channel assemblies, the boxed channel extender assembly, and the platform assembly would be removed

from the container by the truck and would be temporarily stowed on the hatch cover. Using the platform as a lift point, the truck would stack the assemblies, on top of each other, in front of the containers to be unstuffed. Next, the boxed channel extender, standard boxed channel and special boxed channel assemblies would be locked together. Finally, the boxed channel extender assembly would be attached to the bottom of the fourth level container.

5-8. Subsystem Operation

The horizontal movement of the subsystem across the rows of the stacked containers, plus the vertical movement of the platform assembly and the fore to aft movement of the pallet extraction hook would permit the selection and removal of a palletized load from any container in the stack. The platform, with palletized load in place, would be lowered to the hatch cover by the truck. The palletized load would be removed from the platform by the truck. Then, the load would be transferred to the off-loading staging area by the truck.

TABLE 5-1. CONCEPT III - TOWER GUIDED TRUCK LIFTED PLATFORM SUBSYSTEM

Index No.	Assembly Name
1	Boxed Channel Extender
2	Palletized Load
3	Truck Lifted Platform
4	Pallet Extractor
5	Standard Boxed Channel
6	Special Boxed Channel
7	Extra High Lift Industrial Truck

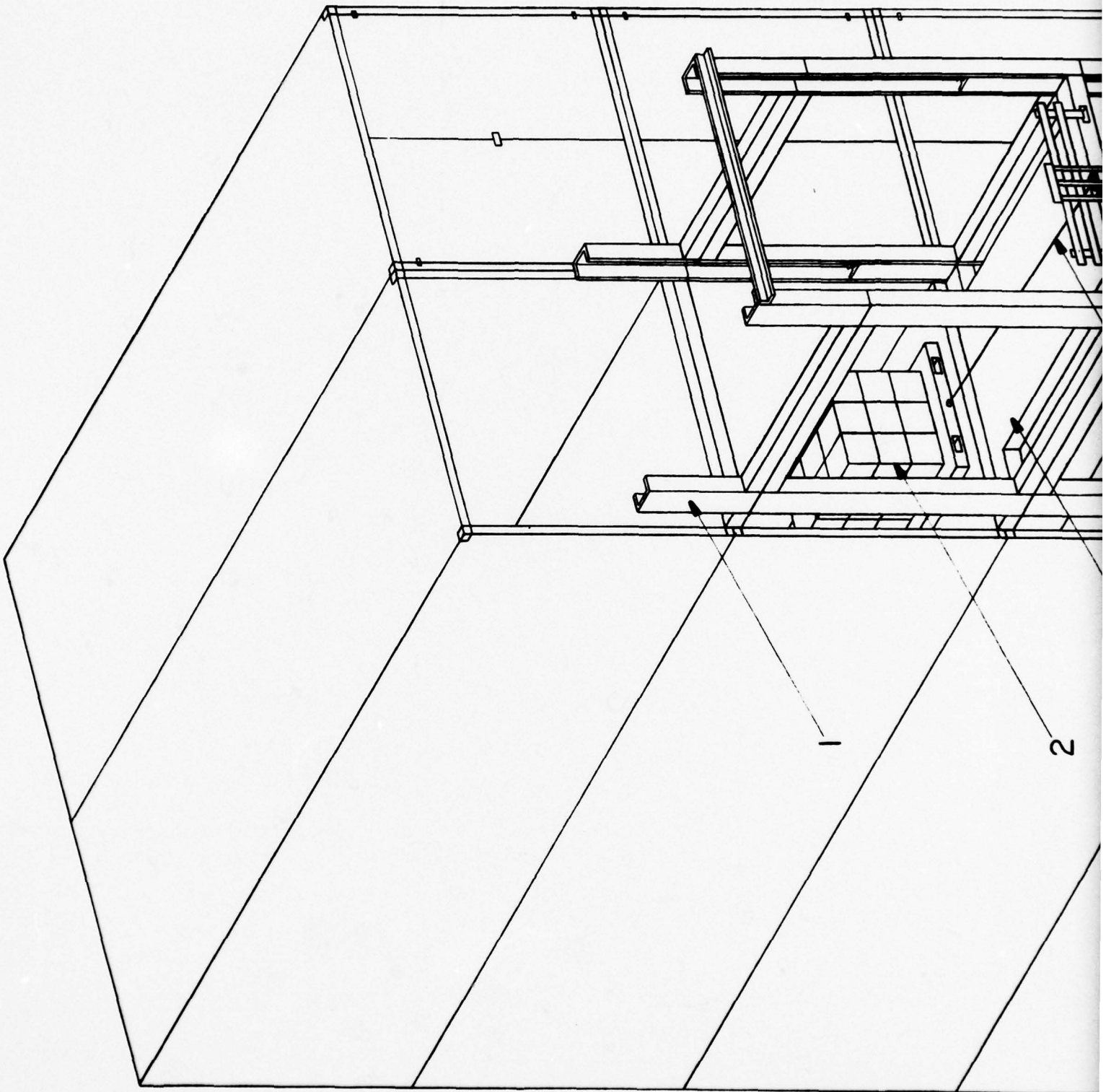

1

2

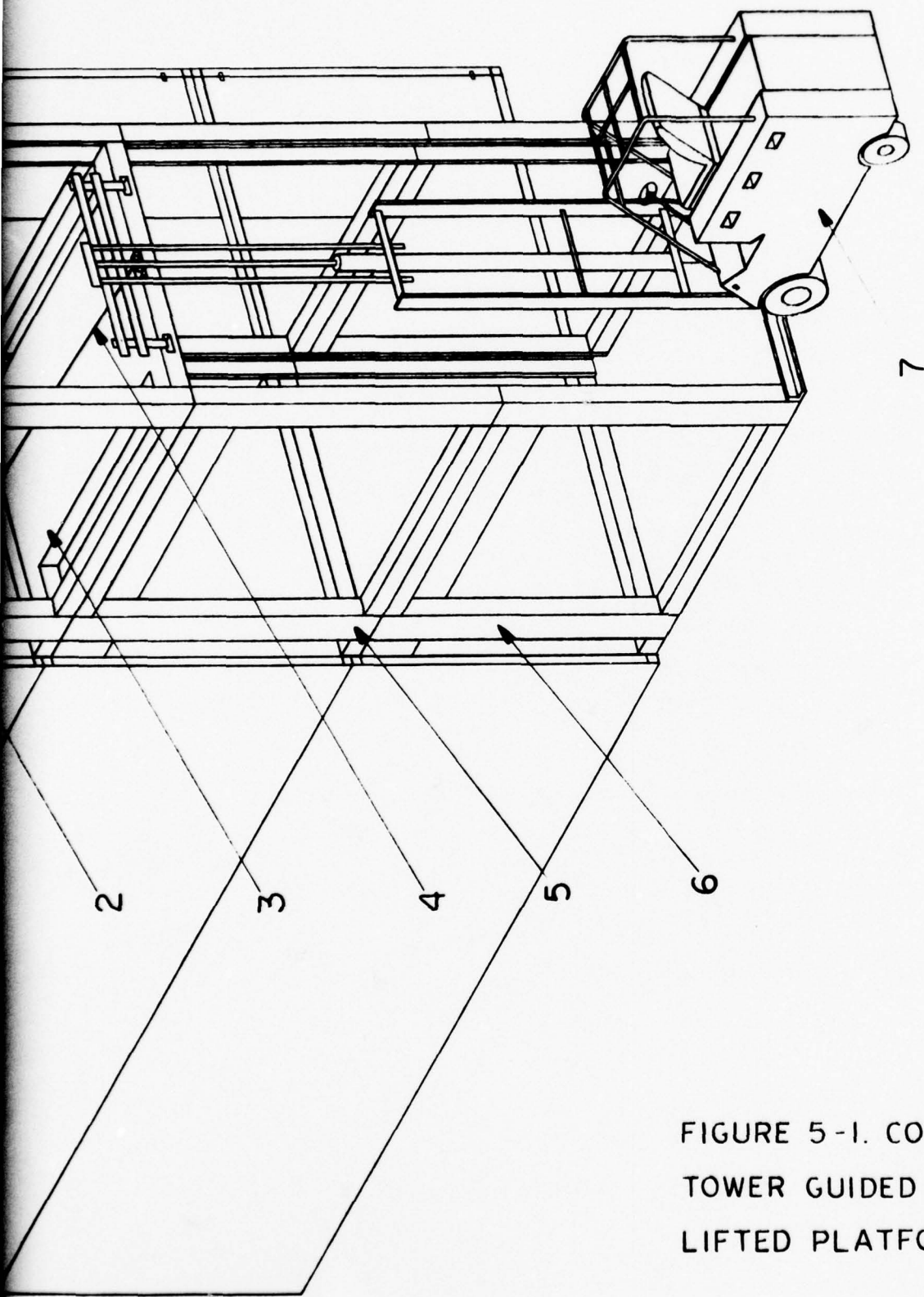

FIGURE 5-1. CONCEPT III -  
TOWER GUIDED TRUCK  
LIFTED PLATFORM SUBSYSTEM

#### 6-1. CONCEPT IV - PARALLEL CHANNEL GUIDED TRUCK LIFTED PLATFORM SUBSYSTEM

This subsystem, Table 6-1 and Figure 6-1 would consist of:

- (a) two channel assemblies,
- (b) a truck lifted platform assembly, and
- (c) an extra high lift industrial truck.

All assemblies, except the truck, would be stowed in one container. The truck would be stowed on the hatch cover.

#### 6-2. Channel Assembly

Each assembly would be 1'0" deep by 1'0" wide by 28' high, and weigh about 810 pounds. One assembly would be attached to the port side of a container stack, while another assembly would be attached to the starboard side of the same container stack. Each assembly would be attached to the corners of each container in a stack by quick acting fasteners. The parallel channel assemblies would guide the platform at all four container levels.

#### 6-3. Truck Lifted Platform Assembly

The assembly would be 5'6" deep by 8'0" wide by 1'6" high and weigh about 700 pounds. The assembly would be guided within the parallel channel assemblies by rectangular bumpers. Also, the assembly would have locking devices which would connect to the parallel channel assemblies. The device would permit lifting and moving of the parallel channel assemblies by the extra high lift industrial truck. In addition, the assembly would incorporate a wide roller. The roller would guide the wire rope of the pallet extracting subassembly.

The pallet landing area of the assembly would be 5' deep by 5' wide by 1'6" high and support a palletized load of 3200 pounds.

6-4. Extra High Lift Industrial Truck

The truck would be 12' deep by 7' wide by 10' high (lift retracted) or 32' high (lift extended), weigh about 16000 pounds. The truck would be able to lift a 4000 pound load to a height of 28'.

A pallet extracting subassembly would be mounted on and controlled from the truck. The subassembly would consist of the following components;

- (a) a safety hook,
- (b) a 60' length of wire rope, and
- (c) a hydraulically powered winch.

The truck would perform the following:

- (a) remove subsystem components from container;
- (b) erect subsystem;
- (c) raise platform to container level;
- (d) slide palletized load from container onto platform landing area;
- (e) lower platform to hatch cover;
- (f) remove palletized load from platform;
- (g) transfer palletized load to off-loading staging area;

(h) dismantle subsystem; and

(i) stow subsystem components in container.

6-5. Subsystem Erection

The extra high lift industrial truck would remove the two channel assemblies and the platform assembly from the container and then, temporarily stow the assemblies on the hatch cover. Using the platform as a lift point, the truck would raise the parallel channel assemblies in front of the row of stack containers to be unstuffed. Next, the parallel channel assemblies would be attached to the container stack. Finally, the platform assembly would be lowered to the hatch cover.

6-6. Subsystem Operation

The subsystem would be operated as follows:

(a) Raise platform to desired level.

(b) Using pallet extracting subassembly, drag palletized load from container onto platform landing area.

(c) Lower platform together with palletized load to hatch cover.

(d) Remove and transfer palletized load to off-loading area.

TABLE 6-1. CONCEPT IV - PARALLEL CHANNEL GUIDED TRUCK LIFTED PLATFORM SUBSYSTEM

Index No.	Assembly Name
1	Palletized Load
2	Truck Lifted Platform
3	Pallet Extractor
4	Sectionalized Channel
5	Extra High Lift Industrial Truck

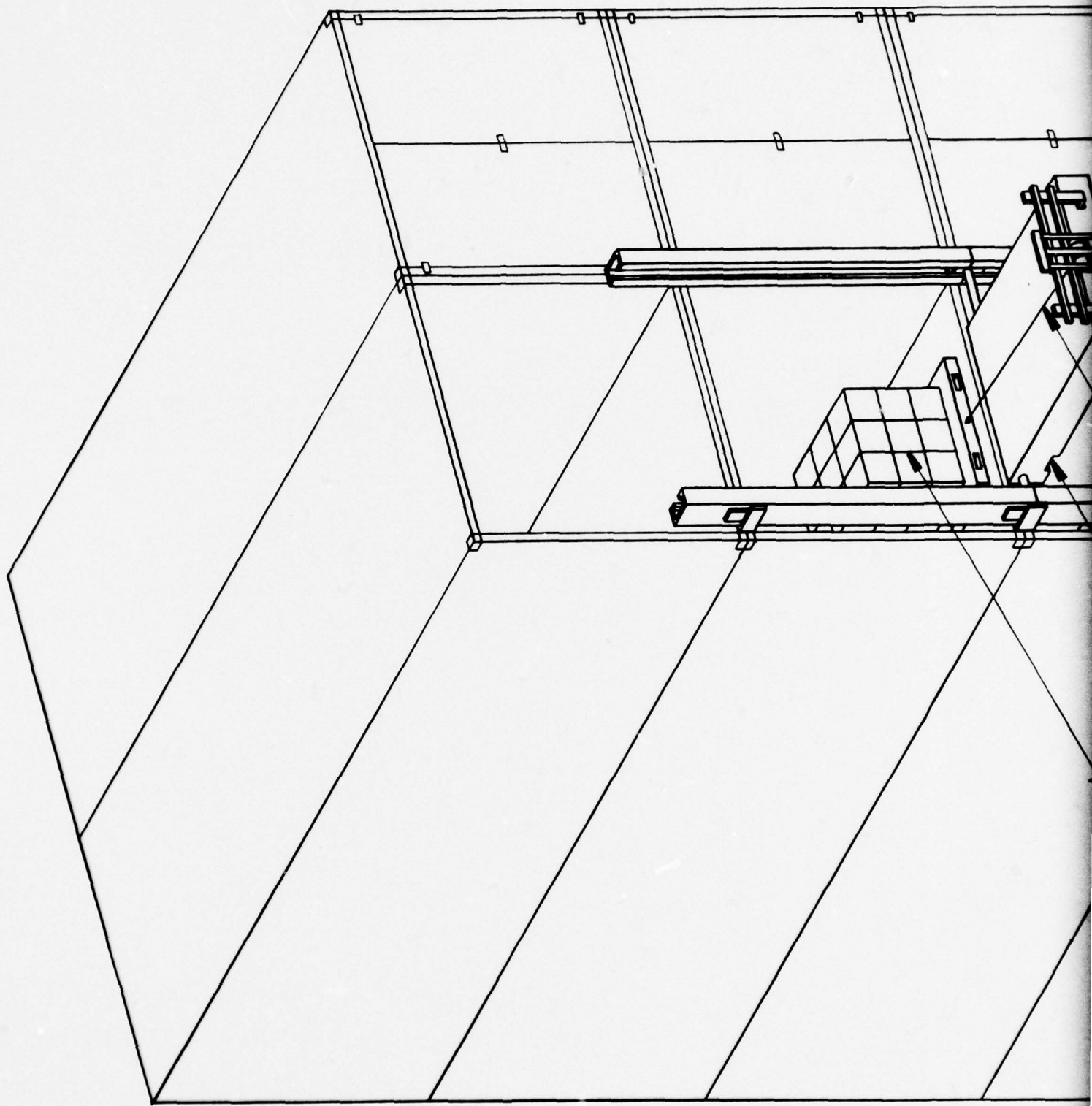

1

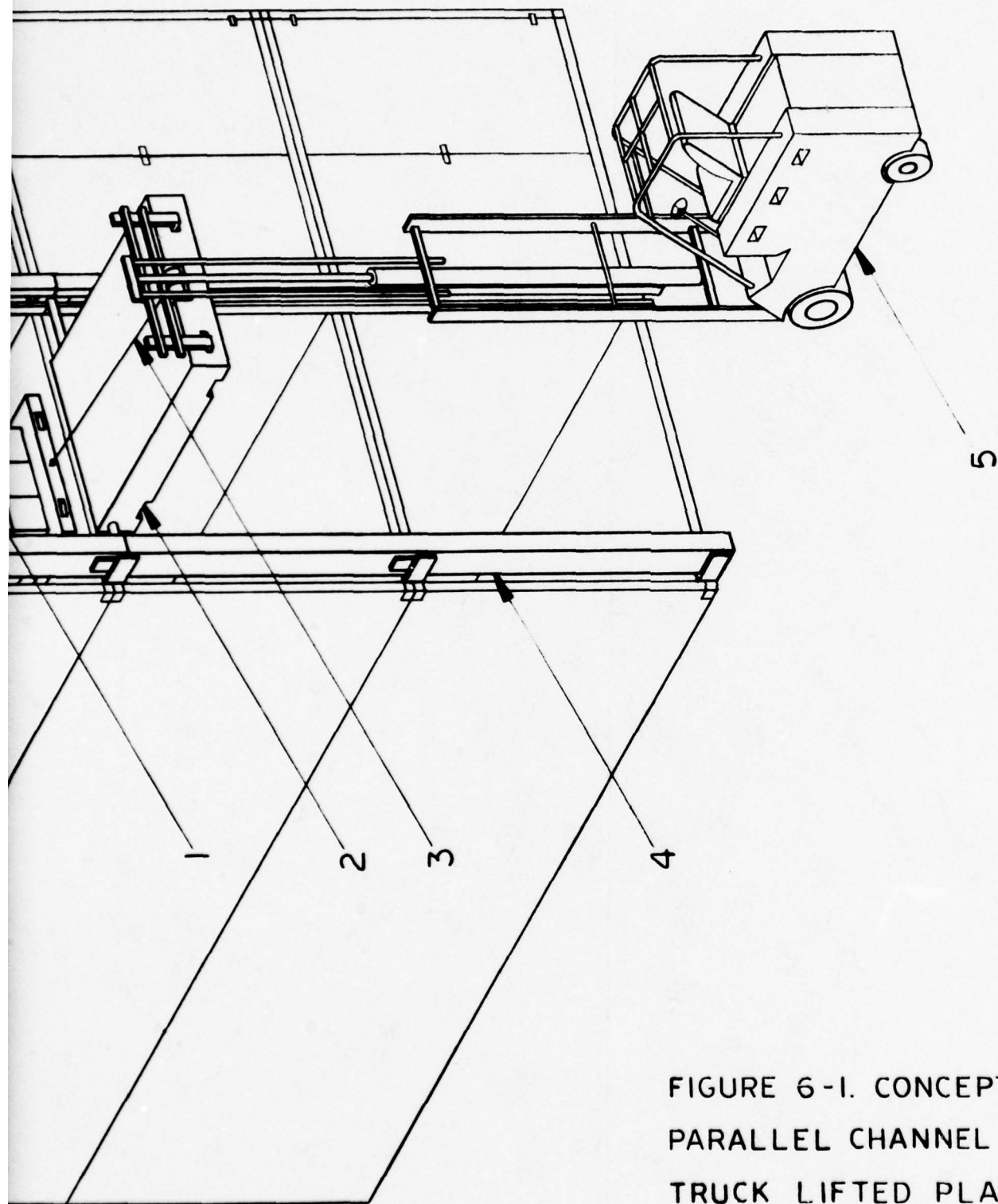

FIGURE 6-1. CONCEPT IV -  
PARALLEL CHANNEL GUIDED  
TRUCK LIFTED PLATFORM  
SUBSYSTEM

7

## 7-1. CONCEPT V - PARALLEL CHANNEL GUIDED ROPE LIFTED PLATFORM SUBSYSTEM

This subsystem, Table 7-1 and Figure 7-2 would feature the following:

- (a) a parallel channel and pulley holder assembly,
- (b) two sectionalized channel assemblies,
- (c) a rope lifted platform assembly,
- (d) a wire rope winch assembly, and
- (e) a medium lift industrial truck.

All assemblies, including the truck, would be stowed in one container.

### 7-2. Parallel Channel and Pulley Holder Assembly

The assembly would be 1'0" deep by 1'0" wide by 8'6" high and weigh about 600 pounds. The assembly would be attached to the corners of the fourth level container and the sectional channel assemblies by quick operating fasteners. The assembly would guide the rope lifted cantilever platform at the fourth container level. The assembly would have a pulley arrangement which would guide the wire rope between the winch and cantilever platform. A ladder would permit the installation of the wire rope from the winch, through the pulley system, to the cantilever platform.

### 7-3. Sectional Channel Assembly

Each assembly would be 1'0" deep by 1'0" wide by 25'6" high and weigh about 490 pounds. An assembly would be divided into three sections, each 8'6" long. The sections would be held together by hardware and would be capable of being

assembled or disassembled for the purposes of stowage, erection and dismantling. One assembly would be attached to the port side of a container stack, while another assembly would be attached to the starboard side of the same container stack. Each assembly would be attached to the corners of the first, second and third level container by quick acting fasteners. The sectional channel assemblies would guide the cantilever platform between the first and third container levels.

#### 7-4. Rope Lifted Cantilever Platform Assembly

The cantilever assembly would be 5'6" deep by 8'0" wide by 7'0" high and weigh about 1200 pounds. The assembly would be guided within the channel assemblies by rollers. Also, the assembly would have locking devices which would connect to the channel assemblies. The devices would permit lifting and moving of the channel assemblies by the medium high lift industrial truck. In addition, the assembly would incorporate a pallet extracting subassembly. The subassembly would consist of the following components;

- (a) a wide roller,
- (b) a safety hook,
- (c) a 60' length of wire rope, and
- (d) an electrically powered wire rope winch.

The safety hook would be attached to one end of the wire rope, while the other end of the wire rope would be connected to the winch. The roller would guide the wire rope hook attached to the palletized load. The subassembly would be mounted in and controlled from the platform. The pallet landing area of the assembly would be 5' deep by 5' wide by 1'6" high and support a palletized load weighing 3200 pounds.

7-5. Wire Rope Winch Assembly

The assembly would be 2' deep by 2' wide by 2' high and weigh about 150 pounds. The wire rope winch would be electrically powered and attached to a channel assembly. The winch would be controlled from either the deck or the cantilever platform, as so desired. An automatic holding brake would be contained in the assembly. The brake would be energized during a power failure.

7-6. Medium Lift Industrial Truck

The truck would be 12' deep by 4' wide by 6' high (lift retracted) or 13' high (lift extended) and weigh 8000 pounds. The truck would be able to lift a 4000 pound load to the height of 9'.

The truck would perform the following:

- (a) remove subsystem assemblies from container;
- (b) erect subsystem;
- (c) remove palletized load from platform;
- (d) transfer palletized load to off-loading staging area;
- (e) dismantle subsystem; and
- (f) stow subsystem assemblies in container.

7-7. Subsystem Erection

The medium lift industrial truck would remove all assemblies from the subsystem stowage container and then temporarily stow the assemblies on the hatch cover.

The parallel channel and pulley holder assembly would be lifted onto the cantilever platform by the truck. The two assemblies would be raised to the second container level by the truck.

A port and starboard portion of section channel assembly would be attached to the parallel channel and pulley holder assembly.

The cantilever platform would be unlocked from the parallel channel and pulley assembly, and then the platform would be lowered down to the first sectional channel assembly.

The platform would be locked to the first sectional channel assembly and then the platform would be raised to the second container level by the truck.

A second sectional channel assembly would be attached to the first sectional channel assembly. The platform would be unlocked from the first sectional channel assembly and then lowered down to the second sectional channel assembly by the truck.

The platform would be locked to the second sectional channel assembly and the platform would be raised to the second container level by the truck.

The third sectional channel assembly would be attached to the second sectional channel assembly. The subsystem would be connected to the container stack and the platform would be lowered to the hold cover. Next, the winch assembly would be attached to lowest sectional channel assembly. Finally, the wire rope from the winch assembly would be fed through the pulley system and would be attached to the cantilever platform.

7-8. Subsystem Operation

The platform would be raised to the desired container level. The extracting hook would be attached to the pallet selected to be removed from the container. The pallet extracting subassembly would be energized and the palletized load would be slid onto the pallet landing area of the platform. The extracting hook would be disconnected from the pallet. The platform would be lowered to the hatch cover. The truck would remove the loaded pallet from the platform and then transfer it to the off-loading staging area.

TABLE 7-1. CONCEPT V - PARALLEL CHANNEL GUIDED ROPE LIFTED PLATFORM SUBSYSTEM

Index No.	Assembly Name
1	Parallel Channel and Pulley Holder
2	Sectionalized Channel
3	Palletized Load
4	Rope Lifted Cantilever Platform
5	Pallet Extractor
6	Wire Rope Winch
7	Medium Lift Industrial Truck

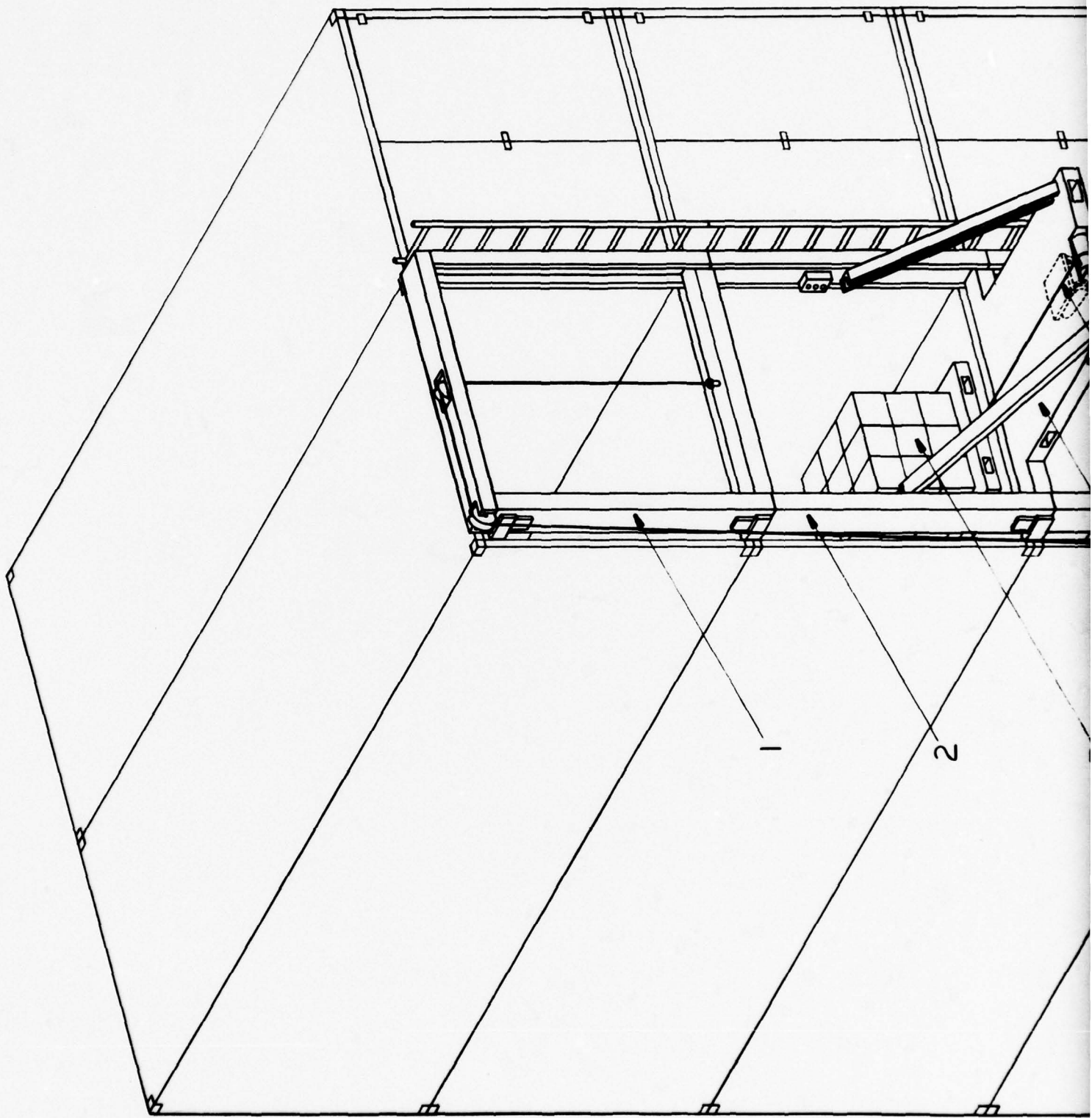

1

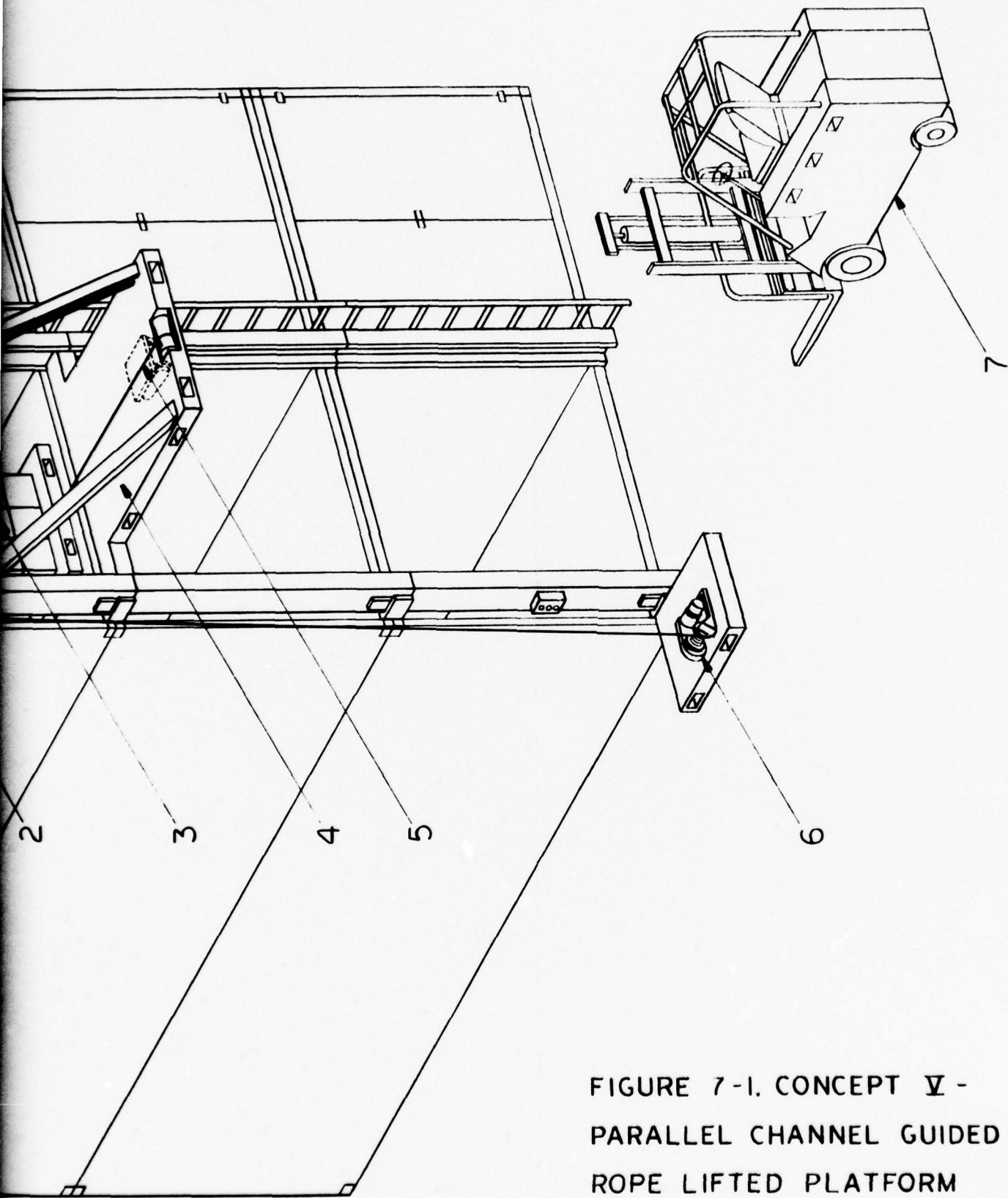

FIGURE 7-1. CONCEPT V -  
PARALLEL CHANNEL GUIDED  
ROPE LIFTED PLATFORM  
SUBSYSTEM

2

## 8-1. ABOVE HATCH VERTICAL MATERIAL HANDLING SUBSYSTEM DETAILED CHARACTERISTICS

Table 8-1 presents the detailed characteristics of subsystems and assemblies. The table is divided into nine elements;

- (a) physical,
- (b) engineering,
- (c) detailing,
- (d) purchasing,
- (e) stowing,
- (f) erecting,
- (g) operating,
- (h) maintenance, and
- (i) failure.

The elements are selected because they would give a starting point of comparison between each assembly and in turn, between each subsystem.

Under each concept, the first line is the total subsystem entry, while the lines below the subsystem are the assembly entries.

Opposite each ASSEMBLY, in the ELEMENT column is the criteria entry (e.g., 5'6", 5'6", 8'6", etc.). The criteria entry is based upon an engineering estimate obtained by examination of all preceding text, figures and tables.

Opposite each SUBSYSTEM, in the ELEMENT column is the totaled criteria

entry (e.g., 5'6", 8'0", 34'0", etc.) The totaled criteria entry provides a detailed overview of the subsystem characteristics.

The following notes pertain to Table 8-1:

<u>Note</u>	<u>Meaning</u>
(a)	Excluding truck
(b)	Including trolley and guide rail subassembly
(c)	Including wire rope winch
(d)	Top mast assembly 1000#
(e)	Lift extended 13'
(f)	Lift extended 32'
(g)	Like letters indicate similarity

The table functions as a source document from which the advantages and disadvantages of each subsystem may be obtained. Subsequent paragraphs list the advantages and disadvantages of each subsystem.



ERIAL HANDLING SUBSYSTEMS CHARACTERISTICS MATRIX

MENTS																	
PURCHASING METHOD		STOWING				ERECTING METHOD			OPERATING METHOD			PREVENTIVE MAINTENANCE PROCEDURE			FAILURE RATE		
LD	OFF-SHELF	CONTAINERS REQUIRED	SHELF LIFE			SIMPLE	INTERMEDIATE	COMPLEX	NONE	SIMPLE	COMPLEX	SIMPLE	INTERMEDIATE	COMPLEX	LOW	MODERATE	HIGH
			SHORT	MODERATE	LONG												
ies 6	1 Assembly out of 6	2	X	X	-	X	-	-	-	X	-	X	X	-	X	X	-
	-	> 3/4	-	X	-	X	-	-	X	-	-	X	-	-	X	-	-
	-	> 1/2	-	X	-	X	-	-	X	-	-	X	-	-	X	-	-
	-	> 1/4	-	X	-	X	-	-	-	X	-	-	X	-	-	X	-
	X	< 1/2	X	-	-	N/A	N/A	N/A	-	X	-	-	X	-	-	X	-

MENTS																	
PURCHASING METHOD		STOWING				ERECTING METHOD			OPERATING METHOD			PREVENTIVE MAINTENANCE PROCEDURE			FAILURE RATE		
LD	OFF-SHELF	CONTAINERS REQUIRED	SHELF LIFE			SIMPLE	INTERMEDIATE	COMPLEX	NONE	SIMPLE	COMPLEX	SIMPLE	INTERMEDIATE	COMPLEX	LOW	MODERATE	HIGH
			SHORT	MODERATE	LONG												
ies 7	1 Assembly out of 7	2	X	X	X	X	-	-	-	X	-	X	X	-	X	X	-
	-	> 1/4	-	-	X	X	-	-	X	-	-	X	-	-	X	-	-
	-	> 1/2	-	-	X	X	-	-	X	-	-	X	-	-	X	-	-
	-	> 1/4	-	-	X	X	-	-	X	-	-	X	-	-	X	-	-
	-	> 1/4	-	-	X	X	-	-	-	X	-	X	-	-	X	-	-
	-	> 1/4	-	X	-	-	-	X	X	-	-	-	X	-	-	X	-
	X	< 1/2	X	-	-	N/A	N/A	N/A	-	X	-	-	X	-	-	X	-

7

TABLE 8-1. ABOVE HATCH VERTICAL MATERIAL HANDLING

SUBSYSTEM AND ASSEMBLY	ELEMENTS													
	PHYSICAL CONFIGURATION					ENGINEERING DESIGN				DETAILING DESIGN			PURCHASING METHOD	
	DEPTH	WIDTH	HEIGHT	WEIGHT	QUANTITY REQUIRED	SIMILAR (g)	SIMPLE	INTERMEDIATE	COMPLEX	SIMPLE	INTERMEDIATE	COMPLEX	NEW BUILD	OFF-SHE
CONCEPT III Tower Guided Truck Lifted Platform	5'6" (a)	8'0" (b)	30'0"	20600#	1	A	X	X	-	X	X	-	6 Assemblies out of 6	None
Boxed Channel Extender	5'6"	5'6"	4'0"	320#	1	B	X	-	-	X	-	-	X	-
Standard Boxed Channel	5'6"	5'6"	8'0"	440#	2	B	-	X	-	-	X	-	X	-
Special Boxed Channel	5'6"	5'6"	8'6"	550#	1	C	-	X	-	-	X	-	X	-
Platform	5'6"	5'6"	1'6"	900#	1	D	-	X	-	-	X	-	X	-
Extra High Lift Industrial Truck	12'0"	7'0"	10'0" (f)	16000#	1	G	-	X	-	-	X	-	X	-

SUBSYSTEM AND ASSEMBLY	ELEMENTS													
	PHYSICAL CONFIGURATION					ENGINEERING DESIGN				DETAILING DESIGN			PURCHASING METHOD	
	DEPTH	WIDTH	HEIGHT	WEIGHT	QUANTITY REQUIRED	SIMILAR (g)	SIMPLE	INTERMEDIATE	COMPLEX	SIMPLE	INTERMEDIATE	COMPLEX	NEW BUILD	OFF-SHE
CONCEPT IV Parallel Channel Guided Truck Lifted Platform	5'6" (a)	8'0"	28'0"	18120#	1	H	X	X	-	X	X	-	4 Assemblies out of 4	None
Channel	1'0"	1'0"	28'0"	810#	2	I	X	-	-	X	-	-	X	-
Platform	5'6"	8'0"	1'6"	500#	1	J	X	-	-	X	-	-	X	-
Extra High Lift Industrial Truck	12'0"	7'0"	10'0" (f)	16000#	1	G	-	X	-	-	X	-	X	-

HANDLING SUBSYSTEMS CHARACTERISTICS MATRIX (Continued)

ELEMENTS																	
PURCHASING METHOD		STOWING			ERECTING METHOD			OPERATING METHOD			PREVENTIVE MAINTENANCE PROCEDURE			FAILURE RATE			
BUILD	OFF-SHELF	CONTAINERS REQUIRED	SHELF LIFE			SIMPLE	INTERMEDIATE	COMPLEX	NONE	SIMPLE	COMPLEX	SIMPLE	INTERMEDIATE	COMPLEX	LOW	MODERATE	HIGH
			SHORT	MODERATE	LONG												
Assemblies of 6	None	1	X	-	X	X	-	-	-	X	X	X	-	X	X	-	X
	-	> 1/4	-	-	X	X	-	-	X	-	-	X	-	-	X	-	-
	-	> 1/2	-	-	X	X	-	-	X	-	-	X	-	-	X	-	-
	-	> 1/4	-	-	X	X	-	-	X	-	-	X	-	-	X	-	-
	-	> 1/4	-	-	X	X	-	-	-	X	-	X	-	-	X	-	-
	-	None - Stowed on Hatch Cover	X	-	-	N/A	N/A	N/A	-	-	X	-	-	X	-	-	X

ELEMENTS																	
PURCHASING METHOD		STOWING			ERECTING METHOD			OPERATING METHOD			PREVENTIVE MAINTENANCE PROCEDURE			FAILURE RATE			
BUILD	OFF-SHELF	CONTAINERS REQUIRED	SHELF LIFE			SIMPLE	INTERMEDIATE	COMPLEX	NONE	SIMPLE	COMPLEX	SIMPLE	INTERMEDIATE	COMPLEX	LOW	MODERATE	HIGH
			SHORT	MODERATE	LONG												
Assemblies of 4	None	1	X	-	X	X	X	-	-	X	X	X	-	X	X	-	X
X	-	> 1/2	-	-	X	-	X	-	X	-	-	X	-	-	X	-	-
X	-	> 1/2	-	-	X	X	-	-	-	X	-	X	-	-	X	-	-
X	-	None - Stowed on Hatch Cover	X	-	-	N/A	N/A	N/A	-	-	X	-	-	X	-	-	X

2



HANDLING SUBSYSTEMS CHARACTERISTICS MATRIX (Continued)

PURCHASING METHOD		STOWING			ERECTING METHOD			OPERATING METHOD			PREVENTIVE MAINTENANCE PROCEDURE			FAILURE RATE			
ID	OFF-SHELF	CONTAINERS REQUIRED	SHELF LIFE			SIMPLE	INTERMEDIATE	COMPLEX	NONE	SIMPLE	COMPLEX	SIMPLE	INTERMEDIATE	COMPLEX	LOW	MODERATE	HIGH
			SHORT	MODERATE	LONG												
ies 6	1 Assembly out of 6	1	X	-	X	-	X	X	-	X	-	X	X	-	X	X	-
	-	> 1/5	-	-	X	-	X	-	X	-	-	X	-	-	X	-	-
	-	> 2/5	-	-	X	-	X	-	X	-	-	X	-	-	X	-	-
	-	> 1/5	-	-	X	-	X	-	-	X	-	X	-	-	X	-	-
	-	> 1/5	-	-	X	-	-	X	X	-	-	-	X	-	-	X	-
	X	< 1/2	X	-	-	N/A	N/A	N/A	-	X	-	-	X	-	-	X	-

2

8-2. Tower Guided Pinion Lifted Platform Subsystem

This subsystem would provide the following advantages:

- (a) medium size volume,
- (b) medium weight,
- (c) 1 out of 6 assemblies purchased from off-shelf stock,
- (d) stowable in two containers,
- (e) simple erecting and operating methods,
- (f) simple-to-moderate maintenance procedures, and
- (g) low-to-moderate failure rate.

This subsystem would provide the following disadvantages:

- (a) complex engineering design and design detailing, and
- (b) short-to-moderate length stowage life.

8-3. Tower Guided Rope Lifted Platform Subsystem

The advantages of this subsystem would be:

- (a) medium weight,
- (b) 1 of 7 assemblies purchased from off-shelf stock,
- (c) stowed in two containers,
- (d) long stowage life,

- (e) simple-to-complex erecting methods,
- (f) simple operating methods,
- (g) simple-to-moderate maintenance procedures, and
- (h) low-to-moderate failure rate.

The disadvantages of this subsystem would be:

- (a) large volume, and
- (b) moderate-to-complex engineering design and design detailing.

8-4. Tower Guided Truck Lifted Platform Subsystem

Subsystem advantages would be:

- (a) long stowage life,
- (b) simple erecting method, and
- (c) simple-to-moderate operating methods.

Subsystem disadvantages would be:

- (a) largest volume,
- (b) heaviest weight,
- (c) moderate engineering design and drafting detailing,
- (d) no assemblies purchased from off-shelf stock,
- (e) industrial truck must be stowed on hatch cover,

- (f) moderate-to-complex preventive maintenance procedures, and
- (g) moderate-to-high failure rate.

8-5. Parallel Channel Guided Truck Lifted Platform Subsystem

The advantages of this subsystem would be:

- (a) smallest volume,
- (b) simple-to-moderate engineering design and design detailing,
- (c) moderate-to-long shelf life,
- (d) simple-to-moderate erecting and operating methods.

The disadvantages of this subsystem would be:

- (a) heavy weight,
- (b) no assemblies purchased from off-shelf stock,
- (c) industrial truck must be stowed on hatch cover,
- (d) moderate-to-complex preventive maintenance procedures, and
- (e) moderate failure rate.

8-6. Parallel Channel Guide Rope Lifted Platform Subsystem

Subsystem advantages would provide:

- (a) small volume,
- (b) lightest weight,

- (c) 1 out of 6 assemblies would be purchased from off-shelf stock,
- (d) single container stowage,
- (e) long stowage life,
- (f) simple operating method,
- (g) simple-to-moderate maintenance procedures, and
- (h) low-to-moderate failure rate.

Subsystem disadvantages would be:

- (a) moderate-to-complex engineering design and design detailing, and
- (b) moderately complex erecting methods.

#### 8-7. ABOVE HATCH VERTICAL MATERIAL HANDLING SUBSYSTEMS COSTS

Table 8-2 provides an approximate overall cost and cost per pound of each subsystem. The cost of assemblies was obtained by multiplying the weight of the assemblies, in pounds, by \$1.50 per pound of assembly weight. The cost of the truck was derived by multiplying the weight of the truck, in pounds, by \$1.00 per pound of truck weight.

The total cost of the subsystem was obtained by adding the cost of the assemblies to the cost of the truck. The cost per pound of subsystem was obtained by dividing the total cost of the subsystem by the total weight of the subsystem.

TABLE 8-2. ABOVE HATCH VERTICAL MATERIAL HANDLING SUBSYSTEMS COSTS

SUBSYSTEM	WEIGHT (LBS)		TOTAL	COST			\$/LB
	ASSEMBLIES	TRUCK		\$1.50/LB ASSEMBLIES	\$1/LB TRUCK	\$ TOTAL	
Tower Guided Pinion Lifted Platform	5260	9000	14260	10520	9000	19520	1.36
Tower Guided Rope Lifted Platform	4450	8000	12450	8900	8000	16900	1.35
Tower Guided Truck Lifted Platform	2600	16000	18600	5200	16000	21200	1.13
Parallel Channel Guided Truck Lifted Platform	2120	16000	18120	4240	16000	20240	1.11
Parallel Channel Guided Rope Lifted Platform	3420	8000	11420	6840	8000	14840	1.29

8-8. ABOVE HATCH VERTICAL MATERIAL HANDLING SUBSYSTEMS WEIGHTED CHARACTERISTICS MATRIX

Table 8-3 presents a condensed version of the general characteristics of each subsystem. The characteristics are assigned a relative value which provides a quick look comparison of each subsystem.

Opposite the SUBSYSTEM, in the ELEMENT columns, between the horizontal lines is the criteria entry (e.g., 1316, 14260, Complex, etc.) The criteria entry was based upon a value decision obtained by analysis and evaluation of all preceding material.

Opposite the SUBSYSTEM, in the ELEMENT columns, to the left of the diagonal line is the weight criteria entry (e.g., 3, 3, 5, etc.) The weighted criteria entry was developed by assigning a number to the criteria entry. The number 1, indicates most desirable criteria. The numbers 2, 3 and 4 indicate less desirable criteria. The number 5, indicates the least desirable criteria.

Opposite the SUBSYSTEM, in the ELEMENT columns, to the right of the diagonal line is accumulated weight entry (e.g., 3, 6, 11, etc.) The accumulated weight entry was obtained by adding together all previously weighted criteria entries.

TABLE 8-3. ABOVE HATCH VERTICAL MATERIAL HANDLING SUBSYSTEMS WEIGHTED CHARAC

SUBSYSTEM	ELEMENT															
	OVERALL		OVERALL		ENGINEERING		DETAILING		PURCHASING		STOWING		ERECTING		OPERATING	
	VOLUME (CU FT)	WEIGHT (LBS)	DESIGN	DESIGN	OFF SHELF (%)	REQUIRED	LIFE	METHOD	METHOD							
Tower Guided Pinion Lifted Platform	1316		14260		Complex		Complex		17		2		Intermediate		Simple	
	3	3	3	6	5	11	5	16	2	18	2	20	5	25	3	28
Tower Guided Rope Lifted Platform	1354		12450		Intermediate		Intermediate		14		2		Long		Simple	
	4	4	2	6	4	10	4	14	3	17	2	19	1	20	2	20
Tower Guided Truck Lifted Platform	1747		20600		Intermediate		Intermediate		0		1		Intermediate		Simple	
	5	5	5	10	3	13	3	16	5	21	3	24	4	28	1	29
Parallel Channel Guided Truck Lifted Platform	956		18120		Simple		Simple		0		1		Long		Intermediate	
	1	1	4	5	1	6	1	7	4	11	3	14	3	17	4	21
Parallel Channel Guided Rope Lifted Platform	1155		11420		Intermediate		Intermediate		17		1		Long		Intermediate	
	2	2	1	3	2	5	2	7	1	8	1	9	2	11	5	16

# ING SUBSYSTEMS WEIGHTED CHARACTERISTICS MATRIX

ELEMENT						
STOWING		ERECTING	OPERATING	PREVENTIVE MAINTENANCE	FAILURE	COST
WEIGHTS	SHELF					
NUMBER	LIFE	METHOD	METHOD	PROCEDURES	RATE	\$/LB
	Intermediate	Simple	Simple	Simple	Low	1.36
20	5 / 25	3 / 28	3 / 31	3 / 34	3 / 37	5 / 42
	Long	Simple	Simple	Simple	Low	1.35
19	1 / 20	2 / 20	2 / 24	2 / 26	2 / 28	4 / 32
	Intermediate	Simple	Intermediate	Intermediate	Moderate	1.13
24	4 / 28	1 / 29	4 / 33	4 / 37	5 / 42	2 / 44
	Long	Intermediate	Intermediate	Intermediate	Moderate	1.11
14	3 / 17	4 / 21	5 / 26	5 / 31	4 / 35	1 / 36
	Long	Intermediate	Simple	Simple	Low	1.29
9	2 / 11	5 / 16	1 / 17	1 / 18	1 / 19	3 / 21

2

8-9. RECOMMENDATIONS

It is recommended that the Tower Guided Rope Lifted Platform Subsystem be adopted as the most desirable above hatch vertical material handling subsystem because of the following reasons:

- (a) wire rope is proven design,
- (b) least effect by environment,
- (c) movable across hatch cover, and
- (d) simple alternate platform lift methods available in case of casualty.

It is recommended that the other subsystems be rejected as the most desirable lift devices because of one or more of the following reasons:

- (a) unproven or limited proof design,
- (b) adverse environmental effect on assemblies,
- (c) requires specially designed and constructed extra high lift industrial truck, and
- (d) no satisfactory alternate platform lift methods available in case of casualty.