

AD-A059 510

GENERAL ELECTRIC CO SYRACUSE N Y ELECTRONIC SYSTEMS DIV F/G 17/9
UNATTENDED RADAR STATION DESIGN FOR DEWLINE APPLICATION, VOLUME--ETC(U)
JAN 78 W E ABRIEL, S E BELL, E J GERSTEN F19628-77-C-0212

FSD-TR-78-176-VOL-2

NL

UNCLASSIFIED

1 OF 3

AD
A059510



18 ESD-TR-78-176, Vol. 2

ESD E259, Volume 2 (of three)

Contract F19628-77-C-0212

Final Technical Report. 19 Jul - 19 Dec 77

Jan 1978

12

AD AU 59510

9

11

10

AUTHORED BY:

- W. E. ABRIEL,
- S. E. BELL,
- E. J. GERSTEN,
- R. M. JOHNSON
- D. J. MURROW

12 245 p.

LEVEL II

6

UNATTENDED RADAR STATION DESIGN FOR DEWLINE APPLICATION. Volume II

GENERAL ELECTRIC COMPANY

15

F19628-77-C-0212

DDC
OCT 6 1978
F 10

DDC FILE COPY

APPROVED FOR PUBLIC RELEASE: DISTRIBUTION UNLIMITED

DEPUTY FOR DEVELOPMENT PLANS
ELECTRONIC SYSTEMS DIVISION
HANSCOM AIR FORCE BASE, MA 01731

78 10 05 042
388 743

mt

REPORT DOCUMENTATION PAGE		READ INSTRUCTIONS BEFORE COMPLETING FORM	
1. REPORT NUMBER ESD-TR-78-176, Vol. II	2. GOVT ACCESSION NO.	3. RECIPIENT'S CATALOG NUMBER	
4. TITLE (and Subtitle) UNATTENDED RADAR STATION DESIGN FOR DEWLINE APPLICATION		5. TYPE OF REPORT & PERIOD COVERED FINAL REPORT 19 JULY 77 TO 19 DEC 77	
7. AUTHOR(s) GENERAL ELECTRIC COMPANY, HEAVY MILITARY ELECTRONIC SYSTEMS		6. PERFORMING ORG. REPORT NUMBER N/A	
9. PERFORMING ORGANIZATION NAME AND ADDRESS GENERAL ELECTRIC COMPANY ELECTRONIC SYSTEMS DIVISION COURT STREET, SYRACUSE, N.Y. 13221		8. CONTRACT OR GRANT NUMBER(s) F19628-77-C-0212	
11. CONTROLLING OFFICE NAME AND ADDRESS ELECTRONIC SYSTEMS DIVISION AIR FORCE SYSTEMS COMMAND HANSCOM AFB, MASS. 01731		10. PROGRAM ELEMENT, PROJECT, TASK AREA & WORK UNIT NUMBERS E-259	
14. MONITORING AGENCY NAME & ADDRESS (if different from Controlling Office) SAME		12. REPORT DATE 19 JANUARY 1978	
		13. NUMBER OF PAGES 230	
		15. SECURITY CLASS. (of this report) UNCLASSIFIED	
		15a. DECLASSIFICATION/DOWNGRADING SCHEDULE	
16. DISTRIBUTION STATEMENT (of this Report) APPROVED FOR PUBLIC RELEASE, DISTRIBUTION UNLIMITED			
17. DISTRIBUTION STATEMENT (of the abstract entered in Block 20, if different from Report) SAME			
18. SUPPLEMENTARY NOTES			
19. KEY WORDS (Continue on reverse side if necessary and identify by block number) DEWLINE UNATTENDED RADAR STATION MAINTENANCE NODES RELIABILITY AVAILABILITY LIFE CYCLE COST			
20. ABSTRACT (Continue on reverse side if necessary and identify by block number) This report examines the feasibility of implementing and maintaining a string of Unattended Radar Stations in the Arctic. The study is conceptual relative to design, installation, operation, maintenance, and support of Unattended Stations and attendant problems such as security, reliability, maintainability, availability, and life cycle cost. Cost Drivers are identified and potential solution alternatives with recommendations presented. The conclusion is that, with reasonable development, economical Unattended Arctic Radar Stations are possible.			

78 30 05 042

PREFACE

This report, prepared by the General Electric Company for Electronic Systems Division under Contract No. F19628-77-C-0212 was compiled by E. J. Gersten, Engineering Project Manager. Major contributors were W. E. Abriel, S. E. Bell, J. R. Golden, J. T. Gorham, R. M. Johnson and D. J. Murrow.

ACQUISITION BY	
NOTE	DATE ACQUIRED <input type="checkbox"/>
DOC	DATE ACQUIRED <input type="checkbox"/>
REPRODUCED	<input type="checkbox"/>
ADDITIONAL	<input type="checkbox"/>
BY	
DATE	
SIGNATURE	
INITIALS	

A

TABLE OF CONTENTS

<u>SECTION</u>	<u>TITLE</u>	<u>PAGE</u>
1	INTRODUCTION	1-1
2	OBJECTIVE AND SCOPE.....	2-1
2.1	Objectives and Scope.....	2-1
2.2	Study Process Flow.....	2-1
3	SYSTEM ARCHITECTURE.....	3-1
3.1	Node Considerations.....	3-1
3.1.1	Introduction.....	3-1
3.1.2	Baseline System.....	3-3
3.1.3	POL Requirements.....	3-4
3.1.4	Arctic Development.....	3-7
3.1.5	Node Operational Alternatives.....	3-11
3.2	Network Operational Considerations, Trades, and Life Cycle Cost.....	3-15
3.2.1	Life Cycle Cost Drivers.....	3-15
3.2.2	Acquisition Costs.....	3-21
3.2.2.1	Development Costs.....	3-21
3.2.2.1.1	Radar Development Costs.....	3-22
3.2.2.1.2	Prime Power Development Costs.....	3-24
3.2.2.1.3	Communications Development Costs.....	3-25
3.2.2.1.4	Weather Package Development Costs.....	3-25
3.2.2.1.5	NAVAIDS Development Costs.....	3-26
3.2.2.1.6	Physical Plant Development Costs.....	3-26
3.2.2.1.7	Software Development Costs.....	3-26
3.2.2.1.8	Systems Integration Activity Costs.....	3-27
3.2.2.2	Site Selection Preparation and Construction.....	3-28
3.2.2.2.1	Site Selection Costs.....	3-29
3.2.2.2.2	New Site Preparation Costs.....	3-30
3.2.2.2.3	Facility Construction Costs.....	3-30
3.2.2.2.4	New Site Real Estate Acquisition Cost.....	3-30
3.2.2.2.5	Logistics Node Support Facility Costs.....	3-30
3.2.2.2.6	Existing Site Preparation/Modification Costs.....	3-31
3.2.2.2.7	Repeater Site Selection, Preparation, and Construction Cost.....	3-31
3.2.2.2.8	Impact of Radar Tower Heights Requirements On-Site Selection, Preparation and Construction Costs.....	3-31
3.2.2.3	Production Costs.....	3-34
3.2.2.3.1	Radar Unit Costs.....	3-35
3.2.2.3.2	Prime Power Units Costs.....	3-35
3.2.2.3.3	Communication Equipment Unit Costs.....	3-35
3.2.2.3.4	Weather Package Unit Costs.....	3-36
3.2.2.3.5	NAVAIDS Unit Costs.....	3-36
3.2.2.3.6	Physical Plant Unit Costs.....	3-36
3.2.2.3.7	Site Mission Hardware Shipping, Storing and Installation Costs.....	3-37
3.2.2.3.8	Logistic Node Facilities.....	3-39
3.2.2.3.9	Impact of Tower Height Requirements on Production Costs...	3-42

TABLE OF CONTENTS (CONTINUED)

<u>SECTION</u>	<u>TITLE</u>	<u>PAGE</u>
3.2.2.4	Acquisition Cost Impact of Network Nodal Configuration Alternatives.....	3-42
3.2.3	Operation and Maintenance Costs.....	3-45
3.2.3.1	Transportation Costs.....	3-45
3.2.3.1.1	Transportation Cost Model.....	3-45
3.2.3.1.2	Helicopter Alternatives.....	3-48
3.2.3.1.3	Civilian Versus Air Force Aircraft and Crews.....	3-51
3.2.3.1.4	Maintenance Philosophies.....	3-58
3.2.3.1.5	Network Reliability.....	3-62
3.2.3.1.5.1	Station Reliability.....	3-68
3.2.3.1.5.1.1	Radar Reliability.....	3-68
3.2.3.1.5.1.2	Prime Power Reliability.....	3-74
3.2.3.1.5.1.3	Line of Site (LOS) Microwave Communications Reliability...	3-76
3.2.3.1.5.1.4	Satellite Station Communications Reliability.....	3-80
3.2.3.1.6	Network MTBF and MTBMV.....	3-84
3.2.3.2	Annual Resupply Costs.....	3-93
3.2.3.3	Personnel Support Costs.....	3-94
3.2.3.3.1	Criteria.....	3-94
3.2.3.3.2	Personnel Requirements/Cost.....	3-95
3.2.3.3.3	Network Nodal Alternatives Impact and Maintenance Manning.	3-96
3.2.3.3.3.1	Baseline.....	3-96
3.2.3.3.3.2	Alternate 1.....	3-99
3.2.3.3.3.3	Alternate 2.....	3-99
3.2.3.3.3.4	Alternate 3.....	3-100
3.2.3.3.3.5	Alternate 4.....	3-100
3.2.3.3.3.6	Alternate 5.....	3-101
3.2.3.3.3.7	Alternate 6.....	3-101
3.2.3.3.4	Maintenance Loading.....	3-101
3.2.3.4	Spares Cost.....	3-103
3.2.3.5	Power Generation Cost.....	3-107
3.3	Station Equipment.....	3-111
3.3.1	Station Functional Analysis.....	3-111
3.3.2	Radar/IFF.....	3-111
3.3.3	Weather Station.....	3-120
3.3.3.1	Weather Station Equipment.....	3-122
3.3.3.1.2	Anemometer/Wind Vane.....	3-123
3.3.3.1.3	Pressure Transducer.....	3-124
3.3.3.1.4	Temperature Dewpoint.....	3-125
3.3.3.1.5	Precipitation Gauge.....	3-125
3.3.3.1.6	Solid State T.V.....	3-126
3.3.3.1.7	Data Conditioner.....	3-127
3.3.3.2	Equipment Summary.....	3-127
3.3.3.3	Weather Station Control.....	3-127
3.3.3.4	Physical Requirements.....	3-130
3.3.3.5	Message Format.....	3-130
3.3.3.6	Weather Station Costs.....	3-130
3.3.4	Navigation Aids.....	3-130
3.3.4.1	NAVAIDS Equipment.....	3-132

TABLE OF CONTENTS (CONTINUED)

<u>SECTION</u>	<u>TITLE</u>	<u>PAGE</u>
3.3.4.2	Lighting.....	3-132
3.3.4.3	Radio.....	3-133
3.3.4.4	Low Frequency Beacon.....	3-135
3.3.4.5	Beacon Communication Backup Alternative.....	3-146
3.3.5	Security System.....	3-148
3.3.6	Communication.....	3-148
3.3.6.1	Station Message Load.....	3-150
3.3.7	Station Controller.....	3-157
3.3.8	Prime Power.....	3-162
3.3.8.1	Uninterrupted Power.....	3-165
3.3.8.2	Prime Power Control.....	3-167
3.3.8.3	Station Prime Power Load.....	3-170
3.3.8.4	Prime Power Generation.....	3-173
3.3.8.5	Minimum Power Load.....	3-181
3.3.8.6	Alternate Power Sources.....	3-184
3.3.8.6.1	Solar Power.....	3-188
3.3.8.6.2	Wind Power.....	3-188
3.3.9	Total Energy Consideration.....	3-206
3.3.10	Microwave Radio Link Repeater Site.....	3-212
3.3.10.1	Repeater Site Power and Heat Transfer Requirements.....	3-212
3.3.10.2	Repeater Site Prime Power Services.....	3-214
3.3.11	Equipment Status.....	3-218
3.3.12	System Safety.....	3-221
3.3.13	Development Testing.....	3-225
3.3.13.1	Category 1 Subsystem Development Testing.....	3-225
3.3.13.2	Category 2 Subsystem Development Testing.....	3-227
3.4	Civil/Mechanical Alternatives.....	3-228
3.4.1	DEWLine Survey.....	3-228
3.4.1.1	Condition of DEWLine Facilities.....	3-229
3.4.1.2	Use of Helicopters.....	3-230
3.4.1.3	Unrest In The Young Eskimos.....	3-235
3.4.1.4	The Eskimo Economy.....	3-236
3.4.2	A/F Consultants.....	3-237
3.4.3	Siting Considerations.....	3-241
3.4.3.1	Existing Sites.....	3-241
3.4.3.2	New Sites.....	3-242
3.4.4	Towers.....	3-244
3.4.4.1	Radar Towers.....	3-244
3.4.4.2	Tower Materials.....	3-246
3.4.5	Storage.....	3-248
3.4.6	Shelters.....	3-254
3.4.6.1	Radar.....	3-254
3.4.6.2	Power.....	3-254
3.4.6.3	Power and Life Support.....	3-259
3.4.7	Fire Protection.....	3-269
3.4.8	Environmental Control and Energy Utilization.....	3-272
3.4.9	Configuration.....	3-274
3.4.10	Security.....	3-295

TABLE OF CONTENTS (CONTINUED)

<u>SECTION</u>	<u>TITLE</u>	<u>PAGE</u>
3.4.11	Construction Considerations.....	3-300
3.4.12	Weather and Terrain Features.....	3-304
3.4.13	Ecological Impact and Protection.....	3-304
3.4.14	Obstruction Lighting.....	3-307
3.4.15	Safety.....	3-308
3.4.16	Growth Potential.....	3-309
3.4.16.1	Logistics Nodes.....	3-310
3.4.16.2	Building Trains.....	3-312
3.4.16.3	Garages.....	3-316
3.4.16.4	Warehouses.....	3-317
3.4.16.5	Hangars.....	3-317
3.4.16.6	Powerhouse.....	3-317
3.4.16.7	Heating Systems.....	3-322
3.4.16.8	POL Storage.....	3-323
3.4.17	Recommendations.....	3-328
3.5	Communication Considerations.....	3-329
3.5.1	Introduction.....	3-329
3.5.2	Identified Alternatives.....	3-329
3.5.3	Selected Alternatives.....	3-344
3.5.3.1	Terrestrial Radio Relay Configuration.....	3-344
3.5.3.1.1	System Description.....	3-344
3.5.3.1.2	Radio Relay Path Considerations.....	3-344
3.5.3.1.3	Channel Plan.....	3-346
3.5.3.1.3.1	General.....	3-346
3.5.3.1.3.2	Backhaul Circuits.....	3-349
3.5.3.1.3.3	Manned Nodes to Unattended Radar Circuits.....	3-350
3.5.3.1.4	Path Calculations.....	3-350
3.5.3.1.5	Terrestrial Radio Relay Equipment.....	3-351
3.5.3.1.5.1	General.....	3-351
3.5.3.1.5.2	Station Block Diagram.....	3-352
3.5.3.1.6	Line of Sight Environmental Considerations.....	3-356
3.5.3.1.7	Line of Sight Electrical Power Requirements.....	3-356
3.5.3.1.8	LOS Configuration-Reliability Requirements.....	3-359
3.5.3.1.9	LOS Configuration - Cost Data.....	3-367
3.5.3.1.10	LOS Configuration-Equipment Packaging and Mounting.....	3-367
3.5.3.1.11	LOS Configuration Vulnerability.....	3-367
3.5.3.1.12	Telephone and Television Service for Local Communities.....	3-368
3.5.3.1.12.1	Telephone Service.....	3-369
3.5.3.1.12.2	Television Service.....	3-369
3.5.3.2	Satellite Configuration.....	3-369
3.5.3.2.1	System Description.....	3-369
3.5.3.2.2	Link Calculation.....	3-370
3.5.3.2.3	Earth Station Equipment.....	3-377
3.5.3.2.4	Satellite Configuration-Electrical Power Requirements.....	3-379
3.5.3.2.5	Satellite Configuration-Reliability Requirements...	3-379
3.5.3.2.6	Satellite Configuration-Cost Data.....	3-394
3.5.3.2.7	Satellite Configuration-P.M. and Control.....	3-398
3.5.3.2.8	Satellite Configuration-Equipment Packaging and Mounting.....	3-400

TABLE OF CONTENTS (CONTINUED)

<u>SECTION</u>	<u>TITLE</u>	<u>PAGE</u>
3.5.3.2.9	Satellite Configuration-Vulnerability.....	3-402
3.5.3.2.10	Television Reception for Local Communities.....	3-403
3.5.3.2.11	Telephone Service For Local Communities.....	3-406
3.5.4	Comparison of Selected Alternatives.....	3-407
3.5.5	Recommendation/Conclusions.....	3-410
3.5.5.1	Assessment of Feasibility.....	3-410
3.5.5.2	Requirements for Additional Analysis.....	3-411
4	LIFE CYCLE COST SUMMARY.....	4-1
5	CONCLUSIONS AND RECOMMENDATIONS.....	5-1
5.1	Conclusions.....	5-1
5.2	Recommendations.....	5-4
6	APPENDIX - EQUIPMENT.....	TEXT
7	APPENDIX.....	7-1
7.1	Network Reliability Analysis.....	7-1
A	Adjacent Radar Failure Problem.....	7-1
B	LOS Communication Failure Span Prob.....	7-3
7-2	Maintenance Loading Analysis.....	7-7
7-3	Unattended Station Spares Analysis.....	7-24

FIGURES

<u>Figure Number</u>	<u>Title</u>	<u>Page</u>
2.2	Study Process Flow.....	2-3
3.1-1	Dew System Transportation Support Sealift.....	3-2
3.1-2	Primary Logistics Zones.....	3-6
3.1-3	Canadian Facilities.....	3-8
3.1-4	Canadian Facilities (Location).....	3-9
3.1-5	Node Operational Alternatives.....	3-12
3.2-1	Adjacent Radar Coverage Vs Tower Heights.....	3-18
3.2-2	Site Selection, Preparation, and Construction Cost Deltas.....	3-33
3.2-3	Production Cost Vs Tower Height Requirements.....	3-43
3.2-4	(DELETED)	
3.2-5	20 Year Maintenance Transportations Cost Versus Mean-Time-Between-Maint.-Visits.....	3-59
3.2-6	20 Year Maintenance Transportation Cost Versus Mean-Time-Between-Maintenance-Visits.....	3-60
3.2-7	LOS Microwave Communications Network.....	3-64
3.2-8	Satellite Communications Network.....	3-47
3.2-9	Station Reliability.....	3-69
3.2-10	Unattended Radar Reliability Block Diagram.....	3-70
3.2-11	Reliability Program Diesel Power System.....	3-75
3.2-12	LOW Microwave Communications Reliability Program..	3-78
3.2-13	Satellite Ground Station Reliability Block Diagram- Transmit Path.....	3-82
3.2-14	Station Reliabilities.....	3-83
3.2-15	Network Reliability Versus Number of Nodes.....	3-85
3.2-16	Network MTBF's and MTBMV's Vs PM Interval.....	3-88
3.2-17	Average Network Logistics Power Consumption Vs Manning Levels & Nodal Configurations.....	3-109
3.3-1	Unattended Radar Network Functional Flow Diagram..	3-112
3.3-2	Fire or Intrusion Alarm, 2nd Level Functional Flow	3-113
3.3-3	Maintenance Helicopter Mission, 2nd Level Functional Flow.....	3-114
3.3-4	Radar Station Functional Block Diagram.....	3-115
3.3-5	Field Strength at 100 nm Vs's Soil Condition.....	3-178
3.3-6	Radiated Power Vs Range.....	3-141
3.3-7	Beacon Prime Power Vs Range.....	3-143
3.3-8	Beacon Cost Vs Range.....	3-144
3.3-9	Station Controller.....	3-159
3.3-10	Data Formatting.....	3-163
3.3-11	Prime Power Control System.....	3-168
3.3-12	Switchgear.....	3-169
3.3-13	Station Power Generation.....	3-178
3.3-14	Fuel Consumption Vs Power.....	3-179
3.3-15	Annual Fuel Consumption Vs Power.....	3-180
3.3-16	Wind Distribution For 10 KT AVG Wind.....	3-198
3.3-17	Vertical Axis Turbine.....	3-199
3.3-18	Beaufort Sea Weather Station.....	3-200

FIGURES

<u>Figure Number</u>	<u>Title</u>	<u>Page</u>
3.3-19	Wind Turbine Power Output.....	3-203
3.3-20	Wind Energy Availability.....	3-204
3.3-21	Rankine-Ormat Generator.....	3-218
3.3-22	Earth Satellite Station.....	3-222
3.3-23	Unattended Station Test Schedule.....	3-226
3.4-1	DYE-Main.....	3-231
3.4-2	FOX-2.....	3-232
3.4-3	BAR-3.....	3-233
3.4-4	Engineering, Design and Construction Consultants...	3-238
3.4-5	The Tower Company.....	3-240
3.4-6	Armor Materials and Products.....	3-251
3.4-7	Applications.....	3-252
3.4-8	Radar Equipment-Shelter Enclosed.....	3-255
3.4-9	Electronics Equipment-Radome Enclosed.....	3-256
3.4-10	Diesel-Electric Generator.....	3-258
3.4-11	Power & Life Support Modules.....	3-260
3.4-12	Power & Life Support Modules.....	3-261
3.4-13	Power and Life Support Min. Conf.....	3-265
3.4-14	Electronic/Power/Life Support-Combined Configuration.....	3-266
3.4-15	Combine Configuration-Elevation.....	3-267
3.4-16	Environmental Control.....	3-273
3.4-17	Enclosed Towers.....	3-276
3.4-18	Open Tower (Rigid or Guyed).....	3-278
3.4-19	Drill Platform.....	3-279
3.4-20	Present Platform Use.....	3-281
3.4-21	Variations.....	3-283
3.4-22	Open Structure.....	3-285
3.4-23	Existing Platform.....	3-286
3.4-24	Tower & Plenum-POW-Main.....	3-287
3.4-25	Secure Tower.....	3-289
3.4-26	Secure Tower-Plan.....	3-290
3.4-27	Baseline LOS System.....	3-294
2.4-28	Existing Tower Utilization.....	3-296
3.4-29	Tall Tower.....	3-297
3.5-1	Circuit Requirements.....	3-334
3.5-2	Traffic Requirements.....	3-336
3.5-3	Typical LOS Communication Section.....	3-345
3.5-4	DEWLine Channel Routing Plan.....	3-347
3.5-5	Line-of-Sight Microwave.....	3-353
3.5-6	Line-of-Sight Microwave Unmanned Stations.....	3-354
3.5-7	Line-of-Sight Microwave Repeater Sites.....	3-355
3.5-8	LOS Reliability Data.....	3-360
3.5-9	MTBF Improvements.....	3-361
3.5-10	LOS Cost Data.....	3-366
3.5-11	LOS Equipment Racks.....	3-368
3.5-12	Satellite Configuration.....	3-371
3.5-13	Satellite Coverage.....	3-373
3.5-14	Unmanned Stations Satellite Configuration.....	3-378
3.5-15	Antenna.....	3-380

FIGURES

<u>Figure Number</u>	<u>Title</u>	<u>Page</u>
3.5-16	High Power Amplifier-Unmanned Radar Station.....	3-381
3.5-17	High Power Amplifier-Manned Logistics Node.....	3-382
3.5-18	Low Noise Receiver-Unmanned Radar Station.....	3-383
3.5-19	Low Noise Receiver-Manned Logistics Node.....	3-384
3.5-20	Converter and Common Equipment.....	3-385
3.5-21	Up-Converter.....	3-386
3.5-22	Down-Converter.....	3-387
3.5-23	Channel Equipment.....	3-388
3.5-24	Common Status and Control.....	3-389
3.5-25	Ground/Air/Ground Radio.....	3-390
3.5-26	Intercom and Public Address.....	3-391
3.5-27	Communications Rack.....	3-401
3.5-28	T.V. Receiver Addition.....	3-404
3.5-29	Comparison.....	3-408
5-1	Summary of Major Study Accomplishments.....	5-2
5-2	Conclusions.....	5-3
5-3	Unattended Radar Recommendations.....	5-5
5-4	Program Recommendations.....	5-6

TABLES

<u>Table Number</u>	<u>Title</u>	<u>Page</u>
3.2-1	Identification of Cost Drivers.....	3-16
3.2-2	C ₁ , Development Costs Summary.....	3-23
3.2-3	C ₂ , Site Selection, Preparation, and Construction..	3-28
3.2-4	C ₃ , Production Cost Summary.....	3-34
3.2-5	Prime Power Unit Costs.....	3-35
3.2-6	Logistics Node Facilities Cost.....	3-40
3.2-7	Test Equipment and Costs.....	3-41
3.2-8	Network Acquisition Cost Vs's Nodal Alternatives...	3-44
3.2-9	Helicopter Alternatives.....	3-49
3.2-10	Air Crew Cost Per Node.....	3-52
3.2-11	LOS Network Reliability Probabilities.....	3-65
3.2-12	Radar Reliability Versus PM Interval.....	3-71
3.2-13	Radar Mean-Time-Between-Failures Versus PM Interval	3-72
3.2-14	Reliability Assessment Diesel Power System.....	3-74
3.2-15	Diesel System Reliability Versus Redundancy.....	3-77
3.2-16	LOS Microwave Communications Satellite Reliability Versus Time and Redundancy.....	3-79
3.2-17	Station Reliability.....	3-80
3.2-18	Satellite Ground Station Reliability.....	3-81
3.2-18(A)	LOS Microwave Network Reliabilities Versus PM Interval.....	3-86
3.2-19	LOS Microwave Network Reliabilities Versus PM Interval.....	3-87
3.2-20	Network Segment Availability Comparison.....	3-90
3.2-21	20 Year Transportation Cost Summary.....	3-92
3.2-22	Maintenance Manning Concepts.....	3-97
3.2-23	20 Year Personnel Costs.....	3-98
3.2-24	Maintenance Loading (Station Failures).....	3-102
3.2-25	Maintenance Loading (Logistics Node Failures).....	3-102
3.2-26	Baseline URS Spares/Repair Parts, Cost Summary.....	3-105
3.2-27	Cost Comparison-Baseline Vs Alt. Maint. Concepts...	3-106
3.2-28	Total Life Cycle Power Generation Costs Versus Alternatives.....	3-110
3.3-1	Unattended Radar Functional Equipment Areas.....	3-116
3.3-2	Project E-259 Typical Radar, Characteristics and Costs.....	3-117
3.3-3	Unattended Radar Design Goals.....	3-118
3.3-4	Weather Station Equipment.....	3-129
3.3-5	Normal Hourly Weather Message.....	3-131
3.3-6	Radio Test Points.....	3-136
3.3-7	L.F. Beacon Equipment Matrix.....	3-142
3.3-8	Intrusion Security.....	3-149
3.3-9	Baseline Station Message Load.....	3-151
3.3-10	Radar Message.....	3-152
3.3-11	IFF Message.....	3-153
3.3-12	Combined Message.....	3-154
3.3-13	Performance Monitor Message.....	3-156

T I T L E S

<u>Table Number</u>	<u>Title</u>	<u>Page</u>
3.3-14	Traffic Requirements.....	3-158
3.3-15	Diesel Power System Characteristics.....	3-164
3.3-16	Prime Power Control Load.....	3-171
3.3-17	Station Power Load.....	3-172
3.3-18	Maintenance Power Load.....	3-174
3.3-19	Operating Characteristics of ST Series Diesel Engines.....	3-176
3.3-20	Operating Characteristics.....	3-177
3.3-21	Station Operational Prime Power Budget.....	3-182
3.3-22	Station Power Load.....	3-183
3.3-23	Diesel System Weight Summary.....	3-185
3.3-24	Prime Power Unit Cost.....	3-186
3.3-25	Prime Power Program Cost.....	3-187
3.3-26	Wind Summary-Canada.....	3-190
3.3-27	Canada Wind Summary.....	3-191
3.3-28	Wind Summary - Alaska.....	3-194
3.3-29	Alaska Wind Summary.....	3-195
3.3-30	DEWLine Wind Velocities.....	3-197
3.3-31	Electrical Power Capability.....	3-203
3.3-32	Arctic Environment.....	3-207
3.3-33	Unmanned Station Heat Transfer.....	3-209
3.3-34	Alternate Station Heat Transfer.....	3-210
3.3-35	Manned Station Heat Transfer.....	3-211
3.3-36	Repeater Prime Power and Heat Transfer Requirements	3-213
3.3-37	Repeater Power Sources.....	3-215
3.3-38	Equipment Status.....	3-220
3.3-39	Production Station Costs.....	3-223
3.3-40	Safety Considerations.....	3-224
3.4-1	Facility Space Requirements for Logistics Nodes Located at a DEWLine Main Station.....	3-314
3.4-2	Facility Space Requirements for Logistics Nodes Located at a DEWLine Aux. Station.....	3-315
3.4-3	Facility Requirements for Logistics Nodes - Ft. Chimo.....	3-224
3.4-4	Electrical Power Generating Capacities of DEWLine Stations and Recommended Modifications for Logistic Node Adaptation.....	3-219
3.5-1	Communications Equipments.....	3-330
3.5-2	Additional Considerations.....	3-332
3.5-3	Candidate Approaches.....	3-337
3.5-4	Line-of-Sight Microwave.....	3-338
3.5-5	VHF Radio.....	3-339
3.5-6	Troposcatter.....	3-340
3.5-7	H.F. Radio.....	3-340
3.5-8	Commercial Satellites.....	3-341
3.5-9	Government Satellites.....	3-341
3.5-10	Advanced Satellite Approaches.....	3-342
3.5-11	Use of Radar For Communications.....	3-343
3.5-12	Tethered Balloons.....	3-343
3.5-13	LOS Microwave Environmental Considerations.....	3-357
3.5-14	LOS Microwave Electrical Power Requirements.....	3-358
3.5-15	LOS Maintenance Data.....	3-363

TABLES

<u>Table Number</u>	<u>Title</u>	<u>Page</u>
3.5-16	LOS Microwave Cost Elements.....	3-364
3.5-17	Domestic Satellites.....	3-377
3.5-18	Uplinks.....	3-375
3.5-19	Downlinks.....	3-376
3.5-20	Satellite Conf. - Electrical Power Requirement.....	3-392
3.5-21	Satellite Conf. - Reliability Data.....	3-393
3.5-22	Satellite Conf. - Maintenance Data.....	3-395
3.5-23	Satellite Conf. - Cost Elements.....	3-396
3.5-24	Satellite Conf. - Cost Data.....	3-399
4-1	Life Cycle Cost Summary Baseline System.....	4-1
4-2	Baseline Life Cycle Cost Deltas Vs Nodal Alt.....	4-3
7.2-A	(DELETED) See Table 3.2-23.....	7-15
7.2-B	Full Logistic Node Personnel Requirements.....	7-16
7.2-C	Mini Logistic Node & Data Node Personnel Requirements.....	7-17
7.2-D	Data Node Personnel Requirements.....	7-17
7.2-E	Reduced Logistics Node Personnel Requirements.....	7-18
7.2-F	Modifications of Full Logistic Node.....	7-19
7.2-G	Full Logistic Node-Personnel Costs.....	7-20
7.2-H	Mini Logistic Node-Personnel Costs.....	7-21
7.2-I	Data Node Personnel Costs.....	7-21
7.2-J	Reduced Logistics Node Personnel Costs.....	7-22
7.2-K	Modified Logistics Nodes 1, 2, 3, 4, 5, & 6 Personnel Costs.....	7-23
7.3-A	(DELETED) See Table 3-2-26.....	TEXT
7.3-B	Spares-Radar.....	7-26
7.3-C	Spares-Power Equipment.....	7-28
7.3-D	Repair Material Calculations.....	7-33
7.3-E	(DELETED) See Table 3.2-27.....	TEXT
7.3-F	Test Equipment Costs.....	7-36
7.3-6	Typical Vehicular Equipment.....	7-37

SECTION 1

INTRODUCTION

The present DEW System consists of a network of high powered long range radars; most of which were developed and installed in the 1950's. The operation and maintenance of this radar network is costly in resources and logistics. Tactical requirements have changed and technology has progressed sufficiently that it is now possible to consider configuration alternatives which will allow cost effective tactical application of the DEWLine for the foreseeable future.

This study addresses the operational feasibility and practicality of replacing the manned DEWLine with a chain of Unattended Stations supported by minimally manned logistics nodes. The equipments required for the Unattended Stations and communications support systems are identified, and power budgets established. The cost drivers effecting the Life Cycle Cost of the system are identified and alternative system concepts are evaluated. Many Unattended Station concepts are presented which take into account the vast geographical and environmental extremes to be found over the extent of the DEWLine. Logistics and fuel requirements are examined and transportation concepts presented. The study culminates with a Life Cycle Cost summary which evaluates the developed concept alternatives. Recommendations are made which, if accepted, should minimize developmental risk and Life Cycle Cost for implementing Unattended Stations for DEWLine.

SECTION 2

OBJECTIVE & SCOPE

2.1 OBJECTIVE AND SCOPE

The primary objective of this study was to establish the technical and economical feasibility for a string of unattended radar stations along the DEWLine. This required an analysis of critical aspects associated with these stations such as design, operation, maintenance and support. In addition, it required the development of preliminary design concepts which took into account the vast environmental and geographical extremes to be encountered. It was necessary to develop alternatives and concepts which satisfied the requirements of these extremes and to provide a cost analysis for twenty year life cycle cost.

The study was limited to a baseline system consisting of 83 unattended radar stations (with maintenance nodes) extending eastward from Cape Lisburne, Alaska to Cape Dyer, on Baffin Island, then south to St. Anthony, Newfoundland. The study did not include consideration of Greenland Ice stations or further exercises pertaining to radar type mixes, DEWLine relocation, and additional site selections. Existing site data was evaluated to establish typical statistical distribution of characteristics effecting concept development and life cycle cost. Unattended station designs and model concept development was limited to implementation through emerging technologies which have reasonable promise of availability in the early 1980's. A specific study ground rule was that no detailed "Black Box" design was to be undertaken.

2.2 STUDY PROCESS FLOW

Figure 2-1 shows the design process flow used to develop the study. The study was divided into five major phases, Indoctrination, Definition, Study,

Design, Documentation. The order of these phases received chronological emphasis although the nature of the study was such that considerable feedback was in evidence.

During the indoctrination phase basic data was assimilated from related studies and available agency files. This included a tour of the DEMLine by a representative study team member.

The definition phase resulted in the establishment of the baseline system, station concept, equipment configuration, life cycle cost model, reliability maintainability concepts and logistic concepts.

The balance of the study modified the plan slightly in that the outcome resulted in a number of concepts and alternatives rather than a single specific design.

STUDY PROCESS FLOW

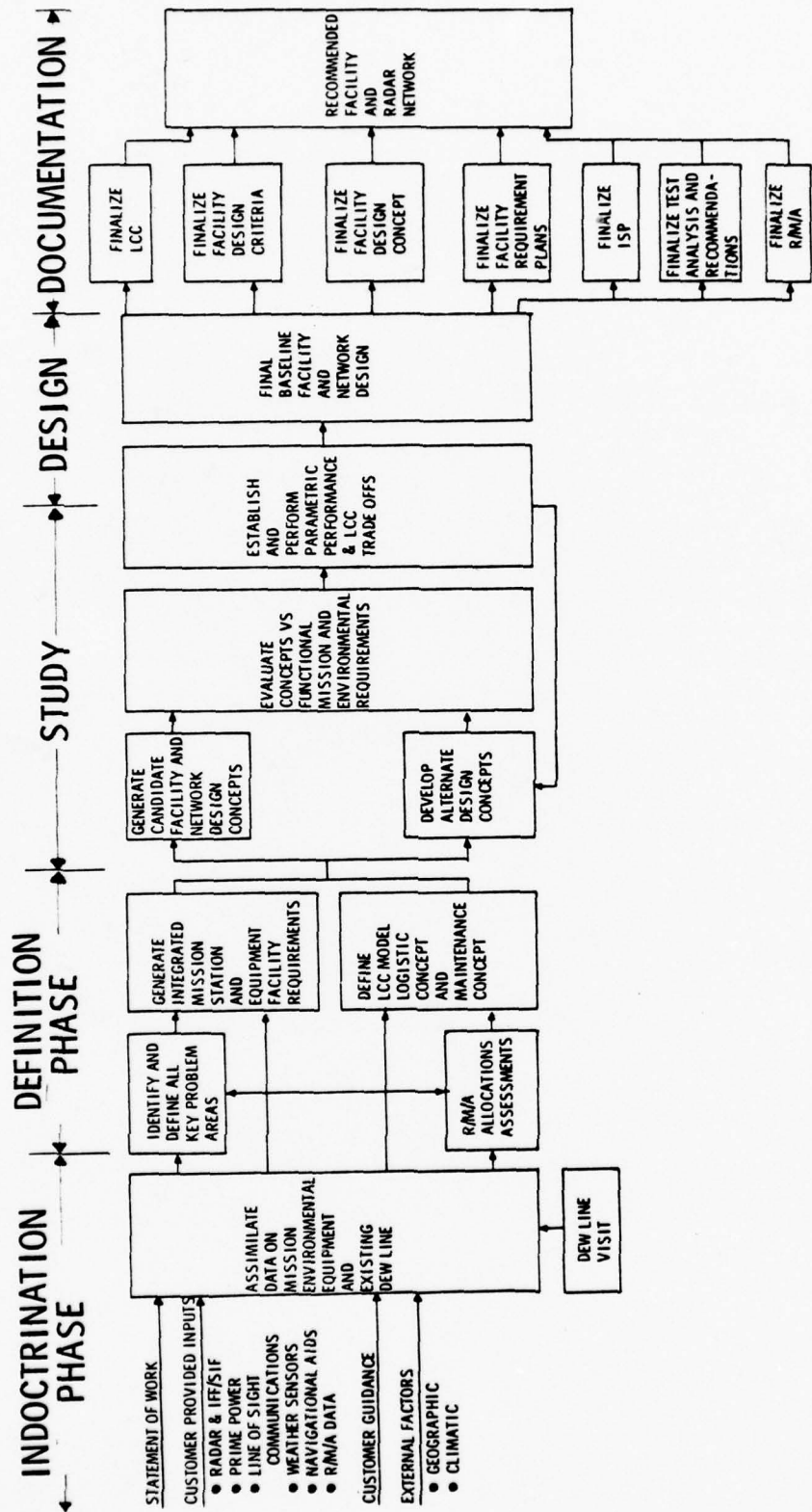

(FIGURE 2-1)

SECTION 3
SYSTEM ARCHITECTURE

3.1 NODE CONSIDERATIONS

3.1.1 Introduction

The DEWLine was established over twenty years ago under conditions considerably different from those related to the concept of an unattended radar. Initial DEW station location decisions were driven considerably by logistic support requirements as well as radar coverage optimization. The radars were large requiring considerable prime power and fuel. They were also complex, requiring maintenance by technicians having many and diversified disciplines. These technicians in turn required support personnel and support facilities. All this added up to large operating facilities requiring sizeable logistic support. Ready access to beaches and airstrips capable of handling large cargos was mandatory. The station support equipment alone accounted for significant tonnage and cost. This system and its required sealift support routes are shown in Figure (3.1-1).

The radar stations proposed for the unattended stations, relatively speaking; are small, low power, and significantly more reliable than their predecessors. In some respects they are more complex. This complexity, however, is functional and any impact it might have on station availability is offset by improved system reliability brought about principally through technology developments of the past 20 years.

The size of the major components comprising the unattended station subsystems are relatively small by previous DEWLine equipment standards. Indeed, the unattended station itself is small by present DEWLine standards and conceptually may require some re-focusing.

FIGURE 3.1-1

DEWSYSTEM
TRANSPORTATION SUPPORT
SEALIFT

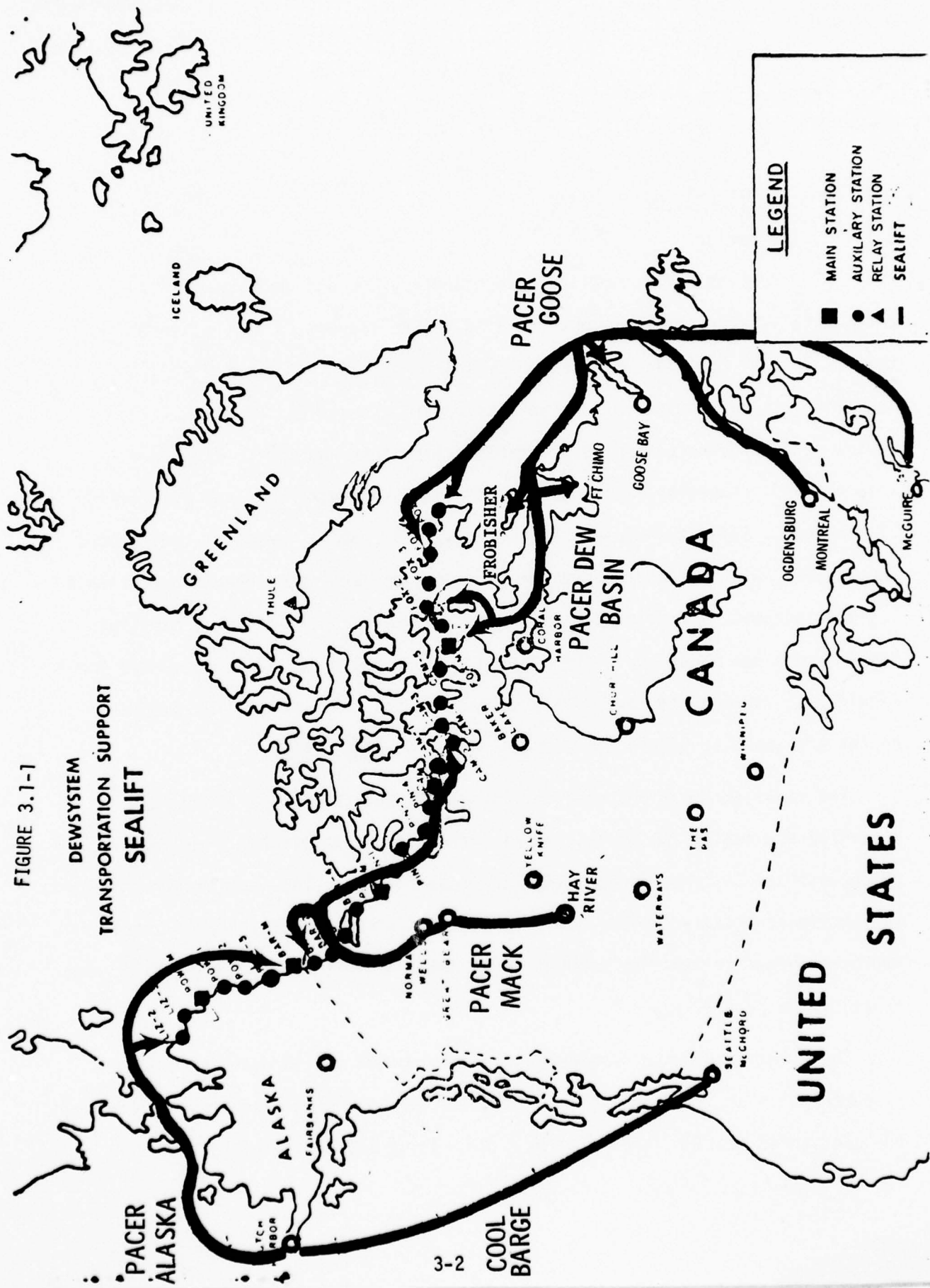

LEGEND

- MAIN STATION
- AUXILIARY STATION
- ▲ RELAY STATION
- SEALIFT

Acceptance and realization of the unattended station concepts put forth in this study raises several interesting points. The structures required for the stations, and the components comprising the equipment configurations can be fabricated and assembled into packages easily transportable by helicopter. Large runways will not be required to either fabricate or support a station. Helicopter landing pads will suffice. The size and the reliability of the stations are such that radar coverage requirements can supersede accessibility for determining station location. Acquisition of large parcels of real estate need not be a concern. Road or large aircraft accessibility is not a mandatory requirement.

3.1.2 Baseline System

The baseline system from which this study evolved was comprised of a line of 83 unattended radar stations and 6 maintenance nodes utilizing operating and abandoned DEW Sites and additional previously identified site locations extending from Cape Dyer, Baffin Island southward to St. Anthony, Newfoundland. Initially 6 maintenance nodes were arbitrarily identified as the 6 operating main stations (POW, PIN, BAR, CAM, FOX, AND DYE, Main). Typically, each node services 14 adjacent unmanned stations spaced by 40 nm intervals and linked by a LOS (Line of Site) microwave relay system. The logistic support for the baseline system was that shown in Figure (3.1-1).

Each node is self sufficient and supported a 17 man maintenance team. In addition each node maintains a support helicopter and full crew.

An essential part of the study was the determination of what equipments were required by the unattended stations, their availability, parameters, and characteristics. These are covered in detail in Section 3.3. In developing the concepts in this report considerable use was made of studies previously

accomplished. Typical unattended radar characteristics and cost were provided by the Government as a result of previous studies establishing concepts for unattended radars. General Electric participated in these studies. Consequently we were able to utilize our radar concept in the unattended station development, since it fits within specified parameters. Other related Government sponsored studies such as the ERDA (Energy Research & Development Adm.) Power Study were factored into the baseline system to avoid study duplication.

3.1.3 POL Requirements

A major consideration in the development of Operational and Maintenance Node concepts for unattended radar stations deals with the requirement for fuel. Principal among these are the quantity used, resupply logistics and secure storage.

Discussions with DEW Office personnel in Colorado Springs and examination of the Civil Engineering data obtained from them showed that the present system uses approximately 11 million gallons of fuel per year and has approximately 20 million gallons storage capacity. It requires fuel resupply by 4 sealift routes referred to as Pacer-Alaska, Mack, DEW Basin, and Goose, following the routes indicated in Figure (3.1-1). In addition it requires that the Air Force maintain several barges and two ships, the AOG Pinnebog, and the floating dry-dock, ARD31, located at Tuktoyaktuk, both of which will eventually require replacement.

The unattended station and manned node concepts described in this report would drastically reduce these POL requirements to as low as .6 million gallons per year. This drastic reduction in fuel requirements prompts some additional cost saving considerations. To evolve these considerations the line is divided

into four logistics zones shown in Figure (3.1-2). Zones I and II derive sealift support from Pacer Alaska and Pacer Mack. Zones III and IV presently must derive their support from Pacer Goose and Pacer, DEW Basin. In addition Zone III contains 8 station sites that require airlift refueling.

In the present logistics system BAR-3 (Tuktoyaktuk) is a main staging area for Zone II and a back up depot for Zone I. Sufficient fuel is stored on the barges to resupply the stations in Zone I in the event that ice prevents resupply from the west. The nodal concepts developed in this study eliminate the manned stations from Zone I, leaving only Point Barrow and Bar Main as manned nodes. Point Barrow is presently supported by the existing Navy Facilities, and Bar Main can be easily supported by Pacer Mack. Pacer Alaska can be eliminated or used as a back up for Pacer Mack, which is a highly unlikely prospect.

There is sufficient fuel storage in the Tuktoyaktuk-Inuvik area and at CAM-Main to provide multi-year storage for all stations in Sector's I and II. The multi-year fuel storage is only limited by quality control and testing requirements. For that reason it is recommended that two year storage is optimum. In addition, there is ample storage capacity at FOX-Main (Hall Beach) and Goose Bay or Frobisher Bay to supply Zones III and IV.

The 8 stations requiring airlift are in Zone III and would receive their support from FOX-Main.

It is conceivable that the sealift support could be reduced to two, Pacer Mack and Pacer DEW Basin.

All unattended station refueling would be accomplished by barge and helicopter, and the need for maintaining deep water vessels would be eliminated.

FIGURE 3.1-2

PRIMARY LOGISTICS ZONES

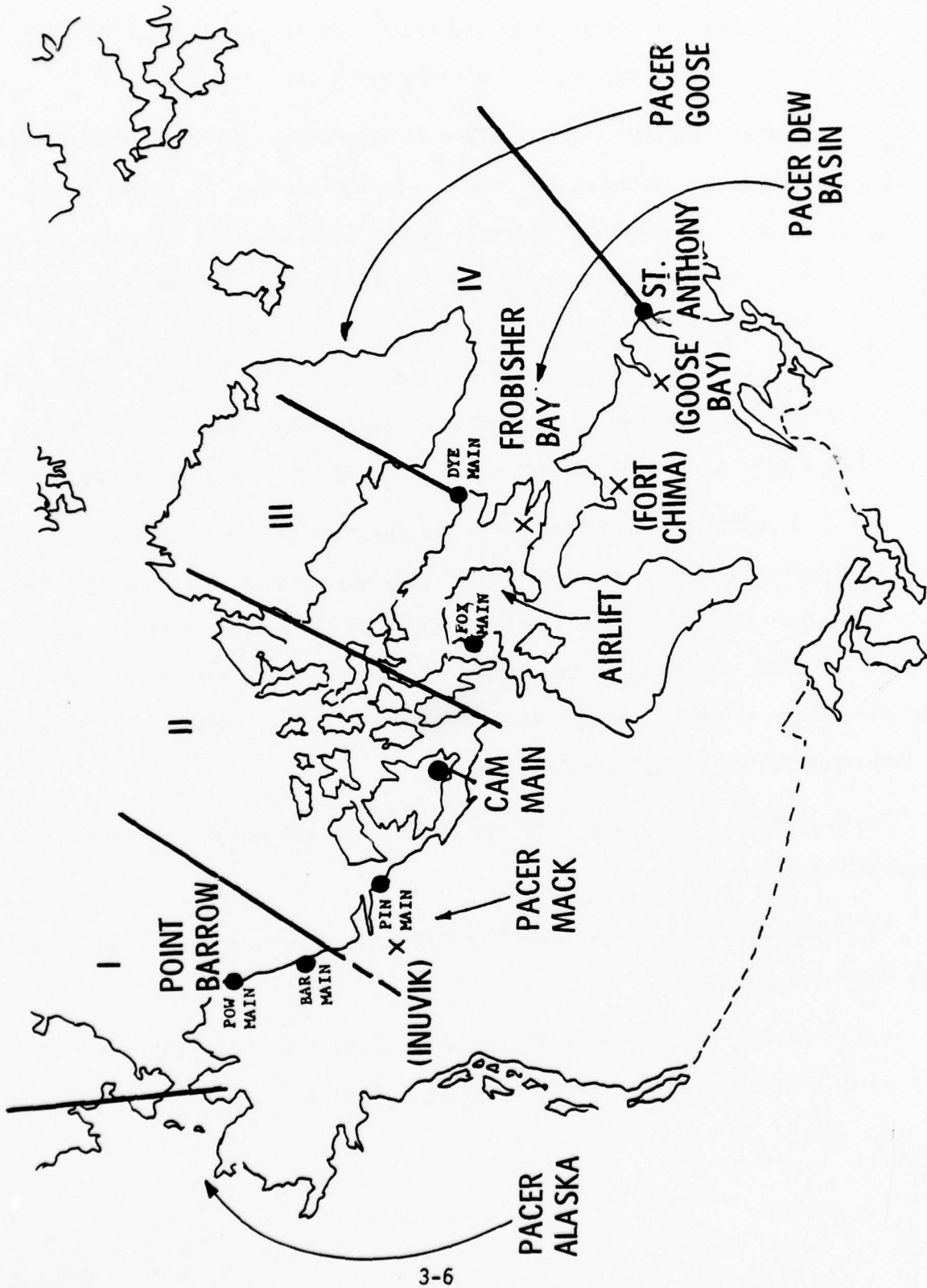

3.1.4 Arctic Development

A basic consideration in the development of an unattended DEWLine having widely dispersed maintenance nodes was that of providing the services that are presently available from the manned stations. These include the support requirements such as Nav aids, cleared airstrips, weather reporting and alternate airstrips required for interstation travel. The average distance between nodes, in the baseline 6 node configuration, is 530 nm. This means that alternate airdrome facilities independent of the present DEW System have to be available .

Arctic development was examined through discussions with Canadian DND personnel, and examination of Canadian Government Documents. It was interesting to note that more facilities were available than originally anticipated. Facility identification was limited to those having airstrips and commercially available power. These are listed in Figure (3.1-3). The Canadian IFR and VFR supplements were examined to determine the commercial availability of aircraft fuel. Those having available fuel are checked in the last column of the listing. Although only about half of those listed show available fuel, there is little question that fuel can be made available at the other locations for Governmental purposes. The locations of these facilities are shown in Figure (3.1-4).

Present major Arctic development activity is located in the Northwest territory, westward from Coppermine. This consist primarily of offshore oil drilling in the Beaufort Sea. Primary activity is in the region around Tuktoyaktuk. Contracted helicopter service is presently active in this area.

As one moves eastward along the DEWLine the degree of activity decreases sharply, and is limited primarily to preliminary geological explorations. Most of the activity taking place is directed toward obligations to the local populace. Some of these have influence on nodal concepts developed during this study. A major concern in developing these concepts was the apparent lack of non-DEWLine

FIGURE 3.1-3

CANADIAN FACILITIES *
(WITH AIRSTRIP)

<u>LOCATION</u>	<u>POPULATION</u>	<u>POWER (KW)</u>	<u>FUEL</u>
INUVIK	2,672	13,700	X
TUKTOYAKTUK	596	13,700	
COPPERMINE	637	975	
CAMBRIDGE BAY	716	2,885	X
SPENCE BAY	209	600	
PELLY BAY	215	160	
HALL BEACH	300	300	X
IGLOOLIK	563	750	
BROUGHTON ISL	334	465	
PANGNIRTUNG	690	930	X
FROBISHER BAY	2,014	9,005	X
CAPE DORSET	357	700	
FT. CHIMO	900	UNK	X
REPULSE BAY	242	365	
GOOSE BAY	-	-	X

* NORTHWEST TERRITORIES STATISTICAL ABSTRACT 1975

FIGURE 3.1-4

CANADIAN FACILITIES

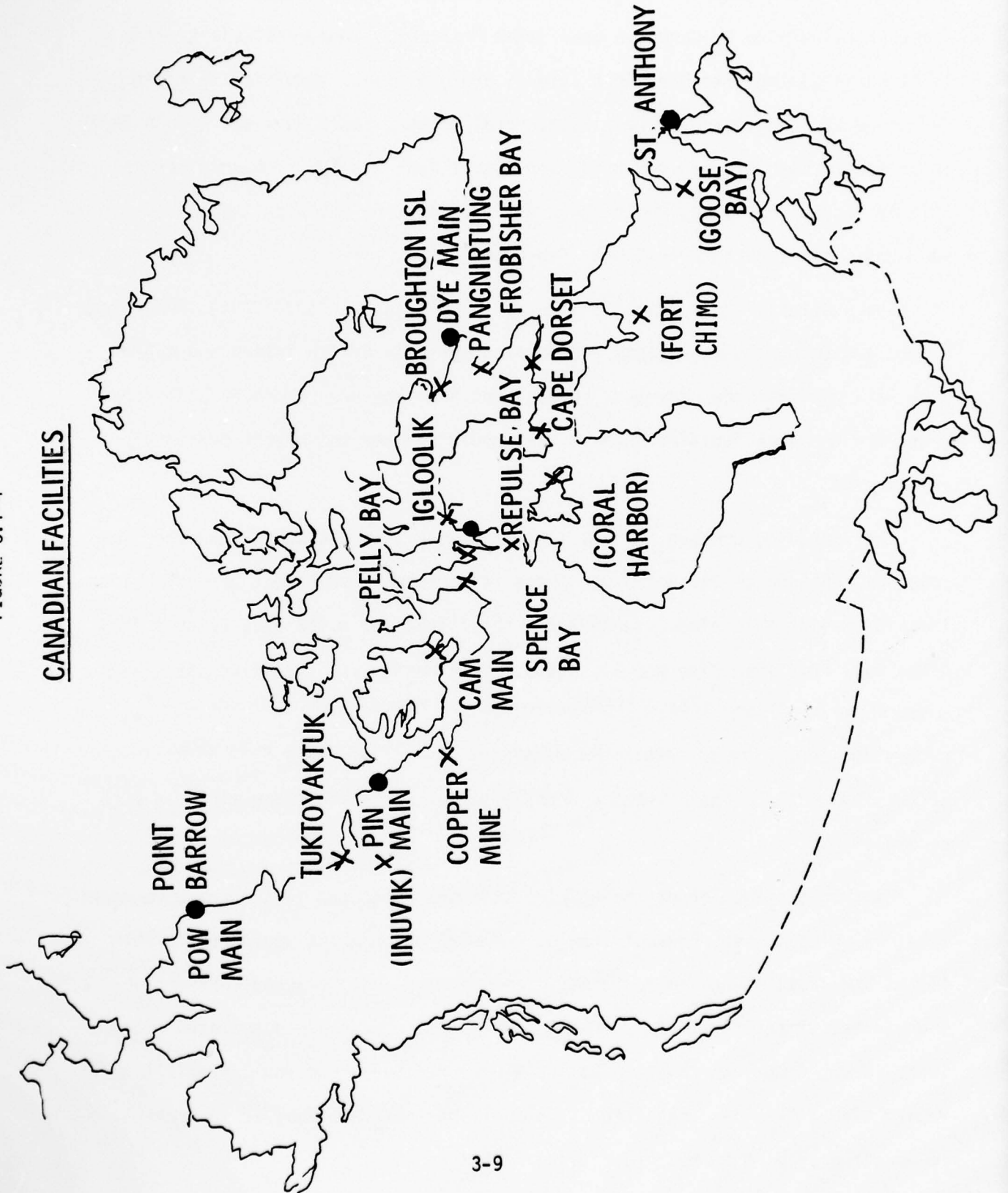

related resources east of Coppermine. This appeared particularly severe on Baffin Island and down the east coast of Labrador. This concern has been somewhat alleviated by Canadian Government Projects. Commercial air traffic is being scheduled into Broughton Island, and additional airstrips have been developed at Pangnirtung, Cape Dorset, Coral Harbor, Pelly Bay, and Spence Bay. These facilities all have potential for secure fuel storage. This is particularly true of Pelly Bay which could be used to store fuel for the inland unattended stations between CAM-3, CAM-4 and CAM-5.

The availability of suitable airstrip facilities at Pangnirtung, Broughton Island and Cape Dorset provides adequate support for Baffin Island and could very well use Frobisher Bay as a node. Frobisher Bay has complete facilities under the Canadian Maritime Command that could be used to support personnel and aircraft.

The remaining concern is that segment of the line extending down the east coast of Labrador to St. Anthony. There is no known development being considered in this area at this time. Support for these stations would have to come from Goose Bay, Frobisher Bay, and Ft. Chimo. Considering the type aircraft being recommended, S-61 and S-76 helicopters, this is an acceptable but marginal separation condition for available alternate facilities. The only other alternative would be to develop a depot at an existing coastline airstrip such as Saglek.

Further examination of the DEWLine stations indicated that there were other services which though presently co-located with the DEWLine would remain even if the DEW stations ceased to exist. Specifically, MOT personnel presently operate the airstrips at BAR-3, CAM-M, and FOX-M. These are associated with Tuktoyaktuk, Cambridge Bay, and Hall Beach respectively and would remain active regardless of DEWLine disposition. In addition there are weather service personnel providing synoptic duties at Cambridge Bay.

Arctic helicopter utilization was similarly examined and yielded some interesting results. Year around helicopter utilization in the Arctic is an established fact. This is due primarily to helicopter support in the development of fuel sources. Commercial services for the class of helicopter required, typically the Sikorski S-61 and S-76, are available, principally; in the Northwest Territory. Service can be made available in the eastern regions, and has been in the past, but presently is not; due to the lack of demand. Commercial Arctic helicopter services are relatively expensive and will cost in the neighborhood of \$60,000 per month per helicopter plus \$280 per operational hour.

3.1.5 Node Operational Alternatives

The assimilation of the information made available from the previous sections contributed to the generation of the nodal concepts that follow.

Figure (3.1-5) is a tabulation of the Node Operational Alternatives that were evaluated during this study. The details of the evaluation are discussed in Section 3.3.

The baseline nodal concept arbitrarily uses the six existing Main Stations as Nodes. This was sufficient to establish some of the questions regarding transportation, facilities and POL requirements which were previously addressed. It was also determined that all nodal concepts considered could be supported by helicopters of the S-61 and S-76 class.

For the baseline system, all Main Stations were supported by a complete 17 man maintenance team and helicopter team, with helicopter.

In addition each alternative shown can be implemented using either LOS microwave, or satellite except the fourth and sixth alternatives which are satellite only, because data is centrally collected.

FIGURE 3.1-5

NODE OPERATIONAL ALTERNATIVES

ALTERNATIVES	POW-M*	BAR-M	BAR-3*	PIN M	CAM-M*	FOX-M*	DYE M	FT CHIMO*	GOOSE BAY*	NO HELICOPTER
BASELINE	X	X		X	X	X	X			6
1) OPTIMIZED FULL	X	X	X		X	X		D	M	6
2) ROVING TEAM	D	D	D		X	D		D		6+S
3) ROVING TEAM	X	D	D		X	D		D		6+S
4) ROCC-DATA	M	M _A	SUP		M	SUP		H		6+S
5) REDUCED FULL	X	M _A	X		X			X		4
6) REDUCE-ROCC DATA	M		SUP		M			SUP		4+S

* = AIRPORT MAINTENANCE OTHER THEN DEW

X = DATA AND MAINTENANCE

D = DATA

M_A = MAINTENANCE AIRSTRIP

M = FULL MAINTENANCE

SUP = SUPPLY ONLY

S = SHUTTLE

H = HELICOPTER + CREW CHIEF

The Baseline concept had several major weaknesses. It created a very unbalanced line with DYE-Main having to support Baffin Island and the entire southeast extension. In addition it did not take full advantage of existing resources, such as available airdrome support from other than DEW personnel. It also did not make full use of available storage.

Alternate 1 is similar to the baseline and is designed to correct the identified shortcomings. BAR-3 replaces PIN-M as a node to take advantage of the MOT manned airstrip and the available staging resources at Tuktoyaktuk. DYE-M becomes an unmanned station. Its original node functions are split with the data monitoring function going to Ft. Chimo, and the maintenance support assigned to Goose Bay. This essentially means that the node functions can be supported by existing facilities. The remaining problem with this concept rest with the LOS microwave system which would require additional relays to bring the data to Ft. Chimo. This shortcoming, however, disappeared with the satellite option.

The next step in developing the node concepts was to design systems which take full advantage of the reliability expected from the unattended stations—thus the development of a roving team concept. It takes advantage of the air-drone manning available at the sites independent of DEWLine presence as was previously discussed. This alternate has two full maintenance crews centrally located at CAM-M with a helicopter and crew chief located at the other nodes. In addition, the other nodes were minimally manned with data teams only. Any required maintenance action would require maintenance team shuttling to the closest node. Shuttling could be accomplished by fixed wing aircraft or helicopter. This is indicated by the S in the final column.

The third alternative is the same as the second with the exception that it recognizes the labor sovereignty between Alaska and the Northwest territories and so now locates a full maintenance team at Pt. Barrow.

Alternate 4 simplifies the system still further by taking full advantage of the satellite capabilities. It recognizes that all data reduction can be accomplished at one location and places it back at the ROCC. The only personnel left on the line are maintenance personnel, a full maintenance team at POW-M and CAM-M, an airstrip maintenance team at BAR-M, supply services at BAR-3 and FOX-M, and a helicopter with crew chief at Ft. Chimo. It should be recognized that this data reduction could also be carried on at a Node such as CAM-M prior to sending reduced data to the ROCC.

Alternate 5 is the same as alternate 4 except it is designed as a four Node system.

Alternate 6 is a reduced four Node system which takes into account the full reliability expected from the satellite system and unattended stations. It is a goal to be strived for. It uses two full roving maintenance teams. One for Alaska, located at POW-M, and one for the remainder of the line located at CAM-M. BAR-3 and Ft. Chimo then utilize existing facilities and are used for supply support only.

Although, the roving team concepts may seem revolutionary, it should be pointed out that Canada, at the present time uses similar concepts for their support of the Arctic Telesat services. They have no maintenance personnel stationed in the Arctic.

Secondly, the adaptation of the various alternates depends on the criticality of station maintenance. The roving team concept is based on the assumption that station outage is unpredictable, and time off the air is unpredictable, in addition, the aggressor response time to take advantage of such a situation is generally longer than the down time. Consequently, extended periods of unscheduled station outages are generally of little concern. All that is necessary is that the maximum time for any maintenance action must be less than minimum time for aggressor action.

3.2 Network Operational Considerations, Trades, and Life Cycle Cost

The objective of this study is to demonstrate the basic technical and economical feasibility of acquiring, maintaining, and operating a network of unattended radar stations in the Arctic environment. The approach which GE has taken to this end is to identify the factors driving the system life cycle costs (LCC), postulate low risk alternative feasible acquisition, operations, and maintenance concepts and procedures, and evaluate these alternatives in terms of network performance, e.g., probability of successful mission, availability, coverage, etc. Finally, with overall network performance goals in mind, trades have been performed to minimize the total DEWLine unattended network life cycle cost. By taking this approach at the outset of the study, life cycle cost has been given the visibility necessary to impact program decision during the study. For the same reason, the network operational considerations and trades are best presented within the framework of LCC factors.

3.2.1 Life Cycle Cost Drivers

The LCC model which has been used in the study is basically that recommended by the Air Force in the post-contract award briefing, "E-259 Unattended Radar Site Study Life Cycle Cost Task". Departures from this model have been few, are of a minor nature, and are explained thoroughly where introduced. This model is in close agreement with the model GE proposed in response to the study RFP, and provides an excellent balance between detail and simplicity. This balance was crucial to the successful accomplishment of the many meaningful major tradeoffs presented in this report. The seven primary factors in the LCC model are categorized as either Acquisition or Operations and Maintenance (O&M) costs, and are:

LIFE CYCLE COST FACTORS

- Acquisition Costs
 - Development Costs
 - Site Selection, Preparation and Construction Costs
 - Production Costs
- O&M Costs
 - Transportation Costs
 - Personnel Support Costs
 - Spares Costs*
 - Power Costs

Throughout the study, effort has been concentrated on those areas which held the most promise of large LCC payoffs for the Air Force. Also, every effort has been made to illuminate and resolve basic feasibility questions associated with the maintenance and operation of a network of unattended radars in the Arctic environment. The major cost drivers associated with such a radar network are summarized in Table 3.2-1 below.

TABLE 3.2-1
IDENTIFICATION OF COST DRIVERS

<u>COST DRIVERS</u>	<u>COST IMPACT</u>
● Tower Heights	Acquisition
● New Sites Required	Acquisition
● Maintenance Concepts	O&M
● Station Reliability Versus Maintenance	Acquisition Versus O&M
● Network Configuration and Maintenance	O&M
--Reduced Logistics Nodes Alternative	

* The Air Force model further subdivides spares costs into initial and replenishment classes.

TABLE 3.2-1 (Continued)

<u>COST DRIVERS</u>	<u>COST IMPACT</u>
● Support Personnel Reduction --Reduced Logistics Nodes --Roving Maintenance Teams	O&M
● Communications Approaches	Acquisition and O&M
● Helicopter Candidates	O&M
● Power Generation	O&M

Preliminary LCC estimates early in the study indicated that support personnel minimization is a critical requirement. The single largest cost factor associated with operating and maintaining the network is the cost of support personnel. Consequently, several network configurations involving reduced numbers and manning levels for logistics nodes have been analyzed for performance, feasibility and cost. These include network configurations employing four to six logistics nodes, and reduced manning maintenance concepts wherein two or three roving maintenance teams service the entire 83 station line. Seven specific network nodal configurations/maintenance concepts have been addressed, and are discussed in Sections 3.1 and 3.2.3.

In the acquisition cost area, significant cost drivers are the number of new sites required, radar and communication tower heights required, station reliability and the lateral communications techniques implemented.

Smooth earth calculations of the radar detection and overlapping coverage corresponding to 40 nmi site separation, indicate that towers 25 feet above terrain and 125 feet above sea level provide 24 to 36 nmi of overlapped coverage. These calculations (figure 3.2-1) take into account multipath phenomemon over smooth

Figure 3.2-1
 ADJACENT RADAR COVERAGE VS TOWER
 HEIGHTS (200' LOW FLYER)

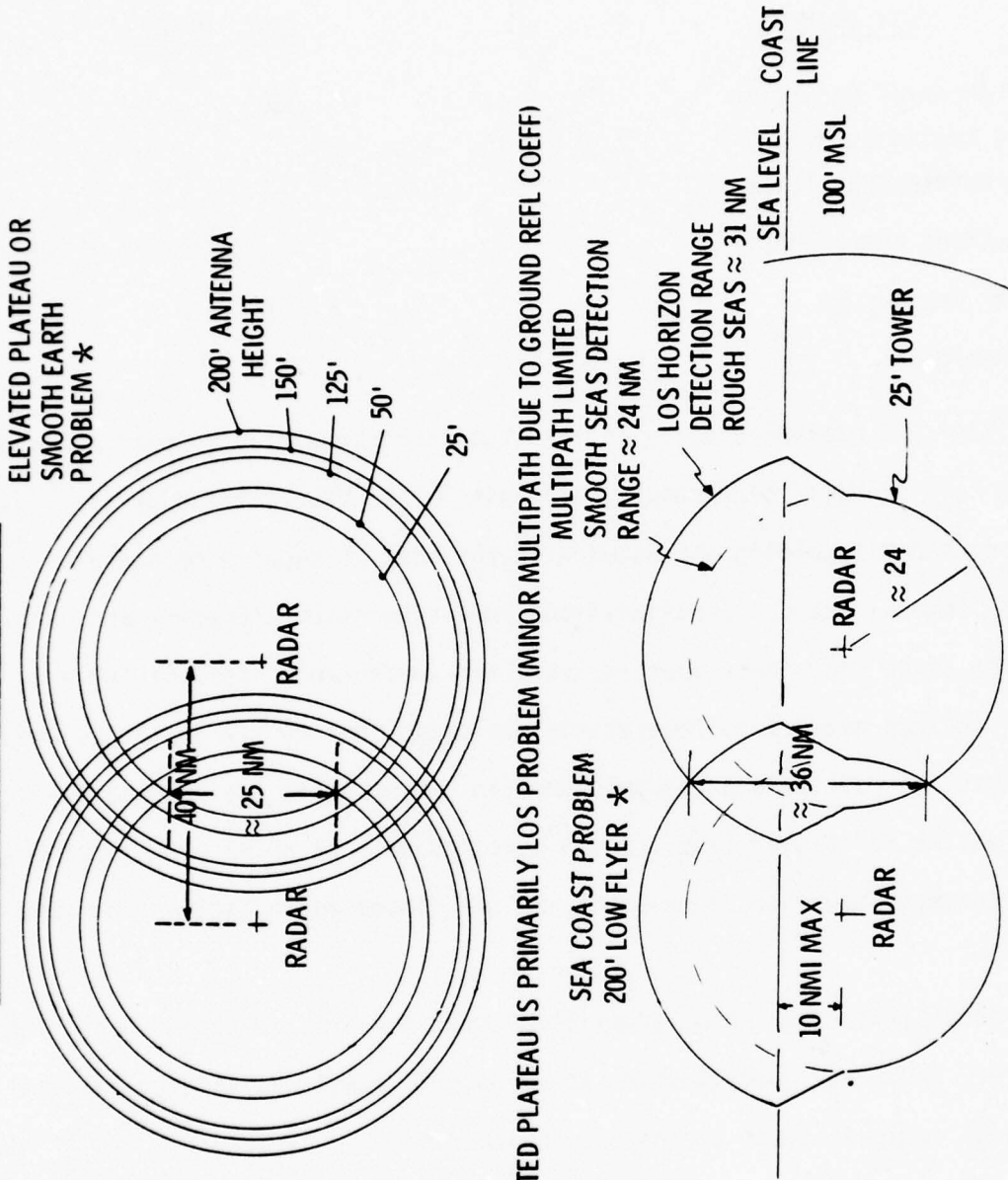

* ELEVATED PLATEAU IS PRIMARILY LOS PROBLEM (MINOR MULTIPATH DUE TO GROUND REFL COEFF)

MULTIPATH LIMITED
 SMOOTH SEAS DETECTION
 RANGE ≈ 24 NM

SEA COAST PROBLEM
 200' LOW FLYER *

LOS HORIZON
 DETECTION RANGE
 ROUGH SEAS ≈ 31 NM

SEA LEVEL
 COAST LINE
 100' MSL

25' TOWER

10 NMI MAX

36 NM

RADAR

≈ 24

RADAR

* ENVELOPE SHOWN IS LOS HORIZON WITH MULTIPATH ON A SMOOTH SEA AND A 60 NMI RADAR DETECTION RANGE IN FREE SPACE, THE RADAR DETECTS SLIGHTLY BEYOND THE LOS HORIZON

seas (or ice) for sites overlooking the coast. An overlap of 24 nmi provides a minimum of eight to nine scans of observation of a 200 foot target at the 4 second data rate of the GE unattended radar design. Furthermore, as illustrated in Figure 3.2-1, coverage increases with the square root of tower heights, while costs tend to rise at least proportionately. For this reason, a minimum above-grade tower height of \geq 25 feet and \geq 125 feet above sea level is recommended.

Should lower targets become a driving factor, or if more detailed analysis (accounting for terrain masking, RCS versus aspect and speed, etc.) so indicates, designs shown in this report can easily be implemented on higher towers--but at greater costs. Delta costs versus the tower height requirement are presented herein, with a baseline reference of 25 feet above grade, or 125 feet above sea level.

The primary communications alternatives which were considered were line-of-site (LOS) microwave and satellite approaches. The baseline communications approach was an all-LOS microwave implementation. The equipment utilized in this implementation was commercially available hardware which is burned-in and pretested for increased reliability. At the station level, the equipment is about equal in cost, quality, and quantity to the satellite ground station alternative, if the cost of repeaters is included in the comparison. However, as will be shown, there is an inherent difference between the network operational performance (especially in terms of R/M/A) for the two alternatives. In fact, for some of the reduced support level concepts considered, such as two or three roving maintenance teams to service the entire line, the cost competitive LOS microwave approach borders on an overloaded maintenance condition, wherein maintenance personnel are busy in excess of 100% of their time. In order to use a LOS microwave communications approach with such reduced manning concepts (without increasing the manning levels), it is necessary to consider increased reliability/cost LOS microwave station equipment. This is a strong argument in favor of an all-satellite communications approach, which GE recommends.

A cost driver which has been addressed involving a direct tradeoff between acquisition cost and O&M cost, is that between station reliability and the frequency of maintenance required. The question is, of course, whether it is more cost effective to have a highly reliable station (e.g., 12 months maintenance free at the .9 level) with few maintenance actions, or better to have a somewhat less reliable station (e.g., 3 months maintenance at the .9 level). Naturally, the former has higher acquisition cost/lower O&M, while for the latter the opposite is true.

Several maintenance philosophies have been investigated, from unscheduled reactive policies to periodic scheduled preventative policies, including mixed

policies. These have primary impact on transportation considerations and costs, but also affect personnel support, spares, and power consumption for the network.

Through correspondence and telephone conversations with aircraft manufacturers and helicopter services (such as Okanagan, Greenland Air, Boeing, Sikorsky, Shirley, and Bow), many of whom have Arctic operations and experience, the helicopter has been determined to be a viable and attractive means of servicing, maintaining, and resupplying an unattended radar network such as the DEWLine. There appear to be no real questions concerning the availability of service, nor of the feasibility of their utilization on the DEWLine.

In the subsequent discussion of system life cycle costs, all costs are in 1977* dollars.

3.2.2 Acquisition Costs

3.2.2.1 Development Costs

It is recommended that two prototype stations be developed; one for in-plant tests and the other for field tests. Both can ultimately be deployed as part of the final system. The bulk of development costs are associated with the radar and IFF equipment. Most of the remaining equipment is the "off-the-shelf" variety. Specific equipment and potential vendors have been identified in the study, where possible; for the purpose of solidifying feasibility and estimating cost. The Air Force development cost model is:

$$(3.2-1) \quad C_1 = \text{REM} + \text{SIA} + \text{SDC} + (\text{NPR} \times \text{CPD}) + (\text{NPR} \times \text{CTP})$$

- REM = Cost of research, engineering and management during development phase of SEEK FROST system.
- SIA = Cost of system integration.
- SDC = Software development costs--mission, fault isolation, support.
- NPR = Number of prototypes required for testing = 2 factory, on-site, R/M/A.

* A 6% inflation factor was used to bring 1976 reported costs to 1977.

- CPD = Estimated cost of each prototype site.
- CTP = Cost of testing each prototype.

The cost has been summarized in Table 3.2-2 for the major equipment items in the baseline station/network. A discussion and rationale for each entry in the table follows.

3.2.2.1.1 Radar Development Costs

Based on costing activities carried out and reported in connection with the GE U/MAR study¹, the radar REM cost in 1977 dollars is estimated to be \$8.28M, comprised of the following:

RADAR REM COST

Design Engineering	\$5.30M
Program Management	.95
Special Tools & Test Equipment	.82
Producibility Engineering	.15
Production Drawings	<u>1.06</u>
	\$8.28M

It is recommended that a total of three engineering units of the radar be fabricated; two for 15-month reliability tests and the third for integration with other station equipments to become the first station prototype. This prototype will be used for in-plant performance tests. The second prototype will be assembled from one of the reliability tested engineering units after these tests are completed. This leaves the radar development and production program outlined in the GE U/MAR study intact.

¹ See Final Briefing, U/MAR Radar Study--Cost Segment, Contract F30602-76-C-0308, 28 January 1977.

TABLE 3.2-2

COST FACTORS	C ₁ , DEVELOPMENT COSTS SUMMARY					
	GE/U-MAR RADAR	GE NASS PRIME POWER	GE DAYTONA STATION COMM	WEATHER PACKAGE	NAVAIDS	PHYSICAL PLANT*
REM	8.28M	.36M	.5M	.1M	NONE	.5M
CTP	1.31M x 2	.21M x 2	.16M x 2	.01M x 2	NONE	.05M x 2
CPD	<u>1.09 x 2</u>	<u>.06M x 2</u>	<u>.59M x 2</u>	<u>.03M x 2</u>	<u>.01M x 2</u>	<u>.4M x 2</u>
	13.08M	.9M	2.0M (1.84)	.18M	.02M	1.4M

SDC = .85M () Satellite Cost

SIA = 1.0M

TOTAL (2 PROTOTYPES) C₁ = \$19.43M (19.27M)

* Unitized Radar Module/Shelter, Towers, Station Monitor and Control, Security Components.

The cost of all development radar testing, including the two prototype radars is \$2.62M, consisting of

RADAR CTP

Reliability Tests	\$.92M (first, second engineering units)
Factory Tests	1.01M (first, second, third engineering units)
Field Test and Integration	<u>.69M (two units)</u>
	\$2.62M

The cost of prototype radar hardware (CPD) is \$2.17M, again based on estimates made during the GE U/MAR study. This cost is based on three engineering radar units at \$.723M per unit.

If the total CTP and CPD costs are divided over the two prototypes, the cost per prototype is \$1.31M for testing and \$1.09M for hardware as indicated in Table 3.2-2.

This gives a total radar development cost of \$13.08M. As was pointed out during the U/MAR study, this cost could grow depending on the extent of reliability testing on critical components within the radar required by the Air Force. The radar radome is considered (somewhat arbitrarily) to be an integral part of the unitized radar module/shelter* and is costed (at \$200K) in the physical plant category.

3.2.2.1.2 Prime Power Development Costs

Using estimates generated and reported in the GE NASS study, the REM cost for a three 2 KW/one 10 KW diesel prime power system is \$.36M; of which \$.32M is for enclosure design/development and \$.04M for special power controller and maintenance equipment design/development.

The cost of testing prototype engines is given in that report to be \$.21M

An alternative prime power system which appears more attractive and is therefore recommended for the DEWLine application is three 4.4 KW generators.** This alternative is discussed more thoroughly in Sections 3.3 and 3.4 of this report. It would require about the same REM and CTP costs, but would take somewhat less in equipment. Prototype equipment costs are \$60K, itemized as:

4.4 KW (\$7K x 3) Generator	\$21K
Switch gear	5K
Battery Chargers	6K
Environment Control Unit	7K
Fuel Tank	4K
Controller	12K
Ducting, Wiring, etc.	<u>5K</u>
TOTAL	\$60K

* See Section 3.3 for details of this recommended station concept.

** These are the same SR1A Lister machines recommended at 2 KW output in the GE NASS study, except run at a more efficient 1800 rpm.

3.2.2.1.3 Communications Development Costs

Development costs for the communications equipments required for the network are based on a preliminary design/sizing undertaken by GE within this study. This activity has revealed that very little development is necessary in the communications area if conventional satellite or LOS microwave approaches are selected. Both LOS microwave and satellite approaches have been life cycle costed. A more detailed break-down of costs (development and production) is included in Section 3.5, where the design and other considerations are also presented. The non-recurring cost of \$.655M shown there for the LOS microwave configuration applies to a single prototype, and covers the development of new capabilities such as remote tuning of the G/A/G radio and to identify high reliability components. Of this, \$.500M is allotted to research, engineering and management, while about \$.16M is required for testing (per prototype). If it is assumed that the cost of prototype unmanned station communications plus repeater hardware is in the same ratio to unit production costs as for the radar (about 2.25:1), the cost of prototype LOS communications hardware (including a repeater) is about \$.59M. The total LOS communications development program would then be \$2.0M for two prototypes. Corresponding development costs for the satellite station are about 92% of the LOS station, or \$1.84M.

3.2.2.1.4 Weather Package Development Costs

The cost of research, engineering and management for a minimum weather package, as described in Section 3.4, is \$100K and consists of development of sensors to meet environmental conditions, development of a ceilometer, and development of analog-to-digital interfaces. A cost of \$10K per prototype covers required interface testing and environmental checks. The prototype equipment is itemized in Section 3.3 and totals \$31.7K per unit.

3.2.2.1.5 NAVAIDS Development Cost

Off-the-shelf equipment will be employed for station NAVAIDS per Section 3.3.

3.2.2.1.6 Physical Plant Development Costs

These costs were generated to account for all development costs not included in the other major component categories, viz. the unitized radar module/shelter*, towers, station monitor and control, and security equipments. The REM cost of \$500K includes development of design specifications and the accomplishment of a detailed design of two prototypes of each of the above equipments, as follows:

Shelters*/Unitized radar module	\$200K
Tower	100K
Station Monitor/Control	150K
Security	<u>50K</u>
TOTAL	\$500K

The equipment in a prototype is the same as in a production unit, which is discussed in more detail under physical plant production costs. The prototype equipment unit cost of \$404K are naturally higher than the corresponding production costs, reflecting the learning process associated with production of 81 units, as summarized below:

Unitized radar module/Shelter*	\$275K
Microwave Tower	20K
Radar Tower	<u>109K</u>
	\$404K

3.2.2.1.7 Software Development Costs

The software development cost of \$850K covers the cost of on and off-line

* See Section 3.3 for details of this recommended concept. The radar radome is considered to be an integral part of this facility.

programming the station monitor and control micro-computer and the prime power controller. In addition, it includes all programming at the logistics nodes. Software development costs have been generated from estimates of the size of the associated software programs.

3.2.2.1.8 Systems Integration Activity Costs

Integration activities associated with major station and node component interfacing total \$1.0M, based on estimated levels of design and test efforts in each activity area, as indicated below.

Radar	\$100K
Prime Power	100K
Communications	100K
NAVAIDS	25K
Weather Package	50K
Security	12K
Performance Monitor	100K
Fault Isolation	100K
Mechanical	<u>213K</u>
	800K
Node Components	<u>200K</u>
	\$1.0M

The foregoing development costs for two prototype stations total about \$19.43M.

If, instead of the GE U/MAR radar development costs of \$13.08M, the Air Force typical E259 radar RDT&E cost of \$25M is used¹, the increase in development cost is about \$11.92M to about \$31.35M. For the performance provided and technology utilized by the GE design, the \$25M figure is considered to be somewhat high. However, should a prime power of 500 watts, and/or 6 to 12 months maintenance free operation at the 90% success level become SEEK FROST requirements, such a development cost would be more nearly applicable. At this time, these requirements do not appear to be necessary for a feasible and economical network.

For prototype stations using one additional standby redundant complement of LOS microwave equipment everywhere, development costs are increased approximately by the cost of the additional hardware, or by about \$1.2 M. As had been pointed out, these more reliable LOS microwave equipments (and increased costs) should be used in conjunction with some of the roving maintenance team network configurations (i.e., alternates 2, 3, and 6).

3.2.2.2 Site Selection, Preparation, and Construction Costs

The Air Force cost model for site selection, preparation, and construction is shown in Table 3.2-3, which also summarizes parameters and costs.

TABLE 3.2-3
C₂, SITE SELECTION, PREPARATION AND CONSTRUCTION
COSTS SUMMARY

$$(3.2-2) \quad C_2 = NNS \times (SSC + SPC + FCC + SAC) + (NCS \times CMF) + (NLN \times CSF) + (NR \times CR)$$

- NNS = Number of new sites = 56 (28 New + 28 Abandoned I)
- SSC = Site selection costs = \$3K
- SAC = Real estate acquisition costs for new sites = None
- SPC = Site preparation costs for new sites = \$200K

¹"Typical E259 Radar Characteristics"post-contract award handout.

- FCC = Facility construction costs = \$292K (25' tower requirement)
 - CMF = Cost of site preparation/modification of current sites = \$118K
 - NCS = Number of current DEWLine sites used = 27
 - NLN = Number of logistics nodes = 6
 - CSF = Cost of support facilities at logistics nodes* = \$.8M
 - NR = Number of repeaters = 74
 - CR = Cost of repeater site selection, preparation, and construction = \$151K
- $C_2 = \$27.7M + \$3.2M + \$4.8M + \$11.17M = \$46.87M$ 6 node baseline with LOS comm.
\$35.7M satellite communications
- * Housing, Maintenance Shop, Operations Room, Hangers, Garages, Warehouses

A total of NNS = 56 new and reactivated sites (28 new and 28 abandoned I) drive this cost, accounting for about 62% of the total. There are 29 sites currently active on the DEWLine which are candidates for use in the upgraded network of which 27 have useable towers. To minimize site selection, preparation, and construction costs, maximal use must be made of existing sites, towers, and facilities as is planned by GE. Further discussion of how the current sites and facilities may be utilized is found in Section 3.4.

3.2.2.2.1 Site Selection Costs

Site selection costs are estimated to be \$3K per site. This cost is based on the level of effort required by GE, with architectural and engineering (A&E) consulting services, and the cost of a dedicated helicopter for 28 days on the DEWLine. Travel and lodging costs are also included.

Site selection requires:

- 1) The review and study of maps and aerial photographs with the A&E firm.
- 2) Making tentative selection of each site.
- 3) Flying over the proposed unattended line to establish exact locations.
- 4) Preparing a report for each siting.

3.2.2.2.2 New Site Preparation Costs

The cost of preparing a new site averages \$200K, which has been developed from the cost of personnel and equipment, housing and provisions, and helicopter support transportation during the preparation phase. This cost accounts for mobilization of the construction team and equipment, site grading, and performing all excavations and backfilling required for foundations.

3.2.2.2.3 Facility Construction Costs

Facility construction costs average \$292K for a new site and includes laying of radar and microwave tower foundations, erection of the towers, construction/installation of temporary housing and living quarters, and construction of the helipad and walkway. The cost of radar towers dominate facility construction costs. Hence, facility construction costs are sensitive to tower height requirements, as are the total costs for modifying current sites.

3.2.2.2.4 New Site Real Estate Acquisition Costs

Real estate for new sites (and old ones) are, in effect, loaned to the U.S. by Canada and involve no direct costs to the Air Force.

3.2.2.2.5 Logistics Node Support Facility Costs

The cost of support facilities at a logistics node depends, of course, on the number of personnel and functions of the nodes.

A full node in the upgraded DEWLine is envisioned to be about the size of an auxiliary station on the present line. The cost of emplacing additional support facilities at such a node is estimated at \$.8M per node. The baseline system consists of six full nodes, resulting in additional support facilities cost of \$4.8M. Additional facilities required will consist of buildings, grounds, hangars, roads, sewers and drains, water distribution and treatment, power generation and distribution, POL storage, fire protection and vehicles.

The cost of \$.8M does not include the cost of mission related operations and maintenance equipment, which is accounted for under the production cost category, specifically under support hardware and test equipment costs.

3.2.2.2.6 Existing Site Preparation/Modification Costs

At an existing site, it will not be necessary to provide temporary quarters and the cost of modifying existing towers is considerably less than to build a new one. These factors reduce the facilities preparation and construction costs to \$118.5K, allowing \$75K for modification of existing steel platforms, \$27.5K for helipad and walkway, and \$16K for the microwave tower foundation and erection.

3.2.2.2.7 Repeater Site Selection, Preparation, and Construction Costs

The same factors go into selecting, preparing, and constructing a repeater site versus a new station site, except the site area and equipment involved is less. A total cost of \$151K for each of the 74 repeater sites required is comprised of \$1K for site selection, \$100K for preparation, and \$50K for facilities construction.

3.2.2.2.8 Impact of Radar Tower Height Requirements on Site Selection, Preparation and Construction Costs

For a radar tower height requirement of at least 25 feet above terrain and 125 feet above sea level, site selection, preparation, and construction costs total \$46.87M (\$35.7M) for the entire line. The sensitivity of this cost to the above terrain height requirement* is illustrated in Figure 3.2-2, in terms of cost difference relative to the 25 foot requirement. This data was generated by reexamining the distribution of useable and new tower heights which result

* The requirement of 125 feet above sea level was considered fixed.

for each new above-terrain height requirement. The break point at 50 feet is where existing towers on the line are not conveniently useable. Requirements for towers more than 50 feet above terrain involve all new towers. As an additional point of reference, the dashed extension of the curve in Figure 3.2-2 shows site selection, preparation, and construction costs for all new low towers. These costs might be of some interest to the extent that relocation of the unattended DEWLine is a consideration.

FIGURE 3.2-2
 SITE SELECTION, PREPARATION, AND CONSTRUCTION COST DELTAS (83 SITES)
 VS
 MINIMUM TOWER HEIGHT REQUIREMENT

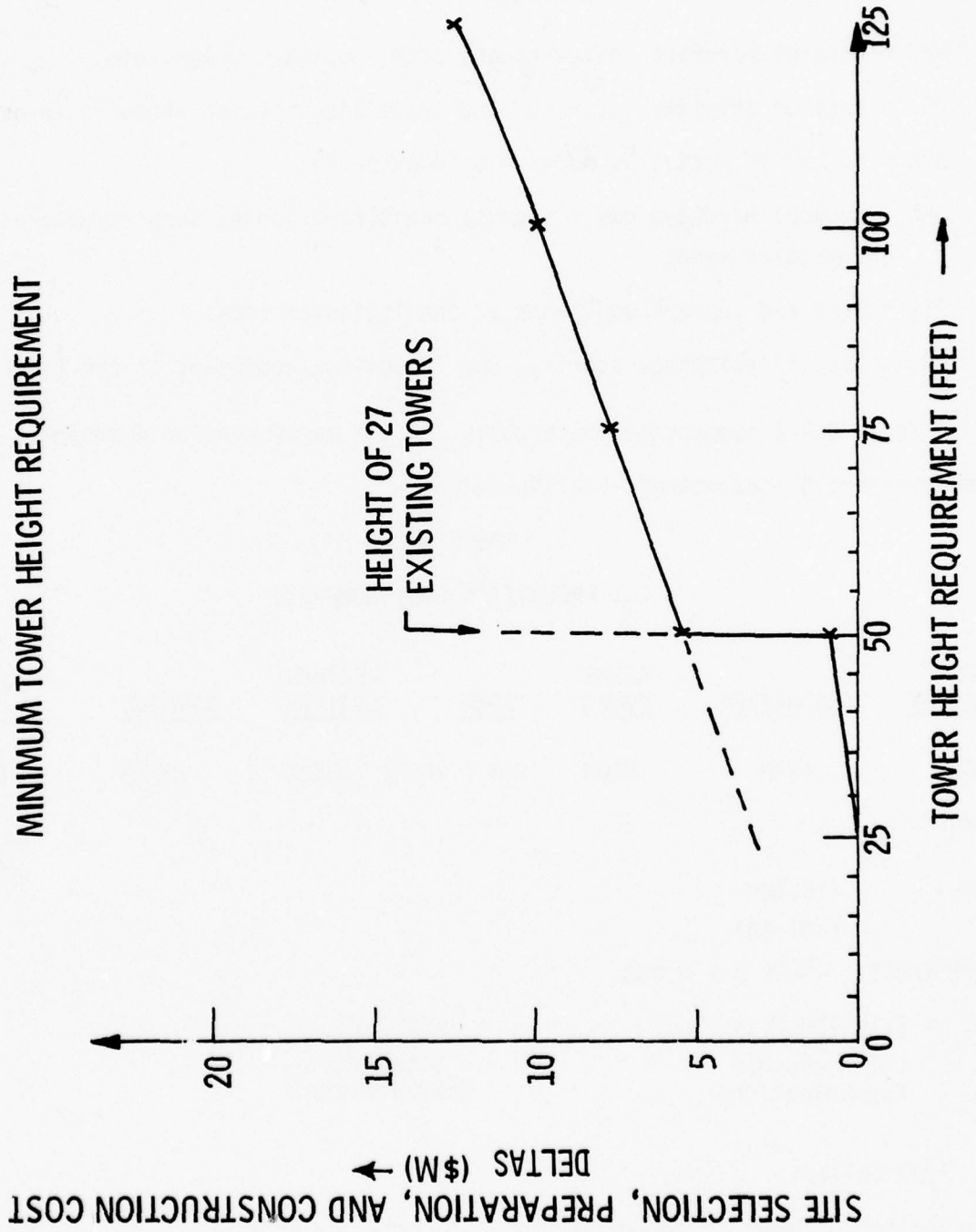

3.2.2.3 Production Costs

The life cycle cost model predicting production costs for 81 stations is:

$$(3.2.3) \quad C_3 = 81 \times (\text{MHC} + \text{HSI}) + \text{NLN} (\text{SHC} + \text{TSE} + \text{NSI})$$

- MHC = Mission hardware costs--radar, comm, weather, prime, etc.
- HSI = Cost of shipping, storing, and installing mission hardware to sites
- NLN = Number of logistics nodes = 6 (down to 4)
- SHC = Support hardware costs--remote monitor/personnel support/comm at logistics nodes
- TSE = Test and support equipment at the logistics nodes
- NSI = Cost of shipping, storing, and installing equipment at the logistics node

Table 3.2-4 summarizes these costs for the major station components for the baseline 6 node network configuration.

TABLE 3.2-4

C_3 , PRODUCTION COST SUMMARY*

<u>COST FACTOR</u>	<u>RADAR/IFF</u>	<u>PRIME POWER</u>	<u>COMM</u>	<u>WEATHER STATION</u>	<u>NAVAIDS</u>	<u>PHYSICAL** PLANT</u>
MHC	.482M	.046M	.26M (.165M)	.032M	.028M	.236M
HSI	-	-	-	-	-	<u>.337M</u>
X81	115.10M (107.40)					.573M
SHC/TSE/NSI	.722 x 6 = 4.33M					
$C_1 = \$119.43M$ (Baseline) LOS Microwave Communications			<u>\$111.73M</u> Satellite Communications			

* 1977 Dollars

** Shelters, towers, station monitor + control, security

3.2.2.3.1 Radar Unit Costs

For the radar recommended in the GE U/MAR study, the unit cost of a production article radar is \$.482M, based on a reasonable production rate of 4 units/month for a total of 81 units.

3.2.2.3.2 Prime Power Unit Costs

Prime power system unit costs of \$46K are derived from the GE/NASS study and Table 3.2-5 below for a three 4.4 KW generator system.

TABLE 3.2-5
PRIME POWER UNIT COSTS

<u>QUANTITY</u>	<u>ITEM</u>	<u>UNIT COST (\$K)</u>	<u>TOTAL COST (\$K)</u>
3	SR1A Diesel Generator Set	5	15
1	Switch Gear	3	3
1	Starter Battery/Charger	1	1
1	Storage Battery/Charger	5	5
1	Environmental Control Unit	5	5
1	Fuel Tank	3	3
1	Controller (including telemetry and inverter)	10	10
MISC	Ducting, Wiring, Etc.	<u>4</u>	<u>4</u>
	TOTAL		46

3.2.2.3.3 Communication Equipment Unit Costs

The LOS communications equipment unit costs of \$.26M are extracted from the preliminary design/sizing described in Section 3.5 of this report. They include \$.156M for each unmanned site and \$.103M for each repeater. The figure of \$.165M covers mission hardware costs for all satellite ground station equipments as also described in Section 3.5.

3.2.2.3.4 Weather Package Unit Costs

The weather station unit cost of \$31.7K is itemized below and discussed in more detail in Section 3.3.

<u>WEATHER STATION EQUIPMENT</u>	<u>COST</u>
Forward Scatter Meter	\$ 15.8K
Anemometer/Wind Vane	1.0K
Pressure Transducer	4.0K
Temperature/Dew Point	4.4K
Solid State TV	5.0K
Data Conditioner	<u>1.5K</u>
TOTAL	\$31.7K

3.2.2.3.5 Nav aids Unit Costs

Navigational aids for the station add up to \$28.15K as follows:

<u>STATION NAVIGATIONAL AIDS</u>	<u>COST</u>
Obstruction Lighting & Rotating Beacon	\$ 1.15K
Ground to Air Radios	10.0K
Low Frequency Beacon	<u>17.0K</u>
TOTAL	\$28.15K

These equipments are described more fully in Section 3.3.

3.2.2.3.6 Physical Plant Unit Costs

The mission hardware in this physical plant category is all mission hardware not heretofore covered, including the radar unitized module/radome, radar and microwave tower materials, microwave module fire detection and protection devices, ancillary lights, life support facilities, and oil storage materials--all installed and checked out in the module. Because minimal radar tower materials are required

where existing towers are used, and because the quantity needed depends on tower heights for new sites, the actual unit costs for the physical plant vary considerably across the line. It is estimated that \$20K is necessary to adapt the support frame on existing towers, \$12K for microwave tower, and \$160K for the unitized radar module/radome*, or \$192K for the physical plant mission hardware at an existing site. For a radar tower height requirement of 25 feet above grade, 125 feet above sea level, of the 56 new towers to be constructed, materials will be required for 42 at 25 feet, eight at 50 feet, and six at 75 feet. Radar tower materials costs for these heights are estimated to be \$80K, \$95K and \$112.5K, respectively. The costs of the unitized radar module/radome* and microwave towers are again \$172K, resulting in the totals of \$252K, \$267K, and \$284.5K for the physical plant mission hardware costs for new sites, respectively. When averaged over the tower height statistics, the average physical plant mission hardware associated with a new site is \$256.6K. When averaged over 56 new and 27 existing sites, the average physical plant mission hardware cost is \$236.3K, as shown in Table 3.2-4.

3.2.2.3.7 Site Mission Hardware Shipping, Storing, and Installation Costs

All shipping, storing and installing costs have been lumped into this single category. Most of the radar, communications, prime power and ancillary equipment will be shipped as integral parts of the unitized radar module/radome, minimizing installation and checkout costs (see Section 3.3). These costs also vary slightly with the degree of utilization of existing towers/tower heights across the line for new towers. Costs are itemized below:

* With ancillary equipment, e.g., fire detection, lights, security, life support oil storage, installed and checked out.

<u>EXISTING SITES</u>	<u>SHIPPING & STORING</u>	<u>INSTALLATION/ CHECKOUT</u>
Unitized radar modules/radome ¹	\$130K	\$27.5K
Tower support frame adaptation	2K	*
Microwave Tower	6K	*
Communications Equipment	165K ² (90K) ³	-
Prime Power Equipment	<u>4K</u>	<u>-</u>
Subtotal	\$307K	\$27.5K
TOTAL	\$334.5K	

<u>NEW SITES</u>	<u>SHIPPING & STORING</u>	<u>INSTALLATION/ CHECKOUT</u>
Unitized radar module/radome ¹	\$130K	\$27.5K
25 Foot Tower	4K	*
Microwave Tower	6K	*
Communications Equipment	165K ² (90K) ³	-
Prime Power Equipment	<u>4K</u>	<u>-</u>
Subtotal	\$309K	\$27.5K
TOTAL	\$336.5K	

When averaged over existing and new sites, and tower heights across the line, the total shipping, storing, installation and checkout costs average \$336.8K.

* Covered in site selection, preparation, and construction costs.

¹ Including ancillary equipment and radar equipment.

² LOS approach--shipping, installation and checkout of station \$111K plus repeater \$54K.

³ Satellite approach--shipping, installation, and checkout.

3.2.2.3.8 Logistics Node Facilities

The facilities envisioned for the baseline six full logistics node(s) to support the unattended radar station network can be categorized as:

- 1) Civil engineering facilities
- 2) Operations equipment
- 3) Intermediate level maintenance equipment

Costs associated with these facilities are summarized in Table 3.2-6.

- a. Civil engineering facilities--These facilities consist of: buildings grounds, aircraft facilities, roads, sewers and drains, water distribution and treatment, power generation and distribution, POL storage, heating, fire protection and vehicular equipment. The current PIN-4 auxiliary station is typical of the reduced main station fuel consumption at about 11,000 gallons/month, which corresponds to about 100 KW monthly power consumption.
- b. Operations equipment--These facilities consist of the operations computer and its peripherals for processing radar/PMFL data from the unattended radar station and display equipment for monitoring system performance. A computer having a memory capability near 64 K will be required. The reliability of the computer and the display equipment are estimated at about 2000 hours MTBF each.
- c. Intermediate level maintenance equipment--These are the tools and test equipments used in effecting repair of the failed LRI's returned from the unattended stations. Table 3.2-7, based on the U/MAR radar study, is considered as representative of test equipment required at a logistics node.

TABLE 3.2-6
LOGISTICS NODE FACILITIES COST

	<u>EXISTING</u>	<u>ADDITIONAL</u>	<u>TOTAL VALUE</u>
Civil Engineering Facilities*	\$5.6M	\$.8M	\$ 6.4M
Operations Equipment **	-	.6M	.6M
Maintenance Equipment **	<u>-</u>	<u>.1M</u>	<u>.1M</u>
TOTAL PER NODE	\$5.6M	\$1.5M	\$7.1M

Baseline Network Node Facilities Value: $6 \times \$7.1M = \$ 42.6M$

Existing Inventory: $6 \times \$5.6M = \$ 33.6M$

Required Additional Facilities $6 \times \$1.5M = \$ 9.0M$

= NLN (CSF + SHC + TSE)

* Based on evaluation of existing inventory at PIN-4. The additional cost shown here is the cost of modifying existing node support facilities (CSF) in C₂.

** Reference Section 3.2.3.4 Spares and Repair Parts of this report. The additional cost here is the cost of additional support hardware and test equipment at the nodes.

TABLE 3.2-7
TEST EQUIPMENT AND COSTS

<u>REQUIRED EQUIPMENT</u>	<u>COST</u>
Analog Board Tester	\$ 8,200
Digital Board Tester	46,500
Tools	4,400
Power Supplies	4,400
Oscilloscope	5,700
Sweep Generator	5,000
Signal Generator	6,400
VTVM	2,700
VOM	200
Power Meter	3,000
RF Couplers	600
Misc. Cables/Adapters	1,000
VSWR Meter	1,200
Spectrum Analyzer	3,500
Attenuator	<u>1,400</u>
	\$94,200.

3.2.2.3.9 Impact of Tower Height Requirements on Production Costs

As has been indicated, the physical plant mission hardware costs and total shipping, storing and installation costs are sensitive to tower heights. For each new above-grade minimum radar tower height required*, a new number of useable existing structures have been developed, along with new distributions of tower heights across the line. This in turn has resulted in new production costs. The cost differences between these and the baseline 25 foot requirement is plotted in Figure 3.2-3. The discontinuity at 50 feet corresponds to the height of existing towers, and reflects the fact that existing towers cannot be used, if the above-grade requirement is above 50 feet.

3.2.2.4 Acquisition Cost Impact of Network Nodal Configuration Alternatives

The only node unchanged in alternate (1) from the baseline configuration is BAR-M. Additional facilities/equipment required there total \$1.5M as in the baseline. The other nodes in this alternate require less additional facilities/equipment because of (a) reductions in manpower permitted by services provided by the Canadian MOT and Alaskan Command and/or (b) reductions in the support functions provided at the node. For example, POW-M, BAR-3, FOX-M, and CAM-M each require six fewer people because their airstrips are maintained by either the Alaskan Air Command or Canadian MOT. By replacing Dye Main with a mini-node at Goose Bay (maintenance only) and a data node* at Ft. Chimo, use can be made of the economies of those villages for some life-support activities (such as housing and meals). Additional facilities/equipments/modifications for alternate (1) are summarized below. These costs were developed from a node-by-node examination of functions and personnel required.

* The requirement of 125 feet above sea level was considered fixed.

PRODUCTION COST VS TOWER HEIGHT REQUIREMENT

FIGURE 3.2-3

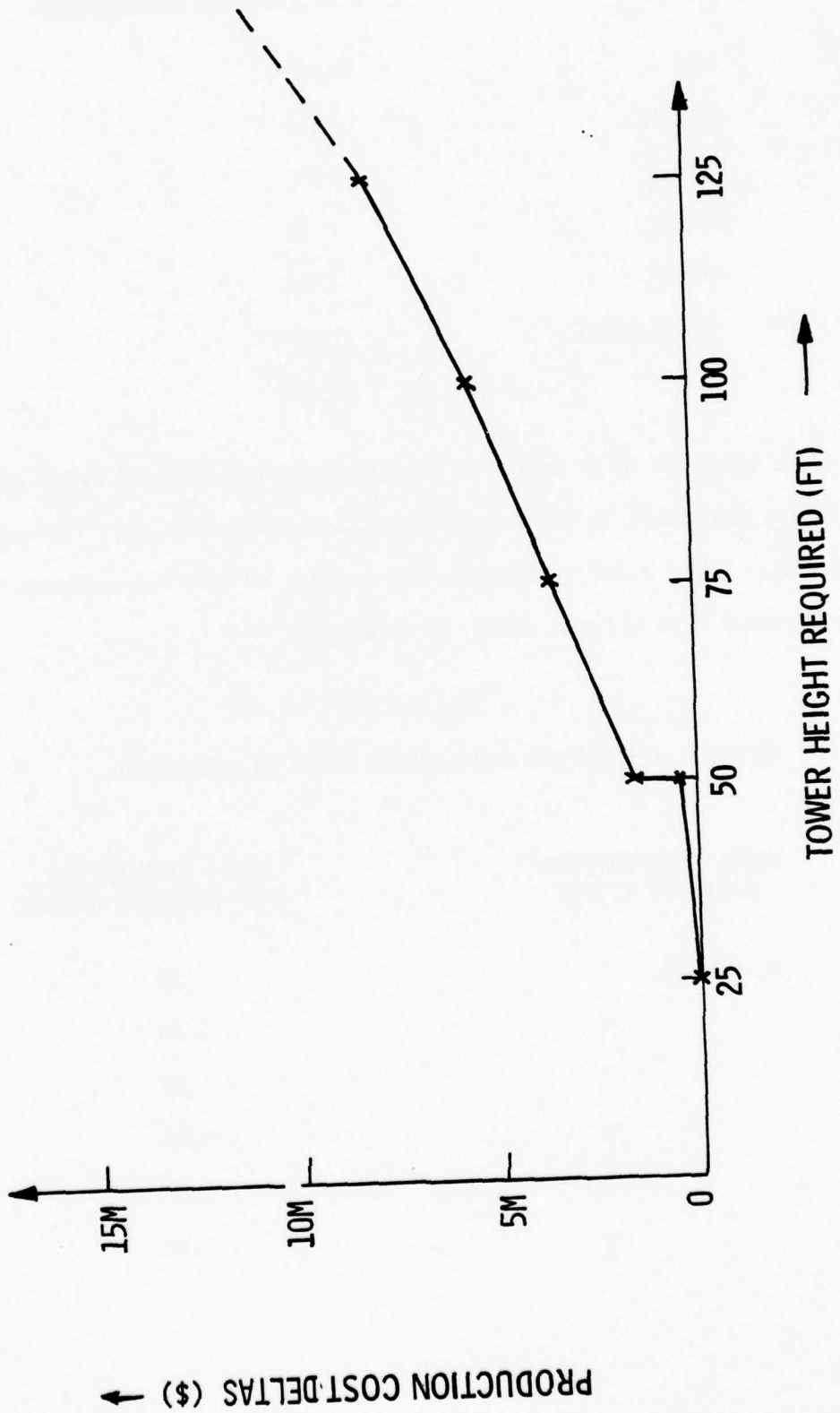

<u>NODE</u>	<u>ADDITIONAL FACILITIES/EQUIPMENT</u>
POW-M	\$1.35M
BAR-M	1.45
BAR-3	1.45
CAM-M	1.40
FOX-M	1.40
CHIMO/GOOSE	<u>1.60</u>
	\$8.65M

This total is to be compared to the \$9.0M required in total additional facilities equipment in the baseline network (Table 3.2-6). The cost differential is $-\$.35M$. Table 3.2-8 summarizes the results of similar analyses performed on the remaining five network nodal alternatives:

TABLE 3.2-8
NETWORK ACQUISITION COST VERSUS NODAL ALTERNATIVES

NODAL ALTERNATIVES BASELINE SYSTEM	COST DIFFERENTIAL FROM BASELINE SYSTEM
ALTERNATE 1	- .3M
2	- 1.8M
3	- 1.6M
4	- 5.5M
5	- 2.6M
6	- 5.4M

3.2.3 Operations and Maintenance Costs

3.2.3.1 Transportation Costs

Although important in their own right, transportation costs are also important because of the many aspects of operational feasibility which must be addressed in order to determine and minimize the cost, especially in the areas of network reliability, availability, and maintainability.

3.2.3.1.1 Transportation Cost Model

It should be established at this time that transportation cost, as used in this report, and as defined in the Air Force LCC model, is the cost of only that transportation involved in maintenance and lateral resupply trips along the line. Naturally, other transportation is utilized in construction and installation, and in vertical resupply via sea lift, air lift, etc. These are factored into the life cycle cost of the unattended radar DEW system through site preparation and construction costs, and power generation (fuel) costs. The Air Force transportation cost model is:

$$(3.2-4) \quad C_4 = \sum_{N=1}^{NLN} PIUP \left(\frac{ADT_N}{AVS} \times CPFH \times \frac{NSS_N \times 12}{MTBMV(\text{mos})} + ENAC_N \times CAC \right)$$

PIUP = 20 years costing period

NLN = Number of logistics nodes (4-6)

ADT_N = Average distance traveled/maintenance visit from N^{th} node

AVS = Maintenance vehicle speed

NSS_N = Number of unattended sites supported by N^{th} node

MTBMV = Mean time (months) between maintenance visits/site (including resupply)

$ENAC_N$ = Estimated number of air crews at N^{th} node

CAC = Average annual cost of air crews stationed at N^{th} node

CPFH = Cost per flying hour of maintenance vehicle

Some additional terms should be added to this model, as follows. The flight-hourly portion of this model applies directly to network nodal alternatives (1) and (5) where no additional roving aircraft is used. For the remaining alternatives, a similar term must be added to account for the cost of flying the roving aircraft. With this modification, the flight-hourly portion of the model applies to either Air Force or contractor helicopters, and is of the form:

$$(3.2-5) \quad C = \sum_{N=1}^{NLN} \text{PIUP} \times \left(\frac{\text{ADT}_H}{\text{AVS}_R} \times \text{CPFN}_H \times \frac{\text{NNS}_H \times 12}{\text{MTBMV}} \right) \\ + \text{PIUP} \left(\frac{\text{ADT}_R}{\text{AVS}_R} \times \text{CPFH}_R \times \frac{\text{NNS}_R \times 12}{\text{MTBMV}} \right)$$

where the subscript "H" refers to helicopter parameters, the subscript "R" refers to roving aircraft parameters, and NNS_R is the number of nodes serviced by the roving aircraft. This aircraft may either be fixed wing, such as the C6 Twin Otter, or helicopter. In the latter case, operating costs are lower but refuel stops would be necessary en route to the nodes.

The second portion of the Air Force transportation cost model, crew costs, applies directly if Air Force helicopters and air crews are used, and indirectly if contractor charter-type arrangements can be made. In such an arrangement, one or more helicopter service organizations would supply (on a first-come first-service basis) a helicopter and crew at the appropriate node(s). Presumably, since the helicopter is then not dedicated to the DEWLine, any overhead costs to the service organization would be distributed among all users. Total charges would then be reasonably well-approximated by the flight hourly costs plus the cost of keeping (civilian) crews available. Unfortunately, according to helicopter services contacted by GE, such charter-type arrangements are only available (year-round) in three regions along the line: Point Barrow, Inuvik, and Goose Bay. Furthermore, service at Goose Bay utilizes smaller helicopters, such as the Bell 206, which have limited non-refuel ranges of about 250 nmi.

A feasible alternative still utilizing contractor aircraft and crews is a long term (1 to 5 year) contract to one or more helicopter service organizations for dedicated helicopters/crews at specified bases (nodes) along the line. This rental-type arrangement is costly, however, because overhead charges are levied which cover the depreciation of each helicopter, insurance, management, profits, crews, etc. Since only one user is involved, that user must bear all of the depreciation. Over the 20 year life cycle of the network, depreciation charges would probably amount to amortization of the helicopters. An appropriate model for this type of arrangement (to be added to flight-hourly costs) is simply the sum of the overhead rates for each dedicated aircraft on the line. Recognizing that a portion of the overhead rate involves crew costs, this overhead charge can be modelled as:

$$(3.2-6) \quad C = \sum_{N=1}^{NAC} PIUP \underbrace{(ENAC \times CAC + \Delta R)}_{\text{total overhead rate } R \text{ per aircraft}}$$

PIUP = costing period

NAC = total number of aircraft used

ENAC = estimated number of crews per aircraft

CAC = cost of an aircrew

ΔR = additional overhead rate per aircraft

Note that this model reduces to the given Air Force model for one aircraft per node and no overhead beyond crew costs ($\Delta R = 0$).

The additional overhead costs and higher civilian crew costs make the use of Air Force helicopters and crews more attractive. It is recognized, however, that the demand on Air Force aircraft is great, and that many political and strategical considerations are involved in any decision to commit military aircraft to a given application. For this reason, transportation costs are presented for both Air Force and contractor (dedicated) helicopters and crews.

For the baseline network and the alternate (1), each of the six helicopters services an average of $83/6 \approx 14$ unattended radar stations. For an intersite distance of 40 nmi, the average round trip distance travelled by a helicopter on a maintenance visit is 280 nmi. Also on this basis, the maximum average trip distance is 560 nmi. With certain nodal configurations and particular nodes, of course, there may be considerable departures from these averages. A good example is in the baseline nodal configuration, where the entire southeast extension (> 1000 nmi) of the line is serviced by helicopter and crews at Dye Main. This is one of the reasons the baseline network nodal configuration is not a preferred configuration. Even so, for the purpose of generating costs, the use of average visit distances should be representative, since if one node services a greater distance, another must service less--the total distance being fixed by the length of the proposed DEWLine.

3.2.3.1.2 Helicopter Alternatives

A partial list of helicopter candidates and pertinent parameters considered in this study is presented in Table 3.2-9. These range in size from very large (38.3 klb-HH53C to very small 5.1 klb, B0105C). Of these, none have sufficient range to make a trip to 520 nmi without refuel, or auxiliary fuel tanks. Also, even with auxiliary tanks, none have sufficient range to service the entire southeast extension of the line from Dye Main without refuel, so some refueling stations are necessary in any event. These require manning for security reasons, though at a very low level (1 to 2 people). Additional undesirable aspects of refueling are bad weather take-off and landing delays. However, the actual refuel operation is a very simple procedure, routinely practiced in the Arctic. A portable pump on the helicopter is plugged into a sealed standard fuel drum. The many populated communities and bases along or near the line could serve as ideal refuel stations and alternate landing sites (Section 3.1, Figure 3.1-4). Along the southeast

TABLE 3.2-9
HELICOPTER ALTERNATIVES

		<u>GROSS WEIGHT (klbs.)</u>	<u>PAYLOAD (klbs.)</u>	<u>MAXIMUM AIRSPEED (Knots)</u>	<u>UNREFUELED RANGE (nmi)</u>	<u>CREW</u>	<u>COST/FLIGHT (hour¹)</u>
Sikorsky (S65)	HH53C	38.3	14.7 ₂ 11	170/162 ²	230/680 ²	3	608
Bell (212)	UH1N	10.5	4.5	101	217	2	224
Sikorsky (S61)	CH3E/B	22/20.5	9.6 10.8	138/133 ²	430/616 ²	3	491
Boeing 105C		5.1	2.4	145	306/520 ²	1	139
Sikorsky (S76)		9.7	4.8	156	600 ²	2	280
		(UNK)	2.0	120	320	2	223
		(UNK)	3.0	110	216	2	239

¹ Fuel, maintenance, parts

² With auxiliary tanks

extension candidate refuel stations are fewer (Frobisher Bay, Pangnirtung, Ft. Chimo, and Goose Bay), but still adequate for the longer range helicopters. Smaller helicopters would require additional refuel stations between all nodes and would be less flexible in payload.

The prime helicopter candidates, as a result, are those with the longest unrefueled range--the CH3 (S61), the HH-53 (S65), and the S76. The first two of these are established aircraft (in the Air Force inventory) with known Arctic capabilities. The third is an extremely attractive commercial aircraft from a projected performance standpoint, but is not as yet in production nor time-tested. The S65 and S76 offer auxiliary tank options allowing the range to be extended to 600 nmi or more (with reserve). The S61 can easily be modified to carry similar tanks and achieve about 500 nmi range with 30 minute reserve. All three aircraft utilize dual engines and have sophisticated and extensive on-board navigational equipment, making them ideal candidates for safety and reliability in negotiating the DEWLine.

The HH-53C has payload capabilities far in excess of that required to maintain the line. A worst case cargo anticipated for this purpose would consist of a cabinet of radar equipment (800 lbs.), a 4 KW diesel generator (about 350 lbs.), two maintenance personnel (400 lbs.), and emergency supplies (200 lbs.) for a total of 1750 lbs. Accounting for the fuel and crew, this worst case cargo is also compatible with the capabilities of the S61 and S76. The first production S76 aircraft are due in July 1978, of which the first 10 will be delivered to Okanagan Helicopters, Ltd. A further excellent discussion of the navigational aids associated with some of these and other helicopters may be found

in a 10 November 1977 paper by Lt. G. A. Fisher, of the AF ESD, entitled "A Preliminary Description of Unattended Radar Station Navigational Aids".

Based on correspondence and telephone conversations with various aircraft manufacturers (such as Sikorsky and Boeing) and with helicopter service organizations (such as Okanagan, Greenland Air, Carson, Shirley, BOW Associates), most of whom have Arctic operations and experience, the consensus opinion is that Arctic travel and service of unattended stations by helicopter is definitely feasible, and offers no particular implementation difficulties. Take-off and landing requirements are minimal. Pads of 40 feet or more in diameter are required, and these do not have to be kept absolutely clear of snow. Elevated pads will tend to blow clear of snow, and landing gusts will also help. A clearance of 200 feet from towers in some direction must be provided. A visibility of about 1/2 mile is required at either the destination or an alternate for take-off.

3.2.3.1.3 Civilian Versus Air Force Aircraft and Crews

The number of air crews required per node is dictated by our desired military posture on the DEWLine. If immediate response to network failures (coverage holes) is an overriding consideration, up to three air crews might be kept at each node, on 8 hour shifts, 24 hours per day, on 1 to 2 hour alert readiness. Otherwise, deferred maintenance policies* based on a single air crew or less per node are candidates. This latter policy is much to be preferred on a cost basis. It would also appear to be adequate from a military standpoint considering that failures and maintenance responses are not predictable by potentially hostile forces. The size of an air crew depends on the aircraft selected, ranging from one (pilot) to three (pilot, co-pilot, mechanic). Contractor costs for helicopter crews are significantly higher than for Air Force personnel. Table 3.2-10 summarizes air

* responding on a weather permitting, 8-hour working day basis

crew costs using annual Air Force salaries of \$24K for a pilot, \$18K for a co-pilot, and \$12K for a flight mechanic, vis a vis contractor salaries of \$72K for a pilot, \$54K for a co-pilot and \$46K for a flight mechanic.

TABLE 3.2-10
AIR CREW COSTS PER NODE

<u>Crew Size</u>	ENAC		
	1	2	3
1	\$24K (72K)	\$48K (144K)	\$72K (216K)
2	42K (126K)	84K (252K)	126K (378K)
3	54K (172K)	108K (344K)	162K (516K)

Using an Air Force S61 helicopter and one Air Force 3-man crew per node in the baseline 6-node network, the 20 year transportation costs are estimated as:

PIUP = 20 years

NLN = 6

ADT_H = 280 nmi

AVS_H = 133 knots

CPFH_H = \$491

NSS_H = 14

ADT_R = 0

NAC = 6

ENAC = 1

CAC = \$54K

ΔR = 0

$$C_4 = \frac{\$20.84M}{MTBMV} + \$6.48M \quad (3.2-7)$$

The use of three crews per node, for an immediate response military posture, for example, would escalate annual costs severely. For the S61:

$$(3.2-8) \quad C_4 = \frac{\$20.84M}{MTBMV} + 19.4M$$

These figures re-emphasize the importance of keeping personnel support at minimum levels, and also illustrate the sensitivity of transportation costs to crew salaries and manning levels.

The same transportation costs for the S65 helicopter are:

$$(3.2-9) \quad C_4 = \frac{21.19M}{MTBMV} + 6.48M \quad \text{One, three-man Air Force crew}$$

$$(3.2-10) \quad C_4 = \frac{21.19M}{MTBMV} + 19.4M \quad \text{Three, three-man Air Force crews}$$

There is so little difference in the costs for this aircraft and the S61 that only the S61 and S76 candidates are costed further.

A budgetary estimate of costs for the baseline 6 node network is now discussed, based on information provided by Okanagan Helicopters Ltd. This estimate assumes a long term (one to five years) leasing contract for service by six dedicated S76 helicopters, one at each node. Flight hourly charges of \$280/hour include fuel, maintenance, and spare parts. The overhead rates quoted by Okanagan ranged from \$45K to \$60K per month (including one, three-man crew) per helicopter, depending on mission details and on the extent of secondary users taking advantage of the DEWLine helicopters.

Subtracting out \$172K in contractor crew costs, the additional overhead charges are estimated to range from $\Delta R = \$368K/\text{year}$ to $\$548K/\text{year}$ per helicopter.

Parameters and costs are summarized as follows:

PIUP = 20 years

NLN = 6

ADT_H = 280 nmi

AVS_H = 160 knots

CPFH_H = \$280

NSS_H = 14

ADT_R = 0

NAC = 6

ENAC = 1

CAC = \$172K

ΔR = \$548K

$$C_4 = \frac{\$9.88M}{MTBMV} + \$86.4M \quad (3.2-11)$$

The fact that this cost is so much higher than Air Force costs is a result primarily of the higher contractor overhead costs.*

Transportation costs do not vary appreciably from the baseline to the first alternate nodal configuration. Both the baseline and alternate (1) involve six helicopter bases, with one helicopter and one crew per base. However, the remaining alternatives represent departures from the first two with respect to transportation costs. In alternate configuration (2), the entire line is serviced by two roving maintenance teams/helicopter crews at CAM-M. The team is transported by a fixed wing aircraft or helicopter** to the helicopter base nearest the failed segment.

* It is recognized that direct comparison here between costs associated with Air Force vis a vis contractor helicopters is not extremely meaningful. The use of Air Force helicopters entails "hidden" overhead costs attributable to helicopter acquisition, planning, management, etc. They are hidden in the sense that most of these overhead costs would not appear as direct annual costs to the AF DEW system office.

** Refuel stops would be necessary but operating costs are lower.

Using the dedicated helicopter at this base, the desired site visits are then completed. Alternates (3) and (4) are more practical implementations of the same concept acknowledging the political sovereignty problems associated with the Alaskan-Canadian boundary. Each features two roving teams at CAM-M and one at POW-M. The difference between the two alternatives (3) and (4) involves equipment required at logistics nodes and not transportation costs.

Assuming fixed wind aircraft costs per flight hour to be proportional to aircraft size, as measured by cargo capacity, the cost per flight hour for a Twin Otter (C6) aircraft (with 4000 lbs. or about 9 pallets capacity) is about \$1200 per flight hour. The parameters and costs involved in the Air Force transportation costs for alternate (2) are:

PIUP = 20 years

NLN = 6

ADT_H = 260 nmi

CPFH_H = \$491

NSS_H = 14

ENAC_H = 2 (at CAM-M)

CAC_H = \$42K

AVS_H = 133 knots (S61)

NAC = 7 (6 helo's + Twin Otter)

ADT_R = 522 nmi

AVS_R = 165 knots (Twin Otter)

CPFH_R = \$1200 (Twin Otter)

NNS_R = 6

ENAC = 1

CAC = \$24K*

$$C_4 = \frac{\$38.34M}{MTBMV} + \$3.36M \quad (3.2-12)$$

* An average of \$24K is used for two, three-man crews at \$54K each and six helicopter flight mechanics (at each node) at \$12K each.

As might be expected for this option, flying costs are greater while air crew personnel costs are lower.

If an S61 helicopter roving aircraft is used instead of the Twin Otter, the only changes to the previous calculation are:

$$AVS_R = 133 \text{ knots} \quad CPFH_R = \$491.$$

The total transportation cost for alternative (2) becomes:

$$(3.2-13) \quad C_4 = \frac{\$29.77M}{MTBMV} + \$3.36M.$$

If this same cost is computed using commercial (S76) helicopters and civilian crews, with

$$AVS_H = 156 \text{ knots} = AVS_R \quad CPFH_H = \$280 = CPFH_R$$

$$CAC = \frac{2(172K) + 5(46K)}{7} = \$82K; \Delta R = \$584K/\text{year overhead rate}$$

the result is:

$$(3.2-14) \quad C_4 = \frac{\$14.11M}{MTBMV} + \$88.2M$$

of which \$76.72M are overhead charges associated with the seven helicopters beyond crew costs.

Similar calculations on network nodal alternatives (3) and (4) result in parameters and total costs for six AF S61 helicopters plus Twin Otter and crews as follows, with all parameters the same as for alternative (1) except:

$$\left. \begin{array}{l} ADT_R = 1570 \text{ nmi} \\ NNS_R = 5 \\ CAC = \$30K/\text{year} = \frac{3(54K) + 4(12K)}{7} \end{array} \right\} C_4 = \frac{\$34.52M}{MTBMV} + \$4.2M \quad (3.2-15)$$

Using a helicopter as the roving aircraft results in:

$$(3.2-16) \quad C_4 = \frac{\$27.79M}{MTBMV} + \$90.72M$$

Alternate (5) is just a reduced number of nodes version of alternate (1).
Using four S61 AF helicopters and crews, the transportation parameters and costs are:

PIUP = 20 years

NLN = 4

ADT_H = 415 nmi

AVS_H = 133 knots

CPFH = \$491

NSS_H = 21

ADT_R = 0

CPFH_R = 0

NAC = 4

CAC = \$54K/year

CAC = 1

$$C_4 = \frac{\$30.89M}{MTBMV} + \$4.32M \quad (3.2-17)$$

Using four S76 commercial helicopters and civilian crews, the costs are:

$$(3.2-18) \quad C_4 = \frac{\$14.64M}{MTBMV} + \$57.6M$$

Alternate (6) is the roving maintenance team version of a four node network (alternate (5)). Parameters and costs for four S61 AF helicopters plus a Twin Otter and crews are:

PUIP = 20 years

NLN = 4

ADT_H = 415 nmi

AVS_H = 133 knots

CPFH_H = \$491

NSS = 21

ADT_R = 1106 nmi

CPFH_R = \$1200

NNS_R = 3

NAC = 5

CAC = \$28.8K*

$$C_4 = \frac{\$33.83M}{MTBMV} + \$2.88M \quad (3.2-19)$$

* [2(54K) + 3(12K)]/5

Using five commercial S76 aircraft and crews, costs are:

$$(3.2-20) \quad C_4 = \frac{\$16.03M}{MTBMV} + \$64.4M$$

Figure 3.2-5 illustrates the behavior of the twenty year costs of transportation using AF S61/S65 helicopters versus the various nodal configuration alternatives. Figure 3.2-6 depicts the same for commercial S76 helicopters.

3.2.3.1.4 Maintenance Philosophies

It is clear from the form of the transportation costs for all network nodal configurations, maintenance concepts, and helicopters that it is desirable to maximize the mean-time-between-maintenance-visits (MTBMV). How the maximum can be achieved is not so obvious. Maintenance philosophies spanning the range of unscheduled reactive only to scheduled periodic only (including combinations) are studied for feasibility and cost impact. These studies lead to an optimum maintenance philosophy in which the mean-time-between-maintenance-visits are minimized, thereby minimizing transportation costs while not sacrificing network availability. The resulting maximum value of MTBMV is then used to finish the evaluation of transportation costs and subsequently in demonstrating realistic maintenance loading levels on site personnel. The intervening trades and results go a long way toward establishing the overall technical and economical feasibility of operating the DEWLine network of 83 unattended radars.

CANDIDATE MAINTENANCE PHILOSOPHIES

- **Unscheduled Reactive Only**

- Site visits only upon adjacent missing/unacceptably degraded radar data condition

- PM accomplished then and at resupply (annual, bi-annual)

FIGURE 3.2-5

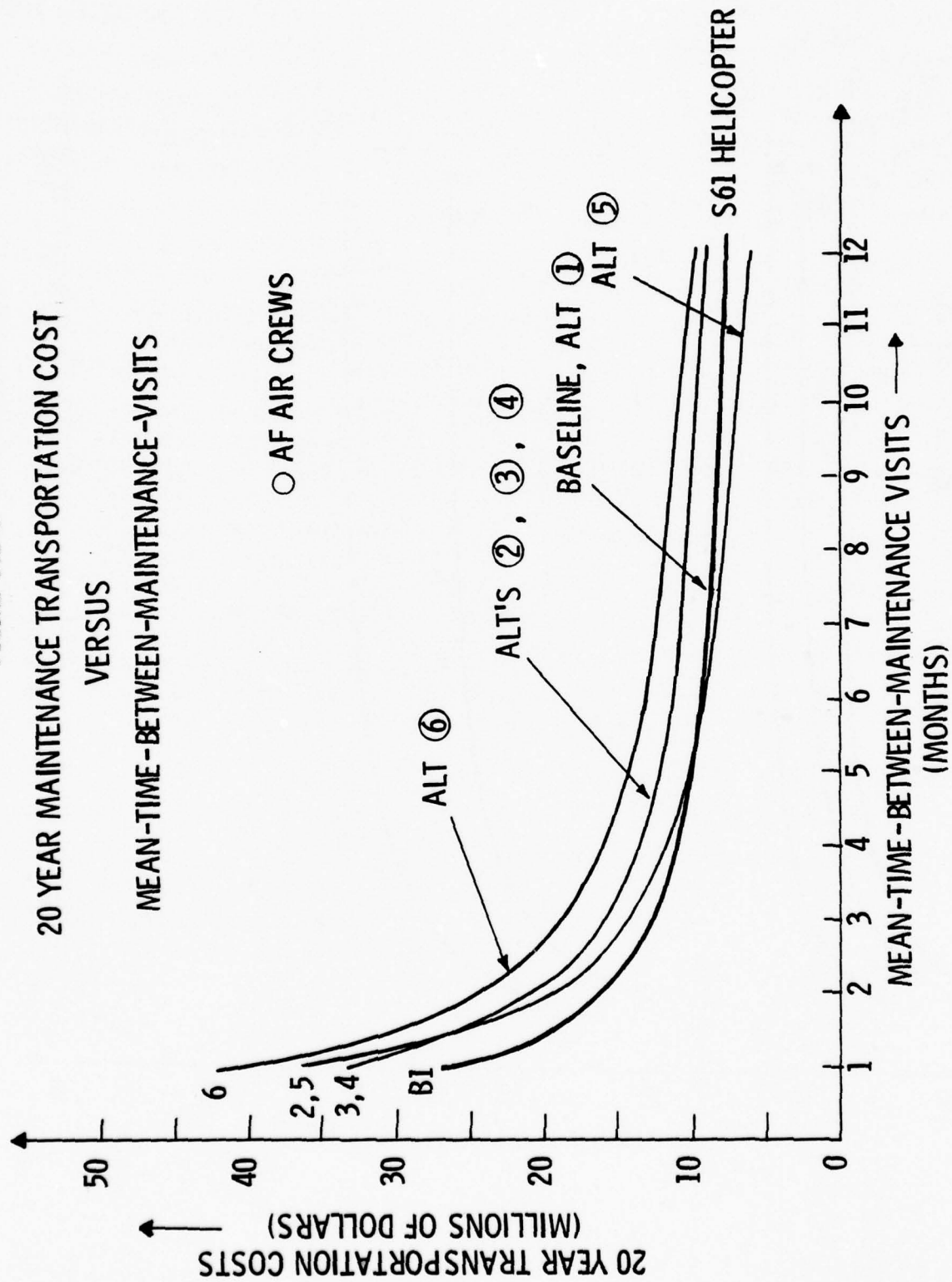
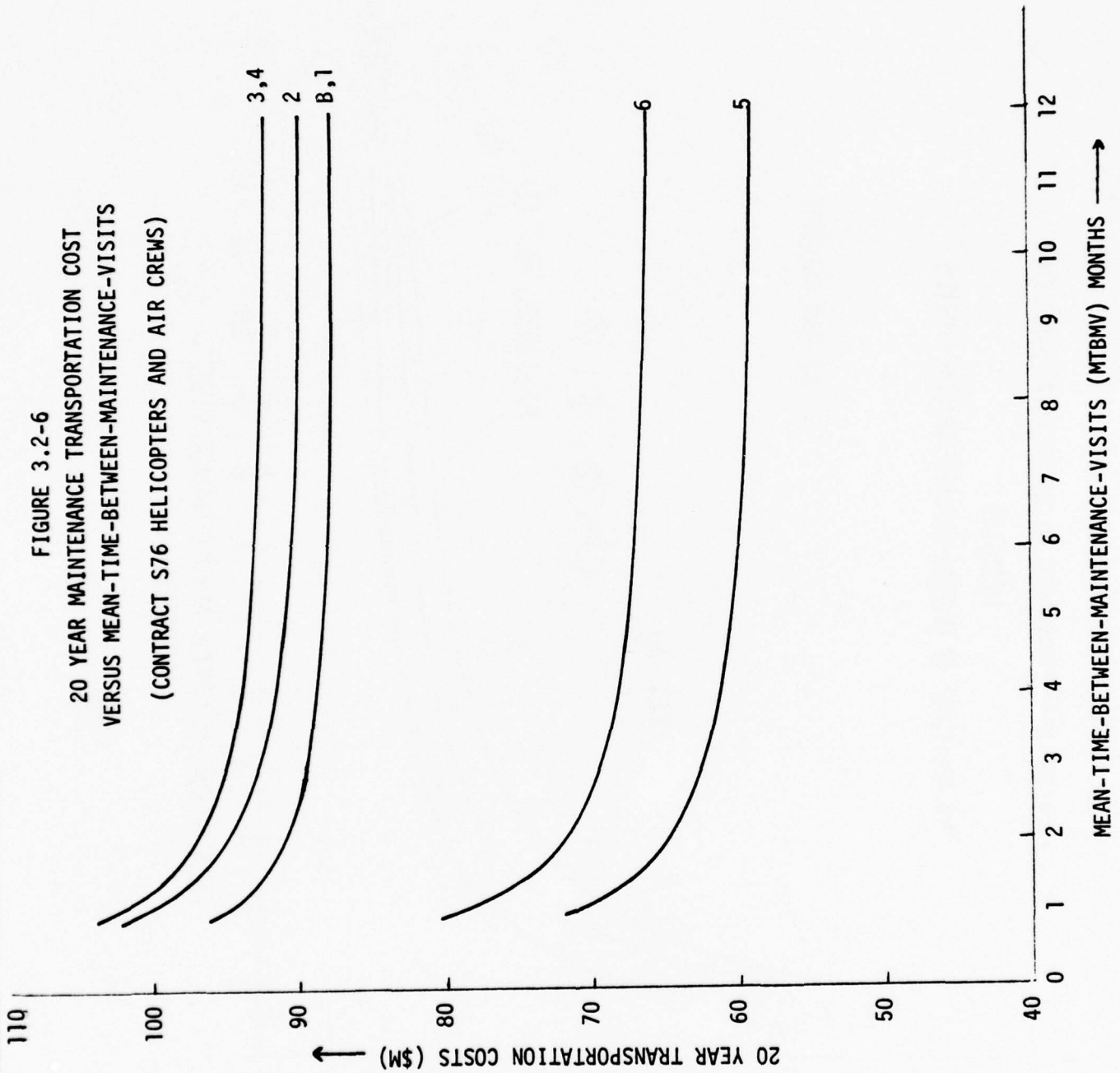

FIGURE 3.2-6
 20 YEAR MAINTENANCE TRANSPORTATION COST
 VERSUS MEAN-TIME-BETWEEN-MAINTENANCE-VISITS
 (CONTRACT S76 HELICOPTERS AND AIR CREWS)



- o Periodic Scheduled PM Only
 - Failures wait
 - 1, 3, 6, 12 month intervals examined
 - Annual or bi-annual resupply (additional PM)
- o Reactive Plus Periodic (Mixed Philosophy)

Consider a mixed philosophy in which periodic preventative maintenance (PM) visits are made at time intervals, T, in addition to responding to network failures.

MIXED MAINTENANCE PHILOSOPHY: A round trip is made to the site from a manned node when adjacent radar data is missing/degraded and for regular periodic preventative maintenance (PM) at intervals, T.

The total rate of visitation at each site is $1/T + 1/MTBF$, so the mean-time-between-visits is:

$$(3.2-21) \quad MTBMV = \frac{1}{\frac{1}{T} + \frac{1}{MTBF}}$$

The MTBF is the mean-time-between-failures of the network (13-14 radar segment) and is related to the network reliability and PM interval by:

$$(3.2-22) \quad MTBF = \frac{\int_0^T R_{NET}(t) dt}{Q_{NET}(t)} \quad Q_{NET}(t) = 1 - R_{NET}(t)$$

The network failure criterion can also be considered a parameter. In this study, the criterion examined has been the loss or unacceptable degradation of radar data from n adjacent radar stations within a segment between two nodes (helicopter stations). It is clear from the way the factor MTBMV appears in the transportation cost equation that a segment between two typical nodes should be

used as a basis for defining network failures. The subsequent network reliability/availability/maintainability analysis is therefore oriented towards obtaining the reliability, or mean-time-between-failures, and availability, of the network segment between two nodes. Values of $n = 1, 2,$ and 3 have been evaluated. Because of the extensive overlap in radar coverage corresponding to 60 nmi radar range with 40 nmi average intersite spacing, the failure of a single radar produces no coverage holes, while loss of adjacent radar data can produce a small potential penetration corridor. The value $n = 2$ is therefore considered to be the prime candidate criterion, at least for the purposes of cost evaluation. In the system finally deployed, if estimates or maps of coverage can be generated in real or near-real time, an even more intelligent definition of network failure can be implemented.

3.2.3.1.5 Network Reliability

Network reliability is defined as the probability of no network failures in the time interval zero to t .

$$(3.2-23) \quad R_{\text{NET}}(t) = P_r(\text{zero network fails in } (0,t))$$

It is related in none too simple a fashion to station reliability. In fact, the exact relation depends on the maintenance concept, the communication approach, and the failure criterion (n). An underlying assumption in the following R/M/A analysis is that when a network failure or PM occurs, the entire line segment between affected nodes is restored to its initial state or quality of operation. Because of the fail soft/graceful degradation of the station equipment, strictly speaking, this means that each site having failed components of any kind in the segment must be visited upon network failure or PM interval at which time such failed components/devices are replaced.

Alternatives to this procedure which might be practical, but which have not been analyzed in detail in this study include visitation and repair of only the pair of stations in a segment which produced the network failure, and visitation and repair of only those stations in the segment which are failed at the time of a network failure. The problem with these alternatives is that another network failure remains imminent, even after a network "repair" has been affected--because of the unrepaired but degraded stations.

Data from a station is transmitted laterally from station-to-station until it reaches its parent data node (roughly speaking--its nearest logistics node). From the logistics node it is transmitted rearward (to two ROCC's and a NORAD center) via two satellites. Data from one logistics node is available at all others through the satellites. If a link in the communications path from a station to its (say eastward) node fails, a secondary LOS route to the westward node can then be used. A general description and requirements for such a system, written by F. McDonald of the MITRE Corporation for the AF ESD, was provided at the post-award briefing. A preliminary microwave LOS implementation has been designed to these requirements and is discussed further in an appropriate section.

Figure 3.2-6 is a conceptual block diagram of a LOS microwave network which may also be interpreted as a network reliability block diagram, taking into account the sequential nature of the LOS communications transmissions and the redundant radar signal paths to a logistics node. Also modeled, but not shown, are the different network failure mechanisms caused by radar, communications and prime power failures. One mechanism for network failure is obviously the failure of adjacent radars. Another mechanism is the failure of any two communications/prime power systems within a network segment (between the nodes) which spans the adjacent radar. In terms of the reliabilities of in-line station components, the network reliability is derived using the following approach.

FIGURE 3.2-7

LOS MICROWAVE COMMUNICATIONS NETWORK

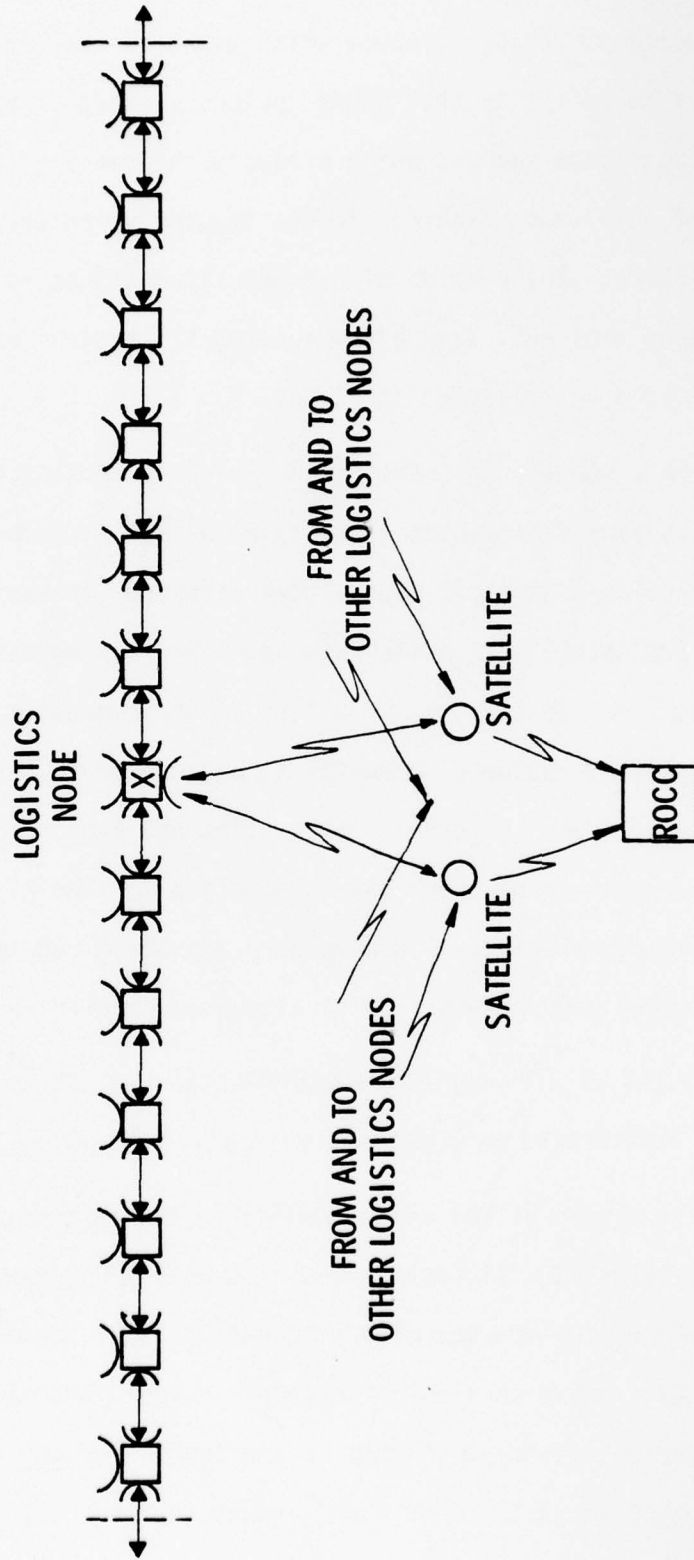

$$\begin{aligned}
 (3.2-24) \quad R_{NET} &= 1 - P_r (\geq n \text{ adjacent radar data lost/degraded}) * \\
 &= 1 - P_r (\geq n \text{ adjacent radar fails or span of communications/prime} \\
 &\quad \text{power failures} \geq n) \\
 &= 1 - P_r (A_n \text{ or } B_n) = 1 - P_r(A_n) - P_r(B_n) + P_r(A_n) P_r(B_n)
 \end{aligned}$$

where

A_n = event: $\geq n$ adjacent radar fails

B_n = event: $\geq n$ span of communications/prime power fails.

These probabilities are summarized in Table 3.2-11, based on an analysis included in Appendix 7.1.

TABLE 3.2-11
LOS NETWORK RELIABILITY PROBABILITIES

n	$P(B_n)$	$P(A_n)$
1	$1 - (PC)^N$	$1 - R^N$
2	$1 + (N-1) (PC)^N - N (PC)^{N-1}$	$1 - (1 - Q^2) \left(1 - \frac{Q^2 R}{1 - Q^2}\right)^{N-2}$

where $P(t)$ is the station prime power system reliability, $C(t)$ is the station communication system reliability, $R(t)$ is the radar reliability, N is the number of radars in a segment between two nodes, and $Q(t) = 1 - R(t)$. The event: $n = 1$ corresponds to a network failure criterion where loss/degradation of a single radar's data is a network failure. Using Table 3.2-11 above, the resulting network reliability is:

$$(3.2-25) \quad R_{NET} = 1 - (1 - (PC)^N) - (1 - R^N) + (1 - (PC)^N) (1 - R^N) = (RPC)^N$$

* The time argument in all reliabilities is understood and is dropped for simplicity of notation where no confusion can arise.

This result implies that the N stations are essentially serial with this criterion. For example, if the number of stations serviced per node is $N = 14$, even if the prime power and communications reliability are unity, a radar reliability of .9 (at the end of three months for example), will result in a network reliability of only $.9^{14}$ or .228. Fortunately, a criterion of two adjacent failures is also acceptable from a coverage point of view, and proves more reasonable from a reliability/maintainability point of view.

On the other hand, with $n = 2$ (adjacent radar data loss/degraded criterion), and ideal prime power and communications equipment ($PC = 1$), the network reliability is:

$$\begin{aligned}
 (3.2-26) \quad R_{NET} &= 1 - (1 - (1 - Q^2) (1 - \frac{Q^2 R}{1 - Q^2})^{N-2}) \\
 &= (1 - Q^2) (1 - \frac{Q^2 R}{1 - Q^2})^{N-2}
 \end{aligned}$$

For a radar reliability of .9 and $N = 14$, the network reliability would be:

$$R_{NET} = (.99) (.896) = .887$$

These simple calculations make clear the benefits of the overlapping coverage on network reliability. More realistic assessments of network reliability will follow based on the reliabilities of in-line station components (radar, prime power, and communications). First, however, consider the relation between these components and the network reliability for an all-satellite system.

Figure 3.2-8 is a conceptual block diagram of an all-satellite system. Two satellites would be recommended, one for back-up in the unlikely event the first fails. An alternative concept, minimizing the impact of a satellite outage is the interleaved station satellite approach, where every other station uses a different one of the two satellites. Thus, only half the line goes down in the

FIGURE 3.2-8

SATELLITE COMMUNICATIONS NETWORK

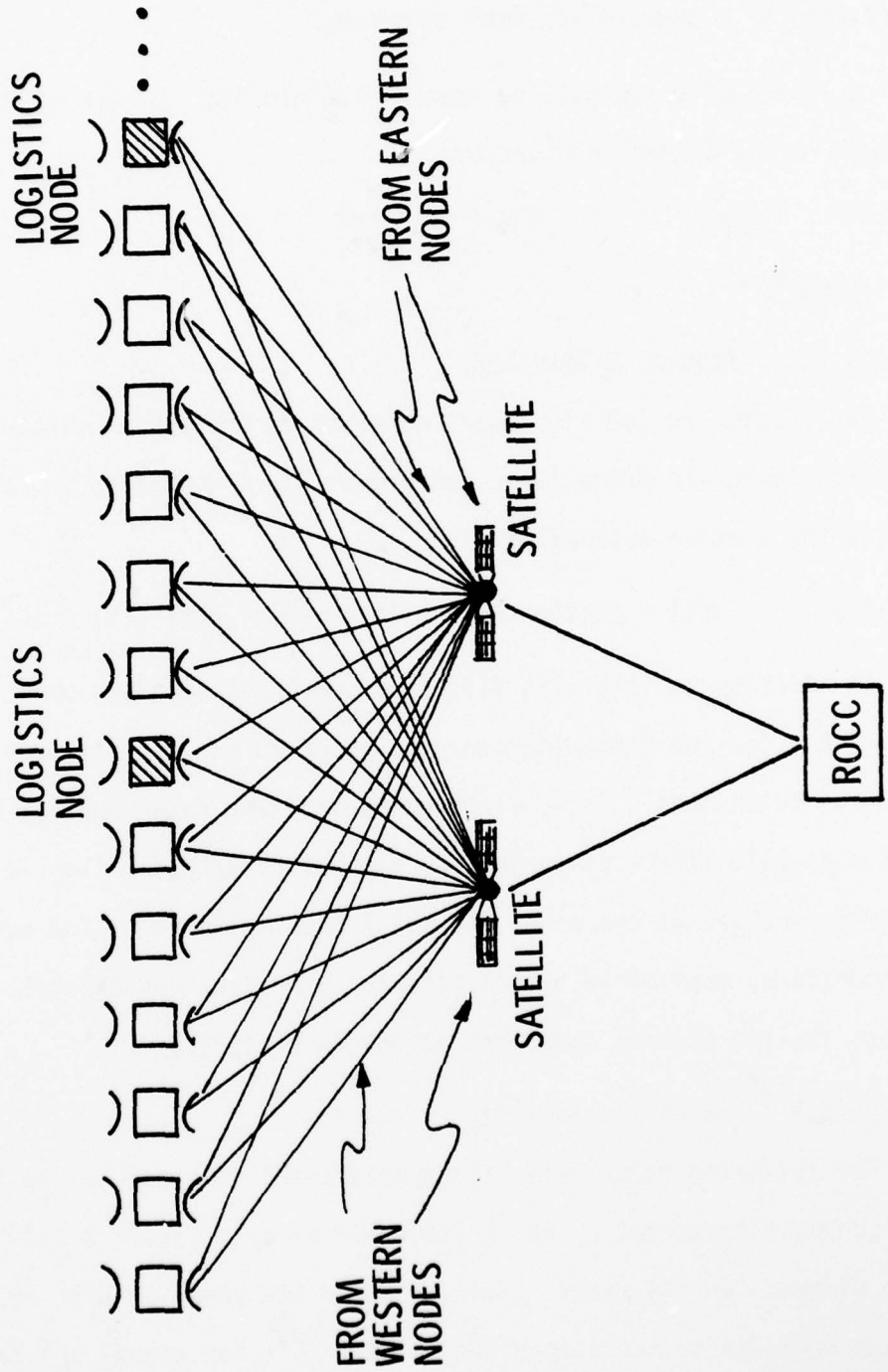

event of a satellite outage. However, these alternates do not affect the following network reliability calculations, as the reliability of the satellite itself is so much greater than those of the network.

The only mode of network failure in the all-satellite system is loss/degradation of n or more adjacent stations.

In terms of the satellite station reliability, S, the network (segment) reliability is therefore given by:

$$(3.2-27) \quad R_{NET} = 1 - (1 - Q^2) \left(1 - \frac{Q^2 S}{1 - Q^2}\right)$$

where $Q = 1 - S$

3.2.3.1.5.1 Station Reliability

The station reliability model consists of the serial cascade of radar, communications, and prime power components, as illustrated in Figure 3.2-9, so that the station reliability is:

$$(3.2-28) \quad S(t) = \text{station reliability} = R(t) P(t) C(t)$$

In addition to involving different communications equipment than the LOS system, the in-line communications equipment in the satellite system involves only the transmit channel. Thus, although control and interrogation of the unattended station is lost if the communication channel receive function fails, radar data is still received at the nodes via the transmit channel. The network reliability is, therefore, unaffected by the receive communications channel. The reliability of each in-line station component is now investigated.

3.2.3.1.5.1.1 Radar Reliability

The following radar reliability assessment is based on the technology and configuration presented by GE in its U/MAR study. Figure 3.2-10 is a reliability block diagram for the radar. Failure rates are based on high reliability JANTXV quality solid-state technology and class A IC's for signal and data processing. Table 3.2-12 summarizes the radar reliability versus time, for various preventative maintenance (PM) intervals.

FIGURE 3.2-9 STATION RELIABILITY

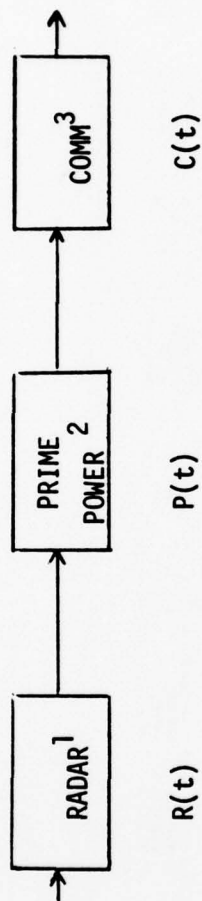

- 1 RADAR RELIABILITY MODELS BASED ON U/MAR STUDY
- 2 PRIME POWER RELIABILITY FROM GE NASS POWER STUDY
- 3 COMMUNICATIONS RELIABILITY FROM
--MCDONALD ESD FOR MID-TERM PRESENTATION
--GE DAYTONA FOR FINAL REPORT

FIGURE 3.2-10
UNATTENDED RADAR RELIABILITY BLOCK DIAGRAM

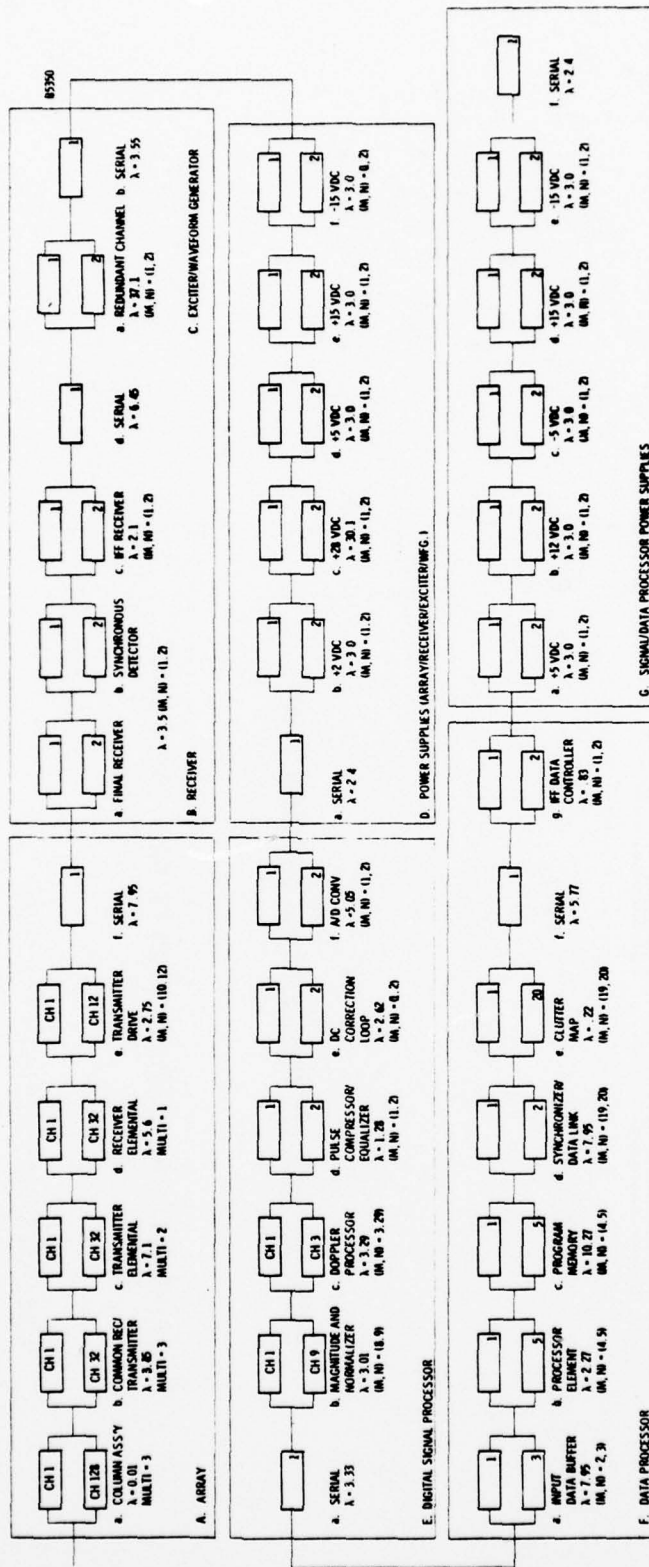

TABLE 3.2- 12

RADAR RELIABILITY VERSUS PM INTERVAL

TIME (Mo)	RELIABILITY PM INTERVAL (Mo)					
	12	6	4	3	2	1
0	1.0000	1.0000	1.0000	1.0000	1.0000	1.0000
1	.9744	.9744	.9744	.9744	.9744	.9744
2	.9449	.9449	.9449	.9449	.9449	.9445
3	.9121	.9121	.9121	.9121	.9207	.9251
4	.8764	.8764	.8764	.8887	.8928	.9015
6	.7978	.7978	.8281	.8319	.8436	.8559
10	.6164	.6992	.7258	.7394	.7532	.7715
12	.5131	.6365	.6731	.6421	.7117	.7326

The radar reliability $R(t)$ associated with periodic maintenance at intervals T , is related to the maintenance free radar reliability $R_0(t)$ by:

$$(3.2-29) \quad R(t) = p_r \text{ (zero failures in } 0, t)$$

$$R(t) = R_0(T) R_0(t - kT) \quad (K)T \leq t \leq (K + 1)T$$

$$K = 0, 1, 2, \dots$$

This expression assumes that the radar is restored to its initial state of quality at each PM (i.e., all failed redundant components replaced).

Since the mean-time-between-failures of a system is related to its reliability by:

$$(3.2-30) \quad \text{MTBF} = \int_0^{\infty} R(t) dt$$

it follows that the radar MTBF depends on the PM interval as:

$$(3.2-31) \quad \text{MTBF} = \frac{\int_0^{\infty} R_0(t) dt}{1 - R_0(T)}$$

Table 3.2-13 summarizes the radar mean-time-between-failures versus PM interval.

TABLE 3.2-13
RADAR MEAN-TIME-BETWEEN-FAILURES VERSUS PM INTERVAL

<u>PM INTERVAL</u> <u>Mo.</u>	<u>MTBF</u>	
	<u>Hours</u>	<u>Months</u>
1	25,070	34.82
2	23,792	33.04
3	22,588	31.37
4	21,449	21.79
6	19,344	26.87
12	14,074	19.55

The mean-time-between-failures indicated in Table 3.2-13 apply to the GE unattended radar design as presented in the GE U/MAR study. This radar was designed and costed for three months maintenance-free operation, with a probability of mission success of 90%. Detailed designs for six and 12 month maintenance-free designs have not been carried out. Furthermore, a

groundrule of this study was that no detailed "black box" designs/redesigns were desired. Even so, it is possible to generate rough estimates of the costs involved. The question of primary interest is whether it is better to have a low acquisition cost three month radar with more maintenance, or a higher acquisition cost six or twelve month radar with less maintenance.

The radar recommended by GE utilized very high quality, highly reliable components. Further increases in radar reliability would, no doubt, be achieved primarily through increased redundancy. The details of the most cost-effective radar components on which to focus for this purpose are beyond the scope of this study. However, a conservative approach, conceptual in nature, would be to make the entire radar operationally redundant. The reliability of n operationally redundant equipments with individual reliability R(t) is:

$$(3.2-32) \quad R_n(t) = 1 - (1 - R(t))^n$$

To achieve a reliability of .9 at six and twelve months respectively with the individual radar reliability R(t) as in the GE design, requires operational redundancy levels of n = 1.5 and n = 3.2 respectively. Since there are no weak areas in the GE design (where adding redundant relatively low cost components produces a large impact on overall radar reliability), it is reasonable to expect that acquisition costs would rise in rough proportion to these factors. The acquisitions costs* for 83, three month unattended radars (including unitized module/radome) is \$65.8M. Acquisition cost increases associated with the above redundancy levels are about \$33M and \$145M respectively for six and twelve month maintenance free operation. It is not clear how these amounts could be recouped through decreased maintenance over the system life. This is one of the reasons a three month maintenance free radar is recommended for the DEWLine application.

* Production and development.

3.2.3.1.5.1.2 Prime Power Reliability

Prime power reliabilities are based on results in the GE/NASS study of 1976. Prime power generation approaches are re-examined for potential trades in this study, and the result has been to reaffirm the diesel system selection, but not in the exact form as presented therein. The diesel system recommended in the GE/NASS report consisted of two 2 KW generators and a 12 KW generator.

Based on a more austere support concept for the maintenance personnel when they are on site, the system recommended in this report consists of three 4 KW generators. This replacement of the 12 KW generator with a 4 KW generator has no effect on the following reliability analysis, however, because the 12 KW, 4 KW, and 2 KW generators all have identical parts, and their failure rates are essentially the same. The prime power system reliability block diagram is presented in Figure 3.2-11, for an arbitrary number of redundant diesel engines.

Table 3.2-14 is a three month reliability assessment of a four engine diesel system, as presented in the GE/NASS study section 4. The reliability of an N engine system is given by:

$$(3.2-32) \quad P(t) = e^{-3.083 \times 10^{-6}t} - 2.96 \times 10^{-6}t \left(\sum_{K=0}^{N-1} (2.96 \times 10^{-6})^K / K \right)$$

where N-1 engines are in a standby back-up role, and t is in hours.

TABLE 3.2-14
RELIABILITY ASSESSMENT DIESEL POWER SYSTEM

COMPONENT	NO. NEEDED/ NO. AVAILABLE	FAILURES PER MILLION HOURS	RELIABILITY	
			NON-REDUNDANT	REDUNDANT
Diesel Engine	(1/1)	1.0	.99781	
Generator	(1/1)	.4	.99912	
Fuel Pump	(1/1)	1.12	.99755	
Starter	(1/1)	.2	.99956	
Controls	(1/1)	.24	.99947	
	(1/4)	2.96	.99354	.99999
Fuel Tank	(1/1)	.083	.99982	.99982
Controls	(1/1)	3.0	.99345	.99345
System				.99326

FIGURE 3.2-11

RELIABILITY DIAGRAM DIESEL POWER SYSTEM

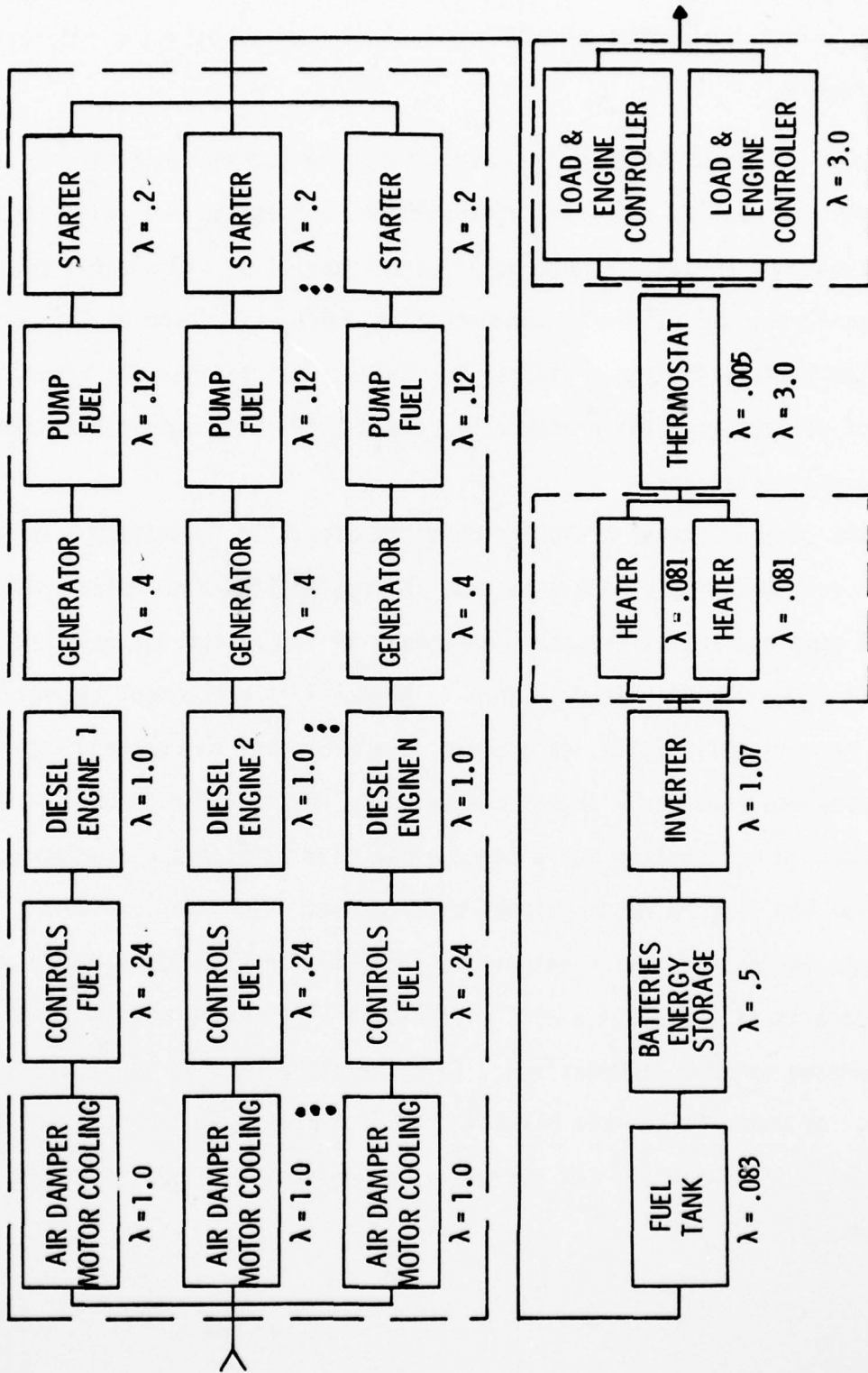

Table 3.2-15 summarizes prime power diesel system reliability versus time and redundancy. For two or more engines, there is little difference in the system reliability since the system reliability is then dominated by the reliability of its controls.

3.2.3.1.5.1.3 Line-of-Sight (LOS) Microwave Communications Reliability

For the purposes of reliability assessment, a repeater and radar station communications are serial. A more detailed discussion of the sizing, design, and performance of the LOS microwave communications system is found in Section 3.5. A simplified reliability block diagram for this system is shown in Figure 3.2-12. In terms of reliability, the repeater has the same in-line components, except for the channel equipment.

The LOS communications equipment which is discussed in Section 3.5 of this report is represented by a single path of the reliability block diagram in Figure 3.2-12. A complete set of (standby) redundant equipment for the radar station and repeater is shown in this figure. This is primarily a conceptual technique to raise LOS network reliability, as opposed to a practical recommended approach. Although complete redundancy is not necessary in the baseline network configurations, some increase in reliability would be necessary for maintenance loading compatibility with some of the reduced manning level alternatives which are considered. Allowing for complete redundancy raises network reliability for the LOS microwave system to a point where it is competitive with an all-satellite system and compatible with the reduced manning network alternatives. This permits a coarse, equal performance comparison of costs to be made between the LOS microwave and satellite approaches.

Table 3.2-16 summarizes LOW microwave communication reliability versus time and redundancy.

TABLE 3.2- 15

DIESEL SYSTEM RELIABILITY VERSUS REDUNDANCY

<u>TIME (Mos)</u>	<u>ENGINE REDUNDANCY</u>			
	<u>1</u>	<u>2</u>	<u>3</u>	<u>4</u>
	1.000	1.000	1.000	1.000
1	.9955	.9977	.9977	.9977
2	.9912	.9954	.9955	.9955
3	.9868	.9932	.9932	.9932
4	.9825	.9910	.9910	.9910
5	.9781	.9887	.9888	.9888
6	.9738	.9865	.9865	.9865
7	.9695	.9842	.9843	.9843
8	.9653	.9820	.9821	.9821
9	.9610	.9797	.9799	.9799
10	.9568	.9775	.9777	.9777
11	.9526	.9752	.9755	.9755
12	.9484	.9730	.9733	.9733
13	.9442	.9707	.9711	.9711
14	.9401	.9685	.9689	.9689
15	.9359	.9663	.9667	.9668
16	.9318	.9640	.9646	.9646
17	.9277	.9618	.9624	.9624
18	.9236	.9595	.9602	.9602
19	.9196	.9573	.9581	.9581
20	.9155	.9551	.9559	.9559
21	.9115	.9528	.9538	.9538
22	.9075	.9506	.9516	.9516
23	.9035	.9484	.9495	.9495

FIGURE 3.2-12

LOW MICROWAVE COMMUNICATIONS RELIABILITY DIAGRAM

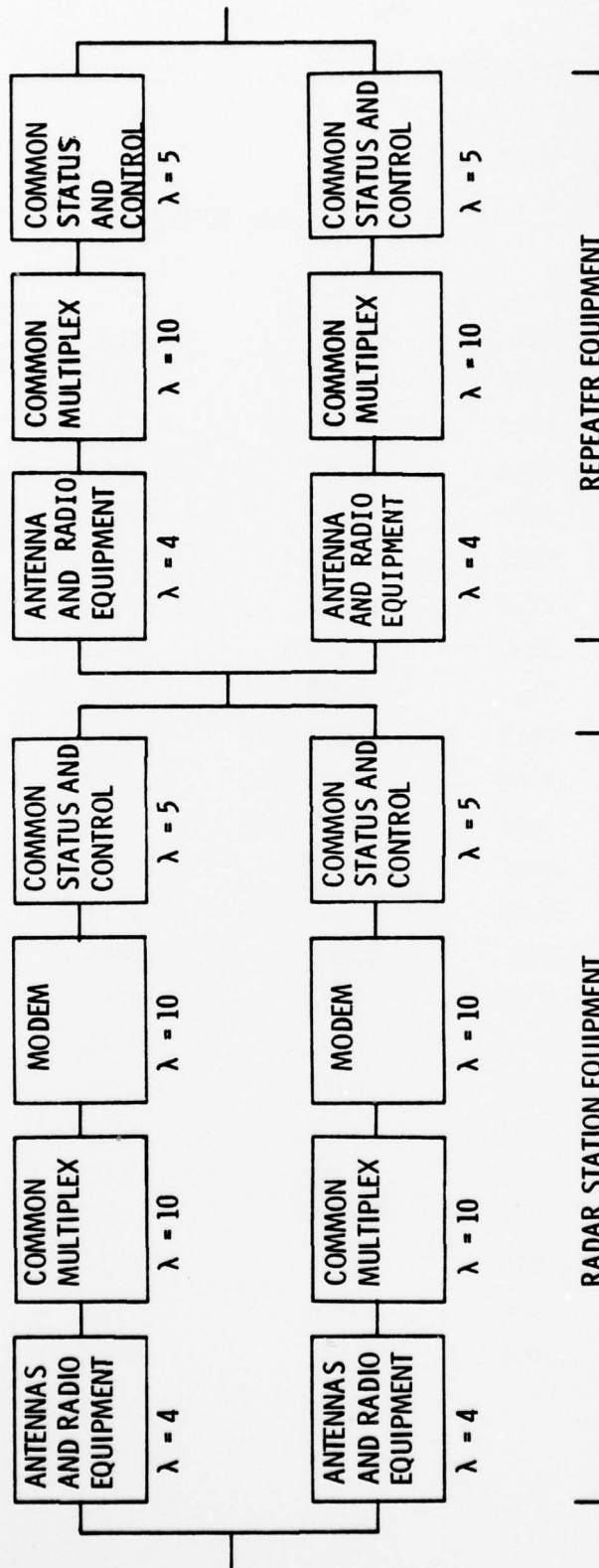

AD-A059 510

GENERAL ELECTRIC CO SYRACUSE N Y ELECTRONIC SYSTEMS DIV F/G 17/9
UNATTENDED RADAR STATION DESIGN FOR DEWLINE APPLICATION. VOLUME--ETC(U)
JAN 78 W E ABRIEL, S E BELL, E J GERSTEN F19628-77-C-0212

UNCLASSIFIED

2 of 3

AD
A059510

FSD-TR-78-176-VOL-2

NL



TABLE 3.2-16
 LOS MICROWAVE COMMUNICATIONS STATION RELIABILITY VERSUS TIME
 AND REDUNDANCY

<u>TIME (Mos)</u>	<u>RELIABILITY</u>	
	<u>1</u>	<u>2</u>
	1.0000	1.0000
1	.9655	.9994
2	.9323	.9976
3	.9002	.9948
4	.8692	.9910
5	.8392	.9863
6	.8103	.9807
7	.7824	.9744
8	.7555	.9673
9	.7295	.9595
10	.7044	.9512
11	.6801	.9423
12	.6567	.9328
13	.6341	.9229
14	.6122	.9126
15	.5912	.9019
16	.5708	.8908
17	.5511	.8795
18	.5322	.8678
19	.5138	.8560
20	.4961	.8439
21	.4791	.8316
22	.4626	.8192
23	.4466	.8066

3.2.3.1.5.1.4 Satellite Station Communication Reliability

in an all-satellite communications network, only the transmit equipment is in-line with radar data. An all-satellite communications network is discussed more fully in Section 3.5. A simplified block diagram of the transmit portion of the satellite ground station is offered in Figure 3.2-13.

Table 3.2-17 shows the satellite ground station reliability versus time.

If the major station in-line components are considered to be cascaded, as implied by the station reliability block diagram in Figure 3.2-9, station reliability is as summarized in Table 3.2-18. All station related reliabilities are plotted in summary in Figure 3.2-14, including reliabilities for the satellite ground station, the LOS microwave station and repeater, and a completely redundant LOS microwave station and repeater.

TABLE 3.2-17
STATION RELIABILITY

<u>T</u>	<u>RADAR</u>	<u>PRIME POWER*</u>	<u>SAT COMM</u>	<u>LOS COMM**</u>
0	1.0000	1.0000	1.0000	1.0000
1	.9744	.9977	.9860	.9655
2	.9449	.9955	.9718	.9323
3	.9121	.9933	.9575	.9002
4	.8764	.9910	.9430	.8692
6	.7978	.9888	.9136	.8104
8	.7030	.9822	.8840	.7555
10	.6164	.9778	.8543	.7044
12	.5181	.9773	.8246	.6567

* Two or more generators

** No standby redundancy equipments

TABLE 3.2-18
SATELLITE GROUND STATION RELIABILITY

<u>TIME (Mos)</u>	<u>1</u>
0	1.0000
1	.9860
2	.9718
3	.9574
4	.9429
5	.9283
6	.9136
7	.8988
8	.8840
9	.8691
10	.8542
11	.8394
12	.8245
13	.8097
14	.7950
15	.7803
16	.7657
17	.7512
18	.7368
19	.7225
20	.7084
21	.6943
22	.6804
23	.6667

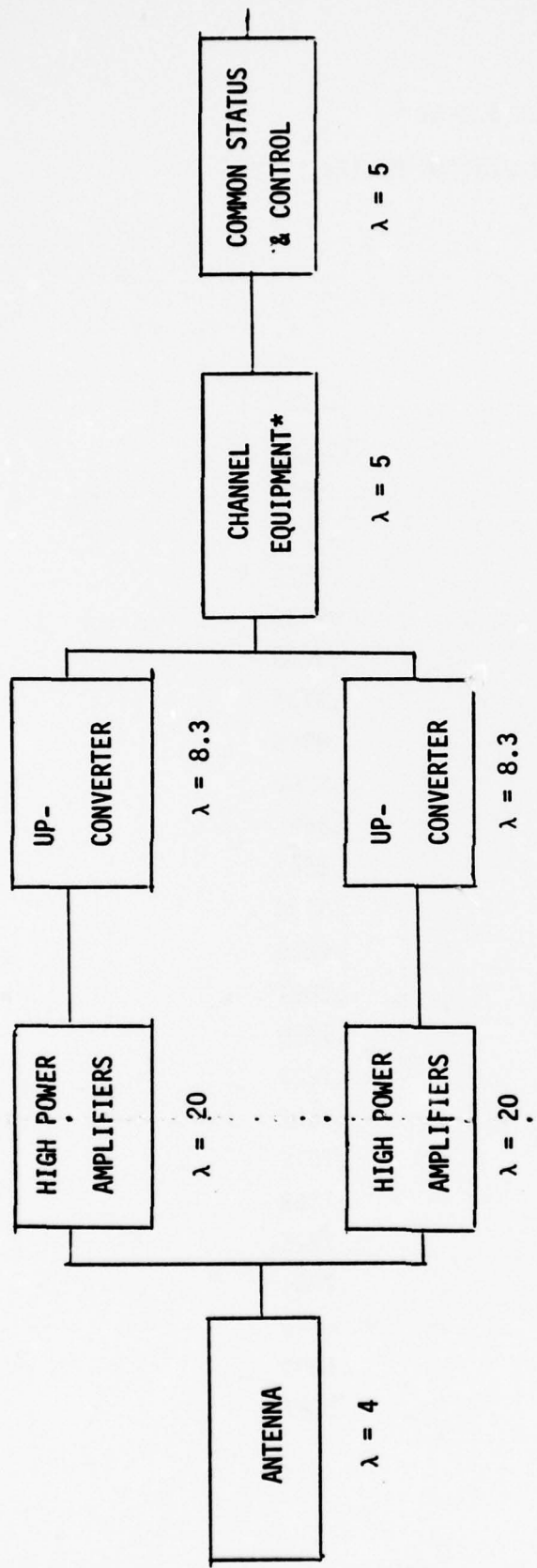

* MODULATOR, MULTIPLEX EQUIPMENT

FIGURE 3.2-13. SATELLITE GROUND STATION RELIABILITY BLOCK DIAGRAM--TRANSMIT PATH

FIGURE 3.2-14
STATION RELIABILITIES

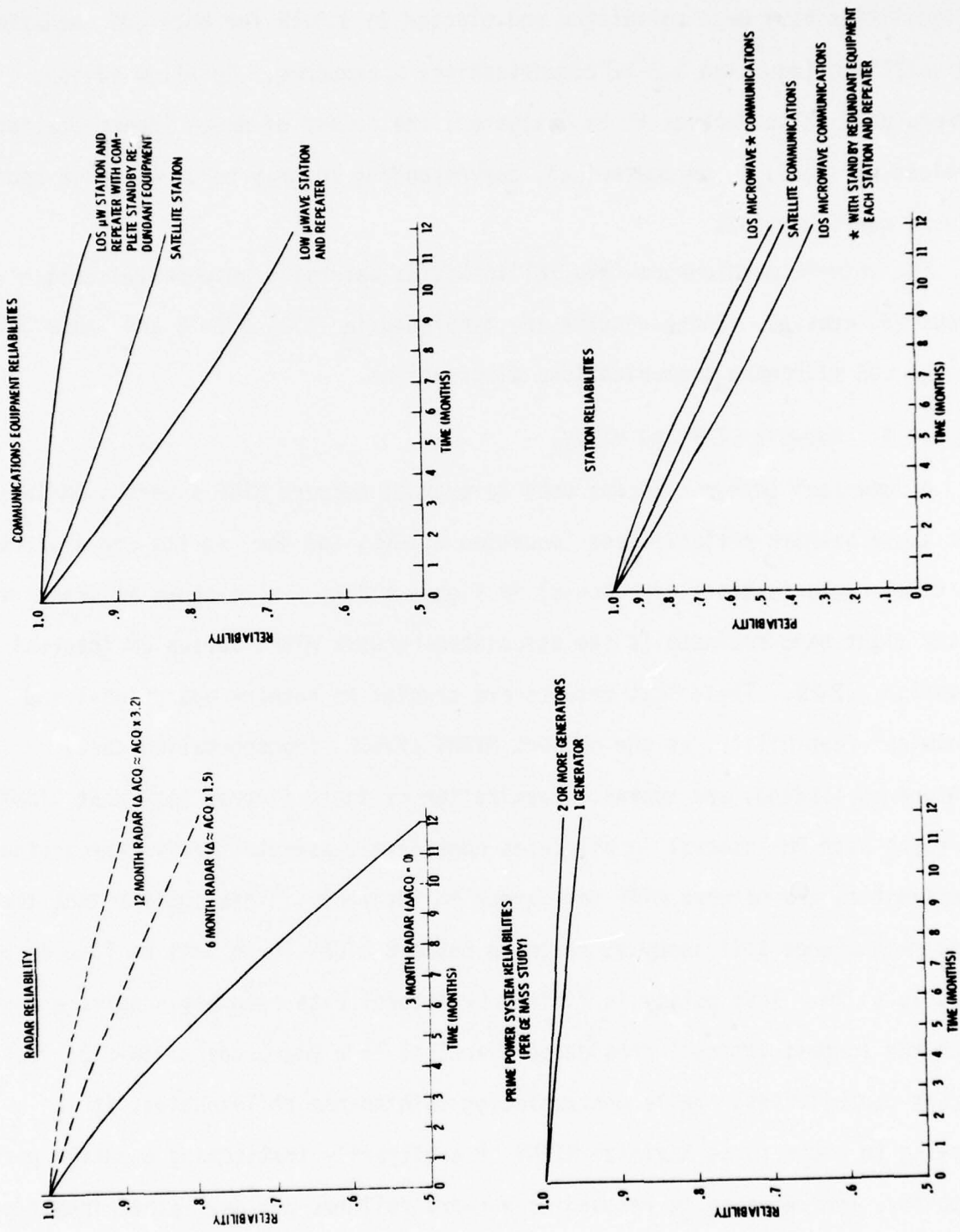

Using the foregoing station in-line component reliabilities, network reliabilities have been calculated and plotted in 3.2-15 for both LOS (equation 3.2-24) and satellite (equation 3.2-27) communications approaches. To allow various network nodal alternatives to be evaluated, the number of nodes (hence stations serviced per node) is parameterized, corresponding roughly to 3, 4, and 6 node network configurations.

The network maintenance-free reliabilities determine network reliabilities versus PM interval. These results are tabulated in Table 3.2-18 and Table 3.2-19 for the LOS microwave communications alternatives.

3.2.3.1.6 Network MTBF and MTBMV

A numerical integration was used to extract network MTBF's versus PM interval from these network reliabilities (equation 3.2-22), and the results are plotted (for the three communications approaches) in Figure 3.2-16. Also shown in these plots on the right hand ordinate is the associated network MTBMV versus PM interval (equation 3.2-21). These last results are crucial to network operational and economical feasibility, as the network MTBMV affects transportation cost, maintenance loading, and spares. Examination of these figures show that MTBMV increases with PM interval in all cases considered; asymptotically approaching the same limit as the network MTBF for larger PM intervals. This implies that the best mixed maintenance philosophy to maximize network MTBMV is to wait as long as possible to PM. This policy is limited by lateral site resupply requirements, for which the longest interval considered practical is a year, due to on-site fuel storage capabilities. While contemplating maintenance philosophies, it is tempting to 'brute force' maximize MTBMV by arbitrarily instituting a purely periodic PM policy, and refusing to respond to network failures per se, rather insisting that they wait for the next scheduled PM visit. Such a policy results in poorer

FIGURE 3.2-15

NETWORK RELIABILITIES VS NUMBER OF NODES

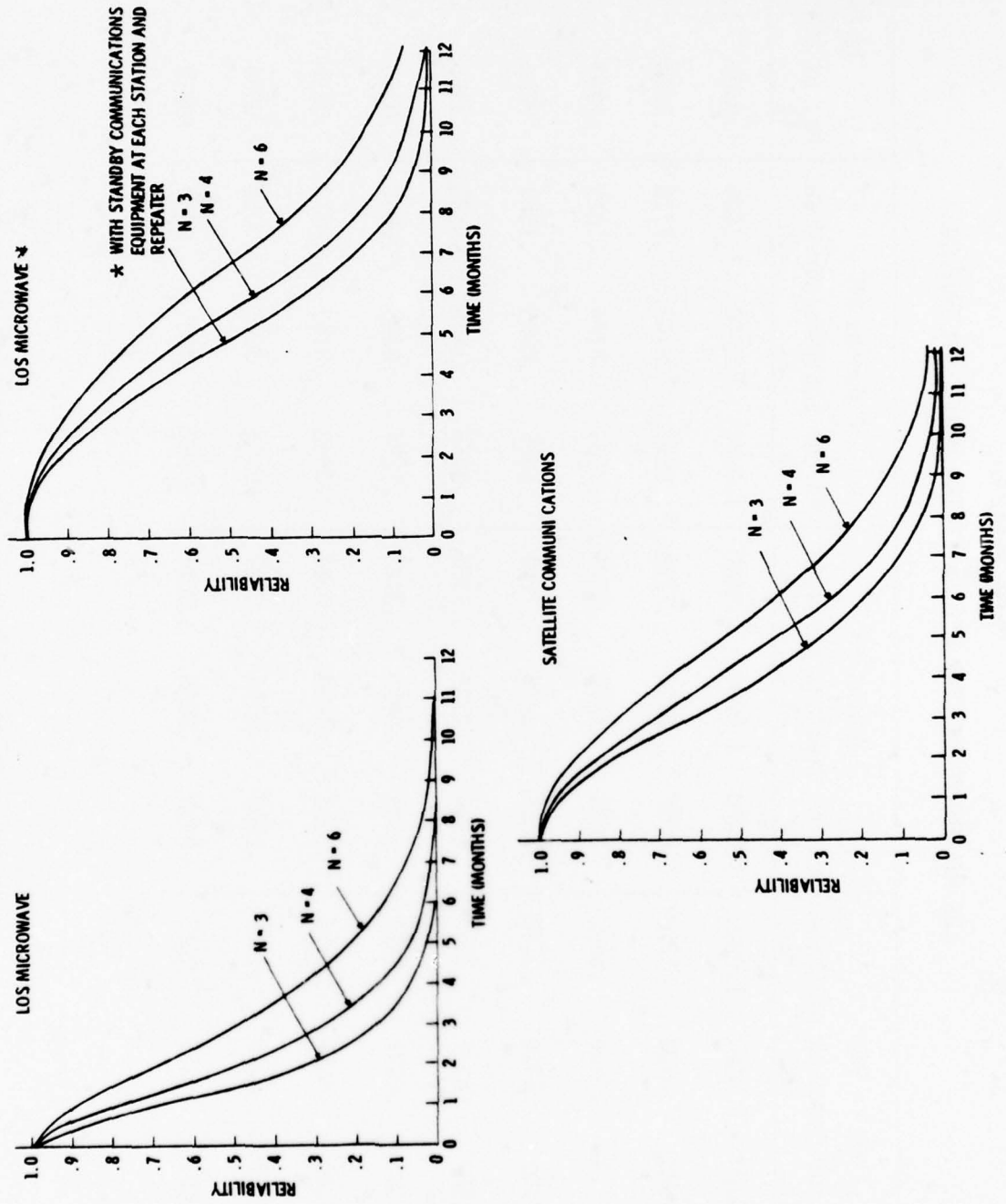

TABLE 3.2-18

LOS MICROWAVE NETWORK RELIABILITIES VERSUS PM INTERVAL

t (MOS)	1 Month PM		3 Months PM		6 Months PM		12 Months PM	
	No. of Stations per Node 14	No. of Stations per Node 21	No. of Stations per Node 14	No. of Stations per Node 21	No. of Stations per Node 14	No. of Stations per Node 21	No. of Stations per Node 14	No. of Stations per Node 21
0	1.0000	1.0000	1.0000	1.0000	1.0000	1.0000	1.0000	1.0000
1	.9008	.8103	.9008	.8103	.9008	.8103	.9008	.8103
2	.8114	.6566	.7063	.5174	.7063	.5174	.7063	.5174
3	.7309	.5320	.5055	.2883	.5055	.2883	.5055	.2883
4	.6584	.4311	.4554	.2336	.3365	.1448	.3365	.1448
6	.5343	.2831	.2555	.0831	.1274	.0295	.0353	.0038
8	.4334	.1859	.1805	.0430	.0900	.0153	.0353	.0038
10	.3518	.1220	.1163	.0194	.0644	.0043	.0088	.0004
12	.2855	.0801	.0653	.0069	.0162	.0009	.0018	.0000

TABLE 3.2-19
LOS MICROWAVE NETWORK RELIABILITIES * VERSUS PM INTERVAL

t (Mos)	No. Stations Per Node 1 Month PM		No. Stations Per Node 3 Month PM		No. Stations Per Node 6 Month PM		No. Stations Per Node 12 Month PM	
	14	28	14	28	14	28	14	28
0	1.0000	1.0000	1.0000	1.0000	1.0000	1.0000	1.0000	1.0000
1	.9909	.9856	.9909	.9856	.9909	.9856	.9909	.9856
2	.9819	.9714	.9591	.9352	.9591	.9352	.9591	.9352
3	.9729	.9574	.9003	.8445	.9003	.8445	.9003	.8445
4	.9641	.9436	.8921	.8323	.8144	.7183	.8144	.7183
6	.9466	.9167	.8105	.7132	.5917	.4314	.5917	.4314
8	.9295	.8904	.7774	.6670	.5675	.4034	.3318	.1716
10	.9126	.8650	.7231	.5936	.4819	.3099	.1646	.0567
12	.8961	.8402	.6570	.5086	.3501	.1861	.0641	.0131

* With standby redundant communication equipment.

FIGURE 3-2-16
 NETWORK MTBF'S AND MTBMV'S VS PM INTERVAL

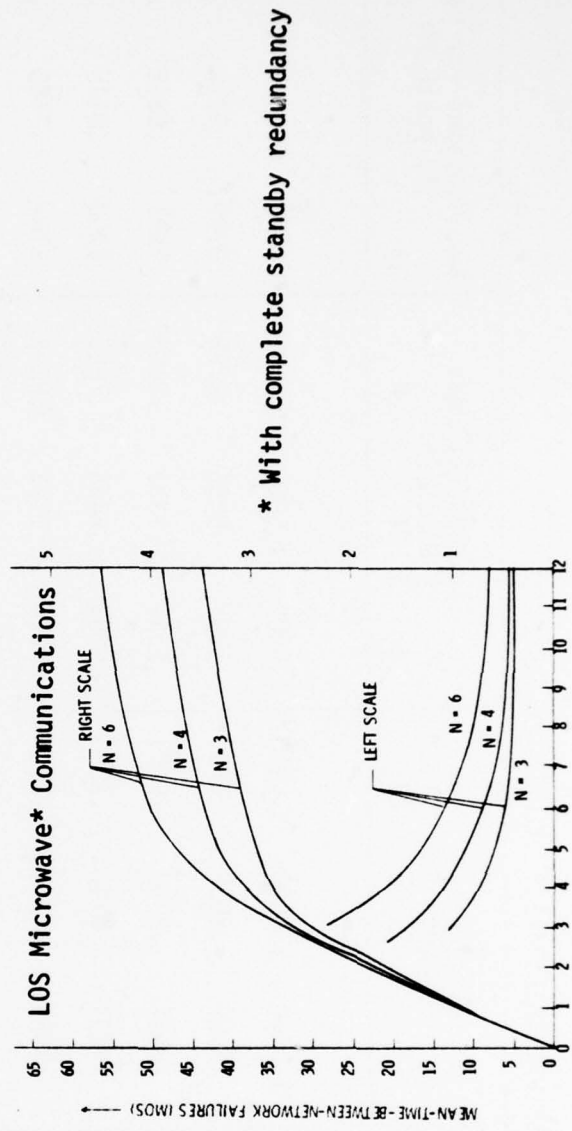
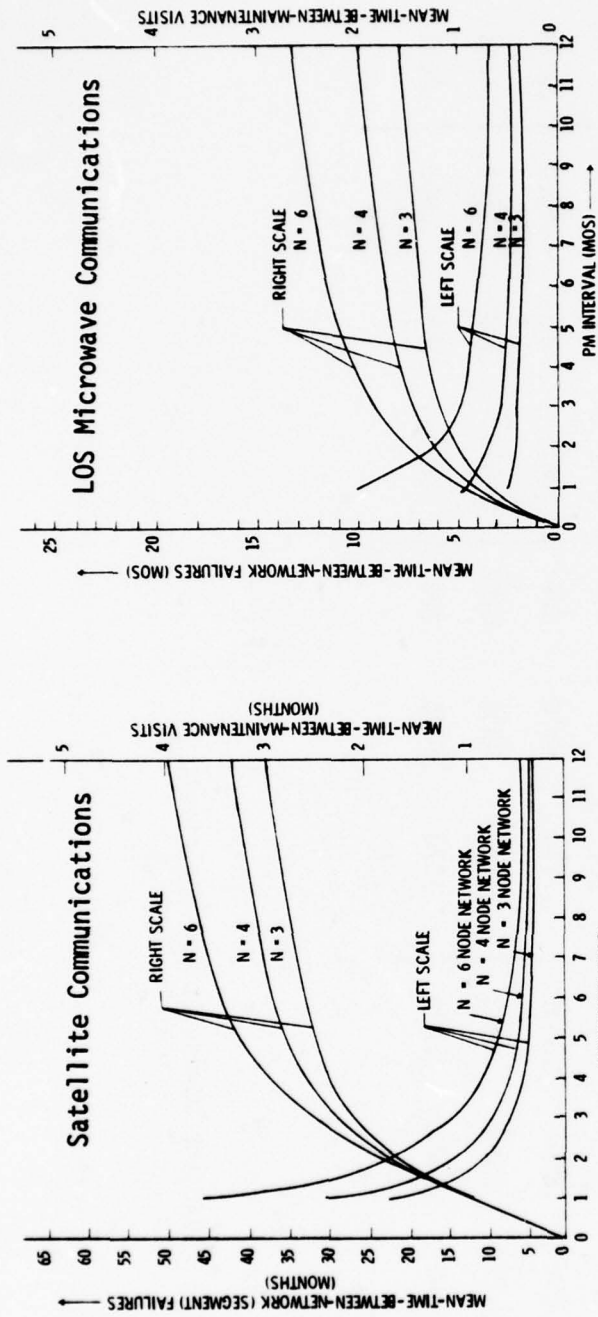

network operational availability. Network segment availability relations for the two types of maintenance policy are as follows:

$$(3.2-34) \quad A = \text{Fractional time network operational/year} \\ = 1 - \text{MTF} \quad \text{MTF} = \text{Network Down Time/Year}$$

- Maintenance Philosophy 1 (Mixed)

$$(3.2-35) \quad \text{MTF} = (\text{MTTR} + \text{FOT} + \text{WD})/\text{MTBF} \quad \left\{ \begin{array}{l} \text{MTTR} = \text{Mean time to repair} \\ \text{FOT} = \text{Fly out time to site} \\ \text{WD} = \text{Weather delay} \end{array} \right.$$

- Maintenance Philosophy 2 (PM Only)

- Down Time dominated by waiting time to PM

$$(3.2-36) \quad \text{MTF} = \frac{T}{1 - R(T)} - \text{MTBF} \quad T = \text{PM Interval}$$

Consider the mixed maintenance philosophy. Assuming that the sites causing the network failure are visited first, the network is operational after one site visit. The mean-time-to-repair a site is, conservatively, three hours according to the GE U/MAR and NASS studies. The average fly-out time to a site depends on the average distance traveled and the aircraft speed. For a 6 node system and a 100 knot aircraft, it is approximately $\frac{14 \times 40/4 \text{ nmi}}{100 \text{ knots}} = 1.4$ hours. Allowing for a (conservative) 24 hour weather delay per trip, the mean-down-time of the network (segment) per failure is about 28.4 hours. The network (segment) MTBF is about 3.4 months for a 6 node network with LOS communications (Figure 3.2-16). Hence, about $12/3.4 \approx 3.53$ failures per year for the network segment are expected. Thus, the total average down-time of a network segment is about $3.53 \times 28.4 \approx 100$ hours per year, which corresponds to a segment availability of nearly 99%. On the other hand, for a purely periodic PM policy, the mean down time per year is dominated by

the waiting time until the next PM. For a 6 node network, which utilizes a LOS communications approach, if a PM interval of, say, three months is arbitrarily specified, then the average network (segment) down time per failure is:

$$MTF = \frac{3}{1 - R(3)} - MTBF(3) = \frac{3}{1 - .5} - 4.77 = 1.23 \text{ months (see Figure 3.2-15 and 3.2-16)}$$

Since failures occur at a yearly rate of $12/MTBF(3) = 12/4.77 \approx 2.5$ per year, the average down time per year is $1.23 \times 2.5 \approx 3.1$ months for an availability of approximately 74%. Network segment availabilities for other combinations of numbers of nodes, communications approaches, and maintenance philosophies are summarized for the satellite system in Table 3.2-20. This table makes the superiority of a mixed policy over a purely periodic PM policy evident.

TABLE 3.2-20
NETWORK SEGMENT AVAILABILITY COMPARISON

PM Interval	Number Sites Per Segment	Network Segment Availability %					
		Mixed Maintenance Philosophy			Periodic PM Only		
		N = 14	N = 21	N = 28	N = 14	N = 21	N = 28
1	Satellite Network	99.92	99.87	99.82	98.92	98.51	97.75
3		99.74	99.61	99.47	92.85	88.89	85.27
6		99.53	99.32	99.13	71.50	56.52	42.04
12		99.35	99.16	99.01	-	-	-
1	LOS Network	99.60	99.17	98.65	94.72		
3		99.19	98.58	97.94	72.81		
6		98.95	98.36	97.79	13.74		
12		98.87	98.34	97.78	-		

Transportation Cost Summary

Baseline Network Configuration

The maximum MTBMV for the baseline 6 node network using LOS microwave communications results from a mixed maintenance policy with response to network failures as they occur plus yearly resupply/PM, and is approximately 2.66 months. (Figure 3.2-16). The resulting transportation cost for AF S61 helicopters and crews over the 20 year life cycle of the system is therefore (see Figure 3.2-5)

$$C_4 = \frac{\$20.84M}{2.66} + \$6.84M = \$14.31M$$

If the same conditions prevail except the LOS microwave communications is implemented with the reliability associated with complete redundancy, as previously described, the MTBMV is 4.5 months, giving a transportation cost of:

$$C_4 = \frac{\$20.84M}{4.5} + \$6.48M = \$11.1M$$

For an all-satellite 6 node network, the MTBMV is approximately four months (Figure 3.2-16). The resulting transportation costs for the same conditions as above are:

$$C_4 = \frac{\$20.84M}{4} + \$6.48M = \$11.69M$$

The transportation cost for each network nodal alternative is summarized in Table 3.2-21. Additional helicopter contractor overhead costs are displayed separately from the flight-hourly plus crew costs in this table to facilitate realistic comparisons of Air Force and contractor costs. It must be assumed that, at some echelon, the Air Force also must incur similar additional overhead costs.

20 YEAR TRANSPORTATION COST SUMMARY ¹

Network Nodal Alternative	C ₄ TRANSPORTATION COST (\$M)		
	Air Force S61 Aircraft/Crews	Commercial S76 Helicopters and Civilian Crews	Additional Overhead ²
Baseline and Alternate 1	\$ 14.31M 11.11 11.69	\$ 24.35M 22.84 23.11	\$ 65.76M
Alternate 2	9.98 10.80	14.62 15.01	76.72
Alternate 3	14.65 10.38 11.15	18.95 16.93 17.29	76.72
Alternate 4	11.15	17.29	76.72
Alternate 5	15.93 11.18 12.04	19.26 17.01 17.42	43.84
Alternate 6	11.34	13.61	54.80

¹ Includes helicopter trip from node to site for resupply but no shuttles from barge to site.

* With complete standby communications redundancy.

² Beyond crew costs.

3.2.3.2 Annual Resupply Cost

An on-site fuel storage capacity of 5000 gallons is sufficient to meet yearly site power requirements with a 25% margin. Fuel is the largest item of on-site storage with an estimated 4000 gallons (27,000 lbs.) required on an annual basis. Resupply would be accomplished by helicopter from the sealift barges. Special tanks filled on the barge can be sling lifted to the site helicopter pad and pumped through an in-place pipe line to the storage tanks. Helicopter airlift is recommended to re-supply land-locked sites such as CAM-4, CAM-5, FOX-3, Dye-2 and Dye-3.

The cost of flying a helicopter to the barge from the logistics node has been included in the transportation cost. The cost of the several trips required to shuttle the fuel from the barge to the site has the effect of increasing the cost of fuel delivered to the sites. The annual resupply cost then becomes a factor in C_g , power generation costs. Data from ADCOM on the present sealift operation gives a base cost of \$.67/gallon for fuel delivered to present DEWLine sites via Pacer Alaska, Pacer Mack, Pacer DEW, Pacer Basin, Pacer Pine, and Pacer Goose. For the land-locked sites, the cost of fuel delivered to Pelly Bay is \$2.08/gallon and is used as a base onto which helicopter shuttle costs are added.

The five land-locked sites involve an average round trip of about 1.14 hours for the S61 (averaging 95 knots). At \$490 per flight hour, the cost per gallon of fuel delivered to the land-locked sites therefore averages to $\$2.08/\text{gallon} + \$490 \times 1.14/600 \text{ gallons} = \$3.0/\text{gallon}$. A total of 78 sites have base fuel costs of \$.67/gallon. The six logistics nodes require no shuttles. Round-trip flying times vary from about 18 minutes to 2.7 hours for the remaining 72 sites, and result in delivered fuel costs from \$.92 to \$2.88 per gallon. Averaging these costs over all 83 sites gives a cost of \$1.33/gallon for all station mission related diesel fuel. The total cost of this fuel for 20 years, 83 stations, 4000 gallons/year, is \$8.83M.

Another \$.06M is required for site lube oil at 20 gallons/year, \$1.90/gallon, 83 sites, 20 years, for a total of \$8.89M 20-year annual resupply costs.

At .12 gallons/KW-hour efficiency, which is expected from the diesel prime power system, The \$1.33/gallon converts to about \$.17/KW-hour for station power while the \$.67/gallon at the nodes converts to about \$.08/KW-hour.

3.2.3.3 Personnel Support Costs

It was verified early in this study that the single largest cost of operating and maintaining the baseline unattended radar network is the cost of manning the logistics nodes, i.e., support personnel costs. Therefore, potential personnel support reduction alternatives have been the focus of considerable attention in this study. The life cycle cost model properly develops personnel support costs by job position and salary at each manned node as follows:

$$(3.2-37) \quad C_5 = \sum_{N=1}^{NLN} PIUP \left(\sum_{M=1}^{JP} (NP_M \times CP_M) + \left(\sum_{M=1}^{JP} ACPS \ NP_M \right) \right)$$

PIUP = 20 years

ACPS = Average cost of personnel support: provisions, recreational, medical, supplies

JP = Number of job positions

NP_M = Number of persons in position M

CP_M = Annual cost of position M

NLN = Number of logistics nodes (4,6)

ACPS = Average cost of personnel support: provisions, medical, recreationa, supplies
 Since aircraft crew costs are included in the transportation costs, they are not included here.

3.2.3.3.1 Criteria

The proposed manning for the logistics nodes is categorized for the baseline system consisting of six full logistics nodes and for the alternate maintenance concepts wherein various combinations of full logistics nodes, mini-nodes, data

nodes, reduced logistic nodes, modified-reduced logistic nodes and modified logistic nodes are envisioned. This nomenclature for logistics nodes is introduced primarily for reference and analysis purposes, according to the functions to be performed at the nodes, and the nature and size of its support crew. A full logistics node on the unattended DEWLine is envisioned to be about the size (in facilities and support personnel) of a present day auxiliary site. Maintenance loading analyses to be presented shortly support this notion. Functions/services provided by a full logistics node include intermediate level maintenance/repair of mission related equipment; data reduction, performance monitoring and fault diagnostics; housing and life support for personnel, airport and helicopter base, aircraft refuel station, and depot for spares storage/ supplies/fuel. Reductions and modifications of these functions at a particular node are defined as introduced. The baseline manning philosophy was derived in consideration of the maintenance concept described in the Integrated Support Plan. The quantities of maintenance/support personnel and their required skill levels consider:

1. The appropriate disciplines required, e.g., Power Equipment Technician, Electronic Technician, etc.
2. Maintenance loading from the unattended stations and logistic nodes.
3. The number of operational shifts.

3.2.3.3.2 Personnel Requirements/Cost

Personnel requirements for each full node, mini-node, data node, reduced nodes, reduced node-modified and modified node are included in Tables in Appendix 7.2, along with individual cost summaries for each of the above node types.

3.2.3.3.3 Network Nodal Alternatives Impact on Maintenance Manning

The baseline network nodal configuration and its alternates are defined herein. The associated node locations, functions, and manning levels are summarized in Table 3.2-22.

Personnel cost comparisons between the baseline system and the alternate maintenance concepts are shown in Table 3.2-23. This table displays the dramatic savings in personnel support costs which can be realized by implementing nodal configuration and maintenance alternatives to the baseline network. Furthermore, except for the political questions of sovereignty surrounding the Alaskan-Canadian border, each of the six alternatives is technically feasible.

3.2.3.3.3.1 Baseline

The baseline concept consists of six full logistics nodes located at POW-M, BAR-M, PIN-M, CAM-M, FOX-M and DYE-M with dedicated helicopters/crews at each node. Because of low utilizations, each helicopter serves as back-up for adjacent nodes.

TABLE 3.2-22

MAINTENANCE MANNING CONCEPTS

	<u>POW-M</u>	<u>BAR-M</u>	<u>BAR-3</u>	<u>PIN M</u>	<u>CAM-M</u>	<u>FOX-M</u>	<u>DYE-M</u>	<u>CHIMO</u>	<u>GOOSE BAY</u>	<u>PERSONNEL TOTALS*</u>
BASELINE	F 17	F 17	--	F 17	F 17	F 17	F 17	--	--	102
ALTERNATE 1	MF ⁽¹⁾ 11	F 17	MF ⁽¹⁾ 11	--	MF ⁽¹⁾ 11	MF ⁽¹⁾ 11	--	DATA 3	MINI 5	69
ALTERNATE 2	MF ⁽⁴⁾ 4	RN 8	MF ⁽⁴⁾ 4	--	MF ⁽²⁾ 13	MF ⁽⁴⁾ 4	--	DATA 3	--	36
ALTERNATE 3	MF ⁽¹⁾ 11	RN 8	MF ⁽⁴⁾ 4	--	MF ⁽²⁾ 13	MF ⁽⁴⁾ 4	--	DATA 3	--	43
ALTERNATE 4	MF ⁽⁶⁾ 8	MRN ⁽¹⁾ 5	MF ⁽⁵⁾ 1	--	MF ⁽³⁾ 10	MF ⁽⁵⁾ 1	--	--	--	25
ALTERNATE 5	MF ⁽¹⁾ 11	MRN ⁽¹⁾ 5	MF ⁽¹⁾ 11	--	MF ⁽¹⁾ 11	--	--	MF ⁽¹⁾ 11	--	49
ALTERNATE 6	MF ⁽⁶⁾ 8	--	MF ⁽⁵⁾ 1	--	MF ⁽³⁾ 10	--	--	MF ⁽⁵⁾ 1	--	20

F = FULL LOGISTICS NODE

MF = MODIFIED LOGISTICS NODE (1, 2, 3, 4, 5 AND 6)

RN = REDUCED LOGISTICS NODE

MRN = MODIFIED REDUCED LOGISTICS NODE (1)

DATA = DATA NODE ONLY

MINI = MAINTENANCE ONLY

NOTE: REFUELING OF THE HELICOPTER CAN BE EFFECTED AT ALL OF THE ABOVE STATIONS.

* These totals do not include helicopter crews.

TABLE 3.2.-23

20 YEAR PERSONNEL COSTS

	<u>FULL NODES</u>	<u>MINI NODES</u>	<u>DATA NODES</u>	<u>REDUCED NODES</u>	<u>(1)</u>	<u>(2)</u>	<u>(3)</u>	<u>(4)</u>	<u>(5)</u>	<u>(6)</u>	<u>MODIFIED REDUCED NODES</u>	<u>TOTAL COST</u>
Baseline System	6 \$102M											\$102M
Alternate 1	1 \$17M	1 \$7M	1 \$3M	1 \$8M	4 \$46M	1 \$14M	3 \$13M					\$73M
Alternate 2			1 \$3M	1 \$8M		1 \$14M	3 \$13M					\$38M
Alternate 3			1 \$3M	1 \$8M	1 \$12M	1 \$14M	2 \$8M					\$45M
Alternate 4								1 \$10M	2 \$2M	1 \$8M	1 \$5M	\$25M
Alternate 5					4 \$46M						1 \$5M	\$51M
Alternate 6								1 \$10M	2 \$2M	1 \$8M		\$20M

3.2.3.3.3.2 Alternate 1

One full logistic node is located at BAR-M; four modified-logistic nodes at POW-M, BAR-3, CAM-M and FOX-M (App. 7.2, Table G, Canadian Ministry of Transportation (MOT) or USAF to provide certain services); one data node* at Fort Chimo, and one mini-node (maintenance only) at Goose Bay. Refueling will be required at Frobisher and Goose Bay. This set of nodes is superior in several respects to the baseline set. Tuktoyaktuk, BAR-3, is selected to replace PIN-M because it is a staging area for resupply activities/fuel storage, has airstrip facilities provided by the MOT, is geographically better located for operations and maintenance, and is more accessible to populated areas and resource. Fort Chimo and Goose Bay were selected to replace Dye Main primarily for geographic and climatic reasons. In addition, advantage has been taken of the life-support facilities/services associated with the Fort Chimo and Goose Bay economics. Frobisher Bay, Pangnirtung, and Broughton Island are used as refuel stations for servicing the southeastern extension of the line. The helicopter maintenance support concept is the same as in the baseline, but is more practical in that utilization is more balanced node-to-node, especially in the southeast extension where the helicopter operates out of Fort Chimo.

3.2.3.3.3.3 Alternate 2

This is a roving maintenance team concept consisting of one modified logistic node (2) (App. 7.2, Table G, additional two-man maintenance team) located at CAM-M to perform intermediate level maintenance for the entire network; one data node at Fort Chimo; one reduced logistics node (App. 7.2, Table E) at BAR-M and three modified logistic nodes (5) located at POW-M, BAR-3 and FOX-M (App. 7.2, Table F, Canadian MOT to provide certain services). The reduced nodes will function as refueling stations and will provide storage for spares complements to be used by the roving maintenance teams. Refueling is also required at Frobisher and Goose Bay. Two helicopter crews and

* Data reduction, performance monitor, fault diagnostics, and helicopter base only.

maintenance teams at CAM-M will service the entire network. As before, helicopters are located at each node, but require only a helicopter crew chief per node for its maintenance instead of the entire crew. One of the roving maintenance teams and helicopter crews at CAM-M is transported to the node nearest the failed network segment via an additional aircraft (fixed wing such as the Twin Otter or helicopter) at CAM-Main. After arriving at the node nearest the failed network segment, the maintenance team and helicopter crew are dispatched from the node in the helicopter stationed there to repair the critical failed site.

An additional crew (e.g., Twin Otter aircraft pilot, co-pilot and crew-chief mechanic) is required at CAM-M to support the roving maintenance team concept. In addition, adequate refuel supplies are provided at each reduced node, Frobisher and Goose Bay.

3.2.3.3.3.4 Alternate 3

"This concept is similar to Alternate 2 except that in recognition of problems associated with traversing national boundaries. The Modified logistics node in the Alaskan sector (POW-M) is upgraded from a Modified node, type 4 (MF4) to a type 1 (MF1). The maintenance concept for the Alaskan sector is the same as the baseline system (i.e., is excluded from the roving team services). The maintenance concept for the remaining sectors is then identical to that described in Alternate 2."

3.2.3.3.3.5 Alternate 4

This roving team concept requires one modified logistic node at POW-M, one modified-reduced node and three modified logistic nodes for the remaining sectors. The modification in all cases is the elimination of the console operator/technicians. This is accomplished by having all data (RADAR & PM/FL) processed at the ROCC*

* Or at CAM-Main if it is desired to keep diagnostic capability on the line.

and having maintenance controlled from that point. The roving maintenance teams would function as in Alternates 2 and 3.

3.2.3.3.3.6 Alternate 5

This is a four logistic node version of the baseline concept. One modified logistic node is required for the Alaskan Sector at POW-M, and in the remaining sectors, modified logistics nodes ⁽¹⁾ are required at BAR-3, CAM-M and Fort Chimo; a modified reduced node ⁽¹⁾ is required at BAR-M; and a modified reduced node ⁽³⁾ is required at FOX-M. The reduced node is required to provide refueling attendant with the four logistic node concept. Additional refueling is also required at Frobisher and Goose Bay. Maintenance is provided by dedicated helicopters and crews at each node as described in the baseline concept and in Alternate 1.

3.2.3.3.3.7 Alternate 6

This concept combines the roving maintenance team concept in Alternate 4 with the reduced node concept in Alternate 5. Intermediate level maintenance will be performed at POW-M (Alaskan Sector) and CAM-M (Canadian sectors). Helicopters (including crew-chiefs) will be located at POW-M, BAR-3, CAM-M and Fort Chimo. All data will be processed at the ROCC (or at CAM-M).

3.2.3.3.4 Maintenance Loading

Maintenance loading must consider both unattended station failures and logistic node failures. Tables 3.2-24 and 3.2-25 reflect the number of maintenance actions/year based on equipment failure (including redundant items). A detailed analysis of maintenance loading is included in Appendix 7.2.

TABLE 3.2-24

MAINTENANCE LOADING (STATION FAILURES)

<u>Equipment</u>	<u>Maintenance Actions (MA) Per Station/Year</u>	<u>λ 10⁶ Hrs</u>	<u>MA/Logistic Node Per Year</u>
Power	* 5.95	17	13.14
Radar	10.02	1144	138.6
	.78 (satellite)	89	10.79
Communications	1.29 (LOS & Repeater)	147	17.84
# NAV AIDS	1.03	3.3	.4
# Weather	<u>1.09</u>	<u>10</u>	<u>1.21</u>
	16.9/17.4	1254/1312	165/172

* 5 MA/Year - Filter/injector replacements
.8/Year - Overhaul 2 KW generators

Based on 1% utilization

TABLE 3.2-25

MAINTENANCE LOADING (LOGISTIC NODE FAILURES)

<u>Equipment</u>	<u>λ 10⁶ Hrs</u>	<u>MA/Logistic Node/Year</u>
Computer	500	4.38
Display	500	4.38
Aircraft Fac. Equip.	333	2.92
Maintenance Test Equip.	<u>750</u>	<u>6.57</u>
	2083	18.25/Year

3.2.3.4 Spares Costs

The life cycle cost models for initial and replenishment spares are given below:

$$(3.2-38) \quad C_6 = \sum_{N=1}^{NLN} \sum_{J=1}^{JS} NSS_J \times \sum_{F=1}^{FTOT} \left(\frac{Q_{OH} \times NRS_F}{MTBF_F} \right) (LNCT_F \times RLN_F * DRCT_F \times NRLN_F) UP_F$$

JS = # different types of sites = 3 (main, UAR, repeater)

FTOT = # separately identifiable functional elements at site

NSS₁ = # main sites (logistics nodes) = 6 baseline

NSS₂ = # unattended radar sites = 77

NSS₃ = # microwave repeaters = 74

Q_{OH} = 2190 hours

NRS_F = Fth function redundancy

MTBF_F = Fth function MTBF

UP_F = estimated unit price of Fth element

LNCT_F = logistics node repair cycle time =

.0222	.0556	.1111
2 days	5 days	10 days

RLN_F = Fraction of failures repairable at logistics node

DRCT_F = Depot cycle repair time 1, 1.33, 2, 3

N_{RLNF} = Fraction not repairable at logistics node 90, 120, 180, 270 days

The provisioning philosophy for the baseline six-logistic node system will require a full complement of LRI spares and their associated repair parts at each node. Spares/repair parts costs associated with unattended radar station equipment, and logistic node equipment are summarized in Table 3.2-26 and are described below.

- 1) Unattended radar station equipment--consists of: a) radar; b) power equipment; c) communications; d) navigational aids; and e) weather package (includes station controller).
- 2) Logistic node equipment--consists of: a) computer; b) display; c) aircraft facility equipment (VHF, UHF, HF radios, rotating beacon, etc); d) maintenance test equipment; e) support equipment; and f) vehicular equipment.

A detailed analysis of spares requirements and costs is included in Appendix 7.3, including an analysis of the cost impact of the 6 network nodal alternatives - summarized in Table 3.2-27.

TABLE 3.2-26
BASELINE URS SPARES/REPAIR PARTS COST SUMMARY \$

	<u>EQUIPMENT</u>	<u>6 NODE INITIAL</u>	<u>REPLENISHMENT</u>	<u>REPAIR MATERIAL</u>	<u>TOTAL COST 20 YEARS</u>
URS	<u>RADAR</u>	198.1K	1,599.2K	998 K	2,795.3K
	<u>POWER</u>	168.0K	1,792.8K	37.4K	1,998.2K
		80.0K	888.0K	128 K	1,096 K
		134.4K	1,061.0K	77.8K	1,273 K
		37.0K	5.2K	2.8K	45 K
		58.5K	9.2K	8.7K	76.4K
		108.8K	62.0K	31.5K	202.3K
		152.3K	86.8K	31.5K	270.6K
		54.4K	31.0K	21.0K	106.4K
		40.9K	23.3K	47.3K	111.5K
LOG NODE	<u>SUPPORT</u>	294.0K	279.3K	*	573.3K
	<u>VEHICULAR</u>	324.6K	308.4K	*	633.0K
		1,516.6K/	5,085.0K	1,256.0K	7,858.0K
		1,571.0K	5,258.2K	1,307.0K	8,136.0K

* INCLUDED AS PART OF REPLENISHMENT

TABLE 3.2-27

SPARES COST COMPARISON* - BASELINE VERSUS ALTERNATE MAINTENANCE CONCEPTS (\$K)

	<u>INITIAL</u>	<u>REPLENISHMENT</u>	<u>REPAIR MATERIAL</u>	<u>TOTAL</u>
BASELINE	\$1517/1571	\$5085/5258	\$1,256K/1,307K	\$7858/8136
(1)	1068/1122	4878/5051	1,256K/1,307K	7202/7480
(2)	1034/1088	4859/5032	1,146K/1,197K	7033/7317
(3)	1041/1095	4863/5036	1,138K/1,189K	7042/7320
(4)	831/885	4743/4916	1,085K/1,136K	6659/6937
(5)	1055/1109	4871/5050	1,174K/1,225K	7120/7834
(6)	492/552	4747/4920	1,077K/1,128K	6316/6600

* LOS/Satellite

3.2.3.5 Power Generation Costs

The life cycle cost model for power generation cost and a summary of parameters for the baseline network is:

$$(3.2-39) \quad C_g = \text{PIUP} ((\text{NUS} \times \text{SPWR} \times \text{SCPR}) + (\text{NLN} \times \text{NPWR} \times \text{NCWR}) + (\text{NCR} + \text{RPWR} + \text{RCPR}))$$

PIUP = 20 years

NUS - Number of unattended sites = 17

SPWR = Unattended site power required = 2.97(3.1) KW x 8760 hours = 26,017
(27,156) KW-Hours

SCPR = Unattended site power cost/KW-Hour = \$.17/KW-Hour

NLN = Number of logistics nodes = 6

NPWR = Logistics node power required = 103 KW x 8760 hours = .902 x 10⁶ KW-hour

NCWR = Cost of power at logistics node = \$.08/KW-Hour

NCR = Estimated number of communications repeaters = 74

RPWR = Repeater power required = .300 KW x 8760 = 2628 KW-Hour

RCPR = Cost of power at repeater = \$.17/KW-Hour

$$\begin{aligned} C_g &= 6.81\text{M} + 8.66\text{M} + .66\text{M} = 16.13\text{M} (15.77\text{M}) \\ &= +3.9\text{M} (\text{heating oil for six nodes}) \\ &= \$20.03\text{M} (\$19.67\text{M})^* \end{aligned}$$

These costs are based on an average unattended site power consumption of 2.97KW(3.1) and additional logistics node support power of 100 KW. These power requirements are developed in Section 3.3 Cost coefficients of \$.17/KW-Hour for site power and

* Costs associated with the satellite communications approach are in parenthesis.

\$.08/KR-hour node power have been generated in this section, 3.2.3.2 Annual Resupply Costs. The repeater cost applies only to the LOS microwave baseline communications implementation. For a satellite implementation, site power consumed is nearly the same but naturally there is no repeater.

The power consumption of 100 KW is based on average consumption at current auxiliary sites, numbers of personnel supported, and new technical load estimates. Power consumed is categorized as either technical or utility. It is estimated that 15 KW of power is required to power the new mission related node equipment, while the remaining 85 KW is required for utilities. About half of the utilities are fixed while the rest are assumed to vary in proportion to the number of people supported at the node, at a rate of about 2.5 KW per person. This model checks well against established utilities power consumption and personnel at existing sites. Figure 3.2-17 illustrates average power consumption estimates versus personnel supported based on the above model. The average power consumption of each network nodal configuration alternative is determined by an appropriate number of nodes and total personnel supported, as is also illustrated on Figure 3.2-17. The average rate of energy consumption at the logistics nodes is about 618 KW, which at \$.08/KW-hour results in a 20 year cost of \$8.66M. The average rate of energy consumption of 77 unattended stations at 2.97KW per station is 238.7 KW, which at \$.17/KW-hour for 20 years is \$6.81M. Including a cost of \$.66M for 74 repeaters at 300 watts each, the total power generation costs for the baseline system network are \$16.13M. An estimated additional \$3.9M in fuel oil should be included for heating for six nodes, for a total cost of \$20.03M.

Cost deltas are presented in Table 3.2-28 for the six network nodal configuration alternatives, indicating that up to \$5.3M may be saved in power generation costs over a 20 year period through personnel support reduction.

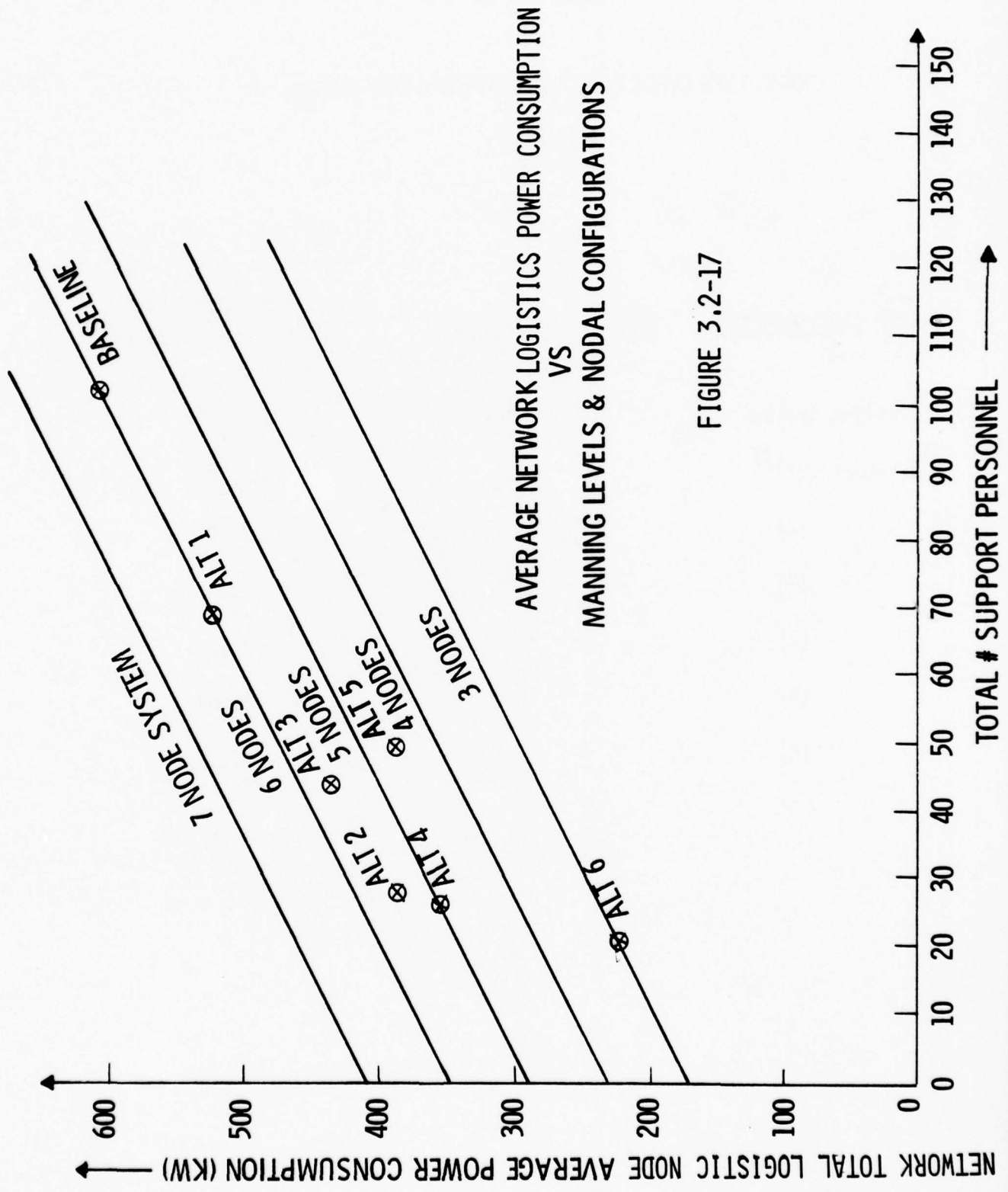

FIGURE 3.2-17

TABLE 3.2-28

TOTAL LIFE CYCLE POWER GENERATION COSTS VERSUS
ALTERNATES

<u>SYSTEM CONFIGURATION</u>	<u>TOTAL COST</u>	<u>COST DIFFERENTIAL FROM BASELINE SYSTEM</u>
Baseline System	\$20.03M	\$ 0
Alternate (1)		- 1.12M
(2)		- 3.10M
(3)		- 2.45M
(4)		- 3.50M
(5)		- 3.10M
(6)		- 5.33M

3.3 STATION EQUIPMENT

3.3.1 Station Functional Analysis

A functional analysis of the unattended radar station was performed at the start of the study. The analysis consisted of defining the functions required, grouping those functions into functional equipment areas, and then defining the equipment requirement for those functional areas. The next step of the study was to identify candidate equipments, and by means of trade-offs studies, define a recommended equipment configuration.

Figure 3.3-1 is a functional flow diagram of the primary functions required to perform the mission. The second level functional breakdown, for the majority of the functions defined, are self explanatory and were not detailed in separate functional diagrams. They are, however, covered in the equipment area descriptions. Second level functional diagrams have been prepared for blocks 13 and 18 and are given in Figures 3.3-2 and 3.3-3.

Grouping the functional requirements of the first, second, and third level analysis into equipment groupings, the unattended radar station functional block diagram was generated, and is given in Figure 3.3-4. To facilitate the equipment discussions the functional areas were further grouped as indicated in Table 3.3-1. These equipment areas are discussed in greater detail in the following equipment sections.

3.3.2 Radar/IFF

The radar and IFF equipment was defined in the Unattended/Minimally Attended Radar Design Studies. The results of these studies was used as the baseline radar/IFF system in the station design. Table 3.3-2 is a summary of the results of these studies that were provided to us by ESD at the start of our study. Table 3.3-3 tabulates the nominal radar performance parameters that were used in the radar design. This data was supplemented as required by the detail results of the General Electric study of the unattended radar.

UNATTENDED RADAR NETWORK FUNCTIONAL FLOW DIAGRAM

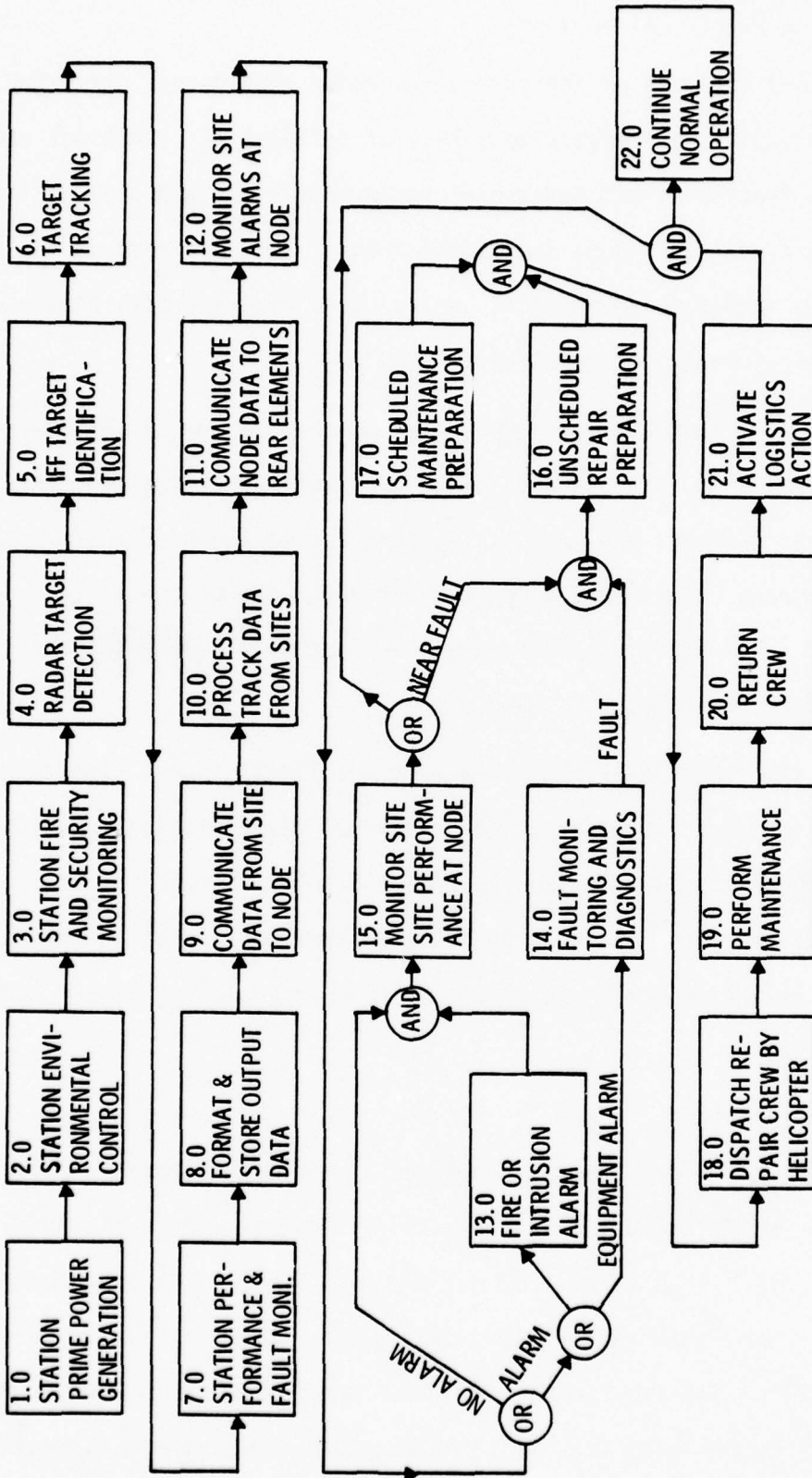

Figure 3.3-1 Unattended Radar Network Functional Flow Diagram

FIRE OR INTRUSION ALARM SECOND LEVEL FUNCTIONAL FLOW DIAGRAM

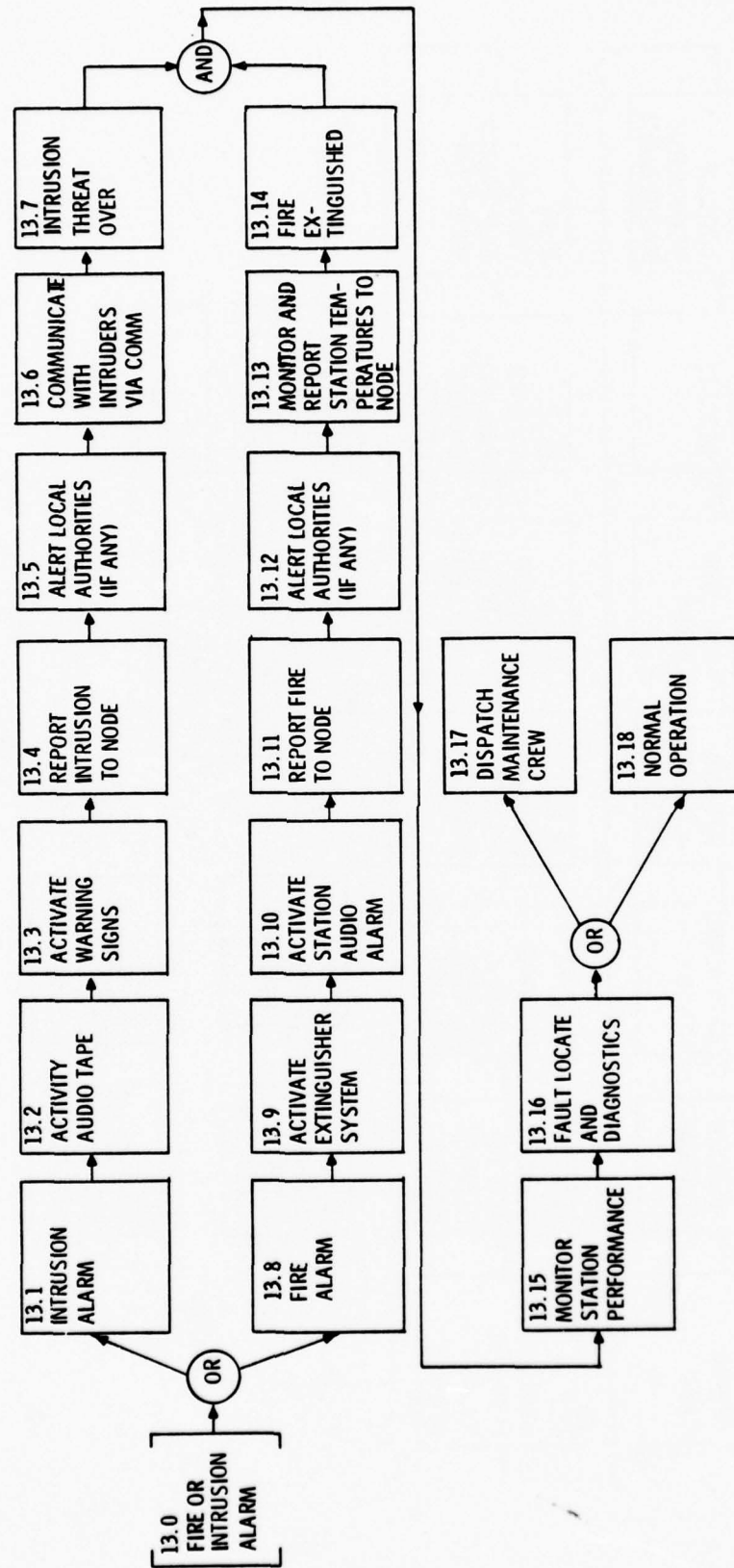

Figure 3.3-2 Fire or Intrusion Alarm Second Level Functional Flow Diagram

MAINTENANCE HELICOPTER MISSION SECOND LEVEL FUNCTIONAL FLOW DIAGRAM

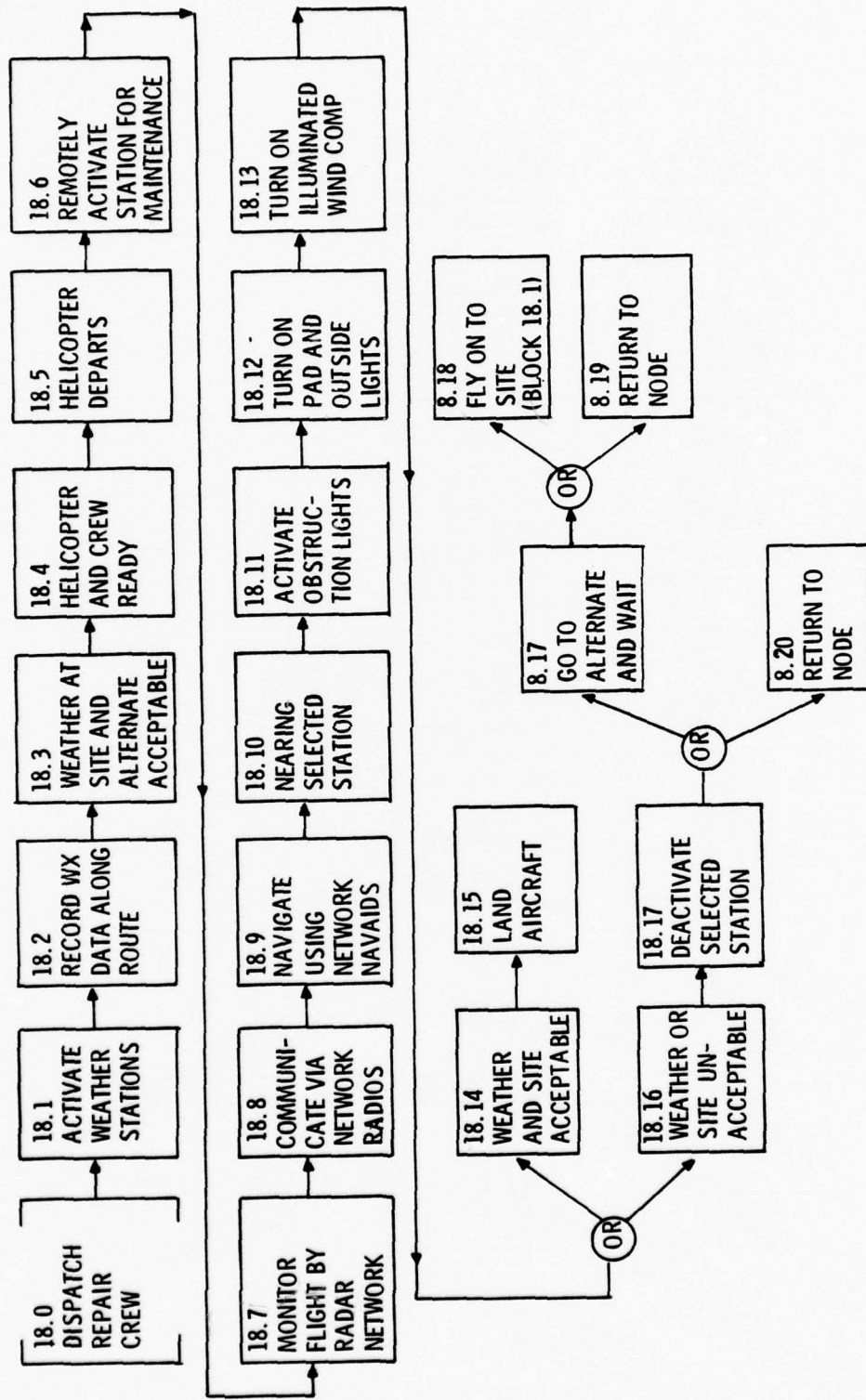

Figure 3.3-3 Maintenance Helicopter Mission
Second Level Functional Flow Diagram

RADAR STATION FUNCTIONAL BLOCK DIAGRAM

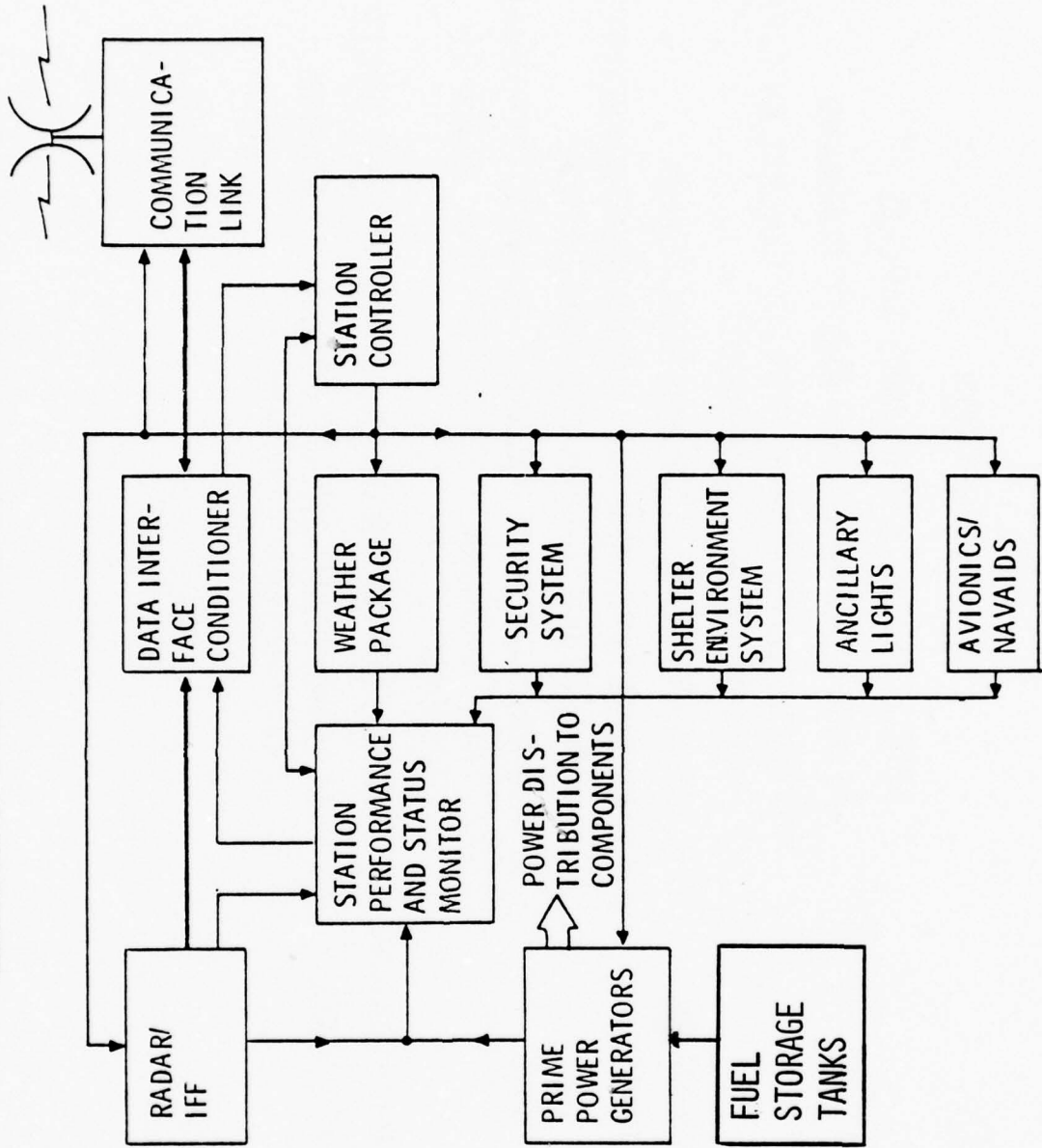

FIGURE 3.3-4

TABLE 3.3-1

UNATTENDED RADAR STATION FUNCTIONAL EQUIPMENT AREAS

<u>FUNCTIONAL AREA</u>	<u>FUNCTION</u>
1. RADAR/IFF	DETECT, TRACK, AND IDENTIFY TARGETS
2. WEATHER STATION	REPORT WEATHER HOURLY AND ON COMMAND
3. NAVAIDS	PROVIDE NAVIGATIONAL AIDS FOR GENERAL AVIATION AND MAINTENANCE MISSIONS
4. SECURITY SYSTEM	PROTECT AGAINST FIRE AND INTRUSION
5. COMMUNICATIONS	PROVIDE VOICE AND DATA COMMUNICATION BETWEEN UNATTENDED STATION AND MANNED NODE
6. STATION CONTROL	CONTROL STATION FUNCTIONS, MONITOR PERFORMANCE, FAULT LOCATION, DATA INTERFACING, AND DATA STORAGE
7. PRIME POWER GENERATION	STORE FUEL, GENERATE AND CONTROL PRIME POWER
8. ENVIRONMENT CONTROL	IMPLEMENT TOTAL ENERGY CONCEPT TO STATION ENVIRONMENTAL CONTROL

TABLE 3.3-2

PROJECT E259 TYPICAL RADAR
CHARACTERISTICS & COST

RADAR FREQUENCY	L-BAND
RADAR RANGE	60 NAUTICAL MILES
RADAR POWER CONSUMPTION	600 WATTS TO 1500 WATTS
ANTENNA TYPE	CYCLINDRICAL ARRAY
ANTENNA SIZE	6' X 18' TO 7' X 30'
ANTENNA WEIGHT	5K POUNDS
RADOME WEIGHT	5K POUNDS TO 12K POUNDS
RADAR & IFF EQUIPMENT WEIGHT	5K POUNDS TO 10K POUNDS
TOWER TYPE	SQUARE FREE STANDING
TOWER HEIGHT	25' TO 125'
TOWER WEIGHT	40K POUNDS TO 60K POUNDS
TOTAL SYSTEM WEIGHT	60K POUNDS TO 80K POUNDS
RDT&E RADAR COSTS	\$25M (2 DIFFERENT PROTOTYPES)
PRODUCTION RADAR COSTS	\$1.5M (79 UNITS)
ANNUAL RADAR O&M COSTS	\$1.5M

TABLE 3.3-3

UNATTENDED RADAR DESIGN GOALS

RF Bandwidth	10%
Site Altitude	50 to 4500 ft
Radar Prime Power	500 W
Frame Time	4 s
Growth	3-D
Target Characteristics	
RCS	1 to 16 m ²
Speed	80 to 2400 knots
Detection Range	30 nmi (1 m ²)/60 nmi (16 m ²)
No. of Tracks	20
Special Features	ECM Warning Zero Doppler Detection Anticlutter Processing CFAR
Coverage	
Max. Range	60 nmi
Min. Range	TBD
Max. Altitude	100 kft
Max. Elevation Angle	50°
Min. Elevation Angle	R _{min} at 0 kt
Azimuth	360°
Resolution/Accuracy	
Range	0.5 nmi/0.25 nmi
Azimuth	3°/0.5°
Angle Sidelobes	
Transmit	≤ -20 dB (First) ≤ -30 dB (Others)
Receive	≤ -30 dB

TABLE 3.3-3
UNATTENDED RADAR DESIGN GOALS (CONT'D)

Detection	
P_D (3 out of 4 scans)	0.95
P_{FA}	10^{-6}
Tracking	
P (Track Initiate and Maintenance)	0.95
P (Drop Track Exiting Coverage)	0.999
False Track Initiation	one per hour
Track Initiate Time	16 s
Track Drop Time (Exiting Target)	12 s

A prime power figure of 1000 watts for the radar and IFF was used in the study, as this is approximately the average value from Table 3.3-2. The 1000 watts is also close to the value determined in the General Electric Radar Study. The antenna sizing was accomplished in a similar manor in determining the 6' x 25' value used in the study. Cost figures in the radar and IFF area where taken solely from the General Electric study due to the availability of detail life cycle cost data.

3.3.3 Weather Station

The primary objective of the weather station is to provide sufficient information on the weather at the unattended radars to insure safe operation of helicopter flights servicing the line. A secondary function is to provide meteorological data for the weather services.

Without the weather data provided by the present DEWLine, weather information for the entire region serviced by the DEWLine would be almost non-existent. The non-DEWLine weather observation stations are scattered, which would leave large areas unmonitored. This would mean that local conditions may exist that are unobserved and therefore unreported. These may include snow or rain showers, thunderstorms, strong winds, fog, cloud conditions, icing, and white-outs.

White-out conditions can be extremely hazardous. The condition can effect visibility to the extent that a pilot may have little or no visual reference by which to control his aircraft. The following phenomena are known to cause white-out and should be avoided if at all possible.

- a) An overcast white-out resulting from light reflected between a snow surface and a cloud base. Judgment may be limited to a few feet.
- b) Water-fog white-out resulting from thin clouds of super-cooled water droplets in contact with the cold snow surface.

- c) Blowing snow white-out resulting from fine snow being plucked from the surface by winds of 20 knots or more. Light is reflected and diffused resulting in a nil visibility white-out condition.
- d) Precipitation white-out resulting from small wind-driven snow crystals falling from low clouds above which the sun is shining. Light reflection, complicated by spectral reflection from the snow flakes with observation of landmarks by falling snow can reduce visibility and depth perception to nil in such conditions.

To insure safe landings a knowledge of actual site conditions in terms of visibility, ceiling, and a direct knowledge of the actual weather is required.

A preliminary safety plan hazard analysis, using the guide lines of MIL-STD-882, established that the absence of a weather station at the unattended facility must be placed in hazard severity Category I, catastrophic. This is due to the possibility of death from a weather related helicopter crash. The hazard probability is however low, and is classed level D, remote. This rating is based on present flight regulations which allow flights into landing facilities such as the unattended radar sites without direct knowledge of the weather provided that a helicopter landing is not attempted without a ceiling of 300 feet and one mile visibility, and that a pre-selected alternate field whose weather conditions are known to be acceptable is available.

In the baseline concept, the weather station at the unattended radar would be operational only prior to and during flights required for the maintenance of the line itself. As the total accumulated operational hours for this service would be low, the availability of the weather station is high. A more realistic operational concept would be that the weather station would be operational on a 24 hours basis for support of general aviation and meteorological services. This would reduce availability of the weather station unless redundant sensors and read out equipment are provided.

Definitive data on the reliability of the sensors was not available during the study, but similar unattended weather stations have demonstrated high availability. The Beaufort Sea unattended weather station has operated satisfactorily for 16 months, the Climatological Automated Recording Stations (CARS) have been operating in the Canadian Arctic since 1973 with few failures, and the Meteorological Automatic Reporting Station (MARS II) has operated in the Canadian Meteorological Network for several years of successful field testing to site a few examples.

Based on the demonstrated availability of unattended weather stations previously built, it is recommended that a non-redundant weather station be provided. During reliability testing, if the reliability of the weather station does not prove adequate, redundancy of the sensors may be incorporated at that time.

3.3.3.1 Weather Station Equipment

The meteorological weather data to be provided is as follows:

- a) Visibility
- b) Wind Direction
- c) Wind Velocity
- d) Pressure - Altimeter
- e) Temperature
- f) Dew
- g) Precipitation

In addition the following weather information for flight safety would be desirable.

- a) Ceiling
- b) Weather Conditions
- c) Obstruction

A description of the sensors forming the weather station follows.

3.3.3.1.1 Forward Scatter Meter

The forward scatter meter measures the atmospheric forward scattering coefficient. In the absence of absorption, this is a measure of the extinction coefficient and therefore of visual range.

The instrument uses a halogen quartz lamp to generate a cone-shaped light beam over an angle of 20 to 50 degrees. A silicon photo detector is located four foot from the source and is pointed in the direction of the source accepting light only from a cone shaped volume of the same angular dimensions as the source. The resultant sampling volume is a torodial-shaped space approximately two feet in diameter and two feet thick, with a total volume of 1.67 cubic feet.

Light energy received by the photo detector from scattering caused by particulates or aerosols in the sampling volume is linearly related to the atmospheric extinction coefficient. Calibration is accomplished by a special device that introduces a standardized scattering medium between the light source and the photo detector. The sensor is calibrated to read from an integrated scattering coefficient of approximately 5×10^{-6} per cm or 20,000 feet visual range to a scattering coefficient of 5×10^{-9} per cm or 200 feet visual range with an accuracy of $\pm 5\%$ of the scattering coefficient. The unit recommended by the Meteorology Division of the Air Force Geophysics Laboratory has been designated as the candidate unit. This unit is EG & G's Model 207 with calibrator. The unit is designed for unattended operation is servicable between -30°C to $+50^{\circ}\text{C}$, weighs 135 lbs, consumes 100 watts of a-c power, and costs \$15,800 with calibrator.

3.3.3.1.2 Anemometer/Wind Vane

A U2A cupwheel anemometer driving a d-c tachometer with a wind vane assembly modified for coupling to a resolver is proposed as the candidate

sensor. This sensor is presently employed by the Canadians in their MARS II stations. The output voltages will drive an analog to digital converter similar to the U2A-SIM-695-22 manufactured by Bristol Aerospace Limited of Winnipeg Canada. This sensor digital interface module is specifically designed to interface with the U2A anemometer.

A cupwheel anemometer was selected primarily because it has been field tested in unattended arctic weather stations. Specifically the U2A was chosen as it is of the non-contacting type. When the state-of-the-art for differential pressure sensors, sonic sensors, or strain gage sensors reach the point that these items are proven in an unattended arctic environment, they should be considered as a replacement for the rotating cup and vane device proposed. These devices offer higher reliability, no problems with lubricant freezing, and are less susceptible to high wind velocity damage. The instrument will measure velocities from 0 to 128 miles per hour in one mile increments. The unit will operate from -50°C to $+70^{\circ}\text{C}$, weighs approximately 20 lbs, consumes less than 8 watts, and cost under \$1,000 with interface module.

3.3.3.1.3 Pressure Transducer

Atmospheric pressure will be obtained from a vibrating diaphragm pressure transducer. The device selected is Sperry Flight Systems Sensor Translator Model 4016012-901, which was recommended by the Air Force Geophysics Laboratory. A vibrating device is employed to eliminate sticktion. The design of the unit is temperature compensated, but may be still temperature sensitive. It is recommended that should the output require temperature correction, that it be made in the micro processor controller, rather than spend power in maintaining temperature within a control range. The sensor will read from 914 to 1084 millibars, within ± 0.17 millibars. The unit weighs 20 pounds, consumes 30 watts of a-c power, and costs \$4,000.

3.3.3.1.4 Temperature/Dewpoint

An aspirated temperature sensor will be employed. This will be protected by triple solar radiation shields instead of a Stevenson screen. The shields must be of open design to allow good air circulation. The sensor will be a precision thermister which will feed a linearizing network and output amplifier.

Dewpoint temperature is obtained by use of a Peltier-cooled, gold surface mirror. The mirror is held at the dewpoint by a closed loop system consisting of a Light Emitting Diode source pointed to reflect from the mirror to a photo detector that controls the power to the thermoelectric cooler. The dewpoint is maintained by sensing the change in light level when condensation on the mirror occurs. The dewpoint is measured using a precision thermister feeding a linearizing network and amplifier. Below freezing the measurement will be made for the frost point.

The device selected is the EG & G Model 220, recommended by the Geophysics Laboratory. It contains a built in calibration circuit and air flow detector in the aspirator, and has an accuracy of 1°F over the operating range of -58°F to $+122^{\circ}\text{F}$. The unit is designed for unattended operation, the sensor may be located up to 500 feet from the control unit, it weighs 19 lbs, consumes 100 watts of a-c prime power, and costs \$4,395 with monitors.

3.3.3.1.5 Precipitation Gauge

Precipitation measurements will be made at the manned nodes only. A tipping bucket sensor will be employed. As the name implies measurement is accomplished by causing a bucket to tip when 0.01 of an inch of precipitation has accumulated in the bucket, causing a contact closure to report the event. The unit weighs 37 lbs, requires 325 watts, and costs \$530.

3.3.3.1.6 Solid-State T.V.

A solid-state television camera is included as part of the weather station to allow remoting of visual weather conditions and ceiling determination to the manned node. This unit will be employed only for flight service and will not be used for the periodic meteorological measurement.

The device selected is General Electric's TN 2201 Automation Camera. The camera uses a Charge Injection Device (CID) as the light sensor. Charge injection imaging makes use of a two dimensional array of coupled MOS capacitors to collect and store photo-generated charge. Shift registers along the two edges of the imaging array are used for raster scanning. The TN 2201 consists of an array of 42 x 342 (14,364) pixels. Using a 1 inch lens with a 6.5 millimeter focal length. This will provide an object height to object distance ratio of 2.1. In normal operation the frame rate for scanning the raster structure is 29.97 hz. This may be decreased to less than 1 hz, which will increase the integration time of the sensor improving its low light level operation. Control of the scanning rate and analog to digital conversion is provided by the PN 2110A Automation Interface Unit. The interface unit contains the master clock whose speed may be controlled remotely. The unit also contains an internal timing generator and a 8 parallel bit analog to digital converter.

Application of the camera as a ceilometer requires the use of a dedicated light source. The reflection of the source from the cloud base is received by the camera and is remotely observed on a calibrated display to determine height. To improve the signal to noise ratio the source is operated on a specific optical wavelength, and the receiver is matched using a filter of the same wavelength in front of the camera. The input filter attenuates the out-of-band background noise resulting in the signal to noise improvement. As the camera is most sensitive in the region of 0.7 microns, which is on the edge of the visible red of the spectrum, the source should be in this region. A c.w.

laser whose radiated energy is well below eye-safe levels is recommended. As the device is only to be used to determine that the ceiling is within an acceptable level for landings, a maximum height capability of 600 feet is recommended. This would place the source 300 feet from the camera. The resolution of each line on the display is under two feet. The major advantage of using a T.V. camera is that it does not require a rotating mechanical device.

Visual observation of the weather will be implemented using a second camera. Alternate techniques using a split image or secondary optical systems could also be employed using a single camera. A normal floodlamp for night illumination will be used. This camera may also be used for security as it will provide a picture of the helipad area.

In the ceilometer mode the frame time will be one second, a single frame will be scanned out and placed in storage in the data conditioner. The stored signal may be read out within a two minute period of a 1200 bit per second rate for remoting to the node. At the node it will be stored and then read out 8 bit parallel for display on a x-y monitor or oscilloscope using z axis modulation. The visual picture will be handled in the same manner except that the scan rate will be 29.97 hz. The picture refresh rate in both cases will be two minutes.

The television camera and interface equipment are designed for unattended operation. The camera will require a 50 watt heater for proper operation. The interface unit will be located with the station control equipment and will not require heaters. The T.V. system weighs 25 lbs, consumes 80 watts including 50 watts for the heater, and costs \$5000, including light sources.

3.3.3.1.7 Data Conditioner

An analog to digital converter will be provided for the forward scatter meter, pressure transducer, temperature, and dewpoint. The analog to digital converter selected is a Analog Devices Inc., A/D Converter ADC-12QM/ET. The device is a 12 bit converter with a $\pm 1/2$ least significant bit linearity error, a selectable input range of $\pm 2.5v$, $\pm 5v$, $\pm 10v$, 0 to 5v, or 0 to +10 volts. The speed of conversion is 25 microseconds using the successive approximation technique. It will operate from $-55^{\circ}C$ to $+85^{\circ}C$, and has good stability over both time and temperature. A 12-bit converter was selected to allow for long term drift in the least significant bits which will be discarded.

3.3.3.2 Equipment Summary

Table 3.3-4 summarizes the parameters of the sensors that form the unattended weather station.

3.3.3.3 Weather Station Control

Control of the weather station will reside in the master station controller. To conserve prime power the sensors will be polled sequentially on the hour. The forward scatter meter, pressure transducer, temperature, and dewpoint will require analog to digital conversion in a data conditioner. Each output will have a dedicated converter. The digital outputs will be stored in the controller's memory and when all sensors have been polled a weather message will be transmitted to the node. Fault sensing and calibration will also be under control of the master station controller.

Activation of the T.V. sensor will only occur by command from the node. This normally will be only for testing and for support of helicopter flights to the site.

TABLE 3.3-4

WEATHER STATION EQUIPMENT

<u>Equipment</u>	<u>Manufacturer</u>	<u>Instrument Range</u>	<u>Accuracy</u>	<u>Cost</u>	<u>Weight in lbs</u>	<u>Power in watts</u>	<u>Operational Temperature Range</u>
Forward Scatter Meter	EG&G Inc. Model 207	200 to 20,000 feet	+5%	\$15,800	135	100	-22°F to 122°F
Anemometer/Wind Vane	U2A Cup Anemometer	0-128 MPH velocity	1 MPH	\$1,000	20	8	-58°F to 122°F
		16 points direction	22.5°				
Pressure Transducer	Sperry Flight Systems Model 4016012-901	914 to 1084 millibars	+0.17 millibars	\$4,000	20	30	-58°F to 122°F
Temperature/Dewpoint	EG&G Inc. Model 220	-58°F to +122°F	1°F	\$4,395	19	100	-58°F to +122°F
Solid State T.V.	General Electric TN2201 Camera TN2110A Interface	0-600 feet ceiling	10 feet	\$5,000	25	80	-58°F to 122°F
Data Conditioner	Analog Device Inc.	---	---	\$1,500	6	12	-58°F to 122°F
Total Station	---	---	---	\$31,695	225	105 aver. 205 peak	-58°F to 122°F

3.3.3.4 Physical Requirements

The forward scatter sensor will be located on the north side of the tower and shielded to avoid sun rays. Placement of the anemometer and wind vane will be in a location to minimize blockage, and be at a height of at least 10 feet. The temperature and dewpoint should preferably be in the shade, and not near any heat source. Finally the solid-state T.V. should be pointed toward the helipad with the ceilometer source at a distance of 300 feet from the camera. The remaining equipment may be placed with the station controller.

3.3.3.5 Message Format

Table 3.3-5 summarizes the weather message that will be transmitted on the hour. In addition the weather message may be transmitted on demand along with transmission of the picture on a voice channel.

3.3.3.6 Weather Station Costs

The major life cycle cost element of the weather station is the \$31,695. acquisition cost per station. The total operating cost for 20 years of 24 hour operation, is \$8,340 per station, which is an annual cost of \$417. To insure proper operation of the weather station, the 105 watts of maintenance power should be provided at all times. The additional cost of obtaining the hourly readings for the weather service is less than \$20 per year of additional prime power expenditure. It is therefore recommended that a full time weather service be provided.

3.3.4 Navigational Aids

Safe passage by the helicopter from the manned node to an unattended station will be facilitated by the navigational aids provided along the network of unattended stations.

TABLE 3.3-5
 NORMAL HOURLY WEATHER MESSAGE

<u>Parameter</u>	<u>Instrument Range</u>	<u>Reporting Increment</u>	<u>Message Bits</u>
Visibility	200-20,000 feet	200 feet	7
Pressure	100 millibars	0.1 millibars	10
Temperature	-58°F to +122°F	1°F	8
Dew Point	-58°F to +122°F	1°F	8
Wind Velocity	0-128 MPH	1 MPH	7
Wind Direction	32 points	11.25°	5
Housekeeping & Address			19
<hr/>			
Total Bits			64

The trip from a manned node to an unattended station may be divided into three segments. The first segment, is the in-route segment. During this portion of the flight the helicopter will use the network of non-directional beacons located at each station for primary navigation. In support, radar guidance from the node may be obtained from the controller at the node, by voice communication using the communication network and the UHF or VHF radios at each station. The UHF radio may also be employed as a radio beacon using an on-board AN/ARD-21 null seeker when the on-site transmitter is keyed. Night time visual navigation will be assisted by obstruction lighting and a rotating beacon which may be energized by command from the node.

In the second, or approach segment, additional obstruction lighting and the rotating beacon will be illuminated in addition to the in-route navigational aids. In the final or landing phase, the wind cone and helipad will be illuminated.

Prior to, and during flight, weather reports will be obtained from stations along the line of flight. Prior to landing a T.V. picture of the station and the helipad will be obtained, and pertinent information will be communicated by voice to the helicopter.

3.3.4.1 NAVAIDS Equipment

The NAVAIDS at the unattended station may be grouped into lighting, radio, and L.F. Beacon groups which are detailed in the following sections.

3.3.4.2 Lighting

Night time obstruction lighting is required on all structures greater than 150 feet in height. If line of sight communication towers are employed, they normally will exceed the 150 foot requirement. The other structures at the unattended station usually will be less than 150 feet. If the station employs satellite communications no obstruction lighting will normally be required.

To insure safety during landing, obstruction lighting of the radar tower, and L.F. Beacon tower will be provided. The radar tower will be outlined by having a light on top and one on diagonal corners. These lights will be activated from the node via the communication network prior to landing.

The obstruction lights will be steady burning red lights. The fixture will house two lamps with a sensor to detect a failure in the operating bulb which will automatically activate the standby lamp. An incandescent lamp was selected over a flash tube strobe light due to its higher reliability. The high reliability of the incandescent is obtained by lowering the applied voltage across the lamp. The price paid for the increased reliability is reduced lamp efficiency causing reduced illumination. The light selected is a Crouse Hinds Aircraft Obstruction Lighting Fixture which consumes 118 watts per lamp. This fixture meets all environmental conditions to be encountered.

A revolving sealed beam beacon light will be provided for visual navigation to the site. The unit selected is Whelen Engineering's, Model 883D. It has a heavy duty two-bearing sealed worm drive motor, hermetically sealed revolving electric connections, three sealed beam bulbs, 135 flashes per minute, drawing 165 watts. The beam candle power will be 16,750 with an effective candle power of 1,134.

Four 200 watt floodlamps will be provided for helipad lighting. Standard low temperature outdoor fixtures will be employed.

The cost of lighting will be \$1,150. The power normal power consumed will be 118 watts. During landings this will go up to 837 watts.

3.3.4.3 Radio

A UHF, and a VHF radio will be provided at all stations. To simplify maintenance commonality of components for the non-r.f. of both transceivers will be implemented.

The modernized version of the multichannel AN/GRC-171 UHF Transceiver System, along with its VHF Transceiver mate, Collins Radio's VHF-400VHF AM, are ideal candidates. Discussion with Collins have indicated that they can provide these radios to meet the requirements of unattended operation for extended periods of time. Except for the r.f. circuitry, which will be similar in design, common components will be employed in both the UHF and VHF versions. Due to the commonality the following descriptions will be true for both transceivers.

The multichannel transceiver is specifically designed for ground to air communication. The equipment is all solid-state and has a mean time between failure (θ_0) of not less than 5,000 hours. The unit consists of the following modules or assemblies.

- A1 D/A Servo Amplifier Module
- A2 Frequency Synthesizer Module
- A3 Receiver RF Module
- A4 Audio Module
- A5 DC-DC Converter Module
- A6 Voltage Regulator Module
- A7 RF Filter Module
- A8 Power Amplifier Module
- A9 Keyer Module
- A10 Chassis and Front Panel

The modular construction will minimize on-site trouble shooting and repair. Due to the commonality of the UHF and VHF non-r.f. modules the logistic problem will also be minimized.

The transceiver will mount in a standard 19 inch cabinet, with a 8-3/4 inch height and 21-1/2 inch depth. The unit weighs less than 100 pounds. Environmentally it will operate in temperatures down to -29°C and up to $+60^{\circ}\text{C}$. The unit will consume 450 watts of prime power.

The following test points given in Table 3.3-6 will be connected to a special selection circuitry not part of the transceiver for selection, analog to digital conversion and transfer to the node upon request.

To complement the transceivers, the Collins 437B-7 UHF and 437B-10 VHF antennas will be employed. Physically both antennas are the same size, 69 inches long and 8 inches in diameter, with a weight of 50 pounds. The coupling flanges on the antennas are such that they may be stacked one on top of the other. To facilitate coupling each antenna is base fed with a 1.5 inch diameter tube.

Each antenna is a dual-dipole, vertically polarized antenna. The antenna will withstand 100 mile per hour winds with a coating of 1 inch of ice when stacked four high. The epoxy-coated fiber glass radome is weather resistant and contains sealed-in elements that are formed in place.

The UHF 437B-7 antenna operates over 225 to 400 Mhz with a gain of 4 to 5 db. The horizontal pattern is omnidirectional, with a 30° to 40° vertical beamwidth.

The VHF 437B-10 antenna operates over 116 to 152 Mhz with a gain of 2 db. The horizontal pattern is omnidirectional, with an 80° vertical beamwidth.

3.3.4.4 Low Frequency Beacon

The energy radiated from a LF Beacon antenna located near the earth's surface may be segregated into a sky wave and a ground wave. The sky wave is the energy radiated at an angle above the horizontal and is dependent on the ionosphere for transmission. The ground wave is the energy traveling along the surface of the earth and depends on the character of the surface involved, and the frequency.

TABLE 3.3-6

RADIO TEST POINTS

<u>TEST POINT</u>	<u>DESCRIPTION</u>
FWD PWR, Test Meter	Indicates Transmitter Forward Power to Antenna
REFLD PWR, Test Meter	Indicates Reflected Power from Antenna
% MOD, Test Meter	Indicates % Modulation
Temp, Test Meter	Indicates For Overtemperature Condition of Power Amplifier
+26V, Test Meter	Indicates DC-DC Converter Output Voltage
+22V, Test Meter	Indicates 22 Volt Regulated Supply Output Voltage
+12V, Test Meter	Indicates 12 Volt Regulated Supply Output Voltage
+5V, Test Meter	Indicates 5.1 Volt Regulated Supply Output Voltage
-12V, Test Meter	Indicates -12 Volt Regulated Supply Output Voltage
SERVO +	Provides Sample of Servo Motor Voltage While Tuning to a Higher Frequency
SERVO -	Provides Sample of Servo Motor Voltage While Tuning to a Lower Frequency
Tune Volt	Provides Sample of Servo Position Feedback Voltage
PLL Out	Provides Sample of Frequency Synthesizer Phase-Locked Loop Output Level
PLL Fault	Indicates Synthesizer Lock Condition
PA FWD PWR	Indicates RF Power Amplifier Forward Power To RF Filter
PA REFLD PWR	Indicates RF Power Amplifier Reflected Power From RF Filter
ALC	Provides Sample of Power Amplifier Automatic Level Control Voltage
KEY	Provides Sample of Key 2 Output
RCV AUDIO	Provides Sample of Receiver Audio Output
XMIT AUDIO	Provides Sample of Audio Module Transmit Output
IF AGC	Provides Sample of AGC Squelch Voltage
RECT DC	Provides Access to Transformer Rectifier Output
GND	Return For all Front Panel Test Points

The ground wave is vertically polarized because the horizontally polarized component in the immediate vicinity of the earth has its electrostatic field short-circuited by the ground. The ground wave is accompanied by charges induced in the earth. These moving charges constitute a current, and since the earth offers resistance to the flow of current, there is a dissipation of energy in the earth that represents energy absorbed from the ground wave. The portion of the wave in contact with the earth is therefore being continuously wiped out, only to be replenished at least in part by diffraction of energy downward from the portions of the ground wave immediately above the earth.

Information obtained from Nautical Electronic Laboratories Limited of Halifax, Nova Scotia indicates that the ground conductivity of Northern Canada is notoriously poor. Figure 3.3-5 is a copy of a graph Nautel prepared from published C.C.I.R. data. The graph shows the low altitude received field strength at three frequencies (200, 300 and 500 KHz) as a function of soil conductivity for a range of 100 nautical miles. The curves are based upon an actual radiated power of 0db watts from an electronically - short, vertical antenna. At higher altitudes, e.g. 6000 feet, the field strengths will be 1 or 2db's higher than shown.

The poor conductivity of the arctic soil demands that the radiated power be higher than for normal soil conditions. This problem may be solved by larger transmitter sizes and bigger antennas with good ground planes. A more serious problem is the night time sky. The sky wave reflected from the darkened ionosphere may propagate to a beacon receiver at long range. This reflected sky wave can interfere with the ground wave causing fading and bearing uncertainty. For normal soil conditions this would occur at about 165 miles. Due to the uncertainties of the ionosphere in high latitudes it is impossible to define a range where this problem may occur. It is possible that this could occur at night at 100 miles.

FIELD STRENGTH AT 100 NAUTICAL MILES VERSUS SOIL CONDUCTIVITY FOR GROUND WAVE PROPOGATION OF 1 WATT RADIATED FROM AN ELECTRICALLY SHORT VERTICAL ANTENNA

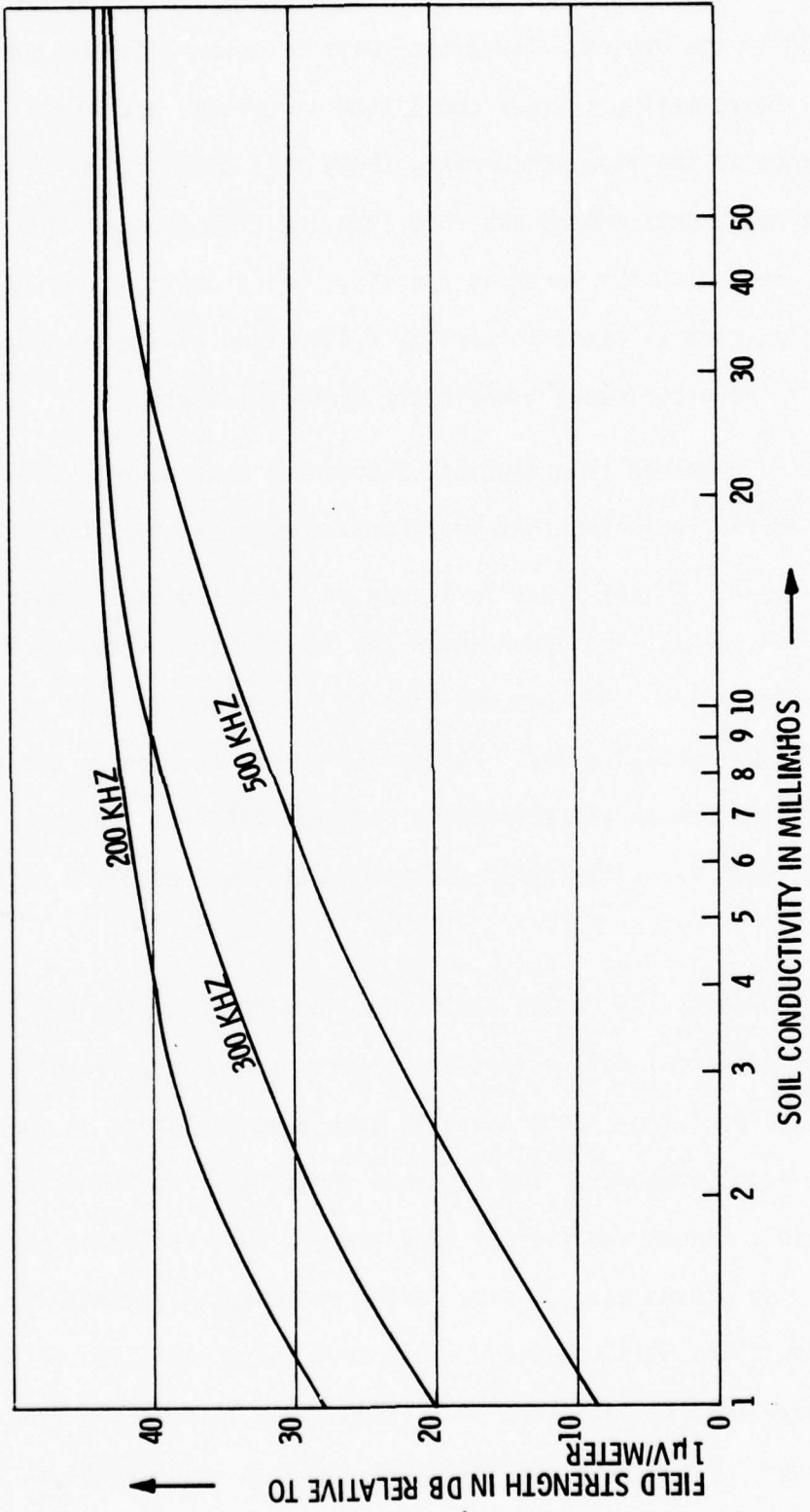

Figure 3.3-5

The requirement that was established for the beacon network, is that aircraft flying the dew line be able to receive a beacon signal at any point. The minimal acceptable beacon range for this to occur would be half the average distance between stations or 23 miles. To accommodate spacings greater than average the beacon frequency would be correspondingly less than the average beacon frequency.

The required radiated power P, in Kilowatts, is given by equation 3.3.1, for a flat earth

$$P = \left(\frac{E \times d}{300 \vartheta A} \right)^2 \quad \text{Eq 3.3.1}$$

where

E = Field strength in microvolts per meter

d = Distance to antenna in kilometers

ϑ = Antenna directivity factor

A = Ground loss factor

For the range, soil conductivity, and frequency band associated with the beacon network, the ground loss factor A is inversely proportional to distance and also inversely proportional to the square of frequency. Substituting for A in equation 3.3.1, the radiated power is found to be proportional to the fourth power of distance and frequency.

Radiated power is determined by the transmitter power and antenna efficiency. A half wave length antenna at 300 Khz would be 1640 feet in length. As antennas of this length are unpractical, a compromise to a shorter antenna with low efficiency is normally made. Antenna efficiency for the antennas normally employed improve in efficiency by roughly the square of the frequency. Using transmitter power times antenna efficiency in place of radiated power, equation 3.3.1 may be further modified to show that the field strength increases approximately by the reciprocal of the square of the frequency.

The maximum spacing between stations which is 60 miles, or a 30 mile minimum beacon range. The ratio to the average minimum distance of 23 miles is 1.3, to maintain the same field strength at the 30 mile range requires 4.62db of additional radiated power. This may be obtained by holding transmitter power constant and lowering the transmitter frequency from 300 Khz to 176 Khz or less. In the same manner shorter site spacing may be operated at higher frequencies.

Due to the sky wave interference problem, a 100 mile minimum range has been established as the upper bound of beacon range. This bounds the beacon range between 23 and 100 miles.

The FAA and Canadian Ministry of Transport require that 70 micro-volts per meter as the minimal signal level for non-directional beacon coverage. The I.C.A.O. recommendation is 50 micro-volts per meter as the minimal signal. NAUTEL based on their Canadian experience recommends the use of the I.C.A.O. standard due to the noise levels found in Northern Canada. To insure a safe operating margin, we have selected the FAA/MOT standard.

Assuming a poor soil conductivity of 2 millimhos/meter, the radiated power required at a frequency of 300 Khz to provide the 70 micro-volts per meter at 100 miles is 90 watts. Figure 3.3-6 shows the radiated power required as a function of range.

NAUTEL produces a series of Non Directional Beacons (NDB) with transmitter powers of 25, 62.5, 100, 250, 500 and 1000 watts. These may be combined with a series of vertical mast antennas with "top hat" capacitive loading structure, with heights of 60 feet, 90 feet, and 120 feet with corresponding differences in antenna efficiencies. Table 3.3-7 is a matrix of the radiated power and range for the 18 possible combinations. Using the data from Table 3.3-7 and the prime power requirements for the six transmitters the trend in beacon prime power vs range was established and plotted in Figure 3.3-7. On the same basis the trend of the acquisition costs vs range are plotted in Figure 3.3.8.

RADIATED POWER VS RANGE

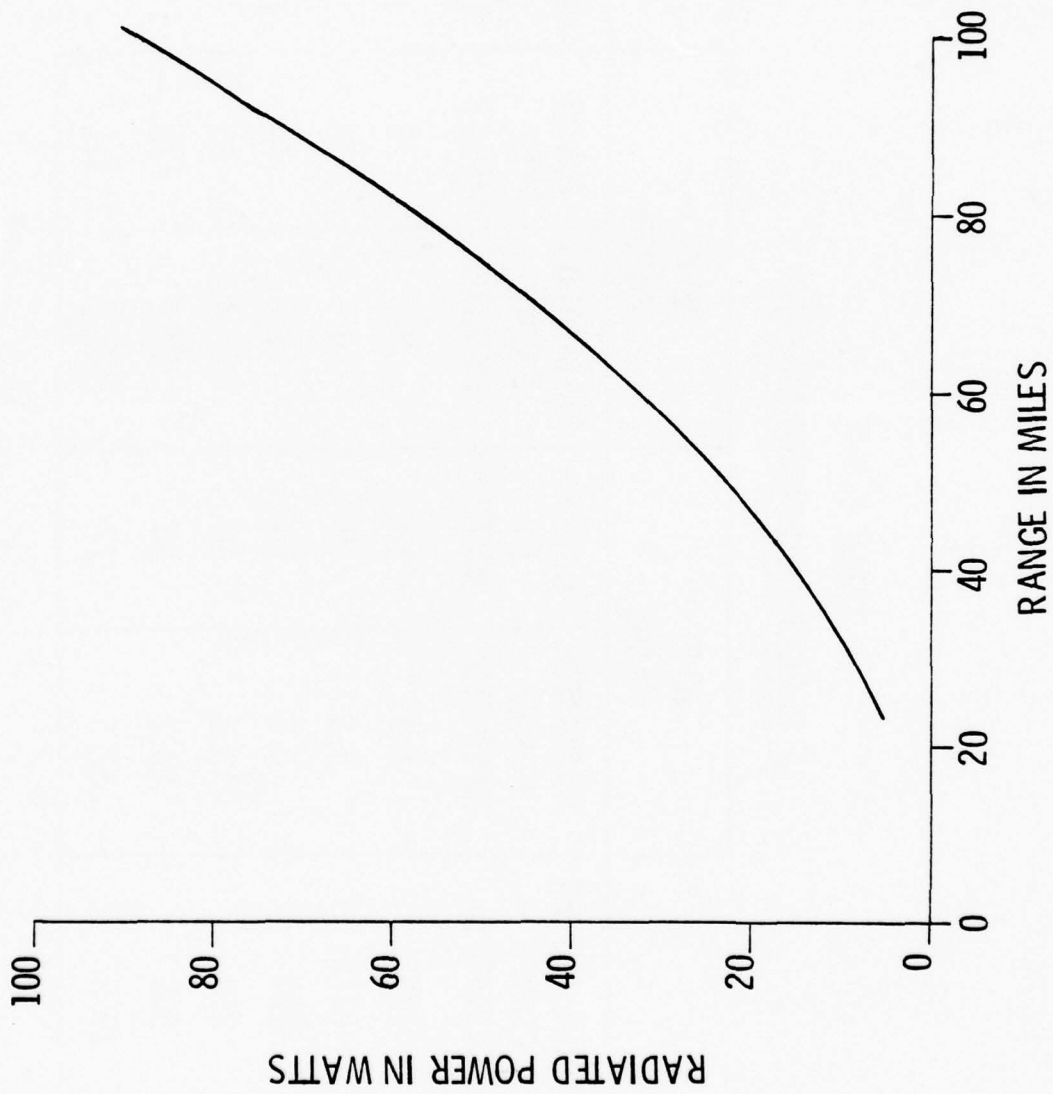

FIGURE 3,3-6

TABLE 3.3-7
LF BEACON EQUIPMENT MATRIX

EQUIPMENT	TRANSMITTER POWER IN WATTS	60 FT PA60B		90 FT PA90B		120 FT PA120B	
		RADIATED POWER IN WATTS	RANGE IN MILES	RADIATED POWER IN WATTS	RANGE IN MILES	RADIATED POWER IN WATTS	RANGE IN MILES
NX 100	25	1.3	12	2.7	18	4.5	22
NX 250	62.5	3.3	19	6.9	28	11.1	35
NX 400	100	5.3	24	11.0	35	17.8	45
NX 1000	250	13.2	38	27.4	55	44.5	71
NX 2000	500	26.2	54	54.2	78	88.9	100
NX 4000	1000	52.5	77	109.7	111	177.8	141

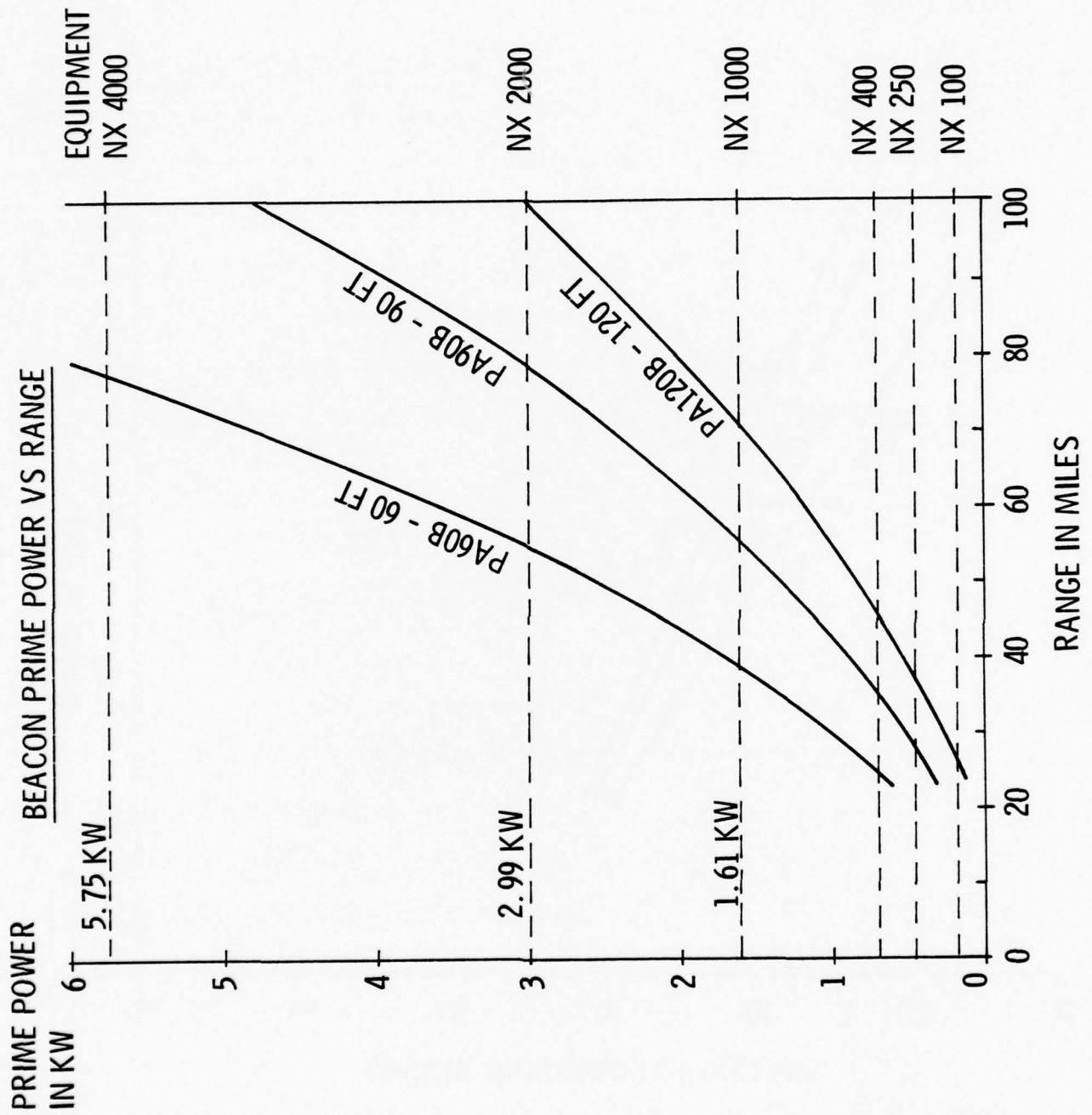

FIGURE 3.3-7

BEACON COST VS RANGE

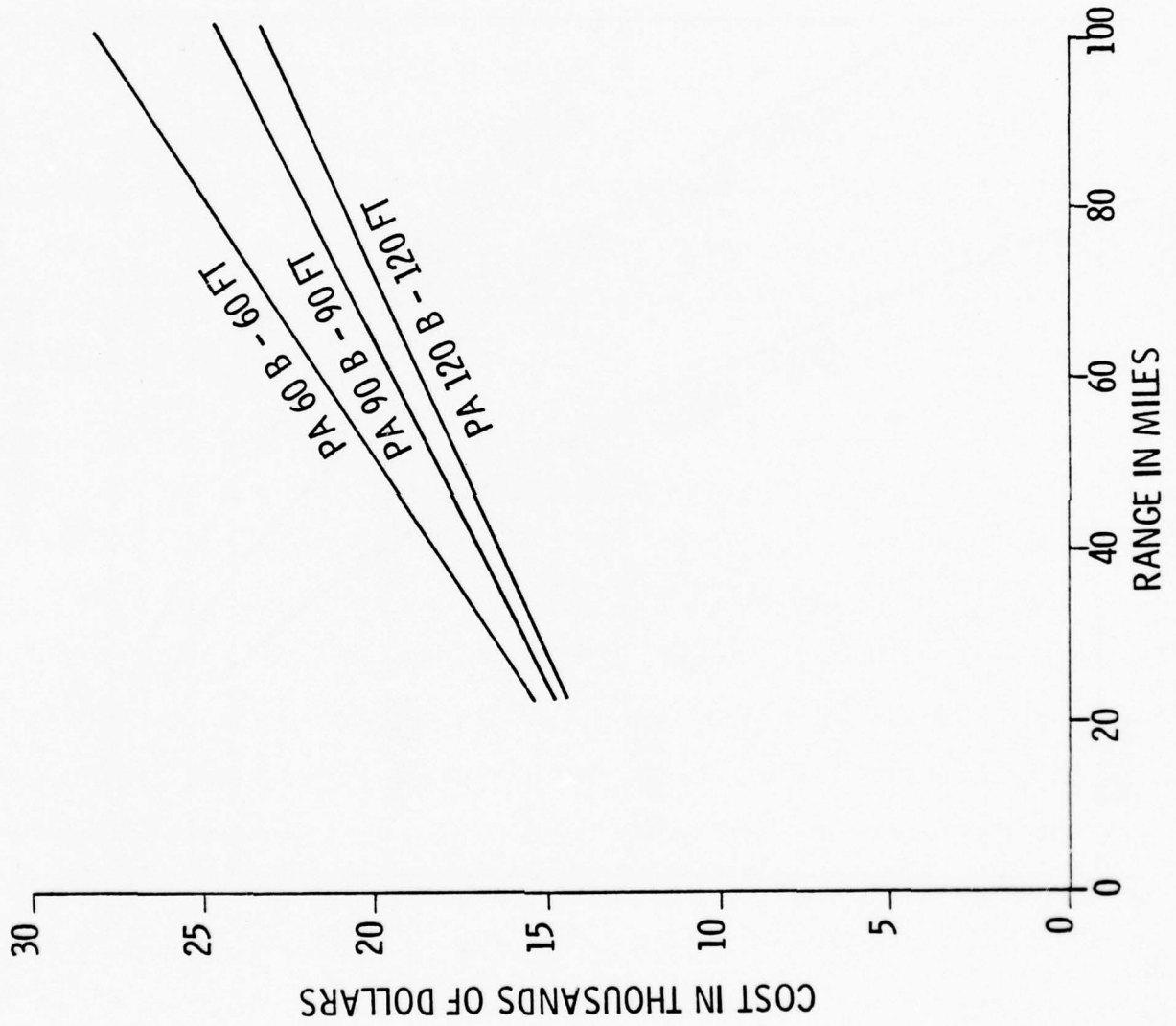

FIGURE 3,3-8

Based on Figure 3.3.8 the lowest cost combinations all use the 120 foot antenna. The same is true for the operating costs as the lowest prime power, from Figure 3.3-7, occurs when using the 120 foot antenna.

Selection of the minimal, 23 mile range, beacon transmitter will require a back-up transmitter to insure beacon coverage. The beacon system would consist of dual NAUTEL's NS 100 BA/D transmitters with a PA 120B Polestar antenna, and specialized transmitter switching circuitry. The acquisition cost of this system would be \$20,000.

Extending the range of the beacon system to 46 miles would establish dual beacon coverage along the entire line. This would eliminate the need for redundant transmitters, for should a transmitter fail the beacons at the adjacent sites may be used to navigate to the site. This beacon configuration would consist of NAUTEL's NX 400 BA/D transmitter working into a PA 120 B Polestar antenna at an acquisition cost of \$17,000.

Implementing the longest range, 100 miles, beacon system would consist of a NAUTEL NX 2000 BA/D transmitter at an acquisition cost of \$23,500.

Operating the beacon network under the baseline assumption that the beacons will be operational only for helicopter flights servicing the line, the life cycle costs will favor a non redundant 23 mile system with an acquisition cost of \$15,000. In practice it is anticipated that there will be a requirement to have the non-directional beacon system operational on a 24-hour basis. The cost of providing this service, using the 46 mile system, will be \$1,050,000 for the 83 stations over a twenty year period. This additional cost may be reduced to \$502,500 by using the 23 mile system on the 24-hour basis due to the lower prime power requirement. In conclusion the 46 mile beacon system is recommended, even for full time operation based on safety considerations.

3.3.4.5 Beacon Communication Backup Alternate

A cursory examination of employing the Low Frequency Beacon as a backup to the communication network, tentatively established the feasibility of this scheme. The procedure postulated, is intended for use only in case of a national defense emergency. The advantages of the scheme are low cost, and minor impact on station design. The scheme was generated primarily as a backup to the earth satellite communication network as it was felt that the earth satellite was more susceptible to intentional interference, but the scheme is applicable to line-of-sight if desired. The ground rules that were established for this mode of operation are as follows:

1. Primary communication system is earth satellite.
2. A national emergency condition exists.
3. Both satellites have been purposely destroyed, or are being intentionally jammed.
4. Frequency allocations may be disregarded.
5. A specialized beacon will be provided.
6. Restricted data flow is acceptable.

The basic problem in using the low frequency beacon for transmission of communication data is in obtaining sufficient bandwidth. The most restrictive element is the bandwidth of the antenna system. This may be overcome, by increasing the transmitter frequency to the 1 to 1.6 Mhz band. Using the NX 400 transmitter and PA120B antenna a 16 Khz bandwidth at a carrier frequency of 1 Mhz may be obtained. At the upper end of the band, 1.6 Mhz, a 31 Khz bandwidth is available. With a transmitter power of 100 watts, a minimum signal strength of 8.5 micro-volts per meter will be obtained at a range of 40 miles using 1 Mhz carrier, and a minimum signal strength of 6 micro-volts per meter at 1.6 Mhz. This is based on the same soil conditions used in the beacon calculations.

Increasing frequency while eliminating the technical problem, creates a jurisdictional problem in that transmission in the broadcast band is required. Broadcasting at the power levels stipulated, in the sparsely populated regions effected, should not cause an interference problem with users of the broadcast band. As it is a violation of the frequency allocation, broadcast on these frequencies should be restricted to use only in an emergency situation where an imminent or active attack is occurring, and the primary communication system has been disabled.

An examination of the station data requirements shows that to communicate all the data, without a voice channel, requires 1100 bits per second from the station to the node and 140 bits per second from the node to the station. The radar and IFF data requires 800 bits of the 1100 allocated. This may be reduced to 600 bits with no loss in information. If the radar and IFF data is outputted once every two scans, the data rate may be dropped to 300 bits per second. The total message load, which translates directly into the bandwidth, is dependent on the compromise of the minimally acceptable data rate, the amount of station status information that must be transmitted, and how many stations are serially reported to a manned node. With a 16Khz bandwidth it should be possible to transmit all data at a 4 second refresh rate, to and from 10 serial stations on either side of a manned node, or 20 stations in total. A special program would be incorporated in the station controller to change the beacon frequency, and to handle data reception, storage, formatting and transmission.

In terms of the equipment design, a modified beacon transmitter and antenna tuner unit would be required. The modification would be required. The modification would be of a minor nature as both devices are inherently capable of operating at the frequencies and powers specified. The only new equipment required would be a low frequency receiver and associated directional receive antenna system.

Transmitting the data back from the nodes presents a major problem area. An obvious solution would be the retention of the existing troposcatter system as a backup. This could be implemented using modern equipment or the existing equipment. A second possible solution would be the use of dedicated aircraft for each node during the emergency period. The aircraft would fly over a designated area in Southern Canada, and function as a relay in place of the satellite. A third possibility would be time or frequency sharing of the Trans-Alaska Pipeline microwave system, and the new microwave relay that is proposed that splits the center of Canada. Finally other techniques such as h.f. radio should be investigated as node to rear element backup systems.

Our examination was not in detail, and this technique is primarily offered as a task requiring further investigation, as part of any forthcoming communication study.

3.3.5 Security System

The Station Security System is primarily discussed in the Station Architectural Section. Table 3.3-8 is a summary of intrusion security.

In terms of prime power load the security system will draw 5 watts for the fire alarm system and door interlocks in the alert condition. The maximum load when the fire extinguisher and audio alarm system, or the audio and visual intrusion warning system is activated is 40 watts.

3.3.6 Communication

The station communication equipment is discussed in the communication consideration section of the study. The major impact that the overall station design has on the communication network is the message traffic load required by the station, which will be examined in the following section.

TABLE 3.3-8

INTRUSION SECURITY

THREAT

- VANDALISM
- THEFT
- SABOTAGE

THREAT REACTION

- LOUD SPEAKER
- DISPATCH LOCAL POLICE
- DISPATCH NODE HELICOPTER

PROTECTION

- INTRUSION RESISTANT DESIGN
- LOUD SPEAKER/MICROPHONE

ALERTING

- DOOR INTERLOCKS

AVERTING

- PROVIDE SINGLE PHONE SERVICE FOR SMALL COMMUNITIES
- PROVIDE ADDITIONAL PHONE & T.V. FOR LARGER COMMUNITIES WHERE
NOT AVAILABLE

3.3.6.1 Station Message Load

The baseline station message load shown in Table 3.3-9 defines the messages to be communicated between man nodes and the unattended stations. As part of the study task the individual message requirements were investigated and are discussed in the following section.

The radar message contains track data on one of the twenty targets that can be processed by the radar. The report contains positional and velocity information on the target. Table 3.3-10 breaks the message down into its elements, the numerical size of the element, the rationale for the number, and the number of bits of message required. A complete radar message on a target contains 58 bits. In similar fashion the IFF message for a target was structured and the results are shown in Table 3.3-11. As both messages carry redundant data on range, azimuth, track number, etc., combining messages would reduce the number of bits to be transmitted.

A composite radar and IFF message structure is depicted in Table 3.3-12. The first portion carries the range, azimuth, data for both radar and IFF, in addition to velocity and heading. The IFF portion contains required code data for modes 2, 3/A, C, and 4. In the message label the content of the message, as to whether it contains only radar, only IFF, or the combination will be provided. Additional information on the IFF coding will also be contained in the message label. Mode 4 operation for the unattended system, if required, presents a problem area. The coder-decoder is classified equipment and may not be physically located in an unattended area. To operate mode 4 from the manned node requires storage of data, or non real time operation of this mode. To accomplish this a development program will have to be undertaken. Although provisions for including in our message structure has been made it is our recommendation that mode 4 be eliminated as an IFF requirement for the unattended station.

TABLE 3.3-9
BASELINE STATION MESSAGE LOAD

<u>FUNCTION</u>	<u>COMMUNICATIONS MODE</u>	<u>FULL DUPLEX CHANNELS</u>
● RADAR TRACKING	DIGITAL	1
● RADAR STATUS AND CONTROL	DIGITAL	1
● COMMON STATUS AND CONTROL	DIGITAL	1
● G/A/G RADIO	VOICE/DIGITAL CONTROL	1
● EMERGENCY/MAINTENANCE VOICE AND PUBLIC ADDRESS	VOICE	1
● IFF	DIGITAL	1
● WEATHER AND NAVIGATION	DIGITAL	1
TOTAL		<u>7</u>

TABLE 3.3-10

RADAR MESSAGE

	<u>QTY</u>	<u>RATIONAL</u>	<u>BITS</u>
NEW - OLD TRACK	2	OLD OR NEW	1
TRACK #	20	20 TRACKS	5
RANGE	240	1/4 MILE ACCURACY, 60 MILE RANGE	8
VELOCITY	600	ACCURACY 10%, MIN VEL + 80 KTS MAX VEL + 2400 (4800/8)	10
AZIMUTH	720	ACCURACY 0.5°, COVERAGE 360°	10
HEADING	180	ACCURACY + 5% (2°)	8
TIME IN STORAGE	20	5 SCANS X 4 SEC	5
HIT COUNT	4		2
HOUSEKEEPING			<u>9</u>
			58 BITS

TABLE 3.3-11
IFF MESSAGE

● NEW - OLD TRACK	1
● TRACK NUMBER	5
● RANGE	8
● AZIMUTH	10
● TIME IN STORAGE	4
● MESSAGE LABEL	5
● MODE 4	16
● MODE 2 "X"	1
● MODE 3/A "X"	1
● MODE 2	12
● MODE 3/A	12
● MODE C	11
● HOUSEKEEPING	12
	<hr/>
	98 BITS

TABLE 3.3-12
COMBINED MESSAGE

● RADAR	49
● MESSAGE LABEL	5
● IFF CODE DATA	53
● HOUSEKEEPING	<u>13</u>
	120 BITS

20 TRACKS X 120 BITS = 2400/4 SECOND = 600 BITS/SECOND

The Radar/IFF message for up to 20 targets should be outputted every 4 seconds, which is the frame time of the radar. This will require that 20 x 120 bits be transmitted every 4 seconds, or a rate of 600 bits per second. To allow for growth, a figure of 800 bits per second was used in determining final message load.

In addition to remoting the data, or Radar/IFF status and control message must be provided for. The actual structure of this message is heavily dependent on the hardware to be used and has not been detailed as part of the study. A 100 bit per second rate has been assumed based on an estimate of the radar proposed in the General Electric Study.

Status and control of the prime power, switchgear, environmental control, security system, and lighting are handled by a common status and control message. A major portion of the message is the performance monitoring that is detailed in Table 3.3-13. A total of 100 bits per second has been allocated for the total common status and control message.

The weather message was given in Table 3.3-5. Additional information on the status of the weather station will be required in addition to the data message. The control and status of the radios, and low frequency beacon must also be structured. The total allocation for the weather station and NAVAIDS is 100 bits per second.

A single voice channel will be sent from the ground to air radios, or station intercomm on a time shared basis. Should voice communication be requested on more than one radio, or radio and station intercomm, an indicator will be illuminated at the manned node notifying the operator.

The signal from the manned node to the unattended station is primarily a voice channel that is time shared between the radios, low frequency voice channel,

TABLE 3.3-13

PERFORMANCE MONITOR MESSAGE

	<u>BITS</u>
A. RADAR & IFF	
- FAULT AREA	4
ARRAY	
RF EXCITER	
RECEIVER	
SIGNAL PROCESSOR	
IFF	
IFF DATA PROCESSOR	
SENSITIVITY	
POWER OUTPUT	
- DEGRADED FAULT	1
- 2ND FAULT	5
B. STATION CONTROLLER	2
C. SECURITY ALARM	4
D. PM/FL	1
E. PRIME POWER	4
F. WEATHER STATION	1
G. NAVAIDS	1
H. GROUND TO AIR RADIO	1
I. MESSAGE CODE & PARITY	4
TOTAL	<u>28</u>

and station intercomm. In addition 10 bits for common status and control, 10 bits for weather and navigation, 10 bits for radio control, and 100 bits for Mode IV IFF input data have been allocated.

The normal traffic load will at times be time shared with diagnostic or special performance monitoring functions, but the total station load will be maintained at the 1100 bit per second rate from the station to the mode. There will be an increased load from the node to the station during this period.

The composite traffic requirement established, is given in Table 3.3-14.

3.3.7 Station Controller

The station controller will consist of one or more microprocessors. The following are the primary functions of the station controller.

- o Station housekeeping
- o Remote control command decoding
- o Equipment power up/down on node command
- o Priority arbitration (message & bus)
- o Data formatting & transfer
- o Buffer storage loading
- o Parity bit encoding
- o Parity bit checking
- o Performance monitoring
- o Fault monitoring and reporting
- o Diagnostic trouble shooting and reporting

Station housekeeping functions such as turning on the weather station for hourly reports, turning on obstruction lights at night, turning on the environmental blowers when the ambient temperature warrants are typical tasks to be performed by the station controller.

TABLE 3.3-14
TRAFFIC REQUIREMENTS

	FROM UNMANNED STATIONS TO MANNED NODE	FROM MANNED NODE TO UNMANNED STATIONS
● RADAR DATA	800 BPS (INCLUDING IFF)	
● RADAR STATUS AND CONTROL	100 BPS	10 BPS
● COMMON STATUS AND CONTROL	100 BPS	10 BPS
● G/A/G RADIO EMERGENCY/ MAINTENANCE	VOICE AS REQUIRED	10 BPS PLUS VOICE AS REQUIRED
● VOICE AND PUBLIC ADDRESS	VOICE AS REQUIRED	VOICE AS REQUIRED
● IFF	INCLUDED WITH RADAR DATA	100 BPS
● WEATHER AND NAVIGATION	100 BPS	10 BPS
TOTAL	1100 BPS PLUS VOICE AS REQUIRED	140 BPS PLUS VOICE AS REQUIRED
INTEGRATED TRAFFIC	ONE MULTIPLEXED CHANNEL PER SITE FOR DATA AND VOICE	ONE MULTIPLEXED PER SEGMENT FOR DATA AND VOICE

STATION CONTROLLER

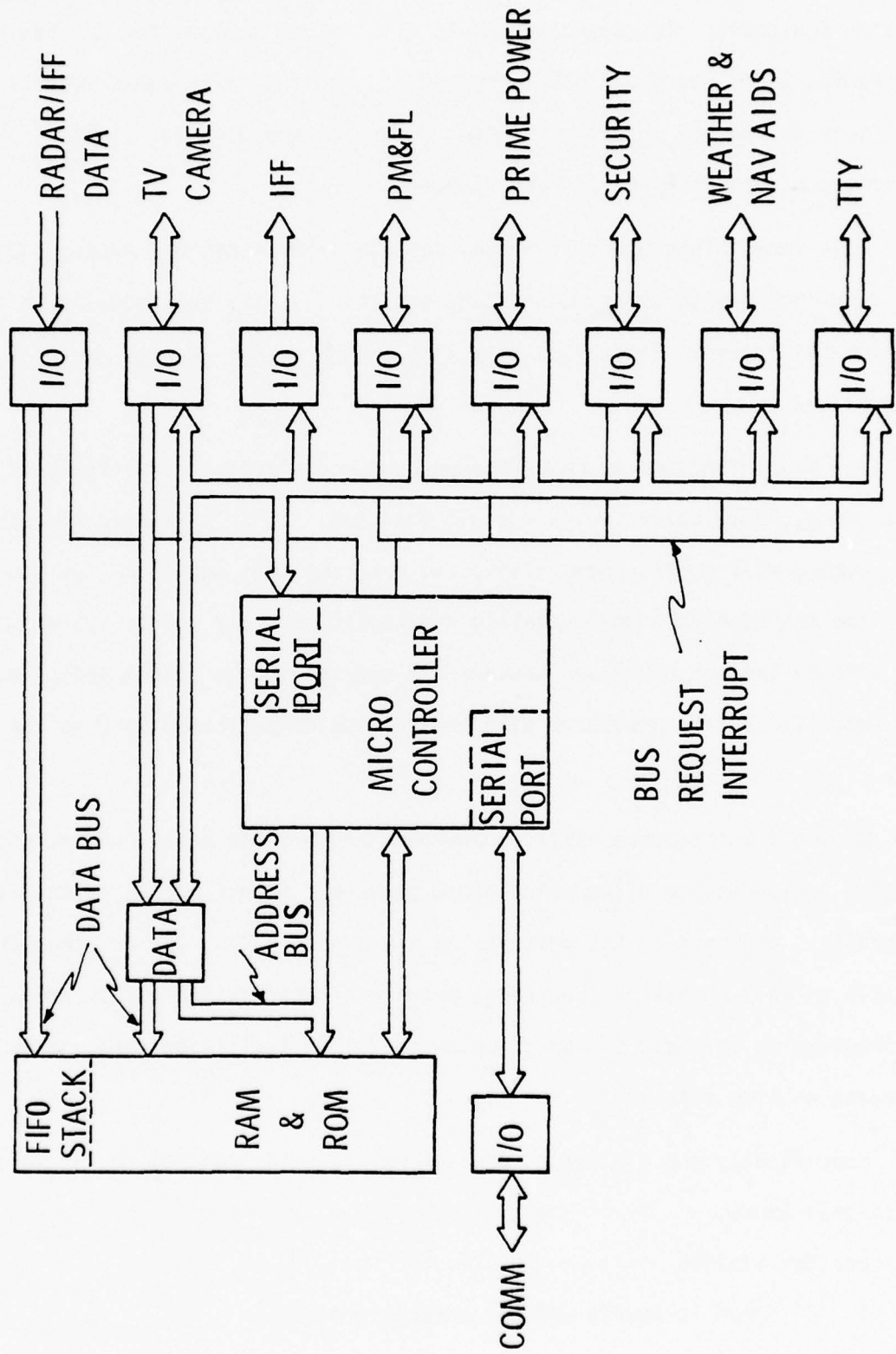

FIGURE 3.3-9

The controller will also be the interface between the command signals received from the manned node by means of the communication system, and the station equipment. In this capacity it will select between the UHF Radio, VHF Radio, L. F. Beacon, or audio system for routing voice communication. It will turn on and off specific equipments such as the Diesels, lights, T.V. camera, and pass on Radar and IFF commands.

Data formatting, buffer storage, message prioritization, message decoding and interfacing with the communication system will also be accomplished in the station controller. Figure 3.3-9 is a functional block diagram of the station controller.

The final function to be performed by the controller is performance monitoring, fault detection, and fault location. It is envisaged that the read only memory will contain some diagnostic programs that may be called upon command from the manned node. More detailed diagnostic programs may be transmitted to the site by the communication network for storage in the random access memory, and execution by the processor with the results communicated back to the manned node.

During a maintenance visit, a keyboard and printer have been included as station equipment, to allow maintenance personnel direct access to the station controller, and back to the computer at the manned node. The maintenance will be able to call up station programs, programs stored at the manned node, as well as programming in their own programs or checks to facilitate maintenance and decrease on site time.

Specifically the station controller will provide control in the following functional areas.

Weather Station

- o Schedule hourly weather message program
- o Power up/down sensors

- o Data sequencing and transfer
- o Message buffer memory storage
- o Weather message formatting
- o Initiate sensor tests on node command
- o Report on sensor tests
- o Power up/down T.V. camera
- o Buffer picture data
- o Format and output picture data

NAVAIDS

- o Power up/down obstruction lighting on node command
- o Power up/down rotating beacon on node command
- o Power Up/down helipad lighting on node command
- o Connect voice channel to radios, L.F. Beacon, or audio
- o Fault monitor
- o Initiate diagnostic programs

Environmental Control

- o Power up/down environmental control devices
- o Monitor environment and provide warning in case of exceeding limits
- o Fault monitoring and reporting of failed devices
- o Diagnostic trouble shooting and reporting

Station Security

- o Monitor alarm system
- o Report intrusion
- o Activate anti-intrusion program including taped voice and lighted warning signs
- o Reset system as required
- o Fault monitoring and reporting of failed devices

Prime Power

- o Communicate with prime power controller

Radar and IFF

- o Communicate with Radar and IFF computer

Message Formats

Figure 3.3-10 depicts the internal and external message formats

The station controller will consist of the following equipment

Microprocessing Unit - Motorola 6800

Random Access Memory - 32K bits

Read Only Memory - 16K bits

Asynchronous Interface Adaptor - Qty. 15 Motorola S6850

VSAAT Serial Adaptor - Qty. 2 Motorola S2350

Sensors - As required

It is estimated that the controller including sensors will not exceed \$10,000 in production, the development and demonstration costs are included in the overall station design and demonstration cost. It is also estimated that the controller including sensors will draw less than 200 watts.

3.3.8 Prime Power

The baseline prime power supply for the station consists of three diesel generator sets, 5,000 gallons of fuel storage, prime power controller, battery chargers, starter and storage batteries, uninterrupted power supply inverter, environmental control, and switch gear.

Normally the load is carried by one of three Lister ST-1 diesel engines coupled to Lima SER-R self-regulated, brushless, synchronous alternators, frame size 280 as recommended in the "ERDA 2KW (e) Unattended Power System Study" final report. The generator provides $\pm 10\%$ voltage regulation, and $\pm 5\%$ frequency regulation. The generator efficiency is 80%. Table 3.3-15 summarizes the ST-1 performance capabilities.

DATA FORMATTING

μ CONTROLLER TO FUNCTION CONTROLLERS

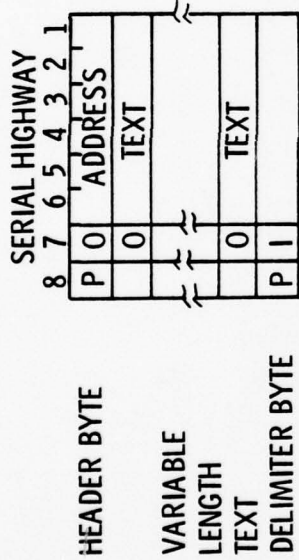

FORMATTED DATA TO/FROM COM AND μ CONTROLLER

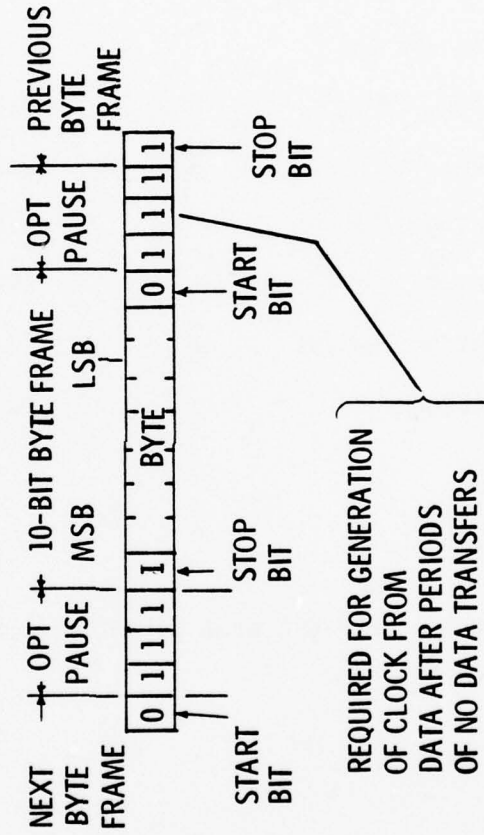

RADAR TO μ CONTROLLER
VECTORED INTERRUPT INITIATED PARALLEL DATA TRANSFER TO MEMORY

TV TO μ CONTROLLER
μ CONTROLLER ADDRESS START AND DMA DATA TRANSFER

FIGURE 3.3-10

TABLE 3.3-15

DIESEL POWER SYSTEM CHARACTERISTICS

DIESEL DESIGNATION	Lister STIA
Lowest/Nominal/Maximum RPM	1200/1800/3000
Overall Efficiency, percent	25.1
Generator Efficiency, percent	80
Continuous Rating, kW (e)	2.8/4.4
Peak Output Rating, kW (e)	4.9
Normal Output, kW (e)	2.8/4.4
Fuel Consumption, gal/hr	0.336/0.528
Fuel Consumption, gal/yr	2943/4625
Lube Oil Consumption, gal/yr	21
Available Heat, Btu/hr *	12,300

* Cooling air only. Exhaust heat potentially available.

In the ERDA Power Study it was recommended that two 2KW, and one 10KW machines be used. This was based on the need for 10KW of power when maintenance team is visiting the site. As will be discussed later, the General Electric power requirements during maintenance visits is significantly less than 10KW. This is primarily due to the innovative station architecture that provides only minimum facilities for maintenance visits. Reducing the maintenance load allows two ST-1 diesel - generators to handle the maintenance load either in parallel or with split loads. With three ST-1 diesel generators at the station the reliability of the station is improved as the previous scheme required the 10KW machine to function as a backup to the 2KW machines.

Operating a 10 KW machine, with a 2KW load, is troublesome due to carbon fouling of the fuel injector and the combustor in general; and fouling of the exhaust system. The carbon fouling problem lowers the reliability of the machine. A second advantage to operating three identical machines occurs in the logistics and maintenance areas. Finally there is a cost reduction of \$1,000 per station when an ST-1 is used in place of a 10KW ST-3.

The diesel will have an electric starting motor driven by a 12 volt NIFE H305 nickel cadmium battery. The battery will take a 50 amp-hr charge allowing at least three consecutive 120 second cranking periods at 20⁰F. Nickel cadmium batteries are used due to their superior storage capabilities in cold weather. Each engine will be equipped with a battery charger.

3.3.8.1 Uninterrupted Power

To provide uninterrupted power in the event of catastrophic failure of a diesel a 24 volt, 185 amp-hour source is provided. The source consists of a battery charger, nickel cadmium batteries, and an inverter for conversion from d.c. to a.c. The time to start, warm up, and bring a standby unit on line is 20 seconds to 2 minutes. Full uninterrupted power for 2 minutes is provided at which time the controller will automatically start dropping load to a

minimum load of the controllers, radar memory, security and single satellite communication channel with minimized transmission. Should all diesels be in a failed condition the station may remain in the above state for up to 18 hours. If a helicopter cannot be dispatched and arrive at the site within this period, the radar memory and security systems should be dropped within the first hour, to extend the low powered state to 24 hours. A reserve of 10 minutes of power has been provided to allow powering of the UHF ground to air radio, beacon, T.V. camera, obstruction lights, wind sock light, and helipad lights just prior to the arrival of the maintenance helicopter.

A reduction in cost of five thousand dollars may be obtained by eliminating the uninterrupted power source and replacing it with emergency power for critical items. The three factors that are critical during power outage are maintenance of memory, station control and security. The critical items would include the prime power controller, station controller, radar processor memories, intrusion alarm, and fire alarm. The total power required by this group in a minimum power consumption configuration is 60 watts. The 60 watts may be obtained directly from the 12 volt engine generator starting battery. The starting battery has been rated to allow for six minutes of continuous cranking in three separate periods. If the emergency power is drawn for nine minutes from the starter battery, only 0.75 amp-hr of the total 50 amp-hr capacity would be required. In the unlikely event that one of the standby diesels cannot be brought on line, a complete station failure will result. This will require reprogramming of memories when power is restored by the maintenance crew. The one other drawback in emergency vs uninterrupted power is the loss in communication with the node during the period of interruption. Using uninterrupted power the manned node may assist in repowering the station, using emergency power, the prime power controller will have to automatically restore power.

It is recommended that uninterrupted power be implemented to maintain node communication. Uninterrupted power for the communication and computers are proven devices, and if the uninterrupted load is kept modest no problem is anticipated.

3.3.8.2 Prime Power Control

The prime power station control will be a microprocessor providing the following functions:

- o Start diesel generator on command or in the event of a failure.
- o Monitor lube oil pressure and temperature.
- o Monitor output voltage and frequency.
- o Monitor enclosure temperature.
- o Shutdown malfunctioning engine-generator set.
- o Transfer load to battery storage in event of failure.
- o Start, warmup, load and monitor backup generator on command.
- o Monitor current flow in branch loads.
- o Monitor and control overload.
- o Close and open circuit breakers on command or to prevent failure.
- o Synchronize two generators.

Figure 3.3-11 is functional block diagram of the prime power controller. The microprocessor will consume 15 watts, the six A/D converters require 25 watts, the sensors multiplexers, drivers, require 20 watts. The total control load including power supplies is 100 watts.

Station power control will be provided by the switchgear shown in Figure 3.3-12. The circuit breakers used are General Electric AK-2-15 motor driven relays. The stored energy closing mechanism utilizes energy stored in springs to close the breaker contacts. A small universal motor drives a gear reducer unit, and the output of this unit charges the closing springs through a charging

PRIME POWER CONTROL SYSTEM

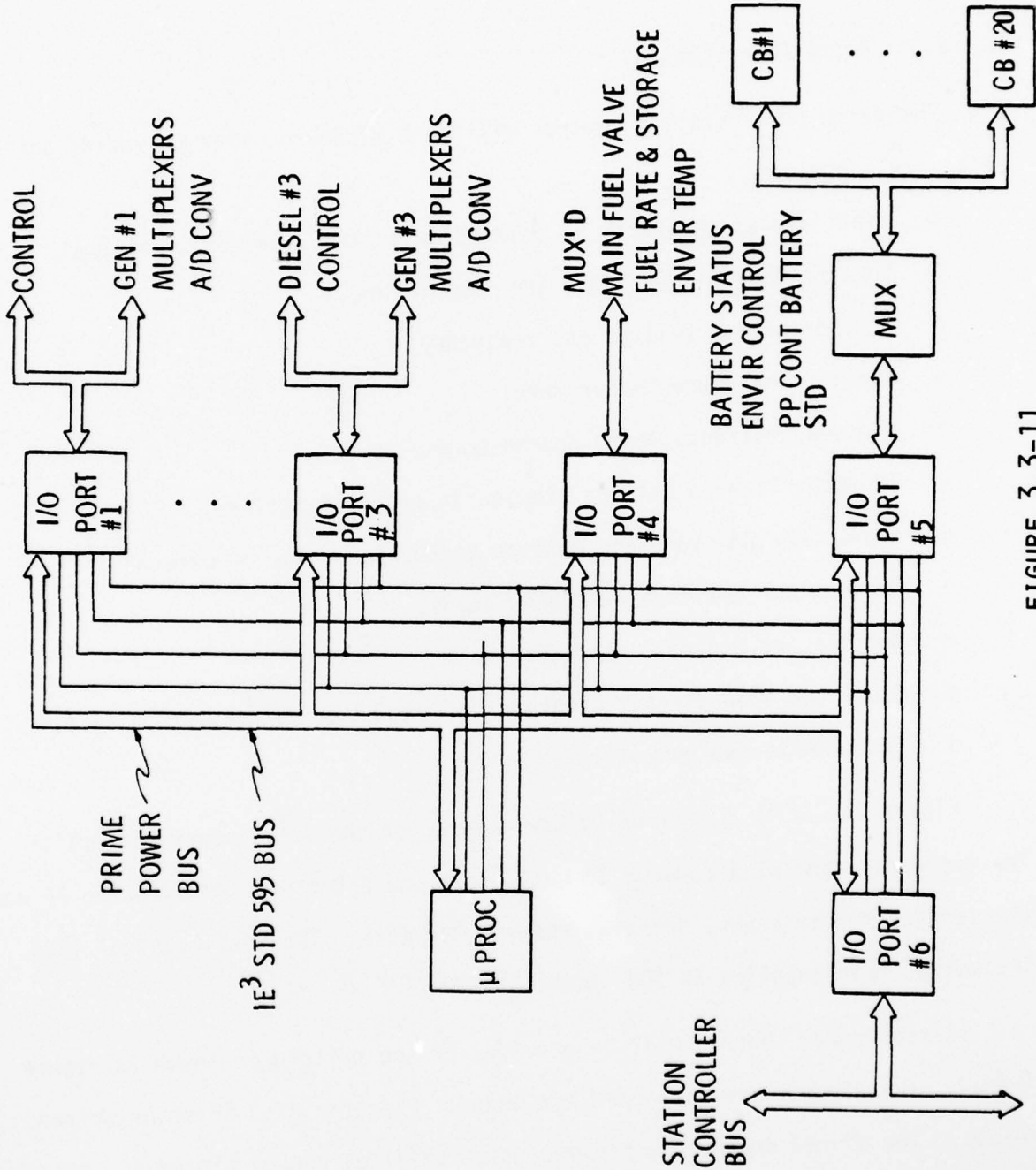

FIGURE 3.3-11

SWITCHGEAR

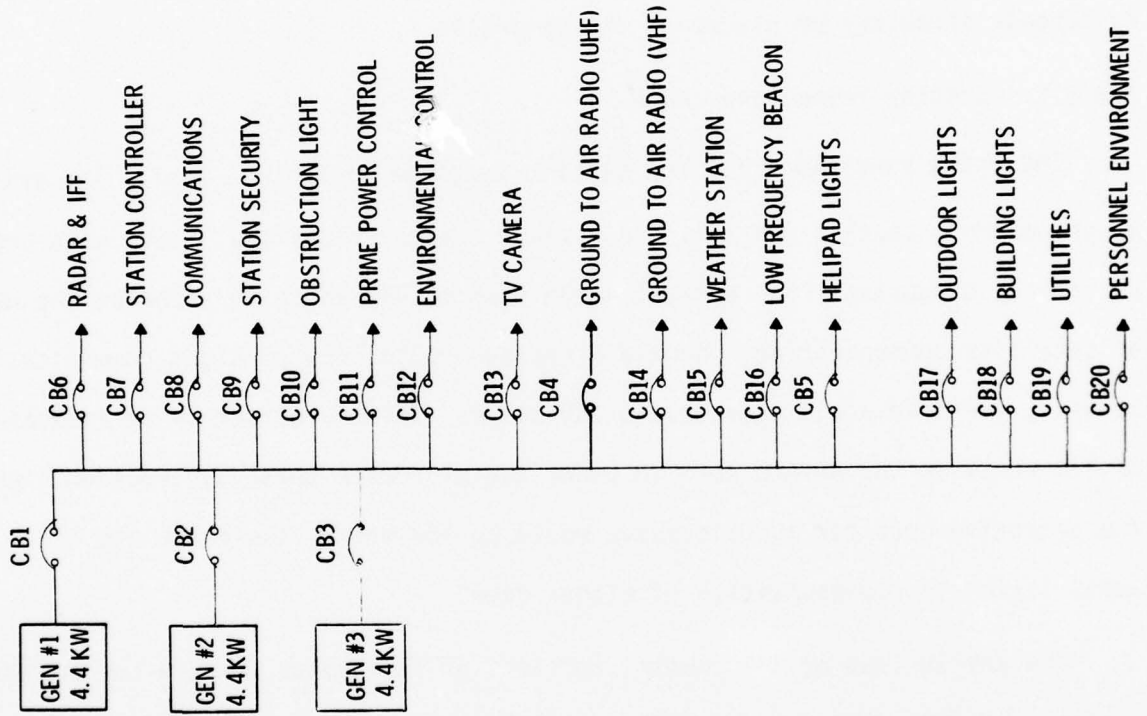

FIGURE 3.3-12

crank and cam. The circuit breaker is activated on command from the prime power controller. A second set of springs is used for tripping the breaker.

The prime power control load is broken down in Table 3.3-16. The environmental control load of 200 watts controls the ducting as discussed in the ERDL Power Study. The full time load for the controller alone is 100 watts. A peak intermittent load of 440 watts is the *maximum that may be seen* by the generator. It consists of the power controller, environmental control, and either one of the charger or the switchgear. The prime power controller will monitor generator load and only if energy is available will the chargers and switchgear circuitry be placed on the generator.

3.3.8.3 Station Prime Power Load

The prime power load for the station is given in Table 3.3-17. The prime power control, station control, and weather station individual loads have been previously discussed. The communication load of 470 watts is based on the use of satellite communication. Should microwave radio line of sight communication be used, the load would decrease to 340 watts. This is offset by an increase of 118 watts in the NAVAID load to power the microwave tower obstruction light. The effective load for the microwave would be 458 watts, therefore the 470 watts listed is representative of either case.

The NAVAID load of 1020 watts, consists of 720 watts for the Low Frequency Beacon, and 300 watts for the UHF and VHF Transceivers in the receive condition. A peak load of 1320 watts occurs when transmitting on either the VHF and UHF radios.

The security load consists of the fire alarm and intrusion alarm systems. The upper bound of 40 watts is based on the intrusion alarm being triggered, and the audio warning system activated. The normal load is based on the alarm systems in alert status.

TABLE 3.3-16

PRIME POWER CONTROL LOAD

● FULL TIME LOAD

1. POWER CONTROLLER 100 WATTS

● INTERMITTENT LOAD

1. STARTER BATTERY/CHARGER 140 WATTS

2. STORAGE BATTERY/CHARGER 140 WATTS

3. ENVIRONMENTAL CONTROL 200 WATTS

4. SWITCH GEAR (REMOTE CIRCUIT BREAKERS) 100 WATTS

PEAK INTERMITTENT LOAD 440 WATTS

TABLE 3.3-17

STATION POWER LOAD

	FULL TIME LOAD IN WATTS	INTERMITTENT LOAD IN WATTS	MAINTENANCE LOAD IN WATTS
A. PRIME POWER CONTROL	100	440	100-440
B. RADAR/IFF	1000	1000	1000
C. COMMUNICATIONS	470	470	470
D. STATION CONTROLLER	200	200	200
E. SECURITY	5	40	5
F. NAVAIDS	1020	1320	1020-1320
G. WEATHER STATION	105	205	105-205
H. MAINTENANCE LOAD	---	---	3000 - 4500
I. GROWTH FACTOR	200	200	200
J. ENVIRONMENTAL CONTROL		340	200-340
GRAND TOTAL	3100	4215	6300 - 8680

Summing the first column, the full time station load is 3100 watts. The peak load as shown by column two is 4215 watts. This figure may be reduced to 3940 watts if desired, by not allowing all overloads to occur at the same time. This may be accomplished by scheduling the prime power and station controllers. The final column, maintenance load, may vary from 6,300 watts to 8,680 watts. A break out of the maintenance load of 3,000 watts to 4,000 watts is further detailed in Table 3.3-18.

3.3.8.4 Prime Power Generation

Radar and IFF prime power is the dominant power requirement. The 1,000 watts used, is an average figure established from the results of the unattended radar studies which ranged from 600 watts to 1500 watts. This is also approximately the figure established by General Electric in our radar study. Assuming the 1500 watt figure the normal load would rise to 3,600 watts with a peak load of 4,440 watts.

In the ERDA Power Study it was proposed to use the Lister Diesels at 1,200 RPM which would develop 2.8KW at full load. This is 300 watts less than the figure required from the power budget of Table 3.3-17. By changing the speed of the diesel to 1,800 RPM the output power may be increased to 4,400 watts at full load. For proper performance of the diesel it is recommended that it not be operated below 3,100 watts to prevent fouling of the injectors. Should the machine be operated below 3.1KW for an extended period of time, the carbon may be cleaned out by loading the machine up to full load for short programmed periods. The maximum one hour in twenty-four overload rating is 4,800 watts. The ST-1 operated at 1,800 RPM appears to be an excellent match to the load. Should additional power be required as the design matures, this may easily be handled by increasing diesel size. The ST-1 is a single cylinder diesel, the ST-2 is a two cylinder diesel only slightly larger, and the ST-3 a three

TABLE 3.3-18
MAINTENANCE POWER LOAD

	<u>MINIMUM</u>	<u>MAXIMUM</u>
BUILDING LIGHTS	1200 WATTS	1500 WATTS
OUTDOOR LIGHTS	800 WATTS	1000 WATTS
TEST EQUIPMENT	600 WATTS	1000 WATTS
ENVIRONMENTAL CONTROL	200 WATTS	500 WATTS
UTILITIES	<u>200 WATTS</u>	<u>500 WATTS</u>
TOTAL	3000 WATTS	4500 WATTS

AD-A059 510

GENERAL ELECTRIC CO SYRACUSE N Y ELECTRONIC SYSTEMS DIV F/G 17/9
UNATTENDED RADAR STATION DESIGN FOR DEWLINE APPLICATION. VOLUME--ETC(U).
JAN 78 W E ABRIEL, S E BELL, E J GERSTEN F19628-77-C-0212

FSD-TR-78-176-VOL-2

NL

UNCLASSIFIED

3 OF 3
AD
A059510

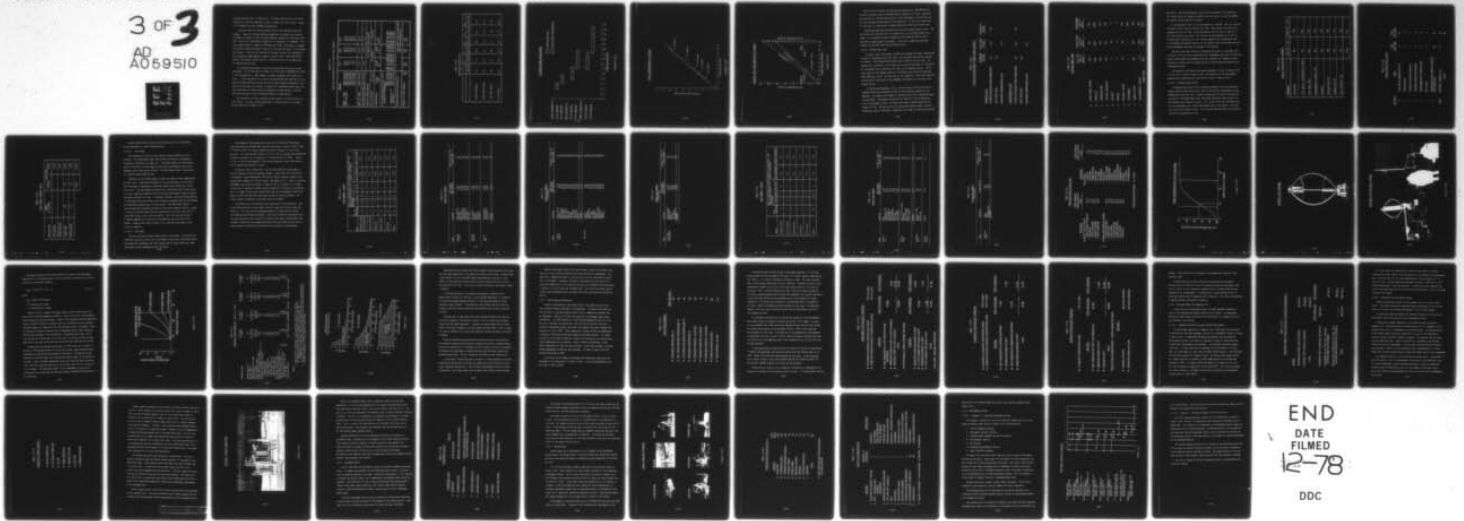

END
DATE
FILMED
12-78
DDC

cylinder machine which is larger again. The power capabilities of the three machines at 1,200 and 1,800 RPM is given in Tables 3.3-19 and 3.3-20. Figure 3.3-13 displays the same information graphically.

The major impact on increasing power load is fuel expenditure and fuel storage. Figure 3.3-14 shows the fuel expenditure in gallons as a function of power in kilowatts for the different machines, operating a 1,200 and 1,800 RPM. The ST-3 at 1,200 RPM was deleted as its information is redundant. The curve shapes reflect a change in efficiency with load. Also shown is a dashed curve which displays the general slope of all the devices which is 0.12 gallons per kilowatt. Using the 0.12 gallons per kilowatt the year fuel consumption as a function of power demand is shown in Figure 3.3-15. Also noted on the figure is the normal station load of 3.1 KW which results in an expenditure of 3,260 gallons per year.

The proceeding calculation is based on the generators operating at peak efficiency. If the 70% points of Figure 3.3-14 are used to determine the slope of fuel consumption vs. power demand, a higher consumption per kilowatt will occur. In field operation it is also to be expected that the machines will not operate at peak efficiency during the entire period between maintenance visits. Using a 0.15 gallons per kilowatt, to account for intermittent peak loads, and lower efficiency, an annual station consumption of 4,000 gallons is derived and should be used in place of the more optimistic 3,260 gallons.

The average cost of fuel delivered to the station is \$1.33 per gallon in 1977 dollars. The cost of the 4,000 gallons is \$5,320, which is also shown on the right axis of Figure 3.3-15.

TABLE 3.3-19

OPERATING CHARACTERISTICS OF ST SERIES DIESEL ENGINES

ENGINE	ST1	ST2	ST3
BS649 : 1958 (bhp rating)	10.5 10.0 8.1 7.3 6.0 4.7	21.0 20.0 16.2 14.6 12.0 9.4	31.5 30.0 24.3 21.9 18.0 14.1
DIN 'B' (PS)	11.7	23.4	35.1
Maximum Gross bhp	2600 rev/min	25.0	37.5
bmp at 1800 rev/min	5.73 kg/cm ² (83 lb/in ²)		
Bore X Stroke	95.25x88.9		
Displacement	litres in ³	1.266 77.4	1.9 115.1
Fuel consumption at full load g/bhp/hr (lb/bhp/hr)	202 (0.445) 184 (0.405) 181 (0.400) 184 (0.405)	202 (0.445) 184 (0.405) 181 (0.400) 184 (0.405)	199 (0.438) 179 (0.395) 181 (0.400) 184 (0.405)
Subject to 5% tolerance			
Lubricating oil consumption	Less than 0.75% of the full load fuel consumption		
Weight of bare engine	107 236	170 375	215 474
	kg lb		

TABLE 3.3-20

OPERATING CHARACTERISTICS

	ST1		ST2		ST3	
	1200 RPM	1800 RPM	1200 RPM	1800 RPM	1200 RPM	1800 RPM
Rated Horsepower:	4.7	7.3	9.4	14.6	14.1	21.9
Rated Power Output	2.8	4.4	5.6	8.7	8.4	13.1
70% Power Output	2.0	3.1	3.9	6.1	5.9	9.2
10% Overload	3.1	4.8	6.3	9.7	9.4	14.6

STATION POWER GENERATION

70% TO FULL LOAD
 FULL LOAD TO 10% OVERLOAD

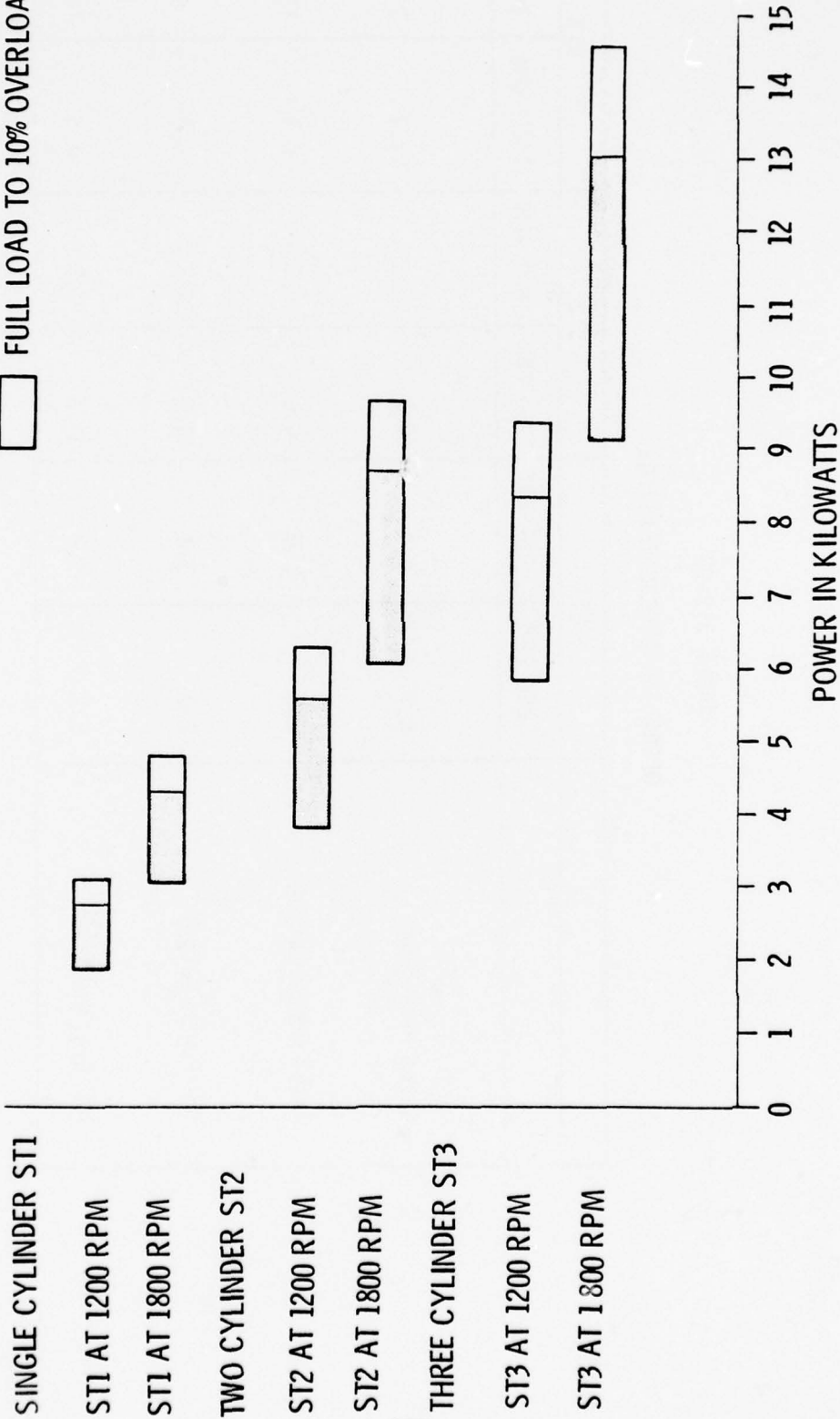

FIGURE 3.3-13

FUEL CONSUMPTION VS POWER

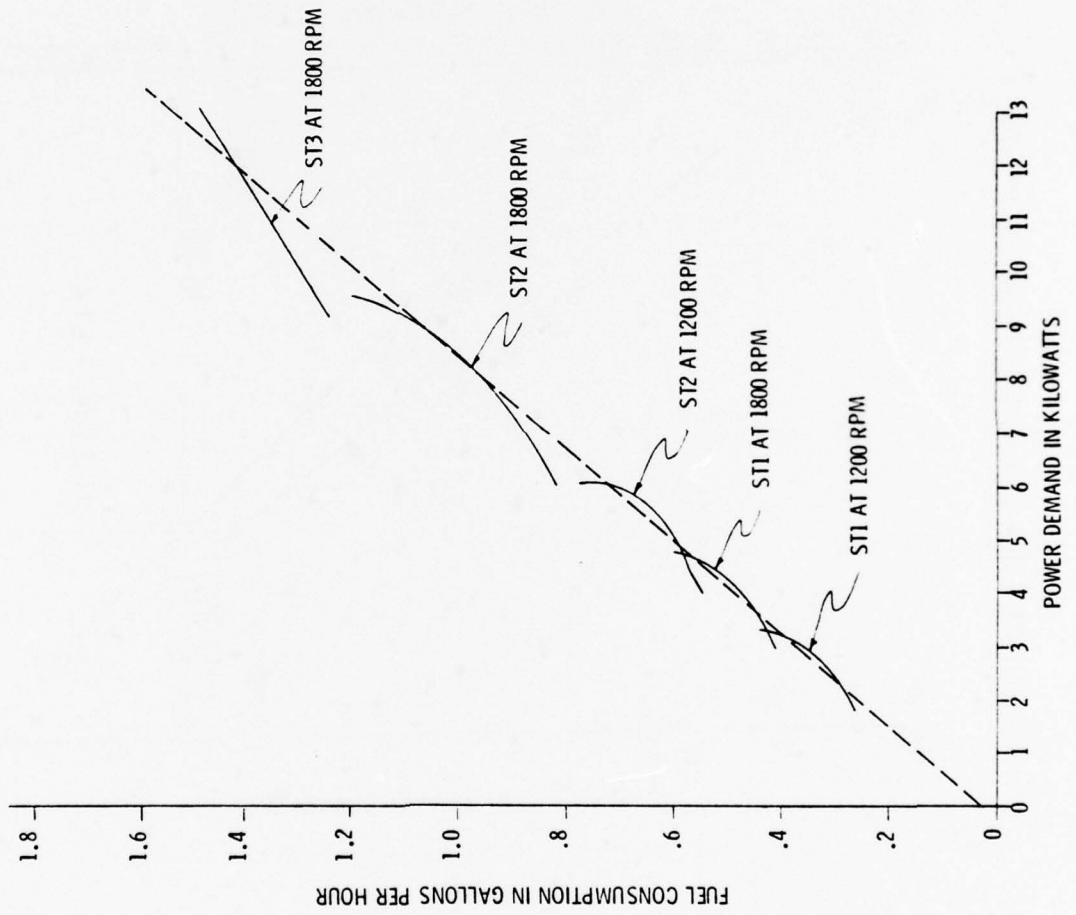

FIGURE 3.3-14

ANNUAL FUEL CONSUMPTION VS POWER

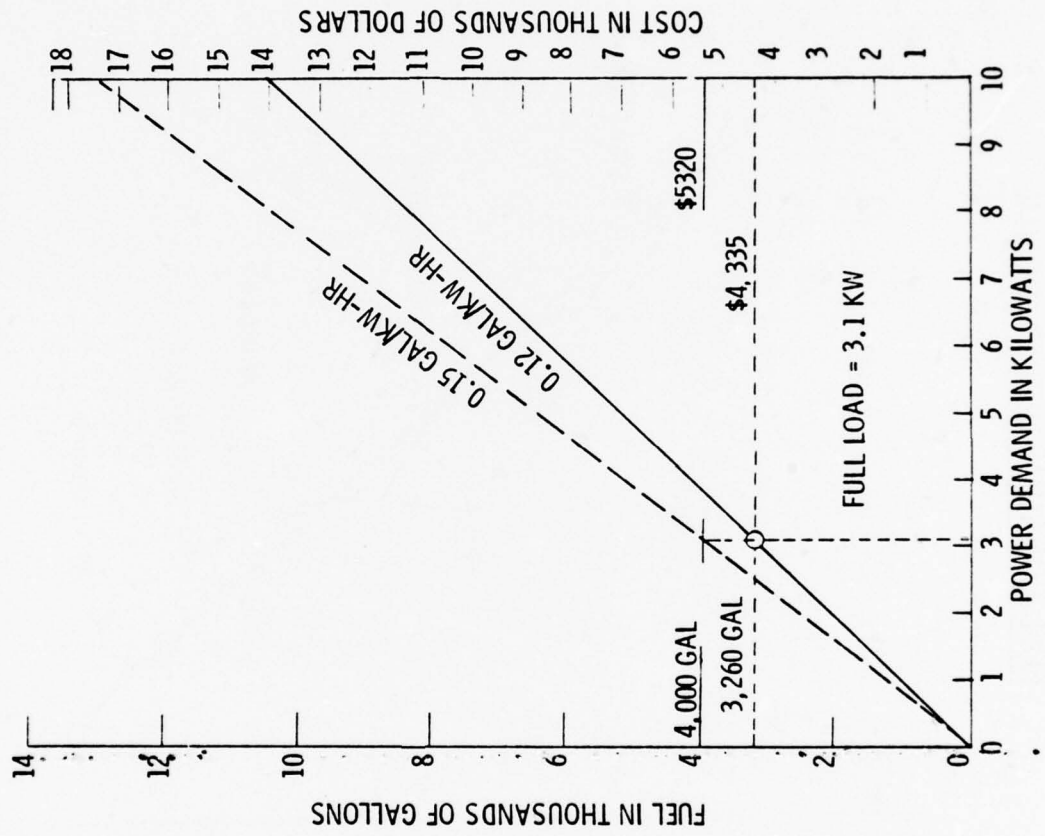

FIGURE 3.3-15

The ST series of diesel are designed for operation at 1,800 RPM and the reliability figures used are representative of operation at 1,800. Operating the machines at 1,200 RPM should result in some improvement in reliability but this has not been substantiated by field operation. In the case of operating at 1,800 the U.S. Coast Guard has demonstrated the reliability figures used.

Maintenance power may be obtained by bringing a second diesel on line. The two diesels will provide from 6.2 to 8.8KW with a 10% overload capability of 9.6KW. As the predicted load is between 6.4 and 8.7KW the match of power available to power demand is excellent. Table 3.3-21 summarizes the power balance for both the normal and maintenance cases.

3.3.8.5 Minimum Power Load

If beacon, radio, and weather services are provided only when a maintenance aircraft is dispatched, and a VHF radio is not provided, the station load may be reduced. This minimum station power load is shown in Table 3.3-22. The reduction of 1,075 watts in full time load is due to elimination of 1,020 watts for the NAVAIDS and a reduction of 55 watts for the weather station. The 50 watts shown for the weather station is for powering the sensors to keep them from freezing or icing. The peak load is also reduced by 1,475, watts based on elimination of 1,320 watts for the NAVAIDS, and reduction of 155 watts for a weather station.

To facilitate maintenance visits, a 25 mile beacon system consisting of a Nautel NX-100 BA/D transmitter, and a PA 120 B Polestar antenna will be employed. The range of this beacon is 25 miles, and it will consume 180 watts of prime power. The weather station and VHF radio will also be powered up prior to maintenance visits. To obtain this power a second diesel must be brought on line. During the visit the station must operate under a reduced maintenance load of 2,500 watts, compared to the 3,000 to 4,500 watts provided

TABLE 3.3-21
STATION OPERATIONAL PRIME POWER BUDGET

<u>NORMAL LOAD</u>	<u>MINIMUM IN KW</u>	<u>FULL LOAD IN KW</u>	<u>OVERLOAD IN KW</u>
POWER AVAILABLE FROM GENERATOR	3.1	4.4	4.8
FULL TIME LOAD	3.1		
MAXIMUM INTERMITTENT LOAD		4.2	
<u>MAINTENANCE LOAD</u>			
POWER AVAILABLE FROM GENERATORS	6.2	8.8	9.6
FULL TIME LOAD	6.3		
MAXIMUM INTERMITTENT LOAD		8.7	

TABLE 3.3-22

STATION POWER LOAD

	<u>FULL TIME LOAD IN WATTS</u>	<u>INTERMITTENT LOAD IN WATTS</u>	<u>MAINTENANCE LOAD IN WATTS</u>
A. PRIME POWER CONTROL	100	440	440
B. RADAR/IFF	1000	1000	1000
C. COMMUNICATIONS	470	470	470
D. STATION CONTROLLER	200	200	200
E. SECURITY	5	40	5
F. NAVAIDS	0	0	0
G. WEATHER STATION	50	50	205
H. MAINTENANCE	---	---	2500
I. GROWTH FACTOR	200	200	200
J. ENVIRONMENTAL CONTROL	<u>0</u>	<u>340</u>	<u>340</u>
GRAND TOTAL	2025	2740	5990

previously. The total maintenance load with all equipment on is 5,990 watts. This normally will be reduced to 5,205 as when the crew is on-site the NAVAIDS and weather station need not be powered.

To provide power the ST-1 will be operated at 1,200 RPM. This will provide from 2KW at 70% of load to 2.8KW at full load. These figures are within the expected load of 2 to 2.7KW. Using two machines the 70% point is 4KW with a full load capability of 5.6KW. The range of the load expected is 5.2 to 6.0. The 6KW load is within the 6.2, 10% overload capability of the machines, and as the NAVAIDS and weather station will not normally occur at the same time the 2.5KW maintenance load occurs no problem is anticipated.

The worst case load situation of operating the diesel at 1,800 RPM, with a load of 3.1KW, was used in determining fuel consumption and costs in the study. Should minimum power be implemented the fuel consumption is reduced to 2,660 gallons at an annual cost of \$3,540 based on \$1.33 per gallon delivered to the unattended stations.

The weight of the station prime power components is given in Table 3.3-23. The unit cost is given in Table 3.3-24. The program costs for development, demonstration, production and installation is given in Table 3.3-25.

3.3.8.6 Alternate Power Sources

Alternate power sources such as Brayton converters, Stirling converters, Organic Rankine either using fossil fuel or nuclear were investigated as were thermoelectric and fuel cells. Based on twenty year life cycle, the decision arrived at in the ERDA Power Study, that these alternative power sources are not economical was found to be valid. This is due to the low investment cost, the low development cost, and low maintenance costs of the diesel. The high cost item for the diesel is fuel. This cost has been minimized, by minimizing the cost of transporting to site.

TABLE 3.3-23

DIESEL SYSTEM WEIGHT SUMMARY

COMPONENT	UNIT WT. (LBS)	TOTAL WT. (LBS)
SWITCHGEAR	300	300
STIA DIESEL (W/GENERATOR & SUMP)	675	2025
FUEL TANK (DRY)	4100	4100
ENVIRONMENTAL CONTROL UNIT	200	200
CONTROLS	400	400
STARTING BATTERY	200	200
STORAGE BATTERY	450	450
MISC (DUCTING, ETC)	200	200
	TOTAL	7,875

TABLE 3.3-24

PRIME POWER UNIT COSTS

<u>QUANTITY</u>	<u>ITEM</u>	<u>UNIT COST (\$K)</u>	<u>TOTAL COST (\$K)</u>
3	STIA DIESEL GENERATOR SET	5	15
1	SWITCH GEAR	3	3
1	STARTER BATTERY/CHARGER	1	1
1	STORAGE BATTERY/CHARGER	5	5
1	ENVIRONMENTAL CONTROL UNIT	5	5
1	FUEL TANK	3	3
1	CONTROLLER (INCLUDING TELEMETRY AND INVERTER)	10	10
MISC	DUCTING, WIRING, ETC.	4	4
	TOTAL		46

TABLE 3,3-25
PRIME POWER PROGRAM COSTS

DESCRIPTION	NUMBER OF SYSTEMS	COSTS (\$K)	
		SYSTEM	TOTAL
DEVELOPMENT			1,664
DEMONSTRATION			1,701
PRODUCTION	83	59	4,897
INSTALLATION	83	65	5,395
		TOTAL	13,657

Natural sources such as solar and wind energy were also investigated and are reported on in the following section.

3.3.8.6.1 Solar Power

The average daily value of solar radiation along the DEWLine is 200 langleys. This measurement takes into account such factors as atmospheric absorption, reflection, sun angle, etc. A maximum radiation of 600 langleys occurs in June prior to the summer solstice, and the minimum of near zero in December prior to the winter solstice. The 200 langley figure is equivalent to 2.3KW per square meter per day.

Conversion of this light energy to electrical power is best accomplished by solar cells. Even then the process is not very efficient, as only 10% of the light power is converted to electrical power using conventional silicon solar cells. The suns energy as received by a stationary array of solar cells, is cyclic, requiring batteries to store the suns peak energy in order to smooth the power available to a load. To develop 3.1KW over a 24 hour period requires a 7,000 square foot array using a very favorable assumption that the 200 langley are uniformly displaced over a 12 hour period. The 7,000 foot² figure in reality should be increased to account for the cyclic nature of the sun. Based on a cost of \$150 per square foot for conventional solar cells, the cost of a 7,000 foot² array is over a million dollars. This is a cost of \$1.93 per kilowatt compared to an acquisition and operating cost of \$0.28 for the diesels. Based on this ratio of costs, it is clear the solar power in the Arctic is expensive.

3.3.8.6.2 Wind Power

The most attractive natural energy source is wind power. As found by the ERDA Power Study the vertical axis wind powered turbine, has significant design and operational advantages over other designs due to system simplicity, high efficiency, and non dependence on wind direction.

Data summary of the average wind velocities for Alaska and Canada have been extracted from the ERDA Power Study and are given in Tables 3.3-26, 3.3-27, 3.3-28 and 3.3-29. The overall summary for the 77 locations is 10.07 miles per hour. This data has been refined in Table 3.3-30 to stations more appropriate to DEWLine locations for an average at 11.7 miles per hour or 10KTS. Figure 3.3-16 is a plot of the percent of time the wind exceeds a given wind velocity for an average wind velocity of 10KTS.

The Vertical Axis Turbine (VAT) line that was primarily investigated, is Bristol Aerospace Limited of Winnipeg, Canada. Unlike other VAT's the Bristol line employs a unique aerodynamic self-starter using a Savonius turbine on the inside shaft instead of an electric motor. See Figure 3.3.17. Power is primarily developed using a Darrieus turbine. Figure 3.3-18 is a picture of a 2 bladed turbine that is powering a weather station located on an ice-pack in the Bearing Sea. For speed limiting, the systems employ the use of aerodynamic flaps which deploy at 25KTS and then limit the speed increase of the wind turbine. The overall system is designed to withstand gusts up to 100KTS.

The vertical axis turbine does have a problem with icing conditions. Due to the characteristics of the blades icing will cause the turbine to stop and freeze up. This does have the advantage however of protecting the turbine from imbalance and vibration problems. The Bristol turbine on the Beaufort Sea has been operational over a period of 16 months which would indicate that icing although a problem has not stopped the machine from providing reliable service. During periods of freeze up the diesel will be available to provide power.

TABLE 3.3-26

WIND SUMMARY - CANADA

AREA	NO. OF LOCATIONS	NO. OF LOCATIONS WITH MEAN ANNUAL WIND VELOCITY IN THE RANGE:				AVERAGE OF MEAN ANNUAL WIND VELOCITY FOR (MPH):	
		0-7	8-11	12 & UP	ALL LOCATIONS	USABLE LOCATIONS	
Northern Islands	7	0	0	4	11.61	11.61	
Barren Northland	1	1	0	0	6.26	-	
Southern Rockies	9	4	5	0	7.61	8.60	
Hudson Bay	3	0	0	3	13.88	13.88	
Eastern Canada	13	1	11	1	10.28	10.54	
Maritimes	16	0	11	5	11.82	11.82	
TOTALS	49	6	30	13	10.28	11.29	

TABLE 3.3-27

CANADA WIND SUMMARY

AREA	LOCATION	MEAN ANNUAL WIND VELOCITY	PERCENT OF TIME FOR USEFUL WIND
Northern Islands	Cambridge Bay	12.79	79
	Cape Dyer	9.03	49
	Cape Parry	12.28	75
	Ft Resolution	9.47	64
	Frobisher Bay	10.30	60
	Hall Beach	13.54	85
	Resolute	13.77	73
	Southern Rockies	Port Hardy	7.95
Sandspit		10.49	61
Terrace		9.15	57
Vancouver		7.74	52
Victoria		7.67	50
Hudson Bay		Chesterfield	14.09
	Coral Harbour	12.80	76
	Churchill	14.74	88
	AVERAGE	11.06	67

TABLE 3.3-27

CANADA WIND SUMMARY
(continued)

AREA	LOCATION	MEAN ANNUAL WIND VELOCITY	PERCENT OF TIME FOR USEFUL WIND	
Eastern Canada	Mount Forest	9.28	64	
	Ottawa	9.56	67	
	Baie Comeau	10.39	69	
	Bagotville	10.45	67	
	Fort Chimo	10.11	66	
	Mont Joli	12.72	78	
	Montreal	9.85	65	
	Quebec	10.57	68	
	St. Hubert	10.33	68	
	Sept-Iles	11.42	73	
	Cartwright	11.87	70	
	Goose	9.92	65	
		AVERAGE	10.54	68
	Maritimes	Charlo	9.78	67
		Chatham	9.57	65
Fredericton		8.92	60	
Moncton		11.84	79	
St. John		11.76	75	
Greenwood		9.79	60	
Halifax		11.52	78	
Sable Island		16.20	90	
Shearwater		11.46	75	
Sydney		14.08	87	
Yarmouth		11.14	74	

TABLE 3.3-27

CANADA WIND SUMMARY
(Continued)

AREA	LOCATION	MEAN ANNUAL WIND VELOCITY	PERCENT OF TIME FOR USEFUL WINDS
Maritimes (continued)	Charlottetown	11.61	77
	Summerside	14.32	84
	Gander	13.03	79
	St. John's	15.29	87
	Stephenville	8.82	60
	AVERAGE	11.82	75

TABLE 3.3-28

WIND SUMMARY - ALASKA

AREA	NO OF LOCATIONS	NO. OF LOCATIONS WITH MEAN ANNUAL WIND VELOCITY IN THE RANGE:			AVERAGE OF MEAN ANNUAL WIND VELOCITY FOR (MPH):	
		0-7	8-11	12 & UP	ALL LOCATIONS	USABLE LOCATIONS
Southeast Coast	4	1	3	0	8.1	8.7
Gulf of Alaska	7	6	1	0	6.1	8.8
Aleutian Chain	3	0	1	2	11.9	11.9
Bering Sea	9	0	7	2	11.2	11.2
Arctic Coast	5	0	4	1	11.4	11.4
TOTALS	28	7	16	5	9.7	10.4

TABLE 3.3-29

ALASKA WIND SUMMARY

AREA	LOCATION	MEAN ANNUAL WIND VELOCITY	PERCENT OF TIME FOR USEFUL WIND
Bering Sea	Nome	9.8	69
	Northeast Cape	11.0	81
	Unalakleet	10.5	75
	Cape Romanzof	11.7	82
	Bethel Mun	11.2	73
	Cape Newenham	9.8	80
	Cold Bay	14.6	87
	King Salmon	9.2	70
	Port Heiden	12.9	82
	AVERAGE		11.3
Arctic Coast	Cape Prince of Wales	15.0	89
	Kotzebue	9.7	73
	Cape Lisburne	10.5	77
	Barter Island	11.3	76
	Point Barron	10.5	77
Southeast Coast	Annette Island	9.5	69
	Juneau	7.5	61
	Haines Mun	9.2	68
Gulf of Alaska	Kodiak	8.8	63

TABLE 3.3-29

ALASKA WIND SUMMARY
(Continued)

AREA	LOCATION	WIND VELOCITY	PERCENT OF TIME FOR USEFUL WIND
Aleutian Chain	Adak	12.2	82
	Umnak	15.6	78
	Driftwood Bay	8.0	78
	AVERAGE	9.1	71

TABLE 3.3-30
DEW LINE WIND VELOCITIES

LOCATION	MEAN ANNUAL WIND VELOCITY MPH	LOCATION	MEAN ANNUAL WIND VELOCITY MPH
ALASKA, ARTIC COAST			
- CAPE PRINCE OF WALES	15.0	MARITIMES	
- KOTZEBUE	9.7	- CHARLO	9.8
- CAPE LISBURNE	10.5	- CHATHAM	9.6
- BARTER ISLAND	11.3	- FREDERICTON	8.9
- POINT BARROW	10.5	- MONCTON	11.8
		- St. JOHN	11.8
		- GREENWOOD	9.8
		- HALIFAX	11.5
CANADA NORTHERN ISLANDS			
- CAMBRIDGE BAY	12.8	- SABLE ISLAND	16.2
- CAPE DYER	9.0	- SHEARWATER	11.5
- CAPE PARRY	12.3	- SYDNEY	14.1
- FT RESOLUTION	9.5	- YARMOUTH	11.1
- FROBISHER BAY	10.3	- CHARLOTTETOWN	11.6
- HALL BEACH	13.5	- SUMMERSIDE	14.3
- RESOLUTE	13.8	- GANDER	13.0
		- St. JOHN'S	15.3
		- STEPHENVILLE	8.8

AVERAGE 28 LOCATIONS - 11.7 MPH

WIND DISTRIBUTION FOR 10 KT AVG WIND

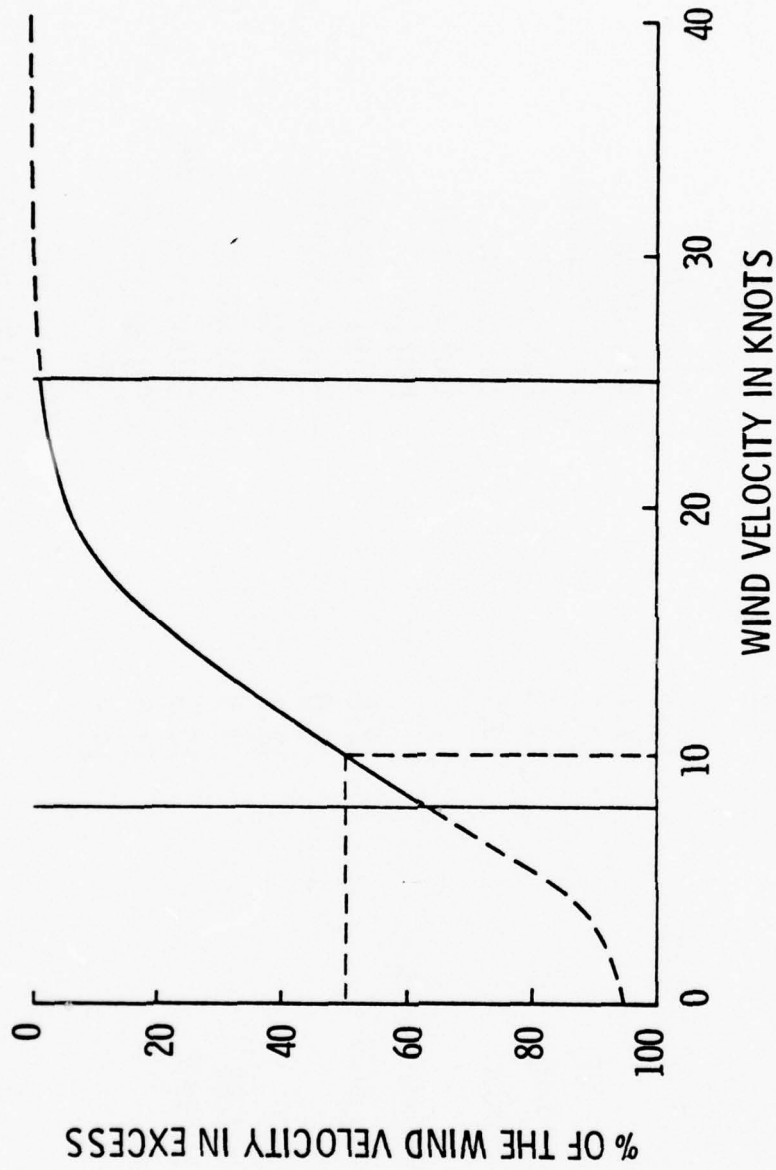
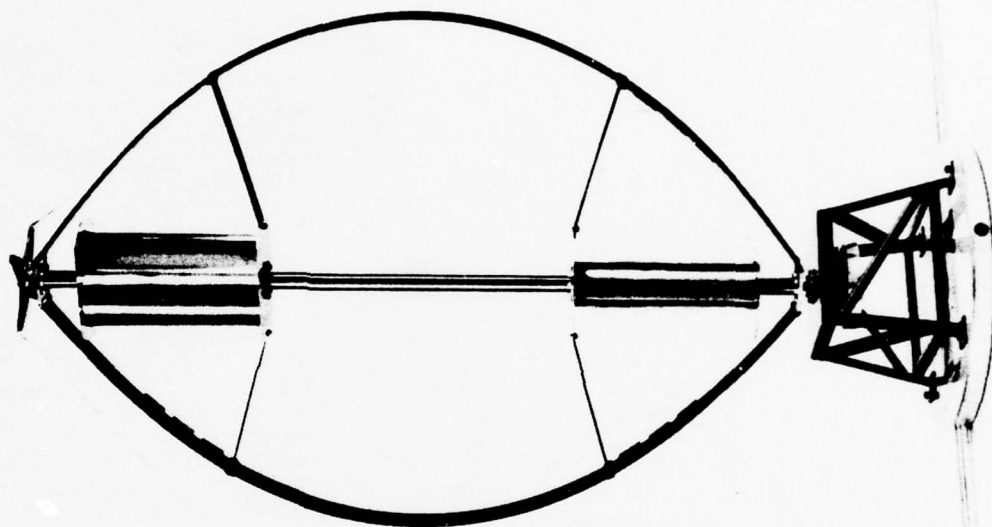

FIGURE 3.3-16

VERTICAL AXIS TURBINE



BEAUFORT SEA WEATHER STATION

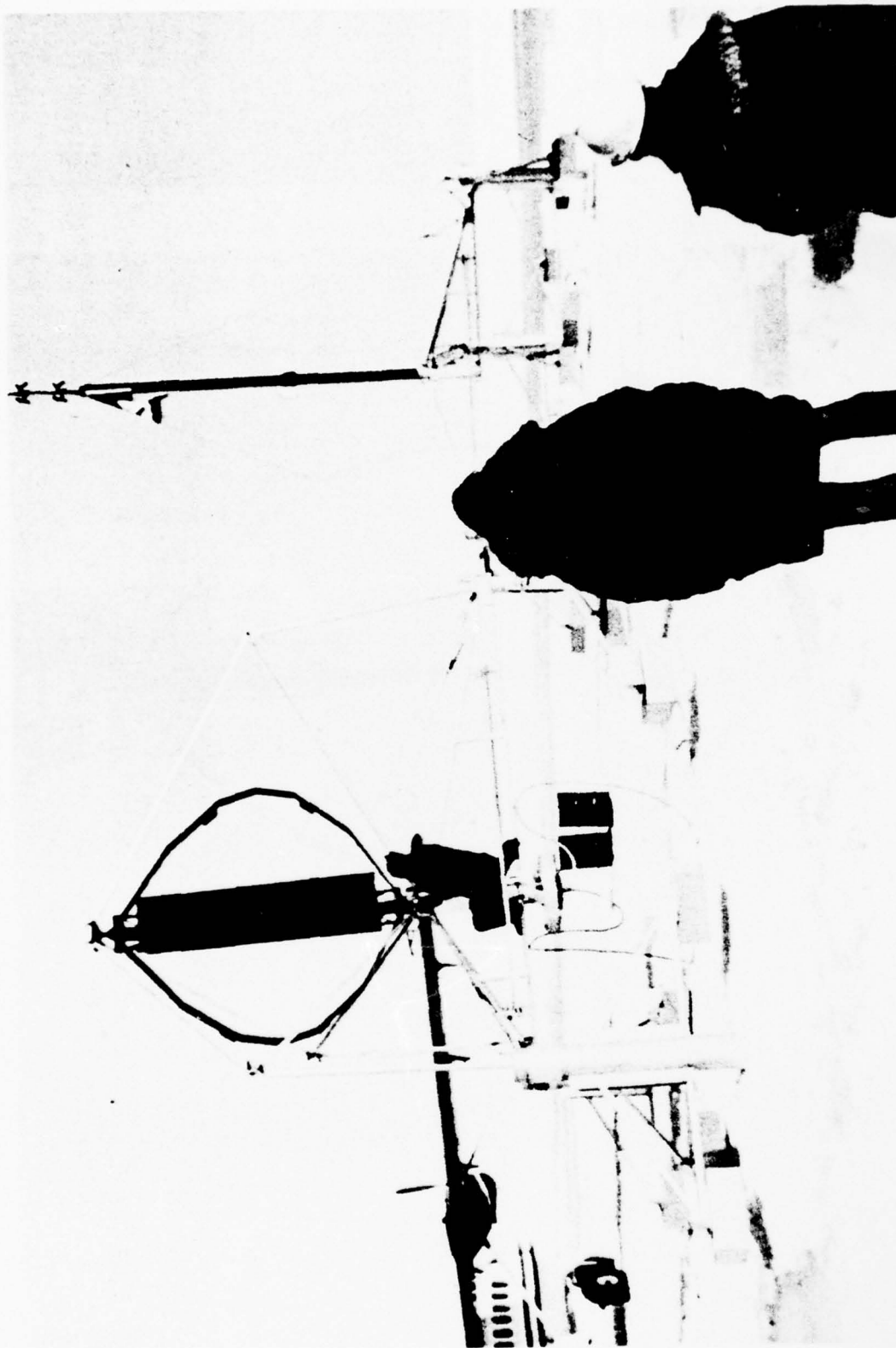

FIGURE 3,3-18

The power available from the wind varies as the cube of the wind speed. Equation 3.3.2 is the power output in KW as a function of turbine size and wind velocity for the Bristol turbines.

$$P_{KW} = 12.88 \times 10^{-7} \cdot D^2 \cdot v^3 \quad \text{Eq 3.3.2}$$

where

P_{KW} = Power in Killowatts

D = Turbine size in feet

v = Wind velocity in knots.

Figure 3.3-19 is a graph of the power output in KW vs wind velocity for four sizes of turbines proposed by Bristol. Table 3.3-31 gives the performance specifications of the four turbines. Figure 3.3-20 combines the wind probability given in Figure 3.3-16 with the power output as a function of wind to develop the power output as a function of the time the power output is exceeded. Power for heating the diesels to maintain their temperature and the fuel storage at 35^oF has been included in the calculations. Integrating the curves, the 15 foot turbine will provide power 11% of the time, the 25 foot turbine provides power 23% of the time, and the 50 foot turbine provides power 46% of the time.

Assuming that the average wind velocity of 10KTS occurs at a height of 30 feet, or the average height for the 50 foot turbine, some advantage may be obtained by increasing the base height of the turbine. Placing the 50 foot turbine on a 100 foot tower, will increase the center height of the turbine to 130 feet. Using a standard temperature lapse rate, and wind sheer associated with a 10KT wind, the wind velocity at the 130 foot level will be 12 knots, or a 19% increase. The additional height is not recommended, as the cost of installation on a rigid tower 50 foot high capable of supporting the turbine is not justified.

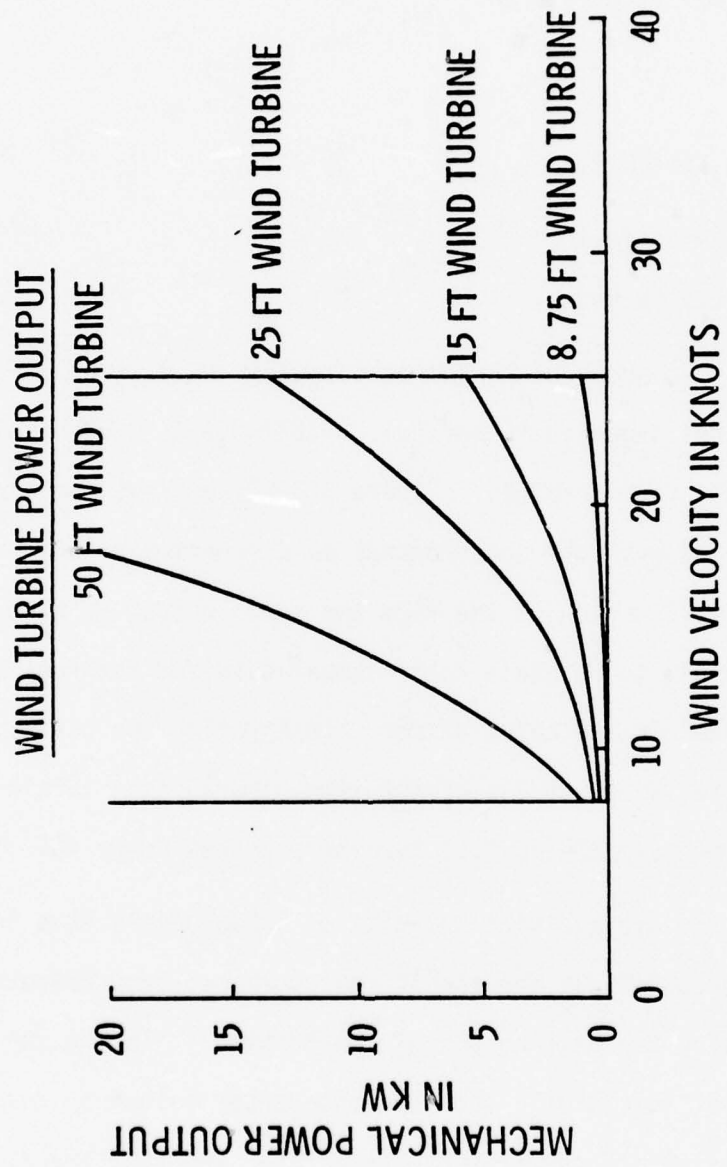

FIGURE 3.3-19

Table 3.3-31

ELECTRICAL POWER CAPABILITY (Rated at 10 mph) ¹

SPECIFICATIONS	"A" SYSTEM 50 WATT	"B" SYSTEM 250 WATT	"C" SYSTEM 700 WATT	"D" SYSTEM 2.8 KW
Turbine Size (ft.)	8.7	15	25	50
No. Of Blades	3	2	2	2
Starter Type	Aerodynamic	Aerodynamic	Aerodynamic	Aerodynamic
Starting Wind Speed (mph)	7	8	8	8
Output Voltage	12/24 DC	12/24 DC	48/96 DC	48/96 DC
Battery Capacity (NOM.)	200 A.H.	2000 A.H.	N.A.	N.A.
Buffer Battery Capacity (NOM.)	N.A.	N.A.	100 A.H.	400 A.H.
Diesel Fuel Savings with 10 mph Av. W.S.	N.A.	N.A.	50%	50%
Alternator and Control System				
- Voltage Limited	No	No	Yes	Yes
- Power Regulated	Yes	Yes	Yes	Yes
- Control Charge Rate	Yes	Yes	Yes	Yes
- Current Limiter	Yes	Yes	Yes	Yes
- Overcharge Protection	Yes	Yes	Yes	Yes
- Diesel Power Monitor	N.A.	N.A.	Yes	Yes
- Diesel On/Off Control	N.A.	N.A.	Yes	Yes
Maintenance Interval (mo.)	12	12	12	12
System Weight (approximate lbs.)	450	740	1490	2970
Expected Electrical Power	.17	.85	2.4	9.5
in KW. at Various W.S. (mph)	3	20	5.6	22.4
(Average Elec. Conversion	25	3.90	10.9	43.8
Eff. of 80%)	30	1.35	18.9	75.6
Furling Wind Speed		AUTO. DEPLOYING	AERODYNAMIC	SPOILERS
			(Variable	Wind Speed)

NOTES:

1. Wind velocity is measured at the equatorial plane of the turbine.
2. Two types of starters are commonly employed with Vertical Axis WPT:
 - 1) Aerodynamic Self Starter as employed in Bristol's WPT, and,
 - 2) A timed motor or wind speed initiated motor powered by the system storage battery.
3. Care must be taken to compare various wind turbines at the same wind speed otherwise a realistic evaluation of various systems cannot be made.

WIND ENERGY AVAILABILITY
AVERAGE WIND VELOCITY 10 KTS

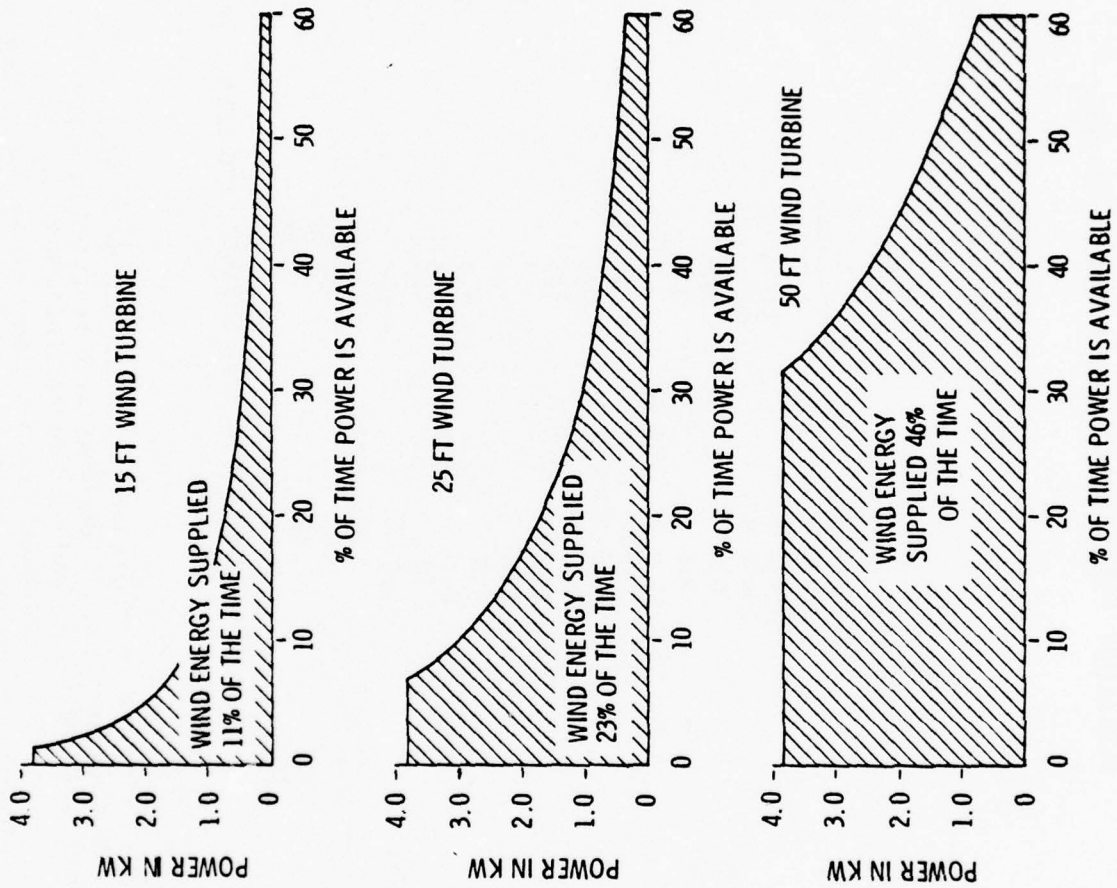

Figure 3.3-20

Combining the wind turbine with nickel cadmium storage batteries will allow the high power capability at the higher wind values to be stored. Assuming that a peak level of 3 times the normal power consumed would be stored, a 3 day supply of 2,500 amp-hours battery capacity would theoretically allow calm of less than 8KTS for 3 days. The cost of controls, batteries, and battery charger is \$85,000.

A surprising feature of the DEWLine wind pattern, reported by the Meteorological Branch, Air Services, of the Canadian Department of Transport, in the period between December and April is the large percentage of calms reported at most stations. Calm conditions occur almost 30% of the time at Isachsen, Mould Bay, Eureka, Resolute, and Frobisher Bay and 45% of the time at Alert.

Assuming that a 3-day supply would allow operation 100% of the time the cost per kilowatt in 1978 dollars is \$0.29. This is 9 cents per kilowatt higher than the diesel generators. Without the storage capability the price drops to \$0.28 per kilowatt or 8 cents higher than the diesel. This is based on a cost of \$75,000 for an installed production turbine including a write-off for RDT&E.

Based on discussions with Dominion Aluminum Fabricators of Toronto who are presently manufacturing 50 foot and larger wind turbines, Canadian Energy Conversion Industries Ltd. of Burnaby, British Columbia, and Bristol Aerospace of Winnipeg the technology is rapidly evolving and wind driven turbines are becoming established. This will hopefully also lead to lower future costs.

A particularly interesting area of research is being conducted by Dominion Aluminum Fabricators who are working on systems that couple directly into the diesel generator mechanically. This and other developments should be closely tracked and a final power source decision made at the time of station design.

Based on the higher costs of the wind turbine, 8 cents per kilowatt hour, the use of a wind turbine cannot be justified, and was not recommended. This decision is somewhat arbitrary if the fuel crisis or the inflationary trend in fuel is considered. Assuming a 6% yearly inflationary rate for the next 20 years the average cost of fuel would be 40 cents per kilowatt, which would mean a savings of 11 to 12 cents per kilowatt hour. This would be reduced some by logistic and maintenance costs, but would still make the turbine an attractive device.

3.3.9 Total Energy Considerations

Primary in developing a total energy plan is the judicious use of the heat energy by-product developed in the equipment. To address the problem of how much heat is required, weather factors such as temperature extremes must be considered. Table 3.3-32 lists the variation in environment found along the DEWLine. The -62°F reported is a peak minimum temperature that will last for only a few hours during the day. Only one Arctic station in two has a record low temperature colder than -60°F , and several have never reported temperatures as low as -50°F . These temperature extremes reflect the moderating influences of relatively warm water beneath ice-covered channels. At inland locations in the larger islands well removed from the open or ice covered seas, lower temperatures may be expected. Based on these considerations a safe design temperature of -65°F has been selected. On the other extreme, a maximum design temperature of 80°F has been selected. As shown in Table 3.3-32 the maximum record peak is 88°F .

To allow the use of commercial equipment the temperature range that the equipment will be subjected to is 35°F to 100°F . In the engine-generator area the range is 35°F to 125°F .

TABLE 3.3-32

ARTIC ENVIRONMENT

DEW LINE DATA

● MINIMUM TEMPERATURE °F	-62
● FEB. MEAN MINIMUM TEMPERATURE °F	-30
● JULY MEAN MAXIMUM TEMPERATURE °F	50
● MAXIMUM TEMPERATURE °F	88
● MAXIMUM SNOWFALL IN INCHES	64
● AVERAGE SNOWFALL IN INCHES	33
● MINIMUM SNOWFALL IN INCHES	15
● WIND MAXIMUM IN KNOTS	197
● WIND AVERAGE IN MPH	11.7

The primary source of heat energy is the diesel generator. All the fuel energy except for that radiated by the radar, IFF, radios, beacon, communication and light as r.f. energy is eventually converted to heat. The diesel produces heat in both exhaust gasses and in direct radiation. Assuming an exhaust stack temperature of 800^oF at a 40 cfm in flow rate, 362 btu per min. are going up the stack. With a recovery efficiency of 36%, 7,762 but/hr may be recovered. The direct radiated energy from the diesel and generator will exceed 7,000 btu/hr. Finally the heat radiated by the equipment group in the radome will exceed 5,360 btu's. The total heat available on a conservative basis is 20,000 btu per hour. Table 3.3-33 shows the heat transfer for this case. An insulation factor of 0.05 was used in the calculations with an infiltration rate of 0.1 room changes per hour.

An alternate scheme would be to enclose the equipment in an environmental shell which would be louvered to provide cooling air in the summer. As there is no requirement for access during the unmanned periods the shell may be made to conform quite closely to the equipment outline. Table 3.3-34 gives the heat transfer for this case. The 5,360 btu of heat generated by the equipment is conservative as this is only 1.6 kw of electrical energy converted into heat. The 11,527 btu in the generator area is also conservative as up to 14,762 could be made available.

In the manned mode of operation with two diesels on line the btu production is double, the additional heat would be used to bring the habitat areas up to 70^oF. Table 3.3-35 gives the heat transfer for this case. If the alternate heat transfer scheme is used, during manned periods the protective shell will be partially removed allowing full access to the equipment.

Cooling for all cases is not a problem as the ambient air temperature will always be low enough to allow natural cooling to occur. To insure proper cooling,

TABLE 3.3-34

ALTERNATE STATION HEAT TRANSFER

	<u>HEATING</u>	<u>BTU'S AVAILABLE</u>	<u>BTU'S REQUIRED</u>
● EQUIPMENT ALLOWABLE TEMPERATURE RANGE		35°F TO 100°F	
● GENERATOR ROOM ALLOWABLE TEMPERATURE RANGE		35°F TO 125°F	
● HEAT GENERATED BY RADOME EQUIPMENT		5,360	
● RADOME EQUIPMENT AT 50°F			5,360
● HEAT GENERATED BY GENERATOR EQUIPMENT		11,527	
● GENERATING EQUIPMENT AT 50°F			<u>11,527</u>
TOTAL		16,887	16,887

TABLE 3.3-35

MANNED STATION HEAT TRANSFER

	70°F TO 100°F	
● ALLOWABLE TEMPERATURE RANGE		
		<u>BTU'S AVAILABLE</u>
		<u>BTU'S REQUIRED</u>
● HEAT GENERATED BY TWO 2 KW GENERATORS	40,000	
● GENERATOR ROOM AT 70°F*		17,600
● RADOME AT 70°F*		<u>22,400</u>
TOTAL	40,000	40,000

*VENTILATION APPROXIMATELY 1 ROOM CHANGE PER HOUR

COOLING

- RADOME AIR FLOW 300 CUBIC FEET/MIN
- GENERATOR ROOM AIR FLOW 600 CUBIC FEET/MIN

however, a 300 cfm fan will be provided in the Radome and a 600 cfm in the generator area.

A problem does exist when visiting the site during the cold months. Heating the air to 70°F will allow it to accept moisture from personnel, when this air chills it will increase in humidity until it reaches 100% and then condense out on the equipment. To prevent this, a rapid exchange of air to purge the station prior to departure will be required. This may be accomplished by opening hatches, and blowers if need be.

3.3.10 Microwave Radio Link Repeater Site

A description of the Microwave Radio Line (RML) Repeater Equipment is given in the Communication Network Section of this report. The equipments required to house, power, and control the environment at a repeater site will be discussed in this section.

3.3.10.1 Repeater Site Power and Heat Transfer Requirements

The total power required at a repeater site is 300 watts, which consists of 265 watts for the radio equipment, and 35 for environmental control, as shown in Table 3.3-36. To determine the amount of equipment heat available for environmental control, the 5 watts of radiated rf energy is subtracted from the 300 watts dissipated by the equipment. The resultant 295 watts produces 1,007 btus. To retain the heat the equipment will be enclosed in a 6 foot high, by 2 foot deep, by 4 foot wide insulated louvered shelter. The insulation will provide an overall "U" factor of 0.05. The shelter with closed louvers will require 427 btus to maintain a +35°F temperature with an outside temperature of -65°F. In summer at 85°F the shelter will require an air flow of 6 cfm to maintain a temperature of less than 125°F. This will be provided by a small fan that is included in the 35 watts allocated for environmental systems opens or closes louvers.

TABLE 3.3-36
REPEATER PRIME POWER AND HEAT TRANSFER REQUIREMENTS

<u>POWER</u>	<u>HEAT AVAILABLE</u>	<u>HEAT REQUIRED</u>
MICROWAVE RADIO LINK EQUIPMENT		265 WATTS
REPEATER SITE CONTROL EQUIPMENT		<u>35 WATTS</u>
TOTAL		300 WATTS
EQUIPMENT HEAT AVAILABLE (295 WATTS)	1007 BTU'S	
EQUIPMENT AT 35°F FOR -65°F OUTSIDE TEMPERATURE HEAT REQUIRED		427 BTU'S
600 GAL FUEL STORAGE AT 35°F FOR -65°F OUTSIDE TEMPERATURE HEAT REQUIRED		<u>580 BTU'S</u>
TOTAL	1007 BTU'S	1007 BTU'S

To insure fuel flow, 600 gallons of fuel will be stored in a heated insulated fuel tank. Heat will be provided by air circulated from the equipment area. The fuel tank will be a cube approximately 5 foot on edge with a "U" factor of 0.05. The heat required to maintain the fuel at +35°F with a -65°F outside temperature is less than 580 btus. A second 600 gallon unheated fuel tank will be positioned over the first tank with gravity feed. This will provide a two year fuel supply.

3.3.10.2 Repeater Site Prime Power Sources

Possible prime power sources for the repeater site are listed in Table 3.3-37. The diesel and gasoline generators may be eliminated, as the smallest diesel is too large, and the gasoline generator is not reliable enough.

The gasoline system also places the additional burden of using a new and more volatile fuel than that used at the unattended station.

Thermo electric power generation is an attractive power source for a repeater site. The device contains no moving parts as it is dependent on the seeback effect, which is implemented using thermo couples. By heating one end of the thermo couple, usually by combustion of a gas in a low temperature catalytic process, electrical energy is produced. The drawbacks are low power and high operating costs. Normally 100 watts is considered as the maximum practical size to be implemented. Parallel units providing 300 watts however are available. Based on a fuel consumption that is approximately 1.5 times higher than existing organic Rankine systems the thermo device is not recommended.

The methanol fuel cell is also an attractive power source. The problem is that this device is still in development as discussed in the ERDA Power Study. If a future commitment is made to produce the device, strong considerations should be given at that time to use it as the repeater prime power source. Until that time the high development cost and risk do not justify recommending this device.

TABLE 3.3-37

REPEATER POWER SOURCES

1) DIESEL GENERATOR

2) GASOLINE GENERATOR

3) SOLAR

4) WIND GENERATOR

5) THERMO ELECTRIC

6) FUEL CELL

7) ORGANIC RANKINE

Organic Rankine generators at the present time offers the most attractive solution. Ormat Systems Inc. of Natick, Mass. has provided a number of these units to power microwave repeater sites for the Trans-Alaska Pipeline, a picture of one of these units is shown in Figure 3.3-21. The units uses a burner to heat an organic liquid to vapor which drives a turbine connected to an electric generator. The gas is then cooled and the condensed organic liquid is recycled in a closed loop system. However, the unit recommended is the Sunstrand Rankine system cited in the ERDA Power Study. This unit was selected based on its higher anticipated efficiency which will provide a significant reduction in life cycle fuel costs. Using the Sunstrand unit it is estimated that the fuel consumption will only be 36% higher than in the unattended station diesel system, or 27 cents per kilowatt hour. The annual fuel consumption will be less than 600 gallons.

An alternate fuel that may be employed is Strontium 90. The use of nuclear isotopes to power an organic Rankine generator is discussed in the ERDA Power Study. Using present fossil fuel costs, the use of nuclear fuel is not justified. In view of the inflationary trend, and fuel crisis, nuclear fuel may be judged to be cost effective. A 20 year supply of nuclear fuel may be installed as part of the acquisition package. The feasibility of nuclear fuel as a source has just recently been established by the FAA in Alaska in an installation meeting all safety and environmental requirements in an unattended site.

Natural energy sources in the form of solar and wind were also considered for the repeater site. Solar was discarded using the same reasoning applied in making the alternate power source determination for the unattended station.

PRECEDING PAGE BLANK - NOT FILMED

RANKINE - ORMAT GENERATOR

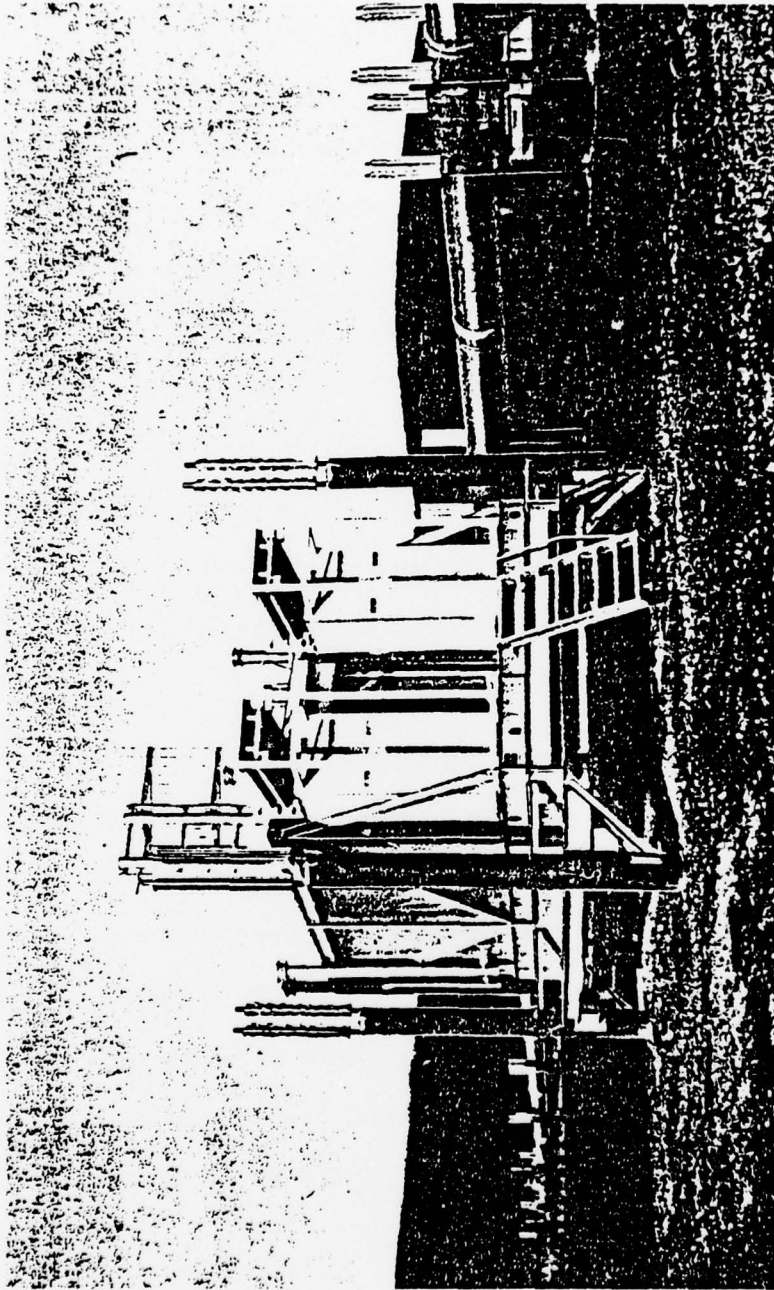

FIGURE 3.3-21

Wind, as an alternate power source is feasible, and may be justified economically. A 15 foot wind generator will be capable of generating the 300 watts over 50% of the time, that is with a wind slightly less than 10 kts. The cost of a 15 foot wind generator from Canadian Energy Conversion Systems installed is \$10,000. The unit is in production, and requires no development. The power required over a 20 year period for a repeater site is 52,560 kilowatt hours. This is a cost of 29 cents per kw-hr for the 66% of the time wind is used as the source. This compares very favorably with the 27 cents per kw-hr for the primary organic Rankine source.

System reliability will also be enhanced by providing the turbine as a secondary source. Reliability of the repeater site has been assessed as being high enough to warrant no beacon, or weather station at the repeater site. Tower obstruction, helipad, and wind sock lighting will be provided, and may be remotely turned on prior to the arrival of the maintenance helicopter. Navigation to the repeater sites may be accomplished using the unattended station beacons, radar guidance, and visually.

3.3.11 Equipment Status

Table 3.3-38 shows the development status of the major equipment functional areas. In summary the equipment for the unattended radar station is available with one notable exception, the radar. Significant development is still required to produce the specific radar, and to demonstrate the extremely high reliability required. The feasibility of such a radar has definitely been established by totally solid-state, high reliability, soft failure radars such as General Electric's TPS-59 and Belgium 3-D radars, and the results of the "Unattended Radar Study."

The other development areas listed are essentially taking known technology and tailoring it to meet the specific requirements of the station design. Hardware for all the functional areas except the radar have been identified.

TABLE 3.3-38

EQUIPMENT STATUS

<u>FUNCTIONAL AREA</u>	<u>STATUS</u>
A. RADAR/IFF	TO BE DEVELOPED
B. COMMUNICATION	INTEGRATE EXISTING EQUIPMENT
C. PRIME POWER GENERATOR	CONTROL (EQUIPMENT AND ENVIRONMENTAL) ONLY DEVELOPMENT ITEM
D. STATION CONTROLLER	TO BE DEVELOPED
E. WEATHER STATION	INTEGRATE EXISTING COMPONENTS TV CAMERA DEVELOPMENT
F. SECURITY	COMMERCIALY AVAILABLE
G. NAVAIDS	COMMERCIALY AVAILABLE
H. SHELTER AND TOWER	TO BE DEVELOPED

The concept of unattended operation in the Arctic has been verified by the Canadian Telesat systems, see Figure 3.3-22, the repeater stations for the Trans-Alaska Pipeline, and FAA navigational equipment.

The overall production cost of the unattended station is given in Table 3.3-39. The significant cost driver in the \$975K total is the \$482K cost of the radar. No attempt was made as part of this study to minimize radar and IFF costs. A conscientious effort was made to minimize life cycle costs for the remaining items. This was accomplished by tradeoff studies when possible, and value judgment when a tradeoff was not feasible. The production equipment costs have not been minimized, as the lowest production cost does not necessarily result in the lowest life cycle cost.

3.3.12 System Safety

System safety was a consideration in all elements of the Unattended Station Study. The primary effort in terms of safety, was identifying hazards and either eliminating the hazard or addressing safety precautions to minimize the risk.

A list of the hazardous elements identified in the study are shown in Table 3.3-40. These elements will require detail attention in any subsequent development efforts. The list shows the hazard, the severity category from MIL-STD-882A, and candidate protective action to reduce the hazard probability to levels D, E and F. These levels place the probability; as "D" remote, so unlikely, it can be assumed that this hazard will not be experienced; "E" Extremely Improvable, probability of occurrence cannot be distinguished from zero; and "F" Impossible, physically impossible to occur. Absolute assignment of a hazard probability is not prudent prior to design of the station.

Electromagnetic radiation hazards may be eliminated entirely once the radar design is established. Because of the low prime power requirements on the

EARTH SATELLITE STATIONS

Cambridge Bay



Resolute

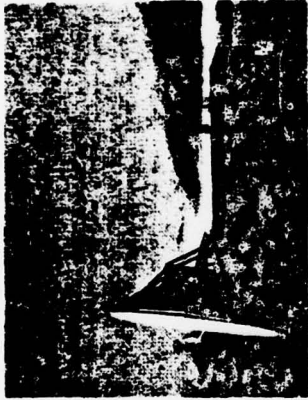

Inuvik



Eskimo Pt.



Fort Chimo



Frobisher Bay



FIGURE 3.3-22

TABLE 3.3-39

PRODUCTION STATION COSTS *

<u>ELEMENT</u>	<u>COST IN K \$</u>
A. RADAR/IFF	482
B. COMMUNICATIONS	165
C. RADOME/EQUIPMENT MODULE	150
D. AVERAGE TOWER	64
E. PRIME POWER	46
F. WEATHER STATION	31
G. NAVAIDS	18
H. STATION CONTROLLER	10
I. SECURITY	<u>9</u>
TOTAL	975

* DOES NOT INCLUDE TRANSPORTATION
OR INSTALLATION

TABLE 3.3-40

SAFETY CONSIDERATIONS

<u>HAZARD</u>	<u>SEVERITY *</u> <u>CATEGORY</u>	<u>PROTECTION</u>
1. ISOLATION OF ENERGY STORAGE	I	FIREWALLS
2. FUEL - HAZARD LEVEL STORAGE TRANSPORT	I	AIR CHANGES TANK CONSTRUCTION SPECIAL HANDLING
3. MAINTENANCE AND OPERATION	I	EQUIPMENT DESIGN
4. LIFE SUPPORT & EGRESS	I	PROVIDED IN STRUCTURE
5. FIRE	I	MATERIALS, AUTOMATIC EXTINGUISHER
6. LIGHTNING	I	GROUNDING
7. HELICOPTER FLIGHTS	I	NAVAIDS & Wx STATION
8. HELICOPTER LANDING	I	OBSTRUCTION & PAD LIGHTING
9. OUTDOOR WINTER ENVIRONMENT	I	MINIMIZE PERSONNEL EXPOSURE
10. ELECTROMAGNETIC RADIATION	III	TOWER HEIGHT
11. SOUND LEVELS	III	SOUND ABSORBANT MATERIAL

* SEVERITY CATEGORY, I CATASTROPHIC, II CRITICAL, III MARGINAL

radar and IFF the radiated power must also be low, and most probably below safety limits.

3.3.13 DEVELOPMENT TESTING

3.3.13.1 Category 1 - Subsystem Development Testing

All Category 1 testing will occur at either the vendors plant or at the prime contractors plant, and will consist of the following tests:

1. Critical component testing.
2. Subassembly and unit testing.
3. Selected radar component reliability testing.
4. Environmental testing.
5. EMI testing.
6. Acceptance (performance) testing.
7. Radar reliability testing.

In Figure 3.3-23 the first three items will occur as part of the design and fabrication cycle. These tests will not require Air Force inspection, but will be open for Air Force observation if desired. Test item 3, and the manufacture of three radar prototypes must be undertaken, to obtain sufficient reliability data within a reasonable period of time if the radar's reliability is to be determined prior to timely production release. This is discussed in more detail in General Electric's Unattended Radar Study.

Factory testing will consist of test items 4 through 6. This will be conducted by the contractor, but will require Air Force inspection.

One prototype radar will be dedicated to reliability testing at the contractors plant, following factory testing, and will be continuously tested up to production release.

The contractor will be required to generate a test plan for each functional equipment area, which will be defined as a subsystem, with an associated B1, B2,

or C1 specification. Each test plan will cover the factory test group, and will conform to the appropriate specification.

3.3.13.2 Category 2 - System Development Test and Evaluation

Two fully equipped prototype stations will be established, as shown in Figure 3.3-23. One will be transported, and installed on the DEWLine near a manned node. The station will be operated as an unattended station, except its performance will be closely monitored. The manned node will also be modified to accept data from the unattended station, and will provide all services to the unattended station in the same manner as anticipated for complete deployment of the unattended DEWLine.

The second prototype station will be located at the contractors plant and will be used for station reliability testing, and in assisting in evaluation of any problems found on the DEWLine system. The second system will also be used to prove in the software, particularly the off line diagnostic programs.

Cost for all phases of the test program are given in the preceding Life Cycle Cost section.