

AD-A059 736

NAVAL ACADEMY ANNAPOLIS MD ENERGY-ENVIRONMENT STUDY GROUP F/G 10/3  
DEVELOPMENT OF COMPOSITE FLYWHEELS FOR ENERGY STORAGE AND GYROS--ETC(U)  
MAR 77 W J BAGARIA

UNCLASSIFIED

USNA-EPRD-43

NL

1 OF 1  
ADA  
069736



END  
DATE  
FILMED  
12-78  
DDC

DDC FILE COPY AD A059736

USNA-EPRD-43

LEVEL

12

DEVELOPMENT OF COMPOSITE FLYWHEELS FOR ENERGY STORAGE AND GYROSCOPIC CONTROLS.

Assistant Professor William J. Bagaria  
Aerospace Engineering Department  
U. S. Naval Academy  
Annapolis, Maryland 21402

DDC  
OCT 11 1978  
F

Interim Report for the period July 1976 - April 1977

Unlimited Distribution

**DISTRIBUTION STATEMENT A**  
Approved for public release;  
Distribution Unlimited

Prepared for:  
Naval Material Command  
Navy Energy & Natural Resources R&D  
Washington, D. C. 20360

Energy-Environment Study Group  
U. S. Naval Academy  
205 Rickover Hall  
Annapolis, Maryland 21402

78 09 29 040

SECURITY CLASSIFICATION OF THIS PAGE (When Data Entered)

REPORT DOCUMENTATION PAGE

READ INSTRUCTIONS BEFORE COMPLETING FORM

1. REPORT NUMBER 14 USNA-EPRD-43	2. GOVT ACCESSION NO.	3. RECIPIENT'S CATALOG NUMBER
4. TITLE (and Subtitle) 6 DEVELOPMENT OF COMPOSITE FLYWHEELS FOR ENERGY STORAGE AND GYROSCOPIC CONTROLS.	5. TYPE OF REPORT & PERIOD COVERED 9 Interim rept. Jul 1976 - Apr 1977	6. PERFORMING ORG. REPORT NUMBER
7. AUTHOR(s) 10 Assistant Professor William J. Bagaria	8. CONTRACT OR GRANT NUMBER(s)	
9. PERFORMING ORGANIZATION NAME AND ADDRESS U. S. Naval Academy Annapolis, Maryland 21402	10. PROGRAM ELEMENT, PROJECT, TASK AREA & WORK UNIT NUMBERS 12 22p.	
11. CONTROLLING OFFICE NAME AND ADDRESS Naval Material Command, MAT 03Z Navy Energy & Natural Resources R&D Washington, D. C. 20360	12. REPORT DATE 11 March 1977	13. NUMBER OF PAGES 20
14. MONITORING AGENCY NAME & ADDRESS (if different from Controlling Office) Energy-Environment Study Group 205 Rickover Hall, U.S. Naval Academy Annapolis, Maryland 21402	15. SECURITY CLASS. (of this report)	15a. DECLASSIFICATION/DOWNGRADING SCHEDULE

16. DISTRIBUTION STATEMENT (of this Report)

**DISTRIBUTION STATEMENT A**  
Approved for public release;  
Distribution Unlimited

17. DISTRIBUTION STATEMENT (of the abstract entered in Block 20, if different from Report)

18. SUPPLEMENTARY NOTES

19. KEY WORDS (Continue on reverse side if necessary and identify by block number)

Flywheels                      Gyroscopic Controls  
Energy Storage                Composites

20. ABSTRACT (Continue on reverse side if necessary and identify by block number)

This report describes a research project to investigate the advantages, disadvantages and construction techniques of three composite flywheel designs. The three designs are based on fabricating the flywheels from unidirectional prepreg fiber/epoxy tape. The designs studied were: 1) circumferential-wound, 2) radial-wound, 3) radial-wrapped core. For each design, construction techniques and geometric design parameters, such as tape width, length, angle of wrap and flywheel diameter, were developed.

## INTRODUCTION

The use of composite materials in structural applications has been increasing in recent years. The composite materials are high strength fibers, such as kevlar, fiberglass, carbon, boron and others, imbedded in a matrix material such as the various epoxys or metals such as aluminum. The composite materials provide very high directional strength and low weight. Some types of structural components which can take advantage of these properties are: aircraft wing leading edges and control surfaces, aircraft empennages, drive shafts such as those for helicopter tail rotors, pressure vessels and solid propellant rocket motor cases. Other applications which require a high directional strength to weight ratio are the flywheels in rotating energy storage systems and the rotors in gyroscopic control systems.

The Navy has many applications of high speed flywheels. They are used for energy storage and in guidance systems such as those in aircraft, ships, submarines and missiles. In order to accomplish greater performance and higher speeds from flywheels, the Navy needs to continually advance the technology of flywheel construction including the use of composite materials.

The purpose of this report is to present the development of the geometric design considerations that are necessary in order to fabricate a flywheel from pre-preged composite fiber tapes. In addition, the progress to date on the design and procurement of the necessary test equipment is reported.

The theoretical design of composite flywheels, which was the first phase of this research, was presented in the report Design Development of Advanced Composite Flywheels, by Dr. Robert A. McCoy, June 1976, USNA-EPRD-28. The testing and evaluation of various flywheel designs will be the final phase of this research.

ACCESSION for	White Section <input type="checkbox"/>	<input type="checkbox"/>
NIS	Buff Section	
DDC		
UNANNOUNCED		
TESTICATION		
BY		
DISTRIBUTION/AVAILABILITY CODES		
REF. FILED, etc./or SPECIAL		
		<b>A</b>

## COMPOSITE MATERIAL DESIGN CONFIGURATIONS

The design configurations for flywheels constructed from composite tapes generally fall into three categories:

- 1) Circumferential wound, Figure 1.
- 2) Radial wound, Figure 2.
- 3) Circumferential wound core with radial wound outer wrap (radial-wrapped core), Figure 3.

Each of the three configurations has advantages and disadvantages.<sup>1</sup> The circumferential wound has the following advantages: 1) it is easy, therefore inexpensive, to wind and 2) it is easy to machine the final desired shape after curing without cutting fibers (see Figure 4). The primary disadvantages are: 1) there is limited strength in the radial direction since there are no fibers in this direction, and 2) there is a discontinuity of the circumferential fibers at the perimeter.

The primary advantage of a radial wound flywheel, fabricated from tape, is that the wraps are at an angle to the diameters, therefore the fibers contribute tangential as well as radial strength. The two main disadvantages are: 1) this method of construction requires a core for winding, and 2) it requires the use of a sophisticated winding apparatus, therefore it is more expensive to wind.

The advantages of the radial-wrapped core construction are: 1) the shape of the core can be changed, in order to vary the final shape, and 2) it overcomes the difficulties of the pure circumferential wound construction. The main disadvantage is that this type of construction is complex to fabricate thereby increasing its cost over the pure radial wound type.

The investigations to date have only considered the above advantages and disadvantages. Construction and testing of the various designs is necessary in order to evaluate other parameters such as specific energy, performance and energy stored per dollar cost.<sup>1</sup>

---

<sup>1</sup>"Economic and Technical Feasibility Study for Energy Storage Flywheels," prepared by Rockwell International Space Div., ERDA 76-65, UV-94B, ERDA Contract AT(04-3)-1066 (Dec. 1975).

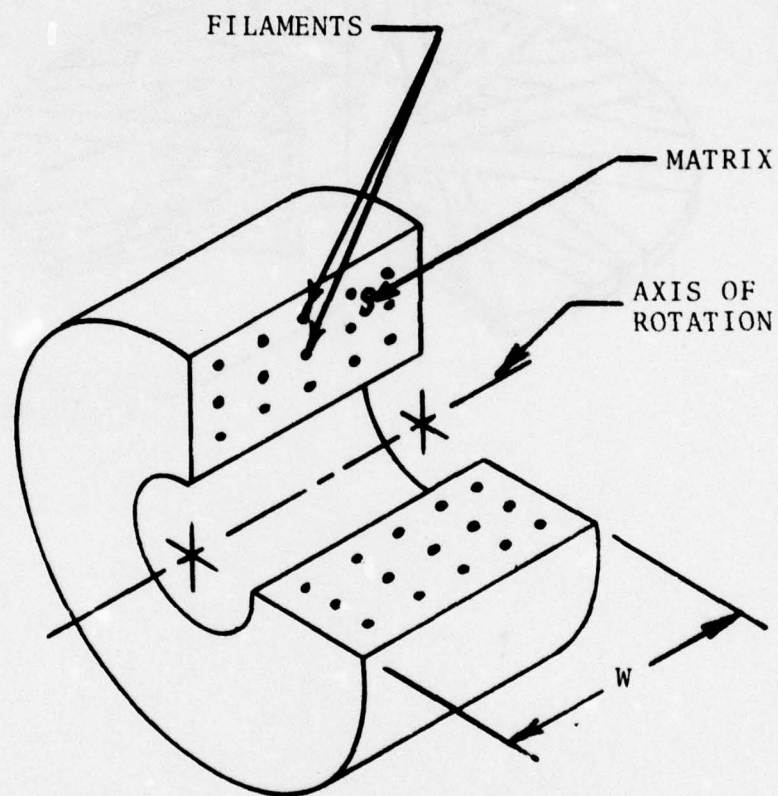

FIGURE 1. CIRCUMFERENTIAL-WOUND FLYWHEEL

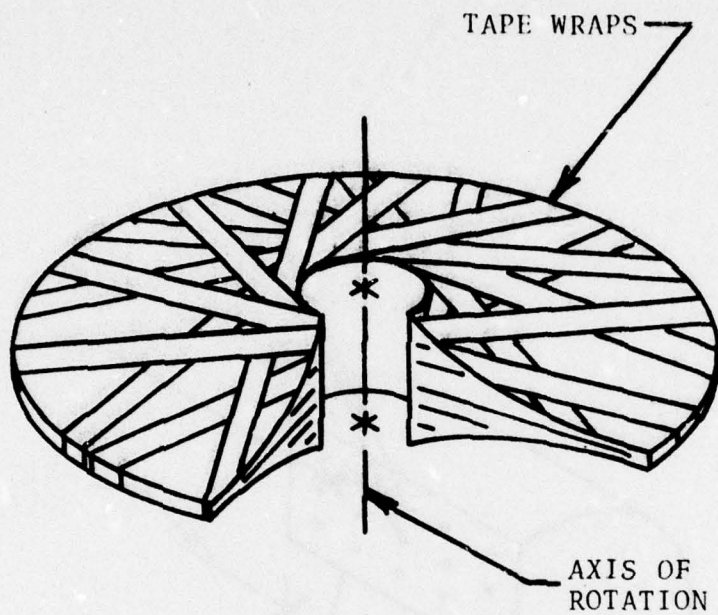

Figure 2. RADIAL-WOUND FLYWHEEL

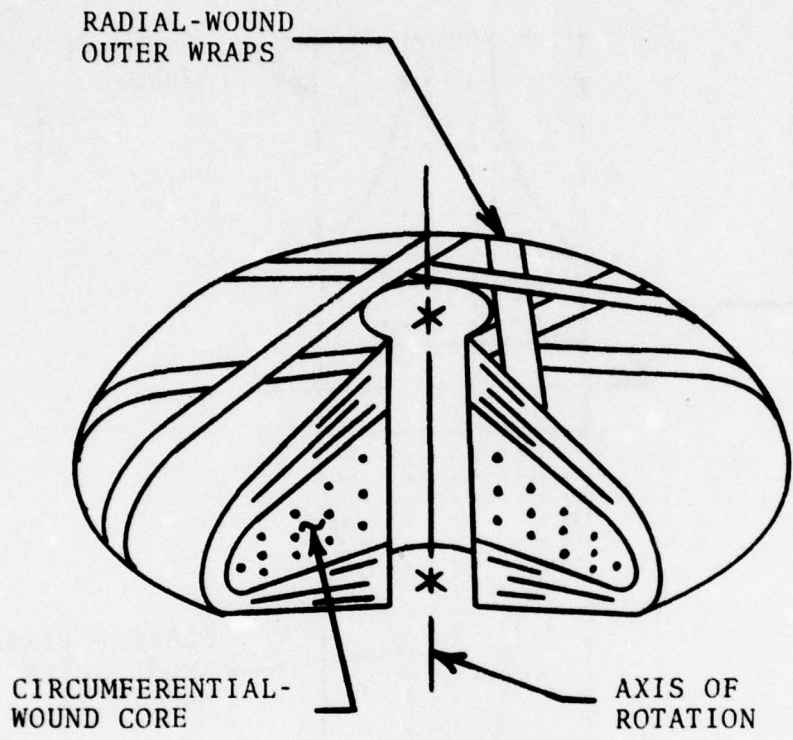

FIGURE 3. RADIAL-WRAPPED CORE FLYWHEEL

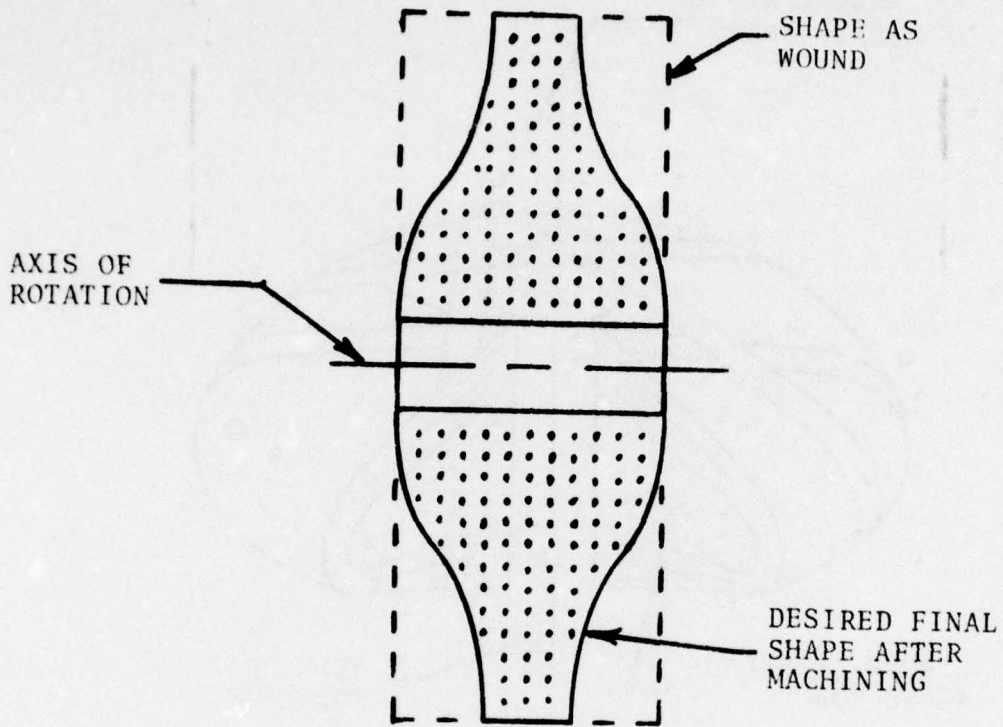

FIGURE 4. MACHINED CROSS-SECTION SHAPE OF CIRCUMFERENTIAL-WOUND FLYWHEEL.

## GEOMETRIC DESIGN

### Circumferential Wound Flywheels

The circumferential wound flywheel requires the minimum of geometric design. Once the theoretical analysis is performed, which includes the selection of the composite tape material, the desired shape can be chosen from those given in reference 2 below. The tape width is selected based on the desired flywheel hub thickness. For this type of construction the tape width,  $W$ , equals the hub thickness.

The only other geometric parameter to be determined is the tape length. The theoretical tape length,  $L$ , is given by:

$$L = n\pi (2R_i + t n).$$

In this equation the variables are:

$R_i$  = the radius of the hole for the mounting shaft

$t$  = the diameter of the tap filaments (therefore, approximately the thickness of the tape)

$n$  = the number of tape layers

$$\text{where } n = (R_o - R_i)/t$$

$R_o$  = radius to the outer perimeter

It is to be noted that for this type of construction, the tap winding tension must be reduced as the diameter increases. This is important for two reasons. First, a constant winding tension will cause an increase in fiber density, as the fibers from successively applied layers partially penetrate the underlying layers. This requires a longer length of tape in addition to possibly causing a general decrease in the radial strength. Second, compressive fiber stress, due to winding, can lead to fiber buckling and possibly matrix cracking.<sup>3</sup>

---

<sup>2</sup>Chang, G.C. "A Design Study of Advanced Flywheels for Space-Craft Applications," Memo CL-5-72, COMSAT Laboratories, Communications Satellite Corp., Clarksburg, Md. (1 Mar 1972).

<sup>3</sup>Dick, W.E. "Design and Manufacturing Considerations for Composite Flywheels," Proc. of the 1975 Flywheel Technology Symposium, ERDA 76-85, UC94B, (Nov. 10-12, 1975).

## Radial Wound Flywheels

The radial wound flywheel is based on a relatively simple winding concept. A thin disk mounted on a shaft is wrapped with the composite tape such that as the tape passes over the front face of the disk it is placed tangentially to the shaft. The tape is then wrapped around the back face of the disk and again passes tangentially to the shaft, but on the opposite side. As the tape is progressively wound, it "walks" around the disk thereby covering the disk. Figure 5 shows the winding pattern after  $2\frac{1}{2}$  wraps of the tape. Even though the winding concept is relatively simple, the winding equipment is complex. The winding equipment must also be highly accurate in order to produce a uniform and accurate wrap pattern. The wrap pattern must be precise in order to insure uniform mass and strength distribution around the flywheel. This will minimize the flywheel out of balance condition and also maximize its strength.

The geometric design considerations for the radial wound flywheel are based on four variables which are:

- 1)  $R_i$  , the mounting shaft radius;
- 2)  $R_o$  , the outer radius of the disk which is to be wrapped;
- 3)  $W$  , the tape width; and
- 4)  $t$  , the tape thickness.

The radial wound geometry is shown in Figure 6; only one full wrap is shown for clarity. The angle  $\alpha$  is the angle that a half-wrap makes with a diameter of the disk. This angle is given by,

$$\alpha = \sin^{-1} [(W/2 + R_i)/R_o].$$

The length of tape,  $l$  for each wrap is given by,

$$l = 4 R_o \cos \alpha.$$

This neglects the amount of tape required to pass over the edge of the disk and the additional lengthening of a wrap as the thickness near the mounting shaft builds up. The total length of tape,  $L$ , thus has to be greater than,

$$L > n l,$$

where  $n$  is the number of wraps.

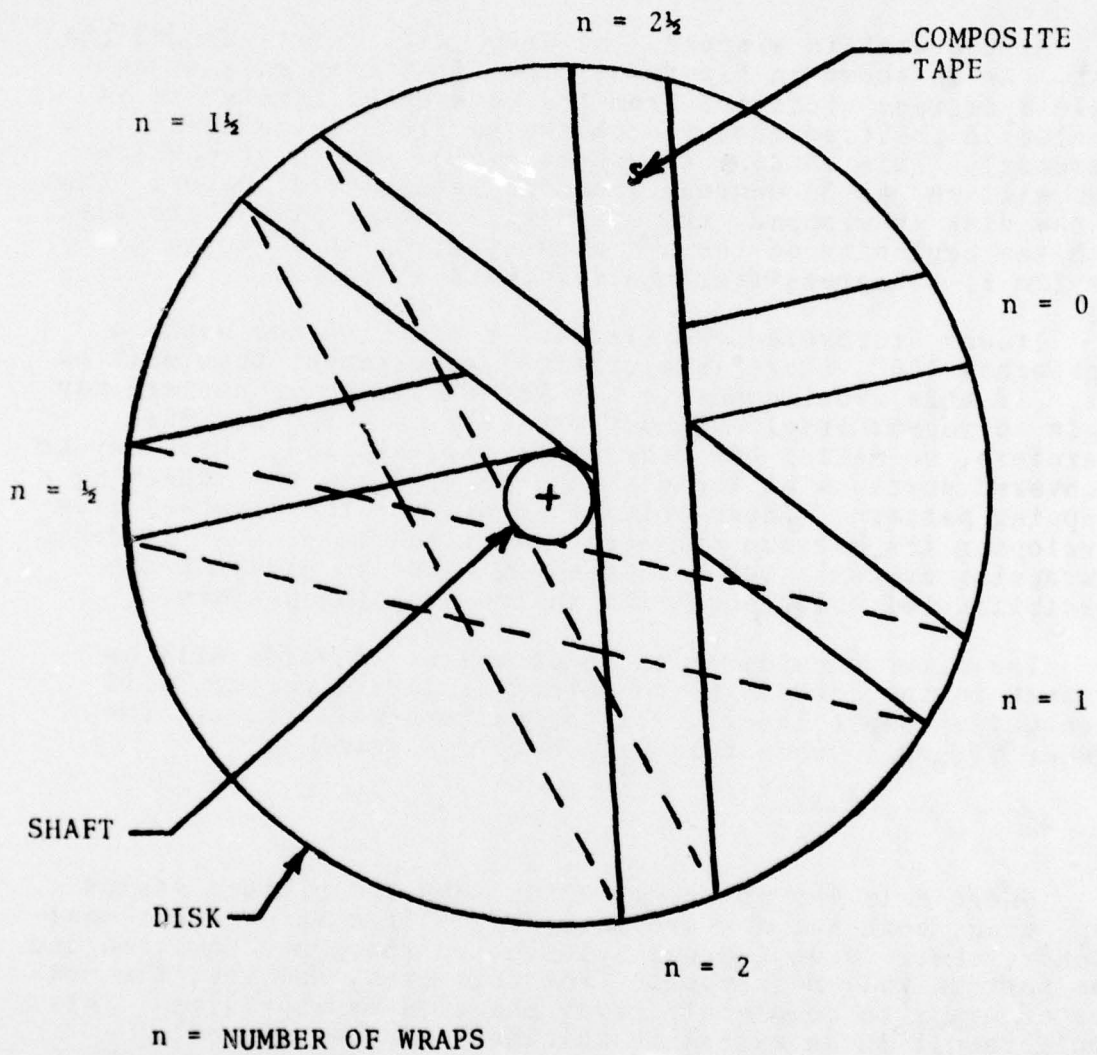

FIGURE 5. RADIAL-WOUND WITH TAPE WRAPPING PATTERN

The angle  $2\theta$  is the angle subtended by the tape width where the tape passes around the edge of the disk. The half angle,  $\theta$ , is then given by:

$$\theta = \tan^{-1} (W/2R_0 \cos \alpha).$$

The angle  $\beta$  is the half angle subtended by the centerlines of the ends of each wrap and is given by:

$$\beta = 2\alpha.$$

As the disk is wrapped, the wraps will rotate around the disk. As is shown in Figure 6, the first wrap ends at an angle  $\beta$  degrees clockwise from the reference diameter ( $\beta$  is considered positive measured clockwise from the reference diameter). This is also the start of the second wrap which then will end at  $3\beta$  degrees from the reference diameter. Thus, as the disk is wrapped, the wraps will rotate around the disk with the beginning of the  $n^{\text{th}}$  wrap starting at an angle of  $\phi = (2n-1)\beta$  degrees from the reference diameter.

It was discovered experimentally that, as the angle  $\phi$  approaches  $180^\circ$ , there is a critical requirement that must be met. If this requirement is not met the wrapping pattern may begin to repeat itself without entirely covering the disk. Therefore, no matter how many wraps are applied, there may be uncovered portions of the disk due to voids in the repeating wrapping pattern. These voids then prevent the flywheel from developing its maximum strength. As a result of this finding, a wrapping criteria was developed in order to preclude the possibility of voids occurring in the wrapping pattern.

The first consideration to determine if voids will be present in the pattern is to determine if the pattern will eventually repeat itself. If the pattern will repeat, the number of wraps when this will occur is given by:

$$N = \frac{k 180^\circ}{\beta}.$$

Where  $N$  is the number of wraps when the pattern starts repeating, both  $N$  and  $k$  are integers. If  $\beta$  is an irrational number, there is no integer solution to the above equation and the pattern will not repeat. For this case, however, the number of wraps to completely cover the disk may be large. This could result in an excessive thickness of the flywheel. Therefore, a better criteria is needed in order to prevent voids in the wrapping pattern.

It was found that a criteria to prevent voids in the wrapping pattern could be based on the angle  $\phi$  when it is the neighborhood of  $180^\circ$ , the angle  $\theta$ , and an angle  $\delta$ . The angle  $\delta$  is shown in Figure 7a. It is the angle subtended by the

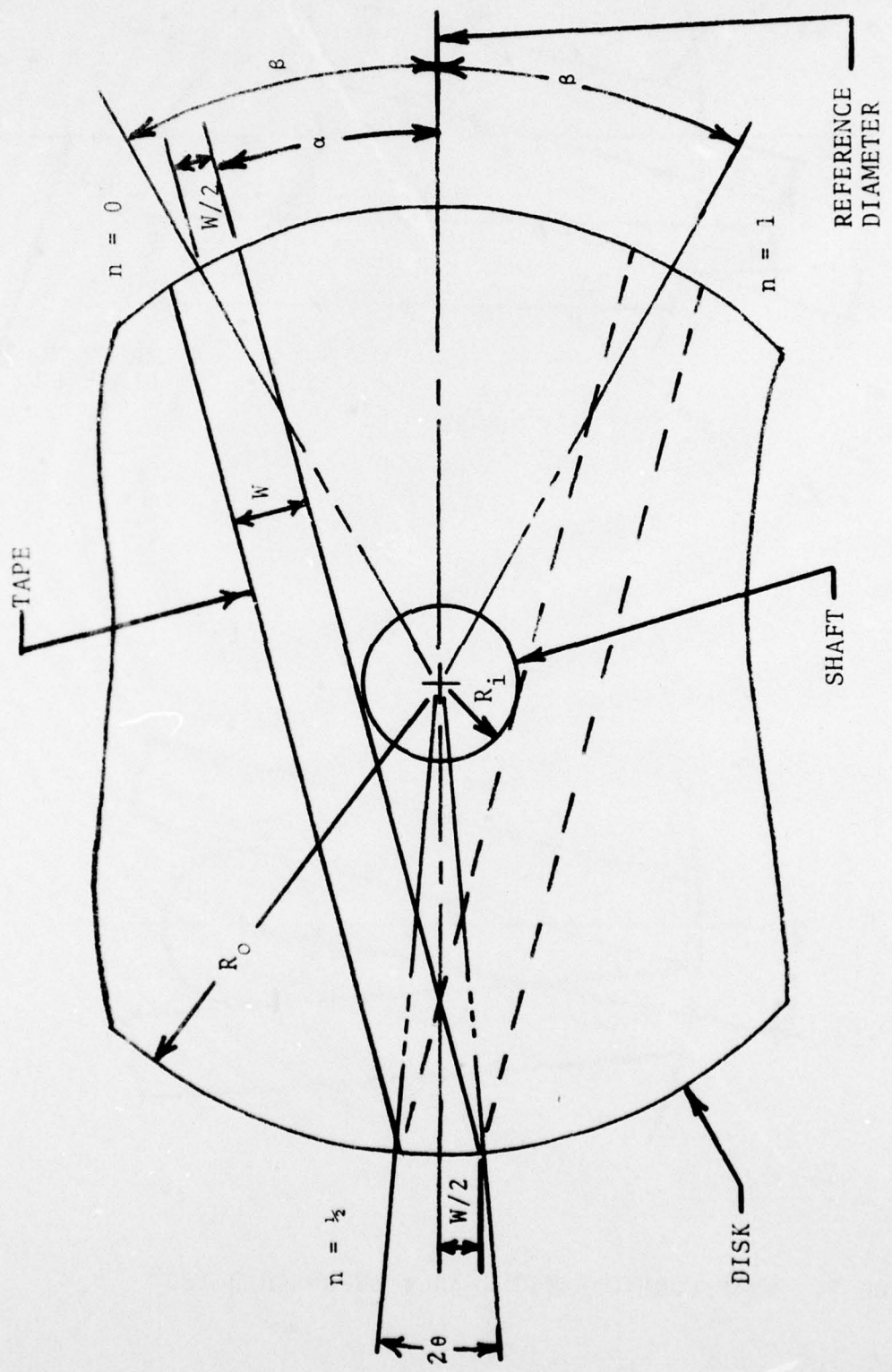

FIGURE 6. RADIAL-WOUND WITH TAPE GEOMETRY

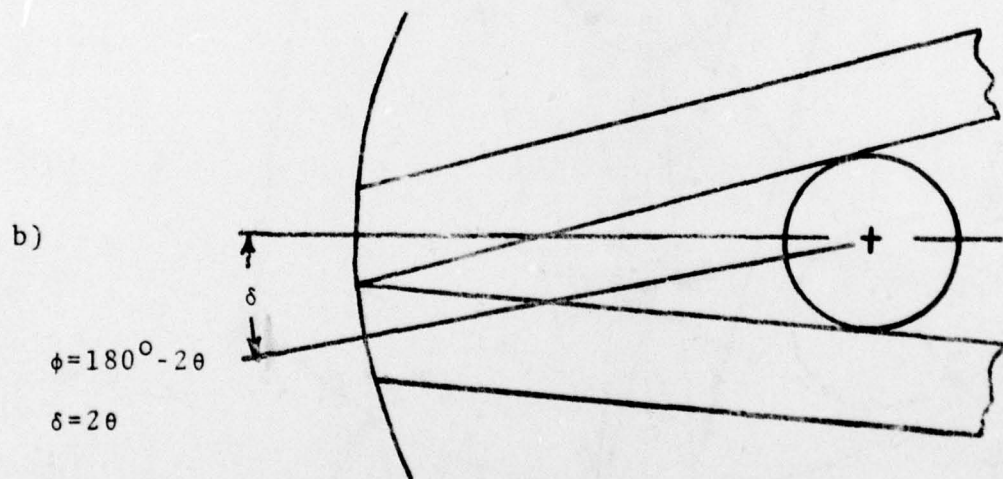
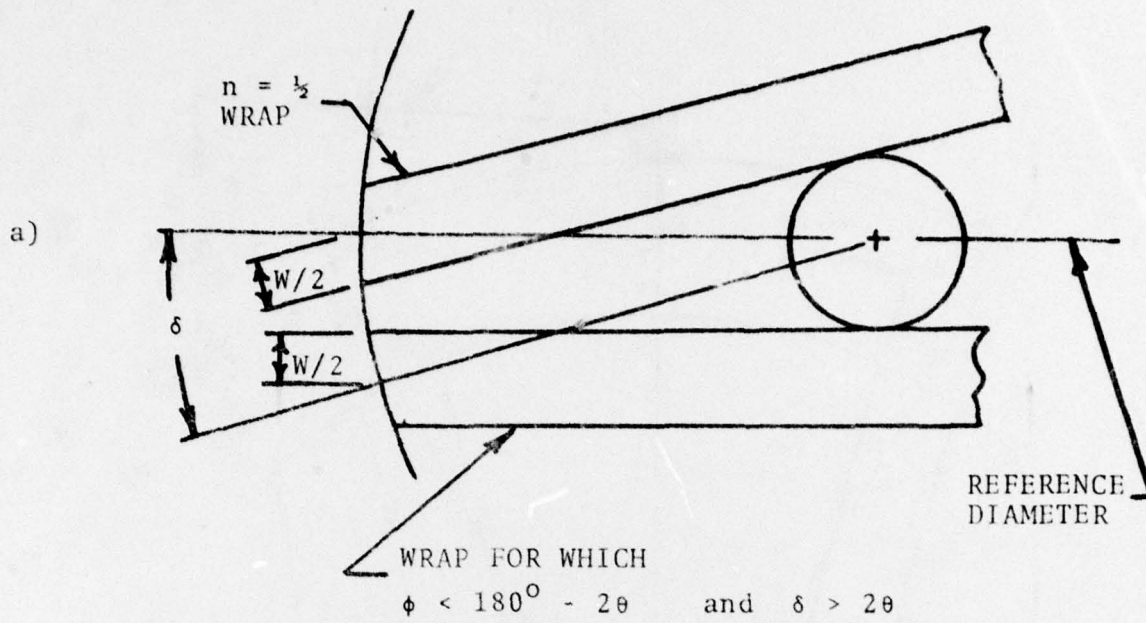

FIGURE 7. WRAP CONFIGURATIONS AS  $\phi$  APPROACHES  $180^\circ$

center lines between the  $n = 1/2$  wrap and the wrap for which  $\phi$  is in the neighborhood of  $180^\circ$ . Figures 7a through 7g illustrate the various possible ranges for  $\phi$  in the neighborhood of  $180^\circ$ , and the associated angle  $\delta$ . It was found experimentally, when a repeating pattern is used, that there will not be voids in the wrapping pattern if the conditions on  $\phi$  shown in Figures 7c and 7e are met. When the conditions on  $\phi$  are as shown in Figures 7a and 7g, where  $\delta > 2\theta$ , voids will be present in a repeating pattern. At this time it is not known whether the three cases:

$$\phi = 180^\circ - 2\theta, \delta - 2\theta = 0; \quad \phi = 180^\circ, \delta = 0; \quad \text{and} \quad \phi = 180^\circ + 2\theta, \\ \delta - 2\theta = 0 \text{ as shown in Figures 7b, 7d and 7f will}$$

produce voids in a repeating pattern. However, the accuracy of the wrapping machine may not be able to physically maintain the condition  $\delta - 2\theta = 0$ . If it cannot, and  $\delta > 2\theta$  then voids will appear in a repeating wrapping pattern. The criteria to prevent voids in a repeating wrapping pattern is then:

$$180^\circ - 2\theta < \phi < 180^\circ + 2\theta,$$

with the possible exception of  $\phi = 180^\circ$ . Letting  $m$  be the number of wraps for which  $\phi$  is in the neighborhood of  $180^\circ$ , the above criteria can be written as:

$$-2 \tan^{-1} \left( \frac{W}{2R_o \cos \alpha} \right) < (2m-1)(2\alpha) - 180^\circ < 2 \tan^{-1} \left( \frac{W}{2R_o \cos \alpha} \right),$$

with the possible exception of  $(2m-1)(2\alpha) = 180^\circ$ .

The next consideration is what is the cross-section shape of the radial wound flywheel? Figure 8 shows the cross-section of a radial wound flywheel. This Figure is based only on the tape width and thickness. Thus, smoothing the shape due to the matrix material flowing during the curing process is not shown. The best fit curve for this cross-section is:

$$h = K R^{-p},$$

where  $h$  is the thickness as a function of the radius, and  $K$  and  $p$  are constants. The constants  $K$  and  $p$  are functions of the tape thickness  $t$ , the tape width  $W$ , and the angle  $\beta$ . Thus, the radial wound technique produces a hyperbolic flywheel.

The radial stress for all flywheels goes to zero at the outer radius. However, the tangential stress approaches some fixed value. Since the tape of the radial wound flywheel passes over the edge of the disk at an angle  $\alpha$ , the fibers contribute strength in the tangential direction. The allowable tangential working stress at the outer edge of the disk,  $\sigma_{oTw}$ , in terms of the tape working stress,  $\sigma_w$ , is then given by

$$\sigma_{oTw} = \sigma_w \sin \alpha.$$

c)

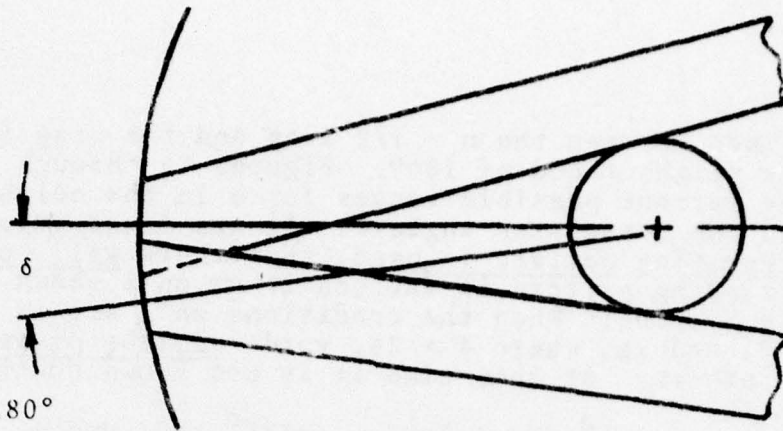

$$180^\circ - 2\theta < \phi < 180^\circ$$

$$\delta < 2\theta$$

d)

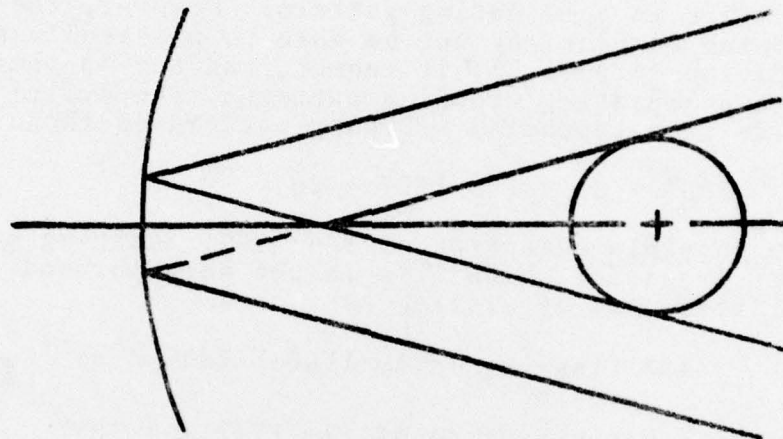

$$\phi = 180^\circ$$

$$\delta = 0$$

e)

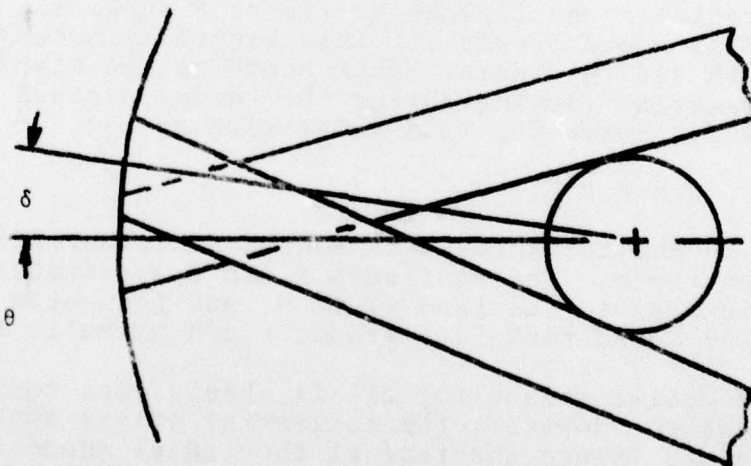

$$180^\circ < \phi < 180^\circ + 2\theta$$

$$\delta < 2\theta$$

FIGURE 7. continued

f)

$$\phi = 180^\circ + 2\theta$$

$$\delta = 2\theta$$

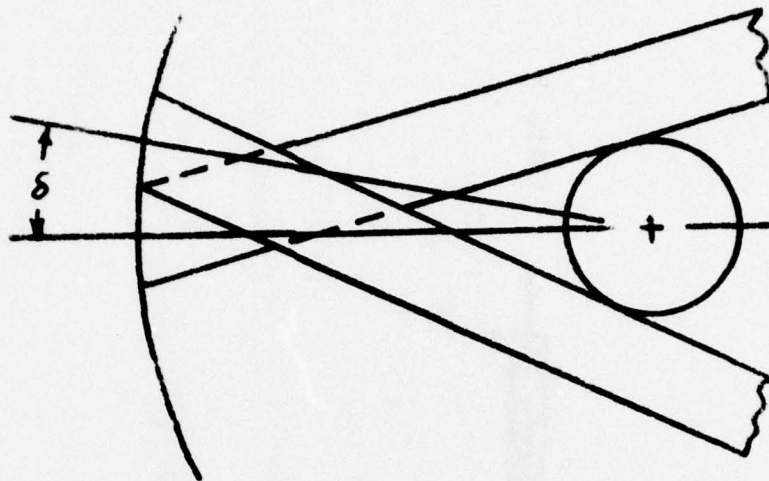

g)

$$\phi > 180^\circ + 2\theta$$

$$\delta > 2\theta$$

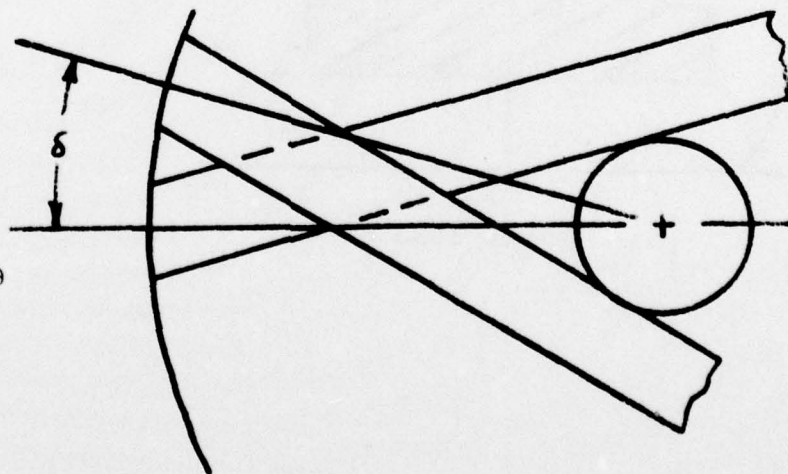

FIGURE 7. continued

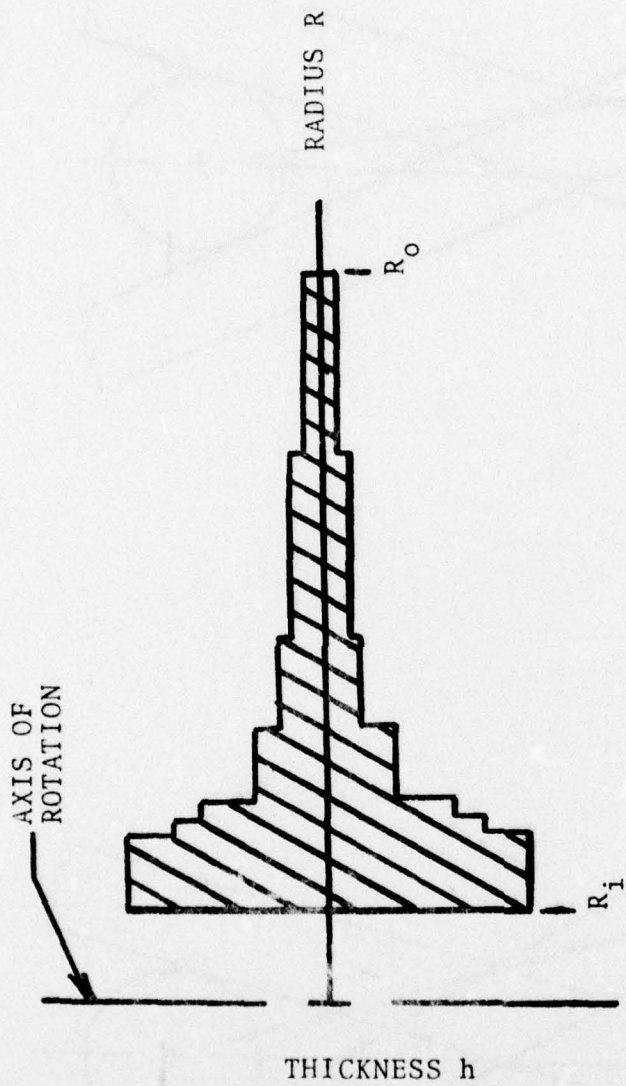

FIGURE 8. RADIAL-WOUND CROSS-SECTION

Substituting for  $\alpha$  gives:

$$\sigma_{oTW} = \sigma_w [(W/2 + R_i)/R_o].$$

At the mounting shaft portion of the flywheel, the tape fibers are tangent to the shaft. The tangential working stress at the shaft,  $\sigma_{iTW}$ , in terms of the tape working stress, is then

$$\sigma_{iTW} = \sigma_w.$$

The tangential working stress at the outer edge of the flywheel is then the limiting factor in the design of radial wrapped flywheels.

#### Circumferential-Wound Core, Radial-Wound Outer Wrap Flywheels

Rockwell International, Space Division, has conducted studies on the circumferential-wound core radial-wound outer wrap flywheels. They call this type of flywheel the radial-wrapped core design concept and their results are published in reference 1.

Since this type of construction is a combination of the circumferential and radial-wound concepts, most of the geometric analysis of the above two sections of this report apply to this type of flywheel. The one exception is the cross-section shape. Since the shape of the core can be varied, the cross-section shape does not have to be limited to the hyperbolic shape of the radial-wound flywheel. Figure 9, shows the configuration studied in reference 1.

---

<sup>1</sup>Ibid.

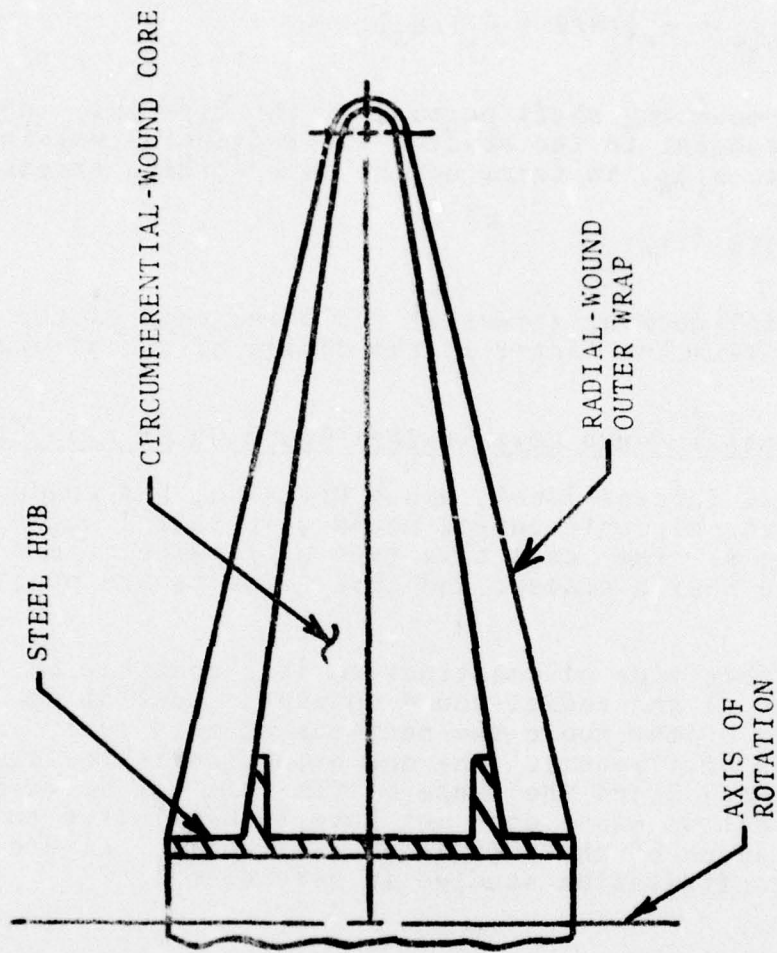

FIGURE 9. ROCKWELL INTERNATIONAL SPACE DIVISION<sup>1</sup>  
RADIAL-WRAPPED CORE FLYWHEEL

<sup>1</sup>Ibid.

PROGRESS TO DATE ON TESTING PROGRAM

As of the writing of this report, work is continuing in order to start the testing phase of this research. The long lead-time equipment and materials have been procured. The detailed design of the test equipment is about 50% completed. The designs of the test flywheels are completed. Construction of the test flywheels and portions of the test equipment can be started at this time. The remaining design work will soon be completed.

DISTRIBUTION EPRD-43

- 1 Academic Dean  
USNA Yard Mail Stop 1c
- 2 Chief of Naval Material  
Mr. Lynne Harris, MAT 03421  
Room 1044, C.P. 5  
Washington, D. C. 20360
- 1 Division of Engineering & Weapons  
USNA Yard Mail Stop 11a
- 1 Naval Systems Engineering Dept.  
USNA Yard Mail Stop 11d
- 12 Defense Documentation Center  
Defense Supply Agency  
Cameron Station  
Alexandria, VA 22314
- 1 Director of Research  
USNA Yard Mail Stop 1c
- 1 Mr. Donald Jermain  
SUP 0431  
Naval Supply Systems Command  
Washington, D. C. 20376
- 6 Naval Academy Library  
USNA Yard Mail Stop 10a (2 Catalog Dept)
- 2 Superintendent  
U.S. Naval Postgraduate School  
Monterey, CA 93940