

AD-A059 894

AIR FORCE INST OF TECH WRIGHT-PATTERSON AFB OHIO  
DEVELOPMENT AND EVALUATION OF A COLUMNAR ION EXCHANGE SYSTEM USING  
AUG 78 A M WACHINSKI  
AFIT-CI-78-114

F/G 7/1

UNCLASSIFIED

NL

| OF |  
AD  
A059894



END  
DATE  
FILMED  
12-78  
DDC

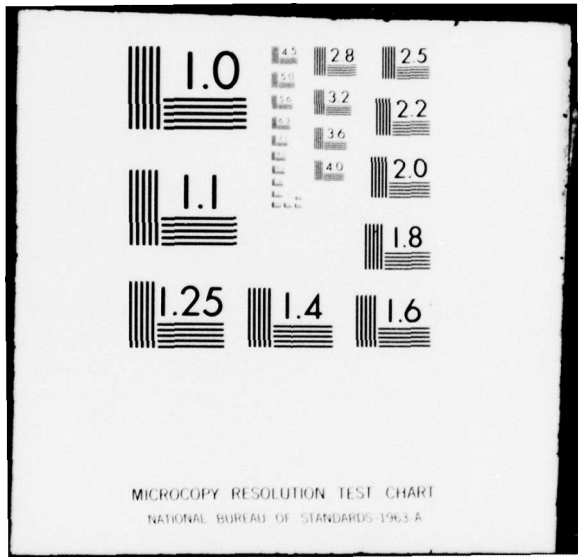

UNCLASSIFIED

SECURITY CLASSIFICATION OF THIS PAGE (When Data Entered)

REPORT DOCUMENTATION PAGE

READ INSTRUCTIONS BEFORE COMPLETING FORM

1. REPORT NUMBER CI 78-114		2. GOVT ACCESSION NO.	3. REPORT'S CATALOG NUMBER
4. TITLE (and Subtitle) Development and Evaluation of a Columnar Ion Exchange System Using Microencapsulated Magnetic Resin.		5. TYPE OF REPORT & PERIOD COVERED 9 Doctoral thesis	
7. AUTHOR(s) 10 Anthony Michael Wachinski Captain Anthony Wachinski		8. CONTRACT OR GRANT NUMBER(s) 14 AFIT-CI-78-114	
9. PERFORMING ORGANIZATION NAME AND ADDRESS AFIT Student at Purdue University Lafayette, IN		10. PROGRAM ELEMENT, PROJECT, TASK AREA & WORK UNIT NUMBERS 11 Aug 78	
11. CONTROLLING OFFICE NAME AND ADDRESS AFIT/CI WPAFB OH 45433		12. REPORT DATE 1978 12/67	
14. MONITORING AGENCY NAME & ADDRESS (if different from Controlling Office)		13. NUMBER OF PAGES 58 Pages	
16. DISTRIBUTION STATEMENT (of this Report) Approved for Public Release, Distribution Unlimited		15. SECURITY CLASS. (of this report) Unclassified	
17. DISTRIBUTION STATEMENT (of the abstract entered in Block 20, if different from Report)		15a. DECLASSIFICATION/DOWNGRADING SCHEDULE	
18. SUPPLEMENTARY NOTES SEP 22 1978 JOSEPH P. HIPPS, Major, USAF Director of Information, AFIT APPROVED FOR PUBLIC RELEASE AFR 190-17.		DDDC PREPARED OCT 4 1978 F	
19. KEY WORDS (Continue on reverse side if necessary and identify by block number)			
20. ABSTRACT (Continue on reverse side if necessary and identify by block number)			

AD A059894

DDC FILE COPY

LEVEL

012 200

78-114T

DEVELOPMENT AND EVALUATION  
OF A  
COLUMNAR ION EXCHANGE SYSTEM  
USING  
MICROENCAPSULATED MAGNETIC RESIN

A Thesis

Submitted to the Faculty

of

Purdue University

by

Anthony Michael Wachinski

In Partial Fulfillment of the  
Requirements for the Degree

of

Doctor of Philosophy

August 1978

78 10 03 056

Atch1

To Linda  
For Her Everlasting Encouragement,  
Patience, and Love.

78 10 03 056

## ACKNOWLEDGMENTS

The author would like to express his sincere appreciation to Dr. James E. Etzel for his advice and guidance during the entire graduate program, and even more important for Dr. Etzel's valued friendship during the author's most memorable stay at Purdue University.

Appreciation is also extended to the members of the thesis committee - Drs. Ronald F. Wukasch, John M. Bell, and Carl Castore.

The writer would like to express his sincere appreciation and admiration to his wife, Linda, for her encouragement and understanding which made this undertaking possible.

To my fellow graduate students, the author expresses appreciation for their assistance and friendship during the author's stay at Purdue. A special thanks goes to Steve Termaath, Rick Lewis, and Ralph Frost for their assistance and companionship during the author's OJT in the "lab".

Acknowledgment is made to Water Refining Company, Inc., for their financial support to Capsulated Systems, Inc. for development of the magnetic resin used in this investigation.

TABLE OF CONTENTS

	Page
LIST OF TABLES . . . . .	v
LIST OF FIGURES . . . . .	vi
ABSTRACT . . . . .	vii
INTRODUCTION AND HISTORICAL PERSPECTUS . . . . .	1
Introduction . . . . .	1
Historical Perspectus . . . . .	2
PURPOSE AND SCOPE OF THE INVESTIGATION . . . . .	5
REVIEW OF THE LITERATURE . . . . .	9
METHODS AND MATERIALS . . . . .	20
RESULTS AND DISCUSSION . . . . .	29
Resin Development . . . . .	29
System Development . . . . .	30
System Evaluation . . . . .	37
Hydraulic Considerations . . . . .	37
Operational Considerations . . . . .	40
Effect of Particle Size . . . . .	41
Effect of Regenerant Concentration . . . . .	42
Effect of Regeneration Contact Time . . . . .	45
Effect of Service Cycle Contact Time . . . . .	48
SUMMARY AND CONCLUSIONS . . . . .	50
Summary . . . . .	50
Conclusions . . . . .	52
LIST OF REFERENCES . . . . .	54
VITA . . . . .	57

ACCESSION for	
NTIS	Write Section <input checked="" type="checkbox"/>
ODC	B. H. Section <input type="checkbox"/>
UNANNOUNCED	<input type="checkbox"/>
JUSTIFICATION	
BY	
DISTRIBUTION/AVAILABILITY COPIES	
SPECIAL	
A	

## LIST OF TABLES

Table	Page
1. Effect of Stirring on Rate of Exchange . . . .	12
2. Salt Dosage vs. Capacity . . . . .	40
3. The Effect of Regeneration Flow Rate on Breakthrough Capacity . . . . .	47

## LIST OF FIGURES

Figure	Page
1. Rates of HCl Uptake by Magnetic Amine Resins, Using Equimolar Amounts of 0.025N Acid in 1100 ppm NaCl . . . . .	14
2. Experimental Ion Exchange System . . . . .	23
3. 50 ml Burette Ion Exchange Column . . . . .	26
4. Schematic of Laboratory Magnet . . . . .	32
5. Pressure Drop Characteristics at Various Flow Rates . . . . .	38
6. Capacity vs Brine Concentration, Dowex 50W x 8, 200-400 mesh . . . . .	43
7. Capacity vs Brine Concentration, ATVA . . . . .	44

## ABSTRACT

Wachinski, Anthony Michael. Ph.D., Purdue University, August 1978. Development and Evaluation of a Columnar Ion Exchange System Using Microencapsulated Magnetic Resin. Major Professor: James E. Etzel.

A unique method using 15-20 micron diameter magnetic ion exchange resin in columnar operation was demonstrated. A barium feritite powder 2 microns in diameter was encapsulated within an experimental synthetic strong-acid ion exchange resin, sulfonated, and magnetized using a laboratory magnet of 15,000 Gauss. A procedure was developed whereby the magnetized resin was allowed to attach itself to a stainless steel wool matrix, which loosely filled the column. By maintaining a high void volume throughout the bed, pressure drop was maintained at acceptable values, i.e., 9 psi/ft of column bed at over 18 gpm/ft<sup>3</sup>. The pressure drop in a column using nonmagnetic ion exchange resin of the same size approached 1000 psi/foot of bed.

Performance of the system was evaluated by monitoring variations in breakthrough capacity, as regeneration flow rates and contact times, and softening flow rates and contact times were varied. Sodium chloride was used to regenerate the column in an upflow mode, countercurrent to the service cycle. A synthetic hard water containing

→ next page

260 mg/l  $\text{Ca}^{++}$  as  $\text{CaCO}_3$  and 130 mg/l  $\text{Mg}^{++}$  as  $\text{CaCO}_3$  was used as feed. For a given regenerate loading and concentration, results showed that regeneration contact times under 5 minutes (normally 30 min.) and regeneration flow rates over 6 gpm/ft<sup>3</sup> (normally 1 gpm/ft<sup>3</sup>) were not only possible but gave significant increases in operating capacity. Softening flow rates of over 18 gpm/ft<sup>3</sup> (normally 4 gpm/ft<sup>3</sup>) and contact times less than 25 seconds (normally 6 min.) were also possible without decreasing operating capacity.

The ion exchange System evolved in these studies is the first known system to utilize fine mesh ion exchange resin in columnar operation and take advantage of the superior properties made possible by small diameter resin.

## INTRODUCTION AND HISTORICAL PERSPECTUS

### Introduction

Current practice by individual, institutional, industrial, and municipal consumers for the production of "soft" water is to utilize a fixed-bed ion exchange system incorporating a sulfonic-type cation exchange resin, usually a styrene-divinylbenzene copolymer. Hydraulic considerations currently limit resin particles to a size which gives maximum capacity with an acceptable pressure drop at high flow rates; (Most ion exchange resins used today are uniform spheres having diameters of 0.3 - 1.0 millimeter (mm), i.e., 20-50 mesh, U.S. Standard Screens.)

The amount of hardness which is not exchanged as the water passes through an ion exchange bed, i.e., slippage, is a function of the service cycle contact time, which in turn is governed by the ion exchange rate of the resin. Current practice in minimizing slippage is to design ion exchange columns with a minimum bed depth of 30 inches and to maintain service cycle flow rates between 2 and 6 gallons per minute per cubic foot of resin ( $\text{gpm}/\text{ft}^3$ ). Leakage, due to incomplete regeneration, is a function of brine concentration and regeneration contact time. Unacceptable leakage occurs when brine contact times are

less than 30 minutes, brine concentration is less than 8% by weight, and regeneration flow rates are greater than 1.0 gpm/cu. ft.

The kinetics of 20-50 mesh resin impose certain limitations on column design that could be eliminated, or at least significantly moderated by using a finer mesh resin. Fine mesh resins, i.e., 15-20 microns in diameter, have exchange rates up to 15 times faster than conventional resins and more efficient resin utilization capacity, but they are not used commercially because of hydraulic considerations. Fine mesh ion exchange resins cause excessive pressure drops, are prone to clogging and fouling, and are extremely difficult to backwash, in that they are easily carried out of the ion exchange column in the backwash cycle.

It is the objective of the research reported in this thesis to investigate and develop a new and unique approach for using fine mesh cationic exchange resin in columnar operations.

#### Historical Perspectus

Records indicate that the concept of ion exchange existed at least back to Aristotle's time (30) and possibly Biblical times (18) when Moses sweetened the waters of Marah. A recent interpretation of the miracle (24) suggests that oxidized cellulose of the log that Moses cast into the waters had formed carboxyl groups that

removed the "bitter" Epsom salt by an ion exchange reaction. Thus Moses succeeded in preparing drinking water, undoubtedly by an ion exchange technique he developed on an industrial scale. However, basic research on the subject is credited to the English agricultural chemist, H. S. Thompson (37), who in 1850 exchanged ammonium with calcium by passing a solution of ammonium sulfate through a column of soil. In that same year, another Englishman, T. J. Way (38) published a more extensive report entitled "On the Power of Soils to Absorb Manure" - it should be noted that the Arrhenius' concept of ions was not published until 1887 - and that Way's conclusion, presented before the Royal Agriculture Society of London in 1854 remain valid today (39). The first synthetic industrial ion exchanger was prepared in 1903 by two German chemists, Harm and Rumpfer (20), while Robert Gan's classic studies of ion exchange in the removal of gold from sea water (19) is thought to be the first attempt in utilizing ion exchange for industrial purposes. In 1935, Adams and Holmes, two English chemists, discovered that crushed phonograph records exhibited ion exchange properties, and published the first paper on the synthesis of organic ion exchange resins (2). In less than a decade following Holmes' discovery, patents were granted for the synthesis of phenol formaldehyde resins. Then, in 1944 D'alelio's (13) synthesis of the sulfonated copolymer of styrene and

divinylbenzene yielded the first monofunctional strong-acid resin.

The synthesis of a resin possessing desirable physical and chemical characteristics for specific applications is inherent in this investigation.

## PURPOSE AND SCOPE OF THE INVESTIGATION

The objective of this research was to investigate and develop a new and unique approach for using fine mesh ion exchange resins in columnar operations. The basic concept of the investigation concerned the use of a magnetic field to fix or hold fine mesh resins possessing magnetic properties onto a matrix of stainless steel wool packing (95-98% void space). The general concept of a magnetic resin, i.e., a ferromagnetic core microencapsulated by an ion exchange resin was introduced by Weiss et al (41), in 1971, however, the technology of microencapsulation has been around since the 1960's and has become an accepted marketing tool for creating new products. Current application of magnetic fields to water purification in the United States is in the area of high gradient magnetic separation (HGMS), the principles, devices, and applications of which are well documented (14,28,29).

HGMS is a relatively new technique (late sixties) capable of extracting weakly paramagnetic, submicron particles at several hundred times the flow rates of conventional filtration (14). A typical HGMS unit consists of a matrix of stainless steel wool packing, placed in a suitable holder and saturated by a strong,

reasonably homogeneous magnetic field (~20 Kgauss). The matrix that fills the HGMS device usually leaves 95-98% void space. Magnetic particles (either paramagnetic or ferromagnetic) are captured from a fluid stream on the magnetized matrix fibers, where they are held until particle loading necessitates purging of the matrix which is accomplished by deactivating the magnetic field and back-washing the unit.

Since HGMS is an efficient means of collecting fine particles, it can be applied to water purification in a variety of ways; however, there is no documented evidence of this principle being used to magnetically fix particles on to a matrix and allowing the fluid stream to contact these particles.

Essentially this research consisted of three phases, resin development, system development, and system evaluation. System development and evaluation depended upon being able to synthesize and sulfonate a magnetic resin. The resin consisted of a micron sized ferromagnetic core encapsulated within a synthetic ion exchange resin. Since the resin was to be sulfonated, an acid tolerant core had to be chosen.

System development entailed construction of a bench scale ion exchange system utilizing the fine mesh magnetic resin. Basic questions to be answered during this phase included, what the magnetic field strength required to fix

the resin had to be and what was the most efficient means of applying the magnetic field? The importance of having a homogeneous distribution of the resin on the matrix also had to be determined.

The final phase consisted of evaluating the hydraulic and operational characteristics of the system.

Operating capacity was used in the determination of the operational characteristics of the column since it was the most representative measure of the actual useful performance obtained with a given ion exchange material under a prescribed set of conditions. Operating capacity was determined by the total capacity of the resin, by the extent to which the resin could be converted to the proper ionic form, by the composition of the solution treated, by flow rates through the column, by temperature, and by resin particle size. Throughout all phases of the investigation particle size, total capacity of the resin, temperature, and composition of the solution to be treated were held constant. The extent to which the resin was converted to the proper ionic form was governed by regenerate loading, concentration, and contact time.

The variation in operating capacity under various dynamic situations was used to quantify exchange rate limitations of the system. In that no operating data were available for the resin, the regeneration conditions giving the maximum operating capacity at a given softening rate

had to be used as a baseline. Variations in operating capacity as regeneration flow rates and contact times, and softening flow rates and contact times were varied was used to evaluate the performance of the system. Sodium chloride was used to regenerate the column in an upflow mode, countercurrent to service cycle.

Hydraulic characteristics were evaluated by measuring pressure drop at various flow rates and measuring the backwashing flow rate necessary to dislodge and carry the magnetic resin out of the column.

## REVIEW OF THE LITERATURE

To establish the current state of technology for using fine mesh cation exchange resins in columnar operations, a review of the literature was conducted. The general areas of investigation included ion exchange kinetics, current uses of fine mesh resins, and the current status of "magnetic" ion exchange resins.

Consideration of the kinetics of cation exchange dates back to the classic work of J. Thomas Way (38,39) who found the rate of exchange to be quite rapid but slightly affected by temperature. Many decades elapsed before Wiegner (42) considered the rates of exchange in silicates to be dependent on the location of the exchange groups. Cernescu (11) confirmed Wiegner's conclusions and indicated that the rate-determining step for cation exchange was concerned with the diffusion rate of the cations to and from the exchange sites. The work of Boyd et al (3,7,8,9) Bauman and Eichhorn (5), and Kunin and Myers (24) indicated that the rate of ion exchange in cation exchange resins was diffusion controlled. Boyd et al distinguished between two diffusion processes: At concentrations less than 0.003M, the diffusion of ions through the film of solution surrounding each particle was considered to be the rate-

determining process, while at concentrations above 0.1M, the diffusion of ions throughout the particle was rate-limiting. Their conclusions have been confirmed by other workers.

A number of factors determine whether a given ion exchange reaction will be controlled by film or particle diffusion. Any factor that slows down the rate of particle diffusion without causing a corresponding decrease in the film diffusion rate will favor particle diffusion control; and any factor that increases the rate of film diffusion without a corresponding increase in the particle diffusion rate will also favor particle diffusion control.

Adamson and Myers (3) were the first to clearly show that both film and particle diffusion processes could be rate controlling, each under different conditions; their conclusions have also been confirmed by other workers.

A decrease in the thickness of the hydrodynamic film or Nernst film whether caused by increased stirring or shaking in a batch process or increased flow rate in a column process, will increase the rate of particle diffusion without affecting the rate of particle diffusion control. It is important to note that an increase in the rate of stirring, shaking or flow rate will decrease the film thickness, but only to a certain limiting value dependent upon the hydrodynamics of the particular system. (10)

With a given exchange resin in a given solution, an increase in particle size decreases the rates of both

particle and film diffusion. However, the rate of film diffusion is inversely proportional to the diameter of the particle while the rate of particle diffusion is inversely proportion to the square of the particle diameter. Therefore, large particles are particle diffusion controlled.

Rieman and Watson (32) presented data supporting the theory that small particle size favors rapid exchange regardless of which method is used to study the rate and regardless of whether film diffusion or particle diffusion is the limiting step. In comparing particle size versus half-life, i.e., the time required for the conversion of one-half of the resin from the hydrogen to the sodium form, it was found that decreasing the resin radius from 0.0446 cm to 0.0273 cm decreased the half-life from 49 to 21 seconds with temperature and percent resin cross-linking being held constant.

Kressman and Kitchener (22) presented data supporting the dependence of rate of exchange on agitation. Table 1 illustrates that the rate of exchange was increased to a limit beyond which further increases in the rate of stirring had no effect on the rate of exchange. The exchange was between an ammonium-form resin and sodium ions under conditions where film diffusion was rate limiting.

Table 1  
Effect of Stirring on Rate of Exchange (22)

Rate of Stirring (rev/min)	Half-life* (min)
470	5.9
660	3.8
750	2.9
860	1.2
990	1.0
1100	1.0

\*The time required for the conversion of one-half of the resin from the ammonium to the sodium form.

The kinetic advantage of fine mesh ion exchange resins versus conventional 20-50 mesh have been reported by Schultz (34), and Weiss et al (41). Schultz presented rate data on batch operations for both micropowders, i.e., resins 25-44 microns in diameter, and ultra fine resins 0.5 - 1.5 microns in diameter. For sulfonic resins in both the sodium and hydrogen form, the times required to reach a limiting equilibrium were 5 to 15 times faster for the micropowder and ultrafine resins than for conventional sized resin. Schultz concluded that the increase in surface area and correspondingly greater accessibility of ionic sites caused the finer mesh resin to be less diffusion-controlled. Weiss et al compared the time required for uptake of sodium chloride by 10-20 micron Zeo-Karb 226 and 400-1000 micron Zeo-Karb 226 and showed both a substantial increase in exchange rate and capacity by the 10-20 micron sized

resin. The kinetic advantages were verified by Weiss et al when they compared effective sodium uptake to time for a fine mesh i.e. (200 mesh or 74 micron diameter resin) to a conventional weak-acid ion exchange resin, i.e., 20-50 mesh. Of particular interest were data presented by Weiss et al comparing fine magnetic weak-base resins and one conventional weak-base ion exchange resin. Of significance in these data was the fact that ferromagnetic materials encapsulated by various weak base resins exhibited higher capacities and exchange rates than did corresponding non-magnetic weak acid resins of the same particle size (these data are presented in Figure 1). The significance of the work done by Weiss, however, has remained academic since, to date, no one has been able to successfully use these fine mesh magnet resins on any significant scale.

The effects of particle size on capacity have been reported by Kunin and Myers (25), Samuelson (33), and Kunin and Barry (23).

Kunin and Myers concluded that a decrease in particle size resulted in an increased rate and therefore an increased break-through capacity. Kunin (25), in unpublished data showed a 57% increase in water softening capacity when he compared 200 micron sized resin beads to 800 micron. He also noted a 20% decrease in capacity when regeneration and service cycle flow rates were doubled

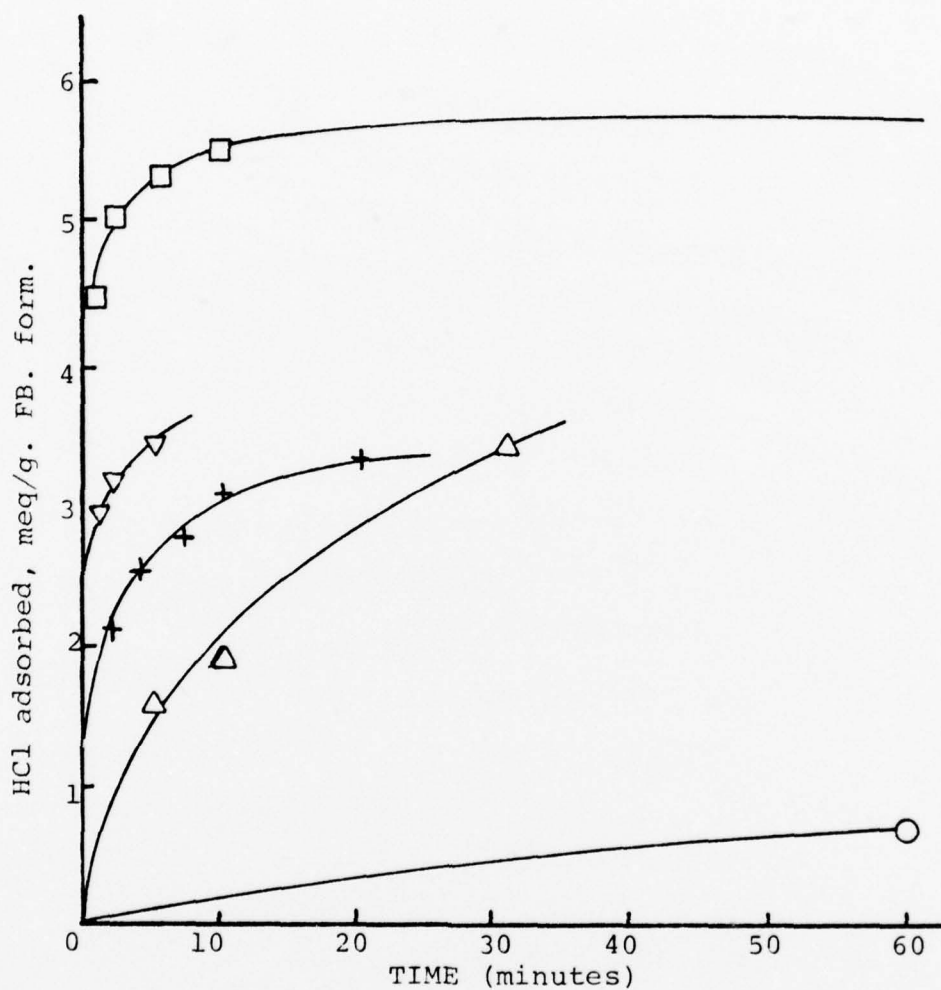

- - Diethylenetriamine/epichlorhydrin resin, -200 mesh 6.5 meq/g.
- ▽ - Phenol-formaldehyde/diethylenetriamine resin -200 mesh, 6.0 meq/g
- + - De-Acidete G, -200 mesh, 4.0 meq/g (Non-magnetic)
- △ - Polyethyleneimine/epichlorhydrin resin, -200 mesh, 7.8 meq/g.
- - De-Acidete G, 16-18 mesh, 4.0 meq/g capacity (non-magnetic)

Figure 1. Rates of HCl Uptake by Magnetic Amine Resins, Using Equimolar Amounts of 0.025N Acid in 1100 ppm NaCl (41)

for the 800 micron size particles, but a 2% increase in capacity when regeneration and service flow rates were doubled for the 200 micron sized resin. Kumin was probably the first to show that finer mesh resins are film diffusion controlled, and that an increase in turbulence via an increase in flow rate will decrease the Nernst film, allowing for an increase in operating capacity. Samuelson (33) showed that the particle size of the exchanger had a very great influence upon capacity breakthrough. Solutions of potassium nitrate were passed through columns containing a sulfonic acid resin in the hydrogen form. The effluent was collected in small fractions in which the amount of nitric acid was determined by titration. The results indicated that break-through capacities were increased: 10 fold when a 0.1 - 0.2 mm particle size resin was used versus a 0.6 - 1.0 mm size; 7 fold when a 0.2 - 0.4 mm particle size resin was used versus a 0.6 - 1.0 mm size, and 5 fold when using a 0.4 - 0.6 mm particle size versus a 0.6 - 1.0 mm size. Kunin and Barry (23) published break-through curves for a carboxylic acid resin, i.e., Amerite IRC-50, confirming Samuelson's work.

Kunin (25) again in unpublished data compared regeneration flow rate to change in standard capacity i.e. 15 kgr as  $\text{CaCO}_3$ /cu. ft., at a regeneration flow of 1 gpm/ft<sup>3</sup>. When the regeneration flow rate was 5.5 gpm/ft<sup>3</sup> capacity had dropped to 11.5 kgr/ft<sup>3</sup>, a significant decrease of 23

percent. Note that service flow rate was held constant at 2 gpm/ft<sup>3</sup> and regeneration loading was 7 lbs of NaCl/ft<sup>3</sup> of resin.

Particle size has been shown to be of greatest importance for the efficiency of regeneration. Djurfeldt and Samuelson (15) showed that the volume of acid necessary for the regeneration of an ion exchange column increased greatly when the particle size of the ion exchange resin was increased and that using a smaller particle size meant a saving of regeneration acid as well as of time.

Ion exchange materials are available in a wide range of particle sizes to meet the needs of any application. Most commercial ion exchange resins are small spheres in the size range of 20-50 mesh, i.e., about 300 to 1000 microns in diameter. Commercial ion exchange systems typically employ resins in this size range, because they appear to give maximum capacity with acceptable pressure drops at high flow rates. Current applications of ultra-fine ion exchange resins (0.5 to 1.5 microns) and micro-powders (25-44 microns) in columns is limited to analytical and/or chromatographic applications, e.g., amino acid separation. (26)

Powdered ion exchangers (with their increased reaction rate and high adsorption power) have found application as supporting materials (34), but current thought is that these exchangers cannot be regenerated and consequently are being used only once. Ultrafine resins offer exchange rates

up to 15 times faster than conventional resins due to the greater accessibility of ionic sites. Their application in columnar operations is limited, however, because of very excessive pressure drop, clogging and fouling problems and loss of particles in backwashing. Instead, ultrafine resins have found application in the production of ion exchange papers and incorporation in plastics, films, coatings and fibers (34).

To date there have been no reported successful attempts in using micropowder sized ion exchange resins or smaller in columnar operation. Weiss et al, (41) compared gamma iron oxide particles encapsulated with trimethylol phenol N,N bis (3-amino propyl methylamine) having a particle size range of 250-500 microns and magnetized in a field of 1000 gauss, with a standard sized 350-1200 micron resin in columnar operation. They reported substantially the same kinetics for both resins, although the magnetized resin permitted substantially higher backwash rates. Insufficient data were presented to evaluate the experimental protocol and their interpretation of the results.

Svyadoshich et al (36) used a column surrounded by an electromagnetic coil which produced a magnetic field of 350 Oersted and a super-paramagnetic cation exchanger 40-60 microns in diameter to obtain exchange rates 8 times faster than conventional sized resin. The method consisted

of contacting the water and resin in the column and "capturing" the resin by using its magnetic properties. No data were provided, however, concerning regeneration.

Poshkov (31) found that the exchange capacity of a cation resin could be increased 50% by applying a thin-layer ultrasonic field during regeneration. His findings were in agreement with Weiss et al that the high reaction kinetics of a fine particle ion exchange could be realized by agitating the resin. Weiss agitated using a mixer in batch operation and subsequently separated the resin from the liquid treated by flocculation and settling of the magnetized resin. All data collected were from batch experiments.

The concept of a "magnetic ion exchange resin" is not new. Blesing et al (6) were some of the first to consider the advantages offered by a magnetic ion exchange resin but considered this special type of resin to be too costly to manufacture at that time (1969). In 1971 Weiss et al (41) patented the first ion exchange process utilizing ion exchange resins with ferromagnetic properties. Weiss proposed encapsulating gamma iron oxide and barium ferrite, with weak acid and weak base ion exchange polymers. These encapsulated resin beads were less than 210 microns in diameter and exhibited increased reaction rates and more efficient resin utilization than did conventional sized resins (300-1200 microns) of the same chemical composition.

Weiss proposed that magnetized resin be mixed vigorously with the liquid to be treated and the resin subsequently magnetically, flocculated to remove it from the treated liquid. In 1973, the Commonwealth Scientific and Industrial Research Organization (12) applied for an Australian patent utilizing powdered iron oxide containing polymers as ion exchangers and filter aids. The emphasis in this patent, however, was on the use of the product as a filter aid. Svyadoshich et al used a "super-paramagnetic cation exchange resin" in a columnar operation in which, after mixing the resin and water, the resin was captured by the use of an electromagnetic coil. Svyadoshich found that a magnetic field of 350 Oersted was sufficient to capture the 40-60 micron diameter particles from water. No physical or chemical data were provided on the cation exchange resin, designated as KU-2-8-f. However, Svyadoshich did verify the findings of others regarding the increased exchange rates associated with fine mesh ion exchange resins in that he was able to treat water at a flow rate 8 times faster with KU-2-8-f than with conventional resins and still obtain the same exchange capacity.

## METHODS AND MATERIALS

Capsulated Systems, Inc., supplied the experimental strong acid magnetic resin used in these investigations as per specification. The resin, designated ATVA, was supplied in the form of a dry powder, 15 to 20 microns in diameter, and consisted of a barium ferrite core ( $\text{BaFe}_{12}\text{O}_{19}$ ) encapsulated within an ethylene-vinyl acetate (EVA) copolymer cross-linked approximately 25% with the 2,6 isomer of Toluene Diisocyanate Adduct (TDI). The average particle size of the barium ferrite (Ferro Ferrite #304/Ferr Corporation, Ottawa Chemical Division/ Toledo Ohio) was 1.8 microns as determined by a 5.1 gram sample in a Fisher sub-sieve. Average wall thickness of the resin was 7 to 8 microns. The EVA copolymer, an elastomer, is currently used to improve the adhesion properties of hot-melt and pressure sensitive adhesives. TDI is used in polyurethane foams, elastomers and coatings, and as a crosslinking agent for nylon 6. Agglomeration problems reported by Capsulated Systems, Inc. with styrene-divinylbenzene at particle sizes less than 500 microns necessitated the use of ATVA.

The ATVA required sulfonation, and initially, a conventional batch sulfonation procedure described by

Guccione (21) was used. In this method, the copolymer powder and sulfuric acid (95-98%) were charged into a 500 ml pyrex boiling flask with a thermometer well and the mixture slowly heated to 80-100°C at the start and to 130-150°C to finish the reaction. After one hour the copolymer was hydrated by stage washing of the resin, i.e., the concentrated acid was first drained from the powder and displaced countercurrently with successively lower concentrations of acid until finally the powder was washed with water. This method of sulfonation proved to be unsatisfactory in that severe agglomeration of the beads occurred, probably to ethylene vinyl acetate's susceptibility to heat.

Although not optimum, oleum, i.e. 120% fuming sulfuric acid was finally used as the sulfonating agent at room temperature. In this procedure, the copolymer was placed in a beaker with 20% Oleum, in an acid to powder weight ratio of 10:1 and allowed to sit for one hour. The oleum was drained from the powder and the copolymer stage washed with 60% fuming, 30% fuming, and finally deionized water until the wash water effluent was within one pH unit of the influent wash water pH. This was followed by stage washing with concentrated sulfuric acid, 80%  $H_2SO_4$ , 50%  $H_2SO_4$ , 20%  $H_2SO_4$ , and finally deionized water. The results of this sulfonation technique yielded a sulfonated copolymer powder of discrete particles which retained their magnetic properties.

This sulfonation technique yielded a low capacity strong acid resin, which proved optimum for these investigations due to the low "run" times required to breakthrough. The low capacity resin was found to be ideal for studying operating kinetic parameters and variable effects although it is obvious that such a resin would not be desirable for commercial application.

The resin was magnetized in the following manner. A magnetic field of 15,000 Gauss was produced by a laboratory magnetic with 15.0 cm diameter poles tapered to 5.0 cm faces. The resin was slurried into a 12 mm square channel (inside dimension), 380 mm in length and 3 mm in thickness, sealed at both ends with Sealastic. The channel and resin were exposed to the magnetic field for 5 minutes.

The experimental ion exchange columns used in this study are diagrammed schematically in Figures 2 and 3. The unit in Figure 2 consists of a chromatographic tube (Scientific Products, 38450-20), 400 mm in length and 20 mm in diameter (inside) with an adjustable liquid leveling device to collect treated water when operating in the downflow mode of operation and to maintain a desired liquid volume in the unit. Placed inside the entire column is approximately 0.013 ft<sup>3</sup> of (grade 1) medium grade, stainless-steel wool (Sala Magnetics, Cambridge, MA). A portion of the stainless steel wool was used as a structural matrix onto which 14 milliliters of ATVA was

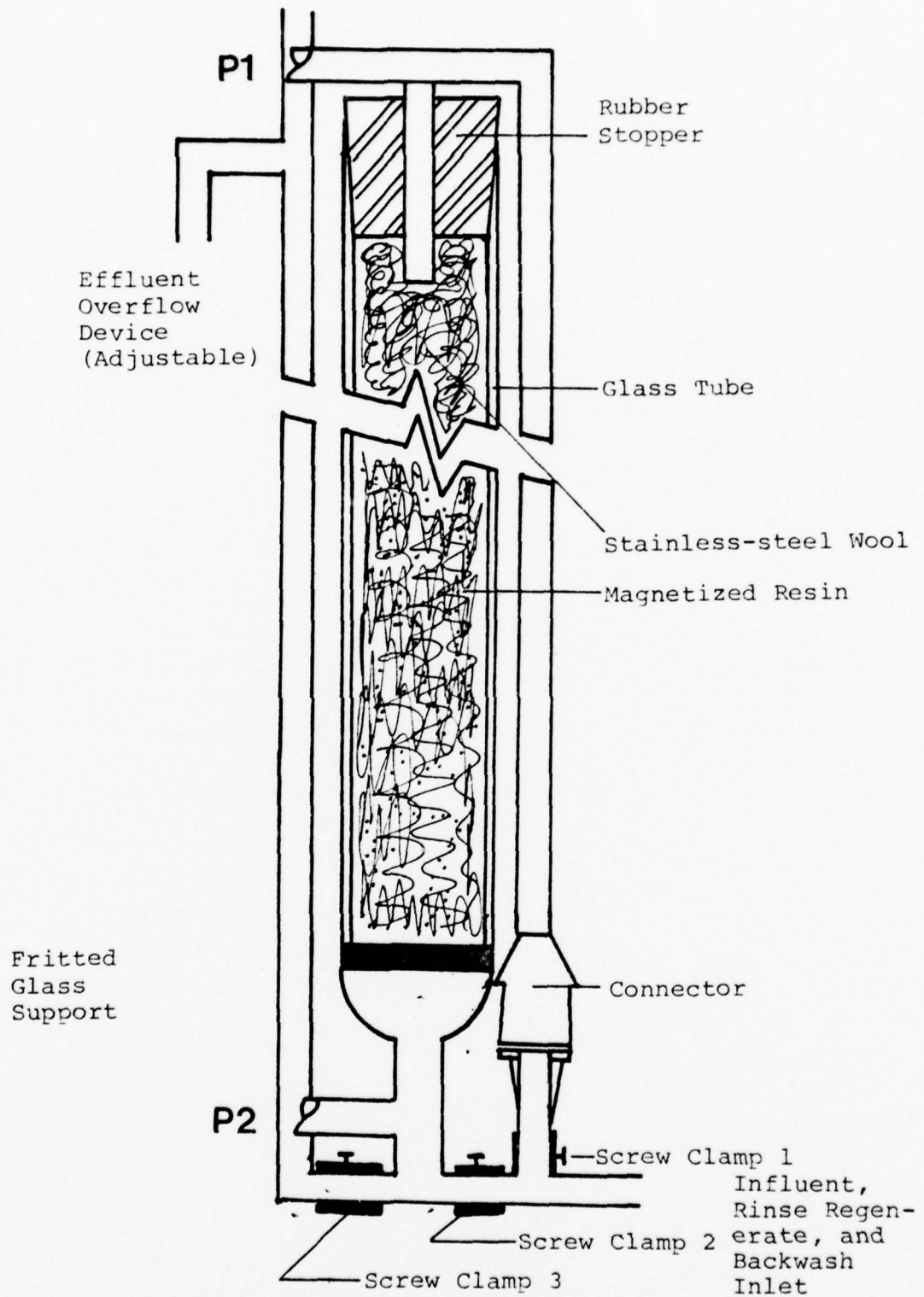

Figure 2. Experimental Ion Exchange System

allowed to magnetically attach itself, the remainder of the stainless-steel wool was to provide a tortuous path and fill space. Thus any resin particles dislodged during backwash or other operating mode could be captured by the extra wool. During the service and rinse cycles, influent was fed to the column via tygon tubing extending from a feed reservoir through a Masterflex peristaltic pump to the top of the exchange column. This was accomplished by closing screwclamp 2, while screwclamps 1 and 3 were left open. The predetermined resin hydraulic loading rate was accomplished by adjusting the Masterflex speed controller and measuring the effluent with a graduated cylinder and timer (GCA/Precision Scientific, 69230), until the desired flow rate was obtained. During backwash and regeneration, screwclamp 2 was opened, screwclamps 1 and 3 closed and connection A opened to serve as an effluent line and thus facilitate an upflow regeneration mode. A number 4 stopper containing a 6.4 mm O.D. glass, T-shaped connector was placed in the top of the column to serve as an inlet/outlet flow-through device from the column. Headloss through the column was measured by a mercury differential manometer connected to the system at sample points P1 and P2. This particular ion exchange set-up was used for all experimental studies involving ATVA. The system was operated at room temperature (20-24°C).

Studies on 200-400 mesh, i.e. (39-74 micron diameter) Dowex 50 W x 8, and 20-50 mesh Dowex 50 W x 10 were conducted

using the buret illustrated in Figure 3. For the 200-400 mesh studies, the service, rinse, backwash and regeneration cycles were all performed upflow using a sigmamotor peristaltic pump to maintain the low flow rates required, i.e. 1-2 mls/min. Studies on the 20-50 mesh resin were conducted using a burette cut-off at the 25 ml mark. A sigmamotor peristaltic pump was also used for these investigations. All cycles except backwashing were performed in a downflow mode for the 20-50 mesh resin.

The following method was used to pack the column with the stainless-steel wool and magnetized resin. Stainless-steel wool was shipped in a roll approximately  $\frac{1}{2}$  inch thick and 14 inches in width. A 2 inch wide by 4 inch long strip was cut, rolled into a cylinder and placed in the column. Approximately 2-3 mls of resin was slurried into the column (see Dow's Lab manual (1)) and allowed to attach itself to strands of the matrix. Another "cylinder" of wool was cut and placed in the column with 2-3 additional mls of resin being attached in the same manner. This procedure was followed until all of the resin, i.e., 14 mls, was in the column. The total bed length of resin plus matrix was 11 inches, and the remainder of the column was filled with the stainless-steel wool. Air was purged from the system by disconnecting the tubing at point A, closing screw clamp #2 and opening clamps 1 and 3. Operating the pump at a low speed allowed all air bubbles to escape at Point A.

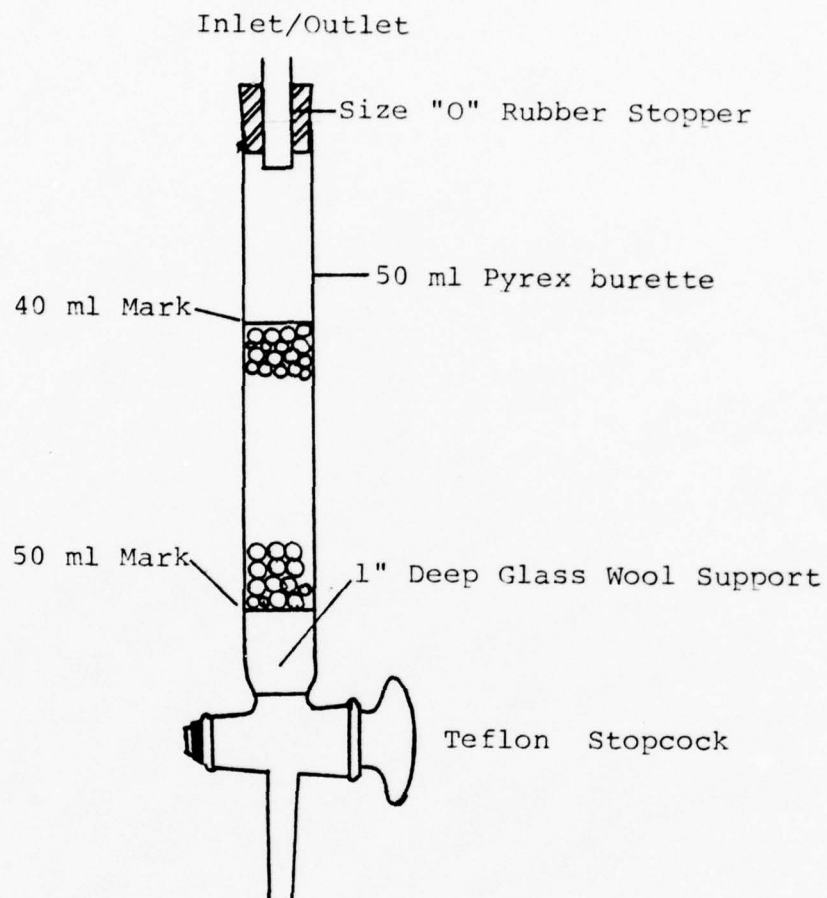

Figure 3. 50 ml Burette Ion Exchange Column

### Softening (Service Cycle) Procedure

The ion exchange column was exhausted with synthetic hardwater, containing 390 mg/l of total hardness as  $\text{CaCO}_3$  (260 mg/l Calcium hardness and 120 mg/l magnesium hardness, both as  $\text{CaCO}_3$ ) at flow rates that varied from 10 to 18 gpm/ft<sup>3</sup>.

Effluent from the column was collected in 50 ml, (smaller if appropriate) aliquots and analyzed for total hardness by the EDTA Titrimetric Method (35) as follows: a 50 ml (or aliquot) volume of sample was adjusted to a pH of approximately 10.0 by addition of 2 mls of hardness buffer. About 0.2 grams of total hardness indicator were added and the solution adequately mixed. The presence of a blue-black color indicated that no hardness was present in the sample while a "wine red" color indicated the presence of hardness. The sample was titrated to the blue-black color with a chelating solution of disodium ethylenedinitrilotetraacetate (EDTA) at a concentration of 0.1 mg  $\text{CaCO}_3$  per ml of titrant standardized with a standard calcium solution. Total hardness for a given sample in mg/l as  $\text{CaCO}_3$  was determined by the following mg/l hardness calculation:

$$\text{CaCO}_3 = \frac{(\text{ml EDTA})(1000)}{\text{ml sample}}$$

Prior to the service cycle, the column was rinsed with deionized water in a downflow mode at 1 gpm/ft<sup>3</sup> slow

rinse and 3 gpm/ft<sup>3</sup> fast rinse until no hardness was detectable in the rinse water effluent.

The volume occupied by all tubing and void spaces in the column was determined to be 114 mls. To insure that capacity determinations did not include the deionized rinse water remaining in the system; this amount was collected and discarded prior to collection of treated aliquots.

The service cycle was terminated when a breakthrough hardness of 17 mg/l (1 grain/gallon) was reached.

#### Regeneration Cycle

The column was regenerated in an upflow mode at various flow rates, from 0.4 to 6.4 gpm/ft<sup>3</sup>. Sodium chloride (NaCl) was used as the regenerate and was used in concentrations from 1% to 20% by wt. of NaCl. Regenerant loadings also varied from 4 to 24 lbs of NaCl/ft<sup>3</sup> of resin. Prior to regeneration, the column was backwashed at 10.5 gpm/ft<sup>3</sup> with 500 mls of deionized water to remove any insoluble matter which may have accumulated in the bed and to disperse any clumps of resin that may have agglomerated during the service cycle. Significant packing was not noted even at service flow rates as high as 18 gpm/ft<sup>3</sup>.

## RESULTS AND DISCUSSION

### Resin Development

Barium feritte was chosen as the magnetic core over elemental iron. Barium feritte exhibits ceramic properties and is therefore highly resistant to acids and bases whereas the corrosive tendencies of iron to these materials is very great (especially to dilute acids). Barium feritte, at \$0.29 per pound, also offers extensive cost savings over elemental iron at \$35.00/per pound. And finally barium feritte exhibits magnetic properties that are more suitable for this type of application, e.g., it has a magnetizing force of 1800 Oersteds (highest except for Platinum Cobalt @ 4,300 and Silmanol @ 6,000 Oersteds) and exhibits a high degree of resistance to self-demagnetization. The barium feritte used was a specially formulated and ground grade that made for easy incorporation into polymeric materials.

The experimental resin chosen to encapsulate the barium feritte was an ethylene vinyl acetate copolymer cross-linked to a level of 25% with toluene diisocyanate adduct. Assuming that after sulfonation, one sulfonic acid group in the sodium form was attached to each benzene ring, the maximum theoretical capacity of the resin was calculated

to be 1.25 meq/g of dry resin, assuming 100% sulfonation. This resin was chosen not for its exchange capacity but for its ease of encapsulation.

#### System Development

Stainless steel wool was chosen as the matrix material. It was found resistant to both dilute and concentrated sodium chloride solutions, but easily attacked by dilute acids. For this reason, no attempts were made to run the system in the hydrogen cycle. If the resin is to be regenerated in the hydrogen form, it will be first necessary to either select a more resistance matrix exhibiting paramagnetic properties or provide a suitable protective coating for the stainless steel wool.

The objective of the System Development phase of the research was to construct a bench scale ion exchange system utilizing the fine mesh magnetic resin evolved in the Resin Development phase. Before the system could be evaluated certain design parameters had to be determined, and questions answered:

1. Was it necessary to provide a homogeneous magnetic field that saturates the entire matrix, and if so what magnetic field strength was required?
2. If an homogeneous field was required, should it be an external one and should it be applied via electro or permanent magnets.

3. Should an internal homogeneous magnetic field be best it then had to be determined if it was feasible to magnetize the resin and utilize the high intrinsic force of the barium ferrite core to fix each resin bead to the strands of the matrix.

The first questions were evaluated by an experiment using a laboratory magnet with 150 cm diameter poles tapered to 5.0 cm faces. Flow of a water slurry containing unmagnetized ATVA was through a clear plastic tube mounted perpendicular to the magnet with a thin nickle wire mounted horizontally (into the paper) inside the tube as shown in Figure 4. This wire was intended to function as a simplified version of the stainless-steel wool matrix proposed as the support in later work. Rate of slurry flow was controlled by using a constant pressure head and orifice at the outlet of the tubing. Flow rate was calculated from measured velocities and the cross-sectional area of the flow path. In the experiment the rate of ATVA deposition on the ferromagnetic wire was monitored. Note that a window was mounted to the front of the tube to allow photography of the wire without distortion.

Results of the experiment indicated that a force of 300-500 Oersteds was required to attach the resin onto the nickle wire and that the ATVA particles would remain fixed to the wire at flow velocities up to 1.0 cm/sec. When the ATVA attached itself to the nickel wire it formed

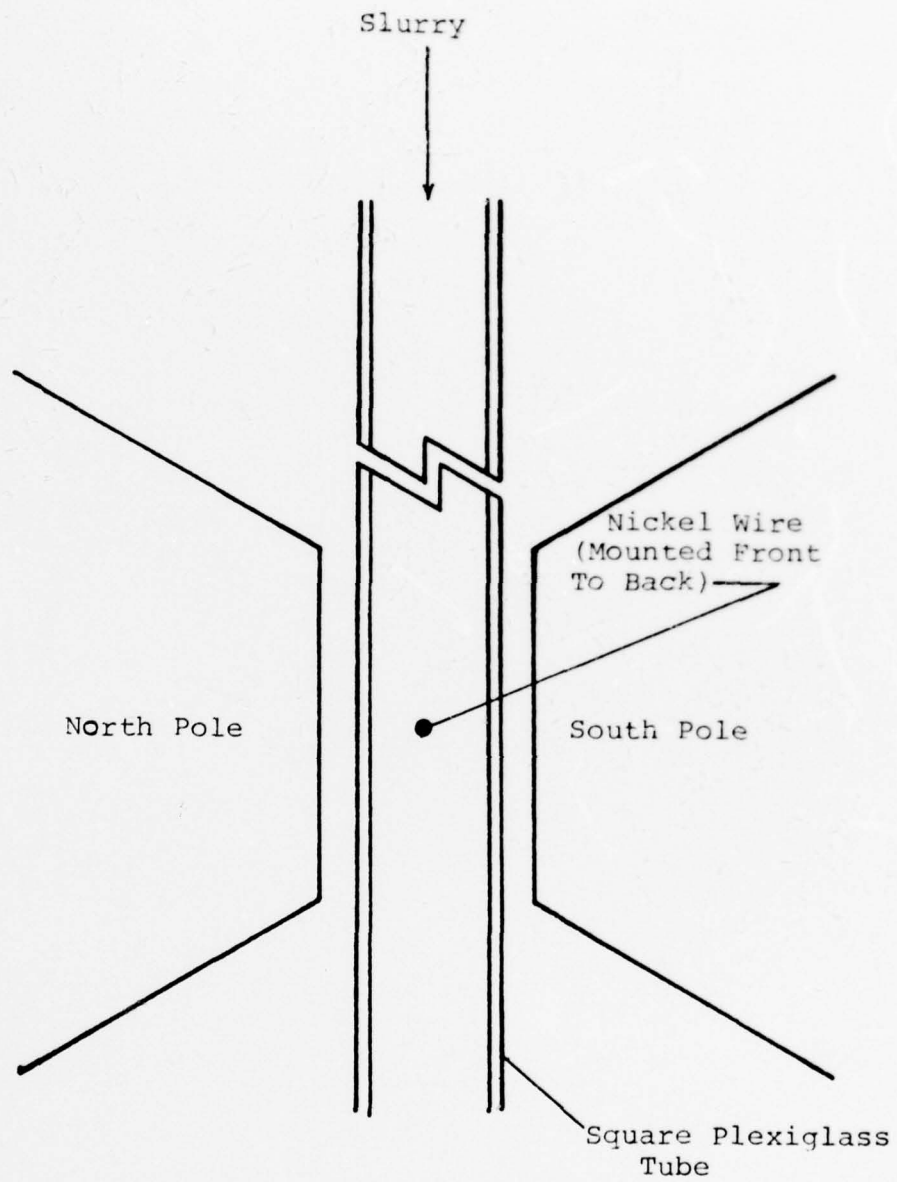
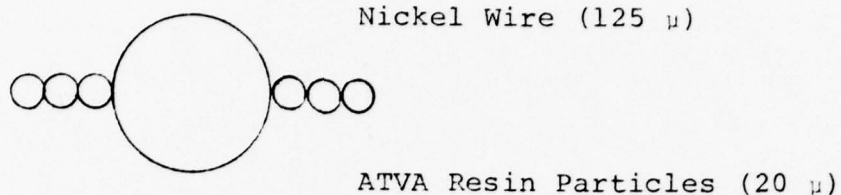

Figure 4. Schematic of Laboratory Magnet

chains as schematically shown below, which oscillated like cilia in the water stream.



The value of 300 Oersteds corresponds to those numbers reported by Szyadoschich et al (36) who stated that 350 Oersted was sufficient to remove 40  $\mu$  paramagnetic materials from a water stream at 40-60 specific volumes/hour, i.e. 5.3 - 8.0 l/min (5.0 - 7.5 gpm/ft<sup>3</sup>).

The results of these experiments provided an answer to the first question but raised another, i.e., is the stainless steel wool matrix really required? Since the magnetized ATVA would form chains, essentially ion exchange fibers, but with more surface area available than a conventional fiber of the same dimensions, would it not be possible to utilize the magnetized resin alone in a column operation. As a result of the nickel wire study, the following column configurations were considered:

1. A column configuration in which stainless steel wool filled the column and a magnetic field of -300-500 Oersted was generated by an electromagnetic coil.
2. A column configuration in which the magnetic field was generated by permanent magnets, mounted

externally on the column which was also filled with stainless steel wool.

3. A column configuration in which no matrix was utilized but the resin magnetized prior to its loading into the column. Due to the high intrinsic coercive force of barium ferrite, magnetization of the resin would result in the formation of "chains" of particles. An upflow mode of operation through the column would minimize headloss and any particles "carried away" in the fluid stream would be retained in the column by permanent magnets placed near the effluent end of the column.
4. A column configuration in which the resin was pre-magnetized and fixed to the matrix. Since the barium ferrite core was ferromagnetic, once magnetized the resin beads would essentially act as tiny magnets and remain magnetically fixed to the matrix without the aid of an external magnetic field.

Of the configurations considered, those requiring external magnets were immediately dropped from consideration even prior to the laboratory studies for the following reasons: If external magnets were to be utilized, the maximum gap between magnets, which corresponds to the column diameter, necessary to maintain the field intensity required, would be limited to  $1\frac{1}{2}$ ", independent of whether permanent or electromagnets were used. A  $1\frac{1}{2}$  inch diameter full scale ion

exchange column would have only limited application, if any. Also, if an electromagnetic field were used to fix the magnetic resin to the matrix, a power failure could conceivably cause the entire resin bed to be lost.

Permanent magnets were therefore judged to be preferable to electromagnets. However, since a ferromagnetic core was selected, once magnetized, the ion exchange resin would act like tiny magnets, retain its magnetism, and remain attached, thus precluding the use of external magnets.

Having dropped configurations 1 and 2 for the stated reasons, the next configuration considered was a bed consisting only of a magnetized resin with no matrix. Preliminary column studies were conducted using 60 mls of ATVA magnetized by a laboratory magnet in a field of 10 kgauss. The resin was regenerated in an upflow mode with 25% NaCl at a flow rate of 0.5 gpm. Salt loading was 30 lb/ft<sup>3</sup> of resin and service flow rate was 1 gpm/ft<sup>3</sup>, also in an upflow mode. A breakthrough capacity, with breakthrough being defined as 1 grain/gal of hardness as CaCO<sub>3</sub> in the column effluent of 2.5 kgr/ft<sup>3</sup> and a total capacity of 4.5 kgr/ft<sup>3</sup> were obtained. The exhausting water was a synthetic feed containing 320 mg/l of Ca<sup>++</sup> as CaCO<sub>3</sub>. The following observations were made during the experiment. The high pressure drop encountered operating a column in a downflow mode with an unmagnetized small mesh resin was also encountered with the magnetized resin used

in these studies. As a means of overcoming the pressure drop limitation it was decided that further work would all be done in an upflow mode. The magnetized ATVA did form chains and exhibited flocculating characteristics similar to those reported by Weiss et al (41), i.e., significantly faster settling rates than non-magnetized particles of the same size. When the incipient fluidization velocity should have been reached, channeling instead of fluidization occurred. This severe channeling limited regeneration and service flow rates and thus precluded obtaining the degree of agitation required to decrease film diffusion. Finally, the entire resin bed would rise in the column as a slug after the bed had settled, in a manner similar to that experienced when air is trapped in the column, yet no air was present during the studies.

It was decided to forgo additional column studies using magnetized ATVA alone, i.e., no matrix, until preliminary work involving magnetized resin attached to a stainless-steel wool matrix had been conducted. It was subsequently determined that no further studies of the magnetized ATVA alone were necessary since the problems encountered in this configuration were eliminated by the addition of the matrix.

In summary, it was established that the most effective column configuration was one in which a stainless-steel wool matrix was used in conjunction with premagnetized

ATVA. Each resin bead acted like a  $-20 \mu$  diameter permanent magnet. The value of 300 Oersteds reported in the literature was confirmed as being sufficient to hold the resin to the matrix at flow rates less than  $15 \text{ gpm/ft}^2$ . By going to this configuration, channeling was essentially eliminated and there was no tendency for the resin bed to behave in a pulsating plug fashion as it did without the matrix.

Having established what seemed to be the optimum column configuration it was then possible to proceed with testing to establish the hydraulic and kinetic parameters which would govern the dynamic operation of the conceived ion exchange system.

### System Evaluation

#### Hydraulic Considerations

The term System to be used in the remainder of this dissertation refers to the ion exchange System described in Figure 2 of the Methods and Materials Section.

The initial experiment in this series sought to compare the pressure drop measured through the experimental column with values usually encountered in commercial ion exchange systems. Data from a Dow Chemical Company publication (1) on the effects of flow rate ( $\text{gpm/ft}^2$ ) versus pressure drop ( $\text{psi/ft}$  of resin bed) in columnar operation for a 850-300 micron and 300-150 micron sized styrene divinylbenzene resin were compared with ATVA (15-20 micron diameter). The results of the comparison are shown in Figure 5.

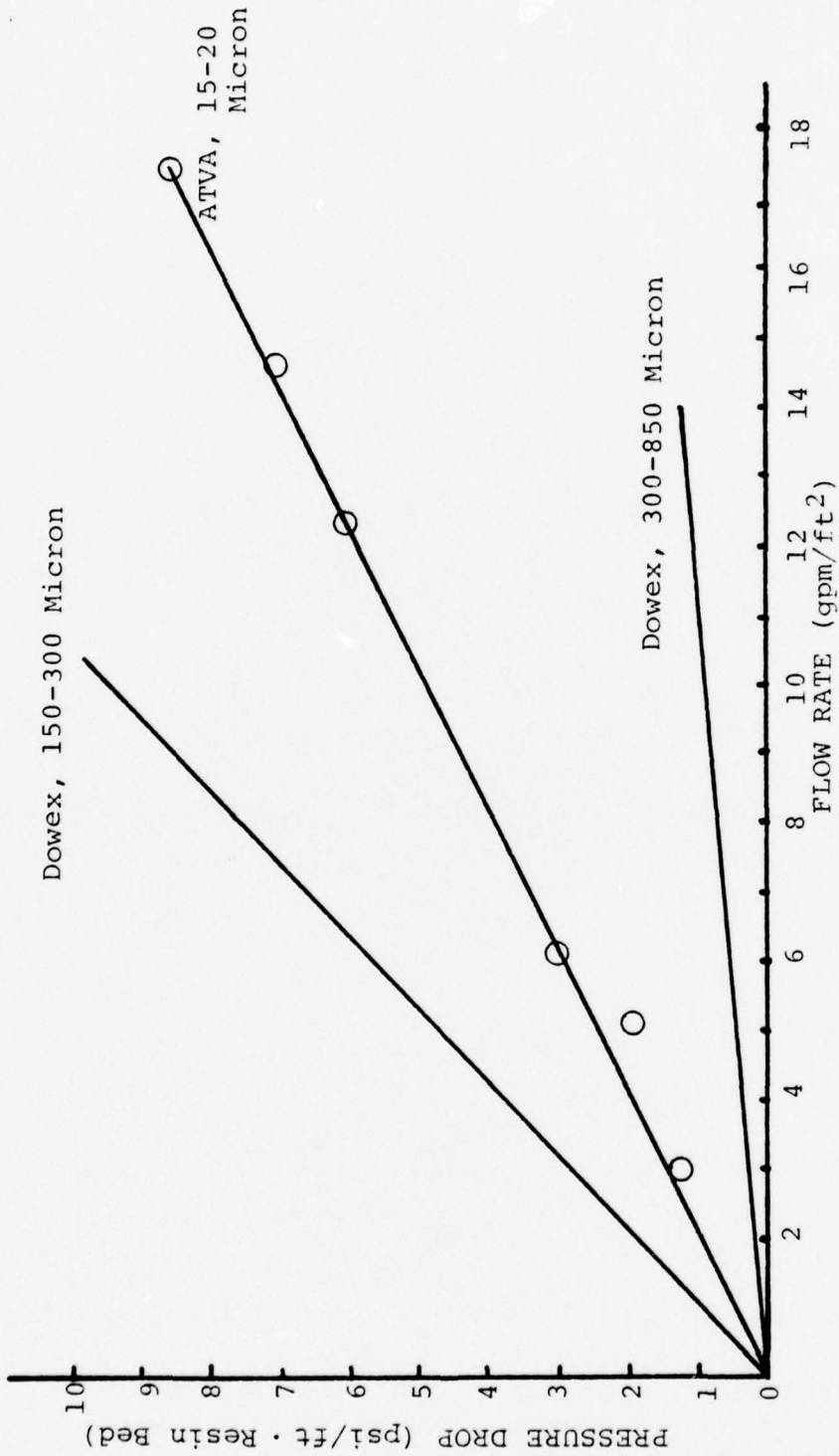

Figure 5. Pressure Drop Characteristics at Various Flow Rates

Resistance to the flow of a fluid through the voids in a packed bed is the sum of the total drag of all the particles in the bed. Under conditions of constant temperature and flow rate, this resistance to flow, or pressure drop, is a function of the particle size and the porosity (the ratio of the volume of voids to the total bed volume). Theoretically, the pressure drop through a packed bed can be decreased by maintaining a high void volume through the bed. This was accomplished in the System by using a matrix of which 95-98% was void space.

The pressure drop values shown in Figure 5 are higher than would normally be expected because the magnetic resin was not homogeneously distributed throughout the stainless-steel wool, thus causing the resin material to clump in some areas of the bed.

The column was backwashed in an upflow mode at various rates to determine the amount of flow needed to cause dislodgement of the resin from the matrix. For micropowder sized unmagnetized resin, a backwash rate of  $1 \text{ gpm/ft}^2$  was sufficient to carry the entire contents of the column out through the top. For this system, there was essentially no visual dislodgement of resin from the matrix at flow rates up to  $10 \text{ gpm/ft}^3$ . When flow reached 11-15  $\text{gpm/ft}^3$ , the resin dislodged but reattached itself to another section of the resin. At  $17 \text{ gpm/ft}^3$ , the magnetic resin would be dislodged and carried out of the column if not restricted.

## Operational Considerations

Countercurrent regeneration gave operating capacities twice as high as cocurrent regeneration and a flow scheme of upflow regeneration and down-flow exchange was adopted and used throughout the study.

An important factor in determining the extent to which a resin has been converted to the proper ionic form is the amount of salt used per volume of resin. However, for this particular resin with its low theoretical and operating capacity, the amount of salt required per Kgr of hardness removed was very high, as seen in Table 2.

Table 2  
Salt Dosage vs. Capacity

lbs NaCl per cu. ft.	Capacity Kgr/cu. ft.	lbs. salt per Kgr removed
4	0.72	5.56
8	1.00	8.00
12	1.01	11.88
24	1.57	15.29

Note that the capacities obtained are not ideal, e.g., by increasing the regeneration flow rate and increasing the softening flow rate, the capacity at 4 lbs of NaCl/ft<sup>3</sup> was increased to 1.96 Kgr/ft<sup>3</sup>, yielding a value of 2.04 lbs/Kgr of hardness removed. It can be recognized from the data in Table 2 that the polymer chosen for the

microencapsulation of the ion exchange material used to prove the feasibility of the System derived in these studies was not optimum. This fact is emphasized since it is felt that some doubts about the applicability of the evolved System could exist in a person's mind as a result of the low resin capacity.

#### Effect of Particle Size

In that non-magnetic ATVA in a particle size of 20-50 mesh was not available to evaluate the effects of particle size on breakthrough capacity, a comparison was made by using strong-acid resins obtained from the Dow Chemical Company. A 200-400 mesh Dowex 50 x 8 resin was compared to 20-50 mesh Dowex 50 x 10 in a burette study. Salt loading and concentration were maintained at 4 lbs/ft<sup>3</sup> and 10% for both resin sizes. The 20-50 mesh resin was operated in the downflow mode and the 200-400 mesh in the upflow mode. Breakthrough capacity at a softening rate of 1.5 gpm/ft<sup>3</sup> was 2.7 Kgr/ft<sup>3</sup> for the 20-50 mesh Dowex and 4.6 Kgr/ft<sup>3</sup> for the 200-400 mesh Dowex. An earlier burette comparison in which both resins were regenerated at 30 lbs/ft<sup>3</sup>, with 20% NaCl at 0.4  $\frac{\text{gpm}}{\text{ft}^3}$  and both operated in the downflow mode at 0.5 gpm/ft<sup>3</sup> gave operating breakthrough capacities of 57 Kgr/ft<sup>3</sup> for the 200-400 mesh and 24 Kgr/ft<sup>3</sup> for the 20-50 mesh resin. These numbers are in agreement with those reported in the early literature, e.g., Kunin (25) noted a 57% increase in softening operating capacity

when he compared a 200 micron sized resin with an 800 micron size resin. Kunin and Myers (25), Samuelson (33), and Kunin and Barry reported similar results.

#### Effect of Regenerant (Brine Concentration)

The effects of regenerant concentration on operating capacity for ATVA and Dowex 50 x 8 200-400 mesh resin are shown in Figures 6 and 7. For the Dowex resin, the highest operating capacity was obtained when the regenerant brine concentration was 1% (all other factors being equal). For the ATVA, on the other hand a 10% brine appeared to be optimum.

Optimum regenerant conditions vary with both the particular resin and the ion exchange process, e.g., in water softening, brine concentrations ranging from 8 to 16% are generally used. Dow publication (1) reports 8% as optimum for their strong-acid resins when a 30 minute contact time is used while a Duolite publication (17) reports 12% to be optimum (contact time is not given).

The effect of using higher or lower brine concentrations is directly related to the degree of resin crosslinking. For conventional sized resins, as the brine approaches saturation, it causes shrinkage of the resin, thereby inhibiting the migration of ions both into and out of the solid phase. At brine strengths below the optimum range, fewer sodium ions are available at any one time to displace hardness ions, and regeneration becomes less efficient.

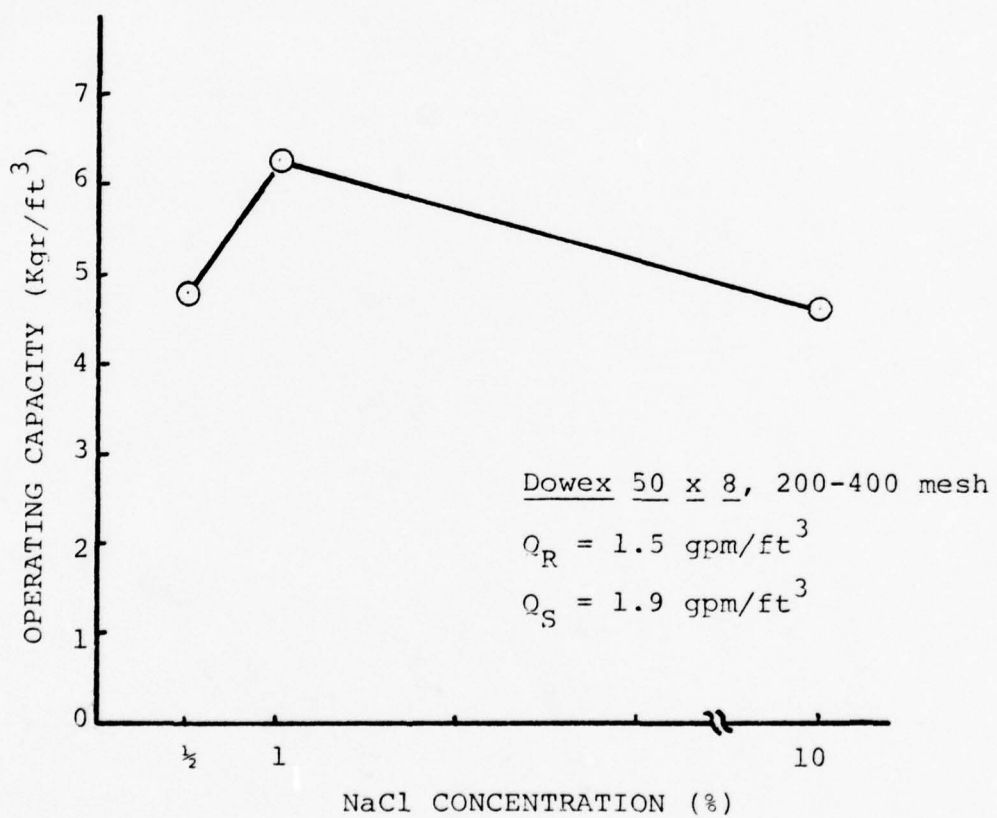

Figure 6. Capacity vs Brine Concentration, Dowex 50W x 8, 200-400 mesh

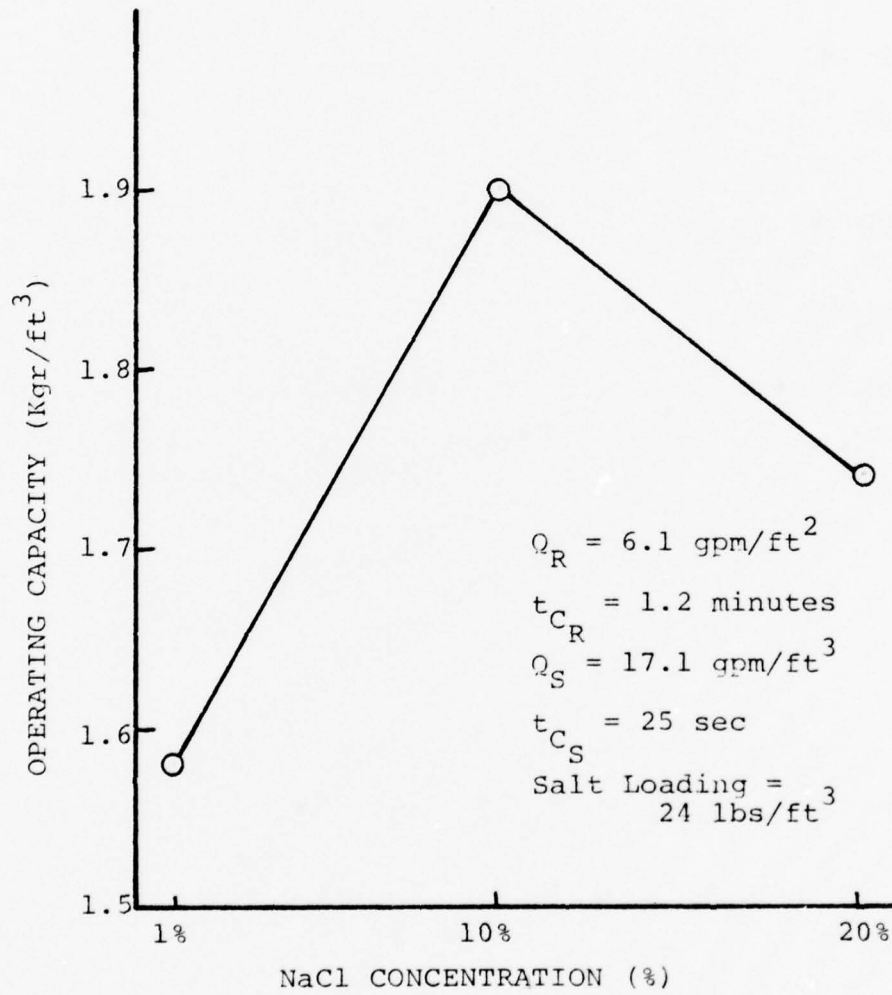

Figure 7. Capacity vs Brine Capacity, ATVA

The differences in the optimum brine concentration for the Dowex and ATVA can be attributed exclusively to the different degree of resin crosslinking, i.e., Dowex 8 percent crosslinked and the ATVA, 25 percent crosslinked, which in turn affects the selectivity of the resin for a particular ion. In general, a resin's selectivity for a particular ion increases as the percent of crosslinking increases. Therefore, ATVA with its 25% crosslinking may have such a high affinity for either calcium or magnesium that a higher concentration of regenerant is needed to displace the ion, whereas the Dowex resin, with its 8% crosslinking offers easy displacement by a lower brine concentration.

#### Effect of Regeneration Contact Time

For maximum efficiency in regenerating most commercial ion exchange systems containing 20-50 mesh styrene divinyl benzene strong-acid resins, brine contact time, i.e., residence time or time the brine is in contact with the resin, should be 50 minutes. However, in most cases, a good "rule of thumb" is 30 minutes. At brine contact times less than 10 minutes, operating capacity of the resin is decreased about 30% and if brine contact time is less than 5 minutes, capacity will be decreased over 50%.

A review of the literature showed that the amount of regenerate required to maintain a given capacity could be substantially reduced by going to a smaller resin (15);

however, there were no data (other than resin manufacturer's literature) to date on the effects of contact time and regeneration flow rates on operating capacity. Resin manufacturers (1,16,17) recommend regeneration flow rates be maintained at 0.2 to 1.0 gpm/ft<sup>3</sup>, noting that lower capacities will result if flow deviates significantly from this range.

In an attempt to better understand the effect of regenerate flow rate and contact time on operating capacity, a number of runs were made in which the only parameter varied was regenerate flow rate ( $Q_R$ ). A summary of these data is shown in Table 3.

The data seem to indicate an inconsistency over results reported by the resin manufacturers; however, an in-depth evaluation of the data shows that there really are no inconsistencies. In this System, in which fine mesh resin particles are 25% crosslinked and ionic sites are on the surface of the resin, film diffusion is limiting. The "thickness" so to speak, of the imaginary Nernst film surrounding each resin particle can only be decreased by agitation at a given solution concentration [see Kressman and Kitehaner (22)]. For fine mesh resins, in which ionic sites to be regenerated are mostly on the surface, it is agitation which governs the degree of regeneration efficiency and not contact time as in the particle diffusion controlled macroporous ion exchange resins. One might argue that for

Table 3  
The Effect of Regeneration Flow Rate  
on Breakthrough Capacity

$Q_R$ (gpm/ft <sup>3</sup> )	$t_{C_R}$ (min)	$Q_S$ (gpm/ft <sup>3</sup> )	$t_{C_S}$ (min)	$X_{B_T}$ (Kgr/ft <sup>3</sup> )
0.42 <sup>a</sup>	18.4	1.2	6.6	1.19
0.83 <sup>a</sup>	9.2	1.2	6.6	1.44
6.43 <sup>a</sup>	1.2	17.7	0.4	1.72
1.65 <sup>b</sup>	4.6	1.2	6.6	1.00
6.4 <sup>b,1</sup>	1.2	1.2	6.6	1.58

<sup>a</sup>brine loading = 4 lbs NaCl/ft<sup>3</sup>

<sup>b</sup>brine loading = 8 lbs NaCl/ft<sup>3</sup>

<sup>1</sup>20% brine, all others at 10%

LEGEND:

$Q_R$  - Regen Flow Rate

$t_{C_R}$  - Regen Contact Time

$Q_S$  - Service Flow Rate

$t_{C_S}$  - Service Contact Time

$X_{B_T}$  - Breakthrough Capacity  
17 mg/l (1.0 grain/gallon)

the run in which the resin was regenerated at 8 lbs/ft<sup>3</sup>, the regenerate concentration was 20% and was responsible for the increase in operating capacity. However, data on previous runs had shown that under the same conditions, when a brine concentration of 20% was used, the operating capacity decreased. Thus, the 50% increase shown in Table 3 was in fact a worst case.

In the past, it was not possible to attain the high flow rates used in this column investigation because of the hydraulic limitations of the small resin. All batch studies, however, in which the resin was agitated or mixed produced data agreeing with what was found in these studies (34,41).

#### Effect of Service Cycle Contact Time

With bed depths of 30 inches or more, capacities obtained with conventional resins are decreased about 10% when flow rates reach 10 gpm/ft<sup>3</sup> (contact time of about 2 minutes) and fall significantly with increasing flow. Decreasing bed depth while maintaining a constant flow rate has essentially the same effect. Therefore, for most purposes, steady flow rates in the range of 2 to 5 gpm/ft<sup>3</sup> (contact times of 7.5 to 3.75 minutes) are recommended. With these numbers as a guide, experiments were performed to determine the exchange rate limitations of the system. Service cycle flow rates ranging from 1.2 to 18.2 gpm/ft<sup>3</sup> with corresponding contact times of 6.6 minutes to 25 seconds were tried,

the following results were obtained. For a salt loading of 4 lbs per ft<sup>3</sup>, salt concentration of 10% and a regenerate loading of 0.83 gpm/ft<sup>3</sup> the following capacities were obtained at a service flow rate of 1.2 gpm/ft<sup>3</sup> ( $t_{CS} = 6.6$  minutes) were 1.04 Kgr/ft<sup>3</sup>, 1.84 Kgr/ft<sup>3</sup>, 1.94 Kgr/ft<sup>3</sup> for an average of 1.61 Kgr/ft<sup>3</sup>. When the service flow rate was increased to 18.2 gpm/ft<sup>3</sup>,  $t_{CS} = 25$  seconds, capacities of 1.72 and 1.73, an average of 1.725 Kgr/ft<sup>3</sup> were obtained, a 7% increase in capacity. At a 24 lb/ft<sup>3</sup> salt loading, 10% salt concentration, and 6.4 gpm/ft<sup>3</sup> regenerate flow rate, breakthrough capacity at 1.2 gpm/ft<sup>3</sup> ( $t_C = 6.6$  min) was 1.57 Kgr/ft<sup>3</sup> while at 18.2 gpm/ft<sup>3</sup> ( $t_C = 25$  sec), capacities of 1.90, 1.58 and 1.74 Kgr/ft<sup>3</sup> were obtained for an average of 1.74 Kgr/ft<sup>3</sup> or an 11% increase in capacity. The data suggest that again the limiting factor is the Nernst film, and that rate of exchange is a function of the agitation necessary to decrease the Nernst film since exchange itself is instantaneous and that the limiting flow rate was not reached; however the pumping capacity of the experimental system was reached. These data are in complete agreement with Schultz's equilibrium times for Amberlite<sup>R</sup> IRF-66M (R-Na<sup>+</sup>), particle size < 44  $\mu$  of 11.4 seconds, since a limiting exchange rate had apparently not been reached in the system with a 25 second contact time.

## SUMMARY AND CONCLUSIONS

Summary

Fine mesh resins, i.e., those 15-20 microns in diameter, offer exchange rates 15 times faster than conventional sized resins in addition to more efficient resin capacity utilization. However, fine mesh resins are not used commercially because of hydraulic considerations, i.e., they cause excessive pressure drops and are extremely difficult to back wash, in that they are easily carried out of the ion exchange column in the backwash cycle.

The objective of this research was to develop a method for using fine mesh resins in columnar operation. The basic concept concerned the use of a magnetic field to hold fine mesh resins possessing magnetic properties onto a stainless-steel wool matrix. Attaching the resin to a matrix solved the pressure drop problem normally associated with fine mesh resins by providing a high void volume and also prevented it from being carried out during the backwash cycle.

A magnetic resin was developed by microencapsulating a barium ferritte core, 2 microns in diameter with an experimental ion exchange polymer. The particular polymer was chosen, not for its exchange capacity, but for its ease of encapsulation.

The columnar ion exchange system developed consisted of a column loosely filled with a stainless-steel wool matrix (90-95% void volume), on to which the magnetic resin was held. The magnetic resin was premagnetized in a field of 15,000 Gauss and allowed to attach itself to the matrix by a method developed in the investigation. By maintaining a high volume throughout the bed, pressure drop was maintained at acceptable values, i.e., 9 psi/ft of column bed at a flow rate of 18 gpm/ft<sup>3</sup>. The pressure drop in a column using nonmagnetic ion exchange resin of the size was almost 1000 psi/foot of bed.

Performance of the system was evaluated by monitoring variations in breakthrough capacity as regeneration flow rates and contact times, and softening flow rates and contact times were varied. Sodium chloride was used to regenerate the column in an upflow mode, countercurrent to the service cycle. A synthetic hard water containing 260 mg/l Ca<sup>++</sup> as CaCO<sub>3</sub> and 130 mg/l of Mg<sup>++</sup> as CaCO<sub>3</sub> was used as feed.

For a given regenerate loading and concentration, results showed that regeneration contact times under 5 minutes and regeneration flow rates over 6 gpm/ft<sup>3</sup> were not only possible but gave significant increases in operating capacity. The results were in agreement with data reported in the literature from batch studies. For fine mesh resins, in which the ionic sites to be regenerated are mostly on the

surface, it is agitation and not contact item which governs the degree of regeneration efficiency. It was also determined that softening flow rates over  $18 \text{ gpm/ft}^3$  and contact times less than 25 seconds were possible without decreasing the operating capacity of the system, as again the limiting factor was not contact time but achieving the agitation necessary.

### Conclusions

These investigations have demonstrated the feasibility of using fine mesh magnetic ion exchange resins in a columnar mode. Premagnetizing the resin in a field of 10,000-15,000 Gauss, enabled each resin bead to act as a tiny magnet and remain fixed to the stainless-steel wool matrix, without the use of external magnets while maintaining a bed porosity of about 80%. The following conclusions were made concerning this new ion exchange System.

1. Fine mesh, i.e., 15-20 micron magnetic ion exchange resin can be used in a columnar mode.
2. Acceptable pressure drop through the system using fine mesh resin can be realized by maintaining a high void volume.
3. The magnetic resin does not have to be homogeneously dispersed throughout the column to function.
4. The fine mesh particles will remain magnetically fixed to the column up to backwash flow rates of  $17 \text{ gpm/ft}^3$  (velocity = 2.2 ft/min).

5. Chemically efficient regeneration contact times of less than 5 minutes are possible with this system.
6. Service cycle contact times of 25 seconds or or flow rates up to 18 gpm/ft<sup>3</sup> had no deleterious effect on resin operating capacity.
7. The degree of agitation necessary to decrease the Nernst film and not contact time is the limiting factor in the use of fine mesh resin.

**LIST OF REFERENCES**

## LIST OF REFERENCES

1. A Laboratory Manual on Ion Exchange, Dow Chemical Company (1971)
2. Adams, B. A., and Holmes, E. L., Journal of the Society of Chemistry in Industry, London, V. 54 T, P. 1 (1935)
3. Adamson, A. W., and Myers, L. S., "The Exchange Adsorption of Ions from Solution by Organic Zeolites; II Kinetics," Journal of the American Chemical Society, V. 69, P. 2836 (1947)
4. Arden, T. V., Water Purification by Ion Exchange, Plenum Press, New York, (1968)
5. Bauman, W. C., and Eichhorn, J., Journal of the American Chemical Society, V. 69, P. 2830 (1947)
6. Blesing, N. V. et al, "Some Ion Exchange Processes for Partial Demineralization," Conference on Ion Exchange, London, (1969)
7. Boyd, G. E., Adamson, A. W., and Myers, L. S., Journal of the American Chemical Society, V. 69, P. 2840 (1947)
8. Boyd, G. E., Myers, L. S., Jr., and Adamson, A. W., Journal of the American Chemical Society, V. 69, P. 2854 (1947)
9. Boyd, G. E., Schubert, J., and Adamson, A. W., Journal of the American Chemical Society, V. 59, P. 2818 (1947)
10. Calmon, C., and Kressman, T. R. E., Ion Exchangers in Organic and Biochemistry, Interscience Publishers, Inc., New York, (1957)
11. Cernescu, N., Anvar. Inst. Geol. Romaniei, V. 16, P. 777-859 (1931)
12. Commonwealth Scientific and Industrial Research Organization, ICI Australia Ltd. British Patent 1,416,004 (Dec 1975)
13. D'Alelio, G. F., U.S. Patent 2,366,007 (1944)

14. DeLatour, C., and Kolm, H. H., "High-Gradient Magnetic Separation A Water-Treatment Alternative," Journal of the American Water Works Association, P. 325-327, June 1976
15. Djurfeldt, R., and Samuelson, O., Acta Chem. Scand., V. 4, P. 165 (1950)
16. Dowex: Ion Exchange, The Dow Chemical Company, Midland, Michigan (1959)
17. Duolite Data Bulletin No. 24, Diamond Alkali Company, (January 1966)
18. Exodus 15: 23-25
19. Gans, R., German Patents 174,097 and 197,111 (1906)
20. Guccione, E., Chemical Engineering, 73, 138 (April, 1963)
21. Harm, F., and Rumpler, A., 5th International Congress of Pure and Applied Chemistry, V. 59 (1903)
22. Kressman, T. R. E., and Kitchener, J. A., Discussions Faraday Society, V. 7, P. 90 (1949)
23. Kunin, R., and Barry, R. E., Industrial Engineering Chemistry, V. 41, P. 1269 (1949)
24. Kunin, R., and Myers, R. J., "The Anion Exchange Equilibria in an Anion Exchange Resin," Journal of the American Chemical Society, V. 69, P. 2874 (1947)
25. Kunin, R., and Myers, R. J., Ion Exchange Resins, John Wiley & Sons, New York, (1950)
26. Lehninger, A. L., Biochemistry, Worth Publishers, Inc., P. 89, (1975)
27. Mikhailov, N. V., and Tatevosyan, R. A., USSR Patent 460,881 (Feb. 1975)
28. Oberteuffen, J. A., IEEE Trans Magnetics, V. 9, n, 3, P. 303-306 (1973)
29. Oberteuffen, J. A., IEEE Trans Magnetics, V. 10, n. 2, P. 223-228 (1974)
30. Patten, H. E., and Waggaman, U.S. Department of Agriculture Bureau of Soils Bulletin, V. 52, (1908)

31. Poshkov, S. I., Energetik, V. 2, P. 14-15 (1976)
32. Rieman, W., and Walton, H. F., Ion Exchange in Analytical Chemistry, Pergamon Press, New York, (1970)
33. Samuelson, O., Tek. Tid., V. 76, P. 561 (1946)
34. Schultz, B. J., and Crook, E. H., "Ultrafine Ion Exchange Resins," Journal of Industrial Engineering, Chemical Products Research Development, V. 7, n. 2, (June 1968)
35. Standard Methods for the Examination of Water and Wastewater, 13th Edition, American Public Health Association, Inc., New York, P. 179-184 (1974)
36. Svyadoshich, et al, "Wastewater Purification Using Superparamagnetic Dispersed Ion Exchanger in Constant Magnetic Field," Soviet Inventions Illustrated, V. x, n. 41, P. 02, (Nov. 1976)
37. Thompson, H. S., Journal of the Royal Agricultural Society of England, V. 11, P. 68 (1850)
38. Way, J. T., "Influence of Time on the Absorptive Properties of Soils," Journal of the Royal Agricultural Society of England, V. 25, P. 313 (1850)
39. Way, J. T., Journal of the Royal Agricultural Society of England, V. 11, P. 313, (1850); V. 13, P. 123 (1852)
40. Wheaton, R. M., and Seamster, A. H., "A Basic Reference on Ion Exchange," reprinted from Encyclopedia of Chemical Technology, V. 11, P. 871-899, (1966)
41. Weiss, D. E., et al, U.S. Patent 3,560,378 (Feb. 2, 1971)
42. Wiegner, G., "Ionenumtausch and Struktur," Transactions of the 3rd International Congress on Soil Science, V. 3, P. 5-28, (1936)

VITA

## VITA

Anthony Michael Wachinski was born October 7, 1946 in Brownsville, Pennsylvania, to Tony and Sophie Wachinski. He was married July 3, 1971 to Linda K. Revi.

Mr. Wachinski attended grade school, junior high and senior high school in the Bethlehem-Center School System, Fredericktown, Pennsylvania, and graduated in 1964. He entered West Virginia University, Morgantown, West Virginia and was granted his Bachelor of Science Degree in Civil Engineering in 1969. In May of 1971 he was awarded the degree of Master of Science in Civil Engineering. In April of that same year he was commissioned into the United States Air Force as a Second Lieutenant.

In June of 1975, Captain Wachinski enrolled in the Graduate School of Civil Engineering at Purdue University, West Lafayette, Indiana, as part of the Air Force Institute of Technology Program. Captain Wachinski is presently a candidate for his Doctor of Philosophy Degree in Civil Engineering in August of 1978.

Publications of Captain Wachinski include:

1. Arnold, E. L., Young, A. L., and Wachinski, A. M., "Three Years of Field Studies on the Soil Persistence and Movement of 2,4-D, 2,4,5-T and TCDD," Presented to the Weed Society of America, February, 1976.

2. Wachinski, A. M., Adams, D. V., and Reynolds, J. H., "Biological Treatment of the Phenoxy Herbicides 2,4-D and 2,4,5-T in a Closed System," A research report submitted to the U.S. Air Force in support of an environmental impact statement on the disposal of Herbicide Orange, March, 1974.
3. Young, A. L., and Wachinski, A. M., "A Potential Field Site for Soil Biodegradation of Herbicide Orange on the AFLC Test Range, Hill AFB, Utah," A report of findings and recommendations in support of an environmental impact Statement on the disposal of Herbicide Orange, February 1973.
4. Young, A. L., Arnold, E. L., and Wachinski, A. M., "Field Studies on the Soil Persistence and Movement of 2,4-D, 2,4,5-T, and TCDD," Presented to the Weed Science Society of America, February, 1974.