

AD-A060 046

ROCKWELL INTERNATIONAL ANAHEIM CALIF AUTONETICS GROUP F/G 14/2
AN INNOVATIVE METHOD FOR MEASURING FREQUENCY STABILITY WITHOUT --ETC(U)
1976 E M HICKS

UNCLASSIFIED

NL

| OF |
AD
AO 60046



END
DATE
FILMED
12-78
DDC

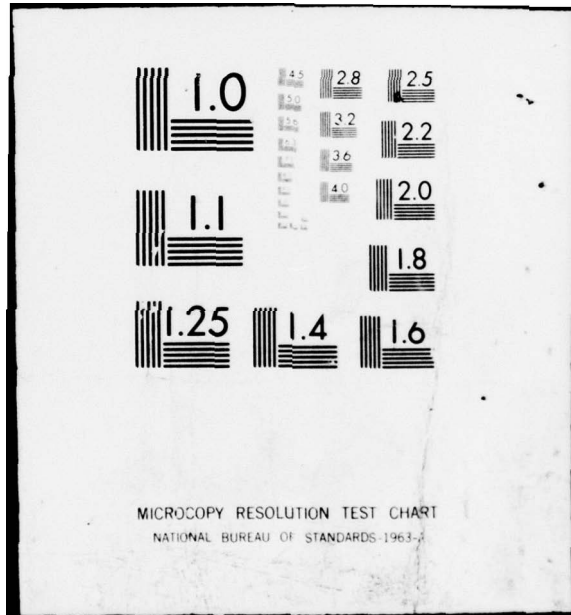

1

LEVEL

AD A060046

6 AN INNOVATIVE METHOD FOR MEASURING FREQUENCY STABILITY WITHOUT DEADTIME

12 16p

BY

10 E. M. HICKS
AUTONETICS GROUP
ROCKWELL INTERNATIONAL
Anaheim, Ca.

11 1976

DDC
OCT 18 1978
RESERVED

DDC FILE COPY

Presented to:

Sixth Cal Poly Measurement
Science Conference
San Luis Obispo, California
December 3-5, 1976

DISTRIBUTION OF THIS
REPORT IS UNLIMITED

390 723

alt 2

INTRODUCTION AND SUMMARY

A primary concern of frequency standards is the stability of the output signal frequency. Numerous methods for determining their stability have been devised. This paper briefly discusses frequency stability and its measurement and describes a simple innovative test system or method which eliminates an undesirable factor known as deadtime in frequency stability analysis.

Several beat frequency methods for measuring frequency stability including single and dual mixer systems have been devised. In measuring frequency stability, using the beat frequency method, dead time or holes between data samples may result depending on the method used to take the data. This deadtime consists of every other period when the period mode of a commercial electronic counter is used. Deadtime may lead to erroneous calculations of sigma (σ), a measure of frequency stability, especially for short averaging times. For long averaging times, deadtime can double the test time required to achieve a desired level of confidence in calculating sigma.

Some methods which eliminate deadtime have undesirable characteristics including complexity, high implementation cost and ambiguity under certain conditions. The method described in this paper (a single mixer time-mark system) eliminates deadtime in measuring the output of a single mixer system. It is useful over a wide range of averaging times (τ or tau) and can be implemented in several ways including a simple and inexpensive modification to certain existing commercial electronic counters.

The single mixer time-mark system has successfully been demonstrated in a production test program for precision frequency standards. The following table summarizes some of the advantages and disadvantages of the beat frequency methods discussed.

ACCESSION FOR	
REFS	White Section <input checked="" type="checkbox"/>
DOC	Buff Section <input type="checkbox"/>
UNANNOUNCED	<input type="checkbox"/>
JUSTIFICATION	
BY	
DISTRIBUTION, AVAILABILITY CODES	
DISC. AVAIL. AND/OR SPECIAL	
A	

COMPARISON OF BEAT FREQUENCY METHODS

<u>METHOD</u>	<u>ADVANTAGES</u>	<u>DISADVANTAGES</u>
Classical Single Mixer with Deadtime	<ul style="list-style-type: none"> ● Simple, inexpensive. ● Excellent precision 	<ul style="list-style-type: none"> ● Cannot measure time or relative time. ● May require synthesizer to obtain desired beat frequency.
Dual Mixer System	<ul style="list-style-type: none"> ● Excellent precision ● No deadtime ● Enables measurement of time and time fluctuations. 	<ul style="list-style-type: none"> ● Complex system. ● Ambiguities in data occur under certain conditions. ● Third frequency source must always be used to obtain beat frequencies.
Single Mixer Time-Mark System	<ul style="list-style-type: none"> ● Appears to have advantages of both classical single mixer and dual mixer systems. 	<ul style="list-style-type: none"> ● May require synthesizer to obtain desired beat frequency.

Frequency Stability and Its Measurement

The beat period or heterodyne technique is a common if not the most prevalent method used to determine the frequency and frequency stability of precision frequency standards. A block diagram showing a set-up for measuring frequency and frequency stability using this method is shown in Figure 1. A frequency synthesizer is needed to obtain a desired beat frequency output from the mixer if tuning of either standard is not possible or impractical. A low phase noise frequency synthesizer is required to avoid significant contribution of noise to the test system. The amplified and filtered period of the beat frequency may be measured using the period mode of an electronic counter. Samples of this beat period provide the data required to calculate both frequency offset from the standard and frequency stability for various sample times (τ).

Since it is relatively easy (e.g., using an oscilloscope) to determine whether the frequency being tested is higher or lower than the reference frequency, the determination of frequency is readily determined. Frequency stability, however, is not as simple. The Allan Variance provides the industry accepted definition of frequency stability.^(3, 4) Figure 2 illustrates a calculation of the square root of the Allan variance or sigma based on hypothetical data with no deadtime (to be explained later). The period of the beat frequency difference out of the mixer represents the minimum sample or averaging time (τ) for which sigma ($\sigma_y(\tau)$) can be calculated. When dead time is not present, calculations of sigma for longer sample times is normally done by first simply averaging adjacent groups of two or more data points resulting in less data points for some multiple of τ . A systematic method is often used in which sigma is calculated, adjacent pair of data points are averaged, sigma for those points calculated and the process repeated until only two data points are left. This very useful technique is not valid if deadtime is present.^(1, 4) Note in the sample calculation shown in Figure 2 that sigma in Hz is divided by the operating frequency (nominal frequency of the frequency standard under test) to obtain

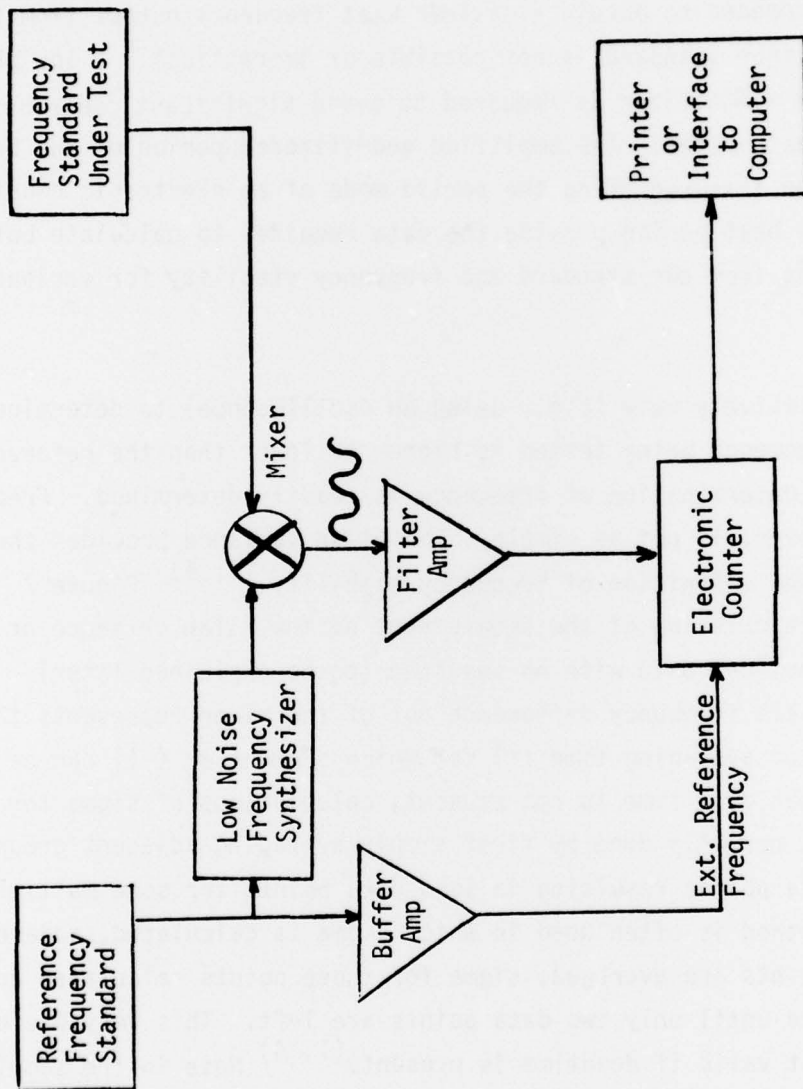
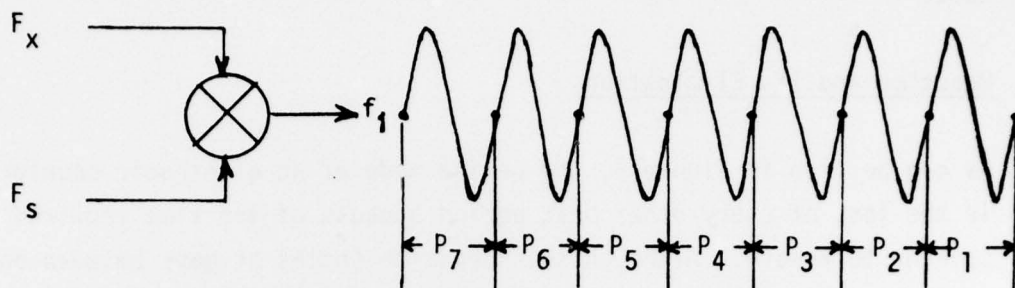

Figure 1. SET-UP FOR MEASURING FREQUENCY STABILITY

$$F_s \approx F_x \approx 10 \text{ MHz}$$



Beat Period (P_i)
Seconds

Beat Frequency (f_i), $f_i = \frac{1}{P_i}$
Hz

$P_1 = 1.00012$
 $P_2 = 1.00025$
 $P_3 = 1.00015$
 $P_4 = 1.00034$
 $P_5 = 1.00022$
 $P_6 = 1.00033$
 $P_7 = 1.00047$

$f_1 = .99988$
 $f_2 = .99975$
 $f_3 = .99985$
 $f_4 = .99966$
 $f_5 = .99978$
 $f_6 = .99967$
 $f_7 = .99953$

$n = 7^*$, $\tau \approx 1$ second, $F_x \approx 10$ MHz

$$\sigma_y(\tau) \approx \frac{\sqrt{\sum_{i=1}^n (f_{i+1} - f_i)^2}}{2(n-1) F_x}$$

*Confidence in σ varies with the number of samples used.

$$\begin{aligned} (f_2 - f_1)^2 &= 1.69 \times 10^{-8} \\ (f_3 - f_2)^2 &= 1.00 \times 10^{-8} \\ (f_4 - f_3)^2 &= 3.61 \times 10^{-8} \\ (f_5 - f_4)^2 &= 1.44 \times 10^{-8} \\ (f_6 - f_5)^2 &= 1.21 \times 10^{-8} \\ (f_7 - f_6)^2 &= 1.96 \times 10^{-8} \end{aligned}$$

$$2(n-1) = 2 \times 6 = 12$$

$$\sum_{i=1}^7 (f_{i+1} - f_i)^2 = 10.91 \times 10^{-8} \text{ Hz}^2; \sqrt{\frac{10.91 \times 10^{-8} \text{ Hz}^2}{12}} = 9.535 \times 10^{-5} \text{ Hz}$$

$$\therefore \sigma_y(1 \text{ second}) = \frac{9.535 \times 10^{-5} \text{ Hz}}{1 \times 10^{-7} \text{ Hz}} = 9.535 \times 10^{-12}$$

Figure 2. SAMPLE CALCULATION OF STABILITY

a more meaningful number for purposes of comparison. By definition, this measure of stability requires that continuous samples of the beat period be used.

Deadtime and Its Elimination

As can be seen in Figure 3, the period mode of an electronic counter results in the loss of every other beat period because of the time required for the counter to re-arm. Although this deadtime (holes or gaps between data samples) is not always critical, for short sample times it may result in significant error in calculating stability. Depending on how much is known about the behavior of the frequency standard being tested, corrections for deadtime using bias functions may or may not be satisfactory.^(4, 6) In addition, loss of every other beat period, although not critical for long sample times, does require twice as much elapsed time to collect data for a given confidence level. This becomes a very significant factor, for example, during production testing of frequency standards used in navigation systems where production schedules are a primary concern.

Measurement methods which eliminate deadtime have been devised. The Dual Mixer system shown in Figure 4 eliminates deadtime and provides a number of excellent features as described by David Allan of the National Bureau of Standards.⁽²⁾ The Dual Mixer system, however, may not be a satisfactory method under certain circumstances, especially when the frequency standard under test is not close in frequency to the reference frequency. Depending on the length of time data is to be collected and the way in which data is to be processed, some ambiguities which occur can be somewhat troublesome. In addition, the Dual Mixer system always requires a third frequency source whose stability requirement depends on the averaging time involved. Then too, the system with two mixers and one common input is inherently more subject to certain noise problems including cross talk than a single mixer system.

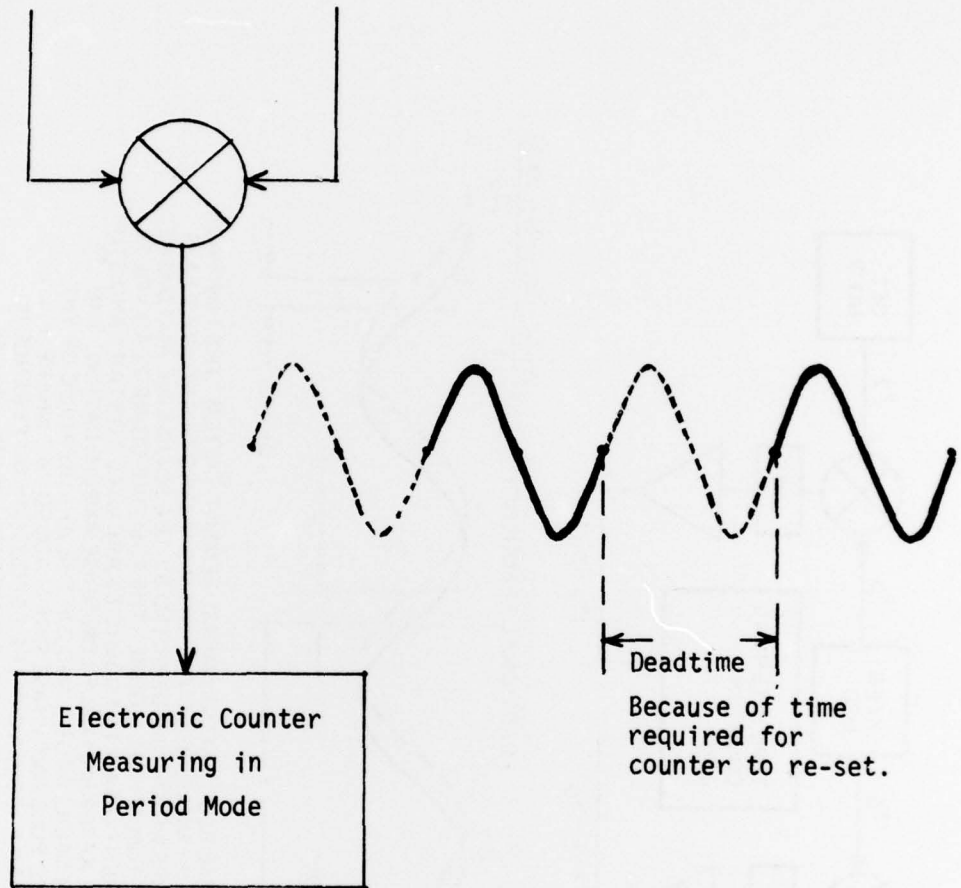
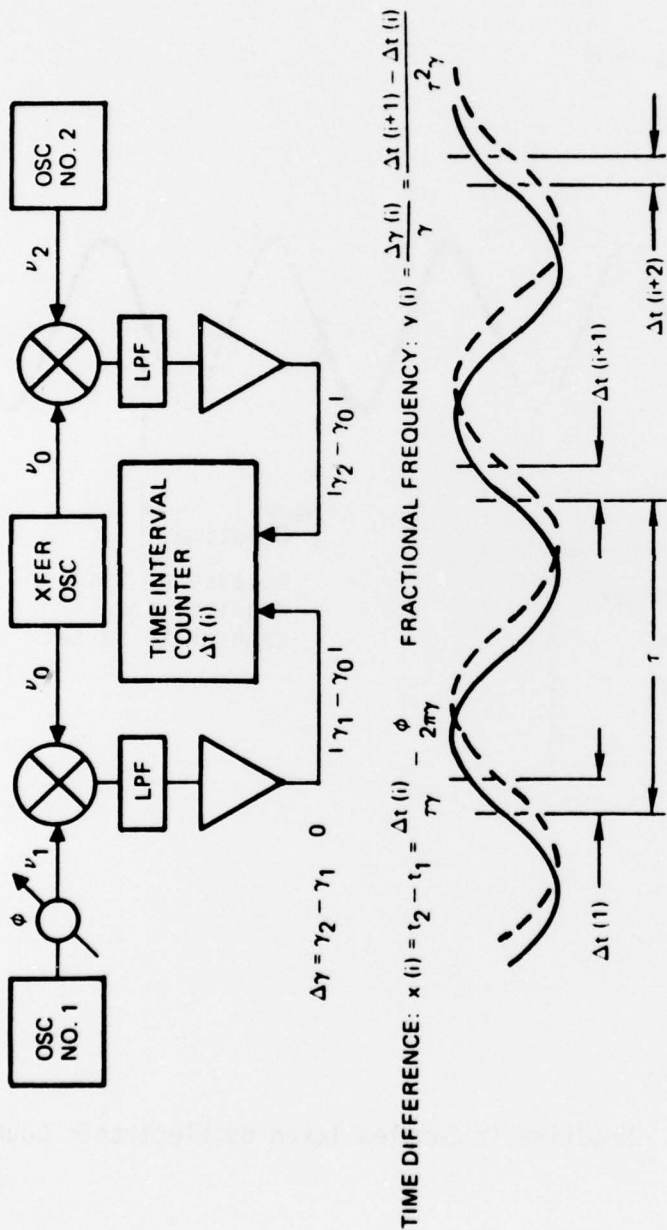

Figure 3. Deadtime in Samples Taken By Electronic Counter



A TIME DIFFERENCE AND TIME FLUCTUATION MEASUREMENT SYSTEM. THE LOW PASS FILTERS (LPS) DETERMINE THE MEASUREMENT SYSTEM BANDWIDTH AND MUST PASS THE DIFFERENT FREQUENCIES WHICH ARE DEPICTED BY THE SOLID-LINE AND DASHED-LINE SINUSOIDS AT THE BOTTOM OF THE FIGURE. THE POSITIVE GOING ZERO VOLTS CROSSING OF THESE DIFFERENT (BEAT) FREQUENCIES ARE USED TO START AND STOP A TIME INTERVAL COUNTER AFTER SUITABLE LOW NOISE AMPLIFICATION. THE i^{th} TIME DIFFERENCE BETWEEN OSCILLATOR 1 AND 2 IS THE $\Delta t(i)$ READING OF THE COUNTER DIVIDED BY τ AND PLUS ANY PHASE SHIFT ADDED, ϕ , WHERE $\nu \approx \nu_1 \approx \nu_2$ IS THE NOMINAL CARRIER FREQUENCY. THE FREQUENCY DIFFERENCE IS STRAIGHT FORWARDLY CALCULATED FROM THE TIME DIFFERENCE VALUES.

Figure 4. Dual Mixer Time Difference System

The Single Mixer Time-Mark System

While examining methods to work around what were considered to be some of the less desirable features of the Dual Mixer system, a simple alternative system was devised. This system, a single mixer time-mark system, is understood to function in a manner similar to a "chronograph" system which has been used for some time by the Time and Frequency Section of the National Bureau of Standards in Boulder, Colorado.⁽⁷⁾ The system described here, however, was implemented using a simple, minor modification to an existing commercially available electronic counter. The modification consisted of adding a switch and an integrated circuit logic chip to enable selection and function of a new mode of operation for the counter. Such a modified counter is currently in use in production testing of frequency standards. A sigma versus tau plot of real data taken using this counter is shown in Figure 5. A commercial counter with this easy to add capability could possibly have other applications.

Figure 6 is a conceptual block diagram illustrating the operating principles of the system. The frequency counter shown has eight BCD digits of resolution. The counter, without being reset, counts continuously using the 10 MHz signal from the reference frequency standard as its input. The filter-amplifier shapes the zero crossing output of the mixer to a narrow pulse with a rise time of less than approximately 20 nanoseconds and 5 volts in amplitude. This pulse is used as a gate enable to transfer, in parallel, the output states of the decade counter, at the time of zero crossing to the buffer. The pulse is also sent through a delay before serving as a print command or flag to indicate new data is ready to be read from the buffer. The period of the beat frequency output of the mixer is the limiting factor of the time allowed to read the data from the buffer. Data from the buffer could be removed in parallel or serially by bit or character depending on the buffer used.

Since the counter counts continuously, the data output represents the times at which zero crossings occur. With eight decimal digits, the maximum

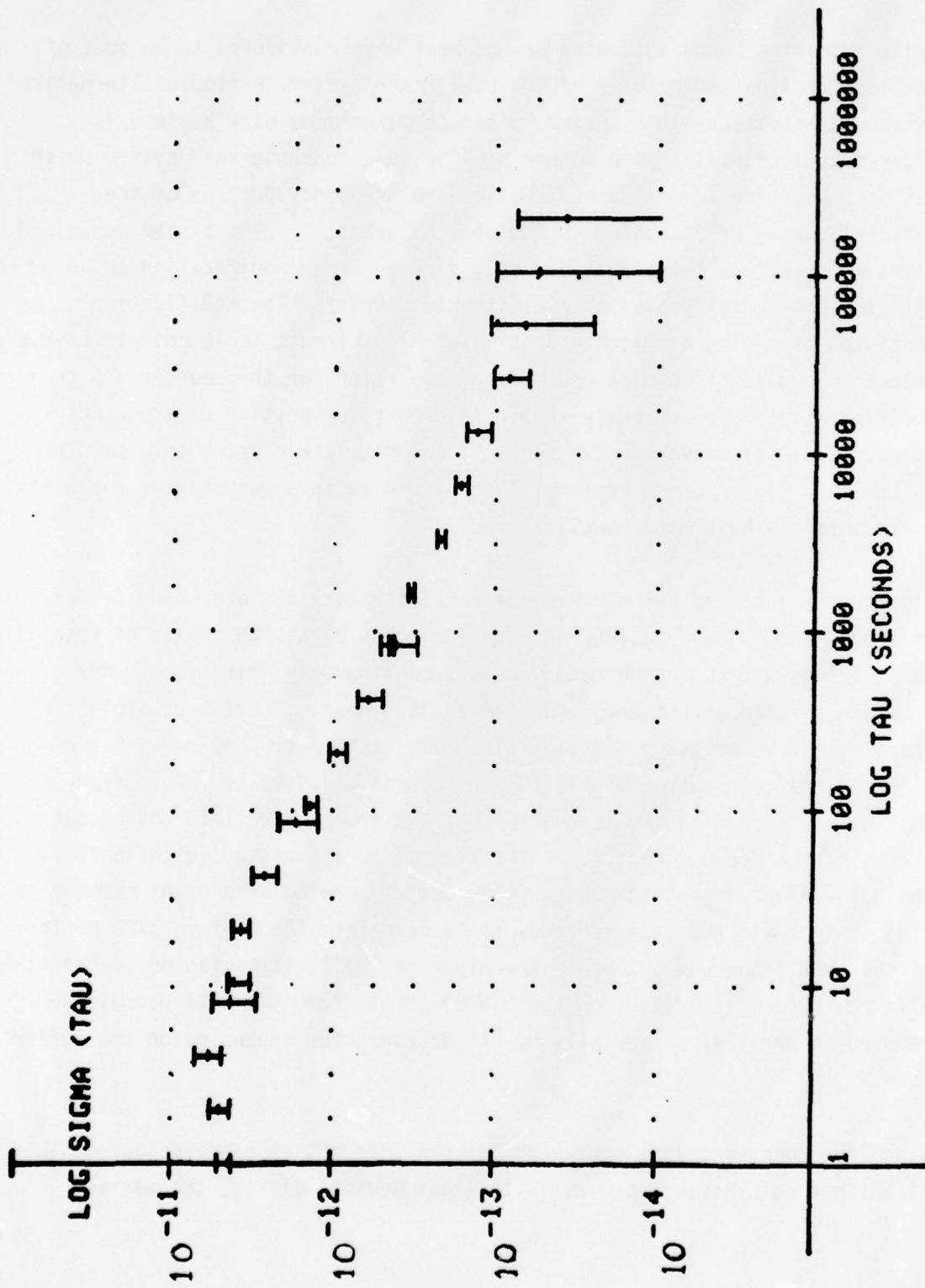

Figure 5.

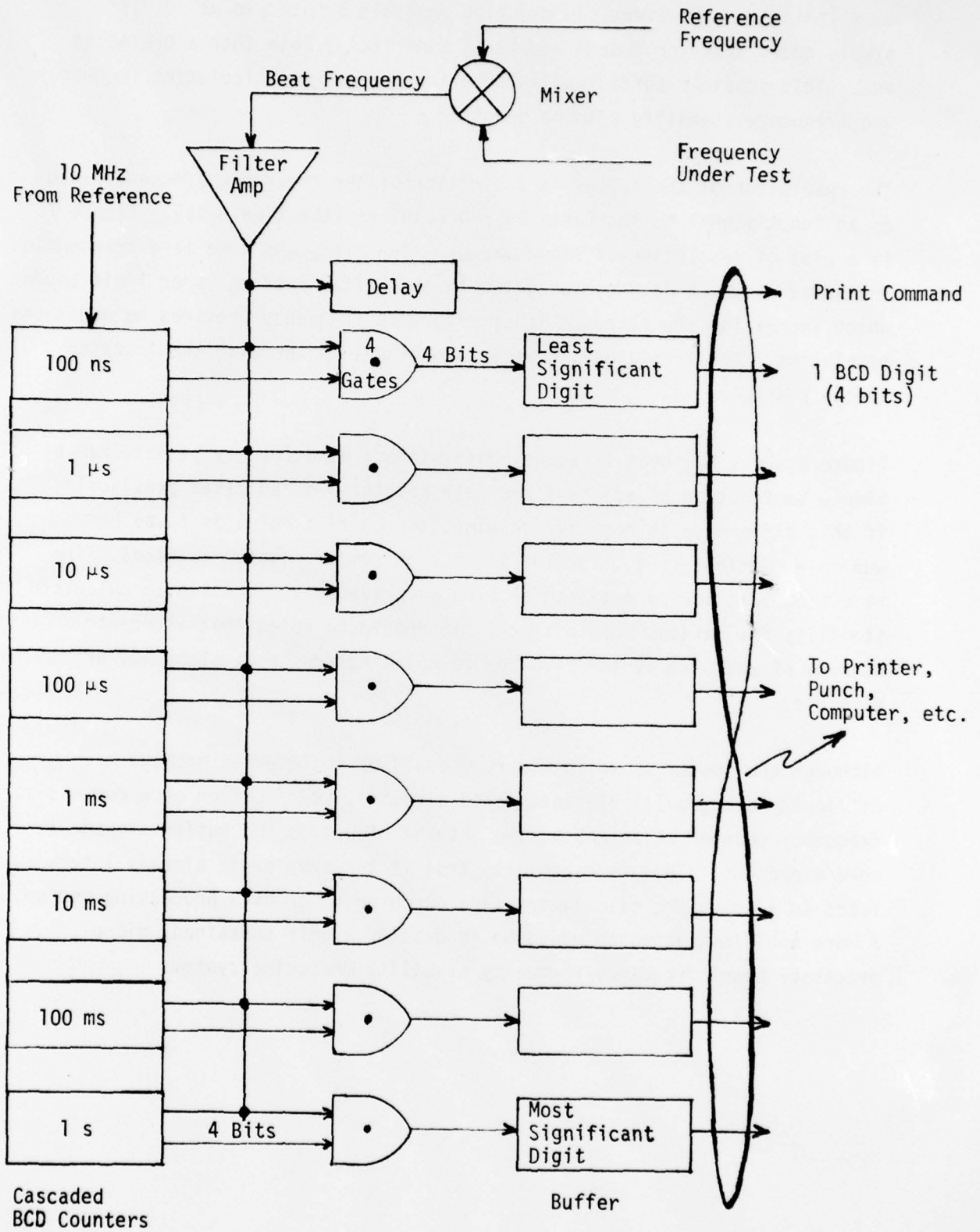

Figure 6. Conceptual Diagram

possible output of the counter shown is 99999999. This does not present a time limitation, however, since during analysis a multiple of 10^9 is simply added whenever a data sample is numerically less than a preceding one. This provides sufficient information for use in calculating frequency and frequency stability with no deadtime.

The resolution of the system is a function of the reference frequency used as an input signal to the Cascaded BCD counters (the time base). Figure 7 is a plot of resolution of sigma versus τ for different time base frequencies. The speed at which data can be gated to the buffer puts an upper limit beyond which increasing the standard input reference frequency provides no additional resolution. New technology, however, continues to increase the transfer speeds possible.

Figure 8 shows how beat frequency data without deadtime may be obtained by simple subtraction of adjacent raw data points. As indicated previously, if this difference is negative in sign, the correct value is found by adding a constant (e.g., 1×10^9 if an eight digit counter is used). The resulting beat period data can be used as previously discussed to calculate stability for various sample times. It should be noted that alternate methods of analysis of the data for calculating frequency stability are possible.

Although the system shown in Figure 6 could be implemented without much difficulty using available integrated circuits, modification of a commercial frequency counter which has a time interval function and buffer storage is more expedient. This is especially true if the counter is already interfaced to a computer, calculator, tape punch or other data processing medium. A more ambitious approach would be to develop a self contained, micro-processor based frequency/frequency stability measuring system.

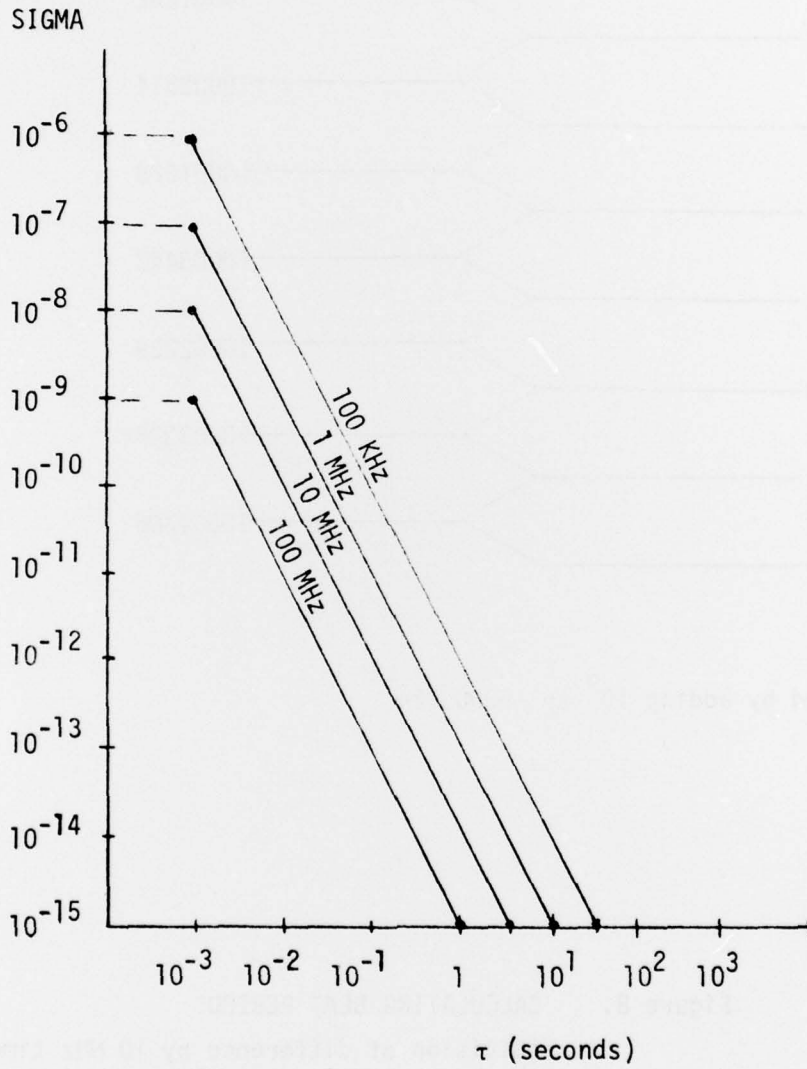
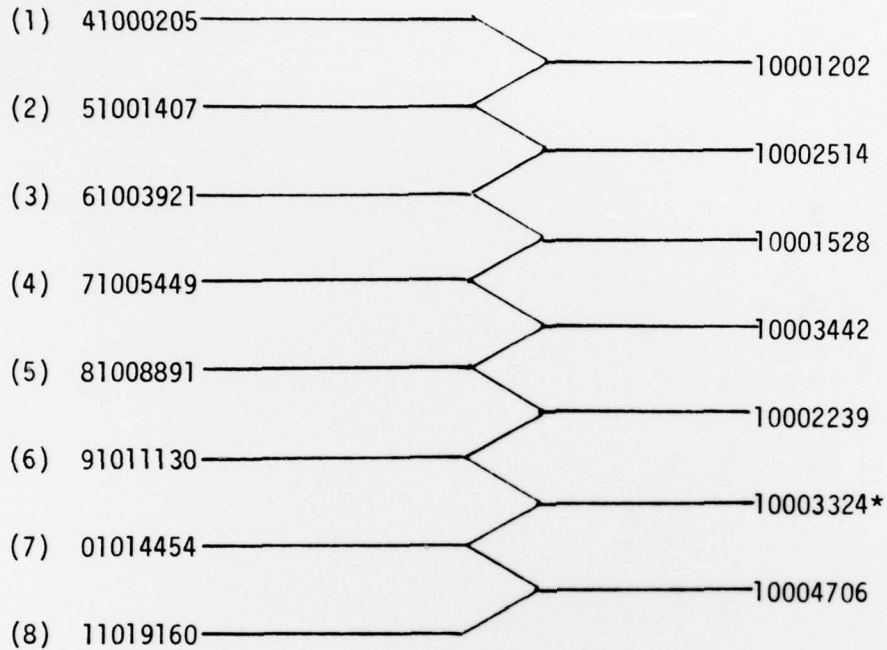

Figure 7. Sigma vs Tau For Different Time Bases for 10 MHz Frequency Standard.

Raw Data From Single Mixer
Time-Mark System with 10 MHz
Reference (Time Base)

Difference of
Adjacent Data Points



*Obtained by adding 10^9 to -90003324.

Figure 8. CALCULATING BEAT PERIODS
(Division of difference by 10 MHz time
base results in nominal 1 second beat.)

Acknowledgement

The author wishes to thank Mr. Frank Koide of Autonetics for his constructive suggestions and support.

REFERENCES

1. David W. Allan, "The Measurement of Frequency and Frequency Stability of Precision Oscillators", NBS Technical Note 669, May 1975.
2. David W. Allan and Herman Daams, "Picosecond Time Difference Measurement System", 1975 Frequency Control Symposium.
3. J. A. Barnes, et al, "Characterization of Frequency Stability", NBS Technical Note 394, Issued October 1970; IEEE Trans. on Instr. and Meas., IM-20, 1971.
4. David W. Allan, "Statistics of Atomic Frequency Standards", Proceeding of the IEEE, Vol. 54, No. 2, February 1966
5. P. Lesage and C. Audoin, "characterization of Frequency Stability", IEEE Transaction on Instr. & Meas., IM-22, June 1975.
6. J. A. Barnes, "Table of Bias Functions, B_1 and B_2 , for Variances Based on Finite Samples of Processes with Power Law Spectral Densities", NBS Technical Note 375, Issued January 1969
7. Private discussion with David W. Allan, NBS, August 1976
8. Atomic Clock Test Program for NAVSTAR by F. K. Koide and E. M. Hicks, presented to Fifth Cal Poly Measurement Science Conference, San Luis Obispo, CA December 1975.