

AD-A060 060

NAVAL OCEAN SYSTEMS CENTER SAN DIEGO CA  
SMALL-SHIP HF DISTRIBUTION SYSTEM WITH AN/USC-34(XN-1) FOR LINK--ETC(U)  
JUN 78 R L DICKSON

F/G 17/2.1

UNCLASSIFIED

NOSC-TR-261

NL

1 OF 1  
AD  
AO 60060

NOSC



END  
DATE  
FILMED  
12-78  
DDC

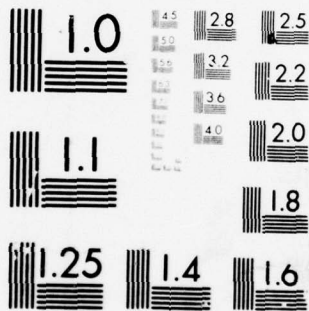

MICROCOPY RESOLUTION TEST CHART  
NATIONAL BUREAU OF STANDARDS-1963-A

AD A060060

LEVEL

12

# NOSC

NOSC TR 261

NOSC TR 261

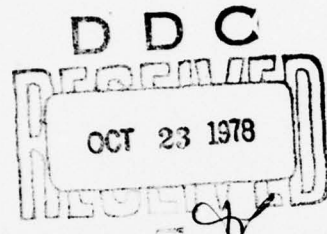

Technical Report 261

DDC FILE COPY

6

## SMALL-SHIP HF DISTRIBUTION SYSTEM WITH AN/USC-34(XN-1) FOR LINK 11.

Standard shipboard components for 2-6 MHz essentially meet the technical objectives, but those for 6-30 MHz provide poor isolation of transmitter broadband noise.

RL Dickson  
29 June 1978

10 R. L. Dickson

Test and Evaluation: December 1977 - February 1978

Prepared for  
Naval Electronic Systems Command (NAVELEX 05)  
Washington, DC 20360

12 34a

14 NOSC-TR-261

16 X0710-CC

9 Technical rept. Dec 77-Feb 78

17 X0710001

APPROVED FOR PUBLIC RELEASE; DISTRIBUTION UNLIMITED

NAVAL OCEAN SYSTEMS CENTER  
SAN DIEGO, CALIFORNIA 92152

78 10 12 010  
393 159

JOB



NAVAL OCEAN SYSTEMS CENTER, SAN DIEGO, CA 92152

---

AN ACTIVITY OF THE NAVAL MATERIAL COMMAND

**RR GAVAZZI, CAPT, USN**

Commander

**HL BLOOD**

Technical Director

### ADMINISTRATIVE INFORMATION

Work was performed under project element 63519N, project X0710-CC, task area X0710001 (NOSC CC53) by members of the Surface/Shore Systems Division. This report covers work from December 1977 to February 1978 and was approved for publication 29 June 1978.

Released by  
CA Nelson, Head  
Surface/Shore Systems  
Division

Under authority of  
RO Eastman, Head  
Communications Systems and  
Technology Department

UNCLASSIFIED

SECURITY CLASSIFICATION OF THIS PAGE (When Data Entered)

REPORT DOCUMENTATION PAGE		READ INSTRUCTIONS BEFORE COMPLETING FORM
1. REPORT NUMBER NOSC Technical Report 261 (TR 261)	2. GOVT ACCESSION NO.	3. RECIPIENT'S CATALOG NUMBER
4. TITLE (and Subtitle) SMALL-SHIP HF DISTRIBUTION SYSTEM WITH AN/USC-34(XN-1) FOR LINK 11 Standard shipboard components for 2-6 MHz essentially meet the technical objectives, but those for 6-30 MHz provide poor isolation of transmitter broadband noise.	5. TYPE OF REPORT & PERIOD COVERED Test and Evaluation December 1977-February 1978	
	6. PERFORMING ORG. REPORT NUMBER	
7. AUTHOR(s) RL Dickson	8. CONTRACT OR GRANT NUMBER(s)	
9. PERFORMING ORGANIZATION NAME AND ADDRESS Naval Ocean Systems Center San Diego CA 92152	10. PROGRAM ELEMENT, PROJECT, TASK AREA & WORK UNIT NUMBERS 63519N, X0710-CC, X0710001, NOSC CC53	
11. CONTROLLING OFFICE NAME AND ADDRESS Naval Electronic Systems Command (NAVELEX 05) Washington DC 20360	12. REPORT DATE 29 June 1978	
	13. NUMBER OF PAGES 32	
14. MONITORING AGENCY NAME & ADDRESS (if different from Controlling Office)	15. SECURITY CLASS. (of this report) Unclassified	
	15a. DECLASSIFICATION/DOWNGRADING SCHEDULE	
16. DISTRIBUTION STATEMENT (of this Report) Approved for public release; distribution unlimited		
17. DISTRIBUTION STATEMENT (of the abstract entered in Block 20, if different from Report)		
18. SUPPLEMENTARY NOTES		
19. KEY WORDS (Continue on reverse side if necessary and identify by block number) Intermodulation                      Radio links Isolation                              Performance (engineering) Couplers                                Communication equipment Communication and radio systems    Electromagnetic compatibility		
20. ABSTRACT (Continue on reverse side if necessary and identify by block number) The characteristics of rf distribution configurations can affect the observable system-level performance of Link 11 communications. This document relates operational performance objectives to technical design criteria for rf distribution systems. It describes the evaluation of a 2-30 MHz rf distribution system most likely to be used with the AN/USC-34(XN-1) for Link 11 on small ships. It reports the results of laboratory tests, primarily of isolation performance and intermodulation product generation, of Antenna Coupler Groups AN/SRA-56 and AN/URA-38.		

DD FORM 1473  
1 JAN 73EDITION OF 1 NOV 65 IS OBSOLETE  
S/N 0102-014-6601

UNCLASSIFIED

SECURITY CLASSIFICATION OF THIS PAGE (When Data Entered)

UNCLASSIFIED

SECURITY CLASSIFICATION OF THIS PAGE(When Data Entered)

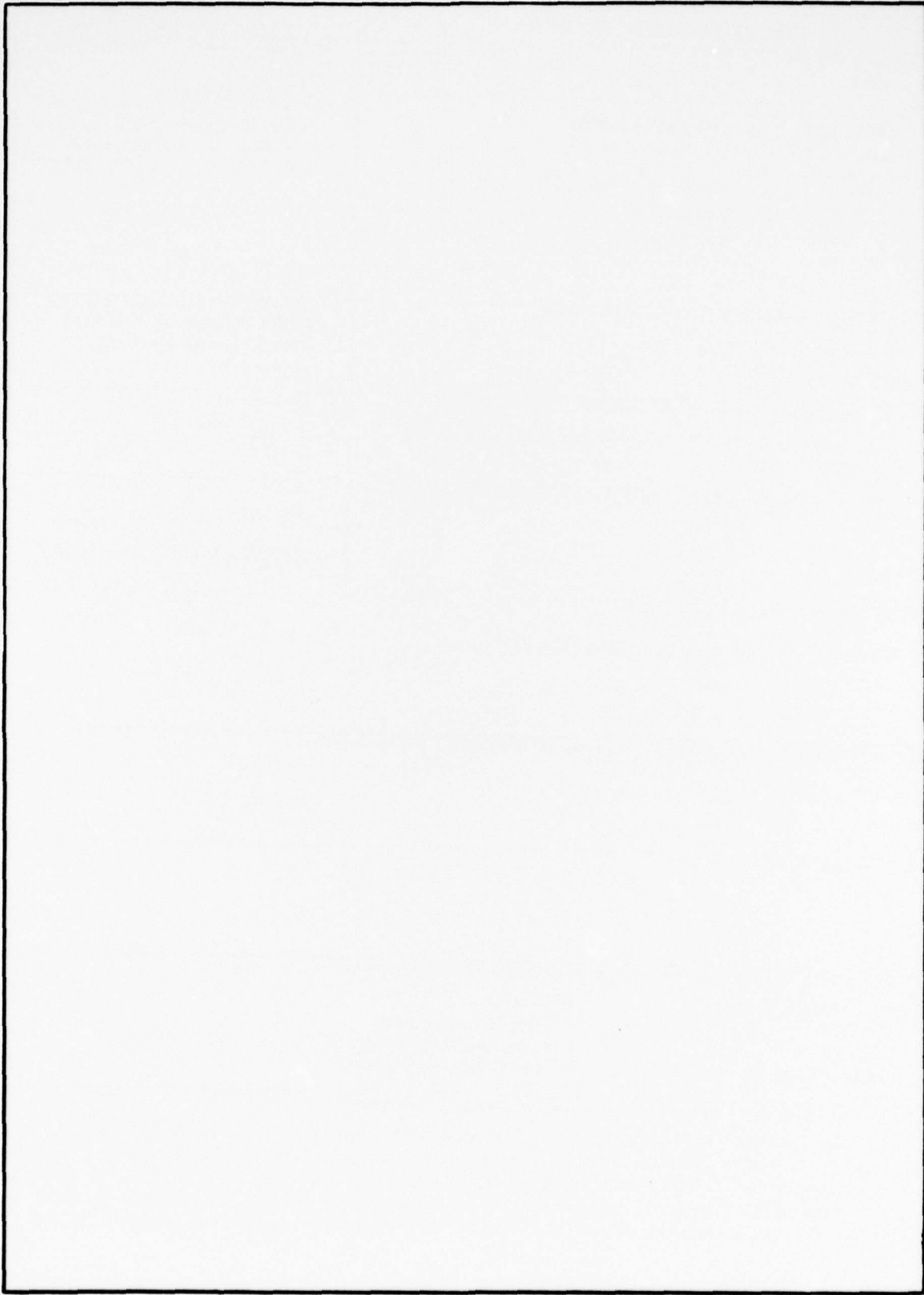

UNCLASSIFIED

SECURITY CLASSIFICATION OF THIS PAGE(When Data Entered)

## OBJECTIVE

Evaluate the rf distribution system most likely to be used with the AN/USC-34(XN-1) for Link 11 on small ships. Assure its compatibility with Link 11 operation and other small-ship requirements for transmission and reception.

## RESULTS

1. The 2-6 MHz portion of the rf distribution system baseline configuration essentially meets the technical objectives, and a favorable operational evaluation is indicated for it. Although broadband transmitter noise isolation may be marginal, depending on the noise performance of the modified AN/URT-23 transmitters used in the Link 11 hf radio, it is extremely unlikely that this characteristic will degrade the operational performance of the 2-6 MHz configuration.

2. The 6-30 MHz portion of the rf distribution system baseline configuration does not meet the technical objectives for transmitter broadband noise isolation. Depending on the transmitter noise performance, this problem could be serious. This deficiency alone would be sufficient for rejection of the 6-30 MHz configuration if good alternatives existed.

3. The lack of transmitter isolation causes a well-documented problem with mistuning in the presence of interfering transmissions, as well as a potential source of IM generation in the transmitter.

4. In view of the deficiencies of the 6-30 MHz configuration, it is difficult to recommend it; but there are presently no good alternatives. Problems are inherent in the AN/URA-38 whip tuner as a transmitting system component.

## RECOMMENDATIONS

These recommendations assume the interim use of the AN/URA-38 whip tuner, but only until a selective tuner can be acquired.

1. Adopt the 2-6 MHz configuration described herein.
2. Plan a transition to a selective tuner to replace the AN/URA-38 tuners on all transmitting whips on Link 11 equipped ships.
3. Ensure frequency management to avoid the generation of third order IM products by transmitters that are operating simultaneously.
4. Check rf distribution installations for excessive IM generation.
5. Minimize mistuning problems with the AN/URA-38 whip tuner by switching the coupler control to manual after tune-up, recording the settings of coupler tuning elements for use in the silent tune method, and—if shipboard tests on a small ship indicate persistent mistuning problems—considering insertion of a 3 dB pad during the tuning sequence.
6. Because modulation affects noise levels and because power supply options (60 or 400 Hz) may affect noise levels, include broadband noise measurements in transmitter testing.

78<sup>1</sup> 10 12 010

## CONTENTS

INTRODUCTION . . .	page 3
OPERATIONAL PERFORMANCE OBJECTIVES . . .	3
System availability . . .	6
Link availability . . .	6
Symbol error rate . . .	6
TECHNICAL PERFORMANCE OBJECTIVES . . .	8
Quasi-minimum noise . . .	8
Topside IM products . . .	8
Frequency separation . . .	9
2-6 MHz SYSTEM EVALUATION . . .	9
System description . . .	9
Transmitter to antenna coupling . . .	11
Antenna to receiver coupling . . .	11
Transmitter to receiver coupling (monitoring) . . .	12
SRA-56 multicoupler isolation . . .	12
Transmitter broadband noise isolation . . .	14
Isolation between transmitters . . .	15
Spurious signals originating in the rf distribution system . . .	16
Transmitter-receiver isolation . . .	16
TESTS OF THE 2-6 MHz SYSTEM . . .	16
Multicoupler isolation measurements . . .	16
Intermodulation product measurements . . .	18
Calibration measurements . . .	21
6-30 MHz SYSTEM EVALUATION . . .	22
System alternatives . . .	22
Transmit mode mistuning . . .	23
Transmit mode intermodulation product generation . . .	23
Transmit mode monitoring . . .	24
Receive mode noise figure . . .	24
Receive mode isolation . . .	24
Transmitter broadband noise . . .	24
Spurious generation . . .	24
TESTS OF THE 6-30 MHz SYSTEM . . .	24
Coupler isolation measurements . . .	25
Intermodulation product measurements . . .	25
Transmitter noise calibration . . .	27
CONCLUSIONS . . .	28
RECOMMENDATIONS . . .	28
REFERENCES . . .	29
APPENDIX A: FUNCTIONS OF AN RF DISTRIBUTION SYSTEM . . .	31

## INTRODUCTION

This task was initiated by the AN/USC-34 Link 11 Development project to evaluate the rf distribution system most likely to be used with Digital Communications Central AN/USC-34(XN-1) for Link 11 on small ships. The objective is to assure that the rf distribution system is compatible with Link 11 operation and other small-ship requirements for transmission and reception.

This document explains how the characteristics of rf distribution configurations can affect the observable system-level performance of Link 11 communications. First it relates a well-documented method for describing operational performance objectives (ref 1) to technical design criteria for rf distribution systems (ref 2, 3). It then describes the evaluation of 2-6 MHz and 6-30 MHz rf distribution systems as well as critical laboratory tests primarily of the isolation performance and intermodulation product generation of the multicoupler (Antenna Coupler Group (AN/SRA-56)) and the whip tuner (Antenna Coupler Group (AN/URA-38)).

Appendix A is a comprehensive checklist of rf distribution system functions that was used in organizing this evaluation.

## OPERATIONAL PERFORMANCE OBJECTIVES

The operational performance of a communications link has been described in terms of link responses to system-level interactions (ref 1). In summary, these responses fall into four categories:

System availability—Link continuity as determined by hardware-related failures

Link availability—Link continuity as determined by failures related to the propagation medium

Symbol error rate—Link utility in terms of received message quality

Handling efficiency—Link usage quality with respect to the continuity of traffic flow

All but the last of these link responses are influenced by system-level interactions involving the rf distribution system. The interactions are shown in figures 1 and 2 (taken from ref 1).

1. Ketrion, Inc report KRF 24-75, Operational Test and Evaluation of Communications Systems, by WC Hardy, JC Wilson, and JR Fish, Contract N00039-74-C-0123, 23 March 1975
2. NOSC Technical Report NELC TR 1786, TRED Hf Communication System Analysis, by WM Chase and CW Tirrell, 24 September 1971
3. NOSC TD 151, EMC Analysis for AN/USC-34(XN-1) Link 11 Hf Radio, by LJ Kinkel, 1 March 1978. This report presents a detailed analysis of electromagnetic compatibility (EMC), including analysis of the impact of 10 and 5 percent frequency separations between systems and the performance of a selective whip tuner to replace Antenna Coupler Group AN/URA-38

ACCESSION for		
NTIS	File Section	<input checked="" type="checkbox"/>
DDC	Buff Section	<input type="checkbox"/>
UNANNOUNCED		<input type="checkbox"/>
JUSTIFICATION		
BY		
DISTRIBUTION/AVAILABILITY NOTES		
Dis.	Avail.	Clear
A		

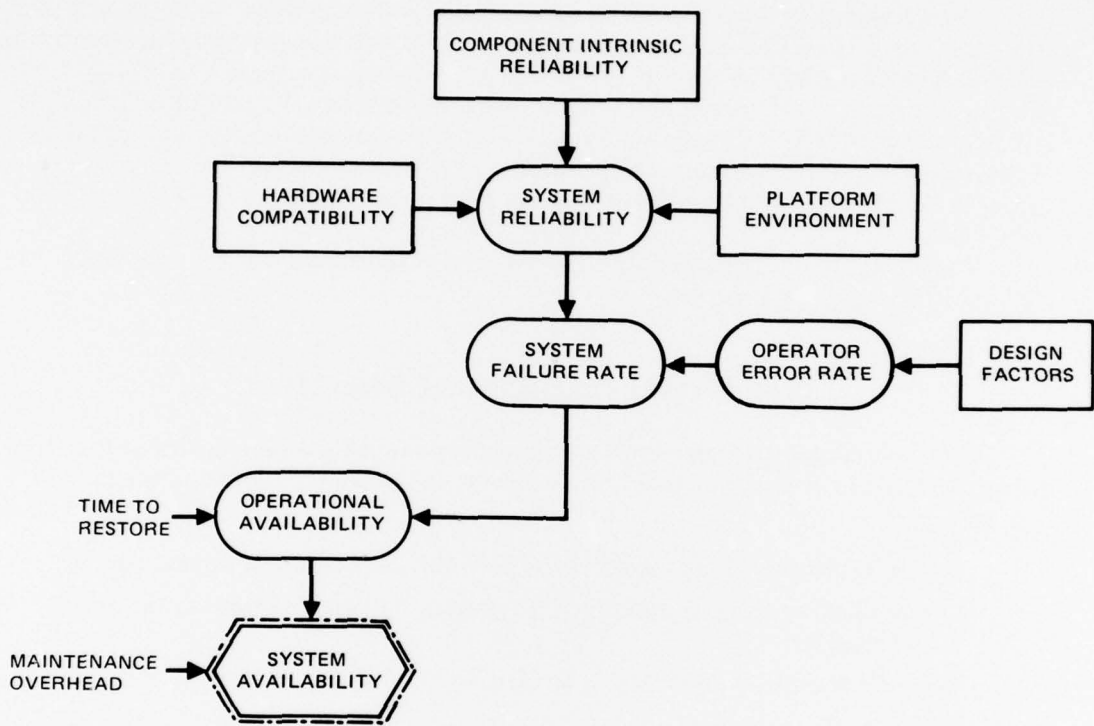

Figure 1. Selected influences on system availability.

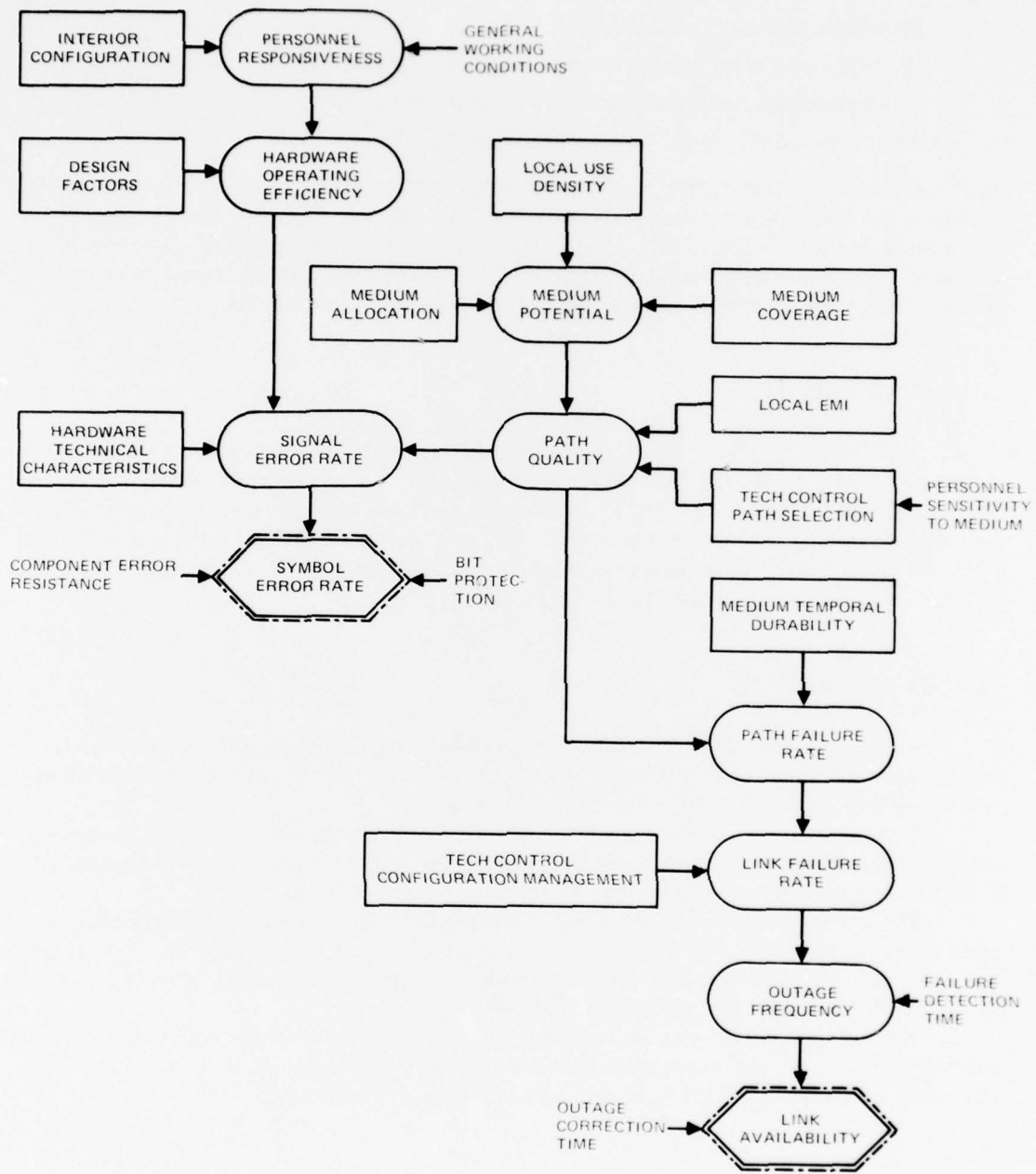

Figure 2. Selected influences on link availability and symbol error rate.

## SYSTEM AVAILABILITY

Except for catastrophic external factors such as power failure, four characteristics of a system affect system availability:

Preventive maintenance schedules

Incidence of system failures attributable to mechanical failure of a system component

Incidence of system failures attributable to operator errors

Time required to restore the system to use after failure

Each component of an rf distribution system must be protected to minimize the time required to restore the system after failure. Operator error can seriously degrade system availability. It can result in the coupling of large amounts of rf energy into sensitive receiving systems. It can allow excessive voltage buildup in transmit components, seriously damaging them. To protect against operator error, isolation and protection functions are vital.

## LINK AVAILABILITY

Path failure rate is the frequency with which one of perhaps several paths being used to support a link deteriorates to the point that it will no longer support reception of a signal (ref 1). One of the functions of the rf distribution system is to isolate EMI threats, which degrade path quality and are the major cause of path failure. The effect of the rf distribution system on link availability is expressed as the probability that inadequate isolation in the rf distribution function will result in such deterioration.

## SYMBOL ERROR RATE

An acceptable symbol error rate also depends on path quality, which is adequately described for this purpose by the signal-to-noise ratio (SNR). Several of the functions of an rf distribution system contribute to an adequate SNR.

Figure 3 exhibits a typical power budget for a Link 11 system. Noise and spurious radiation originating in the rf distribution system or internally coupled by it will be referred to the antenna terminals to equate it to an equivalent external noise.

The combined effects of system noise figure and external noise comprise the operating noise figure of the system. As long as the operating noise figure is dominated by truly external noise sources such as atmospheric noise or topside generated IM, the influence of the receive portion of the rf distribution system on SNR will be negligible.

If the system noise figure is affected by rf distribution loss or internally coupled noise, the rf distribution system will degrade the SNR, potentially threatening the symbol error rate. The actual magnitude of the threat depends on the system SNR margin.

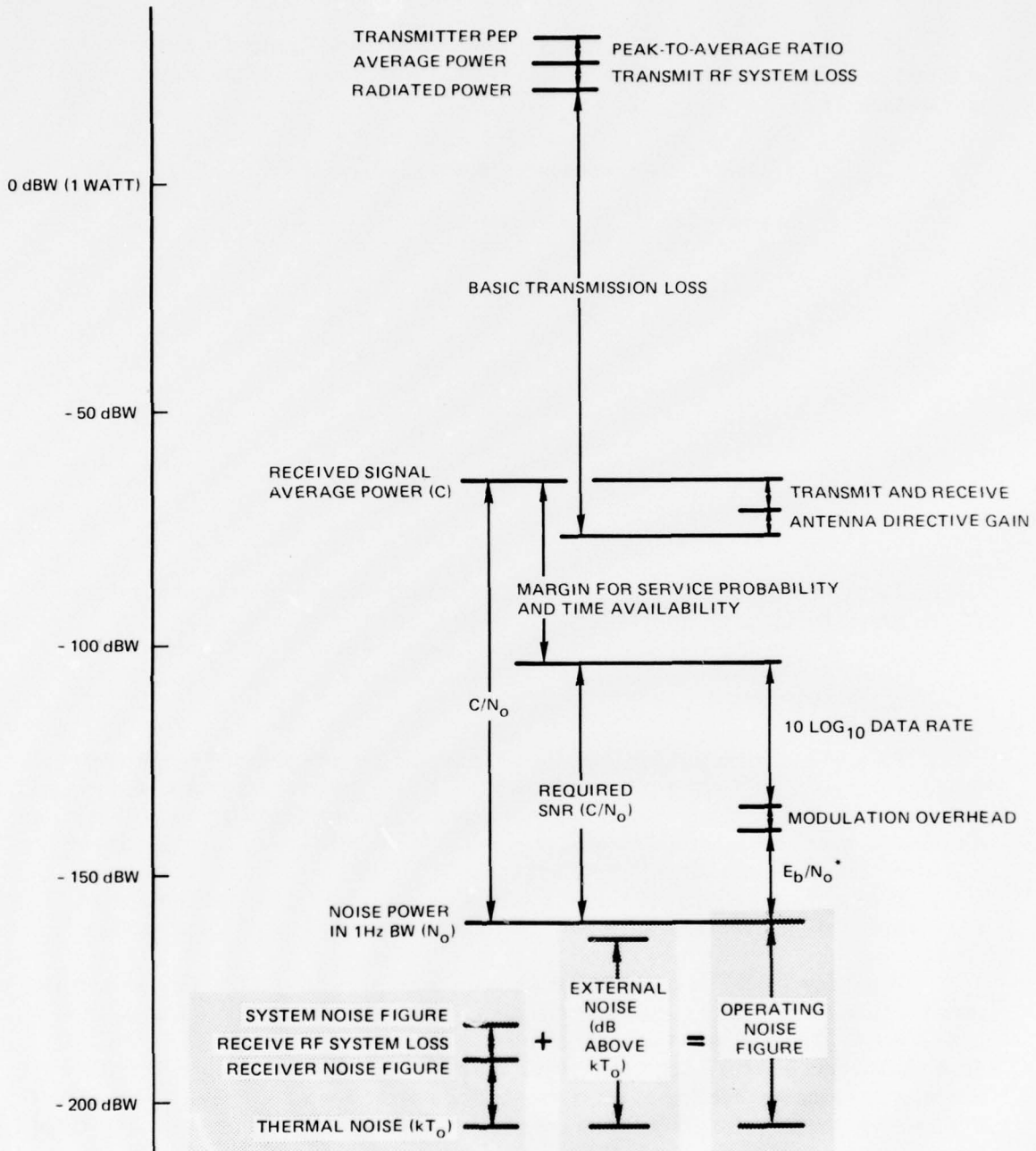

\*RATIO OF ENERGY PER BIT TO NOISE POWER DENSITY (NPD), FOR REQUIRED GRADE OF SERVICE

Figure 3. Hf system power budget.

## TECHNICAL PERFORMANCE OBJECTIVES

### QUASI-MINIMUM NOISE

The design criterion for shipboard rf distribution systems described in reference 2 is based on quasi-minimum noise, which represents a soft lower bound on atmospheric noise at sea (see table 1).

Table 1. Quasi-minimum atmospheric noise levels

Frequency, MHz	Quasi-Minimum Noise Level, dB above $kT_0$
2	52
4	44
6	39
8	36
10	33
12	31
15	28
20	25
25	22
30	20

The contribution of the rf distribution system to symbol error rate can be evaluated on the basis of the levels shown.

### TOPSIDE IM PRODUCTS

Simultaneous transmissions cause intermodulation (IM) products to be generated in topside structures. The level of these products at a receiving antenna may be well above quasi-minimum noise at the discrete frequencies corresponding to low-order IM products. The rf distribution system may generate IM products or may fail to isolate transmitters sufficiently to prevent transmitter-generated IM products.

If the operating noise figure of the receiving system is limited by topside-generated IM, a potential degradation in symbol error rate cannot be assigned to the rf distribution system.

Topside-generated IM levels vary over a wide range, depending on the care with which topside structures have been constructed and maintained. Available data are summarized in table 2 (ref 4). The minimum third order IM level is 10 to 42 dB greater than 2-30 MHz quasi-minimum noise (in a 3 kHz bandwidth). For fifth and higher orders, therefore, the technical performance objective of the rf distribution system is to achieve IM levels equivalent to those observed on a clean ship. Third order intermodulation frequencies should be avoided through frequency planning, due to their high topside-generated levels. For this reason, the rf distribution system performance with respect to third order intermodulation products is irrelevant, provided that through frequency management, third order IM products from simultaneously operating transmitters are avoided.

4. NOSC Technical Report NELC TR 1585, Shipboard Radio Frequency Interference Investigation: Status Report, by WE Gustafson and GC Salisbury, 18 September 1968

Table 2. Observed topside intermodulation levels

IM Order	Maximum Level Before Cleanup, dBm	Minimum Level (Clean Ship), dBm
3rd	-47	-77
5th	-67	-97
7th	-82	-112
9th	-97	-127

## FREQUENCY SEPARATION

The relationship of operational performance to the frequency separation requirements between simultaneously operating hf systems has not been derived. Small-ship needs are assumed here to be met with a 15% frequency separation capability. An analysis of the electromagnetic compatibility (EMC) implications of 5% and 10% separations is given in reference 3.

## 2-6 MHz SYSTEM EVALUATION

### SYSTEM DESCRIPTION

The baseline configuration shown in figure 4 is the specific 2-6 MHz rf distribution system which was evaluated. The communication system in which it is intended to be used is diagrammed in figure 5. This configuration allows a broadband 2-6 MHz antenna to be shared for both transmission and reception with three other ports available on the Antenna Coupler Group AN/SRA-56. It may be shared for receive-only through Coupler-Isolator CU-2113(XG-1)/SRC (also known as the common antenna receive and transmit system, or CARTS), followed by Antenna Coupler CU-1799/SRA, a receiving multicoupler that is part of Antenna Coupler Group AN/SRA-49. Transmit-receive switching is accomplished with the TR switch in the data adaptor unit (DAU), which is part of the Link 11 modification to Radio Transmitting Set AN/URT-23.

Alternative configurations may involve substitution of a CU-1799 receive multicoupler for the 20-dB attenuator in figure 4 or deletion of the CU-2113 receiving coupler.

Performance evaluations of the coupling and isolation functions follow.

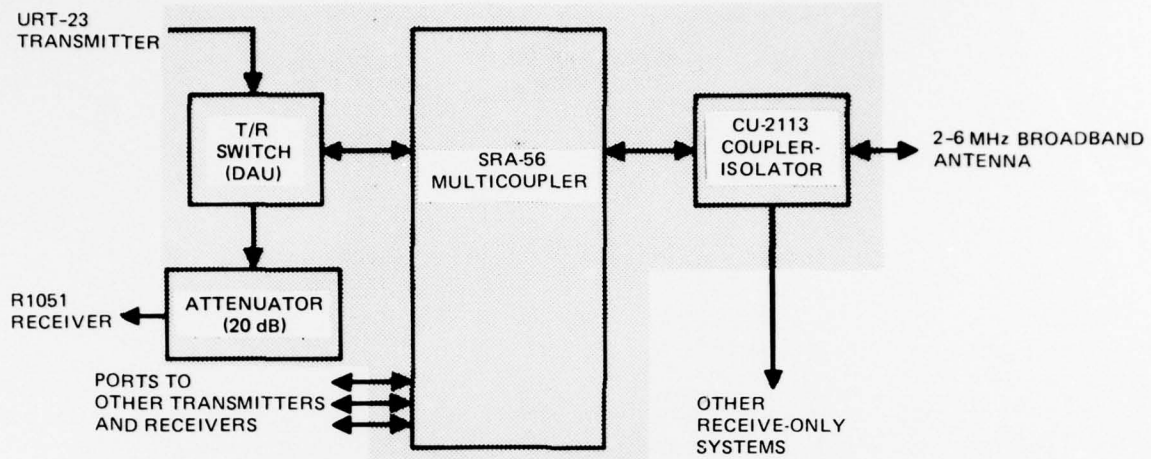

Figure 4. 2-6 MHz baseline configuration, showing signal interfaces.

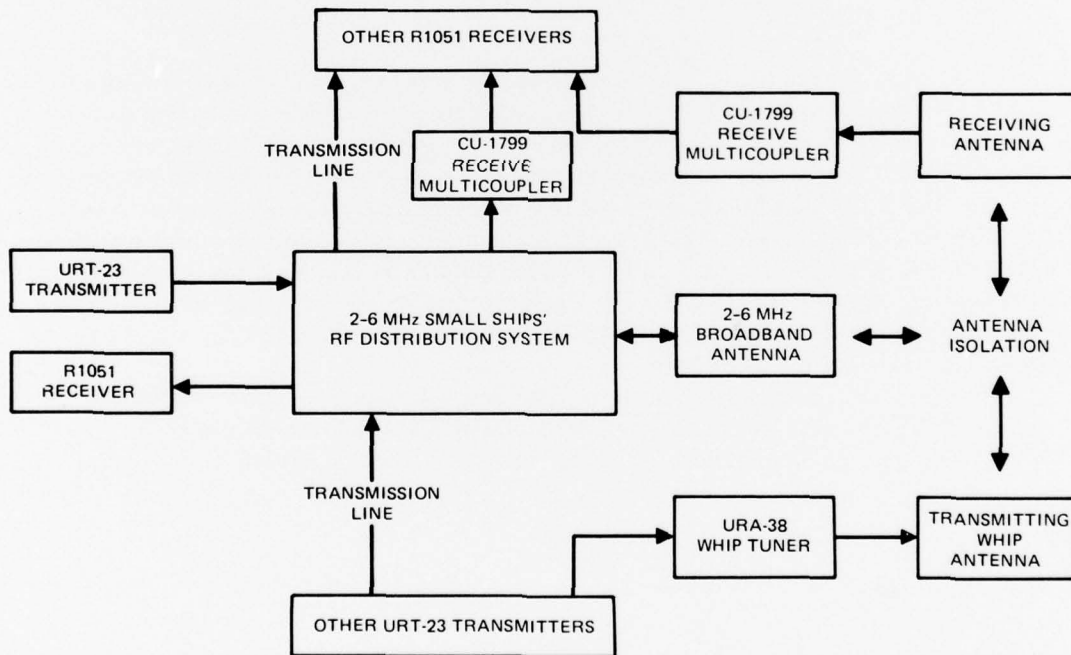

Figure 5. 2-6 MHz small ships communication system.

## TRANSMITTER TO ANTENNA COUPLING

The SRA-56 is specified to match a 3-to-1 VSWR load to within 1.05-to-1 VSWR (ref 5). Since the URT-23 transmitter is specified to load into a VSWR up to 4 to 1, no problem is expected in coupling the transmitter to broadband antennas meeting a design objective of 4-to-1 VSWR, although the above specifications leave some room for doubt.

Compatibility was verified in tests in which a 12-ohm dummy load was used with various lengths of transmission line. The coupling loss was measured to be less than 2 dB.

## ANTENNA TO RECEIVER COUPLING

The R1051 receiver is specified to have a  $1.2 \mu\text{V}$  (open circuit) sensitivity for  $(S+N)/N$  of 10 dB (ref 6). This corresponds to a noise figure of 18 dB. In fact, the R1051 receiver is considerably quieter than this from 2 to 6 MHz, where the noise figure is typically 12 dB. The noise figure of the receiving system is the sum of the receiver noise figure, the multicoupler loss, and the 20 dB loss of the attenuator. Figure 6 compares quasi-minimum noise from 2 to 30 MHz with the resulting receive system noise figure (34 dB between 2 and 6 MHz). The 2-6 MHz performance is entirely satisfactory. The 5 dB margin at 6 MHz implies an SNR degradation of 1 dB at quasi-minimum noise levels.

Receive-only systems using the hf receive port of the CU-2113 coupler will also meet quasi-minimum noise objectives (ref 7).

5. NAVSHIPS 0967-284-6010, Technical Manual for Antenna Coupler Groups AN/SRA-56, AN/SRA-57, AN/SRA-58, 27 March 1969
6. MIL-R-23637G, Specification for R1051G/URR Receiver, October 1977
7. NOSC Technical Document NELC TD 437, CU-2113(XG-1)/SRC Coupler-Isolator: Technical Evaluation, by IC Olson and JL Lievens, 31 July 1975

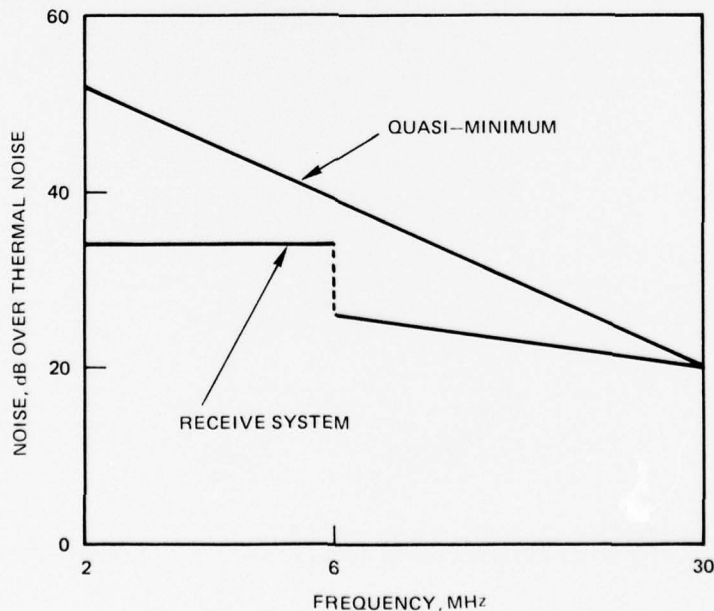

Figure 6. Quasi-minimum and receive system noise for both the 2-6 MHz and the 6-30 MHz configuration.

## TRANSMITTER TO RECEIVER COUPLING (MONITORING)

The 20 dB attenuator is used to sample a transmitter signal and couple it to a monitor receiver. If a typical receiver noise figure of 12 dB is assumed, the required signal level at the receive port of the T/R switch is -90 dBm. Even with the specified receiver noise figure of 18 dB, the DAU specification for a receiver monitor sample of  $-60 \pm 6$  dB (ref 8) leaves a margin of at least 18 dB. The receive monitor sample is entirely adequate as specified.

## SRA-56 MULTICOUPLER ISOLATION

Typical attenuation characteristics of the SRA-56 multicoupler are shown in figure 7. The nominal characteristic (part A) may be described as 40 dB attenuation at 5% frequency separation increasing at 12 dB per octave down to 60 dB at 16%.

The effect of off-frequency conjugate matching (sometimes called suck-out) is shown in part B. It can occur when uncontrolled out-of-band source and load impedances coincidentally approximate a conjugate match. The worst-case effect would be loss of the isolation associated with one filter mesh. Frequencies at which this occurs are a function of cable length as well as multicoupler and transmitter coupling circuits.

Because of these uncertainties, considerable attention was paid to the SRA-56 multicoupler isolation characteristics in testing the rf distribution system.

---

8. Specification: AN/URT-23( ) (V) Modification for Link 11 Data Communications, 24 February 1977 (working paper)

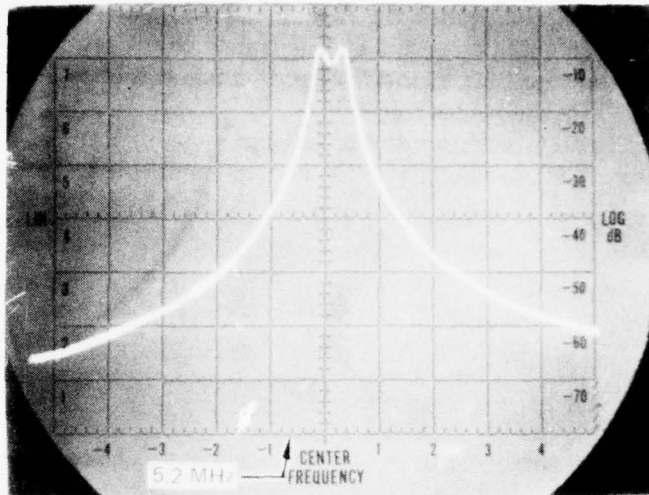

A. ATTENUATION FOLLOWING THE EXPECTED NOMINAL CHARACTERISTIC. (24-FOOT CABLE)

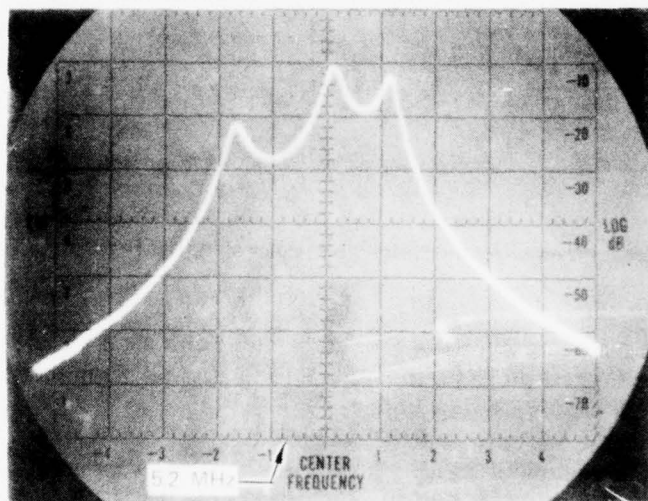

B. ATTENUATION AS AFFECTED BY OFF-FREQUENCY CONJUGATE MATCHING. (57-FOOT CABLE)

Figure 7. Effect of off-frequency conjugate matching on multicoupler isolation. Measurement conditions in each case were identical, except for cable length between the URT-23 transmitter and SRA-56 multicoupler. Abscissa 100 kHz/division. Ordinate 10 dB/division.

## TRANSMITTER BROADBAND NOISE ISOLATION

The URT-23 transmitter has no specification regarding broadband noise. A final determination of rf distribution system isolation adequacy will depend on the results of transmitter testing. For an initial starting point, a tentative specification will be assumed: less than  $-60$  dBm measured in a 3 kHz bandwidth (ref 9).

Figure 8 shows the power budget for transmitter broadband noise isolation when this specification for transmitter noise is used along with the nominal multicoupler isolation characteristics. The resulting performance margin varies from 32 to 19 dB from 2 to 6 MHz.

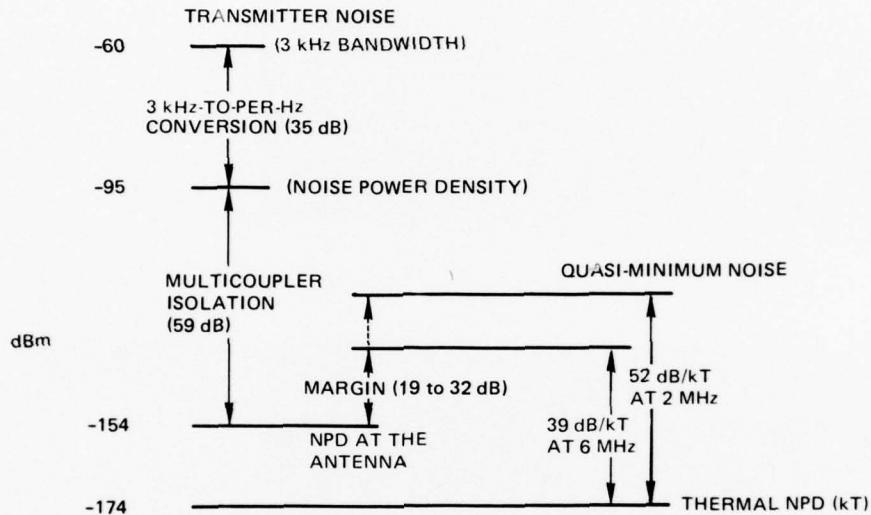

Figure 8. Power budget for transmitter broadband noise isolation (2-6 MHz).

Off-frequency conjugate matching will reduce (or eliminate) this margin part of the time. An important objective of the test program, to measure the statistical parameters of these variations, resulted in the distribution shown in figure 9.

The measured isolation of the SRA-56 multicoupler varied from 39 to 69 dB, or  $-20$  to  $+10$  dB relative to the nominal isolation of 59 dB. In comparison with a computed performance margin of 19 dB, assuming 59 dB SRA-56 multicoupler isolation, the performance is marginal at 6 MHz.

As shown by the probability distribution, figure 9, transmitter noise isolation will be marginal less than 10% of the time, at the worst-case frequency of 6 MHz. Thus for a broadband transmitter noise level of  $-60$  dBm in 3 kHz, the noise isolation is marginally satisfactory in terms of the technical performance objectives.

An evaluation of the effect of this marginality on operational performance (symbol error rate) should take the following factors into account:

9. Military Specification: High Frequency Radio Set, 17 February 1976 (working paper)

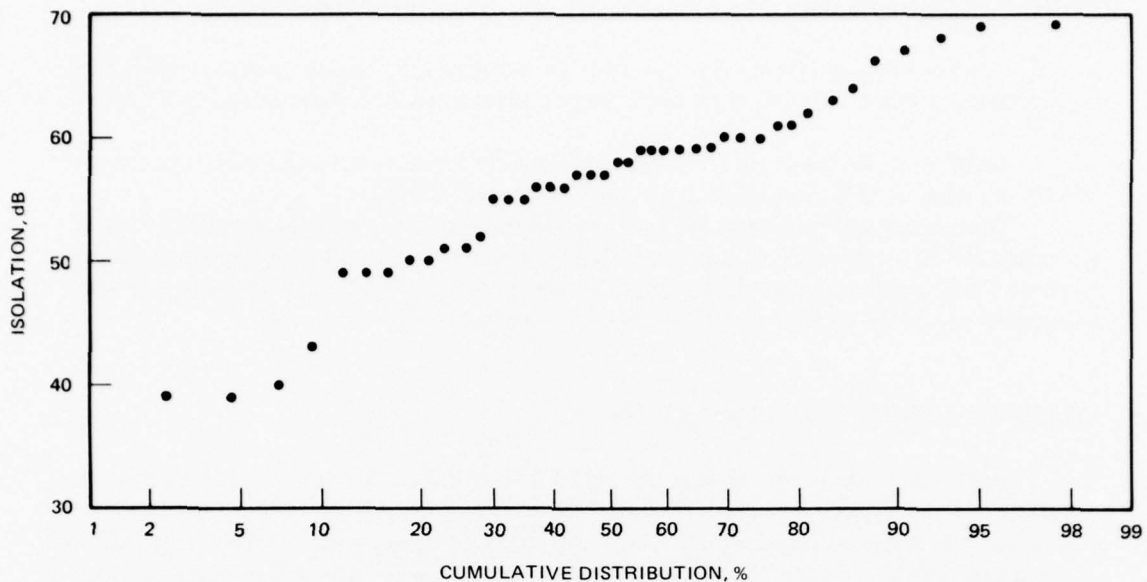

Figure 9. SRA-56 multicoupler isolation at 15% frequency separation: cumulative distribution.

The probability distribution of isolation

The frequency dependence

The range between upper and lower decile atmospheric noise levels (approximately 18 dB at 6 MHz) (ref 10)

Expected SNR margin

A determination of the broadband noise performance of the URT-23 transmitter is necessary to draw final conclusions, but if it is demonstrated to be equal to or less than the specification assumed here, SRA-56 multicoupler isolation will be entirely adequate. The probability that an actual degradation in operational performance will occur is estimated to be less than 0.1%.

## ISOLATION BETWEEN TRANSMITTERS

Isolation between transmitters is necessary to prevent damage to transmitters, prevent interference to transmitter tuning and interlock functions, and minimize intermodulation products generated within transmitters. Of these items, intermodulation generation is the critical, limiting factor. The technical objective is to maintain the IM levels below those expected from topside sources. Isolation between SRA-56 multicoupler ports at 15% frequency separation is more than adequate to meet this objective. Laboratory test measurements indicated that the limiting source of configuration IM is the SRA-56 multicoupler itself, confirming that isolation between transmitters is more than adequate.

10. International Radio Consultative Committee (CCIR) Report 322, World Distribution and Characteristics of Atmospheric Radio Noise, International Telecommunication Union, Geneva, 1964

## **SPURIOUS SIGNALS ORIGINATING IN THE RF DISTRIBUTION SYSTEM**

Intermodulation (IM) product generation in the rf distribution system is minimized by specifying construction practices and selecting parts to avoid nonlinearities in the signal path.

Third order IM products (referred to equivalent levels at the antenna terminals) were -64 to -93 dBm at 15% separation; fifth order products, -96 dBm.

Third order self-generated IM levels were determined to be in the range of topside-generated IM on a clean ship, but fifth and higher order self-generated IM levels were found to be well below the corresponding topside levels. Thus the distribution system more than adequately meets the technical objective for this characteristic.

## **TRANSMITTER-RECEIVER ISOLATION**

The SRA-56 multicoupler and the 20 dB attenuator isolate the Link 11 receiver from simultaneously-operating transmitters connected to the multicoupler. At 15% frequency separation, the isolation totals 79 dB. The threat at the receiver from a 1 kW transmission is -19 dBm (60 dBm - 79 dB). This is well below the 8 dBm level at which receiver overload or cross-modulation occurs. Furthermore, problems with off-frequency conjugate matching (suck-out) would not be expected, since the 20 dB attenuator guarantees a 50-ohm resistive load.

Tests verified that receiver desensitization does not occur.

## **TESTS OF THE 2-6 MHz SYSTEM**

Laboratory tests of the 2-6 MHz distribution system couplers were made to measure SRA-56 multicoupler isolation and the generation of IM products in both the SRA-56 multicoupler and the CU-2113(XG-1)/SRC coupler-isolator (CARTS). Peripheral test equipment included the CU-1799/SRA receive coupler (part of SRA-49, mounted in a special 4-drawer mini-coupler case), AN/URT-23 transmitters, and an R1051D/URR receiver. The transmitters were temporarily available units which had been modified for submarine use. In addition, the following calibration measurements were made on the test system components:

Receiver Noise Figure

Transmitter Noise

CU-2113 Isolation

Furthermore, IM products found to be generated by the dummy load led to the use of a 50 ohm transmission line dummy load in the IM test configuration.

## **MULTICOUPLER ISOLATION MEASUREMENTS**

### **PROCEDURE**

The primary objective was to measure the variation in multicoupler isolation caused by off-frequency conjugate matching. The most serious effect is on broadband transmitter noise isolation.

Figure 10 shows the isolation test setup. To attain a realistic simulation of the actual coupling conditions, a URT-23 transmitter was used. The receiver was connected through a variable attenuator to a port of the multicoupler that was tuned to a frequency separated by 15% from that of the transmitting port. The variable attenuator was adjusted for a 3 dB increase in receiver noise when the transmitter was keyed with a two-tone test signal (USB mode). If a 3 dB increase could not be reached, 0 dB was recorded and a 0, 1, or 2 dB rise in receiver noise was noted.

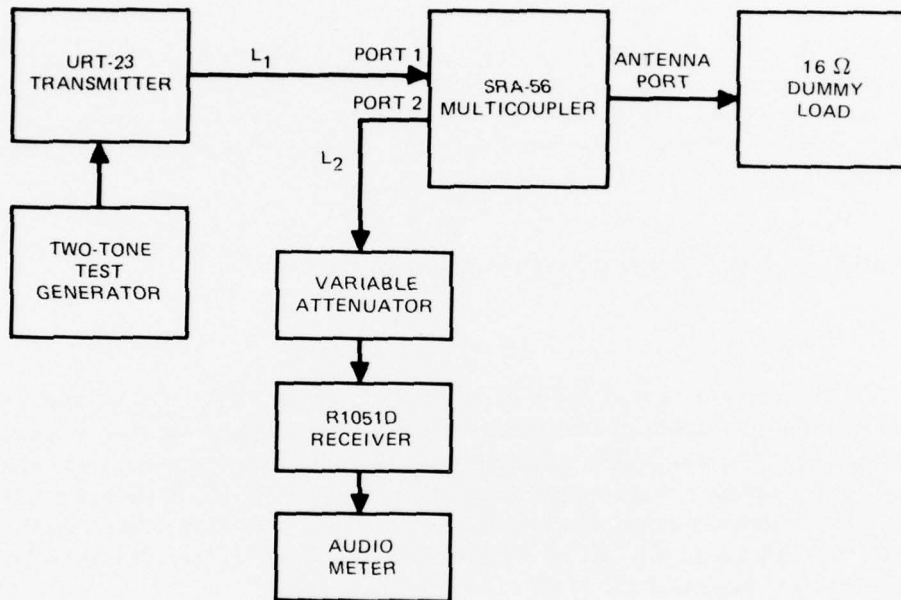

Figure 10. Isolation test configuration

These measurements were made twice over the 2 to 6 MHz range, once for each of two different cable lengths between the transmitter and multicoupler, to increase the size of the statistical sample.

Multicoupler isolation was computed by using these data together with transmitter noise, interpolated between measured calibration points, and receiver noise figure. (See Calibration Measurements.)

The response of the receiver to a signal injected through the 40 dB coupler was checked with the transmitter both keyed and unkeyed, to detect receiver desensitization.

## RESULTS

The results of these measurements are shown in exhibit 1. The multicoupler isolation was computed from the following equation:

$$\text{Isolation (in dB)} = \text{transmitter noise (in dBm)} - \text{received noise (in dBm)}$$

Received noise was calculated as follows from the measured noise power density, NPD. (NPD equals the receiver noise figure plus the attenuator setting.)

$$\text{Received noise (in dB)} = -174 \text{ (dBm at kT)} + \text{NPD (in dB over kT)} + 10 \log_{10} 3000$$

(the assumed received bandwidth).

Since the figures for transmitter noise reflect the same assumed 3 kHz receiver bandwidth, these terms cancel. And since the same receiver was used for the transmitter noise measurements, its actual effective noise bandwidth cancels out of the equation. The results were plotted in the cumulative distribution of figure 9. There was no observable receiver desensitization.

## INTERMODULATION PRODUCT MEASUREMENTS

### PROCEDURE

The test configuration of figure 11 was used to measure IM products. The transmitters provided threat carrier signals at 800–1000 watts each. To minimize the load as a source of IM, a transmission line was used as a dummy load. The measurement process was identical to that used for the isolation measurements in that it used the R1051D receiver as a calibrated detector. The observed spurious response is a carrier in this case, rather than broadband noise; therefore the assumed 3 kHz receiver bandwidth does not cancel. But the scatter in the measurements is so large that the  $\pm 1$  dB error is insignificant.

As shown in figure 11, the observation point was at either a third multicoupler port or the receive signal port of the CU-2113 coupler-isolator. The CU-1799 receiver coupler was used to isolate the receiver from the direct threat signals.

The measured IM levels were corrected for CU-1799 loss, SRA-56 loss, and CU-2113 loss (where applicable). These corrections were measured as part of the calibration process.

The various means used to identify the source of observed IM products included component substitution, observation of frequency dependence, and the effects of physical disturbances (pounding a fist on the multicoupler drawer or tightening connections). Two different SRA-56 multicouplers (four drawers each) were used in these tests.

Table 3-1

2-6 MHz System Isolation Data

Frequency Separation: 158  
Isolation Test Configuration  
Cable lengths:

1. L1 = 24', L2 = 57 ft.
2. L1 = 57', L2 = 24 ft.

Table 3-1 (continued)

2-6 MHz System Isolation Data

Frequency Separation: 158  
Isolation Test Configuration  
Cable lengths:

1. L1 = 24', L2 = 57 ft.
2. L1 = 57', L2 = 24 ft.

FREQUENCY (MHz)	RX	TX	TX #	CABLE LENGTHS	ATT. SETTINGS	RX NF	N.P.D. (dB)	TX-TO-SE ISOLATION (dB)	Observed	Sheet	of	Sheets
2000	2300	2	2	1	15	11	26	-58	55			
2200	2530	2	2	1	13	10	23	-58	58			
2300	2000	1	2	1	17	10	19	-60	62			
2400	2760	2	2	1	32	10	39	-59	40			
2530	2200	1	2	1	16	9	26	-64	55			
2600	2990	2	2	1	11	8	19	-59	61			
2760	2400	1	2	1	10	8	18	-70	51			
2800	3220	2	2	1	22	8	30	-59	50			
2990	2600	1	2	1	1	8	9	-70	60			
3200	3680	2	2	1	21	10	31	-54	50			
3220	2900	1	2	1	5	10	15	-69	55			
3600	4140	2	2	1	24	9	33	-57	49			
3680	3200	1	2	1	14	9	23	-69	59			
					2	0	3		67			

FREQUENCY (MHz)	RX	TX	TX #	CABLE LENGTHS	ATT. SETTINGS	RX NF	N.P.D. (dB)	TX-TO-SE ISOLATION (dB)	Observed	Sheet	of	Sheets
4000	4600	2	2	1	15	11	26	-58	55			
4140	3600	1	2	1	13	10	23	-58	58			
4400	5060	2	2	1	17	10	19	-60	62			
4600	4000	1	2	1	32	10	39	-59	40			
4800	5620	2	2	1	16	9	26	-64	55			
5060	4400	1	2	1	11	8	19	-59	61			
5200	5980	2	2	1	10	8	18	-70	51			
5520	4800	1	2	1	22	8	30	-59	50			
5600	5480	1	2	1	1	8	9	-70	60			
5880	5100	2	2	1	21	10	31	-54	50			
5980	5200	1	2	1	5	10	15	-69	55			
					2	0	3		67			

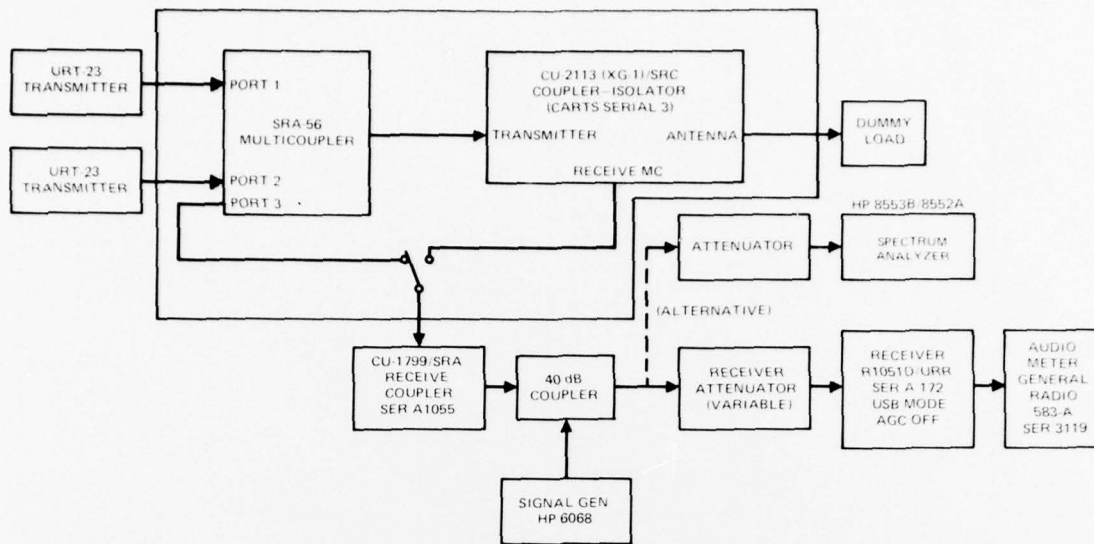

Figure 11. IM test configuration.

### RESULTS—SRA-56 IM GENERATION

The results of the IM product measurement are listed in table 3. The IM levels are referred to an equivalent signal at the antenna port of the SRA-56 multicoupler. With the CU-2113 disconnected, the SRA-56 multicoupler was the dominant source of IM products.

Table 3. SRA-56 IM product measurement

Frequency, kHz		Receiver	Separation, %	Multicoupler	Intermodulation	
Transmitters	Order				Level, dBm	
1	2					
2400	2760	2040	15	1	3rd	-93
2400	2760	3120	15	1	3rd	-77
5200	5980	4420	15	1	3rd	-64
5200	5980	4420	15	2	3rd	-71
2400	2520	2640	5	2	3rd	-59
2400	2520	2280	5	2	3rd	-65
5200	5460	4940	5	1	3rd	-58
2400	2520	2760	5	2	5th	-88
2400	2520	2160	5	2	5th	-106
5200	5980	3640	15	1	5th	-95

## RESULTS—CU-2113 IM GENERATION

The CU-2113 coupler-isolator was tested for IM generation both by observing IM products at a third port of the SRA-56 and by observing those products at its own RECEIVE MC port.

The first method tended to confirm that the SRA-56 was the dominant source of IM generation. The second indicated that there may have been some IM generation in the receive isolation circuit of the coupler-isolator. Although the IM levels determined by these tests were not high enough to be classed as a performance deficiency, the outcome is at variance with previous results which indicated much less IM generation for this unit. Production units, when available, should be tested for IM generation.

## CALIBRATION MEASUREMENTS

The following calibration measurements were performed:

Receiver noise figure

Transmitter noise

CU-2113 receive port isolation

## RECEIVER NOISE FIGURE

An RCA portable noise generator set (serial 11) was used to measure the R1051D receiver noise figure. The entries in table 4 reflect these measurements.

Table 4. URA-38 isolation of broadband transmitter noise

Frequency			Rcvr NF, dB	Amb Noise, dB Over Rcvr Noise	Xmtr Noise, dB Over Rcvr Noise	Xmtr Noise, dBm	Xmt/Rcv Cplg, dB	Aprnt Xmtr Noise, dB	Meas Xmtr Noise, dB	URA-38 Isln, dB
Xmt	Rcv	Separation, %								
6835	5810	17.6	12	18	21	-109	-27	-82	-81	1
6835	7860	15	12	11	19	-108	-28	-80	-86	-6
9305	8333	11.7	13	10	13	-116	-29	-87	—	—
9305	11 274	21	11	6	7	-128	-34	-94	—	—
16 100	13 685	17.6	12	14	14	<-120	-37	<-83	-90	—
16 100	18 515	15	14	12	18	-108	-34	-74	-74	0

## TRANSMITTER NOISE

Transmitter noise was measured at the output of the cable load, with one transmitter keyed with a two-tone test signal. In all other respects the measurement configuration was that of figure 11. The results of these measurements are reflected in table 4.

Two observations are relevant to future noise measurements on Link 11 transmitters:

Broadband noise was significantly higher when the transmitter was keyed with the two-tone test signal in the USB mode than when it was keyed for cw carrier transmission.

The rather high levels of broadband noise measured for these transmitters may be related to the 400 Hz power supply. In measurements, 60 Hz units of the URT-23 transmitter have shown a lower noise level.

## CU-2113 ISOLATION

Isolation between the TRANSMITTER and RECEIVE MC ports of the CU-2113 coupler-isolator was checked with a spectrum analyzer. Results were substantially in agreement with previously published results (ref 7).

## 6-30 MHz SYSTEM EVALUATION

### SYSTEM ALTERNATIVES

It is assumed that the small ship will not be equipped with broadband antennas for 6-30 MHz. A simple vertical whip is the antenna that will probably be available. A base tuner is used to match the antenna for transmitting. The transmitting whip cannot be shared. Three system configurations can be used with vertical whip antennas:

Transmit/receive on one whip antenna, transmitter matched with URA-38 base tuner, and receiver protected by CU-1799 receiving coupler.

Transmit/receive on separate antennas, transmitter matched with URA-38 base tuner, and a separate shared receive system using a modified CU-1799 receive antenna coupler.

Transmit/receive on one whip antenna, with a new selective base tuner—the selective antenna coupler system (SACS).

The first alternative is evaluated below. It and the second alternative share the difficulties associated with mistuning of the URA-38 in the presence of interfering signals (ref 11). The second alternative requires modification of the CU-1799 to permit the receive coupler to recover quickly from an overload condition. The third alternative is the most desirable from a technical point of view, but it is not yet developed. The system under evaluation is shown in figure 12.

---

11. NOSC Technical Document NELC TD 170, Mistuning of AN/URA-38 and AN/URA-38A Antenna Coupler Groups in the Presence of Interfering Signals, by JL Lievens, 20 March 1972

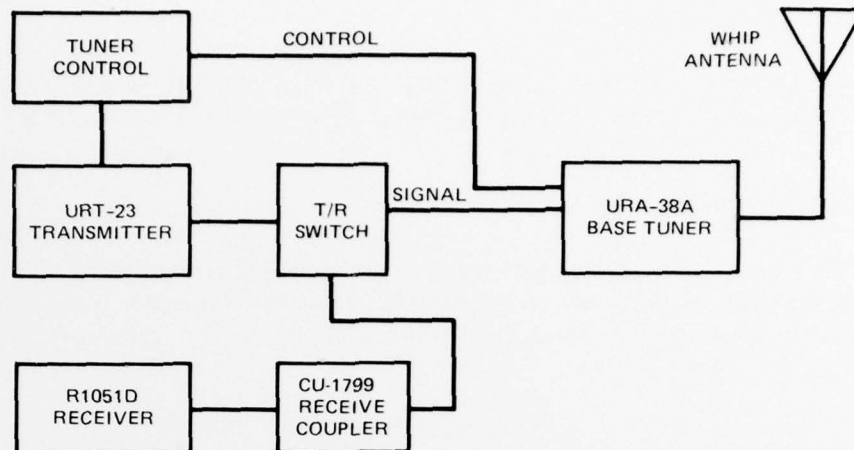

Figure 12. 6-30 MHz baseline configuration.

### TRANSMIT MODE MISTUNING

The function of the URA-38A is to couple a signal line to a standard 35 foot whip. Mistuning of this unit may occur in the presence of interfering signals. This problem appears to be most severe between 6 and 10 MHz (ref 11). The following steps are recommended to minimize it:

Switch the coupler control to manual after tune-up.

Record the settings for coupler tuning elements for use in the silent tune method.

Shipboard evaluations on a small ship should determine whether these steps are adequate. A 3 dB pad inserted in the transmission line at the transmitter during the tuning sequence will lessen the degree of coupler mistuning caused by other radiating sources. This feature is not incorporated in the system shown in figure 12.

### TRANSMIT MODE INTERMODULATION PRODUCT GENERATION

The mistuning problem is a symptom of inadequate isolation between transmitters operating on separate antennas. This lack of isolation might be expected to cause IM product generation within the transmitters. A limited number of measurements (see Tests of the 6-30 MHz System) were inconclusive on this point; transmitter-generated third order IM was probably observed, but fifth and seventh order products were below other IM sources in the measurement setup.

Estimates indicate that transmitter-generated IM products may be well above topside-generated levels (ref 3).

## **TRANSMIT MODE MONITORING**

A function of the T/R switch is to couple the receiver to the transmitter for monitoring. As in the 2-6 MHz system, no performance problem is evident in this function.

## **RECEIVE MODE NOISE FIGURE**

The receive system noise figure is shown in figure 6. The noise figure of the R1051D receiver is typically 16 dB between 6 and 30 MHz. On-channel insertion loss of the CU-1799 receive multicoupler varied between 4 and 10 dB. Noise figure is marginally satisfactory at 30 MHz.

## **RECEIVE MODE ISOLATION**

The CU-1799 provides ample isolation from simultaneously operating transmitters at 15% frequency separation. The sum of antenna and multicoupler isolation is in excess of 90 dB.

## **TRANSMITTER BROADBAND NOISE**

The URA-38 tuner provides little or no rejection of transmitter noise and spurious signals. Analysis based on ship separation of 35 feet and assuming a tentative specification of -70 dBm broadband noise between 6 and 30 MHz measured in a 3 kHz bandwidth (ref 9) indicates that transmitter noise will be 18-23 dB in excess of the quasi-minimum noise objective. Whip decoupling is treated in detail in reference 11.

Transmitter noise actually observed (see Tests of the 6-30 MHz System) was -80 to -90 dBm. If transmitter measurements verify these broadband transmitter noise levels, transmitter noise exceeds quasi-minimum noise by 3 to 8 dB. Although this situation could perhaps be tolerated, the technical objectives are far from met.

## **SPURIOUS GENERATION**

Limited measurements (see Tests of the 6-30 MHz System) could not discriminate between IM products generated in the URA-38 tuner and IM sources in the environment of the antenna. No conclusion could be reached concerning possible IM generation in the URA-38.

## **TESTS OF THE 6-30 MHz SYSTEM**

Laboratory tests of the 6-30 MHz system were made to confirm the expected difficulties surrounding broadband transmitter noise and transmitter-generated IM products. Transmitter noise levels were then calibrated by a separate measurement.

## COUPLER ISOLATION MEASUREMENTS

Coupling of broadband noise from the URT-23 transmitter, through the URA-38 whip tuner and associated antenna, to a second whip antenna 35 feet away was measured by using the test configuration of figure 13. The variable attenuator was adjusted for a 3 dB increase in receiver noise when the transmitter was keyed with a two-tone test signal.

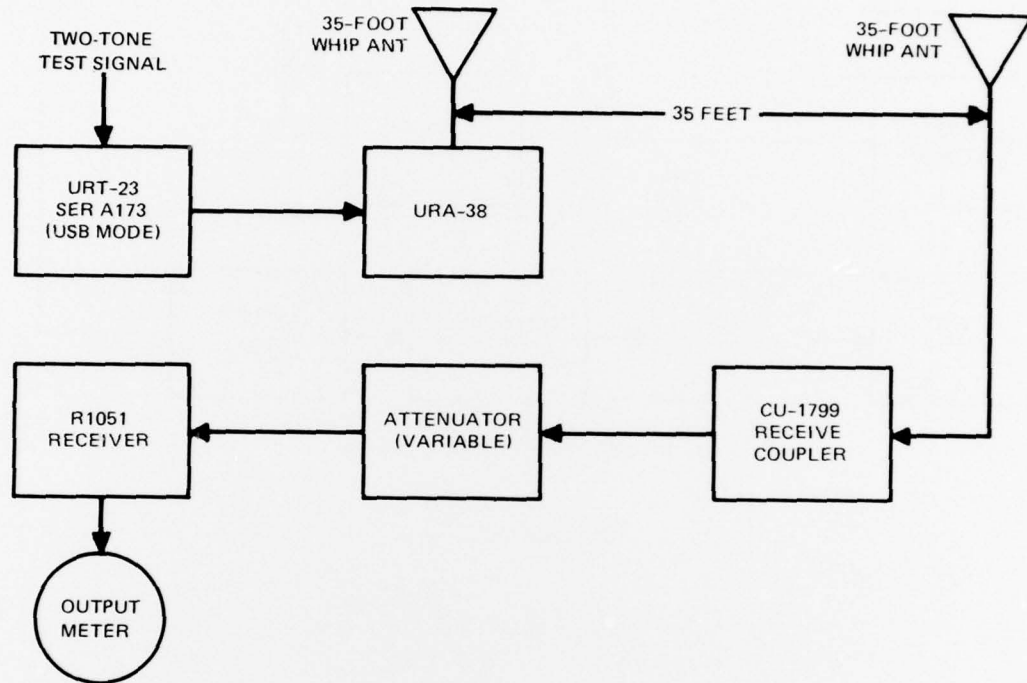

Figure 13. Whip tuner isolation test configuration.

The results of these tests are shown in table 4. The tests were necessarily performed during radiation on assigned frequencies, and receive frequencies were constrained by the lack of a tuner on the receive whip. Measurements were limited by the ambient atmospheric noise level.

The few measurements which permit a direct comparison with the measured transmitter noise confirm that the URA-38 provides no effective isolation function.

## INTERMODULATION PRODUCT MEASUREMENTS

Because of the lack of isolation between simultaneously operating transmitters, transmitter-generated IM products may be a dominant source of intermodulation interference.

The test configuration of figure 14 was used to generate the data shown in table 5. Analysis of these data (ref 3) indicates that third order IM products were in fact dominated by transmitter-generated IM. Unidentified sources, either in the environment of the antenna or in the URA-38, dominated fifth and seventh order products.

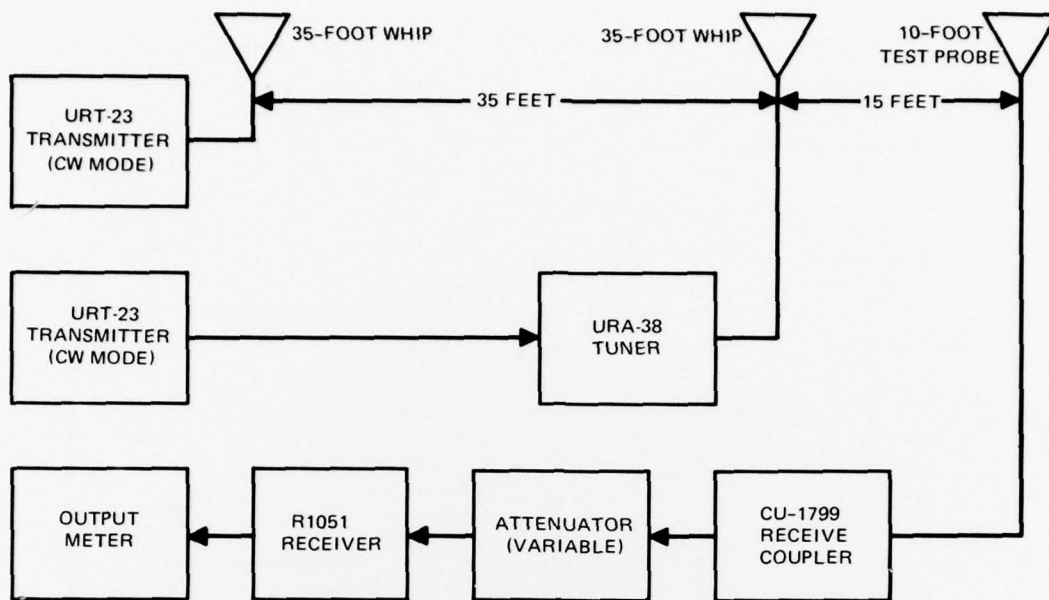

Figure 14. Intermodulation test configuration.

Table 5. Whip configuration intermodulation measurements (xmtr 1—5865 kHz, xmtr 2—6835 kHz).

Rcvr Freq, kHz	IM Order	IM Level			Loss in Rcvr Probe Sys, dB	IM Available Power, dBm,	T/R Isln, dB	IM Level Ref to Xmtr, dBm
		Rcvr, dB Over Rcvr Noise	Rcvr, dBm	Equiv Rcvr IM Level Referred to Ant, dBm				
7805	3rd	81	-46	-36	36	0	54	+18
4895	3rd	50	-77	-66	43	-23	62	-4
8775	5th	34	-93	-84	33	-51	41	-43
3925	5th	19	-108	-96	47	-49	83	-13
9745	7th	16	-111	-103	31	-71	44	-59
2955	7th	-2	-129	-116	51	-65	100	-16

## TRANSMITTER NOISE CALIBRATION

The test configuration of figure 15 was used to generate the measured transmitter noise, and the results are shown in table 6. These results were used to compute URA-38 isolation. The transmitter was used to provide a realistic test of rf distribution components; transmitter testing was not an objective of this work. It was noted, however, that the URT-23 transmitters used for this testing exhibited considerably less broadband noise than those used for the 2 to 6 MHz testing. Possibly the difference is in the power supplies: the transmitters used for this test were powered by 60 Hz supplies, whereas the poorer noise performance in the 2-6 MHz tests was obtained with units powered by 400 Hz supplies. Transmitter testing should take these alternatives into account.

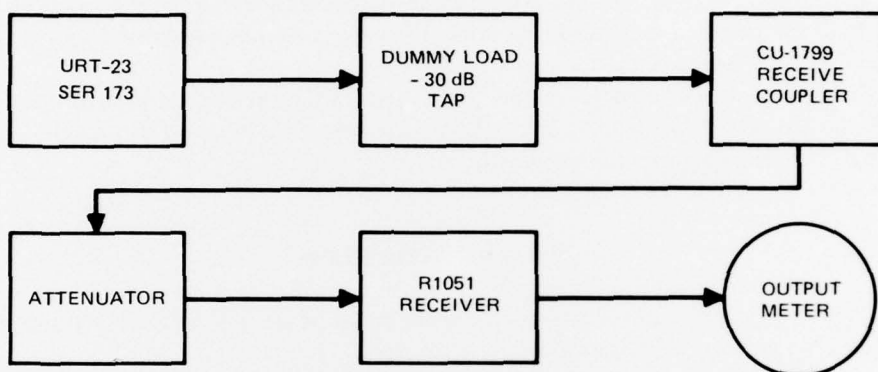

Figure 15. Transmitter noise measurement configuration.

Table 6. Transmitter noise calibration.

Xmt Freq, kHz	Rcv Freq, kHz	Rcv NF, dB	CU-1799 Loss, dB	Dummy Coupling, dB	Xmtr Noise, dB over Rcvr Noise	Xmtr Noise, dBm
2300	2000	12	14	-30	6	-77
2300	2600	9	13	-30	11	-76
5865	4985	12	10	-30	2	-85
5865	6745	12	10	-30	2	-85
6835	5810	12	10	-30	6	-81
6835	7860	12	9	-30	2	-86
9803	8333	13	9	-30	9	-78
9803	11 274	11	8	-30	-6	-96
16 100	13 685	12	8	-30	-1	-90
16 100	18 515	14	6	-30	13	-76

## CONCLUSIONS

The 2-6 MHz baseline configuration essentially meets the technical objectives, which would indicate a favorable operational evaluation for this part of the configuration. Although broadband transmitter noise isolation may be marginal, depending on the noise performance of the modified URT-23 transmitters used in the Link 11 hf radio, it is extremely unlikely (probability less than 0.1%) that this characteristic will degrade the operational performance of the 2-6 MHz configuration.

The 6-30 MHz configuration does not meet the technical objectives for transmitter broadband noise isolation. Depending on the transmitter noise performance, this problem could be serious. This deficiency alone would be sufficient for rejection of the 6-30 MHz configuration if good alternatives existed.

In addition, the lack of transmitter isolation causes a well-documented problem with mistuning in the presence of interfering transmissions, as well as a potential source of IM generation in the transmitter.

In view of the deficiencies of the 6-30 MHz configuration, it is difficult to recommend it; but there are presently no good alternatives. Problems are inherent in the URA-38 whip tuner as a transmitting system component.

## RECOMMENDATIONS

These recommendations assume the interim use of the URA-38 whip tuner, but only until a selective tuner can be acquired.

1. Adopt the 2-6 MHz configuration.
2. Plan a transition to a selective tuner to replace the URA-38 tuners on all transmitting whips on Link 11 equipped ships.
3. Ensure frequency management to avoid the generation of third order IM products by transmitters that are operating simultaneously.
4. Check rf distribution installations for excessive IM generation.
5. Minimize mistuning problems with the URA-38 tuner by switching the coupler control to manual after tune-up, recording the settings of coupler tuning elements for use in the silent tune method, and—if shipboard tests on a small ship indicate persistent mistuning problems—considering insertion of a 3 dB pad during the tuning sequence.
6. Because modulation affects noise levels and because power supply options (60 or 400 Hz) may affect noise levels, include broadband noise measurements in transmitter testing.

## REFERENCES

- i. Ketron, Inc report KRF 24-75, Operational Test and Evaluation of Communications Systems, by WC Hardy, JC Wilson, and JR Fish, Contract N00039-74-C-0123, 23 March 1975.
2. NOSC Technical Report NELC TR 1786, TRED Hf Communication System Analysis, by WM Chase and CW Tirrell, 24 September 1971.
3. NOSC TD 151, EMC Analysis for AN/USC-34(XN-1) Link 11 Hf Radio, by LJ Kinkel, 1 March 1978.
4. NOSC Technical Report NELC TR 1585, Shipboard Radio Frequency Interference Investigation: Status Report, by WE Gustafson and GC Salisbury, 18 September 1968.
5. NAVSHIPS 0967-284-6010, Technical Manual for Antenna Coupler Groups AN/SRA-56, AN/SRA-57, and AN/SRA-58, 27 March 1969.
6. MIL-R-23637G, Specification for R1051G/URR Receiver, October 1977.
7. NOSC Technical Document NELC TD 437, CU-2113(XG-1)/SRC Coupler-Isolator: Technical Evaluation, by IC Olson and JL Lievens, 31 July 1975.
8. Specification: AN/URT-23( ) (V) Modification for Link 11 Data Communications, 24 February 1977 (working paper).
9. Military Specification: High Frequency Radio Set, 17 February 1976 (working paper).
10. International Radio Consultative Committee (CCIR) Report 322, World Distribution and Characteristics of Atmospheric Radio Noise, International Telecommunication Union, Geneva, 1964.
11. NOSC Technical Document NELC TD 170, Mistuning of AN/URA-38 and AN/URA-38A Antenna Coupler Groups in the Presence of Interfering Signals, by JL Lievens, 20 March 1972.

## **APPENDIX A: FUNCTIONS OF AN RF DISTRIBUTION SYSTEM**

### **COUPLING AND ISOLATION**

#### **Transmit Mode**

- Couple the transmitter to the transmitting antenna for power transfer
- Couple the receiver to the transmitter for monitoring
- Isolate transmitters sharing the same antenna and/or provide additional isolation between transmitters on different antennas

#### **Receive Mode**

- Couple the receiver to antenna to achieve design compromise between noise figure and strong-signal performance
- Isolate receivers sharing an antenna
- Isolate the receiver from unkeyed transmitter noise
- Isolate the receiver from simultaneously operating transmitters

#### **Noise and Spurious Signal Isolation**

- Isolate transmitter broadband noise and spurious signals
- Minimize spurious signal generation within the rf distribution system

### **SWITCHING**

#### **Transmit-receive switching**

#### **Configuration switching**

### **PROTECTION**

- Protect the receiver from damaging signal levels
- Protect the transmitter from damage
- Protect the rf distribution system from damaging signal levels

## **TUNING**

Provide means (controls and indicators, or automation) for tuning rf distribution components

Provide a dummy load for transmitter tuning

## **PERFORMANCE MONITORING AND FAULT ISOLATION**