

AD-A060 093

BOEING VERTOL CO PHILADELPHIA PA  
CANOPY GLINT SCREENING INVESTIGATION.(U)  
SEP 78 S J BLEWITT, D R GUNDLING

F/G 1/3

UNCLASSIFIED

USARTL-TR-78-34

DAAJ02-76-C-0061

NL

| OF |

AD  
A0 60093



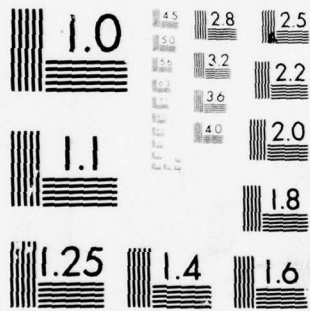

MICROCOPY RESOLUTION TEST CHART  
 NATIONAL BUREAU OF STANDARDS-1963-A

AD A060093

USARTL-TR-78-34

12

LEVEL II



CANOPY GLINT SCREENING INVESTIGATION

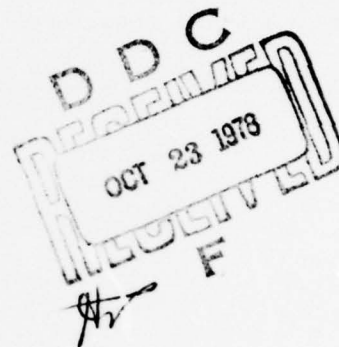

DDC FILE COPY

Stephen J. Blewitt, David R. Gundling  
BOEING VERTOL COMPANY  
(A DIVISION of The Boeing Company)  
Philadelphia, Penn. 19142

September 1978

Final Report for Period August 1976 - July 1977

Approved for public release;  
distribution unlimited.

Prepared for  
APPLIED TECHNOLOGY LABORATORY  
U. S. ARMY RESEARCH AND TECHNOLOGY LABORATORIES (AVRADCOM)  
Fort Eustis, Va. 23604

78 10 19 050

## APPLIED TECHNOLOGY LABORATORY POSITION STATEMENT

This program identified the complexity of the problems associated with helicopter canopy internal reflections and sun glint signature. A satisfactory solution was not found for solving all these problems. However, a new technique was discovered that has the potential of eliminating or reducing reflections from instrument panel lighting. Results of this research program will advance the technology needed to improve operational effectiveness and night flight safety of Army aircraft.

Earl C. Gilbert of the Aeronautical Systems Division served as project engineer for this effort.

### DISCLAIMERS

The findings in this report are not to be construed as an official Department of the Army position unless so designated by other authorized documents.

When Government drawings, specifications, or other data are used for any purpose other than in connection with a definitely related Government procurement operation, the United States Government thereby incurs no responsibility nor any obligation whatsoever; and the fact that the Government may have formulated, furnished, or in any way supplied the said drawings, specifications, or other data is not to be regarded by implication or otherwise as in any manner licensing the holder or any other person or corporation, or conveying any rights or permission, to manufacture, use, or sell any patented invention that may in any way be related thereto.

Trade names cited in this report do not constitute an official endorsement or approval of the use of such commercial hardware or software.

### DISPOSITION INSTRUCTIONS

Destroy this report when no longer needed. Do not return it to the originator.



## SUMMARY

The effectiveness of helicopters in tactical situations is directly related to their ability to survive in an enemy threat environment. Several defense options exist but the most effective is the denial of target acquisition data to the enemy offense. The primary detector employed by the enemy against tactical helicopters flying nap-of-the-earth (NOE) is the human eye. Recognition of this fact led to numerous analytical studies and field tests to define factors involved in visual detection of helicopters. These studies and tests identified sun glint reflection from transparencies as an important detection cue at ranges beyond 2 kilometers (km). Due to the critical nature of the sun glint problem and the need to find a technique that could be incorporated into the AAH and AH-1S then under development, experimental flat-plate canopy designs were incorporated into these systems to control sun glint signature. The flat-plate canopy looked promising and is effective in controlling sun glint; however, subsequent testing has shown that it introduces other problems. One problem is unacceptable internal reflections from both external and internal sources.

This program was undertaken in an attempt to overcome the problems encountered with flat-plate designs, while retaining the desirable features. Another concern was that alternative ideas had not been fully explored due to the initial attractiveness of the flat-plate concept. The intent of the program was to define in the initial phase of the effort as many possible solutions as could be conceived, with the only constraints being that they might have some potential in controlling canopy reflection problems and that they meet Army attack and observation helicopter operational and physical requirements.

Twenty-five concepts were identified which reduced, eliminated, or otherwise addressed the internal and external canopy reflection problems. The concepts identified were then given a comprehensive engineering evaluation of their potential effectiveness and feasibility. Seven of these concepts completely eliminated transparencies and three others involved mechanical reorientation of transparencies to avoid sun reflections. No additional work on these ten concepts was undertaken in this study. Full-scale soft mockups of three other concepts were constructed along with standard AH-1 and OH-58 canopies. These were then tested to evaluate their effectiveness against the baseline configurations. Solutions to both internal and external reflection problems were examined. On the basis of the tests and analyses performed in this study, the best solution at this time for addressing the internal and external reflection problems, is a single facet flat-panel canopy. It

should be canted outward at the top, with some kind of very small louvers in the overhead panels to suppress internal reflections from external sources, and should use light control film over the cockpit instrument faces to reduce internal reflections from the instruments.

PREFACE

This report presents the results of a study to develop and evaluate concepts to reduce external sun glint detection cues from helicopter cockpit transparencies and to reduce associated internal reflection problems. The study was conducted under Contract DAAJ02-76-C-0061 for the Applied Technology Laboratory, U.S. Army Research and Technology Laboratories, Fort Eustis, Virginia.

USARTL technical direction was provided by Mr. E. Gilbert and Mr. J. Ladd.

Project engineers for the Boeing Vertol Company were Mr. S. J. Blewitt and Mr. D. R. Gundling, assisted by Mr. R. Domenic, all of whom are employed in the Product Assurance Department. Program management and technical direction was provided by Mr. J. Gonsalves.

ADMISSION for	
NIS	White Section <input checked="" type="checkbox"/>
DD	B.I. Section <input type="checkbox"/>
DISPATCH	
BY	
DISPATCH/INVENTORY CODES	
SERIAL	
A	

TABLE OF CONTENTS

	<u>Page</u>
Summary . . . . .	3
Preface . . . . .	5
List of Illustrations . . . . .	8
List of Tables. . . . .	9
Introduction. . . . .	10
Program Objectives and Approach. . . . .	13
Concept Identification. . . . .	16
Requirements and Constraints . . . . .	16
Concepts . . . . .	16
Concept Selection . . . . .	19
Preliminary Tests. . . . .	19
Evaluation Matrix. . . . .	25
Concept Ranking. . . . .	27
Soft Mockup Construction . . . . .	33
AH-1 . . . . .	33
OH-58. . . . .	34
Concept Testing . . . . .	34
Internal Reflections from Internal Sources . . . . .	34
Internal Reflections from External Sources . . . . .	38
External Reflections from External Sources . . . . .	45
Conclusions . . . . .	48
Recommendations . . . . .	49
References. . . . .	40
Appendix A. Concept Evaluation . . . . .	51

LIST OF ILLUSTRATIONS

<u>Figure</u>		<u>Page</u>
1	Program Block Diagram . . . . .	14
2	Test Panels . . . . .	21
3	Screen Configurations . . . . .	22
4	Sun Glint Signature of Tilted Flat Panels . .	24
5	Double-Facet Flat-Panel Concept . . . . .	26
6	Internal Reflections from Internal and External Sources. . . . .	31
7	Soft Mockup of Standard AH-1 Canopy . . . . .	35
8	Soft Mockup of Standard OH-58 Canopy. . . . .	35
9	Soft Mockup of Flat-Plate AH-1S Canopy. . . . .	36
10	Soft Mockup of Flat-Plate OH-58 Canopy. . . . .	36
11	Double-Facet Flat-Plate Canopy. . . . .	37
12	Simulated Instrument Panel with Room Lights On . . . . .	39
13	Simulated Instrument Panel with Room Lights Off. . . . .	40
14	Simulated Instrument Panel with Light Control Film. . . . .	40
15	AH-1S Canopy with Light Guide . . . . .	42
16	Glint from Soft Mockup of Flat-Plate OH-58 Canopy. . . . .	47
17	Glint from Soft Mockup of Standard OH-58 Canopy. . . . .	48
A-1	Double-Facet Flat Panel . . . . .	51
A-2	Open Cockpit. . . . .	52
A-3	No Canopy, with Covers . . . . .	53

<u>Figure</u>		<u>Page</u>
A-4	Screens . . . . .	54
A-5	No Canopy, with Visionics . . . . .	55
A-6	Air Screen. . . . .	56
A-7	Retractable or Removable Panels . . . . .	57
A-8	Louvered Canopy . . . . .	58
A-9	Flat Panels . . . . .	59
A-10	Bendable Panels . . . . .	60
A-11	Rotating Panels . . . . .	61
A-12	Small Canopy . . . . .	62
A-13	Small Turrets . . . . .	63
A-14	Canopy with Fences. . . . .	64
A-15	Canopy with Shade . . . . .	65
A-16	One-Way Mirror. . . . .	66
A-17	Large Diameter Rotor Hub. . . . .	67
A-18	High-Solidity Rotor . . . . .	68
A-19	Rough-Surface Canopy. . . . .	69

LIST OF TABLES

<u>Table</u>		<u>Page</u>
1	Canopy Concepts. . . . .	18
2	Final Composite Evaluation Matrix. . . . .	28
3	Sun Glint Evaluation . . . . .	29
4	Panel Tilt Evaluation. . . . .	32
5	Internal Reflection Test Results . . . . .	43
6	Internal Reflection Test Results, Canopies Modified. . . . .	44
7	Internal Reflection Test Results -- OH-58. . . . .	45

## INTRODUCTION

Current operational doctrine for the attack helicopter specifies nap-of-the-earth (NOE) flight into the target area with the intent of preserving a complete radar and visual mask between the target and the helicopter. The aural signature is somewhat attenuated when the aircraft is behind mask at stand-off range, and the ambient noise level at the observer location in a tank versus helicopter situation makes aural detection unlikely. Radar is less effective when the aircraft remains behind mask or within ground clutter, and moving target radar is used reluctantly for fear of exposing the user's location. After arriving at the target area, tactics call for the Scout or the Attack helicopter to pop up, retaining a terrain background, and to acquire the target. The helicopter becomes most vulnerable when line of sight with the target is established, and the key to increased survivability lies in denying or delaying visual detection of the helicopter by the ground observer when the line-of-sight condition is reached.

Army tests including the U.S. Army Europe, Joint Attack Helicopter Instrumented Evaluation, Project Masster series trials and the Combat Development Experimentation Command (CDEC) Experiment 43.8 (References 1, 2, 3) have identified various scout and attack helicopter characteristics as visual detection cues: rotor effects (glint, motion, and flicker), transparency effects (sun glint and sky reflections), and fuselage effects (shape, motion, sun glint, and color). At ranges of 2 kilometers or greater, the most significant detection cues are reflections from transparencies.

The detection of glint by an observer on the ground depends on the relative location of the observer, the aircraft, and the sun, and the azimuth angles of the aircraft and the sun. When the observer and the sun are located so that the line of sight from each to the surface in question is at the same angle to the surface but on opposite sides of the perpendicular, the observer will see the reflection of the sun on the surface. This is called specular reflection, and in the case of glass or plastic, a high percentage of the light incident on the sur-

1. HELICOPTER DISGUISE EVALUATION REPORT, MASSTER test Number 1029, Modern Army Selected Systems Test Evaluation and Review, Fort Hood, Texas, October 1972.
2. ATTACK HELICOPTER DAYLIGHT OFFENSE, USACDEC EXPERIMENT 43.8 GROUND TO AIR VISUAL DETECTION, Volume II, Phases I and IIA, U.S. Army Combat Development Experimentation Command, Fort Ord, California, August 1973.
3. JOINT ATTACK HELICOPTER INSTRUMENTED EVALUATION, Department of the Army, U.S. Army Europe, December 1972.

face is reflected to the observer. The glint seen by the observer is influenced by the curvature or lack of curvature of the reflecting surface.

To eliminate the possibility of an observer seeing a reflection, the geometry of the situation must be changed. This change can be achieved by eliminating the reflective surface, by preventing a direct line between the light source and the reflecting surface, or by preventing a direct line between the observer and the reflecting surface.

One-quarter wavelength coatings have been suggested for reducing reflectivity, but they are successful only in eliminating reflected light of certain wavelengths. Although multiple thin film layers of coatings can be applied, full-scale Army tests have shown that no significant decrease in detection is found using this technique (Reference 1).

In addition, these coated windshields had a tendency to scratch more easily and were difficult to maintain. The problem is made nearly unsolvable by the fact that the sun is so much brighter than anything else on the visual horizon. It can be 10 times brighter than the surrounding sky or 100 times brighter than surrounding terrain. So, when even a small percentage of this sun brightness is specularly reflected by a transparency, it is brighter than anything else in the background. On the other hand, if the sun is obscured by clouds the amount of reflected light is reduced, and coatings could be of some benefit under these circumstances.

Initial attempts at canopy geometry modification were made by the Land Warfare Laboratory (LWL), Aberdeen, Maryland in 1972-73 (Reference 4). This approach was suggested by the Applied Technology Laboratory. LWL constructed a flat-plate canopy which was mounted on an AH-1 over the standard canopy. The modified aircraft was flown side-by-side with a standard AH-1. Various turns and maneuvers were executed simultaneously, and a film of the testing graphically illustrated the reduced frequency and duration of canopy sun glint from the flat-plate canopy. However, when the flat-plate canopy did glint the result was a brief flash of apparently brighter intensity than the standard curved canopy. It should be noted that the flat-plate canopy was larger than necessary, so that it could be mounted over the standard canopy, but this testing did confirm the basic concept that flat-plate canopies could reduce the frequency and duration of sun glint.

- 
4. DeBenedictis, J. A., and Woestman, J. W., REDUCTION OF REFLECTIONS FROM HELICOPTER WINDSHIELDS, ROTOR BLADES, AND ROTOR HUB, LWL-CR-06P73A, Land Warfare Laboratory, Aberdeen, Maryland, April 1973.

Simultaneously the Boeing Company developed a flat-plate canopy configuration as the candidate for its AAH proposal. Laboratory simulation testing indicated significant reductions in canopy sun glint reflections were possible, and a full-scale mockup was built. Since that time the Army has adopted a flat-plate canopy as the choice for its attack helicopter.

During 1973 testing was performed by the Boeing Company under contract to the Army, using scale models. The models were photographed outdoors against various backgrounds, and the resulting 35MM slides were projected and viewed under controlled conditions by subjects who were asked to find the models in the scene. The test results showed that the AH-1 model with a standard canopy was detected more frequently than the AH-1 model with a flat-plate canopy (Reference 5).

Based on the results of the model tests, a contract was awarded by the Army to validate the conclusions through full-scale tests. The results of these tests are documented in a classified report (Reference 6).

More recently, in 1976 the Army conducted its own tests using a standard AH-1, an AH-1 equipped with a flat-plate canopy, and an AH-1 with a slightly curved canopy. Glint from the standard AH-1G canopy was observed during low and high sun angles. Glint from the AH-1Q flat-plate canopy was seldom seen at low sun angles. When observed the glint was very bright and presented a double flash of very short duration. Glint was not observed at high sun angles. Glint from the AH-1Q slightly curved canopy was shorter in duration but brighter than that from the AH-1G standard canopy during low sun angles. Glint was not observed at high sun angles. The major drawback to the flat-plate canopy during these tests, was the mirror-type reflections which appeared in the cockpit during operations over high intensity lights, which created an unsafe condition resulting in pilot vertigo. Louvers installed in the canopy reduced the reflections, but also decreased visibility. In the AH-1Q slightly curved canopy, distorted reflections were

5. Blewitt, S. J., INVESTIGATION OF HELICOPTER VISUAL DETECTION, Boeing Vertol Company; USAAMRDL Technical Report 74-72, U.S. Army Air Mobility Research and Development Laboratory, Fort Eustis, Virginia, September 1974, AD B000297L.
6. Gundling, D. R., and Domenic, R. E., EVALUATION OF CONTRAST REDUCTION TECHNIQUES, Boeing Vertol Company, USAAMRDL Technical Report 76-3, U.S. Army Air Mobility Research and Development Laboratory, Fort Eustis, Virginia, 1976, AD C006316L (Classified Confidential).

present, which were readily distinguishable from the light source and did not produce vertigo (Reference 7).

The most practical solution to the sun glint detection problem, at the present time, appears to be reducing the amount of reflection for elevation angles of interest to helicopters flying nap of the earth. With the helicopter close to the ground, simple geometry shows that potential observer-look angles rapidly approach 0 degrees in elevation as the range to the helicopter exceeds 1 kilometer. Therefore, a significant reduction in probability of detection can be achieved by reducing or eliminating reflections in a narrow band around the horizon. In addition to the flat panel concept, the other options open are shades, screens, panel orientation, and transparency size. Note that these approaches do not eliminate reflections, they reduce the probability of an observer detecting a reflection. This is achieved by reducing the number of possible directions from which the reflections can be seen.

The seriousness of the problems being encountered with experimental flat-panel concepts tested to date, the fact that no other concepts were under consideration for reducing canopy visual detection, and the solution of the reflection problems, were the primary reasons that this program was conceived. Its intent was to examine alternate concepts considering the work previously done, and to address the internal reflection problems as well.

#### PROGRAM OBJECTIVES AND APPROACH

The approach in this program, in addition to reviewing the limited amount of literature available in this area (Figure 1), was to provide a broad range of concepts for initial consideration, a sufficient analysis of the concepts to identify those that showed the most promise for further evaluation, and full-scale test for quantitative and qualitative evaluation of the effectiveness of the most promising concepts in reducing visual signature. This was a logical approach with low risk. Although it was expected that an originally conceived configuration might not prove to be effective after full-scale testing, the use of soft mockup techniques allowed for rapid reconfiguration or reconstruction of concepts.

7. Stewart, P. E., USER EVALUATION OF CANOPIES FOR THE AH-1 (U) HELICOPTER, U.S. Army Aircraft Development Test Activity (Provisional), Fort Rucker, Alabama, March 1976, AD-B010891L.

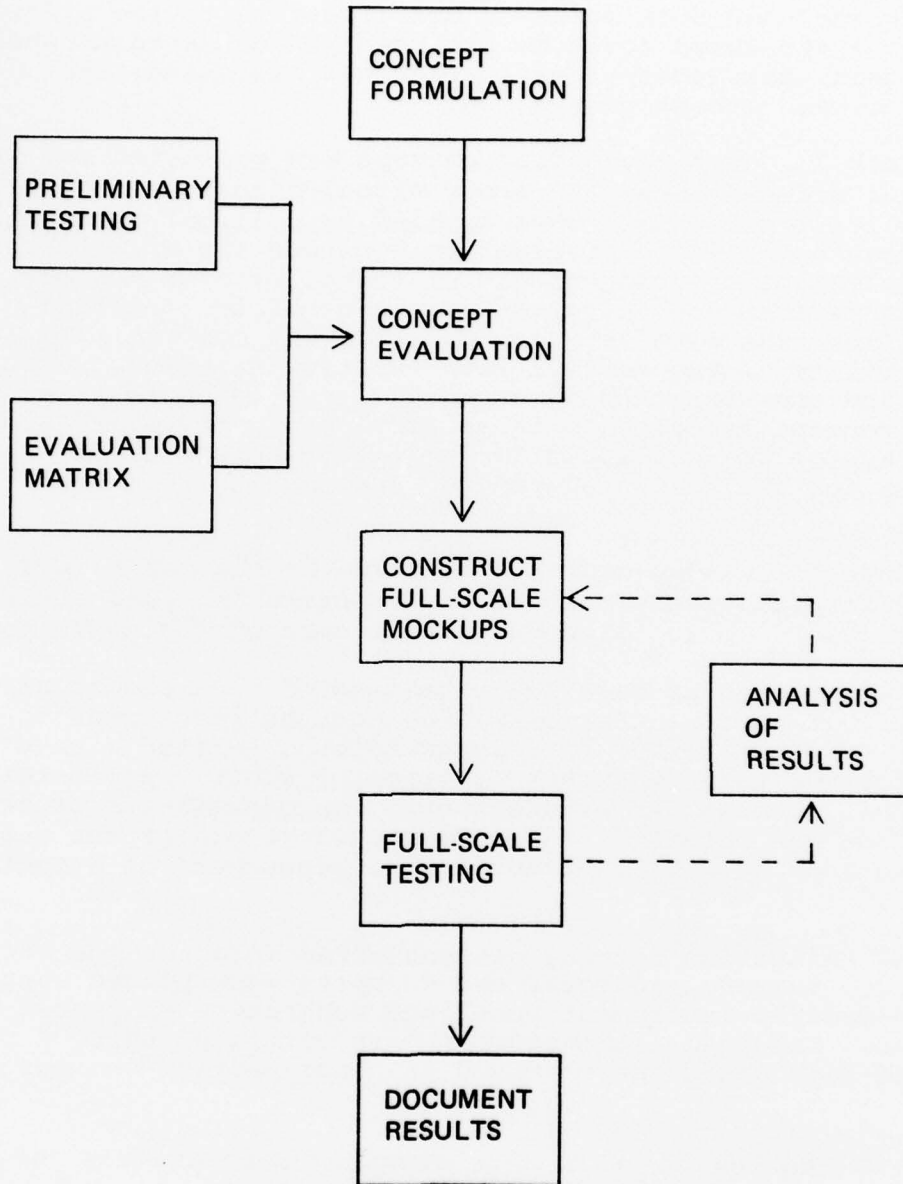

Figure 1. Program Block Diagram

Under Task I, potential visual-signature reduction concepts applicable to canopy transparencies were identified. These concepts included both built-in modifications to the aircraft and also those which could be attached and detached as needed. During this task, concept evaluation was minimized; the objective was concept generation.

Under Task II, each identified concept was evaluated for its potential effectiveness in canopy visual-signature reduction and for its practicality when applied to helicopters intended for combat operations. Evaluation included the effectiveness of visual-signature reduction, the effect of each concept on aircraft performance, aircraft maintainability, internal reflections from both external and internal sources, and compatibility of the concept with existing material. Crew safety and crew functioning aspects of new concepts were noted if the concept appeared to cause problems in those areas. A rating system was developed to facilitate selection of superior concepts for the full-scale mockup and testing in Tasks III and IV.

Under Task III, those concepts approved by the contracting officer for full-scale testing were constructed full scale, using the soft mockup procedures developed by Boeing Vertol.

Task IV consisted of full-scale testing of each promising concept. To perform the tests, the mockups were taken to a location where a near terrain background existed with a line of sight to an observer position of about 2 kilometers. The target concept was rotated until the maximum sun or sky reflection was obtained. A photographic record of the test view was made as well as a subjective assessment of detectability.

Internal reflection testing was conducted indoors. For reflections from internal sources, the canopies were placed over a small simulated instrument panel and subjective responses were recorded. External light sources were simulated using a small penlight-size light source moved in a set pattern outside the canopy.

In Task V the test results were examined subjectively and conclusions and recommendations were developed.

## CONCEPT IDENTIFICATION

### REQUIREMENTS AND CONSTRAINTS

Generation of concepts for reducing or eliminating reflections from transparent canopy surfaces began on an unconstrained basis. The main objectives in concept identification were to generate alternatives to current canopy configurations, with the constraints of making the aircraft less detectable than the standard attack and scout helicopters, and avoiding internal reflections to the aircrew.

Accordingly, attempts were made to identify the maximum number of distinct concepts with little or no judgment as to overall merit. By concentrating on distinct concepts rather than combinations, a better understanding of the individual effects was obtained. With a thorough understanding of individual effects, different concepts could then be combined, if required, with a more confident prediction of the combined effects. In addition, for the initial tries at concept formulation no restraints were considered as far as practicality or feasibility were concerned. This was to allow the free flow of ideas which could be worked into potential solutions to the problems.

The personnel participating in the concept development sessions were comprised of specialists from various skill backgrounds in the helicopter industry and were held in a relaxed noncritical environment. Although each individual had his own biases or restraints, the result was a plethora of ideas. Twenty-five "reasonable" concepts were culled from the suggestions made, seven of which completely eliminated transparencies.

In order to ensure that all possible solutions to the reflection problems were considered, an approach to concept identification was used which is similar to the approach for most survivability/vulnerability problems. In this general approach to S/V, four classes of solutions are considered: elimination of critical components, design for ballistic tolerance, armor protection, and redundancy of components. In this study, concept identification considered: elimination of transparencies, reflection tolerant designs such as flat panels, and reflection protection such as screens and fences. (There was no real counterpart to redundancy.)

### CONCEPTS

The list of candidate concepts can be divided into logical groups by considering the approaches to solving the problems. The first group consists of variations of the flat panel concept:

- Double Facet
- Outward Tilt
- Inward Tilt
- Vertical Sides
- Louvers
- Rotating Panels

The common element here was the use of flat panels in some size, shape or form, with the implication of redirecting the glint away from the eyes of the observer.

Another category called for elimination of the canopy:

- Open Cockpit
- Open Cockpit with Covers
- No Canopy with Visionics (some form of periscope or camera)

These concepts were the best from a reflection standpoint because they eliminated glass entirely, but they had other inherent problems, which will be discussed later.

A different approach made use of screens of varying mesh sizes placed over the canopy glass or used instead of the glass. Another concept in this category (or possibly in the no-canopy category) was the use of an air screen. This configuration consisted of a canopy tubular frame, but with no glass installed; instead, a high-pressure air flow coming from holes in the tubes would seal the cockpit.

Other solutions included shades, fences, rotor modifications, and small canopy size. Table 1 is a listing of the 25 canopy concepts considered in the evaluation phase of the program. The double-facet flat panel is included in the table although it did not appear in the original list. It was conceived as a result of preliminary testing performed to validate some of the other concepts.

TABLE 1. CANOPY CONCEPTS

---

1. Double-Facet Flat Panel
2. Open Cockpit
3. No Canopy, with Covers
4. Pure Screen
5. No Canopy, with Visionics
6. Air Screen
7. Retractable Panels
8. Removable Panels
9. Louvered Canopy
10. Flat Panel, Outward Tilt
11. Bendable Panels
12. Rotating Panels with Bellows
13. Flat Panel, Vertical Sides
14. Flat Panel, Inward Tilt
15. Small Size
16. Small Turrets
17. Honeycomb
18. Fences
19. Shade
20. Fine Mesh Screen
21. Coarse Mesh Screen
22. One-Way Mirror
23. Large-Diameter Rotor Hub
24. High Solidity Rotor
25. Rough-Surface Canopy

## CONCEPT SELECTION

### PRELIMINARY TESTS

In order to reduce the list of feasible canopy concepts to one or two with the greatest potential, three preliminary tests were performed.

#### First Test - Transparency Size Effects

The purpose of the test was to determine whether or not the observation of sun glint could be reduced by reducing the size of the transparency. Since one of the canopy concepts was based on a small canopy design, it was important to know if a reduced glass surface area would be beneficial, before proceeding further with this concept.

A series of external reflection tests were conducted on clear days between 0900 and 1030 on the east side of the Boeing Vertol engineering building near Philadelphia, Pennsylvania. The tests were conducted with observer-to-test-panel ranges of approximately 50 feet and 1320 feet (0.4 kilometer). The sun elevation was 35 to 45 degrees during testing. There were two observers.

The test specimen was a 24-inch by 36-inch plexiglass panel mounted in a frame, with a sliding cover which was used to cover portions of the plexiglass to reduce the area (see Figure 2). The size of the exposed transparency was reduced to 24 inches by 3 inches while the surface was reflecting the light of the sun.

The observers reported that reducing the size of the panel had no effect on reducing the observation of glint at these ranges. At the longer test distance there was no significant difference in the observation of glints from the full 24-inch by 36-inch panel and from the panel reduced to 24 inches by 3 inches. The results of this test implied that concepts for reducing glint based on reducing canopy size would not be effective.

#### Second Test - Effects of Screens

The purpose of this test was to determine whether or not screens of various mesh sizes and depths had the potential for reducing sun glint when placed over the transparency. The results were to be used to decide if additional consideration would be given to the suggested concepts using screens.

Two transparent test specimens were used to evaluate the benefits of screens with respect to the external reflection problem, the flat 24-inch by 36-inch panel from the previous tests and a curved 12-inch by 24-inch panel of plexiglass

which had a radius of curvature of 24 inches. The test specimens are shown in Figure 2.

Four screen configurations were tested. The first was common window screen with roughly 1/6-inch-square holes. The second was a sample of Kool Shade screen, which prevents sunlight from entering large windows on buildings. This screen is constructed of horizontal 1/16-inch-wide flat brass strips wired together on 1/2-inch centers to form a venetian blind type of screen. The black-painted flat strips are tilted 26 degrees from the horizontal with the rear edge high. The third configuration was a screen constructed of 1-inch-deep by 1/8-inch-thick foam-core bars spaced on 2-inch centers perpendicular to the radii of curvature of the curved test panel. The fourth configuration was a grid of 2-inch by 3-1/4-inch rectangles, 2 inches deep with 1/8-inch-thick walls. The screens are shown in Figure 3.

The specimens were again viewed by the same two observers. The window screen and the Kool Shade screen had no significant effect on the glint signature of the flat-panel transparency. Although the honeycomb structure showed some promise in reducing glint, the depth of the structure walls indicated that pilot vision, other than straight through the mesh, would be restricted. This finding supported previous full-scale tests with louvers of less depth than the honeycomb (Reference 7). The results of these tests led to the conclusion that the benefit of using screens increases as the depth of the screen wall increases, but as wall depth increases, pilot visibility decreases.

#### Third Test - Effects of Panel Tilt on Internal Reflections

A simple experiment was undertaken to explore the problem of internal reflections from external sources and to identify potential solutions. The test equipment consisted of a light source and a flat piece of plexiglass.

The test was conducted by darkening the room and viewing the light source while the plexiglass was tilted at various angles.

Two reflections could be seen depending on the geometry of the situation. The first and least important was a low-level diffuse reflection of the light beam due to surface dust or imperfections in the plexiglass. This reflection, while visible, did not appear to be a problem. It was very faint and could be seen regardless of situation geometry as long as the observer could see the point of intersection of the light beam and the plexiglass.

The second and more significant reflection occurred when a normal to the plexiglass surface existed, the light source or external object and the observer's eye had equal angular lines of sight to the normal, and the two lines of sight

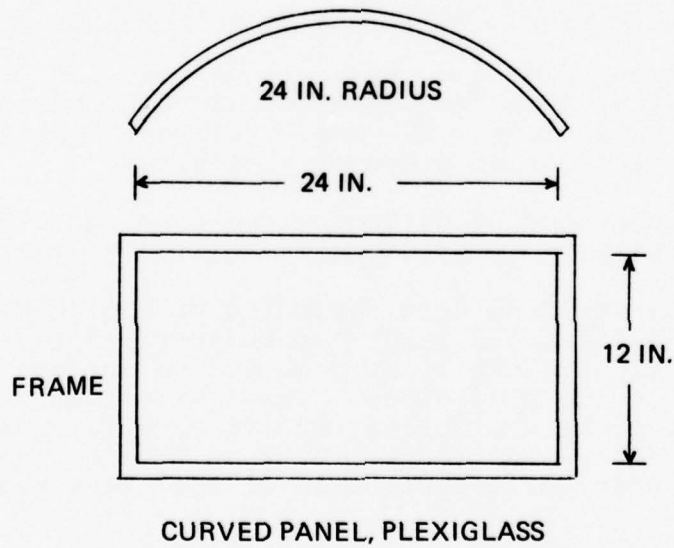
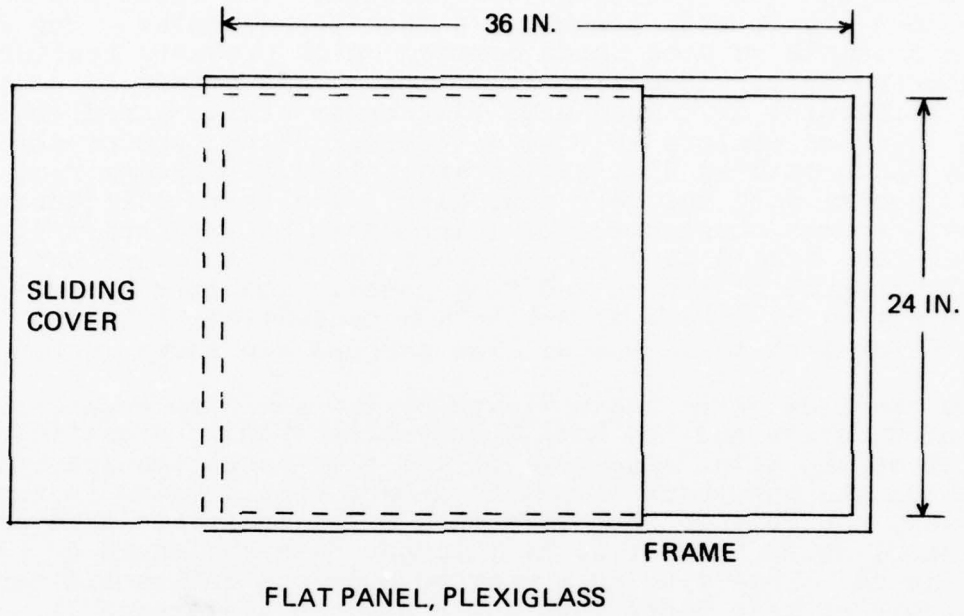
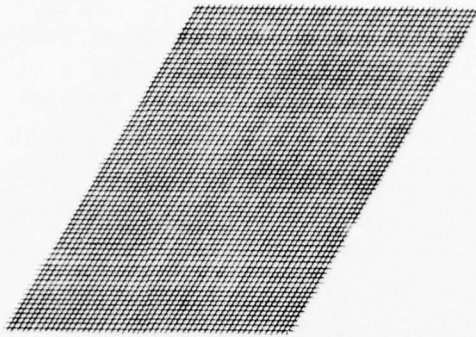
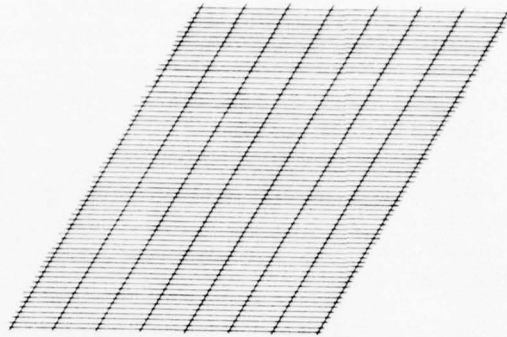

Figure 2. Test Panels



*Common Window Screen*



*Kool Shade*

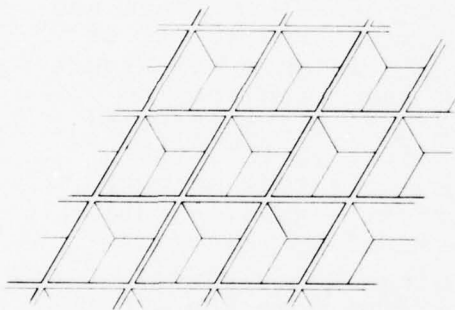

*2" x 2" x 1" Honeycomb*

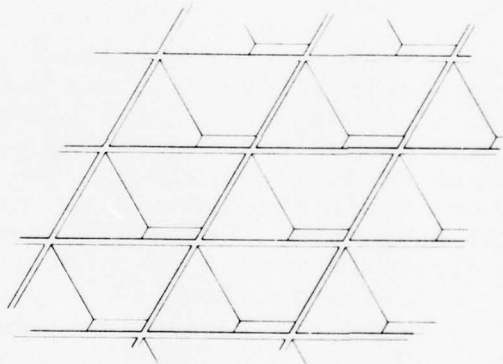

*2" x 3-1/4" x 2" Honeycomb*

*Figure 3. Screen Configurations*

and the surface normal were in the same plane. In such cases, an image of the light source or object was visible on the plexiglass sheet. The quality of the image was as good as the quality of the transparency. In the test described here, the image was excellent. Without prior knowledge the observer could not determine whether the plexiglass was between the source and the observer or the observer was between the source and the plexiglass.

The solution is to prevent the existence of the necessary geometry. Vertical side canopies are least desirable since the appropriate geometry will exist with almost any exterior light position.

The results showed that internal reflections occurred frequently and were very clear. Since lights from the ground (villages, airfields, etc.) are expected to be the major source, and reflections from these are at a minimum when the glass is tilted outward, based on the geometry, an outward-tilted canopy should be better than an inward-tilted one. While lights from overhead sources (flares, aircraft) would cause reflections, these situations are expected to occur much less frequently than lights from ground sources.

#### Panel Tilt

The computer program developed under an earlier contract and contained in Reference 8 was used to examine the effect of panel tilt and slant. The effect of tilt is shown in Figure 4. The figure was constructed by plotting runs with varying degrees of tilt and slant. The reason that slant effects are not visible is that slant has no effect on the total glint signature. Slant affects only the aircraft azimuth to sun direction needed to produce a glint at a given location. The fact of that glint is solely determined by tilt. If a canopy panel has surface tangents ranging from vertical, 0 degrees tilt, to -10 degrees tilt, upper edge more inboard than lower, then for 0 degrees sun elevation the entire area between the 0-degree tilt line, the 10-degree tilt line, and the figure boundaries will be seen as the aircraft rotates through 360 degrees. Similar logic applies to other sun elevations and other combinations of tilt and slant. Using this figure, the sun glint signature of any canopy can be estimated. Curvature in the vertical planes, tilt, determines if a glint will appear. Curvature in the horizontal plane, related to slant, determines the beam-width of the glint. The more curvature that exists

8. Gundling, D. R., and White, F. W. Jr., CANOPY SUN GLINT EVALUATION AND DISPLAY STANDARD, Boeing Vertol Company, USAAMRDL Technical Report 75-42, Eustis Directorate, U.S. Army Air Mobility Research and Development Laboratory, Fort Eustis, Virginia, October 1975, AD A018079.

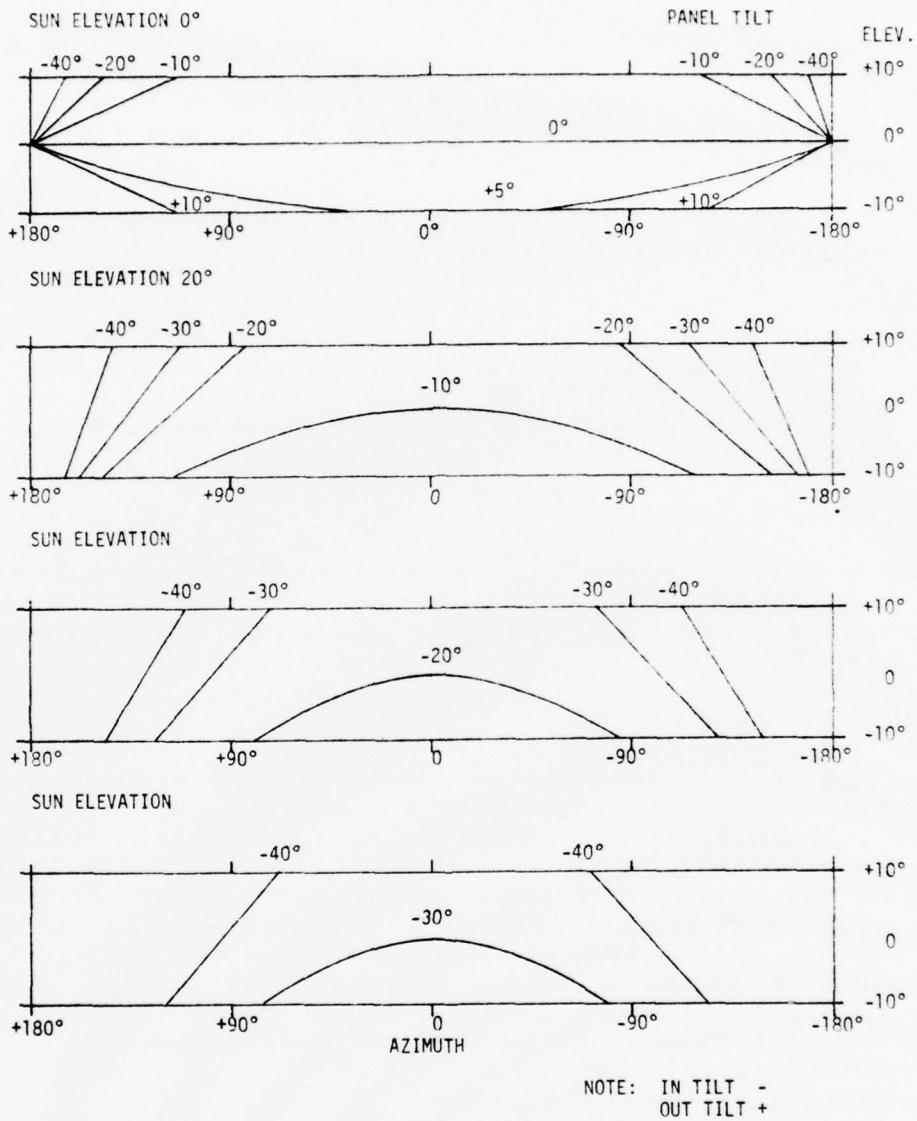

Figure 4. Sun Glint Signature of Tilted Flat Panels

in a canopy in the horizontal plane, the greater the number of potential locations from which glint can be seen for a given sun elevation and aircraft heading with respect to the sun. As can be seen from the figure, an outward tilt (at the top) canopy does not give off observable glint at sun elevations of 20 degrees and above.

It was decided to develop an outward-tilted flat-panel canopy within the constraints of MIL-STD-33573A and MIL-STD-850B, which define cockpit canopy geometry and human factors requirements. Additionally, the canopy had to fit an AH-1 canopy base. The constraints are listed below:

- A 10-inch minimum spherical head clearance from the design eye position
- A 26-inch minimum width at shoulder level (anthropomorphic data gives 8 inches as a representative shoulder-to-eye distance)
- The tandem seat arrangement requires 50 degrees downward vision at 90 degrees azimuth
- A 34-inch cockpit width (AH-1)

In order to have an outward-tilted flat-plate canopy which met all of the requirements stated above, it was necessary to have two facets. The resulting concept, shown in Figure 5, was added to the list.

#### EVALUATION MATRIX

Although the initial attempts at concept formulation were unconstrained in order to generate the maximum number of possible solutions, final concept selection for full-scale testing required the generation of evaluation criteria. The results of the preliminary tests caused some of the concepts to be a questionable value; however, all concepts generated during concept formulation efforts were subjected to the criteria developed below. Since the objectives of the program were to reduce external reflections and to control internal reflections, the primary evaluation parameters were:

1. Probability of Sun Glint
2. Internal Reflection from External Sources
3. Internal Reflection from Internal Sources
4. Sky Reflection

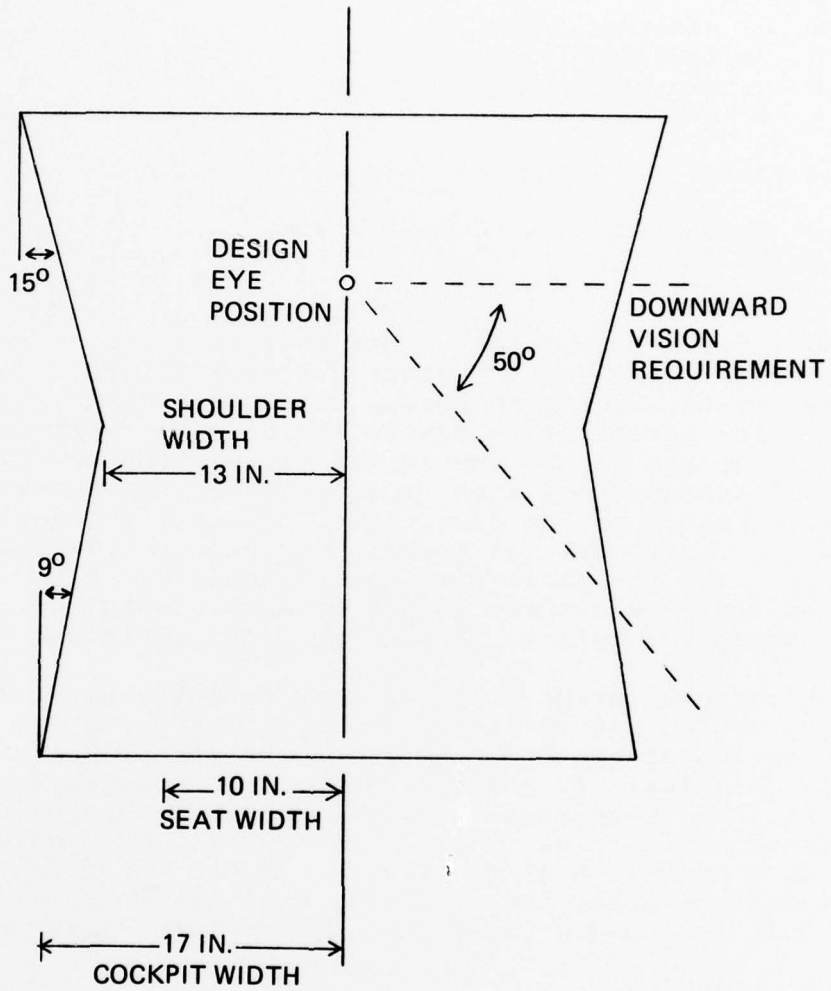

Figure 5. Double-Facet Flat-Panel Concept

The second set of criteria included parameters which go into any aircraft trade study:

- Implementation Cost
- Weight
- Drag
- Maintainability
- Reliability
- Survivability/Vulnerability
- Safety

Three other evaluation factors were included:

- Inclement Weather Suitability
- Visibility
- Optics

These factors were based on criteria relevant to this particular evaluation. Inclement weather suitability was included as a direct result of the no-canopy concepts. Visibility as an evaluation parameter refers to the pilots' capability to see objects on the ground and in the air without restriction from a small transparency area or supporting structure and framework. Optics, on the other hand, concerns the quality of the glass or other material used in the canopy. Therefore, a concept like the small-size canopy could get a low score for visibility, since there is not as much viewing area, but a good score for optics, if good quality plexiglass was used.

After the evaluation criteria were established, a simple rating system was developed to reflect improvement or degradation of the new canopy concept when compared to the AH-1G baseline. If the new canopy did not result in any significant improvement or degradation, a zero value was assigned. If it was judged better, a +1 was used, or if it was much better, a +2 was given. If the new canopy was evaluated as worse than the old, a -1 was given, or if it was felt to be much worse than the old one, a -2 was used.

#### CONCEPT RANKING

Seven individuals were chosen in addition to the project engineer, to evaluate the 25 concepts using the rating system described above. The evaluators comprised a cross section of specialties, including a visual detection expert, an aerodynamicist, a designer, a lighting specialist, a human factors engineer, a maintenance engineer, and a former Army helicopter pilot. Each individual completed an evaluation sheet, and the results were averaged to develop a composite evaluation matrix. The end product is shown in Table 2.

TABLE 2. FINAL COMPOSITE EVALUATION MATRIX

CONCEPT	CRITERIA														TOTAL
	SUN GLINT	SKY REFLECTION	INTERNAL REFLECTION EXTERNAL SOURCE	INTERNAL REFLECTION INTERNAL SOURCE	INCREMENT WEATHER SUITABLE	COST TO IMPLEMENT	WEIGHT	DRAG	MAINTAINABILITY	RELIABILITY	VISIBILITY	OPTICS	SURVIVABILITY/ VULNERABILITY	SAFETY	
FINE MESH SCREEN	+1	+2	0	0	-1	-1	-1	-1	-1	0	0	-1	0	0	-3
COARSE MESH SCREEN	0	+1	0	0	0	-1	0	-1	-1	0	0	-1	0	0	-3
HONEYCOMB	+2	+2	+1	0	-2	-1	-1	-2	0	0	0	-1	0	0	-2
SHADE	+1	0	0	0	0	-1	-1	-2	-1	0	0	0	0	0	-4
SMALL SIZE	0	+1	+1	+1	0	+1	+1	+1	0	0	-1	0	+1	0	6
NO CANOPY WITH COVERS	+2	+2	+2	+2	-2	0	+2	-1	0	0	+2	+2	+1	+1	13
FLAT PANEL VERTICAL SIDE	+1	0	-2	-2	0	+1	-1	-1	0	0	0	+1	0	0	-3
FLAT PANEL INWARD TILT	+1	0	-2	-2	0	+1	-1	-1	0	0	0	+1	0	0	-3
FLAT PANEL OUTWARD TILT	+2	+2	-2	-2	0	+1	-1	-1	0	0	0	+1	0	0	0
FENCES	+1	0	0	0	0	-1	-1	-1	0	0	0	0	-1	0	-3
NO CANOPY WITH VISIONICS	+2	+2	+2	+2	+2	-2	-1	0	-2	-2	-2	+1	-2	-1	-1
SMALL TURRETS	+1	+1	+2	+2	0	-1	0	-1	-2	-2	-2	0	-1	-1	-4
RETRACTABLE WINDOWS	+2	+2	0	0	-1	-1	-1	-2	-2	-2	0	0	+1	+1	-3
REMOVABLE WINDOWS	+2	+2	0	0	-2	-1	-1	-2	-2	-2	0	0	+1	+1	-4
DOUBLE FACET FLAT PANEL	+1	+1	-1	-1	0	-1	-1	-2	0	0	0	0	0	0	-4
AIR SCREEN	+2	+2	+2	+2	0	-2	-1	-1	-2	-2	+2	+2	+1	-1	4
ONE-WAY MIRROR	0	0	-2	+2	0	-1	0	0	0	0	0	-2	0	0	-3
LARGE DIAMETER HUB	+1	0	0	0	0	-1	-1	-1	-1	-1	0	0	-1	-1	-6
EXTERNAL DECOYS	0	0	0	0	0	-2	0	-1	-1	-1	0	0	0	0	-5
HIGH-SOLIDITY ROTOR	+1	0	0	0	0	-1	-1	-2	0	0	0	0	-1	-1	-5
ROUGH-SURFACE CANOPY	-1	+1	+1	0	0	-1	0	-1	0	0	0	-2	0	0	-3
LOUVERED CANOPY	+1	+1	+2	0	-1	-1	-1	-1	0	0	-1	-1	+1	0	-1
OPEN COCKPIT	+2	+2	+2	+2	-2	0	+2	-2	+1	+2	0	+2	+2	+1	14
PURE SCREEN	+2	+2	+2	+2	-1	-1	0	-1	0	0	0	-2	0	0	3
BENDABLE PANELS	+1	0	-2	-2	0	-1	-1	-1	-1	-2	0	+1	0	0	-6
PRESENT CANOPY	0	0	0	0	0	0	0	0	0	0	0	0	0	0	0

RATING VALUES:

MUCH BETTER	+2	1. OPEN COCKPIT
BETTER	+1	2. NO CANOPY WITH COVERS
NEUTRAL	0	3. SMALL SIZE
MUCH WORSE	-2	4. AIR SCREEN
WORSE	-1	5. PURE SCREEN

The completion of the concept evaluation sheets was a parallel effort with the previously described preliminary tests, so the individuals completing the concept evaluation sheets did not have the benefit of the results of these tests prior to completing the forms. The results of the preliminary tests were combined with the composite evaluation matrix, and subjective engineering judgment as to the feasibility of certain concepts and their potential for acceptance by pilots, resulting in a reordering of the concepts. First the concepts were put into logical groupings. Then they were ranked within groups, such that a simpler concept would be placed higher than a more complex one, given that they had equal potential for reducing external and internal reflections. Then the groups would be ranked, based on their potential for solving the reflection problems in a practical manner.

The final ranking is the order in which the concepts were listed in Table 1. Appendix A contains a drawing of each concept that was considered, along with the rationale for its potential in solving external and internal reflection problems.

Based on the analyses and tests that were conducted, the concepts followed by an X in Table 3 were deemed to have low potential for suppressing canopy sun glint. Shades and fences were downgraded because they provide no suppression for transparent panels which are on the sun side of the shade or fence. The only way to achieve complete suppression is to cover the whole surface. This, of course, would prevent external vision. The four concepts toward the bottom of the table were eliminated from further consideration due to their limited potential for solving the problem at hand, and their general impracticality at this time.

The possibility that sky reflections might prove a significant visual detection cue was raised during the Evaluation of Contrast Reduction Techniques contract as a result of examination of some of the slides taken of model AH-1G aircraft. A test was run to assess the validity of the problem. Sky reflections are not apparent on bright sunny days when the aircraft background is well lit. On overcast days when the aircraft background is dark, however, the reflection of the sky can be seen. This effect is not pronounced. The major signature exists when the aircraft is located rather distant from the background. During the tests it was shown that the sky reflection could be seen using the flat test panel. Both reduction of panel size and use of screens could be effective in reducing the observation of sky reflection, since sky reflection is not as bright as solar reflection. However, since sky reflection is of comparatively minor importance, and since the preliminary tests showed screens and small canopy size to be of questionable benefit, these concepts were eliminated from further consideration at this time.

TABLE 3. SUN GLINT EVALUATION

Basic Concepts	Not Effective as Pure Concept
Fine Mesh Screen Over Glass	X
Coarse Mesh Screen Over Glass	X
Honeycomb Screen Over Glass	X
Shades	X
Small Size	X
No Canopy, Covers	
Flat Panel, Vertical Sides	
Flat Panel, Inward Tilt	
Flat Panel, Outward Tilt	
Fences	X
No Canopy, Visionics	
Small Turrets	X
Retract Panels	
Removable Panels	
Double-Facet Flat Panel	
Air Screen	
One-Way Mirror	X
Large Diameter Hub	X
High-Solidity Rotor	X
Rough-Surface Canopy	X
Louvered Canopy	
Open Cockpit	
Pure Screen	
Hinged Flat Panel with Seal	
Bendable Panels	

Furthermore, in pursuing the canopy size reduction concepts, the requirements of MIL-STD-33573A and MIL-STD-850B must be considered. Small-size concepts will not meet cockpit space requirements. The baseline AH-1G canopy is very close to the minimum allowable size and further size reductions would probably restrict pilot effectiveness. This also allows for rejection of the small turrets concept.

Table 4 shows the next three concepts that were eliminated from further consideration in this study. Figure 4 showed that flat-paneled canopies tilted outward at the top gave off solar glint less often than those tilted inward or those which were vertical. Since the primary evaluation criterion was the ability to reduce external sun reflection, the flat panels with vertical sides and inward (at the top) tilted sides were eliminated.

The next two primary criteria involve internal reflections from both internal and external sources. The problem is illustrated in Figure 6 for both internal and external sources. As shown, the crewmember can see an external light either as a direct sighting or as an indirect image. With flat-panel

surfaces, the images are of excellent quality, and it is very difficult, if not impossible, to determine which is the correct source. Images from internal sources obstruct and confuse external vision. Past experience has shown that a curved panel can be used to distort the reflected image, but that the external signature will increase. Despite excellent characteristics for reducing external sun glint observation, the outward (at the top) tilted panel has poor internal reflection characteristics, which will be shown later in the report.

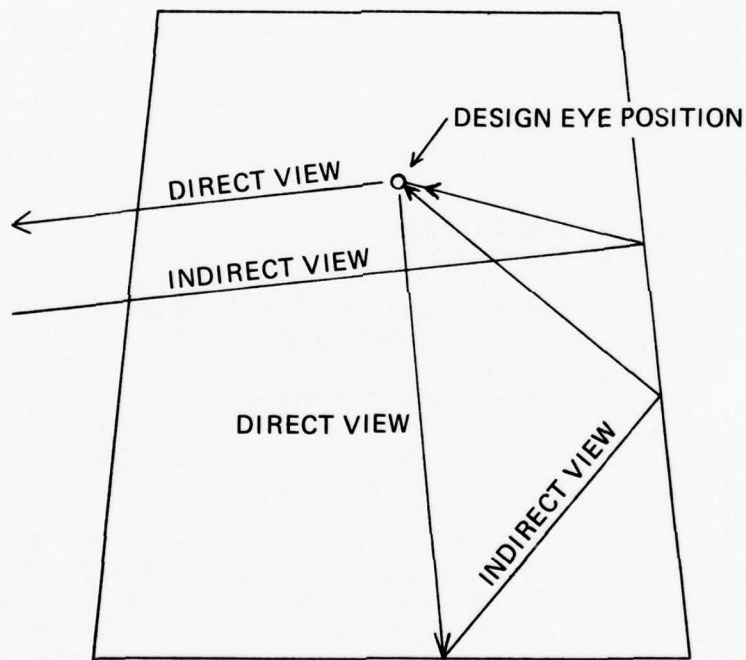

Figure 6. Internal Reflections from Internal and External Sources

TABLE 4. PANEL TILT EVALUATION

Basic Concept	Not Effective or Not Applicable as Pure Concept
No Canopy, With Covers	
Flat Panel, Vertical Sides	X
Flat Panel, Inward Tilt	X
Flat Panel, Outward Tilt	X
No Canopy, Visionics	
Small Turrets	
Retract Panels	
Remove Panels	
Double-Facet Flat Panel	
Air Screen	
Louvered Canopy	
Open Cockpit	
Pure Screen	
Hinged Flat Panel With Bellows	
Bendable Panels	

All of the concepts listed below except the double-facet flat canopy were eliminated from further consideration in this study. The remaining concepts all had the potential for effectively addressing the reflection problems, however further investigation was not to be a part of this study, since it would involve the construction of operating mechanisms or the development of environmental sealing techniques. These concepts should be considered for future study.

- No Canopy, With Covers
- No Canopy, With Visionics
- Retractable Panels
- Removable Panels
- Double-Facet Flat Panel
- Air Screen
- Louvered Canopy
- Open Cockpit
- Pure Screen
- Hinged Flat Panel With Bellows
- Bendable Panels

The double-facet canopy was chosen for further analysis as a conceptual solution for the reflection problem. It is a flat-panel canopy, so that the external sun glint signature is better than a curved canopy. The outward-tilted upper portions will tend to suppress sky reflections while the lower side

portions may be shaded or screened, if desired, to eliminate residual sun and sky reflections from this area. Internal reflections would be controlled by orienting the side panels so that dual images would be reduced. With the geometry shown in Figure 5, the upper side panel canted at 15 degrees and the lower at about 9 degrees, an object on the horizon should only be seen by the crew when looking at the object directly. It was expected that no visible image would be formed on the canopy because the necessary geometry did not exist. Similarly, there would be no visible images formed for objects below the horizon nor from instrument panel lights other than in the immediate vicinity of the component. The only position from which a dual image was expected to exist is for objects located well above the horizon. For the geometry shown, the object would have to be at an angle of 30 degrees or greater, and it was expected that this situation would occur infrequently.

#### SOFT MOCKUP CONSTRUCTION

The next phase of the study was to construct soft mockup canopies. These were to be used for internal reflection testing both from internal and external sources. In addition the soft mockups were to be taken outdoors to be photographed in positions which would cause sun glint. The object of the internal and external reflection analysis was to compare alternate configurations to the baseline.

#### AH-1

Using drawings provided by the government, an AH-1 canopy base was constructed of 1/4-inch Fome-Cor using a technique developed and refined by Boeing Vertol. This base was constructed so that alternate canopy designs could be mounted on it. Next, a full-scale mockup of the double-facet flat-plate canopy was constructed using Fome-Cor for the framework and 1/8-inch plexiglass for the transparencies. Finally, a standard AH-1 canopy was assembled using Government-furnished equipment. Although original plans called for construction of a baseline and one alternate concept for both the AH-1 and OH-58, the findings of initial testing resulted in the building of two more soft mockup canopies. The first of these was a replica of the AH-1S flat-plate configuration, which is canted inward 6 degrees at the top. This design was chosen as an alternate for testing in order to supplement previous information already gained concerning this canopy. The second mockup was identical to the AH-1S except that the side transparencies were canted outward 6 degrees at the top.

## OH-58

Again using drawings provided by the government, an OH-58 canopy base was built using 1/4-inch Fome-Cor. As with the AH-1, this base was capable of accepting the standard canopy configuration or an alternate. A full-scale mockup of a flat-plate canopy with 6-degree outward slanting side panels was constructed using Fome-Cor framework and 1/8-inch plexi-glass. A standard OH-58 canopy was also assembled using material furnished by the Government. Photographs of the mockups are shown in Figures 7 through 11.

### CONCEPT TESTING

The alternate canopy concepts were compared with the baselines in three different areas: external reflections from external sources (sun glint, sky reflection), internal reflections from external sources (other aircraft, flares, ground lights), and internal reflections from internal sources (instrument lights).

#### INTERNAL REFLECTIONS FROM INTERNAL SOURCES

Testing was conducted to evaluate internal reflections from internal sources. Using the simulated cockpit bases for the side-by-side and tandem configurations, a lighted 5.75-inch by 6-inch simulated instrument panel face was moved to each potential location for aircraft instruments. An observer located in each crew seat was instructed to note and identify instances of observable reflections from canopy transparent surfaces. These tests were conducted indoors in a darkened room. The light source was located at three different places in the canopy mockups. Quantitative data was recorded, but is not shown here since reflections were observed in all instrument locations regardless of which canopy was used (flat plate or standard) in both the OH-58 and AH-1 configurations.

During the course of the program a solution to this problem was discovered: the use of 3M brand Light Control Film. Quoting from product literature, "Light Control Film, a thin plastic sheet, incorporating black or colored microlouvers, works like a tiny venetian blind to reduce glare, control light, improve contrast and control viewing angle. When placed in front of a lighted display, Light Control Film directs light into a controlled viewing pattern and blocks out light from external ambient sources."

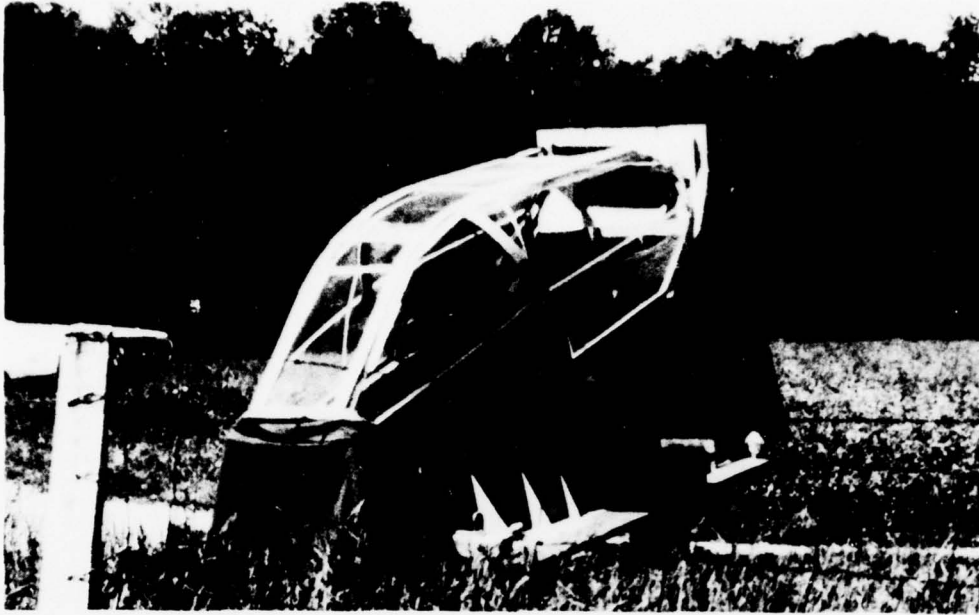

*Figure 7. Soft Mockup of Standard AH-1 Canopy*



*Figure 8. Soft Mockup of Standard OH-58 Canopy*



*Figure 9. Soft Mockup of Flat-Plate AH-1S Canopy*

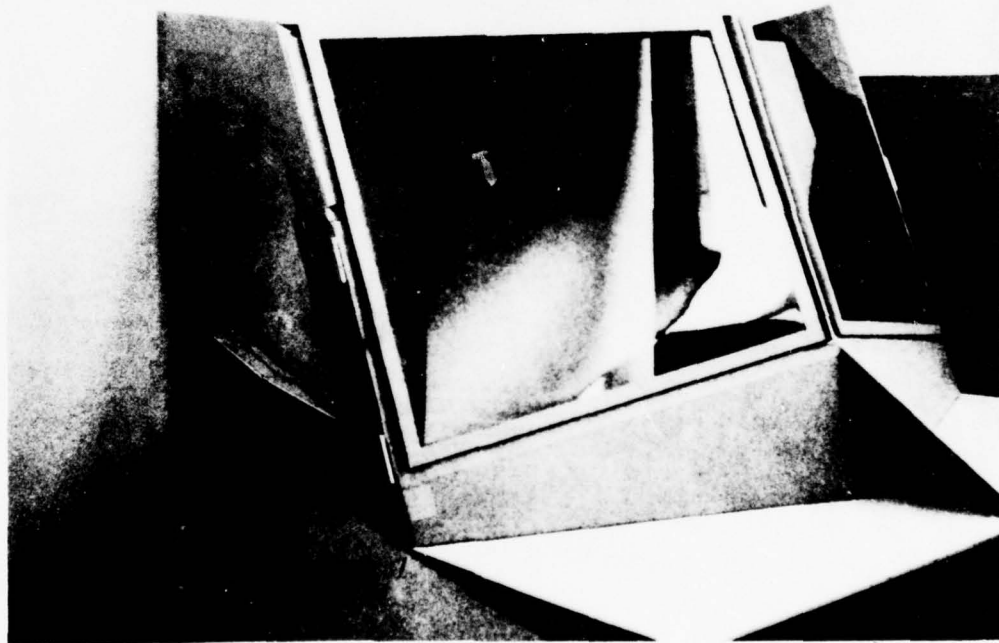

*Figure 10. Soft Mockup of Flat-Plate OH-58 Canopy*

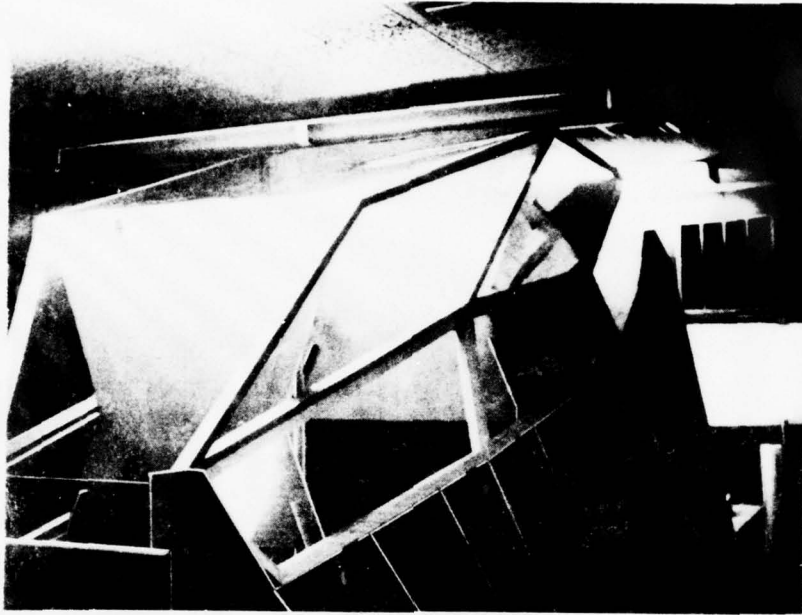

*Figure 11. Double-Facet Flat-Plate Canopy*

Samples of the product were obtained and placed over the simulated instrument panel. The improvement was dramatic. In most cases the reflections were eliminated immediately. In those instances where reflections were not eliminated, tilting the instrument panel caused the reflections to disappear. Since Light Control Film can be produced with the microlouvers at various angles, it is only necessary to determine the angle required to eliminate the reflections and have the film manufactured at that angle.

Figures 12 through 14 illustrate the use of the film. Figure 12 shows the simulated instrument panel located in the AH-1S flat-plate soft mockup. In this photograph, the room lights are on. Figure 13 shows the same view with the lights off and demonstrates the problem of internal reflections from instruments. Two reflections are visible, one in the forward panel and one in the left side panel. Figure 14 is the same view but with Light Control Film over the instrument face. The instruments are still readable, but the reflections are gone.

Light Control Film comes in four louver materials: opaque black, translucent gray, green and transparent black. Base material is cellulose acetate butyrate. Standard panels are 12-inches wide by 40-inches long, with louvers running parallel to the long dimension. Surface treatments are glossy, light matte and medium matte. Standard viewing angles are 48, 60 and 90 degrees. Standard thickness is .030-inch, which can be increased in .020-inch increments. Cross-hatching is available and is accomplished by constructing the film with two sets of louvers at right angles to each other. This allows the viewer to see the display only when he is directly in front of it, the display being opaque at all other angles.

Light Control Film currently appears to be the best solution to the instrument reflection problem. Furthermore, it is inexpensive, lightweight, and could reduce aircraft weight since it could lead to the elimination of instrument panel glare shields.

#### INTERNAL REFLECTIONS FROM EXTERNAL SOURCES

These tests were conducted indoors at an internal-reflection test lab setup at the Boeing Vertol Company. The purpose of the tests was to compare alternate concepts against the baseline in an attempt to solve the problem of internal reflections from external sources such as flares, buildings or other aircraft. The problems reported have only been concerned with night operations, and there doesn't appear to be a problem with daylight flying. The internal reflection problem was described previously in the introductory section of the report, and is documented in Reference 7.

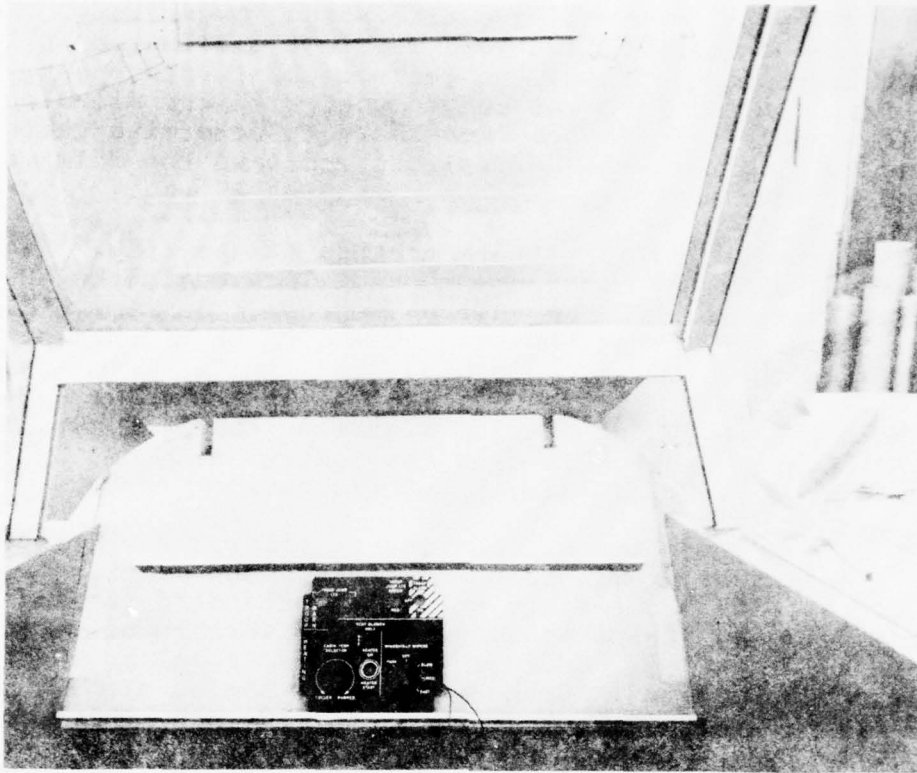

*Figure 12. Simulated Instrument Panel With Room Lights On*

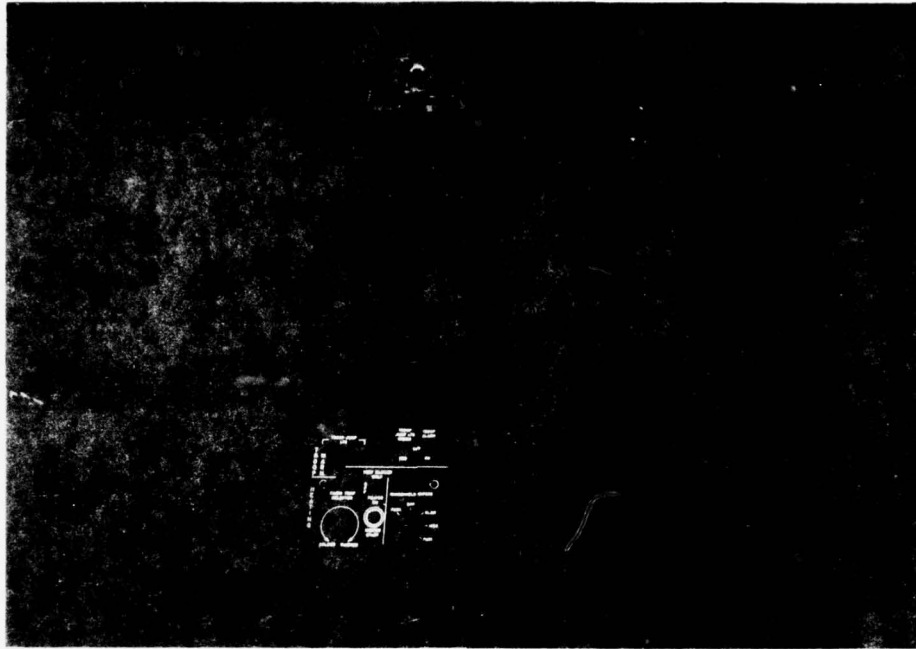

*Figure 13. Simulated Instrument Panel With Room Lights Off*

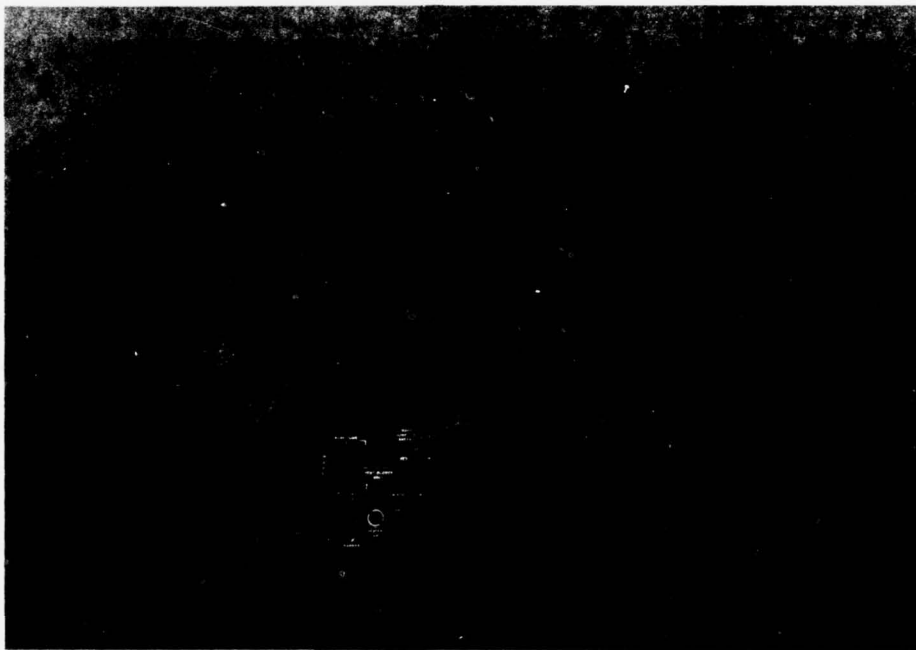
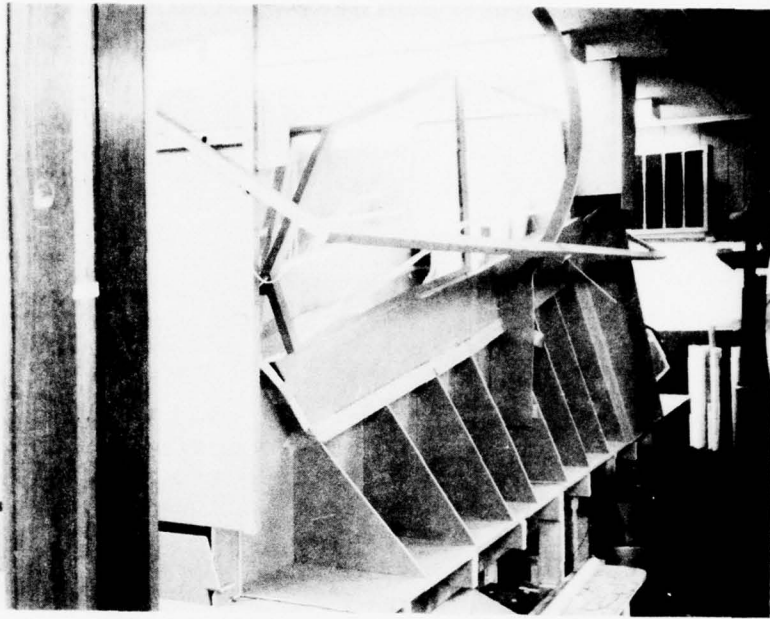

*Figure 14. Simulated Instrument Panel With Light Control Film*

Each canopy to be tested for internal reflection from external sources was placed over a canopy base to simulate the cockpit of either a side-by-side OH-58 configuration or a tandem AH-1 configuration. An observer was placed in simulated crew seats adjusted so that the observer's eye position and the design eye position coincided. The testing was conducted in a darkened room. An external, penlight-size light source was moved around the canopy. The observer's task was to note the existence and location of reflected images from the external light source. The light source was moved in 10-degree increments over the range from 0 to 90 degrees in azimuth and from -40 to +30 degrees in elevation. The view directly forward at the design eye level is designated 0 degrees. The location, azimuth and elevation of light sources which produced images was noted.

Figure 15 shows the AH-1S flat-plate canopy with a horizontal guide mounted on the left side of the canopy exterior. The guide was positioned along a vertical arc for testing at various elevation angles. The arc and the guide were marked at 10-degree increments from the design eye position so that the test manager could accurately position the light source. The observer was seated in the pilot's seat. Since the AH-1 canopy is symmetrical about the pilot, the test was run on only one side of the canopy, whereas on the OH-58 canopies testing was done on both sides of the aircraft with the observer in the pilot's seat. These tests represented a worst-case condition, since all the room lights were out and the light source was very close to the observer. Furthermore, it is expected that in combat conditions external lights from all sources would be at a minimum.

Table 5 shows the results of testing on the baseline AH-1 canopies and three alternate configurations. The first column shows the number of light source locations tested, the second column shows the number of light source locations at which the observer noted reflections, and the last column shows the percentage of light source locations at which reflections were noted. As can be seen, testing confirmed earlier work concerning the problems of flat-plate canopies; however, it was expected that the double-facet canopy would be an improvement.



*Figure 15. AH-1S Canopy with Light Guide*

TABLE 5. INTERNAL REFLECTION TEST RESULTS

Canopy	Number of Light Source Locations	Number of Reflection Locations	Percent
AH-1 Standard (baseline)	90	28	31.1
Double-Facet Canopy	90	90	100.0
AH-1S Flat Plate (6 degrees inward tilt)	80	77	96.3
AH-1 Reverse (6 degrees outward tilt)	80	80	100.0

Unfortunately, what appeared to be a good solution on paper and in preliminary tests was not successful in the full-scale tests. Due to the geometry of flat-plate canopies, the problem is more complex than it was originally thought to be. Reflections are caused three ways. First, light entering the canopy on one side passes across the interior of the cockpit to the other side and is reflected back into the pilot's eyes. Second, external light from below the pilot's eye enters the cockpit on one side, bounces off the overhead panels to the other side and then back to the pilot. And third, light entering from the back end of the side panel strikes the forward glass in front of the gunner, then the side, then the pilot's eyes. This phenomenon resulted in multiple images being reported by the observers. When compared with the outward-tilted canopy, the number of reflections is reduced slightly by panels tilted inward at the top, since this directs some reflections downward below the pilot's eye. However, the change is insignificant.

Next, an attempt was made to prevent some of the reflections from bouncing off the overhead panels. Only the overhead panels were considered because the forward panel in front of the gunner and the side panels are critical to pilot vision. The interior side of the two overhead panels in the AH-1S mockup was covered with Kool Shade screening to block the reflections that were coming from these panels. The test was repeated, and the percentage of light source locations at which reflections were seen dropped from 96.3 percent to 68.8 percent. Two things should be noted regarding this test. First, the screen is produced with louvers only at a 26-degree angle, which is not the optimum for the problem under consideration. Discussions with the vendor indicate that it is possible to change the angle. Secondly, the material is flexible and light enough that perhaps it could be mounted on the forward and side glass panels in an active mode. In this way

the pilot could slide the screening in place for those conditions under which internal reflections occur.

The AH-1 reverse canopy internal reflections were so bad initially that the test was first conducted with the overhead panels removed before covering the panels with screening. In this way, the greatest improvement could be determined by eliminating reflections from the overhead panels. However, the percentage of light source locations at which reflections were noted was only reduced to 90 percent. The number of multiple images was reduced, but those that remained were clear enough to cause confusion or distraction. Since the level of improvement was so small with the panels removed, no tests were run with screening on the AH-1 reverse overhead panels. Table 7 shows the results of these tests.

TABLE 6. INTERNAL REFLECTION TEST RESULTS, CANOPIES MODIFIED

Canopy	Number of Light Source Locations	Number of Reflection Locations	Percent
AH-1S - 6 degrees Inward Tilt (overhead panels screened)	80	55	68.8
AH-1 - 6 degrees Outward Tilt (overhead panels removed)	80	72	90.0

After discussions with USARTL, further testing of the double-facet flat panel was abandoned. The reason for the double facet was to have a canopy which was tilted outward at the top, but which still met the 34-inch cockpit width requirement. The double facet was the only way that both objectives could be met. Since testing showed that this canopy did not alleviate the problem of internal reflection from external sources, and since the double-facet configuration would have to be worse than a single-facet canopy for external reflections because it had two facets to glint, the canopy was eliminated from further consideration.

Testing was performed to compare the standard OH-58 mockup with the flat-plate configuration, and the results were much better than with the AH-1 flat-plate. The observer sat in the right seat for the tests. Although there were more reflections than with the baseline, their number was not high enough to preclude the flat-plate concept from further consideration in side-by-side cockpits. Furthermore, very few multiple images were reported by the observers. Table 7 summarizes the results for the OH-58.

TABLE 7. INTERNAL REFLECTION TEST RESULTS -- OH-58

Canopy	Number of Light Source Locations	Number of Reflection Locations	Percent
OH-58 Standard, Right Side	80	5	6.3
OH-58 Standard, Left Side	80	18	22.5
OH-58 Standard, Combined	160	23	14.4
OH-58 Flat Plate, Right Side	90	29	32.2
OH-58 Flat Plate, Left Side	90	44	48.9
OH-58 Flat Plate, Combined	180	73	40.6

EXTERNAL REFLECTIONS FROM EXTERNAL SOURCES

Tests were conducted outdoors at New Garden Airport at Toughkenamon, near Philadelphia, Pennsylvania, in both full sunlight and bright overcast conditions. The purpose of the test was to make subjective evaluations on the nature of the sun glint and sky reflections coming from the alternate canopies, for comparison with the baselines. It was felt that it would be better to examine the canopies under conditions as close as possible to actual operating environments, rather than in the laboratory.

Each canopy concept to be tested for external reflection was mounted on a trailer capable of 10-degree tilt from the horizontal and 360-degree rotation. The assembly was observed at a distance of 2 kilometers. The test site permitted viewing of the test specimen at the required range with a near vegetation background. The test specimen was rotated and tilted as necessary to yield the maximum glint signature in bright sun and the maximum reflectance in bright overcast conditions. Photographs of the canopies, both with and without reflection, were taken.

Five configurations were examined:

- The AH-1 standard curved canopy (baseline)
- The AH-1S flat-plate canopy, which has a 6-degree inward tilt at the top
- The AH-1 reverse canopy, which has a 6-degree outward tilt at the top
- The OH-58 standard canopy (baseline)
- The flat-plate OH-58 canopy

Testing confirmed previous work done in this area. The results can be summarized as follows:

- When observable sun glint occurred it was always highly visible regardless of canopy configuration. However, it was difficult to produce sun glint from the flat-plate canopies, and they had to be specifically positioned to produce glint, which then disappeared with the slightest canopy movement. This was an indication of how seldom sun glint is observable with flat-plate canopies compared to curved canopies.
- When it occurred, sun glint from the side view of flat-plate canopies was always larger and appeared brighter than sun glint from curved canopies. However for the reasons stated above, it was much less likely to occur. Figures 16 and 17 illustrate the difference typically found in glint intensity of the flat-plate and curved canopies.
- Glint intensity and frequency of occurrence from the front view was approximately equal for all canopies.
- Sky reflection under bright overcast conditions was not as obvious as sun glint and in some cases could be lost in terrain clutter, illustrating the relatively minor nature of this problem when compared to sun glint.
- The side view of the flat-plate canopies produced no sky reflections in most cases.
- Sky reflections from the front view were about equal for all canopies.
- The standard AH-1 canopy produced noticeable sky reflections in most cases, while the standard OH-58 canopy seldom produced noticeable sky reflections, due to the smaller amount of overhead glass in the OH-58 canopy.

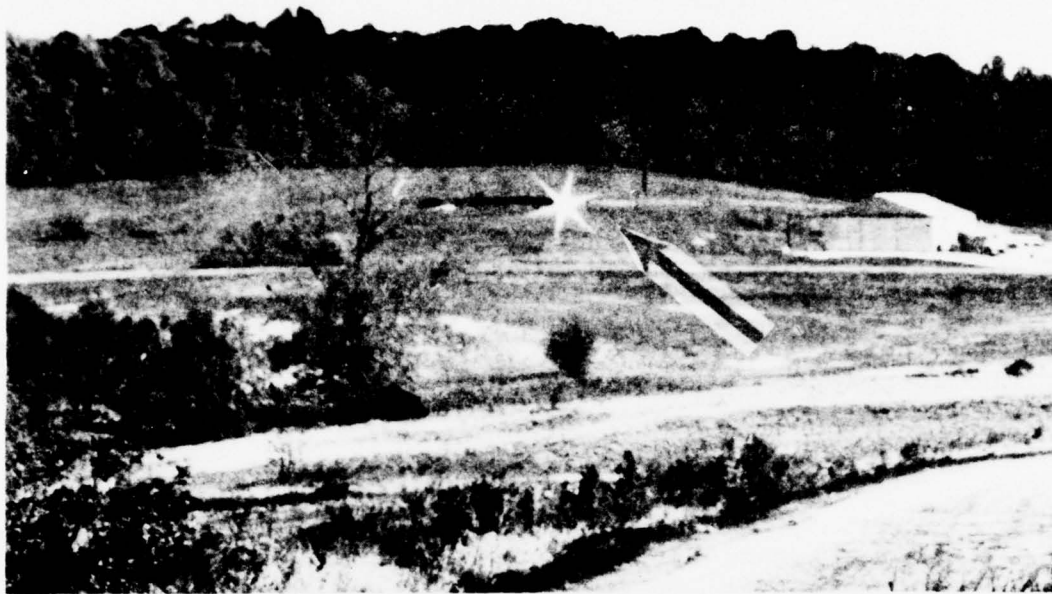

*Figure 16. Glint From Soft Mockup of Flat-Plate OH-58 Canopy*



*Figure 17. Glint from Soft Mockup of Standard OH-58 Canopy*

## CONCLUSIONS

Twenty five concepts were identified which could aid in the solution of canopy reflection problems. Seven of these concepts completely eliminate transparencies and require further work in the area of environmental sealing of the cockpit area. Three concepts involve the mechanical changing of canopy panel orientation to suit operating conditions, and require additional development.

The study found that some variation of the flat panel canopy concept appears to be the best choice at this time for reducing sun glint signature to acceptable levels. However, no simple solution was found to eliminate the internal reflection problems caused by outside light sources. These internal reflections can be reduced through the use of louvered screening in the overhead panels, but not to the level of the standard canopy, at this time.

If carefully tailored for a particular application, the 3M Light Control Film investigated in this study has the potential for eliminating canopy reflections caused by instrument panel lights.

## RECOMMENDATIONS

Based on the analyses contained in this report, the following recommendations are made:

- Additional work should be done to refine the use of louvered screening in flat-plate canopies in order to reduce the internal reflections from external light sources. This includes optimizing the louver angles and screening location, and developing an active system which can be controlled by the pilot.
- Additional work should be done to identify the optimum Light Control Film microlouver angles to permit maximum visibility and minimum internal reflection of cockpit instruments.
- Concepts in this report which completely eliminate transparencies through an active (retractable/removable windows) or passive system should be examined more fully from the design, cost, and R&M viewpoints.

#### REFERENCES

1. HELICOPTER DISGUISE EVALUATION REPORT, MASSTER test Number 1029, Modern Army Selected Systems Test Evaluation and Review, Fort Hood, Texas, October 1972.
2. ATTACK HELICOPTER DAYLIGHT OFFENSE, USACDEC EXPERIMENT 43.8 GROUND TO AIR VISUAL DETECTION, Volume II, Phases I and IIA, U.S. Army Combat Development Experimentation Command, Fort Ord, California, August 1973.
3. JOINT ATTACK HELICOPTER INSTRUMENTED EVALUATION, Department of the Army, U.S. Army Europe, December 1972.
4. DeBenedictis, J. A., and Woestman, J. W., REDUCTION OF REFLECTIONS FROM HELICOPTER WINDSHIELDS, ROTOR BLADES, AND ROTOR HUB, LWL-CR-06P73A, Land Warfare Laboratory, Aberdeen, Maryland, April 1973.
5. Blewitt, S. J., INVESTIGATION OF HELICOPTER VISUAL DETECTION, Boeing Vertol Company; USAAMRDL Technical Report 74-72, U.S. Army Air Mobility Research and Development Laboratory, Fort Eustis, Virginia, September 1974, AD B000297L.
6. Gundling, D. R., and Domenic, R. E., EVALUATION OF CONTRAST REDUCTION TECHNIQUES, Boeing Vertol Company, USAAMRDL Technical Report 76-3, U.S. Army Air Mobility Research and Development Laboratory, Fort Eustis, Virginia, 1976, AD C006316L (Classified Confidential).
7. Stewart, P. E., USER EVALUATION OF CANOPIES FOR THE AH-1 (U) HELICOPTER, U. S. Army Aircraft Development Test Activity (Provisional), Fort Rucker, Alabama, March 1976, AD-B010891L.
8. Gundling, D. R., and White, F. W. Jr., CANOPY SUN GLINT EVALUATION AND DISPLAY STANDARD, Boeing Vertol Company, USAAMRDL Technical Report 75-42, Eustis Directorate, U.S. Army Air Mobility Research and Development Laboratory, Fort Eustis, Virginia, October 1975, AD A018079.

APPENDIX A. CONCEPT EVALUATION

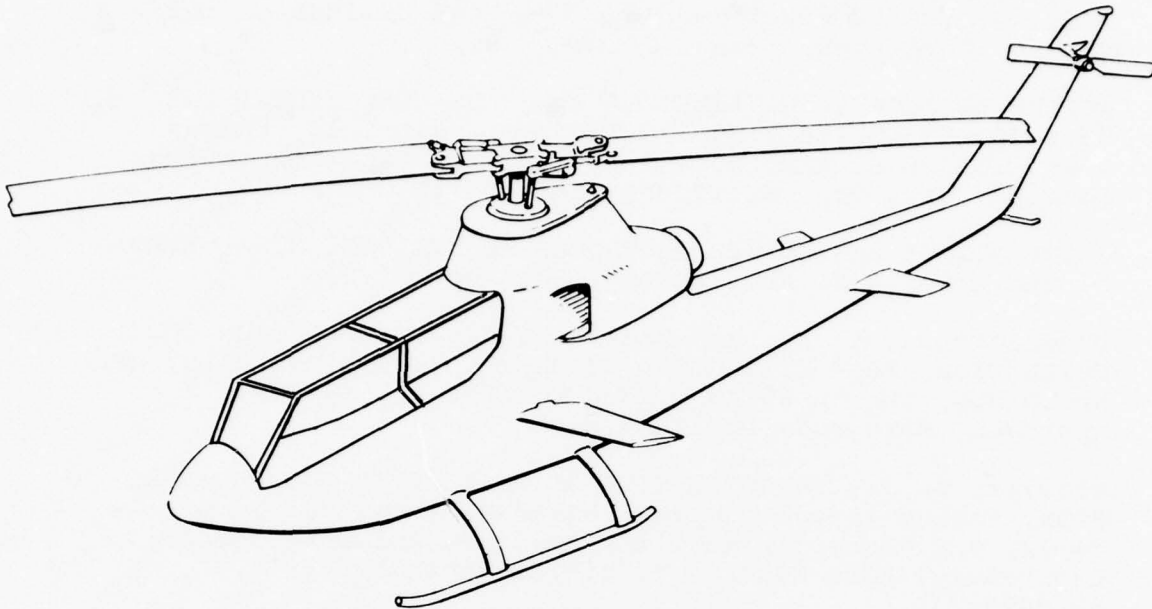

Figure A-1. Double-Facet Flat Panel

Sun Glint Signature:

Sun glint signature could be reduced when compared to that of a standard curved panel canopy.

Sky Reflections:

Better than that of a vertical flat-panel canopy since the outward-tilted portions will not produce a sky reflection and the remaining portion of a given panel will be smaller than that of a single-facet panel.

Internal Reflections:

Testing showed that this concept was unsatisfactory from an internal reflection standpoint.

Discussion:

This concept will be heavier than a standard curved-panel canopy and there will be a drag penalty. If outward-tilted upper side panels are used, the upper surface of the canopy tends to become very wide. The larger number of separate panels in this concept as opposed to simple flat-panel concepts may increase parts stock requirements.

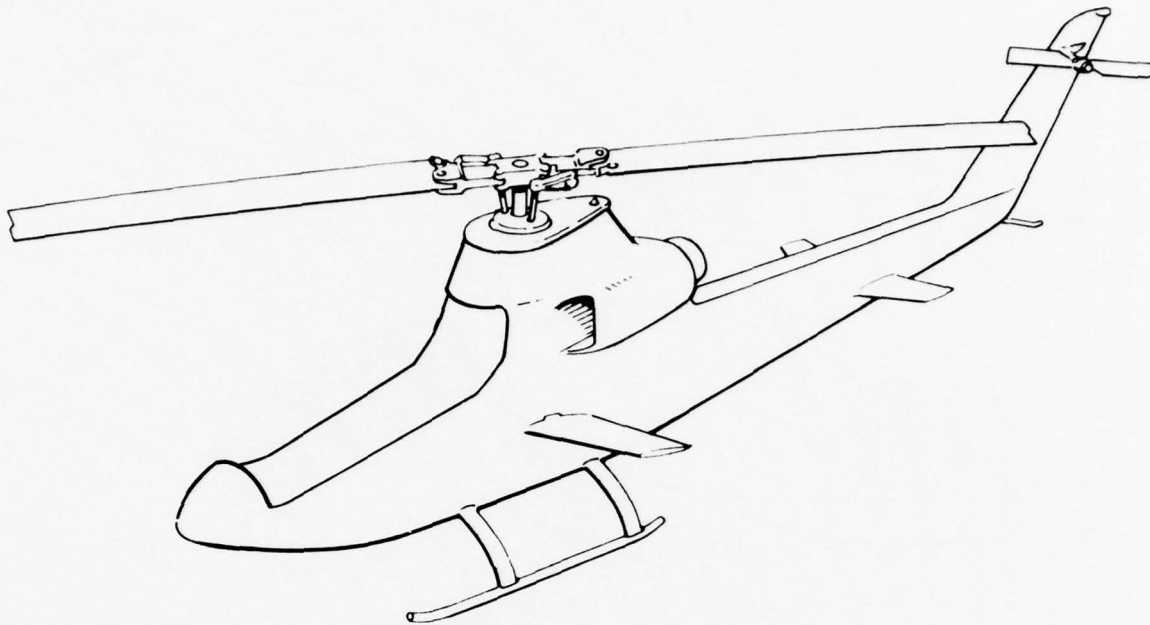

Figure A-2. Open Cockpit

Sun Glint Signature: None

Sky Reflections: None

Internal Reflections: None

Discussion:

This concept offers complete control of all reflections by eliminating the source of the reflections. Aircraft weight decrease due to elimination of the canopy would be partially offset by the weight increase necessary to provide environmental control for the crew. All instruments and controls would require environmental sealing. There is no protection to the crew from bird strikes, although this hazard is not that serious during NOE flight. Survivability would be enhanced through minimization of aircraft presented area. With the canopy removed the crew visors would become reflecting surfaces and might present external sun reflection problems.

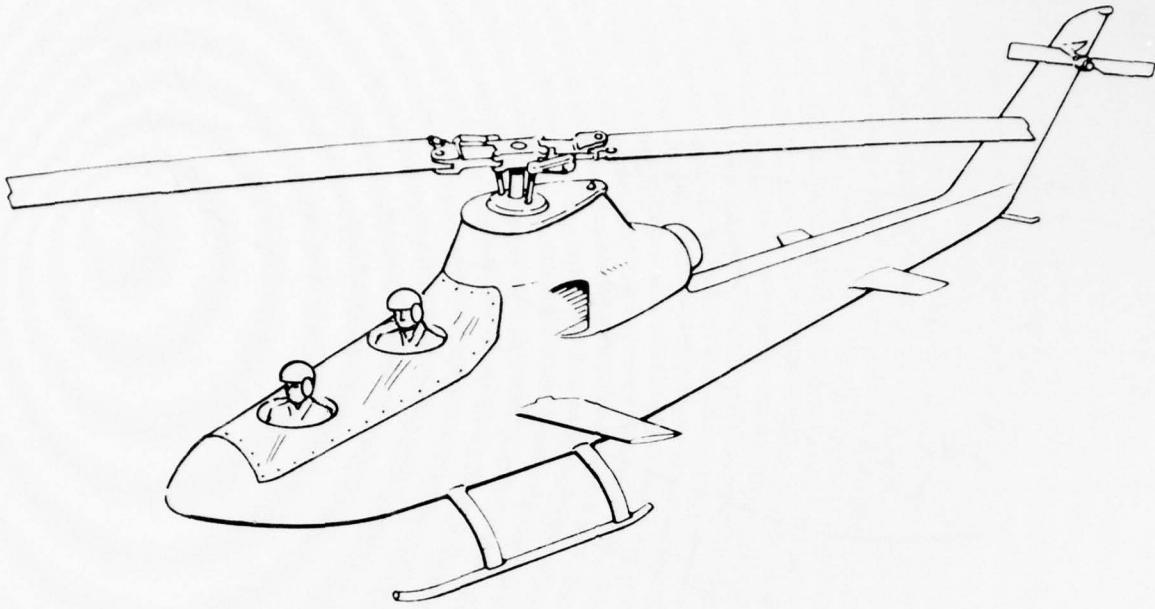

Figure A-3. No Canopy, with Covers

Sun Glint Signature: None

Sky Reflections: None

Internal Reflections: None

Discussion:

With no canopy, provision for draining the cockpit and sealing all avionics and instrumentation is required. Complete environmental control suits must be developed for exposed crew members. Using this concept, there is no crew protection from bird strikes. Total aircraft drag would be expected to increase over the standard AH-1G canopy design. Maintenance and reliability should improve. Crew field of view and visual clarity will be the maximum obtainable. The absence of a canopy would reduce presented area to a minimum, thus improving aircraft survivability and vulnerability. Transparent goggles or face shields would be required for crewmen using this canopy concept, and these items can cause sun glint problems if they are not designed carefully. The ability of the crew to read cockpit instruments would be severely restricted.

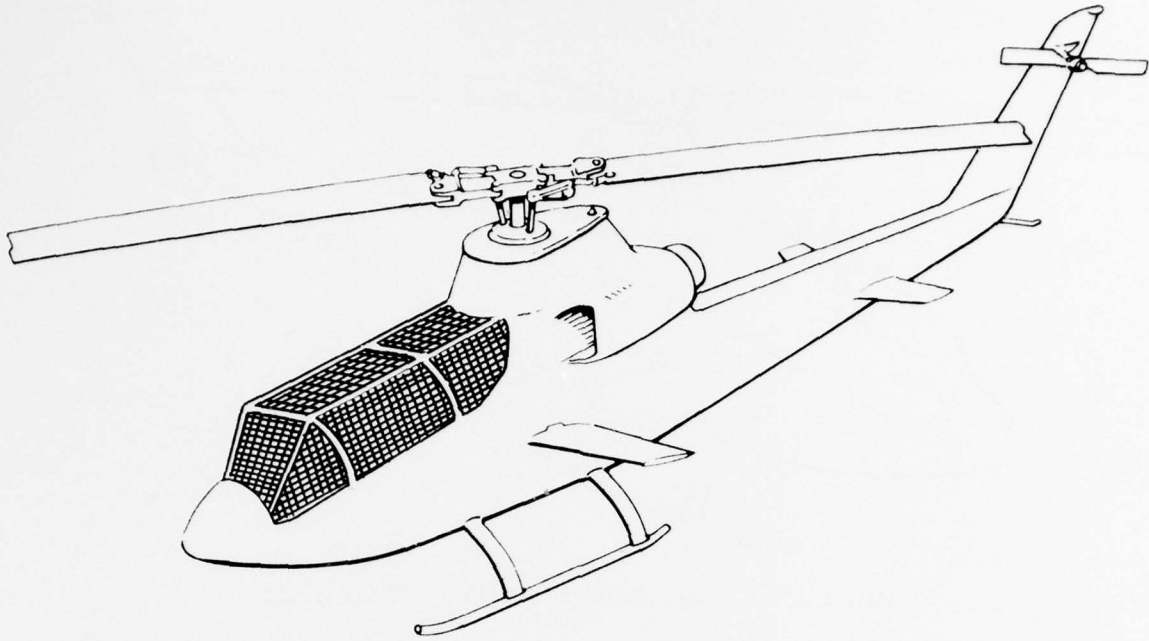

Figure A-4. Screens

**Sun Glint Signature:**

Fine mesh, coarse mesh or honeycomb structure over glass has little or no effect. Pure screen eliminates glint.

**Sky Reflections:**

Screens in most configurations can reduce sky reflections in various degrees.

**Internal Reflections:**

Screens over glass have little or no effect. Pure screens eliminate internal reflections.

**Discussion:**

The main problems with screen concepts are the reduction in pilot visibility; entrapment of dirt, water, and ice; increased maintenance; and increased aerodynamic drag. In addition, the pure screen necessitates environmental protection for the crew and cockpit.

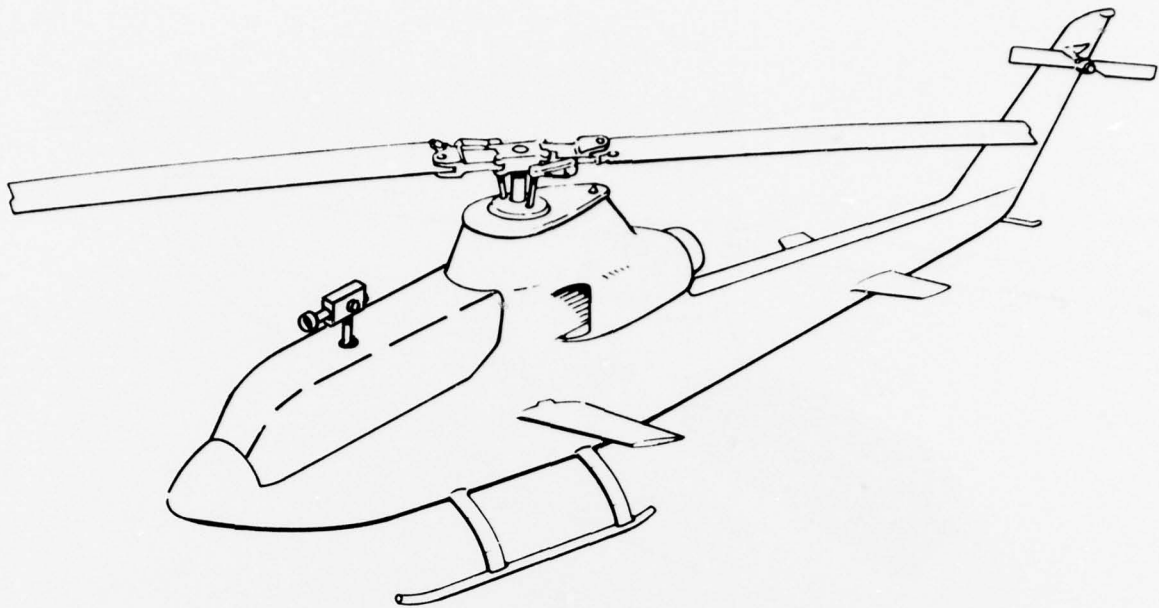

Figure A-5. No Canopy, with Visionics

Sun Glint Signature:

None providing low reflectance paint is used and the visionics head is shielded.

Sky Reflections: None

Internal Reflections:

None assuming low reflectance paint is used inside the cockpit.

Discussion:

This concept is effective from the standpoint of internal and external reflections. The implementation cost would be high compared to more conventional concepts because of the need to purchase a large amount of sophisticated electronics equipment. An increase in aircraft weight due to the visionics will be counterbalanced to some extent by removal of transparent surfaces. Reliability and maintainability would be degraded due to the large number of sophisticated components and the active nature of the system. Crew field of view and visual clarity will depend upon visionics system design. This concept is potentially poor from the standpoint of survivability/vulnerability and safety. A hit in the visionics system or an electrical failure could cause complete loss of external vision. Provision of supplementary transparent panels could recreate external and internal reflection problems.

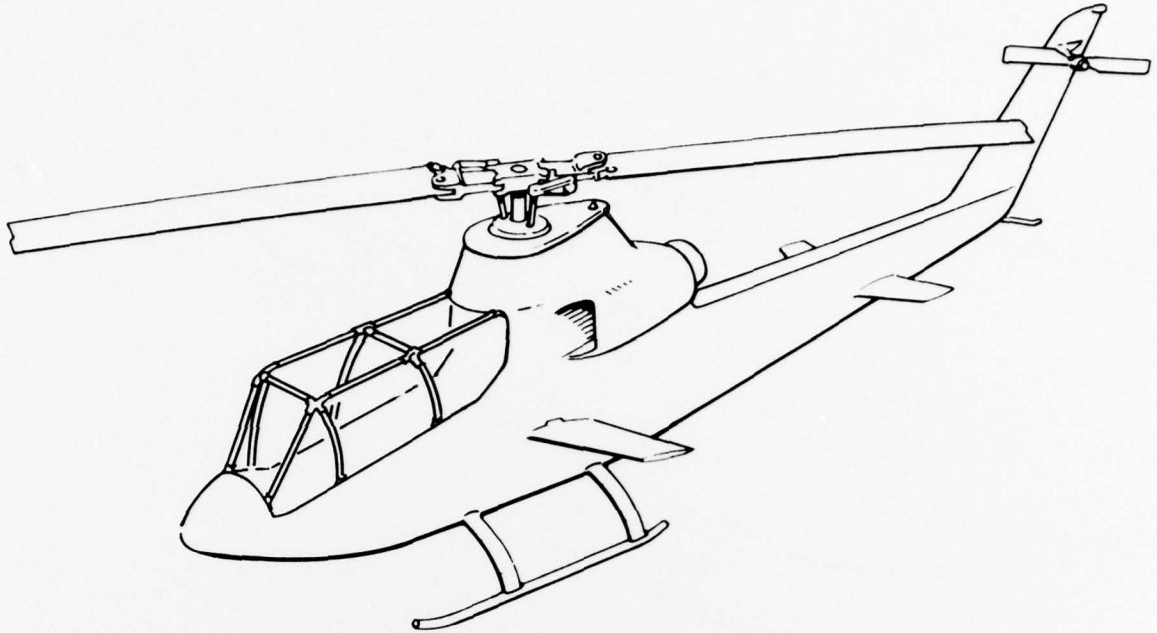

Figure A-6. Air Screen

Sun Glint Signature: None

Sky Reflections: None

Internal Reflections: None

Discussion:

This approach would blow a stream of high pressure air around the perimeter area of the cockpit, to essentially seal the cockpit from the environment. This concept would involve a weight and power penalty to the aircraft. The active nature of the system could mean reduced reliability and increased maintenance compared to conventional canopies. Some form of ground protection for the cockpit area or environmental sealing of instruments and controls would be required.

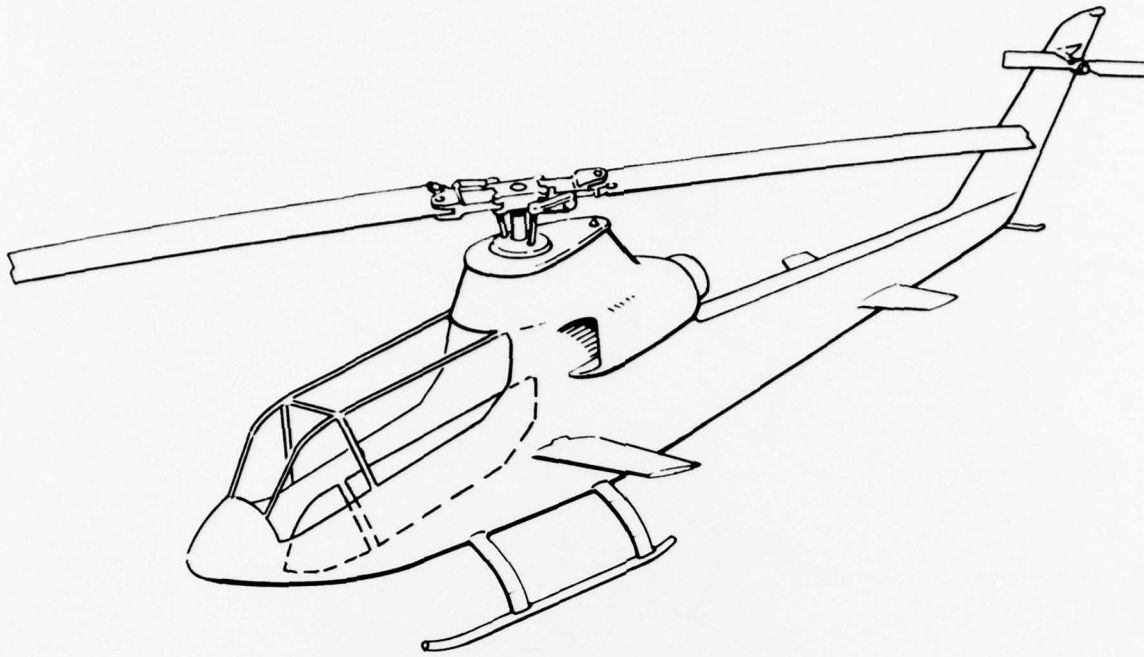

Figure A-7. Retractable or Removable Panels

Sun Glint Signature:

None if all panels are retracted or removed.

Sky Reflections:

None if all panels are retracted or removed.

Internal Reflections:

None if all panels are retracted or removed. Assuming that retracted or removed panels would be extended or replaced for inclement weather flying, this concept would offer no control over internal reflections other than that inherent in the basic canopy configuration.

Discussion:

This concept offers excellent control of external reflections at the expense of temporarily degraded crew environment. With panels retracted or removed, the aircraft would be in a high drag configuration, which is not that critical at NOE speeds. Maintenance problems due to damage to the removed panels or loss of the panels as well as failure of any retract mechanism must be considered. The retractable panels would lead to an aircraft weight penalty. Environmental sealing of instruments and controls would be required.

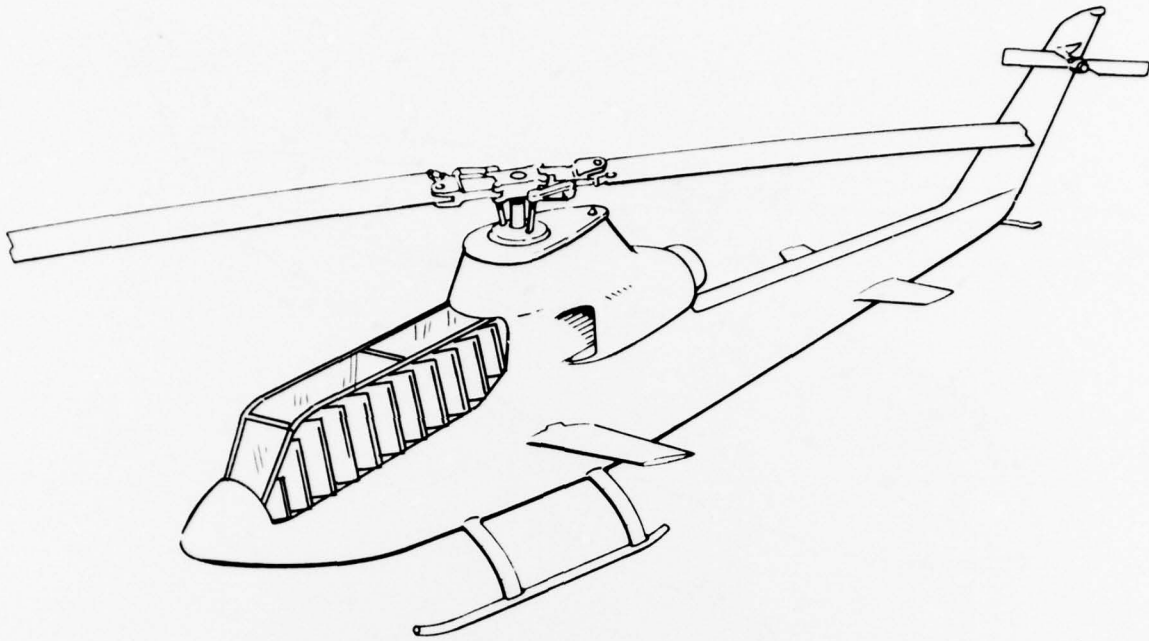

Figure A-8. Louvered Canopy

Sun Glint Signature:

If automatic controls on panel louvers are used, sun glint signature could be reduced over a flat-panel concept.

Sky Reflections:

When louvers are open with planes parallel to the observer there will be no sky reflection. When the louvers are closed no reduction over the reflections of the underlying configuration will occur.

Internal Reflections:

No effect over underlying concept assuming louvers are closed at night and during inclement weather.

Discussion:

There will be a weight penalty for this concept. Reliability and maintenance will degrade due to the potential for failure of the required mechanism. Visual clarity may be impaired by the relatively large number of joints between louver panels. Drag will increase when the louvers are open.

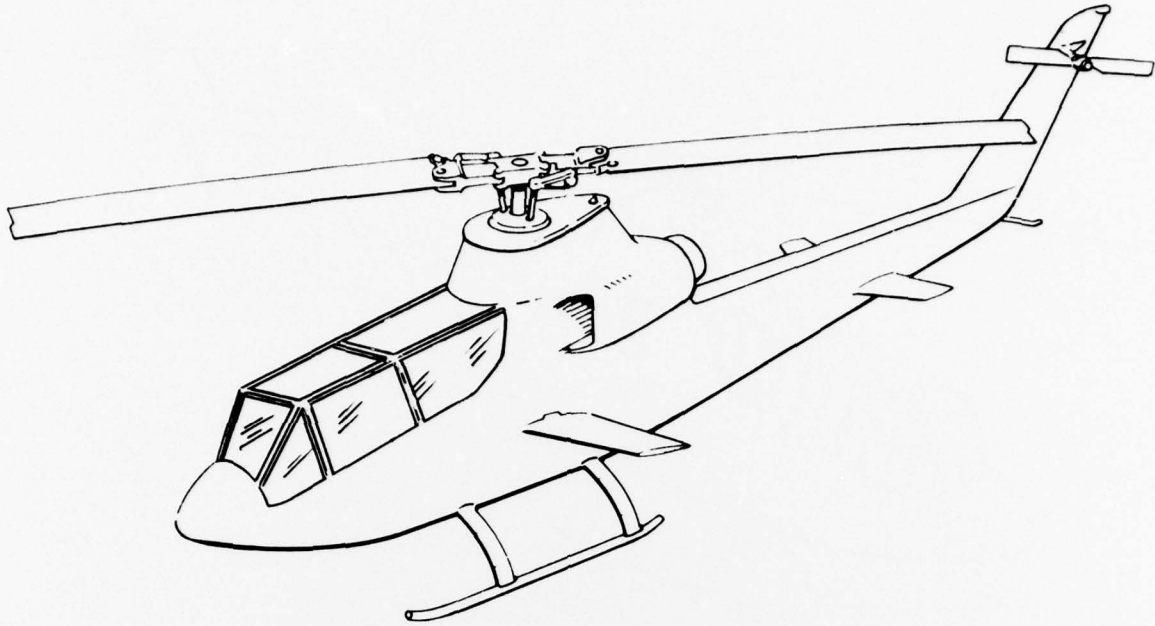

Figure A-9. Flat Panels

**Sun Glint Signature:**

The flat-panel concept can reduce probability of glint when compared to curved canopies, depending on panel orientation. Outward tilted canopies (at the top) are superior to vertical and inward tilted canopies.

**Sky Reflections:**

Outward tilted (at the top) flat-paneled canopies can reduce sky reflections.

**Internal Reflections:**

Flat panels increase the clarity and quantity of internal reflections, with the outward tilted version being the worst.

**Discussion:**

The flat-panel concept can be very efficient in control of sun glint but quite poor in terms of internal reflection problems. Both weight and drag of this concept will be higher than that of curved-panel canopies. With careful design, the drag penalty can be kept small.

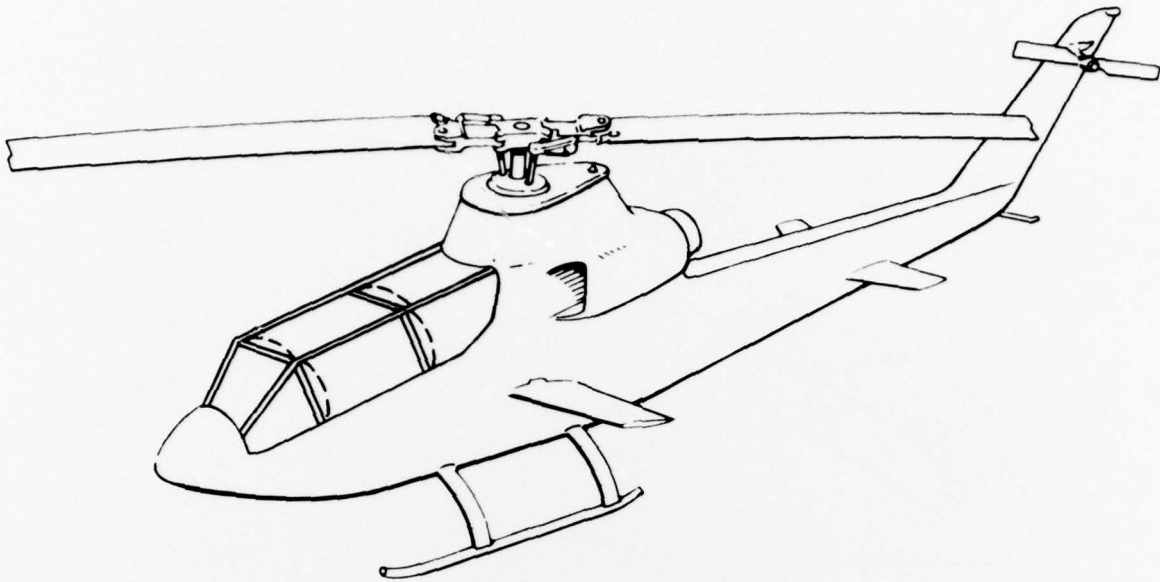

Figure A-10. Bendable Panels

Sun Glint Signature:

This concept can reduce probability of external sun glint when compared to that of a conventional curved-panel canopy.

Sky Reflections: No effect.

Internal Reflections:

By bending the normally flat panels during periods where internal reflections are a problem, discrimination between true external lights and reflections of those lights may be obtained. Control of reflections from internal sources will depend on basic panel orientation. The concept is better with outward tilted panels.

Discussion:

There would be a weight penalty due to the mechanism required. There may be reliability and maintenance problems due to fatigue failure of the plexiglass transparency from bending loads.

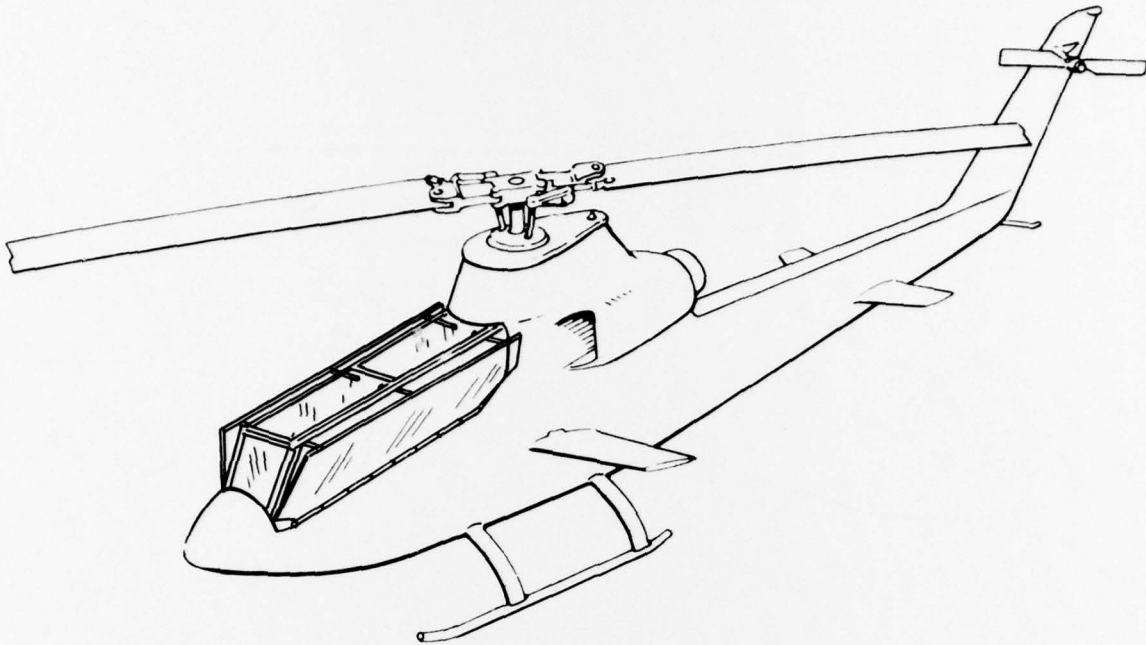

Figure A-11. Rotating Panels

Sun Glint Signature:

With the panels tilted outward, sun glint signature can be reduced when compared to that of a curved-panel canopy.

Sky Reflections:

Effective suppression can be obtained with the panels tilted outward.

Internal Reflections:

There will be extensive internal reflections with this concept regardless of panel orientation.

Discussion:

There will be a weight penalty with this concept due to the mechanism required. Reliability and maintainability will degrade due to the increased number of moving parts.

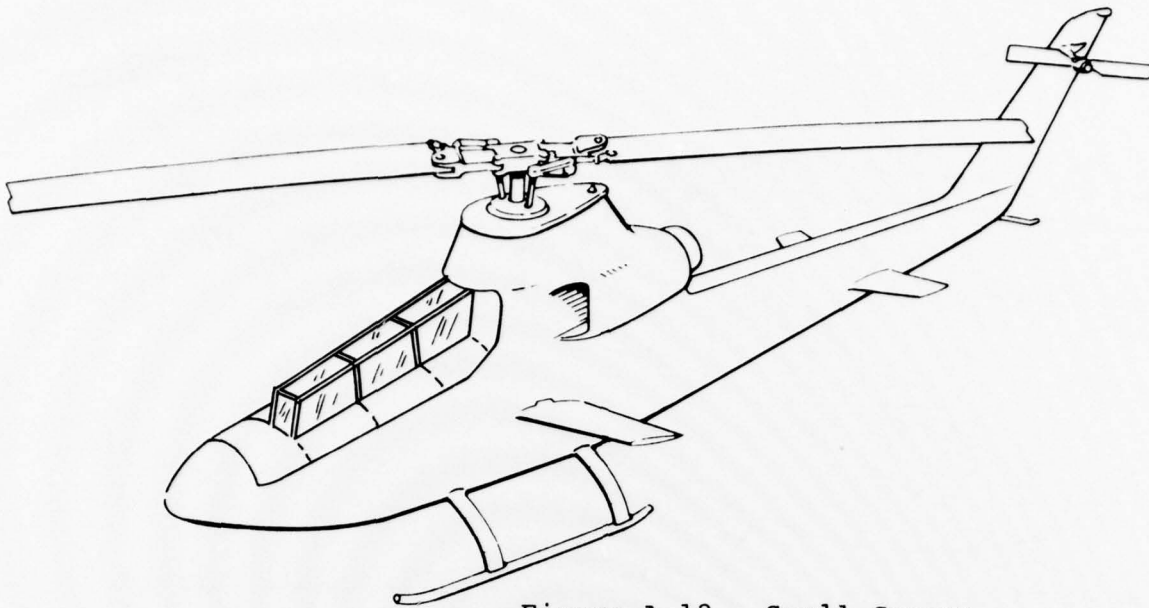

Figure A-12. Small Canopy

Sun Glint Signature:

Tests have shown that sun glint signature is independent of panel size. Thus, sun glint signature of small-size canopies will depend on transparency panel configuration of the particular small-size canopy design.

Sky Reflection:

Small-size canopies will reduce sky reflection signature, particularly at the longer observer-to-aircraft ranges.

Internal Reflections:

Internal reflection problems will be reduced with small-size canopies due to reduced light capture area. However, poor choice of transparency panel orientation can still lead to significant internal reflection problems.

Discussion:

MIL-STD-33573A and MIL-STD-850B constrains the design of small-size canopies. The former specifies a 10-inch spherical head clearance from the design eye position and a 26-inch minimum shoulder width. The latter specifies crew member field of view. The AH-1G canopy as flown in Vietnam is close to the minimum permissible size. Small-size canopy designs tend to reduce weight and drag and increase reliability and maintainability. The smaller presented area will increase survivability.

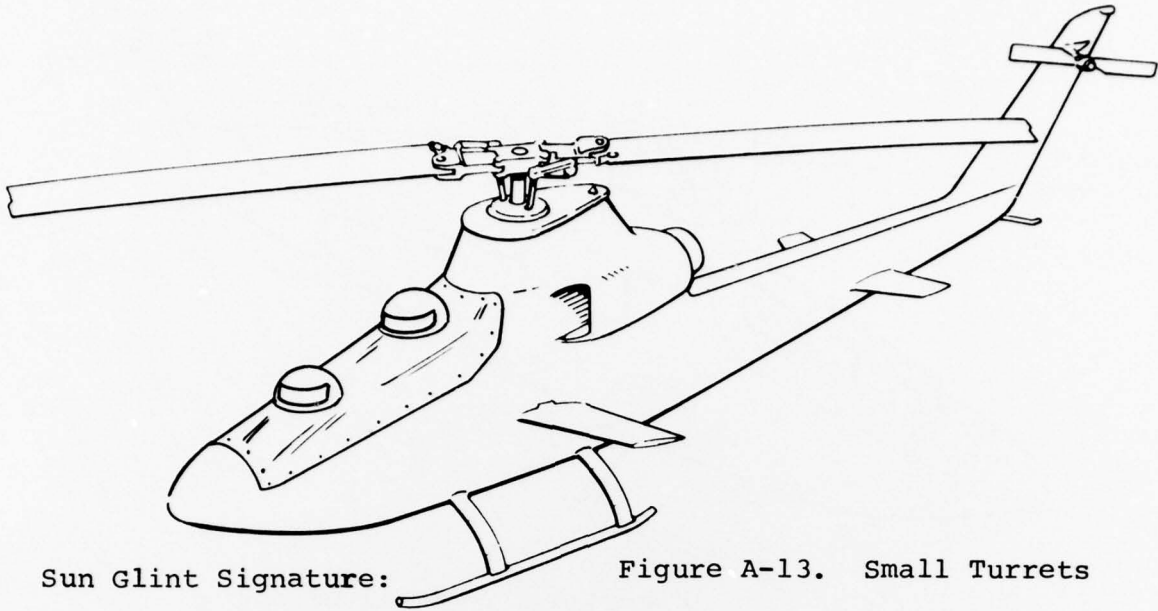

Sun Glint Signature:

Figure A-13. Small Turrets

The small turret concept controls sun glint through control of transparency panel orientation and curvature. An outward-tilted flat panel would significantly reduce sun glint. A double-curved panel would yield only a small reduction in sun glint signature over a conventional curved panel canopy.

Sky Reflections:

The small transparency panel inherent to this concept will yield significantly reduced sky reflections.

Internal Reflections:

This concept offers excellent control of internal reflection problems.

Discussion:

This is an active concept; a method for rotating the turret so that the transparent panel would track the crew member's head movement would have to be defined. There would be a space, weight, and power penalty involved in installing the drive mechanism and controls for the turret. Because of the moving parts, reliability and maintainability degradation would be inherent in the system. There would be a safety problem if combat or operational failures could cause the turret mechanism to jam with the transparency panel not aligned with the flight direction. MIL-STD-33573A and MIL-STD-850B requirements will tend to limit the minimum size and general design of the turret.

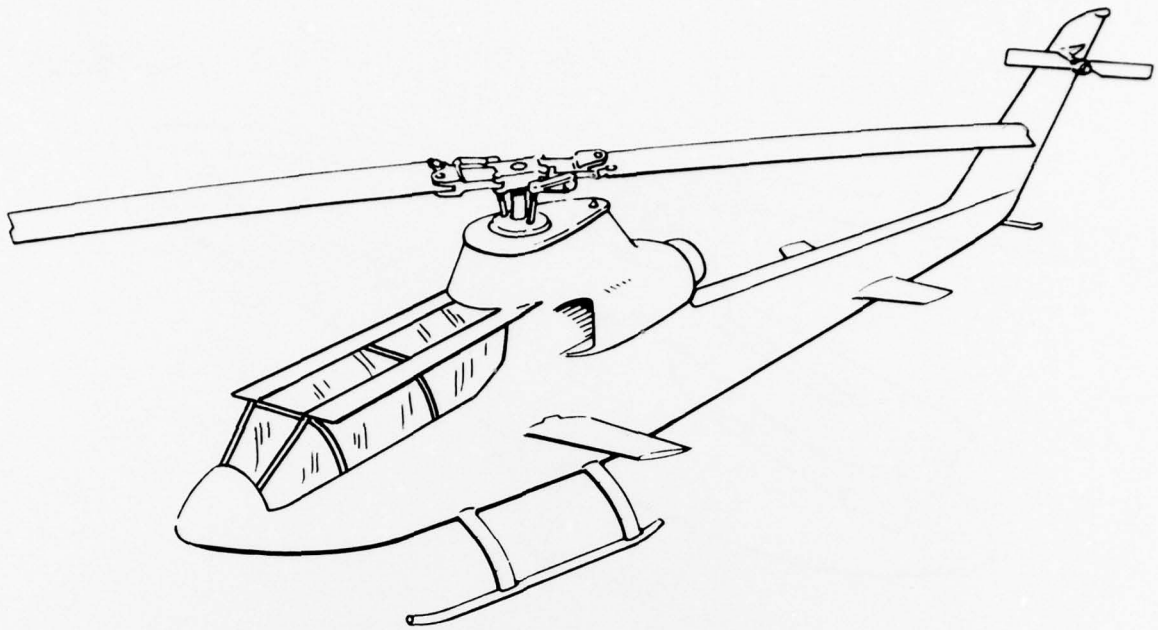

Figure A-14. Canopy with Fences

Sun Glint Signature:

Fences are effective in reducing sun glint as long as the fence is between the sun and the observer, or between the reflection point on the canopy and the observer.

Sky Reflections:

Fences have no effect on sky reflections due to the diffuse light source.

Internal Reflections: No effect.

Discussion:

Fences are generally good only for solving spot external reflection problems. Fences tend to restrict field of view. Because they extend above the surface of the canopy, fences increase presented area and offer a triggering device to high explosive shells. This increases aircraft vulnerability.

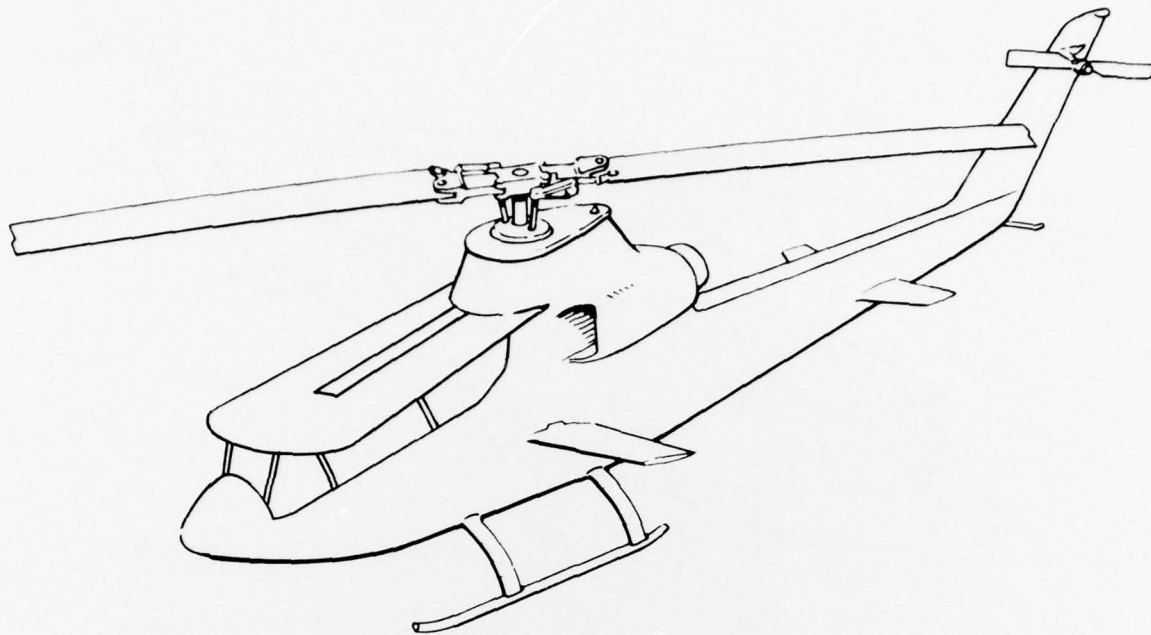

Figure A-15. Canopy with Shade

Sun Glint Signature:

Shades can reduce sun glint signature for high sun elevation angles. The exact angles are a function of shade size. On an AH-1G, a shade (as shown in the sketch) extending 4 feet out from the centerline of the aircraft and 2.5 feet forward of the leading edge of the canopy would provide protection for sun elevation angles above 45 degrees. There would be a sun glint potential for sun elevation angles below 45-degree elevation on the side towards the sun.

Sky Reflections:

Shades would tend to reduce probability of sky reflection.

Internal Reflections:

External shades will have no effect on internal reflection.

Discussion:

Shades would cause increased drag and reduce crew field of view. The degree of penalty would depend on the particular shade configuration. Very large shades could also impose a significant weight penalty.

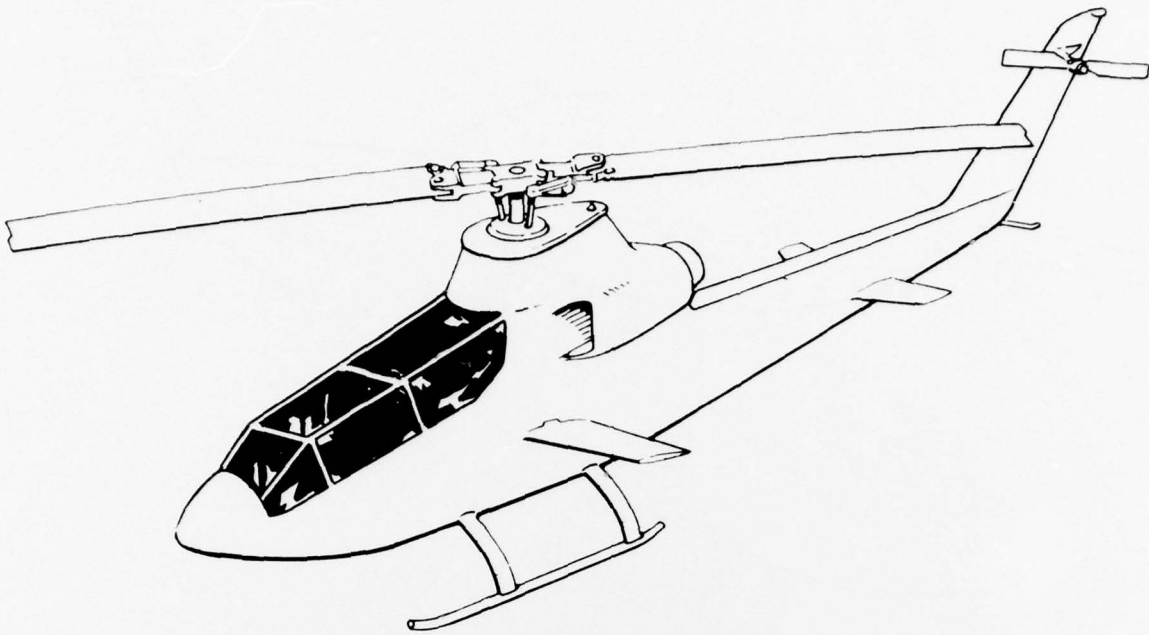

Figure A-16. One-Way Mirror

Sun Glint Signature: No effect.

Sky Reflections: No effect.

Internal Reflection:

One-way mirrors would have no effect on reflections from internal sources, but may allow ready discrimination between source and image on reflection of light from external sources.

Discussion:

Coatings or plastic films to achieve a one-way mirror effect significantly decrease light transmission. This concept would be unsuitable for night flight or other conditions under low ambient light.

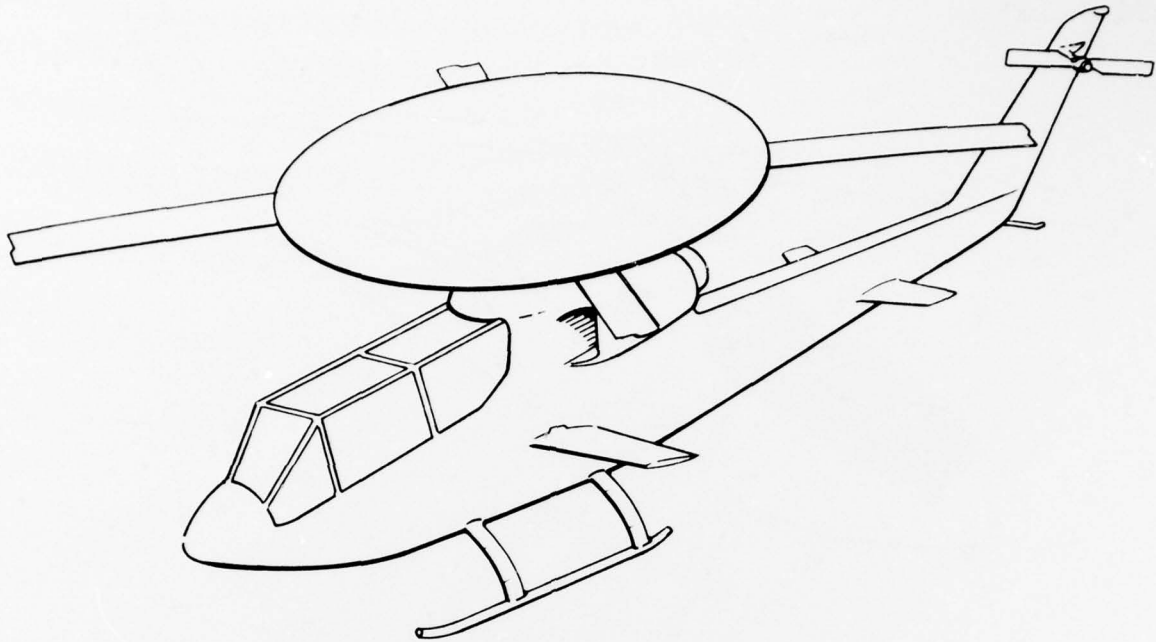

Figure A-17. Large Diameter Rotor Hub

Sun Glint Signature:

This concept is a form of shade. It offers control of sun glint when the sun is at high elevation and is located roughly 180 degrees to the aircraft heading.

Sky Reflections: No effect.

Internal Reflections: No effect.

Discussion:

This concept would produce a weight penalty and possibly a performance penalty on the aircraft.

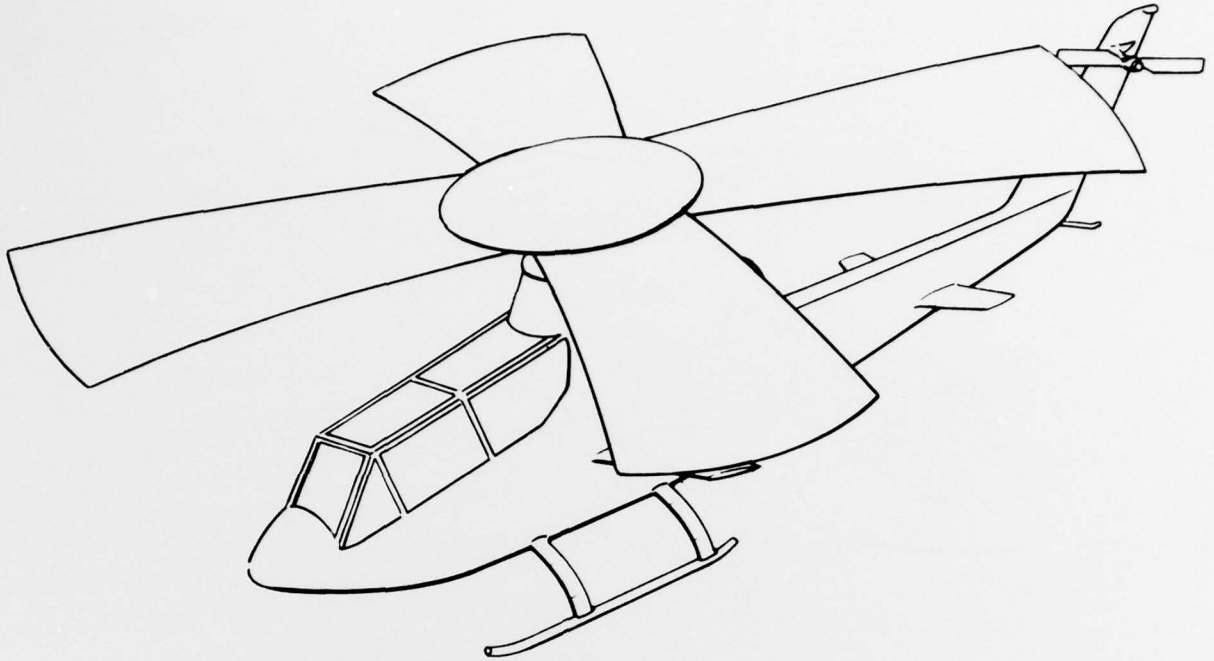

Figure A-18. High-Solidity Rotor

Sun Glint Signature:

This concept is a form of shade. It offers some protection when the sun is at high elevation and located roughly 180 degrees to the aircraft heading.

Sky Reflections: No effect.

Internal Reflections: No effect.

Discussion:

This concept would impose a performance penalty due to the inefficiency of the rotor design in addition to the weight penalty incurred by heavier rotor blades. The chopping of light caused by the moving rotor blades may increase probability of aircraft detection by a distant observer.

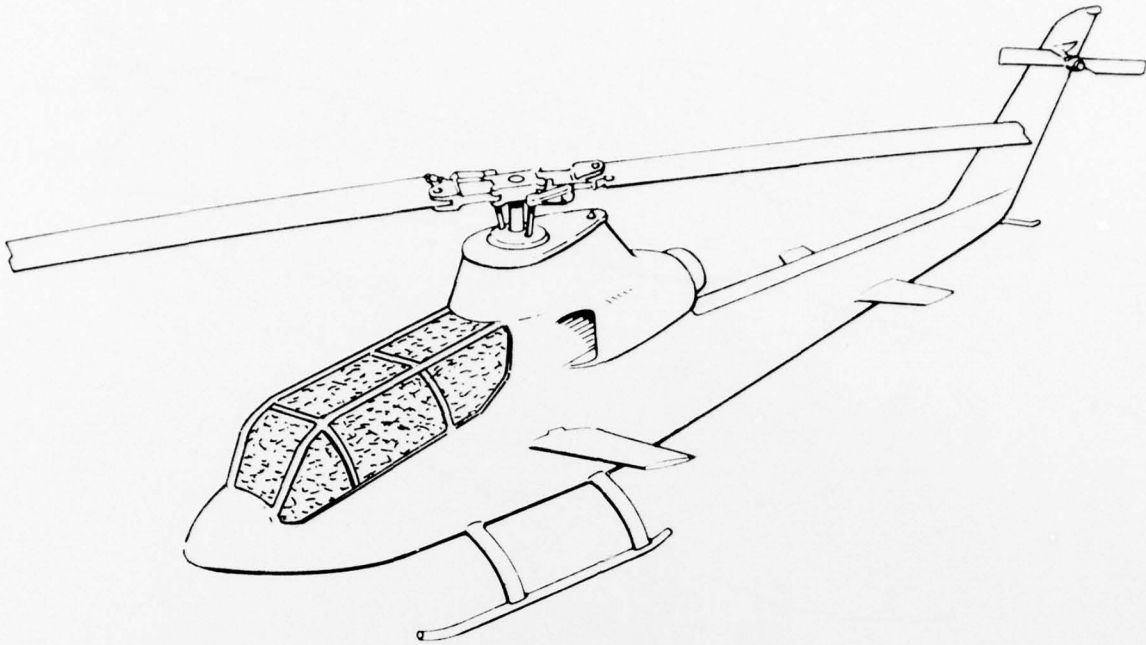

Figure A-19. Rough-Surface Canopy

Sun Glint Signature:

Greater than a conventional canopy design due to the multiple-facet effect of the concept.

Sky Reflections:

Some improvement is possible due to the lower amount of light reflected in any given direction. A test would be required to confirm this effect.

Internal Reflections:

No effect on multiple reflections from internal sources. The rough surface should distort the images from external light sources to the extent that the true direction of the source would be readily seen.

Discussion:

Because of the greater sun glint signature, this concept is not attractive.