

AD-A060 106

ADMIRALTY UNDERWATER WEAPONS ESTABLISHMENT PORTLAND --ETC F/G 14/3
A DESCRIPTION OF A ROBUST DIGITAL RECORDING SYSTEM.(U)
JUN 78 A COMAN

UNCLASSIFIED

AUWE-TN-584/78

DRIC-BR-64756

NL

1 OF 1
AD
A0 60 106



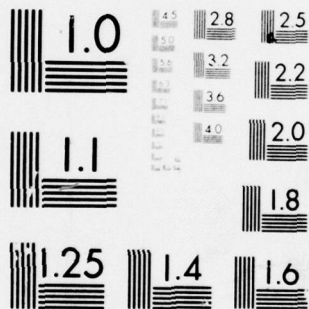

MICROCOPY RESOLUTION TEST CHART
NATIONAL BUREAU OF STANDARDS-1963-A

UNLIMITED

2
NW

U.D.C. No.
681.325.3:
681.327.8:

LEVEL II

A.U.W.E. Tech. Note 584/78
JUNE 1978

Copy No. 14

AD A060106 ACC. No. 46314

DDC FILE COPY

A.U.W.E. Tech. Note 584/78

A DESCRIPTION OF A ROBUST DIGITAL RECORDING SYSTEM

BY
A. COMAN

DDC
RECEIVED
OCT 23 1978
D

ADMIRALTY UNDERWATER WEAPONS ESTABLISHMENT
PORTLAND

78 10 17 118

UNLIMITED

UNCLASSIFIED/ UNLIMITED

LEVEL II

2

ACC. No. 46314

U.D.C. No.
681.325.3:
681.327.8:

A.U.W.E. Tech. Note 584/78

JUN 1978

④ Technical note

⑥ A DESCRIPTION OF A ROBUST DIGITAL RECORDING SYSTEM.

⑭ ACWE-TN-584/78
AUWE-ACC-46314

BY

⑩ A. COMAN

⑫ 18p

ACCESSION NO.	
NTIS	White Section <input checked="" type="checkbox"/>
DDO	Def Section <input type="checkbox"/>
UNANNOUNCED	<input type="checkbox"/>
JUSTIFICATION	
BY	
DISTRIBUTION/AVAILABILITY CODES	
Dist.	AVAIL. RDS/ON SPECIAL
A	

⑮ DRIC

⑰ BR-64756

DDC
RECEIVED
OCT 23 1978
D

A.U.W.E. Tech. Note 584/78

ADMIRALTY UNDERWATER WEAPONS ESTABLISHMENT
PORTLAND

78 10 17 118

(Duplicate Front Cover for filming purposes)

004 550

UNCLASSIFIED/UNLIMITED

Gen

UDC No 681.325.3:
681.327.8

AUWE Technical Note 584/78
July 1978

A DESCRIPTION OF A ROBUST DIGITAL
RECORDING SYSTEM

by

A Coman

CONTENTS

	<u>Page No</u>
Duplicate Front Cover	(i)
	(ii) Blank
Title Page	(iii)
Contents	(iv)
Distribution (Detachable)	(v)
	(vi) Blank
Précis	1
	2 Blank
Introduction	3
The Data Acquisition	3
Sensor Pack	3
Computer	3-4
Program Loading	4
Data Gathering	4
Data Dump	4-5
AUWE Data Gathering Program	5
Conclusions	5
	6 Blank
Appendix A: Sensor Pack Specification	7-8
Fig A1: Instrument Pack Dimensions	
Appendix B: Computer System Specification	9
	10 Blank
Fig B1: Computer Dimensions	
Document Control Sheet	11
	12 Blank
Abstract Cards (Detachable)	13

ILLUSTRATIONS

Figure 1: Paper Tape Format

DISTRIBUTION

	<u>Copy No</u>
AMTE (HASLAR) 	1
AMTE (TEDDINGTON) 	2
DWCA 	3
DRIC 	4-31
AUWE Library for distribution 	32-50

A DESCRIPTION OF A ROBUST DIGITAL
RECORDING SYSTEM

PRÉCIS

1. A description is given of a robust and accurate sensor pack and recording system developed for torpedo water entry trials. The recording medium is a computer controlled solid state memory.

INTRODUCTION

2. This report describes a sensor and data logger pack developed by BAC Stevenage and Sperry Bracknell to an AUWE specification. The pack monitors the rotational speeds and linear accelerations of a body launched into the sea at high speed so that its trajectory can be computed.
3. The complete system was designed to work through levels of shock up to 250g for 5 msec and to monitor 16 channels of data with dynamic ranges of 8000:1.

THE DATA ACQUISITION SYSTEM

4. The data acquisition system consists of two major components. One is the sensor pack which measures the information and the other is the computer that digitises and stores the information.
5. The limited volume of the storage medium means that a careful study must be made of the nature of the items to be sensed, such as bandwidth, accuracy and duration. In general simple digital storage systems are limited by the word length of the computer and its memory management ie 32K for a 12 bit machine and 128K for a 16 bit machine. The system described here uses a 12 bit machine with 8K of memory.
6. The system designed is simple to use. The operator has only to load the desired data gathering program into the computer, gather the data, and then switch the computer to output the data (data dump). During data dump the computer outputs the contents of the storage area onto paper tape in a compact 6 bit format Figure 1. Under normal trials conditions the computer will retain the data gathering program and can alternate between gathering and dumping.

SENSOR PACK

7. This is a self contained battery powered pack with 3 rate-gyros mounted orthogonally, and 3 accelerometers mounted orthogonally and aligned with the rate gyros. The outputs from the sensors are processed so as to provide coarse/fine signals for each channel. The signals are all filtered to prevent aliasing at a sampling rate of once per 2 msec. For lower sampling rates digital filtering is used together with sub sampling. Because the only hardened computer readily available in quantity production was a 12 bit machine, a coarse/fine technique was required to accommodate the large dynamic range of the instruments (8000:1).
8. As the shock resistance of the instruments is of the order of 100g the sensors are mounted on a sub frame within the pack. The sub frame is isolated from the pack by rubber shock mounts, these attenuate the 250g 5 msec shock to less than 100g. The deflection of the shock mounts with load is known; together with the frequency response of the system so that if required these errors can be computed out when the data is being analysed.

9. The rest of the pack has been designed to meet the 250g shock requirement. A detailed specification of the sensor pack is given in Appendix A.

COMPUTER

10. The computer chosen for this equipment was the Sperry 1412A which is a more modern version of the 1412 used in the EXOCET system and in some AUWE underwater trials vehicles. The computer has a good history of working in rough conditions.

11. The computer system has the 1412A computer with 8K of battery supported semiconductor RAM and a 16 channel 12 bit analogue to digital converter. The system specification is detailed in Appendix B.

12. Communication with the computer is via a standard ASR teletype.

13. The computer has three modes of operation.

- a. Program loading.
- b. Data gathering.
- c. Data dumping.

In addition the computer can be used to develop data gathering programs before, during and after a trial, thus giving a great degree of flexibility to the operation.

PROGRAM LOADING

14. Because the computer has a battery supported semiconductor memory, the data gathering program once loaded will stay resident until the batteries are discharged (10 days).

15. To initiate the system after a long period of storage the systems batteries must be recharged and then the program loaded via the teletype. The program loading is quite simple as the 1412A has a ROM bootstrap loader which is initiated when the power is switched onto the computer.

16. The data gathering programs are of necessity short, otherwise they occupy too much valuable storage space, and therefore take only a few minutes to load.

DATA GATHERING

17. How this is done will depend solely on the users program, however the maximum sampling rate is about 500 per sec per channel.

DATA DUMP

18. The computer when switched to the data dump mode outputs the contents of its storage area on to paper tape in a compact 6 bit format. The format chosen for the AUWE work was the MS Byte as the first 6 bits, and the LS Byte as the second 6 bits. The format is illustrated in Figure 1. The start of data is signalled by the code byte 132 then follows 6 12 bit words of data. After the data words is a special status byte that determines whether the data words are coarse or fine. The data block is ended with 3 bytes of data that represent time, stored MS byte first. The sequence then repeats; there is no end of tape character or sumcheck.

19. The compact format was chosen so as to keep the length of paper tape to a minimum, and hence reduce the dump time as much as possible. When using a 110 baud teletype it takes approximately 25 minutes to dump 8K of memory.

20. From experience it has not been found that the compact non standard tape format has been a handicap as the input medium for later analysis programs on other computers.

21. The data dump is completely software controlled and media other than paper tape could be used whose transfer rates are faster, hence permitting the use of a standard data format. The teletype was chosen by AUWE as it represented the absolute minimum of equipment to be taken on trials.

AUWE DATA GATHERING PROGRAM

22. The data gathering is completely software controlled and is constrained only by the A/D converter, total storage area, the speed of the computer, and the accuracy required.

23. The choice of a computer with proven software together with a teletype means that data gathering programs can be altered, and reassembled at the trials site. This is very convenient if the initial results indicate that one has made the wrong choice as to the sampling rate on the signals required.

24. The program specified by AUWE is as follows and is intended as an example only. The trial it was written for was to monitor the behaviour of a body thrown violently into the sea.

25. After switching on, sample 13 channels together at 100 msec intervals, storing the results into a defined storage area by cyclic overwriting. This preserves the 10 seconds immediately before LAUNCH no matter when it occurs.

26. LAUNCH. This is detected by the computer when the voltage level on channel 13 falls to zero. After LAUNCH is detected the sampling interval is reduced to 10 msec, and the data stored in sequential locations following the defined cyclic storage area. The outputs of the accelerometers are monitored so that impact with the sea surface can be detected.

27. After IMPACT the sampling interval is reduced to 2 msec for $\frac{1}{2}$ second, ie 3000 samples and then reverts to 10 msec until the storage area is full.

28. The varying sample rates were chosen to match the expected dynamic behaviour of the instrumented body at different periods of its flight.

CONCLUSIONS

29. The foregoing system has been used as the only recording medium on two trials. The equipment has been reliable and has been subjected to some 20 high 'g' shocks. On one occasion the equipment was shocked beyond the AUWE specification when the AMTE launching equipment failed to release correctly. The recording system faithfully recorded the disaster.

30. During use the volatile nature of the storage medium has not caused any problems as the vehicle has been recovered within a few days.

31. Owing to the limited capacity of the recording system it is necessary to consider carefully what to record and how often. This has had obvious advantages in the subsequent analysis.

APPENDIX A: SENSOR PACK SPECIFICATION1. Electrical Inputs

- a. +24/0/-24 V DC + 2V - 1V from a rechargeable battery pack containing forty varta cells, type RS 1. Maximum current drawn at peak torquing rates 2 amps.
- b. +5 V DC into 10K ohm. Signal to be maintained to hold system in the 'ON' condition during 1 minute runs.

System zero voltage line is the zero volts line in a. and b., and is isolated from the frame of the unit.

2. Rate Inputs

- 0 to 100 deg/sec continuous
0 to 400 deg/sec for less than 0.5 seconds.

3. Acceleration Inputs

- Accelerometer range $\pm 20g$.
Accelerations of 230g 5 mS not to damage the complete system.

4. Electrical Outputs

The output sign will depend on the input direction and will be $\pm 5V$ DC at full scale output, limited to $\pm 5.7V$ DC with inputs above full scale. One side of each output will be connected to the system zero voltage line. Full scale output will represent the following inputs. The exact values of scale factors will be recorded.

Gyro Fine Scale	90 to 110 deg/sec
Gyro Coarse Scale	380 to 440 deg/sec
Accelerometer Fine Scale	4.5 to 5.5 g
Accelerometer Coarse Scale	19 to 22 g

5. Zero Offset

- | | |
|------------------------------|---------------------------|
| Gyro Room temp | 5.0 mV max |
| Gyro 0 to 30°C add | 1.5 mV max |
| Accelerometer Room temp | 3 mV typical
10 mV max |
| Accelerometer 0 to 30°C, add | 3 mV max. |

6. Linearity

Gyro fine scale 0.25% of reading or 0.03 deg/sec whichever is greater.

Gyro coarse scale 0.25% of reading or 0.12 deg/sec whichever is greater.
The brief periods allowed at rates over 100°/sec, limited by torquer dissipation, may degrade rading accuracy. This clause is not mandatory.

Accelerometer Fine Scale	} 30 $\mu g/g^2$ or 10 mg whichever is greater
Coarse Scale	

Sample instruments checked. Not possible to check unit.

7. Natural Frequency

Defined as 90° phase lag of output with respect to input.

Gyro 70 Hz minimum.

Accelerometer 800 Hz minimum (manufacturers data, not mandatory)

8. Linear Acceleration Sensitivity of Gyros

34 deg/hr/g maximum per axis.

44 deg/hr/g maximum vector sum.

9. Gimbal Displacement of Gyros

0 to 400 deg/sec: less than 6° milliradians

Over 400 deg/sec: less than 3°

10. Run up Time

Gyro 30 secs maximum.

Accelerometer not applicable.

11. Running Times

a. On system battery, at least five runs of one minute separated by 3 minutes.

b. On bench power supply, 20 minutes.

12. Environmental Design Parameters

a. Operating temperature 0 to $+30^\circ\text{C}$.

b. Storage temperature -10°C to $+65^\circ\text{C}$.

c. Altitude unlimited when stored in a sealed container at approximately 1 atmosphere.

d. Vibration.

The system to withstand 2 hours each axis, 14 to 30 Hz sine wave 3g, swept in 20 minutes.

e. Shock.

Half sine wave shape 230g peak, duration 5m sec. In any direction. Equipment to be running during shock.

f. Vacuum.

Equipment to withstand a vacuum of 0.1 mm when not operating.

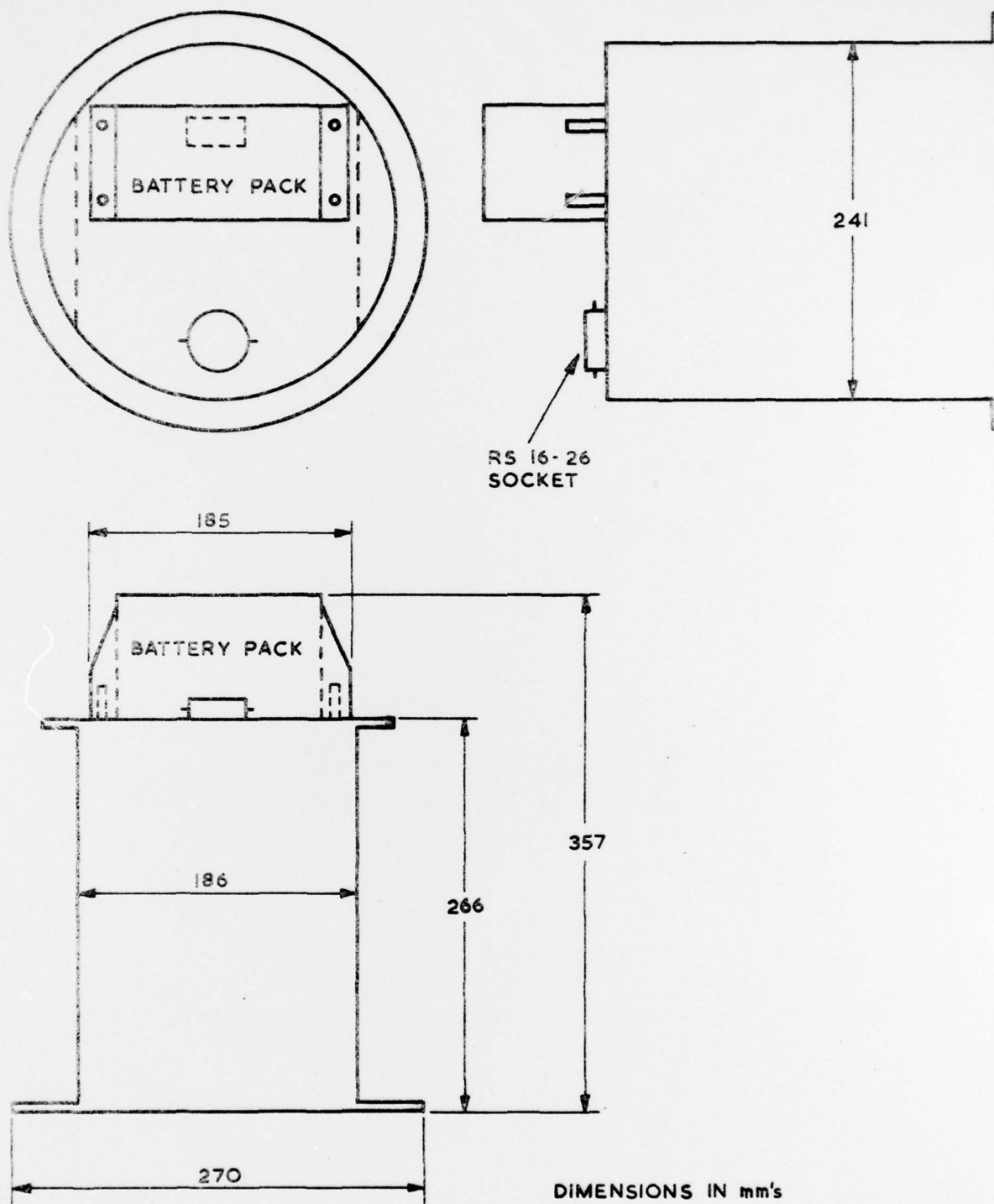

APPENDIX A
INSTRUMENT PACK DIMENSIONS

APPENDIX B: COMPUTER SYSTEM SPECIFICATION

1. Data Inputs

The system will multiplex the following inputs.

- a. Number of inputs 16 off.
- b. Sampling rate - program controlled.
- c. Analogue signal level - $\pm 5V$ for full scale.
- d. Maximum signal level - $\pm 10V$ will not cause damage.
- e. Input impedance $> 1M\Omega$
- f. Single ended inputs with common 0V as pseudo differential input.
- g. Radio Spares 32 way connector 466-703 is used for data and commands.

2. Power and Command Connections

- a. + 5V @ 12A maximum.
- b. Connections to charge store support battery.
- c. Connections to change program start address.
- d. Teletype connections.
- e. Radio Spares connector type 466.624 is used for power connections.

3. Running Times

- a. Program loading < 10 minutes.
- b. Maximum delay before trial without loss of program < 5 days.
- c. Data retrieval within 10 days of trial.

4. CMOS Memory Support

Memory to be supported by battery for a minimum of 10 days after being fully charged. The battery is permanently connected across the memory and can be completely discharged and stored without damage.

5. Environmental

- a. Operating temperature 0° to $+ 70^{\circ}C$.
- b. Will withstand a vacuum.
- c. Vibration 14 - 30 Hz $\pm 3g$.
- d. Shock 250g for 5 msec.

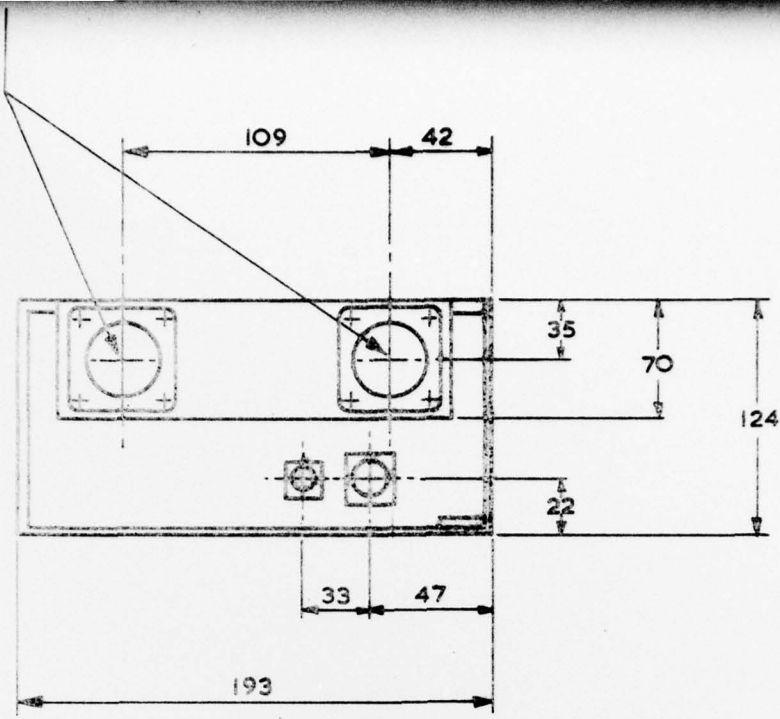

RADIO SPARES
466-624
466-703

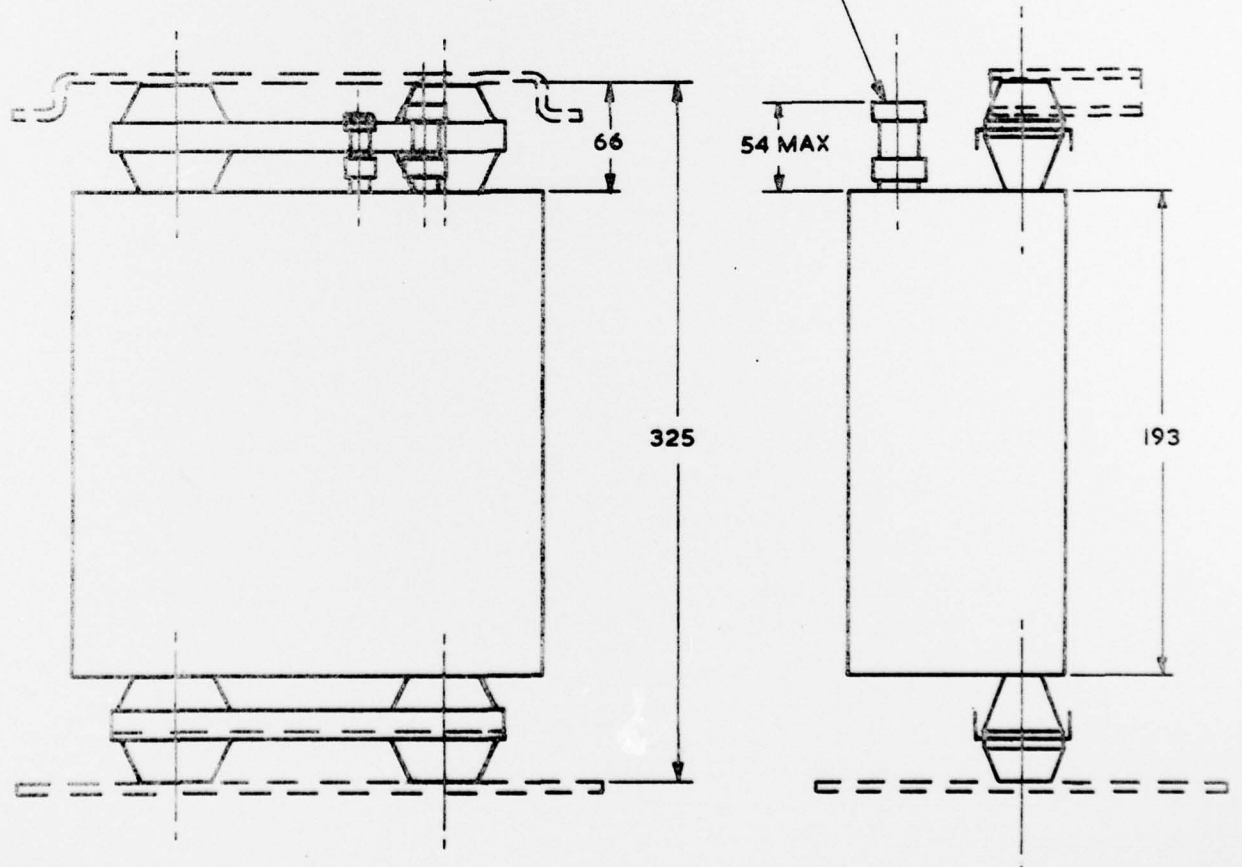

APPENDIX B
COMPUTER DIMENSIONS

TN 584/78

DOCUMENT CONTROL SHEET

Overall security classification of sheet UNCLASSIFIED/UNLIMITED

(As far as possible this sheet should contain only unclassified information. If it is necessary to enter classified information, the box concerned must be marked to indicate the classification eg (R),(C) or (S)).

1. DRIC Reference (if known)	2. Originator's Reference TECH NOTE 584/78 ACC No 46314	3. Agency Reference	4. Report Security Classification UNCLASSIFIED/ UNLIMITED
5. Originator's Code (if known) 012500	6. Originator (Corporate Author) Name and Location Admiralty Underwater Weapons Establishment Portland, Dorset, UK		
5a. Sponsoring Agency's Code (if known)	6a. Sponsoring Agency (Contract Authority) Name and Location		
7. Title A DESCRIPTION OF A ROBUST DIGITAL RECORDING SYSTEM			
7a. Title in Foreign Language (in the case of translations)			
7b. Presented at (for conference papers). Title, place and date of conference			
8. Author 1. Surname, initials A COMAN	9a. Author 2	9b. Authors 3, 4...	10. Date. pp. ref. JULY 78 23 -
11. Contract Number	12. Period	13. Project	14. Other References
15. Distribution statement			
15. Descriptors (or keywords)			
<p>Abstract</p> <p>A description is given of a robust and accurate sensor pack and recording system developed for torpedo water entry trials. The recording medium is a computer controlled solid state memory.</p>			

Detachable Abstract Cards

These abstract cards are inserted in AUWE reports and notes for the convenience of librarians and others who need to maintain an information index

<p><u>UNCLASSIFIED/UNLIMITED</u></p> <p>AUWE Technical Note 584/78 July 1978 A Coman</p> <p>681.325.3: 681.327.8</p> <p>A Description of a Robust Digital Recording System</p> <p>A description is given of a robust and accurate sensor pack and recording system developed for torpedo water entry trials. The recording medium is a computer controlled solid state memory.</p>	<p><u>UNCLASSIFIED/UNLIMITED</u></p> <p>AUWE Technical Note 584/78 July 1978 A Coman</p> <p>681.325.3: 681.327.8</p> <p>A Description of a Robust Digital Recording System</p> <p>A description is given of a robust and accurate sensor pack and recording system developed for torpedo water entry trials. The recording medium is a computer controlled solid state memory.</p>
<p><u>UNCLASSIFIED/UNLIMITED</u></p> <p>AUWE Technical Note 584/78 July 1978 A Coman</p> <p>681.325.3: 681.327.8</p> <p>A Description of a Robust Digital Recording System</p> <p>A description is given of a robust and accurate sensor pack and recording system developed for torpedo water entry trials. The recording medium is a computer controlled solid state memory.</p>	<p><u>UNCLASSIFIED/UNLIMITED</u></p> <p>AUWE Technical Note 584/78 July 1978 A Coman</p> <p>681.325.3: 681.327.8</p> <p>A Description of a Robust Digital Recording System</p> <p>A description is given of a robust and accurate sensor pack and recording system developed for torpedo water entry trials. The recording medium is a computer controlled solid state memory.</p>