

AD-A060 109

ROYAL AIRCRAFT ESTABLISHMENT FARNBOROUGH (ENGLAND)  
WEAPON-AIRCRAFT INTERACTION: LECTURE DELIVERED AT CRANFIELD INS--ETC(U)  
OCT 77 P G PUGH

F/G 1/3

UNCLASSIFIED

RAE-TM-AERO-1731

DRIC-BR-61786

NL

| OF |

AD  
A0 60109

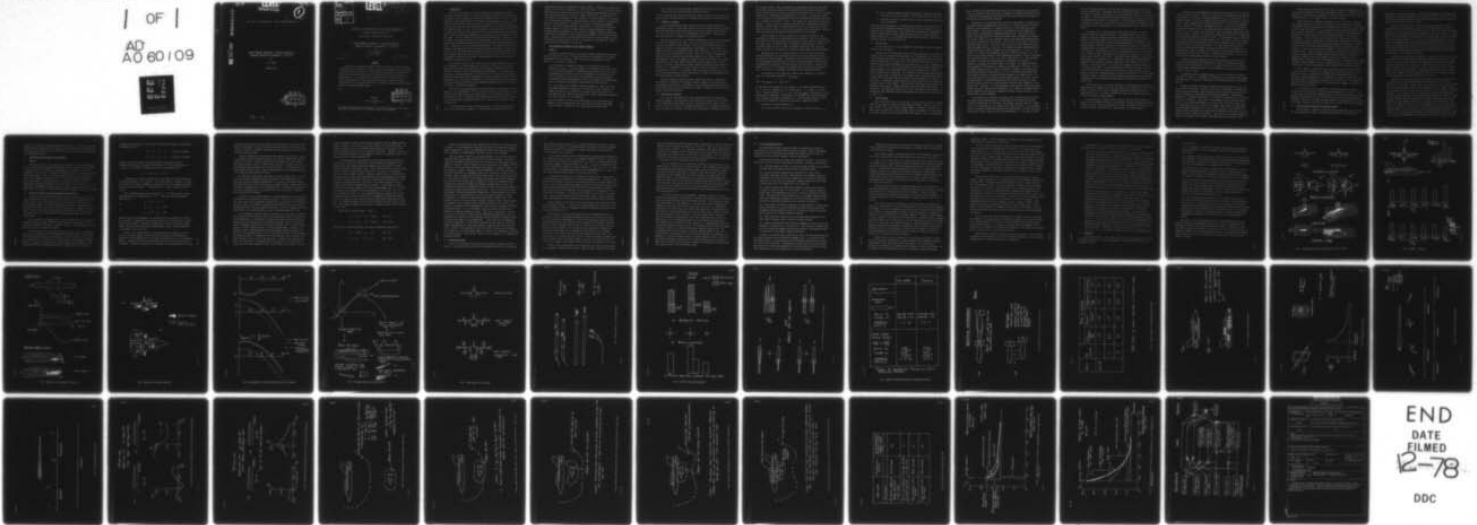

END  
DATE  
FILMED  
12-78  
DDC

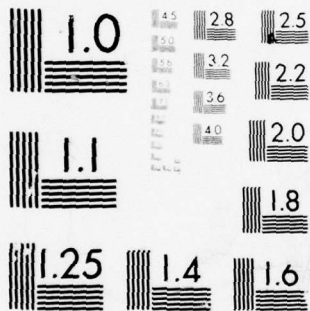

MICROCOPY RESOLUTION TEST CHART  
NATIONAL BUREAU OF STANDARDS-1963-A

**LEVEL  
UNLIMITED**

TECH. MEMO  
AERO 1731 ✓  
**(1)**  
*nu*

**AD A060109**

ROYAL AIRCRAFT ESTABLISHMENT

**DDC FILE COPY**

WEAPON-AIRCRAFT INTERACTION: LECTURE DELIVERED AT  
CRANFIELD INSTITUTE OF TECHNOLOGY, 15 JUNE 1977

by

P. G. Pugh

October 1977

**DDC**  
**RECEIVED**  
OCT 23 1978  
**REGULATED**  
**D**

78 10 17 098

000	Diff Section	<input type="checkbox"/>
UNANNOUNCED		<input type="checkbox"/>
JUSTIFICATION		
BY		
DISTRIBUTION/AVAILABILITY CODES		
Dist.	AVAIL. and/or	SPECIAL
A		

**LEVEL II** (18) DRIC

(19) BR-61786

(9) Technical memo.

ROYAL AIRCRAFT ESTABLISHMENT

Technical Memorandum Aero 1731

Received for printing 31 October 1977

(6) WEAPON-AIRCRAFT INTERACTION: LECTURE DELIVERED AT  
CRANFIELD INSTITUTE OF TECHNOLOGY, 15 JUNE 1977.

by

(10) P. G./Pugh

(12) 54p

(11) Oct 77

SUMMARY

This lecture reviewed the primary effects of the air carriage of stores including both the influence of stores on aircraft performance and the influence of the aircraft on the stores. The main emphasis was placed upon qualitative exposition of the physical processes involved with particular reference to guided weapons. It is issued in the present form as an introduction to the topic and with the aim of assisting those involved with weapon design in understanding the broad implications of air carriage so they can initiate timely studies of potential problem areas.

(14) RAE-TM-AERO-1731

Copyright

©

Controller HMSO London  
1977

DDC  
RECEIVED  
OCT 23 1978  
D

This Memorandum expresses the opinions of the author and does not necessarily represent the official view of the Royal Aircraft Establishment.

*Jm*

310 450 78 10 17 038

1 INTRODUCTION

The aim of this paper is to draw attention to the problems of weapon-aircraft interaction, that is to say the aerodynamic problems that arise when we attempt to carry a weapon on an aircraft and when we come to release it, with emphasis on their implications for the design of guided weapon systems. It may appear natural to think first of a weapon in isolation and of an aircraft in isolation and then to put them together, though this is not entirely logical from the technical point of view. If the weapon is to be air-carried it has first to be mechanically fitted to the aircraft. The aircraft/weapon combination must be able to take-off and cruise economically - otherwise it is never going to reach the target. The pilot must be able to handle the combination - otherwise it will be unable to perform the missions that are required. As hostile territory is approached, the combination must be capable of acceleration to high speed at low level - otherwise it will be excessively vulnerable. The pilot must be able to manoeuvre the combination so as to acquire and attack the target. He must then be able to execute a high speed dash out of hostile territory and cruise home. Once released, the weapon must fly towards its target and not suffer such severe aerodynamic disturbances as to make it lose guidance lock onto the target or to endanger the delivery aircraft.

The essential point is that a weapon in free-flight towards its target is the culmination of a whole sequence of solutions to difficult problems all of which must have worked satisfactorily if the desired effectiveness is to be achieved. Moreover, none of these problems are negligible. Considerations of geometrical clearances, whether the nuts and bolts fit together, installed drag and/or handling problems have stopped more than one otherwise attractive weapon development. As for release disturbances, the aviation journals have chronicled various incidents showing that aircraft shooting themselves down is by no means an unknown or impossible phenomenon.

Obviously, the weapon designer cannot be expected to cope with all these problems. The responsibility for their solution usually lies elsewhere; but the weapon designer should have a good appreciation of the fundamental aspects of such matters as they can influence the design requirements that he may face and will certainly have an important effect on the chances of his product seeing extensive use.

In the following sections, the primary aspects of weapon-aircraft interaction are reviewed giving emphasis to the physical phenomena involved and

indicating some orders of magnitude of various effects. However, both weapon aerodynamics and aircraft aerodynamics are subtle and complex. A full discussion of the difficulties that result from the two sets of problems superimposed and interacting is obviously beyond the scope of a single paper; hence, the limitation of this paper to the exposition of basic concepts. In this exposition it is helpful to use some numerical examples. However, these are merely meant as illustrations and must not be regarded as 'typical' in the sense of being design handbook values. The study of weapon/aircraft interactions is a rapidly developing one in which methods in current use range from very complex mathematical models through elaborate experiments to the exercise of judgement based on experience. It would be unreasonable to expect every weapon designer to be an expert in this field. Instead, he must rely upon specialist advice; but there remains the task of framing the right questions to ask of the experts at the right time. This paper should be of assistance to that end.

## 2 THE INFLUENCE OF WEAPONS ON THE CARRIER AIRCRAFT

### 2.1 General

Scarcely any characteristic of an aircraft escapes modification due to the external carriage of stores. The principle effects are traceable to four main consequences of store carriage - three of which are aerodynamic in nature. These four consequences are (Fig 1):

(i) the increase in moments of inertia of the aircraft due to the addition of stores. It is quite common to find masses of up to 20% of that of the aircraft being added in underwing positions where they have a more than proportionate effect on the aircraft moments of inertia and on the ratios of moments of inertia about the principal axes of the aircraft. Even without associated aerodynamic effects, such changes can significantly alter the stability and handling characteristics of the aircraft.

(ii) the changes in aerodynamic stability derivatives. Most stores have considerable capability to generate lift and, hence, their presence can change the loads on the aircraft due to angles of pitch, yaw and roll. Such changes in the stability derivatives are usually adverse and reductions in lateral stability can be troublesome.

(iii) the presence of stores can readily upset the 'finely-tuned' aerodynamics of the wing with the result that lift-curve slope and maximum lift are reduced - despite the lift generated by the store itself.

(iv) last, but by no means least, addition of stores increases the drag - often by far more than the drag of the store itself.

In brief, external stores increase inertias, degrade stability, reduce lift, and increase drag. We shall now go on to examine each problem in rather more detail.

## 2.2 Changes in inertias

As has been indicated, these effects can be quite large especially for wing-mounted stores. Of particular interest are the principal moments of inertia about the longitudinal and vertical axes. Fig 2 shows changes in roll inertia  $I_X$  and in the ratio  $I_Z/I_X$  for a hypothetical, but typical, combat aircraft when each hard point is loaded to its maximum capacity.

Clearly the changes in  $I_X$  will have significant effects on roll acceleration; but the changes in the ratio  $I_Z/I_X$  are of greater importance to the stability and control of the aircraft. This ratio is directly related to the amount of roll/yaw coupling experienced at high angles of attack which is an essential feature of the handling of most current aircraft. To put the results shown in Fig 2 in perspective, the ratio  $I_Z/I_X$  for a classic straight-wing, subsonic aircraft would be about half that shown for the 'clean aircraft' in this diagram. Thus, fully loading the modern aircraft would change its inertial characteristics from the 'modern' about half way back towards those of World War II. It is very likely that any high incidence instability would change from 'dutch-roll' or 'wing-rock' to a much 'flatter' form of oscillation, *ie* one much closer to pure yaw. It is possible that the change in inertia ratio could cause an entirely different form of instability to become the determining factor in limiting flight at high incidence.

Although changes in inertia can have significant effects of themselves, the addition of external stores usually produces changes in both inertias and in aerodynamic derivatives. Accordingly, we will postpone further discussion of these matters until we have reviewed the influence of external stores on the aerodynamic stability derivatives.

## 2.3 Reduction of stability

It is rare to find addition of stores doing anything other than worsen stability problems. The exceptions to this gloomy rule are usually to be found in the longitudinal derivatives, and Fig 3, which illustrates typical results for the effect of stores on the longitudinal stability of a wing-body combination, shows one such case. However, even here, the stores seem to exacerbate the pitch

up at high incidence. This is qualitatively reasonable because the flow field of the store could well promote local separation of the flow over the wing at lower incidence than for the clean wing and the resulting loss of lift at outboard positions on a swept-back wing would result in pitch up. The effect of stores on the wing flow can be supplemented by loss of tailplane effectiveness when this part is bathed in the wake of a store. The remedies for this latter trouble are obvious - either to make sure that the store has a well streamlined back end (to minimise the store wake) or avoid putting the store in any place such that the wing flow field is liable to carry the store's wake over the tailplane. Here the aims of reduced drag and improved flying qualities are in harmony.

Typical effects on lateral stability are increases in sideforce and reductions in yawing and rolling moments due to sideslip. These are caused by the sideforces on the store which act well ahead of and below the aircraft's fin and, hence, move the overall centre of pressure forward and down. There are associated effects on all the other aerodynamic derivatives; but these are usually secondary to the changes in sideforce, yawing moment and rolling moment.

Obviously, any loss in static stability in the yaw plane is generally undesirable whatever the flight conditions; but the major problems are often encountered at high incidence. Research is active on the whole question of the lateral handling characteristics of aircraft at high incidence; but definitive and comprehensive stability criteria have not yet been evolved. However, one example will serve to illustrate the problems and, in particular, demonstrate the interrelation of aerodynamic and inertia effects mentioned earlier.

A necessary, but not sufficient, condition for stability is a positive value of a 'divergence parameter'  $C_{n\beta}$  dynamic ,

$$\text{where } C_{n\beta} \text{ dynamic} = n_v - \frac{I_Z}{I_X} \ell_v \sin \alpha .$$

At low values of incidence ( $\alpha$ ) this reduces to the familiar requirement that  $n_v > 0$  ; but the importance of the inertias and of  $\ell_v$  at high  $\alpha$  is also clear. Typical variations of  $n_v$  ,  $\ell_v$  , and  $C_{n\beta}$  dynamic are sketched in Fig 5 which gives an impression of the manoeuvre limitations that may be imposed by store carriage. Obviously, reductions in  $n_v$  are the prime culprit in this case; but the changes in inertias have also had a significant effect.

Evidently, we should endeavour to:-

- (a) place the stores as far aft as possible to reduce the loss of  $n_v$  .

- (b) try to minimise changes in aircraft inertias - which means getting the stores as close as possible to the aircraft centre of gravity;
- (c) minimise the extent to which stores are positioned below the aircraft centre of gravity.

Such aims will frequently be in conflict with each other, with the desire for good look-angles from guided weapon carriage location and, possibly, with the demands of low installed drag. This should not be interpreted as implying that lateral handling effects should inhibit exploration of new ideas concerning weapon carriage; but it is necessary that they should be kept in mind when considering radically new or extreme cases.

#### 2.4 Loss of lift

As Fig 6 indicates, we can distinguish two principal effects of carrying stores on aircraft wings.

Firstly, the flow field about the store causes that part of the wing in its vicinity to be in a non-uniform flow field. For an underwing store carried in a typical forward position it is clear that the incidence and curvature induced on the wing are such as to reduce lift. This offset in the lift curve is not usually of major practical import; but the other effect - a loss of maximum lift - can be serious. This is due to the presence of the stores imposing additional pressure gradients on the boundary layers over the wing and, thus, leading to earlier boundary layer separation. It is difficult to give any general guidance on this topic except to remark that the boundary layer on the wing under surface is under less stress than that on the upper surface, and hence, less liable to break down. Accordingly, underwing stores are less likely to give trouble than overwing stores in this respect. Even this 'rule' may become less reliable with advances in wing design. Advanced designs tend to have quite high pressure gradients on the wing lower surfaces at low lift which raises the possibility of separations (and consequent buffet) being induced by stores at low, as well as at high, lift.

#### 2.5 Installed drag

Fig 7 shows three views of an aircraft. At the top is a sketch of a hypothetical, but typical, aircraft, without external stores. Next is a view of the same aircraft with a heavy load of guided weapons. Obviously, these will have their effects on drag but, at first sight, these do not appear to be very large. In reality, things are not always what they first appear to be. To demonstrate

this, the third view shows the frontal area of each item scaled up in proportion to its contribution to the total drag. Evidently, the weapons contribute a drag of about the same magnitude as the clean aircraft and the mission performance of the aircraft can be radically affected.

The impact of the installed drag of stores on performance is brought out in Fig 8 which shows diagrammatically the effects of a typical full load of guided weapons on the performance of a typical aircraft on a representative ground attack mission. The essential feature is the magnitude of the reductions in strike radius, maximum speed and maximum sustained 'g'. The precise values depend on the specification of the mission while speed and range can be traded-off for each other; but such variations cannot avoid substantial degradations of the overall capability of the aircraft. We now turn to the origin of the high installed drag of stores. The first cause is that the stores themselves have a relatively high drag even in free air. For example a typical guided weapon has a drag coefficient, based on frontal area, of anything up to 1.5 at  $M = 0.9$  in contrast to a typical corresponding value for an aircraft of about 0.15. Now, there are often good reasons for the excessively bluff noses, various excrescences, far from perfect surface finish, lap joints, bluff bases, etc. But need there be as many? Perhaps, the weapon designer is sometimes too complacent (or compliant) concerning the free-air drag of the weapon. This might be because the performance of the weapon in isolation is insensitive to its drag. In the bad example quoted earlier, a thrust coefficient (computed in the same way as the drag coefficient) is about 36.5 at  $M = 0.9$ . Obviously, reducing the drag is not going to greatly increase the (thrust-drag) of the weapon itself. In fact, even halving the drag would increase (thrust-drag) at  $M = 0.9$  by only 2%. The modest gain in acceleration that would result from a big effort at drag reduction might not seem very cost-effective viewed from the standpoint of the weapon alone. However, it is the performance of the complete weapon system that matters and, when viewed from the standpoint of the impact of the weapon drag on the performance of the aircraft, substantial efforts at drag reduction on the weapon could be well worthwhile.

The potential for reduction of free-air drag is indicated in Fig 9 where the drag of three guided weapons is sub-divided into skin-friction and the remaining contribution to total drag. The varying, and relatively low, proportion of the total drag that is accounted for by skin friction - even at subsonic speeds - indicates considerable potential for drag savings. The next line gives some outline frontal views of the three guided weapons. It is clear that they

are not very compact devices - at least when viewed from the point of view of aircraft installation. This means that space, rather than weight, constraints are likely to determine the maximum load of guided weapons that can be carried on an aircraft. Also, relatively large mounting devices may be needed to reach past the wings and hold the body of the missile. Such mountings will make their own contribution to the drag - a contribution that can be especially damaging to aircraft range if these mountings have to be brought home as well as carried to the target.

An alternative to cleaning up the weapon itself might be to carry it enclosed within a streamlined container. A container that would enclose a complete, unaltered, weapon could well be impossibly bulky. However, wing folding is relatively common and it has been semi-arbitrarily assumed that it could be used to halve the *net* span of the guided weapon. On this basis, the minimum drags of suitable containers (*ie* skin-friction drag of an enveloping streamline body) are presented in Fig 9 to the same scale as the free-air drags of the weapons. Evidently, this is not a very promising route as, of the three cases considered, small drag reductions are obtained in two cases and a large drag increase results in the third. There may be some advantage in putting the guided weapon in a container if it is possible to nest several guided weapons together before wrapping a container around them. Nevertheless, the main message is clearly that there is no broad, easy highway to avoid the penalties of inadequate attention to the aerodynamic drag of the basic weapon. There is just the familiar path of attention to detail and constant striving for aerodynamic cleanliness. Notwithstanding the numerous constraints on the basic shape of guided weapons, it remains true that a greater priority given to aerodynamic cleanliness at the detailed design stage would bring substantial benefits in reduced drag.

While a desire for low free-air drag may be an unexceptional sentiment, it seems pertinent to suggest that, when the impact on the performance of the carrier aircraft is taken into account, aerodynamic cleanliness might well merit a higher priority *vis a vis* other considerations than has traditionally been the case in the design of guided weapons.

The second cause of high installed drag is that the free-air drag of a weapon can be multiplied manyfold by unfavourable interference between the stores and the aircraft. As Fig 10 reminds us, real-life aerodynamic flow fields, as distinct from the idealised ones of linear theory, are rarely additive.

An indication of the magnitude of the interference effects for some typical stores is given in Fig 11. These are calculations for underwing carriage and the first thing to be observed is the large magnification of the drag that occurs at transonic speeds. Factors even higher than those shown can be found in very bad cases. Closer examination of these data shows that it is the most streamlined bodies that suffer the largest interference effects. This is not unreasonable as there must be some limit to the additional drag that mutual interference can induce or, in other words, the well-ordered flows can be upset whereas poor flows are bad already. However, this must not be regarded as an excuse for having poor flow and, hence, high drag in the first place. To demonstrate this, an additional set of data is given for the guided weapon. This shows what is likely to result from removing all excrescences so as to reduce the subsonic drag to that corresponding to skin friction plus base drag. It is seen that the reductions in installed drag are only slightly less than proportionate to the reductions in free-air drag. There is nothing in the nature of the interference effects that significantly detracts from the value of reducing free-air drag - at least for the drag levels and geometries typical of guided weapons.

Underwing carriage demonstrates the worst interference effects that are likely to be encountered (with the possible exception of overwing carriage). Carriage under the fuselage is much to be preferred with ratios of installed to free-air drags remaining between 1 and  $1\frac{1}{2}$  throughout the entire speed range of interest for most stores.

Fortunately, work on installed drag is not all concerned with charting the paths to disaster. Aerodynamic interference is not necessarily unfavourable and much effort is devoted to identifying and exploring favourable interference effects.

The most elementary and effective method of drag reduction is to put the store inside the aircraft. However, unless we are considering a completely new weapons system (including a new aircraft), there is no need to go into all the diverse arguments for and against re-inventing the bomb-bay. Nevertheless, maximum use of systems already built in - or which can be built into an aircraft has much to commend it. Any 'extras' like designator pods, carriers, release units, etc are especially damaging as far as drag is concerned as they have to be carried back from, as well as to, the target. Their impact on range being thus approximately doubled, they are well worth attention. This implies that weapon carriers should either be cheap and jettisonable or else great attention should be paid to minimising their drag. This could be an area where compromise between two extremes only succeeds in obtaining the worst features of both.

Perhaps the most fruitful field in terms of favourable aerodynamic interference is the influence of one store upon adjacent stores. In essence there are two forms of such beneficial interference. These are indicated in Fig 12 and are commonly referred to as 'tandem effects' and 'axial stagger'.

Tandem effects are obtained by placing one store in the wake of another and, thereby, shielding it from the full impact of the free-stream. Obviously, the maximum beneficial tandem effect is obtained if the stores are closely packed and have large flat bases or if, for any other reason, they have high drags and, hence, generate wide wakes. Tandem carriage is effective at all speeds; but, because of its nature, tends to be a way of ameliorating a situation which is already bad. If the stores are well streamlined they should have relatively small wakes and, hence, tandem effects will be small. Nevertheless, it may be of particular interest in the context of guided weapons since these are usually forced to have a bluff base whose undesirable influence on drag may be much reduced - or, even, turned to positive advantage - through the full exploitation of tandem effect. There are obvious difficulties caused in other aspects of the design by tandem carriage of guided weapons and some solutions could lead to expensive, complex, and non-jettisonable carriers such as have just been anathematised. Nevertheless, the aerodynamic benefits are substantial and tandem carriage of guided weapons could be a worthwhile subject for careful trade-off studies and an interesting challenge to the ingenuity of the weapon designer.

Axial stagger is a much more subtle exercise in which the pressure fields of two stores are so disposed as to promote their mutual cancellation. This delays the onset of shock waves and ameliorates the subsequent drag rise. Obviously, its main application is at transonic speeds and to those stores for which wave drag is an important constituent of the total drag. Such stores are likely to be well streamlined and, in this sense, axial stagger is a means of making the good even better.

To give some idea of the magnitude of these effects, Fig 13 compares various ways of carrying one, two or three guided weapons in a group. It will be seen that the drag of the assembled groups can vary from much greater to substantially less than the sum of the free-air drags of the constituent weapons. Evidently, attention to the ways in which weapons are grouped together as well as to the ways in which such groups are hung on the aircraft could be well rewarded.

## 2.6 Preferred weapon shapes and carriage locations

At this stage, it should be clear that anyone responsible for an aircraft and its performance is liable to have firm views on what is desirable and

undesirable in weapon installations. Effective communications and timely action are greatly facilitated by appreciation of the "other man's" point of view. Thus, it will help the weapon designer if he understands how weapon carriage problems appear from the 'other side of the fence'.

Firstly, the aircraft man is bound to regard most weapons as crude and aerodynamically dirty things for so they are - when judged against aircraft standards. Now, there may be many good reasons for that; but the drag of weapons imposes very severe penalties on the performance of the carrier aircraft. Since, that, in turn, influences the capabilities of the whole weapon system, it should concern the weapon designer too. So, there is a powerful incentive to aim for clean, well-streamlined, low drag, small and well packaged weapons in a system that is not dependent upon many additional 'bits and pieces' that have to be hauled out and hauled back. In view of the potential gains to the performance of the weapons system through the reduction of installed drag, this aim merits high priority in the design of the weapon.

Secondly, some quite subtle aerodynamic interference effects can make a big difference to the installed drag as shown by the examples given earlier. They are only illustrative and precise values depend upon the aircraft, the weapon, the means and location of carriage, etc. Nevertheless, such effects exist, are often large, and can be exploited to reduce installed drag - just as their neglect can bring severe penalties. Tandem carriage of bluff stores and the use of axial stagger for well streamlined stores are well established examples of the exploitation of beneficial effects of this type.

Likewise the stores may, through their effects on lift, stability derivatives and inertias of the aircraft, have a profound effect on the flying qualities of the aircraft. Again, these may be subtle in origin, large in magnitude, and counter-vailing in effect; but minimisation of the distance between the carriage positions of stores and the aircraft centre of gravity is generally desirable. Such a paper as this can only give some idea of the magnitudes involved and draw attention to the problems and possibilities. However, enough has been shown to make clear the merits of aiming from the start for an aerodynamically clean, compact weapon with the minimum of additional 'bits and pieces' and which does not *have* to be mounted under or over the wings or well forward or outboard. If he pursues this end with sufficient determination, the weapon designer is well on the way to offering something which someone can contrive to carry with the very minimum of performance penalty (Fig 14). Above all, aircraft carriage should be an important consideration from the earliest

stages of the design of a weapon intended for such use. If left until the preliminary design is finished, even the most skilful attention to the problems of air-carriage are likely to be so constrained as to yield only modest palliatives to embarrassing problems.

### 3 THE EFFECT OF THE AIRCRAFT ON THE WEAPON

#### 3.1 General

We now come to look at the other side of the coin. Just as the presence of the weapons seriously harms the performance of the aircraft, so the presence of the aircraft can pose difficult conditions for the weapon. Firstly, its attachment to the aircraft - perhaps in proximity to guns - can cause significant vibration problems. Also, its carriage at high speed may raise questions of rain erosion damage to homing heads, etc. We can only note these problems, whose implications to the weapon design are usually specified in terms of generalised requirements applicable to a wide range of cases, and pass on to the specifically aerodynamic problems associated with putting the weapon into the flow field of an aircraft. This starts with typical examples of such flow fields.

#### 3.2 Flow fields about typical swept-wing/body combinations

In practice, the flow field in which a weapon is situated can be significantly influenced by details of the aircraft geometry in the immediate vicinity of the weapon. One obvious example of such local effects is the presence of another weapon nearby. This was discussed in the context of installed drag; but important interference effects may be present on other components of store loads. However, such effects are sensitive to details of particular installations and we are here concerned with the broad principles that apply to all installations.

First, consider the fuselage and its flow field (Fig 15). For a slender, circular-section, fuselage, the flow in the cross-flow plane reduces to two-dimensional potential flow about a cylinder. Thus, a first approximation to the entire flow field is readily calculated.

Even this simplest of approaches demonstrates that local flow conditions close to the fuselage can be very different from the free-stream. For example, at the fuselage sides we find local angles of attack of twice the free-stream value and nearer to the bottom of the fuselage there are considerable outwash angles. In general, we find that the local incidence and yaw angles ( $\alpha_L$  and  $\beta_L$  respectively) can be represented as linear combinations of the aircraft

incidence ( $\alpha$ ) and yaw ( $\beta$ ). In the case of a circular fuselage, we would obtain relationship such as

$$\alpha_L = 2\alpha, \quad \beta_L = 0 \quad (\text{sides of fuselage})$$

or

$$\alpha_L = 0, \quad \beta_L = 2\beta \quad (\text{bottom of fuselage}).$$

However, practical fuselages are of non-circular cross-section and, at unfavourable locations, much greater sensitivity of local flow conditions to  $\alpha$  and  $\beta$  can be found. In some cases we find relationship such as

$$\alpha_L = \alpha + 2\beta, \quad \beta_L = 2\alpha + \beta.$$

Evidently, the store can be exposed to local angles of attack and yaw very different from those of the aircraft. To fix some ideas as to numbers, consider an aircraft with a mass of 20000 kg, a wing area of 27 m<sup>2</sup> and capable of pulling 8 g at M = 0.9 and sea-level. A typical value for  $\partial C_L / \partial \alpha$  might be 0.06 per degree.

Thus, a maximum angle of attack would be  $\alpha = 17^\circ$  which, during a rapid manoeuvre, might be accompanied by  $\beta = 3^\circ$ . Then, the three relationships above yield:-

$$\alpha_L = 34^\circ, \quad \beta_L = 0$$

or

$$\alpha_L = 0, \quad \beta_L = 34^\circ$$

or

$$\alpha_L = 23^\circ, \quad \beta_L = 37^\circ.$$

These are only typical examples, not representative of any particular aircraft; but they serve to demonstrate the potential severity of the local flows in which stores can be mounted. Of particular importance are the side loads and yawing moments associated with high local sidewash angles as many carrier designs are ill-equipped to deal with these.

Further, the transmission of the carriage loads from weapons to the aircraft, via a small number of pick-up points, may produce loads comparable in magnitude to those experienced in free-flight and distributed in a less favourable fashion. Carriage loads can become important design cases for the stressing of the weapon. Further, the weapon will be exposed to the carriage loads for a much

longer period than that for which it will have to sustain the loads associated with its free-flight. Even if the maximum carriage loads can be sustained, the repeated variation of carriage loads associated with manoeuvring of the aircraft can cause fatigue problems.

Similar problems may be encountered with underwing installations. Again, a very simple theoretical representation of the aircraft explains the dominant features of the flow. Consider the thickness distribution of a wing along a line perpendicular to, say, its quarter chord (Fig 16). Evidently, this can be represented by some distribution of sources and sinks. The combined effect of these singularities will be to induce a downwash ahead of the maximum thickness of the wing and upwash behind this point.

An additional complication arises when the wing is swept back. It will be seen that ahead of and behind the wing the affect of the singularities is to reduce the velocity component perpendicular to the line of the quarter chords and, hence the total local velocity vector is swung outboard. Immediately below the wing the combined effect of the singularities is to increase the component of the velocity perpendicular to the quarter chord line and, hence, swings the total velocity vector inboard.

The effect of lift can be deduced in a similar manner with the lift being represented by a distribution of vortices (Fig 17). In this case the singularities reduce the velocity component perpendicular to the wing at all points below the wing. Hence, an outwash is experienced everywhere below the wing and has a maximum value below the local quarter-chord point. Also, the singularities induce upwash ahead of the quarter-chord point and a downwash downstream of this.

To recapitulate, consider making a traverse of the flow along a streamwise line parallel with and below the chord line starting well ahead of the wing and moving downstream. At low angles of incidence the thickness effects will predominate and, we should first find downwash and outwash. As the traverse proceeds the downwash increases but the outwash diminishes until it changes over to inwash at a point roughly opposite to the wing leading edge. Thereafter, the downwash reaches a maximum and then reduces-changing to upwash around a point opposite to the maximum thickness of the wing, where the inwash reaches a maximum. The upwash increases to a maximum near the trailing edge of the wing while the inwash declines to zero at about the same point. Thereafter the upwash decays while the outwash rises to a maximum and then decays also. At high angles of attack the lift effects dominate so that, at the start of the traverse, we find

outwash and upwash. These initially increase together; but the upwash reaches a maximum around, or just ahead of, the point opposite the wing leading edge. The outwash continued to rise to a maximum roughly opposite to the quarter chord while the upwash declines to zero at about the same point. Thereafter the outwash decays monotonically; but the downwash increases to a maximum at about half-chord and then also decays monotonically.

An excellent guide to the subsonic flow fields about wings is given in a report by W.J. Alford Jnr ("Theoretical and experimental investigation of the subsonic-flow fields beneath swept and unswept wings with tables of vortex-induced velocities" NACA Report 1327). This, includes data for a wing of aspect ratio = 4.0 and a (quarter-chord) sweep of  $45^\circ$ . As such, it is reasonably typical of current combat aircraft. Along a traverse line, at a distance from the wing typical of many weapon installations and at mid-semispan, Alford found the results reproduced in Figs 18 and 19. Fig 18 gives the variation of local incidence for wing incidences of  $0^\circ$  and  $8^\circ$ . The features deduced from the elementary theoretical considerations are evident. In particular, it may be noted that at the point opposite to the wing leading edge,  $(x/c) = 0$ , the rate of change of local incidence with wing incidence is 1.5; but at  $x/c \approx 0.5$  this derivative is about 0.3. Local sidewash angles are shown in Fig 19 where we again see much the same overall picture as suggested by elementary theory. The rate of change of local yaw with wing incidence varies comparatively little with  $x/c$  within the range of most practical interest and has a value of about 0.8. Other evidence suggests that the rate of change of local yaw with wing yaw is about unity.

So we have, considering high  $\alpha$  only:-

$$\alpha_L \approx 1.5\alpha, \quad \beta_L \approx 0.8\alpha + \beta \quad (x/c = 0)$$

or

$$\alpha_L \approx 0.3\alpha, \quad \beta_L \approx 0.8\alpha + \beta \quad (x/c = 0.5)$$

which, for the aircraft manoeuvre case that we considered earlier gives:-

$$\alpha_L = 25.5^\circ, \quad \beta_L = 17^\circ \quad (x/c = 0)$$

or

$$\alpha_L = 5^\circ, \quad \beta_L = 17^\circ \quad (x/c = 0.5) .$$

Again, we see that local flow conditions are sensitive to location and can be severe. Local yaw angles are less than the worst cases quoted for underfuselage carriage; but a store on an underwing pylon may be even less well placed to resist sideloads or yawing moments than when carried on the fuselage.

The most obvious lesson for the weapon designer is the need to be able to withstand large forces, especially side-forces, during carriage. Even if the largest of the angles quoted earlier are not likely to be found along the entire length of a weapon, total inclinations of the airstream of up to maxima of  $30^{\circ}$  to  $50^{\circ}$  at  $M = 0.9$  and sea-level should give the designers of control surfaces, etc some pause for thought. Moreover, the non-uniformity of the flow field means that the distribution of aerodynamic forces over the weapon is likely to be very different during carriage from that during free-flight. High loads distributed in a very different fashion to the design loads generated by other requirements may well mean that carriage poses a completely distinct and demanding design stressing case from both ultimate and fatigue strength points of view. The problems thus posed are exacerbated by the difficulties frequently encountered in estimating carriage loads and their distribution. Input to estimates of these loads range from inspired guesswork through (more or less) elaborate flow field calculations, the interpretation of test data on similar weapons in similar circumstances, to specially commissioned wind-tunnel or flight tests. All potential sources of data have their technical limitations and a certain amount of redundancy in the available data is highly desirable as this allows cross-checks for consistency and 'reasonableness' which can often eliminate erroneous or misleading data. It is not possible to give any simple rules such that adherence to them will guarantee success. There are no such things. All that can truly be relied upon is that virtually indefinable combination of careful interpretation, constant cross-checking and forward planning of adequate testing that goes by the name of 'good engineering'. A point that must be emphasised is that the experiments or calculations required to assess carriage loads (and release disturbances) are often time consuming, expensive and have long lead-times. Failure to make adequate provision for these (including some redundancy of information) at an early enough stage in a project is to jeopardize the success of the whole project - whatever the 'reason' for such neglect, be it ignorance or mistaken parsimony.

### 3.3 Interference loads

So far, the discussion has been based on an implied assumption that the loads on a store are directly related to the combined effects of the free-stream

and (clean) aircraft flow field at the location occupied by the store. This is adequate for the purposes of semi-quantitative assessment; but the quantitative predictions needed for calculations of weapon trajectories (following their release) demand closer analysis.

The essential concepts are best illustrated by considering the variation of the forces acting upon a store as it is brought towards an aircraft. Initially, the situation is as depicted in Fig 20 where  $q_\infty$  and  $M_\infty$  are the dynamic pressure and Mach number of the free-stream,  $\alpha_{\infty a}$  and  $\beta_{\infty a}$  are the incidence and yaw of the aircraft with respect to the free-stream,  $\alpha_{\infty w}$  and  $\beta_{\infty w}$  are the incidence and yaw angles of the weapon with respect to the free-stream, and  $\alpha_L$  and  $\beta_L$  are local incidence and yaw within the aircraft flow field.

In this case the store is not influenced by the aircraft, or vice versa, and calculation of its behaviour is relatively straightforward. However, if we move the store towards the aircraft we eventually reach the situation depicted in Fig 21. The store has entered the region in which the aircraft flow field causes the local flow conditions to differ from those of the free-stream. However, these differences are not large and can be accounted for by adjustments to the 'free-stream' conditions, *ie* the store still behaves as if it were in a uniform flow - albeit one that differs from the free-stream. Thus, we have additional loads corresponding to the difference between local and free-stream conditions.

Closer approach of the store to the aircraft gives rise to further effects as illustrated in Fig 22. In this case the non-uniformity of the aircraft flow field is significant and, in consequence, there are additional loads due to the flow non-uniformity *per se*.

When the store is very close to the aircraft a fundamental difference arises as a further complication introduces a fourth set of loads on the store. In all the situations considered so far the store flow field, being much less extensive than that of the aircraft, has not significantly influenced the flow about the latter. However, when the store is close to the aircraft, Fig 23, it does exert such influences. So, we have the store immersed in a highly non-uniform flow field whose form is influenced by the presence of the weapon. Obviously we could "chase our tails" for ever trying to pin down where each contribution to the loads comes from and so we tend just to have an omnibus term, usually denoted "close interference loads", to account for the effects on the store of the changes in the aircraft flow field due to the presence of the store.

Finally, 'close interference' can exist between one store and other stores just as between a weapon and the aircraft. When the other stores are not being

released simultaneously with the weapon under consideration, we could conceptually dispose of their influence by taking the 'aircraft' to mean the aircraft plus the carried stores. However, it is often more convenient, and usually justifiable, to neglect the influence of the carried stores on the flow field of the aircraft except when the released store is very close to the aircraft. Then, as depicted in Fig 24, the effects of the carried stores are accounted for by a further set of loads due to "close interference with other stores".

The five different sets of loads that contribute to the total forces and moments acting on the store are listed in Fig 25. This tabulation also indicates the appropriate characteristic distance and the extents of the zones in which the various loads are significant in terms of these characteristic distances. Obviously, any such summary runs the risk of grossly over-simplifying a very complex situation. This tabulation is only intended to be semi-qualitative guide and, again, must not be regarded as incorporating universal rules. However, it is clear that the relative sizes of the zones in which the various contributions (to the total loads on the store) are encountered will normally be as indicated in Figs 20 to 24) but that these will vary substantially with the aircraft configuration, etc.

To further flesh out the philosophical framework of Figs 20 to 24, two theoretical calculations of the loads on a typical guided weapon as it is dropped from an underwing carriage position have been analysed. Fig 26 shows the normal force broken down into its components. Note that some of these components are negative and the others positive with the result that there is a non-monotonic variation of the normal force with distance below the wing. Some approaches to the problem of release disturbance use the free-stream loads - which are usually known or comparatively easy to predict - and the carriage loads - which are usually measured for other purposes. They then assume some form of decay law with distance for the difference between the free-stream and carriage loads. This example shows the pitfalls of such techniques. A corresponding analysis of the pitching moments is given in Fig 27. As one might expect, the pitching moment is much more sensitive to flow non-uniformities than the normal force. The outstanding feature of this figure is that the combined effect of the interference terms is much greater than the free-stream load and this emphasises the importance of the interference loads in release disturbance studies. While the free-stream aerodynamic characteristics of the store may give some qualitative guide as to the possible difficulties of release, any quantitative treatment must take proper account of the interference loads.

### 3.4 Use of experimental data

The preceding discussion naturally leads to consideration of means of determining the various inter-related interference loads. Various experimental techniques are well established; but methods for making the best use of the results that they yield are, perhaps, less well appreciated.

The potential uses of such results are indicated in Fig 28. On the left-hand side we have the various experimental techniques. Reviewing these briefly:-

- (a) (carriage loads) the loads on the store during carriage can be measured in wind-tunnel experiments using suitably instrumented models;
- (b) (jettison testing) dynamically scaled models of stores can be jettisoned from model aircraft. Unfortunately, exact dynamic scaling or representation of all the relevant parameters is not possible under most conditions; so this does not represent a complete solution to the release problem particularly for weapons with active controls;
- (c) (captive trajectory) loads may be measured on model stores held in proximity to model aircraft in a wind tunnel. In the captive trajectory system these load measurements are used in concurrent trajectory calculations. The wind tunnel is then being used as an analogue computer generating steady aerodynamic load data at the store locations (relative to the aircraft) and attitudes required by the trajectory calculation;
- (d) (grid survey) loads may be measured in a wind tunnel on a model store held at each point in a grid of locations relative to the aircraft that encompasses the anticipated trajectory. At each point loads on the store may be measured for a range of weapon attitudes;
- (e) (flow survey) the flow field of the aircraft may be measured in the wind tunnel by surveys using a variety of suitable probes;
- (f) (free-air aerodynamics) the free-air aerodynamics of the store may be measured as a function of its attitude, etc. Such testing is normally done as part of weapon development and the only additional requirement may then be information on aerodynamic damping derivatives.

Turning to the various loads acting on the store, the free-stream loads may be obtained directly from the free-air aerodynamic data. In conjunction with flow survey results the contributions due to differences between free-stream and local flows can be evaluated. A combination of theoretical calculations using the measured flow fields and examination of the grid survey results should then yield estimates of the contributions due to flow non-uniformity.

Likewise, the grid survey results and the components previously estimated can be combined with appropriate measurements of carriage loads to estimate the close interference loads.

Now, having achieved a complete description of the aerodynamic loads, these can be used to make first order predictions of the trajectory of the store.

This is not the only route to a first-order prediction of store trajectory. In suitable cases, or using suitably advanced techniques such as upward acceleration of the aircraft model, jettison testing alone may give a first order prediction. Alternatively, grid plotting tests only need to be supplemented with carriage load data (to circumvent the practical problems of positioning a separately supported model store very close to an aircraft model) before giving a first-order prediction of trajectories. Also captive trajectory tests, supplemented with carriage load and some free-air weapon data, are sufficient for trajectory prediction.

A natural initial reaction of someone coming fresh to this topic is to query the desirability of so many alternative methods and the necessity to explore the build-up of the interference forces in such depth. It may also appear curious that several alternative approaches to the same end result continue to be in use, whereas it could seem advantageous to identify the best and stick to that.

Part of the answer to such queries is the wide variety of problems that have to be tackled and that no one approach is the best for all types of problems. For example, the relative economics of grid and captive trajectory testing depends on the number of non-aerodynamic variables (ejector release unit settings, etc) that are to be investigated for each flight condition. Neither of these methods is as well adapted to the study of the trajectories of unstable stores as is model jettison testing; but the latter has its own deficiencies and yields less information of the type useful for diagnostic purposes. Detailed analysis of the loads demands considerable experimental and analytical effort; but gives data within a framework that is readily adaptable to cope with minor changes in aircraft or store configurations and which most readily indicates the source of potential difficulties and courses for their avoidance.

Further reason for the coexistence of a multiplicity of methods is that none are absolutely satisfactory for reasons ranging from inadequately complete understanding of the underlying physical phenomena to the fact that many necessitate considerable art and/or educated judgement in their application. No one method will yield predictions that can be regarded as absolutely beyond

suspicion of doubt. For this reason Fig 28 indicates each individual route as leading only to 'first-order' predictions.

By 'first-order' predictions is meant estimates that give a reliable guide as to trends, orders of magnitude and the location of critical areas of the flight envelope, etc. It may be that, in some cases, these first-order predictions show the release of a particular store to be so obviously trouble-free that there is no point in going further. However, in many cases there will be a need for greater confidence in the predicted trajectories. This is where alternative methods (and a certain redundancy in the data) are invaluable. Combination, and cross-checking, of different types of data obtained in different ways is needed to refine the original 'first-order' predictions to an improved state in which they may be regarded as sufficiently reliable for the purposes for which they are needed.

This discussion shows that to fully understand each and every release problem, using every means at our disposal, would be an impossibly expensive and protracted job. Instead, we must follow sufficient routes, using sufficient data from different sources, to gain an adequate confidence level in predicted trajectories for each case. What confidence level is adequate depends on the consequences of an error in the predictions. Amongst other things this will depend upon the difficulty of the problem itself, permitted hazard levels, and on the stage which the project has reached. In the early stages, an assurance that successful release will prove to be possible is all that is required. Very approximate predictions may be adequate for this. Demands on accuracy will increase as the project progresses towards its first flight trials. At that stage, a very high degree of assurance will be needed if the flight trials are not to proceed with unnecessary caution and, hence, involve very large expense and duration.

This increase with time of the demands for accuracy can fit in well with the progress of the experimental and theoretical studies of the release problem. In the beginning many of the terms in the load estimates may be little better than 'educated guesses'. As time goes on and the planned programmes come to fruition, these estimates are refined and confidence in the predicted trajectories grows in step with the accuracy required of them.

Unfortunately, this ideal situation does not always exist. All too often, a problem can be discovered too late for inexpensive remedial action or even with inadequate data to identify what action is appropriate.

Each problem has to be judged on its merits; but past experience suggests two 'golden rules' necessary for success in this area. These are:-

(i) make sufficiently comprehensive plans for experimental and theoretical work on release problems at a very early stage in the life of a project and ensure that each phase is started in good time, allowing for inevitable experimental problems and theoretical difficulties, for the results to be available when required. Now, this will be a long and apparently expensive programme including seeming redundancies. Nevertheless, it is essential that it is not subject to unnecessary economy or delay. The whole point is that the consequences of not doing this job in an adequately extensive or timely fashion may well be very expensive and protracted modifications to the project at a late stage in its development. Adequate programmes must be mounted well ahead of the need for the results that they are intended to obtain. Such programmes can have long lead times so that, if you have to wait until the need for them has been demonstrated by the occurrence of a problem with the project, then it is already too late to do anything useful.

(ii) at an early stage set up a methodology (for treating the complete problem) that is sufficiently comprehensive and precise to make full use of all the data that might become available. Obviously, many parts of a comprehensive model will initially contain little more than 'reasonable guesses'. The important point is that a system exists that will readily accept the incorporation of additional, or better, data and which will highlight any inconsistencies between old and new data - thus giving opportunity to consider and resolve such problems. The worst way of proceeding is to set up mathematical models tailored to the limited data available at any one time. That way leads to increasing amounts of abortive work in reconstructing models *de novo* so that the time-lag between the availability of new data and its being reflected in the trajectory predictions increases as the tempo of the project accelerates and the issues at stake escalate. Further, it increases the chance of the use of inaccurate data, or an erroneous interpretation of data, going undetected.

4 SUMMING UP

This paper attempts a concentrated summary of the salient points of a topic with many ramifications. Any final summary can touch only upon the most outstanding of these.

In particular:-

- (i) The changes in inertias and stability characteristics consequent upon the addition of stores can markedly change the flying qualities of an aircraft.
- (ii) Weapons may well have free-air drags that, even if not important for the performance of the weapon alone, can profoundly degrade the performance of an aircraft to which they are added and, hence, have an important influence upon the performance of the whole weapons system.
- (iii) The increase in drag of an aircraft due to the addition of weapons may be substantially greater or smaller than the free-air drag of the weapons. In many cases, unfavourable interference effects may be changed to favourable interference by relatively modest changes to the installation.
- (iv) The flow field of both fuselages and swept-wings causes local flow conditions in their vicinity to differ markedly from those of the free-stream. The severe loadings found in some cases, combined with their repeated application and differences in their distribution from that of the loads on the weapon in free-flight, can cause carriage loads to be a distinct and severe structural design case.
- (v) The forces acting on a weapon as it is released from an aircraft can differ markedly from those acting on the weapon at the same attitudes but in free-air. These differences are due to a variety of aerodynamic interference effects which can only be disentangled from each other through detailed study and experimental work on individual cases. The successful and economical resolution of release problems is greatly facilitated by a comprehensive programme of work initiated early in the development of a project.

Above all, it must be recognised that air-carriage implies both severe potential problems and worthwhile opportunities. There is a growing body of knowledge, techniques and expertise in this field which is available to assist the weapon designer; but whether this provides first aid to an ailing project or enables the designer to avoid the problems and exploit the opportunities depends crucially upon full account of salient factors being taken from the earliest stage of a design.

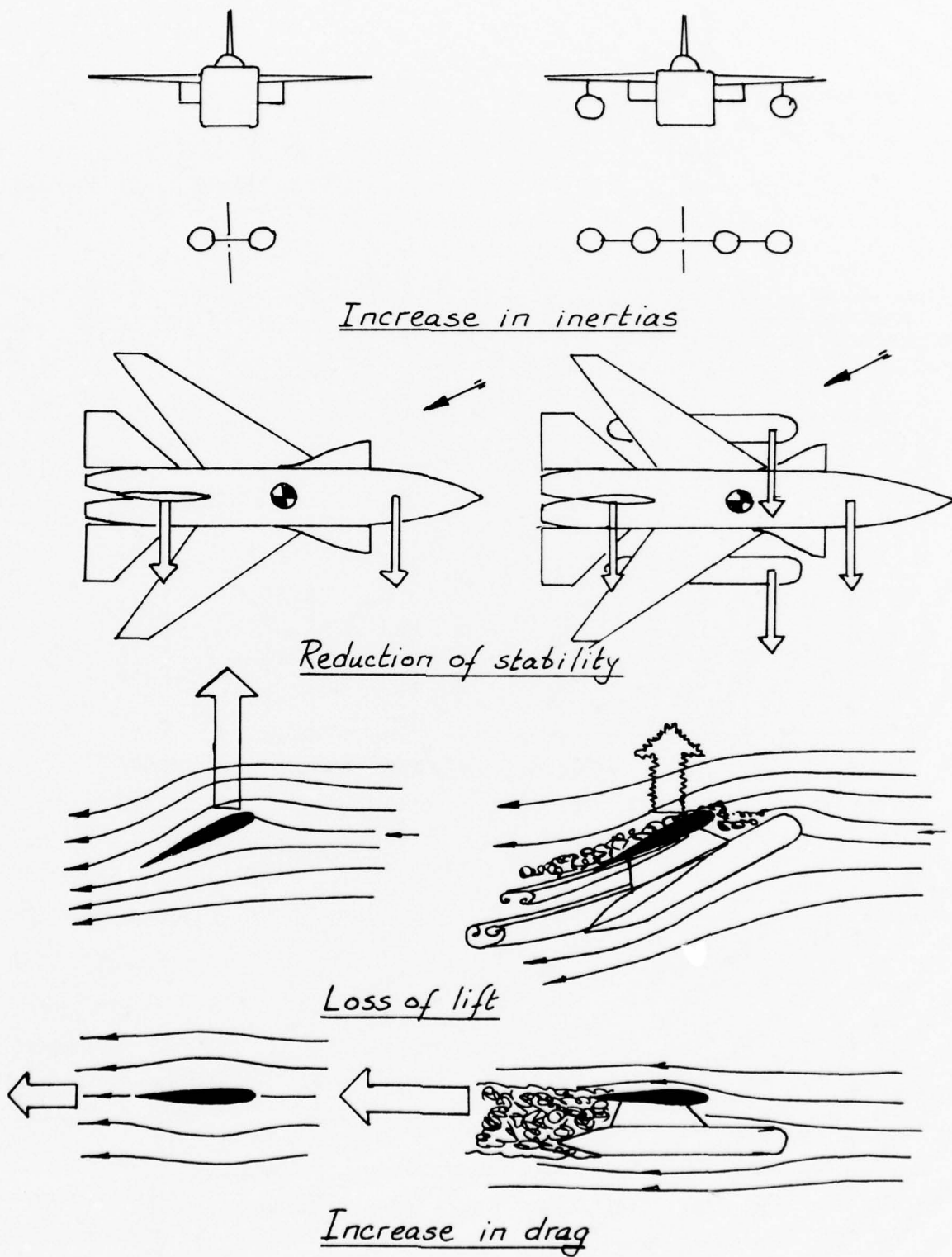

Ae 1731

Fig 1 Primary effects of external stores on the aircraft

Fig 2

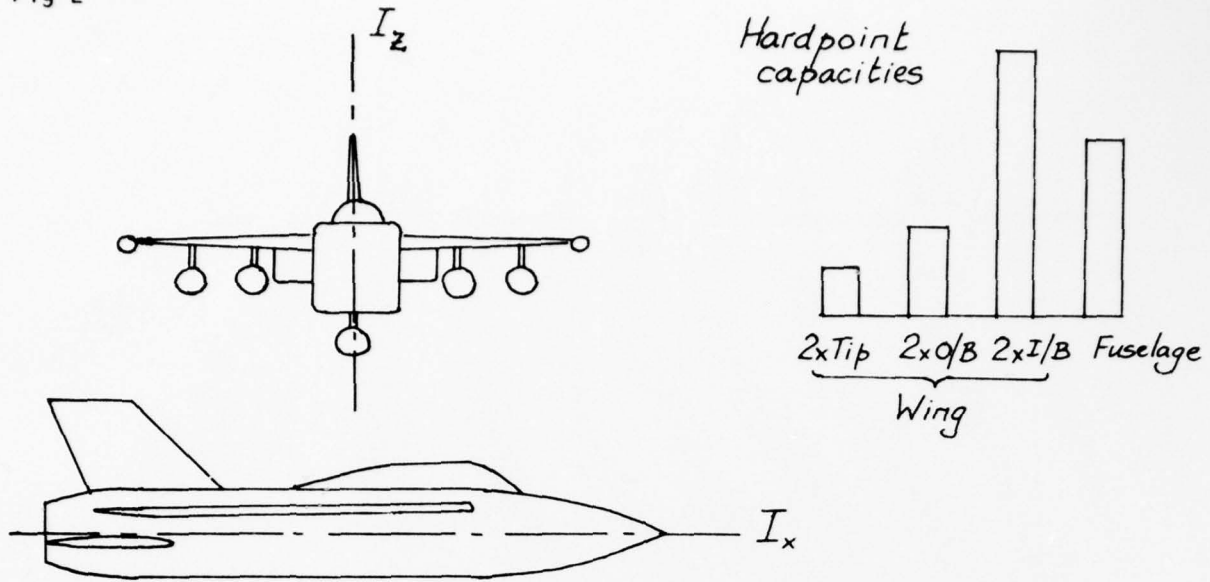

$I_x$

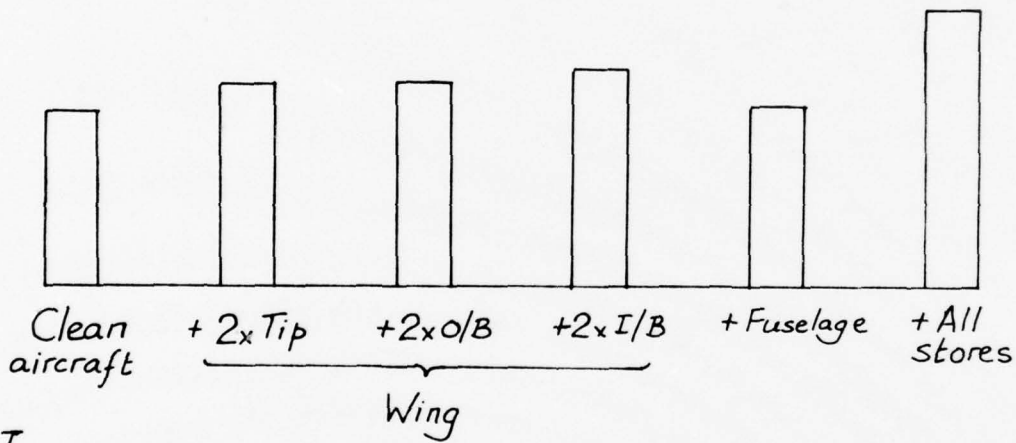

$\frac{I_z}{I_x}$

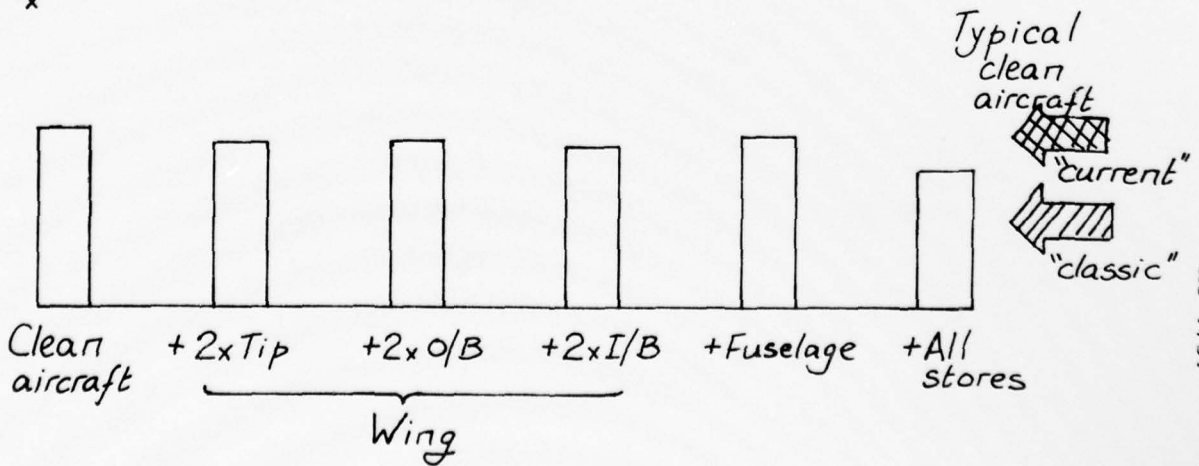

Ae 1731

Fig 2 Changes in inertias

Without tail

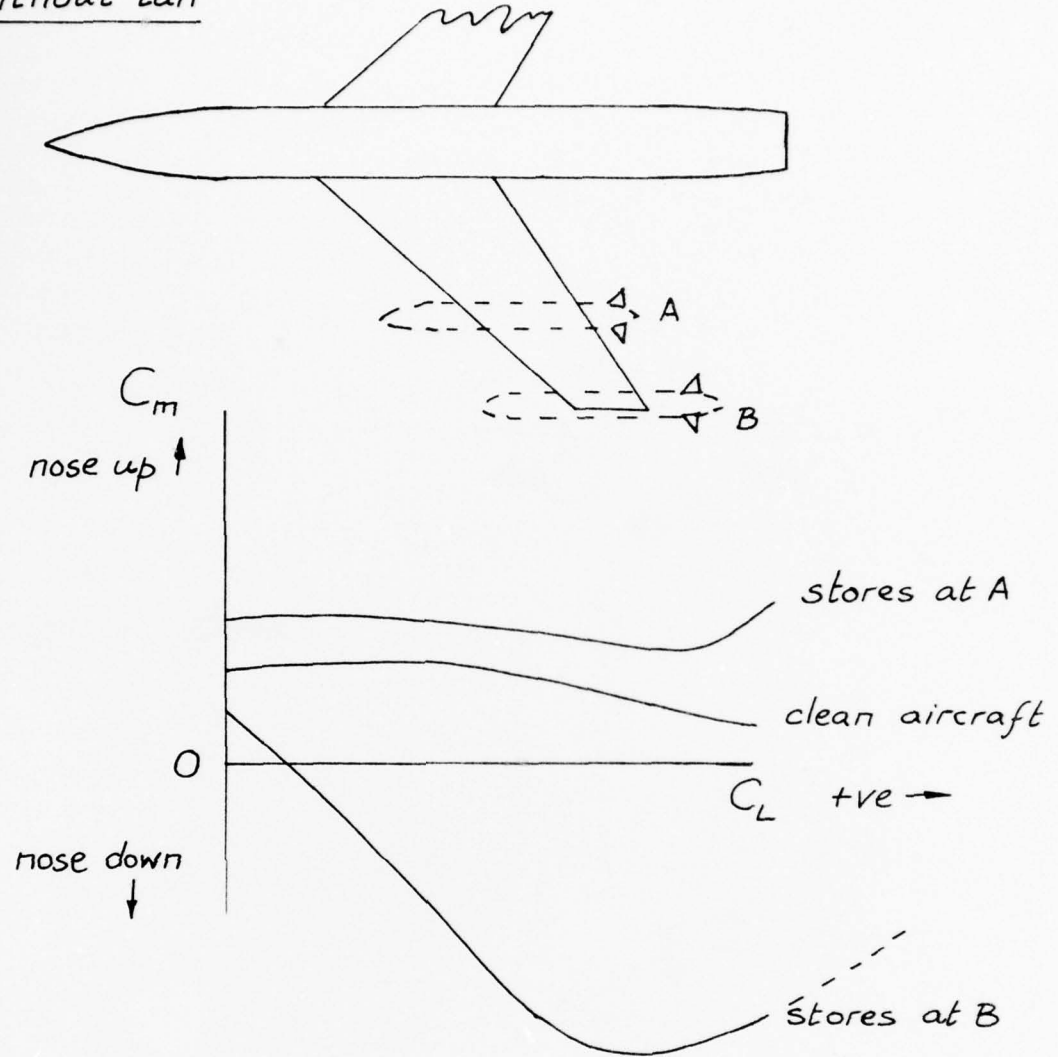

Possible effects on tail

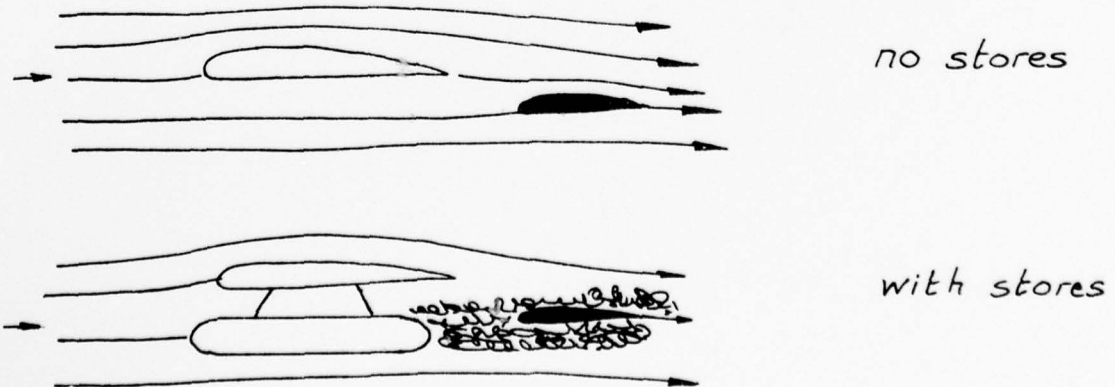

Ae 1731

Fig 3 Reduction of longitudinal stability

Fig 4

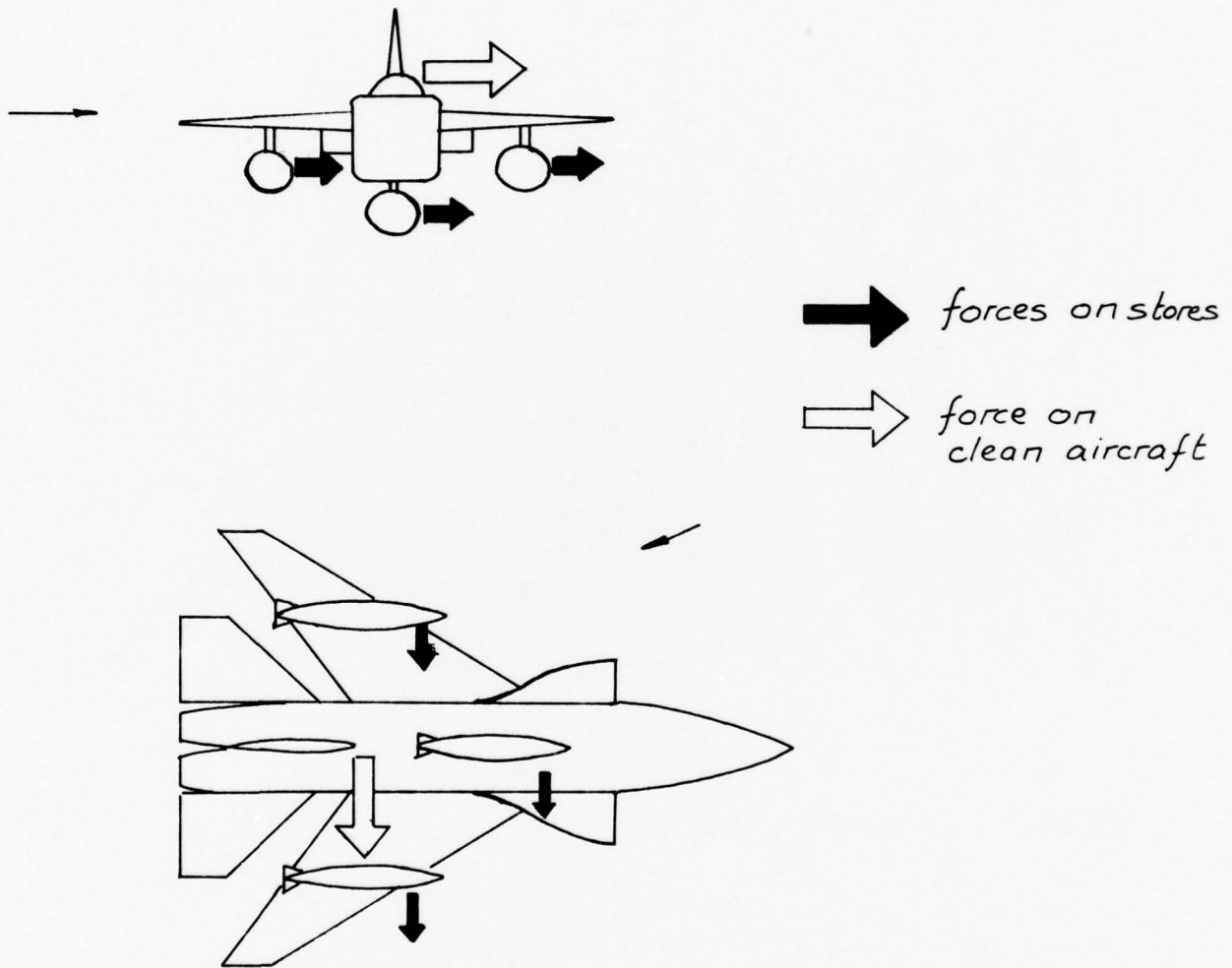

Ae 1731

Fig 4 Reduction of lateral stability

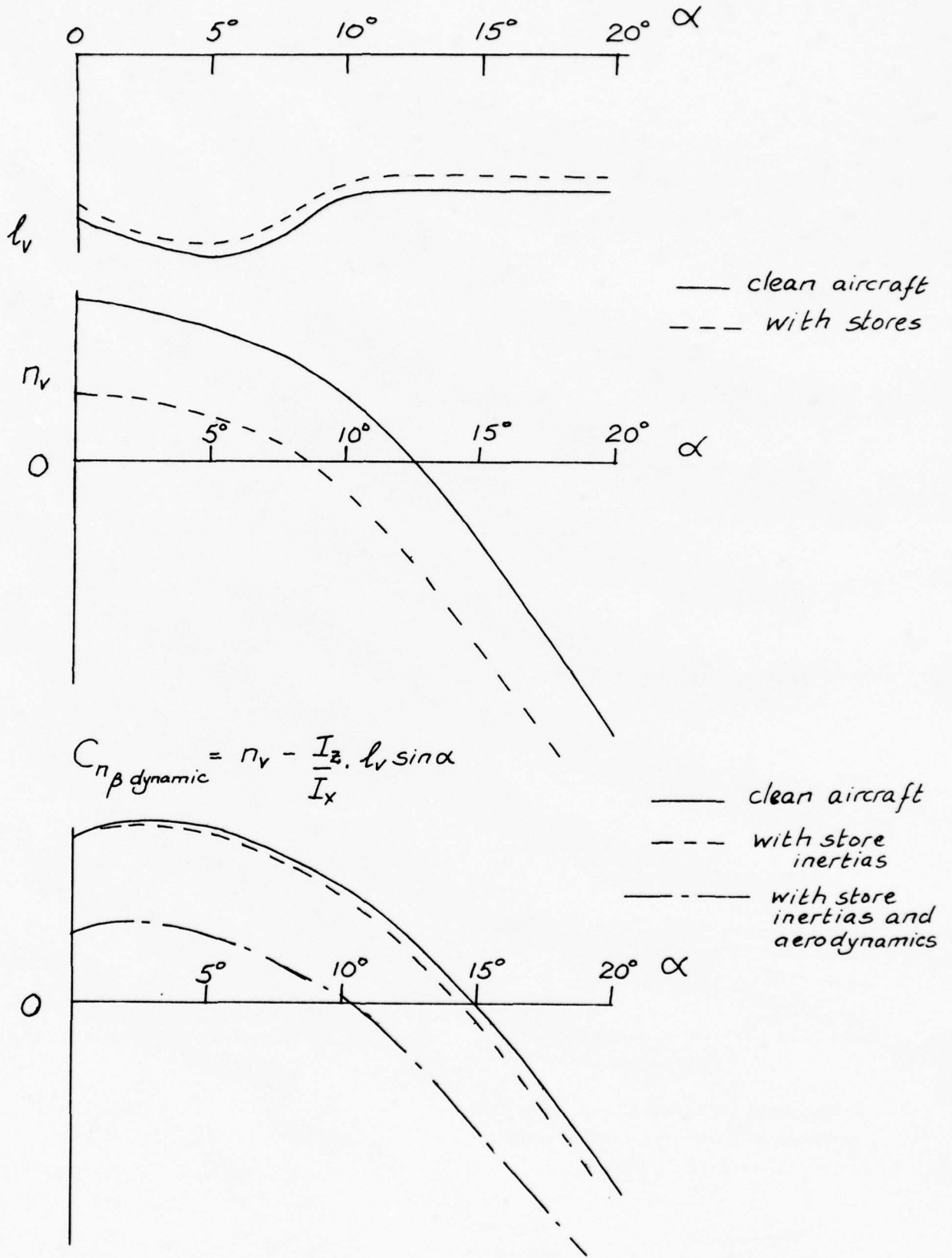

$$C_{n_{\beta} \text{ dynamic}} = n_v - \frac{I_z \cdot l_v \sin \alpha}{I_x}$$

Fig 5 Degradation of lateral stability at high incidence

Fig 6

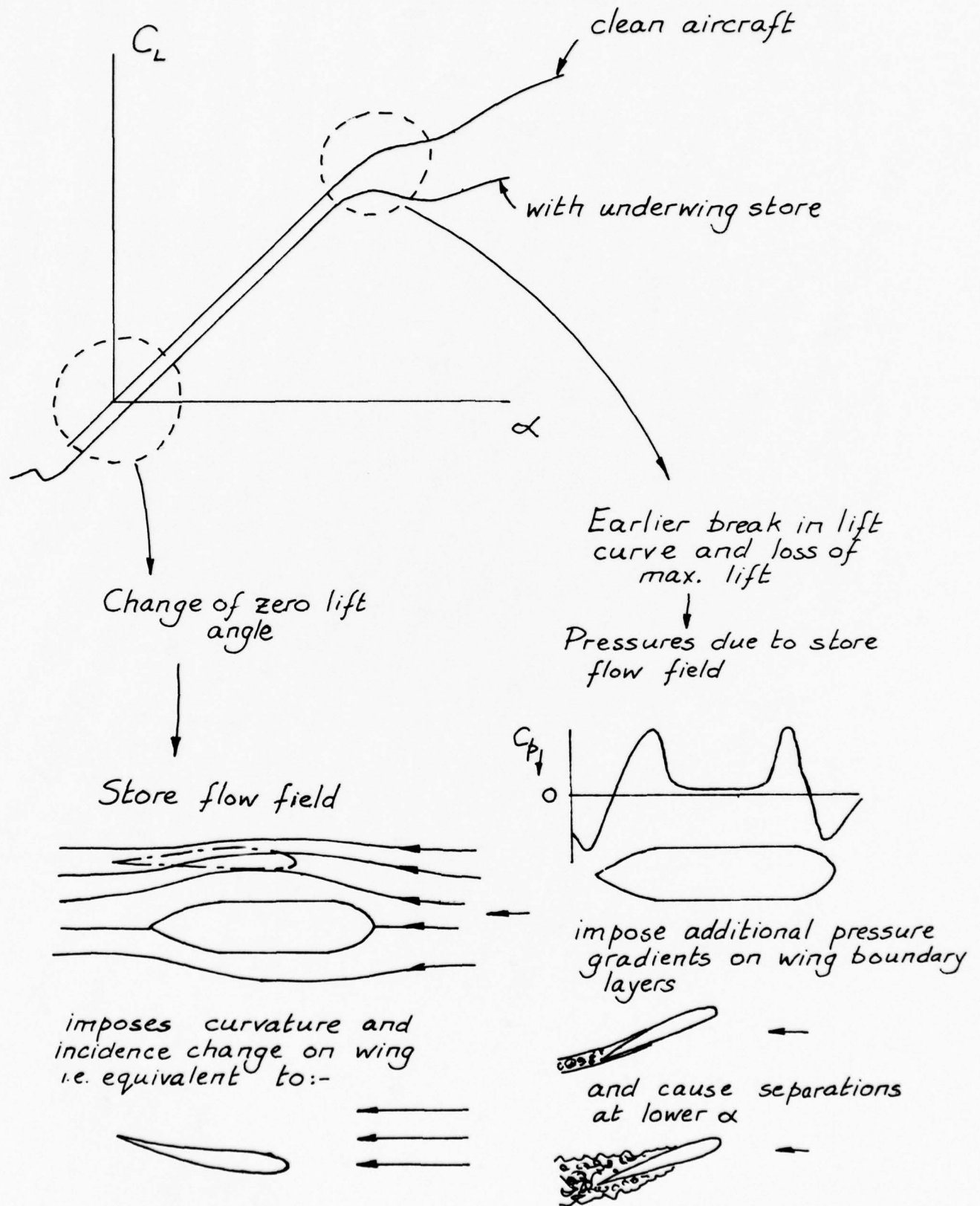
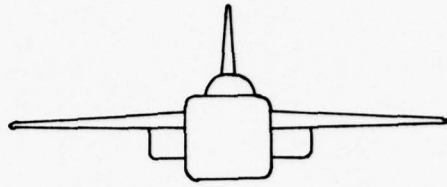
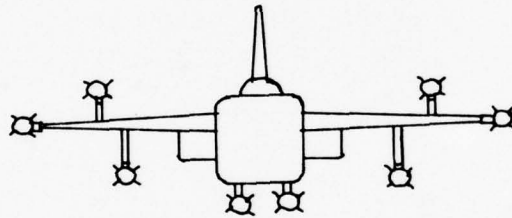

Fig 6 Principal effects of stores on lift



*clean aircraft*



*with weapons  
geometric  
view*

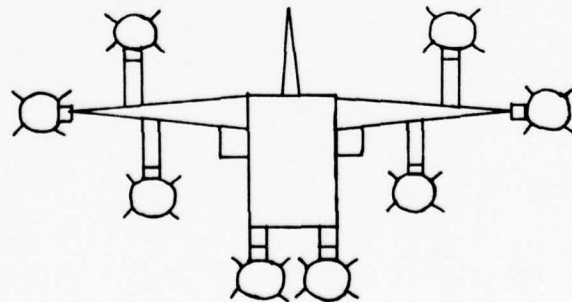

*with weapons  
aerodynamic drag  
view*

Ae 1731

Fig 7 Three views of an aircraft

Fig 8

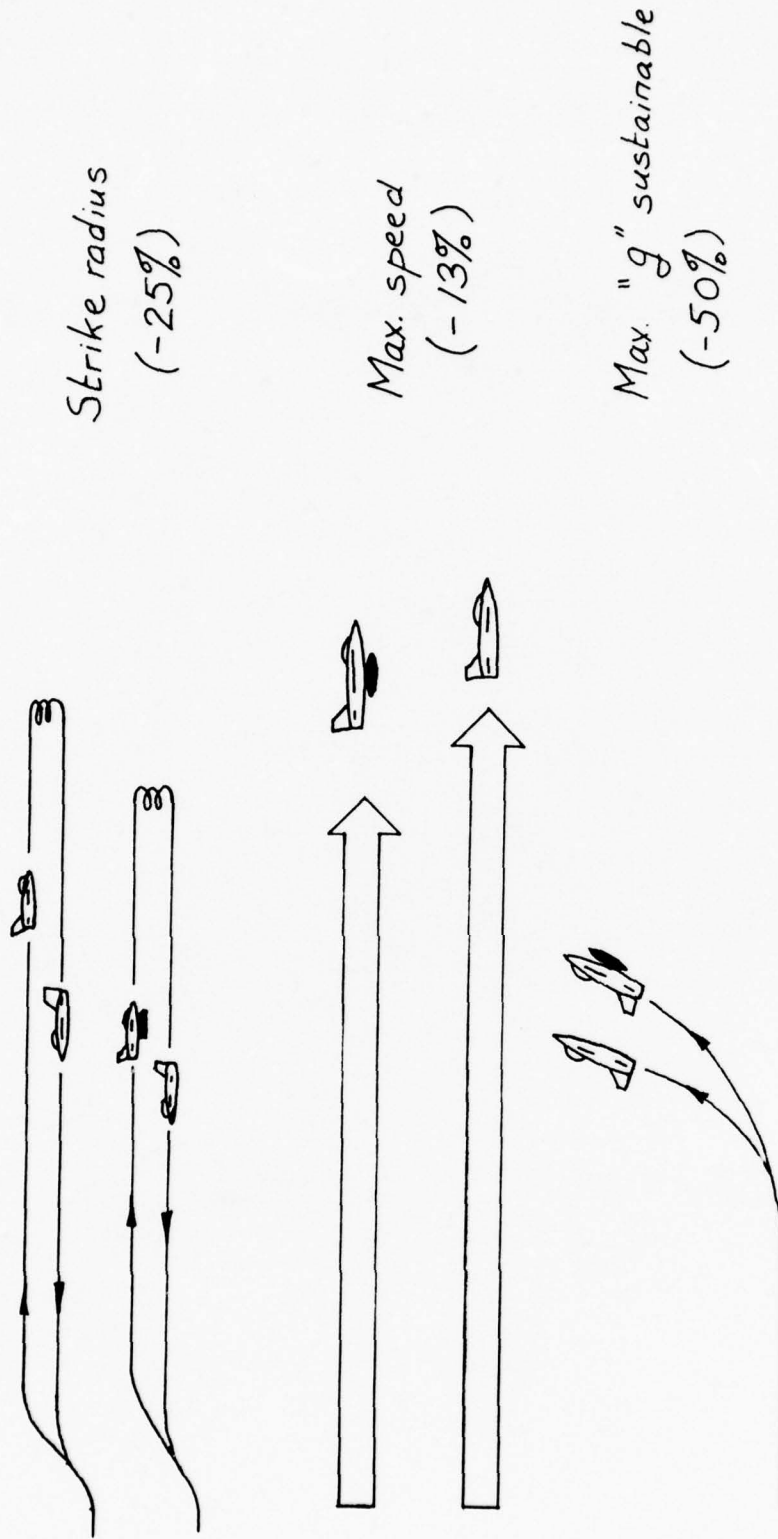
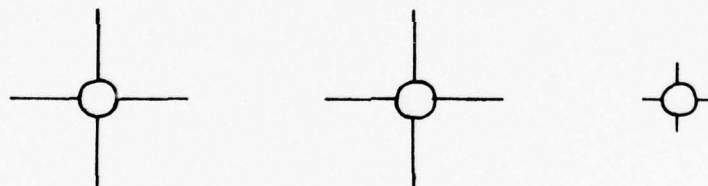

Fig 8 Typical effects of full weapon load



a) Aerodynamic cleanliness



b) Relative compactness

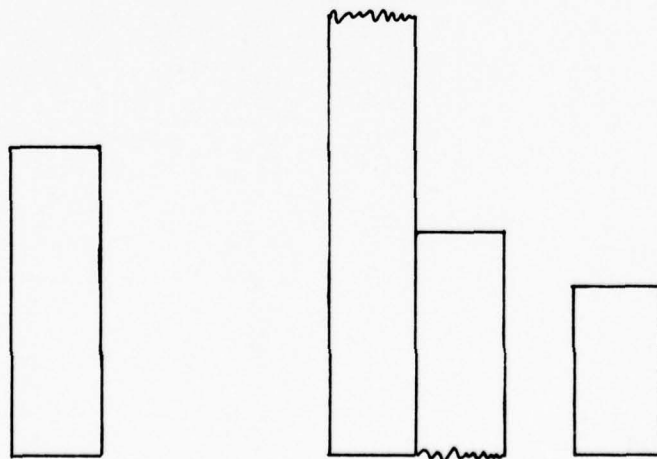

c) Minimum drag when in container with wings folded

Fig 9 Free-air drag and packaging

Fig 10

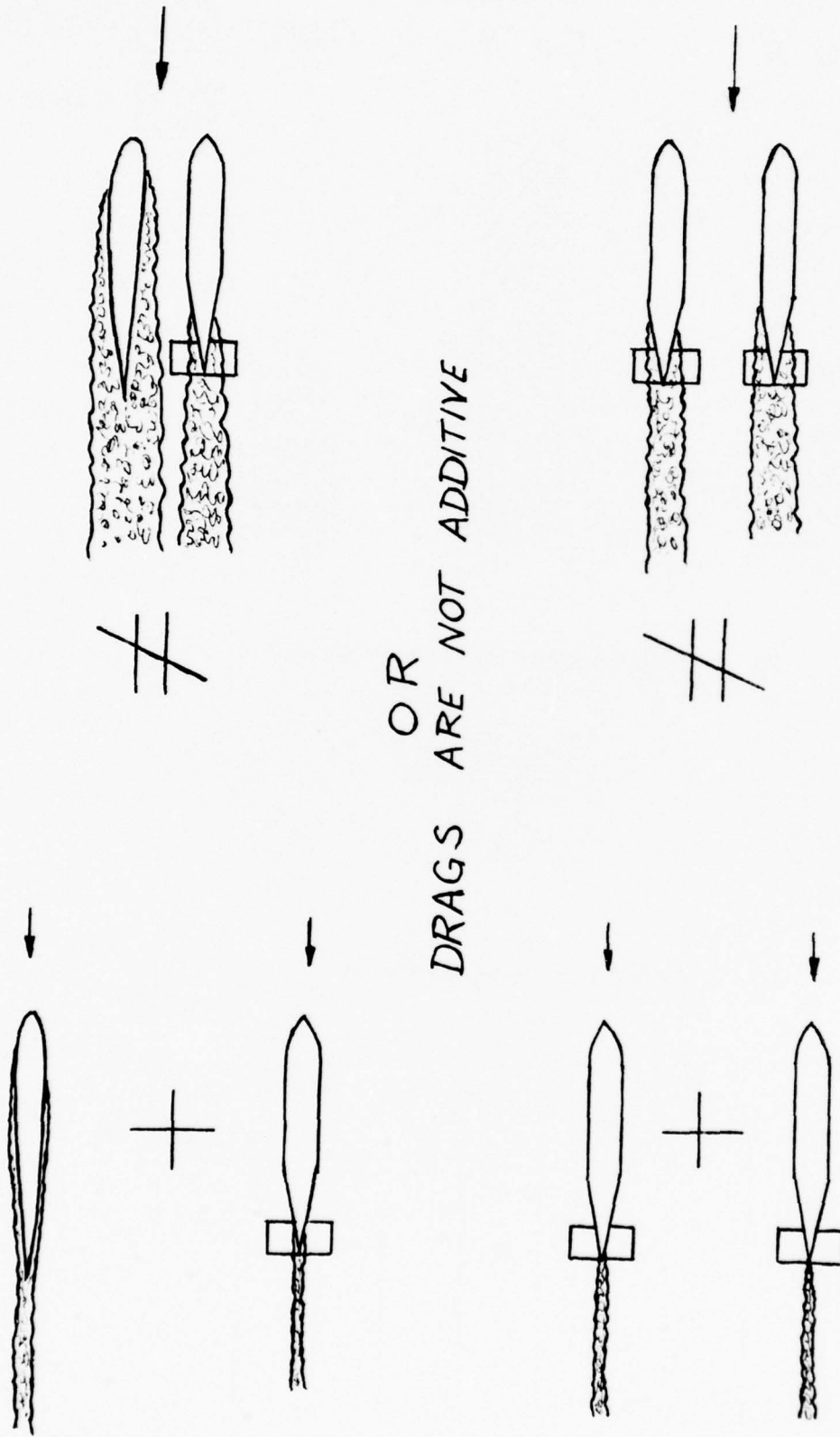
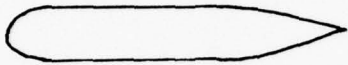
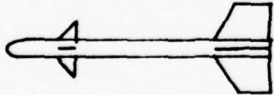

Fig 10 The importance of aerodynamic interference

	Low speed	Transonic
Type of store		
Streamlined tank : 		
free-air $C_D$	typically 0.08	typically 0.27
installed $C_D$	typically 0.10	typically 1.45
$\frac{\text{installed } C_D}{\text{free-air } C_D}$	1 to 1½	5 to 7
Guided weapon (including launcher) 		
free-air $C_D$	1.80 (0.70) *	2.20 (1.10) *
installed $C_D$	2.30 (0.90) *	4.00 (2.60) *
$\frac{\text{installed } C_D}{\text{free-air } C_D}$	1 to 1½	1½ to 3

\* (data for hypothetical "cleaned up" G.W i.e. excrescences removed)

Fig 11 Typical installation effects: underwing carriage

BENEFICIAL INTERFERENCE

Tandem

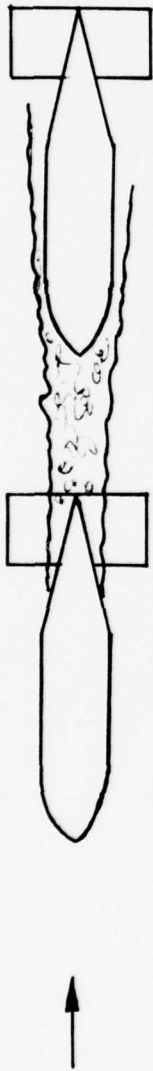

Second store in wake of first and, thus, shielded from flow

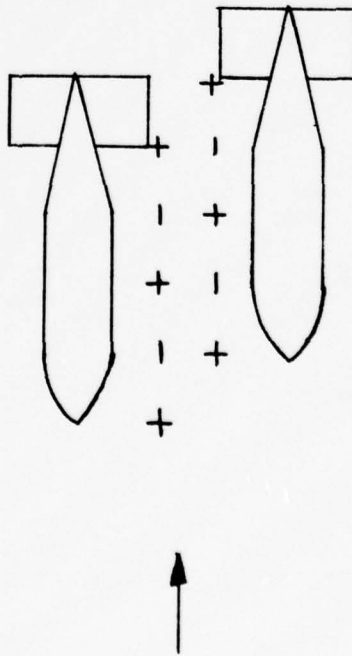

Axial stagger

Second store moved backwards so that its pressure field tends to cancel that of first bomb: onset of shock waves delayed

Fig 12 Beneficial store to store interference

Store	No. carried	Mode of assembly			
		Line abreast	Tandem	Staggered	Individually
GW "B"	1	1.0	1.0	1.0	1.0
	2	2.6	1.5	2.3	2.0
	3	5.1	1.8	3.0	3.0

*Table entries are relative drag levels at a transonic speed.*

Fig 13 Typical effects of assembling several stores

*This :-*

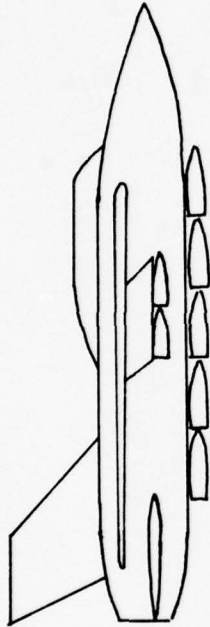

Not *this :-*

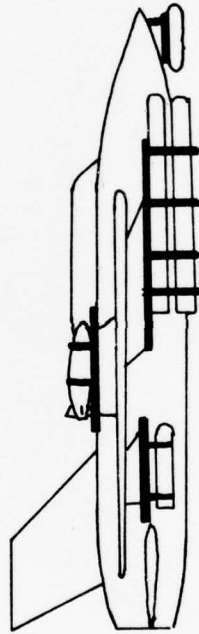

*Keep it clean, compact,  
close to the centre, and  
without "luggage straps"  
or "just another little  
item"*

Fig 14 A message to weapon designers

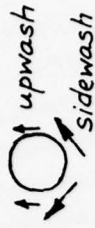
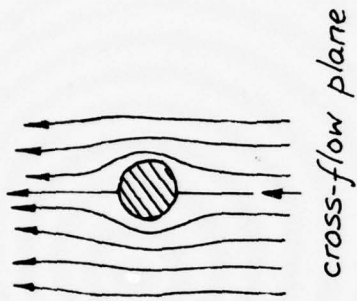
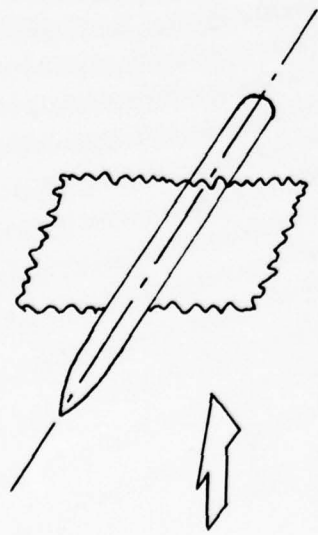

$\epsilon$  is downwash angle

Downwash in horizontal plane of symmetry

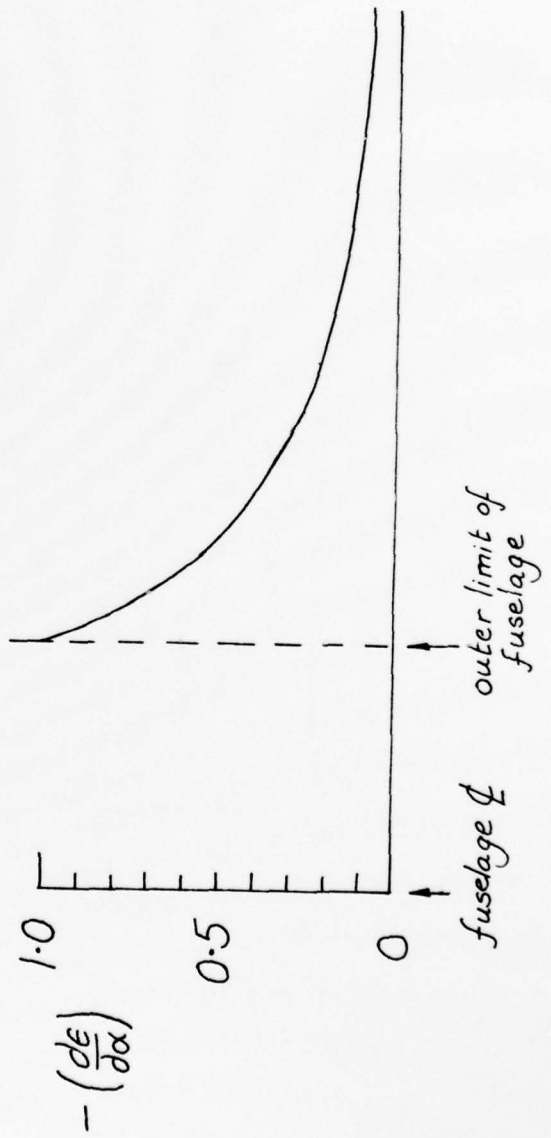

Fig 15 Flow field of fuselage

Fig 16

key  
---> due to sinks  
+++> due to sources  
— resultant perturbation velocity

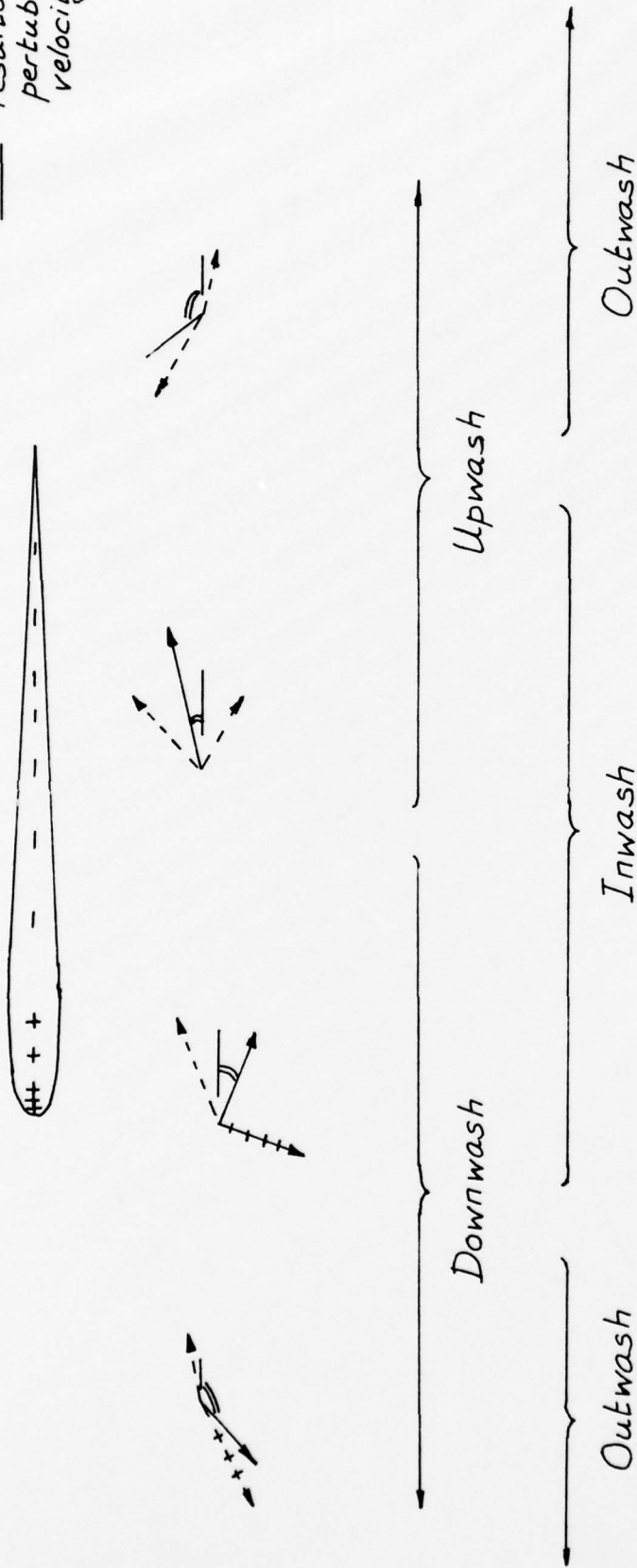

Fig 16 Flow field due to wing thickness

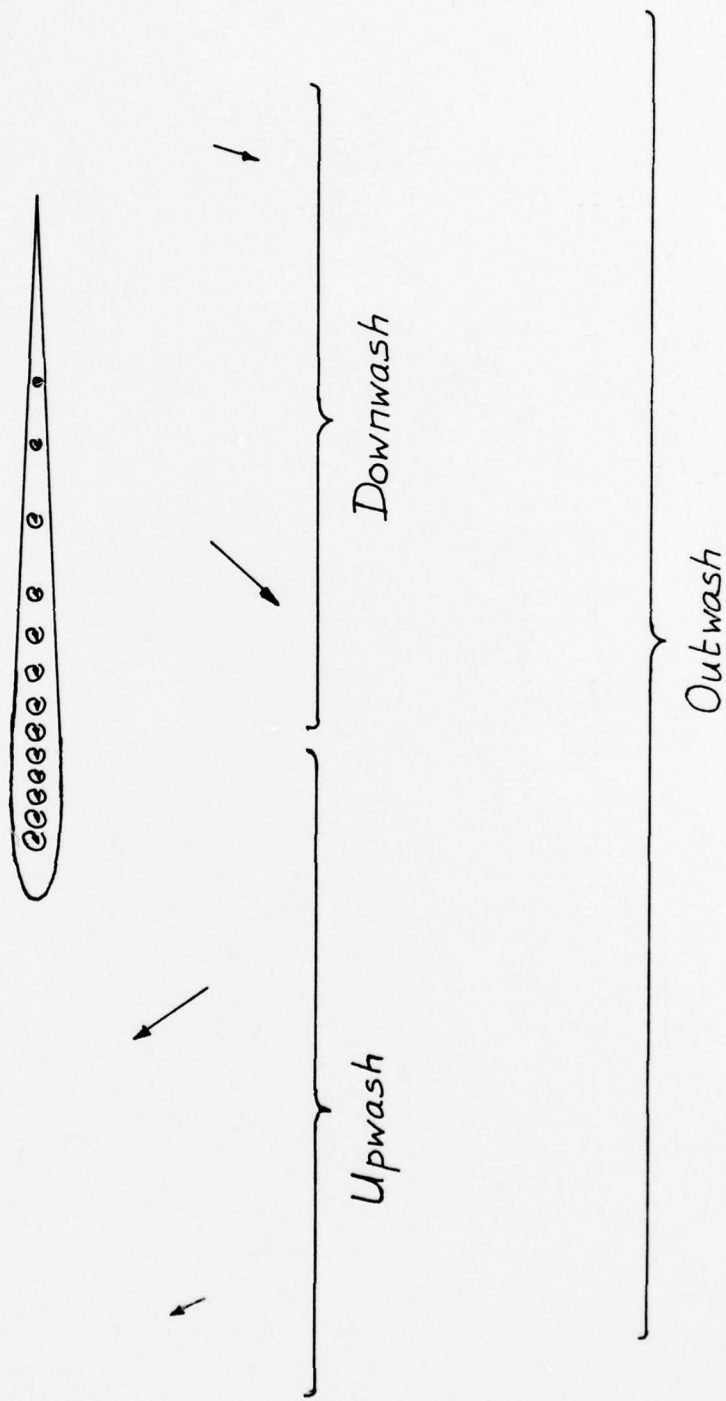

Fig 17 Flow field due to wing lift

Fig 18

Mid-semi span

Aspect ratio = 4.0     $1/4c$  sweep =  $45^\circ$

(From Alford NACA Report 1327)

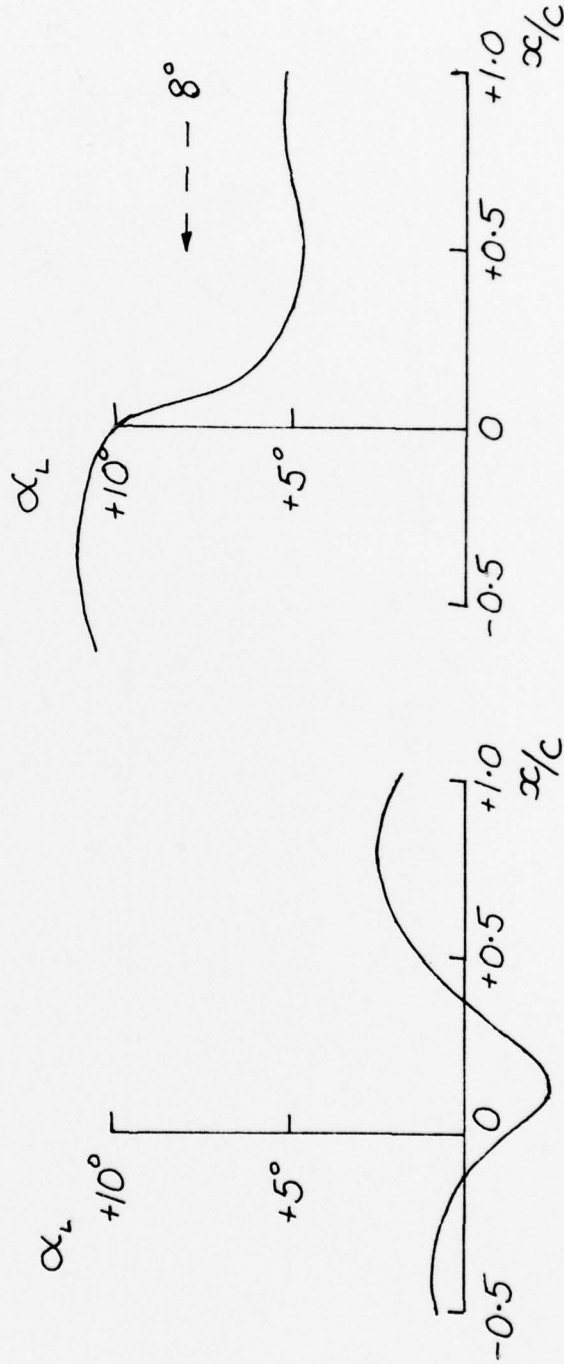

Fig 18 Variation of local incidence with fore and aft position undergoing

Mid-semi-span

Aspect ratio = 4.0 ,  $1/4c$  sweep =  $45^\circ$   
 (From Alford, NACA Report 1327)

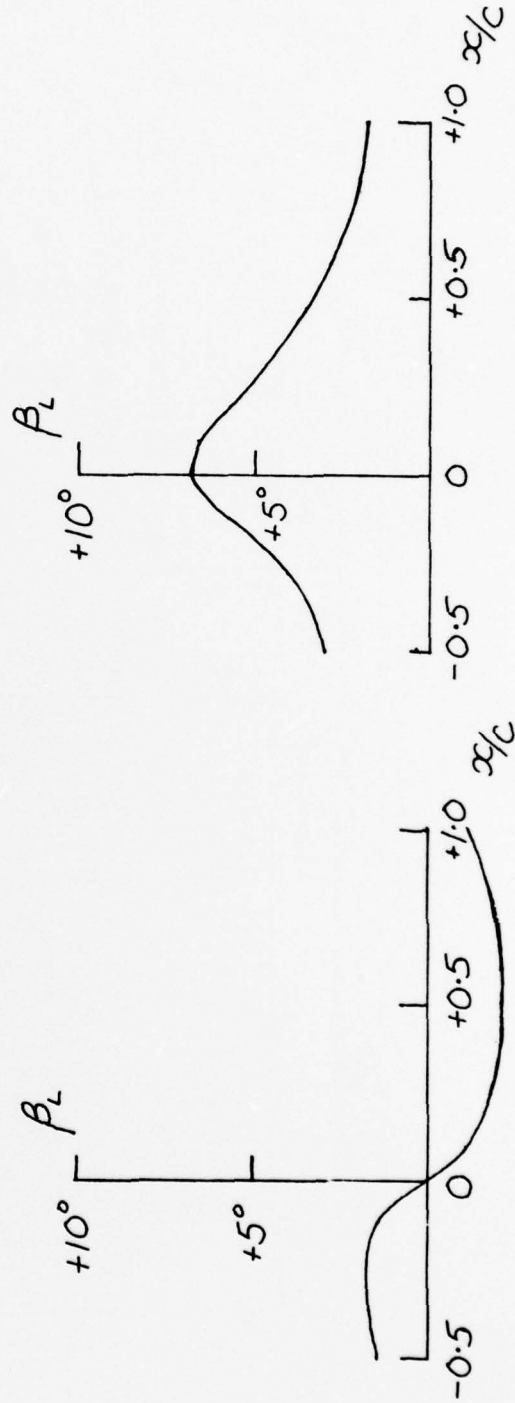
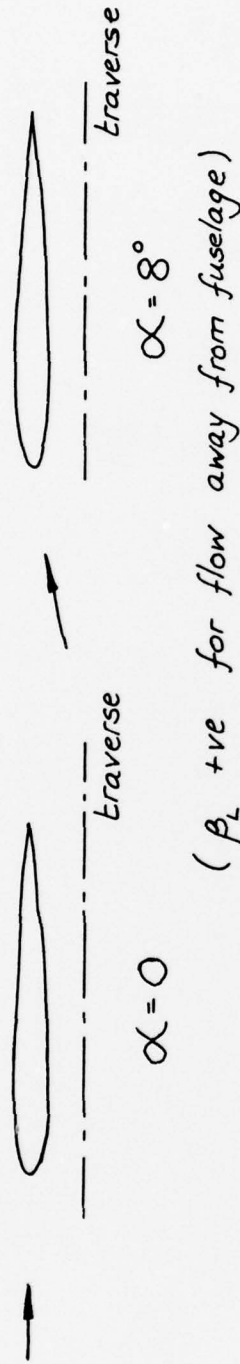

Fig 19 Variation of local yaw angle with fore and aft position underwing

Fig 20

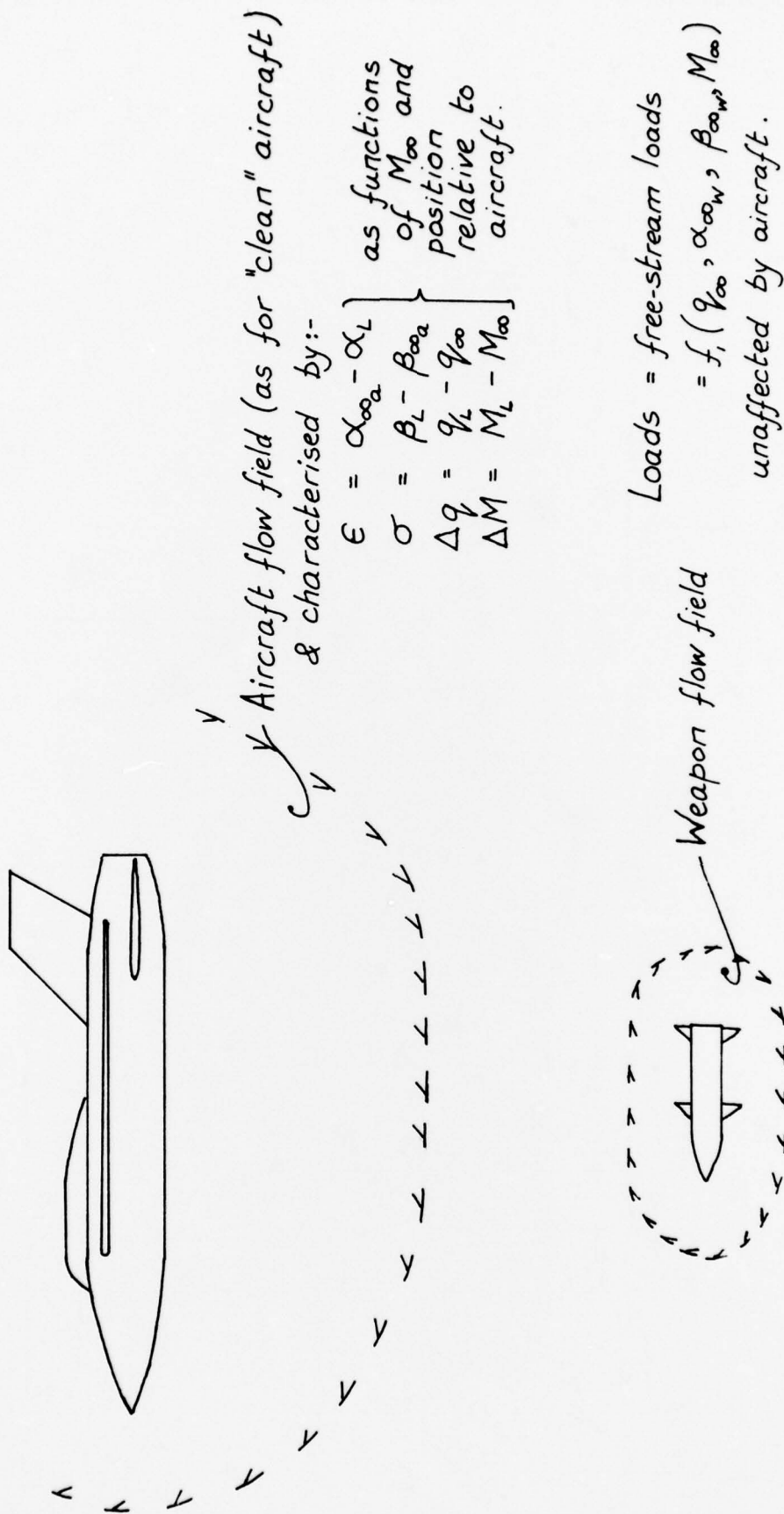
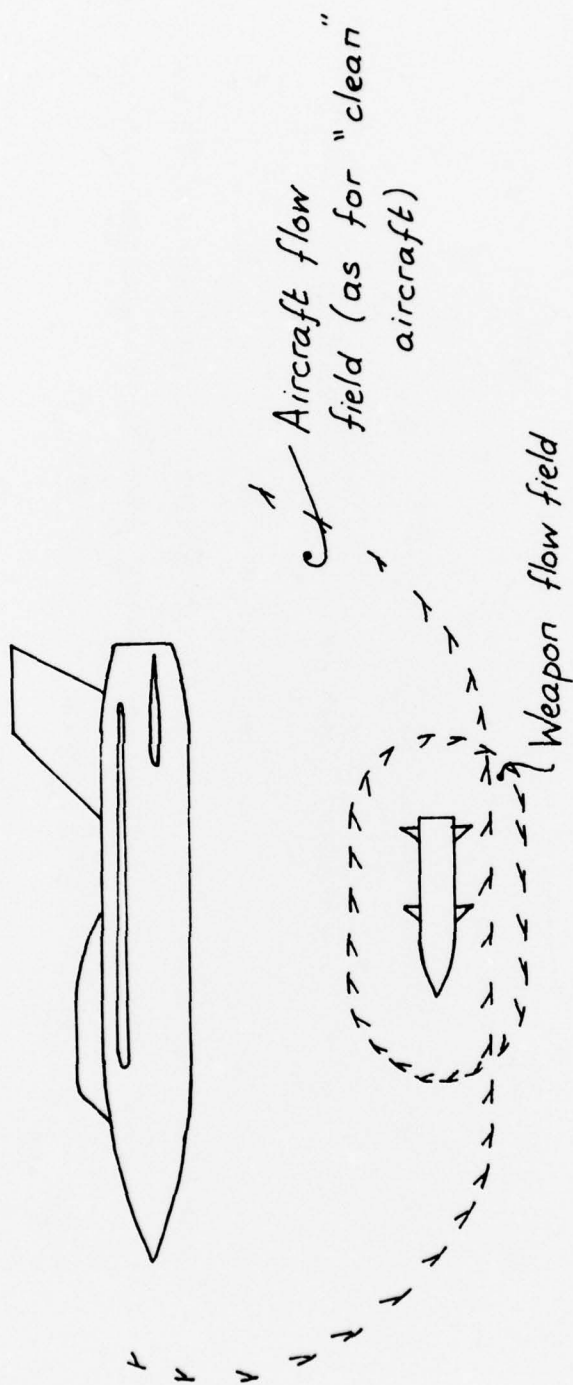

Fig 20 Loads on store when far from aircraft: single store



$$\text{Loads} = f_i (q_{\infty} + \Delta q_i, \alpha_{\infty W} - \epsilon, \beta_{\infty W} + \sigma, M_{\infty} + \Delta M)$$

i.e. Loads  $\hat{=}$  (free-stream loads) + (free-stream derivatives x differences between local flow and free-stream).

Fig 21 Loads on store when store is near 'edge of aircraft flow field': single store

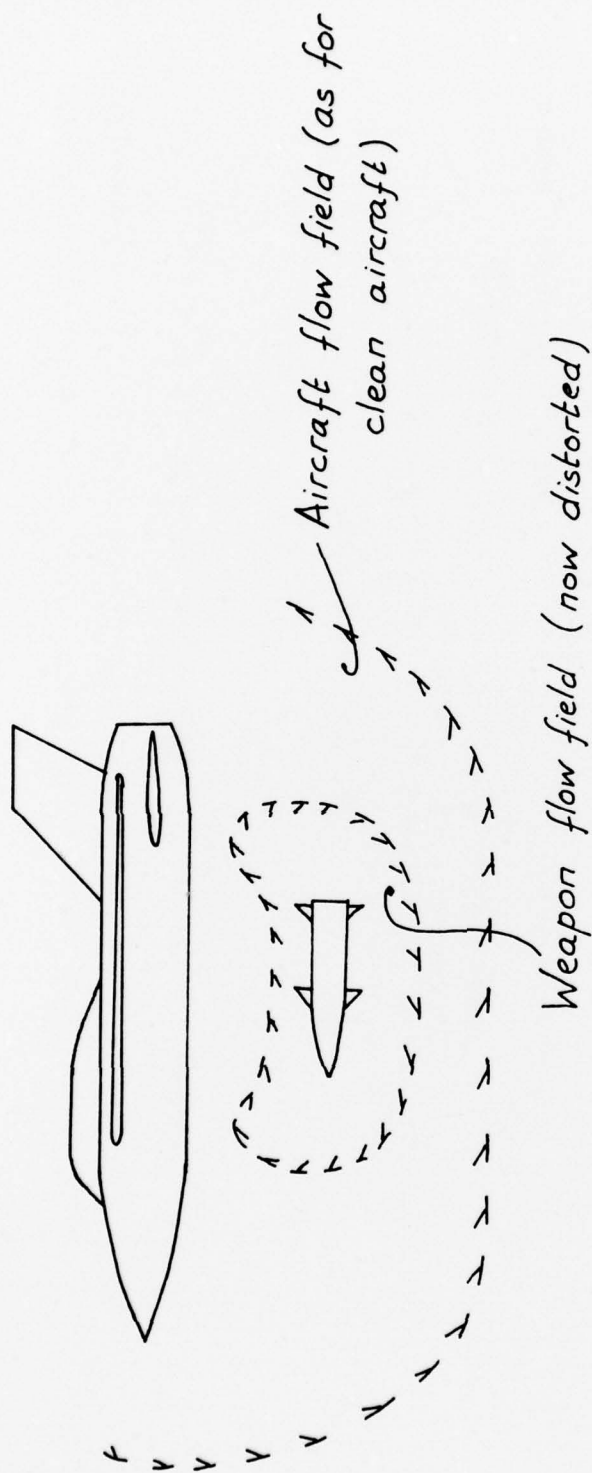

Loads = free-stream loads + (free-stream derivatives x differences between local flow and free-stream) + loads due to non-uniformity of aircraft flow field.

Fig 22 Loads on store when store is well inside aircraft flow field: single store

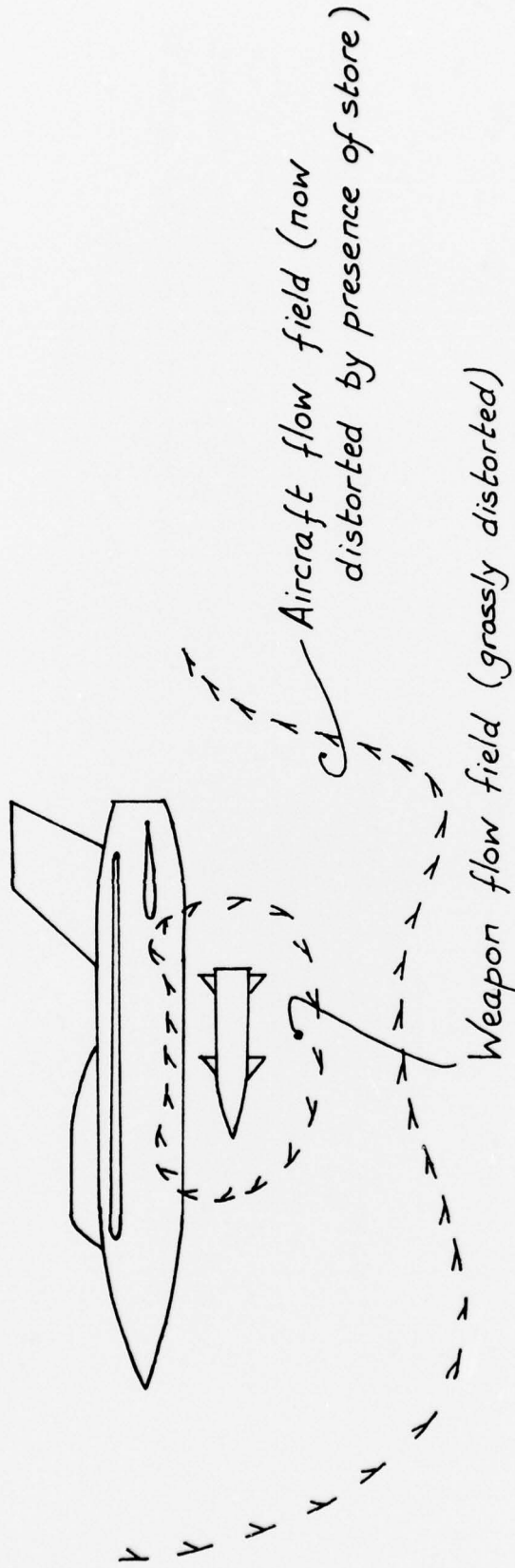

Loads = free-stream loads + (free-stream derivatives x differences between local flow and free-stream) + loads due to non-uniformity of aircraft flow field + "close interference" loads

Fig 23

Fig 23 Loads on store when store is close to aircraft: single store

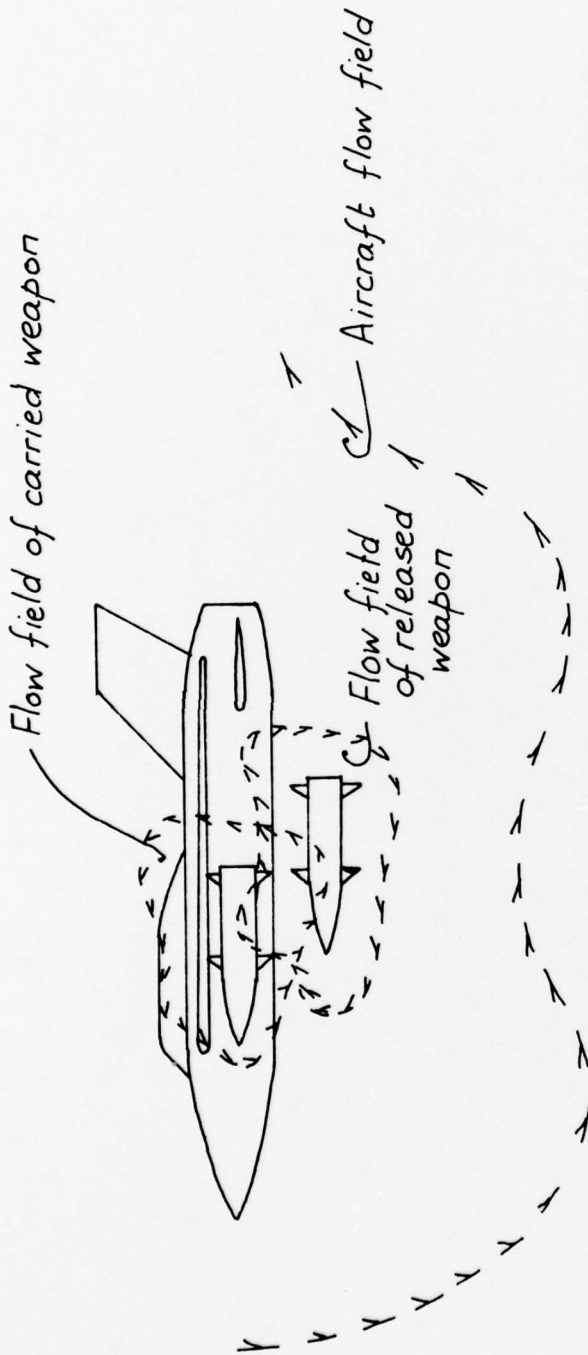

Loads = free-stream loads + (free-stream derivatives x differences between local flow and free-stream) + loads due to non-uniformity of aircraft flow field + "close interference with aircraft" loads + "close" interference with other stores" loads

Fig 24 Loads on store when store is close to aircraft: multiple store carriage

Store loads	Characteristic distance	No. of characteristic distances to half amplitude (typical only)
Free-stream	-	-
Derivatives x differences between free-stream & local flows	Aircraft span	1/4
Due to non-uniformity of aircraft flow field	Fuselage diameter or wing chord	2
Close interference with aircraft	Store diameter	2
Close interference with other stores	Store diameter	1/2

Fig 25 Decay rates of typical store loads

Fig 26

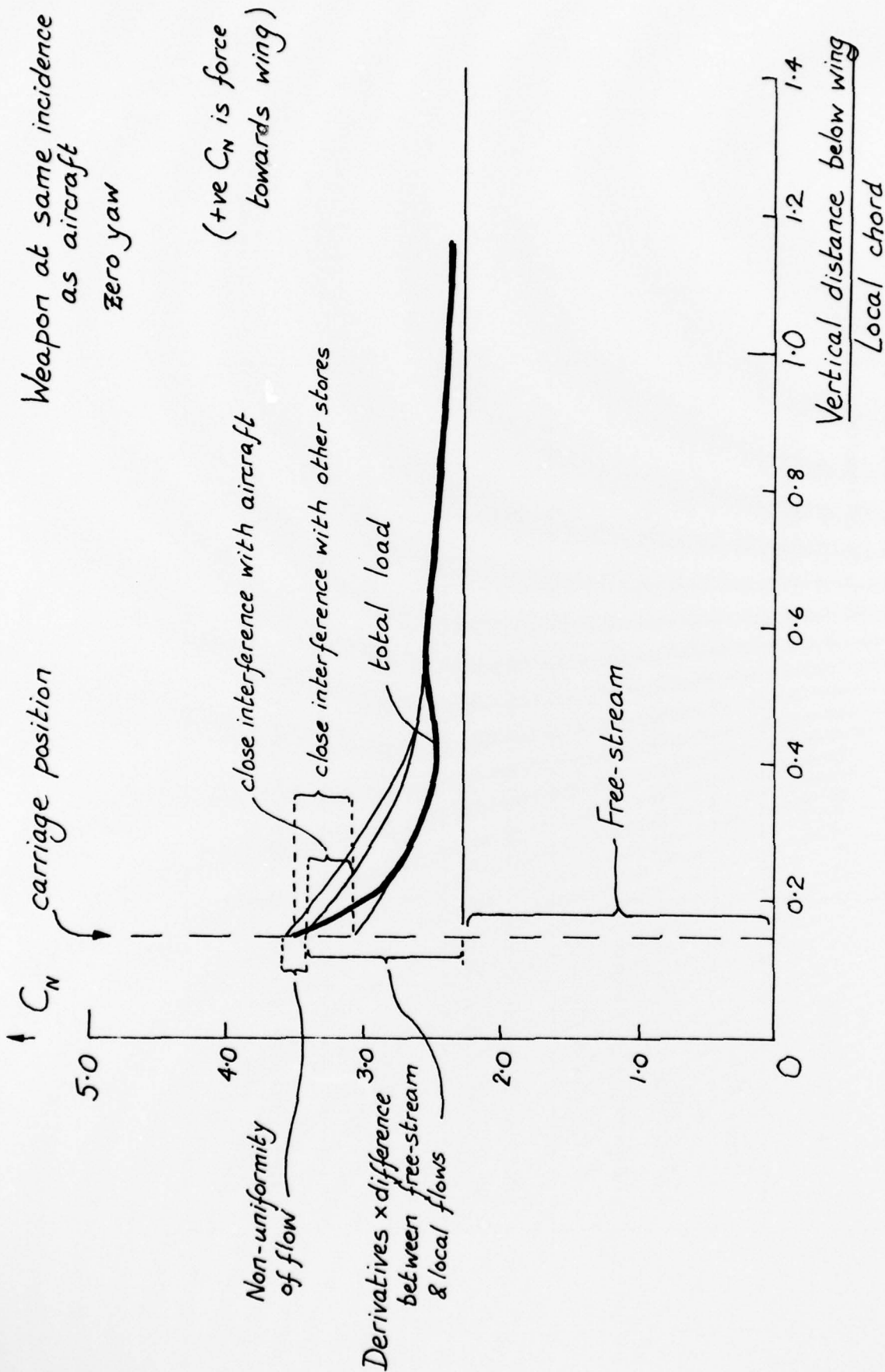

Fig 26 Theoretical analysis of loads on a guided weapon in an underwing flow:  
normal force

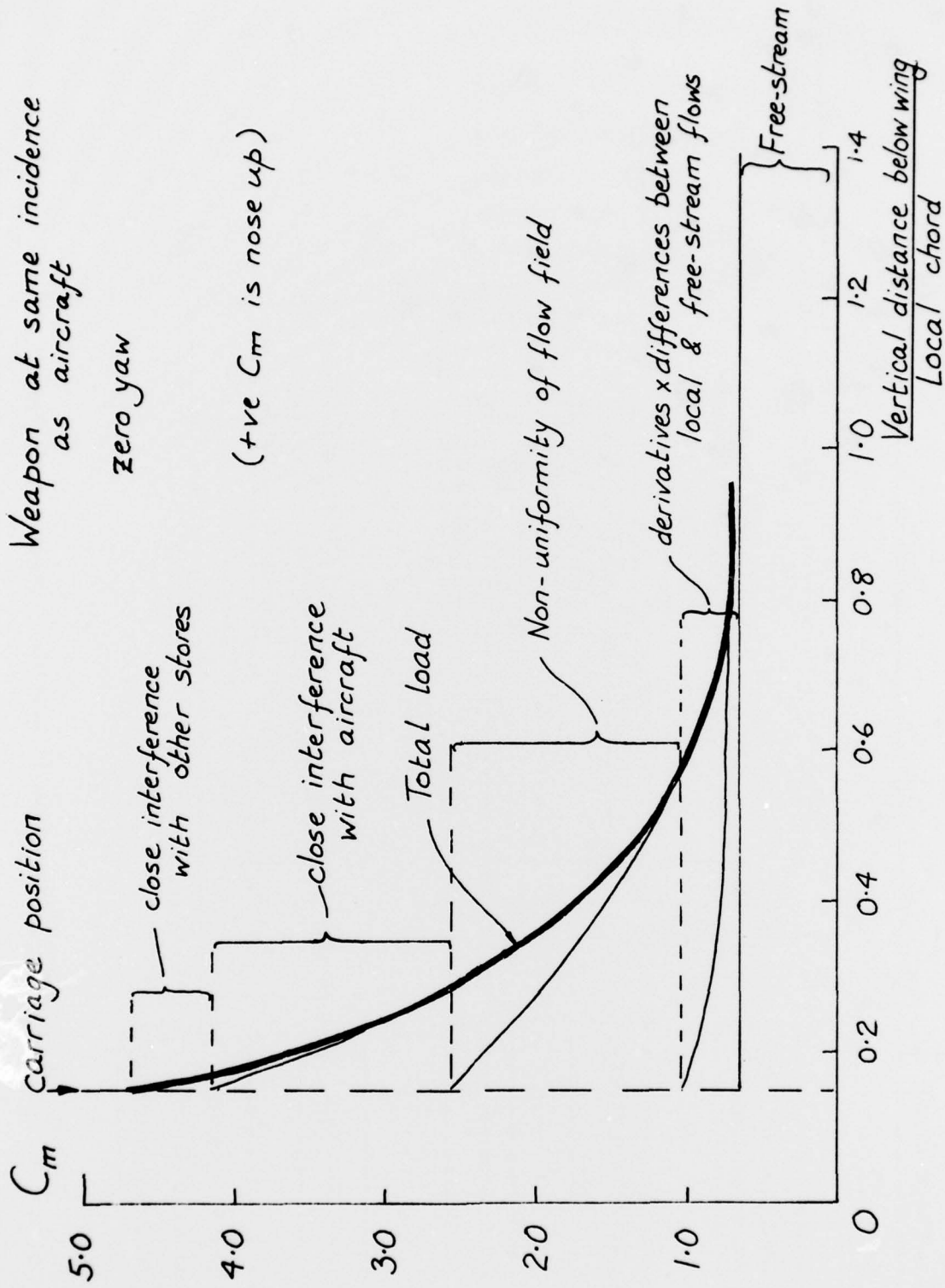

Fig 27

Fig 27 Theoretical analysis of loads on a guided weapon in a typical underwing flow:

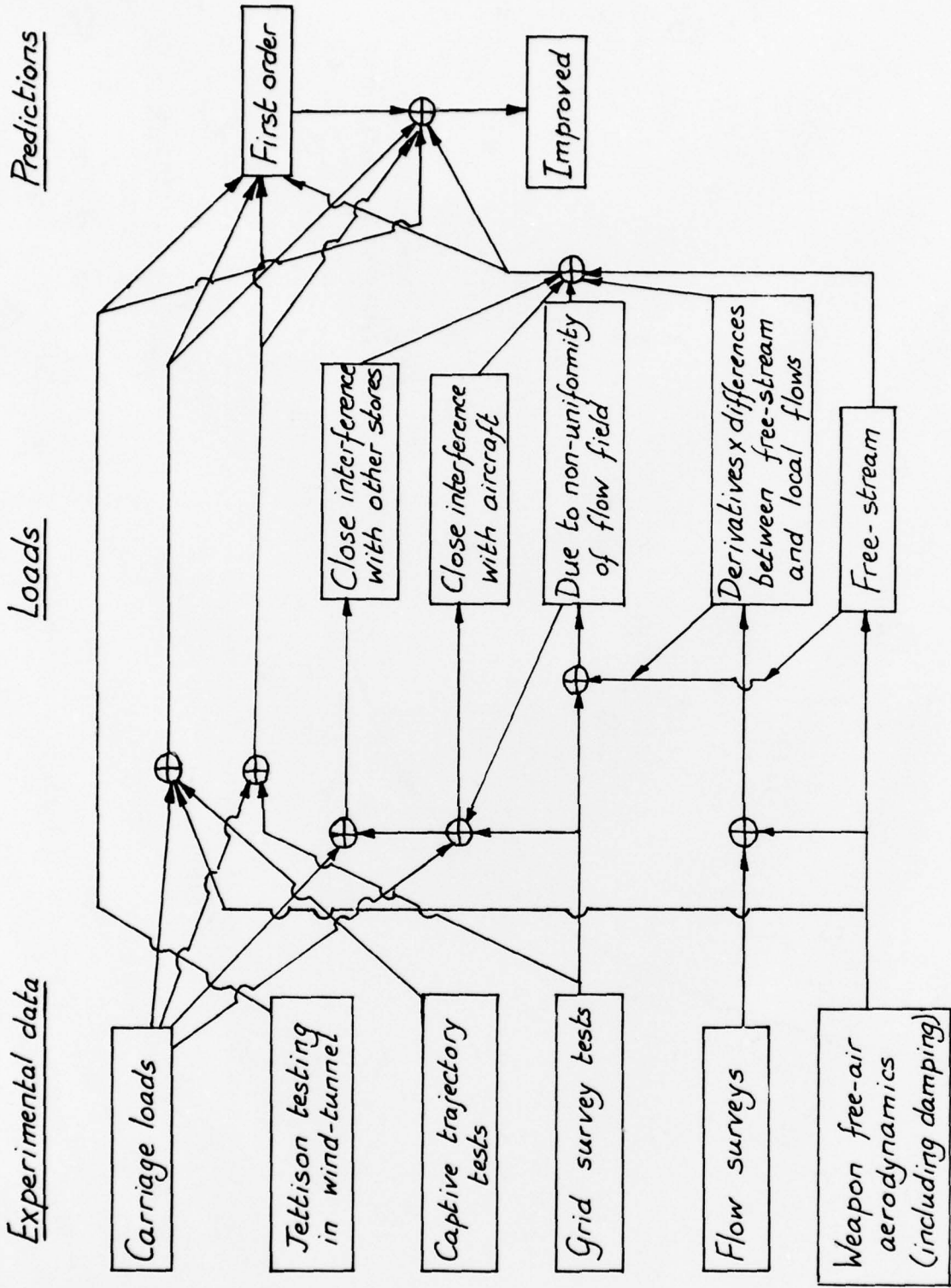

Fig 28 Use of experimental data in studies of release disturbance

**REPORT DOCUMENTATION PAGE**

Overall security classification of this page

UNLIMITED

As far as possible this page should contain only unclassified information. If it is necessary to enter classified information, the box above must be marked to indicate the classification, e.g. Restricted, Confidential or Secret.

1. DRIC Reference (to be added by DRIC)	2. Originator's Reference RAE TM Aero 1731	3. Agency Reference N/A	4. Report Security Classification/Marking  UNLIMITED	
5. DRIC Code for Originator  850100	6. Originator (Corporate Author) Name and Location  Royal Aircraft Establishment, Farnborough, Hants, UK			
5a. Sponsoring Agency's Code  N/A	6a. Sponsoring Agency (Contract Authority) Name and Location  N/A			
7. Title Weapon-aircraft interaction: Lecture delivered at Cranfield Institute of Technology 15 June 1977				
7a. (For Translations) Title in Foreign Language				
7b. (For Conference Papers) Title, Place and Date of Conference  Cranfield Institute of Technology, 15 June 1977				
8. Author 1. Surname, Initials  Pugh, P.G.	9a. Author 2	9b. Authors 3, 4 ....		10. Date   Pages   Refs. October   51   - 1977
11. Contract Number  N/A	12. Period  N/A	13. Project	14. Other Reference Nos.	
15. Distribution statement (a) Controlled by - Unlimited  (b) Special limitations (if any) -				
16. Descriptors (Keywords) (Descriptors marked * are selected from TEST) External stores. Drag. Flying qualities. Release disturbance. Guided weapons.				
17. Abstract  <div style="margin-left: 40px;"> <p>↘ This lecture reviewed the primary effects of the air carriage of stores including both the influence of stores on aircraft performance and the influence of the aircraft on the stores. The main emphasis was placed upon qualitative exposition of the physical processes involved with particular reference to guided weapons.</p> <p style="margin-left: 100px;">↗</p> </div>				

F5910/1

ED.  
78