

AD-A060 147

RESEARCH TRIANGLE INST RESEARCH TRIANGLE PARK N C F/G 13/2
SPECIFIC AIR POLLUTANTS FROM MUNITIONS PROCESSING AND THEIR ATM--ETC(U)
JAN 78 B H CARPENTER, R LIEPINS, J SICKLES DAMD17-76-C-6067
RTI/1342/00-01F-VOL-3 NL

UNCLASSIFIED

1 OF 2
AD
AO 60147



1 P 1 E D

1 OF 2

AD
AO 60 147

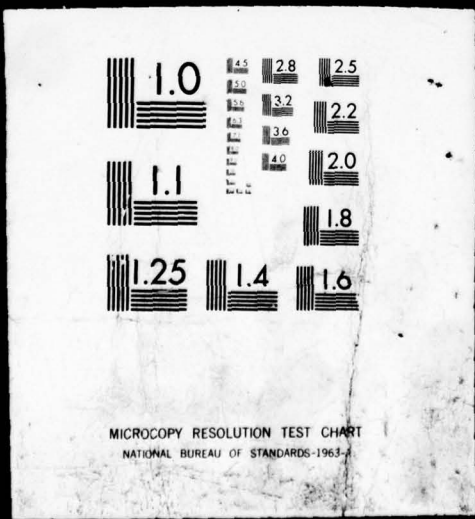

AD A060147

DDC FILE COPY

LEVEL

Vol 2
A060122

(13)

AD
RTI/1342/00-01F ✓

SPECIFIC AIR POLLUTANTS FROM MUNITIONS PROCESSING
AND THEIR ATMOSPHERIC BEHAVIOR

VOLUME 3

TNT PRODUCTION

FINAL REPORT

by

Ben H. Carpenter
Raimond Liepins
Joseph Sickles, II
Harry L. Hamilton
Douglas W. VanOsdel
George E. Weant, III
Lesa M. Worsham

DDC
RECEIVED
OCT 20 1978
F

JANUARY 1978

Project Officer: James C. Eaton, Jr.
Environmental Protection Research Division
US Army Medical Bioengineering
Research and Development Laboratory
Fort Detrick, Frederick, Maryland 21701

Supported by

US ARMY MEDICAL
RESEARCH AND DEVELOPMENT COMMAND
Fort Detrick, Frederick, Maryland 21701

Contract No. DAMD17-76-C-6067
Research Triangle Institute
Research Triangle Park, N. C. 27709

The findings in this report are not to be construed as an official Department
of the Army position unless so designated by other authorized documents.

APPROVED FOR PUBLIC RELEASE: DISTRIBUTION UNLIMITED

REPORT DOCUMENTATION PAGE		READ INSTRUCTIONS BEFORE COMPLETING FORM
1. REPORT NUMBER 14 RTI/1342/06-01F-VOL-3	2. GOVT ACCESSION NO.	3. RECIPIENT'S CATALOG NUMBER
4. TITLE (and Subtitle) Specific Air Pollutants from Munitions Processing and their Atmospheric Behavior. Volume 3. TNT Production.	5. TYPE OF REPORT & PERIOD COVERED Final Report June 1976 - October 1977	
	6. PERFORMING ORG. REPORT NUMBER	
7. AUTHOR(s) B. H. Carpenter, R. Liepins, Joseph Sickles, II, H. L. Hamilton, D.W. VanOsdell, G. E. Weant, III, L. M. Worsham	8. CONTRACT OR GRANT NUMBER(s) DAMD 17-76-C-6067	
9. PERFORMING ORGANIZATION NAME AND ADDRESS Research Triangle Institute Research Triangle Park, North Carolina 27709	10. PROGRAM ELEMENT, PROJECT, TASK AREA & WORK UNIT NUMBERS 62720A 16 3E762720A835/00.063	
11. CONTROLLING OFFICE NAME AND ADDRESS US Army Medical Research and Development Command Fort Detrick, Frederick, Maryland 21701	12. REPORT DATE 11 January 1978	
14. MONITORING AGENCY NAME & ADDRESS (if different from Controlling Office) US Army Medical Bioengineering Research and Development Laboratory Fort Detrick, Maryland 21701	13. NUMBER OF PAGES 606	
	15. SECURITY CLASS. (of this report) Unclassified	
16. DISTRIBUTION STATEMENT (of this Report) Approved for public release; distribution unlimited. 10 Ben H./Carpenter, Raimond/Liepins, Joseph/Sickles, II, Harry L./Hamilton Douglas W./VanOsdell		
17. DISTRIBUTION STATEMENT (of this Report)		
18. SUPPLEMENTARY NOTES		
19. KEY WORDS (Continue on reverse side if necessary and identify by block number) RDX/HMX, TNT, Open Burning, Incineration, Explosive Manufacture, Air Chemistry, Toxicity, Acetic Acid, Acetic Anhydride, Toluene, Tetranitromethane, Nitrotoluene, Nitrous Oxide, Nitric Oxide, Methyl Nitrate, Nitromethane, Nitrosamine, Red Water		
20. ABSTRACT (Continue on reverse side if necessary and identify by block number) This work is directed toward better definition of the specific air pollutants generated from the production of RDX and TNT, together with their attendant raw material manufacture and recovery processes, and the incineration of offgrade and used materials. Plant visits were made to discuss operations and acquire available data. These data, together with survey reports by the USAEHA and technology reports from the arsenals, were used to develop a state-of-knowledge emissions inventory projected to 'mobilization' production rates.		

304 400

cont →

ABBREVIATIONS AND ACRONYMS

AAP	Army Ammunition Plant
HAAP	Holston Army Ammunition Plant
JAAP	Joliet Army Ammunition Plant
RAAP	Radford Army Ammunition Plant
NAAP	Newport Army Ammunition Plant
VAAP	Volunteer Army Ammunition Plant
USAEHA	United States Army Environmental Hygiene Agency
TNT	Trinitrotoluene
RDX	Cyclotrimethylenetrinitramine
NEDS	National Emissions Data System
TPD	Tons per day
SPS	Source Performance Standards
NAAQS	National Ambient Air Quality Standards
N&P	Nitration and Purification
SA	Spent Acid Tanks
ST	Settling Tanks
NAC/SAC	Nitric Acid Concentration/ Sulfuric Acid Concentration
DSN	Direct Strong Nitric Acid Plant
RWP	Red Water Processing
FB	Finishing Building
AOP	Ammonia Oxidation Plant
NAC	Nitric Acid Concentration
SAC	Sulfuric Acid Concentrator
SAR	Sulfuric Acid Regeneration
TNM	Tetranitromethane
SC/SA	Single Contact/Single Absorption Acid Plant
DC/DA	Double Contact/Double Absorption Acid Plant
CAR	Carcinogenic effects - producing cancer
CNS	Central nervous system effects
EYE	Eye effects
GIT	Gastrointestinal tract effects
ham	hamster
hmn	human
ihl	Inhalation

ABBREVIATIONS AND ACRONYMS (cont'd)

ims	Intramuscular
iprl	Intraplueral
ipr	Intraperitoneal
IRR	Irritant effects
itr	Intratracheal
IVN	Intravenous
MAN	Man
MTH	Mouth effects
MUT	Mutagenic effects
mus	mouse
NEO	Neoplastic effects
orl	Oral
par	Parenteral
PNS	Peripheral nervous system effects
PSY	Psychotropic effects
PUL	Pulmonary system effects
rat	Rat
rbt	Rabbit
SKN	Skin effects
scu	Subcutaneous
TER	Teratogenic effects
unk	Unreported route
wmn	Woman

SPECIFIC AIR POLLUTANTS FROM MUNITIONS PROCESSING
AND THEIR ATMOSPHERIC BEHAVIOR

VOLUME 3 -- TNT PRODUCTION

TABLE OF CONTENTS

	<u>Page</u>
ABBREVIATIONS AND ACRONYMS	iv
LIST OF FIGURES	x
LIST OF TABLES	xi
6.0 EMISSIONS ASSESSMENT FROM PLANT OPERATIONS	288
6.B.0 Introduction	288
Approach	288
6.B.1 The Production of Trinitrotoluene	290
6.B.1.1 Introduction	290
Production Processes	290
Overview of Plants	291
6.B.1.2 Emissions Summary	297
Introduction	297
Nitrator Dumping	301
6.B.1.3 Nitration and Purification	304
Process Description	304
Nitration	304
Purification	305
Waste Streams	305
Emissions at VAAP	309
Fume Control	309
Sources, Controls, and Sampling Points	309
Materials Flow	310
Emissions at RAAP	311
Fume Control	311
Sources, Controls, and Sampling Points	311
Materials Flow	312

	<u>Page</u>
6.B.1.4 Acid and Fume Recovery Process (AFR), VAAP	312
Introduction	312
Acids Processing	313
Emissions from Acids Processing	315
Sources, Controls, and Sampling Points	316
Fumes Processing	316
Emissions from Fumes Processing	317
Sources, Controls, and Sampling Points	318
Feed Rate to the Fumes Processing Unit	318
Production Rates for the AFR Unit	319
Emission Rates	319
6.B.1.5 Nitration and Purification Fume Scrubber System, RAAP	320
Process Description	320
Emissions	322
Sources, Controls, and Sampling Points	322
Emissions Rates	323
6.B.1.6 Spent Acid Recovery (SAR), RAAP	323
Process Description	323
Emissions	325
6.B.1.7 Finishing and Packaging	325
Process Description	325
Emissions	327
Materials Flow	327
Emissions Rates	327
6.B.1.8 Ammonia Oxidation Plants (AOP)	328
Process Description	328
Emissions	330
Sources, Controls, and Sampling Points	330
Emission Rates	330
6.B.1.9 Nitric Acid Concentration/Sulfuric Acid Concentration (NAC/SAC), RAAP	331
Process Description	331
NAC	331
SAC	332
Tail Gas Treatment	332

	<u>Page</u>
Emissions	332
Sources, Controls, and Sampling Points	334
Emission Rates	334
6.B.1.10 Direct Strong Nitric Acid Process (DSN), VAAP	334
Process Description	334
Emissions	337
Materials Flow	337
Emission Rates	337
6.B.1.11 Sulfuric Acid Regeneration (SAR)	338
Process Description	338
6.B.1.12 VAAP's SC/SA System	339
Process Description	339
Emissions from VAAP's SC/SA Plant	342
Sources, Controls, and Sampling Points	342
Emission Rates	342
6.B.1.13 RAAP's DC/DA System	343
Process Description	343
Emissions from RAAP's DC/DA Plant	345
Sources, Controls, and Sampling Points	345
Emission Rates	345
6.B.1.14 Conclusions and Recommendations	345
6.B.2 TNT Plant Atmospheric Chemistry	347
6.B.2.1 Introduction and Definition of Terms	347
6.B.2.2 Characteristics of Compounds Emitted in the TNT Process	347
Properties of the Compounds Emitted During the Manufacture of TNT	347
Detection Methods of Compounds Emitted During the Manufacture of TNT	352
6.B.2.3 Atmospheric Transformations	353
Known or Potential Ground State Reactions	353
Known or Potential Excited State Reactions	357
Nitrogen Dioxide	358
Nitrogen Trioxide and Dinitrogen Pentoxide	365
Nitrous and Nitric Acids	366
Tetranitromethane	367
Nitrotoluenes	368

	<u>Page</u>
Ozone	370
Sulfur Dioxide	371
Known or Potential Secondary Reactions	372
Carbon Monoxide	373
Methane	377
Toluene	381
Nitrogen Oxides	385
Nitrous and Nitric Acids	386
Pernitric Acid	386
Tetranitromethane	387
Nitrotoluenes	388
Ozone	392
Sulfur Oxides	394
6.B.2.3 Environmental Consequences of the Emissions from TNT Manufacturing at RAAP and VAAP	395
EPA Criteria Pollutants	396
Non-EPA Criteria Pollutants	402
Atmospheric Chemistry	403
Toxicity	405
6.B.2.4 Conclusions and Recommendations	405
REFERENCES	409

LIST OF FIGURES

<u>Figure</u>		<u>Page</u>
6.B-1	Volunteer Army Ammunition Plant process flow	292
6.B-2	Radford Army Ammunition Plant process flow	293
6.B-3	VAAP showing TNT manufacturing area	294
6.B-4a	Location of RAAP	295
6.B-4b	Radford Army Ammunition Plant, Radford, Va.	296
6.B-5	VAAP production of TNT - nitrators and separators	306
6.B-6	RAAP production of TNT - nitrators and separators	307
6.B-7	Production of TNT - product purification	308
6.B-8	VAAP acid fume recovery system	314
6.B-9	RAAP nitration and purification facilities	321
6.B-10	RAAP spent acid recovery	324
6.B-11	Finishing and packaging diagram	326
6.B-12	Ammonia oxidation plant flow diagram	329
6.B-13	RAAP NAC/SAC process	333
6.B-14	Direct strong nitric acid process flow sheet	335
6.B-15	VAAP SC/SA sulfuric acid regeneration plant	341
6.B-16	RAAP DC/DA sulfuric acid regeneration plant	344

LIST OF TABLES

<u>Table</u>		<u>Page</u>
6B-1	Source Characteristics, VAAP, Six 50 Ton/Day TNT Units and Supporting Processes	298
6B-2	Projected Emissions from TNT Manufacture at RAAP-3 Lines at 50 Tons/Day Each	299
6B-3	Estimated Nitrator Compositions at Volunteer Army Ammunition Plant	302
6B-4	Estimated Nitrator Compositions at Radford Army Ammunition Plant	303
6B-5	VAAP Materials Flow for One Continuous Line Producing 50 Tons of TNT Per Day	310
6B-6	RAAP Materials Flow for One Continuous Line Producing 50 Tons of TNT Per Day	312
6B-7	Design Input to the Acids Processing Segment of the AFR Plant, VAAP	316
6B-8	Design Nitrator Fume Input to the Fume Processing Segment of the AFR Plant VAAP	318
6B-9	AFR Production Rates at Capacity, VAAP	319
6B-10	Design Input to the SAR Plant, RAAP	323
6B-11	Design Acid and Sulfur Input to the VAAP SAR Plant	340
6B-12	Design Production Rate for the VAAP SAR	340
6B-13	Emissions Rates for the VAAP SAR Plant	342
6B-14	Projected Emissions Rates for VAAP's SAR Plant at Capacity	343
6B-15	Physical Properties of Emissions from TNT Installations	348
6B-16	Known Ground State Reactions of Emissions from TNT Installations	354
6B-17	Photochemical Reactions of Emissions from TNT Installations	359
6B-18	Ozone Levels Calculated for PSS for an Irridated Organic-Free Atmosphere Initially Contaminated by Various Levels of NO ₂	364
6B-19	Known or Potential Secondary Reactions of Emissions from TNT Installations	374

LIST OF TABLES (cont'd)

<u>Tables</u>		<u>Page</u>
6B-20	Possible Products Formed from the Addition of Atomic Oxygen to the Aromatic Ring of a Nitrotoluene	389
6B-21	Emissions Summary from TNT Manufacturing at VAAP	395
6B-22	Comparison of RAAP and VAAP Emissions to County-Wide Emissions	396
6B-23	Capacities of Sources Subject to EPA Performance Standards with Emissions Equivalent to the VAAP TNT Installations	398
6B-24	National Ambient Air Quality Standards	399
6B-25	Maximum Allowable Increase in Concentration for SO ₂ and Particulate Matter	400
6B-26	Half-Lives of Selected Air Contaminants Associated with the Manufacture of TNT	404
6B-27	Permissible Threshold Level Values of Emissions from TNT Installations	406

6.0 EMISSIONS ASSESSMENT FROM PLANT OPERATIONS

6.B.0 INTRODUCTION

The Office of the Army Surgeon General is responsible for development of health and environmental guidelines governing emissions of military-related compounds. The U.S. Army Medical Bioengineering Research and Development Laboratory (USAMBRDL) has reported an evaluation of the air pollution potential of seven substances emitted at Army Ammunition Plants (AAP's) for which emissions and air quality standards currently do not exist.¹ The evaluation provides a background for further investigations of possible needs for appropriate air quality standards.

This study provides a continuation of the effort to establish a data base from which either discharge or ambient standards for air pollutants not addressed by the Environmental Protection Agency can be recommended. The study is limited to the production of trinitrotoluene (TNT); the production of cyclotrimethylenetrinitramine (RDX); and the incineration of waste materials. The investigation required consideration of the nature of the explosives manufacturing processes and the emissions controls applied, the possible emissions, their potential for chemical reaction and photochemical reaction, and their toxicity.

APPROACH

Visits were made to army ammunition plants at Kingsport, Tenn.--Holston Army Ammunition Plant (HAAP); Radford, Va.--Radford Army Ammunition Plant; Chattanooga, Tenn.--Volunteer Army Ammunition Plant (VAAP); Joliet, Ill.--Joliet Army Ammunition Plant (JAAP); and Newport, Ind.--Newport Army Ammunition Plant (NAAP). At each, the processing and operating practices were discussed with plant specialists. Available data were acquired relating to emissions sources and emissions controls. The available data were augmented by survey and test data from the U.S. Army Environmental Hygiene Agency (USAEHA), by relevant reports from Picatinny Arsenal, and from the technical reference facilities of the Defense Documentation Center. The data were assessed where

possible to project emissions source characteristics (stack height, diameter, exit gas flow rate, gas composition) to be expected when the explosives-manufacturing processes were operated at mobilization production rates. Mobilization rates themselves were not based upon information obtained from the plants. In developing the projected emissions, many extensive gaps in the existing data were identified. This led to recommendations for future work to fill the information gaps and provide much needed emissions inventory data.

Waste materials were, at the time of the plant visits, burned on open ground, or in air-curtain incinerators. Enclosed burning techniques were undergoing evaluation and development at the arsenals, however. Visits were made to the Picatinny Arsenal and Tooele Army Depot to obtain additional available data for assessment of emissions from closed incineration. Considerable attention was given to assessment of the methodologies for calculation of the products of controlled combustion.

Although the emissions inventories thus developed are incomplete because of data gaps, and include elements necessarily derived from theoretical principles, one inventory (RDX) provided enough approximate information to justify a limited investigation of likely atmospheric concentrations of emitted substances at plant boundaries.

For both RDX and TNT, the literature was searched to collect data on the chemical properties and potential photochemistry, ground state chemistry, and secondary reactions of both the positively identified emissions and selected suspected emissions. Reaction rate data were compiled to the extent available. The extensive numbers of chemical reactions thus obtained have been interpreted in three ways. First, potentially hazardous compounds are identified by assessing the toxicological properties of the reactants and products. Second, the reactions themselves are screened to provide some focus on expected principal products. Third, methodologies were applied toward estimating concentrations of emitted pollutants at the boundary of a mobilized plant. Additional work on modeling the air chemistry over the plant is needed, however, and recommended.

This is Volume 3 of the final report. The study of the TNT process is covered. Other volumes are: 1--Executive Summary and General Appendices; 2--RDX/HMX production; and 4--Open Burning and Incineration of Waste Munitions.

6.B.1 THE PRODUCTION OF TRINITROTOLUENE

6.B.1.1 Introduction

Production Processes

Trinitrotoluene (TNT) is produced by the continuous processes pioneered by Canadian Industries Ltd. (CIL) at Volunteer and Radford Army Ammunition Plants (VAAP and RAAP). The manufacturing operation involves several direct processing steps. Nitration of toluene generates a raw product that must be purified to obtain TNT. Spent acid from the nitration system and fumes from both nitration and purification must be collected and recycled. The continuous nitration and purification (N&P) lines require spent acid tanks and settling tanks as well as provisions for handling red water wastes evolved in purification. Finishing and packaging operations are cleaner but do generate a reddish colored water waste from the dust scrubber.

Processes supporting the manufacture of TNT are concerned primarily with the manufacture and treatment of nitric and sulfuric acids. Weak nitric acid is made either by an acid concentration system or at VAAP, by a strong nitric acid (DSN) plant. The nitric acid concentration/sulfuric acid concentration (NAC/SAC) unit strengthens weak nitric acid from the ammonia oxidation plant. Oleum and strong sulfuric acid are produced from weak sulfuric acid and sulfur in a special kind of oleum plant known as a sulfuric acid regeneration unit. The weak sulfuric acid is derived indirectly from the nitration lines. The waste acid drawn from the first nitrators is a mixture of nitric and sulfuric acids, with various nitrocompounds. At VAAP, a portion of the acid and fume recovery (AFR) process is responsible for separating the acids. At RAAP, the spent acid recovery unit separates the nitrocompounds from nitric and sulfuric acid streams.

The following processing systems appear at both VAAP and RAAP as necessary systems in the production of TNT by the continuous process:

- Nitration and Purification (N&P)
- Spent Acid Tanks (SA)
- Settling Tanks (ST)

Red Water Processing (RWP)
Finishing Building (FB)
Ammonia Oxidation Plant (AOP)
Nitric Acid Concentrator (NAC)
Sulfuric Acid Concentrator (SAC)
Sulfuric Acid Regeneration (SAR)

Despite the common overall manufacturing processes, the two munitions plants are dissimilar in many respects. The most obvious difference is in the number of TNT lines: VAAP has six, RAAP has three. The lines at the two plants will differ in detail when RAAP finishes reconstruction. More readily discernable variances are obvious in the treatment of waste acids and fumes from the nitration and purification lines. VAAP's acid and fume recovery unit performs the tasks of both the spent acid recovery and N&P fume treatment units at RAAP. Nitric acid production is by AOP and NAC/SAC process at RAAP and by AOP and DSN processes at VAAP.

A process schematic diagram of VAAP appears in Figure 6.B-1. The corresponding diagram for RAAP appears in Figure 6.B-2. The flow sheets presented were drawn after modifying and updating sketches given in plant process manuals to show emissions sources.

Overview of Plants

VAAP is located in Tyner, Hamilton County, Tennessee and occupies an area of approximately 7300 acres. The Plant is operated by Imperial Chemical Industries America, Inc. A portion of the facility, producing anhydrous ammonia, ammonium nitrate fertilizers, urea, and nitric acid is leased to the C. F. Industries, Inc. (CFI). Figure 6.B-3 shows the plant layout for TNT and supporting processes.

VAAP has a total of six 50 ton/day CIL designed TNT lines. One of these is a prototype line designed to be operated by a process computer.

RAAP is located in the mountains of southern Virginia in Pulaski and Montgomery Counties. The Plant area is 7095 acres. The main manufacturing plant (4154 acres) is located in Pulaski and Montgomery Counties, situated approximately 4 miles north of Radford, Virginia. The developed manufacturing area consists of 2800 acres. Figures 6.B-4a and 6.B-4b show the plant layout including the TNT manufacturing area and its supporting processes.

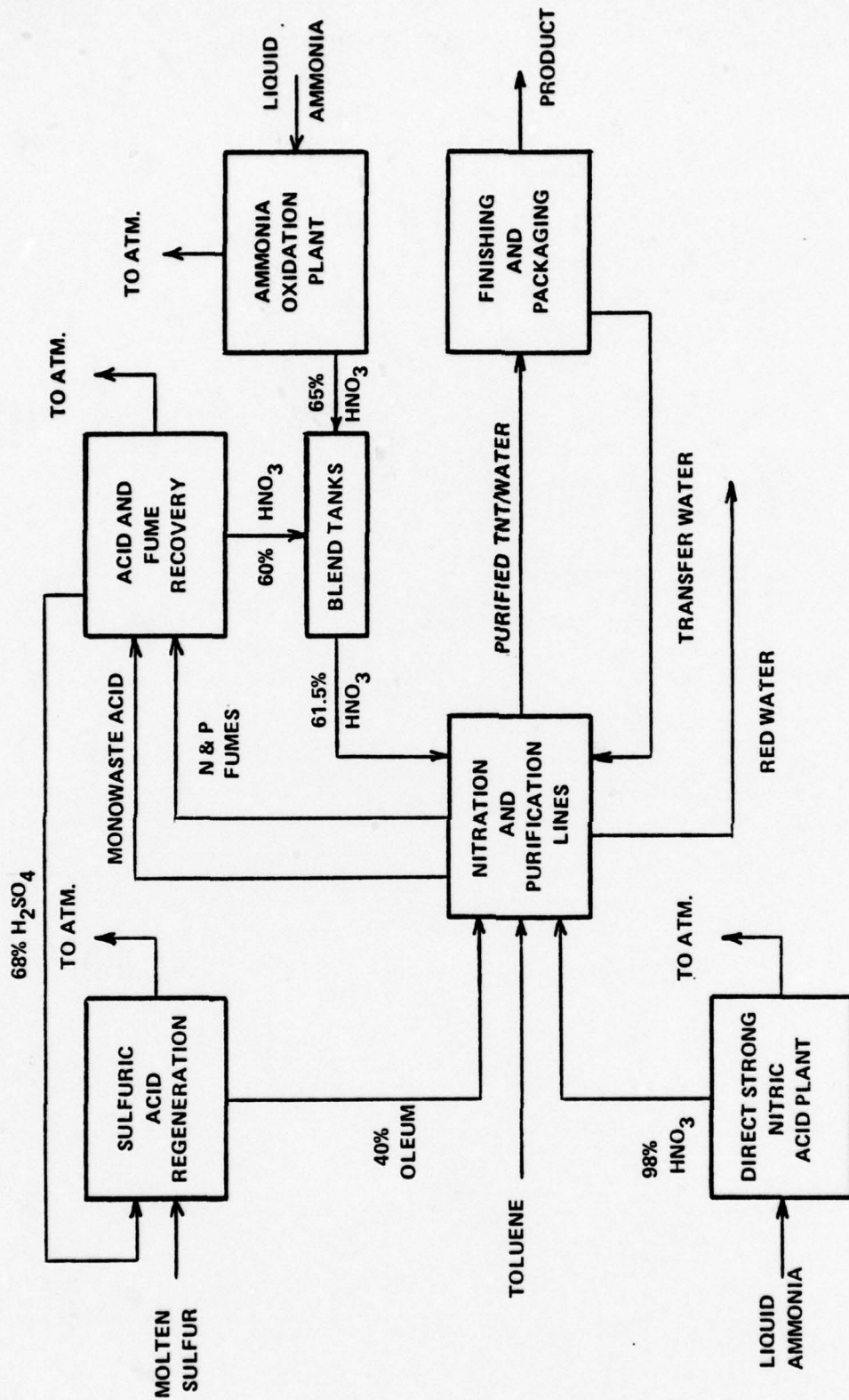

Figure 6.B-1. Volunteer Army Ammunition Plant process flow.

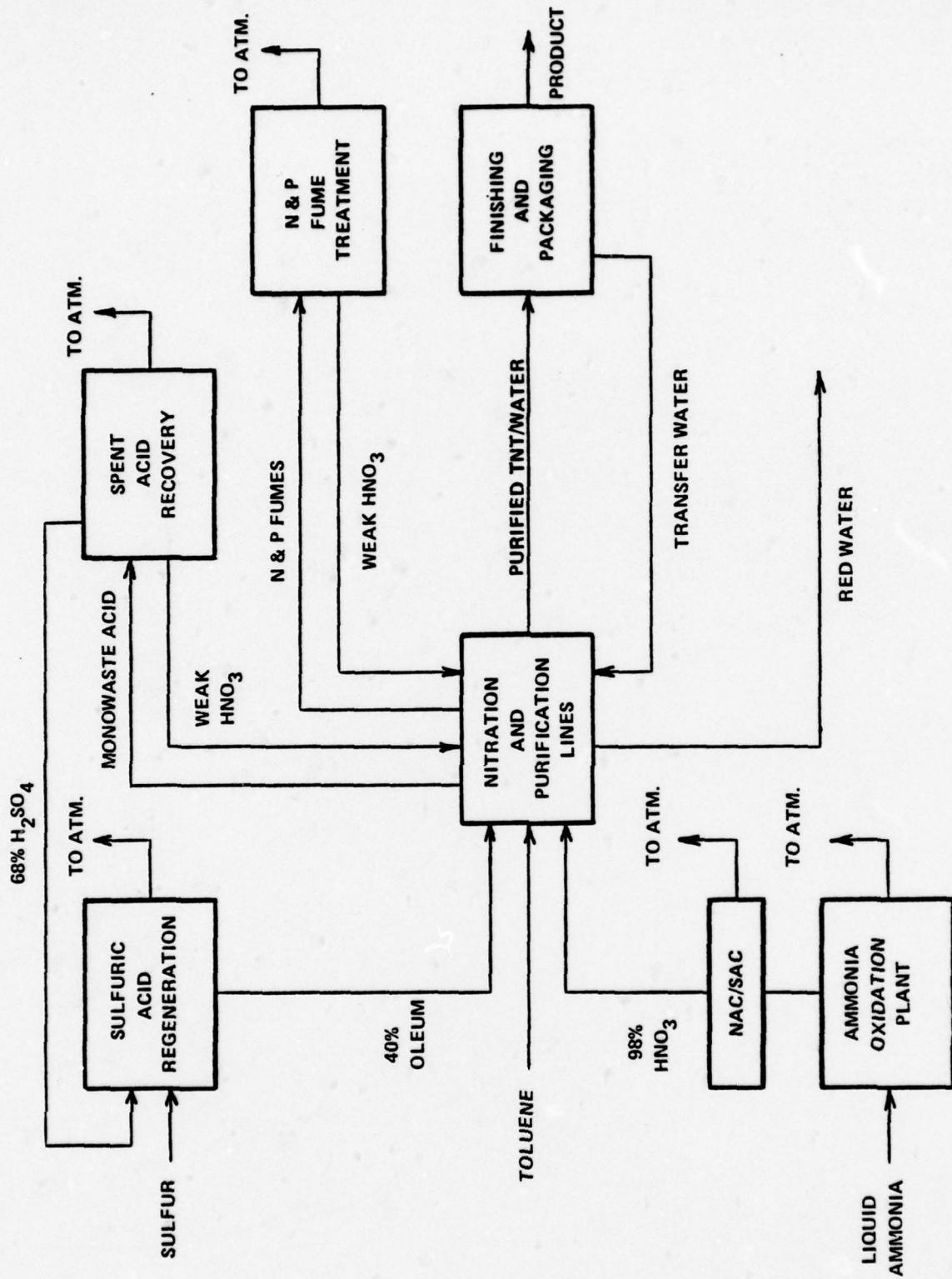

Figure 6.B-2. Radford Army Ammunition Plant process flow.

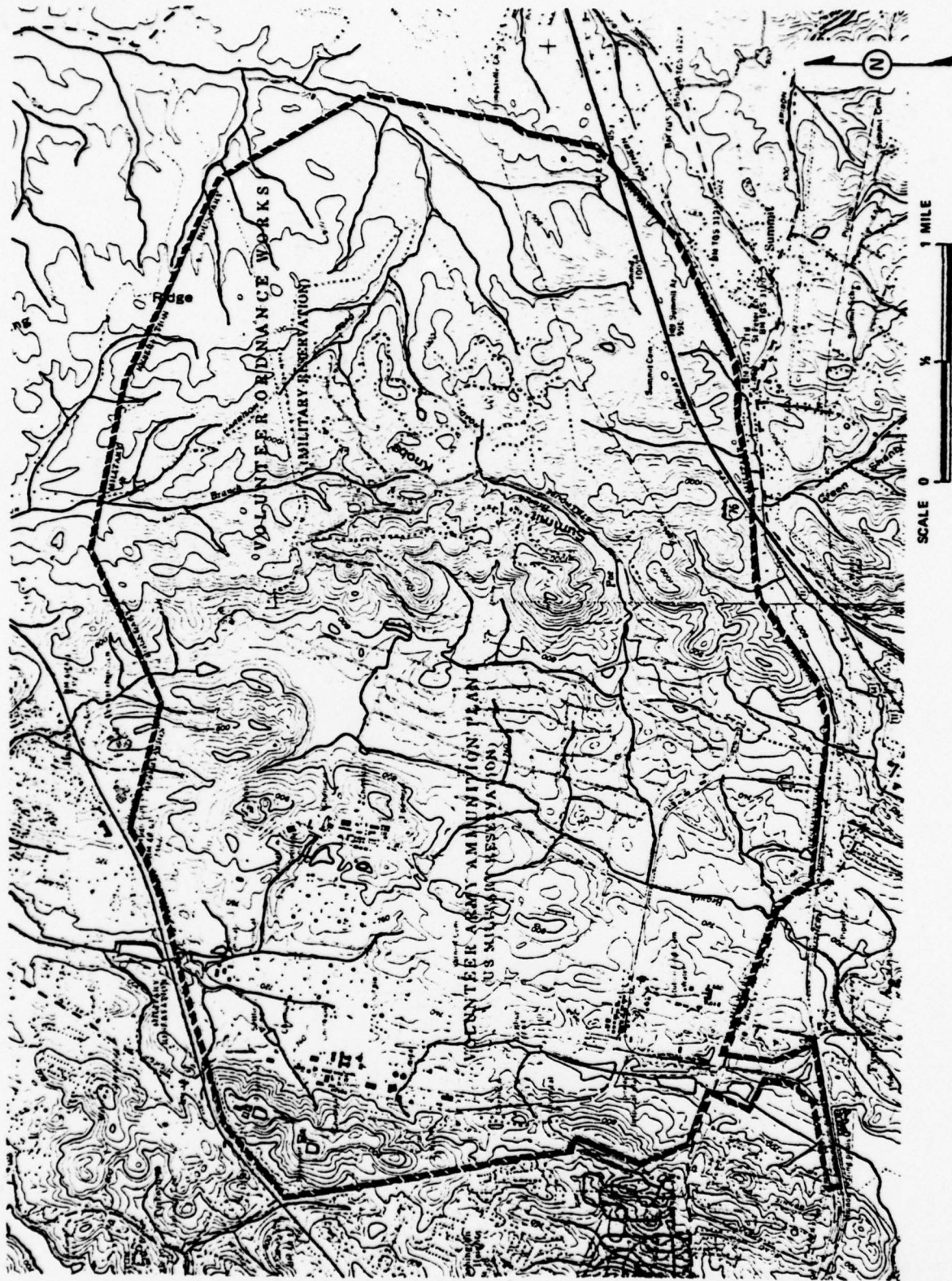

Figure 6.B-3. VAAP showing TNT manufacturing area. (Furnished by the Ecological Research Office, Chemical Systems Lab, Aberdeen Proving Ground, MD 21010.)

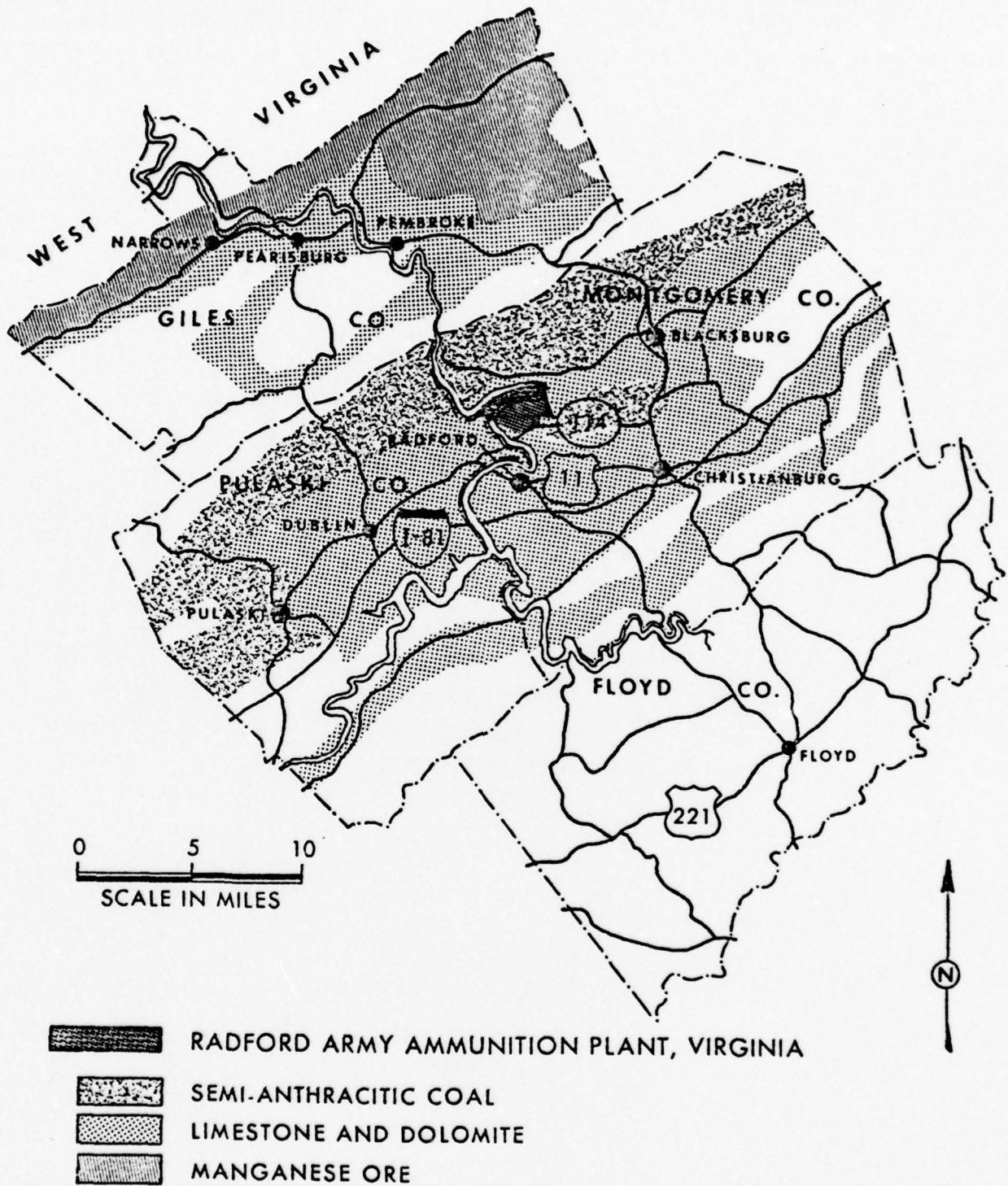

Figure 6.B-4a. Location of RAAP. (Furnished by the Ecological Research Office, Chemical Systems Lab, Aberdeen Proving Ground, MD 21010.)

The RAAP TNT facilities consist of three 50 ton/day lines. Two lines are currently being rebuilt--the third is in future year funding.

6.B.1.2 Emissions Summary

Introduction

To facilitate air chemistry investigations it was necessary to assemble a composite list of the emissions rates for the major processes in TNT manufacture. The initial goal was to typify emissions from a hypothetical model TNT manufacturing facility operated at mobilization. Each of the major processes was to be studied to determine air pollution emissions attributable to TNT manufacture. However, in examining the production processes at VAAP and RAAP, it was decided that the difference (in the lines and particularly in the support process) demand separate treatments of the two facilities.

The literature search uncovered a relative scarcity of useful emissions data. Due to recent modernization programs, most of the TNT facilities at VAAP and RAAP are relatively new. Since the demand for military high explosives has been light in recent years, some units have never run--others have not yet operated at capacity. RAAP is in the midst of an extensive modernization and rebuilding program that should result in sharply reduced emissions from TNT manufacture. VAAP has replaced both weak and strong nitric acid manufacturing processes.

At both plants, the capacities of support processes often exceed that required for the level of TNT manufacture anticipated at mobilization. At VAAP, the apparent overcapacity allows for either the expansion of continuous lines or the operation of older batch facilities. Many of RAAP's systems serve not only the continuous TNT lines but also propellant manufacturing facilities. Whenever possible, the emissions from the individual systems were prorated to simulate rated TNT manufacturing capacities.

Since virtually none of the data pertained to the same TNT production rate, calculations were made to project them to capacity operation. These calculations are given in the appropriate process sections to follow together with references thereto.

The emissions rates and source characteristics derived for VAAP appear in Table 6B-1. Fumes and spent acid from the six continuous N&P lines are treated

TABLE 6B-1. SOURCE CHARACTERISTICS, VAAP, SIX 50 TON/DAY TNT UNITS AND SUPPORTING PROCESSES

Process Source	AOP	N&P	AFR ² #1	AFR #2	DSH ¹	SAK	Power ³ Plant	Finish Bldg	Toluene Tanks	Gasoline Tanks	TOTALS
Height above grade, ft	50	25	50	50	131	100		28			
Stack ID, ft	3	0.5	2.7	2.7	2.5	6		1			
Flow, ACFM	27,744		21,863	21,863	24,705	40,544		2842			
Temperature, °C	350	30	216	216	15	30		30			
Exit Gas Velocity, ft/sec	89	2 points of emission combined	25.3	65.3	84	24	2 stacks	60.3			
Pollutants, ppm (lb/day)											
NO _x	200 ppm 611 lb/day	negligible	196 ppm 442 lb/day	196 ppm 442 lb/day	499 ppm 369 lb/day	353 ppm 2559 lb/day	2632 lb/day				6855 lb/day
H ₂ SO ₄ mist					98 lb/day NO ₂	5.13 mg/scf 599 lb/day					599 lb/day
SO ₂						244 ppm 2176 lb/day	718 lb/day				2894 lb/day
CO							75 lb/day				75 lb/day
Hydrocarbons (nonmethane)							50 lb/day			1900 ppm	123 lb/day
Particulates							200 lb/day				200 lb/day
Organics											
Tetranitromethane			b	b							
Trinitrobenzene			b	b							
Mononitrotoluene			b	b							
Isomers of Trinitrotoluene			b	b							
Micresols ^c			b	b							
Trinitrobenzaldehyde			b	b							
Toluene			b	b					216 ppm		216 ppm
								TFT dust 5 ppm 73 lb/day			

¹Unit operated 13 days/month

²140 lb/day TMM fed to the AFR's

³Coal burning power plants.

^bEmission rates not available although they are believed to be small

^cHighly toxic

in the AFR unit. Although the AFR has been sampled at low capacity, the test results seem ambiguous. For the purposes of emissions estimation, therefore, the design basis and performance guarantee has been used. Finishing and packaging emissions were calculated as 73 lb TNT/day from VAAP's estimates of untreated emissions and collection efficiency.

The remainder of TNT-related processes supply acids or steam to the N&P lines. It is anticipated that the weak nitric acid production pursued in the new AOP will comply with the 5.5 lb NO_x/ton 100 percent HNO₃ product standard. At a production rate of 264 tons 60 percent HNO₃/day, the projected emissions are 611 lb NO_x/day at a production rate of 146 tons 100 percent HNO₃/day. VAAP's sulfuric acid regeneration plant has been sampled at low-capacity operation. By factoring the unit to capacity production, emissions rates of 2176 lbs SO₂/day, 2259 lbs NO_x/day, and 599 lbs H₂SO₄ mist/day are computed. A significant emission source at VAAP is the main power plant. Estimated emissions from Powerhouse No. 1 are: 2632 lb NO_x/day, 718 lb SO₂/day, 75 lb CO/day, 50 lb hydrocarbons/day, and 200 lb particulates/day.¹

Emission rates for each of RAAP's major TNT process units appear in Table 6B-2. Data available from RAAP were insufficient to develop a complete

TABLE 6B-2. PROJECTED EMISSIONS FROM TNT MANUFACTURE AT RAAP-3 LINES at 50 TONS/DAY EACH

All Values Given in lb/day	N&P Fume Treatment	Spent Acid Recovery	Finishing and Packaging	AOP	NAC/SAC	SAR	Power House No. 1	TOTALS
NO _x	123	888		845	342	1027	28,320	41,527
HNO ₃ Mist					252			252
TNT			36					36
SO ₂						3576	55,800	59,376
Nitro bodies		126						126
Particulates							81,600	81,600

source characteristics table as was done for VAAP. Recycling of fumes and spent acid from the three N&P lines is performed in the N&P fume treatment and

spent acid recovery units, respectively. Three types of towers (water, sulfuric acid, and sellite) provide for scrubbing of both NO_x and TNM in the N&P fume treatment system. NO_x emissions are estimated at 123 lb/day. TNM rates should be negligible. Spent acid recovery serves to separate the monowaste acid input into HNO_3 and H_2SO_4 . Since sampling was performed under low-flow conditions, extrapolation was used to estimate capacity operation. For rated production at Radford (3 lines at 50 tons/day each), emissions are estimated at 88 lb NO_x /day and 126 lb nitrobenzenes/day. TNT losses of 36 lb/day from RAAP's finishing and packaging operations are based on VAAP's practice.

Peripheral processes at RAAP include production and concentration of acids as well as the main power plant. Nitric acid is produced in several old and one new AOP. Some units have been modified or designed to meet the 5.5 lb NO_x /ton 100 percent HNO_3 standard. Total NO_x emissions due to nitric acid production are estimated at 845 lb/day assuming all are to be modified. Since there is no DSN unit at RAAP, strong nitric acid must be furnished by concentrating weak HNO_3 . The NAC/SAC provides HNO_3 of the required strength at a penalty of 342 lb NO_x /day and 252 lb HNO_3 mist/day. The old oleum plant has been replaced by a new SAR plant. If the design goals of $\text{SO}_2 < 500$ ppm and $\text{NO}_2 < 200$ ppm are met, pollution rates should be less than 3526 lb SO_2 /day and 1027 lb NO_x /day. Although the main power plant serves propellant manufacture as well as TNT, no basis was known for proportioning the emissions. The burning of bituminous coal makes Powerhouse No. 1 a heavy polluter with 28,320 lb NO_x /day, 55,800 lb SO_2 /day, and 81,600 lb particulates/day.

The emissions inventories reflect the operation of both VAAP and RAAP at mobilization. Certain assumptions have been made--that two new AFR's at VAAP will be in operation to take care of six continuous TNT lines and that these AFR's will have incinerators to remove TNM from the exit gases. Under these conditions, the TNM emissions at mobilization would be much less than 369 lb/day from one old AFR serving batch lines.¹⁵ Mobilization without the new AFR's and their controls would be expected to result in emissions of some 1800 lb/day TNM (5 AFR's times 369 lb/day each).

Similarly, RAAP was inventoried assuming the new sellite scrubbers were in operation. Without them, TNM emissions of 490 lb/day from the AFR's and 810 lb/day from the purification and packaging area would be expected.¹⁵

Nitrator Dumping

Besides the emissions noted for the TNT production and support processes, the common practice of dumping nitrators may prove to be a significant (although intermittent) source of uncontrolled emissions. Dumping entails the discharge of all contents of a nitrator vessel (and always an associated separator) into the water-filled drain tank in the bottom level of the N&P Buildings. The resulting contaminated mixture is routed outside and vented directly to the atmosphere near ground level.

Estimating the possible species emitted during dumping means assessing the contents of the various nitrators. The only chemical composition information found was for RAAP's continuous system as operated in 1973.² Although VAAP's present setup is similar, the new lines at RAAP will be appreciably different when completed. RAAP's six old nitration stages (with two nitrators in the first and third stages) will be replaced with eight stages having one nitrator per stage. Since the compositions were given in percent, the nitrator loadings (in lb per unit) were required to calculate the amount of each compound. Telephone conversations with VAAP³ and RAAP⁴ personnel provided estimates of the proper weights.

The calculated compositional loadings are shown in Tables 6B-3 and 6B-4. Although the numbers given may not be accurate representations of future operation, they should yield valuable information with regard to the chemical species and relative concentrations present. RAAP's new nitrator loadings (which provide less mass in each nitrator) were mated to the old compositions. Although this introduces some error, it does scale the compositions to the predicted mass contents. The matchup at VAAP should be better.

Nitrators may be dumped for either of two reasons: cleaning or safety. It is normal practice to dump the first three nitrators (for example IA, IB, and II at VAAP) to alleviate the accumulation of white compound (2,2'-dicarboxy-3,3',5,5'-tetrinitroazoxybenzene). Also, any of the nitrators may be dumped if the reaction goes out of control.

TABLE 6B-3. ESTIMATED NITRATOR COMPOSITIONS AT VOLUNTEER ARMY AMMUNITION PLANT, IN LBS

NITRATOR	1a	1b	2	3a	3b	4	5	6
COMPOUND								
Toluene	8.01	8.43	--	--	--	--	--	--
2-MNT	337.36	355.25	13.64	--	--	--	--	--
3-MNT	19.36	20.39	1.00	--	--	--	--	--
4-MNT	197.43	207.90	7.52	--	--	--	--	--
Total MNT	554.15	583.54	22.16	--	--	--	--	--
3,4-DNT	0.58	0.61	10.33	14.01	11.99	1.23	0.34	0.15
3,5-DNT	--	--	--	--	--	--	--	--
2,5-DNT	0.32	0.34	4.01	5.51	4.72	0.95	0.58	0.15
2,6-DNT	8.27	8.71	104.51	115.54	98.89	9.96	3.31	0.77
2,4-DNT	50.32	52.99	571.21	753.65	645.04	89.49	35.26	3.34
Total DNT	59.49	62.62	690.06	888.71	760.64	101.63	39.54	4.46
TNB	0.32	0.34	2.41	6.66	5.70	0.95	0.97	0.15
2,3,4-TNT	0.13	0.14	0.80	8.96	7.67	8.45	20.65	8.80
2,3,5-TNT	--	--	--	--	--	0.19	0.78	0.46
2,4,5-TNT	--	--	2.61	26.65	22.81	16.42	36.23	14.20
2,4,6-TNT	18.84	19.85	284.95	1366.03	1169.18	821.45	1850.02	1515.23
Total TNT	18.97	19.99	288.36	1401.64	1199.66	846.51	1907.68	1538.69
Nitrocresols	1.80	1.89	--	--	--	--	--	--
TNBAL	--	--	0.50	1.84	1.57	0.66	--	--
TNBA	--	--	2.61	4.13	3.54	--	--	--
White Compound	--	--	1.00	1.15	0.48	--	--	--
a-Nitrate-TNT	--	--	0.50	2.95	1.04	--	--	--

TABLE 6B-4. ESTIMATED NITRATOR COMPOSITIONS AT RADFORD ARMY AMMUNITION PLANT, IN LBS

NITRATOR	1	2	3	4	5	6	7	8
COMPOUND								
Toluene	3.93	3.93	--	--	--	--	--	--
2-MNT	165.26	105.26	4.27	--	--	--	--	--
3-MNT	9.48	9.48	0.31	--	--	--	--	--
4-MNT	96.71	96.71	2.36	--	--	--	--	--
Total MNT	271.45	271.45	3.23	--	--	--	--	--
3,4-DNT	0.28	0.28	10.17	1.92	1.92	0.41	0.06	0.03
3,5-DNT	--	--	--	--	--	--	--	--
2,5-DNT	0.16	0.16	1.26	0.75	0.75	0.31	0.09	0.03
2,6-DNT	4.05	4.05	32.72	15.79	15.79	3.30	0.53	0.16
2,4-DNT	24.65	24.65	178.82	103.02	103.02	29.61	5.68	0.69
Total DNT	29.14	29.14	222.97	121.48	121.48	33.63	6.36	0.91
TNB	0.16	0.16	0.75	0.91	0.91	0.31	0.16	0.03
2,3,4-TNT	0.06	0.06	0.25	1.22	1.22	2.79	3.33	1.79
2,3,5-TNT	--	--	--	--	--	0.06	0.12	0.09
2,4,5-TNT	--	--	0.82	3.64	3.64	5.43	5.84	2.89
2,4,6-TNT	9.23	9.23	89.21	186.74	186.74	271.80	298.20	308.35
Total TNT	--	--	90.28	191.60	191.60	280.08	307.65	313.15
Nitroresols	0.88	0.88	--	--	--	--	--	--
TNBAL	--	--	0.16	0.25	0.25	0.22	--	--
TNBA	--	--	0.82	0.56	0.56	--	--	--
White Compound	--	--	0.31	0.16	0.16	--	--	--
a-Nitrate-TNT	--	--	0.16	0.47	0.47	0.34	--	--

6.B.1.3 Nitration and Purification

Process Description

The manufacture of TNT takes place in three distinct stages: nitration, purification, and finishing. Nitration and purification utilize chemical reactions to form and extract the desired products from spent reactants and undesirable byproducts. Finishing is a physical treatment used to prepare the TNT for shipment. This section describes briefly the chemical processes encompassed by N&P. Flow sheets shown are updated from plant manuals.

Nitration

Toluene is converted to TNT in a series of nitrators and separators by reaction with a nitrating mixture of nitric and sulfuric acids. VAAP uses a system of eight nitrators (in six nitrating stages) and six gravity separators. RAAP also employs eight nitrators but in eight nitrating stages necessitating the use of eight dynamic separators. The reactants and products travel forward in the nitration process against a counterflow of nitric and sulfuric acids. The toluene enters the nitration at the first stage and moves forward to contact stronger nitrating acid in each succeeding stage.

The nitration takes place in specially designed nitrators. Each nitrator is a cylindrically shaped tank equipped with a draft tube positioned vertically on the central axis of the nitrator, an agitator just below the draft tube, and cooling coils to remove the heat of reaction. The agitator provides the necessary mixing. In addition to its downward pumping action, the agitator causes the liquid within the draft tube to be depressed about eight to ten inches below the level of the liquid surrounding the draft tube. Thus, there is a constant overflow down the tube, through the agitator, and then upwards over the cooling coils in the annulus between the draft tube and inner wall of the vessel. The liquid depression in the draft tube permits the reactants to flow continuously by gravity between the nitrator stages via the separators. VAAP's gravity separators require decanters but RAAP's dynamic (centrifugal) units do not. This aids in displacing nitrobody from the nitrator and in controlling the temperature in the separators. Nitric acid is added continuously to each nitrator to compensate for that consumed in the reaction, while oleum is added only to the last nitrator.

Instrumentation of the nitration section normally provides constant temperature control of all the nitrators but will automatically stop the process if abnormal operating conditions arise. Nitration temperatures are staged from 55-57°C in the first nitrator to 105°C in the last vessel. Since the nitration proceeds continuously, there is relatively little unreacted material in the nitrators at any instant, thus, the reaction will cease (but not necessarily be completed) soon after the feeds are shut off. In the event of an unusual temperature rise, the reaction is quenched by discharging the contents of the nitrators and separators automatically into drowning tanks (partially filled with water) located beneath the nitrators. VAAP's nitrator system is shown in Figure 6.B-5. RAAP's system appears in Figure 6.B-6.

Purification

The liquified crude TNT leaving the last nitration stage is continuously washed with fresh water in a countercurrent acid washer to remove entrained and dissolved acid. The acid washers at VAAP are five-stage units but the type used at RAAP has two stages with dynamic separators. The TNT wash water ("yellow water") is sent to the early nitration stages to both control the activity of the nitrating acid and recover dissolved TNT and acid.

Undesirable nitro bodies are removed from the washed TNT by countercurrent extraction with sellite (sodium sulfite-sodium bisulfite) solution.* The residual sellite solution in the TNT is removed by countercurrent washing with water in the post-sellite washer. VAAP has a two-stage sellite washer and a three-stage post-sellite washer. RAAP has a three-stage sellite washer followed by a two-stage post-sellite washer. The separated spent sellite solution ("red water") is passed to the red water storage area for sale to paper manufacturers. After the last wash, the TNT is slurried with hot water and pumped to the finishing building. VAAP's purification system is shown in Figure 6.B-7.

Waste Streams

The TNT waste stream consists of "red", "yellow", and "casual" waters from purification operations. The sale of the red water is mentioned above.

*Sodium sulfite only, at RAAP.

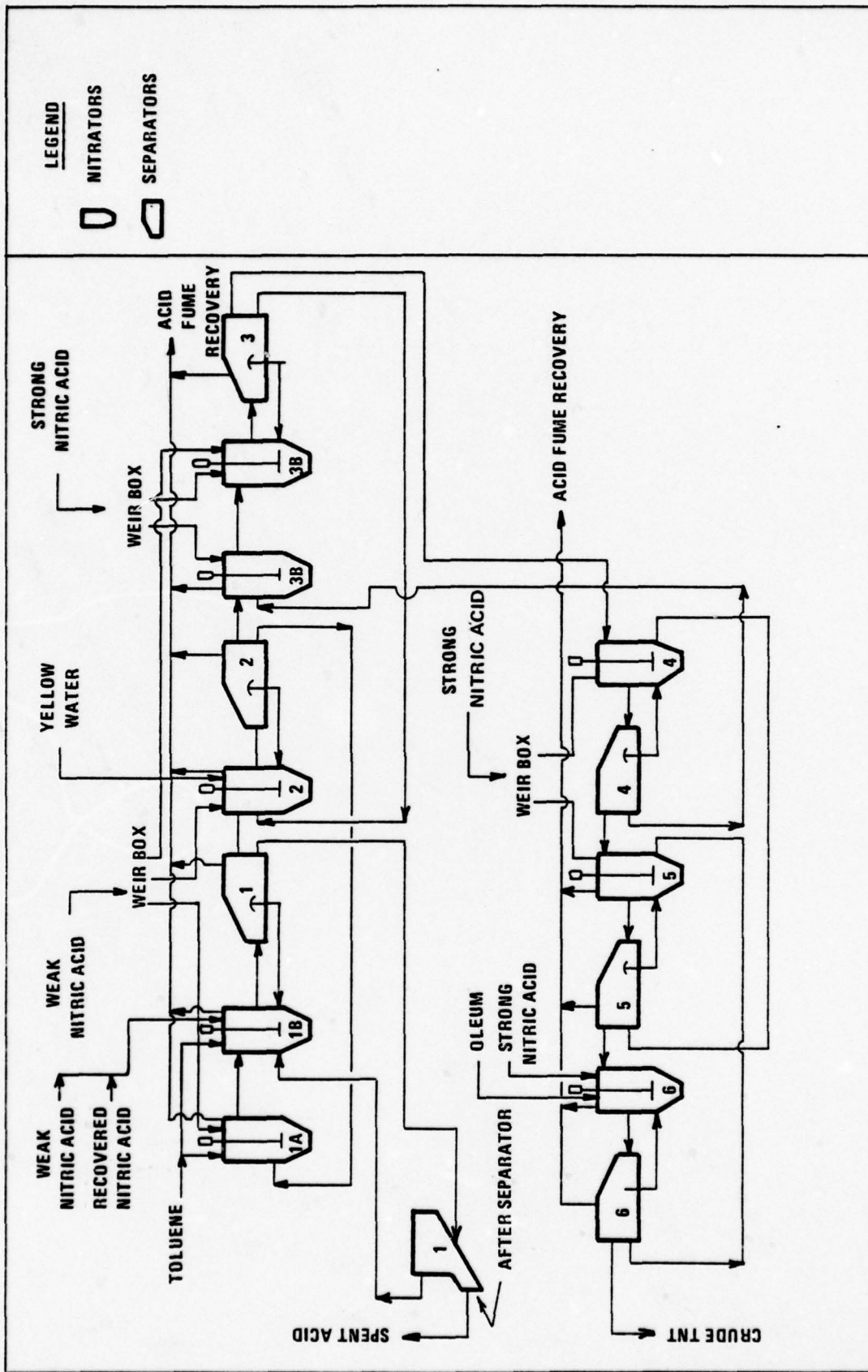

Figure 6.B-5. VAAP production of TNT - nitrotators and separators.

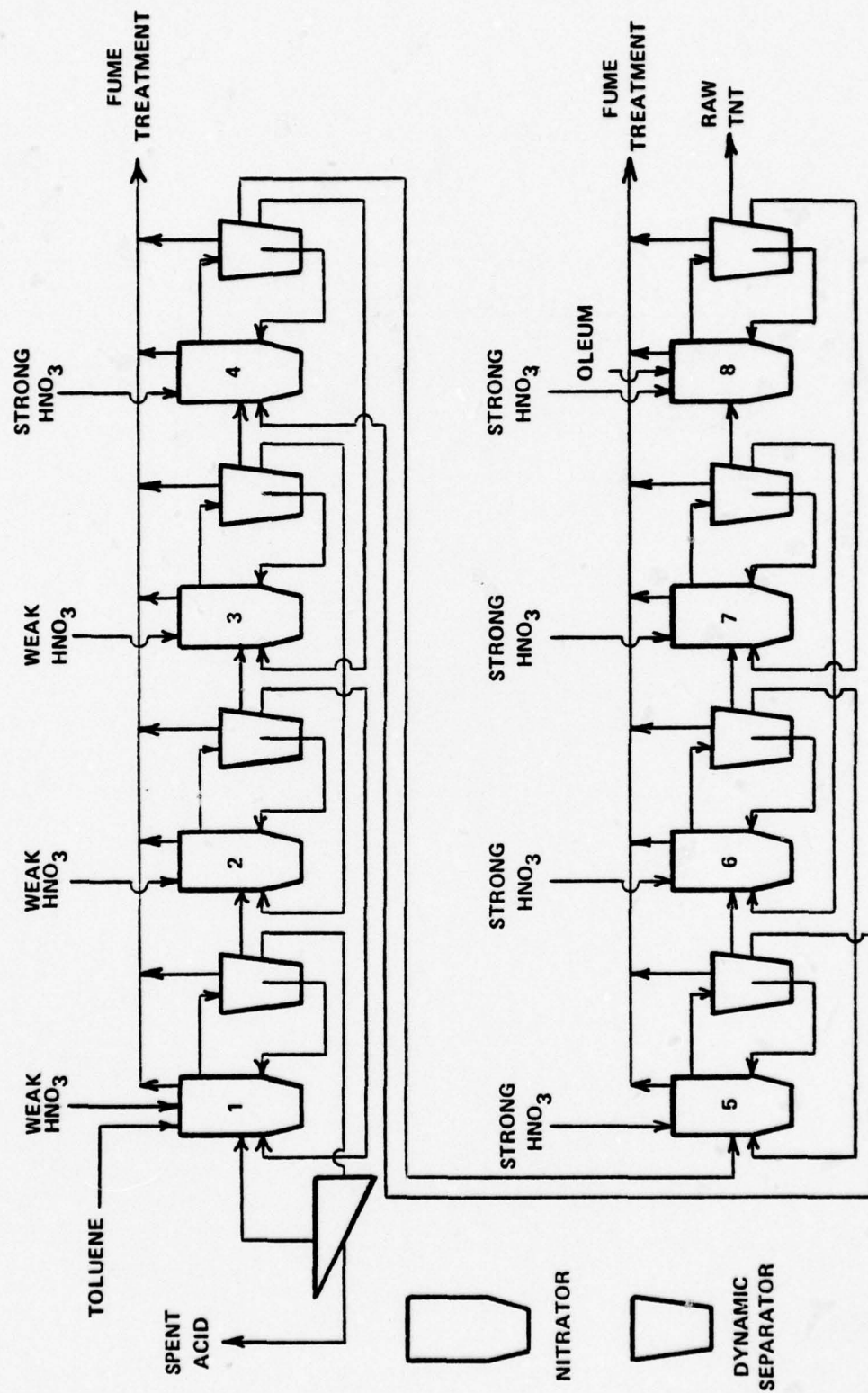

Figure 6.B-6. RAAP production of TNT - nitrators and separators.

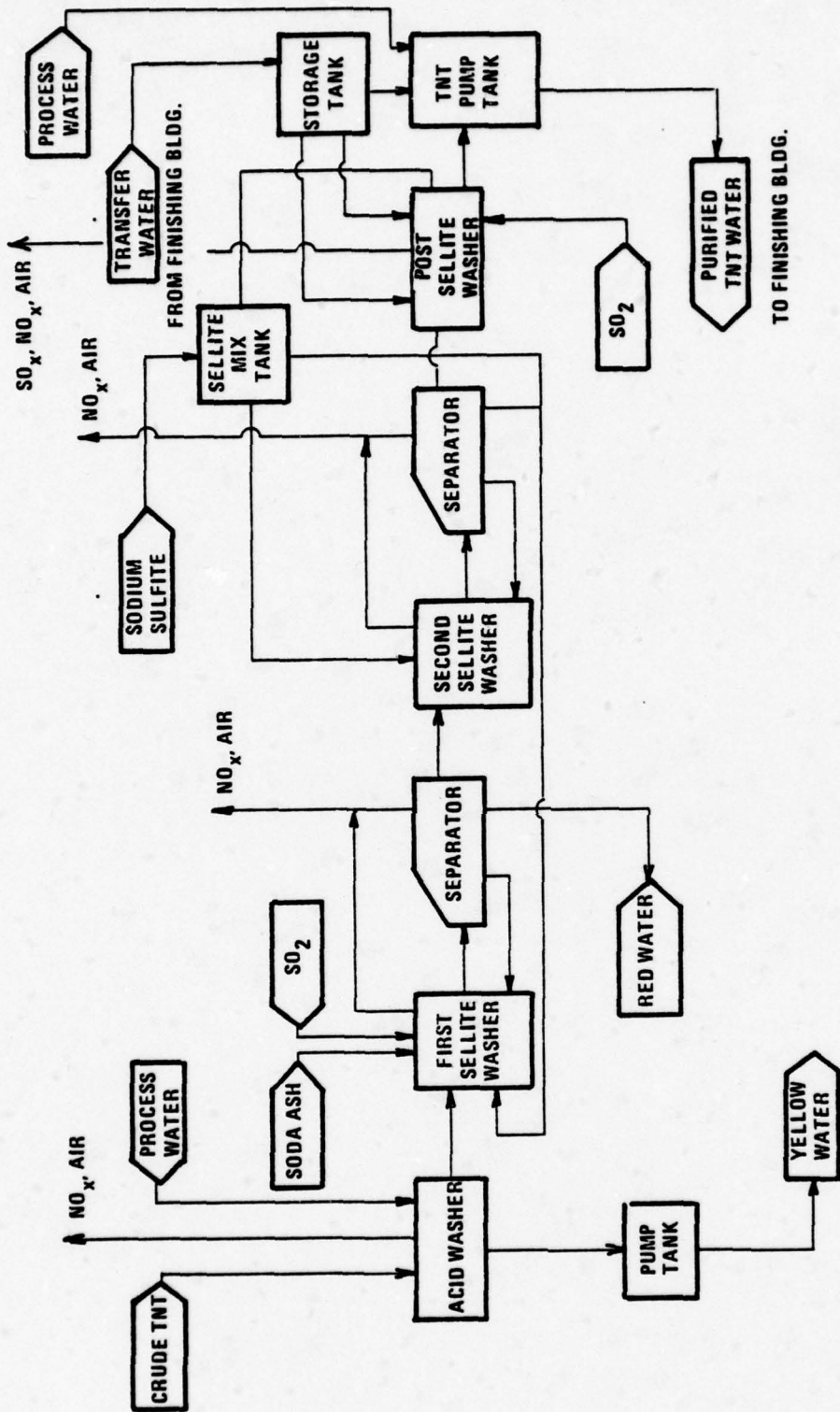

Figure 6.B-7. Production of TNT - product purification.
 Note: RAAP will have dynamic separators in their processes.

Yellow water is usually returned to the nitration process but may be subjected to charcoal adsorption or neutralization. The casual water (surface drainage, floor wash, and condensate) may be pumped to a ditch if uncontaminated.

Emissions at VAAP

Fume Control--Stainless steel ducts are used to contain and direct fumes in four separate systems within the N&P Building:

1. Nitrogen oxide fumes from the eight nitrators, six separators, No. 1A nitrator decanter, the disengagement pot, the afterseparator, and the spent acid tank are collected and pulled by suction to the AFR system where they are absorbed with other fumes to form 47 percent nitric acid.
2. Fumes from the nitrator drowning tanks and the floor area are drawn through ductwork in the basement and exhausted through a vertical duct at a point above the roof of the building.
3. Fumes from the rework melt tank and filter screen in the melt line, the yellow water pump tank, the acid washer, and the acid washer decanter are passed through a water spray scrubber and exhausted to the atmosphere. The acidic water from the scrubber is directed to the yellow water header for disposal.
4. Fumes from the two sellite washers, the sellite separators, post sellite washer, and TNT pump tank are similarly passed through a separate water spray scrubber and exhausted to the atmosphere. The water from this scrubber is also directed to the yellow water header.

Sources, Controls, and Sampling Points--The emission sources for the N&P system are identified below, along with their controls and appropriate points of measurement.

<u>Source</u>	<u>Control</u>	<u>Appropriate Emissions Measuring Point</u>
8 Nitrators 6 Separators No. 1A Nitrator Decanter Disengagement Pot After separator Spent Acid Tank	Pulled by suction to AFR	Emissions from the AFR system should be measured on the tail gas exiting the John Zink incineration abatement system

<u>Source</u>	<u>Control</u>	<u>Appropriate Emissions Measuring Point</u>
Nitrator Drowning Tanks and Floor Area	Exhausted to atmosphere	Building exhaust
Rework Melt Tank Filter Screen Yellow Water Pump Tank Acid Washer Acid Washer Decanter	Passed through water-spray scrubber before being exhausted	Scrubber vent
2 Sellite Washers Sellite Separator Post-Sellite Washer TNT Pump Tank	Passed through a water-spray scrubber before venting to the atmosphere	Scrubber vent

The two scrubbers are both spray chambers two feet in diameter and four feet in height. The fumes are sprayed with water at 80°F, 30 inches Hg and delivered through a full cone spray nozzle. Cleaned gas is vented through a six foot stack. The acid washer scrubber is designed to remove NO_x fed at 300 ppm, and attains an estimated 90 percent efficiency based on observation of the stack. The sellite-wash scrubber is designed to remove SO_x fed at 100 ppm, and attains an estimated efficiency of 99 percent.

Materials Flow--The following table gives the flow of major ingredients, products, and byproducts for one continuous line at VAAP operating at the rated capacity of 50 tons/day.

TABLE 6B-5. VAAP MATERIALS FLOW FOR ONE CONTINUOUS LINE PRODUCING 50 TONS OF TNT PER DAY

<u>Material</u>	<u>lb/100 lb TNT</u>	<u>lb/hr</u>
TNT	---	4139
Toluene	47.31	1958
Oleum	208.43	8627
Weak HNO ₃ from acid area	88.48	3662
Weak HNO ₃ from AFR	22.68	929
Total Weak HNO ₃	111.16	4601
Strong HNO ₃ from acid area	49.07	2031

TABLE 6B-5. (con't)

Material	lb/100 lb TNT	lb/hr
Strong HNO ₃ from Oleum	11.36	470
Total Strong HNO ₃	60.43	2501
Sellite pH 9	7.92	328
Sellite pH 7	37.45	1550
SO ₂ (SCFH)	0.36	15
Spent Acid	313.05	12957
Red Water	53.52	2215

Emissions at RAAP

Fume Control--Three separate fume control systems are connected by stainless steel ducts to RAAP's nitration and purification lines:

1. Nitrogen oxide fumes from the eight nitrators, eight separators, spent acid tank, rework melt tank, filter screen in the melt line, yellow water pump tank, and acid washer are routed to the N&P fume treatment system for scrubbing. The NO_x is absorbed to form weak HNO₃.
2. Fumes from the nitrator drowning tanks and the floor area are drawn through ductwork in the basement and exhausted through a vertical duct at a point above the building.
3. Fumes from the two sellite washers, sellite separators, post sellite washer, and TNT pump tank are passed through a separate water spray scrubber and exhausted to the atmosphere. The water from this scrubber flow to the waste collection system for reuse.

Sources, Controls, and Sampling Points--The emissions sources for RAAP's N&P system are identified below along with their controls and appropriate points of measurement.

<u>Source</u>	<u>Control</u>	<u>Appropriate Emissions Measuring Point</u>
8 Nitrators 8 Separators Spent Acid Tank Rework Melt Tank Filter Screen in the Melt Line Yellow Water Pump Tank Acid Washer	Pulled by suction to the N&P fume treatment system	Tail gas from second sellite tower of the N&P fume treatment system

<u>Source</u>	<u>Control</u>	<u>Appropriate Emissions Measuring Point</u>
Nitrator Drowning Tanks and Floor Area	Vented to the atmosphere	Exhaust duct
Sellite Washers Sellite Separators Post Sellite Washer TNT Pump Tank	Water-spray scrubbers	Exhaust of scrubber to the atmosphere

Materials Flow--The materials flow for RAAP, Table 6B-6, differs from that of VAAP due to the different designs of both N&P equipment and peripheral support processes.

TABLE 6B-6. RAAP MATERIALS FLOW FOR ONE CONTINUOUS LINE PRODUCING 50 TONS OF TNT PER DAY⁴

<u>Material</u>	<u>lb/100 lb TNT</u>	<u>lb/hr</u>
TNT	---	4167
Toluene	48.5	2021
Oleum	250	10418
Weak HNO ₃ from acid area	25 to 37	1045 to 1545
Weak HNO ₃ from SAR	30	1250
Total Weak HNO ₃	60 to 72	2500 to 3000
Strong HNO ₃ from acid area	80	3333
Sellite	9.5	400
SO ₂	0.1	4.2
Spent Acid	265	15200
Red Water	55	2292

6.B.1.4 Acid and Fume Recovery Process (AFR), VAAP

Introduction

The AFR plants recover and recycle waste acids and fumes from VAAP's N&P lines. Each AFR treats three N&P lines. Thus, the six continuous N&P lines at VAAP require two modern AFR units. AFR plants are designed with considerable turndown capacity. For a limited time, a VAAP AFR can operate on the fumes from one N&P line with no monowaste acid input. In normal operation, the monowaste acid (withdrawn from the first nitrators in each line) is separated into weak nitric and sulfuric acids for reuse.

VAAP's AFR plants have two major sections, acid treatment and fumes processing. The acid treatment part of the plant receives monowaste acid from the nitration lines of the continuous TNT process. The fumes processing plant collects fumes (primarily from the nitration lines) to extract NO_x and form nitric acid. The two sections of the plant interact by use of common nitric acid concentraton and bleaching units. A general diagram of VAAP's acid and fume recovery unit appears in Figure 6.B-8.

Acids Processing

The spent acid from the N&P lines contains both nitric and sulfuric acids. Before these acids can be recycled, they must be separated. The acid processing unit utilizes the higher volatility and lower affinity for water of the nitric acid to effect this separation. Major steps in acid processing include preheating, denitration and separation, condensation and bleaching, and cooling and storage of product acids.

Preheating is essential to the separation process. The monowaste acid is a mixture of sulfuric acid, nitric acid, nitrosylsulfuric acid, water, and residual nitrobodyes. This is blended with recycled dilute nitric acid before preheating. A tube and shell heat exchanger uses 300°F steam to warm the acid blend. Heating vaporizes most of the nitric acid but leaves the sulfuric acid in the liquid.

The acid stream flows from the preheater to the top of the denitration towers. As the acid mixture flows down the tower, the nitric acid vaporizes and rises to the top of the tower. The sulfuric acid liquor that collects in the bottom of the tower is essentially free of nitric acid. Stripping of the descending sulfuric acid is accomplished by injecting steam to the bottom of the tower. To prevent dilution of the nitric acid vapors, the stripping steam is routed out of the tower before it reaches the top. The steam contains about 1 percent HNO_3 upon exiting the denitration tower. The nitric acid vapors collected in the top of the tower have a concentration of about 75 percent. Sulfuric acid liquor is tapped from the bottom of the tower. After cooling in water cooled heat exchangers, the product sulfuric acid is directed to denitrated acid storage.

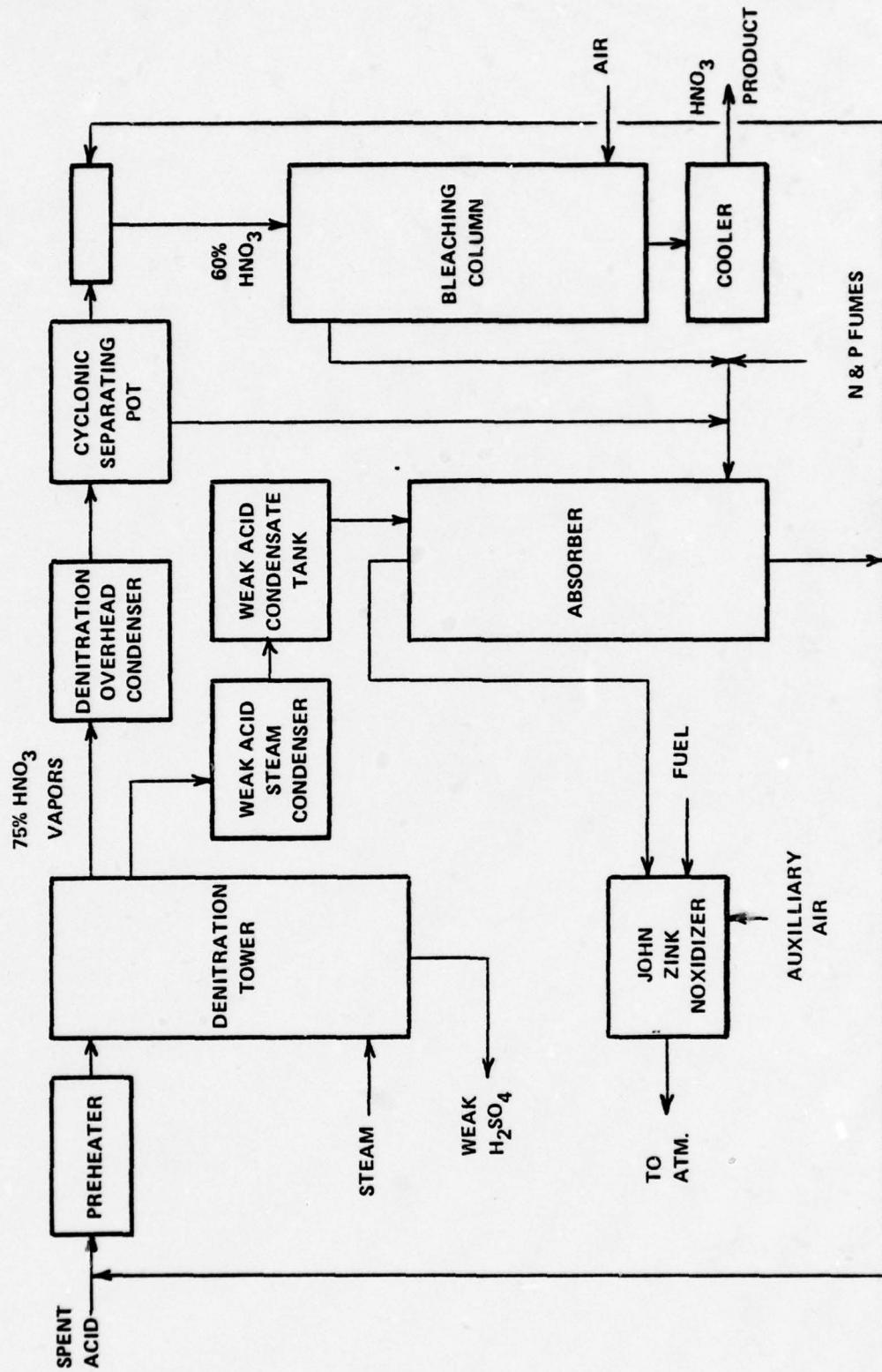

Figure 6.B-8. VAAP acid fume recovery system.

Condensation and bleaching of the nitric acid vapor provides the product acid. Condensation is performed in a water-cooled heat exchanger referred to as the denitrator overhead condenser. The condensate contains about 75 percent HNO_3 and exits at about 140°F . The condensate and vapors (air and oxides of nitrogen) are separated in a cyclonic separating pot. The 75 percent HNO_3 condensate is mixed with enough 45 percent HNO_3 to adjust the strength to 60 percent before entering the bleaching column. The fume blower draws air through a filter and into the bleacher (maintained under a negative pressure) to strip NO_x from the nitric acid. As the nitric acid flows through the bubble-cap trays, the rising air stream removes the NO_x . The bleached product nitric acid falls to the bottom of the tower and is passed through water-cooled heat exchangers to adjust its temperature to 100°F before exiting the plant. The air and NO_x fumes pass from the top of the tower to the fume processing segment of the plant.

The denitrator stripping steam (that exited the side of the denitration tower) is condensed in the weak acid steam condenser. The air and NO_x that will not condense are removed by a vapor line and blower to the fume treatment system. The condensate is stored in the weak acid condensate tank. Some of the condensed steam from the preheater also enters the weak acid condensate tank. This tank supplies water (with 1 to 2 percent HNO_3) to the nitric acid absorber in the fume processing part of the plant.

Emissions from Acids Processing

The acids processing unit separates HNO_3 and H_2SO_4 . Although no pollutants are associated with the H_2SO_4 , some NO_x is evolved in handling HNO_3 . Rather than vent the gases to the atmosphere, the fumes are transported to the fume treatment portion of the plant. Design rates of input to these units are shown in Table 6B-7.

TABLE 6B-7. DESIGN INPUT TO THE ACIDS PROCESSING SEGMENT OF THE AFR PLANT, VAAP

Compound	lb/hr @ 100% design capacity
H ₂ SO ₄	33021
HNO ₃	1971
HNOSO ₄	5806
H ₂ O	15389
Nitrobodies	282

Note: One AFR unit serves three TNT lines.

Sources, Controls, and Sampling Points--Emissions sources and appropriate measuring points are given below:

<u>Source</u>	<u>Control</u>	<u>Appropriate Emissions Measuring Point</u>
Offgases from Denitrator Overhead Condenser, Acid Steam Condenser and Bleacher	Contaminated gases are sent to the fumes processing system	None. Emissions occur in the fumes processing system

Fumes Processing

The gases from the TNT N&P lines are high in NO_x. A considerable portion of nitrogen oxides is also evolved in the acid processing section of the AFR unit. To avoid potential pollution, the fumes processing unit applies absorption and incineration to reduce the level of NO_x emissions from both sources. Absorption of NO₂ produces a useful product, HNO₃. Incineration, however, consumes fuel to convert NO_x to N₂. Some of the energy consumed in incineration is recovered in a waste heat boiler.

Fumes are collected from several sources for reactant recovery and gas cleansing. The input blower system draws fumes from the TNT production lines, the nitric acid storage tanks, the denitrator overhead condenser, the acid steam condenser and the bleacher. The blower can operate at various flow rates but is subject to surging below 50 percent capacity. Air may be bled to the blower intake to avoid surging.

In the absorber, a stream of condensate passes countercurrent to the rising gas stream (Figure 6.B-8). The gas feed to the tower is a mixture of oxides of nitrogen, carbon dioxide, water vapor, nitric acid vapor, tetra-nitromethane, and possibly other nitrocompounds. As the weak (initially 1 to 2 percent) nitric acid condensate flows through the tower, it absorbs some of the rising fumes in an exothermic reaction to form nitric acid. The bubble-cap trays must be cooled to maintain the desired conversion. Low temperatures encourage the formation of nitric acid. Temperature control is accomplished by circulating water through cooling coils. The reaction temperature is maintained at slightly above 100°F. The two most important reactions are:

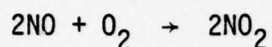

and



Some HNO_2 is also formed and must be reacted to HNO_3 in the bleacher.

The nitric acid recycle system splits the acid from the bottom of the absorber into two streams. Part of the flow is routed to the preheaters and the rest is passed to the bleachers. The bleacher flow is regulated to provide the proper acid concentration when blended with a stream from the denitrator overhead condenser. The portion sent to the preheater is mixed with the incoming monowaste acids (from the nitration lines) and subjected to separation. When no monowaste acid is being processed, no flow is permitted to the preheater.

The fume abatement incinerator (John Zink) is used to cleanse the absorber exit fumes of NO and NO_2 . Partially combusted natural gas reduces these to N_2 .

Emissions from Fumes Processing

The fumes processing unit has only one significant emissions measurement point. All airborne emissions from the AFR plant must pass through the tail gas incinerator. Although the incinerator is designed to reduce NO_x to N_2 , some questions arise when emissions data from the AFR are examined.

Sources, Controls, and Sampling Points--The fume processing units exist at VAAP for the purpose of reducing emissions from the N&P lines by capturing valuable airborne NO_x . No pollution originates with the unit. However, the fume processing unit is the exit point for any NO_x or TNM not recovered from the nitrator feed.

<u>Source</u>	<u>Control</u>	<u>Appropriate Emissions Measuring Point</u>
NO_x from the N&P lines and from the acids processing portion of the AFR	Reaction of NO to NO_2 and absorption of NO_2 to form HNO_3 product-- followed by incineration of tail gases to react residual NO_x to N_2	Exhaust stack from the John Zink Noxidizer

Feed Rate to the Fumes Processing Unit

Although the fumes processing unit receives some input from the acids processing portion of the plant, most of the feed comes from the N&P lines. The following table describes the fumes from the N&P lines.

TABLE 6B-8. DESIGN NITRATOR FUME INPUT TO THE FUME PROCESSING SEGMENT OF THE AFR PLANT VAAP⁵

<u>Compound</u>	<u>lb/hr @ 100% design capacity</u>
N_2	10686
O_2	3107
CO_2	1499
NO_2	895
CO	519
$\text{C}(\text{NO}_2)_4$	86

Note: One AFR serving three lines.

Production Rates for the AFR Unit

Due to the interaction of the fume processing section with the acid treatment portion of the AFR unit, the product (nitric acid) of the fume processing system appears in the output from the acid treatment unit. The product consists of the two separated acid streams.

TABLE 6B-9. AFR PRODUCTION RATES AT CAPACITY, VAAP⁵

<u>Product</u>	<u>Rate, lb/hr at design capacity</u>
68% H ₂ SO ₄	55103
60% HNO ₃	9427

Note: One AFR unit serves three TNT lines.

Emission Rates

Fairly recent data for VAAP's AFR unit exist. A 1976 report gives the NO_x concentration (after the incinerator) as 2449 ppm.⁶ This indicates an abnormally large concentration in light of the observed 0 percent opacity. Normally, 0 percent opacity would imply an NO₂ concentration of less than 400 ppm. When the production is scaled from the 40.4 percent at the time of the test to 100 percent capacity, the detected NO₂ rate calculates as 9281 lb/day for each of the two AFR units.

Since the test method oxidizes nitrogen oxides to NO₂ before counting them, some NO-containing compounds could have been oxidized by the phenol-disulfonic test procedure to give NO₂. If the incinerator does not provide complete reduction of NO_x to N₂, considerable NO could be present in the tail gas. After oxidation, the NO would be detected at NO₂. TNM, if broken into four NO₂ groups by the testing procedure, could induce considerable error in the assessment of NO_x content.

To ascertain what constituted proper operation of the incinerator, some calculations were made for the expected tail gas composition. NO_x emissions at VAAP were limited to 1.7 to 24 lb/hr (as NO₂) from each John Zink incinerator at capacity operation. This is based on Beckman instrument indications of 25 to 350 ppm NO₂ fumes leaving the furnace when the system is in balance.⁷

The total volume rate of vented gases was estimated at 450,000 SCFM (70°F), a total feed from three nitration lines of 214,000 SCFH plus 325,000 SCFH of fuel combustion products.^{5,8} The volume percentage composition of the fumes fed to the absorber system was taken at design conditions for this estimate: 69.2% N₂, 17.6% O₂, 6.2% CO₂, 3.5% NO₂, 3.4% CO, and 0.08% TNM.⁵

Thus, it seems that some NO-bearing compound other than NO₂ was present in the incinerator tail gas at the time of sampling. For the purposes of estimating emissions due to TNT production at VAAP, the excess NO₂ detected was computed to be in the form of TNM.⁶

While this explanation may be satisfactory for the analytical technique alone, it certainly does not follow from the chemistry of TNM that this compound could survive passage through the John Zink Incinerator. The TNM fed to the incinerator is 86 lb/hr per unit.⁵ This totals 4140 lb/day for two units. TNM should be completely decomposed in the incinerator. Using the rate constant for its decomposition ($k = 10^{16.3} e^{-38,300/RT}$) given by Nazin,¹⁴ its half life in the recombustion chambers of the incinerator at 1600°F is 7×10^{-10} seconds. At stack gas temperature (420°F), its half life is 4.3 seconds.

6.B.1.5 Nitration and Purification Fume Scrubber System, RAAP

Process Description

Unlike VAAP, RAAP plans not to process its nitration and purification fumes in an AFR unit. Instead, RAAP will use a five tower scrubbing system on each TNT line. RAAP's three N&P lines will each have an independent fume recovery system. This should impart greater flexibility for low capacity production. (See Figure 6.B-9.)

RAAP's fume recovery system is designed to recover NO_x and nitrobenzenes through the use of three different types of scrubbing towers. The fumes from the N&P Building will be collected and introduced to the bottom of a water-fed bubble cap absorption tower. As the gases rise against the countercurrent flow of water, the NO_x will be absorbed to make the product 55 to 60 percent HNO₃. This weak nitric acid stream can be returned directly to the production lines for consumption in the process.

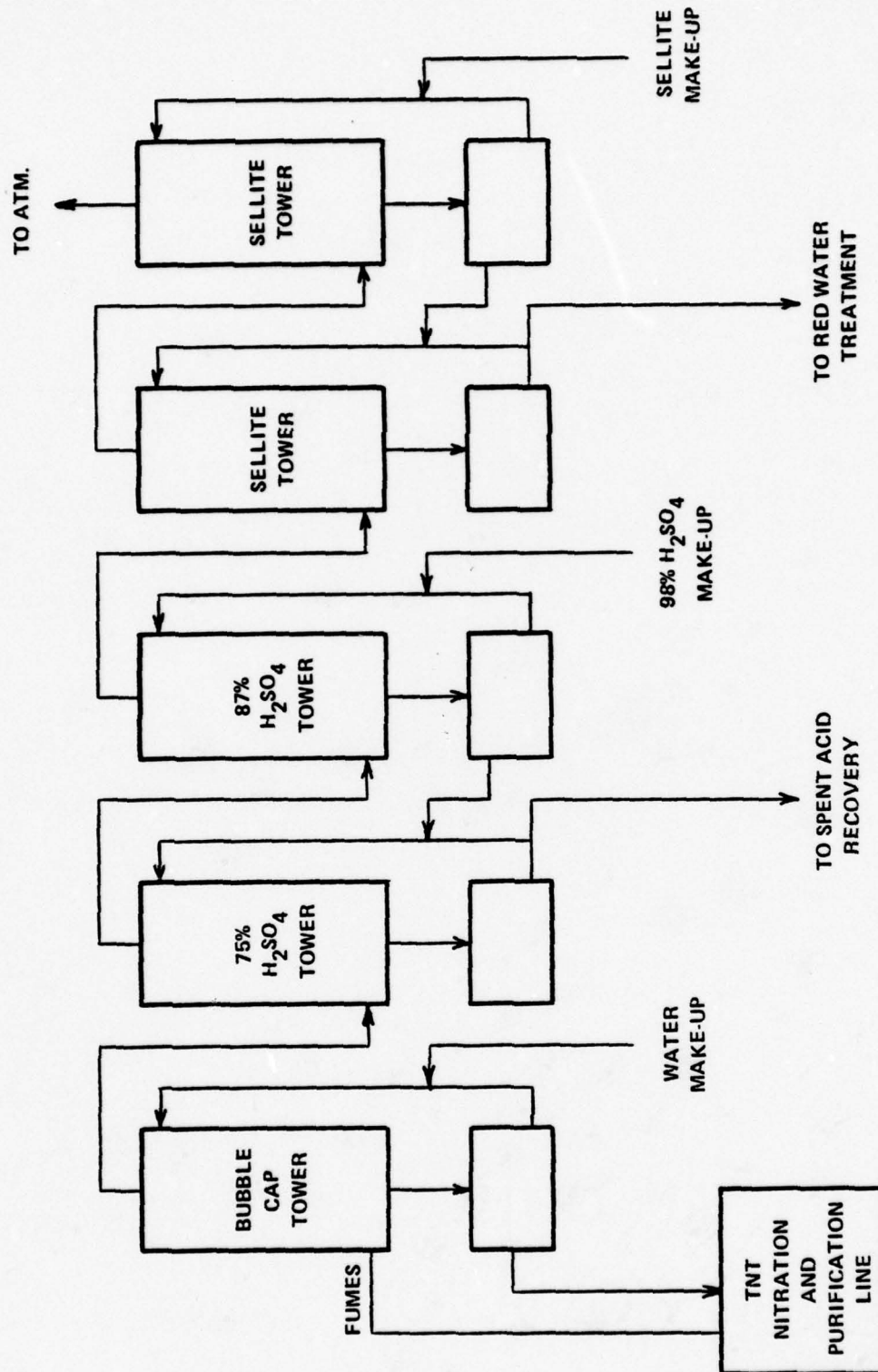

Figure 6.B-9. RAAP nitration and purification facilities.

Two consecutive sulfuric acid towers are used to further scrub NO_x from the gas stream. The first tower is maintained at 75 percent H_2SO_4 by tapping more concentrated liquor from the second. The second tower is maintained at 87 percent H_2SO_4 by the addition of 92 to 98 percent H_2SO_4 produced in the SAR. A small stream of acid must be taken from the 75 percent tower to maintain equilibrium. This contaminated sulfuric acid is blended into the spent acid recovery feed to recover the nitric acid.

At this point, the gas is essentially cleansed of NO_x but still contains nitrobodies. Two sellite towers will scrub these nitrobodies from the gas stream by chemical reaction. Sellite makeup is balanced by tapping some liquor from the first tower to either red water or sodium nitroform salt treatment.

Emissions

The RAAP fume treatment units will both recover reactants and control pollution. Although fume treatment was formerly pursued at RAAP, the old units could not approach the effectiveness of the new design. Formerly, sulfuric acid and water were used to scrub the gases in packed towers. Present plans include an efficient water-feed bubble cap tower for NO_x control in addition to the two sulfuric acid towers and two sellite towers. Pilot plant studies have shown the sellite wash to be highly effective in controlling TNM.⁹ Each of the three TNT lines will have a complete fume treatment system.

Sources, Controls, and Sampling Points--Although no pollutants originate within the fume treatment unit, emissions do result from imperfect control of the N&P fumes. The pollutants and exit points are noted below:

<u>Source</u>	<u>Control</u>	<u>Appropriate Emissions Measuring Points</u>
NO_x released in the nitration process	Waterfed bubble cap tower and sulfuric acid towers	Exhaust from second sellite tower
TNM and other nitrobodies formed in nitration reactions	Sellite towers	Exhaust from second sellite tower

Emissions Rates--The volume flow rate to the new fume treatment should be about 1200 SCFM if the acid washer exhausts are routed in with the other N&P fumes.⁹ NO_x emissions are anticipated to be less than 200 ppm. Three units (one for each TNT line) emitting 1200 SCFM each with an NO_x concentration of 200 ppm would produce about 123 lb/day of NO_x. Control of TNM by the sellite scrubbers should be almost complete.⁹

6.B.1.6 Spent Acid Recovery (SAR), RAAP

Process Description

A SAR Plant is used to recycle waste acids from RAAP's TNT N&P lines. The plant treats the monowaste acid streams from all three N&P lines. The spent acid removed from the mononitrators is a weak mixture of nitric and sulfuric acids. Separation of HNO₃ and H₂SO₄ must be performed without emitting excessive NO_x to the atmosphere.

The monowaste acid is tapped from the TNT lines and routed to spent acid storage. Design rates of input to the SAR plant are shown in Table 6B-10.

TABLE 6B-10. DESIGN INPUT TO THE SAR PLANT RAAP

<u>Compound</u>	<u>lb/hr @ 100% design capacity</u>
H ₂ O	8196
H ₂ SO ₄	36272
HNOSO ₄	2068
HNO ₃	86

A stream from spent acid storage is piped to a steam-fed preheater to prepare it for the separation process. The warm monowaste liquor is introduced to the top of a denitration (or stripping) tower. Steam injected at the bottom of the tower rises countercurrent to the falling liquid. The heat causes the HNO₃ and NO_x to be evolved as vapors while the H₂SO₄ and most of the water fall to the bottom of the tower as a weak sulfuric acid stream. From the bottom of the tower the weak (approximately 68 percent) H₂SO₄ is passed to coolers before delivery to the sulfuric acid regeneration plant.

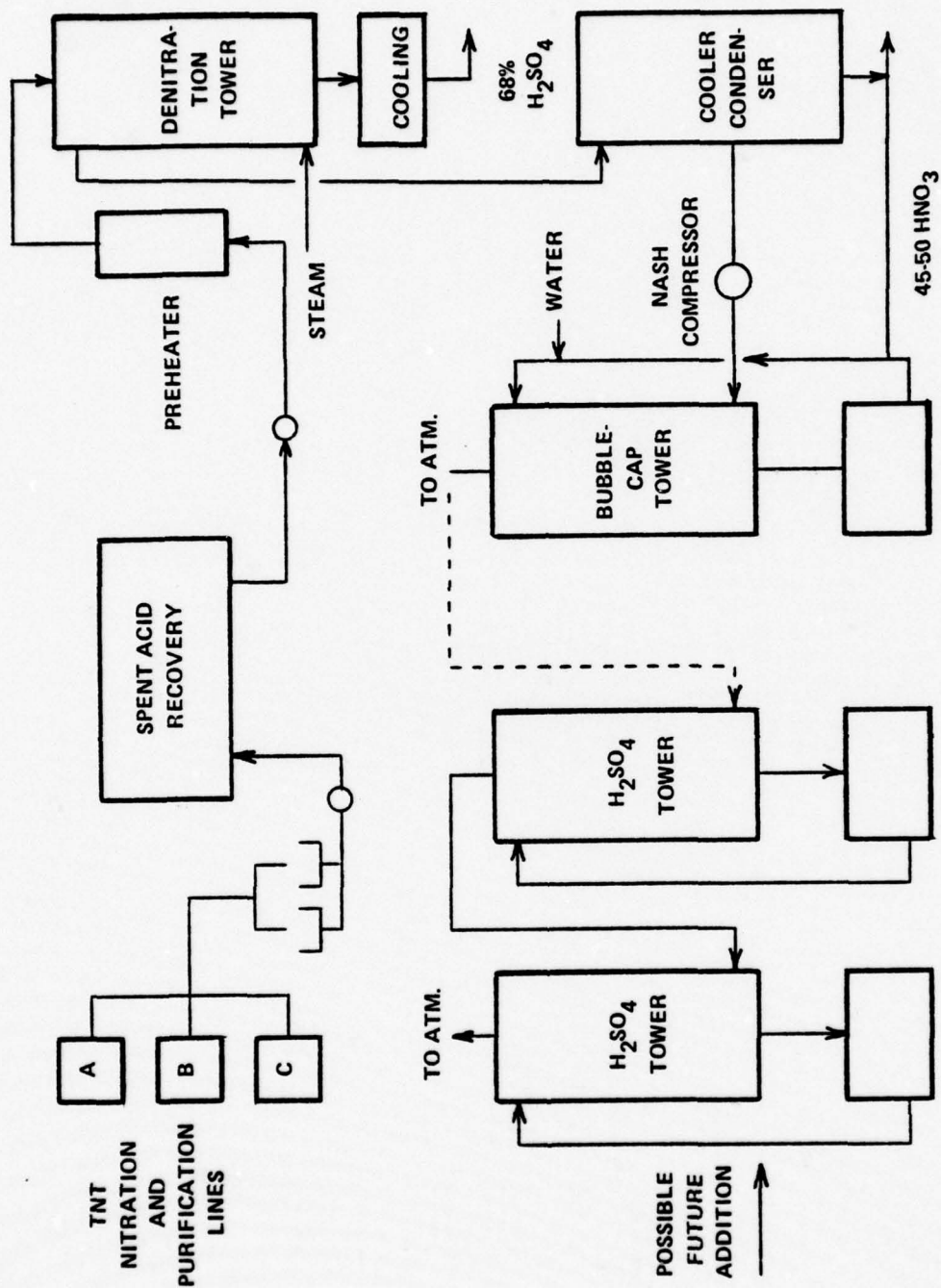

Figure 6.B-10. RAAP spent acid recovery.

The nitric acid-water vapor mixture passes from the top of the denitration tower to the cooler-condenser. Here, most of the stream is liquified to form a 45 to 50 percent HNO_3 stream that is returned to the N&P lines. Some of the HNO_3 and NO_x do not condense but are collected by a Nash Compressor. Compression to 20 to 40 psig greatly enhances the absorption that occurs in the subsequent bubble cap tower. Presently, the fumes from the bubble cap tower are vented to the atmosphere. Future plans include the placement of two sulfuric acid towers in series to remove NO_x from the tail gas.

Emissions

The separation of the HNO_3 and H_2SO_4 in the denitration tower results in appreciable NO_x . Although much of the NO_x is absorbed in the bubble cap tower, some escapes to the atmosphere. Additional scrubbing may be incorporated in future projects. This would consist of two sulfuric acid towers to absorb additional NO_x from the exit gases.

<u>Source</u>	<u>Control</u>	<u>Appropriate Emissions Measuring Point</u>
NO_x generated in the Denitration Process	Absorption by bubble cap tower	Exhaust from the bubble cap tower

6.B.1.7 Finishing and Packaging

Process Description

The finishing and packaging unit receives TNT-laden water and produces dry TNT in sealed and stamped cartons. The product of the N&P Building is a TNT-water slurry that has been cleansed of acids and caustics. Before shipping, the product must be dried, flaked, and boxed.

Finishing and packaging of TNT is a straightforward process with no chemical reactions (Figure 6.B-11). A water slurry of TNT (approximately 3 lbs water per 1b TNT) is piped from the purification facilities to the finishing and packaging building. Dynamic separation allows much of the transfer water to be returned to the N&P Building. The TNT from the separator still contains about 1 percent water when stored in a hold tank. The hold tank feeds the TNT drier where air is blown through the product to remove the remaining water. Screening precedes solidification on a rotating water-cooled drum. Here, the

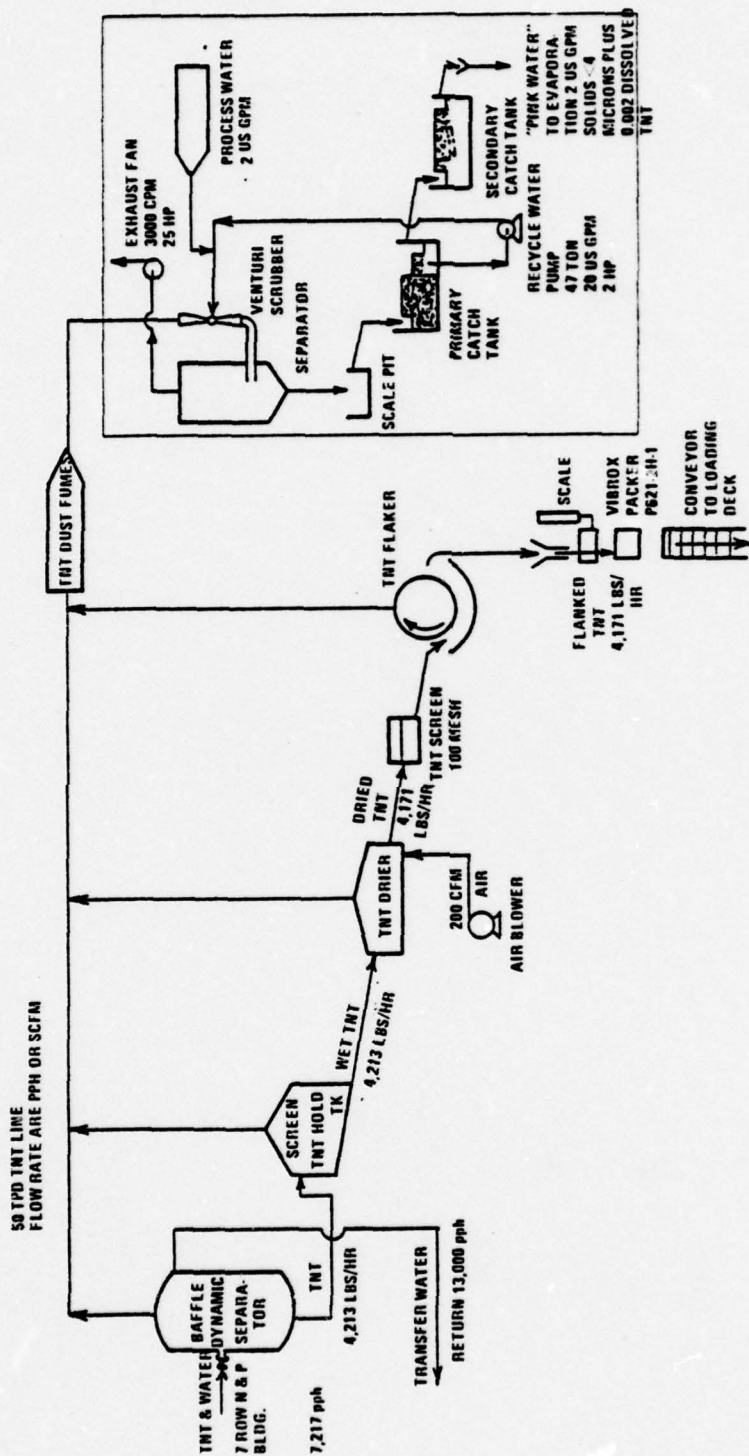

Figure 6.B-11. Finishing and packaging diagram. Note: RAAP will separate wet and dry TNT fumes and only have one catch tank with Sweco Separator to purify water and remove solids.

solid TNT is scraped into small flakes by a blade. The product then falls into a lined box which is weighed, sealed, and stamped automatically. A conveyor delivers the packaged product to the loading area.

Fumes and dusts are generated during separation, storage, drying, and solidification. A blower draws these contaminants through a water-fed venturi scrubber and into a separator. From the separator, "pink water" is drained to a primary catch tank while the air is exhausted through the blower. In the primary catch tank, gravity separation allows some of the water to be returned to the venturi scrubber. The remaining pink water is passed through the secondary catch tank and either routed to the N&P process or subjected to evaporation concentration.

Emissions

The major source of emissions from finishing and packaging is the exhaust from the scrubbing system blower. The emissions consist of TNT fumes and dusts generated in the drying and packaging operations.

<u>Source</u>	<u>Control</u>	<u>Appropriate Emissions Measuring Points</u>
Separator Holding Tank Drier Flaker Drum	Water-fed venturi scrubber	Exhaust from the scrubber blower

Materials Flow--TNT-water slurry is fed to the separator at approximately 17,200 lb/hr (206.4 tons/day), the rate dictated by one N&P line. Packaged TNT is produced at a rate of 4170 lb/hr (50 tons/day).

Emissions Rates--Although no chemical reactions occur in finishing and packaging, some TNT is evolved in the drying and boxing procedure. Hauze estimates that each dust scrubber exhausts 5 ppm of a 3000 ACFM flow.⁷ This implies that VAAP's six lines emit a total of 73 lb TNT/day. Similarly, RAAP's three lines would emit 36 lb TNT/day.

6.B.1.8 Ammonia Oxidation Plants (AOP)

Process Description

AOP's are responsible for the production of weak (60-65 percent) nitric acid from liquid ammonia and ambient air. The process is primarily dependent on the catalytic oxidation of NH_3 to NO followed by reaction of NO to NO_2 and subsequent absorption by water to HNO_3 . Figure 6.B-12 provides a flow diagram for a typical AOP.

The raw materials for the AOP are anhydrous liquid ammonia and air. The liquid ammonia is vaporized in a heat exchanger by 50 psig steam. Further heating by 160 psig steam places the ammonia gas well into the superheat region. The gaseous ammonia stream must then be filtered to remove any contaminants that might harm the catalyst.

Reaction air must also be heated prior to mixing with the superheated ammonia. Ambient air is first filtered and then compressed to about 134 psia and 166°C. Further heating is achieved by passage through a heat exchanger warmed with reaction gases from the converter. Before entering the converter, the air and vaporized ammonia are mixed to a uniform composition of about 10 percent ammonia.

The production of NO_2 is a two-step process involving high and low temperature reactions. NO is formed by conversion of NH_3 over a platinum-rhodium gauze catalyst that is maintained at about 923°C and 126 psig. The primary reaction



is exothermic. The gases must then be cooled to encourage the formation of NO_2 by the reaction:

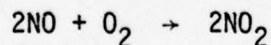

Recovery of the reaction heat is essential to both the chemistry and the economics of the process. The heat exchanger series uses the reaction heat to make hot gas for the expander, to generate steam, and to preheat the converter air.

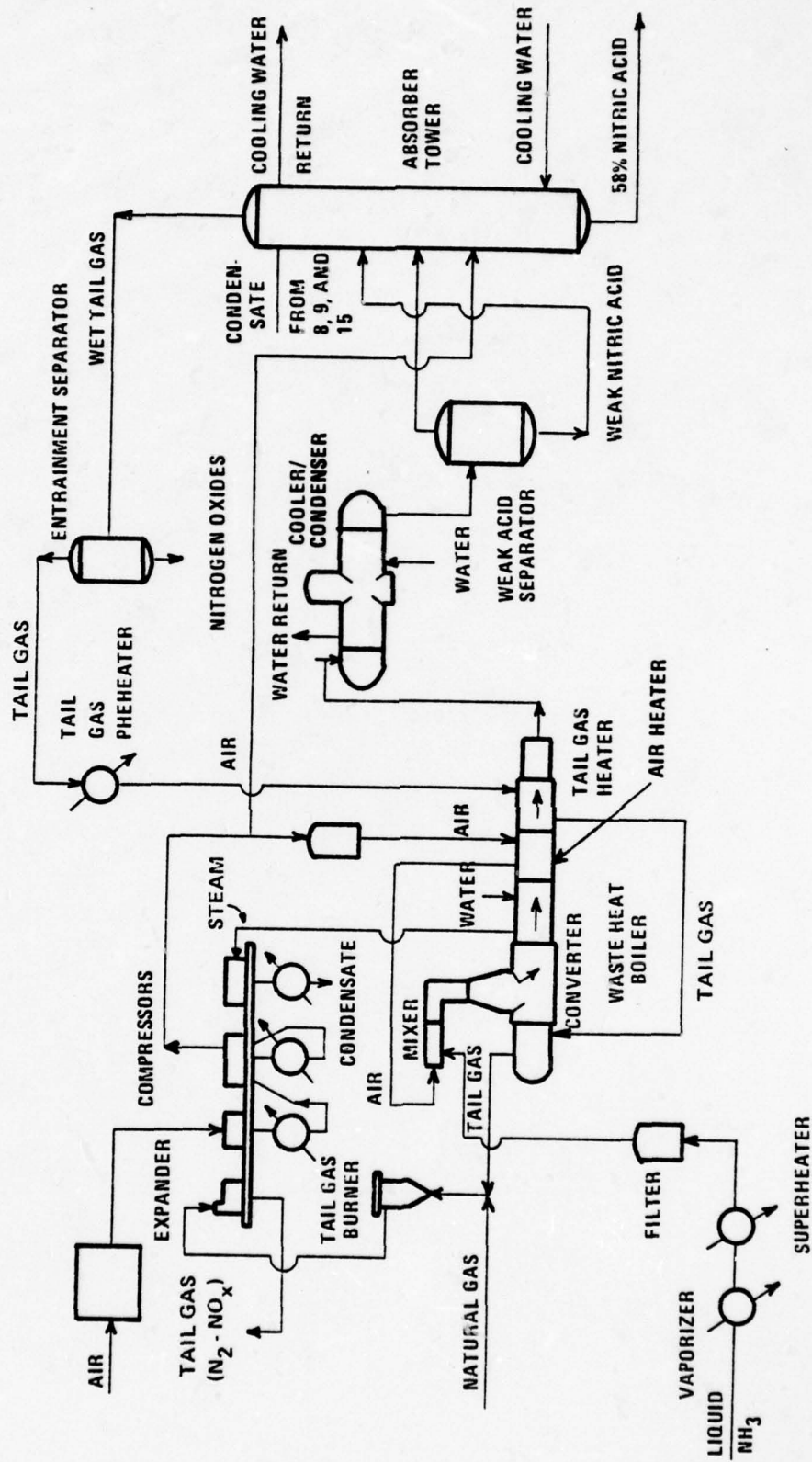

Figure 6.B-12. Ammonia oxidation plant flow diagram.

The weak nitric acid is formed in an absorption tower by the reaction:



Additional water may be added to control the acid strength. Additional air is added to aid the conversion of NO to NO₂.

Emissions

The most significant emission from any ammonia oxidation plant is NO_x. The older plants emitted large amounts of NO_x as an orange plume. Newer AOP units and modified older plants have sharply reduced NO_x emissions attributable to weak HNO₃ production.

VAAP has a new 383 ton weak (~60 percent) HNO₃/day AOP for use in TNT production. The apparent overcapacity (with respect to six continuous TNT lines) allows for the use of the older batch-process lines or the future installation of additional continuous lines. A DuPont Catalytic Combustor System is used for NO_x Control.

RAAP has two older 50 to 55 ton/day AOP's and one new 375 ton/day AOP. The older units in use have been modified to incorporate "extended absorption" in the form of additional bubble cap absorption towers. The new unit may use a combustor or extended absorption for NO_x control.

Sources, Controls, and Sampling Points--Although the units vary in size and controls, the emissions type and origin are the same.

<u>Source</u>	<u>Control</u>	<u>Appropriate Emissions Measuring Points</u>
NO _x not absorbed to make HNO ₃	Gas-fired combustor or extended absorption	Combustor exit or tail gas from last absorption tower

Emission Rates

No emissions measurements are available for VAAP's AOP. Hauze estimates that emissions from VAAP's new AOP would be 11,500 to 12,550 lb NO_x/day if uncontrolled at capacity operation.⁷ Material balance calculations show an exit gas rate of 37,740 cfm at 350°C containing 200 ppm NO₂.⁵ This gives an emissions rate of 611 lb/day.

At RAAP, AOP production per TNT line is greater because all nitric acid originates in AOP's. Since there is no DSN unit, strong (98 percent) HNO_3 must be made by concentrating weak (60 percent) HNO_3 from the AOP. Three TNT lines operating at 50 tons/day would require about 256 tons weak HNO_3 per day. Emissions of 845 lb NO_x /day would result if the standard of 5.5 lb NO_x /ton 100 percent HNO_3 is met. No measurements are available to confirm this.

6.B.1.9 Nitric Acid Concentration/Sulfuric Acid Concentration (NAC/SAC), RAAP

Process Description

NAC/SAC units strengthen weak (60 percent) HNO_3 from RAAP's AOP's to strong (98 percent) HNO_3 for use in the latter nitration stages. The HNO_3 concentration side of the plant is similar to the denitration step in SAR. The H_2SO_4 concentration side of the plant recycles sulfuric acid for reuse in the NAC process. A general diagram of the plant appears in Figure 6.B-13.

NAC--NAC utilizes sulfuric acids' high affinity for water to dry nitric acid. Weak nitric acid is preheated and introduced with strong (93 percent) sulfuric acid to the top of a packed tower maintained at a vacuum. The HNO_3 , NO , and NO_2 are evolved as gas and vapor to be drawn from the top of the tower. The sulfuric acid and most of the water are drained from the bottom. Heating of the sulfuric acid liquor drives dissolved NO and NO_2 into a gas stream that is returned to the column. The weakened (60 percent) sulfuric acid is transferred to the SAC side of the plant.

Strong nitric acid is obtained by converting NO and NO_2 to HNO_3 before condensing the product. The HNO_3 , NO , and NO_2 gas stream from the packed tower is first routed to a bleacher. Excess air is introduced to the bleacher to promote oxidation of NO to NO_2 . As the gas stream passes through the condenser, nitric acid vapors are liquified and collected. The liquid (98 percent) HNO_3 is returned to the bleacher before passing to storage. The gas stream from the condenser still contains appreciable NO and NO_2 which must be removed before release to the atmosphere.

An absorption tower is used to remove most of the remaining NO_x . The gas stream and additional air are introduced at the bottom of the tower to flow countercurrent to a downfall of acid wash. The acid product is maintained at 65 percent HNO_3 . The tail gas contains some NO_x and acid mist. Exhaust to the atmosphere occurs only after blending with gases from the SAC portion of the plant.

SAC--SAC is perhaps the simplest peripheral process in a munitions plant. Weak sulfuric acid from the NAC unit is concentrated to strong sulfuric acid by driving the water off with heat. The resulting strong sulfuric acid is returned to the NAC unit for reuse. That is, the SAC unit rejects the water that has been taken from the weak nitric acid. The sulfuric acid travels in a closed loop between the NAC and SAC. Only a small stream of makeup H_2SO_4 is fed to the NAC/SAC.

Heat is used to drive the water from the weak H_2SO_4 . The weak sulfuric acid liquor is heated by steam in the concentrator. The water is evolved as a vapor that is passed to the condenser. The strengthened sulfuric acid stream is cooled and removed to storage before returning to the NAC. The water evolved in the concentrators is condensed along with a small amount of acid and released to an acid sewer. The portion of the stream that does not condense is blended with the tail gas from the NAC section and vented to the atmosphere.

Tail Gas Treatment--The combined NAC and SAC tail gas will be low in SO_x and H_2SO_4 mist but may contain significant NO_x . To avoid emitting the NO_x to the atmosphere, combustors will be fitted to the two additional NAC/SAC units now planned. The combustors are designed to reduce NO_x to N_2 . Retrofit to the present new NAC/SAC unit is probable.

Emissions

Due to the use of condensers in the SAC process, there is no appreciable emission of H_2SO_4 mist. However, some of the NO and NO_2 created in the NAC system will escape absorption and be released to the atmosphere.

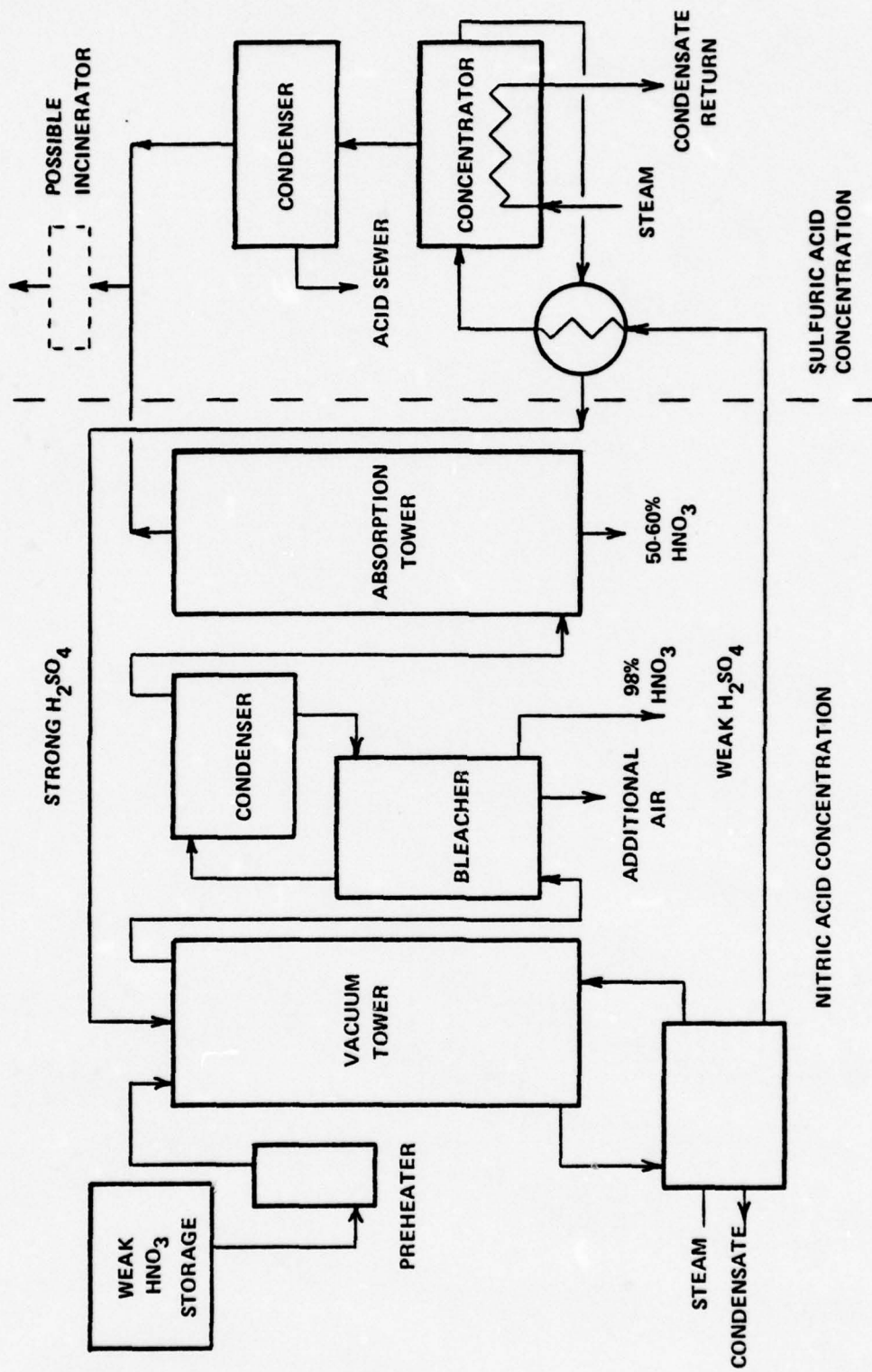

Figure 6B-13. RAAP NAC/SAC process.

Sources, Controls, and Sampling Points--There is a single exhaust stack for all emissions. However, the sources and controls are distinct.

<u>Source</u>	<u>Control</u>	<u>Appropriate Emissions Measuring Points</u>
Uncondensed NO _x fumes generated in the concentration tower	Absorption and reducing combustor	Exit from combustor
H ₂ SO ₄ mist	Condensers	Exit from combustor
SO ₂ generated by burning H ₂ SO ₄ in the combustor	None	Exit from combustor

Emission Rates--As yet, a combustor (for control of NO_x) has not been installed on RAAP's present NAC/SAC unit. The emissions rates for the NAC/SAC unit now in use are 9 lb/hr NO_x and 7.0 lb/hr acid mist.¹⁰ The rate of production at the time of sampling was not sufficient to supply three TNT lines. Linear extrapolation (to the rate required to support three TNT lines) indicates an emission rate of 13.5 lb/hr NO_x (324 lb/day) and 10.5 lb/hr acid mist (252 lb/day).

6.B.1.10 Direct Strong Nitric Acid Process (DSN), VAAP

Process Description

The DSN process utilized at VAAP provides a means of producing strong nitric acid without an intermediate weak nitric acid product. The DSN process, like an AOP plant, oxidizes NH₃ to NO before conversion of NO to NO₂. At this point, however, the method differs. Rather than producing a weak HNO₃ stream, the NO₂ is used to produce the dimer N₂O₄. The N₂O₄ may then be reacted with water and oxygen to form strong HNO₃ directly. Figure 6.B-14 is a block diagram of the process.

Ammonia oxidation is performed in the same manner in both DSN and AOP units. A precious metal alloy gauze is used to catalyze the reaction:



This reaction is very rapid and has an efficiency of about 97 percent. The rest of the NH₃ is converted primarily to N₂.

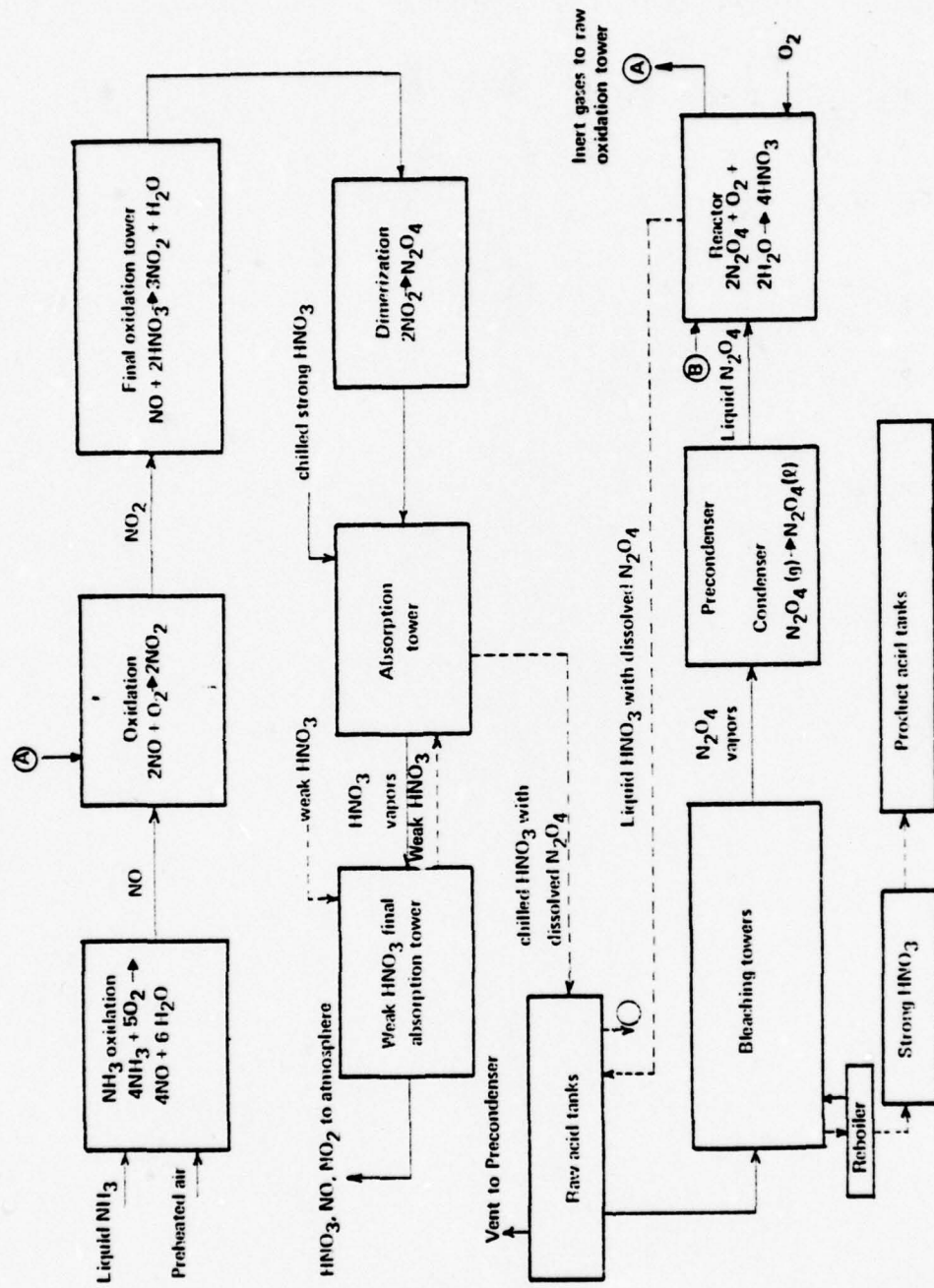
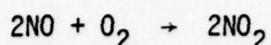

Figure 6.B-14. Direct strong nitric acid process flow sheet.

The conversion of NO to NO₂ results from the simple reaction:



The gas stream must be taken to low temperatures to promote the reaction. A short residence time is employed to minimize absorption of NO₂ in any condensate to form weak nitric acid. Weak nitric acid is considered a waste and is to be avoided. Removal of the condensate is followed by a pressure increase to accelerate the oxidation process. The oxidation of NO by oxygen is limited to 95 percent by the tower volume. A final oxidation tower is then used to convert remaining NO to NO₂:



Reaction efficiency is controlled by maintaining exit acid concentration at 75 percent HNO₃.

The dimerization sequence is the distinguishing feature of the DSN Plant. Maximum dimerization is essential to strong acid production. The product gas from the final oxidation tower is introduced to a gas cooler to promote dimerization. Lower temperatures sustain almost complete conversion to N₂O₄ by the reaction:



Absorption of the N₂O₄ is performed in a special absorber. The nitrous gases (essentially all N₂O₄) are absorbed in chilled strong acid. This strong nitric acid becomes heavily laden with dissolved N₂O₄ before transfer to the raw acid tanks. The offgases from this absorption process are largely free of NO₂ but contain a large amount of HNO₃ vapors. These are controlled by scrubbing in a final absorption tower. Weak nitric acid absorbs the fumes and is piped to the N₂O₄ tank for water requirements.

The bleaching towers are used to extract the N₂O₄ from the raw acid. Raw acid consists of strong HNO₃ with substantial dissolved N₂O₄. The bleaching tower consists of a stripping section, a rectifying section, and a reboiler. The bleaching tower separates the raw acid into strong nitric and N₂O₄ vapors. The product acid is tapped from the bleaching towers for transfer to product acid tanks. The N₂O₄ vapors are withdrawn from the bleaching towers for transfer to the condensers. Condensed N₂O₄ liquid is the primary feed for the reactors.

Reactor production varies widely with the feed composition. A number of reactions occur but the net result can be summarized by the equation:

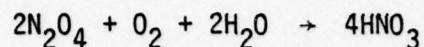

An excess of N_2O_4 sharply increases the reaction rate. However, excess N_2O_4 requires more recycling through the system at added expense in steam and refrigeration. The acid stream formed in the reactor contains large amounts of dissolved N_2O_4 and must be returned to the bleaching towers for separation.

Emissions

The primary source of emissions from the DSN process is the condenser vent for the final absorption tower. Non-condensables from the bleaching tower condenser are fed into suction of the steam driven compressor feeding the oxidation towers. Vapors from the reactor acid separators go to the raw acid tank, which is in turn vented to the N_2O_4 precondensers of the bleaching tower.

<u>Source</u>	<u>Control</u>	<u>Appropriate Emissions Measuring Point</u>
Vent gases from the final absorption tower	Condenser	Condenser vent

Materials Flow--The 340 ton/day 98 percent DSN is designed for the following raw material rates (lb/hr): ammonia, 9044; oxygen, 6111; nitrogen, 188; water, 45; air, 108,500. The corresponding nitric acid production is 28,000 lb/hr (98 percent HNO_3).

Emission Rates--The rated capacity of the DSN Plant is 340 tons 98 percent HNO_3 /day, VAAP's six continuous TNT lines demand only about 146 tons strong HNO_3 /day, therefore operation is projected at capacity for 13 days/month. Design material balances show 15.4 lb/hr NO and 4.1 lb/hr NO_2 , which translates to 469 lb/day NO_x .

6.B.1.11 Sulfuric Acid Regeneration (SAR)

Process Description

The term SAR is applied to oleum plants that produce oleum and sulfuric acid from a feed stock that consists, at least partially, of sulfuric acid. In most SAR plants, the feed of weak (68 percent is common) sulfuric acid is supplemented by liquid sulfur for makeup purposes.

To produce oleum and sulfuric acid, an oleum plant must receive a gas stream rich in SO_2 . Before entering the converter system, the dilute H_2SO_4 and molten sulfur must be reacted to yield SO_2 . This is accomplished by burning sulfuric acid and sulfur in a combustion furnace system. Here, the sulfuric acid, sulfur, and fuel oil are mixed with preheated air and burned to provide 8.5 percent SO_2 . The fuel oil is necessary to maintain proper reaction temperatures. The heat from the combustion reaction is partially recovered in steam production. A waste heat boiler produces 550 psig steam which is routed to another heat exchanger to be superheated. The steam supplies the SAR and provides an excess to be exported to the plant steam distribution system.

The moisture content of the gas stream is critical for a number of reasons. Any moisture content will lessen the mechanical strength of the catalyst pellets. Moisture combined with SO_3 will form H_2SO_4 that can severely corrode the various vessels and the main blower. Since all moisture present after the SO_3 is formed will be retained in the product, too much moisture will lessen oleum production in favor of sulfuric acid. The gas stream from the superheater is cleaned, cooled, and humidified in a humidifying tower using 35 percent H_2SO_4 . The gases must be further cooled to reduce the moisture content to oleum production levels. The chilled gas coolers (supplied with chilled water from a vacuum refrigeration system) operate at low temperatures to condense excess water from the gas stream. The condensate combines with SO_3 to produce a 2 to 3 percent H_2SO_4 liquor that is conveyed by an acid sewer to neutralization facilities. A mist eliminator prevents condensates from continuing through the plant. A packed drying tower is employed to completely dry the gas stream with 93 percent sulfuric acid liquor, sprayed against the

rising gas stream. The purification, cooling, and moisture control occur on the intake side of the acid plant blower. The converter and absorption towers are on the discharge side. The blower is powered by a steam turbine.

The converter-heat exchanger system must provide the proper environment for the production of SO_3 . The catalytic converter uses vanadium pentoxide to produce SO_3 by the simple reaction:

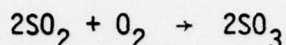

Two distinct types of sulfuric acid plant are used in TNT manufacture. VAAP uses a single contact-single absorption (SC/SA) plant whereas RAAP employs a double contact-double absorption (DC/DA) unit. The two configurations differ in the arrangement of catalyst beds and heat exchangers with respect to the gas flow scheme. A brief description of the two plants will explain the differences.

6.B.1.12 VAAP's SC/SA System

Process Description

SC/SA implies that no SO_3 is removed from the gas stream (i.e., no absorption takes place) until all conversion is performed. At VAAP, the converter has four catalyst beds with interstage cooling between the beds. The conversion attained in the reaction is limited to the equilibrium value dictated by temperature as well as the amount of SO_3 present. External heat exchangers cool the gases leaving the first and fourth beds by preheating the gases about to enter the converter. Cooling coils installed inside the converter reduce the temperature of the gases entering the third and fourth beds. The air, warmed in these coils, is used in the burning of sulfur and fuel oil in the combustion furnace. Conversion of SO_2 to SO_3 is normally about 98 percent.

The SO_3 generated in the converter must be absorbed to form oleum and acid products. Three absorption towers remove the SO_3 from the gas stream. The first tower produces 40 percent oleum and uses 20 percent oleum as makeup. A second tower produces 20 percent oleum and uses 98 percent sulfuric acid as makeup. The last tower produces 98 percent sulfuric acid by the reaction:

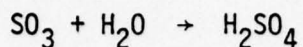

The makeup for the third tower is 93 percent sulfuric acid.

The gas stream may be further cleaned by using the SO_2 to produce sellite. A sodium carbonate solution may be reacted with the SO_2 to form a useful product. The following three reactions allow the sellite mixture of Na_2SO_3 and NaHSO_3 to be formed from Na_2CO_3 and SO_2 :

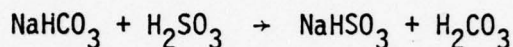
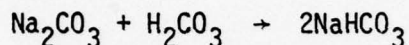
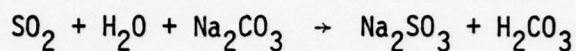

The resulting sellite solution is used in the purification of TNT. A diagram of VAAP's SC/SA plant appears in Figure 6.B-15. Inputs to the plant are shown in Table 6B-11. Production rates are given in Table 6B-12.

TABLE 6B-11. DESIGN ACID AND SULFUR INPUT TO THE VAAP SAR PLANT¹¹

Input	tons/day @ 100% capacity
Sulfur	25
H_2SO_4 (100% basis)	559

TABLE 6B-12. DESIGN PRODUCTION RATE FOR THE VAAP SAR¹¹

Product	tons/day @ 100% capacity
H_2SO_4 (100% basis)	580
Finished Sellite (16% Na_2SO_3 , 0.6% NaHSO_3)	53

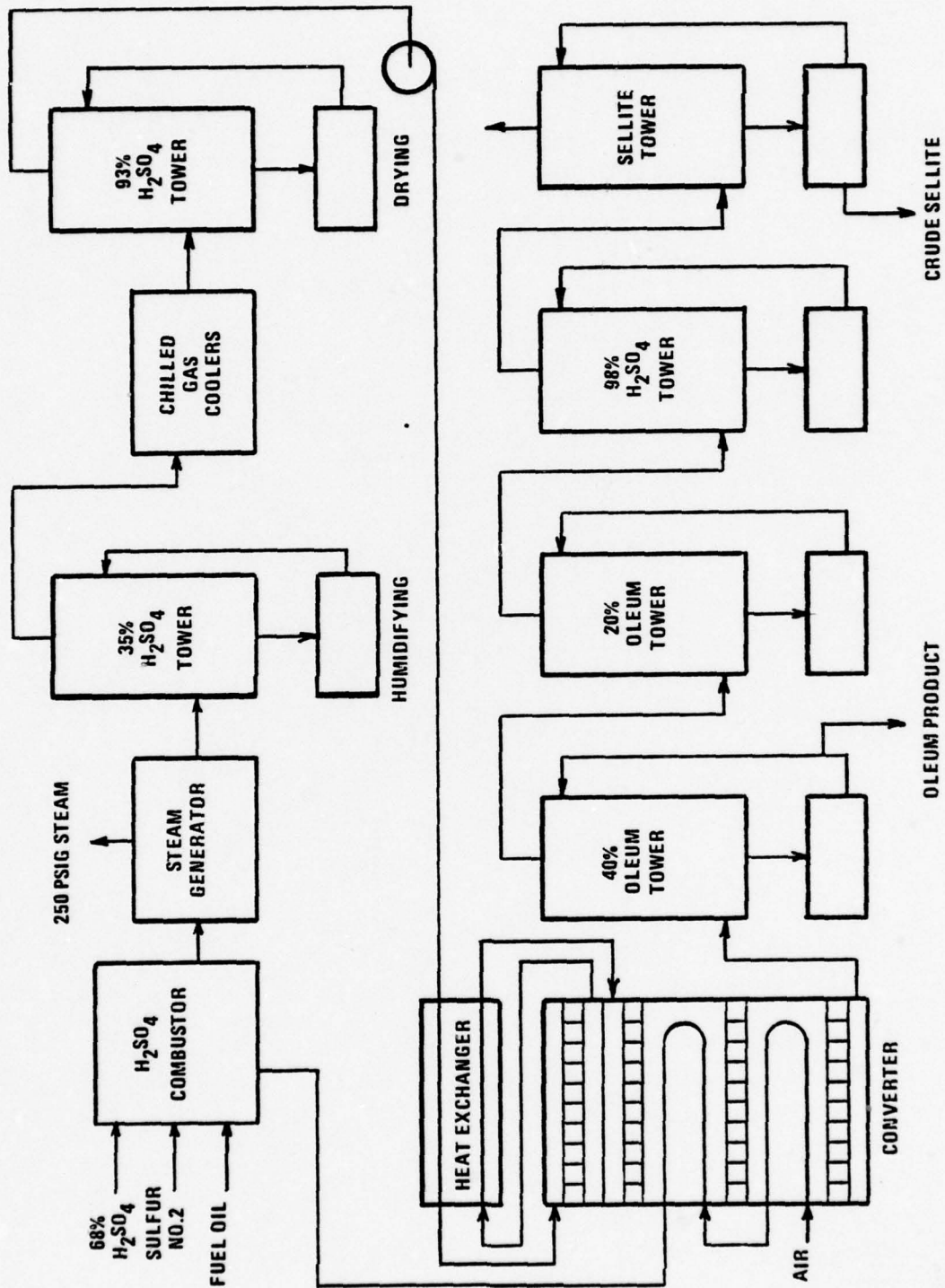

Figure 6.B-15. VAAP SC/SA sulfuric acid regeneration plant.

Emissions from VAAP's SC/SA Plant

Although there is only one major emissions point in VAAP's SAR Plant, there are three significant emission types: NO_x , SO_2 , and H_2SO_4 mist. The NO_x results from the combustion of sulfuric acid containing some HNO_3 . The SO_2 emissions reflect incomplete conversion of SO_2 to SO_3 in the catalytic reactor. Exiting SO_2 must also escape the sellite production scrubber. Acid mists introduced in the absorption process are diminished through the use of mist eliminators.

Sources, Controls, and Sampling Points--The point of origin of emissions from the SAR Plant is noted below, together with controls and appropriate points of measure.

<u>Sources</u>	<u>Controls</u>	<u>Appropriate Emissions Measuring Points</u>
NO_x resulting from combustion of H_2SO_4 containing some HNO_3	None	Exit stack from sellite tower
SO_2 from incomplete conversion of SO_2 to SO_3	Sellite Tower	Exit stack from sellite tower
H_2SO_4 mist generated in absorption towers	Mist Eliminators	Exit stack from sellite tower

Emissions Rates--The following data for the VAAP SAR unit were taken at 71.5 to 94.3 percent capacity operation.

TABLE 6B-13. EMISSIONS RATES FOR THE VAAP SAR PLANT¹²

Compound	Acid Production tons/day	Emissions	
		ppm	lb/ton H_2SO_4
NO_2	546.8	352.5	4.05
SO_2	414.6	244	5.06
H_2SO_4	414.6	---	1.45

Since the exit gas rate did not increase linearly as the acid production rate, emissions were estimated from the average test gas flow of 36,766 SCFM as shown in the following Table.

TABLE 6B-14. PROJECTED EMISSIONS RATES FOR VAAP's SAR PLANT AT CAPACITY

NO ₂	2259 lb/day
SO ₂	2176 lb/day
H ₂ SO ₄ mist	599 lb/day

6.B.1.13 RAAP's DC/DA System

Process Description

DC/DA implies that the conversion process is interrupted to remove (absorb) the SO₃ already formed. The gas stream contacts the catalyst, undergoes absorption, contacts the catalyst again, and undergoes final absorption. The removal of SO₃ in the first absorption system allows the conversion reaction to pass farther in the second catalyst contact than would otherwise be possible. This permits higher overall conversion. At RAAP, the gas stream passes through three of the four catalyst beds before undergoing intermediate absorption. A pass through the fourth catalyst bed precedes entry into the final absorption tower. Interstage cooling maintains the desired gas temperatures in each of the beds.

Four packed towers are used to capture the SO₃ produced in the converter. The SO₃ generated in the first three catalyst beds is absorbed in a series of three absorption towers. The first tower produces 20 percent oleum and uses 98 percent H₂SO₄ as makeup. The third tower produces 98 percent H₂SO₄ from 93 percent H₂SO₄ as makeup. The small amount of SO₃ obtained from the fourth catalyst bed is absorbed in a second 98 percent H₂SO₄ tower.

RAAP buys sellite rather than produce it from the SAR tail gas. A diagram of RAAP's DC/DA oleum production facility appears in Figure 6.B-16.

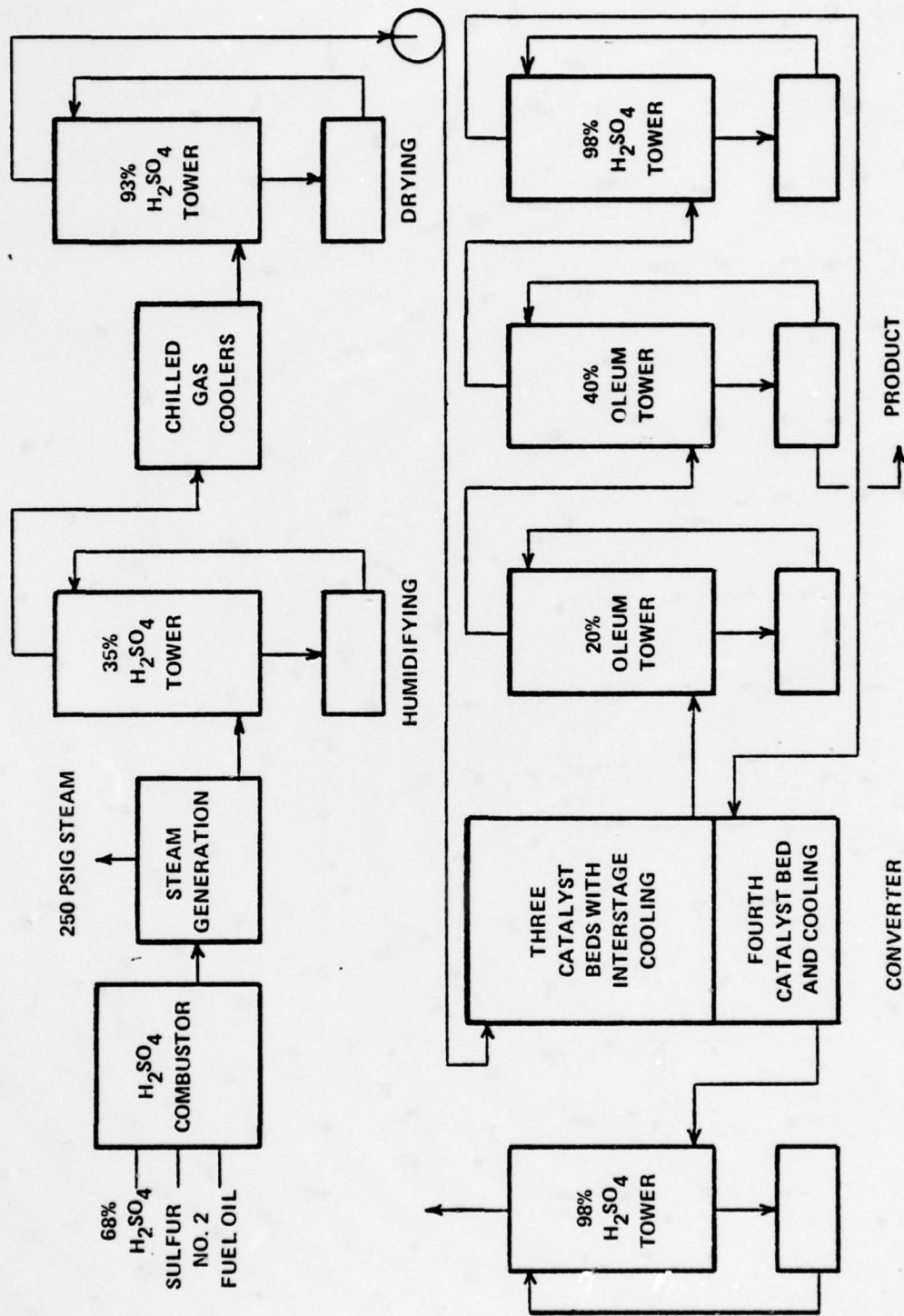

Figure 6.B-16. RAAP DC/DA sulfuric acid regeneration plant.

Emissions from RAAP's DC/DA Plant

Like the unit at VAAP, RAAP's SAR can emit NO_x , SO_x , and H_2SO_4 mist. Although no sellite production occurs at RAAP, the DC/DA plant design has the potential for lower SO_2 emissions. The higher conversion efficiency of the converter-absorption system implies that most SO_2 becomes SO_3 and finally acid. The combustion process does generate some NO_x which will be emitted along with some H_2SO_4 mist.

Sources, Controls, and Sampling Points--The point of origin of emissions from RAAP's SAR is noted below, together with controls and appropriate points of measure.

<u>Sources</u>	<u>Controls</u>	<u>Appropriate Emissions Measuring Points</u>
NO_x resulting from combustion of H_2SO_4 containing some HNO_3	None	Exit stack from last absorption tower
SO_2 from incomplete conversion of SO_2 to SO_3	None	Exit stack from last absorption tower
H_2SO_4 mist generated in absorption towers	Mist Eliminators	Exit stack from last absorption tower

Emission Rates--Although RAAP's old oleum plant had been tested for emissions, there are no data available for the new DC/DA SAR. However, the new plant, at startup, showed SO_2 emissions to be 300 ppm and NO_2 less than 200 ppm.¹³ An estimate by plant personnel places the exit gas volume at 30,000 SCFM. This implies the emission of 2145 lbs of SO_2 and 1027 lbs of NO_2 per day.

6.B.1.14 Conclusions and Recommendations

The TNT process emissions inventory should be considered as preliminary until further sampling and testing define the pollutants more adequately. Without more data, the emissions cannot be identified properly or their

concentrations projected for assessment as was done for the RDX process. Although qualitative data are lacking, suspected non-EPA criteria pollutants (bottom of Table 6B-1) have been included in the study of the air chemistry (Section 6.B.2). However, no meteorological dispersion modeling was attempted. Instead, this effort for the present study was concentrated on the RDX process, which had more data and appeared to have more urgent problems.

Source sampling, of a single continuous process line (e.g., the computer-controlled line at NAAP, or one line at VAAP), should be conducted in depth to provide data on the pollutants and the process parameters plus the condition of the controls. The continuous TNT process has potential for minimizing emissions only if the controls are properly functioning.

Further recommendations for TNT plants are in the Section on incineration.

6.B.2 TNT PLANT ATMOSPHERIC CHEMISTRY

6.B.2.1 Introduction and Definition of Terms

See Section 6.A.2.1 Introduction and Definition of Terms.

6.B.2.2 Characteristics of Compounds Emitted in the TNT Process

Both VAAP and RAAP manufacture TNT; however, the types and quantities of compounds emitted from these plants are different. The emissions from VAAP include (in order of decreasing mass rate as indicated in Table 6B-1): a mixture of nitrogen oxides (NO and NO₂); sulfur dioxide (SO₂); sulfuric acid mist (H₂SO₄); particulates; organic compounds such as methane, toluene, tetranitromethane (TNM), and nitrotoluenes; and carbon monoxide (CO). In contrast, the emissions from RAAP include (again, in order of decreasing mass rate as indicated in Table 6B-2): particulates, sulfur dioxide, nitrogen oxides, nitric acid mist (HNO₃), mono and dinitrotoluenes, and 2,4,6-trinitrotoluene (TNT).

Nitrobodies (e.g., trinitrobenzene, isomers of TNT, nitrocresols, trinitrobenzaldehyde, trinitrobenzoic acid, white compounds, and α -nitrotoluene) present in the nitrators can be vented into the air when these nitrators are dumped. Since these compounds only make up a small fraction of the nitrobodies in the nitrator ($\leq 3.0\%$), their properties have not been tabulated.¹ It should be mentioned, however, that the nitrocresols are highly toxic. Indeed 4,5-dinitro-*o*-cresol, a compound which is used as an insecticide and herbicide, has a reported acute oral lethal dose of 10-50 mg/Kg (LD₅₀(rat) = 10-50 mg/Kg) and permissible threshold level value of 0.2 mg/m³. The *para* isomer, 3,5-dinitro-*p*-cresol, may be even more toxic with a lethal dose of 15-50 mg/kg;* however, its threshold level value was not available in the literature.²

Properties of the Compounds Emitted During the Manufacture of TNT

Table 6B-15 summarizes some of the physical properties of the emissions characteristic of the TNT process: the molecular weight, boiling point, melting point, density, vapor pressure, and UV-visible characteristics of each of the nineteen emitted compounds. For convenience, the compounds are

*Ref: Registry of Toxic Substances (NIOSH, USDHEW, 1976) sequence No. GO 96000.

TABLE 6B-15. PHYSICAL PROPERTIES OF EMISSIONS FROM TNT INSTALLATIONS

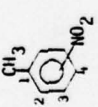
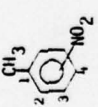
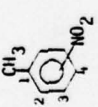
Compound	Chemical Formula	Molecular Weight (g/mole) ^a	Boiling Point (°C)	Melting Point (°C)	Density (g/ml)	Vapor Pressure (mmHg) ^b	Estimated Vapor Pressure (mmHg) ^c	UV - vis Absorption Between 290 - 800 nm ^d
1 Carbon monoxide	CO	28.01	-191.5	-199	1.250 ^e	----	----	0 ^f
2 Hydrocarbon (methane)	CH ₄	16.04	-161.49	-182.48	0.415 ⁻¹⁶⁵	----	----	0 ^f
3 Toluene		92.13	110.6	-95	0.8669 ²⁰	36.7 (30°)	29.3 (25°)	0 ^f
4 Nitric Oxide	NO	30.01	-151.8	-163.6	1.3402 ^d	----	----	0 ^f
5 Nitrogen Dioxide	NO ₂	46.01	21.2	-11.20	1.4494 ²⁰	910 (25°)	----	x ^f
6 Nitrous Acid	HNO ₂	47.01						x ^g
7 Nitric Acid	HNO ₃	63.01	83	-42	1.502 ²⁵	47.9 (20°)	64.6 (25°)	x ^h
8 Tetranitromethane	C(NO ₂) ₄	196.03	126	13	1.6372 ²¹	10 (22.7°)	13.3 (25°)	x ⁱ
9 2-Nitrotoluene		137.14	220.4	-2.9	1.1629	1 (50°)	0.23 (25°)	x ^j
10 3-Nitrotoluene			232.6	15	1.571	1 (50.2°)	0.13 (25°)	x ^j
11 4-Nitrotoluene			230.3	51.7	1.299	1 (53.7°)	0.1 (25°)	x ^j
12 3,4-Dinitrotoluene	C ₇ H ₆ N ₂ O ₄	182.14		61	1.2594 ¹¹¹			x ^j
13 3,5-Dinitrotoluene			Sublime	92.6	1.2772 ¹¹¹			x ^j
14 2,5-Dinitrotoluene				52.5	1.282 ¹¹¹			x ^j
15 2,6-Dinitrotoluene				66	1.2833 ¹¹¹	6.3 x 10 ⁻⁴ (25°)		x ^j

continued

TABLE 6B-15. (cont'd)

Compound	Chemical Formula	Molecular Weight (g/mole) ^a	Boiling Point (°C)	Melting Point (°C)	Density (g/ml)	Vapor Pressure (mmHg) ^b	Estimated Vapor Pressure (mmHg) ^c	UV - vis Absorption Between 290 - 800 nm ^d
16 2,4-Dinitrotoluene			300 ^l	70-1	1.321 ⁷⁰	2.5×10^{-4} (25°)		χ^j
17 2,4,6-Trinitrotoluene	$C_7H_5N_3O_6$	227.13	240 ^l	82	1.654	1.3×10^{-5} (25°) 0.042 (80°)		χ^j
18 Sulfur Dioxide	SO ₂	64.06	- 10	- 72.7	2.927 ^e	2895 (25°)		χ^f
19 Sulfuric Acid	H ₂ SO ₄	98.08	338 ^m	10.36 ⁿ	1.841 ^o	5×10^{-4} (25°)		?

^aFor the following compounds, values for molecular weights, boiling points, melting points, and densities are from Reference 3.

^bVapor pressure data for Compounds 3,8,9,10, and 11 are from Reference 2; Compounds 5 and 18 are from Reference 3; Compound 7 from Reference 4; Compounds 8 and 17 from Reference 5; Compounds 15, 16, and 17 from Reference 6; Compound 19 from Reference 7.

^cThe vapor pressures at 25°C for Compounds 3,8,9,10, and 11 were approximated using the method of Dreisbach, see Reference 7. The vapor pressure for nitric acid at 25° was estimated from the vapor pressures at 20° and 30°C.

^dThe mark (X) indicates the compound absorbs light in the region between 290-800 nm; a zero mark (0) indicates it does not. A question mark (?) signifies that no information was obtained on the UV-visible characteristics of this compound.

^eDensity units for this compound are in g/l.

^fThe UV-visible spectrum of this compound can be found in Reference 9.

^gThe spectrum of nitrous acid was obtained from Reference 10.

^hThe UV-visible spectrum of nitric acid is from Reference 11.

ⁱThe spectrum of TMI can be found in Reference 12.

^jThe UV-visible spectra of the mononitrotoluenes were obtained from References 13 and 14; those of the dinitrotoluenes were also from Reference 14 as well as Reference 15. The TMI spectrum is from Reference 14.

^kBoils with slight decomposition.

^lExplodes upon reaching its boiling point.

^mBoiling point of 98.3% H₂SO₄.

ⁿMelting of 100% H₂SO₄; that of 98% H₂SO₄ is 3.0°.

^oDensity of 96-98% H₂SO₄.

listed according to type, i.e., compounds which contain only carbon, hydrogen, and oxygen (CO, CH₄, and C₇H₈); compounds which contain either NO or NO₂ substituents (NO, NO₂, and RNO₂); and compounds which contain sulfur (SO₂ and H₂SO₄). Of these properties, the vapor pressure and UV-visible characteristics are probably most important in determining the reactivity of a compound in the atmosphere as well as its ability to absorb light and form an excited state from which it may further react.

For the most part, the compounds included in Table 6B-15 are not only characteristic of the TNT process but are also common emissions from other manufacturing processes. These compounds include: carbon monoxide, methane, toluene, nitric oxide, nitrogen dioxide, nitric acid, sulfur dioxide, and sulfuric acid. Because these emissions are so common, a great deal of information about their properties and chemistry has accumulated in the literature.^{16,17} However, little is known of the properties of tetranitromethane and the nitrotoluenes and even less is known of their atmospheric chemistry. Hence, a more thorough discussion of the properties of these compounds will follow.

It can be seen from the vapor pressures of tetranitromethane and the nitrotoluenes that, of these compounds, TNM can achieve the greatest concentration in the atmosphere. It is expected that a portion of these molecules will absorb light within the wavelength region of 240-340 nm.^{*,12} From electron paramagnetic resonance (e.p.r.) investigations of the photochemistry of TNM, it is known that the molecule initially cleaves at one of the carbon-nitrogen bonds to form nitrogen dioxide and the trinitromethyl radical:¹⁸

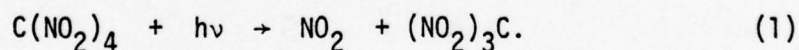

Although the concentration of mononitrotoluenes (MNT) in the atmosphere may not be as great as that of TNM, they may also have a photolytic role in the chemistry of the atmosphere above the TNT manufacturing installation. The UV-spectra of these compounds have been determined in 5 percent ethanol-water solutions¹³ and hexane.¹⁴ The mononitrotoluene isomers have the

*nm = nanometer, 10⁻⁹m = 1 nm = 10 Å.

following λ_{\max} and absorption coefficients (ϵ):

	λ_{\max} (nm) in EtOH/H ₂ O	ϵ 1/mole-cm	λ_{\max} (nm) in C ₆ H ₁₂	ϵ 1/mole-cm
2-MNT	< 210.0	?	212 and 252	8710 and 6630
3-MNT	242.0	16,580	210 and 258	9980 and 6960
4-MNT	265.0	14,400	208 and 234	9770 and 2380

Although maxima do not occur within the 290-800 nm region, the absorption curves do extend into it. In hexane, these curves extend to 410 nm for 2-nitrotoluene, 400 nm for 3-nitrotoluene, and 400 nm for 4-nitrotoluene. Hence, the mononitrotoluenes are capable of absorbing light in the atmosphere and undergoing photochemical reactions. Since data are not available on the photochemistry of these compounds, the photochemistry of a similar compound, nitrobenzene, will be considered. It is known that nitrobenzene photolyzes to produce nitrosobenzene and oxygen atoms or nitrogen dioxide and phenyl radicals:⁹

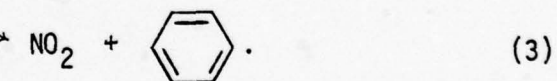
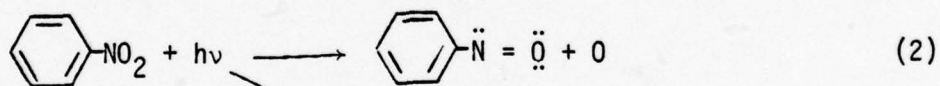

$$\phi_2 > \phi_3$$

Since the vapor pressures and, hence, the atmospheric concentrations of the dinitrotoluenes (DNT) are low, these compounds are not expected to be of concern in the atmosphere. Absorption spectra of the dinitrotoluenes are similar to those of the mononitrotoluenes. The λ_{\max} and absorption coefficients

(ϵ) for these isomers are shown below.¹⁴

	3,4-	3,5-	2,5-	2,6-	2,4-
λ_{\max} (nm) in EtOH/H ₂ O	219.0	248.0	266.5	241.0	252.0
ϵ (1/mole-cm)	10,040	12,020	11,600	8,980	14,100

Similar to the spectra of the mononitrotoluenes, the absorption curve of the spectrum of 2,4-dinitrotoluene [λ_{\max} (C₆H₁₂) = 234 nm (ϵ = 16,000 1/mole-cm)] extends to 380 nm. Therefore, this isomer and, in all probability, the other dinitrotoluene isomers absorb within this region and are capable of photochemical reactions in the atmosphere.

Detection Methods of Compounds Emitted During the Manufacture of TNT

Detection methods for the more common emissions have been recently reviewed,¹⁹ and therefore, only detection methods for two emissions common to TNT manufacturing will be reviewed here, TNM and nitrotoluenes.

TNM can be detected by the color change that occurs when air containing TNM is passed through a basic aqueous ethanol solution containing hydrazine sulfate.²⁰ The concentration of TNM is then determined spectrophotometrically at 350 nm. A less cumbersome method, however, has been recently developed which involves the measurement of frequency shifts of two piezoelectric sensors coated with Hycar 4041 and Acryloid F-10.²¹

Methods for detecting nitrotoluenes include: flame ionization,²² electron capture,²³ bioluminescence, mass spectrometry, ion mobility,²⁴ and infrared and ultraviolet spectroscopy.²⁵ The sensitivity of electron-capture gas chromatography is very high for organic compounds with nitro substituents and very low for other organic compounds. This method can reportedly detect mononitrotoluenes at the 0.014 ppm level. In comparison, gas chromatography with a flame-ionization detector has a minimum detectable concentration for nitrotoluenes of about 1 ppm.

6.B.2.3 Atmospheric Transformations

The atmospheric transformations of the emissions of the TNT manufacturing process fall into two main categories: ground state reactions (reactions which occur without light) and light-induced reactions. Among the reactions considered will be those which occur between a particular pollutant and a compound normally present in the atmosphere as well as those between two pollutants. Reactions which occur because of the presence of light ($290 \leq \lambda \leq 800$ nm) are excited state reactions and may be further classified into those which directly occur because of light ($A + h\nu \rightarrow A^* \rightarrow \text{products}$) and those which indirectly occur because of light ($x + h\nu \rightarrow x^*$, $x^* + A \rightarrow \text{products}$). Known or potential secondary reactions will also be considered.

Known or Potential Ground State Reactions

Ground state reactions which are likely to occur in the atmosphere above the TNT plants are listed in Table 6B-16. In addition to these reactions, their rate expressions, the conditions under which the rate expressions and constants were determined, the rate constants at a particular temperature, and the literature reference are also included. Those reactions in which one of the reactants is a carbon-containing compound are listed first and are followed by those in which one of the reactants is a nitrogen oxide or a sulfur oxide.

The role of each of the tabulated reactions is, of course, dependent on the presence or absence of other reactive species and their absolute concentrations. Over the course of a day, as concentrations change due to reaction, meteorological mixing, and the diurnal variation in solar intensity, the importance of each reaction also changes. To assess the relative importance of any reaction at a given time for a particular pollutant matrix requires the use of computerized diffusion/kinetics models.

Based on the relative amounts of emissions given in Tables 6B-1 and 6B-2, the rate constants given in Table 6B-16, and the results of models of atmospheric chemistry,¹⁷ the following reactions appear to be the most important in the atmosphere above a TNT manufacturing facility: the reaction

TABLE 6B-16. KNOWN GROUND STATE REACTIONS OF EMISSIONS FROM TNT INSTALLATIONS

No.	Reaction	Rate Expression	Condition	T(K)	Rate Constant ^{a, b}		Reference
					k $\frac{\text{cm}^3}{\text{molecule}\cdot\text{sec}}$	k $\frac{1}{\text{ppm}\cdot\text{min}}$	
1	$\text{CO} + \text{O}_3 \rightarrow \text{CO}_2 + \text{O}_2$	$k_1[\text{CO}][\text{O}_3]$		296	$< 4 \times 10^{-25}$	$< 6 \times 10^{-10}$	26
2	$\text{CH}_4 + \text{O}_3 \rightarrow \text{CO}, \text{CO}_2, \text{HCOOH}, \text{H}_2\text{O}$	$k_2[\text{CH}_4][\text{O}_3]$		310	4.3×10^{-24}	6.4×10^{-9}	27
3	$\text{C}_2\text{H}_5\text{CH}_3 + \text{O}_3 \rightarrow \text{products}$	$k_3[\text{C}_2\text{H}_5\text{CH}_3][\text{O}_3]$		298	1.2×10^{-20}	1.8×10^{-5}	28
4	$\text{NO} + \text{O}_3 \rightarrow \text{NO}_2 + \text{O}_2$	$k_4[\text{NO}][\text{O}_3]$		298	1.80×10^{-14}	2.66×10	29
5	$2\text{NO} + \text{O}_2 \rightarrow 2\text{NO}_2$	$k_5[\text{NO}]^2[\text{O}_2]$		298	1.96×10^{-38}	7.1×10^{-10}	26
6	$\text{NO} + \text{NO}_2 \rightarrow \text{N}_2\text{O}_3$	$k_6 = [\text{N}_2\text{O}_3] / [\text{NO}][\text{NO}_2]$		298	2.12×10^{-20}	5.22×10^{-7}	30
7	$\text{NO} + \text{NO}_2 + \text{O}_2 \rightarrow \text{NO}_2 + \text{NO}_3$	$k_7[\text{NO}][\text{NO}_2][\text{O}_2]$		300	3.04×10^{-40}	1.1×10^{-10}	36
8	$\text{NO} + \text{NO}_2 + \text{H}_2\text{O} \rightarrow 2\text{HNO}_2$	$k_8[\text{NO}][\text{NO}_2][\text{H}_2\text{O}]$		300	$\leq 4.4 \times 10^{-40}$	$\leq 1.6 \times 10^{-11}$	31
9	$\text{NO} + \text{NO}_3 \rightarrow 2\text{HNO}_2$	$k_9[\text{NO}][\text{NO}_3]$	1 atm N_2	297	8.7×10^{-12}	1.3×10^4	32
10 ^c	$2\text{HNO}_2 + \text{H} \rightarrow \text{N}_2\text{O}_4 + \text{H}$	$k_{10}[\text{HNO}_2]^2[\text{H}]$	$\text{H} = \text{N}_2$	300	2.64×10^{-36}	9.61×10^{-8}	26
11	$\text{NO}_2 + \text{O}_2 \rightarrow \text{NO} + \text{O}_3$	$k_{11}[\text{NO}_2][\text{O}_2]$		298	2.8×10^{-49}	4.1×10^{-34}	26
12 ^d	$\text{NO}_2 + \text{O}_3 \rightarrow \text{NO}_3 + \text{O}_2$	$k_{12}[\text{NO}_2][\text{O}_3]$		298	3.3×10^{-17}	4.9×10^{-2}	26
13	$\text{NO}_2 + \text{NO}_3 \rightarrow \text{NO}_2 + \text{O}_2 + \text{NO}$	$k_{13}[\text{NO}_2][\text{NO}_3]$		300	8.16×10^{-15}	1.21×10	26
14	$\text{NO}_2 + \text{NO}_3 + \text{H} \rightarrow \text{N}_2\text{O}_5 + \text{H}$	$k_{14}[\text{NO}_2][\text{NO}_3]$	$\text{H} = \text{N}_2\text{O}_5, \text{NO}$	300	3.8×10^{-12}	5.6×10^3	26

TABLE 6B-16. (cont'd)

No.	Reaction	Rate Expression	Condition	T(K)	Rate Constant ^{a,b}		Reference
					k molecule ⁻³ sec	k ppm ⁻¹ min	
15	$\text{NO}_3 + \text{NO}_3 \rightarrow 2\text{NO}_2 + \text{O}_2$	$k_{15}[\text{NO}_3]^2$		300	2.2×10^{-16}	3.3×10^{-1}	26
16 ^c	$\text{N}_2\text{O}_4 + \text{M} \rightarrow 2\text{NO}_2 + \text{M}$	$k_{16}[\text{N}_2\text{O}_4][\text{M}]$	M = N ₂	300	3.8×10^{-15}	5.6	26
17	$\text{H}_2\text{O}_3 + \text{H}_2\text{O} \rightarrow 2\text{HNO}_2$	$k_{17}[\text{H}_2\text{O}_3][\text{H}_2\text{O}]$		298	1.98×10^{-17}	2.94×10^{-2}	30
18	$\text{N}_2\text{O}_5 + \text{M} \rightarrow \text{NO}_2 + \text{NO}_3 + \text{M}$	$k_{18}[\text{N}_2\text{O}_5]$	II = N ₂ O ₅ , NO	300	2.3×10^{-1}	1.4×10	26
19	$\text{H}_2\text{O}_5 + \text{H}_2\text{O} \rightarrow 2\text{HNO}_3$	$k_{19}[\text{H}_2\text{O}_5][\text{H}_2\text{O}]$		300	$< 1 \times 10^{-20}$	$< 1.5 \times 10^{-5}$	26
20	$2\text{HONO} \rightarrow \text{NO} + \text{NO}_2 + \text{H}_2\text{O}$	$k_{20}[\text{HONO}]^2$		300	$\leq 1 \times 10^{-20}$	$\leq 1.5 \times 10^{-5}$	31
21 ^e	$\text{HNO}_2 + \text{HNO}_3 \rightarrow 2\text{NO}_2 + \text{H}_2\text{O}$	$k_{21}[\text{HNO}_2][\text{HNO}_3]$		300	1.55×10^{-17}	2.30×10^{-2}	33
22 ^d	$\text{NO}_3 + \text{O}_2 \rightarrow \text{NO}_2 + \text{O}_3$	$k_{22}[\text{NO}_3][\text{O}_2]$		300	7×10^{-34}	1×10^{-18}	26
23	$\text{NO}_2 + \text{SO}_2 \rightarrow \text{NO} + \text{SO}_3$	$k_{23}[\text{NO}_2][\text{SO}_2]$		300	$< 2 \times 10^{-24}$	$< 3 \times 10^{-9}$	26
	$\text{NO}_2 + \text{SO}_2 \rightarrow \text{NO} + \text{SO}_3$	$k_{56}[\text{NO}_2][\text{SO}_2]$	Water vapor present	300	2×10^{-18}	3×10^{-3}	94
24	$\text{NO}_3 + \text{SO}_2 \rightarrow \text{NO}_2 + \text{SO}_3$	$k_{24}[\text{NO}_3][\text{SO}_2]$		300	$< 7 \times 10^{-21}$	$< 1 \times 10^{-5}$	26
25	$\text{H}_2\text{O}_5 + \text{SO}_2 \rightarrow \text{H}_2\text{O}_4 + \text{SO}_3$	$k_{25}[\text{H}_2\text{O}_5][\text{SO}_2]$		300	$< 4 \times 10^{-23}$	$< 6 \times 10^{-8}$	26
26	$\text{SO}_2 + \text{O}_3 \rightarrow \text{SO}_3 + \text{O}_2$	$k_{26}[\text{SO}_2][\text{O}_3]$		300	$\leq 10^{-22}$	$\leq 10^{-7}$	34
27	$\text{SO}_2 + \text{O}_2 + \text{H}_2\text{O} \rightarrow \text{H}_2\text{SO}_4$	---		---	---	---	35
28	$\text{SO}_3 + \text{H}_2\text{O} \rightarrow \text{H}_2\text{SO}_4$	$k_{28}[\text{SO}_3][\text{H}_2\text{O}]$	I - 1.3 torr	298	9.1×10^{-13}	1.4×10^3	36

355

^a k_{16} is an equilibrium constant and is given in units of cm³/molecule and ppm⁻¹. The units for the rate constant of reaction number 18 is in sec⁻¹ and min⁻¹. The units for the rate constants for reaction numbers 5, 7, 8, and 10 are given in cm⁶/molecule²-sec and ppm⁻²-min⁻¹. To convert from units of cm³-molecule-sec to ppm-min, it was first assumed that the given values of the rate constants in the former units are the same as those under standard conditions, T = 298°K and P = 1 atm. The following conversions were used: to convert cm³/molecule to ppm⁻¹, multiply the values of the rate constant in cm³/molecule by 2.46 x 10¹³; cm³/molecule-sec by 1.478 x 10¹⁵; and cm⁶/molecule²-sec by 3.64 x 10²⁸.

^bA complete listing of reactions and rate constants can be found in Appendix 1.

^cFor reactions 10 and 16, $k_{10}/k_{16} = k_{10}/k_{16} = 7.06 \times 10^{-20}$ cm³/molecule = 1.74 x 10⁻⁶ ppm⁻¹.

^dFor reactions 12 and 22, $k_{12}/k_{22} = k_{12}/k_{22} = 7.14 \times 10^{16}$.

^eThe rate constant for reaction 21 is an upper limit.

between nitric oxide and ozone (4); nitric oxide, nitrogen dioxide, and water (8); nitric oxide and oxygen (5); nitric oxide and nitrogen trioxide (9); nitrogen dioxide and ozone (12); nitrogen dioxide and nitrogen trioxide (13); dinitrogen pentoxide and water (19); sulfur dioxide and nitrogen dioxide (23); sulfur trioxide and water (28); and the dissociation of dinitrogen pentoxide (18).

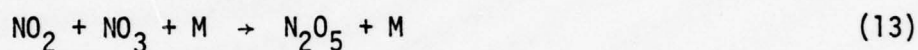
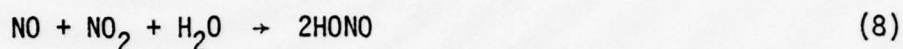

Reactions 1-3, 6, 7, 10, 11, 14-17, and 20-27 in Table 6B-16 are believed to be less important.

In addition to the preceding reactions, nitrous acid can react with any secondary amine in the air to form a nitrosamine:³⁷

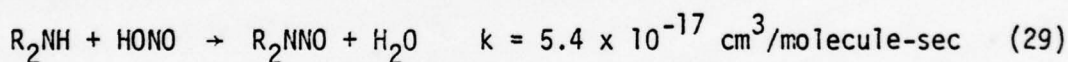

$$k = 8.0 \times 10^{-2} \text{ ppm}^{-1}\text{min}^{-1}$$

Although formation of these species is quite slow, the concentration of N-nitroso dimethylamine, for example, will build up at night. In light, however, both nitrous acid and nitrosamine will photodissociate. Hence, the nitrosamine concentration will diminish during the daylight hours. Half-lives of 30 to 60 min have been observed in ambient irradiations conducted in Teflon bags.³⁷

*Rate constant is the constant for the formation of N-nitroso dimethylamine, that is, R = CH₃.

The reaction between tetranitromethane and a tertiary amine may also lead to the formation of a nitrosamine:³⁸

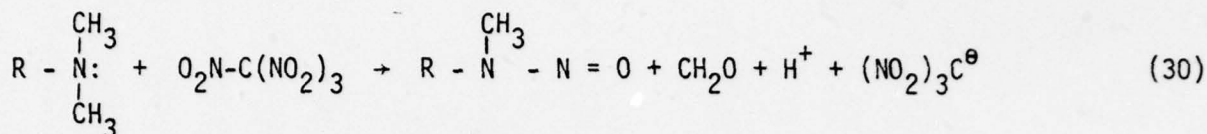

Since this reaction is only known to occur in the presence of glacial acetic acid or pyridine and at high temperatures,^{38,39} its importance in the formation of nitrosamines in the atmosphere is doubtful.

It is believed that only secondary and tertiary amines form stable nitrosamines. Primary amines may react with nitrous acid to form a nitrosamine which may then tautomerize to the diazohydroxide:⁴⁰

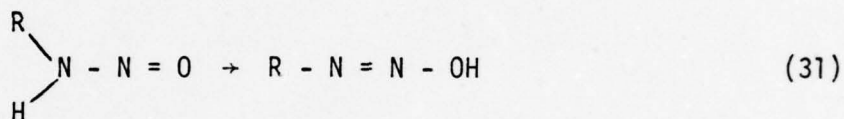

This species decomposes in solution into nitrogen, a carbonium ion, and hydroxide ion:⁴¹

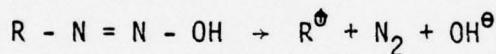

In the atmosphere it may similarly decompose into nitrogen, an alkyl radical, and hydroxyl radical:

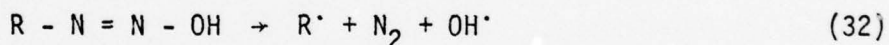

Investigations of the pyrolysis of nitrosamines have shown that these same radical species originate from the decomposition of diazohydroxide tautomer. To date, there is no evidence as to the existence of the parent compound, H_2NNO .⁴⁰

Amines have not been identified as pollutants in TNT production.

Known or Potential Excited State Reactions

Of the nineteen identified compounds emitted from VAAP and/or RAAP, thirteen absorb light within the 290-800 nm wavelength region. These photoacceptors are nitrogen dioxide, nitric acid, tetranitromethane, the nitrotoluenes, and sulfur dioxide; the secondary pollutants: nitrogen trioxide, dinitrogen-pentoxide, nitrous acid, and ozone are also photoacceptors. For these

compounds, the photolyses likely to occur in the atmosphere are listed in Table 6B-17. The majority of these photolyses result in the breaking of bonds. For these reactions, the bond dissociation energies (kcal/mole), the maximum wavelength necessary for the occurrence of bond dissociation, quantum yields (ϕ = number of molecules decomposed or formed per quantum of absorbed light), and rate of product formation or decomposition (sec^{-1}) are given. The remaining photolyses only result in the formation of an excited state species (A^*). The known quantum yields or rates of product formation or decomposition are also given for these reactions. Much information is available on the photochemistry of gaseous nitrogen dioxide, nitrogen trioxide, dinitrogen pentoxide, nitrous acid, nitric acid, and sulfur dioxide. However, little is known of the photochemistry of TNM and nitrotoluenes. Therefore, the photochemistry of these compounds in solution, the photochemistry of model compounds, and the gas-phase decomposition of these compounds have been considered to lend insight into the possible photochemistry of these compounds in the atmosphere.

Nitrogen Dioxide

Light ($h\nu$) can affect nitrogen dioxide in two ways. At wavelengths less than 390 nm ($\lambda < 390$ nm), photodissociation can occur to yield nitric oxide, NO, and ground state atomic oxygen, $O(^3P)$:

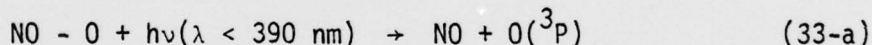

In the atmosphere with a solar zenith angle of 40° ($z = 40^\circ$), the rate constant for the formation of nitric oxide and atomic oxygen is approximately $8 \times 10^{-3} \text{ sec}^{-1}$.¹⁷ From this rate constant, the half-life of this reaction can be calculated ($t_{1/2} = 0.693/k$). Therefore, in the absence of competing reactions the half-life of nitrogen dioxide in the atmosphere would be approximately 90 sec.

Competing reactions, however, are important in dictating the behavior of nitrogen dioxide in the atmosphere. In the absence of organic vapors, the atomic oxygen produced in nitrogen dioxide photolysis interacts with

TABLE 6B-17. PHOTOCHEMICAL REACTIONS OF EMISSIONS FROM TNT INSTALLATIONS

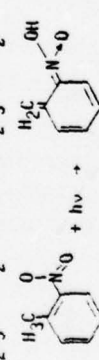
No.	Reaction	Range of Absorption Spectrum (nm)	Bond Dissociation Energy (Kcal/mole) ^a	Max. λ (nm) Required for Bond Dissociation ^b	T(K)	Quantum Yields Φ products	Rate of Product Formation or Decomposition k (sec ⁻¹) ^c
33-a	$\text{NO} - \text{O} + h\nu \rightarrow \text{NO} + \text{O}({}^3\text{P})$	180-410 ^d	73.19	< 390	300	$\Phi_0 = 1(\lambda 295-410)^e$	$8 \times 10^{-3} (z=40)^f$
33-b	$\text{NO}_2 + h\nu \rightarrow \text{NO}_2^*$		---	---			$2.27 \times 10^{-2} (z=40)^f$
34	$\text{NO}_3 + h\nu \rightarrow \text{NO}_2 + \text{O}({}^3\text{P})$	450-680 ^g	50.5	< 567			$2.6 \times 10^{-2} (\lambda 450-578)^e$ $4.34 \times 10^{-2} (\lambda 579-680)$
35	$\text{N}_2\text{O}_5 + h\nu \rightarrow \text{products}$	210-380 ^g	49.9	< 574		$\Phi_{\text{OH}} = 0.92(\lambda 365)^h$	$2.5 \times 10^{-3} (z=30)^h$
36-a	$\text{HO} - \text{NO} + h\nu \rightarrow \text{HO} + \text{NO}$	200-270 ^h 314-393	79.0	< 362			
36-b	$\text{H} - \text{ONO} + h\nu \rightarrow \text{H} + \text{NO}_2$		49.52	< 578		$\Phi_{\text{OH}} = 1(\lambda 300)^j$	$< 3.5 \times 10^{-6} (\lambda < 330)^f$
37-a	$\text{HO} - \text{NO}_2 + h\nu \rightarrow \text{HO} + \text{NO}_2$	185-335 ⁱ	72.8	< 393			
37-b	$\text{HONO}_2 - \text{O} + h\nu \rightarrow \text{HONO}_2 + \text{O}({}^3\text{P})$		101.4	< 283			
37-c	$\text{H} - \text{ONO}_2 + h\nu \rightarrow \text{H} + \text{NO}_3$		118.1	< 242			
37-d	$\text{HONO}_2 - \text{O} + h\nu \rightarrow \text{HONO}_2 + \text{O}({}^1\text{D})$		39.3 ^l	< 728	77		
38	$(\text{NO}_2)_3\text{C} - \text{NO}_2 + h\nu \rightarrow (\text{NO}_2)_3\text{C} + \text{NO}_2$	240-340 ^k			298	$\Phi_{\text{dis}} = 4 \times 10^{-3} (\lambda 253.7)^n$	$1.3 \times 10^2 (\text{EtOH})^o$
39-a		212-410 ^m					

continued

TABLE 6B-17. (cont'd)

No.	Reaction	Range of Absorption Spectrum (nm)	Bond Dissociation Energy (Kcal/mole) ^a	Max. λ (nm) Required for Bond Dissociation ^b	T(K)	Quantum Yields Φ products	Rate of Formation or Decomposition k (sec ⁻¹) ^c
39-b			66.7 ^p	< 428			
39-c							
40-a	$m\text{-(CH}_3\text{)(NO}_2\text{)C}_6\text{H}_4 + h\nu \rightarrow (\text{CH}_3\text{)C}_6\text{H}_4\cdot + \text{NO}_2$	210-400 ^m	70.7 ^p	< 404		$\Phi_{dis} = 0.8 \times 10^{-3}$ ($\lambda 253.7$) ⁿ	
40-b	$m\text{-(CH}_3\text{)(NO}_2\text{)C}_6\text{H}_4 + h\nu \rightarrow m\text{-(CH}_3\text{)(NO)C}_6\text{H}_4 + \text{O}(\cdot^3p)$						
41-a	$p\text{-(CH}_3\text{)(NO}_2\text{)C}_6\text{H}_4 + h\nu \rightarrow (\text{CH}_3\text{)C}_6\text{H}_4\cdot + \text{NO}_2$	203-400 ^m	71.2 ^p	< 402		$\Phi_{dis} = 2 \times 10^{-3}$ ($\lambda 253.7$) ⁿ	
41-b	$p\text{-(CH}_3\text{)(NO}_2\text{)C}_6\text{H}_4 + h\nu \rightarrow p\text{-(CH}_3\text{)(NO)C}_6\text{H}_4 + \text{O}(\cdot^3p)$						
42-a		(2,5)- λ_{max} 266.5 ^q (2,6)- λ_{max} 241 ^q (2,4)-210-380 ^{q,s}					$2 \times 10^3 (\text{H}_2\text{O})^r$

continued

TABLE 6B-17. (cont'd)

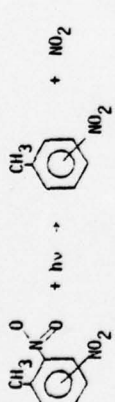
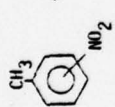
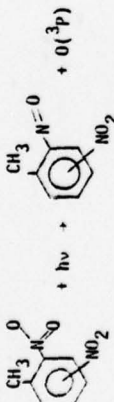
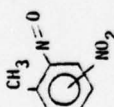
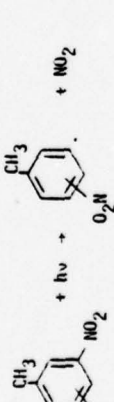
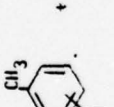
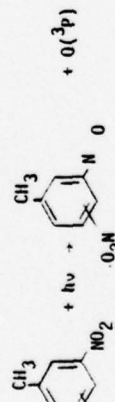
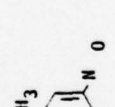
No.	Reaction	Range of Absorption Spectrum (nm)	Dissociation Energy (Kcal/mole) ^a	Max. λ (nm) Required for Bond Dissociation ^b	T (K)	Quantum Yields Φ products	Rate of Formation or Decomposition k (sec ⁻¹) ^c
42-a	 $+ h\nu \rightarrow$  $+ \text{NO}_2$		- 66.4 ^P - 66.1 ^P - 66.1 ^P	< 431 < 433 < 433		$\Phi_{\text{dis}} = 1 \times 10^{-3}$ ($\lambda 253.7$) ⁿ	
42-c	 $+ h\nu \rightarrow$  $+ \text{O}(^3\text{P})$						
43-a	 $+ h\nu \rightarrow$  $+ \text{NO}_2$	(3.4)- λ_{max} 219 ^q (3.5)- λ_{max} 248 ^q	- 51.4 ^P - 66.1 ^P	< 527 < 433			
43-b	 $+ h\nu \rightarrow$  $+ \text{O}(^3\text{P})$						

continued

TABLE 6B-17. (cont'd)

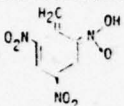
No.	Reaction	Range of Absorption Spectrum (nm)	Dissociation Energy (kcal/mole) ^a	Max. λ (nm) Required for Bond Dissociation ^b	T (K)	Quantum Yields ^c products	Rate of Formation or Decomposition k (sec. ⁻¹) ^c
44	TNT + h ν 	220-230 ^{d,t}				$\tau_{dis} = 1 \times 10^{-3}$ ($\lambda 253.7$) ⁿ	1.04×10^3 (C ₆ H ₅) ^u
45-a	O ₃ + h ν → O(³ P) + O ₂ (³ Σ _g ⁻)	200-350 ^y 450-700	25.4	1120		$\tau = 1$ (450-750) ^e	3.29×10^{-2} (450-750) ^e
45-b	O ₃ + h ν → O(³ P) + O ₂ (¹ Δ _g)		48.8	595		$\tau = 1$ (310-350) ^e	
45-c	O ₃ + h ν → O(¹ D) + O ₂ (³ Σ _g ⁻)		70.7	404			
45-d	O ₃ + h ν → O(¹ D) + O ₂ (¹ Δ _g)		93.2	306		$\tau = 1$ (250-310) ^e	
46-a	SO ₂ (¹ A ₁) + h ν → SO ₂ (³ B ₁)	370-400 ^w				$\tau_{SO_2} = 0.10$ ^w	
46-b	SO ₂ (¹ A ₁) + h ν → SO ₂ (¹ B ₁)	240-320 ^w				$\tau_{SO_2} = 0.09$ ^w	

^aExcept for TNT and the nitrotoluenes, the bond dissociation energies at T = 298°K were calculated using the table of chemical thermodynamic properties in Reference 26, p. 93.

^bThe values for the maximum wavelength necessary for the occurrence of bond dissociation were calculated using the relationship, λ (nm) = $2.86 \times 10^4/D^*$, where D* = bond dissociation energy in Kcal/mole.

^cFor reaction numbers 33-a, 33-b, 34, 36-a, 37-a, and 45-a, the rate of product formation is given. For reaction numbers 39-a, 42-a, and 44, the rate of product decomposition is given. A complete listing of reactions and rate constants can be found in Appendix 1.

^dThe absorption spectrum of nitrogen dioxide can be found in Reference 42.

^eSee Reference 26.

^fSee Reference 17.

^gThe absorption spectrum of this nitrogen oxide is from Reference 49.

^hThe UV-visible spectrum of nitrous acid was obtained from Reference 10. Values for the hydroxyl radical quantum yields and rate of decomposition were also obtained from Reference 10.

ⁱThe UV-visible spectrum of nitric acid was obtained from Reference 11.

^jThe quantum yield, τ_{OH} , for the nitric acid photolysis was obtained from Reference 44.

^kThe UV-vis spectrum of TNT was found in Reference 12.

^lSee Reference 45 for the calculation of the TNT bond dissociation energy.

^mThe UV-vis spectrum of this nitrotoluene is from Reference 13.

ⁿThe quantum yield for the disappearance of the nitrotoluene at $\lambda = 253.7$ nm is from Reference 46.

^oThe rate of product decomposition for this nitrotoluene is from Reference 47. The k_d was determined in ethanol solvent.

^pSee Reference 48. The bond dissociation energies for the dinitrotoluenes are in fact the bond dissociation energies for the corresponding dinitrobenzenes. It is assumed that the value of the bond dissociation energies for the dinitrotoluenes will be close to those for the dinitrobenzenes, since the bond dissociation energies of the nitrotoluenes are close to that of nitrobenzene.

^qThe τ_{max} for this nitrotoluene was obtained from Reference 14.

^rThe rate of product decomposition was found in Reference 49.

^sThe UV-vis spectrum of 2,4-dinitrotoluene was obtained from Reference 15.

^tThe absorption spectrum of TNT was obtained from Reference 46.

^uThe rate of product decomposition for this photolysis is from Reference 50.

^vThe UV-visible spectrum of ozone is from Reference 9.

^wSee Reference 51 for the absorption spectrum of sulfur dioxide. The quantum yield for this photolysis can also be found in this Reference.

atmospheric molecular oxygen to generate small concentrations of ozone. The following are the major reactions that occur under these conditions.



This sequence is represented below as a cycle. The condition under which the photolysis of nitrogen dioxide balances the nitric oxide oxidation by ozone is known as a photostationary state (PSS). Under the PSS assumption, the following equation may be written.

$$\frac{k_{33\text{-a}}}{k_4} = \frac{[\text{NO}][\text{O}_3]}{[\text{NO}_2]}$$

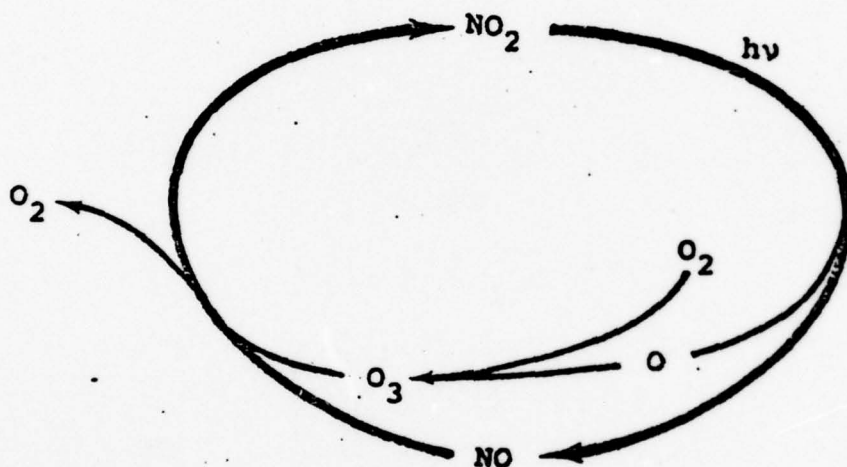

Near the equinox, a $k_{33\text{-a}}$ value representative of the 4-hour period encompassing solar noon at Research Triangle Park, North Carolina would be approximately $8 \times 10^{-3} \text{sec}^{-1}$. Table 6B-18 shows the ozone levels calculated from the PSS assumption for an atmosphere initially contaminated by various levels of only nitrogen dioxide and at a light intensity equal to $8 \times 10^{-3} \text{sec}^{-1}$.

TABLE 6B-18. OZONE LEVELS CALCULATED FOR PSS FOR AN IRRADIATED ($k_{33-a} = 8 \times 10^3 \text{ sec}^{-1}$) ORGANIC-FREE ATMOSPHERE INITIALLY CONTAMINATED BY VARIOUS LEVELS OF NO_2

Initial $[\text{NO}_2]$, ppm	$[\text{O}_3]$, ppm
2.74	0.2135
0.40	0.0764
0.25	0.0588
0.10	0.0344
0.05	0.0223
0.025	0.0141
0.010	0.0072
0.005	0.0041
0.0025	0.0023

Thus, for an organic-free atmosphere, slightly less than 0.4 ppm of NO_2 would be required to generate the oxidant standard concentration (0.08 ppm), and almost insignificant quantities of ozone would result from initial nitrogen dioxide levels below 0.1 ppm.

At wavelengths greater than 390 nm, photodissociation cannot occur and light only serves to activate nitrogen dioxide into an excited state*:

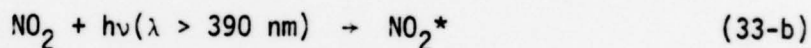

This excited NO_2^* species can then transfer its excess energy to another species present in the atmosphere. To date several quenching studies have been conducted on this excited state species. Transfer of energy to nitrogen dioxide, carbon dioxide, or oxygen may only result in the formation of ground state nitrogen dioxide:^{17,52}

Although wavelengths of light above 390 nm are not energetic enough to produce nitric oxide and atomic oxygen from ground state nitrogen dioxide, excited state nitrogen dioxide (NO_2^) can photodissociate at wavelengths up to 430 nm.

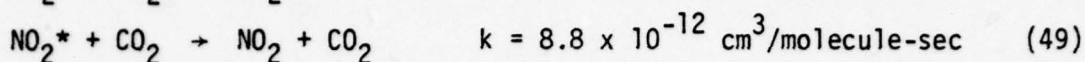
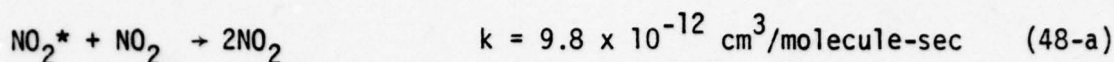

In addition to the formation of ground state nitrogen dioxide, the transfer of energy to nitrogen dioxide, carbon monoxide, and oxygen also may result in further photochemistry. The excited state nitrogen dioxide species can react with a molecule of ground state nitrogen dioxide to form nitric oxide and oxygen,⁵² it can react with carbon monoxide to form nitric oxide and carbon dioxide,⁵³ or it can react with ground state molecular oxygen (triplet oxygen) to form nitrogen dioxide and singlet oxygen.¹⁷

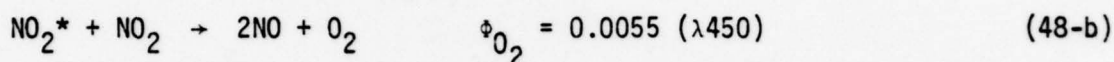

$$k = 4.2 \times 10^{-14} \text{ cm}^3/\text{molecule-sec}$$

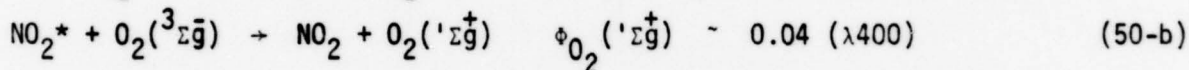
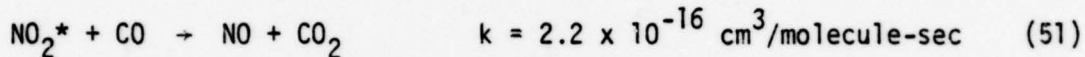

$$k = 1.15 \times 10^{-14} \text{ sec}^{-1}$$

Although these reactions are possible, they are not very efficient. The quantum yields for the reactions of the excited state nitrogen dioxide species with ground state nitrogen dioxide and oxygen are low. Only 0.55 percent of the excited nitrogen dioxide species react with ground state nitrogen dioxide to form nitric oxide. Similarly, only 4 percent of these excited species react with ground state molecular oxygen to form excited state oxygen.

Nitrogen Trioxide and Dinitrogen Pentoxide

At wavelengths below 567 nm, nitrogen trioxide is known only to photodissociate into nitrogen dioxide and ground state atomic oxygen:²⁶

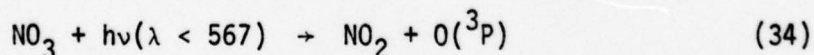

Depending on the wavelength of light absorbed, the half-life of NO_3 in the atmosphere is 16 to 26.6 sec. Hence, it appears that any nitrogen trioxide formed in the atmosphere may quickly photodissociate into nitrogen dioxide and atomic oxygen.

In contrast, the photolysis of dinitrogen pentoxide is not important in the chemistry of the atmosphere because the amount of light absorbed by this species is small. The products formed in this photolysis are nitrogen dioxide, nitrogen trioxide, and atomic oxygen:¹⁷

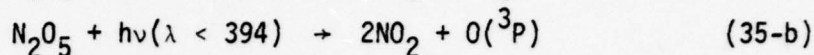
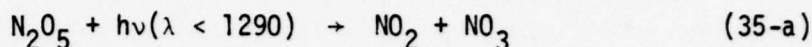

Nitrous and Nitric Acids

Two photodissociation mechanisms are possible in the photochemistry of nitrous acid.¹⁰ Bond breaking can occur either between the oxygen and nitrogen atoms to produce hydroxyl radicals and nitric oxide or between the hydrogen and oxygen atoms to produce atomic hydrogen and nitrogen dioxide:

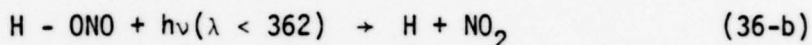
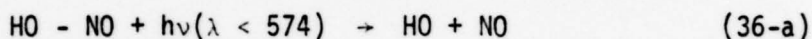

The reported quantum yield in Table 6B-17 shows the first route to be more important. From the rate of formation of hydroxyl radicals ($k = 2.5 \times 10^{-3} \text{ sec}^{-1}$), the half-life of nitrous acid in sunlight ($z = 30^\circ$) will be approximately 280 sec.

The photochemistry of nitric acid is somewhat similar to that of nitrous acid, in that numerous photodissociation mechanisms are possible.¹¹ Photodissociation may result in the formation of hydroxyl radicals and nitrogen dioxide, nitrous acid and ground state atomic oxygen [$\text{O}(^3\text{P})$], hydrogen atoms and nitrogen trioxide, or nitrous acid and excited state atomic oxygen [$\text{O}(^1\text{D})$]:

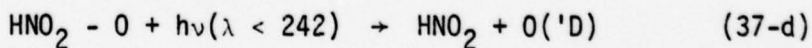
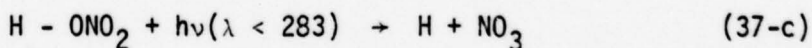
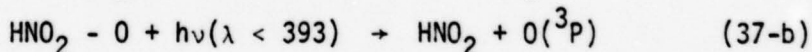
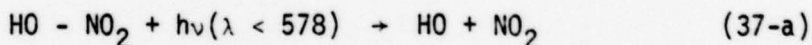

Also like nitrous acid, only one mechanism is important in describing the photochemistry of nitric acid. At wavelengths below 325 nm, nitric acid photodissociates to form hydroxyl radicals and nitrogen dioxide.⁴⁴ However, unlike nitrous acid, the rate of formation of hydroxyl radicals is much slower. As a result of this slow rate of hydroxyl radical formation, the half-life of nitric acid is quite long ($t_{1/2} = 55.5$ hours).¹⁷

Tetranitromethane

In contrast to the photochemistry of the preceding species, little is known about the photochemistry of tetranitromethane. At 77°K, using a high-pressure mercury lamp, the molecule initially photodissociates to form a trinitromethyl radical and nitrogen dioxide:¹⁸

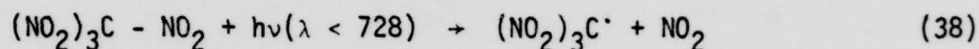

If TNM is photolyzed to 100 percent decomposition, nitrogen, nitrogen dioxide, nitric oxide, carbon monoxide, and carbon dioxide are formed, with nitrogen dioxide as the major product. After the initial bond breaking step, the mechanism of this photodissociation is mere speculation. However, an idea of the photochemistry of this compound may be obtained from studies of its gas-phase decomposition. From the rate of decomposition of TNM at temperatures between 86-177°C, it is deduced that cleavage of a carbon-nitrogen bond is also the initial step in the gas-phase decomposition of this compound.⁵⁴ The rate of decomposition was found to be unaffected by a six-fold excess of nitric oxide, nitrogen dioxide, iodine, cyclohexane, and argon. As in the photolysis of TNM, nitrogen, nitric oxide, nitrogen dioxide, carbon monoxide, and carbon dioxide are also formed in the gas-phase decomposition.⁵⁵ In addition to the previously mentioned products, ICN is also produced when TNM is decomposed in the presence of iodine. Therefore, the CN radical may be formed during the gas-phase decomposition as well as in the photochemical decomposition of TNM.

Nitrotoluenes

Since little is known of the photochemistry of the nitrotoluenes in the gas phase, analogies must be drawn from what is known of the solution photochemistry of this group of compounds or from what is known of the vapor phase photochemistry of model compounds, for example, nitrobenzene. Recently, Sandus and Slagg⁴⁶ studied the photochemistry of nitrobenzene, 1,3-di-nitrobenzene, 2-nitrotoluene, 3-nitrotoluene, 4-nitrotoluene, 2,4-dinitrotoluene, and TNT in nonpolar solvents (heptane and cyclohexane). At a wavelength of 253.7 nm, photolysis of these species exhibited disappearance quantum yields of 10^{-3} . Although products are formed, these photolytic reactions are not very efficient. In the photolysis of a particular aromatic nitrocompound, the corresponding nitrosobenzene or toluene and nitrophenol are formed (reaction 39-c in Table 6B-18). In the photolysis of 2-nitrotoluene, 2-nitrosotoluene is formed in the greatest yield.

An additional reaction pathway is possible for the nitrotoluene in which the methyl and nitro groups are ortho to each other. These nitrotoluenes are photochromic, that is these compounds are colorless in the dark and become colored in light. In the presence of light, these colorless nitrotoluenes rearrange to form the colored aci isomer, via the following mechanism:^{46,47,49,50}

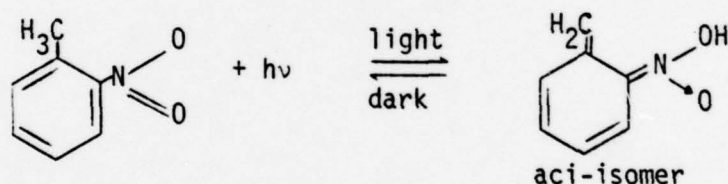

The fading reaction for several of the aci isomers has been investigated; rate constants for these reactions are presented in Table 6B-17. It is believed that this aci species will be present in the atmosphere; however, its role in atmospheric chemistry is unknown. Since it does absorb light, the species is capable of photochemistry. It may also react with other species present in the atmosphere.

The vapor phase photochemistry of nitrobenzene has been studied at wavelengths of 253.7 and 260 nm. In the photolysis at $\lambda = 260$ nm, Hastings and Matsen⁵⁶ found that nitrosobenzene and *p*-nitrophenol were the major products formed. The authors suggested the following mechanism to describe the formation of these products:

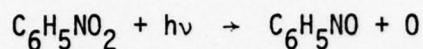

However, Grovenstein and Mosher⁵⁷ found that the photolysis at $\lambda = 253.7$ nm, in a helium atmosphere yielded nitrosobenzene (28%), phenol (51%), and nitrophenols (4% 2-, 1% 3-, and 16% 4- $\text{NO}_2\text{C}_6\text{H}_4\text{OH}$). The ratios of nitrophenol photoproduct isomers were similar to those found in the oxidation of nitrobenzene with atomic oxygen.

From the previous information, two potential photochemical mechanisms are proposed for the nitrotoluenes which do not have methyl adjacent to nitro groups (3-nitrotoluene, 4-nitrotoluene, 3,4-dinitrotoluene, and 3,5-dinitrotoluene). Absorption of light by the nitrotoluenes may result in the cleavage of the nitrogen-oxygen bond to form the nitrosotoluene and atomic oxygen:

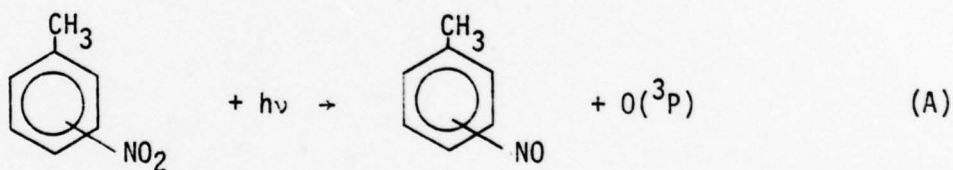

An alternative mechanism involves the cleavage of the carbon-nitrogen bond to form substituted phenyl radical and nitrogen dioxide:

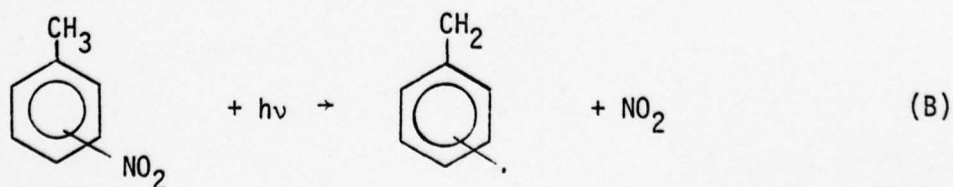

For the nitrotoluenes with adjacent methyl and nitro groups (2-nitrotoluene, 2,5-dinitrotoluene, 2,6-dinitrotoluene, 2,4-dinitrotoluene, and 2,4,6-trinitrotoluene), an alternative mechanism is proposed in which the absorption of light may result in the formation of the aci isomer:

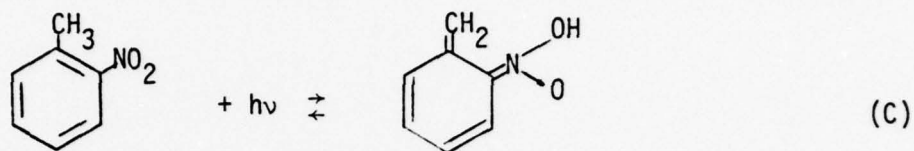

The aci isomer is probably more reactive than its parent isomer. It absorbs light in the visible region and is, therefore, capable of photochemistry as well as reaction with other molecules such as ozone. The high reactivity of this isomer will drive Mechanism C towards completion and the formation of more aci isomer.

From the data available in the literature, it appears that Mechanism A is the most important in describing the photochemistry of the nitrotoluenes. However, Mechanism B may also occur in the atmosphere since the wavelengths which are absorbed by the nitrotoluenes are energetic enough to cleave the carbon-nitrogen bond (see Table 6B-17). Mechanism C may also be an important pathway in the photochemistry of some of the nitrotoluenes. However, it should be remembered that even at 253.7 nm, the number of nitrotoluene molecules absorbing light was not very great ($\phi = 10^{-3}$) and in the 290-800 nm region it will be less. This fact, compounded with the fact that the nitrotoluenes generally have low vapor pressures under standard conditions, suggest that the photochemistry of the nitrotoluenes exerts a minor role in the chemistry of the atmosphere above TNT installations.

Ozone

The products formed in the photolysis of ozone are wavelength dependent. Based on the bond dissociation energies (see Table 6B-17), ground state atomic oxygen and either ground or excited state molecular oxygen can form from the absorption of light within the 450-700 nm wavelength region. However, the

quantum yields given in Table 6B-17 for the photodissociation of ozone indicate that most of the light absorbed within this region leads to the formation of ground state atomic oxygen and ground state molecular oxygen (reaction 45-a).

The more energetic products can form from the absorption of light within the 200-350 nm region. From the quantum yields for reactions 45-b, 45-c, and 45-d, in Table 6B-17, it can be seen that the ozone preferentially photodissociates into ground state atomic oxygen and excited state molecular oxygen between wavelengths of 310 and 350 nm and excited state atomic oxygen and excited state molecular oxygen between 250 and 310 nm.

Rate constants were estimated for the formation of ground state atomic oxygen, excited state atomic oxygen, and excited state molecular oxygen from the photolysis of ozone in sunlight ($z = 40^\circ$). The rate expressions for the formation of these products from the photolysis of ozone are given below.¹⁷

$$\frac{d[O(^3P)]}{dt} \sim 3.5 \times 10^{-4} [O_3] \text{ sec}^{-1}$$

$$\frac{d[O(^1D)]}{dt} \sim 5.7 \times 10^{-5} [O_3] \text{ sec}^{-1}$$

$$\frac{d[O_2(^1\Delta_g)]}{dt} \sim 7.2 \times 10^{-5} [O_3] \text{ sec}^{-1}$$

Sulfur Dioxide

Within the 290-800 nm region, the photolysis of sulfur dioxide can only result in the formation of excited state species. The bond dissociation energy for $SO_2 \rightarrow SO + O(^3P)$ is 131.993 kcal/mole, and for bond dissociation to occur, a wavelength of 216 nm or less is required. In the 370-400 nm region, the absorption of light results in the formation of an excited triplet state species and in the 240-320 nm region, both excited triplet and singlet state species may be formed:⁵¹

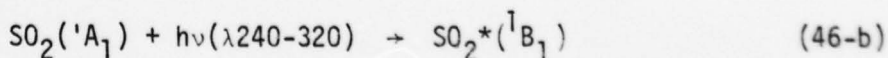
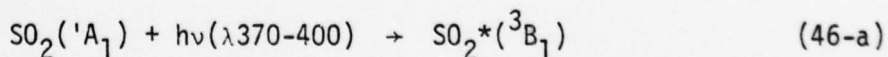

AD-A060 147

RESEARCH TRIANGLE INST RESEARCH TRIANGLE PARK N C F/G 13/2
SPECIFIC AIR POLLUTANTS FROM MUNITIONS PROCESSING AND THEIR ATM--ETC(U)
JAN 78 B H CARPENTER, R LIEPINS, J SICKLES DAMD17-76-C-6067
RTI/1342/00-01F-VOL-3 NL

UNCLASSIFIED

2 OF 2
AD
A060147

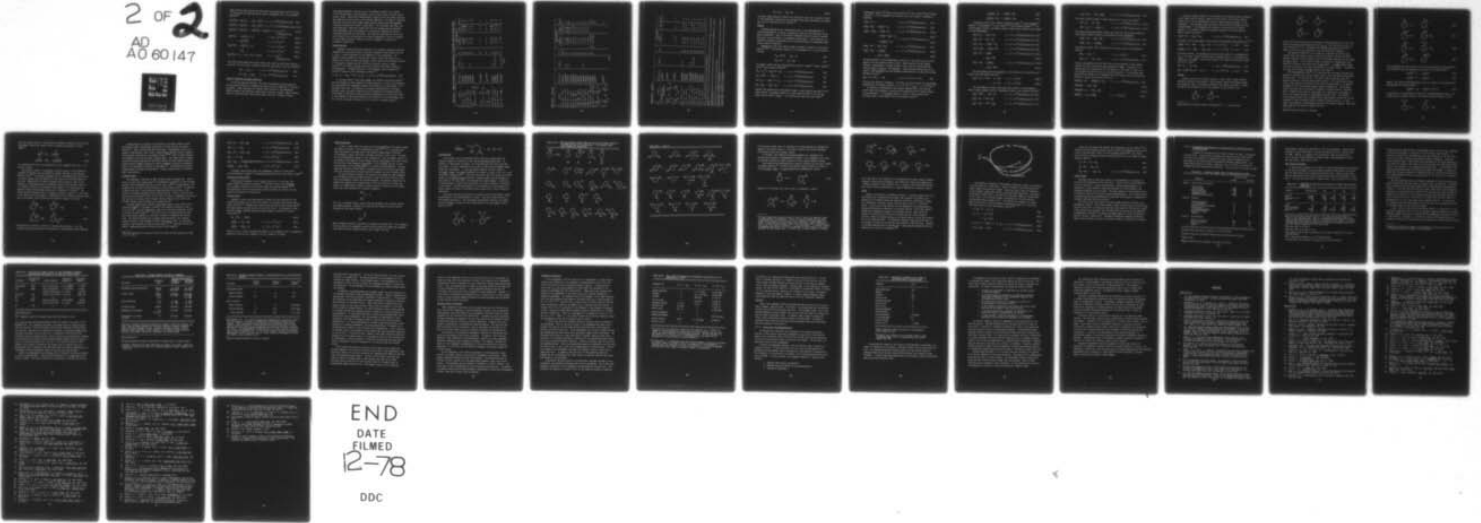

END
DATE
FILMED
12-78
DDC

1 F I E D

2

OF

2

AD

A0 60 147

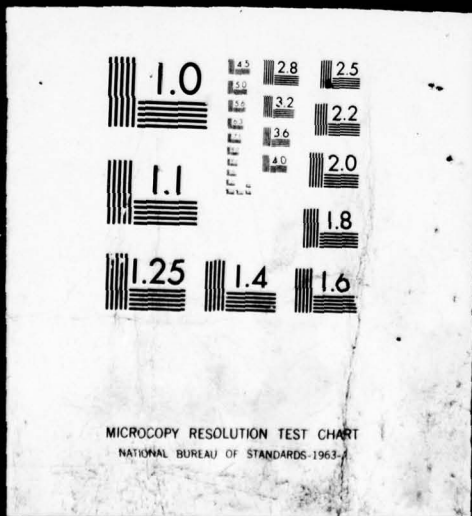

These excited state species can then react with ground state sulfur dioxide to form sulfur trioxide and sulfur oxide or decompose into a less energetic species:⁵⁸

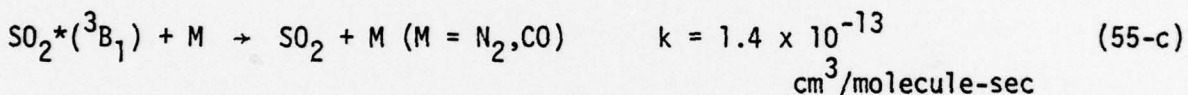
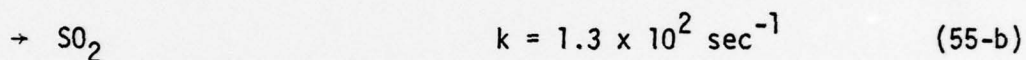
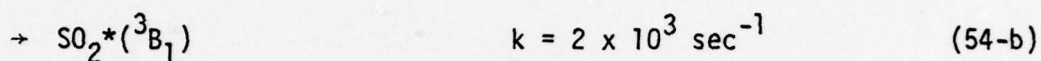
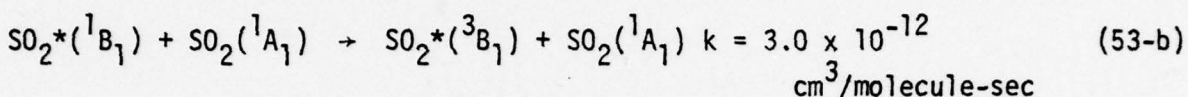
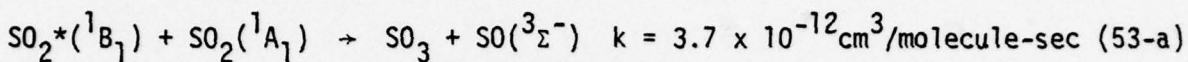
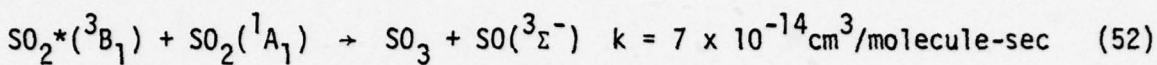

The sulfur oxide formed can further react with itself to form sulfur dioxide and sulfur or with sulfur trioxide to form two equivalents of sulfur dioxide:⁵¹

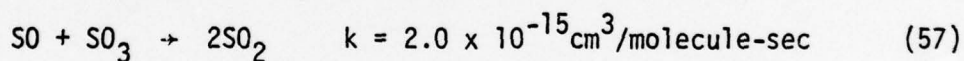
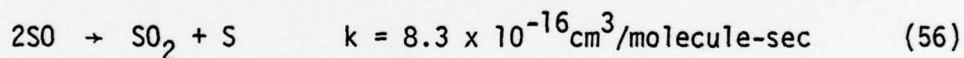

Known or Potential Secondary Reactions

In the two previous sections, the known and potential ground state and excited state reactions of compounds emitted during the production of TNT were discussed. These reactions will produce other species in the atmosphere: atomic oxygen at two different energy levels, molecular oxygen, ozone, hydroxyl radicals, carbon dioxide, substituted phenyl radicals, nitrogen trioxide,

dinitrogen pentoxide, nitrous acid, trinitromethyl radicals, aci isomers of the nitrotoluenes, nitrosotoluenes, sulfur oxide, sulfur trioxide, and of course, water. These newly formed species, some of which are highly reactive, may combine with each other or with emitted compounds. The known or potential reactions which may occur between these reactive species and the compounds originally emitted are listed in Table 6B-19. For the known reactions, the rate expression, conditions under which the rate expressions and constants were determined, the rate constants at a particular temperature, and the literature reference are also shown. For potential reactions for which the rate constants are not available, the heat of formation or the rate constant of an analogous reaction involving a similar compound is reported, as evidence of feasibility.

Carbon Monoxide

Compared to the ground state reactions, the reactions between an emitted compound and a particular reactive species are generally much faster and, as a result, of more importance to the chemistry of this atmosphere. For example, carbon monoxide, a species which reacts slowly with ozone and is unreactive to light at these wavelengths, reacts rapidly with hydroxyl radicals to form atomic hydrogen and the relatively unreactive species, carbon dioxide.⁵⁹ The atomic hydrogen then reacts quickly with species present in the atmosphere. A dominant reaction is that between atomic hydrogen and molecular oxygen to yield hydroperoxy radicals:¹⁷

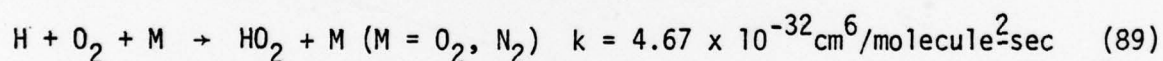

It has been noted in both smog chamber and computer simulation studies¹⁷ that the presence of small amounts of carbon monoxide in a moist, NO_x -polluted, and hydrocarbon-free atmosphere enhances the reactivity of the system. This increased reactivity is evidenced by increased concentrations of nitrogen dioxide, ozone, and atomic oxygen and by the formation of hydrogen peroxide. The increase of nitrogen dioxide and ozone concentrations is the direct result of the presence of the carbon monoxide, the formation of the hydroperoxy radical, and the subsequent oxidation of nitric oxide to nitrogen dioxide:²⁶

TABLE 6B-19. KNOWN OR POTENTIAL SECONDARY REACTIONS OF EMISSIONS FROM TNT INSTALLATIONS

No.	Reaction	Rate Expression	Condition	T(K)	Rate Constant ^{a,b,c,d}		Reference
					k molecule-sec	k ppm-min	
58	$\text{CO} + \text{OH} \rightarrow \text{CO}_2 + \text{H}$	$k_{58} [\text{CO}][\text{OH}]$	1 atm	298	1.4×10^{-13}	2.07×10^2	26
59	$\text{CO} + \text{HO}_2 \rightarrow \text{CO}_2 + \text{OH}$	$k_{59} [\text{CO}][\text{HO}_2]$	1 atm	300	2.7×10^{-13}	4.0×10^2	59
60	$\text{CH}_4 + \text{O}(^3\text{P}) \rightarrow \text{CH}_3 + \text{OH}$	$k_{60} [\text{CH}_4][\text{O}]$	1 atm	350	$< 1 \times 10^{-19}$	$< 1.5 \times 10^{-4}$	26
61	$\text{CH}_4 + \text{OH} \rightarrow \text{CH}_3 + \text{H}_2\text{O}$	$k_{61} [\text{CH}_4][\text{OH}]$	1 atm	298	7.8×10^{-17}	1.2×10^{-2}	26
62	$\text{C}_6\text{H}_5\text{CH}_3 + \text{O}(^3\text{P}) \rightarrow \text{C}_6\text{H}_5\text{CH}_2 + \text{OH}$	$k_{62} [\text{C}_6\text{H}_5\text{CH}_3][\text{O}]$	1 atm	298	7.6×10^{-15}	1.1×10	59
63	$\text{C}_6\text{H}_5\text{CH}_3 + \text{OH} \rightarrow \text{C}_6\text{H}_5\text{CH}_2 + \text{H}_2\text{O}$	$k_{63a} [\text{C}_6\text{H}_5\text{CH}_3][\text{OH}]$		298	1×10^{-12}	1.5×10^3	61
63	$\text{C}_6\text{H}_5\text{CH}_3 + \text{OH} \rightarrow \text{C}_6\text{H}_5\text{CH}_2 + \text{H}_2\text{O}$	$k_{63b} [\text{C}_6\text{H}_5\text{CH}_3][\text{OH}]$		298	6.4×10^{-12}	9.5×10^3	61
64	$\text{NO} + \text{O}(^3\text{P}) + \text{M} \rightarrow \text{NO}_2 + \text{M}$	$k_{64} [\text{NO}][\text{O}]$	M = N ₂	295	3.0×10^{-11}	4.4×10^3	62
65	$\text{NO} + \text{OH} + \text{M} \rightarrow \text{HONO} + \text{M}$	$k_{65} [\text{NO}][\text{OH}]$	M = N ₂ , O ₂ (1 atm)	298	5.6×10^{-12}	8.3×10^3	26
66	$\text{NO} + \text{HO}_2 \rightarrow \text{NO}_2 + \text{OH}$	$k_{66a} [\text{NO}][\text{HO}_2]$	M = N ₂ , O ₂ (1 atm)	298	1.17×10^{-11}	1.73×10^4	59
66	$\text{NO} + \text{HO}_2 + \text{M} \rightarrow \text{HONO}_2 + \text{M}$	$k_{66b} [\text{NO}][\text{HO}_2]$	M = N ₂ , O ₂ (1 atm)	298	1.6×10^{-12}	$2.4 \times 10^{3,e}$	26

continued

TABLE 6B-19. (cont'd)

No.	Reaction	Rate Expression	Condition	T(K)	Rate Constant ^{a,b,c,d}		Reference
					k molecule ⁻³ sec ⁻¹	k ppm ⁻¹ min ⁻¹	
67	$\text{NO}_2 + \text{O}(^3\text{P}) \rightarrow \text{NO} + \text{O}_2$	$k_{67a}[\text{NO}_2][\text{O}]$		293-339	9.12×10^{-12}	1.35×10^4	65
67-a							
67-b	$\text{NO}_2 + \text{O}(^3\text{P}) + \text{M} \rightarrow \text{NO}_3 + \text{M}$	$k_{67b}[\text{NO}_2][\text{O}][\text{M}]$	M = N ₂	298	1.0×10^{-31}	3.6×10^3	26
68	$\text{NO}_2 + \text{OH} + \text{M} \rightarrow \text{HNO}_3 + \text{M}$	$k_{68}[\text{NO}_2][\text{OH}]$	M = N ₂	296	4.5×10^{-12} 1.6×10^{-11}	6.6×10^3 2.4×10^4	26 66a
69	$\text{NO}_2 + \text{HO}_2 \rightarrow \text{HNO}_2 + \text{O}_2$	$k_{69a}[\text{NO}_2][\text{HO}_2]$		300	$3 \times 10^{-14,e}$	4×10^f	26
69-a							
69-b	$\text{NO}_2 + \text{HO}_2 \rightarrow \text{HO}_2\text{NO}_2$	$k_{69b}[\text{NO}_2][\text{HO}_2]$		298	4.83×10^{-13}	$7.15 \times 10^{2,f}$	67
70	$\text{NO}_3 + \text{HO}_2 \rightarrow \text{HNO}_3 + \text{O}_2$	$k_{70}[\text{NO}_3][\text{HO}_2]$		298	1.69×10^{-12}	2.5×10^3	17
71	$\text{N}_2\text{O}_5 + \text{O}(^3\text{P}) \rightarrow \text{products}$	$k_{71}[\text{N}_2\text{O}_5][\text{O}]$		300	$< 2 \times 10^{-13}$	$< 3 \times 10^2$	26
72	$\text{HNO}_2 + \text{O}(^3\text{P}) \rightarrow \text{NO}_2 + \text{OH}$	$k_{72}[\text{HNO}_2][\text{O}]$		300	$\geq 1.5 \times 10^{-14}$	$\geq 2.2 \times 10$	26
73	$\text{HNO}_2 + \text{OH} \rightarrow \text{NO}_2 + \text{H}_2\text{O}$	$k_{73}[\text{HNO}_2][\text{OH}]$		300	2.2×10^{-12}	3.3×10^3	63
74	$\text{HNO}_3 + \text{O}(^3\text{P}) \rightarrow \text{NO}_3 + \text{OH}$	$k_{74}[\text{HNO}_3][\text{O}]$	1 atm	300	$< 1.5 \times 10^{-14}$	$< 2.2 \times 10$	26
75	$\text{HNO}_3 + \text{OH} \rightarrow \text{NO}_3 + \text{H}_2\text{O}$	$k_{75}[\text{HNO}_3][\text{OH}]$		295	9.5×10^{-14}	1.4×10^2	68
76	$\text{C}(\text{NO}_2)_4 + \text{O}(^3\text{P}) \rightarrow (\text{NO}_2)_3\text{C} + \text{NO}_3$	$k_{76}[\text{C}(\text{NO}_2)_4][\text{O}]$		298	$\Delta H_f^\ddagger = -11.25 \text{ Kcal/mole}$		26,45
77	$\text{C}(\text{NO}_2)_4 + \text{OH} \rightarrow (\text{NO}_2)_3\text{C} + \text{HNO}_3$	$k_{77}[\text{C}(\text{NO}_2)_4][\text{OH}]$		298	$\Delta H_f^\ddagger = -10.29 \text{ Kcal/mole}$		26,45
78		$k_{71a}[\text{MWT}][\text{O}]$					57
78-a							
78-b		$k_{78b}[\text{MWT}][\text{O}]$					57

continued

TABLE 6B-19. (cont'd)

No.	Reaction	Rate Expression	Condition	T (K)	Rate Constant ^{a,b,c}		Reference
					k molecule ⁻³ -sec	k ppm ⁻¹ -min	
78 -c	$(\text{CH}_3)_2\text{C}_6\text{H}_4(\text{NO}_2) + \text{O}(\text{^3p}) \rightarrow (\text{CH}_3)_2\text{C}_6\text{H}_3(\text{NO}_2)(\text{OH})$	$k_{78c}[\text{MNT}][\text{O}]$					57
79 -a		$k_{79a}[\text{MNT}][\text{O}]$					
79 -b		$k_{79b}[\text{MNT}][\text{OH}]$				6.14	69
80	$\text{O}_2 + \text{O}(\text{^3p}) + \text{M} \rightarrow \text{O}_3 + \text{M}$	$k_{80}[\text{O}_2][\text{O}][\text{M}]$	M = N ₂	300	5.8×10^{-34}	2.1×10^{-5}	26
81	$\text{O}_3 + \text{OH} \rightarrow \text{O}_2 + \text{HO}_2$	$k_{81}[\text{O}_3][\text{OH}]$		300	5.7×10^{-14}	8.3×10	26
82	$\text{O}_3 + \text{HO}_2 \rightarrow 2\text{O}_2 + \text{OH}$	$k_{82}[\text{O}_3][\text{HO}_2]$		300	1.5×10^{-15}	2.2	26
83	$\text{SO}_2 + \text{O}(\text{^3p}) + \text{M} \rightarrow \text{SO}_3 + \text{M}$	$k_{80}[\text{SO}_2][\text{O}][\text{M}]$	M = N ₂	300	7.8×10^{-34}	2.8×10^{-5}	26
84	$\text{SO}_2 + \text{OH} + \text{M} \rightarrow \text{HSO}_3 + \text{M}$	$k_{84}[\text{SO}_2][\text{OH}]$	M = N ₂ (1 atm)	297	6.0×10^{-13}	8.9×10^2	70
85	$\text{SO}_2 + \text{HO}_2 \rightarrow \text{SO}_3 + \text{OH}$	$k_{85}[\text{SO}_2][\text{HO}_2]$		300	9×10^{-16}	1.3	26
86	$\text{SO}_3 + \text{O}(\text{^3p}) \rightarrow \text{SO}_2 + \text{O}_2$	$k_{86}[\text{SO}_3][\text{O}]$		300	5.7×10^{-17}	8.4×10^{-2}	26
87	$\text{SO} + \text{O}_2 \rightarrow \text{SO}_2 + \text{O}(\text{^3p})$	$k_{87}[\text{SO}][\text{O}_2]$		300	$< 8 \times 10^{-17}$	$< 1 \times 10^{-1}$	26
88	$\text{SO} + \text{O}_3 \rightarrow \text{SO}_2 + \text{O}_2$	$k_{88}[\text{SO}][\text{O}_3]$		300	7.55×10^{-14}	1.12×10^2	26

^aThe rate constants for reactions 67-b, 80, and 83 are in units of cm⁶/molecule²-sec.

^bThe rate constant for reaction 79-b is that for the reaction between the hydroxynitrocyclohexadienyl radical and oxygen. See the Section on nitro-toluenes.

^cTo convert from units of cm³/molecule-sec to ppm⁻¹min⁻¹ multiply the former unit by 1.478 x 10¹⁵, to convert from cm⁶/molecule²-sec to ppm²min⁻¹ multiply by 3.64 x 10²⁸.

^dA complete listing of reactions and rate constants can be found in Appendix 1.

^eSince reaction 66-a is the predominant reaction pathway between nitric oxide and hydroperoxy radicals, reaction 66-b may have little importance in atmospheric chemistry. Hence k_{66b} = 0, see Reference 65.

^fSince reaction 69-b is the predominant reaction pathway between nitrogen dioxide and hydroperoxy radicals, reaction 69-a may have little importance in atmospheric chemistry. Hence k_{69a} = 0, see Reference 64.



The newly formed hydroxyl radical will eventually react with a species present in the atmosphere, conceivably with another carbon monoxide molecule to repeat the cycle of reactions 58, 89, and 66-a.¹⁷

Methane

Although methane has an insignificant role in the photochemistry of polluted atmospheres, it exerts a substantial effect on the chemistry of the global troposphere. Many of the radical-mediated oxidation steps of methane also occur in the oxidation of nonmethane hydrocarbons. These reactions are therefore included as background to aid the understanding of nonmethane hydrocarbon oxidation chemistry.

Methane can react with atomic oxygen or hydroxyl radicals to form methyl radicals.^{26,59} The dominant reaction in the atmosphere will be with hydroxyl radicals.



The methyl radical may then be oxidized by molecular oxygen,⁷¹ atomic oxygen,⁷² ozone,⁷³ and nitrogen dioxide:²⁶

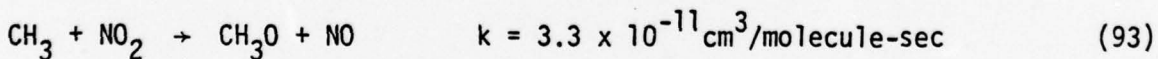
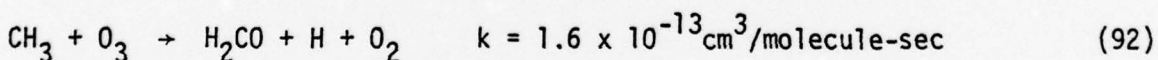
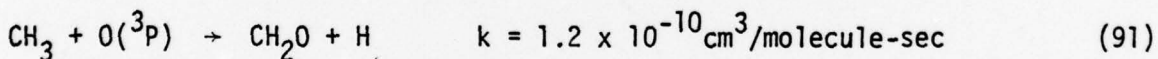
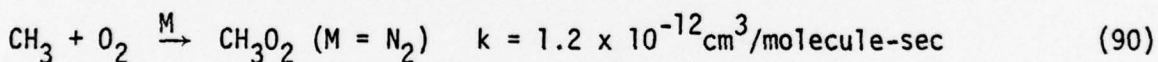

Because the concentration of molecular oxygen is much greater than that of the other species, the methyl radical will react primarily with it to form the methyl peroxy radical (CH_3O_2). This radical may then react with ozone,⁷³

hydroperoxy radicals,²⁶ methyl peroxy radicals,⁷² nitric oxide,⁷⁴ and nitrogen dioxide.⁷⁴ In the atmosphere the reaction with nitric oxide is expected to dominate:

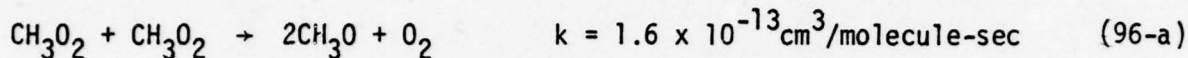
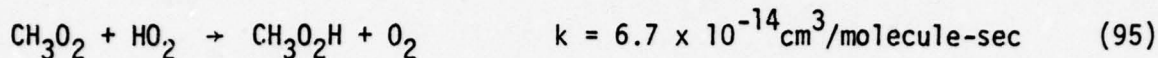
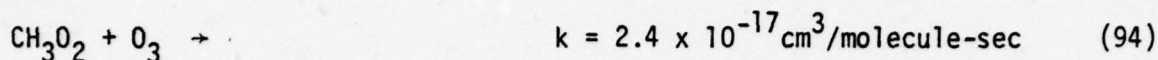

$$k = 3.05 \times 10^{-13} \text{ cm}^3/\text{molecule-sec}$$

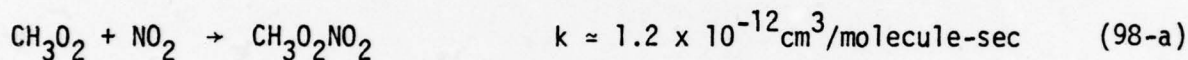
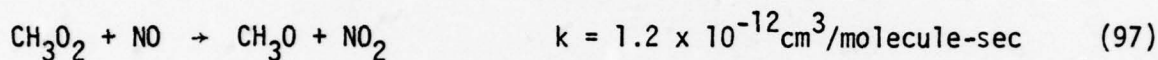

The major product in the decomposition reactions of the methyl peroxy radical appears to be the methoxy radical (CH_3O). Other products include oxygen, methanol, formaldehyde, nitrogen dioxide, nitric acid, and three peroxide species ($\text{CH}_3\text{O}_2\text{H}$, $\text{CH}_3\text{O}_2\text{CH}_3$, and $\text{CH}_3\text{O}_2\text{NO}_2$). These peroxide species may not be stable in the atmosphere and may decompose photochemically as does the analogue hydrogen peroxide:¹⁷

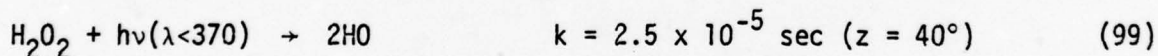

They may also thermally decompose. At 391°K, the rate constant for the thermal decomposition of dimethyl peroxide is $5 \times 10^{15} \text{ sec}^{-1}$ ($t_{1/2} = 1.4 \times 10^{-16} \text{ sec}$).⁷⁵

In addition to photochemical and thermal decomposition, the peroxide species may also decompose by reacting with another molecular species present in the atmosphere. The $\text{CH}_3\text{O}_2\text{NO}_2$ species is known to react rapidly with nitrogen oxides to form methyl nitrite and methyl nitrate.⁷⁶

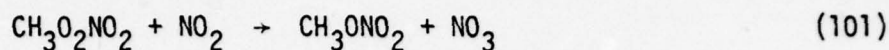
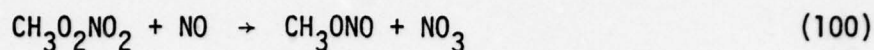

The methoxy radical will further react with oxygen,⁷⁴ carbon monoxide,¹⁷ methane,¹⁷ formaldehyde,¹⁷ nitric oxide,^{16,74} and nitrogen dioxide.^{17,74} As did the methyl radical, the methoxy radical should react primarily with oxygen to form formaldehyde:

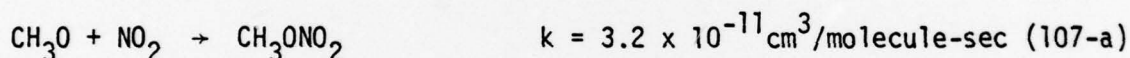
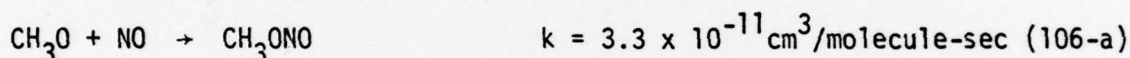
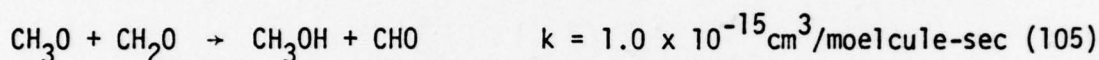
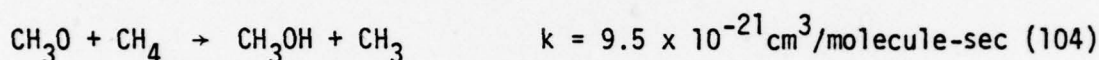
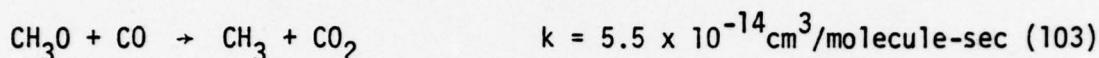
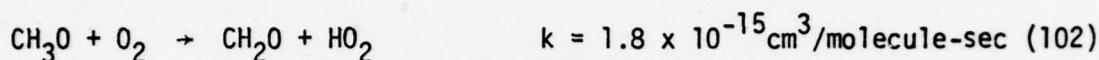

The formaldehyde which was produced in the previous set of reactions can absorb light and photodissociate:¹⁷

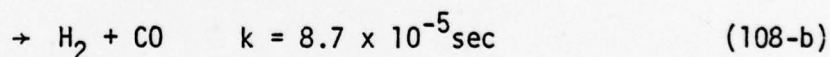
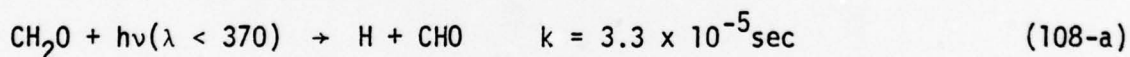

The formaldehyde can also react with other species in the atmosphere; atomic oxygen, hydroxyl radical, hydroperoxy radical, and nitrogen trioxide:¹⁷

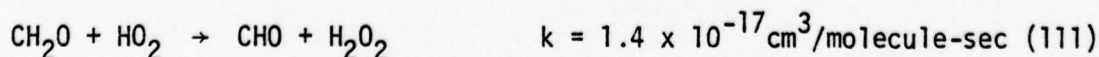
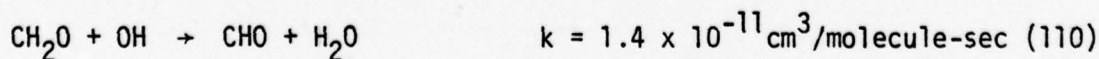
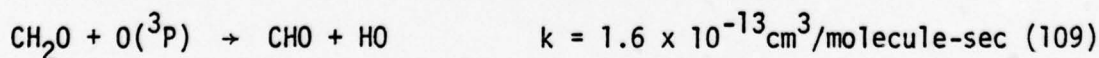

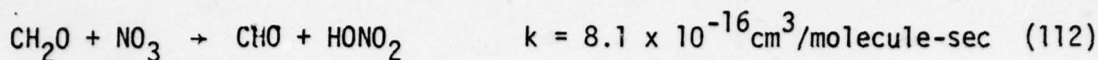

The formyl radical formed in these reactions will react with oxygen:¹⁷

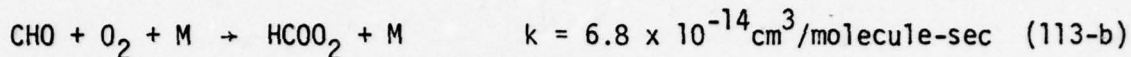
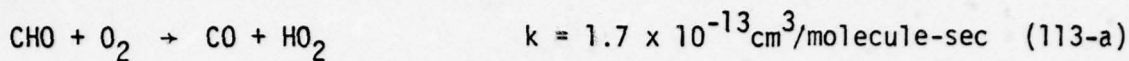

The newly formed peroxyformyl radical may react with the nitrogen oxides to form formate radicals (HCO_2) or peroxyformyl nitrate (HCOO_2NO_2):

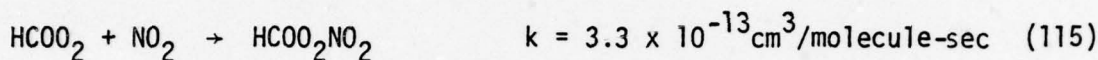
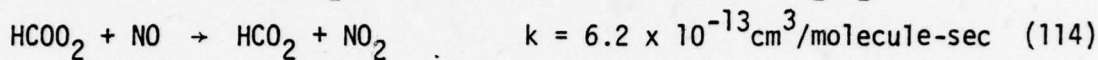

The formate radicals will ultimately yield carbon dioxide and hydroperoxy radicals:

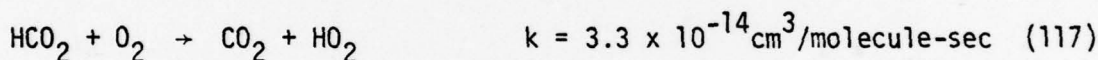
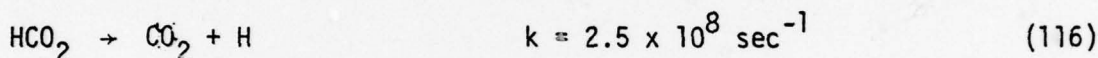

To date, peroxyformyl nitrate (PFN) has not been detected in smog chamber studies in which it might have been expected to appear. Therefore, it is assumed that the concentration of this species is very small or that it is very unstable and exists only as a transient species. It is believed that should PFN be formed it will decompose into the formate radical and nitrogen dioxide or carbon dioxide and nitric acid:

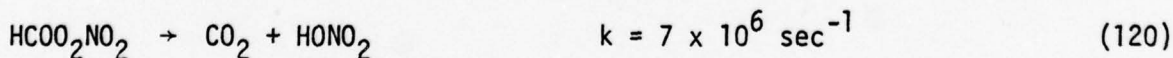
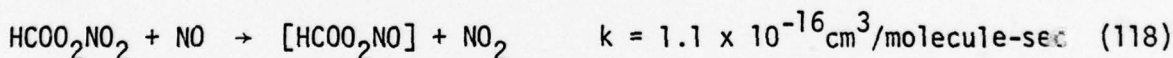

The other products formed in the reactions of the methoxy radical; methanol (104), methyl nitrite (106-a), methyl nitrate (107-a), and nitroxyl radical (106-b)) will also be destroyed by light or reactive species present in the atmosphere. Since methanol does not absorb light within the 290-800 nm range of wavelengths, it can decompose only through its reactions with reactive species. It is known to react with hydroxyl radicals to form the hydroxymethyl radical and water:¹⁷

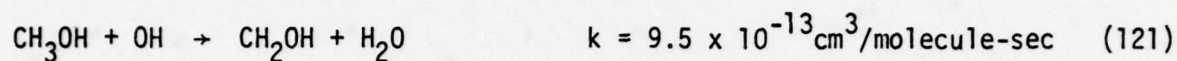

The methyl nitrite and methyl nitrate species may decompose photochemically:^{16,17}

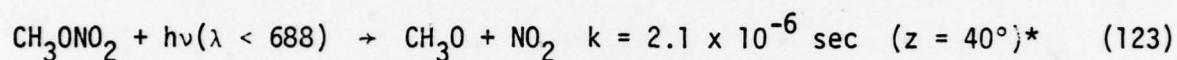
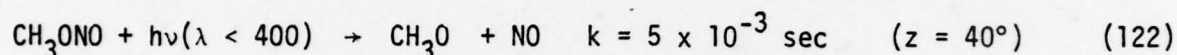

For methyl nitrate, its photolysis may be the chief mode of its decomposition ($t_{1/2} = 120 \text{ sec}$). Methyl nitrate should accumulate due to its low photolysis rate ($t_{1/2} = 3.8 \text{ days}$). The nitroxyl radical will react with molecular oxygen as well as light:¹⁷

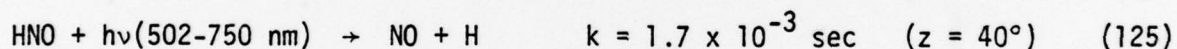
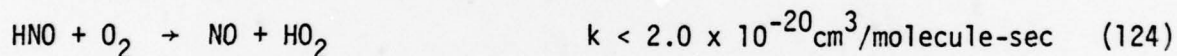

Toluene

Toluene can react with several species: ozone, atomic oxygen, hydroxyl radicals, and other free radicals. Both hydroxyl radicals and atomic oxygen are thought to react by hydrogen abstraction from either the methyl or phenyl portion of the molecule as well as by addition to the aromatic ring.

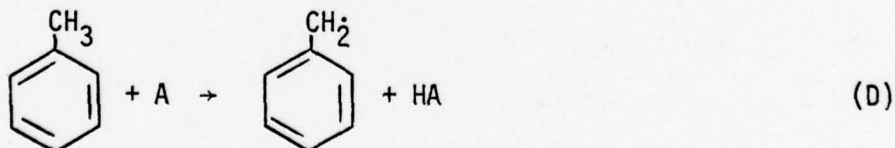

*Rate constant for ethyl nitrate, see Reference 17. z = zenith angle.

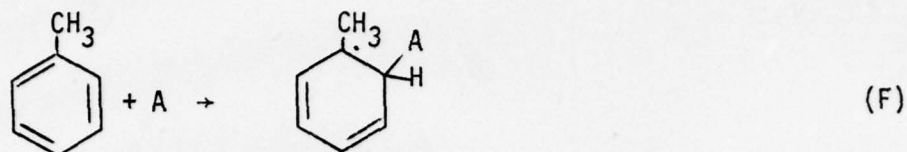
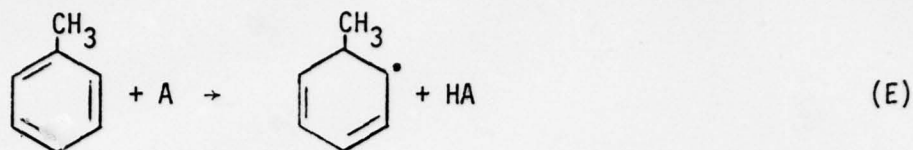

Since the dissociation energy of the methyl carbon-hydrogen bond is less than that of the phenyl carbon-hydrogen bond ($D_{\text{H}_2\text{C}-\text{H}}^\circ = 88.3 \text{ Kcal/mole}$ and $D_{\text{C}^\circ\text{ar}-\text{H}}^\circ = 110.5 \text{ Kcal/mole}^*$),⁷⁸ it is believed that hydrogen abstraction from the methyl group is the more important of the two abstraction pathways.

The products identified in the oxidation of toluene by atomic oxygen indicate that the oxygen initially attacks the aromatic ring and the intermediate rearranges to form cresols, most of which were identified as the ortho and para isomers. Of the cresols formed, the quantity of ortho-cresol was found to be three or four times that of para-cresol. The meta isomer formed less than 4 percent of the total concentration of cresol isomers. In addition to these cresol isomers, polymer material also forms.⁷⁹

From thermochemical data,⁸⁰ it is believed that the oxygen atom may also abstract a hydrogen atom from the methyl group to form the benzyl and hydroxyl radicals ($\Delta H_f^\circ = -17.2 \text{ Kcal/mole}$). The benzyl radical then may react with molecular oxygen to form the peroxy benzyl radical. This species may oxidize nitric oxide yielding the benzoxy radical and nitrogen dioxide in a reaction analogous to that of the methyl peroxy radical (reaction 97). The benzoxy radical may then react with molecular oxygen or nitrogen dioxide. Benzaldehyde is formed by the reaction with oxygen via a route that is analogous to that of the methoxy radical to formaldehyde (reaction 102). The reaction of the benzoxy radical with nitrogen dioxide yields benzyl nitrate via a route analogous to that for methyl nitrate formation (reaction 107-a). In most cases, the formation of benzaldehyde should be the dominant pathway. These proposed reactions are shown as numbers 126-129.

*Bond dissociation energy for benzene.

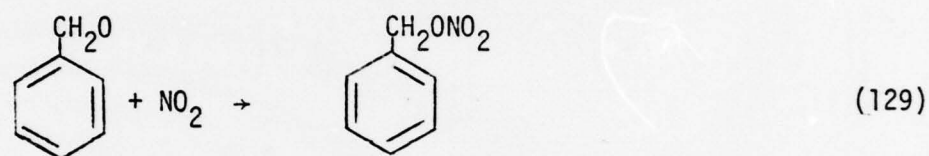
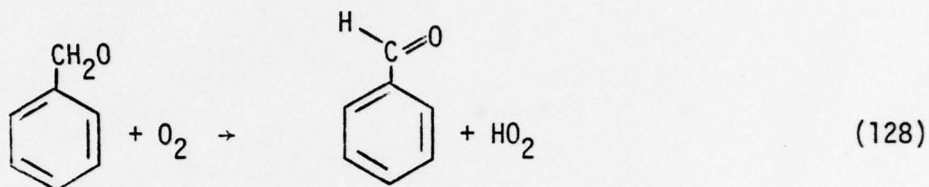
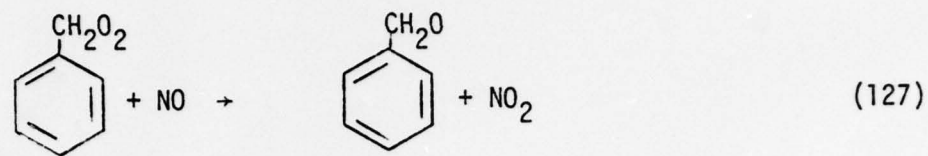
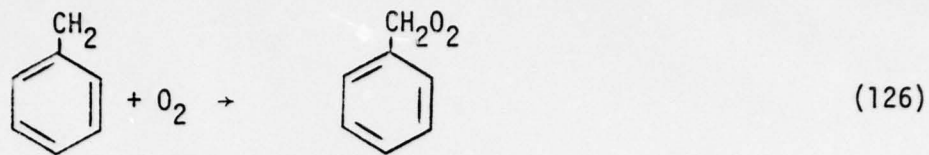

The benzaldehyde may absorb light to form an electronically excited molecule which generally does not decompose but returns to the ground state:¹⁷

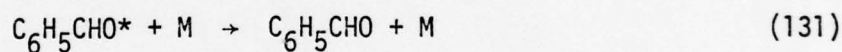

However, the excited benzaldehyde may react with oxygen to form ground state benzaldehyde and singlet oxygen:¹⁷

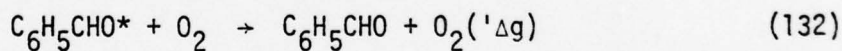

In addition to its photochemical reactions, the benzaldehyde may react with oxygen atoms or hydroxyl radicals, the latter yielding a benzoyl radical:

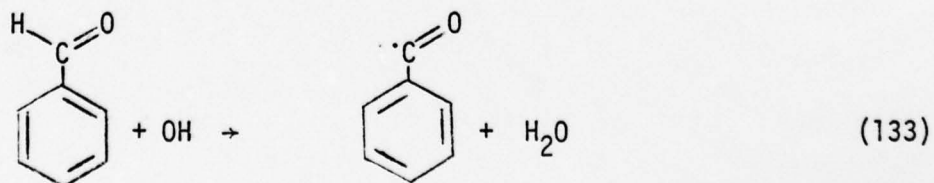

Like the formyl radical in the oxidation of methane (reaction 113-b and 115), the benzoyl radical may further react to produce peroxybenzoyl nitrate (PBN):¹⁷

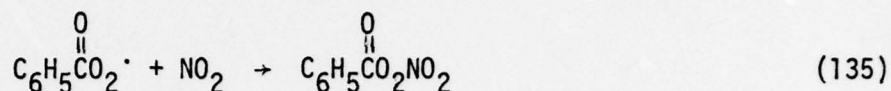
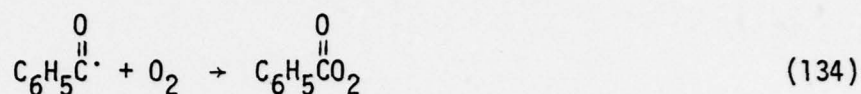

It is believed that only trace quantities of this compound will form. It is an eye irritant.

The hydroxyl radical, the dominant reactive species in the atmospheric oxidation of toluene, may also abstract a methyl hydrogen or add onto the aromatic ring.⁶¹ It has been suggested that at room temperature, abstraction is a minor pathway and that addition to the ring occurs over 80 percent of the time. Abstraction of a methyl hydrogen would eventually lead to the formation of benzaldehyde and to subsequent products such as PBN. Addition of a hydroxyl radical to the aromatic ring results in the formation of a hydroxyl radical-toluene adduct which has a lifetime of 1-30 msec.⁶¹ The adduct may then decompose back to toluene and hydroxyl radical or it may lead to the formation of new products. Examination of the alternative reaction pathways of the adduct favors reaction with molecular oxygen or nitrogen

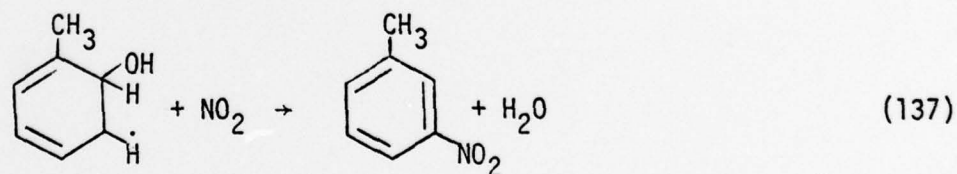
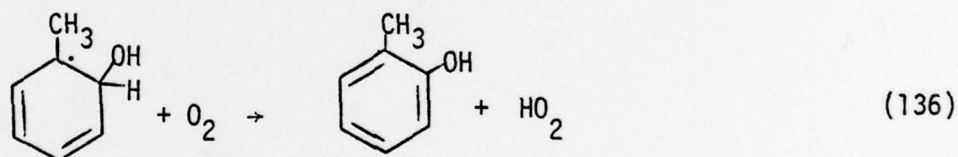

The formation of cresols is favored at low NO_x concentrations. For high nitrogen dioxide concentrations, the pathway to nitrotoluenes may be important.

Photooxidation of toluene in the presence of nitrogen oxides has been reported to produce considerable quantities of carbon dioxide and carbon monoxide.⁸¹ Other species have been identified: formaldehyde, formic acid, glyoxal, methylglyoxal, PAN, cresols, benzaldehyde, hydroxyl benzyl alcohols, nitrotoluenes, nitrocresols, and benzyl nitrate.⁸¹⁻⁸⁴ Many of these products are compatible with the reactions proposed above. The large yields of carbon dioxide and carbon monoxide and the identification of other simple oxidation product species suggest alternative reaction pathways involving ring opening steps in the subsequent oxidation of the adduct.⁸¹ The mechanism describing photooxidation of aromatic hydrocarbons is highly uncertain and is currently under investigation.

Nitrogen Oxides

The atmospheric reactions of the nitrogen oxides are quite fast. Nitric oxide can react with oxygen atoms,⁶² or hydroperoxy radicals²⁶ to form nitrogen dioxide, with hydroperoxy radicals to form nitric acid⁶³ (a minor product, see Reference 64), and with hydroxyl radicals to form nitrous acid.⁵⁹ In addition to these reactions, it was previously mentioned that nitric oxide is also oxidized to nitrogen dioxide by alkyl peroxy radicals. Nitric oxide can also react with alkoxy radicals (RO) to form alkyl nitrites or aldehydes and nitroxyl radicals and with peroxy alkyl carbonyl radicals (RCO₃) to form alkyl substituted formate radicals (RCO₂) and nitrogen dioxide.

Nitrogen dioxide reacts quickly with oxygen atoms to form either nitric oxide and oxygen⁶⁵ or nitrogen trioxide,²⁶ with hydroxyl radicals to form nitric acid,^{66a} and with hydroperoxy radicals to form either pernitric acid⁶⁷ or nitrous acid and oxygen.²⁶ Like nitric oxide, nitrogen dioxide can also react with alkoxy radicals to form alkyl nitrates or aldehydes and nitrous acid. The reaction between this nitrogen oxide and peroxy alkyl carbonyl radicals results in the formation of PAN or analogues of PAN. The reactions leading to the formation of PAN are given below.*^{17,85} Reactions 142 and 143 define a temperature-sensitive equilibrium for PAN formation.

*The rate constants for reactions 138-143 are those for the formation of PAN, i.e., R = CH₃.

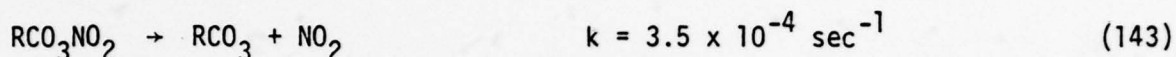
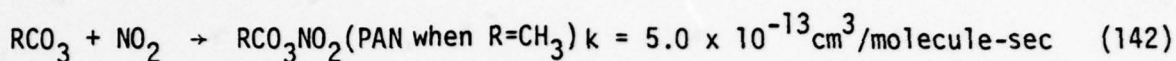
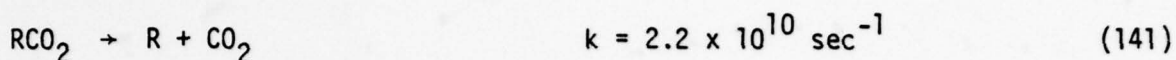
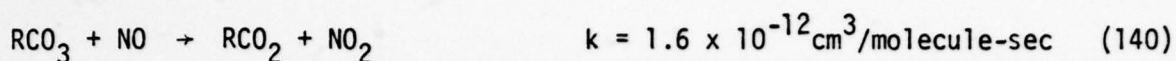
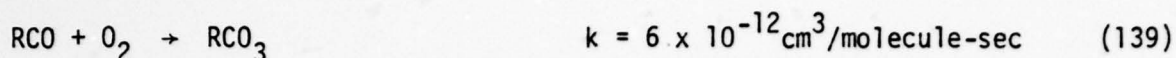
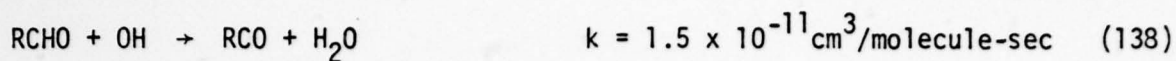

Nitrogen trioxide may react with hydroperoxy radicals to form nitric acid and molecular oxygen;¹⁷ dinitrogen pentoxide may react with atomic oxygen.²⁶

Nitrous and Nitric Acids

Nitrous acid decomposes into nitrogen dioxide by its reactions with oxygen atoms²⁶ and hydroxyl radicals.⁶³ Similarly nitric acid decomposes into nitrogen trioxide by the action of these two reactive species.^{26,68} The reactions of nitric acid and these reactive species are slower than the respective reactions of nitrous acid.

Pernitric Acid

Recently, kinetic and spectroscopic evidence has been reported for the formation of pernitric acid from the reaction of nitrogen dioxide with hydroperoxy radicals.⁶⁷ Although this reaction was believed to form nitrous acid,⁶³ the major product has been shown to be pernitric acid. The sequence of steps describing major formation and destruction pathways of pernitric acid are listed below.⁸⁶

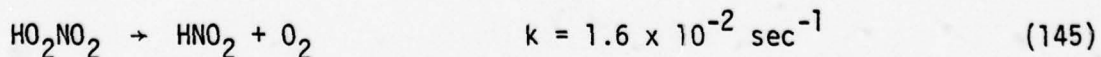
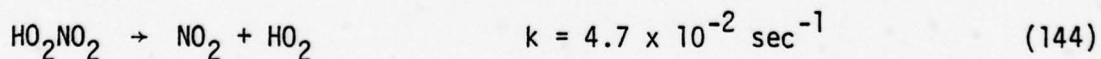

Pernitric acid is highly unstable and should play an important role in atmospheric chemistry by serving as a temporary sink for oxides of nitrogen.

Tetranitromethane

Little is known about the reaction of tetranitromethane with atomic oxygen and hydroxyl radicals. From thermochemical data,^{26,45} it is projected that these two species can break one of the carbon-nitrogen bonds to form the trinitromethyl radical and either nitrogen trioxide or nitric acid. The fate of the trinitromethyl radical is only speculative. Like the methyl radical, it may combine with oxygen to form a peroxy radical $[(\text{NO}_2)_3\text{CO}_2]$, with nitric oxide to form the nitroso compound $[(\text{NO}_2)_3\text{CNO}]$, or with nitrogen dioxide to form trinitromethyl nitrite $[(\text{NO}_2)_3\text{CONO}]$ or to reform tetranitromethane. The most important reaction of these three is probably that of the radical and oxygen since the concentration of oxygen should be greater than the nitrogen oxides.

The peroxy radical formed by the reaction with oxygen may then decompose into nitrogen dioxide and carbon dioxide or react with nitric oxide to form the trinitromethoxy radical and nitrogen dioxide. The methoxy radical may be temporarily trapped by a nitrogen oxide to form the nitrite or nitrate compound. An oxygen atom or hydroxyl radical may also cleave off a nitro group, resulting in the formation of a carbonyl compound,

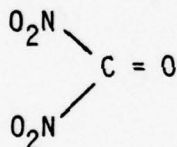

This too is probably highly unstable and may decompose into nitrogen dioxide and carbon monoxide. Another nitro group may be cleaved to form a radical analogous to the formyl radical,

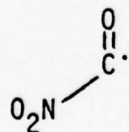

Hence, through a series of reactions an analogue of PAN may form. This compound, like the other nitro compounds, may not be very stable and indeed may decompose into carbon dioxide, nitrogen dioxide, and nitrogen trioxide:

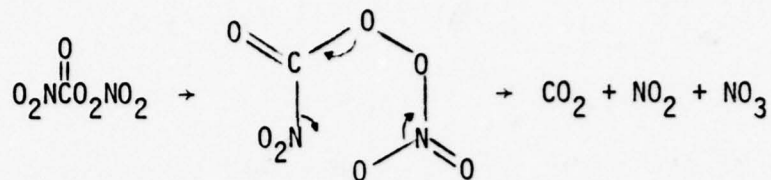

Nitrotoluenes

Like toluene, the nitrotoluenes should react with oxygen atoms and hydroxyl radicals by addition to the ring and hydrogen abstraction. In addition to these modes of attack, it is possible that the nitro group may be cleaved. To date, information exists only on the reaction between oxygen atoms and nitrobenzene. In this gas phase oxidation at 100°C, phenol, and ortho-, meta-, and para-nitrophenol are formed in yields of 20, 16, 4, and 60 percent, respectively.⁵⁷ Since both the methyl and nitro groups facilitate attack at the ortho and para positions, numerous phenols may be produced in the oxidation of a particular nitrotoluene with atomic oxygen. In addition to these products, cresols and nitrocresols can also be formed by cleavage of a nitro group. The possible products of the oxidation of nitrotoluenes with atomic oxygen are found in Table 6B-20; the products most likely formed are underlined.

The oxygen atom may also abstract a hydrogen atom from the methyl carbon and eventually a nitrobenzaldehyde is formed. (See the Toluene Section for the proposed mechanism.) The substituted benzaldehyde compounds with ortho nitro and carbonyl groups can react photochemically to form ortho nitroso-benzoic acid:⁸⁷

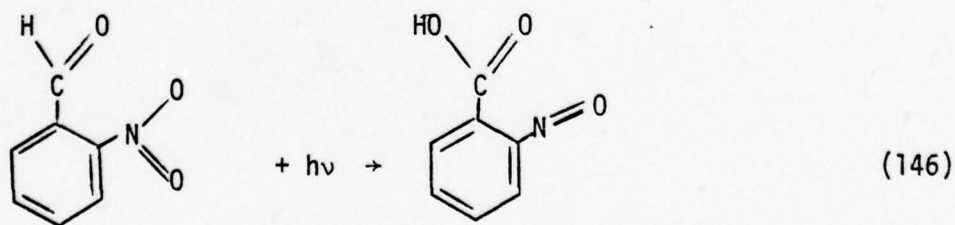

TABLE 6B-20. POSSIBLE PRODUCTS FORMED FROM THE ADDITION OF ATOMIC OXYGEN TO THE AROMATIC RING OF A NITROTOLUENE. (THE PRODUCTS MOST LIKELY FORMED ARE UNDERLINED.)

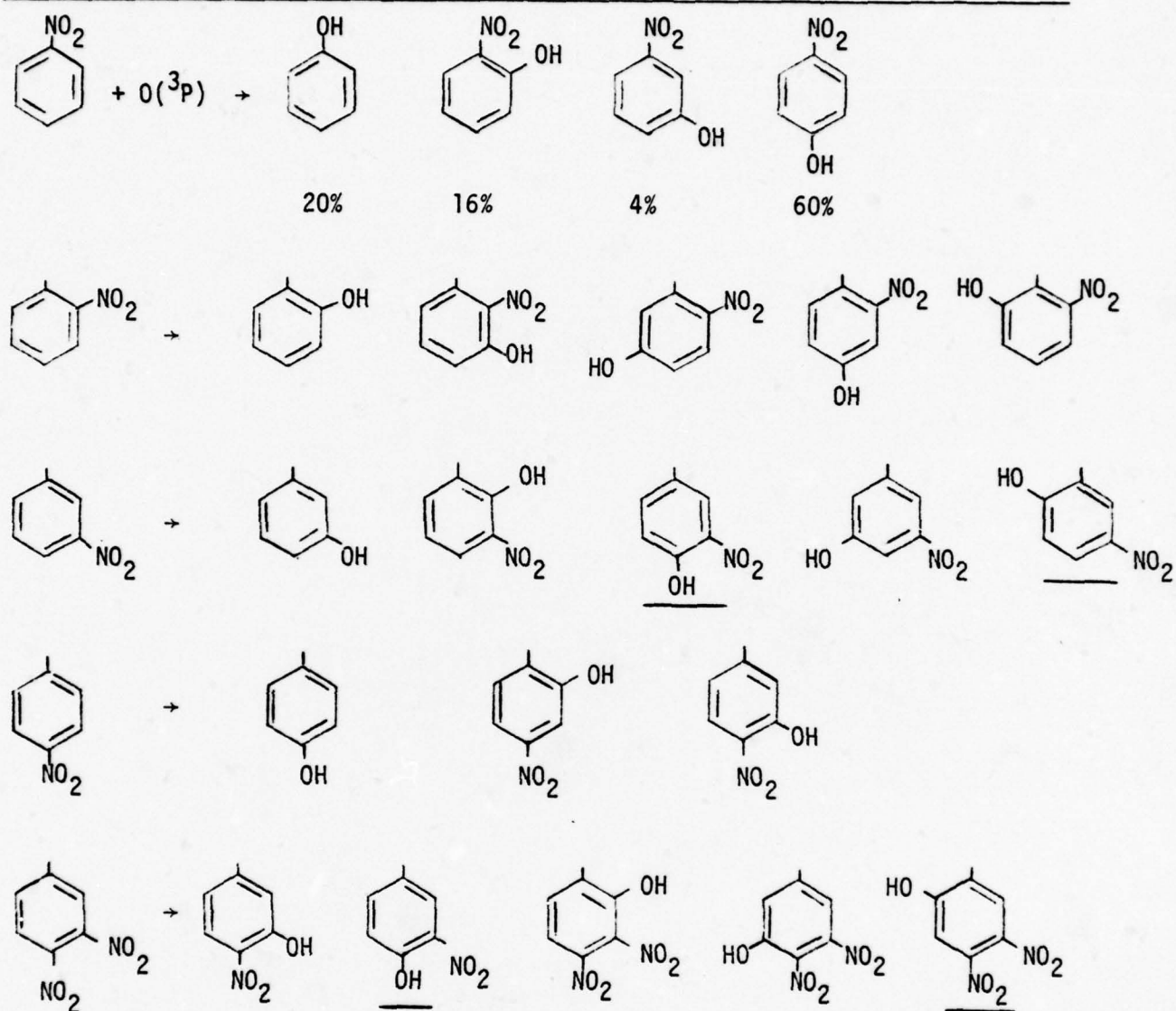
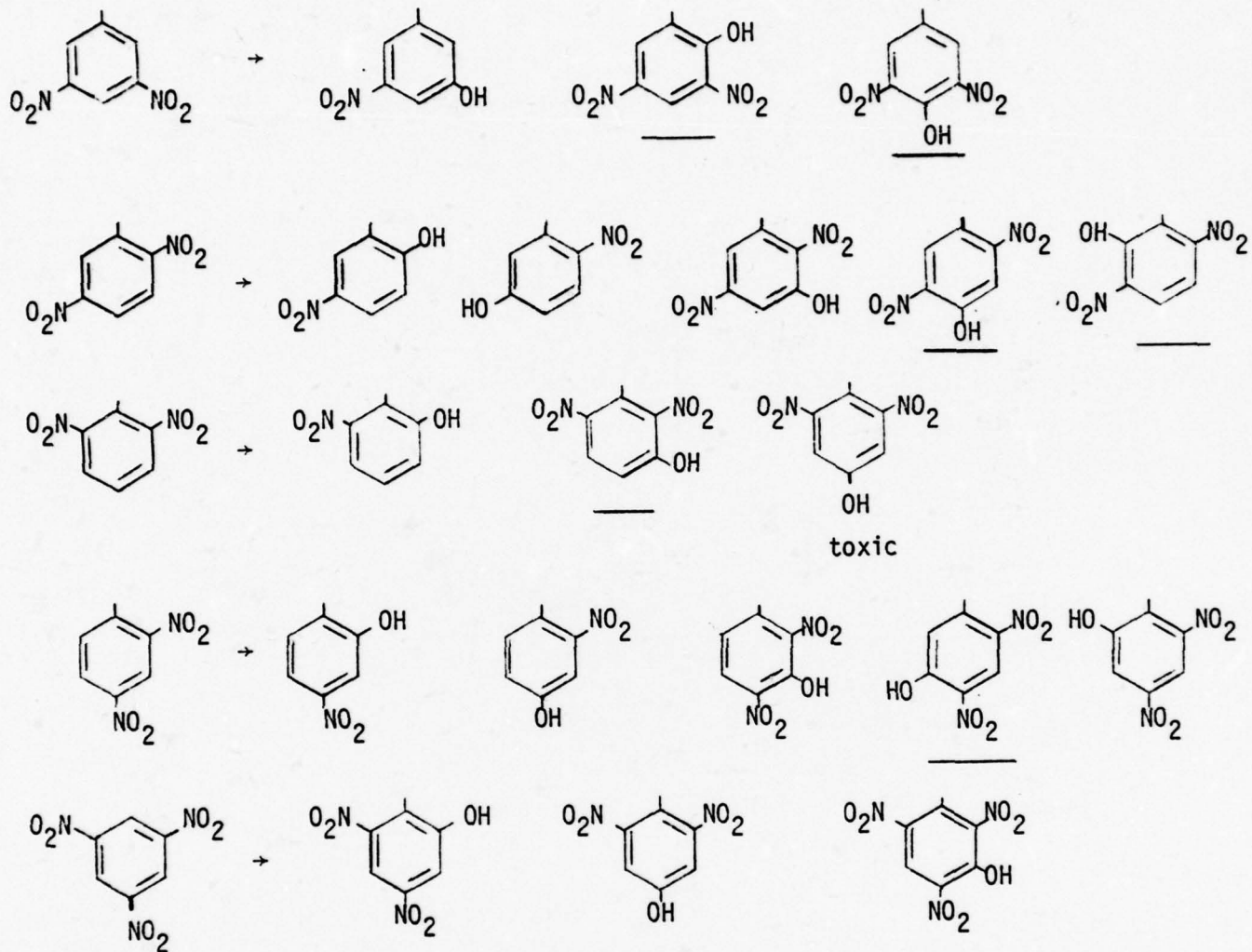

TABLE 6B-20. (cont'd)



The acid may further react via cleavage of the bond between the hydrogen and oxygen of the hydroxy group.* This radical species may further decompose into carbon dioxide and a phenyl radical.

In contrast, the remaining nitrobenzaldehydes will probably be as photolytically stable as benzaldehyde and remain in the atmosphere until they are further oxidized by radical species or form a peroxy benzoyl nitrate.

The oxidation of nitrobenzene with hydroxyl radicals has only been studied in aqueous solution.⁶⁹ Initially the hydroxyl radical attacks the ring to form the ortho-, meta-, or para-hydroxynitrocyclohexadienyl radical:

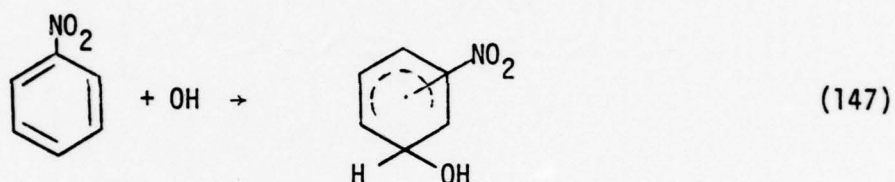

Oxygen will also attack the ring to form a nitrophenol or phenol:

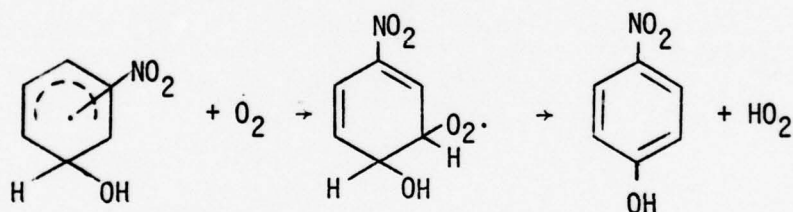

*The bond dissociation energy of the O-H bond in acetic and propionic acids is approximately 110 Kcal/mole.⁹ Hence, it may be assumed that the bond dissociation energy of the O-H bond in this compound is approximately the same. If the bond dissociation energy of the C-H bond in this compound is similar to that found in benzene ($D^\circ = 110.5$ Kcal/mole),⁷⁸ a hydroxyl radical, for example, may abstract either the hydrogen from the aromatic ring or the hydrogen from the oxygen atom. In either case, a phenyl radical is formed.

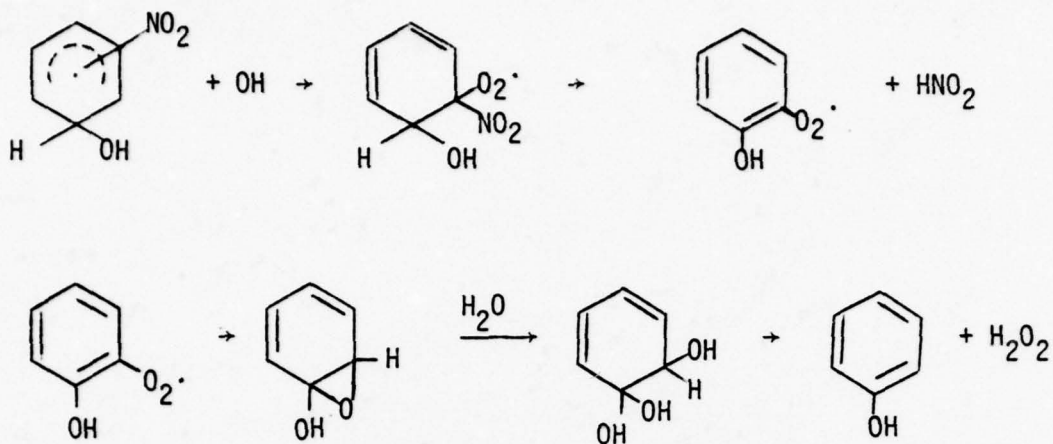

As in the case of the oxidation of nitrotoluenes with atomic oxygen, numerous products, cresols and nitrocresols, may potentially form by the addition of a hydroxyl radical to the aromatic ring. Likewise, substituted benzaldehydes will result from the abstraction of a methyl hydrogen by a hydroxyl radical.

Ozone

Ozone is exclusively a secondary pollutant. If organic vapors and nitrogen dioxide are irradiated with sunlight, the processes initiated by the photolysis of nitrogen dioxide can generate significant quantities of ozone. The intervention of organic vapors into the $\text{NO}_x\text{-O}_3$ cycle is illustrated below. In this cycle, free radicals (R) are generated from hydrocarbons by processes following the photolysis of nitrogen dioxide. These free radicals combine with atmospheric oxygen to form peroxy radicals (RO_2) which are capable of oxidizing nitric oxide to nitrogen dioxide. Each oxidation of nitric oxide to nitrogen dioxide by a nonozone species allows the accumulation of an ozone molecule. To illustrate, consider from Table 6B-18 that in the absence of organics 0.25 ppm NO_2 would generate 0.062 ppm ozone. However, it has been reported that 0.2 ppm NO_x and 12 ppm *n*-butane generated 0.65 ppm ozone after six hours of irradiation.⁸⁸

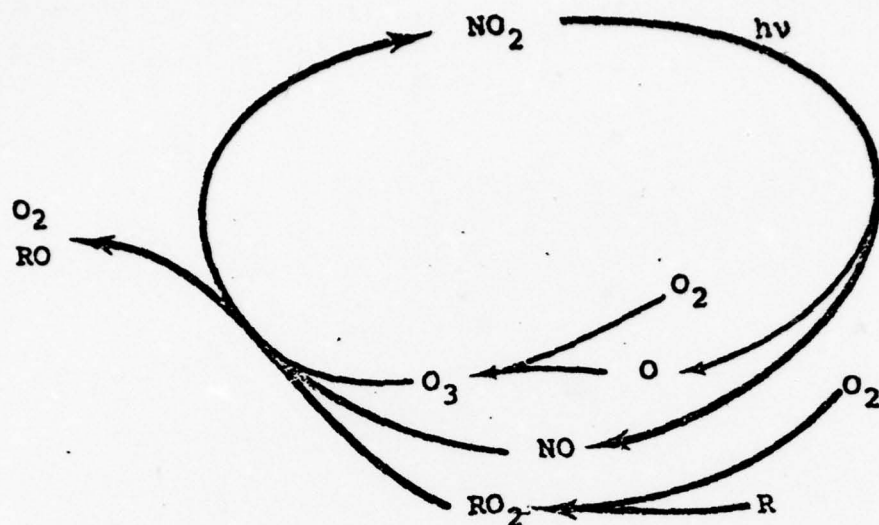

The sequence of photolytic and secondary reactions directly or indirectly involving ozone are listed below. Ozone is formed by the rapid reaction of atomic oxygen with molecular oxygen. Ozone may absorb light and photolyze to yield atomic oxygen (see section on Excited State Reactions). The ground state atomic oxygen, $O(^3P)$, can react with molecular oxygen to reform ozone. If the light is of sufficient energy, the photolysis of ozone can yield excited state atomic oxygen, $O(^1D)$. This species can undergo collisional deactivation with air to yield ground state atomic oxygen or it can react with water vapor to yield two hydroxyl radicals.²⁶

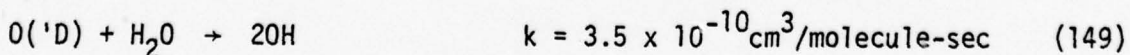
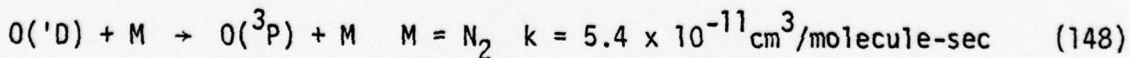

Ozone can also react with hydroxyl and hydroperoxy radical species.²⁶ The reaction with the hydroxyl radical species yields the hydroperoxy radical which in turn, can react with itself to yield hydrogen peroxide,²⁶ with either nitric oxide or nitrogen dioxide as mentioned earlier, or with ozone to reform hydroxyl radicals.

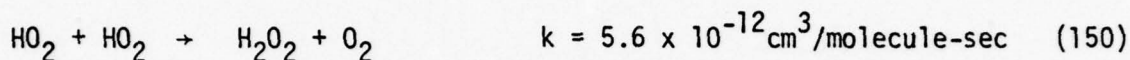

Sulfur Oxides

The major fate of the sulfur oxides in the atmosphere is conversion to sulfates with subsequent sulfate deposition. There are five broad mechanisms for this conversion: direct photooxidation, indirect photooxidation, air oxidation in liquid droplets, catalyzed oxidation in liquid droplets, and catalyzed oxidation on dry surfaces. The major pathway in the pollutant matrix of munitions facilities should be indirect photooxidation. This process occurs in hydrocarbon-NO_x-SO₂ photochemical systems when the oxidation is mediated by secondary reactions involving radicals.

The sulfur oxides can react with atomic oxygen, hydroxyl radicals, and hydroperoxy radicals. With atomic oxygen, sulfur dioxide reacts to form sulfur trioxide; the sulfur trioxide may then react with water to form sulfuric acid.³⁶ Sulfur dioxide can also react with the more reactive species as the hydroxyl⁷⁰ or hydroperoxy radicals²⁶ to produce the HOSO₂ species or sulfur trioxide and hydroxyl radical, respectively. Although the detailed oxidation mechanisms remain poorly defined, the fate of the sulfur oxides is conversion to sulfates.

6.B.2.3 Environmental Consequences of the Emissions From TNT Manufacturing at RAAP and VAAP

A summary of the emissions and emission rates from VAAP is presented in Table 6B-21. These primary pollutants are classified into three groups. The first classification is comprised of those species designated as air pollutants by the United States Environmental Protection Agency (EPA). The second group consists of organic compounds, such as solvents or byproducts, released during TNT manufacturing processes. The third and final group includes

TABLE 6B-21. EMISSIONS SUMMARY FROM TNT MANUFACTURING AT VAAP^a

Compound	Emission Rate	
	lb/day	ton/year
Group 1. EPA Criteria Pollutants		
Particulates	200	37
Sulfur Oxides	2,894	528
Carbon Monoxide	75	14
Nitrogen Oxides	6,855	1,251
Nonmethane Hydrocarbons	123	22
Group 2. Organics		
Tetranitromethane	b	b
Trinitrobenzene	b	b
Isomers of Trinitrotoluene	b	b
Nitrocresols ^c	b	b
Trinitrobenzaldehyde	b	b
Mononitrotoluenes	b	b
Toluene	b	b
Group 3. Miscellaneous		
Sulfuric Acid Mist	599	109
Nitric Acid Mist	b	b
Ammonia	d	d

^aAssumes plant operation at capacity, six 50 TPD units.

^bEmission rates not available although they are believed to be small.

^cHighly toxic.

^dAmmonia emissions are suspected, with data to confirm.

miscellaneous species not considered in the first two groups. Data were not available in sufficient detail to allow the construction of a similar table for RAAP. However, it appears that the emission rates of particulates, sulfur dioxide, carbon monoxide, nitrogen oxides, and hydrocarbons at RAAP are even greater than those at VAAP.

EPA Criteria Pollutants

A qualitative evaluation of the impact of the EPA-designated air pollutants on the local environment can now be made by comparing the emission rates from the TNT installations with county wide emission rates. Emission rates from RAAP and VAAP along with the county-wide emission rates are presented in Table 6B-22. From the available data, it appears that a large fraction of the sulfur

TABLE 6B-22. COMPARISON OF RAAP AND VAAP EMISSIONS TO COUNTY WIDE EMISSIONS (TONS/YEAR)

Location	Particulates	SO ₂	CO	NO _x	HC
RAAP ^{a,b}	13,883	6,357	294	7,933	360
Montgomery Co. ^{a,c}	16,449	7,924	21,251	11,130	4,349
% ^d	85	80	14	72	8

VAAP ^a	36	74 ^f	---	177	---
(RTI Estimate) ^e	37	528 ^f	14	1,251	22
Hamilton Co. ^{a,c}	14,392	10,165	119,070	16,002	24,545
% ^d	0.2	0.7	0	1.1	0

^aData were retrieved from EPA's National Emissions Data System (NEDS) on June 7, 1977 (Reference 89). NEDS is a computerized data bank which holds detailed emissions inventory data for each county in the country. It should be noted that differences in practices of reporting and updating emissions data may prevent comparisons on the same basis.

^bEmission rate is for 1972.

^cEmission rate as of June 2, 1971.

^dThis value is the percent contribution of the army installation to county wide emissions.

^eRTI's emissions estimate at six 50 TPD operations.

^fAn additional 109 tons/year of H₂SO₄ mist are also indicated.

oxides and particulate emissions of Montgomery County, Virginia, are comprised of emissions from RAAP, in particular, from the power plant at RAAP. In contrast, the emissions from VAAP make up a small fraction of the total emissions of the highly industrialized Hamilton County, Tennessee. Since the county emission rates in Table 6B-22 were developed for TNT plant operation at less than full capacity, the impact of emissions under full mobilization would result in an increase in the county-wide emission rates. The fraction of the county-wide emissions due to the TNT plants would also change. It should be noted that the above comparison of NEDS data does not consider the possibility for elevated ambient pollutant concentrations in the vicinity of or downwind from the plants.

EPA has established source performance standards (SPS) which specify the maximum permissible emission rates for several types of industries. Currently, these regulations have not been established for the explosives manufacturing industry. To set the TNT plant emissions rates (Table 6B-21) into perspective, capacities of sources subject to EPA SPS with emissions equivalent to VAAP are presented in Table 6B-23. The nitrogen oxide emissions from VAAP are equivalent to those from a coal fired boiler in a power plant having a capacity of 38 megawatts or a nitric acid plant which produces 2285 TPD. On this basis, the nitrogen oxide emissions appear to be significant and are expected to have a noticeable impact on the local environment.

A major issue for EPA criteria pollutants (Group 1 in Table 6B-21) is the question of compliance with air quality standards (National Ambient Air Quality Standards (NAAQS) are given in Table 6B-24) and nondegradation guidelines (given in Table 6B-25). Although it is outside the scope of the present study, an estimate of ground level concentrations could be made for the primary pollutants.*

* Meteorological dispersion models can be applied to primary pollutants only if these pollutants are assumed to be nonreacting.

TABLE 6B-23. CAPACITIES OF SOURCES SUBJECT TO EPA PERFORMANCE STANDARDS WITH EMISSIONS EQUIVALENT TO THE VAAP TNT INSTALLATIONS

Pollutant	Emission Rate lb/day	Source Category	Emission Regulation ^a	Equivalent Capacity
Particulate	200	Coal Fired Boiler	0.1 lb/10 ⁶ BTU	7.8 MW ^b
SO ₂	2894	Coal Fired Boiler	1.2 lb/10 ⁶ BTU	9.4 MW
		Sulfuric Acid Plant	4 lb/ton	724 TPD
Acid Mist	597	Sulfuric Acid Plant	.15 lb/ton	3980 TPD
CO	75	---	---	---
NO _x	6855	Coal Fired Boiler	.70 lb/10 ⁶ BTU	38 MW
		Nitric Acid Plant	3.0 lb/ton	2285 TPD
HC	123	---	---	---

^aSee Reference 90.

^bMW = megawatt; conversion assumes power plant efficiency of 32%.

This could be done using meteorological dispersion models as was done for the RDX/HMX plant. For secondary pollutants (pollutants that are formed in atmospheric reactions), dispersion models coupling both chemistry and meteorology are required. Because of the inaccuracies inherent to dispersion modeling and the many assumptions that are made (e.g., assumptions involving the plant location, the plant characteristics, and the emission characterization), ambient air concentration estimates from such meteorological models may be in error by a two- or three-fold multiplier or divisor. This dispersion analysis does, however, give a general feeling for the effect that an industry has on air quality such that a comparison with the applicable air quality standards and an assessment of the environmental impact of new facilities can be made.

Once in the atmosphere, the ultimate fate of these EPA criteria pollutants is fairly straightforward. The particulate material will be deposited on the earth's surface. The sulfur dioxide will be oxidized to sulfates and sulfuric

TABLE 6B-24. NATIONAL AMBIENT AIR QUALITY STANDARDS

Pollutant	Averaging Time	Maximum Concentration	
		Primary Standard ^b	Secondary Standard ^c
Suspended particulate matter	Annual	75 $\mu\text{g}/\text{m}^3$	60 $\mu\text{g}/\text{m}^3$
	24 hr	260 $\mu\text{g}/\text{m}^3$	150 $\mu\text{g}/\text{m}^3$
Sulfur oxides	Annual	0.03 ppm	0.02 ppm
	24 hr	0.14 ppm	0.10 ppm
	3 hr		0.5 ppm
Carbon monoxide	8 hr	9 ppm	9 ppm
	1 hr	35 ppm	35 ppm
Nitrogen oxides	Annual	0.05 ppm	0.05 ppm
Nonmethane hydrocarbons	3 hr (6-9 am)	0.24 ppm	0.24 ppm
Photochemical oxidants as ozone	1 hr	0.08 ppm	0.08 ppm

Additional standards have been proposed for asbestos, beryllium, mercury, and lead; they are being prepared for fluorides, polycyclic organic compounds, odors (including hydrogen sulfide), chlorine, hydrogen chloride, arsenic, cadmium, copper manganese, nickel vanadium, zinc, barium, boron, chromium, selenium, pesticides, radioactive substances, and aeroallergens.

^aSee Reference 91.

^bPrimary standards have been established to protect public or human health.

^cSecondary standards have been established to protect soil, water, vegetation, materials, and animals as well as to maintain personal comfort, weather, and visibility.

TABLE 6B-25. MAXIMUM ALLOWABLE INCREASE IN CONCENTRATION FOR SO₂ AND PARTICULATE MATTER^a

Pollutant	Class ₃ I ($\mu\text{g}/\text{m}^3$)	Class ₃ II ($\mu\text{g}/\text{m}^3$)	Class ₃ III ^b ($\mu\text{g}/\text{m}^3$)
Particulate matter			
Annual average	5	10	60
24 hour maximum	10	30	150
Sulfur dioxide			
Annual average	2	15	(0.02 ppm)
24 hour maximum	5	100	(0.10 ppm)
3 hour maximum	25	700	(0.5 ppm)

^aSee Reference 92. The recently promulgated nondegradation regulations affect only new sources, in contrast to NAAQS which affect both existing and new sources. These regulations require weighing the incremental deterioration against social and economic considerations and limiting increases in sulfur dioxide and particulate matter concentrations within each of three classification areas. The nondegradation guidelines will not allow industrial development in areas designated Class I, will permit a modest increase in industrial development in Class II areas, and will allow industrial development in Class III areas as long as NAAQS are met.

^bFederal Secondary Ambient Air Quality Standard.

acid which will form aerosols. The fate of these aerosols will then include rainout or dry deposition. The carbon monoxide in the atmosphere will be oxidized to carbon dioxide. The nitrogen oxides in the atmosphere will be converted to nitric acid and nitrates with subsequent removal by rainout and dry deposition. The hydrocarbons will be oxidized into carbon dioxide, water, and aerosols.

In addition, the hydrocarbons and nitrogen oxides are also precursors of the secondary pollutant, ozone (photochemical oxidant). Ozone is generated and accumulates in the cyclic process illustrated in Section 6B.2.3. In the cycle, free radicals (R) are generated from organic compounds by processes following the photolysis of nitrogen dioxide. These free radicals combine with atmospheric oxygen to form peroxy radicals (RO_2) which are capable of oxidizing nitric oxide to nitrogen dioxide. For each molecule of nitric oxide oxidized to nitrogen dioxide by a nonozone species, a molecule of ozone accumulates in the atmosphere. At high hydrocarbon and nitrogen oxide concentrations representative of urban atmospheres, the concentration of hydrocarbons is more influential than that of nitrogen oxides in dictating the resulting ozone concentration. At lower hydrocarbon and nitrogen oxide concentrations, representative of nonurban atmospheres, the ozone concentration is thought to be influenced more strongly by the nitrogen oxide concentration. Thus, injection of nitrogen oxides into nonurban air may enhance the ozone generative potential of the air mass. It should be noted, however, that under conditions where the concentration of nitrogen oxides is in substantial excess of the concentration of hydrocarbons, oxidant formation is inhibited and any ozone that may enter such an atmosphere is quickly destroyed by its reaction with the nitrogen oxides.

Since explosives plants are sources of both organic and nitrogen-containing compounds, the setting of the facility as well as the magnitude of the emissions relative to the local emissions will determine the impact on both the local and downwind oxidant levels. The data in Table 6B-21 show that the emission rate of nitrogen oxides is much greater than that of any other pollutant and that the ratio of the emission rates of nitrogen oxides to hydrocarbons ranges from 20 to 60. The dominant impact of this emissions

profile in the immediate vicinity of the TNT facility will be to destroy any ozone which may enter the plume and to inhibit its formation until atmospheric processes facilitate attainment of a more favorable nitrogen oxide-hydrocarbon ratio. Thus, the concentration of ozone in the plume should be less than that in the surrounding air parcels. In the atmosphere downwind from the TNT facilities, the ratio may be more favorable to ozone production. However, it is difficult to ascertain the contribution of a single source to rural oxidant levels at long distances downwind because the ozone precursors may be emitted by many sources within the region.

Non-EPA Criteria Pollutants

Other atmospheric emissions also are associated with the TNT facilities. They include such compounds as tetranitromethane, toluene, and nitrotoluenes. Unfortunately, data that would allow an estimate of emission rates for these compounds are not available (see Table 6B-21). Although the source strengths of these compounds are thought to be low, they should not be dismissed simply because their emission rates are currently undefined. Instead, this issue should be addressed by a comprehensive sampling program. The resulting data base could then be used to develop a list of pollutants prioritized on the basis of emission rates and also an estimate of ambient air concentrations.

A discussion of the potential atmospheric chemistry of the emitted compounds was presented in the previous sections. In general, the literature revealed little information on the atmospheric chemistry of these compounds; therefore, mechanisms were proposed by analogy. For example, although the details of the atmospheric decomposition of tetranitromethane are currently undefined it is believed that the TNM will decompose into carbon oxides and nitrogen oxides.

In the atmosphere, the toluene may degrade to carbon monoxide, carbon dioxide, and organic species such as acids, aldehydes, and alcohols. These organic oxidation products may then form aerosols. The toluene may also be nitrated to form a variety of nitro-substituted aromatics such as the nitro-cresols. Nitrotoluenes may be oxidized or nitrated in a similar fashion. The nitro group of the nitrotoluenes may also dissociate from the ring. In addition to numerous oxidized and nitrated products, peroxyacetyl nitrate and peroxybenzoyl nitrate, known eye irritants, may be produced.

Atmospheric Chemistry

In the atmosphere, the life-time of an air contaminant is largely determined by the propensity of the compound to photodissociate and by its reactivity with species such as ozone and hydroxyl radicals. A compilation of half-lives ($t_{1/2}$) has been assembled in Table 6B-26 for selected air contaminants associated with TNT installations. These half-lives consider each pathway to be independent of the others and do not consider secondary or competitive pathways. The photolytic half-life assumes a first order reaction with the light intensity equivalent to that with the sun at a zenith angle of 40° ($z = 40^\circ$).^{16,17} The half-life in the presence of ozone assumes a constant ozone concentration equal to the NAAQS, $[O_3] = 0.08$ ppm (see Table 6B-24). A range of half-lives is presented for the compound in the presence of hydroxyl radicals, because the mean ambient hydroxyl radical concentration is currently not well established. Since it is believed to lie between 0.5 and 5.0×10^{-7} ppm ($0.5 \times 10^{-7} < [OH] < 5 \times 10^{-7}$ ppm),⁹³ these two values were chosen to bound the disappearance rate due to hydroxyl radical attack.

It can be seen that the nitrogen oxides are the most reactive species in the atmosphere. Half of the nitric oxide in the atmosphere may react within minutes with ozone to form nitrogen dioxide and within hours with hydroxyl radicals to form nitrous acid. In the atmosphere, half of the nitrogen dioxide may photodissociate into nitric oxide and atomic oxygen within one minute. The nitrogen dioxide may also react with ozone or hydroxyl radical within hours. Similarly, the secondary pollutant, nitrous acid, also photodissociates rapidly into nitric oxide and hydroxyl radicals. Within six minutes, half of this acid may photodissociate. Nitric acid photodissociates at a negligible rate relative to nitrous acid; it has a half-life of approximately fifty-five hours. Half of the toluene in the atmosphere may react with hydroxyl radicals within two to twenty-one hours. In general, the half-lives of the remaining reactions between the air contaminants and light, ozone, or hydroxyl radicals are either much longer or not available.

To determine the total effect of the emissions from RAAP and VAAP on the atmosphere, the secondary pollutants must also be considered. Two of the chief secondary pollutants in this atmosphere include ozone and nitrous acid. The formation and chemistry of ozone as well as the potential effects of munition

TABLE 6B-26. HALF-LIVES OF SELECTED AIR CONTAMINANTS ASSOCIATED WITH THE MANUFACTURE OF TNT^{a, b}

Compound (A)	A + hv → t _{1/2}	A + O ₃ → t _{1/2}	A + OH → t _{1/2}
Carbon monoxide	---	1 x 10 ⁷ days	4.6-46 days
Methane	---	9.4 x 10 ⁵ days	87-870 days
Toluene	---	330 days	2.1-21 hr
Nitric oxide	---	0.33 min	2.8-28 hr
Nitrogen dioxide	1.1 min	3.0 hr	3.5-35 hr
Nitrous acid	5.8 min	---	7.0-70 hr
Nitric acid	55 hr	---	6.9-69 days
Tetranitromethane	?	?	?
Mononitrotoluenes	?	?	157-1570 days
Sulfur dioxide	102 hr	6 x 10 ⁴ days	26-260 hr
Sulfuric acid	---	---	---

^aThe half-life of a reaction is defined by the equation $t_{1/2} = 0.693/k$ sec. Except for the photolyses of nitrous acid and sulfur dioxide, the rate constants are those reported in the preceding sections. The rate constant for the photolysis of nitrous acid is from Reference 17, and that for the photolysis of sulfur dioxide is from Reference 16.

^bA blank space (---) designates that the reaction between a particular pollutant and light, ozone, or hydroxyl radical is unimportant in the atmosphere. A question mark (?) indicates that the rate constant for the reaction between a pollutant and light, ozone, or hydroxyl radical is unavailable.

emissions on its formation and destruction were discussed earlier. Nitrous acid, a secondary pollutant, is formed in an equilibrium reaction involving nitric oxide, nitrogen dioxide, and water and also in the reaction between nitric oxide and hydroxyl radicals. Nitrous acid, in the presence of secondary amines, can lead to the formation of carcinogenic nitrosamines either in ambient air or in the work place. Based on the findings of this study, nitrosamine formation is not anticipated. However, if future sampling programs reveal amine emissions, then the potential would exist for nitrosamine formation.

Toxicity

None of the compounds emitted from RAAP and VAAP are known to be carcinogenic; however, some are toxic. Previously, it was mentioned that 4,6-dinitro-o-cresol and 3,5-dinitro-p-cresol are toxic. The nitrogen oxides, nitric acid, tetranitromethane, sulfur dioxide, and sulfuric acid are known to irritate the eyes and upper respiratory tract. In addition, TNM is known to damage the liver; nitric and sulfuric acids are known to corrode teeth. Permissible threshold level values (TLV) for the emitted compounds have been established and are presented in Table 6B-27.²

6.B.2.4 Conclusions and Recommendations

If the emissions identified and estimated in the engineering process analysis of the current study were comprehensive and precise, then emission rates of air pollutants from the TNT facility at VAAP could be considered too low to have a significant impact on the local environment. On this basis, no additional action can be recommended.

It should be remembered, however, that the present study is primarily a literature review. If major emissions do exist, were not documented, and therefore were overlooked, then a comprehensive investigation is appropriate. The following is a discussion of an ordered, prioritized approach dealing with such a problem. In this situation, the suggested approach is iterative and involves:

1. Sampling (both source and ambient)
2. Computer modeling (dispersion and photochemical)
3. Laboratory experiments

TABLE 6B-27. PERMISSIBLE THRESHOLD LEVEL VALUES OF EMISSIONS FROM TNT INSTALLATIONS²

Compound	TLV ^a
Carbon Monoxide	50
Methane	---
Toluene	100
Nitric Oxide	25
Nitrogen Dioxide	5
Nitrous Acid	---
Nitric Acid	2
Tetranitromethane	1
Nitrotoluene ^b	5
Dinitrotoluene ^b	1.5 mg/m ³
Trinitrotoluene ^b	0.2
Sulfur Dioxide	5
Sulfuric Acid	1 mg/m ³

^aUnless otherwise stated, the units of the threshold level values are ppm.

^bThreshold level values for this compound refers to the recommended upper limit in concentration which should contact the skin.

To determine the impact of TNT plants on the atmospheric environment, two pieces of information are required: pollutant identity and pollutant emission rate. The engineering process analysis portion of the current study has addressed these points and has shown definitive data to be lacking in many instances. A source sampling program should be initiated to define the emitted species and their emission rates.

On completion of the sampling study, specific programs can be undertaken to elucidate the impact of the identified species on local air quality. The first step includes dispersion modeling to define the range of expected concentrations. Pollutant concentrations are needed for several reasons:

1. To enable an assessment of compliance for the EPA primary criteria pollutants.
2. To estimate bounds for ambient air contaminant concentrations which correspond to the uncertainty range for the corresponding emissions rates.
3. To evaluate the sensitivity of ambient air quality to varying degrees of emissions control.
4. To facilitate an evaluation of the hazard that could result from non EPA pollutants in the local environs.
5. To provide concentration estimates for designing an air monitoring system (instrumentation and siting).
6. To make possible a detailed assessment of the atmospheric chemistry of both primary and secondary air pollutants.

The rate of chemical reaction is dependent on the concentration of the reacting species. Maximum concentrations of emitted species are likely to occur aloft. Formation of secondary pollutants will occur as the plume from emissions sources travels to ground-based receptors. The dispersion model employed should be capable of resolving both primary pollutant concentrations aloft and at ground level. This would help to estimate the rate of destruction of primary pollutants and the concurrent formation rate of secondary species. Ideally, this could be accomplished by a sophisticated airshed model. Development and testing of such tools are currently in progress. Presently available dispersion/kinetics models should be employed to define the expected range of air contaminant concentrations within the zone of influence of plant facilities.

Without modeling effort, it is unlikely that much insight can be gained as to the air chemistry of the plant emissions. The matrix of air contaminants above the TNT plant is highly complex. The individual reactions that may be occurring over a diurnal cycle, number into the hundreds. Many of these reactions may be involved in chain reactions. To rank reactions on the basis of importance is difficult in such an interactive, dynamic system.

The importance of many reactions varies nonlinearly with reactant concentration. A good example is the thermal oxidation of nitric oxide to nitrogen dioxide, which is second order in NO concentration. This reaction is important at high nitric oxide concentrations such as exist in power plant plumes and automobile exhaust. At ambient NO levels, however, thermal oxidation exerts a minor role.

Existing illumination determines the importance of various reactions. It is evident that photolytic reactions which are significant during the daylight hours are unimportant at night. Furthermore, secondary reactions involving products of photolytic reactions assume roles of various importance at night. Even within a daylight or nighttime period, different reactions may assume roles of different importance depending on the reaction time or "state of progression" for the reacting matrix.

Two points implicit in the modeling approach are also potential shortcomings. The individual reactions must be identified in terms of both reactants and products. Secondly, the rate expressions, including rate constants, must be known. The present review of atmospheric chemistry of emissions from TNT installations revealed several cases in which this information was lacking and for which the literature provided little guidance in estimating the desired information. In spite of the shortcomings of the modeling approach, it nevertheless appears to be the best approach for bounding atmospheric chemistry problems. Computerized models of atmospheric chemistry should be employed to identify the significant reactions under various scenarios.

Laboratory experiments should be conducted in those cases where the mechanisms of atmospheric chemical reaction of emitted species is lacking. Two compounds so identified in the current study are tetranitromethane and nitrotoluenes. Experiments can be conducted in large reaction vessels designed to simulate ambient conditions and known as smog chambers.

REFERENCES

Section 6.B.1

1. U.S. Environmental Protection Agency, Environmental Protection Agency Air Pollutant Emissions Report, filed by Volunteer Army Ammunition Plant, Chattanooga, TN, 1974.
2. Kohlbeck, J. A., C. D. Chandler, Jr., and R. L. Dickenson, "Continuous TNT Characterization Study (PE-238), Continuous TNT Process Control and Characterization Study - extension (PE-289)," final engineering report, Radford Army Ammunition Plant, Radford, VA, May 1973.
3. Telephone conversation of April 29, 1977 with Mr. James Fry of Volunteer Army Ammunition Plant, Chattanooga, TN.
4. Telephone conversation of April 27, 1977 with Mr. Everet Pack of Radford Army Ammunition Plant, Radford, VA.
5. Chemical Construction Corporation, "Description of Operations, Acid Recovery and Fume Recovery Systems at Volunteer Army Ammunition Plant," final report, U.S. Army Contract No. DACA01-72-C-0076, December 1972.
6. U.S. Army Environmental Hygiene Agency and Fume Abatement Plant at VAAP, "Air Pollution Engineering Source Study No. 21-023-75/76, Acid and Fume Recovery Unit, Volunteer Army Ammunition Plant, Chattanooga, TN 10-17 December, 1975" U.S. Army Environmental Hygiene Agency, Aberdeen Proving Ground, MD, March 24, 1976.
7. Hauze, R. C., "Pollution Status Memorandum, Project 5754114, Task 1, Volunteer Army Ammunition Plant (PE-AAP-76)," ICI United States, Inc., Volunteer Army Ammunition Plant, Chattanooga, TN, June 1975.
8. ICI America, Inc., Standing Operating Procedure for the Acid-Fume Recovery, S.O.P. #013, ICI America, Inc., Volunteer Army Ammunition Plant, May 1974.
9. Morris, J. A. and R. L. Dickenson, "Propellant Plant Pollution Abatement Elimination of NO_x in Process Tail Gas from TNT Manufacture by Absorption in Sulfuric Acid," final engineering report on Production Project PE-352 (Phase I), Radford Army Ammunition Plant, Hercules, Incorporated, April 1973.
10. U.S. Environmental Protection Agency, "Environmental Protection Agency Air Pollution Emissions Report," filed by Radford Army Ammunition Plant, Radford, VA, 1975.
11. Volunteer Army Ammunition Plant, Standing Operating Procedure for the Sulfuric Acid Regeneration Plant, S.O.P. #010, ICI United States, Inc., Volunteer Army Ammunition Plant, Chattanooga, TN, July 1975.
12. U.S. Army Environmental Hygiene Agency, "Air Pollution Engineering Source Sampling Study No. 21-036-74/75. Sulfuric Acid Regeneration Unit, Volunteer Army Ammunition Plant, Chattanooga, TN, 31 October-14 November, 1974,"

U.S. Army Environmental Hygiene Agency, Aberdeen Proving Ground, MD, February 6, 1975.

13. Mayberry, Donald, Joseph S. Santos, and Bossie Jackson, Jr., "Pollution Status Report, Radford Army Ammunition Plant," Manufacturing Technology Directorate, Technical Report 4933, Picatinny Arsenal, Dover, NJ, April 1976.
14. Nazin, G. M. et al., Thermal Decomposition of Gaseous Tetranitromethane and Hexanitromethane, Lisa ref. 35.
15. Mura, W. R., M. J. Small, David H. Rosenblatt, and J. C. Dacre, "Munitions-Related Substances of Potential Concern as Airborne Pollutants," U.S. Army Medical Bioengineering Research and Development Laboratory, Fort Detrich, Frederick, MD, December 1974 (Report TR 7409).

Section 6.B.2

1. Kohlbeck, J. A., C. D. Chandler, and R. L. Dickenson, Final Engineering Report on Production Engineering Projects PE-238 and PE-289, Continuous TNT Characterization Study (PE-238) and Continuous TNT Process Control and Characterization Study - Extension (PE-289), Manufacturing Technology Directorate, Picatinny Arsenal, Dover, NJ, 1973.
2. Sax, N. I., "Dangerous Properties of Industrial Materials," 4th ed., Van Nostrand Reinhold Co., New York, NY, 1975.
3. Baker, W., and Al L. Mossman, "Matheson Gas Data Book," 5th ed., Matheson Gas Products, East Rutherford, NJ, 1971.
4. Weast, R. C., ed., "Handbook of Chemistry and Physics," 49th ed., the Chemical Rubber Co., Cleveland, OH, 1968.
5. Jordan, T. E., "Vapor Pressure of Organic Compounds," Interscience Publishers, Inc., New York, NY, 1954.
6. Pella, P. A., J. Chem. Thermodyn., 9, 301, (1977).
7. Duecker, W. W., and J. R. West, eds., "The Manufacture of Sulfuric Acid," Robert E. Krieger Publishing Co. Inc., Huntington, NY, 1959, p. 438.
8. Dreisbach, R. R., "Pressure-Volume-Temperature Relationships of Organic Compounds," 3rd ed., Handbook Publishers, Inc., Sandusky, OH, 1952.
9. Calvert, J. G., and J. N. Pitts, Jr., "Photochemistry," John Wiley and Sons, Inc., New York, NY, 1966.
10. Cox, R. A., and R. G. Derwent, J. Photochem., 6, 23, (1976/77).
11. Braume, F., J. Photochem., 2, 139, (1973/74).
12. Kortum, G., Z. physik. Chem., (B), 43, 27, (1939).
13. Lang, L., ed., "Absorption Spectra in the Ultraviolet and Visible Region," Vol. VI, Academic Press, New York, NY, 1965, pp. 9-14.
14. Conduit, C. P., J. Chem. Soc., 3273, 1959.
15. Lang, L., ed., "Absorption Spectra in the Ultraviolet and Visible Region," Vol. XIX, Academic Press, New York, NY, 1974, pp. 63-64.
16. Leighton, P. A., "Photochemistry of Air Pollution," Academic Press, New York, NY, 1961.

17. Demerjian, K. L., J. A. Kerr, and J. G. Calvert, "The Mechanism of Photochemical Smog Formation," in *Advances in Environmental Science and Technology*, J. N. Pitts, Jr., R. J. Metcalf, and A. C. Lloyd, eds., Vol. IV, John Wiley and Sons, Inc., New York, NY, 1974, pp. 1-262.
18. Bielski, B. H. J., and R. B. Timmons, *J. Phys. Chem.*, 68, 347, (1964).
19. Saltzman, B. E., and W. R. Burg, *Anal. Chem.*, 49, 1R (1977).
20. Glover, D. J., and S. G. Landsman, *Anal. Chem.*, 36, 1690, (1964).
21. Varga, G. M., Jr., Development of a Real-Time, On-Line Instrument to Monitor Tetranitromethane. Final Report, Exxon Research and Engineering Company, Picatinny Arsenal Contract DAA-21-73-C-0657, Dover, NJ, 1974.
22. Ivanyuk, _____, and Yu. A. Kolievskaya, *Zavod. Lab.*, 43, 157 (1977), *Chem. Abstr.*, 86, 176151q (1977).
23. Camera, E., and D. Pravisani, *Anal. Chem.*, 39, 1645 (1967).
24. Pella, P. A., *Anal. Chem.*, 48, 1632 (1976).
25. Harrison, J. W., ed., Comparative Evaluation of Trace Gas Technology Vol. II - Analysis and Evaluation of Instrumental Methods, Final Report, Research Triangle Institute, Mine Detection Division of the U.S. Army Mobility Equipment Research and Development Center, Contract DAAK02-73-C-0128, Fort Belvoir, VA, 1973.
26. U.S. Department of Commerce and National Bureau of Standards, "Chemical Kinetic and Photochemical Data for Modeling Atmospheric Chemistry," R. F. Hampson, Jr., and D. Garvin, NBS Technical Note 866, Government Printing Office, Washington, DC, 1975.
27. Dillenmuth, F. J., D. R. Skidmore, and C. C. Schubert, *J. Phys. Chem.*, 64, 1496 (1960).
28. Stedman, D. H., and H. Niki, *Environ. Lett.*, 4, 303 (1973).
29. Leck, T. J., and D. M. Hinton, *J. Chem. Phys.*, 65, 5181 (1976).
30. England, C., and W. H. Corcoran, *Ind. Eng. Chem., Fundamen.*, 14, 55 (1975).
31. Kaiser, C. W., and C. H. Wu, *J. Phys. Chem.*, 81, 1701 (1977).
32. Harker, A. B., and H. S. Johnston, *J. Phys. Chem.*, 77, 1153 (1973).
33. Kaiser, E. W., and C. H. Wu, *J. Phys. Chem.*, 81, 187 (1977).
34. David, D. D., J. Prusaczyk, M. Dwyer, and P. Kim, *J. Phys. Chem.*, 78, 1775 (1974).
35. Novakov, T., S. G. Chang, and A. B. Harker, *Science*, 186, 259 (1974).
36. Castleman, A. W., Jr., R. E. Davis, H. R. Munkelwitz, I. N. Tang, and W. P. Wood, *Int. J. Chem. Kinet., Symp.*, 1, 629 (1975).
37. Hanst, P. L., J. W. Spence, and M. Miller, *Environ. Sci. Technol.*, 11, 403 (1977).
38. Altukhov, K. V., and V. V. Perekalin, *Usp. Khim.*, 45, 2050 (1976); *Chem. Abstr.*, 86, 71774S (1977).
39. Schmidt, E., and R. Schumacher, *Chem. Ber.*, 54, 1414 (1921).

40. Overberger, C. G., J-P. Anselme, and J. G. Lombardino, "Organic Compounds with Nitrogen-Nitrogen Bonds," The Ronald Press Co., New York, NY, 1966, pp. 83-98.
41. Hendrickson, J. B., D. J. Cram, and G. S. Hammond, "Organic Chemistry, 3rd ed., McGraw-Hill Book Co., New York, NY, 1970, p. 540.
42. Bass, A. M., A. E. Ledford, Jr., and A. H. Laufer, J. Res. Natl. Bur. Stand., Sect. A., 80, 143 (1976).
43. Johnston, H. S., and R. Graham, Can. J. Chem., 52, 1415 (1974).
44. Johnston, H. S., S.-G. Chang, and G. Whitten, J. Phys. Chem., 78, 1 (1974).
45. Knobel, Yu. K., E. A. Miroshnickenso, and Yu. A. Libedev, Izv. Akad. Nauk SSSR, Ser. Khim., 20, 485 (1971); Chem. Abstr., 75, 54205n (1971).
46. Sandus, O., and N. Slagg, Reactions of Aromatic Nitrocompounds - I. Photochemistry, Technical Report 4385, Picatinny Arsenal, Dover, NJ, NTIS AD 753923, 1972.
47. Wettermark, G., Nature, 194, 577 (1962).
48. Khrapkovskii, G. M., A. G. Shamov, A. A. Levin, Yu. A. Pankrushev, T. S. Pivina, and S. S. Novikov, Izv. Akad. Nauk SSSR, Ser. Khim., 24, 2317 (1975).
49. Langmuir, M. E., L. Dogliotti, E. D. Black, and G. Wettermark, J. Am. Chem. Soc., 91, 2204 (1969).
50. Suryanarayanan, K., and C. Capellos, Int. J. Chem. Kinet., 6, 89 (1974).
51. Chung, K., J. G. Calvert, and J. W. Bottenheim, Int. J. Chem. Kinet., 7, 161 (1975).
52. Creel, C. L., and J. Ross, J. Chem. Phys., 64, 3560 (1976).
53. Herman, I. P., R. P. Mariella, Jr., and A. Javan, J. Chem. Phys., 64, 3792 (1976).
54. Nazin, G. M., G. B. Manelis, and F. I. Dubovitskii, Dokl. Akad. Nauk SSSR, 177, 1128 (1967); Chem. Abstr., 69, 2317g (1968).
55. Nazin, G. M., G. N. Neckiporenko, D. N. Sokolov, G. B. Manelis, and F. I. Dubovitskii, Izv. Akad. Nauk SSSR, Ser. Khim., 315 (1968), Chem. Abstr., 69, 66758j (1968).
56. Hastings, S. H., and F. A. Matsen, J. Am. Chem. Soc., 70, 3514 (1948).
57. Grovenstein, E., Jr., and A. J. Mosher, J. Am. Chem. Soc., 92, 3810 (1970).
58. Sander, S. P., and J. H. Seinfeld, Environ. Sci. Technol., 10, 1114 (1976).
59. Cox, R. A., R. G. Derwent, and P. M. Holt, J. Chem. Soc., Faraday Trans., 1, 72, 2031 (1976).
60. Atkinson, R., and J. N. Pitts, Jr., J. Phys. Chem., 78, 1780 (1974).
61. Perry, R. A., R. Atkinson, and J. N. Pitts, Jr., J. Phys. Chem., 81, 296 (1977).
62. Hippler, H., C. Schippert, and J. Trol, Int. J. Chem. Kinet., Symp., 1, 27 (1975).

63. Cox, R. A., Int. J. Chem. Kinet., Symp., 1, 379 (1975).
64. Simonaitis, R., and J. Heicklen, submitted for publication, 1977.
65. Davis, D. D., J. T. Herron, and R. E. Huie, J. Chem. Phys., 58, 530 (1973).
66. (a) Anastasi, C., and I. W. M. Smith, J. Chem. Soc., Faraday Trans., 2, 72, 1459 (1976); (b) Erler, K., D. Field, R. Zellner, and I. W. M. Smith, Ber. Bunsenges. Phys. Chem., 81, 22 (1977).
67. Niki, H., P. D. Maker, C. M. Savage, and L. P. Britenbach, Chem. Phys. Lett., 45, 564 (1977).
68. Margitan, J. J., F. Kaufman, and J. G. Anderson, Int. J. Chem. Kinet., Symp., 1, 281 (1975).
69. Bhatia, K., J. Phys. Chem., 79, 1032 (1975).
70. Castleman, A. W., Jr., and I. N. Tang, J. Photochem., 6, 349 (1976/77).
71. Parkes, D. A., Int. J. Chem. Kinet., 9, 451 (1977).
72. Washida, N., and K. D. Bayles, Chem. Phys. Lett., 23, 373 (1973).
73. Simonaitis, R., and J. Heicklen, J. Phys. Chem., 79, 298 (1975).
74. Cox, R. A., R. G. Derwent, P. M. Holt, and J. A. Kerr, J. Chem. Soc., Faraday Trans. 1, 72, 2044 (1976).
75. Barker, J. R., S. W. Benson, and D. M. Golden, Int. J. Chem. Kinet., 9, 31 (1977).
76. Spicer, C. W., A. Villa, H. A. Wiebe, and J. Heicklen, J. Am. Chem. Soc., 95, 13 (1973).
77. Campbell, I. M., D. F. McLaughlin, and B. J. Handy, Chem. Phys. Lett., 38, 362 (1976).
78. McKean, D. C., J. L. Duncan, and L. Butt, Spectrochim. Acta, Part A, 29, 1037 (1973).
79. Jones, G. R. H., and R. J. Cvetanovic, Can. J. Chem., 39, 2444 (1961).
80. Benson, S. W., "Thermochemical Kinetic Methods for the Estimation of Thermochemical Data and Rate Parameters," 2nd ed., John Wiley and Sons, Inc., New York, NY, 1976.
81. O'Brien, R. J., personal communication, 4 November 1976.
82. Laity, J. L., I. G. Burstain, and B. R. Appel, "Photochemical Smog and the Atmospheric Reactions of Solvents," in Advances in Chemistry Series No. 124, R. W. Tess, ed., American Chemical Society, Washington, DC, 1973, pp. 95-112.
83. Finlayson-Pitts, B. J., and J. N. Pitts, Jr., "The Chemical Basis of Air Quality: Kinetics and Mechanisms of Photochemical Air Pollution and Application to Control Strategies," in Advances in Environmental Science and Technology, J. N. Pitts, Jr., R. L. Metcalf, and A. C. Lloyd, eds., Vol. VII, John Wiley and Sons, Inc., New York, NY, 1977, pp. 75-162.
84. Nojima, K., K. Fukaya, S. Fukui, and S. Kanno, Chemosphere, 5, 247 (1974).
85. Hendry, D. G., and R. A. Kenley, J. Am. Chem. Soc., 99, 3198 (1977).
86. Jefferies, H. E., Department of Environmental Sciences, University of North Carolina, Chapel Hill, NC, personal communication, 1977.

87. Morrison, H. A., "The Photochemistry of the Nitro and Nitroso Groups," in *The Chemistry of the Nitro and Nitroso Groups, Part I*, H. Feuer, ed., Interscience Publishers, New York, NY 1969, pp. 165-213.
88. Altshuler, A. P., S. L. Kopczynski, D. Wilson, W. A. Lonneman, and F. D. Sutterfield, J. Air. Pollut. Contr. Ass., 19.
89. Environmental Protection Agency, National Emissions Data System, June 7, 1977.
90. Chaput, L. S., J. Air. Pollut. Contr. Ass., 26, 1055 (1976).
91. 40 CFR 50; 36 FR 22384, November 25, 1971; as amended by FR 25678, September 14, 1973, and 40 FR 7042, February 18, 1975.
92. 40 CFR 52; 39 FR 42510, December 5, 1974.
93. Calvert, J. G., and R. D. McQuigg, Int. J. Chem. Kinet., Symp., 1, 113 (1975).
94. Rissman, E. and E. Saunders, "Study of the Feasibility of Oxidizing the SO₂ in Flue Gases to Sulfuric Acid," First Progress Report, Tyco Laboratories, NAPCA Contract PH 86-68-75 (1968).