

AD-A060 194

NAVY UNDERWATER SOUND LAB NEW LONDON CONN
PREDICTION STUDY FOR DIGITAL COMPUTER SIMULATION OF AN OPTIMUM --ETC(U) .
JUN 67 R R KNEIPFER
USL-TM-2242-217-67

F/G 17/1

UNCLASSIFIED

NL

1 of 1
AD
A060 194

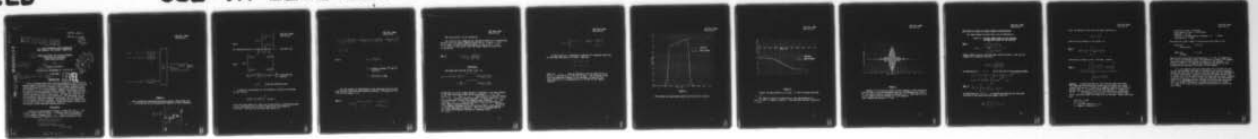

END
DATE
FILMED
-12-78
DDC

001762

Handwritten: NW Hood

Handwritten: MOST Project #3
1622

Copy NO. 21

Code No. (1) NW

OOVI LIBRARY COPY

U. S. NAVY UNDERWATER SOUND LABORATORY
FORT TRUMBULL, NEW LONDON, CONNECTICUT

PREDICTION STUDY FOR DIGITAL COMPUTER
SIMULATION OF AN OPTIMUM
SPACE-TIME PROCESSOR.

by

Ronald R. Kneipfer

USL Technical Memorandum No. 2242-217-67

7 June 1967

Handwritten: 12 13p.

Handwritten: 9 10

DDC
OCT 23 1978
F

ADA060194

DDC FILE COPY

Handwritten: 14

USL-TM-2242-217-67

Handwritten: 11

INTRODUCTION

LEVEL

Work on optimum space-time filtering at USL has consisted of an analog computer simulation of a narrow-band Mermoz processor which was optimum only at its center frequency, and of single frequency array gain studies. It is now planned to simulate the Mermoz processor in non-real time on a general purpose computer using digital filters and data from a bottom-mounted, vertical array. This simulation will differ from earlier work in three ways: (a) real sea noise will be used instead of electronic noise generators, (b) the system will be optimum at more than one frequency in the band, and (c) the system will be digital instead of analog. The purpose of this report is to present the results of a theoretical study undertaken to predict the performance of the simulated optimum processor.

Definitions

Consider the system shown in Figure 1, where the $\{Z_i\}$ are linear filters, $s(f) = F[s(t)]$, F denotes Fourier transform, $*$ denotes complex conjugate, and $\tau_{i,j}$ = time for a plane wave to travel from phone #1 to phone # i for a given direction of look.

This document has been approved for public release and sale; its distribution is unlimited.

2 242-217-67

001762

Handwritten: 44-13

67-711-253

254 200

LB

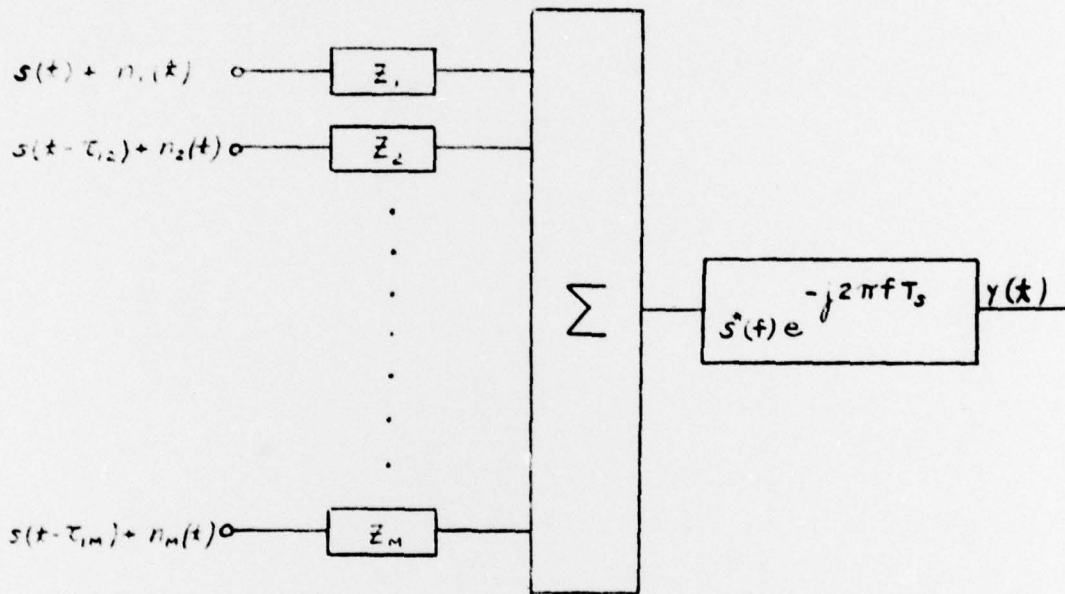

Figure 1

The conventional time-shift-and-sum processor results when the $\{Z_i\}$ are given by the following matrix equation at each frequency.

$$Z = V^*$$

ACCESSION for	
NTIS	Section <input checked="" type="checkbox"/>
DDC	Section <input type="checkbox"/>
UNANNOUNCED	<input type="checkbox"/>
JUSTIFICATION	<i>Per the</i>
BY	<i>on file</i>
DISTRIBUTION/AVAILABILITY CODES	
Dist.	SPECIAL
A	

$$V = \begin{bmatrix} 1 \\ e^{j2\pi f\tau_{1,2}} \\ \vdots \\ e^{j2\pi f\tau_{1,n}} \end{bmatrix}$$

where:

The optimum processor is obtained when the $\{z_i\}$ are given by:

$$Z = Q^{-1} V$$

where:

$$Q = \begin{bmatrix} Q_{11}(f) & \cdots & Q_{1n}(f) \\ \vdots & & \vdots \\ Q_{n1}(f) & \cdots & Q_{nn}(f) \end{bmatrix}$$

$$Q_{ik}(f) = \mathcal{F} \left\{ E [\eta_i(t) \eta_k(t + \tau)] \right\} = \text{cross-spectral density}$$

$E [\quad]$ denotes expected value

A slope of -6 db/octave will be assumed for the noise spectrum at each receiver.

$$Q_{ii}(f) = \left(\frac{750}{f} \right)^2 \text{ for all } i$$

Since the actual data will come from a fixed array, a surface generated ambient noise model will be used to specify the cross-spectral densities.² For vertical receivers the result is:

$$Q_{ik} = 2 Q_{ii} \left[\left(\frac{\sin \alpha_{ik}}{\alpha_{ik}} + \frac{(\cos \alpha_{ik} - 1)}{(\alpha_{ik})^2} \right) - j \left(\frac{\sin \alpha_{ik}}{(\alpha_{ik})^2} - \frac{\cos \alpha_{ik}}{\alpha_{ik}} \right) \right]$$

$i < k$

$$Q_{ik} = Q_{ki}^*$$

$i > k$

where:

$$\alpha_{ik} = \frac{2\pi f d_{ik}}{c}$$

d_{ik} = distance between i^{th} and j^{th} receivers

c = velocity of sound

For the purpose of simplification, the simulation will be done with only two receivers and broadside steering. A CW pulse will be used for the signal, i.e.,

Equ. 4

$$s(t) = \begin{cases} A \cos 2\pi f_0 t & , 0 \leq t \leq T_s \\ 0 & , \text{otherwise} \end{cases}$$

The top receiver will be labeled #1.

The criterion for comparing the optimum processor to a conventional processor will be output signal-to-noise ratio. If $y(t) = \sigma(t)$ for an input of signal alone (see Figure 1), and $y(t) = \gamma(t)$ for an input of noise alone, then the output signal-to-noise ratio is defined as:

Equ. 3

$$\left(\frac{S}{N}\right)_{\text{out}} = \frac{\sigma^2(T_s)}{E[\gamma^2(t)]}$$

Discussion

The amplitude spectrum of the signal is:

$$S(f) = F[s(t)] = \frac{AT_s}{2} e^{-j\pi(f+f_c)T_s} \frac{\text{SIN } \pi(f+f_c)T_s}{\pi(f+f_c)T_s} + \frac{AT_s}{2} e^{-j\pi(f-f_c)T_s} \frac{\text{SIN } \pi(f-f_c)T_s}{\pi(f-f_c)T_s}$$

Essentially all of the signal energy is contained in the band defined by the zero crossings of $S(f)$ which are nearest f_c , i.e., the points $f_c - \frac{1}{T_s}$ and $f_c + \frac{1}{T_s}$. Hence there is no need to design the $\{Z_i\}$ filters outside this band. In other words, the $\{Z_i\}$ will be band-pass filters with arithmetic mean frequency f_c and bandwidth $\frac{2}{T_s}$. Since the optimum filters are band-limited, their impulse responses extend from $-\infty$ to $+\infty$. Obviously, if the impulse responses are to be convolved with a finite amount of real data, they must be truncated. This will be accomplished by multiplying each impulse response by a Hanning window given by:

$$P_r(t) = \begin{cases} \frac{1}{2} \left(1 + \cos \frac{\pi t}{T} \right) , & |t| \leq T \\ 0 & , |t| > T \end{cases}$$

At this point it is necessary to specify two constants which will be used when real data is recorded. They are:

$$f_0 = 750 \text{ Hz}$$

$$T_s = 13.3 \text{ ms}$$

Thus, the $\{Z_i\}$ must be determined over the band 675 Hz to 825 Hz. A resolution of 10 Hz will be used. The following figure shows the amplitude response of the optimum Z_1 along with the approximation to it corresponding to $T = 40 \text{ ms}$ for the impulse response.

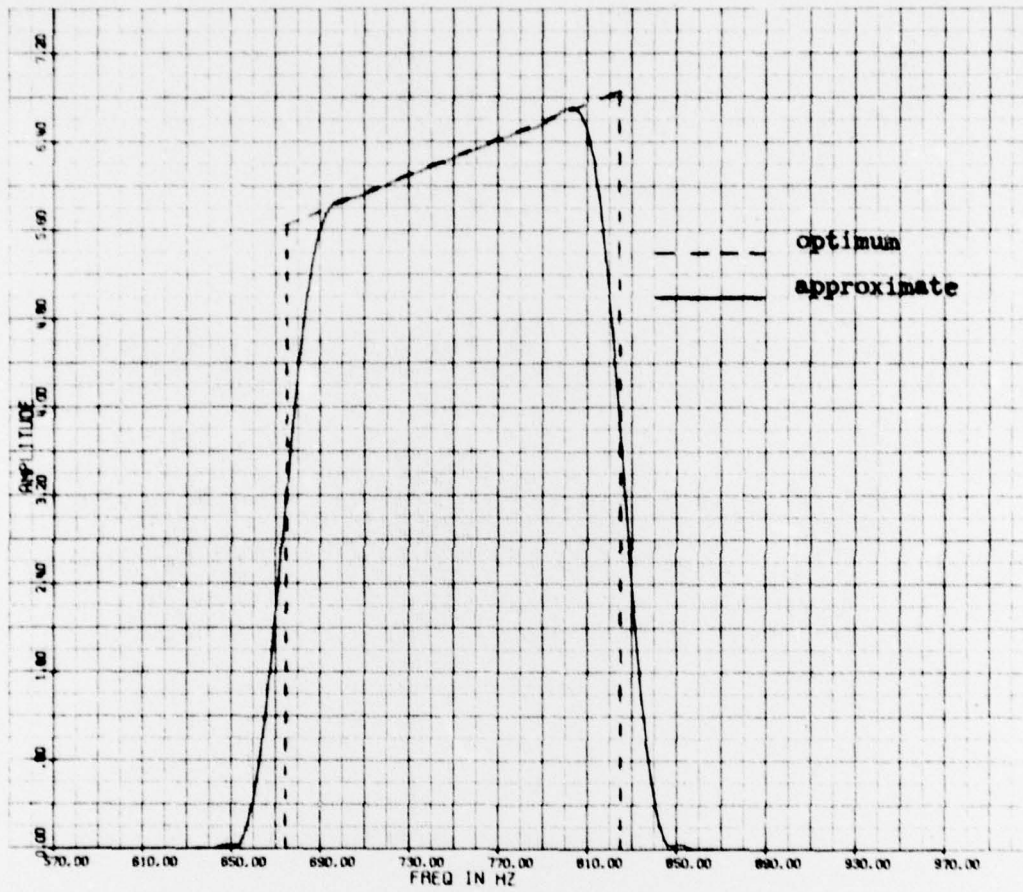

Figure 3

The optimum and approximate phase functions are as follows:

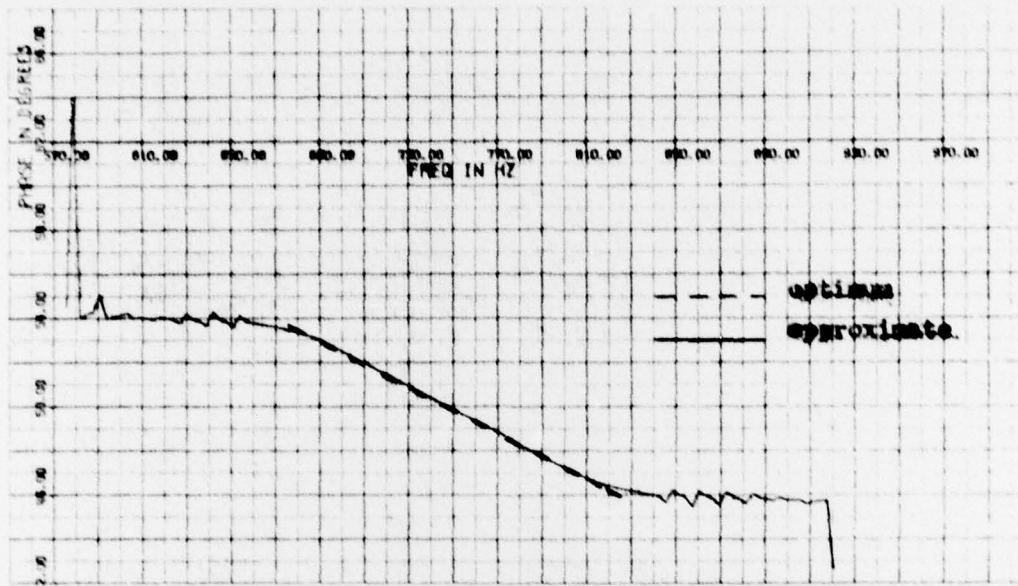

Figure 4

Clearly the approximations are good. It should be mentioned that

$$\frac{M_2}{M_1} = \frac{M_4}{M_3}$$

The impulse response corresponding to the approximations of Figure 3 and 4 is shown in Figure 5. The amplitude has been normalized to unity.

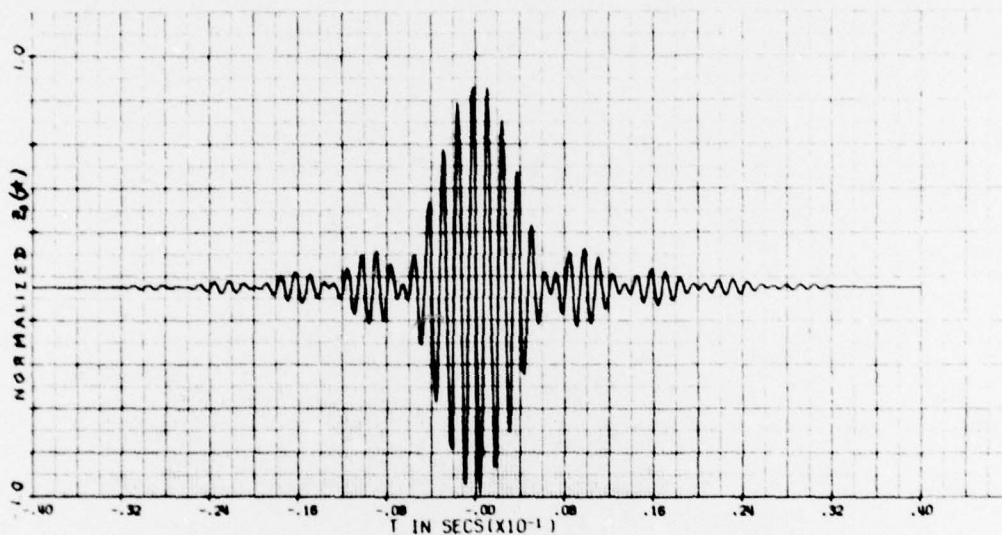

Figure 5

Samples of $z,(t)$ will be used as filter weights in the convolution process, and it has been determined that an 8 KC sampling rate should be sufficiently high to accurately represent $z,(t)$. Thus there will be a total number of filter weights for $z,(t)$ equal to $(8000 \text{ samples/sec})(80 \text{ ms}) + 1 = 641$.

Derivation of Input and Output Signal-to-Noise Ratios

The input signal-to-noise ratio will be defined as:

$$(S/N)_{in} = \frac{\text{average signal power at one receiver}}{\text{average noise power at one receiver}}$$

Equ. 5

$$(S/N)_{in} = \frac{\frac{1}{T} \int_{-\infty}^{\infty} |S(f)|^2 df}{\int_{-\infty}^{\infty} Q_{in}(f) df}$$

Output signal-to-noise ratio has been defined by Equ. 3, and will be repeated for convenient reference.

$$(S/N)_{out} = \frac{\sigma^2(T_s)}{E[Z^2(t)]}$$

An expression for $\sigma(T_s)$ can be derived in the following manner.

$$\sigma(t) = \mathcal{F}[\sigma(t)] = S(f) [Z_1 + Z_2] S^*(f) e^{-j2\pi f T_s}$$

$$\sigma(t) = \mathcal{F}^{-1}[\sigma(f)] = \int_{-\infty}^{\infty} \sigma(f) e^{j2\pi f t} df$$

Equ. 6

$$\sigma(T_s) = \int |S(f)|^2 [Z_1 + Z_2] df$$

An expression for $E[Z^2(t)]$ is derived by starting with the power spectrum of the noise after the summer, which is:

$$N_Z = \sum_{i=1}^2 \sum_{k=1}^2 Z_i^* Z_k Q_{i,k}$$

After the matched filter the noise power spectrum is:

$$N_{\Sigma} |S(f)|^2$$

Therefore the variance of the output is:

Equ. 7

$$E[z^2(t)] = \int_{-\infty}^{\infty} N_{\Sigma} |S(f)|^2 df$$

Substitution of Equ's 6 and 7 into Equ. 3 gives:

Equ. 8

$$\left(\frac{S}{N} \right)_{out} = \frac{\left[\int_{-\infty}^{\infty} |S(f)|^2 [Z_1 + Z_2] df \right]^2}{\int_{-\infty}^{\infty} N_{\Sigma} |S(f)|^2 df}$$

Results: As mentioned earlier, the criterion that was chosen for comparing the optimum and conventional processors was output signal-to-noise ratio. Therefore a computer program was written to evaluate Equ. 8. It should be mentioned that Equ. 8 is perfectly general, and therefore is valid for both optimum and conventional $\{Z_i\}$. All parameters were chosen so as to accurately model actual conditions under which data will be recorded. These conditions are:

(S/N) in = -20db
 Ts = 13.3 ms
 d = receiver separation = 2 ft.
 M = number of receivers = 2

Direction of look = broadside
Noise spectral slope = -6 db/octave
Bandwidth = 150 Hz
Duration of optimum impulse responses = $2T = 80$ ms.
Sampling rate = 8 KHz

The resulting output signal-to-noise ratios were found to be:

(S/N) out = -12.5 db
conventional

(S/N) out = -5.3 db
optimum

Thus overall conventional processing gain is 7.5 db, as compared to 14.7 db for the optimum system. The difference of about 7 db between these two figures is attributable primarily to the optimum $\{Z_i\}$, as one discovers if he computes and compares array gains for the frequencies and spacing of receivers in this system.

It is not expected that processing gains of 7.5 db and 14.7 db will be obtained when real data is filtered in the future simulation because the preceding calculations have been made under the assumption of signal known exactly, whereas in practice the amplitude and time of arrival will not be exactly known, and there may be slight frequency spreading of the pulse due to a required reflection from the surface. However, the difference between optimum and conventional processing should be roughly the same as calculated above since the inexact knowledge of the signal should degrade both processors to about the same extent.

REFERENCES

1. Kennedy, Robert M. and Robert O'Neill, "Adaptive Beamforming for Sonar Signal Processing", USL Technical Memorandum No. 914-184-66, June 29, 1966.
2. Becker, Clair J. and Benjamin F. Cron, "Optimum Array Gain for Directional Noise", USL Report No. 656, Oct. 5, 1965.
3. Cron, Benjamin F., Norbert P. Fisch, and Robert L. Shaffer, "Array Gain for the Case of Horizontal Noise", USL Report No. 731, April 11, 1966.
4. Cron, Benjamin F. and Ronald R. Kneipfer, "The Effect of Spatially Uncorrelated Noise on the Maximum Array Gain Processor", USL Technical Memorandum No. 2242-324-66, Dec. 15, 1966.
5. Cron, Benjamin F., Beverly C. Hassell, and Frank J. Keltonic, "Addendum, Spatial-Correlation Functions for Various Noise Models", J. Acoust. Soc. Am., Vol. 38, p. 885, Nov. 1965.