

AD-A060 208

ARMY COMMUNICATIONS COMMAND FORT HUACHUCA ARIZ
STANDARD ENGINEERING INSTALLATION PACKAGE. KEY TELEPHONE SYSTEM--ETC(U)
AUG 78

F/G 17/2

UNCLASSIFIED

ACC-SEIP-016

NL

1 of 2

AD
A060 208



ADA060208

DDC FILE COPY

VOICE OF THE ARMY



LEVEL II

SEIP 016

12

STANDARD
ENGINEERING INSTALLATION PACKAGE

KEY TELEPHONE SYSTEMS

31 AUGUST 1978

DDC
RECEIVED
OCT 23 1978
RECEIVED
D

APPROVED FOR PUBLIC RELEASE. DISTRIBUTION UNLIMITED.

HEADQUARTERS
U. S. ARMY COMMUNICATIONS COMMAND
FORT HUACHUCA, ARIZONA 85613

78 10 17 071

DISPOSITION INSTRUCTIONS

Destroy this document when no longer needed.

Do not return it to the originator.

DISCLAIMER

The use of trade names in this document does not constitute an official endorsement or approval of the use of such commercial hardware or software. This document may not be cited for purpose of advertisement.

AVAILABILITY

This publication is available to non-Government agencies and may be purchased through the Defense Documentation Center, Cameron Station, Alexandria, VA 22314.

Government activities may requisition copies by writing to the Commander, Headquarters, Fort Huachuca, ATTN: CCH-PCA-ASP, Fort Huachuca, Arizona 85613.

NEUTRAL LANGUAGE

The word "he" when used in this publication represents both the masculine and feminine genders, unless specifically stated.

14

SECURITY CLASSIFICATION OF THIS PAGE (When Data Entered)

ACC- REPORT DOCUMENTATION PAGE		READ INSTRUCTIONS BEFORE COMPLETING FORM	
1. REPORT NUMBER SEIP-016	2. GOVT ACCESSION NO.	3. RECIPIENT'S CATALOG NUMBER	
4. TITLE (and Subtitle) Standard Engineering Installation Package, Key Telephone Systems.		5. TYPE OF REPORT & PERIOD COVERED Final interim rept.	
7. AUTHOR(s)		6. PERFORMING ORG. REPORT NUMBER	
9. PERFORMING ORGANIZATION NAME AND ADDRESS US Army Communications-Electronics Engineering Installation Agency ATTN: CCC-CED-SEP, Fort Huachuca, AZ 85613		10. PROGRAM ELEMENT, PROJECT, TASK AREA & WORK UNIT NUMBERS	
11. CONTROLLING OFFICE NAME AND ADDRESS US Army Communications Command ATTN: CC-PA-AMP Fort Huachuca, AZ 85613		12. REPORT DATE 31 August 1978	
14. MONITORING AGENCY NAME & ADDRESS (if different from Controlling Office) US Army Communications Command ATTN: CC-OPS-SM Fort Huachuca, AZ 85613		13. NUMBER OF PAGES	
		15. SECURITY CLASS. (of this report) Unclassified	
16. DISTRIBUTION STATEMENT (of this Report) Approved for public release. Distribution unlimited.			
17. DISTRIBUTION STATEMENT (of the abstract entered in Block 20, if different from Report)			
18. SUPPLEMENTARY NOTES			
19. KEY WORDS (Continue on reverse side if necessary and identify by block number) Key Telephone System, Key Telephone Units, Key Service Units, Site Survey Data, Connectorized Back Panels, Installation Sequence, Quality Assurance, Test and Acceptance.			
20. ABSTRACT (Continue on reverse side if necessary and identify by block number) This Standard Engineering Installation Package (SEIP) is prepared for projects which require overall standardization for implementation by communications- electronics commands in various parts of the world. It is used for guidance in preparing an Engineering Installation Package (EIP) for a specific site, tailored to its peculiar requirements. This SEIP provides guidance for selecting, acquiring, and installing key telephone systems equipment. This SEIP also contains site survey information, installation specifications			

12-124 p.

(cont) JB

20. Abstract - Continued and instructions, engineering drawings, bill of materials, and quality assurance and control information. Additionally, this SEIP provides a list of applicable documents for reference purposes.

LEVEL II

ACCESSION NO.	
DTIC	White Section <input checked="" type="checkbox"/>
DDC	Diff Section <input type="checkbox"/>
UNANNOUNCED	<input type="checkbox"/>
JUSTIFICATION	
BY	
DISTRIBUTION/AVAILABILITY CODES	
Dist.	AVAIL. and/or SPECIAL
A	

DDC
RECEIVED
OCT 23 1978
RECEIVED
D

DEPARTMENT OF THE ARMY
HEADQUARTERS, US ARMY COMMUNICATIONS COMMAND
Fort Huachuca, Arizona 85613

USACC SEIP
No. 016

31 August 1978

Standard Engineering Installation Package
KEY TELEPHONE SYSTEMS

Paragraph		Page
<u>SECTION 1. GENERAL</u>		
1.1	BACKGROUND	1-1
1.2	PURPOSE.	1-1
1.3	SYSTEM DESCRIPTION	1-1
1.4	TECHNICAL DESCRIPTION.	1-3
1.5	LIST OF APPLICABLE DOCUMENTS	1-5
<u>SECTION 2. SITE SURVEY DATA AND CHECKLIST</u>		
2.1	GENERAL.	2-1
2.2	SITE SURVEY CRITERIA	2-1
2.3	EQUIPMENT CHARACTERISTICS.	2-2
<u>SECTION 3. INSTALLATION SPECIFICATIONS AND INSTRUCTIONS</u>		
3.1	GENERAL.	3-1
3.2	INSTALLATION INSTRUCTIONS.	3-1
3.3	CHANGES IN SCOPE	3-34
3.4	CHANGES TO SPECIFICATIONS.	3-34
3.5	AS-BUILT DRAWINGS.	3-35
3.6	CUTOVER INFORMATION.	3-35
<u>SECTION 4. ENGINEERING INSTALLATION DRAWINGS</u>		
4.1	GENERAL.	4-1
4.2	USACEEIA DRAWINGS.	4-1
<u>SECTION 5. BILL OF MATERIALS</u>		
5.1	GENERAL.	5-1
5.2	MAJOR ITEMS.	5-1

Paragraph Page

SECTION 6. QUALITY ASSURANCE PROCEDURES

6.1	GENERAL	6-1
6.2	INSPECTION RESPONSIBILITIES	6-1
6.3	DOCUMENTATION	6-17
6.4	QUALITY ASSURANCE PLAN	6-17

SECTION 7. OPERATIONAL TEST PLAN AND CHECKOUT PROCEDURES

7.1	SCOPE	7-1
7.2	TEST CRITERIA	7-1
7.3	TEST EQUIPMENT	7-1
7.4	TEST PLAN ORGANIZATION	7-1
7.5	ACCEPTANCE TEST PLAN	7-2

SECTION 8. COMPLETION CERTIFICATION

8.1	GENERAL	8-1
8.2	DISTRIBUTION	8-1
8.3	RECORD	8-1

LIST OF ILLUSTRATIONS

Figure No.	Title	Page
1-1	Key telephone system	1-2
1-2	KS 19252-L-1 three-way adapter	1-2
1-3	Key telephone system using KS 19252-L-1 adapters	1-2
1-4	Type 66E3-25 connecting block.	1-4
1-5	Key telephone system using 66E3-25 connecting blocks	1-4
1-6	Bridged type key telephone system.	1-4
2-1	Sample site survey checklist	2-2
3-1	Typical key telephone system using bridging adapters and 66-type connecting blocks.	3-2
3-2	Typical key telephone system using system 66 connectorized back panels.	3-3
3-3	Typical 515 key service unit with jack and 66 block locations.	3-7
3-4	Typical 4- and 8-inch key telephone units.	3-10
3-5	20C2 power unit.	3-13
3-6	66B4-type connecting block	3-15
3-7	66CB1-6-type connecting block.	3-16
3-8	66E3-type connecting block	3-17
3-9	Typical B3/B4 series connectorized block	3-19
3-10	Typical M2 series connectorized block.	3-19
3-11	Three-way bridging adapter for 6-button telephones, 25 pair cable.	3-20
3-12	Three-way bridging adapter for key telephones, 50 pair cable.	3-21
3-13	Three-way bridging adapter for 18-button telephones, 75 pair cable.	3-22
3-14	Crossover adapter for connecting key telephones to cables.	3-23
3-15	Size comparison 66-type back panels.	3-26
3-16	Key telephone system using conventional and connectorized back panels.	3-29
3-17	Typical Amphenol plug and connector.	3-30
5-1	Bill of materials.	5-2
6-1	Sample of final installation inspection checklist.	6-2
6-2	Sample of cognizant agency, command, and facility points of contact	6-14
7-1	Sample key system data sheet	7-4
8-1	Sample technical acceptance record	8-3

LIST OF TABLES

Table No.	Title	Page
2-1	Sample Format for Physical and Electrical Characteristics.	2-11
3-1	Recommended 1A2 Key Telephone System Key Service Units.	3-4
3-2	Recommended 1A2 Key Telephone System Panels.	3-5
3-3	Recommended 1A2 Key Telephone System 69-Type Apparatus Mountings.	3-6
3-4	400-Series Key Telephone Units	3-9
3-5	Recommended Connector Selection and Arrangement of 400-Series Key Telephone Units in 513-, 514-, and 515-Type Key Service Units	3-11
3-6	Output and Features 19- and 20-Type Power Units.	3-14
3-7	183- and 184-Type Backboard Selection.	3-24
3-8	66-Type Back Panel Selection	3-27
3-9	System 66 Connectorized Back Panel Selection	3-28
3-10	A- and B-Type Connector Cables Selection	3-31

SECTION 1. GENERAL

1.1 BACKGROUND. Key telephone systems (KTS) are required at US Army Communications Command (USACC) camp, post, and station facilities to support local requirements for multiline pickup, line lamp signals, common audible signaling, intercom, and additional optional services. Multikey telephone sets are used to receive and initiate calls in the KTS. KTS equipment is provided to satisfy new requirements, relocations, and expansion to obtain maximum service at minimum cost.

1.2 PURPOSE. The purpose of this standard engineering installation package (SEIP) is to provide guidance and standard engineering data to be used in the development of an engineering installation package. This SEIP provides site survey data, installation specifications and instructions, typical installation drawings, a bill of materials (BOM), quality assurance procedures, test and acceptance procedures, and completion certification format.

1.3 SYSTEM DESCRIPTION. The KTS is comprised of equipment necessary to connect any one of a number of stations (key telephone sets) to any one of its associated central office/private branch exchange (CO/PBX) dial lines. The KTS provides the basic line services of line pick-up, line hold, and call status indicators for multiline service. Intercom and auxiliary services such as exclusion, power failure transfer, call transfer, common audible signaling, conferencing, tie lines, and speaker phones may also be incorporated into the system.

1.3.1 The major functional components of the KTS are the relay switches called key telephone units (KTU), telephones equipped with keys called key stations, and a power supply. Single line telephones without intercom but with modification may be provided as an extension from the system trunk by tie lines.

1.3.2 Figure 1-1 is a system whereby connector cables are used for distribution. This layout requires a separate connector cable from the apparatus to each telephone set. Although this configuration provides maximum flexibility in the use of dial intercom signaling, it is not economical in the use of cable. A three-way adapter such as the KS 19252-L-1, figure 1-2, is used to reduce the number of cables and permit straight-forward cabling. Figure 1-3 illustrates a KTS using the three-way adapters; however, flexibility in dial intercom signaling is minimal in this system.

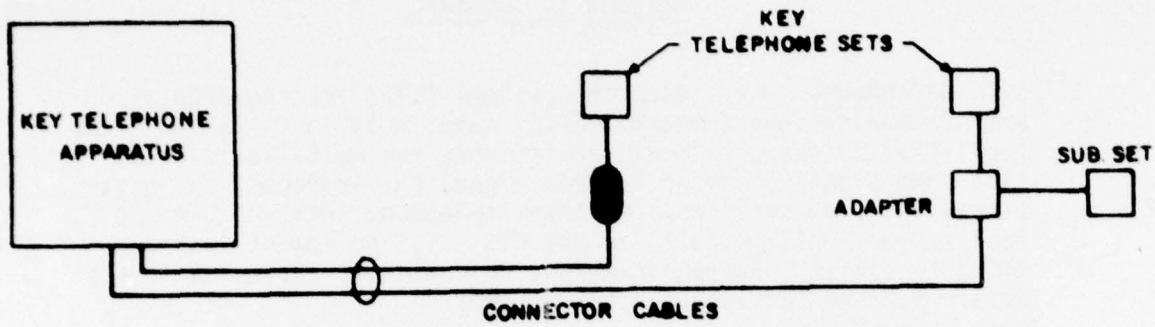

Figure 1-1. Key telephone system.

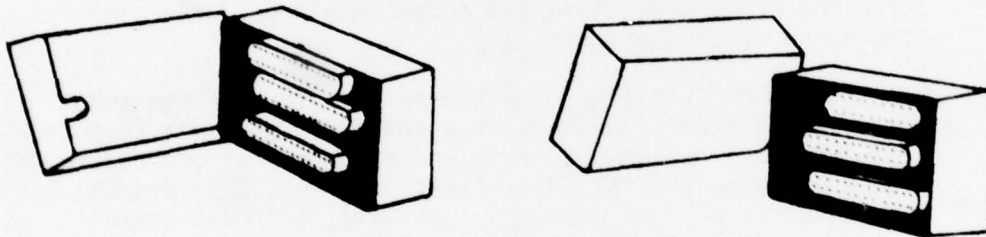

Figure 1-2. KS 19252-L-1, three-way adapter.

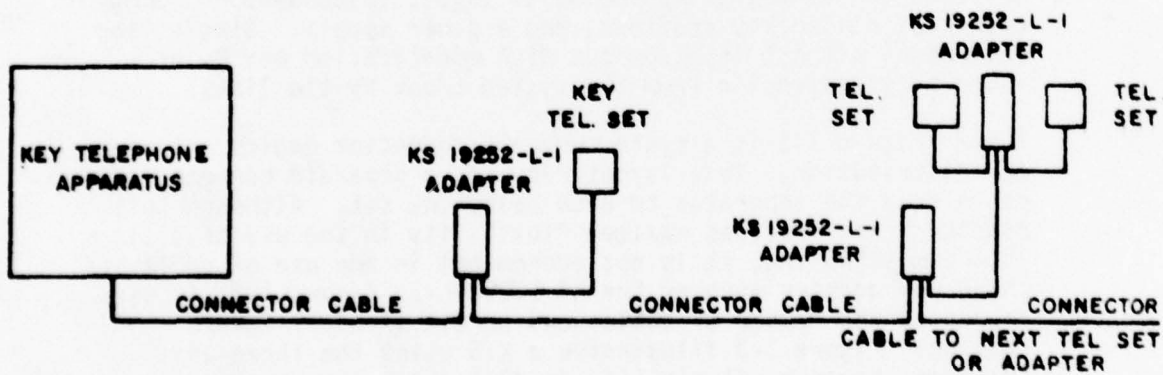

Figure 1-3. Key telephone system using KS 19252-L-1 adapters.

1.3.3 Type 66E3-25 connecting blocks, figure 1-4, provide a convenient way of terminating cut cables at station locations and permit the use of plug-ended telephone set cords which are plugged into a receptacle in the block. A straight-forward KTS layout using 66E3-25 connection blocks is shown in figure 1-5. This system, using 66E3-25 connecting blocks and bulk cable, provides maximum flexibility of dial intercom and is economical when cable and installation are considered. When cable runs are excessive and the system has more than nine stations, the stations at the outer end of the cable may not receive enough power to properly illuminate the keys; therefore, a bridged type KTS is used. Figure 1-6 depicts a bridged type KTS that reduces the voltage drop at the outer ends of the system and ensures enough power to properly illuminate the keys.

1.4 TECHNICAL DESCRIPTION. Although KTS's are available with many options, this SEIP will only provide information on a commonly used system with features that are adaptable to the average size military telephone facility.

1.4.1 The Army procures key telephone equipment from several American and foreign manufacturers; however, most of the equipment in use at the present time has been supplied by Western Electric Company (WECO). The 1A2 KTS, manufactured by WECO will be used as the basic KTS for this SEIP.

1.4.2 The 1A2 is a solid state KTS that uses printed wiring boards and plug-in type KTU's. The 1A2 KTS consists of the following major functional components:

a. Key telephone sets (i.e., 564 HL) capable of "A" lead control.

b. Four hundred-series KTU's to provide switching and control functions. Detailed information on the 400-series KTU's is provided in chapter 6 of FM 11-31, Telephone Substation Installation and in the Bell System Practices (BSP), sections 518-215-400, 518-215-401, 518-215-402, and 518-215-403.

c. Key service units (KSU), panels, and apparatus mountings are prewired and provide mounting and connecting facilities for the 400-series KTU's. Detailed information on the KSU's is also provided in chapter 6 of FM 11-31, and in BSP, section 518-215-405. Further, detailed information on 1A2 panels and apparatus mounting is available in BSP, sections 518-215-410, 518-215-417, 518-215-418, 518-215-419, 518-215-420, 518-250-101, and 518-255-101.

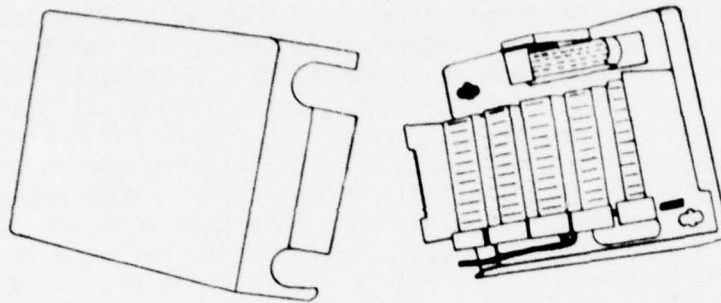

Figure 1-4. Type 66E3-25 connecting block.

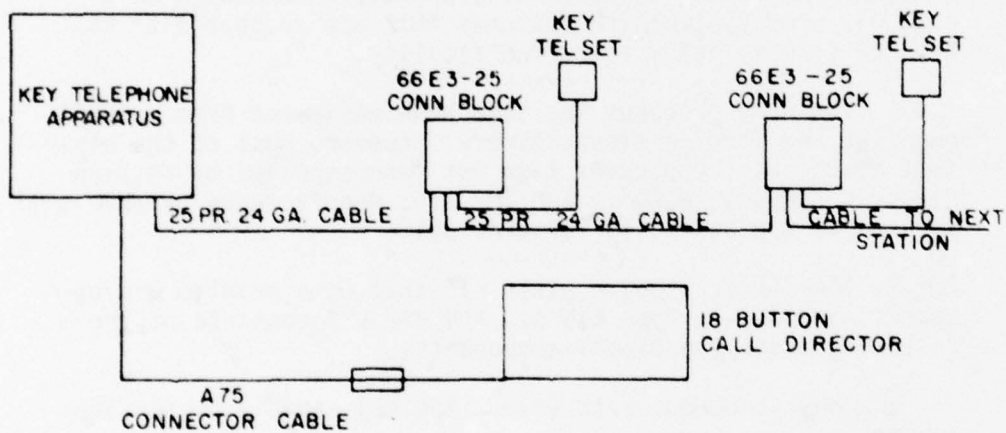

Figure 1-5. Key telephone system using 66E3-25 connecting blocks.

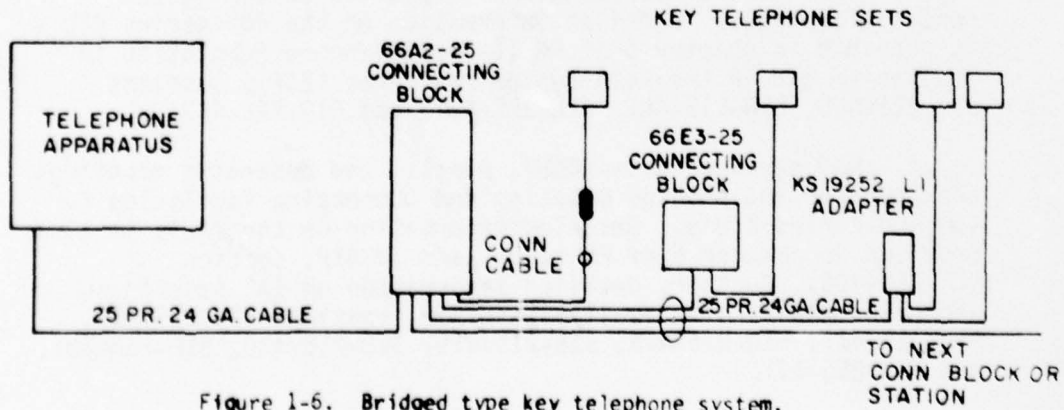

Figure 1-6. Bridged type key telephone system.

d. A local power supply (for example, power units 19C2 and 20C2) provides power for relay operations, talking, control lamp, and signaling functions. Additional information on power supplies for the 1A2 system is available in FM 11-31 and BSP, section 518-215-100.

1.4.3 KTU's manufactured by American companies are, in most cases, compatible and interchangeable within a single installation. KTS's other than the 1A2 that can be used are the 10A2, 12A2, and 16A; which are used at Army airfield locations, and the 6A, 7A, and 14A; each of which is similar and available from several manufacturers. However, special engineering considerations and justification will be required for their use. No matter which KTS is selected, state-of-the-art modular prewired equipments should be considered. Equipment manufacturers provide nomenclatures of KTU's similar to those of WECO and many state which KTU's are compatible with WECO equipment.

1.4.4 KTS performance is determined by inherent line and intercom capabilities. For example, a 1A2 KTS can provide intercom, dial central office (DCO) lines, conferencing and automatic tie lines, and is expandable to any number of DCO lines and intercoms by stacking arrangements. The 6A KTS provides an intercom capability but must be tied into a 1A1 or 1A2 KTS for DCO/private branch exchange (PBX) lines, and the 14A provides 14 lines and 34 intercoms with some options. The 10A2 KTS is similar to the 1A2 configuration and can be used where local procurement is recommended. Detailed information on the 10A2 KTS is provided in General Telephone and Electronic (GTE) Practices, sections 484-401-100 and 484-401-200. It should be noted that the 1A2 configuration is variable and there are several panels available that can provide desired expansion.

1.5 LIST OF APPLICABLE DOCUMENTS.

1.5.1 Government documents.

Manuals

FM 11-31

Telephone Substation Installation
(Key Telephone System Installation and Maintenance of 1A1, 1A2, and 6A)

CCTM 105-50-21

Telecommunications Engineering-
Installation Practices,
Installation-General

Regulations

CCR 702-1-2

USACC Quality Assurance Program for
Engineering, Installation, and
Acceptance of Communications-
Electronics Equipment and Systems

CCCR 702-3

Role of the Test Director

Circulars

(DCAC) 370-160-3

Site Survey Data Book for Communi-
cations Facilities1.5.2 Non-Government documents.

BELL SYSTEM PRACTICES (BSP) SECTIONS:

461-604-100	Connecting Blocks 66-Type - Tools, Terminating, Adapters, and Maintenance
461-604-102	Connecting Blocks 66A, B, C, and M1- Type - Identification
461-604-103	Connecting Blocks 66E3-25, 66E4-25 - Identification and Installation
518-010-101	Centralized Key Telephone Installa- tions
518-215-100	1A2 Key Telephone System - Identi- fication and Arrangements
518-215-400	1A2 Key Telephone System - Key Telephone Units - 400 Series
518-215-401	1A2 Key Telephone System - Key Telephone Units - Auxiliary Line Services
518-215-402	1A2 Key Telephone System - Key Telephone Units - Intercom Services
518-215-403	1A2 Key Telephone System - Key Telephone Units - Control Services
518-215-405	1A2 Key Telephone System - Key Service Units - 513-, 514-, and 515-Type

31 August 1978

SEIP 016

518-215-410	1A2 Key Telephone System - Panels - 583- and 584-Type
518-215-417	1A2 Key Telephone System - 597- and 598-Type Panels
518-215-418	1A2 Key Telephone System - Panels - 601-, 602- and 603-Type
518-215-419	1A2 Key Telephone System - System 620A, 641A, and 642A Modular Panels
518-215-420	1A2 Key Telephone System - 69B, D, and G Apparatus Mountings
518-410-100	6A Key Telephone System - Identification and Installation
518-450-100	7A Communications Systems (COM KEY* 718)
518-450-102	14A Communications Systems (COM KEY 1434)

*Trademark of AT&T Company

GENERAL TELEPHONE and ELECTRONICS (GTE) PRACTICES SECTIONS:

484-401-100	Type 10A2 Key Telephone System - Description and Operation
484-401-201	Six-Line Type 10A2 - Key Telephone System - Installation
484-401-202	10A2 Key Telephone System - 13-Line and 15-Line Panels - Installation
491-360-100	Connector Cable Adapters Description and Application
491-501-100	Type 66 Connecting Blocks Description and Installation

1.5.3 Ordering procedures for Bell System and General Telephone and Electric Practices. BSP will be ordered following the procedures outlined in USACEEIA Regulation 310-1, Procedures for Ordering Bell System Practices, 4 March 1977. GTE Practices may be acquired by writing directly to the GTE Services Corporation, 400 North Wolfe Road, North Lake, Illinois, 60164.

1.5.4 Comments on Publication. Users of this publication are invited to submit recommendations for its improvement. Comments should be keyed to the drawing, page, paragraph, and line of the text for which the change is recommended. For convenience, a mailing card is found with this SEIP. Comments should be sent directly to the Commander, Headquarters (HQ), USACEEIA, ATTN: CCC-CED-SEP, Fort Huachuca, Arizona 85613.

SECTION 2. SITE SURVEY DATA AND CHECKLIST

2.1 GENERAL. This section provides the necessary information to accomplish the preliminary engineering, equipment layout, and site surveys associated with the installation of a KTS.

2.2 SITE SURVEY CRITERIA. Site survey requirements can vary by project or in the same type of installation. Further, all projects do not require a site visit if sufficient data for engineering is available. However, if a site survey is required, it should be conducted in accordance with the guidelines and criteria delineated in Defense Communications Agency Circular (DCAC) 370-160-3, Site Survey Data Book for Communications Facilities.

2.2.1 Site survey checklist. Whenever a site survey is required, a checklist, in accordance with the sample at figure 2-1, should be prepared by the project engineer for use as a guideline in conducting the survey. A set of drawings also should be available onsite for use with the checklist. The checklist is used by the survey team for technical data identification and assembly.

2.2.2 Use of the site survey checklist. The checklist, when completed, will aid in preparing an official survey report. The report will be an inclosure to the site concurrence letter which shall be forwarded through responsible agencies for concurrence, nonconcurrence, or comment. The following items, as applicable, are to be included with the checklist:

- a. Floor plan of the building containing a controlled area (if any) and indicating personnel and equipment adjacent to the controlled area. (Reproducibles from the District Engineer or using unit.)
- b. Plot layout indicating the buildings and equipment within 200 feet of the controlled area (if any), the number of occupants, and the electrical equipment in the buildings.
- c. Single-line drawings of the existing electrical distribution system and power supply. If possible, show required changes or additions to meet new requirements.
- d. Copy of DA Form 2701, Job Order Request (repairs and utilities) or Military Construction, Army (MCA) project previously submitted, if any.
- e. Floor plan (sketched to scale).

f. Comments on anticipated difficulties in the flow of materials, work, or personnel in the operations area.

g. Local telephone directory.

h. Memorandum of Understanding (MOU) between using unit, District Engineer, and District Space Coordinator, if required.

2.3 EQUIPMENT CHARACTERISTICS. The physical and electrical characteristics of equipment selected should be obtained and provided in accordance with the sample format at table 2-1.

31 August 1978

SEIP 016

SITE SURVEY CHECKLIST
FOR

DATE: _____

PROJECT NUMBER: _____

SITE LOCATION: _____

CITY: _____ COUNTRY _____

INSTALLATION _____

BUILDING _____ ROOM _____

PROJECT ENGINEER: _____

CLASSIFICATION: _____

Figure 2-1. Sample site survey checklist (sheet 1 of 8).

SEIP 016

31 August 1978

PROJECT OR TASK NO: _____

1. PURPOSE OF SITE SURVEY: _____

2. PERSONNEL CONTACTED OR PRESENT DURING SURVEY:

<u>Name, Grade, and Title</u>	<u>Organization</u>	<u>Phone No.</u>
-------------------------------	---------------------	------------------

a. _____

b. _____

c. _____

d. _____

e. _____

f. _____

g. _____

h. _____

3. EQUIPMENT TO BE INSTALLED:

a. Contractor furnished and installed.

b. GFE, Government installed.

c. GFE, contractor installed.

d. Equipment description chart.

Figure 2-1. Sample site survey checklist (sheet 2 of 8).

31 August 1978

SEIP 016

PROJECT OR TASK NO: _____

<u>Nomen- clature</u>	<u>Weight</u>	<u>Dimensions</u>	<u>Ambient operating ranges</u>	<u>Heat dissipation</u>	<u>Access clearance requirements</u>
---------------------------	---------------	-------------------	---	-----------------------------	--

4. DOCUMENTATION:

a. Documentation of the status of the physical plant should be completed by requisition and review of the appropriate as-built drawings. The list of as-built drawings obtained is as follows:

<u>Drawing Number</u>	<u>Title</u>	<u>Revision date</u>	<u>Source</u>
_____	_____	_____	_____
_____	_____	_____	_____
_____	_____	_____	_____
_____	_____	_____	_____
_____	_____	_____	_____
_____	_____	_____	_____
_____	_____	_____	_____
_____	_____	_____	_____
_____	_____	_____	_____
_____	_____	_____	_____

b. Drawings not available during the site survey should be requested by the local military authorities through the most expeditious channels. Once obtained, the drawings should be immediately forwarded to responsible area electronics engineering installation agency.

Figure 2-1. Sample site survey checklist (sheet 3 of 8).

PROJECT OR TASK NO: _____

c. If as-built drawings of the physical plant are not available, lack sufficient details, or are otherwise inadequate, provide a dimensioned sketch of the floor plan including location, dimensions, and identity of each equipment. (Please attach sketch.)

d. Additional general information, which bears on the engineering of the facility, is as follows:

5. ROOM CONFIGURATION (to be supported by scaled drawings):

a. Room numbers: _____

b. Floor:

(1) Material: _____

(2) Condition: _____

(3) Loading capacity: _____

(4) Obstructions: _____

Figure 2-1. Sample site survey checklist (sheet 4 of 8).

31 August 1978

SEIP 016

PROJECT OR TASK NO: _____

(5) Space available under raised flooring, if installed:

c. Walls:

(1) Material: _____

(2) Condition: _____

(3) Load bearing: _____

(4) Obstructions: _____

(5) Height: _____

(6) Possible removal: _____

d. Doors:

(1) Number of outer doors: _____

(2) Number of inner doors: _____

(3) Material: _____

(4) Condition: _____

(5) Dimensions: _____

(6) Opening: In _____ Out _____

e. Windows:

(1) Quantity on outer walls: _____

(2) Dimensions: _____

(3) Type (double hung, projected, etc.): _____

Figure 2-1. Sample site survey checklist (sheet 5 of 8).

PROJECT OR TASK NO: _____

(4) Height above floor: _____

(5) Number of windows: Barred _____ Opaques _____

f. Ceiling:

(1) Material: _____

(2) Condition: _____

(3) Height (suspended or other): _____

(4) Obstructions: _____

(5) Space available for ducting if a drop ceiling is installed: _____

g. Lighting (if wiring is to be removed, check here _____)

(1) Type: Incandescent _____ Flourescent _____

(2) Type of fixtures: _____

(3) Number of fixtures: _____

(4) Size of lamps in watts: _____

(5) Height above floor: _____

(6) All power cable for lights in ferrous conduit: Yes _____
No _____

(7) Foot candle rating: _____

(8) Total power loading: _____

Figure 2-1. Sample site survey checklist (sheet 6 of 8).

31 August 1978

SEIP 016

PROJECT OR TASK NO: _____

h. Convenience outlets (if wiring is to be removed, check here _____):

(1) Type: _____ Number: _____

(2) Voltage: _____ Phase: _____

Frequency: _____ Ampere rating: _____

(3) Number of wires: _____

(4) Protective ground to ac outlets: Yes ___ No ___

(5) All power cable in ferrous conduit: Yes ___ No ___

i. Environmental systems:

(1) Type of heating: _____

Btu/hr capacity: _____

(2) Type of air conditioning: _____

Btu/hr capacity: _____

(3) Maximum number of personnel who normally occupy area: _____

(4) Humidity controlled: Yes ___ No ___

(5) Heat dissipation capacity of existing equipment: _____

Btu/hr

(6) Surplus air-conditioning capacity available for this installation: _____ Btu/hr

(7) Feasibility of expansion (if necessary): _____

(8) Monitoring equipment: _____

Figure 2-1. Sample site survey checklist (sheet 7 of 8).

PROJECT OR TASK NO: _____

6. STATION GROUND:

a. Signal ground installed: Yes ___ No ___

(1) Type (water pipe, rod, etc.) _____

(2) Resistance of true earth ground _____ ohms

(3) Date measured: _____

(4) Method used: _____

b. Protective ac ground installed: Yes ___ No ___

(1) All equipment grounded to ac protective ground by separate wires: Yes ___ No ___

(2) Ferrous shields tied to ac protective ground bus: Yes ___ No ___

7. UTILITIES AVAILABLE (water and gas):

a. Size and capacity of each: _____

b. Supplier: _____

c. Available capacity: _____

8. PRESENTLY INSTALLED EQUIPMENT (List type and quantity of installed equipment that will be associated with or used for this installation.):

<u>Item No.</u>	<u>Room location</u>	<u>Nomenclature</u>	<u>Qty in operation</u>	<u>Qty reserved</u>

9. MISCELLANEOUS:

Site Survey Team Chief

Figure 2-1. Sample site survey checklist (sheet 8 of 8).

Table 2-1. Sample Format for Physical and Electrical Characteristics

<u>Nomenclature</u>	<u>Dimensions</u>	<u>Ambient Operating Range</u>	<u>Heat Dissipation</u>	<u>Access Power Input</u>	<u>Clearance Requirements</u>	<u>Wt</u>
KSU 515AW3	25 1/2" X 17" X 11"	*	*	110 V ac	9 1/2" each side of assembly	*
Interrupter KS 15900L	4 1/16" X 3 11/32" X 2 9/32"	100-500 C 40-90% relative humidity	*	10 V ac, -3A	Installed in 16C Apparatus Mounting	*
KTU 400DW	4", 18 Contact	*	*	-24 V dc(B Batt) -24 V dc(A Batt) ±10 V 105 V	**	*
KTU 407B	8", 80 Contact	*	*	-24 V dc(B Batt) -24 V dc(A Batt) ±10 V 105 V	**	*
KTU 418AW	4", 20 Contact	*	*	-24 V dc(B Batt) -24 V dc(A Batt) ±10 V 105 V	**	*
KTU 417AW	4", 40 Contact	*	*	-24 V dc(B Batt) ±10 V	**	*
KTU 469A	4", 18 Contact	*	*	10 V ac	*	*

* Not available
** Mounted in KSU 515AW3

SECTION 3. INSTALLATION SPECIFICATIONS AND INSTRUCTIONS

3.1 GENERAL. The installation specifications and instructions outlined in this section provide standard engineering guidance for use by responsible activities during the engineering and installation of KTS's. Documents listed in 1.5 form a part of this installation package. Unless otherwise indicated, the issue in effect on the date of publication of this document shall apply. When these documents conflict, the SEIP shall govern.

3.2 INSTALLATION INSTRUCTIONS. The KTS typified in this SEIP provides telephone service from a DCO/PBX line to one or more telephone sets with multiline pickup, line lamp and common audible signaling, and intercom capabilities. Additionally, the KTS uses 57P telephone service fittings, bridging adapters, and 66-type back panels and connecting blocks. The use of 66-type back panels and blocks reduces onsite installation time and cost, and increases telephone capacity in a given space. This system simplifies system planning and troubleshooting. Figure 3-1 is a typical KTS using bridging adapters and 66-type connecting blocks. Figure 3-2 is a typical KTS using system 66 connectorized back panels.

3.2.1 Equipment to be installed. The following major items of equipment are provided as a reference/guide. However, it will be the project engineer's responsibility to determine the type KTS and equipment necessary to meet operational requirements.

a. Key service units. The KSU's accommodate the 1A2 services by providing mounting and connecting facilities for the 400-series KTU's that provide the switching and control features. Recommended KSU's to be used with the 1A2 KTS are listed in table 3-1; further, tables 3-2 and 3-3 list the recommended KTS panels and 69-type apparatus mountings respectively. Figure 3-3 depicts a typical 515 KSU with jacks and 66-type block locations. The 515 KSU is comprised of two units, the 513 and 514 KSU's, and is capable of satisfying most operational requirements. The WECO 515 KSU provides 16 DCO/PBX lines and either a 10 or 19 selector code intercom. The use of available options reduces the number of lines available; however, by relocating the power supply and replacing it with a 69F apparatus mounting, additional lines can be obtained. Generally the 515 KSU is wall mounted and the installation can

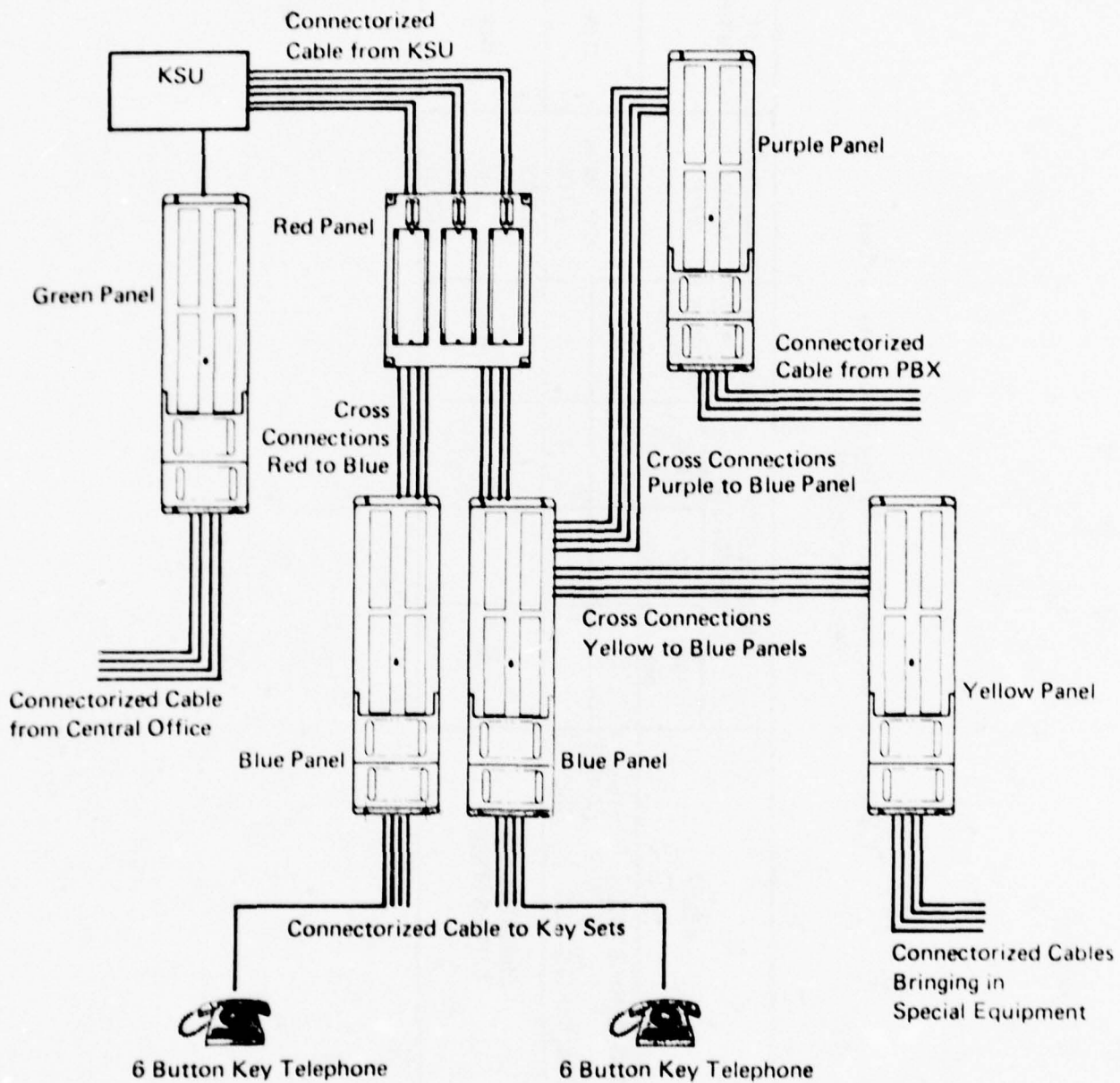

Figure 3-2. Typical key telephone system using system 66 connectorized back panels.

Table 3-1. Recommended 1A2 Key Telephone System Key Service Units

KSU	NUMBER OF CONNECTORS			MAX NO. OF CO OR PBX LINES	PRIMARILY WIRED FOR	TYPE MOUNTING
	18-pin	20-pin	40-pin			
513 SERIES KSU		4	4	8	All Series KTUs	Wall
514 SERIES KSU		4	4	8		
550 AND 551 SERIES KSU	4			4	400D, 401A and 415A KTUs	Wall

Table 3-2. Recommended 1A2 Key Telephone System Panels

PANEL	NO. OF CONN	PRIMARILY WIRED FOR	SIZE (IN.)	TYPE MOUNTING
584-TYPE	13 (18-pin)	400D 401A and 415A KTUs	4x23	
597A	14 (20-pin)	400D or E 401A 404A 413A 414A 415A 416A 418A 420A 430A	4x23	
598A	14 (40-pin)	400D or E 401A 404A 413A 414A 415A 416A 417A 418A 420A 421A 422A 428A 429A 430A	4x23	Relay rack or standard App Cabinets
601A	6 (40-pin)	407B 424A	8x6	
602A	6 (40-pin)	407B 422A 423A 424A 425A	8x6	
603A	4 (40-pin)	426A 427A	8x4½	

Table 3-3. Recommended 1A2 Key Telephone System
69-Type Apparatus Mountings

Apparatus mounting	No. of conn		Max. No. of CO or PBX lines	Primarily wired for	Size (in.)	Type mounting
	20-pin	40-pin				
69B	2		2	4-inch 18- or 20-contact KTUs	2x8	Relay rack or standard apparatus cabinet
69B		2	2	All KTUs except 407B, 424A and 425-Type		
69G		2	—	407B-, 424A-, and 425-Type		
69E		2	2	All KTUs except 407B or 424A		One may be added to 514 KSU
69F		2	2			3 may be added to 513A1 KSU

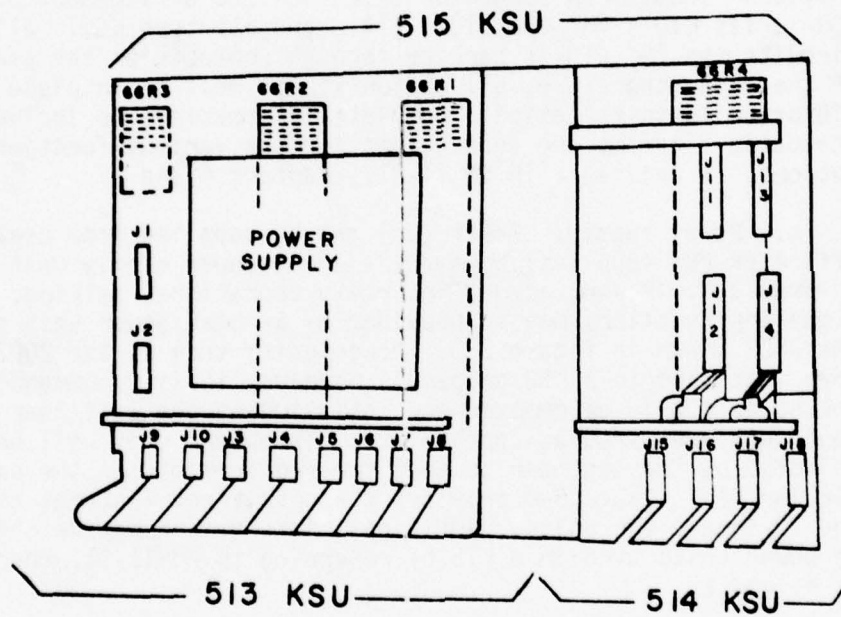

Figure 3-3. Typical 515 key service unit with jack and 66 block locations.

be stacked to provide additional lines. Complete information to include wiring and schematic diagrams for the KSU, KTS panels, and 60-type apparatus mountings is available in FM 11-31, chapters 6 and 7.

b. Key telephone units. The 400-series KTU's, table 3-4, used with the 1A2 KTS are solid state, plug-in type KTU's mounted on 4- or 8-inch printed wiring boards. Figure 3-4 depicts the 4- and 8-inch printed wiring boards. The KTU is installed by inserting the plug-end of the printing wiring boards into the selected connector of the 513-, 514-, or 515-type KSU. Table 3-5 provides recommended connector selection and arrangement of 400-series KTU's for the 513-, 514-, and 515-type KSU. All circuitry to the KTU is carried through contacts on the plug-end of the unit; therefore, all option straps must be in place on the KTU prior to installation. Complete information, to include schematic diagrams and connections for the various function and options, is available in FM 11-31, chapters 6 and 7.

c. Power supply. Power (dc) may be supplied from central office or PBX supplies; however, a local power supply unit should be provided. Power, ac/dc, for relay operations, talking, and signaling functions may be provided by a local power unit such as the 20C2 shown in figure 3-5. Power units such as the 20C2 may come installed in a KSU or panel; however, it is recommended that the power supply be removed and installed on the wall near the equipment and wired as appropriate. The power unit will be selected by the engineer to meet the requirements of the particular KTS. Table 3-6 provides the output and features of 19- and 20-type power units. Additional information may be obtained on power units used in a KTS by referring to FM 11-31, chapters, 5, 6, and 7.

d. Connecting blocks and bridging adapters. The 66-type connecting blocks are used in KTS's such as the 1A1, 1A2, 6A, 10A2, 7A, or 14A. The engineer must determine which of the various 66-type connector blocks must be used. The 66-type connecting blocks consist of multiple terminal connectors inserted in a molded plastic block and is held in place by retaining plates. The terminal is a quick-connect terminal and connections are made by inserting unskinned conductors into the terminals. The 66-type connecting block is mounted in the KSU and used to terminate the cables. The 66-type connecting blocks are also used for bridging and to provide a convenient way to terminate cut cables at a station location. Figures 3-6, 3-7, and 3-8 depict 66B4-, 66CB1-6-, and 66E3-type connecting blocks respectively. System 66 connectorized blocks that are fully

Table 3-4. 400-Series Key Telephone Units

KTU	FUNCTION	SIZE (In.)	CONTACTS	QUANTITY
400D	CO or PBX line circuit	4	18	1 per line
401A	Manual intercom line circuit	4	18	As required
407B	Dial intercom 10-code selector circuit	8	80	1 per intercom system
412A	Auxiliary lamp relay circuit	Special-Req. AKS-8586 L32 Connector		Used in place of interrupter for LW and LF functions
413A	Auxiliary ringup circuit	4	18	As required
414A	Manual signaling, ringdown tie line circuit	4	20	2 per line (1 at originating end, 1 at terminating end)
415A	Automatic, DC signaling, tie line circuit	4	18	2 per line (1 at originating end, 1 at terminating end)
416A	Station line circuit	4	20	1 per line
417A	Add-on conference circuit	4	40	1 per conf Ckt
418A	Short range, DC signaling tie line circuit	4	20	1 per line
419A	Automatic signaling, ringdown tie line circuit	8	80	2 per line (1 at originating end, 1 at terminating end)
420A	Dial intercom long line Ckt	4	18	One per off-premise line
421A	Power failure, transfer Ckt gen purpose relay or DSS	4	40	1 per com aud transfers 1 per DSS code, or as reqd.
422B	Station busy selector circuit	4	40	1 per single-digit codes 1 per two-digit codes
423A	Dial tone, busy tone, and aud ring back tone	4	20	1 per dial intercom line
424A	Dial intercom 19-code selector circuit	8	80	1 per intercom system
425B	Flashing lamp circuit	8	80	1 per dial intercom system
426A and 427B (Series 4) or C	TOUCH-TONE adapter Ckt	8	80	1 of each required per dial intercom system
		8	80	
428A	Multiline exclusion circuit	4	40	1 per 2 lines
429A or B	Supplementary hold detector circuit	4	40	1 per 2 lines
430A	Flutter generator circuit	4	20	1 per 100 lamps and 20 sup- plementary and/or reg hold keys

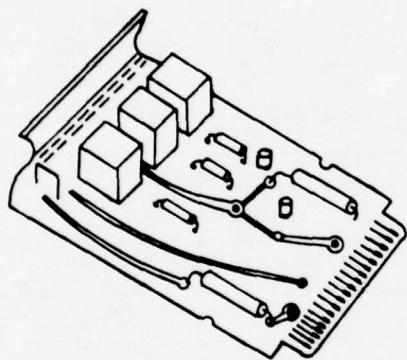

TYPICAL 4 INCH KTU

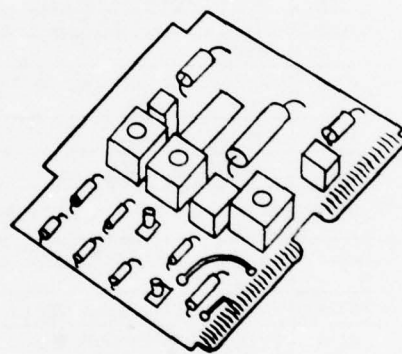

TYPICAL 8 INCH KTU

Figure 3-4. Typical 4- and 8-inch key telephone units.

Table 3-5. Recommended Connector Selection and Arrangement of 400-Series Key Telephone Units in 513-, 514-, and 515-Type Key Service Units

KTU	SIZE		SERVICE FUNCTION	515KSU															
				(SEE NOTE)															
	(In.)	Pins		513KSU								514KSU							
				CONNECTORS				CONNECTORS				CONNECTORS				CONNECTORS			
				J 1	J 2	J 3	J 4	J 5	J 6	J 7	J 8	J 9	J 10	J 11	J 12	J 13	J 14	J 15	J 16
40	40	20	20	20	20	40	40	40	40	40	40	40	40	20	20	20	20		
407B	8	80	Dial intercom 10-code ckt	1	*	*	*	*	*	*	*	*	*	*	*	*	*	*	*
424A	8	80	Dial intercom 19-code ckt	1	*	*	*	*	*	*	*	*	*	*	*	*	*	*	*
426A & 427B (series 4) or 427C	8	80	"TOUCH-TONE" adapter ckt	*	*	*	*	*	*	*	*	1	*	*	*	*	*	*	*
	8	80		*	*	*	*	*	*	*	*	*	*	1	*	*	*	*	*
425A (MD) or B	8	80	Dial intercom flashing lamp circuit	*	*	*	*	*	*	*	*	1		2	*	*	*	*	*
419A**	8	80	Automatic ring-down tie line ckt	3	*	*	*	*	*	*	*	1		2	*	*	*	*	*
429A or B	4	40	Supplementary hold detector ckt	*	*	*	*	*	*	1	2	*	*	*	*	*	*	*	*
421A	4	40	Power failure transfer ckt (general purpose)	7 †	8 †	*	*	*	*	1	2	3 †	4 †	5 †	6 †	*	*	*	*
422A or B	4	40	Dial intercom station busy ckt	*	*	*	*	*	*	1	2	3	*	4	*	*	*	*	*
417A	4	40	Add-on conference circuit	*	*	*	*	*	*	1	2	5 ‡	3 ‡	6 ‡	4 ‡	*	*	*	*
428A	4	40	Multiline exclusion circuit	16 §	15 §	14 §	13 §	12 §	11 §	1	2	3	10 §	4 §	5 §	6 §	7 §	8 §	9 §
420A	4	18	Dial intercom long line ckt	*	*	8	7	6	5	10	9	14	13	12	11	4	3	2	1

Table 3-5. Recommended Connector Selection and Arrangement of 400-Series Key Telephone Units in 513-, 514-, and 515-Type Key Service Units (Continued)

KTU	SIZE (IN.) PINS	SERVICE FUNCTION	515 KSU															
			(SEE NOTE)															
			†513 KSU								514 KSU							
			CONNECTORS								CONNECTORS							
			J 1	J 2	J 3	J 4	J 5	J 6	J 7	J 8	J 11	J 12	J 13	J 14	J 15	J 16	J 17	J 18
423A	4 20	Dial intercom & ringback, dial, & busy tone ckt	*	*	8	7	6	5	10	9	14	13	12	11	4	3	2	1
400-TYPE	4 18	CO/PBX line Ckt	15	†	1	2	3	4	9	10	11	12	13	14	5	6	7	8
401A	4 18	Manual intercom ckt	15	†	8	7	6	5	10	9	8	7	6	5	4	3	2	1
413A	4 18	Aux ring-up ckt	15	†	8	7	6	5	10	9	14	13	12	11	4	3	2	1
414A**	4 20	Ringdown tie line ckt	15	†	**	**	**	**	**	**	**	**	**	**				
415A	4 18	Automatic tie line ckt	15	†	8	7	6	5	10	9	14	13	12	11	4	2	2	1
416A	4 20	Station tie line ckt	15	†	8	7	6	5	10	9	14	13	12	11	4	3	2	1
418A	4 20	Short range tie line ckt	15	†	8	7	6	5	10	9	14	13	12	11	4	3	2	1
430A	4 20	Flutter generator ckt	15	†	8	7	6	5	10	9	14	13	12	11	4	3	2	1

* NOT USABLE.

† RESTRICTED TO TRANSFER OF ONE STATION RINGER.

‡ SPARE TERMINALS FOR 13 LEADS REQUIRED ON CONNECTING BLOCK.

§ ONE CIRCUIT ONLY.

¶ SEE (1) AND (r) OF DESIGN FEATURES FOR APPARATUS REQUIRED IF ADDITIONAL CONNECTORS ARE DESIRED.

**SEE FIG. 61, NOTE B.

††IF ONLY 513 KSU IS USED, CONNECTOR SELECTION BEGINS WITH LOWEST NUMBER AVAILABLE.

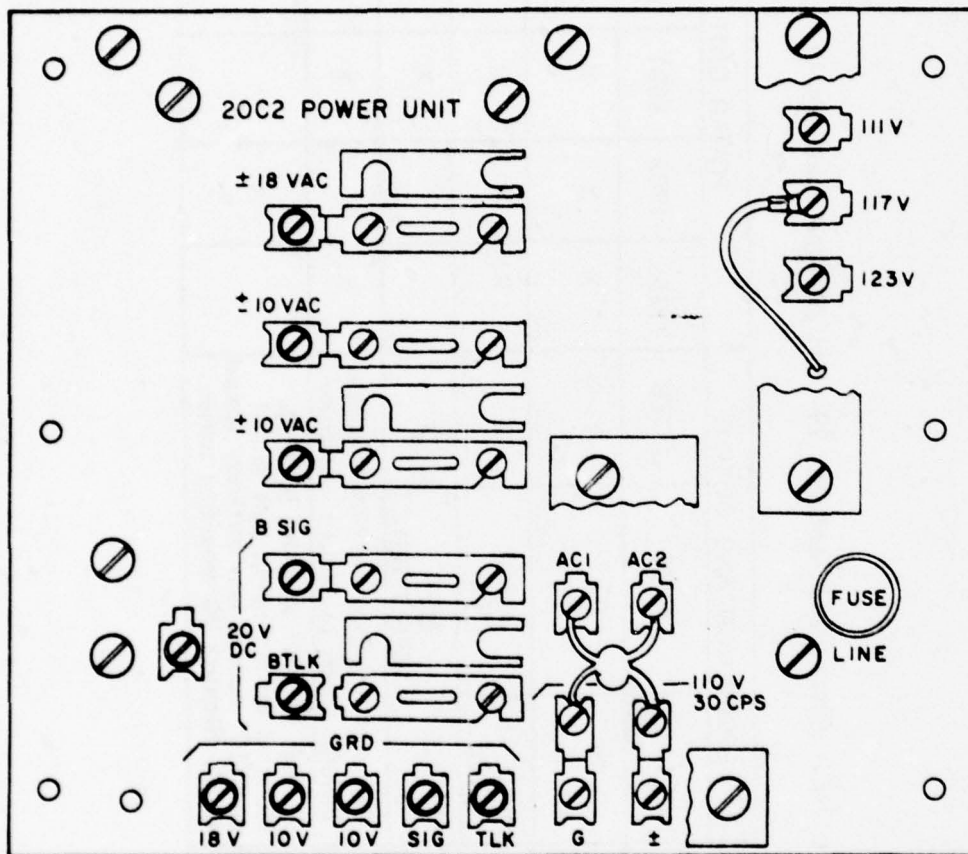

Figure 3-5. 20C2 power unit.

Table 3-6. Output and Features 19- and 20-Type Power Units

FEATURE	DESCRIPTION AND OUTPUT			POWER UNIT				
	VOLTAGE	AMPS	NOTE	19B2	19C2	20B1	20B2	20C2
DC OUTPUT Talk Sig	18-26	0.6	1	X	X	X	X	X
	20-26	1.5						
AC (60~) OUTPUT	8.75-11	4.5	2	X	X	X	X	X
	16-20	1.4						
AC (30~) OUTPUT (RINGING SUPPLY)	110-125	NOT SPECIFIED	3			X	X	X
WALL MOUNTING	9 1/2" high by 8 3/4" wide by 5" deep. Includes metal backboard and cover			X		X	X	
RACK MOUNTING	7" high by 8 1/2" wide by 5" deep. Mounted on horizontal bars drilled on 7/16" centers and vertically spaced at 7". Requires 20 mounting spacers.				X			X

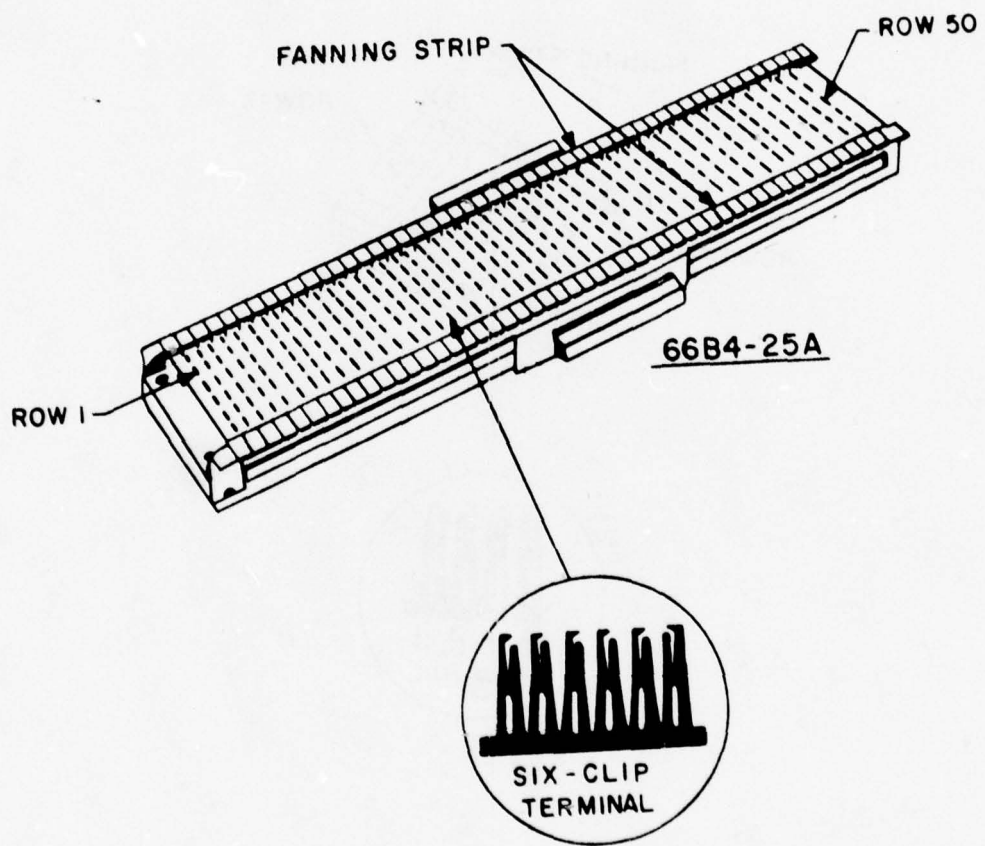

Figure 3-6. 66B4-type connecting block.

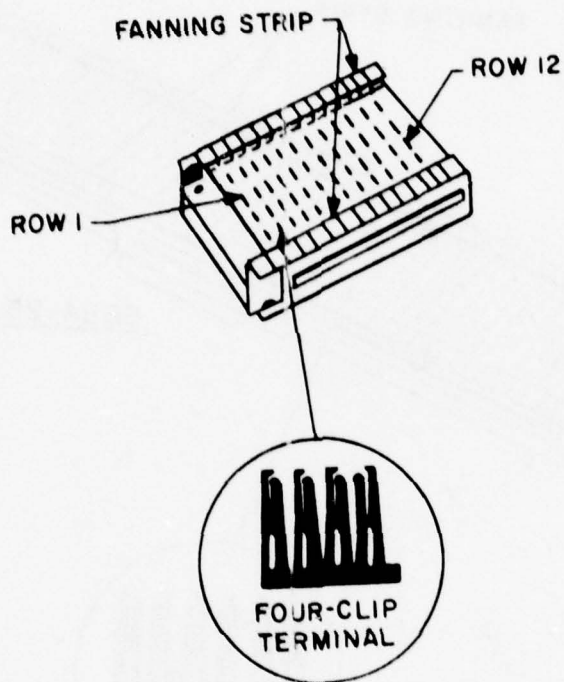

Figure 3-7. 66CB1-6-type connecting block.

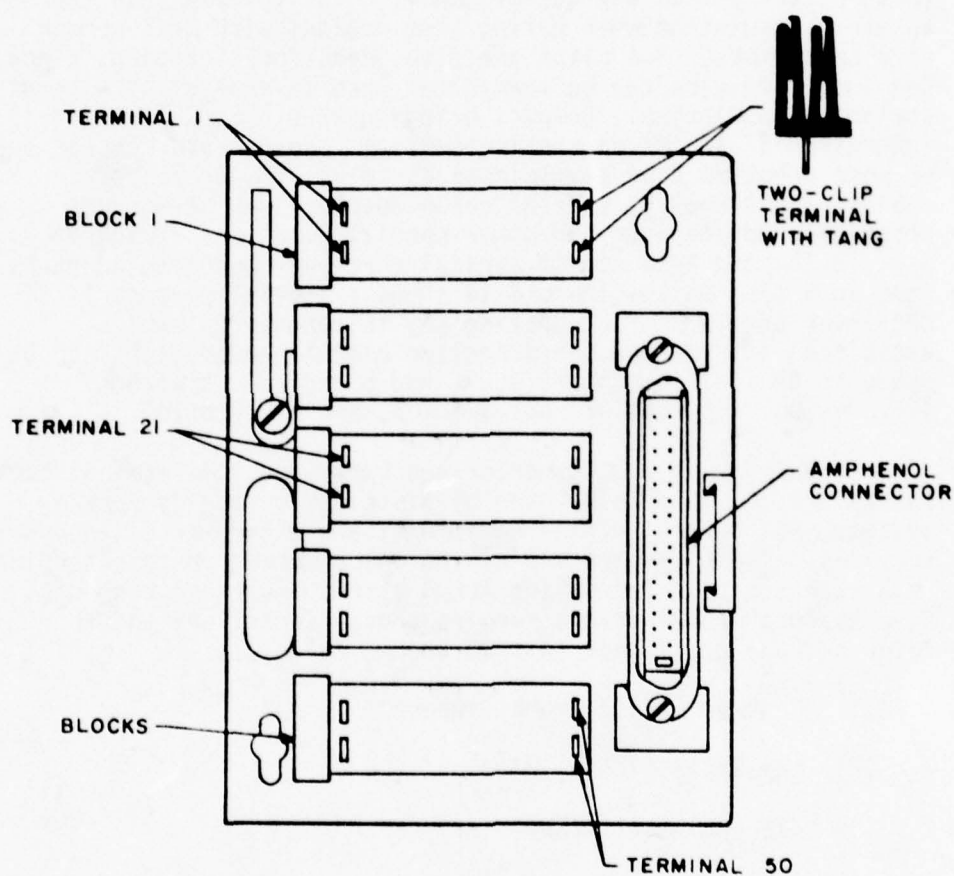

Figure 3-8. 66E3-type connecting block.

prewired and equipped with Amphenol 157-series connectors are also available. The system 66 blocks are wired in strict accordance with telephone wiring standards. The connectorized blocks such as those in the B3/B4 and M2 series, figures 3-9 and 3-10 respectively, are designed for rapid interconnection and significant space savings. The 66-type connectorized blocks use the 157-series connectors to prevent misalignment and bent pins; further, the blocks use quick-connect clips to eliminate the need to strip insulation when making terminations with most common size conductors. The clips are also ideal for strapping, since the insulated wire can be terminated into several clips without stripping insulation. Compact bridging adapters, which contain interwired 57-series connecting devices, are used to connect one or more 6-button type key telephones to 25, 50, or 75 pair cables; additionally, special cable adapters may be used as cross-over adapters or for other special functions. Figures 3-11, 3-12, and 3-13 depict typical three-way bridging adapters used in a KTS, while figure 3-14 shows a special purpose crossover adapter for connecting key telephones to cables. Additional information on connecting blocks and adapters can be found in FM 11-31, chapters 4, 5, and 6 and BSP, sections 461-604-100, 461-604-102, 461-604-103, and 518-010-101.

e. Backboards and connectorized back panels. Terminal backboards are designed to be used as distribution fields for key systems, PBX central office equipment, and other miscellaneous services. The backboard and wiring color scheme in this section is a standard plan for making terminations and cross-connects. Five types of terminations require cross-connections and the color backboard assigned to them are as follows:

- (1) Central office trunk - Green.
- (2) Keyset stations - Blue.
- (3) KTS equipment - Red.
- (4) Auxiliary equipment - Yellow.
- (5) PBX connections - Purple.

This standardized color coding of backboards and connectorized back panels provides easy identification of the terminations for the telephone service involved. Table 3-7 provides information for the selection of 183- and 184-type backboards. The 66-type and system 66 connectorized back panels perform the same functions as the backboards listed in table 3-7 and are color

31 August 1978

SEIP 016

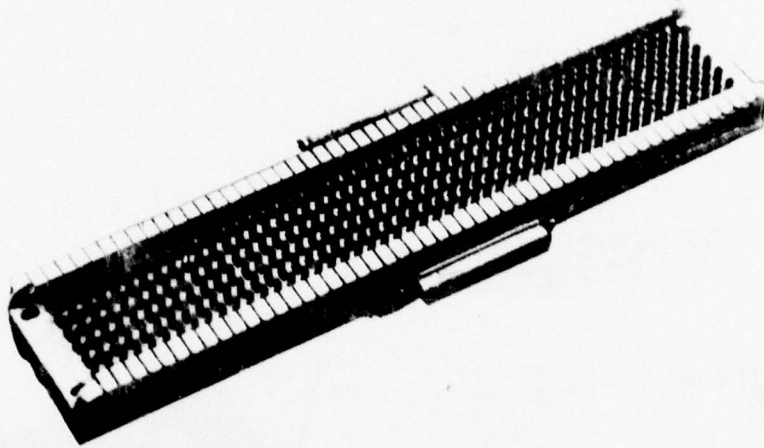

Figure 3-9. Typical B3/B4 series connectorized block.

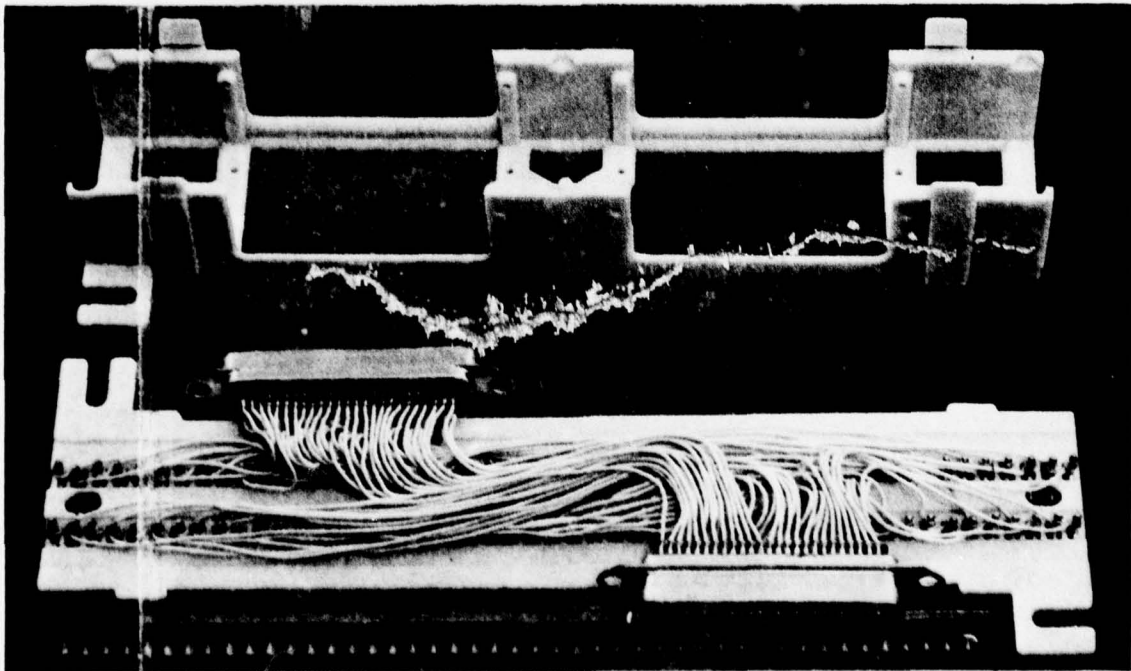

Figure 3-10. Typical M2 series connectorized block.

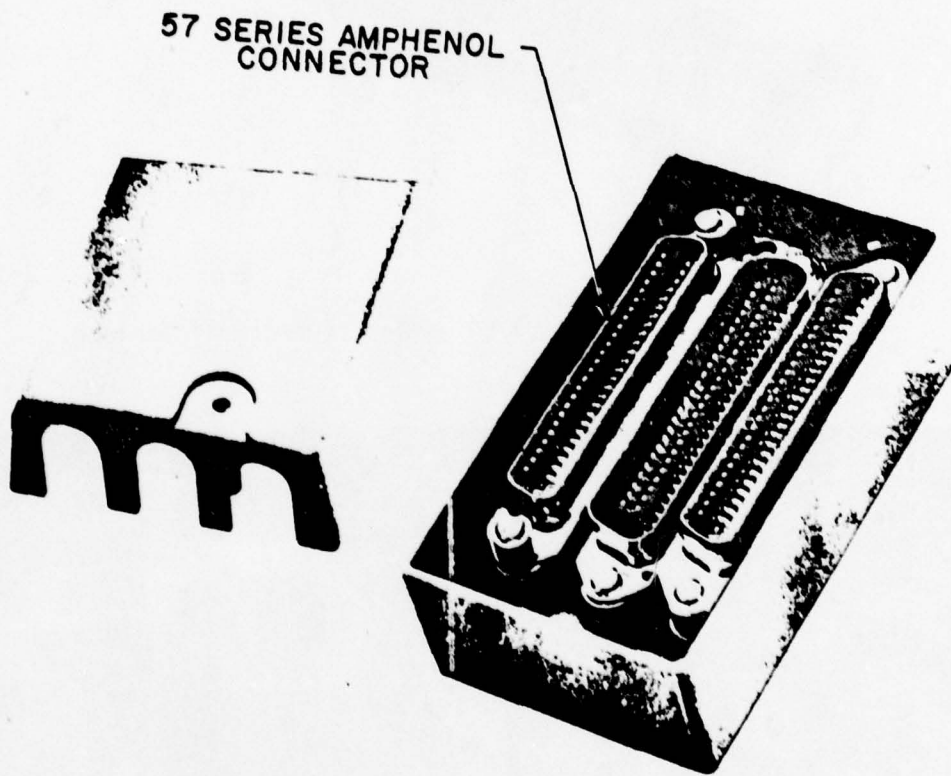

Figure 3-11. Three-way bridging adapter for 6-button telephones, 25-pair cable.

31 August 1978

SEIP 016

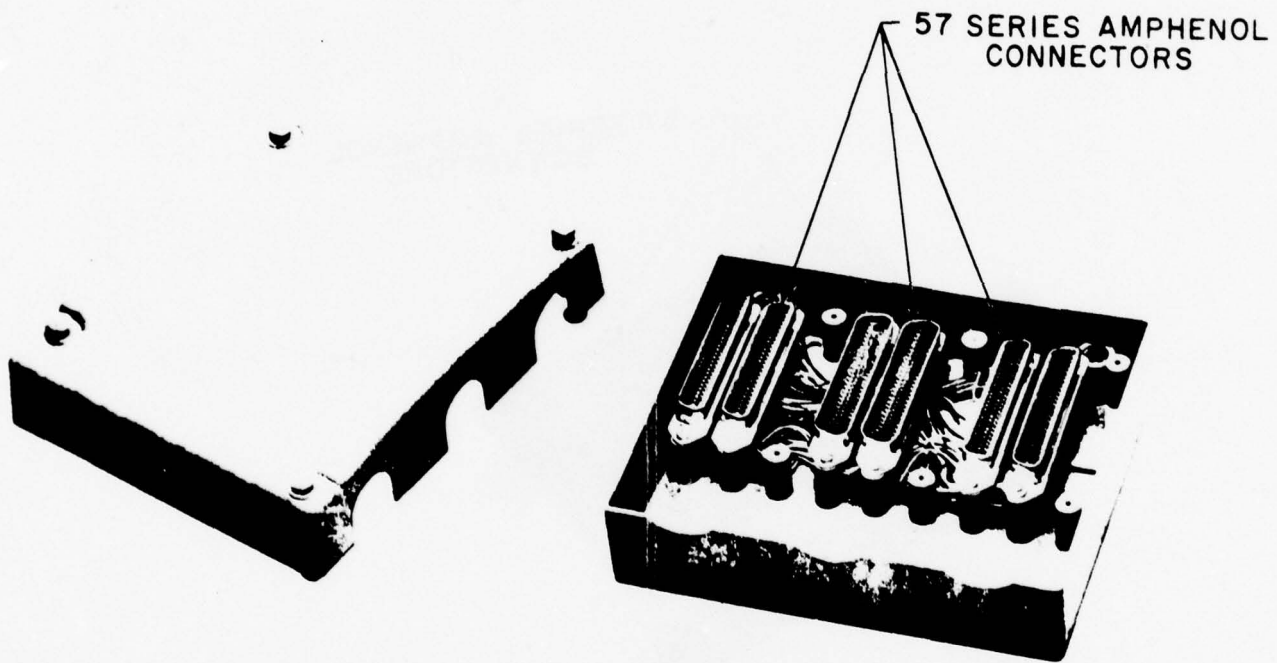

Figure 3-12. Three-way bridging adapter for key telephones, 10-pair cable.

SEIP 016

31 August 1978

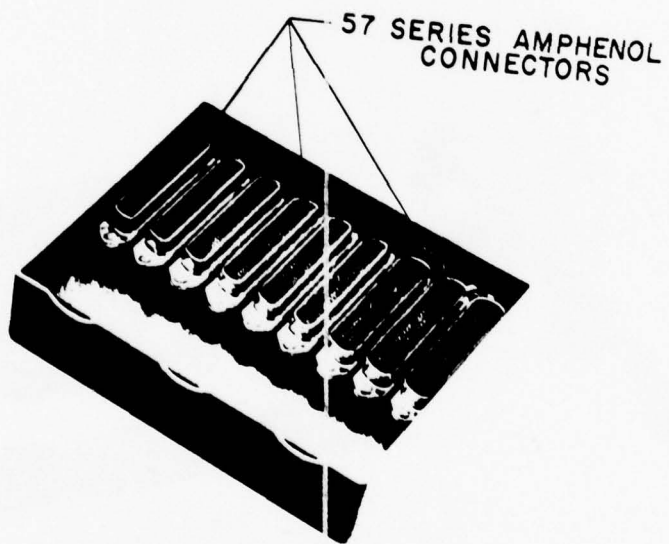

Figure 3-13. Three-way bridging adapter for 18-button telephones, 75-pair cable.

31 August 1978

SEIP 016

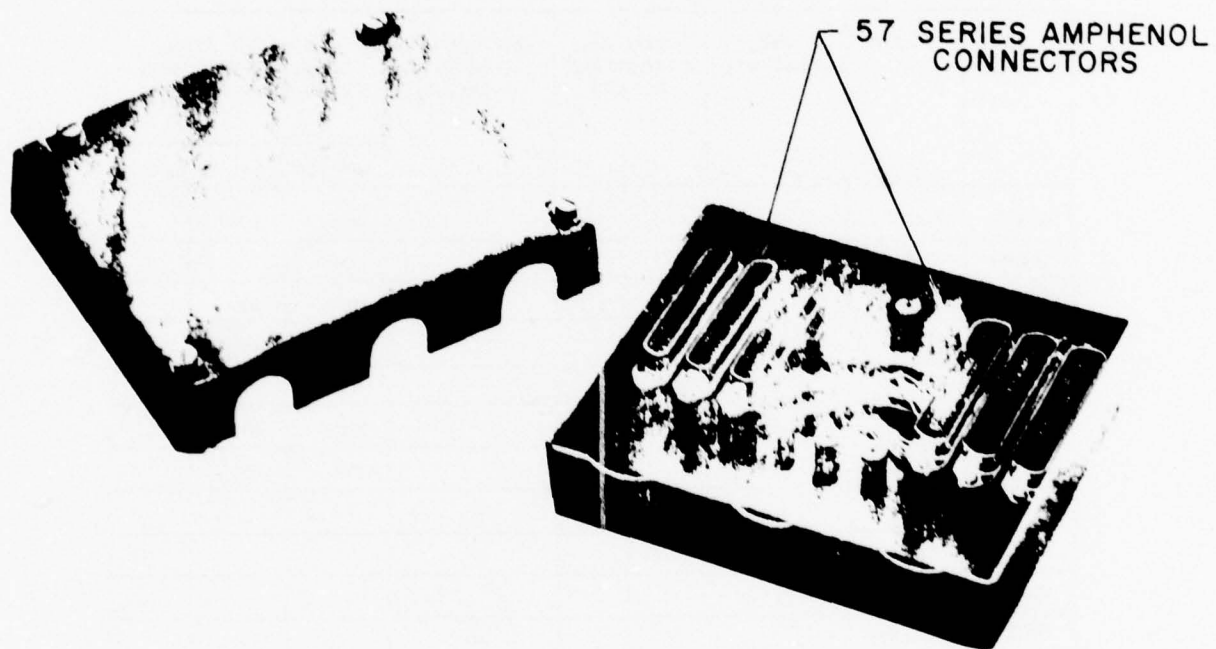

Figure 3-14. Crossover adapter for connecting key telephones to cables.

SEIP 016

31 August 1978

Table 3-7. 183- and 184-Type Backboard Selection

CODE	COLOR	88B BRACKETS	66B4-25 CONNECTING BLOCKS	DISTRIBUTING RINGS P-43X237	MAXIMUM PAIR TERMINATIONS USING CONNECTING BLOCKS		
					66MI-25	66MI-50	66B4-25
183A1	BLUE	4			100	200	
183A2	GREEN	4			100	200	
183A5	YELLOW	4			100	200	
183B1	BLUE	8			200	400	
183B2	GREEN	8			200	400	
183B3	RED	8			200	400	
183B5	YELLOW	8			200	400	
184A1	RED		2	6			50
184B1	RED		4	12			100
184B2	RED		4				100
185A1	YELLOW			6			
187B1	WHITE*			16			
188A1	WHITE*			4			

*USED TO ADD DISTRIBUTING RINGS BETWEEN CROSS CONNECTING PANELS.

31 August 1978

SEIP 016

coded identically. Connectorized back panels permit almost twice the telephone capacity in the same wall space as the 183-, 184-, and 66-type backboards. Figure 3-15 is a size comparison of 66-type and connectorized 66-type back panels to provide the same service. Tables 3-8 and 3-9 provide information for the selection of 66-type and system 66 connectorized back panels respectively. Full blue and one-half blue 66-type panels are used as a junction point for the 25 twisted pair cable from the telephone. The terms full and one-half relate to the number of telephones that can be terminated. The color coded back panels are equipped with 66M1-50 connecting blocks, eight on the full and four on the one-half; therefore, the full and one-half panels can terminate 16 and 8 telephones respectively. One-half, 1/4, and 1/8 connectorized 66-type panels are used as a compact connectorized junction point for 25, 50, 75, and 100 twisted pair cable from telephones. The one-half blue connectorized back panel has twice the telephone capacity as the forementioned 66-type back panel. This is accomplished by using all four rows of pushdown clips on the 66M1-50 block for cross connections. The other connectorized 66 back panels incorporate the same features and functions as the one-half blue panel. Amphenol connectors at the bottom of each panel, for each row of pushdown clips, provide a terminating point for telephones equipped with Amphenol 157-series plugs. Figure 3-16 illustrates and compares a KTS using conventional 66-type and system 66 connectorized back panels. The number, type, and arrangement of backboards and back panels will be determined by the project engineer to meet operational requirements. The engineer will then prescribe the arrangement of the backboards stating the wall space to be used and the height from the floor. BSP, sections 518-010-101, 518-215-410, 518-215-417, 518-215-418, and 518-215-419 will provide additional information on KTS panels.

f. A- and B-type connector cables. Telephones in a KTS may be connected to the inside cable by means of plug-ended or connector-ended cables that are available in various length of 24-gauge conductors with 50 contact connectors or plugs. A-type connector cables are double ended while B-type connector cables have a connector at one end and a plug at the other. A typical Amphenol plug and connector used to terminate A- and B-type connector cables is shown in figure 3-17. Table 3-10 lists the A- and B-type connector cables available and provides the necessary information for proper selection to satisfy the intended use. Additional information on A- and B-type connector cables is available in FM 11-31, chapter 4.

g. Associated apparatus and optional components. Complete information on associated apparatus and optional components such

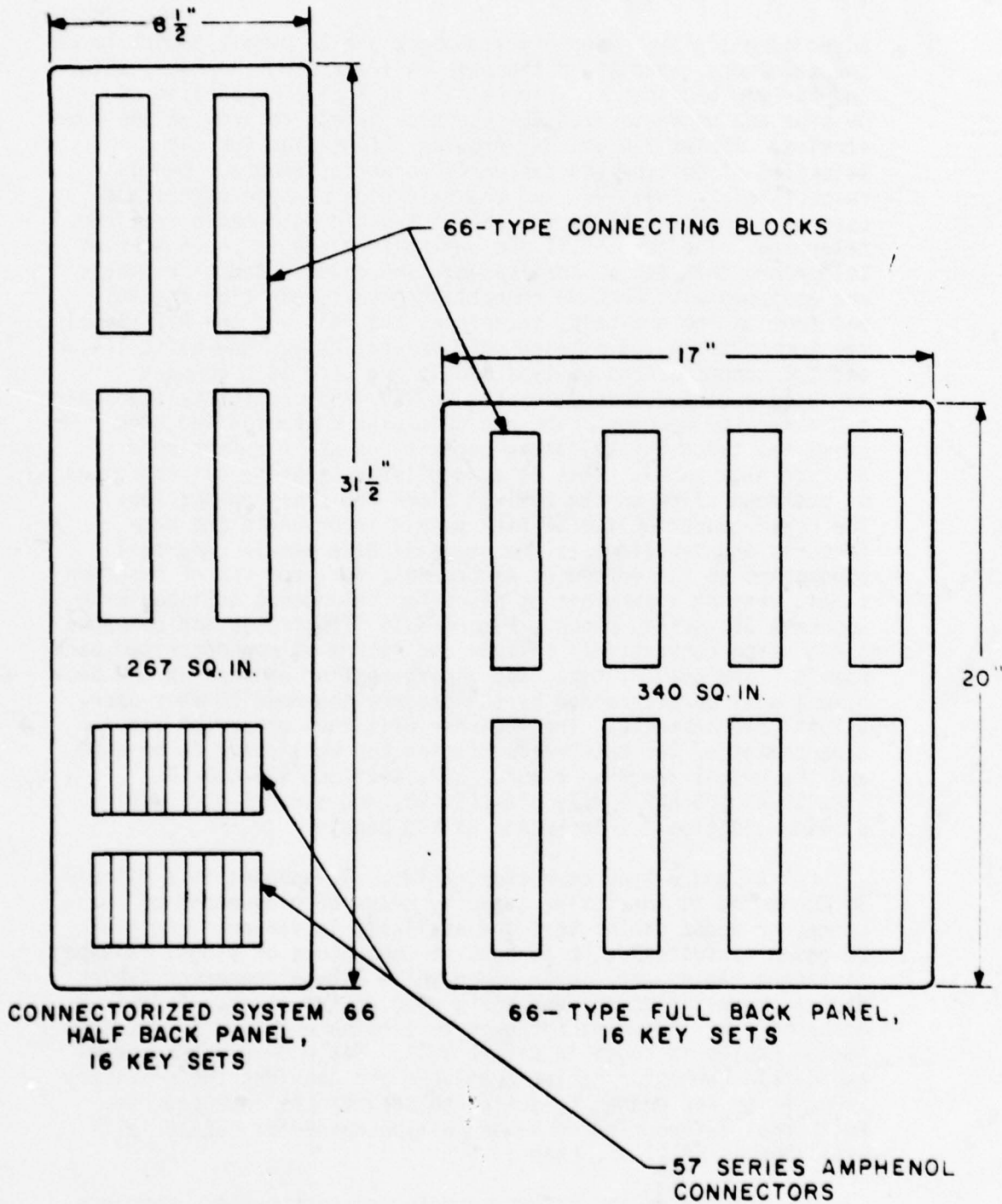

Figure 3-15. Size comparison 66-type back panels.

Table 3-8. 66-Type Back Panel Selection

AMPHENOL DESIGNATION	COLOR	*DIMENSIONS			PHONE CAPACITY	NUMBER OF PUSHDOWN CLIPS
		HEIGHT	WIDTH	DEPTH		
16 KEY SET	BLUE	20	17	3/4	16	200
8 KEY SET	BLUE	20	8 1/2	3/4	8	100
16 KEY SET	GREEN	20	17	3/4	16	200
8 KEY SET	GREEN	20	8 1/2	3/4	8	100
16 KEY SET	YELLOW	20	17	3/4	16	200
8 KEY SET	YELLOW	20	8 1/2	3/4	8	100
16 KEY SET	PURPLE	20	17	3/4	16	200
8 KEY SET	PURPLE	20	8 1/2	3/4	8	100
FULL RED	RED	20	17	3 1/2	500 Twisted Pairs	1000
HALF RED	RED	20	8 1/2	3 1/2	250 Twisted Pairs	500

*ALL DIMENSIONS ARE IN INCHES.

Table 3-9. System 66 Connectorized Back Panel Selection

AMPHENOL CODE	COLOR	DIMENSIONS*			PHONE CAPACITY	NUMBER OF PUSH DOWN CLIPS
		HEIGHT	WIDTH	DEPTH		
410 CBF 66/16	BLUE	3 1/4	8 3/4	2 1/4	16	400
410 CBF 66/8	BLUE	3 1/4	4 1/4	2 1/4	8	200
410 CBF 66/4	BLUE	1 1/4	4 1/4	2 1/4	4	100
410 CGF 66/16	GREEN	3 1/4	8 3/4	2 1/4	16	400
410 CGF 66/8	GREEN	3 1/4	4 1/4	2 1/4	8	200
410 CGF 66/4	GREEN	1 1/4	4 1/4	2 1/4	4	100
410 CYF 66/16	YELLOW	3 1/4	8 3/4	2 1/4	16	400
410 CYF 66/8	YELLOW	3 1/4	4 1/4	2 1/4	8	200
410 CYF 66/4	YELLOW	1 1/4	4 1/4	2 1/4	4	100
410 CPF 66/16	PURPLE	3 1/4	8 3/4	2 1/4	16	400
410 CPF 66/8	PURPLE	3 1/4	4 1/4	2 1/4	8	200
410 CPF 66/4	PURPLE	1 1/4	4 1/4	2 1/4	4	100
410 CRF 66/1500	RED	20	17	1 3/16	750 Twisted Pairs	1500
410 CRF 66/1000	RED	20	11 1/4	1 3/16	500 Twisted Pairs	1000
410 CRF 66/500	RED	20	6	1 3/16	250 Twisted Pairs	500

*ALL DIMENSIONS ARE IN INCHES.

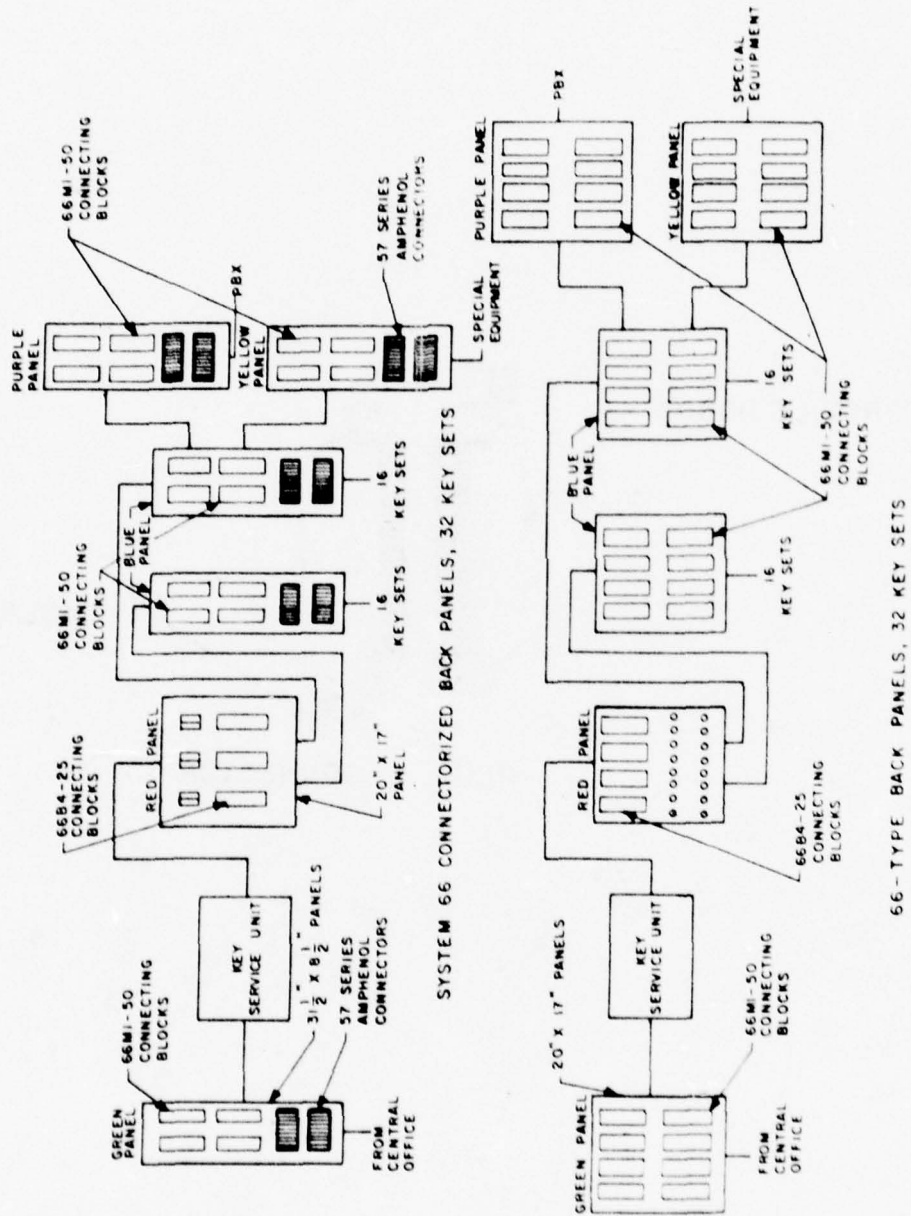

Figure 3-16. Key telephone system using conventional and connectorized back panels.

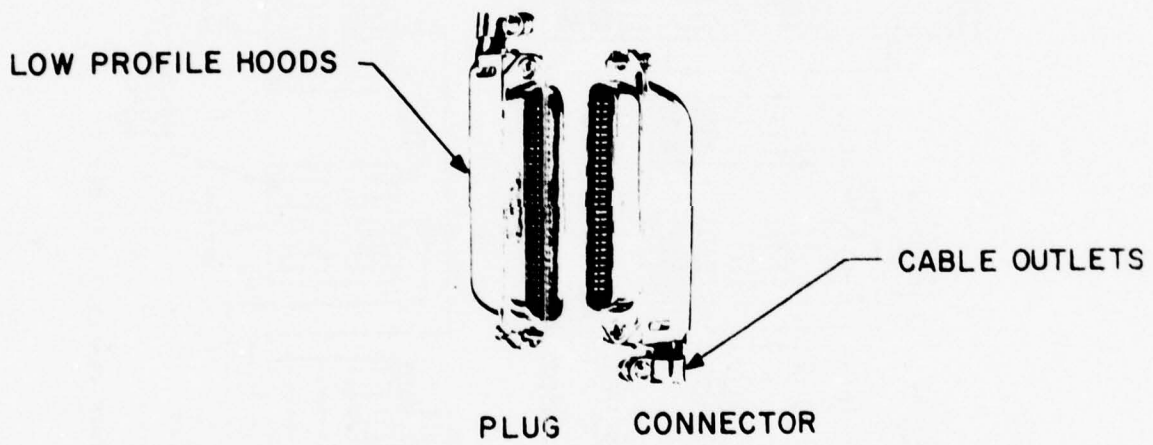

Figure 3-17. Typical Amphenol plug and connector.

Table 3-10. A- and B-Type Connector Cables Selection

CODE	CONDUCTOR FINISH	TOTAL NO. OF CONDUCTORS OR CONTACTS EACH PLUG OR CONNECTOR		NO. OF ARMS AT CONN OR PLUG END	NO. OF CONDUCTORS IN EACH ARM	CONNECTOR OR PLUG	INTENDED USE	STANDARD AVAILABLE LENGTHS (IN FEET)	
		Conductors	Contacts					SINGLE-ENDED	DOUBLE ENDED
A12A	Tinned	24	24	1	24	RS 16780L8 Plug	301 Sw Sys Equip in Airport Towers and Radar Rooms	4 and 8	
A12B			50						
A12D	Untinned	40	24	1	40	RS 16690L5 Connector	3A Comm Sys	13, 80 and 100	30, 80, 100 and 200
A12E			40			RS 16780L8 Plug	AUTOVON No. 300 Sw Sys	4 and 8	
A20B	Untinned	40	40	1	40	RS 16690L10 Connector	804 2064 606 2066 Telephone Sets Replaces A20A Connector Cable	13, 80, 100 and 200	30, 80, 100 and 200
A25A	Untinned	50	50	1	50	RS 16671L1 Plug	8080 Keys	80 and 100	
A25B						RS 16690L1 Connector	233A Key Telephone Units 834D Key Telephone Sets	13, 80, 100 and 200	30, 80, 100 and 200
A25C	Tinned	50	50	1	50	RS 16780L8 Plug	Consoles for Strategic Air Command Installations	Any length as specified	
A25D	Untinned					RS 16690L1 Plug	701A PBX and 702A Small Hospital PBX	13, 20, 22, 24 and 26	3, 6 and 9
A25E	Tinned	50	50	1	50	RS 16690L1	8081 Key in Antiaircraft Operations Control System Battery Locations	Any length as specified	
A25F	Tinned					RS 16671L1 Plug	128 and 148 Apparatus Units in 2A and 3A ACD Systems	80, 100, and 180	
A25M	Untinned	50	50	1	50	RS 16690L1	Shielded Connector Cable for use where RFI encountered in Pictophone Installations	Any length as specified	
A40A	Untinned					50	50	2	50
A50A	Untinned	100	50	1	50	RS 16690L1 Connector	8081 Keys	80 and 100	30, 80, 100 and 200
A50B			50			RS 16690L1 Connector	810A Key Telephone Sets	80, 100, 180 and 200	100 and 200
A50C	Untinned	100	50	1	50	RS 16780L8 Plug	Telephone Secretarial Service Concentrator Identifier	50 and 100	
A50D (A&M ONLY)	Tinned					RS 16671L1 Plug	12A and 14A Apparatus Units in 2A and 3A ACD Systems	80, 100, and 180	
A50E	Untinned	130	50	1	50	RS 16690L1 Connector(2)	830D and 832A Key Telephone Sets	8, 80, 100, 180, 200 and 280	30, 80, 100 and 200
A66A	Untinned		30			RS 16690L8 Connector(1)	804C Panel	8, 80, 100, 180, 200 and 280	30, 80, 100 and 200
A75A	Untinned	160	60	1	60	RS 16690L1 Connector	818D Key and Amplifier Indicator in No. 304 Batching System (NASA Project)	8, 80, 100, 180, 200 and 280	30, 80, 100 and 200
A75B	Tinned					RS 16780L8 Plug	80, 100		
A100C	Untinned	200	60	1	60	RS 16690L1 Connector	4A and 8A Telephone Consoles	80, 100, and 200	30, 80, 100 and 200
A100D			60			40	RS 16690L1 Connector	8088, 831B and 837A Key Telephone Sets Replaces A100A(MD) Connector Cable	80, 100, and 200
A100E	Untinned	250	50	1	50	RS 16780L8 Plug	2A ACD System	80	
A100F	Tinned					4	50	RS 16690L1 Connector	3A Communications Systems
A125A	Untinned	300	50	1	50	RS 16690L1 Connector	701A PBX Consoles for Hotel/Motel and Small Hospital Systems	80, 75 and 100	
A150A	Untinned					50	50	RS 16690L1 Connector(B)	Extension Cable for use between Attendant Console and 801A PBX Termination Field
B20A	Untinned	40	40	1	40	RS 16690L1 Connector	804 2064 606 2066 Telephone Sets	8, 15, 30, 60 and 100	
B25A		50	50			RS 16690L1 Connector	Extension Cable to Connect Plug Ended Key Telephone Sets to Connector or Plug Equipped Bridging Terminal Apparatus Cabinets, etc.		
B25C	Untinned	100	50	1	50	RS 16690L3 Plug	No. 8081 Keys Terminal Brisk Arranged in Tandem	5, 4	
B60A	Untinned					50	50	RS 16671L1 Plug(2)	Extension Cable for use between 800A PBX and Console
B60B	Untinned	180	50	1	50	RS 16690L1 Plug (2)	No. 8081 Keys Terminal Brisk Arranged in Tandem	4	
B75A	Untinned					50	50	RS 16690L1 Connector	Extension Cable for use between 800A PBX and Console

as the 564- and 630-series KTS's, interrupters, and matrix block 1A1 is found in the appropriate chapters of FM 11-31. Additional or amplifying information on associated and optional components may be obtained by referring to the appropriate section of the BSP or GTE practices.

3.2.2 Installation sequences. The procedures required to install the equipment will be accomplished in a definite order. This will ensure that work accomplished is in compliance with the drawings. Minor changes to the sequence may be made in consideration of manpower, time, equipment, material, and safety. The following steps are recommended.

3.2.3 Preinstallation steps. Prior to starting installation, the following should be accomplished by the team chief:

a. Coordinate installation tasks with the operating agencies and/or other cognizant organizations. This will include clearance to proceed, logistics, review of support requirements, and requesting of any other support necessary to the accomplishment of tasks.

b. Verify that all support requirements are completed or will be completed in time to prevent delays.

c. Brief team members on particular hazards that may be encountered and emphasize safety by reviewing safety procedures and practices.

d. Inventory the BOM to ensure all items are on hand. Missing items or shortages should be noted prior to bringing the team on site.

e. Arrange for transportation of personnel and equipment and determine the methods of control for storage of BOM items, tools, and other required equipment.

f. Review all requirements and drawings and propose any questions, or request additional engineering assistance, prior to starting installation.

g. Coordinate outages that may be required for the transfer of service or modification of the telephone system. Service outages should be held to a minimum.

3.2.4 Detailed instructions. This paragraph provides general and specific installation instructions for a KTS. Drawings referenced are contained in section 4 . Installation of the KTS

31 August 1978

SEIP 016

will be governed by the requirements in this section; CCTM 105-50-21, Telecommunications Engineering-Installation Practices Installation-General; and FM 11-31, Telephone Substation Installation. Equipment specifications furnished by the manufacturer with new equipment shall be applicable to that piece of equipment only. Detailed instructions provided in CCTM 105-50-21 and FM 11-31 will not be repeated.

- a. Relocate existing equipment as required.
- b. Replace defective or outmoded equipment and cables.
- c. Install power conduit.
- d. Install junction boxes.
- e. Install local cabling.

(1) Wall or floor duct requirements are determined by the engineer. Square D, 2 1/2 X 2 1/2 inch ducts provide an efficient cover for cables. Refer to drawing STD-TL-0002, detail A.

(2) For cable sizes refer to drawing STD-TL-0002, detail C. This drawing displays a method of distribution providing a minimum of 25 pairs to each key station and 50 pairs to each call director.

(3) Cable installed through conduit between floors and directly from DCO/PBX line terminals to satellite equipment or other local systems should be no less than 22-gauge telephone cable.

(4) Cables serving telephone sets from the equipment room will be no less than 24-gauge.

- f. Install power wiring.
- g. Install grounding connections.
- h. Install color coded backboards or back panels.

(1) Backboard or back panel arrangements will be determined by the engineer stating the wall space to be used and the height above the floor.

(2) Refer to drawing STD-TL-0004 for the description of the 66-type, color coded back panels and drawing STD-TL-0005 for a description of the system 66 connectorized color coded back panels.

- i. Install 1A1 matrix and 446 diodes as required.
- j. Install key stations, key strips, disconnect devices, and ringers.
- k. Terminate signal cables.
- l. Check cable pair continuity and document test data.
- m. Install KSU's as required.
 - (1) The 515 KSU consists of the 513 and 514 KSU and is generally wall mounted. The 515 is 25 1/2 X 17 X 11 inches and requires 9 1/2 inches on each side to open the carrier assembly.
 - (2) Detailed instructions for adding a 514 KSU to a 513 KSU are available in FM 11-31, chapter 7.
- n. Install KTU's as required. Refer to drawing STD-TL-0003 for typical 1A2 KTS cross connects.
- o. Install key telephone stations.
- p. Make final continuity check and document test data.
- q. Test all segments of the KTS for operational adequacy.

3.3 CHANGES IN SCOPE. The installation team chief shall not accomplish work requested by local post, camp, or station personnel unless such work is covered in the specification. Requests which are not covered shall be referred to the project engineer.

3.4 CHANGES TO SPECIFICATIONS.

3.4.1 Minor changes. The installation team chief is authorized to make minor changes to the requirements and instructions contained in this specification without prior approval of the engineer. These changes shall be documented by the team chief either on the marked-up drawings or in the letter of transmittal which forwards the marked-up drawings. A minor change is one which DOES NOT:

- a. Alter the intended operational capability of the specification.

31 August 1978

SEIP 016

- b. Violate a mandatory standard.
- c. Alter the intent or end-result of the required testing.

3.4.2 Major changes. The installation team chief shall not make major changes to the requirements and instructions contained in the specification without the specific approval of the project engineer. Request for approval of a major change may be made by telephone; however, a follow-up message or letter is required. These changes shall be documented by the team chief either on the marked-up drawings or in the letter of transmittal. In all cases, the document which authorized the change, shall be included with the marked-up drawings package.

3.5 AS-BUILT DRAWINGS.

3.5.1 Upon completion of the installation, the installation team chief shall mark up two sets of drawings to show the as-built condition of the site, facility, building, or room covered by this specification.

3.5.2 As-built drawings will be prepared using red, yellow, and blue pencils. Red for additions, yellow for deletions, and blue for notes to the engineer or draftsman. Drawings will conform with basic engineering practices.

3.6 CUTOVER INFORMATION.

3.6.1 Coordinate with the local wire chief or appointed personnel to determine the exact location of telephone sets, intercom, and line numbers. Establish continuity from the telephone set through the 1A2 key equipment by means of a cross connect cable. Stencil equipment, tag cables and terminals, and provide cable numbers with room locations and telephone numbers for the installers involved.

3.6.2 The project engineer will provide cut sheets and installer personnel will terminate all telephone circuits required by the user.

SECTION 4. ENGINEERING INSTALLATION DRAWINGS

4.1 GENERAL. The following standard drawings are applicable to the installation of a 1A2 KTS. KTS's are available with many options and the engineer must design a system to meet operational requirements; therefore, the drawings furnished provide guidance and standard engineering data to be used in the development of an engineering installation package (EIP).

4.1.1 Three sets of engineering drawings are furnished an installation team. One set is used as working drawings while a record of approved changes and work completed will be made on the remaining two sets. Information will be recorded on the drawings as follows:

- a. Red will be used to denote additions and work completed.
- b. Yellow will be used to indicate deletions.
- c. Blue will be used to provide notes to the draftsman or engineer.

4.1.2 When the installation is completed, one set of marked-up drawings will be left with the local USACC commander and another marked-up set will be forwarded to the USACEEIA engineer for project review and preparation of as-installed drawings.

4.2 USACEEIA DRAWINGS.

<u>DRAWING NO.</u>	<u>TITLE</u>
STD-TL-0002	Typical Key Telephone System Engineering Support and Circuit Requirements
STD-TL-0003	Typical 1A2 Key System Crossconnects
STD-TL-0004	66-Type Backboards
STD-TL-0005	System 66 Connectorized Backboards

5 4 3 2 1

REVISION				
ZONE	REV	DESCRIPTION	DATE	APPROVED

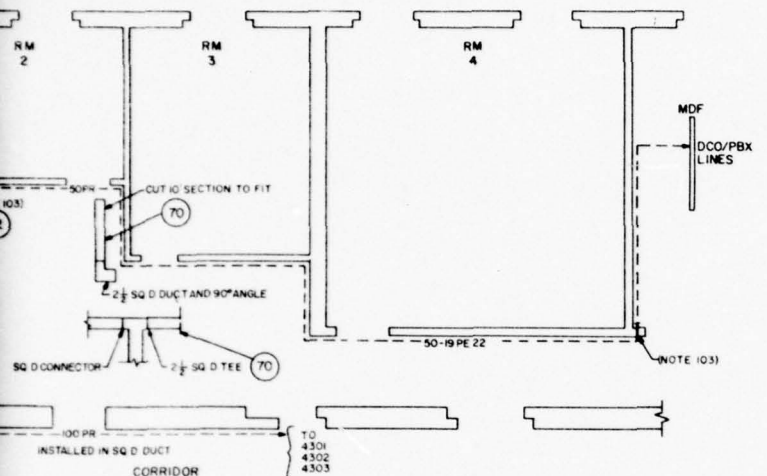

LEGEND

- WECO 564 KEY TELEPHONE
- TERMINAL BOX
- INTERCOM NUMBER W/NUMBER
- SLEEVE THRU WALL
- CALL DIRECTOR
- CROSS-CONNECT LOCATION DETAIL B
- CROSS-CONNECT
- AUD AUDIBLE RING

GENERAL NOTES:

- 1 THIS DRAWING IS BASED ON A WECO IA2 SYSTEM HOWEVER OTHER MANUFACTURERS SYSTEM CAN BE ENGINEERED IN A SIMILAR MANNER.
- 2 6A KEY SYSTEM WILL PROVIDE INTERCOM FEATURES ONLY AND RELY ON OTHER SYSTEMS TO PROVIDE LINE FACILITIES.

NOTES:

- 101 INSTALL PLYWOOD BACKBOARD.
- 102 INSTALL PLYWOOD BACKBOARD.
- 103 INSTALL 3" SLEEVE THRU WALL, MAX 4" BELOW CEILING LEVEL.
- 104 PROVIDE DUAL OUTLET FROM PRIMARY 110/120 CIRCUIT.
- 105 PROVIDE EXTERNAL GND NO 14 AWG.

**DETAIL A
SUPPORT REQUIREMENTS**

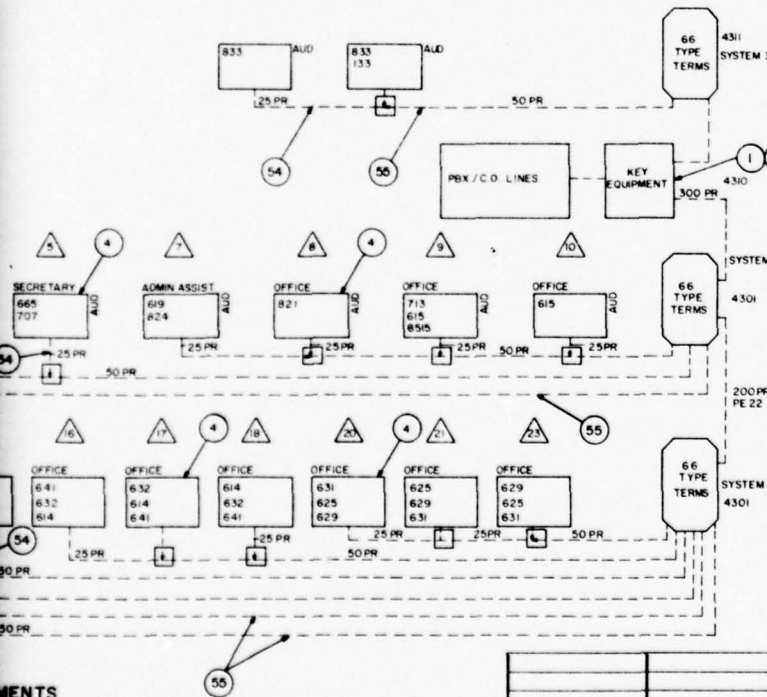

ITEM	AEL	DESCRIPTION	NSN	UI	QTY
92	09160M	PLYWOOD, EXTERIOR, 4x8x1/2"	5530-00-128-5059		A/R
70	12250M	DUCT, ELEC, 2 1/2x2 1/2 IN, SQUARE D			A/R
56	11570K	CABLE, STATION-PBX, 100 PAIR, WECO AT-7441	6145-00-229-3867		A/R
55	05795K	CABLE, STATION-PBX, 50 PAIR, WECO AT-7441	6145-00-926-6443		A/R
54	05796J	CABLE, STATION-PBX, 25 PAIR, WECO AT-7441	6145-00-926-6444		A/R
16	17047L	KTU WECO 425BW (FLASHING LIGHT)			1
15	18354N	KTU WECO 424CW (19 CODE INTERCOM)			2
13	17045N	KTU WECO 422BW (STATION BUSY)			2
8	14108F	KTU WECO 400DW (LINE CIRCUIT)	5805-00-422-4605		A/R
7	14362M	POWER CORD WECO P40J329			2
5	06353N	CALL DIRECTOR WECO 636 CW	5805-00-878-6489		A/R
4	11290P	TELEPHONE SET, MULTILINE, WECO 564HLW-3	5805-00-722-2955		A/R
3	11565D	INTERRUPTER WECO KS-15900L	5805-00-882-2074		2
2	15508W	POWER SUPPLY WECO 20CW2			2
1	12575B	KSU WECO 515 AW3	5805-00-236-8433		2

LIST OF MATERIALS

IDENT NO STD-TL-0002		ORGANIZATION U.S. ARMY COMMUNICATIONS-ELECTRONICS ENGINEERING INSTALLATION AGENCY	
DESIGNED BY W. BESS		DATE 10 MAR 78	
DRAWN BY W. GUNNING		DATE 4 APR 78	
CHECKED BY [Signature]		DATE 10 APR 78	
APPROVED BY [Signature]		DATE 10 APR 78	
DESIGN ACTIVITY CCC-CEC-SEP		SIZE D 50470	DRAWING NO
NEXT ASSEMBLY		SCALE NONE	SHEET OF
USED ON			
DWG INDEX NO			

MENTS

5 4 3 2 1

D

C

B

A

2

8

7

6

5

4

KTU 400 D
LINE CIRCUIT I FOR EA PBX/CO LINE

18/20/40 PIN CONNECTOR		*CABLE TO TERMS
FROM	TO	
1 400-OP (8)	1 A1 MATRIX TO STA	
2 400-OP (10)	INTER LW	
3		
4 400-OP (9)	INTER LV - 10V±	
5 400B	ST INTER MOTOR	
6 400B	INTER PS	
7 400	INTER LF	
8 400	STA LAMP	*
9 400R	CO LINE R	*
10 400	INTER 105V+ AUD R	
11 400	INTER RING SEQ	
12 400 T	STA T 417 (24)	*
13 400 R	STA R 417 (19)	*
14 400 T	CO LINE T	*
15 400	TB GND	*
16 400-24 DC	STA HOLD A 417 (26)	*
17 400-B 24V	B BAT 20-26V DC	*

KTU 415A
AUTOMATIC TIE LINE CIRCUIT
2 REQD LOCAL AND FAR END

18/20/40 PIN CONNECTOR		*CABLE TO TERMS
FROM	TO	
1 415 TB 6	1 A1 MATRIX	*
2 415 NET	INTER LP FLASH SEQ	
3 415 GND A	PS TALK SUP 20-26V DC	
4 415 10V±	PS 10V± LAMPS	*
5 415 B NET	INTER MOTOR SERIES	
6 415 B NET	INTER MOTOR SUPPLY LG/MG	
7 415 C NET	INTER LP FLASH SEQ	
8 415 B NET	STA LAMP	*
9 415 NET	TIE LINE DIST STA R	*
10 415 105V±	PS AUD SIG	*
11 415 TB (4)	INTER SIG RING SEQ	
12 415 NET	STA T	*
13 415 NET	STA R	*
14 415 NET	TIE LINE DIST STA T	*
15 415 GND B	PS B BATT 20-26V DC	*
16 415 A	STA PU GND	*
17 415 B-24	PS B BAT 20-26V DC	*
18 415 A-24	PS A BAT 20-26V DC	*

KTU 422 B
STA BUSY SELECTOR
2 FOR 19 CODE INTER

40 PIN CONNECTOR		*CABLE TO TERMS
FROM	TO	
0 422 NET	424 (A37) (WC427)	A5 425 L
1 422 TB1 (5)	422 (J1) (J3)	A6 425 L
8 422 NET	424 (B25)	A15 425 B
9 422 TB1 (6)	424 B35Y1	A17 425 B
14 422 NET	423 (B)BL - 24V	A19 425 L
16 422 TB1 (1)	CONN AS REQ-J	A35 425 L
17 422 TB1 (5)	PS 20-26V DC B BAT	A38 425 Y
19 422 TB1 (4)	CONN AS REQ BY-1	A39 425 L
20 422 NET	OTHER ASOC TEL SETS	5 OR X 5 * B16 425 B
21 422 NET	OTHER ASOC TEL SETS	6 OR X 6 * B19 425 B
22 422 NET	424-B24(WC427)	B27 425 L
23 422 NET	OTHER ASOC TEL SETS	2 OR X 2 * B28 425 L
25 422 NET	OTHER ASOC TEL SETS	3 OR X 3 * B34 425 B
26 422 NET	OTHER ASOC TEL SETS	4 OR X 4 * B35 425 L
27 422 NET	424 (A36)	637 425 B
28 422 NET	OTHER ASOC TEL SETS	1 OR X 1 *
29 422 NET	STA GND REQ DIODE PU KEY	*
30 422 NET	OTHER ASOC TEL SETS	8 OR X 8 *
31 422 LT	422 (J1) (J3)	
32 422 NET	OTHER ASOC TEL SETS	7 OR X 7 *
33 422 LT	422 (J1) (J2)	
34 422 NET	OTHER ASOC TEL SETS	0 OR X 0 *
35 422 LT	424 (A35, A39, A34)	

KTU 420A
LONG LINE DIAL INTER COMM CIRCUIT
U/W OFF PREMISE STA 2 REQD

18/20/40 PIN CONNECTOR		*CABLE TO TERMS
FROM	TO	
1 420 TTG NET	424 (B39)	
3 420 GND	PS A GND +	*
8 420 RG GND	PS RG	*
9 420 NET	424-R (B13)	*
10 420 105V±	PS 105V±	*
12 420 NET	OFF PREM STA T	*
13 420 NET	OFF PREM STA R	*
14 420 NET	424 T (B12)	*
15 420 GND	PS B-20-26VDC	*
16 420 TB1 (4)	424,R,O,R9,RX,O,RX9, ANY DIGIT	*
17 420 B-24V	PS B BAT 20-26V DC	*
18 420 A-24V	PS A BAT 20-26V DC	*

KTU 417A
ADD ON CONFERENCE
1 OR 2 STA

40 PIN CONNECTOR		*CABLE TO TERMS
FROM	TO	
0 417 T	400 T (12)	*
4 417 ±10V	PS STA LAMP	*
8 417 A	PS STA LAMP FOR CONF	*
9 417 NET	CO LINE R (1ST)	*
12 417 NET	STA T PU KEY	*
13 417 NET	STA R PU KEY	*
14 417 NET	CO LINE T (1ST)	*
15 417 +24GND	PS 20-26V DC B+	*
16 417 GND	STA HOLD DIODE REG PU KEY	*
17 417 -24V	PS 20-26V DC B-	*
19 417 -R	400R (19)	*
24 417 NET T	424 (B12) 400 T (12) 2D LINE	*
25 417 NET R	424 (B13) 400 R (13) 2D LINE	*
26 417 NET	400-A (16)	*
28 417 NET	STA THRU 400 1ST LINE T	*
29 417 NET	STA THRU 400 1ST LINE R	*
30 417 NET	STA THRU 400 1ST LINE A	*
32 417 TB (10)	STA NON LOCK KEY SWHK TIE	*
33 417 TB (4)	STA TO 2ND STA	*
35 417 TB (3)	STA EXCLUSION KEY	X
36 417 TB (1) (2)	STA NON LOCK KEY	*
	STRAP STA FOR 2ND STA	
	36,16,13,12,30,29 AND 28 AT HANSET AND SWHK TIE	

KTU 423 A
AUD RING BACK/DIAL TONE CIRCUIT
1 PER DIAL INTER LINE

20 OR 40 PIN CONNECTOR		*CABLE TO TERMS
FROM	TO	
0 423 TB1 (1) 18V+	INTER RING SEQ GND B	1
1 423 18V±	PS 18V±	2
8 423 NET	422 (14)	3
9 423 NET BY1	424 (B19)	4
10 423 105V±	PS 105V±	5
11 423 TB1 (4)	INTER RING SEQ	6
12 423 NET	424 (B2) T	7
13 423 BY1 (6)	424 (B14) INTER	8
14 423 NET	424 (B30)	9
15 423 B GND	PS B GND	10
16 423 TB1 (2)	424 (B34)	11
17 423 B-24V	PS B BAT 20-26V DC	12
19 423 TB1 BL	INTER B GND BUSY TONE SEQ	

LEGEND
OP — OPTION BLOCK
A16 — EQPT BLOCK PIN NO
* — WIRE TO CROSS CONNECT PANEL
PS — POWER SUPPLY
INTER — INTERRUPTER
NET — CIRCUIT NET WORK
TB — TERMINAL BOARD (CIRCUIT)
LW — LAMP WINK

LEGEND (CONT)
LF — LAMP FLASH
R — RING OF LINE
T — TIP OF LINE
STA — KEY TEL SET
TTG — TOUCH-TONE GND

NOTES:
101. NOT ALL CIRCUITS HAVE BEEN INCLUDED IN THIS STANDARD DRAWING, ADDITIONAL ITEMS WILL BE ADDED AS REQUIRED

8

7

6

5

4

REVISION				
ZONE	REV	DESCRIPTION	DATE	APPROVED

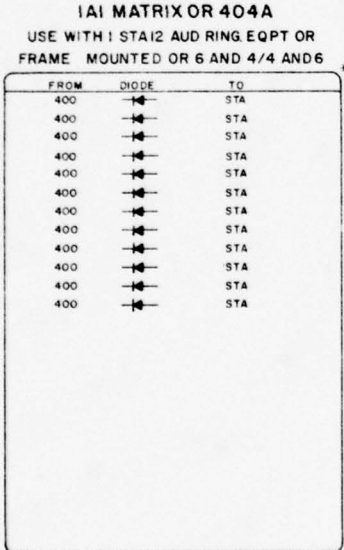
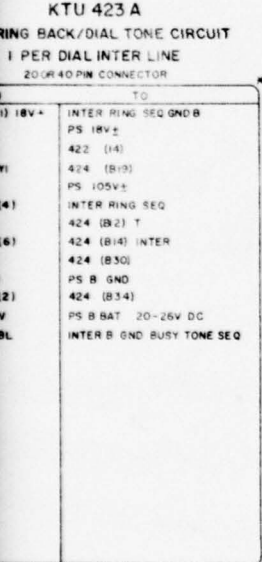
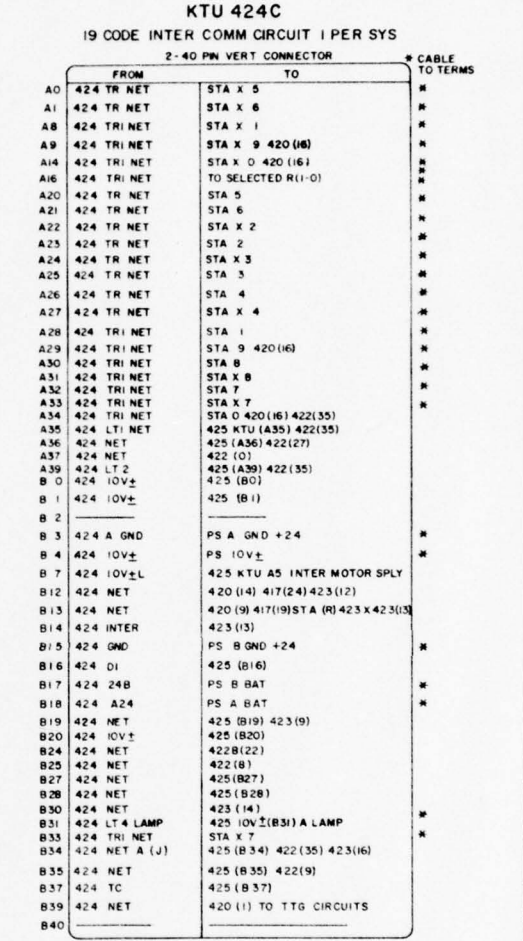
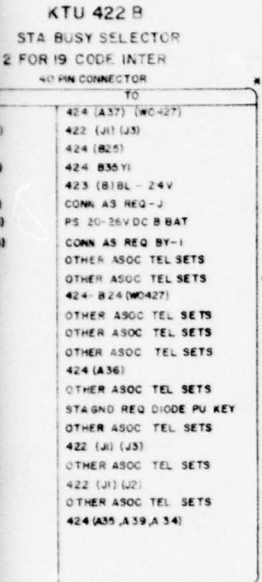

NOTES:
101. NOT ALL CIRCUITS HAVE BEEN INCLUDED IN THIS STANDARD DRAWING, ADDITIONAL ITEMS WILL BE ADDED AS REQUIRED.

ITEM	AEL	DESCRIPTION	NSN	UI	QTY
LIST OF MATERIALS					
IDENT NO STD-TL-0003		ORGANIZATION U.S. ARMY COMMUNICATIONS-ELECTRONICS ENGINEERING INSTALLATION AGENCY			
DESIGNED BY W. BESS		DATE 8 MAR 78			
DRAWN BY D.S. ROBB		DATE 15 MAY 78			
CHECKED BY [Signature]		DATE 15 MAY 78			
APPROVED BY [Signature]		DATE 15 MAR 78			
NEXT ASSEMBLY		USED ON		DESIGN ACTIVITY	
DWG INDEX NO		SIZE D		FSCM NO 50470	
		SCALE NONE		DRAWING NO	
				SHEET OF	

D
C
B

A

2

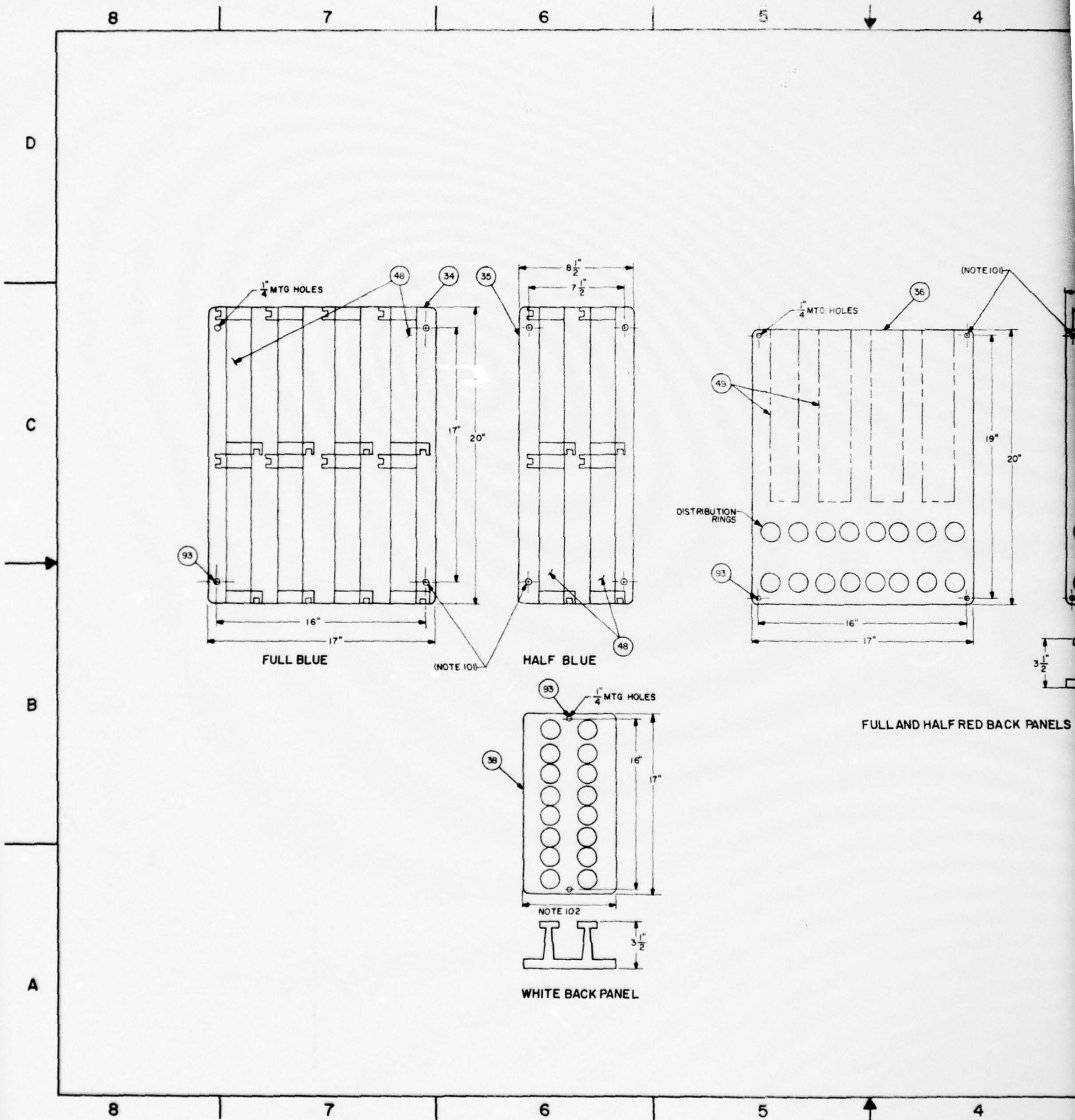

4 | 3 | 2 | 1

REVISION				
ZONE	REV	DESCRIPTION	DATE	APPROVED

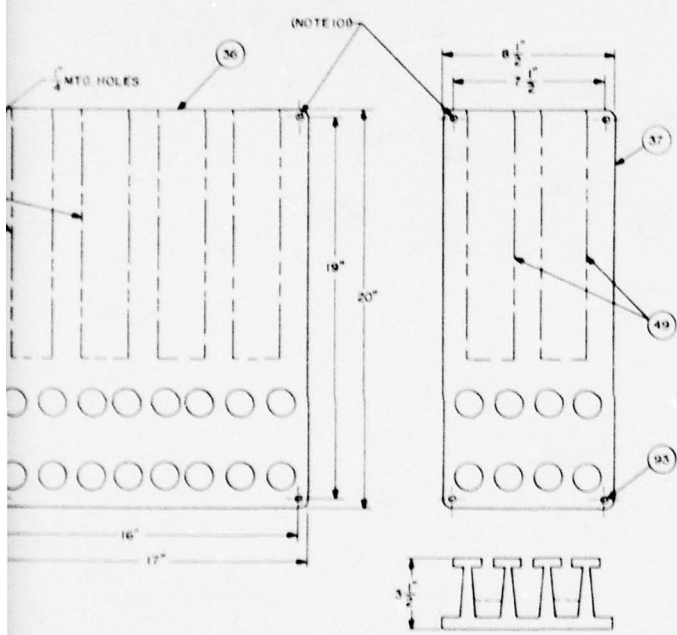

FULL AND HALF RED BACK PANELS

GENERAL NOTES:

1. GREEN, YELLOW AND PURPLE PANELS ARE AVAILABLE IN THE SAME SIZE AND BLOCK CONFIGURATION AS THE BLUE.

NOTES:

- 101 REFER TO CCTM 105-50-21 AND TO 31-10-10 FOR PROPER ANCHORING DEVICES AND MOUNTING INSTRUCTIONS.
- 102 WHITE BACK PANEL IS USED TO ADD DISTRIBUTION RINGS TO CROSS CONNECT PANELS.

D

C

B

ITEM	AEL	DESCRIPTION	NSN	U1	QTY
95	07804M	SCREW, WOOD, 1/4 X 1/2	NSN 00-001-2607		A/R
39	0567F	BLOCK, CONNECTING, WECC 66B4-25	NSN 43-296-0303		A/R
37	05500A	BLOCK, CONNECTING, WECC 66M1-50			A/R
36	17568B	BACKBOARD, STEEL, PANEL, WHITE FINISH, E/W WIRE DISTRIBUTION RINGS			A/R
37	21139H	BACKBOARD, STEEL, PANEL, RED FINISH, 8 1/2 X 20" E/W 2EA 66B4-25 CONNECTING BLOCKS (WELLS)			A/R
36	17566J	BACKBOARD, STEEL, PANEL, RED FINISH, 17 X 20"			A/R
35	18038C	BACKBOARD, BLUE, 8 1/2 X 20"			A/R
34	17568A	BACKBOARD, STEEL, BLUE FINISH, 17 X 20"			A/R

LIST OF MATERIALS

DESIGNED BY DRAWN BY CHECKED BY APPROVED BY DATE 17 APR 78 1 APR 78 17 APR 78	ORGANIZATION U.S. ARMY COMMUNICATIONS-ELECTRONICS ENGINEERING INSTALLATION AGENCY	DRAWING NO 50470
NEXT ASSEMBLY USED ON CCC-CED-SEP	DESIGN ACTIVITY CCC-CED-SEP	SCALE NONE

66-TYPE BACKBOARDS

A

4 | 3 | 2 | 1

2

8

7

6

5

4

D

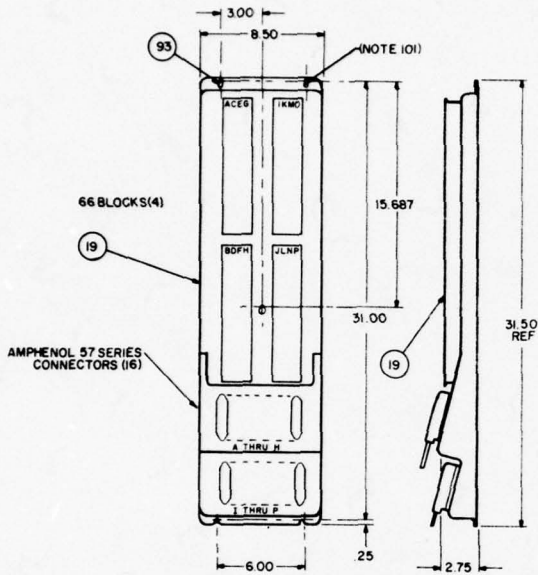

CONNECTORIZED ONE-HALF BLUE FIELD BACK PANEL

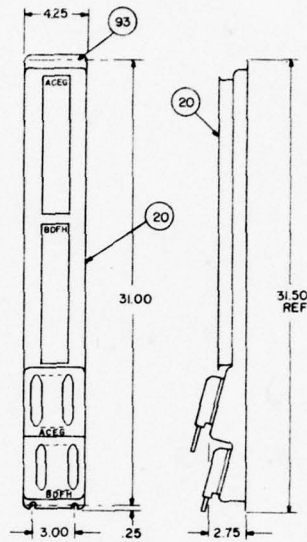

CONNECTORIZED ONE-QUARTER BLUE FIELD BACK PANEL

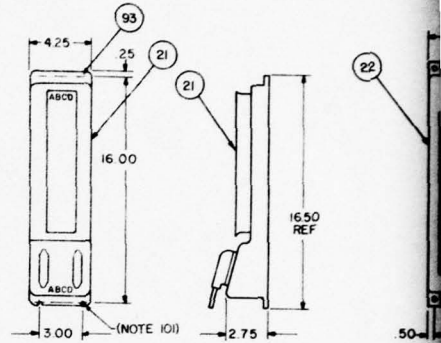

CONNECTORIZED ONE-EIGHTH BLUE FIELD BACK PANEL

C

B

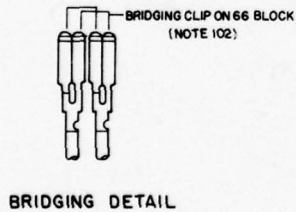

BRIDGING DETAIL

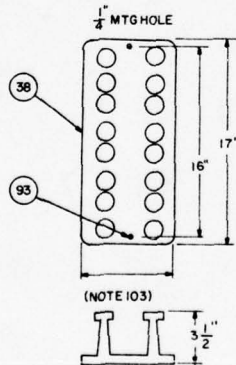

WHITE BACK PANEL

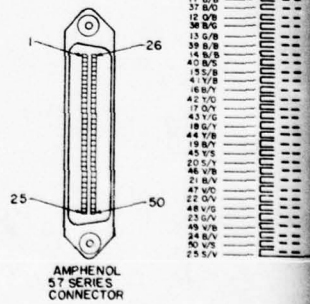

TYPICAL BLOCK AND CONNECTOR

CONN PIN NO'S	66 BLOCK
25	
27 W/C	
2 O/W	
28 W/C	
3 O/W	
29 W/B	
4 O/W	
30 W/S	
5 O/W	
31 R/B	
6 B/R	
32 R/O	
7 O/R	
33 R/O	
8 O/R	
34 R/B	
9 B/R	
35 R/S	
10 S/R	
36 B/B	
37 B/O	
38 B/C	
12 O/B	
13 O/B	
39 B/B	
14 B/B	
40 B/S	
15 S/B	
16 B/Y	
42 Y/O	
17 O/Y	
43 Y/G	
18 B/Y	
19 B/Y	
45 Y/E	
20 Y/Y	
46 Y/B	
21 B/Y	
47 B/O	
22 O/Y	
48 Y/G	
23 O/Y	
49 Y/B	
24 B/Y	
50 Y/S	
25 S/Y	

A

8

7

6

5

4

5 4 3 2 1

REVISION				
ZONE	REV	DESCRIPTION	DATE	APPROVED

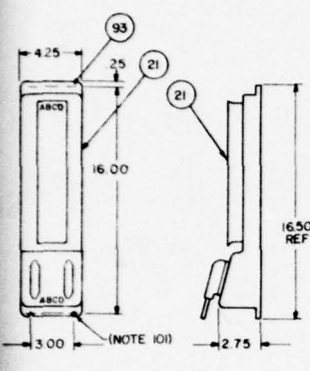

CONNECTORIZED ONE-EIGHTH BLUE FIELD BACK PANEL

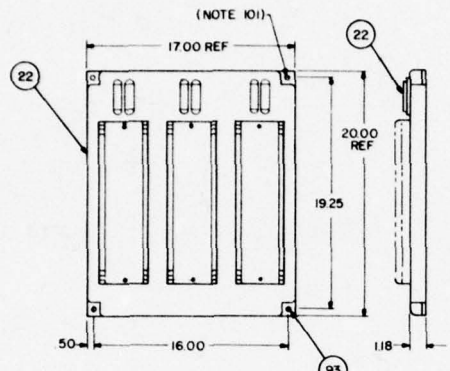

CONNECTORIZED FULL RED FIELD BACK PANEL

GENERAL NOTES:
 1. ONE HALF, ONE QUARTER AND ONE EIGHTH GREEN, PURPLE AND YELLOW CONNECTORIZED PANELS ARE IDENTICAL IN SIZE AND FUNCTION AS THE BLUE PANELS.

NOTES:
 101. CONNECTORIZED PANELS ARE READY FOR MOUNTING, REFER TO OCTM 105-50-21 AND TO 3-10-10 FOR PROPER ANCHORING DEVICES AND MOUNTING INSTRUCTIONS.
 102. USE OF A BRIDGING CLIP ON THE 66 BLOCK PERMITS THE CONNECTION OF TWO 50-TWISTED PAIR BY BRIDGING A,C AND B,D.
 103. WHITE BACK PANEL IS USED TO ADD DISTRIBUTION RINGS BETWEEN CROSS CONNECTING PANELS.

CONN PIN NO'S	66 BLOCK
24	R/W
27	W/O
28	W/O
29	W/O
30	W/O
31	R/B
32	R/O
33	R/G
34	R/B
35	R/B
36	R/B
37	R/B
38	R/B
39	R/B
40	R/B
41	R/B
42	R/B
43	R/B
44	R/B
45	R/B
46	R/B
47	R/B
48	R/B
49	R/B
50	R/B
51	R/O
52	R/O
53	R/O
54	R/O
55	R/O
56	R/O
57	R/O
58	R/O
59	R/O
60	R/O
61	R/O
62	R/O
63	R/O
64	R/O
65	R/O
66	R/O

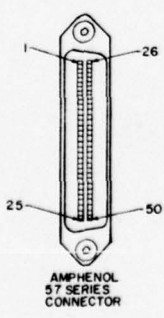

TYPICAL BLOCK AND CONNECTOR WIRING DIAGRAMS

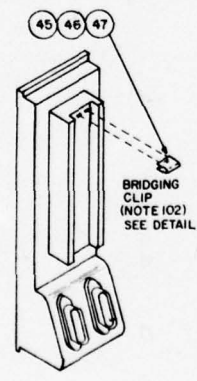

ITEM	AEL	DESCRIPTION	NSN	UI	QTY
93	07894M	SCREW WOOD 1/4 X 1 IN LG	5305-00-901-2607		A/R
38	17569B	BACK BOARD, STEEL PANEL, WHITE FINISH			A/R
47	21147E	CLIP, BRIDGING, 4 POSN, BUNKER-RAMO	410-C49769		A/R
46	21146D	CLIP, BRIDGING, 3 POSN, BUNKER-RAMO	410-C49770		A/R
45	21145C	CLIP, BRIDGING, 2 POSN, BUNKER-RAMO	410-C49341		A/R
22	19163X	BACKBOARD, RED, 6 CONN, 3 TERMINALS 66M1-50, BUNKER-RAMO CADRE DIV 410-CRF-66-1900			A/R
21	21127G	BACKBOARD, BLUE, 4 CONN, CONNECTORIZED BLUE FIELDS BUNKER-RAMO CORP NO 410-CBF66-4			A/R
20	21126F	BACKBOARD, BLUE, 8 CONN, CONNECTORIZED BLUE FIELDS BUNKER-RAMO CORP NO 410-CBF66-8			A/R
19	19985K	BACKBOARD, BLUE, 16 CONN, CONNECTORIZED BLUE FIELDS BUNKER-RAMO CORP NO 410-CBF66-16			A/R

LIST OF MATERIALS	
IDENT NO STD-TL-0005	ORGANIZATION U.S. ARMY COMMUNICATIONS-ELECTRONICS ENGINEERING INSTALLATION AGENCY
DESIGNED BY W. BESS	DATE 7 MAR 78
DRAWN BY M. BURNING	DATE 4 APR 78
CHECKED BY [Signature]	DATE 5 APR 78
APPROVED BY [Signature]	DATE 7 APR 78
NEXT ASSEMBLY	USED ON
DESIGN ACTIVITY CCC-CED-SEP	SIZE PCHM NO D 50470
DWG INDEX NO.	DRAWING NO
	SCALE NONE
	SHEET OF

5 4 3 2 1

D
C
B
A

2

31 August 1978

SEIP 016

SECTION 5. BILL OF MATERIALS

5.1 GENERAL. This section identifies major items of equipment and installation materials necessary to install a KTS. The items identified are intended as a guide for preparing a BOM associated with a particular EIP. Items may be added or deleted as required to meet the requirements of a specific installation.

5.2 MAJOR ITEMS. The major items are listed on USACC Form 60-R, Bill of Materials, shown in figure 5-1. The authorized equipment list (AEL) identification and national stock numbers (NSN) are provided when available; however, when these numbers are not available the nomenclature will include the manufacturer's part number.

BILL OF MATERIALS						
PROJECT NO.	LOCATION CODE		DRAWING LIST NO.		SHEET OF	
DATE	UNIT IDENT CODE					
ITEM	NSN	AEL ID	NOMENCLATURE	UNIT	QTY	REMARKS
1	5805-00-236-8453	12575B	KSU WECO 515AM3	ea		
2	NSNR	15508W	Power Supply WECO 20CW2	ea		
3	5805-00-882-2074	11565D	Interrupter WECO KS-15900L	ea		
4	5805-00-722-2955	11290P	Telephone Set, Multiline, WECO 564HLW-3	ea		
5	5805-00-878-6489	06353N	Call Director WECO 636CW	ea		
6	6350-00-504-2020	11596B	Buzzer WECO KS-8109-12	ea		
7	NSNR	14362M	Power Cord WECO P40J329	ea		
8	5805-00-422-4609	14108F	KTU WECO 400DW (Line Circuit)	ea		
9	5805-00-403-6789	12566D	KTU WECO 407B (10 Code Intercom)	ea		
10	NSNR	15938Z	KTU WECO 418AW (Short Range Tie Line)	ea		
11	NSNR	17523Z	KTU WECO 417AW (Add On Conference)	ea		
12	NSNR	18362Q	KTU WECO 415AW (Automatic Tie Line)	ea		
13	NSNR	17045N	KTU WECO 422BW (Station Busy)	ea		
14	NSNR	17046W	KTU WECO 423AW (Busy Tone, Audible Line Back)	ea		

USACC

Figure 5-1. Bill of materials (sheet 1 of 10).

31 August 1978

SEIP 016

BILL OF MATERIALS									
PROJECT NO		LOCATION CODE			DRAWING LIST NO				
DATE		UNIT IDENT CODE			SHEET OF				
ITEM	NSNR	AEL ID	NOMENCLATURE	UNIT	QTY	REMARKS			
15	NSNR	12577D	KTU WECO 424CW (19 Code Intercom)	ea					
16	NSNR	17047L	KTU WECO 425BW (Flashing Light)	ea					
17	NSNR	19161K	KTU WECO 454AW (3 Way Access)	ea					
18	NSNR	19162J	KTU WECO 469A (Lamp Extender)	ea					
19	NSNR	19985K	Backboard, Blue, 16 Connectors Connectorized Blue Fields. Bunker-Ramo Corp Number 410- CBF-66-16	ea					
20	NSNR	21126F	Backboard, Blue, 8 Connectors, Connectorized Blue Fields. Bunker-Ramo Corp Number 410- CBF-66-8	ea					
21	NSNR	21127G	Backboard, Blue, 4 Connectors, Connectorized Blue Fields. Bunker-Ramo Corp Number 410- CBF-66-4	ea					
22	NSNR	19163X	Backboard, Red, 6 Connectors, 3 Terminals 66M1-50. Bunker-Ramo Cadre Div Number 410-CRF66-1500	ea					
23	NSNR	21128H	Backboard, Red, 4 Connectors, 2 Terminals 66M1-50. Bunker-Ramo Cadre Div Number 410-CRF66-1000	ea					

USACC

Figure 5-1. Bill of materials (sheet 2 of 10).

BILL OF MATERIALS						
PROJECT NO	LOCATION CODE		DRAWING LIST NO		SHEET OF	
DATE	UNIT IDENT CODE		REMARKS			
ITEM	NSNR	AEL-ID	NOMENCLATURE	UNIT	QTY	REMARKS
24	NSNR	21129W	Backboard, Red, 2 Connectors, 1 Terminal 66M1-50. Bunker-Ramo Cadre Div Number 410-CRF66-500	ea		
25	NSNR	21130J	Backboard, Green, 16 Connectors, Connectorized Green Field. Bunker-Ramo Corp Number 410-CGF66-16	ea		
26	NSNR	21131Z	Backboard, Green, 8 Connectors, Connectorized Green Field. Bunker-Ramo Corp Number 410-CGF66-8	ea		
27	NSNR	21132A	Backboard, Green, 4 Connectors, Connectorized Green Field. Bunker-Ramo Corp Number 410-CGF66-4	ea		
28	NSNR	21133B	Backboard, Yellow, 16 Connectors, Connectorized Yellow Field. Bunker-Ramo Corp Number 410-CYF66-16	ea		
29	NSNR	21134C	Backboard, Yellow, 8 Connectors, Connectorized Yellow Field. Bunker-Ramo Corp Number 410-CYF66-8	ea		

Figure 5-1. Bill of materials (sheet 3 of 10).

31 August 1978

SEIP 016

BILL OF MATERIALS						
PROJECT NO	LOCATION CODE		DRAWING LIST NO.			
DATE	UNIT IDENT CODE		SHEET	OF		
ITEM	NSN	AELID	NOMENCLATURE	UNIT	QTY	REMARKS
30	NSNR	21135D	Backboard, Yellow, 4 Connectors, Connectorized Yellow Field. Bunker-Ramo Corp Number 410-CYF66-4	ea		
31	NSNR	21136E	Backboard, Purple, 16 Connectors, Connectorized Purple Field. Bunker-Ramo Corp Number 410-CPF66-16	ea		
32	NSNR	21137F	Backboard, Purple, 8 Connectors, Connectorized Purple Field. Bunker-Ramo Corp Number 410-CPF66-8	ea		
33	NSNR	21138G	Backboard, Purple, 4 Connectors, Connectorized Purple Field. Bunker-Ramo Corp Number 410-CPF66-4	ea		
34	NSNR	17568A	Backboard, Steel Panel, Blue Finish E/W Eight 89B Brackets for Mounting 66M1-50 Connecting Blocks	ea		
35	NSNR	18538C	Backboard, Blue, E/W 4 ea 89B Brackets	ea		
36	NSNR	17566J	Backboard Steel Panel, Red Finish E/W Four 66B4-25 Blocks	ea		

Figure 5-1. Bill of materials (sheet 4 of 10).

BILL OF MATERIALS						
PROJECT NO.	LOCATION CODE	DRAWING LIST NO.		SHEET OF		
DATE	UNIT IDENT CODE	UNIT IDENT CODE		REMARKS		
ITEM	NSN	AEL ID	NOMENCLATURE	UNIT	QTY	REMARKS
37	NSNR	21139H	Backboard, Steel Panel, Red Finish, 8 1/2 x 20" E/W Two 6684-25 Connecting Blocks	ea		
38	NSNR	17569B	Backboard, Steel Panel, White Finish, E/W 16 Distribution Rings	ea		
39	NSNR	21140K	Backboard, Steel Panel, Green Finish 17 x 20" E/W Eight 89B Brackets for Mounting 66M1-50 Connecting Blocks	ea		
40	NSNR	21141J	Backboard, Steel Panel, Green Finish 8 1/2 x 20" E/W Four 89B Brackets for Mounting 66M1-50 Connecting Blocks	ea		
41	NSNR	21142Z	Backboard, Steel Panel, Yellow Finish, 17 x 20" E/W Eight 89B Brackets for Mounting 66M1-50 Connecting Blocks	ea		
42	NSNR	20333E	Backboard, Metal Panel, Yellow, E/W Four 89B Brackets, 8 1/2 x 20"	ea		
43	NSNR	21143A	Backboard, Metal Panel, Purple Finish, 17 x 20", E/W Eight 89B Brackets for Mounting 66M1-50 Connecting Blocks	ea		

USA CC 1978 NSN

Figure 5-1. Bill of materials (sheet 5 of 10).

31 August 1978

SEIP 016

BILL OF MATERIALS						
PROJECT NO.	LOCATION CODE	DRAWING LIST NO.				
DATE	UNIT IDENT CODE	SHEET	OF			
ITEM	NSNR	AEL-ID	NOMENCLATURE	UNIT	QTY	REMARKS
44	NSNR	211448	Backboard, Metal Panel, Purple Finish, 8 1/2 x 20", E/M Four 89B Brackets for Mounting 66M1-50, Connecting Blocks	ea		
45	NSNR	21145C	Clip, Bridging, 2 Position, Bunker-Ramo Number 410-C149341	ea		
46	NSNR	21146D	Clip, Bridging, 3 Position, Bunker-Ramo Number 410-C149770	ea		
47	NSNR	21147E	Clip, Bridging, 4 Position, Bunker-Ramo Number 410-C149769	ea		
48	NSNR	15500A	Block, Connecting, WECO 66M1-50	ea		
49	5805-00-256-0303	11567F	Block, Connecting, WECO 66B4-25	ea		
50	5940-00-494-9697	08783Y	Block, Connecting, WECO 66B3-50	ea		
51	NSNR	13702G	Terminal Block w/Cover Type 66E3, 25 pair	ea		
52	5805-00-727-4127	11566E	Block, Connecting WECO 66E3-25	ea		
53	NSNR	21148F	Terminal Block Type 66E4-25	ea		
54	6145-00-926-6944	05796J	Cable, Station-PBX, 25 pair, WECO AT-7441	ft		

USACC FORM 42-11

Figure 5-1. Bill of materials (sheet 6 of 10).

BILL OF MATERIALS									
PROJECT NO.		LOCATION CODE		DRAWING LIST NO.					
DATE		UNIT IDENT CODE		SHEET OF					
ITEM	NSN	AEL-ID	NOMENCLATURE	UNIT	QTY	REMARKS			
55	6145-00-926-6443	05795K	Cable, Station-PBX, 50 pair WECO AT-7441	ft					
56	6145-00-229-3867	11570K	Cable, Station-PBX, 100 pair, WECO AT-7441	ea					
57	NSNR	21149F	Connector KSI6690L1	ea					
58	NSNR	21150L	Connector KSI6690L10	ea					
59	NSNR	21151K	Plug KS 16689L1	ea					
60	NSNR	21152J	Plug KS 16689L10	ea					
61	NSNR	12599D	Cable Assembly 25', WECO A25825	ea					
62	NSNR	12570L	Cable Assembly 50', WECO A25850	ea					
63	NSNR	12598C	Cable Assembly 100', WECO B25A100	ea					
64	NSNR	17076P	Cable Assembly 100', 25 pair, Connectors Each End WECO A25A100	ea					
65	NSNR	16346Z	Connector Cable, 50', WECO A75A	ea					

USACC FORM 60-4
1 MAR 78

Figure 5-1. Bill of materials (sheet 7 of 10).

31 August 1978

SEIP 016

BILL OF MATERIALS									
PROJECT NO.		LOCATION CODE		DRAWING LIST NO.					
DATE		UNIT IDENT CODE		SHEET		OF			
ITEM	MSNR	AEL ID	NOMENCLATURE	UNIT	QTY	REMARKS			
66	MSNR	12593K	Cable Assembly 30', WECCO 825A30	ea					
67	MSNR	17044Y	Connector Cable 50', Single End WECCO A25B	ea					
68	MSNR	14367A	Connector Cable, 75 Pair, 100', WECCO A75A	ea					
69	MSNR	15226B	Wire, Ground, 14 AWG Solid	ft					
70	MSNR	12250M	Duct, Elec, 2 1/2 x 2 1/2" x 10' Length, Square D	ea					
71	5975-00-978-5223	13809E	Elbow Wireway 2 1/2 x 2 1/2", Square D	ea					
72	5975-00-978-5221	10584B	Connector, Duct 2 1/2 x 2 1/2", Square D	ea					
73	5340-00-978-5175	10587E	Hanger, Universal, 2 1/2 x 2 1/2", Square D	ea					
74	5975-00-978-5224	10585C	Plate Closing, Duct, 2 1/2 x 2 1/2", Square	ea					
75	MSNR	10581J	Duct, Elec, 2 1/2 x 2 1/2", Telescoping Sections, Square D	ea					
76	MSNR	12251L	Bracket, Gusset 2 1/2 x 2 1/2", Square D	ea					

USACC 10-54-10-10-10

Figure 5-1. Bill of materials (sheet 8 of 10).

BILL OF MATERIALS									
PROJECT NO.		LOCATION CODE		DRAWING LIST NO.					
DATE		UNIT IDENT CODE		SHEET OF					
ITEM	NSN	AEL ID	NOMENCLATURE	UNIT	QTY	REMARKS			
77	5805-00-138-0720	11598D	Adapter, Bridging WECO KS 19252L2PCP	ea					
78	5805-00-471-5072	11597C	Adapter, Bridging, WECO 19252L1CPC	ea					
79	5805-00-138-0719	13483L	Adapter, Bridging, Contains 3 Plugs KS 16671L1	ea					
80	5805-00-140-8643	11568G	Box, Apparatus WECO 115A1 25 Pair	ea					
81	5805-00-017-4390	11569H	Box, Apparatus WECO 115B1 50 Pair	ea					
82	NSNR	12588D	Cover, WECO 117A	ea					
83	NSNR	12264J	Adapter, F/U/W /R66E3-25, Connecting Block Reliable Number R-152A-G	ea					
84	NSNR	17080M	Block, Matrix, WECO 1A1	ea					
85	NSNR	17081L	Diode, WECO 446F	ea					
86	5340-00-200-2729	10428A	Clamp, Loop 7/8"	ea					
87	6240-00-318-7162	11579G	Lamp, 10 Volt, WECO 51A	ea					
88	NSNR	17048K	Panel, WECO 584C	ea					
89	NSNR	17049K	Panel, WECO 602A	ea					

Figure 5-1. Bill of materials (sheet 9 of 10).

31 August 1978

SEIP 016

BILL OF MATERIALS									
PROJECT NO.		LOCATION CODE		DRAWING LIST NO.					
DATE		UNIT IDENT CODE		SHEET OF					
ITEM	NSNR	AEL ID	NOMENCLATURE	UNIT	QTY	REMARKS			
90	NSNR	188348	Apparatus, Mounting 69F	ea					
91	NSNR	19987Z	Guide Assembly, WECO P40V590	ea					
92	5530-00-128-5059	09160M	Plywood, Exterior, 4'x8'x1/2"	sh					
93	5305-00-901-2607	07894M	Screw Wood, 14 x 1" LG	hd					
94	5305-00-901-3793	00205G	Screw Wood 8 x 3/4" LG	hd					
95	5347-00-089-2828	05708Z	Anchor, Plastic 8 x 3/4" LG	hd					
96	5975-00-978-5225	10583A	TEE, 2 1/2 x 2 1/2", Square D LD2T	ea					
97	5340-00-264-7620	09691J	Shield, Expansion, Anchor 3/4" LG	ea					
98	5340-00-514-0656	09655L	Shield, Expansion, Anchor 1" LG	ea					
99	NSNR	21631E	Contacts, Plug, Amphenol Number 157-125000	ea					
100	NSNR	21632F	Contacts, Receptacle, Amphenol Number 157-225000	ea					

USA CC 10-64-90-8
10-64-90-8

Figure 5-1. Bill of materials (sheet 10 of 10).

SECTION 6. QUALITY ASSURANCE PROCEDURES

6.1 GENERAL. The quality assurance (QA) criteria defined in CCR 702-1-2, chapter 5, will be applied to this project. The QA procedures in this section will be used to determine the acceptability of the installation and the functional performance as defined in sections 1 and 3.

6.2 INSPECTION RESPONSIBILITIES.

6.2.1 Installation agency. The installation agency is responsible for quality control (QC) inspections in accordance with CCR 702-1-2, CCTM 105-50-21, and this SEIP. QC inspections will be performed to ensure compliance with equipment, subsystems, and system level requirements. A QC representative (QCR) shall be identified, prior to start of installation, to serve as a point of contact for the QC effort. The QCR is responsible for ensuring that the following actions are accomplished in a timely manner.

- a. Complete a checklist similar to figure 6-1 during QC inspections in accordance with CCR 702-1-2.
- b. Prepare QC reports using approved installation agency forms.
- c. Provide test equipment.
- d. Perform shakedown tests and maintain a daily log of results using approved installation agency forms.
- e. Issue a statement of readiness, certifying that the installation is ready for acceptance testing, to the applicable USACEEIA-QA element in writing, 20 days prior to the estimated completion date of shakedown tests.
- f. Identify one installer to assist in the final QA inspection and acceptance test.
- g. Correct QC discrepancies and perform installation rework if test results are not satisfactory.
- h. Make QC inspection records and related installation documents available to the QA representative/test director, referred to as the QAR.

FINAL QUALITY ASSURANCE INSPECTION CHECKLIST

Project Name _____ Site _____

QUALITY ASSURANCE OF EQUIPMENT INSTALLATION

(Refer to paragraphs as listed below in CCTM 105-50-21.)

	<u>YES</u>	<u>NO</u>	<u>N/A</u>
A. <u>Installation, drawings, and specifications.</u> (Para 3-2, 3-3)			
1. Are floor plan drawings available?	---	---	---
2. Are equipment location drawings available?	---	---	---
3. Are face layout drawings of equipment in bays available?	---	---	---
4. Are drawings for distributing frame block assignments available?	---	---	---
5. Are pin connections on terminal blocks shown on drawings?	---	---	---
6. Is stenciling of terminal blocks shown on drawings?	---	---	---
7. Are drawings of power distributing equipment available?	---	---	---
8. Are wire sizes indicated on drawings?	---	---	---
9. Are schematic diagrams of circuit types to be installed included in drawings?	---	---	---
10. Are drawings of site grounding systems available?	---	---	---
11. Are drawings showing arrangement of cable racks, ducts, and trenches available?	---	---	---

Figure 6-1. Sample of final installation inspection checklist (sheet 1 of 11).

31 August 1978

SEIP 016

	<u>YES</u>	<u>NO</u>	<u>N/A</u>
12. Do specifications contain a list of reference material required by installers?	___	___	___
13. Do specifications contain a cable running list for power distribution?	___	___	___
14. Do specifications contain a cable running list for signal cabling?	___	___	___
15. Do specifications contain a cable running list for cabling?	___	___	___
16. Do specifications contain detailed information on grounding?	___	___	___
17. Do specifications contain details on all special instructions for installers?	___	___	___
18. Do drawings reference all applicable items on BOM?	___	___	___
 B. <u>Installation Tools.</u> (Para 3-8)			
1. Is equipment damaged or unserviceable?	___	___	___
2. Are all installation materials on hand and serviceable?	___	___	___
3. Are all tools necessary for completion of the job on hand?	___	___	___
4. Is all test equipment needed for test and checkout of installation available?	___	___	___
 C. <u>General Safety Practice.</u> (Chapter 4)			
1. Are goggles being worn when drilling and grinding?	___	___	___

Figure 6-1. Sample of final installation inspection checklist (sheet 2 of 11).

SEIP 016

31 August 1978

	<u>YES</u>	<u>NO</u>	<u>N/A</u>
2. Are sharp edges left on frame or duct work?	---	---	---
3. Are all hand tools properly used?	---	---	---
4. Are electric power tools properly grounded?	---	---	---
D. <u>Floor Plan Layout.</u> (Para 3-7)			
1. Are equipment layout plans in accordance with drawings?	---	---	---
2. Was layout plan completed before equipment was moved into area?	---	---	---
E. <u>Erecting and Mounting.</u> (Para 3-9)			
1. Is equipment laid out in accordance with floor plan drawing?	---	---	---
2. Are equipment bays level and plumbed within tolerances?	---	---	---
3. Has proper spacing been provided between equipment racks?	---	---	---
4. Are base angles of frames secured to floor in proper location?	---	---	---
5. Are all cabinets flush mounted and plumbed?	---	---	---
6. Has finish of equipment, cabinets, and racks been touched up?	---	---	---
7. Are bolts and screws free from stripped threads and defaced heads?	---	---	---

Figure 6-1. Sample of final installation inspection checklist (sheet 3 of 11)

31 August 1978

SEIP 016

	<u>YES</u>	<u>NO</u>	<u>N/A</u>
8. Have sufficient clearances been provided between apparatus for heat dissipation?	___	___	___
9. Are terminal blocks aligned on distributing frames?	___	___	___
10. Has equipment been installed in cabinets or racks in accordance with face layouts?	___	___	___
11. Are all nuts and bolts securely tightened?	___	___	___
12. Are exposed or cut ends of metal filed smooth and painted?	___	___	___
13. Have lock and flat washers been used?	___	___	___
14. Is the C-E equipment BOM available at the facility?	___	___	___
15. Has the C-E equipment been inventoried and discrepancies posted?	___	___	___
16. Is all required C-E equipment at the site?	___	___	___
17. Is all C-E equipment installed?	___	___	___
F. <u>Cable Racks.</u> (Para 3-10) (Inspect new installation)			
1. Location of cable racks:			
a. Are cable racks located in accordance with cable plan drawing?	___	___	___
b. Does height of cable racks conform to height above floor as indicated on cable plan drawing?	___	___	___
c. Are cable racks located so that clearance is provided for installation and maintenance of ultimate equipment?	___	___	___

Figure 6-1. Sample of final installation inspection checklist (sheet 4 of 11).

SEIP 016

31 August 1978

	<u>YES</u>	<u>NO</u>	<u>N/A</u>
d. Are cable racks located so cables are not subject to damage, exposure, or other detrimental conditions?	---	---	---
2. Assembly of cable racks:			
a. Are long sections of cable racks used where possible?	---	---	---
b. Have clamping details been altered where necessary to avoid interference?	---	---	---
c. Are open ends of cable racks properly closed?	---	---	---
d. Are vertical cable racks properly terminated on floors?	---	---	---
3. Support of cable racks:			
a. Are cable racks properly supported and fastened?	---	---	---
b. Are cable racks installed so no excessive load or binding is imposed on the equipment?	---	---	---
c. Are horizontal cable racks supported on approximately 5-foot centers but not to exceed 6 feet?	---	---	---
d. Has support been provided within 3 feet of free end of cable rack?	---	---	---
e. Are cable racks braced where necessary to prevent sway?	---	---	---
G. <u>Cabling Practices.</u> (Para 3-11)			
1. Are cable runs made in accordance with the cable running list?	---	---	---

Figure 6-1. Sample of final installation inspection checklist (sheet 5 of 11).

31 August 1978

SEIP 016

	<u>YES</u>	<u>NO</u>	<u>N/A</u>
2. Are cables twisted or crossed on cable rack?	---	---	---
3. Do cables conform to the bending radii and position? (See table 3-1, page 3-55, and figures 3-55 and 3-56, page 3-56.)	---	---	---
4. Is protection provided where cable sheaths contact rough or sharp edges or metal?	---	---	---
5. Are cables which are turned off over side of cable racks formed with minimum allowable radii? (See table 3-1, page 3-55.)	---	---	---
6. Are cables turned off rack horizontally and then up?	---	---	---
7. Do cables to the distributing frame enter on the vertical side?	---	---	---
8. Are cables serving the horizontal side of a distributing frame secured to the transverse arms near the vertical upright?	---	---	---
9. Are cables tags properly prepared and in accordance with the cable running list?	---	---	---
10. Are cable tags secured at each end of cable run?	---	---	---
11. Have cable tags been removed upon completion of verification and termination?	---	---	---
12. Are cables butts located as near as practicable to the point where the first wires turn out?	---	---	---

Figure 6-1. Sample of final installation inspection checklist (sheet 6 of 11).

SEIP 016

31 August 1978

	<u>YES</u>	<u>NO</u>	<u>N/A</u>
13. Are cable butts properly treated?	---	---	---
14. Is insulation of wires undamaged at butt location?	---	---	---
15. Are unused and spare wires protected at butt location?	---	---	---
<u>H. Securing Cables. (Para 3-13)</u>			
1. Is starting stitch properly made and placed?	---	---	---
2. Is required Kansas City stitch properly made?	---	---	---
3. Are first and succeeding layers of cable properly secured?	---	---	---
4. Are cables secured at every cable rack cross strap?	---	---	---
5. When cable butt is between securing devices, are cables secured together with an appropriate stitch?	---	---	---
6. Are lock stitches properly made and spaced?	---	---	---
7. Are splices in twine properly made?	---	---	---
<u>I. Sewed Forms. (Para 3-14)</u>			
1. Is proper size twine used for the diameter of the form?	---	---	---
2. Are proper number of strands used?	---	---	---
3. Are stitches properly spaced?	---	---	---

Figure 6-1. Sample of final installation inspection checklist (sheet 7 of 11).

31 August 1978

SEIP 016

	<u>YES</u>	<u>NO</u>	<u>N/A</u>
J. <u>Butting and Stripping.</u> (Para 3-15)			
1. Are proper tools used for butting and stripping of cable?	___	___	___
2. Are cable butts properly dressed?	___	___	___
3. Is proper distance maintained from cable butt to fanning strip?	___	___	___
K. <u>Fanned Forms.</u> (Para 3-16)			
1. Are cables fanned and connected to the left side of verticle mounted terminal blocks and to the bottom of horizontal terminal blocks?	___	___	___
2. Are conductors in fanned forms twisted and bunched?	___	___	___
3. Are fanned forms straight and taut from butt location to fanning strip?	___	___	___
4. Is length of skimmers correct?	___	___	___
5. Has color code been properly followed?	___	___	___
6. Are spare wires disposed of properly?	___	___	___
L. <u>Stenciling.</u> (Para 3-17)			
1. Is equipment correctly identified and stenciled in accordance with floor plan drawings?	___	___	___
2. Are designations located correctly?	___	___	___
3. Are correct size designations used on particular types of apparatus or equipment?	___	___	___

Figure 6-1. Sample of final installation inspection checklist (sheet 8 of 11).

	<u>YES</u>	<u>NO</u>	<u>N/A</u>
M. <u>Strapping.</u> (Para 3-18)			
1. Are straps properly placed?	---	---	---
2. Is correct type of strap wire used?	---	---	---
3. Does insulation extend to terminal?	---	---	---
4. Are straps placed not to interfere with operation of apparatus?	---	---	---
5. Is removal of apparatus blocked?	---	---	---
6. Are designations of apparatus obscured?	---	---	---
N. <u>Connecting and Soldering.</u> (Para 3-19)			
1. Is soldering clamp used when connecting wires?	---	---	---
2. Are connections made on terminal blocks in proper manner?	---	---	---
3. Is all soldering done with standard rosin core solder?	---	---	---
4. Are connections secure and free of foreign substances?	---	---	---
5. Has all unsightly flux and excess globules of solder been removed?	---	---	---
6. Is insulation on skimmers free of burn or other damage?	---	---	---
7. Do skimmers on connected terminals exceed 1/16 of an inch?	---	---	---
8. Are all conductors given a continuity test after connection is made?	---	---	---

Figure 6-1. Sample of final installation inspection checklist (sheet 9 of 11).

31 August 1978

SEIP 016

	<u>YES</u>	<u>NO</u>	<u>N/A</u>
0. <u>Wrapped Connections.</u> (Para 3-20)			
1. Are wrapped connections applied only on suitable terminals?	---	---	---
2. Are connections essentially straight and free of angular bends or crimps?	---	---	---
3. Are the required number of turns in contact with the terminal in accordance with criteria for gage of wire used? (22G-5 turns; 24G-6 turns; 26G-8 turns.)	---	---	---
4. Are wrapped connectors soldered where applicable?	---	---	---
P. <u>Cross Connections.</u> (Para 3-21)			
1. Are jumpers properly routed at distributing frame?	---	---	---
2. Do jumpers have sufficient slack after connection?	---	---	---
3. Are conductors twisted between fanning strip and terminal?	---	---	---
4. Does twist remain in conductors beyond rear of fanning strip?	---	---	---
5. Are jumpers properly dressed?	---	---	---
6. Has excess solder been removed from terminals?	---	---	---
Q. <u>Equipment and Signal Grounds.</u> (Para 3-23)			
Are equipment and signal grounds installed in accordance with applicable codes and standards and in accordance with installation drawings?	---	---	---

Figure 6-1. Sample of final installation inspection checklist (sheet 10 of 11).

	<u>YES</u>	<u>NO</u>	<u>N/A</u>
R. <u>Conduits.</u> (Para 3-24)			
1. Are burrs removed from conduit after cutting?	---	---	---
2. Is bending radii in accordance with table 3-14, page 3-152?	---	---	---
3. Are there no more than four 90-degree bends in a single conduit run?	---	---	---
4. Does number of conductors in conduit conform to table 2-3, page 2-9?	---	---	---
5. Are conduits supported at intervals not exceeding 6 feet?	---	---	---
6. Have all fittings been tightened after installation?	---	---	---
S. <u>Ducts.</u> (Para 3-25)			
1. Are hangers for overhead ducts mounted first?	---	---	---
2. Is proper type mallet used in assembly?	---	---	---
3. Are flange sections cleaned before installation?	---	---	---
T. <u>Installation Drawings.</u> (Para 3-2)			
Have drawings been reviewed to assure "as-built" accuracy?	---	---	---

Figure 6-1. Sample of final installation inspection checklist (sheet 11 of 11).

6.2.2 Testing agency. The testing agency is responsible for periodic in-process QA checks, final QA inspection, and acceptance testing in accordance with provisions of USACEEIA Regulation 702-3. QA inspections will be performed to monitor the QC effort and to ensure that the installation meets the required performance parameters at the equipment, subsystem, and system levels, as applicable. A QAR will be identified, prior to start of installation, to serve as a point of contact for the QA and test effort and to ensure that the following actions are taken in a timely manner.

a. Establish a QA program that monitors the QC and installation efforts to ensure compliance with stated requirements.

b. Record the information required by figure 6-2, pertaining to cognizant agency, command, and facility points of contact.

c. Review QC and installation records and perform periodic in-process QA inspections, if deemed necessary because of the size and complexity of the installation, and report discrepancies to the responsible agency. Recommendations for corrective action will be included in any discrepancy reports.

d. Perform a final QA inspection in accordance with CCR 702-1-2.

e. Conduct functional performance tests, in accordance with section 7 to determine if the installed equipment, subsystem, or system meets the required performance parameters. If the results of any portion of the acceptance test are not satisfactory, corrective action will be taken immediately by onsite personnel, if possible. If discrepancies are resolved, the QAR may retest to verify the results and continue the acceptance test. If discrepancies cannot be corrected immediately, the QAR may reject the equipment, subsystem, or system or attempt to complete the test with exceptions. Exceptions will be noted in the final test and acceptance report.

f. Record and analyze test results, prepare a final test and acceptance report, and make distribution in accordance with CCCR 702-2.

6.2.3 Operation agency. The operating agency is responsible for providing support during installation and test. An operation and maintenance (O&M) representative shall be

COGNIZANT AGENCY, COMMAND, AND FACILITY
POINTS OF CONTACT

COGNIZANT AGENCY:

Mailing Address _____

Electrical Address _____

Commander _____ Phone No. _____ Bldg. No. _____

Deputy/
Exec Off _____ Phone No. _____ Bldg. No. _____

COMMAND:

Mailing Address _____

Electrical Address _____

Commander _____ Phone No. _____ Bldg. No. _____

Deputy/
Exec Off _____ Phone No. _____ Bldg. No. _____

FACILITY:

Commander/
OIC _____ Phone No. _____ Bldg. No. _____

Deputy _____ Phone No. _____ Bldg. No. _____

Operations
Officer _____ Phone No. _____ Bldg. No. _____

Figure 6-2. Sample cognizant agency, command, and facility points of contact (sheet 1 of 3).

AD-A060 208

ARMY COMMUNICATIONS COMMAND FORT HUACHUCA ARIZ
STANDARD ENGINEERING INSTALLATION PACKAGE. KEY TELEPHONE SYSTEM--ETC(U)
AUG 78

F/6 17/2

UNCLASSIFIED

ACC-SEIP-016

NL

2 OF 2
AD
A060 208



END
DATE
FILMED
-12-78
DDC

31 August 1978

SEIP 016

	Phone No.	Bldg. No.	Rm No.
Operations NCO _____	_____	_____	_____
Maintenance Officer _____	_____	_____	_____
Maintenance NCO _____	_____	_____	_____
COMSEC Officer _____	_____	_____	_____
COMSEC NCO _____	_____	_____	_____
SECORD NCOIC _____	_____	_____	_____
<u>BASE SUPPORT ACTIVITIES</u>			
<u>Telephone:</u>			
Base Telephone: Exchange Officer _____	_____	_____	_____
Chief NCO/ Operator _____	_____	_____	_____
Base Security NCO _____	_____	_____	_____
Provost Marshall _____	_____	_____	_____

Figure 6-2. Sample cognizant agency, command, and facility points of contact (sheet 2 of 3).

SEIP 016

31 August 1978

Logistics/Supply:

	Phone No.	Bldg. No.	Rm No.
Logistics Officer _____	_____	_____	_____

Logistics NCO _____	_____	_____	_____
---------------------	-------	-------	-------

Base Engineer/Civil Engineer:

Electrical Shop _____	_____	_____	_____
-----------------------	-------	-------	-------

Plumbing Shop _____	_____	_____	_____
---------------------	-------	-------	-------

Machine Shop _____	_____	_____	_____
--------------------	-------	-------	-------

Building/Grounds Shop _____	_____	_____	_____
-----------------------------	-------	-------	-------

INSTALLATION:

Team Leader _____	_____	_____	_____
-------------------	-------	-------	-------

Assistant Team Leader _____	_____	_____	_____
-----------------------------	-------	-------	-------

QUALITY ASSURANCE:

Coordinator _____	_____	_____	_____
-------------------	-------	-------	-------

Alternate Coordinator _____	_____	_____	_____
-----------------------------	-------	-------	-------

Figure 6-2. Sample cognizant agency, command, and facility points of contact (sheet 3 of 3).

identified, prior to start of installation, to serve as the point of contact for the project and to ensure that the following actions are taken in a timely manner.

- a. Provide administrative supplies and typing support.
- b. Assist in resolution of discrepancies.
- c. Make operation and maintenance personnel available to assist on an as-required basis.
- d. Provide a representative to witness the acceptance test and sign the technical acceptance request (TAR).

6.3 DOCUMENTATION.

6.3.1 Quality control documentation. The installation QC will be documented using a QC checklist similar to the one at figure 6-1 and the approved installation agency report forms. A QC inspection log will be maintained on a daily basis during inspection periods. The daily log may be in any format unless installation agency policy dictates otherwise.

6.3.2 Quality assurance documentation. QA inspections will be documented using a QC checklist similar to the one at figure 6-1 and the sample cognizant agency, command, and facility points of contact form, figure 6-2. The final QA inspection shall be documented utilizing the TAR forms shown in section 8. The Test and Acceptance Report shall be in accordance with CCCR 702-2. A QA inspection log will be maintained on a daily basis during inspection periods. The daily log may be in any format unless testing agency policy dictates otherwise.

6.4 QUALITY ASSURANCE PLAN. The inspection responsibilities assigned in this section constitutes the QA plan and established an independent evaluation loop. The evaluation loop consists of the installation agency QC effort and the testing agency QA and test effort. Acceptance of the installation by the O&M command is contingent upon the successful demonstration, during acceptance testing, that the installed equipment meets required performance parameters. A coordinated effort between the installation effort between the installation, testing, and operating agency personnel is required to assure that the highest standards of quality are maintained in accordance with QA procedures.

6.4.1 QA inspections and tests may be interrupted at any point if disrupted by a hardware malfunction. They also may be interrupted at a compatible breaking point to permit scheduled duty breaks. Any inspection that is interrupted because of a hardware malfunction shall be restarted at a point determined by the QAR.

6.4.2 Spare equipment may be substituted for malfunctioning equipment with the approval of the QAR. Any equipment which has been replaced shall be repaired and reinspected.

6.4.3 During acceptance tests any piece of equipment, including items such as cables and conduits, may not be changed or adjusted without the approval of the QAR.

SECTION 7. TEST AND ACCEPTANCE PROCEDURES

7.1 SCOPE. This section provides for acceptance testing of the KTS. Equipment, subsystem, and system tests are performed to assure that the equipment operates in accordance with performance parameters specified in this SEIP and supporting technical literature.

7.2 TEST CRITERIA. The criteria for acceptance is based on requirements stated in sections 1 and 3, associated drawings, and technical specifications. If any of the test results fail to meet the desired performance parameters corrective action will be taken by the responsible onsite engineering and installation personnel. Faulty equipment, cabling, or other installed BOM items, will be reworked and retested to ensure that faults have been corrected.

7.3 TEST EQUIPMENT.

7.3.1 Tools and test equipment required for shakedown testing will be identified and provided by the installation agency.

7.3.2 The acceptance test is a functional performance test requiring no tools or test equipment.

7.4 TEST PLAN ORGANIZATION.

7.4.1 Shakedown tests will be conducted, and results recorded by the installation agency in accordance with normal installation agency policy and procedures.

7.4.2 The acceptance tests will be conducted by the QAR after completion of a QA inspection. The following tests are applicable and shall be conducted to ensure that all equipment complies with pertinent manufacturers specifications.

7.4.3 Pretest checks will be made prior to the start of acceptance testing, the QAR shall contact the operating agency representative to ensure that any changes in the post telephone system have been noted. The following specific information is required:

- a. Central office line number assignments.
- b. Intercom number assignments.

- c. Tie line changes.
- d. Addition or deletion of end instruments.
- e. Preset conference assignments.
- f. Add-on conferencing capability.
- g. Changes or corrections to installations and equipment specifications.
- h. Instruments equipped with ringers or buzzers.

7.4.4 The onsite test and acceptance schedule will be determined by the QAR, with concurrence of the project engineer, installation team chief, and the operation agency representative.

7.4.5 One repairman with 36H MOS or equivalent is required from the operating agency to assist on a full time basis during acceptance testing.

7.5 ACCEPTANCE TEST PLAN.

7.5.1 Central office line test. Perform tests of each telephone instrument within the key system by making at least one outgoing call and receiving one incoming call on each associated central office line. Verify working condition of all lamps, ringers, buzzers, hold features, and time-out features associated with normal key system functions.

7.5.2 Intercom test. Perform tests of each telephone instrument within the key system having intercom capability by making at least one outgoing call and receiving one incoming call on each intercom station. Verify condition of all lamps, ringers, buzzers, hold features, and time-out features associated with normal intercom service.

7.5.3 Conference test.

a. Preset conference test. Perform tests of each preset conference station by originating at least one conference call and receiving one incoming conference call.

b. Add-on conference test. Perform tests by originating and receiving at least one conference call and then adding other instruments to the call by operating the appropriate buttons.

31 August 1978

SEIP 016

c. Selective conferencing test. This test is performed by operating the push button for signaling the additional instruments which are to be added to conference (maximum of six). Record the results of all tests on the sample key system acceptance test data sheets shown at figure 7-1.

SEIP 016

31 August 1978

KEY SYSTEM ACCEPTANCE TEST DATA SHEETS

LOCATION: _____ DATE: _____

STATION: _____

TEST DIRECTOR: (Initials) _____

<u>LINE NO.</u>	ACCEPT	REJECT*	<u>COMMENTS</u>
	(Check one)		
____ LAMP	_____	_____	
____ RINGER	_____	_____	
____ BUZZER	_____	_____	
____ LAMP	_____	_____	
____ RINGER	_____	_____	
____ BUZZER	_____	_____	
____ LAMP	_____	_____	
____ RINGER	_____	_____	
____ BUZZER	_____	_____	
____ LAMP	_____	_____	
____ RINGER	_____	_____	
____ BUZZER	_____	_____	
____ LAMP	_____	_____	
____ RINGER	_____	_____	
____ BUZZER	_____	_____	
INTERCOM:	OUT _____	_____	TO: EXT. NO. _____
	IN _____	_____	FROM: EXT. NO. _____

*NOTE: Use N/A if instrument not equipped for tests shown.

Figure 7-1. Sample key system data sheet (sheet 1 of 2).

31 August 1978

SEIP 016

	ACCEPT	REJECT*		
	(Check one)		<u>COMMENTS</u>	
CONFERENCING:				
PRESET:	OUT _____	_____	TO: EXT. NO. _____	
	IN _____	_____	FROM: EXT. NO. _____	
ADD-ON:	OUT _____	_____	TO: EXT. NO. _____	
	IN _____	_____	FROM: EXT. NO. _____	
SELECTIVE	_____	_____		

REMARKS:

*NOTE: Use N/A if instrument not equipped for tests shown.

Figure 7-1. Sample key system data sheet (sheet 2 of 2).

SECTION 8. COMPLETION CERTIFICATION

8.1 GENERAL. The completed document shall consist of the information indicated by the sample technical acceptance record (TAR) (fig. 8-1). The information and documentation provided by these sheets may be expanded to meet the requirements of the specific project.

8.2 DISTRIBUTION. The distribution list for the TAR will be provided in the tasking document, QA test plan, or contractual document.

8.3 RECORD. Prescribed TAR items are as follows: (Record may be locally reproduced.)

8.3.1 Paragraph 1 (Project). Identify project.

8.3.2 Paragraph 2 (Facility). Identify facility.

8.3.3 Paragraph 3 (Location). Identify geographic location.

8.3.4 Paragraph 4 (Operating Agency). Identify organization.

8.3.5 Paragraph 5 (Engineering Agency). Identify organization.

8.3.6 Paragraph 6 (Installation Agency). Identify organization.

8.3.7 Paragraph 7 (Quality Assurance/Test Agency). Identify organization.

8.3.8 Paragraph 8 (Project Description). Provide brief description of the project purpose.

8.3.9 Paragraph 9 (Equipment Provided). This paragraph normally lists two parts: paragraph 9A, operational equipment installed, and paragraph 9B, test equipment successfully tested and calibrated. All hardware listed is correlated to the project BOM item number, and quantities shown are for items successfully tested/calibrated only.

8.3.10 Paragraph 10 (Documentation Provided). This paragraph normally lists two parts: paragraph 10A, drawings provided to operator, and paragraph 10B, technical manuals provided to the operator. Drawings are listed in numerical sequence, with the title and sheet quantity identified for each. Technical manuals are listed by equipment BOM item in numerical sequence, with the equipment described and the manual quantity identified for each item.

8.3.11 Paragraph 11 (Exceptions). Exceptions to project completion and to full facility operation are identified in detail. Each exception will be identified separately and categorized according to the agency or 11A, B, C, or D anticipated to be responsible for corrective action. This categorization constitutes the test director's recommendation and is not binding. The project manager retains tasking authority regarding resolution of all exceptions.

8.3.12 Paragraph 12 (Remarks). Comment by the QA/test, installation, and operating agencies or respective paragraphs 12A, B, or C is encouraged. In the event a representative of the engineering agency is at hand during execution of final documentation, comment from that source is also encouraged. Remarks should be confined to technical matters affecting the project. Laudatory comment relative to support received, or work accomplished, although commendable, should be addressed in separate correspondence. Standard statements to be entered on all TAR's by the QA/test agency are shown in this paragraph as well as reference to other documentation, if required.

8.3.13 Paragraph 13 (Certification). Signatures are affixed by installation, operating, and QA/test agency representatives to authenticate activity which transpired during the acceptance test phase and to verify that system status is as stated in the document. The certifications contained in or prescribed by this publication are essential to the conduct of the Government's business.

8.3.14 Paragraph 14 (Acceptance). The O&M commander, or his/her representative, indicates by his/her signature that the system described in the document is accepted for full operation, less exceptions noted, if any.

31 August 1978

SEIP 016

TECHNICAL ACCEPTANCE RECORD

1. Project: _____

2. Facility: _____

3. Location: _____

4. Operating Agency: _____

5. Engineering Agency: _____

6. Installation Agency: _____

7. Quality Assurance/Test Agency: _____

8. Project Description: _____

Figure 8-1. Sample technical acceptance record (sheet 1 of 14).

SEIP 016

31 August 1978

9. Equipment Provided:

A. Operational Equipment:

BOM Item No.	Description	Part Number	Qty On Rqr Site
--------------------	-------------	-------------	-----------------------

Figure 8-1. Sample technical acceptance record (sheet 2 of 14).

31 August 1978

SEIP 016

9. Equipment Provided:

B. Test Equipment:

BOM Item No.	Description	Part Number	Qty On Rqr Site
--------------------	-------------	-------------	-----------------------

Figure 8-1. Sample technical acceptance record (sheet 3 of 14).

SEIP 016

31 August 1978

10. Documentation Provided: A. Drawings:

Drawing Number	Title	Sheet
-------------------	-------	-------

Figure 8-1. Sample technical acceptance record (sheet 4 of 14).

31 August 1978

SEIP 016

10. Documentation Provided:

B. Technical Manuals:

BOM	Description	Part Number	Technical Manual
Item			
No.			

On
Rqr Site

Figure 8-1. Sample technical acceptance record (sheet 5 of 14).

SEIP 016

31 August 1978

11. A. Exceptions for which the operating agency assumes
responsibility:

Figure 8-1. Sample technical acceptance record (sheet 6 of 14).

31 August 1978

SEIP 016

11. B. Exceptions for which the installation agency assumes
responsibility:

Figure 8-1. Sample technical acceptance record (sheet 7 of 14).

SEIP 016

31 August 1978

11. C. Exceptions requiring resolution by the engineering agency:

Figure 8-1. Sample technical acceptance record (sheet 8 of 14).

31 August 1978

SEIP 016

11. D. Exceptions requiring resolution by the project manager:

Figure 8-1. Sample technical acceptance record (sheet 9 of 14).

12. Remarks:

A. QA/Test Agency:

(1) This document signifies that the equipment identified in paragraph 9 is technically acceptable for operation. This document does not signify acceptance of the equipment by the O&M command, nor does it serve to transfer accountability for property book purposes; both of these are actions which must be consummated by the project manager (PM)/O&M commander.

(2) Paragraph 11 contains agreements by personnel involved in acceptance testing relative to agency responsibility for correction of exceptions identified. Assignments will be adjusted and confirmed by the PM subsequent to distribution of this document.

(3) Disposition of excess project material is a USACSA function.

(4) One copy of each marked-up drawing listed at paragraph 10A is provided to the operating command with execution of this document.

(5) All technical manuals listed at paragraph 10B are provided to the operating command with execution of this document.

(6) One copy of each test data sheet, prepared during the installation shakedown test and during acceptance test, is provided to the operating command with execution of this document.

Figure 8-1. Sample technical acceptance record (sheet 10 of 14).

31 August 1978

SEIP 016

12. Remarks:

B. Installation agency:

Figure 8-1. Sample technical acceptance record (sheet 11 of 14).

SEIP 016

31 August 1978

12. Remarks:

C. Operating agency:

Figure 8-1. Sample technical acceptance record (sheet 12 of 14).

31 August 1978

SEIP 016

13. Certification: Acceptance test and quality assurance inspections are complete for this project.

Without exception _____. With exception cited para 11 _____.

INSTALLATION AGENCY REPRESENTATIVE

Printed: _____
Signed: _____
Title: _____
Organization: _____
Date: _____

OPERATING AGENCY REPRESENTATIVE

Printed: _____
Signed: _____
Title: _____
Organization: _____
Date: _____

QA/TEST AGENCY REPRESENTATIVE

Printed: _____
Signed: _____
Title: _____
Organization: _____
Date: _____

Figure 8-1. Sample technical acceptance record (sheet 13 of 14).

SEIP 016

31 August 1978

14. Acceptance: This project is accepted for full operation:
Without exception _____. With exception cited para 11 _____.

OPERATING COMMAND

Printed: _____
Signed: _____
Title: _____
Organization: _____
Date: _____

Figure 8-1. Sample technical acceptance record (sheet 14 of 14).

31 August 1978

SEIP 016

(CC-OPS)

FOR THE COMMANDER:

OFFICIAL:

EUGENE J. VITETTA
Colonel, GS
Chief of Staff

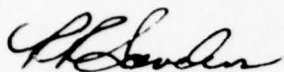

R. R. SANDERS
Major, AGC
Assistant Adjutant General

DISTRIBUTION:

Special

- 5 - CC-PA-AMP
- 10 - CCC-CED-SEP
- 4 - CCC-CED-SW
- 4 - CCC-TED
- 5 - USACEI Bn
- 10 - USACEEIA-CONUS, ATTN: CCCN-TR, Fort Ritchie, MD 21719
- 10 - USACEEIA-EUR, APO New York 09056
- 10 - US Army Signal School, ATTN: ATSN-CD-MS, Fort Gordon, GA 31905
- 2 - US Army Materiel Development and Readiness Command, ATTN: CCN-PI-P, Washington, DC 20315
- 5 - 5th Signal Command, APO New York 09056
- 5 - 7th Signal Command, Fort Ritchie, MD 21719
- 2 - US Army Communications Command, ATTN: CC-OPS-SM, Fort Huachuca, AZ 85613
- 2 - US Army Training and Doctrine Command, ATTN: ATCE, Fort Monroe, VA 23351
- 2 - US Army Forces Command, ATTN: AFCE, Fort McPherson, GA 30330
- 2 - Defense Communications Agency, Technical Library Center, Code 205, Washington, DC 20305
- 12 - Defense Documentation Center, Cameron Station, Alexandria, VA 22314
- 2 - US Air Force, ATTN: USAFSAAS/TE00A, Keesler AFB, MS 39534
- 2 - Air Force Communications Service, ATTN: 1842 EEG/EEM, Scott AFB, IL
- 2 - Naval Electronic Systems Command (NAVELEX), Code 51032, Washington, DC 20315

DEPARTMENT OF THE ARMY
US Army Communications-Electronics
Engineering Installation Agency
Fort Huachuca, Arizona 85613

POSTAGE AND FEES PAID
DEPARTMENT OF THE ARMY
DoD 314



OFFICIAL BUSINESS
PENALTY FOR PRIVATE USE \$300

COMMANDER
US ARMY COMMUNICATIONS-ELECTRONICS
ENGINEERING INSTALLATION AGENCY
ATTN: CCC-CED-SEP
Fort Huachuca, Arizona 85613

DEPARTMENT OF THE ARMY
US Army Communications-Electronics
Engineering Installation Agency
Fort Huachuca, Arizona 85613

POSTAGE AND FEES PAID
DEPARTMENT OF THE ARMY
DoD 314



OFFICIAL BUSINESS
PENALTY FOR PRIVATE USE \$300

COMMANDER
US ARMY COMMUNICATIONS-ELECTRONICS
ENGINEERING INSTALLATION AGENCY
ATTN: CCC-CED-SEP
Fort Huachuca, Arizona 85613