

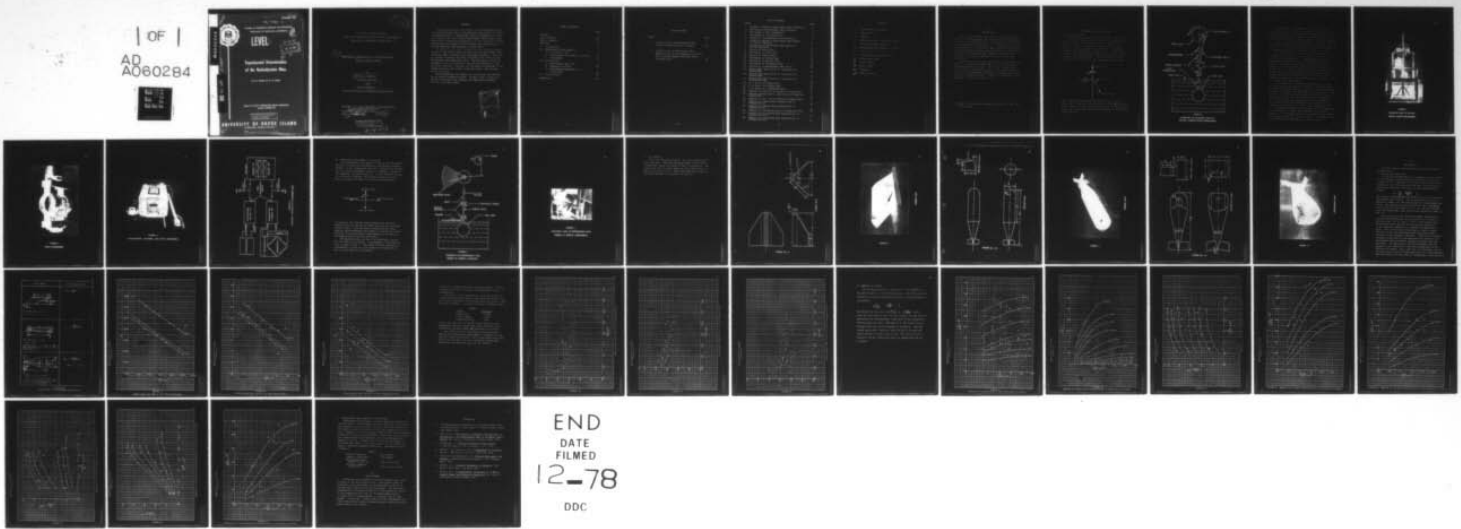
AD-A060 284

RHODE ISLAND UNIV KINGSTON DIV OF ENGINEERING RESEAR--ETC F/6 13/10
EXPERIMENTAL DETERMINATION OF THE HYDRODYNAMIC MASS OF VARIOUS --ETC(U)
SEP 65 R R MILLER, W M HAGIST N70024-1162

UNCLASSIFIED

NL

| of |
AD
A060284



END
DATE
FILMED
12-78
DDC

This copy for BUSHIPS Code 1622E
SEPTEMBER, 1965

MOST Project -4

DIVISION OF ENGINEERING RESEARCH AND DEVELOPMENT
DEPARTMENT OF MECHANICAL ENGINEERING

Q
NW

LEVEL II

DDC
OCT 23 1978
F

Experimental Determination of the Hydrodynamic Mass

by R. R. MILLER and W. M. HAGIST

Sponsor: U. S. NAVY UNDERWATER SOUND LABORATORY
Contract: N70024-1162

This document has been approved
for public release and sale; its
distribution is unlimited.

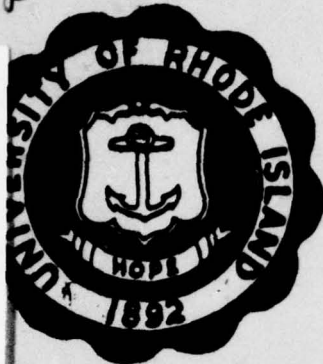
UNIVERSITY OF RHODE ISLAND
KINGSTON, RHODE ISLAND

Encl. 1 to USNUSL Ser 994-710

AD A060284

DDC FILE COPY

003085



2008

18-15

DDC
RECEIVED
OCT 23 1978
RECEIVED
F

University of Rhode Island
Division of Engineering Research and Development
Department of Mechanical Engineering

6
EXPERIMENTAL DETERMINATION OF THE HYDRODYNAMIC
MASS OF VARIOUS BODIES,

by
10 Robert R. Miller
Research Assistant
and
Warren M. Hagist

Associate Professor of Mechanical Engineering

Sponsor: U.S. Navy Underwater Sound Laboratory
15 New London, Connecticut
Contract: N70024-1162 new
Date: 11 September 1965 12 45p.

This document has been approved
for public release and sale; its
distribution is unlimited.

404 005

LB

ABSTRACT

This report presents the results of an experimental study of the hydrodynamic mass and hydrodynamic mass moment of inertia of submerged bodies. Hydrodynamic mass and damping force data were obtained for three "towed body" shapes translating in the direction of towing and perpendicular to the direction of towing. Hydrodynamic mass moment of inertia data were obtained for a prolate spheroid rotating about its minor axis.

The data for the bodies translating in a direction perpendicular to the towing direction show that the hydrodynamic mass decreases almost linearly with increasing frequency. Tests run at constant frequency show that a minimum point occurs in the hydrodynamic mass-amplitude curve. The amplitude at which the minimum occurs is a function of the body streamlining in the direction of motion. The data for the bodies translating in the towing direction were widely scattered; hence, only average values are given.

The hydrodynamic mass moment of inertia data was obtained by the natural frequency method. Further study is being conducted to determine the frequency and amplitude dependence for the towed body shapes.

ACCESSION for	
NTIS	White Section <input checked="" type="checkbox"/>
GDC	Buff Section <input type="checkbox"/>
UNANNOUNCED	<input type="checkbox"/>
JUSTIFICATION	
BY	
DISTRIBUTION/AVAILABILITY CODES	
BT	SPECIAL
A	

TABLE OF CONTENTS

	Page
Abstract	i
List of Tables	iii
List of Figures	iv
Notation	v
I Introduction	1
II Experimental Investigation	
A. Hydrodynamic Mass	2
B. Hydrodynamic Mass Moment of Inertia	9
C. Test Bodies	12
III Test Results	
A. Hydrodynamic Mass Data	19
B. Damping Force Data	28
C. Hydrodynamic Mass Moment of Inertia Data	37
IV Test Accuracy	37
References	38

LIST OF TABLES

Table		Page
1	Average Values of Hydrodynamic Mass Factor in the Direction of Towing	24
2	Average Value of Hydrodynamic Mass Moment of Inertia and Damping Coefficient for a Prolate Spheroid Rotating About its Minor Axis	37

LIST OF FIGURES

Figure		Page
1	Schematic Diagram of Hydrodynamic Mass Apparatus	3
2	Photograph of Hydrodynamic Mass Apparatus	5
3	Photograph of Force Dynamometer	6
4	Photograph of Instrumentation	7
5	Diagram of Instrumentation Configuration	8
6	Schematic Diagram of Hydrodynamic Mass Moment of Inertia Apparatus	10
7	Photograph of Hydrodynamic Mass Moment of Inertia Apparatus	11
8	Drawing of Winged Body	13
9	Photograph of Winged Body	14
10	Drawing of Torpedo Body	15
11	Photograph of Torpedo Body	16
12	Drawing of Streamlined Body	17
13	Photograph of Streamlined Body	18
14	Definition of Hydrodynamic Mass Factor	20
15	Hydrodynamic Mass Factor vs. Frequency for Winged Body	21
16	Hydrodynamic Mass Factor vs. Frequency for Torpedo Body	22
17	Hydrodynamic Mass Factor vs. Frequency for Streamlined Body	23
18	K vs. ω A/c for Winged Body	25
19	K vs. ω A/c for Torpedo Body	26
20	K vs. ω A/c for Streamlined Body	27
21	Damping in Direction of Towing for Winged Body	29
22	Damping Perpendicular to Direction of Towing for Winged Body	30
23	Damping in Direction of Towing for Torpedo Body	31
24	Damping for Torpedo Body Perpendicular to Towing Direction	32
25	Damping for Torpedo Body Perpendicular to Towing Direction	33
26	Damping for Streamlined Body in Towing Direction	34
27	Damping for Streamlined Body Perpendicular to Towing Direction	35
28	Damping for Streamlined Body Perpendicular to Towing Direction	36

NOTATION

A	amplitude of oscillation
D	damping force
d	diameter
c	damping constant or speed of sound
c_t	torsional damping constant
J_h	hydrodynamic mass moment of inertia
K	hydrodynamic mass factor
l	characteristic length of body
m_h	hydrodynamic mass
ρ	fluid density
ϕ	phase angle
ω	frequency
μ	fluid viscosity

I

INTRODUCTION

This report presents the results of an experimental study of the hydrodynamic mass and hydrodynamic mass moment of inertia of submerged bodies. The work is a continuation of that reported in reference (1).^{*} Hydrodynamic mass data are presented for "towed body" shapes moving in translation in the direction of towing and perpendicular to the direction of towing. Hydrodynamic mass moments of inertia were obtained for a prolate spheroid oscillating about its minor axis.

The purpose of the investigation was to determine the effect of frequency and amplitude of oscillation on the hydrodynamic mass of a body. The results are presented in the form of dimensionless plots. The complete data are on file in the Department of Mechanical Engineering of the University of Rhode Island. A portion of the data is also available in the work by Miller (2).

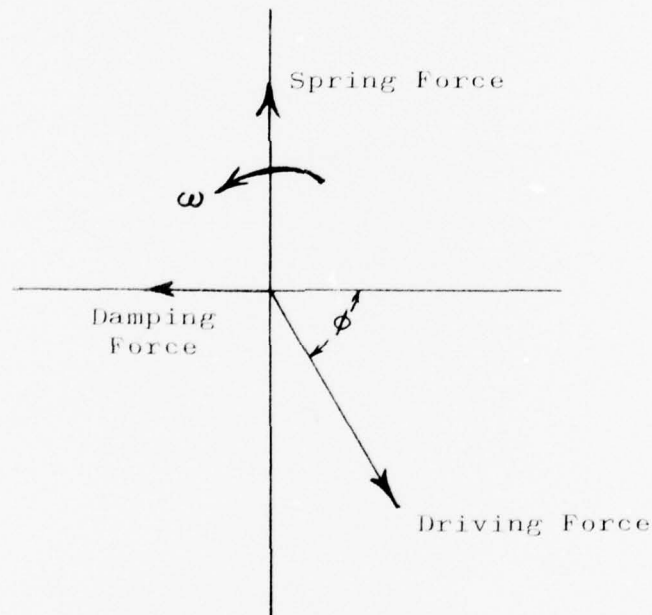
* Numbers in parenthesis designate references at the end of the report.

II

EXPERIMENTAL INVESTIGATION

A. Hydrodynamic Mass

The hydrodynamic mass data for the bodies moving in translation were obtained by using the forced oscillation method. In this method the test body is mounted as the mass in a simple spring-mass system and the system is driven at a given frequency and amplitude. A schematic diagram of the apparatus is shown in Fig. 1. The forces acting on the test body are related to each other as shown in the vector diagram below. (See reference 3.) The acceleration and the force were simultaneously recorded



while the immersed body was being driven at a given frequency ω . From this record the phase angle ϕ was determined. With the total force, acceleration, and phase angle known the hydrodynamic mass and the damping coefficient were calculated (1).

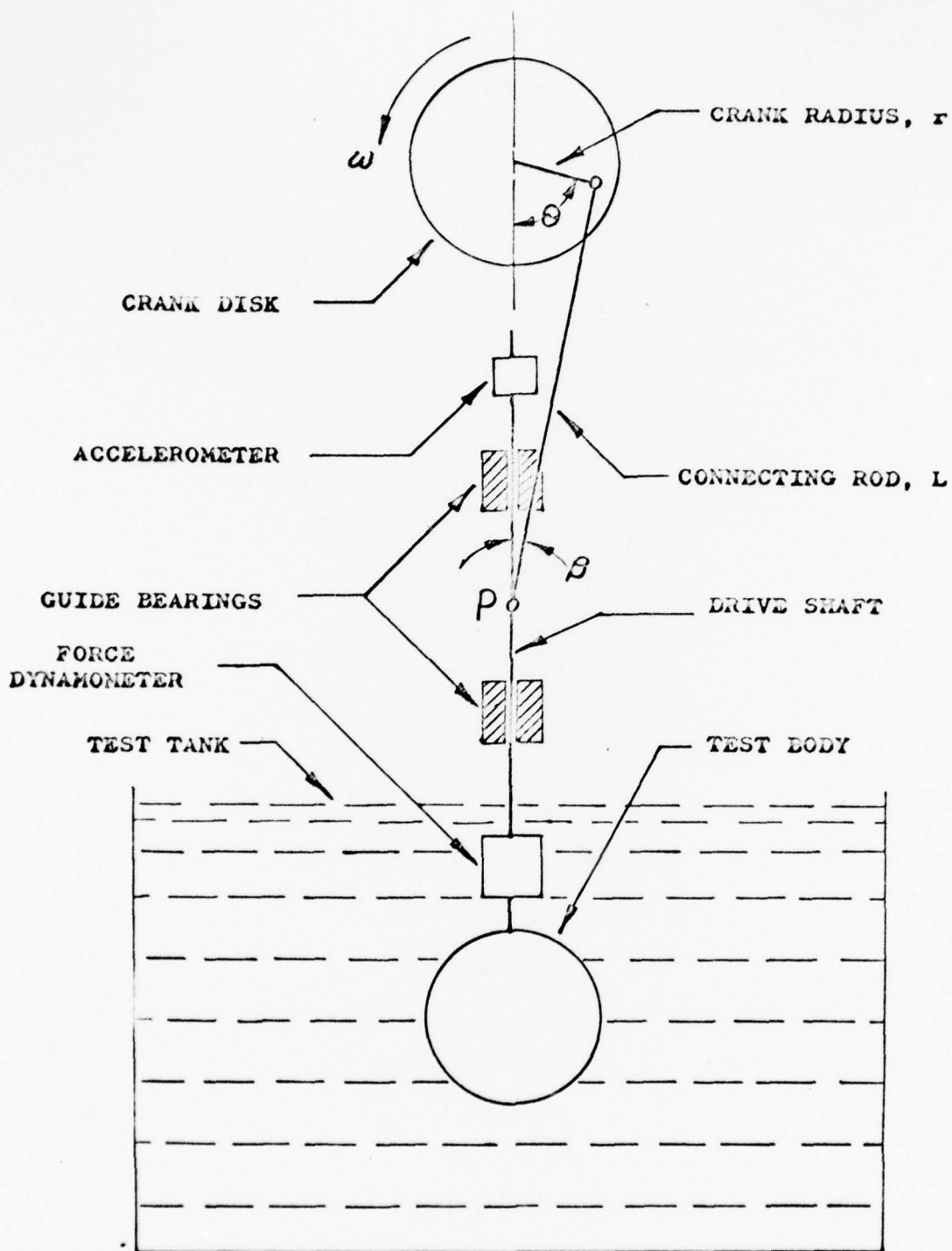


FIGURE 1

SCHMATIC OF APPARATUS USED IN
DRIVEN, DAMPED SYSTEM EXPERIMENTS

A photograph of the apparatus is shown in Fig. 2. Design details are available in reference (2). The drive assembly consisted of a three-quarter horsepower motor connected through a single V-belt to a Graham variable speed transmission. The motor and transmission were shock mounted on a frame separate from the main frame. This drive assembly allowed the test body to be driven at any frequency from zero to 3.3 cycles per second. The T-slot in the crank disk allowed any amplitude of oscillation up to five inches.

The force exerted on the test body was measured by a dynamometer consisting of two octagonal force rings fitted with SR-4 strain gages (5). A photograph of the force dynamometer is shown in Fig. 3. The gages were connected so that the opposite gages on each force ring were in series. The four pairs of gages were then connected in a bridge circuit. With the gages in this configuration, the system was within three per cent of being insensitive to bending moments and horizontal forces. The gages and submerged connections were waterproofed by a liberal coating of a rubber-like epoxy resin.

An accelerometer (Servonic Instruments, Inc., type 111.002) with a $\pm 1g$ range was attached to the drive shaft above the upper guide bearing. While the accelerometer was not used to determine the magnitude of acceleration, it was necessary to record the accelerometer output in order to determine the points of zero acceleration. The magnitude of the acceleration was calculated from the kinematic relationship among the crank radius, the connecting rod length, and the angular velocity of the crank disk (6).

The outputs from the accelerometer and the dynamometer were recorded by a Massa, Model BSA-260A two channel recorder. A photograph of the accelerometer, force dynamometer, and recorder are shown in Fig. 4. A diagram of the instrumentation configuration is shown in Fig. 5.

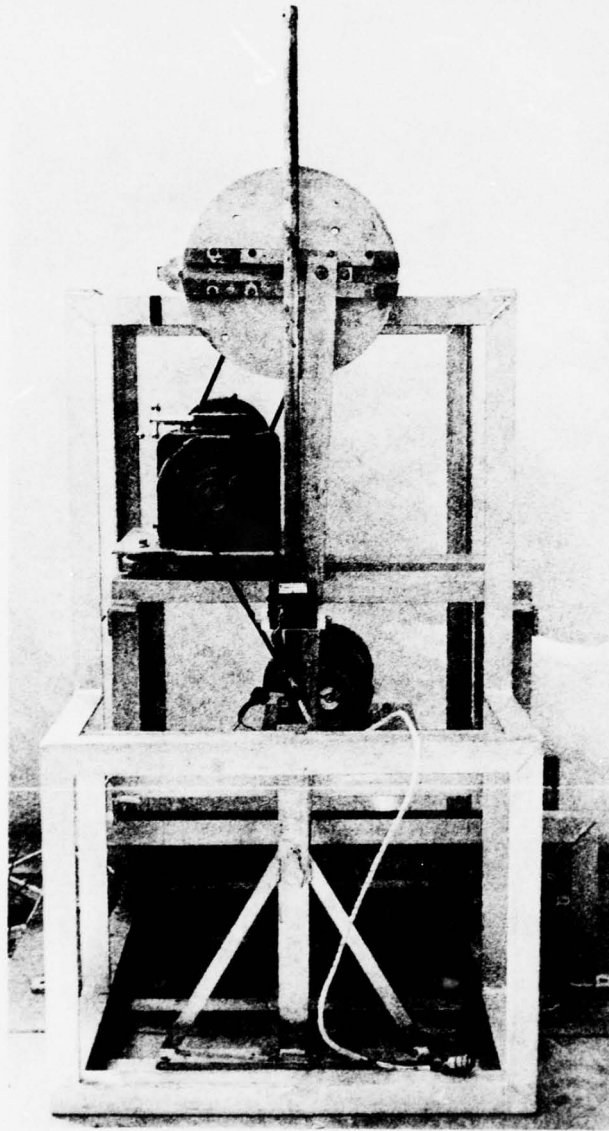


FIGURE 2
APPARATUS USED IN DRIVEN,
DAMPED SYSTEM EXPERIMENTS

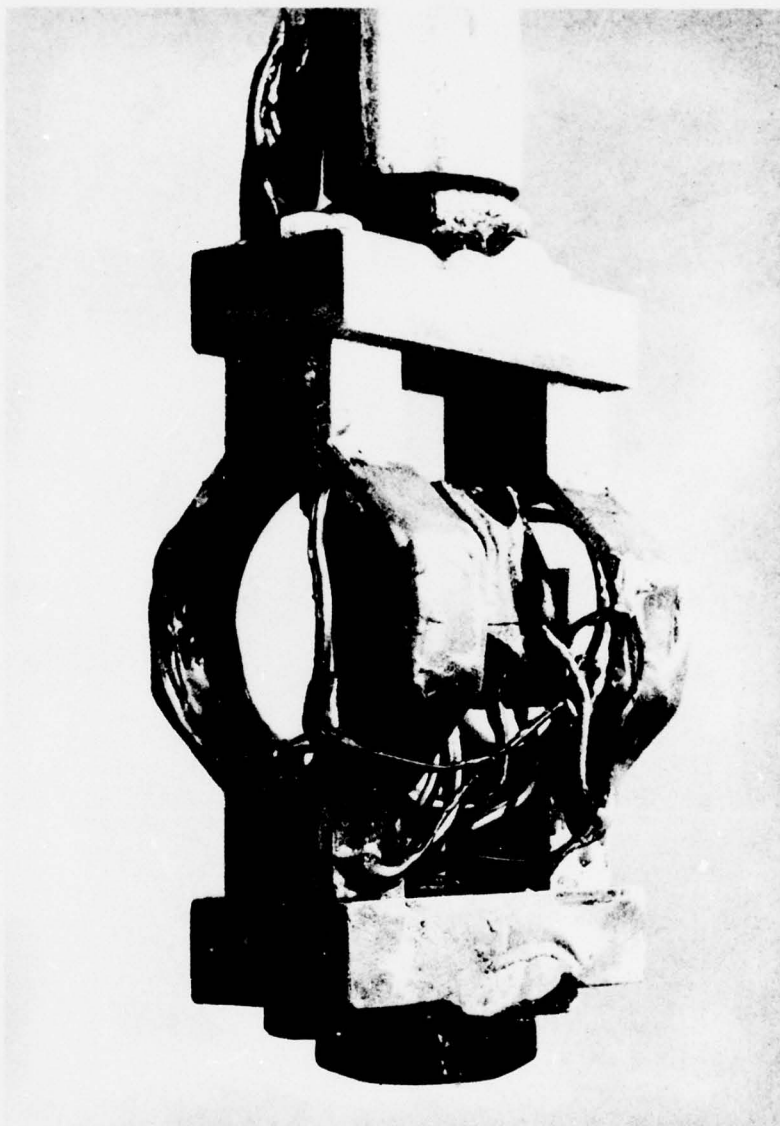


FIGURE 3
FORCE DYNAMOMETER

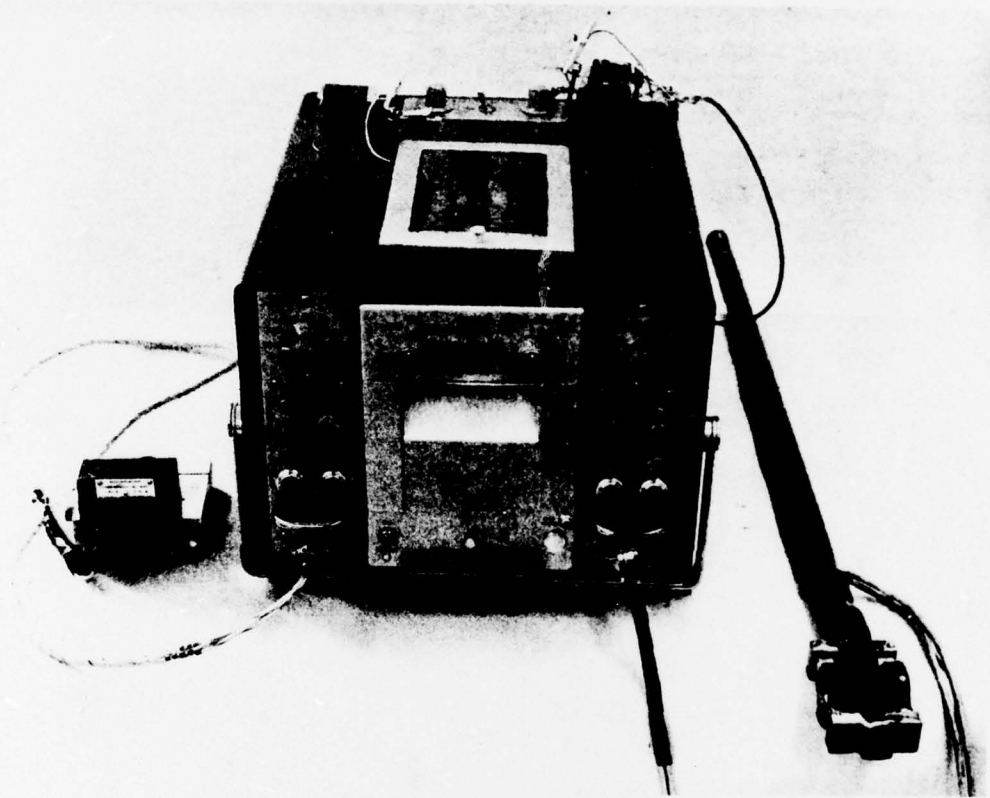


FIGURE 4

ACCELEROMETER, RECORDER, AND FORCE DYNAMOMETER

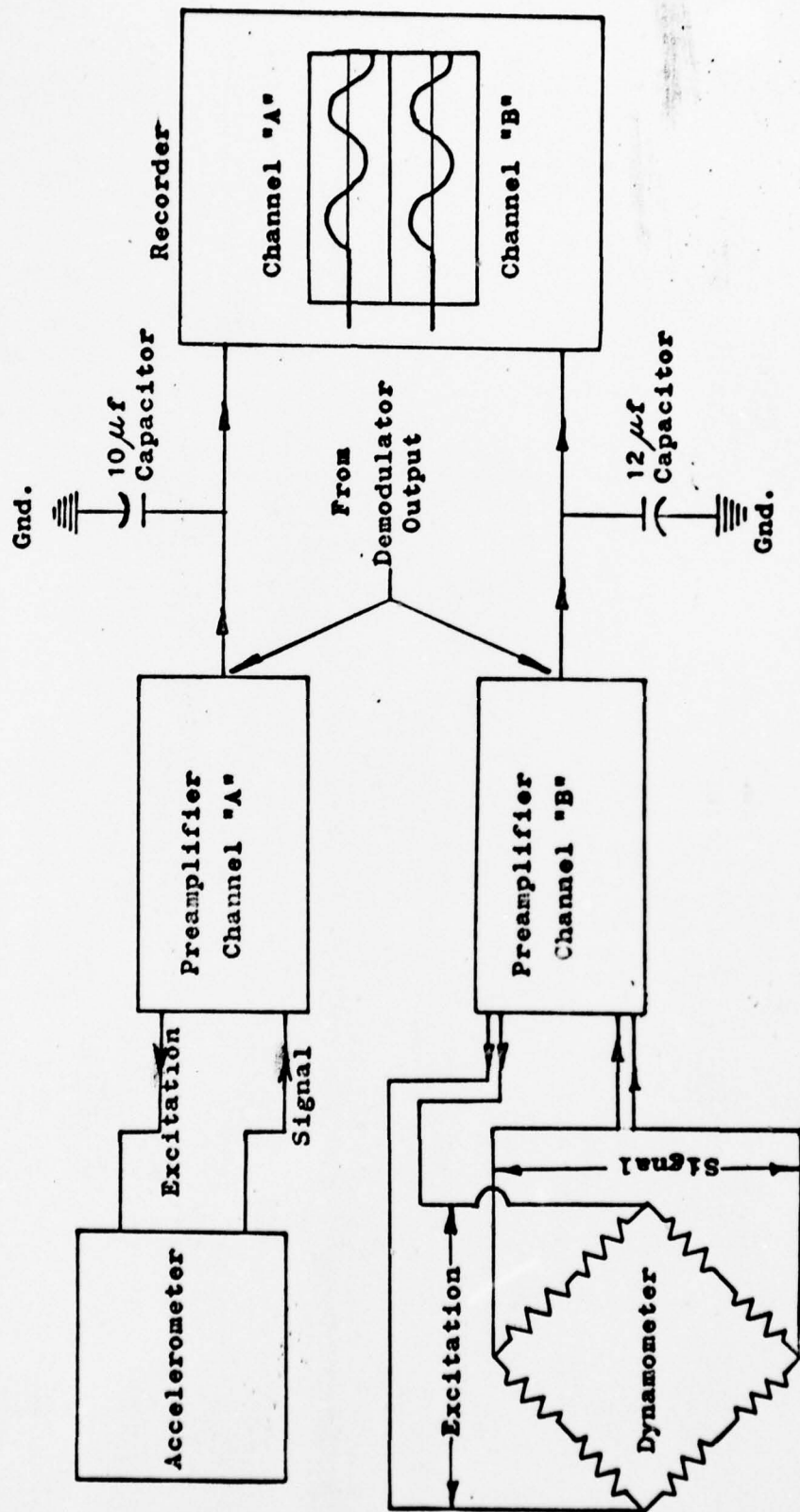
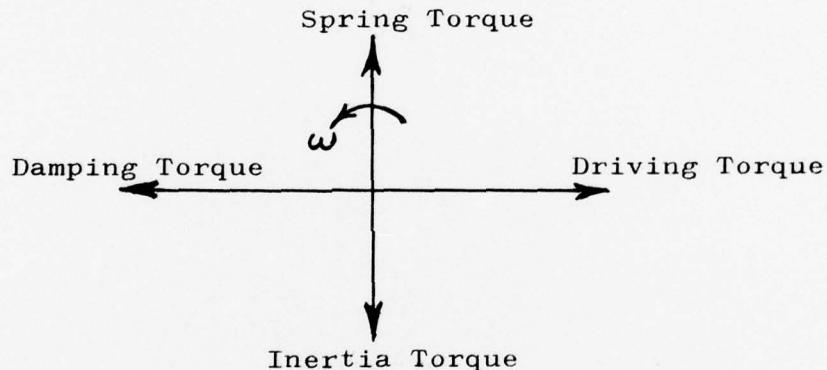


FIGURE 5
SCHEMATIC DIAGRAM OF INSTRUMENTATION

B. Hydrodynamic Mass Moment of Inertia

The hydrodynamic mass moment of inertia for the bodies moving in rotation was determined by the natural frequency method. In this method the test body is mounted as the mass in a torsional spring-mass system. A schematic diagram of the apparatus is shown in Fig. 6. If this system is driven at its natural frequency the torques acting on the test body are related as shown in the vector diagram below.



At resonance the driving torque balances the torsional damping force and the spring torque balances the so-called inertia torque. From the spring torque-inertia torque equality the hydrodynamic mass moment of inertia was calculated and from the driving torque-damping force equality the damping coefficient was calculated.

The apparatus shown in Fig. 2 was modified to allow the test body to be rotated. A photograph of the modification is shown in Fig. 7. The change from the translation configuration of Fig. 2 to the rotation configuration of Fig. 7 can be made in a few minutes.

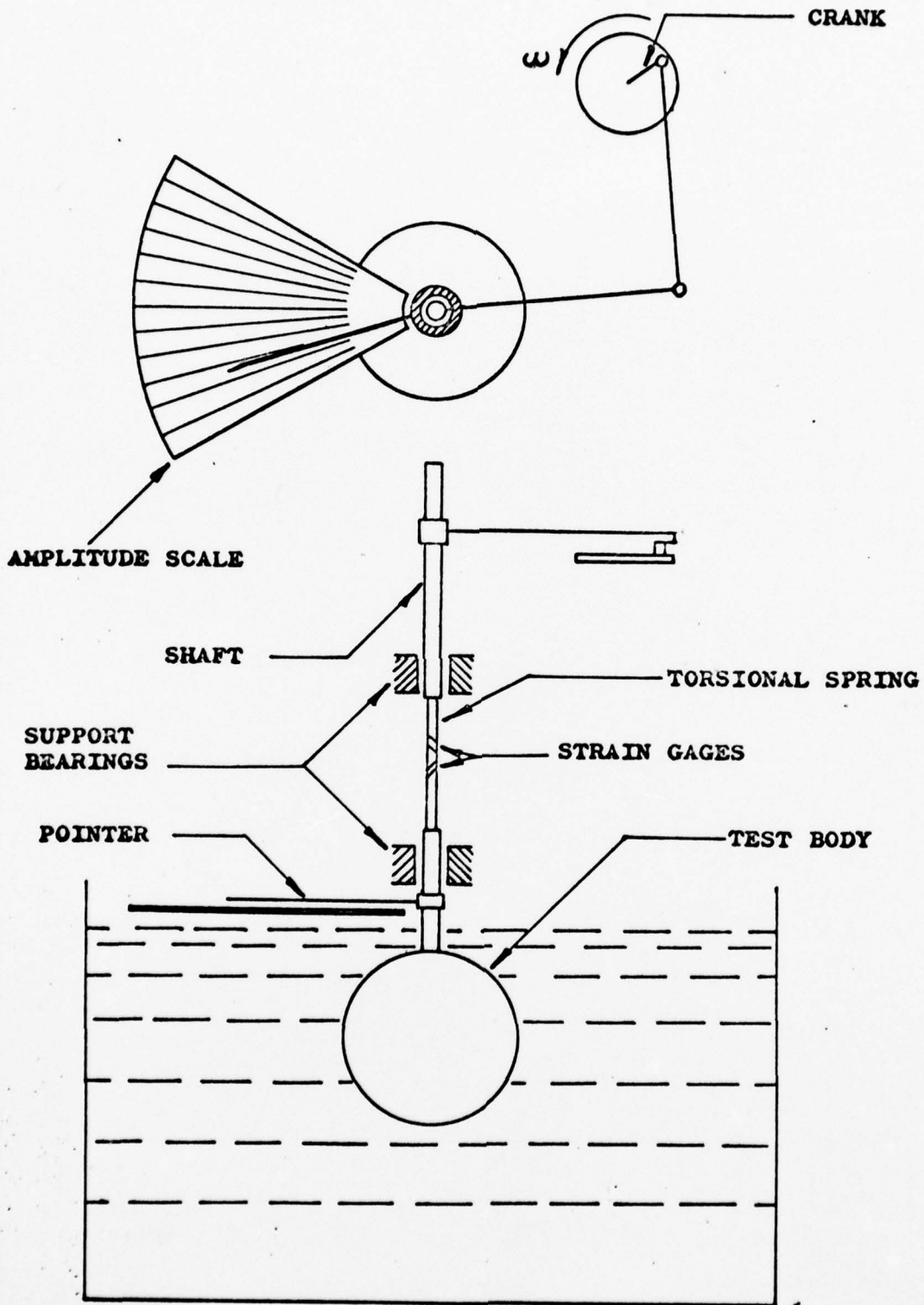


FIGURE 6
SCHEMATIC OF HYDRODYNAMIC MASS
MOMENT OF INERTIA APPARATUS

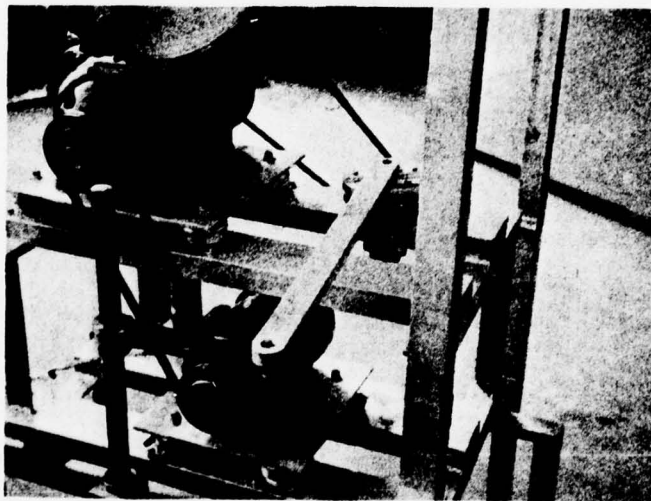
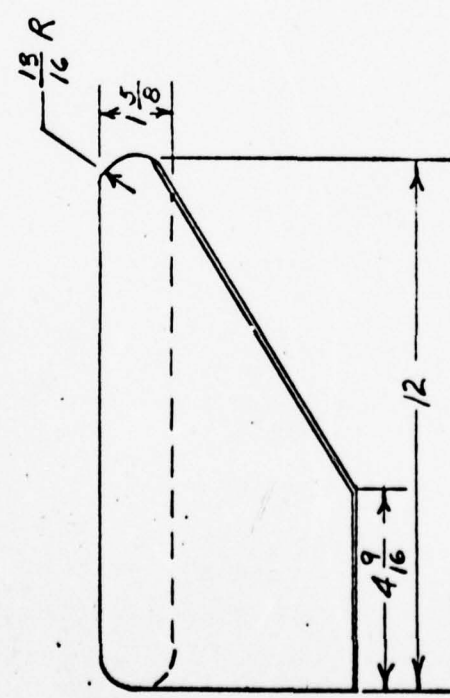
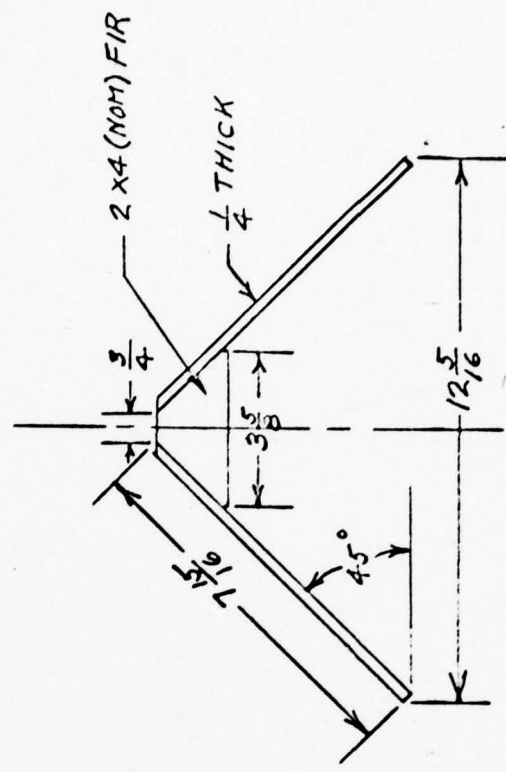
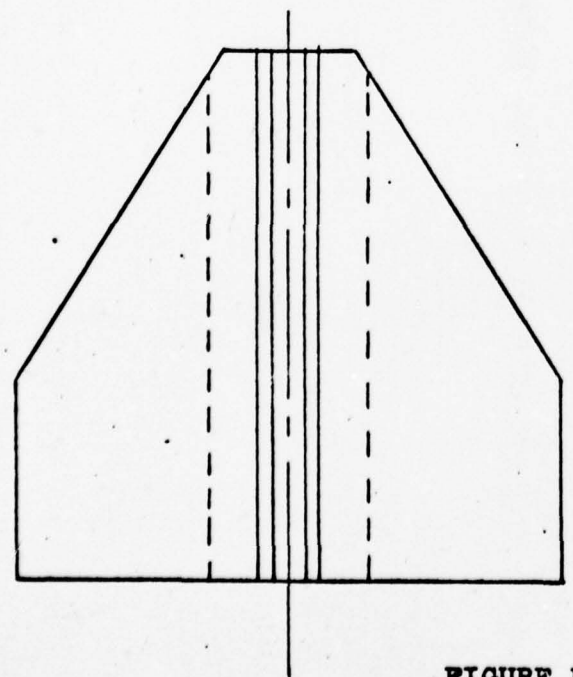


FIGURE 7
APPARATUS USED IN HYDRODYNAMIC MASS
MOMENT OF INERTIA EXPERIMENTS

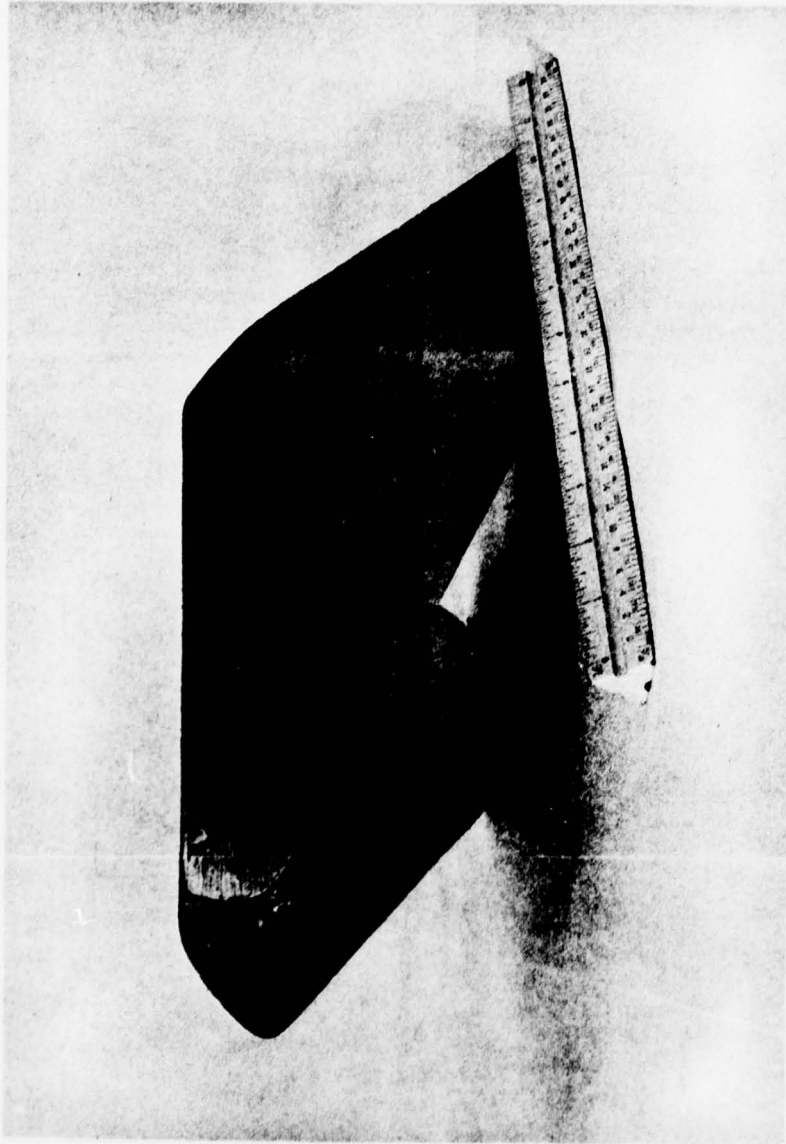
C. Test Bodies

Four test bodies were used. All were constructed of soft pine wood. Drawings and photographs of the three "towed body" shapes are shown in Figs. 8 through 13. The fourth body was a prolate spheroid with a major axis to minor axis ratio of two. These same bodies were used in the work reported in references (1) and (7).



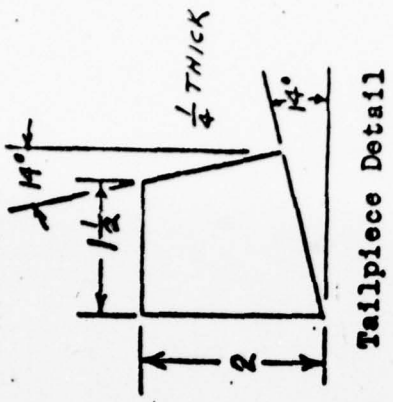
WINGED BODY

FIGURE No. 8

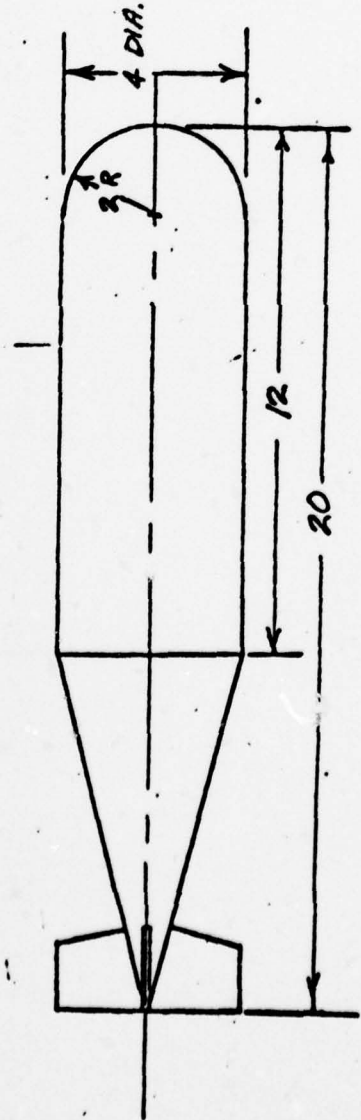
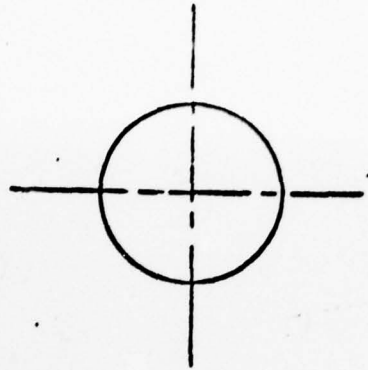
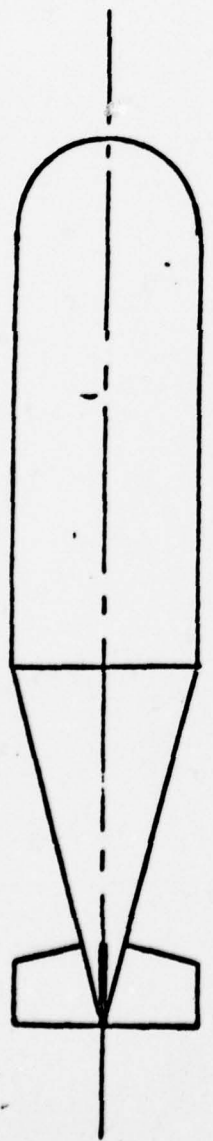


WINGED BODY

FIGURE 9

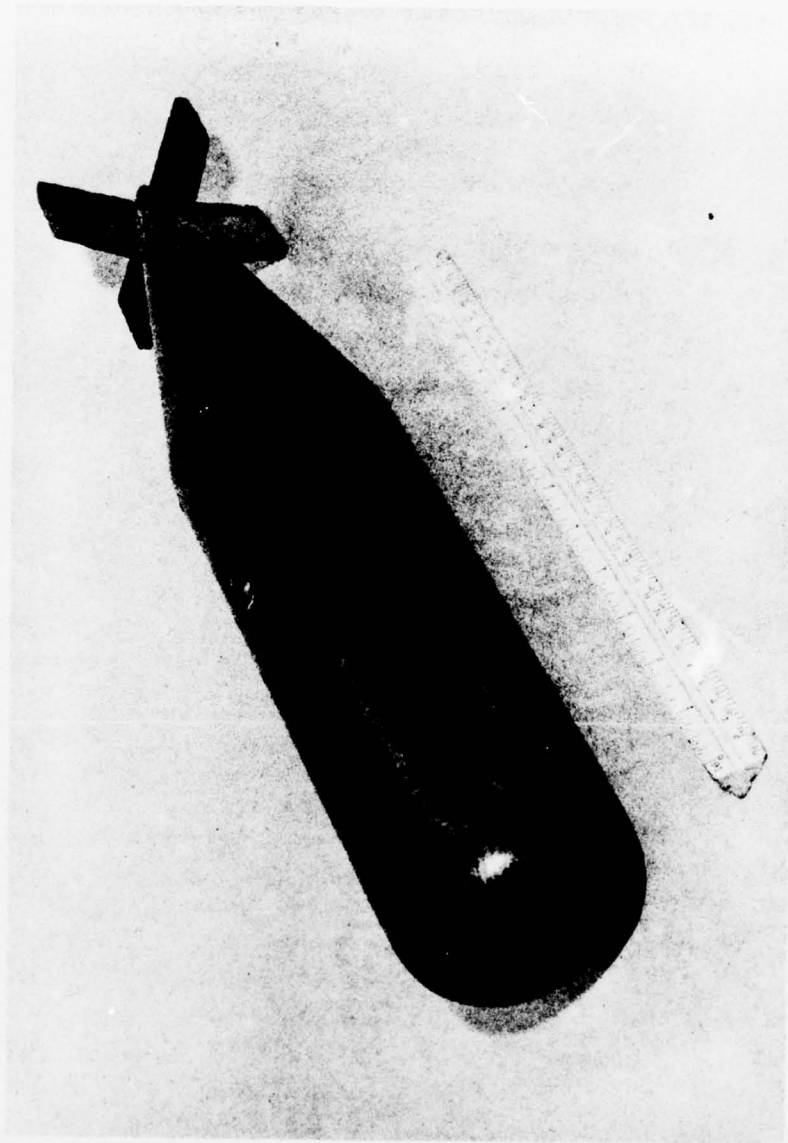


Tailpiece Detail



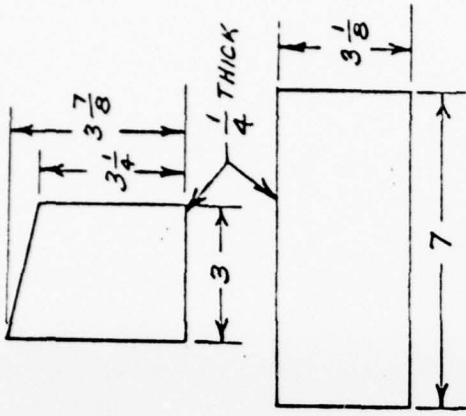
TORPEDO BODY

FIGURE No. 10

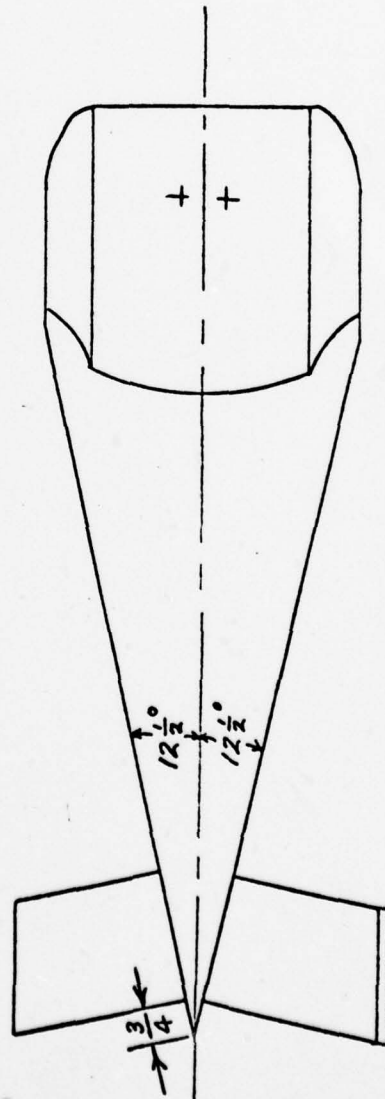
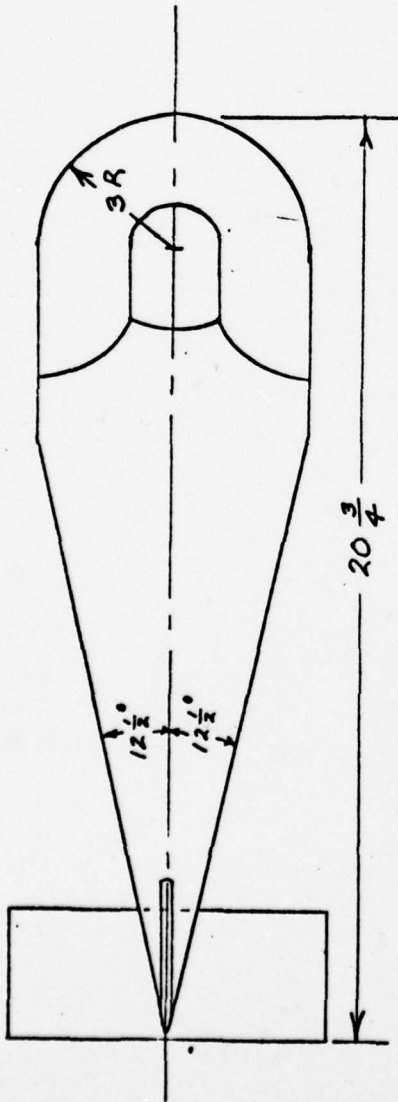
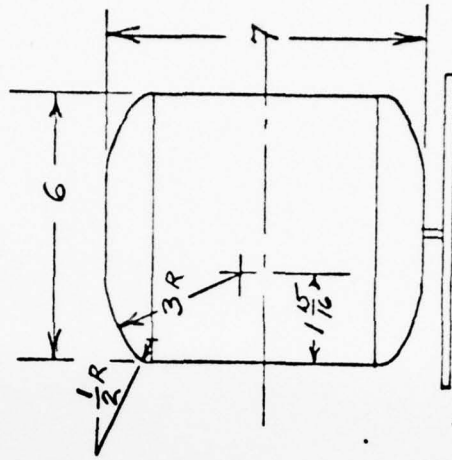


TORPEDO BODY

FIGURE 11

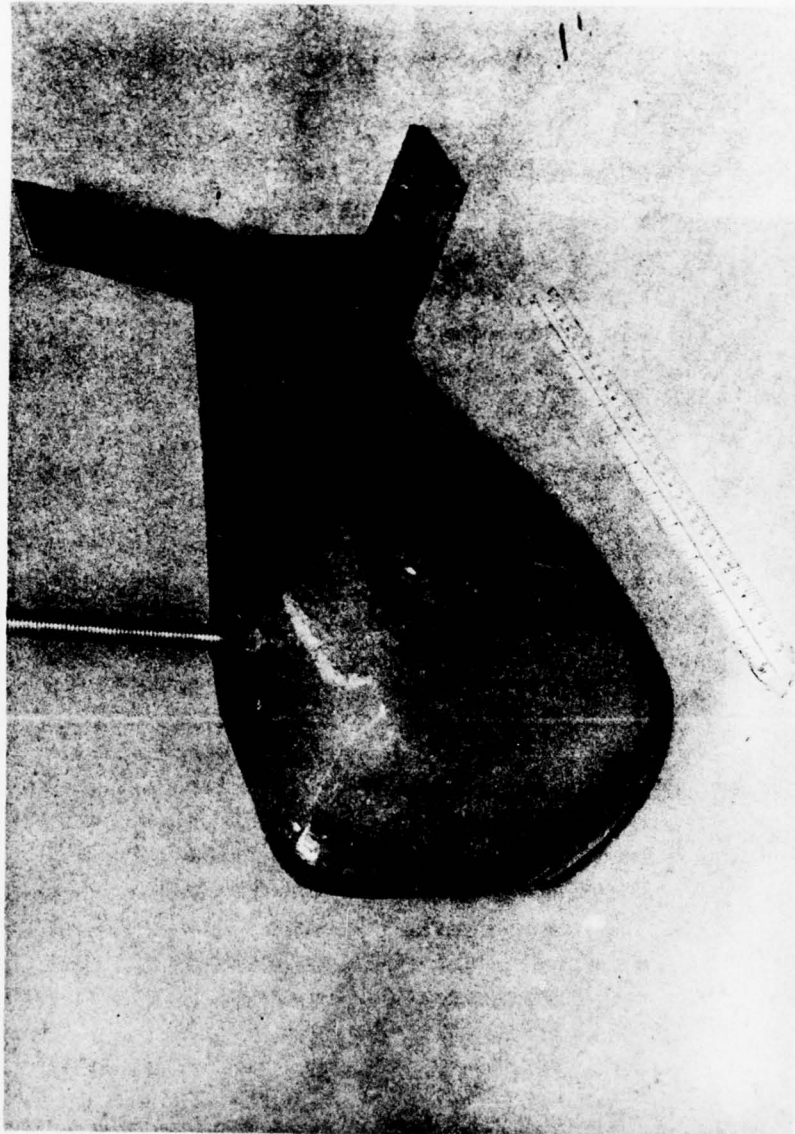


Tail Piece Details



STREAMLINED BODY

FIGURE No. 12



STREAMLINED BODY

FIGURE 13

III

TEST RESULTS

The test results are presented in the form of dimensionless plots.

A. Hydrodynamic Mass Data

If the hydrodynamic mass is considered to be a function of the frequency and amplitude of oscillation of the body, a characteristic dimension of the body, and the density and viscosity of the fluid in which the body is oscillating, a dimensional analysis yields the following dimensionless groups:

$$K = \frac{m_h}{\rho l^3}, \frac{\omega l^2 \rho}{\mu}, \frac{1}{A}$$

This first of these groups is denoted by K and is called the hydrodynamic mass factor. The second group is a form of Reynolds' number, and the third group is a length-amplitude ratio. The results are given as plots of K vs. $\omega l^2 \rho / \mu$ with a curve for each value of $1/A$. For the three bodies used the hydrodynamic mass factor K was defined as shown in Fig. 14.

The results for the towed body shapes translating in a direction perpendicular to the direction of towing are shown in Figs 15, 16, and 17. (For a body being towed horizontally this would be in the vertical direction.) A very definite dependence on frequency and amplitude is shown. For a given body oscillating at a given length-amplitude ratio the hydrodynamic mass decreases almost linearly as the frequency increases. Tests run at constant frequency showed that as the amplitude was increased the hydrodynamic mass decreased, reached a minimum, and then increased. The amplitude at which the minimum occurred appears to be a function of the body streamlining in the direction of motion. For a body that is relatively flat in the direction of motion the minimum occurs at a much smaller amplitude than for a body that is streamlined in the direction

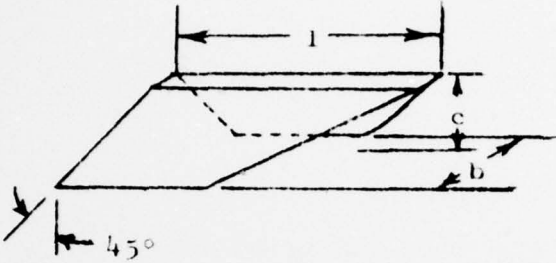
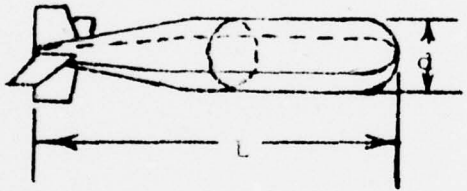
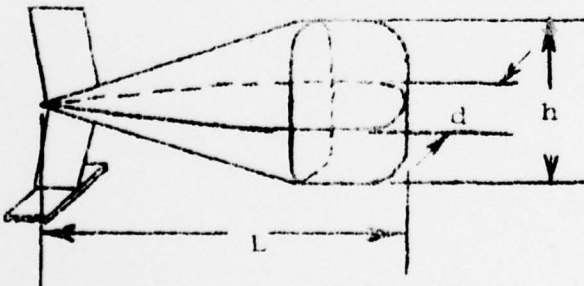
Body Shape	Hydrodynamic Mass
 <p data-bbox="316 682 738 766">For the body tested $l/b = 1.0$, $l/c = 2.0$</p>	$m_h = K \rho l^3$
 <p data-bbox="316 1144 893 1312">For the body tested $L/d = 5.0$ Area of Horizontal Tail = 10% of Body Maximum Horizontal Cross- Sectional Area</p>	$m_h = K \frac{\pi}{4} \rho d^2 L$
 <p data-bbox="332 1711 868 1869">For the body tested $L/h = 2.96$, $L/d = 3.46$ Area of Horizontal Tail = 20% of Body Maximum Horizontal Cross sectional Area</p>	$m_h = K \frac{4}{3} \pi \rho \left(\frac{L}{2}\right) h^2$ <p data-bbox="1039 1522 1307 1575">where $b = \frac{d + h}{4}$</p>

FIGURE 14
 Definition of Hydrodynamic Mass Factor

K&E 20 X 20 TO THE INCH 46 1240
7 X 10 INCHES
MADE IN U.S.A.
NEUFFEL & ESSER CO.

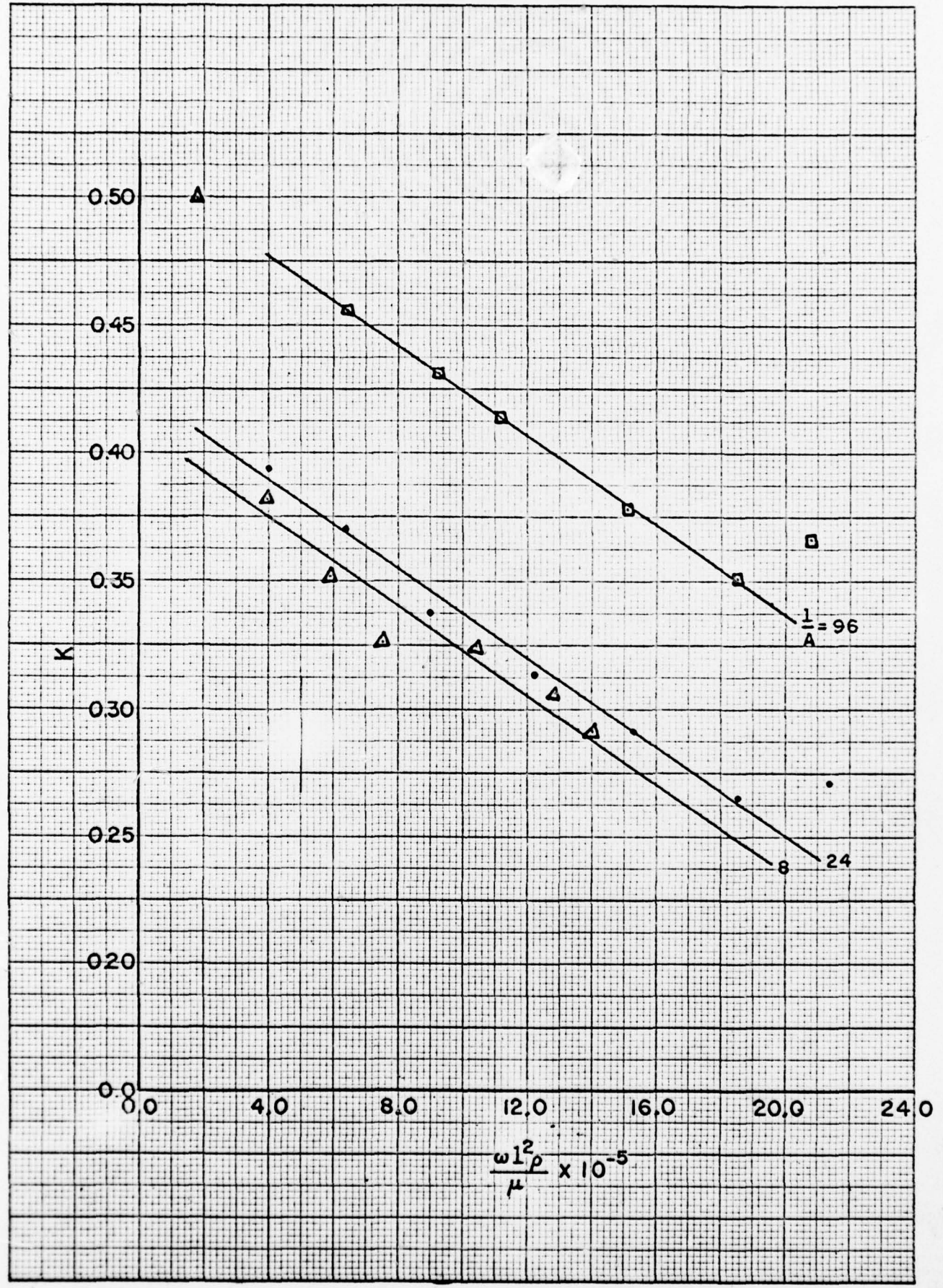


FIGURE 15
Hydrodynamic Mass Factor for the Winged Body

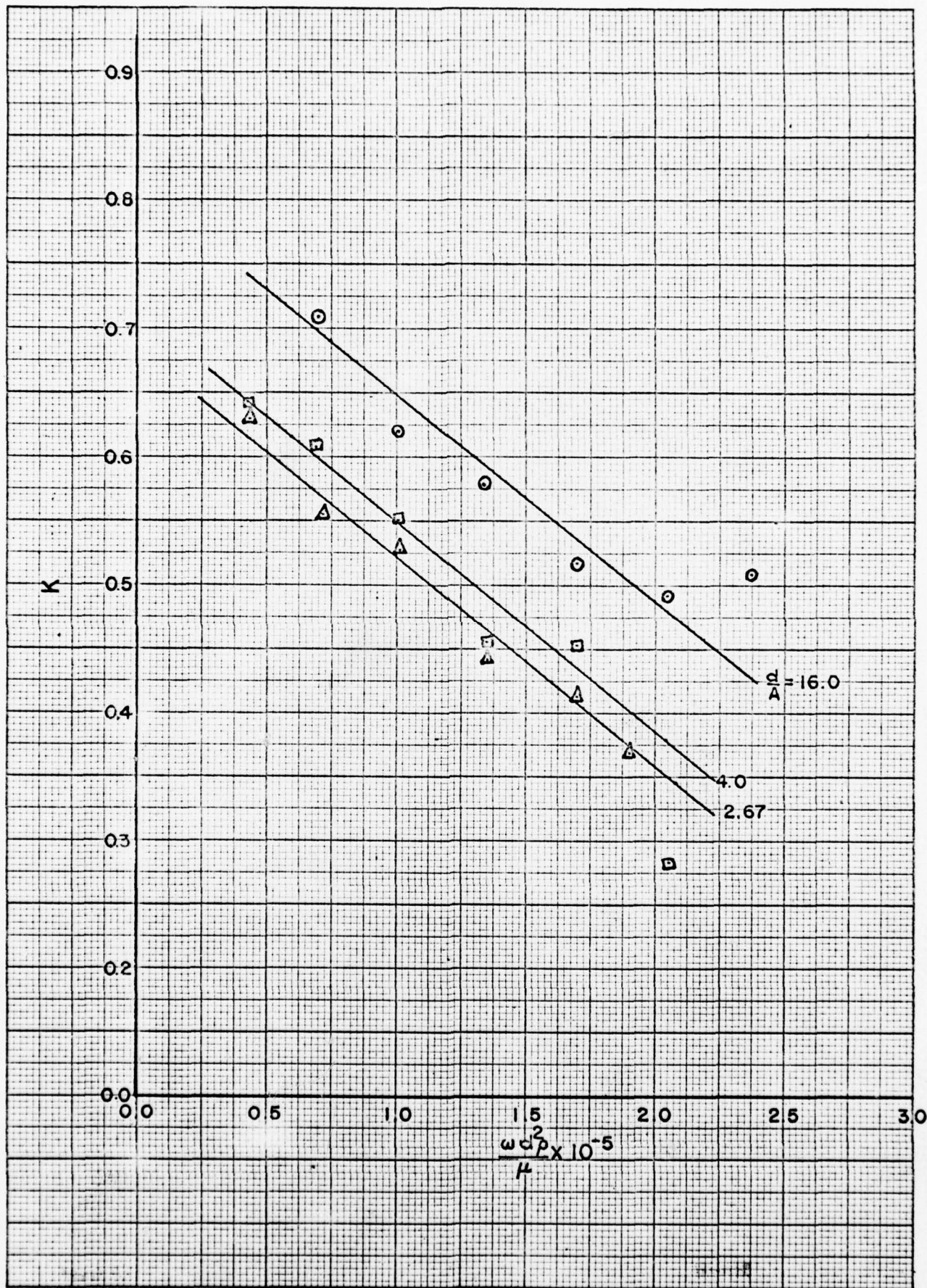


FIGURE 16
Hydrodynamic Mass Factor for the Torpedo Body

KE 20 X 20 TO THE INCH 46 1240
 7 X 10 INCHES MADE IN U.S.A.
 KEUFFEL & ESSER CO.

K_Σ 20 X 20 TO THE INCH 46 1240
 7 X 10 INCHES MADE IN U.S.A.
 REUFFEL & ESSER CO.

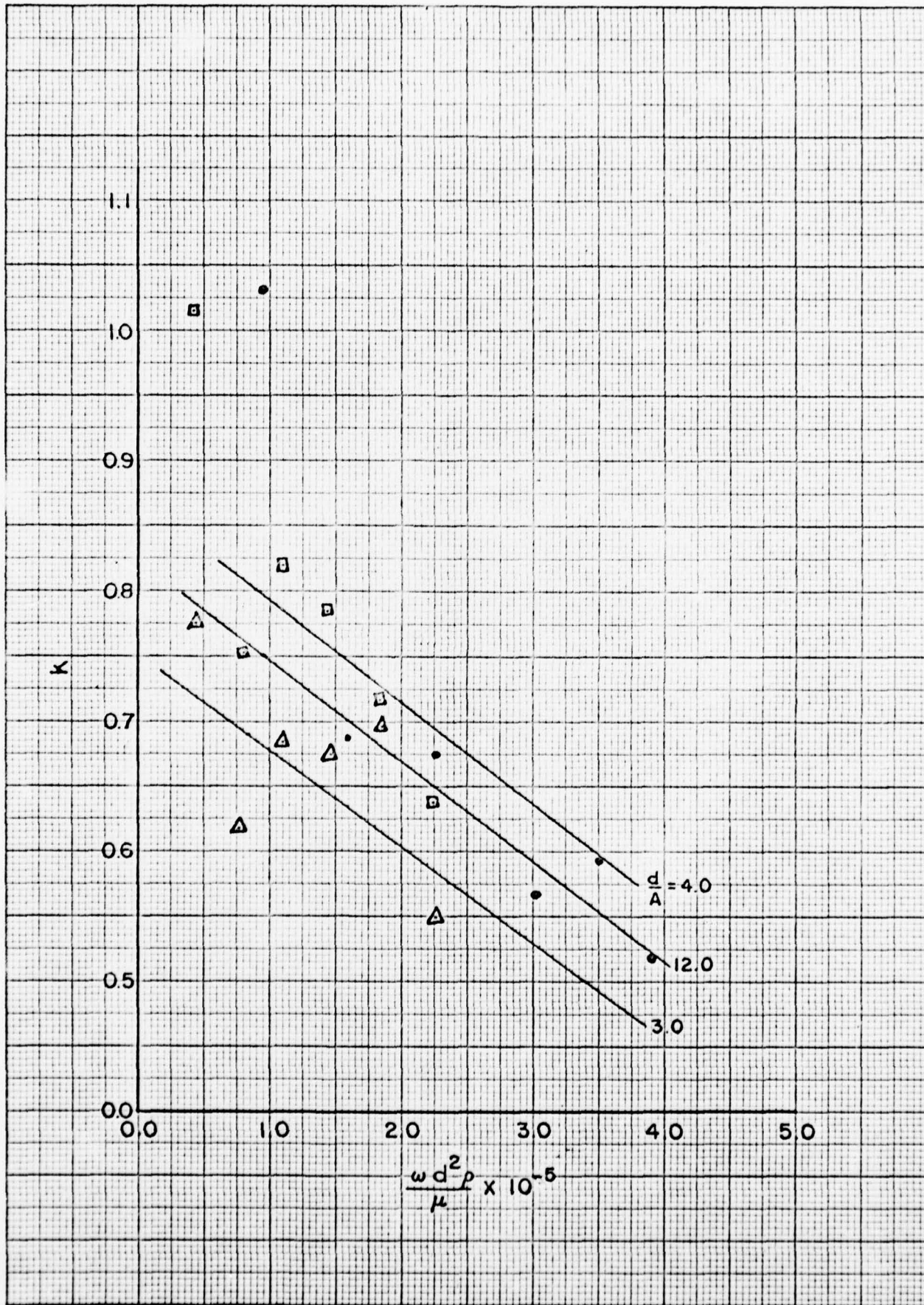


FIGURE 17
 Hydrodynamic Mass Factor for the Streamlined Body

of motion. Further study with disks and spheres is being carried on in order to clarify the appearance of this minimum point.

For motion of the towed bodies in the direction of towing the hydrodynamic masses were small and the data was quite scattered; hence only average values are given. These are given in Table 1. To more accurately determine values

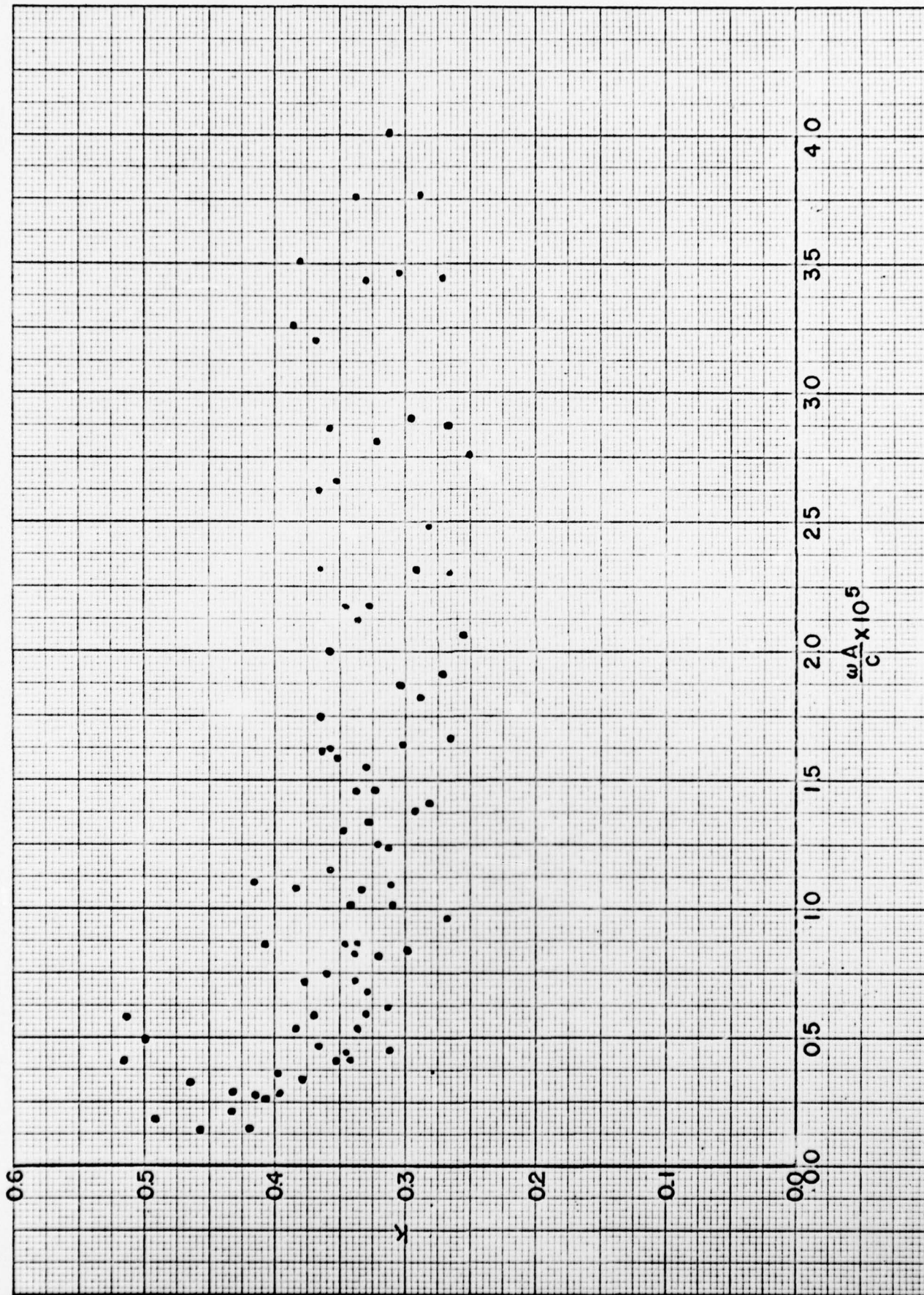
TABLE 1

<u>Body</u>	<u>Average K</u>
Winged Body	0.0037
Torpedo Shape	0.036
Streamlined Body	0.20

of K in the direction of towing a more sensitive force dynamometer would be needed, and a more accurate way of determining the phase angle ϕ would have to be found.

The values of K for each body were also plotted against the dimensionless group $\omega A/c$, in which c is the speed of sound in the fluid. All of the data points, when plotted in this way, fell in a relatively narrow band. These plots are shown in Figs. 18, 19, and 20.

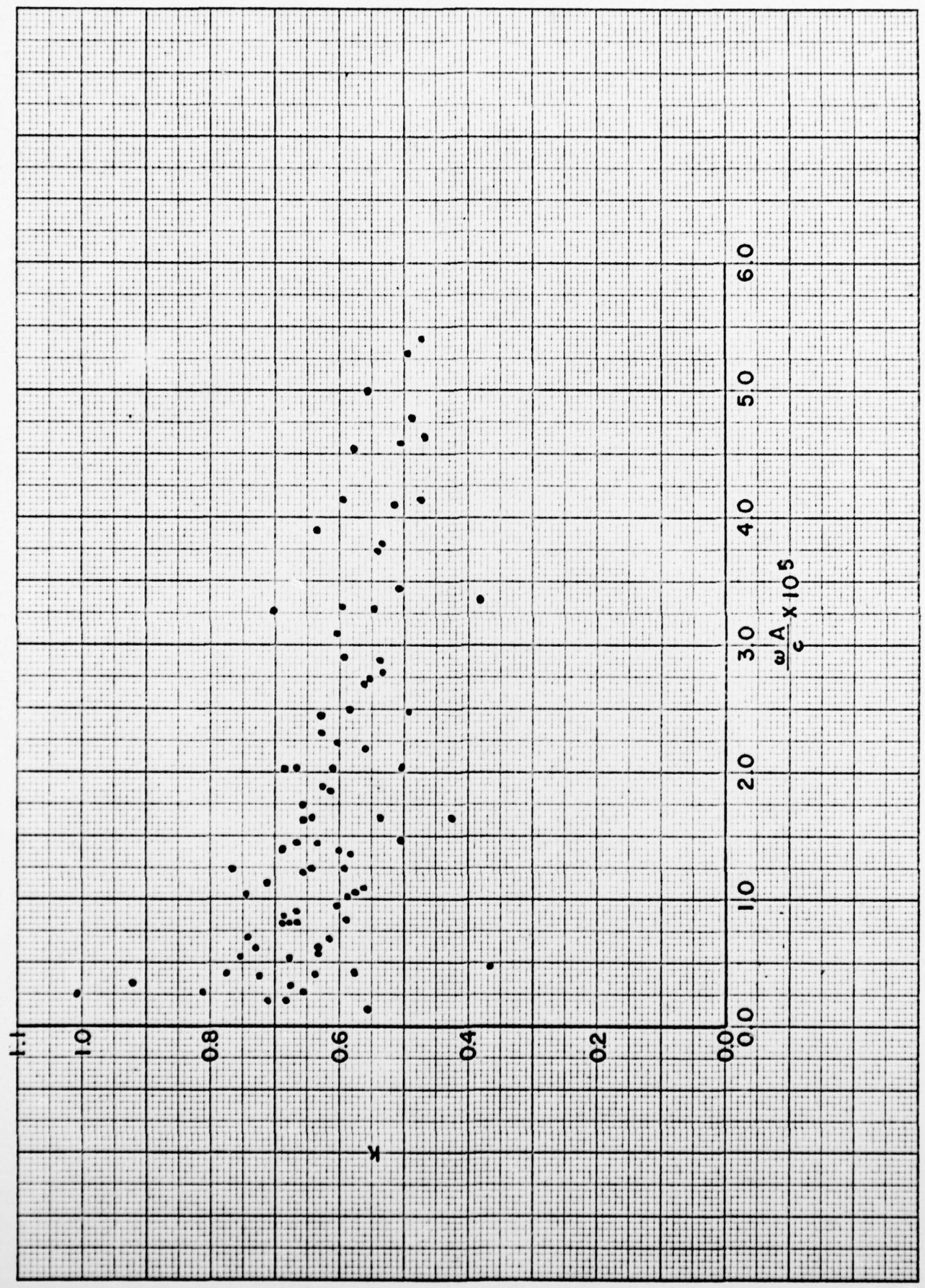
K^oE 20 X 20 TO THE INCH 46 1240
7 X 10 INCHES MADE IN U.S.A.
KEUFFEL & ESSER CO.



Hydrodynamic Mass Factor for the Winged Body

FIGURE 18

K&E 20x20 TO THE INCH 46 1240
7 x 10 INCHES
KEUFFEL & ESSER CO.



Hydrodynamic Mass Factor for the Torpedo Body

FIGURE 19

20 X 20 TO THE INCH 46 12410
7 X 10 INCHES
KEUFFEL & ESSER CO.

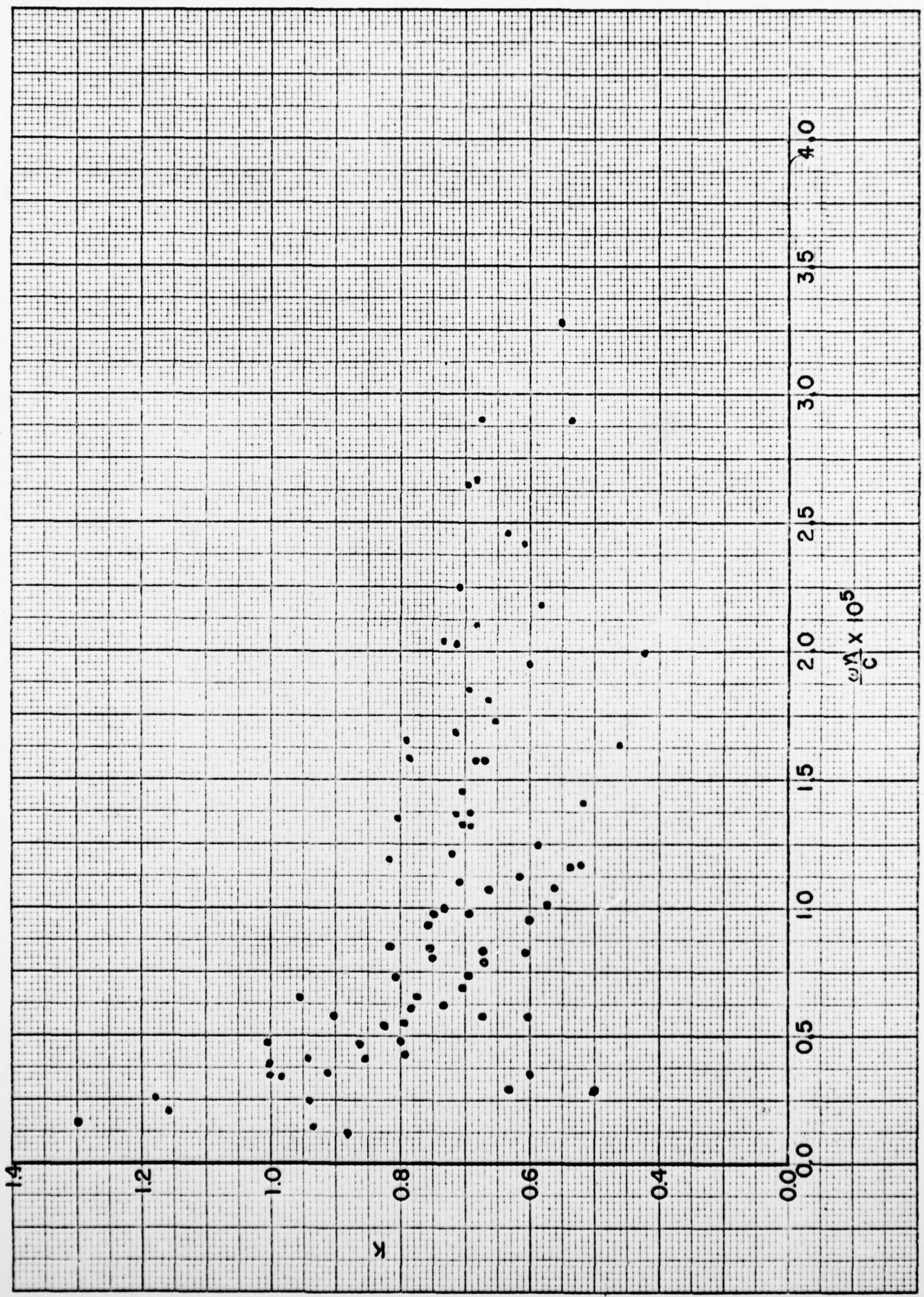


FIGURE 20

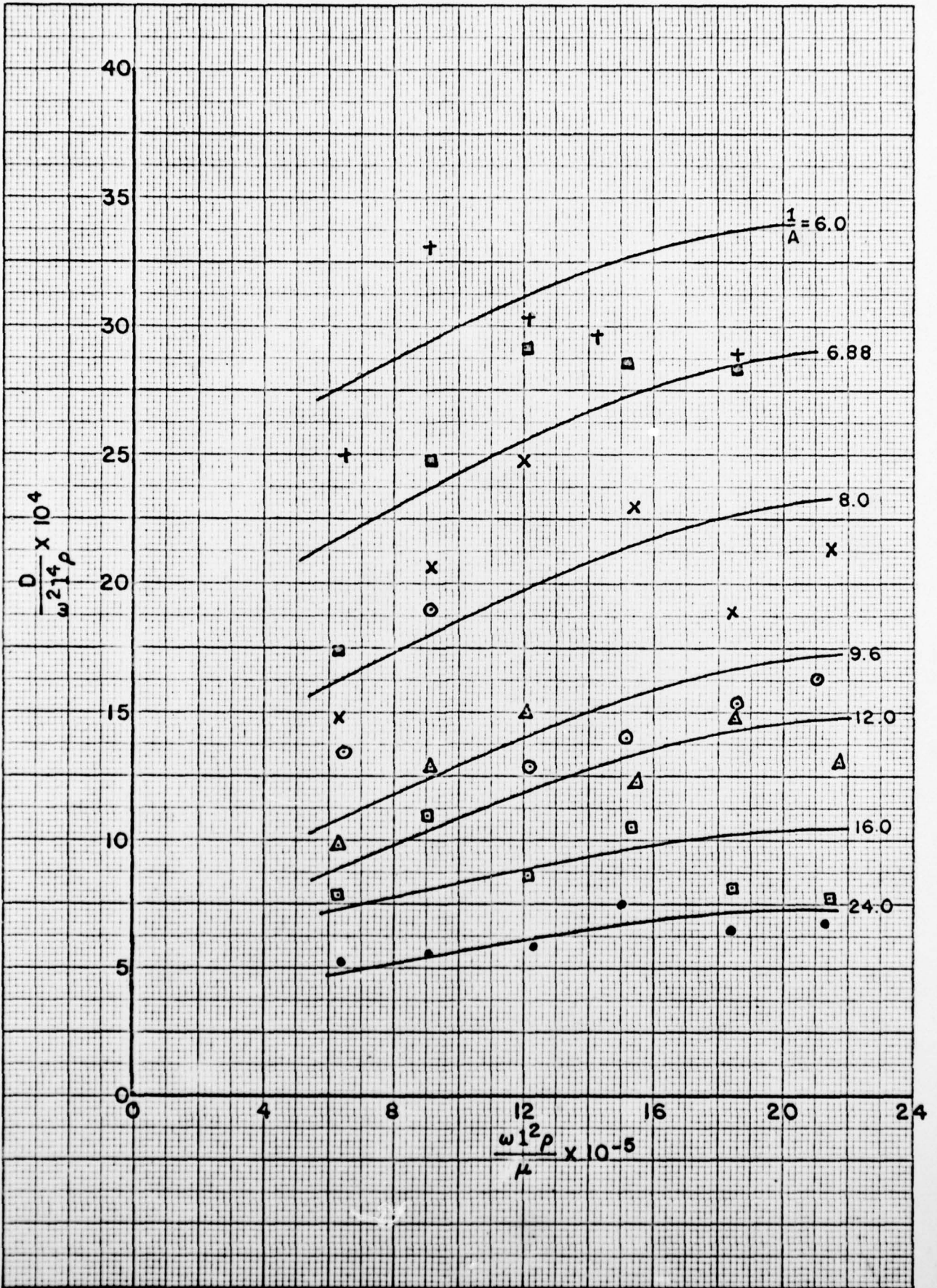
Hydrodynamic Mass Factor for the Streamlined Body

B. Damping Force Data

If the damping force is considered to be a function of the same variables as was the hydrodynamic mass in the previous section, a dimensional analysis yields the following dimensionless groups:

$$\frac{D}{\omega^2 l^2 \rho}, \quad \frac{\omega l^2 \rho}{\mu}, \quad \frac{1}{A}$$

The results are as plots of $D/\omega^2 l^2 \rho$ vs. $\omega l^2 \rho / \mu$ with a curve for each value of $1/A$. For the torpedo body the diameter was used as the characteristic length and for the streamlined body the width was used. (See Fig. 14.) The results for the various bodies are shown in Figures 21 through 28. The data showed considerable scatter at small values of $1/A$ and very little scatter at large values of $1/A$. The curves for small values of $1/A$ were drawn using those at large values of $1/A$ as guides.



KE 20 X 20 TO THE INCH 46 1240
 7 X 10 INCHES
 KEUFFEL & ESSER CO.

FIGURE 21
 Damping for Winged Body in the Direction of Towing

KE 20 X 20 TO THE INCH 46 1240
7 X 10 INCHES
MADE IN U.S.A.
KEUFFEL & ESSER CO.

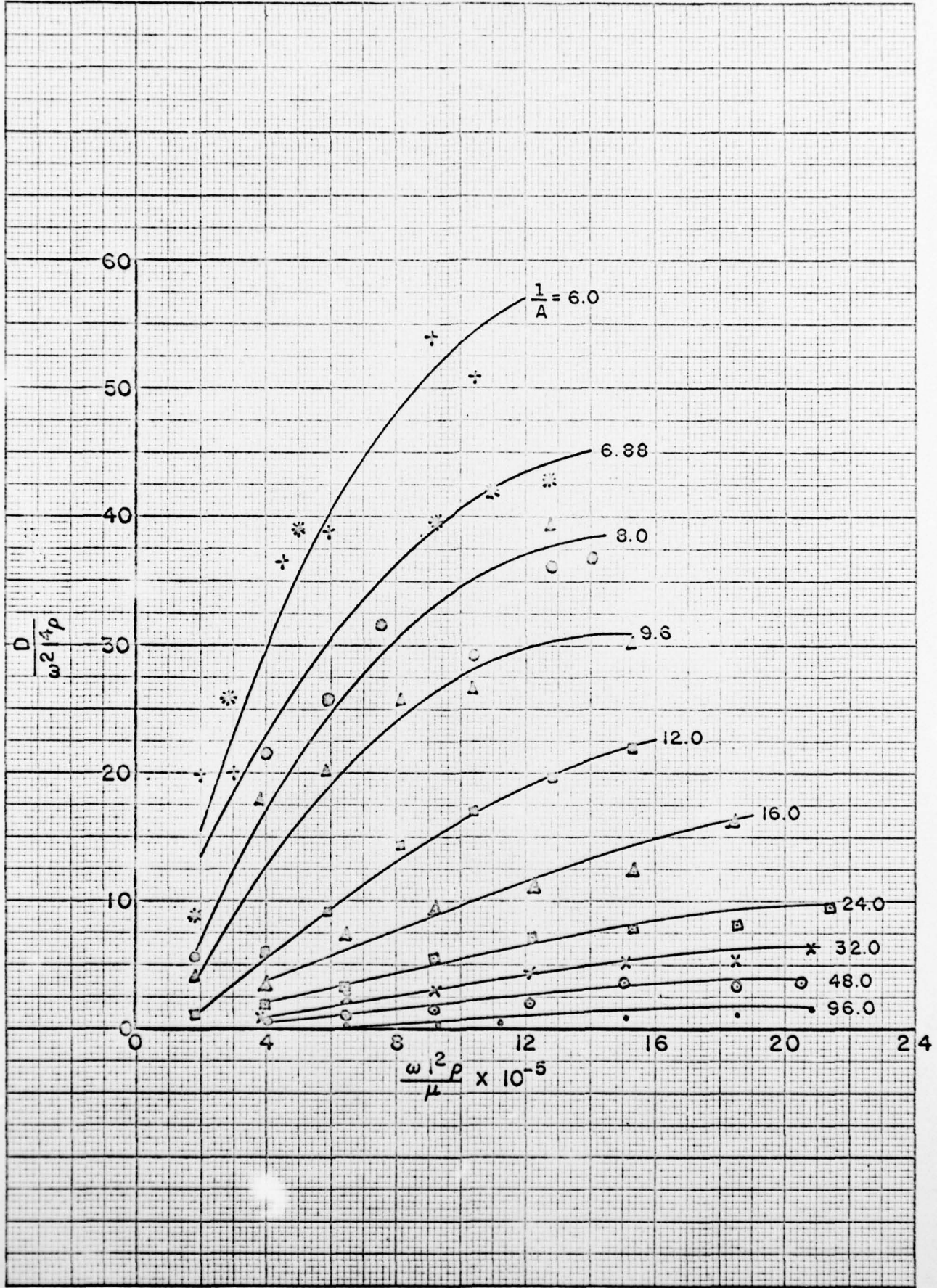


FIGURE 22
Damping for Winged Body Perpendicular to Direction of Towing

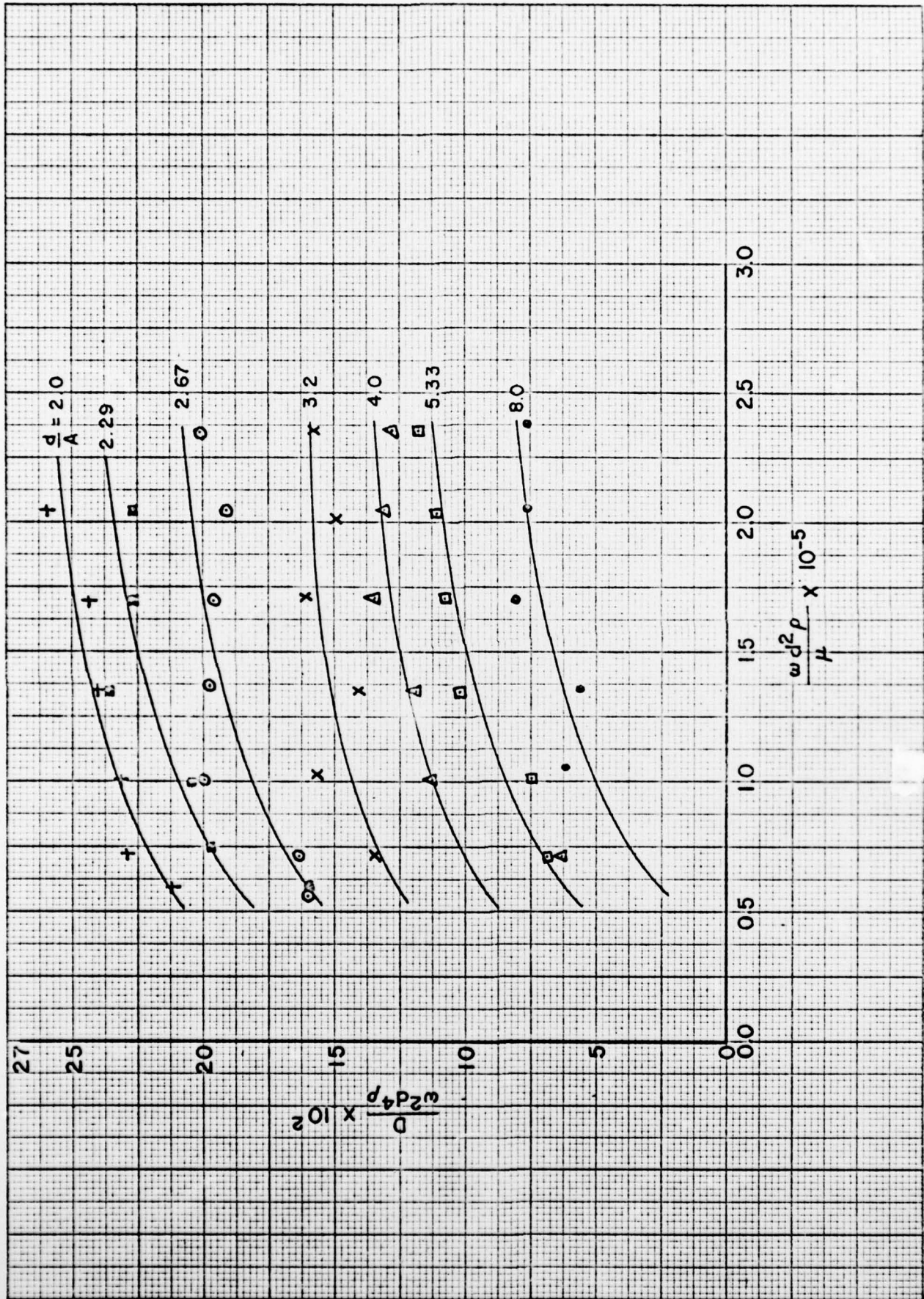


FIGURE 23

Damping for Torpedo in the Direction of Towing

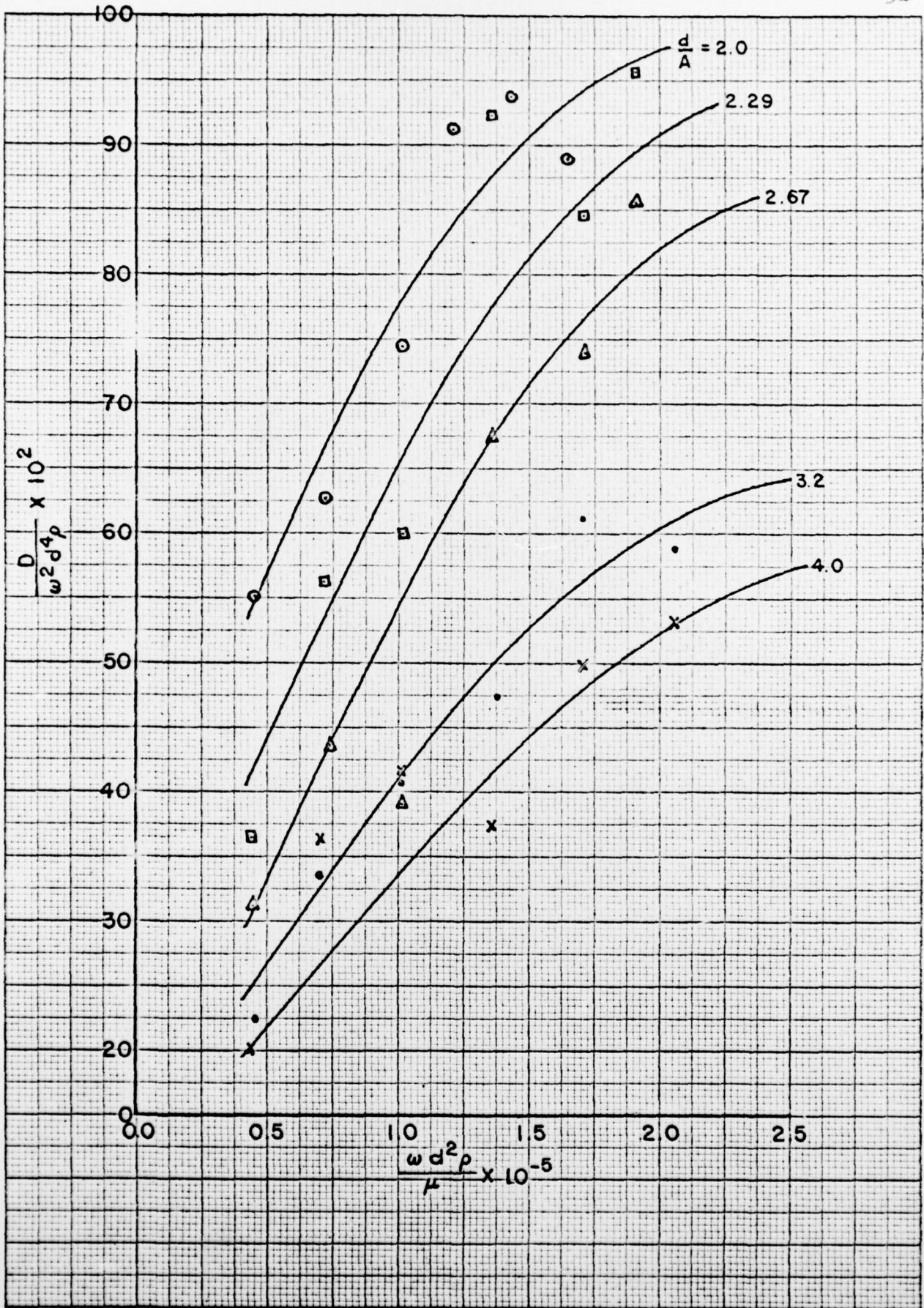
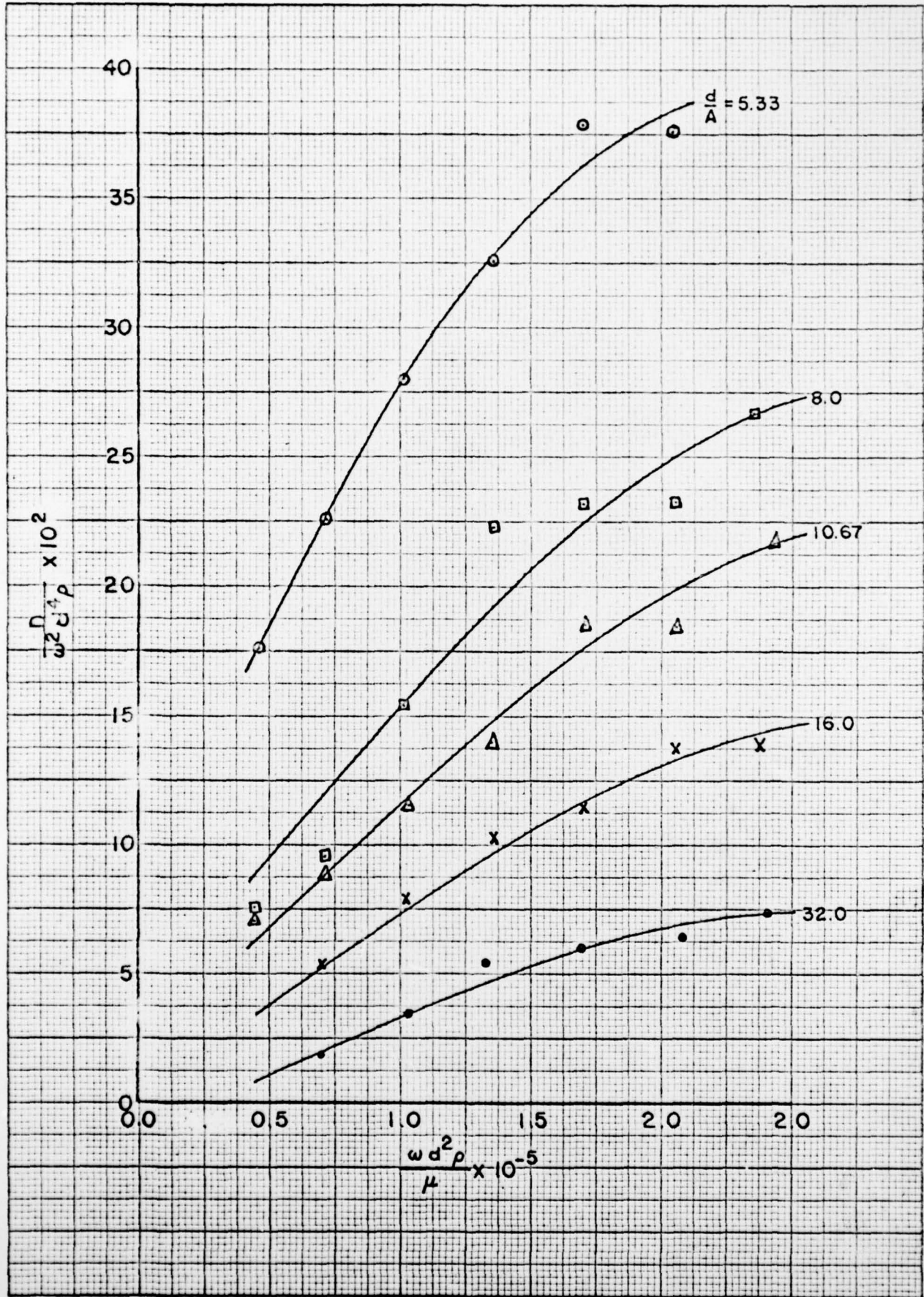


FIGURE 24 Damping for Torpedo Perpendicular to Direction of Towing

20 X 20 TO THE INCH 46 1240
 7 X 10 INCHES MADE IN U.S.A.
 KRUPP & ESSER CO.



K-2 20 X 20 TO THE INCH 46 1240
 7 X 10 INCHES MADE IN U.S.A.
 KEUFFEL & ESSER CO.

FIGURE 25 Damping for Torpedo Perpendicular to the Direction of Towing

K&E 20 X 20 TO THE INCH 45 1240
 7 X 10 INCHES
 KEUFFEL & ESSER CO.

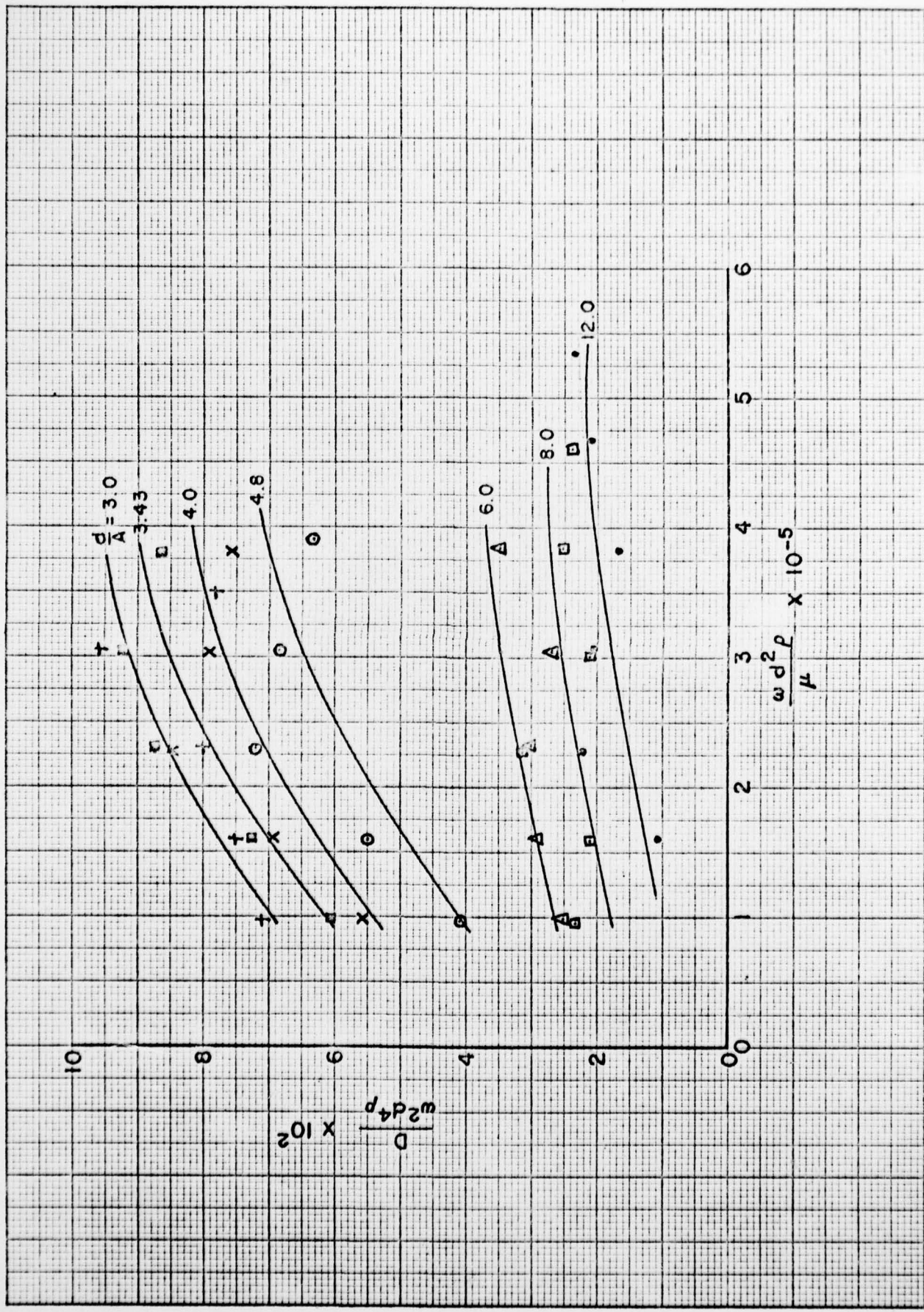


FIGURE 26

Damping for Streamlined Body in Direction of Towing

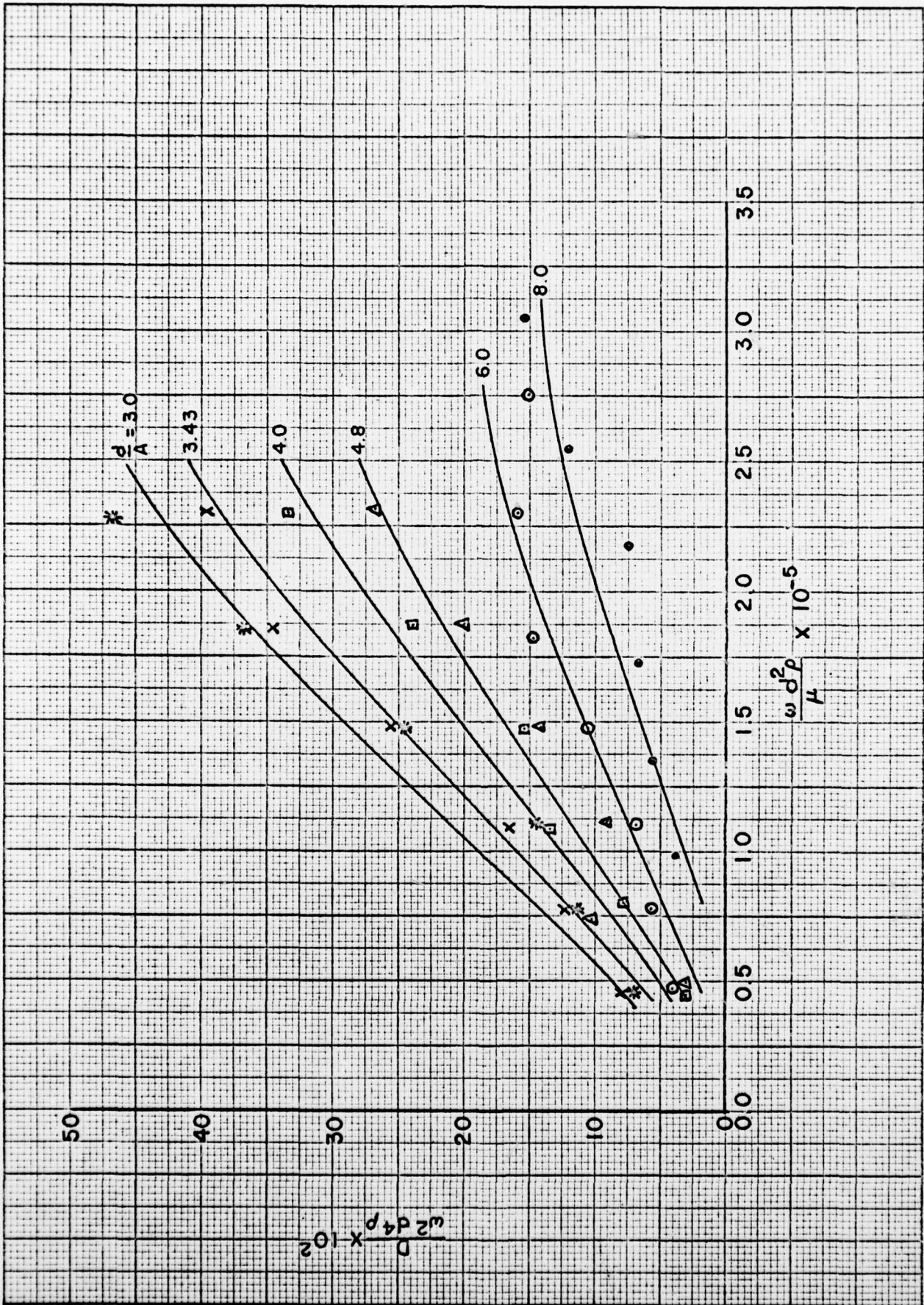


FIGURE 27

Damping for Streamlined Body Perpendicular to Direction of Towing

K&E 20 X 20 TO THE INCH 46 1240
 7 X 10 INCHES MADE IN U.S.A.
 KEUFFEL & ESSER CO.

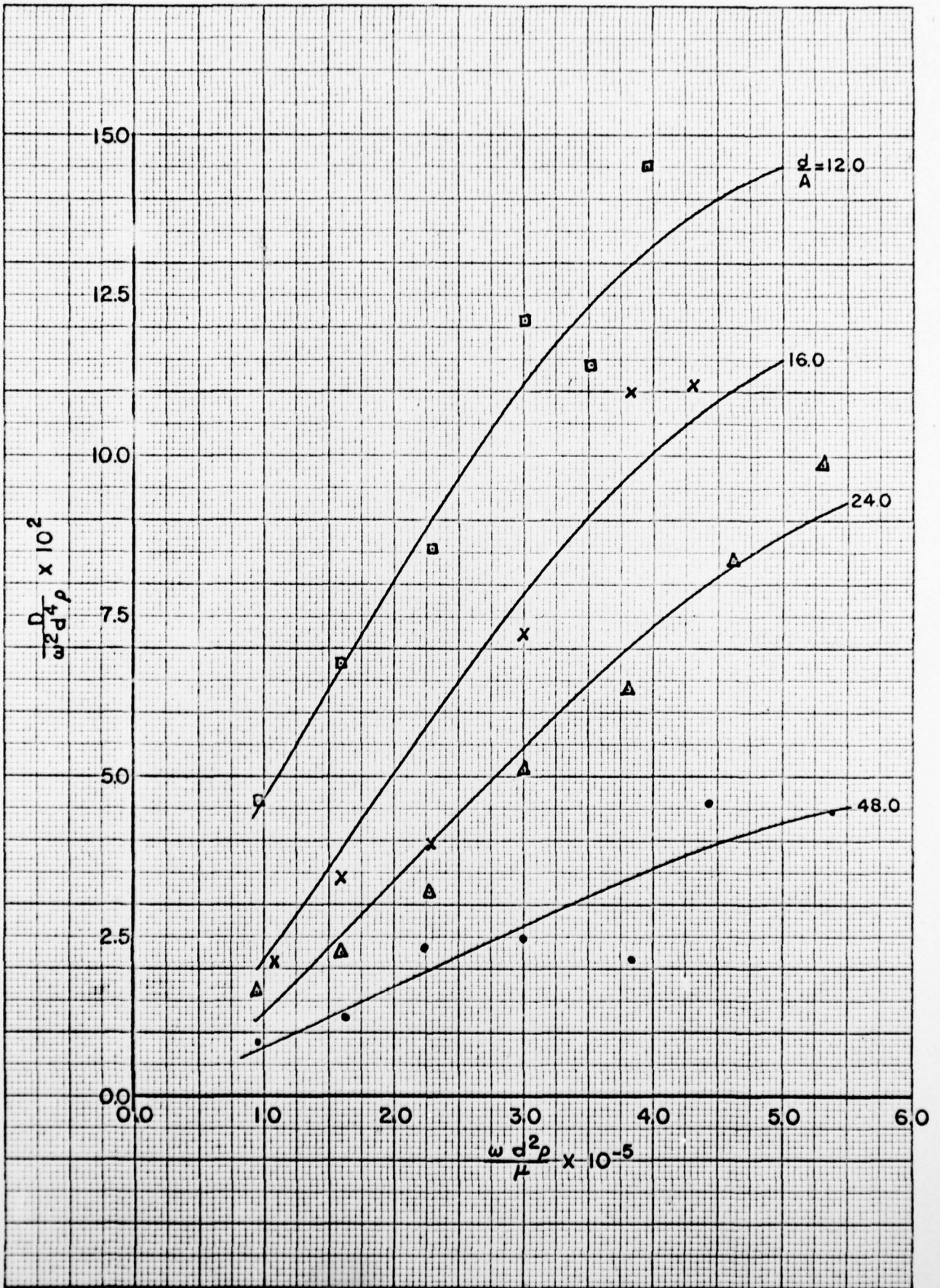


FIGURE 28

Damping for Streamlined Body Perpendicular to Direction of Towing

C. Hydrodynamic Mass Moment of Inertia Data

Hydrodynamic mass moment of inertia data were obtained for only one body, a prolate spheroid with a major axis of 24 inches and a minor axis of 12 inches. Only one torsional spring was available so values are given for only one frequency of oscillation. Further tests on the prolate spheroid are being performed using the forced oscillation method. These tests will determine the frequency-amplitude dependence of the hydrodynamic mass moment of inertia. Similar tests will also be performed on the towed body shapes. Tests will also be run on spheres and disks to determine damping coefficients. The data are given in Table 2.

TABLE 2

Natural frequency	23.9 rad/sec
Angular displacement	17.8 degrees
Hydrodynamic mass moment of inertia	1.22 in.-lb.-sec ²
Torsional damping coefficient	7.18 in.-lb. sec/rad

IV

TEST ACCURACY

A detailed error analysis of the hydrodynamic mass data is given in the work by Miller (2). The largest source of error was in the measurement of the magnitude of the force and the phase angle from the recorder paper. The data were obtained over a frequency range of 0 to 20 radians per second. At low frequencies the error in the hydrodynamic mass is ± 17 per cent; at medium speeds, ± 5 percent; and at high speeds, ± 11 percent. A more sensitive force dynamometer and a more satisfactory means of measuring phase angle would allow these errors to be reduced.

REFERENCES

1. "An Experimental Determination of the Hydrodynamic Mass of Various Bodies," Final report on USNSL Contract N70024-1024, March 1965.
2. Miller, R.R., The Effects of Frequency and Amplitude of Oscillation on the Hydrodynamic Mass of Irregular Shaped Bodies, M.S. Thesis, University of Rhode Island, 1965.
3. Timoshenko, S., Vibration Problems in Engineering, D. Van Nostrand Co. Inc., Princeton, N.J., 1937.
4. Kinsler, L.E. and Frey, A.R., Fundamentals of Acoustics, 2nd ed., John Wiley & Sons Inc., New York, 1962.
5. Cook, N.H. and Rabinowicz, E., Physical Measurement and Analysis, Addison-Wesley Publishing Co. Inc., Reading, Mass., 1963.
6. Church, A.H., Guillet's Kinematics of Machines, John Wiley & Sons, Inc., New York, 1950.
7. Patton, K.T., An Experimental Determination of Hydrodynamic Masses and Mechanical Impedances, M.S. Thesis, University of Rhode Island, 1965.