

AD-A060 336

TELEDYNE RYAN AERONAUTICAL SAN DIEGO CA  
RPV ELECTRIC POWER SYSTEM STUDY PHASE I. TECHNOLOGY ASSESSMENT.(U)  
JUN 78 F L MILLER  
TRA-29318-06

F/G 1/3

F33615-76-C-2069

UNCLASSIFIED

AFAPL-TR-78-38

NL

1 OF 3  
AD  
A060336



18 AFAPL TR-78-38 19

LEVEL II

2

AD A060336

6 RPV ELECTRIC POWER SYSTEM STUDY PHASE I TECHNOLOGY ASSESSMENT

10 MILLER, FREDERIC L. / miller  
Author (s)

TELEDYNE RYAN AERONAUTICAL  
SAN DIEGO, CALIFORNIA

11 JUN 78 12 276 p.

TECHNICAL REPORT AFAPL-TR-78-38  
REPORT FOR PERIOD 9 *Interim technical rept.*  
23 AUG 1976 - 31 MAR 1978

D D C  
RECEIVED  
OCT 23 1978  
D

15 F33615-76-C-2069

14 TRA-29318-06

Approved for public release; distribution unlimited.

16 3145 17 29

78 10 17 067

AIR FORCE AERO-PROPULSION LABORATORY  
AIR FORCE WRIGHT AERONAUTICAL LABORATORIES  
Air Force Systems Command  
Wright-Patterson Air Force Base, Ohio 45433

389 357

mt

NOTICE

When Government drawings, specifications, or other data are used for any purpose other than in connection with a definitely related Government procurement operation, the United States Government thereby incurs no responsibility nor any obligation whatsoever; and the fact that the government may have formulated, furnished, or in any way supplied the said drawings, specifications, or other data, is not to be regarded by implication or otherwise as in any manner licensing the holder or any other person or corporation, or conveying any rights or permission to manufacture, use, or sell any patented invention that may in any way be related thereto.

This report has been reviewed by the Information Office (OI) and is releasable to the National Technical Information Service (NTIS). At NTIS, it will be available to the general public, including foreign nations.

This technical report has been reviewed and is approved for publication.



DUANE G. FOX  
Project Engineer



PAUL R. BERTHEAUD  
Technical Area Manager

FOR THE COMMANDER



"If your address has changed, if you wish to be removed from our mailing list, or if the addressee is no longer employed by your organization please notify AFAPL/POP, W-PAFB, OH 45433 to help us maintain a current mailing list".

Copies of this report should not be returned unless return is required by security considerations, contractual obligations, or notice on a specific document.

UNCLASSIFIED

SECURITY CLASSIFICATION OF THIS PAGE (When Data Entered)

REPORT DOCUMENTATION PAGE		READ INSTRUCTIONS BEFORE COMPLETING FORM
1. REPORT NUMBER AFAPL-TR-78-38	2. GOVT ACCESSION NO.	3. RECIPIENT'S CATALOG NUMBER
4. TITLE (and Subtitle) RPV Electric Power System Study, Phase I: Electrical Technology Assessment.	5. TYPE OF REPORT & PERIOD COVERED Interim Technical 23 Aug. 76 to 31 March 78	
	6. PERFORMING ORG. REPORT NUMBER TRA 29318-06	
7. AUTHOR(s) Miller, Frederic L.	8. CONTRACT OR GRANT NUMBER(s) F33615-76-C-2069 <i>ml</i>	
9. PERFORMING ORGANIZATION NAME AND ADDRESS Teledyne Ryan Aeronautical 2701 Harbor Drive San Diego, California 92138	10. PROGRAM ELEMENT, PROJECT, TASK AREA & WORK UNIT NUMBERS 31452943	
11. CONTROLLING OFFICE NAME AND ADDRESS Air Force Aero Propulsion Laboratory Vehicle Power Branch, POP-2 Wright-Patterson Air Force Base, Ohio 45433	12. REPORT DATE June 1978	
	13. NUMBER OF PAGES 264	
14. MONITORING AGENCY NAME & ADDRESS (if different from Controlling Office)	15. SECURITY CLASS. (of this report) Unclassified	
	15a. DECLASSIFICATION/DOWNGRADING SCHEDULE	
16. DISTRIBUTION STATEMENT (of this Report) Approved for public release; distribution unlimited.		
17. DISTRIBUTION STATEMENT (of the abstract entered in Block 20, if different from Report)		
18. SUPPLEMENTARY NOTES		
19. KEY WORDS (Continue on reverse side if necessary and identify by block number) Electric power, technology assessment, pilotless aircraft, cost effectiveness, system engineering, electric generation, electric power distribution.		
20. ABSTRACT (Continue on reverse side if necessary and identify by block number) The RPV Electric Power Study explores ways for exploiting technology and resolving critical issues affecting the electrical subsystems of remotely piloted vehicles. The objective is to define electrical components and system concepts that offer significant cost, weight, and performance improvements over present day systems. Phase I is an assessment of technologies capable of benefitting RPV electrical systems. Phase II develops a plan to transfer viable technologies into RPV systems.		

DD FORM 1473 1 JAN 73 EDITION OF 1 NOV 65 IS OBSOLETE

UNCLASSIFIED

SECURITY CLASSIFICATION OF THIS PAGE (When Data Entered)

78 10 17 067

Block 20 (Continued)

The scope of the Phase I study is limited to four classes of RPV:

- Advanced multi-mission tactical RPV (ARPV),
- High-altitude, long endurance RPV (HALE),
- Mini - RPV, and
- Tactical expendable decoy system (TEDS).

The approach is to first survey suitable technology, estimate future requirements, determine the most critical problems in RPV electrical systems, and suggest changes to military specifications and standards to make them more compatible with RPVs. For each RPV class, a series of candidate electrical systems is synthesized spanning the spectrum of potentially viable systems. These are evaluated against a set of weighted evaluation criteria and the best approaches selected.

In each class (except Mini-RPV), the better candidate systems showed significant improvement over the baseline, which is an existing system representative of the class.

**LEVEL II**

ACCESSION FOR	
NTIS	Wallo Section <input checked="" type="checkbox"/>
DDI	Staff Section <input type="checkbox"/>
UNANNOUNCED	<input type="checkbox"/>
JUSTIFICATION.....	
BY.....	
DISTRIBUTION/AVAILABILITY CODES	
Dist.	AVAIL. and/or SPECIAL
A I	

DDC  
RECEIVED  
OCT 23 1978  
D

## PREFACE

This document is the technical report for the first phase of a two-phase study entitled "RPV Electric Power System Study; Phase 1: Technology Assessment". The work was performed by the Aerospace Division of Teledyne Ryan Aeronautical, San Diego, California under Air Force contract No. F33615-76-C-2069.

The work was administered under the direction of the Air Force Aero Propulsion Laboratory, Air Force Wright Aeronautical Laboratories, Wright-Patterson Air Force Base, Ohio 45433, by Mr. Duane Fox (POP-2) Project Engineer.

The Principal Investigator was Frederic Miller. Also contributing significantly to the work was Marvin Crossley and David Spitz, Electrical Design, Anthony Navoy and George Noonan, Operations Analysis, James Paul, Specifications and Standards, and Lou Pico, Advanced Systems.

This manuscript was released by the author in April 1978.

## TABLE OF CONTENTS

<u>SECTION</u>		<u>PAGE</u>
1.0	INTRODUCTION	1
	1.1 Background	1
	1.2 Program Objectives and Scope	2
	1.3 Method of Approach	3
2.0	SUMMARY	5
3.0	ELECTRIC POWER REQUIREMENTS	9
	3.1 Introduction	9
	3.2 RPV Systems Requirements Summary	9
	3.3 ARPV	12
	3.4 Mini-RPV	21
	3.5 HALE RPV	22
	3.6 TEDS	22
4.0	PROBLEM AREAS IN RPVs	24
	4.1 Introduction	24
	4.2 Power Extraction	24
	4.3 Batteries	26
	4.4 Wiring and Interconnecting Problems	27
5.0	SPECIFICATIONS/STANDARDS REVIEW	31
6.0	TECHNOLOGY	39
	6.1 Introduction	39
	6.2 Permanent Magnet Materials	39
	6.3 Semiconductors	42
	6.4 Batteries	43
	6.5 Wire and Fiber Optics	48
	6.6 Summary	50
7.0	ANALYTICAL APPROACH AND GENERAL DISCUSSION	51
	7.1 Introduction	51
	7.2 Assumptions and Ground Rules	52
	7.3 Candidate Selections	53
	7.3.1 EPS Design Philosophy	53
	7.3.2 Spectrum of FPS Architectures	56

TABLE OF CONTENTS (Continued)

<u>SECTION</u>	<u>PAGE</u>
7.4 Evaluation Process	67
7.4.1 Evaluation Criteria and Procedures	67
7.4.2 Cost Analysis	78
8.0 ARPV CLASSIFICATIONS	79
8.1 Introduction	79
8.2 Assumptions	79
8.3 Candidates	81
8.3.1 General Discussion	81
8.3.2 LVDC System	82
8.3.3 HVDC System	82
8.3.4 CSCF System	86
8.3.5 VSCF System	91
8.3.6 VSVF System	91
8.3.7 ARPV Baseline	91
8.4 Evaluation and Analysis	97
8.4.1 Evaluation	97
8.4.2 Cost Analysis	97
8.4.3 Discussion of Results	105
9.0 HALE RPV	109
9.1 Introduction	109
9.2 Assumptions	109
9.3 Candidate Systems	110
9.3.1 General Discussions	110
9.3.2 Baseline	115
9.3.3 LVDC	118
9.3.4 HVDC System	120
9.3.5 CSCF System	120
9.3.6 VSCF System	122
9.3.7 VSVF System	122
9.3.8 AC/DC System	126
9.4 Analysis	126

## TABLE OF CONTENTS (Continued)

<u>SECTION</u>	<u>PAGE</u>
10.0 MINI-RPV	133
10.1 Summary	133
10.2 Assumptions	133
10.3 Candidates	134
10.3.1 General Discussion	134
10.3.2 LVDC (Single Output)	136
10.3.3 LVDC (Multiple Voltage Generator)	137
10.3.4 Mini-RPV Baseline	137
10.4 Analysis	139
11.0 TACTICAL EXPENDABLE DRONE SYSTEM	142
11.1 Introduction	142
11.2 Assumptions	142
11.3 Candidates	143
11.3.1 General Discussion	143
11.3.2 LVDC System	145
11.3.3 VSVF System	149
11.3.4 AC/DC System	150
11.4 Discussion of the Results	151
12.0 CONCLUSIONS AND RECOMMENDATIONS	155
APPENDIX A. PRICE Cost Model	163
B. Excerpts from Parts Selection List (BGM-34C)	240
C. Organization of (Class) Drone/RPV Design Handbook	254
REFERENCES	261
BIBLIOGRAPHY	263

## LIST OF FIGURES

<u>FIGURE</u>		<u>PAGE</u>
1	Work Flow Diagram	3
2	Cost vs Bulk for Leading RPV Battery Candidates	47
3	Figures Affecting EPS Characteristics	55
4	Electric Power System Elements	58
5	Basic Candidate System Configurations	58
6	Motor Performance for Voltage/Frequency = Constant	62
7	Power Supplies Within the EPS	66
8	ARPV LVDC/HVDC	83
9	ARPV - CSCF	87
10	ARPV - VSCF	89
11	ARPV - VSVF	92
12	ARPV Baseline	95
13	Sensitivity of Various Evaluation Parameters	106
14	Compressor Characteristics	112
15	HALE Baseline	116
16	LVDC/HVDC Systems	119
17	HALE CSCF System	121
18	HALE VSCF System	123
19	HALE VSVF System	124
20	Frequency Ranges for a VSVF Generator	125
21	HALE AC/DC System	127
22	Mini-RPV LVDC (Single Output)	136
23	Mini-RPV LVDC (Multi-Output)	137
24	LVDC System	145
25	Unregulated Generator Load Profile	147
26	VSVF System	149
27	AC/DC System	150

## LIST OF TABLES

<u>TABLE</u>		<u>PAGE</u>
1	Summary Vehicle Characteristics	10
2	Reliability Requirements	11
3	Equipment Complements	13
4	Vehicle Configuration Listing, Recce	15
5	Vehicle Configuration Listing, EW	16
6	Vehicle Configuration Listing, Strike	17
7	Vehicle Configuration Listing, HALE	18
8	Vehicle Configuration Listing, Mini-RPV	19
9	Vehicle Configuration Listing, TEDS	20
10	Existing Design Standards	34
11	Applicability of Selected Specifications	37
12	Approximate Energy Density	45
13	Electronic Power System Evaluation Parameters	75
14	Electronic Power System Evaluation Data Requirements	76
15	ARPV-LVDC	84
16	ARPV-HVDC	85
17	ARPV-CSCF	88
18	ARPV-VSCF	90
19	ARPV-VSVF	93
20	Baseline ARPV	96
21	Evaluation Weights	98
22	EPS Evaluation, Raw Data	99
23	EPS Evaluation, Raw Score	100
24	EPS Evaluation, Adjusted Score	101
25	EPS Evaluation, Weighted Score	102
26	Electric Power Study, Electrical Systems	103
27	Electric Power Study, ARPV High Voltage DC System	104
28	Electric Power Study, ARPV Low Voltage DC System	104
29	Mission Failure Rate	113
30	RPV Recovery Failure Rate	114
31	Summary of HALE Physical Characteristics	128

LIST OF TABLES (Continued)

<u>TABLE</u>		<u>PAGE</u>
32	EPS Evaluation, HALE Raw Data	130
33	EPS Evaluation, Weighted Score - Mini	131
34	Mini-RPV Physical Characteristics	139
35	EPS Evaluation, Raw Data	140
36	EPS Evaluation, Weighted Score	141
37	Comparison: TEDS and ARPV LVDC	146
38	TEDS EPS Physical Characteristics	152
39	TEDS EPS Evaluation	153
40	TEDS Evaluation, Weighted Score	154

## GLOSSARY

- Cyclo-conv. - Cyclo-converter-Electronically modifies variable frequency generator output into constant frequency, regulated voltage, electrical power.
- Hybrid relay - A combination of solid state and mechanical contacts relay.
- Hybrid generator- A generator with both AC and DC outputs.
- Rare earth - An exotic material, such as samarium, used with cobalt to make permanent magnets smaller and stronger.
- Solid state - Electronic devices, such as semiconductors, used to control current without using moving parts or heated filaments.
- Wild frequency - Electrical power supplied by a generator where the frequency output is unregulated and, therefore, governed by generator RPM.

## ABBREVIATIONS

AC	-	Alternating current
AMPS	-	Amperes
AMP-HR	-	Ampere-hours
APU	-	Auxiliary power unit
ARPV	-	Advanced remote piloted vehicle
BC	-	Battery control (relay)
BT	-	Bus tie (relay)
BTC	-	Bus tie contactor
BTLC	-	Battery line contactor
CSCF	-	Constant speed constant frequency (AC)
CSD	-	Constant speed drive
DC	-	Direct current
ECM	-	Electronic countermeasure
EMI	-	Electro-magnetic interference
EMIC	-	Electro-magnetic interference control
EMLC	-	Emergency line contactor
EPC	-	External power contactor
EPS	-	Electrical power system
FLIR	-	Forward looking infrared
GC	-	Generator control (relay)
GLC	-	Generator line contactor
HALE	-	High altitude long endurance
IEG	-	Integrated engine generator
IWTS	-	Integrated wiring termination system
LVDC	-	Low voltage direct current
MEPU	-	Mono-fuel emergency power unit
MTBF	-	Mean time before failure
MTTR	-	Mean time to repair
NB CMND	-	Narrow band command
NI	-	Nickel
NICAD	-	Nickel cadmium
OTH	-	Over the horizon
PCU	-	Power control unit
RAT	-	Ram air turbine
RCR	-	Reverse current relay
RPV	-	Remote piloted vehicle
RPM	-	Revolutions per minute
RTU	-	Remote terminal unit
SCR	-	Silicon controlled rectifier
SHP	-	Shaft horsepower
SmCo <sub>5</sub>	-	Samarium cobalt
SSIU	-	Solid state interface unit
SSS	-	Solid state switchgear
STAR	-	Ship-based tactical RPV
TCAE	-	Teledyne Continental aircraft engine
TEDS	-	Tactical expendable drone system
TR	-	Transformer-rectifier
TRA	-	Teledyne Ryan Aeronautical
TRR	-	Transformer-rectifier regulator
V/F	-	Voltage to frequency ratio
VR	-	Voltage regulator
VSCF	-	Variable speed constant frequency (AC)
VSI	-	Variable speed input
VSVF	-	Variable speed variable frequency
W-H/IN <sup>3</sup>	-	Watt-hours per cubic inch
W-H/LB	-	Watt-hours per pound
WSMR	-	White Sands Missile Range

## SECTION 1 INTRODUCTION

### 1.1 BACKGROUND

This study has its roots in the growing obsolescence of the electrical subsystems of current remotely piloted vehicles (RPV). The need for RPVs has been growing in an evolutionary manner to fill a range of requirements from real-time battlefield surveillance with mini-RPVs to multi-mission low altitude tactical RPVs to very large strategic RPVs capable of staying aloft for periods exceeding 24 hours. The complexity of RPVs has been correspondingly driven in an evolutionary manner from simple targets to multi-mission reconnaissance/strike RPVs. As RPV capabilities continue to expand and the cost of manned aircraft systems soars, more attention is being given to applications of lower cost RPVs to ease military budget problems. While this development enhances the status of RPVs, the RPV budget has also suffered. Costs are beginning to drive RPV performance just as they do in manned aircraft. Unfortunately, as new mission requirements develop, available hardware is often used to minimize development time and costs. Thus, introduction of new technology has been slow. Most of the new technology that has found its way into RPVs has been in avionics: payloads, navigation, digital computation, etc. Advances in electrical power systems have lagged noticeably.

Concern has risen out of the continued use of off-the-shelf hardware, some of which is 10 - 15 years old. For example, some current target drones still have carbon pile regulators, a technology that certainly qualifies as being antiquated. The outdated equipment is causing sufficient operational difficulties in performance, life cycle costs, and maintenance that this study was initiated to look at the problems and their potential solutions.

While electric power generation and distribution is considered a mature technology, continuing developments in materials, fabrication processes, and related electronics technologies provide many new avenues for evolutionary improvements. The increasing gap between the potentiality of available and developing technology and the reality of existing systems has produced significant and unavoidable pressure to exploit that gap. As this study amply demonstrates, the situation currently exists such that cost can drive technology to both improve performance and reduce cost - a desirable circumstance. Exploiting the available technology can solve such problems as:

- Lack of adequate generated power
- High acquisition and life cycle costs

- Wiring and interconnect difficulties
- Reliability and maintainability problems, such as are associated with batteries
- Excessive complexity, weight, and volume

Another factor is the constant dilemma designers face in trying to satisfy military specifications and standards not written for RPVs.

## 1.2 PROGRAM OBJECTIVES AND SCOPE

With this background the Aero Propulsion Laboratory of the Wright Aeronautical Laboratories contracted Teledyne Ryan Aeronautical to study ways for exploiting technology and resolving critical issues affecting the electrical systems of future RPV. The ultimate goal of the study is to define electrical components and systems that will offer significant cost and performance improvements over present RPV electrical systems. This includes acquisition costs, life cycle costs, reliability, and maintainability. A secondary goal is weight and volume improvements.

The program is divided into two phases. The first phase effort, reported in this volume, is an assessment of current and developing technologies capable of alleviating the electrical problems mentioned earlier. The subsequent second phase, reported separately, develops a plan to transfer viable technologies into RPV systems.

The scope of the Phase I study is limited to four classes of RPV:

- Advanced multi-mission tactical RPV (ARPV)
- High altitude, long endurance RPV (HALE), such as Compass Cope
- Mini-RPV
- Tactical Expendable Drone System (TEDS)

The scope implicitly eliminates targets and cruise missiles from consideration. However, the range of RPV classes is broad enough that little generality is lost by their exclusion. The conclusions apply largely to them also. The study also limits consideration to the next generation of RPV. This implies projecting available "off-the-shelf" technology into the 1983 - 85 time period.

### 1.3 METHOD OF APPROACH

The method of approach to the electrical technology assessment is depicted in the work flow diagram, Figure 1. Phase I starts by developing the overall requirements for the electrical power subsystems of the four classes of RPVs: ARPV, Mini-RPV, Compass Cope, and TEDS. This involves combining the outputs of three parallel tasks. The first task categorizes the problems and limitations known to exist in current RPVs. They are categorized by electrical system function to be compatible with the technology survey and requirements analysis. These data come largely from existing data files and from people having first-hand knowledge of the facts. (This is discussed in Section 4). The second task summarizes suggested changes to military specifications and standards to make them directly suitable to RPVs rather than manned aircraft, missiles, and spacecraft. (This is discussed in Section 5). The third task generates a set of electrical subsystem functional and performance requirements for each of the four classes of RPV. These are based on known and projected missions, payloads, operational requirements, RPV system requirements, maintenance requirements, turnaround time, launch technique, recovery method, etc. We draw on actual data from such systems as BGM-34C, STAR (Ship-based Tactical RPV) Mini-RPV, and Compass Cope and preliminary design data for ARPV and TEDS. Additionally, the results of the ASD ARPV Studies are also available for this study. (Refer to Section 3).

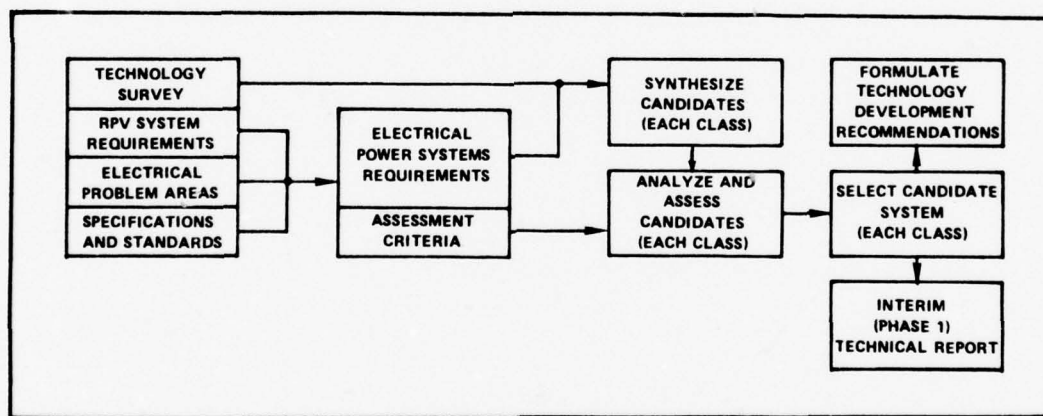

Figure 1. Work Flow Diagram

Combining the outputs of these three tasks provides a complete picture of the requirements, design criteria, and interfaces of the electrical subsystem for each RPV class. This encompasses generation, conversion, regulation, distribution, etc. This task also includes generating criteria or figures of merit for evaluating candidate electrical system configurations later on in the study. The figure of merit measures the relative worth of candidates. It consists of a set of characteristics each weighted according to its relative importance to the electrical system. The weighting factors vary with the class of RPV. The set of characteristics includes five major factors: (1) weight and volume, (2) performance, (3) reliability, (4) maintainability, and (5) life cycle cost. The PRICE and PRICE L models are used for estimating relative costs. Normally life cycle costing is done on a system basis. But this is too expensive and is not justified for this subsystem study. Therefore, we have simplified the model to handle the subsystem variables in a more suitable way. (Refer to Section 7).

The next step is synthesizing and evaluating candidate electrical system configurations for each of the four RPV classes. These tasks are reported in Sections 8 thru 11. The overall conclusions and recommendations of the study are in Section 12.

## SECTION 2 SUMMARY

The study addresses the problems and technology application in remotely pilot vehicle (RPV) electrical power systems. Today's systems use relatively old off-the-shelf hardware that is becoming inadequate for the tasks and is causing operational difficulties in performance, maintenance, and life cycle costs. The primary objective of the study is to define the available and developing technologies that can be exploited to resolve the problems and provide significant cost and performance improvements over present day systems. Some specific problems caused by the off-the-shelf design philosophy are the lack of adequate generated power, interconnection difficulties, reliability and maintainability problems such as associated with batteries, and high life cycle costs. A secondary objective is weight and volume improvements.

The study is carried out in two phases. The first phase, reported in this volume, assesses the capabilities of available and developing technologies in alleviating the problems and deficiencies in current RPVs and for optimizing future RPVs. The second phase develops a plan to establish laboratory techniques to demonstrate and verify the feasibility of the technology applications derived in Phase I.

The scope of Phase I encompasses all aspects of electric power systems: generation, control, conversion, distribution, and interfaces. The scope is limited to four classes of RPV: (1) advanced tactical multi-mission RPV (ARPV), (2) high altitude, long endurance (HALE) RPV, (3) Mini-RPV, and (4) tactical expendable drone system (TEDS). Four preliminary tasks lay the groundwork for the analytical class studies, which (1) establish a basis for projecting future electrical requirements, (2) define the most critical problem areas in RPVs today and potentially into the future, (3) review the applicability of military specifications and standards to RPV, and (4) survey available and developing technology that would be most suitable for RPV use in the 1983-85 time period.

Candidate electrical power systems are evaluated for each of the four RPV classes using a method of applying relative weights to the five most significant system parameters: (1) physical characteristics (weight and volume), (2) performance, (3) reliability, (4) maintainability, and (5) life cycle cost. PRICE and PRICE L are used to compare relative acquisition and life cycle costs. The results of the analyses indicate that the best architecture for the electrical system varies with each class of RPV. The ARPV class prefers either low voltage (28 volts) or high voltage (270 volts) DC over either constant or variable speed fixed-frequency AC systems; a wild frequency AC approach is a possible alternative.

The HALE class clearly prefers a hybrid wild frequency AC/DC system, where 28VDC has little preference over 270VDC. The AC section supplies primarily the payload. Since the engine runs at nearly constant RPM at altitude when the payload is operating, the directly-driven generator supplies power at nearly constant frequency. Furthermore, the payloads

are primarily avionics, which easily tolerate the sort of frequency changes involved. This hybrid approach results in the simplest, lightest, and least expensive system architecture. It requires the least power conversion.

For the TEDS class (and its close relative, the cruise missile), simplicity is of paramount importance to weight, volume, reliability, and cost. The concept that best meets the criterion is a wild frequency AC system that depends on inherent regulation. The basic operational concept of TEDS (and cruise missile) requires that the engine run at 100% RPM at all times. To a directly driven generator, the engine is a constant speed drive. By specification and actual field experience, such engines run within a fraction of a percent of a nominal value. Furthermore, a rare-earth permanent magnet synchronous generator has excellent inherent voltage regulation, e.g., seven percent droop from no load to 5KW full load in a 1.5 pound generator running at 60,000 RPM (about 2000 Hz line frequency). The concept requires conversion and regulation only within the avionics suite itself for circuit applications and about 100 watts for the flight control actuators (rare earth PM motors help here too).

Mini-RPVs are not compatible with AC systems because of the small size and wide speed range of the reciprocating engines. High voltage DC offers no advantage. Therefore, a 28 volt DC system is the only practical choice. The difficulty experienced in Mini-RPVs has not been technology, but the availability of suitable components. Ongoing development is easing that situation.

In each class (except Mini-RPV), an existing system representative of the class was selected as a baseline against which four candidate systems could be compared. In all cases, the better candidate systems showed significant improvement in weight, volume, cost, and other factors when compared to the baseline.

Interestingly high voltage DC, which is being considered by some for manned aircraft, does not provide significant benefits for RPV. One reason is that lighter gage wire does not save as much weight in a smaller RPV. Another is that some components become larger at higher voltages; e.g., the battery and main line contactors. Unfortunately one compensates for the other, so that a 270V system weighs about the same (or perhaps even more) as a 28V system.

Considerable benefits can accrue to high voltage wild frequency systems and for line frequencies greater than the conventional 400 Hz for those systems where engine speeds do not vary widely. Future RPV are expected to have few, if any, loads that are sensitive to higher frequencies. Similar to the TEDS case, inherent regulation may be adequate for other applications, thus simplifying the system noticeably. Higher frequencies allow smaller magnetics, a significant weight contributor. Main line current interruption is also simpler for AC than DC.

The electrical sub-system of each class benefits from higher levels of integration with the propulsion and avionics subsystems. Optimizing power extraction from the engine remains a difficult task where

an engine is used in several applications. The ARPV and HALE RPV are expected to have a central digital avionics processor and a data bus, both of which would be shared by the electrical system. This greatly reduces control wiring and logic since control and power management would be done in software. A separate electrical power data bus is unwarranted. TEDS and Mini-RPV would not have a data bus, but they will have central microprocessors, which would also be shared by the electrical system for control and management. In both cases, control and some distribution would be done via fiber optics and flat wire or printed circuit cable. Solid state or hybrid solid state/mechanical contact switching would be used. RPV have always used remote power controller concept (albeit very simple), since no one is available in flight to replace a fuse or reset a circuit breaker.

Rare earth permanent magnets and newer high temperature insulation combined in generators and actuators benefit all systems to a some degree. The Mini-RPV is least benefited, because the components are already small and performance is not critical. TEDS electrical system weight is cut by 55 percent, due either directly or indirectly to rare earth PMs. Other benefits are higher power (generator or actuator), better regulation, and it won't demagnetize. Its cost is still higher than other materials and components, but the difference is diminishing as production of rare earth PM material increases.

Review of Military Specifications and Standards that are applied to RPV re-confirms the Teledyne Ryan (and ARINC) position that a RPV Design Handbook is needed to help the designer tailor military specifications to specific systems. However, our position has shifted slightly to recommend a separate handbook for each class (or appropriate grouping) to avoid the unwieldy bulkiness of a single handbook.

The following areas have been identified as having sufficient payoff potential to warrant further work to either exploit developing technology or to ease current and future problems in RPVs:

- 1) Generate a series of RPV-class design handbooks for tailoring military specifications and standards
- 2) Continued exploitation of rare-earth PM materials in RPV size generators and actuators, including regulation techniques that are compatible with PM generators
- 3) Develop hybrid multi-purpose technologies, such as starter-generators, AC/DC generators, other segmented generators for multiple voltages, and multi-mode emergency or auxiliary (air turbine) power units in RPV-compatible sizes
- 4) Exploit the potential of inherently regulated, high speed, high and wild frequency electrical power
- 5) Exploit newer interconnection techniques, such as flat wires, printed circuit cables, and fiber optics

- 6) Exploit the potential for sharing the avionics data bus and/or central processor for electrical system control and power and redundancy management. This includes development of smart interface units for data bus terminals, where a microprocessor can exert local control
- 7) Develop hybrid solid state/mechanical contact line contractors
- 8) Continue development of battery systems which can adequately maintain battery condition and accurately monitor status

## SECTION 3

### ELECTRIC POWER REQUIREMENTS

#### 3.1 INTRODUCTION

This section establishes the ground rules used in the study for the basic requirements for electrical power systems in the four classes of RPV.

The assumed requirements establish a framework for subsequent synthesis and analysis of candidate system configurations. The methodology is to first generate brief representative mission scenarios, overall RPV system performance, payloads, avionics suites, etc., to the extent that these factors impact the requirements and constraints on the electrical power system.

Then from this assumed base, the specific electrical power system requirements for each class of RPV are generated, such as power capacity and format, reliability, maintainability, interfaces, constraints, adaptability, etc.

#### 3.2 RPV SYSTEMS REQUIREMENTS SUMMARY

RPV technology is rapidly demonstrating capabilities for performing a broad spectrum of missions. Vehicle applications are limited primarily by the imagination and acceptance of developers and users. The discussion of RPV applications and mission considered in this section is intentionally simplified; the details are adequately documented elsewhere. Rather it is intended to establish the RPV equipment complements and to develop the general framework for establishing electrical power system requirements.

This study addresses four basic size classes of RPV systems. These are the (1) advanced tactical multi-mission RPV (ARPV), (2) Mini-RPV, (3) high altitude, long endurance RPV (such as Compass Cope), and (4) tactical expendable drone system (TEDS). Table 3-1 summarizes the more significant characteristics of the four classes and the major variants within a class. For example, the Navy Over-The-Horizon RPV is physically too large at 400-500 pounds to be considered a Mini-RPV, but it is much smaller than an ARPV (the Navy might term it a Midi-RPV). The OTH RPV is closer to ARPV in complexity, but it is closer to Mini-RPV in payload carrying capability. Therefore, we have arbitrarily listed it as a Mini-RPV variant for this study. The Mini-RPV class includes STAR, Aquila and the harassment drone, which is an expendable weapon system.

Two variants of TEDS are shown to indicate the impact of the propulsion system on electrical power requirements. One variant uses

TABLE 1

## SUMMARY VEHICLE CHARACTERISTICS

CHARACTERISTICS	MINI		STRIKE	ARPV RECCE	EM	HALE	TEDS	
	TYPE A	TYPE B					TYPE A	TYPE B
Reliability goal	0.94	0.95	0.980	0.990	0.980	0.999	0.85	
Endurance (hours)	1-4 hrs	1-3 hrs	2-3 hrs	4-8 hrs	2-3 hrs	24 hrs	1 hr	
Altitude (feet)	20K	SL 40K		40K		60K	25K	
Airspeed range	60-120 kts	35-300 kts	Mach 0.4 - 0.95	Mach 0.4 - 0.8	Mach 0.4 - 0.85	Mach 0.1-0.75 (constraint q)	400 kts	
Launch/recovery	Catapult/net or para- chute		Ground RATO or air drop/runway or para- chute			Runway takeoff & landing	RATO launch	
Propulsion types	Reciprocating	Turbofan	Turbofan			Turbofan	Turbofan Pressure jet	
Secondary power extrac- tion limit/perfor- mance	3% at SL 10% at 13K	3% SL 10% 13K	3% at SL 15% at service ceiling			3% at SL 25% at service ceiling	3% SL Thermal or ram air	
Core avionics	Microcomputer central processor 300W	Microcomputer data bus 600W	Minicomputer central processor, data bus, 1500W			Dual avionics, central digital processor, limited triple redundancy data bus, 2000W	Microcomputer Hybrid flight control 400W	
Mission payloads (see Table 4-3)	400-800W	400- 1200W	2.6KW	3.2KW	4KW to 10KW	4KW to 20KW	1.2-4KW	
Significant factors	Weight, launch/re- covery, endurance	Endur- ance weight	Mission modularity rapid reconfiguration			Mission relia- bility, endurance	Low cost, high launch rate	

a low cost turbojet, while the other uses a pulse jet. Since a pulse jet has no rotating parts, a conventional engine-driven generator cannot be used. Therefore, less efficient, alternative energy sources must be used, such as engine thermal energy, ram air, or an independent self-contained power unit.

The system reliability requirements listed in Table 1 are broken down and apportioned in Table 2 to indicate the level of reliability that would be assigned to the electrical power subsystem. As a first approximation to apportionment, each of the major subsystems (6 to 10) would be assigned equal values. The subsequent apportionments would refine this value. Since electrical power reliability is critical to flight safety and recovery, it typically is assigned a greater than equal share of the system reliability, i.e., the electrical subsystem MTBF would be at least an order of magnitude greater than the system MTBF.

TABLE 2  
RELIABILITY REQUIREMENTS

Probability of not having a catastrophic failure (loss of vehicle)	MINI	OTH	COPE	ARPV	TEDS
RPV	0.94	0.95	0.999	0.98	0.85
AVIONICS	0.97	0.99	0.9996	0.991	0.92
ELECTRICAL	0.97	0.99	0.9998	0.999	0.93

The probable equipment complement for each class of RPV to satisfy the functional requirement is given in Table 3. By assigning approximate power requirements for representative hardware to the complements given in Table 3 and allowing for redundancy, the approximate maximum power requirements can be derived for each class. These values are shown in Tables 4 thru 9; the three ARPV payload variants are included for comparison.

### 3.3 ARPV

The ARPV is a multi-mission vehicle design being considered for the 1985 time frame, which will permit rapid reconfiguration of a basic airframe to satisfy the singular tasks of reconnaissance, delivery of an air-to-ground weapon, or electronic-countermeasures missions (ECM). The modular nature of the basic vehicle calls for a basic equipment complement that remains constant for all configurations. This encompasses a core avionics suite (data processor and data bus, navigation and flight control sensors, actuators, and communications), electrical power subsystem, identification and environmental control. Each unique configuration adds to the basic complement its payload, navigation, or communications equipment. The approximate power requirements are listed in Tables 4 thru 6 for each of the mission variants.

The weapon delivery mission is configured for the specific purpose of delivering an air-to-ground weapon to a high certainty kill envelope basket. This weapon must be integrated with the avionics control system and often requires the aid of other sensor and data link functions. This weapon may be simple free-fall bomb, TV-guided boosted missile, or a gliding laser-guided bomb.

To present the greatest flexibility and versatility, the RPV is configured for both mobile ground launch as well as a cargo or a fighter/bomber air launch. The ground launch technique is the intended primary tactical operational configuration. The RPV will require a real time, wide bank data link to permit video transmission of both the RPV video sensor as well as the weapon sensor in the Maverick missile or Hobo glide bomb. The data link will require a steerable high gain antenna.

The RECCE mission is a very loosely defined mission, primarily because of the variety of payloads that can be carried and configured for a particular mission. The configuration also has mixed launch capability for the basic reasons described in the strike profile; although the primary launch mode will be the air drop, owing to the deeper penetration and/or the variety of azimuth approaches available to the target area. Unlike the mission, however, the need for real time data link is only one of the several equipment configurations. The basic mission is one of intelligence gathering: photographic, FLIR, TV, and electromagnetic signal frequency identification and location operating in covert manner.

TABLE 3  
EQUIPMENT COMPLEMENTS

EQUIPMENT CLASS POWER	ARPV (Multi-Mission)		MINI		HALE		TEDS
	Strike	EW	RECCE	Jet	Recip	SIGINT	
<u>PAYLOAD CANDIDATES</u>							
1. IR Detection & Warning	x	x	x	x		x	x
2. ESM Radar Quad Detect	x	x	x	x		x	x
3. IFF AN/APX-101	x		x	x		x	x
4. X-Band Xponder	x		x	x		x	x
5. Fwd Look Radar	x		x	x		x	x
6. Side Look Radar	x		x	x		x	x
7. Radar Altimeter	x		x			x	x
8. C Band Xponder	x		(x)	(x)		(x)	(x)
9. L Band Xponder	x					x	x
10. TOA/DME Emitter Detect	x	x	x			x	x
11. Electronic Countermeasure Set	x	x					x Expendable
12. A			x			x	
13. B			x			x	
14. C			x			x	
15. Video Camera & Control Unit	x			x	x		
16. Film Camera & Control Unit				(x)			
17. FLIR	x		x	x			
18. Laser Desig.	x		x	x			
19. Video (Onboard Bulk Recorder)	x		x	x			
20. Chaff Dispensers	x		x				
21. Weapon Pod	x		x				
22. Weapon Control Box	x		x				
<u>NAVIGATION AIDS</u>							
23. LORAN Nav Set	x	x	x			x	
24. Omega Nav Set	x	x	x			x	
25. GPS Nav Set	x	x	x			x	
26. Carousel Nav Set	x		(x)			(x)	(x)
27. Microwave Landing Instl. (2)			(x)			(x)	(x)

TABLE 3 (Continued)

	ARPV (Multi-Mission)			MINI		HALE		TEDS
	Strike	EW	RECCE	Jet	Recip	SIGINT	Relay	
<u>DATA LINKS</u>								
28.	X		X	X	X	X	X	
29.	X		X	X	X			
30.	X		X	X	X			
<u>VEHICLE FLIGHT CONTROL</u>								
31.	X		X	X	X	X	X	X
32.	X		X	(X)	(X)	X	X	X
33.	X		X	X	X	X	X	X
34.	X		X	X	X	X	X	X
35.	4		4	4	4	8	8	2
36.	8		-	8				
37.	X		X	X	X	X	X	X
<u>RECOVERY AIDS</u>								
38.				(X)				
39.				(X)		X	X	
40.				X	X			
41.	X		X					
<u>ENVIRONMENTAL CONTROL</u>								
42.	X		X			X	X	(X)
43.	X		X			X	X	X
44.	X		X	X	X	X	X	X
45.	X		X	X	X	X	X	X
46.	X		X	X	X	X	X	X
47.					X			

TOTAL POWER 3120W Max  
1000W Min

TABLE 4  
VEHICLE CONFIGURATION LISTING

RECCE: CONFIGURATION  
ARPV: MISSION DESCRIPTION

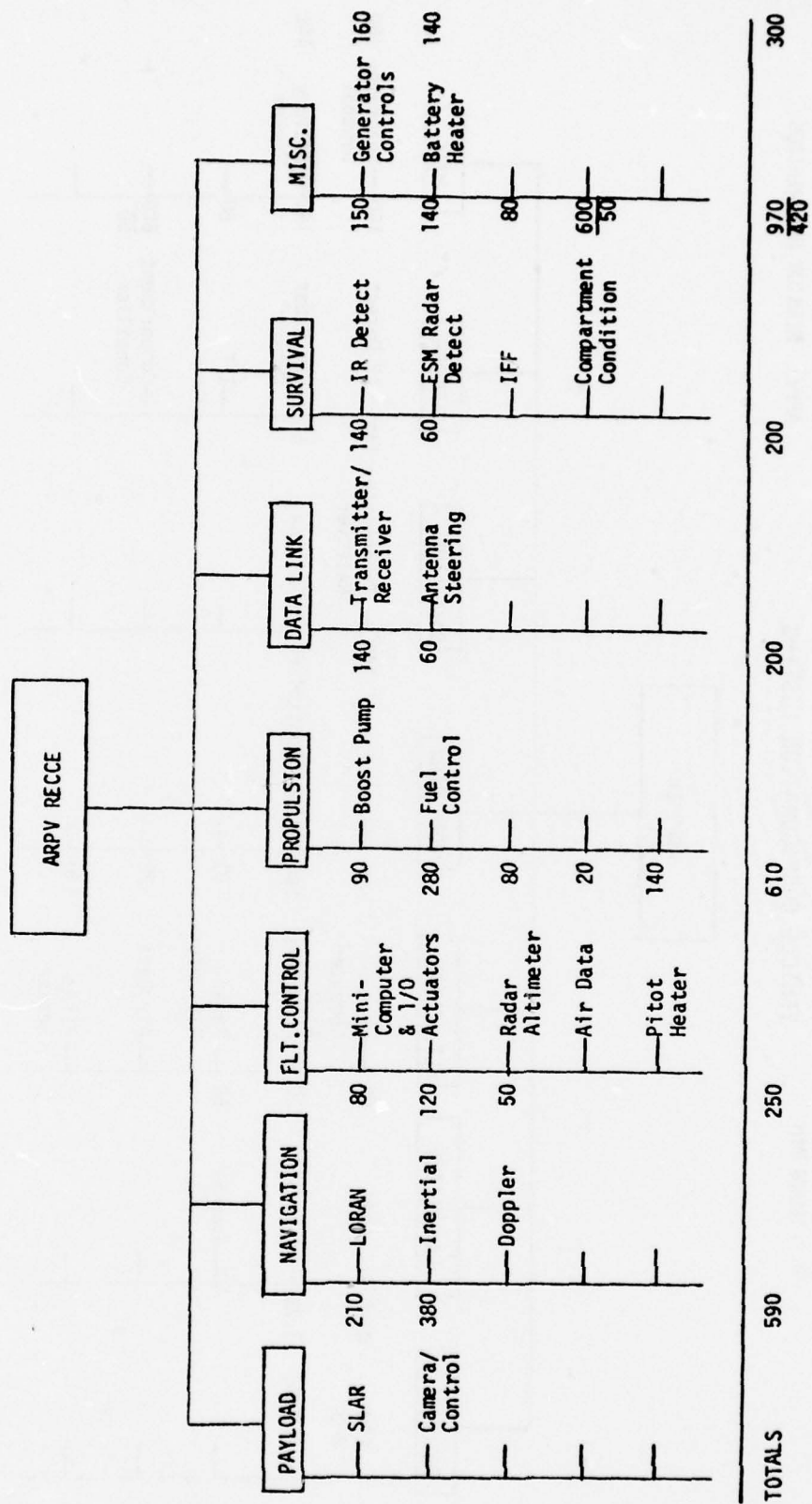

TABLE 5  
VEHICLE CONFIGURATION LISTING

TOTAL POWER 8430W Max  
1000W Min

EW: CONFIGURATION

ARPV: MISSION DESCRIPTION

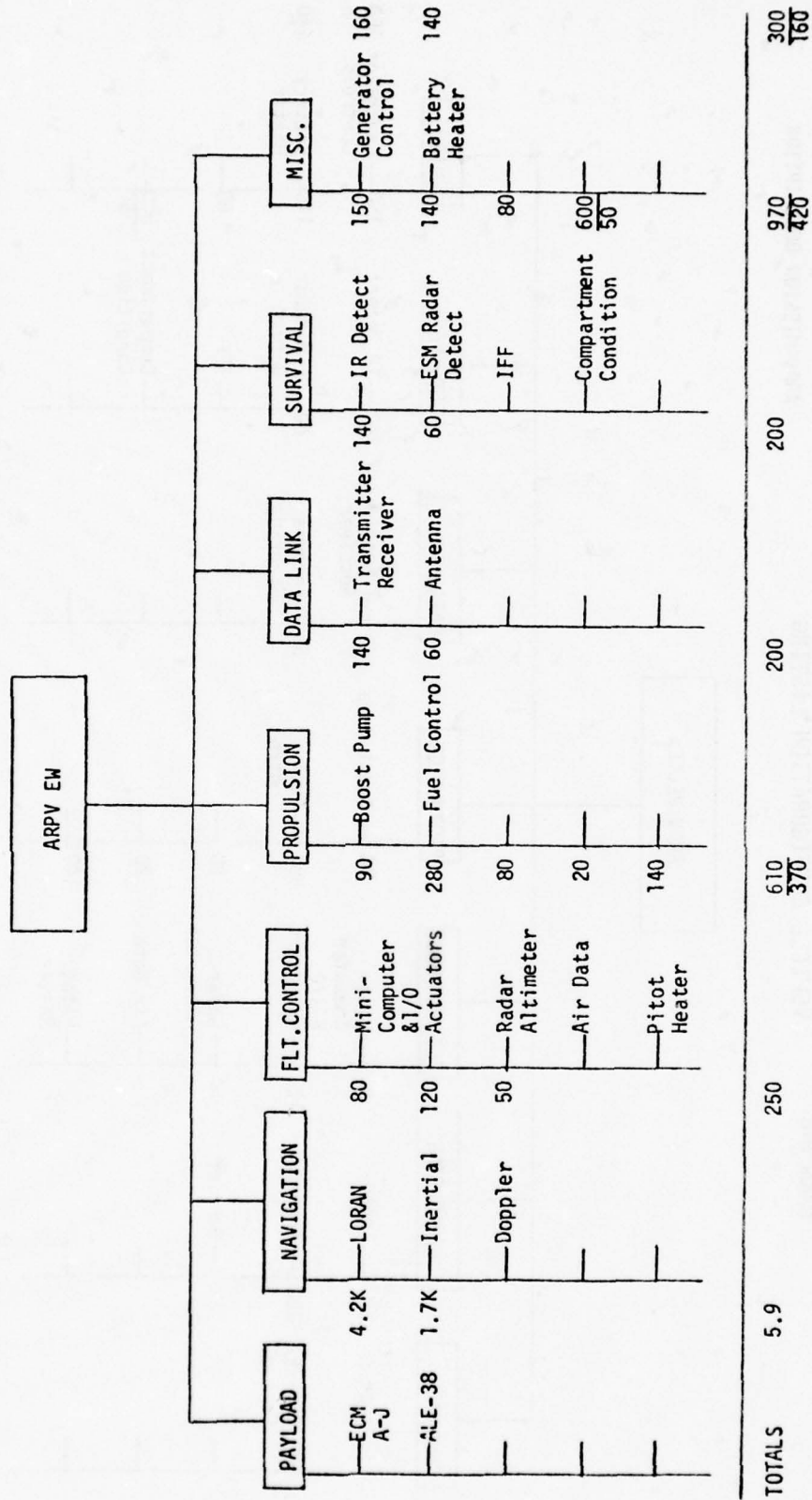
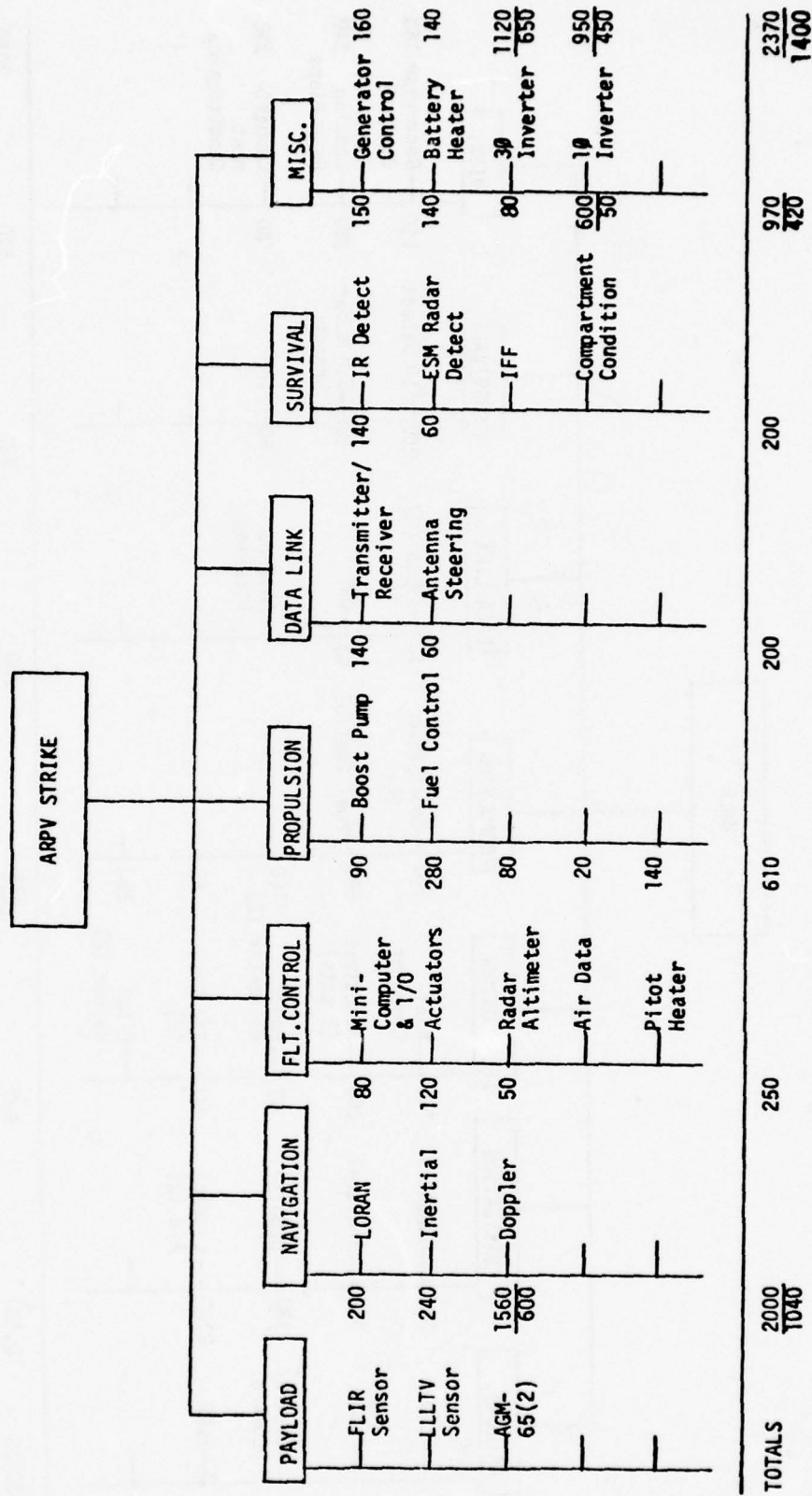

TABLE 6  
VEHICLE CONFIGURATION LISTING

TOTAL POWER 6610W Max  
1000W Min

STRIKE: CONFIGURATION  
ARPV: MISSION DESCRIPTION



EW/RECCE: CONFIGURATION

TABLE 7  
VEHICLE CONFIGURATION LISTING

TOTAL POWER 14500W Max  
2250W Min

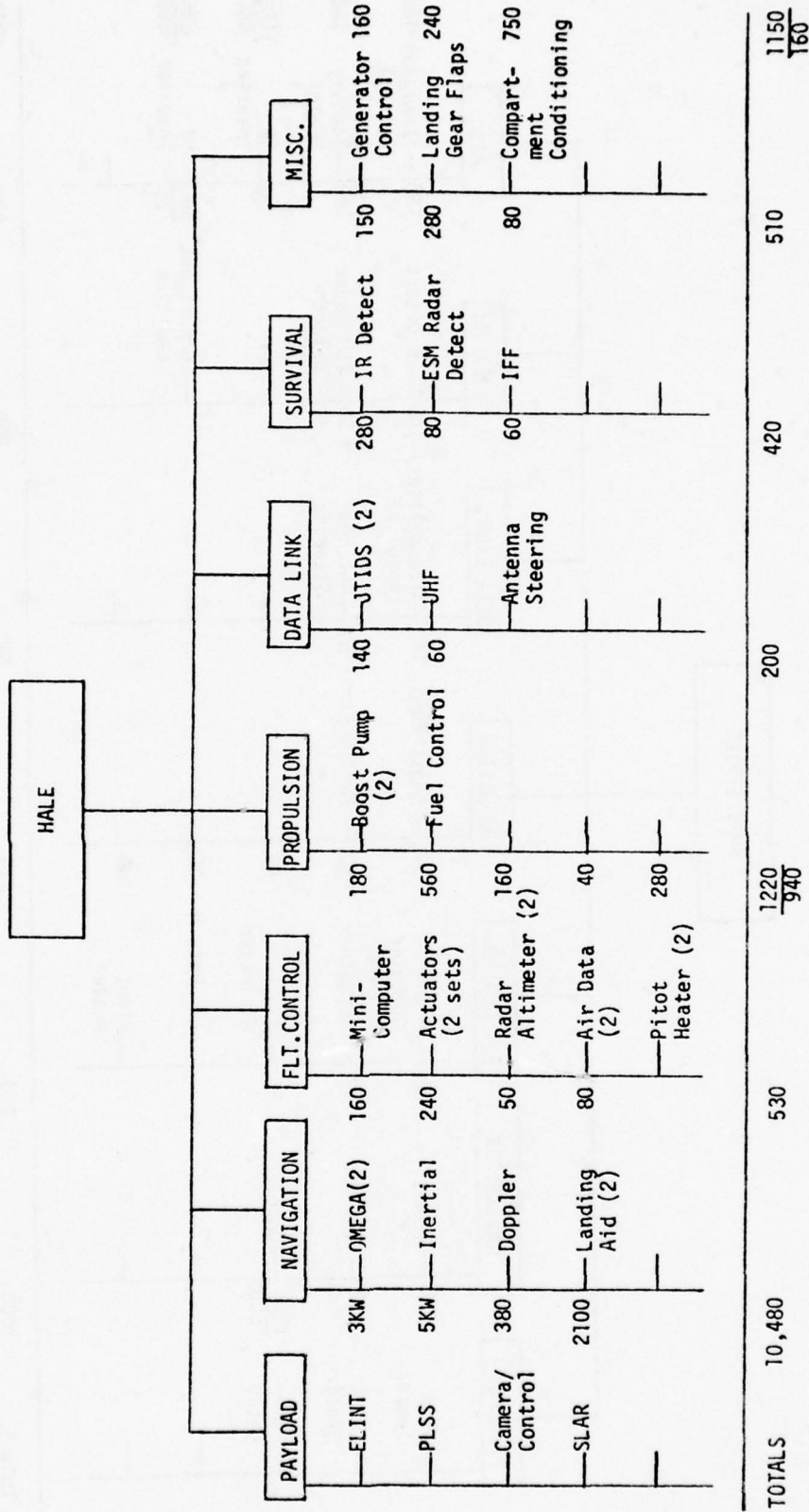
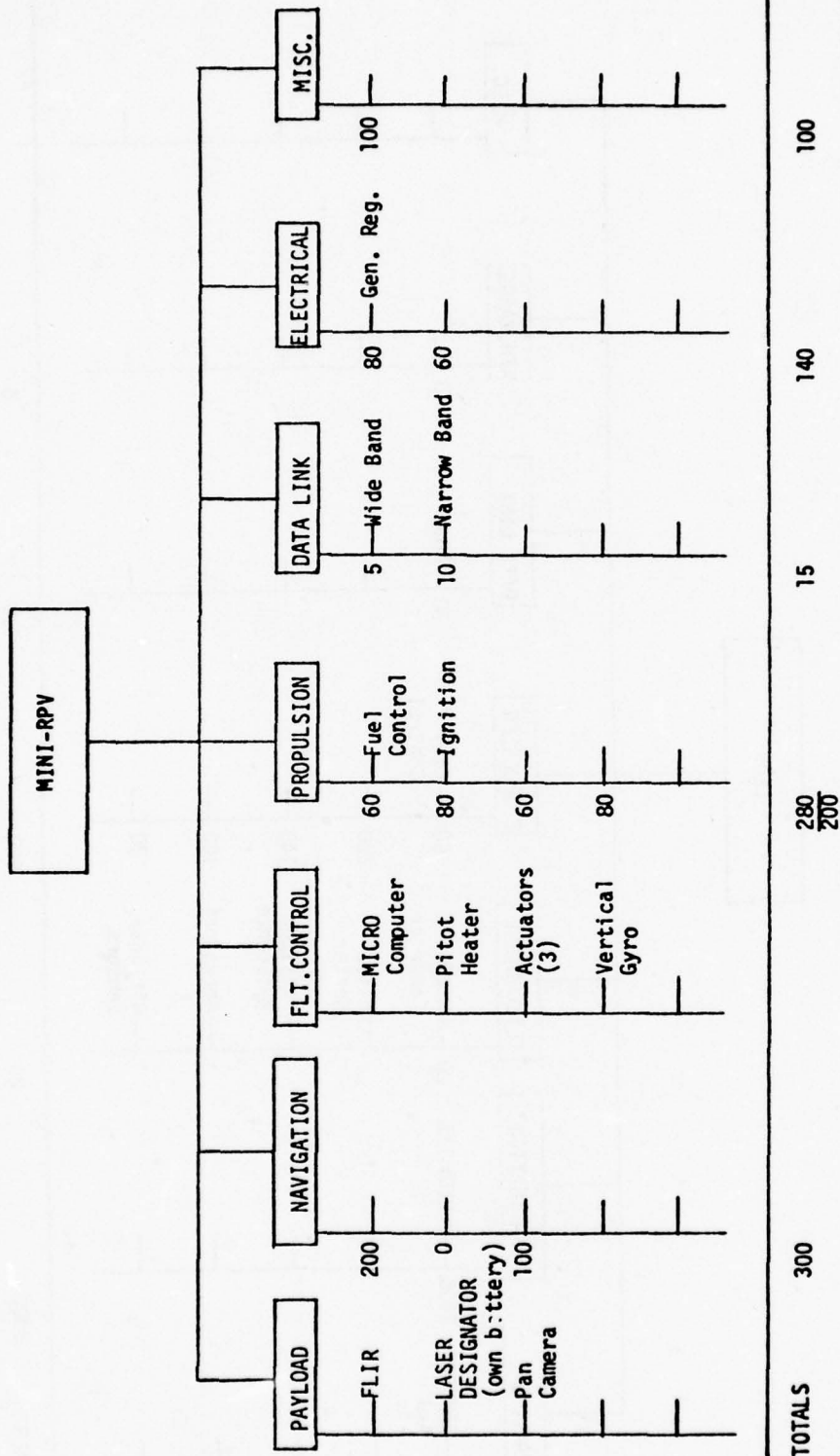

TABLE 8  
VEHICLE CONFIGURATION LISTING

TOTAL POWER 825W Max  
445W Min



TOTAL POWER 3650W Max  
370W Min

TABLE 9  
VEHICLE CONFIGURATION LISTING

EW: CONFIGURATION  
DECOY: MISSION DESCRIPTION

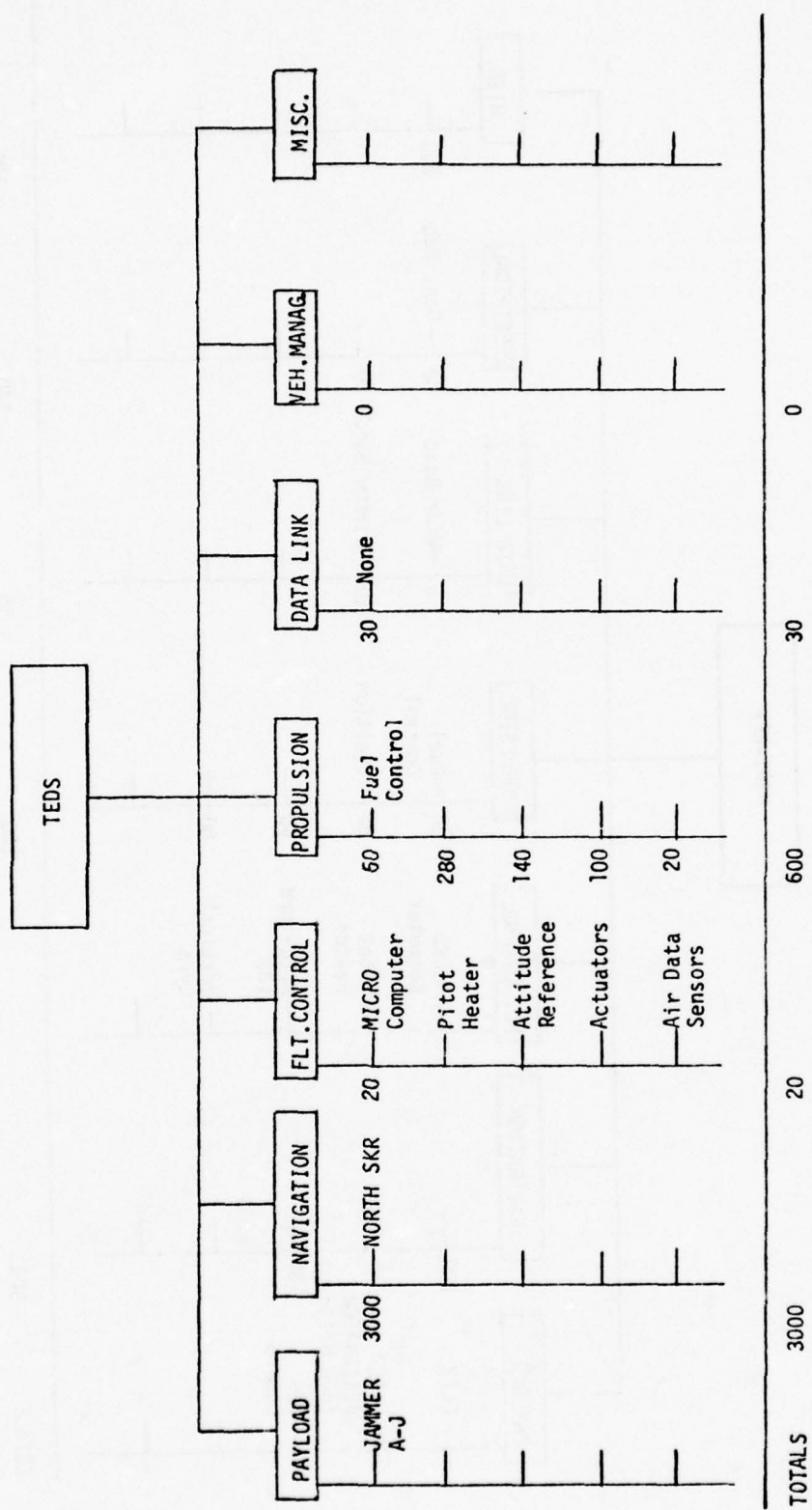

Typical payload equipment for the RECCE configuration includes the primary camera equipment co-installed with a side looking radar, forward looking radar, or IR set. The equipment selection is mission dependent. Each configuration combination offers a particular strategic benefit over some other combination. Therefore, the need for the variety of sensors and installations depends on the range of end uses.

The electronic countermeasure mission is used to support manned fighter attack or as penetration decoys to introduce search radar target confusion.

Electronic warfare tactical doctrine calls for a mix of ECM techniques and aircraft. An RPV ECM support force jamming and dispensing chaff can initially provide standoff or buffer jamming against an early warning net to mask penetration routes and the size of the approaching strike force. "Burst" chaff dispensing techniques can be employed to provide false targets as an additional confusion tactic. ECM configured RPVs can then penetrate just ahead of the strike force, dispensing chaff in a "Stream" mode to provide chaff corridors through which strike aircraft will ingress, affording en route protection against GCI tracking and SAM acquisition. Electronic jamming will simultaneously be employed against GCI and SAM acquisition radars. The ECM support force is complementary to the ECM pods carried by the strike force to counter terminal threat AAA and SAM target and missile track functions. The combination of ECM support force jamming and chaff coupled with ECM pods on strike fighters will provide a significant degree of strike force penetration. To present the greatest flexibility and versatility, the RPV is configured for both ground launch (RATO) as well as a cargo or a fighter/bomber air launch. The air launch configuration permits a deeper penetration from the FEBA owing to the long range capability of the launch aircraft.

#### 3.4 MINI-RPV

The Mini-RPV applications are singularly unique in that they are being actively followed by all three military services. The Army and Navy applications are primarily RECCE oriented; the Air Force application is for an expendable harrassment weapon system. The launch and recovery requirements for each service are markedly different. Insofar as the electrical power requirements are concerned, the various applications requirements would not differ markedly, and therefore the core avionics and payloads can be treated similarly. The mission profiles consist of launch and climbout to a constant mission altitude and airspeed. The payloads are primarily RECCE oriented, employing real time data transfer for low-light-level TV or forward-looking IR for intelligence gathering and target identification and classification. Some tactical configurations would require a laser designator used for targeting a separately launch weapon. Table 8 lists the approximate power requirements for a target location and designator

mission. A future higher power requirement may develop out of an EW role, where a jammer would be the payload.

### 3.5 HALE (High Altitude, Long Endurance) RPV

The HALE vehicle flies subsonically at altitudes above 50,000 feet for up to 24 hours. Typical missions are communications relay or very high altitude photographic and/or electromagnetic signal location and identification. Other sensitive applications are obvious. Because of the extreme flight duration, these vehicles carry a very large fuel load and therefore are limited to conventional landing and takeoff launch and recovery techniques. Because of the very long on-station mission time the payload and core avionics equipment reliability must be exceptionally high when compared with the TEDS and ARPV vehicles. The core avionics equipment is highly redundant. The safety of the vehicle is the prime concern. Therefore, equipment selection and reliability assessments are of prime importance. Following takeoff and climbout, the vehicle would be flown or programmed to fly to the assigned station altitude and geographic area for the particular mission involved. Once on station, the vehicle would continue to operate at the prescribed mission operational conditions, airspeed, and patterns until scheduled return time or any early unscheduled recall based upon a subsystem deficiency. Activation of the various payload can be sequential or continuous depending upon the particular operation being conducted. A final operational avionic payload carried by the vehicle is the landing aid guidance system. For runway operations, the use of a cooperative landing aid system that is also used with manned aircraft is carried. Like the manned counterpart, this system is duplicated for increased reliability. Table 7 lists the representative electrical loads for a HALE-class RPV.

### 3.6 TEDS

The expendable decoy mission is an independent interdiction vehicle. The TEDS is a low cost, one way vehicle, and mission reliability is not as important an issue as it is in the HALE vehicle. The payloads carried vary from simple ordnance to a variety of ECM payloads. The vehicles can either be ground launched from a magazine battery (multiple launched/multiple targeted) to single air launched vehicles from a cargo or fighter/bomber attack aircraft. Inasmuch as these vehicles are used solely for a tactical operation, the readiness preflight operations are brief, i.e., long term storage with no extensive preflight operations. The preflight validation is a one time, go, no-go test followed by an immediate launch. The expected flight time and/or penetration range is in the order of one hour/350 miles. The mission profile is very simple. The climbout would be on a preprogrammed heading and altitude profile. In the interest of economy, the navigation would consist of simply holding a magnetic heading. The onboard ECM jammer systems would be programmed to activate following a predetermined time from launch.

With the development of very effective microprocessor devices, more sophisticated control sequences for activating the ECM equipment are possible. ECM is the primary function. A secondary mission sometimes considered includes using a small warhead and a RF radiation seeker as a practical tactical weapon against communications or radar sites. Table 9 lists the projected electrical loads for a TEDS vehicle.

SECTION 4  
PROBLEM AREAS IN RPVS

4.1 INTRODUCTION

This section identifies those problems associated with RPV electrical systems that are considered most significant in present RPVs. Their potential solutions are discussed with the hope that such problems can be avoided in future RPVs. Specifically three problem areas have been identified as significant: Power extraction, batteries, and wiring and interconnections. The first and third are not unique to RPV; they plague aircraft of all sizes and types. The second is rather unique to RPV, since a battery is an integral part of the normal parachute recovery process used by most RPV and target drones. Excluded would be the HALE-class RPV, which has an emergency battery but no parachute. The battery serves the same function as in manned aircraft. In the 17 flights of Compass Cope-R (YQM-98A), the battery was never needed.

4.2 POWER EXTRACTION

The demands of today's electrical power generation systems are overtaking the capability of the engine to provide adequate power to accommodate both the propulsion and the electrical power extraction requirements of advanced and extended RPV mission profiles. This problem becomes even more acute at the high altitudes of some of the present day missions because the output of a jet type engine above 50,000 feet will drop to less than 10% of sea level output. The discussion of this problem area centers on those engines currently in use and those under consideration for use in near term advanced systems. It will relate primarily to specific engines in the RPV classes of concern in this study.

Experience with Mini-RPV and TEDs has not yet uncovered significant problem areas relative to power extraction. Therefore, reference to these classes of vehicle will be commentary only.

The engines currently used in RPV (and target) include the TCAE J69 and J402 series, GE J85-7, Garrett ATF-3, and Williams J400 and F107 series. Studies for RPV's have also considered such engines as the G. E. J85-4A and -17A, TCAE 373, and Lycoming ALF502. All of the engines listed above, with the exception of the Garrett ATF3, GE J85-7, and the TCAE 373, were designed with the standard AND 20002, type XII B accessory pad which limits the accessory drive speed to approximately 8,000 RPM. This drive speed has been found to be, at best, marginal for the more advanced RPV. To provide the power extraction latitude required, with sufficient safety margin to accommodate adequate system performance and growth, the TCAE J69-T406 and -J100 have been modified with a 12,000 RPM drive speed pad. In addition, the TCAE J69-T41A is currently under consideration for conversion to the 12,000 RPM drive speed. The Garrett ATF3 is designed with a 12,000 RPM pad, the TCAE J402 series and Williams F107 series are designed for either a high speed (30,000-40,000 RPM) pad or direct shaft coupling, and the GE J85-7 has no pad. The J85-7 is used on the

Army's high maneuverability version of the BQM-34A. In this target, engine bleed air drives an air turbine motor which drives a generator. Using currently available generators, the increased RPM can be expected to provide a maximum power output of approximately 8 KW without exceeding the overhung moment on the pad and without reducing the overall engine performance below critical levels. Studies based on known and anticipated electrical power requirements for the ARPV class of vehicles indicate that it could exceed 10 KM in the 1980 to 1985 time regime. This power extraction level cannot be achieved without major engine modifications and/or new generator designs. As RPV missions become more and more sophisticated, power demands in the new systems will increase to a point where the capability of present engine/drive combinations will be far exceeded. Viewing the present day levels as the limit to which the existing engine/drive combinations can be pushed, the obvious conclusion is that new development or alternate approaches to electric power extraction must be accelerated to meet the demands of the near future.

Possible solutions to the above problem are as follows:

- A. Use of bleed air to drive an air-turbine type generator.
- B. Use of bleed air to drive an air-turbine that would supplement the torque derived from the accessory pad.
- C. Use of an auxillary power plant as a separate prime mover for the electric generator.
- D. Use of a larger engine which could provide adequate torque at the accessory pad as well as sufficient power for the RPV at all altitudes within the mission profile.
- E. Use of a new generator based on rare earth permanent magnet technology and/or operating at higher speeds to increase the power generating density and thereby produce more electrical power with less volume and weight than generators in use today.

Another example is a proposed fix for the Garrett ATF3 engine. The concept is to add a tower shaft off the power turbine to provide an additional generator pad. It would have less affect on engine performance than would increasing the torque limits on the regular accessory pad.

The TCAE 373 engine is designed for an integrated engine generator (IEG). It would be an ideal candidate for the new high speed, rare earth generator which could utilize the 30,000 to 40,000 RPM pad output and also fit into the limited space available.

Another approach to supplying increased power levels in either AC or DC systems is the auxiliary emergency power unit. Examples of such units are the ram air turbine, bleed air to drive an air turbine motor, pneumatic constant speed drive, auxiliary power unit, and hypergolically fueled turbine. A particularly attractive possibility is a combination of techniques, whereby any of two or three sources of air could power a turbine drive. Turbine power could come from engine bleed air, ram air, gas generator, or ground air cart.

#### 4.3 BATTERIES

RPV batteries are not charged in flight, and it is therefore imperative that a fully charged battery be installed. The problem is to determine the status of the battery before it is committed to flight.

The flight control system and recovery systems of an RPV are required to operate on battery power during a normal recovery cycle as well as an emergency generator off situation. The voltage sensitivity of the avionics and recovery systems requires a battery voltage nearly the same as normal generator voltage, which means that the battery cannot be charged directly by the generator.

For normal operations, the batteries must be installed prior to flight in a fully charged condition. The no-load voltage of a battery is considerably higher than the voltage under operating loads. This makes it difficult to accurately determine the charge condition of the battery as it is being installed. Also, different types of batteries require different charging procedures. Therefore, checking the status of the battery before it is considered ready for use is essential. A further problem evolves as the battery is recycled because its ability to take a charge will decrease with age and the numbers of times it has been recharged. This means different readings for fully charged condition, or with some types of batteries the same reading may not indicate the same ampere-hour availability. With no one on board to monitor electrical loads on an RPV as they are on manned aircraft, a battery must be capable of handling all of the electrical loads as dictated by the RPV's mission profile or the vehicle may well be lost.

One solution to status checking would be to incorporate a means of checking a battery under load after its installation in the vehicle. To make a load check with the RPV loaded and ready for launch, both the launcher and vehicle would have to be modified from present day standards.

An alternative to an on-board load test is to make a check in the battery charging facility where equipment is available to place the battery under load. Obviously this is not as satisfactory as checking the battery after it has been installed because several hours or even days can pass between completion of charge and actual flight.

Despite improvements in wiring and connector hardware, interconnection difficulties still account for a significant portion of the manufacturing cost and life cycle cost of RPV's. With this vastly improved wiring hardware, the problems have been reduced largely to people problems.

The success of today's conventional wiring system is dependent on how well people who fabricate, assemble, install and test it perform the many thousands of individual operations necessary to complete the system. Obviously the system is only as good as the people who put it together. The inherently complex and time consuming fabrication and maintenance procedures, however, contribute significantly to the life cycle costs.

Over the years, many wire termination methods have evolved, and improvements in termination devices have been developed. Each brings with it an increase in the number of different tools and processes necessary for operations. At this point a virtual storehouse of tools and processes are required for the installation and maintenance of any aerospace system. Reduction of this great number of tools, processes, training, certification of tools and personnel and the attendant system and procurement costs would all be reflected in the life cycle costs of the RPV.

In addition, excessive space and weight penalties are imposed over all four classes of RPV's through the use of hardware designed primarily for manned air vehicles. This problem becomes critical in the smaller Mini & TEDS classes of RPV. Serious problems have been encountered in these classes on the basis of size relationship alone. Our early experience with mini drone design demonstrated that conventional wiring and wiring hardware together with specified application limitations are not compatible with the size and weight constraints of such a vehicle.

Specific problems inherent to the present day conventional wiring system are the following:

- 1) Variety of electric wire termination methods, each of which requires unique tooling, process coverage, training, wire preparation techniques, and quality assurance procedures.
- 2) Excessive size and weight.
- 3) EMI Shielding.
- 4) Susceptibility to physical damage, cross wiring, misrouting, and mismating.
- 5) Individual wire termination techniques, as opposed to mass termination methods embraced by flat conductor cable.
- 6) Individual wire identification, as opposed to fixed wiring patterns which require no identification.
- 7) Connection strain relief.

Utilization of recent and ongoing revolutionary wiring, connection, and interconnect developments would result in a significant reduction in the people problems and improved system reliability. Consequently life cycle costs and long turn around times would be reduced. Such developments include the Integrated Wiring Termination System, flexible printed wiring circuits, flat conductor cable, and fiber optics as follows.

#### Integrated Wiring Termination System (IWTS)

One way of alleviating the above problems is through implementation of a common termination system, IWTS. Idealistically, IWTS assumes all interconnect wires can be terminated in a single device type with a single tool type and a single application process. This ideal can be achieved only if all of the components switches, relays, lights, etc., have been modified to accept the single terminating device. To date some actions have been initiated in this direction.

MIL-STD-1549, Common Termination System for Electrical and Electronic Parts, tends to promote the IWTS concept by establishing standards for wire terminating devices. The requirement has, however, been imposed on very few functional devices by the military. Consequently, devices to accommodate IWTS are not generally available. In view of the unavailability of the hardware to fully utilize the system it has received only token consideration in the industry.

Research in connection with this study program indicates that the only place this system can be utilized to good advantage is where conventional round wire is used. This would take the place of the MS 27212 type terminal strip and associated hardware. The IWTS system when (and if) fully developed may lend itself better to full scale piloted aircraft rather than RPV's, especially in the Mini and TED classes, i.e., the more complex the system, the greater the benefit.

#### Flexible Printed Circuits

The advantages of flexible printed circuits in electronic packaging and retractible wiring applications have long been known but only minimally applied to current RPV's. The factors of minimum fabrication time, reduced rework, smaller package size, less weight, greater flexibility, improved reliability, etcetera that designers are continually striving to obtain are all available in this commodity.

The use of flexible printed circuits requires that the entire packaging and wiring concept take into account the new hardware, materials, and design and manufacturing techniques required to produce, assemble, and install. This must be done during the initial stages of a program. The revolutionary nature of this interconnect system dictates the implementation of new design, manufacturing, quality control and maintenance techniques

prior to the start of design. In addition, the advantages can only be fully realized if the program does not presume the use of previously developed equipment designed to accommodate conventional round conductor wiring. In other words the use of printed wiring requires a degree of design latitude that has been denied the RPV equipment designer by contract, specification, and schedule limitations. However, the relatively higher initial design costs and material costs can be offset by the value of space savings, reduced weight, and, more significantly, reduced production costs. Unfortunately, low-volume production together with design and schedule limitations are primary factors responsible for the minimal use of flexible printed circuits in RPV equipment.

#### Flat Conductor Cable

Like flexible printed circuits, flat conductor cable appears to offer significant life cycle costs advantages for interconnect wiring systems. Weight savings of 60 to 70%; space savings of 80 to 90%; cost savings of 25% have been established for flat conductor cable over conventional round wire systems. In addition, system performance is improved by tailoring the cable to suit the circuit requirements, and reliability is enhanced by improved mechanical properties and by controlled and simpler termination techniques. Such advantages can only be achieved on a complete system design basis and then only when considered very early in a new program.

Flat conductor cable can and has been adapted to conventional round conductor cable terminating devices. Various transition methods have been developed but all fall short of the ideal connector/cable relationship afforded by the complete flat conductor cable system. More significant, the advantages begin to disappear at a rate that might be described as inversely proportional to the square of the number of transitions.

On the basis of past experience, RPV programs seldom if ever afford the luxury of a completely new electrical/electronics system. Consequently, previous consideration has been adversely affected by the degree of transition required. In addition, our study indicates that the availability of military approved hardware, even at this point in time, is practically nil.

The foregoing suggests that, with the exception of a few special applications, flat conductor cable in aircraft has been the victim of questionable cost effectiveness considerations.

#### Fiber Optics

Fiber optics as a data transmission medium is at last becoming a practical reality. Recent developments in fiber optics performance and mechanical characteristics are impressive. Analysis of data accumulated on this subject indicates that it will command considerable attention for application in future RPV's.

The application potential of this exciting new technology, however, is just beginning to surface and is not fully developed. Its application in aircraft has already been proven practical in a multiplexed data bus transmission system. Since use of fiber optics is limited to control and monitor signal transmission, it must be combined with one of the power conducting technologies to produce a complete interconnect system.

## SECTION 5

### SPECIFICATIONS/STANDARDS REVIEW

For the last two decades, Teledyne Ryan Aeronautical has been at the focal point of the controversy associated with the inapplicability of many military specifications for use on remotely piloted vehicle programs. The dilemma is not simply one of approximately selecting specifications originally prepared for manned aircraft systems or for guided missile systems. It is more complex in that certain parts of the specifications for both types of systems are applicable and that certain RPV requirements are covered by neither. This section evaluates those Specifications and Standards that have the greatest impact on RPV design and costs.

The list of "Existing Specs/Std's Applied to RPVs" (Table 10) consists of System Design and Components Control specifications. Sub-tier specifications are not listed because they are so numerous and therefore cannot be examined in detail within the scope of this study. The documents listed are all by number and title. Except for MIL-T-18232, all are oriented toward manned aircraft or guided missile systems.

The list was screened to select those documents which are most often specified in RPV contracts. These selected documents were analyzed in detail to determine the degree of latitude in their application. This detailed analysis includes all of the documents listed in Paragraph 4.2.1.3; Section F of the RFP, except Mil-Std-704 and Mil-Std-883 which will be treated separately in the following paragraphs. With this exception and the addition of certain other pertinent documents, the results of the analysis are shown in Table 11. At a glance, some parts of the documents are seen to be applicable, other parts invoke undue restrictions, and for certain classes of RPVs, the requirements are not applicable at all.

Specifically:

- 1) MIL-W-5088 is very explicit about what hardware should be used for electrical wiring installation in aircraft. Such hardware, designated for use in piloted aircraft, is of necessity more rugged than necessary for RPV wiring installations. Its rugged composition introduces size and weight factors that are inconsistent with RPVs in general, and intolerable in the Mini and TEDS classes. In addition, when this document is specified, alternate design approaches (i.e., microminiature connectors, flat conductor wiring, etc.) are discouraged.
- 2) MIL-E-5400 is also very explicit about what hardware must be used for airborne electronic equipment. The scope relates to equipment "primarily in piloted aircraft". Again, the size and weight of components specified in this document are inconsistent with RPV

designs in general, and are intolerable in the Mini and TEDS classes. Flexible printed circuits and associated hardware, which could afford significant advantages in RPV electronic equipment are not covered at all.

- 3) MIL-STD-1553A precludes the use of coaxial cables or fiber optics. However, the B version in preparation may rectify the situation.
- 4) MIL-T-18232 as written applies only to "Powered Aerial Targets" and is only approved by the Naval Air Systems Command. When involved, it restricts RPV design to outmoded hardware and equipment designed for a prior generation of unmanned vehicles. For example, it specifies wiring per MIL-W-8160 which has been cancelled.
- 5) MIL-E-25500 requirements are compatible with all classes of RPVs. It should be included in any major RFP.
- 6) MIL-E-7080 contains requirements for meters, switches, circuit breakers, etc., all not applicable to RPVs. It also specifies other equipment and procedures with the same size and weight disadvantages cited previously.
- 7) MIL-E-25499 invokes MIL-W-5088 and MIL-E-7080; see comments on these specifications. The specified reserve capacity of the system is usually eroded by the demands of specified subsystems and limitations of the prime mover. The document generally assumes piloted aircraft only. It makes no provisions for RPVs or utilization of advance technologies. Wiring separations specified are not practical in RPVs.
- 8) MIL-B-83769 lead-acid batteries are no longer used in RPVs, but are used in some targets. Nicke-Cadmium is used almost exclusively. The reason is better size, weight, -life, etc.
- 9) MIL-B-26220 Nickel-Cadmium batteries are compatible with all classes of RPV.
- 10) MIL-G-6162 is for Starter Generators. Advanced design considerations indicate that given the design latitude, this type of device could be eliminated from RPVs in favor of more efficient machines.
- 11) MIL-P-8636 APU is not compatible with RPV start/run at altitude requirements. New equipment development is needed in this area.
- 12) MIL-G-21480 A.C. Generator System, 400 Hz is not consistent with MIL-STD-704 voltage drop requirements. Fault clearing requirements are not applicable to RPVs.
- 13) MIL-E-23001 A.C. Generator System Variable Speed Constant Frequency is not consistent with MIL-STD-704 requirements.

- 14) MIL-E-25366 invokes requirements strictly applicable to missiles and are not compatible with RPV design requirements. It also specifies MIL-W-8160 wiring installation, which has been cancelled.
- 15) MIL-STD-454 allows tailoring of requirements to be consistent with program design requirements. It should never be specified in its entirety.
- 16) MIL-P-81653 solid state devices are the direction advance design considerations are taking. They lend themselves very well to some of the new interconnect systems such as fiber optics.
- 17) MIL-STD-883 is a micro-electronic component test standard. It is considered only indirectly pertinent to this study, because it imposes no requirements directly on the vehicle design. It is of course, considered a necessary and effective component document.
- 18) MIL-STD-704 is considered "largely inapplicable to drone power systems" due to the drastic changes made in Revision B. MIL-STD-704B is an "idealized" specification requiring critical control and regulation of power similar to that which might be required for a test lab installation. MIL-STD-704B ignores the system concept of MIL-STD-704A since all utilization equipment is treated equally (the categories A, B, and C of MIL-STD-704A have been eliminated). The system generator voltage is not specified (i.e., only the using equipment voltage is specified; linedrop is not specified). The using equipment effect upon the generating system is ignored (See Paragraph 6. of MIL-STD-704B versus Paragraph 6.8 to 6.12 of MIL-STD-704A). Comparative transient surge and spike parameters indicate that MIL-STD-704B stringencies will be very difficult (if not impossible) to meet on an RPV installation. MIL-STD-704B appears to be written for multiple generator, constant frequency AC systems and cannot be used with a DC generator-inverter type system. This is evident when the extremely tight AC tolerances (i.e., 108 to 118 volts, +2 degree phase displacement +5 Hz frequency deviation) are compared with the relatively loose DC voltage levels (i.e., 22 to 29 volts) and with the  $\pm 4^\circ$  and  $\pm 7$  Hz of the general static inverter specification MIL-I-7032 and its detail specifications MS 17406 and MS 21983. Even though MIL-STD-704B appears to be written for AC systems, no limits are set for using-equipment load unbalance (reference Figure 12 of MIL-STD-704A). Paragraph 5.1.1.2 of MIL-STD-704B requires that the maximum voltage unbalance at the utilization equipment terminals be less than 3 volts regardless of how the equipment is distorting the system.

The list of standard components used on RPVs and TRA/Vendor-unique subsystems used on RPVs is best defined in an example, such as the Program Preferred Part List prepared by the TRA Standards Department for use on the BGM-34C system which can be found in Appendix B. The elements of this document are established and maintained as a matter of routine when selecting standards for any given RPV program.

TABLE 10  
EXISTING DESIGN STANDARDS THAT ARE  
APPLIED TO RPVS

1. DESIGN STANDARDS - SYSTEM DESIGN

1.	MIL-STD-704	Electric Power, Aircraft, Characteristics and Utilization of
2.	MIL-STD-883	Test Methods and Procedures for Micro-electronics
3.	MIL-STD-454	Standard General Requirements for Electronic Equipment
4.	MIL-E-25499	Electrical System Aircraft, Design and Installation of General Specification for
5.	MIL-G-21480	AC Generator System
6.	MIL-E-5400	Electronic Equipment, Airborne, General Specification for
7.	MIL-E-23001	Electric Generating System, Variable Speed, Constant Frequency, Aircraft General Specification
8.	MIL-W-5088	Wiring, Aircraft, Installation of
9.	MIL-G-6162	DC Generators
10.	MIL-B-26220	Battery, NiCd
11.	MIL-B-83769	Battery, Lead Acid
12.	MIL-P-8686ASG	Auxiliary Power Unit
13.	MIL-STD-1553A	Digital Data Bus
14.	MIL-P-81653	Solid State Power Control
15.	MIL-T-18232	Targets Design and Construction
16.	MIL-E-7080	Equipment Installation
17.	MIL-E-25366	Equipment Installation
18.	MIL-M-25500	Mockup Testing, Electric Systems, Piloted Aircraft and Guided Missile, General Requirements
19.	MIL-B-5087	Bonding, Electrical, and Lighting Protection, for Aerospace Systems
20.	MIL-C-6781	Control Panel, Aircraft Equipment, Rack or Console Mounted
21.	MIL-STD-463	Definition and System of Units, Electromagnetic Interference Technology
22.	MIL-STD-108	Definition of and Basic Requirement for Enclosure for Electric and Electronic Equipment
23.	MIL-STD-721	Definitions of Effectiveness Terms for Reliability, Maintainability, Human Factors and Safety
24.	MIL-STD-280	Definitions of Item Levels, Item Exchangeability, Models and Related Terms
25.	MIL-D-46845	Design Requirements for Missile Weapon Systems, Packaging and Packing
26.	MIL-D-1000	Drawing, Engineering and Associated List
27.	MIL-STD-255	Electric Voltages Alternating and Direct Current
28.	MIL-STD-461	Electromagnetic Interference Characteristics, Requirements for Equipment
29.	MIL-STD-100	Engineering Drawing Practices
30.	MIL-STD-810	Environmental Test Methods

TABLE 10 (Continued)

31.	MIL-STD-205	Frequency for Electric Power
32.	MIL-H-46855	Human Engineering Requirements for Military Systems, Equipment and Facilities
33.	MIL-STD-1472	Human Engineering Design Criteria for Military Systems, Equipment and Facilities
34.	MIL-STD-681	Identification Coding and Application of Hookup and Lead Wire
35.	MIL-STD-130	Identification Marking of U. S. Military Property
36.	MIL-STD-783	Legends for Use in Aircrew Stations and on Airborne Equipment
37.	MIL-STD-470	Maintainability Program, Requirements (for) Systems and Equipments
38.	MIL-STD-1285	Marking of Electrical and Electronic Parts
39.	MIL-STD-129	Marking for Shipment and Storage
40.	MIL-STD-188	Military Communication System Technical Standards
41.	MIL-N-18307	Nomenclature and Identification for Electronic, Aeronautical, and Aeronautical Support Equipment Including Ground Support Equipment
42.	MIL-STD-706	Power Supply Voltages, Regulated, DC Within Electronic Equipment
43.	MIL-STD-189	Racks, Electrical Equipment, 19-inch and Associated Panels
44.	MIL-STD-469	Radar Engineering Design Requirements, Electromagnetic Compatibility
45.	MIL-R-9673	Radiation Limits, Microwave and X-X-radiation Generated by Ground Electronic Equipment (As Related to Personal Safety)
46.	ANSI-Y32.16A	Reference Designations for Electrical and Electronics Parts and Equipment
47.	MIL-STD-785	Reliability Program for Systems and Equipment Development and Production
48.	MIL-STD-143	Standards and Specifications, Order to Precedence for the Selection of
49.	MIL-STD-882	System Safety Program for Systems and Associated Subsystems and Equipment, Requirements for
50.	MIL-STD-22	Welded Joint Designs
51.	MIL-W-8160	Wiring, Guided Missile, Installation of, General Specification for
52.	MIL-W-83575	High Potential and Insulation Resistance Tests
2.	<u>DESIGN STANDARDS - COMPONENT CONTROL</u>	
1.	MIL-STD-198	Capacitor, Selection and Use of
2.	MIL-STD-1498	Circuit Breakers, Selection and Use of
3.	MIL-STD-1353	Electrical Connectors and Associated Hardware, Selection and Use of
4.	MIL-STD-1328	Coupler Directional (Coaxial and Waveguide), Selection of
5.	MIL-STD-683	Crystal Units, Quartz and Holders, Crystal
6.	MIL-STD-200	Electron Tube, Selection of
7.	MIL-STD-1395	Filters and Networks, Selection and Use of
8.	MIL-STD-1327	Flange Coaxial and Waveguide and Coupling, Assemblies Selection of

TABLE 10 (Continued)

9.	MIL-STD-1360	Fuse, Fuseholders and Associated Hardware, Selection and Use of
10.	MIL-STD-1348	Knob, Control Selection of
11.	MIL-STD-701	List of Standard Semiconductor Devices
12.	MIL-STD-1562	Lists of Standard Microcircuits
13.	MIL-STD-1346	Relay, Selection and Application
14.	MIL-STD-790	Reliability Assurance Program for Electronic Parts Specification
15.	MIL-STD-199	Resistor, Selection and Use of
16.	MIL-STD-1451	Resolver, Electrical, Selection of
17.	MIL-STD-1132	Switch and Associated Hardware, Selection and Use of
18.	MIL-STD-1329	Switch, Rf Coaxial, Selection of
19.	MIL-STD-1286	Transformer, Inductors, and Coils Selection and Use of
20.	MIL-STD-1358	Coupler Directional (Coaxial and Waveguide), Selection of
21.	MIL-STD-891	Contractor Parts Control and Standardization Program
22.	MIL-STD-863	Wiring Data and Systems Schematic Diagrams, Preparation of
23.	MIL-STD-1352	Attenuator, Fixed Selection of

TABLE 11  
 APPLICABILITY OF  
 SELECTED SPECIFICATIONS TO RPVS

APPLICABLE LATITUDE	PILOTED AIRCRAFT BASIS	MISSILES BASIS	DISCOURAGES ALTERNATE DESIGN APPROACH	SIZE AND WEIGHT NOT COMPATIBLE WITH MINI/TED	RESTRICTS RPV DESIGN	REQUIREMENTS OVERLAP WITH OTHER SPECS	FULL COMPLIANCE EFFECTIVE ON ALL CLASSES	SELECTED COMPLIANCE EFFECTIVE ON ALL CLASSES	GENERAL COMPLIANCE WOULD BE ADVERSE TO MINI/TED COMPONENTS REQUIREMENTS ADEQUATE	
SPECS. REVIEWED										
MIL-W-5088	X		X	X	X			X	X	Wiring Installation
MIL-E-5400	X		X	X	X			X	X	Equipment General Spec.
MIL-STD-1553			X				X			Data Bus
MIL-T-18232		X	X	X	X			X	X	Targets Des. and Constr.
MIL-M-25500	X	X					X			Mock Up
MIL-E-7080	X			X	X			X	X	Equipment Instl.
MIL-E-25499	X				X			X	X	Elec. System Design
MIL-B-83769					X					Battery Lead - Acid
MIL-B-26220					X					Battery Nicad
MIL-G-6162	X		X		X			X	X	Gen. DC
MIL-P-8686	X		X		X				X	APU
MIL-G-21480	X				X	X		X		AC Gen. System
MIL-E-23001	X				X			X		AC Gen. System
MIL-E-25366		X	X	X	X	X		X	X	Equipment Instl.
MIL-STD-454	X	X	X	X	X				X	Electronic Equip. Spec.
MIL-P-81653					X				X	Solid State Power Control

Designers have long experienced the complex dilemma of attempting to apply specifications and standards, originally prepared for manned aircraft systems or missile systems, to RPVs. TRA worked closely with ARINC and in general concurs with the conclusions of the ARINC study (Reference 1) that a design handbook containing specifications and standards specifically tailored to RPVs would be highly beneficial. TRA support of this conclusion is reconfirmed by review of applicable specifications and standards relative to this RPV Electrical Power System Study.

The ARINC study recommends a design handbook for a general category vehicle "drone/RPV". It also recommends that the handbook contain explicit requirements extracted from related specifications and standards.

However, a document comprehensive enough to cover all classes of vehicles would be rendered useless by virtue of its complexity and volume. In addition, the wide spectrum of requirements and the continuing changes in design philosophies together with evolving new technologies will make such a document impossible to keep up to date.

Instead, the objectives of cost savings, acquisition/modification effectiveness, and design direction would be better served by modifying the ARINC recommendation to prepare a separate handbook for each class of RPV. For convenience purposes, the outline in Reference 2 has been extracted, modified slightly, and reproduced in Appendix C.

Also, individual class handbooks should cover only general requirements applicable to each RPV class to be tailored later to specific needs. Furthermore, the handbooks could be utilized to prepare explicit subsystem specifications for each of the design disciplines (avionics, fuel, electric power, etc.) on any given program. An example of how a section of an ARPV/HALE Handbook might look for the interconnect requirements is also in Appendix C.

Such subsystem specifications should become a part of any proposal. By this means, the electrical power system, as well as others, will be able to tailor the applicable requirements to the specific RPV mission environment and state of the design and technological art, thus minimizing cost drivers introduced through inapplicable specifications and standards.

## SECTION 6 TECHNOLOGY

### 6.1 INTRODUCTION

This section summarizes the currently available and developing technologies that can provide the most significant benefits to future RPV electrical subsystems. Electric power generation and distribution is generally considered a mature technology. However, developments in materials, fabrication processes, and related electronics technologies continuously provide new avenues for improvements. The increasing gap between the potentiality of technology and the reality of existing systems is producing increasing pressure to exploit that gap. As this study amply demonstrates, the current situation is such that cost can drive technology to both improve performance and reduce cost - a desirable circumstance.

The discussion focuses on four basic technologies: (1) permanent magnet materials, (2) semiconductors (power devices and large scale integrated circuitry), (3) wire and fiber optics, and (4) batteries. While other technologies could also be included, their impact is not expected to be nearly as great or their implications as far reaching. The immediately obvious impact of these technologies is on components, which is discussed here, such as generators, actuators, microprocessors, and interconnects; their secondary impact on the system, such as on architectures and performance as is discussed in Section 7, can be synergistic. For example, the synergistic effect of RPV digital avionics on the electrical system simplifies the power control and management elements.

### 6.2 PERMANENT MAGNET MATERIALS

Clearly one of the technologies having a dramatic impact on electrical components today is rare earth permanent magnet materials. Development started slowly, but is increasing rapidly. The history of the rare earth - transitional element family dates back to 1917. The first rare earth (cerium) cobalt material was found in 1947. Concentrated R&D started in the early 1960s, with the commercialization of magnets starting about 1971.

Of the large family of rare earth - cobalt (R-Co) materials available and in development,  $\text{SmCo}_5$  (stoichiometric ratio of samarium to cobalt 1:5) is the most common. The exciting properties of  $\text{SmCo}_5$  are its high energy product of 10-18 million gauss-oersteds ( $\text{MO}_e$ ), which is at least an order of magnitude greater than for the Alnico family, its extreme resistance to demagnetization, linear demagnetization curve, and long term stability with time and temperature. It is also more expensive, with samarium being the more costly of the two. Other rare earth materials (La, Ce, Pr, Y, Nd, Gd, et al) are being substituted in part or all for Samarium to reduce cost and/or to modify specific properties. Other transition metals (Fe, Ni, Mn, Cu) are also sometimes substituted in part for cobalt for the same reasons. For example, a natural occurring cerium-rich mixture of light rare earth metals, known as mischmetal (MM), is also being substituted for Samarium because it is much cheaper and more plentiful. The properties of  $\text{MMCo}_5$  are not as good as  $\text{SmCo}_5$ , but they are acceptable for many applications.

A "second generation" of material  $R_2$  (Co, Fe)<sub>17</sub> should be cheaper in terms of cost per unit energy product and superior to  $RCO_5$  for some applications. Energy products up to 60MOe appear possible, and costs may be less. Early work indicates that  $Sm_2Co_{17}$  has greater flux, higher curie temperature, better temperature coefficients, greater environmental stability, and better mechanical strength.  $R_2$  (Co, Fe)<sub>17</sub> is largely developmental, altho it is available in limited production quantities.

$RCO_5$  material is finding many applications, wherever PM materials are used. In RPV this means primarily generators and actuators (and perhaps some sensors). For example, section 11 describes a  $SmCo_5$  synchronous alternator that mounts on a turbojet engine shaft, produces over 5KW at 60,000 RPM, and yet weighs only 1.5 pounds. This is nearly an order of magnitude lower weight than a comparable capacity homopolar alternator (without regulator). For the TEDS application (Section 11), the inherent regulation of  $SmCo_5$  is such that no regulator is required. The regulator designed for the 1.5-pound generator weighs over 8 pounds. This points up a need for series regulators or new concepts in flux regulation to take maximum advantage of  $SmCo_5$  in synchronous PM machines. For example, Simmonds Precision has developed a flux shunt concept for regulating such machines. The concept is to place a movable cylindrical sleeve between the rotor and stator. The cylinder has alternating magnetic and non-magnetic bars, where the magnetic bars become the T-caps for the stator pole pieces. Rotating the sleeve slightly causes the bars to shunt part of the flux across the pole pieces thereby reducing the effective stator flux density and regulating output. Regulation from 10 to 100% is achievable in this way with less than six degrees of cylinder rotation. Regulation speed is limited by the sleeve positioning servo control loop.

Another technique is to build a hybrid machine that employs both permanent and electromagnetic excitation (both brushless, of course). This allows voltage regulation (over narrower limits:  $\pm$  to 40% range of control) with a low power field regulator (a few percent of generator output) instead of a full control series line regulator. Generally field controlled machines do not exhibit the power-to-weight ratios of a straight PM machine using  $RCO_5$  magnets, but when considering the overall system size and weight including an in-line voltage regulator, there may be an overall advantage in using the EM-PM machine from the standpoint of total size, weight, cost, and reliability, assuming this type of machine is suitable for the specific application.

In general, generators are being designed and produced today that exhibit specific power ratings of 3000 to 4000\* watts/pound and operating efficiencies of 95% or more at those ratings on a continuous duty basis. This brings the designs up to where they are utilizing the material to about the maximum limits. This includes the magnetic materials, the conductors, insulators, and the materials used to retain the physical integrity of the machine. As a result, advances will have to be made

---

\*based upon generator-rotor-stator sub-assemblies, less bearings, housings, and other parts which might vary in volume and weight with specific systems.

in the area of material improvements before much more can be accomplished in the power-to-weight and size ratios.

In addition to higher materials costs, RCo<sub>5</sub> magnets are also more difficult to fabricate, magnetize, and assemble into the end product than other magnets. A finished magnet attracts particles in shipment and handling. The strong field can make assembly difficult. Since the material is relatively soft and brittle, it can be easily damaged. All these problems notwithstanding, the end product may still be less expensive than when using other materials for a variety of reasons and depending on the performance needs. The product may be simpler, smaller, or have a higher manufacturing yield because the higher field strength allows looser tolerances.

Another application of RCo<sub>5</sub> important to RPV is in actuators. Most RPV use electromechanical actuators for flight control. The exception is supersonic vehicles, which use electrohydraulic actuators because the greater power and power density requirements exceed that which electro-mechanical devices have yet been able to supply. However RCo<sub>5</sub> technology may be able to provide an alternative approach. For example, in a technology demonstration program for the Air Force Flight Dynamics Laboratory (References 3,4,5), AiResearch has fabricated a primary flight control hingeline actuator for the F100 that uses two SmCo<sub>5</sub> motors producing four horsepower each. The project demonstrates the viability of current electrical technology as an alternative to conventional hydraulic actuation in high performance vehicles. In another example of high power actuators, Delco Electronics has fabricated for NASA (Reference 6) a brushless DC SmCo<sub>5</sub> motor designed to actuate an elevon of the NASA/Rockwell Space Shuttle. The 270 VDC motor produces 17 horsepower and weighs just 17 pounds.

TRA has recently performed preliminary tests on an available SmCo<sub>5</sub> actuator, which was of the same size class as the BGM-34C rudder actuator. The results of the tests are as follows.

<u>Parameter</u>	<u>SmCo<sub>5</sub> Actuator</u>	<u>BGM-34C Specification</u>
Weight	7.5 lbs.	6.5 lbs.
Stall torque	1031* in-lb	600 in-lb
Input power at stall	2.5A* @ 28 V	6A @ 28VDC
Frequency response	-3db -24° @ 31 rad/sec	-3db @ 18 rad/sec

\*Not stalled; test terminated due to fixture limit.

Altho not optimized, the actuator shows significant improvement in torque, power input efficiency, and frequency response over the current actuator, which performs near to the specification values. The SmCo<sub>5</sub> actuator has approximately four times the power gain of the existing actuator, that is, 14.7 in-lb/watt versus 3.6 in-lb/watt. (A more accurate statement would relate output power to input power as in-lb/sec/watt, but this loose interpretation still makes the point.) This gain increase is available to the designer to use in different ways: to increase output power for the same or less input power, to reduce the input power needed (and weight) for equal or greater output power, and/or to improve control system dynamic performance.

In a related example, TRA recently asked for proposals on an actuator very similar to the above rudder actuator. The leading response was for an actuator that complied with all the performance requirements at about half the specified weight using SmCo<sub>5</sub> technology. Other responses also complied with the performance specifications using older conventional technology, but they were at the specified weight or heavier by as much as 60 percent.

Based on the simple tests and the examples cited above, one could speculate that R-Co actuators could be used in the supersonic RPVs in place of the hydraulics. This could simplify the secondary power system and improve overall system efficiency.

### 6.3 SEMICONDUCTORS

Two areas of semiconductor technology are of particular interest to RPV electrical systems: high power devices and integrated circuit devices. Considerable 'off-the-shelf' capability already exists in these areas, very little of which is found in RPVs, and the potential continues to grow.

Solid state switches, transistors and thyristors, can meet a large share of the various RPV power handling requirements. At 28 volts DC, devices are available to switch over 400 amperes. At 270 volts, the capacity drops drastically to less than 10 amperes today. In five years, this could increase tenfold. In AC systems (400 Hz to 4 KHz), members of the thyristor family can handle up to 400 amperes at 1200 volts or 1350 amperes at low voltages. Advanced gate turn-off thyristors have demonstrated interrupting 200 amperes at about 1000 volts (Reference 7).

The devices in the higher power end of the spectrum are large by RPV standards because the heat rejection requirements call for hefty heat sinks. Recent adaptation of heat pipes has reduced the volume by factors of 4 to 10, and weight by 7 to 20. Such advances could make the higher power units RPV competitive for generator line contactors. Lower power devices are already competitive for load and bus switching.

One of the drawbacks of semiconductor devices is their forward voltage drop. Development of hybrid combinations of metal contactors and semiconductors could combine the best of both worlds - controlled turn-on and turn-off of the semiconductor and the low voltage drop and low heat

generation of mechanical contacts. So far this approach has yielded limited success.

Light activated semiconductor switches have been available for low power applications for at least 15 years. Now high power technology is emerging (Reference 8) in thyristors and transistors that have the same performance as conventional electrical devices. This adds the advantages of electrical isolation between control and power circuits and lower susceptibility to EMI and noise. Thyristors that can handle up to 1300 amperes are coming available.

Addition of integrated circuits to electrical systems has been increasingly beneficial in two areas. One is in protecting power devices from overvoltage, undervoltage, and overloading and in controlling semiconductor switching and power modulation. The latter includes zero-voltage switching, pulse-width modulation, phase angle firing, and the phase lock loop. Many of these functions are considered standard practice now.

The other area is in the large scale integrated circuits of microprocessors, programmable logic arrays, firmware, and software. The application of software and firmware for control, power management, system test, and redundancy management is a proven technology and a growing reality in industrial and military systems.

In aircraft the multiplexed data bus is also becoming the way of the future to minimize the maze of aircraft wiring. This implies a need to develop simple data bus interfaces and 'smart' terminals that can provide a measure of local control in larger systems. The size of multiplexed terminal units is continuously decreasing, currently being on a single printed circuit card, approximately 5 by 7 inches. The goal of future development is to reduce this cardful to a single chip. In high volume production, such a chip could be cheap enough to be an integral part of a remote power controller, for example, or a simple local power management center (Reference 9). The remote power controller, which is in development for manned aircraft applications (References 10, 11), is too complex for use in most RPVs. However, the larger RPVs, especially a HALE RPV with its redundant subsystems, would benefit from local power management centers.

#### 6.4 BATTERIES

Emergency power sources, primarily batteries, play a different role in most RPVs than in manned aircraft. A battery is often an essential element of the RPV recovery cycle, where power must be supplied to the automatic flight control system, communications, and parachute release mechanism after the engine has run down (whether accidental or intentional). This critical role demands that the battery design incorporate accessibility and serviceability for maintenance prior to each flight to insure that the battery starts with a full charge. Another use of a battery is to provide bus protection for those avionics units, such as a computer, that cannot tolerate the zero voltage switching transients allowed under MIL-STD-704. RPVs that operate from runways, such as the HALE RPV and possibly the ARPV, may require an alternate to the battery, where longer

service times are needed. A turbine-driven generator may be a better choice in such cases. (For a discussion of problems in RPV batteries, see Section 4.3).

RPVs with parachute recovery present a peculiar loading characteristic for a battery. A typical loading profile is:

<u>Mode</u>	<u>Amperes</u>	<u>Interval</u>
1. Flight Phase (Cruise)	zero to 0.5	30 mins. to over 24 hrs
2. Glide Phase (Optional)	25 to 45	3 to 10 minutes
3. Parachute Descent	10 to 20	5 to 20 minutes
4A. Ground Impact (Recovery beacon)	0.2 to 0.5	Up to 24 hours
or		
4B. Mid-Air Retrieval	10 to 20	Approx. 30 minutes

In general, RPV battery requirements may be categorized as follows:

<u>Vehicle</u>	<u>Usage</u>	<u>Capacity</u>	<u>Max. Service</u>
Base RPV *	Parachute Recovery	10-20 Amp-hours	30-35 Amps
ARPV/COPE	Emergency	15-20 Amp-hours	30-60 Amps
Mini	Emergency (if required)	1-2 Amp-hours	10-15 Amps
TEDS	Transient (if required)	(1)	(1)

\*Base RPV is the BGM-34C.

(1) By definition a TEDS vehicle is expendable and could need a battery for launch to provide interim power until the generator is functional. This time interval should be less than 60 seconds. For a load of 20 to 30 amperes, the energy required is very small (i.e., less than 0.5 ampere-hour).

A large variety of materials are currently in use and in development for use in secondary battery cells. Their effectiveness is often measured in watt-hours per cubic inch (w-h/in<sup>3</sup>) and watt-hours per pound (w-h/lb.). However, such figures are dependent upon the rate of discharge. Typical energy density values for some of the types of cells considered applicable to RPV are listed in Table 12 for discharge rates of 30 minutes (typical RPV usage) and 300 minutes (standard rating value). (Discharge rate refers to the time required to discharge the specified ampere-hours, i.e., the 30 minute rate for a 25 ampere-hour battery is 50 amps.)

Other factors also important to battery effectiveness and utility are cost, availability, charge characteristics, cycle life, safety, reliability in

TABLE 12

## APPROXIMATE ENERGY DENSITY OF STORED ENERGY SOURCES

TYPE	WATT-HOURS/POUND		WATT-HOURS/CUBIC INCH	
	30 Min. Rate	300 Min. Rate	30 Min. Rate	300 Min. Rate
Lead-Acid	5.0	10.6	0.32	0.74
Sealed Lead-Acid	7.9	11.3	0.58	0.92
Nickel-Cadium	8.2	11.7	0.60	0.96
Nickel-Zinc	15.4	18.8	1.15	1.55
Lithium	N.A.	47.0	N.A.	3.3
Nickel-Hydrogen	9.3	13.3	0.31	0.44
Silver-Hydrogen	16.2	23.2	0.40	0.64
Metal-Air	N.A	70.0	N.A.	4.90
Silver-Zinc (Remote)	30.0	38.6	2.31	3.00
Silver-Zinc	35.0	45.0	2.70	3.50
MEPU	30.0	Better	1.50	Better
Thermal	14.0	N.A.	1.40	N.A.

## NOTE:

1. The above figures include battery case, heater, thermostats, filters, connectors, etc., required for a complete RPV battery. These values should not be used as absolute values but as comparisons.
2. MEPU = Monofuel emergency power unit.

an airborne environment, and maintenance requirements. For example, one general rule of thumb is that the smaller and lighter the battery, for a given capacity, the more it will cost (see Figure 2 ). One exception is nickel-zinc, which is both smaller and cheaper than nickel-cadmium. This is one reason why nickel-zinc is becoming the leading RPV battery choice for the foreseeable future.

The lithium based batteries have an excellent energy density, but the maximum discharge rate - at present - is between 5 to 10 hours. This effectively rules out this battery type for RPV usage as discharge rates must be on the order of 30 minutes for the battery to be cost and size effective.

While sealed cells have been used only to a limited degree in Mini-RPV, they are possible replacement for the flooded (excess electrolyte) cells normally used. Both NiCd and lead-acid are possibilities.

The metal-air batteries show a very high energy density, but they have a low altitude limitation (oxygen is required), and no data is available at high discharge rates.

The thermal remotely activated battery is smaller than a liquid electrolyte remotely activated battery. The major disadvantages of the thermal battery are short life (30 minute life is about the practical limit) and activation time. The activation time can be controlled by using two thermal batteries piggybacked (in parallel) one of which is a fast activated - short life (i.e., typically, 0.1 second rise time and 15 second life) and the other which is a slow activated - long life (i.e., typically two second rise time and 20-30 minute life).

Cost savings are possible by considering a remotely-activated battery for emergency applications. Remotely activated batteries are slightly heavier and larger than a standard battery of the same type (space and weight is required for electrolyte storage and pressure tank), but the cost savings are considerable. An example of this trade off is found in the YQM-98A test program, in which the emergency batteries were never required in the vehicle's 17 flights. However, since the batteries were activated, they were removed after each flight, tested, and discharged/recharged when required. They were replaced several times during the program due to their limited activated life.

Another attractive source emergency power is the monofuel emergency power unit (MEPU). This unit uses a hypergolic-fueled turbine driving a generator (either AC and/or DC output) and/or hydraulic pump. It is also available as a dual mode unit where the air turbine motor is energized by engine bleed air or hypergolic fuel. Still further advances are possible whereby such a unit could also be driven by other air sources, including ram air and external air from a ground source for check out. This level of capability would provide considerable flexibility not only in RPVs but in manned aircraft as well. A multi-mode air turbine motor would be most attractive where the energy capacity requirements exceed that which could be reasonably supply by practical batteries, or where an AC output would be preferable, or where the operational flexibility is important. With generator designs progressing toward smaller machines and higher

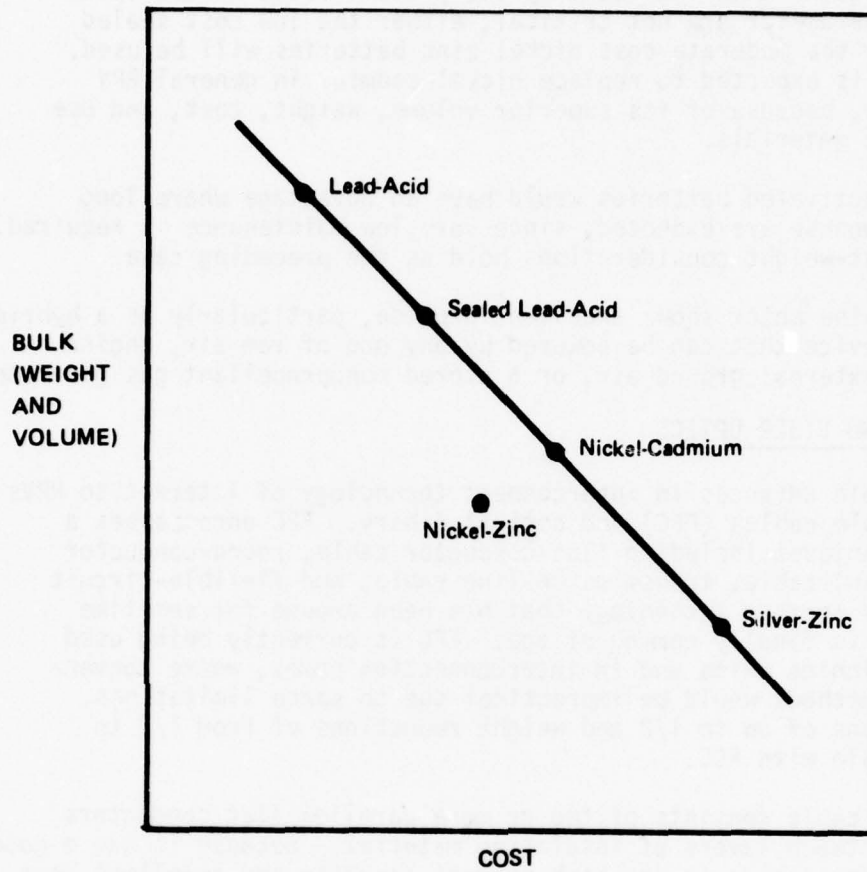

Figure 2. Cost vs. Bulk for Leading RPV Battery Candidates

speeds, direct turbine drive at speeds from 50,000 to 200,000 RPM indicates a trend in decreasing size and weight and increasing efficiency that enhances the air turbine motor concept.

### Conclusions

- Where space and weight parameters are critical, a higher cost silver-zinc secondary battery will be used, unless the metal-air development progresses faster than indicated by the present rate. Where space and weight parameter are not critical, either the low cost sealed lead-acid or the moderate cost nickel zinc batteries will be used. Nickel-zinc is expected to replace nickel-cadmium in general RPV applications, because of its superior volume, weight, cost, and use of strategic materials.
- Remotely - activated batteries would have an advantage where long periods of nonuse are expected, since very low maintenance is required. The same cost-weight considerations hold as the preceding case.
- The air turbine motor shows excellent promise, particularly as a hybrid multimode device that can be powered by any one of ram air, engine bleed air, external ground air, or a stored monopropellant gas generator.

### 6.5 WIRE AND FIBER OPTICS

The two principle advances in interconnect technology of interest to RPVs are flat flexible cables (FFC) and optical fibers. FFC encompasses a variety of techniques including flat-conductor cable, round-conductor (ribbon or woven) cable, transmission-line cable, and flexible-circuit table. This is another technology that has been around for sometime (20 years) and is finally coming of age. FFC is currently being used within some avionics units and in interconnection boxes, where conventional wiring methods would be impractical due to space limitations. Volume reductions of up to 1/2 and weight reductions of from 1/2 to 1/10 are possible with FCC.

Flat-conductor cable consists of two or more parallel flat conductors encapsulated between layers of insulating material. Because it has a good surface-to-volume ratio, it has high current capacity and excellent heat dissipation efficiency.

Round-conductor cable consists of more conventional insulated wires woven, bonded, or laminated together. They can be different sizes and types, shielded or not, coax, and possibly even optical fibers all incorporated into a flat cable.

Transmission-line cable is designed for high speed data transmission, as in a data bus. It uses small gauge flat or round conductors. Flexible circuit cable is essentially a pliable printed circuit board on which components could be mounted.

A key feature of FCC, resulting from a relatively recent series of developments, is that it can be mass terminated. That is, it can be terminated, isolated, sealed, and strain relieved in a single operation.

Terminations are crimped, soldered, or welded. This plus conductor coding results in a process where little operator training is needed to produce error-free harnesses with less labor than conventional methods. Furthermore both cable and connectors are available that meet military specifications. These features help explain why FCC is described as a much needed solution to interconnect problems in RPVs (Section 4).

FCC could be used in RPV electrical systems for nearly everything except generator feeder lines. The maximum current handling capability of FCC today is about 30 amperes. Because FCC requires different connectors, tools, etcetera than conventional wiring, it can only be economically incorporated when considered early in the design cycle.

Fiber optics (and optoelectronics) has also been around for some time, and it is striving to come of age. An optical fiber is an optical transmission line or waveguide. A light emitting diode or laser diode transmitter converts electrical signals to light or infrared and transmits it into the fiber. At the other end, the photodetector converts the optical signals back to electrical ones. If the fiber is relatively long, e.g., 10 to 1000 meters, the term fiber optics is used. If the optical path is very short, e.g., 1 mm to 10 cm, the term optoelectronics or optoisolator is used. The basic idea is the same, although optoelectronic power levels are much lower. A great deal of development and testing has occurred in the last few years to demonstrate feasibility in military applications. Included is the successful flight of the Navy A7 ALOFT (airborne light optical fiber technology) and Boeing's YC-14.

Commercial fiber optic communication lines are a reality. Optoelectronic isolators are being used in increasing numbers in commercial and military systems. A large measure of the surge in this technology is a result of the tremendous expansion in digital data processing and communications systems. Remote data processing is becoming very common. This has created a need for wide bandwidth, low loss, low noise, interference free data links and multiplexed data busses. The fiber optic data link meets all the requirements, and therefore, its development and application are being pursued vigorously by industry and the government.

The current demonstrations and applications of the multiplexed fiber optic data bus in industrial and military systems use 7- or 19-fiber (glass or plastic) bundles, as opposed to the single fiber links being used in telephone and television communication systems. The connectors, couplers, and cables are more available, less expensive, and easier to handle for multi-fiber cables than for single fiber cables. A single fiber cable potentially has at least an order of magnitude lower losses. This can be an important factor in large aircraft like a bomber or transport aircraft. However, single fiber connectors are not yet developed well enough to provide the consistent low-loss coupling that aerospace applications demand. For a vehicle as small as RPVs, the loss differences between multiple and single fiber cables is not very important.

The feasibility of point-to-point communications with multiple access points has been amply demonstrated. Therefore, the existing technology,

whether single or multi-fiber, is ready for application in RPV whenever time and price are right. This could be in a multiplexed data bus system, such as in an ARPV or HALE RPV, or it could be in a simple point-to-point power control system. Several potential trouble areas exist. One is the reliability of the optical diode transmitters. It is improving as manufacturers gain experience in fabrication. However, the spread and unpredictability of reliability is still large. The other is in the detector. The optical signals at the detector are very weak, being measured in nanowatts. Because very high sensitivities are needed, these circuits are susceptible to EMI. Therefore, special care is needed to protect them.

## 6.6 SUMMARY

A significant amount of technology is available today and in development that could be applied to electrical power systems. Among those technologies which could benefit RPV the most are the following.

- Rare earth permanent magnet materials, which is already impacting aerospace systems in generators, actuators, and sensors. Complement to PM synchronous generators are new series and flux control regulator technology; also actuator drive technology.
- High power semiconductor switches and hybrid semiconductor/mechanical contact relays to provide controlled turn-on and off characteristics, among other features. Optical control compatible with fiber optics.
- Flat wire or printed circuit cable to conserve space, reduce weight, simplify assembly, and reduce interconnect problems.
- Fiber optics and optoelectronics to reduce (if not eliminate) EMI susceptibility, isolate potential ground loops. Fiber optics could be integrated with flat wire and printed circuit cables.
- Microprocessor control and management, dedicated for local or back-up control or shared with avionics for normal control to reduce control and distribution wiring and replace relay logic. Control logic could be in software module or firmware.
- NiZn and sealed lead acid (starved electrolyte) cell batteries to improve reliability, reduce cost, enhance ability to monitor status; small high speed turbine with rare-earth PM generator as battery alternate or replacement.

SECTION 7  
ANALYTICAL APPROACH AND  
GENERAL DISCUSSION

7.1 INTRODUCTION

The preceding sections have presented background and supporting data for the analytical studies. The discussion of the analyses is presented in two parts. The first part, presented in this section, applies to all classes of RPV. The second part is presented as a series of four sections (8.0 through 11.0), each dealing with the details and peculiarities of one of the four classes of RPV.

This section presents the general approach and the procedures used in analyzing the electric power systems of the four classes of RPVs:

- 1) Advanced tactical multi-mission RPV (ARPV)
- 2) High altitude, long endurance RPV (HALE)
- 3) Mini-RPV
- 4) Tactical expendable drone system (TEDS)

The discussion includes the basic assumptions and ground rules, RPV electrical power system design philosophy, spectrum of architectures considered, and the evaluation criteria and procedures that apply to all four classes of RPV.

In each class, a number of candidate system architectures are analyzed that represent the spectrum of practical system mechanizations given the available technology and components as projected into 1982 - 85 period.

The objectives of these analyses are:

- 1) To determine trends and major issues.
- 2) To determine the optimum architectures and application of technology to RPVs.
- 3) To determine the need for additional research and development.
- 4) To find ways to overcome current operational problems and limitations and to avoid potential future ones.
- 5) To define architectures and components which will offer significant improvements over present day systems in terms of cost, performance, weight, reliability, maintainability, etc.

The scope of the analysis is limited to the four classes of RPV. These classes encompass nearly the complete spectrum of RPV. Some classes of unmanned vehicles not included are targets (especially supersonic targets) and cruise missiles. Wherever possible, the peculiarities of such systems are considered by including them in one of the basic four classes as is appropriate. For example, the peculiar requirements of the Navy FIREBRAND target (Mach 2, ramjet powered) are woven into the TEDS class of vehicles. In this way, the study scope is kept as all-inclusive as is practical. (For simplicity sake, the term RPV is used throughout the study to include all unmanned vehicles. Strictly speaking, an RPV is an unmanned vehicle requiring a man in the control loop to perform remotely a precision tracking task (e.g., target acquisition or landing) during some phase of flight. A target normally requires man's involvement to a lesser extent (e.g., mid-course navigation or air safety) or even none at all (e.g., AQM-37 target which has no remote control capability). This latter case is also true for cruise missiles. In any case, no differentiation is necessary for the purposes of this study.)

The performance, cost, and physical parameters of candidate systems are based on the use of components and technology either currently available or expected to become available in the near future. The preliminary design work for each candidate is limited in detail to a level just sufficient to allow estimating weight, volume, cost, and performance relative to a baseline system.

Section 7.2 summarizes the assumptions and ground rules used in the analyses that apply to all of the classes of RPV. Section 7.3 discusses the design philosophy used to develop the EPS candidates. It summarizes the unique design requirements of RPV in comparison with those of manned aircraft or missiles. It also categorizes the spectrum of possible architectures from which the candidates are selected for detailed analysis. This step ensures that the study achieves a practical level of comprehensiveness. Section 7.4 describes the evaluation criteria and the evaluation process including the PRICE model and its application.

## 7.2 ASSUMPTIONS AND GROUND RULES

The assumptions and ground rules used in this study were primarily developed to establish a common basis for generating, comparing, and evaluating alternative electric power system architectures and technologies for the various classes of RPVs. Section 6.0 provides the background and discussion of the general operations and needs of RPVs as they impact the EPS specifically. From this we have developed a set of ground rules to estimate future EPS requirements and their trends. Since such ground rules and the assumptions based on them tend to be largely class dependent, they are listed in the section dealing with each class (Sections 8.0 through 11.0).

## General

- Preliminary cost estimates in constant 1977 dollars
- No economic discounting
- G&A burden included but not fee

## Development Phase

- Development phase to start in FY 1983 and last for (A) months
- One prototype system will be built and tested

## Production Phase

- Production to start in FY 1986 and last for (B) months
- Quantity of (C) will be produced

## Operational Phase

- 10 years of peacetime operation with each year repetitive using non-dedicated personnel
- Logistics will use (D) organizational, (E) intermediate, and 1 depot unit

Where A, B, C, D, and E are class-dependent constants that are specified in each class analysis. Initiation of system development in 1983 implies that technology in development today and the very near future would be available as "off-the-shelf" technology by then.

### 7.3 CANDIDATE SELECTION

#### 7.3.1 EPS Design Philosophy

The design philosophy and requirements for RPV EPS lie somewhat between that for manned aircraft and missiles. Some needs are basic to any EPS; some are the same as for manned aircraft or for missiles; some are unique to RPV or even to a class of RPV.

The following characteristics or attributes of RPVs are key factors in establishing design philosophy:

- 1) RPVs are intended to be inexpensive and recoverable, in general, but expendable, if necessary.
- 2) The expected life of an RPV ranges from 5 to 25 flights for a typical Mini-RPV or ARPV to many hundreds of flights for a HALE RPV. It is long compared to a missile, which flies once. It is short compared to a manned aircraft, which flies thousands of times over many years service.

- 3) RPVs are shipped and kept in storage containers, often for years, until they are unpacked and assembled for use. Some expendable concepts (e.g., Harassment drone and TEDS) call for launching directly from the storage container in the manner of the Harpoon missile. The long-term storage aspect of RPVs is very much like missiles.
- 4) A flight mode of a recoverable RPV calls for a period of flight with engine out for recovery, whether it be for normal or emergency operations. The recovery mode requires battery power (or equivalent) to operate essential flight control equipment (autopilot, communications) during glide, parachute deployment (if used), and a recovery beacon to help locate the vehicle. This implies that battery voltage equals normal bus voltage to allow for voltage dropoff with use, which precludes in-flight charging.
- 5) Electric power requirements for most RPVs generally ranges between 2 KW and 10 KW, most of which (if not all) is DC. The flight essential equipment (i.e., automatic flight control, communications, and recovery) is DC powered as much as possible to be compatible with the battery power used during recovery. The power capacity required is greater than for a missile, and an order of magnitude below that required for most military manned aircraft. Furthermore, manned aircraft power system designs generally favor an AC waveform for better generation and distribution efficiency.
- 6) Except for HALE class vehicles and recovery systems, RPVs require little redundancy. In manned aircraft, redundancy is used primarily to ensure flight crew safety, which is not an issue in RPVs, and sometimes to enhance probability of mission success. The HALE class RPV requires it both for economic reasons and for ensuring the safety of ground personnel, especially during takeoffs and landings. Other RPVs require minimal command redundancy to ensure range safety.
- 7) The size and complexity of RPV EPS are equal or greater than those of missiles and are considerably simpler than those for manned aircraft.
- 8) Circuit protection is limited to those elements which are not essential to flight but which, if failed and not switched out, could cause loss of the vehicle. For instance, if failure of a mission payload caused failure of the EPS, the RPV would be lost. Therefore the EPS is protected from mission payload faults. In such cases, current and/or voltage sensors are used with monitor/control logic to operate relays which isolate circuits. These can be re-energized on command as desired, as opposed to fuses and circuit breakers which are one-shot devices that

cannot be replaced or reset in the air. Conversely flight essential elements (such as the AFCS) are not protected, except in redundant systems such as in HALE RPV, since failure of the element will cause loss of RPV whether it is switched out or not. Circuit protection can only reduce RPV reliability and add cost; hence it is used judiciously.

- 9) Military specifications and standards for RPVs do not exist as they do for missiles and manned aircraft, and the existing documents are inadequate or detrimental in some cases for RPVs. Therefore, the documents must be tailored to the specific application as is discussed in Section 5.0.

The remaining factors in the EPS design philosophy are essentially the same as are used in manned aircraft or missiles. They derive from common sense and good system engineering practice. Figure 3 illustrates the familiar factors affecting the characteristics of any EPS. Implied in the figure are some key factors as:

- 1) Matching the electrical source to the loads in quantity, quality, waveform, etc., and similarly matching the generator to the prime mover.
- 2) Providing the proper levels of monitoring, fault sensors, redundancy, and circuit protection.
- 3) Minimizing the generation and effects of transients, electromagnetic interference, and load interaction.
- 4) Minimizing losses and maximizing efficiency.
- 5) Minimizing life cycle costs.

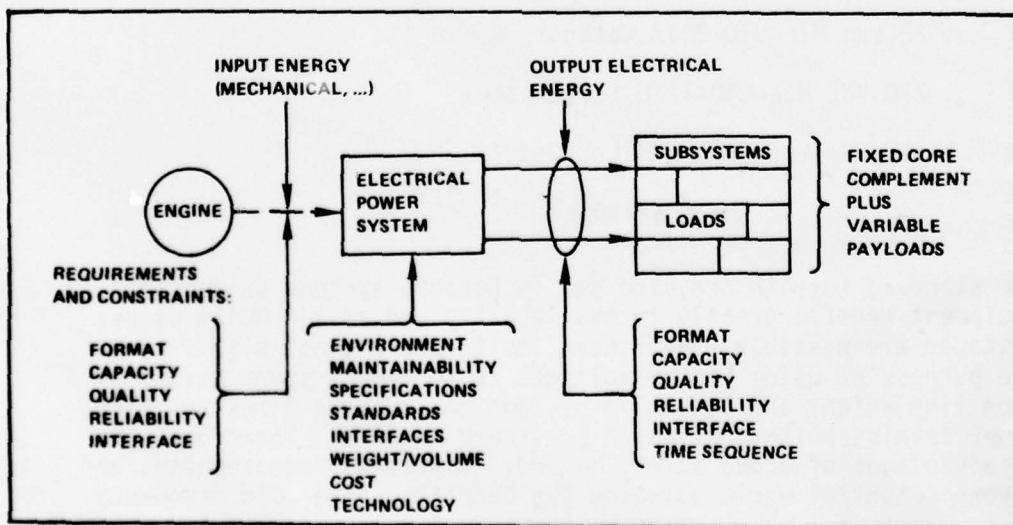

Figure 3. Factors Affecting EPS Characteristics

### 7.3.2 Spectrum of EPS Architectures

Achieving the study objectives listed in Section 7.1 requires taking a comprehensive look at alternative architectures and components. Accomplishing this task effectively and efficiently means starting from the universe of possibilities and quickly narrowing the field to manageable proportions that make sense for each particular class of RPV. Therefore the architectural concepts will be kept as simple as possible so as to avoid unnecessary detail and clutter.

To help narrow the universe in an orderly manner, consider partitioning a typical EPS into two major subsystems as indicated in Figure 4. The two subsystems consist of the following functional elements:

- 1) Power generation (including regulation, filtering, and generator drive) and conversion.
- 2) Power distribution, control, and management (including redundancy management and data transmission).
- 3) Loads, while not part of the EPS play a significant role in its architecture.

#### Subsystem 1: Power Generation and Conversion

In this study, the candidate systems are categorized according to the method of generating and distributing electric power. The spectrum of the power distribution waveforms considered ranges from DC to 400 Hz (regulated) to 5 KHz (variable) and from low voltage (28 V) to high voltage (270 V).

Specifically four voltage formats have been used:

- 1) 28 Vdc MIL-STD-704A Category B
- 2) 270 Vdc MIL-STD-704B (alternate)
- 3) 115/208 Vac 400 Hz MIL-STD-704A
- 4) 240 Vac 1-2 KHz (variable)

The standard formats are used simply because systems using standard equipment benefit greatly in availability and cost. While higher voltages are possible, their benefits to RPV are not significant. The purpose of using higher voltages is to reduce power transmission line weight and losses in systems having long lines and high power levels, neither of which are found in RPVs. Therefore, the disadvantages of added safety hazard, insulation requirements, and corona potential would outweigh the benefits. The wild frequency

format (No. 4) is an attempt to gain the benefits of AC in simpler current interruption while eliminating constant speed drives (or the equivalent).

The types of generators, regulators and drives considered include all of the known and familiar varieties, although only a handful of the more common ones are discussed in the text. Nothing much new has developed in basic generation, regulation, and drives for some time. However advances in materials technology and fabrication techniques in permanent magnets, insulation, high power switching semiconductors, integrated circuits, fiber optics, etc., have resulted in some significant increases in performance and/or reduction in size and cost in recent years.

Architecturally generators are broadly subdivided according to the method of field generation (i.e., electromagnetic, permanent magnet, or a hybrid combination), means of regulation, if any (e.g., closed loop control of the magnetic field, external series control, or inherent), and the number of phases. A generator can be homopolar, flux switching, synchronous, etc., and it can have multiple sections. Series regulators can be a switching type, magnetic amplifier, or saturable reactor among others. A generator may be (1) integral with the engine (i.e., generator rotor mounted on or integral with an engine rotor shaft), (2) driven (either directly or indirectly) from an engine accessory pad, (3) driven by an air turbine motor operating from engine bleed air, or (4) driven by a source other than the RPV prime mover, such as a ram air turbine or auxiliary power source. Emergency power sources in RPVs are most generally batteries although an alternate generator can also be used.

The candidate generation system configurations selected as being representative for study are illustrated in simplified schematic form in Figure 5 (a through f). Obviously many other configurations are possible. For example, the TEDS class analyzes a variation of VSVF (d) which has no regulator and depends on inherent regulation instead. Configuration (f) depicts a brush-type starter-generator currently in use on the BQM-34 series RPV.

High voltage for aircraft has been considered for some time with voltages of 120 DC having actually been used, and some additional experimental work is now underway. The USN has studied the use of 270 Vdc extensively, and the Garrett Corporation at Torrance, California, is presently building a 50-60 KW, 270 volt DC unit.

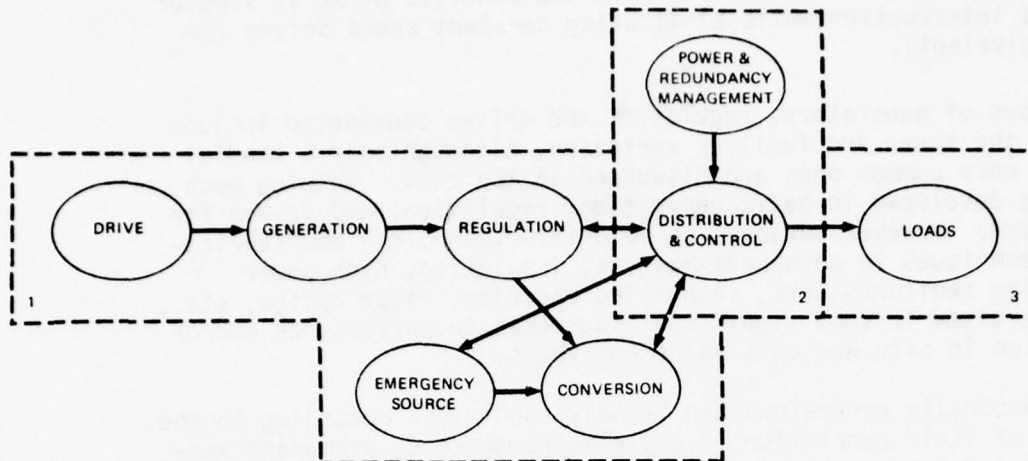
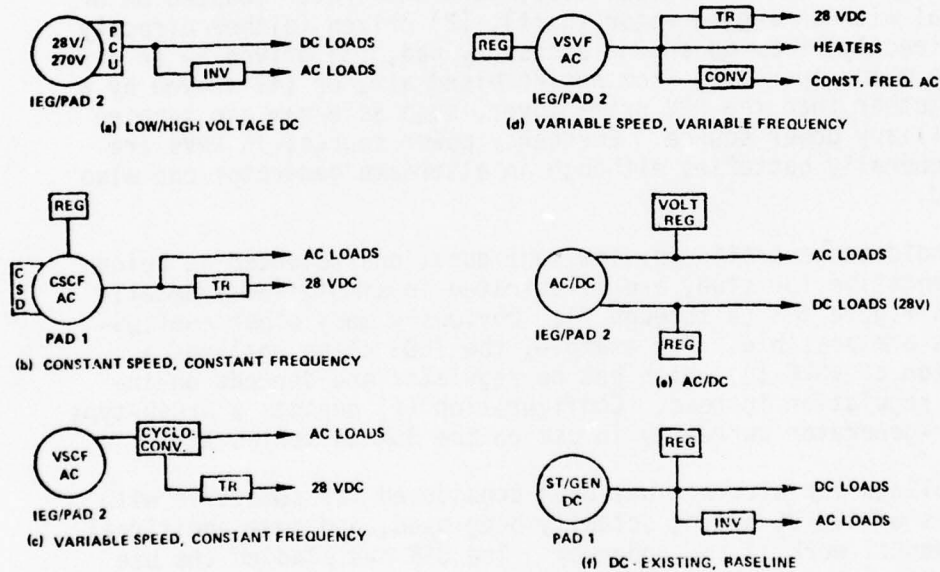

Figure 4. Electric Power System Elements



**LEGEND:**

- CONV = AC-AC CONVERTER
- IEG = INTEGRATED ENGINE GENERATOR
- INV = AC TO DC INVERTER
- PAD 1 = ENGINE ACCESS, PAD MOUNTED
- CSP = CONSTANT SPEED DRIVE

- PAD 2 = ENGINE ACCESS, PAD MOUNTED, WITH SPEED ADAPTER
- REG = VOLTAGE REGULATOR
- TR = TRANSFORMER RECTIFIER

Figure 5. Basic Candidate System Configurations

Studies have shown that 270 Vdc offers much (References 12, 13), but several problems exist. A personnel safety hazard will always exist with 270 volts HVDC and though not as great as 100V AC, it is obviously greater than 28V LVDC (Reference 14). With the higher voltage, the current is reduced approximately tenfold, but the insulation qualities will need to be improved.

The pin-to-pin insulation in connecting devices may be marginal at altitudes above 40,000 feet. Measures to preclude arc over include sealing the units or increasing the mechanical spacing or creepage distance.

Potentially, by the time frame of 1985 and with a greater funding level for research and development, existing problems with high voltage DC switchgear will have been overcome and their size, weight, and cost greatly reduced, thus making 270 V systems more competitive.

The most common way of generating a constant frequency output is to drive the generator at a constant speed - hence, a CSCF system. Several types of constant speed drives exist. Engines with accessory pads could accommodate a hydro-mechanical drive which fastens directly to the pad while the generator attaches to the drive. Thus, while the speed of the engine may vary, the generator will see only a constant speed. The existing family of constant speed drives are too large to fit within the envelope available in the RPV's with AND 10305 space envelope. Manufacturers are constantly endeavoring to reduce size and bulk and improve reliability. The latest effort is an integrated drive and generator, but except for possibly the largest (HALE) class RPV, even this unit is too large for RPV use.

Another type of constant speed drive is a combination gear drive augmented by an air turbine. Bleed air from the engine driving the air turbine is controlled to increase or decrease the speed of the generator, which is primarily being driven by the accessory pad through an overrunning clutch.

A third type, although less efficient, has been used successfully on the AQM-98A (Compass Cope R). It consists of an engine mounted, variable displacement hydraulic pump supplying hydraulic fluid to a remotely located, constant speed hydraulic motor driving an AC generator.

Still another type of constant speed drive, currently in use by TRA and the U. S. Army on the Model 274 Firebee target at WSMR, is the air turbine motor. This unit uses engine bleed air to operate a turbine driving a 3.5 KVA, three-phase alternator providing AC power to a transformer rectifier unit for DC. The air to the air turbine motor is monitored to maintain the generator at a constant speed so that constant frequency AC power is available.

Another technique for generating a constant frequency is to electrically convert a higher, variable frequency to 400 Hz.

Two vendors of VSCF systems are General Electric and Bendix (References 15 and 16). As is the case with the constant speed drives, both of these systems are too large and heavy, in their existing configurations, for RPV use except for the HALE RPV class. Bendix has made an effort to comply with the military specification (Reference 17) by containing the generator and the converter within the same envelope. General Electric is repackaging their unit to more nearly conform to the MIL-STD requirements. Their documents have a claimed efficiency of approximately 72 percent on the system.

A variable or wild frequency generator is driven directly by the engine, either from an accessory pad or as an integral machine. Therefore, the frequency varies proportionally to engine speed.

The VSVF or frequency wild system has been used successfully in turboprop aircraft, such as the Lockheed Electra. This particular system uses a shifting gearbox or transmission, due to the engine turn-down ratio, to maintain frequency within acceptable bounds.

The AQM-91 Compass Arrow RPV used a direct drive AC-DC hybrid machine which was a success. That same AC-DC machine was later used on the Compass Cope R, but driven at a constant speed hydraulically. Design of the Compass Arrow AC-DC machine is such that a constant  $\frac{V}{F}$  ratio is maintained down to a frequency of 320 Hz.

For a man-rated engine adapted to RPV use, such as the GE J-85 or Garrett ATF-3, idle is at about 50 percent rpm for a 2:1 speed range. For a typical RPV engine, such as TCAE J69 series or Williams engines, idle is at 70 - 80 percent rpm for 1.5:1 speed range. As a representative example, the TCAE Model 373 engine would drive an integral alternator at 30,000 to 40,000 rpm resulting in generated frequencies of 1500 to 2000 Hz for a 6-pole machine.

The output voltage can be regulated either to a constant value or to maintain a constant ratio of voltage to frequency. The approach taken would have different effects on the various types of AC loads. For example, electromagnetic devices, such as AC motors and transformers, are sensitive to both voltage and frequency variations, whereas heaters and avionics voltage regulators (excluding the input transformer) are voltage sensitive but not frequency sensitive.

For example, the equation describing maximum motor torque is

$$T_{\max} = \frac{1}{4\pi f} \left[ \frac{n V^2}{R_1 + \sqrt{R_1^2 + (X_1 + X_2)^2}} \right]$$

where

f = frequency  
n = number of phases  
V = phase voltage  
R<sub>1</sub> = stator resistance  
X<sub>1</sub> = stator reactance  
X<sub>2</sub> = rotor reactance

For discussion purposes if we assume  $X \gg R$  (which would tend to be true in an efficient motor), the equation would reduce to

$$T_{\max} \approx c \left( \frac{V}{f} \right)^2$$

where

c = constant

When  $V/f$  is held constant,  $T_{\max}$  is approximately constant over a wide frequency range (better than the 2:1 range of concern) in conventional AC motors. Further since the magnetic flux density also remains approximately constant (or at least it remains within the linear region and does not saturate the core), motors and transformers of conventional ("standard") design are usable over a frequency range of a decade or more. Of course the power transmitted or converted by these devices varies with frequency. Figure 6 illustrates this characteristic in an experiment performed on a conventional 115V 400 Hz motor. The solid lines are a family of computer-generated performance curves for constant  $V/f$  at various frequencies ranging from 25 to 700 Hz. Experimental data points were then taken in the laboratory to verify the performance curves.

Generally, AC motors are used in RPVs in fuel boost pumps and blower motors. Flight control actuators are normally either a DC motor or hydraulic, because of their superior control characteristics. Fuel boost pump load requirements vary as the cube of engine speed to satisfy fuel consumption needs. This requirement is matched by a wild-frequency motor driving a centrifugal pump, which minimizes size. Conversely a constant-frequency motor has to be sized to satisfy the maximum power requirement, which equates to larger motor than in the wild-frequency case.

Fans or blowers have a constant load requirement, which is independent of engine speed. A wild-frequency motor would have to be sized to meet the cooling load at the lowest frequency; hence it would be oversized at all other speeds. (See Reference 12 for discussion of these factors.)

Avionics power supplies are commonly provided with input transformers that are designed to hand 50 to 400 Hz. These transformers are slightly larger than ones designed for a fixed frequency.

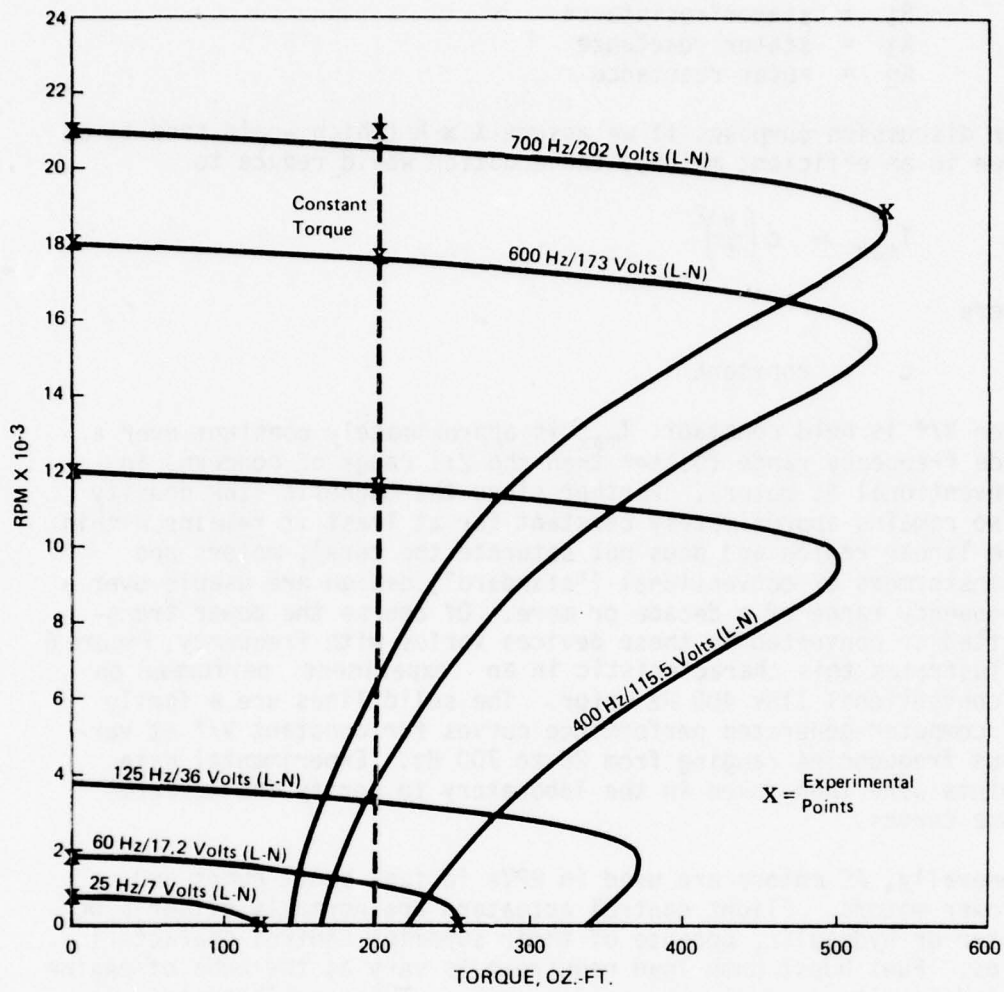

Figure 6. Motor Performance for Voltage = Constant  
Frequency

Either would be compatible with a constant V/f input. Power supply regulators can be designed to handle varying input voltages, but these would be heavier, more costly, and non-standard.

The electromagnetic interference generated by a variable frequency system would inherently be greater than for a fixed frequency one simply because of the broader power bandwidth. This is especially so where power conditioning is done in or near the loads. In this case, higher frequencies (2 KHz to 20 KHz) will appear on lines distributed throughout the vehicle. Adequate distribution design, such as lead twisting and shielding, will have to be utilized to control this potential difficulty.

Conditioning the power at the source would eliminate some EMI problems and would probably be the most desirable of the two alternatives.

In either case, EMI filtering will have to be used extensively to decouple the generated interference from one component to another. The rectifier circuits required to convert AC to DC produce high harmonic levels; however, power line filters at each component can decrease this interference to an acceptable level.

An AC/DC generator provides both AC and DC outputs from the same machine. The two outputs may derive from one rotor/stator combination as in the present AQM-98A generator or from two rotor/stator units on one shaft, which eliminates interaction between AC and DC loads. With a single rotor machine, the regulation has to be confined to either the AC or DC output with the unregulated output just following along. This means that the quality of power will suffer unless the AC and DC loads are nearly equal and reasonably constant. A dual rotor machine would have separate regulation for AC and DC and, although confined to the same operating speed, would still have some weight and space savings over two separate machines. The development of rare earth type permanent magnet generators provides additional advantages that can make AC/DC machines more attractive for certain types of electrical loads in the future.

The AC/DC hybrid system has not been used very extensively, but the Compass Arrow RPV used a machine rated at 235 amp DC and 4.2 KVA AC at 8,000 rpm and oil cooled. Because the engine rpm was reasonably constant during flight, most of the AC loads could be operated directly off generator power. An inverter was used to supply power to flight control components requiring a closer tolerance on frequency and to provide AC power during engine-off operations. The regulation was three-phase AC averaging for field current control which resulted in AC load changes affecting the DC output.

Tests were run at TRA using a Compass Arrow/Compass Cope type generator and converter developed by Lear Jet Industries to show

that MIL-STD-704 AC power can be obtained from an AC/DC machine operated at a variable speed. This could supply power at a minimum weight to a vehicle having large AC and DC electrical loads.

## Subsystem 2: Power Distribution, Control, and Management

New directions in power management and control continue to come out of advances in electronics, such as large scale integrated circuits, microprocessors on a chip, data multiplexing (data bus), and fiber optics signal transmission and isolation. An important consequence of these developments is that all future generations of RPV will have a digital avionics system of some sort. This trend affects EPS design in that power (and redundancy) management will be almost universally performed in software in either the avionics processor or a dedicated microprocessor or in the firmware of a programmed logic array. Both the ARPV and HALE classes are expected to have an avionics data bus, which can be shared by the electric power system for control and data transmission. The simpler TEDS and Mini-RPV classes will not have a data bus, but they will have a central avionics processor. In all four classes fiber optics is expected to play a dominant role in control and data signal transmission along with the avionics subsystems.

The above developments impact EPS architecture in several ways. Obviously performing control logic, checkout, and power (and redundancy) management in software reduces the EPS hardware requirements. This is especially true when the software resides in a data processor that already exists; that is, it is part of the avionics system and memory space is reserved for EPS use. Furthermore, in those systems having a data bus, the bus performs much of the function of transmitting control signals and sensor data thus reducing the EPS wiring requirements significantly. Therefore, while architecturally the EPS functions do not necessarily change with the use of a data processor or data bus, the mechanization of the functions and the interfaces change considerably. The fact that a RPV is quite simple compared to most manned aircraft implies that a single data bus system would adequately service all RPV subsystems. That is, a separate EPS data processing and data bus system, such as is used in the B-1 for example, is unnecessary.

Partitioning the EPS into independent sections is used in several classes. This architecture allows optimization in several ways. It allows for providing a preferred power format to certain loads, such as AC to payloads and DC to the avionics, so as to minimize the amount of power conversion required within the system. It also allows isolating loads that generate a great deal of noise and high current transients, such as actuators and drive motors, from loads that are especially sensitive to EMI and line transients, such as receivers and computers. Another form of partitioning is a redundant architecture, which the HALE class of RPV requires. The reliability requirements of a 24-hour mission are such as to require at least triplex redundancy in flight critical circuits that involve getting the vehicle home safely. The

additional power circuitry needed for the payloads must be at least duplex. Proper partitioning is important to ensure that a fault in one circuit does not affect the normal operation of a parallel standby circuit. Achieving inherent circuit independence and automatic fault isolation is the key to an efficient redundant architecture.

### Subsystem 3: Loads

The composition of loads in a vehicle plays a significant role in EPS design. It establishes the basic requirements in the EPS for power format, quantity, quality, distribution bus partitioning, emergency/recovery power, and control and management. A review of RPV power requirements from Section 3.0 indicates that the major fraction of RPV loads is avionics power supplies (60 - 80 percent), next is heaters (9 - 12 percent) or motors (3 - 23 percent) depending on the payload, last is actuators (3 - 7 percent). Contrast this breakdown with typical large transport aircraft in which heaters are 35 - 50 percent of the total load, motors are 20 - 35 percent, lights are 15 percent, avionics 5 - 10 percent, and actuators 5 percent.

The fact that the avionics is such a high percentage of RPV electrical loads suggests a potential variation of EPS architectures in which the avionics power supplies are included within the EPS. That is, the EPS interfaces with the avionics would be at the circuit voltage level rather than the normal 28 Vdc or 115 Vac 400 Hz level. Hence, a common power supply would provide all of the various electronics circuit voltages rather than have such avionics unit provide its own as is normally done. The benefit of the concept is that it minimizes, if not eliminates, power supply redundancy thereby minimizing overall avionics weight and cost and improving reliability. The approach was used to a limited degree in the TRA STAR mini-RPV with good results. In this system, described in Section 10.0, the common power supply provides  $\pm 15V$ ,  $+5V$ ,  $-9V$  to the avionics microprocessor and flight control components. These elements perform the functions of automatic flight control, stabilization, dead reckoning navigation, mission program guidance, communications data encoding and test. The remaining STAR subsystems, namely the TV payload and data links, use 28 Vdc in the usual manner.

The concept is illustrated in Figure 7, which shows (b) a common power supply replacing the individual power supplies of the collective black boxes being serviced as opposed to a conventional architecture (a). A circuit power distribution network is then needed. A variation of (b) is to provide a separate power supply for each circuit voltage (or  $\pm$  conjugate pair), rather than a single multiple output supply, in conjunction with a multi-winding generator having a separate output for each supply. Note that only one of the multiple outputs of the generator can be regulated (e.g., 28 Vdc), and all other outputs will vary in proportion to the variations in the controlled voltage. Transmitting the unregulated

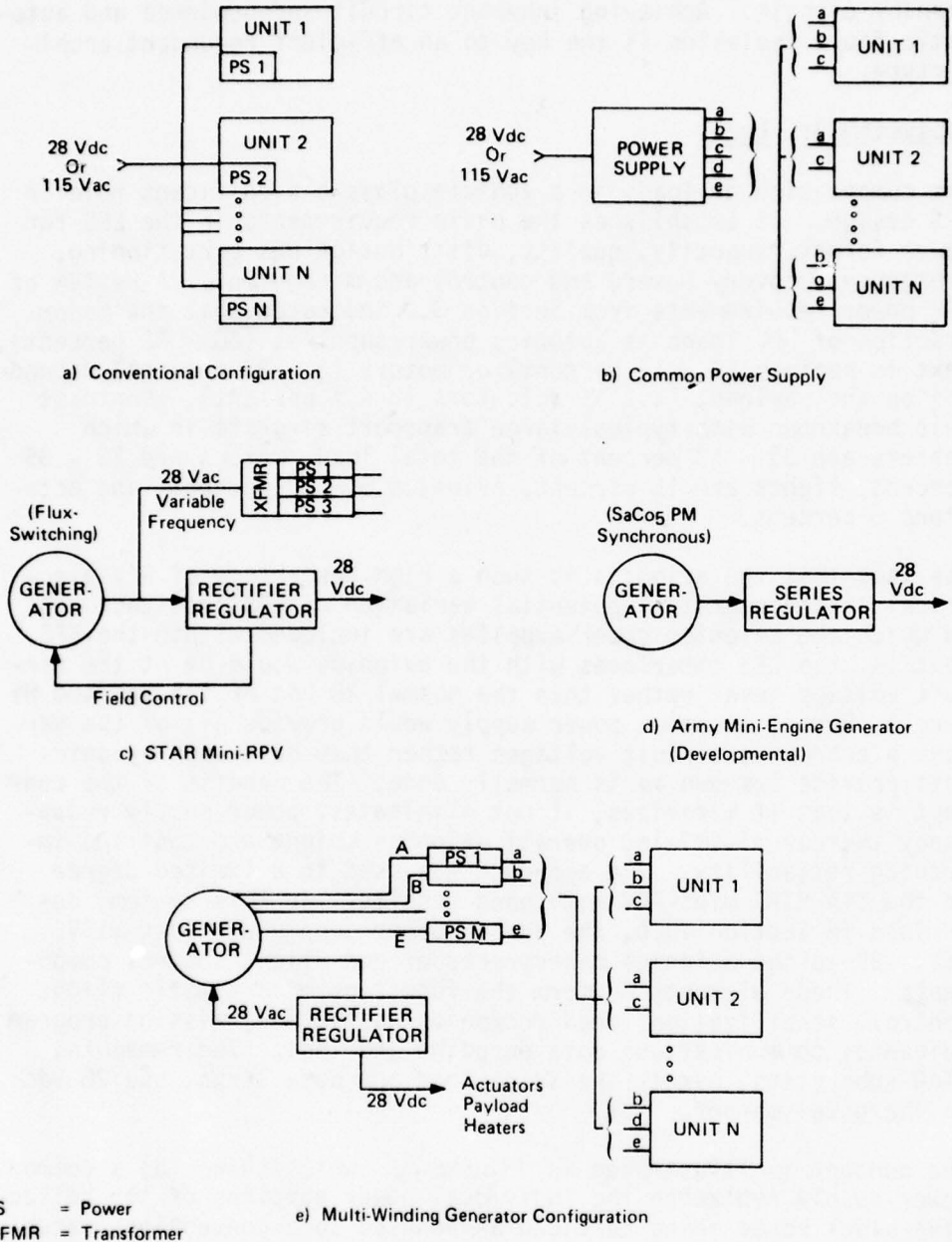

Figure 7. Power Supplies Within the EPS

voltages as wild frequency ac (in c) to the power supplies would result in the simplest system. The line voltage into (b) as in (a) could be any standard format.

The benefits claimed for the concept are reduced by several factors, which tends to limit its usefulness to small and highly integrated systems such as the Mini-RPV and TEDS:

- 1) Placing circuit power distribution lines outside of the avionics exposes them to external EMI, which is normally buffered by the power supply.
- 2) Operating multiple units on a circuit voltage bus exposes those units to intra-avionics interference. That is, circuit noise generated by one unit will cross-couple into another unit just as it does between modules within a unit.

Both of the above effects impose a need to add filters within each unit on each power line to restore the buffering formerly provided by the power supplies.

- 3) Circuit voltages are not standard, although some voltages, such as 5 and 15 are more commonly used than others. Each avionics unit may have four to six (or more) different circuit voltages, and the commonality of voltages between units would be very low. Multiply this factor by the number of different avionic units that exist, the variations in power levels required, form factors used, and choice of input line voltages and the reason for the proliferation in power supply designs can be readily seen. Thus even in the simpler systems, six to ten (or more) different circuit voltage buses would have to be provided as opposed to a single 28 volt bus.
- 4) In a larger system having longer bus lines and/or varying loads, the voltages at the loads will vary with time or location (due to different line lengths). Such conditions could be unacceptable to some circuitry that is more sensitive to power variations. These effects could be minimized by partitioning the vehicle and providing a common power supply for each equipment compartment.

#### 7.4 EVALUATION PROCESS

##### 7.4.1 Evaluation Criteria and Procedures

The evaluation procedure is a comparison of the relative merits of two or more systems. This is contrasted with "trade-offs" which are used to optimize, or compare, alternate designs of a given system. The evaluation is based on scores derived from a set of five items, divided into subsets. Each of the second level items is scored on a scale of zero to ten (ten best). The score of the first-level

items for each system are the sums of the scores of the second level items. Lower-level items are not scored. Data indicated for these parameters are merely used to derive the second-level scores. The evaluation parameters used in the analysis and the data requirements are listed in Tables 13 and 14. Determination of these scores are discussed below for each item. The scores so determined do not complete the evaluation however. These scores must be further adjusted and weighted as indicated in the discussion.

- 1.1 Weight. Let  $W_1$  be the weight of the lightest system. Then the score of the  $i$ th system is:

$$S_i = 10 \left( \frac{W_1}{W_i} \right)^\alpha, \alpha \geq 1$$

The exponent is chosen to adequately penalize the high weight systems.  $\alpha$  is therefore a sensitivity factor. The larger  $\alpha$ , the larger this penalty. Individual component weights are used only as an input to the PRICE model to determine system cost. It is to be emphasized that the above formula, and those that follow, are suggestive only. There are many, many relationships that can do as well or better. For example we might write:

$$S_i = 10 \left( 1 + \ln \frac{W_1}{W_i} \right)^\alpha, \alpha \geq 1$$

or even

$$S_i = 10 \sin^\alpha \left( \frac{W_1 \pi}{2 W_i} \right), \alpha \geq 1$$

The particular formula used is a judgement of the evaluation engineer. It should be chosen to adequately describe the benefits and penalties of the particular parameters in question.

- 1.2 Volume. Let  $V_1$  be the volume of the smallest system. Then

$$S_i = 10 \left( \frac{V_1}{V_i} \right)^\alpha$$

The volume of the individual components are used only as inputs to the costing models.

- 1.3 Total Available Power. This item is combination of current and growth power as indicated under data requirements. Let  $P_{CI}$  be the power for the system with the highest current

power available. Let  $P_{GI}$  be the potential power available for the system with the highest future growth potential. The same system need not be represented by the  $P_{CI}$  and  $P_{GI}$ . The score for the  $i$ th system is:

$$S_i = 10 \left[ \beta \frac{P_{Ci}}{P_{C1}} + (1 - \beta) \frac{P_{Gi}}{P_{G1}} \right]$$

$$\alpha > 1$$

$$0 \leq \beta \leq 1$$

$\beta$  is the relative weighting factor between current and growth power available. If the weighting factors are equal  $\beta = 0.5$ . As before,  $\alpha$ , the sensitivity factor, is chosen to penalize the worst (lower power) system.

- 2.1 Steady State Parameters. This item is a combination of steady state voltage and frequency variation, measured in percent. These variations have an upper and lower limit. Let  $V_{ui}$  and  $f_{ui}$  be the upper limits of the voltage and frequency variations of the  $i$ th system, and  $V_{li}$  and  $f_{li}$  be the lower limits. Then:

$$S_i = 10 - \alpha \left[ \beta \frac{V_{ui} - V_{li}}{20} + (1 - \beta) \frac{f_{ui} - f_{li}}{20} \right] \geq 0$$

where as before  $\beta$  is the relative weighing factor.

- 2.2 Transient Parameters. This item is a combination of the transient voltage and frequency variations. The score is computed as above.

$$S_i = 10 - \alpha \left[ \beta \frac{V_{ui} - V_{li}}{20} + (1 - \beta) \frac{f_{ui} - f_{li}}{20} \right] \geq 0$$

- 2.3 Filtering Requirements. These data are all qualitative. Scoring is accomplished through engineering judgement. Note: Items for which quantitative data is required but not available must also be scored through engineering judgement.

- 2.4 Ability to Operate in Parallel. Again the scoring is based on engineering judgement. In this instance the ability of the individual components as well as the system as a whole to operate in parallel is taken into consideration.

- 2.5 Penalties. This item is a combination of the losses,  $L_i$ , and the weight penalties,  $W_i$  of each of the systems. Let  $L_1$  be the losses attributed to the system with the smallest losses, and  $W_1$  be the weight penalty attributed to the system with the smallest weight penalty. Then:

$$S_i = 10 \left[ \beta \frac{L_1}{L_i} + (1 - \beta) \frac{W_1}{W_i} \right]^\alpha$$

Note that the same system need not be represented by both  $L_1$  and  $W_1$ .

- 2.6 Efficiency. The efficiency of a system,  $E$ , is measured in percent.

$$S_i = \frac{E_i}{10}$$

- 3.1 MTBF. Let  $M_1$  be the largest MTBF of the system being evaluated. Then:

$$S_i = \left( \frac{M_1}{M_i} \right)^\alpha$$

- 3.2 Probability of Mission Success. These probabilities,  $P$ , of the electrical power systems operating as required during the mission are computed using the data of the lower-level items. It is scored:

$$S_i = 10 P_i^\alpha$$

- 4.1 MTTR. Let  $M_1$  be the lowest meantime to repair of the system to be evaluated. Then:

$$S_i = 10 \left( \frac{M_1}{M_i} \right)^\alpha$$

- 4.2 Fault Isolation. This item is a combination of accessibility, automatic/manual fault isolation, and meantime required for fault isolation. Let  $T_{F1}$  be the smallest meantime required for fault isolation. Let  $S_{ai}$  and  $S_{mi}$  be engineering judgement derived scores for accessibility and automatic/manual respectively for the  $i$ th system. Then:

$$S_i = \beta_1 S_{ai} + \beta_2 S_{mi} + 10 \beta_2 \left( \frac{T_{F1}}{T_{Fi}} \right)^\alpha$$

$$0 \leq \beta_i \leq 1$$

$$\sum \beta_i = 1$$

If quantitative data is obtainable for accessibility, let  $T_{a1}$  be the smallest system meantime average overall components to gain access to components. Then:

$$S_i = 10\beta_1 \left(\frac{T_{a1}}{T_{ai}}\right)^{\alpha_a} + \beta_2 SM_i + 10\beta_3 \left(\frac{T_{F1}}{T_{Fi}}\right)^{\alpha_F}$$

where  $\alpha_a$  and  $\alpha_F$  are the sensitivity factors for access time and fault isolation time respectively.

- 4.3 Maintenance Actions. All data except time for alignment and adjustment times are qualitative. Let  $T_1$  be the smallest system meantime averaged overall components for alignment and adjustment. Then:

$$S_i = \beta_1 S_{R1i} + \beta_2 S_{R2i} + \beta_3 S_{Ei} + \beta_4 S_{Si} + 10\beta_5 \left(\frac{T_1}{T_i}\right)^\alpha$$

$$0 \leq \beta_i \leq 1$$

$$\sum \beta_i = 1$$

where  $S_{R1}$ ,  $S_{R2}$ ,  $S_E$ , and  $S_S$  are scores derived from engineering judgement for repairability, replaceability, expendability, and standardization.

- 4.4 Mean Preventive Action Time. Let  $T_1$  be the smallest mean preventive action time. Then:

$$S_i = 10 \left(\frac{T_1}{T_i}\right)^\alpha$$

- 4.5 Mean Down Time. Mean down time for each system is computed from data previously discussed. Let  $T_1$  be the smallest mean down time for the systems being evaluated. Then:

$$S_i = 10 \left(\frac{T_1}{T_i}\right)^\alpha$$

- 4.6 - Availabilities. Availabilities,  $A$ , for each system are computed from data previously discussed. These items are scored:

$$S_i = 10 A_i^\alpha$$

5.1 - Cost. Let  $C_1$  be the lowest cost for the systems being  
 5.3 evaluated (development cost or production cost or O&S costs). Then:

$$S_i = 10 \left( \frac{C_1}{C_i} \right)^\alpha$$

As mentioned previously, the scores of the first-level items (physical parameters, performance, reliability, maintainability, and cost) are the sums of the appropriate second-level items. From the list of the evaluation parameters (Table 1) it is seen that the maximum possible score for the first-level items ranges from 20 points for 3.0, reliability, to 80 points for 4.0, maintainability. This inadvertent biasing of the first-level items is due to the accident of the development of the list of evaluation parameters. Any other list would result in a similar bias.

The next step in the evaluation procedure is to take out the accidental bias discussed above. This can be accomplished by assigning each first-level item an arbitrary maximum score of 200 points: 1000 points maximum for the electrical power system. Let  $N_i$  be the maximum number of points for the  $i$ th first-level item due to the accidental bias. Then if each of the second-level scores are multiplied by  $\frac{200}{N_i}$  the result will be to adjust the scores so that each first-level group of evaluation parameters have an equal weight. This "adjusted score" is therefore the true unweighted score for each system.

Depending upon the RPV system for which the electrical power system is designed the first level items can be assigned weights by varying the maximum points assigned. 1000 points for the whole system is kept constant however. For example, the following weights may be assigned:

1.0	Physical Parameters	150
2.0	Performance	120
3.0	Reliability	250
4.0	Maintainability	200
5.0	Cost	280
	Total System	<u>1000</u>

The second level-items can now be weighted so that their total score adds up to the score assigned to the first-level item. For example:

1.0	Physical Parameters	150
1.1	Weight	50
1.2	Volume	50
1.3	Total Available Power	50

Multiplying the adjusted (unweighted) score by the appropriate factor will result in the weighted evaluation of the electrical power system.

The following illustrates the scoring as outlined above. Consider the raw data (Table 22) for the physical parameters. The lightest weight system is the VSVF at 103 pounds. The baseline system weighs 191 pounds. Applying the formula given above with 2 the raw score for weight is:

$$S = 10 \left( \frac{W_1}{W_i} \right)^\alpha = 10 \left( \frac{103}{191} \right)^2 = 2.91$$

The smallest volume is the LVDC with 2011 in<sup>3</sup>. The volume of the baseline system is 2992 in<sup>3</sup>. The raw score then is:

$$S = 10 \left( \frac{V_1}{V_i} \right)^\alpha = 10 \left( \frac{2011}{2992} \right) = 6.72$$

Total available power is a combination of the current and growth power. The formula for the raw score is:

$$S = 10 \left[ \beta \frac{P_{ci}}{P_{c1}} + (1 - \beta) \frac{P_{Gi}}{P_{G1}} \right]^\alpha$$

For the case of the baseline, this score becomes ( $\beta = 0.5$ )

$$S = 10 \left[ (0.5) \frac{3.4}{7} + (0.5) \frac{5.3}{10} \right] \\ = \left[ \frac{4.86}{2} + \frac{5.30}{2} \right] = 5.08$$

As described above,  $\beta$  is the relative weight given lower level parameters. In this report, all lower level (third level) parameters are weighted equally.

The total "raw score" for the baseline physical parameters is the sum of the scores just evaluated: 14.71. Now note the maximum score possible for physical parameters is 30 points; while that of maintainability is 80 points. The reason for this difference is due only to the choice of evaluation parameters. It results in a bias for items for which the evaluator can think of the largest number of parameters. In order to remove this bias, each of the five first level items are awarded the same possible maximum score: 200 points. These 200 points are then divided equally among the second level items.

For example, each of the three second level items under physical parameters is awarded 66-2/3 points. The "adjusted score" is then the indicated proportion of these points. For example, the

the adjusted score for the baseline for physical parameters is:

$$\text{Weight} = \left(\frac{2.91}{10}\right) (66-2/3) = 19.47$$

$$\text{Volume} = \left(\frac{6.72}{10}\right) (66-2/3) = 44.79$$

$$\text{Total Available Power} = \left(\frac{5.08}{10}\right) (66-2/3) = 33.54$$

$$\text{Total Adjusted Score, Physical Parameters} = 97.74$$

Finally, the weighted score is evaluated:

$$\text{Weight} = \left(\frac{19.47}{66-2/3}\right) (50) = 14.60$$

$$\text{Volume} = \left(\frac{44.79}{66-2/3}\right) (50) = 33.59$$

$$\text{Total Available Power} = \left(\frac{33.54}{66-2/3}\right) (50) = 25.16$$

$$\text{Final Score, Physical Parameters} = 73.31$$

TABLE 13  
ELECTRIC POWER SYSTEM EVALUATION PARAMETERS

1.0	Physical Parameters
1.1	Weight
1.2	Volume
1.3	Total Available Power
1.3.1	Current
1.3.2	Growth
2.0	Performance
2.1	Steady State Parameters
2.1.1	Voltage Variation
2.1.2	Frequency Variation
2.2	Transient Parameters
2.2.1	Voltage Variation
2.2.2	Frequency Variation
2.3	Filtering Requirements
2.4	Ability to Operate in Parallel
2.5	Penalties
2.5.1	Losses
2.5.2	Weight Penalty Due to Losses
2.6	Efficiency
3.0	Reliability
3.1	MTBF
3.2	Probability of Mission Success
3.2.1	Component Probability of Failure
3.2.1.1	Launch
3.2.1.2	Outbound/Inbound Flight
3.2.1.3	Mission Flight Segment
3.2.1.4	Recovery
3.2.2	Redundancy
4.0	Maintainability
4.1	MTR
4.2	Fault Isolation
4.2.1	Accessibility
4.2.2	Automatic/Manual
4.2.3	Meantime Required
4.3	Maintenance Actions
4.3.1	Repairability
4.3.2	Replaceability
4.3.3	Expendability
4.3.4	Standardization
4.3.5	Alignment and Adjustment
4.4	Mean Preventive Action Time
4.5	Mean Down Time
4.6	Inherent Availability
4.7	Achieved Availability
4.8	Operational Availability
5.0	Cost
5.1	Development Cost
5.2	Production Cost
5.3	Operations and Support Costs

TABLE 14  
ELECTRIC POWER SYSTEM EVALUATION  
DATA REQUIREMENTS

- 1.0 Physical Parameter: No data required for this item.
- 1.1 Weight: Weight in pounds for each component and for the system as a whole.
- 1.2 Volume: Volume in ft.<sup>3</sup> or in.<sup>3</sup> for each component and for the system as a whole.
- 1.3 Total Available Power: No data required for this item.
- 1.3.1 Current: Total power available for the system as a whole for current requirements expressed in convenient units.
- 1.3.2 Future: Total power available for the system as a whole for future growth potential expressed in convenient units.
- 2.0 Performance: No data required for this item.
- 2.1.1 Voltage Variation: Steady state voltage variation expressed in percent for the system as a whole.
- 2.1.2 Frequent Variation: Steady State Frequency variation expressed in percent for the system as a whole.
- 2.2 Transient Parameters: No data required for this item.
- 2.2.1 Voltage Variation: Transient voltage variation expressed in percent for the system as a whole.
- 2.2.2 Frequency Variation: Transient frequency variation expressed in percent for the system as a whole.
- 2.3 Filtering Requirements: Filtering requirement for the system as a whole expressed qualitatively (e.g., some, none, medium, heavy, etc.)
- 2.4 Ability to Operate in Parallel: Yes or no answer for the system as a whole and for each component.
- 2.5 Penalties: No data required for this item.
- 2.5.1 Losses: Heat losses for each component and for the system as a whole expressed in convenient units.
- 2.5.2 Weight Penalty Due to Losses: Additional weight in pounds required to dissipate losses for each component and for the system as a whole.
- 2.6 Efficiency: System efficiency expressed in percent.
- 3.0 Reliability: No data required for this item.
- 3.1 MTBF: Mean time between failure for each component and the total system in hours.
- 3.2 Probability of Mission Success: No data required for this item.
- 3.2.1 Component Probability of Failure: No data required for this item.
- 3.2.1.1 Launch: Yes or no that each component will be used during the launch phase.

TABLE 14 (Continued)

- 3.2.1.2 Outbound/Inbound Flight: Yes or no that each component will be used during the outbound and inbound flight phase.
- 3.2.1.3 Mission Flight Segment: Yes or no that each component will be used during the mission flight segment phase.
- 3.2.1.4 Recovery: Yes or no that each component will be used during the recovery phase.
- 3.2.2 Redundancy: Number of redundant elements for each component and for the system as a whole. No redundant element = 1; one (1) redundant element - 2, etc.
- 4.0 Maintainability: No data required for this item.
- 4.1 MTTR: Meantime to repair or replace each component and for the system as a whole in hours.
- 4.2 Fault Isolation: No data required for this item.
- 4.2.1 Accessibility: Accessibility for each component and for the system as a whole expressed qualitatively, or by time required to gain access.
- 4.2.2 Automatic/Manual: Automatic or manual fault isolation for each component and for the system as a whole.
- 4.2.3 Meantime Required: Time in hours required for fault isolation for each component and for the system as a whole.
- 4.3 Maintenance Actions: No data required for this item.
- 4.3.1 Repairability: Yes or no that each component is repairable.
- 4.3.2 Replaceability: Yes or no that each component and the system as a whole is replaceable.
- 4.3.3 Expendability: Yes or no that each component is a throw-away expendable.
- 4.3.4 Standardization: Yes or no that each component is military standard.
- 4.3.5 Alignment and Adjustment: Time, in hours, required to align and adjust each component after repair or replacement.
- 4.4 Mean Preventive Action Time: Meantime in hours, to perform preventive maintenance actions for the system as a whole.
- 4.5 Mean Down Time: No data is required for this item.
- 4.6-4.8 Availability: No data is required for this item.
- 5.0 Costs: Cost will be computed using a variety of models. In addition to the data mentioned above the following will be required for costing purposes.
  - a. Complexity: A qualitative description of the complexity of each component (e.g., low, high, medium, etc.)
  - b. New Design: A qualitative (or quantitative) description of the degree to which each component is new design (e.g. high, low, 25%, etc.)

#### 7.4.2 Cost Analysis

The cost analysis objective is to provide the life cycle cost data associated with the defined electric power systems in this study. In addition to total LCC for comparison purposes, a breakdown is analyzed to determine which phases dominates the cost and then which items within each phase are the cost drivers.

The methodology for this analysis includes the establishment of ground rules for cost estimates and a baseline electric power system. Then with advanced power systems defined into "make" and "buy" items, preliminary costs are estimated for comparison purposes. The "make" items have both development and production costs. While the "buy" items do not have to be developed, hence only recurring costs are involved. The PRICE model is used to estimate the development and production costs, and the PRICE L model is used to perform a maintenance analysis, spares, and support costs. The manufacturing and engineering complexities are estimated relative to the baseline system. A description of both PRICE and PRICE L and how they work together can be found in Appendix A.

## SECTION 8 ARPV CLASS

### 8.1 INTRODUCTION

This section treats the electric power system of the ARPV class. It shows how the available and developing technology and design art can best be applied to satisfy the projected ARPV requirements and to resolve the problems of current RPV (Section 4). The analysis follows the general approach described in Section 7. This ARPV portion of the electric power study is intended to complement the three ASD ARPV studies. The purpose of the three studies was to determine how to reduce life cycle cost of advanced RPVs for use in tactical, low-altitude, multimission operations. They are general in nature, and do not specifically address the electrical power subsystem.

Five candidate systems have been analyzed:

- 1) Low voltage (28V) DC
- 2) High voltage (270V) DC
- 3) Constant speed, constant frequency
- 4) Variable speed, constant frequency
- 5) Variable speed, variable frequency

The BGM-34C multimission RPV system is used as a baseline reference for the comparative analysis, since it represents current operational capability in ARPV class systems.

The material presented in this section includes the assumptions and ground rules used in the analysis, description of the candidate and baseline systems, the performance and cost analyses, and evaluation.

### 8.2 ASSUMPTIONS

The assumptions and ground rules used in the ARPV analysis are as follows:

- 1) The maximum power requirement of the three payloads is approximately 7KW for the EW and strike missions with 10KW a possibility. Therefore 7KW with growth capability to 10KW is taken as the nominal requirement. The waveform may be either AC or DC, although AC may

be preferred by those payloads that are adapted from manned aircraft.

- 2) The core avionics will not require precision 400 Hz power. The preferred power format is DC to be consistent with the emergency battery. Core avionics power requirements are approximately 1.5 KW.
- 3) A battery is required for 7 minute glide.
- 4) The avionics computer will control and manage the EPS via a data bus.
- 5) The propulsion will have a single engine.
- 6) Runway takeoff and landing is the primary operating mode; air launch is a secondary mode; emergency recovery is by parachute.
- 7) Maximum altitude is 40,000 feet; endurance is four hours.

The cost analysis uses the following ground rules:

- 1) Development phase begins in 1983 and lasts for 14 months; one prototype is tested.
- 2) Production phase begins in 1986 and lasts for 18 months; a quantity of 1,000 is produced.
- 3) Operational phase lasts for 10 years; logistics will use 3 organizational, 3 intermediate, and 1 depot unit.

The trend in RPV avionics and payload designs is such that the ARPV may require no AC power, which would simplify the system noticeably. Today the only requirement in RPV avionics for precision AC power is for the attitude and/or heading reference gyros. Future RPV (and target drones, such as the Navy Firebrand) will use strapdown attitude and heading reference systems that require only DC power. The few payloads that could prefer AC power are the high power users, such as transmitters (communications or jammers), and these are not frequency sensitive. However, the state of the art in DC-to-DC converters is such that the AC preference is disappearing. Furthermore, where the payload requires both AC and DC power, an inverter is usually carried as part of the payload. As a consequence of this trend, we have required the ARPV EPS to convert 1KW of the 7KW into 400 Hz AC power as an option. The option provides a more conservative comparison between DC and AC architectures.

The ARPV studies call for runway recovery rather than parachute recovery, which current RPVs use. The EPS study assumes a parachute for back-up recovery from up to 5000 feet altitude, an

assumption not made in the ARPV studies. RPV descent rate in a parachute is typically 1000 feet per minute. A safety factor of 20 to 50% is added, depending on the degree of operational risk factors involved. For the BGM-34C, battery operation time is seven minutes.

### 8.3 CANDIDATES

#### 8.3.1 General Discussion

The six candidates electrical systems considered as potential ARPV power sources are configured with two representative engines.

The two engines were selected to be consistent with recommendations of the ARPV trade studies conducted by Boeing, Northrup, and Rockwell. The selected power plants are TCAE Model 373-PD1 and GE J85-4 and GE J85-17. The two engines are considered appropriate to the study in that the GE engines have conventional low speed and 20002 pads for mounting generators, whereas the TCAE engine uses a recent innovation, the integrally engine-mounted high speed generator. These choices represent two basic prime mover concepts.

In the case of the GE J85 engine, a suitable speed adapter would permit the use of this new type of generator. Its use will greatly reduce the weight and overhung moment on the engine pad. It will also reduce overall power extraction losses even with high speed adapters, due to increased generator efficiency. Not all J85 engines have accessory drive pads, however; the J85-7 currently used in a high speed version of the BQM-34A has no pad. An air turbine motor drives a generator from engine bleed air in that configuration.

The high speed, rare earth magnet generator, due to its reduction in size and volume, along with its inherently superior MTBF/MTTR, permits its use within the engine with this type of installation. The generator is driven directly by the main rotor shaft at high RPM and its power control unit is remotely located. This is the concept used by the TCAE 373 engine.

The six electrical power generating systems analyzed are as follows:

- a) LVDC, Low Voltage DC (28V)
- b) HVDC, High Voltage DC (270V)
- c) CSCF, Constant Speed Constant Frequency, AC
- d) VSCF, Variable Speed Constant Frequency, AC
- e) VSVF, Variable Speed, Variable Frequency, AC
- f) Baseline (LVDC) BGM-34C

### 8.3.2 LVDC System

The candidate LVDC system would generate 10KW of MIL-STD-704 power regulated at 27.5 volts. The generator is a 30,000 to 40,000 RPM, solid rotor, rare earth magnets, air cooled machine that is either pad mounted or integral with the engine. The accompanying power control unit (PCU), which can be integral with the generator or separately mounted nearby, rectifies and filters the wild frequency AC output of the brushless generator and regulates the generator voltage at 27.5 volts.

Generators using samarium cobalt magnets are presently in use in the Tomahawk cruise missile with a 4 KW rating and integral PCU. The proposed unit for the FIREBRAND is a 7 KW unit in a ram air turbine, and 10 KW and larger units have been designed.

Sm Co generators can be made smaller than conventional generators. This plus a generator speed of 30,000 to 40,000 RPM or higher, permits a weight reduction of approximately 30% over a standard 8,000 RPM machine. Permanent magnet generators are also brushless, which improves their high altitude characteristics and the overall MTBF.

Figure 8 shows a LVDC system as it might apply to an ARPV utilizing the high speed, samarium cobalt generator with its PCU. Monitor and control of the electrical power system is by the avionics computer via the data bus into the remote terminal unit and its interface unit for control of the solid state switchgear.

The solid state switchgear can be two types, one simply a switch, the other a current limiting switch or circuit breaker. The power feeder and distribution wire weights and volumes were determined by use of conventional round wire and conventional connectors. The control wiring between the remote terminal unit and the power controllers uses flat wires to minimize weight and volume and fiber optics to minimize EMI susceptance.

Table 15 lists data pertinent to the LVDC system components for comparison with the baseline system.

### 8.3.3 HVDC System

The high-voltage DC system is functionally identical to the LVDC system. The difference is that the transmission voltage is 270 volts rather than 28 volts. The generator is essentially the same high speed machine, similar to the 28 volt one used in the LVDC system but optimized for 270 volts. The PCU can be an integral part of the generator or mounted separately nearby. Table 16 lists the pertinent data for the system components.

The higher voltage definitely reduces wire weight compared to

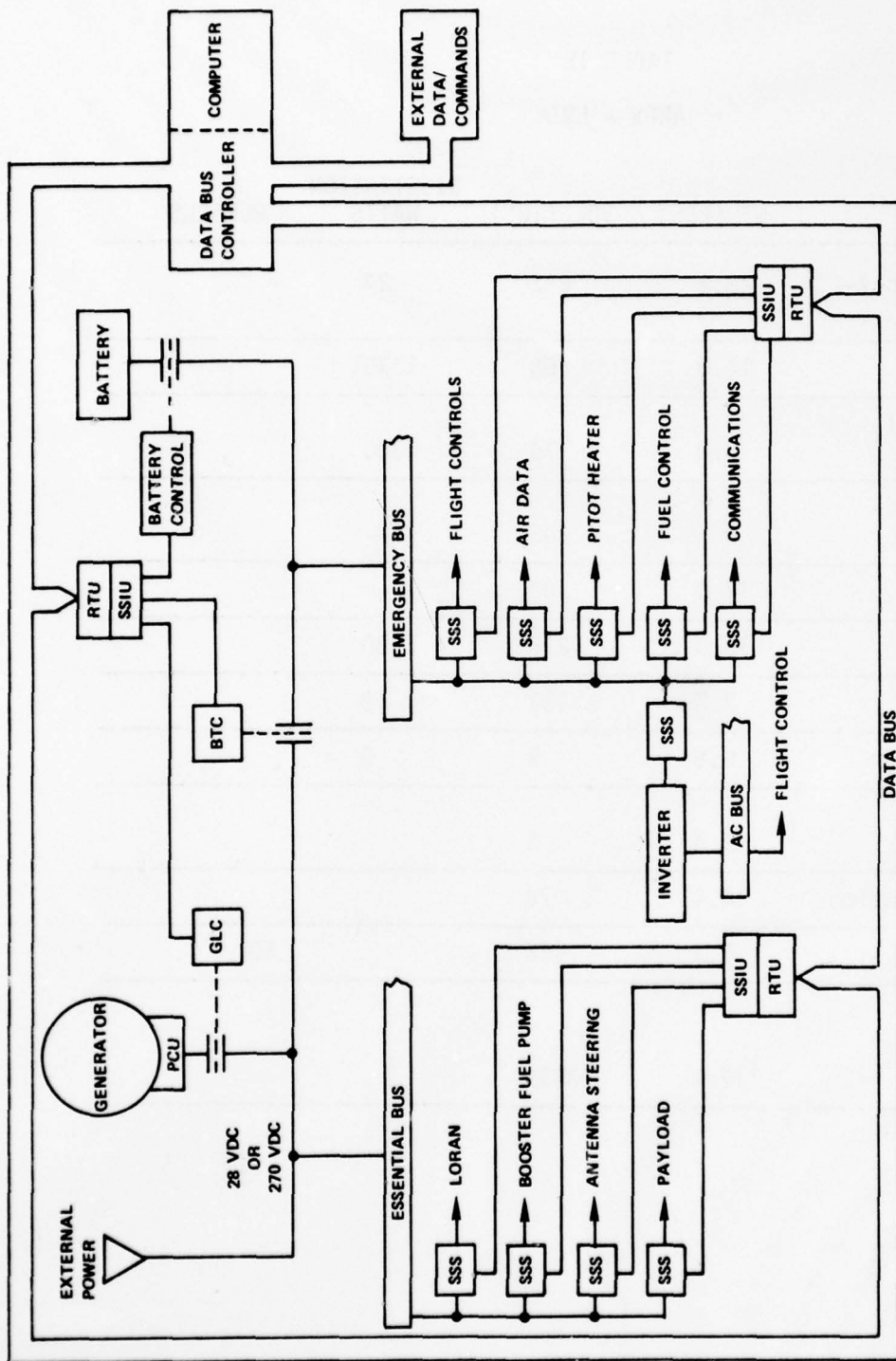

LEGEND: RTU = REMOTE TERMINAL UNIT  
 SSIU = SUBSYSTEM INTERFACE UNIT  
 SSS = SOLID STATE SWITCH

Figure 8. ARPV LVDC/HVDC

AD-A060 336

TELEDYNE RYAN AERONAUTICAL SAN DIEGO CA  
RPV ELECTRIC POWER SYSTEM STUDY PHASE I. TECHNOLOGY ASSESSMENT. (U)  
JUN 78 F L MILLER  
TRA-29318-06

F/G 1/3

F33615-76-C-2069

UNCLASSIFIED

AFAPL-TR-78-38

NL

2 OF 3  
AD A060336



TABLE 15  
 ARPV - LVDC

NAME	WT (LBS)	VOL (IN <sup>3</sup> )	DISSIPATION WATTS	REMARKS
Main Power Control Box	22.2	672	24	
Generator	14.0	66	1175	
Power Control Unit	3.0	75	300	
Umbilical Distribution Box	9.5	305	---	
Battery	17.0	300	---	
Inverter	12.0	216	530	
Contactors	7.2	132	18	
Battery Sensor	0.8	9	6	
Wire Power Feeders	9.4	6		
Wire Distribution	14.9	78		
Connectors	7.1	152		50
Totals	117.1	2011		

TABLE 16  
 ARPV - HVDC

NAME	WT (LBS)	VOL (IN <sup>3</sup> )	DISSIPATION WATTS	REMARKS
Main Power Control Box	22.2	672	180	
Generator	13.0	62	1760	
Power Control Unit	2.0	45	300	
Umbilical Distribution Box	9.5	305	---	
Battery	29.0	525	---	
Inverter	12.0	216	530	
Contactors	21.0	360	---	
Battery Sensor	1.5	20	---	
Wire Power Feeders	0.6	4.8		
Wire Distribution	4.4	3.4		
Connectors	7.1	152		50
Totals	122.3	2365		

the 28V system. Also the maximum altitude of an ARPV (40,000 feet) is not so high as to cause significant corona problems. However, high power switchgear that is available now and in the near future all use very conventional and bulky arc quenching techniques. In addition, a 270 volt battery weight and volume is nearly twice that of a 28 volt battery of the same capacity.

Potentially, by the time frame of 1985, existing problems with high voltage DC switchgear will have been overcome and their size, weight, and cost greatly reduced, thus making 270 V systems more competitive.

#### 8.3.4 CSCF System

The CSCF is a conventional approach to electric power systems that is dominant in commercial and military manned aircraft. It is used where significant quantities of AC power are needed or are desirable at a controlled frequency. A schematic diagram of the CSCF systems is shown in Figure 9. Table 17 lists the pertinent data for the system components. The avionics computer controls and monitors the system via the data bus. The design, components, and operation of the CSCF are conventional and straightforward otherwise. The constant speed alternator provides three-phase AC power for normal operation. Transformer-rectifier units convert the AC to 28V DC as required. A battery and static inverter provides power during emergency and recovery conditions.

A prime AC power generating system such as the CSCF is probably not applicable to the ARPV in that the loads are almost totally DC. This study, however, assumes that the AC system is required (possibly due to payload requirements) and that the necessary system components, and their application, are feasible and practical.

#### 8.3.5 VSCF System

In an effort to eliminate the constant speed drive on an AC system, electronic converters have been developed that convert the wild frequency output of the variable speed three-phase generator into precision 400 Hz AC power. A number of variations are possible for doing this. The one used here is to rectify the generator output to DC power and a full wave, three-phase bridge. The DC power is fed to two converters - the first a DC-to-DC converter changes the 30 to 300 volts input to regulated 28 volt operating power; the second DC-to-AC converter employs suitable electronics and an output transformer to produce constant frequency (400 Hz) AC power. Figure 10 depicts schematically the VSCF system. Except for the cyclo-converter, it is functionally identical to the CSCF system. Table 18 lists the pertinent data for the system components.

As is the case with the CSCF systems, VSCF systems are large and heavy, in their existing configurations, for ARPV use. In an

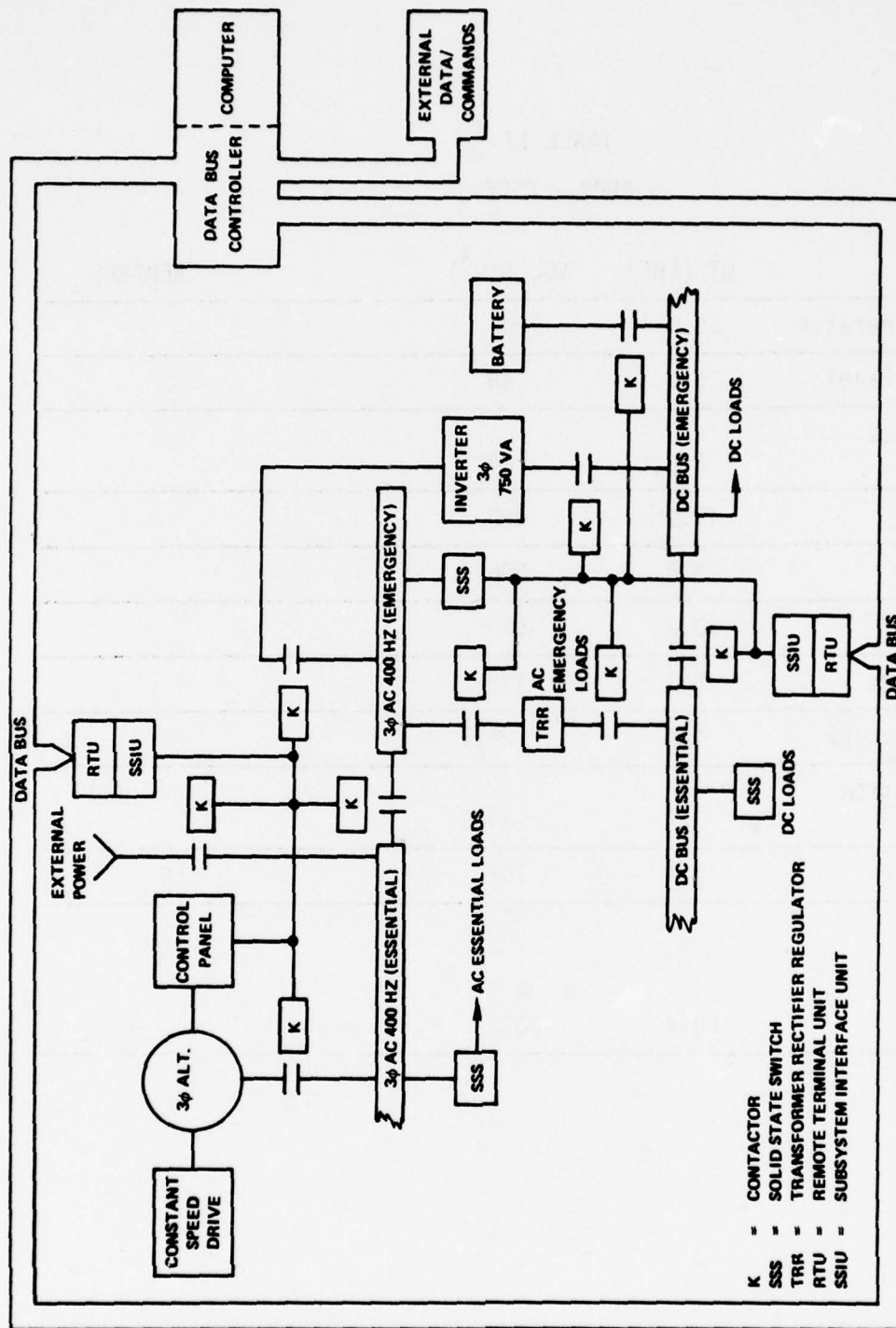

Figure 9. ARPV-CSCF, Constant Speed Constant Frequency

TABLE 17  
 ARPV - CSCF

NAME	WT (LBS)	VOL (IN <sup>3</sup> )	REMARKS
CSD + Generator	55.0	804	
Control Panel	5.0	48	
∅ Sequence Relays	2.0	24	
TR Unit	15.0	480	
Inverter	23.0	506	
Battery	30.2	690	
Contactors	8.0	179	
Power Feeders	1.4	29.1	
Distribution Feeders	3.7	30.6	
Connectors	7.1	152	50
Totals	150.4	3052	

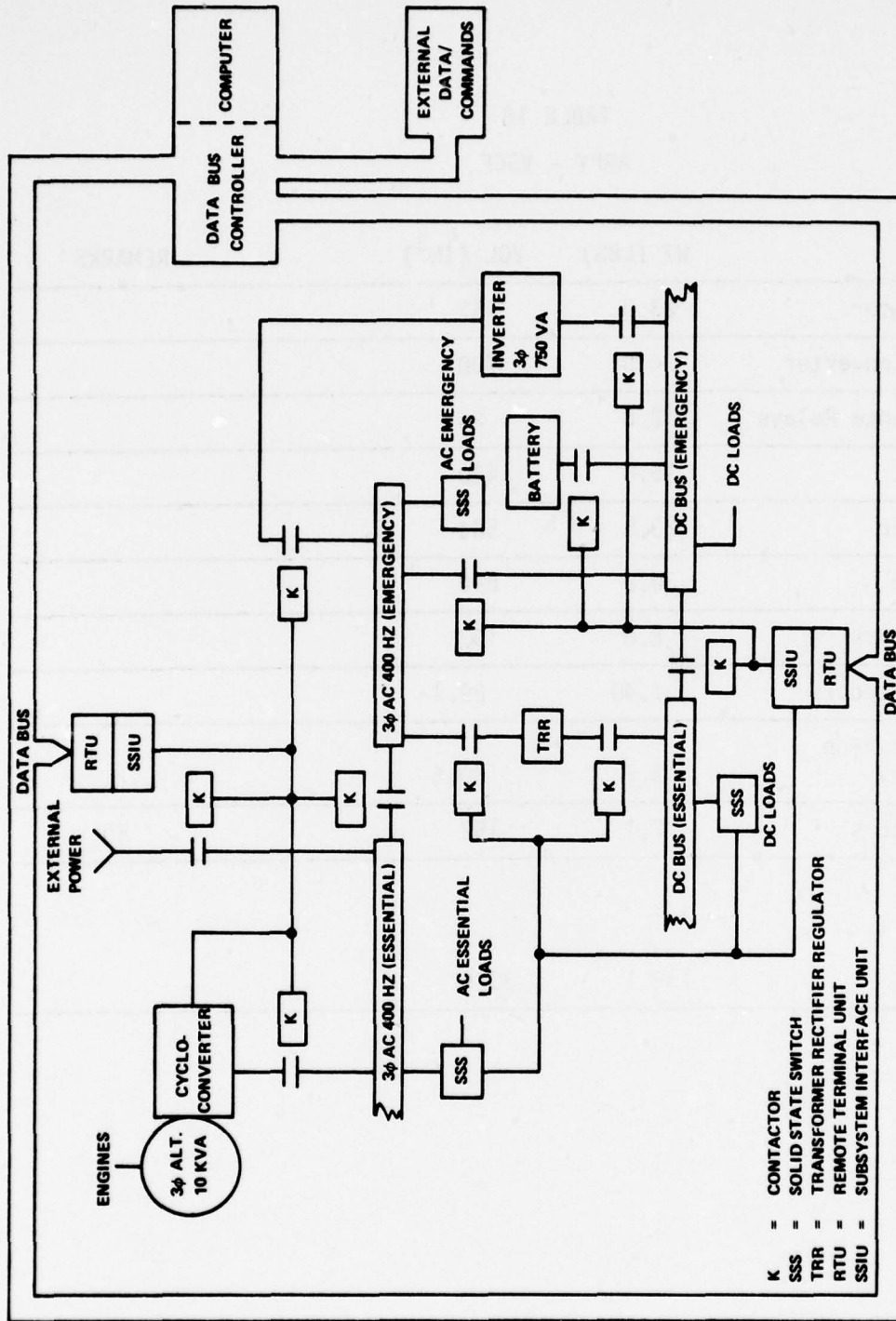

Figure 10. ARPV-VSCF, Variable Speed Constant Frequency

TABLE 18  
 ARPV - VSCF

NAME	WT (LBS)	VOL (IN <sup>3</sup> )	REMARKS
Alternator	23.0	157	
Cyclo-Converter	24.0	700	
∅ Sequence Relays	2.0	24	
TR Unit	15.0	480	
Inverter	23.0	506	
Battery	30.2	690	
Contactors	8.8	197	
Power Feeders	1.40	29.1	
Distribution Feeders	3.7	30.6	
Connectors	7.1	152	50
Totals	138.1	3075	

ARPV, if an AC system is necessary due to payload requirements and the component technology is improved to permit installation on the engine, the VSCF system would be a viable candidate.

#### 8.3.6 VSVF System

The VSVF or wild frequency system is a hybrid variety of the HVDC system in which conversion to DC power is deferred to the load or equipment compartment. That is, the alternator is the same high speed, directly driven machine used in the DC systems. The generated frequency is designed to be as high as the system elements will tolerate. The lowest frequency is no lower than 400 Hz. A practical range is between 400 Hz and 4000 Hz. The output voltage is regulated to either a constant level or to a constant v/f ratio (see Section 7), filtered, and transmitted to the equipment compartments. The voltage would be 270V AC, which would solve the arc quenching problem prevalent in the 270V DC system, but the personnel hazard is increased. The relatively high and variable frequency will contribute to the EMIC problem, which will require heavier filtering. The higher frequency and voltage permits a reduction in size and weight of conversion equipment and of electromagnetic components.

Figure 11 schematically depicts the VSVF system. Power conversion and conditioning uses conventional converters, inverters, and filters. Table 19 lists the pertinent data for the system components. Since ARPV payloads are primarily avionic rather than electromechanical, they tend to not be frequency sensitive. Hence most if not all of the wild frequency power can be used directly by the loads without further conversion. Except for the need to be compatible with battery power, the same comments would apply to the core avionics. Conversion to DC would be required for the flight servoactuators, however, in any case; this is a small part of the overall load.

#### 8.3.7 ARPV Baseline

The logical baseline for the ARPV version is the BGM-34C which was designed and built as a multi-mission RPV. By concentrating the payload in the nose section of the BGM-34C, it is possible to change configurations by removing and replacing the nose without changing anything in the basic vehicle.

The BGM-34C evolved from a 1959 target vehicle design, and it has retained much of the target configuration. This results in the electrical power generating system, while adequate to perform its task, being heavy, bulky, and less efficient than necessary. Also, it offers little or no growth factor. The starter-generator unit is rated at 400 amp, at 30.0 volts output as a generator at sea level; it is derated at altitude due to cooling restrictions.

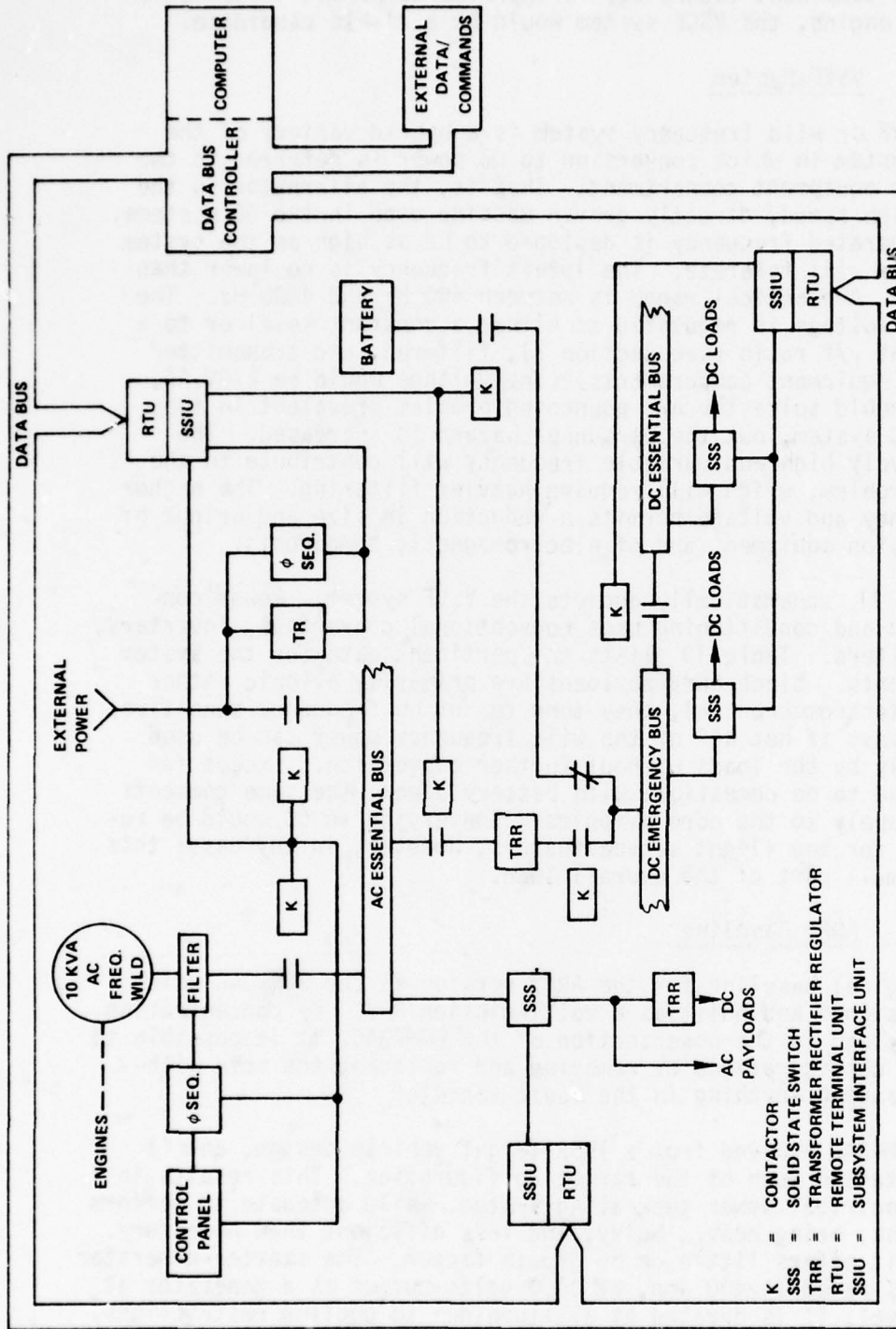

Figure 11. ARPV-VSVF, Variable Speed Variable Frequency

TABLE 19  
 ARPV - VSVF

NAME	WT (LBS)	VOL (IN <sup>3</sup> )	REMARKS
Main Power Control Box	22.2	672	
Generator	13.0	62	
Control and Filter	3.0	60	
Battery	17.0	300	
TR Units	24.0	390	2 TRU @ 75A each
Contactors	9.2	185	
External TR Unit	2.3	200	
Power Feeders	1.4	29	
Distribution Feeders	3.7	31	
Connectors	7.1	152	50
Totals	103.0	2084	

Using the generator as a starter obviously adds weight to the electrical system, but the overall system is lighter than using a separate starter and generator.

Figure 12 shows a simplified schematic of the existing BGM-34C system, which is manually or automatically controlled. The system is manually controlled primarily for checkout prior to launch. Once the vehicle is in flight, the electrical power generating system is automatically controlled by high voltage and low voltage sensors, time delay relays, and bus tie relays to provide the maximum protection against complete power failure and equipment damage. AC power is supplied by static inverters. Table 20 lists the functional equipment in the system and their approximate costs, weight, size, efficiency, and other data that was used in arriving at a baseline for the evaluation of the candidate ARPV electrical systems.

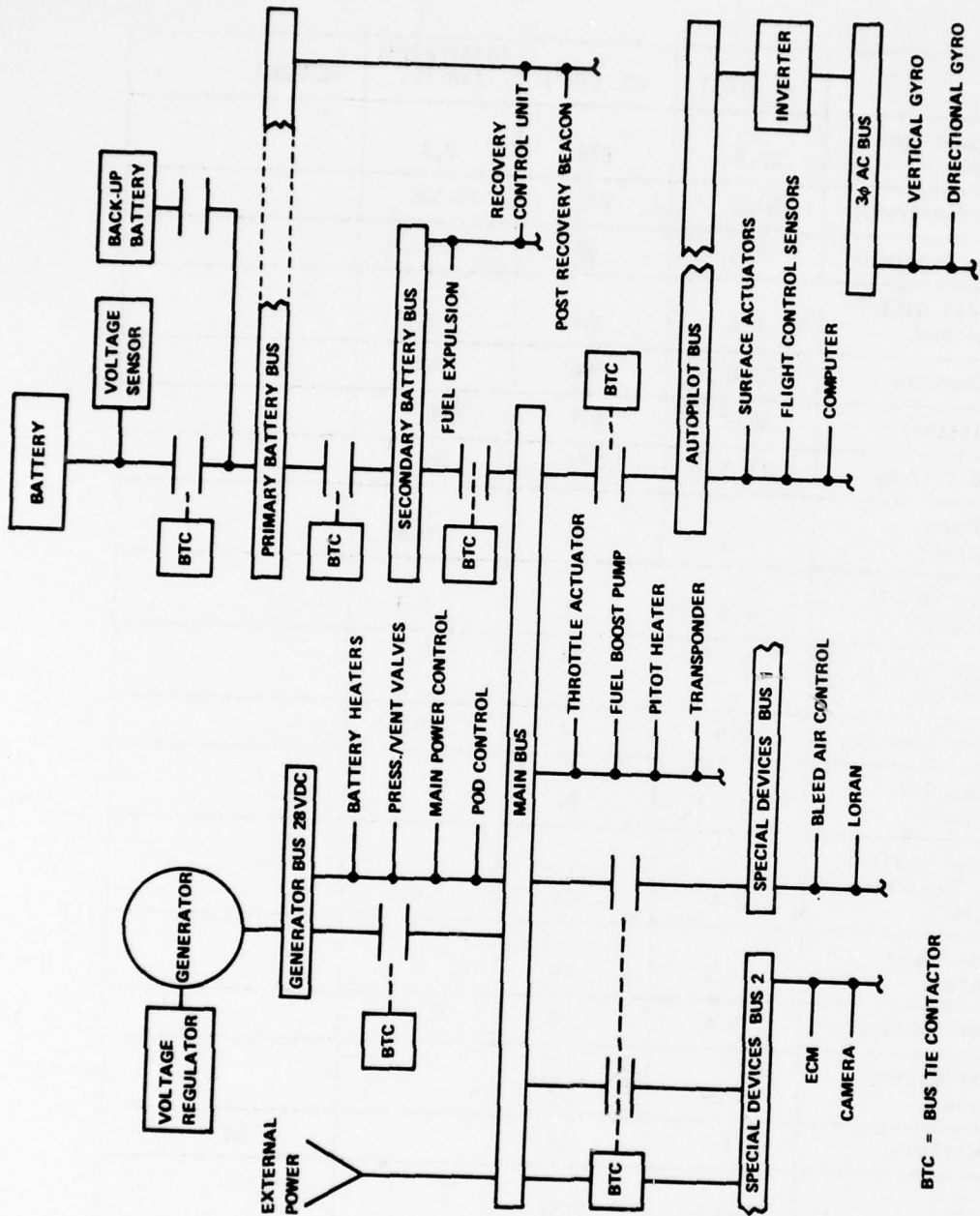

Figure 12. ARPV Baseline (BGM-34C)

TABLE 20  
BASELINE ARPV BGM-34C

NAME	WT (LBS)	VOL (IN <sup>3</sup> )	DISSIPATION (WATTS)	REMARKS
Main Power Control Box	22.2	672	0.3	
Starter/Generator	51.5	241	20-30%	
Voltage Regulator	2.5	94	69	
Umbilical Distribution Box	9.5	305	--	
750A Inverter	23.0	506	35%	
Main Battery	30.2	614	100	
Backup Battery	11.3	179	69	
Int. Power Contactor	2.3	44	0.3	
Battery Cutoff Contactor	0.1	1	0.1	
Battery Select Contactor	1.3	24	0.2	
Battery Sensor	0.6	4	0.1	
A/P Bus Tie Contactor	1.3	19		
Special Devices Bus Tie Contactors	2.4	34	0.2	
Glide Power Contact	1.3	19		
Power Feeders	9.4	6		
Distribution Wiring	14.9	78		
Connectors	7.1	152		50
Totals	190.9	2992		

## 8.4 EVALUATION AND ANALYSIS

### 8.4.1 Evaluation

The evaluation of ARPV candidate systems was performed according to the procedures described in Section 7. The systems evaluated were:

- Baseline BGM-34C
- Low Voltage Direct Current (LVDC)
- High Voltage Direct Current (HVDC)
- Constant Speed Constant Frequency (CSCF)
- Variable Speed Constant Frequency (VSCF)
- Variable Speed Variable Frequency (VSVF)

Scores for each of the evaluation elements for each system were developed from the raw data according to the formulae presented in Section 7 and the weighting factors given below with the sensitivity factor ( $\alpha$ ) being set to unity. The exception is for EPS weight where the sensitivity factor was assumed to be 2. If an evaluation element consists of more than one measurable factor, equal relative weights ( $\beta$ ) were assumed.

The evaluation was based on the parameters presented in Table 21. The raw data for each of these parameters for each system are listed in Table 22. Where data is not available, scoring is based on engineering judgement. Cost data from the PRICE model was not available for the last three systems listed above. These data were estimated based on the assumption that the cost per pound would be the same as the other systems. The development costs for this Baseline BGM-34C system were assumed to be zero. Also, the Baseline system was assumed to have the least amount of technical risks, since it is an operating system. Table 23 presents the final evaluation scores, the significance of which are discussed in the next section.

To help demonstrate the evaluation scoring process, as described in Section 7.4, the raw scores ( Table 24 ) and adjusted scores ( Table 25 ) are included. These intermediate data are not included in the evaluation of subsequent RPV classes, since it would serve no useful purpose.

### 8.4.2 Cost Analysis

The life cycle cost comparison for the ARPV electrical systems ( Table 26 ) shows that the low voltage DC system has the lowest LCC cost. However, the high voltage DC system has the lowest support cost. In all cases, the production costs dominated the LCC.

TABLE 21  
EVALUATION WEIGHTS

<u>ITEM</u>	<u>PARAMETER</u>	<u>WEIGHT</u>	<u>TOTAL WEIGHT</u>
1.0	Physical Parameters		150
1.1	Weight	50	
1.2	Volume	50	
1.3	Total Available Power	50	
2.0	Performance		120
2.1	Steady State	10	
2.2	Transient	10	
2.3	Filtering Requirements	10	
2.4	Ability of Parallel Operation	10	
2.5	Penalties	35	
2.6	Efficiency	45	
3.0	Reliability		250
3.1	MTBF	125	
3.2	Probability of Mission Success	125	
4.0	Maintainability		200
4.1	MTTR	75	
4.2	Fault Isolation	25	
4.3	Maintenance Actions	20	
4.4	Preventive Action Time	40	
4.5	Mean Down Time	10	
4.6	Inherent Availability	10	
4.7	Achieved Availability	10	
4.8	Operational Availability	10	
5.0	Cost and Risk		280
5.1	Development Costs	55	
5.2	Production Costs	75	
5.3	Q&S Costs	75	
5.4	Technical Risk	75	

TABLE 22  
EPS EVALUATION  
Raw Data

ITEM	PARAMETER	LVDC	HVDC	CSCF	VSCF	VSVF	BASELINE
	TOTAL SYSTEM						
	PHYSICAL PARAMETERS						
1.0							
1.1	Weight	117	122	150	138	103	191
1.2	Volume	2011	2365	3052	2075	2084	2992
1.3	Total Available Power						
1.3.1	Current	7	7	7	7	7	3.4
1.3.2	Growth	10	10	10	10	10	5.3
2.0	PERFORMANCE						
2.1	Steady State						
2.1.1	Voltage	+3%	+1%	+3%	+2%		+8.6%
		-5%		-5%	-3%		
2.1.2	Frequency Variation	---	---	+5%	+0.25%		---
2.2	Transient						
2.2.1	Voltage Variation	+3%	+1.8%	+39%	+15.6%		
		-5%		-53%	-1.9%		
2.2.2	Frequency Variation	---	---	+5%	+0.075%		
2.3	Filtering Requirements	---	---	---	---	---	---
2.4	Ability of Parallel Ops	---	---	---	---	None	---
2.5	Penalties						
2.5.1	Losses	24%	22%	25%	26.67%		
2.5.2	Weight due to Losses	11.55	8.19	6.75	18.5		
2.6	Efficiency	70%	78.15%	75% AC 60%DC	75%AC 50%DC		75%
3.0	RELIABILITY						
3.1	MTBF	(10)	(10)	(5)	(5)	(10)	(2.5)
3.2	Prob. of Mission Success						
3.2.1	Component Failure Prob.						
3.2.2	Redundancy	1	1	1	1	1	1
4.0	MAINTAINABILITY						
4.1	MTR	(10)	(10)	(7.5)	(7.5)	(10)	(5)
4.2	Fault Isolation	None	None				
4.2.1	Accessibility						
4.2.2	Automatic/Manual	---	---	---	---	---	---
4.2.3	Mean Time Required	---	---	---	---	---	---
4.3	Maintenance Actions						
4.3.1	Repairability	yes	yes	Depot	Depot		
4.3.2	Replaceability	yes	yes	yes	yes	yes	
4.3.3	Expendability	no	no	no	no	no	
4.3.4	Standardization	yes	yes	yes	yes	partial	
4.3.5	Alignment & Adjust.	15 min	15 min	30 min	15 min		
4.4	Preventive Action Time	(10)	(10)	(10)	(10)	(10)	(7.14)
4.5	Mean Down Time						
4.6	Inherent Availability						
4.7	Achieved Availability						
4.8	Operational Availability						
5.0	COST AND RISK						
5.1	* Development Cost	704	1330				0
5.2	* Production Cost	29224	3380				46260
5.3	* O&S Costs	2559	1509				2340
5.4	Technical Risk	(8)	(6)	(5)	(5)	(6)	(10)

(\*) Thousand of Dollars

( ) RAW SCORE  
WILD FREQ. DATA ALL ESTIMATES  
34C DATA FROM PRICE INPUTS

TABLE 23  
EPS EVALUATION  
Weighted Score

<u>ITEM</u>	<u>PARAMETER</u>	<u>LVDC</u>	<u>HVDC</u>	<u>CSCF</u>	<u>VSCF</u>	<u>VSVF</u>	<u>BASELINE</u>
	TOTAL SYSTEM	887.13	874.13	666.27	685.75	870.91	619.24
1.0	PHYSICAL PARAMETERS	138.79	128.14	106.54	110.35	148.23	73.31
1.1	Weight	38.75	35.64	23.60	27.86	50.00	14.60
1.2	Volume	50.00	42.50	32.94	32.69	48.24	33.59
1.3	Total Available Power	50.00	50.00	50.00	50.00	50.00	25.16
2.0	PERFORMANCE	93.78	105.15	97.13	88.04	86.00	87.10
2.1	Steady State	8.00	8.50	8	8.5	5.00	7.85
2.2	Transient	8	9.55	2.50	4.98	9	8.00
2.3	Filtering Requirements	10.00	10.00	10.00	10.00	8	10.00
2.4	Ability of Parallel Ops.	10.00	10.00	10.00	10.00	0	10.00
2.5	Penalties	26.27	31.91	32.89	20.82	30.00	17.51
2.6	Efficiency	31.51	35.19	33.74	33.74	34.00	33.74
3.0	RELIABILITY	238.13	238.13	164.89	164.89	238.13	107.11
3.1	MTBF	125.00	125.00	52.50	62.50	125.00	31.28
3.2	Prob. of Mission Success	113.13	113.13	102.39	102.39	113.13	75.86
4.0	MAINTAINABILITY	197.30	197.30	145.88	168.47	186.98	124.97
4.1	MTRR	75.00	75.00	56.25	56.25	75.00	37.53
4.2	Fault Isolation	25.00	25.00	25.00	25.00	25.00	25.00
4.3	Maintenance Actions	20.00	20.00	13.99	20.00	12.00	12.00
4.4	Preventive Action Time	40.00	40.00	40.00	40.00	40.00	28.56
4.5	Mean Down Time	10.00	10.00	10.00	10.00	10.00	7.14
4.6	Inherent Availability	9.10	9.10	4.44	5.04	8.33	5.04
4.7	Achieved Availability	9.10	9.10	2.86	5.04	8.33	3.34
4.8	Operational Availability	9.10	9.10	3.34	7.14	8.33	6.36
5.0	COST AND RISK	219.13	205.41	151.83	154.01	211.57	226.75
5.1	Development Cost	39.05	20.60	30.47	33.11	44.39	55.00
5.2	Production Cost	75.00	64.73	48.68	45.15	70.95	47.40
5.3	O&S Costs	45.08	75.00	35.18	38.25	57.73	49.35
5.4	Technical Risk	60.00	45.00	37.50	37.50	45.00	75.00

TABLE 24  
EPS EVALUATION  
Raw Score

ITEM	PARAMETER	LVDC	HVDC	CSDS	VSCF	WILD FREQ	34C STANDARD
	<b>TOTAL SYSTEM</b>	<b>205.94</b>	<b>210.33</b>	<b>158.75</b>	<b>170.10</b>	<b>186.16</b>	<b>155.26</b>
1.0	<b>PHYSICAL PARAMETERS</b>	27.75	25.63	21.31	22.11	29.65	14.71
1.1	Weight	7.75	7.13	4.72	5.57	10.00	2.91
1.2	Volume	10.00	8.50	6.59	6.54	9.65	6.72
1.3	Total Available Power	10	10	10	10	10	5.08
1.3.1	Current	10	10	10	10	10	4.86
1.3.2	Growth	10	10	10	10	10	5.30
2.0	<b>PERFORMANCE</b>	<b>50.76</b>	<b>59.99</b>	<b>47.40</b>	<b>46.93</b>	<b>38.11</b>	<b>48.35</b>
2.1	Steady State	8.0	8.5	8	8.5	5	7.85
2.1.1	Voltage Variation	8	9.0	6.0	7.85		5.7
2.1.2	Frequency Variation	10.0	10.0	7.5	9.99		10.0
2.2	Transient	6.25	9.55	2.5	4.98	9	8.0
2.2.1	Voltage Variation	2.5	9.10	0	0		
2.2.2	Frequency Variation	10.0	10.0	5	9.96		
2.3	Filtering Requirements	10.0	10.0	10	10.0	8	10
2.4	Ability of Parallel Ops	10.0	10.0	10	10.0	0	10
2.5	Penalties	7.51	9.12	9.40	5.95	8.56	5
2.5.1	Losses	9.17	10.0	8.80	8.25		
2.5.2	Weight due to Losses	5.84	8.24	10.0	3.65		
2.6	Efficiency	7.0	7.82	7.5	7.5	7.55	7.5
3.0	<b>RELIABILITY</b>	<b>19.05</b>	<b>19.05</b>	<b>13.19</b>	<b>13.19</b>	<b>19.05</b>	<b>9.2</b>
3.1	MTBF	10.0	10.0	5.00	5.00	10.00	2.5
3.2	Prob. of Mission Success	9.05	9.05	8.19	8.19	9.05	6.7
3.2.1	Component Failure Prob.						
3.2.2	Redundancy						
4.0	<b>MAINTAINABILITY</b>	<b>77.27</b>	<b>77.27</b>	<b>55.13</b>	<b>64.72</b>	<b>70.99</b>	<b>50.01</b>
4.1	MTTR	10	10	7.5	7.5	10	5
4.2	Fault Isolation	10	10	10	10	10	10
4.2.1	Accessibility						
4.2.2	Automatic/Manual						
4.2.3	Mean Time Required						
4.3	Maintenance Actions	10	10	7	10	6	6
4.3.1	Repairability	10	10	0	0	0	0
4.3.2	Replaceability	10	10	10	10	10	10
4.3.3	Expendability	10	10	10	10	10	10
4.3.4	Standardization	10	10	10	10	5	10
4.3.5	Alignment & Adjustment	10	10	5	10	5	0
4.4	Preventative Action Time	10	10	10	10	10	7.14
4.5	Mean Down Time	10	10	10	10	10	7.14
4.6	Inherent Availability	9.09	0.09	4.44	5.04	8.33	5.04
4.7	Achieved Availability	9.09	9.09	2.86	5.04	8.33	3.33
4.8	Operational Availability	9.09	0.09	3.33	7.14	8.33	6.36
5.0	<b>COST AND RISK</b>	<b>31.11</b>	<b>28.09</b>	<b>21.72</b>	<b>23.18</b>	<b>30.36</b>	<b>32.90</b>
5.1	Development Cost	7.10	3.76	5.54	6.02	8.07	10.00
5.2	Production Cost	10.00	8.63	6.49	7.06	9.46	6.32
5.3	O&S Costs	6.01	10	4.69	5.10	6.83	6.58
5.4	Technical Risk	8	6	5	5	6	10.00

SCORES AS DESCRIBED IN SECTION 7.4 . WHERE DATA IS MISSION, ENGINEERING JUDGEMENT IS USED.

SCORES OF COST OF CSDC, VSCF, AND WILD FREQUENCY ARE BASED ON WEIGHT. .

TABLE 25  
EPS EVALUATION  
Adjusted Score

<u>ITEM</u>	<u>PARAMETER</u>	<u>LVDC</u>	<u>HVDC</u>	<u>CSDS</u>	<u>VSCF</u>	<u>WILD FREQ</u>	<u>34C STANDARD</u>
1.0	TOTAL SYSTEM	892.08	889.76	678.50	711.64	847.54	634.14
1.1	PHYSICAL PARAMETERS	184.98	170.85	142.05	147.13	197.64	97.74
1.1	Weight	51.66	47.52	31.47	37.14	66.66	19.47
1.2	Volume	66.66	56.67	43.92	43.59	64.32	44.79
1.3	Total Available Power	66.66	66.66	66.66	66.66	66.66	33.54
2.0	PERFORMANCE	168.36	183.27	157.98	154.90	127.11	161.16
2.1	Steady State	26.67	28.32	26.67	28.33	16.68	26.16
2.2	Transient	26.67	31.83	8.34	16.59	30.00	26.67
2.3	Filtering Requirements	33.33	33.33	33.33	33.33	26.67	33.33
2.4	Ability of Parallel Ops	33.33	33.33	33.33	33.33	0	33.33
2.5	Penalties	25.02	30.39	31.32	19.83	28.57	16.68
2.6	Efficiency	23.34	26.07	24.99	24.99	25.19	24.99
3.0	RELIABILITY	190.50	190.50	131.91	131.91	190.50	85.69
3.1	MTBF	100.00	100.00	50.00	50.00	100.00	25.00
3.2	Prob. of Mission Success	90.50	90.50	81.91	81.91	90.50	60.69
4.0	MAINTAINABILITY	193.19	193.19	137.96	161.80	180.49	125.05
4.1	MTTR	25.00	25.00	18.75	18.75	25.00	12.51
4.2	Fault Isolation	25.00	25.00	25.00	25.00	25.00	25.00
4.3	Maintenance Actions	25.00	25.00	17.49	25.00	15.00	15.00
4.4	Preventive Action Time	25.00	25.00	25.00	25.00	25.00	17.85
4.5	Mean Down Time	25.00	25.00	25.00	25.00	25.09	17.85
4.6	Inherent Availability	22.74	22.74	11.10	12.60	20.82	12.60
4.7	Achieved Availability	22.74	22.74	7.14	12.60	20.82	8.34
4.8	Operational Availability	22.74	22.74	8.34	17.85	20.82	15.90
5.0	COST AND RISK	155.55	141.95	108.60	115.90	151.80	164.50
5.1	Development Cost	35.50	18.80	27.70	30.10	40.35	50.00
5.2	Production Cost	50.00	43.15	32.45	35.20	47.30	31.60
5.3	O&S Cost	30.05	50.00	23.45	25.50	34.15	32.90
5.4	Technical Risk	40.00	30	25.00	25.00	30.00	50.00

The cost drivers in the low voltage system (Table 27) are the umbilical distribution box and the main power control box. These dominate the development and production costs. The buy group, composed of seven separate components dominates the support costs, because it is expected to have a lower composite reliability.

The cost drivers in the high voltage system (Table 28) are the umbilical box, main power control box, and reverse current relay. The umbilical box dominates the production cost, and the reverse current relay dominates the development cost.

The computer printouts of the PRICE and PRICE-L inputs and outputs for the LVDC and HVDC systems are presented in Appendix A. It serves as an example of the detailed data required on each component of system.

TABLE 26  
ELECTRIC POWER STUDY  
LIFE CYCLE COST COMPARISON  
ARPV ELECTRICAL SYSTEMS  
THOUSAND DOLLARS (1977)

<u>ITEM</u>	<u>DEVELOP.</u>	<u>PRODUCTION</u>	<u>SUPPORT</u>	<u>TOTAL</u>
Baseline	--	46,210	2,340	48,550
High Voltage, DC	1,333	33,826	1,539	36,698
Low Voltage, DC	704	29,224	2,559	32,437

TABLE 27

ELECTRIC POWER STUDY  
LIFE CYCLE COST  
ARPV HIGH VOLTAGE DC SYSTEM  
THOUSAND DOLLARS (1977)

<u>ITEM</u>	<u>DEVELOP.</u>	<u>PRODUCTION</u>	<u>SPARES</u>	<u>SUPPORT</u>	<u>TOTAL</u>
Pwr Control Unit	84	1,009	18	8	1,120
Main Pwr Control Box	159	6,996	75	19	7,248
Generator	34	761	15	1	811
Umbilical Box	244	12,553	130	34	12,963
Battery (270V)	15	1,467	16	11	1,510
Inverter	114	2,965	119	114	3,313
Rev. Current Relay	618	5,987	185	118	6,907
Buy Group	1	1,232	56	193	1,550
Integration & Test	63	857	84	273	1,277
Total	1,333	23,826	767	772	36,649

TABLE 28

ELECTRIC POWER STUDY  
LIFE CYCLE COST  
ARPV LOW VOLTAGE DC SYSTEM  
THOUSAND DOLLARS (1977)

<u>ITEM</u>	<u>DEVELOP.</u>	<u>PRODUCTION</u>	<u>SPARES</u>	<u>SUPPORT</u>	<u>TOTAL</u>
Pwr Control Unit	114	1,425	26	13	1,580
Inverter	74	1,865	75	62	2,076
Main Battery	10	965	19	3	997
Power Relay Control	9	413	8	1	431
Main Pwr Control Box	177	10,073	105	27	10,383
Umbilical Distribution Box	244	12,553	133	34	12,963
Generator	36	405	8	1	449
Buy Group	1	1,481	156	228	1,875
Integration & Test	38	46	1,647	2	1,732
Total	704	29,224	2,186	373	32,487

### 8.4.3 Discussion of the Results

The ARPV analysis has evaluated five candidate electric power system configurations in comparison with the BGM-34C baseline system. All candidates scored better than the baseline system, an unsurprising result in view of the relative technologies. As can be seen in Table 23, the LVDC, HVDC, and VSVF systems finished with scores which are all considerably better than the scores of the other three systems. In general the DC systems scored better than the AC systems because the DC systems are simpler, lighter, and more reliable. (The VSVF is more correctly a DC rather than AC system, since it is essentially a variant of the LVDC and HVDC systems that defers rectification and power conditioning to the using equipment area. Conversion or inversion is needed to meet constant frequency power requirements just as in a DC system). Furthermore, the load requirements are primarily DC. While the core avionics will use all DC, some types of mission payloads may still require 400 Hz power. However, future trends are toward lower AC power requirements, perhaps being all DC by 1985. A future payload candidate requiring large amounts of AC power (i.e., larger than an inverter could supply) would impose such a penalty on an ARPV that it would either be considered impractical or would have to be modified to accept DC power.

The scores of the three leading candidates are close enough together that each could be considered a potential candidate in future systems. Selection would require a more detailed analysis for the specific system requirements, and it would depend on such secondary factors as availability of components, compatibility of development schedules, and possible reassignment of weighting factors, e.g., to account for heavier emphasis on cost or performance.

The situation above points up the criticism often levied against a weighted evaluation, such as is being used here, as being arbitrary and forcing the result to favor a given system. In this case, the LVDC is best overall. It is second best in two measures (physical parameters and performance) and first in one measure (cost). The VSVF system is best in physical parameters and the HVDC system is best as concerns performance. It might be reasoned that adjusting the weighting factor differently could conceivably make one of the other systems come out on top.

To investigate the sensitivity of the final result to the weights given to cost, performance, etc., these weights were varied. The result is shown in Figure 13. Over a wide range of values, the order of ranking is insensitive to the weighting given the physical, parameters, performance, and cost (other weights being held constant). Changing the emphasis placed on performance or physical parameters (weight and volume) can change the results, however, as can be seen by the crossovers in Figure 13.

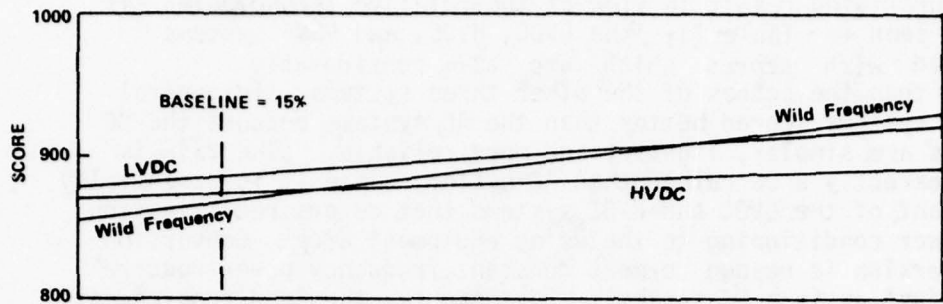

A) PHYSICAL PARAMETERS

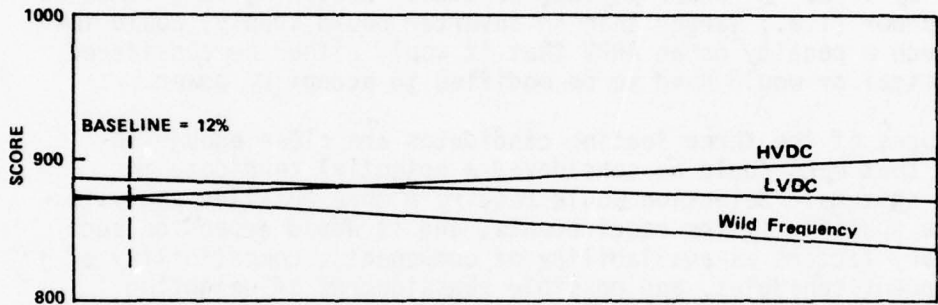

B) PERFORMANCE

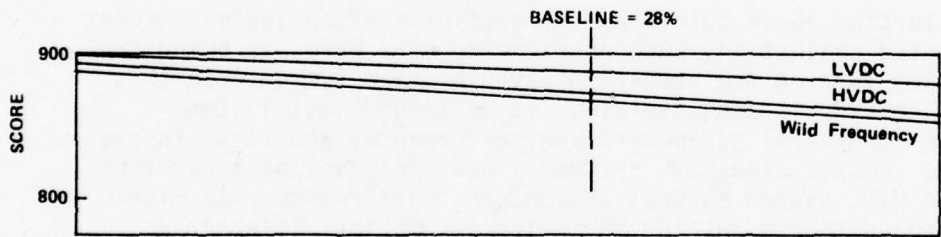

C) COST

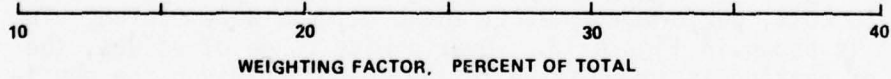

Figure 13. Sensitivity of Various Evaluation Parameters to Weighting Factor

## LVDC

Generally speaking, the LVDC architecture will continue in the near future to be the preferred approach in ARPV class systems. This is primarily because it uses an established standard power format and the other candidates do not offer significantly superior benefits. Since no development is required, LVDC would present little, if any, technical risk, and cost would be lowest.

## HVDC

The HVDC system is an acceptable alternate to LVDC. It has better performance, but is slightly heavier and more costly than the LVDC system. The difference is due in part to the fact that high voltage, high power switching in bus contactors cannot be handled by solid state technology today although future solutions may be possible in hybrid form. High power switching can be handled today by more conventional arc quenching techniques using long arc chute (Hartman Model A751D) or vacuum (ITT-Jennings) contactors. Both companies believe they can handle up to 80A at 270 VDC and 50,000 feet (a representative 10K watt load at 270 VDC draws about 40A). Such a switch would weight 5-7 pounds and occupy 75-100 cubic inches; at least three are required. (A 28 VDC reverse current relay (Main bus contactor) typically weighs 1/4 pound and occupies 2 cu.in.). Additionally, a HVDC system requires a 270V battery. While not a technological problem, development would be required, and a 270V battery would weigh nearly twice as much as a 28V battery of the same capacity. Consequently the increased weight and volume of the above components overpowers the weight savings due to use of lighter gage wire. Hence a HVDC system would be heavier than a LVDC system in an ARPV. If lighter solid state switches were available, however, the weights would be essentially the same.

The fact that switch gear development is needed and that some high voltage components, such as DC-DC converters, would be non-standard indicates that some technical risk exists.

## VSVF

The VSVF system is also an acceptable alternative to LVDC. It is the lightest system. It has but one conversion (as does LVDC), and it has the high voltage benefit of lighter transmission lines (as does HVDC) with an easier current interruption task. The amount of filtering required and complexity of the DC conversion process depends somewhat on the speed range of the particular engine being used. The variable frequency power may penalize some types of utilization equipment in terms of size and weight. While VSVF is not adaptable to parallel operations, this factor is of little importance in a system as simple as an ARPV where parallel operation is seldom, if ever, necessary.

### CSCF

The CSCF is a standard approach in manned aircraft. However scaling down a constant speed drive to meet the ARPV requirements results in a relatively heavy unit, i.e., lower power capacity per unit weight. Consequently the CSCF is the heaviest of the candidate systems. Reliability and maintainability is not as good as the top three candidates, because of the complexity of the constant speed drive.

One of the significant reasons for the poor showing of this system is that the output format does not match ARPV power requirements. An ARPV will need little, if any, constant frequency power. Hence a significant fraction of the 400 Hz power must be converted to DC, an inefficient process.

### VSCF

The VSCF system is identical to the CSCF except that constant frequency is achieved electronically rather than by a constant speed drive. Consequently VSVF is lighter and has better performance than CSCF, i.e., more precise frequency and voltage control, particularly during the transient conditions. Reliability, maintainability, and cost are similar to that of the CSCF. However, the rating score is only slightly better than CSCF for ARPV applications for similar reasons.

## SECTION 9

### HALE RPV

#### 9.1 INTRODUCTION

This section summarizes the analysis of the HALE-class RPV electric power system. It is the largest and highest capacity of the classes studied. The components used are often common to the ARPV class. However, its architecture differs significantly in that duplex and triplex redundancy are needed to achieve the reliability demanded of a 24 hour mission. Also, its payloads will typically demand relatively larger quantities of power, very possibly AC power. This class of EPS comes the closest of all the RPV classes to the architectures found in manned aircraft in terms of design philosophy and component selection.

Six candidate systems have been evaluated. Five are identical with the ARPV EPS candidates, i.e., LVDC, HVDC, CSCF, VSCF, and VSVF. The sixth is a hybrid AC/DC approach, which has been successfully used on the TRA Compass Cope-R YQM-98A vehicle. The EPS of the YQM-98A is used as a baseline reference to calibrate the PRICE model and for comparative analysis.

The following subsections present the assumptions used, descriptions of the candidate and baseline systems, the performance and cost analyses, and the evaluation.

#### 9.2 ASSUMPTIONS

The assumptions and ground rules used in the HALE RPV analysis are as follows:

- 1) The minimum payload power requirements are 7.5 KW; maximum payload power can exceed 20 KW. The waveform may be either AC, DC, or combination; however, AC may be preferred since payloads are apt to be adapted from manned aircraft, which predominately have AC power systems. Precision 400 Hz AC power is not required.
- 2) The core avionics will not require precision 400 Hz power. The power format may be AC or DC as long as it is consistent with the emergency power source. Core avionics power requirements are approximately 2 KW.
- 3) If a battery is used for emergency power, it must provide 1.5 hours service.
- 4) Maximum altitude is at least 60,000 feet; endurance is 24 hours.
- 5) Runway takeoff and landing
- 6) The engine will be running at maximum continuous power from shortly after takeoff thru the mission until letdown begins for landing.

- 7) The avionics computers will control and manage the EPS via a data bus.
- 8) The propulsion will have a single engine.

The EPS cost analysis uses the following ground rules.

- 1) Development phase begins in 1983 and lasts for 18 months; one prototype is tested.
- 2) Production phase begins in 1986 and lasts for 37 months; a quantity of 50 is produced.
- 3) Operational phase lasts for 10 years; Logistics will use 3 organizational, 3 intermediate, and 1 depot unit.

### 9.3 CANDIDATE SYSTEMS

#### 9.3.1 General Discussion

This section presents some considerations for HALE RPV that specifically impacts the EPS. These involve RPV engine configurations, power requirements, and reliability/redundancy among others. For example, the two Compass Cope HALE RPV that have flown were each powered by a single jet engine; one a turbojet and one a fanjet. The two proposed versions for engineering development and production also had a single (fanjet) engine. Twin engine versions were considered at times for a variety of reasons, such as to take advantage of the availability of suitable engines. However, a single engine configuration has generally been decided to be the most efficacious. This study is based on a single engine HALE RPV; the assumption has important redundancy implications to be discussed later.

The electric power requirements were developed in Section 3. Estimates of total power range from 6 KW to over 25 KW. For this analysis, we will assume a need for 20 KW capacity, with growth capability to 30K. Of the 20 KW, approximately 2 KW is needed for core avionics and general housekeeping power. As in the ARPV case, HALE core avionics are moving toward all DC power with little, if any, precision 400 Hz power needed.

The core avionics also must work efficiently with whatever emergency power source (usually a battery) that supplies power during engine-out flight, i.e., glide condition. Battery compatibility tends to drive the core avionics toward all DC, because a design objective is to minimize the size of the emergency source. This entails maximizing power conditioning and conversion efficiency, minimizing or eliminating the number of conversions, and minimizing the power required by the avionics.

Another emergency source is a gas turbine-driven generator, where the turbine can be driven by ram air (RAT), gas generator, engine bleed air, or even external air from a ground power cart for ground checks. The gas generator could be a self-contained unit using its own stored

fuel, i.e., a monofuel emergency power unit (MEPU), or it could be a small turbine engine that burns the same fuel as the primary propulsion, i.e., a turbojet. An advantage of the turbojet is that its exhaust can supply thrust to extend the glide thereby increasing the recovery range of the RPV. Since a HALE RPV flies at essentially constant dynamic pressure, a RAT would do well at all altitudes. However, at some point in the landing flare, it would drop out of operation, and a battery for other equivalent source would have to take over through flare and roll-out. Such complexity makes a RAT less desirable. A variation of RAT and MEPU (at least theoretically possible) is a multi-mode MEPU in which the gas driving the generator (and/or hydraulic pump in the general case) could come from any of several sources: a monofuel gas generator, engine bleed air, ram air, or air from ground support equipment. Such a device would be capable of providing emergency or auxiliary power under nearly any set of circumstances imaginable in HALE RPV operations. Dual mode MEPU's exist, but a multi-mode MEPU as described above does not. Potential vendors believe that such a device is feasible and would require some development.

An additional use for the air turbine motor is to unload the engine at maximum altitudes. Shaft horsepower extraction limitations at altitude have been a governing factor in the selection of HALE RPV engines. This problem is primarily related to approaching and exceeding the design HP extraction limit of the engine, which may result in a compressor surge condition. The problem is graphically illustrated by Figure 14 which shows a typical compressor map for a gas turbine engine. This figure shows the normal compressor operating line and the effects of shaft horsepower extraction from the spool. The normal compressor operating condition will move into the surge boundary region if the design HP extraction limit is exceeded. Extracting bleed air has the opposite effect. As illustrated, the operating point moves away from the surge boundary because more compressor airflow is required to satisfy the turbine airflow plus the bleed air extraction (See also Reference 18). Therefore, for a typical two-spool engine power via bleed air in addition or alternatively to mechanical extraction near maximum altitude could improve overall system performance. However, optimizing power extraction is a complex process. It requires investigating many options. Since the best solution is application sensitive, it can only be achieved by a team approach between the engine manufacturer and aircraft system designer. This is especially true for operation near maximum altitude where power extraction requirements approach total available power.

Another important consideration is reliability and the inherent need for redundancy in the EPS to meet the 24-hour requirement. The levels of redundancy assumed for the study are triplex for flight critical elements and duplex for the additional elements affecting mission reliability (i.e., payload power). These levels were employed in the TRA Compass Cope-R, both the YQM-98A and proposed production version. Tables 29 and 30 show representative failure rates for the ten major subsystems for mission and RPV recovery, respectively, in the above systems. An RPV recovery failure is one which causes a loss of the

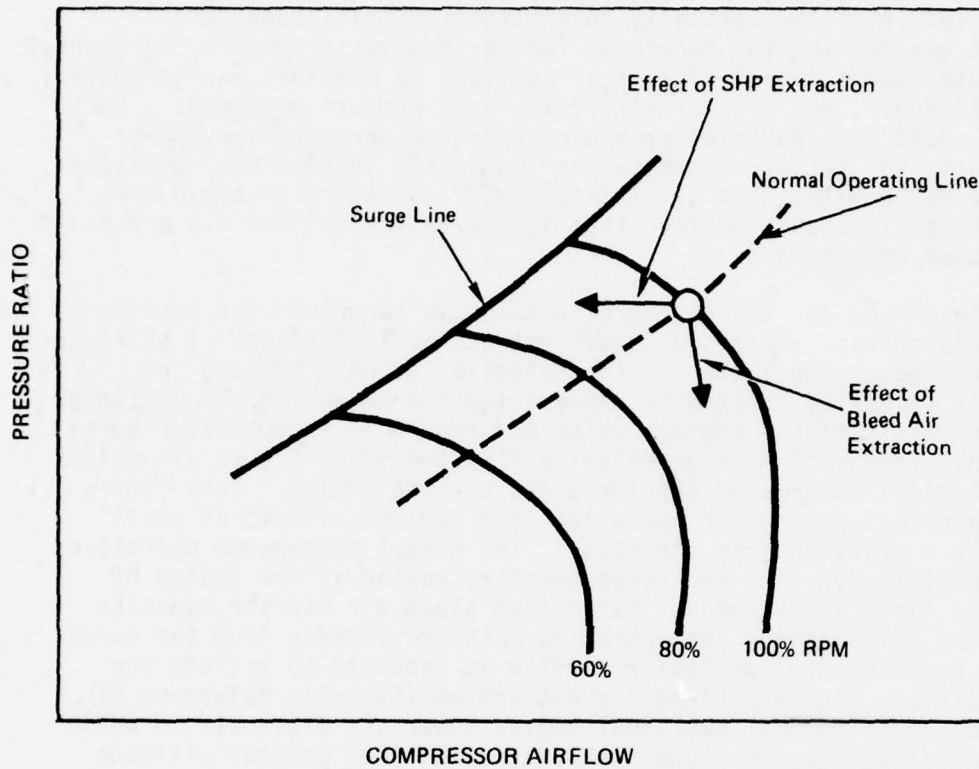

Figure 14. Compressor Characteristics with Power Extraction

TABLE 29

MISSION FAILURE RATE  
(Failures/10<sup>6</sup> Hours)

MODEL 275

SUBSYSTEM	SINGLE ENGINE		TWIN ENGINE	
	GE TF-34	LYCOMING ALF 502		GARRETT ATF 3-7
Airframe	30.00	30.00	30.00	30.00
Fuel	405.00	405.00	405.00	405.00
Oil	25.00	25.00	25.00	5.00
Electrical	33.00	33.00	33.00	33.00
Flight Control	107.00	107.00	107.00	107.00
Hydraulic/Pneumatic	1030.00	1030.00	1030.00	989.00
Command/Control/Communication	124.66	124.66	124.66	124.66
Environmental Control	271.00	271.00	271.00	271.00
Landing Gear (Mechanical)	23.00	23.00	23.00	23.00
Engine	100.00	28.80	58.82	0.10
$\Sigma$ MS	2148.66	2077.46	2107.48	1987.76
$\Sigma$ MTBF	465.41	481.36	474.50	503.08

TABLE 30

 RPV RECOVERY FAILURE RATE  
 (Failures/10<sup>6</sup> Hours)

MODEL 275

SUBSYSTEM	SINGLE ENGINE		TWIN ENGINE
	GE TF-34	LYCOMING ALF 502	GARRETT ATF 3-7
Airframe	30.000	30.000	30.000
Fuel	1.568	1.568	1.568
Oil	25.000	25.000	0.000
Electrical	0.003	0.003	0.003
Flight Control	0.001	0.001	0.001
Hydraulic/Pneumatic	8.664	8.664	8.664
Command/Control/Communication	0.000	0.000	0.000
Environmental Control	2.013	2.013	2.013
Landing Gear (Mechanical)	0.383	0.383	0.383
Engine	10.000	14.400	28.571
$\Sigma \lambda r$	77.632	82.032	96.203
$\Sigma MTBCF$	12881.286	12190.365	10394.686
			23456.558

vehicle or damage beyond repair. A mission failure causes an aborted mission and forces the RPV to return to base. Notice that the electrical subsystem is one of the lesser contributors to system failure rate. The data indicates that the redundancy used is at the appropriate level. The critical failure rates are associated with the remaining non-redundant elements, such as the propulsion system (engine, fuel, and oil), hydraulics, and the airframe itself. Triplex redundancy for flight safety can be implemented in a number of ways. It could be, for example, two engine-driven generators and a battery (YQM-98A), two engine-driven generators, and an ATM-driven generator, or an engine-driven generator and an ATM-driven generator and a battery. A twin engine configuration is shown for comparison to point out its reliability advantage. Unfortunately, the twin version suffers in performance. The desire to have a second electrical source that is independent of primary propulsion makes the air turbine motor (or turbojet) concept discussed earlier an attractive approach.

In addition to power extraction differences between engines, starting requirements also differ to affect the EPS. For example, the Garrett ATF-3 used in the YQM-98A had a DC starter-generator that produced 37 ft-lb. of torque. However, the starting torque requirements of the TF-34 engine exceed 225 ft-lbs, which could be too high for a starter-generator. Therefore, air start would be used on these engines, as is done in commercial applications.

The six electrical power systems studied for the HALE class RPV are as follows:

- A. LVDC, Low Voltage Direct Current (28V)
- B. HVDC, High Voltage Direct Current (270V)
- C. CSCF, Constant Speed Constant Frequency (120/208V AC)
- D. VSCF, Variable Speed Constant Frequency (120/208V AC)
- E. VSVF, Variable Speed Variable Frequency (120/208V AC)
- F. AC/DC, Variable Speed Hybrid AC/DC Output (120/208V AC and 28V DC)

For the purpose of this study, the HALE power components are derivations of the ARPV components with two 10 KVA generators used per system rather than the one generator used in an ARPV. Although 10 KVA represents a minimum capacity generator, the results would not differ had 20 KVA generators been assumed. The difference is one of sizing to meet a specific set of requirements.

### 9.3.2 Baseline

The electrical system used on the YQM-98A is a redundant system that consists of a direct engine-driven DC starter-generator and a remotely driven AC/DC generator, that derives its primary power from an engine-driven hydraulic pump delivering to a remote hydraulic constant speed motor. Also included are an emergency battery, a static single-phase inverter, associated bus contactors, reverse current relays, and distribution wiring. A simplified schematic diagram of the system is shown in Figure 15.

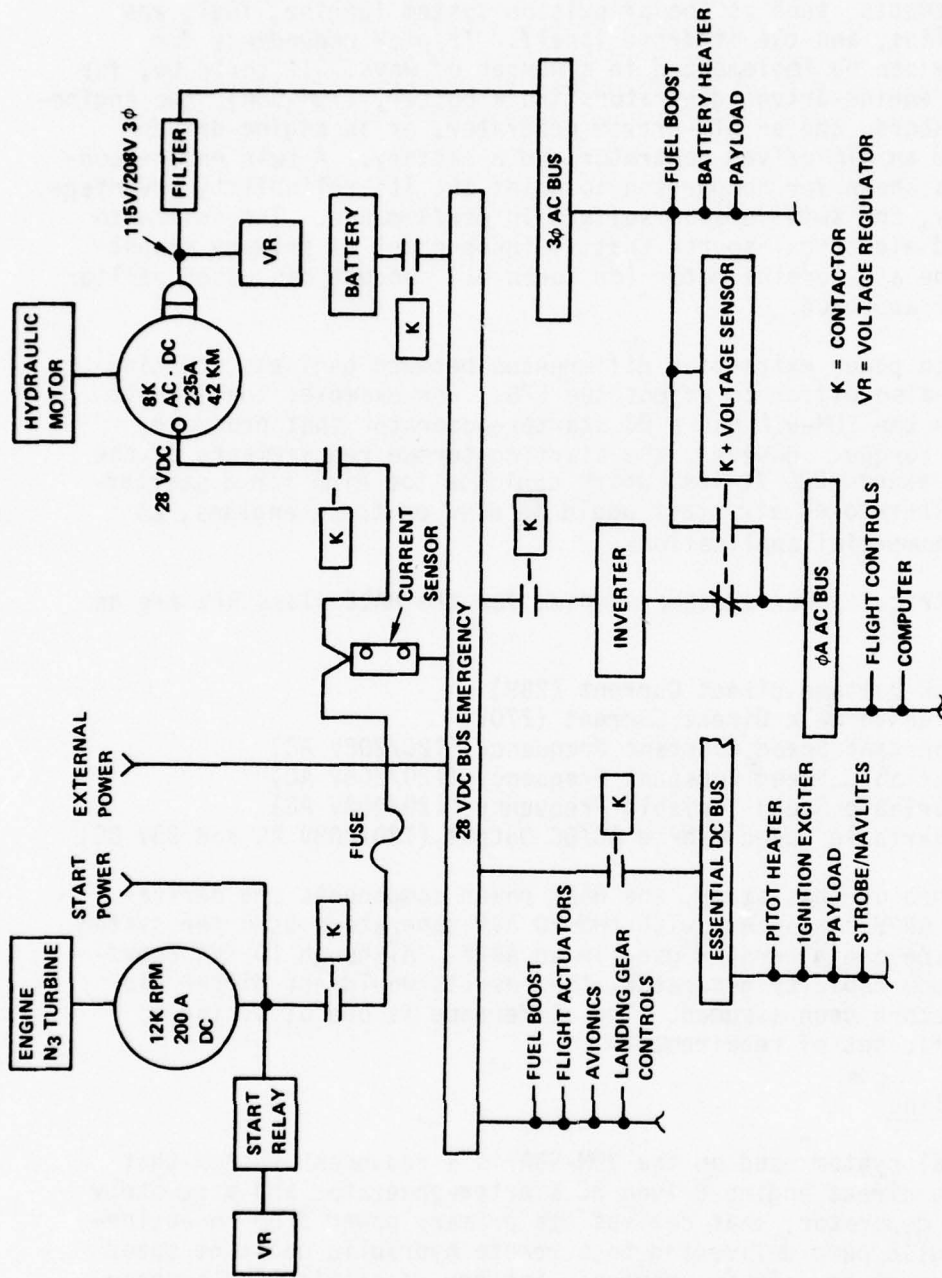

Figure 15. HALE Baseline

If the engine should fail after takeoff, thereby disabling both generators, two parallel batteries will supply DC energy for over 1.5 hours to enable the vehicle to land safely from any altitude. AC power is supplied to both the three-phase and single-phase AC buses. The inverter or one-phase of the three phase bus supplies the AC single phase bus loads. The AC/DC generator also can be driven utilizing an AGE hydraulic cart to power the constant speed motor via an AGE hydraulic connection.

The particular ratings of the power system components are:

AC/DC Generator:	8,000 RPM
	4.2 KVA, AC
	235 Amps, DC
	Oil Cooled, brushless
	MIL-STD-704A quality power
Starter Generator:	5-12,000 RPM
	200 Amps, DC
	Air Cooled, Brush tupe
	MIL-STD-704A quality power
Inverter:	115 Volt, 400 Hz
	Single Phase
	1,000 VA
	MIL-STD-704A quality power
Battery:	Two 23 Ampere-hour in parallel
	Silver-zinc
Generator Reverse Current Relay	300 ampere rating
	9 - 25 Ampere reverse cutout threshold
	0.3 to 0.7 volt differential pickup
Battery Reverse Current Relay	75 Ampere rating
	1-3 Ampere reverse cutout threshold
	1.0 to 1.5 volt differential pickup

A typical power system operational sequence would be:

1. Vehicle checkout on external power
2. Engine start - individual generator system checkout, followed by enabling both generators.
3. Switch to "takeoff mode" - Battery enable; AC/DC generator supplying both DC buses and the 3Ø AC bus; the inverter supplying 1Ø AC bus; the starter generator on standby.
4. Vehicle mission phase including takeoff, landing, and rollout.
5. Engine shutdown, with battery RCR disabled, both generators off.

In the event of a malfunction of the power system, the following corrective actions would automatically be taken:

1. AC/DC generator failed: Starter-Generator supplies DC load, three phase AC bus off. Inverter continues to power AC single phase bus.
2. Starter-generator failed: No effect
3. Inverter failed: AC/DC generator "A" phase supplies single phase load.
4. Both generators fail or engine off: Battery supplies DC emergency bus, and inverter powers AC single phase bus. Battery is sized to provide over 90 minutes glide time. Load is 43 amperes at 27.5V.

### 9.3.3 LVDC

The HALE system as shown in Figure 16 is very similar to the ARPV system (shown in Figure 8); it differs in that a second generator is APU driven and is arranged to power the emergency bus. The HALE flight control system will require only DC power, which eliminates the requirement for an inverter.

External power need only be applied to enable preliminary tests and engine start. Thereafter, all preflight checks can be conducted on internal power. The umbilicals will then be disconnected, the vehicle buttoned up and taxied to takeoff.

One advantage of the LVDC configuration is that it may be operated independently of external power. The following sequence could be followed: Start the APU using the onboard battery. Then, use the APU output (either electrical or bleed-air/pneumatic) to start the engine. The weight of the fuel used in this sequence would be more than offset by the weight reduction in eliminating the engine starting umbilical, relay, and power feeder lines.

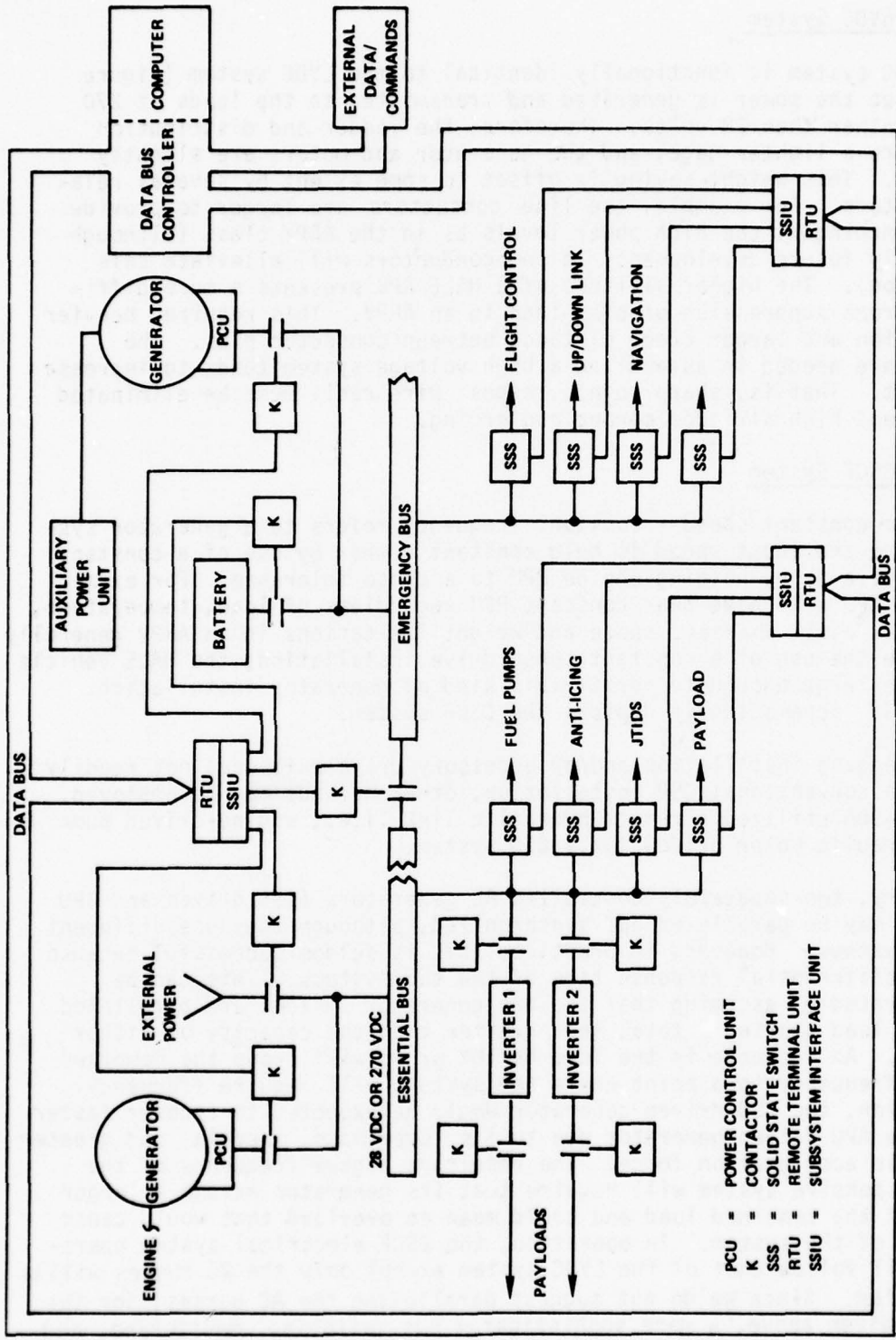

Figure 16. LVDC/HVDC Systems

#### 9.3.4 HVDC System

The HVDC system is functionally identical to the LVDC system (Figure 16, but the power is generated and transmitted to the loads at 270 volts rather than 28 volts. Therefore, the feeder and distribution lines are a lighter gage, and the generator and motors are slightly smaller. This weight saving is offset to some extent by several related factors. For example, the line contactors are larger to provide arc quenching at the high power levels as in the ARPV class (although hopefully future developments in semiconductors will alleviate this situation). The higher altitude of a HALE RPV presents a more difficult corona suppression problem than in an ARPV. This requires heavier insulation and larger creep distance between connector pins. The extra care needed in assembling a high voltage system tends to increase its cost. That is, sharp points, edges, wire radii must be eliminated to prevent high altitude corona and arcing.

#### 9.3.5 CSCF System

The term constant speed - constant frequency refers to a generator system where the input speed is held constant either by use of a constant speed drive or by holding engine RPM to a close tolerance. For example, an APU will have near constant RPM regardless of load, temperature, altitude, etc. Whereas, space and weight limitations in an ARPV generally preclude the use of a constant speed drive installation, the HALE vehicle would be large enough to permit this kind of generator installation. Figure 17 schematically depicts the CSCF system.

If the engine installation and/or accessory drive unit does not readily permit a conventional CSD installation, other methods may be employed. The YQM-98A utilized a remote hydraulic link (i.e., engine-driven pump and hydraulic motor drive) for a CSD system.

In theory, two separately controlled AC generators (CSD driven and APU driven) may be paralleled and synchronized, although they use different drive systems. However, in practice, this is seldom successful because of the differential response time of the two systems. This can be demonstrated by assuming that the two generator systems are paralleled and are load sharing a total load greater than the capacity of either machine. An increase in the load by 10% or so will droop the combined system frequency to a point where the systems will require frequency correction, the CSD driven generator would be expected to recover faster than the APU driven generator due to its lower mass, inertia, and greater available acceleration force. The resultant higher frequency of the more responsive system will require that its generator assume a larger share of the combined load and could mean an overload that would cause failure of the system. In operation, the CSCF electrical system operation will follow that of the LVDC system except only the DC busses will be paralleled. Since we do not suggest paralleling the AC busses, for the reason given above, a more sophisticated bus switching, monitoring, and control system will have to be implemented to avoid overloading either AC generator or transformer-rectifier unit.

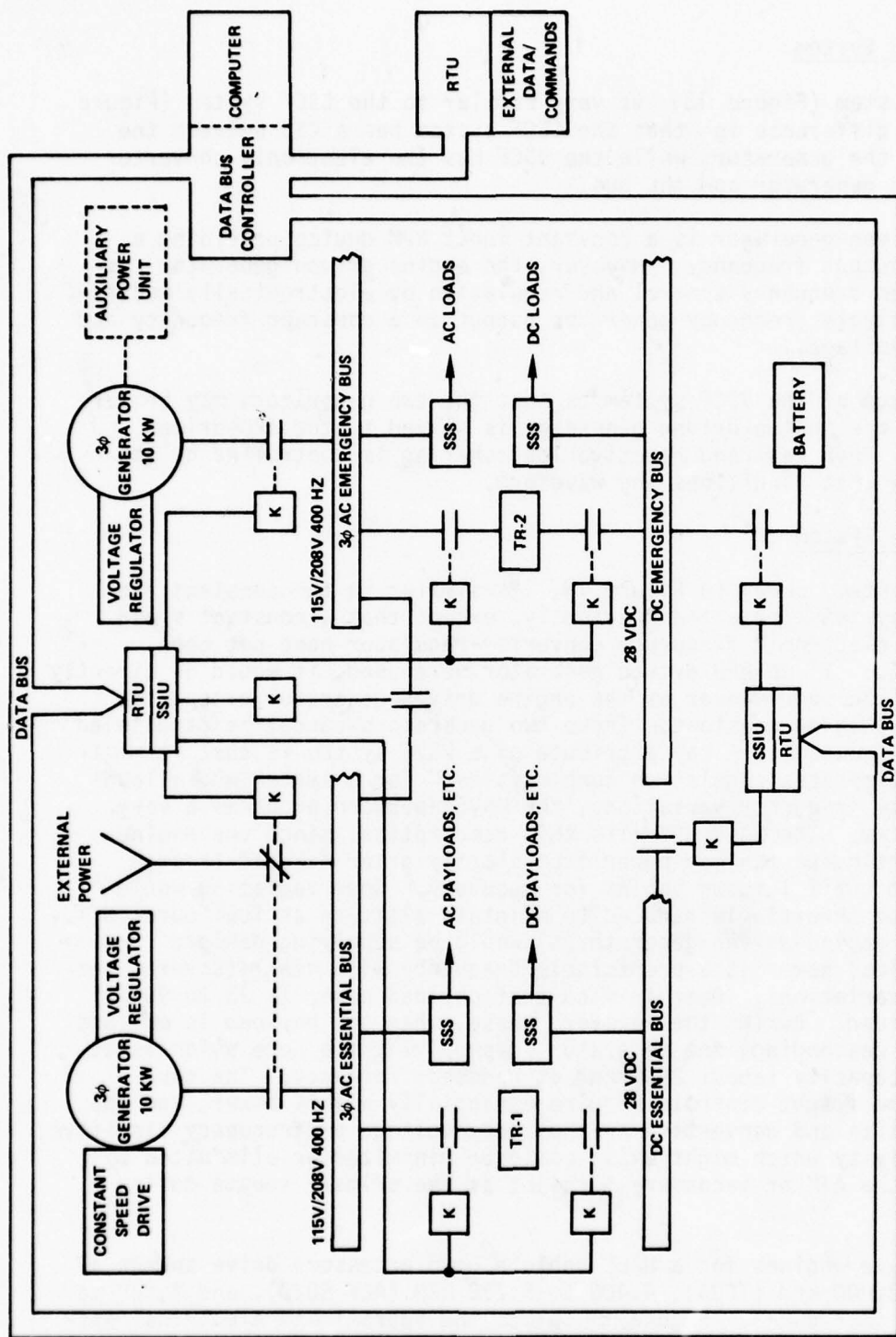

Figure 17. HALE CSCF System

### 9.3.6 VSCF System

The VSCF system (Figure 18) is very similar to the CSCF system (Figure 17); the difference is that the CSCF system has a CSD between the engine and the generator, while the VSCF has the electronic converter between the generator and the bus.

The APU driven generator is a constant input RPM device providing a regulated output frequency. However, the engine driven generator system achieves frequency control and regulation by electronically modifying the variable frequency generator output to a constant frequency and regulated voltage.

One advantage of the VSCF system is that the two generators may be paralleled if the engine-driven generator is slaved to the APU-driven generator. Then real and reactive load sharing is controlled by the same device that conditions the waveform.

### 9.3.7 VSVF System

The VSVF system, shown in Figure 19, is similar to the constant frequency AC systems presented previously, except that a constant speed device and electronic frequency converter-regulator have not been incorporated. If an APU driven generator were used, it would be directly coupled in the same manner as the engine driven generator except the frequency would be constant. These two generators cannot be paralleled for obvious reasons. A key attribute of a VSVF system is that it minimizes or eliminates regulation complexities. For a system whose loads can tolerate frequency variations, the VSVF approach produces a very simple system. The HALE RPV fits this description, since the engine runs at continuous maximum power from shortly after takeoff through the mission until letdown begins for recovery. Some variation would occur if the throttle is reduced to maintain altitude as fuel burns off. Therefore, engine-driven generator(s) would be supplying payload (and core avionics) power at a predictable frequency with small (several percent RPM) variations. Bear in mind that payload power is 75 to 90% of the total load. During the recovery phase, when the payload is off and the RPV is descending, the generator is supplying the core avionics at 10 to 25% capacity (about 2KW) and at reduced frequency. The core avionics and flight controls require essentially all DC power, and the power supplies and converters are not very voltage or frequency sensitive. Any sensitivity which might exist could be minimized or eliminated by operating the ATM or secondary turbojet as the primary source during recovery.

The candidate engines for a HALE vehicle have accessory drive speeds of 7,500 to 12,000 RPM (TF34), 4,400 to 8,700 RPM (ALF 502D), and 8,900 to 17,650 RPM (ALF 502H). Figure 20 plots the approximate electrical system frequency ranges near 400 Hz that might be obtained with a direct drive VSVF system. Obviously higher frequencies are readily obtainable.

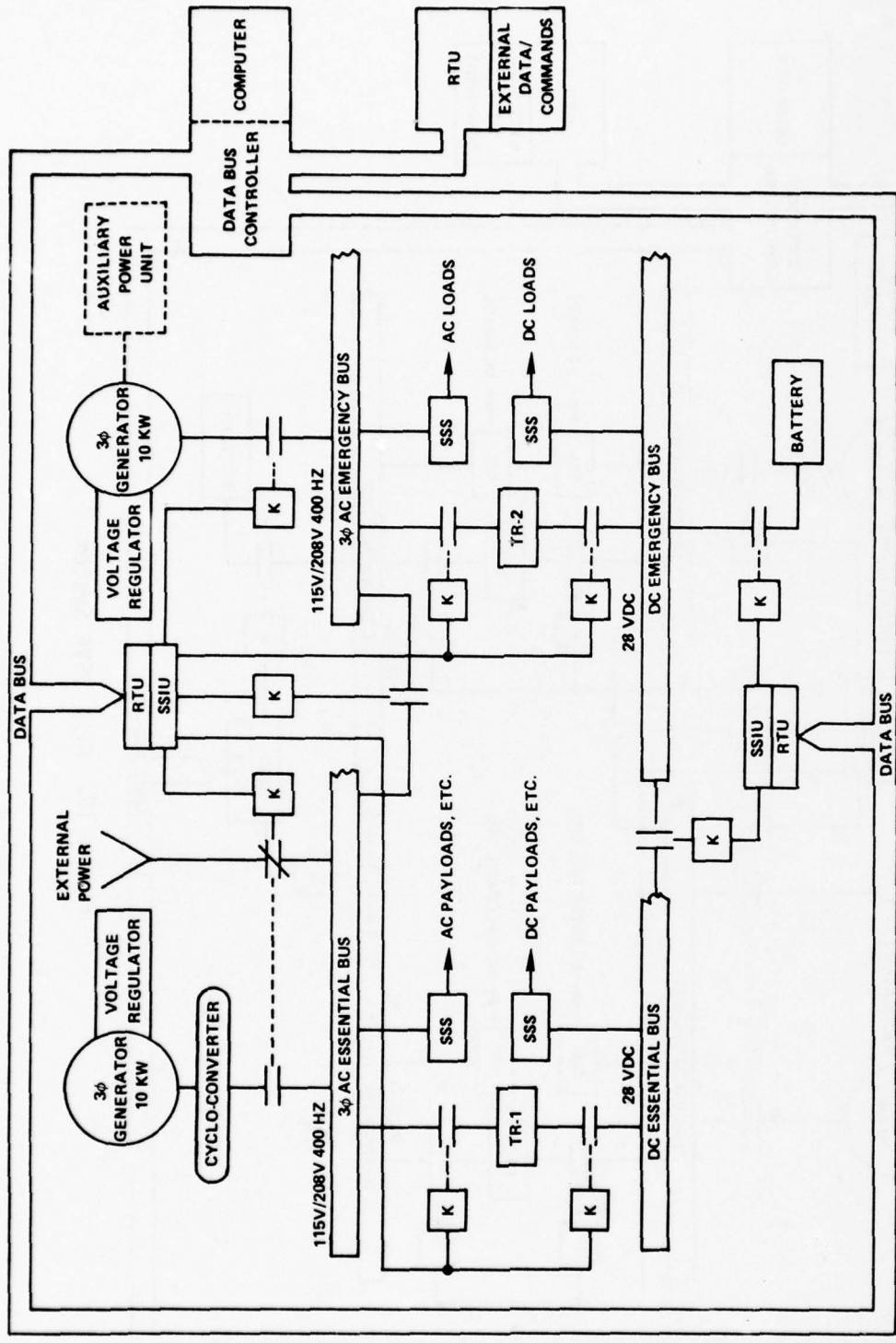

Figure 18. HALE VSCF System

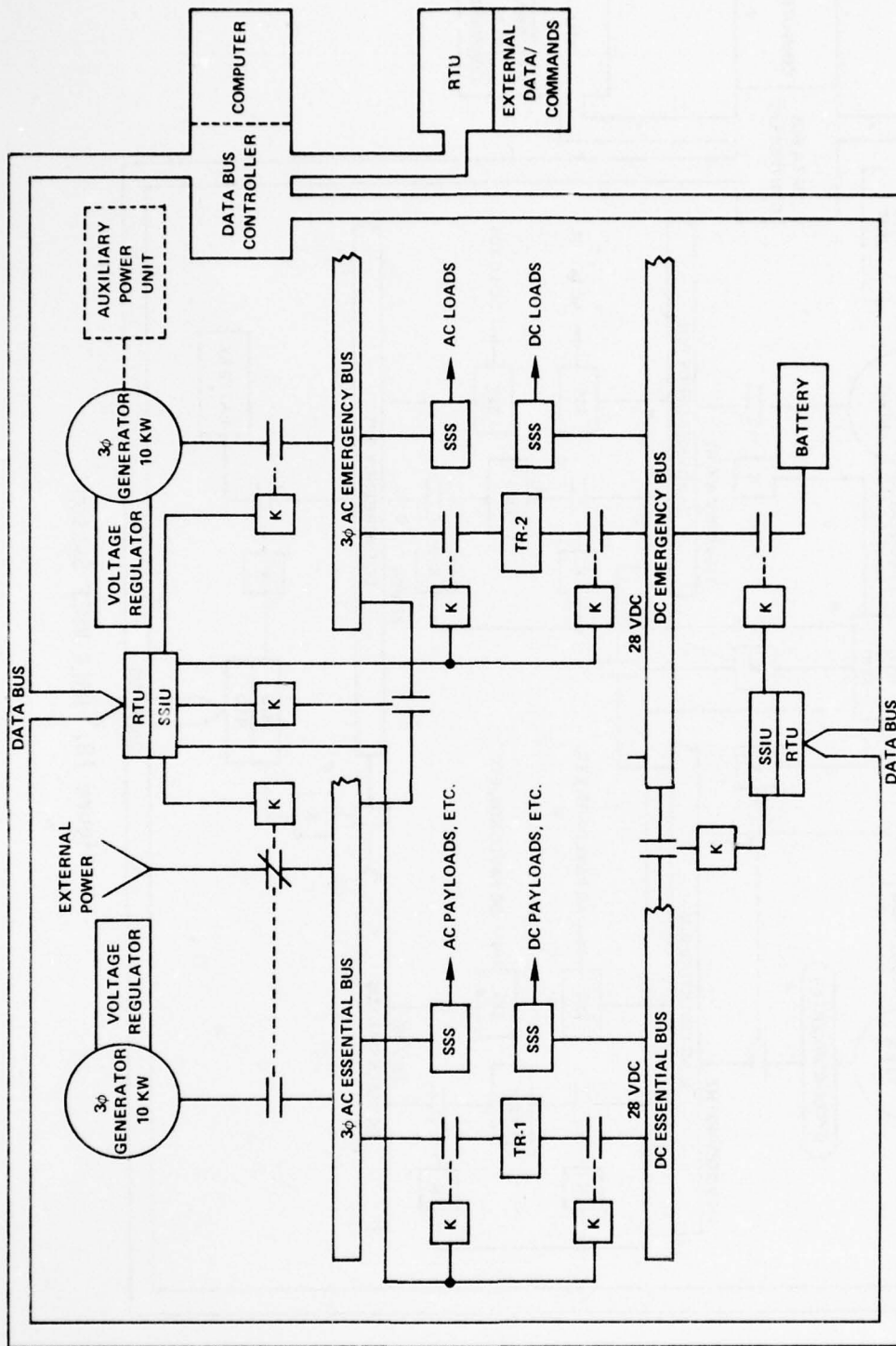

Figure 19. HALE VSVF System

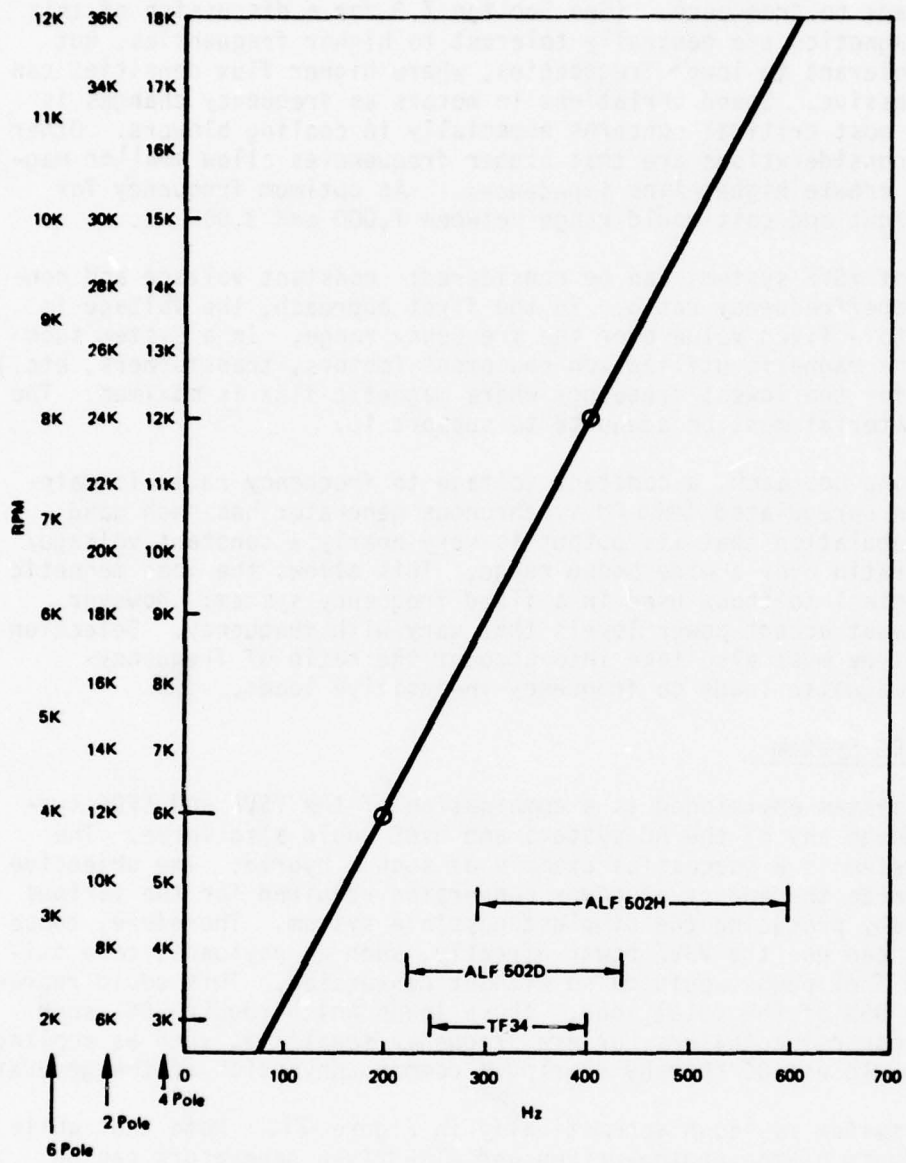

Figure 20. Frequency Ranges for a VSVF Generator

The most suitable frequency range depends on the sensitivity of the various loads to frequency. (See Section 7.3 for a discussion of this issue). Magnetics are generally tolerant to higher frequencies, but not very tolerant to lower frequencies, where higher flux densities can become excessive. Speed variations in motors as frequency changes is one of the most critical concerns especially in cooling blowers. Other important considerations are that higher frequencies allow smaller magnetics but create higher line impedances. An optimum frequency for minimum weight and cost would range between 1,000 and 3,000 Hz.

Two types of VSVF systems can be considered: constant voltage and constant voltage/frequency ratio. In the first approach, the voltage is regulated to a fixed value over the frequency range. In a system such as this, the magnetic utilization equipment (motors, transformers, etc.) are sized for the lowest frequency where magnetic flux is maximum. The magnetic material must be adequate to support it.

In the second approach, a constant voltage to frequency ratio is maintained. An unregulated SmCo PM synchronous generator has such good inherent regulation that its output is very nearly a constant voltage/frequency ratio over a wide speed range. This allows the load magnetic to be identical to those used in a fixed frequency system; however, the loads must accept power levels that vary with frequency. Selection of system type must also take into account the ratio of frequency-sensitive magnetic loads to frequency-insensitive loads.

#### 9.3.8 AC/DC System

The AC/DC system envisioned is a combination of the VSVF and LVDC systems, although any of the AC systems and HVDC would also serve. The YQM-98A system is a successful example of such a hybrid. The objective is to minimize the amount of power conversion required for the various loads thereby producing the simplest possible system. Therefore, those loads that can use the VSVF power directly, such as payloads, core avionics, and fuel pumps would do so without conversion. This could represent 50 to 95% of the total load. Those loads which require DC, such as flight control actuators, or are frequency sensitive, such as cooling blowers, would use DC thereby sharing a common conversion at the generator.

The AC/DC system is shown schematically in Figure 21. Note that while the DC outputs of the engine-driven and ATM-driven generators can be paralleled, the AC outputs cannot. Recent developments, such as the hybrid PM/EM or flux-shunt regulator, allow regulating the AC and DC generators independently where both AC and DC loads require close regulation.

#### 9.4 ANALYSIS

The candidate EPS architectures for the HALE-class RPV described in Section 9.3 are evaluated in this section. Their weights and volumes are listed in Table 31. The weighting factors are based on the sensitivity

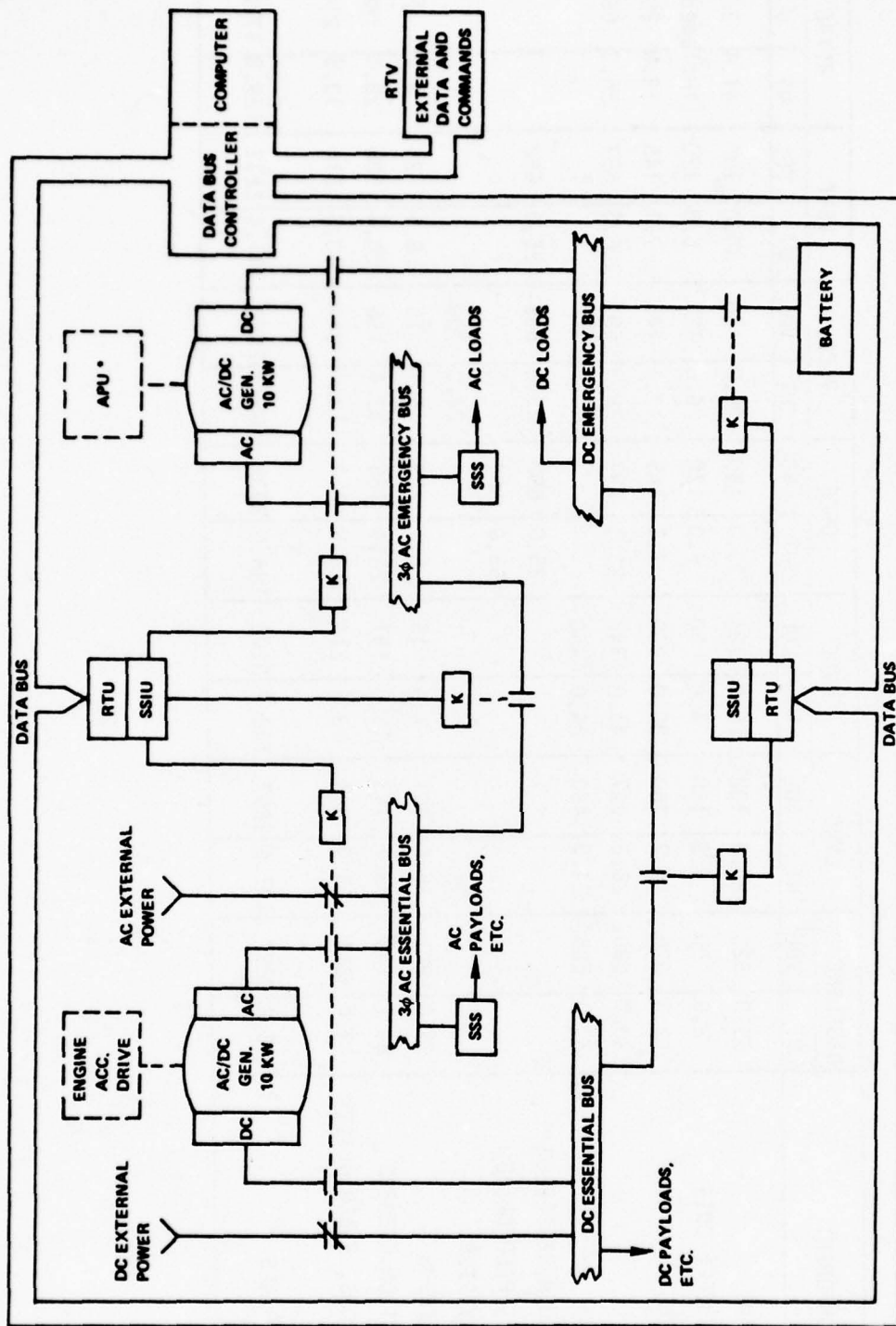

Figure 21. HALE AC/DC System

TABLE 31  
SUMMARY OF HALE PHYSICAL CHARACTERISTICS

COMPONENT	BASELINE		LVDC		HVDC		CSCF		VSCF		VSVF		AC/DC	
	WT	VOL	WT	VOL	WT	VOL	WT	VOL	WT	VOL	WT	VOL	WT	VOL
GENERATORS	55.0	523	28.0	132	26.0	124	30.0	160	30.0	160	30.0	160	41.4	322
POWER CONTROL UNIT	2.0	90	6.0	150	4.0	90	6.0	120	6.0	120	6.0	120	(included)	
CONTACTORS	12.3	320	14.7	260	30.0	700	7.1	145	7.1	145	7.1	145	13.0	268
BATTERY	30.2	690	26.3	697	45.8	1348	26.3	697	26.3	697	26.3	697	26.3	697
INVERTER	23.0	506	24.0	460	24.0	460								
TRANSFORMER-RECTIFIER							25.0	682	25.0	682	25.0	682		
CONSTANT SPEED DRIVE							55.0	804						
CYCLOCONVERTER									24.0	700				
POWER FEEDERS	35.4	801	35.4	801	1.9	15	5.1	29	5.1	29	5.1	29	6.2	35
DISTRIBUTION FEEDERS	23.7	143	23.7	143	11.0	151	28.4	186	12.4	186	28.4	186	28.4	186
CONNECTORS, FIBER OPTICS	13.4	214	13.5	214	13.5	214	13.5	214	13.5	214	13.5	214	13.5	214
TOTALS	195.2	3287	171.6	2857	156.2	3102	196.4	3037	165.4	2933	141.4	2233	128.8	1722

factor  $\alpha$  being set to unity, except for EPS weight for which  $\alpha$  is two. The weighting factors are listed along with the final evaluation scores in Table 32. The raw data are listed in Table 33.

Clearly, the hybrid AC/DC system is the best candidate in three of the five evaluation categories as well as overall, at least for the ground rules used during the analysis. Also, all of the candidates are as good or better than the baseline system, which has the lowest score in three of five categories. This is an unsurprising result due primarily to older technology, which yields higher weights and complexity, and lower power capacities. The VSVF system is also a good candidate. The primary reason that it is rated second is because a ground rule used during candidate synthesis was that a battery would provide emergency power. If a multimode ATM were to provide emergency power rather than a battery, then the VSVF approach would very likely score as well as the AC/DC system.

All candidate systems must supply 2 KW of DC to the avionics; however, they will differ in the power format supplied to the payload. The two DC systems will supply primarily DC power with provisions for 2 KVA of 115V/230 VAC, 400 Hz by means of inverters. The CSCF and VSCF systems provide all controlled frequency power; converters are needed to supply the DC power. The VSVF and AC/DC systems supply wild frequency AC. Since payload power is supplied while the engine is operating at nearly constant RPM, the generator drive can be designed to produce any desired frequency at that speed within a practical range of 400 to 4000 Hz.

The AC/DC system is a hybrid of the LVDC (or HVDC) and VSVF systems that matches the power source to the loads in an optimal way. The hybrid architecture features a dual generator, one AC and one DC, stacked in a common frame and having independent voltage regulation. The capacities of the two generators are selected, or even changed later, to best match the expected load requirements. This approach eliminates (or at least minimizes) the need for converters and inverters. Hence, the resulting system is the simplest and therefore the lightest, most reliable, and least expensive one. Notice that as the ratio of AC to DC power required by the payload goes toward zero, the hybrid configuration converges to a LVDC (or HVDC) configuration. Conversely, as the payload AC/DC ratio moves toward infinity (i.e., little or no DC), the hybrid system converges toward a VSVF configuration. It never reaches a VSVF configuration, however, because a core avionics DC requirement always exists. Interestingly, should the requirement for regulated 400 Hz power be imposed by the payload, the optimal configuration would still be a hybrid AC/DC one. However, the AC portion would develop out of one of the regulated AC configurations (i.e., CSCF or VSCF) rather than the wild frequency VSVF.

As a footnote to the previous ARPV study, it did not include the AC/DC system because the trends in payload power requirements lean so strongly toward all DC. Because of the similarities in the systems, one could conclude that a hybrid AC/DC architecture would also be optimum for an ARPV, if a definite and significant need for AC power were to develop.

TABLE 32  
EPS EVALUATION

HALE Raw Data

ITEM	PARAMETER	BASELINE	LVDC	HVDC	CCCF	VSCF	VSVF	AC/DC
1.0	PHYSICAL PARAMETERS							
1.1	Weight (lbs)	195.2	171.6	156.2	196.4	165.4	141.4	128.8
1.2	Volume (in <sup>3</sup> )	1.9	1.65	1.8	1.76	1.70	1.29	1.00
1.3	Total Available Power (KW)							
1.3.1	Current	10.5	15	15	15	15	15	15
1.3.2	Growth	17.5	20+	20+	20+	20+	20+	20
2.0	PERFORMANCE							
2.1	Steady State							
2.1.1	Voltage Variation	+3-5	+3-5	± 1	+3-5	+3-5	± 5	+3-5
2.1.2	Frequency Variation	± 1	-	-	-	-	-	± 1
2.2	Transient							
2.2.1	Voltage Variation	+3-5	+3-5	± 1.8	+3-5	+3-5	+3-5	+3-5
2.2.2	Frequency Variation	-	-	-	-	-	-	-
2.3	Filtering Requirements							
2.4	Ability of Parallel Ops							
2.5	Penalties							
2.5.1	Losses	52%	67%	70%	43%	60.7%	69.5%	51.2%
2.5.2	Weight due to Losses	21.75	32.1	23.5	37.3	11.9	6.6	10.3
2.6	Efficiency	72	73.6	73.6	47.5	72	74.3	76
3.0	RELIABILITY							
3.1	MTBF	265	524	610	548	362	508	696
3.2	Prob. of Mission Success	0.913	0.955	0.961	0.957	0.936	0.954	0.966
3.2.1	Component Failure Prob.							
3.2.2	Redundancy							
4.0	MAINTAINABILITY							
4.1	MTTR							
4.2	Fault Isolation							
4.2.1	Accessibility							
4.2.2	Automatic/Manual							
4.2.3	Mean Time Required	1	1	1	1	1	1	1
4.3	Maintenance Actions							
4.3.1	Repairability	+	+	+	+	+	+	+
4.3.2	Replacibility	+	+	+	+	+	+	+
4.3.3	Expendability	-	-	-	-	-	-	-
4.3.4	Standardization	--	00+	00+	00-	+++	++	0-
4.3.5	Alignment & Adjustments	0.5	0.5	0.5	0.5	0.5	0.5	0.5
4.4	Preventive Action Time							
4.5	Mean Down Time							
4.6	Inherent Availability							
4.7	Achieved Availability							
4.8	Operational Availability							
5.0	COST AND RISK							
5.1	Development Cost	0	248	484	281	267	189	252
5.2	Production Cost	2490	965	1844	5606	4625	1652	843
5.3	O/S Costs	1296	1089	799	1104	1362	387	730
5.4	Technical Risk							

NOTE: Estimates from Crossley  
 + = Best  
 0 = Medium  
 - = Worst

TABLE 33  
EPS EVALUATION

Weighted Score - Mini

ITEM	PARAMETER	WEIGHTS	GASLINE	LVDC	HVDC	CSCF	VSCF	VSVF	AC/DC
	TOTAL SYSTEM*	1000	636	789	755	645	654	804	894
1.0	PHYSICAL PARAMETERS	150	98.5	117.80	118.95	111.15	118.10	133.90	150
1.1	Weight (lbs)	50	32.8	37.50	41.15	32.75	38.85	45.45	50
1.2	Volume (in <sup>3</sup> )	50	26.3	30	27.80	28.40	29.25	33.45	50
1.3	Total Available Power (kW)	50	39.40	50	50	50	50	50	50
1.3.1	Current								
1.3.2	Growth								
2.0	PERFORMANCE	120	93.00	93.86	94.82	73.11	100.18	110.2	105.12
2.1	Steady State	15	10.50	15	15	15	15	15	10.50
2.1.1	Voltage Variation								
2.1.2	Frequency Variation								
2.2	Transient	15	15	15	15	15	15	15	15
2.2.1	Voltage Variation								
2.2.2	Frequency Variation								
2.3	Filtering Requirements								
2.4	Ability of Parallel Ops								
2.5	Penalties	40	22.60	16.96	17.92	23.56	25.28	32.40	29.62
2.5.1	Losses								
2.5.2	Weight due to Losses								
2.6	Efficiency	50	44.90	46.90	46.90	19.55	44.90	47.80	50
3.0	RELIABILITY	250	163.20	212.10	226.20	216.10	183.40	209.50	250
3.1	MTBF	100	38.10	75.30	87.60	78.70	52	73	100
3.2	Prob. of Mission Success	150	125.10	136.80	138.60	137.40	131.40	136.50	150
3.2.1	Component Failure Prob.								
3.2.2	Redundancy								
4.0	MAINTAINABILITY	200	120.46	189.17	191.69	158.75	167.05	165.44	182.79
4.1	MTR	75	37.50	75	75	56.25	56.25	56.25	75
4.2	Fault Isolation	25	25	25	25	25	25	25	25
4.2.1	Accessibility								
4.2.2	Automatic/Manual								
4.2.3	Mean Time Required								
4.3	Maintenance Actions	20	10	16	16	18	20	14	12
4.3.1	Repairability								
4.3.2	Replacibility								
4.3.3	Expendability								
4.3.4	Standardization								
4.3.5	Alignment & Adjustments								
4.4	Preventive Action Time	40	26.69	37.33	37.33	32.69	36.69	35.33	34.69
4.5	Mean Down Time	10	7.5	10	10	8.75	8.75	8.75	10
4.6	Inherent Availability	10	3.88	8.83	9.98	6.92	5.98	6.76	9.09
4.7	Achieved Availability	10	4.68	8.18	8.40	7.36	7.4	7.71	7.92
4.8	Operational Availability	10	5.21	8.83	9.98	7.78	6.98	7.64	9.09
5.0	COST AND RISK	280	161.33	176.20	173.39	85.91	85.12	185.10	206.59
5.1	Development Cost	55	55	22.17	11.39	19.58	20.63	29.10	21.84
5.2	Production Cost	100	33.90	87.40	45.70	15	18.20	51	100
5.3	O&S Costs	75	22.43	26.63	36.30	26.33	21.30	75	39.75
5.4	Technical Risk	50	50	40	30	25	25	30	45

However, reason must be tempered with the fact that an ARPV engine operates over a wider RPM range throughout a mission. If the payloads can tolerate the wider frequency variations, then the conclusion appears valid. If it cannot tolerate the variation, then the penalty of including frequency regulation would have to be evaluated.

Several areas exist where development would benefit future HALE-class RPVs as well as possibly manned aircraft. One is the AC/DC generator, and the other is the multimode air turbine motor.

## SECTION 10

### MINI-RPV

10.1 This section summarizes the analysis of the Mini-RPV class of electric power subsystem. Inherently it is the smallest in size and power capacity of the four classes studied. The Mini-RPV and the TEDS (Section II) are similar in their simplicity; both are significantly less complex than the ARPV and HALE systems. Historically, all Mini-RPV have had low voltage DC electrical power, generally 28 V, because of its simplicity and compatibility with small reciprocating engines. These conditions will continue on into the foreseeable future. Therefore, by inspection, all of the various types of generating schemes, except low voltage DC, have been eliminated from consideration. Several variants of LVDC architecture were studied to determine whether one would show an advantage.

#### 10.2 ASSUMPTIONS

The following assumptions and ground rules were used for the Mini-RPV EPS analysis.

- 1) The electric power requirement is 1500 watts or less for most applications; special future missions, such as electronic warfare, could require power levels to 2000 watts or more. Hence, growth to at least 2000 watts must be possible.
- 2) Flight time up to 4 hours. (Conceivably future systems could develop requiring 8 to 12 hours endurance for relay missions, for example).
- 3) No redundancy
- 4) Altitude ceiling 15,000 feet.
- 5) Propeller driven with engine shaft speeds between 3000 and 10,000 RPM.
- 6) MIL-STD-704A (Category B) must be met.
- 7) Battery is required for 15 minute glide.

The ground rules used in the EPS cost analysis are:

- 1) Development phase starts in 1983 and lasts for 6 months; one prototype is tested.
- 2) Production phase starts in 1986 and lasts for 11 months; quantity of 1500 are produced.

- 3) Operational phase logistics will use 50 organizational, 3 intermediate, and 1 depot unit.

### 10.3 CANDIDATES

#### 10.3.1 General Discussion

To be consistent with the other areas of the power system study, the same six electrical systems were initially considered as candidates for the Mini-RPV plus a second version of a low voltage DC system. However, most of them were eliminated by inspection as being obviously unsuited to this class of vehicle. The resulting candidates are compared with the Navy STAR Mini-RPV, which serves as a baseline reference. Because of its contemporary nature, the STAR EPS is also considered a viable candidate.

Two types of propulsion systems were considered: one being the reciprocating engine, the other the electric motor. In reciprocating engines, consideration was given to the internal combustion as well as the hypergolic types. Each of these could accommodate either an integral or pad mounted generator.

The electric motor has been successfully demonstrated by NASA as technically feasible. However, its practicability has yet to be proven because of its limited power and endurance. While electric propulsion is a fascinating subject, it is beyond the scope of this study and is not considered further.

Generating the 1 to 2 KW (or more) of power required by Mini-RPVs is practical. However, even this modest amount extracts approximately 1-1/2 to 3 HP, which is a sizable fraction of the horsepower available from Mini engines (10 to 25 HP). Power conversion efficiency is therefore very important.

Some missions require a laser for target designation. A laser requires several hundred watts average power during its operating time with periodic bursts of high peak power at 20 pulses per second and pulse width. The power peaks nearly match the power demanded by all other loads combined; which makes regulation very difficult at best even with a great deal of added filtering. Therefore, lasers in Minis typically operate from their own battery, which can be kept charged by the EPS under more tolerable conditions.

The reliability requirements for the next generation of Mini-RPVs are such as to not require redundancy, but they will call for good reliability design practice. The preliminary Army requirement calls for a total air vehicle MTBF of at least 20 to 30 hours. Based on this, the minimum EPS MTBF should be at least on order of magnitude higher or 300 hours. Exceeding this value with the relatively simple EPS envisioned for Mini-RPVs is well within the state-of-the-art.

In addition to the baseline STAR system, which was used to calibrate PRICE as well as being a candidate, the six electrical power generating systems considered are as follows:

- 1) a. LVDC, Low Voltage, DC, Single Output  
b. LVDC, Low Voltage DC, Multi-Output
- 2) HVDC, High Voltage DC
- 3) CSCF, Constant Speed Constant Frequency (AC)
- 4) VSCF, Variable Speed Constant Frequency (AC)
- 5) VSVF, Variable Speed Variable Frequency (AC)
- 6) AC-DC, Variable Speed Hybrid AC-DC Output

Candidate systems 2 through 5 of the above list were eliminated by inspection from further consideration in the analysis as being inappropriate for Mini-RPV applications.

HVDC: While HVDC could be used in a Mini-RPV, it would provide no benefit because the vehicle is so small. Transmission lines are one or two feet long and the motors and generators are already quite small. Furthermore, HVDC components will very likely never be as available for small system applications as would be LVDC components, which in themselves are not yet readily available as off-the-shelf items.

CSCF, VSCF, VSVF: No known or anticipated requirement exists for AC power in a Mini-RPV. The core avionics are all DC as are known payloads. Therefore, the added complexity of generating regulated AC is unnecessary. VSVF is also impractical because of the effect of the wide speed range of small reciprocating engines on magnetics; its use would offer no benefit.

AC/DC hybrid: The same comments as above apply to the AC portion of a hybrid system. In fact, if a small amount of wild frequency AC power were needed, the LVDC system could supply it. The generator is an alternator with its output rectified; power could be obtained before the rectification process.

The remaining LVDC system is considered the only viable alternative in the foreseeable future. Several variants are described in the following sections. In both cases, a central core avionics power supply is considered part of the EPS as opposed to the more typical situation where each avionics unit has its own power supply that is considered an EPS load. (See Section 7.3.2 for a discussion of this concept).

The primary difference between the two systems is in the method of generating the multiple circuit voltages: whether in a multi-tapped transformer winding in a series regulator or in a multi-winding generator.

Another variation (not analyzed) would be to speed up the generator drive, as was done in STAR by 2.6:1, versus a direct drive, that is, an integrally mounted generator. The latter is being done on the two U.S. Army engine development programs currently in progress (Teledyne Continental Motors and Aerotech). The trade here is a smaller, higher-speed generator and gear train (or belt drive) versus a heavier, larger, slower, simpler integral generator. So far the choice appears to be more one of convenience and availability than anything else.

### 10.3.2 LVDC (Single Output)

The single output architecture is essentially that of the Navy STAR Mini-RPV described in Section 10.3.4, but with a higher capacity generator supplying 1500 watts at 27.5 VDC. Because the Mini-engine has a relatively low output shaft speed, a speed increaser may be required for some generators, the belt drive used in the STAR system is such an example. A simplified schematic is shown in Figure 22.

Several candidate generators are available such as a flux-switch generator and a permanent magnet (SmCo) alternator. The major difference between these two machines is that the flux-switch generator has an electromagnetic field, which is also used for regulation, while the PM alternator, which has no means of controlling the field, uses a series switching regulator. These approaches provide comparable overall performance.

To save weight, size, and cost, the voltage regulator is combined with the rectifier. If the regulator-rectifier is made an integral part of the generator the need for shielding the power leads is eliminated.

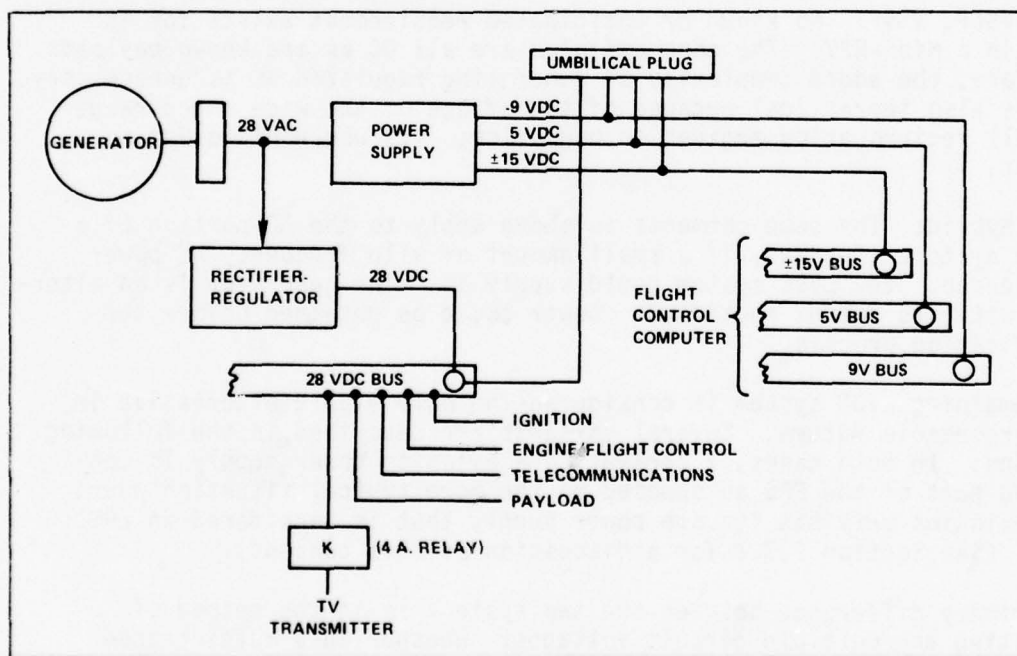

Figure 22. MINI-RPV LVDC (Single Output)

However, additional generator volume in a crowded engine compartment commands a high premium, and the environment is severe. A preferred solution is to locate the rectifier-regulator outside the engine compartment, even though power lead shielding is needed.

Utilization equipment normally require voltages other than that supplied by the generator. These can be obtained in various ways: a) by a power supply within the utilization equipment, b) by a multi-output generator, or c) by a central power supply that could be a separate unit or a part of the regulator rectifier.

### 10.3.3 LVDC (Multiple Voltage Generator)

The multiple output LVDC system differs from the previous single output system in that the required electronics circuit voltages are created within the generator. Each voltage, or conjugate voltage pair, goes to a rectifier-regulator which feeds the appropriate circuit bus. The configuration is shown schematically in Figure 23.

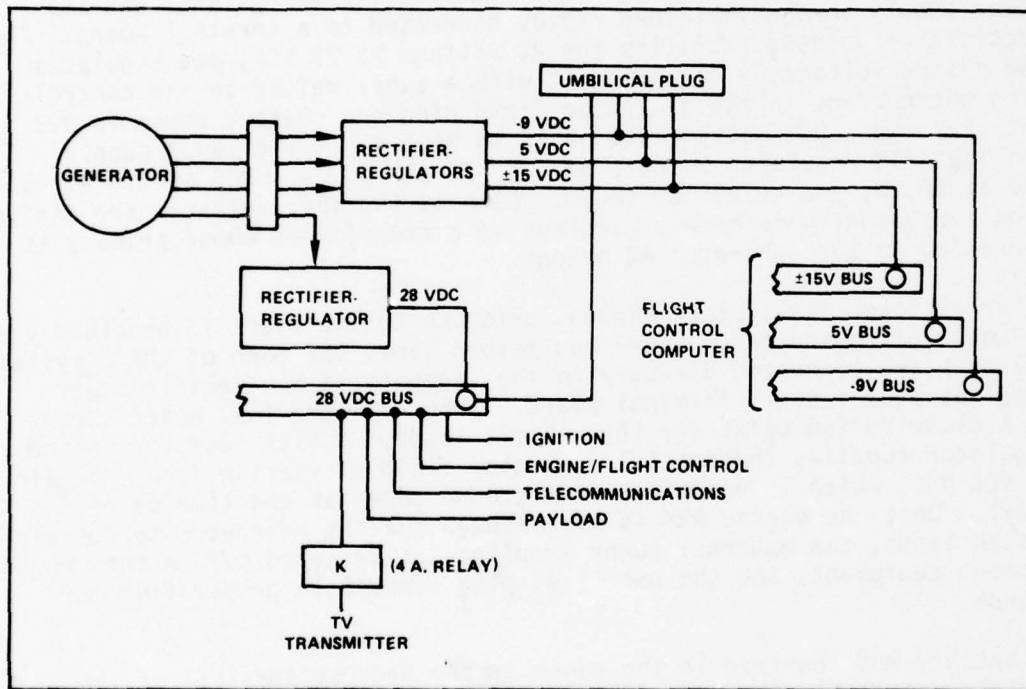

Figure 23. MINI-RPV LVDC (Multi-Output)

### 10.3.4 Mini-RPV Baseline

The electrical system used on the STAR Mini-RPV consists of a belt driven AC generator, a rectifier-regulator, a regulated power supply, a power

distribution assembly, and the distribution wiring. The generator, rectifier-regulator, and power supply are supplied by Electro-Pacific, Inc. The power distribution assembly consists of a 4 amp relay to switch 28 VDC power to the video transmitter payload. Power is distributed from a central terminal board to the various loads using conventional interconnecting wire. A block diagram of the system is shown in Figure 22.

The generator is hard-mounted to the two-stroke internal combustion engine and driven through a V-belt and pulleys to increase the RPM at the generator shaft to 2.62 times the engine RPM. The generator RPM range is from 9200 at engine idle to 24,950 at maximum engine RPM. The generator is a flux-switching type. The single phase frequency is proportional to RPM and ranges from 1533 Hz at engine idle to 4158 Hz at maximum RPM. The AC voltage waveform is approximately a square wave with a magnitude of 60 volts peak-to-peak. Field excitation is electro-magnetic, and field current is 1.8 amps maximum at 28 VDC.

The generator output is connected to the rectifier-regulator and the power supply through shielded cables connected to a terminal board. The rectifier-regulator rectifies the AC voltage to 28 VDC, and regulates the output voltage by comparing it with a zener reference and controlling the current in the generator field winding. Output power is 392 watts average, 533 watts peak, at 26 to 28.5 VDC. The power supply provides  $\pm 1\%$  regulated outputs of +15 VDC at 10W, -15 VDC at 8.6 W, +5 VDC at 28.2W, and -9 VDC at 10.3W. Each of the four voltages are derived from individually secondary windings of a transformer whose primary is connected to the generator AC output.

External power for system checkout prior to engine start is provided via an umbilical connector. Power and return lines for each of the 5 systems voltages are connected directly to the outputs of the vehicle power supplies at a central terminal board. This same terminal board serves as a distribution point for the vehicle loads. A bias resistor in the regulator supplies the initial generator field excitation from the main 28 VDC bus, which is energized from ground power at the time of engine start. Once the engine RPM is high enough for the generator to sustain system loads, the external power supplies are switched off in the ground support equipment, and the umbilical plug removed in preparation for launch.

No battery was required in the power system because survival of the vehicle was contingent upon engine-on net recovery, as compared to glide/engine-off-parachute recovery modes typical of other RPVs. Size and weight constraints prohibited addition of a battery which would power the essential systems until net recovery in the event of generator, rectifier-regulator, or power supply failure. A small battery to fire the pyrotechnics for parachute deployment was employed in the flight test vehicles, wherein a parachute system replaced the payload during initial test flights.

10.4 ANALYSIS

The Mini-RPV systems evaluated were:

LVDC Baseline STAR Mini-RPV

LVDC with multi-output generator

The component weights and volumes are listed in Table 34. Scores for each system were developed from the raw data listed in Table 35 and the formulae presented in Section 7. The weighting factors are given in Table 36 along with the final scores. As before where an evaluation element consists of more than one measurable factor, equal relative weights were assumed. The sensitivity factor was assumed to be four for weight, two for volume, and unity for all other factors. This set of values differs from the other three classes because the candidate scores are very close. Increasing the sensitivity was an attempt to help differentiate between the two systems. However, the attempt only served to strengthen the fact that the two are too much alike to be able to draw any conclusive inferences from the data: 942 points for one system versus 945 points for the other out of a possible 1000 points.

TABLE 34  
MINI-RPV EPS PHYSICAL CHARACTERISTICS

COMPONENT	STAR		MULTI-OUTPUT	
	WT. (lbs.)	VOL. (in <sup>3</sup> )	WT. (lbs.)	VOL. (in <sup>3</sup> )
Generator	5.0	12.5	6.5	18.7
Rectifier/Regulator	2.5	52.5	2.5	52.5
Power Supply	2.5	52.5	1.7	40.0
Power Feeders	0.3	0.2	0.4	0.3
Connectors, Terminals	1.5	1.5	1.5	1.5
Power Distribution Assy.	0.2	1.0	0.2	1.0
	<u>12.0</u>	<u>120.2</u>	<u>12.8</u>	<u>114.0</u>

TABLE 35  
EPS EVALUATION  
Raw Data - Mini-RPV

ITEM	PARAMETER	STAR	MULTI- OUTPUT
	TOTAL SYSTEM		
1.0	PHYSICAL PARAMETERS		
1.1	Weight (lbs)	12.0	12.8
1.2	Volume (cu. ft.)	0.075	.066
1.3	Total available power		
1.3.1	Current	1200	1200
1.3.2	Growth	2000	2000
2.0	PERFORMANCE		
2.1	Steady State		
2.1.1	Voltage Variation	+3-5	+3-5
2.1.2	Frequency Variation	-	-
2.2	Transient		
2.2.1	Voltage Variation	+3-5	+3-5
2.2.2	Frequency Variation	-	-
2.3	Filtering Requirements	-	-
2.4	Ability of Parallel OPS	-	-
2.5	Penalties		
2.5.1	Losses	214	214
2.5.2	Weight due to losses	1.42	1.36
2.6	Efficiency	76.5	76.5
3.0	RELIABILITY		
3.1	MTBF	925	1084
3.2	Prob. of mission success		
3.2.1	Component failure prob.		
3.2.2	Redundancy		
4.0	MAINTAINABILITY		
4.1	MITR		
4.2	Fault Isolation		
4.2.1	Accessibility	(10)	(7)
4.2.2	Automatic/Manual		
4.2.3	Mean Time Required	0.5	0.5
4.3	Maintenance Actions		
4.3.1	Reparability		
4.3.2	Replaceability		
4.3.3	Expendability		
4.3.4	Standardization		
4.3.5	Alignment & Adjustment	0.2	0.2
4.4	Preventive Action		
4.5	Mean Downtime		
4.6	Inherent Availability		
4.7	Achieved Availability		
4.8	Operational Availability		
5.0	COST AND RISK		
5.1	Development Cost	0	14
5.2	Production Cost	5409	5604
5.3	O and S Costs	785	745
5.4	Technical Risk	10	9

( ) = Raw Score

TABLE 36  
EPS EVALUATION  
Weighted Score - Mini

ITEM	PARAMETER	WEIGHTS	STAR	MD LVDC
	TOTAL SYSTEM	1000	942.00	945.00
1.0	PHYSICAL PARAMETERS	300	277.40	265.47
1.1	Weight	150	150	115.47
1.2	Volume	100	77.40	100
1.3	Total Available Power	50	50	50
1.3.1	Current			
1.3.2	Growth			
2.0	PERFORMANCE	200	187.28	200
2.1	Steady State	40	40	40
2.1.1	Voltage Variation			
2.1.2	Frequency Variation			
2.2	Transient	40	40	40
2.2.1	Voltage Variation			
2.2.2	Frequency Variation			
2.5	Penalties	80	67.28	80
2.5.1	Losses			
2.5.2	Weight due to losses			
2.6	Efficiency	40	40	40
3.0	RELIABILITY	150	135.83	147.30
3.1	MTBF	75	63.98	75
3.2	Prob. of Mission Success	75	71.85	72.30
3.2.1	Component Failure Prob.			
3.2.2	Redundancy			
4.0	MAINTAINABILITY	100	95.28	93.13
4.1	MTR	10	10	10
4.2	Fault Isolation	10	10	8.5
4.2.1	Accessibility			
4.2.2	Automatic/Manual			
4.2.3	Mean Time Required			
4.3	Maintenance Actions	15	15	15
4.3.1	Reparability			
4.3.2	Replaceability			
4.3.4	Expendability			
4.3.5	Alignment & Adjustment			
4.4	Preventive Action Time	10	10	10
4.5	Mean Down Time	10	10	9.30
4.6	Inherent Availability	15	13.43	13.64
4.7	Achieved Reliability	15	13.43	13.05
4.8	Operational Availability	15	13.43	13.64
5.0	COST AND RISK	250	246.25	239.00
5.1	Development Cost	50	50	45
5.2	Production Cost	100	100	96.50
5.3	O and S Costs	75	71.25	75
5.4	Technical Risk	25	25	22.5

## SECTION 11

### TACTICAL EXPENDABLE DRONE SYSTEM (TEDS)

#### 11.1 INTRODUCTION

This section treats the TEDS class electric power system. The TEDS EPS is a very simple system, much like the Mini-RPV EPS. Unlike the Mini-RPV, the TEDS engine operates as essentially a constant speed drive to a generator whether turbojet or RAT, throughout the mission. This factor presents several interesting alternatives not available to the Mini-RPV, but they were useful in the HALE RPV. Aside from payload differences, TEDS can be considered to be in the class of cruise missile vehicles. Therefore the analysis and the results would apply equally well to cruise missiles. In fact the baseline system used for comparison is based on current cruise missile technology.

The material presented in this section includes the assumptions and ground rules used in the analysis, description of candidate systems, the performance and cost analysis and evaluation and the conclusions.

#### 11.2 ASSUMPTIONS

The assumptions and ground rules used for the TEDS analysis are as follows:

- 1) Payload power requirements are 3 to 5 KW AC or DC.
- 2) Vehicle power requirements are less than 1 KW DC.
- 3) Minimum 5 year storage life.
- 4) Single flight, no recovery, 30 to 60 minutes endurance.
- 5) Engine is at full throttle at all times.
- 6) Very brief pre-flight preparation period (e.g., less than 2 minutes) to insert mission program data and verify system status.
- 7) Primary launch from ground, zero-length launcher; alternate air launch.
- 8) Central avionics (microprocessor) control and management of electric power.
- 9) Turbojet propulsion or possibly a non-rotating engine.
- 10) MIL STD 704 applies.

The cost analysis ground rules used are as follows:

- 1) Development phase starts in 1983 and lasts for 6 months; one prototype is tested.
- 2) Production phase starts in 1986 and quantity of 5,000 are produced over five years.
- 3) Operational phase logistics will use 10 organizational, 10 intermediate, and 1 depot unit.

### 11.3 CANDIDATES

#### 11.3.1 General Discussion

The TEDS system keyword is "expendable"; therefore, the principal considerations for the electrical power subsystem is directed toward simplicity. A single generator supplying no more than two busses, vehicle and payload loads respectively, is postulated. The use of a generator system, rather than a battery or other stored energy power source, is dictated by the mission time (30-60 minutes) and the size and nature of the anticipated electrical loads (up to 4KW).

The primary power plant candidates fall into the following categories:

- 1) Turbojet with available pad which may require a speed-increasing interfacing drive, or preferably an integrally mounted generator.
- 2) Turbojet without available pad, but with either bleed air or exhaust gas available for generator drive.
- 3) Ramjet, pulsejet, or rocket without a power takeoff for a generator drive. The generator system would use a ram air turbine (RAT) drive.

Efficient low speed turbines (air screws) capable of delivering the required RAT horsepower for TEDS generator operation at airspeeds as low as 70-100 KIAS exists today. A practical system could be devised to provide the required inertia for operation between initial spin-up (air start) prior to ground launch and sustaining air speed after launch. The stored energy capability of such a system would eliminate the need for a battery to provide electrical power during the period after removal of external power at launch and effective cut-in of the RAT-driven generator. Therefore, a battery is unnecessary with this system. However, where providing sufficient inertia is not feasible, a primary remotely-activated battery would be required for providing interim dc power.

The candidate electrical systems considered for a TEDS vehicle are:

- 1) Low voltage DC (LVDC)
- 2) Variable speed variable frequency (VSVF)
- 3) Hybrid VSVF/DC
- 4) Baseline (Harpoon)

Additional candidate systems that were examined in other sections will not be examined here for the following reasons:

- 1) High voltage DC (HVDC) would offer no significant advantage in a system as simple as TEDS. The wire runs are relatively short, and any savings in wire weight over LVDC would be negligible. Conversely some component weights, such as the bus contactor, could be heavier for a HVDC system.
- 2) Constant Frequency systems: The TEDS system concept is directed toward simplicity, embodying low cost-minimum weight design. The higher cost and weight for a constant speed drive or cyclo-converter cannot be justified.

The payload equipment is designed specifically for the TEDS requirements; it is not adapted from another application. Therefore its power supply can be designed to work equally well with whatever power format is optimum for the overall system, whether that is AC or DC. Payload vendors have not expressed a strong preference for a particular format, although obviously format and quality will affect power supply design, cost, weight, etc., to some degree.

Based on current developments in rare earth permanent magnet technology, the simplest EPS configuration for any of the TEDS candidates is an unregulated, synchronous PM starter-generator integrally mounted in the engine. An example of such a machine is one recently demonstrated by Electro-Pacific Inc. The AC starter-generator is designed for integral turbine shaft mounting on a TEDS-class turbojet engine. The generator itself weighs 1.5 pounds and produces 5 KVA at 60,000 RPM, where the output frequency is 2 KHz. The converter that drives the generator as a brushless DC motor mounts outside the vehicle as AGE. This technology is representative of what can be expected in future operational systems.

Each candidate system also includes the central avionics power supply in a manner similar to the Mini-RPV class systems. The TEDS avionics suite is expected to be very much like a Mini-RPV suite in simplicity, and therefore, a reasonable speculation would be that it would be designated as an integrated system having a common central power supply. (Actually whether or not the speculation is

ever borne out will have no effect on any conclusions drawn from the analysis.) As is the case with the ARPV and Mini-RPV classes, TEDS avionics will not require controlled AC power; hence it will not be sensitive to power format.

In keeping with the minimum cost and complexity, objective of an expendable vehicle, the following guidelines are also suggested.

- 1) Circuit Protection: No fuses, circuit breakers, etc., should be used in the EPS; wiring should be sized so that a component under fault conditions would burn free.
- 2) Bus Isolation: No bus isolation is needed except in cases where a fault might cause a system failure condition during test.
- 3) Back-up Systems: The TEDS philosophy is to use vehicle redundancy rather than sub-system redundancy.
- 4) Fiber optic control signal isolation and transmission to eliminate EMI coupling and ground loops; flat wire strips as an alternative to fiber optics, if the latter were unsuitable for some reason (eg., availability or cost).

### 11.3.2 LVDC System

The LVDC system consists of a starter-generator (unregulated), a power conditioning unit, one contactor connecting the PCU output to the vehicle power bus, a payload contactor controlled by the avionics central processor, and the avionics power supply. The architecture is shown schematically in Figure 24.

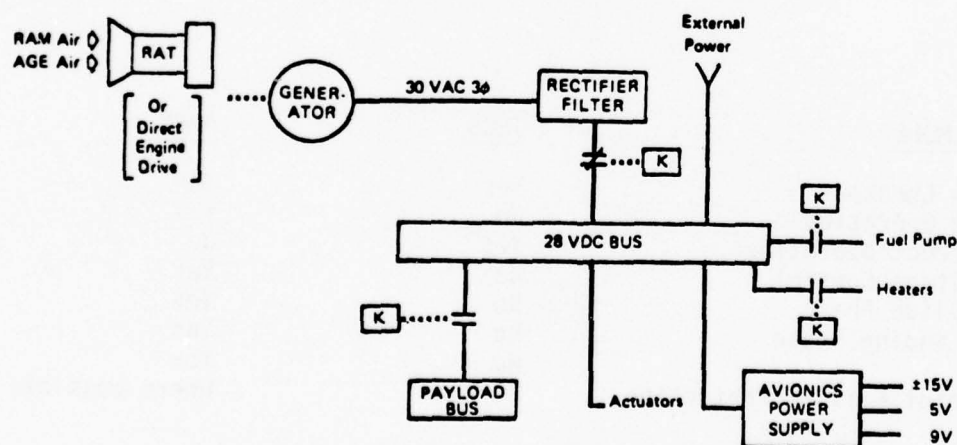

Figure 24. LVDC System

The candidate generator/PCU weights 7.5 pounds. The reduced weight derives primarily from increased speed (40,000 to 60,000 RPM) and the fact that no electromagnetic fields are generated; other lesser contributors are improved insulation materials and fabrication techniques. The complete baseline system weighs 29 pounds compared 20.8 pounds for the candidate LVDC system.

TABLE 37

COMPARISON: TEDS AND ARPV LVDC

<u>ITEM</u>	<u>TEDS</u>	<u>ARPV</u>
Generator	1	1
Regulator	--	1
PCU	1	1
Battery	--	1
Data Bus	--	1
Bus Contactors	2	3
Inverter (DC to AC)	No	1 if req'd
Sensors	--	2
Junction Boxes	None	2
Total Components:	4	12 or 13
Weight	21.5 lbs.	117 lbs.
Volume	319 cu. in.	2011 cu. in.

<u>MODE</u>	<u>TEDS</u>	<u>ARPV</u>
Prelaunch Checkout	Yes	Yes
Fail Safe Operation	No	Yes
Fail Destruct Operation	Yes	No
Close Voltage Control	No	Yes
Vehicle Glide Phase	No	Yes
Vehicle Landing Phase	No	Yes
Reusable	No	Yes
Single Point Failure Protection	No	Where possible

As was mentioned earlier, the generator is an integrally mounted, synchronous, PM (SmCo) machine. The capability of using a generator that is both integrally mounted and unregulated to simplify the system derives from the performance advantages of SmCo permanent magnets. A generator capable of being regulated must be larger than an unregulated one of the same capacity and may be too large to be compatible with the engine internal air flow requirements, and a non-SmCo unregulated generator would have inadequate performance. Such machines would have to be mounted on a high-speed external pad, an added complexity. Specifically the generator referenced previously has a 240 VAC output. The voltage droop from no load to a 5 KW load was measured at 17 volts or 7% at 60,000 RPM. By comparison, an unregulated generator using Alnico magnets or an electromagnetic field, sized for the same capacity at the same speed, would typically experience a droop closer to 30%. Further, such a generator would be 3 to 4 times as large as the SmCo PM one. In a 28 VDC system, 7% is about 2 volts whereas 30% is about 9 volts. The MIL STD 704 steady state voltage range, at the generator adjusted for a one-volt line drop, is 23 to 30 volts. Figure 25 illustrates the situation. A 7% droop would provide acceptable performance from 100% RPM to slightly above 80% RPM. The comparable unregulated flux-switch generator performance (assuming a 30% droop) would be unacceptable even at 100% RPM.

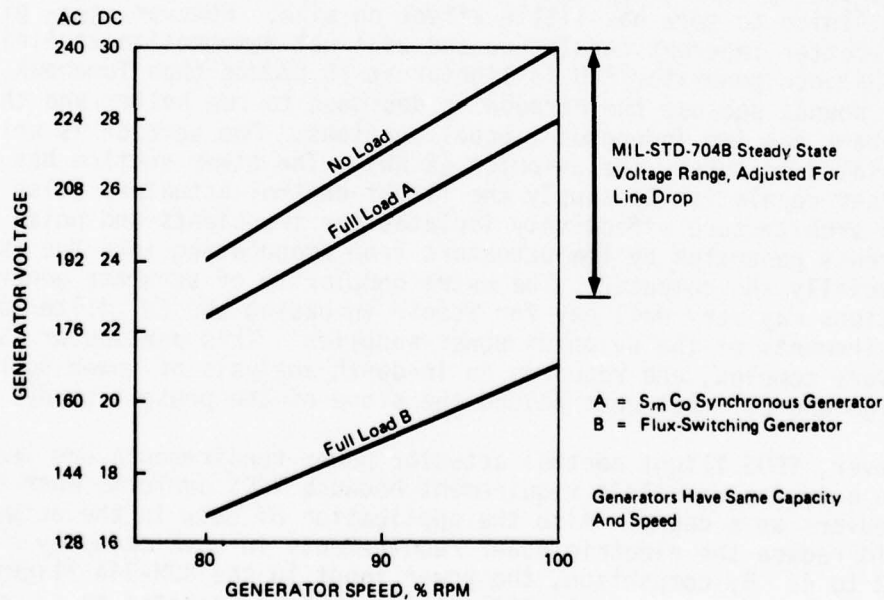

Figure 25. Unregulated Generator Load Profile

The earlier comment that a regulated generator (implying internal field regulation of some sort) may be too large to be compatible with a turbojet engine was somewhat speculative. The Harpoon generator has a 4-inch outside diameter, which according to the engine manufacturers is the largest acceptable diameter in that class engine. Similar limits exist on larger engines, such as for the ARPV or even HALE classes. This volume constraint limits the power capacity of a regulatable generator. However the capacity of an unregulated (or remotely regulated) SmCo PM generator would be limited by the acceptable power extraction from the turbine itself.

An interesting comparison of the TEDS and ARPV electrical systems (Table 37) shows that the TEDS system is approximately 1/3 the complexity and 1/6 the weight and volume of an ARPV system. Another comparison that is instructive is the following. Before incorporating the newer starter-generator technology described above, we had developed a baseline system using existing hardware to calibrate PRICE. The baseline LVDC system includes the generator and power control unit used on Tomahawk (or Harpoon), since cruise missile technology is much like TEDS. The remaining components are those used in the candidate LVDC system described in this section. The Harpoon and Tomahawk generators are essentially the same hybrid PM-homopolar regulated 28 VDC machine rated at 4 KW at 40,000 RPM. Harpoon is 7 year old technology while Tomahawk is 3 years old. Harpoon uses Alnico PM, while Tomahawk uses SmCo PM. Since the homopolar aspect determines generator size, changing from Alnico to SmCo has little affect on size. However, SmCo gives much better inherent regulation and will not demagnetize as Alnico can. The Harpoon generator/PCU is lighter at 15 pounds than Tomahawk at 16.5 pounds because the Harpoon is designed to run hotter and the Tomahawk has two independent equal sections. One section is well regulated to supply the avionics (2 KW). The other section has coarser regulation to supply the flight control actuators (also 2 KW). This architecture effectively isolates the transients and noise currents generated by the actuators from propogating into the avionics, especially the computer. The extra complexity of separate generator sections may very well pay for itself in easing the EMI filtering requirements of the avionics power supplies. This particular issue is very complex, and requires an in-depth analysis of power supply design and EMI that goes beyond the scope of the present study.

However, TEDS flight control actuator power requirements are less than a cruise missile's requirement because TEDS performs much simpler maneuvers as a decoy. Also the application of SmCo in the actuators would reduce the electric power requirements in both cases by a factor of 2 to 4. By comparison, the power input to the BQM-34A flight control actuators is approximately 400 watts. TEDS is expected to be smaller than a BQM-34A, and with SmCo actuators, the power input is expected to be close to 100 watts.

### 11.3.3 VSVF System

The VSVF system shown in Figure 26 is similar to the previous LVDC system, except that conversion of the generator output is deferred to the load areas. Transmitting 240 VAC allows using lighter gage feeder wires and smaller line contactors than 28 VDC. Neither voltage nor frequency of the generator output is regulated. Since the TEDS engine is expected to operate at a single throttle setting (100% RPM), then frequency variation throughout the flight would be negligible. For example, the Harpoon engine specification calls for the engines to operate at a nominal maximum RPM  $\pm 3/4$  percent. Field experience shows the variation to be  $\pm 0.3$  percent actual. Therefore assuming a single throttle setting, the system would behave as a constant frequency in area of 2000 to 4000 Hz (for 4 and 8 poles respectively). Such frequencies are low enough to not cause excessive feeder line reactance for the relatively short lines in a TEDS and high enough to allow very small transformers in the power converters.

While the line frequency is essentially constant, voltage variations due to load changes (such as cycling the payload) will change the voltage/frequency ratio. The voltage drop in the referenced SmCo generator when cycling a 3 KW payload would be about 4%. The magnetics would have to be designed to allow for such variations. However, at the frequencies involved, the magnetics are very small, and a 4% increase in size would be insignificant.

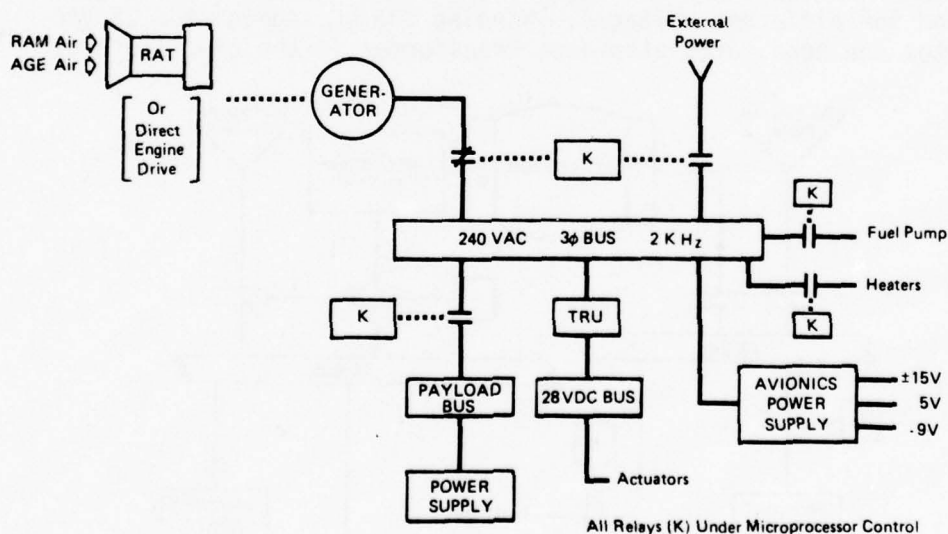

Figure 26. VSVF System

If future TEDS mission scenarios should call for a second throttle setting, such as 92% or 95% for example, then generator voltage and frequency will change together and at approximately a constant ratio. Such a change by itself would have no more effect on power supplies, TRUs, and heaters than in the previous DC case, since the primary effect is in the voltage change. DC motors, i.e., flight control actuators, would similarly not be affected. AC motors would run slower, of course. The only AC motor envisioned in a TEDS vehicle would be a fuel pump and possibly a cooling fan. Changing speed proportional to engine speed is an ideal situation for a fuel pump. However, a cooling fan would have to be sized for the lowest expected frequency to ensure adequate air flow. Hence it would be slightly larger than for a fixed frequency case.

#### 11.3.4 AC/DC System

The AC/DC system is a hybrid combination of the LVDC and VSVF systems. Neither voltage or AC frequency is regulated as in the previous systems. The objective of the hybrid is to minimize the amount of power conversion required where some loads either demand or prefer one power format over the other resulting in mixed requirements.

The AC/DC system is shown schematically in Figure 27. The primary load division assumed for the analysis is that the payload, fuel pump, and heaters use AC power and the avionics and flight controls use DC power. This somewhat arbitrary division places the majority of the loads on the AC system. It minimizes the size of the rectifier-filter needed for conditioning the DC power. The integrally mounted generator is slightly larger than for the other two systems (by 0.2 lb) because two segments are wound for different voltages. Winding the DC segment for 28 VAC eliminates the need for a step-down transformer in the conditioner.

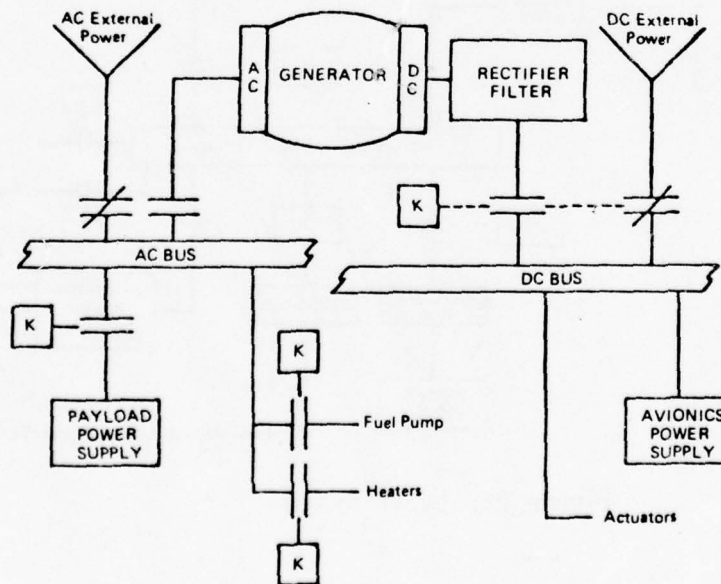

Figure 27. AC/DC System

#### 11.4 Discussion of the Results

The analysis and evaluation of the three candidate electric power system configurations and the baseline system reveals that all three candidates are lighter and simpler than the baseline and that the VSVF is easily the best system overall. Table 38 summarizes the weights and volume for the four systems. The VSVF is the lightest, weighing 13.2 pounds versus 17 pounds for the AC/DC system, 21.5 pounds for the LVDC system, and 29 pounds for the baseline (also LVDC).

The VSVF system is also the simplest primarily because it has the least power conversion of the four systems. This result was initially somewhat surprising, since the AC/DC system had been configured specifically to minimize conversion complexity as it did for the HALE class EPS. The reason for the VSVF outcome is that the major electrical loads in TEDS are avionics and payload power supplies, which can be readily designed for either AC or DC power formats. Therefore providing them with AC power directly from the generator eliminates a conversion step. By continuing the philosophy of converting only as necessary, the only other conversion needed would be to develop 28 VDC for the flight control actuators. This requires a transformer-rectifier-filter unit, but it can be relatively small (capacity 100 watts - see Section 6.2) compared to the rectifier-filter units required to supply 28 VDC in the LVDC (4 KW) and AC/DC (1KW) systems.

Another factor in favor of VSVF is that transmitting power at 240 volts minimizes wire weight, which can save several pounds over 28 volt transmission. Furthermore, AC line contactors are smaller than DC contactors, since current interruption is easier, especially at zero voltage crossings, thus saving a little more weight.

The raw data for the four systems are listed in Table 39. The final evaluation scores, listed in Table 40, show that the VSVF is equal or better than the other two systems in each of the five categories. Hence, a sensitivity analysis would be expected to show that changing weights within a meaningful range would not change the relative scores noticeably.

The TEDS EPS cost analysis differ somewhat from previous class studies in that new and significant technology developments were uncovered after the original cost analysis (based on Harpoon technology) was essentially completed. Lack of time prevented gathering new cost data, so the existing data was revised by assuming that cost differences would be directly proportional to half the weight differences. Even if the costs were assumed equal, the final scores would not change significantly and the rankings would remain the same. If the costs were assumed to be

TABLE 38  
TEDS EPS PHYSICAL CHARACTERISTICS

COMPONENT	BASELINE		LVDC		VSVR		AC/DC	
	WT (LBS)	VOL (IN <sup>3</sup> )	WT (LBS)	VOL (IN <sup>3</sup> )	WT (LBS)	LBS (IN <sup>3</sup> )	WT (LBS)	VOL (IN <sup>3</sup> )
Generator	15.0	130	1.5	10	1.5	10	1.7	12
Rectifier-Filter		(Included)	6.0	90	---	--	4.0	60
Bus contactors					0.4	2	1.4	
Transformer-rectifier-filter			---	--	2.5	50	---	--
Avionics power supply	2.5	50	2.5	50	2.5	50	2.5	50
Power feeders	1.9	12	1.9	12	0.3	2	1.1	7
Distribution feeders	4.0	24	4.0	24	3.5	20	3.8	22
Connectors	2.5	41	2.5	41	2.5	41	2.5	41
Totals	28.3	303	20.8	273	13.2	175	17.0	217

TABLE 39  
TEDS EPS EVALUATION  
Raw Data

<u>Item</u>	<u>Parameter</u>	<u>Baseline LVDC</u>	<u>LVDC</u>	<u>LSVF</u>	<u>AC/DC</u>	<u>Comments</u>
1.0	PHYSICAL PARAMETERS					
1.1	Weight (lbs)	28.3	20.8	13.2	17	
1.2	Volume (in <sup>3</sup> )	303	273	175	217	
1.3	Total Available Power (KW)					
1.3.1	Current	4	4	4	4	
1.3.2	Growth	4.5	6	6	6	
2.0	PERFORMANCE					
2.1	Steady State					
2.1.1	Voltage	28VDC +2%	28VDC +3%	240VAC @2KH +3% <sup>z</sup>	240VAC @2KH +3% <sup>z</sup>	
2.1.2	Frequency Variation	-	-	+1%	+1%	at 100% RPM
2.2	Transient					
2.2.1	Voltage Variation	+2%	+3%	+3%	+3%	at 100% RPM
2.2.2	Frequency Variation		-	+1%	+1%	at 100% RPM
2.3	Filtering Requirements	-	-	-	-	
2.4	Ability of Parallel Ops	-	-	-	-	
2.5	Penalties					
2.5.1	Losses	700	400	230	250	
2.5.2	Weight due to Losses	2.5	1.1	0.3	0.3	
2.6	Efficiency	85%	90%	95%	94%	
3.0	RELIABILITY					
3.1	MTBF	800	1000	1000	1000	
3.2	Prob. of Mission Success					
3.2.1	Component Failure Prob.					
3.2.2	Redundancy	1	1	1	1	
4.0	MAINTAINABILITY					
4.1	MTTR	(10)	(10)	(10)	(10)	
4.2	Fault Isolation					
4.2.1	Accessibility					
4.2.2	Automatic/Manual					
4.2.3	Mean Time Required					
4.3	Maintenance Actions					
4.3.1	Repairability	Yes	Yes	Yes	Yes	
4.3.2	Replacibility	Yes	Yes	Yes	Yes	
4.3.3	Expendability					
4.3.4	Standardization					
4.3.5	Alignment & Adjustments					
4.4	Preventive Action Time	15 min	15 min	15 min	15 min	
4.5	Mean Down Time					
4.6	Inherent Availability					
4.7	Achieved Availability					
4.8	Operational Availability					
5.0	COST AND RISK					
5.1	* Development Cost	39	34	28.7	31.3	
5.2	* Production Cost	52671	45900	38751	42325	
5.3	* O&S Costs	759	661	558	610	
5.4	Technical Risk	10	10	10	10	

(\*) Thousand of Dollars

directly proportional to weight, the final score differentials would be even greater than those indicated in Table 40. The costs assumed are between the two extremes. The baseline LVDC system has the lowest score because of its greater weight and complexity and, therefore, presumably greater costs. Interestingly, altho the baseline has better regulation, the overall performance is lower than the other systems because of its lower efficiency; i.e., 85% versus 90 to 95% for the simpler candidate systems.

TABLE 40  
TEDS EVALUATION  
Weighted Score

<u>Item</u>	<u>Parameter</u>	<u>Weights</u>	<u>Baseline</u>	<u>LVDC</u>	<u>VSVF</u>	<u>AC/DC</u>
	TOTAL SYSTEM	1000	720	827	998	898
1.0	PHYSICAL PARAMETERS	300	128	174.6	300	221
1.1	Weight	150	32.7	60.5	150	90.4
1.2	Volume	100	57.8	64.1	100	80.6
1.3	Total Available Power	50	37.5	50.0	50	50
2.0	PERFORMANCE	200	166.1	187.3	198.2	196.1
2.1	Steady State	30	30	28.9	28.9	28.9
2.2	Transient	30	30	29.3	29.3	29.3
2.3	Filtering Requirements	30	30	30	30	30
2.4	Ability of Parallel Ops.	-				
2.5	Penalties	50	22.1	42.1	50	48.5
2.6	Efficiency	60	54	57	60	59.4
3.0	RELIABILITY	150	135	150	150	150
4.0	MAINTAINABILITY	100	100	100	100	100
5.0	COST AND RISK	250	190.6	215.3	250	231.1
5.1	Development Cost	50	36.8	42.3	50	45.8
5.2	Production Cost	100	73.6	84.6	100	91.6
5.3	O&S Costs	75	55.2	63.4	75	68.7
5.4	Technical Risk	25	25	25	25	25

SECTION 12  
CONCLUSIONS AND RECOMMENDATIONS

INTRODUCTION

The first phase of the RPV electrical power study, which is reported in the preceding sections, assesses the available and developing technologies that can be fruitfully exploited to resolve current problems and provide significant cost and performance improvements over present day systems. This concluding section first reproduces the significant results and conclusions are drawn from the work as a whole to help put the pieces into perspective. This is followed by recommendations for future work.

RPV REQUIREMENTS

The future electrical power requirements grow with the size of the RPV.

Mini-RPV	1000 - 2000 Watts
TEDS	3000 - 5000 Watts
ARPV	7000 - 10,000 Watts
HALE RPV	10,000 - 25,000 Watts

The core avionics for all classes will require very little, if any precision 400 Hz power. It will use whatever power format is compatible with the recovery power source (where appropriate), that is, DC (battery) for Mini-RPV and ARPV and DC (battery) or AC (auxiliary power unit) for HALE.

PROBLEM AREAS

The most significant problem area in RPV electrical subsystems are:

- 1) Engine power extraction limitation problems are due to one or more limits, such as raw horsepower extraction (especially when near maximum altitude), cooling, gear stress, overhang moment, and drive RPM.
- 2) Battery performance and reliability problems are due to the maintenance difficulties in being able to monitor charge state and compacity.
- 3) Wiring and interconnection problems are due largely to the many connections that must be made, assembled, and checked out and the accumulation of human errors in the process; a secondary factor is the sheet bulk of wiring that an RPV requires in a relatively small airframe.

## REVIEW OF SPECIFICATIONS AND STANDARDS

Review of Military Specifications and Standards that are applied to RPV reconfirms the Teledyne Ryan (and ARINC) position that an RPV Design Handbook is needed to help the designer tailor military specifications to specific systems. Making changes to the specifications themselves is not a viable solution. However, our position has shifted slightly to recommend a separate handbook for each class (or appropriate grouping) to avoid the unwieldy bulkiness of a single handbook.

## TECHNOLOGY SURVEY

Electrical power generation and distribution is considered a relatively mature technology. However, continuing developments in materials, fabrication processes, and related electronics technologies are providing many new avenues for evaluatory improvements.

Among those technologies which could benefit RPV the most are the following:

- 1) Rare earth permanent magnet materials, which are already impacting aerospace systems in generators, actuators, and sensors. Complement to PM synchronous generators are new series and Flux control regulator technology; also actuator drive technology.
- 2) High power semiconductor switches and hybrid semiconductor/mechanical contact relays to provide controlled turn-on and off characteristics, among other features. Optical control compatible with Fiber optics.
- 3) Flat wire or printed circuit cable to conserve space, reduce weight, simplify assembly, and reduce wiring problems.
- 4) Fiber optics and optoelectronics to reduce (if not eliminate) EMI susceptibility, isolate potential ground loops. Fiber optics could be integrated with flat wire and printed circuit cables.
- 5) Microprocessor control and management, dedicated for local or backup control or shared with avionics for normal control to reduce control and distribution wiring and replace relay logic. Control logic could be in software module or firmware.
- 6) NiZn and sealed lead acid (starved electrolyte) cell batteries to improve reliability, reduce cost, enhance ability to monitor status; small high speed turbine with rare-earth PM generator as battery alternate or replacement.

## ARPV

The ARPV analysis has evaluated five candidate electric power system configurations in comparison with the BGM-34C baseline system. The systems weights and their evaluation scores (maximum possible score = 1000 points) are:

	<u>Score</u>	<u>System Weight (lbs.)</u>
Baseline (BGM-34C)	619	191
Low Voltage Direct Current (LVDC) 28V	887	117
High Voltage Direct Current (HVDC) 270V	874	122
Constant Speed Constant Frequency (CSCF)	666	150
Variable Speed Constant Frequency (VSCF)	686	138
Variable Speed Variable Frequency (VSVF)	871	103

The scores of the three leading candidates are close enough together that each could be considered a potential candidate in future systems. Selection would require a more detailed analysis for the specific system requirements, and it would depend on such secondary factors as availability of components, compatibility of development schedules, and possible reassignment of weighting factors, e.g., to account for heavier emphasis on cost or performance.

All candidates scored better than the baseline system, an unsurprising result in view of the relative technologies. As can be seen, the LVDC, HVDC, and VSVF systems scores are all considerably better than the scores of the other three systems. In general, the DC systems scored better than the AC systems because the DC systems are simpler, lighter, and more reliable. (The VSVF is essentially a variant of the LVDC and HVDC systems that defers rectification and power conditioning to the using equipment area. Conversion or inversion is needed to meet constant frequency power requirements just as in a DC system). Furthermore, the load requirements are primarily DC. While the core avionics will use all DC, some types of mission payloads may still require 400 Hz power. However, future trends are toward lower AC power requirements, perhaps being all DC by 1985. A future payload candidate requiring large amounts of AC power (i.e., larger than an inverter could supply) would impose such a penalty on an ARPV that it would either be considered impractical or would have to be modified to accept DC power.

## HALE RPV

The HALE analysis considered the same set of candidate systems as ARPV, with many of the same components, plus a hybrid AC/DC system. The baseline is the YQM-98A Compass Cope R vehicle. Their weights and evaluation scores are as follows:

	<u>Score</u>	<u>System Weight (Lbs.)</u>
Baseline	636	195
LVDC	789	172
HVDC	755	156
CSCF	645	196
VSCF	654	165
VSVF	804	141
AC/DC	894	129

Clearly, the hybrid AC/DC system is the best candidate in three of the five evaluation categories as well as overall, at least for the ground rules used during the analysis. Also, all of the candidates are as good or better than the baseline system, which has the lowest score in three of five categories. This is an unsurprising result due primarily to older technology, which yields higher weights and complexity, and lower power capacities. The VSVF system is also a good candidate. The primary reason that it is rated second is because a groundrule used during candidate synthesis was that a battery would provide emergency power. If a multitude air turbine motor were to provide emergency power rather than a battery, then the VSVF approach would very likely score as well as the AC/DC system.

The AC/DC system is a hybrid of the LVDC (or HVDC) and VSVF systems that matches the power source to the loads in an optimal way. Since the engine runs at nearly constant RPM at altitude when the payload is operating, the directly-driven generator supplies power at nearly constant frequency. Furthermore, the payloads are primarily avionics, which easily tolerate the sort of frequency changes involved. The hybrid architecture features a dual generator, one AC and one DC, stacked in a common frame and having independent voltage regulation. The capacities of the two generators are selected, or even changed later, to best match the expected load requirements. This approach eliminates (or at least minimizes) the need for converters and inverters. Hence, the resulting system is the simplest and therefore the lightest, most reliable, and least expensive one. Notice that as the ratio of AC to DC power required by the payload goes toward zero, the hybrid configuration converges to a LVDC (or HVDC) configuration. Conversely, as the payload AC/DC ratio moves toward infinity (i.e., little or no DC), the hybrid system converges toward a VSVF configuration. Interestingly, should the requirement for regulated 400 Hz power be imposed by the payload, the optimal configuration would still be a hybrid AC/DC one. However, the AC portion would develop out of one of the regulated AC configurations (i.e., CSCF or VSCF) rather than the wild frequency VSVF.

As a footnote to the previous ARPV study, it did not include the AC/DC system because the trends in payload power requirements lean so strongly toward all DC. Because of the similarities in the systems, one could

conclude that a hybrid AC/DC architecture would also be optimum for an ARPV, if a definite and significant need for AC power were to develop. However, reason must be tempered with the fact that an ARPV engine operates over a wider RPM range throughout a mission. If the payloads can tolerate the wider frequency variations, then the conclusion appears valid. If it cannot tolerate the variation, then the penalty of including frequency regulation would have to be evaluated.

#### MINI-RPV

Mini-RPVs are not compatible with AC systems because of the small size and wide speed range of the reciprocating engines. High voltage DC offers no advantage. Therefore, a 28 volt DC system is the only practical choice. The difficulty experienced in Mini-RPVs has not been technology, but the availability of suitable components. Ongoing development is easing that situation. For comparison purposes, a representative Mini-RPV electrical system weighs about 12 pounds, including the avionics power supply. To optimize overall electrical/avionics subsystems weight (and efficiency), the power supply is simultaneously optimized for the two subsystem requirements.

#### TEDS

The number of potentially viable candidate systems evaluated for the TEDS class is reduced to three. The baseline system is an approximation of the Tomahawk cruise missile system, since TEDS and cruise missiles are so closely related in electrical requirements. The system weights and evaluation scores are:

	<u>Score</u>	<u>System Weight (Lbs.)</u>
Baseline	720	28.3
LVDC	827	20.8
VSVF	998	13.2
VSVF/LVDC Hybrid	898	17.0

The analysis shows that all three candidates are lighter and simpler than the baseline and that the VSVF approach is easily the best system overall. While HVDC was not explored, it would be an acceptable candidate. However, it would offer no significant advantage over LVDC in such a small vehicle.

VSVF is a wild frequency AC system that depends on inherent regulation. The basic operational concept of TEDS (and cruise missiles) requires that the engine run at 100% RPM at all times. To a directly driven generator, the engine is a constant speed drive. By specification and actual field experience, such engine run within a fraction of a percent of a nominal value. Furthermore, a rare-earth permanent magnet synchronous

generator has excellent inherent voltage regulation, e.g., seven percent drop from no load to 5KW full load in a 1.5 pound generator running at 60,000 RPM (about 2000 Hz line frequency). The concept requires conversion and regulation only within the avionics suite itself for circuit applications and about 100 watts for the flight control actuators (rare-earth PM motors help here too).

#### GENERAL CONCLUSIONS

On reviewing all of the study results, several additional overall observations can be made.

- 1) In each class (except the Mini-RPV which is in fact a developmental system), the better candidate systems showed significant improvement in weight, volume, cost, and other factors when compared to the baseline, which is representative of current operational technology. This result confirms the initial prognosis of the study regarding the probable impact of developing technology on RPV electrical systems.
- 2) High voltage DC, which may do good things for manned aircraft, does not provide significant benefits for RPV. One reason is that lighter gage wire does not save as much weight in a smaller vehicle. Another is that some components become larger at higher voltages; e.g., the battery and main line contactors. Unfortunately one compensates for the other, so that a 270V system weight and volume is about the same (or perhaps even more) than a 28V system.
- 3) Considerable benefits can accrue to high voltage wild frequency systems and for line frequencies greater than the conventional 400 Hz for those systems where engine speeds do not vary widely. Future RPV are expected to have few, if any, loads that are sensitive to higher frequencies. Similar to the TEDS case, inherent regulation may be adequate for other applications, thus simplifying the system noticeably. Higher frequencies allow smaller magnetics, a significant weight contributor. Main line current interruption is also simpler for AC than DC.
- 4) The electrical sub-system of each class benefits from higher levels of integration with the propulsion and avionics sub-systems. Optimizing power extraction from the engine remains a difficult task where an engine is used in several applications. The ARPV and HALE RPV are expected to have a central digital avionics processor and a data bus, both of which would be shared by the electrical system. This greatly reduces control wiring and logic since control and power management would be done in software. A separate electrical power data bus is unwarranted. TEDS and Mini-RPV would not have a data bus, but they will have central microprocessors, which would also be shared by the electrical system for control and management.

- 5) Rare earth permanent magnets and newer high temperature insulation combined in generators and actuators benefit all systems to a some degree. The Mini-RPV is least benefited, because the components are already small and performance is not critical. TEDS electrical system weight is cut by 55 percent, due either directly or indirectly to rare earth PMs. Other benefits are higher power (generator or actuator), better regulation, and it won't demagnetize. Its cost is still higher than other materials and components, but the difference is diminishing as production of rare earth PM material increases.
- 6) In all classes, control and some distribution would be done via fiber optics and flat wire or printed circuit cable. Solid state or hybrid solid state/mechanical contact switching would be used. RPVs have always used the remote power controller concept (albeit very simple), since no one is available in flight to replace a fuse or reset a circuit breaker, as well as the power by wire concept.

#### RECOMMENDATIONS

The following areas have been identified as having sufficient payoff potential to warrant further work to either exploit developing technology or to ease current and future problems in RPVs:

- 1) Generate a series of RPV-class design handbooks for tailoring military specifications and standards
- 2) Exploit rare-earth PM materials in RPV-size generators and actuators, including regulation techniques that are compatible with PM generators.
- 3) Develop hybrid multi-purpose components, such as starter-generators, AC/DC generators, other segmented generators for multiple voltages, and multi-mode emergency or auxiliary (air turbine) power units in RPV-compatible sizes.
- 4) Exploit the potential of inherently regulated, high speed, high and wild frequency electrical power systems.
- 5) Exploit newer interconnection techniques, such as flat wires, printed circuit cables, and fiber optics.
- 6) Exploit the potential for sharing the avionics data bus and/or central processor for electrical system control and power and redundancy management. This includes development of smart interface units for data bus terminals, where a microprocessor can exert local control.
- 7) Develop hybrid solid state/mechanical contact line contactors
- 8) Continue development of battery systems which can adequately maintain battery condition and accurately monitor status.

## APPENDIX A

### A1 PRICE COST MODEL

The Programmed Review of Information for Costing and Evaluation (PRICE) model is a cost estimating model developed by RCA that is available to Government and industry. The computerized model is used to estimate the engineering and manufacturing costs of systems in the development and production phases of its life cycle. It provides estimates of timely cost data for system evaluations based upon physical characteristics of the design concepts, quantities produced in development and production, engineering and manufacturing complexities, engineering and manufacturing schedules, economic escalations, program factors, etc. Since various modes (e.g., type of equipment and whether purchased) are available, only the appropriate sub-set of inputs are used for each computer run. The outputs provide recurring and non-recurring costs for engineering and manufacturing. Sensitivities can be readily performed by varying selected inputs.

PRICE is a parametric cost model used to estimate engineering and manufacturing cost of electronic, electromechanical, mechanical, and structural components. The following abbreviated list of definitions of the model inputs and outputs will further describe the operation and capabilities of PRICE.

#### A1.1 PRICE Input Form Variables

AMULTD	Development cost percentage multiplier - converts costs to desired level (100% represents \$K at engineering cost level).
AMULTP	Production cost percentage multiplier - converts costs to desired level (100% represents \$K at manufacturing cost level).
BVCOST	Purchased item cost in \$K.
CMPEFF	Empirical factor used to define an electronic component along with its associated factors PWRFAC and MCPLXE.
CMPID	Variable descriptor of class of electronic componentry - used to measure reasonableness of MCPLXE and/or PRODE.
CMPNTS	Number of electronic components.

CURVE	Production quantity at which a "short cut" learning curve computation will be used.
DATA	Level of data requirements covering the development phase.
DESIGN	Empirical factor controlling level of engineering design. (Does not represent scope of work).
DESRPE	Decimal equivalent of amount of electronic design redundancy (see NEWEL).
DESRPS	Decimal equivalent of amount of mechanical design redundancy (see NEWST).
DRAFT	Empirical factor controlling level of drafting. (Does not represent scope of work).
DRWG	Empirical factor controlling amount of drawings relative to drafting cost.
ECMPLX	Engineering complexity.
ECNE	Decimal equivalent level of electronics engineering changes during the production phase.
ECNS	Decimal equivalent level of mechanical/structural engineering changes during the production phase.
ENMTHP	Number of calendar months from start of engineering effort to completion (in-house) of first prototype. (Does not include field test, if any).
ENMTHS	Number of calendar months from January 1 of YEAR to start of the engineering effort.
ENMHT	Number of calendar months from start of engineering effort to completion of last prototype. (Does not include field tests, if any).
ESC	Rate of annual escalation (in percent) to be applied to all costs.
INTEGE	Level of integration and test requirements applicable to electronics.
INTEGS	Level of integration and test requirements applicable to mechanical/structural areas.
LCURVE	Decimal equivalent to the learning curve rate (improvement) applicable to the production quantity.
MCONST	Empirical constant that defines (with MEXP) the material type, construction and fabrication methods.

MCPLXE	Manufacturing complexity factor for electronics. (One of the most significant empirical inputs).
MCPLXS	Manufacturing complexity for mechanical/structural features. (One of the most significant empirical inputs).
MEXP	Empirical material exponent (see MCONST).
MODE	Numerical designator for PRICE processing mode.
NEWEL	Decimal equivalent level of new design for electronics appropriate to the unique efforts only (see DESRPE).
NEWST	Decimal equivalent level of new design for mechanical/structural areas - appropriate to the unique efforts only (see DESRPS).
PDATA	Level of data/documentation requirements during the production phase.
PLTFM	Product platform multiplier - establishing specification/reliability computation profiles.
PPROJ	Level of project management covering the production period only.
PRMTHF	Number of calendar months from January 1 of YEAR to completion of production quantity.
PRMTHS	Number of calendar months from January 1 of YEAR to start of the production (see PRMTHF).
PRNF	Prototype schedule factor. Defines the sequential manner the prototypes will be produced during the development period.
PRNT	Type of PRICE output desired.
PRODE	Empirical producibility factor for electronics - used only when MCPLXE is not known.
PRODS	Empirical producibility factor for mechanical/structural devices only - used only when MCPLXS is not known.
PROJECT	Level of project management covering the development phase.

PROSUP	Empirical factor controlling level of prototype cost.
PROTOS	Number of prototypes.
PTECIM	Level of production technological improvement trend.
PTLGTS	Level of special tools and test equipment required for production.
PWR	Average dissipated power in watts.
PWRFAC	Factor that quantifies the average power dissipated per component.
QTY	Production quantity.
QTYSYS	No. of equipments required for the system integration and test.
SYSTEM	Level of systems engineering covering the development phase.
TECIMP	Level of engineering technological improvement trend.
TLGTST	Level of special tools and test equipment required for the manufacture of the prototypes.
USEVOL	Used or usable electronic volume.
VOL	Size in cubic feet.
WECF	Density of electronics or weight per cubic foot.
WT	Total weight in pounds.
WS	Weight of mechanical/structural areas.
YEAR	Year number to establish starting period of the PRICE analysis.

#### A1.2 PRICE Output Data

##### Program Cost - Engineering

DATA	Documentation cost that includes reports, lists, manuals, handbooks, etc. Does not include computer software or programming costs.
------	--

DESIGN Engineering costs to convert system specifications to design detail (T&L and computer charges are in project Management). Provides inputs and guidance for drafting effort. Supports prototype construction and test.

DRAFTING Costs for converting engineering design into drawings. Includes layout and checking. Allowances for obsolescence of drawing and engineering changes are provided.

PROJ MGMT Project management cost, covering operations control, T&L, computer charges, etc., for both engineering and manufacturing. Includes factory releases and follow as well as budget/cost management.

SYSTEMS System engineering cost covering the development of design specifications predicated on the performance requirements. Includes reviews of concepts and configurations.

Program Cost - Manufacturing

PRODUCTION Manufacturing cost (including material, labor, OII and test) for the total production quantity.

PROTOTYPE Total cost for producing and in-house testing of prototypes (and breadboards). Includes technician costs and is affected by the engineering schedule and complexity.

TOOL - TEST EQ Total cost for the design, construction, and maintenance of all special tools and test equipment.

Additional Data

AVCOST Average production cost, excluding engineering and special tools and test equipment. It is the total production cost divided by the production quantity.

LCURVE The learning or improvement curve applied to the first piece cost.

PRODUCTION - ENG. COST Total engineering cost for the production phase only.

TOTAL AVER PROD COST Average production cost that includes engineering and tooling charges. It is the total cost for production (engineering and manufacturing) divided by the production quantity.

MCPLXS	Manufacturing complexity, adjusted to reflect technological improvement.
PRODS	Producibility factor - adjusted to reflect technological improvement.
WSCF	Average density of mechanical area in pounds per cubic foot.
CMPEFF	Empirical component definition factor (operates in conjunction with MCPLXE and PWRFAC).
CMPNTS	Number of electronic components as set forth by the definition generated by the empirical values of MCPLXE, PWRFAC and CMPEFF (if not entered).
MCPLXE	Manufacturing complexity, adjusted to reflect technological improvement.
PRODE	Producibility factor adjusted to reflect technological improvement.
PWR	Average dissipated power in watts (controlled by CMPNTS and PWRFAC) (if not entered).
PWRFAC	Factor representing average power dissipated by each component (if not entered).
WECF	Density of electronics in pounds per cubic foot.
WE	Weight of electronics in pounds.
ECMPLX	Engineering complexity adjusted to reflect technological improvement. If not an input value, it is a program calculated assessment.

A2 PRICE L COST MODEL

The "PRICE L" Model is a life cycle cost model developed by RCA that is intended to be used in conjunction with the basic PRICE model, which estimates development and production costs. PRICE L operates with a system breakdown at the Line Replaceable Unit (LRU) level, and it computes the additional production and support costs. The production costs include support equipment, supply (initial spares), supply administration, and contractor support (if used). The support costs include the same categories with the addition of maintenance manpower. Operational manpower is not included. PRICE L has over 250 variables, where many can be developed from the basic PRICE model.

The flow of data and the interaction between the PRICE and PRICE L models is depicted in the figure below. The input (1) and output (2) data of PRICE are described in Section A1. PRICE L input (3) (4) (5) and output data (6) are described below. Note that the deployment data (4) for the system(s) being analysed is an input to the PRICE model and a throughput to PRICE L model. From these data and the basic PRICE inputs (1), PRICE generates additional LRU data (3) as inputs to PRICE L. All inputs to PRICE L are available for review, and their values can be changed, if necessary.

APPENDIX A  
PRICE COST MODELS DATA FLOW

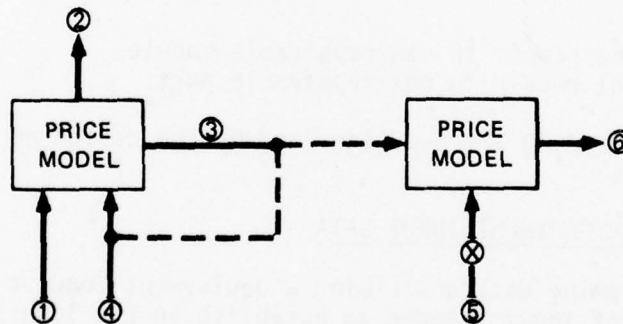

	<u>DEFINED IN SECTION</u>
① Equipment Design & Development Data	A1.1
② Engineering & Manufacturing Cost Outputs	A1.2
③ LRU LCC File Input Data	A2.3
④ Deployment Input Data	A2.2
⑤ Maintenance Support Concepts & Global File Input Data	A2.1;A2.4
⑥ Life Cycle Cost Outputs	A2.5
⊗ Data Review Points	

A2.1 During the operation of PRICE L, 19 maintenance support concepts are examined and the most cost-effective, cost-availability, concept is selected. Any concept or set of concepts can be set up for each LRU, if desired. The standard maintenance support concepts are listed in the following table.

#### STANDARD MAINTENANCE SUPPORT CONCEPTS IN PRICE L

1. LRU discard at failure.
2. LRU repair at Organization. Module discard.
3. LRU repair at Intermediate. Module discard.
4. LRU repair at Depot. Module discard.
5. LRU repair at Organization. Module repair at Intermediate.
6. LRU repair at Organization. Module repair at Depot.
7. Repair LRU to piece part at Intermediate.
8. LRU repair at Intermediate. Module repair at Depot.
9. Repair LRU to piece part at Depot.
10. Repair LRU to piece part at Organization.
11. On-equipment repair to module. Module discard.
12. On-equipment repair to module. Module repair at Organization.
13. On-equipment repair to module. Module repair at Intermediate.
14. On-equipment repair to module. Module repair at Depot.
15. LRU repair at Contractor Depot. Module discard.
16. On-equipment repair to module. Module repair at Contractor Depot.
17. LRU repair at Organization. Module repair at Contractor Depot.
18. LRU repair at Intermediate. Module repair at Contractor Depot.
19. Repair LRU to piece part at Contractor Depot.
- .
- .
29. On-equipment repair to non-repairable module.
30. On-equipment repair to non-repairable part.

NOTE: Cases 29 and 30 are predetermined by the design of the hardware.

#### A2.2 PRICE L DEPLOYMENT INPUT DATA

The following data describing a deployment concept is the minimum number of inputs needed to establish an LRU life cycle cost file.

- DD - Number of depot support locations
- DI - Number of intermediate support locations
- ED - Number of equipment installations (vehicles, sites, ships, etc.)
- OD - Number of organization support locations
- OTF - Operating time fraction or on-time fraction
- YR - Years of support

### A2.3 PRICE LCC FILE INPUT DATA

The following data are generated by PRICE for inclusion in the LRU life cycle cost file.

- CEND - Cost of development
- CFIM - Cost for LRU test set
- CFIP - Cost for LRU and module test set
- COMP - Reference cost for a module
- CMR - Contractor cost for Module repair
- CPE - Non-recurring production cost
- CPP - Reference cost for a part
- CPPE - Reference cost for parts used for or equipment repair
- CUBEM - Storage volume of a module
- CUBEP - Storage volume of a part
- CUBEU - Storage volume of an LRU
- CUP - Reference cost for an LRU
- CUR - Contractor cost for LRU repair
- EE - Number of LRU's per equipment installation
- EMP - Cost quantity exponent for modules
- EPP - Cost quantity exponent for parts
- EUP - Cost quantity exponent for LRU
- FNSP - Fraction non-standard parts
- FTSQF - Floor space for LRU test set
- FTSQP - Floor space for LRU and module test set
- MTBF - LRU mean time between failure
- P - Number of module types
- PP - Number of part types per LRU
- RNM - Reference quantity for modules
- RNP - Reference quantity for parts
- RNU - Reference quantity for LRU's
- TF - Mean time to repair an LRU
- TMO - Mean time to repair a Module
- WM - Shipping weight of a module
- WP - Shipping weight weight of a part
- WU - Shipping weight of an LRU
- YD - Duration of the development period
- YP - Duration of the production period

A2.4 PRICE L GLOBAL FILE INPUT DATA - The GLOBAL file stores the variable values that seldom vary between projects, such as the following:

- AXXX\* - Multiplication factor for selected variables
- CAD - Annual cost to maintain item in supply system
- CDXX - Shipping cost factors
- CEN - Cost to enter item in supply system
- CFTXX - Space cost factors
- CKXX - Safety stock coefficients
- CRX - Reorder burden cost factors
- CUX - Labor rates

\*The Xs are for designation of each equipment level, or each maintenance level, or each combination, or other variable.

CXXXPG - Programming and documentation cost  
FNGF - False No-Go fraction  
FXX - Repair fractions  
GXX - Maintenance concept array  
HX - Control of LRJ stock placement  
PCTS - Annual support for support equipment  
QMX - Minimum reorder quantities  
SXX - Scrap fractions  
TEX - Logistic times  
TRX - Maintenance times  
TXXX - Supply allowance time factors  
WX - Scheduled work week  
ZXX - Stock quantity round off factor

A2.5 PRICE L OUTPUT - The following list summarizes the PRICE L output data parameters.

- Reliability and Maintainability Data

MTBF - Mean time before failure  
MTTR-LRU - Mean time to repair for LRU  
MTTR-MOD - Mean time to repair for module

- Deployment

EQUIPS - Number of installations  
ORGANIZATION - Number of organization levels  
INTERMEDIATE - Number of intermediate levels  
DEPOT - Number of depot levels  
LRU/EQUIPS - Number of LRU's per installation  
MODS/LRU - Number of modules per LRU  
PARTS/LRU - Number of parts per LRU

- Employment

SUPPORT PERIOD - years in operations phase  
HRS/MON - Hours per month utilization  
OTF - Operating time fraction

- Global

EQU SUP - Number of equipment support locations  
ORGSUP - Number of organization support locations  
INTSUP - Number of intermediate support locations  
DEPSUP - Number of depot support locations  
ESC - Escalation flag  
LRU FAIL ALLOW - LRU failure allowance

- Maintenance Concept

The most cost-effective (cost-availability) maintenance concept is selected by the model as the basis for life cycle cost and indicated by number and title. Then a ranking cost-effective-

ness list is provided showing the order of all concepts by numbers and the present difference from the chosen concept.

- Program Cost

A cost matrix for each LRU is provided for equipment, support equipment, manpower, supply (spares), supply administration, contractor support, and other under the headings of development production, and support.

**EQUIPMENT:** Development and production costs are only for the LRUs (equipment). Essentially this cost is a through-put from the basic PRICE model.

**SUPPORT EQUIPMENT:** The acquisition cost is for all support test sets at each location according to maintenance concept and work demand. The additional cost for operational support of test sets is taken as an annual fraction of the value of the test sets.

**MANPOWER:** Men working at each support level for the work done is the normal expected value for manpower, i.e., the men are not treated as dedicated. A flag can be introduced to force integer crews of men at the organizational level.

**SUPPLY:** Costs are computed for initial spares (production) and for additional spares consumed beyond the initial level during the operational period.

**SUPPLY ADMINISTRATION:** The administration cost is computed as the cost to enter items into the supply system (production) and the cost to retain them as the supply system (support).

**CONTRACTOR SUPPORT:** In maintenance concepts calling for contractor depot, this cost is based on the expected number of LRU and module repairs over the years of support.

**OTHER:** The catch-all category has five subcategories.

(1) Support Equipment Programming/Documentation is computed based on the type of supply equipment (LRU and/or module repair) used by the selected maintenance concept.

(2) Support Equipment Space cost is computed for equipment floor space during the support period.

(3) Supply Space cost is the monthly costs per cubic foot for storage at the maintenance levels.

(4) Reorder Burden cost is to cover the burden cost of placing orders for additional material above the initial spares.

(5) Transportation cost is shipping and handling computed from the complex network of LRU and module and parts movements through the support network. Most of these costs require adjusted inputs in the GLOBAL file. Otherwise their default value remains at zero.

- Availability

The inherent and operational availabilities are computed from failure rates, maintenance times, and allowance times between maintenance levels.

- Support Equipment

The number of support equipments and utilization are established for the maintenance concept selected and each maintenance level.

- Supply

The number of initial spares per type (LRU, modules, and parts) and the balance of spares consumed for the support period are provided.

The PRICE L mode does not calculate costs for field testing, operational personnel, site facilities, anticipated system modification changes, software maintenance, and government administration.

### A3 EXAMPLE DATA PRINTOUT

The computer printouts presented in this example are for the ARPV LVDC and HVDC system described in Section 8. The data is presented first for PRICE then for PRICE-L for each system, the same order followed when using the two models. The table beginning each system lists all of the system components broken down according to whether it is made by the producer or a vendor or purchased off the shelf from a vendor. Each "make" item then must be further described in terms of its complexity; percent newness; percent electronic, electromechanical, or mechanical; etcetera.

#### ARPV Low Voltage D.C. Power System Breakdown

##### Make Items

- Main Power Control Box
- Power Relay Control Assembly

##### Vendor Make Items

- Generator
- Umbilical Distribution Box
- Power Control Unit
- Main Battery
- Inverter

##### Vendor Buy Items

- Reverse current relay
- Batter sensor
- Main bus contactor
- Payload bus contactor
- Power feeders/distribution
- Fiber optics cable
- Fiber optics interconnectors

MAIN POWER CONTROL BOX

INPUT DATA

QTY 1000. PROTOS 1.0 WT 22.200 VOL 0.389 MODE 2.  
 QSYSYS 1. INTEGE 0.000 INTEGS 0.300 AMULTE 120.00% AMULTM 120.00%

MECH/STRUCT

WS 22.200 MCPLXS 7.389 PRODS 0.000 NEWST 0.750 DESRPS 0.000

ENGINEERING

ENMTHS 96.0 ENMTHP 10.0 ENMTHT 10.0 ECMPLX 0.846 PRNF 0.000

PRODUCTION

PRMTHS 108.0 PRMTHF 123.0 LCURVE 0.000 ECNE 0.000 ECNS 0.000

GLOBAL

YEAR 1977. ESC 0.00% PROJCT 1.000 DATA 1.000 TLGTST 1.000  
 PLATFM 1.700 SYSTEM 1.000 FPRDJ 1.000 PDATA 1.000 PTLGTS 1.000

PROGRAM COST

	DEVELOPMENT	PRODUCTION	TOTAL COST
ENGINEERING			
DRAFTING	32.	4.	35.
DESIGN	85.	13.	98.
SYSTEMS	9.	0.	9.
PROJ MGHT	12.	354.	366.
DATA	5.	17.	22.
SUBTOTAL (ENG)	144.	387.	532.

MANUFACTURING

PRODUCTION	0.	9474.	9474.
PROTOTYPE	29.	0.	29.
TOOL-TEST EQ	4.	211.	216.
SUBTOTAL (MFG)	33.	9686.	9719.

TOTAL COST	DEVELOPMENT	PRODUCTION	TOTAL COST
	177.	10073.	10250.

VOL 0.389 AVCOST 9.47 TOTAL AV PROD COST 10.07 LCURVE 0.919  
 WT 22.200 ECNE 0.001 ECNS 0.049 DESRPE 0.000 DESRPS 0.000

MECH/STRUCT

WS 22.200 WSCF 57.069 MECID 0.000 PRODS 5.027 MCPLXS 7.389

SCHEDULES

ENMTHS 96.000 ENMTHP 10.000 ENMTHT 10.000 ECMPLX 0.846 PRNF 0.000  
 PRMTHS 108.000 PRMTHF 123.000 AVER. PROD RATE PER MONTH 66.667

COST RANGES

	DEVELOPMENT	PRODUCTION	TOTAL COST
FROM	153.	8323.	8476.
CENTER	177.	10073.	10250.
TO	210.	12280.	12490.

POWER RELAY CONTROL ASSY.

INPUT DATA

QTY 1000. PROTOS 1.0 WT 0.300 VOL 0.001 MODE 2.  
 QTYSYS 1. INTEGE 0.000 INTEGS 0.300 AMULTE 120.00% AMULTM 120.00%

MECH/STRUCT

WS 0.300 MCPLXS 8.027 PRODS 0.000 NEWST 0.500 DESRFS 0.000

ENGINEERING

ENMTHS 96.0 ENMTHF 12.0 ENMHT 12.0 ECMLX 0.978 PRNF 0.000

PRODUCTION

PRMTHS 108.0 PRMTHF 124.0 LCURVE 0.000 ECNE 0.000 ECNS 0.000

GLOBAL

YEAR 1977. ESC 0.00% PROJCT 1.000 DATA 1.000 TLGTST 1.000  
 PLATFM 1.700 SYSTEM 1.000 PPRDJ 1.000 PDATA 1.000 PTLGTS 1.000

PROGRAM COST

	DEVELOPMENT	PRODUCTION	TOTAL COST
ENGINEERING			
DRAFTING	2.	0.	2.
DESIGN	5.	1.	6.
SYSTEMS	1.	0.	1.
PROJ MGMT	1.	15.	16.
DATA	0.	1.	1.
SUBTOTAL(ENG)	7.	17.	25.

MANUFACTURING

PRODUCTION	0.	375.	375.
PROTOTYPE	1.	0.	1.
TOOL-TEST EQ	0.	21.	22.
SUBTOTAL(MFG)	1.	396.	398.

TOTAL COST 9. 413. 422.

VOL 0.001 AVCOST 0.37 TOTAL AV PROD COST 0.41 LCURVE 0.913  
 WT 0.300 ECNE 0.001 ECNS 0.062 DESRPE 0.000 DESRFS 0.000

MECH/STRUCT

WS 0.300 WSCF 300.000 MECID 0.000 PRODS 4.903 MCPLXS 8.027

SCHEDULES

ENMTHS 96.000 ENMTHF 12.000 ENMHT 12.000 ECMLX 0.978 PRNF 0.000  
 PRMTHS 108.000 PRMTHF 124.000 AVER. PROD RATE FER MONTH 62.500

COST RANGES

	DEVELOPMENT	PRODUCTION	TOTAL COST
FROM	8.	340.	348.
CENTER	9.	413.	422.
TO	11.	509.	520.

GENERATOR

INPUT DATA

QTY 1000. PROTOS 1.0 WT 14.000 VOL 0.038 MODE 2.  
 QTYSYS 1. INTEGE 0.000 INTEGS 0.500 AMULTE 150.00% AMULTM 150.00%

MECH/STRUCT

WS 14.000 MCPLXS 4.300 PRODS 0.000 NEWST 0.800 DESRPS 0.000

ENGINEERING

ENMTHS 96.0 ENMTHP 5.0 ENMTHT 5.0 ECMLPX 1.000 PRNF 0.000

PRODUCTION

PRMTHS 108.0 PRMTHF 115.0 LCURVE 0.900 ECNE 0.000 ECNS 0.000

GLOBAL

YEAR 1977. ESC 0.00% PROJCT 1.000 DATA 1.000 TLGTST 1.000  
 PLATFM 1.700 SYSTEM 1.000 PPROJ 1.000 PDATA 1.000 PTLGTS 1.000

PROGRAM COST

	DEVELOPMENT	PRODUCTION	TOTAL COST
ENGINEERING			
DRAFTING	6.	0.	6.
DESIGN	15.	0.	15.
SYSTEMS	4.	0.	4.
PROJ MGMT	4.	13.	17.
DATA	2.	1.	2.
SUBTOTAL(ENG)	31.	14.	45.

MANUFACTURING

PRODUCTION		365.	365.
PROTOTYPE	3.	0.	3.
TOOL-TEST EQ	2.	27.	28.
SUBTOTAL(MFG)	5.	392.	397.

TOTAL COST	36.	406.	442.
------------	-----	------	------

VOL 0.038 AVCOST 0.37 TOTAL AV PROD COST 0.41 LCURVE 0.900  
 WT 14.000 ECNE 0.001 ECNS 0.007 DESRPE 0.000 DESRPS 0.000

MECH/STRUCT

WS 14.000 WSCF 368.421 MECID 0.000 PRODS 2.592 MCPLXS 4.300

SCHEDULES

ENMTHS 96.000 ENMTHP 5.000 ENMTHT 5.000 ECMLPX 1.000 PRNF 0.000  
 PRMTHS 108.000 PRMTHF 115.000 AVER. PROD RATE PER MONTH 142.857

COST RANGES

	DEVELOPMENT	PRODUCTION	TOTAL COST
FROM	28.	313.	342.
CENTER	36.	406.	442.
TO	55.	665.	720.

UMBILICAL DISTR. BOX

INPUT DATA  
 QTY 1000. PROTOS 1.0 WT 9.500 VDL 0.177 MODE 2.  
 QTYSYS 1. INTEGE 0.000 INTEGS 0.500 AMULTE 120.00% AMULTM 120.00%

MECH/STRUCT  
 WS 9.500 MCPLXS 8.538 PRODS 0.000 NEWST 0.800 DESRFS 0.000

ENGINEERING  
 ENMTHS 96.0 ENMTHP 14.4 ENMHT 14.4 ECMLX 1.102 PRNF 0.000

PRODUCTION  
 PRMTHS 108.0 PRMTHF 126.0 LCURVE 0.000 ECNE 0.000 ECNS 0.000

GLOBAL  
 YEAR 1977. ESC 0.00% PROJECT 1.000 DATA 1.000 TLGTST 1.000  
 PLATFM 1.700 SYSTEM 1.000 PPROJ 1.000 PDATA 1.000 PTLGTS 1.000

PROGRAM COST	DEVELOPMENT	PRODUCTION	TOTAL COST
ENGINEERING			
DRAFTING	40.	6.	46.
DESIGN	122.	23.	146.
SYSTEMS	17.	0.	17.
PROJ MGMT	13.	454.	468.
DATA	6.	22.	27.
SUBTOTAL(ENG)	198.	505.	703.

MANUFACTURING	DEVELOPMENT	PRODUCTION	TOTAL COST
PRODUCTION	0.	11730.	11730.
PROTOTYPE	39.	0.	39.
TOOL-TEST EQ	7.	318.	325.
SUBTOTAL(MFG)	45.	12047.	12093.
TOTAL COST	244.	12552.	12796.

VOL 0.177 AVCOST 11.73 TOTAL AV PROD COST 12.55 LCURVE 0.907  
 WT 9.500 ECNE 0.001 ECNS 0.080 DESRFE 0.000 DESRFS 0.000

MECH/STRUCT  
 WS 9.500 WSCF 53.672 MECID 0.000 PRODS 5.832 MCPLXS 8.538

SCHEDULES  
 ENMTHS 96.000 ENMTHP 14.400 ENMHT 14.400 ECMLX 1.102 PRNF 0.000  
 PRMTHS 108.000 PRMTHF 126.000 AVER. PROD RATE PER MONTH 55.556

COST RANGES	DEVELOPMENT	PRODUCTION	TOTAL COST
FROM	213.	10491.	10705.
CENTER	244.	12552.	12796.
TO	280.	14751.	15030.

PWR CONTROL UNIT

INPUT DATA

QTY 1000. PROTOS 1.0 WT 3.000 VOL 0.043 MODE 1.  
 QTYSYS 1. INTEGE 0.500 INTEGS 0.500 AMULTE 120.00% AMULTM 120.00%

MECH/STRUCT

WS 1.200 MCPLXS 5.697 PRODS 0.000 NEWST 1.000 DESRPS 0.000

ELECTRONICS

USEVOL 0.980 MCPLXE 7.714 PRODE 0.000 NEWEL 0.700 DESRFE 0.000  
 PWR 525.000 CMPNTS 0. LMPID 0.000 PWRFAC 0.500 CMPEFF 0.000

ENGINEERING

ENMTHS 96.0 ENMTHP 11.0 ENMHT 11.0 ECMLX 0.911 PRNF 0.000

PRODUCTION

PRMTHS 108.0 PRMTHF 136.0 LCURVE 0.900 ECNE 0.000 ECNS 0.000

GLOBAL

YEAR 1977. ESC 0.00% PROJCT 1.000 DATA 1.000 TLGTST 1.000  
 PLATFM 1.700 SYSTEM 1.000 PPROJ 1.000 PDATA 1.000 PTLGTS 1.000

PROGRAM COST

	DEVELOPMENT	PRODUCTION	TOTAL COST
ENGINEERING			
DRAFTING	23.	4.	28.
DESIGN	66.	12.	77.
SYSTEMS	8.	0.	8.
PROJ MGMT	8.	66.	74.
DATA	4.	3.	7.
SUBTOTAL (ENG)	108.	84.	193.

MANUFACTURING

PRODUCTION	0.	1279.	1279.
PROTOTYPE	5.	0.	5.
TOOL-TEST EQ	1.	66.	67.
SUBTOTAL (MFG)	6.	1345.	1351.

TOTAL COST	114.	1429.	1544.
------------	------	-------	-------

VOL 0.043 AVCOST 1.28 TOTAL AV PROD COST 1.43 LCURVE 0.900  
 WT 3.000 ECNE 0.076 ECNS 0.024 DESRFE 0.000 DESRPS 0.000

MECH/STRUCT

WS 1.200 WSCF 27.907 MECID 0.000 PRODS 4.061 MCPLXS 5.697

ELECTRONICS

WE 1.800 WECF 42.715 CMPID 0.000 PRODE 4.230 MCPLXE 7.714  
 PWR 525.000 CMPNTS 4157. PWRFAC 0.500 CMPEFF 74.993

SCHEDULES

ENMTHS 96.000 ENMTHP 11.000 ENMHT 11.000 ECMLX 0.911 PRNF 0.000  
 PRMTHS 108.000 PRMTHF 136.000 AVER. PROD RATE PER MONTH 35.714

COST RANGES

	DEVELOPMENT	PRODUCTION	TOTAL COST
FROM	97.	1151.	1248.
CENTER	114.	1429.	1544.
TO	140.	1863.	2003.

AD-A060 336

TELEDYNE RYAN AERONAUTICAL SAN DIEGO CA  
RPV ELECTRIC POWER SYSTEM STUDY PHASE I. TECHNOLOGY ASSESSMENT.(U)  
JUN 78 F L MILLER F33615-76-C-2069

F/G 1/3

UNCLASSIFIED

TRA-29318-06

AFAPL-TR-78-38

NL

3 of 3

AD  
A060336



END  
DATE  
FILMED  
12-78  
DDC

MAIN BATTERY

INPUT DATA

QTY 1000. PROTOS 1.0 WT 17.000 VOL 0.174 MODE 2.  
 QTYSYS 1. INTEGE 0.000 INTEGS 0.300 AMULTE 150.00% AMULTM 150.00%

MECH/STRUCT

WS 17.000 MCFLXS 4.610 PRODS 0.000 NEWST 0.300 DESRPS 0.000

ENGINEERING

ENMTHS 96.0 ENMTHP 6.0 ENMHT 6.0 ECMLX 0.400 PRNF 0.000

PRODUCTION

PRMTHS 108.0 PRMTHF 120.0 LCURVE 0.000 ECNE 0.000 ECNS 0.000

GLOBAL

YEAR 1977. ESC 0.00% PROJCT 1.000 DATA 1.000 TLGTST 1.000  
 PLATFM 1.700 SYSTEM 1.000 PPROJ 1.000 PDATA 1.000 PTLGTS 1.000

PROGRAM COST DEVELOPMENT PRODUCTION TOTAL COST

ENGINEERING			
DRAFTING	2.	0.	2.
DESIGN	3.	0.	3.
SYSTEMS	0.	0.	0.
PROJ MGMT	1.	34.	36.
DATA	0.	2.	2.
SUBTOTAL(ENG)	7.	37.	43.

MANUFACTURING

PRODUCTION	0.	912.	912.
PROTOTYPE	3.	0.	3.
TOOL-TEST EQ	1.	18.	18.
SUBTOTAL(MFG)	4.	929.	933.

TOTAL COST 10. 966. 976.

VOL 0.174 AVCOST 0.91 TOTAL AV PROD COST 0.97 LCURVE 0.957  
 WT 17.000 ECNE 0.001 ECNS 0.010 DESRPE 0.000 DESRPS 0.000

MECH/STRUCT

WS 17.000 WSCF 97.701 MECID 0.000 PRODS 3.029 MCPLXS 4.610

SCHEDULES

ENMTHS 96.000 ENMTHP 6.000 ENMHT 6.000 ECMLX 0.400 PRNF 0.000  
 PRMTHS 108.000 PRMTHF 120.000 AVER. PROD RATE PER MONTH 83.333

COST RANGES DEVELOPMENT PRODUCTION TOTAL COST

FROM	8.	763.	771.
CENTER	10.	966.	976.
TO	15.	1434.	1449.

INVERTER

INPUT DATA

QTY 1000. PROTOS 1.0 WT 12.000 VOL 0.125 MODE 1.  
 QTYSYS 1. INTEGE 0.500 INTEGS 0.300 AMULTE 120.00% AMULTM 120.00%

MECH/STRUCT

WS 4.400 MCPLXS 4.813 PRODS 0.000 NEWST 1.000 DESRPS 0.000

ELECTRONICS

USEVOL 0.800 MCPLXE 6.333 PRODE 0.000 NEWEL 0.500 DESRPE 0.000  
 PWR 500.000 CMPNTS 0. CMPID 0.000 PWRFAC 0.400 CMPEFF 0.000

ENGINEERING

ENMTHS 96.0 ENMTHP 6.0 ENMTHT 6.0 ECMLPX 0.638 PRNF 0.000

PRODUCTION

PRMTHS 108.0 PRMTHF 120.0 LCURVE 0.920 ECNE 0.000 ECNS 0.000

GLOBAL

YEAR 1977. ESC 0.00% PROJCT 1.000 DATA 1.000 TLGTST 1.000  
 PLATFM 1.700 SYSTEM 1.000 PPROJ 1.000 PDATA 1.000 PTLGTS 1.00

PROGRAM COST

	DEVELOPMENT	PRODUCTION	TOTAL COST
ENGINEERING			
DRAFTING	16.	3.	19.
DESIGN	38.	6.	44.
SYSTEMS	4.	0.	4.
PROJ MGMT	7.	66.	74.
DATA	3.	3.	7.
SUBTOTAL(ENG)	68.	79.	147.

MANUFACTURING

	DEVELOPMENT	PRODUCTION	TOTAL COST
PRODUCTION	0.	1714.	1714.
PROTOTYPE	5.	0.	5.
TOOL-TEST EQ	1.	81.	82.
SUBTOTAL(MFG)	6.	1794.	1800.

TOTAL COST

74. 1873. 1947.

VOL 0.125 AVCOST 1.71 TOTAL AV PROD COST 1.87 LCURVE 0.920  
 WT 12.000 ECNE 0.040 ECNS 0.014 DESRPE 0.000 DESRPS 0.000

MECH/STRUCT

WS 4.400 WSCF 35.200 MECID 0.000 PRODS 3.379 MCPLXS 4.813

ELECTRONICS

WE 7.600 WECF 76.000 CMPID 0.000 PRODE 3.167 MCPLXE 6.333  
 PWR 500.000 CMPNTS 2838. PWRFAC 0.400 CMPEFF 52.401

SCHEDULES

ENMTHS 96.000 ENMTHP 6.000 ENMTHT 6.000 ECMLPX 0.638 PRNF 0.000  
 PRMTHS 108.000 PRMTHF 120.000 AVER. PROD RATE PER MONTH 83.333

COST RANGES

	DEVELOPMENT	PRODUCTION	TOTAL COST
FROM	60.	1444.	1504.
CENTER	74.	1873.	1947.
TO	103.	2839.	2941.

PURCH ITEM  
BUY GROUP

INPUT DATA

QTY	1000.	PROTOS	1.00	BVCOST	0.995	AMULTM	150.00%
LCURVE	0.950						
WT	45.427	QTYSYS	1.				

MECH/STRUCT							
WS	37.000	INTEGS	0.700	MCFLXS	4.108		
ELECTRONICS							
WE	8.427	INTEGE	0.700	MCFLXE	4.700		

PROGRAM COST		DEVELOPMENT		PRODUCTION		TOTAL COST
PURCH ITEM		1.		1493.		1494.

I&T ELECTRICAL SYSTEM

INPUT DATA

QTY 1000. PROTOS 1.0 IWT 3.667 IVOL 0.173 MODE 5.  
 QTYSYS -1. INTEGE 0.000 INTEGS 0.000 AMULTE 120.00% AMULTM 120.00%

MECH/STRUCT

IWS 2.601 MCPLXS 6.045 PRODS 0.000 NEWST 0.300 DESRPS 0.000

ELECTRONICS

I-UVOL 0.176 MCPLXE 5.591 PRODE 0.000 NEWEL 0.300 DESRPE 0.000  
 PWR 0.000 CMFNCS 0.000 CMFID 0.000 PWRFAC 0.000 CMPEFF 0.000

ENGINEERING

ENMTHS 96.0 ENMTHP 14.4 ENMHT 14.4 ECMPLX 0.000 PRNF 0.000

PRODUCTION

PRMTHS 108.0 PRMTHF 126.0 LCURVE 0.000 ECNE 0.000 ECNS 0.000

GLOBAL

YEAR 1977. ESC 0.00% PROJCT 1.000 DATA 1.000 TLGTST 1.000  
 PLATFM 1.700 SYSTEM 1.000 FPROJ 1.000 PDATA 1.000 PTLGTS 1.00

PROGRAM COST

DEVELOPMENT

PRODUCTION

TOTAL COST

ENGINEERING

DRAFTING	6.	0.	6.
DESIGN	17.	1.	19.
SYSTEMS	6.	0.	6.
PROJ MGMT	4.	22.	25.
DATA	2.	1.	3.
SUBTOTAL (ENG)	34.	25.	59.

MANUFACTURING

PRODUCTION	0.	513.	513.
PROTOTYPE	3.	0.	3.
TOOL-TEST EQ	1.	21.	22.
SUBTOTAL (MFG)	4.	534.	537.

TOTAL COST	38.	558.	596.
------------	-----	------	------

COST RANGES

DEVELOPMENT

PRODUCTION

TOTAL COST

FROM	31.	454.	485.
CENTER	38.	558.	596.
TO	51.	738.	789.

TOTAL COST, LESS INTEGRATION COST			
PROGRAM COST	DEVELOPMENT	PRODUCTION	TOTAL COST
ENGINEERING			
DRAFTING	121.	17.	138.
DESIGN	334.	56.	390.
SYSTEMS	42.	0.	42.
PROJ MGMT	47.	1003.	1050.
DATA	20.	48.	68.
SUBTOTAL (ENG)	564.	1124.	1687.
MANUFACTURING			
PRODUCTION	0.	25848.	25848.
PROTOTYPE	84.	0.	84.
TOOL-TEST EQ	17.	741.	757.
PURCH ITEMS	1.	1493.	1494.
SUBTOTAL (MFG)	102.	28082.	28184.
TOTAL COST	666.	29205.	29872.
COST RANGES			
	DEVELOPMENT	PRODUCTION	TOTAL COST
FROM	569.	24318.	24887.
CENTER	666.	29205.	29872.
TO	814.	35833.	36648.

TOTAL COST, WITH INTEGRATION COST			
PROGRAM COST	DEVELOPMENT	PRODUCTION	TOTAL COST
ENGINEERING			
DRAFTING	126.	18.	144.
DESIGN	351.	57.	408.
SYSTEMS	48.	0.	48.
PROJ MGMT	51.	1024.	1075.
DATA	22.	49.	71.
SUBTOTAL (ENG)	598.	1148.	1746.
MANUFACTURING			
PRODUCTION	0.	26361.	26361.
PROTOTYPE	87.	0.	87.
TOOL-TEST EQ	18.	762.	780.
PURCH ITEMS	1.	1493.	1494.
SUBTOTAL (MFG)	106.	28616.	28722.
TOTAL COST	704.	29764.	30468.
COST RANGES			
	DEVELOPMENT	PRODUCTION	TOTAL COST
FROM	599.	24773.	25372.
CENTER	704.	29764.	30468.
TO	865.	36571.	37437.

PRICE LIFE CYCLE COST

PWR CONTROL UNIT

LC: LARP3

INPUT DATA

R&M DATA

MTBF 2806. MTTR-LRU 1.4 MTTR-MOD 2.8

DEPLOYMENT

EQUIPS 1000. ORGANIZATION 10. INTERMEDIATE 10. DEPOT 1.  
LRUS/EQUIP 1. MODS/LRU 5. PARTS/LRU 803.

EMPLOYMENT

SUPPORT PERIOD 10. HRS/MON 3.7 OTF 0.005

GLOBAL

EQUUSUP 1000. ORGSUP 10. INTSUP 10. DEPSUP 1.  
ESC 0.000 LRU FAIL ALLOW 0.

MAINTENANA CONCEPT 19

LRU REPAIR TO PIECE PART AT CONTRACTOR DEPOT.

PROGRAM COST	DEVELOPMENT	PRODUCTION	SUPPORT	TOTAL
EQUIPMENT	114.	1425.	0.	1540.
SUPPORT EQUIP	0.	0.	0.	0.
MANPOWER	0.	0.	0.	0.
SUPPLY	0.	26.	0.	26.
SUPPLY ADM.	0.	0.	1.	1.
CONTRACTOR SUPPORT	0.	0.	12.	12.
OTHER	0.	0.	0.	0.
<b>TOTAL COST</b>	<b>114.</b>	<b>1452.</b>	<b>13.</b>	<b>1580.</b>

AVAILABILITY  
INHERENT

0.9999 OPERATIONAL 0.9999

SUPPORT EQUIPMENT  
NO. UTILIZATION

ORG	INT	DEPOT
0.	0.	0.
0.000	0.000	0.000

SUPPLY  
INITIAL, PER TYPE  
BALANCE CONSUMED

UNITS	MODULES	PARTS
20.	0.	2.
0.000	0.000	0.000

COST/EFFECTIVNESS LIST (%)

19= 100.0	15= 115.6	1= 116.8	4= 118.8	9= 131.6	18= 141.0
17= 144.3	2= 144.5	3= 146.7	7= 166.2	8= 168.8	10= 170.0
6= 172.0	5= 203.2	11= 488.9	16= 489.7	14= 517.5	12= 545.7
13= 549.1					

INVERTER

PRICE LIFE CYCLE COST

INVERTER

LC: LARF3

INPUT DATA

R&M DATA

MTBF 819. MTTR-LRU 1.1 MTTR-MOD 2.3

DEPLOYMENT

EQUIPS 1000. ORGANIZATION 10. INTERMEDIATE 10. DEPOT 1.  
LRUS/EQUIP 1. MODS/LRU 8. PARTS/LRU 550.

EMPLOYMENT

SUPPORT PERIOD 10. HRS/MON 3.7 OTF 0.005

GLOBAL

EQUUSUP 1000. ORGSUP 10. INTSUP 10. DEPSUP 1.  
ESC 0.000 LRU FAIL ALLOW 0.

MAINTENANCE CONCEPT 19

LRU REPAIR TO PIECE PART AT CONTRACTOR DEPOT.

PROGRAM COST	DEVELOPMENT	PRODUCTION	SUPPORT	TOTAL
EQUIPMENT	74.	1865.	0.	1939.
SUPPORT EQUIP	0.	0.	0.	0.
MANPOWER	0.	0.	0.	0.
SUPPLY	0.	75.	0.	75.
SUPPLY ADM.	0.	0.	1.	1.
CONTRACTOR SUPPORT	0.	0.	55.	55.
OTHER	0.	0.	6.	6.
<b>TOTAL COST</b>	<b>74.</b>	<b>1940.</b>	<b>62.</b>	<b>2076.</b>

AVAILABILITY

INHERENT 0.9998 OPERATIONAL 0.9998

SUPPORT EQUIPMENT

NO. 0. INT 0. DEPOT 0.  
UTILIZATION 0.000 0.000 0.000

SUPPLY

INITIAL, PER TYPE 40. UNITS 1. MODULES 2. PARTS  
BALANCE CONSUMED 0.000 0.000 0.000

COST/EFFECTIVENESS LIST (X)

19=	100.0	9=	116.3	15=	122.0	4=	122.8	18=	124.3	17=	125.5
7=	132.6	2=	133.7	10=	134.4	8=	135.1	3=	136.1	6=	136.2
5=	152.4	1=	152.4	11=	371.8	16=	373.8	14=	384.6	12=	398.7
13=	401.0										

MAIN BATTERY

PRICE LIFE CYCLE COST

MAIN BATTERY

LC: LARP3

INPUT DATA

R&M DATA

MTBF 13300. MTTR-LRU 3.0 MTTR-MOD 0.0

DEPLOYMENT

EQUIPS 1000. ORGANIZATION 10. INTERMEDIATE 10. DEPOT 1.  
LRUS/EQUIP 1. MODS/LRU 0. PARTS/LRU 20.

EMPLOYMENT

SUPPORT PERIOD 10. HRS/MON 3.7 OTF 0.005

GLOBAL

EQUISUP 1000. ORGSUP 10. INTSUP 10. DEPSUP 1.  
ESC 0.000 LRU FAIL ALLOW 0.

MAINTENANCE CONCEPT 19

LRU REPAIR TO PIECE PART AT CONTRACTOR DEPOT.

PROGRAM COST	DEVELOPMENT	PRODUCTION	SUPPORT	TOTAL
EQUIPMENT	10.	965.	0.	975.
SUPPORT EQUIP	0.	0.	0.	0.
MANPOWER	0.	0.	0.	0.
SUPPLY	0.	19.	0.	19.
SUPPLY ADM.	0.	0.	1.	1.
CONTRACTOR SUPPORT	0.	0.	2.	2.
OTHER	0.	0.	1.	1.
<b>TOTAL COST</b>	<b>10.</b>	<b>984.</b>	<b>3.</b>	<b>997.</b>

AVAILABILITY

INHERENT 1.0000 OPERATIONAL 1.0000

SUPPORT EQUIPMENT NO.	ORG	INT	DEPOT
UTILIZATION	0.000	0.000	0.000
SUPPLY INITIAL, PER TYPE	UNITS	MODULES	PARTS
BALANCE CONSUMED	20.000	0.000	2.000

COST/EFFECTIVENESS LIST (%)

19= 100.0 10= 100.1 7= 100.7 9= 101.1 1= 101.8  
AC POWER RELAY CONTROL ASSY.

PRICE LIFE CYCLE COST

POWER RELAY CONTROL ASSY.

LC: LARP3

INPUT DATA

R&M DATA

MTBF 25728. MTTR-LRU 4.9 MTTR-MOD 0.0

DEPLOYMENT

EQUIPS 1000. ORGANIZATION 10. INTERMEDIATE 10. DEPOT 1.  
LRUS/EQUIP 1. MODS/LRU 0. PARTS/LRU 20.

EMPLOYMENT

SUPPORT PERIOD 10. HRS/MON 3.7 OTF 0.005

GLOBAL

EQUISUP 1000. ORGSUP 10. INTSUP 10. DEPSUP 1.  
ESC 0.000 LRU FAIL ALLOW 0.

MAINTENANCE CONCEPT 19

LRU REPAIR TO PIECE PART AT CONTRACTOR DEPOT.

PROGRAM COST	DEVELOPMENT	PRODUCTION	SUPPORT	TOTAL
EQUIPMENT	9.	413.	0.	421.
SUPPORT EQUIP	0.	0.	0.	0.
MANPOWER	0.	0.	0.	0.
SUPPLY	0.	8.	0.	8.
SUPPLY ADM.	0.	0.	1.	1.
CONTRACTOR SUPPORT	0.	0.	0.	0.
OTHER	0.	0.	0.	0.
TOTAL COST	9.	421.	1.	431.

AVAILABILITY

INHERENT 1.0000 OPERATIONAL 1.0000

SUPPORT EQUIPMENT

NO. 0. INT 0. DEPOT 0.  
UTILIZATION 0.000 0.000 0.000

SUPPLY

UNITS 20. MODULES 0. PARTS 2.  
INITIAL, PER TYPE 0.000 0.000 0.000  
BALANCE CONSUMED

COST/EFFECTIVENESS LIST (%)

19= 100.0 1= 100.1 10= 101.9 7= 102.4 9= 102.7

MAIN POWER CONTROL BOX

PRICE LIFE CYCLE COST

MAIN POWER CONTROL BOX

LC: LARP3

INPUT DATA

R&M DATA

MTBF 9220. MTTR-LRU 5.0 MTTR-MOD 0.0

DEPLOYMENT

EQUIPS 1000. ORGANIZATION 10. INTERMEDIATE 10. DEPOT 1.  
LRUS/EQUIP 1. MODS/LRU 0. PARTS/LRU 47.

EMPLOYMENT

SUPPORT PERIOD 10. HRS/MON 3.7 OTF 0.005

GLOBAL

EQUUSUP 1000. ORGSUP 10. INTSUP 10. DEPSUP 1.  
ESC 0.000 LRU FAIL ALLOW 0.

MAINTENANCE CONCEPT 10

LRU REPAIR TO PIECE PART AT ORGANIZATION.

PROGRAM COST

	DEVELOPMENT	PRODUCTION	SUPPORT	TOTAL
EQUIPMENT	177.	10073.	0.	10250.
SUPPORT EQUIP	0.	0.	0.	0.
MANPOWER	0.	0.	3.	3.
SUPPLY	0.	103.	0.	103.
SUPPLY ADM.	0.	2.	24.	26.
CONTRACTOR SUPPORT	0.	0.	0.	0.
OTHER	0.	0.	0.	0.
TOTAL COST	177.	10178.	27.	10383.

AVAILABILITY  
INHERENT

1.0000 OPERATIONAL 1.0000

SUPPORT EQUIPMENT

NO. 10. INT 0. DEPOT 0.  
UTILIZATION 0.003 0.000 0.000

SUPPLY

INITIAL, PER TYPE 0. UNITS 0. MODULES 22. PARTS  
BALANCE CONSUMED 0.000 0.000 0.000

COST/EFFECTIVENESS LIST (X)

10= 100.0 7= 100.4 19= 100.7 9= 100.7 1= 104.7  
UMBILICAL DISTR. BOX

PRICE LIFE CYCLE COST

UMBILICAL DISTR. BOX

LC: LARP3

INPUT DATA

R&M DATA

MTBF 7489. MTTR-LRU 5.8 MTTR-MOD 0.0

DEPLOYMENT

EQUIP'S 1000. ORGANIZATION 10. INTERMEDIATE 10. DEPOT 1.  
LRUS/EQUIP 1. MGDS/LRU 0. PARTS/LRU 59.

EMPLOYMENT

SUPPORT PERIOD 10. HRS/MON 3.7 OTF 0.005

GLOBAL

EQUISUP 1000. ORGSUP 10. INTSUP 10. DEPSUP 1.  
ESC 0.000 LRU FAIL ALLOW 0.

MAINTENANCE CONCEPT 10

LRU REPAIR TO PIECE PART AT ORGANIZATION.

PROGRAM COST	DEVELOPMENT	PRODUCTION	SUPPORT	TOTAL
EQUIPMENT	244.	12553.	0.	12797.
SUPPORT EQUIP	0.	0.	0.	0.
MANPOWER	0.	0.	5.	5.
SUPPLY	0.	130.	0.	130.
SUPPLY ADM.	0.	3.	30.	32.
CONTRACTOR SUPPORT	0.	0.	0.	0.
OTHER	0.	0.	0.	0.
TOTAL COST	244.	12685.	34.	12963.

AVAILABILITY

INHERENT 1.0000 OPERATIONAL 1.0000

SUPPORT EQUIPMENT

NO. 10. ORG 0. INT 0. DEPOT 0.  
UTILIZATION 0.005 0.000 0.000

SUPPLY

INITIAL, PER TYPE 0. UNITS 0. MODULES 0. PARTS 22.  
BALANCE CONSUMED 0.000 0.000 0.000

COST/EFFECTIVENESS LIST (%)

10= 100.0 7= 100.3 9= 100.7 19= 100.7 1= 106.4  
GENERATOR

PRICE LIFE CYCLE COST

GENERATOR

LC: LARP3

INPUT DATA

R&M DATA

MTBF 59865. MTTR-LRU 2.6 MTTR-MOD 0.0

DEPLOYMENT

EQUIPS 1000. ORGANIZATION 10. INTERMEDIATE 10. DEPOT 1.  
LRUS/EQUIP 1. MODS/LRU 0. PARTS/LRU 20.

EMPLOYMENT

SUPPORT PERIOD 10. HRS/MON 3.7 OTF 0.005

GLOBAL

EQUISUP 1000. ORGSUP 10. INTSUP 10. DEPSUP 1.  
ESC 0.000 LRU FAIL ALLOW 0.

MAINTENANCE CONCEPT 19

LRU REPAIR TO PIECE PART AT CONTRACTOR DEPOT.

PROGRAM COST	DEVELOPMENT	PRODUCTION	SUPPORT	TOTAL
EQUIPMENT	36.	405.	0.	440.
SUPPORT EQUIP	0.	0.	0.	0.
MANPOWER	0.	0.	0.	0.
SUPPLY	0.	8.	0.	8.
SUPPLY ADM.	0.	0.	1.	1.
CONTRACTOR SUPPORT	0.	0.	0.	0.
OTHER	0.	0.	0.	0.
TOTAL COST	36.	412.	1.	449.

AVAILABILITY

INHERENT 1.0000 OPERATIONAL 1.0000

SUPPORT EQUIPMENT

NO. 0. INT 0. DEPOT 0.  
UTILIZATION 0.000 0.000 0.000

SUPPLY

UNITS 20. MODULES 0. PARTS 2.  
INITIAL, PER TYPE 0.000 0.000 0.000  
BALANCE CONSUMED

COST/EFFECTIVNESS LIST (%)

19= 100.0 1= 100.0 10= 101.6 7= 102.2 9= 102.5  
BUY GROUP

PRICE LIFE CYCLE COST

BUY GROUP

LC: LARP3

INPUT DATA

R&M DATA

MTBF 369. MTRR-LRU 0.9 MTRR-MOD 1.9

DEPLOYMENT

EQUIPS 1000. ORGANIZATION 10. INTERMEDIATE 10. DEPOT 1.  
LRUS/EQUIP 1. MODS/LRU 3. PARTS/LRU 13.

EMPLOYMENT

SUPPORT PERIOD 10. HRS/MON 3.7 OTF 0.005

GLOBAL

EQUISUP 1000. ORGSUP 10. INTSUP 10. DEPSUP 1.  
ESC 0.000 LRU FAIL ALLOW 0.

MAINTENANCE CONCEPT 9  
LRU REPAIR TO PIECE PART AT DEPOT.

PROGRAM COST	DEVELOPMENT	PRODUCTION	SUPPORT	TOTAL
EQUIPMENT	1.	1481.	0.	1483.
SUPPORT EQUIP	0.	8.	8.	16.
MANPOWER	0.	0.	43.	43.
SUPPLY	0.	155.	118.	273.
SUPPLY ADM.	0.	1.	8.	8.
CONTRACTOR SUPPORT	0.	0.	0.	0.
OTHER	0.	0.	52.	52.
TOTAL COST	1.	1646.	228.	1875.

AVAILABILITY

INHERENT 0.9996 OPERATIONAL 0.9986

SUPPORT EQUIPMENT

NO. ORG INT DEPOT  
0. 0. 1.  
UTILIZATION 0.000 0.000 0.041

SUPPLY

UNITS MODULES PARTS  
INITIAL, PER TYPE 90. 0. 16.  
BALANCE CONSUMED 0.000 0.000 75.244

COST/EFFECTIVENESS LIST (%)

9= 100.0 19= 100.6 10= 100.9 7= 102.7 6= 106.2 8= 107.8  
5= 109.1 17= 134.3 18= 135.8 2= 191.9 4= 195.1 3= 196.4  
15= 197.4 1= 197.7 14= 325.3 12= 325.5 13= 328.2 11= 334.1  
16= 353.4

I&T ELECTRICAL SYSTEM

PRICE LIFE CYCLE COST

I&T ELECTRICAL SYSTEM

LC: LARP3

INPUT DATA

R&M DATA

MTBF 1732. MTTR-LRU 0.0 MTTR-MOD 0.0

DEPLOYMENT

EQUIPS 1000. ORGANIZATION 10. INTERMEDIATE 10. DEPOT 1.  
LRUS/EQUIP 1. MODS/LRU 1. PARTS/LRU 0.

EMPLOYMENT

SUPPORT PERIOD 10. HRS/MON 3.7 OTF 0.005

GLOBAL

EQUISUP 1000. ORGSUP 10. INTSUP 10. DEPSUP 1.  
ESC 0.000 LRU FAIL ALLOW 0.

MAINTENANCE CONCEPT 29

ON-EQUIPMENT REPAIR TO NON-REPAIRABLE MODULE.

PROGRAM COST	DEVELOPMENT	PRODUCTION	SUPPORT	TOTAL
EQUIPMENT	38.	46.	0.	83.
SUPPORT EQUIP	0.	0.	0.	0.
MANPOWER	0.	0.	0.	0.
SUPPLY	0.	1647.	0.	1647.
SUPPLY ADM.	0.	0.	1.	1.
CONTRACTOR SUPPORT	0.	0.	0.	0.
OTHER	0.	0.	1.	1.
<b>TOTAL COST</b>	<b>38.</b>	<b>1693.</b>	<b>2.</b>	<b>1732.</b>

AVAILABILITY

INHERENT 1.0000 OPERATIONAL 1.0000

SUPPORT EQUIPMENT

NO. 0. INT 0. DEPOT 0.  
UTILIZATION 0.000 0.000 0.000

SUPPLY

INITIAL, PER TYPE 0. UNITS 1078. MODULES 0. PARTS 0.  
BALANCE CONSUMED 0.000 0.000 0.000

COST/EFFECTIVENESS LIST (%)

29= 100.0

PRICE LIFE CYCLE COST

SYSTEM TOTALS

PROGRAM COST	DEVELOPMENT	PRODUCTION	SUPPORT	TOTAL
EQUIPMENT	704.	29224.	0.	29928.
SUPPORT EQUIP	0.	8.	8.	16.
MANPOWER	0.	0.	51.	51.
SUPPLY	0.	2171.	118.	2289.
SUPPLY ADM.	0.	7.	67.	73.
CONTRACTOR SUPPORT	0.	0.	69.	69.
OTHER	0.	0.	60.	60.
TOTAL COST	704.	31411.	373.	32487.
ADDITIONAL COST	0.	0.	0.	0.
GRAND TOTAL	704.	31411.	373.	32487.
SYSTEM SERIES MTBF	191.			

END OF JOBS

FUNCTION:

LARF3.DAT 01-SEP-77 19:12

00100	1000.	10.	10.	1.	10.00		
00110	0.005						
00120	FWR CONTROL UNIT						
00130	2806.	1.40	2.83	1.			
00140	1279.	1279.04		0.92	0.92		
00150	114393.	150186.		63.95	447.67		
00160	5.	803.	0.50				
00170	26421.	30723.		0.56	0.65		
00180	.900	.950	.975				
00190	1000.	1000.	1000.				
00200	3.0	1.00	0.001				
00210	0.052	0.017	0.0000				
00220	0.92	2.33					
00230	INVERTER						
00240	819.	1.12	2.26	1.			
00250	1714.	734.44		1.81	1.81		
00260	74231.	159137.		85.69	257.06		
00270	8.	550.	0.50				
00280	18874.	21947.		0.40	0.46		
00290	.920	.960	.980				
00300	1000.	1000.	1000.				
00310	12.0	1.71	0.004				
00320	0.150	0.021	0.0001				
00330	0.50	1.00					
00340	MAIN BATTERY						
00350	13325197.	3.03	0.00	1.			
00360	912.	0.00		45.59	45.59		
00370	10315.	54131.		45.59	0.00		
00380	0.	20.	0.50				
00390	0.	0.	0.	0.00	0.00		
00400	.957	.000	.989				
00410	1000.	0.	1000.				
00420	17.0	0.00	0.850				
00430	0.209	0.000	0.0104				
00440	0.50	1.00					
00450	POWER RELAY CONTROL ASSY.						
00460	25728.	4.90	0.00	1.			
00470	375.	0.00		18.74	18.74		
00480	8860.	38587.		18.74	0.00		
00490	0.	20.	0.50				
00500	0.	0.	0.	0.00	0.00		
00510	.913	.000	.978				
00520	1000.	0.	1000.				
00530	0.3	0.00	0.015				
00540	0.001	0.000	0.0001				
00550	1.00	1.33					
00560	MAIN POWER CONTROL BOX						
00570	9220.	5.03	0.00	1.			
00580	9474.	0.00		200.00	200.00		
00590	177352.	598864.		473.71	0.00		
00600	0.	47.	0.50				
00610	0.	0.	0.	0.00	0.00		
00620	.919	.000	.980				
00630	1000.	0.	1000.				
00640	22.2	0.00	0.469				
00650	0.467	0.000	0.0099				
00660	0.83	1.25					

(Continued)

00670	UMBILICAL DISTR. BOX					
00680	7489.	5.83	0.00	1.		
00690	11730.		0.00	200.00	200.00	
00700	243610.		822890.	586.48		0.00
00710	0.	59.	0.50			
00720		0.	0.	0.00	0.00	
00730	.907	.000	.977			
00740	1000.		0.	1000.		
00750	9.5		0.00	0.162		
00760	0.212		0.000	0.0036		
00770	1.20	1.50				
00780	GENERATOR					
00790	59865.	2.59	0.00	1.		
00800	365.		0.00	18.26	18.26	
00810	35850.		40717.	18.26		0.00
00820	0.	20.	0.50			
00830	0.		0.	0.00	0.00	
00840	.900	.000	.975			
00850	1000.		0.	1000.		
00860	14.0		0.00	0.700		
00870	0.046		0.000	0.0023		
00880	0.42	0.58				
00890	BUY GROUP					
00900	369.	0.93	1.89	1.		
00910	1493.		1492.50	213.21	213.21	
00920	1493.		0.	74.63		522.38
00930	3.	13.	0.50			
00940	7000.		8140.	0.15	0.17	
00950	.950	.975	.988			
00960	1000.		1000.	1000.		
00970	45.4	15.14		2.163		
00980	1.111	0.370		0.0529		
00990	0.42	0.58				
01000	I&T ELECTRICAL SYSTEM					
01010	1732.	0.00	0.00	1.		
01020	0.		1538.07	0.00	0.00	
01030	37789.		45547.	0.00		0.00
01040	1.	0.	0.50			
01050	0.		0.	0.00	0.22	
01060	.000	.953	.000			
01070	0.		1000.	0.		
01080	0.0	3.67		0.000		
01090	0.000	0.208		0.0000		
01100	1.20	1.50				
*M350						
00350	13300.	3.03	0.00	1.		
*SAVE						
FILE SAVED						

LC FILE INPUT DATA

PWR CONTROL UNIT

DEPLOYMENT  
EQUIPS(ED) 1000. ORGANIZATION(OD) 10. INTERMEDIATE(DI) 10. DEPOT(DD) 1.

DURATION OF SUPPORT PERIOD, YEARS(YR) 10.00  
ON-TIME FRACTION(OTF) .005

LRU MTBF, HOURS(MTBF) 2806.  
LRU REPAIR TIME, HOURS(TF) 1.40  
MODULE REPAIR TIME, HOURS(TMO) 2.83  
LRU PER SYSTEM, (EE) 1.  
LRU COST, \$(CUF) 1279.  
MODULE COST, \$(CMP) 1279.04  
PART COST, \$(CFP) 0.92  
PART COST ON-EQUIPMENT REPAIR, \$(CPPE) 0.92  
DEVELOPMENT COST, \$(CEND) 114393.  
NON-RECURRING PRODUCTION COST, \$(CPE) 150186.  
CONTRACTOR LRU REPAIR COST, \$(CUR) 63.95  
CONTRACTOR MODULE REPAIR COST, \$(CMR) 447.67  
MODULE TYPES, (P) 5.  
PART TYPES, (PF) 803.  
FRACTION NON-STD. PARTS, (FNSF) 0.50  
LRU SUPPORT EQPT. COST, \$(CFIM) 26421.  
LRU+MODULE SUPPORT EQPT., \$(CFIP) 30723.  
LRU S.E. FLOOR SPACE, SQ.FT.(FTSQF) 0.56  
LRU+MODULE S.E. FLOOR SPACE, SQ.FT.(FTSQF) 0.65

COST-QUANTITY EXPONENTS (LEARNING FACTORS):  
UNIT(EUF) 0.900 MODULE(EMP) 0.950 PART(EPP) 0.975

REFERENCE QUANTITIES:  
UNIT(RNU) 1000. MODULE(RNM) 1000. PART(RNP) 1000.

SHIPPING WEIGHT, POUNDS:  
UNIT(WU) 3.0 MODULE(WM) 1.00 PART(WP) 0.001

STORAGE CUBES, CUBIC FEET:  
UNIT(CUBEU) 0.052 MODULE(CUBEM) 0.017 PART(CUBEP) 0.0000

DEVELOPMENT PHASE, YEARS (YD) 0.92  
PRODUCTION PHASE, YEARS (YP) 2.33

LC FILE INPUT DATA

INVERTER

DEPLOYMENT  
EQUIPS(ED) 1000. ORGANIZATION(OD) 10. INTERMEDIATE(DI) 10. DEPOT(DD) 1.

DURATION OF SUPPORT PERIOD, YEARS(YR) 10.00  
ON-TIME FRACTION(OTF) .005

LRU MTBF, HOURS(MTRF) 819.  
LRU REPAIR TIME, HOURS(TF) 1.12  
MODULE REPAIR TIME, HOURS(TMO) 2.26  
LRU PER SYSTEM, (EE) 1.  
LRU COST, \$(CUP) 1714.  
MODULE COST, \$(CMP) 734.44  
PART COST, \$(CPF) 1.81  
PART COST ON-EQUIPMENT REPAIR, \$(CPPE) 1.81  
DEVELOPMENT COST, \$(CEND) 74231.  
NON-RECURRING PRODUCTION COST, \$(CPE) 159137.  
CONTRACTOR LRU REPAIR COST, \$(CUR) 85.69  
CONTRACTOR MODULE REPAIR COST, \$(CMR) 257.06  
MODULE TYPES, (P) 8.  
PART TYPES, (PP) 550.  
FRACTION NON-STD. PARTS, (FNSTP) 0.50  
LRU SUPPORT EQPT. COST, \$(CFIM) 18874.  
LRU+MODULE SUPPORT EQPT., \$(CFIP) 21947.  
LRU S.E. FLOOR SPACE, SQ.FT.(FTSQF) 0.40  
LRU+MODULE S.E. FLOOR SPACE, SQ.FT.(FTSQP) 0.46

COST-QUANTITY EXPONENTS (LEARNING FACTORS):  
UNIT(EUP) 0.920 MODULE(EMP) 0.960 PART(EPP) 0.980

REFERENCE QUANTITIES:  
UNIT(RNU) 1000. MODULE(RNM) 1000. PART(RNP) 1000.

SHIPPING WEIGHT, POUNDS:  
UNIT(WU) 12.0 MODULE(WM) 1.71 PART(WP) 0.004

STORAGE CUBES, CUBIC FEET:  
UNIT(CUBEU) 0.150 MODULE(CUBEM) 0.021 PART(CUBEP) 0.0001

DEVELOPMENT PHASE, YEARS (YD) 0.50  
PRODUCTION PHASE, YEARS (YF) 1.00

LC FILE INPUT DATA

MAIN BATTERY

DEPLOYMENT  
EQUIPS(ED) 1000. ORGANIZATION(OD) 10. INTERMEDIATE(DI) 10. DEPOT(DD) 1.

DURATION OF SUPPORT PERIOD, YEARS(YR) 10.00  
ON-TIME FRACTION(OTF) .005

LRU MTBF, HOURS(MTBF) 13300.  
LRU REPAIR TIME, HOURS(TF) 3.03  
MODULE REPAIR TIME, HOURS(TMO) 0.00  
LRU PER SYSTEM, (EE) 1.  
LRU COST, \$(CUP) 912.  
MODULE COST, \$(CMP) 0.00  
PART COST, \$(CPF) 45.59  
PART COST ON-EQUIPMENT REPAIR, \$(CPPE) 45.59  
DEVELOPMENT COST, \$(CEND) 10315.  
NON-RECURRING PRODUCTION COST, \$(CPE) 54131.  
CONTRACTOR LRU REPAIR COST, \$(CUR) 45.59  
CONTRACTOR MODULE REPAIR COST, \$(CHR) 0.00  
MODULE TYPES, (P) 0.  
PART TYPES, (PP) 20.  
FRACTION NON-STD. PARTS, (FNSF) 0.50  
LRU SUPPORT EQPT. COST, \$(CFIM) 0.  
LRU+MODULE SUPPORT EQPT., \$(CFIP) 0.  
LRU S.E. FLOOR SPACE, SQ.FT. (FTSQF) 0.00  
LRU+MODULE S.E. FLOOR SPACE, SQ.FT. (FTSQP) 0.00

COST-QUANTITY EXPONENTS (LEARNING FACTORS):

UNIT(EUP) 0.957 MODULE(EMP) 0.000 PART(EPP) 0.989

REFERENCE QUANTITIES:

UNIT(RNU) 1000. MODULE(RNM) 0. PART(RNP) 1000.

SHIPPING WEIGHT, POUNDS:

UNIT(WU) 17.0 MODULE(WM) 0.00 PART(WP) 0.850

STORAGE CUBES, CUBIC FEET:

UNIT(CUBEU) 0.209 MODULE(CUBEM) 0.000 PART(CUBEP) 0.0104

DEVELOPMENT PHASE, YEARS (YD) 0.50

PRODUCTION PHASE, YEARS (YP) 1.00

LC FILE INPUT DATA

POWER RELAY CONTROL ASSY.

DEPLOYMENT  
EQUIPS(ED) 1000. ORGANIZATION(OD) 10. INTERMEDIATE(DI) 10. DEPOT(DD) 1.

DURATION OF SUPPORT PERIOD, YEARS(YR) 10.00  
ON-TIME FRACTION(OTF) .005

LRU MTBF, HOURS(MTBF) 25728.  
LRU REPAIR TIME, HOURS(TP) 4.90  
MODULE REPAIR TIME, HOURS(TMO) 0.00  
LRU PER SYSTEM, (EE) 1.  
LRU COST, \$(CUP) 375.  
MODULE COST, \$(CMP) 0.00  
PART COST, \$(CPP) 18.74  
PART COST ON-EQUIPMENT REPAIR, \$(CPPE) 18.74  
DEVELOPMENT COST, \$(CEND) 8860.  
NON-RECURRING PRODUCTION COST, \$(CPE) 38587.  
CONTRACTOR LRU REPAIR COST, \$(CUR) 18.74  
CONTRACTOR MODULE REPAIR COST, \$(CMR) 0.00  
MODULE TYPES, (F) 0.  
PART TYPES, (PP) 20.  
FRACTION NON-STD. PARTS, (FNSTP) 0.50  
LRU SUPPORT EQPT. COST, \$(CFIM) 0.  
LRU+MODULE SUPPORT EQPT., \$(CFIP) 0.  
LRU S.E. FLOOR SPACE, SQ.FT. (FTSQF) 0.00  
LRU+MODULE S.E. FLOOR SPACE, SQ.FT. (FTSQP) 0.00

COST-QUANTITY EXPONENTS (LEARNING FACTORS):

UNIT(EUP) 0.913 MODULE(EMP) 0.000 PART(EPP) 0.978

REFERENCE QUANTITIES:

UNIT(RNU) 1000. MODULE(RNM) 0. PART(RNP) 1000.

SHIPPING WEIGHT, POUNDS:

UNIT(WU) 0.3 MODULE(WM) 0.00 PART(WP) 0.015

STORAGE CUBES, CUBIC FEET:

UNIT(CUREU) 0.001 MODULE(CUBEM) 0.000 PART(CUBEP) 0.0001

DEVELOPMENT PHASE, YEARS (YD) 1.00

PRODUCTION PHASE, YEARS (YP) 1.33

LC FILE INPUT DATA

MAIN POWER CONTROL BOX

DEPLOYMENT

EQUIPS(ED) 1000. ORGANIZATION(OD) 10. INTERMEDIATE(DI) 10. DEPOT(DD) 1.

DURATION OF SUPPORT PERIOD, YEARS(YR) 10.00  
ON-TIME FRACTION(OTF) .005

LRU MTBF, HOURS(MTBF) 9220.  
LRU REPAIR TIME, HOURS(TF) 5.03  
MODULE REPAIR TIME, HOURS(TMO) 0.00  
LRU PER SYSTEM, (EE) 1.  
LRU COST, \$(CUP) 9474.  
MODULE COST, \$(CMP) 0.00  
PART COST, \$(CPF) 200.00  
PART COST ON-EQUIPMENT REPAIR, \$(CPPE) 200.00  
DEVELOPMENT COST, \$(CEND) 177352.  
NON-RECURRING PRODUCTION COST, \$(CPE) 598864.  
CONTRACTOR LRU REPAIR COST, \$(CUR) 473.71  
CONTRACTOR MODULE REPAIR COST, \$(CMR) 0.00  
MODULE TYPES, (P) 0.  
PART TYPES, (PF) 47.  
FRACTION NON-STD. PARTS, (FNSP) 0.50  
LRU SUPPORT EQPT. COST, \$(CFIM) 0.  
LRU+MODULE SUPPORT EQPT., \$(CFIP) 0.  
LRU S.E. FLOOR SPACE, SQ.FT. (FTSQF) 0.00  
LRU+MODULE S.E. FLOOR SPACE, SQ.FT. (FTSQP) 0.00

COST-QUANTITY EXPONENTS (LEARNING FACTORS):

UNIT(EUP) 0.919 MODULE(EMP) 0.000 PART(EPP) 0.980

REFERENCE QUANTITIES:

UNIT(RNU) 1000. MODULE(RNM) 0. PART(RNP) 1000.

SHIPPING WEIGHT, POUNDS:

UNIT(WU) 22.2 MODULE(WM) 0.00 PART(WP) 0.469

STORAGE CUBES, CUBIC FEET:

UNIT(CUBEU) 0.467 MODULE(CUBEM) 0.000 PART(CUBEP) 0.0099

DEVELOPMENT PHASE, YEARS (YD) 0.83  
PRODUCTION PHASE, YEARS (YP) 1.25

LC FILE INPUT DATA

UMBILICAL DISTR. BOX

DEPLOYMENT

EQUIPS(ED) 1000. ORGANIZATION(OD) 10. INTERMEDIATE(DI) 10. DEPOT(DD) 1.

DURATION OF SUPPORT PERIOD, YEARS(YR) 10.00  
ON-TIME FRACTION(OTF) .005

LRU MTBF, HOURS(MTBF) 7489.  
LRU REPAIR TIME, HOURS(TF) 5.83  
MODULE REPAIR TIME, HOURS(TMO) 0.00  
LRU PER SYSTEM, (EE) 1.  
LRU COST, \$(CUP) 11730.  
MODULE COST, \$(CMP) 0.00  
PART COST, \$(CPF) 200.00  
PART COST ON-EQUIPMENT REPAIR, \$(CPPE) 200.00  
DEVELOPMENT COST, \$(CEND) 243610.  
NON-RECURRING PRODUCTION COST, \$(CPE) 822890.  
CONTRACTOR LRU REPAIR COST, \$(CUR) 586.48  
CONTRACTOR MODULE REPAIR COST, \$(CMR) 0.00  
MODULE TYPES, (P) 0.  
PART TYPES, (PF) 59.  
FRACTION NON-STD. PARTS, (FNSP) 0.50  
LRU SUPPORT EQPT. COST, \$(CFIM) 0.  
LRU+MODULE SUPPORT EQPT., \$(CFIP) 0.  
LRU S.E. FLOOR SPACE, SQ.FT. (FTSQF) 0.00  
LRU+MODULE S.E. FLOOR SPACE, SQ.FT. (FTSQP) 0.00

COST-QUANTITY EXPONENTS (LEARNING FACTORS):

UNIT(EUP) 0.907 MODULE(EMP) 0.000 PART(EPP) 0.977

REFERENCE QUANTITIES:

UNIT(RNU) 1000. MODULE(RNM) 0. PART(RNP) 1000.

SHIPPING WEIGHT, POUNDS:

UNIT(WU) 9.5 MODULE(WM) 0.00 PART(WP) 0.162

STORAGE CUBES, CUBIC FEET:

UNIT(CUBEU) 0.212 MODULE(CUBEM) 0.000 PART(CUBEP) 0.0036

DEVELOPMENT PHASE, YEARS (YD) 1.20

PRODUCTION PHASE, YEARS (YF) 1.50

LC FILE INPUT DATA

GENERATOR

DEPLOYMENT  
EQUIPS(ED) 1000. ORGANIZATION(OD) 10. INTERMEDIATE(DI) 10. DEPOT(DD) 1.

DURATION OF SUPPORT PERIOD, YEARS(YR) 10.00  
ON-TIME FRACTION(OTF) .005

LRU MTBF, HOURS(MTBF) 59865.  
LRU REPAIR TIME, HOURS(TF) 2.59  
MODULE REPAIR TIME, HOURS(TMO) 0.00  
LRU PER SYSTEM, (EE) 1.  
LRU COST, \$(CUP) 365.  
MODULE COST, \$(CMP) 0.00  
PART COST, \$(CPF) 18.26  
PART COST ON-EQUIPMENT REPAIR, \$(CPFE) 18.26  
DEVELOPMENT COST, \$(GEND) 35950.  
NON-RECURRING PRODUCTION COST, \$(CPE) 40717.  
CONTRACTOR LRU REPAIR COST, \$(CUR) 18.26  
CONTRACTOR MODULE REPAIR COST, \$(CMR) 0.00  
MODULE TYPES, (P) 0.  
PART TYPES, (PF) 20.  
FRACTION NON-STD. PARTS, (FNSP) 0.50  
LRU SUPPORT EQPT. COST, \$(CFIM) 0.  
LRU+MODULE SUPPORT EQPT., \$(CFIP) 0.  
LRU S.E. FLOOR SPACE, SQ.FT.(FTSQF) 0.00  
LRU+MODULE S.E. FLOOR SPACE, SQ.FT.(FTSQP) 0.00

COST-QUANTITY EXPONENTS (LEARNING FACTORS):

UNIT(EUP) 0.900 MODULE(EMP) 0.000 PART(EPP) 0.975

REFERENCE QUANTITIES:

UNIT(RNU) 1000. MODULE(RNM) 0. PART(RNP) 1000.

SHIPPING WEIGHT, POUNDS:

UNIT(WU) 14.0 MODULE(WM) 0.00 PART(WP) 0.700

STORAGE CUBES, CUBIC FEET:

UNIT(CUBEU) 0.046 MODULE(CUBEM) 0.000 PART(CUBEF) 0.0023

DEVELOPMENT PHASE, YEARS (YD) 0.42

PRODUCTION PHASE, YEARS (YF) 0.58

LC FILE INPUT DATA

BUY GROUP

DEPLOYMENT  
EQUIPS(ED) 1000. ORGANIZATION(OD) 10. INTERMEDIATE(DI) 10. DEPOT(DD) 1.

DURATION OF SUPPORT PERIOD, YEARS(YR) 10.00  
ON-TIME FRACTION(OTF) .005

LRU MTBF, HOURS(MTBF) 369.  
LRU REPAIR TIME, HOURS(TF) 0.93  
MODULE REPAIR TIME, HOURS(TMO) 1.89  
LRU PER SYSTEM, (EE) 1.  
LRU COST, \$(CUP) 1493.  
MODULE COST, \$(CMP) 1492.50  
PART COST, \$(CPF) 213.21  
PART COST ON-EQUIPMENT REPAIR, \$(CPPE) 213.21  
DEVELOPMENT COST, \$(CEND) 1493.  
NON-RECURRING PRODUCTION COST, \$(CPE) 0.  
CONTRACTOR LRU REPAIR COST, \$(CUR) 74.63  
CONTRACTOR MODULE REPAIR COST, \$(CMR) 522.38  
MODULE TYPES, (P) 3.  
PART TYPES, (PF) 13.  
FRACTION NON-STD. PARTS, (FNSP) 0.50  
LRU SUPPORT EQPT. COST, \$(CFIM) 7000.  
LRU+MODULE SUPPORT EQPT., \$(CFIP) 8140.  
LRU S.E. FLOOR SPACE, SQ.FT.(FTSQF) 0.15  
LRU+MODULE S.E. FLOOR SPACE, SQ.FT.(FTSQP) 0.17

COST-QUANTITY EXPONENTS (LEARNING FACTORS):  
UNIT(EUP) 0.950 MODULE(EMF) 0.975 PART(EFP) 0.988

REFERENCE QUANTITIES:  
UNIT(RNU) 1000. MODULE(RNM) 1000. PART(RNP) 1000.

SHIPPING WEIGHT, POUNDS:  
UNIT(WU) 45.4 MODULE(WM) 15.14 PART(WP) 2.163

STORAGE CUBES, CUBIC FEET:  
UNIT(CUBEU) 1.111 MODULE(CUBEM) 0.370 PART(CUBEP) 0.0529

DEVELOPMENT PHASE, YEARS (YD) 0.42  
PRODUCTION PHASE, YEARS (YP) 0.58

LC FILE INPUT DATA

I&T ELECTRICAL SYSTEM

DEPLOYMENT  
EQUIPS(ED) 1000. ORGANIZATION(OD) 10. INTERMEDIATE(DI) 10. DEPOT(DD) 1.

DURATION OF SUPPORT PERIOD, YEARS(YR) 10.00  
ON-TIME FRACTION(OTF) .005

LRU MTBF, HOURS(MTBF) 1732.  
LRU REPAIR TIME, HOURS(TF) 0.00  
MODULE REPAIR TIME, HOURS(TMO) 0.00  
LRU PER SYSTEM, (EE) 1.  
LRU COST, \$(CUP) 0.  
MODULE COST, \$(CMP) 1538.07  
PART COST, \$(CPF) 0.00  
PART COST ON-EQUIPMENT REPAIR, \$(CPFE) 0.00  
DEVELOPMENT COST, \$(CEND) 37789.  
NON-RECURRING PRODUCTION COST, \$(CPE) 45547.  
CONTRACTOR LRU REPAIR COST, \$(CUR) 0.00  
CONTRACTOR MODULE REPAIR COST, \$(CMR) 0.00  
MODULE TYPES, (P) 1.  
PART TYPES, (PF) 0.  
FRACTION NON-STD. PARTS, (FNSTP) 0.50  
LRU SUPPORT EQPT. COST, \$(CFIM) 0.  
LRU+MODULE SUPPORT EQPT., \$(CFIP) 0.  
LRU S.E. FLOOR SPACE, SQ.FT. (ETSQF) 0.00  
LRU+MODULE S.E. FLOOR SPACE, SQ.FT. (FTSQP) 0.22

COST-QUANTITY EXPONENTS (LEARNING FACTORS):  
UNIT(EUP) 0.000 MODULE(EMP) 0.953 PART(EPP) 0.000

REFERENCE QUANTITIES:  
UNIT(RNU) 0. MODULE(RNM) 1000. PART(RNP) 0.

SHIPPING WEIGHT, POUNDS:  
UNIT(WU) 0.0 MODULE(WM) 3.67 PART(WP) 0.000

STORAGE CUBES, CUBIC FEET:  
UNIT(CUBEU) 0.000 MODULE(CUBEM) 0.208 PART(CUBEP) 0.0000

DEVELOPMENT PHASE, YEARS (YD) 1.20  
PRODUCTION PHASE, YEARS (YP) 1.50

ARPV HIGH VOLTAGE D.C. POWER SYSTEM BREAKDOWN

Make Items

Main Power Control Box

Vendor Make Items

Generator

Umbilical Distribution Box

Power Control Unit

Battery (270 volts)

Reverse current relay

Inverter

Vendor Buy Items

Battery sensor

Main bus contactor

Payload bus contactor

Power feeders/distribution

Fiber optics cable

Fiberoptics/interconnectors

MAIN PWR CONTROL BOX

INPUT DATA

QTY 1000. PROTOS 1.0 WT 19.980 VOL 0.350 MODE 2.  
 QTYSYS 1. INTEGE 0.000 INTEGS 0.300 AMULTE 120.00% AMULTM 120.00%

MECH/STRUCT

WS 19.980 MCPLXS 7.100 PRODS 0.000 NEWST 0.750 DESRPS 0.000

ENGINEERING

ENMTHS 96.0 ENMTHF 10.0 ENMHT 10.0 ECMPLX 1.000 PRNF 0.000

PRODUCTION

PRMTHS 108.0 PRMTHF 123.0 LCURVE 0.000 ECNE 0.000 ECNS 0.000

GLOBAL

YEAR 1977. ESC 0.00% PROJCT 1.000 DATA 1.000 TLGTST 1.000  
 PLATFM 1.700 SYSTEM 1.000 PPROJ 1.000 PDATA 1.000 PTLGTS 1.000

PROGRAM COST

	DEVELOPMENT	PRODUCTION	TOTAL COST
ENGINEERING			
DRAFTING	28.	3.	31.
DESIGN	79.	9.	88.
SYSTEMS	12.	0.	12.
PROJ MGMT	11.	248.	258.
DATA	5.	12.	17.
SUBTOTAL (ENG)	134.	271.	406.

MANUFACTURING

PRODUCTION	0.	6573.	6573.
PROTOTYPE	21.	0.	21.
TOOL-TEST EQ	4.	152.	155.
SUBTOTAL (MFG)	24.	6725.	6750.

TOTAL COST 159. 6996. 7155.

VOL 0.350 AVCOST 6.57 TOTAL AV PROD COST 7.00 LCURVE 0.919  
 WT 19.980 ECNE 0.001 ECNS 0.043 DESRPE 0.000 DESRPS 0.000

MECH/STRUCT

WS 19.980 WSCF 57.086 MECID 0.000 PRODS 4.831 MCPLXS 7.100

SCHEDULES

ENMTHS 96.000 ENMTHF 10.000 ENMHT 10.000 ECMPLX 1.000 PRNF 0.000  
 PRMTHS 108.000 PRMTHF 123.000 AVER. PROD RATE PER MONTH 66.667

COST RANGES

	DEVELOPMENT	PRODUCTION	TOTAL COST
FROM	137.	5769.	5906.
CENTER	159.	6996.	7155.
TO	189.	8615.	8804.

GENERATER

INPUT DATA

QTY 1000. PROTOS 1.0 WT 13.000 VOL 0.036 MODE 2.  
 QTYSYS 1. INTEGE 0.000 INTEGS 0.500 AMULTE 150.00% AMULTM 150.00%

MECH/STRUCT

WS 13.000 MCPLXS 4.300 PRODS 0.000 NEWST 0.800 DESRPS 0.000

ENGINEERING

ENMTHS 96.0 ENMTHP 5.0 ENMHT 5.0 ECMLPX 1.000 PRNF 0.000

PRODUCTION

PRMTHS 108.0 FRMTHF 126.0 LCURVE 0.000 ECNE 0.000 ECNS 0.000

GLOBAL

YEAR 1977. ESC 0.00% PROJCT 1.000 DATA 1.000 TLGTST 1.000  
 PLATFM 1.700 SYSTEM 1.000 PPROJ 1.000 PDATA 1.000 PTLGTS 1.00

PROGRAM COST

	DEVELOPMENT	PRODUCTION	TOTAL COST
ENGINEERING			
DRAFTING	6.	0.	6.
DESIGN	14.	0.	15.
SYSTEMS	4.	0.	4.
PROJ MGMT	4.	33.	37.
DATA	1.	2.	3.
SUBTOTAL(ENG)	29.	34.	64.

MANUFACTURING

	DEVELOPMENT	PRODUCTION	TOTAL COST
PRODUCTION	0.	716.	716.
PROTOTYPE	3.	0.	3.
TOOL-TEST EQ	2.	11.	12.
SUBTOTAL(MFG)	5.	727.	731.

TOTAL COST 34. 761. 795.

VOL 0.036 AVCOST 0.72 TOTAL AV PROD COST 0.76 LCURVE 1.004  
 WT 13.000 ECNE 0.001 ECNS 0.009 DESRPE 0.000 DESRPS 0.000

MECH/STRUCT

WS 13.000 WSCF 361.111 MECID 0.000 PRODS 2.595 MCPLXS 4.300

SCHEDULES

ENMTHS 96.000 ENMTHP 5.000 ENMHT 5.000 ECMLPX 1.000 PRNF 0.000  
 PRMTHS 108.000 FRMTHF 126.000 AVER. PROD RATE PER MONTH 55.556

COST RANGES

	DEVELOPMENT	PRODUCTION	TOTAL COST
FRJM	27.	583.	610.
CENTER	34.	761.	795.
TO	53.	1273.	1326.

UMBILICAL BOX

INPUT DATA

QTY 1000. PROTS 1.0 WT 9.500 VOL 0.177 MODE 2.  
 QTYSYS 1. INTEGE 0.000 INTEGS 0.500 AMULTE 120.00% AMULTM 120.00%

MECH/STRUCT

WS 9.500 MCPLXS 8.538 PRODS 0.000 NEWST 0.800 DESRFS 0.000

ENGINEERING

ENMTHS 96.0 ENMTHP 14.4 ENMHT 14.4 ECMLX 1.102 PRNF 0.000

PRODUCTION

PRMTHS 108.0 PRMTHF 126.0 LCURVE 0.000 ECNE 0.000 ECNS 0.000

GLOBAL

YEAR 1977. ESC 0.00% PROJCT 1.000 DATA 1.000 TLGTST 1.000  
 PLATFM 1.700 SYSTEM 1.000 PPRDJ 1.000 PDATA 1.000 PTLGTS 1.000

PROGRAM COST

	DEVELOPMENT	PRODUCTION	TOTAL COST
ENGINEERING			
DRAFTING	40.	6.	46.
DESIGN	122.	23.	146.
SYSTEMS	17.	0.	17.
PROJ MGMT	13.	454.	468.
DATA	6.	22.	27.
SUBTOTAL (ENG)	198.	505.	703.

MANUFACTURING

PRODUCTION	0.	11730.	11730.
PROTOTYPE	39.	0.	39.
TOOL-TEST EQ	7.	318.	325.
SUBTOTAL (MFG)	45.	12047.	12093.

TOTAL COST 244. 12552. 12796.

VOL 0.177 AVCOST 11.73 TOTAL AV PROD COST 12.55 LCURVE 0.907  
 WT 9.500 ECNE 0.001 ECNS 0.080 DESRFE 0.000 DESRFS 0.000

MECH/STRUCT

WS 9.500 WSCF 53.672 MECID 0.000 PRODS 5.832 MCPLXS 8.538

SCHEDULES

ENMTHS 96.000 ENMTHP 14.400 ENMHT 14.400 ECMLX 1.102 PRNF 0.000  
 PRMTHS 108.000 PRMTHF 126.000 AVER. PROD RATE PER MONTH 55.556

COST RANGES

	DEVELOPMENT	PRODUCTION	TOTAL COST
FROM	213.	10491.	10705.
CENTER	244.	12552.	12796.
TO	280.	14751.	15030.

PWR CONTROL UNIT (GEN)

INPUT DATA

QTY 1000. PRODS 1.0 WT 2.000 VOL 0.026 MODE 1.  
 QTSYS 1. INTEGE 0.500 INTEGS 0.500 AMULTE 120.00% AMULTM 120.00%

MECH/STRUCT

WS 0.800 MCPLXS 5.697 PRODS 0.000 NEWST 1.000 DESRPS 0.000

ELECTRONICS

USEVOL 0.980 MCPLXE 7.714 PRODE 0.000 NEWEL 0.700 DESRPE 0.000  
 PWR 700.000 CMPNTS 0. CMPID 0.000 PWRFAC 0.500 CMPEFF 0.000

ENGINEERING

ENMTHS 96.0 ENMTHP 10.6 ENMHT 10.6 ECMPLX 0.911 PRNF 0.000

PRODUCTION

PRMTHS 108.0 PRMTHF 136.0 LCURVE 0.900 ECNE 0.000 ECNS 0.000

GLOBAL

YEAR 1977. ESC 0.00% PROJECT 1.000 DATA 1.000 TLGTST 1.000  
 PLATFM 1.700 SYSTEM 1.000 PPROJ 1.000 PDATA 1.000 PTLGTS 1.000

PROGRAM COST DEVELOPMENT PRODUCTION TOTAL COST

ENGINEERING  
 DRAFTING 17. 3. 20.  
 DESIGN 48. 9. 57.  
 SYSTEMS 6. 0. 6.  
 PROJ MGMT 6. 47. 53.  
 DATA 3. 2. 5.  
 SUBTOTAL (ENG) 80. 61. 141.

MANUFACTURING

PRODUCTION 0. 900. 900.  
 PROTOTYPE 3. 0. 3.  
 TOOL-TEST EQ 1. 51. 52.  
 SUBTOTAL (MFG) 4. 952. 956.

TOTAL COST 84. 1012. 1096.

VOL 0.026 AVCOST 0.90 TOTAL AV PROD COST 1.01 LCURVE 0.900  
 WT 2.000 ECNE 0.076 ECNS 0.024 DESRPE 0.000 DESRPS 0.000

MECH/STRUCT

WS 0.800 HSCF 30.769 MECID 0.000 PRODS 4.035 MCPLXS 5.697

ELECTRONICS

WE 1.200 WECF 47.096 CMPID 0.000 PRODE 4.165 MCPLXE 7.714  
 PWR 700.000 CMPNTS 5543. PWRFAC 0.500 CMPEFF 88.674

SCHEDULES

ENMTHS 96.000 ENMTHP 10.600 ENMHT 10.600 ECMPLX 0.911 PRNF 0.000  
 PRMTHS 108.000 PRMTHF 136.000 AVER. PROD RATE PER MONTH 35.714

COST RANGES DEVELOPMENT PRODUCTION TOTAL COST

FROM 71. 814. 885.  
 CENTER 84. 1012. 1096.  
 TO 104. 1327. 1431.

BATTERY (270 V)

INPUT DATA

QTY 1000. PROTOS 1.0 WT 29.000 VOL 0.303 MODE 2.  
 QTYSYS 1. INTEGE 0.000 INTEGS 0.300 AMULTE 150.00% AMULTH 150.00%

MECH/STRUCT

WS 29.000 MCPLXS 4.610 PRODS 0.000 NEWST 0.300 DESRFS 0.000

ENGINEERING

ENMTHS 96.0 ENMTHP 6.0 ENMHT 6.0 ECMLX 0.400 PRNF 0.000

PRODUCTION

PRMTHS 108.0 PRMTHF 120.0 LCURVE 0.000 ECNE 0.000 ECNS 0.000

GLOBAL

YEAR 1977. ESC 0.00% PROJCT 1.000 DATA 1.000 TLGTST 1.000  
 PLATFM 1.700 SYSTEM 1.000 PPROJ 1.000 PDATA 1.000 PTLGTS 1.000

PROGRAM COST

	DEVELOPMENT	PRODUCTION	TOTAL COST
ENGINEERING			
DRAFTING	2.	0.	3.
DESIGN	4.	0.	5.
SYSTEMS	0.	0.	0.
PROJ MGMT	2.	52.	54.
DATA	1.	3.	3.
SUBTOTAL (ENG)	10.	55.	65.

MANUFACTURING

PRODUCTION	0.	1387.	1387.
PROTOTYPE	5.	0.	5.
TOOL-TEST EQ	1.	24.	25.
SUBTOTAL (MFG)	6.	1412.	1417.
TOTAL COST	15.	1467.	1482.

VOL 0.303 AVCOST 1.39 TOTAL AV PROD COST 1.47 LCURVE 0.957  
 WT 29.000 ECNE 0.001 ECNS 0.010 DESRFE 0.000 DESRFS 0.000

MECH/STRUCT

WS 29.000 WSCF 95.710 MECID 0.000 PRODS 3.033 MCPLXS 4.610

SCHEDULES

ENMTHS 96.000 ENMTHP 6.000 ENMHT 6.000 ECMLX 0.400 PRNF 0.000  
 PRMTHS 108.000 PRMTHF 120.000 AVER. PROD RATE PER MONTH 83.333

COST RANGES

	DEVELOPMENT	PRODUCTION	TOTAL COST
FROM	12.	1151.	1164.
CENTER	15.	1467.	1482.
TO	22.	2195.	2217.

REVERSE CURRENT RELAY

INPUT DATA

QTY 1000. PROTOS 1.0 WT 9.000 VOL 0.145 MODE 1.  
 QTYSYS 1. INTEGE 0.500 INTEGS 0.300 AMULTE 150.00% AMULTM 150.00%

MECH/STRUCT

WS 1.000 MCPLXS 5.500 PRODS 0.000 NEWST 1.000 DESRPS 0.000

ELECTRONICS

USEVOL 0.800 MCPLXE 7.700 PRODE 0.000 NEWEL 1.000 DESRPE 0.000  
 PWR 200.000 CMPNTS 0. CMPID 0.000 PWRFAC 0.400 CMPEFF 0.000

ENGINEERING

ENMTHS 96.0 ENMTHP 10.0 ENMHT 10.0 ECMPLX 1.000 PRNF 0.000

PRODUCTION

PRMTHS 108.0 PRMTHF 130.0 LCURVE 0.900 ECNE 0.000 ECNS 0.000

GLOBAL

YEAR 1977. ESC 0.00% PROJCT 1.000 DATA 1.000 TLGTST 1.000  
 PLATFM 1.700 SYSTEM 1.000 PPROJ 1.000 PDATA 1.000 PTLGTS 1.000

PROGRAM COST

	DEVELOPMENT	PRODUCTION	TOTAL COST
ENGINEERING			
DRAFTING	125.	14.	140.
DESIGN	361.	38.	399.
SYSTEMS	46.	0.	46.
PROJ MGMT	42.	257.	299.
DATA	18.	12.	30.
SUBTOTAL(ENG)	591.	322.	914.

MANUFACTURING

PRODUCTION	0.	5434.	5434.
PROTOTYPE	21.	0.	21.
TOOL-TEST EQ	5.	255.	260.
SUBTOTAL(MFG)	26.	5689.	5715.

TOTAL COST 618. 6011. 6629.

VOL 0.145 AVCOST 5.43 TOTAL AV PROD COST 6.01 LCURVE 0.900  
 WT 9.000 ECNE 0.077 ECNS 0.023 DESRPE 0.000 DESRPS 0.000

MECH/STRUCT

WS 1.000 WSCF 6.897 MECID 0.000 PRODS 4.293 MCPLXS 5.500

ELECTRONICS

ME 8.000 WECF 68.966 CMPID 0.000 PRODE 3.911 MCPLXE 7.700  
 PWR 200.000 CMPNTS 1135. PWRFAC 0.400 CMPEFF 24.417

SCHEDULES

ENMTHS 96.000 ENMTHP 10.000 ENMHT 10.000 ECMPLX 1.000 PRNF 0.000  
 PRMTHS 108.000 PRMTHF 130.000 AVER. PROD RATE PER MONTH 45.455

COST RANGES

	DEVELOPMENT	PRODUCTION	TOTAL COST
FROM	519.	4688.	5207.
CENTER	618.	6011.	6629.
TO	774.	8322.	9097.

INVERTER

INPUT DATA

QTY 1000. PROTOS 1.0 WT 16.100 VOL 0.204 MODE 1.  
 QTSYS 1. INTEGE 0.500 INTEGS 0.300 AMULTE 150.00% AMULTM 150.00%

MECH/STRUCT

WS 5.900 MCPLXS 4.813 PRODS 0.000 NEWST 1.000 DESRPS 0.000

ELECTRONICS

USEVOL 0.800 MCPLXE 6.333 PRODE 0.000 NEWEL 0.500 DESRPE 0.000  
 PWR 250.000 CMPNTS 0. CMPID 0.000 PWRFAC 0.400 CMPEFF 0.000

ENGINEERING

ENMTHS 96.0 ENMTHP 6.0 ENMHT 6.0 ECMLX 0.638 PRNF 0.000

PRODUCTION

PRMTHS 108.0 PRMTHF 120.0 LCURVE 0.920 ECNE 0.000 ECNS 0.000

GLOBAL

YEAR 1977. ESC 0.00% PROJCT 1.000 DATA 1.000 TLGTST 1.000  
 PLATFM 1.700 SYSTEM 1.000 PPROJ 1.000 PDATA 1.000 PTLGTS 1.00

PROGRAM COST

	DEVELOPMENT	PRODUCTION	TOTAL COST
ENGINEERING			
DRAFTING	25.	4.	29.
DESIGN	58.	10.	68.
SYSTEMS	5.	0.	5.
PROJ MGMT	11.	105.	116.
DATA	5.	5.	10.
SUBTOTAL (ENG)	105.	124.	229.

MANUFACTURING

PRODUCTION	0.	2739.	2739.
PROTOTYPE	8.	0.	8.
TOOL-TEST EQ	2.	116.	118.
SUBTOTAL (MFG)	10.	2855.	2864.
TOTAL COST	114.	2979.	3093.

VOL 0.204 AVCOST 2.74 TOTAL AV PROD COST 2.98 LCURVE 0.920  
 WT 16.100 ECNE 0.040 ECNS 0.014 DESRPE 0.000 DESRPS 0.000

MECH/STRUCT

WS 5.900 WSCF 28.922 MECID 0.000 PRODS 3.423 MCPLXS 4.813

ELECTRONICS

WE 10.200 WECF 62.500 CMPID 0.000 PRODE 3.268 MCPLXE 6.333  
 PWR 250.000 CMPNTS 1419. PWRFAC 0.400 CMPEFF 32.915

SCHEDULES

ENMTHS 96.000 ENMTHP 6.000 ENMHT 6.000 ECMLX 0.638 PRNF 0.000  
 FRMTHS 108.000 FRMTHF 120.000 AVER. PROD RATE PER MONTH 83.333

COST RANGES

	DEVELOPMENT	PRODUCTION	TOTAL COST
FROM	93.	2311.	2404.
CENTER	114.	2979.	3093.
TO	156.	4414.	4570.

PURCH ITEM  
BUY GROUP

INPUT DATA

QTY	1000.	PROTOS	1.00	BVCOST	0.821	AMULTM	150.00%
LCURVE	0.950						
WT	45.658	QTYSYS	1.				

MECH/STRUCT

MS	29.043	INTEGS	0.700	MCPLXS	3.733
ELECTRONICS					
WE	16.615	INTEGE	0.700	MCPLXE	4.450

PROGRAM COST  
PURCH ITEM

DEVELOPMENT  
1.

PRODUCTION  
1232.

TOTAL COST  
1233.

I&T ELECTRICAL PWR SYSTEM

INPUT DATA

QTY 1000. PROTOS 1.0 IWT 4.588 IVOL 0.161 MODE 5.  
 QTYSYS 1. INTEGE 0.000 INTEGS 0.000 AMULTE 120.00% AMULTM 120.00%

MECH/STRUCT

IWS 2.414 MCPLXS 5.984 PRODS 0.000 NEWST 0.300 DESRFS 0.000

ELECTRONICS

I-UVOL 0.386 MCPLXE 5.929 PRODE 0.000 NEWEL 0.300 DESRPE 0.000  
 PWR 0.000 CMFNTS 0.000 CMPID 0.000 PWRFAC 0.000 CMPEFF 0.000

ENGINEERING

ENMTHS 96.0 ENMTHP 15.0 ENMHT 15.0 ECHPLX 0.000 PRNF 0.000

PRODUCTION

FRMTHS 108.0 PRMTHF 136.0 LCURVE 0.000 ECNE 0.000 ECNS 0.000

GLOBAL

YEAR 1977. ESC 0.00% PROJCT 1.000 DATA 1.000 TLGTST 1.000  
 PLATFM 1.700 SYSTEM 1.000 PPROJ 1.000 PDATA 1.000 PTLGTS 1.000

PROGRAM COST

	DEVELOPMENT	PRODUCTION	TOTAL COST
ENGINEERING			
DRAFTING	9.	1.	10.
DESIGN	29.	3.	32.
SYSTEMS	10.	0.	10.
PROJ MGMT	7.	39.	46.
DATA	4.	2.	6.
SUBTOTAL(ENG)	58.	45.	103.

MANUFACTURING

	DEVELOPMENT	PRODUCTION	TOTAL COST
PRODUCTION	0.	797.	797.
PROTOTYPE	3.	0.	3.
TOOL-TEST EQ	1.	23.	25.
SUBTOTAL(MFG)	5.	820.	825.

TOTAL COST	DEVELOPMENT	PRODUCTION	TOTAL COST
	63.	865.	929.

COST RANGES

	DEVELOPMENT	PRODUCTION	TOTAL COST
FROM	51.	693.	744.
CENTER	63.	865.	929.
TO	86.	1188.	1274.

TOTAL COST, LESS INTEGRATION COST			
PROGRAM COST	DEVELOPMENT	PRODUCTION	TOTAL COST
ENGINEERING			
DRAFTING	244.	31.	275.
DESIGN	688.	89.	777.
SYSTEMS	90.	0.	90.
PROJ MGMT	89.	1196.	1284.
DATA	38.	57.	95.
SUBTOTAL (ENG)	1148.	1373.	2521.
MANUFACTURING			
PRODUCTION	0.	29479.	29479.
PROTOTYPE	100.	0.	100.
TOOL-TEST EQ	21.	926.	947.
PURCH ITEMS	1.	1232.	1233.
SUBTOTAL (MFG)	122.	31637.	31759.
TOTAL COST	1269.	33010.	34280.

COST RANGES	DEVELOPMENT	PRODUCTION	TOTAL COST
FROM	1074.	27039.	28113.
CENTER	1269.	33010.	34280.
TO	1579.	42130.	43709.

TOTAL COST, WITH INTEGRATION COST			
PROGRAM COST	DEVELOPMENT	PRODUCTION	TOTAL COST
ENGINEERING			
DRAFTING	253.	32.	285.
DESIGN	716.	92.	809.
SYSTEMS	100.	0.	100.
PROJ MGMT	95.	1235.	1330.
DATA	42.	59.	101.
SUBTOTAL (ENG)	1206.	1418.	2624.
MANUFACTURING			
PRODUCTION	0.	30276.	30276.
PROTOTYPE	103.	0.	103.
TOOL-TEST EQ	22.	949.	972.
PURCH ITEMS	1.	1232.	1233.
SUBTOTAL (MFG)	127.	32457.	32584.
TOTAL COST	1333.	33876.	35208.

COST RANGES	DEVELOPMENT	PRODUCTION	TOTAL COST
FROM	1125.	27732.	28857.
CENTER	1333.	33876.	35208.
TO	1665.	43318.	44983.

PRICE LIFE CYCLE COST

PWR CONTROL UNIT (GEN)

LC: LARP2

INPUT DATA

R&M DATA

MTBF 3486. MTTR-LRU 1.4 MTTR-MOD 2.8

DEPLOYMENT

EQUIPS 1000. ORGANIZATION 10. INTERMEDIATE 10. DEPOT 1.  
LRUS/EQUIP 1. MODS/LRU 3. PARTS/LRU 982.

EMPLOYMENT

SUPPORT PERIOD 10. HRS/MON 3.7 DTF 0.005

GLOBAL

EQUISUP 1000. ORGSUP 10. INTSUP 10. DEPSUP 1.  
ESC 0.000 LRU FAIL ALLOW 0.

MAINTENANCE CONCEPT 19

LRU REPAIR TO PIECE PART AT CONTRACTOR DEPOT.

PROGRAM COST	DEVELOPMENT	PRODUCTION	SUPPORT	TOTAL
EQUIPMENT	84.	1009.	0.	1093.
SUPPORT EQUIP	0.	0.	0.	0.
MANPOWER	0.	0.	0.	0.
SUPPLY	0.	18.	0.	18.
SUPPLY ADM.	0.	0.	1.	1.
CONTRACTOR SUPPORT	0.	0.	7.	7.
OTHER	0.	0.	0.	0.
<b>TOTAL COST</b>	<b>84.</b>	<b>1027.</b>	<b>8.</b>	<b>1120.</b>

AVAILABILITY  
INHERENT

1.0000 OPERATIONAL 1.0000

SUPPORT EQUIPMENT  
NO. UTILIZATION

ORG  
0.  
0.000

INT  
0.  
0.000

DEPOT  
0.  
0.000

SUPPLY  
INITIAL, PER TYPE  
BALANCE CONSUMED

UNITS  
20.  
0.000

MODULES  
0.  
0.000

PARTS  
2.  
0.000

COST/EFFECTIVENESS LIST (%)

19=	100.0	1=	113.3	15=	118.7	4=	122.5	18=	147.7	17=	150.6
9=	152.8	2=	154.2	3=	156.2	7=	193.8	8=	195.6	10=	197.1
6=	198.5	5=	236.5	11=	448.4	16=	449.5	14=	497.4	12=	532.8
13=	535.8										

ADD =: 1

NEXT BOX;OK=: 1

MAIN PWR CONTROL BOX

PRICE LIFE CYCLE COST

MAIN PWR CONTROL BOX

LC: LARP2

INPUT DATA

R&M DATA

MTBF 10812. MTTR-LRU 4.8 MTTR-MOD 0.0

DEPLOYMENT

EQUIPS 1000. ORGANIZATION 10. INTERMEDIATE 10. DEPOT 1.  
LRUS/EQUIP 1. MODS/LRU 0. PARTS/LRU 33.

EMPLOYMENT

SUPPORT PERIOD 10. HRS/MON 3.7 OTF 0.005

GLOBAL

EQUUSUP 1000. ORGSUP 10. INTSUP 10. DEPSUP 1.  
ESC 0.000 LRU FAIL ALLOW 0.

MAINTENANCE CONCEPT 10

LRU REPAIR TO PIECE PART AT ORGANIZATION.

PROGRAM COST	DEVELOPMENT	PRODUCTION	SUPPORT	TOTAL
EQUIPMENT	159.	6996.	0.	7155.
SUPPORT EQUIP	0.	0.	0.	0.
MANPOWER	0.	0.	3.	3.
SUPPLY	0.	73.	0.	73.
SUPPLY ADM.	0.	2.	17.	19.
CONTRACTOR SUPPORT	0.	0.	0.	0.
OTHER	0.	0.	0.	0.
<b>TOTAL COST</b>	<b>159.</b>	<b>7070.</b>	<b>19.</b>	<b>7248.</b>

AVAILABILITY

INHERENT 1.0000 OPERATIONAL 1.0000

SUPPORT EQUIPMENT

NO. 10. INT 0. DEFOT 0.  
UTILIZATION 0.003 0.000 0.000

SUPPLY

INITIAL, PER TYPE UNITS 0. MODULES 0.  
BALANCE CONSUMED 0.000 0.000 22. 0.000

COST/EFFECTIVENESS LIST (%)

10= 100.0 7= 100.4 19= 100.6 9= 100.7 1= 103.7

ADD =: 1  
NEXT BOX;OK=: 1  
GENERATER

PRICE LIFE CYCLE COST

GENERATER

LC: LARF2

INPUT DATA

R&M DATA

MTBF 61210. MTTR-LRU 2.6 MTTR-MOD 0.0

DEPLOYMENT

EQUIPS 1000. ORGANIZATION 10. INTERMEDIATE 10. DEPOT 1.  
LRUS/EQUIP 1. MODS/LRU 0. PARTS/LRU 20.

EMPLOYMENT

SUPPORT PERIOD 10. HRS/MON 3.7 OTF 0.005

GLOBAL

EQUUSUP 1000. ORGSUP 10. INTSUP 10. DEPSUP 1.  
ESC 0.000 LRU FAIL ALLOW 0.

MAINTENANCE CONCEPT 19

LRU REPAIR TO PIECE PART AT CONTRACTOR DEPOT.

PROGRAM COST	DEVELOPMENT	PRODUCTION	SUPPORT	TOTAL
EQUIPMENT	34.	761.	0.	795.
SUPPORT EQUIP	0.	0.	0.	0.
MANPOWER	0.	0.	0.	0.
SUPPLY	0.	15.	0.	15.
SUPPLY ADM.	0.	0.	1.	1.
CONTRACTOR SUPPORT	0.	0.	0.	0.
OTHER	0.	0.	0.	0.
TOTAL COST	34.	776.	1.	811.

AVAILABILITY

INHERENT 1.0000 OPERATIONAL 1.0000

SUPPORT EQUIPMENT

NO. 0. INT 0. DEPOT 0.  
UTILIZATION 0.000 0.000 0.000

SUPPLY

INITIAL, PER TYPE 20. UNITS 0. MODULES 0. PARTS 2.  
BALANCE CONSUMED 0.000 0.000 0.000

COST/EFFECTIVENESS LIST (%)

19= 100.0 1= 100.0 10= 100.4 7= 100.9 9= 101.4

ADD =: 1

NEXT BOX:OK=: 1

UMBILICAL BOX

PRICE LIFE CYCLE COST

UMBILICAL BOX

LC: LARP2

INPUT DATA

R&M DATA

MTBF 7489. MTTR-LRU 5.8 MTTR-MOD 0.0

DEPLOYMENT

EQUIPS 1000. ORGANIZATION 10. INTERMEDIATE 10. DEPOT 1.  
LRUS/EQUIP 1. MODS/LRU 0. PARTS/LRU 59.

EMPLOYMENT

SUPPORT PERIOD 10. HRS/MON 3.7 OTF 0.005

GLOBAL

EQUUSUP 1000. ORGSUP 10. INTSUP 10. DEPSUP 1.  
ESC 0.000 LRU FAIL ALLOW 0.

MAINTENANCE CONCEPT 10

LRU REPAIR TO PIECE PART AT ORGANIZATION.

PROGRAM COST	DEVELOPMENT	PRODUCTION	SUPPORT	TOTAL
EQUIPMENT	244.	12553.	0.	12797.
SUPPORT EQUIP	0.	0.	0.	0.
MANPOWER	0.	0.	5.	5.
SUPPLY	0.	130.	0.	130.
SUPPLY ADM.	0.	3.	30.	32.
CONTRACTOR SUPPORT	0.	0.	0.	0.
OTHER	0.	0.	0.	0.
TOTAL COST	244.	12685.	34.	12963.

AVAILABILITY

INHERENT 1.0000 OPERATIONAL 1.0000

SUPPORT EQUIPMENT

NO. ORG INT DEPOT  
UTILIZATION 10. 0. 0.  
0.005 0.000 0.000

SUPPLY

UNITS MODULES PARTS  
INITIAL, PER TYPE 0. 0. 22.  
BALANCE CONSUMED 0.000 0.000 0.000

COST/EFFECTIVNESS LIST (%)

10= 100.0 7= 100.3 9= 100.7 19= 100.7 1= 106.4

ADD =: 1

NEXT BOX:OK=: 1  
BATTERY (270 V)

PRICE LIFE CYCLE COST

BATTERY (270 V)

LC: LARP2

INPUT DATA

R&M DATA

MTBF 13300. MTTR-LRU 3.0 MTTR-MOD 0.0

DEPLOYMENT

EQUIPS 1000. ORGANIZATION 10. INTERMEDIATE 10. DEPOT 1.  
LRUS/EQUIP 1. MODS/LRU 0. PARTS/LRU 20.

EMPLOYMENT

SUPPORT PERIOD 10. HRS/MON 3.7 OTF 0.005

GLOBAL

EQUISUP 1000. ORGSUP 10. INTSUP 10. DEPSUP 1.  
ESC 0.000 LRU FAIL ALLOW 0.

MAINTENANCE CONCEPT 10

LRU REPAIR TO PIECE PART AT ORGANIZATION.

PROGRAM COST	DEVELOPMENT	PRODUCTION	SUPPORT	TOTAL
EQUIPMENT	15.	1467.	0.	1482.
SUPPORT EQUIP	0.	0.	0.	0.
MANPOWER	0.	0.	1.	1.
SUPPLY	0.	15.	0.	15.
SUPPLY ADM.	0.	1.	10.	11.
CONTRACTOR SUPPORT	0.	0.	0.	0.
OTHER	0.	0.	0.	0.
TOTAL COST	15.	1483.	11.	1510.

AVAILABILITY  
INHERENT

1.0000 OPERATIONAL

1.0000

SUPPORT EQUIPMENT

NO. 10. ORG 0. INT 0. DEPOT 0.  
UTILIZATION 0.001 0.000 0.000

SUPPLY

INITIAL, PER TYPE 0. UNITS 0. MODULES 22. PARTS  
BALANCE CONSUMED 0.000 0.000 0.000

COST/EFFECTIVENESS LIST (%)

10= 100.0 19= 100.3 7= 100.5 9= 100.9 1= 102.0

ADD =: 1

NEXT BOX:OK=: 1  
INVERTER

PRICE LIFE CYCLE COST

INVERTER

LC: LARP2

INPUT DATA

R&M DATA

MTBF 700. MTTR-LRU 1.1 MTTR-MOD 2.3

DEPLOYMENT

EQUIPS 1000. ORGANIZATION 10. INTERMEDIATE 10. DEPOT 1.  
LRUS/EQUIP 1. MODS/LRU 9. PARTS/LRU 339.

EMPLOYMENT

SUPPORT PERIOD 10. HRS/MON 3.7 OTF 0.005

GLOBAL

EQUISUP 1000. ORGSUP 10. INTSUP 10. DEPSUP 1.  
ESC 0.000 LRU FAIL ALLOW 0.

MAINTENANCE CONCEPT 19

LRU REPAIR TO PIECE PART AT CONTRACTOR DEPOT.

PROGRAM COST	DEVELOPMENT	PRODUCTION	SUPPORT	TOTAL
EQUIPMENT	114.	2965.	0.	3080.
SUPPORT EQUIP	0.	0.	0.	0.
MANPOWER	0.	0.	0.	0.
SUPPLY	0.	119.	0.	119.
SUPPLY ADM.	0.	0.	1.	1.
CONTRACTOR SUPPORT	0.	0.	103.	103.
OTHER	0.	0.	10.	10.
TOTAL COST	114.	3085.	114.	3313.

AVAILABILITY

INHERENT 0.9998 OPERATIONAL 0.9996

SUPPORT EQUIPMENT

NO. ORG INT DEPOT  
UTILIZATION 0.000 0.000 0.000

SUPPLY

INITIAL, PER TYPE UNITS MODULES PARTS  
BALANCE CONSUMED 40. 1. 2.  
0.000 0.000 0.000

COST/EFFECTIVNESS LIST (%)

19=	100.0	9=	106.1	7=	118.7	18=	119.0	17=	119.7	4=	119.8
10=	120.0	15=	120.1	8=	120.7	6=	121.5	2=	127.5	3=	129.9
5=	134.1	1=	161.1	11=	336.9	16=	339.0	14=	340.7	12=	351.6
13=	353.6										

ADD =: 1

NEXT BOX:OK=: 1

REVERSE CURRENT RELAY

PRICE LIFE CYCLE COST

REVERSE CURRENT RELAY

LC: LARP2

INPUT DATA

R&M DATA

MTBF 1258. MTTR-LRU 1.4 MTTR-MOD 2.9

DEPLOYMENT

EQUIPS 1000. ORGANIZATION 10. INTERMEDIATE 10. DEPOT 1.  
LRUS/EQUIP 1. MODS/LRU 13. PARTS/LRU 323.

EMPLOYMENT

SUPPORT PERIOD 10. HRS/MON 3.7 OTF 0.005

GLOBAL

EQUISUP 1000. ORGSUP 10. INTSUP 10. DEPSUP. 1.  
ESC 0.000 LRU FAIL ALLOW 0.

MAINTENANCE CONCEPT 19

LRU REPAIR TO PIECE PART AT CONTRACTOR DEPOT.

PROGRAM COST	DEVELOPMENT	PRODUCTION	SUPPORT	TOTAL
EQUIPMENT	618.	5987.	0.	6605.
SUPPORT EQUIP	0.	0.	0.	0.
MANPOWER	0.	0.	0.	0.
SUPPLY	0.	185.	0.	185.
SUPPLY ADM.	0.	0.	1.	1.
CONTRACTOR SUPPORT	0.	0.	114.	114.
OTHER	0.	0.	3.	3.
TOTAL COST	618.	6172.	118.	6907.

AVAILABILITY

INHERENT 0.9999 OPERATIONAL 0.9999

SUPPORT EQUIPMENT

NO. 0. INT 0. DEPOT 0.  
UTILIZATION 0.000 0.000 0.000

SUPPLY

INITIAL, PER TYPE 30. UNITS 1. MODULES 2. PARTS  
BALANCE CONSUMED 0.000 0.000 0.000

COST/EFFECTIVENESS LIST (%)

19=	100.0	9=	103.9	15=	108.1	4=	109.0	18=	118.4	7=	118.6
2=	119.2	17=	119.6	10=	120.4	8=	120.6	3=	120.7	6=	121.8
1=	134.5	5=	135.5	11=	342.7	16=	343.4	14=	345.5	12=	357.6
13=	359.6										

ADD =: 1

NEXT BOX#OK=: 1

BUY GROUP

PRICE LIFE CYCLE COST

BUY GROUP

LC: LARP2

INPUT DATA

R&M DATA

MTBF 222. MTTR-LRU 0.9 MTTR-MOD 1.7

DEPLOYMENT

EQUIPS 1000. ORGANIZATION 10. INTERMEDIATE 10. DEPOT 1.  
LRUS/EQUIP 1. MODS/LRU 5. PARTS/LRU 112.

EMPLOYMENT

SUPPORT PERIOD 10. HRS/MON 3.7 OTF 0.005

GLOBAL

EQUUSUP 1000. ORGSUP 10. INTSUP 10. DEPSUP 1.  
ESC 0.000 LRU FAIL ALLOW 0.

MAINTENANCE CONCEPT 10

LRU REPAIR TO PIECE PART AT ORGANIZATION.

PROGRAM COST	DEVELOPMENT	PRODUCTION	SUPPORT	TOTAL
EQUIPMENT	1.	1232.	0.	1233.
SUPPORT EQUIP	0.	67.	67.	134.
MANPOWER	0.	0.	65.	65.
SUPPLY	0.	50.	0.	50.
SUPPLY ADM.	0.	6.	61.	67.
CONTRACTOR SUPPORT	0.	0.	0.	0.
OTHER	0.	0.	0.	0.
TOTAL COST	1.	1355.	193.	1550.

AVAILABILITY

INHERENT 0.9993 OPERATIONAL 0.9993

SUPPORT EQUIPMENT NO.	ORG	INT	DEPOT
UTILIZATION	10. 0.062	0. 0.000	0. 0.000
SUPPLY INITIAL, PER TYPE	UNITS	MODULES	PARTS
BALANCE CONSUMED	0. 0.000	10. 0.000	25. 0.000

COST/EFFECTIVENESS LIST (%)

10= 100.0 19= 102.7 7= 104.4 6= 105.5 9= 105.5 5= 103.3  
8= 109.9 17= 128.6 18= 133.0 2= 192.5 3= 199.9 4= 201.9  
15= 205.6 1= 270.0 14= 323.5 12= 323.7 13= 326.2 11= 333.8  
16= 346.8

ADD =: 1  
NEXT BOX;OK=: 1  
I&T ELECTRICAL PWR SYSTEM

PRICE LIFE CYCLE COST

I&T ELECTRICAL PWR SYSTEM

LC: LARP2

INPUT DATA

R&M DATA

MTBF 1366. MTTR-LRU 1.5 MTTR-MOD 0.0

DEPLOYMENT

EQUIFS 1000. ORGANIZATION 10. INTERMEDIATE 10. DEPOT 1.  
LRUS/EQUIP 1. MODS/LRU 3. PARTS/LRU 0.

EMPLOYMENT

SUPPORT PERIOD 10. HRS/MON 3.7 OTF 0.005

GLOBAL

EQUISUP 1000. ORGSUP 10. INTSUP 10. DEPSUP 1.  
ESC 0.000 LRU FAIL ALLOW 0.

MAINTENANCE CONCEPT 1

LRU DISCARD AT FAILURE

PROGRAM COST	DEVELOPMENT	PRODUCTION	SUPPORT	TOTAL
EQUIPMENT	63.	857.	0.	920.
SUPPORT EQUIP	0.	0.	0.	0.
MANPOWER	0.	0.	0.	0.
SUPPLY	0.	84.	270.	354.
SUPPLY ADM.	0.	0.	1.	1.
CONTRACTOR SUPPORT	0.	0.	0.	0.
OTHER	0.	0.	2.	2.
<b>TOTAL COST</b>	<b>63.</b>	<b>941.</b>	<b>273.</b>	<b>1277.</b>

AVAILABILITY

INHERENT 0.9999 OPERATIONAL 0.9991

SUPPORT EQUIPMENT

NO. ORG INT DEPOT  
0. 0. 0.  
UTILIZATION 0.000 0.000 0.000

SUPPLY

INITIAL, PER TYPE UNITS MODULES PARTS  
106. 0. 0.  
BALANCE CONSUMED 278.706 0.00 0.000

COST/EFFECTIVENESS LIST (%)

1= 100.0 15= 109.4 4= 111.3 2= 124.3 3= 125.6 11= 352.4

ADD =: 1  
NEXT BOX#OK=: 1

PRICE LIFE CYCLE COST

SYSTEM TOTALS

PROGRAM COST	DEVELOPMENT	PRODUCTION	SUPPORT	TOTAL
EQUIPMENT	1333.	33826.	0.	35159.
SUPPORT EQUIP	0.	67.	67.	134.
MANPOWER	0.	0.	74.	74.
SUPPLY	0.	688.	270.	959.
SUPPLY ADM.	0.	12.	122.	134.
CONTRACTOR SUPPORT	0.	0.	224.	224.
OTHER	0.	0.	15.	15.
TOTAL COST	1333.	34594.	772.	36699.
ADDITIONAL COST	0.	0.	0.	0.
GRAND TOTAL	1333.	34594.	772.	36699.
SYSTEM SERIES MTBF	124.			

1537

END OF JOBS

FUNCTION: P

FUNCTION: EDITOR

NEW OR OLD? O  
FILE NAME? LARP2  
\*L  
FILE SEQUENCED

LARP2.DAT 02-SEP-77 13:40

00100	1000.	10.	10.	110.	<del>0.00</del>		
00110	0.005						
00120	PWR CONTROL UNIT (GEN)						
00130	3486.	1.37	2.79		1.		
00140	900.	1350.70			0.49	0.49	
00150	84377.	111607.			45.02	472.74	
00160	3.	982.	0.50				
00170	22170.	25779.			0.47	0.55	
00180	.900	.950	.975				
00190	1000.	1000.	1000.				
00200	2.0	1.00	0.000				
00210	0.031	0.016	0.0000				
00220	0.88	2.33					
00230	MAIN PWR CONTROL BOX						
00240	10812.	4.83	0.00		1.		
00250	6573.		0.00		200.00	200.00	
00260	158950.	422767.			328.67	0.00	
00270	0.	33.	0.50				
00280	0.		0.		0.00	0.00	
00290	.919	.000	.980				
00300	1000.	0.	1000.				
00310	20.0	0.00	0.608				
00320	0.420	0.000	0.0128				
00330	0.83	1.25					
00340	GENERATOR						
00350	61210.	2.60	0.00		1.		
00360	716.		0.00		35.79	35.79	
00370	33987.	45187.			35.79	0.00	
00380	0.	20.	0.50				
00390	0.		0.		0.00	0.00	
00400	1.004	.000	1.001				
00410	1000.	0.	1000.				
00420	13.0	0.00	0.650				
00430	0.043	0.000	0.0022				
00440	0.42	1.50					
00450	UMBILICAL BOX						
00460	7489.	5.83	0.00		1.		
00470	11730.		0.00		200.00	200.00	
00480	243610.	822890.			586.48	0.00	
00490	0.	59.	0.50				
00500	0.		0.		0.00	0.00	
00510	.907	.000	.977				
00520	1000.	0.	1000.				
00530	9.5	0.00	0.162				
00540	0.212	0.000	0.0036				
00550	1.20	1.50					
00560	BATTERY (270 V)						
00570	38507.	3.03	0.00		1.		
00580	1387.		0.00		69.36	69.36	
00590	15315.	79893.			69.36	0.00	
00600	0.	20.	0.50				
00610	0.		0.		0.00	0.00	
00620	.957	.000	.989				
00630	1000.	0.	1000.				
00640	29.0	0.00	1.450				
00650	0.364	0.000	0.0182				
00660	0.50	1.00					

(Continued)

00670	INVERTER				
00680	700.	1.13	2.29	1.	
00690	2739.	912.96		5.78	5.78
00700	114429.	239792.		136.94	319.54
00710	9.	339.	0.50		
00720	23860.	27745.		0.50	0.59
00730	.920	.960	.980		
00740	1000.	1000.	1000.		
00750	16.1	1.79	0.011		
00740	0.245	0.027	0.0002		
00770	0.50	1.00			
00780	REVERSE CURRENT RELAY				
00790	1258.	1.42	2.88	1.	
00800	5434.	1358.51		14.30	14.30
00810	617576.	577166.		271.70	475.48
00820	13.	323.	0.50		
00830	53570.	62291.		1.13	1.32
00840	.900	.950	.975		
00850	1000.	1000.	1000.		
00860	9.0	0.75	0.008		
00870	0.174	0.014	0.0002		
00880	0.83	1.83			
00890	BUY GROUP				
00900	222.	0.85	1.72	1.	
00910	1232.	738.90		9.47	9.47
00920	1232.	0.		61.57	258.61
00930	5.	112.	0.50		
00940	5782.	6723.		0.12	0.14
00950	.950	.975	.988		
00960	1000.	1000.	1000.		
00970	45.7	9.13	0.117		
00980	1.100	0.220	0.0028		
00990	0.83	1.83			
01000	I&T ELECTRICAL PWR SYSTEM				
01010	1366.	1.47	0.00	1.	
01020	797.	1195.40		0.00	0.00
01030	63332.	68304.		39.85	0.00
01040	3.	0.	0.50		
01050	11295.	0.		0.24	0.00
01060	.938	.969	.000		
01070	1000.	1000.	0.		
01080	4.6	2.29	0.000		
01090	0.193	0.097	0.0000		
01100	1.25	2.33			
*M100					
00100	1000.	10.	10.	1.	10.
*SAVE					
FILE SAVED					
*					

LC FILE INPUT DATA

PWR CONTROL UNIT (GEN)

DEPLOYMENT

EQUIPS(ED) 1000. ORGANIZATION(OD) 10. INTERMEDIATE(DI) 10. DEPOT(DD) 1.

DURATION OF SUPPORT PERIOD, YEARS(YR) 10.00  
ON-TIME FRACTION(OTF) .005

LRU MTBF, HOURS(MTBF) 3486.  
LRU REPAIR TIME, HOURS(TF) 1.37  
MODULE REPAIR TIME, HOURS(TMO) 2.79  
LRU PER SYSTEM, (EE) 1.  
LRU COST, \$(CUP) 900.  
MODULE COST, \$(CMP) 1350.70  
PART COST, \$(CPF) 0.49  
PART COST ON-EQUIPMENT REPAIR, \$(CPPE) 0.49  
DEVELOPMENT COST, \$(CEND) 84377.  
NON-RECURRING PRODUCTION COST, \$(CPE) 111607.  
CONTRACTOR LRU REPAIR COST, \$(CUR) 45.02  
CONTRACTOR MODULE REPAIR COST, \$(CMR) 472.74  
MODULE TYPES, (P) 3.  
PART TYPES, (PF) 982.  
FRACTION NON-STD. PARTS, (FNSP) 0.50  
LRU SUPPORT EQPT. COST, \$(CFIM) 22170.  
LRU+MODULE SUPPORT EQPT., \$(CFIP) 25779.  
LRU S.E. FLOOR SPACE, SQ.FT.(FTSQF) 0.47  
LRU+MODULE S.E. FLOOR SPACE, SQ.FT.(FTSQP) 0.55

COST-QUANTITY EXPONENTS (LEARNING FACTORS):

UNIT(EUP) 0.900 MODULE(EMF) 0.950 PART(EPP) 0.975

REFERENCE QUANTITIES:

UNIT(RNU) 1000. MODULE(RNM) 1000. PART(RNP) 1000.

SHIPPING WEIGHT, POUNDS:

UNIT(WU) 2.0 MODULE(WM) 1.00 PART(WP) 0.000

STORAGE CUBES, CUBIC FEET:

UNIT(CUBEU) 0.031 MODULE(CUBEM) 0.016 PART(CUBEP) 0.0000

DEVELOPMENT PHASE, YEARS (YD) 0.88

PRODUCTION PHASE, YEARS (YP) 2.33

OK =1

LC FILE INPUT DATA

MAIN PWR CONTROL BOX

DEPLOYMENT  
EQUIPS(ED) 1000. ORGANIZATION(OD) 10. INTERMEDIATE(DI) 10. DEPOT(DD) 1.

DURATION OF SUPPORT PERIOD, YEARS(YR) 10.00  
ON-TIME FRACTION(OTF) .005

LRU MTBF, HOURS(MTBF) 10812.  
LRU REPAIR TIME, HOURS(TF) 4.83  
MODULE REPAIR TIME, HOURS(TMO) 0.00  
LRU PER SYSTEM, (EE) 1.  
LRU COST, \$(CUP) 6573.  
MODULE COST, \$(CMP) 0.00  
PART COST, \$(CPF) 200.00  
PART COST ON-EQUIPMENT REPAIR, \$(CPPE) 200.00  
DEVELOPMENT COST, \$(CEND) 158950.  
NON-RECURRING PRODUCTION COST, \$(CPE) 422767.  
CONTRACTOR LRU REPAIR COST, \$(CUR) 328.67  
CONTRACTOR MODULE REPAIR COST, \$(CHR) 0.00  
MODULE TYPES, (P) 0.  
PART TYPES, (PP) 33.  
FRACTION NON-STD. PARTS, (FNSP) 0.50  
LRU SUPPORT EQPT. COST, \$(CFIM) 0.  
LRU+MODULE SUPPORT EQPT., \$(CFIP) 0.  
LRU S.E. FLOOR SPACE, SQ.FT.(FTSQF) 0.00  
LRU+MODULE S.E. FLOOR SPACE, SQ.FT.(FTSQF) 0.00

COST-QUANTITY EXPONENTS (LEARNING FACTORS):  
UNIT(EUP) 0.919 MODULE(EMP) 0.000 PART(EPP) 0.980

REFERENCE QUANTITIES:  
UNIT(RNU) 1000. MODULE(RNM) 0. PART(RNP) 1000.

SHIPPING WEIGHT, POUNDS:  
UNIT(WU) 20.0 MODULE(WM) 0.00 PART(WP) 0.608

STORAGE CUBES, CUBIC FEET:  
UNIT(CUBEU) 0.420 MODULE(CUBEM) 0.000 PART(CUBEP) 0.0128

DEVELOPMENT PHASE, YEARS (YD) 0.83  
PRODUCTION PHASE, YEARS (YP) 1.25

OK =1

LC FILE INPUT DATA

GENERATER

DEPLOYMENT

EQUIPS(ED) 1000. ORGANIZATION(OD) 10. INTERMEDIATE(DI) 10. DEPOT(DD) 1.

DURATION OF SUPPORT PERIOD, YEARS(YR) 10.00  
ON-TIME FRACTION(OTF) .005

LRU MTBF, HOURS(MTBF) 61210.  
LRU REPAIR TIME, HOURS(TF) 2.60  
MODULE REPAIR TIME, HOURS(TMO) 0.00  
LRU PER SYSTEM, (EE) 1.  
LRU COST, \$(CUP) 716.  
MODULE COST, \$(CMP) 0.00  
PART COST, \$(CPF) 35.79  
PART COST ON-EQUIPMENT REPAIR, \$(CPPE) 35.79  
DEVELOPMENT COST, \$(CEND) 33987.  
NON-RECURRING PRODUCTION COST, \$(CPE) 45187.  
CONTRACTOR LRU REPAIR COST, \$(CUR) 35.79  
CONTRACTOR MODULE REPAIR COST, \$(CMR) 0.00  
MODULE TYPES, (P) 0.  
PART TYPES, (PP) 20.  
FRACTION NON-STD. PARTS, (FNSP) 0.50  
LRU SUPPORT EQFT. COST, \$(CFIM) 0.  
LRU+MODULE SUPPORT EQFT., \$(CFIP) 0.  
LRU S.E. FLOOR SPACE, SQ.FT. (FTSQF) 0.00  
LRU+MODULE S.E. FLOOR SPACE, SQ.FT. (FTSQP) 0.00

COST-QUANTITY EXPONENTS (LEARNING FACTORS):

UNIT(EUP) 1.004 MODULE(EMP) 0.000 PART(EPP) 1.001

REFERENCE QUANTITIES:

UNIT(RNU) 1000. MODULE(RNM) 0. PART(RNP) 1000.

SHIPPING WEIGHT, POUNDS:

UNIT(WU) 13.0 MODULE(WM) 0.00 PART(WP) 0.650

STORAGE CUBES, CUBIC FEET:

UNIT(CUBEU) 0.043 MODULE(CUBEM) 0.000 PART(CUBEF) 0.0022

DEVELOPMENT PHASE, YEARS (YD) 0.42  
PRODUCTION PHASE, YEARS (YP) 1.50

OK =1

LC FILE INPUT DATA

UMBILICAL BOX

DEPLOYMENT  
EQUIPS(ED) 1000. ORGANIZATION(OD) 10. INTERMEDIATE(DI) 10. DEPOT(DD) 1.

DURATION OF SUPPORT PERIOD, YEARS(YR) 10.00  
ON-TIME FRACTION(OTF) .005

LRU MTBF, HOURS(MTBF) 7489;  
LRU REPAIR TIME, HOURS(TF) 5.83  
MODULE REPAIR TIME, HOURS(TMO) 0.00  
LRU PER SYSTEM, (EE) 1.  
LRU COST, \$(CUP) 11730.  
MODULE COST, \$(CMP) 0.00  
PART COST, \$(CPP) 200.00  
PART COST ON-EQUIPMENT REPAIR, \$(CPPE) 200.00  
DEVELOPMENT COST, \$(CEND) 243610.  
NON-RECURRING PRODUCTION COST, \$(CPE) 822890.  
CONTRACTOR LRU REPAIR COST, \$(CUR) 586.48  
CONTRACTOR MODULE REPAIR COST, \$(CMR) 0.00  
MODULE TYPES, (P) 0.  
PART TYPES, (PP) 59.  
FRACTION NON-STD. PARTS, (FNSP) 0.50  
LRU SUPPORT EQPT. COST, \$(CFIM) 0.  
LRU+MODULE SUPPORT EQPT., \$(CFIP) 0.  
LRU S.E. FLOOR SPACE, SQ.FT.(FTSQF) 0.00  
LRU+MODULE S.E. FLOOR SPACE, SQ.FT.(FTSQP) 0.00

COST-QUANTITY EXPONENTS (LEARNING FACTORS):  
UNIT(EUF) 0.907 MODULE(EMF) 0.000 PART(EFP) 0.977

REFERENCE QUANTITIES:  
UNIT(RNU) 1000. MODULE(RNM) 0. PART(RNP) 1000.

SHIPPING WEIGHT, POUNDS:  
UNIT(WU) 9.5 MODULE(WM) 0.00 PART(WP) 0.162

STORAGE CUBES, CUBIC FEET:  
UNIT(CUBEU) 0.212 MODULE(CUBEM) 0.000 PART(CUBEP) 0.0036

DEVELOPMENT PHASE, YEARS (YD) 1.20  
PRODUCTION PHASE, YEARS (YP) 1.50

OK =1

LC FILE INPUT DATA

BATTERY (270 V)

DEPLOYMENT

EQUIPS(ED) 1000. ORGANIZATION(OD) 10. INTERMEDIATE(DI) 10. DEPOT(DD) 1.

DURATION OF SUPPORT PERIOD, YEARS(YR) 10.00  
ON-TIME FRACTION(OTF) .005

LRU MTBF, HOURS(MTBF)	38507.
LRU REPAIR TIME, HOURS(TF)	3.03
MODULE REPAIR TIME, HOURS(TMO)	0.00
LRU PER SYSTEM, (EE)	1.
LRU COST, \$(CUP)	1387.
MODULE COST, \$(CMF)	0.00
PART COST, \$(CPF)	69.36
PART COST ON-EQUIPMENT REPAIR, \$(CPPE)	69.36
DEVELOPMENT COST, \$(CEND)	15315.
NON-RECURRING PRODUCTION COST, \$(CPE)	79893.
CONTRACTOR LRU REPAIR COST, \$(CUR)	69.36
CONTRACTOR MODULE REPAIR COST, \$(CMR)	0.00
MODULE TYPES, (P)	0.
PART TYPES, (PP)	20.
FRACTION NON-STANDARD PARTS, (FNSTP)	0.50
LRU SUPPORT EQPT. COST, \$(CFIM)	0.
LRU+MODULE SUPPORT EQPT., \$(CFIP)	0.
LRU S.E. FLOOR SPACE, SQ.FT. (FTSQF)	0.00
LRU+MODULE S.E. FLOOR SPACE, SQ.FT. (FTSQP)	0.00

COST-QUANTITY EXPONENTS (LEARNING FACTORS):

UNIT(EUP) 0.957 MODULE(EMP) 0.000 PART(EPP) 0.989

REFERENCE QUANTITIES:

UNIT(RNU) 1000. MODULE(RNM) 0. PART(RNP) 1000.

SHIPPING WEIGHT, POUNDS:

UNIT(WU) 29.0 MODULE(WM) 0.00 PART(WP) 1.450

STORAGE CUBES, CUBIC FEET:

UNIT(CUBEU) 0.364 MODULE(CUBEM) 0.000 PART(CUBEP) 0.0182

DEVELOPMENT PHASE, YEARS (YD) 0.50

PRODUCTION PHASE, YEARS (YP) 1.00

OK =  
ENTER %NL NAMLIST  
%NL MTBF=13300%

LC FILE INPUT DATA

INVERTER

DEPLOYMENT  
EQUIPS(ED) 1000. ORGANIZATION(OD) 10. INTERMEDIATE(DI) 10. DEPOT(DD) 1.

DURATION OF SUPPORT PERIOD, YEARS(YR) 10.00  
ON-TIME FRACTION(OTF) .005

LRU MTBF, HOURS(MTBF) 700.  
LRU REPAIR TIME, HOURS(TF) 1.13  
MODULE REPAIR TIME, HOURS(TMO) 2.29  
LRU PER SYSTEM, (EE) 1.  
LRU COST, \$(CUP) 2739.  
MODULE COST, \$(CMP) 912.96  
PART COST, \$(CPF) 5.78  
PART COST ON-EQUIPMENT REPAIR, \$(CPPE) 5.78  
DEVELOPMENT COST, \$(CEND) 114429.  
NON-RECURRING PRODUCTION COST, \$(CPE) 239792.  
CONTRACTOR LRU REPAIR COST, \$(CUR) 136.94  
CONTRACTOR MODULE REPAIR COST, \$(CHR) 319.54  
MODULE TYPES, (P) 9.  
PART TYPES, (PF) 339.  
FRACTION NON-STD. PARTS, (FNSP) 0.50  
LRU SUPPORT EQPT. COST, \$(CFIM) 23860.  
LRU+MODULE SUPPORT EQPT., \$(CFIP) 27745.  
LRU S.E. FLOOR SPACE, SQ.FT.(FTSQF) 0.50  
LRU+MODULE S.E. FLOOR SPACE, SQ.FT.(FTSQF) 0.59

COST-QUANTITY EXPONENTS (LEARNING FACTORS):  
UNIT(EUP) 0.920 MODULE(EMP) 0.960 PART(EPP) 0.980

REFERENCE QUANTITIES:  
UNIT(RNU) 1000. MODULE(RNM) 1000. PART(RNP) 1000.

SHIPPING WEIGHT, POUNDS:  
UNIT(WU) 16.1 MODULE(WM) 1.79 PART(WP) 0.011

STORAGE CUBES, CUBIC FEET:  
UNIT(CUBEU) 0.245 MODULE(CUBEM) 0.027 PART(CUBEP) 0.0002

DEVELOPMENT PHASE, YEARS (YD) 0.50  
PRODUCTION PHASE, YEARS (YF) 1.00

OK =1

LC FILE INPUT DATA

REVERSE CURRENT RELAY

DEPLOYMENT  
 EQUIPS(ED) 1000. ORGANIZATION(OD) 10. INTERMEDIATE(DI) 10. DEPOT(DD) 1.

DURATION OF SUPPORT PERIOD, YEARS(YR) 10.00  
 ON-TIME FRACTION(OTF) .005

LRU MTBF, HOURS(MTBF) 1258.  
 LRU REPAIR TIME, HOURS(TF) 1.42  
 MODULE REPAIR TIME, HOURS(TMO) 2.88  
 LRU PER SYSTEM, (EE) 1.  
 LRU COST, \$(CUP) 5434.  
 MODULE COST, \$(CMP) 1358.51  
 PART COST, \$(CPP) 14.30  
 PART COST ON-EQUIPMENT REPAIR, \$(CPPE) 14.30  
 DEVELOPMENT COST, \$(CEND) 617576.  
 NON-RECURRING PRODUCTION COST, \$(CPE) 577166.  
 CONTRACTOR LRU REPAIR COST, \$(CUR) 271.70  
 CONTRACTOR MODULE REPAIR COST, \$(CMR) 475.48  
 MODULE TYPES, (P) 13.  
 PART TYPES, (PP) 323.  
 FRACTION NON-STD. PARTS, (FNSP) 0.50  
 LRU SUPPORT EQPT. COST, \$(CFIM) 53570.  
 LRU+MODULE SUPPORT EQPT., \$(CFIP) 62291.  
 LRU S.E. FLOOR SPACE, SQ.FT. (FTSQF) 1.13  
 LRU+MODULE S.E. FLOOR SPACE, SQ.FT. (FTSQP) 1.32

COST-QUANTITY EXPONENTS (LEARNING FACTORS):  
 UNIT(EUP) 0.900 MODULE(EMP) 0.950 PART(EPP) 0.975

REFERENCE QUANTITIES:  
 UNIT(RNU) 1000. MODULE(RNM) 1000. PART(RNP) 1000.

SHIPPING WEIGHT, POUNDS:  
 UNIT(WU) 9.0 MODULE(WM) 0.75 PART(WP) 0.008

STORAGE CUBES, CUBIC FEET:  
 UNIT(CUBEU) 0.174 MODULE(CUBEM) 0.014 PART(CUBEPP) 0.0002

DEVELOPMENT PHASE, YEARS (YD) 0.83  
 PRODUCTION PHASE, YEARS (YP) 1.83

OK =1

LC FILE INPUT DATA

BUY GROUP

DEPLOYMENT  
EQUIPS(ED) 1000. ORGANIZATION(OD) 10. INTERMEDIATE(DI) 10. DEPOT(DD) 1.

DURATION OF SUPPORT PERIOD, YEARS(YR) 10.00  
ON-TIME FRACTION(OTF) .005

LRU MTBF, HOURS(MTBF) 222.  
LRU REPAIR TIME, HOURS(TF) 0.85  
MODULE REPAIR TIME, HOURS(TMO) 1.72  
LRU PER SYSTEM, (EE) 1.  
LRU COST, \$(CUP) 1232.  
MODULE COST, \$(CMP) 738.90  
PART COST, \$(CFP) 9.47  
PART COST ON-EQUIPMENT REPAIR, \$(CPPE) 9.47  
DEVELOPMENT COST, \$(CEND) 1232.  
NON-RECURRING PRODUCTION COST, \$(CPE) 0.  
CONTRACTOR LRU REPAIR COST, \$(CUR) 61.57  
CONTRACTOR MODULE REPAIR COST, \$(CMR) 258.61  
MODULE TYPES, (P) 5.  
PART TYPES, (PP) 112.  
FRACTION NON-STD. PARTS, (FNSP) 0.50  
LRU SUPPORT EQPT. COST, \$(CFIM) 5782.  
LRU+MODULE SUPPORT EQPT., \$(CFIP) 6723.  
LRU S.E. FLOOR SPACE, SQ.FT.(FTSQF) 0.12  
LRU+MODULE S.E. FLOOR SPACE, SQ.FT.(FTSQP) 0.14

COST-QUANTITY EXPONENTS (LEARNING FACTORS):  
UNIT(EUP) 0.950 MODULE(EMP) 0.975 PART(EPP) 0.988

REFERENCE QUANTITIES:  
UNIT(RNU) 1000. MODULE(RNM) 1000. PART(RNP) 1000.

SHIPPING WEIGHT, POUNDS:  
UNIT(WU) 45.7 MODULE(WM) 9.13 PART(WP) 0.117

STORAGE CUBES, CUBIC FEET:  
UNIT(CUBEU) 1.100 MODULE(CUBEM) 0.220 PART(CUBEP) 0.0028

DEVELOPMENT PHASE, YEARS (YD) 0.83  
PRODUCTION PHASE, YEARS (YP) 1.83

OK =1

LC FILE INPUT DATA

I&T ELECTRICAL PWR SYSTEM

DEPLOYMENT  
EQUIPS(ED) 1000. ORGANIZATION(OD) 10. INTERMEDIATE(DI) 10. DEPOT(DD) 1.

DURATION OF SUPPORT PERIOD, YEARS(YR) 10.00  
ON-TIME FRACTION(OTF) .005

LRU MTBF, HOURS(MTBF) 1366.  
LRU REPAIR TIME, HOURS(TF) 1.47  
MODULE REPAIR TIME, HOURS(TMO) 0.00  
LRU PER SYSTEM, (EE) 1.  
LRU COST, \$(CUP) 797.  
MODULE COST, \$(CMP) 1195.40  
PART COST, \$(CPF) 0.00  
PART COST ON-EQUIPMENT REPAIR, \$(CPPE) 0.00  
DEVELOPMENT COST, \$(CEND) 63332.  
NON-RECURRING PRODUCTION COST, \$(CPE) 68304.  
CONTRACTOR LRU REPAIR COST, \$(CUR) 39.85  
CONTRACTOR MODULE REPAIR COST, \$(CMR) 0.00  
MODULE TYPES, (P) 3.  
PART TYPES, (PP) 0.  
FRACTION NON-STD. PARTS, (FNSP) 0.50  
LRU SUPPORT EQPT. COST, \$(CFIM) 11295.  
LRU+MODULE SUPPORT EQPT., \$(CFIP) 0.  
LRU S.E. FLOOR SPACE, SQ.FT.(FTSQF) 0.24  
LRU+MODULE S.E. FLOOR SPACE, SQ.FT.(FTSQP) 0.00

COST-QUANTITY EXPONENTS (LEARNING FACTORS):

UNIT(EUP) 0.938 MODULE(EMP) 0.969 PART(EPP) 0.000

REFERENCE QUANTITIES:

UNIT(RNU) 1000. MODULE(RNM) 1000. PART(RNP) 0.

SHIPPING WEIGHT, POUNDS:

UNIT(WU) 4.6 MODULE(WM) 2.29 PART(WP) 0.000

STORAGE CUBES, CUBIC FEET:

UNIT(CUBEU) 0.193 MODULE(CUBEM) 0.097 PART(CUBEP) 0.0000

DEVELOPMENT PHASE, YEARS (YD) 1.25  
PRODUCTION PHASE, YEARS (YF) 2.33

OK =1

**BIBLIOGRAPHY**  
**(APPENDIX A)**

1. PRICE Reference Manual, October, 1975, RCA/PRICE Systems, Cherry Hill, New Jersey
2. Reference Manual for PRICE Life Cycle Cost Model, August 1977, RCA/PRICE Systems, Cherry Hill, New Jersey

REPORT NO. 25925-2  
DATE: 11-6-75

APPENDIX B  
(EXCERPTS FROM)

PROGRAM  
PARTS SELECTION LIST  
BGM-34C  
CONTRACT F33657-75-C-0274

TELEDYNE RYAN AERONAUTICAL COMPANY  
SAN DIEGO, CALIFORNIA 92112

## PROGRAM PARTS SELECTION LIST

### BGM-34C SYSTEM

SCOPE: This document provides a list of electrical, electronic, and electromechanical parts approved for use in the BGM-34C system. Parts listed herein may be specified and used with no further approval required.

CONTENTS: The list is divided into two major sections; "Section I, Standard Parts; and Section II, Limited Application Parts. Each of these two groups is broken down to the subgroups "Electronic, "Electrical," and" Electromechanical. "The part categories within each of these subsections are typically as follows:

<u>ELECTRONICS</u>	<u>ELECTRICAL</u>	<u>ELECTROMECHANICAL</u>
Resistors	Circuit Breakers	Connectors
Capacitors	Switches	Lugs, Terminals, Splices and Terminal Strips
Filters and Network	Relays	Insulators
Fuses and Lightning Arrestors	Lamps	Synchros
Coils and Transformers	Meters	Motors and Generators
Diodes		Actuators And Valves
Transistors		Cables
Integrated Circuits		Wire
Waveguides		

APPLICATION:

All parts in the controlled categories must be contained in this list. When it becomes necessary to use a part that is not currently listed, that part must be submitted for customer approval. In addition, use of the part, documentation, and support data are subject to approval by the Parts Advisory Group (PAG). Parts approved by the PAG will be added to this document in the form of a supplement issued every 30 days. Parts submittals will be processed by Engineering Standards Group. In order to expedite approvals and avoid delays the approval requests should be coordinated in the very early stages of design.

Not all devices listed herein are on a Qualified Products List (QPL). Consult the latest QPL before specifying part on the engineering drawing or ALM. If the required standard part is not listed in the appropriate QPL, an alternate part shall be selected and specified with proper interchangeability notations. The alternate part will be subject to Nonstandard Parts Approval.

SECTION I: STANDARD PARTS

ELECTRONIC PARTS SEGMENT

INDEX NO.	PART NAME	DESCRIPTION	STYLE OR TYPE	SPECIFICATION OR DRAWING NUMBER	PART NUMBER	LIST AUTH	REMARKS
01	Resistor	Fixed, Carbon Comp. 1/4W, +5% 1/2W, ±5% 1W, +5% 2W, ±5%	RCR07	MIL-R-39008	RCR07GXXJ*		
02			RCR20	MIL-R-39008/1	RCR20GXXJ*		
03			RCR32	MIL-R-39008/2	RCR32GXXJ*		
04			RCR42	MIL-R-39008/3	RCR42GXXJ*		
05	Resistor	Fixed, Film, G.P. 1/4W, ±2% 1/2W, ±2% 1W, ±2%	RLR07	MIL-R-39017	RLR07CXXG*		
06			RLR20	MIL-R-39017/1	RLR20CXXG*		
07			RLR32	MIL-R-39017/2	RLR32CXXG*		
08	Resistor	Fixed, Film, Precision 1/10W, +1% 1/8W, ±1% 1/4W, ±1%	RNC55	MIL-R-55182	RNC55HXXXF*		
09			RNC60	MIL-R-55182/1	RNC60HXXXF*		
10			RNC65	MIL-R-55182/3	RNC65HXXXF*		
11	Resistor	Fixed, Wire Wound, Power, Precision 1W, +1% 2W, ±1% 3W, ±1% 5W, ±1% 7W, ±1% 10W, ±1%	RMR81	MIL-R-39007	RMR81SXXXF*		
12			RMR80	MIL-R-39007/9	RMR80SXXXF*		
13			RMR89	MIL-R-39007/8	RMR89SXXXF*		
14			RMR74	MIL-R-39007/11	RMR74SXXXF*		
15			RMR84	MIL-R-39007/6	RMR84SXXXF*		
16	RMR78	MIL-R-39007/10	RMR78SXXXF*				
*	The Designer shall select the lowest failure rate consistent with his design.						

SECTION I: STANDARD PARTS

ELECTRONIC PARTS SEGMENT

INDEX NO.	PART NAME	DESCRIPTION	STYLE OR TYPE	SPECIFICATION OR DRAWING NUMBER	PART NUMBER LIST AUTH	REMARKS
01	Capacitor	<u>Tantalum, Solid</u> Polar, .0047 to 330 $\mu$ f, $\pm$ 10%, 6 to 50 VDC Non-Polar, .0023 to 160 $\mu$ f, $\pm$ 10%, 6 to 100 VDC	CSR13 CSR91	MIL-C-39003 MIL-C-39003/1 MIL-C-39003/4	M39003/01-XXXX M39003/04-XXXX	
03	Capacitor	<u>Tantalum, Non-Solid</u> Polar, 1.7 to 1200 $\mu$ f, $\pm$ 10%, 6 to 125 VDC Non-Polar, .47 to 100 $\mu$ f, $\pm$ 20%, 15 to 300 VDC	CLR65 CLR37	MIL-C-39006 MIL-C-39006/9 MIL-C-39006/4	M39006/09-XXXX M39006/04-XXXX	
04	Capacitor	<u>Ceramic, General Purpose</u> Rect., 10 to 10,000 $\mu$ f, $\pm$ 10%, 100 to 200 VDC Rect., 12,000 $\mu$ f to 1 $\mu$ f, $\pm$ 10%, 50 to 200 VDC Tub., 10 to 4700 $\mu$ f, $\pm$ 10%, 100 VDC Tub., 5,600 to 10,000 $\mu$ f, $\pm$ 10%, 100 VDC Tub., 12,000 to 47,000 pf, $\pm$ 10%, 100 VDC Tub., 56,000 to 330,000 pf, $\pm$ 10%, 100 VDC Tub., 470,000 to 1,000,000 pf, $\pm$ 10%, 100 VDC	CKR05 CKR06 CKR11 CKR12 CKR14 CKR15 CKR16	MIL-C-39014/1 MIL-C-39014/2 MIL-C-39014/5 MIL-C-39014/5 MIL-C-39014/5 MIL-C-39014/5 MIL-C-39014/5	MJ9014/01-XXXX MJ9014/02-XXXX MJ9014/05-XXXX MJ9014/05-XXXX MJ9014/05-XXXX MJ9014/05-XXXX MJ9014/05-XXXX	
05	Capacitor	<u>Glass Dielectric</u> 0.5 to 300 pf, $\pm$ 1%, 500VDC 330 to 1,200 pf, $\pm$ 1%, 500 VDC 1300 to 5100 pf, $\pm$ 1 %, 500 VDC	CYR10 CYR15 CYR20	MIL-C-23269 MIL-C-23269/1 MIL-C-23269/2 MIL-C-23269/3	M23269/01-XXXX M23269/02-XXXX M23269/03-XXXX	
06						
07						
08						
09						
10						
11						
12						
13						
14						

SECTION I: STANDARD PARTS

ELECTRONIC PARTS SEGMENT

INDEX NO.	PART NAME	DESCRIPTION	STYLE OR TYPE	SPECIFICATION OR DRAWING NUMBER	PART NUMBER	LIST AUTH	REMARKS	
1-01	Semiconductors	<u>Diodes</u>		MIL-S-19500			JANTX screened diodes are required.  Reference MIL-STD-701	
1-02		General Purpose & Low Power Rectifiers	IN	MIL-S-19500/240 ↓	JANTXIN645-1 JANTXIN647-1 JANTXIN649-1			
1-03								
1-04		Power Rectifier, Axial Lead	IN	MIL-S-19500/427 ↓	JANTXIN 5614 JANTXIN 5616 JANTXIN 5618			
1-05								
1-06								
1-07								
1-08						JANTXIN5550 JANTXIN5551 JANTXIN5552		
1-09								
1-10		Power	IN	MIL-S-19500/260 ↓	JANTXIN1202A JANTXIN1204A JANTXIN1206A			
1-11								
1-12								
1-13		Switching	IN	MIL-S-19500/116 MIL-S-19500/169	JANTXIN4148 -1 JANTXIN4938			
1-14								
1-15	Voltage Reference	IN	MIL-S-19500/159 ↓	JANTXIN821 JANTXIN823 JANTXIN825				
1-16								
1-17								
1-18					JANTXIN9358 thru			
Thru					JANTXIN9458			
1-28								
1-29	Voltage Regulator	IN	MIL-S-19500/127 ↓	JANTXIN4370A JANTXIN4371A JANTXIN4372A JANTXIN748A thru				
1-30								
1-31								
1-32								
Thru								
1-42					JANTXIN758A			

SECTION I: STANDARD PARTS

ELECTRONIC PARTS SEGMENT

INDEX NO.	PART NAME	DESCRIPTION	STYLE OR TYPE	SPECIFICATION OR DRAWING NUMBER	PART NUMBER	LIST AUTH	REMARKS	
2-01	Semiconductors	<u>Transistors</u> NPN Low-Power	2N	MIL-S-19500	JANTX2N718A		JANTX screened transistors are required. Reference MIL-STD-701	
2-02				MIL-S-19500/181	JANTX2N1893			
2-03				MIL-S-19500/182	JANTX2N2484			
2-04				MIL-S-19500/391	JANTX2N3700			
2-05				MIL-S-19500/366	JANTX2N3501			
2-06				MIL-S-19500/255	JANTX2N2224			
2-07				MIL-S-19500/287	JANTX2N3013			
2-08				MIL-S-19500/301	JANTX2N918			
2-09				PNP Low-Power	MIL-S-19500/354			JANTX2N2605
2-10					MIL-S-19500/291			JANTX2N2907A
2-11				NPN Power	MIL-S-19500/374			JANTX2N3997
2-12					MIL-S-19500/374			JANTX2N3999
2-13				PNP Power	MIL-S-19500/315			JANTX2N2880
2-14					MIL-S-19500/371			JANTX2N3902
2-15					MIL-S-19500/441			JANTX2N3741
2-16				RF	MIL-S-19500/433			JANTX2N5303
2-17					MIL-S-19500/301			JANTX2N918
2-18				Dual (Diff. Amp)	MIL-S-19500/270			JANTX2N2060
2-19					MIL-S-19500/355			JANTX2N2920
2-20				Unijunction	MIL-S-19500/388			JANTX2N4949
2-21				Junction Field Effect	MIL-S-19500/375			JANTX2N3823
2-22					MIL-S-19500/385			JANTX2N4856
2-23				Low Power Chopper	MIL-S-19500/313			JANTX2N2432A

SECTION I: STANDARD PARTS

ELECTRONIC PARTS SEGMENT

INDEX NO.	PART NAME	DESCRIPTION	STYLE OR TYPE	SPECIFICATION OR DRAWING NUMBER	PART NUMBER	LIST AUTH	REMARKS
	Microcircuits	<u>Digital</u> <u>MAND Gates</u>		MIL-M-38510 MIL-M-38510/1	M38510/ 00101BCB 00102BCB 00103BCB 00104BCB 00105BCB 00106BCB		Screening Level B Hermetic Sealed
001		Single, 8-input positive	5430				
002		Dual, 4-input positive	5420				
003		Triple, 3-input positive	5410				
004		Quadruple, 2-input positive	5400				
005		Hex, 1-input inverter	5404				
006		Triple, 3-input positive (open collector output)	5412				
007		Quadruple, 2-input positive (open collector output)	5401		00107BCB		
008		Hex, 1 input inverter (open collector output)	5405		00108BCB		
009		Quadruple, 2-input positive (open collector output)	5403		00109BCB		
		<u>Flip-Flops</u>		MIL-M-38510/2	00201BCB 00202BCB 00203BCB 00204BCB 00205BCB 00206BCB 00207BCB		
010		Single J-K master-slave	5472				
011		Dual J-K master-slave (no preset)	5473				
012		Dual J-K master-slave (no preset)	54107				
013		Dual J-K master-slave	5476				
014		Dual D-type edge-triggered	5474				
015		Single edge-triggered J-K	5470				
016		Dual D-type edge-triggered buffered output	5479				

SECTION I STANDARD PARTS

ELECTRICAL PARTS SEGMENT

INDEX NO.	PART NAME	DESCRIPTION	STYLE OR TYPE	SPECIFICATION OR DRAWING NUMBER	PART NUMBER	LIST AUTH	REMARKS
1	CIRCUIT BREAKER	TRIP FREE, PUSH-PULL 5 THRU 60 AMP 3 PHASE	I	MIL-C-5809	MS21984		
2	CIRCUIT BREAKER	TRIP FREE, PUSH-PULL 1 THRU 50 AMP	I	MIL-C-5809	MS25244		
3	CIRCUIT BREAKER	TRIP FREE, PUSH-PULL 1/4 THRU, 10 AMP	I	MIL-C-5809	MS22073		
4	CIRCUIT BREAKER	TRIP FREE, PUSH-PULL 50 THRU 100 AMP	I	MIL-C-5809	MS25361		
5	CIRCUIT BREAKER	TRIP FREE, TOGGLE 3 THRU 35 AMP	I	MIL-C-5809	MS24509		
6	CIRCUIT BREAKER	TRIP FREE, TOGGLE MAGNETIC, SEALED 0.5 THRU 20 AMP	1P	MIL-C-39019	M3901/1-		
7			1P		M39019/2-		
8			2P		M39019/3-		
9			3P		M39019/5-		
1-1	FUSE	INSTRUMENT, POWER & TELEPHONE (NON INDICATING)	F01	MIL-F-15160/1	F01AXXXVXX		
1-2			F09	MIL-F-15160/09	F09AXXXVXX		
1-3			F10	MIL-F-15160/10	F10AXXXVXX		

SECTION I STANDARD PARTS

ELECTRICAL PARTS SEGMENT

INDEX NO.	PART NAME	DESCRIPTION	STYLE OR TYPE	SPECIFICATION OR DRAWING NUMBER	PART NUMBER	LIST AUTH:	REMARKS
2-1	SWITCH	PUSH, DUSTTIGHT		MIL-S-8805/03	MS25089		
3-1	SWITCH	ROTARY		MIL-S-3786	M3786/4-XXX		USE FOR THROWS OF 30° TO 90° ONLY
4-1 4-2	SWITCH	GUARD 2 POSITION 3 POSITION		MIL-G-7703	MS25224 MS25225		

SECTION 1 STANDARD PARTS

ELECTRICAL PARTS SEGMENT

INDEX NO.	PART NAME	DESCRIPTION	STYLE OR TYPE	SPECIFICATION OR DRAWING NUMBER	PART NUMBER	LIST AUTH.	REMARKS
1-1	RELAY	HERMETICALLY SEALED MAGNETIC LATCH SOLDER TERMINALS 10 AMP 2PDT	I	MIL-R-6106	MS27744		
1-2		10 AMP 4PDT			MS27745		
2-1	RELAY	GENERAL PURPOSE, ELECTROMAGNETIC, ESTABLISHED RELIABILITY 1 AMP DPDT	TO-5	MIL-R-39016	M39016/19- 001M thru 02M		
2-2		2 AMP DPDT	1/2 X-TAL		M39016/6- 104M thru 124M		

SECTION I: STANDARD PARTS

ELECTROMECHANICAL PARTS SEGMENT

INDEX NO.	PART NAME	DESCRIPTION	STYLE OR TYPE	SPECIFICATION OR DRAWING NUMBER	PART NUMBER	LIST AUTH:	REMARKS
1-01	CONNECTOR	G.P. RND. BAYONET CPL STRAIGHT PLUG	PIN	MIL-C-83723	M83723-14 RXXXX		
1-02	CONNECTOR	G.P. RND THREADED CPL CA. CONN. RECEPT.	SKT	MIL-C-83723	M83723-17 RXXXX		
1-03	CONNECTOR	G.P. RND THREADED CPL CA. CONN. RECEPT.	PIN	MIL-C-83723	M83723-18 RXXXX		
1-04	CONNECTOR	G.P. RND THREADED CPL WALL. MTG. RECEPT.	SKT	MIL-C-83723	M83723-19 RXXXX		
1-05	CONNECTOR	G.P. RND THREADED CPL WALL. MTG. RECEPT.	PIN	MIL-C-83723	M83723-20 RXXXX		
1-06	CONNECTOR	G.P. RND THREADED CPL BOX MTG. RECEPT.	SKT	MIL-C-83723	M83723-21 RXXXX		
1-07	CONNECTOR	G.P. RND THREADED CPL BOX RECEPT.	PIN	MIL-C-83723	M83723-22 RXXXX		
1-08	CONNECTOR	G.P. RND THREADED CPL STRAIGHT PLUG	SKT	MIL-C-83723	M83723-23 RXXXX		
1-09	CONNECTOR	G.P. RND THREADED CPL STRAIGHT PLUG	PIN	MIL-C-83723	M83723-24 RXXXX		

SECTION I: STANDARD PARTS

ELECTROTECHNICAL PARTS SEGMENT

INDEX NO.	PART NAME	DESCRIPTION	STYLE OR TYPE	SPECIFICATION OR DRAWING NUMBER	PART NUMBER	LIST AUTH.	REMARKS
7-1	CONN ACCESSORIES	BACKSHELL, ENVIR. W/KELLUMS GRIP		VENDOR BULLETIN	G1601L40A08A3	MSP-72	GLENAIR
7-1-1		BACKSHELL, ENVIR. W/KELLUMS GRIP		VENDOR BULLETIN	G1601L2BA07A3	MSP-72	GLENAIR
7-2		ADAPTER, ENVIR. W/KELLUMS GRIP		VENDOR BULLETIN	56-244107-3A2	MSP-72	SURIBAKI
7-3		ADAPTER, EMI, ENVIR.		VENDOR BULLETIN	G6788-X	MSP-49	GLENAIR
7-4		BACKSHELL, SHIELD TERMINATION		MIL-C-5015	MS3419-X	MSP-49	
7-5		RING, SHIELD CRIMP		MIL-C-5015	MS3161-X	MSP-49	
7-8		PLUG, SEALING, FOR MIL-C-26482 SER.2 & MIL-C-81703 SER.3			MS3187-XX-2	MSP-49	
7-9		ADAPTER ENVIR		VENDOR BULLETIN	G1688-X	MSP-49	GLENAIR
7-10		RECP. DUMMY		MIL-C-26482	MS3115-X	MSP-59	
7-11		COVER, RECP.		MIL-C-5015	MS25043-X	MSP-61	

SECTION I: STANDARD PARTS

ELECTROMECHANICAL PARTS SEGMENT

INDEX NO.	PART NAME	DESCRIPTION	STYLE OR TYPE	SPECIFICATION OR DRAWING NUMBER	PART NUMBER	LIST AUTH.	REMARKS
7-12	CONN ACCESSORIES	GASKET EMI		VENDOR BULLETIN	85-61423	NSP-61	TECKNIT
7-13		GASKET EMI		VENDOR BULLETIN	85-61439	NSP-61	TECKNIT
7-14		GASKET EMI		VENDOR BULLETIN	85-61455	NSP-61	TECKNIT
7-15		SEALING PLUG		VENDOR BULLETIN	10-482099	NSP-2	BENDIX
7-16		BACKSHELL		VENDOR BULLETIN	94002-24263	NSP-4	DEUTSCH
7-17		BACKSHELL		MIL-C-5015	MS3416-X	NSP-18	
7-18		BACKSHELL		MIL-C-83723	M83723-35-X	NSP-18	
7-19		SEALING PLUG		MIL-C-83723	M83723-28-X	NSP-18	
7-20		BACKSHELL		MIL-C-83723	M83723-15-X	PAG	OMITTED IN INIT. ISSUE
7-21		S/R BOOT		MIL-C-83723	M83723-16-X	PAG	OMITTED IN INIT. ISSUE
7-22		RECPT. DUMMY		MIL-C-83723	M83723-44-X	PAG	OMITTED IN INIT. ISSUE

## APPENDIX C

### ORGANIZATION OF (CLASS) DRONE/RPV DESIGN HANDBOOK

#### C1. HANDBOOK OUTLINE

The suggested outline for a design handbook is broken into the following major subsections. The objectives of each section are briefly noted.

##### 1.0 INTRODUCTION

##### 1.1 Intent of Handbook

This subsection will state the intent of the handbook, which is to:

- a. Provide guidelines for minimizing the cost of ownership for an acceptable mission capability.
- b. Provide a self-contained specification reference for the system procurement.
- c. Permit the program manager flexibility consistent with realistic product reliability, performance, and quality requirements.
- d. Prevent the costly generation of data and analyses where not justified.
- e. Permit the application of proven contractor techniques, design practices, components, and tests where cost savings are clear.

##### 1.2 Authority and Obligation

This subsection will:

- a. Present a disclaimer stating that in the event of any conflict between its contents and existing regulations (Air Force or DOD), the latter shall govern.
- b. Explain that variations from the requirements contained therein must be justified on the basis of life-cycle cost, time-urgency, or existing DOD regulations.
- c. Direct the program manager to certain regulations which require direct application of military specifications or standards.

##### 1.3 Scope

This subsection will state the scope of the design handbook, i.e.:

### 1.3 Scope (Continued)

- a. Military specifications and standards are not to be considered unless specifically identified in the handbook.
- b. The handbook is not concerned with functional performance specifications, nor with management techniques.

## 2.0 SYSTEM DEFINITION

This section will describe the details of the procurement procedure for drone acquisition and modification programs, and assist the program manager in the proper use of the handbook.

### 2.1 Phase Description

This subsection will describe the acquisition process in terms of its constituent phases (e.g., contract definition, engineering development, etc.). Such identification will be required for utilization of the specification-application matrix of Subsection 2.3.

### 2.2 Functional Description

This subsection will present a generalized work breakdown structure (WBS) of a total drone/RPV system, including the controller, launch and recovery subsystem, payload/weapon, etc., and will be outlined in a system relationship. With the WBS, the program manager can identify his system as a coded subset useful in standardizing contractor responses, and in applying the program matrix of Section 2.3.

### 2.3 Program Matrix

This section will contain a matrix with program/system descriptors (e.g., speed, altitude) along one axis and applicable specification areas (e.g., environmental) along the other. Matrix intersections will be the applicable handbook paragraph numbers.

## 3.0 DESIGN SPECIFICATIONS

This section will address specification requirements applicable to the design process. It will be divided into "general" and "detailed" categories as discussed below.

### 3.1 General Specifications

These specification requirements are applicable across-the-board or at the system level. Some examples are:

### 3.1 General Specifications (Continued)

- a. Reliability/maintainability allocation, prediction, and testing.
- b. Human engineering
- c. Environmental conditions
- d. System safety
- e. Quality assurance

### 3.2 Detail Specifications

Detail specifications are peculiar to components of an RPV system. They reflect component conditions and usages that are sufficiently different from the general case that cost savings or performance improvement can be realized if treated as a special case. In cases of apparent conflict with general specifications, the detail specification will take precedence. Detailed specifications will be coded by the WBS element to which they relate.

## 4.0 PRODUCTION SPECIFICATIONS

Production specifications pertain to manufacturing processes, materials, and criteria applicable to the contract item (CI) and to its acceptability as a deliverable to the Air Force. As for the design specifications, the production specifications will be broken into:

### 4.1 General Specifications

### 4.2 Detail Specifications

## 5.0 DD-1423 DATA REQUIREMENTS

This section will provide a subset of those contract data requirements contained in AFR-310-1\* judged to be applicable to the spectrum of procurements defined for RPV's in the design handbook. With specific exceptions, the required data will probably be acceptable in contractor format (depending on contractor experience), provided that certain basic elements are included. Specific paragraphs or items from this section will be referenced in the matrix of Section 2.3.

### 5.1 Periodic Data Requirements

Periodic data requirements will include status reporting of technical cost and production progress.

\* Air Force Regulation 310-T, Management of Contractor Data

## 5.2 One-Time Data Requirements

One-time data requirements will include program plans, analyses, lists, drawings, and other data as necessary.

## 6.0 DESIGN/PROCUREMENT CHECKLIST

This section will present a checklist of those items relating to system design and procurement that the program manager or system designer should consider.

### Handbook Appendix

In an appendix to the design handbook, the framework of a system development specification will be generated. This specification will be based on the MIL-STD-490, Type B1 (prime-item development specification requirements). A rough outline of the specification is shown below (taken from MIL-STD-490, Appendix II). This development specification framework will permit the program manager to draft a detail specification properly and quickly by completing details relating to his particular program through use of the handbook utilization matrix, checklist, and other appropriate handbook sections.

1. Scope
2. Applicable Documents
3. Requirements
  - 3.1 Item Definition
  - 3.2 Characteristics
  - 3.3 Design and construction
  - 3.4 Documentation
  - 3.5 Logistics
  - 3.6 Personnel and training
  - 3.7 Major component characteristics
  - 3.8 Precedence
4. Quality Assurance Provisions
  - 4.1 General
  - 4.2 Quality conformance inspections
5. Preparation for Delivery

C2. ELECTRICAL POWER SYSTEM INTERCONNECTION REQUIREMENTS  
FOR ARPV/HALE CLASSES (EXAMPLE)

I. Interconnect Wire and Cable

A. Conventional round conductor insulated wire.

1. Description and applicable specifications

- a) MIL-W-22759/16 - Tin coated copper stranded conductor with extruded Ethylene-tetrafluoroethylene (ETFE-Tefzel) insulation.
- b) MIL-W-81381-11 - Silver coated copper stranded conductor insulated with spiral wrap laminated polyimide (H Film) film with a fluorinated ethylene propylene (FEP-Teflon).
- c) MIL-C-27500, Type TE-1 to 7 MIL-W-22759/16 wires with a tin coated copper wire shield and an extruded white ETFE-Tefzel jacket.
- d) MIL-C-27500, Type MW-1 to 7 MIL-W-81381/11 wires with a silver coated copper wire shield and a jacket of natural polyimide tape combined with FEP, wrapped and heat sealed with an FEP outer surface.

2. Application preferences

- a) MIL-W-22759/16 and MIL-C-27500 Type TE; to be used in general purpose wiring applications where the total operating temperature of the conductor will not exceed 150°C (302°F).
- b) MIL-W-81381/11 and MIL-C-27500 Type MW; to be used in high temperature wiring applications where the total operating temperature of the conductor exceeds 150°C (302°F) but does not exceed 200°C (394°F).

B. Conventional round wire assembly and installation hardware

- a) Connectors - Multicontact, mass disconnect, power.
  - (1) General purpose round - MIL-C-83723 Series II.

- (2) General purpose round miniature - MIL-C-83723 Series I
  - (3) High density round - MIL-C-38999 Series II.
  - (4) General purpose rectangular - MIL-C-81733.
  - (5) Miniature rectangular - MIL-C-
  - (6) Printed Circuit board - MIL-C-
  - b) Terminals.
    - (1) Lugs, preinsulated, crimp type - MIL-T-7928.
    - (2) Studs, insulated and uninsulated, solder type MIL-T-55155.
  - c) Splices.
    - (1) Preinsulated crimp type - MIL-T-7928
  - d) Solder sleeves.
    - (1) Overlap splice - STS 9101.
    - (2) Shield terminating - STS 9102.
  - e) Terminal strips.
- C. Radio Frequency cable.
- 1. Description and applicable specifications.
    - a) Cable, R.F. flexible and semiflexible MIL-C-17
- D. Radio frequency cable assembly and installation hardware.
- 1. Connectors and adapters.
    - a) Connectors R.F. MIL-C-29012
    - b) Adapter
- E. Flat conductor cable and flexible printed circuits.

E. (Continued)

1. Flat conductor cable.

a)

b)

2. Flexible printed circuits.

a)

b)

F. Flat conductor cable and flexible printed circuits assembly and installation hardware.

1. Connectors.

a)

b)

2. Support devices.

a)

b)

G. Fiber optics.

1. Multifiber cable.

a)

b)

2. Connectors.

a)

b)

H. Integrated Termination system.

## REFERENCES

- 1 "Design Handbook Study for Drone/RPV Acquisition and Modification Programs", ARINC Publication 1035-01-1-1286, February 1974
- 2 Tjelle, Dunbar; Boeing Aerospace Co., "High Voltage Power Supply Problems and Design Techniques", 77CH1203-0 NAECON '77 Record Page 858, May 1977
- 3 Johnson, AFFDL/FGL, WPAFB; "Primary Flight Control Actuation with Electric Motors", 77CH1203-9 NAECON '77 Record Page 1102, May 1977
- 4 Voight, General Dynamics Corp., "Electric Flight Control Systems: Applicable Now", 77CH1203-9 NAECON '77 Record Page 1094, May 1977
- 5 Wood, N., AiResearch Mfg. Co., "Advances in Primary Flight Control Actuation Using Electromechanical Technology", 77CH1203-9 NAECON '77, Record Page 1113, May 1977
- 6 Edge, J. T. and Sawyer, B., "Design of a Samarium Cobalt Brushless DC Motor for Electromechanical Actuator Application", 77CH1203-9 NAECON '77 Record, Page 1108, May 1977
- 7 Harnden, J. D., Jr., "Power Semiconductors: Looking Ahead", IEEE Spectrum, August 1977, Page 40
- 8 Page, Lowry, Westinghouse Electric Corp., "Light Activated Semiconductor Switches", 77CH1203-9 NAECON '77 Record Page 616, May 1977
- 9 Marek, Perkins, Vought Corp., "Overview of Advanced Aircraft Electrical System (AAES) A-7E Prototype Design", 77CH1203-9 NAECON '77 Record Page 178, May 1977
- 10 Billings, Sundberg, Westinghouse Electric Corp., NASA "Solid State Remote Power Controllers for High Voltage DC Distribution Systems", 77CH1203-9 NAECON '77 Record Page 186, May 1977
- 11 Fox, D. A., Westinghouse Electric Corp., "Remote Power Controllers for the NASA Space Shuttle Orbiter," AIAA Conference, Paper No. 77-494, March 1977
- 12 AiResearch Manufacturing Co., "Study of Aircraft Electrical Power Systems", NASA CR-120939, AIR 72-8414, June 1972

REFERENCES (Continued)

- 13 Riddle III, J. H., Columbus Aircraft Div., Rockwell International, "High Voltage DC Secondary Power Systems Concepts for Future Aircraft", Rockwell Report NR74H-53, "NADC Report No. N62269-74-C-0157), April 1974
- 14 "Let-Go Currents and Voltages", Transactions AIEE, May 1956
- 15 General Electric, "Airborne 20 KVA VSCF Generating System", GEZ-5206A (Brochure), December 1973
- 16 Bendix Electric Power Division, "A Technical Introduction to the Bendix Constant Frequency Generator", 73-6-11, August 1973
- 17 Talbot, General Electric Co., "20 KVA VSCF Electrical Power System Readiness Test Report", R74 AEE 308, December 1974
- 18 Emerson, Pratt & Whitney Aircraft Corp., "An Engine Designer's View for Advanced Secondary Power Systems", AIAA Conference 77-517, March 1977

## BIBLIOGRAPHY

ACCARDI, "U. S. Army Target Guided Missile Program, AMC", June 1976, U. S. Army Missile Command, Attn: DRSMI-IM, Redstone Arsenal, Alabama 35809

AGARD Conference, "Energetics for Aircraft Auxiliary Power Systems", AGARD-CPP-104, May 1972

Bailey, Lafuze, Messenger, Triebel, General Electric Co., "150 KVA Samarium Cobalt VSCF Starter Generator Electrical System, Phase I", AFAPL-TR-76-8, March 1976

Bendix Corp., "Constant Frequency Generator System", Report No. 1338, October 1974

Bogner, Jet Propulsion Lab., "NASA Advanced Chemical Batteries Program", AIAA Conference Paper No. 77-516, March 1977

Bishop, AF Aero Propulsion Laboratory, "Electromechanical Battery Trends for Aircraft and Missile Applications", AIAA Conference 77-481, March 1977

Caputo, Fox, "Future Trends in Air Force Aircraft Electrical Power Distribution and Control", AIAA Conference, 77-493, March 1977

Condon, Aero Propulsion Lab. "The Super Integrated Power Unit - The Aircraft Power Unit of the Future", AIAA Conference Paper No. 77-502, March 1977

Due, Jr., Teledyne CAE, "The Expendable Gasifier", AIAA Conference Paper No. 77-497, March 1977

"Final Technical Report on Results of Flight Demonstration for Teledyne Ryan Model 235, YQM-98A Compass Cope R", Report No. TRA 23569-1, dated February 1975

Gangl, ASD/ENAI Wright-Patterson AFB, "Proceedings Multiplex Data Bus Conference", Dayton, Ohio, November 1976

Grasmere, Newman, Pierce, Gulton Industries, Inc., "Maintenance Free Battery System Model EMBC (NICAD)", AFAPL-TR-72-85, December 1972

Jones, Marek, Bates, Vought Aeronautics Co., "Solid State Aircraft Electrical Power Transmission System", AFAPL-TR-71-30; July 1971

Kerr, Pickett, AF Aero Propulsion Laboratory, "Space Battery Technology for the 1980's", AIAA Conference Paper No. 77-482, March 1977

## BIBLIOGRAPHY (Continued)

Kevern, "Evaluation of the Solid State Simulator for the A7-B Aircraft Electrical System", AFAPL-TR-72-88, April 1978

Lautner, Perkins, Cought Corp., "Electrical Load Management for Advanced Aircraft Electrical Systems", 77CH1203-9 NAECON '77 Record Page 1102, May 1977

The Marquardt Company, "FVPS Generator Requirements", A75-3-731-18

PRICE Reference Manual, RCA/PRICE Systems, Cherry Hill, N. J., October 1975

PRICE Life Cycle Cost Model Reference Manual, RCA/PRICE Systems, Cherry Hill, N. J., August 1977

Steunenberg, Argonne National Lab., "Lithium-Aluminum/Metal Sulfide Batteries", AIAA Conference Paper No. 77-483, March 1977

Wood, Echols, Ashmore, AiResearch Manufacturing Co., "Electro-mechanical Actuation Feasibility Study", AFFDL-TR-76-42, May 1976