

AD-A060 342

HARRIS CORP MELBOURNE FLA ELECTRONIC SYSTEMS DIV
26-PAIR FIBER CABLE STUDY.(U)

F/G 20/6

UNCLASSIFIED

1 OF 2

AD
A060342

JAN 76 C R PATISAUL, I B SLAYTON, J W BRUCE

DAAB07-75-C-0363

ECOM-75-0363-F

NL



LEVEL II

2

AD A060342



RESEARCH AND DEVELOPMENT TECHNICAL REPORT ECOM 75-0363-F

18

19

6

26-PAIR FIBER CABLE STUDY

DDC FILE COPY

10

C. R./Patisaul,
I. B./Slayton,
J. W./Bruce
C. M./Abrahamson

Harris Corporation Electronic Systems Division
Melbourne, Florida 32901

DDC
OCT 25 1978
F

11

January 1976

12

147 p.

9

Final Report 15 Jun 1975 - 15 Nov 1975

15 DAAB07-75-C-0363

DISTRIBUTION STATEMENT

Approved for public release; distribution unlimited

Prepared for

ECOM

78 10 12 029

U.S. ARMY ELECTRONICS COMMAND FORT MONMOUTH, NEW JERSEY 07703

408 972

mt

UNCLASSIFIED

SECURITY CLASSIFICATION OF THIS PAGE (When Data Entered)

REPORT DOCUMENTATION PAGE		READ INSTRUCTIONS BEFORE COMPLETING FORM
1. REPORT NUMBER ECOM-75-0363-F ✓	2. GOVT ACCESSION NO.	3. RECIPIENT'S CATALOG NUMBER
4. TITLE (and Subtitle) FIBER OPTIC 26-PAIR CABLE SYSTEM STUDY	5. TYPE OF REPORT & PERIOD COVERED Final 15 June - 15 November 1975	
	6. PERFORMING ORG. REPORT NUMBER	
7. AUTHOR(s) C. R. Patisaul I. B. Slayton	J. W. Bruce C. M. Abrahamson	8. CONTRACT OR GRANT NUMBER(s) DAA807-75-C-0363 ✓
9. PERFORMING ORGANIZATION NAME AND ADDRESS Harris Corporation Electronic Systems Division ✓ Melbourne, Florida 32901		10. PROGRAM ELEMENT, PROJECT, TASK AREA & WORK UNIT NUMBERS
11. CONTROLLING OFFICE NAME AND ADDRESS U.S. Army Electronics Command Attn.: AMSEL-NL-RM-1	12. REPORT DATE November 1975	
	13. NUMBER OF PAGES 112	
14. MONITORING AGENCY NAME & ADDRESS (if different from Controlling Office)	15. SECURITY CLASS. (of this report) UNCLASSIFIED	
	15a. DECLASSIFICATION/DOWNGRADING SCHEDULE	
16. DISTRIBUTION STATEMENT (of this Report) Approved for Public Release; Distribution Unlimited		
17. DISTRIBUTION STATEMENT (of the abstract entered in Block 20, if different from Report)		
18. SUPPLEMENTARY NOTES		
19. KEY WORDS (Continue on reverse side if necessary and identify by block number) Optical Cable Communications, Fiber Optic Cable Communications, Optical Fiber Communications.		
20. ABSTRACT (Continue on reverse side if necessary and identify by block number) Because of the significant size, weight, and cost savings and the elimination of EMP, EMI, RFI, crosstalk and grounding problems, fiber optic cables are being considered as a replacement for the CX-4566, 26-Pair cable. A study was performed to establish the most effective method of utilizing optical cable technology for analog and digital voice communications over a 1000 foot link between a field deployed junction box and AN/TTC-38 and AN/TTC-39 tactical switchboards. Specific subscriber sets connecting		

→ next page

with the fiber optic link through the junction box and tactical switches, include the Digital Secure Voice Terminal (DSVT), Digital Nonsecure Voice Terminal (DNVT) and the TA-838/TT, TA-341/TT conventional touch tone analog voice terminals.

As part of the study, alternative multiplexing techniques were compared (based on cost, performance and physical parameters), and a preliminary hardware design performed for the recommended approach. Alternative multiplexing techniques, considered, included Time Division Multiplexing (TDM), Frequency Division Multiplexing (FDM), Space Division Multiplexing (SDM) and a hybrid combination of FDM and SDM (FDM/SDM). It was determined that for both analog and digital voice, the (FDM/SDM) approach offers the best compromise between cost, performance, fault tolerance and physical parameters.

The designed system uses a six-fiber cable with 3 fibers dedicated to each direction of transmission, for full duplex operation. Channel assignments are such that five channels are dedicated to one fiber and four channels dedicated to each of two other fibers. Five common subcarriers are used including 0.6 MHz, 1.6 MHz, 2.6 MHz, 3.6 MHz and 4.6 MHz, requiring a total bandwidth of 5 MHz.

Implementation of the fiber optics link will involve replacement of the J-1077 junction box with a new junction box, to house the multiplexer and electro-optic hardware. The new fiber optic junction box is housed in an enclosure 8" x 10" x 16", weighs forty pounds and consumes 26 watts of power. The fiber cable used with the system weighs approximately 17 pounds in contrast to the CX-4566, which weighs 304 pounds. The fiber optic system can accommodate up to fifteen telephones (either analog or digital) at a distance of up to 2.5 kilometers, operating in DC or AC supervisory modes.

Voice channel performance through the system provides an error rate of less than 10^{-9} in the digital channels and a SNR of better than 40 dB for the analog sets. Crosstalk isolation is better than 60 dB, when, all channels transmit 32 kilobit conditioned diphas.

ACCESSION for	
NTIS	<input checked="" type="checkbox"/>
DDI	<input type="checkbox"/>
UNCLASSIFIED	<input type="checkbox"/>
J. S. I. O. N. T. V.	
BY	
DISTRIBUTION/ADVISORY CODES	
CIAL	
A	

TABLE OF CONTENTS

<u>Paragraph</u>	<u>Title</u>	<u>Page</u>
1.0	INTRODUCTION	1-1
2.0	SUMMARY	2-1
2.1	Requirements Summary	2-1
2.2	Conclusions and Recommendations	2-3
3.0	SIGNAL CHARACTERISTICS	3-1
3.1	Conditioned Diphase PCM	3-1
3.2	Analog Voice	3-6
4.0	OPTICAL LINK COMPONENTS AND CHARACTERISTICS	4-1
4.1	Optical Cable Characteristics	4-1
4.2	Optical Source Characteristics	4-3
4.3	Photodetector Characteristics	4-3
4.4	Received Optical Carrier Power	4-4
5.0	PERFORMANCE ANALYSES	5-1
5.1	Space Division Multiplexing	5-1
5.2	Time Division Multiplexing	5-5
5.3	Frequency Division Multiplexing	5-10
5.3.1	FDM With AM Subcarriers	5-12
5.3.2	FDM With FM Subcarriers	5-18
5.3.3	Summary	5-21
5.4	Hybrid FDM/SDM	5-21
6.0	TRADE-OFF ANALYSIS AND RECOMMENDATION	6-1
6.1	Size and Weight Comparison	6-1
6.2	Power Consumption	6-3
6.3	Fault Tolerance	6-4
6.4	Performance	6-4
6.5	Cost Considerations	6-6
6.6	Conclusions	6-7

TABLE OF CONTENTS (Continued)

<u>Paragraph</u>	<u>Title</u>	<u>Page</u>
7.0	RECOMMENDED APPROACH	7-1
7.1	System Design	7-1
7.1.1	System Description	7-2
7.1.2	Frequency Plan	7-4
7.1.3	Crosstalk Isolation	7-5
7.1.4	Interface Description	7-11
7.1.4.1	Subscriber/Junction Box Interface	7-11
7.1.4.1.1	Message and Dc Power Interface	7-11
7.1.4.1.2	Dc Supervision	7-14
7.1.4.1.3	Ac Supervision	7-14
7.1.4.2	Fiber Optics Link/Patch Panel Interface	7-14
7.1.4.2.1	Message Interface/Ac Supervision	7-14
7.1.4.2.2	Dc Supervision	7-14
7.1.4.3	Dc Power Interface	7-16
7.1.4.3.1	Dc Power Requirements	7-16
7.2	Hardware Design	7-18
7.2.1	Circuitry	7-18
7.2.1.1	Transmitter	7-18
7.2.1.1.1	Subcarrier Oscillator	7-20
7.2.1.1.2	Modulation Leveling Circuit	7-25
7.2.1.1.3	Modulator	7-25
7.2.1.1.4	Amplifier and Filters	7-30
7.2.1.1.5	Power Amplifier	7-30
7.2.1.1.6	Power Combiner	7-38
7.2.1.1.7	Power Leveling Circuit	7-43
7.2.1.2	Receiver	7-43
7.2.1.2.1	Filters (Predetection)	7-45
7.2.1.2.2	Amplifier/Detector Circuit	7-49
7.2.1.2.3	Voltage Amplifier	7-50
7.2.1.2.4	Power Amplifier	7-50
7.2.1.3	Power Conditioning, Power Requirements	7-50
7.2.1.4	Ac/Dc Supervision	7-53
7.2.1.5	LED Circuitry	7-56
7.2.1.6	Optoelectronic Receiver	7-58
7.2.2	Mechanical	7-60
7.2.2.1	Transformer/Binding Post Subassembly	7-60
7.2.2.2	Electronics Subassembly	7-60
7.2.2.2.1	Transmitter	7-63
7.2.2.2.2	Receiver	7-63
7.2.2.2.3	Oscillator Group	7-63
7.2.2.2.4	Power Combiners	7-63
7.2.2.2.5	Fiber Optic Receiver/Transmitter	7-63

TABLE OF CONTENTS (Continued)

<u>Paragraph</u>	<u>Title</u>	<u>Page</u>
7.2.2.2.6	Fiber Optic Splicing Assembly (FOSA)	7-64
7.2.2.3	Power Supply	7-64
7.2.2.4	Weight	7-64
7.2.2.5	Coupling Between Optical Source and Optical Connector	7-65
7.3	Manufacturing Considerations	7-65

APPENDICES

A	DC POWER AND DYNAMIC RANGE	A-1
B	MULTICARRIER INTERMODULATION	B-1

LIST OF ILLUSTRATIONS

<u>Figure</u>	<u>Title</u>	<u>Page</u>
2.1-1	Tactical Fiber Optic Link System Summary	2-2
3.1-1	An Idealized Conditioned Diphase Waveform	3-2
3.1-2	Power Spectrum for Conditioned Diphase PCM	3-2
3.1-3	Percent of Total Power Contained in a $-\omega_B$ to $+\omega_B$ Bandwidth for Conditioned Diphase PCM	3-3
3.1-4	A Receiver Structure for Conditioned Diphase in White Gaussian Noise	3-5
4.1	Modal Dispersion Frequency Response of the Optical Fiber Cable	4-2
4.4-1	Illustrative Diagram for Received Optical Power Calculation	4-5
5.1-1	SDM Approach Block Diagram	5-2
5.1-2	SNR Performance for the SDM Approach	5-4
5.2-1	TDM Approach Block Diagram	5-6
5.2-2	Receiver Model for TDM Approach	5-8
5.3	FDM Approach Block Diagram	5-11
5.3.1-1	Analysis Model for FDM With AM Subcarriers (Only One Channel Shown)	5-12
5.3.1-2	SNR Performance for the FDM-AM Approach	5-17
5.3.2-1	Analysis Model for FDM With FM Subcarriers (Only One Channel Shown)	5-18
5.3.2-2	SNR Performance for the FDM-FM Approach	5-22
5.4-1	FDM/SDM Approach Block Diagram	5-24
5.4-2	SNR Performance for the FDM-AM/SDM Approach	5-25
5.4-3	SNR Performance for the FDM-FM/SDM Approach	5-26
6.4-1	Summary of SNR Performance for Analog Multiplexing Approaches	6-5
7.1.1-1	Overall Block Diagram	7-3
7.1.3-1	Illustrating Direct Subcarrier Crosstalk	7-6
7.1.3-2	Illustrating Adjacent Channel Spillover (DSVT Signals)	7-8
7.1.3-3	Addition of IM Products	7-12
7.1.4.1.1-1	Subscriber/Junction Box Interface	7-13
7.1.4.2.2-1	Fiber Optics/Patch Panel Interface	7-15
7.1.4.3-1	Dc Power Interface	7-17
7.2.1.1-1	Typical Transmitter	7-19
7.2.1.1-2	Typical Transmitter	7-21
7.2.1.1.1-1	Oscillator Block Diagram	7-22
7.2.1.1.1-2	Typical Oscillator Circuit	7-23
7.2.1.1.2-1	Modulation Leveling Circuit	7-26

LIST OF TABLES

<u>Table</u>	<u>Title</u>	<u>Page</u>
2.2-1	Key Trade-Off Parameters	2-5
4.2	LED Characteristics	4-3
4.3	Photodetector Characteristics	4-4
6.0-1	Key Trade-Off Parameters	6-2
7.2.1.1.1-1	Oscillator/Buffer Amplifier Elements	7-24
7.2.1.1.1-2	Oscillator Output Amplifier Elements	7-24
7.2.1.1.2	VCR Voltage Levels Versus Resistance	7-28
7.2.1.1.4-1	Bandpass Filter Elements (Transmit Side)	7-32
7.2.1.1.5	Harmonics of RF Carriers Due to Power Amplifier	7-38
7.2.1.2.1	Bandpass Filter Elements (Receiver Side)	7-48
7.2.1.2.2	Element Values for Detector Circuit	7-50
7.2.1.3	Power Requirements	7-52

LIST OF ILLUSTRATIONS (Continued)

<u>Figure</u>	<u>Title</u>	<u>Page</u>
7.2.1.1.2-2	J-FET Characteristics	7-27
7.2.1.1.3	Test Circuit for Modulator	7-29
7.2.1.1.4-1	Typical BPF (Transmit or Receive)	7-31
7.2.1.1.4-2	600 kHz BPF	7-33
7.2.1.1.4-3	Frequency Response of 1.6 MHz BPF	7-34
7.2.1.1.4-4	Frequency Response of 2.6 MHz BPF	7-35
7.2.1.1.4-5	Frequency Response of 3.6 MHz BPF	7-36
7.2.1.1.4-6	Frequency Response of 4.6 MHz BPF	7-37
7.2.1.1.5-1	Frequency Response of 600 kHz LPF	7-39
7.2.1.1.5-2	Frequency Response of 1.6 MHz LPF	7-40
7.2.1.1.5-3	600 kHz Lowpass Filter	7-41
7.2.1.1.5-4	1.6 MHz Lowpass Filter	7-41
7.2.1.1.6	Power Combiner Configuration	7-42
7.2.1.1.7	Power Leveling Circuit	7-44
7.2.1.2-1	Typical Receiver	7-46
7.2.1.2-2	Typical Receiver Channel	7-47
7.2.1.2.1	Single Tone Amplitude Modulated Waveform	7-49
7.2.1.3	Power Supply	7-51
7.2.1.4-1	ON/OFF Hook Sensing Circuit (Transmit Side)	7-55
7.2.1.4-2	ON/OFF Hook Sensing Circuit (Receive Side)	7-57
7.2.1.6-1	Input Capacitance Neutralized Optoelectronic Receiver	7-59
7.2.1.6-2	Equalized Impedance-Matched Optoelectronic Receiver	7-59
7.2.2-1	Junction Box	7-61
7.2.2-2	Junction Box, Electronics Cover Open	7-62
7.2.2.5-1	Single Fiber Splicing Connector	7-66
7.3-1	Typical Transmitter Module	7-68
7.3-2	Typical Receiver Module	7-69

SECTION 1.0
INTRODUCTION

1.0

INTRODUCTION

This document is the result of a 5 month program of study (Contract Number DAAB07-75-C-0363), conducted by the Harris Corporation Electronic Systems Division, for the Army Electronics Command, Fort Monmouth. The objective of the study was to establish the most effective method of utilizing optical cable technology for digital and analog voice communications between the J-1077 junction boxes and the AN/TTC-38 and AN/TTC-39 tactical switchboards. The fiber optic link, ultimately, will be a replacement for the CX-4566 26-Pair conventional metallic cable, with the objective of achieving significant size, weight and cost advantages. Specific subscriber terminals which connect with the fiber optic link, through the J-1077 junction box and tactical switches include the Digital Secure Voice Terminal (DSVT), Digital Nonsecure Voice Terminal (DNVT) and the TA-838/TT, TA-341/TT conventional touch tone analog voice terminals.

In arriving at the conclusions of the study substantial performance and hardware trade-off analyses were performed for alternative multiplexing and modulation schemes, involving Time Division Multiplexing (TDM), Frequency Division Multiplexing (FDM), Space Division Multiplexing (SDM) and a hybrid combination of FDM and SDM. Subsequent sections of this report provide the results of this analysis, the associated conclusions, and a preliminary hardware design for the recommended approach.

SECTION 2.0

SUMMARY

2.0 SUMMARY

2.1 Requirements Summary

Because of the significant size, weight, and cost savings, and reduction or elimination of EMP, EMI, RFI, crosstalk and grounding problems, fiber optic cables are being considered as a replacement for the CX-4566, 26-Pair cable. The CX-4566 cable connects between a standard J-1077 junction box and patch panel assemblies associated with the AN/TTC-38 and AN/TTC-39 tactical switchboards. As shown in Figure 2.1-1, the junction box provides a connection point for a maximum of thirteen full duplex subscriber sets consisting of DSVT, DNVT, TA-838()/TT, and TA-341()/TT field telephones. The signals associated with the digital telephones are transmitted as 32 kilobit or 16 kilobit conditioned diphas. Analog phone sets consist of voice and associated supervisory tones. The analog channels are to be operated with a signal-to-noise objective of better than 40 dB. Error rate performance for the digital channels shall be better than 10^{-9} . Crosstalk isolation between channels is to be -60 dB, when all channels are connected to digital telephones.

The telephones connect to the junction box by means of standard WF-16 field wire, at a distance not to exceed 2.5 kilometers. The distance between the junction box and patch panel assemblies is a maximum of 1000 feet. The existing cable is produced in standard 250 foot lengths and hence 4 sections are required for the 1000 foot distance. However, because of its small size and light weight, the optical cable used would involve standard lengths of 1000 feet. Optical transmitters, receivers and multiplexer/demultiplexer electronics, at each end of the link will be housed in the J-1077 junction box and patch panel.

The optical devices used in the design of the link were specified by ECOM, including fiber cable, optical source, and hybrid photodetector receiver. It is understood that these devices are being developed as standard devices for satisfying ECOM system requirements. The optical cable, which was specified, has a fiber with a 3 mil pure fused silica core, and a numerical aperture of 0.3. Attenuation for this fiber will be 20 dB per kilometer or less. Detail characteristics for the source and photodetector receiver, as forwarded by ECOM, are summarized in Section 4.0 of this report.

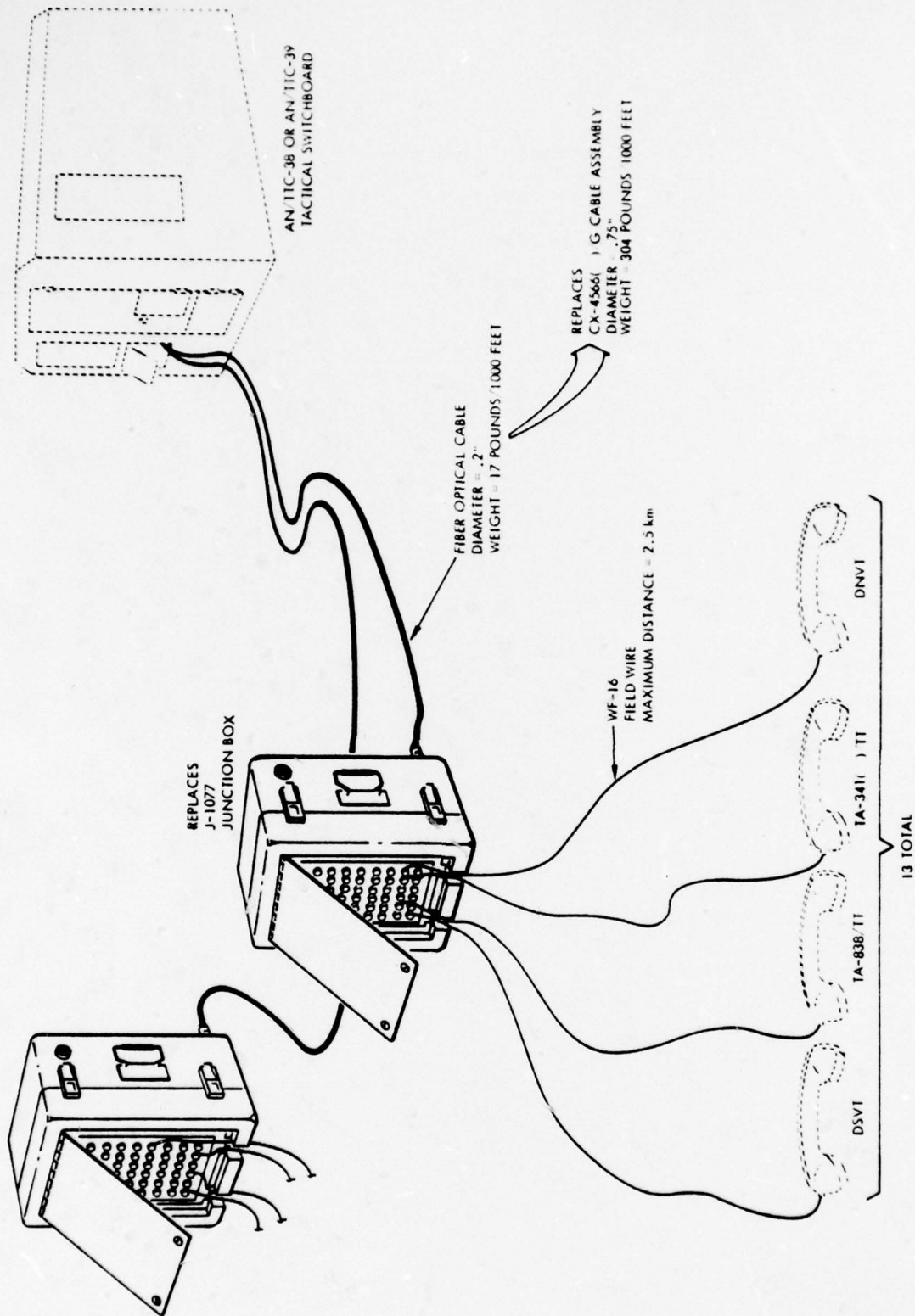

Figure 2.1-1. Tactical Fiber Optic Link System Summary

Conclusions and Recommendations

Based on the results of the study it is recommended that the 26-Pair system be implemented using hybrid frequency division and space division multiplexing. The modulation base recommended is Amplitude Modulation. Frequency modulation was also considered, however the AM approach provides satisfactory link performance and will ultimately provide the simplest, most cost effective implementation.

A total of six optical fibers will be required for the recommended approach. For satisfying full duplex operation three fibers will be dedicated to each direction of transmission. Channel assignments are such that five channels will be dedicated to one fiber and four channels dedicated to each of two other fibers. The subcarrier frequency plan has been arranged such that none of the subcarriers are harmonically related. Five subcarriers are used including 0.6 MHz, 1.6 MHz, 2.6 MHz, 3.6 MHz, and 4.6 MHz requiring a total bandwidth of 5 MHz. This common set of subcarriers is used for each of the three fiber transmitters. The electronics was designed such that the analog phone sets may operate in either ac or dc supervisory modes.

Each of the 13 channels accommodated by the fiber optics link has been designed to be totally transparent and may be connected to either an analog or digital subscriber set. The frequency plan and associated filter networks have been arranged such that the system achieves better than 60 dB of crosstalk isolation when all channels are connected to DSVT's.

Based on the ECOM specified devices, the optical link has been designed such that it operates with 14.6 dB of optical margin, achieving better the 10^{-9} BER in the digital channels and better than 40 dB SNR in the analog channels.

A new junction box was designed to house the fiber optic electronics. This new ruggedized enclosure which includes all electronics as well as the binding post assembly, has outside dimensions of 8 x 10 x 16 inches. The combined weight of the optical transmitters, receivers and multiplexer/demultiplexer electronics is 6.3 pounds. The largest percentage of total weight is contributed by the enclosure, transformers, and binding post assembly, such that the combined weight of the junction box assembly including electronics is 40 pounds. Power consumption for the multiplexer and optical electronics is 26 watts when all channels are active and 16 watts when all phones are on-hook. More details concerning the recommended approach are provided in Section 7.0 of this report. It is estimated that the purchase price per junction box (including ruggedized enclosure, multiplexer electronics, and power supplies) will be approximately \$2600.00, when mass-produced in quantities of 10,000 units.

Other design approaches also considered during this study included SDM, FDM, and TDM. The characteristics of all approaches considered, are summarized in Table 2.2-1. Within the TDM category, both TTL and SOS/C-MOS devices were evaluated. All alternatives exhibited comparable size and weight characteristics. The TTL/TDM design involves the highest power consumption, requiring 40% more power than either of the other approaches. The other approaches, including FDM/SDM require approximately the same amount of power.

From the standard point of performance all approaches provide an adequate link margin to achieve the specified performance. With the exception of FDM, all approaches also are capable of achieving a crosstalk isolation of better than 60 dB. For the FDM approach, combining all thirteen channels within a 5 MHz bandwidth, causes a crosstalk isolation of less than 40 dB. Consequently the FDM approach is not recommended.

The SDM approach excels in all trade parameter categories including size, weight, power consumption, simplicity, high modularity (and hence ease of construction), performance, and maximum crosstalk isolation. However this approach requires the use of 26 optical fibers, transmitters and receivers. Not only would such a cable structure be much more bulky, but the costs of the fibers and devices would also be prohibitive. Consequently for this reason the SDM approach is not recommended.

TABLE 2.2-1. KEY TRADE-OFF PARAMETERS

Approach	Power (Watts)	Weight (Lbs)	Size (Inches)	Min. No. of Fibers	Optical* XMTRS	Optical* RCVRS	Cross-talk (dB)	Rise Time (µsec)	Channel Bandwidth (MHz)	Optical Margin (dB)	Lost Channels Per Failure
SDM	16	6	7.8X3X2	26	13	13	< -60	< 1	5	26	1
FDM/SDM	18	6.3	8X8X6	6	3	3	< -60	~1.8	5	AM 15 / 25 FM	5
FDM	17.5	6.3	8X8X6	2	1	1	> -40	> 4	5	AM 10 / 21 FM	13
TDM	CMOS 15 / 26 TTL	CMOS 4.6 / 5.5 TTL	CMOS 7X8X6 / 8X10X6 TTL	2	1	1	< -60	~1.2	~20	33	13

*Per Junction Box.

The TDM approaches require significantly more bandwidth than the 5 MHz capability of the optical receiver. Although this approach does have certain attractive features, the general requirements of the system (to accommodate both analog and digital channels) require complex analog voice processing and filtering. Consequently, because of its relative complexity, this approach is not recommended. It should be noted that if the requirements are modified, such that only digital channels are used, then the TDM design could be significantly simplified. In view of the fact that much of the all digital system would be amendable to an LSI implementation, it is projected that this approach would be smaller, lighter and cheaper than all of the other approaches considered.

In view of the general requirements specified, the FDM/SDM approach offers the best compromise between cost, performance, fault tolerance and physical parameters. The DSVT rise time is degraded by only 1.8 μ s yet a crosstalk isolation of approximately 60 dB is achieved. The FDM/SDM approach is inherently fault-tolerant, involving the loss of only 5 user channels in the event of the failure of an optical transmitter, detector, fiber, multiplexer or demultiplexer. In view of the good performance available with AM and simple envelope detectors, it is felt that the additional optical margin offered by the use of an FM subcarrier system does not justify the additional complexity associated with its implementation. Therefore, FDM-AM/SDM is the recommended approach to the 26-Pair Fiber Optic Cable System. The detailed implementation of this approach is presented in Section 7.0 of this report.

SECTION 3.0
SIGNAL CHARACTERISTICS

3.0 SIGNAL CHARACTERISTICS

This section presents a summary of the characteristics of the DSVT and analog voice signals which are pertinent to the design of the 26-Pair Fiber Optic Cable System. Section 3.1 examines the conditioned diphase PCM employed by the DSVT. The analog voice signals from the TA-838 and TA-341 telephone sets are considered in Section 3.2.

3.1 Conditioned Diphase PCM

The digital data format used by the DSVT is baseband conditioned diphase PCM, also known as biphase space PCM [1,2]. This format is characterized by a transition at every bit boundary. A ONE is represented by no second transition, while a ZERO is represented by a second transition at mid-bit. Figure 3.1-1 illustrates this type of signaling with an idealized waveform. The power spectrum for such a waveform, made up of random bits with equally likely ONE's and ZERO's, is given by the following:

$$S(\omega) = \frac{E_T^2}{2\pi} \left[\frac{\sin^4\left(\frac{\omega T}{4}\right)}{\left(\frac{\omega T}{4}\right)^2} \right] \quad 3.1-1$$

This power spectrum is plotted in Figure 3.1-2. Figure 3.1-3 shows the fraction of the total signal power contained in a given bandwidth. These curves will be useful in the analysis of crosstalk isolation given in a later section.

[1] Batson, B. H., "An Analysis of the Relative Merits of Various PCM Code Formats", NASA Internal Note No. MSC-EB-R-68-5, November 1968.

[2] Powers, S. G., "Baseband PCM Modulation and Detection Schemes", part of Avionics Multiplex Study, Contract F-33615-71-C-1917, October 1971.

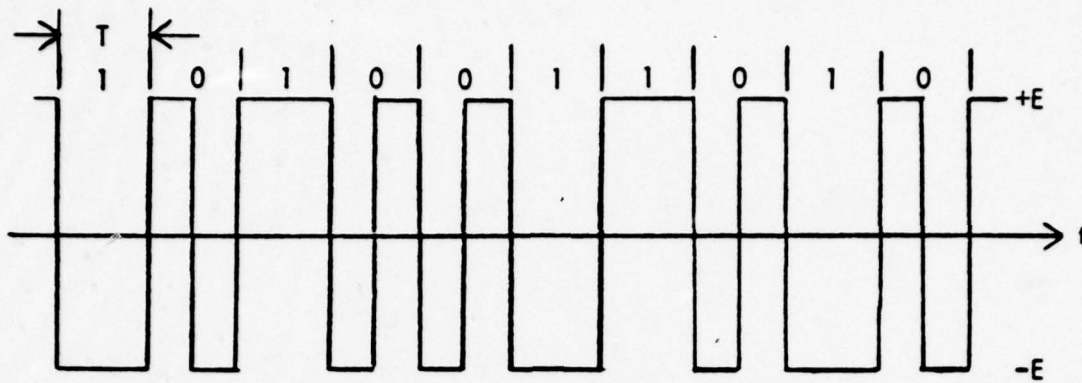

Figure 3.1-1. An Idealized Conditioned Diphase Waveform

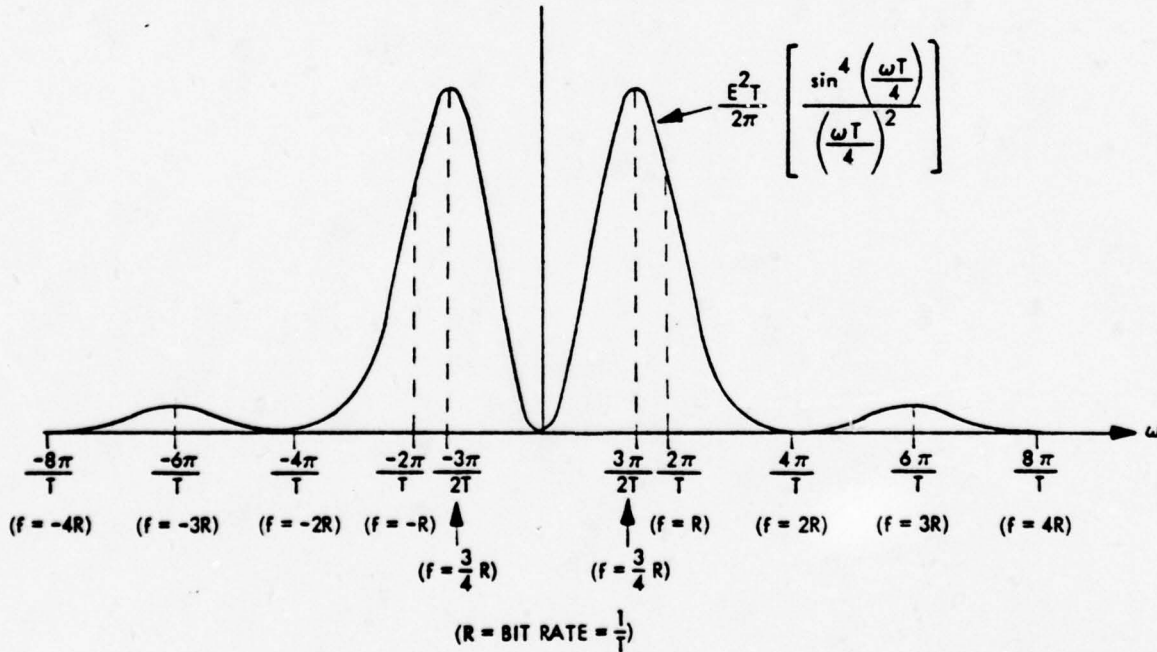

Figure 3.1-2. Power Spectrum for Conditioned Diphase PCM [1]

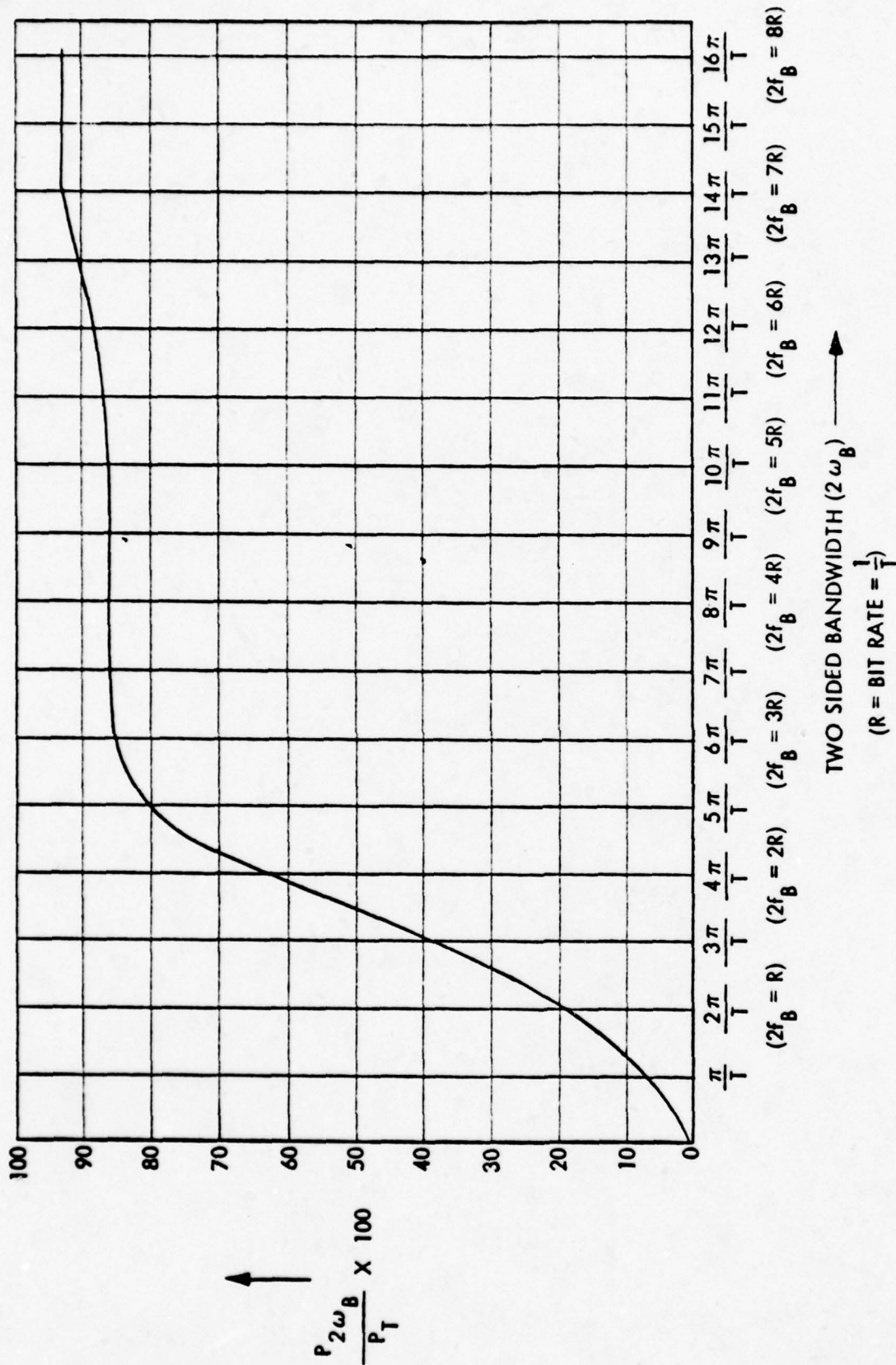

Figure 3.1-3. Percent of Total Power Contained in a $-\omega_B$ to $+\omega_B$ Bandwidth for Conditioned Diphas PCM [1]

It is possible to structure a matched filter receiver for the detection of conditioned diphase in white Gaussian noise. Such a receiver structure is shown in Figure 3.1-4. The probability of error for this receiver can be shown to be

$$P_{\epsilon} = 2 \left[\operatorname{erfc} \left\{ \sqrt{\operatorname{SNR}} \right\} - \left(\operatorname{erfc} \left\{ \sqrt{\operatorname{SNR}} \right\} \right)^2 \right] \quad 3.1-2$$

where SNR is the input signal-to-noise ratio with the noise measured in the bit rate bandwidth (single-sided) and

$$\operatorname{erfc} |x| = \frac{1}{\sqrt{2\pi}} \int_x^{\infty} e^{-y^2/2} dy \quad 3.1-3$$

For practical error probabilities,

$$\operatorname{erfc} \left\{ \sqrt{\operatorname{SNR}} \right\} \gg \left(\operatorname{erfc} \left\{ \sqrt{\operatorname{SNR}} \right\} \right)^2$$

so that

$$P_{\epsilon} \cong 2 \operatorname{erfc} \left\{ \sqrt{\operatorname{SNR}} \right\} \quad 3.1-4$$

Although this receiver is not the optimum receiver for conditioned diphase, it provides "near optimum" performance. A practical receiver should achieve performance within 3 dB of that predicted above, e.g., Powers [2] describes a receiver employing a single-pole lowpass filter that is only 2.4 dB worse than (3.1-4). Using (3.1-4), a tabulation of erfc and a 3 dB degradation for a practical receiver leads to a SNR of 18.7 dB for a probability of error of 10^{-9} , the performance desired for the optical cable system.

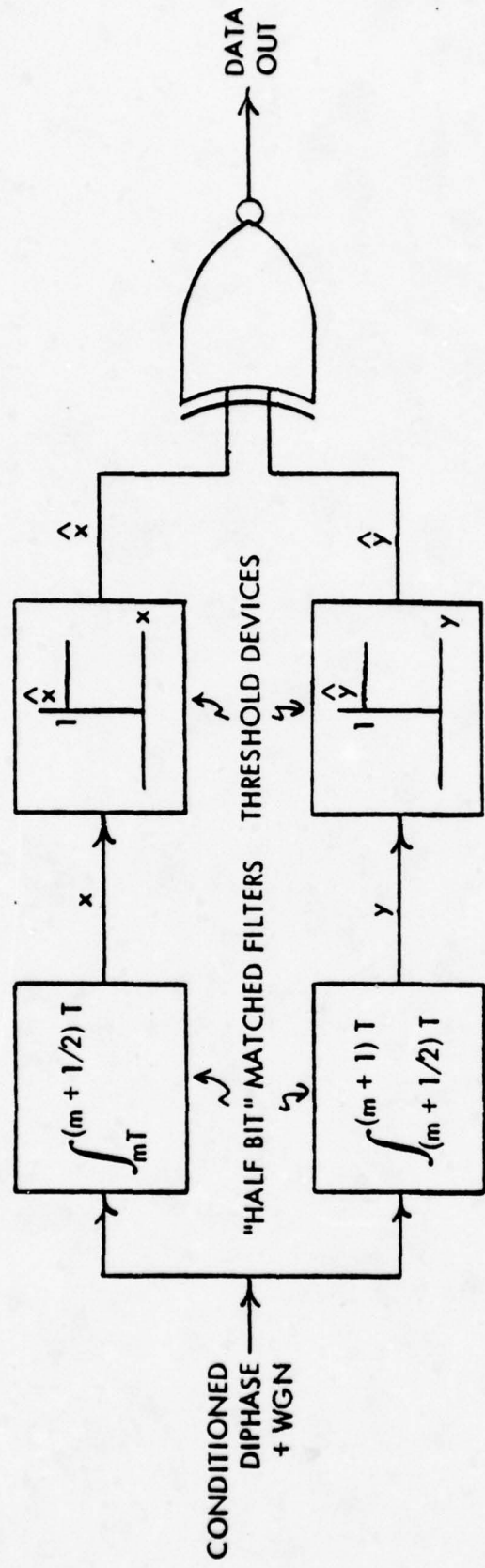

Figure 3.1-4. A Receiver Structure for Conditioned Diphasse in White Gaussian Noise

The DSVT operates at a bit rate of either 16 kb/s or 32 kb/s. The output waveform from the DSVT transmitter has rise and fall times in the range 0.65 to 1.95 μsec and a maximum droop of 5% when properly terminated. It is desirable that the optical cable link degrade this signal quality as little as possible. The nominal DSVT output signal is 3V p-p across 125 ohms. The optical cable system digital output must be capable of driving a 125 ohm load at this level. The DSVT will be connected to the optical cable system junction box by up to 2.5 km of WF-16 wire. Over the DSVT bandwidth this wire displays a maximum attenuation of 9.9 dB/mile or 6.2 dB/km. Thus the minimum DSVT signal level expected at the junction box is 0.5V p-p across 125 ohms.

3.2 Analog Voice

The output from the TA-341 telephone set ^[3] and the TA-838 telephone set ^[4] is either analog voice over the frequency range of 300 to 3500 Hz or audio tones for signaling. The nominal long term average speech output level from each set is -4 dBm in 600 ohms, with a maximum output level of +5 dBm. Typical signal tone levels are -4 to -7 dBm. The analog output circuitry of the optical cable system must be capable of delivering these levels into 600 ohms. It is required that the optical cable link, deliver a 40 dB SNR in a 3500 Hz bandwidth when the telephone output is -4 dBm. Up to 2.5 km of WF-16 wire will be used to connect the telephone set to the optical cable junction box. At the voice frequencies this wire exhibits an attenuation of approximately 2 dB/mile or 1.2 dB/km. The resulting minimum long-term average at the junction box is -7 dBm in 600 ohms.

[3] ECOM Technical Requirement SCL-1759J, Telephone Set TA-341()/TT,
16 December 1968.

[4] ECOM Development Specification EL-CP006I-0001D, Telephone Set TA-838()/TT,
16 May 1974.

A major concern in the transmission of analog voice is dynamic range. It is known that the short-term (1/8 second) RMS value of normal speech can exceed the long-term RMS by as much as 10 dB [5,6]. Thus it should be expected that, during normal speech, the +5 dBm output level of the telephone sets will be exercised. In addition, instantaneous speech peaks may exceed the short-term RMS value by 10 dB and, hence, the instantaneous peaks may be 20 dB greater than the long-term RMS level. This dynamic range can place stringent requirements on amplifiers and modulators in order to achieve the desired level of amplification or modulation at the average level with acceptably small distortion due to peak clipping or over modulation.

[5] Flanagan, J. L., Speech Analysis, Synthesis and Perception, Springer-Verlag, New York, 1972.

[6] Reference Data for Radio Engineers, Fifth Edition, Howard W. Sams and Company, Inc., Indianapolis, 1969.

SECTION 4.0

OPTICAL LINK COMPONENTS AND CHARACTERISTICS

4.0 OPTICAL LINK COMPONENTS AND CHARACTERISTICS

This section summarizes the characteristics of the ECOM specified optoelectronic devices and optical fiber cable which make up the optical portion of the 26-Pair Fiber Optic Cable System. The cable, optical source and photodetector are described and an optical power analysis is presented.

4.1 Optical Cable Characteristics

The optical transmission medium for the system studied is a ruggedized optical cable having six fiber waveguides which may be used as independent optical channels. The fibers have a step index profile with a numerical aperture (NA) of 0.3. The maximum attenuation of the cable at a wavelength of 840 nm is 20 dB/Km. Each end of the 1000 foot (~300m) cable is terminated in a connector which allows fiber-to-fiber coupling to a mating bulkhead connector on the terminal equipment. The assumed connector loss is 1 dB per connector. The six active fibers in the cable are assumed continuous, i.e., no in-line splices or connectors.

The frequency response of the cable can be estimated by applying the theory for modal dispersion in step-index fibers to obtain [7]

$$|S(f)| = \left| \frac{\sin(\pi \tau f)}{\pi \tau f} \right|$$

$$\tau = \frac{L(\text{NA})^2}{2Cn_1} \quad 4.1-1$$

[7] Mc Devitt, F. R. and Slayton, I. B., Optical Cable Communications Study, RADC, Contract F30602-74-C-0193, April 1975.

where

L = fiber length

C = speed of light in free space

n_1 = refractive index of the fiber core

Using $NA = 0.3$, $L = 300\text{m}$ and $n_1 = 1.5$ leads to the frequency response shown in Figure 4.1.

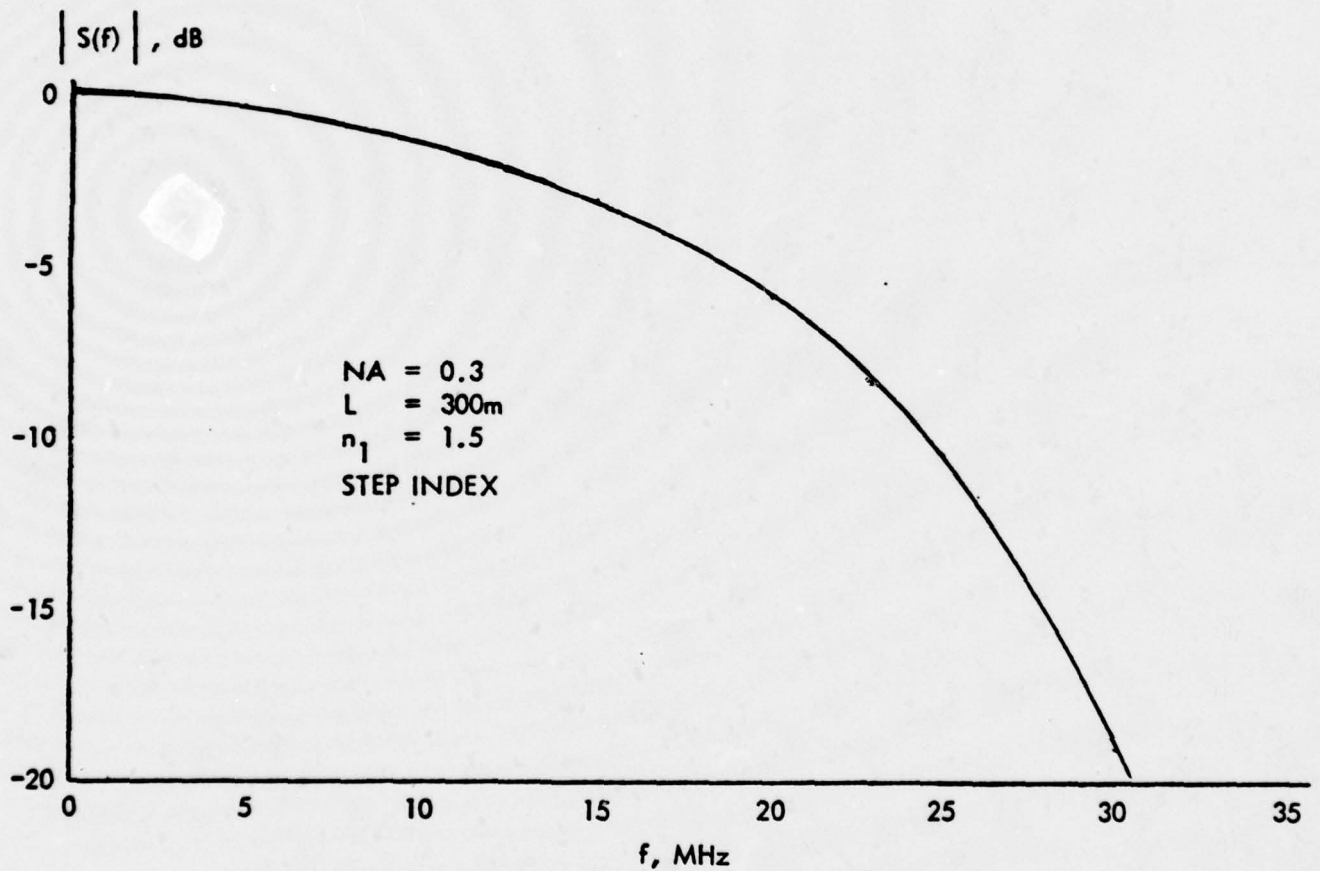

Figure 4.1. Modal Dispersion Frequency Response of the Optical Fiber Cable

4.2 Optical Source Characteristics

The optical source is a light-emitting diode (LED) similar to the Bell-Northern Research 40-3-30-3^[8]. This LED is designed specifically for coupling to a single optical fiber. A fiber stub of NA = 0.3 is permanently bonded to the LED, to facilitate coupling the optical energy to the cable fiber. Table 4.2 gives typical characteristics for the LED.

TABLE 4.2. LED CHARACTERISTICS

Peak Emission Wavelength	840 nm
Spectral Width	40 nm
Radiant Intensity	3 mW/sr @ $I_F = 150$ mA
Radiance	66 W/sr/cm ² @ $I_F = 150$ mA
Forward Voltage	1.7V @ $I_F = 100$ mA
Reverse Breakdown Voltage	3.0V @ $I_R = 10$ μ A
Emitting Area Diameter	75 μ m
Rise and Fall Time	20 ns maximum
Linearity	-50 dB 2nd harmonic distortion @ 100 \pm 50 mA, 1 MHz drive.

4.3 Photodetector Characteristics

The photodetector is a PIN photodiode and preamp hybrid circuit. The preamp has a linear AGC which operates when the incident optical power is greater than 10^{-5} watt. The important electrical parameters of this device appear in Table 4.3.

[8] Tentative Specifications for High Radiance Infrared Light-Emitting Diodes, BNR 40-3-30-2 and BNR 40-3-30-3, Issue 0475, Bell-Northern Research, Ltd., Ottawa, Canada.

TABLE 4.3. PHOTODETECTOR CHARACTERISTICS

Responsivity*	$1.5 \times 10^4 \text{ V/W @ } 820 \text{ nm, } P < 10^{-5} \text{ W}$ $0.15/P \text{ V/W, } P > 10^{-5} \text{ W}$
Output Noise Voltage (RMS)	$2.3 \times 10^{-8} \text{ V}/\sqrt{\text{Hz}}$
Bandwidth	5 MHz
Output Impedance	50Ω
Preamp V_{cc}	$\pm 12\text{V dc}$
Diode V_b	50V

*Use $1.5 \times 10^4 \text{ V/W}$ for signal-to-noise ratio calculations.

4.4 Received Optical Carrier Power

Figure 4.4-1 provides a diagram which illustrates the assumed configuration. The power which can be coupled from the LED into a single fiber stub of acceptance half-angle θ_A may be computed using the relation [9].

$$P = I_0 \pi \sin^2 \theta_A \quad 4.4-1$$

where I_0 is the on-axis radiant intensity of the LED. The assumptions implicit in (4.4-1) are that the fiber core area is at least as large as the emitting area of the diode and that the diode may be characterized as a Lambertian source. Using a typical radiant intensity of 2 mW/sr at a bias current of 100 mA for the BNR 40-3-30-3 diode yields a coupled power of 0.56 mW into the fiber stub. For an analog or FDM system, this bias point power corresponds to the average optical carrier power. For a pulsed or digital system, several times this value (1 to 2 mW) of peak pulse power could be obtained with a 50% duty cycle.

[9] Diersche, E. G., "Surface Emitting Sources for Optical Waveguides", Proceedings, Seminar on Guided Optical Communication, Society of Photo-Optical Instrumentation Engineers 19th Annual Technical Symposium, San Diego, August 1975.

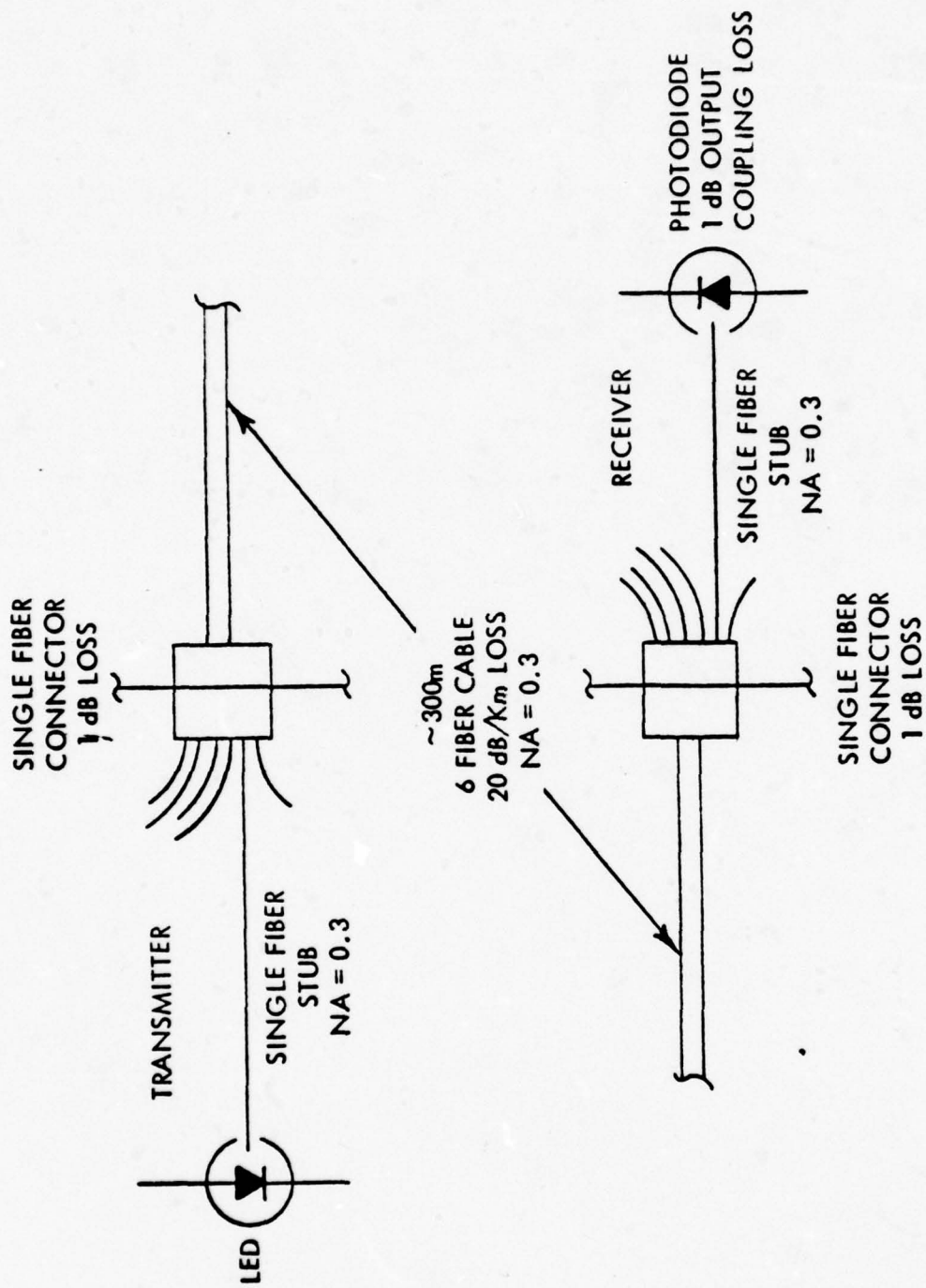

Figure 4.4-1. Illustrative Diagram for Received Optical Power Calculation

The average received optical carrier power is computed by subjecting the power coupled into the fiber stub to the various losses in the system. The single fiber connectors are assumed to have 1 dB of loss each; the cable attenuation is 20 dB/Km or 6 dB for 300m distance and the output coupling loss at the photodetector is 1 dB. The net loss is 9 dB and the average optical carrier power incident on the detector is thus 70 μ W.

SECTION 5.0
PERFORMANCE ANALYSES

5.0 PERFORMANCE ANALYSES

Four approaches for the implementation of the 26-Pair Fiber Optic Cable System have been studied. These are space division multiplexing, time division multiplexing, frequency division multiplexing and hybrid frequency and space division multiplexing. In the following paragraphs, these approaches are described and their noise performances are analyzed.

5.1 Space Division Multiplexing

One approach which might be considered for the 26-Pair Fiber Optic Cable System is the one-for-one replacement of the present wire channels with optical fiber channels. In other words, a single fiber channel would be dedicated to the transmission of a single user channel. This approach is referred to as space division multiplexing (SDM). In such a system the user input intensity modulates an LED at baseband. Baseband direct detection of the optical signal is performed by a photodetector at the receiver in order to recover the transmitted signal. A simplified diagram of an SDM system is given in Figure 5.1-1. This section investigates the SNR performance of the SDM system.

The optical carrier intensity incident on the photodetector of a baseband intensity modulation system may be written as^[7]

$$c(t) = 2P_R \left[1 + M_{IM} M(t) \right] \cos^2 \omega_c t \quad 5.1-1$$

where

P_R = average received optical carrier power

M_{IM} = intensity modulation index (≤ 1)

$M(t)$ = normalized modulating signal, $|M(t)| \leq 1$

ω_c = optical carrier frequency

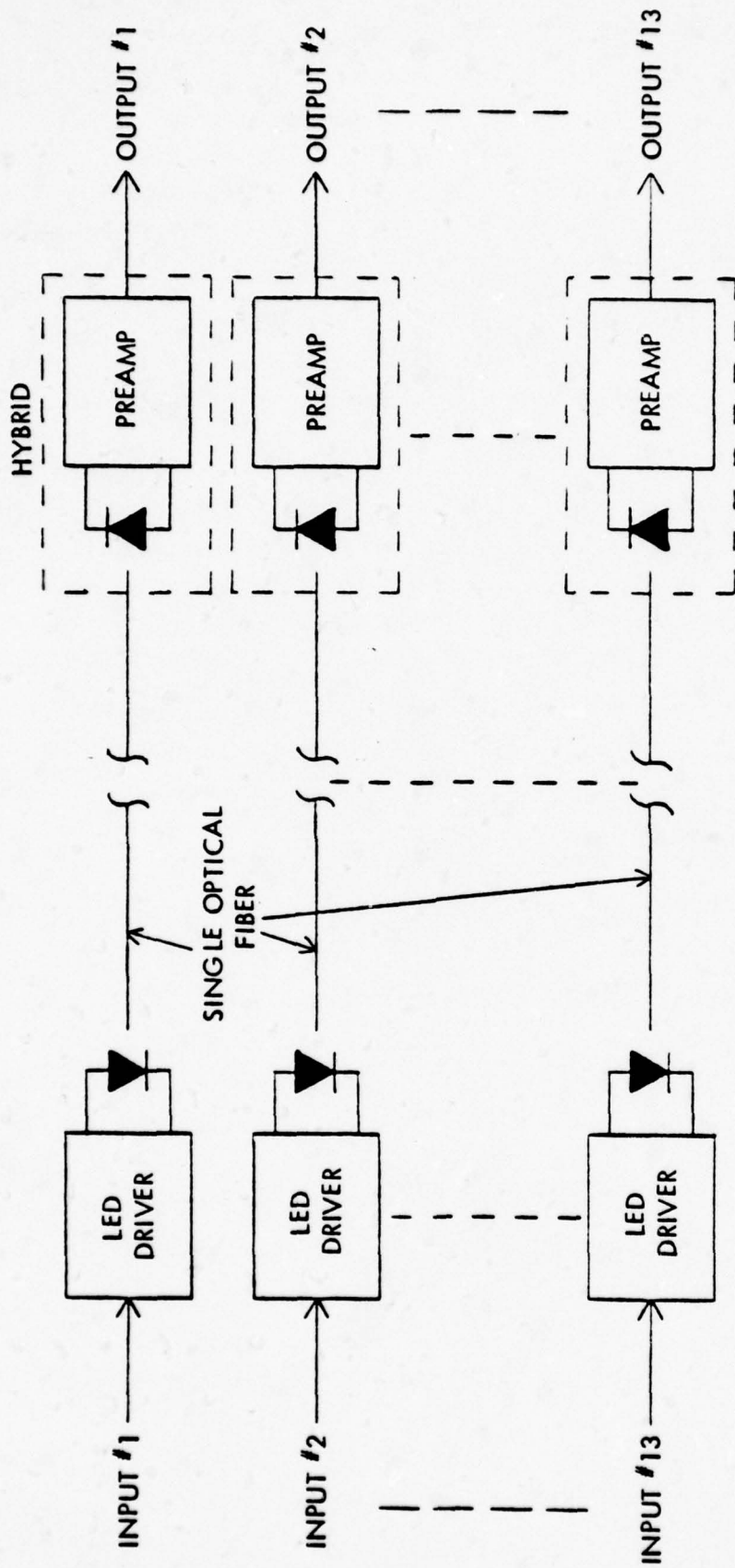

Figure 5.1-1. SDM Approach Block Diagram

The output voltage from the preamplifier is given by

$$V_p(t) = R_V P_R \left[1 + M_{IM} M(t) \right] + n_p(t) \quad 5.1-2$$

R_V is the responsivity (volts/watt) of the photodetector hybrid and $n_p(t)$ is zero-mean white Gaussian noise. The noise performance of the photodetector hybrid is specified by the parameter v_n , the single-sided RMS noise voltage density at the output (volts/ $\sqrt{\text{Hz}}$). Thus the SNR with the noise measured in a single-sided bandwidth b is

$$\text{SNR} = \frac{(R_V P_R M_{IM})^2 \langle M^2 \rangle}{v_n^2 b} \quad 5.1-3$$

where $\langle M^2 \rangle$ is the mean-square value of $M(t)$.

As stated in Paragraph 3.2, the optical link is required to deliver a 40 dB SNR in a 3500 Hz bandwidth when the telephone output is -4 dBm in 600 ohms, i.e., the nominal long-term average analog voice level is to be transmitted with a 40 dB SNR. In this and subsequent analyses it is assumed that an AGC operates on the analog voice signal to eliminate variations in the long-term average power caused by the variable lengths of WF-16 wire that connect the telephone sets to the optical cable junction box. It is further assumed that the largest instantaneous peak that can be handled without clipping is 20 dB larger than the long-term RMS value of the voice signal. Thus, the -4 dBm output from the telephone corresponds to $\langle M^2 \rangle = 0.01$. Using this value and the parameters

$$\begin{aligned} R_V &= 1.5 \times 10^4 \text{ V/W} \\ v_n &= 2.3 \times 10^{-8} \text{ V}/\sqrt{\text{Hz}} \\ M_{IM} &= 0.5 \end{aligned}$$

from Paragraph 4.0, allows the plotting of the analog voice SNR as a function of average received optical carrier power. This plot appears in Figure 5.1-2.

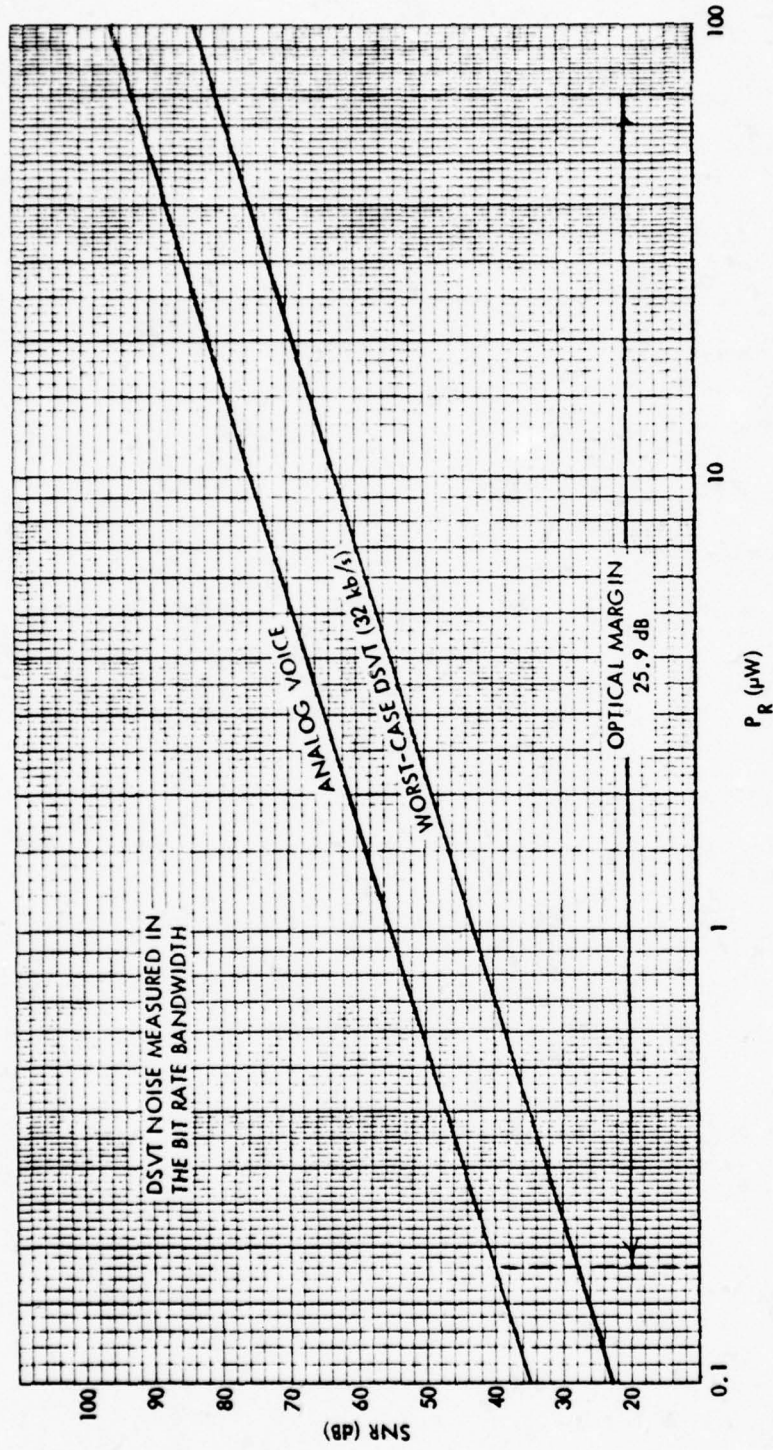

Figure 5.1-2. SNR Performance for the SDM Approach

In the case of the DSVT input, no AGC action is assumed. Instead it is assumed that the maximum signal level (3V p-p, see Paragraph 3.1) is adjusted to correspond to $M(t) = \pm 0.9$, $\langle M^2 \rangle = 0.2$. Hence the minimum signal level (0.5V p-p) corresponds to $M(t) = \pm 0.15$, $\langle M^2 \rangle \cong 0.006$. The worst case SNR for the DSVT can now be calculated by using the highest bit rate (32 kb/s) and the lowest signal level. The result of this calculation is shown in Figure 5.1-2.

As Figure 5.1-2 shows, the SDM link can be closed with excellent (25.9 dB) optical power margin, with the analog voice signal determining the margin. In addition to the good SNR performance offered by SDM, there is ample bandwidth available for the transmission of the DSVT signals without distortion. On the other hand, this approach requires two optical transmitters, two optical receivers and two fibers for each of the 13 channels (full duplex), and consequently would be the most expensive, based on contemporary prices.

5.2 Time Division Multiplexing

The 13 user channels can be transmitted over a single optical fiber by multiplexing them onto a single optical carrier. In this section a time division multiplexing (TDM) approach is discussed.

A simplified diagram of this approach is shown in Figure 5.2-1. The incoming DSVT signals are converted from conditioned diphas to NRZ format and are presented to the 13 channel digital multiplexer. The analog voice inputs are digitized into 32 kb/s serial NRZ data streams by a digital adaptive delta modulator (DADM) encoder. These data streams are then fed to the multiplexer. Time division multiplexing of the 13 asynchronous digital signals is accomplished by sequentially sampling the channels at a rate of 800 kHz or 25* times per bit for the 32 kb/s signals. The resultant composite bit rate is thus 10.4 Mb/s. The composite bit stream is transmitted over the optical cable by means of binary pulse position modulation (BPPM). Synchronization and control information is amplitude modulated onto the eighth and thirteenth channel sample bits.

*A sampling rate of 25 times per bit was selected to ensure that the phase error of the TDM multiplexer is less than the bit rate correction capabilities of the DSVT.

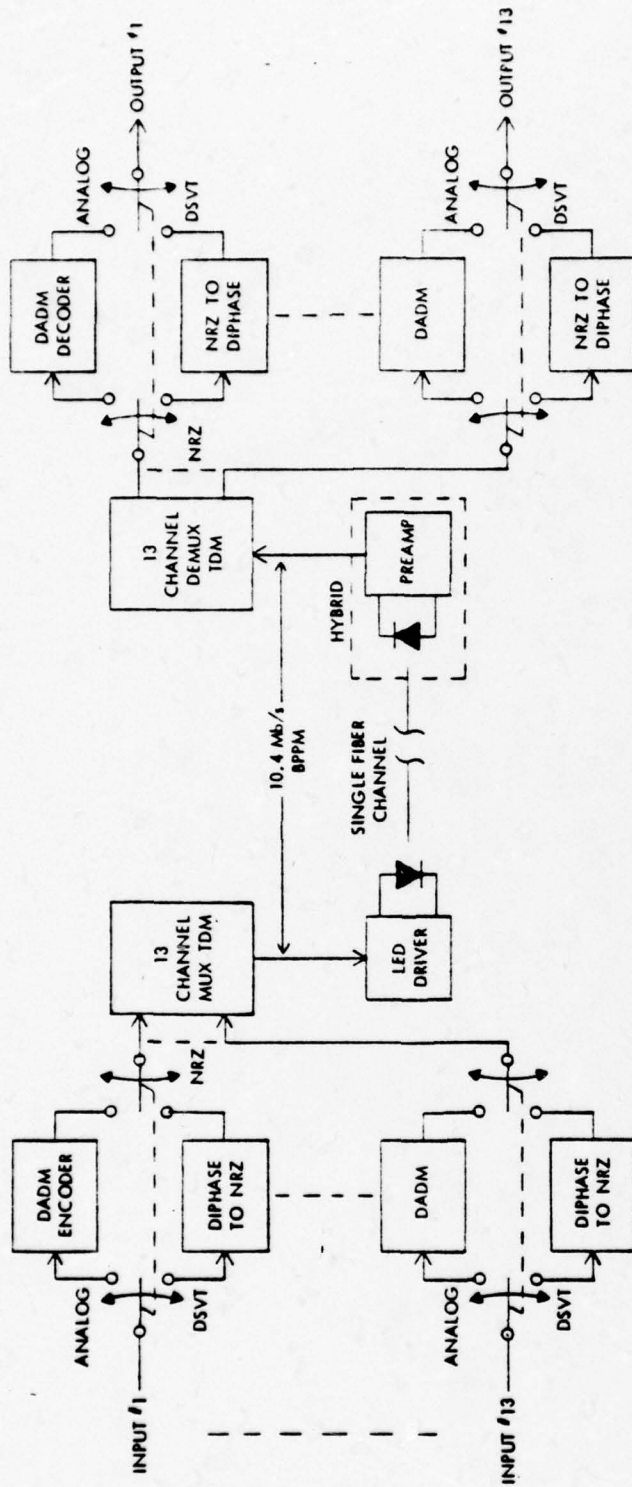

Figure 5.2-1. TDM Approach Block Diagram

At the receiver the 10.4 Mb/s BPPM data stream is detected, the channel samples are decommutated and the channel data streams regenerated. The DSVT channels are converted from NRZ to conditioned diphas and the analog voice channels are reconstructed in analog form by the DADM decoder.

The SNR for an analog voice channel is largely determined by the quantizing and overload voice of the DADM process. The SNR for the DSVT is set by the BER of the optical link. Thus the optical link will have negligible effect on the SNR's if the optical BER is small ($\leq 10^{-8}$) since a bit error on the optical link influences only 1/25 of a bit (at 32 kb/s) for the individual channel.

The bit error rate (BER) performance of the TDM link is determined from the receiver model shown in Figure 5.2-2. The output of the photodetector hybrid is a unipolar BPPM waveform. After ac coupling, the signal has the characteristic of biphas level or Manchester PCM for which the bit symbols are anticorrelated ($\rho = 1$). In the presence of white Gaussian noise, the receiver structure shown is the optimum detector and its performance is [10, 11]

$$\text{BER} = \text{erfc} \left\{ \sqrt{\frac{2E_b}{N_o}} \right\} \quad 5.2-1$$

where

E_b = energy in a bit symbol at matched filter input

N_o = single-sided noise power spectral density at the matched filter input

[10] Stein, S. and Jones, J. J., Modern Communication Principles, McGraw-Hill Book Co., New York, 1967.

[11] Van Trees, H. L., Detection, Estimation and Modulation Theory, Part I, John Wiley and Sons, Inc., New York, 1968.

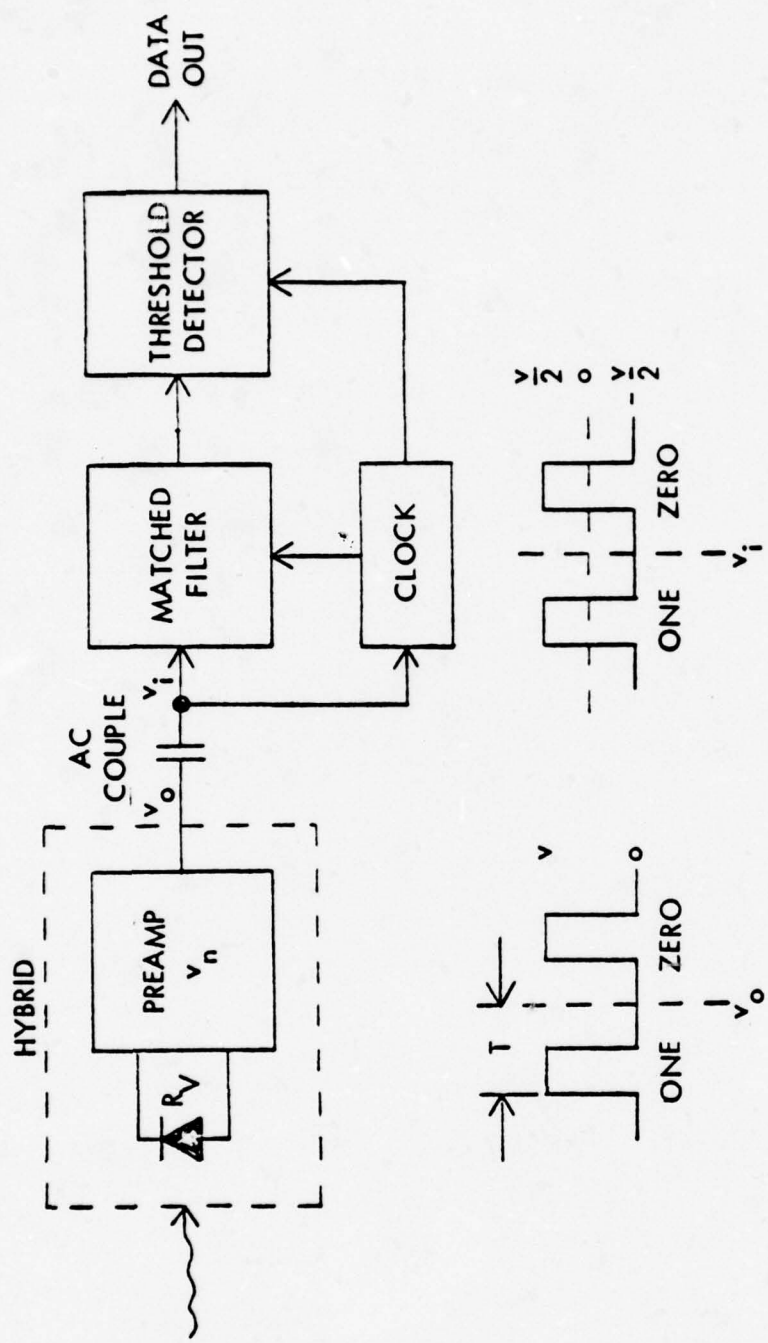

Figure 5.2-2. Receiver Model for TDM Approach

$$\operatorname{erfc} |x| = \frac{1}{\sqrt{2\pi}} \int_x^{\infty} e^{-y^2/2} dy$$

Normalizing to a 1Ω resistance,

$$E_b = \left(\frac{V}{2}\right)^2 T = \frac{V^2 T}{4} = \frac{(R_V \hat{P}_R)^2 T}{4} \quad 5.2-2$$

where \hat{P}_R is the peak received optical pulse power. Therefore

$$\frac{E_b}{N_o} = \frac{(R_V \hat{P}_R)^2 T}{4 v_n^2} \quad 5.2-3$$

and

$$\operatorname{BER} = \operatorname{erfc} \left\{ \frac{R_V \hat{P}_R}{v_n} \sqrt{\frac{T}{2}} \right\} \quad 5.2-4$$

For the hybrid photodetector of interest

$$R_V = 1.5 \times 10^{-4} \text{ V/W}$$

$$v_n = 2.3 \times 10^{-8} \text{ V}/\sqrt{\text{Hz}}$$

and T is given by

$$T = (25 \times 13 \times 32 \text{ kHz})^{-1} = 96 \text{ nsec}$$

Substituting

$$\text{BER} = \text{erfc} \left\{ 0.14 \hat{P}_R \right\}, \hat{P}_R \text{ in } \underline{\text{nW}} \quad 5.2-5$$

For a BER of 10^{-8} , $0.14 \hat{P}_R \cong 5.6$ and $\hat{P}_R \cong 40 \text{ nW}$. Degrading the performance of the receiver by 3 dB to account for practical implementation gives a required peak pulse power at the receiver of

$$\hat{P}_R = 80 \text{ nW}$$

Comparing this to the approximately 150 μW peak pulse power actually available at the receiver (Paragraph 4.3) gives 32.7 dB of optical margin for the TDM system.

It must be pointed out that the TDM system could not be implemented with the optical receiver assumed for this study. This is because the 5 MHz bandwidth is insufficient to accommodate the 10.4 Mb/s BPPM bit stream. It should be possible, however, to implement a photodetector receiver of equivalent performance with adequate bandwidth.

5.3 Frequency Division Multiplexing

This section examines the SNR performance obtainable when frequency division multiplexing (FDM) is used to transmit all 13 user channels on a single optical fiber. The FDM approach is shown in block diagram form in Figure 5.3. In this approach the user inputs modulate individual electrical subcarriers. The composite of the subcarrier signals in turn intensity modulates the LED. At the receiver, direct detection of the intensity modulated optical signal is accomplished by the photodetector. The subcarrier signals are then separated by bandpass filters and demodulated.

Two subcarrier modulation techniques are considered. In Paragraph 5.3.1 the performance of the FDM system with amplitude modulated (AM) subcarriers is analyzed. Paragraph 5.3.2 treats frequency modulated (FM) subcarriers.

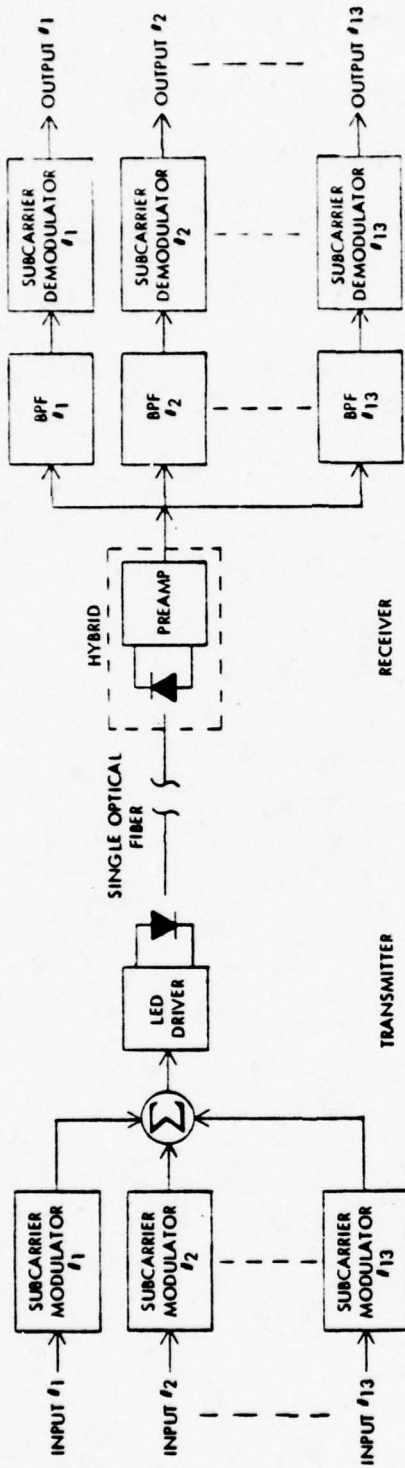

Figure 5.3. FDM Approach Block Diagram

5.3.1 FDM With AM Subcarriers

The SNR performance of the FDM-AM approach is determined with the aid of the receiver model shown in Figure 5.3.1-1.

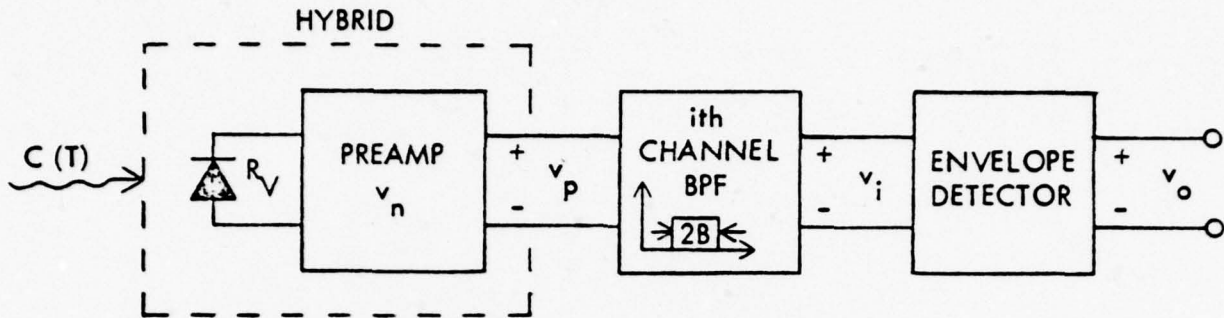

Figure 5.3.1-1. Analysis Model for FDM With AM Subcarriers (Only One Channel Shown)

The intensity of the received optical signal may be written as ^[7]

$$C(t) = 2P_R \left\{ 1 + \sum_{i=1}^{13} m_{sc} \left[1 + m_a M_i(t) \right] \cos \omega_i t \right\} \cos^2 \omega_c t \quad 5.3.1-1$$

Where

P_R = average received optical carrier power

m_{sc} = maximum intensity modulation index for each unmodulated subcarrier

m_a = maximum amplitude modulation index for each subcarrier

$M_i(t)$ = normalized modulating signal for the i th channel, $|M_i(t)| \leq 1$

ω_i = i th subcarrier frequency

ω_c = optical carrier frequency

The output voltage from the preamplifier is given by

$$V_p(t) = R_V P_R \left\{ 1 + \sum_{i=1}^{13} m_{sc} \left[1 + m_a M_i(t) \right] \cos \omega_i t \right\} + n_p(t) \quad 5.3.1-2$$

R_V is the responsivity (volts/watt) of the photodetector hybrid and $n_p(t)$ is zero-mean white Gaussian noise. After this waveform is filtered by the i th bandpass filter, the resultant voltage is

$$V_i(t) = R_V P_R m_{sc} \left[1 + m_a M_i(t) \right] \cos \omega_i t + n_i(t) \quad 5.3.1-3$$

Using the narrowband representation for $n_i(t)$ [10, 12]

$$n_i(t) = E(t) \cos \left[\omega_i t + \phi(t) \right] \quad 5.3.1-4$$

where the envelope $E(t)$ is Rayleigh distributed and $\phi(t)$ is uniformly distributed over $[0, 2\pi]$.

The output of an ideal envelope detector operating on $V_i(t)$ is

$$V_o(t) = \sqrt{\left\{ R_V P_R m_{sc} \left[1 + m_a M_i(t) \right] \right\}^2 + 2 R_V P_R m_{sc} \left[1 + m_a M_i(t) \right] E(t) \cos \phi(t) + E^2(t)}$$

5.3.1-5

[12] Thomas, J. B., An Introduction to Statistical Communication Theory, John Wiley and Sons, Inc., New York, 1969.

For a large input carrier-to-noise ratio (CNR), this can be approximated by [10,12]

$$\begin{aligned}
 V_o(t) &\cong \sqrt{\left\{ R_V P_R m_{sc} \left[1 + m_a M_i(t) \right] \right\}^2 + 2 R_V P_R m_{sc} \left[1 + m_a M_i(t) \right] E(t) \cos \phi(t)} \\
 &\cong R_V P_R m_{sc} \left[1 + m_a M_i(t) \right] + E(t) \cos \phi(t)
 \end{aligned}
 \tag{5.3.1-6}$$

The mean-square output voltage is

$$\langle V_o^2 \rangle = (R_V P_R m_{sc})^2 + (R_V P_R m_{sc} m_a)^2 \langle M_i^2 \rangle + \frac{\langle E^2 \rangle}{2}$$

5.3.1-7

Thus, the output signal-to-noise ratio is

$$\text{SNR}_o = \frac{(R_V P_R m_{sc} m_a)^2 \langle M_i^2 \rangle}{\frac{\langle E^2 \rangle}{2}}$$

5.3.1-8

but $\frac{\langle E^2 \rangle}{2} = \langle n_i^2 \rangle$, the mean-square noise voltage is the noise bandwidth of the bandpass filter. The hybrid detector noise performance is specified by the parameter v_n which is the single-sided RMS noise voltage density at the output in volts/ $\sqrt{\text{Hz}}$. Thus,

$$\langle n_i^2 \rangle = v_n^2 (2B)$$

5.3.1-9

where 2B is the single-sided noise bandwidth of the bandpass filter. Substituting yields

$$\text{SNR}_o = \frac{(R_V P_R m_{sc} m_a)^2 \langle M_i^2 \rangle}{2B v_n^2} \quad 5.3.1-9$$

This is the SNR measured in the single-sided baseband bandwidth, B . If the SNR in a smaller baseband bandwidth is desired, then*

$$\text{SNR} = \text{SNR}_o \left(\frac{B}{b} \right) = \frac{(R_V P_R m_{sc} m_a)^2 \langle M_i^2 \rangle}{2b v_n^2} \quad 5.3.1-11$$

where b is the desired single-sided baseband bandwidth.

In optical communication systems that use AM subcarriers to intensity modulate an optical source, special attention must be directed toward the selection of the modulation indices for the amplitude modulators and the optical intensity modulator. In particular, the indices are constrained such that

$$m_a \leq 1$$

5.3.1-12

$$m_{sc} |1 + m_a| \leq m_{IM}$$

Where m_{IM} is the maximum effective intensity modulation index for the modulated sub-carrier signal. Under these constraints, the SNR of (5.3.1-11) is maximized when $m_a = 1$ and $m_{sc} = \frac{m_{IM}}{2}$ [7]. Making this substitution in (5.3.1-11) yields

$$\text{SNR} = \frac{(R_V P_R m_{IM})^2 \langle M_i^2 \rangle}{8b v_n^2} \quad 5.3.1-13$$

*Assuming flat spectrum noise at the output of the envelope detector. This is a good assumption when the input carrier-to-noise ratio is high (the basic assumption of this derivation).

All of the parameters in the above equation have been previously established except for m_{IM} , the intensity modulation index for the modulated subcarrier. A conservative selection can be made by using the relation

$$\sum_{i=1}^{13} m_{sc} (1 + m_a) = 13 m_{IM} = M_{IM}$$

5.3.1-14

$$m_{IM} = M_{IM}/13$$

Determination of M_{IM} in this manner assures that the maximum total intensity modulation index for the LED is not exceeded even if all 13 subcarrier signals are instantaneously at the maximum. A less conservative approach can be based on a crest factor analysis predicated on an acceptable level of overmodulation of the LED.

Figure 5.3.1-2 shows the SNR's for the two types of signals calculated from (5.3.1-13) using

R_V	=	1.5×10^4	V/W	
v_n	=	2.3×10^{-8}	$V/\sqrt{\text{Hz}}$	
m_{IM}	=	$0.5/13$	$= 0.04$	
b	=	3500	Hz	}
$\langle M_i^2 \rangle$	=	0.01		
b	=	$32,000$	Hz	}
$\langle M_i^2 \rangle$	=	0.006		

Based on SNR considerations alone, the FDM-AM link can be closed with a margin of 10.4 dB as determined by the analog voice performance.

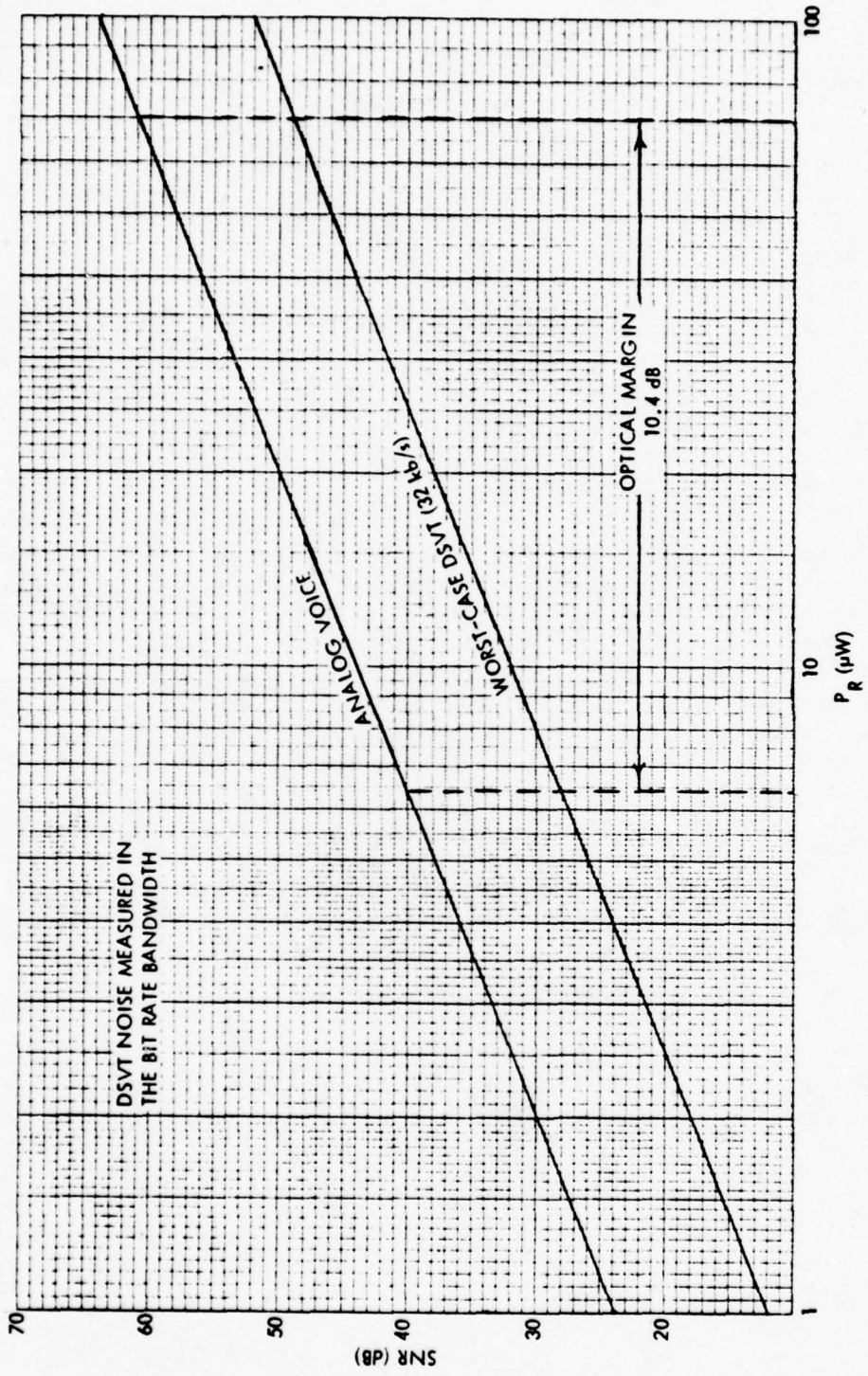

Figure 5.3.1-2. SNR Performance for the FDM-AM Approach

5.3.2 FDM With FM Subcarriers

The optical power margin of the FDM approach can be extended by taking advantage of the SNR improvement of FM over AM. The improvement available may be determined by analyzing the SNR performance of the receiver model of Figure 5.3.2-1. The received optical carrier intensity may be expressed as [7]

$$c(t) = 2 P_R \left\{ 1 + \sum_{i=1}^{13} m_{IM} \left[\cos \left(\omega_i t + 2\pi f_d \int_{-\infty}^t M_i(\tau) d\tau \right) \right] \right\} \cos^2 \omega_c t \quad 5.3.2-1$$

and the output of the photodetector hybrid is

$$V_p(t) = R_V P_R \left\{ 1 + \sum_{i=1}^{13} m_{IM} \left[\cos \left(\omega_i t + 2\pi f_d \int_{-\infty}^t M_i(\tau) d\tau \right) \right] \right\} + n_p(t) \quad 5.3.2-2$$

where $n_p(t)$ is zero-mean white Gaussian noise. The bandpass filter output is

$$V_i(t) = R_V P_R m_{IM} \cos \left(\omega_i t + 2\pi f_d \int_{-\infty}^t M_i(\tau) d\tau \right) + n_i(t) \quad 5.3.2-3$$

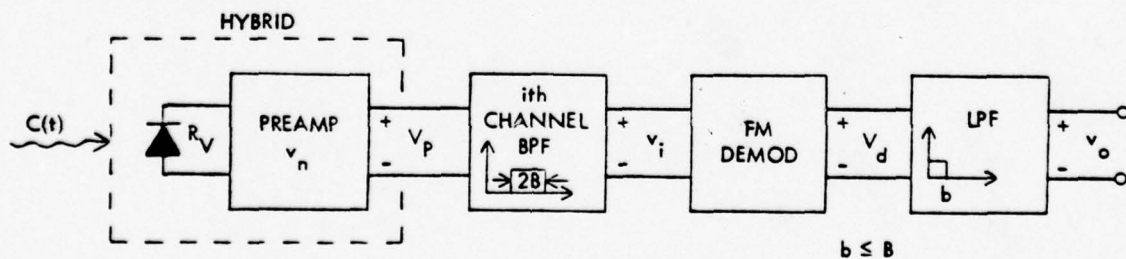

Figure 5.3.2-1. Analysis Model for FDM With FM Subcarriers (Only One Channel Shown)

If ideal filters and demodulators are assumed, standard results [10, 13] can be applied to 5.3.2-3 to show that the output SNR is

$$\text{SNR} = \frac{3 (R_V P_R m_{IM})^2 f_d^2 \langle M_i^2 \rangle}{2 v_n^2 b^3} \quad 5.3.2-4$$

for large CNR at the demodulator input, i.e., above the FM threshold. Define

$$\phi(t) = \omega_i t + 2\pi f_d \int_{-\infty}^t M_i(\tau) d\tau \quad 5.3.2-5$$

and note that the instantaneous subcarrier frequency in Hertz is

$$f = \frac{1}{2\pi} \frac{d\phi(t)}{dt} = \frac{\omega_i}{2\pi} + f_d M_i(t) = f_i + f_d M_i(t) \quad 5.3.2-6$$

Since $|M_i(t)| \leq 1$, f_d is just the maximum subcarrier frequency deviation. A useful parameter to describe the FM subcarrier signal is the frequency modulation index defined as

$$\beta \triangleq \frac{f_d}{b} \quad 5.3.2-7$$

where b may be interpreted as the highest baseband modulating frequency of interest. Making this substitution gives

[13] Carlson, A. B., Communication Systems: An Introduction to Signals and Noise in Electrical Communication, McGraw-Hill Book Co., New York, 1968.

$$\text{SNR} = \frac{3 (R_V P_R m_{IM})^2 \beta^2 \langle M_i^2 \rangle}{2 v_n^2 b} \quad 5.3.2-8$$

Comparing this result to that obtained for the AM subcarrier, we see that

$$\frac{\text{SNR}_{\text{FM}}}{\text{SNR}_{\text{AM}}} = 12 \beta^2 \quad 5.3.2-9$$

if all other system parameters are equal. The potential for SNR improvement with FM is evident since β may be large. However, the AM subcarrier signal may be transmitted in a single-sided bandwidth of $2b$ whereas the FM subcarrier signal requires a single-sided bandwidth of approximately $2(\beta + 1)b$.

For satisfactory operation, the subcarrier FM channels must operate above the FM threshold which means that the CNR at the input to the FM demodulator must be greater than 10-13 dB depending on the value of β [10]. Since

$$V_i(t) = R_V P_R m_{IM} \cos(\omega_i t + 2\pi f_d \int_{-\infty}^t M_i(\tau) d\tau) + n_i(t) \quad 5.3.2-10$$

and

$$\langle n_i^2 \rangle = 2 B v_n^2 \quad 5.3.2-11$$

then

$$\text{CNR} = \frac{1/2 (R_V P_R m_{IM})^2}{2 B v_n^2} \quad 5.3.2-12$$

Using the system parameters selected in the previous section on FDM-AM and $f_d = 32$ kHz leads (after verification of operation above threshold) to the SNR curves of Figure 5.3.2-2. Note that the optical margin is 20.7 dB for the FM case as compared to 10.4 dB for the AM case and that the margin is determined by the DSVT signal rather than the analog voice. It should be pointed out that the interpretation of the SNR measured in the bit rate bandwidth as a performance parameter for the DSVT's conditioned diphase is not the same as in the case of the SDM and FDM-AM. This is because the output noise power spectrum from the FM demodulator is parabolic in shape instead of flat. However, as Figure 5.3.2-2 shows, more than adequate SNR for bit detection of the conditioned diphase is provided. A preemphasis/deemphasis scheme could be employed to provide a flat spectrum noise output and some further SNR improvement [13].

5.3.3 Summary

The FDM approaches offer good SNR performance (particularly the FM system) and require the minimum number of optical transmitters, fibers and receivers. Multiplex equipment is required, however. In addition, the presence of 13 subcarriers in the limited (by the optical receiver) bandwidth leads to problems of intermodulation distortion, crosstalk isolation and rise time preservation.

5.4 Hybrid FDM/SDM

The most attractive approach for the 26-Pair Fiber Optic Cable System is a combination of FDM and SDM such as that shown in Figure 5.4-1. In this system, five user channels are frequency division multiplexed onto a single optical carrier using either AM or FM subcarriers. This scheme represents a compromise between the complexity of multiplexer and optical subsystems. It offers improvements over the purely FDM approach in the areas of intermodulation distortion, crosstalk isolation and rise time preservation because of the reduced number of subcarriers per optical channel and increased bandwidth available for each subcarrier. In addition, system capacity is increased from 13 to 15 user channels.

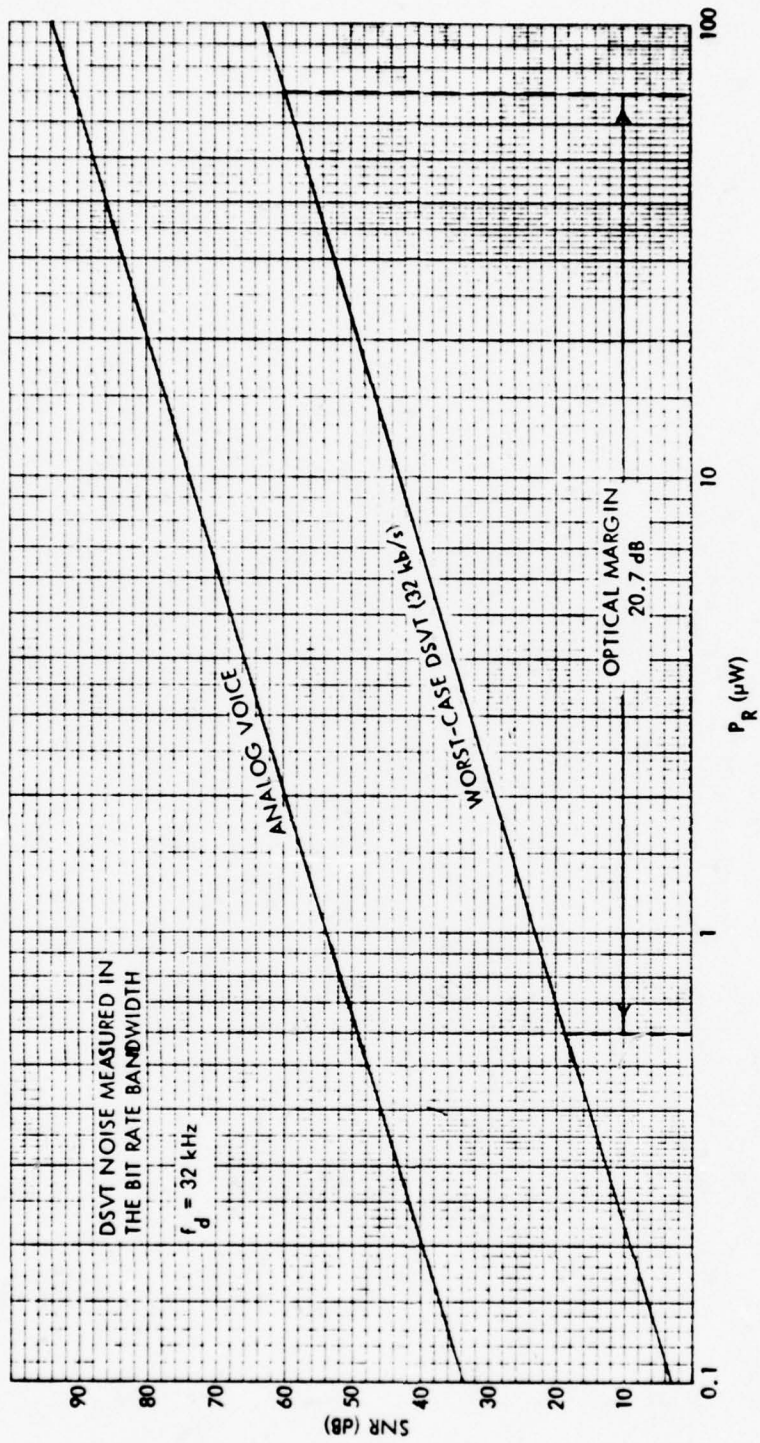

Figure 5.3.2-2. SNR Performance for the FDM-FM Approach

The SNR performance of the FDM/SDM system is analyzed in exactly the same manner as for the purely FDM system, except that in the present case, a larger intensity modulation index, m_{IM} , can be assigned to each subcarrier signal because fewer subcarrier signals modulate the LED's. As a result, the SNR's are improved over the FDM case and, hence, greater optical margin is available. In particular, the intensity modulation index for the subcarriers may be increased by a factor of $(13/5) = 2.6$. The SNR's are improved by a factor of $(2.6)^2 = 6.76$ or 8.3 dB. The curves of Figures 5.4-2 and 5.4-3 reflect this improvement. The optical margin is 14.6 dB for FDM-AM/SDM and 24.5 dB for FDM-FM/SDM.

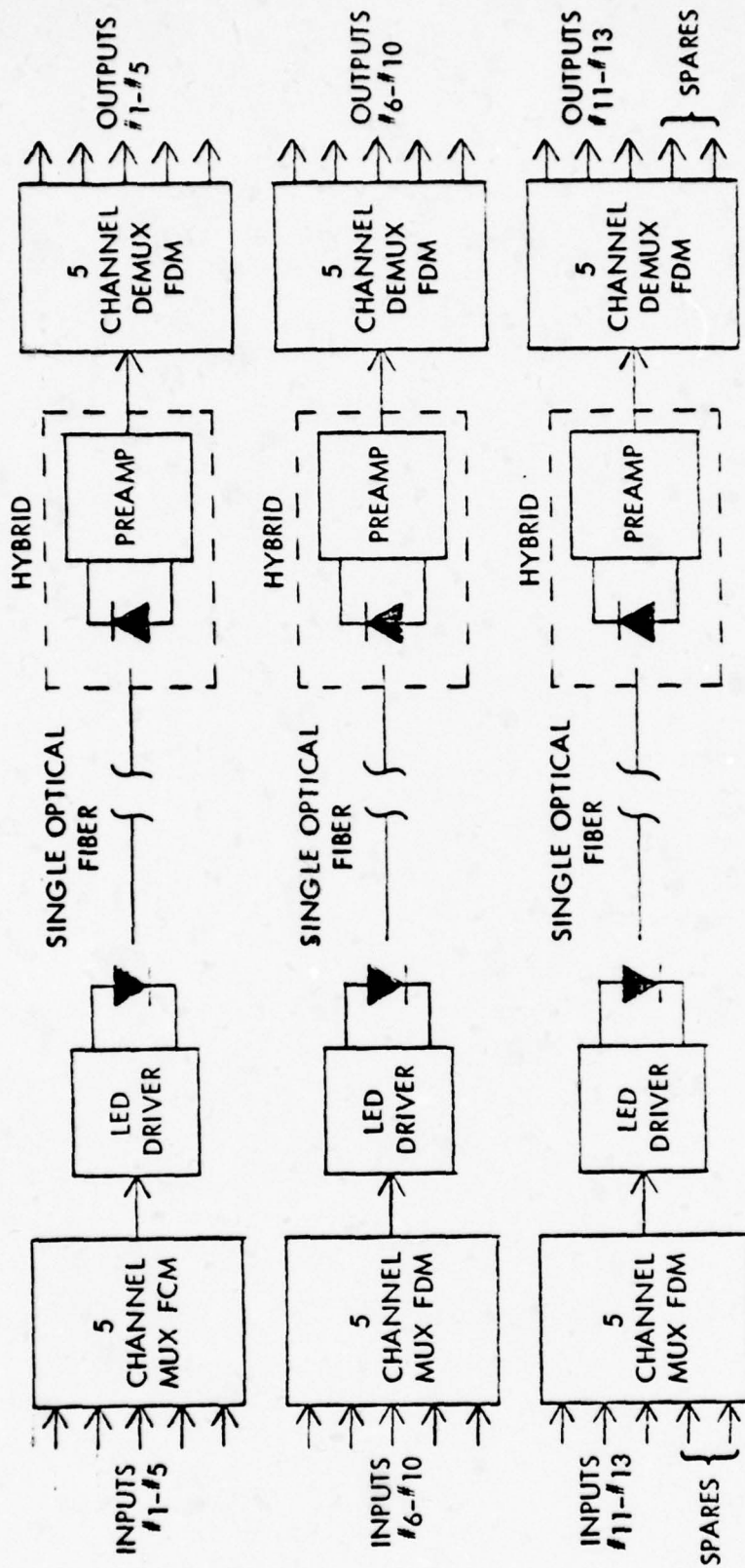

Figure 5.4-1. FDM/SDM Approach Block Diagram

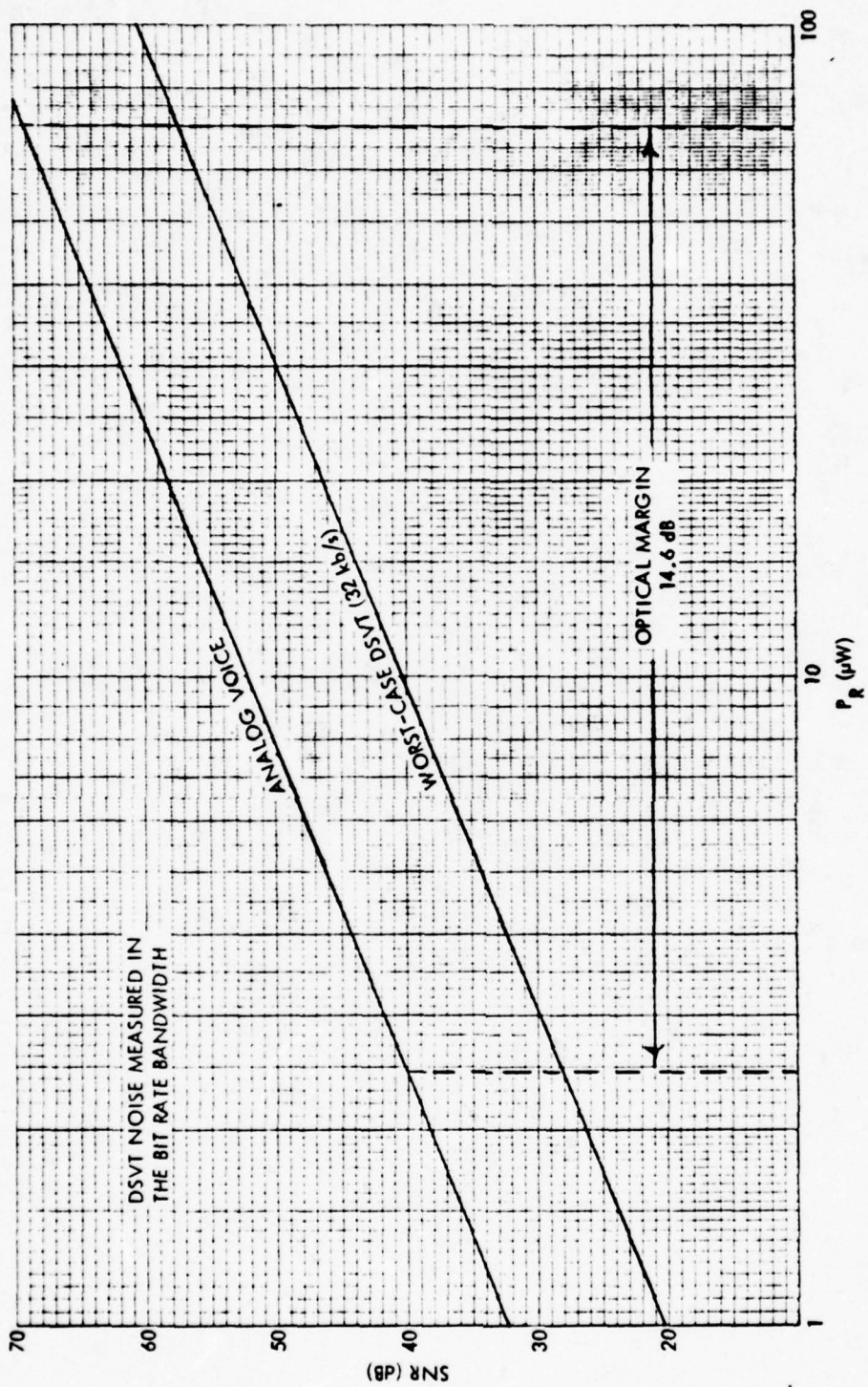

Figure 5.4-2. SNR Performance for the FDM-AM/SDM Approach

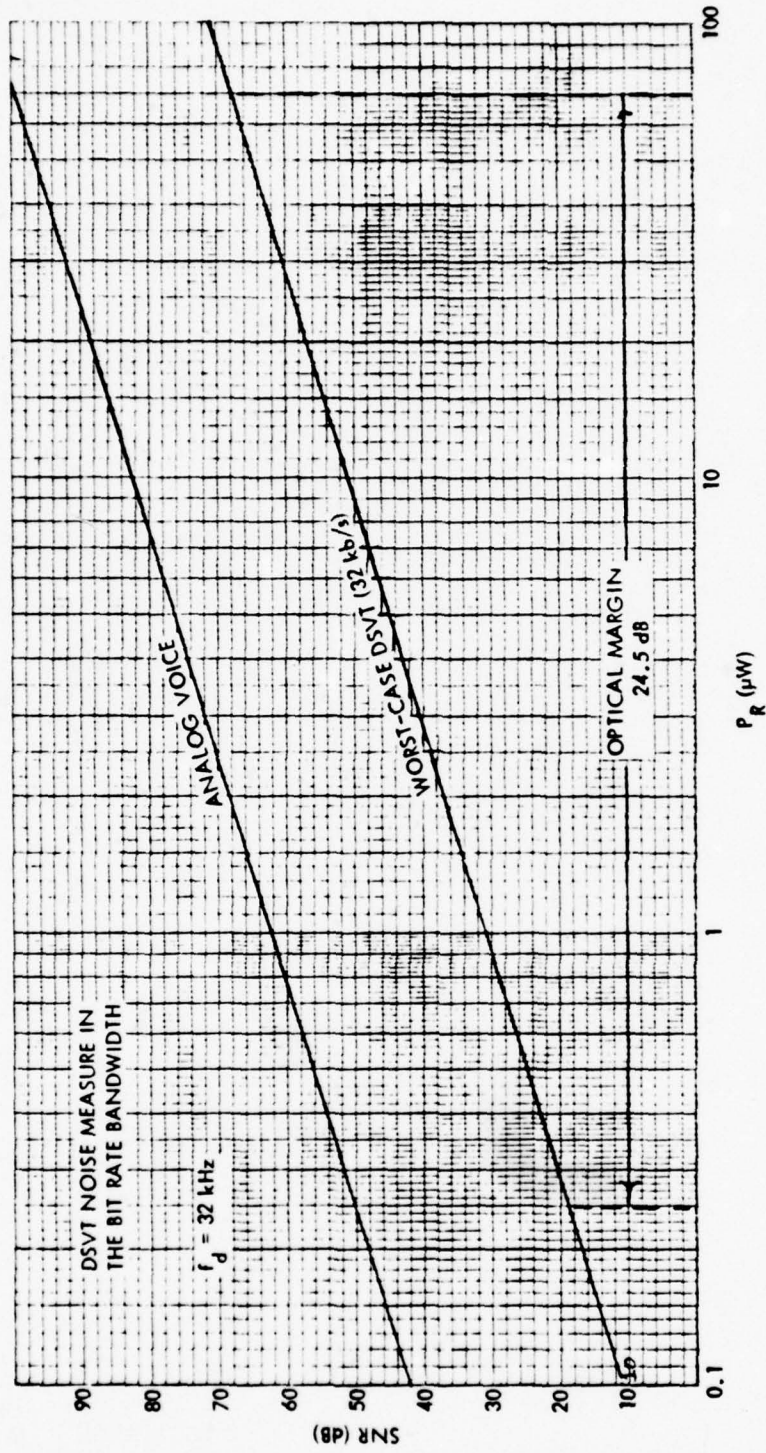

Figure 5.4-3. SNR Performance for the FDM-FM/SDM Approach

SECTION 6.0

TRADE-OFF ANALYSIS AND RECOMMENDATION

6.0 TRADE-OFF ANALYSIS AND RECOMMENDATION

This section summarizes the rationale used in arriving at the recommended design. Table 6.0-1 itemizes the key trade parameters which were considered in the analysis. As shown, consideration was given to SDM, FDM, FDM/SDM and TDM. Within the FDM and FDM/SDM categories, both AM and FM subcarrier modulation were considered. However, in view of the simplicity of envelope detection in contrast to frequency discrimination within the receivers, amplitude modulation was given the greatest attention. Although it is recognized that the ECOM preferred hybrid receiver has a 5 MHz bandwidth, the TDM approach of necessity requires substantially more channel bandwidth than each of the other approaches.

6.1 Size and Weight Comparison

The size and weight estimates of Table 6.0-1 are based on the multiplexing electronics which are unique to each alternative considered. That portion of the total design which is common to all approaches such as line drivers, transformers, power conditioner, junction box and terminal standoffs have been omitted from this portion of the analysis but are included in detail in Section 7.0 of the report.

As shown in the table, the two TDM approaches provide the smallest weight. The functional implementation of both the silicon on sapphire (SOS) CMOS and TTL TDM approaches are the same. The TTL approach was implemented using a total of 150 SSI and MSI dual inline packages (DIPS). The SOS CMOS approach involves the replacement of 85 of the SSI and MSI functions with 4 custom LSI SOS CMOS chips packaged as 36 pin hybrids. Inherent in the TDM design is the inclusion of 26 custom digital adaptive delta modulation (DADM) dual function voice processor LSI chips developed by Harris ESD and 13 commercially available 7-pole elliptic interpolation filters mounted in 1" x 1" x 0.3" packages. The remainder of the digital functions associated with the SOS CMOS approach were of necessity implemented with standard TTL logic. Discrete CMOS was also considered briefly. However, the limited speed of these logic cells was considered inadequate for this system which requires logic speeds of 10.4 Mb/s.

TABLE 6.0-1. KEY TRADE-OFF PARAMETERS

Approach	Power (Watts)	Weight (Lbs)	Size (Inches)	Min. No. of Fibers	Optical* XMTRS	Optical* RCVRS	Cross-talk (dB)	Rise Time (µsec)	Channel Bandwidth (MHz)	Optical Margin (dB)	Lost Channels Per Failure
SDM	16	6	7.8X3X2	26	13	13	<-60	<1	5	26	1
FDM/SDM	18	6.3	8X8X6	6	3	3	<-60	~1.8	5	AM 15 / 25 FM	5
FDM	17.5	6.3	8X8X6	2	1	1	>-40	>4	5	AM 10 / 21 FM	13
TDM	CMOS 15 / 26 TTL	CMOS 4.6 / 5.5 TTL	CMOS 7X8X6 / 8X10X6 TTL	2	1	1	<-60	~1.2	~20	33	13

*Per Junction Box.

The SDM approach involves the smallest size with each of the other approaches occupying approximately the same volume. The FDM and FDM/SDM approaches are approximately the same in both size and weight categories. Both the FDM and FMD/SDM designs require 26 bandpass filters in each junction box. The FDM approach requires only 1 optical transmitter/receiver pair. However, this reduction is offset by the necessity for including 8 additional local oscillators for subcarrier modulation. In addition, in the interest of fault tolerance, it is recommended that the FDM approach (also the TDM approach) should also include appropriate fault detection electronics and at least one backup optical transmitter/receiver pair, since all channels are placed on a single optical carrier.

There are distinguishable differences in the physical parameters of the design approaches. However, in view of the relative closeness of these estimates, their influence on the final system selection was relatively minor.

6.2 Power Consumption

The TTL TDM approach will consume the largest amount of power (26 watts). This power estimate does not include any fault detection electronics nor any backup transmitters and receivers. Furthermore, idle power consumption (all subscribers on hook) is the same as when all circuits are off hook.

The power consumption for each of the other approaches is approximately the same with the FDM/SDM approach being the largest consumer. However, it should be noted that the FDM and SOS CMOS estimates do not include allowances for fault detection circuitry and backup transmitters and receivers which would increase the power consumption of these approaches. A key consideration in the SDM approach in addition to its relative low power consumption is that its idle power consumption is almost negligible since an LED transmitter and receiver will not be turned on unless used. Both the FDM and FDM/SDM approaches will involve an idle power consumption which is approximately 40% less than when all connected subscribers are off hook.

6.3 Fault Tolerance

The FDM and TDM approaches have the disadvantage that all subscriber channels are placed on a single optical fiber. A failure in either the transmitter, receiver or optical fiber will result in total loss of all user channels (in one direction). Consequently, as a minimum, it is recommended that at least one fully redundant duplex link be included with the appropriate fault detection and automatic switchover electronics. The SDM approach on the other hand, has the maximum amount of fault tolerance in that the loss of one optical channel will result in the loss of only one user channel. The FDM/SDM is a good compromise between the SDM and FDM approaches because of its high level of modularity. The complete loss of one multiplexer, optical transmitter or receiver would result in the maximum loss of only 5 user channels with no affect on the remaining user channels. The loss of a single local oscillator will result in the loss of only 3 user channels, one from each multiplexer group. On the other hand, the loss of the multiplexer/demultiplexer circuitry within the TDM system would result in the total loss of the system. In view of the relative complexity of the TDM multiplexer or demultiplexer, it would be quite difficult to include sufficient redundant circuitry to be competitive with the other approaches.

6.4 Performance

Figure 6.4-1 gives plots of output SNR versus received optical carrier power for each of the analog multiplexing techniques. Table 6.0-1 summarizes the optical power margin offered by each approach. Recall that a 40 dB SNR is required for analog voice, 18.7 dB for the DSVT and that the average received optical carrier power is 70 μ W.

An examination of Figure 6.4-1 suggests that there is no clear-cut choice among the approaches based on noise performance alone. This is because all of the techniques have good SNR in the expected range of operation. In addition, there is a certain amount of overlap of performance which tends to complicate the decision. It appears that optical power margin establishes an orderly ranking of the approaches. However, questions must be raised concerning how much margin is necessary and what is

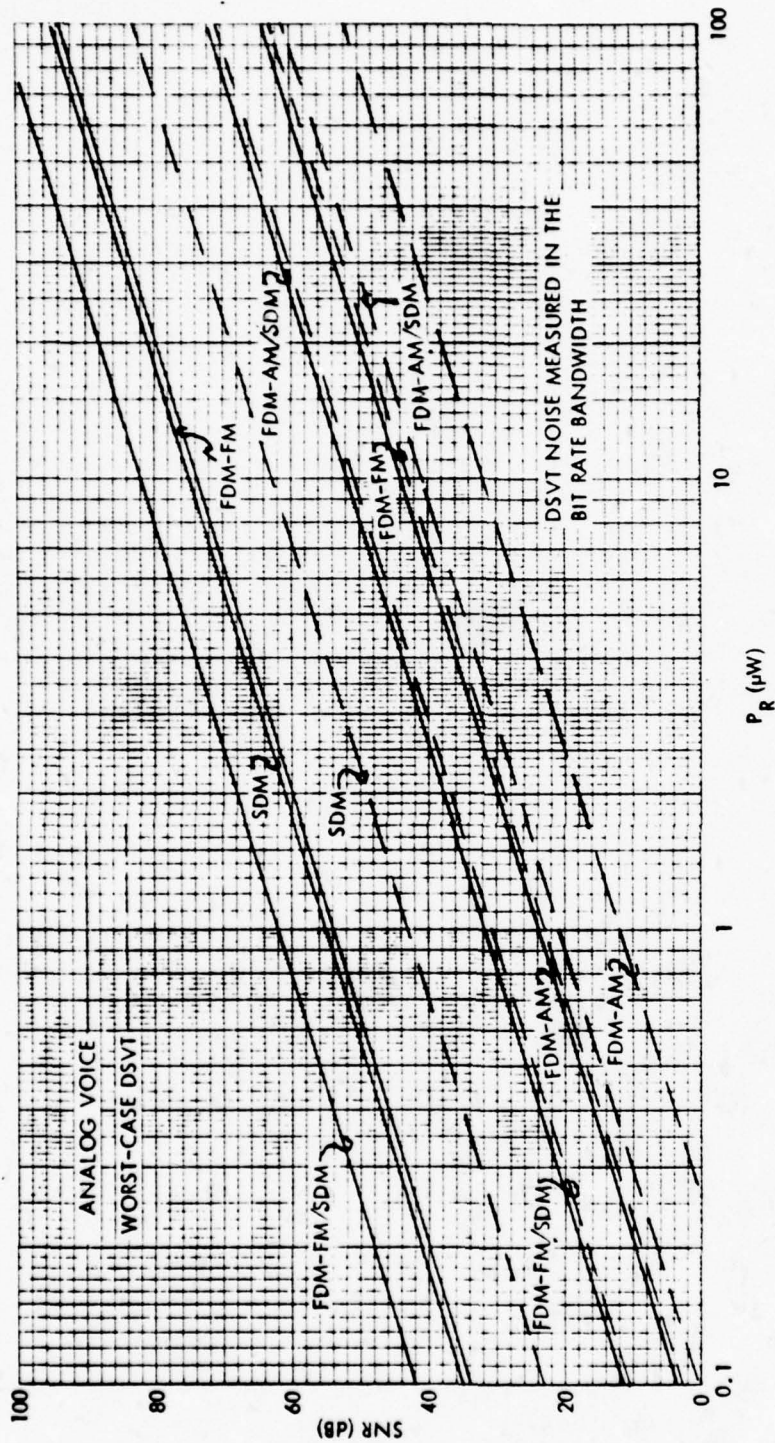

Figure 6.4-1. Summary of SNR Performance for Analog Multiplexing Approaches

the price paid for additional margin. The selection of a multiplexing technique for the 26-Pair Fiber Optic Cable System cannot be based on noise performance alone. Instead, SNR and optical margin must be traded against other factors such as crosstalk isolation, equipment complexity, size, weight, power consumption, etc. Thus, the good noise performance of all the approaches allows an additional degree of freedom in the ultimate configuration of the system, i.e., a particular system concept is not dictated by the SNR requirements.

All of the approaches with the exception of FDM give excellent crosstalk isolation. The desired level of isolation cannot be obtained in the FDM system with practical filters because of the 5 MHz total bandwidth imposed by the ECOM preferred optical detector. This limited bandwidth does not allow adequate subcarrier spacing and guardbands. In addition, the presence of 13 subcarriers in the restricted bandwidth contributes to crosstalk through intermodulation.

Except for FDM, all of the approaches provide good rise time preservation for the DSVT signal. The bandwidth limitation of the photodetector is also responsible for this shortcoming of FDM since the bandwidth available for the individual user channels is insufficient for the desired rise time performance without the addition of regeneration circuitry.

6.5 Cost Considerations

The key cost drivers for this system based on today's prices are the optical cable, sources and detectors. From the viewpoint of ease of construction, the SDM approach would involve the lowest manufacturing cost because of its high level of modularity and low circuit complexity. Aside from the material cost, this approach would also entail the smallest initial development cost. However, the prices of the devices and fibers would make the cost of this approach prohibitive.

The other approaches are approximately the same from the standpoint of production cost, involving approximately the same number of components and assembly operations. However, the TTL TDM approach would entail a materials cost which is approximately 10% greater. The SOS CMOS TDM, FDM and FDM/SDM schemes would entail the highest overall development cost because of the LSI and hybrid development. Present projections are that the initial development cost of the SOS CMOS approach involving 3 custom LSI circuits will be 25% greater than either the FDM or FDM/SDM technique. It is estimated that when manufactured in production quantities of 10,000 units each junction box will cost approximately \$2600. This estimate includes the cost of the ruggedized enclosure, multiplexer electronics, and power supplies.

6.6 Conclusions

SDM offers excellent performance in all respects. However, the approach requires a 26 fiber cable, a feature which is regarded as unacceptable by ECOM. The channel bandwidth required by the TDM approach exceeds the capabilities of the preferred photodetector and, in fact, approaches the theoretical dispersion limitation of the 0.3 NA fiber. Without redundant hardware, TDM has very little tolerance to failures. Furthermore, the DADM algorithm is tailored to voice characteristics and the effects of the algorithm on other types of audio signals is uncertain.

The FDM system with the 5 MHz photodetectors significantly degrades the rise time of the DSVT signal and cannot provide the desired level of crosstalk isolation. Unless redundant circuitry is provided, the FDM approach is vulnerable to single point failures.

FDM/SDM offers the best compromise between cost, performance, fault tolerance and physical parameters. The DSVT rise time is degraded by only 1.8 μ s yet a crosstalk isolation of approximately 60 dB is achieved. The FDM/SDM approach is inherently fault-tolerant, involving the loss of only 5 user channels in the event of the failure of an optical transmitter, detector, fiber, multiplexer or demultiplexer. In view of the good performance available with AM and simple envelope detectors, it is felt that the additional optical margin offered by the use of an FM subcarrier system does not justify the additional complexity associated with its implementation. Therefore, FDM-AM/SDM is the recommended approach to the 26-Pair Fiber Optic Cable System. Section 7.0 examines the implementation of such a system in detail.

SECTION 7.0
RECOMMENDED APPROACH

7.0 RECOMMENDED APPROACH

As a result of this study HESD recommends that the hybrid FDM/SDM approach be used in the 26-Pair system. With this approach, individual baseband message sources are used to amplitude modulate RF subcarriers which are frequency division multiplexed together for intensity modulation of the LED optical source. At the receiving end of the link, the composite signal is detected and the individual baseband messages demultiplexed by appropriate filtering. To accommodate thirteen full duplex channels, three fibers have been dedicated to each direction of transmission. Grouping of the channels with respect to each fiber is such that five channels are assigned to one and four channels to each of the other two fibers. The design of this link at both the system level and circuit level is described in more detail, in subsequent sections.

7.1 System Design

This section describes the system configuration evolved for satisfying the program performance objectives. Simultaneous operation with both analog telephone and digital data sets is possible, in any mix, up to a maximum of thirteen sets. The sets operate in a four wire mode, with all of the analog telephones set up with the appropriate patch panel for either ac or dc supervision. The complete link, from calling to answering party, is transparent in the sense that the Fiber Optics Link does not discriminate between analog or digital information. The only special set-up precaution presently envisioned is the requirement for ensuring that analog and digital users connect, at the junction box, with the appropriate common battery. This is accomplished by a switch, which also provides the proper line terminating impedance.

The major performance objectives for the system are:

Analog Channels:	40 dB SNR
Digital Channels:	10^{-9} BER
Crosstalk Isolation:	60 dB (all channels digital)

The analog SNR and digital BER performance is linked primarily to the characteristics of the optical components: LED modulation depth and optical power, optical device to optical connector coupling, optical fiber numerical aperture and attenuation, noise performance of the hybrid photodetector and preamplifier. Crosstalk isolation is influenced heavily by the multiple-carrier intermodulation characteristics of the LED and the hybrid photodetector and preamplifier.

A primary concern in this study was that of ensuring isolation between the subscriber sets and the fiber optics electronics sufficient to prevent unbalancing the four wire characteristics or inducing electronics power or signal ground currents into the telephone/data set loops. Securing the isolation is accomplished by providing transformer coupling at the junction box and patch panel interfaces with the fiber optic electronics. Transfer of dc information (e.g., for dc supervision) is performed by activating high frequency oscillators, the outputs of which are transformer coupled and detected.

7.1.1 System Description

As shown in Figure 7.1.1-1, up to thirteen field sets connect via WF-16 field wire to a modified J-1077 junction box. The sets may be any mix of DSVT's and analog telephones operating in the four wire mode. The individual sets may be any distance from the junction box up to a maximum of 2.5 kilometers. All analog sets must operate with either dc or ac supervision; supervisory modes are not mixed.

The four wire connections at the junction box are made in pairs to two balanced, center-tapped transformers. The center-taps are switch-connected to the common supply plus and minus voltages appropriate to the type of set being interfaced. The switch also provides the proper terminating impedance (i.e., 600 ohms or 125 ohms) for the line.

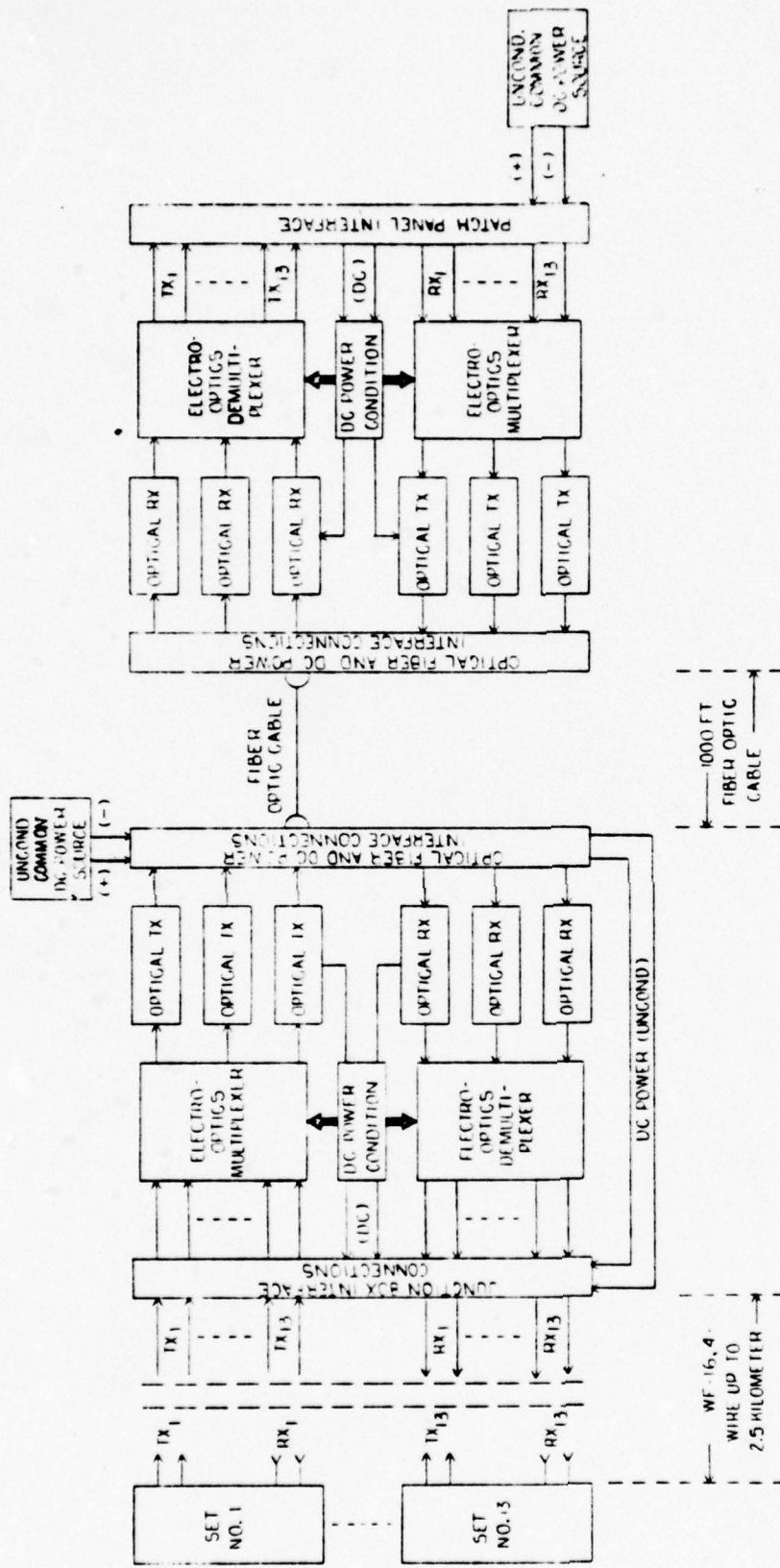

Figure 7.1.1-1. Fiber Optic Link Overall Block Diagram

Taking the transmit side first (transmit with respect to the data or telephone set), the signal power of each of the circuits is leveled and then used to amplitude modulate a high-frequency subcarrier generated in the electro-optics multiplexer. By way of illustration, transmit signals 1 through 5 are used to modulate subcarrier oscillators f_1 through f_5 . The modulated subcarriers are then combined and applied as a group to intensity modulate the LED in optical transmitter #1. Transmit signals 6 through 9 modulate subcarriers f_1 through f_4 which in turn modulate optical transmitter #2. Transmit signals 10 through 13 modulate subcarriers f_1 through f_4 which in turn modulate optical transmitter #3. In this fashion, all thirteen subscriber's are multiplexed onto three separate optical fibers.

The total optical power coupled from one of the optical transmitters into the 1000 feet fiber is approximately 560 microwatts. The optical power coupled to the photo-detector in the optical receiver is approximately 70 microwatts, corresponding to a transmission loss of 9 dB. The output of the optical receiver is five (or four) high frequency amplitude modulated subcarriers and noise. These subcarriers are separated with filters, and envelope detected in the electro-optic demultiplexer. The detected baseband is amplified and applied to the patch panel. In identical fashion, the other optical carriers are processed and all calling subscriber's basebands are available at the patch panel.

According to the supervision mode and the address, the patch panel identifies and routes the baseband back into a electro-optic multiplexer for retransmission back to a junction box and, ultimately to the called subscriber.

7.1.2 Frequency Plan

Several factors influence the choice of frequencies for the subcarriers. The overriding factor is the 5 MHz maximum frequency response of the receiver hybrid. This requires that the upper modulation sidebands of the highest frequency subcarrier must be less than 5 MHz. A second factor is the requirement to preserve the rise time for the DSVT services through the electro-optics link. This necessitates a minimum RF bandwidth and hence a minimum subcarrier frequency spacing. Thirdly, the subcarrier frequencies should not be harmonically related and, ideally, the frequency spacing between subcarriers should not be equal. Observing these precautions minimizes the magnitude of unintelligible crosstalk between subcarriers due to subcarrier harmonics and subcarrier intermodulation products.

The final choice of subcarrier frequencies is $f_1 = 0.6$ MHz, $f_2 = 1.6$ MHz, $f_3 = 2.6$ MHz, $f_4 = 3.6$ MHz, and $f_5 = 4.6$ MHz. The highest significant sidebands of the DSVT spectrum fall well below 5 MHz and only the 6th harmonic of f_1 is coincident with another subcarrier, f_4 . All other harmonics of the subcarriers fall either between subcarriers or above 5 MHz.

The subcarrier frequencies are evenly spaced, however, and as will be discussed in a later section, this causes two and three signal third order and all higher odd order intermodulation (IM) products to be exactly coincident with the subcarriers, creating noise-like unintelligible crosstalk. The frequencies of these IM products, generated in the LED and in the receiver hybrid, may be randomized to some extent by breaking up the equal frequency spacings of the subcarrier frequencies. An actual breadboard test would be desirable to determine how much real benefit this would yield.

With 1 MHz frequency spacings between subcarriers, it is possible to design the multiplexer and demultiplexer filters with a cascaded bandwidth adequate to provide a rise time through the electro-optics portion of the link of less than 2 microseconds. The filter requirements are discussed in a later section.

7.1.3 Crosstalk Isolation

Crosstalk occurs when signals on one circuit produce interference on another circuit. It may be intelligible or unintelligible. In baseband circuits, crosstalk is inherently intelligible and therefore very important. In the Fiber Optic Link, this type of crosstalk is possible at any point in the system before the baseband is used to modulate the subcarriers, and after the subcarriers have been demodulated to baseband. Control of crosstalk at the baseband level is accomplished by good EMI practice; including, shielding, spatial isolation, control of signal current ground loops, and otherwise minimizing coupling via common impedances such as power supply circuits.

After the baseband signals are modulated onto the subcarriers, i.e., in the carrier portion of the system, the probability of intelligible crosstalk occurring decreases sharply. Before the subcarriers are multiplexed and after they are demultiplexed, direct subcarrier coupling from one circuit to another is possible. However, the interfering subcarrier is suppressed by RF bandpass filtering before demodulation and by baseband low-pass filtering after demodulation. Any crosstalk would be unintelligible, appearing in the baseband as a modulated "tone" with a center frequency equal to the RF frequency spacing between the desired and interfering subcarriers. With the intended frequency plan, this would be a minimum of 1 MHz. This mechanism is depicted in Figure 7.1.3-1.

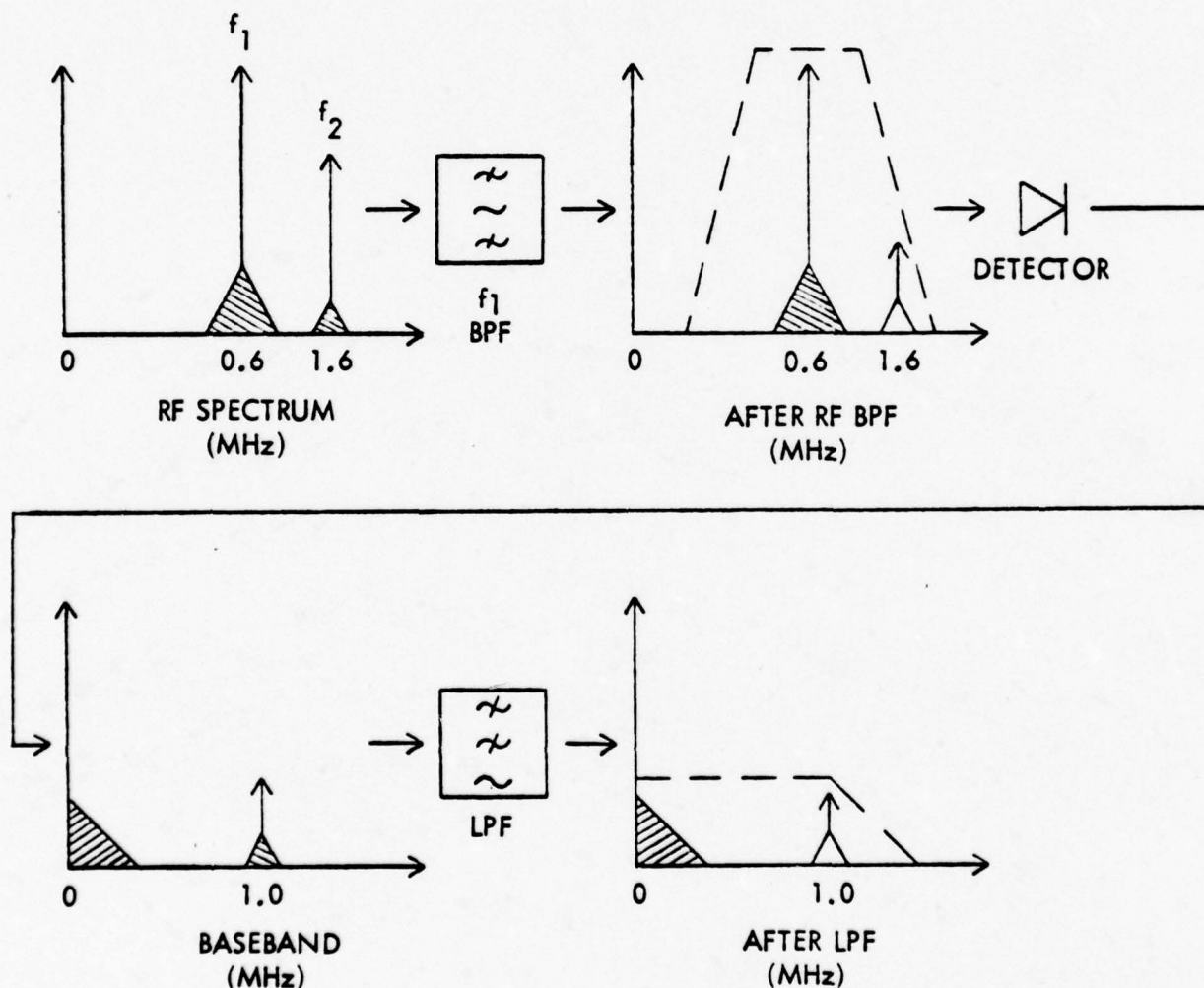

Figure 7.1.3-1. Illustrating Direct Subcarrier Crosstalk

After the subcarriers are multiplexed, there are a number of other mechanisms which can produce crosstalk. These are discussed separately below.

Adjacent Channel Spillover

We consider here only the DSVT signal because it occupies the most bandwidth and because the crosstalk requirement applies only to the DSVT signal. After modulation by the DSVT signal, the subcarrier has an RF power spectral density described (see Section 3.0) by the following:

$$P(\omega) = \frac{E^2 T}{2\pi} \left[\frac{\sin^4\left(\frac{\omega T}{4}\right)}{\left(\frac{\omega T}{4}\right)^2} \right] \quad 7.1.3-1$$

Where ω is a frequency relative to the subcarrier frequency, and $R = \text{bit rate} = \frac{1}{T}$.

It can be shown that the ratio of the peak power spectral density in both main lobes of the RF signal to the peak power spectral density in one "rth" side lobe is equal to:

$$R(\text{dB}) = 10 \log \left[2.6 (2r-1)^2 \right] \quad 7.1.3-2$$

Where $r \neq 1, = 2, 3, 4, \dots$ ($r = 1$ is the main lobe) and $(2r-1) = n = f/R$, where f is the single sided frequency offset from the subcarrier's center frequency and R is the bit rate.

The modulated subcarrier is next bandlimited to minimize the energy in the lobes far from the main lobe that would "spillover" into the 3 dB bandwidth of the adjacent channel. The total side lobe suppression, relative to the power in the main lobe, will be the sum (in dB) of the value calculated in Equation 7.1.3-2 and the rejection provided by the bandpass filter. The goal is a total suppression greater than 60 dB. See Figure 7.1.3-2.

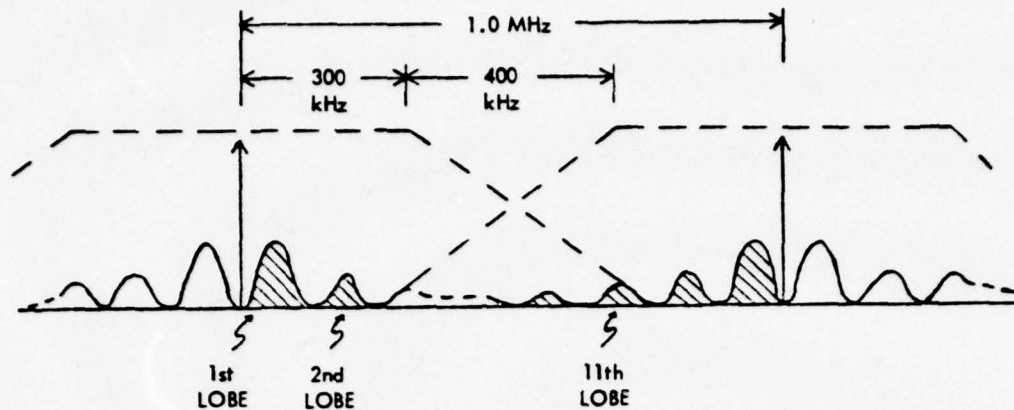

Figure 7.1.3-2. Illustrating Adjacent Channel Spillover (DSVT Signals)

The subcarriers are 1 MHz apart, and to preserve the rise time for the DSVT signal, the single sided RF bandwidth of each filter must be at least 300 kHz. Therefore, we are interested in the power spectral density of the signal at a frequency offset of $(1 \text{ MHz} - 300 \text{ kHz})$ 700 kHz because that power will spill over within the 3 dB bandwidth of the adjacent channel. For a bit rate, R , of 32 kb/s,

$$n = f/R = 700 \text{ kHz}/32 \text{ kb/s} \cong 22 \quad 7.1.3-3$$

Since the lobes peak for only odd values of n , we will use $n = 21$, giving $f = 672 \text{ kHz}$. $n = 21$ corresponds to a value, r , given by the following:

$$r = \frac{1}{2} (n + 1) = 11 \text{ (i.e., 11 th side lobe)}$$

The peak power spectral density of the 11th side lobe is therefore down

$$R \text{ (dB)} = 10 \log \left[2.6 (21)^2 \right] = 30 \text{ dB} \quad \text{(from 7.1.3-2)}$$

from the peak power spectral in both of the main lobes. The filter must then give in excess of 30 dB at an offset from the center frequency of the subcarrier of 672 kHz. To allow for implementation the filters provide approximately 35 dB as apposed to the required 30 dB. This implies the power spectral density is flat which, although not true, is a convenience and is conservative.

The bandpass filters in the multiplexer and demultiplexer are designed with the above requirements in mind. They are described more completely in Paragraph 7.2.

Multicarrier Intermodulation

At any point in the system where the RF subcarriers appear together in a nonlinear device, intermodulation (IM) products are created. Any IM product which falls close to a desired subcarrier is demodulated with the subcarrier in the receiver. The principal result is a "beat-note" appearing at baseband, with a frequency equal to the RF frequency spacing between the subcarrier and the IM product. The level of this interference below the total power level of the desired baseband is approximately equal to the level difference between the subcarrier and IM product at RF before demodulation. It is concluded from this, that the total power level of all IM products that fall within plus or minus the postdetection bandwidth of the subcarrier must be at least 60 dB below the subcarrier.

At an earlier stage in the study, it was envisioned that the subcarriers would be combined at a low level and then amplified simultaneously in a driver amplifier before they were applied to intensity modulate the LED. In order to maintain acceptable IM performance with this concept, the driver amplifier's dynamic range would have been very high, with an attendant large dc power consumption. Specifically, an amplifier with a power output at the 1 dB gain compression point of about 600 mW using 3.6 W of dc power, would have been required to meet the IM performance. Appendix A describes in more detail the relationship between the intermodulation performance of typical RF amplifiers and their dc power requirements; this appendix also describes a vendor amplifier which was a candidate for the LED driver.

As a result of the high dc power requirement, the system was designed so that the subcarriers are combined at a high level and intensity modulate the LED directly with no further amplification. The following discussion relates to establishing the intermodulation ratio (IMR) budget - the dB difference between the IM power and the subcarrier power - for the link. The principal contributors to IM production will be the LED in the transmitter and the optical detector and detector preamp in the receiver. It is assumed that they contribute equally. The IM budget for the complete link (one transmit and one receive) will be an IMR of -60 dB. Of concern here are only those IM products which are coincident with the desired signal. It is desired to derive an IMR budget for either transmit or receive which is in terms of an easily measured/specified two-tone third order IM performance.

With five equally spaced signals, it is shown in Appendix B that the largest number of IM products will be coincident with the central carrier. There are a total of six, and on an absolute power level basis they contribute as follows:

<u>Two-Tone</u>	<u>Level</u> <u>(for equal level signals)</u>
2 (2) - 1 (i.e., $2 f_2 - f_1$)	1 mW (0 dB)
2 (4) - 5	1 mW (0 dB)
 <u>Three-Tone</u>	
1 + 4 - 2 (i.e., $f_1 + f_4 - f_2$)	4 mW (6 dB)
2 + 4 - 3	4 mW (6 dB)
1 + 5 - 3	4 mW (6 dB)
2 + 5 - 4	<u>4 mW (6 dB)</u>
Total	18 mW (12.5 dB)

It is seen that the total IM power coincident with the central carrier is 12.5 dB greater than that due to a single two-tone third order product. Therefore, the two-tone IMR specification for either transmit or receive must be 12.5 dB better than the required total IMR. Since these products will combine in-phase, the IMR budget for either transmit or receive must be 66 dB (60 dB end-to-end). The two-tone IMR requirement for either transmit or receive must then be $(-66.0 - 12.5)$ or -79 dB.

The attached block diagram Figure 7.1.3-3 indicates how the IM products are expected to combine. Individual products (rows) combine in-phase, while the total (columns) combine rms-fashion.

7.1.4 Interface Description

The Fiber Optics Link has two principal message interfaces: at the junction box where the subscribers connect analog telephones and data sets (DSVT's), and at the patch panel where subscriber supervision and call routings are performed. In addition a dc power source ("common battery") interfaces via a copper circuit with both the Fiber Optics Link and the subscriber's sets, supplying operational power to the fiber optics electronics and analog telephone sets and trickle charging current for the DSVT's.

7.1.4.1 Subscriber/Junction Box Interface

7.1.4.1.1 Message and Dc Power Interface

Figure 7.1.4.1.1-1 depicts the interface between the subscribers and the junction box. Functionally, electrical balance of the four wire subscriber circuits is maintained by transformer coupling to/from the fiber optic electronics. With the switch in the position shown (analog), the line terminating impedance will be 600 ohms (300 - 3400 Hz) and ± 12 Vdc will be supplied from the dc power conditioner (located in the fiber optics electronics compartment) to power the analog sets. With the switch in the other position (DSVT), a termination is put across each line pair which results in a line impedance of 125 ohms (20 - 40 kHz), and supplies ± 28 Vdc from the system common battery to trickle charge the DSVT's.

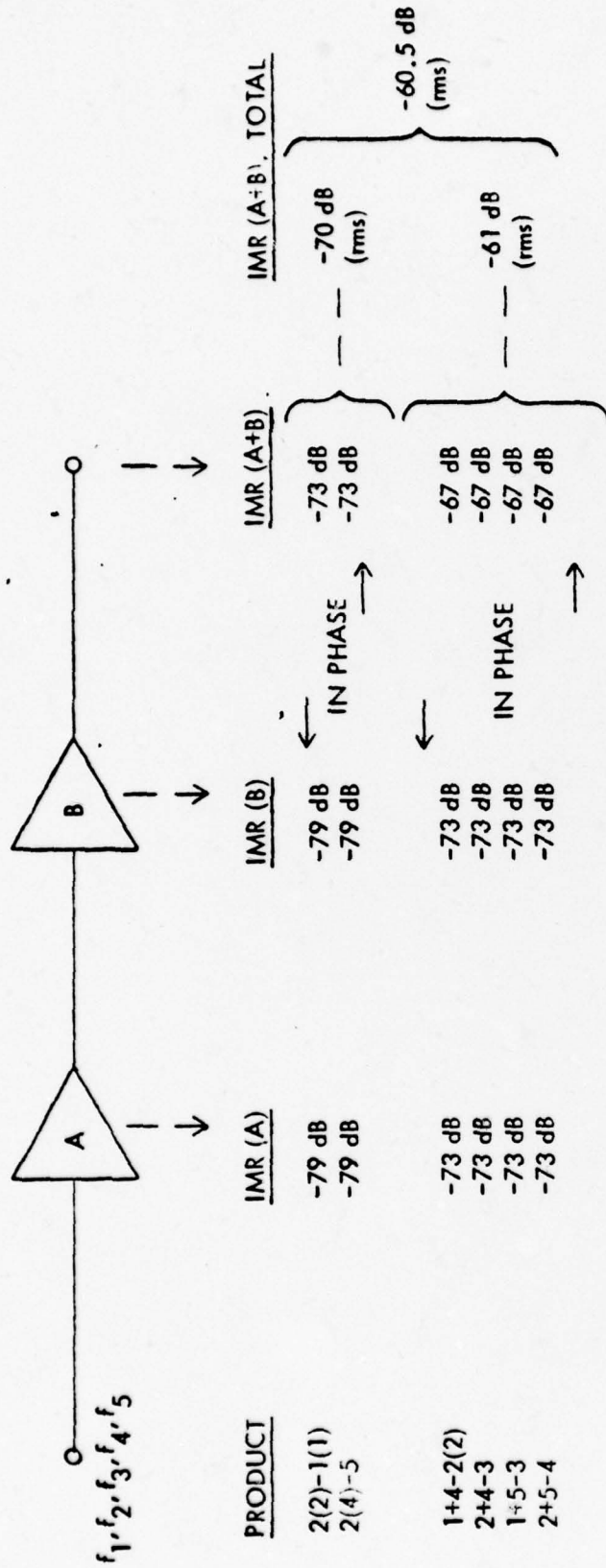

NOTES: (1) 2(2)-1 MEANS $2f_2 - f_1$, etc.

(2) 1+4-2 MEANS $f_1 + f_4 - f_2$, etc.

Figure 7.1.3-3. Addition of IM Products

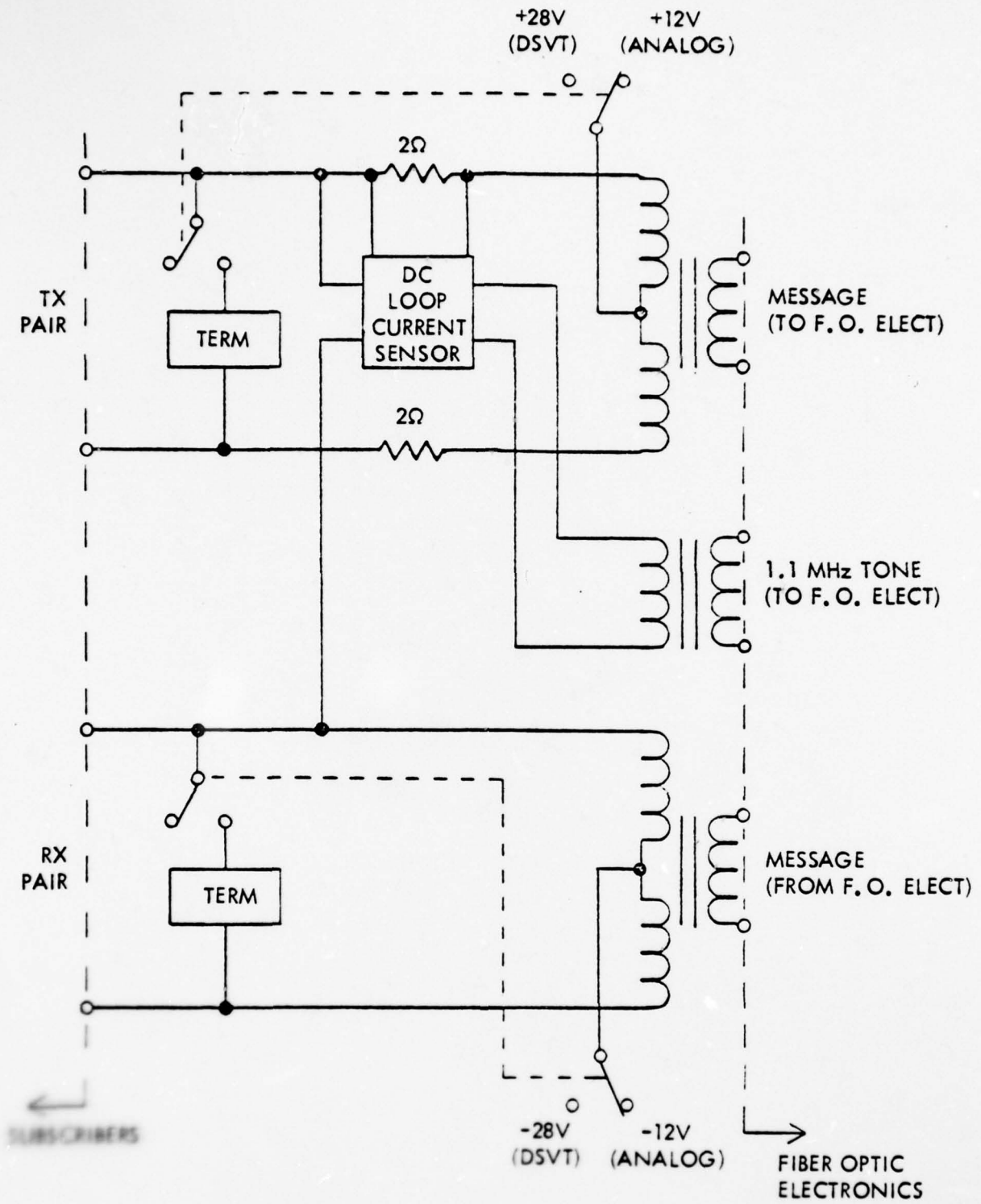

Figure 7.1.4.1.1-1. Subscriber/Junction Box Interface

7.1.4.1.2 Dc Supervision

The dc loop current sensor detects the difference between the on-hook and off-hook dc loop currents when the analog sets are in the dc supervisory mode. In the off-hook condition, a 1.1 MHz oscillator is enabled, the output of which is transformer coupled to a detector in the fiber optics electronics. The detector output enables the subcarrier oscillator output to be transmitted across the Fiber Optic Link to the patch panel electronics. There, the subcarrier presence is detected and used to put the proper off-hook dc current load on the patch panel.

7.1.4.1.3 Ac Supervision

In the ac supervisory mode, the junction box is set up so that the off-hook 1.1 MHz oscillators are always enabled, resulting in continuous transmission of the subcarriers across the Fiber Optic Link to the patch panel.

7.1.4.2 Fiber Optics Link/Patch Panel Interface

7.1.4.2.1 Message Interface/Ac Supervision

At the patch panel end of the Fiber Optic Link, the subcarriers are demultiplexed and detected. Demodulated traffic is transformer coupled and made available to the patch panel operator for action and/or routing to the called subscriber.

7.1.4.2.2 Dc Supervision

When operating with a Dc Supervisory patch panel, the presence of an unmodulated subcarrier signifies that an analog subscriber wishes to pass traffic. The dc level obtained by detecting the subcarrier is used to increase the dc current flow through the subscriber's terminals in patch panel, signifying an off-hook condition. These circuits are shown functionally in Figure 7.1.4.2.2-1.

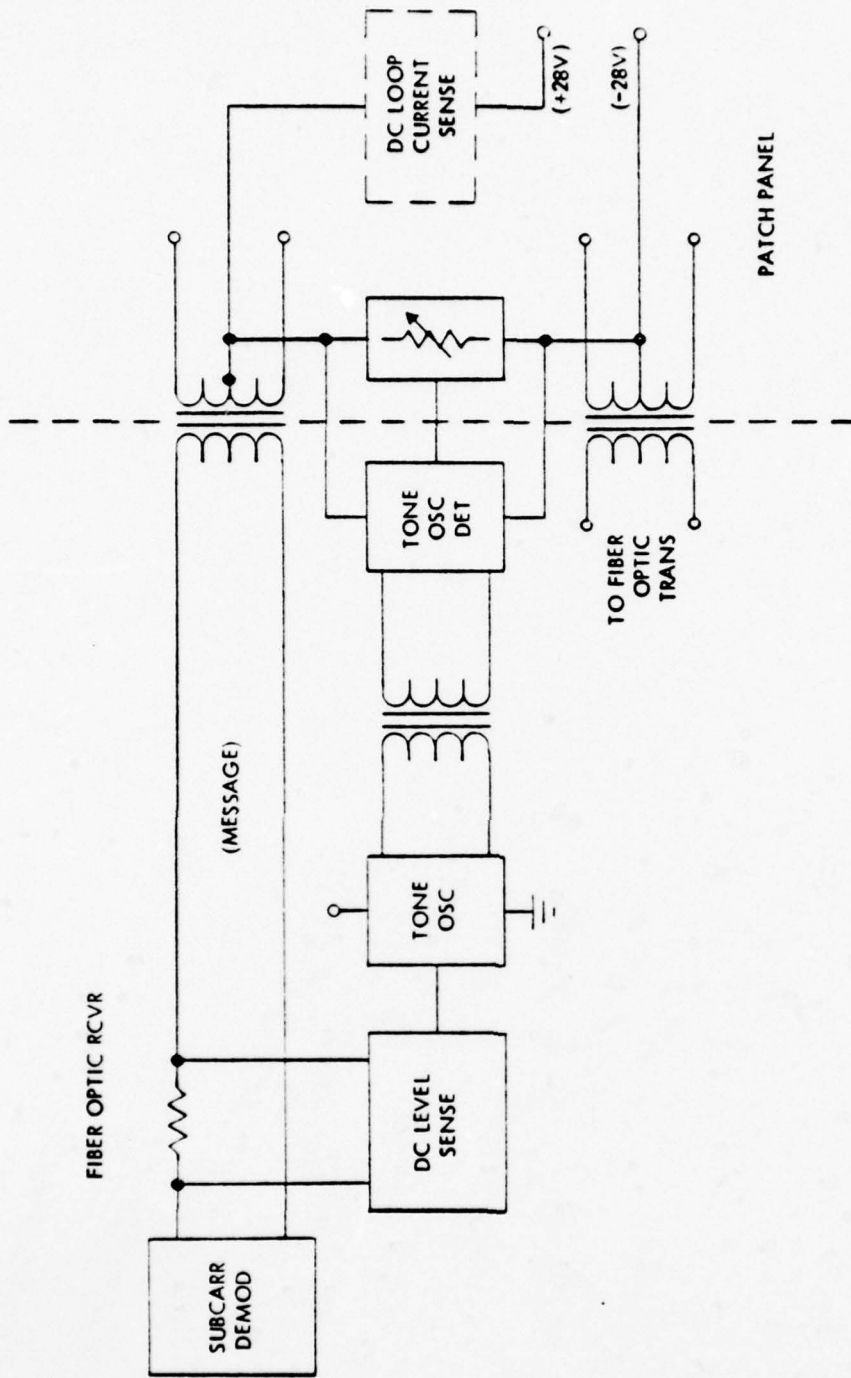

Figure 7.1.4.2.2-1. Fiber Optics/Patch Panel Interface

7.1.4.3 Dc Power Interface

The prime power sources for the link are ± 28 Vdc common batteries located near the junction box and the patch panel. These voltages are distributed in the following manner (see Figure 7.1.4.3-1):

- a. They supply power to the patch panel fiber optic electronics via the dc power conditioner.
- b. They supply power to the junction box fiber optic electronics via the dc power conditioner.
- c. They supply current directly to the DSVT's.
- d. They supply via the junction box dc power conditioner, current to the analog telephones.

7.1.4.3.1 Dc Power Requirements

The total dc power requirement placed on each of the ± 28 Vdc common batteries by the fiber optic electronics is comprised of the following individual items:

	<u>Junction Box</u>	<u>Patch Panel</u>
Receiver Electronics (3/location)	1.7 W	1.7 W
Transmitter Electronics (3/location)	12.3 W	12.3 W
Subcarrier Generator (1/location)	0.9 W	0.9 W
Supervision (1/location)	3.0 W	3.0 W
LED (3/location)	0.9 W	0.9 W
Dc Power Conditioner (1/location)	7.3 W	7.3 W
Fiber Optic Electronic Total	26.1 W	26.1 W

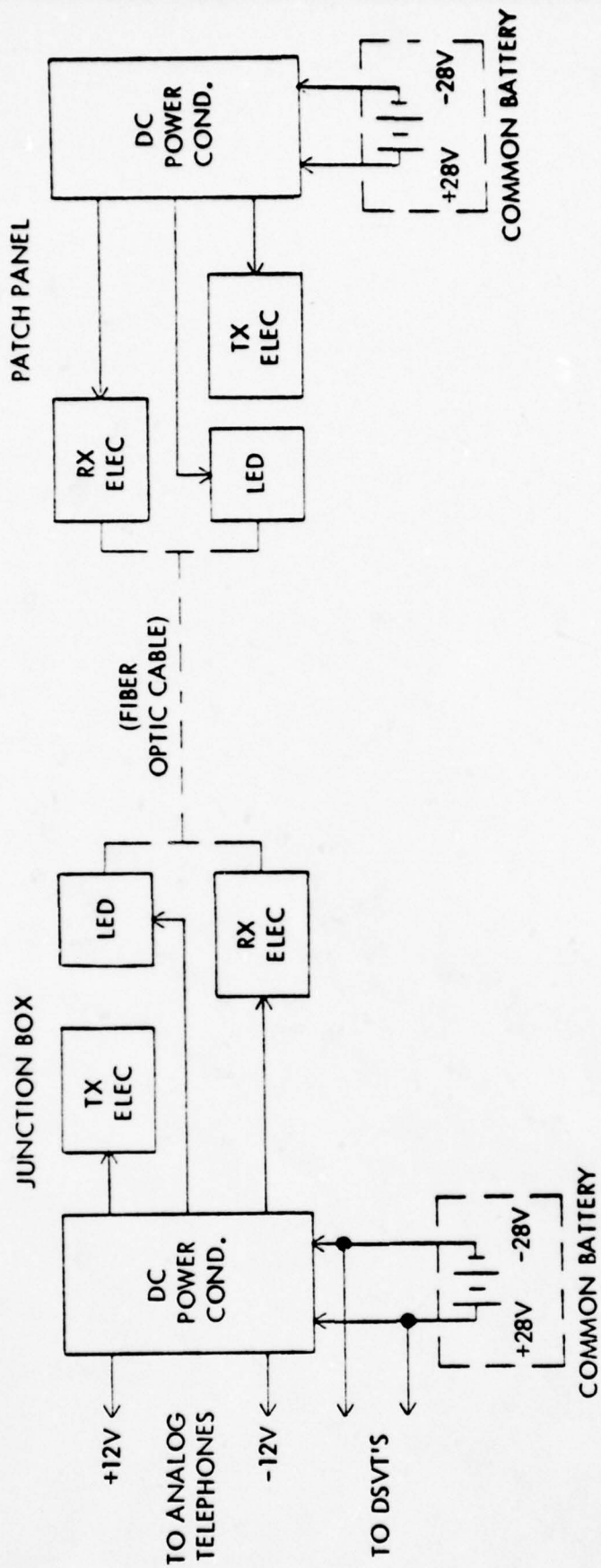

7-17

Figure 7.1.4.3-1. Dc Power Interface

7.2 Hardware Design

The philosophy used in the electronics for the modulator/demodulator was to achieve a reasonable compromise between system power consumption and system cost. It is recognized that greater power savings can be realized by utilization of special low-current devices but that this would entail a higher cost in the final system(s). A special effort has been made to minimize the parts count in order to retain a size that is comparable with the size of the junction box used in the present system.

All of the circuit component values that are of particular importance have been calculated and are included on the schematics but in cases where the same component can take on different values a chart has been provided and the schematic will reflect the appropriate table entry. Bypass capacitor and coupling capacitor values which have minimal significance are not included.

7.2.1 Circuitry

7.2.1.1 Transmitter

The transmitter is a conventional AM/AM unit utilizing a biased balanced mixer to impress the message content on the RF carriers and an LED whose intensity is modulated by one or more of the aforementioned amplitude modulated carriers. AGC leveling circuits are included in the design for the following purposes:

- Maintain the desired degree of modulation.
- Set the correct power level into the LED circuitry.

Figure 7.2.1.1-1 is the simplified block diagram of a typical transmitter channel. The signal from the DSVT's or analog telephones are applied via inputs No. 1 through No. 5 and after leveling in the AGC amplifier are used to amplitude modulate the carrier in the balanced modulator. The modulated waveform is then amplified and applied to a 4-pole, one zero bandpass filter to bandlimit the information to a 600 kHz bandwidth. This bandlimiting ensures that crosstalk between channels is greater than 60 dB below the desired signal. This signal is applied to a power amplifier (EF) and then to a combiner

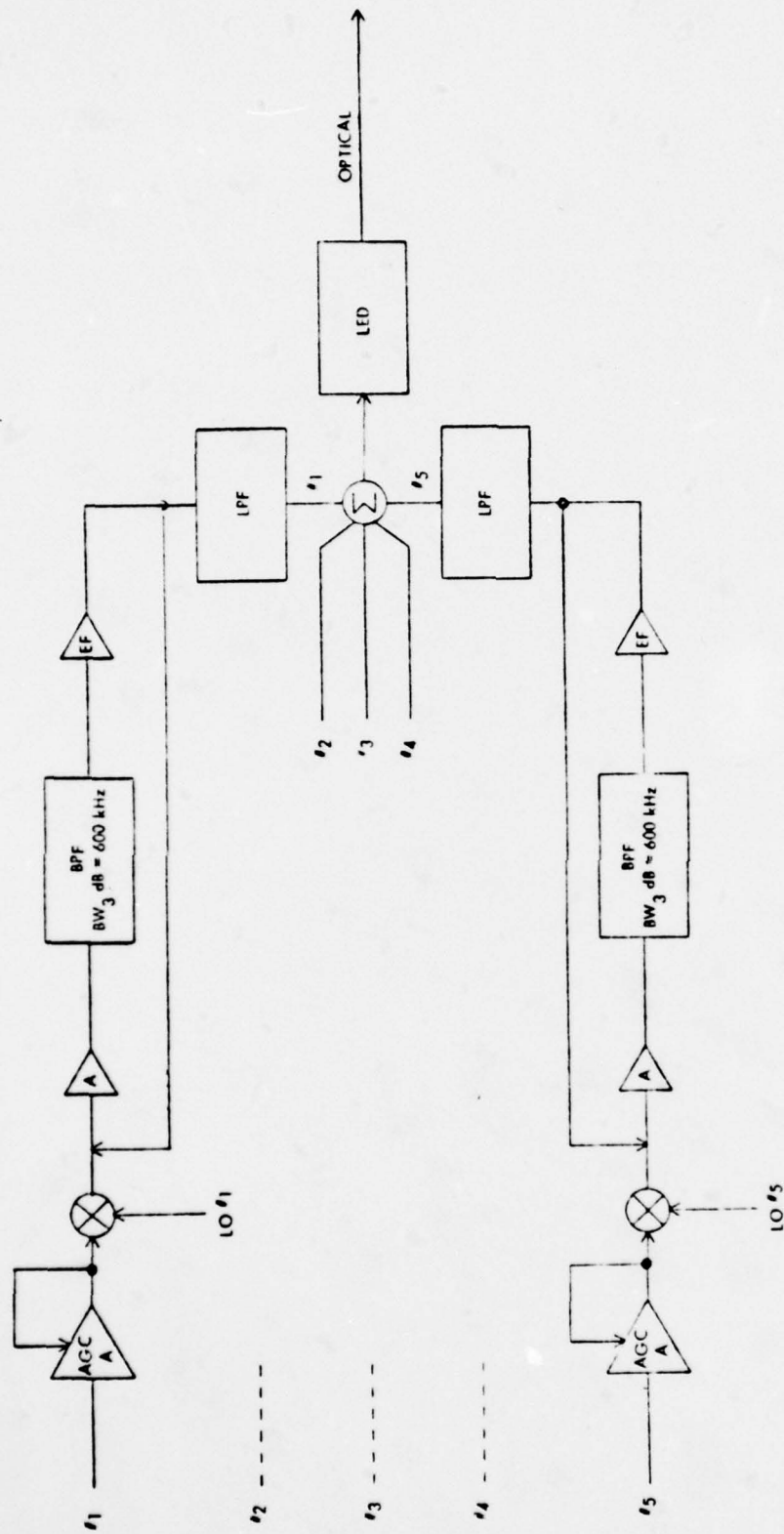

Figure 7.2.1.1-1. Typical Transmitter

circuit. The power level of each of the 5-channels is adjusted so that the total input power of the LED circuitry is +10 dBm. The signal at the output of each EF is detected and used to control the power level at the input to the amplifier so that the signal to the LED circuit is maintained at a relatively constant level around +10 dBm.

7.2.1.1.1 Subcarrier Oscillator

Figure 7.2.1.1.1-1 is the simplified block diagram and 7.2.1.1.1-2 is the schematic for a typical subcarrier oscillator. The oscillators are crystal controlled to prevent drifting over the environmental extremes and thus allowing the information content of one channel to be present in an adjacent channel.

The oscillator/buffer amplifiers are connected in a differential pair configuration to minimize the loading effects on the oscillator which could cause it to shift in frequency. The output from the buffer amplifier is power divided three ways and used to drive the three tuned output amplifiers. The calculated values for the tuning components are shown in Tables 7.2.1.1.1-1 and 7.2.1.1.1-2.

The crystal controlled oscillator, of which there are five groups, are tuned to 0.6 MHz, 1.6 MHz, 2.6 MHz, 3.6 MHz and 4.6 MHz.

Particular attention has been given to the problem of the modulating signal from one channel feeding through its modulator back into and through one of these amplifiers and returning to the modulator of another channel via the local oscillator distribution system. Calculations have shown (see Paragraph 7.1) that power distribution of the signals from the DSVT fall off to greater than 20 dB below the main power lobe at 224 kHz and are greater than 26 dB down at approximately 600 kHz (center of lowest oscillator frequency). The 600 kHz is chosen for discussion because it is the most critical since the tuned circuits of the other oscillators (1.6 MHz, 2.6 MHz, 3.6 MHz and 4.6 MHz) are far removed from these interfering signals and will provide adjacent channel rejection by an amount far greater than the required 60 dB.

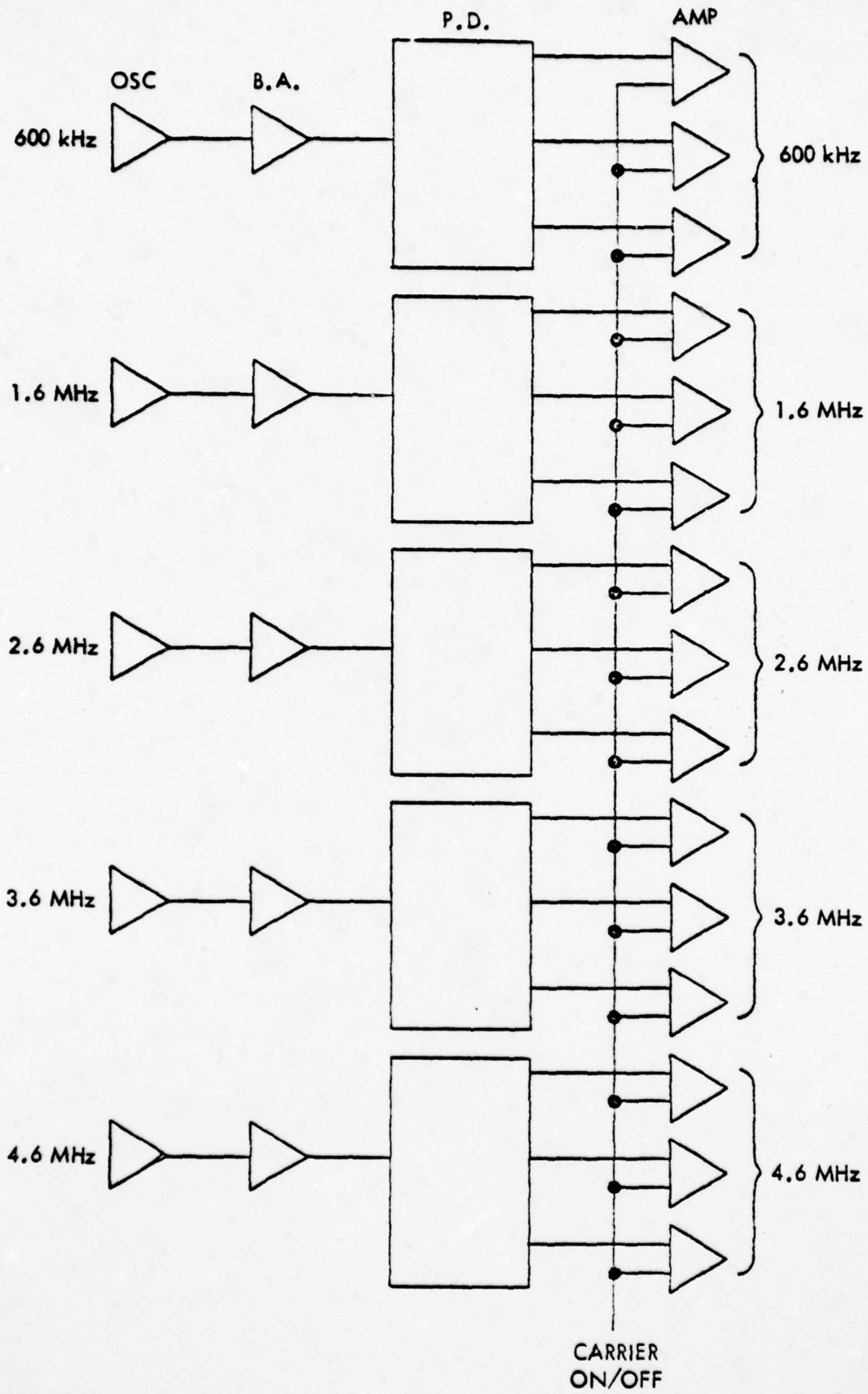

Figure 7.2.1.1.1-1. Oscillator Block Diagram

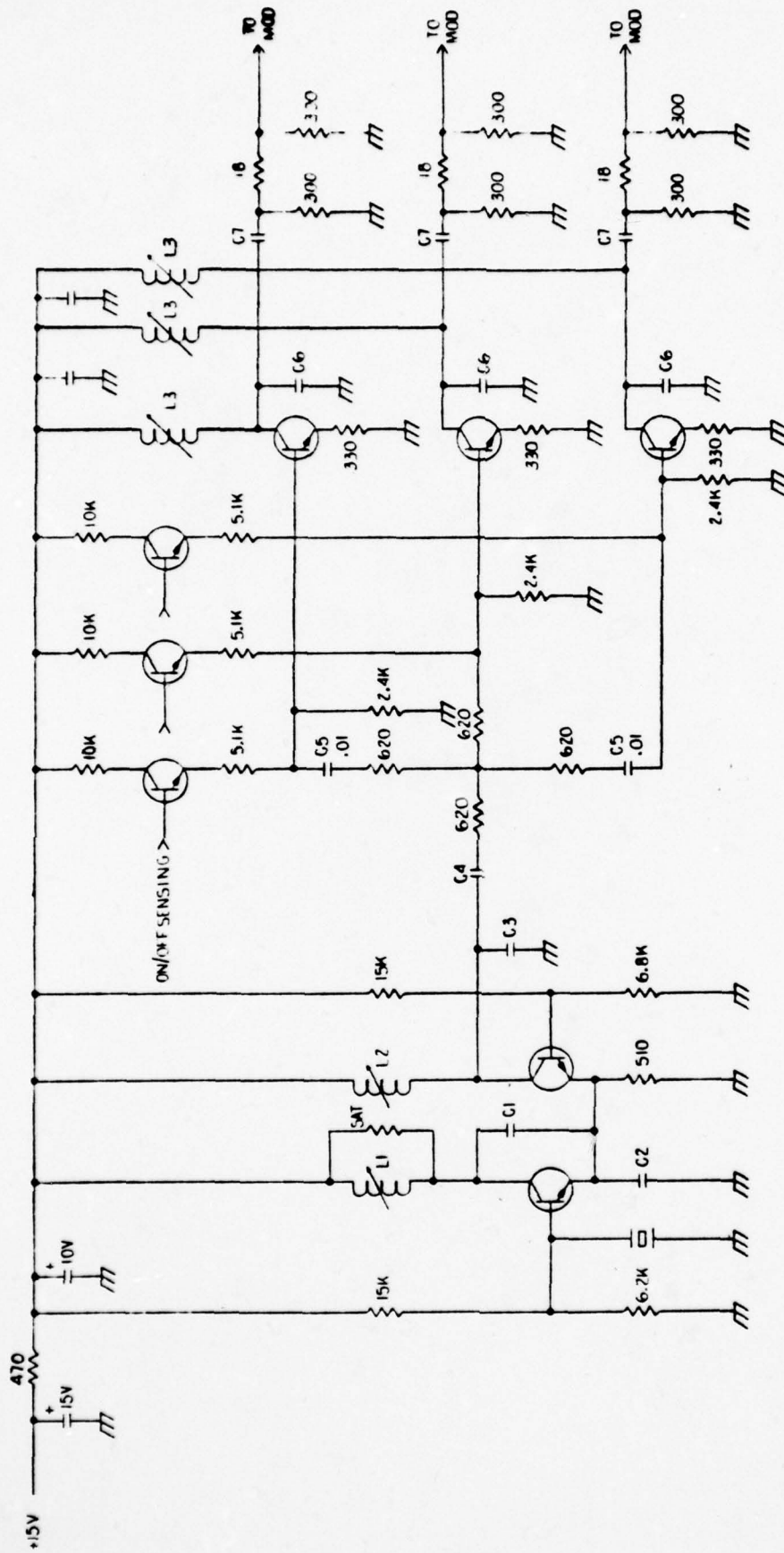

Figure 7.2.1.1.1-2. Typical Oscillator Circuit

TABLE 7.2.1.1.1-1. OSCILLATOR/BUFFER AMPLIFIER ELEMENTS

Frequency	L1	L2	C1	C2	C3	C4
0.6 MHz	300	300	270	1800	100	130
1.6 MHz	19.9	20	560	3600	430	51
2.6 MHz	12.2	18.35	350	2258	180	30
3.6 MHz	8.23	15.45	270	1800	100	22
4.6 MHz	5.88	13.8	230	1500	68	18

*All values in microhenries and picofarads.

TABLE 7.2.1.1.1-2. OSCILLATOR OUTPUT AMPLIFIER ELEMENTS

Frequency	L3	C6	C7	C5
0.6 MHz	72.5	120	820	0.01
1.6 MHz	21.7	120	330	0.01
2.6 MHz	12.23	100	200	0.01
3.6 MHz	8.8	68	150	0.01
4.6 MHz	6.9	62	110	0.01

*All values in microhenries and picofarads.

Tests have demonstrated that isolations greater than 30 dB can be achieved at these low frequencies from the output of an amplifier to its input and, in addition, the modulator used in the transmitter will reduce the audio feedthrough to the RF port by 40 dB (see Paragraph 7.2.1.1.3). The isolation from one channel to another via the common oscillator path will therefore be far greater than the required 60 dB.

The power from any output amplifier will be +6 dBm into a 3.0 dB pad. Thus the carrier power applied to the modulator will be +3 dBm.

The biasing circuit of each of the output amplifiers contains a transistor that is biased on or off by the action of the dc signaling condition. If the DSVT or telephone

is in an on-hook condition, this transistor is biased off and prevents that particular carrier from being applied to its respective modulator.

7.2.1.1.2 Modulation Leveling Circuit

Because the input signals from the telephones can vary over a wide voltage range it is required to select some nominal level as reference at which the modulation index is set to the desired value. The modulation index has been chosen to be 15 percent as a result of system analysis and this is to be achieved at an input signal level of -7 dBm across 600 ohms.

From the discussion on the modulator it is seen that 35 mV RMS is required to produce 15 percent modulation. Figure 7.2.1.1.2-1 is a simplified schematic of the circuit which sets the modulation index at 15 percent and which prevents a change of not more than 1-2 percent for a 12 dB increase in signal. This is achieved by sampling the modulating signal at the emitter of Q3 and using this to control the resistance of the J-FET's Q1 and Q2. The combination of Q1, R1 and Q2, R2 form a voltage divider network whose attenuation is a function of the voltage on the emitter of Q3. Figure 7.2.1.1.2-2 is a plot of the characteristics of the J-FET which is functioning as a voltage controlled resistor (VCR).

Several voltage levels versus resistance of the VCR have been calculated and in turn are used to determine the attenuation of this network. The input impedance of the emitter follower, Q3, along with its biasing network has been calculated to be 10K Ω . The results are shown in Table 7.2.1.1.2.

7.2.1.1.3 Modulator

Tests were performed on the balanced mixer to be used as the modulator for the multiplexing process. The modulator was tested with RF inputs from 0.5 MHz to 5 MHz and with modulating signals from 300 Hz to 300 kHz. The results of the tests are discussed in the following paragraphs.

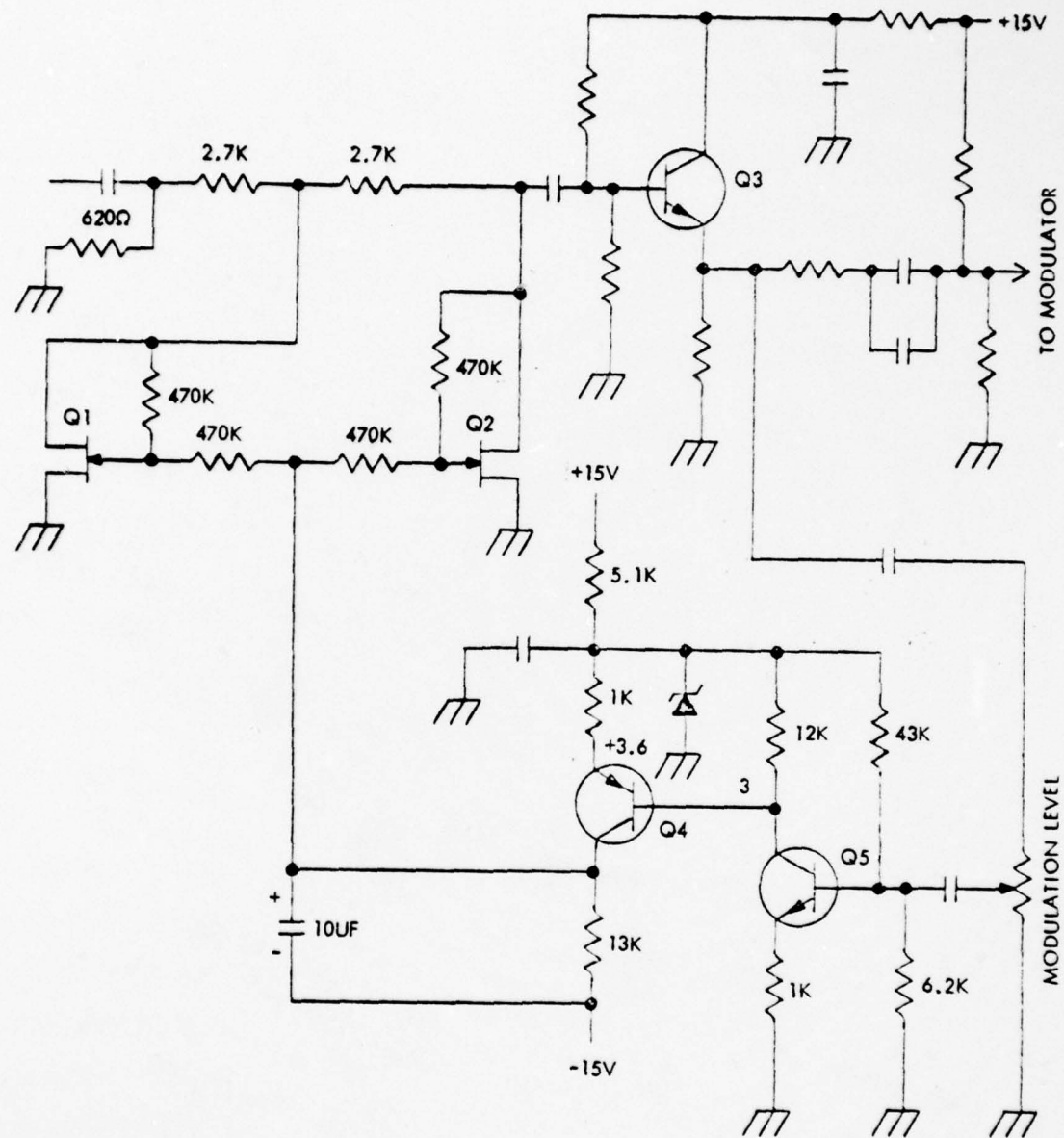

Figure 7.2.1.1.2-1. Modulation Leveling Circuit

AD-A060 342

HARRIS CORP MELBOURNE FLA ELECTRONIC SYSTEMS DIV
26-PAIR FIBER CABLE STUDY.(U)

F/G 20/6

UNCLASSIFIED

JAN 76 C R PATISAUL, I B SLAYTON, J W BRUCE

DAAB07-75-C-0363

ECOM-75-0363-F

NL

2 OF 2
AD
A060342

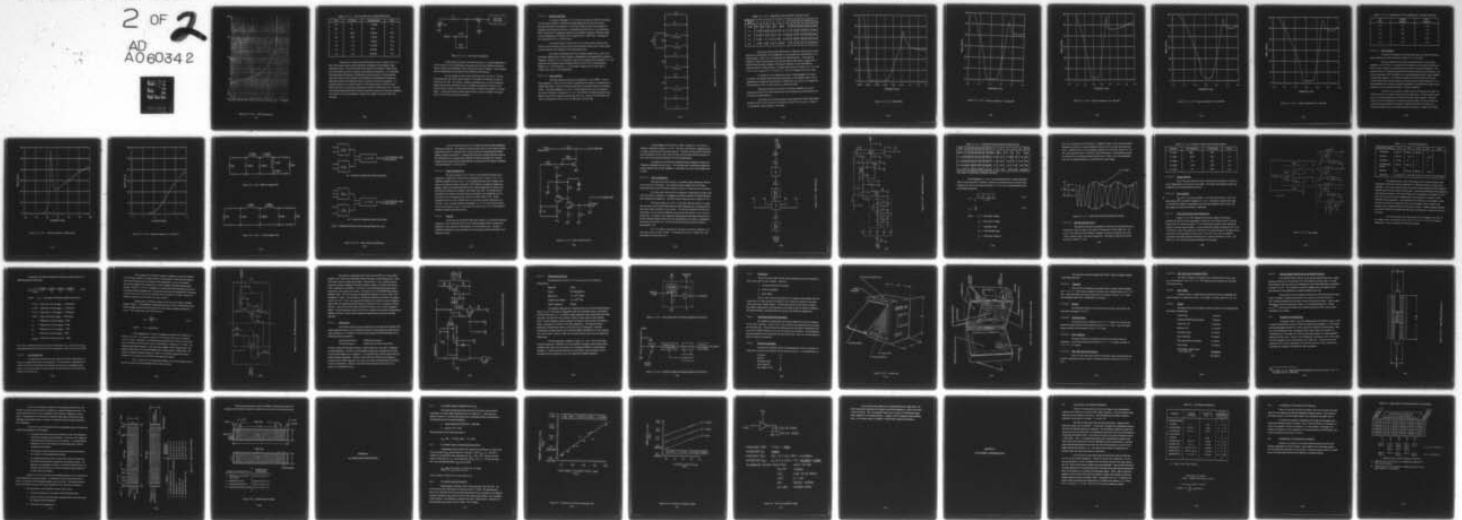

END
DATE
FILMED
12-78
DDC

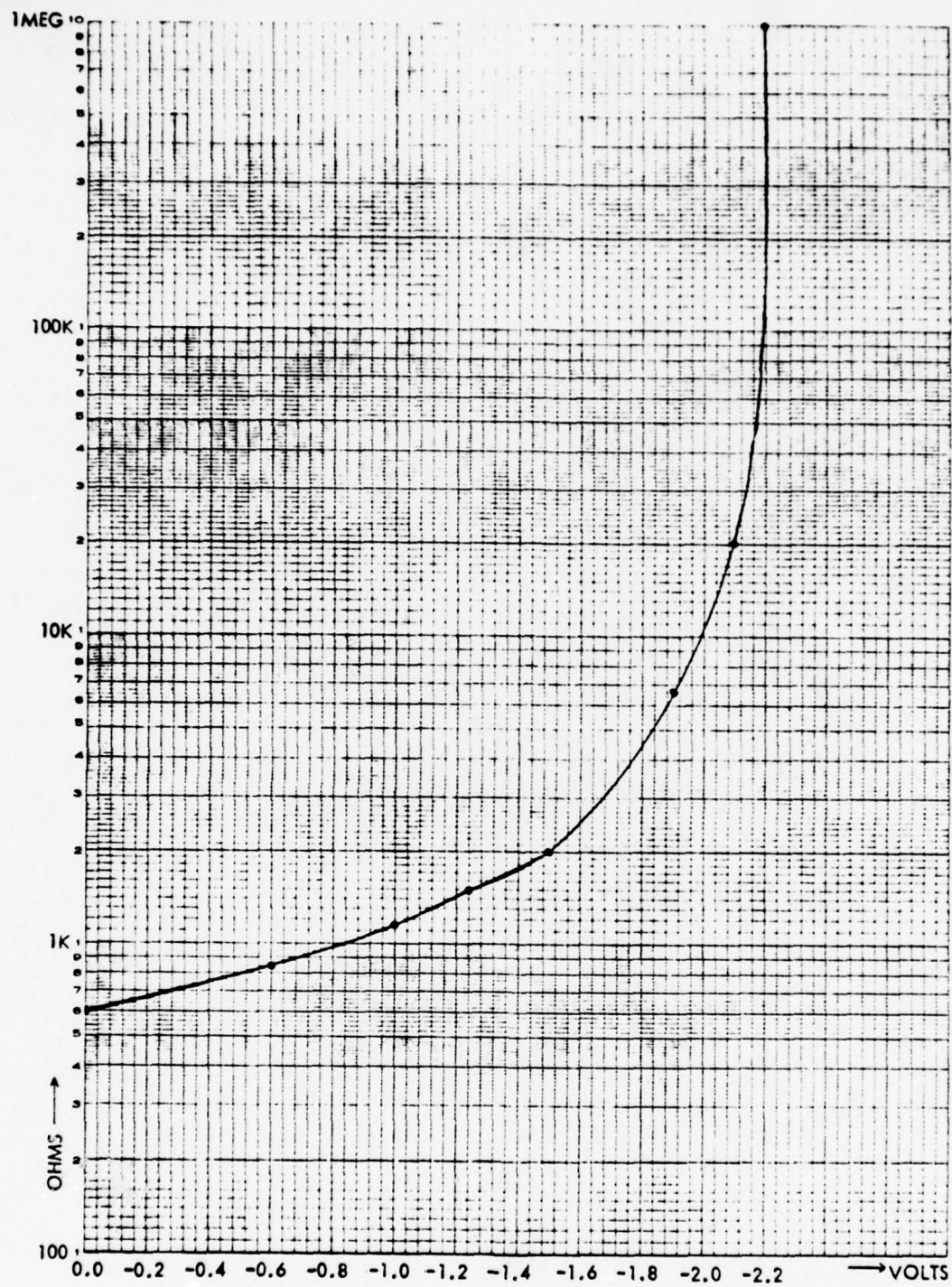

Figure 7.2.1.1.2-2. J-FET Characteristics

TABLE 7.2.1.1.2. VCR VOLTAGE LEVELS VERSUS RESISTANCE

Volt	VCR (K Ω)	Attenuation dB	dB/V
2.3	∞	3.75 dB	—
2.2	∞	3.75	0
2.1	20.0	6.02 dB	22.7
2.0	10.0	7.94 dB	19.2
1.9	6.5	9.80 dB	18.6
1.8	4.5	11.74 dB	19.4
1.7	3.2	13.98 dB	22.4
1.6	2.5	15.89 dB	19.1

The test circuit used for collecting the data is shown in Figure 7.2.1.1.3. One of the primary concerns was the distortion introduced by the modulator at high modulation indices. For all of the tests the RF input level was held at +3 dBm and the audio input level was varied to produce various degrees of modulation. At a modulation index approaching 100 percent (>90 percent) the second harmonic of the modulating signal was found to be down greater than 35 dB below the fundamental side band and approached 45 dB as the modulation index was reduced to 35 percent modulation. It is proposed to operate at a nominal 15 percent in the present system to allow for voice spikes which can very easily push the modulation toward the 100 percent level. The tests indicated that approximately 35 mV RMS was required to produce the 15 percent modulation. The transmitter circuits are designed to produce this voltage at the audio input of the modulator.

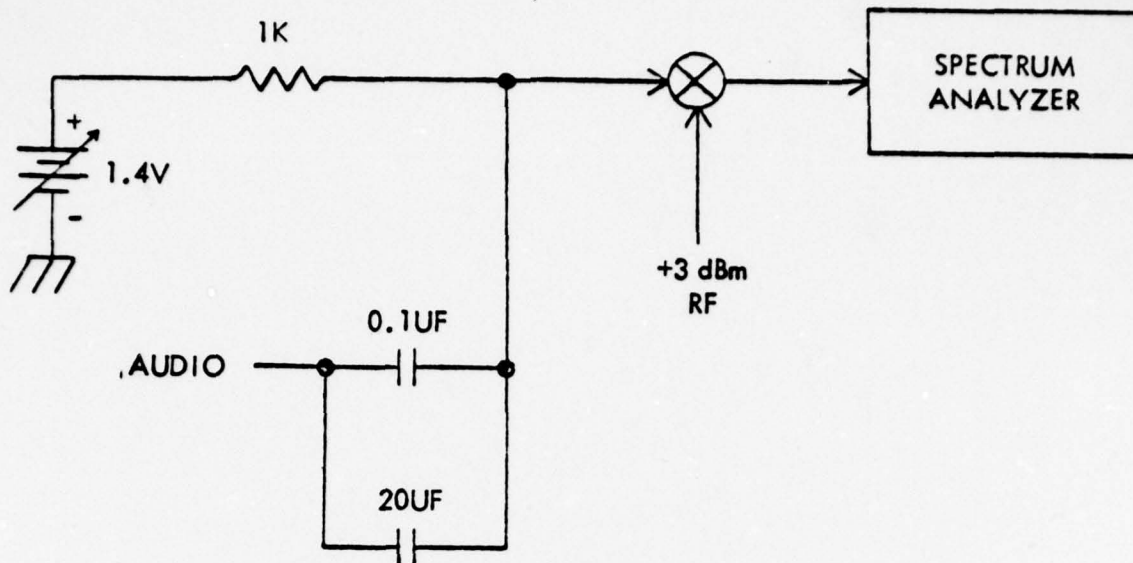

Figure 7.2.1.1.3. Test Circuit for Modulator

Another point of interest in the tests was the amount of audio feedthrough to the RF input port, as this feedthrough could progress into the local oscillator system and then be carried to the modulators of other channels and result in crosstalk. Tests indicated that this feedthrough was down greater than 40 dB at the RF input port.

The bias voltage was also varied up and down from 1.8 volts to 1.09 volts which produced a total carrier level variation (in the output) of ± 2 dB about a nominal insertion loss of 8 dB. This change in voltage is considered to be an order of magnitude greater than would be experienced over any voltage and temperature variation in the system so that a variation in carrier level of less than 1.0 dB can be expected in the final system. It should be pointed out that a power leveling circuit is included in the design which will reduce this variation even further.

7.2.1.1.4 Amplifier and Filters

It is shown in Paragraph 7.2.1.1.6 that a maximum of 0.70V RMS is required from each power amplifier to produce the desired signal level into the LED circuitry. From the discussion on the modulator it is seen that -5 dBm of carrier will be present as measured across 50 ohms at the input to the amplifier and filter circuit. From this we are able to determine the voltage gain required by the amplifier to produce the desired output by thus corresponding to -5 dBm the input voltage level is 0.1257V RMS. Consequently the required gain is 5.6 or 15 dB minimum.

In the actual design, this gain was set to a nominal 24 dB to allow for the insertion loss of the filters and also to ensure that the power leveling circuit remains within its active region for the regulation of the output power level.

The transmit bandlimiting filters are multipole bandpass filters, with a 3 dB bandwidth of 600 kHz and a center frequency corresponding to the appropriate RF subcarrier frequency. Figure 7.2.1.1.4-1 provides a typical circuit configuration and Table 7.2.1.1.4-1 summarizes the component values (computed with the aid of [6]), for each subcarrier. Figures 7.2.1.1.4-2 through 7.2.1.1.4-6 provide a computer plot for each filter to validate the accuracy of the computations.

7.2.1.1.5 Power Amplifier

The power amplifier selected for this application is the LH0002. It has an input impedance of 5 K Ω at 5 MHz and 50 K Ω at 600 kHz thus making it straightforward to establish the proper 2 K Ω load for the preceding filter by the proper choice of a swamping resistor. The output impedance is in the 6 - 10 ohm range which serves its intended use very well as discussed in Paragraph 7.2.1.1.6. This amplifier was tested during this study phase and was found to suppress its second and third, etc., harmonics by 45 dB below the carrier at output power levels of up to +15 dBm across a 50 ohm load.

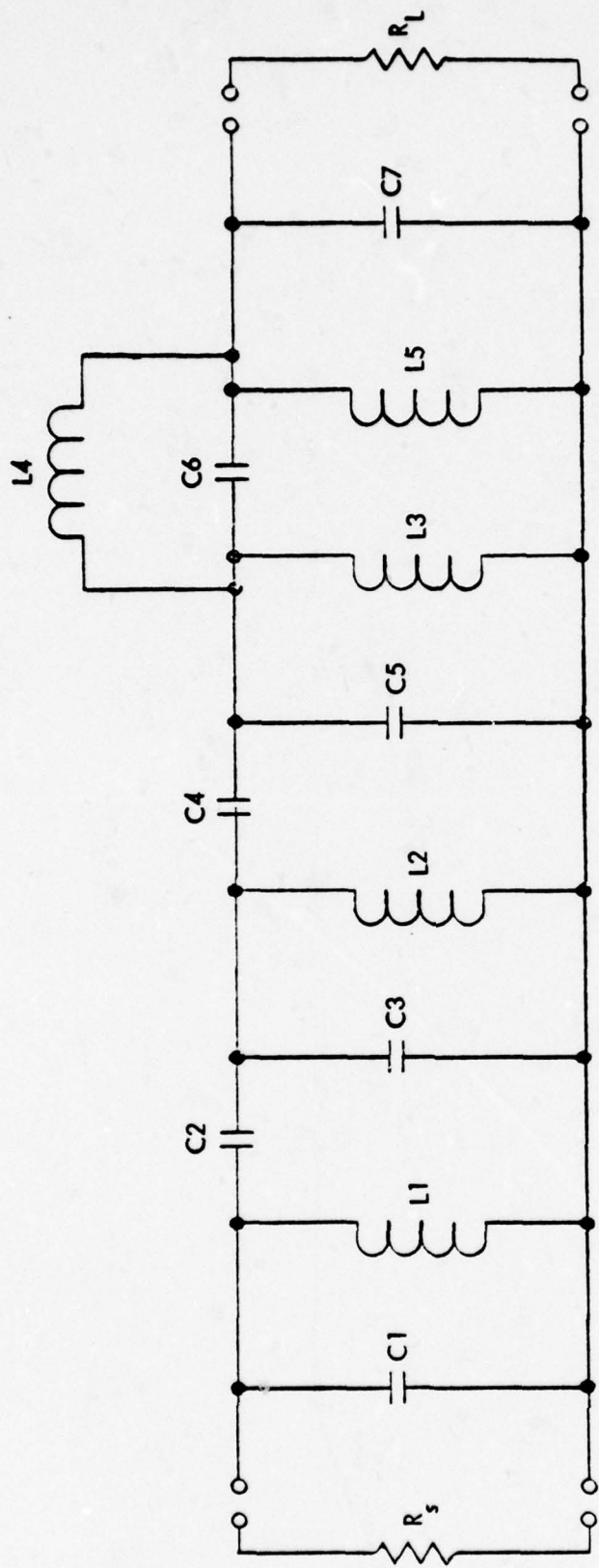

Figure 7.2.1.1.4-1. Typical BPF (Transmit or Receive)

TABLE 7.2.1.1.4-1. BANDPASS FILTER ELEMENTS (TRANSMIT SIDE)

Frequency MHz	L1	L2	L3	L4	L5	C1	C2	C3	C4	C5	C6	C7	R _S /R _L
0.600	706.4	353.2	566.4	372	2856	44	205	89	205	143	40	98	2000
1.6	77.32	38.64	52.69	92.48	165.4	91	51	182	51	182	51	91	2000
2.6	28.65	14.32	18.25	41.96	54.25	105	31	210	31	193	55	88	2000
3.6	14.84	7.4	9.52	23.84	26.64	112	22	225	22	200	57	87	2000
4.6	9.08	4.54	5.78	15.44	1587	29	18	58	18	51	15	22	2000

Because the 60 dB crosstalk specification is imposed on the system the inband harmonics of this amplifier must be suppressed to a level greater than 60 dB relative to the desired signals. Table 7.2.1.1.5 summarizes the inband harmonics. To preclude the possibility of these being detected in the receiver portion of the system a lowpass filter is added between the power amplifier and the power combiner in each of the 600 kHz channels and the 1.6 MHz channels. Computer plots are given in Figures 7.2.1.1.5-1 and 7.2.1.1.5-2. Figures 7.2.1.1.5-3 and 7.2.1.1.5-4 are schematics for the two filters.

An inspection of the computer plot of the 1.6 MHz bandpass filter used in the receiver (transmitter) shows that the second harmonic of the 600 kHz channel will be suppressed by an additional 18 dB and the 3.6 MHz filter in the receiver will suppress the second harmonic of the 1.6 MHz carrier by an additional 12 dB.

Combining the harmonic rejection of the power amplifier with the LPF rejection and the receiver filter rejection shows that far greater than 60 dB rejection will be realized for these harmonics.

The harmonics of the other signals are down greater than 45 dB while passing through the LED circuitry and will be rejected by the filters in the receivers. These are not considered to pose a problem in this system.

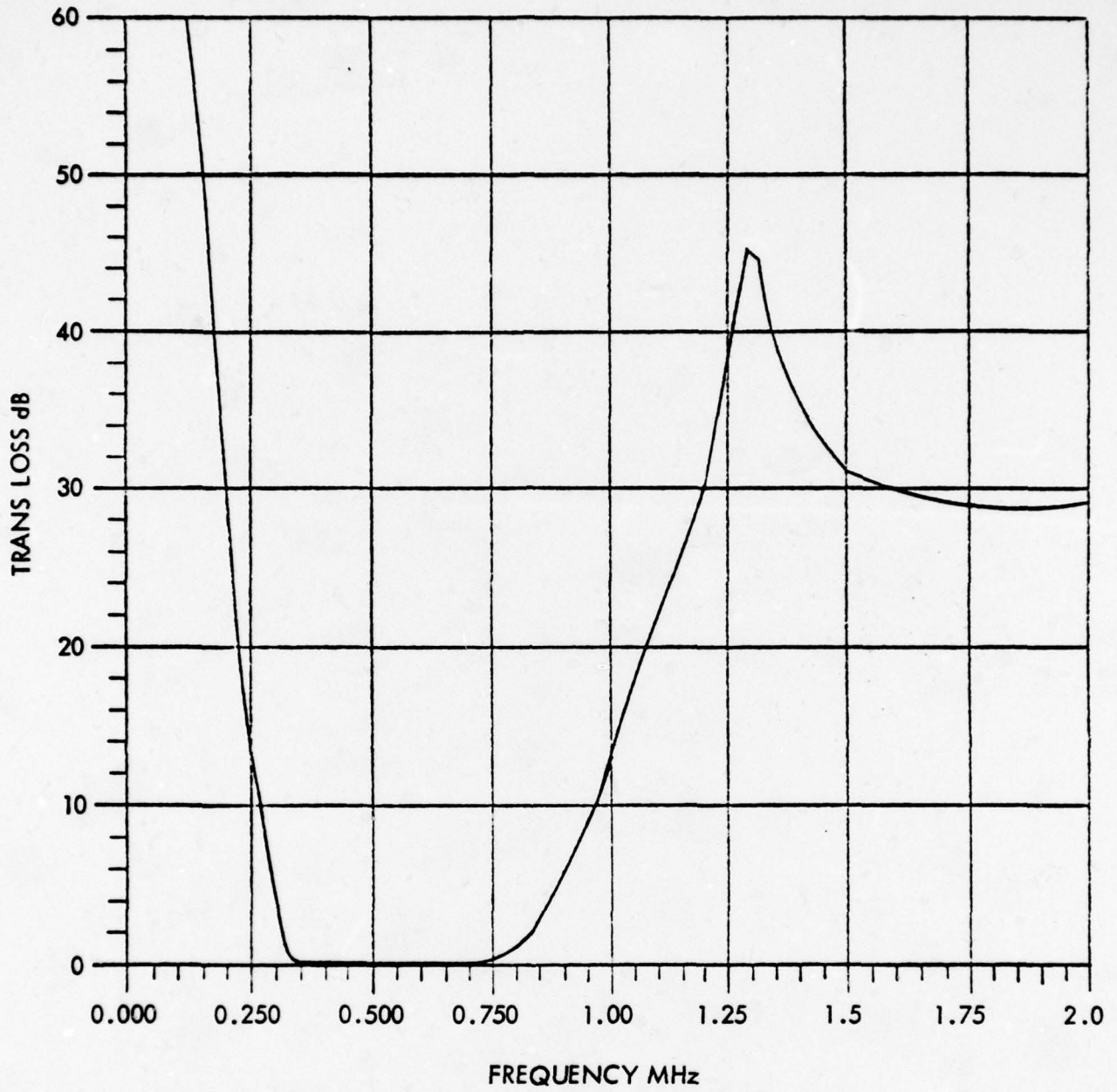

Figure 7.2.1.1.4-2. 600 kHz BPF

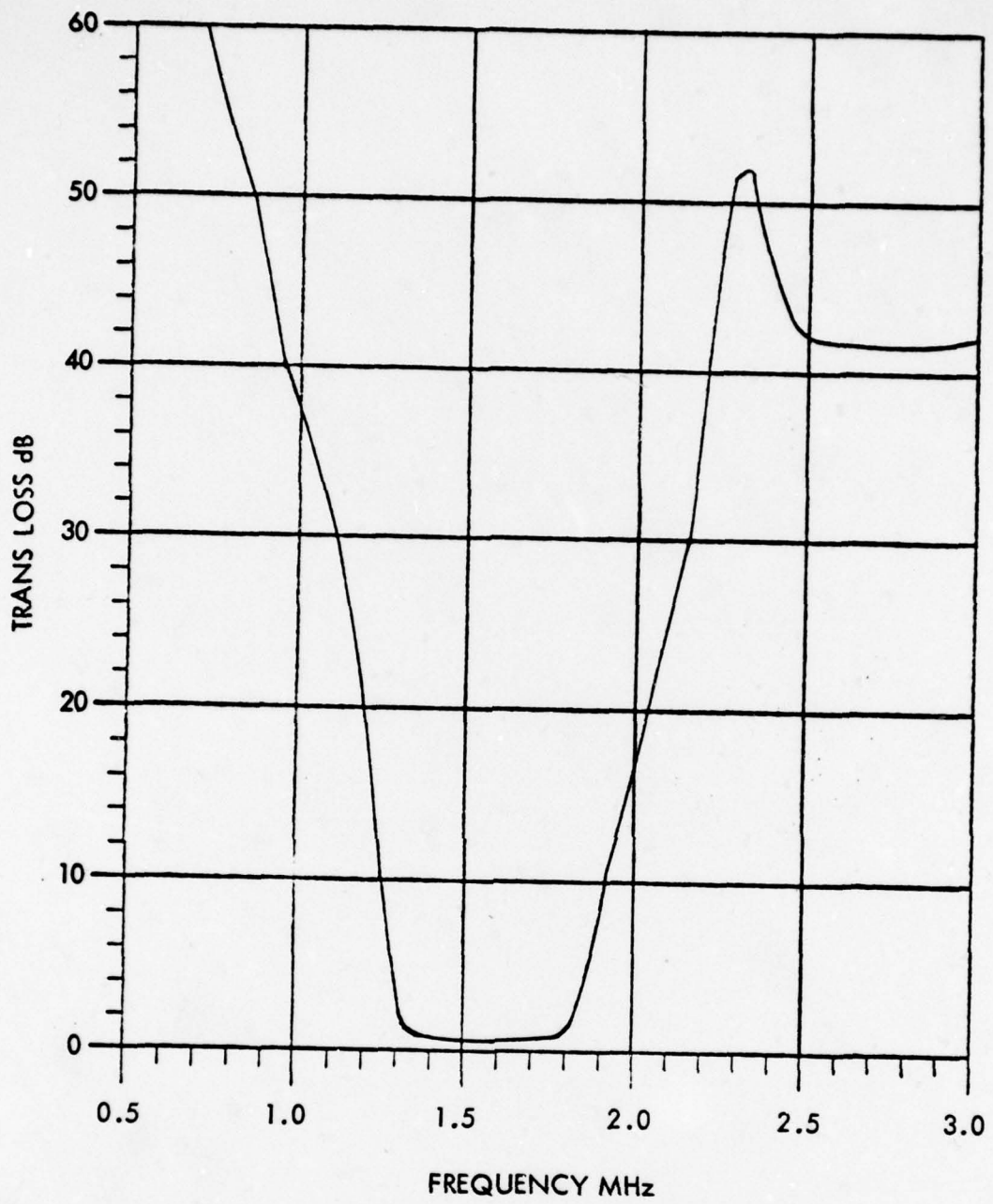

Figure 7.2.1.1.4-3. Frequency Response of 1.6 MHz BPF

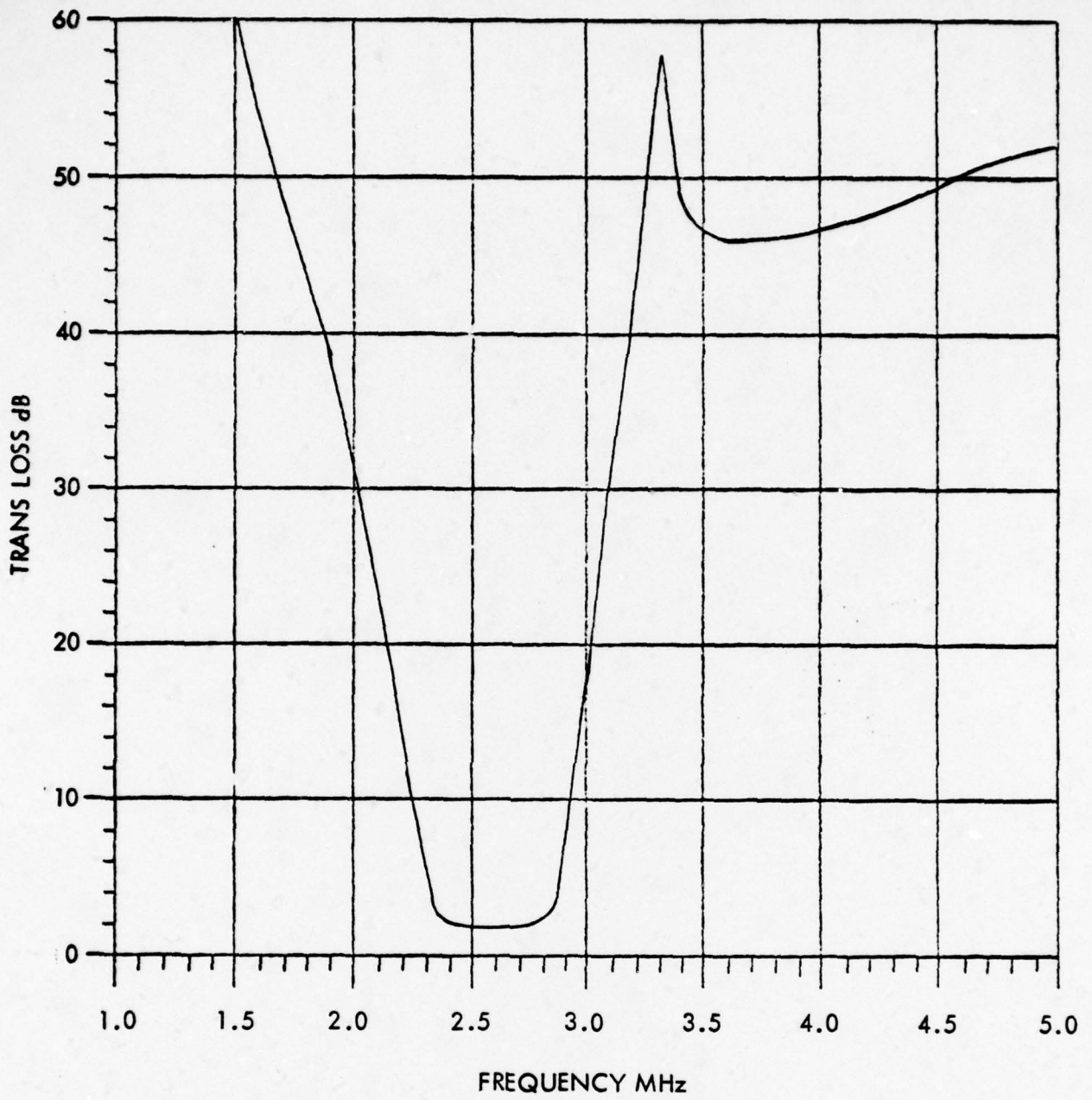

Figure 7.2.1.1.4-4. Frequency Response of 2.6 MHz BPF

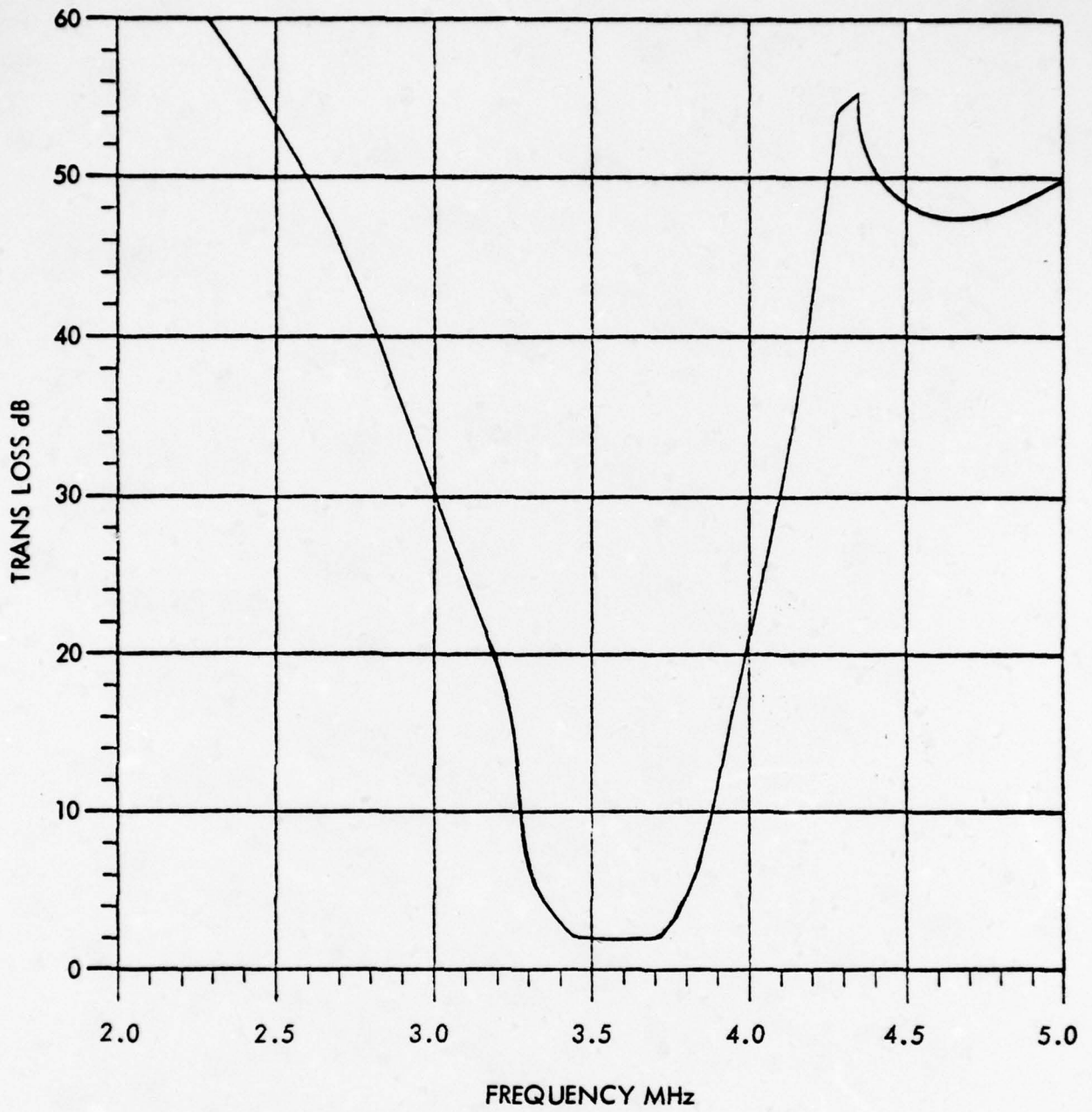

Figure 7.2.1.1.4-5. Frequency Response of 3.6 MHz BPF

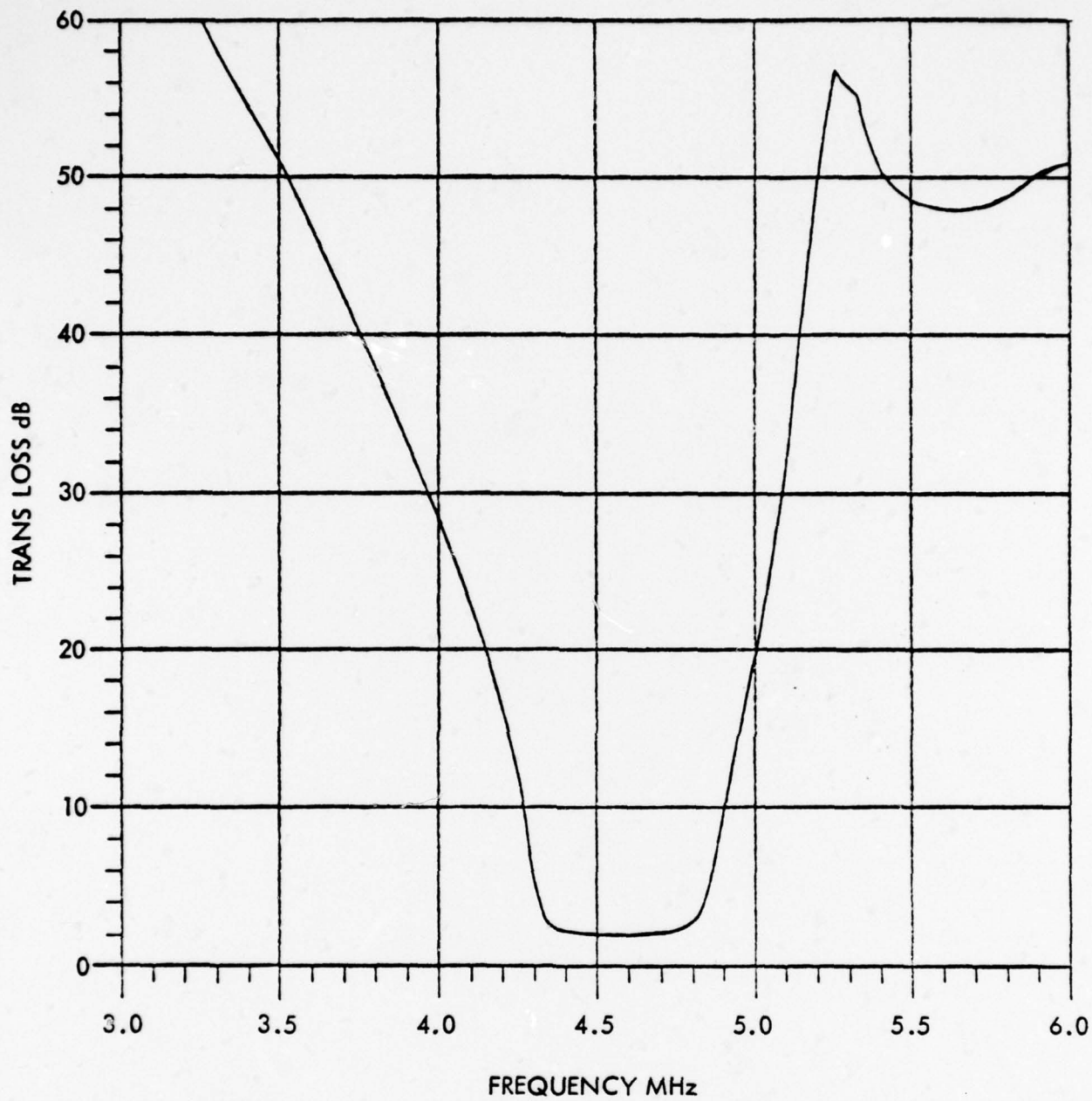

Figure 7.2.1.1.4-6. Frequency Response of 4.6 MHz BPF

TABLE 7.2.1.1.5. HARMONICS OF RF CARRIERS DUE TO POWER AMPLIFIER

RF MHz	Second Harmonic	Third Harmonic
0.6	1.2	1.8
1.6	3.2	4.8
2.6	5.2	7.8
3.6	7.2	10.8
4.6	9.2	13.8

7.2.1.1.6 Power Combiner

To combine all channels into a single signal path, two-way and three-way power combiners are utilized as shown in Figure 7.2.1.1.6 A and B.

The power amplifier which drives the combiners have a typical output impedance of only 10 ohms. To ensure that the combiners are terminated into 50 ohms, a 39 ohm resistor is added in series between the combiner and the power amplifiers. This resistor results in a 5.0 dB power loss between the power amplifier and the combiner, but serves to add nearly 14 dB of isolation to any signal attempting to enter a power amplifier via the power combiners. This isolation coupled with the 30 dB typical port-to-port isolation of the power combiners produces a total of 44 dB of isolation between any two power amplifiers and virtually precludes the possibility of intermodulation products being produced by any two adjacent channels in the power amplifiers.

The LED circuitry requires +10 dBm (10 mw) of total power from either the 5-channel input or a 4-channel input to drive the fiber optics. For the 5-channel input then, each must contribute 2 mw (+3 dBm) at the output of the combiner. When the insertion loss of the combiners (1.0 dB) and the 39 ohm resistor (5.0 dB) are taken into account each power amplifier must deliver +9 dBm (0.63V RMS) to its load for the 5-channel combiners and the 4-channel amplifiers must deliver +10 dBm (0.707V RMS).

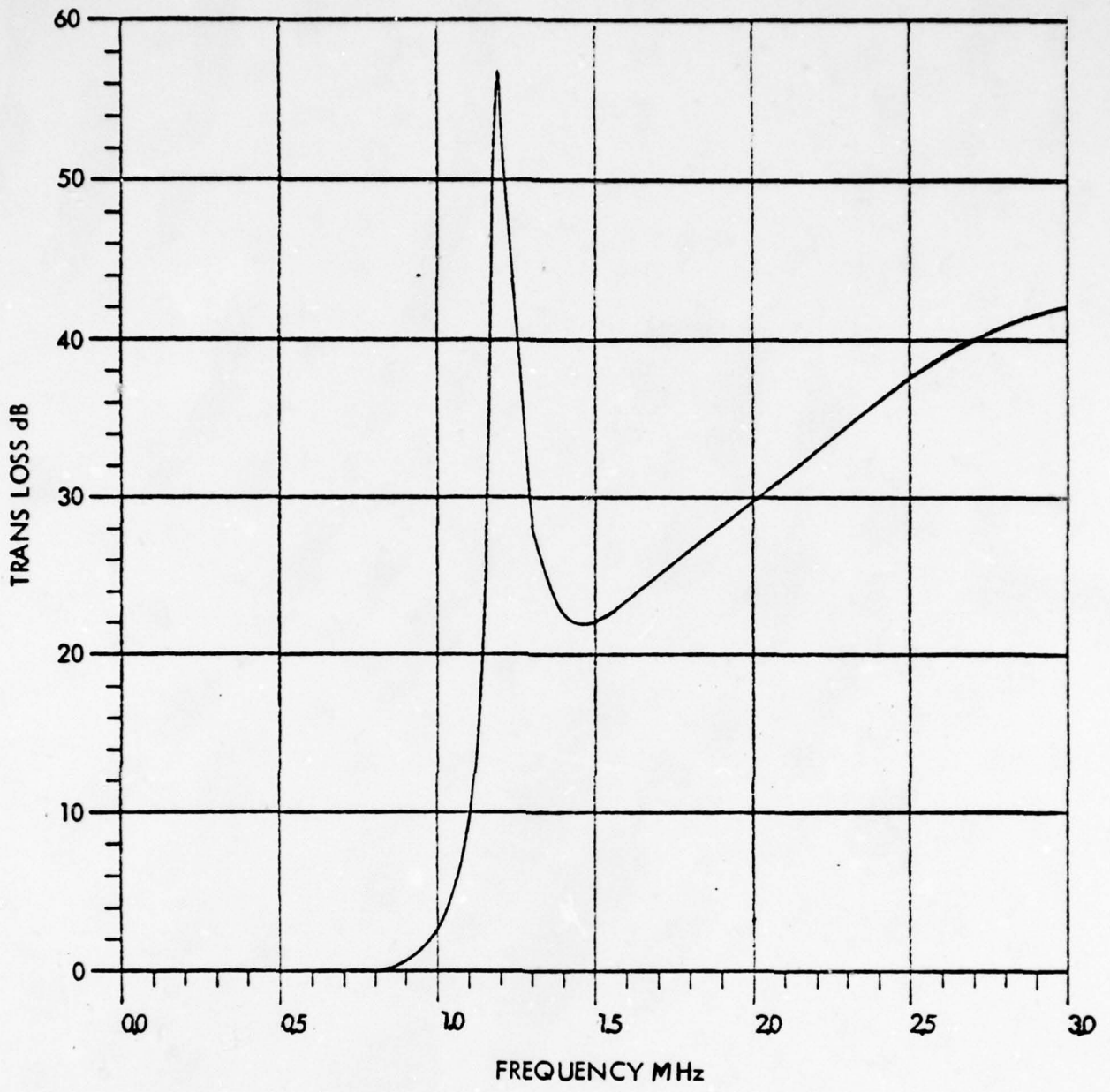

Figure 7.2.1.1.5-1. Frequency Response of 600 kHz LPF

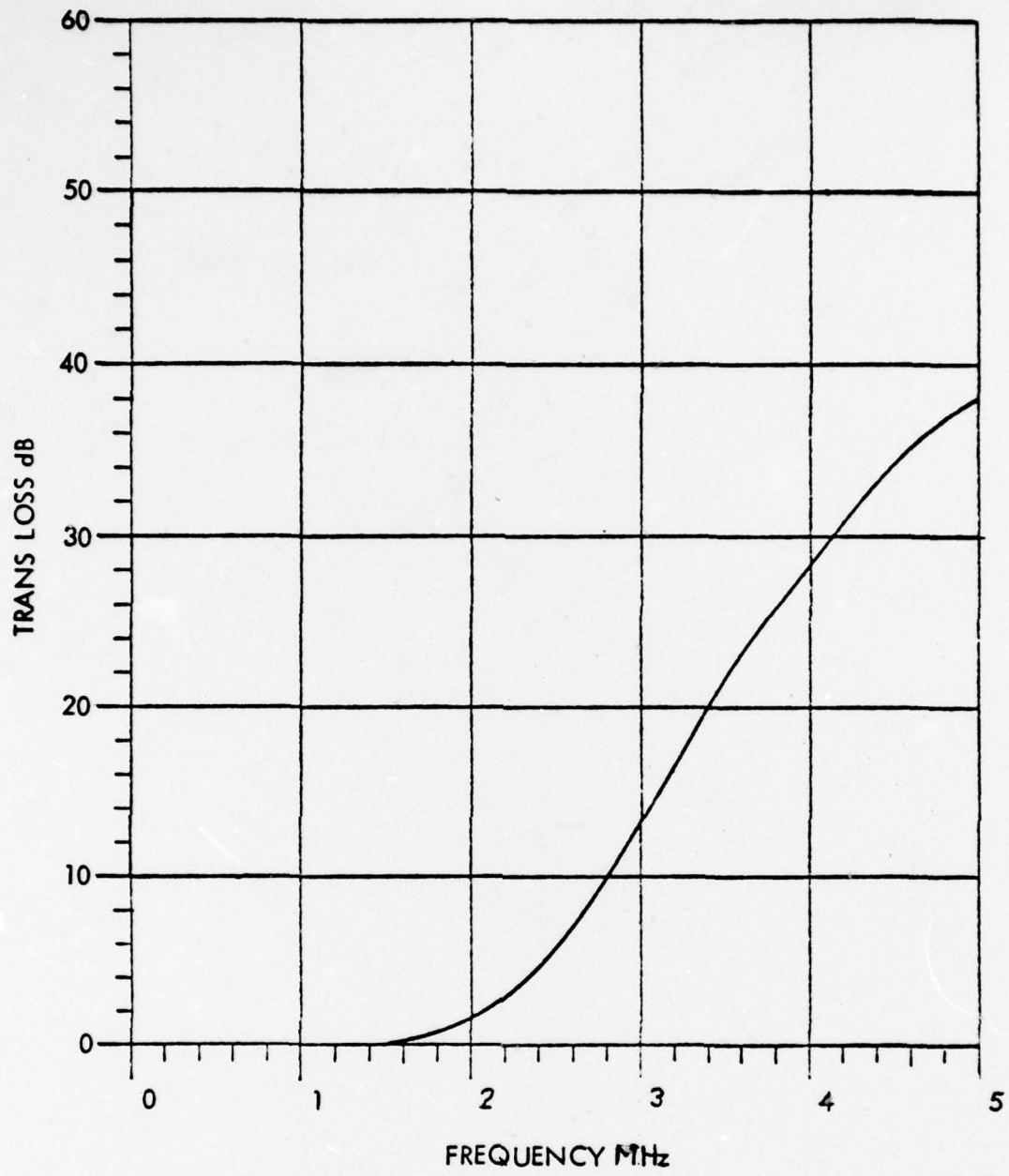

Figure 7.2.1.1.5-2. Frequency Response of 1.6 MHz LPF

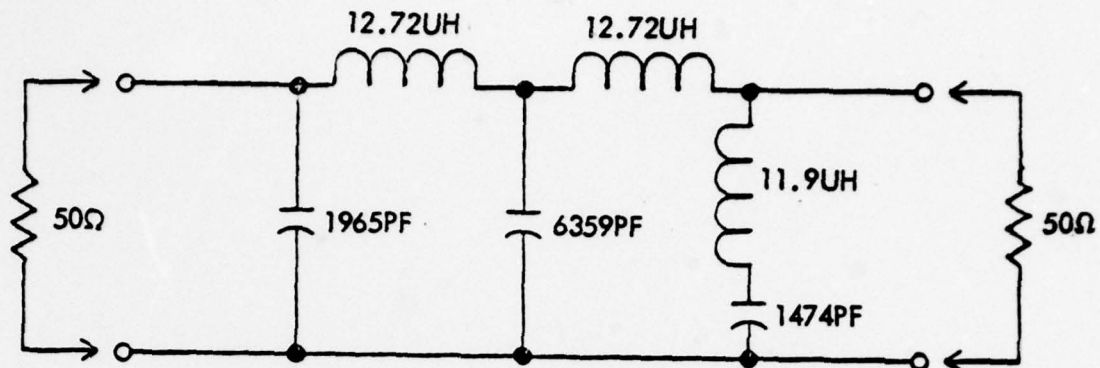

Figure 7.2.1.1.5-3. 600 kHz Lowpass Filter

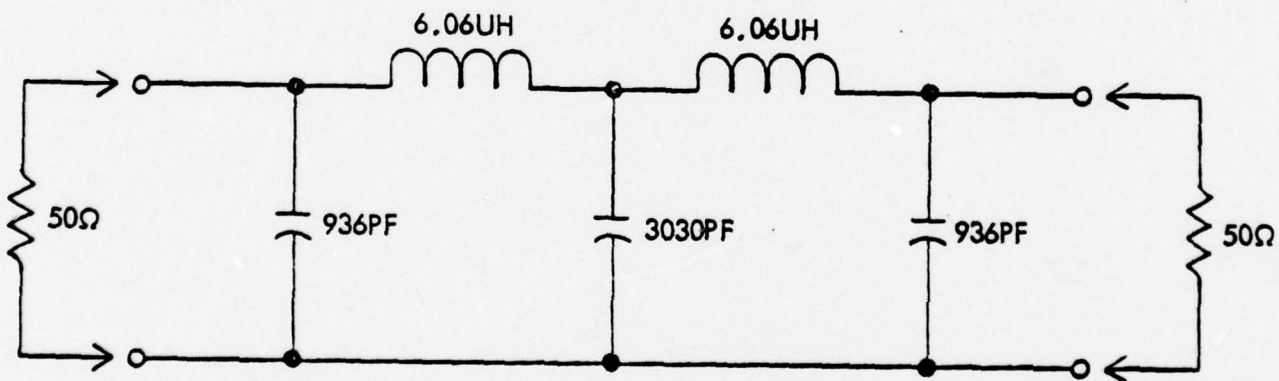
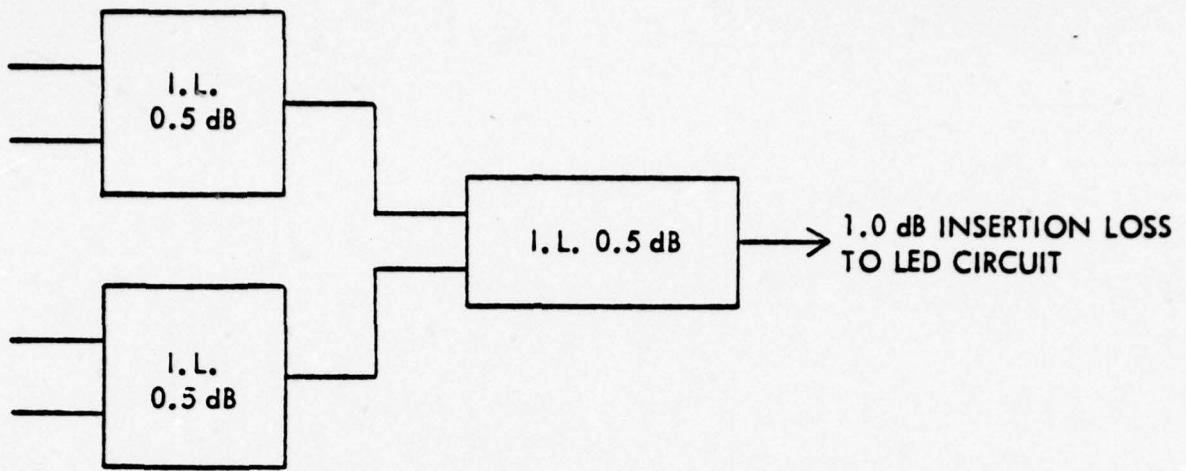
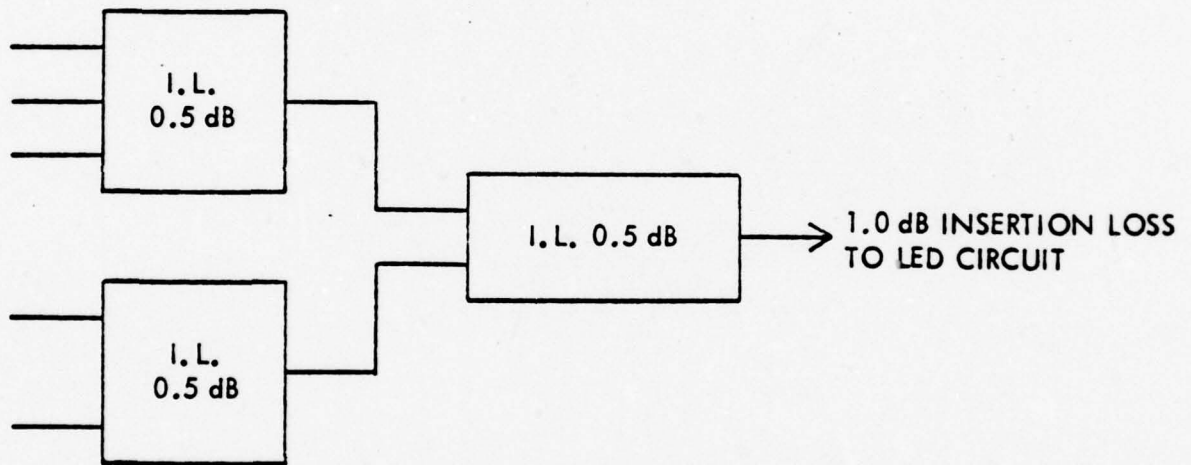

Figure 7.2.1.1.5-4. 1.6 MHz Lowpass Filter



(A) 4 CHANNEL COMBINER (TWO PER SYSTEM)



(B) 5 CHANNEL COMBINER (ONE PER SYSTEM)

NOTE: COMBINER MODULES ARE AVAILABLE FROM MCL INC.

Figure 7.2.1.1.6. Power Combiner Configuration

It will be noted that this level is well below the power handling capability of the power amplifiers. This method of raising the power level of each channel and then combining just prior to entering the LED circuitry reduces the intermodulation problem between channels significantly. If these channels had been combined and then raised to the +10 dBm level by a common power amplifier the power consumption of a one-way transmit-receive system would be approximately 15 watts greater than presently estimated or 30 watts greater for a two-way link.

7.2.1.1.7 Power Leveling Circuit

The power leveling circuit is similar to the modulating leveling circuit except that a single J-FET is used to control the power level. Figure 7.2.1.1.7 is a simplified schematic for this circuit. It is anticipated that power level changes at the input to the combiners will be on the order of ± 2.0 dB due to voltage and temperature changes. When one considers that there are five signals undergoing this change, then the ± 2.0 dB is reflected as a change in total power to the LED. This change must be controlled but not nearly to the extent that was necessary in the modulating circuitry. The circuit used in the design has one voltage controlled resistor (VCR). Design calculations for this circuit, indicate that this circuit has a transfer characteristic of 7 dB/volt. Thus, using the rationale of Paragraph 7.2.1.1.2 it can be shown that less than ± 0.5 dB change will occur in the output to the LED circuits, for a 4.0 dB change in oscillator and power generating circuits.

7.2.1.2 Receiver

The receiver for the 26-Pair Fiber Optic System is a conventional amplitude modulation receiver utilizing a bank of five multipole bandpass filters for preselection followed by a gain stage and a diode detector for recovering the data. The data is amplified and applied to a power amplifier of the same type as used and described in the transmitter section.

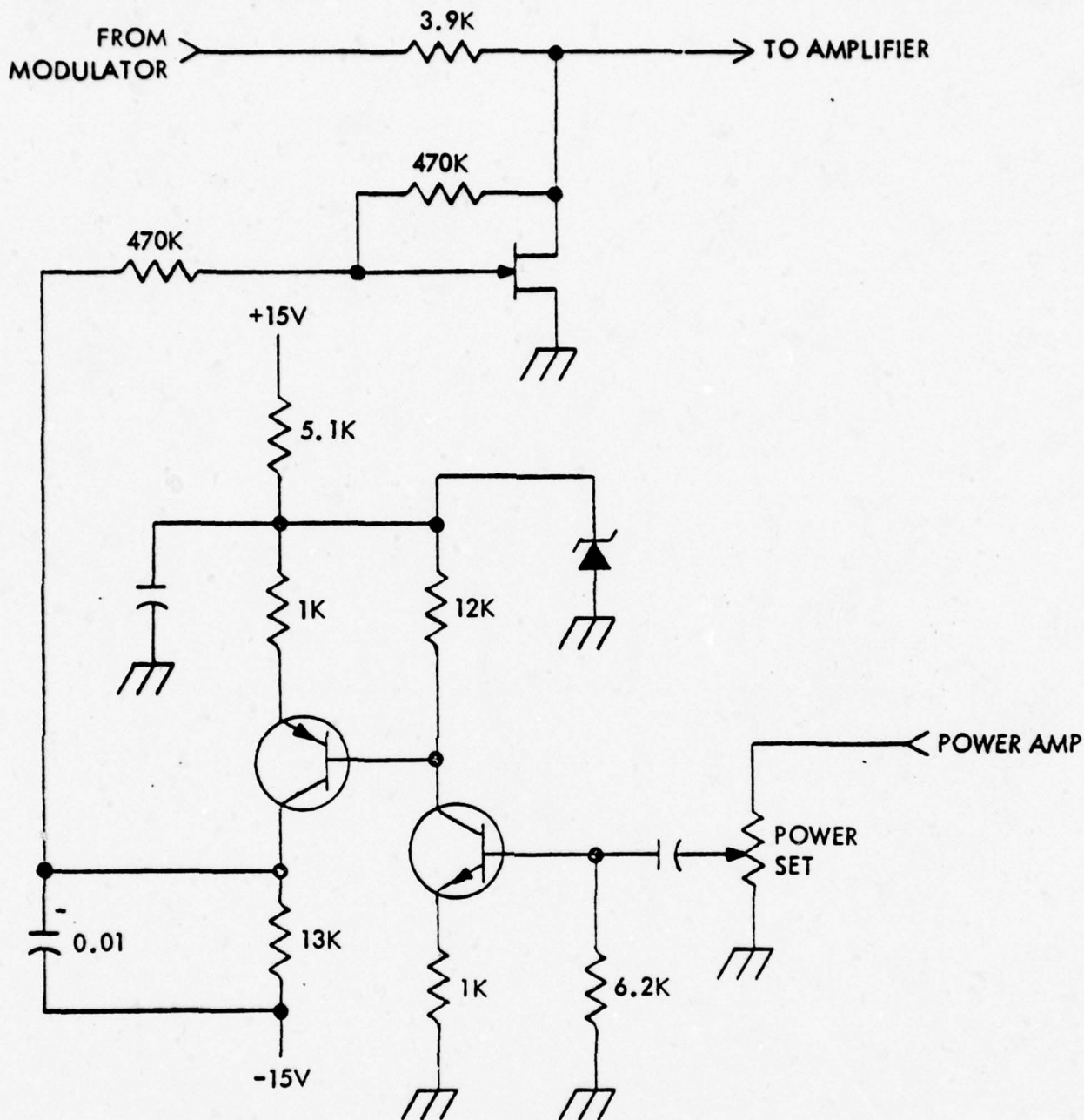

Figure 7.2.1.1.7. Power Leveling Circuit

A block diagram of this receiver is shown in Figure 7.2.1.2-1 and the schematic is depicted in Figure 7.2.1.2-2. The input to the receiver is applied directly to a power divider from the fiber optics detector. The power divider provides impedance matching between the fiber optics and the filters while providing isolation between the filter inputs which prevents distorting of the filter characteristics.

The output from the filters are amplified and then detected to recover the intelligence impressed onto the carrier. This recovered data is amplified and applied to a power amplifier whose output impedance is sufficiently low to drive the minimum load of 125Ω .

7.2.1.2.1 Filters (Predetection)

The output of the LED circuitry is a composite signal consisting of from one to five channels of information. This composite signal is applied to the five filters simultaneously and each filter selects the band to which it is tuned and rejects all others.

The filters used in the receiver are identical in characteristics to those used in the transmitter but operate at an impedance of 500 ohms instead of the $2K\Omega$ because of other impedance considerations. The filter element values are given in Table 7.2.1.2.1.

Referring to Figure 7.2.1.2-2 it is seen that a 470 ohm resistor is in series with the input to each filter and that these are fed simultaneously by the signal from the fiber optics detector through a 10 ohm resistor. This resistive configuration allows each of the filters to be driven from a 500 ohm source and the fiber optics circuitry to drive a 50 ohm load. In addition to the impedance transforming function these resistors provide 23 dB of isolation between filters so that the characteristics of one filter is unaffected by the presence of the other four. The insertion loss of the series resistors and filters is approximately 7 dB.

When all channels are present on the input to the optical transmitter, the output power across 50 ohms is 0 dBm. If we assume this to be a 5- channel link, then each signal will contribute 0.2 mv.

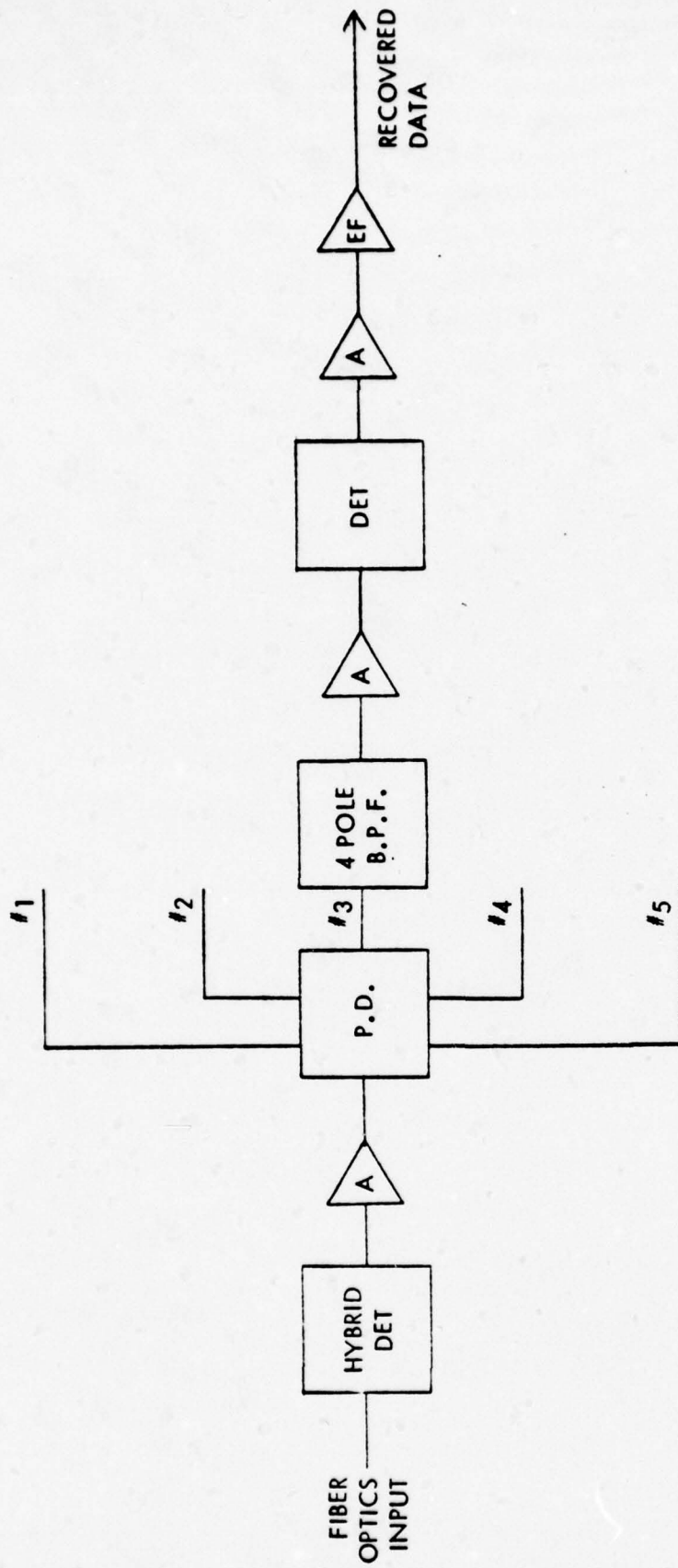

Figure 7.2.1.2-1. Typical Receiver

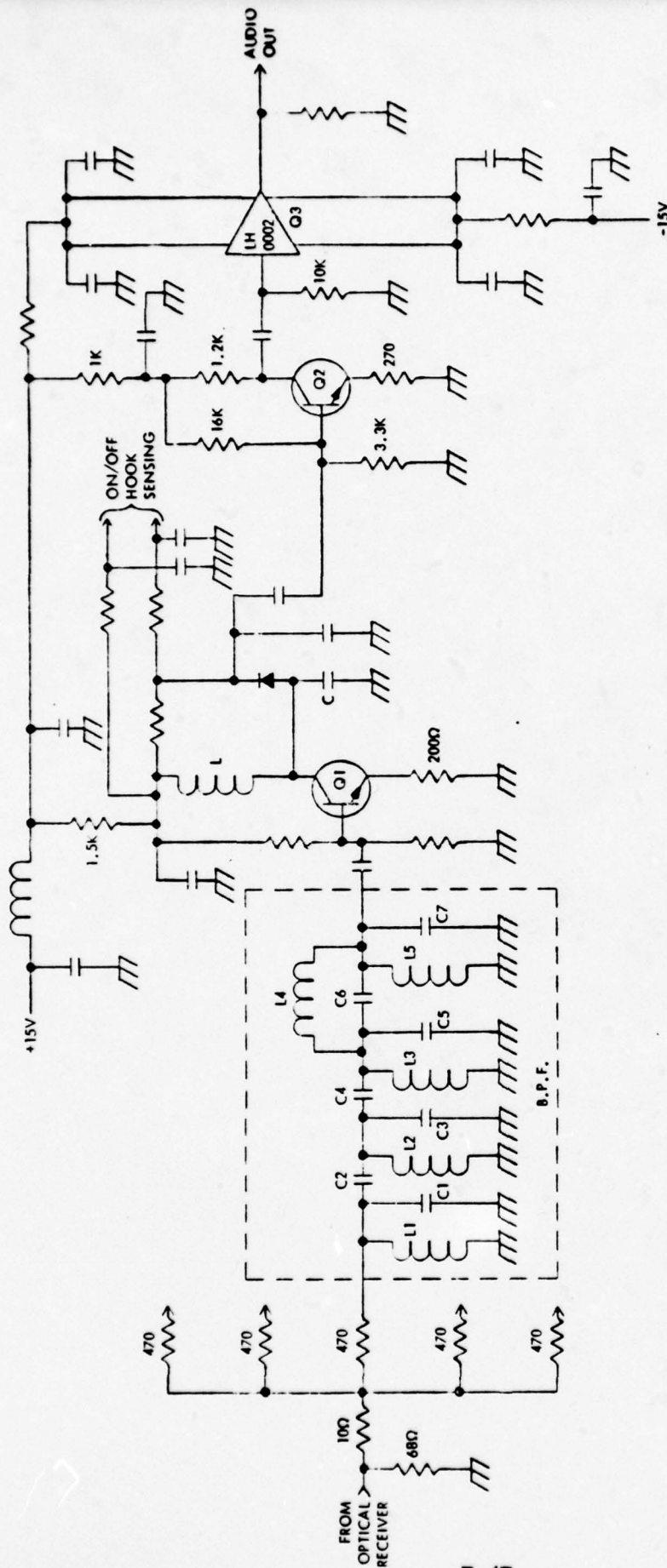

Figure 7.2.1.2-2. Typical Receiver Channel

TABLE 7.2.1.2.1. BANDPASS FILTER ELEMENTS (RECEIVER SIDE)

Filter	C1	C2	C3	C4	C5	C6	C7	L1	L2	L3	L4	L5	R_S/R_L
600 kHz	177	820	354	820	570	161	393	176.6	88.3	141.6	93	714	500
1.6 MHz	363	206	726	206	726	207	362	19.33	9.66	13.173	23.12	41.35	500
2.6 MHz	420	124	840	124	773	220	353	7.15	3.58	4.68	10.5	13.52	500
3.6 MHz	449	89	898	89	797	229	348	3.71	1.85	2.38	5.96	6.66	500
4.6 MHz	116	70	232	70	202	58	86	2.27	1.135	1.445	3.86	3.968	500

*All values in microhenries, picofarads, and ohms.

From Paragraph 7.2.1.1.2, it was determined that the nominal modulation index for each subcarrier is 15 percent. Based on a sinusoidal analysis, the peak signal voltage at the input to the network of Figure 7.2.1.2-2, may be estimated with the aid of the following equation.

$$V_S = \sqrt{\frac{2 \cdot m^2 \cdot P_S \cdot R_L}{1 + m^2}} \quad 7.2-1$$

$$V_C = \frac{V_S}{m} \quad 7.2-2$$

where: V_S = peak signal voltage
 V_C = peak carrier voltage
 m = modulation index
 P_S = input average power
 R_L = termination resistance

Thus, for an input power of 0.2 milliwatt, a modulation index of 15%, and a termination impedance of 50 ohms, the peak sinusoidal voltage levels for the signal and carrier are 21 mV. Combined results for the modulated waveform are illustrated in Figure 7.2.1.2.1. This is the waveform present at the input to the 10 ohm resistor. As discussed previously, the insertion loss of the power dividers and the filters is 7 dB such that the recoverable audio into the amplifier/detector is 18.8 millivolts, peak-to-peak.

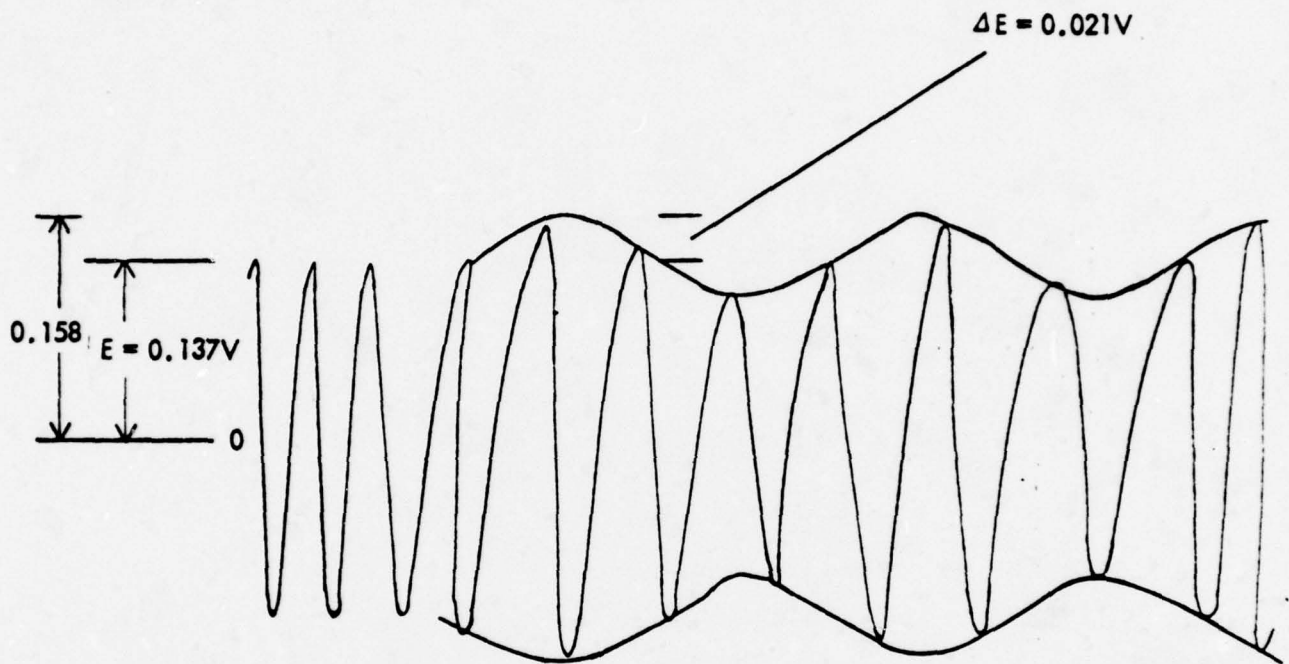

Figure 7.2.1.2.1. Single Tone Amplitude Modulated Waveform

7.2.1.2.2 Amplifier/Detector Circuit

The amplifier following the predetection filters provides 20 dB of gain prior to detection so that the audio at the output of the detector will be 0.188V p-p. The circuit in the collector of the amplifier is designed to produce a bandwidth of at least 1 MHz centered at each of the carrier frequencies. The element values for this circuit are given in Table 7.2.1.2.2.

TABLE 7.2.1.2.2. ELEMENT VALUES FOR DETECTOR CIRCUIT

Frequency	L (microhenries)	C (picofarads)	Filter Q
0.6 MHz	882	78.7	—
1.6 MHz	124.2	78.7	1.6
2.6 MHz	47	78.7	2.6
3.6 MHz	24.5	78.7	3.6
4.6 MHz	15	78.7	4.6

7.2.1.2.3 Voltage Amplifier

Q_2 is a low gain amplifier (12 dB, utilizing negative feedback in the form of emitter degeneration to set the gain of the stage). The output of this stage for single tone modulation will be approximately 0.75V p-p.

7.2.1.2.4 Power Amplifier

Q_3 , which is the power amplifier, is the same type transistor as used in the output stage of the transmitter (Paragraph 7.2.1.1.5). The primary purpose of this stage is to provide the impedance transformation from the high impedance output of Q_2 to the low impedance of the load (125 ohms, or 600 ohms).

7.2.1.3 Power Conditioning, Power Requirements

Figure 7.2.1.3 is the schematic for the power supply for the system. Transistor Q1 and Q2 with the associated circuitry form a multivibrator circuit to convert the dc input to an alternating output. T1 is a multiwinding transformer which permits the selection of several output voltages. It will be noted that fullwave rectification and π -type LC filtering is used in the output of the $\pm 15V$ and 1.7V circuits because of the large currents which must be accommodated by these circuits. The +45V circuit uses only halfwave rectification and simple capacitive filtering since its current requirement is so low. See Table 7.2.1.3 for current and power requirements for the system.

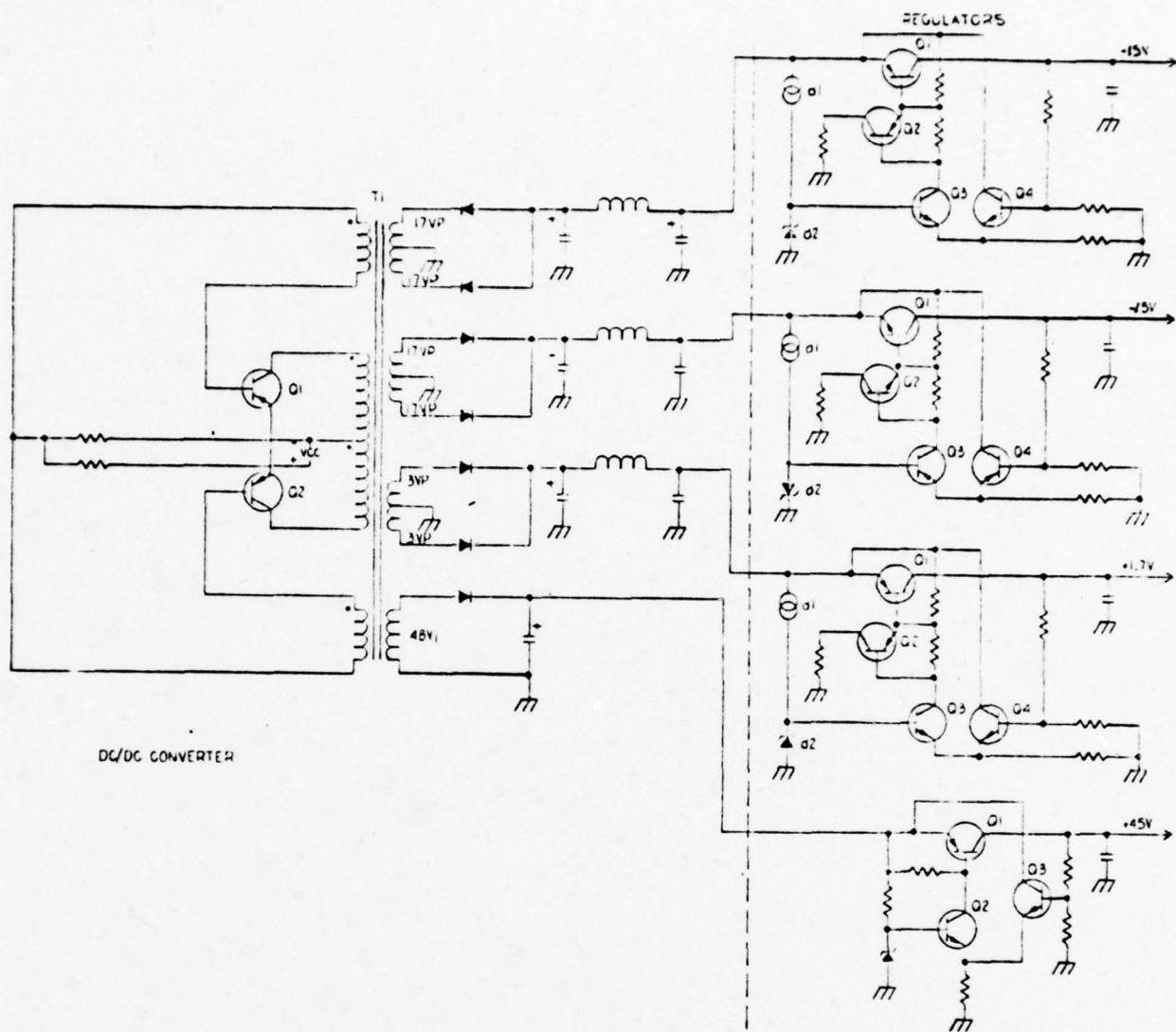

Figure 7.2.1.3. Power Supply

TABLE 7.2.1.3. POWER REQUIREMENTS

Functional elements	+15V	-15V	+1.7V	+45V	Total
Transmitters	455 mA	364 mA	540 mA	0	
Receivers	100 mA	7 mA	0	3 mA	
Oscillators	60 mA	0	0	0	
On/Off-Hook Sensing	104 mA	104 mA	0	0	
Total mA	719	475 mA	540 mA	3 mA	
Total Power	10.785 W	7.125 W	0.918 W	0.134 W	18.963 Watts

The regulators used in each of the supply lines are chosen because of their high degree of efficiency which can approach 97 - 98 percent under low voltage input conditions. This circuit has been used by Harris ESD on other programs and their regulation characteristics have been found to be very good. One distinct advantage of these regulators over switching regulators is that when the lower limit of regulation is reached this circuit will continue to track the input voltage and will not shut down as is common in most efficient switching regulators. As an example of the efficiency one can expect in these circuits we need only to consider the ratio of input voltage to output voltage of the regulator with an assumed efficiency of the dc/dc converter. Properly designed regulators can achieve efficiencies of greater than 80 percent and 80 percent is used for the calculations here.

It is to be noted here that in the case of the $\pm 15V$ supplies, that only 1.3 volts appear across the regulators and 0.7V and 2.4V in the +1.7V and +45V supplies, respectively. We can calculate the efficiency as follows.

To determine the overall requirements of the power supply network, the following equation may be used:

$$P_{in} = \frac{1}{n_{dc/dc}} \left[\frac{P(+15)}{n_1} + \frac{P(-15)}{n_2} + \frac{P(+1.7)}{n_3} + \frac{P(+45)}{n_4} \right] \quad 7.2-3$$

where: P_{in} = Input power to the power conditioning circuitry

$P(+15)$ = Power from +15 volt supply = 10.785 watts

$P(-15)$ = Power from -15 volt supply = 7.125 watts

$P(1.7)$ = Power from 1.7 volt supply = 0.918 watts

$P(45)$ = Power from 45 volt supply = 0.135 watts

n_1 = Efficiency of +15 volt supply = 92%

n_2 = Efficiency of -15 volt supply = 92%

n_3 = Efficiency of 1.7 volt supply = 74%

n_4 = Efficiency of 45 volt supply = 95%

$n_{dc/dc}$ = Efficiency of dc/dc converter = 80%

Thus it may be determined that the input power requirements (P_{in}) to the junction box or patch panel electronics is 26.05 watts; which corresponds to a net efficiency of 72.79%.

7.2.1.4 Ac/Dc Supervision

Ac supervision as envisioned for this system would be the application of a tone at the regular audio input to the transmitter. This tone should be impressed onto a carrier in the form of AM and be carried through the system as any analogue or data stream. At the receive side, this tone would be recovered and used to signal the patch panel of an incoming call.

For dc supervision the system increases in complexity as the only indication of an off-hook condition is a slight increase in current drawn for that particular channel. Since no wires connect the user directly to the patch panel, a means of transferring this current change at the junction box to a current change at the patch panel must be devised. Figure 7.2.1.4-1 is a schematic for a typical ON/OFF Hook Sensing circuit for the transmit side for dc supervision. The circuitry to the left of the dotted line is the actual current sensor while the circuitry to the right serves to generate a voltage to control the presence or absence of an RF carrier for a given channel.

Consider that an ON-hook condition exists and a small current is flowing through resistor R1. The differential voltage between pins 2 and 3 of LM107 will be small and the voltage across R3 will be less than 0.6V, the minimum voltage to allow Q1 to turn on. This voltage output across R3 is given by:

$$V_0 = \frac{R_1 R_3}{R_2} I_L \quad 7.2-4$$

where: I_L = Load current.

If for example the $I_L = 4$ mA, the voltage on the base of Q1 relative to its emitter is 0.4 volt. An increase in current to a 10 mA level will cause this voltage to rise to 1.0 volts. Assuming a 0.6V drop from base to emitter of Q1, then its current will rise to a maximum of 2 mA and the circuit will oscillate at a frequency of 1.1 MHz. This frequency was chosen because it is well above any message content frequency and at the same time falls exactly in the notch between the 0.6 MHz and the 1.6 MHz filter. This signal is transformer coupled to diode D1, where it is rectified to produce the control voltage for turning the carrier ON/OFF for that particular channel.

R6, L1, and C5 serve to isolate the oscillator circuit from the power lines to prevent this signal from being coupled to each of the user lines.

The method of controlling the RF carrier ON and OFF is to turn the buffer amplifier ON or OFF and use the buffer amplifier transistor as the isolating device. When an off-hook condition exists, the transistor in the bias leg is in an on condition and the correct bias voltage is applied to the buffer amplifier causing it to amplify the RF carrier which is applied to the modulator. This carrier is transmitted through the system where it is detected in the receiver as a dc level. See Figure 7.2.1.4-2 ON/OFF Hook Sensing (Receiver Side). This dc level causes the operational amplifier to bias Q1 so that it will oscillate at 1.1 MHz. This oscillation is rectified and filtered by the diode, RC combination D1, R1, VC1. This in turn causes Q2 to conduct with a steady dc current of approximately 8 mA, thus approximating the load that is normally on this line during an off-hook condition. The carrier will be present to hold this line open with or without modulation present. The RC combination serves to filter the ac variation at the input to the operational amplifier such that a constant load is presented to the patch panel during an off-hook condition.

7.2.1.5 LED Circuitry

The inherent nonlinear junction capacitance of the light emitting diode (LED) creates undesired harmonics and intermodulation products which degrade the communication system performance. For example, the Bell Northern Research BNR 40-3-30 LED has the following linearity performance.

Second Order Products	35 dB down from carrier
Third Order Products	Greater than 50 dB down from carrier

In order to obtain 60 dB channel isolation, a special effort has to be made to compensate the LED nonlinearity. The RF or optical feedback compensation technique requires fine tuning and high degree circuit complexity. The "pre-distortion" method cannot fulfill the systems stringent requirement. However, Harris ESD has an effective and inexpensive technique using a simple balanced circuit which can improve LED performance and reduce the device nonlinearity. However, Harris ESD cannot presently disclose this circuit because of its proprietary nature.

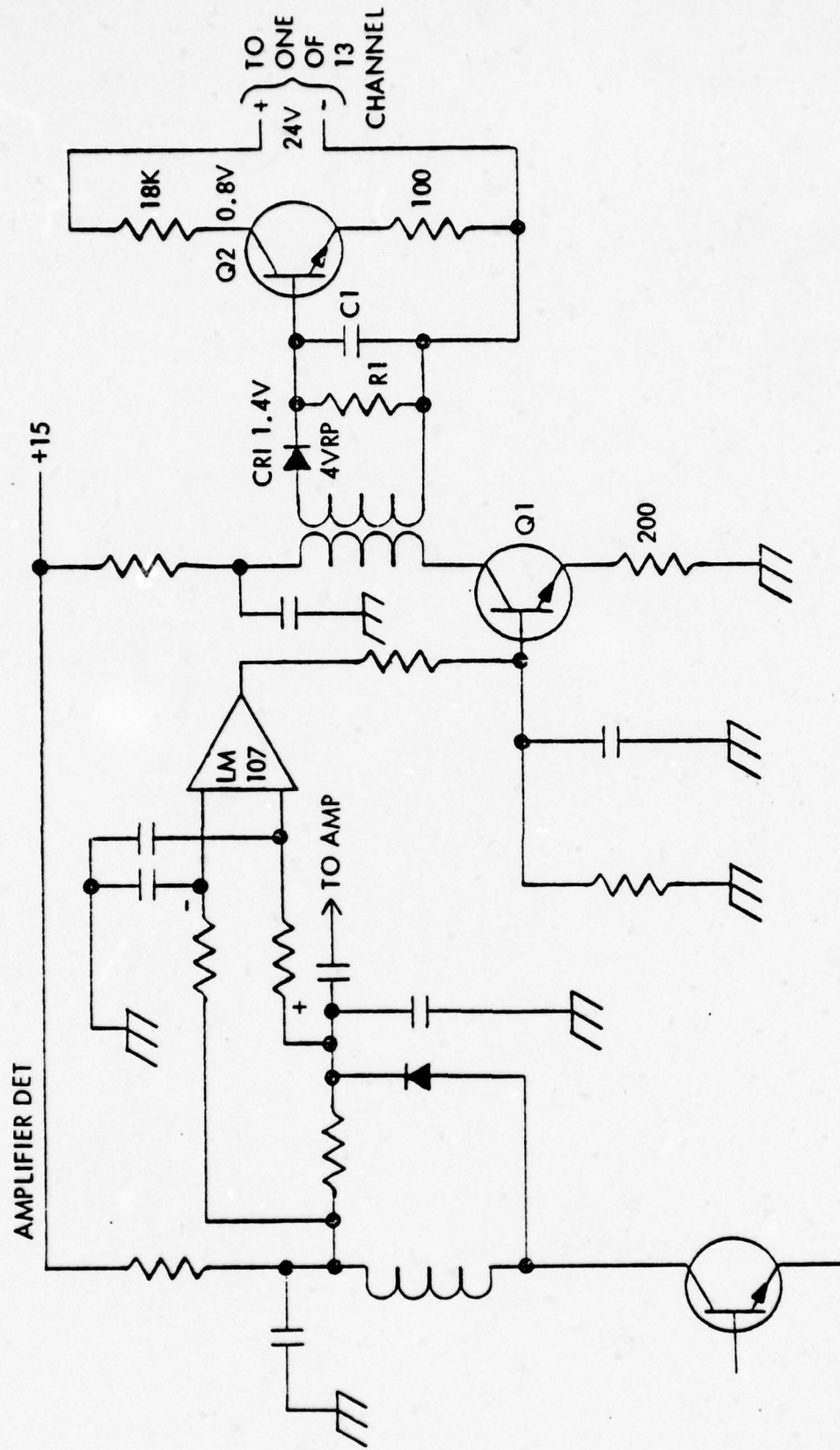

Figure 7.2.1.4-2. ON/OFF Hook Sensing Circuit (Receive Side)

7.2.1.6 Optoelectronic Receiver

The optoelectronic receiver of the current system has the following characteristics:

Bandwidth	5 MHz
Device	PIN photodetector
Responsivity	1.5×10^4 V/Watt
Output Noise Voltage	$2.3 \times 10^{-8} \sqrt{\text{Hz}}$
Output Impedance	50 ohms

Two different approaches are considered which can satisfy these specifications. Figure 7.2.1.6-1 illustrates a configuration which the transresistance gain is provided by the direct load resistor R_L . The amplifier stage composes an input capacitance-neutralized, unity gain, low-noise FET source follower driving an output bipolar emitter follower buffer. Positive feedback is applied through the network to the bias side of the detector diode, to bootstrap out a portion of the diode capacitance. This approach has the advantage of unconditional stability arising from lack of voltage gain in the loop. Commercially available devices such as the RCA C30815 and C30816 are in this configuration in hybrid form. However, these two units have relatively poor noise and responsivity performance.

The other approach is depicted in Figure 7.2.1.6-2. The first FET stage provides voltage gain, followed by the main amplifier and output emitter follower buffer. Automatic gain control can be achieved with a dual-gate MOSFET or matched bipolar transistors. It has been demonstrated that up to 8 dB better noise performance may be achieved with this configuration over the standard shunt feedback approach.

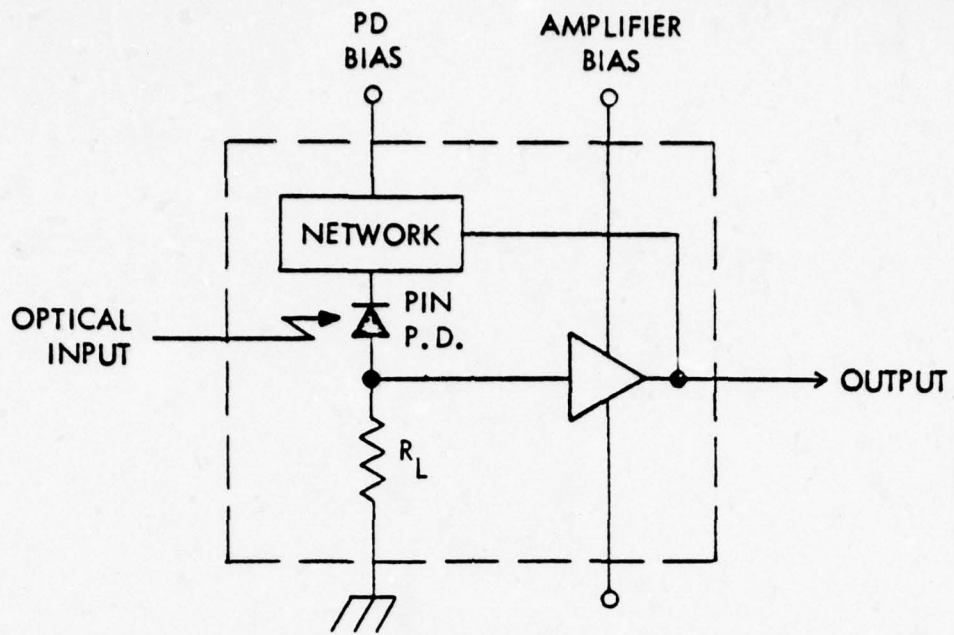

Figure 7.2.1.6-1. Input Capacitance Neutralized Optoelectronic Receiver

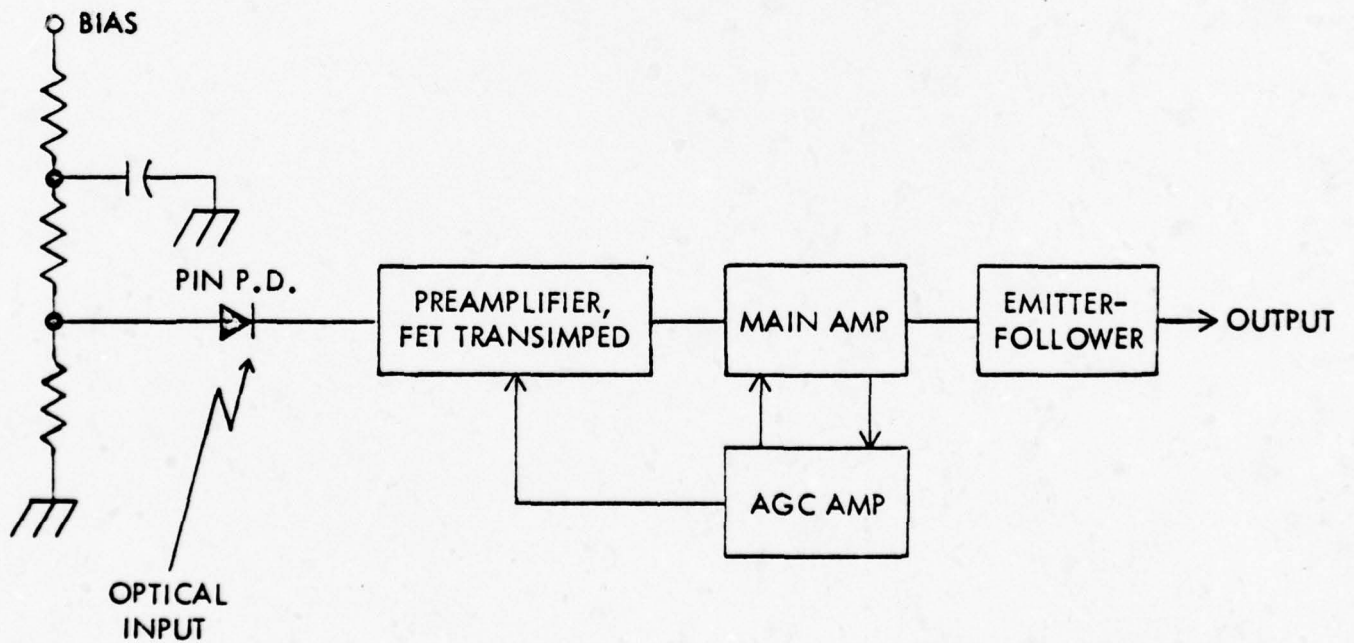

Figure 7.2.1.6-2. Equalized Impedance-Matched Optoelectronic Receiver

7.2.2 Mechanical

The junction box consists of three major assemblies which may be removed in their entirety from the main assembly. These are:

1. Transformer/Binding Post Assembly
2. Electronics Assembly
3. Power Supply

Figure 7.2.2-1 shows the junction box in a closed or field condition with the access cover in an open position while Figure 7.2.2-2 shows the electronics cover open with the electronic modules exposed. The electronics portion of the system is housed in the weather-sealed portion of the junction box and access to them is gained by unhooking the latches located on the handle side of the junction box lifting the hinged cover.

7.2.2.1 Transformer/Binding Post Subassembly

This assembly is located within the hinged compartment and may be removed for servicing if necessary. Figure 7.2.2-1 with the access cover opened shows the location of the binding posts. Directly behind the binding posts are the isolation transformers which serve as the interface between the user and the junction box electronics. The binding posts are spring loaded so that the operator need only push the post, insert the wire and release to obtain an electrical connection.

7.2.2.2 Electronics Subassembly

The electronics assembly consists of 33 subassemblies which are attached to a single plate so that the entire assembly can be removed as one unit. The subassemblies are:

Transmitter	13
Receiver	13
Oscillator Group	1
Power Combiner	3
Fiber Optics TX/RX	<u>3</u>
	33

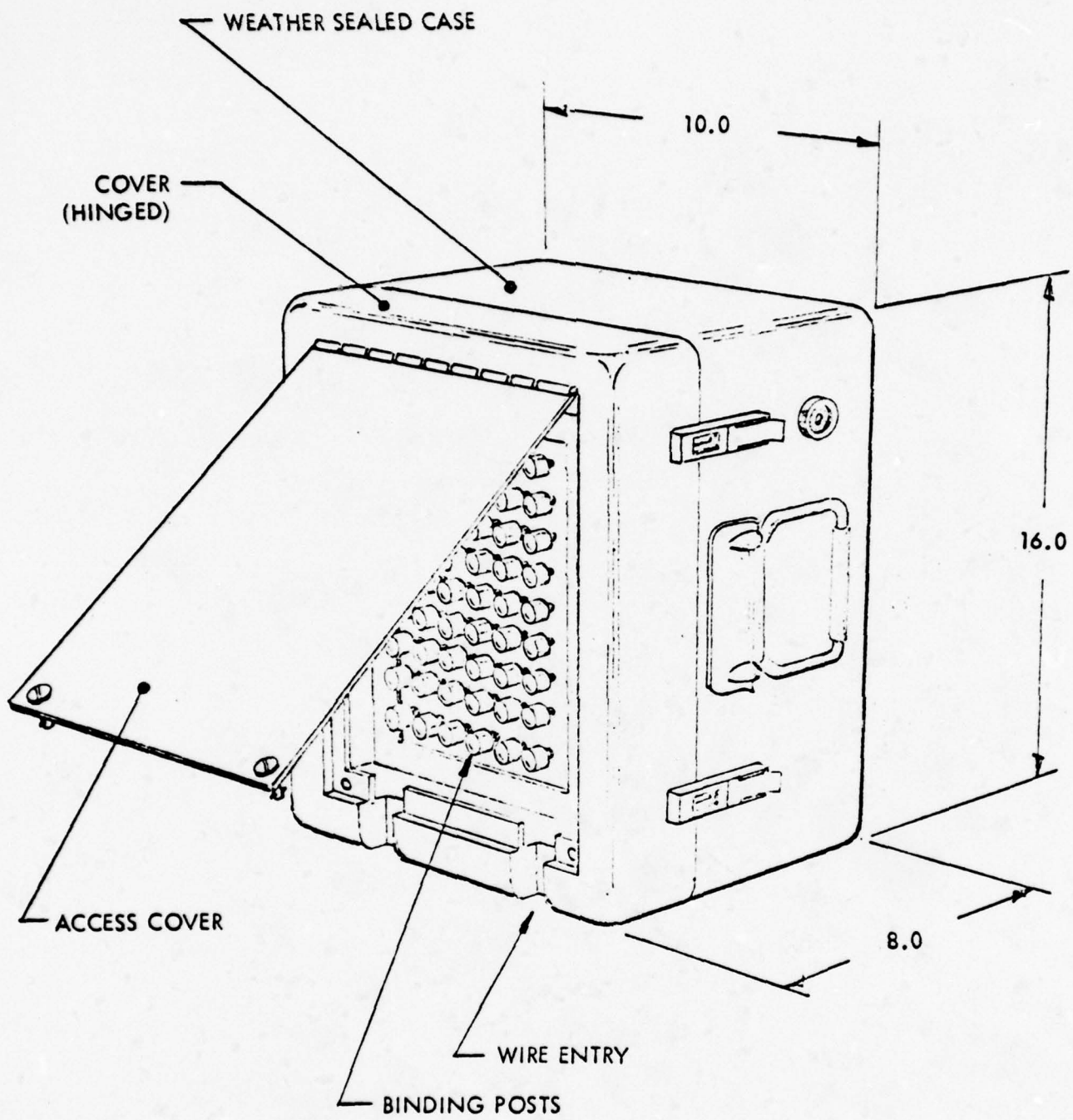

Figure 7.2.2-1. Junction Box

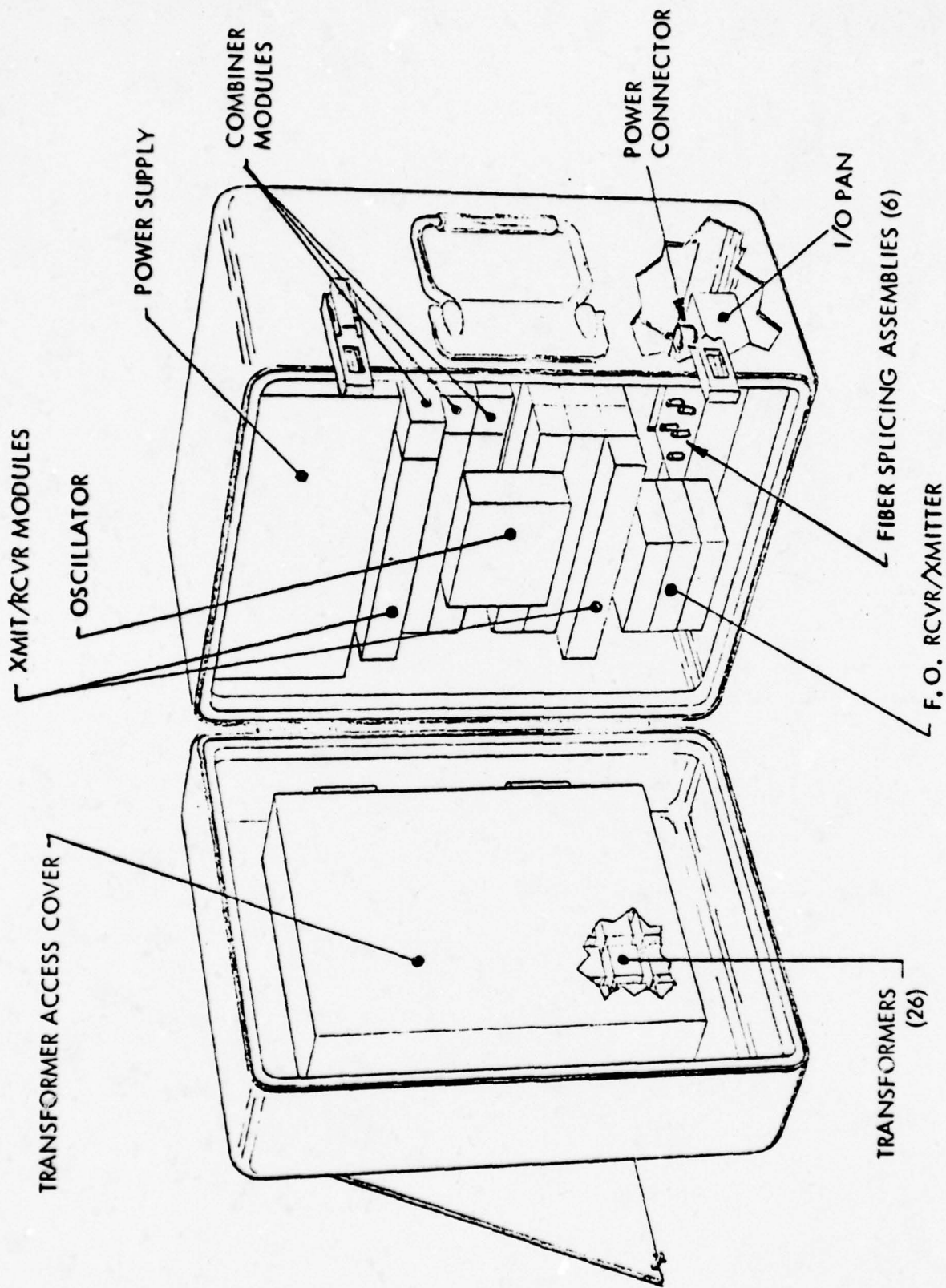

Figure 7.2.2-2. Junction Box, Electronics Cover Open

The remaining electronics package (Fiber Optics Splicing Assembly (FOSA)) is removable separately.

7.2.2.2.1 Transmitter

Each of the 13 transmitters are contained within a module whose dimensions are 1" x 1" x 6". Each module is sealed on five sides with a removable cover on a 1" x 6" face. Power and signal input/output connections are accessed on the two 1" x 1" faces. The estimated weight of the 13 transmitters is 2.5 pounds.

7.2.2.2.2 Receiver

The mechanical features of the receivers are the same as described for the transmitters (Paragraph 7.2.2.2.1).

7.2.2.2.3 Oscillator Group

The oscillator group is housed in a 4" x 3" x 1" module with access to the electronics being obtained by the removable cover on a 4" x 3" face. Power and input/output connections are accessed on the two 1" x 3" faces.

7.2.2.2.4 Power Combiners

The power combiners are located at one end of the thirteen electronic transmitters. Two of these combiners are housed in a 1" x 1" x 6" module and three are in a 1" x 1" x 5" module.

7.2.2.2.5 Fiber Optic Receiver/Transmitter

There are three Fiber Optic Receiver/Transmitter modules located below the electronic packages and each is housed in a separate enclosure whose size is 2.5" x 2" x 0.8".

7.2.2.2.6 Fiber Optic Splicing Assembly (FOSA)

The FOSA is located in a recessed area on the bottom side of the junction box, with dimensions of 6" x 3" x 1.5". This assembly may be accessed from the bottom of the junction box.

7.2.2.3 Power Supply

The power supply is located directly above the electronics subassembly and may be removed in a single unit by itself. It is housed in a module which is 8" x 5" x 4".

7.2.2.4 Weight

The weight of each of the modules and the box itself has been calculated and the results are listed below.

Junction Box	13 pounds
Transformer/Binding Post Assembly	10 pounds
Transmitter (13)	2.5 pounds
Receivers (13)	2.5 pounds
Oscillator Group	0.5 pound
Power Combiners	0.8 pound
Fiber Optics Splicing Assembly	1.0 pound
Power Supply	8.0 pounds
Miscellaneous cable harness, nuts, bolts, etc.	<u>2.0 pounds</u>
Total	40.3 pounds

7.2.2.5 Coupling Between Optical Source and Optical Connector

Since BNR 40-3-30-3 LED has a nylon jacketed optical fiber lead, a single splicing connector has to be utilized to join LED transmitter and fiber cable. A simple and inexpensive splicing connector was designed as a Harris ESD IR&D project as depicted in Figure 7.2.2.5-1. The connector is actually a modified screw with elastic slots at both ends and can be tightened by two special designed screw nuts.

The physical size of the complete connection is 0.33 inches long and 0.218 inches in diameter. Before being inserted into the connector the fibers must have flat, smooth and perpendicular end faces to ensure minimum splice losses. There are many techniques for fiber end preparation; however, the method developed by D. Gloge, et. al. [14] is the fastest and simplest way of producing perfectly clean surfaces uncontaminated by lossy residue.

7.3 Manufacturing Considerations

Of primary interest in the final implementation of the 26-Pair system, is that it should be reproducible, using cost effective manufacturing techniques. In constructing the most advantageous method is to utilize large scale integration (LSI) techniques. After the initial development costs, this approach allows large numbers of functions to be incorporated into a very small unit, which may be mass produced, for almost negligible materials and labor costs. However, the LSI approach is economical, only if all or nearly all of the components can be incorporated into a single chip. If there are many other components which must be assembled on the same card with the LSI chip, then the cost advantages are negated by the additional labor requirements.

[14] D. Gloge, et. al., "Optical Fiber End Preparation for Low-Loss Splices, "B.S.T.J. November 1973, PP. 1579-1588.

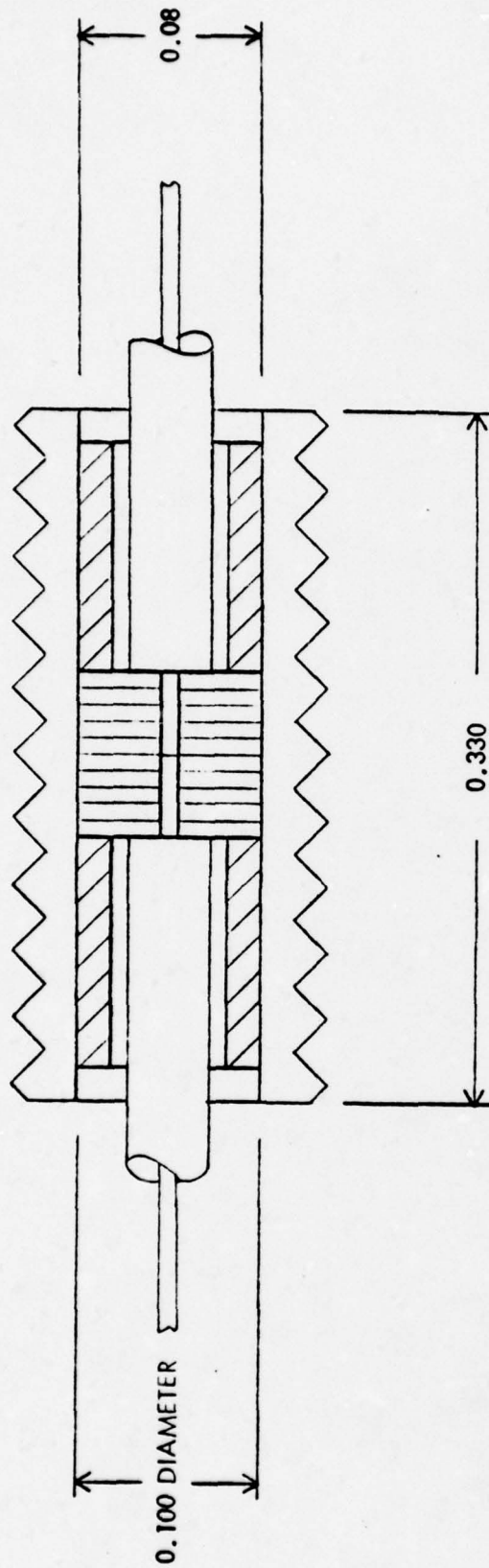

Figure 7.2.2.5-1. Single Fiber Splicing Connector

A review of the schematics presented in the preceding sections shows that because of the large value inductors and capacitors, required throughout the system, the resistors and transistors are the only components which could be integrated on a large scale. The placement of the inductors and capacitors about these chips would be same regardless of the approach taken, and hence no significant savings would be realized by the LSI approach.

In view of the circuit requirements of the recommended design, the following manufacturing approach is recommended:

1. All resistors would be placed on the substrates as thick film components utilizing the accepted screening method. A maximum of four passes per substrate would be required to lay up all resistors. It is possible that by refinements in the circuit design this resistor emplacement could be completed in three passes.
2. All transistors would be placed on the substrate and then connected to the circuitry via thermocompression bonding.
3. All tuneable inductors would be a chip variety while all inductors for the critical filters would be manufactured from standard toroids. This approach is recommended to achieve a) small size where high-Q is not required (chip inductors) and b) high-Q inductors (toroids) where Q's of 100 or more are necessary.

Figures 7.3-1 and 7.3-2 show the recommended approach for the construction of the transmitter and receiver modules. The dimensions of each substrate and filter is given in conjunction with the spacing between each circuit card. The drawing is keyed to show the location of each of the major components of the transmitter and receiver.

The construction of the transmitter-receiver would involve:

1. Placing a motherboard on the bottom of the preformed module.
2. Build-up and test of each the major components after which they would be inserted into the motherboard.
3. Final test of the completed unit.

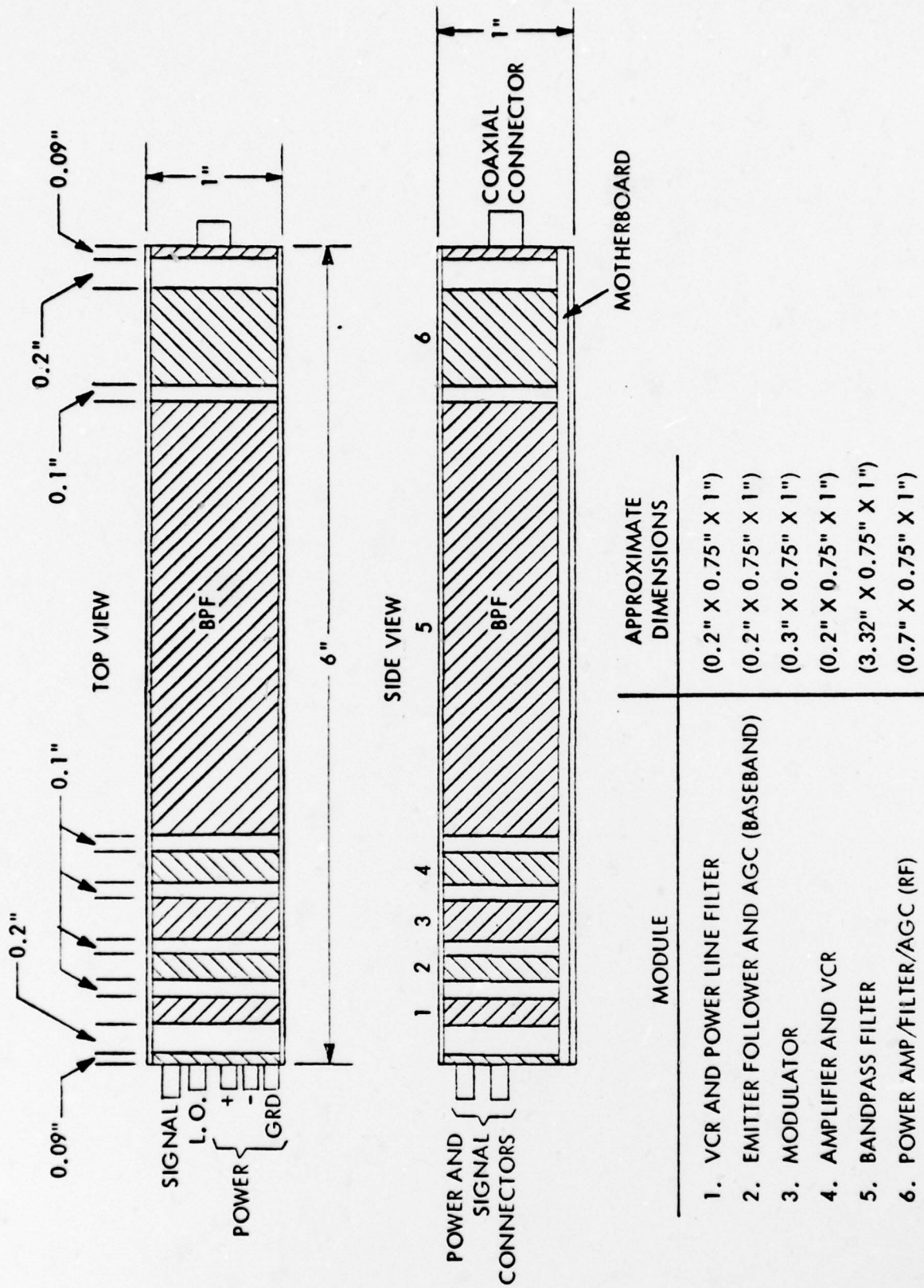

MODULE	APPROXIMATE DIMENSIONS
1. VCR AND POWER LINE FILTER	(0.2" X 0.75" X 1")
2. EMITTER FOLLOWER AND AGC (BASEBAND)	(0.2" X 0.75" X 1")
3. MODULATOR	(0.3" X 0.75" X 1")
4. AMPLIFIER AND VCR	(0.2" X 0.75" X 1")
5. BANDPASS FILTER	(3.32" X 0.75" X 1")
6. POWER AMP/FILTER/AGC (RF)	(0.7" X 0.75" X 1")

Figure 7.3-1. Typical Transmitter Module

This process would greatly reduce the problem of locating faulty parts prior to assembly and facilitate the repair of a module in the event that a failure should occur.

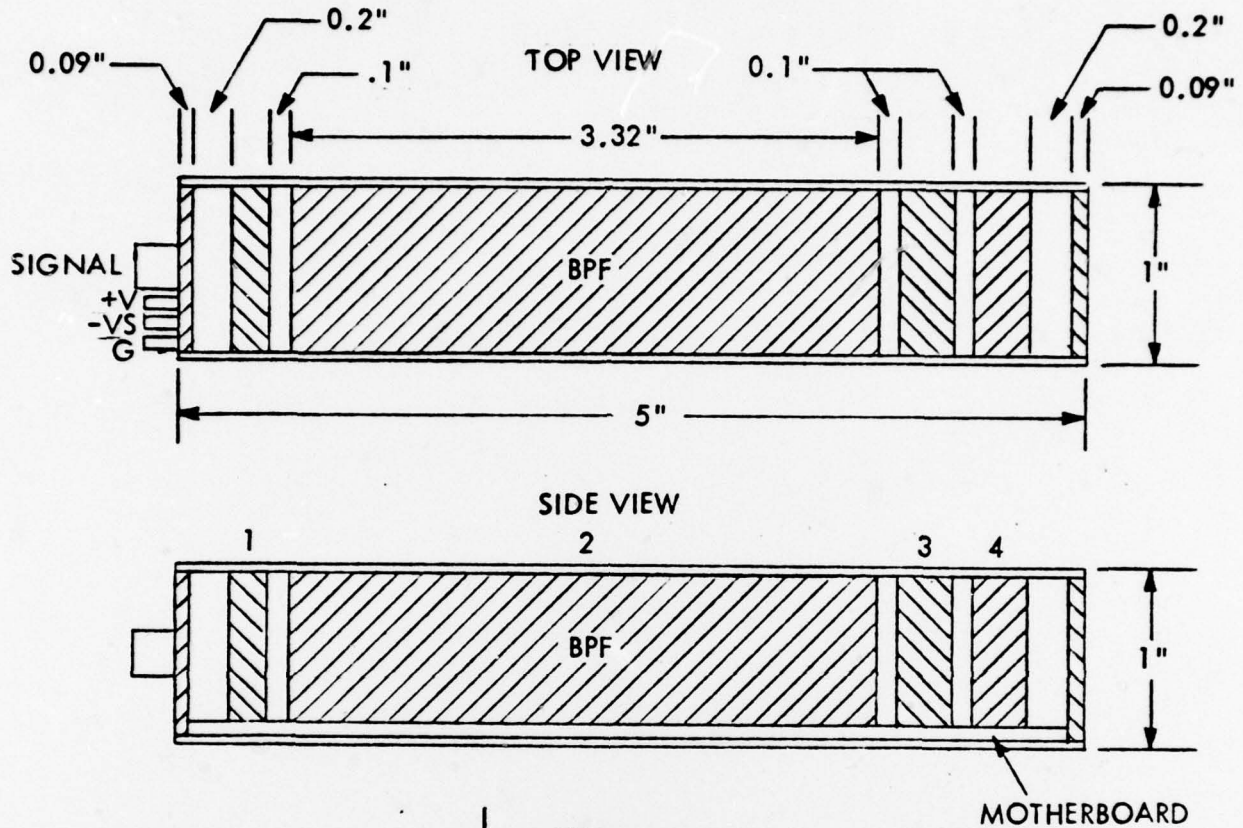

MODULE IDENTIFICATION	APPROXIMATE DIMENSIONS
1. RESISTIVE DIVIDER AND LINE FILTER	(0.2" X 0.75" X 1")
2. BANDPASS FILTER	(3.32" X 0.75" X 1")
3. AMPLIFIER/DETECTOR	(0.3" X 0.75" X 1")
4. AUDIO AMP/POWER AMP	(0.3" X 0.75" X 1")

Figure 7.3-2. Typical Receiver Module

APPENDIX A

DC POWER AND DYNAMIC RANGE

A-1 DC POWER VERSUS INTERCEPT POINT (IP_3)

Third order intercept point data (referred to the output) versus dc power requirements on eleven different amplifiers from two vendor (W. J. and Anzac) are plotted in Figure A-1 with the least squares linear relationship between the data points. The amplifiers are all of a general category;

- decade bandwidth RF (500 kHz - 1500 MHz)
- low gain (10 - 14 dB)

The least squares linear relationship found is:

$$P_{DC}, \text{ dBm} = 0.39 IP_3, \text{ dBm} + 17.5, \text{ dBm}$$

A-2 DC POWER VERSUS INTERMODULATION RATIO

Intermodulation Ratio (IMR) in dB is defined as the difference in power level of the IM product (P_{IM}) and the signal (P_s) creating it: $IMR = P_{IM} - P_s$. The IMR is related to P_s and the third order intercept point, IP_3 : $IMR + 2 P_s = 2IP_3$ for two tone products of the type $2f_a - f_b$. Solving the latter for IP_3 : $IP_3 = P_s + 1/2 IMR$ and using this in the relationship between P_{DC} and IP_3 yields:

$$\underline{P_{DC}, \text{ dBm} = 0.4 P_s \text{ dBm} - 0.2 IMR, \text{ dB} + 17.5 \text{ dBm}}$$

which is plotted in Figure A-2, for three values of P_s .

A-3 LED DRIVER AMPLIFIER BUDGET

Approximately +5 dBm per carrier will be required to drive the LED. The two-tone third-order IMR objective for the Driver-LED is -79 dB. The attached sheet, Figure A-3, shows the two-tone third-order intercept point (IP_3) requirement, the expected dc power requirement (P_{DC}) derived from the linear least squares analysis, and a candidate vendor amplifier. The assumption is that the LED itself is distortion-free. The total five signal average output power will be (+5 dBm + 7 dB) +12 dBm.

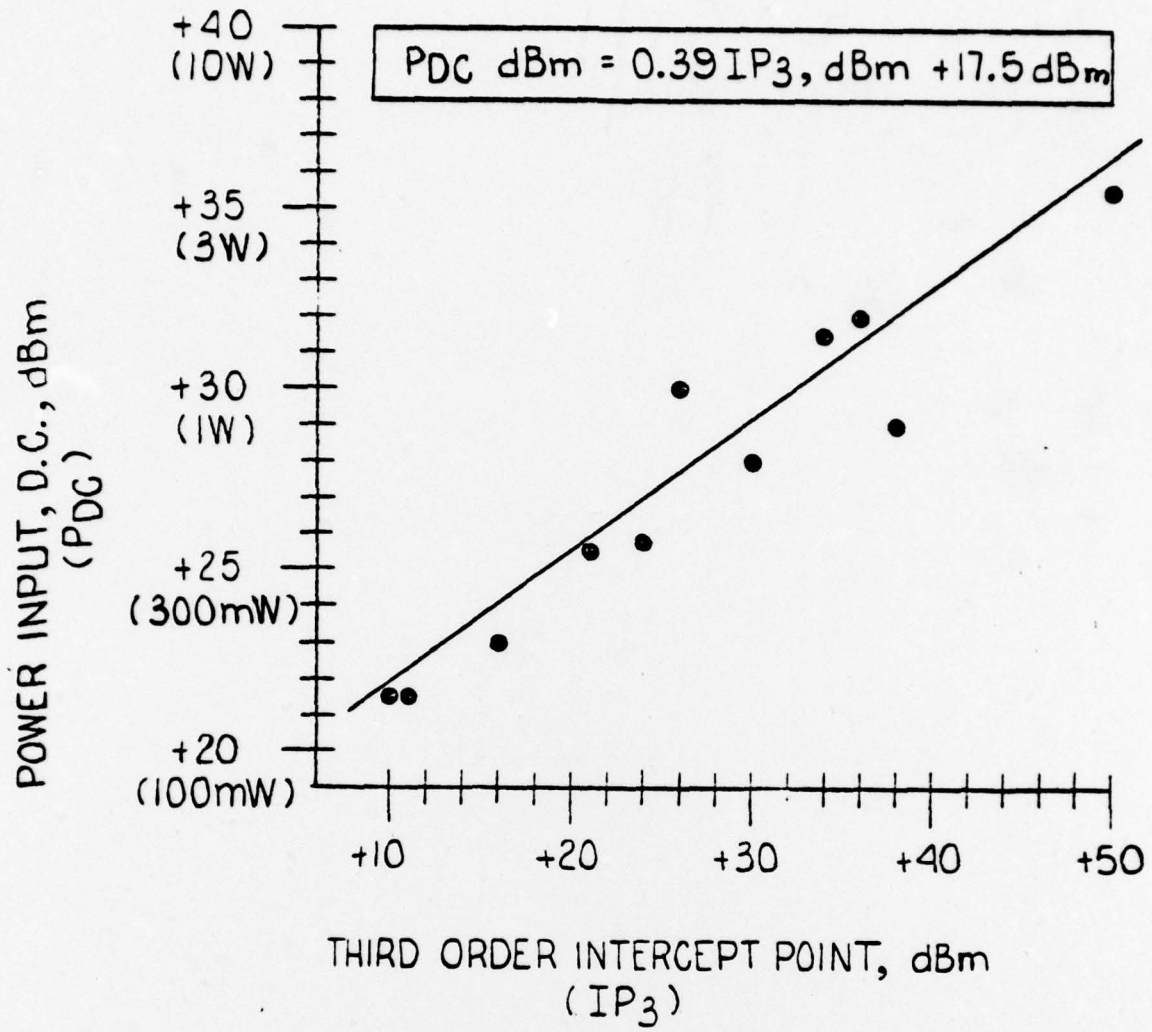

Figure A-1. Dc Power as a Function of Intercept Point

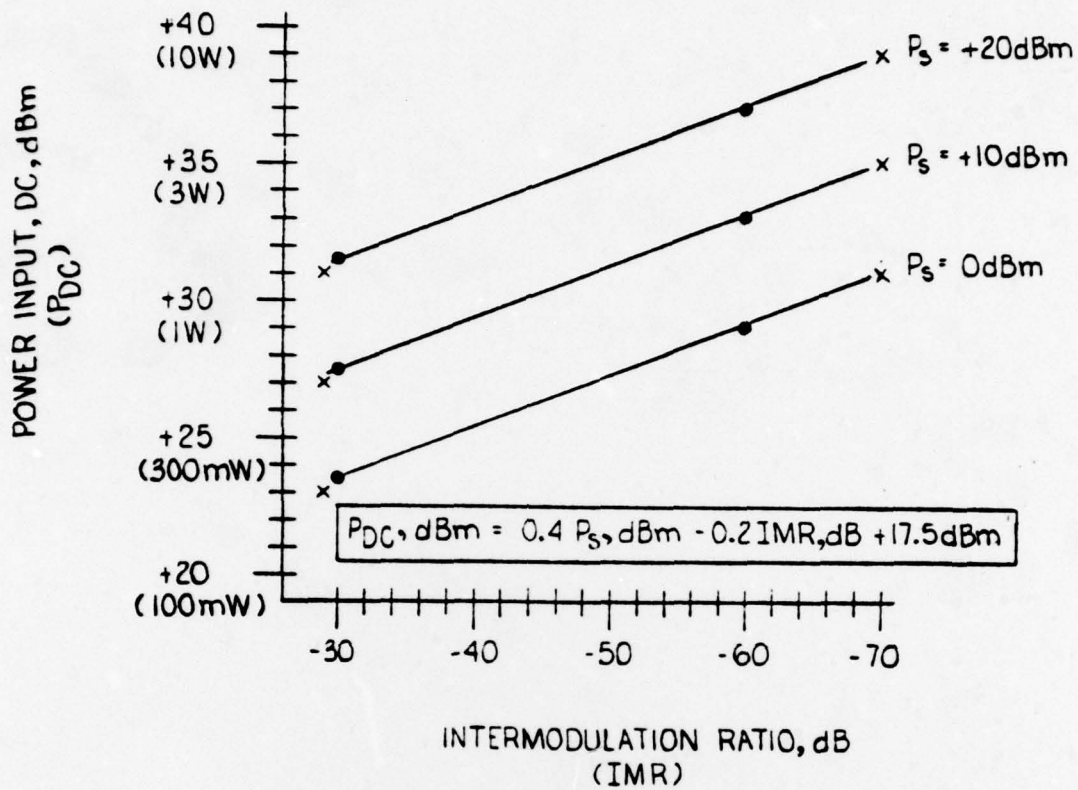
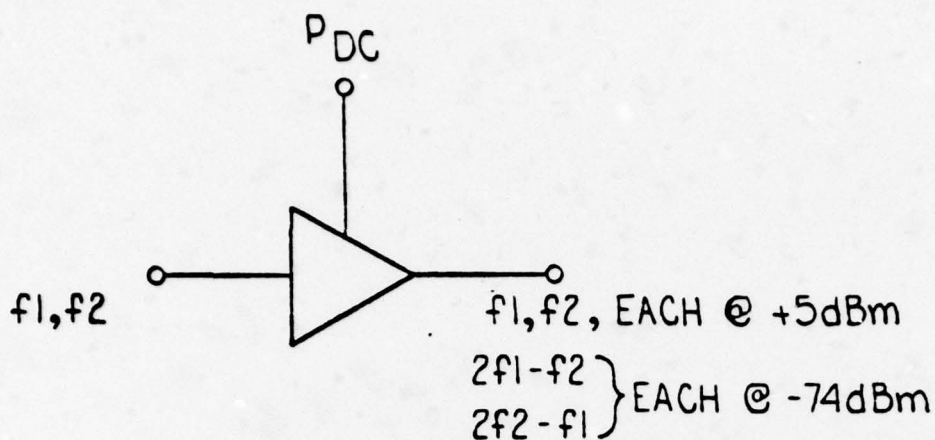

Figure A-2. Dc Power as a Function of IMR



- REQUIRED IMR: $(-74-5) = \underline{-79\text{dB}}$
 - REQUIRED P_S : $\underline{+5\text{dBm}}$
 - DERIVED IP_3 : $IP_3 = 1/2 (2 P_S - \text{IMR}) = +44.5\text{dBm}$
 - EXPECTED P_{DC} : $P_{DC} \cong 0.4 (IP_3) + 17.5 = \underline{35.3\text{dBm}} = \underline{3.39\text{W}}$
 - CANDIDATE VENDOR AMPLIFIER: ANZAC AM-109
- | | |
|----------------------|--------------------|
| IP_3 TYP: | +48dBm |
| P_{DC} : | 3.6W (20V @ 180MA) |
| GAIN: | 10 - 11 dB |
| BW: | 500KHz - 60MHz |
| $P_O(-1\text{dB})$: | +28dBm (MIN) |

Figure A-3. LED Driver Amplifier Budget

Assuming the output signals are of equal amplitude and random phase, the total instantaneous amplitude will exceed the total RMS amplitude by 10 dB no more than 0.01% of the time. Thus, the amplifier should have a minimum of 10 dB excess output power capability to avoid peak-limiting. It appears that the candidate vendor amplifier shown, with a power output of +28 dBm (-1 dB saturation) should be satisfactory.

APPENDIX B
MULTICARRIER INTERMODULATION

Table B-1 lists the second and third order harmonic and intermodulation products, their number (as a function of the number of signals, n) and their relative level, assuming all input signals of equal level. Also tabulated are the number of products generated of each type for the cases: $n = 4$ and $n = 5$.

The relative level column deserves some clarification. Assume several equal level signals into an amplifier. At the output, the equal level fundamental products and all of the distortion products are obtained. Let the distortion products be sorted into second order and third order; then, let the absolute level of the second and third harmonics be measured and called "0 dB", or the reference level for each group of products (second or third order). Then, it is expected that second order intermodulation products of the type $f_a \pm f_b$ will be generated at a level 6 dB higher than the second harmonic, and third order intermodulation products of the type $2f_a \pm f_b$ will be generated at a level 9.5 dB higher than the third harmonic, etc. The relative level column thus applies only to products within the same group (second or third order).

As can be seen from the table three-tone third order products of the type $f_a + f_b - f_c$ are the most "dangerous". They are by far the most numerous for $n \geq 4$ or 5, and are generated at a level 6 dB greater than the familiar two-tone third order product, $2f_a - f_b$. Both of these types of products have other bad habits. Many of them fall within the band occupied by the desired signals and if the signals have equal frequency separation many of the products are coincident with the desired signals. Worse, these are the only products out of all those listed which will combine in-phase as the signals and distortion products progress through an amplifier chain, a transmission line, etc. (In general, any product whose coefficients add algebraically to +1 displays this property; e.g., $2f_a - f_b$: $2-1 = +1$; $f_a + f_b - f_c$: $1+1-1=+1$. $2f_a + f_b$: $2+1=+3$ will not combine in-phase.)

TABLE B-1. DISTORTION PRODUCTS

PRODUCT	NO. OF PRODUCTS	RELATIVE LEVEL (1)	NO. OF PRODUCTS FOR	
			n=4	n=5
1. SECOND ORDER				
$\cos 2Wpt$	n	0dB	4	5
$\cos(Wp+Wq)t$	$1/2n(n-1)$	+6dB	6	10
$\cos(Wp-Wq)t$	$1/2n(n-1)$	+6dB	6	10
2. THIRD ORDER				
$\cos 3Wpt$	n	0dB	4	5
$\cos(2Wp+Wq)t$	$1/2n(n-1)$	+9.5dB	6	10
$\cos(2Wp-Wq)t$	$n(n-1)$	+7.5dB	12	20
$\cos(Wp+Wq+Wr)t$	$1/6n(n-1)(n-2)$	+15.5dB	4	10
$\cos(Wp-Wq-Wr)t$	$1/6n(n-1)(n-2)$	+15.5dB	4	10
$\cos(Wp+Wq-Wr)t$	$n(n-1)(n-2)$	+15.5dB	24	60

(1) EQUAL LEVEL INPUT SIGNALS

DISTORTION PRODUCTS
(EXCEPT FUNDAMENTALS AND DC FOR:)

$$e_0 = a_1 e_i + a_2 e_i^2 + a_3 e_i^3$$

[WHERE $e_i = \sum_{\alpha=1}^n E_{\alpha} \cos W_{\alpha} t$]

B-2

IM PRODUCTS COINCIDENT WITH SIGNALS

Table B-2 lists the third order IM products which are coincident with each signal of a five signal group which has equidistant frequency spacing. As can be seen, the central signal, f_3 , has the highest number (6) of IM products coincident with it.

At the top of the page is a tabulation of the number of IM products with which each individual signal is involved. Thus, f_1 and f_5 contribute to 10 products, f_2 and f_4 to 14 products, and f_3 to 16 products. If it were desired to "randomize" the position (in frequency) of the IM products, best results would be had by shifting f_3 , next best by shifting f_2 and f_4 , finally f_1 and f_5 .

B-3

DISTRIBUTION OF DISTORTION PRODUCTS

Figure B-1 is a picture of the various distortion products for the initial frequency assignments for the five signals. Most notable are the third-order products (two and three-tone) coincident with each signal. Distortion products which are in-band but not coincident generally fall within 200 kHz of the desired signals.

TABLE B-2. THIRD ORDER INTERMODULATION (IM) PRODUCTS

CARRIER POSITION	NUMBER OF I.M. PRODUCTS (column) FALLING ON EACH f_n INVOLVING EACH CARRIER POSITION (row)									TOTAL EACH POSITION
1	0	3	3	2	2					10
2	3	1	4	4	2					14
3	3	4	2	4	3					16
4	2	4	4	1	3					14
5	2	2	3	3	0					10

f_1	f_2	f_3	f_4	f_5
↑	↑	↑	↑	↑
2+3+4 2+4-5	1+3-2 1+4-3 1+5-4 3+4-5	1+4-2 2+4-3 1+5-3 2+5-4	2+3-1 1+5-2 2+5-3 3+5-4	3+4-2 2+4-1
2(2)-3 2(3)-5	2(3)-4	2(2)-1 2(4)-5	2(3)-2	2(3)-1 2(4)-3

$f_a \pm f_b \mp f_c$ PRODUCTS

$2f_a - f_b$ PRODUCTS

(CARRIERS HAVE EQUAL FREQUENCY SPACING)

- A. TABULATION OF 3rd ORDER I.M. PRODUCTS COINCIDENT WITH EACH CARRIER.
- B. TABULATION OF THE NUMBER OF PRODUCTS WITH WHICH EACH CARRIER IS INVOLVED.

FIGURE B-1
DISTRIBUTION OF DISTORTION PRODUCTS
(5 CARRIER CASE)
EQUALLY SPACED CARRIERS

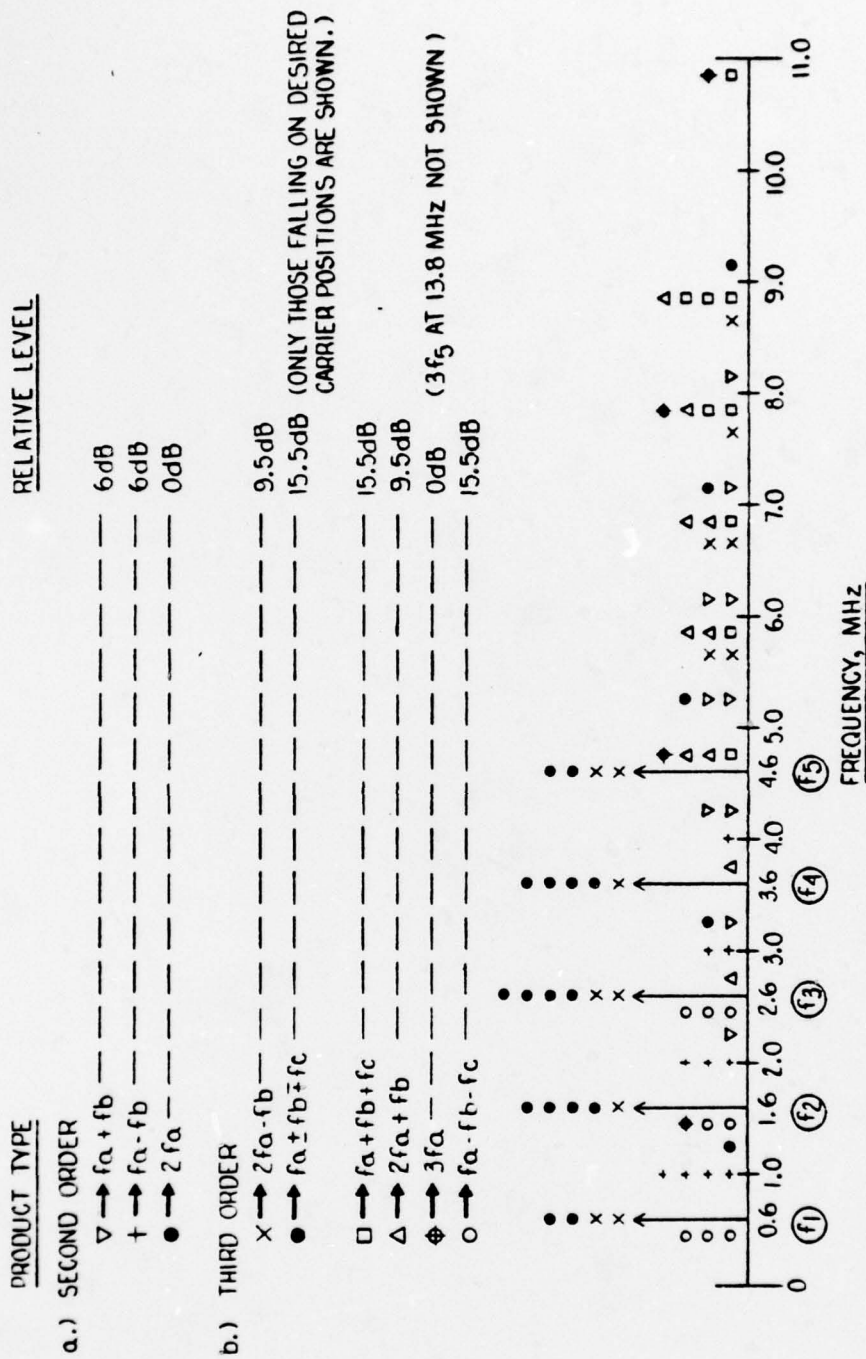

Figure B-1. Distribution of Distortion Products