

AD-A060 382

J B F SCIENTIFIC CORP WILMINGTON MA

F/G 8/8

AN ANALYSIS OF THE FUNCTIONAL CAPABILITIES AND PERFORMANCE OF S--ETC(U)

JUL 78 E E JOHANSON

DACW39-77-C-0085

UNCLASSIFIED

WES-TR-D-78-39

NL

1 OF 3
AD
AO 60382



AWAU 6U 382

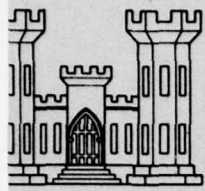

LEVEL II

12

DREDGED MATERIAL RESEARCH PROGRAM



TECHNICAL REPORT D-78-39

AN ANALYSIS OF THE FUNCTIONAL CAPABILITIES AND PERFORMANCE OF SILT CURTAINS

by

JBF Scientific Corporation
2 Jewel Drive
Wilmington, Mass. 01887

July 1978
Final Report

Approved For Public Release; Distribution Unlimited

DDC FILE COPY

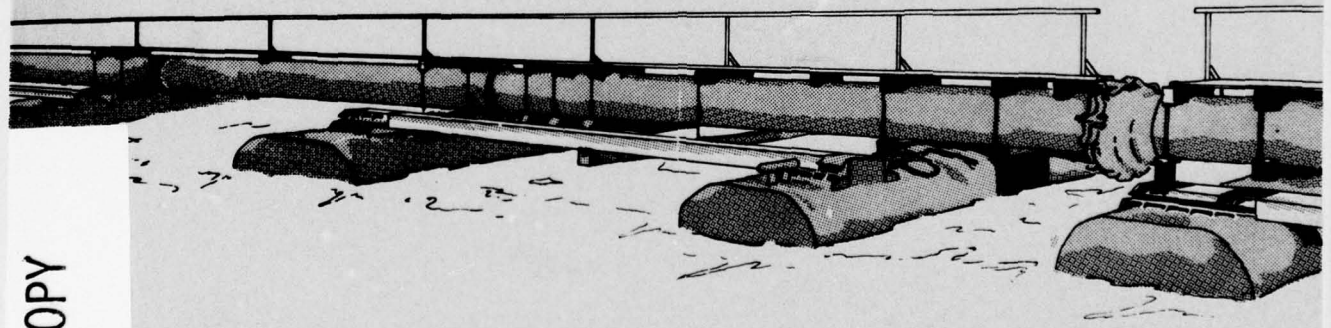

Prepared for Office, Chief of Engineers, U. S. Army
Washington, D. C. 20314

Under Contract No. DACW39-77-C-0085 (Neg.)
(DMRP Work Unit No. 6C06)

Monitored by Environmental Laboratory
U. S. Army Engineer Waterways Experiment Station
P. O. Box 631, Vicksburg, Miss. 39180

DDC
RECEIVED
OCT 26 1978
D

78 10 16 044

Destroy this report when no longer needed. Do not return
it to the originator.



DEPARTMENT OF THE ARMY
WATERWAYS EXPERIMENT STATION, CORPS OF ENGINEERS
P. O. BOX 631
VICKSBURG, MISSISSIPPI 39180

IN REPLY REFER TO: WESEV

15 September 1978

SUBJECT: Transmittal of Technical Report D-78-39

TO: All Report Recipients

1. The technical report transmitted herewith represents the results of one research effort (work unit) initiated as part of Task 6C (Turbidity Prediction and Control) of the Corps of Engineers' Dredged Material Research Program (DMRP). Task 6C, part of the Disposal Operations Project of the DMRP, was concerned with investigating the problem of turbidity; developing methods to predict the nature, extent, and duration of turbidity around dredging and disposal operations; and evaluating methods for controlling the generation and dispersion of turbidity.
2. Although there are still many questions about the direct and indirect effects of different levels of turbidity on aquatic organisms, turbidity generated by dredging and disposal operations at least can be aesthetically displeasing. Therefore, regardless of ecological effects, high levels of turbidity generated by both dredging and disposal operations must be controlled when such measures are deemed necessary. To this end, the study reported herein was conducted to provide guidance on the use of silt curtains. The study was conducted by the JBF Scientific Corporation, Wilmington, Massachusetts.
3. Although silt curtains have frequently been used over the past several years to enclose areas containing turbid water, very little was known about their functional capabilities. This particular study was undertaken to inventory and evaluate silt curtain specifications and deployment systems; determine effectiveness with respect to curtain construction and deployment, operational conditions, and limitations of environmental conditions; and develop guidelines for silt curtain implementation. These goals were accomplished through a combination of analytical studies and field measurements made during actual silt curtain operations.
4. Silt curtains or turbidity barriers are flexible impervious barriers that hang vertically from surface flotation to a specified water depth. When silt curtains are used to enclose open-water pipeline disposal operations, the vast majority (95 percent or more) of the dredged material slurry descends to the bottom of the disposal area where it forms a fluid mud layer. The remaining 5 percent or less of the dredged material slurry is responsible for the turbidity in the water column. While the curtain

WESEV

15 September 1978

SUBJECT: Transmittal of Technical Report D-78-39

encloses an area where some of the fine-grained material may flocculate and/or settle, most of this fine-grained suspended material remains in the water column above the fluid mud layer and escapes with the flow of water and fluid mud under the curtain. In this manner, a silt curtain that is properly deployed and maintained provides a mechanism for controlling the dispersion of turbid water by diverting its flow under the curtain. Silt curtains, however, are not designed to contain the fluid mud layer on the bottom within the curtain area. In fact, when the fluid mud layer accumulates to the depth of skirt, the curtain must be moved out of the way of the discharge to prevent sediment buildup that will pull the curtain underwater and eventually bury it.

5. The effectiveness of the silt curtain (defined as the degree of turbidity reduction outside the curtain relative to turbidity levels inside the curtain) depends on the nature of the operation, the characteristics of the material in suspension, the type, condition, and deployment of the silt curtain, the configuration of the enclosure, and the hydrodynamic regime present at the site. Under quiescent conditions turbidity levels outside a curtain that is properly deployed and maintained may be reduced by 80 to 90 percent. In other cases where the curtain skirt sweeps the bottom and resuspends sediment as the tidal currents change direction, turbidity levels outside the curtain can be higher than inside. Unfortunately, the effectiveness of a silt curtain decreases as the current velocity in the area increases due to flare of the curtain and resuspension of sediment. An upper limiting current velocity for typical silt curtain usage appears to be approximately 1.5 ft/sec.

6. The results of this study were used to prepare final guidelines for specifying and proper operation of silt curtains. These final guidelines will be contained in the DMRP synthesis report on Task 6C.

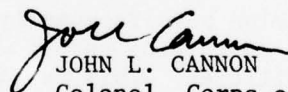

JOHN L. CANNON
Colonel, Corps of Engineers
Commander and Director

Unclassified

SECURITY CLASSIFICATION OF THIS PAGE (When Data Entered)

REPORT DOCUMENTATION PAGE		READ INSTRUCTIONS BEFORE COMPLETING FORM
1. REPORT NUMBER Technical Report D-78-39	2. GOVT ACCESSION NO.	3. RECIPIENT'S CATALOG NUMBER
4. TITLE (and Subtitle) AN ANALYSIS OF THE FUNCTIONAL CAPABILITIES AND PERFORMANCE OF SILT CURTAINS		5. TYPE OF REPORT & PERIOD COVERED Final report
7. AUTHOR(s) Edward E. Johanson		8. CONTRACT OR GRANT NUMBER(s) Contract No. DACW39-75-C-0085 (Neg.)
9. PERFORMING ORGANIZATION NAME AND ADDRESS JBF Scientific Corporation 2 Jewel Drive Wilmington, Mass. 01887 410 464		10. PROGRAM ELEMENT, PROJECT, TASK AREA & WORK UNIT NUMBERS DMRP Work Unit No. 6C06
11. CONTROLLING OFFICE NAME AND ADDRESS Office, Chief of Engineers, U. S. Army Washington, D.C. 20314		12. REPORT DATE July 1978
14. MONITORING AGENCY NAME & ADDRESS (if different from Controlling Office) U. S. Army Engineer Waterways Experiment Station Environmental Laboratory P.O. Box 631, Vicksburg, Miss. 39180		13. NUMBER OF PAGES 190
16. DISTRIBUTION STATEMENT (of this Report) Approved for public release; distribution unlimited. 12 197 p.		15. SECURITY CLASS. (of this report) Unclassified
17. DISTRIBUTION STATEMENT (of the abstract entered in Block 20, if different from Report) 18 WES 19 TR-D-78-39		15a. DECLASSIFICATION/DOWNGRADING SCHEDULE
18. SUPPLEMENTARY NOTES		
19. KEY WORDS (Continue on reverse side if necessary and identify by block number) Dredged material disposal Turbidity Sediment control Silt curtains Silts		
20. ABSTRACT (Continue on reverse side if necessary and identify by block number) Under quiescent conditions (where current velocities are less than 0.2 ft/sec) silt curtains that are properly deployed and maintained can effectively control the dispersion of turbid water in the upper part of the water column. Silt curtain effectiveness depends on the nature of the operation, the quantity and type of material in suspension, the characteristics and configuration of the silt curtain, the method of deployment, cont.		

DD FORM 1 JAN 73 1473 EDITION OF 1 NOV 65 IS OBSOLETE

Unclassified
SECURITY CLASSIFICATION OF THIS PAGE (When Data Entered)

410 464

alt

Cont

20. ABSTRACT (Continued)

and the hydrodynamic conditions at the site. Under ideal conditions, turbidity levels in the water column outside the curtain can be as much as 80 to 90 percent lower than those levels inside or upstream of the curtain. When silt curtains are used to inclose open-water pipeline disposal operations, the vast majority (95 percent) of the dredged material slurry descends to the bottom of the disposal area where it forms a fluid mud layer. In most cases, the turbid water in the water column above the fluid mud layer will flow under the curtain along with the fluid mud layer on the bottom. As current velocities increase, the effective depth of the silt curtain is reduced due to flare, and associated turbulence may cause significant resuspension of the fluid mud layer. When tidal currents cause a poorly deployed curtain to sweep back and forth over the fluid mud in the inclosed area, the turbidity levels outside the curtain may actually be higher than the levels inside the curtain. In addition, silt curtains are not designed to control the accumulation of fluid mud and must be removed when the fluid mud reaches the depth of the lower skirt edge to prevent burial of the curtain. Silt curtains are not recommended for use in environments where currents exceed 1.5 ft/sec.

LEVEL II

ACCESSION FOR	
DTIC	White Section <input checked="" type="checkbox"/>
DDC	Buff Section <input type="checkbox"/>
UNANNOUNCED	<input type="checkbox"/>
JUSTIFICATION	
BY	
DISTRIBUTION/AVAILABILITY STATEMENT	
Dist.	UNCL. FROM SOURCE
A	

DDC
 RECEIVED
 OCT 26 1978
 D

THE CONTENTS OF THIS REPORT ARE NOT TO
BE USED FOR ADVERTISING, PUBLICATION, OR
PROMOTIONAL PURPOSES. CITATION OF TRADE
NAMES DOES NOT CONSTITUTE AN OFFICIAL
ENDORSEMENT OR APPROVAL OF THE USE OF
SUCH COMMERCIAL PRODUCTS.

78 10 16 044

SUMMARY

Dredging and open-water disposal operations often generate turbidity by suspending fine-grained dredged material in the water column. Although silt curtains have frequently been used over the past several years to inclose areas containing turbid water, very little is known about their functional capabilities. This particular study was undertaken to inventory and evaluate silt curtain specifications and deployment systems; determine their effectiveness with respect to curtain construction and deployment, operational conditions, and limitations of environmental conditions; and develop guidelines for silt curtain implementation. These goals were accomplished through a combination of analytical studies and field measurements collected during actual silt curtain operations.

Silt curtains or turbidity barriers are flexible, impervious barriers that hang vertically from surface flotation to a specified water depth. When silt curtains are used to inclose open-water pipeline disposal operations, the vast majority (95 percent or more) of the dredged material slurry descends to the bottom of the disposal area where it forms a fluid mud layer that slopes away from the discharge point at a gradient of 1:100 to 1:200. The remaining 5 percent or less of the dredged material slurry is responsible for the turbidity in the water column above the fluid mud layer. While the curtain incloses an area where some of the fine-grained material may flocculate and/or settle, most of this fine-grained suspended material remains in the water column above the fluid mud layer and escapes with the flow of water and fluid mud under the curtain. In this manner a silt curtain that is properly deployed and maintained provides a mechanism for controlling the dispersion of turbid water by diverting its flow under the curtain, thereby minimizing the dispersion of the turbid water in the upper water column outside the silt curtain. Silt curtains, however, are not designed to contain the fluid mud layer on the bottom within the curtailed area. In fact, when the fluid mud layer accumulates to the depth of the skirt, the curtain must be moved out away from the discharge to prevent sediment buildup on the lower edge of the skirt, which will pull the curtain underwater and eventually bury it.

The effectiveness of a silt curtain, defined as the degree of turbidity reduction outside the curtain relative to the turbidity levels inside the curtain, depends on the nature of the operation; the characteristics of the material in suspension; the type, condition of, and method for deploying the silt curtain; the configuration of the inclosure; and the hydrodynamic regime present at the site. Under quiescent conditions turbidity levels outside a curtain that is properly deployed and maintained may be reduced by 80 to 90 percent of the levels inside; in other cases, where the curtain skirt sweeps the bottom and resuspends sediments as the tidal currents change direction, turbidity levels outside the curtain can be higher than levels inside. This situation can be improved by anchoring the curtain at 100-ft intervals from both sides and allowing approximately 1 ft of clearance between the lower edge of the skirt and the surface of the fluid mud layer. Unfortunately, the effectiveness of a silt curtain decreases as the current velocity in the area increases due to flare of the curtain and resuspension of sediment. An upper-limiting current velocity for typical silt curtain usage appears to be approximately 1.5 ft/sec.

PREFACE

The U. S. Army Corps of Engineers was authorized by the River and Harbor Act of 1970 to conduct a comprehensive nationwide study concerned with the disposal of dredged material. The task of developing and implementing the study was assigned to the U. S. Army Engineer Waterways Experiment Station (WES), which established the Dredged Material Research Program (DMRP). The DMRP was sponsored by the Office, Chief of Engineers, U. S. Army.

The purpose of the DMRP was to provide more definitive information on the environmental impact of dredging and related disposal operations and to develop new or improved disposal practices. Task 6C of the DMRP, entitled "Turbidity Prediction and Control," included several research efforts to evaluate techniques that might be implemented to control or mitigate turbidity generation.

In the work reported herein, one such technique, the use of silt curtains, was investigated. Mr. Edward E. Johanson coordinated the study for JBF Scientific Corp., Wilmington, Mass. The work was supervised by the WES Environmental Laboratory (EL). Mr. Charles C. Calhoun, Jr., Manager, DMRP Disposal Operations Project, was the Contracting Officer's Representative. Under Mr. Calhoun's supervision, Mr. Thomas K. Moore and Dr. William D. Barnard, manager of Task 6C, provided guidance to the work and monitored progress throughout the contract. Mr. A.J. Breithaupt was Contracting Officer.

Directors of WES during the study were COL G. H. Hilt, CE, and COL J. L. Cannon, CE. Technical Director was Mr. F. R. Brown. Chief of EL was Dr. John Harrison.

CONTENTS

	<u>Page</u>
SUMMARY	2
PREFACE	4
LIST OF FIGURES	6
LIST OF TABLES	11
CONVERSION FACTORS, U. S. CUSTOMARY TO METRIC (SI) UNITS OF MEASUREMENT	12
CHAPTER I: INTRODUCTION	14
CHAPTER II: PRESENT DESIGN AND UTILIZATION OF SILT CURTAINS	18
Historical Framework	18
Present Curtain Characteristics	21
Present Curtain Utilization	33
CHAPTER III: DETERMINATION OF SILT CURTAIN EFFECTIVENESS	37
Descriptive Model	37
Analytical Investigations	39
Field Measurements	104
Field Testing of Curtains in Heron Bay, Alabama	134
Comparison of Field Measurements and Analytical Results	149
CHAPTER IV: RECOMMENDED CURTAIN DESIGN AND UTILIZATION	157
Curtain Design Specifications	157
Turbidity Barrier Utilization	160
CHAPTER V: RESULTS AND CONCLUSIONS	179
REFERENCES	184
APPENDIX A: MANUFACTURERS OF SILT CURTAINS	A1
APPENDIX B: NOTATION	B1

LIST OF FIGURES

<u>No.</u>	<u>Title</u>	<u>Page</u>
1.	Construction of a typical silt curtain section	15
2.	End connection modes	30
3.	"No-Load" type connectors	31
4.	"Load" type connectors	32
5.	Typical silt curtain configurations	34
6.	Mechanisms involved in turbidity control by a silt curtain . .	38
7.	Schematic of control volume for material balance analysis. . .	42
8.	Example for material balance analysis	45
9.	Curtain moored in a current field showing coordinate system used in analysis	48
10.	Forces on an element of the curtain	51
11.	Effect of gap ratio, R, on tension parameter	52
12.	Curtain flare in a current	54
13.	Curtain design	59
14.	Effective depth in current - 5-ft curtain	60
15.	Effective depth in current - 10-ft curtain	61
16.	Effective depth as function of ballast chain weight - 5-ft curtain, center tension	62
17.	Effective depth as function of ballast chain weight - 10-ft curtain, center tension	63
18.	Dual tension cable	64
19.	Effective depth as a function of ballast weight - dual tension curtain, 10-ft boom	67
20.	Axes for curtain motion in waves	69

LIST OF FIGURES

<u>No.</u>	<u>Title</u>	<u>Page</u>
21.	American Marine "double center tension" turbidity curtain	73
22.	Amplification factor vs. wave period	74
23.	Phase angle vs. wave period	75
24.	Wave length vs. wave period for sinusoidal waves	77
25.	Immersion amplitude vs. wave length	79
26.	Particle motion in a wave relative to the flotation element	81
27.	Wave, orbital, and transport speeds for waves of maximum height; i.e. $H/L = 1/10$	83
28.	Free-body diagram of forces acting on a silt curtain	84
29.	Minimum current for total submergence of a 5-ft silt curtain with bottom tension member, 60 lb/ft net buoyancy	87
30.	Anchoring loads for a totally submerged 5-ft silt curtain with bottom tension member, 60 lb/ft net buoyancy	88
31.	Symmetrical discharge configuration used in this model	96
32.	The conical mound	98
33.	Silt curtain deployment requirements	102
34.	Conical mound dimensions for slope of 1:200	103
35.	Schematic showing sampling stations at site 1	105
36.	NTU levels at site 1	106
37.	Correlation between NTU and suspended solids at site 1	108
38.	Schematic showing sampling stations at site 2	109
39.	NTU levels at site 2	110
40.	Correlation between NTU and suspended solids at site 2	111

LIST OF FIGURES

<u>No.</u>	<u>Title</u>	<u>Page</u>
41.	Curtain driven onto pipeline by storm at site 3	113
42.	Curtain configuration after storm at site 3	113
43.	Anchor configuration and background suspended solids levels at site 3	114
44.	Correlation between NTU and suspended solids at site 3	116
45.	Suspended solids levels on flood tide at site 3	117
46.	Suspended solids levels on ebb tide at site 3	118
47.	Sediment trap design used at site 3	119
48.	Sediment trap data for site 3	120
49.	Discharge area at site 3	122
50.	Closer view of discharge area at site 3	122
51.	Sample station locations, second field trip to site 3	124
52.	Near-bottom fluid mud data (in percent solids) outside the curtain at site 3	125
53.	Change in curtain configuration with tide-induced currents at site 3	128
54.	Configurations used in Heron Bay tests	135
55.	U test configuration	137
56.	Center tension curtain attachments	138
57.	Shapes of curtain profile in flare	138
58.	Center tension curtain flare in U configuration at a current velocity of 0.5 kts	139
59.	Top tension curtain flare in U configuration at a current velocity of 0.8 kts	139
60.	D test configuration	140

LIST OF FIGURES

<u>No.</u>	<u>Title</u>	<u>Page</u>
61.	Flare behavior in the D configuration, top tension curtain in a current of 0.25 kts	141
62.	Turbulence in the U configuration deployment area	142
63.	Current velocity variation with distance from a center tension silt curtain along the centerline of the U configuration . .	144
64.	Current measurements, center tension, D configuration, low current period	145
65.	Current measurements, top tension, D configuration, high current period	146
66.	Current measurements, top tension, D configuration, low current period	147
67.	Current measurements, center tension, D configuration, high current period	148
68.	Field measured vs. analytically derived curtain configuration in current - top tension curtain in .4 - .5 kts current . .	151
69.	Field measured vs. analytically derived curtain configuration in current - center tension curtain in .4 kts current . . .	152
70.	U configuration curtain, near mooring point (bottom), showing folds (arrows) caused by tension in the lower part of the curtain	154
71.	Theoretical vs. measured effective depth at apex for curtain in current - top tension, normal to current direction . . .	156
72.	Theoretical vs. measured effective depth at apex for curtain in current - center tension, normal to current direction . .	156
73.	Packaging a silt curtain	166
74.	Recommended silt curtain mooring system	169
75.	Recommended anchoring configurations	170
76.	Effect of water current on anchor tension for various curtain configurations	171

LIST OF FIGURES

<u>No.</u>	<u>Title</u>	<u>Page</u>
77.	Mooring tension in straight and corner segments of a silt curtain	172
78.	Anchor data (holding power of anchors in lb)	172

LIST OF TABLES

<u>No.</u>	<u>Title</u>	<u>Page</u>
1.	Silt Curtain Buoyancy	24
2.	Approximate Tension Member Strengths (pounds)	27
3.	Tension Member Loads (in lb) for an Open Catenary Curtain Configuration	28
4.	Silt Curtain Effectiveness Data	132
5.	Recommended Silt Curtain Specifications	158
6.	Comparison of Existing Manufactured Silt Curtains	159
7.	Ultimate Tensile Strength of Various Line	174

CONVERSION FACTORS, U. S. CUSTOMARY TO METRIC (SI)
UNITS OF MEASUREMENT

U. S. customary units of measurement used in this report can be converted to metric (SI) units as follows:

<u>Multiply</u>	<u>By</u>	<u>To Obtain</u>
cubic feet	0.02832	cubic metres
cubic yards	0.76455	cubic metres
degrees (angular)	0.01745	radians
feet	0.3048	metres
feet per hour	0.3048	metres per hour
feet per second	0.3048	metres per second
foot-pounds (force) per second	1.35582	newton-metres per second
gallons (U. S. liquid)	3.7854	litres
gallons (U. S. liquid) per minute	3.7854	litres per minute
inch-pounds (forces) per inch	4.448222	newton-centimetres per centimetre
inches	2.54	centimetres
knots (international)	1.852	kilometres per hour
mils	0.0254	millimetres
ounces (mass)	28.3495	grams
ounces (mass) per square yard	33.906	grams per square metre
pounds (force)	4.448222	newtons
pounds (force) per foot	14.5939	newtons per metre
pounds (force) per inch	1.75127	newtons per centimetre
pounds (force) per square inch	6.89476	kilopascals
pounds (mass)	0.45359	kilograms
pounds (mass) per foot	1.4882	kilograms per metre
pounds (mass) per gallon	0.11983	kilograms per litre

<u>Multiply</u>	<u>By</u>	<u>To Obtain</u>
pounds (mass) per minute	0.45359	kilograms per minute
pounds (mass) per square inch	0.07031	kilograms per square centimetre
slugs	14.594	kilograms
slugs per foot	47.8802	kilograms per metre
square feet per second	0.0929	square metres per second
square inches	6.4516	square centimetres
square yards	0.83613	square metres

AN ANALYSIS OF THE FUNCTIONAL CAPABILITIES
AND PERFORMANCE OF SILT CURTAINS

CHAPTER I: INTRODUCTION

1. Dredging and the disposal of dredged material in open water generate turbidity by suspending fine-grained particles of dredged material in the water column. While the direct and indirect effects of different levels of turbidity on water quality and aquatic organisms have not been quantified in detail, the aesthetic effects of discoloring the water and reducing its clarity are displeasing. Turbidity can be mitigated under some conditions, by the proper use of silt curtains.

2. Silt curtains or turbidity barriers are vertical barriers, designed to inclose or contain the turbid water generated by a dredging operation. Curtains are manufactured for a variety of depths and, in general, their design includes four elements (as shown in Figure 1): a skirt that forms the barrier, flotation material at the top, ballast weight at the bottom, and usually a tension cable. The flotation and ballast serve to maintain the deployed curtain in a vertical position, while the tension cable absorbs the loads imposed by the hydrodynamic (current) forces. In some curtain designs the skirt absorbs this load and the tension cable is not included.

3. The basic purpose of silt curtains is to provide a barrier extending from the water surface to several feet below the surface (or, in the case of shallow water, to the bottom), which prevents the turbid water near the surface from spreading either by dispersion or by current flow. Flow may occur under the curtain; however, this sub-surface flow of turbid water usually becomes well dispersed before it rises to the surface downstream of the curtain and, hence, surface turbidity outside the curtain is reduced. In this study curtain effectiveness is defined as the degree of turbidity reduction outside as compared to inside the curtain inclosure.

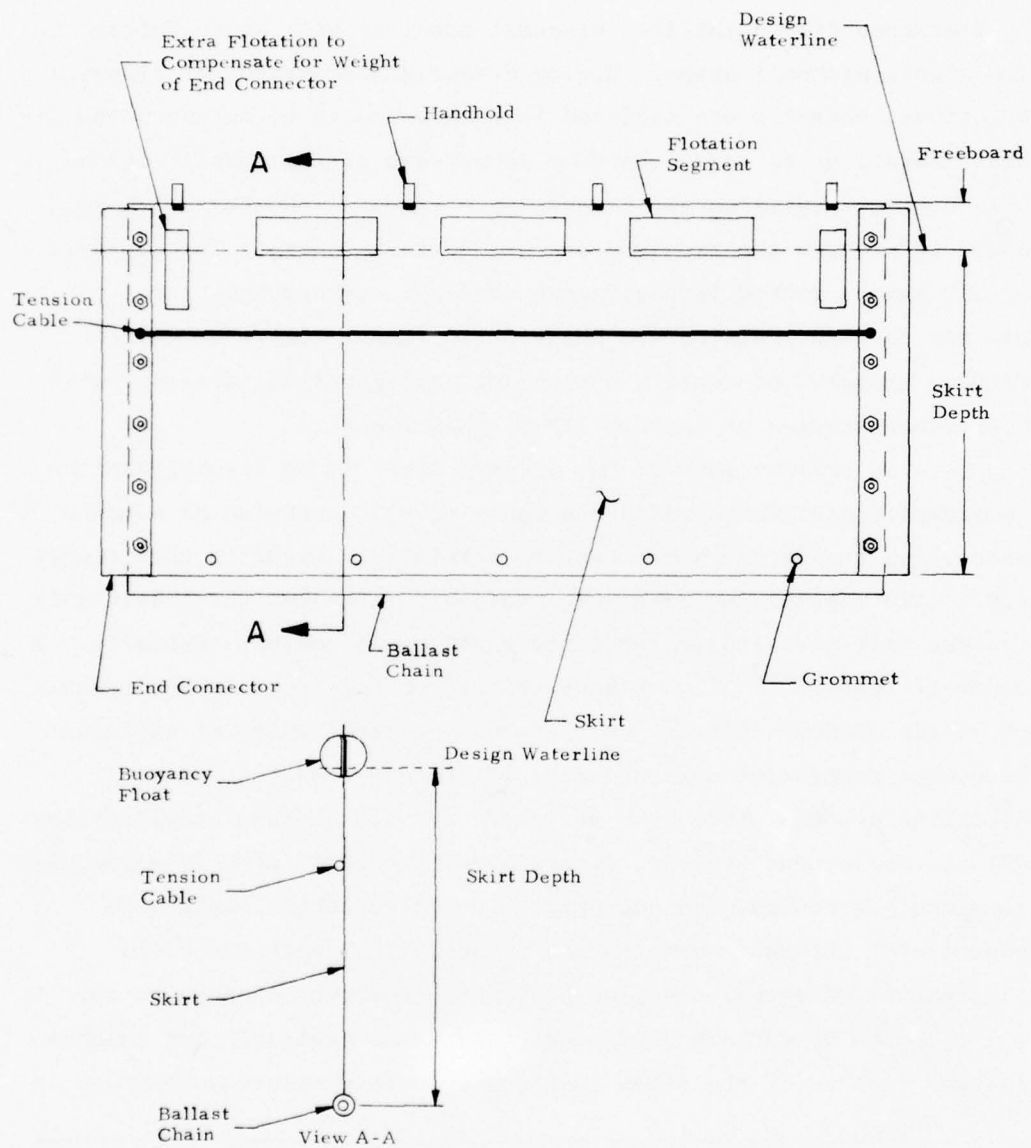

Figure 1. Construction of a typical silt curtain section

4. Silt curtains have been used on a wide variety of engineering and construction projects. In addition to dredging operations they have also been used across ditches and spillways; on marine construction jobs including outfalls, pile driving, highways, and a bridge across a lake; as baffling with several tiers across the mouth of a canal; to enclose the discharge from a confined disposal area, as well as to baffle the flow within disposal areas. During dredging and open-water disposal operations, curtains are deployed in such a way as to surround the discharge point, or to form a barrier downstream of the turbid region. Fully deployed curtains may be made up of several 100-ft* sections joined to provide the required overall curtain length. The deployed curtain may be moored in position by several anchors that serve to hold the curtain position and shape during tidal cycles or current shifts. Examples of curtain deployment configurations are presented in the case studies of Section III of this report.

5. The primary goal of the present study is to investigate the functional capabilities and performance of silt curtains as a means of controlling the degree and extent of turbidity. Prior to this study, very little engineering data were available to assess the feasibility of using silt curtains or turbidity barriers to control turbidity. A number of reports^{1,2,3,4} had been written on silt curtain performance, but little useable information concerning effectiveness of different deployment geometries was included. Therefore, the four primary objectives of this study were to inventory silt curtain specifications, evaluate deployment systems, determine silt curtain effectiveness, and recommend new designs and concepts. The latter three tasks were accomplished through a combination of analytical work and field measurements on actual dredging projects. However, because of the limited range of curtain deployment conditions available for observation and because of the often inadequate curtain maintenance found in

*A table of factors for converting U.S. customary units of measurement to metric (SI) units is presented on page 11.

the field, the field measurements had to be supplemented by a special field test program of the physical behavior of silt curtains.

6. In the following sections of this report, the experiences of early users are summarized, the analytical studies are presented, and the field measurements are described and compared to the analytical results. These discussions are followed by a description of silt curtain characteristics and a section on silt curtain utilization, which may be helpful in preparing silt curtain specifications and providing guidance for the purchase and deployment of silt curtains.

CHAPTER II: PRESENT DESIGN AND UTILIZATION OF SILT CURTAINS

Historical Framework

Past Usage

7. A recognition of the need to control turbidity caused by dredging, disposal, and highway construction operations led to the early attempts to develop and use silt curtains. In general, these attempts were limited by the materials available to the contractor doing the work. The first curtains used pervious filter cloth or untreated canvas. Flotation was provided by logs, lobster floats, and barrels. Chains, cans of concrete, sections of pipe, and the like were used as ballast, attached to grommets in the bottom edge of the curtain. These devices were then tied to poles driven into the bottom. The adjacent sections of curtain were presumably joined by lacing through grommets on the ends of each section. The pervious material quickly became plugged with silt, grew heavy, and sank. Untreated canvas supported marine growth and rapidly disintegrated. Storms invariably destroyed the curtains. Such primitive attempts, with their attendant problems, undoubtedly formed the basis for the surviving negative opinions of silt curtains. Some of the early studies of silt curtain use and curtain performance are outlined in the following paragraphs.

8. Ekey¹ reported on a pervious "diaper" made of 12-oz untreated canvas sailcloth, supported on the surface by styrofoam lobster trap floats. While the curtain did reduce turbidity initially, it rapidly deteriorated and sank. Later models of flexible 16-mil vinyl plastic and 10-mil Visqueen were torn and penetrated by sharks and turtles. Since the author concluded that the curtain need not be porous, most subsequent curtains were constructed with nonporous fabric with the exception of one manufacturer who provides webbing and screen material that may be used as a curtain or as a control for debris. Roberts² also discussed the diaper and documented many of the problems that were

observed, including silt washing over the top of the curtain and leakage around the ends.

9. Morneault³ documented tests where a curtain was used around a dredge as well as around the return flow from land disposal areas. Effectiveness of the curtain around the dredge was not established, and the turbidity levels in the return flow were so low that curtain effectiveness could not be evaluated in the disposal area.

10. The Mobile District⁴ conducted an extensive silt curtain experiment in 1971. Two thousand ft of 20-mil commercial (vinyl) curtain were deployed in a circle, attached to peeled pine poles driven into the bottom. Wave action pushed the curtain up the poles causing the curtain material to be punctured. It was repaired and lashed to the poles. Due to chafing, the lines parted and the curtain was severely damaged.

11. To offset the problems encountered with these early curtains, the skirt material was replaced with various thicknesses of polymeric films and reinforced with embedded woven fiber. Flotation and ballast were heat-sealed into the material to become integral members of commercial silt curtains. Pole and timber supports yielded to conventional anchor-buoy systems. Many of these developments were spin offs from oil boom technology, and their incorporation into the design of the silt curtain greatly enhanced its deployment, general effectiveness, and survival. Thus the early, primitive silt curtain has evolved into a product that equals, and in some cases, exceeds, the oil boom in terms of its construction.

Present Usage

12. In order to describe current silt curtain use, additional information was solicited from the U.S. Army Corps of Engineers, dredging contractors, and silt curtain manufacturers. Typical information sought concerned the nature of the project where the curtain was used, the characteristics of the environment in which it was placed, the contractor performing the work, the type and specifications

of the silt curtains employed, the degree of success achieved by the curtains, problems encountered in any aspect of their use, any quantitative data generated by monitoring the effectiveness of the curtains while in use, methods of transporting, mooring, and maintaining the curtain.

13. Despite the improvements in silt curtain design and deployment techniques, the contractors who had more recent experience with silt curtains were almost unanimous in describing their lack of success in areas of high currents, extreme wave action, large tidal ranges, and high winds. The tendency of the curtains to tangle, tear, and become encrusted with marine growth resulted in some cases in the total loss of the equipment. Other problems reported were damage by boat traffic and marine life, as well as difficulties in mooring, moving, and recovery after use. In general, contractors agreed that in areas of moderate current, containment of turbidity could be achieved. No agreement was obvious on the limits of current within which silt curtains could be effective. There was also a total lack of any quantitative data for assessing the effectiveness of turbidity reduction and no standardization on sampling and measuring the turbidity in and around the curtain.

14. One engineering firm contacted was able to report extensively on the use of silt curtains in the construction of a runway from dredged coral reef material at an international airport, which involved hydraulic dredging from four borrow areas to build up the runway. Dikes were constructed to contain the fill material. Dike construction required the open-water dumping of 19 million yd³ (14.5 million m³) of material, and commercially available silt curtains were used on that operation. Although some limited success was reported in controlling turbidity where multiple curtains were used in areas of still water, several problems were reported in areas of relatively strong tidal currents, substantial breaking waves, and rough coral bottom. The problems reported were in the installation, maintenance, and effective utilization of the curtains. Curtains were expensive to buy and were often

lost; swimmers were required to deploy them and put them back into position after moorings failed from current and wave action; they required continual repositioning with changing tides, badly wearing them on the bottom; and they required heavy load lines and large anchors to hold them.

15. By way of contrast, one contractor reported that his firm had used one curtain and successfully recovered it three times. It was ready for a fourth use. Still another engineering firm reported on the use of improvised curtains (pervious fabric suspended from logs) in a low-lying soft bottom bay with essentially no wave or current action. The application was much less demanding with commensurately fewer curtain problems. Runoff from the dragline excavation of earth cofferdams was introduced to the curtained inclosure after passing through a settling pond. The effluent from the settling pond was as clear as background, so the curtain had no noticeable effect. A case was reported, however, in which a curtain of the above description was successful in containing turbid water produced by the rupturing of a dike.

16. It was readily apparent at the end of the survey that little was known quantitatively about the effectiveness of silt curtains and that little information existed to verify the assumed physics of the interaction of the curtain with the turbid water and with the other effects of dredging operations. The program described in the next chapter was conducted to fill this void.

Present Curtain Characteristics

17. This section describes the general design and construction of silt curtains that are available today. The description of curtain fabrication is grouped into six major headings: general construction, skirt fabric, buoyancy and ballast, tension member, connectors, and miscellaneous. The importance of each component is discussed and specifics for each are developed.

General Construction

18. Figure 1 shows the major components of a typical silt curtain. The curtain consists essentially of a fabric skirt of sufficient strength to resist tearing or abrasion. This skirt is attached to buoyancy segments that provide proper flotation. Ballast, either as chain or separate lead weights, is attached to the bottom of the skirt so the curtain will remain vertical in moderate currents. Flotation and ballast are installed in such a way as to distribute their loads along the curtain length and minimize failures. The buoyancy and weight elements are placed in pockets and either sewn or heat-sealed into the skirt. A separate tension cable is usually added to absorb longitudinal stresses in the curtain due to current drag, while permitting the curtain to flare in a current to relieve hydrodynamic pressure. End connectors of various designs are provided to join individual curtain sections without permitting leakage at the joints; they also provide anchor points for mooring cables.

Fabric

19. Most fabric used in silt curtains consists of a woven nylon base with a flexible PVC coating. The final material weight is usually 18 or 22 oz/sq yd, but a range from 8 to 50 oz/sq yd is available. The fabric surface should have the following characteristics: anti-fouling properties, resistance to ultraviolet light and mildew, and easy cleaning. The anti-fouling property is important since silt curtains often remain in the water for long periods and a significant portion of dredging in the U.S. occurs in warm waters where marine growth is extensive. Because curtains are used outdoors and usually stored outdoors, the fabric must not deteriorate due to the effects of ultraviolet (UV)* radiation. The resistance to mildew is important because curtains are frequently folded up and stored while wet.

20. Three structural properties of the fabric that are important in silt curtain use are tensile strength, tear strength, and abrasion resistance. Tensile strength is important since the curtain will be

*For convenience, symbols and unusual abbreviations are listed and defined in the Notation (Appendix B).

stressed due to current, wind, and tide action. A review of fabric manufacturers' literature shows that the maximum value attainable for tensile strength is 450 lb/in. (FED TEST METHOD STD 191, Method 5102). A value of 300 lb/in., which is required of oil booms, would give a six-ft silt curtain an overall (theoretical) tensile strength of 21,600 lb, which is sufficient for all current conditions where silt curtains can be used effectively. Tear strength is important because the skirt will be subjected to intrusion by marine life or sharp objects while being deployed and utilized. The value of 100 lb (FED TEST METHOD STD 191, Method 5134) specified in the oil boom specifications appears to be typical for 18-oz curtain fabric. Abrasion resistance is also important because silt curtains are often dragged over the ground or beach while being cleaned, stored, loaded, and deployed. The oil boom specification requires that after abrasion (FED TEST METHOD STD 191, Method 5304) the tensile strength will not be less than 200 lb/in. This allows for abrasion to weaken the fabric to 2/3 its original strength.

Buoyancy and Ballast

21. The buoyancy must maintain the specified skirt draft and provide a continuous barrier above the waterline. Based on the review of manufacturers' literature, buoyancy ratios ranging from 1.03 to 14.7 are available in commercial curtains (see Table 1). Some reserve buoyancy is provided to ensure a continuous barrier under the expected wind and wave conditions; a buoyancy value between five and ten times the total weight of the curtain is typical. The flotation material is usually enclosed in a pocket within the curtain. It is usually in the form of a solid closed-cell plastic foam "log" so that buoyancy will not be lost if the curtain pocket is punctured or torn. Each flotation segment should have a maximum length of less than 10 ft so the curtain may be easily folded for storage and transport.

22. The ballast causes the skirt to hang vertically from the flotation. Ideally, the ballast weight is sufficient to ensure that the curtain will hang vertically under moderate current (e.g. 0.5 kt)

Table 1
Silt Curtain Buoyancy

<u>Curtain Model</u>	<u>Draft (ft)</u>	<u>Flotation log Diameter (in)</u>	<u>Flotation log Buoyancy* (lb/ft)</u>	<u>Curtain Dead Weight in air (lb/ft)</u>	<u>Buoyancy Ratio**</u>
A	2	6	12.4	2.16	5.7
B	10	12	49.5	3.76	13.2
C	3	6	12.4	1.3	9.5
D	20	12	49.5	6	8.25
E	3	8	22	1.5	14.7
F	10	8	22	4.2	5.2
G	12	12	49.5	7	7.1
H	7	3	3.1	2.5	1.2
I	30	6	12.4	10	1.2
J	2	4	5.5	2	2.8
K	20	20	137	9	15.2
L	2	3	3.1	3	1.03

*Calculated from: $(\text{Diam}/24)^2 \pi \cdot 63 = \text{Buoyancy in lb/ft}$

**Buoyancy ratio \equiv Flotation log buoyancy \div Curtain dead weight

but will flare to relieve tension under excessive current (e.g. 2 kt). Quantitative relationships between ballast, current, and flare are developed in Chapter III. Because the ballast material must be resistant to corrosion from seawater, galvanized chain or lead weights are usually chosen. In some curtain designs where the ballast chain also acts as a tension member, the chain should be examined for corrosion frequently.

Tension Member

23. The tension member, which must resist corrosion by seawater, is intended to absorb the stresses that occur when the curtain is subjected to significant currents or while being towed. The greatest forces occur when the curtain is anchored perpendicular to a current. The three criteria of interest in evaluating the tension member are: material, location on the curtain, and the mode of connecting the tension member/fabric between sections.

24. Material. There are three types of tension member material. First, the fabric itself can absorb all the stress. There are three potential disadvantages to this method. In the first place, if the end connector is bolted to the curtain fabric there will be stress concentrations on those holes whenever the curtain is under tension. This could cause the connector to tear out of the curtain. Secondly, while the fabric might be strong enough for expected normal usage, during storms it will be subjected to very high stress and the curtain could tear apart. Thirdly, the fabric (nylon or polyester) can stretch up to 30 percent under high stresses. This amount of curtain elongation can allow the curtain to shift and possibly interfere with nearby equipment or operations. The only advantage of using the fabric as the only tension member is that the construction of the curtain is simpler and less expensive.

25. A second method of tension support is to attach a galvanized or stainless steel wire rope to the curtain as a separate tension member.

When the tension member is a separate cable, it should be slightly shorter than the curtain, and the fabric and tension member should be connected in a manner so that the fabric is free to slide on the cable. The advantage of this method is that the tension member absorbs most of the tension load in all configurations and improves the life expectancy of the fabric. This advantage also holds for the third tension member material, the ballast chain.

26. The load capacities of tension members of various types of material are shown in Table 2. These values may be compared with examples of theoretical tensions in specific curtain configurations subject to currents as shown in Table 3. It appears from the values in the first column that the fabric itself is a very strong tension member, but the fabric's lack of durability dictates use of a tension member. With a chain or wire rope the fabric absorbs little of the tension load and, under high current conditions, it flares to relieve some of the tension on the ballast chain or wire tension member.

27. Location. Various manufacturers have chosen different locations for the metal tension member on their particular curtain models. These locations are: above the flotation, just under the flotation, one ft under the flotation, and the bottom of the skirt. For low current conditions (e.g., a small lake or pond) a separate tension member is not required as long as it can reasonably be expected that the curtain will never be subjected to substantial tension loads. For moderate currents, a separate tension member located above or slightly below the flotation is acceptable. This location will allow the curtain to flare and relieve the tension under high current conditions. For high current situations, the tension cable may be above or below the flotation or near the vertical center of the skirt. The curtain will flare to relieve tension with either configuration. However, the center tension configuration flares less and maintains greater effective skirt depth than the top tension configuration for a given current, but as a result also requires stronger tension members and more effective anchor systems to absorb the greater load.

Table 2
Approximate Tension Member Strengths (Pounds)

Size <u>Skirt Depth, ft</u>	<u>Material Type</u>		
	<u>Fabric*</u>	<u>Chain**</u>	<u>Wire Rope***</u>
3	10,800		
6	21,600		
10	36,000		
15	54,000		
20	72,000		
 <u>Diam., in</u>			
1/4		3,400	5,500
5/16		5,300	8,500
3/8		7,700	12,000

*Assumes a tensile strength of 300 lbs/in.

**Zero safety factor, proof-coil chain, ref. (5)

***Zero safety factor, improved plow steel, ref. (6)

Table 3
Tension Member Loads (in lb) for an Open
Catenary Curtain* Configuration

Current Velocity (knots)	Curtain Effective Skirt Depth (ft)				
	3	6	10	15	20
0	0	0	0	0	0
0.25	40	80	133	200	266
0.5	160	319	532	798	1064
1	639	1277	2129	3193	4258
1.5	1437	2874	4790	7185	9580
2	2555	5109	8515	12773	17031

*Assumptions: Curtain length = 1000 ft
Mouth opening = 300 ft
Calculated from equation (20) and Figure 11

Connectors

28. End connectors are designed to permit two curtain sections to be attached or disengaged easily and to provide a positive water seal between sections to prevent leakage. The two major types of connectors are the no-load and load type connectors (Figure 2). With no-load connectors, the tension cables are fastened to each other and bypass the connectors. Figure 3 shows three examples of no-load connectors: rope bolt with a slotted tube, plastic zipper and Velcro[®] material. The no-load connectors must provide for transfer of tension between curtain sections as well as sealing between fabric sections. However, based on field installations examined on this study, no-load connectors frequently do allow leakage through gaps between the curtain sections. In increasing currents the curtain begins to flare and considerable tension can be applied to no-load connectors due to the change in curtain shape. Shape changes under flare also place restrictions on the interconnection method chosen.

29. With load type connectors, the tension members are fastened to the curtain and connectors, which are capable of supporting the expected loads and will transfer the tension between curtain sections. Figure 4 shows three examples of load type connections; rope lacing through grommets, nuts and bolts through grommets, and aluminum extrusion. Among the load connectors, the rope lacing and nuts and bolts through grommets are unsatisfactory due to leakage. Based upon the above considerations, aluminum extrusion load connectors appear to be preferable for any curtain installation that may be subject to current loads. Other types of connectors may be acceptable when curtains are used in environments where there are no currents.

Miscellaneous

30. Two additional items to be considered are handholds and repair kits. The handholds should be on the top of the curtain between flotation segments. These handholds are used to handle the curtain during cleaning, loading, and while in the water. Repair kits, usually provided with each curtain, permit repair of minor tears or damage to

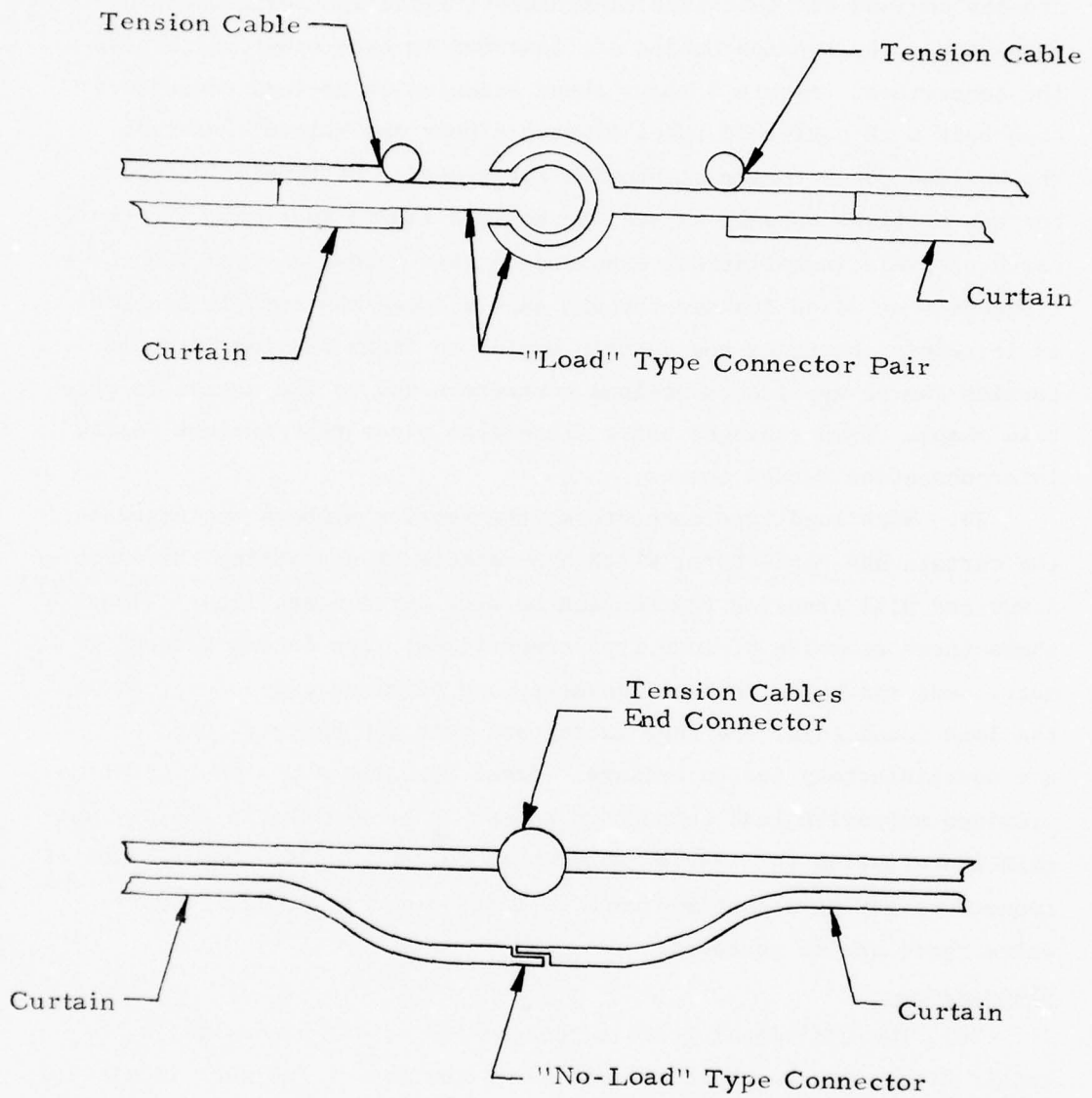

Figure 2. End connection modes

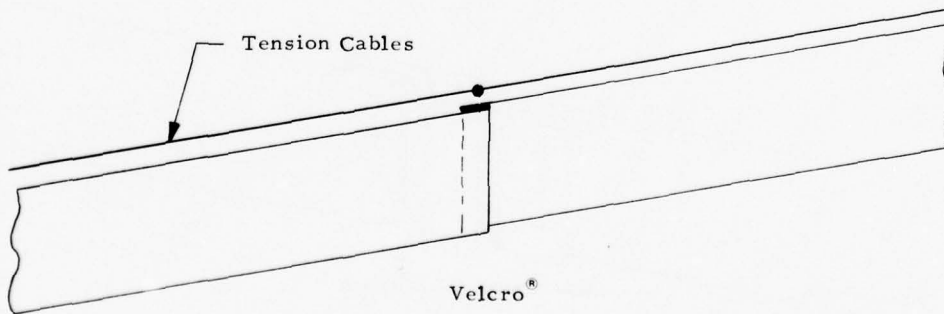
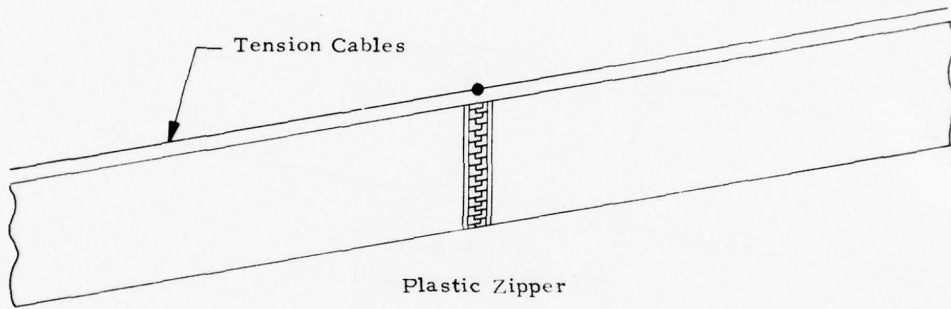
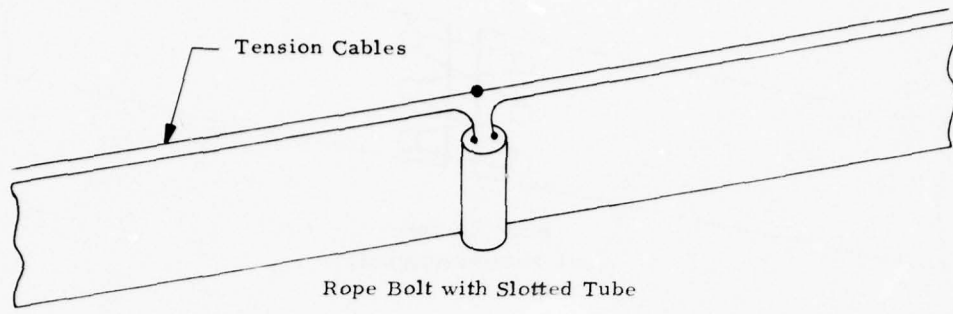
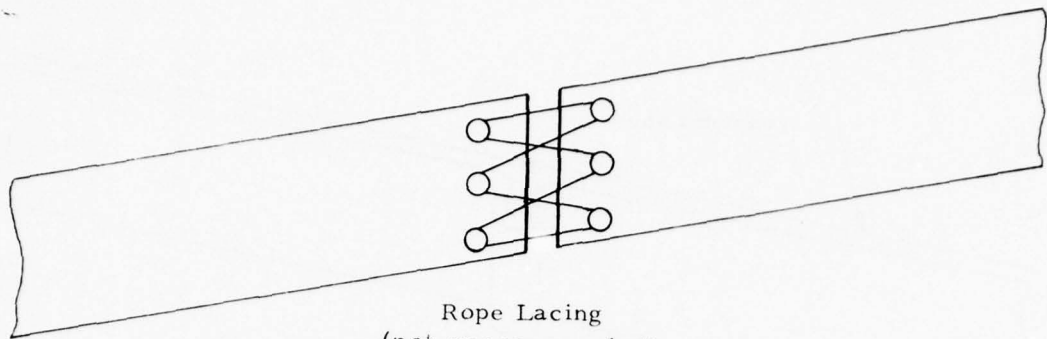
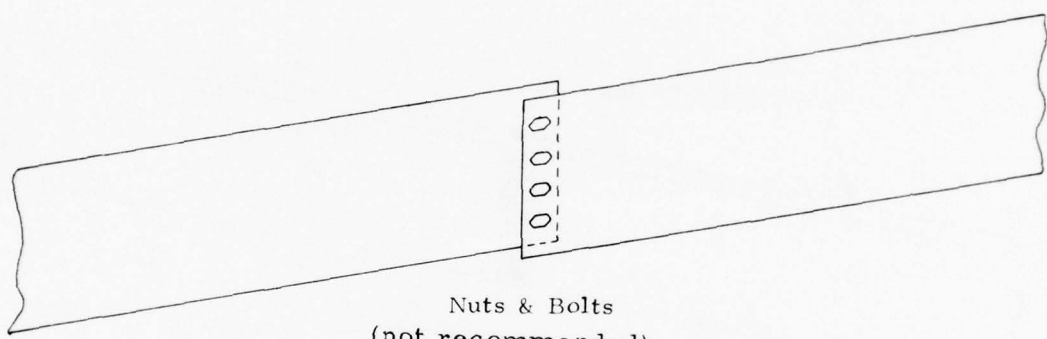

Figure 3. "No-Load" type connectors



Rope Lacing
(not recommended)



Nuts & Bolts
(not recommended)

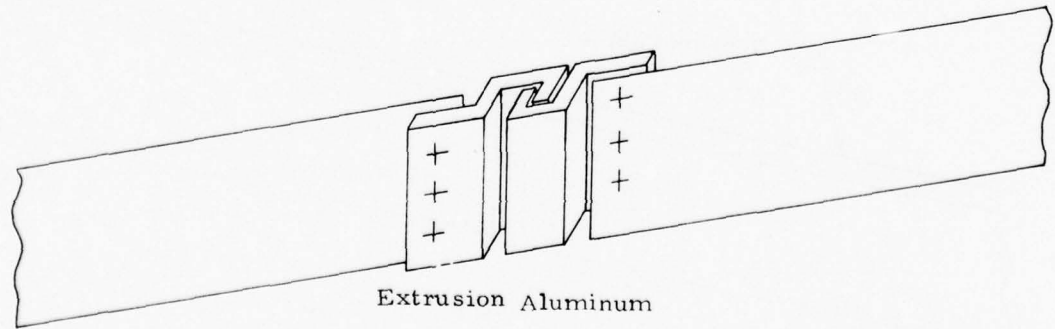

Extrusion Aluminum

Figure 4. "Load" type connectors

the curtain. This is important because significant amounts of turbidity can escape through damaged curtains and certainly it is essential to ensure that dredging operations are not shut down due to unsatisfactory curtain performance. Instructions for repair are an essential component of a repair kit. Tears are generally repaired by gluing a patch over the tear. Kits should also contain a sail maker's kit, so that large tears can be sewn together before patching.

Present Curtain Utilization

31. Since the range of applications for silt curtains is very large, there probably is no one typical configuration. However, most installations form a closed configuration, an open configuration, or a maze (Figure 5). The closed configuration may be attached to shore, as shown, or it may be a circle or ellipse. Anchoring is normally done using several large (250 - 500-lb) anchors with mooring floats and small (25-lb) anchors at joints between curtain segments. The anchors are placed outside the curtain so that they may be recovered after the project is completed. The open configuration is used in rivers and situations where the curtain must be moved frequently for boat traffic. Few data are available on this configuration. The maze configuration is also used in areas with boat traffic but it appears to be relatively ineffective due to direct flow through the aperture between the curtains.

32. New curtains are often transported to the dredging site stored accordion fashion in shipping containers or in a trailer. The skirt should be furled against the flotation segments to conserve space and to facilitate moving the curtain into position when in the water. At the site the curtain may be deployed directly into the water from the container by pulling one end away from the container using a small tow boat or work boat. Once in the water, the curtain is moved to the deployment position by towing it with a work boat. Curtains tow easily at 2 to 3 knots and track well behind the tow boat

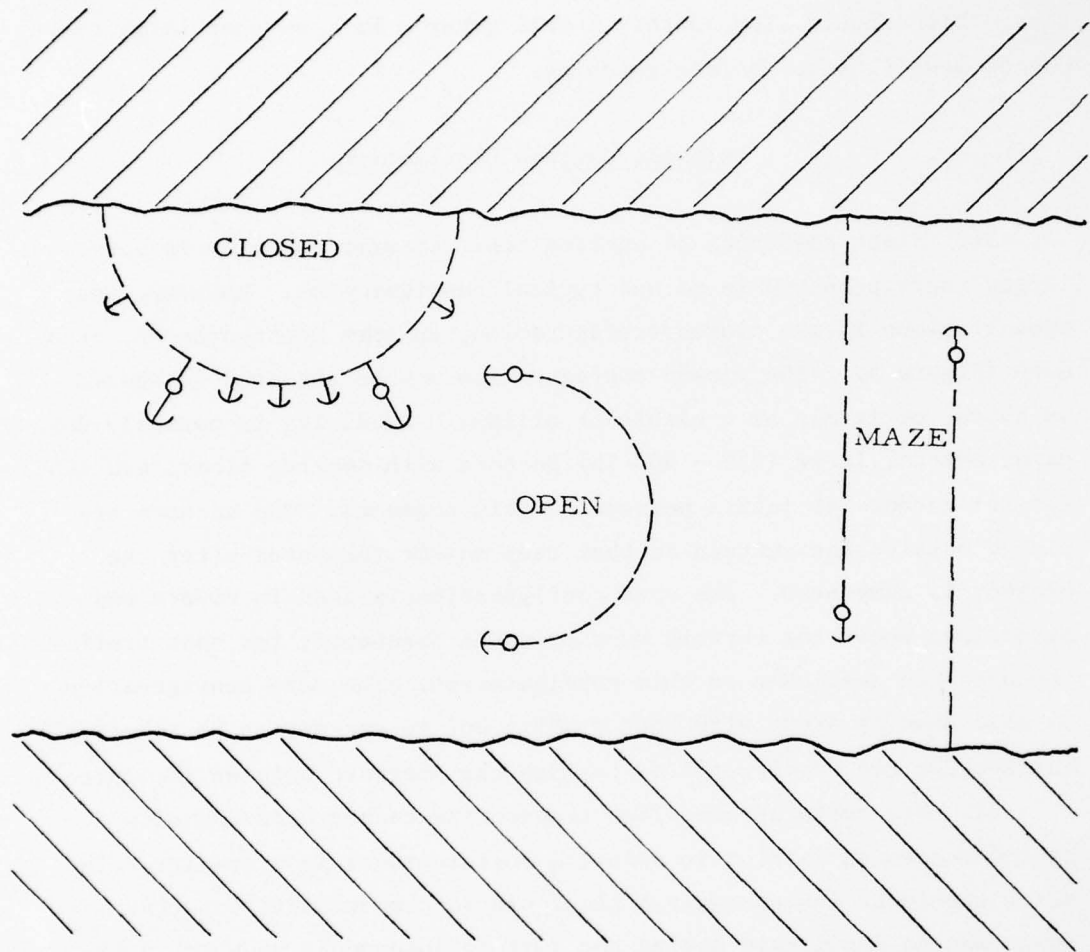

Figure 5. Typical silt curtain configurations

through normal maneuvering. Curtains over 2000 ft long have been towed this way.

33. An alternative method for transporting curtains used by the U.S. Navy to transport oil booms is to stack the curtain on a flat top multihulled boat, transport it to the site, and then pull it into the water using another boat. The curtain may also be lifted by means of a crane, with a chain or cable sling and deployed into the water. With any method of deployment, care should be taken to prevent tearing by ensuring that the curtain does not drag across rocks, across the ground, or over other equipment. Upon arrival at the site, the curtain is attached to shore points and mooring floats, depending upon the desired configuration. After it is attached to the primary support points, lightweight anchors are planted and tied off to the tension member at points where segments of curtains are joined. The skirts are then unfurled before dredging commences.

34. During the dredging phase, considerable attention must be paid to the curtain to prevent its failure. The most common failure results when dredged material from the discharge flow builds up until it reaches the skirt bottom. If the curtain is not moved to deeper water when this happens, dredged material accumulates on the skirt causing the curtain to be drawn under and buried. This buildup may also occur during tidal changes, because as the curtain shifts position due to changing tidal conditions, it may drag across the bottom trapping silt along the way. Another common problem encountered is failure of the float material or inadequate flotation at the joined sections, causing the skirt top to sink allowing leakage over the curtain top. Still another failure mode that is commonly observed is parting of the seam between joined segments resulting in a gap and subsequent leakage.

35. Catastrophic failure has been observed in a number of instances associated with local storms such as gales and thunderstorm activity. In these cases the anchors have pulled out, anchor lines have parted, and weak curtains ripped or the tension members failed.

However, newer curtains are less susceptible to direct curtain failure due to improvements in the type and location of the main strength member and due to curtain designs that flare, thus reducing stresses in high currents. Curtain damage in the newer curtains is usually caused by secondary effects such as anchor lines parting and allowing the curtain to ride up against abrasive elements such as pipeline floats, docks, etc.

36. Thus silt curtains have evolved into a product that has overcome many of the early deficiencies. The fabric has been strengthened to reduce the tendency for it to tear or abrade. Chains and flotation have been sewn in to distribute their load and reduce failures. Tension cables have been added to relieve strain on the curtain and to allow flaring to relieve pressure. Flotation has been placed into a pocket and either sewn or heat-sealed to the skirt. A number of methods for joining curtain sections have been developed; anchors have replaced poles and sticks for holding the curtain in place. However, virtually all changes in the curtain's evolution have dealt with improving its physical integrity rather than evaluating the effectiveness of the curtains and optimizing their ability to reduce turbidity in the water column.

CHAPTER III: DETERMINATION OF SILT CURTAIN EFFECTIVENESS

Descriptive Model

37. Several hypotheses exist as to how silt curtains operate, but observation of curtain behavior indicates that, in the presence of a current, the curtain does not actually contain turbidity, but rather, changes the flow patterns and water current velocity in the vicinity of the curtain so that the flow entering the curtained area from the pipeline or other source is redirected. It is clear that the curtain neither holds back the tide nor permanently contains the flow from a pipeline discharge but instead restricts the flow of turbid water near the surface.

38. A number of mechanisms are simultaneously at work within the curtain as shown in Figure 6. The discharge (pipeline) often consists of material that readily settles out (sand), material that will settle out in a short time (silt), and material that takes a long time to settle out (clay). Sand and coarse silt fractions quickly settle out and are of little interest to this study, except as they affect the curtain. Most of the finer material moves out of the discharge area in a mud flow on the bottom; however, some fine silt and clay remain suspended in the water column (turbidity) and are carried by the water velocity field. While some of this material settles out inside the curtain due to flocculation, the remaining fine material is carried under the curtain by the current flow.

39. Based upon the descriptive model of Figure 6, a number of analytical investigations and field measurements were made to examine the relative importance of these mechanisms and to determine the effectiveness of the curtain. Unfortunately, establishing the effectiveness of curtains under a wide range of material types and environmental conditions is a difficult task. Additionally, there is no general agreement as to what constitutes turbidity or how to measure it. Some turbidimeters measure turbidity in terms of light scattering;

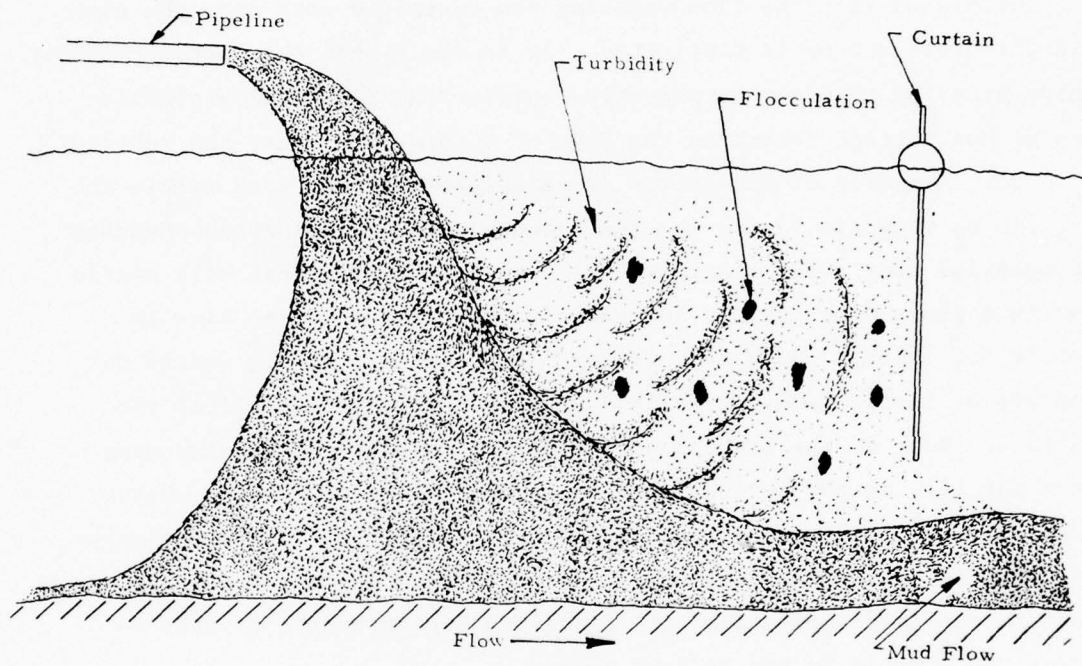

Figure 6. Mechanisms involved in turbidity control by a silt curtain

others measure percent transmission. Turbidity can also be evaluated by measuring the concentration of suspended solids.

Analytical Investigations

40. Several factors that influence the sedimentation process and the physical behavior of silt curtains can be easily evaluated analytically to determine their relative importance in controlling the dispersion of turbid water in the vicinity of silt curtains. The following analytical section evaluates particle settling rates inside a curtained area, develops a mass balance model, and analyzes curtain behavior relative to current velocity, wave condition, and construction of the curtain. Based on these results a methodology is developed for deploying and maximizing the effectiveness of a silt curtain surrounding an open-water pipeline disposal operation.

Particle Settling Rate

41. Early investigators felt that silt curtains reduced turbidity by allowing particles inside the curtain to settle out of the water column. According to this hypothesis, the settling action of particles is governed by weight and drag forces acting on the particle as well as the electrostatic forces associated with flocculation. Flocculation tends to form larger particles that settle at higher velocity. The settling velocity of individual particles is the terminal velocity under the forces of gravity, buoyancy, and fluid drag. The developed relation for the settling velocity, V_S , of spherical particles is

$$V_S = \frac{4}{3} \left(\frac{\rho_p - 1}{\rho_w} \right) \frac{d_p}{C_d} \quad (1)$$

V_S = settling velocity, ft/hr

d_p = particle diameter, in

C_d = drag coefficient of particle

ρ_p = density of particle

ρ_w = density of water

Because of small particle sizes and very low velocity levels, Reynolds numbers are well below 1.0 and deep in the viscous region where

$$C_d = \frac{24}{Re} \text{ for a sphere.} \quad (2)$$

Making this substitution results in:

$$v_s = \frac{1}{18} \left(\frac{\rho_p}{\rho_w} - 1 \right) \frac{d_p^2}{\nu_w} \quad (3)$$

Where ν_w = kinematic viscosity of water

The above equation (Stokes' Law) shows that the terminal velocity depends primarily on d_p^2 so that flocculation or the aggregation of particles will be a significant factor in determining the settling rate of silt and clay size particles. Assuming the reference particle diameter is to be of the order of 0.0001 in. and solving for the constant obtains

$$v_s = 10^6 d_p^2 \quad (4)$$

42. Typical sedimentation rates for particles on the order of 0.001 in. are one ft/hr. Thus a curtain with a skirt depth of five ft would have to retain a water mass for approximately five hr to allow settling of particles of this size. Clearly, this is only achieved under very low water current conditions and low rates of turbid water input into the contained area. Thus if silt curtains effectively reduce turbidity, other mechanisms must be operating in conjunction with simple settling.

Material Balance in the Silt Curtain Enclosure.

43. It is of interest to determine what fraction of the discharged solid material becomes suspended in the water column and what fraction enters the mud flow on the bottom. Measuring these fractions precisely in the field would be extremely difficult, but it is possible to estimate them from the solids concentrations measured in the water column

and in the mud layer using an estimate of the flow through the curtained region. This approach determines the rate of flow of mud and of suspended solids required to keep the suspended solids concentration and the mud concentration within the range of values measured in the field.

44. For the purpose of this analysis consider the area within the curtain as a closed volume with two sources of inflow and two sources of outflow (see Figure 7). The first inflow is the dredge discharge, which discharges into the control volume at a rate of Q gpm total flow and, within this flow, q lb/min solids flow. The second source of inflow is the ambient current flow that actually enters the control volume under the curtain. This introduces W gpm of water into the region.* It is assumed that the flow out of the control volume occurs as a mud flow, discharging R gpm total flow with r lb/min of solids and a flow of turbid water, discharging T gpm total flow with t lb/min of solids. Both of these flows move under the curtain. Some material from the mud flow may actually be deposited on the bottom within the curtain but for the purpose of the analysis this material can still be considered as leaving the control volume as a mud flow.

45. It is also assumed, for this analysis, that the water column solids concentration and the mud flow solids concentration have reached an equilibrium with respect to the inflows and outflows of the control volume. These assumptions are obviously gross simplifications, but they do serve to provide a basis for very approximate estimates of the ultimate fate of the discharged material.

46. First it is noted that solids concentration in the mud flow (m) and water column (c) can be expressed as follows:

$$m = r/R \quad (5)$$

$$\text{and } c = t/T \quad (6)$$

*Note that in this analysis the background concentration is not considered because this can be treated as a datum and subtracted from concentrations measured inside the control volume.

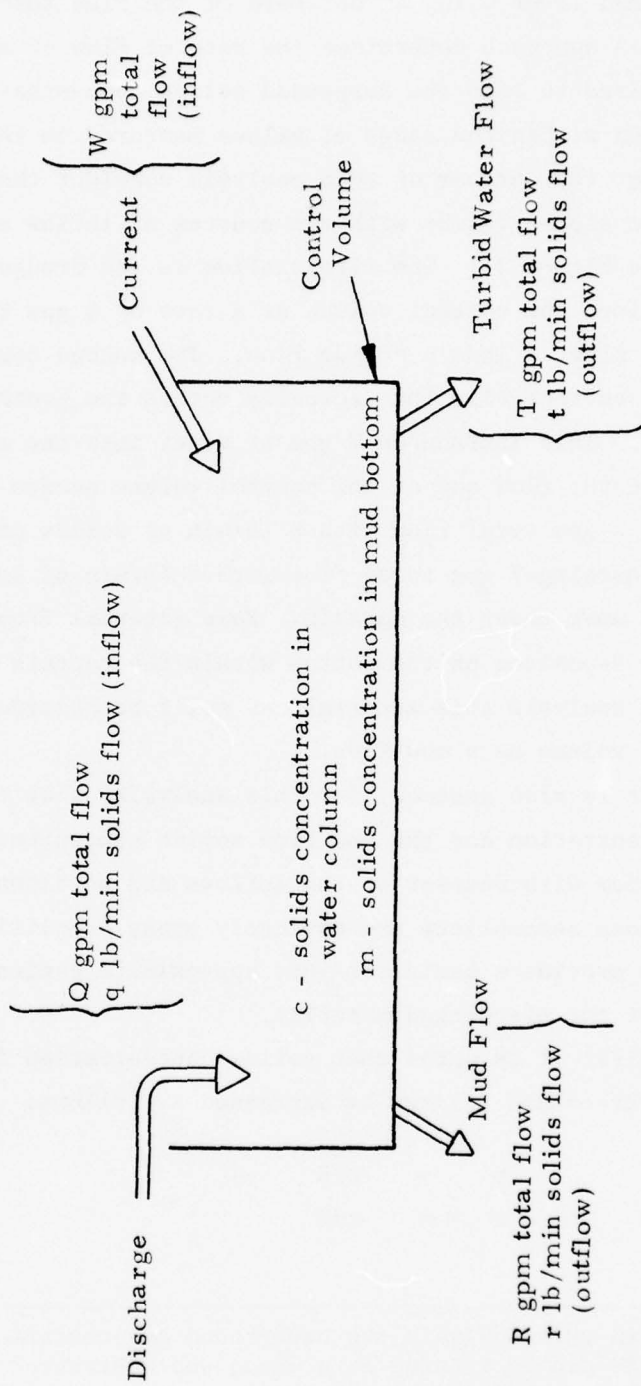

Figure 7. Schematic of control volume for material balance analysis

where

m = mud flow concentration, lb/gal
r = rate of solids outflow in the mud flow, lb/min
R = total rate of outflow in the mud flow, gpm
c = water column concentration, lb/gal
t = rate of solids outflow in the turbid water flow, lb/min
T = total rate of outflow in the turbid water flow, gpm

47. Next it is noted that from the balance of inflow and outflow for both total flow gpm and solids flow lb/min we have:

$$Q + W = R + T \quad (7)$$

and $q = r + t \quad (8)$

where

Q = the total inflow from the dredge discharge, gpm
W = the inflow due to current, gpm
q = the inflow of solids from the dredge discharge, lb/min

48. Now equations 5 through 8 form a set of four simultaneous equations with four unknowns. The four unknowns are the rates of total flow and solids flow for the turbid water (T and t) and for the mud flow (R and r). The equations can be solved to give:

$$\begin{aligned} t &= \left(Q + W - \frac{q}{m} \right) / \left(\frac{1}{c} - \frac{1}{m} \right) \\ r &= \left(Q + W - \frac{q}{c} \right) / \left(\frac{1}{m} - \frac{1}{c} \right) \\ R &= r/m \\ T &= t/c \end{aligned} \quad (9)$$

49. It should be emphasized that these equations do not give precise estimates of material flow but do provide an approximate indication

of the relative amounts of material entering suspension and entering the mud flow. The mathematics is actually determining the levels of outflow for both mud flow and turbid water that are required to keep the observed concentrations in equilibrium while still balancing the inflow rates to the outflow.

50. The following is an example of this analysis. The flow rates and concentrations are consistent with data taken in the Winyah Bay field study described later in this chapter. For this example the following has been taken as input data (see Figure 8):

- a) dredge discharge - 10,000 gpm flow
12,600 lb/min solids
giving about 15 percent solids by weight

- b) current flowing in - 400,000 gpm flow. This is based on
typical observed parameters:
1/2-knot current entering through
a 1-ft gap along 500 ft of curtain length

- c) water column concentration - 150 mg/l less 20 mg/l
background = 130 mg/l = 1.086×10^{-3} lb/gal

- d) mud flow concentration - 25 percent by weight = 2.1 lb/gal

Applying these values to equation 9 gives the following:

- r = 7,563 lb/min solids leaving in mud flow
- t = 437 lb/min solids leaving in water flow
- R = 7,880 gpm total flow leaving in mud flow
- T = 402,120 gpm total flow leaving in water flow
(most of this is current flowing through)

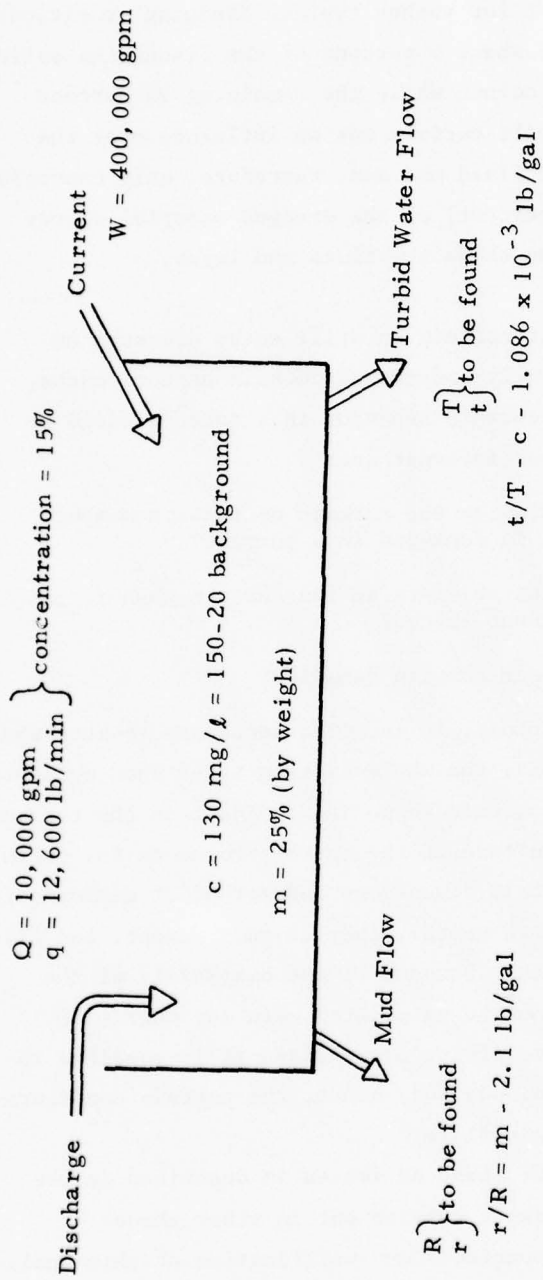

Figure 8. Example for material balance analysis

Thus the analysis indicates that for rather typical dredging conditions and silt curtain configuration, about 5 percent of the discharged solids remains suspended in the water column while the remaining 95 percent forms a fluid mud layer. The silt curtain has no influence over the accumulation or movement of the fluid mud and, therefore, only controls a very small percentage (five percent) of the dredged material slurry that remains in the water column above the fluid mud layer.

Curtain Behavior

51. The behavior of a silt curtain in still water presents no problem; however, in order to fully understand curtain effectiveness, it is necessary to analyze the curtain behavior in a current field or in waves. The questions of major interest are:

- a. What is the tension on the curtain or tension member when the curtain is deployed in a current?
- b. What is the amount of flare in the curtain when it is subjected to current forces?
- c. How do waves affect curtain behavior?

52. To address these questions, it is first necessary to know what shape (e.g., catenary or parabola) the whole curtain takes when deployed in a water current field. The curtain shape is dependent on the current forces on the curtain. The magnitude of the current force on the curtain is in turn dependent on the curtain dimensions and method of deployment, the current velocity profile (with depth), and, to some extent, the size of the gap underneath the curtain. Because of the complexity of the flow phenomena these forces cannot be calculated with any degree of accuracy; however, with some simplifying assumptions it is possible to make estimates of the force magnitude and, hence, the curtain configuration, curtain tension, and curtain flare.

53. The analytical work for these estimates is described in the sections that follow. The fieldwork carried out in other phases of this study was essential for comparisons and verification of this analysis and the comparison of analytical and field results is discussed in

a later section of this chapter. The major underlying assumptions for the analytical work are:

- (1) The current field into which the curtain is inserted is uniform. That is, current velocity is constant with depth and with horizontal position.
- (2) The curtain maintains a uniform effective depth and cross-sectional shape along its length. (This is not necessarily so because the curtain flares when current pressure is high, thus changing both its cross-sectional shape and effective depth. Since current pressure is not constant along the length of a deployed curtain, even in a uniform current field, the cross-sectional shape and the depth of a deployed curtain will also vary.)
- (3) The gap beneath the curtain is relatively uniform with length along the curtain. Violations of this assumption may be significant when considering curtains deployed in water depths not much greater than the curtain depth.
- (4) The curtain is entirely flexible and cannot resist any bending or torsion moments. It can only accommodate tension forces. This is a reasonable assumption for the force magnitudes being considered here.

54. Shape and Tension of a Curtain Anchored in a Current. The most basic curtain configuration is one in which the curtain is deployed across a current field with an anchor point at each end of the curtain (Figure 9). Any more complicated arrangement can be considered as a combination of this basic configuration since the section between any two anchors behaves in the same way as the basic configuration shown in Figure 9. The problem of a barrier (or curtain) in a steady current has been examined by Hoult⁷, Robbins⁸, and Milgram⁹. This is the case where a barrier of length L is anchored (at its end points) in a current of speed V_c . The coordinate system is chosen so that the x-y origin is located at the minimum y coordinate of the curtain when the Y axis is positive in the direction from which the current flows (Figure 9). The current flow may be expressed as a tangential and a normal component (V_{cn} and V_{ct}) at any point along the curtain by the following:

$$V_{cn} = V_c \cos \theta \quad (10)$$

$$V_{ct} = V_c \sin \theta \quad (11)$$

where the angle θ is the local angle between a tangent to the curtain and the x axis. The tangential flow, V_{ct} is assumed to have negligible effect and the normal flow can be expressed in terms of the local slope of the curtain $\left(\frac{dy}{dx}\right)$:

$$V_{cn} = V_c \left[1 + \left(\frac{dy}{dx}\right)^2 \right]^{-1/2} \quad (12)$$

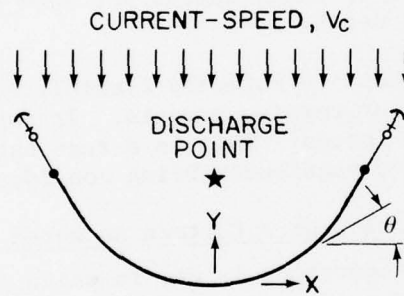

Figure 9. Curtain moored in a current field showing coordinate system used in analysis

55. The force on an elemental length of the curtain is equivalent to the force on a uniform longitudinal barrier at an angle to the current. This is given by:

$$P_c = 1/2 \rho_w V_{cn}^2 C_d h \quad (13)$$

where P_c = the net current force per unit length of curtain, lb/ft
 ρ_w = water density, slugs
 h = actual curtain depth, ft
 C_d = a drag coefficient

Because the effect of the tangential flow is negligible, P_c is the only hydrodynamic force acting on the curtain. This force is normal to the curtain and, therefore, the curtain tension must be constant throughout the curtain length. The pressure force is opposed by components of the tension force in an elemental length of curtain. This is illustrated in Figure 10 which shows an elemental length of the curtain with tension force components opposing the normal force P_c .

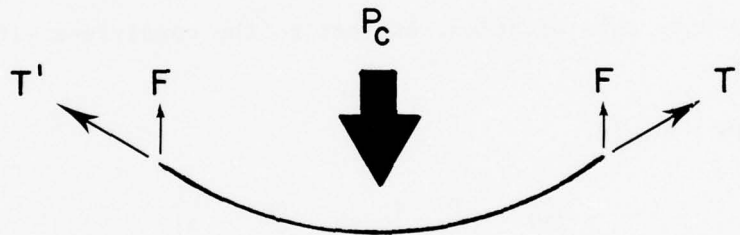

Figure 10. Forces on an element of the curtain

This opposing force, F , is equal to the tension, T , divided by the local radius of curvature:

$$F = T \frac{d^2 y}{dx^2} \left[1 + \left(\frac{dy}{dx} \right)^2 \right]^{-3/2} \quad (14)$$

Where F is the force per unit length. Therefore, in equilibrium,

$$F = P_c \quad \text{and}$$

$$1/2 \rho_w v_{cn}^2 C_d h = T \frac{d^2 y}{dx^2} \left[1 + \left(\frac{dy}{dx} \right)^2 \right]^{-3/2}$$

but, since $v_{cn} = v_c \left[1 + \left(\frac{dy}{dx} \right)^2 \right]^{-1/2}$, this is equivalent to the following differential equation:

$$T \frac{d^2 y}{dx^2} = 1/2 \left[1 + \left(\frac{dy}{dx} \right)^2 \right]^{1/2} \rho_w v_c^2 h C_d \quad (15)$$

The solution to this equation, subject to the conditions $y(0) = 0$ and

$\frac{dy}{dx}(0) = 0$, is:

$$y(x) = \left(\frac{T}{\sigma} \right) \left(\cosh \frac{\sigma x}{T} - 1 \right) \quad (16)$$

where $\sigma = 1/2 \rho_w v_c^2 h C_d$

and this is the equation of a catenary. This equation is correct for any case of a curtain moored between two points. However, for simplicity of solution consider a symmetrical case where the mooring points each have the same y coordinate (up current coordinate). Using actual curtain length (L), and mouth opening (M) along with the above equation to express tension in terms of curtain configurations, gives:

$$\tau \sinh \left(R/2 \tau \right) = 1/2 \quad (17)$$

where $R = M/L$, the curtain gap ratio (18)

and $\tau = T/(L 1/2 \rho_w V_c^2 h C_d)$, the dimensionless curtain tension parameter. (19)

This is sufficient to determine curtain tension given curtain length and gap ratio. The actual configuration will always be a catenary. The parameter least understood in this relationship is the drag coefficient, C_d . This coefficient has a value of nearly 2 for a high aspect ratio flat plate that does not pierce the surface and a value near 1 for low aspect ratio plates. (Aspect ratio is the ratio of side dimensions, and is always between 0 and 1; a square has the highest aspect ratio of any flat quadrangle.) For a surface piercing plate, Robbins⁸, has observed drag coefficients to take values around 1.5 in the Froude number range typical for a silt curtain in a moderate current. These values apply to flat plates, however, and in the case of a curtain flaring due to current pressure, they may vary considerably. There are no data available to estimate precise drag coefficients for this application but values of 1.2 to 1.5 appear to be sufficiently accurate to suit the simplifying assumptions made earlier.

36. For convenience in determining the tension in a curtain, the relationship between the tension parameter, τ , and gap ratio, R , is shown graphically in Figure 11. This figure can be used to derive τ given the ratio of mouth opening to curtain length ($M/L = R$) for a curtain configuration. Tension in the curtain, T , can then be determined from τ by:

$$T = \tau L 1/2 \rho_w V_c^2 h C_d \quad (20)$$

where L = curtain length, ft
 ρ_w = water density, slugs, = 1.99 for sea water
 V_c = current speed, ft/sec
 h = curtain depth, ft

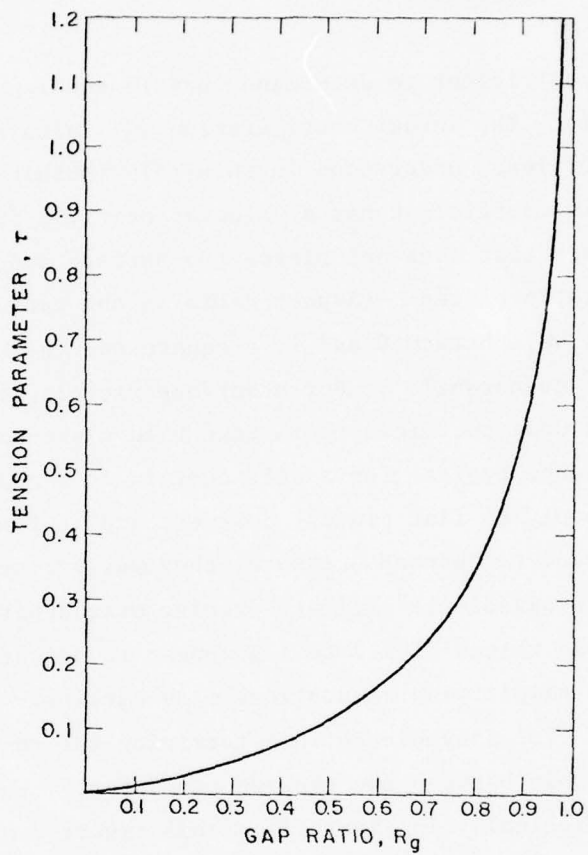

Figure 11. Effect of gap ratio, R , on tension parameter

C_d = drag coefficient (1.2 to 1.5)

T = tension (lb)

The curtain shape is known when τ and L are known. Using the coordinates shown in Figure 9, curtain shape is given by:

$$y(x) = L \tau \left(\cosh \frac{x}{L\tau} - 1 \right) \quad (21)$$

This equation is important because it expresses the precise catenary shape that a curtain will assume when subject to current forces and therefore it will be important in subsequent analyses. Note that the curtain shape depends only on the gap ratio (which determines the value of τ) and the curtain length.

57. Effective Depth of a Silt Curtain in a Current. The objective in this phase of the analytical study is to examine curtain effectiveness as a function of current and curtain design parameters. For this purpose the vertical extent of the skirt (vertical distance from the bottom of the flared skirt to the water surface) is defined as the curtain's effective depth. It is of interest to achieve maximum effective depth for a curtain in a current. Hydrodynamic current forces cause the skirt to flare at an angle to the flow thus reducing the skirt's effective depth. In order to determine effective depth the following assumptions are made:

(1) The curtain consists of (Figure 12)

- . a flexible skirt
- . a flotation element at the top whose buoyancy is B_c lb/ft of length
- . A ballast element at the bottom that contains W_c lb/ft of length
- . a tension element (cable) that may be located anywhere between the top and bottom of the curtain

(2) Pressure forces due to current are assumed to be uniform over the curtain depth. (This may not be the case; however, there is no basis for more refined approximation.)

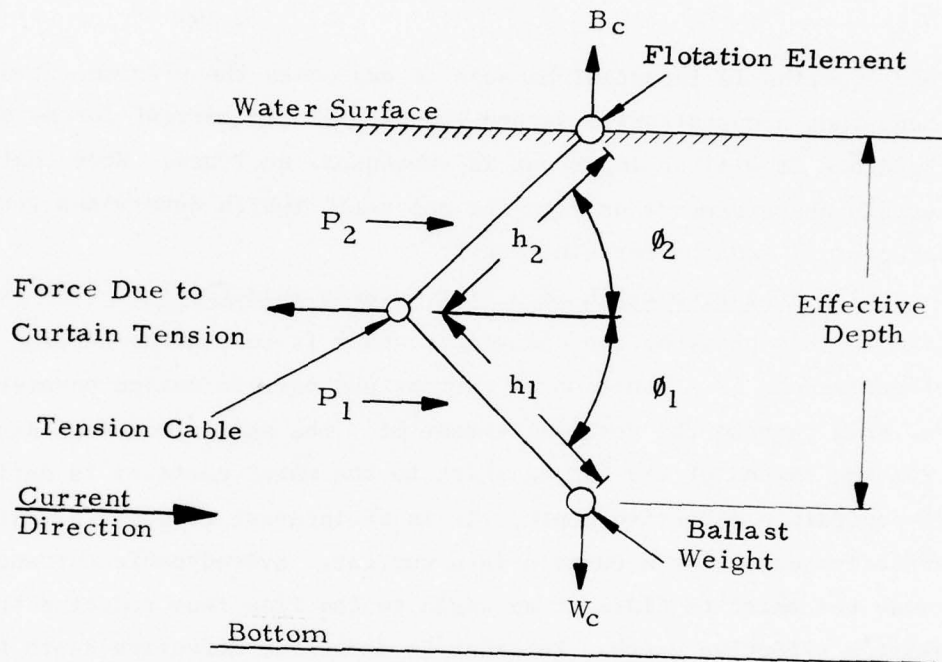

Figure 12. Curtain flare in a current

- (3) Curtain loads are absorbed entirely by the tension cable and no tension is taken up by the curtain fabric or the ballast chain. (This assumption is discussed further, later in this section.)

58. As stated in this last assumption, all curtain tension is assumed to be absorbed entirely by the tension cable; no tension is taken up by the curtain fabric or ballast chain. Clearly, at high angles of flare the extreme top and bottom of the curtain will form an arc of larger radius than the tension cables. Therefore, the fabric will be stretched and thus absorb part of the tension load. In practice, however, the amount of tension the fabric will absorb will depend on the initial tension of the fabric with respect to the tension cable. For example, if the curtain is longer than the cable the flare may take up the extra length of curtain before the fabric absorbs any tension. Secondly, the fabric is capable of stretching considerably while absorbing a significant amount of tension. In fact in any practical configuration, the radius of curvature at any point will be sufficiently large so that the degree of curtain stretching, even under extreme flare, will be a relatively small percentage of the total curtain length.

59. In a similar view, the amount of tension absorbed by the ballast chain will depend on the initial tension in the chain. Since the prime purpose of the chain in a silt curtain is to provide weight, it is assumed that it does not support tension loads even under curtain flare. This means that the curtain can absorb significant flare without stretching the curtain fabric or tightening the ballast chain to the point that either one relieves any significant part of the tension from the cable. Thus the following analysis probably provides a good first order estimate of curtain performance (flare) in a current and an estimate of effective curtain depth.

60. Given these assumptions, the cross-sectional shape of the curtain can be determined given the current pressure force. The pressure force will cause the curtain to flare in the direction of the

current force; the flare is caused by the moments of the pressure forces about the tension cable. These moments are opposed by the righting moments of the ballast weight and the buoyancy of the flotation element. The buoyancy moment will increase with increasing angle of flare. Thus the form that the curtain cross section assumes will be such that the flaring moments are in equilibrium with the moments due to the weight and buoyancy. This is illustrated in Figure 12.

61. Referring to the figure and considering the lower half of the curtain, the lower flaring force P_1 is expressed as:

$$P_1 = ph_1 \sin \phi_1 \quad (22)$$

where P = current pressure, lb/in²
 h_1 = lower curtain half-depth, in

The lower flaring moment is:

$$M_1 = 1/2 ph_1^2 \sin^2 \phi_1 \quad (23)$$

At equilibrium the lower flaring moment is equivalent to the righting moment:

$$\frac{ph_1^2}{2} \sin^2 \phi_1 = W_c h_1 \cos \phi_1$$

or

$$\cos^2 \phi_1 + \frac{2W_c}{ph_1} \cos \phi_1 - 1 = 0 \quad (24)$$

The relation for upper flare angle is of similar form:

$$\cos^2 \phi_2 + \frac{2Bc}{ph_2} \cos \phi_2 - 1 = 0 \quad (25)$$

The angles of flare, ϕ_2 and ϕ_1 , for both top and bottom portions of the curtain section can now be determined in terms of curtain dimensions, weight and buoyancy elements and the current pressure p which is estimated by:

$$p = 1/2 \rho_w V_c^2 C_d \quad (26)$$

where V_c = current velocity in the horizontal plane, in/sec

C_d = drag coefficient, a value between 1.2 and 1.5 is suggested.

The effective depth, h_e , can be determined from the flare angles:

$$h_e = h_1 \sin \phi_1 + h_2 \sin \phi_2 \quad (27)$$

62. It should be realized that, to some extent, the decrease in effective depth due to curtain flaring in a current is a positive effect. In a high current this effect helps relieve tension on the curtain and therefore acts as a safety device to relieve stresses due to high current before failure of the curtain, tension cable, or mooring can occur. For this reason it might not be practicable to increase curtain performance by providing vertical stiffness (e.g. by inserting vertical stiffener bars at intervals along the curtain length, such as battens). However, this technique was examined but the stiffener size that would be required to resist buckling under high current is excessive.

63. In addition to current velocity, the following factors affect curtain effective depth: (a) position of tension cable, (b) weight of chain ballast, and (c) number of tension cables. Each of these will be discussed in the paragraphs that follow.

64. Position of Tension Cables. The location of the tension cable in a silt curtain may be near the top, near the bottom, or any point in between. For the present analysis 3 positions - top, center, and bottom are assumed. Using the analysis outlined above, effective curtain depth as a function of current for each cable position has

been investigated. The type of curtain used for this calculation is similar to that shown in Figure 13.

65. This curtain was assumed to be anchored in a free current so that it formed a catenary shape. In this case the current force on the curtain is a maximum at the apex (where its direction is perpendicular to the curtain direction) and decreases towards the mooring points. Figures 14 and 15 show curtain effective depth at the apex as a function of current for curtains of 5-ft and 10-ft depth, respectively, with top, center, and bottom tension cable positions. These figures indicate that for both 10-ft and 5-ft curtains, effective depth is improved slightly with the center tension configuration as compared to top or bottom tension cable. For example, a 10-ft curtain in a 1-knot current has a minimum effective depth of about 4-1/2 ft for top and bottom tension cases and about 5-1/2 ft for the center tension case.

66. Weight of Chain Ballast. Another means of increasing effective curtain depth is to increase the ballast weight in the curtain bottom. The effect of ballast chain weight has been investigated by the analysis described above, and the results are shown in Figures 16 and 17 for 5-ft and 10-ft center tension curtains, respectively. The type of curtain assumed for this investigation is similar to that shown in Figure 13. The water current direction for the analysis is perpendicular to the curtain.

67. It can be seen from these figures that in high currents (above one knot) predicted effective curtain depth cannot be increased significantly without resorting to very high ballast weights. High ballast weights require, in turn, bulky flotation members to counteract their weight, thus making the curtain both cumbersome and heavy.

68. Number of Tension Cables. The use of dual tension cables in the curtain is another possibility that was considered for increasing effective depth. In this case the tension cables were assumed to be at the top and bottom of the curtain so that curtain cross section would be similar to that shown in Figure 18. The following assumptions were made for the analysis of this configuration:

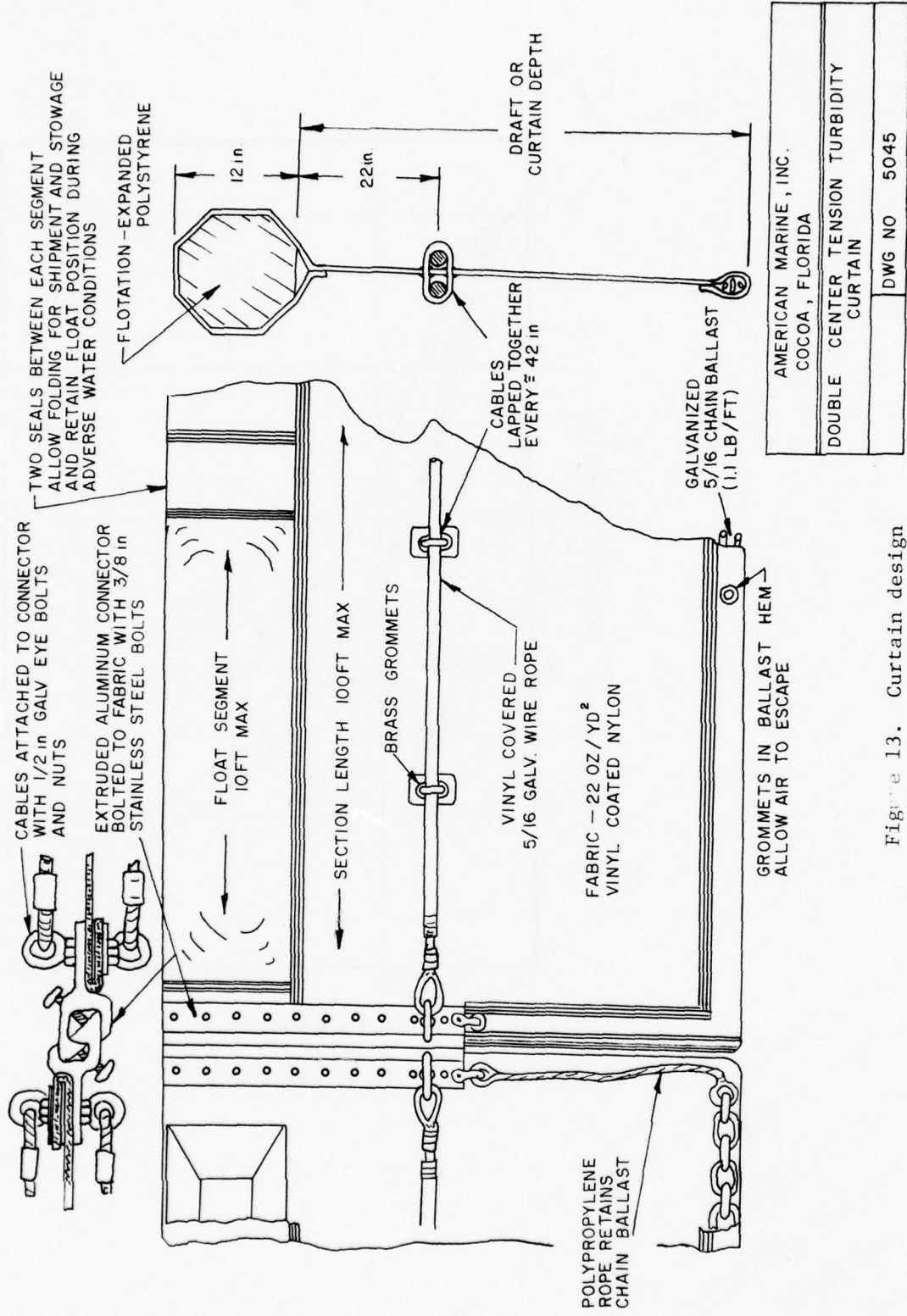

AMERICAN MARINE, INC. COCOA, FLORIDA	
DOUBLE CENTER TENSION TURBIDITY CURTAIN	
DWG NO	5045

Figure 13. Curtain design

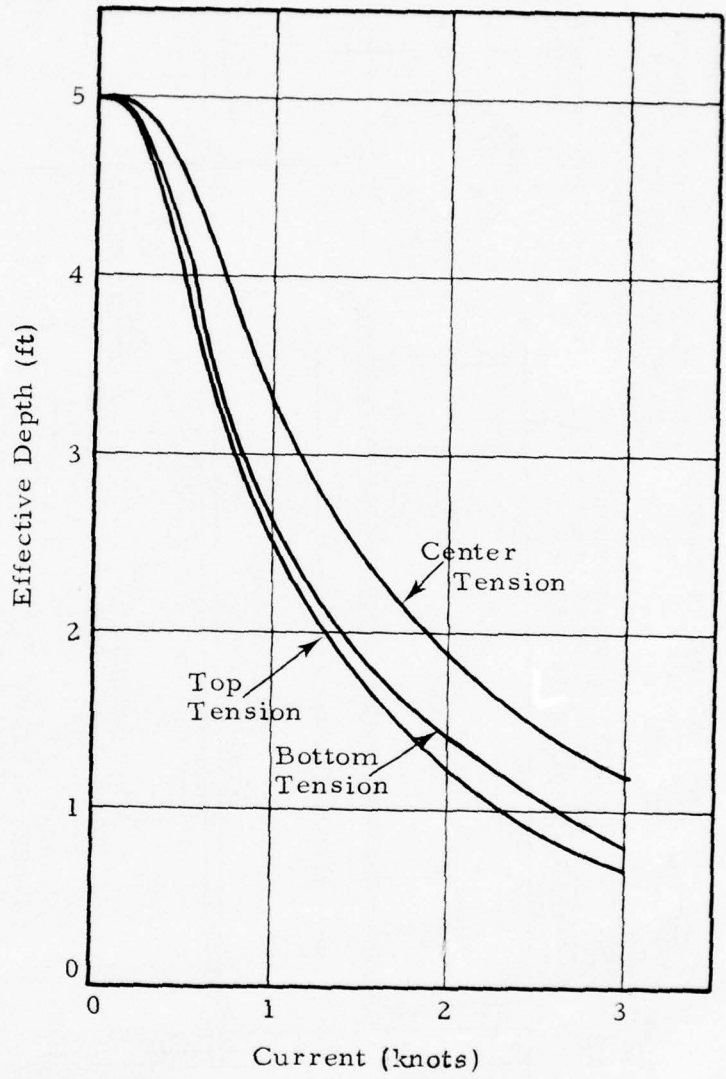

Figure 14. Effective depth in current - 5-ft curtain

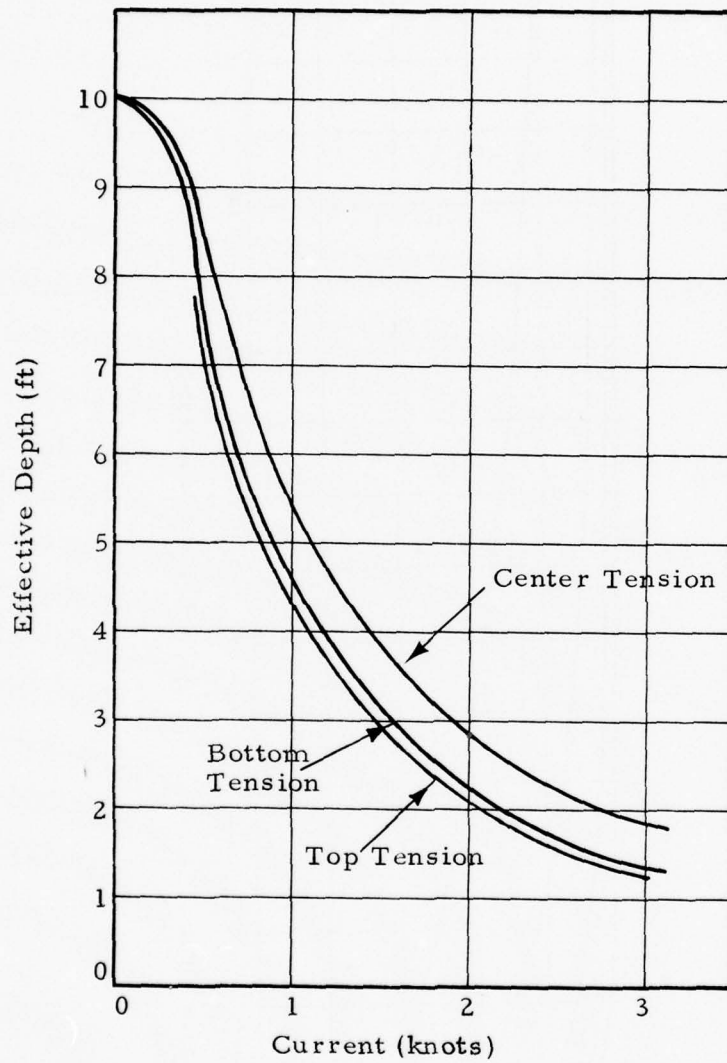

Figure 15. Effective depth in current - 10-ft curtain

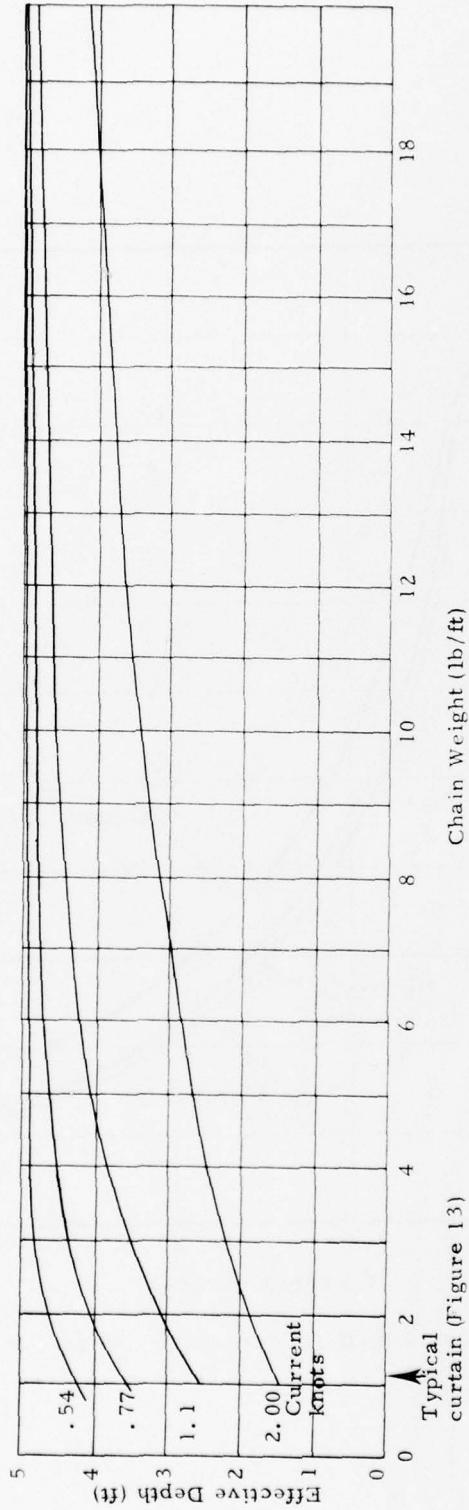

Figure 16. Effective depth as function of ballast chain weight - 5-ft curtain, center tension; data valid for curtain type shown in Figure 13

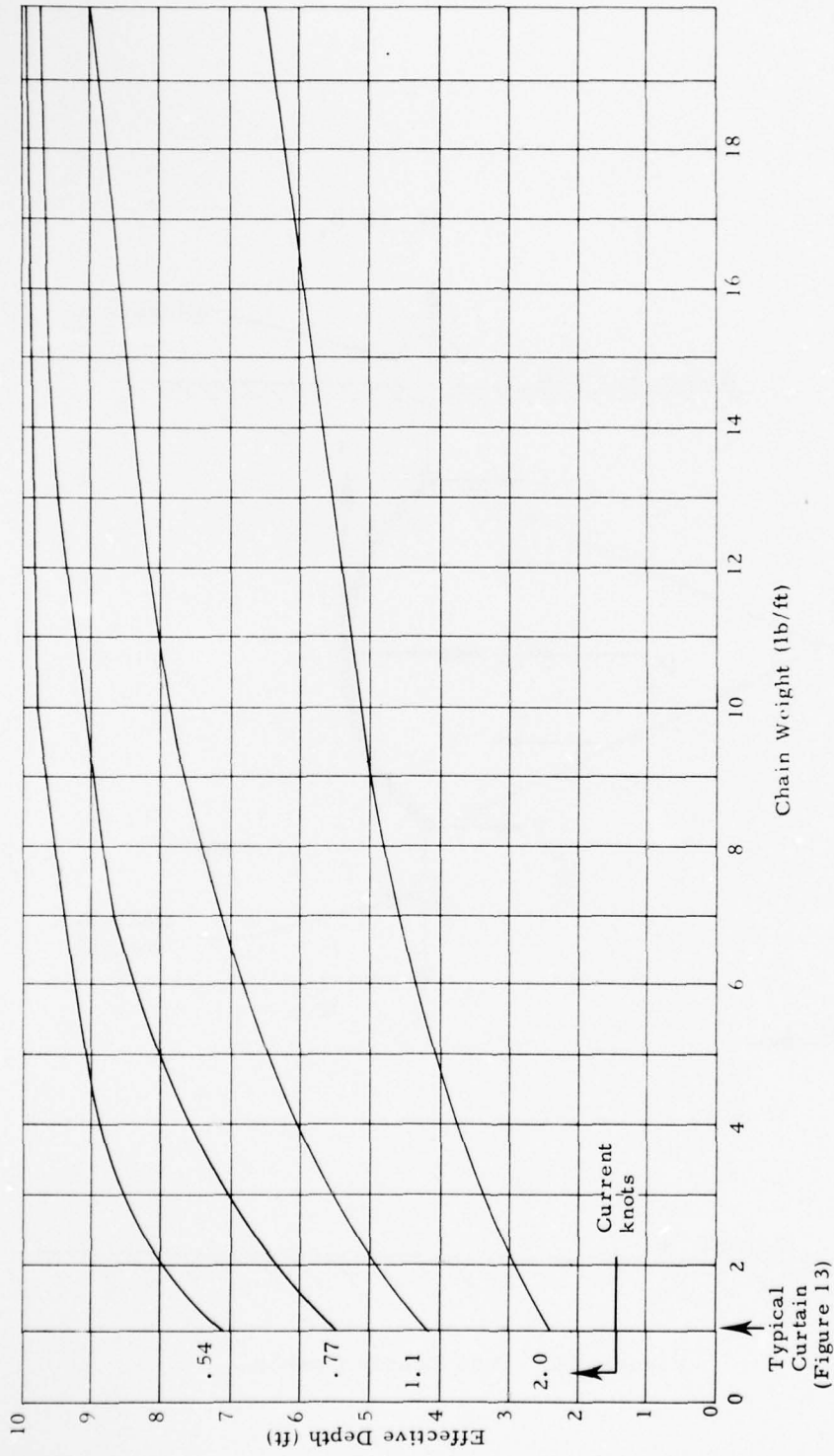

Figure 17. Effective depth as function of ballast chain weight -
 10-ft curtain, center tension; data valid for curtain type shown in Figure 13

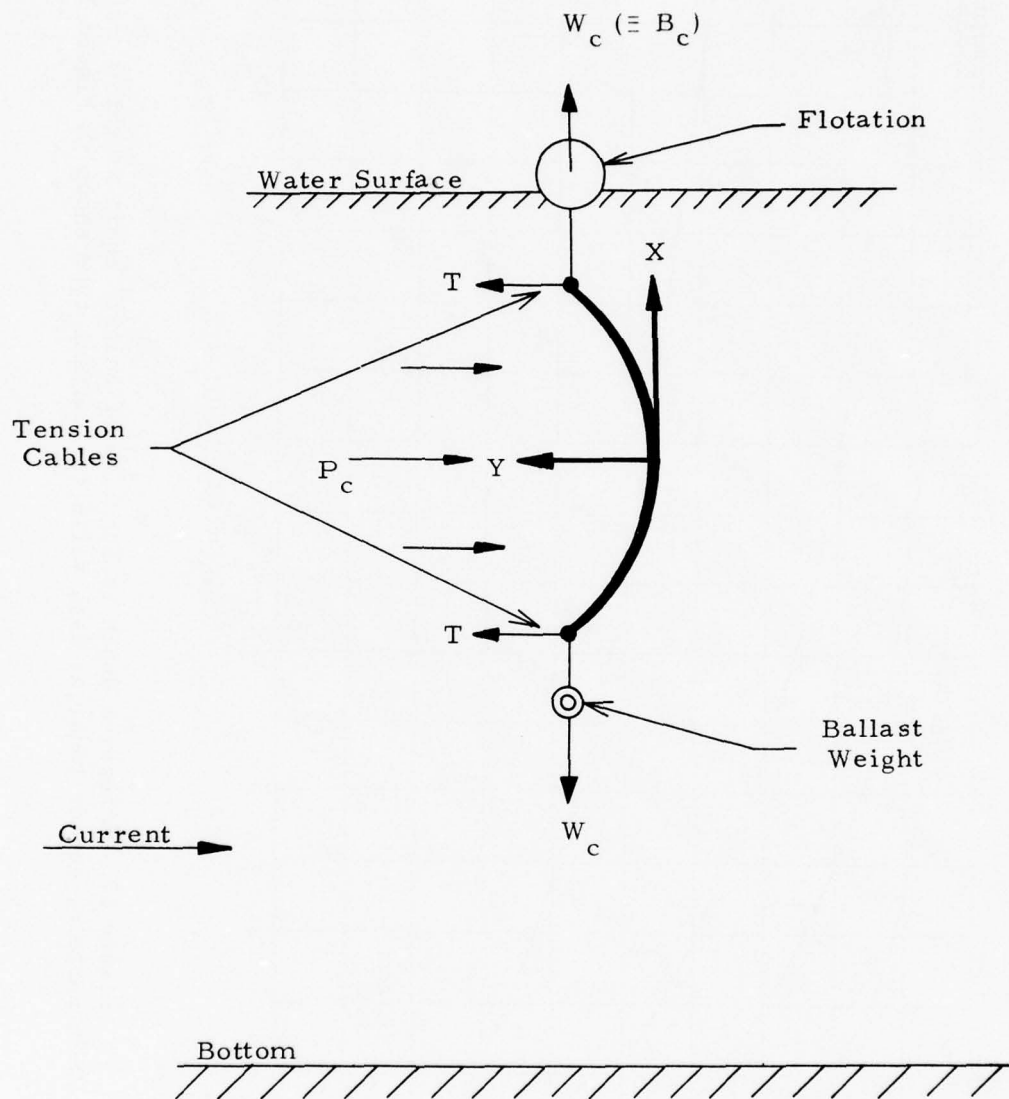

Figure 18. Dual tension cable

- a. The current pressure was assumed to be uniform over the curtain depth.
- b. The tension cables are assumed to be approximately balanced so that each carries one-half of the current pressure load without significantly affecting the attitude of the curtain.
- c. The curtain cross section is assumed to take a parabolic form under the uniform current load. The actual form may be closer to a catenary, but, except in very high current forces, the parabolic assumption is approximately equivalent.

Under these assumptions the forces on the curtain cross section are as shown in Figure 18. Each cable carries a tension that acts to counter current force and the net current force per unit length of curtain, P_c is equal to:

$$P_c = ph_e = 1/2 \rho_w v_c^2 C_d h_e \quad (28)$$

where p = current pressure

h_e = effective depth

v_c = current speed

In equilibrium, therefore, the current force, P_c , is balanced by the cable tensions so that the tension in each cable is:

$$T = 1/2 P_c = 1/2 ph_e$$

The force, W_c is equal to the weight force at the bottom and the equilibrium buoyancy force at the top of the curtain. Assuming parabolic form and using axes shown in Figure 18, the generalized equation for curtain cross section is:

$$y = ax^2 \quad (29)$$

The first derivative of this is:

$$dy/dx = 2ax$$

At the curtain top and bottom, since the fabric is flexible and must assume the direction of the restraining force:

$$\frac{dy}{dx} = 2ax = \frac{T}{W_c} = \frac{ph_e}{2W_c}$$

where x is equal to $1/2 h_e$ so:

$$a = \frac{p}{2W_c} \quad (30)$$

Also the actual curtain depth here is equal to the arc length of the parabolic form:

$$D = \int d\ell = 2 \int_0^{1/2 h_e} \left[1 + \left(\frac{dy}{dx} \right)^2 \right]^{1/2} dx$$

The solution to this is:

$$l = 1/2 R_h \left\{ \left[\frac{R_h^2 h^2 p^2}{4W_c^2} + 1 \right]^{1/2} + \frac{2W_c}{R_h h p} \ln \left[\frac{R_h h p}{2W_c} + \left(\frac{R_h^2 h^2 p^2}{4W_c^2} + 1 \right)^{1/2} \right] \right\} \quad (31)$$

$$\text{where } R_h = \frac{h_e}{h} \quad (32)$$

and this allows determination of the curtain cross-sectional form (R_h) in terms of $W_c/(h)(p)$. This relationship can be used to derive effective curtain depth in terms of curtain weight (or buoyancy) per unit length (W_c), curtain actual depth (h) and current pressure ($p = 1/2 \rho_w V_{cn}^2 C_d$). The relationship has been used to estimate effective depth as a function of current speed and curtain ballast weight for a 10-ft curtain. These estimates are shown in Figure 19. By comparison of this figure to Figure 17, it will be seen that utilization of dual

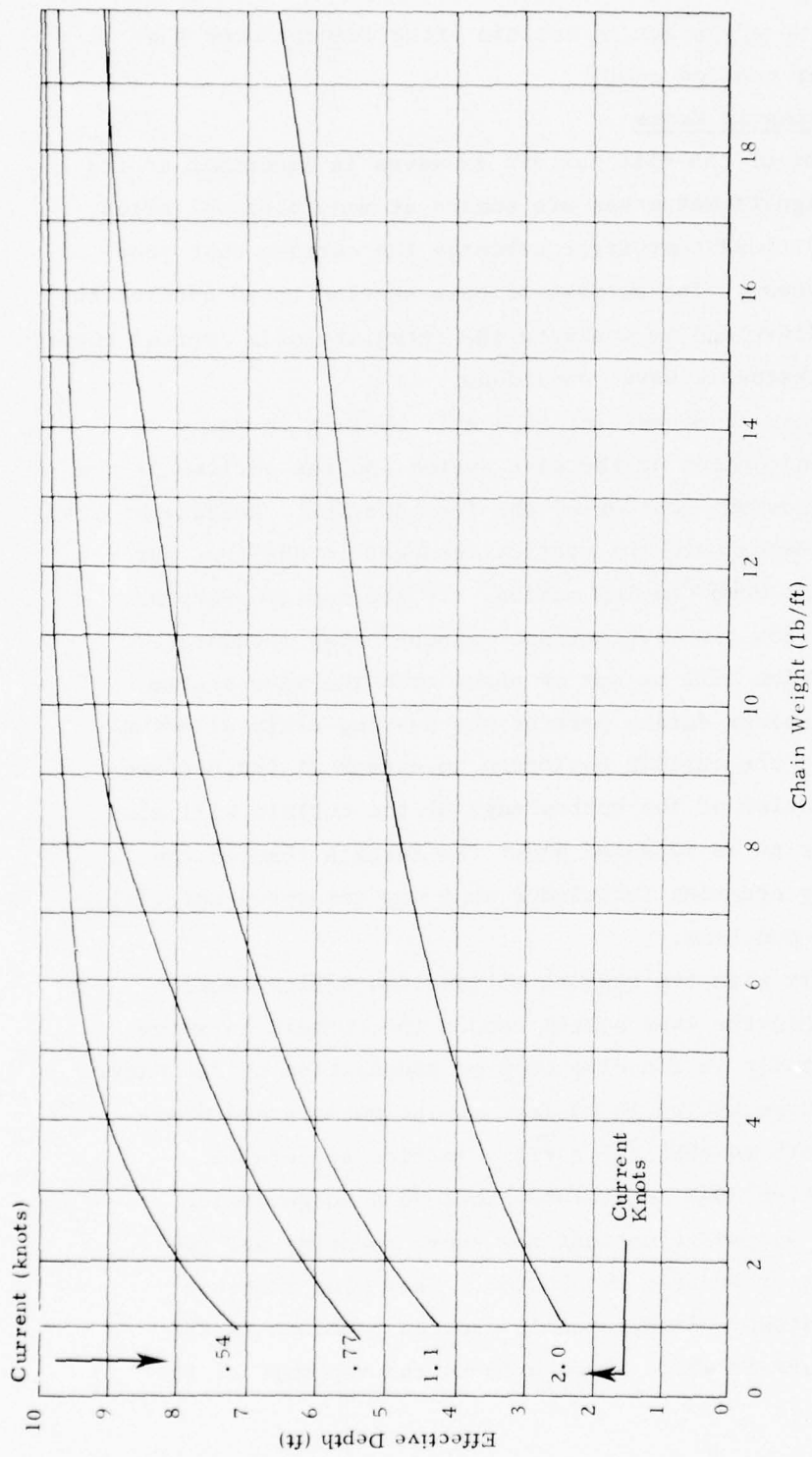

Figure 19. Effective depth as function of ballast weight -
dual tension curtain, 10-ft boom

tension cables offers no advantage in curtain effectiveness over the case of a single center tension cable.

Behavior of Silt Curtains in Waves

69. The behavior of the silt curtain in waves is important to its performance because significant waves are common at many disposal sites, and under certain conditions they might submerge the curtain thus jeopardizing its effectiveness. The purpose of this section is to outline the potential modes of failure and to evaluate the integrity of a typical curtain configuration under reasonable wave conditions.

70. Heave Response. The behavior of a silt curtain in waves is dependent on the forcing action of the wave system and the ability of the buoyant curtain to follow the contour of the free surface. Because of its buoyancy the curtain responds to the vertical changes in the free surface in the form of an up and down heaving motion. If the curtain responds adequately, it will follow the wave surface without being inundated. If not, the heaving motion will be out of phase with the wave system and the curtain may submerge during part of the heaving cycle allowing the turbid water inside the curtain enclosure to escape at the surface levels. The heaving motion of the bottom edge of the curtain will also cause more turbid water to be released under the curtain than in the calm case, primarily by creating turbulence that may resuspend materials from the bottom or the mud flow.

71. Simultaneously with the heaving motion, the orbital motion of fluid particles within the wave system causes the curtain to surge back and forth horizontally in the direction of propagation of the wave. The amplitude of the surge motion is maximum at the surface and diminishes rapidly with depth so that the curtain section appears to oscillate about its bottom edge as it moves through a surge cycle.

72. Both heaving and surge motions may cause scouring and re-suspension of sediments at or near the bottom. They also increase stresses on mooring systems. Heave usually creates problems in the bottom region of the curtain while surge affects the top part of the curtain.

73. In the presence of broadside waves the silt curtain section is very narrow compared to the length of the waves and it responds as a stable float that possesses damping properties, virtual mass, and heave stiffness. The heaving motion of the curtain can be analyzed by relating the vertical forces and acceleration terms as outlined by Comstock¹⁰. The force term includes a hydrostatic force that depends only on the draft of the float and a hydrodynamic force that depends on the relative motion between the float and the water. The analysis is valid for the following conditions:

- a. The flotation element of the curtain represents the float in a train of progressive sinusoidal waves.
- b. The wave length is large compared to the width of the float.
- c. Only vertical motion is considered.
- d. The wave peaks and troughs lie parallel to the length dimension of the silt curtain so that it moves as a single body along its length.
- e. The float experiences damping forces.

The calm water surface and the vertical symmetry plane of the curtain are the axes to which all motion is referenced. Figure 20 shows the coordinate system.

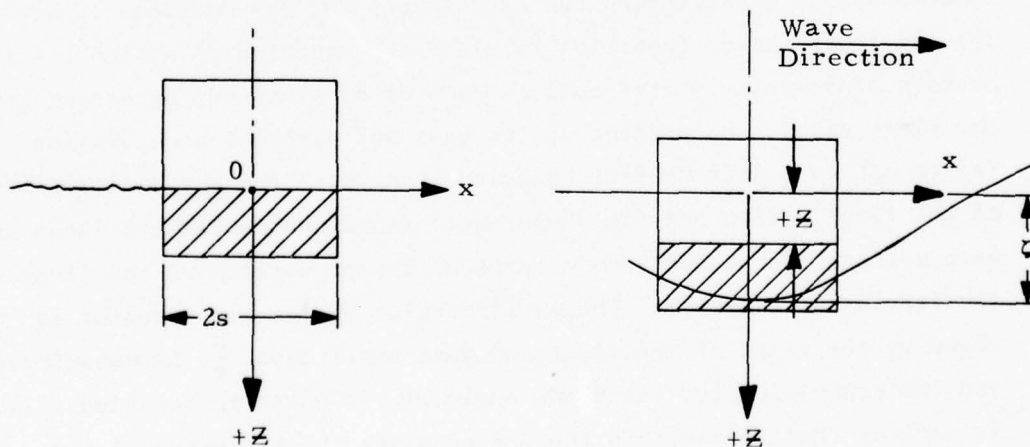

Figure 20. Axes for curtain motion in waves

The motion of the waves with respect to the calm water surface is

$$\zeta = r \cos \omega t \quad (33)$$

where ζ = vertical distance between the wave surface at the float and the calm-water surface

r = amplitude of wave motion

ω = circular frequency of the wave

t = time

The motion of the curtain float with respect to the calm water surface is given by:

$$z = z_0 \cos (\omega t + \epsilon) \quad (34)$$

where z = vertical distance between the float origin and the calm water surface

z_0 = amplitude of the float motion

ϵ = phase angle by which the float motion lags the wave motion

From equations (33) and (34) it can be seen that the wave motion and the curtain motion occur at the same frequency, ω , and are out of phase by the angle ϵ . The solution to the heave response of the silt curtain is obtained by substituting the expressions for wave motions (equation 33) and float motion (equation 34) into the equation of motion for the curtain float which states that the sum of vertical forces acting on the float equals the product of its mass and vertical acceleration. The result is a differential equation from which the vertical amplitude of the float motion and the phase angle relationship between float and wave motions can be derived in terms of the properties of the float and the forcing wave system. The amplification of the float motion is given by the ratio of the float and wave amplitudes, $\frac{z}{r}$, in equation (35) and the expression for the phase angle, ϵ , is given in equation (42). In each of these parameters the Λ represents the frequency of the forcing wave system as it relates to the natural frequency, ω_n , of

the silt curtain, κ is the damping term, and α incorporates the actual and virtual masses of the silt curtain.

$$\frac{z_o}{r} = \left[\frac{(1 - \frac{\Lambda^2}{\alpha})^2 + \kappa^2 \Lambda^2}{(1 - \Lambda^2)^2 + \kappa^2 \Lambda^2} \right]^{1/2} \quad (35)$$

where $\Lambda = \frac{\omega}{\omega_n}$ (36)

$$\omega_n = \left[\frac{c}{m+a} \right]^{1/2}, \text{ natural frequency of the silt curtain} \quad (37)$$

$$\alpha = (m+a)/a \quad (38)$$

m = mass of the silt curtain

a = virtual mass of the silt curtain, given by

$$a = \rho_w \frac{\pi}{4} s^2 \quad (39)$$

ρ_w = mass density of the water

s = half width of the flotation element

$$c = \text{heaving stiffness, given by } c = \rho_w g A_w \quad (40)$$

A_w = waterplane area of flotation element

g = gravitational constant

$$\kappa = \text{damping parameter, given by } \kappa = \omega_n \frac{b}{c} \quad (41)$$

b = coefficient of water damping force on curtain

ϵ = phase angle between wave and float motion, given by

$$\epsilon = \tan^{-1} \frac{\kappa \Lambda}{(1 - \Lambda^2)} - \tan^{-1} \frac{\kappa \Lambda}{(1 - \frac{\Lambda^2}{\alpha})} \quad (42)$$

74. The preceding solution will now be applied to an existing silt curtain configuration in order to evaluate its heave response in waves. For this purpose, the American Marine "Double Center Tension" curtain shown in Figure 13 will be used. The pertinent dimensions and

features are given below and in Figure 21. The flotation element is pictured with a square cross section so that the water plane area, A_w , and the heave stiffness, c , are constant with draft.

75. The numerical values for pertinent boom parameters are listed below:

$$m = 0.101 \text{ slugs/ft}$$

$$a = 1.57 \text{ slugs/ft}$$

$$c = 201 \text{ lb/ft}$$

$$\omega_n = 11.0 \text{ rad/sec}$$

$$f_n = 1.75 \text{ Z}$$

$$T_n = .572 \text{ sec}$$

$$\alpha = 1.06$$

$$A = 1 \text{ ft}^2$$

$$b = 1 \text{ lb/ft/sec based on estimated vertical drag at 1 fps}$$

$$\kappa = 0.0546$$

76. The amplification factor, Z_o/r , is plotted in Figure 22 against T , the period of the wave system. Wave period is used as a convenience in relating real wave conditions to the behavior of the curtain. It is noteworthy that the silt curtain mass is small compared to the virtual mass, when combined with the heaving stiffness, results in a comparatively high natural frequency of 1.75 Z (0.57 sec period), thus implying fast response to the wave system. The damping effect of drag forces on the curtain is seen to limit the maximum amplification factor to 1.5.

77. The phase angle, ϵ , shown in Figure 23, remains at or close to zero as the wave period, T , gets shorter, until the wave period reaches and passes through the natural period of the curtain, T_n . At this point, the phase angle shifts abruptly from zero to almost 180 degrees so that the curtain is in its trough as the wave crest passes. This is the state where the curtain can submerge if the relative amplitude of the motion is sufficiently large.

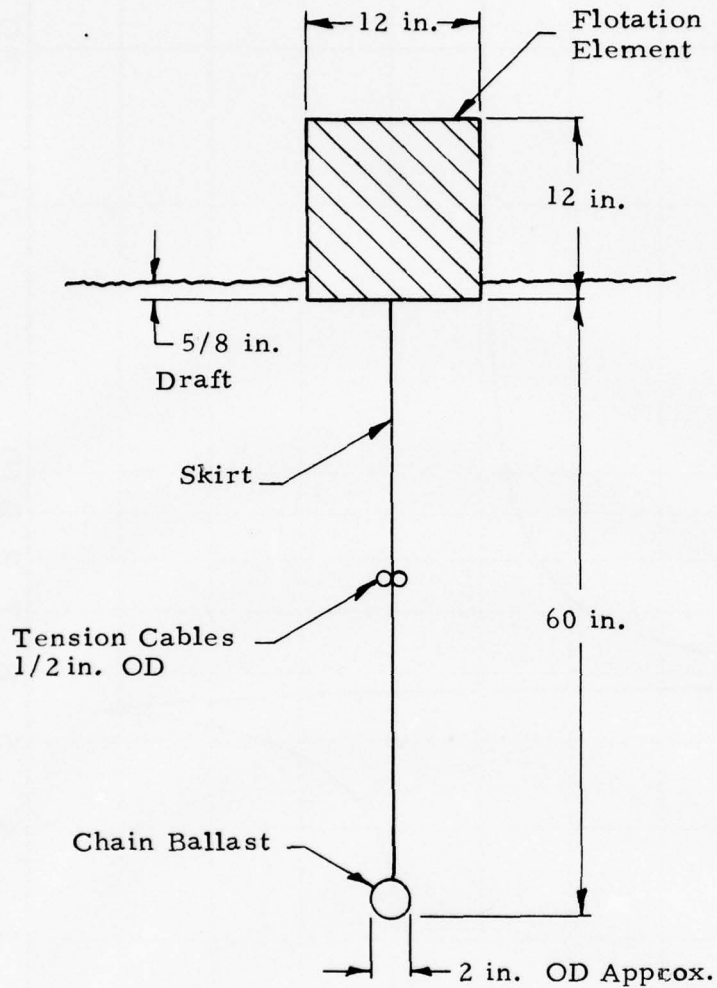

Total Dry Weight = 325 lb/100-ft Section

Figure 21. American Marine "double center tension" turbidity curtain

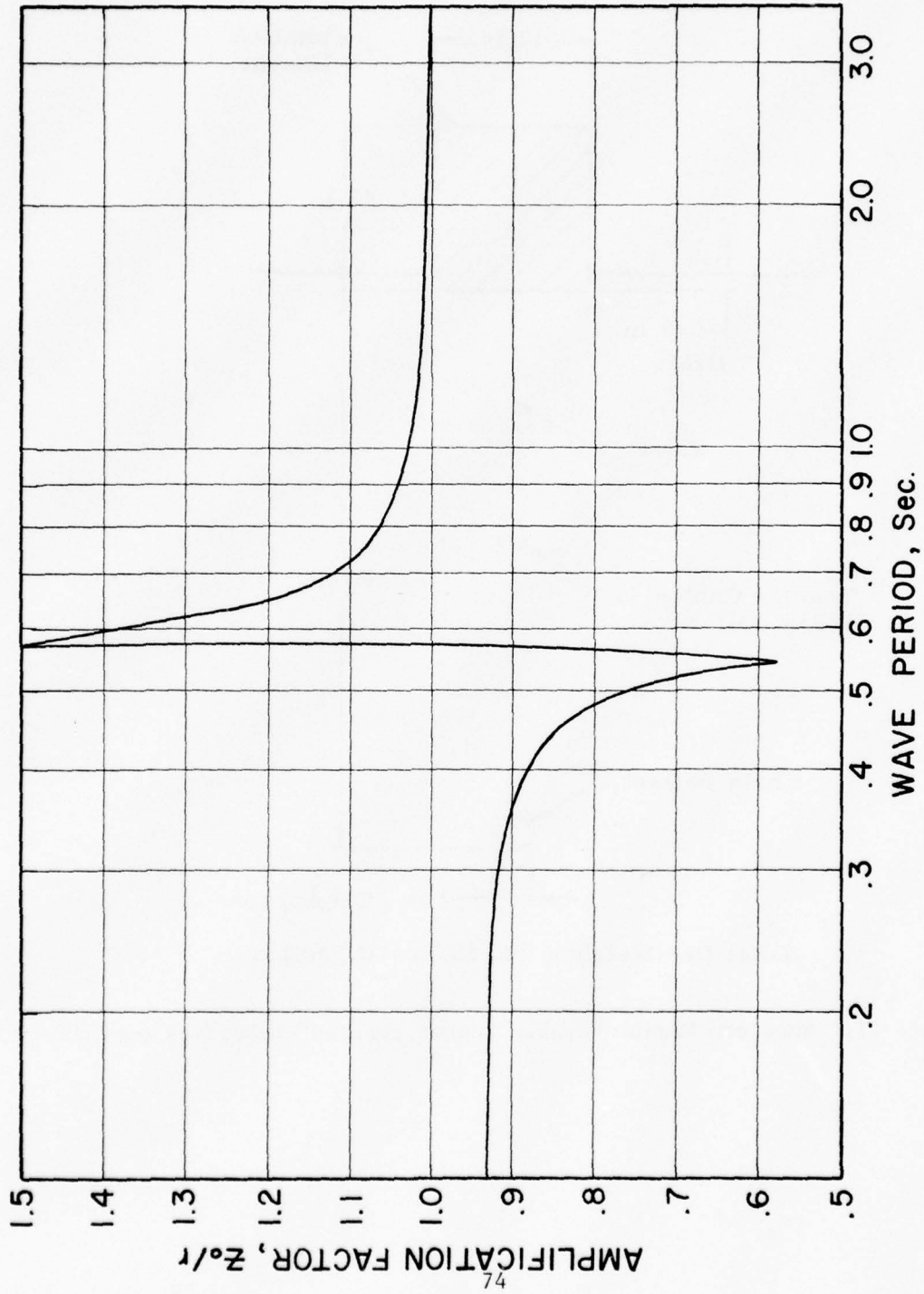

Figure 22. Amplification factor vs. wave period

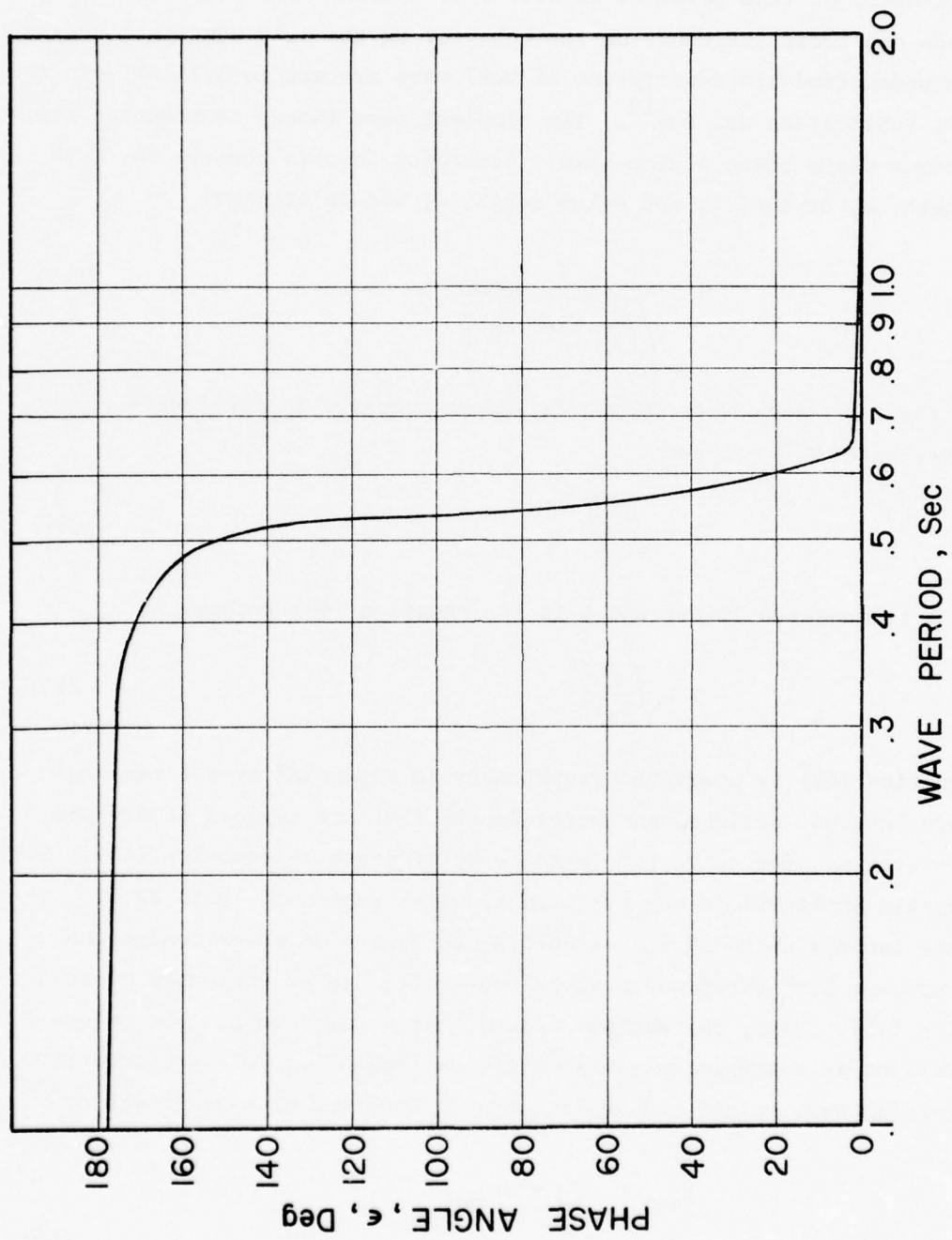

Figure 23. Phase angle vs. wave period

78. Because the relative amplitude of the waves is such a critical parameter, at this point, it is useful to consider the properties of real waves and their influence on the behavior of the silt curtain. A simple and understandable description of real wave systems is available in the H.O. Publication No. 604¹⁰. The simplest wave theory is based on the surface shape being a sine wave. According to this theory, the wave length, L, period, T, and water depth, d, are related by:

$$T = \frac{1}{\sqrt{\frac{g}{2\pi L} \tanh 2\pi \frac{d}{L}}} \quad (43)$$

In the case where water depth is larger compared to the length of the wave, $\tanh 2\pi \frac{d}{L} = 1$ and

$$T = \sqrt{\frac{2\pi L}{g}} \quad (44)$$

If T is measured in sec and L in ft, equation (44) reduces to

$$T = \sqrt{\frac{L}{5.12}} \quad (45)$$

Equation (43) is presented graphically in Figure 24 over a range of wave lengths, periods, and water depths that are typical of dredging operations. The curve for infinite water depth is equation (45). Silt curtain applications are typified by water depths of 10 to 20 ft. and wave lengths up to 30 ft. According to Figure 24 these conditions represent deep water waves whose properties can be estimated by equation (45). Also, the maximum height that a wave can achieve before breaking is approximately 1/10 its wave length¹¹. This provides the limiting wave height and amplitude as a function of wave length or

$$H_{\max} = \frac{L}{10} = 2r_{\max}$$

and

$$r_{\max} = \frac{L}{20} \quad (46)$$

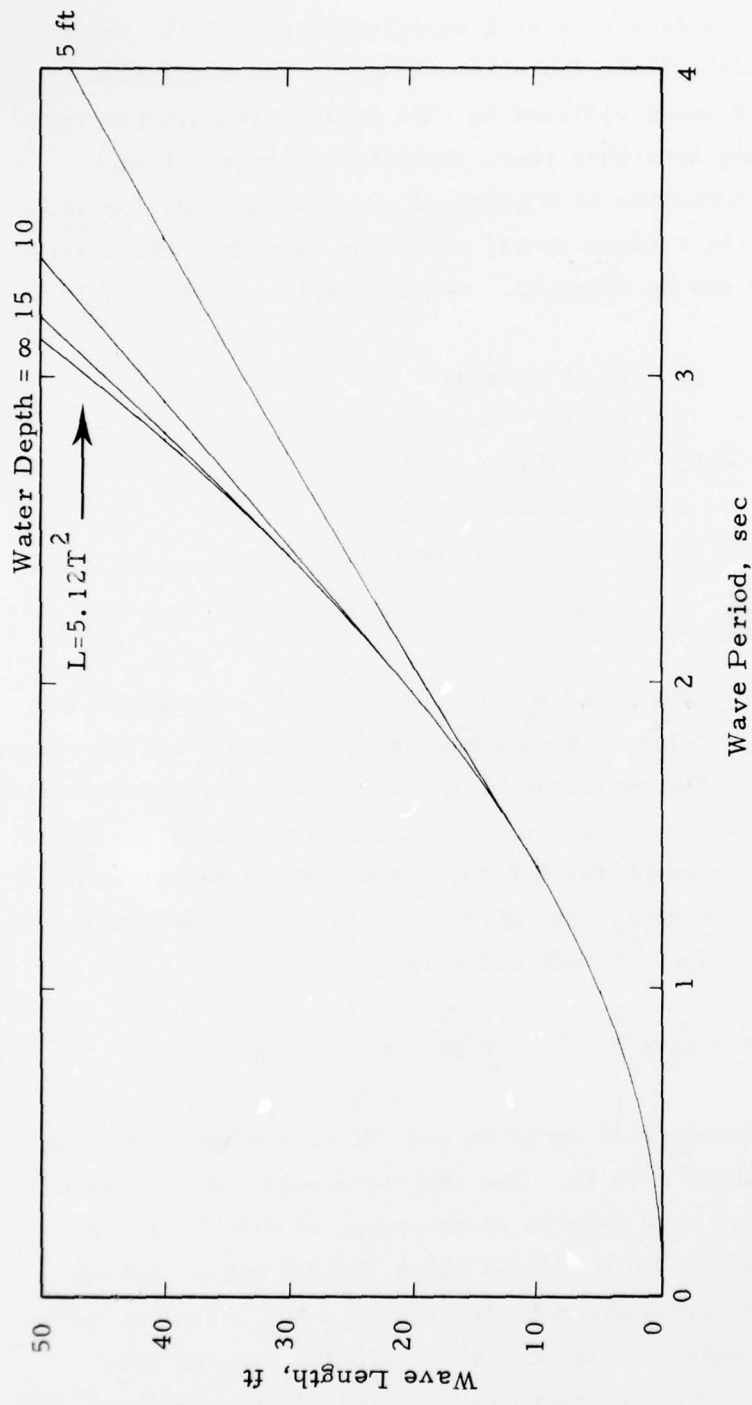

Figure 24. Wave length vs. wave period for sinusoidal waves

A comparison of Figures 22 and 23 with 24 shows that the curtain's critical frequency (1.75 Z) occurs at a wave length of 1.7 ft, which is approaching the width of the flotation element. The assumption that $L \gg 2p$ is probably being violated in this region although the real amplitudes are probably less than those predicted by this solution.

79. With the information of Figures 22, 23, 24 and Equation 46, the response of the silt curtain to any wave that is within the limits of the above solution can be examined. As an example, consider a 10-ft long wave:

$$\begin{aligned} L &= 10 \text{ ft (assumed)} \\ T &= 1.4 \text{ secs (Figure 24)} \\ z_o / \zeta &= 1.01 \text{ (Figure 22)} \\ \epsilon &= 0 \text{ (Figure 23)} \\ r_{\text{max}} &= 6 \text{ in. (Equation 46)} \\ z_o_{\text{max}} &= 6.06 \text{ in.} \end{aligned}$$

The \vec{z} and $\vec{\zeta}$ vectors are defined by z_o , r , and ϵ and must be subtracted vectorially to give the relative motion between the curtain and the water surface. Particularly, the amplitude of the vector $\vec{z} - \vec{\zeta}$ gives the draft of the flotation element in the water. If this draft exceeds the free-board of the flotation element (11-3/8 in.), the curtain submerges and ϵ allows turbid water to escape on the surface. Since the phase angle is zero, the two amplitudes subtract directly:

$$|\vec{z} - \vec{\zeta}| = z_o - r = 6.06 - 6.00 = .06 \text{ in.}$$

The curtain in this example will cycle in and out of the water with an amplitude of approximately 1/16 in. The immersion amplitude has been similarly determined for wave lengths in the range of 1 to 20 ft and is presented in Figure 25. This plot is valid for all water depths since the related corrections are not significant. For 3-ft-long waves and up, the immersion amplitude is less than 0.25 in. As the wave length shortens to 1.75 ft, the immersion amplitude increases to a

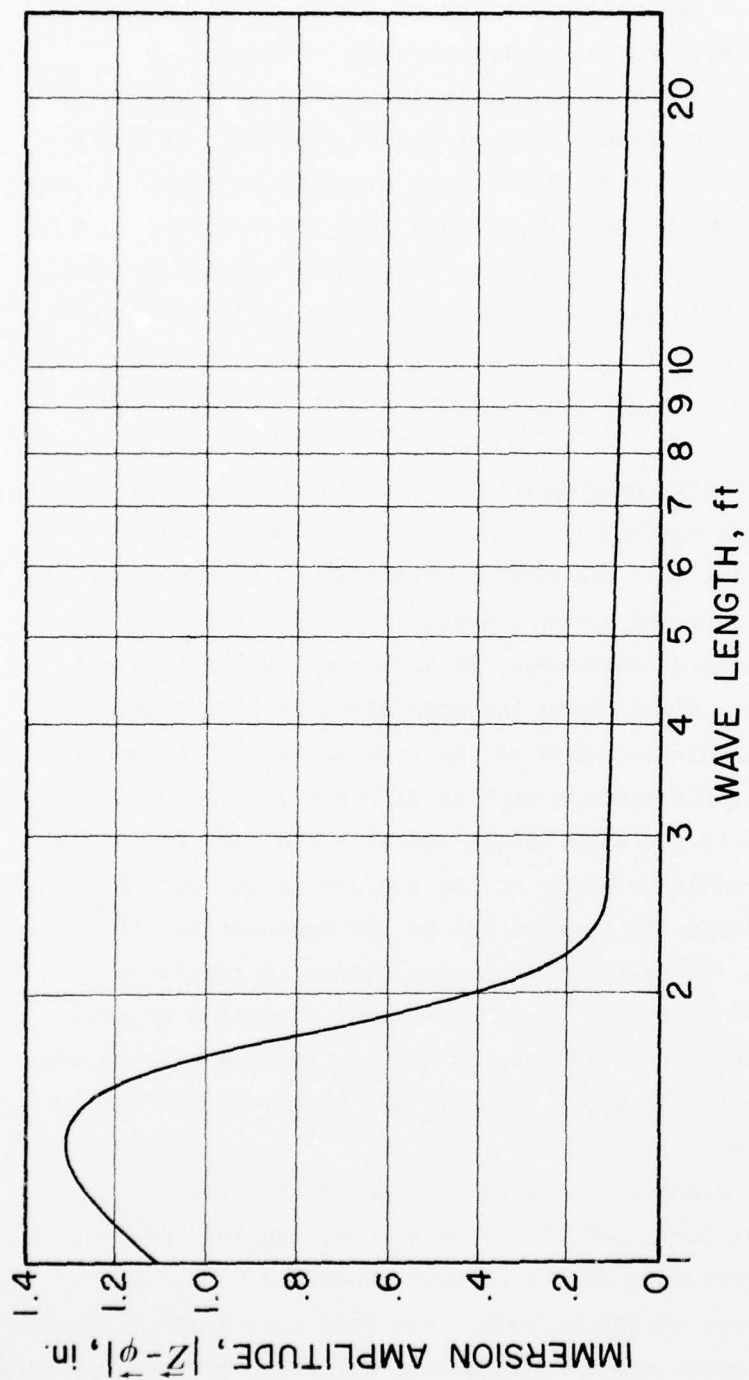

Figure 25. Immersion amplitude vs. wave length

maximum of approximately 1.3 in. and then falls off toward zero at shorter wave lengths. The entire profile of Figure 25 is well below the freeboard of the silt curtain (approximately 12 in.).

80. The results of the foregoing analysis show that the curtain used in the example is extremely buoyant and responsive. It follows the broadside heaving motion of those waves expected in disposal areas without being swamped or submerged provided that the waves are not breaking and the silt curtain is free to respond to the forcing motion of the waves; i.e., it is not restrained by anchor cables. Since silt curtains are generally similar in design, the performance of the sample curtain applies as well to any curtain with similar buoyancy and physical properties.

81. Horizontal Surge Response. The horizontal surging motion of the silt curtain is derived from the orbital and mass transport motions of the wave system. The entire water column undergoes orbital motion due to the travelling surface waves. The silt curtain, having high drag in the broadside direction, follows clearly the horizontal movement of the water column while its good heave response causes it to track the vertical displacement of the free surface. The orbital motion is circular at the surface with amplitude (i.e. radius of the circular orbit) of half the wave height and with the same period as the wave system. Orbital velocity at the surface is ωr , and it decreases with depth below the surface due to the exponential alternation of the orbit radius, r . The mass transport motion is generated by a small displacement of each water particle in the direction of wave travel with every orbital excursion. As a free-floating curtain undulates in the wave system it moves steadily but slowly in the same direction as the waves.

82. Once the curtain is anchored in place it is restrained from following the orbital motion of the water column, and the resultant motion of the water relative to the curtain generates larger hydrodynamic forces that act on the curtain. The transport velocity is a steady current that moves the curtain in the direction of wave travel

thereby taking up the slack in the anchor cables. With the curtain so restrained against an oncoming wave it tries to follow the surface up, through and over the crest and in the process sees the particle motion at and near the surface of the incident wave (see Figure 26). In the trough-half of the wave the horizontal motion of particles moves the

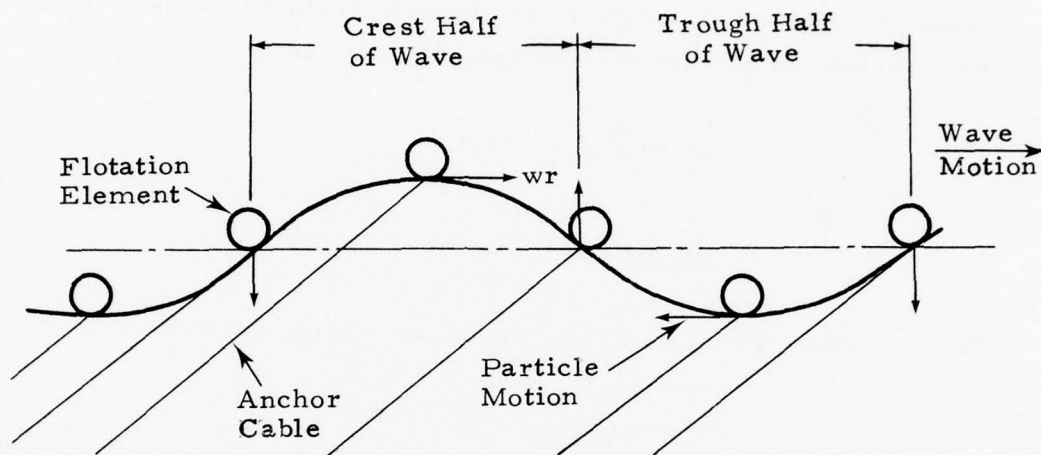

Figure 26. Particle motion in a wave relative to the flotation element

curtain rearward tending to slacken the cables with maximum rearward velocity occurring at the bottom of the trough. As the curtain passes through the crest-half of the wave the particle motion moves the curtain in the direction of wave travel thereby tensioning the anchor cables. The maximum forward particle velocity occurs at the crest of the wave and is equal to the sum of orbital and transport velocities. If the anchor cables are taut when the wave crest passes, hydrodynamic loads on the curtain will be determined by the crest particle velocity. If the crest of the wave breaks, the breaking water travels with the wave and hence at wave speed (celerity) which is considerably higher than particle velocity.

83. The orbital and transport velocities are related to wave speed and to each other through the height-to-length ratio of the wave. Using the nomenclature of equation (16), the expression for wave speed is¹⁰

$$c = \sqrt{\frac{gL}{2\pi} \tanh 2\pi \frac{d}{L}} \quad (47)$$

Since the rotational speed, ω , of the wave train is $\frac{2\pi}{T}$ where T , the wave period, is $\frac{L}{c}$, then orbital velocity, ωr , is

$$\omega r = \frac{2\pi}{T} = 2\pi \frac{c}{L}$$

or

$$\omega r = \frac{H}{L\pi} c \quad (48)$$

The transport speed, ω , is $\frac{H}{L\pi}$ times the orbital velocity¹¹ or

$$\omega = \left(\frac{H}{L\pi}\right)^2 c \quad (49)$$

The maximum value for $\frac{H}{L}$ represents the highest wave possible without breaking: where substituted in equations (48) and (49), the resultant particle velocities represent the maximum values for a given wave length. Since $\left(\frac{H}{L}\right)_{\max} = \frac{1}{10}$ (equation 46)

$$(\omega r)_{\max} = \frac{\pi}{10} c \quad (50)$$

and

$$\omega_{\max} = \frac{2}{100} c \quad (51)$$

The value for wave speed and the particle speeds are presented in Figure 27 for 10 to 1000 ft long waves and applicable water depths. At a water depth of 35 ft, 20 kt wave speeds are possible as well as 6 kt orbital speeds and 2 kt transport speeds. If the wave height is

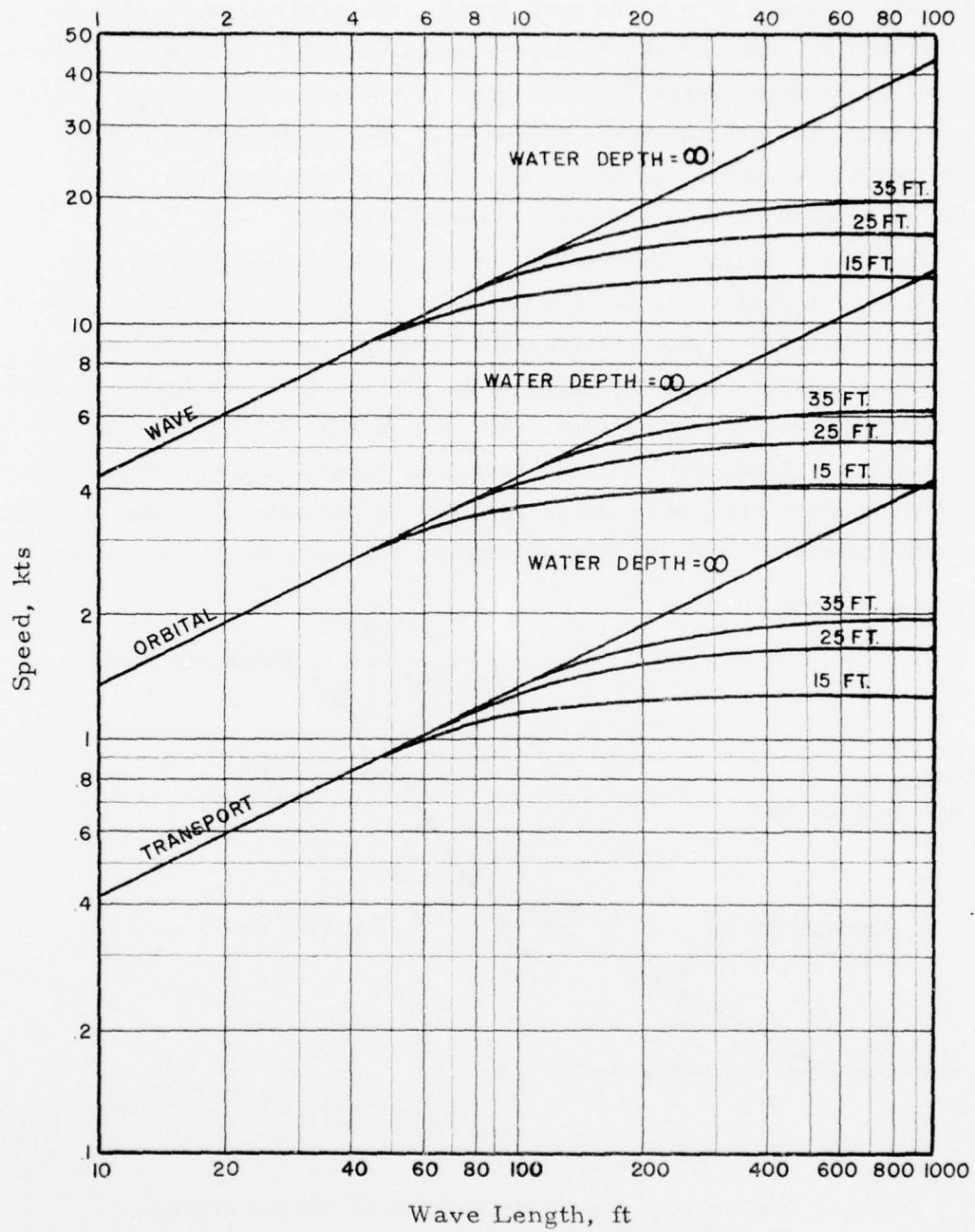

Figure 27. Wave, orbital, and transport speeds for waves of maximum height; i.e., $\frac{H}{L} = \frac{1}{10}$

less than maximum for a given wave length, the orbital speed will be proportionally less and the transport speed will fall according to the square of the wave height ratio. Thus, if the wave height is one-half the maximum, the orbital speed is one-half the corresponding maximum value and the transport speed is one-quarter of the maximum. Wave speed is assumed to be unaffected by wave height.

84. The velocity required to keep a curtain submerged can be estimated by considering the drag and buoyancy forces that act on the curtain. Figure 28 shows the free-body diagram for a curtain with the tension member along the bottom edge of the skirt and with vertical stiffness as provided by battens. The net buoyant force, B , acts to keep the curtain afloat; the drag force, D , rotates the curtain about the bottom edge; the anchor cable tension, T , balances the other forces. By taking moments about the bottom edge of the curtain, forces B and D can be related.

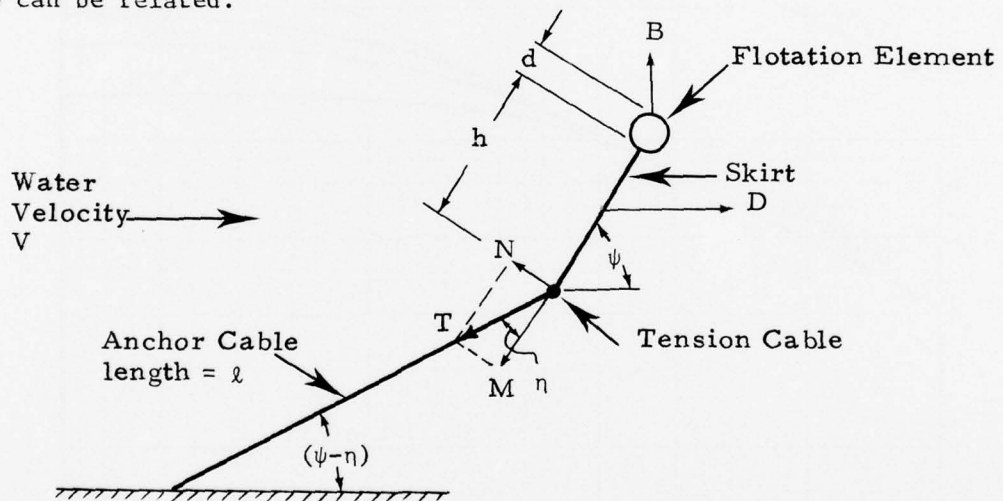

Figure 28. Free-body diagram of forces acting on a silt curtain

$$B\left(h + \frac{d}{2}\right) \cos \psi = D \frac{h}{2} \sin \psi \quad (52)$$

where h = curtain depth
 d = diameter of flotation element
 B = net buoyancy of submerged curtain per unit length of curtain
 D = hydrodynamic drag per unit length of curtain due to water velocity
 V = water velocity

The hydrodynamic drag, D , is given by

$$D = C_D \left[\left(h + \frac{d}{2}\right) \sin \psi + \frac{d}{2} \right] \frac{1}{2} \rho_w V^2 \quad (53)$$

which when substituted into equation (52) gives

$$V = \sqrt{\frac{4B}{C_D \rho_w h \tan \psi \left[\sin \psi + \left(\frac{1}{2\frac{h}{d} + 1}\right) \right]}} \quad (54)$$

and

$$T = \sqrt{B^2 + D^2} \quad (55)$$

$$N = D \sin \psi - B \cos \psi \quad (56)$$

$$\eta = \sin^{-1} \frac{N}{T} \quad (57)$$

Equation (24) expresses the water velocity required to flare the submerged curtain at angle ψ . If the top of the flotation element is just beneath the surface of water whose depth is H , the silt curtain is just submerged and the length of the anchor cable, l , must be

$$l = \frac{H - \left[\left(h + \frac{d}{2}\right) \sin \psi + \frac{d}{2} \right]}{\sin (\psi - \eta)} \quad (58)$$

85. From equations 52 through 58, the submergence characteristics can be developed for a particular curtain configuration. For the silt curtain used in the heave response analysis (Figure 21), the parameter values are as follows:

Curtain height, h	= 5 ft
Flotation element diameter, d	= 14 in
Residual buoyancy, B	= 60 lb/ft
Drag coefficient, C_D	= 1.5
Sea water density, ρ_w	= 1.99 slugs
Water depth, H ,	= 15, 20, 25, 30, 35 ft

The submergence characteristics of the 5 ft curtain are presented in Figure 29 in the form of plots of anchor cable length as a function of the minimum current required to submerge the curtain with water depth as the parameter. If the point determined by the cable length and actual current falls to the right of the actual water depth line, the silt curtain will be submerged by the flow condition. The anchoring load, t , for the submerged curtain (equation 55) is presented in Figure 30 as a function of current.

86. The surge limits of operation for a silt curtain in waves can be estimated by combining the swamping characteristics of the curtain and the dynamic properties of the wave system. It has been shown that as long as the vertical motion of the typical curtain is not restrained, the curtain will not swamp in heave. The anchor system by design provides maximum horizontal restraint with minimum vertical restraint thus allowing the curtain to respond to depth changes, waves and tides at the same time securing it against the horizontal motions of currents and wave surge. It is therefore reasonable to assume that for a typical curtain the horizontal particle motion perpendicular to the curtain determines whether the curtain gets swamped. The most severe condition is a broadside wave moving against the silt curtain whose anchor lines are taut as the wave crest passes. The velocity of the

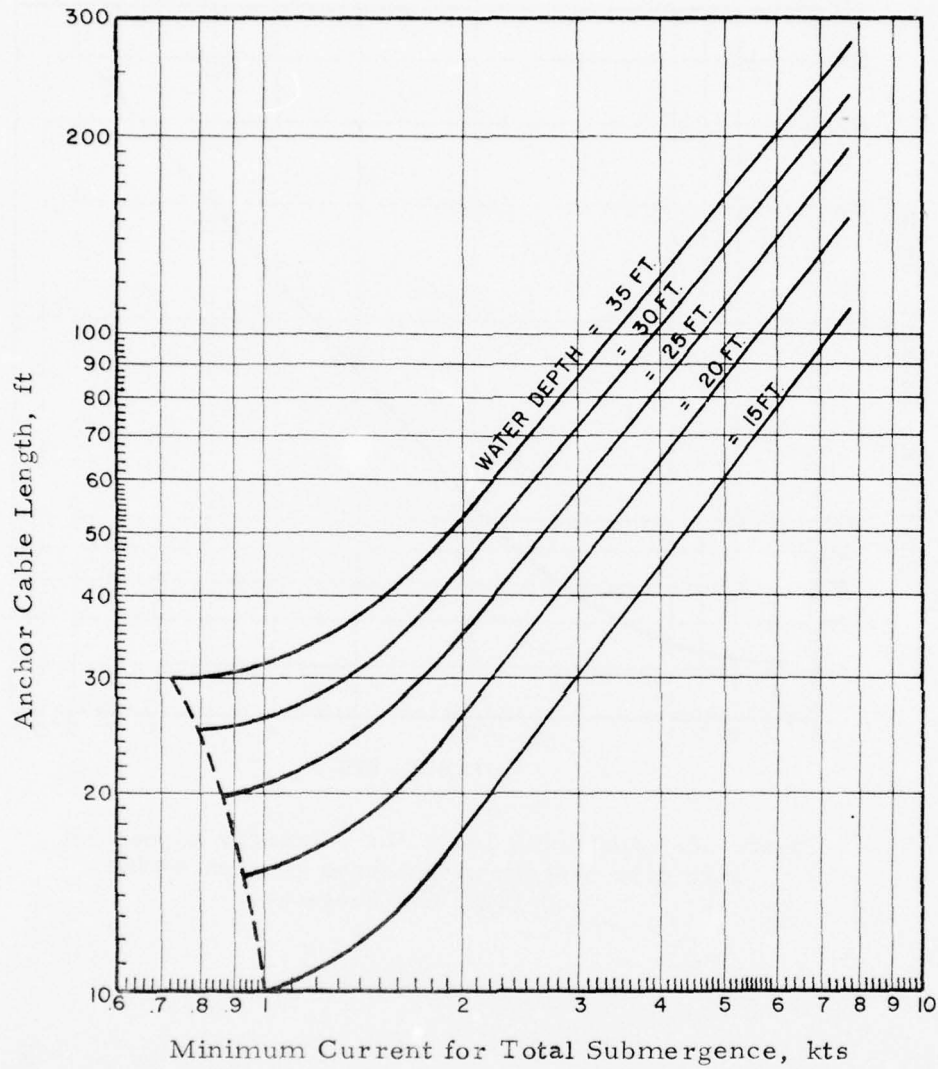

Figure 29. Minimum current for total submergence of a 5-ft silt curtain with bottom tension member 60 lb/ft net buoyancy

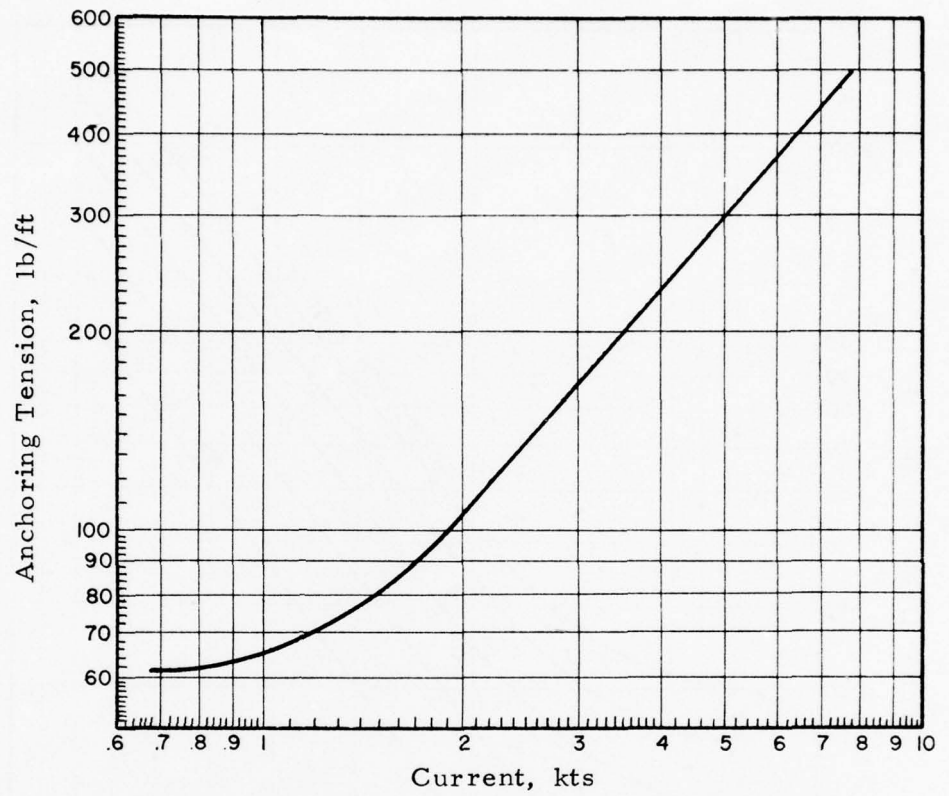

Figure 30. Anchoring loads for a totally submerged 5-ft silt curtain with bottom tension member 60 lb/ft net buoyancy

water flowing by the curtain is maximum at the crest and is the sum of orbital and transport velocities. The limit of functional operation is therefore defined as any condition where the maximum particle velocity of the wave system is equal to or exceeds the minimum submergence velocity for the curtain as given in Figure 29.

87. Although the criteria is not an exact solution for the anchored curtain, it does provide a reasonable estimate of failure conditions. Since the criterion applies only at the crest, the curtain may swamp only at this point but operate effectively through the remainder of the wave. It therefore indicates incipient swamping which represents the most conservative warning. The tendency of the slope of the wave to aggravate the swamping of the curtain is not taken into account. The good heave response of the curtain and the fact that the maximum slope on the steepest wave ($\frac{H}{L} = \frac{1}{10}$) is only 17.4 deg both tend to affect the aggravation.

88. The procedure of determining whether a curtain will operate satisfactorily can be best illustrated with an example. A silt curtain is to be installed around an open water discharge pipe in an area where the water is 20 ft deep. The dredging operation is closed down when wave heights reach 3 ft. In heavy weather 6 ft waves are usual. The silt curtain has a 5 ft skirt, reserve buoyancy of 60 lb/ft, bottom tension member, and is secured in place by 60 ft anchor cables. Assuming waves of maximum height but not breaking, how will the silt curtain perform? The summary of wave, current, and anchoring condition is tabulated below.

<u>Property</u>			<u>Reference</u>	
			<u>Figure</u>	<u>Note</u>
Wave height, ft	3	6		
Wave length, ft ($\frac{H}{L} = \frac{1}{10}$)	30	60		
Water depth, ft				
calm	20	20		
from wave crest	21.5	23		
Velocity, kts				
orbital	2.3	3.4	27	a

<u>Property</u>	<u>Reference</u>			
			<u>Figure</u>	<u>Note</u>
transport	0.7	1.0	27	a
orbital & transport	3.0	4.4		
Wave height, ft	3	6		
Velocity, kts, continued wave	7.4	10.2	27	a
Anchor cable length, ft	60	60		
Maximum allowable current, kts	3.6	3.4	29	b,c
Minimum anchor cable length, ft	49	84	29	b,d
Anchoring load, lb/ft	167	260	30	e

Notes

- a Figure 27 must be entered with the calm water depth.
- b Figure 29 must be entered with the water depth as measured from the wave crest. This is equal to the calm water depth plus half the wave height.
- c Maximum allowable current is the value that will just submerge the curtain. Its value is obtained from Figure 29 using actual anchor cable length and the wave crest water depth.
- d Minimum anchor cable length denotes the length at which the curtain just submerges at a specified current and water depth. Its value is obtained from Figure 29 using the actual water particle velocity (orbital & transport) and the wave crest water depth.
- e The anchoring load is the force required to secure the curtain along the bottom edge of the skirt. Its value is obtained from Figure 30 as a function of water particle or current speed. Note that these are the loads for a submerged curtain.

In the 3 ft sea the curtain is seen to be functional since the allowable current (3.6 kts) is greater than the actual (3.0 kts). The cable margin is 11 ft as given by the excess of the actual over the minimum required cable lengths (i.e., 60 - 49 ft). The tension load in anchor

AD-A060 382

J B F SCIENTIFIC CORP WILMINGTON MA
AN ANALYSIS OF THE FUNCTIONAL CAPABILITIES AND PERFORMANCE OF S--ETC(U)
JUL 78 E E JOHANSON

F/G 8/8

DACW39-77-C-0085

WES-TR-D-78-39

NL

UNCLASSIFIED

2 OF 3
AD
AO 60382

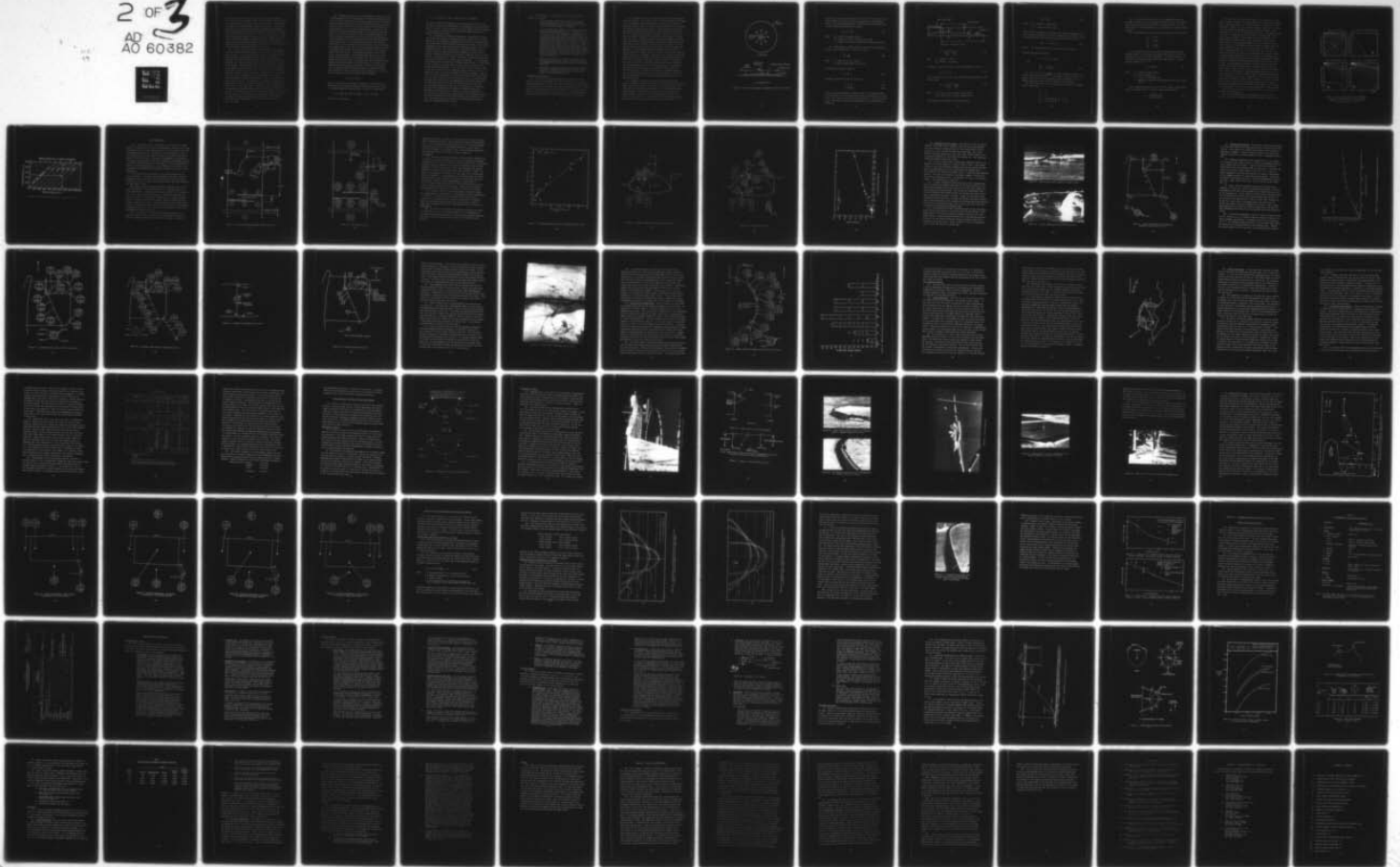

cables that are spaced 100 ft apart is 16,700 lb assuming adjacent curtain sections are similarly loaded. This represents the peak value of a load cycle that is in phase with the wave system. The peak value is reached as the curtain moves through the wave crest. The tension load falls off as the curtain moves down the back side of the wave, and when the particle motion reverses going into the trough the cables go slack and the tension loads fall to zero. The tension cycle begins anew as the curtain proceeds up the face of the following wave. The cyclic load pattern weakens the support system by creating stress concentrations at the attachment points where (1) the anchor grabs the bottom, (2) the anchor cable attaches to the anchor, and (3) the anchor cable attaches to the tension member of the curtain.

89. In the 6 ft sea the curtain will be swamped by the crests since the actual water particle speed (4.4 kts) exceeds the allowable value (3.4 kts). In this case the anchor cable is too short at 60 ft and would have to be lengthened to more than 84 ft to prevent the swamping. The tension forces on anchor cables (100 ft spacing) would be 26,000 lb at peak load through wave crests and would fall to zero in the troughs. Unless anchor, cable, and cable attachment points are all designed for this load type and level, a failure of any element could result in the total loss of the silt curtain. The loads determined above entail a very high capacity anchoring system. The anchors for 100 ft curtain segments must be the equivalent of ten 100 lb Danforth anchors for a mud bottom (Figure 74) and 1 in braided nylon anchor lines (Table 6). The equivalent is a single 100 lb Danforth anchor every ten ft (10 ft segments rather than 100 ft segments) each with a 3/8 in. nylon anchor line. Although the anchor configuration is reasonable, the spacing would require 100 anchors per 1000 ft of curtain for restraint in one direction and 200 per 1000 ft for restraint in two directions. This represents a considerable expense not only in hardware but also installation labor since the curtain must be moved each time the discharge is relocated which operation occurs every few weeks.

90. Breaking waves have the same hydrodynamic properties as waves of maximum height with the added feature of the mass of breaking water. A wave will break when the water particle velocity at the crest equals the wave speed (celerity) and it will spill down the front of the wave when the particle velocity at the crest exceeds the wave speed; i.e., water particles try to move faster than the wave. According to the theory for deep and intermediate waves¹⁵, this condition is reached when $H/L = 1/\pi$ but in reality the wind, which usually generates the waves, shears the water particles in the crest and increases their velocity causing the wave to break when H/L has reached approximately $1/10$ rather than $1/\pi$. The water involved in the break rides the forward face of the wave and travels at wave speed. As the anchored silt curtain moves up the face of the oncoming breaking wave, the mass of breaking water impacts and flows over that part of the flotation element above the surface. The submerged portions of the curtain are not exposed directly to the breaking water mass since it is an above surface phenomenon. As the water flows over the flotation element turbid surface water is released with each breaking wave that passes and a load is imposed on the curtain due to the drag of the breaking water flowing over the curtain. This load is transmitted from the flotation element through the skirt to the anchor cables and therefore all parts of the curtain are stressed by it. The drag force is given by the form of equation (53) as follows:

$$D = C_D d \frac{1}{2} \rho_w C^2$$

where C is wavespeed (equation 17, Figure 28). Referring to the conditions of the numerical example the drag loads for the 3 ft and 6 ft breaking waves are outlined below. For the 3 ft wave system

$$D = 1.5 \times \frac{14}{12} \times \frac{1}{2} \times 1.99 \times (1.6878 \times 7.4)^2 = 272 \text{ lb/ft}$$

For the 6 ft wave system

$$D = 1.5 \times \frac{14}{12} \times \frac{1}{2} \times 1.99 \times (1.6878 \times 10.2)^2 = 516 \text{ lb/ft}$$

The level of these loads indicates that the breaking wave could cause structural failure of any reasonably sized component in the load path for the silt curtain. These include the flotation element and its attachment to the curtain, the curtain itself, the anchor cable attachment, the anchor cable and the anchor.

91. Although the preceding discussion has concentrated on broadside waves that intercept a straight section of curtain along its entire length, the usual deployment configuration is such that a unidirectional wave system will produce broadside waves along one section of the curtain, longitudinal waves along other sections and quartering waves along the remaining sections. The broadside wave causes the curtain to move as a whole along its length and horizontal components of water particle velocity are always transverse to the curtain. When the curtain is inundated by a broadside wave or breaker the amount of turbid water released is greater than for waves of lesser angle of incidence. The longitudinal wave travels along the length of the curtain at wave speed. If the curtain is very flexible to vertical shear, it will follow the contour of the travelling longitudinal wave. If the curtain is still in vertical shear, it will not follow closely the crest and trough of the wave and consequently the crest will tend to submerge the flotation element. When this occurs the turbid water does not escape across the curtain because there is no horizontal component of water particle velocity in that direction. The drag load on the curtain is predominantly skin friction acting over the wilted surface of the curtain and therefore will be lower than the form drag encountered in the case of broadside waves. Quartering waves have both longitudinal and transverse components and hence introduce the features of each. Based on the above considerations of wave types, the broadside or transverse wave system inflicts maximum functional interruption and structural damage, the longitudinal wave causes the least functional interruption and damage, and quartering waves are intermediate between the two.

92. The behavior of a typical silt curtain in waves can be summarized as follows:

- a. Heave response of the unrestrained silt curtain is sufficiently good that it can follow the vertical motion of virtually any wave expected in the disposed area without being swamped or submerged.
- b. The horizontal surging motion in linear broadside waves generates particle velocities (i.e., orbital and transport) of sufficient magnitude to submerge a typical silt curtain. The resistance to swamping may be increased by adjusting the reserve buoyancy of the curtain together with the length of the anchor cable. The limiting dredging condition is simulated by 3 ft high maximum waves that impose loads of 17,000 lb on anchoring systems that are spaced at 100 ft intervals. A storm condition at the discharge sight is simulated by 6 ft high maximum waves, and these generate 26,000 lb tension loads in the 100 ft anchor systems. These are extremely high loads for a silt curtain and would require extra anchoring components. On the other hand, medium capacity anchor systems could be expected to fail under these operating conditions.
- c. Breaking waves incur nearly double the loads of the linear broadside waves of 3 and 6 ft heights and hence the ordinary anchoring systems discussed in this report would fail.
- d. Functional and loading considerations indicate that the broadside or transverse waves system are most severe, longitudinal waves are least severe, and quartering waves are of intermediate severity.

Deployment and Maintenance

93. For any silt curtain application there are several basic questions related to deployment that must be addressed. For the existing water depth, how far should the curtain extend and how large should the bottom opening be? How far from the pipe discharge should the curtain be located and how long can the curtain be left at that location before it must be moved? This section describes a simple model that can be used in the selection of curtain installation specifications.

94. In general, the silt curtain configuration is established in a practical manner. As the area within a curtain surrounding a discharge barge is increased, the retention time also increases so that more settling can occur inside the curtain and less turbid water is released. The larger enclosure area also means a longer time period before the curtain array must be moved to prevent sediment buildup on the skirt. The size of the curtain enclosure is limited, however, by the total length of curtain available to the project and the proximity of land areas and shores. The depth of the curtain is determined by the water depth and the desired bottom opening. The bottom opening cannot be so great that excessive turbidity is released, and it cannot be so small that the settled solids seal the bottom of the curtain and entrap the sediment. If the discharge operation continues after the curtain becomes sealed, the mudflow buries the bottom of the curtain, eventually causing the curtain to submerge. Recovery of the curtain is costly and incurs delay while the dredge is shut down and the discharge barge is moved to a new location. Therefore, when the curtain is threatened by sealing along most of its length, the enclosure must be enlarged or the curtain must be moved to a new disposal area. In either case the curtain is moved only after the sediment buildup threatens to seal the bottom edge. Therefore, this volume of sediment buildup is used in the following model as a basis for estimating the effects of curtain configuration on the expected operating time before the curtain must be moved.

95. Consider a disposal site where the currents and bottom slope are negligible; the fluid mud moves radially outward in all directions, and the silt curtain is deployed in a circular configuration centered on the discharge barge (Figure 31). As the discharge operation progresses, a large portion of the solids settle out near the discharge barge. This material mounds under the barge until the critical slope is realized. The sediment then moves radially outward and spreads until the slope is reduced to the critical value. The

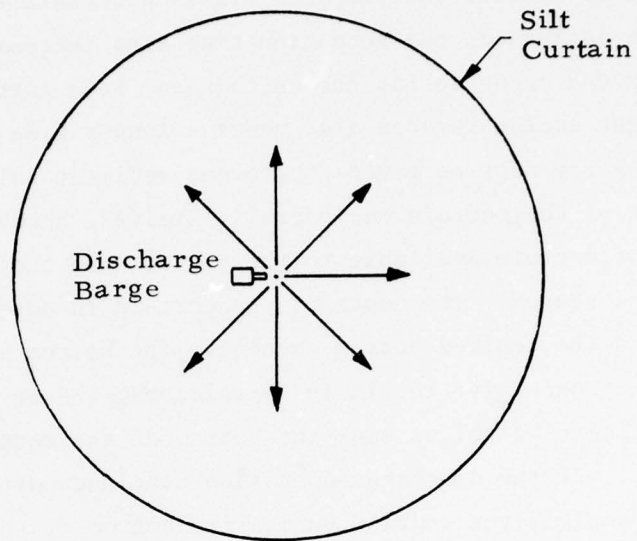

a. Plan View

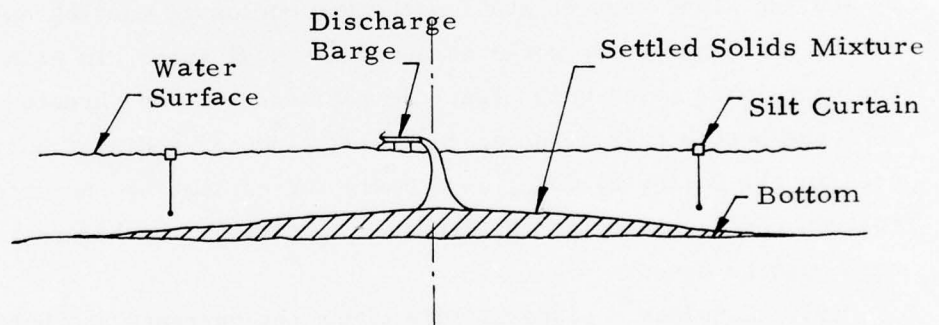

b. Elevation View

Figure 31. Symmetrical discharge configuration used in this model

gross effect is that the thickness of the mound falls off linearly with radial distance from the barge and the mound shape is approximately conical. The corresponding volume of the settled solids mixture when the silt curtain becomes sealed is given by

$$V_B = \frac{1}{3} \pi R^2 H \quad (59)$$

where V_B = volume of mounded material
 R = radius of the base of the conical mound
 H = height of the conical mound under the discharge barge

96. From Figure 32, which illustrates the physical configuration and the critical dimensions, it can be seen that

$$\frac{R}{H} = \frac{r}{H-h} \quad (60)$$

where r = radius of the silt curtain
 h = bottom opening under silt curtain

The slope of the mound is given by

$$S = \frac{H}{R} \quad (61)$$

Combining equations (60) and (61) results in

$$H = h + Sr \quad (62)$$

$$R = \frac{H}{S} = \frac{h}{S} + r \quad (63)$$

So that for any combination of bottom opening, h , and curtain radius, r , the dimensions of the conical mound (R , H) can be determined as well as the total volume of the settled solids mixture. If α_B is the solids ratio of the settled mixture by weight and β_B is the solids ratio by volume then

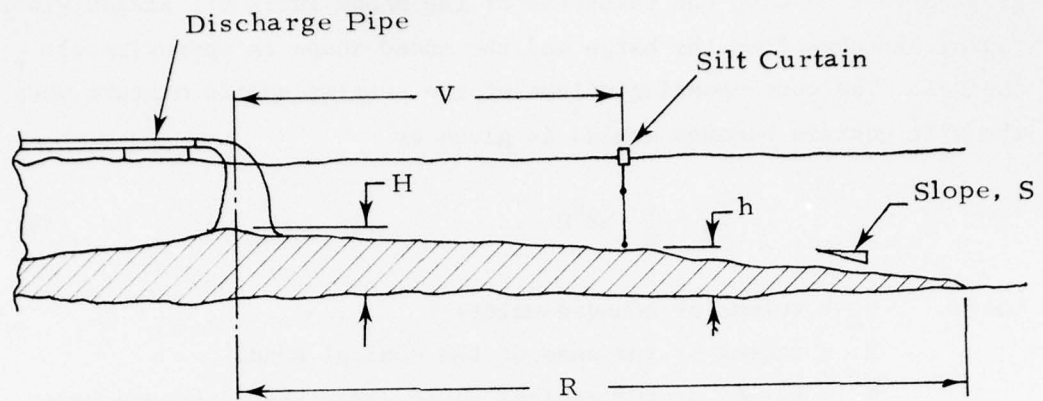

Figure 32. The conical mound

$$\beta = \frac{1}{1 + \left(\frac{1}{\alpha_B} - 1 \right) \frac{\rho_p}{\rho_w}} \quad (64)$$

where ρ_p = density of solids
 ρ_w = density of the water

The volume of the solids alone in the bottom mixture is given by

$$V_{sB} = \beta_B \times V_B \quad (65)$$

In the same manner the solids ratio by volume can be obtained for the pumped slurry

$$\beta_p = \frac{1}{1 + \left(\frac{1}{\alpha_p} - 1 \right) \frac{\rho_p}{\rho_w}} \quad (66)$$

where α_p = solids ratio by weight, pumped slurry
 β_p = solids ratio by volume, pumped slurry

The volume of solids pumped is therefore given by

$$V_{sp} = \beta_p V_p \quad (67)$$

where V_{sp} = volume of solids pumped
 V_p = volume of slurry pumped

Since a small percentage of the pumped solids becomes suspended in the water column as turbidity and does not contribute to the settled solids, the settled solids volume from equation (67) can be expressed as

$$V_{sB} = (1 - k) \beta_p V_p \quad (68)$$

where k = volume fraction of the solids that do not settle.

Equating (24) and (27) produces

$$(1 - k) \beta_p V_p = \beta_B V_B$$

and

$$\frac{V_p}{V_B} = \frac{\beta_B}{(1 - k) \beta_p} \quad (69)$$

97. The slope of the sediment, S , can be estimated, based on a limited amount of field data.^{12,13} The slope, or angle of repose, will depend on the initial bottom topography and the properties of the dredged material; for this analysis assume a slope of 1:200.

98. The values taken for the constants in equations (64) through (69) are given below.

$$\begin{aligned} \alpha_B &= .25 \\ \alpha_p &= .15 \\ \rho_p &= 5.16 \text{ slugs (Sp. Gr.} = 2.66) \\ \rho_w &= 1.96 \text{ slugs (Sp. Gr.} = 1.01) \end{aligned}$$

99. The value for the solids ratio of the mounded material, α_B , is based on the data for bottom samples taken from a site in Georgetown, South Carolina (data are reported later in Figures 45, 46, 51). The solids ratio for the pumped mixture, α_p , is typical for a pipeline dredge operation.

100. Substituting the above values into equations 23 and 25 yields

$$\begin{aligned}\beta_B &= 0.112 \\ \beta_p &= 0.0628 \\ \frac{V_p}{V_B} &= \frac{1.78}{(1-k)}\end{aligned}$$

101. By matching up the total volume of pumped mixture and the pumping capacity of the dredge, the pumping time required to seal off the bottom of the curtain can be determined. This also represents the allowable operating time before the curtain must be moved. The pump capacity equation is given by

$$V_p = \frac{\pi}{4} \overline{ID}^2 UT \quad (70)$$

where V_p = volume of pumped mixture
 ID = ID of discharge pipe
 U = velocity of discharge flow
 T = duration of pumping or operating period for silt curtain array

102. Combining equations 59, 63, 70, and 71 results in the expression for operating time, T , in terms of the system variables.

$$T = \frac{(200 h + r)^3}{83.8 (1-k) \overline{ID}^2 U} \quad (71)$$

103. Equation (71) is plotted in Figure 33 in the form of a nomograph. Figure 34 presents the mound dimensions as a function of curtain radius and bottom opening. To illustrate the use of Figure 33, assume approximately 3800 ft of silt curtain or enough to install in a circular enclosure around the discharge barge with a radius of 600 ft. The water depth is 14 ft and the curtain depth is 10 ft. The pumping system is capable of developing 18 fps in the 18 in. discharge pipe. Enter Figure 33 with a 500-ft curtain radius and a bottom opening of 4 ft and determine the mound volume to be 11.5 million ft³ before the curtain seals. Trace the mound volume over to the "escape fraction" plot. These curves incorporate the solids ratios of pumped slurry and bottom sediment as well as the "escape" fraction (k). The escape fraction represents that part of the solids that gets carried out of the system and does not settle out in the mound. For initial estimates of pumped volumes required to seal the curtain it is recommended that the escape fraction be taken as zero, since this represents the shortest operating period and the threshold beyond which the curtain is likely to seal. As more operating experience is gained with silt curtains, the equivalent escape fraction may be determined by back plotting to these curves. Using an escape fraction of zero, find that 20.5 million ft³ of slurry must be pumped. Enter the pumping capacity plot with a slurry velocity of 18 fps and an 18-in. pipe ID and find the flow rate to be 2.75 million ft³ per day. Project this over to the total pumped volume and find that the curtain can be operated for at least 7.5 days at 24 hr per day before the curtain should start to seal. Figure 34 shows that the mound will be 6.5 ft high at the center of the circular area (water depth = 7.5 ft) and that it extends 1300 ft from the center.

104. If the array is semi-circular, treat it as a circle and use one-half the operating time.

105. If the configuration is approximately a square of side S, treat the application as though it were a circle with a radius of S/2.

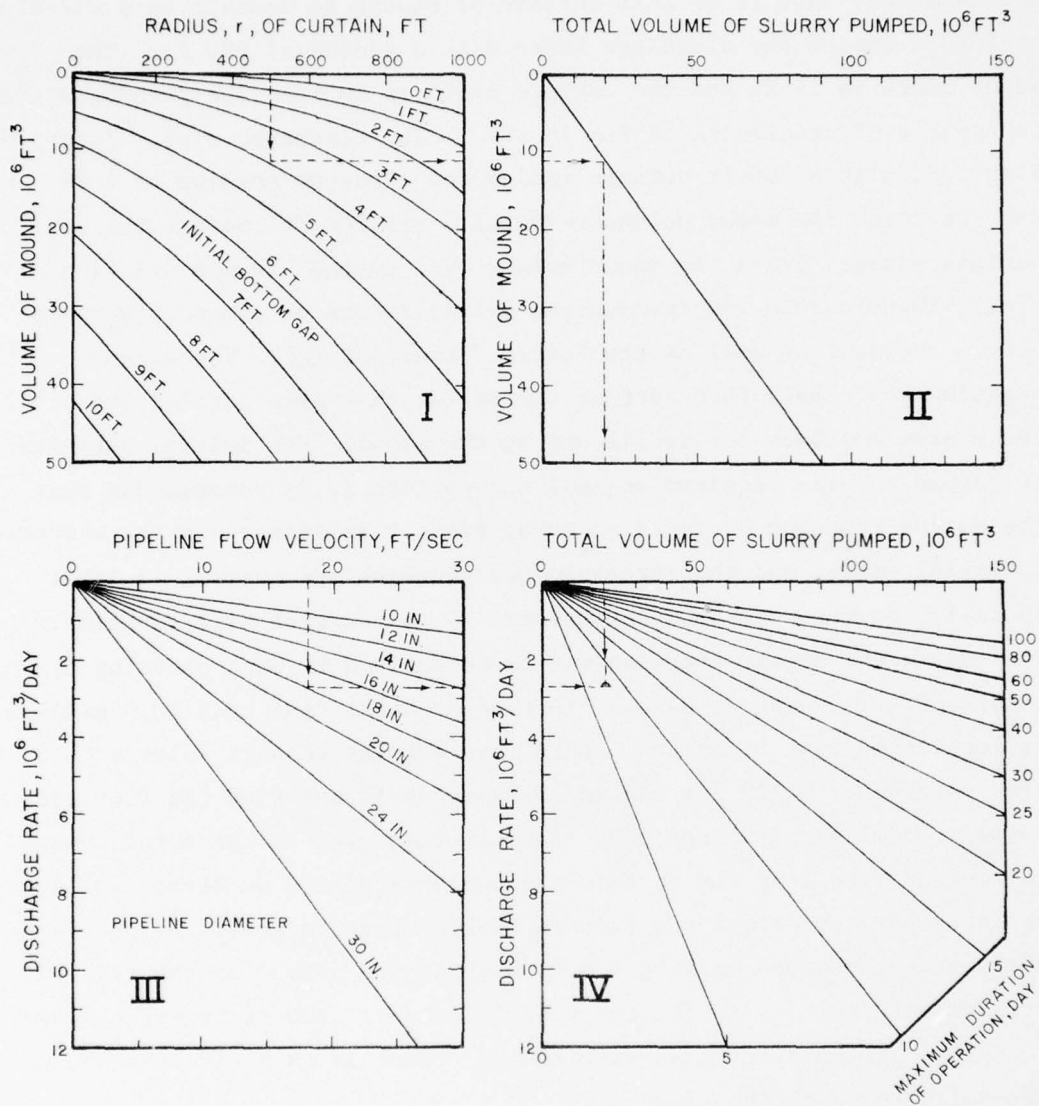

Figure 33. Silt curtain deployment requirements for dredged material slurry of 15% solids by weight, fluid mud of 25% solids by weight, and a mound slope of 1:200

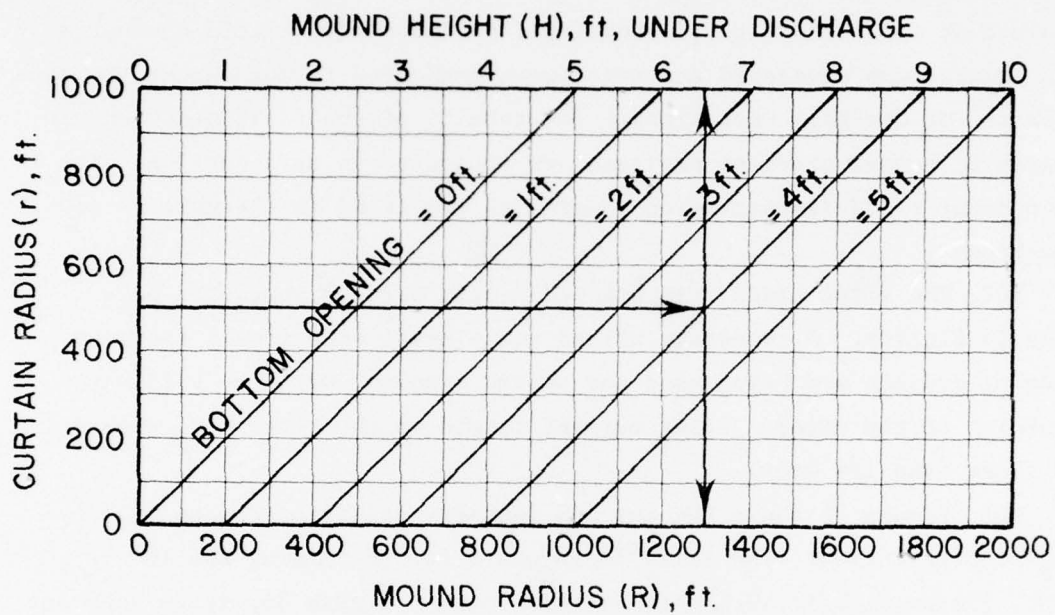

Figure 34. Conical mound dimensions for slope of 1:200

Field Measurements

106. As originally proposed, this study was to consist of a combination of technical analyses and field measurements, the latter to be made opportunistically on actual dredging projects. After several field trips on dredging projects had been conducted, it became evident that the required engineering data and range of variables of interest could not be obtained at the field sites. Therefore, an independent field demonstration program was developed and tests were conducted to supplement the data collected on dredging operations. The results of the field measurements program at actual dredging projects are presented in this section. The independent field demonstration program is presented in the next section.

Case Study 1

107. The first field trip studied a silt curtain operation on a river in Florida. A two-stage upland containment area from a previous dredging project was being used for upland disposal with the effluent returning to the river. Water current levels in the river were extremely low (less than 1/4 knot).

108. Figure 35 shows the curtain geometry utilizing a maze or labyrinth configuration. The skirt depth was 5 ft. Examining the levels of NTU (Nephelometric Turbidity Units) shown in Figure 36, it is apparent that there is not a substantial decrease in turbidity levels from one side of the curtains to the other. Surface water in the gap has higher levels of turbidity (station 6) than exist behind the curtain (stations 4 and 5). High levels exist at intermediate depths on both sides of the curtain. Two miles downstream, surface turbidity levels are approximately the same as those levels at the curtain exit gap (station 1), but levels at middepth are lower at station 7.

109. If a criterion of 50 NTU's above background (station 8) is used, the curtain is seen to be "effective" in reducing the station 6 levels to acceptable values downstream from the curtain at station 3,

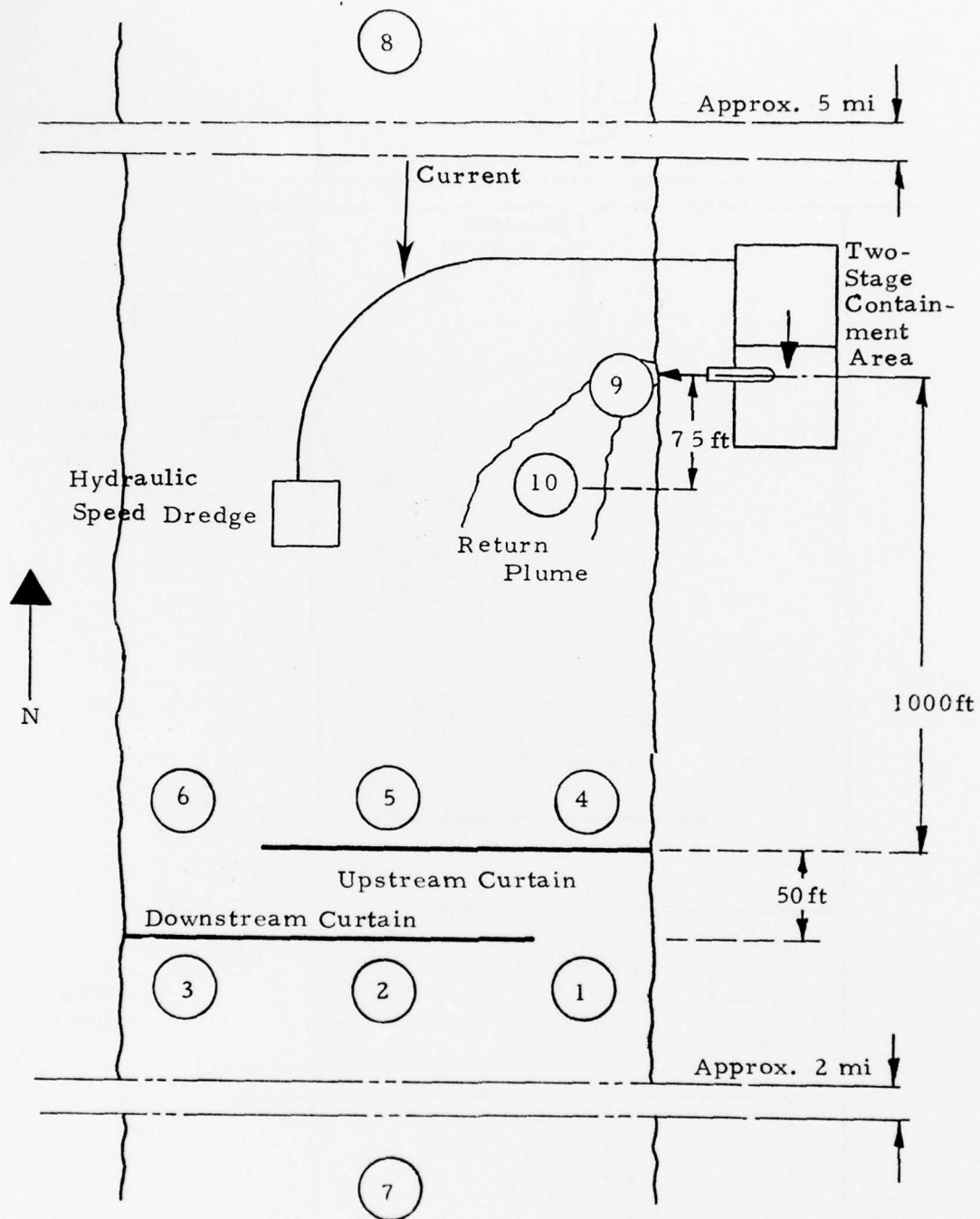

Figure 35. Schematic showing sampling stations at site 1

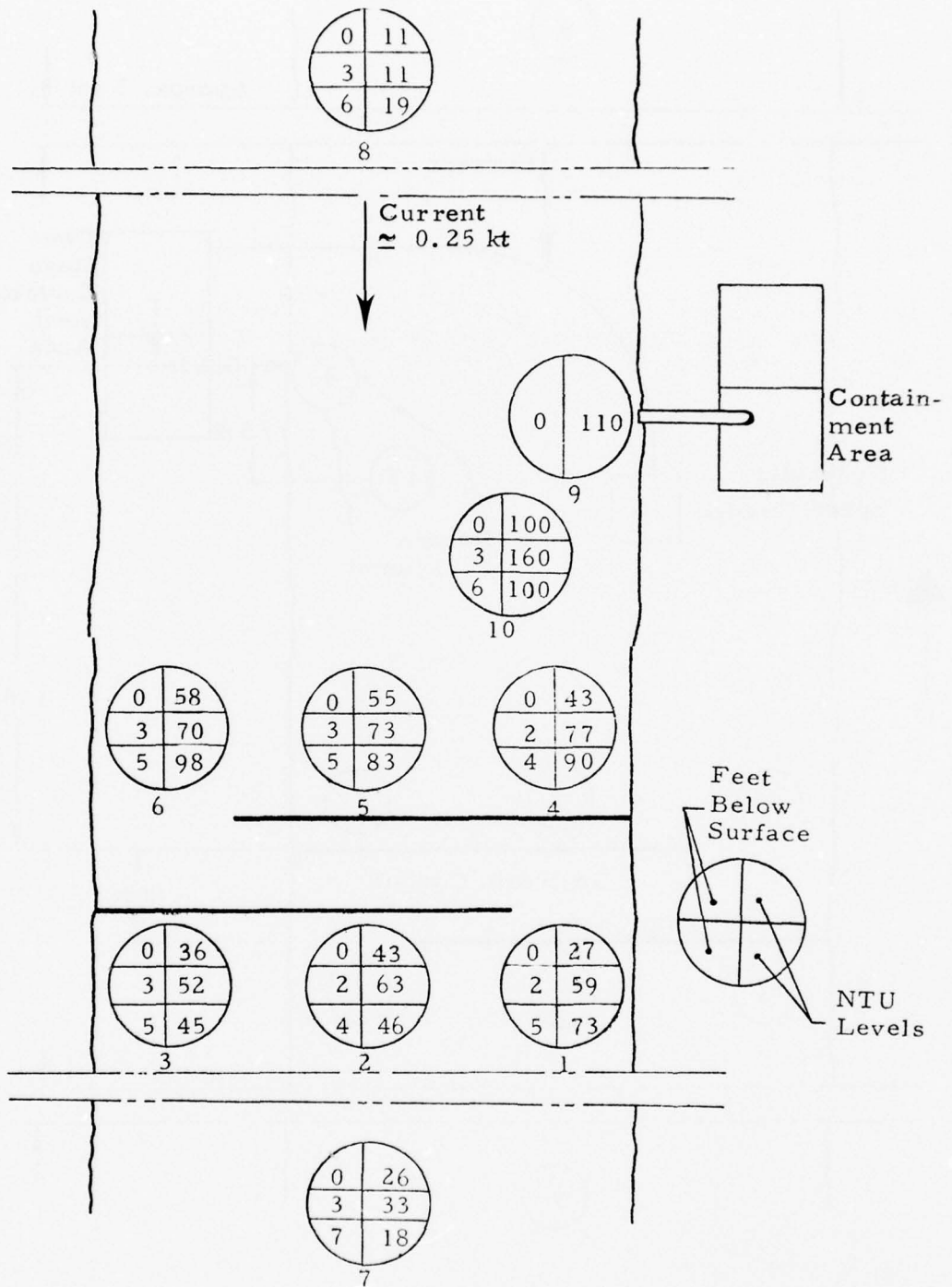

Figure 36. NTU levels at site 1

marginally effective at station 2, and not effective at station 1 where direct flowthrough resulted. These observations suggest the possibility that a closed curtain around the discharge area, or a curtain extending across the entire river, would probably have been a better choice to reduce the turbidity to acceptable levels. The correlation between NTU and suspended solids for this site is shown in Figure 37.

Case Study 2

110. Another operation monitored was in Riviera Beach, Florida, and consisted of an upland containment area with the overflow going through a standpipe into a closed silt curtain as shown in Figure 38. A previously deployed, partially submerged silt curtain was inside the outer curtain. Apparently it had been placed too close to the discharge point and was submerged by buildup on the bottom of the skirt, pulling it under. The material being pumped was observed to be very sand, with a considerable content of seashells. An investigation of the bottom inside the curtain showed an almost linear buildup of soft material between the shore and the barrier. This material was approximately 8 inches thick at 50 feet from the shore; water depth was 6 feet and the barrier was 5 ft. long so it nearly touched the 8 inch layer. Water current velocities were estimated to be less than a few tenths of a knot at the curtain.

111. Turbidity levels at the discharge point, as shown in Figure 39, ranged between 35 and 350 NTU's. Background levels were approximately 1 to 4 NTU's. If 50 NTU's above background is again selected as a criterion, it is readily apparent that the curtain was very effective except in the plume resulting from a gap in the curtain. Figure 40 shows the relationship between NTU's and suspended solids for this site.

Case Study 3

112. The purpose of the third field study was to observe in detail the deployment of a silt curtain and to monitor its effectiveness in containing turbid water generated by a 16-in. pipeline disposal operation. The site was a marsh creation project adjacent to an island in South Carolina.

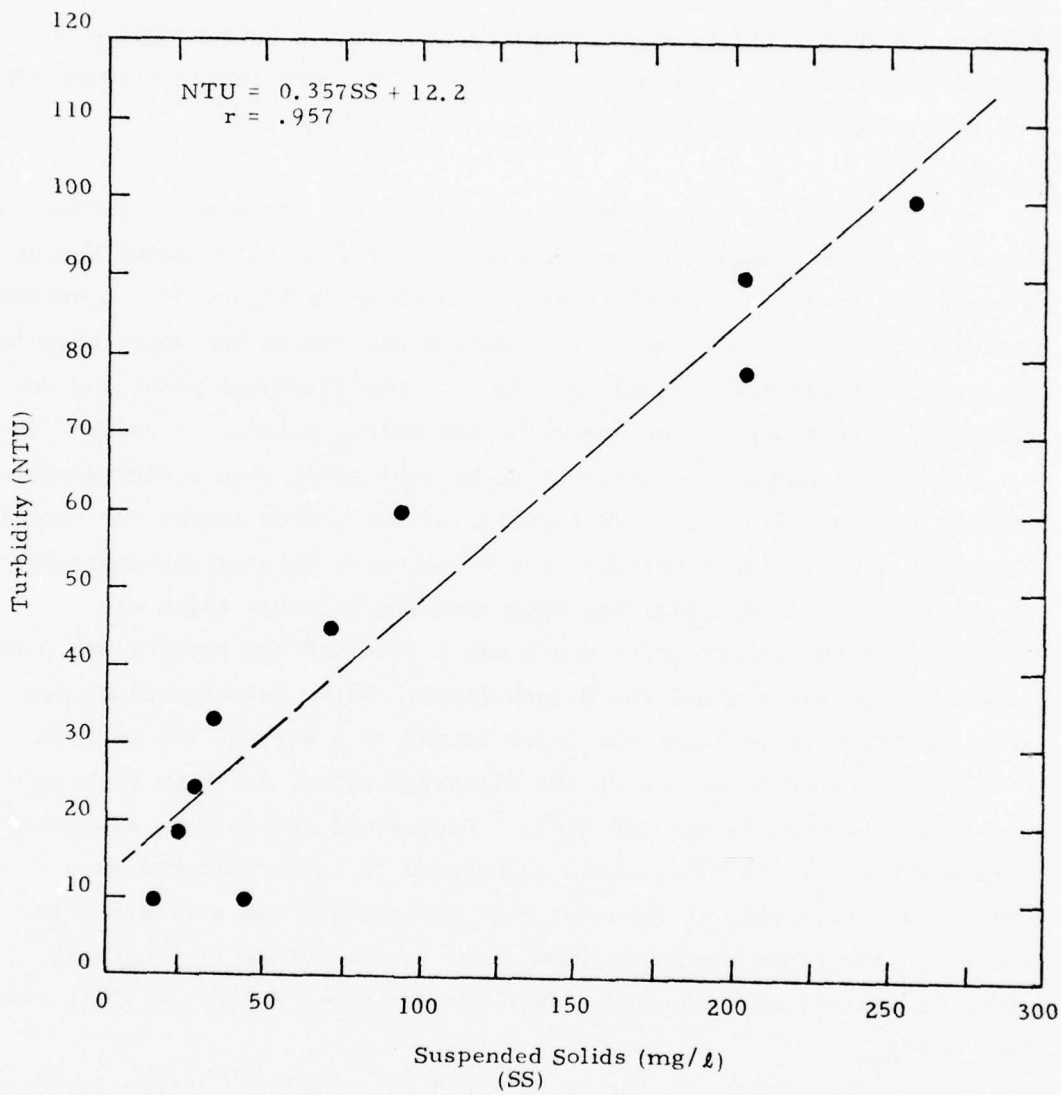

Figure 37. Correlation between NTU and suspended solids at site 1

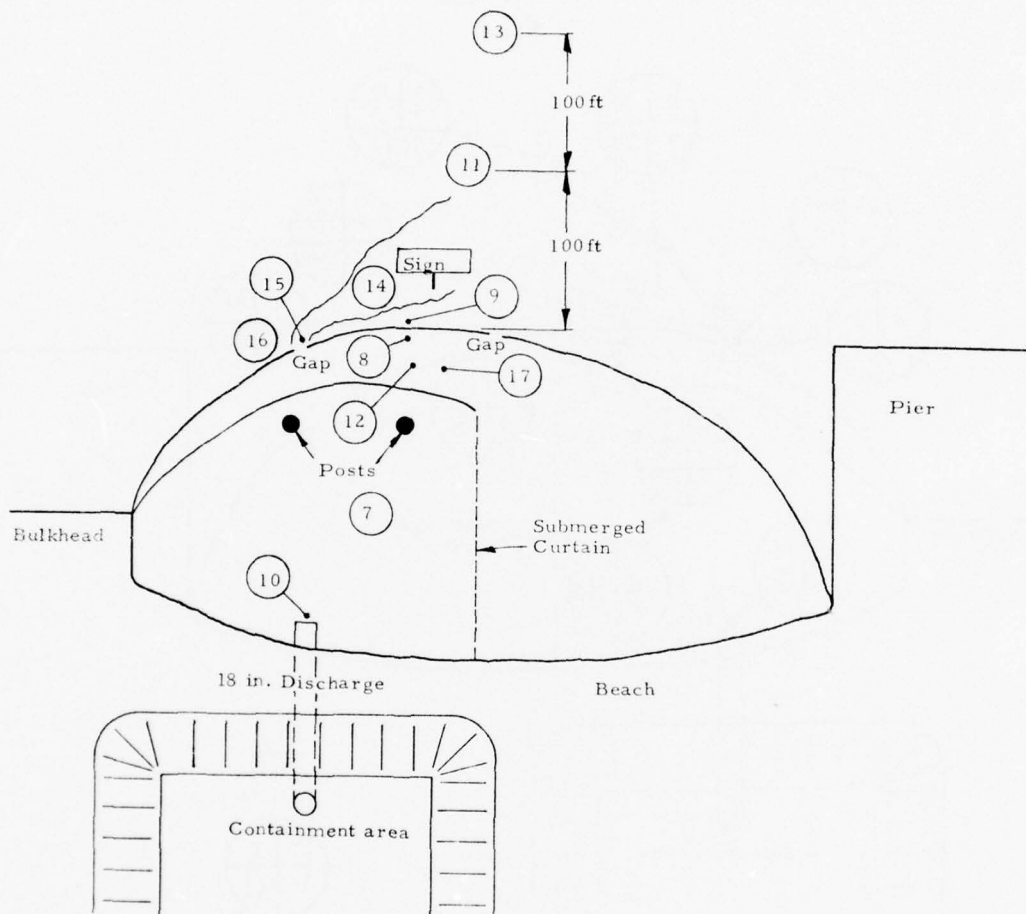

Figure 38. Schematic showing sampling stations at site 2

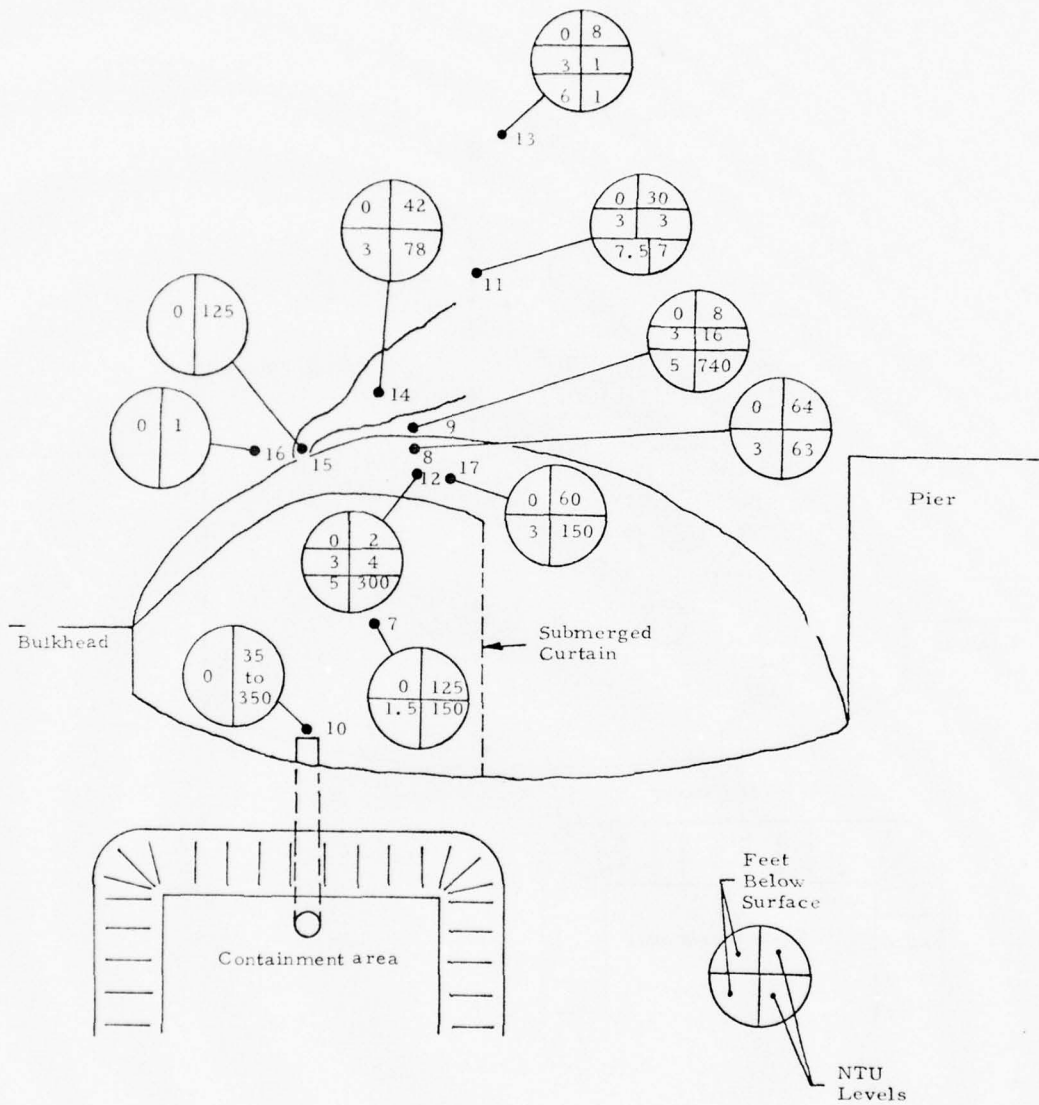

Figure 39. NTU levels at site 2

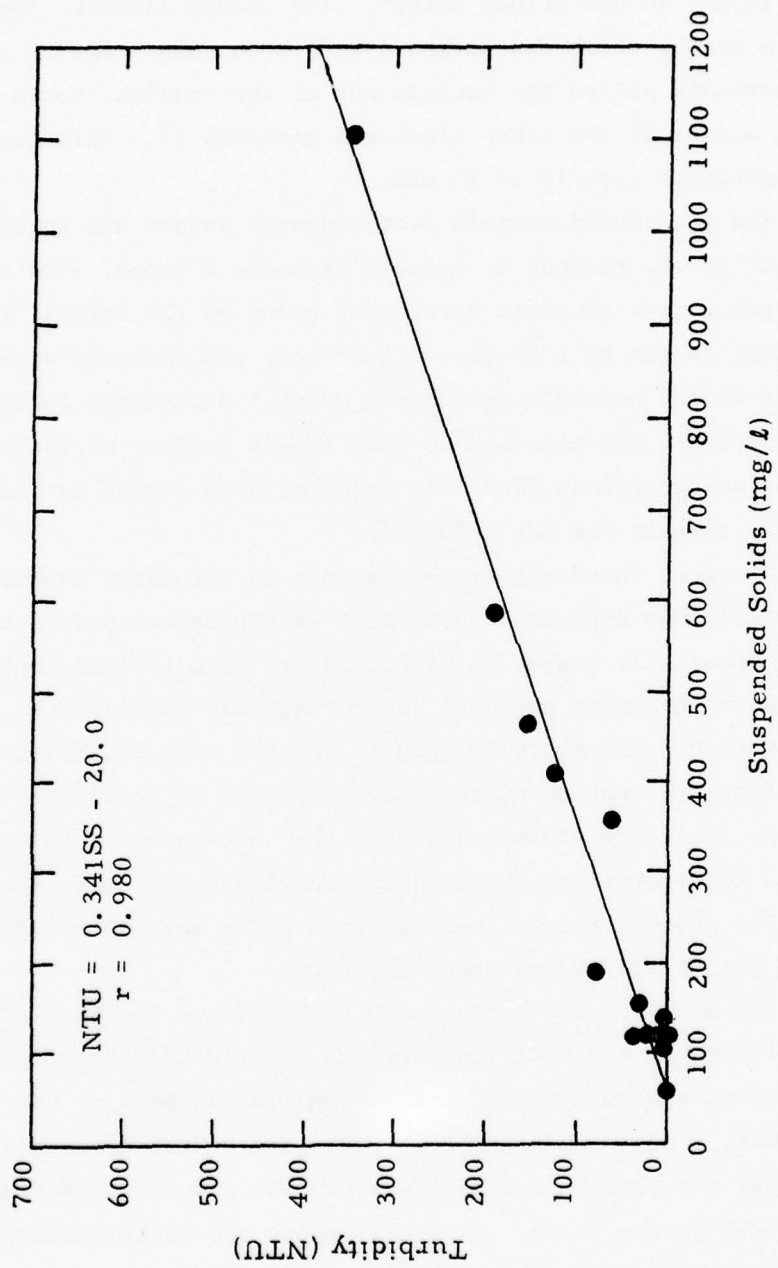

Figure 40. Correlation between NTU and suspended solids at site 2

113. Deployment of Silt Curtain. One 1100-ft. section of curtain remained in the water from a previous operation, and it was anchored next to an island in Georgetown Harbor. The second 1100-ft. section arrived in a truck, which was backed down a boat ramp. One of the dredger's towboats pulled the curtain out of the trailer, towed it into position alongside the other piece and anchored it. This towing and anchoring operation took 10 to 15 min.

114. The two furled curtain sections were joined and towed to the disposal site by the towboat at a speed of about 2 knots. The towboat pulled one end to the southern attachment point on the island; the other end was pushed ashore by a 20-ft. utility boat and anchored with a 20-lb anchor at the northern attachment point. A Danforth anchor weighing between 5 and 20 lb was attached to each 100-ft segment of the barrier with 3/8-in. polypropylene line. It required 3 to 4 min. to place each anchor. (The curtain was not unfurled).

115. A severe thunderstorm that struck on the first evening after the silt curtain was deployed caused most of the anchor points to fail. The anchors apparently stayed in place, but it is not clear whether the lines failed or the knots parted. The curtain was subsequently blown over the discharge pipe pontoons (Figure 41) and onto the island, resulting in chafing and tearing of the skirt. Figure 42 shows the curtain configuration after the storm. Although the curtain was totally ineffective in this configuration, the dredging and discharge operation continued. The photo also shows furling lines still in place some 24 hr after the curtain had been deployed and dredging begun.

116. The next day the dredge crew repositioned the barrier approximately 100 ft to the south of its previous position and secured it with large anchors at the outside corners and smaller anchors at the intermediate points. Longer mooring lines were used on the anchors since the crew felt that the failure during the storm was caused in part by the tautness of the anchor lines. Figure 43 shows the anchor configuration used to secure the curtain the second time.



Figure 41. Curtain driven onto pipeline by storm at site 3



Figure 42. Curtain configuration after storm at site 3

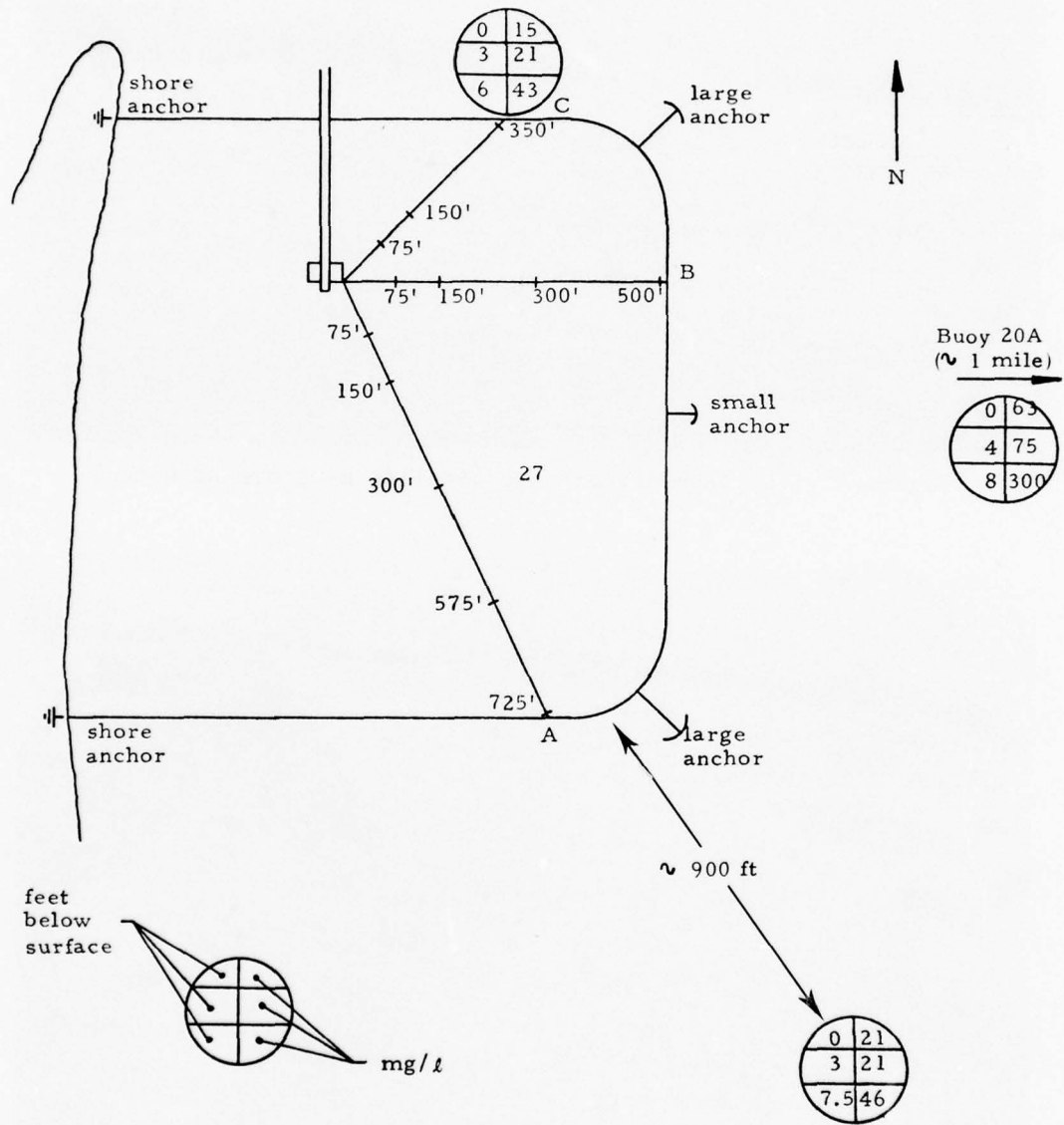

Figure 43. Anchor configuration and background suspended solids levels at site 3

117. Turbidity Measurements. The disposal operation was monitored by taking water samples from sampling boats both inside and outside the barrier. Water samples were taken at the surface, at the bottom, and sometimes at middepth. Figure 43 shows the radial lines to mark the sampling stations and the typical ambient levels of suspended solids in mg/l.

118. Background suspended solids concentrations in the vicinity of the disposal pipe ranged from 15 to 43 mg/l; corresponding turbidity values ranged from 8 to 19 NTU's. Figure 44 shows the correlation between NTU values and suspended solids at field site 3. The water was chocolate brown with a Secchi depth of only 3 to 6 in. Large, low density aggregates indicating flocculation were observed, independent of the dredging operation, at many places in Winyah Bay. Currents in the disposal area ranged from 0.25 to 0.52 knots depending on location and depth. Water depth varied from 1 to 8 ft, and the curtain depth was 5 ft.

119. Figure 45 shows suspended solids levels obtained during dredging on a flood tide. There is considerable variability in surface measurements within the curtain probably due to directional properties of the discharge jet. At the corners A and B/C surface turbidity levels were the same on both sides of the curtain because these sections of the curtain had not been unfurled. Figure 46 shows data collected on an ebb tide. High levels of suspended solids were found near the bottom, indicating a fluid mud condition on the bottom. Water column measurements made on radials up to 900 ft beyond the curtain indicate high suspended solids levels at the surface both inside and outside the curtain.

120. To evaluate "sedimentation rates" at various locations within the silt curtain at site 3, sediment traps were deployed (Figure 47) to collect sediment settling into a "suspended" jar with a top opening of 3.87 in.² The sediment accumulation rates in the sediment traps (Figure 48) increase with increasing distance from discharge point. However, all values appear to be low relative to the concentration and volume of

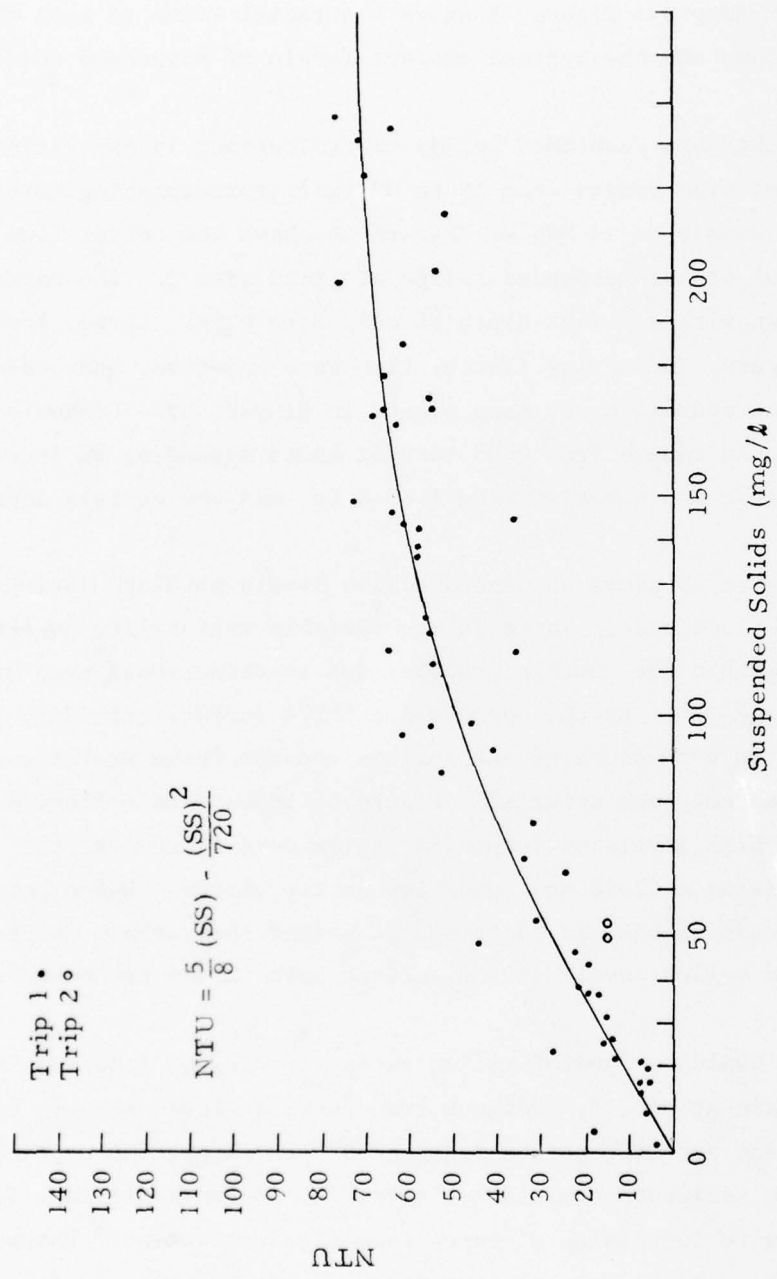

Figure 44. Correlation between NTU's and suspended solids at site 3

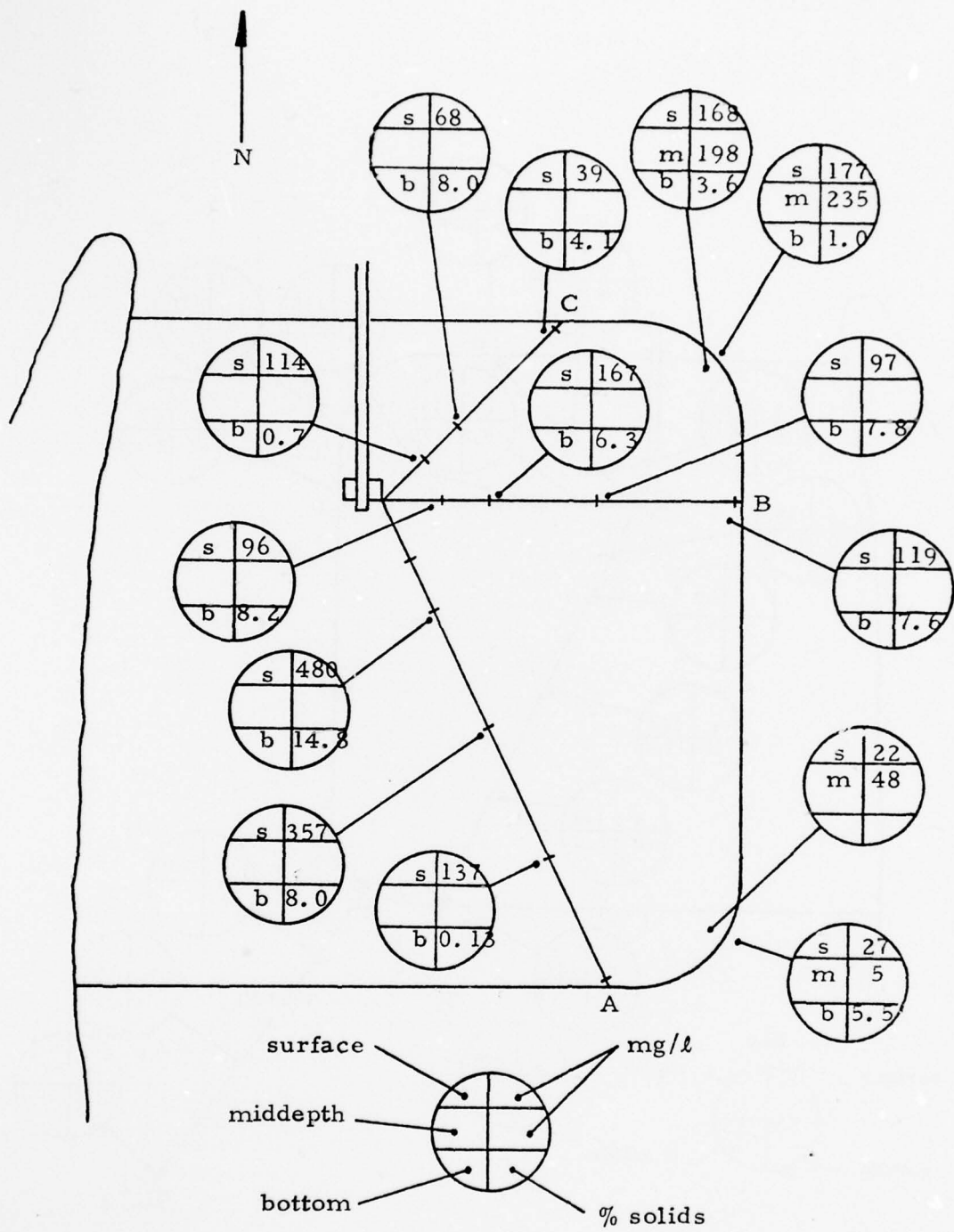

Figure 45. Suspended solids levels on flood tide at site 3

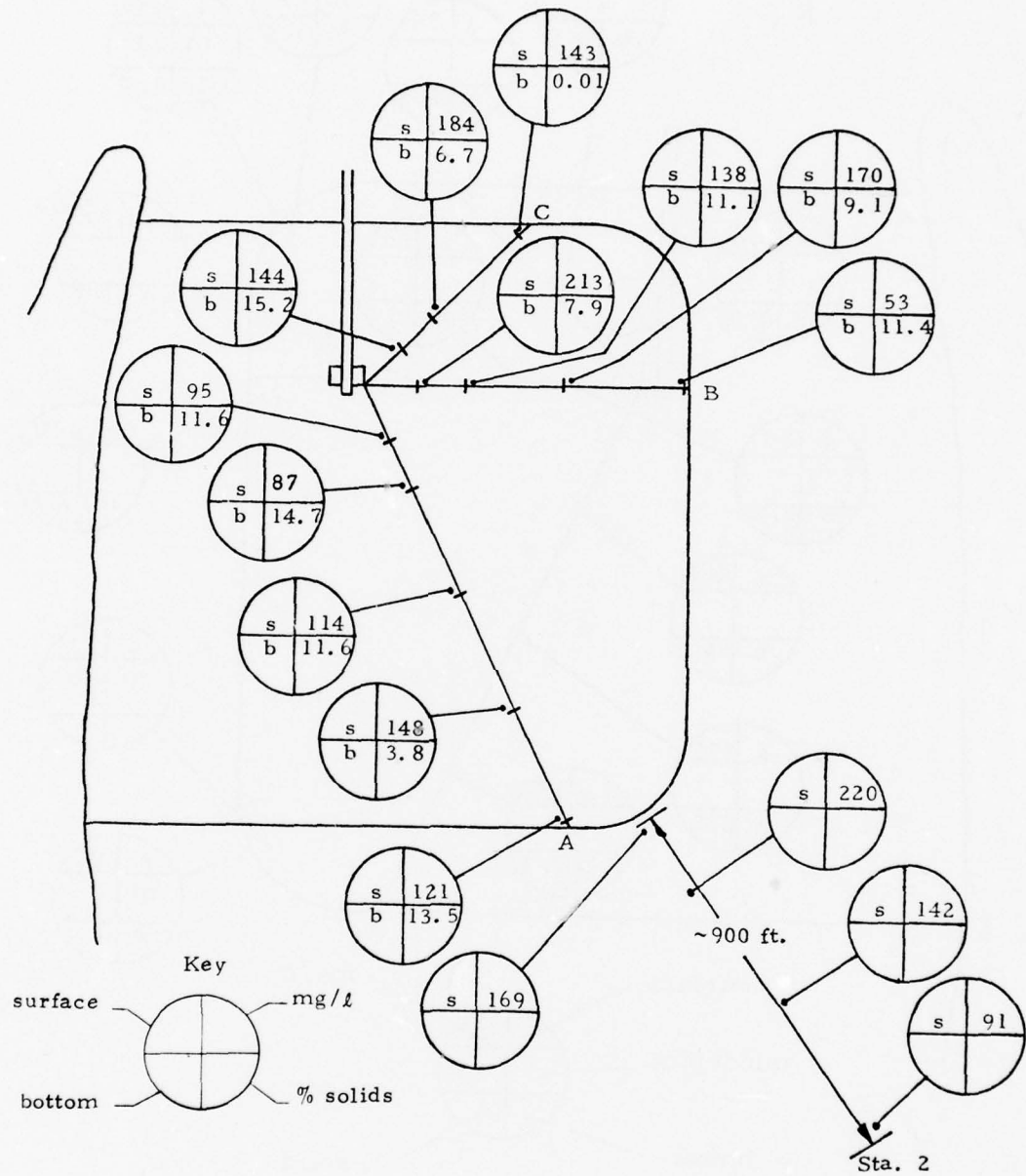

Figure 46. Suspended solids levels on ebb tide at site 3

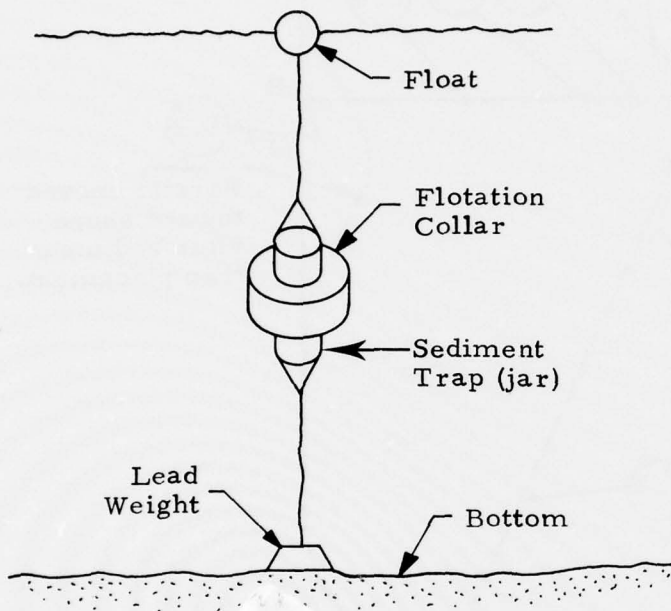

Figure 47. Sediment trap design used at site 3

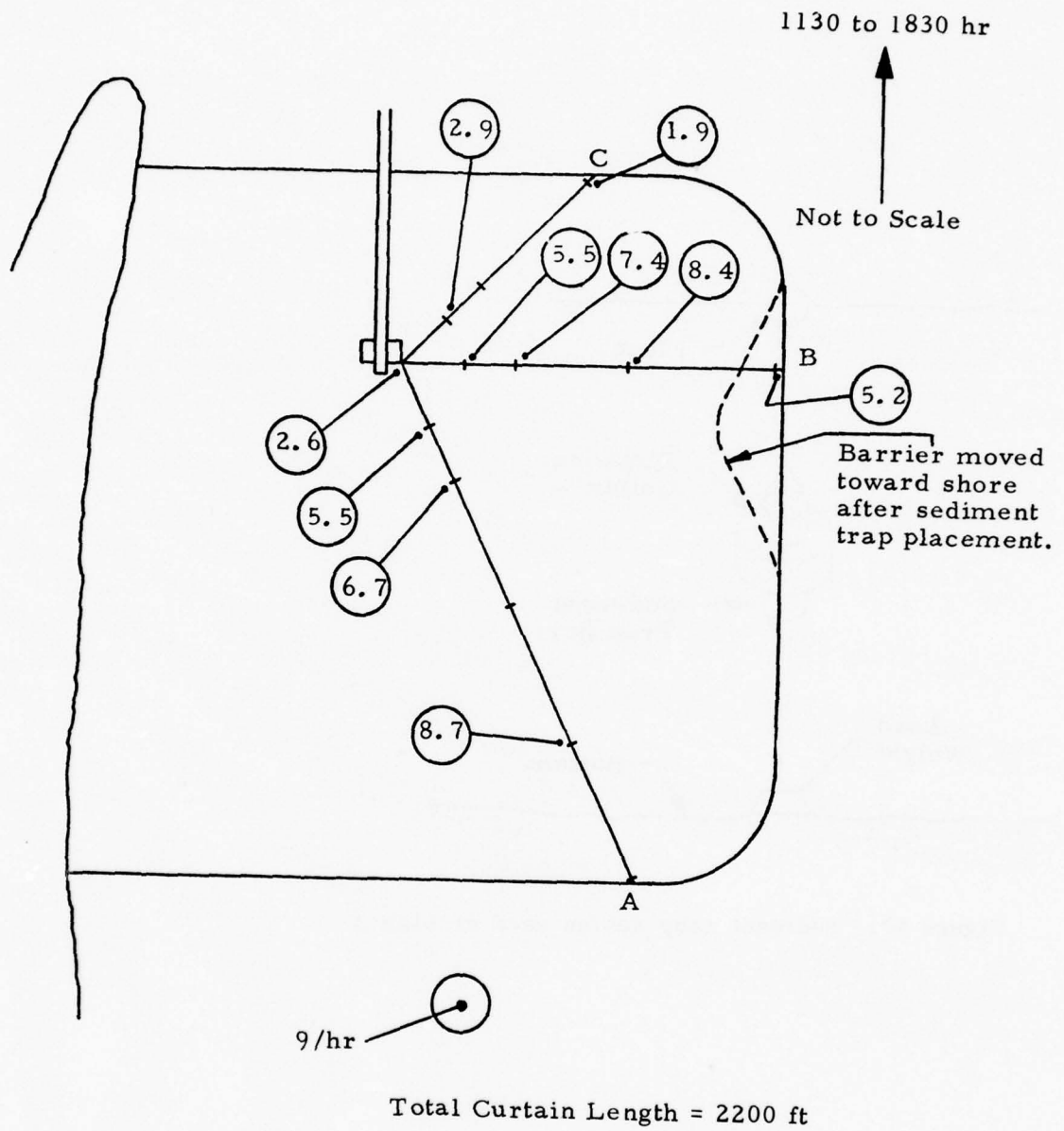

Figure 48. Sediment trap data for site 3

material being discharged. This supports the hypothesis that most of the material descends to the bottom to form a fluid mud layer while relatively small amounts of material remain suspended in the water column. As the turbid water above the fluid mud layer is carried away from the discharge point by currents, flocculation and subsequent setting of the flocs may occur. Since several hours are required for these fine-grained particles to settle, as shown in the early analytic discussion the maximum settling rate occurs at a considerable distance from the discharge point.

121. The suspended solids levels near the bottom during flood or ebb were between 0.13 and 14.8 percent solids. Almost all bottom solids concentrations were in the 1 to 17 percent range, which characterizes fluid mud. In addition the 5.5 percent level on the bottom outside corner, near Radial A, indicates that fluid mud existed outside the curtain. Since there was no other source for this fluid mud, it appears that the discharged mud was flowing under the curtain.

122. During a second field trip approximately one month later to the same site, it was noted that a considerable number of "new" mud flats had emerged within the area inclosed by the silt curtain and the discharge site had been moved to the south. The curtain was moored essentially the same as it had been. However, the pontoon floats supporting the discharge pipe were resting on a flotation member of the silt curtain at the point where the discharge pipe crossed the curtain, causing the flotation member to sink below the surface producing a "turbidity leak." The situation was subsequently corrected by the contractor.

123. An aerial survey of the site from an approximate altitude of 700 ft was conducted during the middle of an ebb tide to assess the effectiveness of the silt curtain (Figures 49 and 50). The large dark streak was apparently a turbidity leak emanating from the center of the curtain where the discharge pipe crossed it. It extended eastward toward the channel and then generally southward in the direction of the outgoing tide. Another phenomenon that was observed was a peripheral band of light brown coloration extending northward from the point of the pipe crossing and at the southeast corner of the inclosed area.

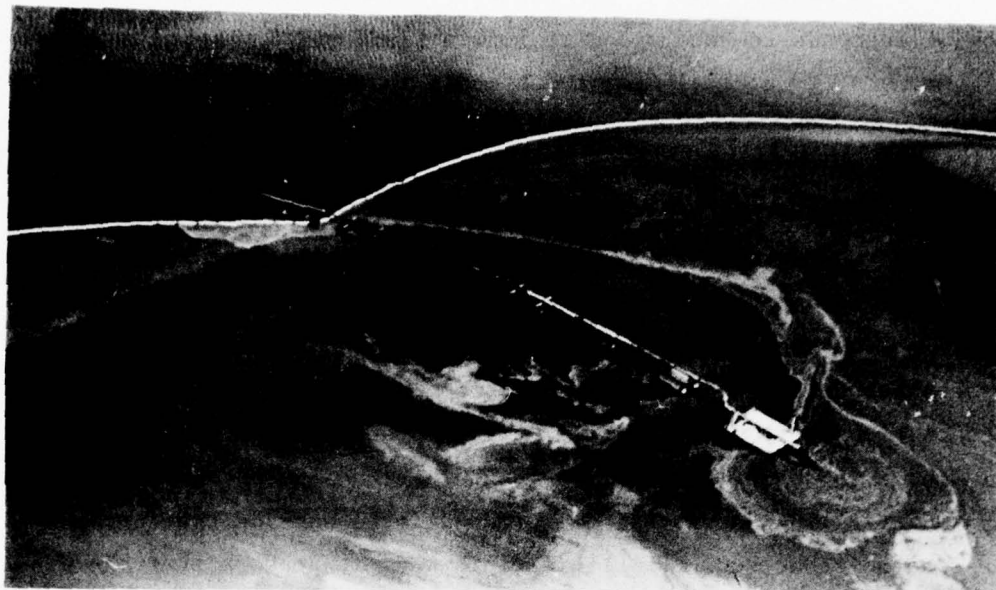

Figure 49. Discharge area at site 3

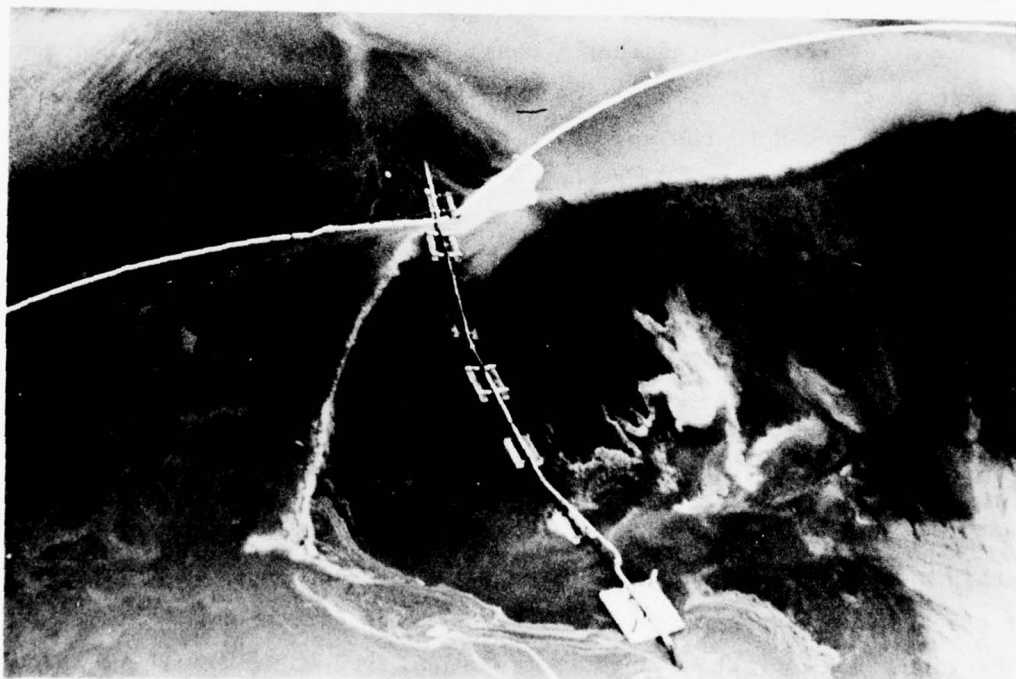

Figure 50. Closer view of discharge area at site 3

124. An outboard runabout was used for surface surveillance. Background samples were taken near the dredge approximately two miles north of the discharge site and at buoy 20A, about one mile west of the discharge site. Six sample stations were made around the curtain, three north and three south of the discharge pipe. Water samples were taken with a Van Dorn sampler at the surface, middepth, and just above the bottom, both inside and outside the curtain at each station. Near-bottom samples were also taken at precise distances off the bottom at each station to characterize the mudflow. This was done with a stiff rod having a 6-in. square "foot" and a series of hypodermic syringes rigidly attached to it at various heights above the foot. Once the apparatus was deployed with the foot resting on the bottom, a sample was taken by withdrawing the piston of the syringe with a cord attached to the handle.

125. Hypothetical Considerations. Figure 51 shows very high levels of suspended solids outside the curtain at middepth levels and below. In some cases, the levels tended to be higher outside than at the corresponding levels inside. Since the curtain is impervious, the only mechanism that can satisfactorily account for these levels would be underflow and upward transport of sediment outside the curtain. Two considerations tend to support this hypothesis. First, the solids concentration of the bottom samples is in the fluid mud range of 1 to 17 percent solids¹³ so that the material is likely to flow as a density layer near the bottom. Secondly, the aerial observations showing dark (suspended dredged material) and light (background turbidity) areas are consistent with the sample depicted in Figure 51 showing movement of material out of the curtain area. Leakage was also occurring at the pipe crossing point as a result of the pontoon resting on top of the silt curtain flotation, and the surface levels inside and outside the curtain are similar in this area.

126. The solids content of the near-bottom samples taken outside the curtain (Figure 52) indicates that fluid mud is present outside most of the curtain perimeter. Three near-bottom samples taken at 100-ft increments east of station V indicate that at that part of the curtain the fluid mud extends approximately 200 ft outside the curtain. It was observed on this

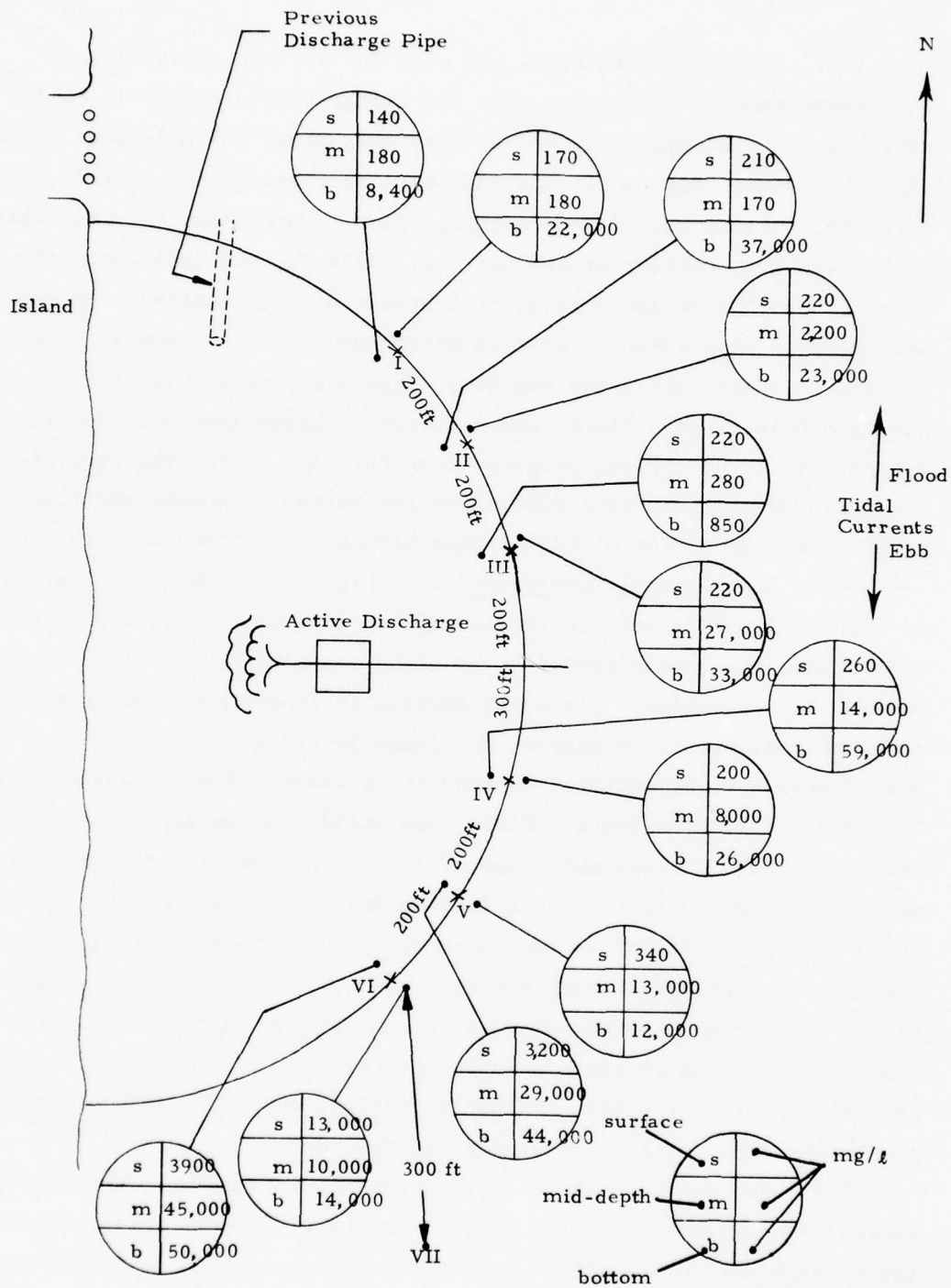

Figure 51. Sample station locations, second field trip to site 3

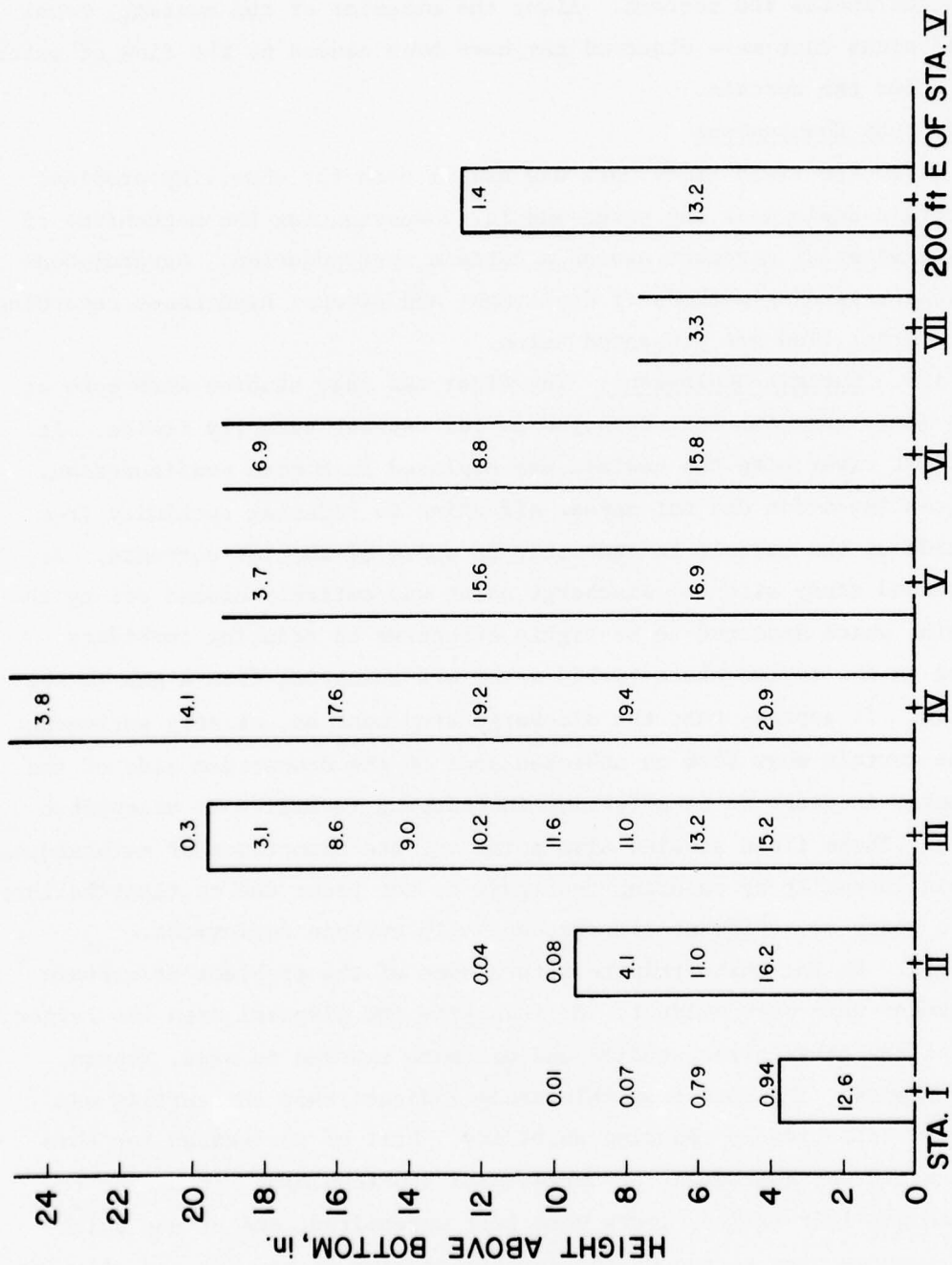

Figure 52. Near-bottom fluid mud data (in percent solids) outside the curtain at site 3

second trip that the 5-ft curtain skirt was located in a region where the water depth had been reduced from 2.5 to 3 ft due to the material deposited inside the curtain. Along the exterior of the curtain, local turbid areas that were observed may have been caused by the flow of water out, under the curtain.

Field Study Conclusions

127. The field study work was useful both for observing problems in curtain deployment and usage and for investigating the mechanisms of dredged material movement around a curtain configuration. Several conclusions regarding methods of deployment and several hypotheses regarding the material flow are presented below.

128. Curtain Deployment. The first two case studies were both at sites where curtains were deployed in low current velocity fields. At the first river site the curtain was deployed in a maze configuration. This configuration did not appear effective in reducing turbidity from one side of the curtain to the other in spite of the low currents. At the second study site the discharge point was entirely closed off by the curtain, which appeared to be highly effective in reducing turbidity except in the region where turbid water was emanating from a gap in the curtain. It appears that the discharge area must be entirely surrounded or the curtain must form an unbroken seal on the downstream side of the discharge in order to be effective in reducing turbidity to acceptable levels. These field studies also point out the importance of maintaining curtain integrity by ensuring that gaps do not occur due to float failure, fabric tears or equipment interference with curtain deployment.

129. On the third trip to site 3 some of the problems of curtain deployment were more evident. At this site the disposal area was larger than at the other sites studied and was more exposed to wind, storms, and currents. The data from this study indicate that the curtain was not very effective in reducing turbidity. Part of the reason for this was a matter of deployment or operational shortcomings. In places the curtain was left furled, tears were left unrepaired, and at one point the discharge pipe rested on the curtain causing it to sink and allowing

turbid water to leak out. In addition, the silt curtain was not moved when sediment had accumulated to the depth of the lower edge of the skirt. During changes in the tides the curtain dragged on the bottom and resuspended the fluid mud creating turbid water outside the inclosed area. In addition, the mud buildup tended to pull the curtain underwater when the skirt lay down on the bottom.

130. Operational shortcomings also took a toll during the storm that occurred at Winyah Bay. Due to inadequate moorings the curtain broke loose and was driven ashore and onto dredging equipment resulting in chafing and tearing of the skirt. It appears that insufficient anchors were laid and the mooring lines used were too weak.

131. Other important reasons for reduced curtain effectiveness at the Winyah Bay site were the water currents and the tidal action. With the current magnitudes present at this site, considerable curtain flare must have reduced the effective depth of the curtain and allowed turbid water to escape under the curtain, close to the water surface. During the tidal cycles the curtain itself was causing resuspension of bottom materials because the mooring arrangement permitted the curtain to move back and forth over a considerable distance as the direction of the tidal currents changed. This is shown dramatically in Figure 53 where the flood tide configuration shows the curtain spread to the north by the tidal current and the ebb tide configuration shows it spread in a southerly direction. The crosshatched areas show where the curtain swept over the bottom during tidal changes. Material deposited inside the northern edge of the curtain during the flood tide was exposed (outside the curtain) during ebb tide and was then susceptible to resuspension by the current. In addition, the movement of the curtain during this period tended to resuspend material directly as the curtain changed its orientation with the tide. It is important to recognize that this is not a shortcoming of silt curtains, but rather a result of inadequate mooring and anchoring techniques.

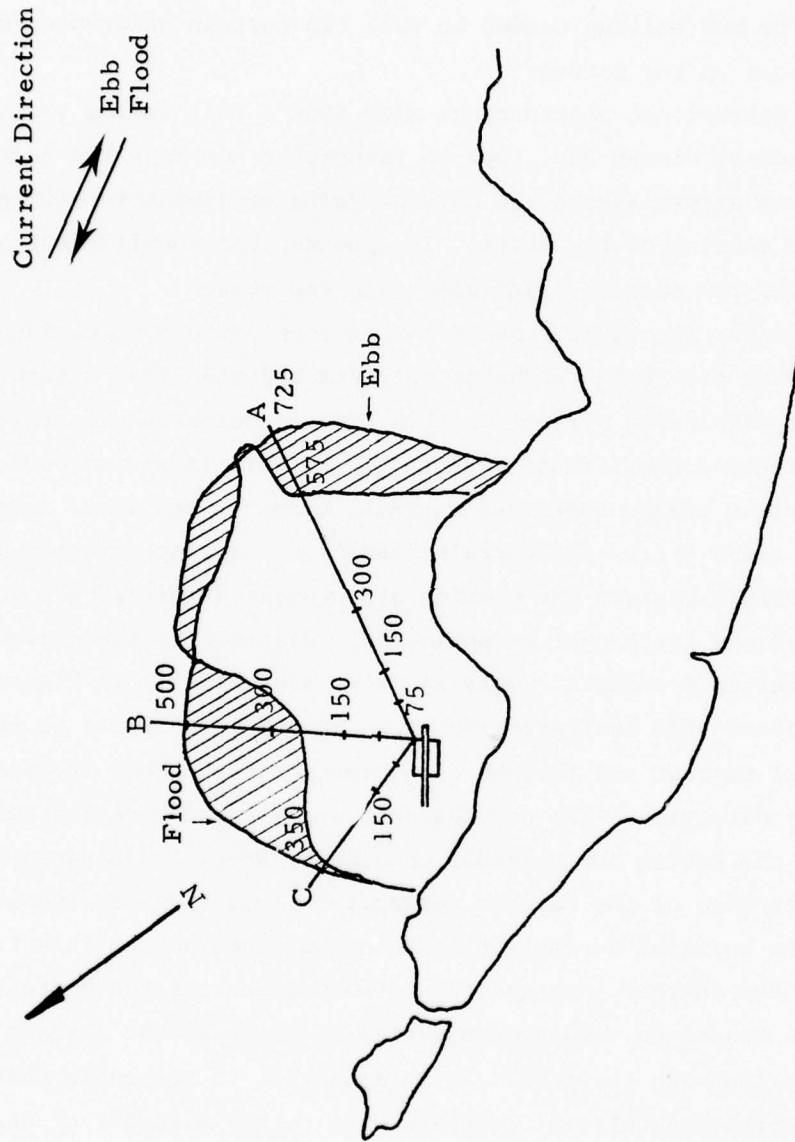

Figure 53. Change in curtain configuration with tide-induced currents at site 3. Numbers indicate distance in feet

132. Curtain Performance. The extensive data collected at Winyah Bay give some basis for determining the mechanisms of silt curtain performance. In the first place concentration measurements near the surface and near the bottom indicate that all but a very small amount of the discharged material forms a fluid mud layer on the bottom. The remaining small amount of material becomes suspended and will not readily settle out because several hours are required for sedimentation. Instead, it moves as a fine suspension subject to tides and currents and its flow could be influenced by silt curtains. Flocculation may occur causing some settling out.

133. This hypothesis is supported by the material balance analysis of Chapter III, which indicates that approximately 95 percent of the discharged slurry forms a fluid mud layer leaving only about 5 percent of the discharged solids in suspension in the water column. This hypothesis is also supported by the sediment trap data indicating relatively low settling velocities of the fine-grained suspended material compared to the higher velocity of the discharge rate. Most of the discharged material was not deposited inside the curtain but probably moved out under the curtain in the form of a fluid mud layer.

134. Analysis of near-bottom samples shows that fluid mud existed within the curtain and to a distance of about 200 ft outside the curtain. It should be noted that limiting concentrations for movement of fluid mud by density flow are about 1 to 17 percent solids by weight.¹³ When there is less than 1 percent, the excess density of the solids water mixture is not sufficient to drive the flow, and the mixture moves with the ambient velocity. When concentration exceeds 17 percent, the mixture is too viscous to be moved by the excess density. Between these values, the excess density of the mud provides sufficient driving force so that the material will flow unless it is contained in an enclosure or pocket. Since the bottom at site 3 was essentially flat with no means of containing the flow, the existence of these concentrations near the bottom indicates that the fluid mud was probably flowing out under the curtain

to a distance of up to 200 ft (no velocity measurements of the flow were taken, however).

135. It appears, therefore, that most of the discharged dredged material forms a fluid mud layer that can flow under the curtain. Once outside the curtain enclosure, resuspension and upward transport of the material may create turbidity outside the curtain. Evidently, only a small proportion of the discharged material remains in suspension at the discharge point although that amount is sufficient to cause high turbidity levels. This material settles at a very low velocity and therefore moves with the current and tides. Where a silt curtain is intact to a depth of several feet, this turbidity will be contained at the surface. It can flow under the curtain, however, and then upward transport can bring it back to the surface some distance downstream of the curtain where it will be diluted to lower concentrations.

136. Silt Curtain Effectiveness. The silt curtain acts as a barrier to suspended solids by holding them in a stagnation pocket behind the curtain. Since only a small fraction of the solids are so contained, the large percentage escapes under the curtain in the fluid mud cover that is generated within the curtain enclosure and flows along the bottom away from the discharge point. As it moves under the curtain the fluid mud layer generally carries with it a cover of turbid water that has escaped under the stagnation zone behind the curtain. If conditions are quiescent, the fluid mud system flows stably along the bottom beyond the curtain with virtually no apparent turbidity in the region of the surface. The theoretical scene has highly turbid water on the inside of the curtain and virtually clear water outside the curtain down to the bottom edge of the curtain. Down in the fluid mud layer on the bottom, the suspended solids concentration is very high and does not necessarily undergo a strong reduction in value as the mud flows under the curtain.

137. In accordance with the preceding description, the effectiveness of the silt curtain was quantified by comparing the turbidity level on

the inside with that on the outside of the curtain at each of several locations along its length. The percent reduction in turbidity level across the curtain was used as the effectiveness parameter. The dimensionless form accounted for the possibility of the difference in readings being a function of the level of turbidity. Percent reduction was defined as 100 times the ratio of the difference in readings to the higher reading. The reduction was positive (+) when the turbidity level on the inside (or upstream side) of the curtain was higher than on the outside, and negative (-) when the outside reading exceeded the inside level. This definition allowed equal differences in opposite directions to cancel each other exactly and limited reduction values to 100 or less.

138. During field tests at the three test sites, a considerable number of readings were taken across the curtain not only at points along its length but also at several water depths at each sample station. These data have been copied from Figures 36, 39, 45 and 51 and compiled in Table 4 along with the conditions of each test and the percent reduction values. At Site 1 where the maze array was used, the reduction values ranged from 14 to 54 percent and were all in the positive direction. These results reflect the very quiet, stable conditions that were obtained at this site as well as the apparent absence of phenomena that cause high turbidity levels downstream of the curtain; i.e., reversing tidal currents, severe wave action, gaps in the curtain, etc. The turbidity levels also indicate that no readings were taken in the mud layer if such existed. The average of all reduction values was 31 percent which is probably indicative of the quiescent conditions and low turbidity levels rather than the maze configuration.

139. The remainder of the effectiveness data was collected on curtains arrayed in the D configuration. During the field trip to Site 2 and the first to Site 3 relatively few measurements were made across the curtain; these are presented in Table 4. The second trip to Site 3 was conducted specifically to obtain turbidity levels across the curtain, and the body of Table 4 is comprised of the data from this trip. Water

Table 4
Silt Curtain Effectiveness Data

Site	Configuration (Skirt Depth)	Current	Sample Depth	Reading		Units	Turbidity Reduction	Ref. Figure No.	
				Upstream or Inside Curtain	Downstream or Outside Curtain				
	ft	kts	(a)	(b)	(b)		% (c)		
1	maze (5)	~ 0.25	0	58 (6)	36 (3)	NTU	38	36	
			3	70	52		25		
			5	98	45		54		
			0	55 (5)	43 (2)		22		
			3	73	63		14		
			5	83	46		45		
			0	43 (4)	27 (1)		37		
			3	77	59		23		
			5	90	73		19		
							0 Ave.		
			3 Ave.				21		
			5 Ave.				39		
2	"D" (5)	~ 0.25	0	64 (8)	8 (9)	NTU	88	39	
			3	63	16		75		
3 (trip 1)	"D" (5)	0.25 to 0.5	s	22 (A)	27 (A)	mg/l	-19	45	
			m	48	5		90		
			s	168 (B)	177 (B)		-5		
			m	198	235		-19		
			b	36,000	10,000		72		
				s Ave.					-12
	m Ave.			36					
	b Ave.			72					
3 (trip 2)	"D" (5)	0.25 to 0.5	s	140 (I)	170 (I)	mg/l	-18	51	
			m	180	180		0		
			b	8,400	22,000		-62		
			s	210 (II)	220 (II)		-5		
			m	170	2,200		-92		
			b	37,000	23,000		38		
			s	220 (III)	220 (III)		0		
			m	280	27,000		-99		
			b	850	33,000		-97		
			s	260 (IV)	200 (IV)		23		
			m	14,000	8,000		43		
			b	59,000	26,000		56		
			s	3,200 (V)	340 (V)		89		
			m	29,000	13,000		55		
			b	44,000	12,000		73		
			s	3,900 (VI)	13,000 (VI)		-70		
			m	45,000	10,000		78		
			b	50,000	14,000		72		
				s Ave.					3
				m Ave.					-3
	b Ave.			13					

Note: (a) numbers refer to water depth in feet
s - surface
m - middepth
b - bottom

(b) numerals in parentheses refer to sample station locations, see ref. figure.

(c) % reduction given by the ratio of the difference in readings to the larger reading, multiplied by 100. Reduction is positive (+) when outside reading less than inside reading. Reduction is negative (-) when outside reading greater than inside reading.

samples were taken at six stations that were located at 200-ft intervals around the semicircular curtain array and at surface, intermediate, and bottom depths at each curtain station. The reduction values extend from a high of 89 percent in the positive direction to 99 percent in the negative direction. Approximately 40 percent of the data points showed a negative reduction. This condition was attributable to the wide excursion of the curtain in the tidal currents (see Figure 53) and was made possible by the use of only two anchor points on the ocean side of the curtain array. The lower edge of the curtain was allowed to drag along the muddy bottom and resuspend sediment on the outside of the curtain. Although the effectiveness of the curtain might have been improved significantly with the use of more anchors, the data do reflect the performance of a typical curtain installation and highlight the obstacles to be overcome in order that the silt curtain function efficiently in the tidal zone. The top three stations in the northeast quadrant all appeared to suffer the buildup of turbidity outside the curtain while those in the southeast quadrant with the exception of one measurement all recorded positive (+) turbidity reductions across the curtain. If the two quadrant groups are separated, the northeast average is -37 percent and the southeast is +47 percent. The latter compares favorably with the 31 percent average for the maze configuration and probably is a reasonable measure of the effectiveness of the D configuration. Tidal effects reduced this to nearly zero (5 percent) as shown by the overall average of all Site 3 data (second trip).

140. The overall averages for all measurements combine the good and bad features of curtain configuration and environmental conditions. These values are tabulated below for each sample depth and all depths combined. Turbidity reduction at the surface and middepth positions

Overall reduction, surface	-	15 percent
middepth	-	16 percent
bottom	-	27 percent
all depths	-	19 percent

are approximately the same at a conservative 15 percent. The larger reduction at bottom depth was probably due to the presence of higher suspended solids concentrations and concentration gradients.

Field Testing of Curtains in Heron Bay, Alabama

141. After the field studies that were discussed in the previous section, it became evident that the required engineering data and the range of variables of interest for investigating curtain performance could not be achieved through field programs at dredging sites alone. Therefore, a field demonstration program was developed and tests conducted in Heron Bay, Alabama to supplement the data collected at the three field sites. Data gathered during the physical tests included measurement of current velocity, mouth opening, shape of curtain, skirt draft, and skirt flare direction.

Description of Tests

142. A 100-ft section of each of two different types (American Marine's "Dual Center Tension" and "Fastwater Screen") of silt curtain was installed in a "D" shape in Heron Bay and a "U" shape in the cut between Heron and Mobile Bays (Figure 54). These two configurations were chosen since they represent typical field applications. For each configuration, physical behavior of the curtain was measured in various current regimes, and for selected configurations, turbidity characteristics of generated plume were measured.

143. The purpose of the physical measurements was to provide insight into the behavior of the silt curtain and to verify the analytical predictions under the influence of various current velocities. Physical measurements included an evaluation of the shape of the curtain profile as well as the velocity field near the curtain. Since flaring reduces the effective depth, hence the effectiveness of the curtain, its behavior as a function of current velocity is a critical factor. Measurements of the velocity field were made at a control point outside the curtain at a number of locations inside the curtain and in the gap between the bottom of the curtain and the bay bottom.

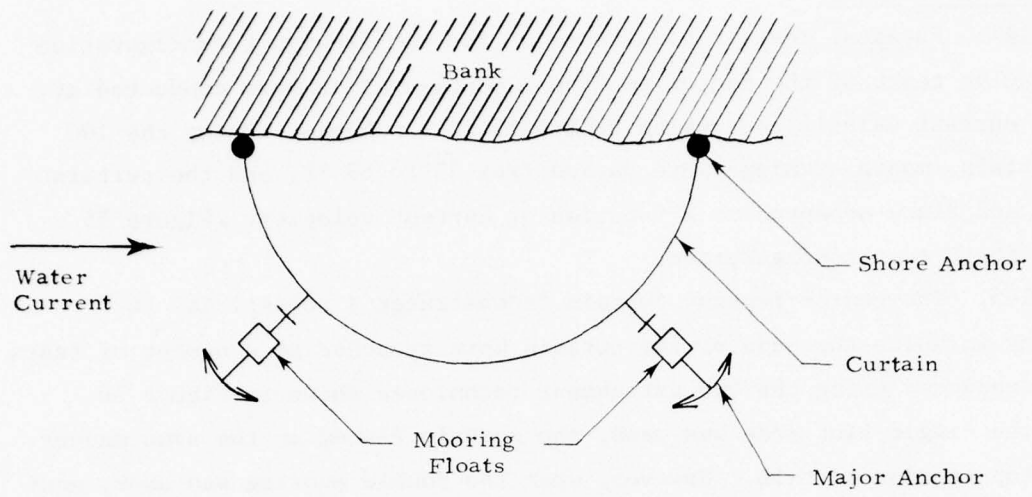

a. "D" Shape

Water Current ↓

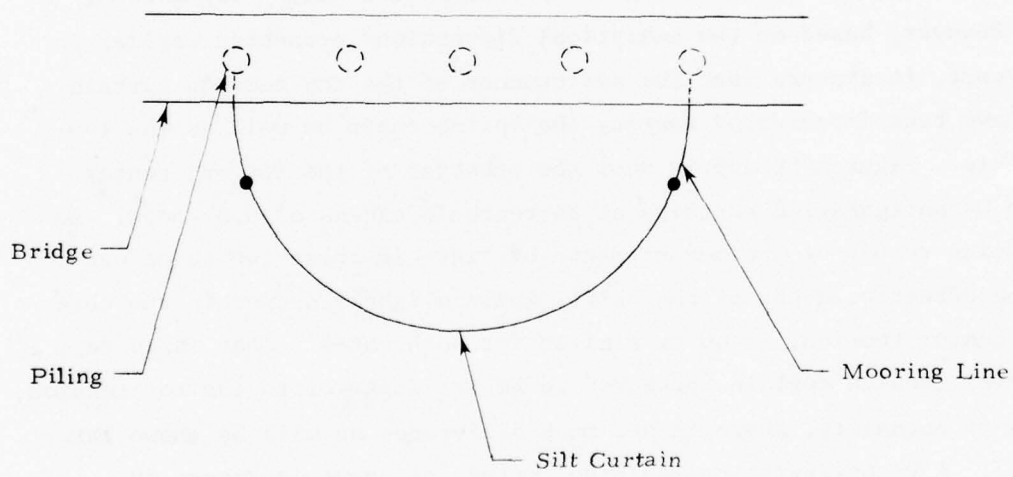

b. "U" Shape

Figure 54. Configurations used in Heron Bay tests

Discussion of Tests

144. Physical Tests. Nine tests of the top tension U-configuration and twelve tests of the center tension U-configuration were conducted at water current velocities ranging from 0.15 to 2.0 knots. Using the 100 ft curtain, mouth openings were varied from 33 to 89 ft, and the curtain shape and flare measured as a function of current velocity. Figure 55 shows the U test configuration.

145. The center tension curtain demonstrated a sensitivity to the way in which the ends of the curtain were attached so a number of tests were conducted using the two attachment techniques shown in Figure 56. When the single line yoke was used, the curtain flared in the same manner as a top tension curtain. However, when the double mooring was used, most of the tension was picked up by the lower mooring line and the type of flaring observed was much different as shown in Figure 57. The top tension curtain flared in an inverted "L" shape and the double mooring center tension curtain flared in a "gull-wing."

146. The top tension curtain was less sensitive to the way in which it was moored, since it was designed to hang from a single top mooring line. However, based on the analytical discussions presented earlier in this report, it appears that the performance of the top tension curtain could have been improved by mooring the bottom chain as well as the tension cable. Figures 58 and 59 show the behavior of the top and center tension U-configuration curtains at currents in excess of 0.5 knots. An interesting result of the measurements of flare in these two cases was that the effective depth of the skirt, while slightly deeper in the case of the center tension, is quite similar for both cases. That is to say, the center tension curtain "appears" to be far superior to the top tension, whereas in actuality, there is not much difference as will be shown later.

147. A D-configuration was also tested, as shown in Figure 60. Physical measurements were made on three tests of the center tension curtain and three tests of the top tension curtain, over currents ranging from 0.15 to 0.9 knots. These tests verified the assumed behavior of the curtain in a velocity field. As shown in Figure 61, the curtain flared in on the up current side and out on the down current side. At a corner, the curtain



Figure 55. U test configuration

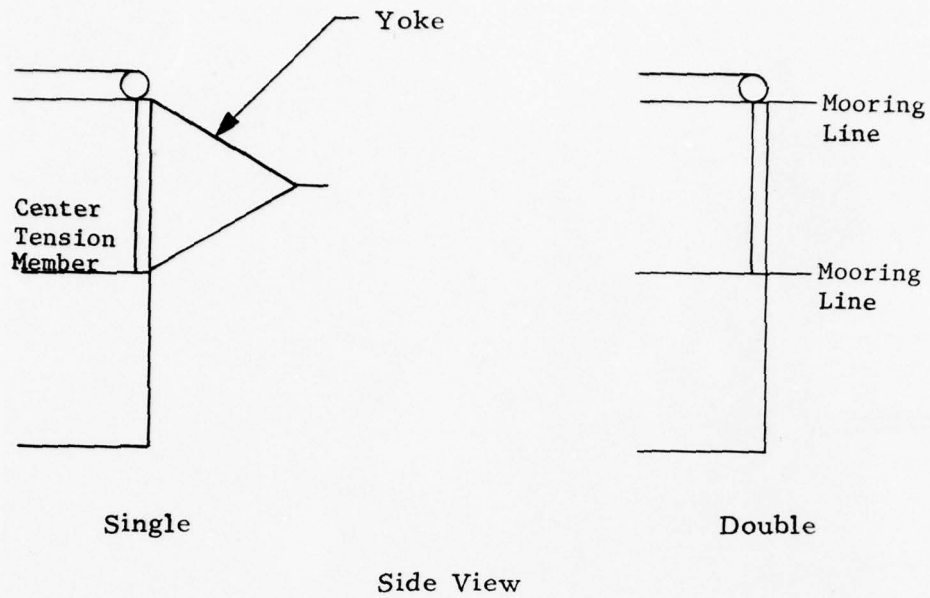
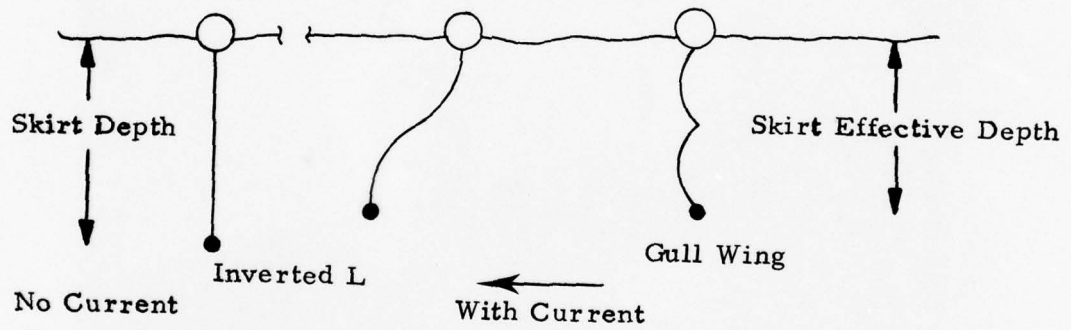

Figure 56. Center tension curtain attachments



Note: These shapes would exert different hydrodynamic effects on the water currents that they are deployed in.

Figure 57. Shapes of curtain profile in flare

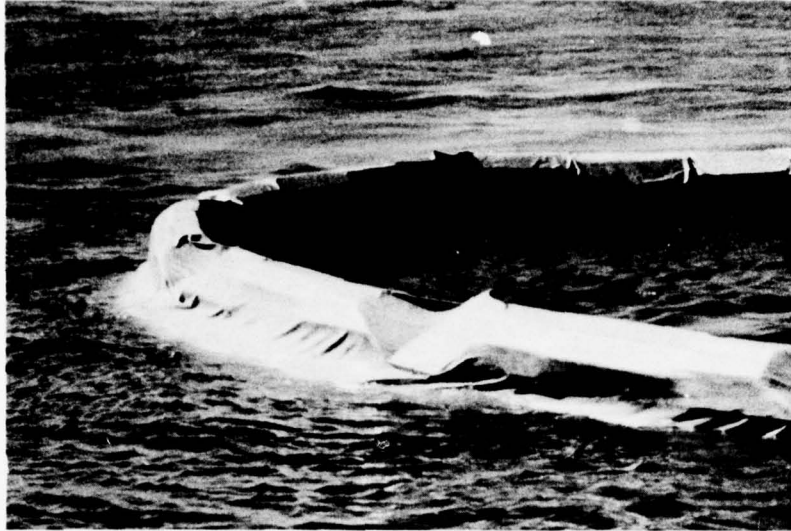

Figure 58. Center tension curtain flare in U configuration at a current velocity of 0.5 kts



Figure 59. Top tension curtain flare in U configuration at a current velocity of 0.8 kts

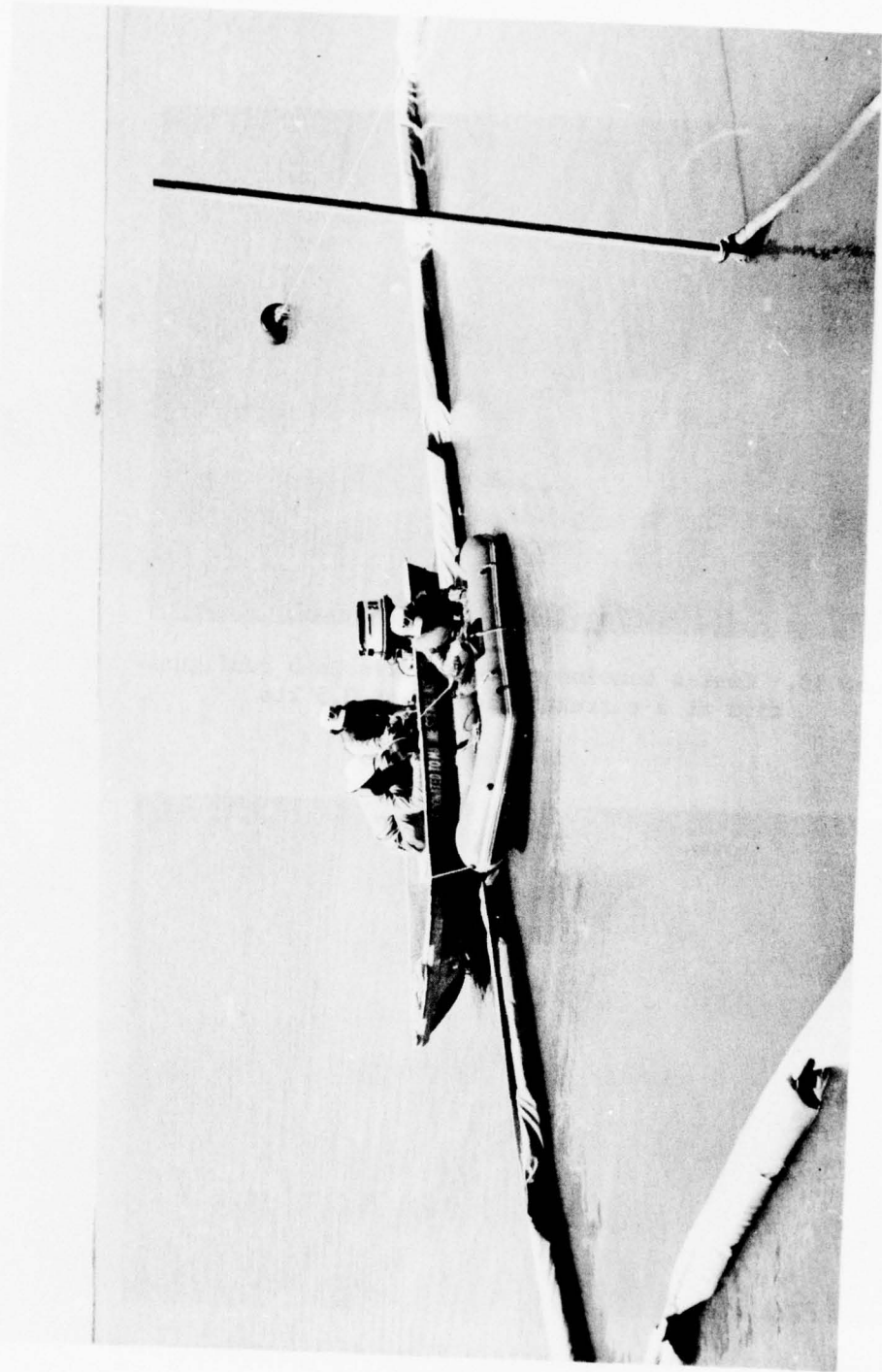

Figure 60. D test configuration

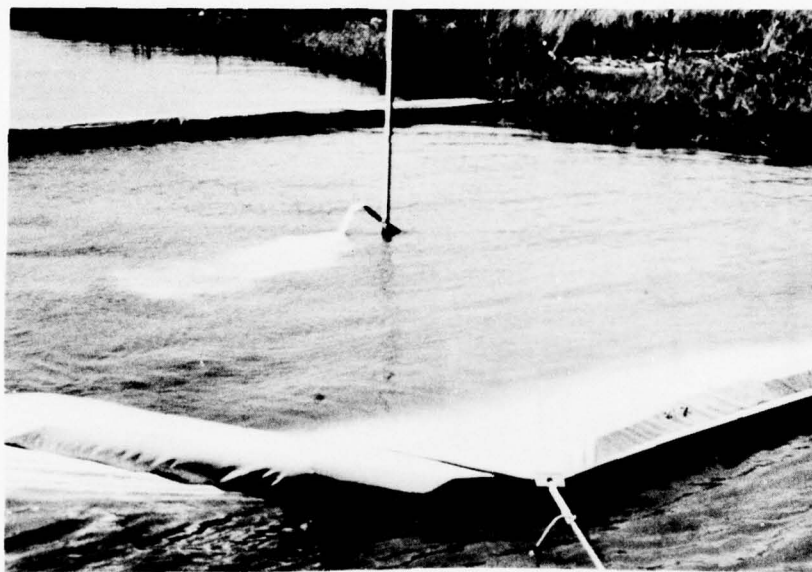

Figure 61. Flare behavior in the D configuration, top tension curtain in a current of 0.25 kts

would twist such that the top of the curtain would change direction 180° within a few feet. Flare measurements of the center tension vs. the top tension once again verified that the center tension curtain maintains a greater effective depth for a given current, but that the difference is not as dramatic as expected from viewing the curtain.

148. In the U-configuration a low frequency vertical oscillation of the skirt was observed. This was not observed in the D-configuration. It is likely this effect is primarily due to water turbulence in the particular area where the U-configuration curtain was deployed (see Figure 62) and not directly related to the curtain itself. This turbulence, however, can be critical in terms of the turbidity control as will be discussed in the next section.



Figure 62. Turbulence in the U-configuration deployment area

149. Current Velocity Tests. The flow of water around a curtain was examined by measuring the current field in the vicinity of both the U-configuration and the D-configuration curtains. Figure 63 shows the velocity variation with distance from the curtain at 2-ft and 6-ft depths along the centerline of the U-configuration. The velocity reduction at both depths, immediately in front of the lower curtain edge is due to the diversion of most of the flow around the entire U-configuration. Velocity at the 6-ft depth increased right at the curtain due to the concentration of flow going under the curtain. Immediately downstream of the curtain, velocity decreased slightly at 6 ft as the flow expanded out of the curtain gap; still farther downstream the flow at all levels returned to the free stream velocity. Note that velocity under the curtain was about equal to the free stream velocity that is expected from the hydrodynamic pressures on the curtain. This velocity distribution confirms the expectations of water flow in the vicinity of a curtain moored in a free stream. Much of the flow is diverted around the entire curtain, especially if there is little depth under the curtain. Sufficient flow passes into the U and under the curtain so that velocity under the curtain will be close to the free stream velocity.

150. Figures 64 thru 67 show current velocity measurements for the curtain in the D-configurations. Examination of these figures shows several interesting characteristics of the flow around the D-configuration. In the first place, a high velocity (upstream) and a low velocity (downstream) side of the configuration can be identified. The velocity inside the curtain usually is at a level somewhere between the high and low velocities outside, indicating that a significant amount of the water flow passes into and under the D while the remaining flow is diverted around the D. It is also interesting to note that within the D there is a trend for velocity to increase with depth due to the unobstructed flow through the gap under the curtain. In conclusion, these surveys indicate that flow in the vicinity of a D-configuration is split such that significant amounts of flow are directed both through and around the D.

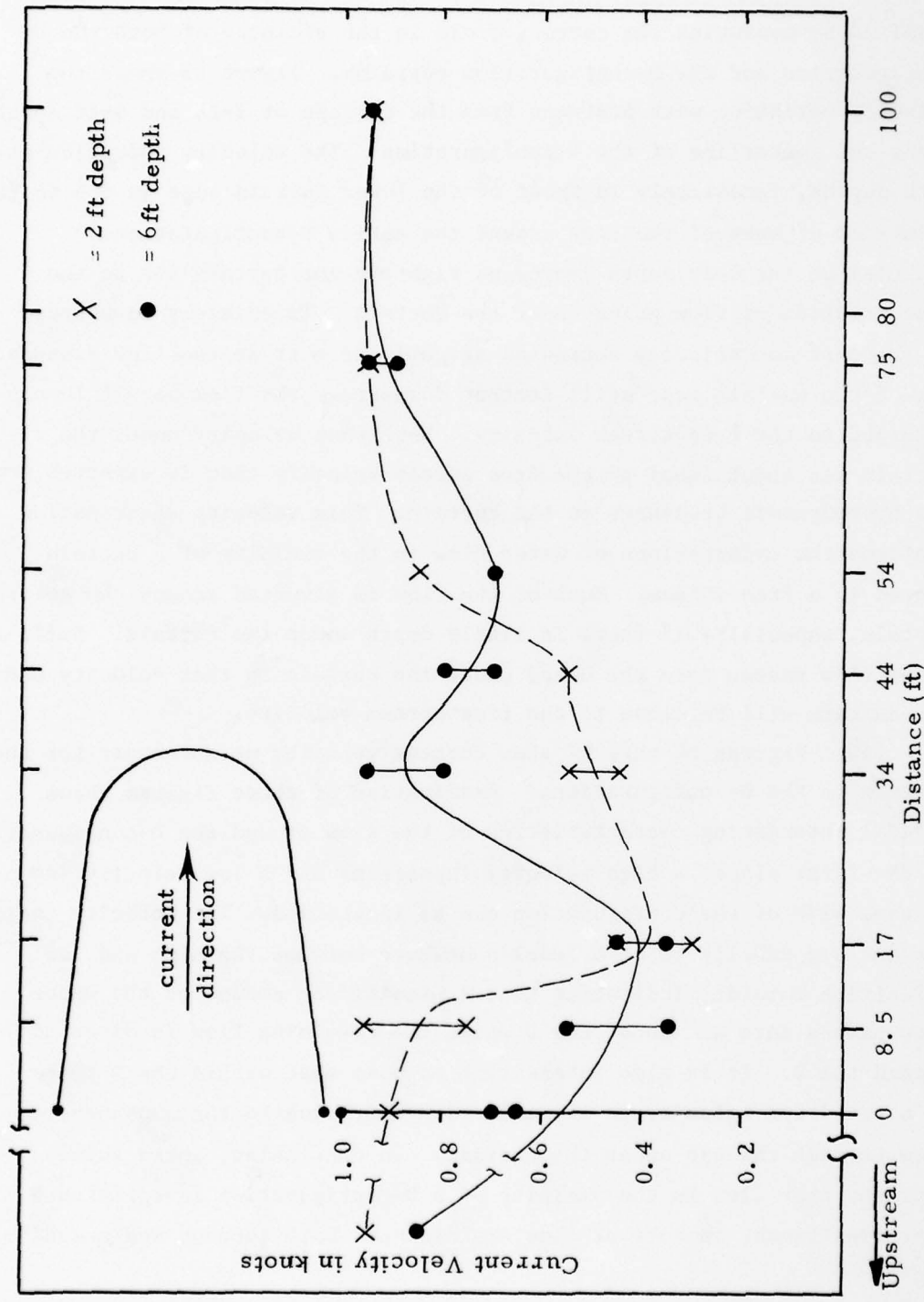

Figure 63. Current velocity variation with distance from a center tension silt curtain along the centerline of the U-configuration; skirt depth 5 ft

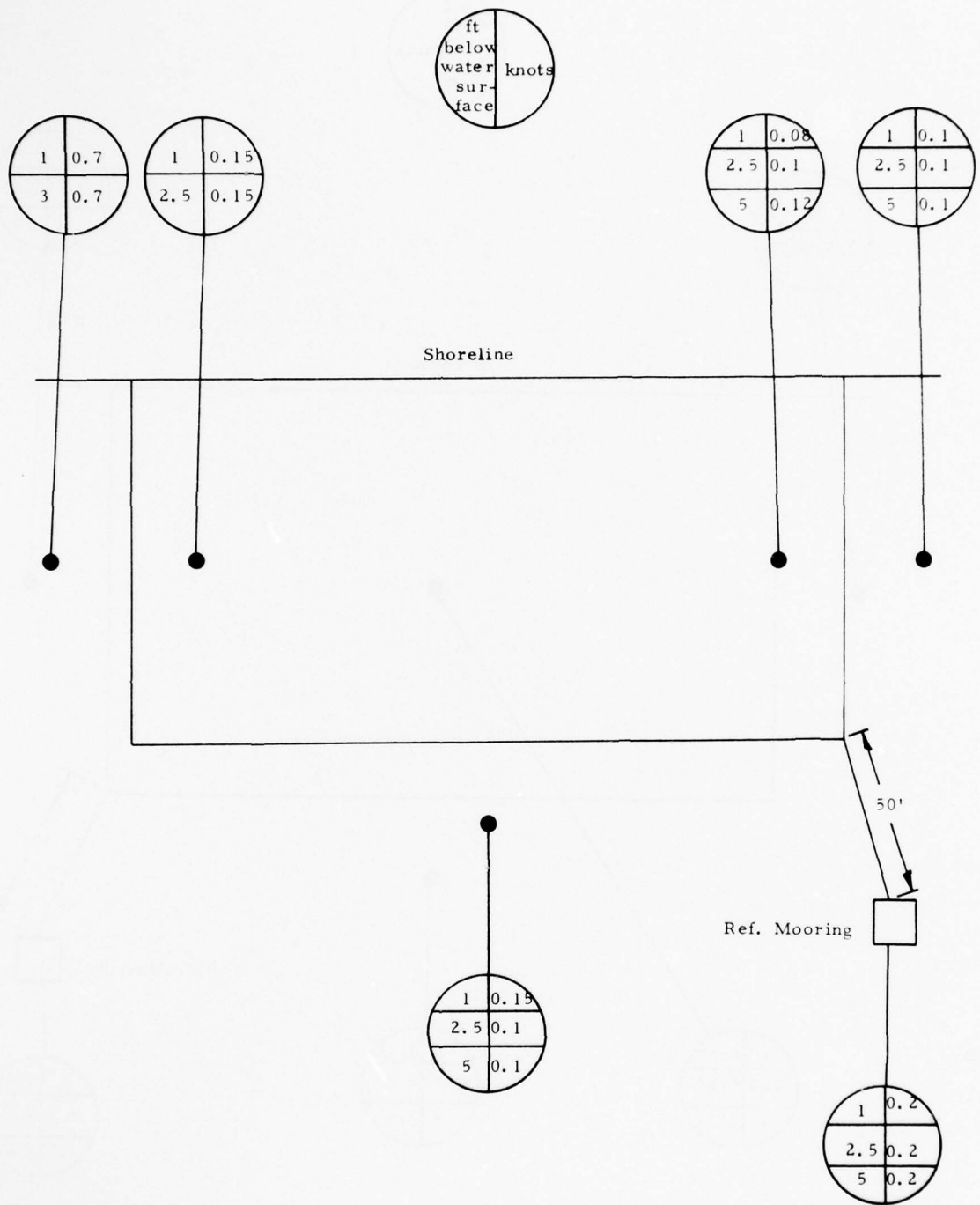

Figure 64. Current measurements, center tension, D configuration, low current period

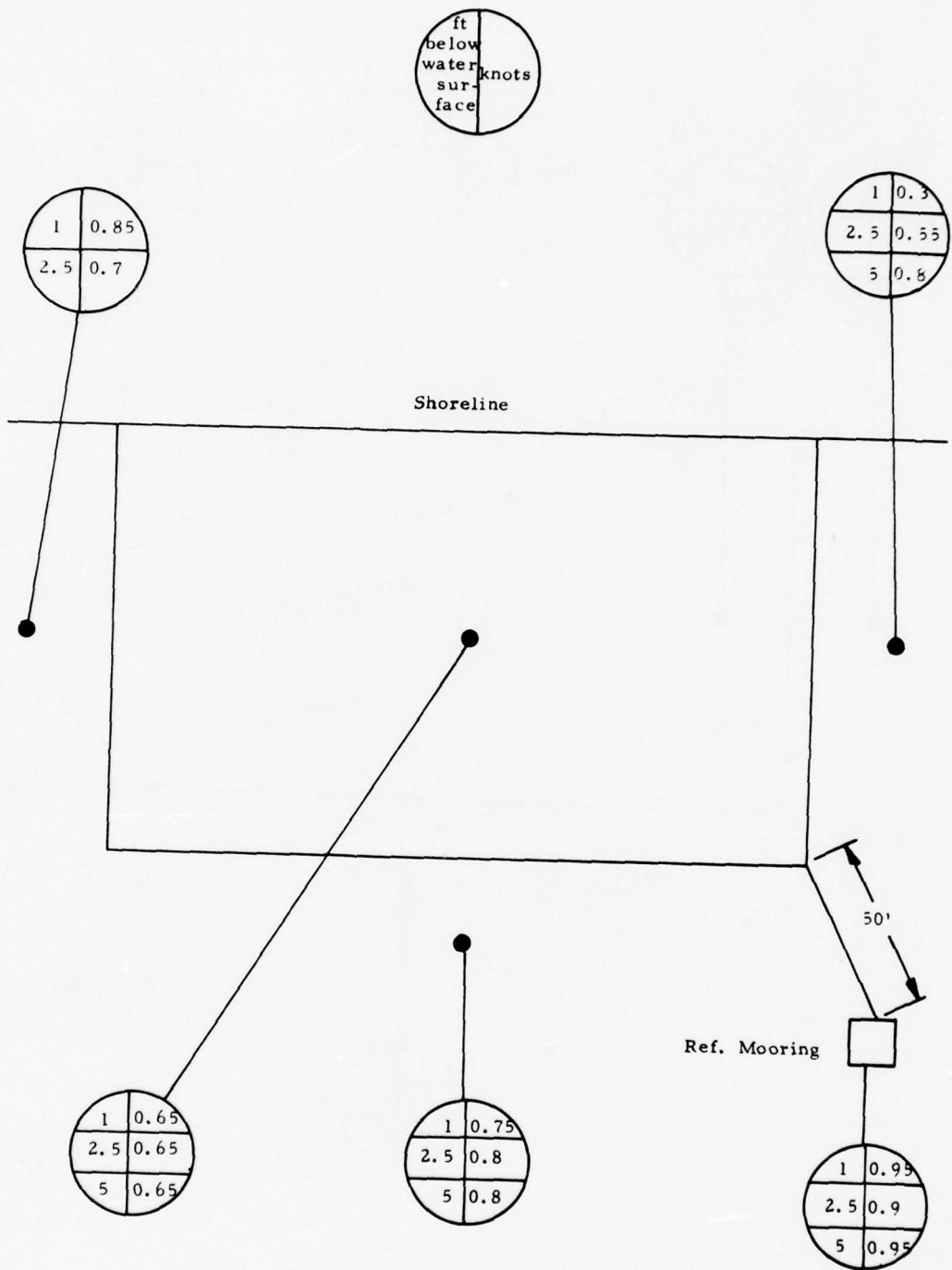

Figure 65. Current measurements, top tension, D configuration, high current period

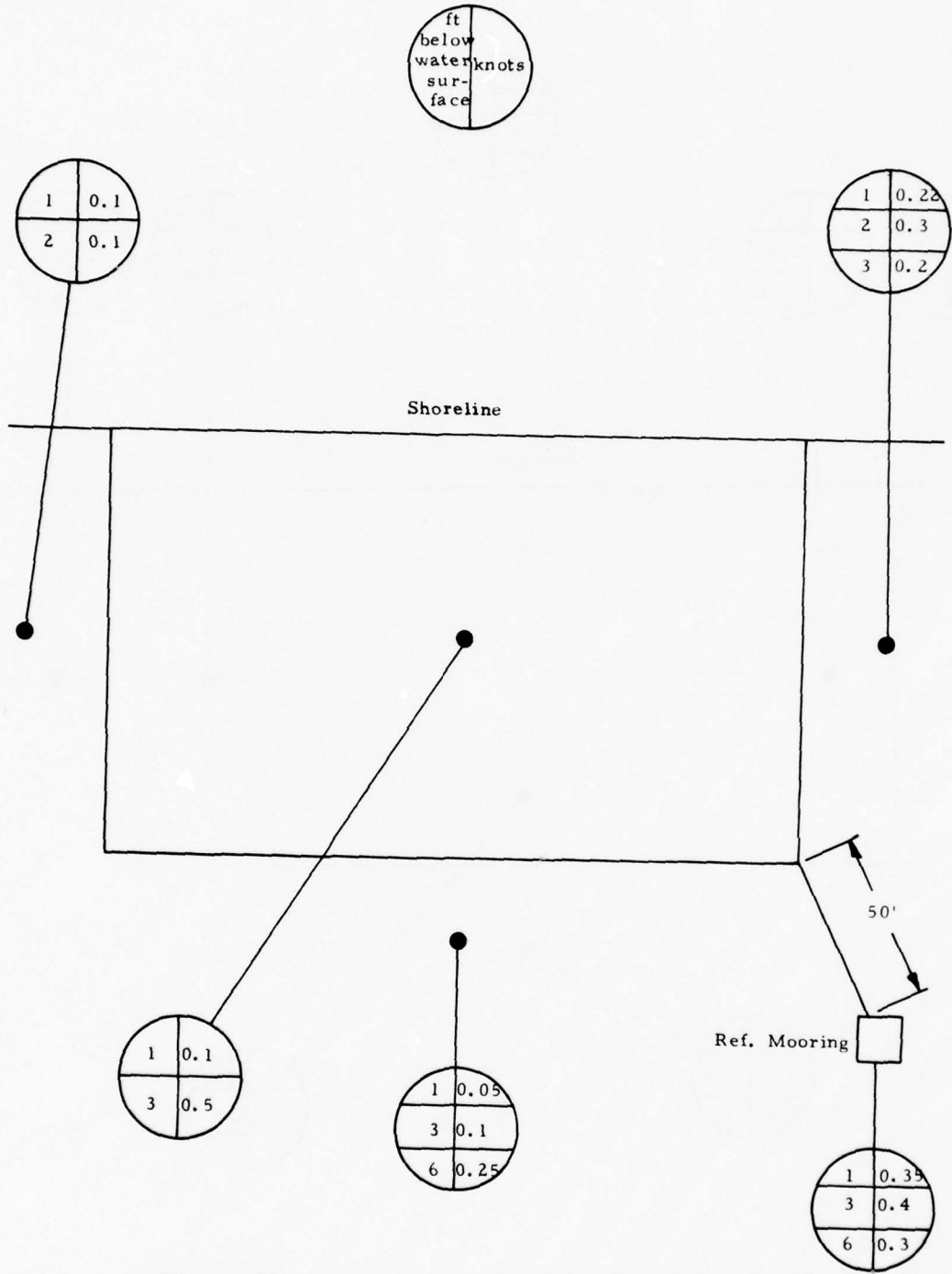

Figure 66. Current measurements, top tension;
D configuration, low current period

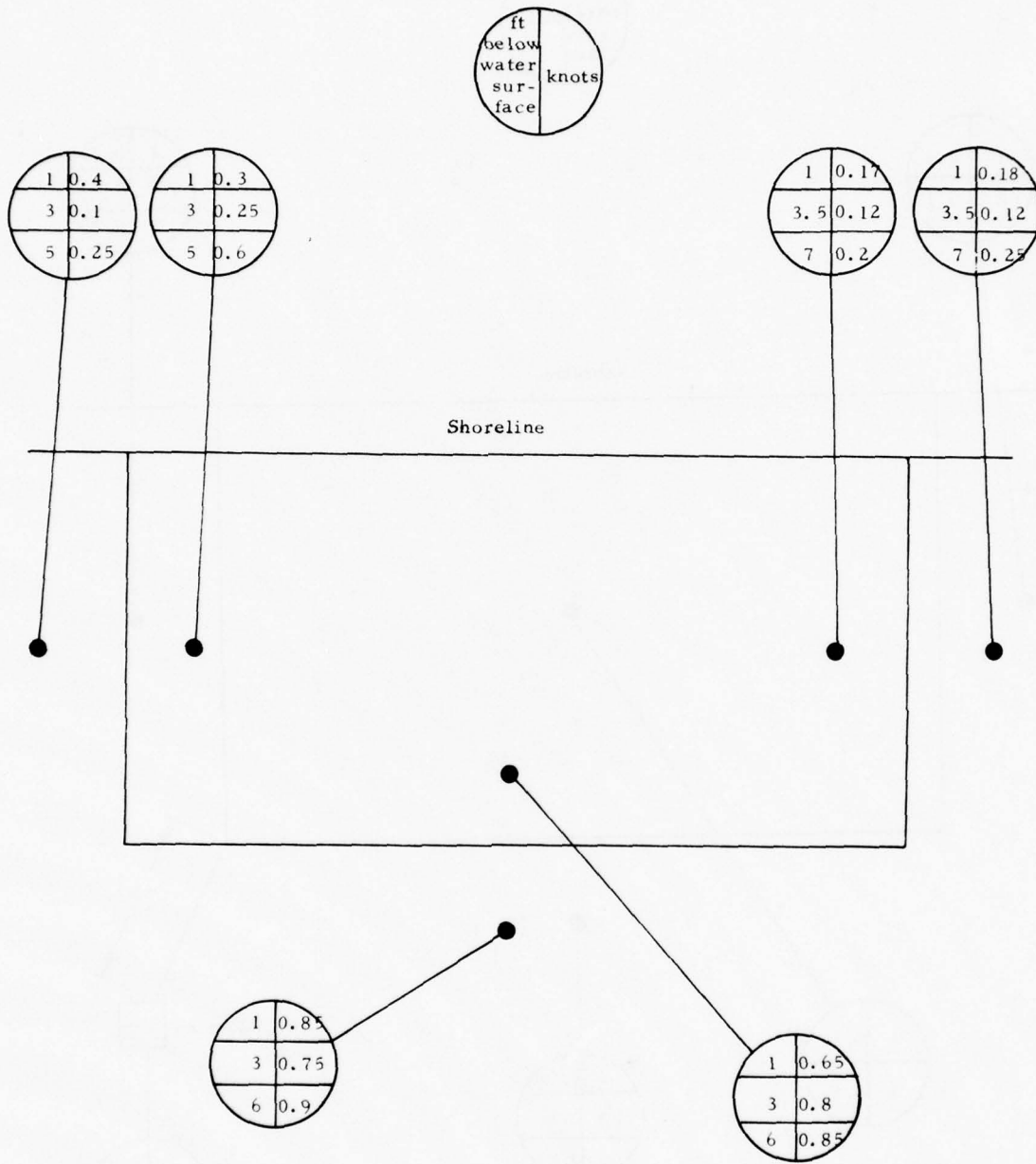

Figure 67. Current measurements, center tension, D configuration, high current period

Comparison of Field Measurements and Analytical Results

151. The physical behavior of the curtain in a current was the subject of analytical study earlier in this chapter. In the field testing described in the preceding section, physical behavior of the curtain (i.e., the shape taken by the deployed curtain in a current and the effective depth of the curtain) was observed and measured for a 100-ft curtain deployed in currents up to 2 knots. In this section, the field testing results will be compared with the analytical results in order to evaluate the analytical approach.

Curtain Shape and Curtain Tension in a Current

152. The curtain shape in a current was measured during the field testing for several curtain configurations. The method of determining curtain shape was to measure distances from the mouth of the "U" (the bridge) to points on the curtain. These offsets were then used to plot the curtain location.

153. For validation of the analytical study of curtain shape, catenary forms were plotted for comparison against the field test plots. The analytical study hypothesized that the curtain would take a catenary shape in a current and that the shape would be approximated by equation 21 which is repeated below:

$$y(x) = L\tau \left(\cosh \left(\frac{x}{L\tau} \right) - 1 \right) \quad (21)$$

where y is measured parallel to the current direction
 x is measured perpendicular to the current direction
 L is curtain length
 τ is the tension parameter (defined in equation 19)
that is related to the curtain length to mouth wide ratio

Using this equation, the hypothetical curtain shape was plotted for each curtain configuration (mouth width) that was measured in the field test. The catenary plots were then overlaid on the field test plots for comparison.

Figures 68 and 69 show typical comparisons of hypothetical and field test results. In all cases the differences are within expected measurement variations and, therefore, it appears that the catenary equation presented above is a reasonable representation of the curtain form in a current.

154. Since tension cable loads were not measured in the field, only analytical estimates can be made based on the measured shape of the curtain. The estimated tension loads are outlined below for specified water currents.

Curtain deployed at 50-ft mouth width:

1-knot current	165 # curtain tension
2-knot current	374 # curtain tension

Curtain deployed at 70-ft mouth width:

1-knot current	332 # curtain tension
2-knot current	752 # curtain tension

Inasmuch as the tension estimates depend on the curtain shape equations, which according to Figures 68 and 69 predict the shape quite closely, the above tension values are felt to be reasonably accurate.

Effective Depth of the Curtain in a Current

155. Effective depth is defined as the depth from the water surface to the bottom of the curtain. In other words, it is the vertical measurement of depth of the flared curtain. The curtain effective depth in a current was measured during the field testing for several curtain configurations, several currents and at several points along the curtain length. The method for determining effective depth was to use a calibrated line attached to the bottom of the curtain. By pulling the line into a vertical position from the surface, the effective depth could be read from the length markings. Effective depth was measured at several points along the curtain length to determine how flare is affected by the angle of attack of the curtain to the current.

156. One important effect observed in the field test results was that the curtain had greater flare near the mooring points (at the ends) than it had at the apex of the "U." Analytical prediction expected curtain flare in currents to be greatest at the apex of the "U" where

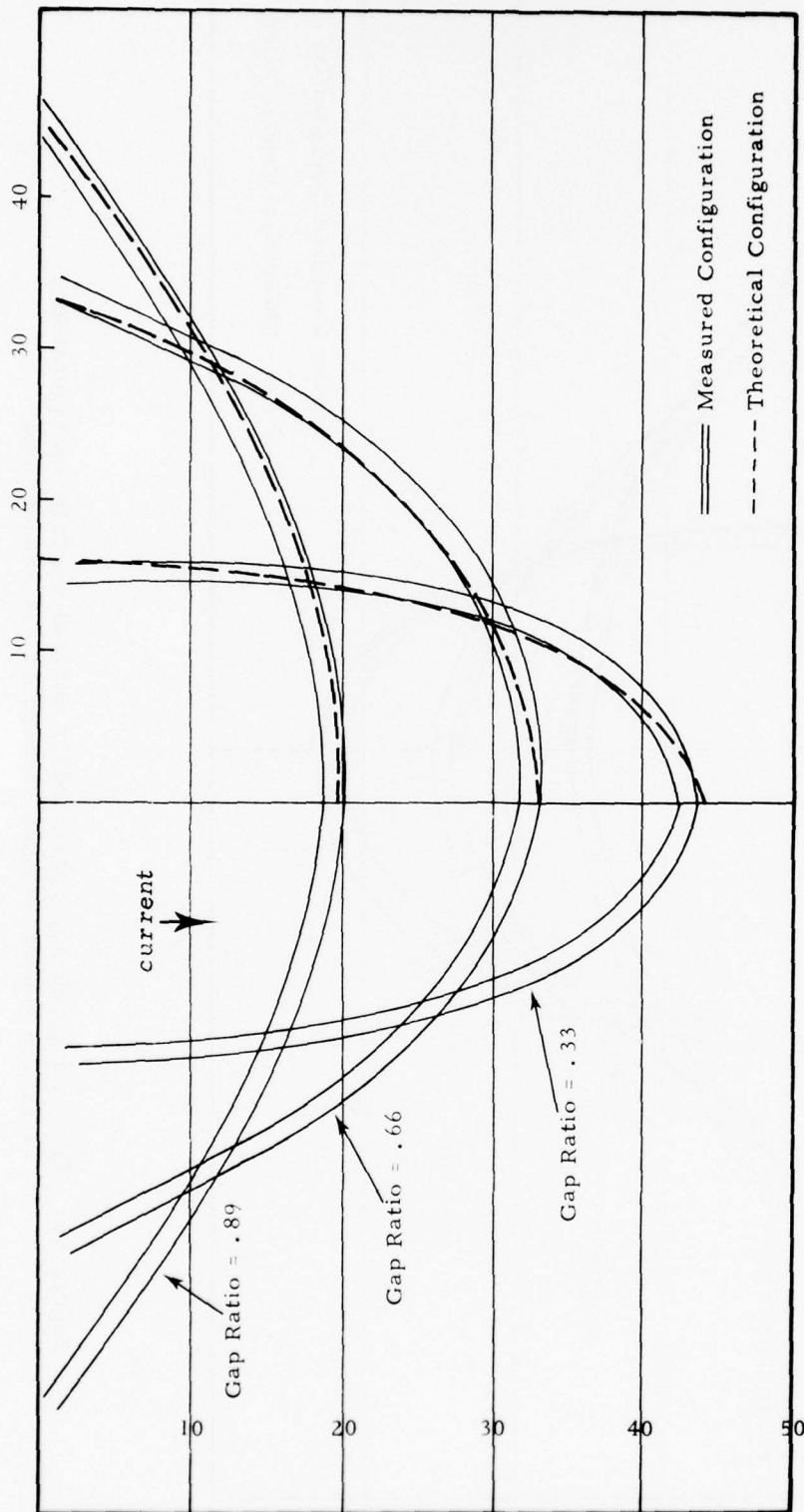

Figure 68. Field measured vs. analytically derived curtain configuration in current - top tension curtain in 0.4 - 0.5 kts current

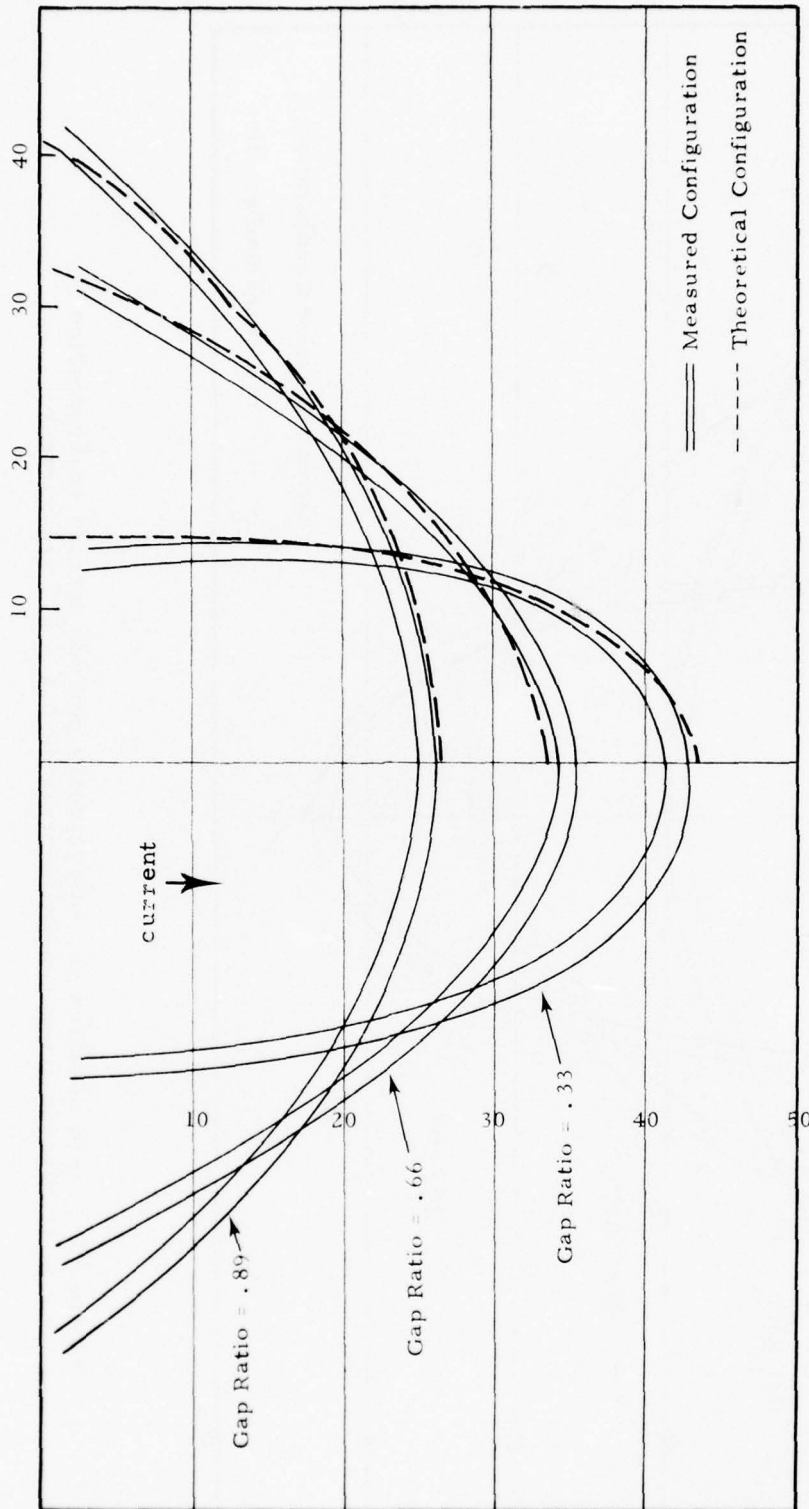

Figure 69. Field measured vs. analytically derived curtain configuration in current - center tension curtain in 0.4 kts current

the curtain orientation is normal to the current and least near the mooring point where the curtain is at a smaller angle to the current. Thus it appears that the factors controlling curtain flare near the mooring points may be different from those that influence the curtain flare at the apex.

157. It was also noted that measurements of effective depth at the apex matched very well with analytical predictions and, therefore, the question to be resolved was what caused the extreme flare near the mooring points. One clue to this behavior was the observation that a significant tension existing in the lower part of the curtain acted along the entire curtain length. This could be observed from the shape and the folds in the curtain near the mooring point (Figure 70). The implication of this observation is that the curtain's ballast chain was acting as a second tension member because it did not have sufficient initial slack to permit the curtain to flare without bringing the chain under tension. In fact the chain did appear to be acting, at least partly, as a tension member, although the chain was not purposely anchored for tension at the curtain's mooring points. The result was that the curtain itself absorbed the tension from the chain near the mooring points and this, in turn, caused a distortion of the curtain shape at the ends (Figure 70). This end distortion places unpredictable stresses in the curtain fabric, the tension cable, and the ballast chain near the ends. Thus analytical predictions of effective depth cannot be applied to the end parts of the curtain. It should be noted, however, that this problem is partly a consequence of the method of end attachment of the curtain. If the ballast chain as well as the tension cable were anchored, the end distortion probably would not occur. Also if curtain sections were linked into a much larger deployment, this end distortion would not affect much of the boom length.

158. As indicated in the above discussion, it appears that the end distortion is a peculiar consequence of the testing conditions and thus, for comparing field and analytical results only that data measured at the apex have been used. At the apex the curtain is

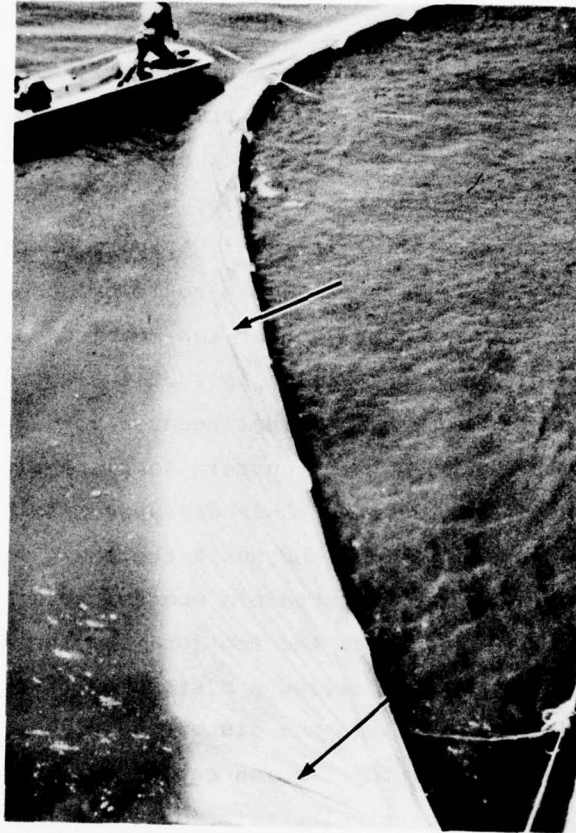

Figure 70. U configuration curtain, near mooring point (bottom), showing folds (arrows) caused by tension in the lower part of the curtain

essentially normal to the current and, therefore, comparisons have been made to predictions for a curtain normal to a free current.

159. Figures 71 and 72 show a comparison of theoretical results to measured results for several curtain configurations and several currents. Figure 71 shows the top tension curtain and Figure 72 shows the center tension curtain. On each figure the continuous line shows the theoretically calculated effective depth as a function of current for the specific curtain deployed. The data points on the graph show the measured effective depths. It should be noted that the theoretical lines on these graphs are calculated for the single tension (top or center) curtain although there is some indication that the curtains act at least in part as dual tension curtains with the ballast chain acting as the second tension member. Theoretical calculations for single and dual tension curtains show no significant difference in effective depth as a function of current, however, and therefore the comparison is valid regardless of the extent to which the chain acts as a tension member. It will be seen from the figures that, for currents up to about two knots, the measured values are reasonably close to the theoretical curve. The measurements of effective depth also verify the theoretical prediction that the center tension curtain is somewhat more effective in current than the top tension.

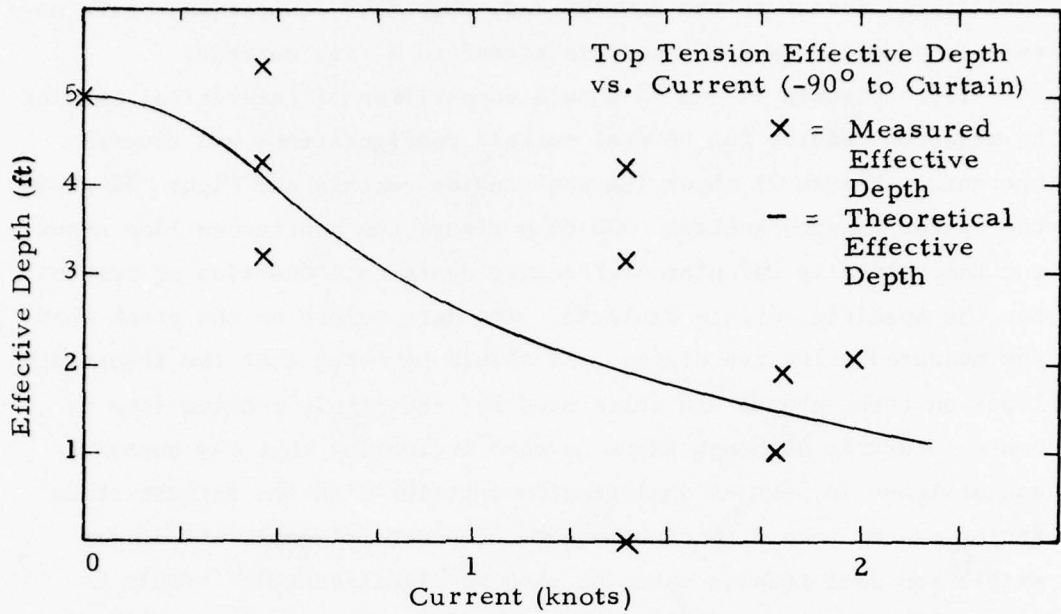

Figure 71. Theoretical vs. measured effective depth at apex for curtain in current - top tension, normal to current direction

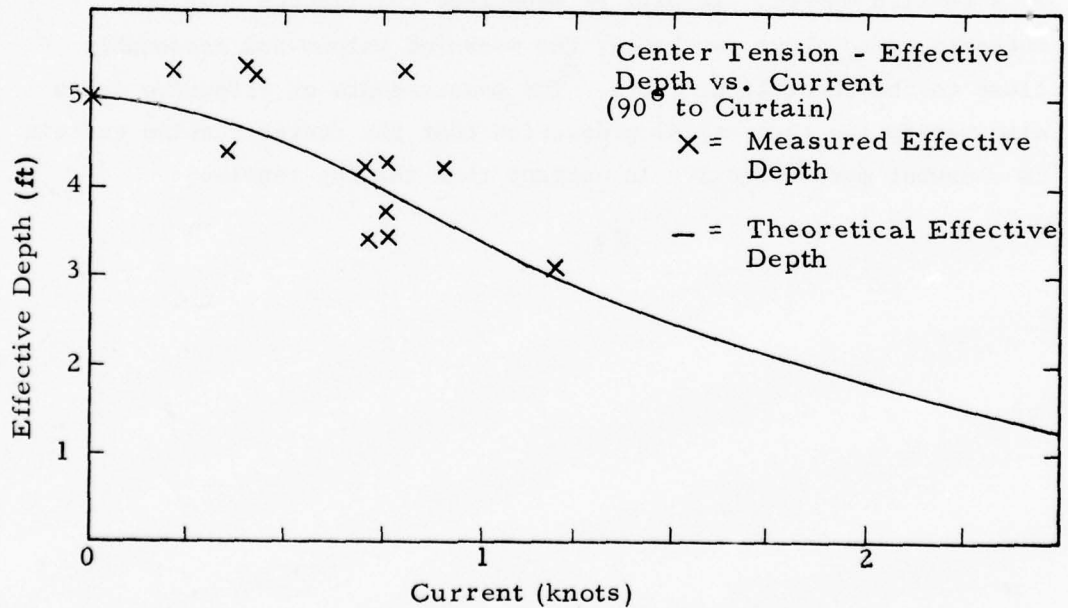

Figure 72. Theoretical vs. measured effective depth at apex for curtain in current - center tension, normal to current direction

CHAPTER IV: RECOMMENDED CURTAIN DESIGN AND UTILIZATION

Curtain Design Specifications

160. Based upon an evaluation of the design considerations discussed in Chapter II and on observations that were made in the field, the silt curtain specifications shown in Table 5 were developed.

161. Skirt depth should be selected so that the curtain is about one foot off the bottom at low water. The 10-ft maximum skirt depth specification was selected primarily due to the difficulty in handling large curtains as well as the fact that underflow must take place anyway. A curtain with a greater skirt depth may be used in low current situations where handling and anchoring problems are less severe. In most situations a 5-ft skirt is adequate.

162. It is strongly recommended that the load transfer type connector be used between sections of curtain. This may be metal or other suitable material as long as it adequately seals the space between curtain sections and allows the tension to be transferred along the vertical extent of the curtain or at least to middepth to assure proper vertical orientation of the curtain in the water.

163. Tension members may be of the top or center type. The center tension type provides more effective skirt depth than the top tension in a given current but requires more effective mooring due to the increased drag caused by the extra skirt depth.

164. The results of a comprehensive review of some of the curtains available commercially at the time of this study are shown in Table 6. While most manufacturers did not provide all of the data requested, the table provides insight into the products available. It should be emphasized that silt curtain manufacturing is a dynamic field and the user is urged to contact the manufacturers for the latest available information.

Table 5
Recommended Silt Curtain Specifications

<u>Parameter</u>	<u>Recommended Value</u>
1. <u>Skirt depth</u>	10-ft maximum allowing 1-2 ft clearance between skirt & bottom
2. <u>Fabric</u>	
a. Tensile strength	≥ 300 lb/in.
b. Tear strength	
18 oz	≥ 100 lb - quiescent conditions
22 oz	≥ 200 lb - medium to high current
c. Abrasion resistance	≥ 200 lb/in. tensile strength after abrasion
d. Material	Nylon
e. Coating	PVC
f. Weight	18 - 22 oz (depending on material used)
g. Seams	Heat sealed
3. <u>Buoyancy</u>	
a. Ratio	> 5
b. Type	Solid, closed cell, and inclosed in a fabric pocket
4. <u>Connector</u>	Load transfer type - aluminum extrusive or equivalent
5. <u>Ballast</u>	
a. Type	Noncorrosive
b. Weight	See Figures 16 and 17
6. <u>Tension member</u>	
No current	Fabric only
Current (0.1 - 1.0 knots)	Top or center tension; center tension provides slightly greater effective skirt depth

Note: In 1976 a 100-ft section of silt curtain with the above specifications and a skirt depth of 5 ft could be purchased at an approximate cost of \$1200.

Table 6
 Comparison of Existing Manufactured Silt Curtains
 With Desired Design Specifications

LEGEND:
 + = Meets or exceeds Table 5 value
 - = Fails to meet Table 5 value
 NA = No data available

Curtain Parameters	Values Min.	Curtain Model (Reference Table 1)													Remarks		
		A	B	C	D	E	F	G	H	I	J	K	L	M		N	
FABRIC		+	+	+	+	+	+	+	+	+	+	+	+	+	+	-	
Breaking Strength	300 lb/in.	+	+	+	+	+	+	+	+	+	+	+	+	+	+	+	
Tearing Strength	100 lb/in.	NA	NA	+	+	+	+	+	+	+	+	+	+	+	+	-	
Abrasion	200 lb/in.	NA	NA	NA	NA	NA	NA	+	+	+	+	+	+	+	+	NA	
Coating		+	+	+	+	+	+	+	+	+	+	+	+	+	+	-	Coating should be resistant to oil, sun-light, seawater, and mildew
BUOYANCY		+	+	+	+	+	+	+	+	+	+	+	+	+	+	+	
Reserve Ratio	5:1	+	+	+	+	+	+	+	+	+	+	+	+	+	+	+	
BALLAST		+	+	+	+	+	+	+	+	+	+	+	+	+	+	+	
Presence		+	+	+	+	+	+	+	+	+	+	+	+	+	+	+	+ for ballast; - for none
TENSION MEMBER		+	+	+	+	+	+	+	+	+	+	+	+	+	+	+	
Location		-	-	-	-	-	-	-	-	-	-	-	-	-	-	-	+ for added tension member; - for none
Material		-	-	-	-	-	-	-	-	-	-	-	-	-	-	-	+ for center; - other (top or bottom)
Strength	5000 lb	+	+	+	+	+	+	+	+	+	+	+	+	+	+	+	+ for cable; - other
CONNECTORS		+	+	+	+	+	+	+	+	+	+	+	+	+	+	+	
Quick Connect		+	+	+	+	+	+	+	+	+	+	+	+	+	+	+	+ for Yes; - for No

Turbidity Barrier Utilization

Predredging Site Survey

165. Prior to specifying or selecting a curtain for a project, it is necessary to obtain certain data about the site where the curtain is to be used. The types of data required to help select the most effective curtain are discussed in the following section.

- a. Water depth. The water depth at the deployment site is required so that the curtain with the proper skirt depth can be selected and its placement geometry determined. The bathymetric survey should extend from the shoreline out to a distance that will cover the area in which the silt curtain will be deployed. If the curtain is used to surround a pipeline disposal operation, the curtain must be moved outward as the disposal area fills. The survey must, therefore, cover an area encompassing the maximum likely curtain perimeter. All water depth measurements should be corrected to a common datum so that the effects of tidal changes can be interpreted. The survey should be conducted by a vessel equipped with a precision navigation system and a fathometer.
- b. Tide and current. Tidal changes should be established, including the tidal range, height referenced to a common datum, and the time cycle. Tidal change affects water depth, which affects the selection of the skirt depth. A simple tide gauge, or calibrated vertical rod, may be used for these measurements.

Water current speed and direction must also be established. Since the site is often near shore, where spatial current variations may be large, the measurements should be made in the region where the curtain will be deployed. While not absolutely essential, it is desirable to note the degree of turbulence in the area to be curtained since this can affect the behavior of the plume after it passes under the curtain. This is especially important in areas near bottom obstructions, pilings, and bridge supports. Current measurements for a tidal cycle can be conveniently displayed using a current rose, as rotary currents are displayed on navigation charts. Current measurements should be made at the surface, middepth, and near the bottom.

- c. Sediment type. The sediment type should be established in the proposed deployment area. This may be done using a grab sampler or a coring tool, supplemented by visual observations. The type of bottom and evidence of vegetation will dictate the type of anchors to use and may assist in establishing the possibility of suspension or erosion taking place during the operation. Finally, establishing the predredging bottom type will provide data that are useful in postdredging surveys to supplement bathymetric data in establishing the effectiveness of the curtain.
- d. Background water samples. Determination of the background turbidity at the disposal site is critical to establish the effectiveness of silt curtains during the operation. In some states open-water disposal is only allowed if turbidity levels do not exceed some predetermined level above background. The background levels should be measured under a variety of conditions (i.e., low and high current, waves and calm conditions, pre- and poststorm conditions, etc.). These data will be of value in determining under what conditions the disposal operation may take place.
- Samples may be taken with a conventional water sampler or any bottle that can have the stopper removed and replaced at a predetermined depth. The samples should be taken at the surface, middepth, and near the bottom. Care should be exercised not to disturb the bottom when obtaining the latter sample.
- e. Miscellaneous. A number of other observations should be made during the predredge survey phase, as follows.
- Convenient anchor points should be noted that may be used to moor the curtain, both in-stream and along the shore, if required. These may be pilings, bridge supports, piers, etc.
- A location for launching and retrieving the silt curtain should be established. Since these actions will undoubtedly involve the use of a large truck and boats, a launching ramp, crane services, etc. should be located as near the site as possible.
- Boat traffic in the area should be noted as this may affect the navigational markings that are used on the curtain and mooring system, the allowable scope of anchor lines, the wave conditions that the curtain will experience, the background turbidity, etc.

Curtain Selection

166. There are a number of factors that must be considered prior to specifying a curtain for a specific application. The following guidelines will assist the potential user in making a selection. (Also see the recommended curtain specifications earlier in this chapter).

- a. Skirt depth. The primary purpose of the curtain is to reduce turbidity in the water column outside the curtain, not to retain the fluid mud or the bulk of the suspended solids. This may be accomplished with a relatively short skirt depth unless there is turbulence present. Without turbulence, the fine-grained suspended material flows under the curtain, disperses, and settles to the bottom. Under turbulent conditions a longer skirt may be required to minimize the turbidity that returns to the upper water column. Turbulence occurs in high current areas. Therefore this implies using deeper curtains in higher currents; however, the higher the current the more difficulty there is in handling a deep curtain.

The basic criterion for specifying skirt draft is that the skirt should extend as deep as practical without touching the bottom at lowest water. Ideally, the skirt should be approximately one ft off the bottom to allow relatively uninterrupted passage of the mud flow and to prevent sediment buildup at the lower edge of the skirt that would submerge it. However, if the disposal area fills rapidly this may require frequent moving of the curtain; larger gaps may be desirable to avoid this situation.

At a site where current exists, a 10 ft curtain is the largest that can be handled and maneuvered in the water; in calm water a deeper curtain is manageable. In most cases, however, a skirt depth of 5 ft is sufficient.

If the bottom is irregular, the curtain skirt should be selected so that, at lowest water, it still clears the bottom by approximately one ft. It should be recognized that for configurations where the curtain is anchored to the shore, the skirt must lay on the bottom, and this requires periodic inspection to prevent submergence of the curtain due to sediment buildup.

Water current can have a significant effect on the skirt behavior. In the case of low currents (i.e., 0.1 knot, or less), the full skirt depth is maintained. For higher currents, the effective skirt depth is less. This will

be discussed further in the following paragraphs on tension members. It is important to note that the skirt depth is selected from considerations of water depth but its behavior (effective skirt depth) is determined by the water current.

- b. Location of tension member. The tension member may be located on top or just under the flotation (top tension system) or part way down the skirt (center tension system).

For use in low current situations under 0.1 knot, either the top or center tension member may be used. As the current increases, the center tension member will retain more effective skirt depth in any given current than the top tension. It is important to note that current may be induced by wind and waves, perhaps from the passage of a storm front, and that this should be considered in selecting a tension member location. If a center tension member is selected, the skirt will not flare to relieve tension as much as a top tension system; thus, the center tensioning system requires a more substantial anchoring and mooring system.

- c. Curtain selection connectors. For low current situations under 0.1 knot, most connectors that maintain physical contact along the entire skirt joint are acceptable, such as the rope bolt and slotted tube, plastic zipper, Velcro[®], or aluminum extrusion. Rope lacing, nut and bolts through grommets, or other connections that do not maintain physical contact along the full length of the skirt are unacceptable. The connectors may also be of the load or the no-load type.

In a high current situation, the connector must be of the load type, so that tension is transmitted through the connector. The connector should provide physical contact with the skirt along the entire vertical dimension of the skirt. An aluminum extrusion type connector, or equivalent, should be specified. Because the load type connector is in constant tension the seal will be more efficient and less subject to developing leaks than the no-load type. This is particularly important under conditions of flare, when most no-load connectors either open or develop gaps that allow leakage.

- d. Fabric. The fabric should have adequate tensile and tear strength; resistance to abrasion, ultraviolet deterioration, and mildew; and be of a clearly visible color.

A material such as nylon base with PVC coating or equivalent, should be specified. The weight should be at least 18 oz/yd². A minimum tensile strength of 300 lb/in, a

minimum tear strength of 100 lb, and a minimum abrasion resistance, as determined by a tensile strength of not less than 200 lb/in after abrasion, should be specified.

- e. Buoyancy. The buoyancy should be selected so that the buoyancy ratio (ratio of buoyancy to curtain weight) is at least 5. The material should be sections of solid closed-cell plastic foam "log," with a maximum length of 10 ft, and should be contained in sealed fabric pockets in the curtain. Individual logs attached to grommets are unsatisfactory.
- f. Ballast. The ballast should be in the form of a chain sewn into a pocket at the base of the skirt. The chain should be slightly longer than the skirt, should be physically terminated at the connector, and should be resistant to corrosion in fresh water or sea water.

Curtain Geometry

167. There are two basic cases to consider in selecting a curtain geometry for disposal operations: disposal on or near shore, such as beach nourishment or upland disposal with a return flow, or open-water disposal when the disposal area is completely surrounded with water. The primary factors influencing curtain configuration for these two cases are tide and current as well as boat traffic.

- a. Nearshore case. In the case of a return flow from an upland disposal area, a beach nourishment project, or a marsh creation project, the basic configuration should be a semicircle with the curtain ends anchored on shore. The radial distance from the beach is partly determined by the water depth and partly by the desired volume to be enclosed by the curtain. It may also be determined by environmental regulations that specify the allowable turbidity levels at a fixed distance from the disposal pipe. Since high concentrations of suspended solids within the curtain are desirable to enhance flocculation, the curtain need not be excessively large. Most of the material either settles out immediately within the curtain, or is transported under the curtain as a fluid mud flow. The primary function of the curtain is to control the dispersion of the remaining suspended solids. These considerations suggesting a small enclosure must be balanced against the possibility of the skirt being buried by deposited material. Procedures for estimating the likelihood of burial for the scheduling movements of the curtain to avoid burial were presented in the discussion of deployment in the earlier section on analytical investigations.

Moreover, it is critical that the curtain maintains its shape as the tide and currents change. (This will be discussed in the anchoring and mooring section.) Discharge should take place near the beach to minimize the dissipation of the momentum of the discharged material.

- b. Open-water case. In this case the curtain is completely surrounded by water and the current may or may not be reversible. Curtain geometry choices include the maze, a U-configuration, and an elliptical (or circular) configuration. The maze configuration has been shown earlier in this report to be unsatisfactory.

If the current is unidirectional and does not reverse with the tide, a U-configuration is acceptable. If it reverses, an elliptical configuration is required. The latter case requires extensive anchoring, as will be described in the anchor and mooring section. From an anchoring point of view, the circular configuration is more acceptable than the ellipse.

As the current increases, the flow through the volume within the curtain increases and the retention time decreases. In currents over a few tenths of a knot, there is a retention time of only a few seconds and virtually all of the suspended solids are rapidly transported under the skirt and downstream. Dilution reduces the turbidity levels and unless turbulence is present, most of the suspended material do not return to the upper water column. Since the primary effects are caused by changes in the vertical water current velocity profile near the curtain, the goal should be to provide an adequate length of curtain to completely inclose the plumes so that there is no leakage around the ends of the curtain. Typical curtain lengths for the U-configuration might be 500 to 1500 ft with perhaps double this length for the elliptical or circular configuration. As the current decreases, the plume may spread farther due to the decreased current within the enclosure so that a larger gap ratio (ratio of mouth opening to curtain length) may be required to prevent end leakage.

Transport and deployment

168. This section covers the transportation of a curtain from the storage facility to an unloading site and the deployment of the curtain from the unloading site to the position in the water where it will be used.

- a. Transport. The critical item in transporting is the care-in-handling that must be exercised. All curtains, new or used, should be furled and folded into a compact package before being moved. The furling operation, shown in Figure 73, consists of laying a section of curtain flat on the ground and then rolling it up lengthwise starting with the bottom (ballast). After being rolled up it should be tied every 3 - 5 ft with light straps or cord that can be easily cut during deployment.

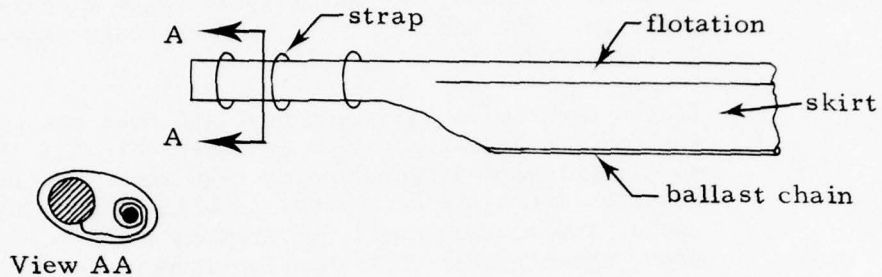

Figure 73. Packaging a silt curtain

After the curtain has been furled, the furled segments should be folded against each other accordion style and tied with heavy straps or rope. The packages should be lifted in and out of the transport vehicles (large trucks or trailers) and not dragged on the ground.

- b. Deployment. There are two distinct methods of curtain deployment. The first method is to load the curtain onto the open deck of a workboat, transport it to the site, and then maneuver the curtain into the water. The second method is to unload the curtain from the transport vehicle into the water and then tow it to the site where it will be moored. Each of these methods will be discussed in detail below.

(1) From land.

The first step is to unload the curtain from the transport vehicle, maneuver it into the water, and then move the curtain from the launching area to the site where it will be used. Here again, the critical item is care-in-handling. Launching a curtain is usually done from a ramp, pier, or the shore. A launching ramp is ideally suited for this purpose, since the truck is down at water level. Additionally, the body is angled down toward the

water, minimizing the angle at which the last few sections of the curtain are dragged over the tailgate of the truck during withdrawal. On a ramp, the rear tires should be as far into the water as feasible, so that the curtain will not scrape bottom as it pays out. Care should be taken that the curtain is not torn while dragging it over the truck tailgate. One method of minimizing this danger is to cover the tailgate with a heavy sheet of cardboard. This not only reduces the friction between the curtain and the truck but also covers any sharp projections on the tailgate. A roller may also be installed on the tailgate.

If a pier is used, the truck should be positioned such that the curtain can pass directly into the water, without being dragged over the edge of the pier. Launching from the shore is a suitable alternative only if the beach is smooth without any sharp objects that could tear or abrade the curtain.

As the curtain is payed out the sections may be joined together. All furling lines except for those near the end connectors must be kept tied for ease in towing. After the furled curtain is in the water and assembled, it is towed to the disposal site by boat.

(2) From a boat

There are three steps involved in this deployment procedure. First, the curtain is unloaded from the transport vehicle and maneuvered onto the open deck of a workboat. The boat must have an adequate open deck area to hold the curtain sections. After the curtain has been loaded aboard the boat, it can be taken to the site. The third step, deployment, can be accomplished in a manner similar to that described above for deployment from a launching ramp.

Anchoring and mooring

169. Improper anchoring and mooring has historically been one of the major reasons for silt curtain ineffectiveness and catastrophic failure. Under no circumstances should the curtain be directly attached to pilings or poles driven into the bottom. While this is especially critical in areas where there are tidal variations, it is equally important in any situation where waves or tides may cause the curtain to move vertically against the supports.

170. The recommended mooring system (Figure 74) consists of an anchor with adequate holding power, a chain to reduce chafing and to decrease the rode angle, an anchor rode (line or cable) of sufficient length to minimize the angle between the rode and the bottom, a mooring buoy to pull the curtain horizontally, and a crown buoy to locate and release the anchor.

171. Anchoring configurations are shown in Figure 75 for the U and D configurations. It is best to use a radial anchor line for every 100 ft of curtain. If the water current changes direction with the tide anchoring must be done on both sides of the curtain to minimize curtain movement. The amount of curtain movement occurring between anchor points is determined by the gap ratio (mouth opening/curtain length). Small ratios allow more movement and possible scouring if the curtain touches the bottom; large ratios (≈ 1) require heavy mooring and anchoring systems to carry the load generated by the current.

172. Figure 76 shows the anchor tension in each line when the lines are radially attached to a curtain at intervals of 100 ft and 300 ft, as a function of water current for two different gap ratios. Thus, the tension in each anchor line of a silt curtain system radially anchored every 300 ft in a one-knot current is about 3300 lb for a gap ratio of 0.9 and 950 lb for a ratio of 0.5. In the case of 100-ft radial anchoring, the tensions are 1100 lb and 325 lb, respectively.

173. The tensions in Figure 76 were calculated assuming a long curtain with segments that are essentially straight lines. (Figure 77) Where the tensions in adjacent segments have opposing components and partially balance each other, the tension can be somewhat higher for configurations with a corner (Figure 77b) (i.e., a rectangular configuration) because the tensions of adjacent segments tend to be aligned and therefore reinforce each other. In addition, the analysis did not take into account the catenary effect of the anchor rode itself; thus, the values in Figure 76 are low and should probably be increased by 1.5 to 2.0 times.

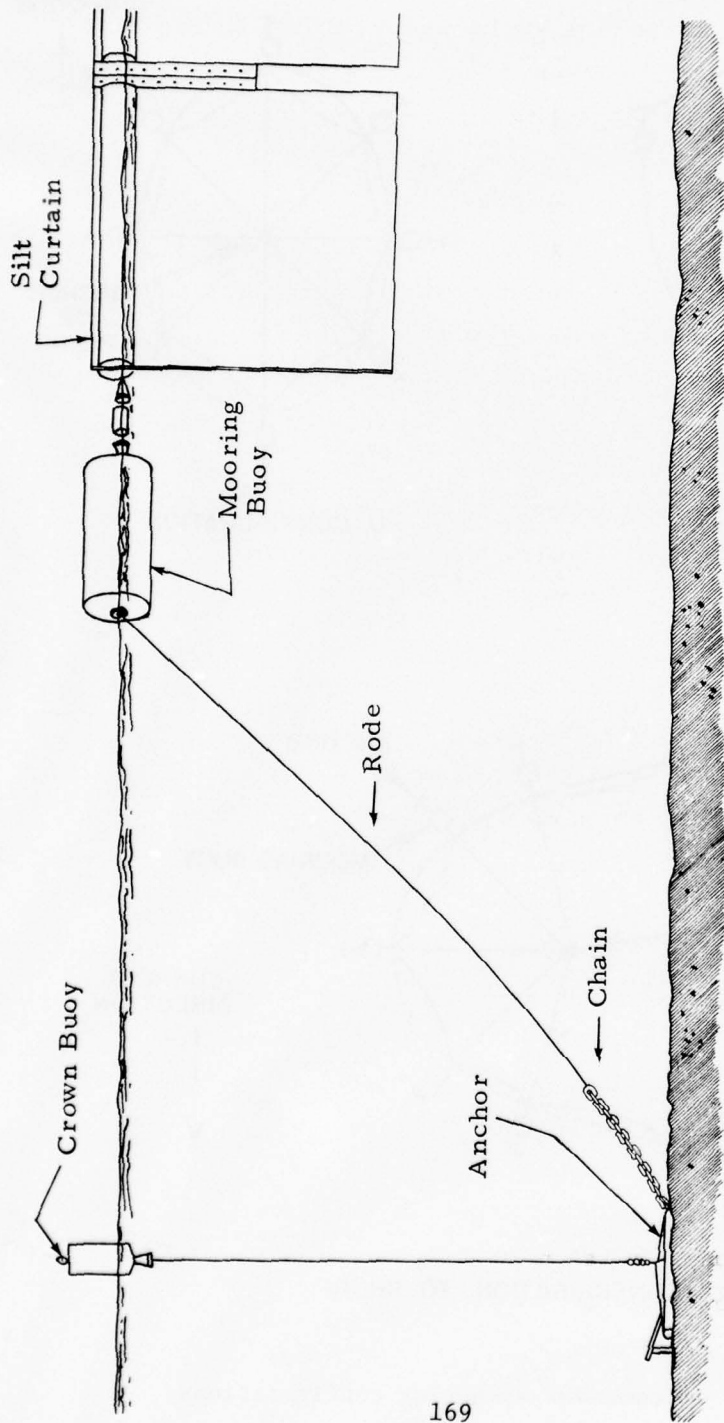

Figure 74. Recommended silt curtain mooring system

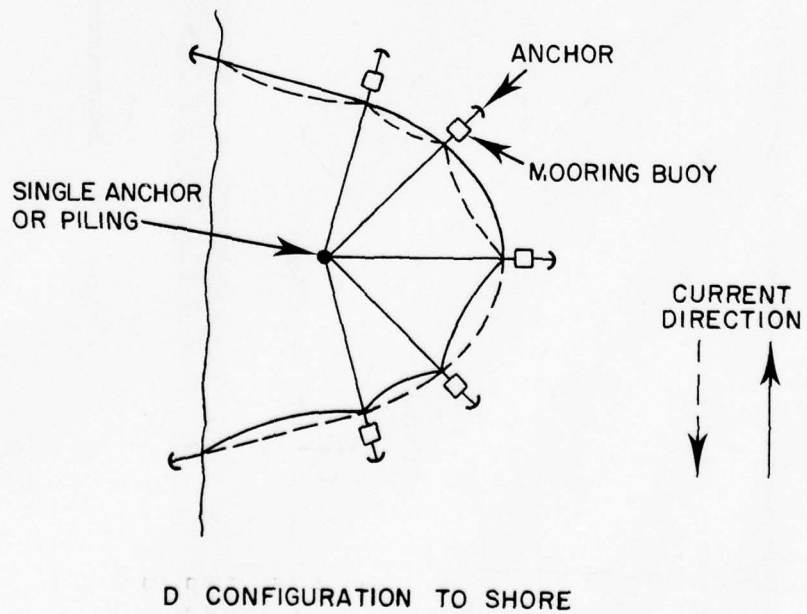
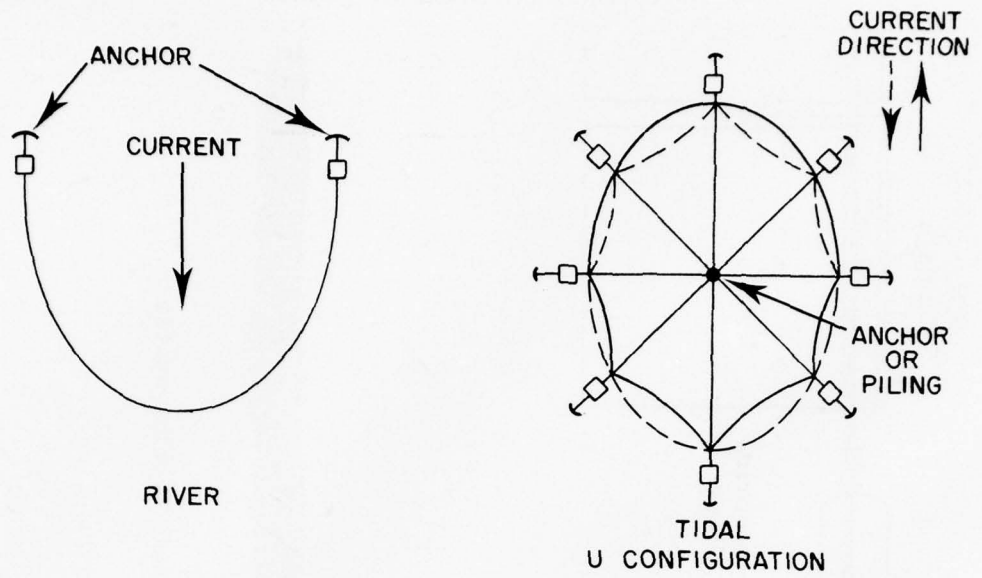

Figure 75. Recommended anchoring configurations
170

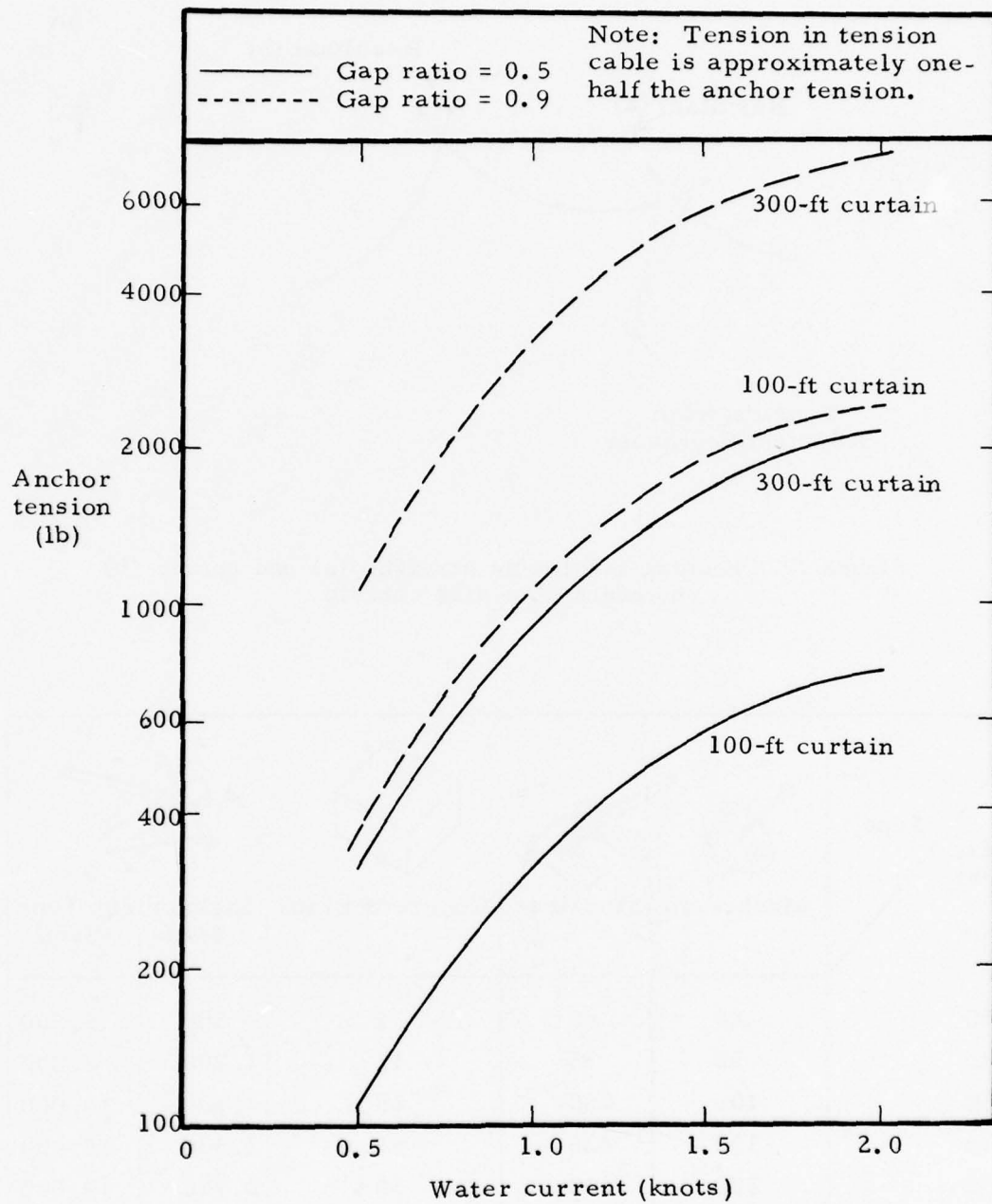

Figure 76. Effect of water current on anchor tension for various curtain configurations

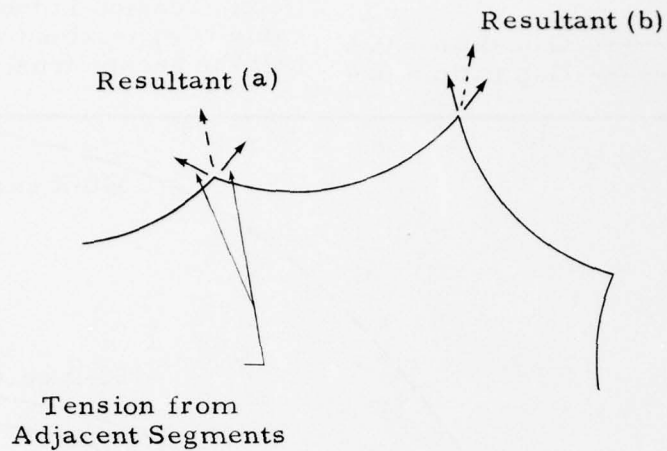

Figure 77. Mooring tension in straight (a) and corner (b) segments of a silt curtain



Size (lb)	Type					
		Mushroom	Stockless	Concrete Block	Lightweight Type Mud	Sand
10		20	30	5	500	3,500
25		50	75	12	1,200	8,000
50		100	150	25	1,500	10,000
75		150	225	35	2,300	15,000
100		200	300	50	2,700	19,000

Figure 78. Anchor data (holding power of anchors, in lb)

174. Figure 78 shows the typical holding power for a number of different anchors. It is interesting to note that most anchor types do not have adequate holding power for silt curtains in high currents (i.e., greater than 0.5 knots).

175. Table 7 shows the ultimate tensile strength of various lines that may be used as anchor rodes. Assuming a safe working load of one-third the ultimate tensile strength, it can be seen that the case of a 100-ft radial anchoring system, as described above, (gap ratio of 0.9) would be adequately sized by using a one-half inch polypropylene line.

176. Thus, the anchoring and mooring requirements for a given water current environment can be arrived at by:

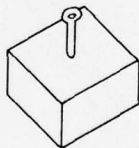
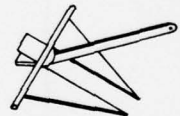
- a. Selecting a configuration (U, D, or perhaps circular in a tidal situation with reversing currents).
- b. Selecting the spacing between radial anchor lines (100 or 300 ft).
- c. Determining anchor holding power and anchor rode tension from Figure 74.
- d. Selecting the anchor from Figure 74.
- e. Selecting the anchor rode from Table 7.

Maintenance

177. A proper maintenance program extends the life of the silt curtain by a substantial margin and thereby minimizes the overall expense of a silt curtain installation. The procedures recommended below are designed to provide this service.

178. Daily Maintenance. The silt curtain installation should be checked each day for failures that occurred in the previous 24 hr. period. The purpose of daily inspection is to detect a failure quickly and to repair or isolate it to prevent the spread of damage. The inspection should be made in situ from a small outboard workboat that can be brought up close to the curtain. It is recommended that the workboat be run along one side of the curtain and then moved to the other side so that both sides are thoroughly examined for the following:

Table 7
Ultimate Tensile Strength of Various Line (lb)

<u>Diam (In.)</u>	<u>Type</u>				<u>High Strength Chain</u>
	<u>Manila</u>	<u>Polypropylene</u>	<u>Nylon</u>	<u>Braided Nylon</u>	
1/4	600	1,100	1,500	2,200	6,500
3/8	1,350	2,150	3,000	4,800	13,000
1/2	2,650	3,700	5,500	8,300	22,000
3/4	5,400	7,000	11,500	18,000	46,000

- a. Check flotation logs for abrasion, cuts, and holes in the skin that seals them. Also check for tears in the skirt at the point of attachment to the flotation log.
- b. Check the connectors for mechanical damage and tears in the fabric where they are attached to the skirt.
- c. Look for turbidity leaks that might be caused by holes in the submerged skirt.
- d. Inspect the anchor assemblies for parted lines and signs that the anchors have dragged under mooring loads.
- e. Watch for indications that the bottom of the curtain is being buried by the mud flow from the discharge operation. When this occurs, the mud pulls the curtain downward causing the local flotation logs to submerge gradually and disappear.

Damage to a curtain section can be repaired in three ways. If the damage is relatively small and is accessible, as with cuts in the log skin, repairs can be made from the workboat without removing the section from the water. If the damage is severe, the damaged section should be removed from the array and taken ashore to be repaired. A spare section can be installed to replace the damaged section or possibly the silt curtain array can be closed up sufficiently so that it can be rejoined without using a spare. Anchor lines can be replaced and anchors moved back to and reset at their original locations with the assistance of a work barge and a pair of scuba divers.

179. Retrieval Maintenance. Each time the silt curtain sections are retrieved and brought ashore, curtain maintenance should be carried out immediately before the curtain is placed back into service or storage. All marine growth and barnacles must be removed from fabric while still wet because on drying the barnacles become very hard and when broken the shells are sharp and abrasive. If the curtain is handled in this condition, the barnacle remains can cut and abrade the fabric severely. In the wet state, marine growth can be removed by wire brushing and scraping. For this procedure it is helpful to lay each section out at full length on a clean, flat surface. If the curtain has been exposed

to oil or oil scum, those sections must be washed with an appropriate detergent, rinsed clean, and thoroughly dried.

180. Each curtain section should then be examined thoroughly and all rips, tears, and abrasions marked for repair. In the case of extensive damage the curtain section must be returned to the manufacturer for repair. Spare curtain sections should be stocked as replacements for badly damaged sections while they are out being repaired. Lesser damage can be repaired in the field using kits furnished by the manufacturer. These usually include patch fabric, cement, and instructions for their use. All damaged or broken hardware such as carry handles, curtain connectors, and tension cable clamps should be repaired or replaced. Anchor assemblies should be inspected for damages or breakage and the necessary repairs made. Upon completion of retrieval maintenance procedures, each curtain section should be in as good working order as it was originally.

Retrieval

181. Retrieval can be the most difficult and damaging phase of silt curtain handling operations. Unlike the deployment phase the curtain must be handled in the unfurled state which makes it very bulky and unwieldy. Because of this the curtain is prone to damage during its loading onto the workboat. Particularly susceptible are the flotation logs if they are molded, rigid foam and any protuberances such as fittings, handles and connectors that can hang up on workboat obstacles and tear the fabric. In order to avoid these problems the retrieval process must be thoroughly developed, well organized, and operating personnel properly trained beforehand. The following set of guidelines can be used as a basis for such a retrieval procedure.

- a. If possible, conduct the retrieval operation during periods of calm weather and low currents.
- b. Disconnect the intermediate anchor lines from the curtain and haul in each anchor assembly (ref. Figure 74) before opening the silt curtain enclosure.

- c. Open the curtain at a point or points such that the two free-floating lengths are secured by at least one major anchor and they float freely in enough water to accommodate the workboat. From the downstream side come up on the end of the first length of curtain to be removed from the water and begin the retrieval operation.
- d. A manual operation requires 4 to 6 men (depending on curtain size and weight) working from a flat deck at least 15 ft wide by 30 ft long. An outboard trimaran flattop workboat is well suited for this task. The curtain is hauled aboard by 2 to 3 men stationed along each edge (bottom and top) of the curtain. Care must be exercised so that projecting hardware and the flotation legs do not hang up on the forward edge of the deck over which the curtain is hauled. A 4 to 6 in. diameter by 15 ft long roller mounted along this edge virtually eliminates such damage. As the curtain is hauled onboard, the workboat should be advanced along the curtain so the deck crew does not have to haul the boat as well as the curtain. Once onboard the curtain can be arranged in flat folds or it can be furled, tied and zig-zagged around the deck. Furling the curtain on the workboat is far more difficult than furling it on shore and should not be attempted other than under emergency conditions. Since the curtain must be laid out flat for cleaning and maintenance after it has been brought ashore, it should be stacked on deck in flat folds preferably on a large pallet or skid that allows the stack to be craned off at the shore unloading point. The stack is then transported to the maintenance area where the curtain sections are craned off the skid and laid out flat at full length. If shore crane services are not available, the curtain sections must be unloaded manually from the workboat and laid out flat. Abrasion wear is virtually unavoidable in this operation since the curtain must be dragged over the rough pavement.
- e. If a work barge is available with power crane and winching services, the retrieval operation can be accomplished faster and more efficiently than by manual means. This will be an important consideration when the retrieval periods are time-limited as in the case of high tidal currents.

Storage

182. When the repair and maintenance procedures have been completed on the retrieved silt curtain, it is placed in storage until the next occasion for its use. The method of storage should provide proper protection against physical damage and the weather and it should enable a smooth moving operation into and out of storage. The recommended method is to lay the curtain sections in flat folded piles on the same deck pallets that were recommended for the retrieval operation (paragraph 181). The loaded pallets are carried into a shed or warehouse and stacked neatly on top of each other undercover from the weather. For the next curtain job the palletted sections are moved directly to the piers, loaded onto the deck of the workboat, transported at high speed to the discharge site, deployed, and installed in the curtain array. If for some reason the pallet concept cannot be implemented, the original shipping container should then be utilized for storage. Under no conditions should the curtain sections be stored on the ground in an open area where their exposure to the weather can create mildew and corrosion problems, vehicles can run over sections and damage flotation logs, and personnel can climb over the stacked sections and puncture the skirt fabric.

CHAPTER V: RESULTS AND CONCLUSIONS

183. Silt curtains or turbidity barriers are impervious, vertical barriers that extend from the water surface to a specified depth. They are commonly used around dredging and disposal operations to inclose an area containing turbid water. The flexible, nylon-reinforced vinyl fabric forming the barrier is maintained in a vertical position by flotation material at the top and a ballast chain along the bottom. A tension cable is often built into the curtain to absorb loads imposed by currents and other hydrodynamic forces. The curtains are usually manufactured in 100-ft sections that can be joined together at a particular site to provide a curtain of specified length. Anchored lines hold the curtain in its deployed configuration.

184. Data obtained from detailed analytical investigations and several field operations where silt curtains were used to surround open-water pipeline disposal operations or upland containment area effluent discharges indicate that silt curtains that are properly deployed and maintained do control the flow characteristics of the turbid water in the vicinity of the area inclosed by the silt curtain. In the case of open-water pipeline disposal operations the vast majority (95 percent or more) of the dredged material slurry descends rapidly to the bottom where it forms a fluid mud layer that slopes away from the discharge at an approximate gradient of 1:200. The remaining 5 percent or less of the dredged material slurry is responsible for the turbidity in the water column above the fluid mud layer. While the curtained area provides an inclosure where some of the fine-grained material may flocculate and/or settle, most of this fine-grained suspended material remains in the water column above the fluid mud layer and escapes with the flow of water and fluid mud under the curtain. In this manner a silt curtain that is properly deployed and maintained provides a mechanism for controlling the dispersion of turbid water by diverting its flow under the curtain, thereby minimizing the turbidity in the water column

outside the silt curtain. Unfortunately as the current velocity in the vicinity of the silt curtain increases, the amount of turbulence also increases. This results in resuspension of the fluid mud and may cause some turbid water to come up toward the surface outside the curtain.

185. Whereas silt curtains may effectively control the flow of turbid water, they are not designed to contain the fluid mud layer within the curtailed area and apparently have little effect on the accumulation of fluid mud except possibly in the immediate vicinity of the curtain. In fact, when the fluid mud layer reaches the depth of the ballast chain along the lower edge of the skirt, the curtain must be moved out away from the discharge; otherwise sediment accumulation on the lower edge of the skirt will pull the curtain underwater and eventually bury it.

186. In this particular study the effectiveness of a silt curtain in controlling turbidity is defined as the degree of turbidity reduction outside the curtain relative to the turbidity levels inside the curtain inclosure. Silt curtain effectiveness depends on several factors such as the nature of the operation; the quantity and type of material in suspension within or upstream of the curtain; the characteristics, construction, and condition of the silt curtain as well as the area and configuration of the curtain inclosure; the method of deployment; and the hydrodynamic conditions (i.e., currents, tides, waves, etc.) present at the site. Because of the high degree of variability in these factors, the effectiveness of different silt curtains operations is also highly variable. In some cases where relatively quiescent current conditions (0.1 knot or less) are present, turbidity levels (measured in terms of NTU's or mg/l) in the water column outside the curtain can be as much as 80 to 90 percent lower than the levels inside or upstream of the curtain. While there may be a turbid layer flowing under the curtain, the amount of suspended material in the upper part of the water column, as a whole, is substantially reduced. However, the effectiveness of silt curtains can be significantly reduced in high energy regimes characterized by currents and turbulence. High currents cause silt curtains to flair,

thus reducing the curtain's effective depth; turbulence also tends to resuspend the fluid mud layer and may cause the turbid layer flowing under the curtain to resurface just beyond the curtain. However, even under conditions of medium current (up to 0.5 knot), a properly deployed and maintained center tension curtain can be effective. In other cases, where anchoring is inadequate and particularly at sites where tidal currents dominate the hydrodynamic regime and probably cause resuspension of the fluid mud as the curtain sweeps back and forth over the fluid mud with changes in the direction of the tidal currents, the turbidity levels outside the curtain can be higher (as much as 10 times) than the levels inside the curtain. With respect to overall effectiveness and deployment considerations a current velocity of approximately 1 knot appears to be a practical limiting condition for silt curtain use.

187. To maximize the effectiveness of silt curtains, a predredging survey should be conducted to evaluate the water depth, tides and currents, sediment types, and background levels of turbidity at the site of operation. The silt curtain used should be compatible with the environmental conditions at the deployment site and should be selected such that the skirt is always at least 1 ft off the bottom to allow the fluid mud to flow under the curtain, thus preventing sediment buildup along the lower edge of the skirt. The skirt should be no longer than 10 ft, except possibly in environments where there is no current. With respect to the tension member a center tension curtain will provide a slightly greater effective skirt depth than either the top or bottom tension designs in a specified current because it does not flair as much as a top tension curtain; however, the center tension system requires a more substantial anchoring/mooring system. Dual tension cables provide no advantage over a single center tension. In high current situations, the curtain sections should be joined with load type (preferably aluminum extrusion) connectors. The curtain fabric should be equivalent to an 18 oz nylon reinforced vinyl material with a

tension strength of at least 300 lbs/in and a minimum tear strength of 100 lb. The ratio of buoyancy to curtain weight should be at least five. Ballast should consist of a corrosion resistant chain sewn into a pocket at the base of the skirt. Off-the-shelf silt curtain products which meet the specifications developed in this study are available.

188. Regardless of their construction, silt curtains must be handled very carefully while they are being transported and deployed at the site. Transportation in a compact package with the curtain furled and folded accordian style into a van is recommended. It can then be transported from the shore to the site on a transport barge or it can be maneuvered into the water, towed to the site with the skirt in the furled position, and deployed. After deployment the skirt is unfurled.

189. The type of deployment configuration used at the site has a substantial influence on the effectiveness of the curtains. There are three basic configurations: open, closed, and maze configuration. With the closed configuration the ends of the curtain may be anchored to the shore or the entire length may be deployed in a circular or elliptical shape. The open configuration, which forms a catenary shape when moored at its ends in a current normal to a line between the two mooring points, may be used in rivers when there is considerable boat traffic or where it must be moved frequently. The maze configuration can also be used where boat traffic is present; however, it appears to be only marginally effective in controlling turbidity. The curtain must form an unbroken seal around the downstream of the turbidity source to effectively reduce the turbidity levels.

190. In most cases, and especially where current flow reverses direction over a tidal cycle, the curtain should be anchored on both sides at 100-ft intervals to minimize its movement. The recommended mooring system consists of an anchor with adequate holding power, a chain to reduce chafing and to decrease the rode angle, an anchor rode

(line or cable) of sufficient length, a mooring buoy to pull the curtain horizontally, and a crown buoy to locate and release the anchor.

191. After a silt curtain has been properly deployed, its effectiveness can be maximized only if the curtain is properly maintained. This entails moving the curtain away from the turbidity source just before the fluid mud layer reaches the depth of the skirt, maintaining the integrity of the curtain by repairing leaking connectors and/or tears in the curtain fabric, and replacing worn or broken anchor lines. Improper maintenance will not only decrease the curtain's effectiveness on a particular operation but will also increase the cost of reconditioning the curtain for reuse.

REFERENCES

1. Ekey, D.W., "The Big Diaper," Florida Dept. of Transportation, undated mimeo.
2. Roberts, W.S., "Florida's Big Diaper - Its Use and Results," Florida Dept. of Transportation, undated mimeo.
3. Morneault, A.W., "Barton Maintenance Dredging and Water Quality," presented at Dredging Seminar, Texas A & M University, June, 1973.
4. U.S. Army Engineer District, Mobile, "Silt Barrier Experiment, Control of Sedimentation Effects Resulting from Hydraulic Dredging," February 1971.
5. Baumeister, T., ed., Mechanical Engineers' Handbook, McGraw-Hill, New York, 1958, pp. 8-90.
6. Rossnagel, W.E., Handbook of Rigging, McGraw-Hill, New York, 1964, p. 74.
7. Hoult, D.P., "Containment of Oil Spills by Physical and Air Barriers," Massachusetts Institute of Technology, Dept. of Mechanical Engineering, undated mimeo.
8. Robbins, R.J., "The Oil Boom in a Current," Master's Thesis, Massachusetts Institute of Technology, June, 1970.
9. Milgram, J.H., "Physical Requirements for Oil Pollution Control Barriers," Proc. Joint Conference on Prevention and Control of Oil Spills, March, 1973.
10. Comstock, J.P., ed., Principles of Naval Architecture, Society of Naval Architects and Engineers, 1967, pp. 628 to 633.
11. U.S. Naval Oceanographic Office, "Techniques for Forecasting Wind Waves and Swell," Hydrographic Office Pub. No. 604, 1951.
12. Biggs, R.B., "Trace Metal Concentrations in the Sediments of Baltimore Harbor at the Dundalk Marine Terminal," Chesapeake Biological Lab. Ref. No. 68-97, 1968.
13. Nichols, M., Virginia Institute of Marine Sciences, personal communication.
14. Einstein, H.A. and Krone, R.B., "Experiments to Determine Modes of Cohesive Sediment Transport in Salt Water," Journal of Geophysical Research, Vol. 67, April 1962.
15. McCormack, M.E., Ocean Engineering Wave Mechanics, John Wiley and Sons, New York, 1973, Chapter 2.

APPENDIX A: MANUFACTURERS OF SILT CURTAINS

The following is an alphabetical listing of companies who manufacture silt curtains and whose products were reviewed during this study.

- a. Acme Products, Inc.
2666 N. Darlington Street
P.O. Box 51368
Tulsa, Oklahoma 74151
Tel. (918) 836-7184
- b. American Marine, Inc.
401 Shearer Blvd.
Cocoa, Florida 32922
Tel. (305) 636-5783
- c. Erosion Control
320 Lakeview Avenue
West Palm Beach, Florida 33401
Tel. (305) 655-3651
- d. Kepner Plastics Fabricators, Inc.
4221 Spencer Street
Torrance, California 90503
Tel. (213) 772-3246
- e. Slickbar, Inc.
250 Pequot Avenue
P.O. Box 139
Southport, Connecticut 06490
Tel. (203) 255-2601
- f. Uniroyal Plastic Products
Mishawaka, Indiana 46544
Tel. (219) 255-2181
- g. William Warne and Co., Ltd.
U.S. Distributor
Surface Separator Systems, Inc.
103 Millar Avenue
Baltimore, Maryland 21228
Tel. (301) 747-4744

APPENDIX B: NOTATION

- a - constant in parabolic equation for curtain shape, ft^{-1}
- a - virtual mass of silt curtain $\frac{\pi}{4} \rho_w s^2$, slugs/ft
- A_w - waterplane area of flotation element, ft^2/ft
- b - coefficient of water damping force on curtain, $(\text{ft-lb})/\text{sec}$
- B - residual buoyancy of silt curtain, lb/ft
- B_c - buoyant force acting on curtain, lb/ft
- c - water column concentration, lb/gal
- c - heaving stiffness of curtain $\rho_w A_w$, lb/ft
- c - surface wave speed (celerity), ft/sec
- C_d - drag coefficient dimensionless
- d - diameter of flotation element, ft
- d - water depth, ft
- d_p - particle diameter, in.
- D - actual curtain depth, ft
- D - hydrodynamic drag force acting on silt curtains, lb/ft
- f_n - natural frequency of silt curtain in heave, H_z
- F - force opposing P_c , lb/ft
- h - curtain depth, ft
- h - initial bottom opening under silt curtain, ft
- h_e - effective depth of curtain, ft
- h_1 - depth of lower curtain half, in.
- h_2 - depth of upper curtain half, in.
- H - wave height $2r$, ft.

AD-A060 382

J B F SCIENTIFIC CORP WILMINGTON MA
AN ANALYSIS OF THE FUNCTIONAL CAPABILITIES AND PERFORMANCE OF S--ETC(U)
JUL 78 E E JOHANSON

F/G 8/8

DACW39-77-C-0085

UNCLASSIFIED

WES-TR-D-78-39

NL

3 OF 3

AD
AO 60382



END
DATE
FILMED

1-79
DDC

- H - height of the conical mound under the discharge barge, ft
- H - water depth for submerged curtain, ft
- H_{max} - maximum wave height before breaking, ft
- ID - inside diameter of discharge pipe, ft
- k - volume fraction of solids that do not settle in mound, dimensionless
- ℓ - length of anchor cable, ft
- L - curtain length, ft
- L - length of surface wave, ft
- m - mud flow concentration, lb/gal
- m - mass of silt curtain, slugs/ft
- M - mouth opening of curtain array, ft
- M - component of anchor cable tension that acts normal to the skirt of a bottom tension curtain, lb/ft
- M₁ - flaring movement on lower curtain half, (in.-lb)/in.
- component of anchor cable tension that acts tangent to the skirt of a bottom tension curtain, lb/ft
- NTU - nephelometric turbidity unit
- P - current pressure, lb/in.²
- P₁ - flaring force of lower curtain half, lb
- P_c - net current force, lb/ft
- q - mass flow rate of solids for dredge discharge, lb/min
- Q - volume flow rate of dredge discharge, gpm
- r - mass flow rate of solids leaving silt curtain control volume, lb/min

- r - amplitude of wave motion, ft
- r - radius of circular silt curtain array, ft
- r_{max} - maximum wave amplitude before breaking, ft
- R - volume flow rate of mixture leaving silt curtain control volume, gpm
- R - curtain gap ratio M/L, dimensionless
- R - radius of the circular base of the conical mound, ft
- R_h - effective curtain depth ratio h_e/h, dimensionless
- s - half-width of flotation element, ft
- S - slope of the conical mound, dimensionless
- t - mass flow rate of solids in turbid mixture leaving silt curtain control volume, lb/min
- t - time, sec
- T - volume flow rate of turbid mixture leaving silt curtain control volume, gpm
- T - period of wave system, sec
- T - tension in curtain, lb
- T - tension in anchor cables of dual tension curtain, lb/ft
- T - tension in anchor cable of bottom tension curtain, lb/ft
- T - duration of pumping or operation period for silt curtain array, days
- T_n - natural period of silt curtain in heave, sec
- UV - ultra violet radiation
- V - water velocity, ft/sec
- V_b - volume of mounded material, ft³

- V_c - current velocity, ft/sec
 V_{cn} - component of current velocity, V_c , normal to curtain, ft/sec
 V_{ct} - component of current velocity, V_c , tangent to curtain, ft/sec
 V_p - total volume of slurry pumped, ft³
 V_s - settling velocity, ft/hr
 V_{sb} - total volume of solids in the conical mound, ft³
 V_{sp} - total volume of solids pumped, ft³
 w - transport speed, ft/sec
 w_{max} - transport speed in waves of maximum height, ft/sec
 W - volume flow rate of water into silt curtain control volume, gpm
 W_c - weight of curtain, lb/ft
 x - transverse coordinate of curtain shape, ft
 y - longitudinal coordinate of curtain shape, ft
 Z - vertical displacement of float, ft
 Z_o - amplitude of float motion, ft

 α - mass parameter $(m+a)/a$, dimensionless
 α_B - solids ratio of the mounded material by weight, dimensionless
 α_p - solids ratio of pumped slurry by weight, dimensionless
 β_B - solids ratio of the mounded material by volume, dimensionless
 β_p - solids ratio of pumped slurry by volume, dimensionless
 ϵ - phase angle by which float motion lags wave motion, deg
 η - angle between anchor cable tension T and its component M tangent to the skirt, deg

- κ - damping parameter $\omega_n b/c$, ft^2/sec^2
- Λ - circular frequency parameter ω/ω_n , dimensionless
- ν_w - kinematic viscosity of water, ft^2/sec
- ω - circular frequency of wave motion, radians/sec
- ω_n - natural frequency of silt curtain in heave, radians/sec
- ϕ_1 - flare angle of lower half of curtain, deg
- ϕ_2 - flare angle of upper half of curtain, deg
- ψ - angle between curtain skirt and horizontal plane, deg
- σ - curtain drag parameter $1/2 \rho_w V_c^2 h C_d$, lb/ft
- ρ_p - density of particle, slugs
- ρ_w - density of water, slugs
- γ - curtain tension parameter $2T/(L\rho_w V_c^2 h C_d)$, dimensionless
- θ - angle between tangent of curtain and X - axis, ft/sec
- ζ - vertical displacement of wave surface at the float, ft

In accordance with letter from DAEN-RDC, DAEN-ASI dated 22 July 1977, Subject: Facsimile Catalog Cards for Laboratory Technical Publications, a facsimile catalog card in Library of Congress MARC format is reproduced below.

JBF Scientific Corporation.

An analysis of the functional capabilities and performance of silt curtains / by JBF Scientific Corporation, Wilmington, Mass. Vicksburg, Miss. : U. S. Waterways Experiment Station ; Springfield, Va. : available from National Technical Information Service, 1978.

184, 1, 5 p. : ill. ; 27 cm. (Technical report - U. S. Army Engineer Waterways Experiment Station ; D-78-39)

Prepared for Office, Chief of Engineers, U. S. Army, Washington, D. C., under Contract No. DACW39-75-C-0085 (Neg.) (DMRP Work Unit No. 6C06)

References: p. 184.

1. Dredged material disposal. 2. Sediment control. 3. Silt curtains. 4. Silts. 5. Turbidity. I. United States. Army. Corps of Engineers. II. Series: United States. Waterways Experiment Station, Vicksburg, Miss. Technical report ; D-78-39. TA7.W34 no.D-78-39