

AD-A060 464

COMPUTER SCIENCES CORP FALLS CHURCH VA SYSTEMS DIV F/G 17/2
STUDY OF AUTOMATION OF MESSAGE HANDLING FUNCTIONS AT USCG COMST--ETC(U)
MAY 78 D SMILEY, G KEENE, P KENNEDY DOT-CG-71522-A
UNCLASSIFIED CSC/SD-78/3034 USC6-D-18-78. NL

1 of 4
AD
7060 464

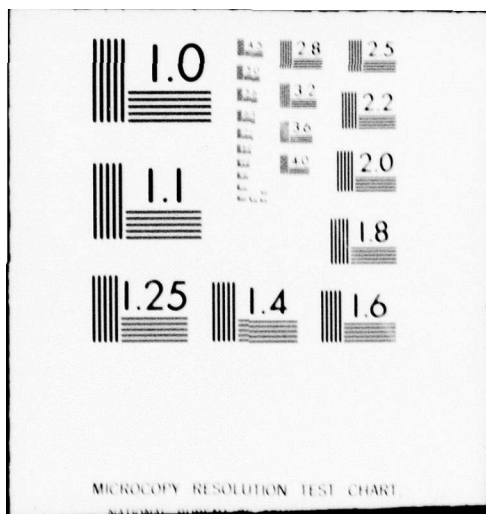



MICROCOPY RESOLUTION TEST CHART

REPORT NO. CG-D-18-78

LEVEL #

17 R

STUDY OF AUTOMATION OF MESSAGE HANDLING FUNCTIONS AT USCG COMSTA/RADSTA AND COMMUNICATION CENTERS

AD A060464

COMPUTER SCIENCES CORPORATION

6565 Arlington Boulevard
Falls Church, Virginia 22046



MAY 1978

FINAL REPORT

DDC
RECEIVED
OCT 30 1978
A

DDC FILE COPY

DOCUMENT IS AVAILABLE TO THE U. S. PUBLIC THROUGH THE
NATIONAL TECHNICAL INFORMATION SERVICE,
SPRINGFIELD, VIRGINIA 22161

This document is disseminated under the sponsorship of the Department of Transportation in the interest of information exchange. The United States Government assumes no liability for its contents or use thereof.

The contents of this report do not necessarily reflect the official view or policy of the U. S. Coast Guard and do not constitute a standard, specification, or regulation.

Prepared for

U.S. DEPARTMENT OF TRANSPORTATION
UNITED STATES COAST GUARD
OFFICE OF RESEARCH AND DEVELOPMENT
WASHINGTON, D.C. 20590

78 10 27 10 4

The United States Government does not endorse products or manufacturers. Trade or manufacturers' names appear herein solely because they are considered essential to the object of this report.

(19) (18) USCG

1. Report No. CG-D-18-78		2. Government Accession No.		USCG COMSTA/RADSTA and Communication Centers	
4. Title and Subtitle Study of Automation of Message Handling Functions at Coast Guard Communications Centers, Communications Stations and Radio Stations		6. Performing Organization Code May 1978		8. Performing Organization Report No. CSC/SD-78/3034	
7. Author(s) D./Smiley, G./Keene, P./Kennedy		10. Work Unit No. (TRAIS)		11. Contract or Grant No. DOT-CG-71522-A	
9. Performing Organization Name and Address Computer Sciences Corporation, Systems Division 6565 Arlington Boulevard Falls Church, Virginia 22046		13. Type of Report and Period Covered FINAL REPORT. AUG 1977 - MAY 1978		14. Sponsoring Agency Code	
12. Sponsoring Agency Name and Address Commandant U. S. Coast Guard 400 7th Street, S.W. Washington, D. C. 20591		15. Supplementary Notes (12) 294p.			
16. Abstract This study examines current Coast Guard message handling functions to (1) confirm the need for the application of communications automation techniques to such operations and (2) develop alternative approaches to accomplishing such automation. Information collected during surveys of four facilities is presented in detail then extrapolated to establish system-wide requirements. Several design options are described and evaluated for responsiveness and operational, technical, and cost benefits. Three configurations of the recommended alternative are proposed for installation in high, medium, and low volume Communications Centers and a fourth, for Communication and Radio Stations. The study identifies several administrative actions which must be accomplished preliminary to implementation of an automation program and, further, recommends a detailed analysis of systemwide operations to determine whether a major reconfiguration of the record traffic portion of the Coast Guard Communication System, to include consolidation of relay activity, would provide the basis for a more cost effective application of communications automation techniques.					
17. Key Words Communications Automation Peak Loading Traffic Trends Processing Functions AUTODIN System Configuration Minicomputers			18. Distribution Statement Document is available to the U. S. public through the National Technical Information Service, Springfield, Virginia 22161.		
19. Security Classif. (of this report) Unclassified		20. Security Classif. (of this page) Unclassified		21. No. of Pages 288	22. Price

LB

390 546 78 10 27 104

TABLE OF CONTENTS

Section 1 - Introduction

1.1	Purpose.	1-1
1.2	Study Approach.	1-1
1.2.1	Contract Support.	1-1
1.2.2	Data Collection.	1-1
1.3	Report Organization.	1-3

Section 2 - Summary of Significant Findings

2.1	General.	2-1
2.2	Requirements.	2-1
2.3	Complicating Factors.	2-2
2.4	Conclusions.	2-4

Section 3 - Summary of Existing System and Operating Procedures

3.1	Purpose.	3-1
3.2	System Definition.	3-1
3.2.1	Nodal Relationships.	3-2
3.2.2	Connectivity.	3-2
3.2.3	System Interfaces.	3-4
3.3	Physical Description.	3-5
3.3.1	Equipment and Facilities.	3-6
3.3.1.1	Communication Equipment.	3-6
3.3.1.2	Supporting Equipment.	3-7
3.3.1.3	Facilities and Arrangements.	3-8
3.3.2	Personnel.	3-9
3.3.2.1	Manning.	3-9
3.3.2.2	Training.	3-9
3.3.2.3	Administrative Work Load.	3-11
3.3.3	Procedures.	3-11
3.4	Description of Nodal Functions.	3-13
3.4.1	Incoming Sequence.	3-15
3.4.1.1	Reception and Translation.	3-15
3.4.1.2	Inspection.	3-15
3.4.1.3	Logging.	3-15
3.4.1.4	Routing.	3-16
3.4.2	Outgoing Sequence.	3-17
3.4.2.1	Inspection.	3-17
3.4.2.2	Logging.	3-18
3.4.2.3	Routing.	3-18

	Section <input checked="" type="checkbox"/>
	Action <input type="checkbox"/>
	<input type="checkbox"/>

BY		
DISTRIBUTION/AVAILABILITY CODES		
Dist.	Avail.	and/or SPECIAL
A		

Section 3 - (Continued)

3.4.2.4	Preparation for Transmission	3-19
3.4.2.5	Translation and Transmission	3-19
3.4.2.6	Logging	3-20
3.4.3	Relay Sequence	3-20
3.4.3.1	Preparation for Transmission	3-21
3.4.3.2	Translation and Transmission	3-21
3.4.3.3	Logging	3-21
3.4.4	Common Functions	3-22
3.4.4.1	Reproduction	3-22
3.4.4.2	Distribution	3-22
3.4.4.3	Review	3-23
3.4.4.4	Filing	3-23
3.4.4.5	Destruction	3-23
3.4.4.6	Data Management	3-24
3.5	Traffic	3-24
3.5.1	General	3-24
3.5.2	Gross Volume	3-25
3.5.3	Traffic Growth	3-25
3.5.4	Message Length	3-25
3.5.5	Classified Traffic	3-29
3.5.6	Distribution by Precedence	3-29
3.5.7	Handling Times	3-29
3.6	Cost	3-29
3.6.1	Facility Costs	3-31
3.6.2	Owned Equipment	3-31
3.6.3	Leased Equipment	3-32
3.6.4	Leased Line Costs	3-33
3.6.5	Maintenance and Repair	3-33
3.6.6	Consumable Supplies	3-34
3.6.7	Personnel Cost	3-34

Section 4 - Summary of Requirements

4.1	Introduction	4-1
4.2	System Capacity-Messages	4-3
4.3	System Capacity - Circuits	4-8
4.4	Functions	4-8
4.4.1	Outgoing Message Processing	4-10
4.4.2	Incoming Message Processing	4-11
4.4.3	Relay Traffic Processing	4-12
4.4.3.1	Landline to Landline	4-12

Section 4 - (Continued)

4.4.3.2 Landline to Radio Positions/Radio Positions to Landline. 4-13
4.4.4 Logs and Journals 4-14
4.4.5 Speed of Service 4-15
4.4.6 Interface Requirements. 4-15
4.4.7 Related Considerations. 4-15
4.4.7.1 On-Going Automation Efforts. 4-15
4.4.7.2 Procedural. 4-17
4.4.7.3 System Configuration 4-18
4.4.8 New Requirements. 4-19

Section 5 - Design Options

5.1 Introduction 5-1
5.2 Assumptions. 5-2
5.3 Options 5-3
5.3.1 Option 1 5-3
5.3.2 Option 2 5-3
5.3.3 Option 3 5-4
5.3.4 Option 4 5-4
5.3.4.1 Option 4A AUTODIN and TWPL (Basic System) 5-4
5.3.4.2 Option 4B Other Landline TTY 5-9
5.3.4.3 Option 4C In-Routing. 5-9
5.3.4.4 Option 4D Optical Character Reader 5-10
5.3.4.5 Option 4E File System 5-11
5.3.4.6 Option 4F Radio Circuits and Remote Entry/Delivery 5-12
5.3.4.7 Equipment and Software Costs - Option 4 5-13
5.4 Alternative Approach 5-15

Section 6 - Operational and Technical Benefits

6.1 Introduction 6-1
6.2 Discussion 6-1
6.3 Methodology 6-3
6.4 Impacts on Functions 6-3
6.4.1 Reception and Translation - Incoming Messages 6-3
6.4.2 Inspection - Incoming Messages 6-4
6.4.3 Logging - Incoming Messages 6-4
6.4.4 Routing - Incoming Messages. 6-4
6.4.5 Inspection - Outgoing Messages 6-5
6.4.6 Logging - Outgoing Messages. 6-5
6.4.7 Routing - Outgoing Messages. 6-5

Section 6 - Operational and Technical Benefits (Continued)

6.4.8	Preparation for Transmission - Outgoing Messages	6-5
6.4.9	Translation and Transmission - Outgoing Messages	6-6
6.4.10	Relay Sequence	6-6
6.4.11	Reproduction	6-6
6.4.12	Distribution	6-6
6.4.13	Review	6-6
6.4.14	Filing	6-7
6.4.15	Data Management	6-7
6.5	Handling Times/Manpower Implications	6-7
6.5.1	General	6-7
6.5.2	Handling Times - COMMCENS.	6-8
6.5.3	Handling Times - RADSTA/COMMSTAs	6-11
6.6	Operational Evaluation	6-11
6.6.1	Option 1.	6-11
6.6.2	Option 2.	6-11
6.6.3	Option 3.	6-13
6.6.4	Option 4A.	6-13
6.6.5	Option 4B.	6-14
6.6.6	Option 4C.	6-14
6.6.7	Option 4D.	6-14
6.6.8	Option 4E.	6-15
6.6.9	Option 4F.	6-15
6.6.10	Workload Reduction Summary	6-15
6.7	Reliability and Maintainability	6-19
6.8	Interfaces	6-20
6.9	Facility Impact	6-20
6.10	Implementation Implications	6-21
6.10.1	Problems	6-21
6.10.2	Operational	6-21
6.10.3	Training	6-21
6.11	Summary Evaluation	6-23

Section 7 - Costs Versus Benefits

7.1	Introduction	7-1
7.2	Methodology	7-1
7.3	Cost Analysis of Options.	7-2
7.3.1	Option 1.	7-2
7.3.2	Option 2.	7-2
7.3.3	Option 3.	7-2
7.3.4	Option 4.	7-2

Section 7 - Costs Versus Benefits (Continued)

7.4	Maintenance Arrangements	7-9
7.5	Lease Versus Purchase	7-9

Section 8 - Recommended Solutions

8.1	Introduction.	8-1
8.2	Recommended Priority Order.	8-1
8.3	Recommended Configurations.	8-2
8.3.1	Large Volume COMMCENS	8-2
8.3.2	Medium Volume COMMCENS	8-3
8.3.3	Small Volume COMMCEN	8-3
8.3.4	COMMSTA/RADSTAs	8-3
8.4	Implementation Schedule	8-3
8.5	Alternative Approach	8-3

Appendix A - Communications Center, Governors Island, N. Y.

A.1	Introduction.	A-1
A.2	General Description	A-2
A.3	Growth and Future Requirements	A-5
A.4	Personnel	A-7
A.4.1	Manning	A-7
A.4.2	Training	A-8
A.5	Equipment and Facilities	A-8
A.5.1	Communications Center Equipment	A-8
A.5.2	Connected Station Terminal Equipment	A-10
A.5.3	Facilities	A-10
A.5.4	Maintenance	A-10
A.5.5	Miscellaneous Communications Facilities.	A-10
A.5.6	Cost Data	A-11
A.6	Functional Description	A-12
A.6.1	General	A-12
A.6.2	Forms and Formats	A-12
A.6.3	Drafting and Releasing	A-14
A.6.4	Processing of Outgoing Messages	A-14
A.6.5	Processing of Incoming Messages	A-16
A.6.5.1	AUTODIN Traffic.	A-17
A.6.5.2	Traffic Received via Other Circuits.	A-17
A.6.5.3	Classified Messages	A-17
A.6.5.4	General Messages	A-18
A.6.5.5	Relay Traffic.	A-18

Appendix A - Communications Center, Governors Island, N. Y. (Continued)

A.6.6	Internal Routing, Reproduction, and Distribution	A-19
A.6.7	Logs and Records	A-20
A.6.8	Storage and Retrieval	A-21
A.6.9	Waste Disposal	A-21
A.7	Traffic	A-21
A.7.1	General	A-21
A.7.2	Gross Traffic Volumes	A-22
A.7.3	Specific Traffic Data	A-24
A.7.4	Message Length	A-28
A.7.5	Handling Times	A-28
TAB I	Operation Sequence Diagram - Outgoing	A-I-1
TAB II	Operation Sequence Diagram - Incoming AUTODIN	A-II-1
TAB III	Operation Sequence Diagram - Incoming Loop	A-III-1

Appendix B - Communications Center, Portsmouth, Virginia

B.1	Introduction	B-1
B.2	General Description	B-1
B.3	Growth and Future Requirements	B-3
B.4	Personnel	B-3
B.4.1	Manning	B-3
B.4.2	Training	B-4
B.5	Equipment and Facilities	B-4
B.5.1	Communications Center Equipment	B-4
B.5.2	Connected Station Terminal Equipment	B-4
B.5.3	Facilities	B-6
B.5.4	Maintenance	B-6
B.5.5	Miscellaneous Communications Facilities	B-6
B.5.6	Cost Data	B-6
B.6	Functional Description	B-6
B.6.1	Forms and Formats	B-6
B.6.2	Drafting and Releasing	B-12
B.6.3	Processing of Outgoing Messages	B-12
B.6.4	Processing of Incoming Messages	B-13
B.6.5	Internal Routing, Reproduction, and Distribution	B-14
B.6.6	Logs and Records	B-15
B.6.7	Storage and Retrieval	B-15
B.6.8	Waste Disposal	B-16
B.7	Traffic	B-16
B.7.1	General	B-16
B.7.2	Gross Traffic Volumes	B-16
B.7.3	Specific Traffic Data	B-17

Appendix B - Communications Center, Portsmouth, Virginia (Continued)

B.7.4	Message Length	B-22
B.7.5	Handling Times	B-24
B.7.5.1	Recorded.	B-24
B.7.5.2	Synthesized	B-24
B.7.5.3	Handling Time Summary	B-30
TAB I	Operation Sequence Diagram - Outgoing	B-I-1
TAB II	Operation Sequence Diagram - Incoming AUTODIN	B-II-1
TAB III	Operation Sequence Diagram - Incoming Loop	B-III-1

Appendix C - Communications Station, Portsmouth, Virginia

C.1	Introduction	C-1
C.2	General Description	C-1
C.3	Growth and Future Requirements	C-3
C.4	Personnel	C-3
C.4.1	Manning	C-3
C.4.2	Training	C-5
C.5	Equipment and Facilities	C-5
C.5.1	Communications Center Equipment	C-5
C.5.2	Maintenance.	C-5
C.5.3	Miscellaneous Communications Facilities	C-5
C.5.4	Cost Data	C-6
C.6	Functional Description	C-6
C.6.1	General	C-6
C.6.2	Forms and Formats	C-7
C.6.3	Drafting and Releasing.	C-7
C.6.4	Processing of Outgoing Messages	C-7
C.6.5	Incoming Messages	C-7
C.6.5.1	Land Line TTY Traffic (Including AUTODIN).	C-8
C.6.5.2	Radio Teletype (RATT) Traffic	C-8
C.6.5.3	CW and Voice Traffic	C-8
C.6.5.4	Classified Traffic	C-10
C.6.5.5	Relayed Traffic	C-10
C.6.5.6	Compiling	C-11
C.6.5.7	Broadcast Makeup.	C-12
C.6.6	Internal Routing, Reproduction and Distribution	C-12
C.6.7	Logs and Records	C-12
C.6.8	Storage and Retrieval	C-13
C.6.9	Waste Disposal	C-13
C.7	Traffic	C-13
C.7.1	General	C-13

Appendix C - Communications Station, Portsmouth, Virginia (Continued)

C. 7.2	Gross Traffic Volumes	C-14
C. 7.3	Specific Traffic Data	C-16
C. 7.4	Message Length	C-19
C. 7.5	Handling Times	C-19
C. 7.5.1	Recorded Times	C-19
C. 7.5.2	Synthesized Times	C-19
TAB I	Operation Sequence Diagram - Incoming Landline.	C-I-1
TAB II	Operation Sequence Diagram - Incoming Radio	C-II-1
TAB III	Operation Sequence Diagram - Relay Traffic	C-III-1

Appendix D - Communications Center, Headquarters U.S. Coast Guard

D.1	Introduction.	D-1
D.2	General Description	D-1
D.3	Growth and Future Requirements	D-2
D.4	Personnel	D-2
D.4.1	Manning	D-2
D.4.2	Training	D-4
D.5	Equipment and Facilities	D-4
D.5.1	Communications Center Equipment	D-4
D.5.2	Facilities	D-4
D.5.3	Maintenance	D-4
D.5.4	Miscellaneous Communications Facilities	D-4
D.5.5	Cost Data	D-8
D.6	Functional Description	D-8
D.6.1	General	D-8
D.6.2	Forms and Formats	D-8
D.6.3	Drafting and Releasing	D-8
D.6.4	Processing of Outgoing Messages	D-9
D.6.5	Incoming Messages	D-11
D.6.5.1	Incoming AUTODIN	D-11
D.6.5.2	Incoming other than AUTODIN	D-12
D.6.5.3	Relays and Readdressals	D-13
D.6.6	Internal Routing, Reproduction and Distribution	D-13
D.6.7	Logs and Records.	D-14
D.6.8	Storage and Retrieval	D-15
D.6.9	Classified Waste Disposal	D-15
D.7	Traffic	D-15
D.7.1	General	D-15
D.7.2	Gross Traffic Volumes	D-16
D.7.3	Specific Traffic Data	D-17

Appendix D - Communications Center, Headquarters U.S. Coast Guard (Continued)

D. 7.4	Message Length.....	D-20
D. 7.5	Handling Times.....	D-20
TAB I	Operation Sequence Diagram - Outgoing Message	D-I-1
TAB II	Operation Sequence Diagram - Incoming Message	D-II-1

LIST OF ILLUSTRATIONS

<u>Figure</u>		<u>Page</u>
3-1	Teletypewriter System Connectivity	3-3
3-2	Functional Sequence, Nodal System	3-14
5-1	Block Diagram - Option 4 with Sub-Options	5-5
8-1	Recommended Implementation Schedule	8-4
A-1	Third CG District Communications Organization	A-2
A-2	Third CG District Teletypewriter Circuit Diagram	A-3
A-3	SARLANT Network Diagram	A-4
A-4	COMMCEN Floor Plan	A-6
A-5	COMMCEN Operations - Functional Block Diagram	A-15
A-6	Synthesized Handling Times - Incoming AUTODIN	A-31
A-7	Synthesized Handling Times - Incoming LOOP	A-32
A-8	Synthesized Handling Times - Originated Traffic	A-33
B-1	Fifth CG District Teletypewriter Diagram	B-2
B-2	COMMCEN Floor Plan	B-7
B-3	Fixed Message Format (Camp Lejeune Firing Exercises)	B-9
B-4	Fixed Message Format (Bloodsworth Island Bombardment)	B-10
B-5	Fixed Message Format (Wallops Station Rocket Firing)	B-11
B-6	Synthesized Handling Times - Incoming AUTODIN	B-26
B-7	Synthesized Handling Times - Incoming LOOP	B-27
B-8	Synthesized Handling Times - Originated Messages	B-28
C-1	COMMSTA Operational Spaces Floor Plan	C-2
C-2	COMMSTA Portsmouth Circuit Diagram	C-4
C-3	COMMSTA MPDS - Simplified Block Diagram	C-9
C-4	Synthesized Handling Times - Incoming AUTODIN	C-21
C-5	Synthesized Handling Times - Incoming RATT	C-22
C-6	Synthesized Handling Times - Incoming CW or Voice	C-23
D-1	Headquarters COMMCEN Circuit Diagram	D-3
D-2	COMMCEN Floor Plan (Existing)	D-6
D-3	COMMCEN Floor Plan (Future)	D-7
D-4	COMMCEN Operations - Functional Block Diagram	D-10
D-5	Synthesized Handling Times - Incoming Traffic	D-23
D-6	Synthesized Handling Times - Outgoing Traffic	D-24

LIST OF TABLES

<u>Table</u>	<u>Page</u>	
3-1	Personnel Allowances (1976)	3-10
3-2	Administrative Workload (Weekly)	3-12
3-3	Traffic Summary for Communication/Radio Stations (1976)	3-26
3-4	Traffic Summary for Districts and Headquarters (1976)	3-27
3-5	Growth in Traffic Volume (1970-1976)	3-28
3-6	Off-Line Crypto 1976	3-30
3-7	Consumables Cost Summary	3-35
4-1	Peak Load Ratios	4-4
4-2	Projected Annual Totals (Messages)	4-5
4-3	Projected Busy Hour/Busy Four Hour Loading (Messages)	4-6
4-4	Projected Busy Hour/Busy Four Hour Loading (Line Blocks)	4-7
4-5	Circuit Summary (Landline)	4-9
5-1	Representative Costs	5-14
6-1	Traffic Distribution Estimates (Messages per Busy Day)	6-9
6-2	COMMCEN Handling Time Reductions (Per Message)	6-10
6-3	RADSTA/COMMSTA Handling Time Reductions (Per Message)	6-12
6-4	COMMCEN Workload Reduction Estimates (Minutes/Day)	6-16
6-5	RADSTA/COMMSTA Workload Reduction Estimates (Minutes/Day)	6-18
6-6	Automation Implications - Summary Evaluation	6-24
7-1	Estimated Automation Costs (\$K per Year)	7-4
7-2	Estimated Consumable Costs (\$ per Year)	7-6
7-3	Estimated Military Pay Savings (\$K/Year)	7-7
7-4	Systemwide Cost Implications-Option 4 (\$K/Year)	7-5
7-5	Cost Implications by Facility (1979-1987) (\$K)	7-8
8-1	Busy Day Handlings - Selected Facilities	8-5
A-1	COMMCEN Communications Equipment	A-9
A-2	Annual Cost-Consumables	A-11
A-3	Summary of Messages Requiring Wide Dissemination	A-13
A-4	Traffic by Functional Category	A-22
A-5	Traffic by Circuit Mode	A-23
A-6	Multiple Handlings	A-24
A-7	Traffic Volumes for August 1977	A-25
A-8	Traffic Volume for Average Day	A-26
A-9	Traffic Volume for Busy Day	A-27
A-10	Hourly Distribution-Busy Day (Originated/Terminated Traffic)	A-29
A-11	Relay Pattern	A-30
A-12	Handling Time Summary	A-36
B-1	COMMCEN Communications Equipment	B-5
B-2	Annual Consumable Costs	B-8

LIST OF TABLES

<u>Table</u>		<u>Page</u>
B-3	Traffic by Functional Category	B-17
B-4	Traffic by Circuit Mode	B-18
B-5	Multiple Handlings	B-18
B-6	Traffic Volumes for August 1977	B-19
B-7	Classified Traffic - August 1977	B-20
B-8	Traffic Volume for Average Day	B-21
B-9	Traffic Volume for Busy Day	B-22
B-10	Hourly Distribution - 18 August (Originated/Terminated Traffic)	B-23
B-11	Relay Pattern	B-24
B-12	In-Station Handling Times (Recorded)	B-25
B-13	Handling Time Summary	B-31
C-1	Three Quarter Costs - Consumables	C-6
C-2	Traffic by Functional Category	C-14
C-3	Traffic by Circuit Mode	C-15
C-4	Multiple Handlings	C-15
C-5	Compiled Traffic	C-15
C-6	Traffic Volumes for August 1977	C-17
C-7	Traffic Volume for Busy Day	C-18
C-8	Hourly Traffic Volume - Busy Day	C-20
C-9	Relay Pattern	C-24
C-10	In Station Handling Time (Recorded)	C-24
C-11	Handling Time Summary	C-25
D-1	COMMCEN Communications Equipment	D-5
D-2	Annual Consumable Costs	D-8
D-3	Traffic by Functional Category	D-16
D-4	Traffic by Circuit Mode	D-17
D-5	Traffic Volumes for Survey Period	D-18
D-6	Traffic Summary - Classification/Precedence	D-19
D-7	Traffic Volume for Busy Day	D-20
D-8	Hourly Distribution - Busy Day (Originated/Terminated Traffic)	D-21
D-9	Handling Time Summary	D-25

SECTION 1 - INTRODUCTION

1.1 PURPOSE

The purpose of this study effort is to analyze present Coast Guard message handling operations, as conducted at major Communications Centers; to identify those operations for which the application of communications automation technology offers tangible benefits; and to examine alternative approaches toward achieving these benefits. The overall objective is to develop a cost-effective system architecture with sufficient flexibility to permit application to Communications Centers with a broad range of requirements. An equally important objective is to identify the resource savings, particularly in the area of manpower utilization, and operational benefits, such as enhanced responsiveness, which can be achieved through and, thus, provide justification for automation.

1.2 STUDY APPROACH

1.2.1 Contract Support

Consultant support in the conduct of this study was provided by Contract DOT-CG-71522-A dated 8 August 1977.

1.2.2 Data Collection

A comprehensive study of this nature requires the collection and analysis of a substantial volume of information. A portion of the background information necessary to support this study was available in Commandant, U.S. Coast Guard (G-OTM) files. Such information included the Coast Guard Telecommunications Manual (CG-233) and files of Landlines Communications Facilities (CG-4031) and Communications Summary (CG-2614) Reports. It should be noted at this point that a wide variance exists in the manner in which Coast Guard activities prepare Landlines Communications Facilities Reports. In a number of cases, it was necessary to refer to Defense Commercial Communications Office (DECCO) and National Communications System (NCS) printouts for additional data on Coast

Guard circuits. It was also noted that numerous conflicts exist in information presented in CG-4031 reports and DECCO and NCS circuit listings.

In addition to access to information contained in Headquarters files, the consultant was authorized visits to selected Coast Guard facilities. On-site visits and surveys were conducted at the Third Coast Guard District Communications Center (6-9 September 1977); Fifth Coast Guard District Communications Center (13-15 September 1977); Coast Guard Communications Station, Portsmouth (19-21 September 1977); and the Headquarters Communications Center (12-17 October 1977). At each of the facilities visited, personnel had obviously been briefed on the purpose of this study. Personnel at each site were cooperative and, most importantly, made no attempts to disguise facility inadequacies. It can be assumed with a high confidence factor that the operations observed during each visit are typical of day-to-day operations.

Despite the cooperative attitude noted at each facility, the collection of required operational data, in general, and traffic data, in particular, was difficult and extremely time consuming. It was anticipated that in-station procedures might differ slightly from site to site due primarily to equipment configuration variances. In actuality, however, in-station procedures and practices vary markedly. Differences were observed in the sequence of events performed during the flow of message traffic through centers; the manner in which logs and records are maintained; the annotating of messages with time of file (TOF), time of receipt (TOR), and time of delivery (TOD); and the filing of traffic.

The development of valid traffic data was further complicated by the fact that, within a specific facility, logs, records, and message servicing practices (i. e. annotating TOF, TOR, TOD) differ by circuit. It is virtually impossible, therefore, to determine, with any degree of accuracy, the speed of service now being provided by the various COMMCENs. The lack of such information, which provides a basic measure of COMMCEN effectiveness, will make it extremely

difficult to evaluate, fully, the operational benefits to be gained by automating, or improving by any other means, COMMCEN operations.

One feature common to all sites, however, was the complete absence of useful statistical data on message traffic. The one record available was the traffic counts on which preparation of the Communications Summary Report (CG-2614) is based. The manner in which these records are developed also differs from facility to facility indicating that statistics developed by use of CG-2614 summaries may be of questionable validity. As a consequence of the absence of useful data, the traffic counts required to develop relay patterns, distribution by precedence and classification, and hourly loading were obtained by laborious, message by message search through station files. It must be noted, therefore, that this effort was limited, necessarily, to analysis of traffic handled during the immediately preceding 30-day period due to routine destruction of traffic more than 30 days old.

1.3 REPORT ORGANIZATION

This report is organized into eight sections, as follows:

- Section 1 - Introduction
- Section 2 - Summary of Significant Findings
- Section 3 - Summary of Existing System and Operating Procedures
- Section 4 - Summary of Requirements
- Section 5 - Candidate Design Options
- Section 6 - Operational and Technical Impacts
- Section 7 - Costs versus Benefits
- Section 8 - Recommended Solutions.

SECTION 2 - SUMMARY OF SIGNIFICANT FINDINGS

2.1 GENERAL

During the data collection and analysis phase of this study, primary emphasis was placed on the identification of requirements and development of criteria which would provide an acceptably reliable base for system design efforts. Concurrently, efforts were made to identify factors which might complicate, or make extremely expensive, the automation of message handling functions. Requirements, criteria, and complicating factors are discussed in detail in Sections 3 and 4. A brief summary of the more significant findings in each area is presented below.

2.2 REQUIREMENTS

Comparison of statistical data for calendar years 1970 and 1976 indicates that the volume of discrete messages handled by Coast Guard Headquarters and Area/District Communications Centers, and Communications Stations and Radio Stations increased, overall, by 12.6 percent, which equates to an annual growth rate of 2.0 percent.

Total message handlings, which reflect multiple handlings of individual messages, increased by a slightly higher ratio (15.8 percent) indicating that relay activity, system-wide, may also have increased.

Based on data collected at operating sites, classified traffic constitutes no more than one percent of the total traffic load. Sampling of messages in Headquarters COMMCEN files indicates a much higher (10 percent) proportion of classified traffic.

Peak hour loading at facilities surveyed ranged, for the busy hour, from 8.0 to 12.0 percent of the day's traffic; and for the busy four-hour period, from 28.5 to 36.0 percent. Of the four sites visited, peak loading was most severe at the Headquarters COMMCEN and least at the COMMSTA Portsmouth.

Except for increased activity in Law Enforcement areas, noted at the Third and Fifth District COMMCENS, and the assumption of additional broadcast responsibilities by the COMMSTA Portsmouth, there appear to be no factors which may cause an abnormal increase in Coast Guard message volumes or drastic changes to traffic patterns. With regard to Law Enforcement requirements, the installation of an interactive terminal to provide a more rapid interface with the El Paso Intelligence Center (EPIC) is being considered by both Third and Fifth District Headquarters. Should this approach materialize, installation of the terminal in Rescue Coordination Center (RCC) spaces rather than the COMMCEN is suggested.

In examining the functional flow of traffic through each site visited, it was possible to identify those functions which are the more time consuming and manpower demanding. These include the processing of originated messages for transmission, the reprocessing of traffic received via teletypewriter private line (TWPL) for relay into AUTODIN, and the in-routing or determination of required distribution of received traffic. Where installed, the optical scanner/message header generator capability has eased only partially the workload involved in preparing originated traffic for transmission.

It was noted earlier that the collection of traffic data was difficult and time consuming. Traffic data can provide, when properly collected and manipulated, useful resource management information. Any automated system for COMMCEN applications should be designed to produce, periodically or on demand, statistical reports for management purposes.

2.3 COMPLICATING FACTORS

While conducting on-site surveys and reviewing data available in Headquarters files, it became apparent that there are a number of areas which may warrant in-depth

examination or, as a minimum, administrative decisions either prior to or in coordination with the development of plans to automate message handling functions. Each area in which further action is suggested has a potential adverse impact on the complexity and, hence, the cost of an automated system.

First, all District COMMCENs operate a number of traffic channels, including AUTODIN, Group and other local loops, various links to other Agencies (i.e., the National Weather Service), and commercial refile (TWX and TELEX) facilities. A significant portion of the traffic received over one circuit requires retransmission over another. Thus, each facility for which automation is contemplated serves two primary purposes - as a message center and as a message switch. While direct comparison with the Navy Automation Program may not be completely accurate, early cost studies for that program indicated that the cost of a NAVCOMPARS, which automates both message center and message switching functions, was approximately 1.8 times the cost of an LDMX, which automates the message center function. The earlier study also indicated that a NAVCOMPARS required more than twice the manning level for an LDMX terminal. This suggests that costs for automating Coast Guard message handling functions might be lessened considerably by consolidating relay and commercial refile functions. The detailed analysis which would precede such a realignment of functions should examine, among other things, Coast Guard use of AUTODIN, the extensive network of leased lines which comprise the Coast Guard Communications System, and the means of providing message services to units below the Group level.

A second major factor influencing automation costs are the operating procedures (disciplines) employed on terminated circuits. Each site visited is required to use JANAP 128 procedures (AUTODIN) as well as procedures unique to SARLANT operations. Different network protocols are employed on District loops, National Weather Service drops, and commercial refile facilities. Software costs in an automated system increase rapidly when numerous formats and format conversions require accommodation. The Navy solution to this problem was to standardize on two formats (JANAP 128 and ACP 126).

Most messages delivered to the COMMCENs visited are drafted on CG Form 2655 or, at the Headquarters, OCR Form CCHQ-5010. Traffic is accepted, however, on various other forms, including the standard DOT message form used by DOT offices served by the Headquarters COMMCEN and the preprinted forms used by District offices for promulgation of operationally oriented messages such as safety warnings, weather, etc. Adoption and mandatory use of one standardized form, such as DD Form 173, should be considered long before implementation of an automation program.

Successful implementation of a program to automate the processing of outgoing and relay traffic will require strict adherence to the Plain Language Address Designators (PLAD) contained in the U.S. Coast Guard Supplement to NTP3. The program to implement the PLAD should be expedited and monitored.

Perhaps the most difficult function to automate is the internal routing of traffic at major headquarters. Automation of the subject index/look-up system now in use, while not impossible, would be prohibitively expensive. Adoption of a system such as the Standard Subject Identification Code (SSIC) used by the Navy would provide a more realistic base for automation.

2.4 CONCLUSIONS

This study concludes that present message handling operations, as conducted in Coast Guard Communication Centers, Communication Stations, and Radio Stations can be improved significantly by installation of an automated system utilizing a small general purpose digital processor with appropriate peripheral equipment. Such a system will provide an excellent growth capability, improved speed of service, and essentially error free message service. By eliminating virtually all manual functions in large centers and substantially reducing the manual workload in others, automation will, potentially, reduce the total manpower requirements of Headquarters and District COMMCENs by up to 48 billets.

Workload reductions achievable at COMMSTAs and RADSTAs will eliminate the collateral functions now being performed by radio operators.

This study also suggests that a detailed analysis of the Coast Guard Communication System might be a desirable prelude to embarking on a COMMCEN/COMMSTA/RADSTA automation program. No on-going studies, for example, attempt to measure System responsiveness to the broad command and control requirements of the Coast Guard. There is a possibility, which is considered worthy of investigation, that a more responsive System could be realized by an extensive reconfiguration of existing landline circuitry and consolidating all relay activity into a small number of selected facilities.

SECTION 3 - SUMMARY OF EXISTING SYSTEM AND
OPERATING PROCEDURES

3.1 PURPOSE

The purpose of this section is to describe the existing Coast Guard message Processing and Distribution System (MPDS) in sufficient detail to establish a reference base line for system analysis, future projections, and development of system improvement options. This description is presented in detail for those stations and centers visited and surveyed by the contractor teams, and in general terms for the remainder of the system. The general summary is derived from data available at the Headquarters, U.S. Coast Guard; from interviews with headquarters personnel, and extrapolations of known data. Detailed descriptions of the stations and centers surveyed are contained in Appendices as follows:

- A. Communication Center Third District
- B. Communication Center Fifth District
- C. Communication Station Portsmouth
- D. Communication Center Coast Guard Headquarters

Data collection efforts in all cases were concentrated in the areas of services provided; current and historical traffic data; current methods, doctrine and procedures employed; manning; equipment; and physical and functional arrangements of existing facilities.

3.2 SYSTEM DEFINITION

This study is concerned with internal message center operations and with the total effort involved in the handling and processing of record message traffic addressed to, handled by, or emanating from the major communication centers and stations serving the U.S. Coast Guard. While there are some significant differences between the system nodes as they reside in the several headquarters

and stations, the physical and functional characteristics are similar and can be described in a generic sense. Two significant differences between nodes are the number and type of input/outputs and the volume of traffic handled. In general, the similarities are: the external interfaces, internal procedures and time and cost parameters.

3.2.1 Nodal Relationships

The nodal communication stations and centers addressed in this study are those identified as having the heaviest traffic loads, and thus having the greatest potential for improved efficiency by automation. Figure 3-1 presents a schematic display of the major and minor nodes and the teletypewriter system connectivity between these nodes. The Coast Guard Headquarters, the 10 major Communication/Radio Stations, and the 12 District Headquarters Communication Centers are considered candidates for automation in this study. Each of these 23 centers constitutes a discrete system within the terms of the definition applied herein. While some of the subordinate nodes have a significant record message throughput, they are not addressed directly in this study.

3.2.2 Connectivity

The major nodal stations are connected with each other, with their subordinate and supporting activities, and with various common user systems by a variety of landline circuitry. This connectivity includes:

- a. Dedicated, point-to-point or netted circuits, owned (or leased) by the Coast Guard and on which the message format, protocols, disciplines and other characteristics are controlled by the Coast Guard. (Group Loops - SARLANT - SARPAC).
- b. Government owned common user networks to which the Coast Guard is a subscriber, and in which the message formats, protocols and other circuit characteristics are dictated by the system manager. (AUTODIN-NAVCOMPARS).

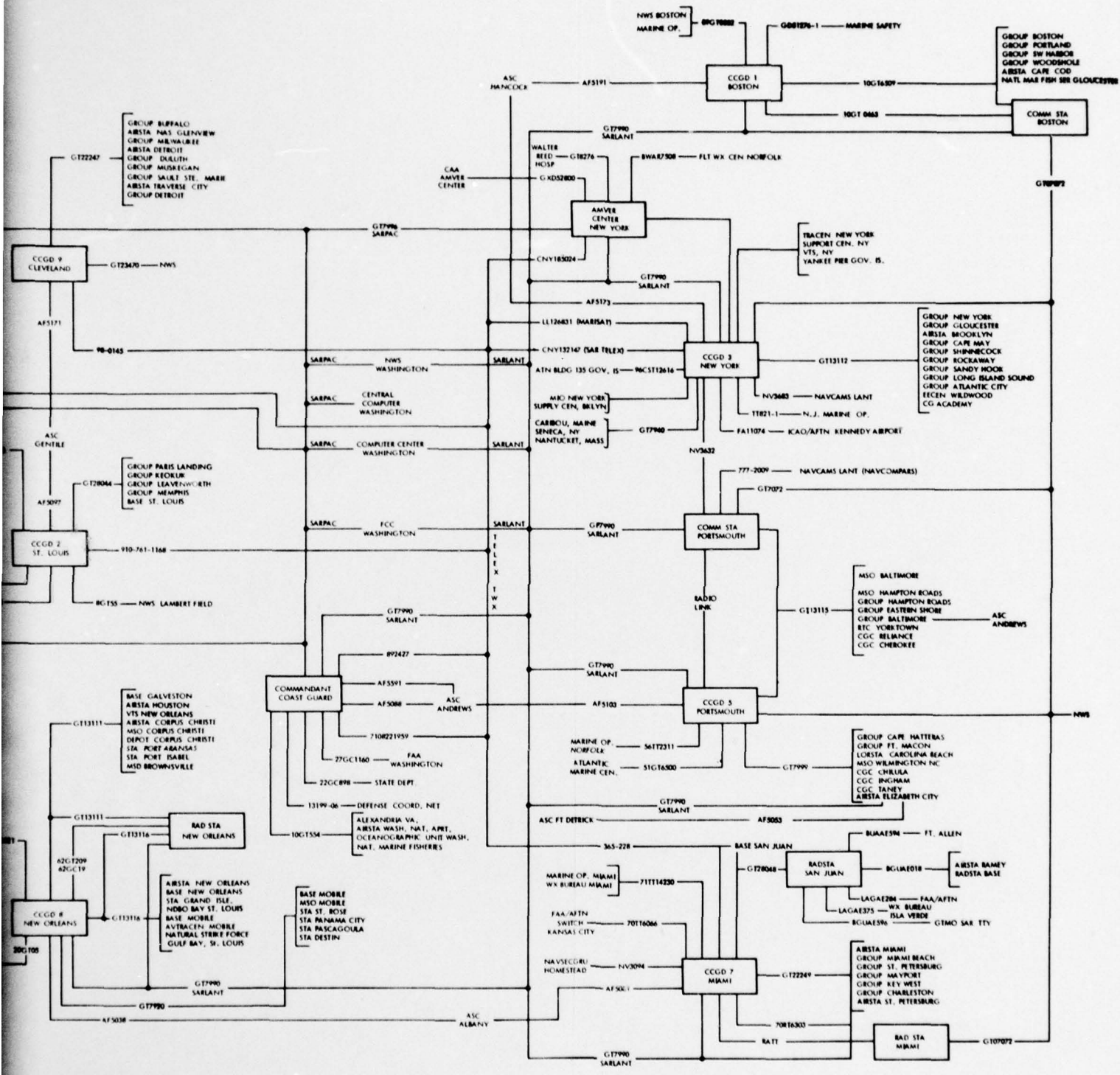

Figure 3-1. Teletypewriter System Connectivity

2

c. Common User public utility systems in which the Coast Guard is a paying subscriber, and in which the formats, protocols, etc., are dictated by the utility. (TWX-TELEX - Marine Radio).

d. Special purpose, dedicated, point to point or netted circuits provided by government agencies in which the Coast Guard is a participant for the purpose of inputting or exchanging special mission information. The message formats, protocols and other circuit characteristics are generally dictated by the sponsoring agency, but may or may not be negotiable. (Weather Bureau - FAA).

3.2.3 System Interfaces

Each of the nodal systems has clearly definable boundaries within which the message handling and processing functions reside. With regard to the existing system within a representative node, these interfaces are defined as follows:

a. Inputs

(1) A paper copy of an outgoing message in approved format presented to the message center for processing and transmission.

(2) An incoming electrical signal having characteristics compatible with the terminal equipment resident in the center.

b. Outputs

(1) A paper copy of a received message in proper format available to the intended local reader.

(2) An outgoing electrical signal having characteristics compatible with the transmission network and distant terminal equipment.

(3) Unclassified residue from shredded or pulped classified paper copies, tapes, etc.

(4) Management reports of traffic volume, or other significant system characteristics.

3.3 PHYSICAL DESCRIPTION

This study is concerned with the message center operations and total handling of message traffic received by and sent from the major nodal systems of the Coast Guard. With few exceptions, the efforts associated with the message handling process are manual and include such functions as logging, formatting, preparation for transmission/editing, distribution, filing, and disposition. These functions can best be described as Message Processing and Distribution functions, and the system within which these functions are performed is identified as the Message Processing and Distribution System (MPDS). This system includes personnel, equipment, facilities and procedures. Each of these is further defined.

a. Personnel - MPDS personnel are those persons who devote all or a significant portion of their activities to MPDS functions. The writer, reader, and release authority are not included in this category, although some non-communication clerical personnel may be.

b. Equipment - MPDS equipment is that which is designed for and devoted exclusively to the MPDS functions. Included in this category are teletypewriter terminal equipment, OCR/CRT devices, and other equipments devoted to conversion of page copy to electrical form and vice versa. Also included are any transmitting and receiving equipments used for the local distribution or reception of message traffic which are not electrically connected to an external communications network.

c. Facilities - MPDS facilities are those items of equipment and infrastructure which are devoted entirely or in part to the MPDS. Included in this category are:

Reproduction Equipment

Office files and furnishings

Building space and utilities

Typewriters and office machines

Destruction devices

d. Procedures - MPDS procedures are contained in various doctrinal publications, directives, staff instructions, and SOPs used by MPDS personnel and those persons outside the MPDS who must interface with the system.

As was previously stated, the characteristics of the major nodal systems are similar, with the differences being primarily in magnitude. It is then considered suitable to address this physical description in generic terms, with significant differences addressed by exception or by reference to the detailed description of typical systems in the appropriate appendix. The system is considered from the standpoint of the equipment and physical layout, number and duties of personnel, and operational procedures used.

3.3.1 Equipment and Facilities

The appendices to this report provide detailed listings of communications dedicated equipment, supporting equipment and facility arrangements for the four nodal stations surveyed. These stations are considered typical of those serving similar headquarters and the equipment mix and arrangements are comparable.

3.3.1.1 Communication Equipment

Currently installed communication equipment of interest in this study consists largely of Teletype Corporation Model 28 teletypewriters in various configurations. The few exceptions are the Model 37 equipment installed at the more modern communication stations, and the commercial type Models 32 and 33 machines terminating TELEX and TWX circuits, respectively.

The Model 28 equipment appears in Automatic Send/Receive with Keyboard and Tape Punch (ASR), Keyboard Send Receive (KSR), Page Printer (RO), and Tape Transmitter Distributer (TD) configurations. The Model 32 appears in ASR configurations only. The Model 28 equipments operate at 75 baud (100 wpm) high level, except for those dedicated to cryptographically covered circuits. Model 32 equipment on TWX also operates at 100 wpm while TELEX operates at 60 wpm.

On-line cryptographic equipments include KG-13, KW-26 and KW-7. Off-line crypto is also available in some centers, although the number of centers so equipped is decreasing.

At the present time only one center (Headquarters) is equipped with an optical scanner for processing of outgoing messages, although most other centers are scheduled to be so equipped. Likewise only a limited number of centers have Message Header Generators (MHG). There are plans to produce MHG for most other centers.

3.3.1.2 Supporting Equipment

Non-communication support equipment includes such things as reproduction machines, files and furniture, typewriters and other office machines, and destruction devices. While there are some significant variations, the centers surveyed had comparable equipment and it must be assumed that other centers are similarly equipped.

Reproduction is accomplished by electro-optical devices such as IBM-2, IBM-3, XEROX 3600 or SCM. These equipments are generally leased and would be retained in any anticipated automated system for copying for internal distribution.

Most furnishings, such as files, desks, tables, etc. are of standard GSA catalogue configurations and, with some reduction in quantity, will serve the same functions in an automated center.

Typewriters and other office machines such as time stamps are in use in all centers and are of common or standard types. In some conceivable automation options these devices might be dispensed with, although manual fall-back operations may require retention on a case-by-case basis.

In most cases, the device used for destruction of classified residue is a large commercial capacity shredder or pulverizer. While an automated system will produce considerably less paper waste, these devices will still be required. A reduced capacity might be acceptable.

3.3.1.3 Facilities and Arrangements

With few exceptions, the communication center facility is located within a Coast Guard owned or leased building, in space dedicated to the MPDS functions. Utilities such as heat, light, air conditioning and technical power are furnished as part of the total support of the building or base. Special power conditioning is provided, as are signal connections for external communication circuits. The facilities are constructed so as to satisfy appropriate security requirements, including tempest and physical access.

Although the physical arrangements may have originally been laid out to provide the most efficient time/motion and space configuration, changes in equipment or physical dimensions of the spaces have resulted, in some cases, in what are now less than optimum arrangements. Most facilities are now undergoing or have planned major rearrangements or total relocations in order to accommodate already committed major equipment acquisitions. Most prominent of these are the planned installation of Mode I AUTODIN and Optical Scanning equipment. The Mode I system requires more space and power than the existing Mode V.

With these noted exceptions, and in the absence of detailed site studies of all facilities, it must be assumed that the most likely options available for automation could be accommodated within existing spaces with minimum modification. It is anticipated that the total equipment requirement will be reduced at any given facility, and that a more efficient arrangement of remaining equipment can be accomplished concurrently.

3.3.2 Personnel

3.3.2.1 Manning

The personnel allowances for Coast Guard message centers have been extracted from the CG-3614 reports submitted by each center for calendar year 1976. The allowances for each center are displayed in Table 3-1.

Since Headquarters and District personnel must perform certain staff and administrative functions, no more than 80 percent are normally dedicated to message handling functions. At the Communication/Radio station, the majority of personnel are employed in operating radio equipment and circuits, and only collaterally handle message traffic within the station. For example, at the Communication Station, Portsmouth, only three members of a 12-man watch were dedicated to in-station or relay functions.

Typically the personnel allowance is made up of day workers and watch standers. Watches vary from 8 to 12 hours, and the size of the regular watch varies from 2 to 5. (Note the exception at the COMMSTAs.) One- to three-day workers may be assigned to handle traffic checking, filing, classified material control, or peak load traffic, as well as supervisory functions.

Operating personnel are assigned by the supervisor to duties or operating positions in accordance with experience and work load demands. Operators are rotated to various positions and duties for training. Typical position descriptions (depending on station and traffic load) include: AUTODIN Operator, Send Operator, Receive Operator, Loop/SARLANT Operator, Run-off and Distribution, Utility man. Not all such positions exist in all centers although most of the functions are performed.

3.3.2.2 Training

Although no formal technical training programs are in effect at any of the stations surveyed, all have an effective informal and on-the-job (OJT) program.

TABLE 3-1. PERSONNEL ALLOWANCES (1976)

STATION OR CENTER	E-9	E-8	E-7	E-6	E-5	E-4	TOTAL
HEADQUARTERS	1	2	4	12			19
1st District	1	1	4	4	4		14
2nd District	1	1	-	4	5		11
3rd District	1	1	4	8	8		22
5th District	1	1	4	4	4		14
7th District	1	1	4	4	5		15
8th District	1	1	4	4	4		14
9th District	1	1	1	4	5		12
11th District	1	1	2	4	4		12
12th District	1	1	4	3	8		17
13th District	1	1	1	4	5		12
14th District	1	1	4	4	4		14
17th District	1	1	4	4	4	2	16
TOTAL	12	14	40	63	60	2	192
ADAK			1	1	2	3	7
SAN JUAN		1	4	4	4	5	18
NEW ORLEANS		1	4	5	8	9	27
BARROW			1				1
MIAMI		1	4	5	8	11	29
SAN FRAN	1		4	9	9	22	45
BOSTON	1		4	9	9	17	40
PTSMTH	1		4	8	9	23	45
HONOLULU		1	4	5	9	14	33
KODIAK		1	4	11	11	18	45
TOTAL	3	5	34	57	69	122	290

It was estimated that from 3 to 6 months is required to qualify a new operator for duties in all operating positions. A senior petty officer requires 1 to 4 months to qualify as a supervisor. All personnel are required to be graduates of Radioman "A" school before assignment.

3.3.2.3 Administrative Work Load

While Communication Center personnel are not normally assigned outside duties, some internal administrative work is required that detracts from the overall effectiveness of the manning allowance. All personnel have certain duties not directly related to normal message processing. Although these duties impact on required manning to some extent, it is anticipated that most will be required in an automated system. Such duties include: equipment preventive maintenance, cleaning operating spaces, disposition of classified waste, and training. Table 3-2 illustrates the magnitude of the effort expended on administrative duties in each center.

3.3.3 Procedures

The Communication Centers in the Coast Guard system operate in accordance with the following doctrinal and procedural publications. This list is not all inclusive, but provides some insight into the complexity of the system operations.

a. Coast Guard Telecommunications Manual (CG-233)

This publication sets forth requirements for administration of the system; management of facilities; operational communications procedures and radio frequencies.

b. Naval Telecommunications Procedures (NTP)

- (1) NTP 2. Navy Satellite Operations Section IIB Navy Gapfiller SOP.
- (2) NTP 3. Telecommunications Users Manual
- (3) NTP 4. Fleet Communications

TABLE 3-2. WEEKLY ADMINISTRATIVE WORKLOAD (MANHOURS)

COMMUNICATION CENTERS	CLASS. MATERIAL CONTROL	COMTAC	OTHER	TOTAL
HEADQUARTERS	80	20	40	150
1st District	20	14	24	58
2nd District	20	10	20	50
3rd District	40	10	40	90
5th District	35	15	40	90
7th District	20	15	110	145
8th District	20	20	80	160
9th District	12	13	40	65
11th District	16	8	40	64
12th District	30	24	110	164
13th District	40	15	5	60
14th District	95	18		113
17th District	25	5	10	40
AVERAGE	35	14	44	96

COMMUNICATION RADIO/STATIONS	CLASS. MATERIAL CONTROL	COMTAC	OTHER	TOTAL
Miami	5	10	66	81
San Francisco	4	4	36	44
Boston	6	12	8	26
Portsmouth	4	3	20	27
Honolulu	5	12	12	29
Kodiak	8	20	20	48
Adak			46	46
San Juan	5	15	90	120
New Orleans	2	6	48	56
Barrow	2	2	40	44
AVERAGE	4.1	8.4	38.6	52.1

- c. ACP 121 - Communication Instructions - General
- d. ACP 124 - Radiotelegraph Procedure.
- e. ACP 125 - Radiotelephone Procedure.
- f. ACP 126 - Teletypewriter Procedure.
- g. JANAP 128 - AUTODIN Procedure.
- h. CG-261-Preparation and Handling of messages at Headquarters.
- i. Local equivalent of CG-261 at other centers.
- j. Local SOPs.
- k. Operating procedures issued by the controlling agencies of special purpose circuits terminating in Coast Guard centers.

3.4 DESCRIPTION OF NODAL FUNCTIONS

The Message Processing and Distribution System presently in existence is designated as the "Baseline" for this analysis. The representative nodal center described above is intended to serve as a terminal providing message transmission, reception, processing and distribution functions for one or more operational/administrative headquarters; or as a relay, providing reception and retransmission of messages not addressed to the nodal center itself. In many cases the functions are combined and messages are handled that require relay over one or more circuits as well as processing for internal distribution. For purposes of this description the operational functions are grouped in four general categories: those associated with incoming traffic, those associated with outgoing traffic, relay operations and common functions. The sequence of operations performed in a representative nodal system is shown in the block diagram in Figure 3-2. This diagram presents the basic functions in terms of key operations common to all or most of the nodes, and identifies nodal system interfaces.

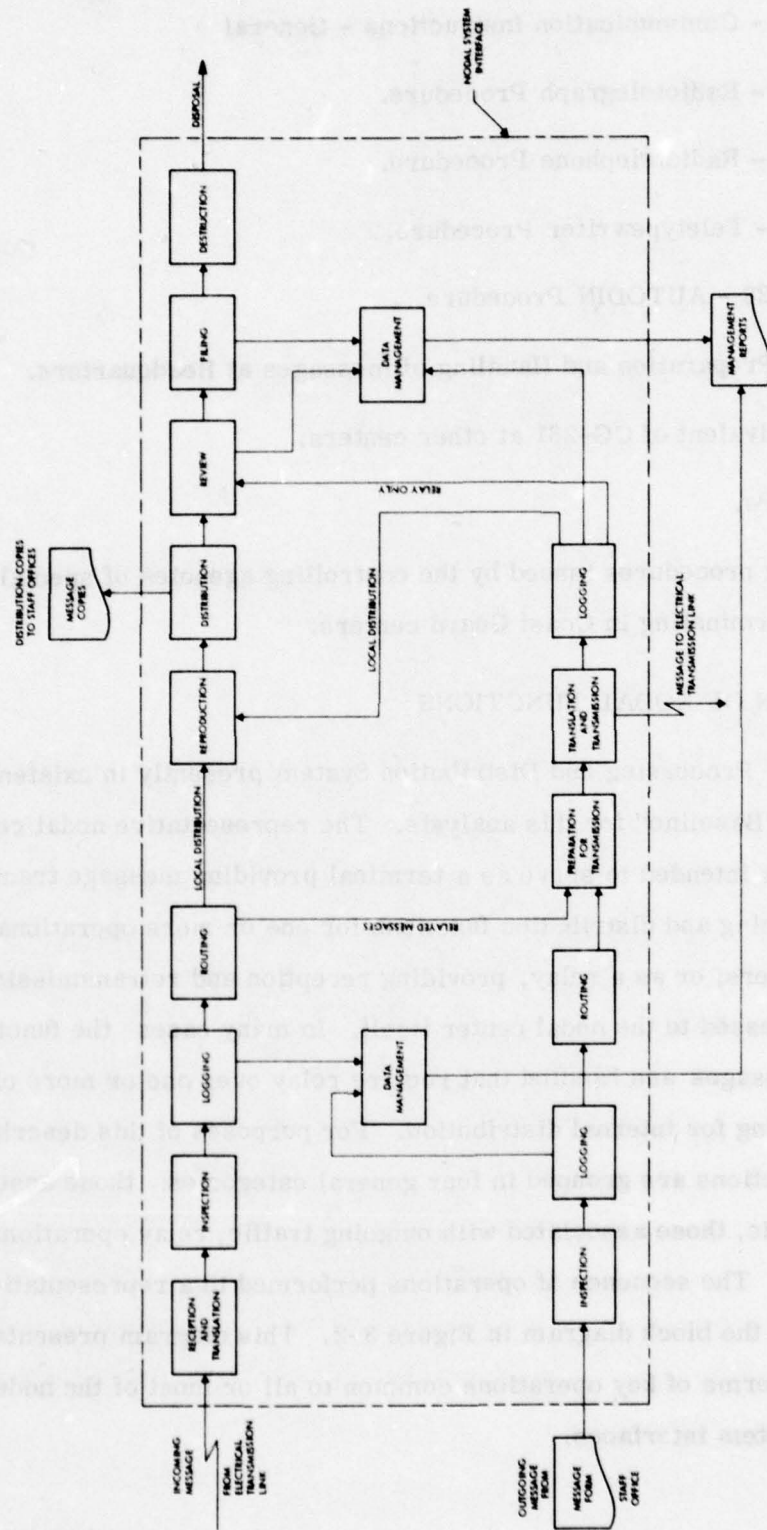

Figure 3-2. Functional Sequence, Nodal System

3.4.1 Incoming Sequence

3.4.1.1 Reception and Translation

The point of entry of an incoming message into the nodal system is that point where the message intelligence in electrical form enters a device designed to translate the intelligence into a form useable by the nodal system. This device may be a teletypewriter, page printer, paper tape punch, facsimile, radio receiver, or tone converter. The translation function may be performed by a device alone or by a human operator interpreting the signals produced by the device. The output may be a paper copy of a message, a punched paper tape or both.

In conjunction with the reception and translation function, there may be an acknowledgement of the receipt of the message transmitted back to the sending station. This acknowledgement may be generated and transmitted automatically by the receiving device, or may require human operator action.

3.4.1.2 Inspection

The next successive function to be performed is an inspection of the message. This inspection encompasses the entire message; heading, text and ending. The precedence and classification are noted and a check may be made to determine if the message was previously received. The inspection includes the verification that the message is addressed to the station or to another addressee for which the station must protect delivery. It may also include a cursory examination of the text to verify completeness and general readability. The previously discussed acknowledgement of receipt may be delayed pending the result of this inspection and notation may be made on the message attesting to the inspection.

3.4.1.3 Logging

This term is used to describe several related functions. It includes a recording of the time of receipt of the message in relation to the circuit and a specific identification of the message, usually by date time group (DTG). It may include a more

detailed record for messages requiring relay, including the originator; a listing of protected addressees; and a listing of the circuits over which it must be sent. Related to the logging function and concurrently performed is the notation on the message of such information as the time of receipt (TOR), circuit designation, operator identity and/or operator position. These items of information may be recorded manually by an operator, on a typewriter or teletypewriter, with time stamps or other mechanical devices or a combination of several means. These logging functions may be performed by a single person in one log or by several operators in more than one location and format.

3.4.1.4 Routing

The routing function, as pertains to incoming messages, supports two different objectives. First, to determine the need for, and method of effecting relay of the message to other stations, commands, or activities not served directly by paper copy distribution; and second, to determine the need for, and extent of internal reproduction and distribution of copies. This function may result in additional log entries as previously described, and may thus be performed concurrently with the inspection and logging functions. The routing function normally requires notations to be made on a paper original of the message indicating circuits on which the message must be sent, and/or the number of copies and recipients of internal distribution. The application of these and other notations may be expedited by the use of rubber stamps. The determination of internal distribution is assisted in most cases by the use of a routing guide, keyed to the message subject matter. The routing function may also include the determination and notation of a selected staff section or office that is responsible for taking action on certain messages, including preparation of a reply, if appropriate. The requirement for notification of the action office of the receipt of high precedence traffic, and the segregation of traffic by precedence for sequential handling, are also considered part of the routing function.

3.4.2 Outgoing Sequence

The point at which an outgoing message enters the system is that point where it is transferred from the custody or control of the drafter (or his agent) into the custody or control of the nodal message processing system. It is considered to have passed into the system when it is delivered to the message/communication center by hand or mechanical device (conveyer or pneumatic tube), or when picked up from the drafter by a system messenger. The drafter may require a receipt or the return of an annotated copy as evidence of delivery of the message to the message center.

3.4.2.1 Inspection

The first function to be performed after an outgoing message enters the system is a rather detailed inspection. The message is normally presented to the system as a typewritten paper original in one of several formats. The inspection is performed in order to verify any or all of the following:

- a. An acceptable format has been used.
- b. The message has been properly released. (Verification of the releasing signature is not normally required.)
- c. The production quality of the original is such that it is useable by the person or device (OCR) that must read (interpret) the message.
- d. That references have been properly identified and annotated or attached.
- e. Classification and precedence designations have been noted.
- f. Internal distribution information has been provided.

If the inspection produces a negative response to any of these descriptors, the message may be returned to the drafter; the drafter may be queried for correcting information; or the inspector may make minor corrections based on available information, knowledge and experience. When the message is fully acceptable under system standards, its receipt is acknowledged to the drafter (if required), and processing for transmission can begin.

3.4.2.2 Logging

The logging functions as applied to outgoing messages are similar to those for incoming messages in that they are intended to provide a record of the progress of a message as it passes through the system. Logging of outgoing messages normally includes only the recording of the time of file (TOF) in the message center. In the case of classified messages, the originating office, classification and other data may also be recorded. As a part of the logging function, the TOF may be time-stamped or handwritten on the original message and this may be the only recording of the TOF. The TOF usually becomes the date-time-group (DTG) of the message; although when several messages are delivered to the center at the same time, sequential times are assigned as DTG.

3.4.2.3 Routing

The routing of outgoing messages may, in some cases, support two different objectives. First, a determination of the internal distribution of copies - or "Back Routing" - may be required if the drafter has not indicated that information on his original; and second, the determination and designation of the proper "Out-Routing" to the external addressees.

In Out-Routing, several actions may be required:

- a. Designation of the circuit or circuits over which the message must be sent.
- b. Look-up and recording on the message forms of the routing indicators to be used.
- c. Look-up and recording on the message form of the code numbers associated with the routing functions of a Message Header Generator.
- d. Making the message form available to the proper operator or operating position for further processing.

These functions are abbreviated in many cases when the operating personnel can remember commonly used routing indicators or codes and the "look up" action is not required; or when the router is also the circuit operator.

3.4.2.4 Preparation for Transmission

This is a function that may include a number of sub-functions depending on the equipment available in the center and the types of circuits terminating. Basically stated it is the function of conversion of the original paper page copy of the message into a form suitable for input to the transmission equipment.

In most cases, the primary action included is the production of a punched paper tape of the message acceptable to teletypewriter tape reading equipment. This tape may be produced entirely manually by keyboard operation, or with varying degrees of automation if Optical Character Reader (OCR) or Message Header Generator (MHG) equipment is available. Depending on the circuit mode to be used for transmission, a complete AUTODIN heading may be required; but in most other cases a tape with the plain language heading and text will be sufficient.

In exceptional cases, no preparation will be required. Messages to be transmitted by facsimile are transmitted as received in paper copy form, and except for scheduled broadcasts, voice and CW, are read directly from the paper original by an operator. Broadcast messages are discussed under Relay Functions.

3.4.2.5 Translation and Transmission

This function encompasses all those activities required to translate the message from paper copy or punched tape into an electrical signal compatible with the circuit or network, and the initiation of the transmission into the external network. The translation may be accomplished by a teletypewriter tape transmitter distributor (TD) or manual keyboard, or a combination of both; by an operator reading the text

into a microphone or operating a CW key; or by a facsimile scanner/transmitter. Some messages will require multiple transmissions and thus may require translations by more than one device or technique.

3.4.2.6 Logging

As it pertains to the originated outgoing message, this post-transmission logging function is primarily intended to record the time of transmission of the message from the nodal system into the connecting network. This recording may be accomplished automatically by the transmitting terminal equipment (AUTODIN), manually with a teletypewriter keyboard, or with a time stamp. In addition to this notation made on the "as sent" copy, the time of transmission (delivery) may also be noted on a separate log form for each circuit, and again on a central log maintained by a supervisor. In the case of radio transmissions, the operator also notes the circuit, TOD, frequency and operator identification on the message form. On some circuits, the distant station may acknowledge receipt of the message by transmission of a time of receipt (TOR). This also becomes a matter of record and is considered part of the logging function.

After the completion of all logging actions, the flow proceeds to the Common Function Sequence. (Para 3.4.4).

3.4.3 Relay Sequence

A message received electrically in the nodal system that requires retransmission on one or more other external links is considered a relay, whether or not it also requires internal distribution. The routing function of the incoming sequence is the point at which the relay decision is made. If relay is required, the message moves to the relay sequence which includes preparation, translation/transmission and logging functions.

3.4.3.1 Preparation for Transmission

The extent of preparation required for a relay message will depend on the mode or format in which it is received and the circuit or format required for transmission. The message form available at the input to this function may be a teletypewriter hard copy and paper tape or a typewritten original as copied by a manual Voice/CW operator. The tape produced in the receive translation function may or may not be reuseable, depending on the quality of the circuit and on the relay mode to be used.

In many cases then, the preparation for transmission may require manual preparation of a complete new tape including AUTODIN heading, preparation of a heading tape only for use with a received text tape, or no preparation at all.

In exceptional cases, such as relays to broadcast, and the compiling of certain formatted messages, special preparation is required. This may involve preparation of consolidated broadcast paper tape, voice tape recordings, and preparation or splicing of paper tape.

Messages requiring multiple transmissions may require preparation in more than one format.

3.4.3.2 Translation and Transmission

This function for relayed messages is the same as for originated outgoing traffic. The only unique requirement is that multiple translations and transmissions may be required using different procedures and devices.

3.4.3.3 Logging

The logging requirement for a relayed message is also generally the same as for originated traffic. The same logging and recording of data takes place regarding the circuit logs and operator notations. In addition, a special continuity log may be

maintained to verify and record the accomplishment of all deliveries as identified and recorded in the routing and logging functions of the incoming sequence.

After the completion of all relays and logging functions, the message flow proceeds to the common functions sequence. There are two variations to this flow. If the message must be internally distributed as well as relayed, it proceeds to the reproduction function. If it has been relayed only, it by-passes the internal distribution functions and proceeds to the review function of the common sequence.

3.4.4 Common Functions

3.4.4.1 Reproduction

If the routing requires local distribution of copies, the functional flow leads to the reproduction function. Copies of the message are produced in accordance with the decisions made as a part of the routing function. Any of several types of optical-electro-mechanical devices may be used that output black-on-white paper copies of either teletypewriter or typewritten paper originals. Prior to production of copies, the classification may be stamped on the original, and after production, an "ACTION" copy may be designated, if required. If the message also requires relay, the reproduction function is normally delayed until all relays have been accomplished.

3.4.4.2 Distribution

After the copies are produced, they must be made available to the intended readers in the appropriate staff or supported organization. In some cases, this distribution function may consist of sorting and storing copies pending pickup by a staff personnel; while in others it may include scheduled or unscheduled hand delivery to the staff offices. The readers may be alerted to the availability of high precedence messages or delivery may be made expeditiously by messenger. Special accountability requirements exist for controlling distribution of copies of classified messages. This function also may include the preferential advance delivery of information copies of all messages to selected offices, such as the Rescue Coordination Center. This advance delivery may be accomplished by hand, mechanical conveyer or pneumatic tube.

3.4.4.3 Review

After all internal processing has been accomplished there is a need in a manual system for a quality control and verification procedure. In this function, a review is made of each message to verify that delivery has been accomplished to all addressees, that internal distribution has been made in accordance with the drafters instructions or the subject routing guide, and that proper notations have been made on the message form. In most cases, the paper tapes of the message will have been discarded before beginning the review function. The input will normally be an original "as drafted" or "as received" copy of the message and a complete set of all "as sent" copies for each transmission. The review will normally result in a final notation being made on the original message and may require a final entry in a master log. This review or traffic check is normally made by a senior member of the watch and may be duplicated by a senior member of a following watch.

3.4.4.4 Filing

After processing and review, the messages are filed in the communication center file in date time group order by hour and day. Doctrine requires retention for 30 days. Classified and unclassified messages are normally intermingled if stowage security allows, although in some cases they may be segregated. Certain other messages may be filed separately for convenience (such as Weather Observations or AMVER), while General Messages are filed separately as required by regulation. Oldest files are normally disposed of on a daily basis after the 30 day holding period.

Completed radio logs, circuit logs and special supervisor logs are filed separately in paper form on a daily basis and are normally retained for six months.

3.4.4.5 Destruction

Paper copies of messages after 30 days, obsolete or cancelled general messages, logs, tapes and other residue of communication center operation must be disposed of properly on a daily basis. In most cases, all trash and waste material in the center is treated as classified and disposed of accordingly. This material may be destroyed

or rendered unclassified by shredding, pulping or burning. This is accomplished by regular watch stander personnel on a scheduled or casual basis. The equipment used to accomplish this destruction is normally shared with other users and is not considered part of the Message Processing System. The disposal of the residue is likewise outside the system and considered an administrative support function.

3.4.4.6 Data Management

Data management is the function of recording and management of statistical data pertaining to the operation of the nodal message handling system and the message traffic handled. Periodic and special purpose reports are produced containing traffic and circuit statistics.

3.5 TRAFFIC

3.5.1 General

System traffic data has been compiled from statistical reports submitted by District and Communication/Radio Stations, and from observations and on-site tabulations of samples taken at selected stations. An analysis of these data provides a summary of system traffic volume by station in terms of circuit mode and functional traffic category, as well as growth and distribution pattern.

In interpreting the gross traffic figures in this section, two significant characteristics of the system and traffic reporting procedures must be considered. First, in the comparison of messages by functional category with the total count of messages handled, it should be noted that the same message, reported once by functional category, may be counted several times under the circuit mode totals by virtue of multiple circuit transmissions or relays. Second, the system totals, as tabulated, provide significant insight into the total number of messages handled, but should not be used as a measure of total throughput or instantaneous system loading. An undetermined count of messages must be assumed to be addressed from one node to one, several, or all other nodes and will thus be counted at least once by all reporting nodes through which it passes. Any effort to determine true system loading or total

through-put would require a detailed traffic study and development of a dynamic system model.

3.5.2 Gross Volume

Table 3-3 provides a summary of traffic volume by functional category and circuit mode for ten Communication/Radio Stations for calendar year 1976. Table 3-4 tabulates the same data for the 12 Districts and Headquarters. The extreme right column on each table provides a comparison of messages to times handled. This figure gives a general indication of the magnitude of the relay function at each station.

3.5.3 Traffic Growth

Table 3-5 provides a summary of the growth in traffic volume in the seven-year period from 1970 to 1976. The table presents the growth for the Headquarters and Districts as well as for the Communication/Radio Station and illustrates the growth for messages by category, number of messages handled and the number of multiple handlings or relays. The column headed "MSGG RELAYED" is not a true count of multiple handlings but represents the difference between the count of discrete messages and the number of messages by circuit category. As such, it is useful only as an indication of the order of magnitude of the growth of multiple handling in the system as a whole.

3.5.4 Message Length

Based on the AUTODIN Tributary Station reports over a 3-year period, the Coast Guard Headquarters Comm Center traffic into and received from AUTODIN averaged 217 groups (13.6 line blocks) and 314 groups (19.6 line blocks) respectively. When compared with reports at the Comm Centers at 3rd and 5th Districts, these averages were somewhat high as might be expected at the higher headquarters. However, unless a detailed study of actual message length is to be undertaken, the adoption of a 20-line block average for all traffic appears to be a reasonable base for computation of throughput requirements. This excess capacity should be sufficient to accommodate growth or unpredictable traffic surges.

TABLE 3-3. TRAFFIC SUMMARY FOR COMMUNICATION/RADIO STATIONS (1976)

STATIONS	CIRCUIT MODE										MESSAGE CATEGORIES							# TIMES HANDLED
	TWPL	AUTO-DIN	FAX	RATT	CW	VOICE	OTHER	TOTAL	AMVER	BATHY/METEO	OCEANO	OTHER GOVT	SAR	OTHER	TOTAL			
ADAK	S 7631				2319		346	10296	222*	20883		133*	437		24886	1.51		
	R 1732				25194		79	27295										
BARROW	S 1557			1301		41	24*	3647		1259	270	624	13	1913	4109	1.87		
	R 1946			1080		352	34*	3726										
BOSTON	S 40657		126	1-321	23172	17622	6	99907	16506	40644	544	17454	2746	32380	110274	1.90		
	R 34250			13189	62135	690	10	110274										
HONOLULU (3)	S 26139	619*		4772	17717	20453	2290	77569	9136	46162	13	29914	311*	22165	110448	1.72		
	R 16906	28804		5042	58452	4266	170	1138340										
KODIAK (4)	S 55786	17742	16	19257	6328	7292	13674	120095	2076	23152	4	16702	3005	48063	93002	2.40		
	R 38313	21916	456	13122	15680	11700	2471	103655										
MIAMI	S 61615			31412	9709	512	23431	128439	6466	6344	2	105710	4156	22745	145432	1.74		
	R 29554			52984	14031	1492	27616	125077										
NEW ORLEANS	S 13599			1828	529*	17927	85	38737	8401	4207		2438	1392	12477	25915	2.29		
	R 10800			2069	14281	754	230	27734										
PORTSMOUTH (1)	S 24570	270*2		47329	4589	13025	2358	118963	25722	44199	15	44430	561	65465	180512	1.61		
	R 28367	45796		10823	78936	153*	1101	172555										
SAN FRANCISCO	S 56595		2534	14424	3406	5455	17	82454	13418	42516	3	10274	2015	36805	105055	1.91		
	R 36398			11843	58333	905	56	107536										
SAN JUAN	S 17460				15544	3	19*	33205	26911	57032	5	9314	1627	6047	100936	1.31		
	R 5151				98769		152	99072										
TOTAL	S 305429	51022	2095	138659	87984	26300	45203	213472	70914	286428	58	238198	19090	248000	903572	1.77		
	R 263117	96516	456	116152	426700	21697	32233	896618										
GRAND TOTAL	S/R 508546	147538	3151	254811	508689	104327	77436	1,003,840										

NOTES:

- (1) Portsmouth Totals for period 1 July 76-30 June 77.
- (2) AUTODIN Traffic via NAVCOMPARS at NAVCOMSTA Norfolk.
- (3) AUTODIN Traffic via ASC, Whidbey.
- (4) AUTODIN Traffic via ASC, McClellan.

TABLE 3-4. TRAFFIC SUMMARY FOR DISTRICTS AND HEADQUARTERS (1976)

COMMUNICATION CENTERS	CIRCUIT MODE										MESSAGE CATEGORIES							# TIMES HANDLED
	TWPL	AUTO-DIN	VWX	FAX	RATT	OTHER	TOTAL	AMVER	BATHY/ME/FO	OCEANO	OTHER GOVT	SAR	OTHER	TOTAL				
HEADQUARTERS	S 26452	477*0	81*9	901		101*	84670	452	2499	75*	47397	4412	227260	282,778	1.01			
	R 43101	136157	7701	520		5277	19*436	703	27021	844	311*3	10616	66*894	137261	1.85			
1ST DISTRICT	S 1*013	33347			90*	35744	11*012				8333	1420	20036	30359	2.63			
	R 57911	60246			437	7497	136091	102604	4957	42130	23112	21650	133203	327656	1.62			
2ND DISTRICT	S 9729	5653	4570			30343	54295											
	R 7719	10171	1506			6165	25561											
3RD DISTRICT	S 1*013	29459	1041	3947	991	16139	235205											
	R 125642	1521*6	6025	1255	1019	8400	294*27											
5TH DISTRICT	S 40269	1*029		26	1*96	4*83	69403											
	R 61395	41915		23	1446	160	105129	2713	13127	20	39163	27559	77649	160331	1.69			
7TH DISTRICT	S 58*49	29623		4	2115	34096	1246*7											
	R 76120	65725		33	3523	8*92	146609											
8TH DISTRICT	S 38847	28221				1*356	82427											
	R 79*52	32122				311	1122*5											
9TH DISTRICT	S 42964	9846	4940			1455	55105											
	R 75479	16072	3024			610	95185											
11TH DISTRICT	S 315*0	16779		502	329	7431	50621											
	R 46094	24028		251	336	478	71145	81	15630		17040	7963	38998	79712	1.53			
12TH DISTRICT	S 43008	30971		14*8		1522	77559	908	13545	75	4910	9059	88607	117154	1.56			
	R 44749	58*16		1526		1074	106165											
13TH DISTRICT	S 36950	13728				14671	68830	456	17226		16629	7136	44100	85647	1.70			
	R 3*054	30221				1669	75994											
14TH DISTRICT	S 42946	27422	3553			7856	81777	7666	2328	32	19932	5566	77043	112567	1.91			
	R 62964	62758	12*9			2663	133965											
17TH DISTRICT	S 54511	19672		133		13760	8*356	3690	19317	1511	4947	2*22	68497	101054	1.60			
	R 39331	33707		96		800	74024											
TOTAL	S 544477	302347	29598	7001	6239	194*74	1194236	119613	1645*3	4*816	26*005	132069	1041562	177454*	1.56			
GRAND TOTAL	R 14227*9	1032*01	49194	10705	13000	231463	2,709,952											

TABLE 3-5. GROWTH IN TRAFFIC VOLUME - (1970-1976)

STATION/ CENTER	NUMBER MSGS.		GROWTH		TRAFFIC HANDLED		GROWTH		MSGS. RELATED		GROWTH	
	1970	1976	*	%	1970	1976	*	%	1970	1976	*	%
HEADQUARTERS	173100	242778	109678	63.3	158203	283106	124903	78.9	-14897*	328	15225	"
1st District	104327	137261	33294	31.9	152685	254103	101418	66.4	116842	116842	68484	141.6
2nd District	35734	30389	-5345	-14.9	80271	79856	-415	00.5	44537	49467	4930	11.1
3rd District	222651	327656	105005	47.1	297810	530032	232221	77.9	75159	202376	127217	169.3
5th District	82112	105860	23848	29.0	160844	174542	14196	8.8	78232	68582	-9650	-12.3
7th District	115180	160331	45151	39.2	246584	271296	24712	10.0	131404	110965	-20439	-15.6
8th District	95423	120699	25277	26.4	133021	194712	64561	48.5	37598	74013	36415	96.9
9th District	61219	113440	52185	85.2	80656	153290	72634	90.0	19437	39850	20413	105.0
11th District	62713	79712	16999	27.1	106241	121806	15565	14.6	43528	42094	-1434	-3.2
12th District	175413	117154	-58259	-33.2	175431	183654	10125	5.7	18	66500	66482	"
13th District	86336	85547	4382	5.0	150215	14583	-4822	-3.2	63879	59836	-4048	-6.3
14th District	108061	112867	4806	4.1	205095	215742	10647	5.1	97034	103175	6141	6.3
17th District	90542	101054	10512	11.6	177528	162350	-15148	-8.5	56986	61326	-25660	-29.4
SUB-TOTAL	1412811	1,774,548	361737	25.6	2,124,084	2,769,902	645,818	30.4	711,273	995,354	284,081	39.9

ADAK	18678	24886	6199	33.1	26838	37601	10763	40.1	8160	12715	4555	55.8
BOSTON	49967	110274	60307	120.6	94105	210181	116076	123.3	44138	99907	55769	126.4
HONOLULU	91108	110448	19340	21.2	148227	190909	42682	28.7	57119	80461	23342	40.9
KODIAK	35350	93002	57652	163.0	73924	223753	149829	202.6	38574	130751	92177	239.0
MIAMI	70613	145432	74819	105.9	137157	254116	116959	85.2	66544	106684	42140	63.3
NEW ORLEANS	38589	28915	-9684	-25.1	77926	66471	-11355	-14.6	39227	37556	-1671	-4.3
PORTSMOUTH	47484	180512	132664	277.2	77920	290883	212967	273.3	30436	110371	79835	262.6
SAN FRANCISCO	84421	105058	10637	11.2	166628	198890	23262	13.9	72207	84832	12625	17.5
SAN JUAN	80110	100936	20826	25.9	167187	132277	-34910	-20.8	87077	31341	-55736	-64.0
ALL OTHERS	514761	98699	-425062	-82.5	803529	147545	-655984	-81.6	288768	57846	-230922	-80.0
SUB-TOTAL	1,043,091	969162	-51929	-4.9	1,773,341	1,743,626	-29715	-1.6	732250	754,464	22214	3.0

SYSTEM TOTAL	2453902	2,763,710	309804	12.6	3,897,425	4,513,253	616,103	15.8	1,448,523	1,748,618	306,295	21.8
---------------------	---------	-----------	--------	------	-----------	-----------	---------	------	-----------	-----------	---------	------

*Statistical Anomaly

3.5.5 Classified Traffic

The amount of classified traffic handled in the system is quite low, with less than one percent at the Districts and understandably higher (about 9 percent) at the Headquarters. Nearly all classified traffic is handled by on-line means with the exception primarily of messages to and from smaller vessels that are not on-line equipped. Although statistical data was not available, information provided indicates that the amount of off-line encrypted traffic has been decreasing, and the number of shore stations having the capability is being reduced. In any case, the recorded volume is not considered a significant factor in this study. Table 3-6 presents a summary of 1976 off-line activity by District and Station.

3.5.6 Distribution By Precedence

A total of 2368 messages (incoming and outgoing) were examined for precedence analysis. This limited sampling indicates the distribution by precedence to be as follows:

<u>PRECEDENCE</u>	<u>RANGE</u>	<u>AVERAGE (%)</u>
Immediate	4-9	7
Priority	27-50	38
Routine	45-64	55

3.5.7 Handling Times

Logs, records, and files maintained by COMMCENs surveyed do not support definitive analysis of actual in-station handling times.

3.6 COST

The total cost of operation of a communication system can be expressed in terms of:

- Facilities Cost
- Owned Equipment

TABLE 3-6. OFF-LINE CRYPTO 1976
 (# MESSAGES)

STATION OR CENTER	ENCRYPT	DECRYPT	TOTAL
HEADQUARTERS	1	0	1
1st District	49	79	128
3rd District	220	158	378
5th District	78	55	133
7th District	23	20	43
8th District	5	14	19
9th District	6	6	12
11th District	8	37	45
12th District	18	6	24
13th District	155	47	202
14th District	4	1	5
17th District	188	53	241
COMMSTA SAN FRAN	6	1	7
TOTAL	761	477	1238

- Equipment Lease Costs
- Leased Line Cost
- Maintenance and Repair
- Consumables
- Personnel Cost

In this study of the Coast Guard system, only limited cost data has been available and that has been primarily in the area of equipment and leased line cost, maintenance and repair parts, and consumable supplies. (See Appendices). These data have been derived from a review of records at the sites surveyed, at Headquarters, and from personnel interviews. In addition to recorded data, some observations can be made in the other areas, both for the surveyed nodes and for the system as a whole. It should be noted, however, that any detailed study of the automation of any selected node or of the entire system will require a much more precise definition of these observations in order to establish a basis for cost trade-offs.

3.6.1 Facility Costs

These costs include such things as building lease costs, utilities, security, and maintenance. These costs are included in the facility costs of the complete District Headquarters installation. The COMMCEN facility cost would be most difficult, if not impossible, to separate. In the case of the communication/radio stations, while the total operating cost is also available, it would be equally difficult to break out that portion of the facility cost that is chargeable against message processing and handling.

In any event, this cost item is not considered sensitive in the automation process, unless a system-wide reconfiguration plan should propose the elimination of complete centers or addition of new ones.

3.6.2 Owned Equipment

A large part of the communication, crypto, and support equipment (furnishings, etc.) used in the message processing system is Coast Guard-owned. While only a

small sampling of the cost and age of this equipment is available, it is not considered to be a critical factor.

a. Crypto equipment is essentially "on loan" to the Coast Guard and has no recoverable value. No reduction in cryptographic requirements is anticipated.

b. Communication equipment, such as teletypewriter, control units, polling devices while Coast Guard-owned, must be considered as sunk costs. Most of these equipments are from 10 to 15 years old, and if disposed of, would have very little recoverable value. The exception is the new Model 37 Teletype equipment which should have some resale value.

c. AUTODIN equipment costs are borne by the Navy.

d. Furnishings, such as desks, files, tables, and time stamps would still be required in an automated system, although perhaps in lesser quantities. Most of this type of equipment observed is rather old and would have very little compensating recoverable value, although it might be diverted to other use.

In general, it must be concluded that currently owned Coast Guard equipment is not a significant cost item and has little potential as an off-set in performing automation cost trade-offs.

3.6.3 Leased Equipment

There are three categories of leased equipment in the system:

a. Copiers are leased from the vendors on a monthly basis, with or without per-copy charges. In most cases, maintenance services are included in the lease cost.

b. Teletypewriter equipment on the SARLANT/SARPAC networks is leased as a part of the overall system charges. This cost includes maintenance.

c. Equipment on TWX and TELEX is leased and maintenance as well as line charges are included on an availability and message rate basis.

The cost of leased equipment may be considered sensitive in the analysis of automation options. Copying requirements will probably remain essentially the same

for internal distribution, although there may be some reduction in number of copies. The need for dedicated terminal equipment on the SAR and TWX/TELEX networks may disappear if these circuits are terminated in a processor or common user terminal device. There may be some cost benefit available in leased equipment options.

3.6.4 Leased Line Costs

Information on leased line costs has not been available except to a very limited degree. In most cases, the line costs are either not known or are included in system or availability/message unit costs. Detailed data could be obtained if considerable time and effort were expended in researching local command records, telephone company bills, etc. However, leased line cost is not considered a sensitive item in a node by node approach to automation. In most cases the circuit connectivity will remain the same, with options limited primarily to the methods of termination and processing.

3.6.5 Maintenance and Repair

Five categories of equipment maintenance and repair have been identified in the Coast Guard system.

- a. In station maintenance of Coast Guard-owned equipment by message center personnel. No cost can be associated with this echelon of maintenance.
- b. Service or support unit repair of Coast Guard-owned equipment. The methods of record keeping do now allow the identification of these costs with any individual item or class of equipment at the sites surveyed.
- c. Contract maintenance of Coast Guard-owned equipment. This arrangement, while it may exist at other stations, was noted only at the Headquarters.
- d. Cryptographic equipment repair is contracted for with the most conveniently available Military Crypto Repair Facility. In some cases the cost was identified and in others it was not. Detailed study of repair facility records would probably reveal more data.

e. Contract maintenance of terminal and copying machines as an adjunct to the equipment or system lease cost.

Of all the above maintenance and repair cost burdens, the ones most likely to influence the automation cost trade-offs are those relating to Coast Guard-owned equipment. These equipments appear to be the most likely to be affected by the program. They are, coincidentally, the ones about which the least is known. Crypto and copying equipment is probably the least sensitive to cost off-set.

3.6.6 Consumable Supplies

Consumables constitute one of the most visible cost items in the system. While not the most expensive item in dollar terms, it is one of the most sensitive to off-set in the automation process. Included in this category of materials are such things as: teletype paper, ribbons, paper tape, and copier supplies, all of which will probably be required in smaller quantities under most conceivable automation options. Details of annual consumables costs for the stations surveyed are tabulated in the appendices.

If adjustment is made for the fact that the Portsmouth Communication Station and the Headquarters do not include copier supply costs in their consumables, it would appear that supplies required for teletypewriter operation alone places an average cost burden on a typical center of approximately \$3.40 per hundred messages (See Table 3-7).

3.6.7 Personnel Cost

The current Coast Guard message handling system is almost totally manual, and therefore very labor sensitive. Thus, the cost of personnel is likely to be one of the key factors in automation cost trade-offs.

While there are natural variations due to rank structure, dependency and local conditions, the gross personnel costs for each station can be estimated. There are several bases for planning personnel cost. The first of these is the basis of pay and allowances. This is quite adequate when computing simple station operating

TABLE 3-7. CONSUMABLES COST SUMMARY

Facility	Traffic (Msgs)	Consumable Cost (\$) *	\$/100 Msgs
3RD District	327,656	10,659	\$3.25
5TH District	105,963	3,164	\$2.98
COMMSTA	180,512	6,269	\$3.47
CG HQ	282,778	10,245	\$3.62
TOTAL	896,909	30,337	\$3.38

*Less copier supplies

cost for budgetary purposes. Using these criteria, the average man/year cost can be estimated at \$10,800.

However, in establishing a basis for cost trade-offs, different criteria should be used. If the options being considered can reduce station manning, then the true cost per man should be used in computing cost off-set. This cost should properly include, among other things, the cost of: recruitment, training, pay and allowances, medical, dental and recreational facilities, dependent benefits, housing and an allowance for retirement annuity. If all these costs are included, a more reasonable per-man cost off-set can be obtained by multiplying the Standard Personnel Cost (Commandant Notice 7100) by a factor of 2.0. Thus, the average cost per man year (based on E-5) should be \$21,600.

SECTION 4 - SUMMARY OF REQUIREMENTS

4.1 INTRODUCTION

The Coast Guard Communication System has been developed and is maintained and operated to:

- Provide a reliable, secure, and rapid means for the command, control, and administration of Coast Guard forces.
- Satisfy the safety needs of both commercial and recreational elements of the maritime community.
- Ensure compatibility between the U.S. Coast Guard, as an active member of the Armed Forces of the United States, and the U.S. Navy.
- Support the maritime communications requirements of other Government Agencies.

The Coast Guard Communication System includes a significant complex of Coast Guard leased or owned landlines; channels allocated for Coast Guard use from facilities of the Defense Communications System (DCS); extensive MF, HF, and VHF radio facilities; access to the switched networks of the DCS, including the Automatic Digital Network (AUTODIN), the Automatic Voice Network (AUTOVON), and the Automatic Secure Voice Communications (AUTOSEVOCOM) system; and access to the long-distance direct dial services provided by the General Services Administration (GSA) Federal Telephone System (FTS). More detailed descriptive data on those portions of the Coast Guard Communication System involved in the record message handling functions performed by major COMMCENS, COMMSTAs and RADSTAs were provided in Section 3.

While it is not the purpose of this study to evaluate the effectiveness of the Coast Guard Communication System in performing its four-fold mission, Section 3 identifies several areas which have the potential to influence, in varying degrees,

the development of a COMMCEN automation program. These areas are addressed further in this section.

It is considered appropriate to preface this section with a brief discussion on the term "communication requirements". Any organization, whether it be military, civil government, or business, exists for a purpose. To achieve this purpose, the organization must do certain things. The accomplishment of some of these things require some sort of communications. In the military, the purpose is normally called "mission"; the things to be done, "operating requirements"; and the supporting communications, "communication need-lines" or "communication requirements". The precise manner in which the "communication requirements" are to be satisfied is influenced by a number of factors including, among others, the type and volume of information involved, community of interest, and speed of service required. The Coast Guard Communication System, as presently constituted, contains a mix of dedicated and common use facilities configured in such a manner as to provide the communications required to support Coast Guard operating requirements. Each of the Communications Centers which are candidates for automation can be considered a common use facility even though it may terminate or provide an interface with dedicated networks/circuits. Irrespective of source, destination, or operating requirement, each Communications Center must accept, process, and deliver all message traffic offered, with minimum delay. The primary requirements base for the design of an automated system is, therefore, message traffic in terms of volume and distribution. The operating requirements which generate message traffic need be examined only to the degree necessary to identify significant changes in traffic volume or distribution patterns. Except for relatively minor and localized impacts, this study effort has identified no factors with significant message traffic implications. A secondary requirements base, the number of terminating circuits, also appears to be relatively stable. This subject is, however, addressed later in this section.

Subsequent paragraphs develop the requirements for COMMCEN automation. In view of the above discussion, it may be more accurate to describe this effort as development of system parameters and criteria rather than system requirements.

4.2 SYSTEM CAPACITY - MESSAGES

As stated earlier, each COMMCEN under consideration must, as a primary requirement, be capable of accepting, processing, and delivering all message traffic offered with minimum delay.

The traffic data presented in Section 3 and supporting appendices provide the initial basis for predicting future traffic loads and hourly distribution trends. Table 3-5, which summarizes messages handled by District, COMMSTA, and RADSTA COMMCENs for the years 1970 and 1976, indicates a system-wide growth of 12.6 percent over the six-year period, equating to a growth rate of 2 percent per year. During this period the traffic variations for District COMMCENs ranged from an increase of 85.2 percent to a decrease of 33.2 percent, with an overall increase of 25.6 percent, or an average growth of 3.87 percent per year. Similarly, COMMSTA/RADSTA variations ranged from +277.2 percent to -25.1 percent, with an overall decrease of 4.9 percent. Based on available documentation, the sole explanation for this wide range of traffic trends is the realignment of COMMSTA/RADSTA missions and functions implemented during this period. In the absence of documented plans for further system reconfigurations or significant changes to the Coast Guard mission and operating requirements, the system-wide growth rate of 2 percent per year is used to develop anticipated traffic loading for the next 10-year period. Coincidentally, this is identical to the planning factor used in the DCS.

The maximum volume of traffic which may be within a COMMCEN can be predicted by applying busy period ratios to the annual totals. The busy day/busy hour/busy four-hour ratios developed during the on-site surveys varied, with strong indications that the COMMSTA experiences a somewhat lesser affect from peak

loading than do the COMMCENs serving larger staffs. Since the sampling opportunity was limited to available files, "worst case" patterns are used to develop peak load predictions in this study. These ratios are summarized in Table 4-1.

TABLE 4-1. PEAK LOAD RATIOS

PERIOD	HQ/DISTRICT COMMCEN	COMMSTA/RADSTA
BUSY DAY (% OF ANNUAL TOTAL)	0.400	0.400
BUSY HOUR (% OF BUSY DAY TOTAL)	12.000	8.000
(% OF ANNUAL TOTAL)	0.048	0.032
BUSY FOUR HOURS (% OF BUSY DAY TOTAL)	36.000	28.500
(% OF ANNUAL TOTAL)	0.144	0.114

Based on the assumptions that (1) the Coast Guard mission and derived operating requirements will remain relatively constant through 1987, (2) no major reconfiguration of the Coast Guard Communication System will be effected during that period, (3) Coast Guard message totals will continue to increase at a rate of 2 percent per year, and (4) peak loading patterns identified in Table 4-1 will not change significantly, the traffic projection presented in Tables 4-2 and 4-3 can be considered one of the basic building blocks for the architecture of an automated system. Table 4-4 presents the same peak load projection based on line-blocks, a term more meaningful to the system architect. One line-block equates to 80 eight-bit characters, or 640 bits. AUTODIN statistics indicate Coast Guard traffic averages slightly less than 20 line-blocks or 12.8 kilobits per message. Use of this figure for system sizing will provide a desirable growth potential.

TABLE 4-2. PROJECTED ANNUAL TOTALS (MESSAGES)

FACILITY	BASE (1976)	1977	1978	1979	1980	1981	1982	1983	1984	1985	1986	1987
HEADQUARTERS	282778	288434	294202	300086	306088	312210	318454	324823	331319	337946	344705	351599
1st DISTRICT	137261	140006	142806	145662	148576	151547	154578	157670	160823	164040	167320	170667
2nd DISTRICT	30389	30997	31617	32249	32894	33552	34223	34907	35606	36318	37044	37785
3rd DISTRICT	327656	334209	340893	347711	354665	361759	368994	376374	383901	391579	399411	407399
5th DISTRICT	105960	108079	110241	112446	114695	116988	119328	121715	124149	126632	129165	131748
7th DISTRICT	160331	163538	166808	170145	173547	177018	180559	184170	187853	191610	195443	199351
8th DISTRICT	120699	123113	125575	128087	130648	133261	135927	138645	141418	144246	147131	150074
9th DISTRICT	113440	115709	118023	120383	122791	125247	127752	130307	132913	135571	138283	141048
11th DISTRICT	79712	81306	82932	84591	86283	88008	89769	91564	93395	95263	97168	99112
12th DISTRICT	117154	119497	121887	124325	126811	129347	131934	134573	137265	140010	142810	145666
13th DISTRICT	85547	87258	89003	90783	92599	94451	96340	98267	100232	102237	104281	106367
14th DISTRICT	112567	114818	117115	119457	121846	124283	126769	129304	131890	134528	137219	139963
17th DISTRICT	101054	103075	105137	107239	109384	111572	113803	116079	118401	120769	123184	125648
ADAK	24886	25384	25891	26409	26937	27476	28026	28586	29158	29741	30336	30943
BOSTON	110274	112479	114729	117024	119364	121751	124186	126670	129204	131788	134423	137112
HONOLULU	110448	112657	114910	117208	119552	121944	124382	126870	129407	131996	134635	137328
KODIAK	93002	94962	96759	98694	100668	102682	104735	106830	108967	111146	113369	115636
MIAMI	145432	148341	151307	154334	157420	160569	163780	167056	170397	173805	177281	180826
NEW ORLEANS	28915	29493	30063	30655	31299	31924	32563	33214	33879	34556	35247	35952
PORTSMOUTH	180512	184122	187805	191561	195392	199300	203286	207352	211499	215729	220043	224444
SAN FRANCISCO	108058	107159	106302	111488	113718	115993	118312	120679	123092	125554	128065	130626
SAN JUAN	100836	102955	105014	107114	109256	111441	113670	115944	118262	120628	123040	125501

TABLE 4-3. PROJECTED BUSY HOUR/BUSY FOUR HOUR LOADING (MESSAGES)

FACILITY	BASE (1970)		1977		1978		1979		1980		1981		1982		1983		1984		1985		1986		1987	
	HR	4HR	HR	4HR	HR	4HR	HR	4HR	HR	4HR	HR	4HR	HR	4HR	HR	4HR	HR	4HR	HR	4HR	HR	4HR	HR	4HR
HEADQUARTERS	136	407	139	415	141	423	144	432	147	441	150	449	153	458	156	468	159	477	163	486	169	496	169	506
1st DISTRICT	66	198	67	202	68	206	70	210	71	214	73	219	74	223	76	227	77	232	79	237	80	241	82	246
2nd DISTRICT	15	44	15	45	16	46	16	47	16	48	17	49	17	50	17	51	18	52	18	53	18	54	19	55
3rd DISTRICT	157	471	160	480	163	490	167	500	170	510	173	520	177	530	180	541	184	552	188	563	191	574	195	586
5th DISTRICT	51	153	52	156	53	159	54	162	55	166	56	169	57	172	59	176	60	179	61	183	62	187	63	190
7th DISTRICT	77	231	79	236	80	240	82	245	83	250	85	255	87	260	88	265	90	271	92	276	94	282	96	287
8th DISTRICT	58	174	59	177	60	181	62	185	63	188	64	192	65	196	67	200	68	204	69	208	71	212	72	216
9th DISTRICT	54	163	55	166	56	170	57	173	58	176	60	180	61	184	62	187	63	191	65	195	66	199	67	203
11th DISTRICT	38	115	39	117	40	120	40	122	41	124	42	127	43	130	44	132	45	135	45	137	46	140	47	143
12th DISTRICT	56	169	57	172	58	176	59	179	61	183	62	187	63	190	64	194	66	198	67	202	68	206	70	210
13th DISTRICT	41	123	42	125	43	128	44	131	44	133	45	136	46	139	47	141	48	144	49	147	50	150	51	153
14th DISTRICT	54	162	55	165	56	169	57	172	58	175	60	179	61	182	62	186	63	190	65	194	66	197	67	201
17th DISTRICT	49	146	50	149	51	152	52	155	53	158	54	161	55	164	56	167	57	171	59	174	60	178	61	182
ALASKA	2	8	2	8	2	8	2	8	2	8	2	8	2	8	2	8	2	8	2	8	2	8	2	8
BOSTON	35	126	36	129	36	131	37	134	38	136	39	139	39	142	40	145	41	148	42	151	43	154	44	157
BONOLU	35	126	36	129	36	131	37	134	38	136	39	139	39	142	40	145	41	148	42	151	43	154	44	157
KOBIAN	30	106	31	108	31	110	32	112	32	115	33	117	34	119	34	122	35	124	36	127	37	129	37	132
MIAMI	47	166	48	169	49	173	50	176	51	180	52	183	53	187	54	191	55	194	56	198	57	202	58	206
NEW ORLEANS	9	33	9	34	9	34	10	35	10	36	10	36	10	37	10	38	11	39	11	39	11	40	11	41
PORTSMOUTH	58	206	59	210	60	214	62	219	63	223	64	227	65	232	67	237	68	241	69	246	71	251	72	256
SAN FRANCISCO	34	120	35	122	35	125	36	127	37	130	38	132	38	135	39	138	40	141	41	143	41	146	42	149
SAN JUAN	32	115	33	117	33	120	34	122	35	124	35	127	36	130	37	132	37	135	38	137	39	140	40	143

NOTE: Projections computed by applying growth factor of .02 year to 1976 base.

TABLE 4-4. PROJECTED BUSY HOUR/BUSY FOUR HOUR LOADING (LINE BLOCKS)

FACILITY	BASE (1976)		1977		1978		1979		1980		1981		1982		1983		1984		1985		1986		1987	
	HR	4HR	HR	4HR	HR	4HR	HR	4HR	HR	4HR	HR	4HR	HR	4HR	HR	4HR	HR	4HR	HR	4HR	HR	4HR	HR	4HR
HEADQUARTERS	2715	8144	2769	8307	2825	8473	2881	8642	2939	8815	2998	8992	3058	9171	3119	9355	3180	9542	3245	9733	3310	9927	3376	10126
1st DISTRICT	1318	3953	1344	4032	1371	4113	1398	4195	1427	4279	1455	4364	1484	4452	1514	4541	1544	4632	1575	4724	1607	4819	1639	4915
2nd DISTRICT	262	875	298	883	304	910	310	929	316	947	322	966	328	985	335	1005	342	1025	349	1046	356	1067	363	1088
3rd DISTRICT	3145	9436	3208	9625	3272	9817	3337	10014	3404	10214	3472	10418	3542	10626	3613	10839	3685	11056	3759	11277	3834	11502	3910	11732
5th DISTRICT	1017	3052	1037	3113	1058	3175	1079	3239	1101	3304	1123	3370	1145	3437	1168	3506	1192	3576	1215	3647	1240	3720	1265	3795
7th DISTRICT	1529	4618	1570	4710	1601	4805	1633	4901	1666	4999	1699	5099	1733	5201	1768	5305	1803	5411	1839	5519	1876	5629	1914	5742
8th DISTRICT	1159	3476	1182	3546	1206	3616	1230	3689	1255	3763	1280	3838	1305	3915	1331	3993	1358	4073	1385	4154	1413	4237	1441	4322
9th DISTRICT	1089	3267	1111	3332	1133	3399	1156	3467	1179	3536	1202	3607	1225	3679	1251	3753	1276	3828	1301	3904	1327	3982	1354	4062
11th DISTRICT	765	2296	780	2342	796	2389	812	2437	828	2485	845	2535	862	2586	879	2637	896	2690	914	2744	933	2799	951	2855
12th DISTRICT	1125	3374	1148	3441	1170	3510	1194	3581	1218	3652	1242	3725	1267	3800	1292	3876	1318	3953	1344	4032	1371	4113	1399	4195
13th DISTRICT	821	2464	837	2513	854	2564	871	2615	889	2667	906	2720	925	2775	943	2830	962	2887	981	2945	1001	3004	1021	3064
14th DISTRICT	1081	3242	1103	3307	1125	3373	1147	3440	1170	3509	1194	3579	1217	3651	1242	3724	1267	3799	1292	3874	1318	3952	1344	4031
17th DISTRICT	576	2010	589	2068	602	2128	616	2189	630	2250	645	2313	660	2377	675	2442	690	2508	705	2574	720	2641	735	2708
ADAK	159	567	162	578	165	590	169	602	172	613	176	626	179	639	183	651	186	664	190	678	194	691	198	705
BOSTON	706	2314	720	2364	735	2416	749	2468	764	2521	779	2576	795	2631	811	2688	827	2746	844	2804	861	2865	878	2926
HONOLULU	707	2518	721	2568	736	2620	750	2672	765	2726	781	2780	796	2836	812	2892	828	2950	845	3009	862	3069	879	3131
KODIAK	585	2126	607	2162	619	2206	631	2250	644	2295	657	2341	670	2387	683	2435	697	2484	711	2534	725	2584	740	2636
MIAMI	331	3316	350	3382	369	3450	388	3519	408	3589	428	3661	448	3734	469	3809	491	3885	513	3963	535	4042	558	4123
NEW ORLEANS	185	659	189	672	192	686	196	699	200	713	204	728	208	742	213	757	217	772	221	788	226	803	230	819
PORTSMOUTH	1155	4116	1178	4198	1202	4282	1226	4368	1250	4455	1275	4544	1301	4635	1327	4728	1353	4823	1380	4919	1409	5017	1486	5118
SAN FRANCISCO	672	2395	685	2443	699	2492	713	2542	727	2592	742	2644	757	2697	772	2751	787	2806	803	2862	819	2919	836	2978
SAN JUAN	646	2301	659	2347	672	2394	686	2442	699	2491	713	2540	728	2591	742	2643	757	2696	772	2750	787	2805	803	2861

4.3 SYSTEM CAPACITY - CIRCUITS

A fully automated system would provide sufficient input/output ports to accommodate all circuits terminating in the respective COMMCENs and, in COMMSTA/RADSTA applications, an interface with radio operating positions. While it may not prove cost-effective to provide this capability, at least in the near term, the implications of the total requirement must be examined. To support such an examination, the types and quantities of circuits terminated in each COMMCEN are summarized in Table 4-5, which is based on information contained in CG-2614 Reports and Defense Commercial Communications Office (DECCO) and National Communications System (NCS) printouts. Each COMMSTA and RADSTA also maintains a variety of radio operating positions. The COMMSTA Portsmouth will, upon assumption of the additional responsibilities identified in Appendix C, operate the following:

- 1 - 500 kHz CW position
- 3 - AMVER CW positions
- 1 - Air-Ground Voice/RATT position
- 3 - Ship-Shore RATT positions
- 1 - Voice Broadcast position
- 1 - CW Broadcast position
- 1 - Composite CW Broadcast (LCMP) position.

The radio position/automated COMMCEN interface requirement is somewhat less, quantitatively, at other COMMSTAs and substantially less at all RADSTAs.

4.4 FUNCTIONS

The traffic handling and circuit termination requirements discussed in Paragraphs 4.2 and 4.3 are primarily basic "sizing" parameters, important in selecting hardware which may be appropriate for COMMCEN automation applications. The specific functions to be automated will have a lesser impact on the

TABLE 4-5. CIRCUIT SUMMARY (LANDLINE)

FACILITY	AUTODIN	DISTRICT & LOCAL LOOPS	SARLANT/SARPAC	NATL WX SVC	OTHER	COMML REFILE	TOTAL # CIRCUITS
HEADQUARTERS	Mode V (1)	1	2		3	2	9
1st DISTRICT	Mode V (2)	1	1	1	1		5
2nd DISTRICT	Mode V (2)	1		1		1	4
3rd DISTRICT	Mode V (2)	3	1	1	5	2	13
5th DISTRICT	Mode V (2)	2	1	1	3		8
7th DISTRICT	Mode V (2)	2	1	1	6	1	11
8th DISTRICT	Mode V (1)	2	1	1	1		6
9th DISTRICT	Mode V (2)	1		1	1		4
11th DISTRICT	Mode V (2)	5	1				7
12th DISTRICT	Mode V (2)	2	1		7	1	12
13th DISTRICT	Mode V (1)	2	1	1	2		7
14th DISTRICT	Mode V (1)	2	1		2	1	7
17th DISTRICT	Mode V	2	1		3		7
ADAK		2					2
BOSTON		1	1	1			7
HONOLULU		1	1	1	4		4
KODIAK		2	1		1		5
MIAMI		1	1	1	2		5
NEW ORLEANS		1	1		2		4
PORTSMOUTH	(3)	1	1	1	2		6
SAN FRANCISCO	(4)	2	1		1		5
SAN JUAN		1			5		6

NOTES:
 1 Replacement by RDXT B planned
 2 Replacement by Mode I terminal planned
 3 AUTODIN Access provided via NAVCAMS LANT NAVCOMPARS
 4 AUTODIN Access planned via NCS STOCKTON NAVCOMPARS

"sizing" requirement but will exert a major influence on operating program (software) development and on the determination of required peripheral equipment. The functions which are candidates for automation are discussed in the following subparagraphs.

4.4.1 Outgoing Message Processing

One of the more time- and manpower-sensitive functions performed in a manual COMMCEN is the preparation of traffic received over-the-counter for transmission. In a fully automated Center the system should, as a minimum, perform the following:

- Accept page copy and validate procedural accuracy
- Read message into processor
- Queue message for handling in first-in first-out (FIFO) sequence by precedence
- Check classification of message. Refer to operator if circuit not cleared.
- Look up and assign Routing Indicators and/or Station Designators. Refer to operator for assistance if required.
- Prepare message in proper format(s). For AUTODIN, this will include addition of Originating Station Routing Indicator (OSRI), Station Serial Number (SSN), and Time of File (TOF).
- Queue message in FIFO sequence by precedence for transmission on appropriate circuits.
- Make entries into appropriate logs, journals, and files for accountability and historical purposes.
- Provide hard copy of transmitted message.

Among other things, accomplishment of these functional steps identifies the need for an Optical Character Reader (OCR), a Supervisory/Operator Video Data Terminal (VDT), and on-line storage (tape) facilities. The determination of transmission mode and assignment of Routing Indicators/Station Designators will require a look-up table at least the equivalent in size of the 150 capability of existing header generators. Operating programs must be capable of formatting traffic in accordance with procedures utilized by each network into which transmission is to be effected (such as JANAP 128 for AUTODIN). The operating programs must also be capable of accomplishing protocol sequences (such as call up and transmission of TOD) required in certain networks.

4.4.2 Incoming Message Processing

The processing of incoming traffic, from the incoming link through to ultimate delivery, involves one extremely time- and manpower-sensitive operation i. e., the determination of proper internal distribution. For analysis purposes it is appropriate to address this particular function as one step in the processing of incoming traffic. The specific functions to be performed by an automated system in processing incoming traffic include the following:

- Check Channel Sequence Number (AUTODIN only) - send notice to supervisor if out of sequence
- Transmit QSL if required by network protocol
- Write message into processor
- Queue for processing in FIFO sequence by precedence
- Analyze header to determine delivery responsibilities (terminate only, relay only, or terminate and relay). Display to supervisor (in-router) if delivery responsibility cannot be determined. (Note: The relay function is addressed separately in Paragraph 4.4.3.)

- Determine whether message is a duplicate (received previously). Send notice to supervisor.
- Examine header for unique procedural requirement such as ZFF. Send appropriate notice to supervisor.
- Process in FIFO sequence by precedence, for internal distribution (determine action office if message is addressed for action, identify other offices to receive copies, and number the copies to be distributed to each office). Display to supervisor if internal distribution cannot be determined.
- Print message for reproduction. (The hard copy will include distribution instructions.)
- Throughout process make appropriate log and journal entries.
- File message for future recall.

Again, this sequence identifies the need for a supervisory console to provide a man/machine interface. Each function also has software implications. Critical to the successful application of the in-route process is the establishment of an effective look-up table which can relate message content to organizational responsibilities. Conversion of the existing look-up files to an automated table would be almost unmanageable and prohibitively expensive.

4.4.3 Relay Traffic Processing

4.4.3.1 Landline-to-Landline

Traffic received on one landline circuit for relay on another is subject to both incoming and outgoing message processing. In one sense, automation substitutes an electrical cross-office link for the torn-tape procedure used in a manual facility. In order to support the landline-to-landline relay function, the automated system must accomplish the following:

- Transfer messages requiring relay (as determined during incoming message processing), with an indication of delivery responsibilities, to the queue of outgoing messages awaiting processing

- Make appropriate log and journal entries.

Automation of this function will require software support but no additional peripheral equipment.

4.4.3.2 Landline to Radio Positions/Radio Positions to Landline

Although not addressed specifically in Paragraphs 4.4.1 and 4.4.2 above, a relatively insignificant portion of the traffic handled by COMMSTAs and RADSTAs is originated by or addressed to (i. e. intended for distribution within) the station. Most traffic received via landlines is destined for transmission by broadcast or relay to specific addresses by other radio circuits. Most traffic which must be processed for transmission via landline is received via radio circuits. Thus, while the COMMSTA/RADSTA automated system can be similar in many respects to the HQ/District system (using the same basic hardware and software), the fact that the requirements to be satisfied by the two systems differ will dictate some differences in operating routines and peripheral equipment needs. These differences are described below.

In processing traffic received via landline, a major difference will occur at the first decision point (i. e. determining whether a message terminates, requires relay, or both). Traffic destined for broadcast will be addressed to the station and, in most cases, contain insufficient information for automatic processing to the appropriate broadcast position. Thus all messages addressed to the station must be queued for operator call-up, via VDT, and decision. The operator will direct: (1) printout of hard copy for internal distribution; (2) printout, at the voice broadcast remote terminal, of a hard copy; or (3) printout, at the appropriate CW Broadcast remote terminal, of tape and hard copy. The volume of traffic

requiring internal distribution does not warrant automation of the in-routing process. Traffic not addressed to the station must be examined against a look-up file for disposition. Messages addressed to units terminated via ship-shore RATT or air-ground voice or RATT circuits must print out (both tape and hard copy) on remote terminals at the appropriate operating positions. Other messages will be processed as landline-to-landline relays or displayed to the operator if delivery responsibilities cannot be identified. Each remote terminal must have the capability to key in appropriate log and journal entries.

The outgoing message processing subsystem must also provide capabilities unique to COMMSTA/RADSTA operations. Each radio operating position, except broadcast, can be considered a message originating point requiring a remote terminal through which all messages which require relay in record form may be entered into the system. Operating software should accomplish all logging/journaling requirements for each position and also perform the compilation of AMVER and OBS traffic if this practice is to continue. Station originated traffic can be entered into the system through the supervisory console or any remote terminal. The volume of such traffic does not justify the use of an OCR.

4.4.4 Logs and Journals

The logging and journaling function should provide the following:

- Log. The automated system must provide a record of traffic sent and received on each traffic channel. This can be a concise file listing the channel sequence number; identification of the message, by date time group or an internally assigned station sequence number (SSN); and TOR or TOD.
- Journal. The automated system must provide a detailed record on each message processed to include identification (SSN (if used), DTG, originator, precedence, classification), time entered into the system, disposition (including internal distribution), and time of disposition. Other information, such as message length, may be included. The journal provides the historical record through which

readdressal actions may be expedited, investigation of delays or suspected non-deliveries can be traced, and which will support the preparation of management reports.

4.4.5 Speed of Service

Department of Defense speed of service criteria for message traffic are contained in the U. S. Supplement to ACP 121:

Flash - 10 minutes

Immediate - 30 minutes

Priority - 3 hours

Routine - 6 hours

These performance standards cover end to end times from the time of receipt in the originating COMMCEN to the time the message is ready for delivery in the addressed COMMCEN. The six-hour criteria for a routine message includes, therefore, all processing required at the originating station; transmission time (including processing in an intermediate relay point); and all processing, including reproduction, at the addressed station. This would indicate that, even if transmission and relay time is ignored, routine messages should be processed at both originating and terminating stations in less than three hours.

4.4.6 Interface Requirements

The automated COMMCEN must interface electrically and procedurally with all terminated networks and circuits. The electrical interface should include fail-safe provisions to prevent transmission of classified messages over non-approved circuits.

4.4.7 Related Considerations

4.4.7.1 On-Going Automation Efforts

Current system planning includes two programs which address partial automation

of the Headquarters and District COMMCENs. A third program, although not related directly to message processing, has a potential application to COMMCEN operations.

The first major program, partially implemented, is for the procurement of optical scanners and message header generators for the Headquarters and each District Communications Center. At approximately \$74,000 per installation, the cost of this program will fall into the \$900,000 to \$1,000,000 range. This installation, while providing assistance in the processing of originated traffic, represents a fragmented approach to the automation program and presupposes that the preparation of originated messages for transmission is the most critical problem systemwide. This is valid in only two of the facilities surveyed (Headquarters and Third District). The processing of originated traffic at Fifth District is a far less significant problem. Based on traffic volumes alone, the need for the OCR/Message Header Generator at Second, Eleventh, Thirteenth, and Seventeenth Districts may also be questionable.

The second program which addresses partial COMMCEN automation is the Navy-sponsored plan to provide Remote Information Exchange Terminals (RIXT) to selected sites (Headquarters and Thirteenth and Fourteenth Districts in 1979 and Eighth District in 1982). The RIXT-B, satellited off the Navy LDMX/NAVCOMPARS, will provide a basic capability for total automation of AUTODIN incoming, as well as outgoing, traffic if Coast Guard internal routing look-up tables are loaded on the host LDMX/NAVCOMPARS. The potential of these terminals to provide assistance in the preparation of originated traffic for transmission via links other than AUTODIN and in the in-routing of non-AUTODIN traffic should also be investigated with the Navy.

The Fifth District Headquarters recently completed procurement and installation of a word processing system to ease administrative workloads. The full capabilities of the system selected should be examined to determine: (1) possible application for COMMCEN operation, and (2) staff/COMMCEN interface implications.

4.4.7.2 Procedural

The on-site visits revealed several practices or areas of operation which may exert unnecessary influence upon the design of an automated system. These practices or areas of operation are addressed herein under the general category of procedural.

In an automated COMMCEN, the procedures or network protocols employed on terminated circuits can: (1) be modified for compatibility with the automated system, or (2) force development of software to make the automated system compatible. For example, an AUTODIN tributary station (i. e., a station which accesses an AUTODIN switch) must utilize JANAP 128 procedures. During on-site visits, numerous procedures were observed. These included JANAP 128, modified ACP 126, modified ACP 127, commercial (TWX and TELEX), and those unique to the National Weather Service. Software costs will rise rapidly if compatibility with all such procedures is required.

Automation of the internal routing process can be extremely complex and expensive. The current basis for internal routing, as examined at sites visited, is an extremely complex and difficult to use file of subject and cross indexed tables. Adoption of a flagword or coded subject index, such as the Navy SSIC, must be considered before any attempt can be made to automate the COMMCEN internal routing process.

A major influence on COMMCEN operations is the "traditional" peak loading caused by the high volume customer who holds originated traffic until the end of the work day. This communicator's problem cannot be solved by communicators. It will, however, require a communicator's decision in respect to the influence peak loading will exert on the automated system design.

COMMCENs visited (and probably others) perform two functions which do not appear appropriate. First, the Third District COMMCEN is authorized to effect the readdressal of selected General Messages to designated activities. This appears to be, more appropriately, a staff function. Second, it appears common practice

to require the COMMCEN to examine all originated messages containing references to ensure that the reference is held by all addressees. This is, properly, the responsibility of the message drafter.

4.4.7.3 System Configuration

As presently configured, the Coast Guard Communication System is of an essentially hierarchical design, so that message traffic flows from the Headquarters to operating units through communication channels which parallel the chain of command. AUTODIN provides primary linkage from the Headquarters to District Headquarters and between District Headquarters. Intra-District links provide District Headquarters to Group and Group to Unit connectivity. Selected units, including Air Stations, Shipyards, and Supply Centers may also be provided AUTODIN access and other landline capabilities. Communication links to COMMSTAs and RADSTAs may include AUTODIN and intra-district links.

As a result, each District COMMCEN performs both message center and significant relay functions, as does each Group. District COMMCENs also perform commercial refile functions, primarily for the transmission of locally generated traffic. Both District COMMCENs and COMMSTA/RADSTAs operate links to other government activities such as the National Weather Service and local weather bureaus.

As noted earlier, two of the more significant factors impacting on the size of an automated system are traffic volume and circuit density. Even though the relay function will be relatively simple to automate, the fact that under the present system configuration each District COMMCEN performs a relay function will tend to inflate the total automation cost. Although not a direct parallel, it should be noted that the Navy NAVCOMPARS is approximately 1.8 times as costly as the LDMX. There is a distinct possibility that Coast Guard automation costs could be lessened if relay responsibilities were realigned and consolidated at perhaps four to six locations, relegating the remaining facilities to terminal

stations responsible for processing only that traffic originated by and addressed to the Headquarters staff and other over-the-counter customers served. Such a realignment might also identify potential leased line savings and support more effective utilization of personnel.

Any action to consolidate relay functions should be preceded by an in depth analysis of overall system requirements and operations.

4.4.8 New Requirements

As noted earlier, the survey revealed no new or changing requirements of such significance to cause systemwide impacts. Both Third and Fifth Districts reported increasing activity in the drug enforcement and smuggling areas of the Coast Guard Law Enforcement mission, resulting in the requirement for more frequent and more rapid reference to the El Paso Intelligence Center (EPIC). Consideration is being given to installing an interactive terminal which would provide direct access to the EPIC Computer. If such action is taken, the terminal should be installed in the RCC, rather than in COMMCEN spaces.

Plans are being developed to transfer the present Navy responsibility for operation of the CW Composite Broadcast (LCMP) to the Coast Guard COMMSTA Portsmouth. During the past eight months (June 1977-January 1978), the traffic load associated with this broadcast has averaged 1586 messages per month, ranging from a high of 1871 to a low of 1148. An additional drop from the NAVCAMS Atlantic NAVCOMPARS will be provided to support this traffic increase.

SECTION 5 - CANDIDATE DESIGN OPTIONS

5.1 INTRODUCTION

This section presents a series of options through which automation techniques may be applied to the message handling functions performed by Coast Guard Communications Centers, Communication Stations, and Radio Stations. A building block approach has been employed in order to provide the basis for phased transition from the existing system to an essentially fully automated system. The design addresses all functions performed within system nodes, as depicted in Figure 3-2, except the reproduction of copies required for local distribution which remains manual in all options. While the design does not specifically address functions performed by message drafters, partial automation of these functions could be accomplished by providing remote terminals off the COMMCEN processor or an electrical interface between staff office word processing systems and the COMMCEN. Such terminals could also provide the means for electrical distribution of traffic to designated staff offices.

The design also addresses the several modes of operations prevalent at the various facilities which have been designated as candidates for automation. These modes include landline teletypewriter, ranging from Coast Guard private line to DCS AUTODIN, radio teletypewriter, voice and CW, hard copy, and perforated paper tape. These modes of operation govern, in general terms, the quantities and types of inputs and outputs to be accommodated within each node.

Traffic data presented earlier indicate that candidate facilities can be categorized, based upon present and predicted traffic volumes, as follows:

- Small - less than 50,000 messages/year
- Medium - from 50,000 to 200,000 messages per year
- Large - more than 200,000 messages per year

The "small" category includes the Second District, the COMMSTA New Orleans, and RADSTA Adak. The Headquarters, Third District, and COMMSTA Portsmouth can be categorized as "large." The remaining 16 facilities fall into the "medium" category. It can be expected that no cost or manpower savings can be realized by automating operations within the "small" facilities. Nevertheless, such facilities must continue to be considered as candidates for at least partial automation (i.e., of selected functions) for reasons of standardization, availability of stand-alone automation techniques/devices, potential benefits to communications reliability and accuracy, and more effective use of available manpower.

More detailed descriptive data on the design options presented in this section, including evaluation of their respective responsiveness to the requirements criteria established in Section 4, are contained in Section 6. Cost analyses are provided in Section 7. Sections 6 and 7 also address the impacts upon the total automation effort should present programs to achieve partial automation be continued.

5.2 ASSUMPTIONS

The following assumptions have been made in developing design options:

- Logging to a printer is required for message headers only.
- On-line storage of one day's traffic is required, three day's desired.
- Off-line storage of 30 days' traffic is required.
- Only one printout is to be provided for messages requiring internal distribution. Unique requirements for advance copies may be satisfied by the use of multiply paper.
- Format conversion, when required for relay traffic, can be accomplished without operator intervention.
- Internal routing determination is possible with operator assistance on an exception basis.

5.3 OPTIONS

5.3.1 Option 1

Option 1 is the base line system consisting of presently installed equipment with continuation of manual operations. This option ignores all currently planned actions toward partial automation of selected facilities. It is included solely as a basis for evaluating the relative operational benefits and cost effectiveness of subsequent options.

5.3.2 Option 2

Option 2 is to complete present plans to:

- Install the optical scanner/message header generator (OPSCAN/MHG) equipment in District COMMCENS.
- Replace existing Mode V AUTODIN terminals, except that installed in the Seventeenth District, with Mode I terminals or, at Headquarters and Eighth, Thirteenth, and Fourteenth Districts, with Remote Information Exchange Terminals (RIXT).
- Provide AUTODIN access via the NAVCOMMSTA Stockton NAVCOMPARS to the COMMSTA San Francisco.

This option will:

- Partially automate the preparation of originated traffic for transmission in the First, Second, Third, Fifth, Seventh, Ninth, Eleventh, Twelfth, and Seventeenth Districts.
- Automate the preparation of originated traffic and the reprocessing of relay traffic for transmission via AUTODIN, and the in-routing of traffic received from AUTODIN in the Headquarters, and Eighth, Thirteenth and Fourteenth Districts. The host LDMX/NAVCOMPARS will also provide logging, journalling, management reporting and filing capabilities.

- Eliminate, from the Twelfth District, the relay of traffic between AUTODIN and the COMMSTA San Francisco.

5.3.3 Option 3

Option 3 is to install a RIXT, satellited off designated Navy LDMX/NAVCOM-PARS terminals, in all other District COMMCENs and COMMSTAs/RADSTAs. In addition to the capabilities described in Option 2, this option will result in the elimination of the AUTODIN-COMMSTA/RADSTA relay function performed by other District COMMCENs. Although attractive, successful prosecution of this option is highly dependent upon the capability of the Navy to accommodate additional Coast Guard RIXT installations.

5.3.4 Option 4

In order to provide both a functional and physical modularity that would allow a selective or phased implementation, the Nodal System Automation Option is defined in terms of six sub-options. This modularity scheme offers maximum flexibility in terms of phasing, cost, functions, and traffic loading. It would be noted that sub-options 4B through 4F represent capabilities added to or enhancing those afforded by sub-option 4A. Option 4A offers a basic capability by providing a processor with limited but general automation functions. This basic system is described in the following paragraph. Subsequent paragraphs address the additional capabilities that may be achieved by the addition of processor hardware, peripheral equipment and software programs. Figure 5-1 presents a block diagram of the sub-options included in Option 4.

5.3.4.1 Option 4A - AUTODIN and TWPL (Basic System)

This option is designed to automate the reception, transmission, and relay switching of traffic handled via AUTODIN and intra-Coast Guard Teletypewriter Private Line (TWPL) networks (i. e. those circuits defined in subparagraphs (a) and (b) of Paragraph 3.2.2). Equipment required to support the implementation of this option

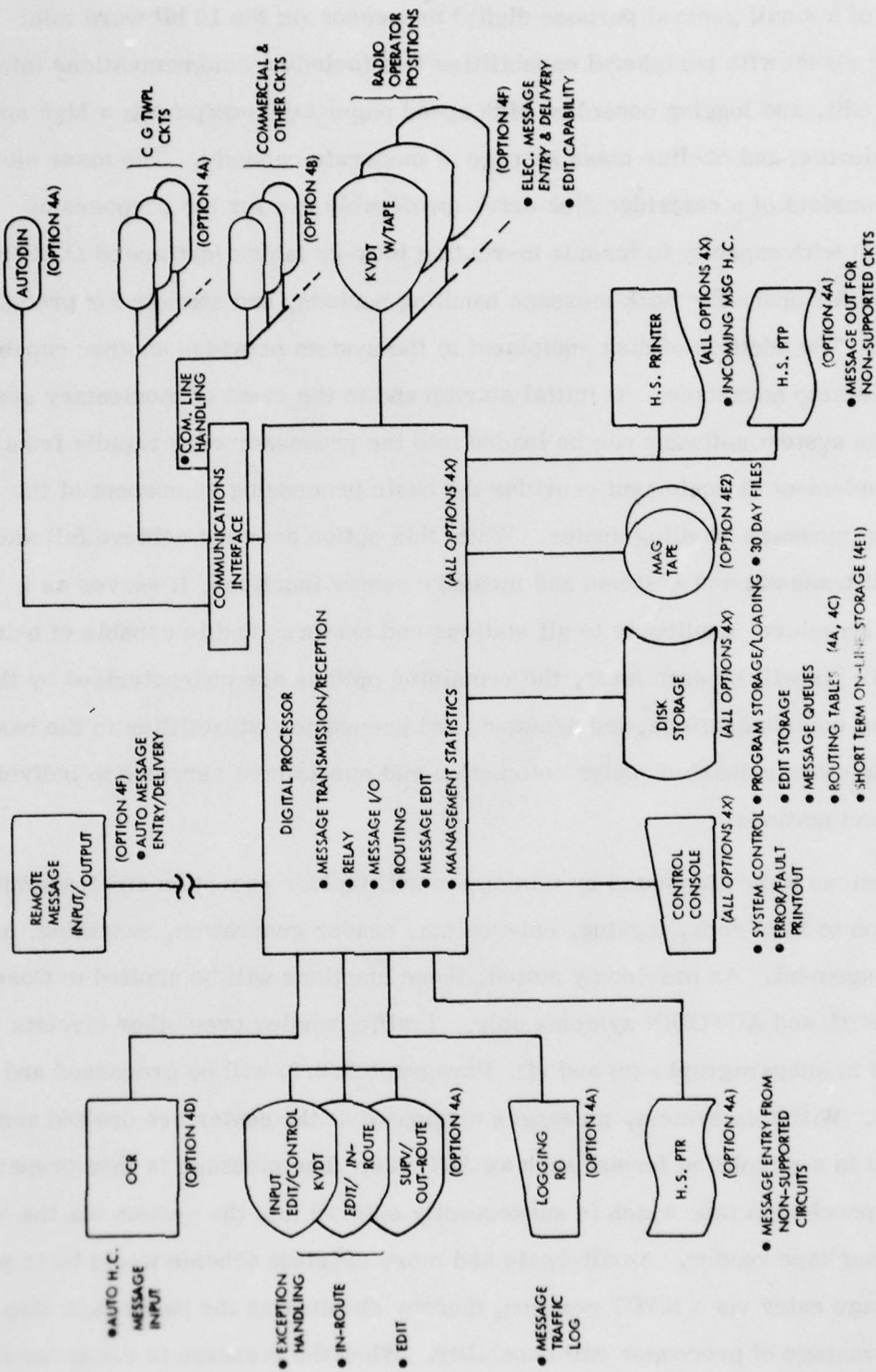

Figure 5-1. Block Diagram - Option 4 With Sub-Options

consists of a small general purpose digital processor (in the 16 bit word mini-computer class) with peripheral capabilities that include a communications interface; control, edit, and logging consoles; high speed paper tape equipment; a high speed printing device; and on-line mass storage of moderate capacity. The mass storage system consists of a cartridge disk drive (preferably two for the purposes of reliability) with capacity to include in-routing look-up tables (estimated at 100K bytes), buffer space for peak message handling periods, and storage for processor software. The addition of disk equipment to the system provides another capability of considerable advantage. At initial startup and in the event of momentary system failure the system software can be loaded into the processor very rapidly from disk. This complement of equipment provides the basic processing component of the automated message handling center. While this option does not achieve full automation of all transmission systems and message center functions, it serves as a common structure applicable to all stations and centers and is capable of being upgraded. As will be seen later, the remaining options are characterized by the addition of communications, input/output, and processing capabilities to the basic system to provide more extensive center automation and specialized services to individual centers and stations.

Functions to be automated by this option will include reception and transmission, translation to hard copy, logging, out-routing, header generation, switching, and data management. As previously stated, these functions will be applied to Coast Guard TWPL and AUTODIN systems only. Traffic handled over other circuits (as identified in subparagraphs (c) and (d), Paragraph 3.2.2) will be processed and handled manually. With this system, messages originated at the center are drafted and submitted in a simplified format such as ACP 126. The message is then prepared for entry by punching a tape which is subsequently entered into the system via the high-speed paper tape reader. An alternate and more efficient scheme would be to provide for message entry via a KVDT position, thereby eliminating the paper tape step and taking advantage of processor edit capability. When the message is ready for release

the operator entering the message issues a transmit command. The system responds by performing the out-routing function consisting of a determination of the circuits to be used, implementing format changes and header generation as required, performing message and circuit security validation checks, preparing a logging template for the message and finally queuing the messages by precedence for subsequent transmission. The final step in the automated transmission process is the selection of waiting messages for transmission as circuits for outgoing traffic become available. In the transmit activity the processor releases queued messages over the designated lines and automatically handles transmission protocol including preambles and receipt acknowledgements. After the transmission process the logging template, mentioned previously, is completed with time of transmission, sequence numbers, and acknowledgement information for the circuit or circuits used. The completed log for the message is then printed on the logging device as a hardcopy record of transmission. In the event that difficulties arise in the out-routing process, the operator would be called upon by the system with displays and suitable prompts to enable resolution of the problem. It can be anticipated that, with the exception of transmission difficulties, out-routing problems would be flagged within a very brief time from operator release and would not pose a significant problem with regard to throughput at the message entry position. Transmission problems such as line outage, being of a more serious nature, would require an alarm display on the control console.

Incoming messages will be received by the processor which handles protocol functions such as acknowledgement per the individual line requirements. Once a message has been received and acknowledged, a log template is prepared for it and disposition is determined. This is accomplished by examining the addressing information which could indicate one or more of three possibilities; namely, addressed to the center (actually the center or the command(s) it serves), to be relayed over processor supported lines, or to be relayed over lines not supported by the processor. In the first case, i. e. , messages requiring in-routing, the message

is queued for in-route address determination by operator assistance. In the second case, messages for processor supported relay, case 2, undergo any required format transformations and are queued for transmission with a procedure similar to the outgoing message function. In the third case - messages to be relayed by non-processor supported communications system - the message is queued for an interactive process in much the same manner as incoming messages. However, in this case the edit capability of the processor is made available to permit reformatting as required to permit transmission external to processor control.

The final step in the disposition of these messages consists of printing the completed log entries for each message via the logging device and printing the message itself on the high speed printer. Messages that are to be relayed on circuits not supported by the processor are punched on paper tape via processor control in response to operator command. Since a hardcopy of these relay messages will subsequently be produced during their transmission, the hard copy processor output is optional. As automated in-routing is not supported by this option, this step could be implemented by existing procedures (i. e. adding distribution lists to printed text) applied to the message printout or by an edit step via KVDT prior to printout. Printouts may consist of duplicate copies of each message processed. This could be accomplished by means of two-ply paper. One of the copies could serve as an advance distribution copy and the other channeled to the reproduction process; alternatively, one of the copies could serve as the message center file copy.

Data management functions for this option consist of running tabulations of a limited number of statistics regarding message handling activities. This information could be made available as a summary printout at designated intervals or on a demand basis.

Equipment required to support this option will include the following:

- 1 - Minicomputer with 64K words memory, communications controller with interface configurations as required (up to 16 line capacity), and I/O channels and controllers for peripheral devices

- 1 - Control Console (KSR)
- 1 - Logging printer (RO) 30 char/sec
- 1-2 - Supervisor/Edit Console (KVDT)
- 1 - High Speed Printer (100-300 lines/min.)
- 1 - High Speed Paper Tape Reader/Punch
- 1 - Disk system, capacity > 1M byte, 2 drives for reliability

The software size is estimated at 32K words of memory, most of which can be developed in a high order language.

5.3.4.2 Option 4B - Other Landline TTY

This option will automate the handling of traffic on the remaining TTY circuits in the various COMMCENs. The same degree of automation provided for AUTODIN and intra-Coast Guard (TWPL) traffic by the basic option 4A will be extended over additional TTY circuits. The implementation of this option will require the handling of additional message formats and circuit protocols. The software system developed in option 4A must be expanded to include new routing disciplines and format conversions and will require the implementation of additional software drivers to accommodate circuit protocols. Hardware requirements for this option consist of interface circuitry as required for lines supported. In the absence of any backup requirements, full implementation of this option (that is, over all COMMCEN circuits) will eliminate the need for tape punch equipment as specified in option 4A.

5.3.4.3 Option 4C - In-Routing

This additional capability can be applied to either of the above options with the incorporation of in-route software and expansion of on-line mass storage to accommodate the in-route lookup tables. Software requirements include applications software to identify and interpret message subject indicators and to access the

distribution (in-routing) look-up tables in obtaining distribution data. Additional software will also be required to build and maintain the tables. Added disk storage required for this option is estimated at 1M bytes.

Operationally, this option will handle in-routing automatically with operator intervention required on an exceptional basis; however, since the tables are maintained and manipulated under processor control, the procedures for that manual routing assistance are greatly simplified when compared to current methods.

5.3.4.4 Option 4D Optical Character Reader

This option is a modular addition to any of the above which will provide translation of originated traffic from paper copy to electrical forms acceptable by the processor. The incorporation of OCR equipment into an automated message center could range from utilizing this equipment in much the same manner as current procedures to adapting the OCR equipment as an on-line device, communicating directly to the message processor. In the stand-alone approach the OCR would be operated without header generation equipment to translate message text prepared in ACP 126 format to paper tape form which is subsequently entered into the processing system via the high speed paper tape reader. This form of operation would impose no additional requirements on processor hardware or software. In the on-line approach to OCR usage the OCR equipment would be electrically interfaced to the processor, thereby eliminating the paper tape transfer. The interface between processor and OCR could be a relatively simple one supporting only serial character transfer to the processor, or a more complex interface could be implemented whereby the interface could support the interactive functions associated with message release activities as described in option 4A. This configuration would take advantage of the keyboard and display equipment integral to the OCR and provides more efficient control of initiation functions directly at the OCR operator position.

Assuming the implementation of the on-line approach without interactive capability, adding this option will require an additional I/O channel for the OCR and minimal changes to the software (approximately 500 words of memory). Since OCRs are presently being procured, an interface device may have to be developed.

5.3.4.5 Option 4E File System

This option envisions two possible sub-options. The first, identified as 4E(1) would be a modular add-on of disk capacity oriented to provide ready access (on-line) files containing message traffic sent, received or relayed via the processor controlled system. The capacity of the disk storage required to implement this option is dependent upon the average message load of the automated center and the time over which the majority of calls for message access (such as for re-addressal) are received. Based on the range of message loads determined during the surveys, and assuming average traffic for small, medium, and large volume centers, this option would require formatted disk capacity of the orders 200, 700, and 2000K bytes per day of on-line storage. Software requirements include file handling utilities to support file maintenance and access in automatic and interactive modes. Hardware additions consist of upgrading the capacity of the disk system provided in option 4A.

Sub-option 4E (2) would add a tape controller and magnetic tape drive to implement a more efficient off line storage system for the 30-day file of message traffic. With this system, operating in concert with the disk file of option 4E(1), blocks of messages are periodically transferred to the magnetic tape media as the allocated disk storage area fills with message traffic. Simultaneously, a tape volume index is maintained on disk corresponding to the current tape contents. The index could be reviewed via terminal display or hard copy and will contain information sufficient to locate and reload individual messages from tape. Accessing a message stored on tape will consist of disabling the processor-controlled message dump system and, by means of a utility program, positioning and reading the desired

message per referencing information provided by the tape index listing. With the message read into the processor working storage, it may be printed, modified, or re-transmitted as required. During the tape library access procedure the disk system, which is not now supported by an on line tape, must absorb ongoing message activity until the current dump tape is installed and positioned for continued dump action. This can be circumvented in the case of library accesses to previously filled tapes by the addition of a second tape drive. The capability of independent tape handling equipment has the added advantage of permitting the analysis of message records stored on tape to be performed without disturbing ongoing message center operations. This feature can be viewed as an augmentation of the data management and statistics capability implemented as a real-time function in option 4A.

Implementation of this sub-option requires the installation of tape drives and a controller and software consisting of drivers and tape handling utility programs. If standard (10 1/2-inch reel) drives are used in this application, the high volume centers will use approximately five reels of tape per month in maintaining the 30-day file; smaller drives in the 7-inch reel class will require about four times that number of tape volumes.

5.3.4.6 Option 4F Radio Circuits and Remote Entry/Delivery

The automation of radio circuits is treated as a separate option due to the more limited application. It would appear that only partial automation of this traffic is technically feasible due to the unique operating procedures and radio circuit quality. Thus, this option envisions the automation of send and receive RATT, voice, and CW traffic only to the extent that the radio operator position is treated as a peripheral or subscriber to the system. The operator positions would be terminated in the processor by means of KVDT terminals with a tape option. The processor would receive traffic from these positions and handle as any other relay message, and would route traffic to the appropriate operator terminal in accordance with guard list or other instructions. The extent of service provided to these "remote" positions may range from simple delivery and acceptance of messages to a full interactive capability with message edit services.

Just as radio circuit operator positions can be handled remotely by means of terminal devices, this concept can also be applied to the remote entry and delivery of messages within a headquarters. In this application the processor can support remote printing terminals to enable direct message entry by the originator and electrical distribution of single copies.

5.3.4.7 Equipment and Software Costs - Option 4

The equipment and software specification and development costs illustrated in Table 5-1 show representative costs for full implementation of Option 4 (including sub-options A, B, C, D, E1, and E2) at centers with high and medium volume levels of message traffic. For hardware costs, it should be noted that this costing is not comparative between manufacturers of similar equipment but is a configuration selected from Digital Equipment Corp. hardware, priced in single quantities. The CPU system chosen is a medium power machine with more than adequate power for large and medium centers. Should the small volume centers be automated, a lower capacity machine of the same family may be suitable. This reasoning also applies to the peripheral equipment - disks, printer, etc. The configurations shown in the table include dual disk drives and tape transports which are recommended for reliability and backup considerations as well as to allow for peak system loading and ancillary processing activities and maintenance. A paper tape reader/punch was also included in anticipation of phase-in implementation, non-supported circuits, and to provide for backup message I/O. The table does not include terminal equipment such as would be installed at RADSTAs (KVDTs, paper tape equipment) or at message centers supporting remote entry/printout capabilities. Use of existing Model 37 ASRs could provide the desired remote capability at COMMSTAs and RADSTAs.

Software development cost estimates with a reasonable degree of confidence are difficult to make at this time. The complexity of the software is strongly dependent on the routing and format transformation functions where the effectiveness of the software exerts a strong influence on overall system utility (i. e., reducing manual intervention). Overall software costs are also affected by language used, operating

TABLE 5-1. REPRESENTATIVE COSTS

REPRESENTATIVE HARDWARE COSTS

(Single Quantity Pricing, Digital Equipment Corp.)

Item	Medium Volume	High Volume	10-19 Quantity ¹ Discount	Maintenance	
	COMMEN (MV) \$	COMMEN (HV) \$		MV	HV
<u>Processor</u>					
DEC 11/34A CPU with 64K words MOS memory, 7.5 M byte or 5.0 M byte dual disk system (o. s. software included) software reduction after 1st system	34000 (-1650)*	34000 (-1650)*	23%	270	270
<u>High Speed Printer</u>					
LA11 Printer and control unit 180 char/sec ~100 LPM	3770		23%	55	
LP11 Printer and control unit 300 lines/min.		11800	10%		95
<u>Magnetic Tape Equipment</u>					
TUIDW Controller + 1 drive 10½ reel capacity additional 10½" drive		13280 10300	16%		101 74
TS03 Controller + 1 drive 7" reel capacity additional 7" drive	7650 3850		16%	75	
mounting rack (TS03)	1210		16%		
CPU expansion chassis (required for either tape sys.)	1600	1600	16%		
<u>Logging Printer</u>					
LA36 30 char/sec (included in CPU package) deduct for no keyboard	(2100)* -200	(2100)* -200			
<u>Paper Tape Equipment</u>					
PC11 High Speed Reader/Punch	5060	5060	16%	41	41
<u>Video Terminal</u>					
VT52 Terminal @ \$1900 ea.	(1) 1900	(2) 3800	23%	20	40
<u>Communications I/O Components</u>					
DH11 Multiplexer 16 line capacity	5500	5500	16%	32	32
DZ11 Multiplexer 8 line capacity (may be required for RADSTA implementations of option 4F)	(2310)*		(23%)		(25%)
<u>Installation</u>					
Installation and 30 day warranty @ 3% list price	(2044)*	(2668)*			
TOTALS	64340	85140		543	653

¹ Quantity discount per system

13104 15592

Estimated Software Development Costs

Including specification, development, and documentation - \$251K

()* = non add

system availability and commonality in installed systems. It is anticipated that with the selection of a hardware system, a suitable operating system would be available that can provide basic resource management, task scheduling and common I/O drives software as a basis for system development. The use of a high level language for most of the developed software can enhance the efficiency of software production and maintenance (at some cost in code efficiency). Finally, it should be recognized that while the various communications centers may differ in numbers and types of lines supported, a relatively high degree of commonality in software will exist through the various installations.

5.4 ALTERNATIVE APPROACH

The design options discussed above address the application of communications automation technology to the operation of 22 centers which perform tape relay as well as terminal station functions. A separate study is addressing similar operations at many other facilities such as Group Headquarters. Both studies address only segments of the end-to-end flow of message traffic, from originator to addressee. Neither study addresses the growing requirement for the transfer of information in data pattern (i. e. card) format. More basically, current study efforts make no attempt to evaluate the effectiveness with which the Coast Guard Communication System fulfills its role in the broad C³ efforts of the Coast Guard. There is no assurance, therefore, that the application of communications automation techniques to message handling functions at the 22 candidate terminal/relay facilities represents the most operationally sound or cost-effective application of available automation technology to total Coast Guard needs.

Based on an extremely limited examination of systemwide traffic patterns and the interconnecting links between system nodes, it appears that systemwide reliability, responsiveness and speed of service could be improved, with or without automation, by the consolidation of all relay activity into a small number (perhaps 4 to 6) of strategically located Area Major Relay Stations. Each Area Major Relay

Station could be provided high speed, high capacity access into AUTODIN for inter-node connectivity. All Coast Guard activities within each specified area could be connected to the Area Major Relay Station (by single station or multi-station tributary lines) for record communications (narrative message or data pattern) services, including access into AUTODIN. Such a reconfigured complex would be amenable to a number of automation options, responsive to both systemwide and local needs.

A more detailed examination of this alternative approach appears to be essential before developing any firm program for automation of all 22 centers/stations examined in this report. It also appears desirable that any interim steps to automate selected functions be limited to those centers/stations where an urgent operational need for such actions can be demonstrated.

SECTION 6 - OPERATIONAL AND TECHNICAL BENEFITS

6.1 INTRODUCTION

This section examines the series of design options developed in Section 5 in order to identify the operational and technical benefits, if any, offered by each option, and to measure the responsiveness of each option to existing requirements.

6.2 DISCUSSION

An in-depth evaluation of the effectiveness of COMMCEN operations would normally take into consideration three major factors:

- Speed of Service. The time required to process a message through a center, if compared to a standard or to the average times achieved by a group of similar centers, provides one measure of center effectiveness. Speed of service, or in-station handling time, can be influenced by station configuration, in-station practices and procedures, manning levels, and personnel capabilities. Customers served by COMMCENs can also influence in-station handling times adversely if they fail to prepare messages properly or if traffic which has been prepared and released is collected and delivered to the COMMCEN at the end of the work day.
- Accuracy. The accuracy with which a center performs its functions is highly personnel dependent. Performance may also be degraded by poor maintenance practices leading to malfunctioning equipment. Some of the factors which might indicate an error-prone operation would be a high AUTODIN reject rate, abnormal service message activity, non-deliveries, frequent delays, repeated misroutes, and the recurring need to redistribute messages internally to correct routing.
- Customer Complaints. Frequent customer complaints are generally indicative of less than optimum performance.

As stated earlier, the manner in which COMMCEN logs and records are maintained, in particular, and the lack of standardized in-station practices, in general, make it virtually impossible to determine the speed of service now being provided. This proved true at three of the four sites surveyed during this study. At the COMMSTA Portsmouth it was possible, utilizing station files, to develop actual in-station handling time data. Based on limited sampling (200 messages, which is about 35 percent of one day's traffic), a message processes through the COMMSTA in approximately 42 minutes. To provide a base for evaluation, synthesized handling times were developed for all sites, including the COMMSTA. These figures accurately depict the time required to perform each function from entry into the COMMCEN until all processing has been completed, but ignore all delay times (e.g. awaiting action). It is interesting to note that the COMMSTA average actual handling time (42 minutes) is approximately 6.4 times the synthesized handling time (6 minutes, 36 seconds as derived from Table C-11, Appendix C). Since these statistics represent averages of averages, application of the 6.4 factor at the three COMMCENs to develop actual handling times would be of questionable validity.

As in the case of handling times, available records provide little basis for evaluating the accuracy with which the facilities visited perform their functions. Each site visited was manned by well trained personnel who were obviously fully capable of performing assigned duties. In reviewing message files, the incidence of corrected copies (to change internal distribution) and service messages (to correct originated messages transmitted earlier) was relatively minor. There is no evidence, therefore, that Coast Guard COMMCENs, in general, and those surveyed, specifically, are particularly error prone.

Each of the sites visited appeared to be providing satisfactory service to its users.

AD-A060 464

COMPUTER SCIENCES CORP FALLS CHURCH VA SYSTEMS DIV F/G 17/2
STUDY OF AUTOMATION OF MESSAGE HANDLING FUNCTIONS AT USCG COMST--ETC(U)
MAY 78 D SMILEY, G KEENE, P KENNEDY DOT-CG-71522-A
CSC/SD-78/3034 USC6-D-18-78 NL

UNCLASSIFIED

2 of 4
AD
7060 464

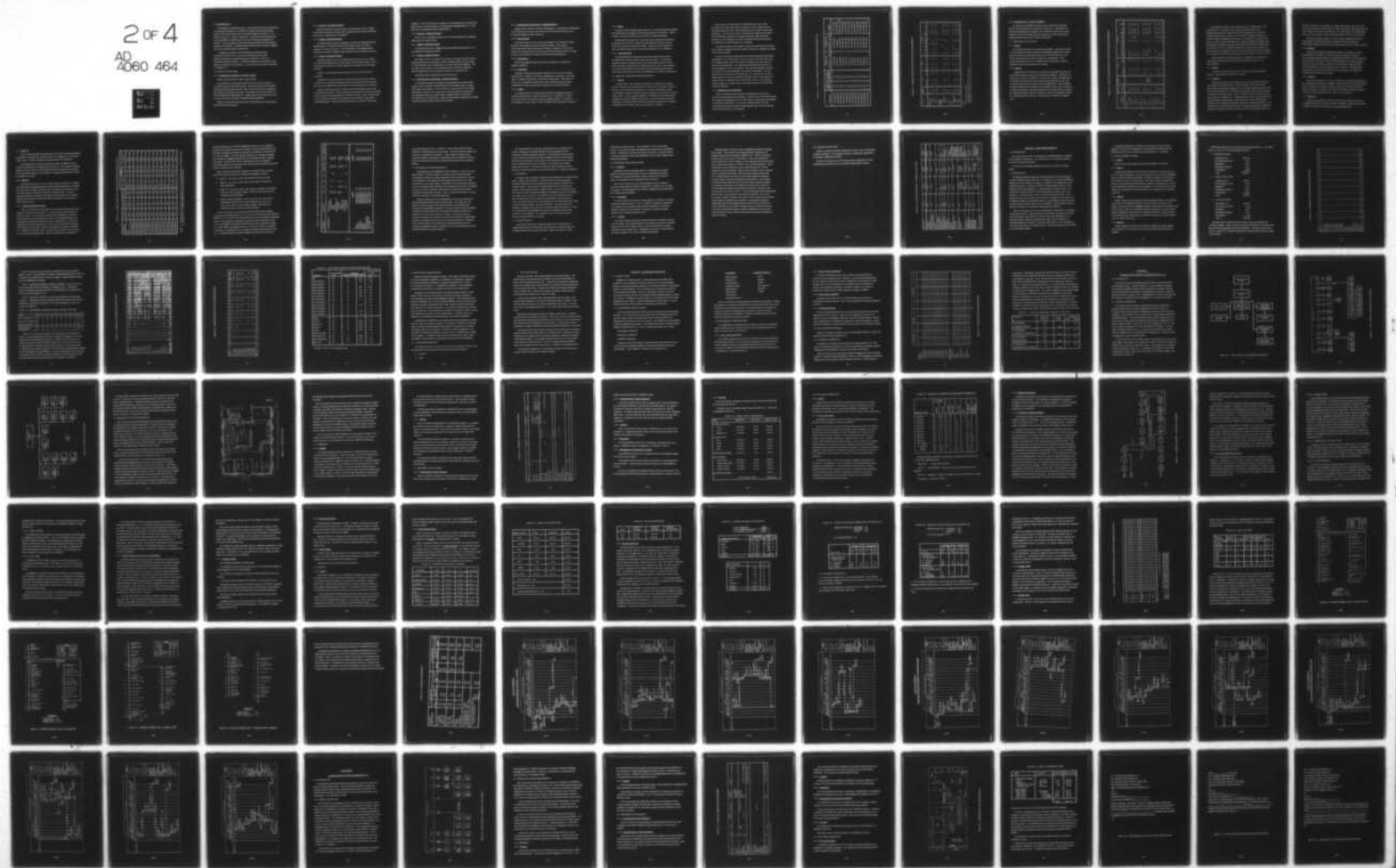

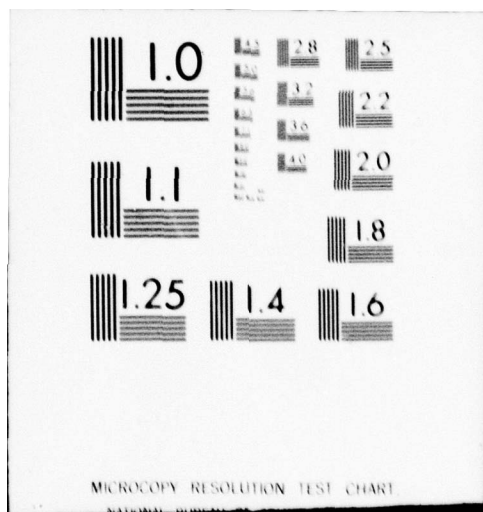

MICROCOPY RESOLUTION TEST CHART

6.3 METHODOLOGY

In the absence of established criteria, valid measures of current performance, or documented deficiencies, it is difficult to quantify the operational benefits offered by the optional approaches to automation suggested in Section 5. It is possible, however, to examine qualitatively the impact each option might have on accomplishing the nodal functions which were described in Paragraph 3.4, Section 3. It is also possible, using the synthesized handling times developed in Appendices A through D, to identify potential improvements in in-station handling times and to predict manpower implications.

Paragraph 6.4 addresses each nodal function identified earlier, providing in narrative form a description of the improvements which might be achievable by implementing options 2 through 4F. There is no operational advantage to option 1. In-station handling time and manpower implications are addressed in Paragraph 6.5. These evaluations are then summarized in Paragraph 6.6.

6.4 IMPACTS ON FUNCTIONS

6.4.1 Reception and Translation - Incoming Messages

Options 2 and 3 will have no affect on this function.

Under Option 4A, the processor would become the receive terminal for AUTODIN and intra-Coast Guard circuits. The automated system will translate incoming messages to page copy and, where relay via circuits not terminated on the processor is required, paper tape. The requirement to produce paper tape will be eliminated by adding option 4B. Adding option 4E will eliminate the need for page copy except on messages requiring internal distribution.

Options 4A and 4B will provide automatic acknowledgement of receipt where required by network protocols.

6.4.2 Inspection - Incoming Messages

Options 2 and 3 will have little impact on the inspection process. Options 4A and 4B will automate all aspects of the inspection process except examination of the text for completeness and readability.

6.4.3 Logging - Incoming Messages

The requirement for manual maintenance of circuit and associated logs and annotating time of receipt will continue under options 2 and 3, but will be eliminated by options 4A and 4B. Partial automation of the logging functions performed by RADSTA/COMMSTA radio operators will be provided by option 4F.

6.4.4 Routing - Incoming Messages

Assuming adoption and use of a standardized subject index code, the RIXT (to be provided designated stations under option 2 and all stations under option 3) will provide an automated in-routing capability for messages received through AUTODIN.

Option 4C, when implemented with options 4A and 4B will automate all in-routing.

Regardless of the option selected, manual look-up tables must be retained to assist in the in-routing of messages received from non-Coast Guard activities and Coast Guard traffic from which the index code was omitted by the originator.

Options 2 and 3 will provide no assistance in determining the need for relay or in effecting such relay. These functions will be automated for circuits terminated on the processor upon implementation of options 4A and 4B. Option 4F will provide a basic capability to automate the switching of received traffic to appropriate operating positions. Certain procedural actions may be required to exploit this

capability. These could involve the assignment of routing indicators to mobile units and inclusion, in message headers, of an appropriate operating signal (i. e. ZON1, ZON2, etc.) to indicate broadcast responsibilities.

6.4.5 Inspection - Outgoing Messages

There will be a continuing requirement for the manual inspection of originated traffic under any selected option.

6.4.6 Logging - Outgoing Messages

The discussion relative to logging of incoming messages (Paragraph 6.4.3) is also applicable to outgoing messages.

6.4.7 Routing - Outgoing Messages

With options 2 and 3, the operator will continue to designate circuits on which outgoing traffic is to be transmitted. In RIXT equipped centers, the out-routing of AUTODIN traffic will be accomplished by the host LDMX/NAVCOMPARS. The non-RIXT centers (option 2) will be equipped with the OCR/MHG combination which simplifies but does not eliminate the manual out-routing process.

This function will be automated by options 4A and 4B.

6.4.8 Preparation for Transmission - Outgoing Messages

The manual preparation of messages for transmission will continue under options 2 and 3, except for AUTODIN traffic at OCR equipped centers. Manual preparation of paper tapes in ACP 126 format, or entry via KVDT will continue with options 4A and 4B. The requirement for manual preparation of tapes will be eliminated by option 4D, except on those messages which are delivered to the COMMCEN on non-OCR forms. Option 4F will simplify the preparation of traffic received via radio circuits for entry into the system.

6.4.9 Translation and Transmission - Outgoing Messages

Options 2 and 3 will have no impact on this function. Translation and transmission on AUTODIN and intra-Coast Guard circuits will be automated by option 4A and on all other landline circuits by option 4B.

6.4.10 Relay Sequence

The functions involved in processing relay traffic are a combination of those involved in processing incoming and outgoing messages. Thus, options 2 and 3 offer little toward improving this operation. Options 4A and 4B would eliminate the requirements for tape relay and format conversions which are among the more time-sensitive of COMMCEN functions now being performed.

6.4.11 Reproduction

None of the suggested options address the reproduction of messages for internal distribution.

6.4.12 Distribution

Although not addressed specifically, options 4A, 4B, 4C, and 4F together would provide a capability for electrical distribution of messages to, and remote entry of messages originated by, selected high volume users. With options 4A, 4B, and 4C, an electrical interface between the COMMCEN processor and an administrative word processing system should also be technically feasible.

6.4.13 Review

The requirement for the manual review of traffic is designed primarily to avoid non-deliveries and to detect personnel errors. In options 2, 3, and 4A (to a lesser extent), this manual review will probably continue. The need for and capability to conduct manual "traffic checking" will be eliminated by option 4B.

6.4.14 Filing

In options 2 (RIXT equipped stations only) and 3, the host LDMX/NAVCOMPARS will maintain files of messages received and transmitted via AUTODIN. Files of messages sent/received by other means would be maintained manually.

Implementation of options 4A, 4B, and 4E1 would continue the requirement to maintain hard copy files, although 4E1 would automate reference to/recall of the most recent (up to three days') traffic. Option 4E2 would eliminate the need to maintain hard copy files, except those required by law or regulation.

6.4.15 Data Management

The host LDMX/NAVCOMPARS will provide selected statistical data on AUTODIN traffic to RIXT equipped centers (options 1 and 2). An automated capability to produce management data will be provided by options 4A and 4B. In this connection, requirements for statistical data will exert a major influence on the types of information to be entered into the automated logs and journals. Such requirements should, therefore, be identified prior to software development.

6.5 HANDLING TIMES/MANPOWER IMPLICATIONS

6.5.1 General

As noted earlier, the synthesized handling times developed in the annexes provide a basis for measuring improvements which may be expected, in speed of service, by automating selected functions. In order to relate the time saved in processing a message to potential manpower savings, it is necessary to examine traffic volumes. Since message handlings in a COMMCEN fall into three general categories (i. e., those originated locally; those received and requiring internal distribution; and others, which would include multiple transmission of originated messages as well as relay), totals in each category are required.

Data reviewed at the Headquarters COMMCEN indicated that a high percentage of the send traffic (about 55 percent) is locally originated and an extremely high portion of the received traffic (about 85 percent) requires local distribution. For a busy day, when 0.4 percent of the annual total is handled, the HQ COMMCEN processed 186 originated messages, effected internal distribution of 672 messages, and relayed (including multiple transmissions of originated and received messages) 274 messages.

The review of traffic at the COMMSTA Portsmouth indicated that originated and terminated (requiring distribution) traffic represented a negligible percentage of total traffic handlings.

Surveys at the Third and Fifth Districts revealed distributions which differ substantially. At the Third District only 9.4 percent of the total send volume was originated locally, while 38.6 percent of messages received required reproduction and distribution. The Fifth District distribution pattern was 21.6 percent originated and 58.3 terminated. The composite distribution of these two centers is 12 percent originated and 44 percent terminated. The latter distribution has been utilized to develop Table 6-1. Since this may result in inflated figures for Third and possibly the Twelfth Districts, and conservative estimates for the remaining District COMMCENS, Table 6-1 also includes, within parentheses, message count in each category based on Third and Fifth District COMMCENS.

6.5.2 Handling Times - COMMCENS

Table 6-2 summarizes the reductions in handling times which can be achieved by implementing selected options. These data have been developed from the synthesized handling times for the Third District, as generally representative of all District COMMCENS. For each type message reflected, the total processing time has been reduced by subtracting the time involved to manually perform those functions to be automated.

TABLE 6-1. TRAFFIC DISTRIBUTION ESTIMATES (MESSAGES PER BUSY DAY)

COMMEN	BUSY DAY VOLUME		ORIGINATED 12% (9.4% - 21.6%)	TERMINATED 44% (38.6% - 58.3%)	OTHER
	SEND	RECEIVE			
1ST DISTRICT	472	544	57 (44-102)	240 (210-317)	719 (762-597)
2ND DISTRICT	217	102	26 (20-47)	45 (39-59)	248 (260-213)
3RD DISTRICT	940	1179	112 (88-363)	519 (455-687)	1488 (1576-1069)
5TH DISTRICT	278	420	33 (26-60)	185 (162-245)	480 (510-393)
7TH DISTRICT	498	586	60 (47-107)	258 (226-342)	766 (811-635)
8TH DISTRICT	330	449	40 (31-71)	198 (173-262)	541 (575-446)
9TH DISTRICT	232	381	28 (22-50)	167 (147-222)	418 (444-341)
11TH DISTRICT	202	285	24 (19-44)	125 (110-166)	338 (358-277)
12TH DISTRICT	310	425	37 (29-67)	187 (164-248)	511 (542-420)
13TH DISTRICT	278	304	33 (26-60)	134 (117-177)	415 (439-345)
14TH DISTRICT	327	536	39 (31-71)	236 (207-312)	588 (625-480)
17TH DISTRICT	353	296	42 (33-76)	130 (114-173)	477 (502-400)

TABLE 6-2. COMMEN HANDLING TIME REDUCTIONS (PER MESSAGE)

ACTIVITY	OPTION 1 (BASE)		OPTION 2		OPTION 3		OPTION 4											
	RED	NET	RED	%	RED	%	RED	NET	4A RED	4B RED	4C RED	4D RED	4E RED	4F RED	Σ RED	NET	% RED	
ORIGINATED																		
AUTODIN	12:25	5:35	6:50	55.0	9:14	74.4	4:54	3:11	-	-	4:20	:05	-	-	9:19	3:06	75.0	
OTHER	9:05	4:45	4:20	47.7	4:20	47.7	1:44	4:25	:09	-	4:20	:05	-	-	6:18	2:47	69.4	
BOTH	14:10	7:20	6:50	48.2	6:50	48.2	6:17	7:20	:10	-	4:20	:05	-	-	10:52	3:18	76.7	
INCOMING AUTODIN																		
TERMINATE	2:55	2:55	0	0.0	1:00	34.2	:54	1:55	-	-	:54	-	-	-	1:53	1:02	64.6	
RELAY	2:30	2:30	0	0.0	0	0.0	2:02	2:30	:11	-	-	-	-	-	2:18	:12	92.0	
BOTH	4:40	4:40	0	0.0	1:00	21.4	2:17	3:40	:11	-	-	-	-	-	3:32	1:08	75.7	
OTHER																		
TERMINATE	2:55	2:55	0	0.0	0	0.0	:48	2:55	:06	-	-	-	-	-	1:53	1:02	64.6	
RELAY	4:55	4:55	0	0.0	:22	7.4	4:34	4:33	:04	-	-	-	-	-	4:43	:12	95.9	
BOTH	7:05	7:05	0	0.0	:22	5.2	4:47	6:43	:06	-	-	-	-	-	5:37	1:08	84.0	

NOTES:

RED = Reduction in Time by Option

Option 2 based on OCR/MHG only. RIXT impact reflected in option 3.

Option 3 reduction for "OTHER RELAY" based on 3 minutes reduction on TWPL-AUTODIN, which comprises approximately 12% of relay activity.

6.5.3 Handling Times - RADSTA/COMMSTAs

The reductions in handling times which may be realized by automating RADSTAs and COMMSTAs are summarized in Table 6-3. These utilize the synthesized handling times developed at the COMMSTA Portsmouth as a base. Options 4C and 4D are excluded from the analysis due to the low terminated/originated activity noted at the COMMSTA Portsmouth.

6.6 OPERATIONAL EVALUATION

6.6.1 Option 1

The baseline option offers no operational advantages. Some improvements in current operations might be realized by establishing standardized in-station practices and circuit operating procedures and, where work flow (time and motion) studies indicate the need, by equipment reconfiguration. Such improvements would, however, be relatively minor and provide a marginal capability to absorb increasing volumes of traffic.

6.6.2 Option 2

Replacement of AUTODIN Mode V terminals with the Mode I terminal will provide higher capacity access into AUTODIN and a capability, which does not exist today, to process card traffic. At a high volume center, the higher speed of the Mode I terminal would tend to smooth out the peak loading curve, with a resultant improvement in overall in-station handling times. The OCR/MHG capability will provide an operation less susceptible to human error and improve in-station handling times (by about 6 minutes and 50 seconds [6:50] per message) for outgoing messages, which also represents a reduction in manpower loading. As a stand-alone device, however, it will not enable a reduction in manning level.

TABLE 6-3. RADSTA/COMMSTA HANDLING TIME REDUCTIONS (PER MESSAGE)

RELAY ACTIVITY	OPTION 1	OPTION 2	OPTION 3		OPTION 4								
	(BASE)		RED NET	% RED	4A RED	4B RED	4C RED	4D RED	4E RED	4F RED	Σ RED	% RED	
AUTODIN TO:													
SHIP-SHORE	3:20		0 3:20	0.0	1:38	1:19	-	-	:05	-	3:02	:18	91.0
CW BCST	7:15		0 7:15	0.0	1:28	-	-	-	:05	1:25	2:58	4:17	40.9
VOICE BCST	5:15		0 5:15	0.0	1:28	-	-	-	:05	1:30	3:03	2:12	58.1
TWPL	3:05		0 3:05	0.0	2:42	-	-	-	:05	-	2:47	:18	90.3
SHIP-SHORE TO:													
AUTODIN	11:05		3:00 8:05	27.1	8:37	1:48	-	-	:05	-	10:30	:35	94.7
TWPL	8:45	NOT APPLI-CABLE	0 8:45	0.0	5:34	1:48	-	-	:05	-	7:27	1:18	85.1
AMVER/WX	4:55		0 4:55	0.0	-	3:11	-	-	:10	-	3:21	1:34	68.1
CW/VOICE TO:													
AMVER/WX	3:20		0 3:20	0.0	-	1:23	-	-	:10	:25	1:58	1:22	59.0
AUTODIN	10:40		3:00 7:40	28.1	8:37	-	-	-	:05	1:26	10:05	:32	95.0
TWPL	8:20		0 8:20	0.0	5:34	-	-	-	:05	1:26	7:05	1:15	85.0

The utilization of a RIXT in lieu of the Mode I for AUTODIN access, with a companion OCF, will ensure a more accurate operation and provide a substantial improvement in speed of service for messages sent or received by AUTODIN (approximately 9 minutes and 14 seconds on originated messages and 1 minute on traffic terminating in the center). Since traffic sent, received, and relayed via other circuits will continue to be processed manually, the RIXT, while providing some reduction in workload, offers limited manning level compensation. The capability of the host LDMX/NAVCOMPARS to maintain logs, journals, and files and to provide management data will be of questionable value since systemwide only 25 percent of send traffic and 50 percent of received traffic involves AUTODIN.

The RIXT would be an ideal application of communications automation to a large volume message center with terminal responsibilities only (i. e., no relay functions).

6.6.3 Option 3

Comments on application of the RIXT to Coast Guard message handling functions are included in the discussion of option 2.

6.6.4 Option 4A

Option 4A will provide a more efficient and accurate COMMCEN operation. By automation of the TWPL-TWPL, TWPL-AUTODIN, and AUTODIN-TWPL relay activity and associated logging and record keeping, substantial improvements of in-station handling times and reductions in personnel workload will be achieved. Elimination of the requirement to prepare originated traffic in JANAP 128 format will also improve handling times. Although this option does not specifically address the in-routing of received traffic, improved speed of service will result upon diverting a major portion of the manpower effort from manual relay activity. This option will save, insofar as operator time is involved, approximately 4 minutes 54 seconds per message on originated traffic, 54 seconds on terminated traffic, and

2 minutes 2 seconds on relay traffic. At a high volume center, such as the Third District, this represents a total manhour savings in the order of 3990 minutes per day, which equates to two men per watch section. At a small station, for example Fifth District, the time savings would be about 1285 minutes, or less than one man day.

It should be noted that option 4A as well as other configurations proposed within option 4 would replace existing or planned AUTODIN terminals and teletypewriter equipment associated with circuits terminated on the central processor.

6.6.5 Option 4B

Option 4B will extend the capabilities of option 4A to include all circuits terminating in the COMMCEN with the exception of functional, non-Coast Guard circuits such as the Defense Coordination Net installed in the HQ COMMCEN. Implementation of the options 4A and 4B will eliminate the need for all teletypewriter terminals except those retained for tape preparation (originated traffic) and backup purposes. All relay functions will be automated. Although further improvements in COMMCEN effectiveness can be anticipated, the potential for manning level reductions appears slight.

6.6.6 Option 4C

Option 4C, and add-on to 4A and 4B, will provide a substantial improvement in processing terminated traffic, eliminating a manual function now consuming approximately one minute per message. Together, options 4A, 4B, and 4C will reduce manpower loading, by message, on the order of 4 minutes 54 seconds (originated), 1 minute 48 seconds (terminated) and 1 minute 34 seconds (relay).

6.6.7 Option 4D

Option 4D, when added to options 4A and 4B, will complete the automation of originated message processing, providing a substantial, additional improvement (4 minutes 20 seconds per message) to in-station handling times.

6.6.8 Option 4E

Partial implementation of this option (4E1) will provide a limited improvement in operations, supporting near real-time recall of, or reference to, most recent (3 days) files. It will not eliminate the requirement for hard copy files.

Full implementation (4E2) will eliminate the need for printing out copies of relay only traffic and for maintaining hard copy files. This option will simplify reference to files, provide a base (when used with the automated log and journal) for in-depth traffic analyses, and contribute to a reduced administrative workload on COMMCEN personnel.

6.6.9 Option 4F

This option will expedite the flow of traffic through a RADSTA or COMMSTA to appropriate radio operating positions and provide the operator with a capability for remote entry of traffic received via radio circuits into the automated system. This option will also simplify the maintenance of operator logs. The most important operational advantage to this option is the elimination of the collateral functions which now tend to prevent the full time dedication of radio operators to their primary duties.

6.6.10 Workload Reduction Summary

Table 6-4 summarizes the potential overall workload reductions and, hence, manpower implications of each option. It is based on data presented earlier in Tables 6-1 and 6-2. The estimates provided for the Headquarters COMMCEN are based upon the observed distribution which has a significantly higher ratio of originated and terminated traffic than District COMMCENs (e.g. 55 percent originated and 85 percent terminated, provide a busy day total of 186 originated, 672 terminated, and 274 other). Since no clear pattern of in-station traffic flow (i.e. originated to AUTODIN, TWPL, and other circuits; TWPL to other circuits, etc.) has emerged during this study, Table 6-4 was developed by applying the

TABLE 6-4. COMMEN WORKLOAD REDUCTION ESTIMATES (MINUTES/DAY)

COMMEN	OPTION 1	OPTION 2 ¹	OPTION 3	OPTION 4					
				4A	4B ²	4C	4D	4E	TOTAL 4
HQ	None	2389	2389	2005	14	672	806	94	3591
1ST DISTRICT	None	389	766	1933	16	216	247	84	2496
2ND DISTRICT	None	177	285	667	5	40	112	26	850
3RD DISTRICT	None	625	1553	3990	34	467	485	176	5152
5TH DISTRICT	None	225	490	1285	11	166	142	58	1662
7TH DISTRICT	None	410	812	2058	18	232	260	90	2658
8TH DISTRICT	None	567	567	1454	12	178	173	65	1882
9TH DISTRICT	None	191	425	1121	10	150	121	51	1453
11TH DISTRICT	None	164	346	904	8	112	104	40	1168
12TH DISTRICT	None	253	528	1370	12	168	160	61	1771
13TH DISTRICT	None	439	439	1112	9	120	143	48	1432
14TH DISTRICT	None	596	596	1576	14	212	169	72	2043
17TH DISTRICT	None	287	518	1280	11	117	182	54	1644

Notes: 1. Includes RIXT at HQ, Eight, Thirteenth, and Fourteenth Districts with OCR/MHG at others
 2. Assumes 10% of "OTHER" traffic involves non-Coast Guard circuits

estimated reductions for AUTODIN ORIGINATED (Table 6-2) to all originated messages; the estimated reduction for INCOMING AUTODIN TERMINATED to all terminated messages; and estimated reductions for INCOMING AUTODIN RELAY to all other messages. The total estimated reductions for originated messages may, therefore, be slightly optimistic and, for terminated and other messages, conservative. Since the total number of terminated and other messages is considerably higher than the originated total, actual workload reductions in excess of those computed may be achievable.

Table 6-4 indicates (when total reductions are divided by 1440, one man-day) that the options would provide manpower compensation as follows:

- Option 2 - one man per watch, HQ COMMCEN (total four billets)
- Option 3 - one man per watch, HQ and Third District COMMCENS. (total eight billets)
- Option 4A - two men per watch, Third District COMMCEN; one man per watch, HQ, First, Seventh, Eighth, Twelfth, and Fourteenth District COMMCENS (total 32 billets)
- Option 4 (with all suboptions) - three men per watch, Third District COMMCEN; two men per watch, HQ COMMCEN; and one man per watch, First, Fifth, Seventh, Eighth, Twelfth, Fourteenth, and Seventeenth District COMMCENS (total 48 billets).

Table 6-5 summarizes the potential workload reductions which might be realized by implementing options 4A, 4B, 4E, and 4F at RADSTAs and COMMSTAs. Options 2, 3, 4C, and 4D are not addressed since none offer operational advantages. Table 6-5 was developed by applying the potential reduction identified in Table 6-3 to the COMMSTA Portsmouth relay/distribution pattern illustrated in Table C-9. Since Table C-9 represents 22 percent of busy day volume, the computed reductions are multiplied by 4.5 to derive total anticipated reductions for a busy day. Predicted reductions for other COMMSTAs and RADSTAs are based on

TABLE 6-5. RADSTA/COMMSTA WORKLOAD REDUCTION ESTIMATES (MINUTES/DAY)

FACILITY	ACTIVITY	4A	4B	4E	4F	SUBTOTAL	TOTAL	MAN/DAYS
PORTSMOUTH	AUTODIN TO:							
	SHIP-SHORE	109	88	6	-	203	914	
	BCST	19	-	1	20	40	180	
	TWPL	148	-	4	-	152	684	
	SHIP-SHORE TO:							
	AUTODIN	224	47	2	-	273	1228	
	TWPL	167	54	2	-	223	1004	
	AMVER/WX	-	44	2	-	46	207	
	CW/VOICE TO:							
	AMVER/WX	-	69	8	21	98	441	
						<u>4658</u>	<u>3.2</u>	
						<u>TOTAL</u>		
ADAK	37601/291518 = .13					606	0.4	
BOSTON	210181/291518 = .72					3354	2.3	
HONOLULU	190909/291518 = .65					3028	2.1	
KODIAK	223753/291518 = .77					3586	2.5	
MIAMI	254116/291518 = .87					4052	2.8	
NEW ORLEANS	66471/291518 = .23					1071	0.7	
SAN FRANCISCO	189890/291518 = .65					3028	2.1	
SAN JUAN	132277/291518 = .45					2096	1.4	

total traffic handled ratios (i. e. , RADSTA "A" total send and receive versus COMMSTA Portsmouth total send and receive). The total workload reductions are converted to man-days for convenience. These manpower savings are not considered potential compensation for automation costs but additional resources which can be utilized to improve the operational effectiveness of the respective stations.

6.7 RELIABILITY AND MAINTAINABILITY

The reliability and maintainability aspects of options 1, 2 and 3 are essentially identical. With these options, the message center operation consists of independent machines and manual integration of those machines into a system. The independence of the equipment protects against total failure of the center (except in the case of power outage). Reliability factors are therefore expressed in terms of the independent reliabilities of the equipment and the overall reliability of human procedure. Similarly, maintainability encompasses the individual maintenance of independent machines. Thus, in the first three options, recovery consists of repairing or substituting equipment.

Option 4 provides for processor integration of many of the circuit handling and procedural functions of the message center. In so doing, the reliability of overall message center operations tends to be centralized at the processor and its peripheral equipment. The state-of-the-art in small computer technology is such that processor mean-time-between-failure (MTBF) can be expected to be in the order of 1000 hrs (=42 days). As with any system of hardware components, the incidence of failure can be minimized by establishing preventive maintenance procedures for all operational equipment. Deleterious effects of system failure can be minimized by establishing suitable backup procedures consisting of software, hardware, and manual substitutions to permit graceful degradation of system operation.

The maintainability of a processor automated system is facilitated by the modular construction of currently available processor equipment and the availability of effective diagnostic software. If the automated center maintains a stock of substitute modules for critical components the mean-time-to-repair (MTTR) can be expected to be of the order of 10-15 minutes for the processor. Critical peripherals such as the line printer and disk system may require longer repair periods. The effects of a failure to these components could be minimized by the implementation of alternate procedures or equipment redundancy.

6.8 INTERFACES

In message center automation, interfaces can be addressed in two general categories - physical and procedural. Physical interfaces encompass adapting automation equipment to the communication systems currently available at the message centers. This resolves to a design problem at the communications interface of the processor system of option 4 and is a minor concern in options 2 and 3 since they involve equipment additions or substitutions which are compatible. The design must accommodate, for example, both 5-level Baudot and 8-level ASCII and part-time as well as 24-hour per day distant terminal operations. From a procedural point of view, human interfaces to an automated message center are least impacted by option 2 and most by option 4. All options involve the handling of messages in hard copy form at input and output and options 2, 3, and 4 are characterized by decreasing hard copy and tape handling and increasing activity at KVDT equipment. The net effect in option 4 is to focus operator activity at specific stations in the center.

6.9 FACILITY IMPACT

Comparisons with option 1 indicate that options 2 and 3 will result in a slightly higher demand on facility space and power and no particular impact on operating supplies and supporting equipment. Option 4 may involve a major

modification to existing centers. Most operational TTY equipment will be removed. The volume of supporting equipment and supplies will be substantially reduced. Additionally, processor automation would produce a marked reduction in personnel movement in the facility indicating a need for layout changes beyond equipment installation.

6.10 IMPLEMENTATION IMPLICATIONS

6.10.1 Problems

Retention of present operations (option 1) or continuation of currently planned improvement actions (option 2) pose no implementation problems. The feasibility of implementing option 3 appears extremely problematical since it is dependent upon the availability of Navy resources.

Option 4 will require the most detailed planning to ensure continuity of operations during substantial facility alterations and modifications to in-station procedures. The implementation plan must also identify the need and provision for a limited backup capability.

6.10.2 Operational

In order to achieve the maximum benefits offered by automation of outgoing message processing (options 2, 3, or 4), adoption of a standard message form for mandatory use by message drafters and strict adherence to prescribed drafting procedures will be essential. Automated in-routing will require effective use of a standardized subject code.

6.10.3 Training

The current training requirements include preparatory training in radioman school to supply a basic understanding of communications systems and procedure followed by OJT at the message center to provide familiarization in specific operations at the message center. Additionally, operators are rotated through the various positions at the center to maintain that training.

Automation option 2 would not require a significant alteration in training requirements. The operation of new equipment and its integration with existing procedures can be handled by additional OJT. Option 3 will impact training requirements to only a small degree. In this case training will require instruction in center operation as is currently provided plus instruction in the concepts and operation of the RIXT, OCR, and MHG equipment. These requirements could be handled by means of self study and OJT at levels comparable to current training. Option 4 can be expected to have a moderate impact on training requirements. With this option, training requirements at the message centers must include current requirements plus additional training in system operation and equipment familiarization. As this option is developed totally within the Coast Guard and requires significant changes in equipment and procedure, the training requirements can be expected to be fairly extensive during the implementation phase with a reduction to near current levels as the system matures. Current background training supplemented with self study, class instruction for supervisory personnel, and OJT will be required. Specific coverage would include processor concepts and operation, human interface, diagnostics and maintenance, and peripheral operation. Additionally, higher level training should be provided at some development center (which may be an operational message center) to provide for in-house Coast Guard development support for system modification and improvement. This training would require additional instruction in processor operation and software concepts.

6.11 SUMMARY EVALUATION

Table 6-6 provides a summary evaluation and relative order of desirability of options 1 through 4. The evaluation of option 4 is applicable regardless of the suboption configuration selected.

Section 8 will address the recommended ultimate configuration for each candidate facility and provide a recommended implementation schedule.

Option	1	2	3	4
OPTION 1
OPTION 2
OPTION 3
OPTION 4
OPTION 5
OPTION 6
OPTION 7
OPTION 8
OPTION 9
OPTION 10
OPTION 11
OPTION 12
OPTION 13
OPTION 14
OPTION 15
OPTION 16
OPTION 17
OPTION 18
OPTION 19
OPTION 20
OPTION 21
OPTION 22
OPTION 23
OPTION 24
OPTION 25
OPTION 26
OPTION 27
OPTION 28
OPTION 29
OPTION 30
OPTION 31
OPTION 32
OPTION 33
OPTION 34
OPTION 35
OPTION 36
OPTION 37
OPTION 38
OPTION 39
OPTION 40
OPTION 41
OPTION 42
OPTION 43
OPTION 44
OPTION 45
OPTION 46
OPTION 47
OPTION 48
OPTION 49
OPTION 50

TABLE 6-6. AUTOMATION OPTIONS - SUMMARY EVALUATION

PARAMETER	OPTION 1	OPTION 2	OPTION 3	OPTION 4
GROWTH CAPABILITY	None	Limited	Limited	Excellent
RESPONSIVENESS TO AUTOMATION REQUIREMENTS	None	Limited	Limited	Excellent
MEET SPEED OF SERVICE CRITERIA	No	No	Partial	Yes
RELIABILITY	Good	Good	Good	Good
MAINTAINABILITY	Good	Good	Good	Good
INTERFACE REQUIREMENTS	Simple	Simple	Simple	Sophisticated
FACILITY IMPACT	None	Limited	Limited	Extensive (reconfiguration)
IMPLEMENTATION PROBLEMS	N/A	Minor	Complicated	Requires detailed engineering and cutover planning
OPERATIONAL IMPACTS	None	On Drafter (new message form/OCR font)	Same as 2 plus need for SSIC	Same as 3 plus possible need for network protocol changes
TRAINING REQUIREMENTS	Simple	Increased OJT	Increased OJT	Significant
WORKLOAD REDUCTIONS	None	Minor	Moderate	Substantial
MANPOWER REDUCTIONS	None	Minor (maximum of 4 billets)	Minor (maximum 5 billets)	Substantial (up to 48 billets depending on suboptions)
RELATIVE RANKING	4	3	2	1

SECTION 7 - COSTS VERSUS BENEFITS

7.1 INTRODUCTION

This section examines the cost implications, including potential cost benefits, of each candidate design option. Also addressed are the comparative benefits of the leased versus purchase option.

All costs and cost savings identified in this section are stated in constant dollars.

7.2 METHODOLOGY

The analyses presented herein are limited somewhat by the lack of detailed cost data regarding current operations. For example, it is virtually impossible to identify total costs, in dollars or manpower, allocated to the maintenance of teletypewriter equipment. Typically, the costs for leased landline services include equipment rental and maintenance. In implementing an automated system, most teletypewriter equipment will be removed offering some, perhaps minor, cost savings (i. e. equipment rental charges or resale if government owned). These savings, however, may be offset, when circuits are terminated on a processor, by termination penalties, retermination charges, or miscellaneous costs such as those associated with the rental of line modems, if required. These potential savings or costs are, therefore, not considered in subsequent cost analyses.

Table 3-7 summarizes the costs for teletypewriter consumables as documented during on-site surveys. Although this summary indicates an average cost of \$3.38 per 100 messages, approximately 25 percent of that total represents costs for expendable supplies other than teletyperwriter paper, tape, and ribbons. In developing potential consumable cost savings in this section, a more conservative cost factor of \$2.50 per 100 messages is used. Note that this figure does not include the cost of copier supplies.

In computing military pay cost off-sets, the average E-5 man/year cost (Standard Personnel Cost as identified in Commandant Notice 7100) of \$10,800, multiplied by a factor of 2.0 as discussed in paragraph 3.6.7, is utilized.

7.3 COST ANALYSIS OF OPTIONS

7.3.1 Option 1

Option 1 is the baseline against which all other options are compared.

7.3.2 Option 2

Assuming implementation in 1979, option 2 would involve an investment cost, for 12 OCR/MHG installations, of \$609,600 (based on the cost of the HQ installation). Mode I AUTODIN and Remote Information Exchange Terminals would be provided by the Navy at no cost to the Coast Guard. This option will have no appreciable impact on consumables but will offer limited manpower compensation (one man per watch Headquarters COMMCEN, total four billets). Over a nine-year period, total military pay reductions (\$777,600) will offset the 1979 expenditure for OCR/MHG equipment.

7.3.3 Option 3

Option 3 assumes that Remote Information Exchange Terminals can be provided by the Navy, for all candidate facilities, at no cost to the Coast Guard. As in option 2, this option will exert negligible influence on operating and maintenance costs. It will, however, offer more substantial manpower reductions in the order of eight billets, translating to annual military pay savings of \$172,800. If implemented in 1979, this option will, in the nine-year period 1979 through 1987, reduce manpower costs by a total of \$1,555,200.

7.3.4 Option 4

Option 4 analyses are based on the purchase of equipment at single quantity prices (Table 5-1) in accordance with the implementation schedule proposed in Section 8.

Estimated automation costs, by facility are presented in Table 7-1. The initial entry (i. e., 106, 81, or 61) was developed as follows:

- High Volume Center:

Acquisition Cost -	\$85,140
Site Preparation (10%) -	8,514
Installation -	2,668
Maintenance (Annual) -	7,836
Consumables -	<u>1,755</u>
Total -	\$105,913

- Medium Volume Center:

Acquisition Cost -	\$64,340
Site Preparation (10%) -	6,434
Installation -	2,044
Maintenance (Annual) -	6,516
Consumables -	<u>1,548</u>
Total -	\$80,882

- Low Volume Center:

Acquisition Cost -	\$48,330
Site Preparation (10%) -	4,833
Installation -	2,044
Maintenance (Annual) -	5,016
Consumables -	<u>750</u>
Total -	\$60,973

Subsequent entries represent annual recurring costs for maintenance and consumable supplies. Again it should be noted that consumables do not include costs associated with reproduction and internal distribution. Consumable costs include, however, periodic (i. e. quarterly) replacement of magnetic tapes at high and medium volume centers.

TABLE 7-1. ESTIMATED AUTOMATION COSTS (\$K PER YEAR)

FACILITY	1977	1978	1979	1980	1981	1982	1983	1984	1985	1986	1987
HQ	-	-	106	10	10	10	10	10	10	10	10
1ST DISTRICT	-	-	-	81	8	8	8	8	8	8	8
2ND DISTRICT	-	-	-	-	-	-	-	-	-	-	61
3RD DISTRICT	-	-	106	10	10	10	10	10	10	10	10
5TH DISTRICT	-	-	-	-	-	81	8	8	8	8	8
7TH DISTRICT	-	-	-	106	10	10	10	10	10	10	10
8TH DISTRICT	-	-	-	-	81	8	8	8	8	8	8
9TH DISTRICT	-	-	-	-	81	8	8	8	8	8	8
11TH DISTRICT	-	-	-	-	-	-	-	-	81	8	8
12TH DISTRICT	-	-	-	81	8	8	8	8	8	8	8
13TH DISTRICT	-	-	-	-	-	-	-	81	8	8	8
14TH DISTRICT	-	-	-	81	8	8	8	8	8	8	8
17TH DISTRICT	-	-	-	-	-	81	8	8	8	8	8
ADAK	-	-	-	-	-	-	-	-	-	-	81
BOSTON	-	-	-	-	81	8	8	8	8	8	8
HONOLULU	-	-	-	81	8	8	8	8	8	8	8
KODIAK	-	-	-	-	-	81	8	8	8	8	8
MIAMI	-	-	-	81	8	8	8	8	8	8	8
NEW ORLEANS	-	-	-	-	-	-	-	-	-	81	8
PORTSMOUTH	-	-	81	8	8	8	8	8	8	8	8
SAN FRANCISCO	-	-	-	-	81	8	8	8	8	8	8
SAN JUAN	-	-	-	-	-	81	8	8	8	8	8
SOFTWARE	-	-	251	-	-	-	-	-	-	-	-
TOTAL	-	-	544	539	402	434	142	223	231	239	308

Table 7-2 projects, for each facility, the estimated costs for consumable supplies by year. These estimates are based on anticipated traffic totals (Table 4-2) multiplied by the cost factor of 2.5 cents per message. Entries within the shaded area are identifiable cost savings.

Table 7-3 summarizes anticipated military pay savings. These are based on the potential billet reductions identified in paragraph 6.6.10. The potential workload reductions achievable at RADSTAs and COMMSTAs are not reflected for reasons stated in paragraph 6.6.10.

Table 7-4 provides an overall summary of the systemwide cost implications of option 4. Noting that the figures presented include procurement, operations and maintenance, and military pay dollars, the net affect of option 4 is a nine-year savings of \$5,806,000.

TABLE 7-4. SYSTEMWIDE COST IMPLICATIONS - OPTION 4 (\$K/YEAR)

ITEM	1979	1980	1981	1982	1983	1984	1985	1986	1987	TOTAL
AUTOMATION COSTS	544	539	402	434	142	223	231	239	308	3062
SAVINGS-CONSUMABLES	21	43	56	68	70	74	77	80	83	572
SAVINGS-MANPOWER	432	778	864	1037	1037	1037	1037	1037	1037	8296
NET INCREASE(+)/ DECREASE (-)	+91	-282	-518	-671	-965	-888	-883	-878	-812	-5806

Table 7-5 is a summary, by facility, of the long range cost implications of option 4. Due to rounding off and exclusion of software development costs, totals will not agree precisely with earlier tables. Included as a non-add item is the military pay value of RADSTA/COMMSTA billets which may be diverted to more essential functions. This table indicates that automation, as proposed by option 4, represents a cost effective approach toward improving message handling operations at most candidate Coast Guard facilities. On cost considerations alone, automation of the Second, Ninth, Eleventh, and Thirteenth District COMMCENs and the Adak and New Orleans radio operating facilities does not appear cost effective.

TABLE 7-2. ESTIMATED CONSUMABLE COSTS (\$/YEAR)

FACILITY	1977	1978	1979	1980	1981	1982	1983	1984	1985	1986	1987
HQ	7210	7354	7501	7651	7804	7960	8119	8280	8445	8617	8793
1ST DISTRICT	3502	3572	3643	3716	3792	3868	3944	4023	4104	4188	4274
2ND DISTRICT	775	790	806	822	839	856	873	890	908	926	945
3RD DISTRICT	8355	8522	8692	8866	9044	9224	9407	9592	9779	9968	10159
5TH DISTRICT	2702	2756	2811	2867	2925	2983	3043	3104	3166	3229	3293
7TH DISTRICT	4088	4170	4253	4338	4425	4513	4604	4696	4789	4883	4978
8TH DISTRICT	3074	3140	3202	3266	3332	3398	3467	3536	3606	3677	3749
9TH DISTRICT	2493	2531	2571	2610	2651	2694	2738	2783	2829	2877	2926
11TH DISTRICT	2633	2674	2715	2757	2801	2845	2890	2935	2981	3027	3074
12TH DISTRICT	2947	3047	3104	3179	3253	3328	3404	3481	3559	3637	3716
13TH DISTRICT	2141	2225	2269	2314	2361	2408	2456	2504	2552	2600	2649
14TH DISTRICT	2470	2527	2596	2666	2735	2806	2878	2951	3024	3097	3171
17TH DISTRICT	2577	2624	2681	2735	2789	2845	2902	2959	3017	3075	3133
ADAK	624	647	660	673	686	700	714	728	743	758	773
BOSTON	2412	2404	2320	2344	2368	2392	2417	2441	2465	2489	2513
HONOLULU	2416	2472	2500	2508	2515	2522	2529	2535	2541	2547	2553
KODIAK	2372	2419	2464	2517	2568	2619	2671	2722	2773	2824	2875
MIAMI	3704	3742	3754	3765	3775	3784	3793	3802	3811	3820	3829
NEW ORLEANS	737	732	727	722	718	714	710	706	702	698	694
PORTSMOUTH	4603	4635	4729	4805	4882	4962	5044	5127	5211	5295	5381
SAN FRANCISCO	2679	2733	2747	2843	2899	2958	3017	3077	3137	3197	3258
SAN JUAN	2574	2625	2678	2732	2786	2842	2898	2954	3011	3068	3125
POTENTIAL SAVINGS	-	-	20992	42646	55955	69239	82525	95815	109111	122413	135722

TABLE 7-3. ESTIMATED MILITARY PAY SAVINGS (\$K/YEAR)

FACILITY	1977	1978	1979	1980	1981	1982	1983	1984	1985	1986	1987
HQ	-	-	172.8	172.8	172.8	172.8	172.8	172.8	172.8	172.8	172.8
1ST DISTRICT	-	-	-	86.4	86.4	86.4	86.4	86.4	86.4	86.4	86.4
2ND DISTRICT	-	-	-	-	-	-	-	-	-	-	-
3RD DISTRICT	-	-	259.2	259.2	259.2	259.2	259.2	259.2	259.2	259.2	259.2
5TH DISTRICT	-	-	-	-	-	86.4	86.4	86.4	86.4	86.4	86.4
7TH DISTRICT	-	-	-	86.4	86.4	86.4	86.4	86.4	86.4	86.4	86.4
8TH DISTRICT	-	-	-	-	86.4	86.4	86.4	86.4	86.4	86.4	86.4
9TH DISTRICT	-	-	-	-	-	-	-	-	-	-	-
11TH DISTRICT	-	-	-	-	-	-	-	-	-	-	-
12TH DISTRICT	-	-	-	86.4	86.4	86.4	86.4	86.4	86.4	86.4	86.4
13TH DISTRICT	-	-	-	-	-	-	-	-	-	-	-
14TH DISTRICT	-	-	-	86.4	86.4	86.4	86.4	86.4	86.4	86.4	86.4
17TH DISTRICT	-	-	-	-	-	86.4	86.4	86.4	86.4	86.4	86.4
TOTAL	-	-	432.0	777.6	864.0	1036.8	1036.8	1036.8	1036.8	1036.8	1036.8

TABLE 7-5. COST IMPLICATIONS BY FACILITY (1979-1987) (\$K)

FACILITY	AUTOMATION COST	SAVINGS		NET SAVINGS (-) OR COST (+)
		CONSUMABLES	MILPAY	
HQ	186	73	1555	-1442
1ST DISTRICT	137	28	691	- 582
2ND DISTRICT	61	1	-	+ 60
3RD DISTRICT	186	85	2333	-2232
5TH DISTRICT	121	19	518	- 416
7TH DISTRICT	176	37	691	- 552
8TH DISTRICT	129	25	604	- 500
9TH DISTRICT	129	23	-	+ 106
11TH DISTRICT	97	7	-	+ 90
12TH DISTRICT	137	27	691	- 581
13TH DISTRICT	105	10	-	+ 95
14TH DISTRICT	137	26	691	- 580
17TH DISTRICT	121	18	518	- 415
ADAK	81	1	-	+ 80
BOSTON	129	23	1210*	+ 106
HONOLULU	137	26	1382*	+ 111
KODIAK	121	17	1037*	+ 104
MIAMI	137	34	1382*	+ 103
NEW ORLEANS	89	2	-	+ 87
PORTSMOUTH	145	47	2333*	+ 98
SAN FRANCISCO	129	22	1210*	+ 106
SAN JUAN	121	18	518*	+ 103

*Non-add. Divert to more essential duties.

7.4 MAINTENANCE ARRANGEMENTS

Based on data collected during the conduct of this study, COMMCENs possess no in-house maintenance capabilities. Maintenance of teletypewriter equipment is obtained by leasing arrangements or through reimbursable intra- or inter-service support agreements. At COMMSTAs and RADSTAs, such maintenance is performed by station forces, supported by ready stores of repair parts.

Maintenance of an automated system will require trained personnel; a ready supply of spare modules, circuit boards, and other repair parts; specialized test equipment; and a limited repair facility (workshop). At the Headquarters and District COMMCENs, the cost of one technician (\$21,600 per year) and other items required to maintain a government owned system would far exceed the estimated cost (Table 5-1) for contract maintenance. It is considered unlikely that a one-man in-house repair force could provide the same degree of responsive, reliable service which might be expected from contract arrangements. For these reasons, the automation costs developed earlier include the cost of leased maintenance.

At RADSTAs and COMMSTAs, the in-house versus leased maintenance decision should be made on a case-by-case basis. For example, at COMMSTA Portsmouth, where a processor based automated control system is in operation, the required maintenance skills are now available. In this case, in-house maintenance of an automated communications subsystem may prove more cost effective and, possibly, more responsive. At facilities where no other automated system exists, leased maintenance of the automated communications system appears more desirable.

7.5 LEASE VERSUS PURCHASE

Discussion with vendors of systems such as those represented in Table 5-1 and limited literature search indicate three primary acquisition strategies:

- Purchase
- Lease

- Term Lease/Purchase

From the cost aspect, the purchase approach is the least expensive. The representative system illustrated for the high volume center would require an initial, one-time investment of \$85,140. A typical 36-month leasing arrangement will involve a monthly lease charge equating to 2.33 percent of the purchase price, or for the high volume center a monthly cost of \$1984 (not including maintenance service in either case). Under such a leasing arrangement, monthly charges would approach the purchase cost in about 43 months.

The term lease/purchase option, again assuming a three year plan, would involve monthly charges of 3.42 percent of the purchase price, or \$2912. At the end of the three year period, the lessee acquires title to the system. The total cost, in this case, approaches \$105,000, or over 120 percent of the basic purchase price.

Minicomputer technology has advanced rapidly in recent years. Continued advancements can be expected in the future. Thus, there is some risk that a system purchased today may approach obsolescence in the near future, or where enhancements can be provided, involve additional investment costs. This risk can be reduced substantially if system acquisition has been accomplished through short term leases.

The proposed Coast Guard automation program is, when compared to programs being pursued by other Military Services, relatively modest. If systemwide implementation in the immediate future were being considered, acquisition by purchase would appear desirable. In considering implementation over a 9-10 year period, leasing appears somewhat attractive, since by avoiding periodic peak funding surges, the program would be implemented by essentially constant funding levels.

It would appear appropriate, as this program develops, to solicit from prospective vendors cost data on all acquisition options.

SECTION 8 - RECOMMENDED SOLUTIONS

8.1 INTRODUCTION

Initially, this section presents a recommended order of priority for the application of communications automation techniques to the message handling functions now being performed by candidate Communication Centers, Communication Stations, and Radio Stations. The recommended order of priority is based upon current and anticipated traffic volumes, the operational mission of the parent command/commands supported, and potential benefits (including manpower savings) to be realized. Following this priority listing is a description of the recommended configuration, from option 4, considered appropriate for each facility. The time phasing proposed for implementation is summarized in tabular form,

8.2 RECOMMENDED PRIORITY ORDER

Priority I includes only those facilities where immediate improvements appear essential. It is reasonably certain that neither of the two COMMCENs which fall into this category could accommodate future traffic increases without some degradation in the quality of service to its users. One COMMSTA is also considered a primary candidate for automation. The facilities toward which automation efforts should be directed initially, as a matter of operational urgency are, in order:

Third District COMMCEN

Headquarters COMMCEN

COMMSTA Portsmouth

Priority II includes those District COMMCENs where automation in the mid-term will provide substantial benefits; all Communication Stations; and major Radio Stations. These facilities, in relative order of urgency, are:

COMMCENS

COMMSTA/RADSTAS

Seventh District

Miami

First District

Honolulu

Twelfth District

Boston

Fourteenth District

San Francisco

Eighth District

San Juan

Ninth District

Kodiak

Fifth District

Seventeenth District

Priority III includes all remaining District COMMCENS and RADSTAs. Within this category are two District COMMCENS (Thirteenth and Eleventh) where traffic handlings, based on anticipated growth, will justify automation in the long term. Except in the interest of standardization, automation of the Second District COMMCEN should not be considered. Similarly, automation of RADSTAs Adak and New Orleans does not appear warranted.

8.3 RECOMMENDED CONFIGURATIONS

The configuration recommended herein constitute an approach to automation which surplants and, thus, obviates the need to pursue existing programs (e.g. Mode I AUTODIN, RIXT, and OCR/MHG).

8.3.1 Large Volume COMMCENS

This category includes the Third District COMMCEN and the HQ COMMCEN, both of which now handle more than 200,000 messages per year; and the Seventh District COMMCEN where annual handlings will approach 200,000 about 1987. For maximum benefits, these COMMCENS should be provided the complete option 4 configuration (i. e. with all suboptions).

8.3.2 Medium Volume COMMCENs

All District COMMCENs except Third, Seventh, and Second fall into the 50,000 to 200,000 messages per year category. The recommended configuration for these facilities is the complete option 4 configuration less suboption 4D (OCR). Message entry via a KVDT position is recommended in order to eliminate the need for tape preparation and handling. Inclusion of option 4E is considered desirable for enhancement of the data management/statistics capability.

8.3.3 Small Volume COMMCEN

Automation of the Second District COMMCEN should be oriented toward eliminating tape relay operations. This can be accomplished by providing suboptions 4A and 4B.

8.3.4 COMMSTA/RADSTAs

The recommended configuration for Communication and Radio Stations includes suboptions 4A, 4B, 4E, and 4F. Options 4C (in-routing) and 4D (OCR) are not required in view of the negligible originated, terminated message loading. Initially, use of existing Model 37 teletypewriter equipment is considered sufficient to support delivery of messages to and remote entry of messages from radio operating positions.

8.4 IMPLEMENTATION SCHEDULE

Figure 8-1 provides a proposed, ten-year implementation schedule, based on the priority order developed in paragraph 8.2.

8.5 ALTERNATIVE APPROACH

Paragraph 5.4 discussed the desirability of an in-depth analysis of all Coast Guard communications operations as a basis for possible system redesign, including realignment and consolidation of relay and commercial refile activity.

While the limited scope of this study precluded investigation into the "alternative approach", certain of the data developed, in Section 6, while examining the operational benefits of the various options, further illustrate the need for a system approach

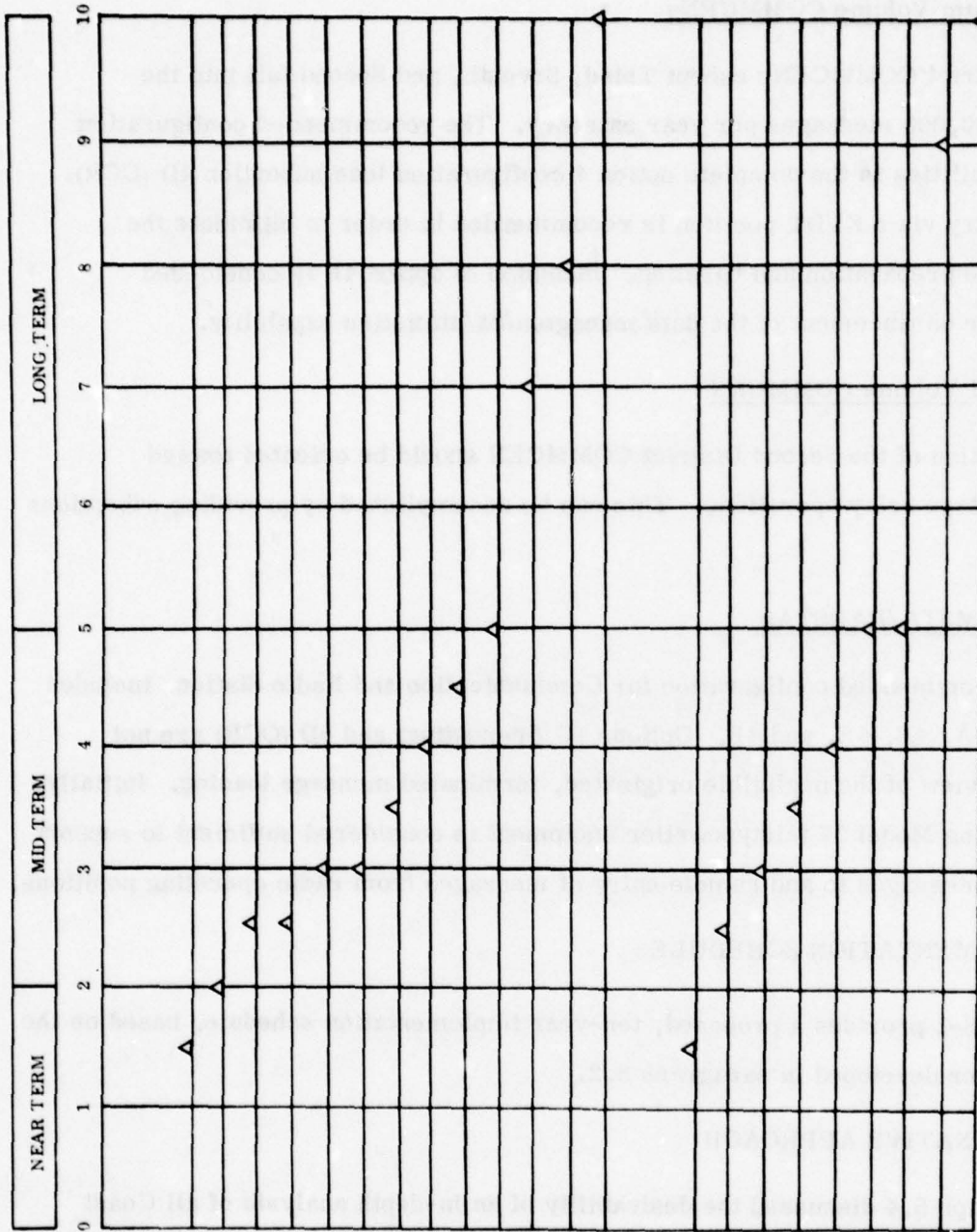

YEARS

Figure 8-1. Recommended Implementation Schedule

to automation. Specifically, along the East and Gulf Coasts, there are five District COMMCENs and four COMMSTA/RADSTAs which are considered candidates for communications automation. By far, the greatest need for automation exists in the Third District COMMCEN where handlings total 2120 messages on a busy day. Table 8-1 illustrates that composite totals (i. e., District COMMCEN and adjacent COMMSTA/RADSTA) in the First, Fifth, Seventh, and Eighth Districts are less than the Third District COMMCEN total. The volume of originated and terminated traffic at the four District COMMCENs is relatively low, reflecting a workload well within the capabilities of a one- to two-man watch section. Although other factors should be examined before reaching any firm conclusions, the possibility exists that circuits terminated in these COMMCENs could be reterminated in the adjacent COMMSTA or RADSTA who would then be automated, providing service (including in-and out-routing) to the District COMMCEN by a suitably designed remote terminal.

TABLE 8-1. BUSY DAY HANDLINGS - SELECTED FACILITIES

FACILITY	BUSY DAY TOTALS	AREA TOTAL	COMMCEN	
			ORIG	TERM
1ST DISTRICT	1016		57	240
COMMSTA BOSTON	840	1856		
5TH DISTRICT	686		33	185
COMMSTA PORTSMOUTH	1166	1852		
7TH DISTRICT	1085		60	258
RADSTA MIAMI	1016	2101		
8TH DISTRICT	778		40	198
COMMSTA NEW ORLEANS	265	1043		

APPENDIX A

COMMUNICATIONS CENTER, GOVERNORS ISLAND, N. Y.

A.1 INTRODUCTION

This appendix provides descriptive data on the Third Coast Guard District Communications Center, Governors Island, N. Y. and an analysis of Message Processing and Distribution System (MPDS) operations as currently conducted. Information presented is based upon a comprehensive on-site survey, conducted during the period 6-9 September 1977, supplemented by a review of statistical data and related files maintained by the Commandant, U.S. Coast Guard (G-OTM).

A.2 GENERAL DESCRIPTION

The Third Coast Guard District Communications Center (COMMCEN) is physically located in the basement of Building 125, Governors Island. In accordance with the normal District organizational structure, and as illustrated in Figure A-1, the COMMCEN is an element of the Communications Branch of the Operations Division. The Communications Center provides message services to the Third Coast Guard District Headquarters, Atlantic Area Headquarters, and other on-island activities. Major users, located in Buildings 52, 105, 107, 108, and 135, provide messengers for pickup and delivery of messages. One multi-point, electronic courier circuit (i. e., pony loop) serves Coast Guard Cutters berthed at Yankee Pier, the Training Center in Building 400D, the Support Center in Building 130, and one off-island activity.

A total of 13 75-baud record traffic circuits are terminated in the Communications Center. These include the on-island loop, a Mode V AUTODIN Terminal, the District Group Loop, and the SARLANT network. A block diagram of terminated circuits is presented in Figure A-2. Composition of the SARLANT leased 83B3 teletype system, which operates under the control of Commander, Atlantic Area, is illustrated in Figure A-3.

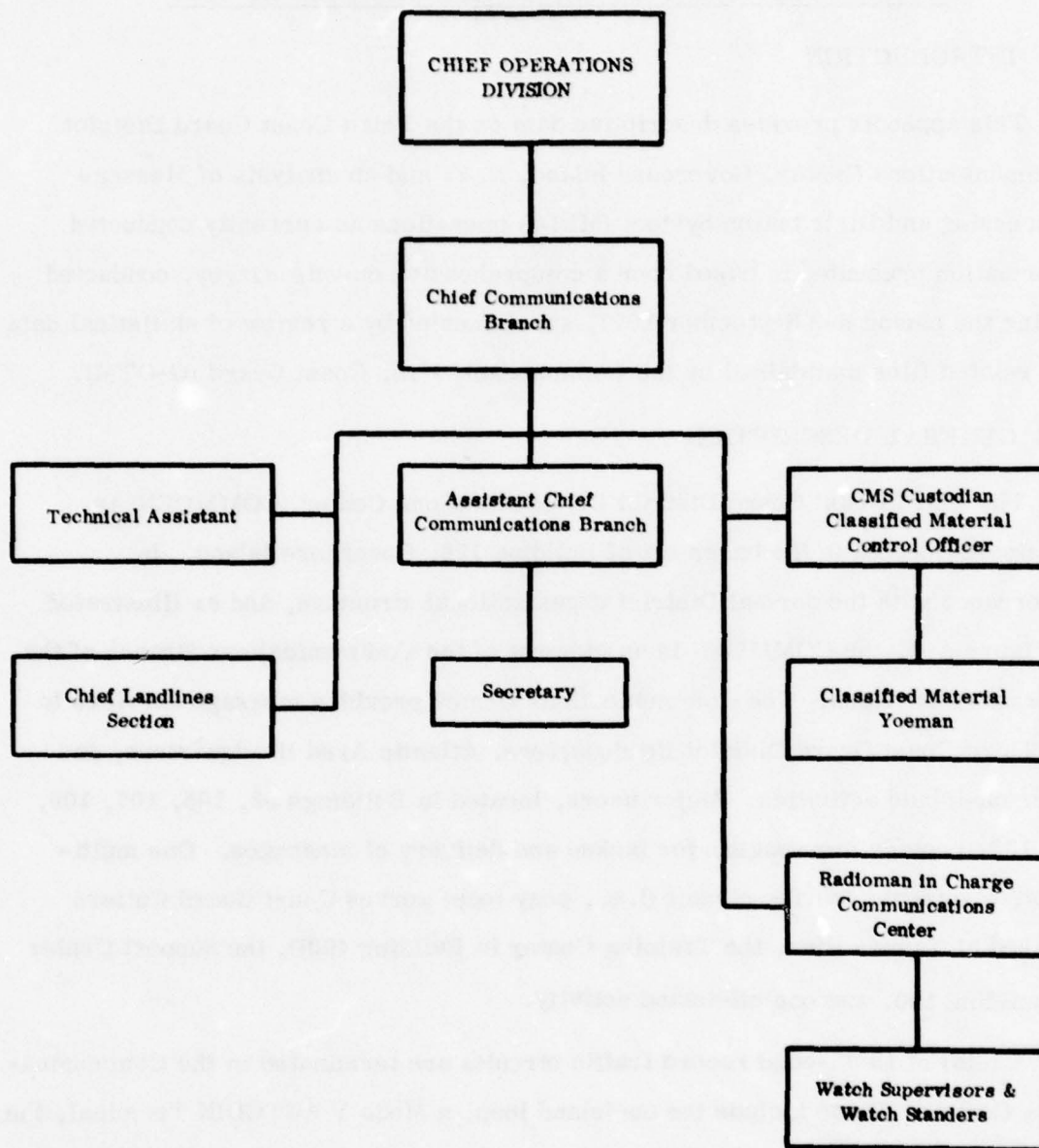

Figure A-1. Third CG District Communications Organization

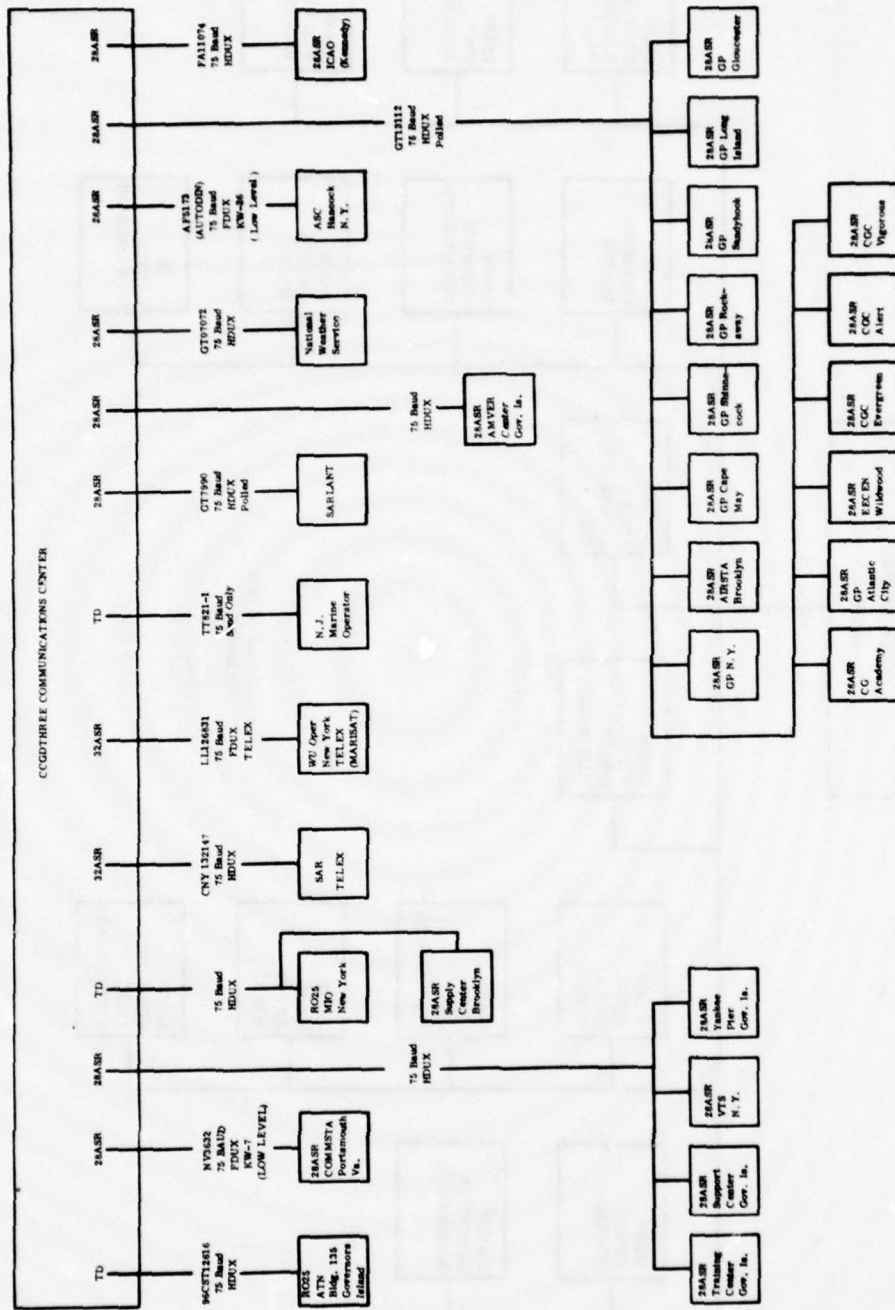

Figure A-2. Third CG District Teletypewriter Circuit Diagram

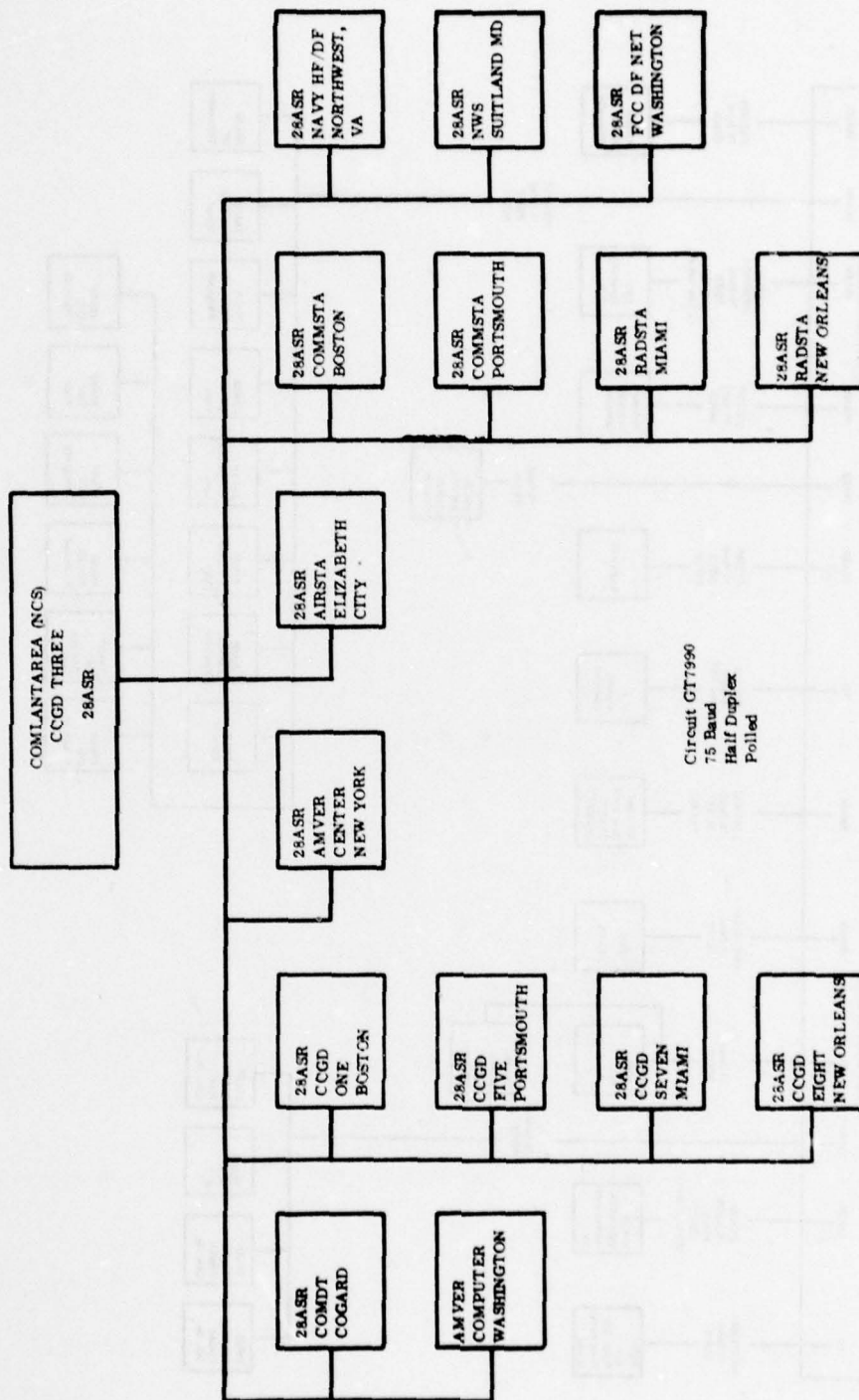

Figure A-3. SARLANT Network Diagram

Message traffic is prepared and handled in accordance with procedures set forth in the U. S. Coast Guard Telecommunications Manual (CG-233) and a local Headquarters Staff Instruction. COMMCEN Standing Operating Procedures (SOPs) provide detailed guidance and instructions for operating personnel relative to the inviolability of message traffic and the handling of classified and For Official Use Only (FOUO) matter. There are no existing requirements for affording "special privacy" protection for unclassified messages.

A.3 GROWTH AND FUTURE REQUIREMENTS

A plan to relocate the COMMCEN function from the basement to the first floor of Building 125 has been approved and funded. The plan is now in early stages of implementation with completion scheduled in June 1978. Except for the addition of an Optical Character Reader (OCR) and, in late 1978 or early 1979, the replacement of the Mode V AUTODIN terminal with a Mode I, existing equipment will be utilized. Figure A-4 is the floor plan for the new Communications Center. Among OCRs being considered are equipments capable of performing functions now being accomplished by the Message Header Generator. Should such a unit be procured, the Message Header Generator will be removed.

There is a possibility that the AMVER Center will be removed, in the near future, from the on-island loop (Circuit 96CST11857) and provided service via a dedicated link. This arrangement is not reflected in Figure A-4.

As Coast Guard involvement in Law Enforcement, particularly in drug enforcement and smuggling areas, increases, more rapid and more frequent interface with the El Paso Intelligence Center (EPIC) is required. Afloat units engaged in intercept and boarding operations currently transmit message inquiries via ship-shore radio teletypewriter (RATT) circuits. These messages are relayed to EPIC by telephone, using the Federal Telecommunication System (FTS). The EPIC response is relayed to the afloat unit by voice radio. One method under consideration to achieve a more timely query-response capability and to provide privacy to the ship-shore-ship exchanges is to install an interactive terminal in

the COMMCEN and to equip the COMMCEN and afloat units for secure voice operations.

Since the objective of the on-site survey was to collect data required to support analysis of message handling functions within the COMMCEN, no attempt was made to examine card traffic requirements or handling at the Supply Center, Brooklyn. It was ascertained, however, that at the present time the Supply Center hand carries such traffic to the Army COMMCEN, Fort Hamilton for transmission via AUTODIN. There are indications that it may be necessary to shift the card relay function to the Third District COMMCEN at a date not yet determined but after installation of the Mode I AUTODIN terminal. This possible transfer of function and the manner in which it may be accomplished should be monitored closely to ensure minimal impact on COMMCEN operations.

It can be expected that traffic handlings in the Third District COMMCEN will continue to experience annual increases. The survey revealed no local factors which would cause a major increase or decrease to COMMCEN requirements.

A.4 PERSONNEL

A.4.1 Manning

The personnel allowance for the Third District COMMCEN totals 22 (two day workers and 20 watch standers). The two day workers are the Chief Radioman-in-Charge (E-9) and Classified Chief (E-7). Current watch standers, all rated radiomen, include two E-7, eight E-6, eight E-5, and two E-4. The watch standers are assigned to four watch sections. Watches are of 12 hours duration (i. e., 0600-1800 and 1800-0600 local). The typical watch section stands three day watches (e. g., Monday, Tuesday, Wednesday), is off three days, stands three night watches (e. g., Sunday, Monday, Tuesday), is off three days, then starts a new string with the day watch on Saturday. The average work week on this schedule is 42 hours.

Each watch supervisor assigns members of his section to operating positions based upon their experience and workload demands. Typical positions include AUTODIN operation, SARLANT and Group Loop operator, and checker, run-off, and distribution.

COMMCEN personnel are assigned no outside duties such as cleaning details or guard assignments. Watch standers are expected to attend to personal affairs during off-duty periods.

A.4.2 Training

There is no formal training program for COMMCEN personnel. An estimated six months of on the job training (OJT) is required to qualify new personnel for duties in all operating positions. Chief and First Class Petty Officers are normally capable of assuming watch supervisor duties within three to four months after reporting.

The Communications Center is required, on occasion to provide advice or limited instructions to non-communications personnel who operate terminal equipment at connected stations such as the Supply Center, Brooklyn and the Training and Support Centers on Governors Island. Such training is intended to simplify the formatting and routing functions which must be performed by COMMCEN personnel.

It is planned that COMMCEN personnel will provide staff message drafters additional training in message preparation to ensure effective utilization of the OCR when installed.

A.5 EQUIPMENT AND FACILITIES

A.5.1 Communications Center Equipment

Table A-1 provides a listing of the communications equipment which will be in place upon completion of the relocation to the first floor, Building 125, and upon

TABLE A-1. COMMEN COMMUNICATIONS EQUIPMENT

EQUIPMENT	QTY	OWNER	UNIT COST	LEASED COSTS (YR)	SERVICE DATE	MAINTENANCE ACTIVITY	REMARKS
TSEC KW-26	1	CG				CG Support Activity	
TSEC KW-7	1	CG				CG Support Activity	Maintenance Cost - \$3200/Yr
TSEC KG-3	2	CG				Army (Ft Dix)	Included in Above
TSEC/KG-13	1	CG				Army (Ft Dix)	Maintenance Cost - \$1500/Yr
AN SGA-3	1	CG				Navy (CRF Phila)	Included in Above
TSEC KL-47	1	CG				Navy (CRF Phila)	
MODEL 2-ASR	7	CG	\$3,246		1965(1), 1966(1) 1968(4), 1976(1)	CG Support Center	
MODEL 2-ASR	2	WT				WT	
MODEL 2-ASR	1	AT&T		\$17,800		AT&T	Cost includes Maintenance/Lines
MODEL 32ASR	2	WT			1976, 1977	WT	
MODEL 130 NC-DATA							
POLLING EQUIP	1				1965		
TYPE 82B POLLING							
EQUIP	1				1968		
OPSCAN UNIT	1				1978 (Planned)		
LINE CONTROL UNIT	1						
LINE PRINTER	1						
CARD PUNCH	1				1977 1978 (Planned)		
CARD READER	1						
PAPER TAPE PUNCH	1						
PAPER TAPE READER	1						
DISC DRIVE	1						
IBM-3 COPIER	1	IBM		\$32,400			To Be Removed
IBM-2 COPIER	1	IBM					
XEROX 3000	2			\$24,000			

NOTE: Data, other than that reflected above, not available

addition of the OCR and Mode I AUTODIN terminal.

A.5.2 Connected Station Terminal Equipment

Coast Guard activities which operate the distant end of circuits terminated in the Third District COMMCEN, other than the SARLANT networks, are equipped with Model 28 Automatic Send Receive (28ASR) teletypewriter sets, with two exceptions. The Marine Inspection Office (MIO) New York and the Aids to Navigation Office (ATN), Governors Island have been provided Model 25 Receive Only (R025) equipment. Acquisition costs of the 28ASR and R025 were \$3246 and \$1800, respectively.

A.5.3 Facilities

Figure A-4 provides the floor plan for COMMCEN spaces on the first floor, Building 125. Existing administrative offices of the Communications Branch will remain in the basement of Building 125.

A.5.4 Maintenance

The Communications Branch has no maintenance responsibilities or capabilities. Maintenance support arrangements are indicated in Table A-1.

A.5.5 Miscellaneous Communications Facilities

The COMMCEN is served by two extensions off the local telephone exchange. FTS access is also available.

The COMMCEN and the Rescue Control Center (RCC) are interconnected by voice intercomm. A conveyor belt is utilized for delivery of message traffic to the RCC.

Access to the Defense Communications System (DCS) Automatic Secure Voice Communications (AUTOSEVOCOM) system is provided through a terminal in the RCC.

A. 5.6 Cost Data

Recurring costs for maintenance and leased services (other than leased lines) are summarized in Table A-1.

The annual cost for consumable supplies approximates \$21,186. These costs are identified in Table A-2.

TABLE A-2. ANNUAL COST - CONSUMABLES

ITEM	QUANTITY	UNIT COST	ANNUAL COST
Teletype Paper Rolls			
3 PLY	100 Cases	38.00	3800.00
2 PLY	50 Cases	34.00	1700.00
SINGLE PLY	15 Cases	12.00	180.00
Perforator Tape			
Red	46 Cases	19.00	874.00
Green	10 Cases	27.00	270.00
White	10 Cases	27.00	270.00
Buff	20 Cases	20.00	400.00
Teletypewriter Ribbons	273 Dozen	5.00	1365.00
Copier Supplies			
Xerox Paper	365 Cases	17.00	6205.00
Nashua Paper Rolls	183 Cases	12.08	2210.00
Copier II Toner	12 Cases	32.00	384.00
Copier III Toner	24 Cases	72.00	1728.00
Miscellaneous Supplies			1800.00
TOTAL ANNUAL COST			\$21,186.00

A.6 FUNCTIONAL DESCRIPTION

A.6.1 General

During the visit to the Third District COMMCEN, the survey team recorded and diagramed in-station operations, noted the sequence of functions performed, and examined equipment, space, and personnel/equipment relationships. The description of operations and procedures which follows is based on these observations.

A.6.2 Forms and Formats

The standard message form (CG Form 2655) now employed will be replaced by DD Form 173 upon activation of the OCR in mid-1978.

There are currently in use four pre-formatted forms for preparation of Notices to Mariners, six for the preparation of messages of wide distribution, and one for the delivery of General Messages other than the Atlantic Area LANTOP to all or selected Third CG District activities. Most of these include afloat units whose location, and hence guard arrangements, change from time to time. Routing to shore based activities can be considered stable. Table A-3 lists these messages, includes the number of addressees, either individual or included in the Address Indicating Group, and provides an indication of the number of separate transmissions required to protect delivery to all intended recipients. None of these messages are of the rigid format structure which is amenable to operator assisted automatic generation.

No distinctive forms or colors are employed to identify originating offices, precedence, or classification. It was noted that the COMMCEN presently accepts messages in handwritten form. While this practice cannot always be avoided, message drafters should be made aware of the fact, particularly after installation of the OCR, that the time required by COMMCEN personnel to process such messages for transmission may exceed that required by the originating office to prepare the message in the proper format.

TABLE A-3. SUMMARY OF MESSAGES REQUIRING WIDE DISTRIBUTION

MESSAGE TYPE	# ADEES		AUTODIN	SARLANT	GP LOOP	ICAO	ON-ISLAND LOOP	MARINE OPERATOR
	SHORE	A FLOAT						
AIG 8916	25	VAR	X	X		X		
AIG 8918	6	11	X					
AIG 8921	19	46	X		X		X	
AIG 8966	53	30	X		X		X	
AIG 8967	14	11	X		X		X	
AIG 8975	9	2	X		X			
AIG 8976	10	4	X		X		X	
AIG 8977	12	4	X		X		X	X
AIG 8978	10	4	X		X		X	X
GEN. MSGS.								
LANTOP	30	30	X		X		X	
OTHER	70	30			X		X	

Messages must be prepared for transmission or reprocessed for relay in one or more of the following formats:

JANAP 128 () - employed on AUTODIN

ACP 127 () (PLAINDRESS) - employed on Group and On-Island Loops and SARLANT

ACP 127 () (Modified) - employed on Weather, Marine, and ICAO/FAA circuits

Commercial - employed on TELEX.

A. 6.3 Drafting and Releasing

A Staff Instruction provides local guidance to message drafters and instruction covering releasing authority. The COMMCEN is responsible for insuring all messages received for transmission are properly released. A card file containing the signature of all personnel to whom releasing authority has been granted is maintained in the COMMCEN.

A. 6.4 Processing of Outgoing Messages

This paragraph contains a narrative description of the actions taken to process originated traffic for transmission. A simplified block diagram of this sequence of events is provided in Figure A-5. TAB I to this appendix provides a detailed flow diagram identifying each action/decision point in the outgoing message process.

Originating offices deliver outgoing messages, with references attached, to the COMMCEN, placing them in an incoming message box. An operator time stamps the message with time of receipt in the COMMCEN examining it for classification, format and addressees. References are reviewed for assistance in routing and to ensure that all addressees of the outgoing message hold the references. The message is delivered to the watch supervisor who checks the format and performs the outrouting function, designating the circuit/circuits over which the message is to be transmitted, then placing it in the distribution wheel. The circuit operator takes the message and prepares the message tape. He takes the tape and hard copy from the tape cutting machine, puts the tape in the TD, effects transmission, and marks the TOD on the hard copy. If the message has to be sent on another circuit, he puts the tape and hard copy on the distribution wheel for the appropriate circuit and the next operator cuts a header, (or types a station call up or preamble), sends the message, and records the TOD on the hard copy. The last operator to send the message puts the tape in the classified waste receptacle and all hard copies in the distribution wheel for the watch supervisor. The supervisor reviews the message for TOR, TOD and acknowledgement of receipt by the receiving stations. He then

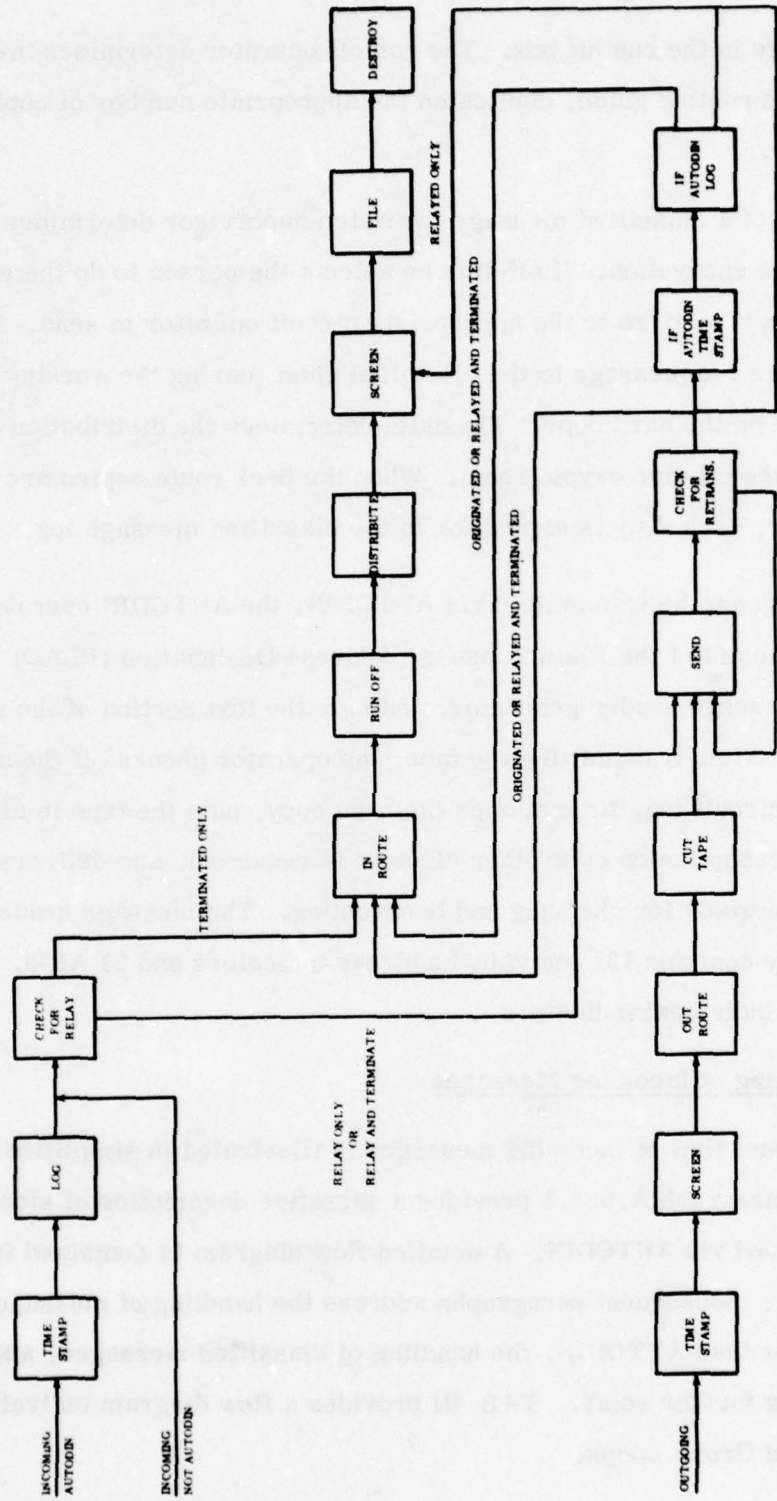

Figure A-5. COMMEN Operations - Functional Block Diagram

puts the message in the run off box. The run off operator determines in-house routing from the routing guide, duplicates the appropriate number of copies and slots them for pickup.

In the case of a classified message the watch supervisor determines if it requires off-line encryption. If off-line he selects the person to do the encryption. After encryption it is given to the appropriate circuit operator to send. The send operator delivers the message to the classified chief (during the working day) after putting the TOD on the hard copy. The chief determines the distribution and files the original in the off-line crypto room. When the back route copies are picked up by the customer, each copy is signed for in the classified message log.

For messages to be transmitted via AUTODIN, the AUTODIN operator prepares a header with the aid of the Plain Language Address Designation (PLAD) look up table and the message header generator, and cuts the text portion of the message tape manually. After transmitting the tape, the operator checks off the channel number on the circuit log, time stamps the hard copy, puts the tape in classified waste (unless transmission over other circuits is required), and delivers the hard copy to the supervisor for checking and backrouting. The message header generator (MHG) presently contains 131 individual address indicators and 21 AIGs. It has a capacity of 150 individual indicators.

A.6.5 Processing of Incoming Messages

The functional flow of incoming messages is illustrated in simplified form in Figure A-5. Paragraph A.6.5.1 provides a narrative description of steps followed on traffic received via AUTODIN. A detailed flow diagram is contained in TAB II. to this appendix. Subsequent paragraphs address the handling of messages received on circuits other than AUTODIN, the handling of classified messages, and incoming traffic requiring further relay. TAB III provides a flow diagram on traffic received via the local and Group Loops.

A.6.5.1 AUTODIN Traffic

At the AUTODIN terminal, the operator takes the incoming tape and hard copy (two ply) from the machine, time stamps the hard copy and checks off the channel number on the channel log. He then scans the addresses for possible relay. If no relay is involved, he puts the tape in the classified waste receptacle and the hard copy in the distribution wheel for the watch supervisor. The supervisor checks the hard copy for TOR, addressees and message content, checks the routing guide, and assigns routing, including the designation of ACTION on action messages. He then puts the original copy in the box for run off and the carbon copy on the belt to the RCC. The run off operator checks the distribution guide for the number of copies to be reproduced, runs the copies, time stamps the hard copy with the distribution time, files the hard copy and slots the distribution copies. He also notifies the action office by telephone if the message is of priority or higher precedence. The additional actions taken if further relay is involved are discussed in paragraph A.6.5.5.

A.6.5.2 Traffic Received via Other Circuits

Messages received on circuits other than AUTODIN include a Time of Delivery (TOD). This TOD is used as Time of Receipt (TOR). Such traffic is, therefore, not time stamped. With this exception, and the processing of messages requiring relay (discussed in paragraph A.6.5.5), messages received on circuits other than AUTODIN are processed in much the same manner as AUTODIN traffic.

A.6.5.3 Classified Messages

The majority of incoming classified messages are received on-line via AUTODIN. The only differences in handling occurs at the distribution point where each copy is entered on the classified log by DTG. A COMMCEN messenger delivers each message and has the log signed to indicate receipt of the message. Three ships have an off-line capability only. When one or more of these ships are at sea, off-line traffic may be received. Off-line encrypted messages are delivered to the

classified chief for logging and decryption. After being written-up and run-off the copies are hand delivered to the addressees and signatures obtained to account for each copy.

A.6.5.4 General Messages

The COMMCEN has been authorized to readdress selected General Messages to designated Coast Guard activities. These are processed in the same manner as all other originated messages. A readdressal form, listing all Third District activities is attached to all other General Messages before routing to the staff office most concerned with the subject matter. This office is responsible for determining activities to which delivery is required. The readdressal form, properly released, is then returned to the COMMCEN.

A.6.5.5 Relay Traffic

A significant portion of traffic received over circuits terminated in the COMMCEN requires further relay. Such traffic may or may not require local distribution and may, in a number of cases, require relay over more than one circuit.

Accountability of messages received by the COMMCEN, but not addressed to the Third District or Atlantic Area Headquarters, is maintained by retaining file copies (with time stamped or typed TOD) of all versions sent and received, with a supervisor check to protect against non-deliveries. This differs somewhat from normal tape relay procedures where Channel Numbers are used to audit the path of messages through a facility.

Since many of the messages must be processed before relay, such as converting from ACP 127 () to JANAP 128 () format, the operation could be considered a refile rather than relay in the accepted sense.

As a routine practice, the flow of messages through the COMMCEN, as described in paragraph A.6.5.1, is interrupted when the operator determines relay is required. The tape and hard copy is placed in the distribution wheel for the appropriate circuit. The circuit operator examines the message for addressees and, at send positions other than AUTODIN or TELEX, inserts the tape in the TD, types the required call and preamble, and releases the tape for transmission. For relay via AUTODIN or TELEX, the operator is required to reprocess the tape as appropriate. After all relays have been effected, the last operator involved discards the tape and places all hard copies in the distribution wheel for the supervisor. The remaining checking, in-routing, reproduction, distribution, and filing functions are then accomplished.

A.6.6 Internal Routing, Reproduction, and Distribution

An internal routing and distribution guide is maintained in the COMMCEN to assist in determining the proper distribution of message traffic within the Atlantic Area and Third District Headquarters staff organizations. The guide identifies 110 key words (primary subjects) with 36 cross references and 202 subheadings (secondary subjects) with 19 cross references. The more experienced operators are able to route messages of a frequently recurring nature without reference to the guide. During the survey, however, in-routers, normally the watch supervisor, were observed checking the routing guide before annotating most messages with internal distribution instructions, including the designation of ACTION office on action messages. In this connection, it was noted that, in those cases where the ACTION office designation was incorrect and so reported to the COMMCEN, re-distribution of corrected copies is required.

Two Xerox 3600 copiers are available to reproduce messages. Normally, only one is used. Since reproduction functions are not assigned to any particular operator, any available operator will remove, from the distribution wheel, hard copies of messages awaiting distribution, and reproduce and slot copies for pickup.

Except for one staff office, only one copy of each message is provided to offices on distribution.

There are 15 offices within the Atlantic Area staff and 30, within the Third District Staff to which copies of messages may be provided. It is estimated that approximately 75 percent of the total number of copies distributed is to the Atlantic Area staff. The heaviest distribution (over 50 percent) is concentrated in six Atlantic Area staff offices. Nine Third District staff offices receive approximately 20 percent of all distributed copies.

The COMMCEN provides messenger service on classified messages only. Each staff office makes periodic visits to the COMMCEN to pick up traffic in the distribution slots. Staff offices are also responsible for the pick up of high precedence traffic upon notification by the COMMCEN.

A. 6. 7 Logs and Records

The COMMCEN maintains the following logs:

(1) Classified material log which contains the DTG of classified messages and receipt signatures for each copy distributed.

(2) AUTODIN log consisting of incoming and outgoing channel number check off forms.

(3) Monitor rolls are retained on the SARLANT circuit and Group Loop.

Originated messages are time stamped on receipt in the COMMCEN, annotated with a handwritten TOD when transmitted (with separate notations when multiple transmissions occur), and time stamped after reproduction and distribution.

Incoming AUTODIN messages are time stamped upon receipt and, again, after distribution.

Messages received on other circuits utilize the distant terminal TOD as time of receipt. They are time stamped after distribution. The COMMCEN maintains no "awaiting action" files.

A.6.8 Storage and Retrieval

Message files are maintained for 30 days. Classified message files are stored in a safe in the off-line crypto room. Unclassified messages are filed in Columbia binders and stored in shelves in the distribution area. Separate files are maintained for AMVER, weather, and General Messages.

Reference to files (i. e., frequency of access) is low, particularly after two days. Reference to traffic during the first 48 hours after receipt occurs three to four times per day. Location of a specific message normally requires a 10-15 minute search.

A.6.9 Waste Disposal

All waste, which totals approximately 100 pounds daily, is handled as classified matter. It is stored in off-line crypto spaces and destroyed in a shredder by the evening watch. No backup destruction capability exists.

Cryptographic key cards are destroyed in a blender.

A.7 TRAFFIC

A.7.1 General

Third District traffic data were compiled from statistical reports submitted by the District and by on-site observation and tabulation. By analysis of these data it is possible to determine traffic volumes by function and category, estimate growth rates, identify traffic handling methods, compute in-station handling time, and establish routing/distribution patterns. This section of the report is devoted to presentation of the conclusions reached from analysis of available traffic data.

In interpreting the gross traffic figures presented in this summary, it must be noted that methods used to report traffic data by functional category and by circuit mode can result in apparent discrepancies. For example, a Search and Rescue message will be counted as one message in the SAR functional category. If received on one circuit and relayed on two circuits, it will be counted three times

when developing traffic statistics by circuit mode. Thus, in examining Third District COMMCEN traffic, totals by circuit mode will be substantially higher than totals by category.

A.7.2 Gross Traffic Volumes

Table A-4 provides comparative summaries of traffic, by functional category, for the years 1970 and 1976. The growth percentage (47.2) represents an annual growth pattern, in messages, of approximately 6.6 percent.

Table A-5 summaries traffic, by circuit mode, for 1976, and compares the total to 1970 data. The six year growth, in message handlings, is 78 percent which equates to an annual growth rate of slightly more than 10 percent. The change in message and messages handled totals is further illustrated in Table A-6. The handling/message ratio indicates that the statistical average number of handlings for each discrete message has increased from 1.34 in 1970 to 1.62 in 1976. This table also illustrates that the relay/refile function in this COMMCEN is significant and increasing.

TABLE A-4. TRAFFIC BY FUNCTIONAL CATEGORY

FUNCTION	1970	1976	Δ	% Δ
AMVER	87,908	102,604	+14,696	16.7
BATHY/METEO	29,383	42,130	+12,747	43.4
OCEANO	2,097	4,957	+2,860	136.4
OTHER GOV.	12,967	23,112	+10,145	78.2
SAR	15,000	21,650	+6,650	44.3
USMER	-	54,669	+54,669	
OTHER CG	75,296	78,534	+3,238	4.3
TOTAL	222,651	327,656	+105,005	47.2

TABLE A-5. TRAFFIC BY CIRCUIT MODE

CIRCUIT MODE	SEND	RECEIVE	TOTAL
TWPL	180,189	125,642	305,831
AUTODIN	29,893	152,486	182,379
TWX	4,046	6,025	10,071
FAX	3,947	1,255	5,202
RATT	991	1,019	2,010
OTHER	16,139	8,400	24,539
TOTAL (1976)	235,205	294,827	530,032
TOTAL TRAFFIC 1970			297,810
INCREASE 1970 - 1976			232,222
PERCENT INCREASE 1970 - 1976			78.0

TABLE A-6. MULTIPLE HANDLINGS

Year	Number of Messages	Number of Handlings	Handling/Message Ratio
1970	222,651	297,810	1.34
1976	327,656	530,032	1.62

A.7.3 Specific Traffic Data

Examining traffic by annual totals can provide useful statistical data. Such statistical data may, however, prove misleading if used as a basis for manpower allocations, circuit engineering, or, as in the case of this study, the application of automation techniques to a COMMCEN operation. Ideally, a more detailed examination of traffic patterns should commence with selection of a busy month and an average month within a specific time period. Since Third District COMMCEN files are retained for 30 days only, as specified in CG-233, the survey team, of necessity, conducted the more detailed data collection effort using August 1977 files. Coincidentally, the August totals equate to 8.5 percent of the projected annual figure for 1977, indicating that August may represent an average month.

August message totals are summarized in Table A-7. The messages handled/discrete messages ratio (42937/27486) is 1.56, which is comparable to the statistical average number of handlings (1.62) computed for 1976.

Message files for 9 August (an average day) and 19 August (the busy day) were selected for detailed analysis. Tables A-8 and A-9 summarize messages, in tabular form, originated by staff elements served by the COMMCEN and received messages which required distribution within the staff. Originated and terminated traffic is tabulated by precedence and classification. (It can be noted at this point that classified traffic comprises less than one percent of traffic processed in the COMMCEN). Footnotes in each table provide information regarding relay and multiple

TABLE A-7. TRAFFIC VOLUMES FOR AUGUST 1977

TOTAL MESSAGES: 27486
 TOTAL MESSAGES HANDLED: 42937
 % OF ANNUAL TRAFFIC: 8.5

MESSAGES BY MODE	RECEIVED		SENT	
	#	%	#	%
AUTODIN	15,615	60	3,079	18
TWPL	9,882	38	13,321	79
TELEX	380	01	301	02
FAX	100	< 1	129	01
OTHER	130	< 1		
TOTALS	26,107	100	16,830	100

BY CATEGORY	#	%
AMVER	6,435	23
OCEANO	251	01
BATHY/METEO	3,184	11
OTHER GOVT	766	03
SAR	729	03
OTHER CG	11,987	44
USMER	4,134	15
TOTALS	27,486	100

TABLE A-8. TRAFFIC VOLUME FOR AVERAGE DAY (09 AUGUST 1977)

MESSAGES HANDLED - INCOMING: 913
 - OUTGOING: 410
 - TOTAL: 1323

% OF YEAR TRAFFIC: 0.3

	TERMINATED		ORIGINATED	
	#	%	#	%
TOTAL FOR DAY	461	100	87	100
DISTRIBUTION BY PRECEDENCE				
O - Immediate	17	4	2	2
P - Priority	209	45	26	30
R - Routine	235	51	59	68

- a. No Classified Traffic this date.
- b. A Total of 913 messages were received during this day. These included service messages, duplicate transmissions and messages received for relay only, as well as the 461 terminated.
- c. A total of 410 messages were transmitted this day. In addition to the 87 originated, these included relay and multiple relay totals.

TABLE A-9. TRAFFIC VOLUME FOR BUSY DAY (19 AUGUST 1977)

MESSAGES HANDLED - INCOMING: 1033
 - OUTGOING: 610
 - TOTAL 1643
 % OF YEAR TRAFFIC: 0.4

	TERMINATED		ORIGINATED	
	#	%	#	%
TOTAL	455	100	88	100
DISTRIBUTION BY PRECEDENCE				
O - Immediate	18	4	2	3
P - Priority	202	44	26	29
R - Routine	235	52	60	68
DISTRIBUTION BY CLASSIFICATION				
S - Secret	2	1	-	-
C - Confidential	2	1	-	-
U - Unclassified	451	99	88	100

- a. A total of 1033 messages were received during this day, including service messages, duplicate transmissions, and messages for relay as well as 455 terminated.
- b. A total of 610 messages were transmitted, including relay and multiple relay totals.

transmission activity. The significant conclusions to be drawn from these tables, as applicable to Third District COMMCEN operations, are that the average day does, in fact, equate to 1/365th of the annual figure, and a distribution by precedence trend appears.

Table A-10 tabulates terminated/originated traffic handled during the busy day, 19 August, by hourly periods, in local time. This table is important since it identifies throughput needs. For example, on the day sampled, 11 percent of the total handlings for the day occurred between 1900-2000 local time; 18 percent, between 1800-2000; and close to one-third, or 31 percent, during the four hour period 1600-2000.

The average day file (9 August) was examined to extract data which might reveal relay patterns. Since the community of interest can be considered more or less stable (i. e., independent of traffic volumes), the relay patterns identified in Table A-11 should be representative and generally applicable to any day, month, or other desired period.

A.7.4 Message Length

No attempt was made during this survey, due to the magnitude of the task, to measure message lengths. Based on AUTODIN Tributary Station reports over a three year period, the Coast Guard Headquarters COMMCEN traffic transmitted into and received from AUTODIN averages 217 groups (or 13.6 line blocks) and 314 groups (or 19.6 line blocks), respectively. These averages may be high, if applied to Third District COMMCEN operations. Adoption of a 20 line block average, for all traffic, appears a reasonable base for throughput requirement computations, providing an excess capacity to accommodate unpredictable traffic surges.

A.7.5 Handling Times

An attempt was made to record and compare actual handling times from the message files. However, a wide disparity was noted between the time stamps,

TABLE A-10. HOURLY DISTRIBUTION-BUSY DAY (ORIGINATED/TERMINATED TRAFFIC)

HOURLY INCOMING (LOCAL)	01	02	03	04	05	06	07	08	09	10	11	12	13	14	15	16	17	18	19	20	21	22	23	24
INCOMING BY PRECEDENCE	O 1	1 1	1 1	2 2	2 2	1 1	1 1	1 1	1 1	1 1	1 1	1 1	2 1	1 1	1 1	1 1	1 1	1 1	1 1	1 1	1 1	1 1	1 1	2 2
	P 3	3 3	3 3	5 5	1 2	1 2	1 1	1 1	1 4	1 4	1 9	1 9	14 9	18 19	18 19	12 22	16 13	5 11	8 15	15 15	8 15	8 15	8 15	8 15
	R 4	4 4	4 4	3 3	3 4	4 4	4 3	1 1	1 1	1 4	7 7	11 15	15 19	10 10	26 7	19 29	19 8	17 9	9 9	9 9	9 9	9 9	9 9	9 9
INCOMING BY CLASSIFICATION	S					1 1	1 1																	
	C	1 1									1 1													
	U 13	12 7	8 6	7 5	3 3	5 3	3 3	5 5	3 3	5 5	15 15	27 25	27 30	37 30	38 29	36 42	25 19	27 24	24 24	24 24	24 24	24 24	24 24	24 24
TOTAL INCOMING	13	12	8	8	6	8	6	3	3	5	5	16	27	25	37	30	38	29	36	42	25	19	27	24
OUTGOING BY PRECEDENCE	O			1 1																				1 1
	P 8	1 4											1 2							1 4	2 1			2 2
	R 9	7 6	3 3				1 1						4 1	4 1	4 1	4 1	2 1	14 6	1 1					1 1
OUTGOING BY CLASSIFICATION	S																							
	C																							
	U 17	7 1	10 4				1 1						5 3	4 4	2 2	18 8	2 1	3 3						3 3
TOTAL OUTGOING	17	7	1	10	4		1						5	3	4	2	18	8	2	1	3			3

(ALL TIMES BASED ON TOR/TOD - LOCAL TIME)

	20	09	MEAN	2 HOUR	4 HOUR	*	C
BUSY	60	11.0	19-20	98	18.0	157	31.0
SLOW	3	0.5	08-09	7	1.3	07-10	19
MEAN	22	4.0		45	8.3	90	16.6

operator applied service, and TOD in a significant number of cases. This disparity rendered all time records suspect and led to the decision to observe and synthesize the system timing.

TABLE A-11. RELAY PATTERN

TO FROM	SUPPLY CENTER	AUTODIN	GROUP LOOP	PONY LOOP	AMVER/ USMER	TOTAL
SUPPLY CENTER		25	1			26
AUTODIN	50		103	39	312	504
GROUP LOOP	2	25		6		33
PONY LOOP	1	15	6			22
TOTAL	53	65	110	45	312	585

Figures A-6, A-7, and A-8 summarize the times associated with each function performed while processing incoming AUTODIN, incoming LOOP, and originated traffic, respectively. The function, operations, personnel, and stations correspond to those utilized in preparing the flow diagrams presented in TABs I, II, and III. It should be noted that these synthesized handling times consider the flow of one message through the total operational process, from start to finish, disregarding the delays (interruptions, distractions, competition with other messages, idle time in the distribution wheel, etc.) which are often unavoidable in a busy COMM-CEN. The value of synthesized handling times is the base they provide for assessing the relative affect of a change in procedures. Any attempt to compare these synthesized times with recorded handling times would lead to grossly inaccurate conclusions.

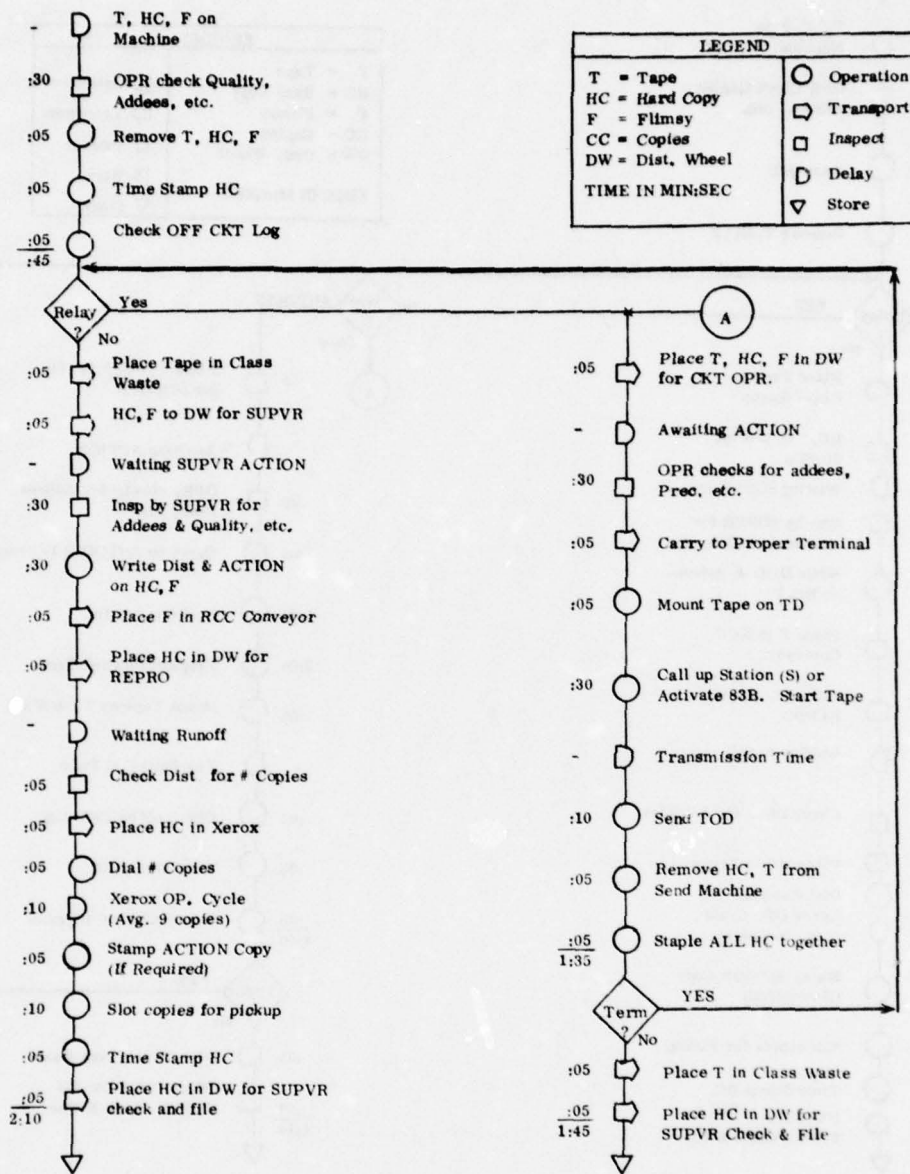

TIME SUMMARY
(Excluding Delay Time)

TERMINATE ONLY	=	2:55
RELAY ONLY	=	2:30
TERMINATE AND RELAY	=	4:40
ADDITIONAL RELAYS	=	1:35 Each

Figure A-6. Synthesized Handling Times - Incoming AUTODIN

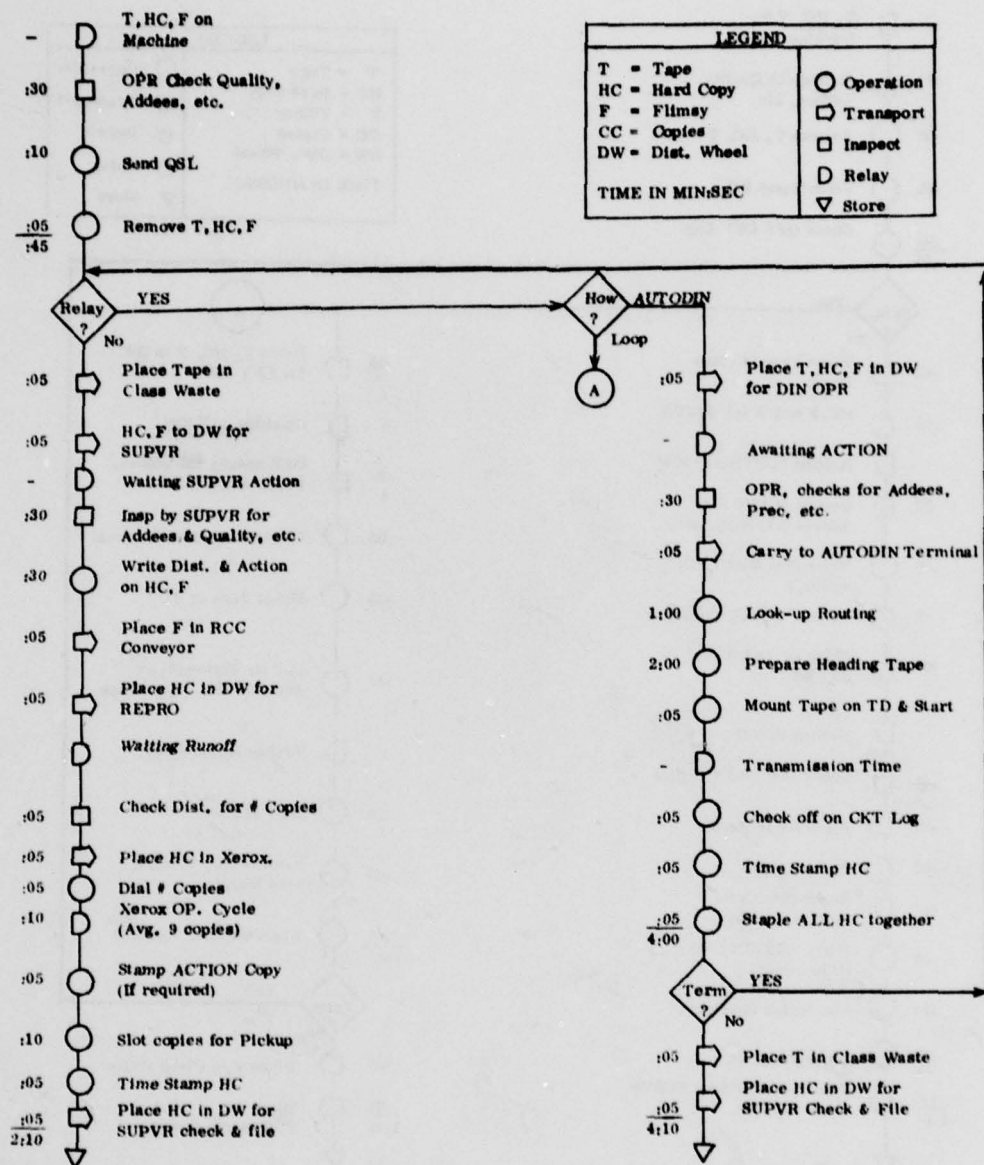

TIME SUMMARY
(Excluding Delay Time)

TERMINATE ONLY	=	2:55
RELAY AUTODIN ONLY	=	4:55
TERMINATE AND RELAY	=	7:05
ADDITIONAL RELAYS	=	1:35 Each

Figure A-7. Synthesized Handling Times - Incoming LOOP

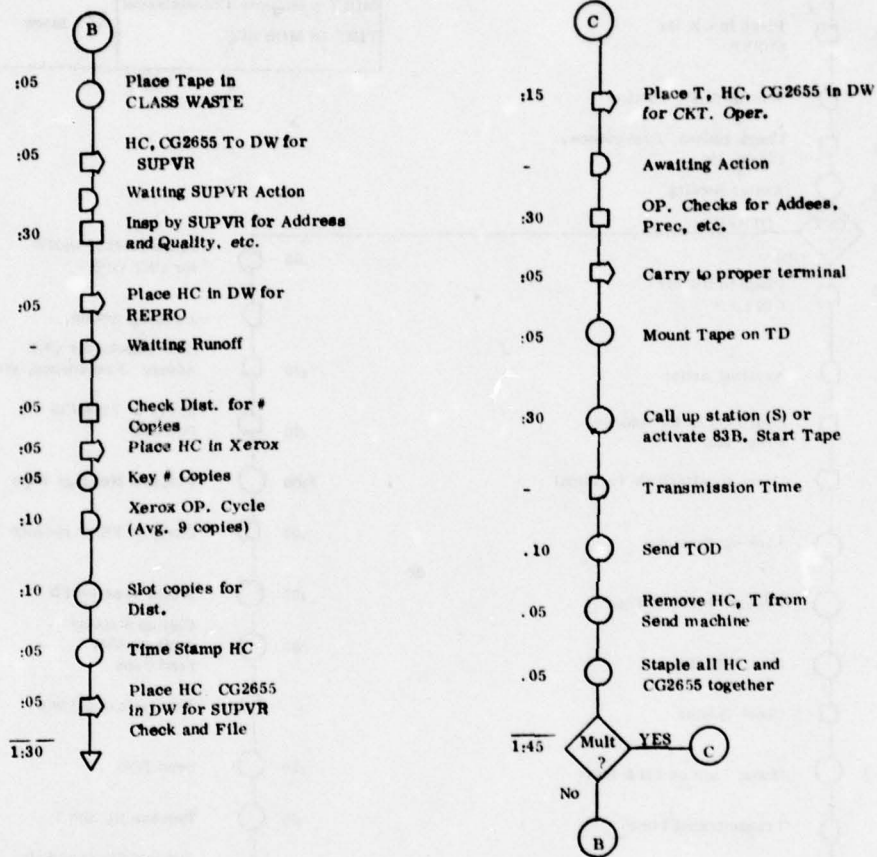

TIME SUMMARY
(Excluding Delay Time)

OUTGOING AUTODIN ONLY	=	12:25
OUTGOING LOOP ONLY	=	9:05
OUTGOING AUTODIN & LOCP	=	14:10
ADDITIONAL TRANSMISSION (Mult)	=	1:45

Figure A-8. Synthesized Handling Times - Originated Traffic (Continued)

Such a comparison could, but should not be used as a basis for evaluating what was observed to be the extremely professional performance of COMMCEN personnel.

An analysis was performed to correlate the synthesized handling times with the traffic patterns observed for the selected average day (09 August) and busy day (19 August). Table A-12 presents the results of this analysis. The summary does not consider off-line functions such as filing and destruction, nor does it allow for rest and relaxation. Allowing 20% for these activities produces a correlation with present manning. A key factor to note in this handling time summary is the amount of effort devoted exclusively to manual tape relay operations and multiple transmissions.

TABLE A-12. HANDLING TIME SUMMARY

HANDLING REQUIREMENT	9 AUGUST 1977				19 AUGUST 1977				
	#	UNIT TIME (MIN:SEC)	TOTAL TIME (MIN)	#	UNIT TIME (MIN:SEC)	TOTAL TIME (MIN)	#	UNIT TIME (MIN:SEC)	TOTAL TIME (MIN)
	MSGs			MSGs			MSGs		
Terminating +Relay Din	461	-	1871	455	-	1877	455	-	1877
+Relay Loop	65	6:55	450	66	6:55	456	66	6:55	456
Term. Only	168	4:30	756	170	4:30	765	170	4:30	765
	228	2:55	665	225	2:55	656	225	2:55	656
Relay Only	452	-	1347	578	-	1773	578	-	1773
From: DIN	362	2:30	905	442	2:30	1105	442	2:30	1105
From Loop	90	4:55	442	136	4:55	668	136	4:55	668
Outgoing	87	-	1150	88	-	1163	88	-	1163
To DIN	87	12:25	1080	88	12:25	1093	88	12:25	1093
MULTIPLE	40	1:45	70	40	1:45	70	40	1:45	70
Total Handling Time - Minutes			4368			4813			4813
Total Handling Time - Hours			72.8			80.2			80.2
Total Handling Time - Man - Days			3.03			3.34			3.34
Time Devoted to Relay Functions and Multiple Transmissions:									
		Minutes	1943			2376			2376
		Hours	32.4			39.6			39.6
		Man/Days	1.35			1.65			1.65

TAB I TO APPENDIX A

OPERATION SEQUENCE DIAGRAM - OUTGOING

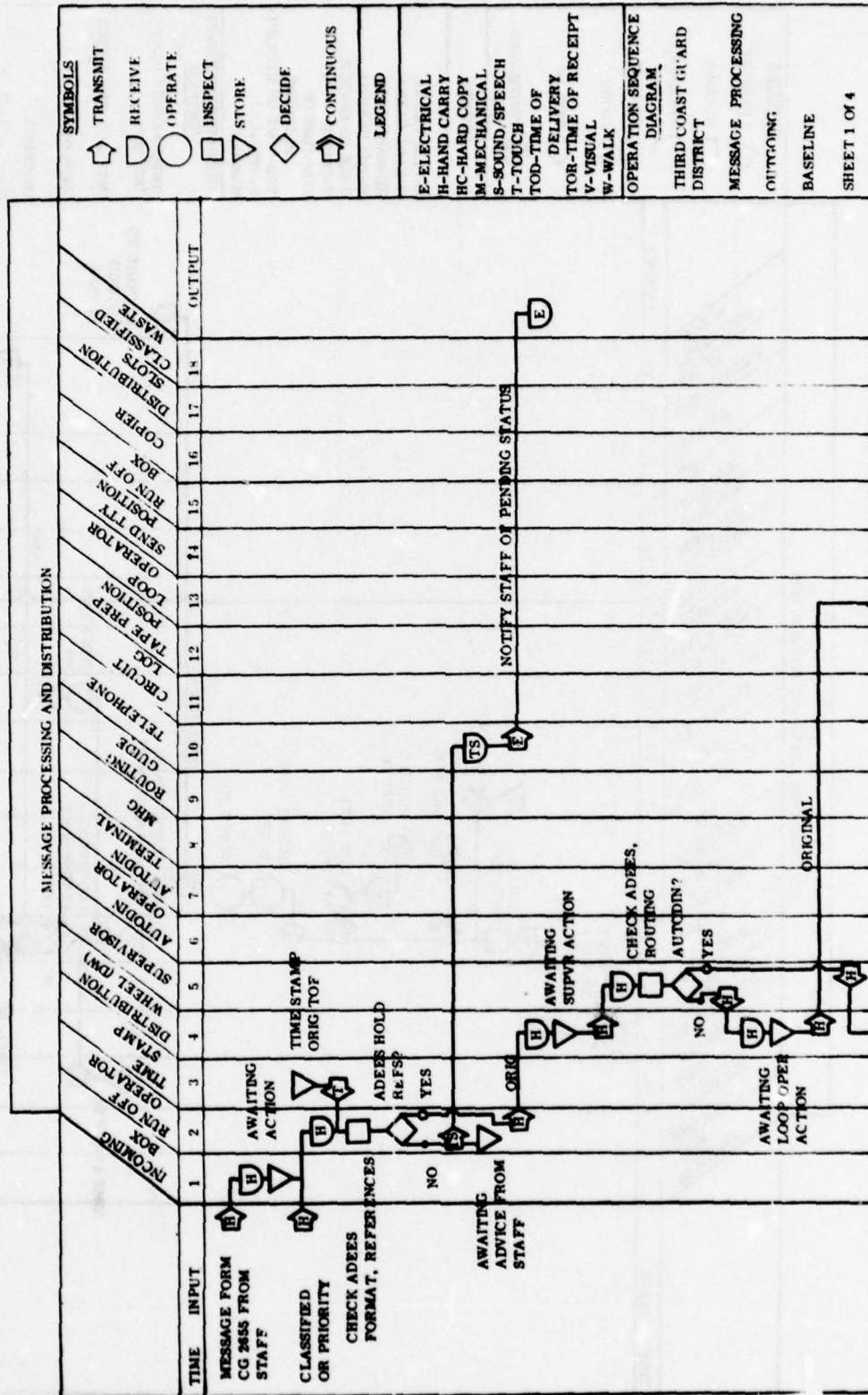

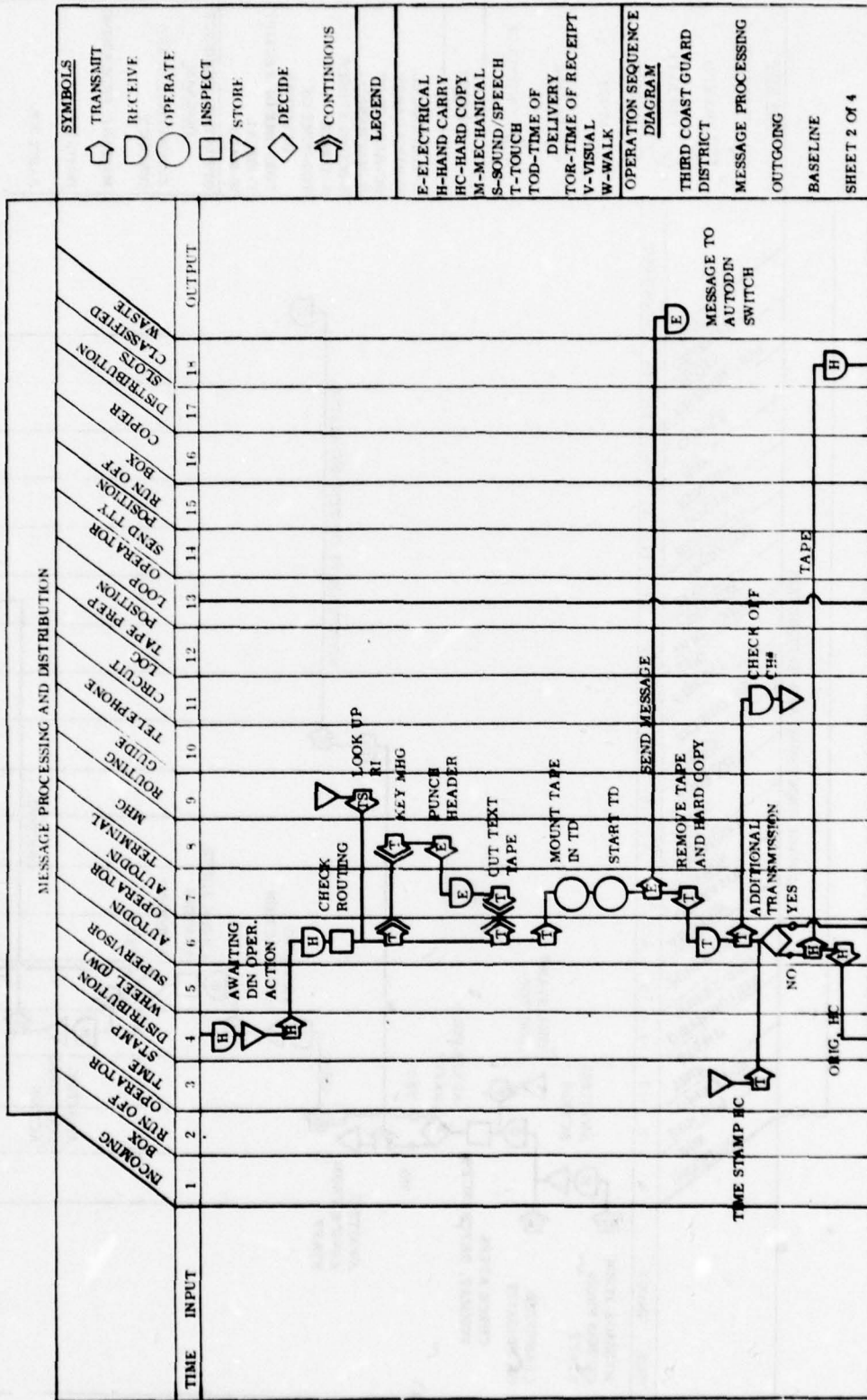

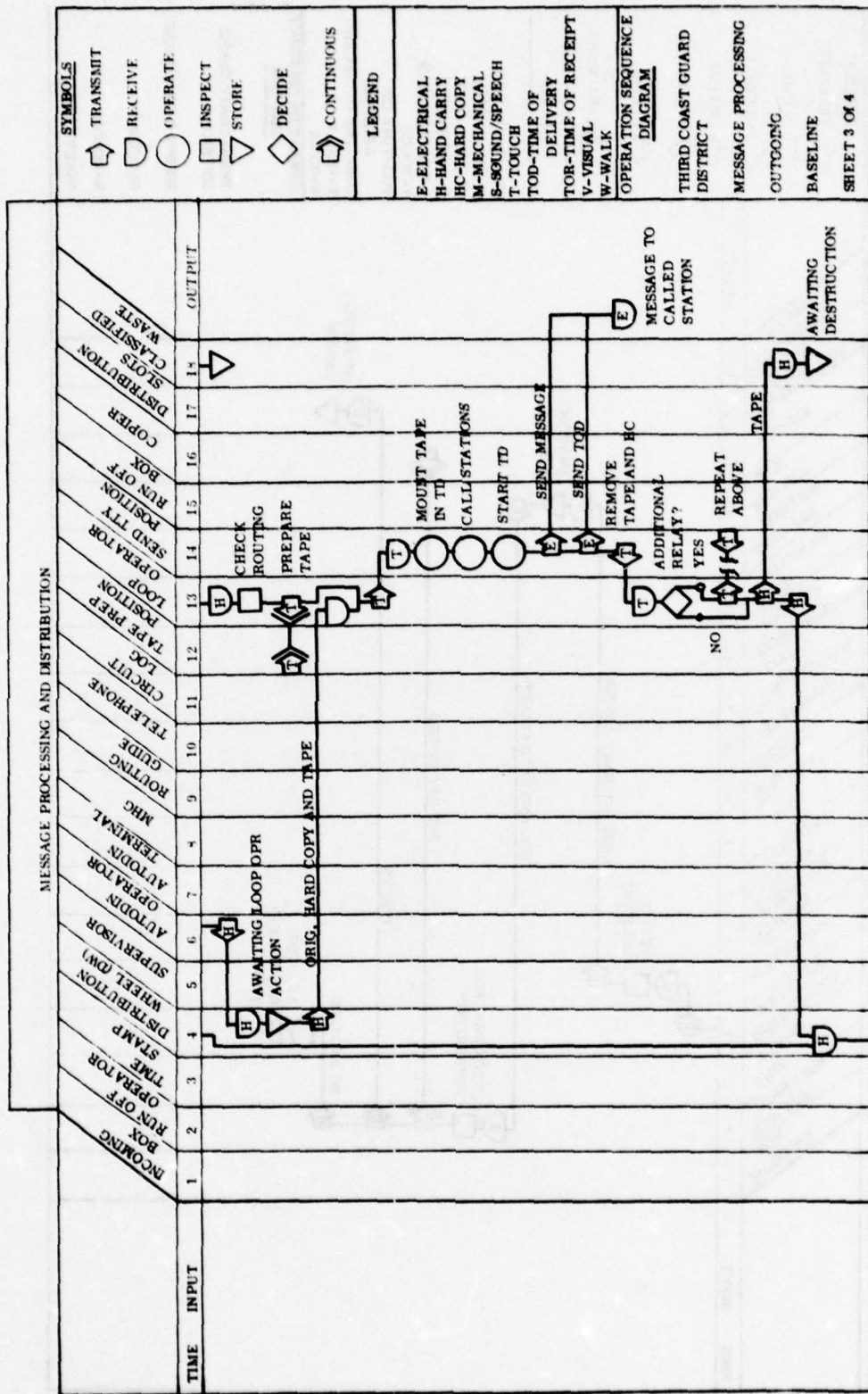

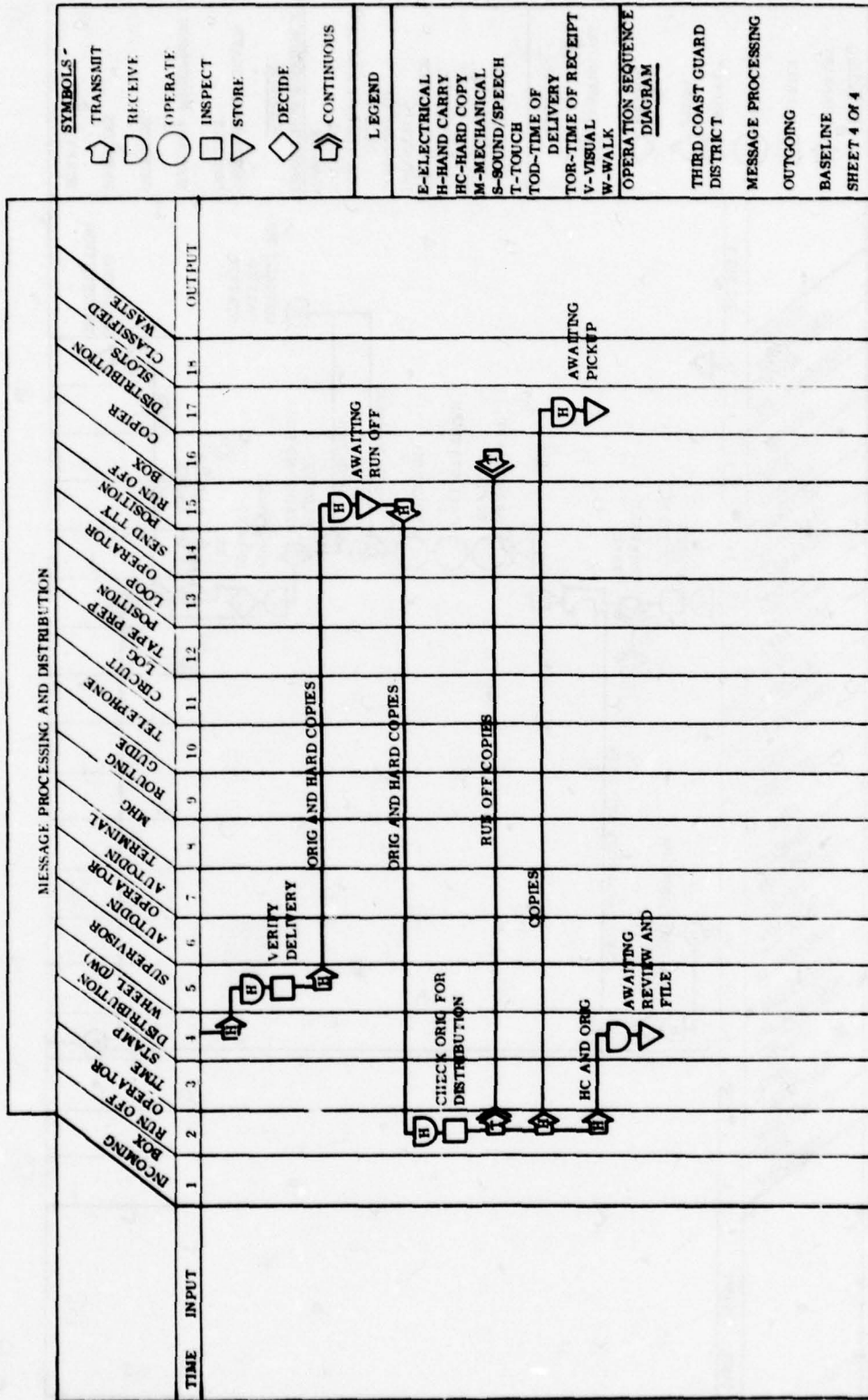

TAB II TO APPENDIX A
OPERATION SEQUENCE DIAGRAM - INCOMING AUTODIN

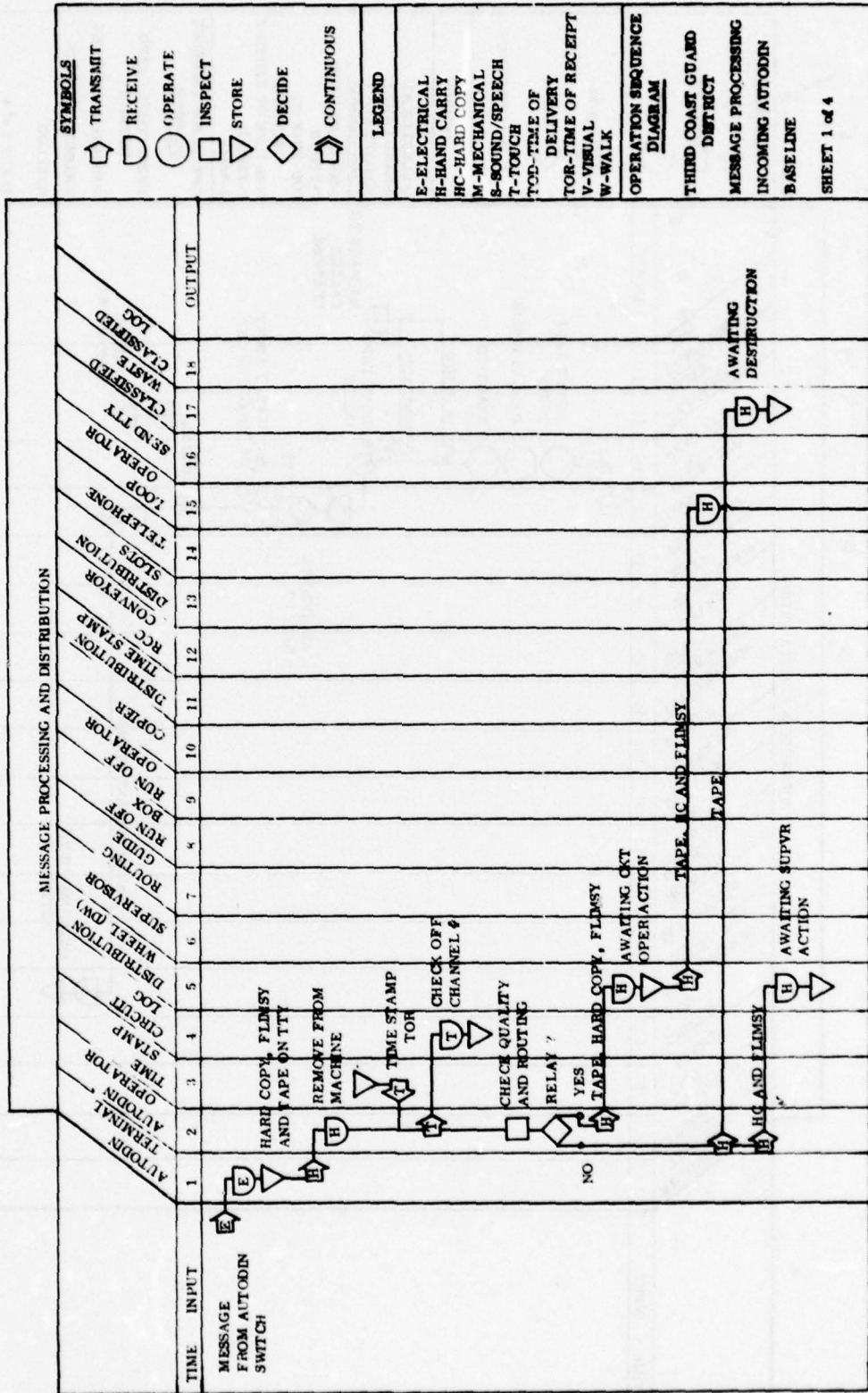

- SYMBOLS**
- ◻ TRANSMIT
 - ◻ RECEIVE
 - OPERATE
 - ◻ INSPECT
 - ◻ STORE
 - ◻ DECIDE
 - ◻ CONTINUOUS

LEGEND

- E-ELECTRICAL
- H-HAND CARRY
- HC-HARD COPY
- M-MECHANICAL
- S-SOUND/SPEECH
- T-TOUCH
- TOR-TIME OF DELIVERY
- TOR-TIME OF RECEIPT
- V-VISUAL
- W-WALK

OPERATION SEQUENCE DIAGRAM

- THIRD COAST GUARD DISTRICT
- MESSAGE PROCESSING
- INCOMING AUTODIN
- BASELINE

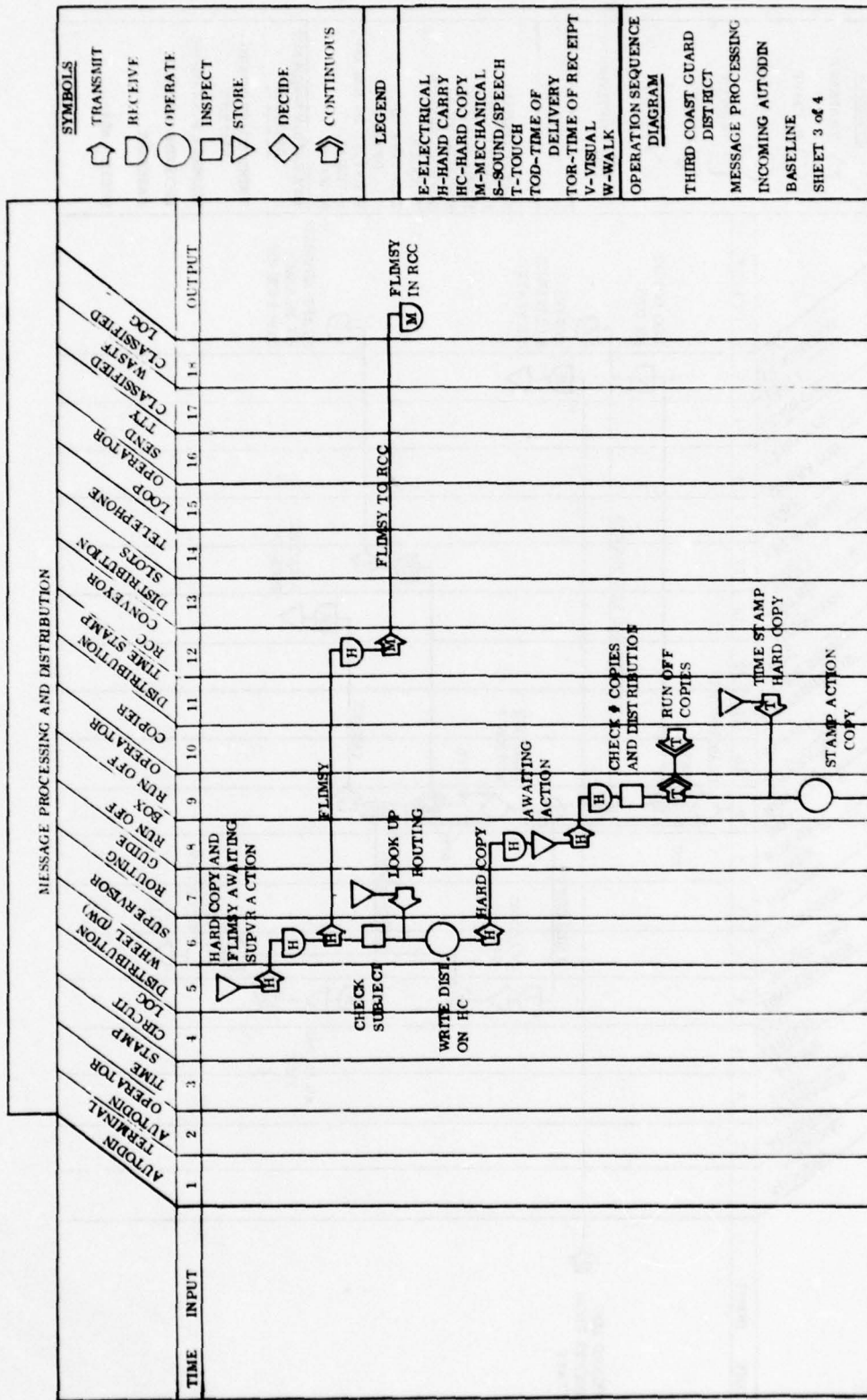

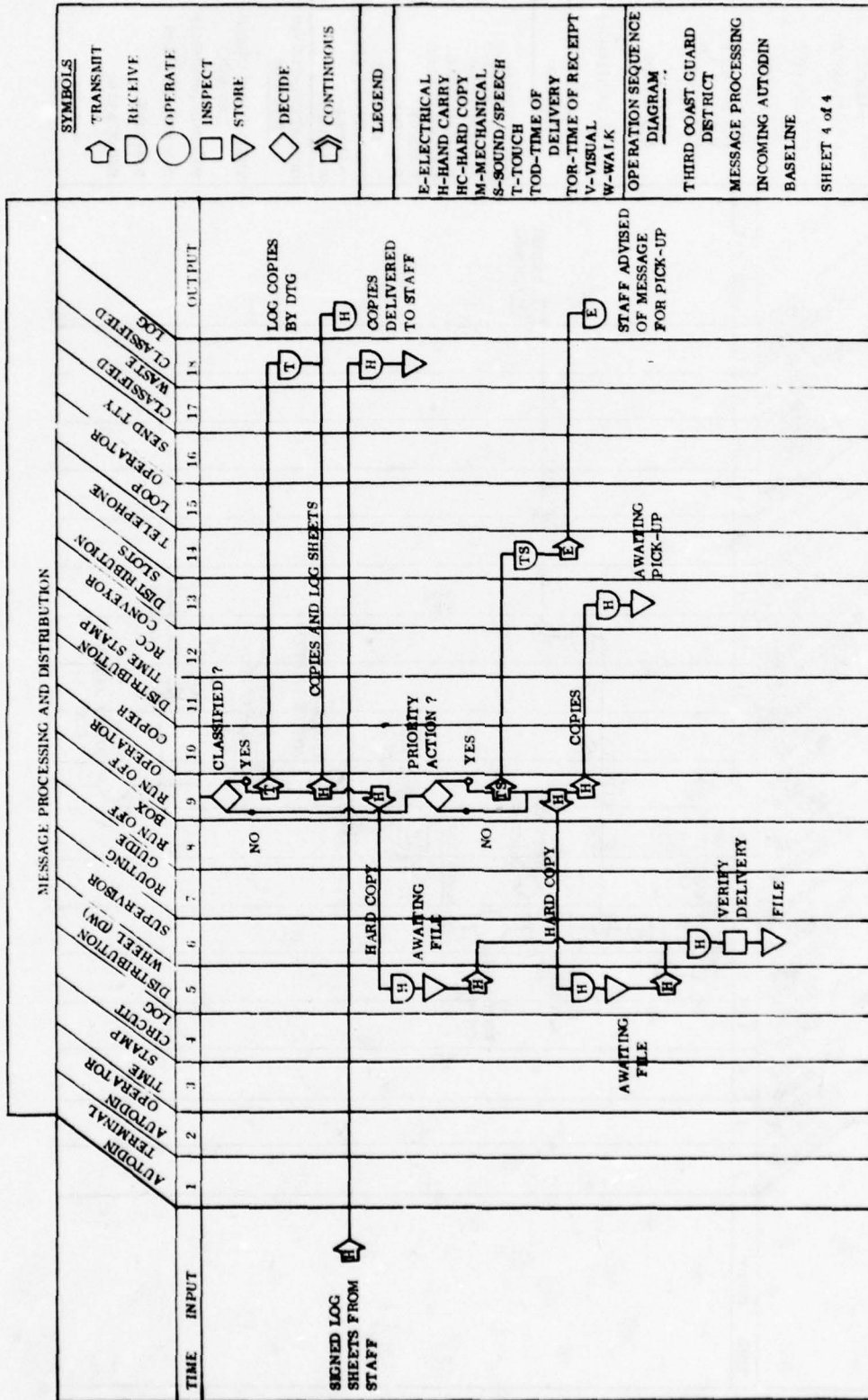

TAB III TO APPENDIX A
OPERATION SEQUENCE DIAGRAM - INCOMING LOOP

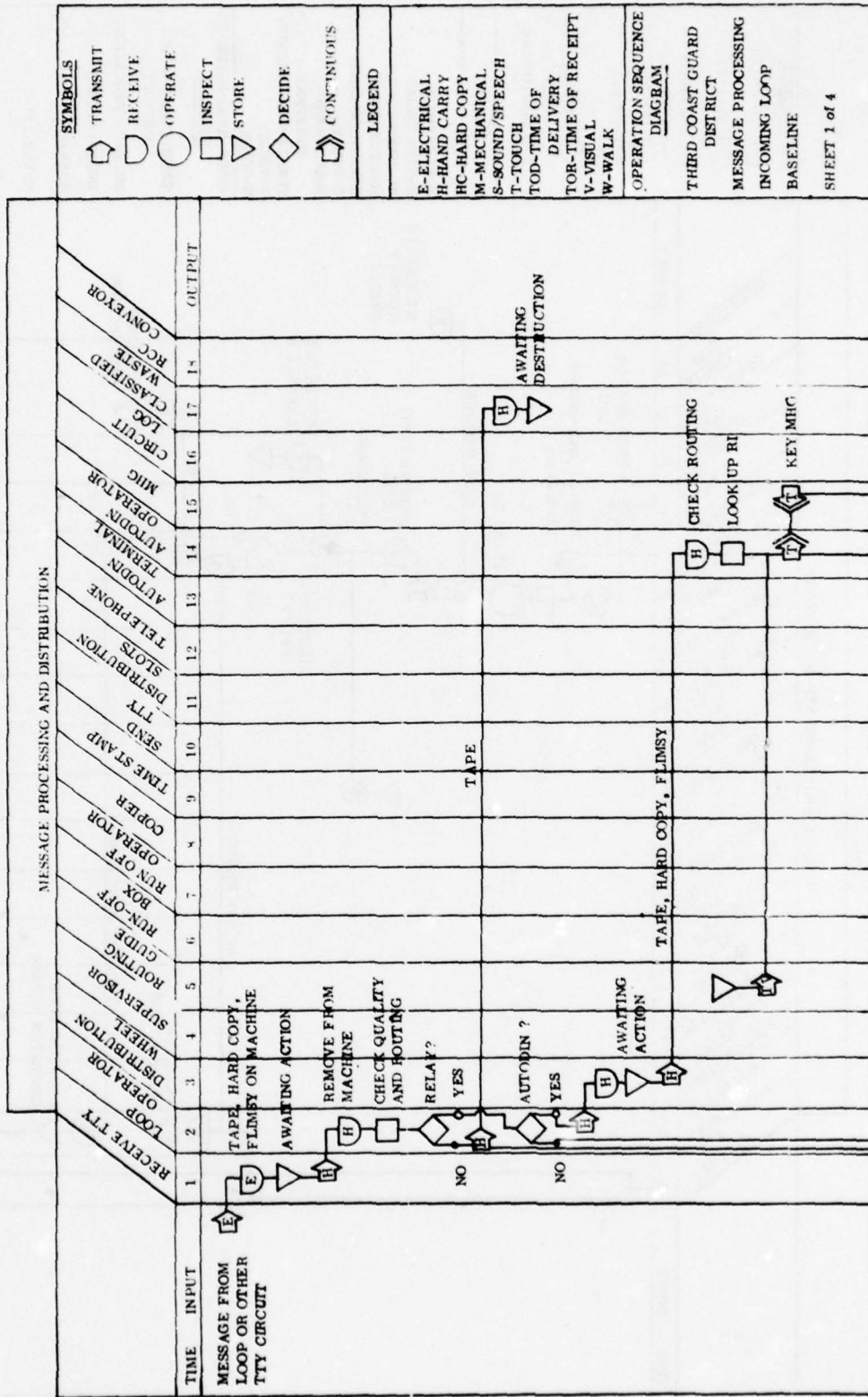

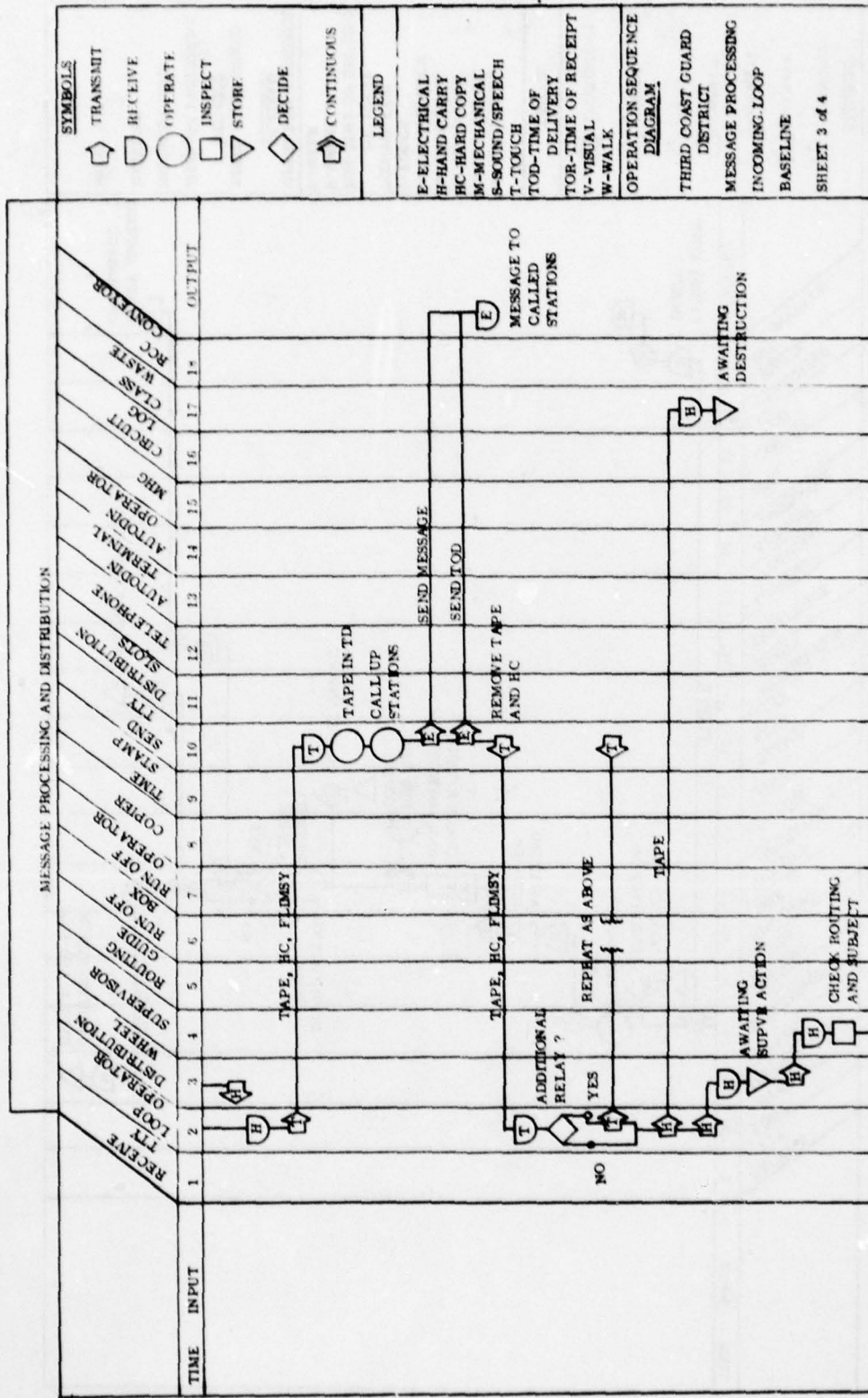

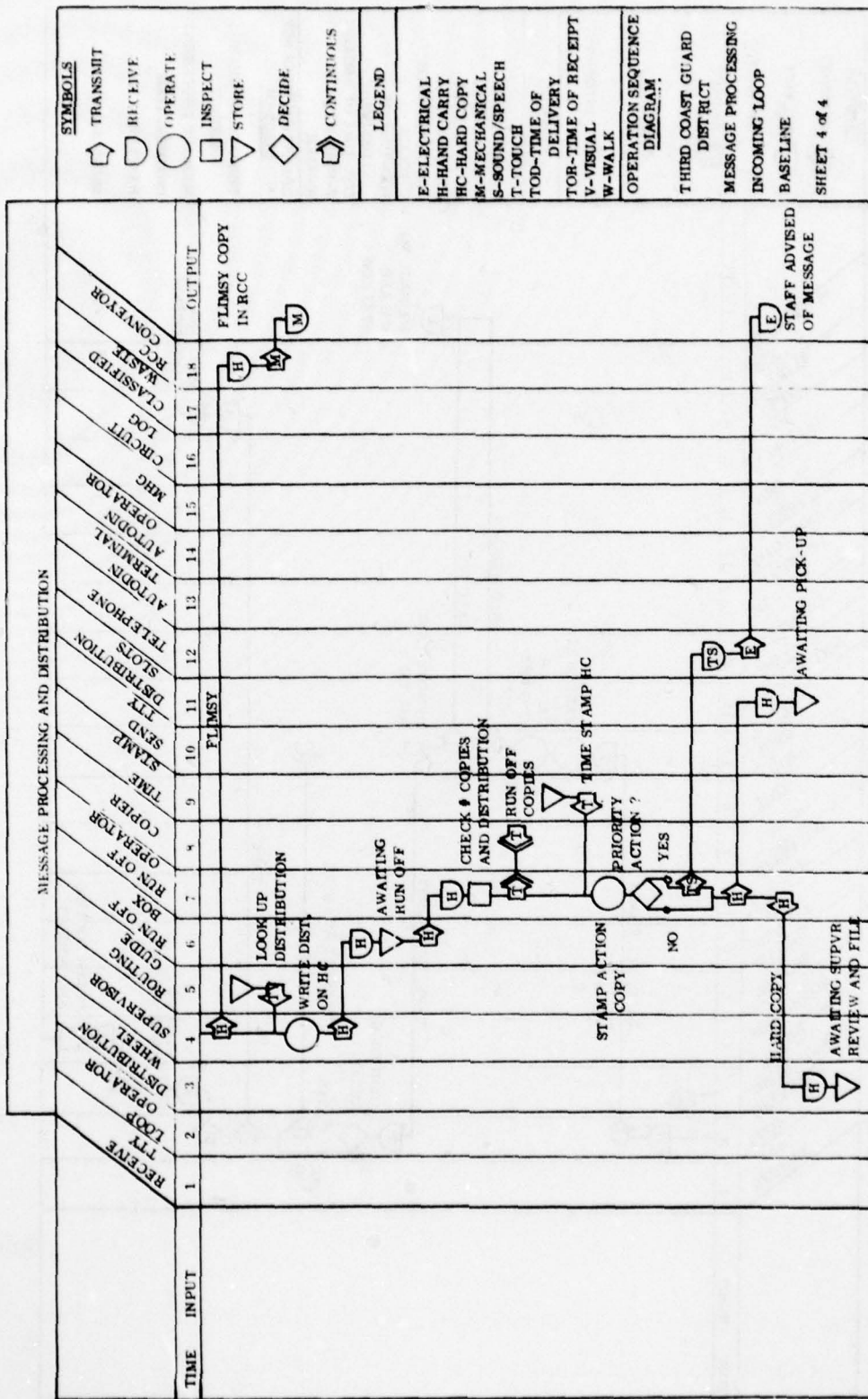

APPENDIX B

COMMUNICATIONS CENTER, PORTSMOUTH, VA

B.1 INTRODUCTION

This appendix describes the facilities and operations of the Fifth Coast Guard District Communications Center. Data upon which this appendix is based were collected during an on-site survey conducted between 13 and 15 September 1977. Supplementary information was obtained from files and records maintained by the Commandant, U. S. Coast Guard (G-OTM).

B.2 GENERAL DESCRIPTION

The Fifth District Communications Center (COMMCEN) is located on the sixth floor of the Federal Building, 431 Crawford Street, Portsmouth, Virginia. Spaces adjacent to the COMMCEN are occupied by the Rescue Coordination Center (RCC), Staff Communications Branch administrative offices, and the telephone switchboard. Organizationally, the COMMCEN is an element of the Communications Branch of the Operations Division. The COMMCEN provides over-the-counter message service to the Fifth Coast Guard Headquarters Staff, located in the Federal Building, and to several, very low volume customers in the same and adjacent buildings. No messenger service is provided by the COMMCEN. A total of eight teletypewriter circuits, illustrated in Figure B-1, are terminated in the COMMCEN, including a Mode V AUTODIN terminal which is homed on the Andrews switch. The two Group Loops (North-circuit GT13115 and South-circuit GT7990) may be operated independently, or by bridging in the COMMCEN, as one multipoint circuit. The COMMCEN also operates a terminal in the SARLANT network which is depicted in Figure A-2, Appendix A.

Instructions for the preparation and handling of message traffic are contained in CG-233 and amplified for local use in a Fifth CG District Staff Instruction.

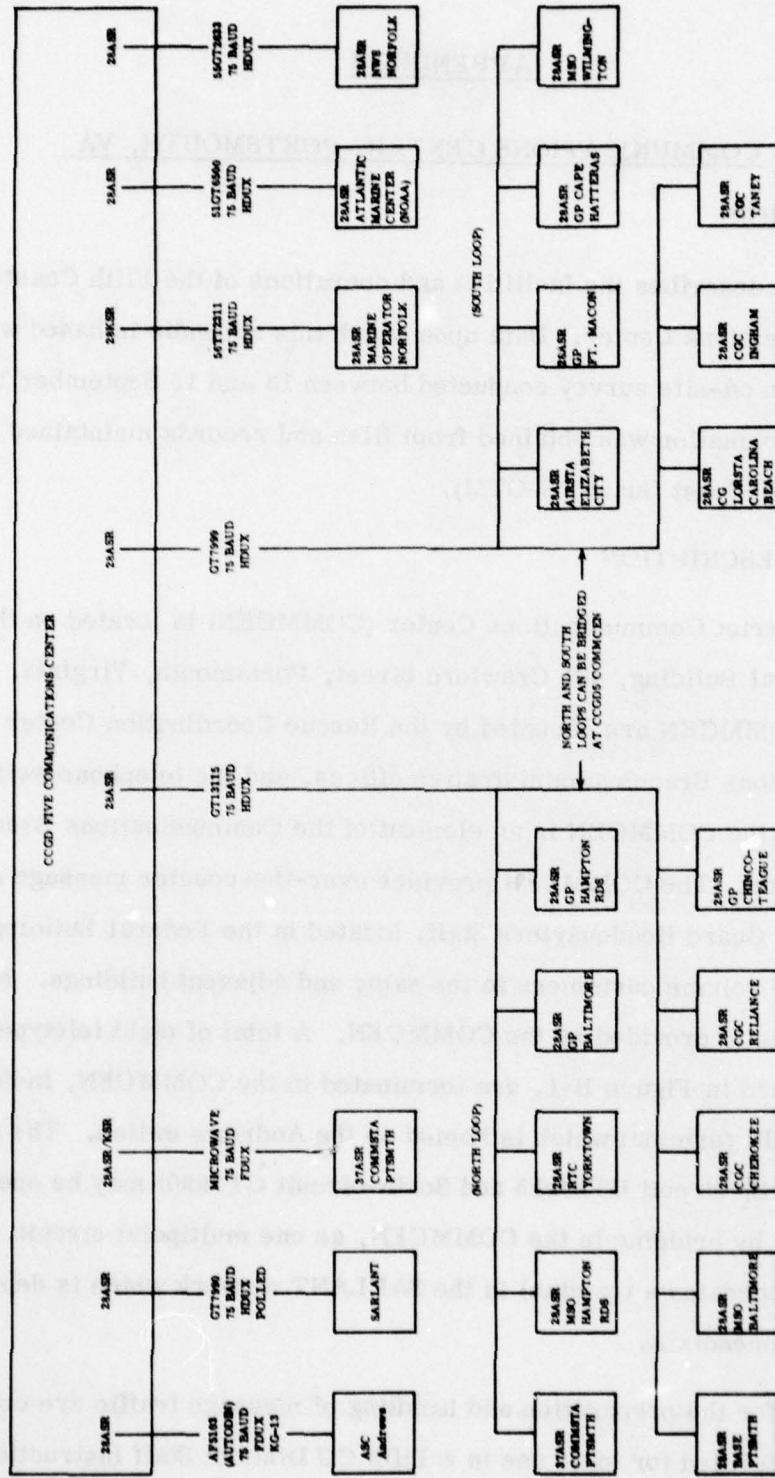

Figure B-1. Fifth CG District Teletypewriter Circuit Diagram

Detailed guidance for COMMCEN personnel is contained in COMMCEN Standing Operating Procedures (SOPs). There are, at the present, no requirements for "special privacy" on unclassified traffic.

B.3 GROWTH AND FUTURE REQUIREMENTS

There is an approved and funded plan to enlarge and reconfigure the COMMCEN. The target date for completion is December 1978. Other planned improvements include equipping the COMMCEN-COMMSTA microwave circuit for on-line (KW-7) operations; replacement of the Mode V by a Mode I AUTODIN terminal in October 1978; and installation of an Optical Character Reader (OCR) and Message Header Generator. There is also an existing project to upgrade power and environmental control systems.

A word processing system will be installed within the Headquarters, by the end of calendar year 1977, for use by various staff elements. The potential of this system to provide some degree of support to the existing message preparation and distribution system should be investigated.

No data were collected during the survey which indicate that Fifth District traffic volumes or patterns should change significantly in the foreseeable future. The gradual increase in Law Enforcement activity noted in the Third CG District is also being experienced in the Fifth CG District. A similar solution (i. e., interactive terminal with El Paso Intelligence Center (EPIC) and a capability for secure voice (phone patch) to forces afloat) is under consideration.

An electronic courier circuit between the COMMCEN and the RCC may be required upon completion of the COMMCEN modernization. Advance copies of all incoming messages are currently provided the RCC through a connecting window.

B.4 PERSONNEL

B.4.1 Manning

The personnel allowance for the COMMCEN totals 11 (one radioman-in-charge and 10 watch standers). All radiomen currently assigned are E-5 or above. The

day watch (0600-1800 local) normally consists of three operators plus the RM-in-C. Two operators are assigned during night (1800-0600) watches. The average work week is 42 hours. COMMCEN personnel are not assigned other duties or provided time for personal business during assigned duty periods.

B.4.2 Training

A formal training program is being developed. When implemented, training sessions will be scheduled for one hour in alternate weeks.

Approximately six months on-the-job training (OJT) is required to qualify an E-5 to perform all COMMCEN functions. An E-7 is normally able to perform all duties within two weeks.

It can be anticipated that COMMCEN personnel will be required to provide message drafters throughout the staff further assistance and training in message preparation, including the use of the Plain Language Address Designators (PLAD), if an OCR is installed.

B.5 EQUIPMENT AND FACILITIES

B.5.1 Communications Center Equipment

Table B-1 summarizes communications equipment which will be in place upon completion of the planned COMMCEN improvement project. The OCR is not included.

B.5.2 Connected Station Terminal Equipment

Fifth District shore activities which operate the distant end of circuits terminated in the Headquarters COMMCEN, and Coast Guard Cutters normally served by the District Group Loops are equipped with Model 28ASR teletypewriter terminals. Based on an acquisition cost of \$3,246 per terminal, the total plant investment for subscriber sets was \$51,936.

TABLE B-1. COMMEN COMMUNICATIONS EQUIPMENT

EQUIPMENT	QTY	OWNER	UNIT COST	LEASED COSTS (YR)	SERVICE DATE	MAINTENANCE ACTIVITY	REMARKS
TSEC /KG-13	1	CG				CRF NAVSHIPYD	
TSEC /KW-7	1	CG				CRF NAVSHIPYD	
TSEC /KY-3	1	CG				CINCLANTFLT	
2*ASR	4	CG	\$14,000		1962(1), 1965(2), 1972(1)	Support Center	
2*ASR /KSR	1	CG	\$3,500		1976	Support Center	
2*ASR MOD 46	1	AT&T				AT&T	
2*ASR (AUTODIN)	1	WT				WT	Lease Includes Circuit & Maintenance
2*ASR	3	C&P		\$17,340/YR		C&P	
MESSAGE HEADER GENERATOR	1						Planned Installation Date Unknown
LINE CONTROL UNIT	1						
MEDIUM SPEED LINE PRINTER	1				October 1974		
PAPER TAPE PUNCH	1						
PAPER TAPE READER	1						
CARD PUNCH	1						
CARD READER	1						
IBM-2 COPIER	1	IBM				IBM	Maintenance for 8 months \$5,087.60
IBM-3 COPIER	1	CG	\$24,000			IBM	

NOTE: Data, other than that reflected above, not available

The Communication Station (COMMSTA), Portsmouth operates Model 37ASR equipment on the South Group Loop and the microwave circuit to the District COMMCEN. The unit cost of the Model 37ASR is \$6,500.

B.5.3 Facilities

The floor plan for the reconfigured COMMCEN is provided in Figure B-2. A location for the OCR and Message Header Generator has not been determined.

B.5.4 Maintenance

The Communications Branch has no maintenance responsibilities or capabilities. Maintenance arrangements and costs, where identified, are included in Table B-1.

B.5.5 Miscellaneous Communications Facilities

The COMMCEN is served by two extensions off the local telephone exchange. Access to the FTS, AUTOVON, and AUTOSEVOCOM is also available.

A pass through window now exists between the COMMCEN and RCC. Following completion of the COMMCEN upgrade, this window will be approximately 30 feet from the reproduction/distribution position. Other means of delivering messages to the RCC are being considered.

B.5.6 Cost Data

Recurring costs for maintenance and leased services, where available, are included in Table B-1.

The annual cost for consumable supplies are identified in Table B-2.

B.6 FUNCTIONAL DESCRIPTION

B.6.1 Forms and Formats

The standard message form (CG Form 2655) is currently prescribed for the preparation of originated messages. The COMMCEN accepts both typed and hand-written messages for transmission.

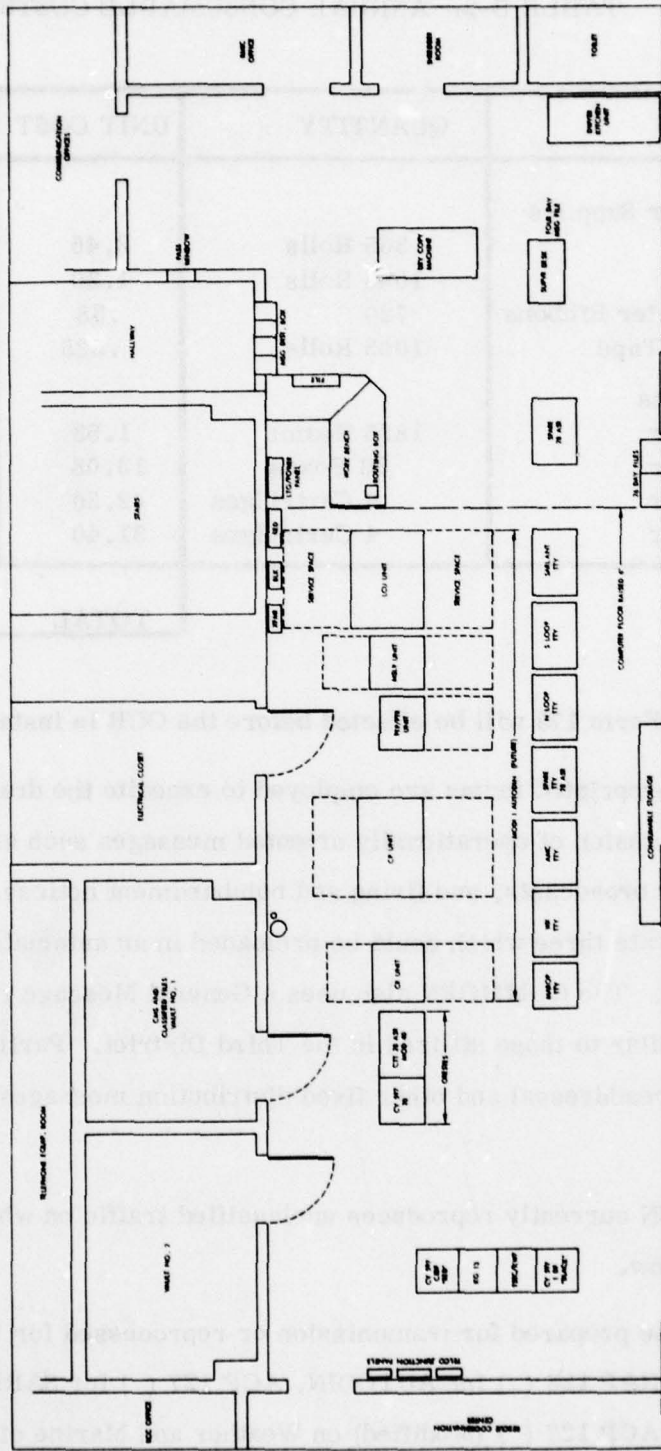

Figure B-2. COMMEN Floor Plan (After Renovation)

TABLE B-2. ANNUAL CONSUMABLE COSTS

ITEM	QUANTITY	UNIT COST	ANNUAL COST
Teletypewriter Supplies			
2 Ply	365 Rolls	2.45	894.25
Single Ply	1095 Rolls	1.30	1423.50
Teletypewriter Ribbons	720	.38	273.60
Perforator Tape	1095 Rolls	.525	574.88
Copier Supplies			
IBM 3 Paper	1825 Reams	1.53	2792.25
IBM 2 Paper	36 Boxes	13.08	470.88
IBM 3 Toner	8 Cartridges	42.50	340.00
IBM 2 Toner	4 Cartridges	31.40	125.60
		TOTAL	6894.96

Conversion to DD Form 173 will be effected before the OCR is installed.

A number of preprinted forms are employed to expedite the drafting and processing for transmission of operationally oriented messages such as safety warnings, NOTAMs, weather broadcasts, and firing and bombardment notices. Figures B-3 through B-5 illustrate three which could be preloaded in an automated system for call out by an operator. The COMMCEN also uses a General Message readdressal form and procedure similar to those utilized in the Third District. Partial automation of General Message readdressal and other fixed distribution messages should be feasible.

The COMMCEN currently reproduces unclassified traffic on white paper; classified, on yellow.

Traffic must be prepared for transmission or reprocessed for relay in one or more formats: JANAP 128 () for AUTODIN, ACP 127 () for SARLANT and the Group Loops, and ACP 127 () (Modified) on Weather and Marine circuits.

FM: CCGDFIVE PORTSMOUTH VA
TO: AIG EIGHT NINE THREE SIX
ALL AFLOAT UNITS ATLANTIC COMM AREA
ZEN/COMCOGARDGRU FT MACON NC
INFO: RUCLAKK/USA ENGDIST WILMINGTON NC

BT

UNCLAS

BROADCAST UNTIL _____

LOCAL MAJOR WARNING NR _____

NORTH CAROLINA. SEACOAST. THE U. S. MARINE CORPS ADVISES THAT
FIRING EXERCISES WILL BE CONDUCTED IN WARNING AREA W-122 WITHIN A
SEVEN MILE RADIUS OF POSITION 34-32-45 NORTH 77-07-55 WEST FROM _____
_____ TO _____. MARINERS ARE ADVISED
TO EXERCISE CAUTION WHEN TRANSITING THE AREA.

BT

Figure B-3. Fixed Message Format (Camp Lejeune Firing Exercises)

(P) (R) _____ Z (MO) (YR)

FM: CCGDFIVE PORTSMOUTH VA

TO: AIG EIGHT NINE THREE SIX

ALL AFLOAT UNITS ATLANTIC COMM AREA

ZEN/COMCOGARDGRU CHINCOTEAGUE VA

BT

UNCLAS

BROADCAST UNTIL _____.

LOCAL MAJOR WARNING NR. _____.

MARYLAND. CHESAPEAKE BAY. BLOODSWORTH ISLAND. THE U. S. NAVY

ADVISES THAT BOMBARDMENT EXERCISES WILL BE CONDUCTED FROM _____

_____ TO _____ THROUGH _____

WITHIN THE RESTRICTED AREAS SURROUNDING BLOODSWORTH ISLAND AS

SHOWN ON CHART 12231 (C&GS 555).

Figure B-4. Fixed Message Format (Bloodsworth Island Bombardment)

FM: CCGDFIVE PORTSMOUTH VA
TO: AIG EIGHT NINE THREE SIX
ALL AFLOAT UNITS ATLANTIC COMM AREA
ZEN/COGARD COMMSTA PORTSMOUTH VA
ZEN/COMCOGARDGRU CHINCOTEAGUE VA
INFO: ZEN/MAROP NORFOLK VA
RUEBPAA/VIRGINIA PILOTS ASSN NORFOLK VA
RUEBEDA/VCOAC VIRGINIA BEACH VA
BT
UNCLAS
BROADCAST UNTIL _____
LOCAL MAJOR WARNING NR _____
VIRGINIA, SEACOAST. THE NATIONAL AERONAUTICS AND SPACE ADMINISTRATION WOLLOPS STATION ADVISES THAT ROCKET FIRING WILL BE CONDUCTED FROM _____

IN AREA ONE BOUNDED BY THE FOLLOWING COORDINATES: 38-00N 75-15W
38-00N 74-30W 37-15N 74-30W 37-15N 75-15W 37-30N 75-30W 37-50N 75-30W.
MARINERS ARE ADVISED TO EXERCISE CAUTION WHEN TRANSITING THE AREA.
BT

Figure B-5. Fixed Message Format (Wallops Station Rocket Firing)

AD-A060 464

COMPUTER SCIENCES CORP FALLS CHURCH VA SYSTEMS DIV F/G 17/2
STUDY OF AUTOMATION OF MESSAGE HANDLING FUNCTIONS AT USCG COMST--ETC(U)
MAY 78 D SMILEY, G KEENE, P KENNEDY DOT-CG-71522-A
CSC/SD-78/3034 USC6-D-18-78 NL

UNCLASSIFIED

3 of 4
AD
7080 464



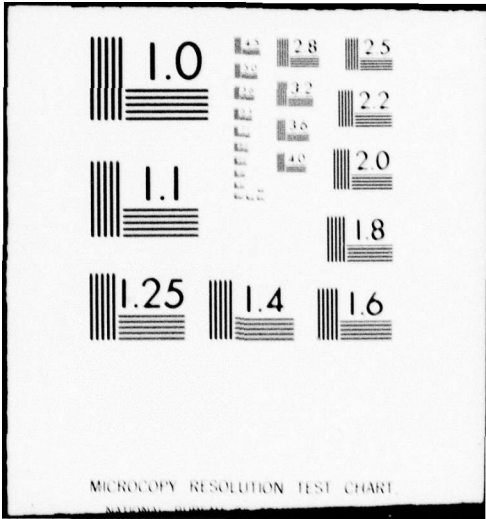

MICROCOPY RESOLUTION TEST CHART

B. 6.2 Drafting and Releasing

Local guidance for message drafters is contained in CCGD5 Staff Instruction 2100.1. The COMMCEN is not required to maintain a listing of personnel authorized to release messages. Messages received for transmission are checked to ensure that a signature is contained in the "released by" block in the message form.

B. 6.3 Processing of Outgoing Messages

This paragraph describes the actions taken to process originated traffic through the COMMCEN. The basic functions performed are similar to those described in the Third District, as illustrated in Figure A-5, Appendix A. Since the Fifth District does not use a distribution wheel, the specific steps performed vary from the steps noted in the Third District COMMCEN. A detailed flow diagram of all actions performed is contained in TAB I to this appendix.

Each originating office delivers its outgoing traffic by messenger to the COMMCEN, placing it in the "In Box". If traffic is of priority or higher precedence, the messenger rings a bell to alert COMMCEN personnel. Routine traffic may remain in the "In Box" for some time before being picked up by an operator. Messages taken from the "In Box" are time stamped. This time is used as the Time of File (TOF) in the COMMCEN. The operator examines the message for addressees, format, and a releasing signature and determines the mode of transmission and routing. From traffic reviewed during the survey, it appears that the vast majority of Fifth District traffic is routed to a relatively small (less than 50) group of Routing Indicators. He then cuts the tape, using JANAP 128 () format if transmission is to be via AUTODIN, and carries the tape, original message and hard copy to the appropriate send position. Upon completion of transmission, the operator adds to the TOD, on non-AUTODIN transmissions. If sent via AUTODIN, the operator time stamps the TOD on the hard copy, checks off the channel sequence number and adds, to the same log, the date-time group of the message. If a single transmission is

involved, the operator then discards the tape and places the original message and circuit hard copy in the in-routing box. The router types the internal distribution on the hard copy (based on instructions provided by the drafter), reproduces and slots the required copies, time stamps the original message with time of distribution, and places the original and hard copy in the file box. Classified messages (all copies) are delivered to the classified clerk.

On those originated messages requiring multiple transmission (for example via AUTODIN and Group Loop), the operator will effect all transmissions before discarding the tape and placing copies in the in-routing box.

B. 6. 4 Processing of Incoming Messages

The functional flow of incoming messages is similar to that observed in the Third District COMMCEN as depicted in Figure A-5, Appendix A. The detailed flow diagrams contained in TABS II and III to this appendix differ somewhat from similar diagrams identifying steps performed at Third District.

Upon the arrival of traffic at any receive position, the operator must, before taking any other action, determine whether the message requires (1) internal distribution only, (2) relay only, or (3) both.

If only internal distribution is required, the operator at the AUTODIN position takes the tape and hard copy from the terminal equipment, discards the tape, time stamps the TOR on the hard copy, logs receipt by channel number and DTG, and places the hard copy in the in-routing box. On circuits other than AUTODIN, the operator removes the tape and hard copy, discards the tape, and places the hard copy in the in-routing box. In this case, the TOD affixed by the distant terminal serves as the TOR.

If incoming AUTODIN traffic requires relay only, the operator removes the tape and card copy, time stamps the TOR on the hard copy and completes the channel number log. He then takes the tape and hard copy to the appropriate send

position, places the tape in the TD, calls the station(s) addressed, types transmission instructions and starts the TD. After the tape has been sent, he types the TOD, removes the hard copy, and if no other transmission are required, discards the tape, and places the hard copy in the file box. All required transmissions are made before discarding the tape and placing hard copies in the file box. Traffic received on the Group Loop or other non-AUTODIN circuits and requiring relay only are processed in generally the same manner. On these messages, the TOD inserted by the distant terminal serves as the TOR. If transmission via AUTODIN is required, the received tape must be processed into JANAP 128 () format.

On incoming traffic requiring both relay and distribution, the operator completes all relays before placing hard copies in the in-routing box.

B. 6.5 Internal Routing, Reproduction, and Distribution

A guide for internal routing, based on subject matter, is maintained in the COMMCEN and updated semi-annually. This guide is utilized to determine the internal distribution, including the designation of ACTION office, for incoming messages. Internal routing of originated messages is specified by the message drafter. The COMMCEN must redistribute ACTION messages if the initial designation is incorrect.

Two IBM copiers are installed, an IBM 2 and an IBM 3. The number of copies reproduced is determined by the routing guide and varies from a maximum of 35 to a minimum of 3. Normally, reproduction and distribution are accomplished by the operator who has effected the in-routing.

Unclassified routine traffic is slotted for periodic pickup by staff offices. The ACTION office is notified on messages of higher precedence.

All classified traffic is distributed by the Classified Clerk who maintains an accountability log. Incoming classified messages are delivered by COMMCEN messenger. Back routed copies of originated classified messages are picked up

by staff office messengers. In either event, recipients must sign for each copy received.

B.6.6 Logs and Records

The COMMCEN maintains the following logs:

- (1) Classified message log - contains the DTG of classified messages and receipt signature for each copy distributed.
- (2) AUTODIN log - maintained for incoming and outgoing traffic. Operators check off each channel sequence number and log DTG of message received or sent under that number.
- (3) Awaiting transmission log. Messages received for transmission or relay to part time stations during periods such stations are closed are entered in this log and checked off later when stations reopen and messages are transmitted and receipted for.
- (4) Destruction log - used to record destruction of key cards.

A receipt is received from connected stations for messages transmitted on all circuits except AUTODIN and SARLANT.

Originated messages are time stamped (TOF) when first handled by COMMCEN personnel. Incoming and outgoing AUTODIN messages are time stamped upon receipt (TOR) or transmission (TOD). On incoming messages on other circuits, the distant terminal TOD serves as TOR. The TOD on messages sent via other than AUTODIN is inserted by the operator on the message after the end-of-message.

B.6.7 Storage and Retrieval

The COMMCEN maintains 30 days files of classified and unclassified messages. The most current (four days) unclassified files are stored at the supervisor position, the remainder on shelves in the COMMCEN. The classified file is stored in the vault.

Frequent reference is made to the four day file, primarily for readdressals. The remaining files are seldom accessed.

B.6.8 Waste Disposal

All waste is treated as classified. The accumulated waste, approximately 75 pounds per day, is destroyed in a shredder each night by watch personnel. There is no alternate destruction means.

Key cards are destroyed in a blender.

B.7 TRAFFIC

B.7.1 General

Traffic data were compiled from statistical reports submitted by the Fifth District and from on-site observations and tabulations of current traffic. From analysis of these basic data, it is possible to determine traffic volumes by function and category, past and future growth rates, mode and method of handling, and handling times. Conclusions reached are presented in this section in tabular and narrative form.

It is again emphasized that in interpreting the gross traffic figures presented in this summary, it must be remembered that the reporting of traffic in statistical reports is on two different bases. Traffic by functional category is by actual message count. Thus, the total count for all categories equals the number of discrete messages on file. In reporting traffic by circuit mode, a message is counted each time it is handled (sent or received). Circuit mode totals will, under this reporting method, always exceed message by category counts.

B.7.2 Gross Traffic Volumes

Comparative summaries of Fifth District traffic, by functional category, for the years 1970 and 1976 are presented in Table B-3. The six year increase, in messages, of 29.1 percent equates to an annual growth of slightly less than 4.4 percent.

TABLE B-3. TRAFFIC BY FUNCTIONAL CATEGORY

FUNCTION	1970	1976	Δ	% Δ
BATHY/METEO	2,223	491	- 1,732	- 77.9
OCEANO	2,493	2,389	- 104	- 4.2
OTHER GOV.	10,257	19,075	+ 8,818	+ 86.0
SAR	6,525	10,838	+ 4,313	+ 66.1
OTHER CG	60,584	73,170	+12,586	+ 20.8
TOTAL	82,082	105,963	+23,881	+ 29.1

Table B-4 provides a summary of messages handled, during 1976, by circuit mode. In comparing 1976 to 1970 statistics, it can be seen that message handlings increased, over a six year period, by 8.9 percent, or at an annual rate of about 1.42 percent. Table B-5, which compares message and messages handled totals for the same two years (1970 and 1976), reveals that, based on statistical averages, the number of handlings per message has dropped from 1.95 in 1970 to 1.65 in 1976. Despite this marked decrease, it is apparent that relay functions performed in the Fifth District COMMCEN represent a significant workload.

B. 7.3 Specific Traffic Data

As during the earlier survey of the Third District COMMCEN, it was necessary to use August 1977 files for the collection of data which would support a more detailed analysis of Fifth District COMMCEN traffic. In this case, August totals equate to approximately 9.1 percent of the project annual figure, indicating, statistically, that August represents a somewhat busier than average month.

TABLE B-4. TRAFFIC BY CIRCUIT MODE

	SEND	RECEIVE	TOTAL
TWPL	40369	61595	101964
AUTODIN	18629	41915	60544
FAX	26	23	49
RATT	1896	1446	3342
OTHER	8483	160	3643
TOTAL	69403	105139	174542
TOTAL TRAFFIC 1970			160344
INCREASE 1970 - 1976			14198
% INCREASE			8.9

TABLE B-5. MULTIPLE HANDLINGS

Year	Number of Messages	Number of Handlings	Handling/Message Ratio
1970	82082	160344	1.95
1976	105963	174542	1.65

August totals are summarized in Table B-6. The messages handled/discrete messages ratio (15978/10278) is 1.55 as compared to the statistical average number of handlings (1.65) computed for 1976.

Classified originated and received message totals are summarized in Table B-7. This summary indicates that less than one percent of the traffic handled is classified.

TABLE B-6. TRAFFIC VOLUMES FOR AUGUST 1977

TOTAL MESSAGES	<u>10278</u>
TOTAL MESSAGES HANDLED	<u>15978</u>
% OF YEAR TRAFFIC	<u>9.1</u>

MESSAGES BY MODE	RECEIVED		SENT	
	#	%	#	%
AUTODIN	3,177	31	1,670	30
TWPL	7,139	69	3,905	69
TWX				
FAX	12	<1		
OTHERS	16	<1	59	01
TOTALS	10,344	100	5,634	100

BY CATEGORY	#	%
OCEANO	257	02
BATHY/METEO	5	<1
OTHER GOVT	1,917	19
SAR	739	07
OTHER CG	7,360	72
TOTALS	10,278	100

TABLE B-7. CLASSIFIED TRAFFIC - AUGUST 1977

	INCOMING		OUTGOING	
	#	%	#	%
TOTAL FOR MONTH	58	100	4	100
BY PRECEDENCE				
O - Immediate	2	03	1	25
P - Priority	8	13	1	25
R - Routine	48	84	2	50
BY CLASSIFICATION				
Secret	34	58	1	25
Confidential	24	42	3	75
NOTE: This tabulation includes only originated and terminated traffic. Classified traffic is not normally relayed. Three of the four outgoing were readdressals.				

Message files for 18 August and 7 September were selected for further analysis of average day and busy day patterns, respectively. Tables B-8 and B-9 provide summaries of messages handled, categorized by precedence and classification, on these two days. The totals indicate that 18 August was somewhat busier (by about .06 percent) than an average day. The distribution by precedence trend is generally similar to that observed in the Third District.

Terminated/originated traffic for 18 August is tabulated in Table B-10 by hourly periods, in local time. While distribution patterns, in respect to specific hours, may fluctuate from day to day, the one day sampling upon which Table B-10 is based provides useful data. More extensive sampling and analysis should confirm that the Fifth District COMMCEN will normally handle 11 percent of the total daily traffic during the busiest hour; 20 percent in the busiest two hour period; and over one-third or 34 percent during the most active four hour period.

TABLE B-8. TRAFFIC VOLUME FOR AVERAGE DAY (18 AUGUST 1977)

MESSAGES HANDLED - INCOMING: 365
 - OUTGOING: 227
 - TOTAL: 592
 % OF YEAR TRAFFIC - 0.33

	TERMINATED		ORIGINATED	
	#	%	#	%
TOTAL FOR DAY	245	100	60	100
DISTRIBUTION BY PRECEDENCE				
O - Immediate	18	7	4	7
P - Priority	115	47	41	68
R - Routine	112	46	15	25
DISTRIBUTION BY CLASSIFICATION				
S - Secret	1	<1		
C - Confidential				
U - Unclassified	244	99	60	100
Note:				
a. Of 365 messages received, 120 required relay only.				
b. The 227 outgoing messages included one or more transmissions of the 60 messages originated, the 120 incoming which required relay only, plus a number of incoming which terminated and required relay also.				

Both 18 August and 7 September files were examined to extract data which might identify relay patterns. The results of this analysis are compiled in Table B-11. One important factor revealed by these data is the indication that a significant portion of the traffic received on any one circuit requires relay on one or more other circuits.

TABLE B-9. TRAFFIC VOLUME FOR BUSY DAY (7 SEPTEMBER 1977)

MESSAGES HANDLED - INCOMING: 438
 - OUTGOING: 238
 - TOTAL: 676
 % OF YEAR TRAFFIC - 0.38

	TERMINATED		ORIGINATED	
	#	%	#	%
TOTAL FOR DAY	251	100	49	100
DISTRIBUTION BY PRECEDENCE				
O - Immediate	14	6	2	4
P - Priority	121	48	29	59
R - Routine	116	46	18	37
DISTRIBUTION BY CLASSIFICATION				
Secret	1	< 1		
Confidential	2	< 1		
Unclassified	248	99		
NOTE:				
a. Of 438 messages received, 187 required relay only.				
b. The 238 send total includes one or more transmissions of the 49 originated messages plus incoming messages which required relay.				

B.7.4 Message Length

No attempt was made during this survey to measure message lengths. The most practical method of supporting an effort to collect such data on non-AUTODIN circuits would be the establishment and retention of tape monitor reels.

TABLE B-10. HOURLY DISTRIBUTION - 18 AUGUST (ORIGINATED/TERMINATED TRAFFIC)

HOUR ENDING (LOCAL)	01	02	03	04	05	06	07	08	09	10	11	12	13	14	15	16	17	18	19	20	21	22	23	24
INCOMING		1											1	1	1	1	1	2	1	1	4		2	2
BY																								
PRECEDENCE		4	7	3	1	1	3	2	2	2		5	8	9	3	6	4	4	4	15	15	3	7	5
											1	3	3	2	6	13	2	13	6	4	10	12	17	6
INCOMING																								
BY																					1			
CLASSIFICATION																								
U	4	8	4	2	4	4	5	4	2	2	1	8	12	12	9	20	7	19	13	21	28	16	26	13
TOTAL INCOMING	4	8	4	2	4	4	5	4	2	2	1	8	12	12	9	20	7	19	13	21	29	16	26	13
OUTGOING																								
BY																								
PRECEDENCE																								
S																								
C																								
U																								
TOTAL OUTGOING	1		2	3		1	3	1	1	1		2	2	3	8	3	4	3	6	5	6	1	2	6

NO OUTGOING CLASSIFIED THIS DATE

(ALL TIMES BASED ON TOR/TOD - LOCAL TIME)

HOUR	#	%	2 HOUR	#	%	4 HOUR	#	%
BUSY	34	11.1	20-21	61	20.0	19-23	105	34.4
SLOW	11	<1	10-11	3	1.0	8-11	12	3.9
MEAN	12.7	4.2		25.4	8.3		50.6	16.7

TABLE B-11. RELAY PATTERN

TO FROM	AUTODIN	GROUP LOOP	OTHER	TOTAL
AUTODIN		141	58	199
GROUP LOOP	90		43	133
OTHER	85	110		195
TOTAL	175	251	101	527

B.7.5 Handling Times

B.7.5.1 Recorded

Files maintained in the Fifth District COMMCEN provide sufficient information to collect factual handling time statistics. Samplings were made of incoming, relayed, and originated messages for 18 August and on originated only for the busy day (7 September). A summary of these samplings appears in Table B-12. It should be recognized that the average in-station handling times indicated are influenced heavily by the distribution pattern illustrated earlier in Table B-10. It is also apparent that in-station handling times increase substantially during busier days.

B.7.5.2 Synthesized

The sequence of operations and the time associated with each operation are illustrated in Figures B-6 (Incoming AUTODIN), B-7 (Incoming Loop), and B-8 (Originated Messages). The functions, operations, personnel, and stations depicted correspond to those used on the flow diagrams contained in TABs I, II and III.

It must be emphasized that these synthesized handling times are based on the unobstructed flow of an individual message through the complete process without

TABLE B-12. IN-STATION HANDLING TIMES (RECORDED)

INCOMING 18 AUGUST

	#MSGs	TOTAL HANDLING TIME (MIN)	AVERAGE IN-STATION TIME (MIN)
Incoming Total	221	11,523	52
Terminated	127	4,484	35
Relayed	94	7,039	75

OUTGOING 18 AUGUST

	#MSGs	TOTAL HANDLING TIME (MIN)	AVERAGE IN-STATION TIME (MIN)
Outgoing Total	57	3,183	56
Single	29	1,062	37
Multiple	28	2,121	76

OUTGOING 07 SEPT

	#MSGs	TOTAL HANDLING TIME (MIN)	AVERAGE IN-STATION TIME (MIN)
Outgoing Total	42	5,543	132
Single	26	3,282	126
Multiple	16	2,261	141

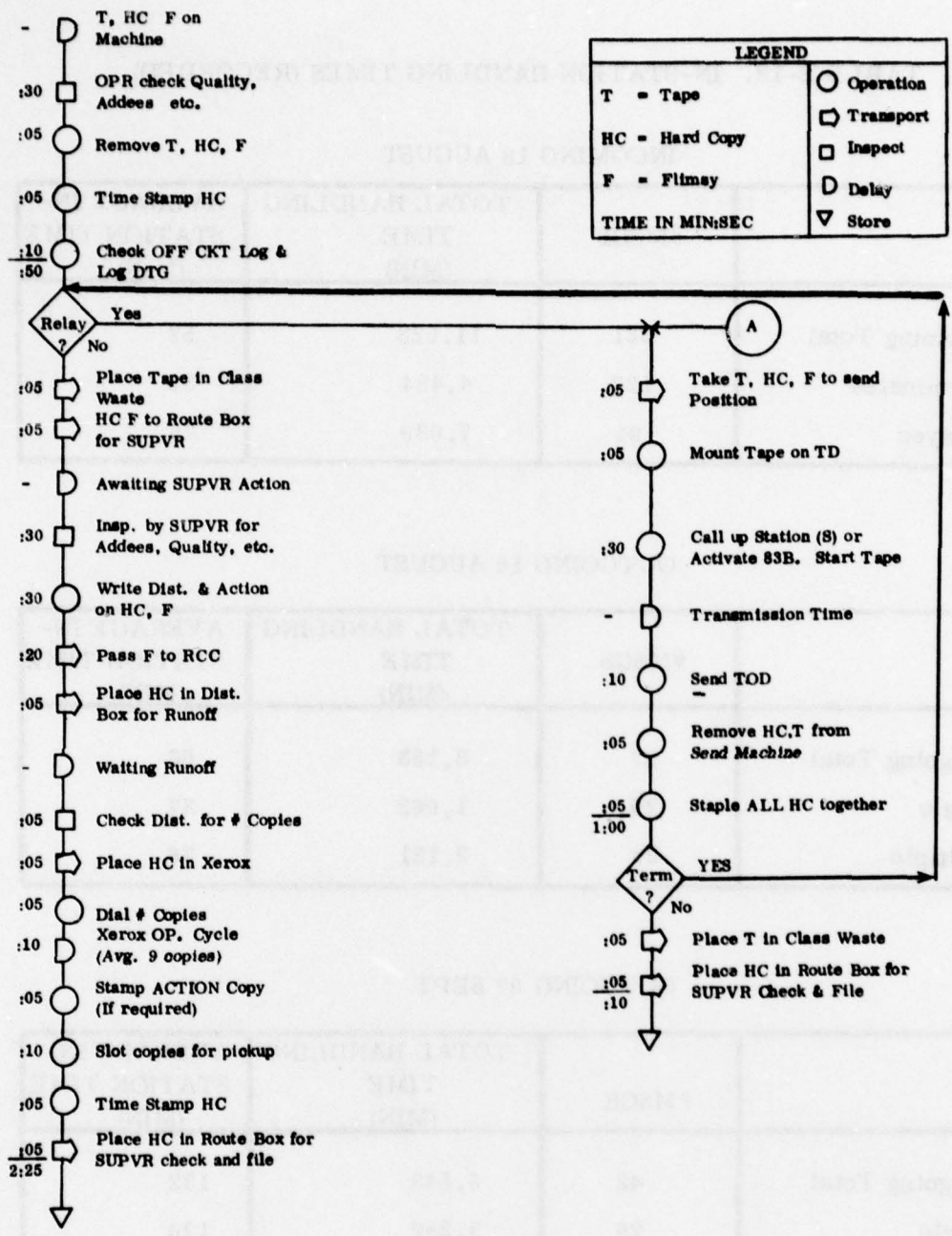

TIME SUMMARY
(Excluding Delay Time)

TERMINATE ONLY	= 3:15
RELAY ONLY	= 2:00
TERMINATE AND RELAY	= 4:15
ADDITIONAL RELAYS	= 1:00 Each

Figure B-6. Synthesized Handling Times - Incoming AUTODIN

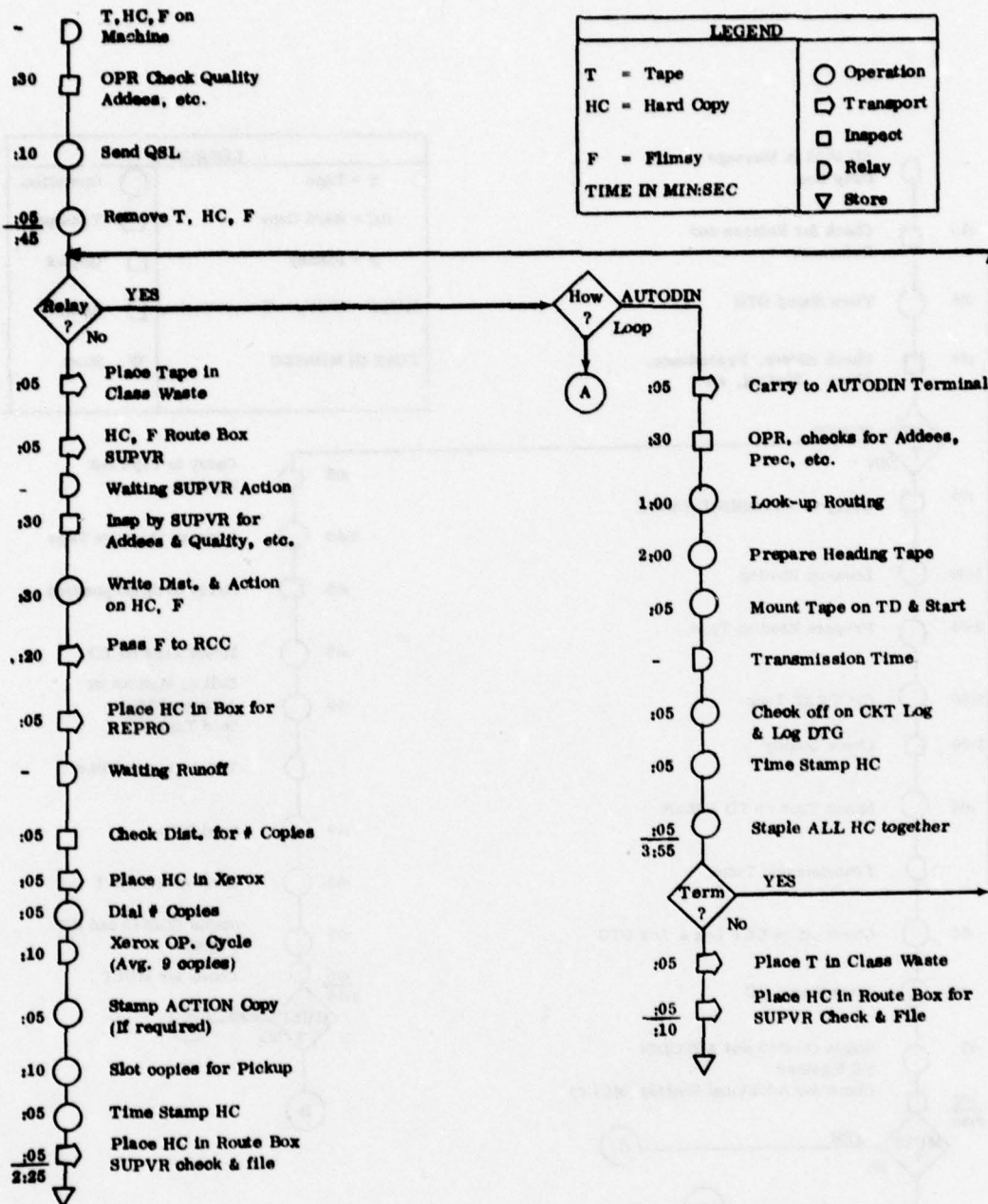

TIME SUMMARY
(Excluding Delay Time)

TERMINATE ONLY	= 3:10
RELAY AUTODIN ONLY	= 4:50
TERMINATE AND RELAY	= 7:05
ADDITIONAL RELAY	= 1:00 Each

Figure B-7. Synthesized Handling Times - Incoming Loop

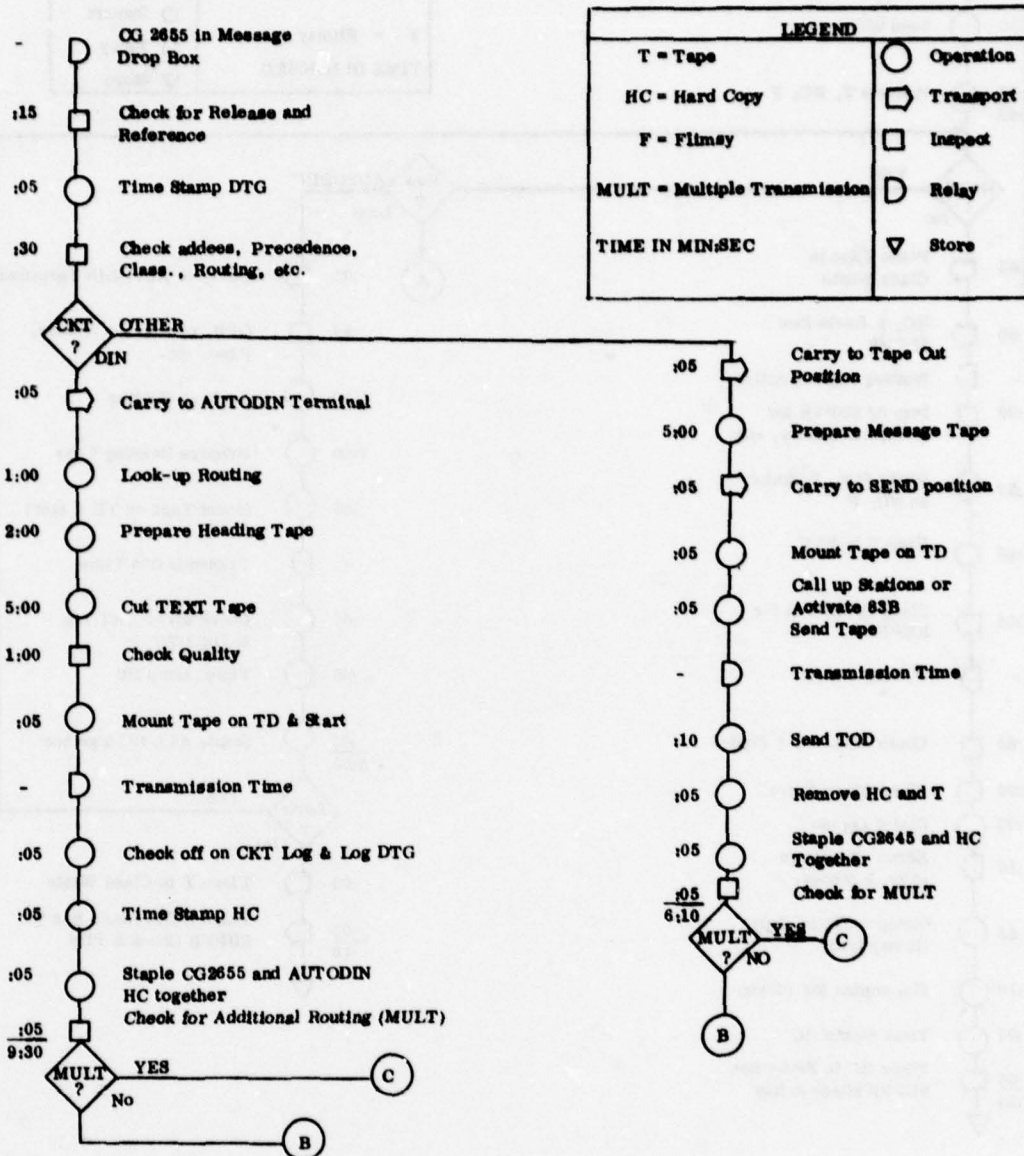
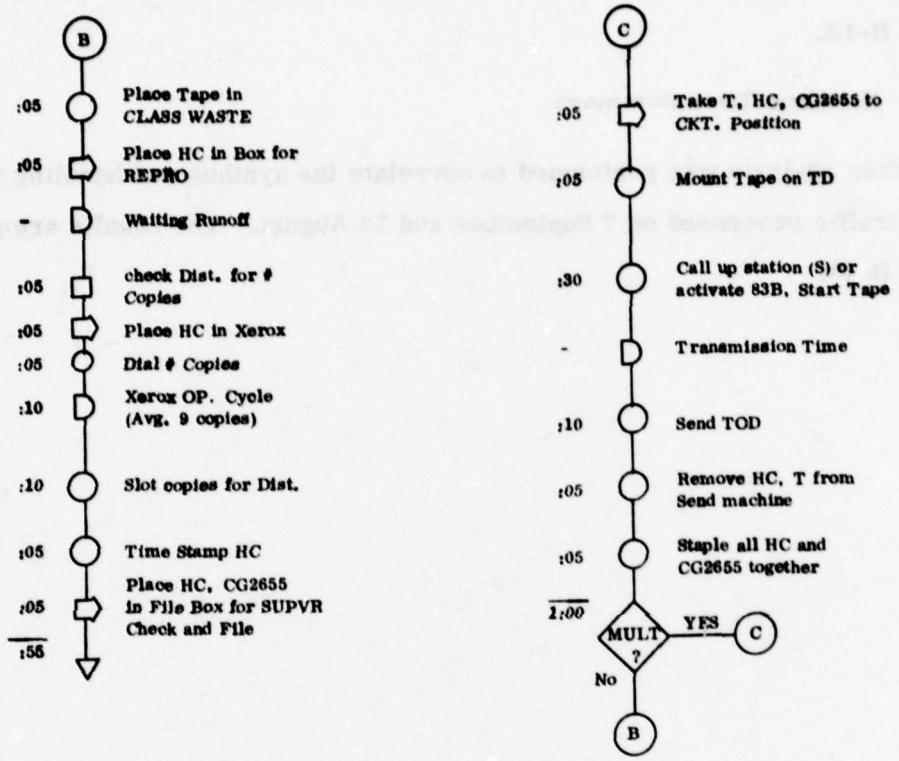

Figure B-8. Synthesized Handling Times - Originated Messages



TIME SUMMARY
(Excluding Delay Time)

OUTGOING AUTODIN ONLY	= 11:20
OUTGOING LOOP ONLY	= 8:00
OUTGOING AUTODIN & LOOP	= 12:20
ADDITIONAL TRANSMISSION (Mult)	= 1:00

Figure B-8. Synthesized Handling Times - Originated Messages (Continued)

regard to the delays which are essentially unavoidable in a COMMCEN of this nature. No comparison should be attempted between the synthesized handling times presented in Figure B-6, B-7, and B-8 and the recorded handling times contained in Table B-12.

B.7.5.3 Handling Time Summary

Further analysis was performed to correlate the synthesized handling times with the traffic processed on 7 September and 18 August. The results are presented in Table B-13.

TABLE B-13. HANDLING TIME SUMMARY

HANDLING REQUIREMENT	7 SEPTEMBER 1977			18 AUGUST 1977		
	#	UNIT TIME (MIN:SEC)	TOTAL TIME (MIN)	#	UNIT TIME (MIN:SEC)	TOTAL TIME (MIN)
	MSGs			MSGs		
Terminating + Relay Din + Relay Loop Term. Only	251	-	1029	245	-	1033
	45	7:05	319	36	7:05	255
	40	4:15	170	99	4:15	421
	166	3:15	540	110	3:15	357
Relay Only From DIN From Loop	187	-	507	120	-	373
	140	2:00	280	73	2:00	146
	47	4:50	227	47	4:50	227
Outgoing To DIN MULTIPLE	49	-	394	60	-	488
	33	11:20	374	40	11:20	453
	20	1:00	20	35	1:00	35
Total Handling Time - Minutes						
1930						
Total Handling Time - Hours						
32.2						
Total Handling Time - Man - Days						
1.34						
Time Devoted to Relay Functions and Multiple Transmissions						
Minutes						
743						
Hours						
12.4						
Man/Days						
.515						
648						
10.8						
.45						

TAB I To APPENDIX B

OPERATION SEQUENCE DIAGRAM - OUTGOING

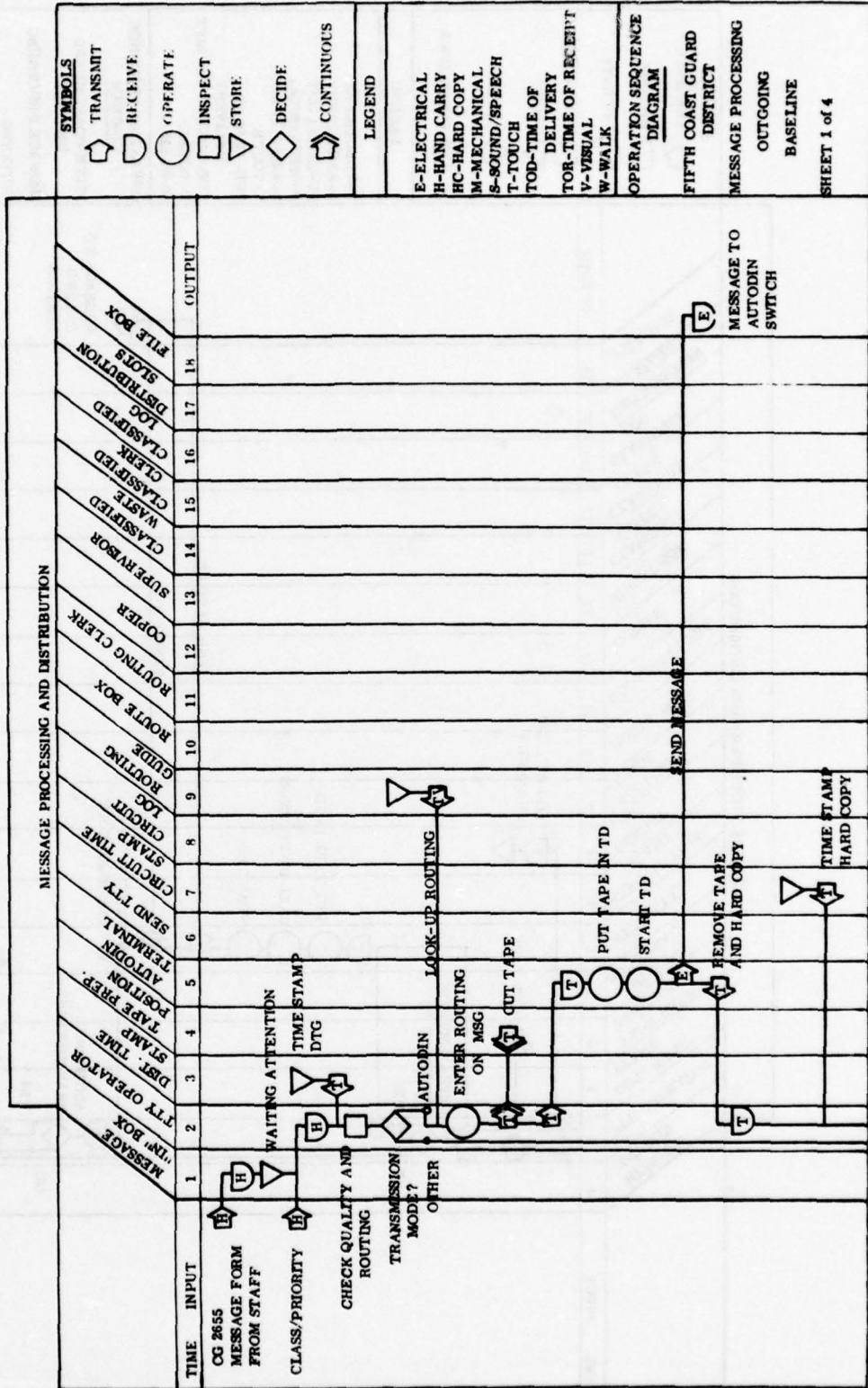

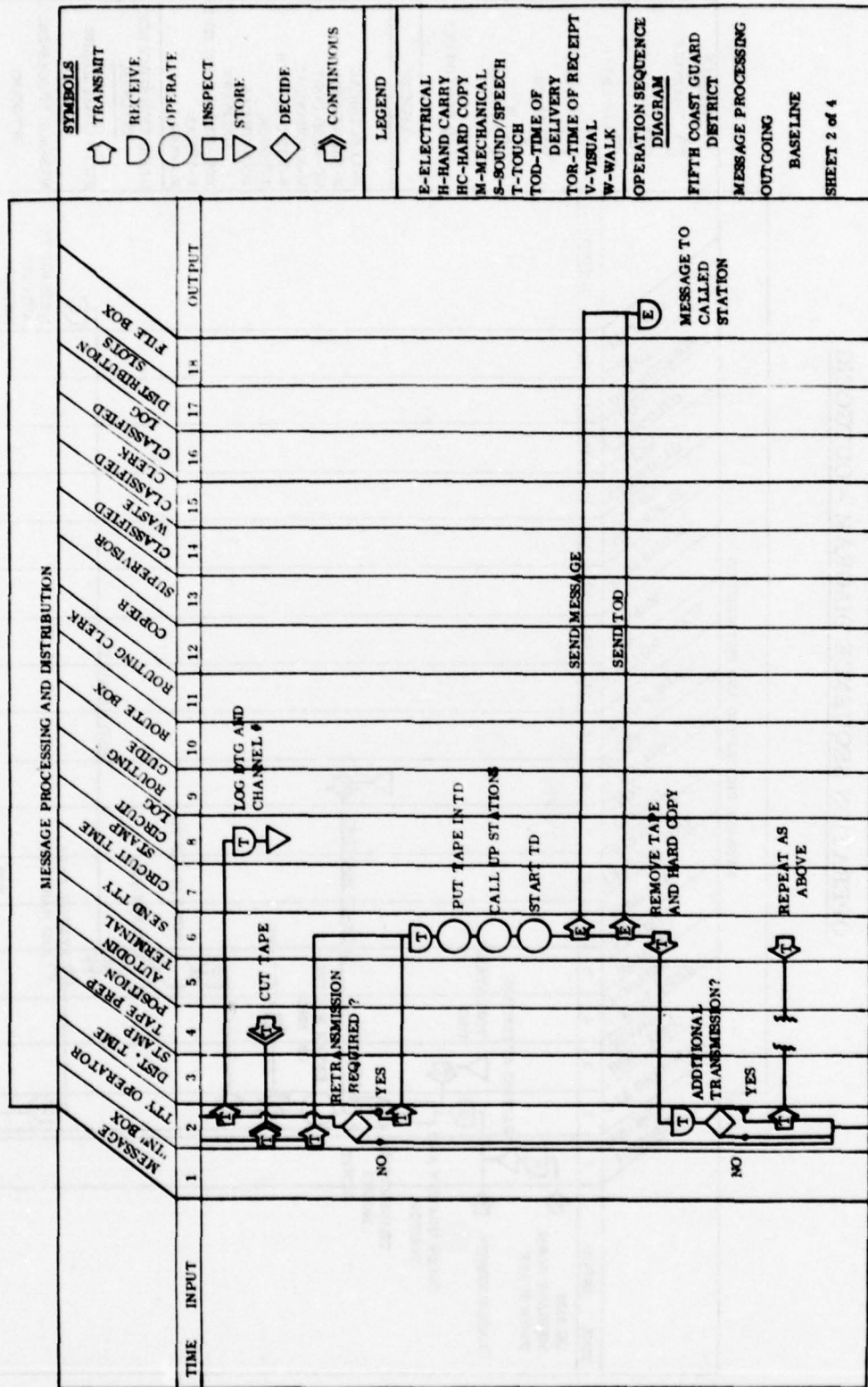

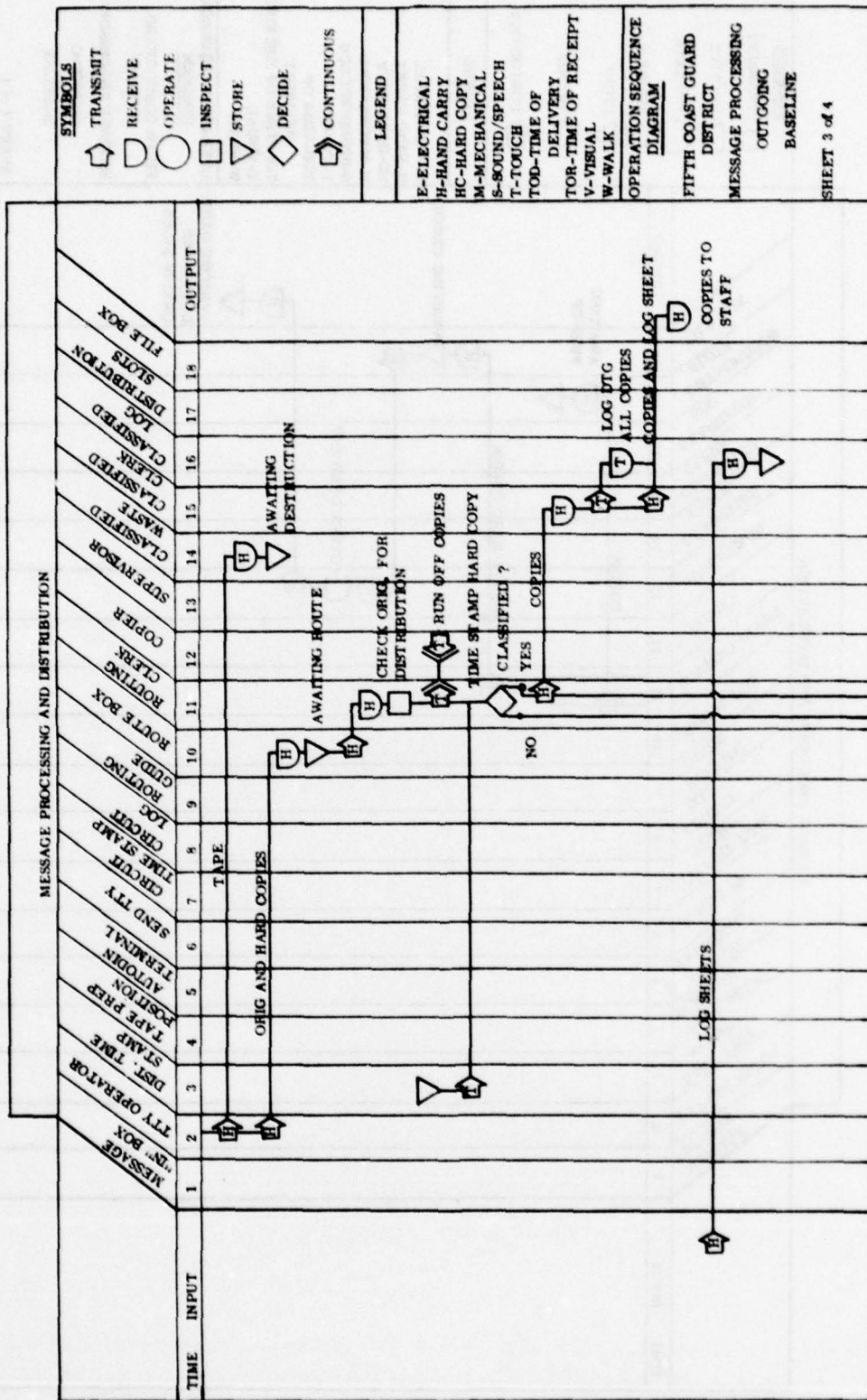

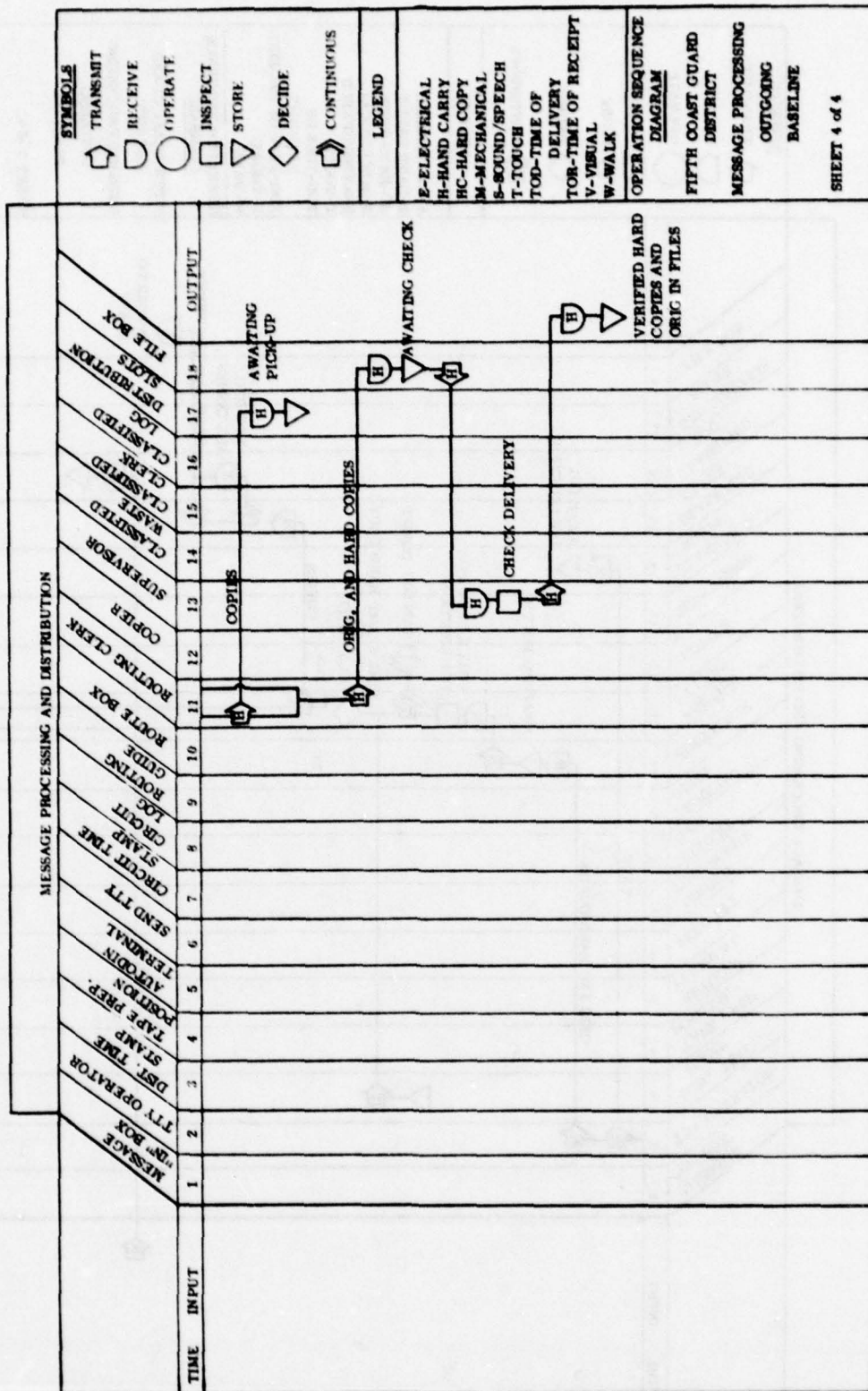

TAB II To APPENDIX B

OPERATION SEQUENCE DIAGRAM - INCOMING AUTODIN

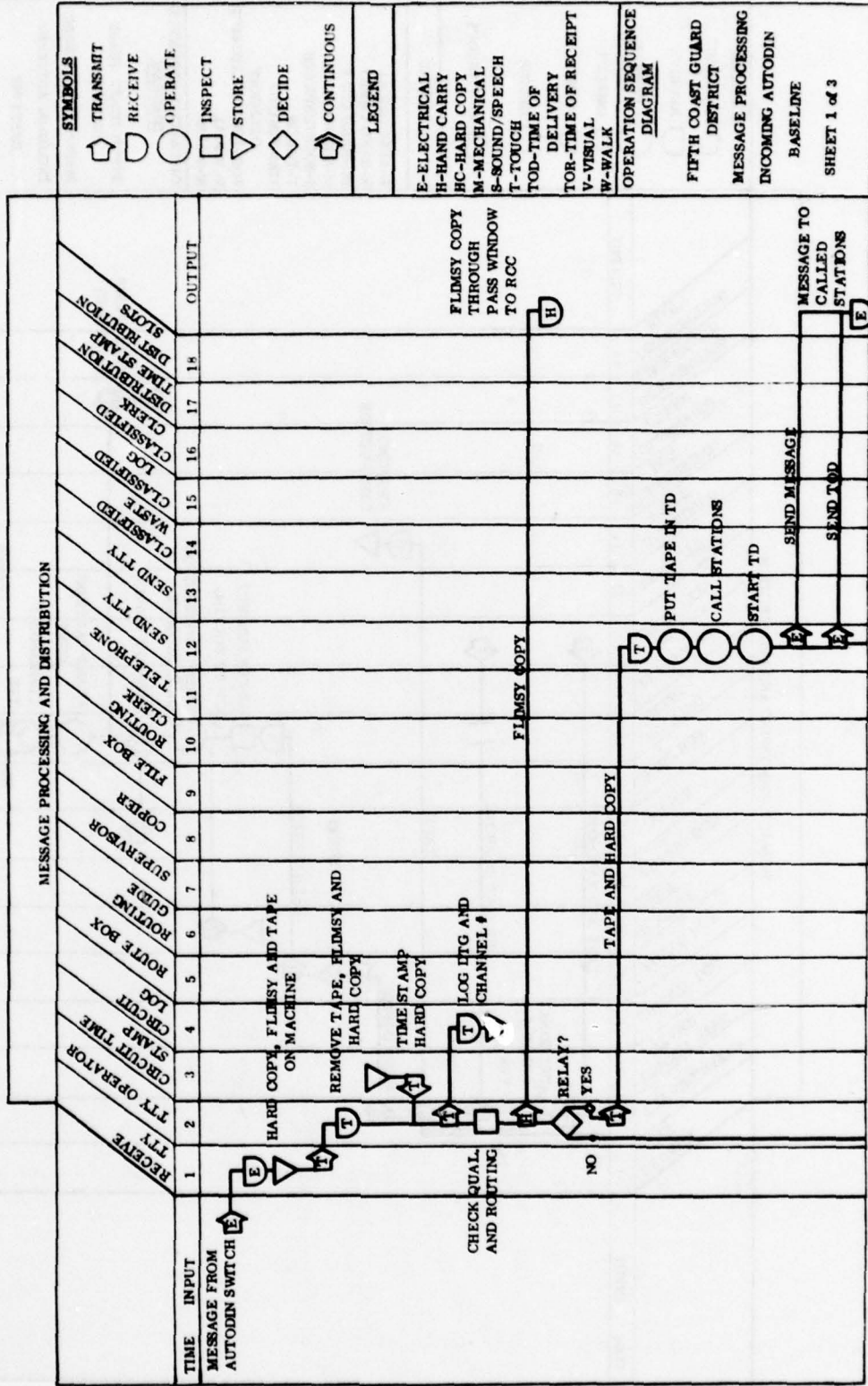

SYMBOLS

- ◻ TRANSMIT
- ◻ RECEIVE
- OPERATE
- ◻ INSPECT
- ◻ STORE
- ◊ DECIDE
- ◻ CONTINUOUS

LEGEND

- E-ELECTRICAL
- H-HAND CARRY
- HC-HARD COPY
- M-MECHANICAL
- S-SOUND/SPEECH
- T-TOUCH
- TOD-TIME OF DELIVERY
- TOR-TIME OF RECEIPT
- V-VISUAL
- W-WALK

OPERATION SEQUENCE DIAGRAM

- FIFTH COAST GUARD DISTRICT
- MESSAGE PROCESSING INCOMING AUTODIN BASELINE
- SHEET 1 of 3

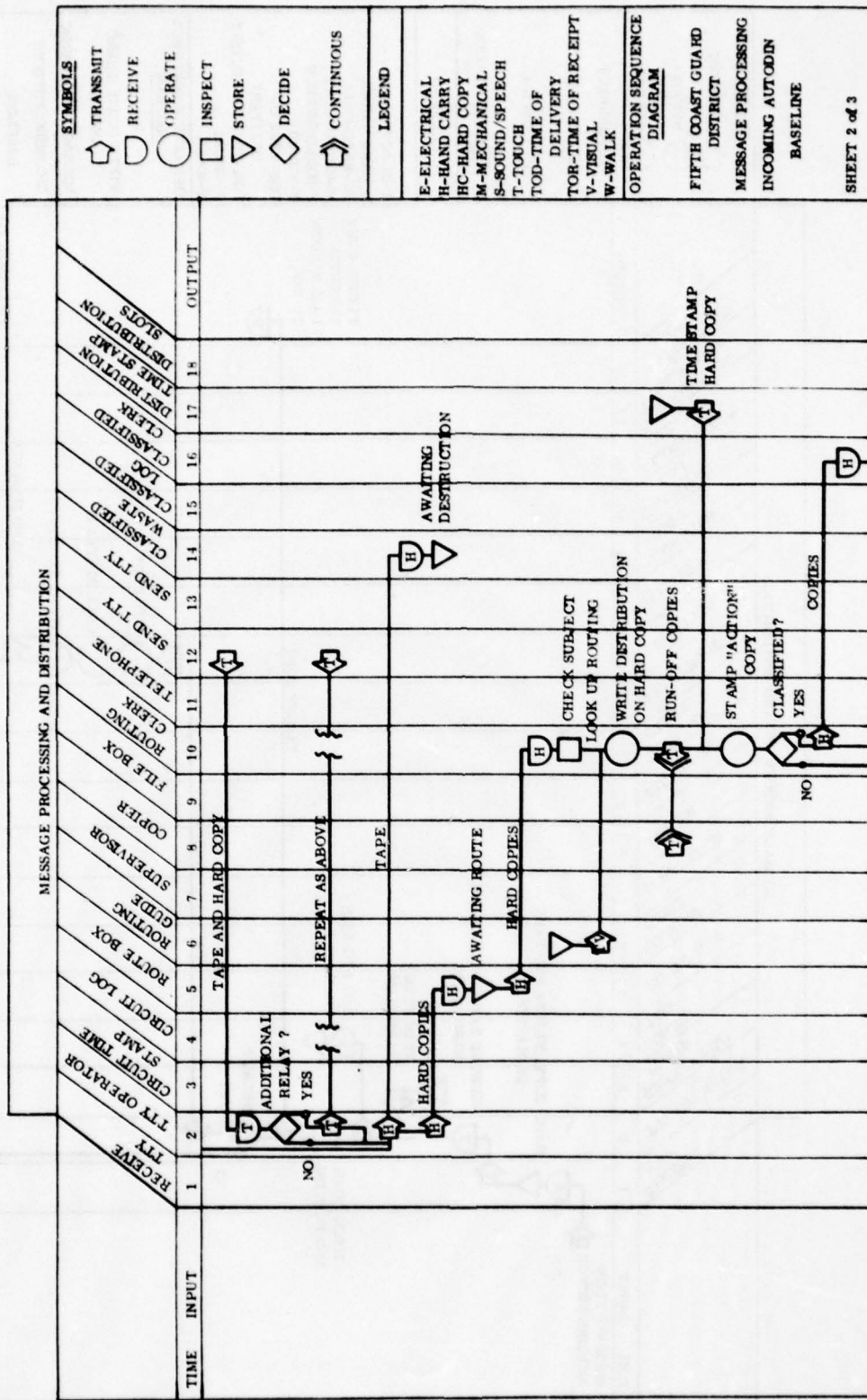

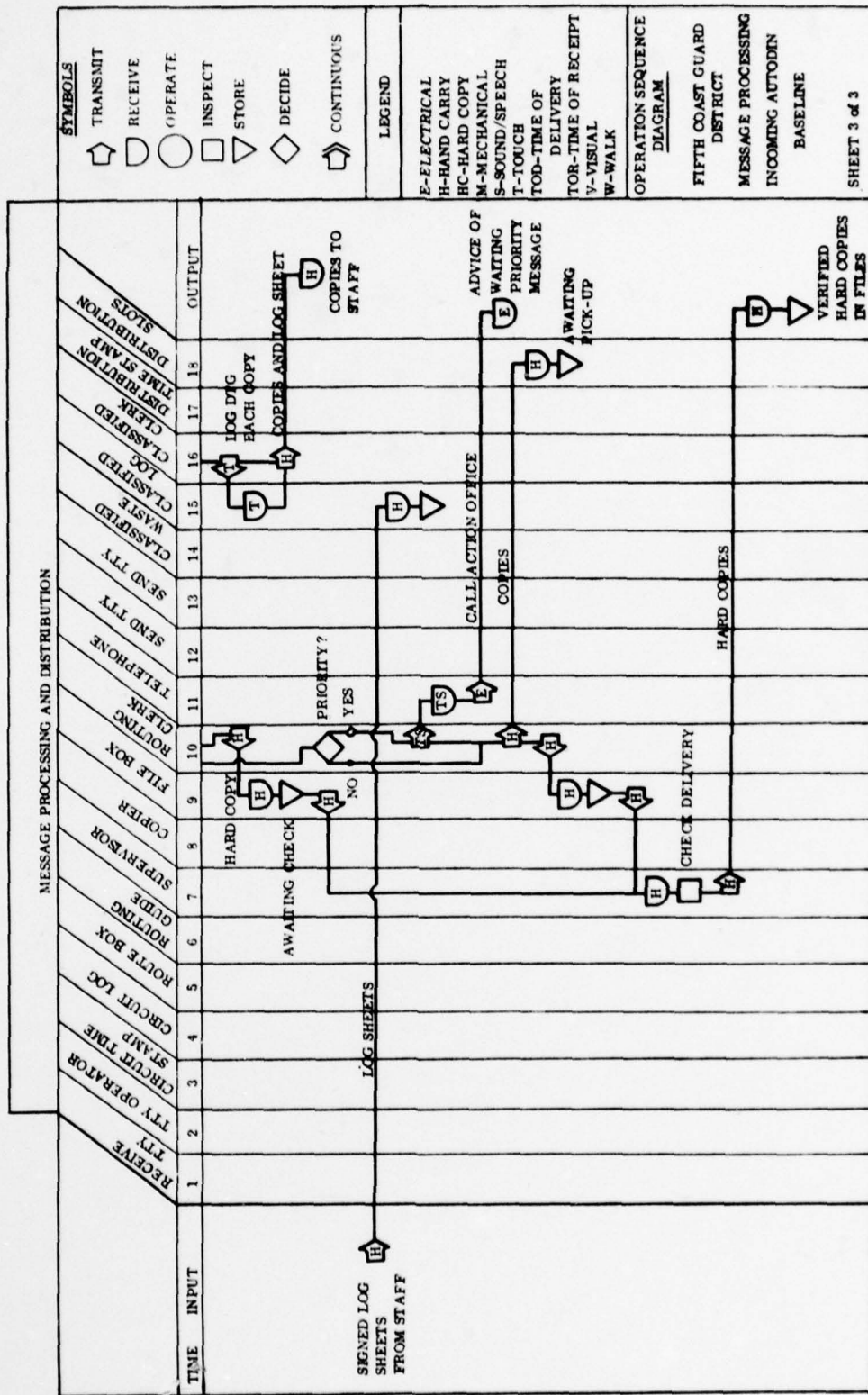

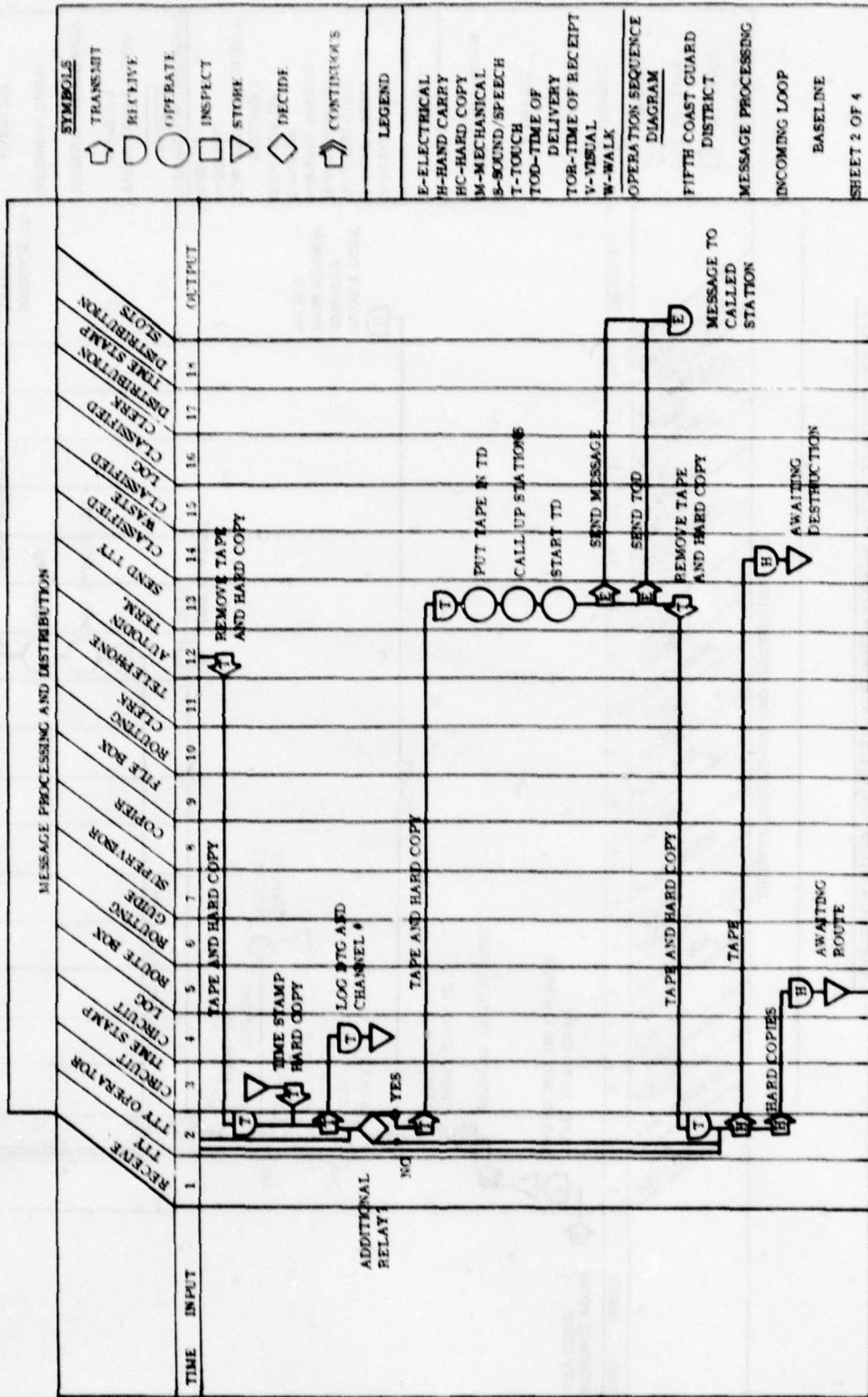

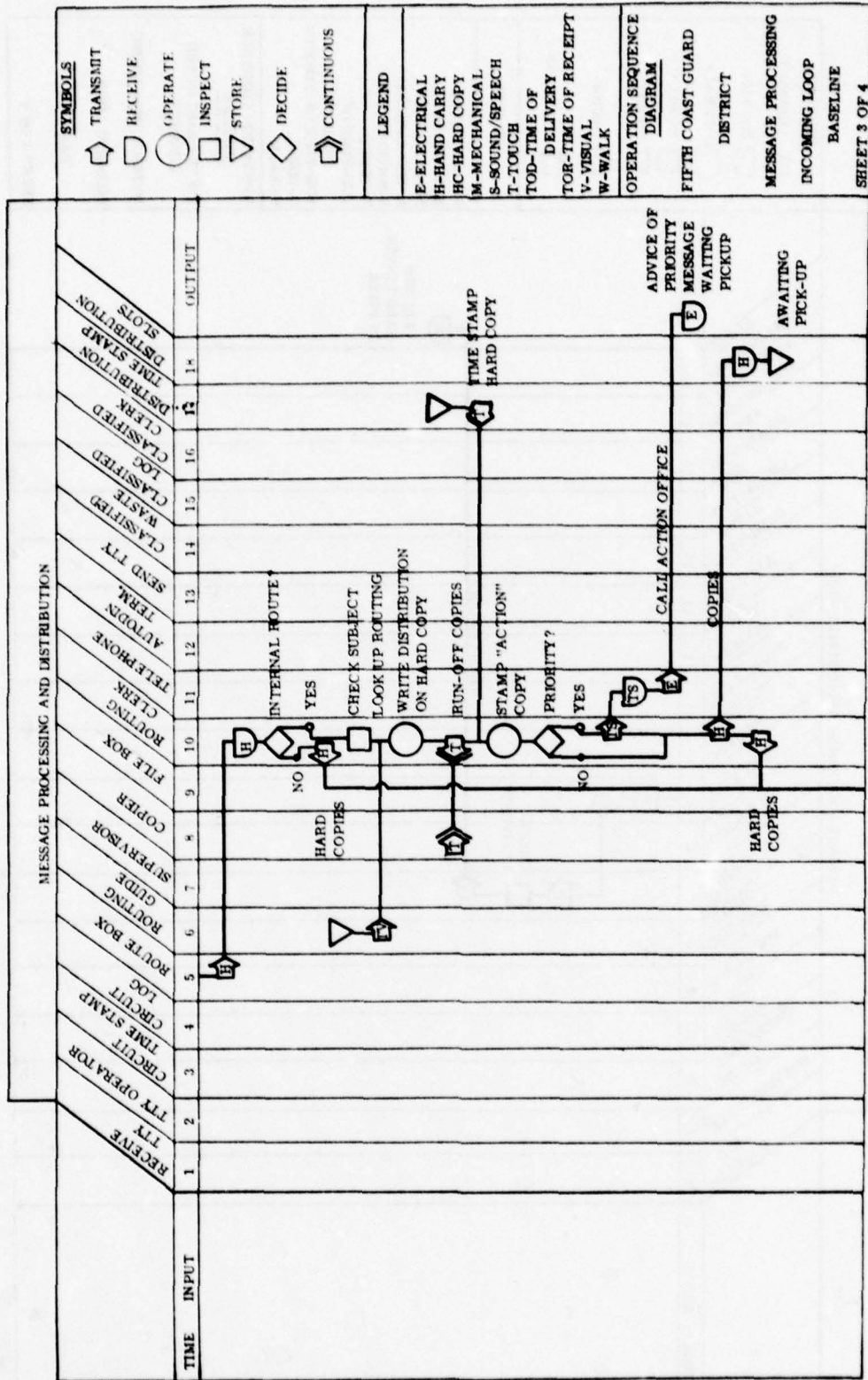

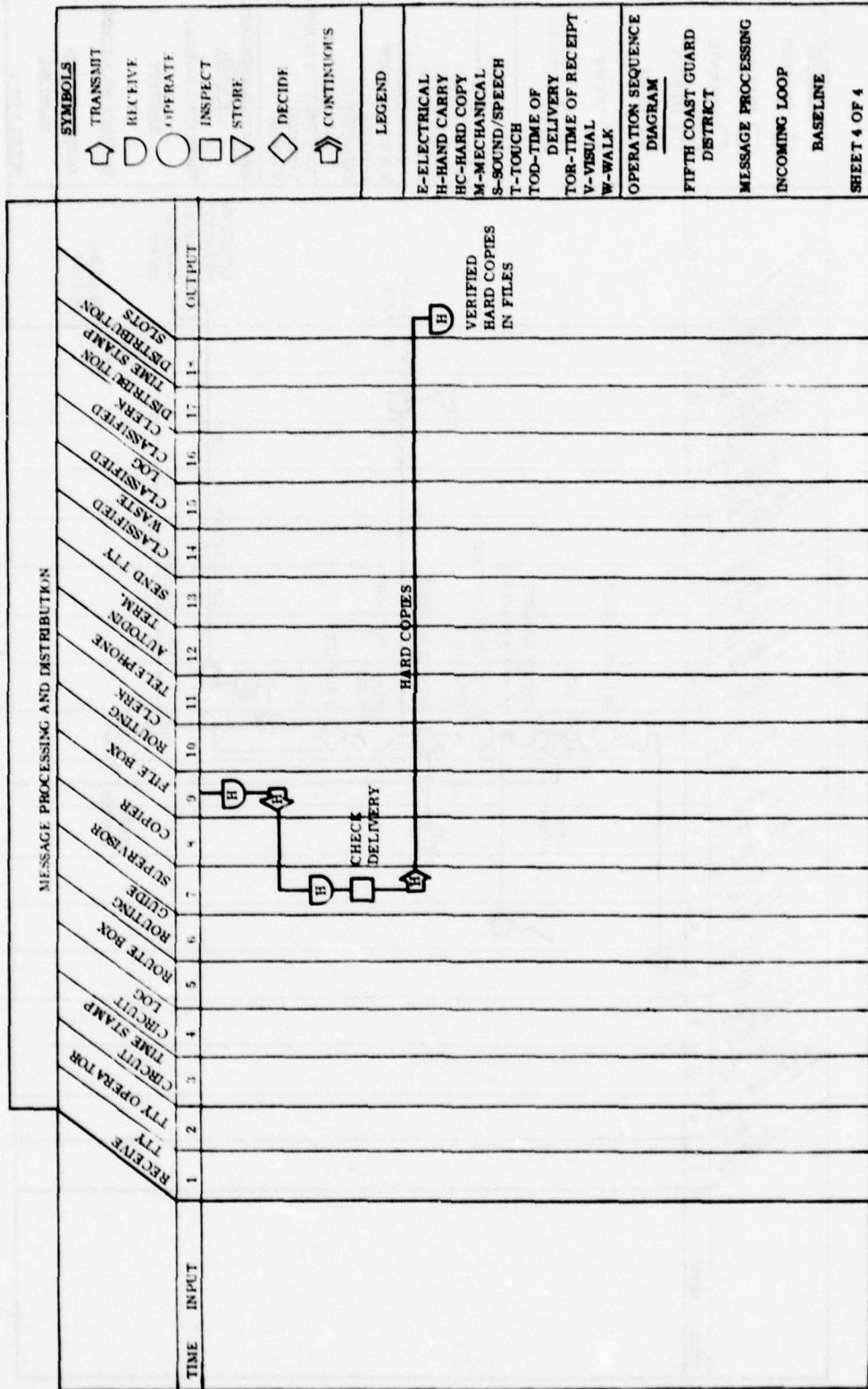

APPENDIX C

COMMUNICATIONS STATION, PORTSMOUTH, VA

C.1 INTRODUCTION

This appendix describes the message handling functions performed by the U. S. Coast Guard Communications Station, Portsmouth, Va. The information contained herein is based upon data collected during an on-site survey of the COMMSTA, 19-21 September 1977.

C.2 GENERAL DESCRIPTION

The Coast Guard COMMSTA, Portsmouth consists of administrative, receiving, control, and relay facilities located in the CG Operations Building, U. S. Naval Security Group Activity, Northwest, Chesapeake, Va.; and transmitting facilities at Pungo, Va. The operations/transmitting facilities are interconnected by a Coast Guard owned microwave system. An existing Inter Service Support Agreement (ISSA) defines the services provided the COMMSTA by the host command (NAVSEC-GRUACT Northwest).

A floor plan of COMMSTA operating spaces, illustrating the layout of message processing and distribution system equipment, is displayed in Figure C-1.

The COMMSTA operates under the technical control of the Commander Atlantic Area, U. S. Coast Guard. A substantial share of COMMSTA resources is dedicated to the operation of ship-shore and shore-ship, including broadcast, and ground-air-ground facilities. The record message relay function serves primarily as the interface between Coast Guard and other mobile elements and commands served by Coast Guard and other communications systems ashore.

The COMMSTA operates terminals in the SARLANT network and the Fifth District Group Loop. AUTODIN access is provided through the Naval Communications Processing and Routing System (NAVCOMPARS) operated by the Naval Communications

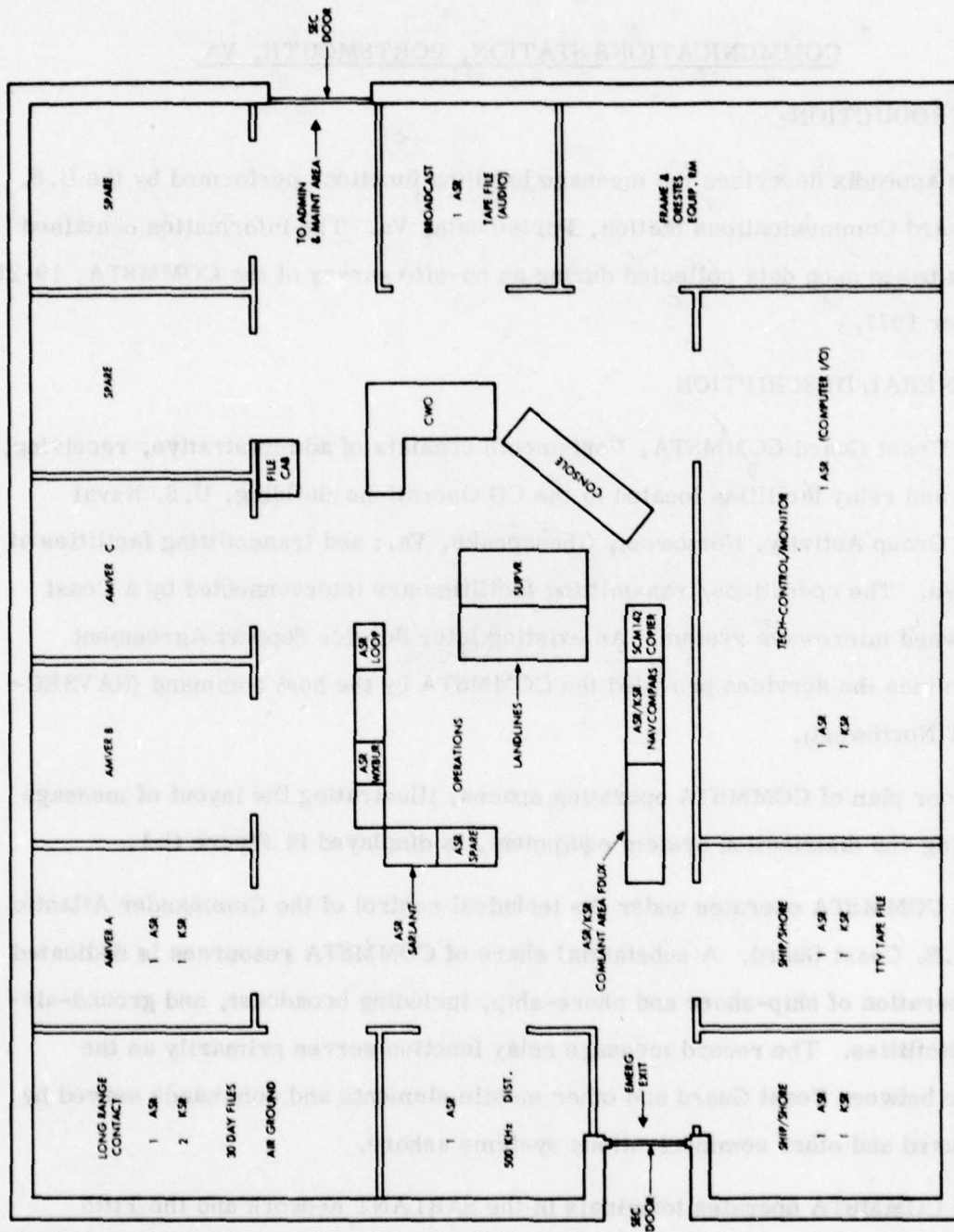

Figure C-1. COMMSTA Operations Spaces - Floor Plan

Area Master Station Atlantic (NAVCAMS LANT), Norfolk, Va. Direct links are also maintained with COMLANTAREA, CCGD5, and the National Weather Service, Norfolk. Figure C-2 summarizes these COMMSTA circuit terminations.

A comprehensive station SOP covers all operational functions and procedures. No requirements for affording special privacy to unclassified traffic exist.

C.3 GROWTH AND FUTURE REQUIREMENTS

Four planning actions now in progress will generate a further increase in COMMSTA traffic handlings. These include:

- (1) Transfer from the Navy of responsibilities for operating the Atlantic Composite (LCMP) CW broadcast.
- (2) Activation of a third, ORESTES covered, ship-shore-ship, radioteletype-writer (RATT) position.
- (3) Possible activation of a Coast Guard, single channel, RATT broadcast.

As noted during the survey of the Fifth District COMMCEN, a plan also exists to provide cryptographic cover (KW-7) for the COMMSTA - Fifth District COMMCEN link.

It can be expected that the over-the-counter message service now provided the Navy SATCOM terminal at Northwest will continue.

C.4 PERSONNEL

C.4.1 Manning

Total manning for the center averages 52. There are four 12-man watches (8 hours) plus 2 peak loaders on the day watch and 1 on the evening. Of this number, only three watch standers are devoted full time to the tape relay operation: the Supervisor, Land Lines Operator, and AUTODIN operator. The remainder, including the CWO and most circuit operators perform certain message handling functions periodically. These include editing, logging, servicing, and hand carrying traffic between operating positions.

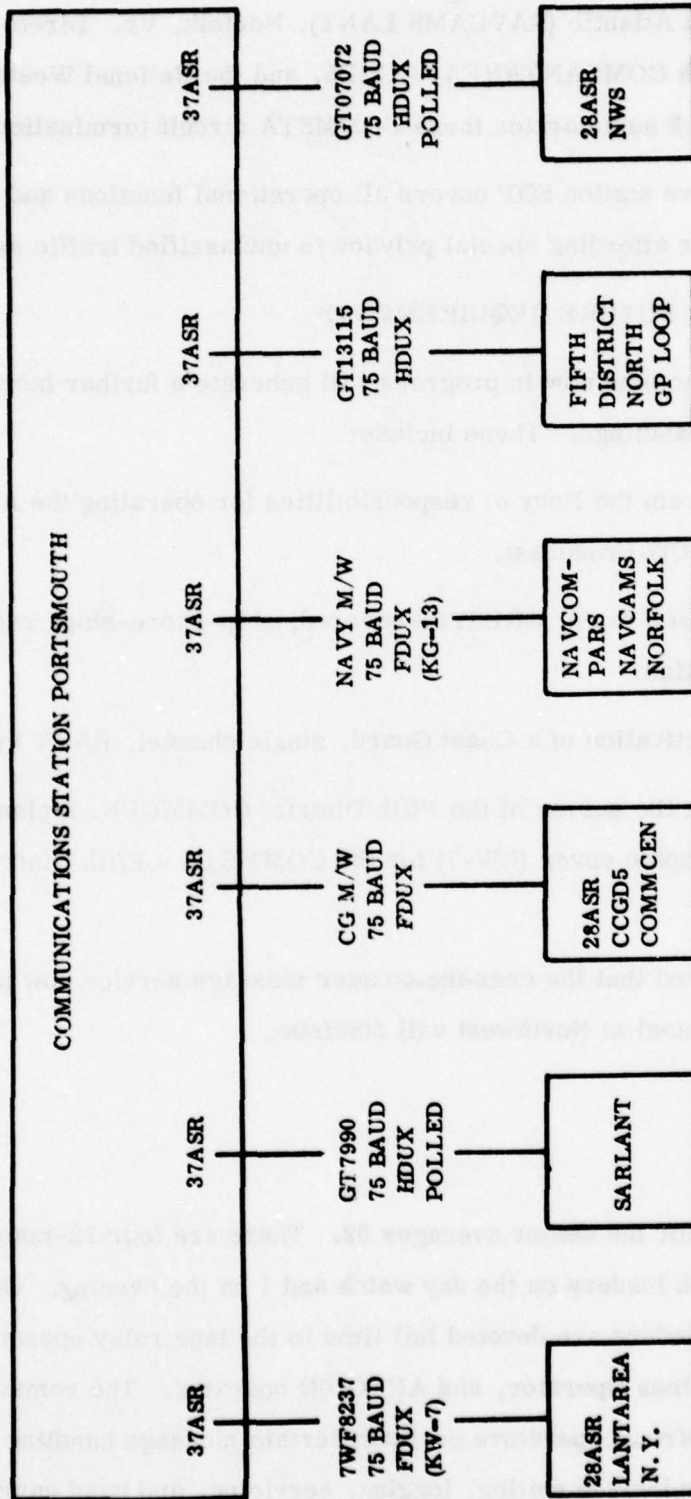

Figure C-2. COMMSTA Portsmouth Circuit Diagram

Watch assignments are adjusted from time to time to enable cross training and to respond to unusual traffic surges and emergency situations. COMMCEN personnel are assigned no non-communications duties.

C.4.2 Training

Formal technical training is scheduled for 2-4 hours per month during off watch time. A 3-6 month period of OJT is required before an operator is thoroughly familiar with all operating positions and duties.

C.5 EQUIPMENT AND FACILITIES

C.5.1 Communications Center Equipment

COMMSTA teletypewriter equipment is reflected in Figure C-1. All equipment is Coast Guard owned.

C.5.2 Maintenance

The COMMSTA has an organic electronic equipment maintenance and repair capability. All Model 37 sets are maintained by station forces. Maintenance support for cryptographic equipment is provided by the Norfolk Naval Shipyard.

Facility maintenance is provided by the host command (NAVSECGRUACT Northwest) under the terms of a formal ISSA.

C.5.3 Miscellaneous Communications Facilities

The COMMSTA is served by a 99-line private automatic telephone exchange, currently loaded to 25 percent capacity. AUTOVON and FTS access is provided.

An in-station intercommunications system connects all operating positions with the supervisor and CWO. A telephone orderwire connects the receiver/operations and transmitter sites.

The COMMSTA is linked with the CG Air Station, Elizabeth City, by hot-line telephone.

C.5.4 Cost Data

During the first year of operations, cryptographic equipment maintenance services provided by the Naval Shipyard cost approximately \$300. The station budgets \$337.50 per quarter (\$1350.00 annually) for teletypewriter equipment repair parts. The maintenance schedule provides for the overhaul/repair of three teletypewriter sets each month.

Table C-1 summarizes other consumable supplies procured through the first three quarters, FY 78. The projected annual cost of consumables, including teletypewriter repair parts, is approximately \$7632.00.

TABLE C-1. THREE QUARTER COSTS-CONSUMABLES

ITEM	QUANTITY	COST(\$)
Teletype Paper		
Two Ply	27 Cases	907.20
Single Ply	90 Cases	1350.00
Perforator Tape	90 Cases	1890.00
Typewriter Paper (AMVER Positions)	16 Cases	302.40
Typewriter Ribbons	34 Boxes	204.00
Columbia Binders	36 Each	48.60
TOTAL THREE QTR COST		4702.20

C.6 FUNCTIONAL DESCRIPTION

C.6.1 General

During the visit to the COMMSTA Portsmouth, the survey team observed and recorded the sequence of operations performed and examined equipment/space/

personnel relationships. The descriptive data which follow are based on these observations.

C. 6. 2 Forms and Formats

Outgoing traffic originated by COMMSTA elements is prepared on the standard CG Form 2655. No distinctive formats or colors are in use to identify traffic by precedence or classification.

As at other facilities visited, a variety of formats are in use, including JANAP 128 (), ACP 127 () PLAINDRESS/Modified, and modified ACP 126 (). It was noted that traffic transmitted into AUTODIN via the NAVCAMS LANT NAVCOMPARS must be prepared in JANAP 128 () format. The NAVCOMPARS is capable of converting ACP 126 () input into JANAP 128 () format. Since the processing of traffic into JANAP 128 () format is time sensitive, it is suggested that COMMSTA representatives investigate, with Navy, the possibility of eliminating this requirement.

C. 6. 3 Drafting and Releasing

CCGD5 Instruction 2100.1 and CG-233 provide guidance for message drafters. Seven officers have been granted Message Releasing authority. The COMMCEN is not required to maintain a card file of releasing authority signatures.

C. 6. 4 Processing of Outgoing Messages

The volume of traffic originated by the COMMSTA and the one over-the-counter customer (Navy SATCOM Detachment) is relatively insignificant, averaging less than 10 messages per day. This represents a negligible impact on the COMMCEN operation. Primary emphasis will be placed, therefore, on relay operations.

C. 6. 5 Incoming Messages

The functional flow of incoming messages is illustrated in simplified form in Figure C-3. The figure is designed to illustrate the flow in four different cases:

Incoming - Terminate

Incoming - Multiple Relay

Incoming - Terminate and Relay

Incoming - Relay Only.

Paragraph C. 6. 5. 1 provides a narrative description of steps followed for traffic received via Land Line TTY. This includes AUTODIN, SARLANT, District Loop, and the direct link to the CCGD5 COMMCEN. A detailed flow diagram is contained in TAB I to this Appendix. Subsequent paragraphs address the handling of messages received on other circuits, and traffic requiring relay or other special handling. TAB II provides a flow diagram of traffic received via circuits other than Land Line.

C. 6. 5. 1 Land Line TTY Traffic (Including AUTODIN)

At the receive terminal the operator takes the tape and hard copy from the machine, time stamps the hard copy, checks off the channel number (or logs nr. and DTG), and scans the message for quality, precedence, and routing. He then places the tape and hard copy in the route box on the supervisor's desk. The supervisor checks for quality and routing. If the message does not require relay, he places the tape in the classified waste and the hard copy in the run-off box. The operator then examines the message for subject matter, determines the number of copies required, makes copies, and slots the copies for distribution. The hard copy is then placed in the file box for later check and filing.

C. 6. 5. 2 Radio Teletype (RATT) Traffic

Messages received via ship-shore or Air-ground RATT will include a time of receipt, annotated by the receiving operator as a part of his acknowledgement of receipt, or operator service. For those messages received by RATT and not requiring relay, handling is otherwise the same as for land-line traffic.

C. 6. 5. 3 CW and Voice Traffic

Traffic received by CW or Voice is typewritten as copied by the receiving operator who types his operator service (including TOR) on the message and logs the message in his circuit log. He then carries the message to the supervisor position where it is time stamped and placed in the route box. The supervisor then scans the message to determine the routing. If the message does not require relay, it is handled as other incoming traffic.

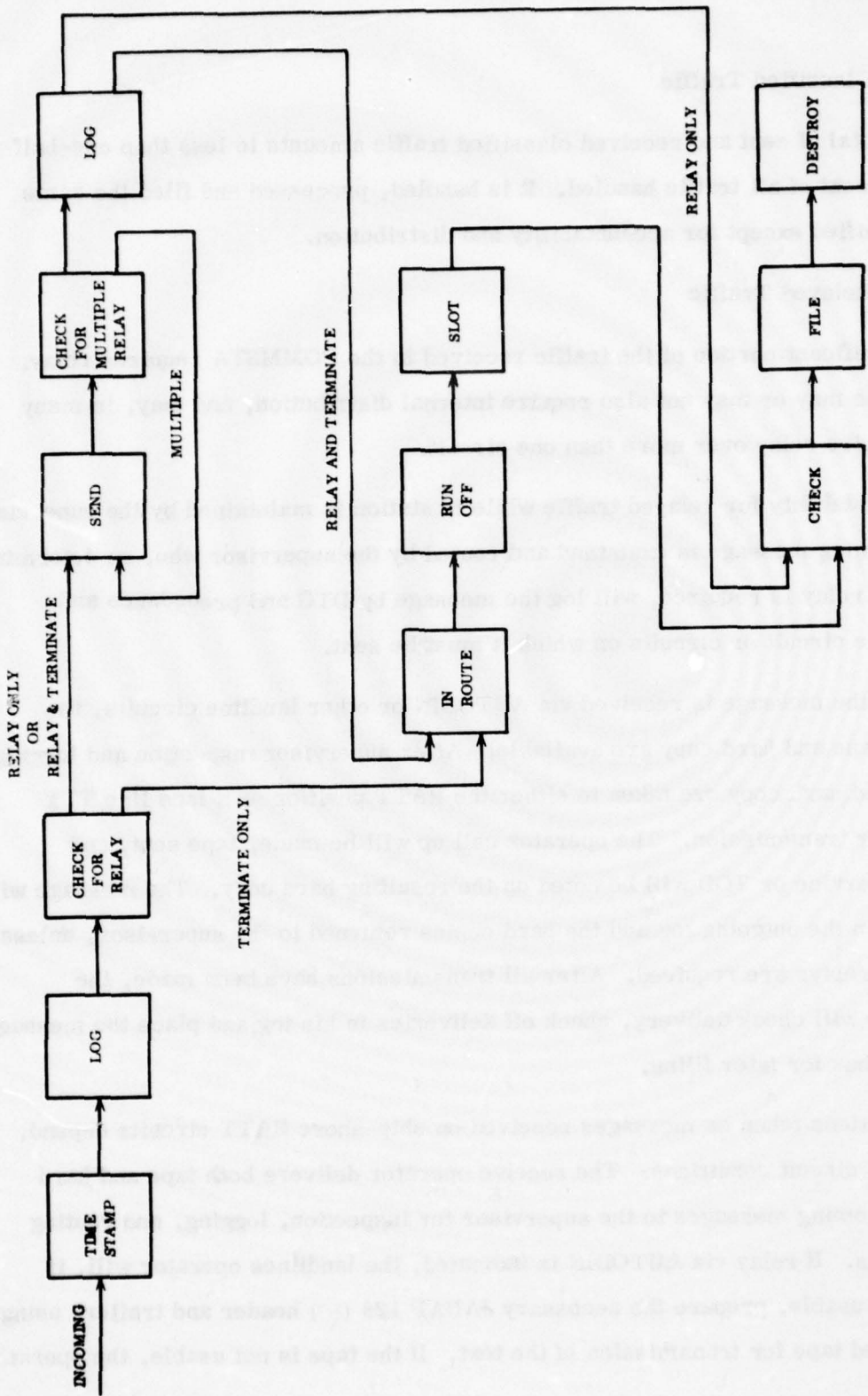

Figure C-3. COMMSTA MPDS Operation - Simplified Block Diagram

C.6.5.4 Classified Traffic

The total of sent and received classified traffic amounts to less than one-half of one percent of all traffic handled. It is handled, processed and filed the same as unclassified except for accountability and distribution.

C.6.5.5 Relayed Traffic

A significant portion of the traffic received in the COMMSTA requires relay. Such traffic may or may not also require internal distribution, and may, in many cases require relay over more than one circuit.

Accountability for relayed traffic while in station is maintained by the supervisor. Each incoming message is examined and routed by the supervisor who, on determination that a relay is required, will log the message by DTG and precedence and indicate the circuit or circuits on which it must be sent.

a. If the message is received via AUTODIN or other landline circuits, the received tape and hard copy are available. After supervisor inspection and logging, the tape and hard copy are taken to either the RATT position or a land line TTY position for transmission. The operator call up will be made, tape sent, and operator service or TOD will be noted on the resulting hard copy. The message will be logged in the outgoing log and the hard copies returned to the supervisor, unless additional relays are required. After all transmissions have been made, the supervisor will check delivery, check off deliveries in his log, and place the message in the file box for later filing.

b. Actions taken on messages received on ship-shore RATT circuits depend, in part, on circuit conditions. The receive operator delivers both tape and hard copy of incoming messages to the supervisor for inspection, logging, and routing instructions. If relay via AUTODIN is indicated, the landlines operator will, if the tape is usable, prepare the necessary JANAP 128 () header and trailer, using the received tape for transmission of the text. If the tape is not usable, the operator

will, of necessity, recut the entire message. On traffic requiring relay via other landlines, or via the second RATT circuit, the same general procedures (less preparation of the AUTODIN header/trailer) will be followed. After all required transmissions have been effected, and proper notations made in each circuit log, the tape is discarded and all hard copies returned to the supervisor for delivery checks, log check off, and subsequent filing.

c. Messages received by CW or voice and requiring relay via AUTODIN or other TTY circuits always require manual tape preparation. Otherwise, the handling is the same as described above.

Accountability for messages relayed but not addressed to the COMMSTA is maintained by retaining file copies (with TOR/TOD) of all versions as sent or received. The supervisor suspense log protects against non-deliveries.

TAB III to this appendix presents a detailed diagram of the sequence of relay operations.

C.6.5.6 Compiling

Compiling is the term applied to describe the practice of collecting several related messages addressed for relay to the same addressee, and assembling them into a single message for retransmission. This practice is often followed in the handling of AMVER messages and Weather Observations (OBS). AMVER and OBS may be received by Voice, CW or RATT, from Coast Guard, merchant or private vessels, for relay to the AMVER Center, New York, or to the Weather Bureau. It is the practice, on occasion, to hold these messages during busy periods for up to two hours and compile as many as 8 or 10 into a single message. Except for those received by RATT it is necessary to manually prepare a tape of the series of short messages which, individually, normally contain only two lines of text.

C. 6.5.7 Broadcast Makeup

Messages intended for scheduled or special broadcast are normally received in TTY format and handled as incoming traffic until screened by the supervisor. The message is passed to the broadcast operator who makes up a "Time of Broadcast" log sheet and prepares the message for transmission. If urgent, the broadcast will be made immediately, otherwise it will be held for the next schedule. After each transmission, the broadcast is noted on the circuit log and on the "Time of Broadcast" sheet. After the last directed broadcast, the message is returned to the supervisor for check and file.

C. 6.6 Internal Routing, Reproduction and Distribution

Internal routing is determined by the Communications Watch Officer or the supervisor on the basis of subject matter. No routing guide is used. The office having ACTION or INFO responsibility is indicated by means of a number stamp. Follow-up action is the responsibility of the designated Action officer and no tickler file is maintained in the COMMCEN.

An SCM duplicator is used for internal reproduction. This is a very slow machine but appears adequate for the low volume required. Three copies of incoming messages is average, with 15 being the maximum. Classified messages are not normally reproduced, but are routed for action and information on a classified read board. The copy machine is normally used by the landlines operator and copies are slotted on the supervisor's desk. The station staff normally picks up traffic from the COMMCEN at irregular intervals. One copy of each terminated message is placed on the Commanding Officer's read board.

C. 6.7 Logs and Records

The COMMCENTER maintains the following logs:

- (1) Communication Watch Officers (CWO) narrative log.

(2) Supervisor's Serial Log in which each message to be relayed is logged by DTG, precedence, and circuits on which it is to be sent. It serves as a tickler for verifying that all deliveries have been made. Traffic addressed to the station but not relayed and AMVER/OBS messages are not logged.

(3) Circuit logs are maintained by each circuit operator.

Service notations are made on each message by the sending/receiving operator. TOR/TOD is sent on TWPL traffic. The time stamp is used in addition to note the time of receipt or transmission.

C. 6.8 Storage and Retrieval

Message files containing classified and unclassified messages are maintained for a nominal 30 days. Separate files are maintained for AMVER, Weather, General Messages, and Broadcast traffic.

Reference to files is infrequent (about twice per week). Location of a particular message in the 30 day file takes about 10-15 minutes.

C. 6.9 Waste Disposal

All waste in the center is treated as classified. The volume amounts to about 15 large grocery bags per day. Disposal is by means of a pulverizer which is located in the secure portion of the center. Storage pending disposal is in the same secure space. The disposal operation is handled by watchstanders during the Mid Watch.

C. 7 TRAFFIC

C. 7.1 General

Portsmouth COMMSTA traffic data were compiled from statistical reports submitted by the Station and by on-site observation and tabulation. By analysis of these data it is possible to determine traffic volumes by function and category, identify traffic handling methods, compute in-station handling time, and establish routing/distribution patterns. This section of the report is devoted to presentation of the conclusions reached from analysis of available traffic data.

In interpreting the gross traffic figures presented in this summary, it must be noted that methods used to report traffic data by functional category and by circuit mode can result in apparent discrepancies. For example, a Search and Rescue message will be counted as one message in the SAR functional category. If received on one circuit and relayed on two circuits, it will be counted three times when developing traffic statistics by circuit mode. Thus, in examining traffic volume, totals by circuit mode will be substantially higher than totals by category.

C. 7.2 Gross Traffic Volumes

Tables C-2 and C-3, provide a tabulation of total traffic handled by the Portsmouth COMMSTA for the 12 month period July 1976 to June 1977. This period was selected due to availability of data. The station was activated in May 1976. In these tabulations, as opposed to those in the preceding appendices, no attempt is made to develop a growth pattern. Although figures for preceding years are available, perturbations due to the realignment of Radio/Communications Stations over the last several years render any statistical conclusion suspect. It is anticipated, however, that a growth projection for the overall Coast Guard system will be applicable to Portsmouth.

**TABLE C-2. TRAFFIC BY FUNCTIONAL CATEGORY
(JULY 1976 - JUNE 1977)**

AMVER	BATHY MET	OCEANO	OTHER GOVT	SAR	OTHER CG	TOTAL
25772	44199	15	44430	581	65,465	180,512

The ratio of number of messages handled to messages is illustrated in Table C-4. This ratio indicates that the relay/refile function of the Portsmouth COMMSTA is significant. The ratio is somewhat distorted by the compiling activity described in Paragraph C. 6. 5. 6. The ratio, as applied to compiled AMVER and OBS messages on a busy day (23 AUG 77) is displayed in Table C-5. If each AMVER/OBS message

TABLE C-3. TRAFFIC BY CIRCUIT MODE
(JULY 1976 - JUNE 1977)

CIRCUIT MODE	SEND	RECEIVE	TOTAL
TWPL	24,570	28,367	52,937
AUTODIN	27,082	45,796	72,878
CW	4,589	78,930	83,519
VOICE	13,025	1,538	14,563
RATT	47,339	16,823	64,162
OTHER	2,358	1,101	3,459
TOTAL	118,963	172,555	291,518

TABLE C-4. MULTIPLE HANDLINGS
(JULY 1976 - JUNE 1977)

Number of Messages	Number of Handlings	Handling/ Message Ratio
180,512	291,518	1.61

TABLE C-5. COMPILED TRAFFIC
(23 AUG 77)

CATEGORY MSG	RECEIVED	COMPILED/SENT	RATIO
AMVER	70	21	3.33/1
OBS	79	29	2.72/1

had been relayed when received, the number of handlings would have been increased by 45,990, resulting in a messages handled/messages ratio of 1.87/1, which appears to be a more realistic indication of COMMSTA relay activity.

C.7.3 Specific Traffic Data

Examining traffic by annual totals can provide useful statistical data. Such statistical data may, however, prove misleading if used as a basis for manpower allocations, circuit engineering, or, as in the case of this study, the application of automation techniques to a COMMCEN operation. Ideally, a more detailed examination of traffic patterns should commence with selection of a busy month and an average month within a specific time period. Since COMMSTA Message files are retained for only 30 days, as specified in CG-233, the survey team, of necessity, conducted the more detailed data collection effort using August 1977 files. Coincidentally, the August totals equate to 8.9 percent of the projected annual figure for 1977, indicating that August may represent an average month in terms of traffic handled.

August message totals are summarized in Table C-6. The messages handled/discrete messages ratio (26009/17260) is 1.50 which is comparable to the statistical average number of handlings (1.61) computed for the year.

Message files for the busy day (23 August) were selected for detailed analysis. Table C-7 summarizes, in tabular form, a sampling of sent and received traffic for that date. In addition to the normal precedence breakdown, a special listing for OBS and AMVER messages is included.

It should be noted here that while OBS and AMVER messages do not carry a precedence, they are handled as routine and priority, respectively. If this is considered, the percentage of traffic by precedence relates closely to that discovered at other stations.

Classified traffic is not included due to the small volume. Footnotes on the table provide information on the nature of the sampling.

TABLE C-6. TRAFFIC VOLUMES FOR AUGUST 1977

TOTAL MESSAGES: 17260
 TOTAL MESSAGES HANDLED: 26009
 % OF ANNUAL TRAFFIC: 8.9

MESSAGES BY MODE	RECEIVED		SENT	
	#	%	#	%
AUTODIN	4605	29	3258	33
TWPL	2060	13	1705	17
CW	7471	46	386	4
RATT	1689	11	3849	38
VOICE	88	< 1	477	5
OTHER	121	< 1	305	3
TOTALS	16034	100	9975	100

BY CATEGORY	#	%
AMVER	2096	12
OCEANO	87	< 1
BATHY/METEO	4280	25
OTHER GOVT	5374	31
SAR	35	< 1
OTHER CG	4939	29
USMER	449	2
TOTALS	17260	100

TABLE C-7. TRAFFIC VOLUME FOR BUSY DAY (23 AUGUST 1977)

MESSAGES HANDLED - INCOMING: 640
 - OUTGOING: 394
 - TOTAL: 1034

% OF YEAR TRAFFIC: 0.35

TOTAL FOR DAY DIST. BY PRECEDENCE	RECEIVED		SENT	
	#	%	#	%
	372	100	295	100
AMVER	70	19	21	7
OBS	79	21	29	10
O - Immediate	24	6	31	10
P - Priority	96	26	112	38
R - Routine	103	28	102	35

- a. Only 6 classified messages handled this date.
- b. A Total of 640 messages were received during this day. These included service messages, duplicate transmissions and messages compiled for relay only, as well as the 372 sampled.
- c. A total of 410 messages were transmitted this day. In addition to the 295 sampled these included broadcast and multiple relay totals.

Table C-8 tabulates the same sampling for the busy day by hourly periods in order to identify throughput needs. For example, on the day sampled, 8% of the total traffic was handled in the busy hour; 15% in the busy two hours; and nearly 1/3, or 28.5% during the four hour period 1800-2159.

The busy day file (23 August) was examined to extract data pertaining to the relay pattern. Since approximately 75% of the messages received by the station are relayed one or more times, whether or not terminated, the relay function is primary to this station's mission. A major part of the work load is devoted to tape handling, tape cutting, reformatting and compiling traffic for retransmission. Table C-9 identifies the relay pattern for a sampling of the busy day traffic.

C. 7.4 Message Length

No attempt was made during this survey to measure message lengths. The 20 line block average mentioned in previous appendices appears reasonable in assessing throughput requirements. The practice of compiling AMVER/OBS messages could perturb this assumption, and merits a closer examination.

C. 7.5 Handling Times

C. 7.5.1 Recorded Times

A sampling was made of the in station handling time of 200 messages relayed on the busy day of 23 Aug. This sample is based on the TOR logged from the incoming circuit and the TOD recorded at the time of transmission. In the case of those sent on more than one circuit the last TOD was recorded. The results of this sample are tabulated in Table C-10.

C. 7.5.2 Synthesized Times

The sequence of operations and the time associated with each operation are illustrated in Figures C-4, C-5, and C-6. The functions, operations, personnel and stations correspond to those used on the flow diagrams in TABS I, II and III to this appendix.

It must be emphasized that these handling times are based on the unobstructed flow of an individual message through the complete process without regard to delays that are essentially unavoidable in a COMMCEN of this nature. No comparison should be made between these synthesized handling times and the recorded times in Table C-10.

TABLE C-8. HOURLY TRAFFIC VOLUME - BUSY DAY

HOURLY ENDING (LOCAL)	01	02	03	04	05	06	07	08	09	10	11	12	13	14	15	16	17	18	19	20	21	22	23	24
INCOMING RECORD TRAFFIC	R	4	6	7	2	7	4	1	1	1	3	1	2	5	4	3	4	7	10	4	8	11	3	3
BY	P	3	3	4		5	4	5		1	3	1	4	9	6	4	8	4	4	9	5	6	3	4
PRECEDENCE	O		4		1	1	1					3	1	1	1	1	1		2	1	2		4	
INCOMING SPECIAL CATEGORIES	Amvet	7	1	2	2	2	1				1	2	7	7	5	1	3	5	1	6	8	4	5	
OBS		4	1		1		6		2	2	1	1	11	7	7	2	1	2	12	5	2	5		6
TOTAL INCOMING		21	15	13	6	15	11	12	1	4	6	9	25	29	23	11	17	18	29	25	25	26	15	13
OUTGOING RECORD TRAFFIC	R	3	6	5	2	6	3	2	3	1	4	1	3	2	2	3	4	4	8	9	9	4	7	8
BY	P	6	1	4	2	3	5	6		1	1	2	4	5	8	2	2	14	15	10	4	9	2	5
PRECEDENCE	O	1	4		1	1	2				1	1	3	1		2	1	1		2	3	1	4	2
OUTGOING SPECIAL CATEGORIES	Amvet		1	1	2		1	1			1			2	2	1	1	1	2		3		1	1
OBS		2	1	1	1		5		1	3	2		2	1	1	2	1		2		4			
TOTAL OUTGOING		12	13	11	8	10	11	14	3	3	8	6	11	11	14	10	9	20	27	21	23	14	14	16
TOTAL FOR HOUR		33	28	24	14	25	22	26	4	7	14	12	36	40	37	21	26	38	56	46	48	40	29	29

(ALL TIMES BASED ON TOR/TOD - LOCAL TIME)

NOTE: Weather and Broadcast Traffic and Service Messages not Included.

2 HOUR	3	4	5	6	7	8	9	10	11	12	13	14	15	16	17	18	19	20	21	22	23	24
18	55	8	18-20	102	15.3	19-22	180	26.3														
08	4	<1	08-09	11	1.6	08-11	37	5.5														
02	28	4.2	02-03	52	7.8	01-04	99	14.8														

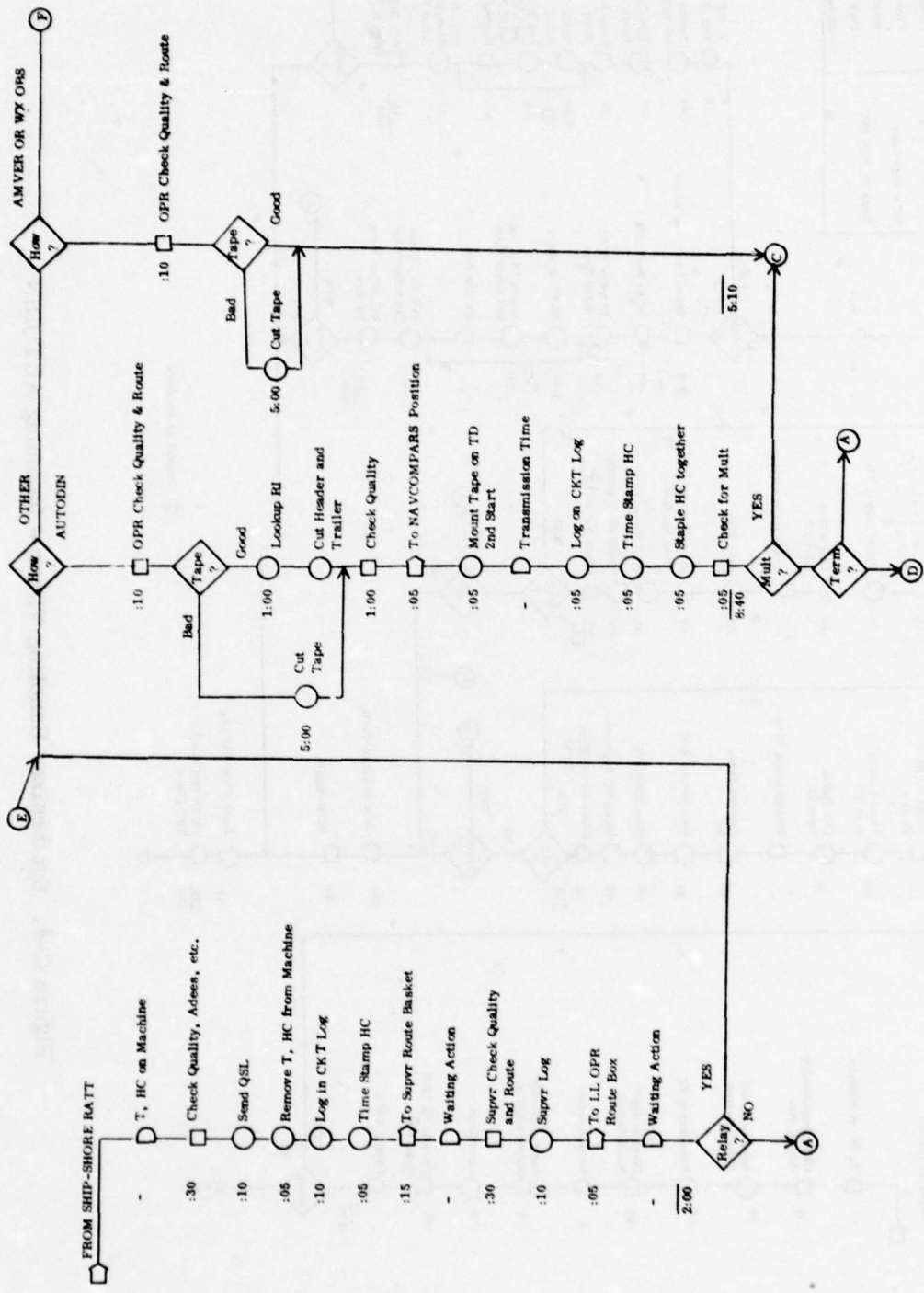

Figure C-5. Synthesized Handling Times - Incoming RATT

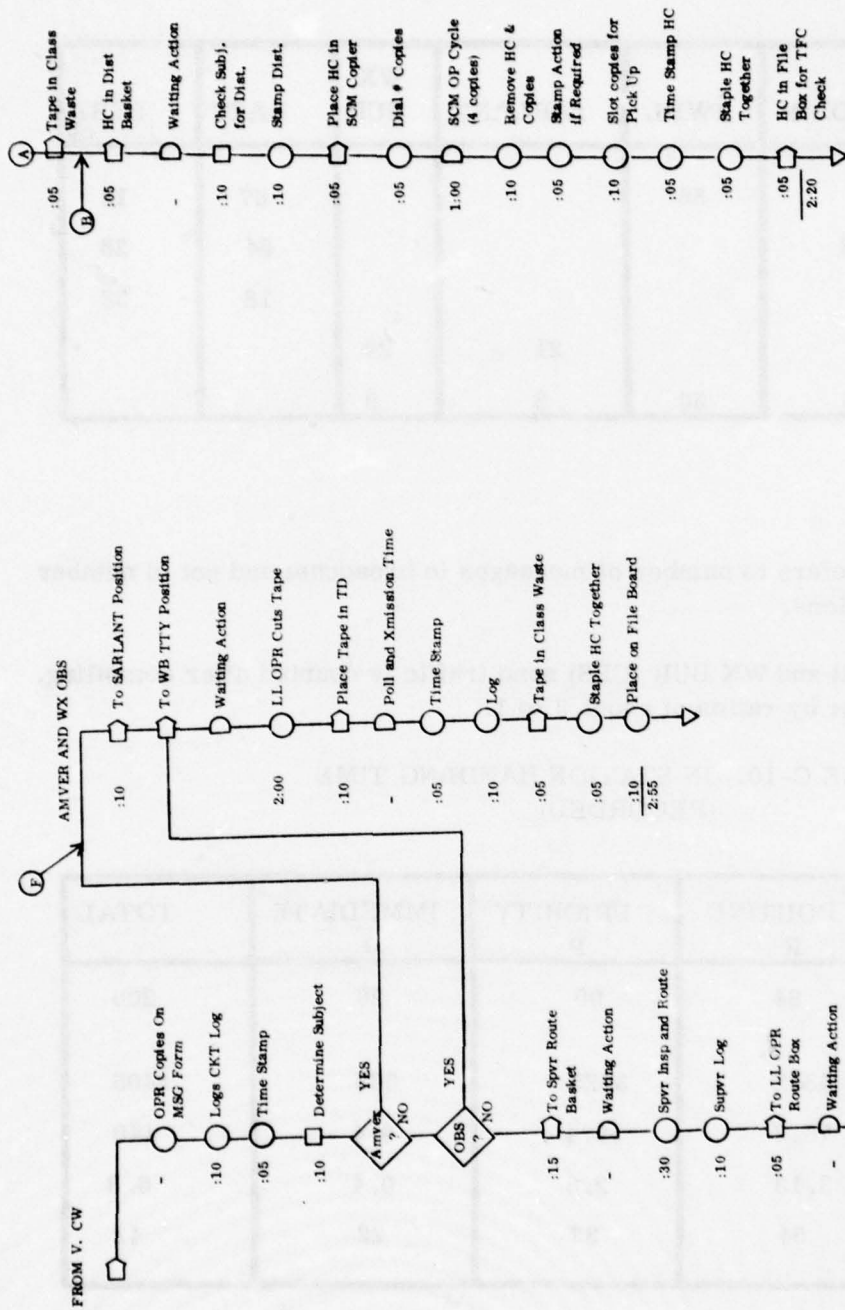

Figure C-6. Synthesized Handling Times - Incoming CW or Voice

TABLE C-9. RELAY PATTERN

TO FROM	AUTODIN	TWPL	SARLANT	WX BUR	RATT	BCST
AUTODIN		55			67	13
LOOP	51				64	26
WX BUR					18	33
CW			21	29		
RATT	26	30	5	9		

Note:

(1) Broadcast traffic refers to number of messages to broadcast and not to number of broadcast transmissions.

(2) SARLANT (AMVER) and WX BUR (OBS) send traffic is counted after compiling. Received count is higher by ratios of about 3 to 1.

TABLE C-10. IN STATION HANDING TIME
(RECORDED)

PRECEDENCE	ROUTINE R	PRIORITY P	IMMEDIATE 0	TOTAL
Number Msgs	84	90	26	200
Minutes	4512	3325	568	8405
Hours	75.2	55.4	9.4	140
Man Days	3.13	2.3	0.4	5.8
Average/Msg (MIN)	54	37	22	42

These synthesized handling times are summarized in Table C-11 in terms of the time devoted to selected typical messages. In the case of multiple relays, the times would not be directly additive but must consider common linear functions.

TABLE C-11. HANDLING TIME SUMMARY

FROM	TO	HANDLING TIME (MIN:SEC)	NOTES
AUTODIN	SHIP-SHORE	3:20	(1)
	CW BCST	7:15	(1) (2)
	VOICE BCST	5:15	(1) (2)
	TWPL	3:05	(1)
SHIP-SHORE	AUTODIN	11:05	(3)
	TWPL	8:45	(3)
	AMVER/WX	4:55	(4)
CW/VOICE	AMVER/WX	3:20	(4)
	AUTODIN	10:40	
	TWPL	8:20	
ANY ABOVE	TERMINATE	2:20	(5)

Notes:

- (1) Assumes reusable tape.
- (2) Time includes single BCST only.
- (3) Assumes text tape not reusable
- (4) Compiling not considered. Tape cutting time would increase.
- (5) Add to relay time if message addressed to COMMSTA.

TAB I TO APPENDIX C

OPERATION SEQUENCE DIAGRAM - INCOMING LANDLINE

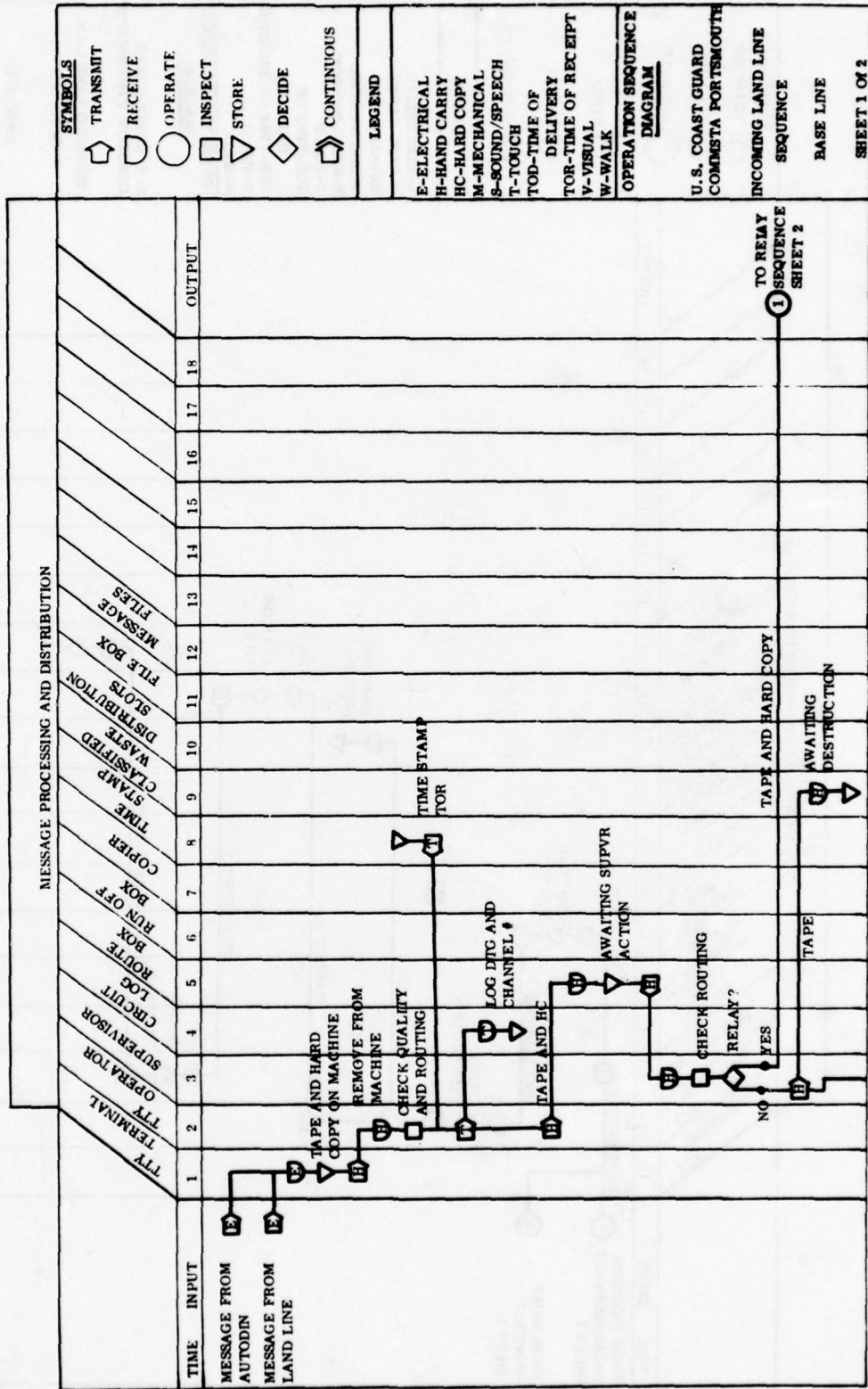

- SYMBOLS**
- ◻ TRANSMIT
 - ◻ RECEIVE
 - ◯ OPERATE
 - ◻ INSPECT
 - ◻ STORE
 - ◊ DECIDE
 - ◻ CONTINUOUS

- LEGEND**
- E-ELECTRICAL
 - H-HAND CARRY
 - HC-HARD COPY
 - M-MECHANICAL
 - S-SOUND/SPEECH
 - T-TOUCH
 - TOD-TIME OF DELIVERY
 - TOR-TIME OF RECEIPT
 - V-VISUAL
 - W-WALK

OPERATION SEQUENCE DIAGRAM

U.S. COAST GUARD
COMMSTA PORTSMOUTH

INCOMING LAND LINE
SEQUENCE

BASE LINE

SHEET 1 OF 2

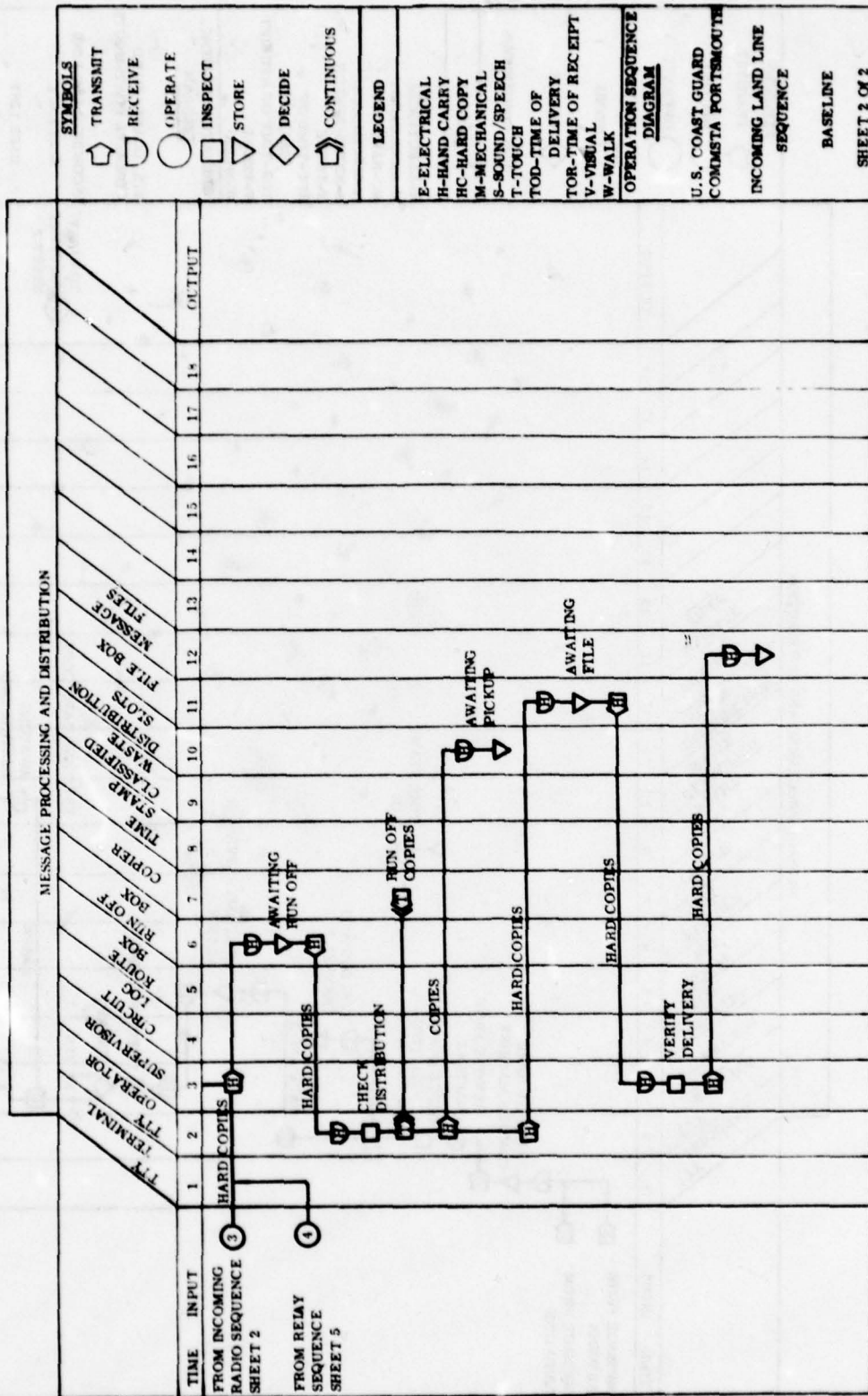

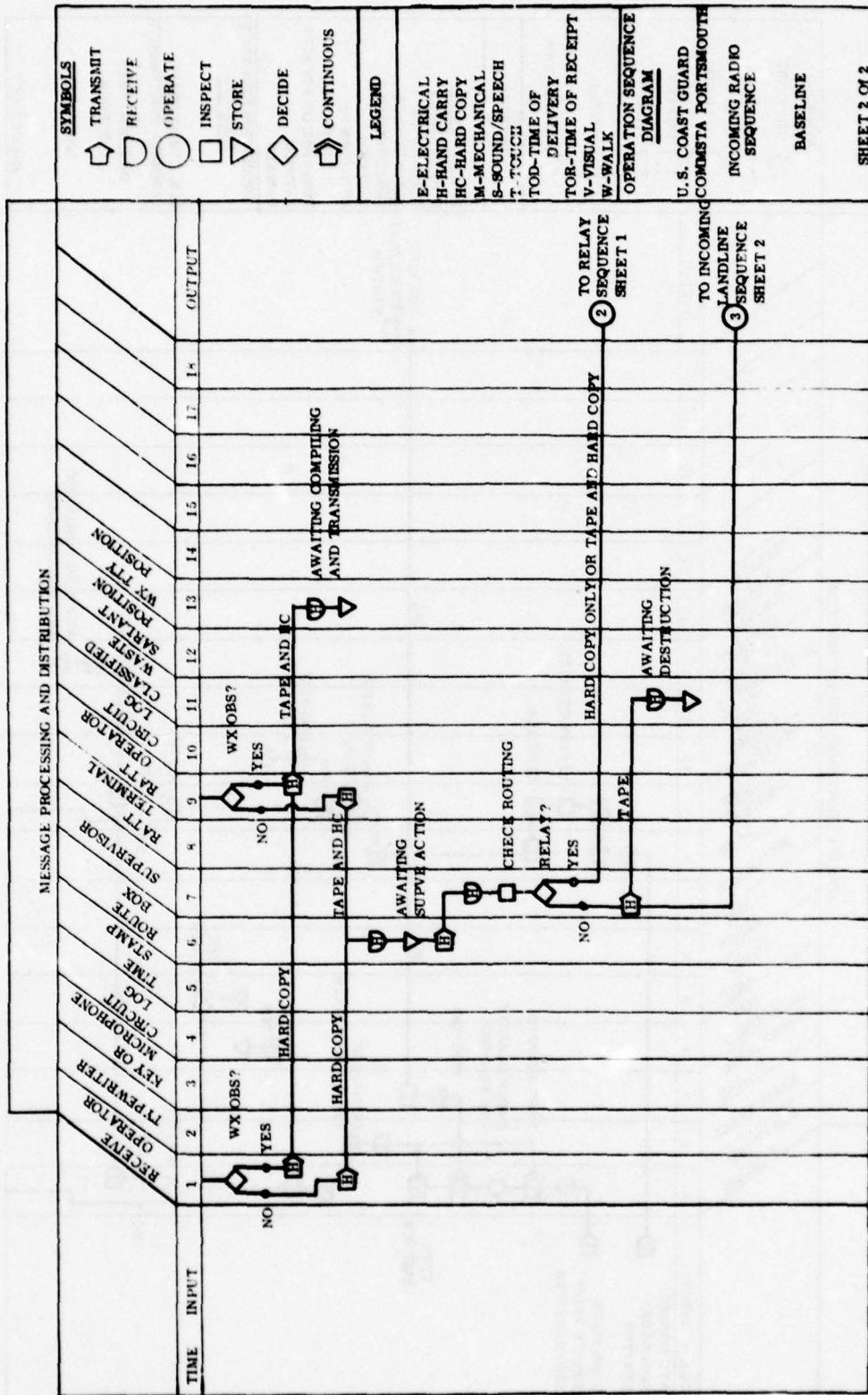

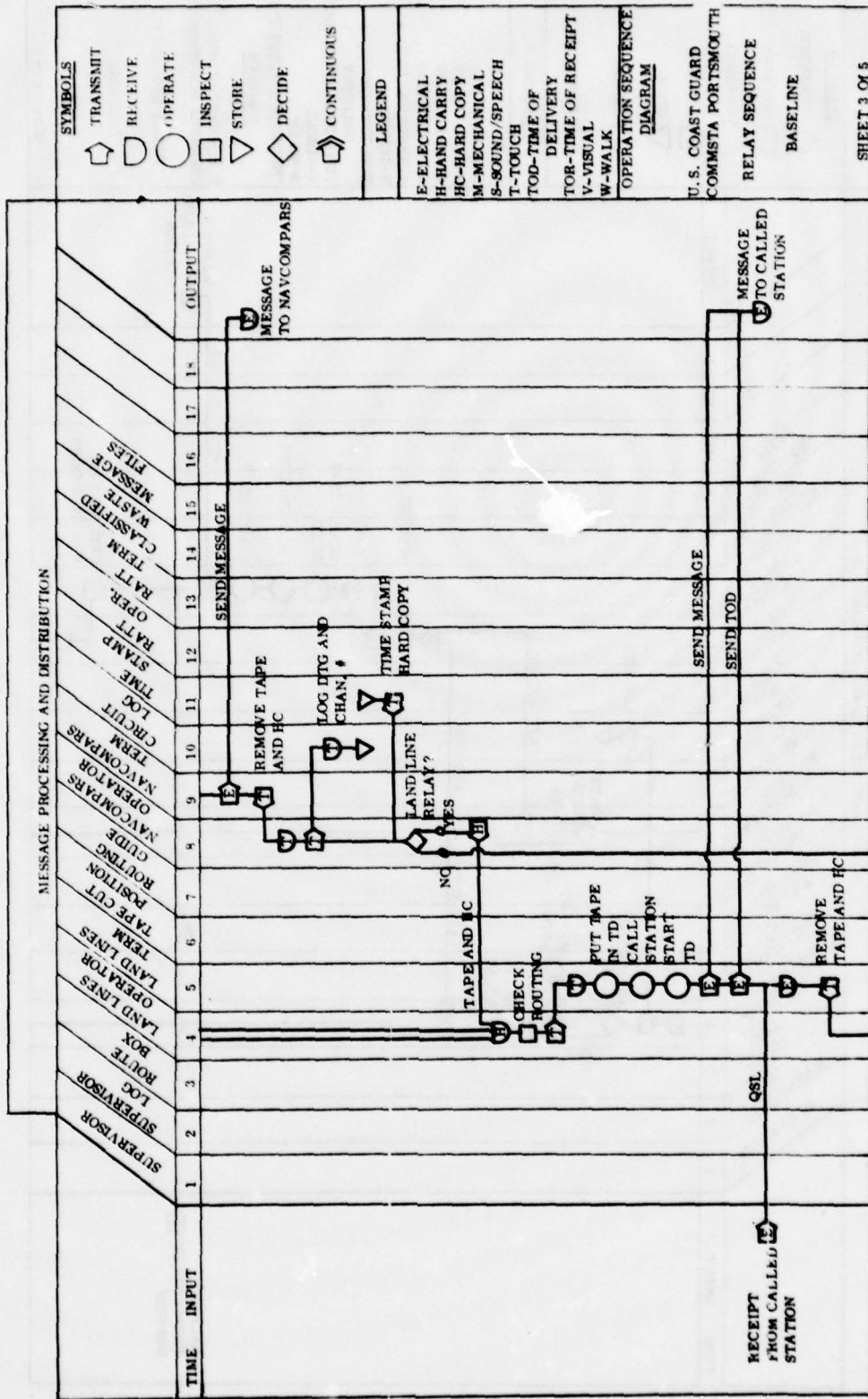

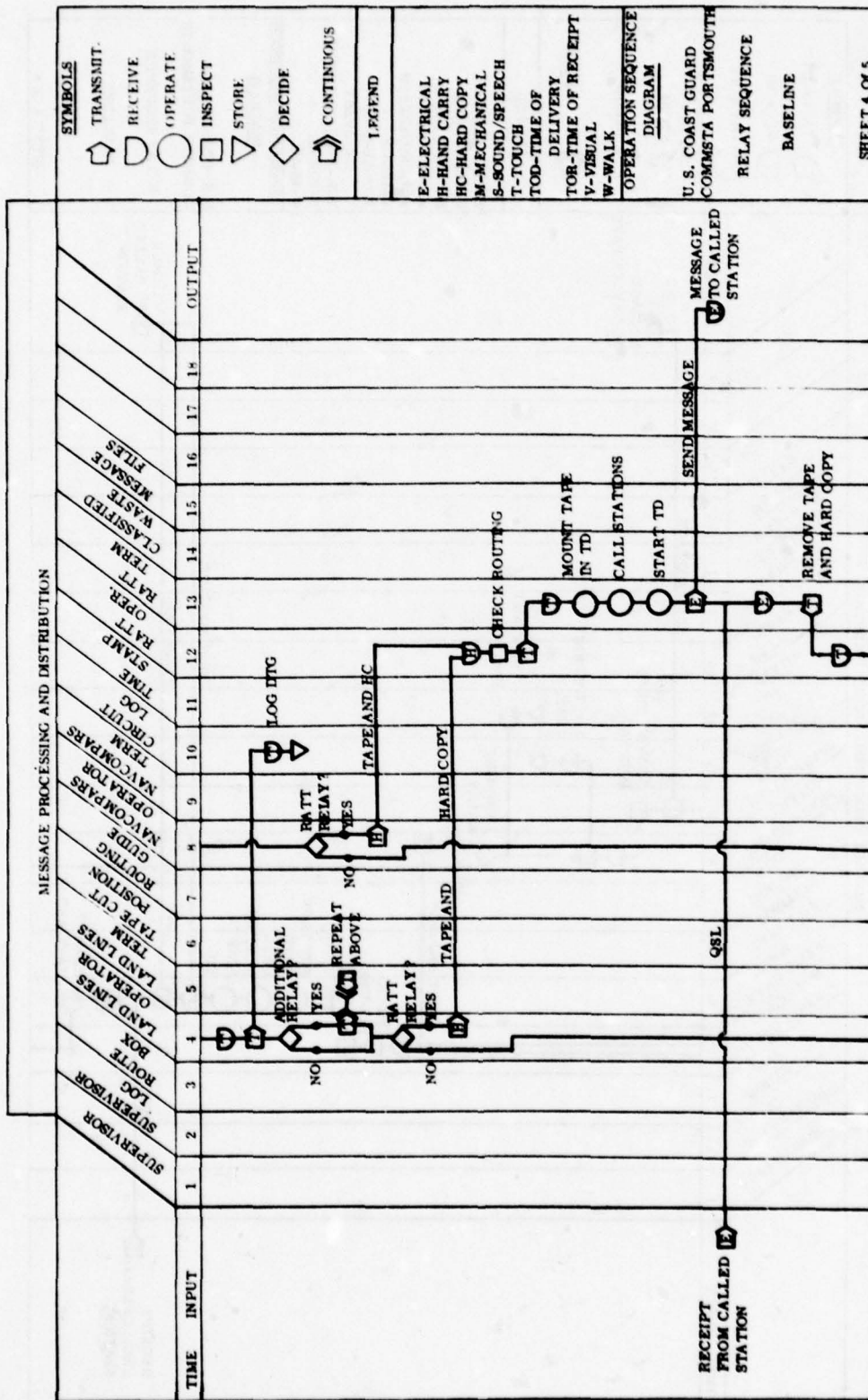

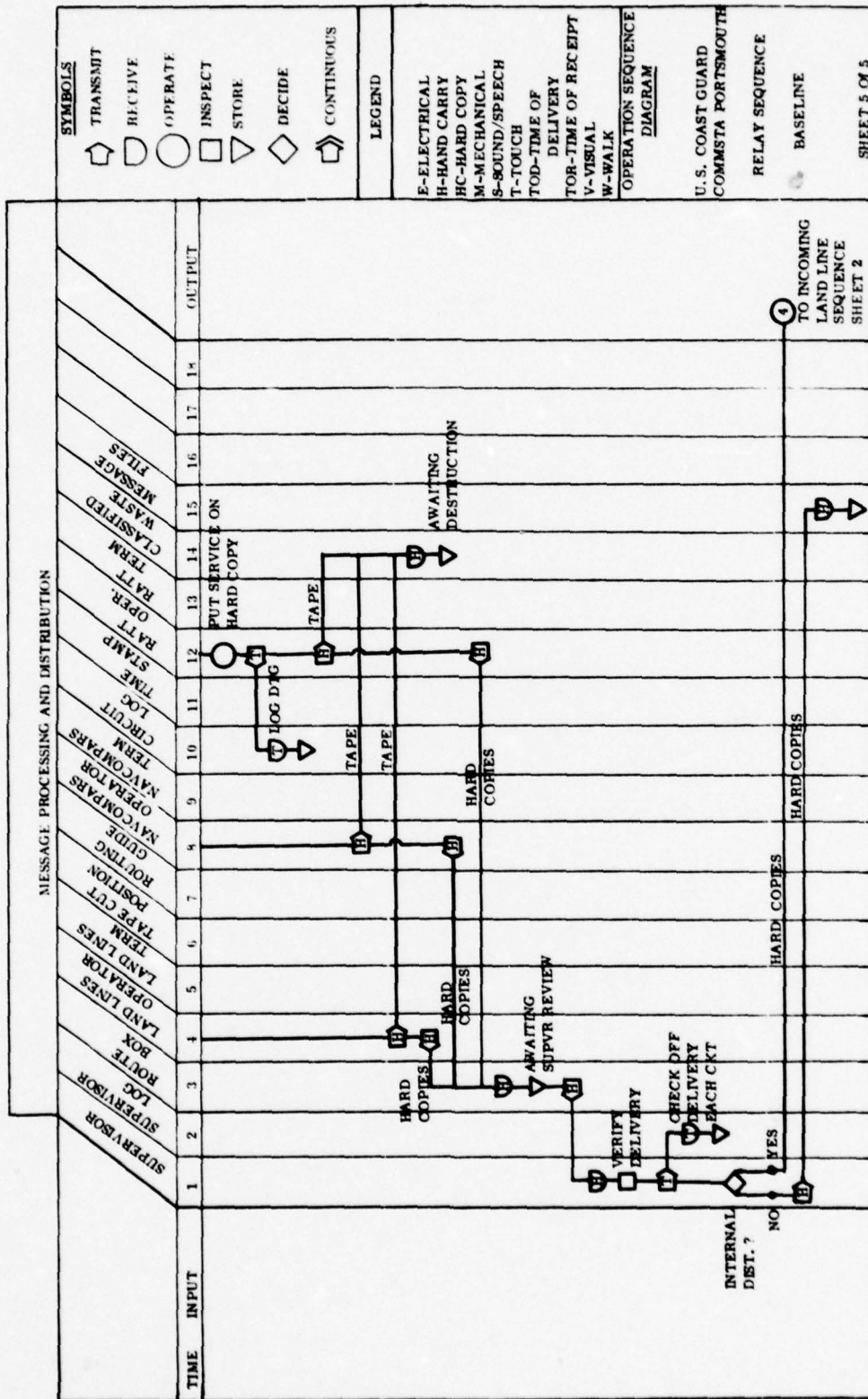

APPENDIX D

COMMUNICATIONS CENTER, HEADQUARTERS

U.S. COAST GUARD

D.1 INTRODUCTION

This appendix provides descriptive data on the Communication Center, Headquarters, U. S. Coast Guard, and an analysis of the Message Processing and Distribution System (MPDS) operations as currently conducted. Information presented is based on a comprehensive site survey conducted on 12-17 October 1977 with follow-up visits for data collection and review of files later in October.

D.2 GENERAL DESCRIPTION

The U. S. Coast Guard Headquarters Communications Center (COMMCEN) is located on the seventh floor of the Nassif Building, 400 Seventh St. S.W., Washington, D.C. Organizationally, the COMMCEN is an element of the Telecommunications Management Division within the Office of Operations.

Telecommunications Management Division Offices are immediately adjacent to the COMMCEN on one side, Flag Plot and Flag Plot offices on two sides and a corridor on the fourth side. There are two doors with cypher locks for access and one secure door for egress only.

The COMMCEN serves the Commandant of the Coast Guard, the Headquarters Staff, the Secretary of Transportation, and other activities in the Nassif Building and the Washington area as authorized. There are no electronic courier circuits (pony loops) in the building. Originated messages are delivered to the COMMCEN by messenger from the originating office. A COMMCEN messenger delivers incoming messages on a regular schedule.

The COMMCEN operates 10 record traffic circuits. A block diagram of terminated circuits is provided in Figure D-1. All circuits are low level and operate, except where otherwise indicated, at 75 baud (100 WPM).

Message traffic is prepared and handled in accordance with procedures set forth in CG-261 (E) and CG-233.

D.3 GROWTH AND FUTURE REQUIREMENTS

A plan for the installation, in December 1979, of a Remote Information Exchange Terminal (RIXT), homed on the Naval Communications Processing and Routing System (NAVCOMPARS) at Crystal City, has been approved and funded.

Installation of a VHF link between the headquarters and the Coast Guard Yard in Baltimore will be completed by the end of 1977. This circuit will provide the Headquarters COMMCEN an alternative access into AUTODIN and also serve as a contingency capability in the event of catastrophic failure of landlines in the Washington area.

D.4 PERSONNEL

D.4.1 Manning

The Headquarters COMMCEN personnel allowance is 1 officer (CWO) and 19 enlisted. Present strength is 1 CWO and 18 enlisted. Watches are of 12 hours duration (0630-1830 and 1830-0630). Each section consists of 3 men. One peak loader is used during the period 0900-1830 to assist in run off and routing.

All personnel assigned are graduates of Class "A" Radioman school. Two of those currently assigned are graduates of Class "B" Radioman school. There is no requirement for Class "B" school training for any of the positions in the COMMCEN.

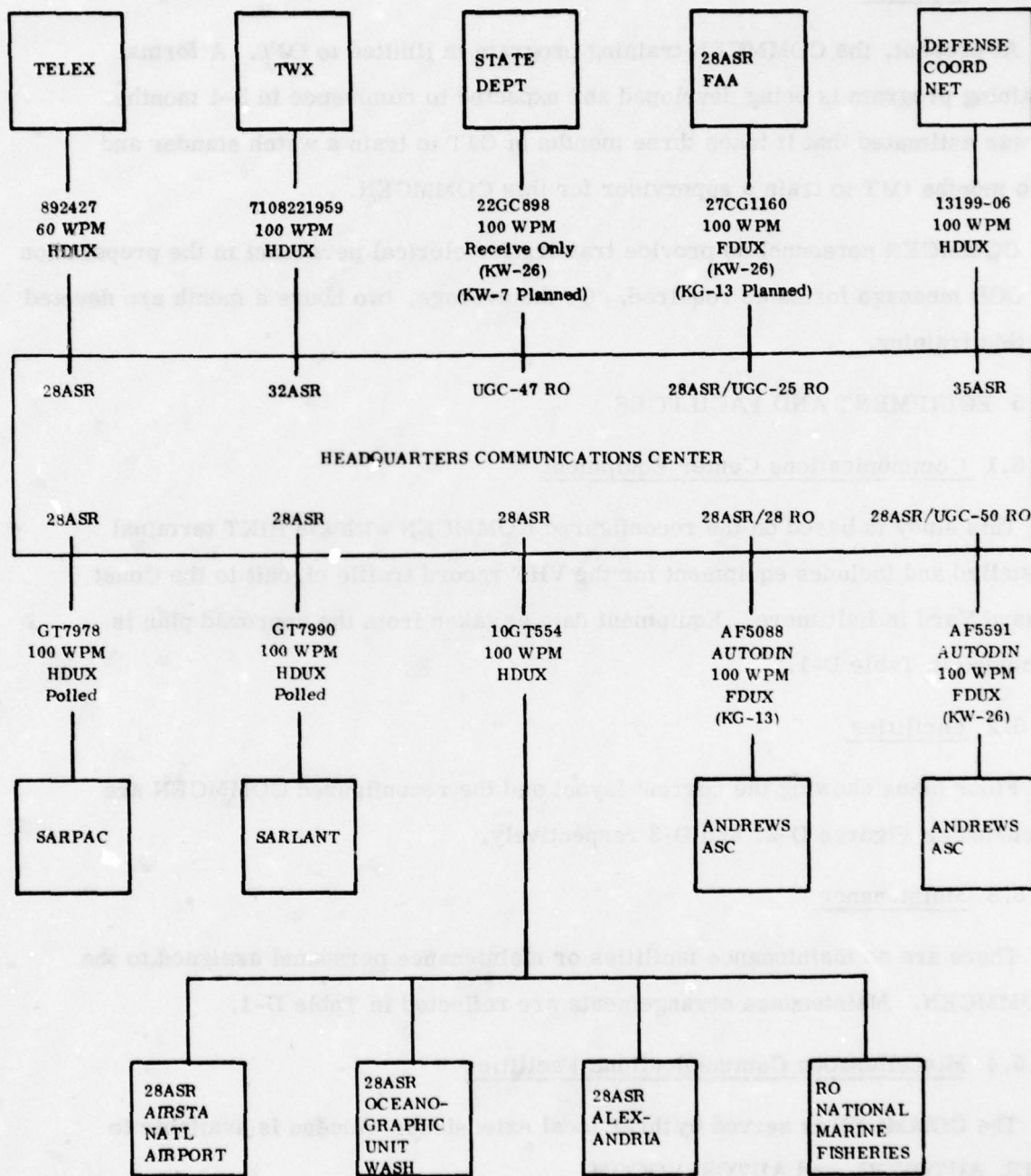

Figure D-1. Headquarters COMMEN Circuit Diagram

D. 4. 2 Training

At present, the COMMCEN training program is limited to OJT. A formal training program is being developed and expected to commence in 3-4 months. It was estimated that it takes three months of OJT to train a watch stander and two months OJT to train a supervisor for this COMMCEN.

COMMCEN personnel do provide training for clerical personnel in the preparation of OCR message forms as required. On the average, two hours a month are devoted to this training.

D. 5 EQUIPMENT AND FACILITIES

D. 5.1 Communications Center Equipment

This study is based on the reconfigured COMMCEN with the RIXT terminal installed and includes equipment for the VHF record traffic circuit to the Coast Guard Yard in Baltimore. Equipment data as taken from the approved plan is included in Table D-1.

D. 5.2 Facilities

Floor plans showing the current layout and the reconfigured COMMCEN are included as Figures D-2, and D-3 respectively.

D. 5.3 Maintenance

There are no maintenance facilities or maintenance personnel assigned to the COMMCEN. Maintenance arrangements are reflected in Table D-1.

D. 5.4 Miscellaneous Communications Facilities

The COMMCEN is served by three local extensions. Access is available to FTS, AUTOVON, and AUTOSEVOCOM.

A redundant pneumatic tube system interconnects the COMMCEN and Flag Plot.

TABLE D-1. COMMEN COMMUNICATIONS EQUIPMENT

EQUIPMENT	QTY	OWNER	ACQUISITION OR LEASE COST (\$)	SERVICE DATE	MAINTENANCE ACTIVITY	REMARKS
TSEC/KWR-26	4	CG			NAVELEX Sys Eng Cen	\$4000/YR Maintenance Cost For All Crypto Equipment
TSEC/KWR-26	4	CG			NAVELEX Sys Eng Cen	
TSEC/KG-13	3	CG			NAVELEX Sys Eng Cen	
TSEC/KW-7	2	CG			NAVELEX Sys Eng Cen	\$250/YR Maintenance Cost included in Above
2*ASR	5	CG	\$27,500		Advance Technical Service Corp	
AN/UGC-25A	1	CG	\$1,500		Advance Technical Service Corp	
AN/UGC-47/RO	2	CG			Advance Technical Service Corp	Lease Includes Maintenance Lease Includes Maintenance Funded by Dept of Trans Cost Unk. Lease Includes Maintenance Included in Above
AN/UGC-50/RO	2	CG			Advance Technical Service Corp	
AN/UGC-13	2	CG			Advance Technical Service Corp	
2*ASR	5	C&P	\$3,190/YR		C&P	Lease Includes Maintenance Lease Includes Maintenance Funded by Dept of Trans Cost Unk. Lease Includes Maintenance Included in Above
2*ASR	1	WTU	\$29,340/YR		WTU	
3*ASR	1	C&P			C&P	
2*RO	1	WTU	\$94*/YR		WTU	\$2452/YR/Maintenance Cost Lease includes Maintenance
3*ASR	1	WTU			WTU	
Message Header Generator (Note 1)	1	CG	\$10,000			
OPSCAN-37 (Note 1)	1	CG	\$40,500		OPSCAN	\$2452/YR/Maintenance Cost Lease includes Maintenance
IBM-2 Copier w Collator	2	IBM	\$13,000		IBM	
Line Control Unit	1					Equipment to be installed and operational 12-79
Low Speed Printer	1					
Medium Speed Printer	1					
Card Reader	1					
Card Punch	1					
Storage Module	1					
Magnetic Tape Unit	1					
Paper Tape Punch	1					
OCR	1					

Note 1: These Equipments will be removed when the RIXT terminal is installed 12-79.

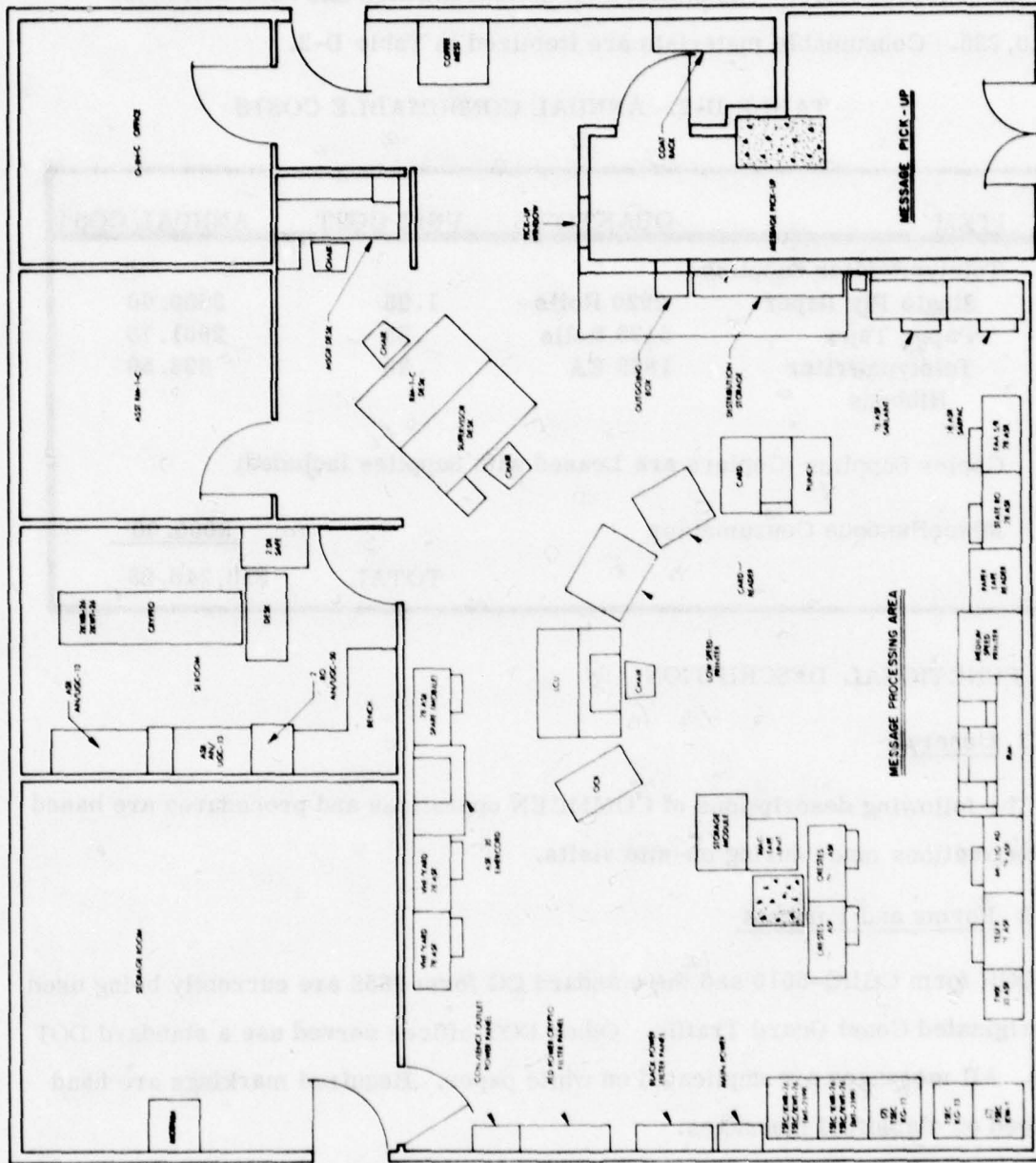

Figure D-3. COMMEN Floor Plan (Future)

D. 5.5 Cost Data

Recurring leased costs are listed in Table D-1. These figures do not include the cost of leased lines. The annual cost of consumables has been estimated at \$10,235. Consumable materials are itemized in Table D-2.

TABLE D-2. ANNUAL CONSUMABLE COSTS

ITEM	QUANTITY	UNIT COST	ANNUAL COST
Teletypewriter Supplies			
Single Ply Paper	2920 Rolls	1.25	3650.00
Paper Tape	5475 Rolls	.53	2901.75
Teletypewriter Ribbons	1825 EA	.38	693.50
Copier Supplies (Copiers are Leased with Supplies Included)			
Miscellaneous Consumables			<u>3000.00</u>
		TOTAL	\$10,245.25

D. 6 FUNCTIONAL DESCRIPTION

D. 6.1 General

The following descriptions of COMMCEN operations and procedures are based on observations made during on-site visits.

D. 6.2 Forms and Formats

OCR form CGHQ-5010 and the standard CG form 2655 are currently being used for originated Coast Guard Traffic. Other DOT offices served use a standard DOT form. All messages are duplicated on white paper. Required markings are hand stamped on classified messages.

D. 6.3 Drafting and Releasing

Message drafters are guided by the provisions of CG-261(E). Signature cards are not maintained by the COMMCEN. The presence of a releasing signature is verified when accepting a message for transmission.

D. 6.4 Processing of Outgoing Messages

This paragraph contains a narrative description of the actions taken to process originated traffic for transmission. A simplified block diagram of the sequence of operations is provided in Figure D-4. TAB I to this Appendix provides a detailed Flow Diagram identifying each action and decision point in the outgoing message process.

Messages originated by the headquarters staff are delivered by office messenger to the COMMCEN. If the message is classified or of priority or higher precedence, it is hand delivered to a COMMCEN representative. In other cases, it is put in the incoming slot. The supervisor inspects the message for addressees, format, classification and references. If any addressee does not hold the reference(s), the originating office is called to pick up the message for corrections. If the format is incorrect (on an OCR form), the message is returned for correcting. The watch supervisor performs out-routing, using the routing guide or ACP 117. He then puts the message in a box according to precedence and mode of transmission. The out-router takes the message from the box, assigns a DTG, and removes and slots any references attached. He then duplicates the number of copies required for internal distribution. If the message is classified, the copies are delivered to the messenger for logging and delivery, otherwise he slots the copies.

If the message is on a CG form 2655 he takes it to a spare teletype machine to cut the entire message, header and text. If it is on the OCR form, he takes it to the OPSCAN reader and inserts it. He then punches the keys on the message header generator for the indicated routing. On messages requiring commercial refile, formatting is accomplished manually. The tape generated by the OPSCAN reader and the original message are taken to the proper send position, and the tape is put in the TD. If it is being sent on the AUTODIN circuit, the message is sent immediately. On other circuits, a callup must be initiated prior to sending the message and at the end of the message a TOD must be sent. The hard copy and tape are taken from

the machine. If the message was sent by AUTODIN, the hard copy is time stamped and the channel sequence number is checked off. On all circuits, the DTG of the message sent is logged and the hard copy is stapled to the original. If additional transmissions are required, the above actions are repeated. After the last transmission, the tape is put in the classified waste and the stapled hard copies are put in the watch supervisor's box. He inspects the copies to ensure all actions have been completed and then files them.

D.6.5 Incoming Messages

The functional flow of incoming messages is illustrated in simplified form in Figure D-4. A detailed flow diagram for AUTODIN and other traffic is contained in TAB II to this appendix.

D.6.5.1 Incoming AUTODIN

The in-router is responsible for handling of all incoming messages. He takes the hard copy and tape from the mode V terminal; time stamps the hard copy for time of receipt (TOR); checks off the channel sequence number; and inspects the message for addressees, classification and relay requirements. If the message is for internal distribution only (no relay), he checks the content of the message and the routing guide to determine the action office and distribution. He then types the distribution and, if classified, stamps the classification on the hard copy. He duplicates the proper number of copies and puts the hard copy in the supervisor's box and the copies in the messengers box (classified messages are put in a special box). The messenger slots the messages for delivery on the next scheduled run (0800, 1300, 1500). If the message is classified, he logs each copy by DTG and copy number and obtains a signature for each copy when delivered. If the message is Priority or higher precedence, the messenger telephones the action office and an office messenger is sent to pick it up. The supervisor inspects the hard copy to ensure that all actions have been completed and files it.

In the case of a message that requires relay on one or more other circuits, the in-router takes the tape and hard copy from the mode V terminal; time stamps the hard copy; checks off the channel sequence number and inspects the message for addressees. He takes the tape and hard copy to the proper send position, puts the tape in the TD, calls up the receive station and starts the TD. At the end of the message he sends the TOD and removes the tape and hard copy from the machine. He then staples the hard copy with TOD to the original AUTODIN hard copy. If relay is required on another circuit, he repeats the above action for each relay. He then performs the routing and duplication procedures explained in the previous paragraph and delivers the copies to the messenger and the stapled hard copies to the supervisor. If the message that was received via AUTODIN was classified and required relay, it would be delivered to the messenger (after duplication) for logging and mailing to the addressees.

D.6.5.2 Incoming Other Than AUTODIN

The in-router removes the tape and hard copy from the machine, time stamps the hard copy, logs the message by DTG (or checks off number on some circuits) and inspects it for addressees. If the message is for internal distribution only, duplication and distribution are the same as cited above for AUTODIN. If the message requires relay via AUTODIN a header must be cut using the message header generator or a spare teletype machine. The tape and hard copy are then taken to the mode V terminal, the tape is put in the TD and the message sent. The hard copy from the AUTODIN terminal is then time stamped for TOD, the channel sequence number checked off and the DTG entered on the send log. The hard copy is then stapled to the original and if another relay is required, the hard copies and tape are taken to the appropriate send position and the message is sent after first calling-up the receive station. When the last relay is completed, the tape is put in classified waste and copies are made for internal distribution, if required. The copies for internal distribution, if any, are put in the box for the messenger and the stapled hard copies are put in the box for the supervisor to review and file.

D. 6. 5. 3 Relays and Readdressals

The COMMCEN performs no automatic readdressal functions. All readdressals are originated by a staff office. The in-router determines which incoming messages may require readdressal so that the tapes may be saved for one week and then destroyed. If the message requires readdressal within that time, only a header need be cut. As a general rule, SAR, Fisheries, and special interest message tapes are saved for possible readdressal.

Messages that are received via AUTODIN and require retransmission on one or more other circuits are sent as a simple torn-tape relay requiring only a call up on the other circuit(s) without a separate header tape being cut. Messages received on a circuit other than AUTODIN, for relay by AUTODIN, require a header tape to be cut.

D. 6. 6 Internal Routing, Reproduction and Distribution

Incoming messages are routed by the in-router (one of three watch positions), using a routing guide based on message content. The in-router designates the action office. If the action designated is incorrect, the office that received it for action notifies the COMMCEN by phone and a correction slip is made out and given to the in-router who makes and redistributes a corrected copy. The corrected copy is stamped "Corrected copy, destroy previous copies." The COMMCEN does not maintain a tickler of action messages. It is the responsibility of the action office to ensure that required action is taken.

For outgoing messages originated by the headquarters staff, internal routing is indicated by the originator of the message. Flag Plot receives a copy of each outgoing message with the exception of personnel messages.

Reproduction is accomplished on either of two IBM-2 copiers. Collating is currently manual, but will be automated in the near future.

The in-router and out-router both perform duplication functions. During peak hours, an extra man (peak loader) assists in this function. The number of copies of each message to be duplicated is determined from a routing guide and varies from a maximum of 40 to a minimum of 1 copy.

As noted earlier, the COMMCEN provides messenger delivery service three times a day, during normal working hours. For high precedence traffic, the action office is called to send a messenger to the COMMCEN. Classified and special category messages are delivered, to offices other than Flag Plot, by the COMMCEN messenger on his normal runs. He logs each classified and special category message by copy number and DTG and obtains a signature for each copy delivered. A separate log sheet is maintained for each office. Each office receiving classified or special category messages is responsible for the internal routing and custody of the copies. Confidential messages delivered to Flag Plot are not logged. The hard copies of secret and above are sent to Flag Plot. These copies are returned to the COMMCEN with a suitable notation if Flag Plot requires a copy. After reproduction, a copy is delivered by pneumatic tube with delivery indicated in the log.

Flag Plot receives a copy of each message, incoming and outgoing, and assumes the responsibility for the internal delivery of important messages outside normal working hours.

D.6.7 Logs and Records

A circuit log is maintained for each circuit. Messages handled on some, but not all circuits, are recorded by DTG in this log. In the case of AUTODIN, the channel sequence number is also checked off in the log. For classified and special category messages a log sheet is maintained for each staff office. The DTG, classification, precedence and originator are logged as well as the number of copies and date. A signature is obtained on the log sheet for each item delivered, except those delivered to Flag Plot.

All originated messages are time stamped with DTG as the TOF in the COMMCEN. Messages sent via AUTODIN are time stamped with TOD when sent. Messages sent on most other circuits have a TOD added at the end of the message. The receiving station receipts for each message.

The hard copy of each AUTODIN receive message is time stamped for TOR. Messages received on other circuits use the TOD on the message as the TOR in the COMMCEN.

D. 6. 8 Storage and Retrieval

Classified and unclassified messages are filed together in Columbia Binders in the COMMCEN. Files are kept for 30 days and then destroyed.

Recent files (4-5 days) are accessed frequently whereas files over 5 days old are seldom accessed. The speed of accessing the files was estimated at five minutes.

D. 6. 9 Classified Waste Disposal

All waste in the COMMCEN is treated as classified. Approximately 125 lbs of waste are collected each day and destroyed at 0700 daily (Monday through Friday) in a disintegrator located 8 floors below. Waste is stored in a storeroom in the COMMCEN until taken to the disintegrator.

D. 7 TRAFFIC

D. 7. 1 General

Coast Guard Headquarters traffic data were compiled from statistical reports submitted by the COMMCEN and by on-site observation and tabulation. By analysis of these data it is possible to determine traffic volumes by function and category, estimate growth rates, identify traffic handling methods, and establish routing/distribution patterns. This section of the report is devoted to presentation of the conclusions reached from analysis of available traffic data.

In interpreting the gross traffic figures presented in this summary, it must be noted that methods used to report traffic data by functional category and by circuit mode can result in apparent discrepancies. For example, a Search and Rescue message will be counted as one message in the SAR functional category. If

received on one circuit and relayed on two circuits, it will be counted three times when developing traffic statistics by circuit mode. Thus, in examining COMMCEN traffic, totals by circuit mode may be higher than totals by category.

D.7.2 Gross Traffic Volumes

Table D-3 provides comparative summaries of traffic, by functional category, for the years 1970 and 1976. The growth percentage (63.3) represents an annual growth pattern, in messages, of approximately 8.5 percent.

Table D-4 summarizes traffic, by circuit mode, for 1976, and compares the total to 1970 data. The six year growth, in message handlings, is 44 percent which equates to an annual growth rate of 10.2 percent.

Based on Tables D-3 and D-4, the messages handled/discrete message ratio (283,106/282,778) is 1.001 to 1, indicating that, statistically, the relay function performed by this COMMCEN is insignificant. While observing COMMCEN operations and reviewing traffic files, however, relay activity appeared to be substantially higher than statistics indicate.

TABLE D-3. TRAFFIC BY FUNCTIONAL CATEGORY

FUNCTION	1970	1976	Δ	% Δ
AMVER	1,114	452	-662	-59.4
BATHY/METEO	4,009	2,499	-1510	-37.6
OCEANO	1,667	758	-909	-54.5
OTHER GOV.	4,781	47,397	+42,616	+891.3
SAR	2,191	4,412	2221	+101.3
OTHER CG	159,338	227,260	+67,922	+42.6
TOTAL	173,100	282,778	+109,678	+63.3

TABLE D-4. TRAFFIC BY CIRCUIT MODE

CIRCUIT MODE	SEND	RECEIVE	TOTAL
TWPL	26,482	48,191	74,673
AUTODIN	47,780	136,187	183,967
TWX	8,489	7,761	16,250
FAX	901	520	1,421
OTHER	1,018	5,777	6,795
TOTAL (1976)	84,670	198,436	283,106
TOTAL TRAFFIC 1970			158,203
INCREASE 1970 - 1976			124,903
PERCENT INCREASE 1970 - 1976			79.0

D. 7. 3 Specific Traffic Data

Examining traffic by annual totals can provide useful statistical data. Such statistical data may, however, prove misleading if used as a basis for manpower allocations, circuit engineering, or, as in the case of this study, the application of automation techniques to a COMMCEN operation. Ideally, a more detailed examination of traffic patterns should commence with selection of a busy month and an average month within a specific time period. Since Headquarters COMMCEN

files are retained for 30 days only, as specified in CG-233, the survey team, of necessity, conducted the more detailed data collection effort using 12 September - 12 October 1977 files. Coincidentally, the traffic totals for the 31 day period studied constitutes about 8 percent of the projected annual figure for 1977, indicating that the sample represents an average month.

Message totals for the period examined are summarized in Table D-5. The messages handled/discrete messages ratio (25449/25269) is 1.007 to 1, which is slightly higher than the 1976 ratio.

TABLE D-5. TRAFFIC VOLUMES FOR SURVEY PERIOD
(12 SEPT - 12 OCT)

TOTAL MESSAGES:	<u>25269</u>
TOTAL MESSAGES HANDLED:	<u>25449</u>
% OF ANNUAL TRAFFIC:	<u>8</u>

MESSAGES BY MODE	RECEIVED		SENT	
	#	%	#	%
AUTODIN	14559	78	4074	60
TWPL	695	3.7	696	10
TWX/TELEX	682	3.6	869	13
STATE	2646	14	-	-
OTHER	87	< 1	1141	17
TOTALS	18669	100	6780	100

BY CATEGORY	#	%
AMVER	4	< 1
OCEANO	8	< 1
BATHY/METEC	11	< 1
OTHER GOVT	4085	16
SAR	159	< 1
OTHER CT	21,002	83
TOTALS	25,269	100

Table D-6 presents a summary of total traffic handled during the survey period, broken down by precedence and classification. These figures were taken directly from message files and unaccountably differ from the totals in Figure D-5 which were derived from COMMCEN logs and traffic reports.

Message files for 23 Sept (the busy day) were selected for detailed analysis. Table D-7 summarizes messages, in tabular form, originated by staff elements served by the COMMCEN and received messages which required distribution within the staff. Originated and terminated traffic is tabulated by precedence and classification. While this table does identify a distribution by classification trend, the total number of messages handled equate to somewhat less than 1/365th of the projected annual total, indicating that 23 September may not be representative of busy day activity.

TABLE D-6. TRAFFIC SUMMARY-CLASSIFICATION/PRECEDENCE
(12 SEPT - 12 OCT 1977)

	INCOMING		OUTGOING	
	#	%	#	%
TOTAL FOR PERIOD	15870	100	3796	100
BY PRECEDENCE				
FLASH	115	1.0	1	0.0
IMMEDIATE	1832	12.0	215	6.0
PRIORITY	5695	36.0	531	14.0
ROUTINE	8228	51.0	3049	80.0
BY CLASSIFICATION				
SECRET	860	5.0	127	3.0
CONFIDENTIAL	943	6.0	113	3.0
UNCLASSIFIED	14067	89.0	3556	94.0

Table D-8 tabulates terminated/originated traffic handled during the busy day, 23 September, by hourly periods. This table is important since it identifies throughput needs. For example, on the day sampled, 12 percent of the total handlings for the day occurred between 1600-1700 local time; 21 percent, between 1500-1700; and more than one-third, or 36 percent, during the four hour period 1400-1800.

TABLE D-7. TRAFFIC VOLUME FOR BUSY DAY (23 SEPT 1977)

MESSAGES HANDLED - INCOMING: 672
 - OUTGOING: 186
 - TOTAL: 858
 % OF YEAR TRAFFIC: 0.3

	TERMINATED		ORIGINATED	
	#	%	#	%
TOTAL FOR DAY	672	100	186	100
DISTRIBUTION BY PRECEDENCE				
O - Immediate	73	11		
P - Priority	217	32	18	10
R - Routine	382	57	168	90
DISTRIBUTION BY CLASSIFICATION				
S - Secret	31	4.5		
C - Confidential	30	4.5	1	1
U - Unclassified	611	91	185	99

D. 7. 4 Message Length

No attempt was made during this survey, due to the magnitude of the task, to measure message lengths. Based on AUTODIN Tributary Station reports over a three year period, the Coast Guard Headquarters COMMCEN traffic transmitted into and received from AUTODIN averages 217 groups (or 13.6 line blocks) and 314 groups (or 19.6 line blocks), respectively. Adoption of a 20 line block average appears a reasonable base for throughput requirement computations, providing an excess capacity to accommodate unpredictable traffic surges.

D. 7. 5 Handling Times

No attempt was made to record and compare actual handling times from the message files. The staff practice of delivering 90% of outgoing traffic to the COMMCEN in a six hour period coinciding with the period in which 50% of incoming

TABLE D-8. HOURLY DISTRIBUTION-BUSY DAY (ORIGINATED/TERMINATED TRAFFIC)

HOUR ENDING (LOCAL)		01	02	03	04	05	06	07	08	09	10	11	12	13	14	15	16	17	18	19	20	21	22	23	24
INCOMING BY PRECEDENCE	O	2		2	1	3	2		8		2	3		1	5	3	2	4	5	8	1	5	7	2	7
	P	11	8	8	11	9	7	3	10	4	4	5	5	12	8	8	11	10	19	14	13	14	9	3	11
	R	17	13	15	15	24	15	11	6	11	4	4	11	19	6	19	12	23	28	28	16	28	32	14	11
INCOMING BY CLASSIFICATION	S			1	2	2	2	1		1		4						3	2	1	3	6	1	2	
	C	1	2	1	1	2	3		1		1	3				2		2	2	3		3	2	1	
	U	29	19	23	24	32	19	13	23	14	9	8	13	32	19	28	25	32	48	46	27	38	45	19	26
TOTAL INCOMING		30	21	25	27	36	24	14	24	15	16	12	16	32	19	30	25	37	52	50	30	47	48	19	29
OUTGOING BY PRECEDENCE	O																								
	P	1		1	1	1	1					1			2					1	2	5			
	R			1	1	1									1	3		31	1	12	45	55	17		
OUTGOING BY CLASSIFICATION	S																								
	C																					1			
	U	1	1	1	1	7							1		3	3	3	31	1	13	46	60	17		
TOTAL OUTGOING		1	1	1	1	7						1		3	3	3	31	1	13	47	60	17			
		31	22	26	34	36	24	14	24	15	16	12	17	32	22	33	25	68	53	63	77	107	65	19	19

NOTES: 40% of total received traffic and 91% of originated traffic for 23 Sept. appeared in COMMEN between noon and 1:00 local.

(ALL TIMES BASED ON TOR/TOD - ZULU TIME)

HOURLY	#	7	2 HOUR	#	7	4 HOUR	#	
BUSY	21	107	12	20-21	194	21	19-22	307
SLOW	10	10	1	10-11	22	2	09-12	54
MEAN	09	26	2	14-15	55	6	01-04	113

traffic is received, so grossly distorts the even flow of traffic through the center, as to make any such data meaningless. This condition led to the decision to use synthesized handling times exclusively in this analysis.

Figures D-5 and D-6 summarize the times associated with each function performed while processing incoming and originated traffic, respectively. The function, operations, personnel, and stations correspond to those utilized in preparing the flow diagrams presented in TABs I and II. These flow charts have been simplified by combining AUTODIN and other incoming and by abbreviating the multiple transmission and relay functions. Foot notes are used to explain minor differences in the flow and timing. It should be noted that these synthesized handling times consider the flow of one message through the total operational process, from start to finish, disregarding the delays (interruptions, distractions, competition with other messages, idle time, etc.) which are often unavoidable in a busy COMMCEN. The value of synthesized handling times is the base they provide for assessing the relative affect of a change in procedures. Any attempt to compare these synthesized times with recorded handling times would lead to grossly inaccurate conclusions. Such a comparison could and should not be used as a basis for evaluating what was observed to be the extremely professional performance of COMMCEN personnel.

These synthesized handling times are summarized in Table D-9 in terms of the times devoted to selected typical messages. In the case of variances from the normal flow, the footnotes should be applied.

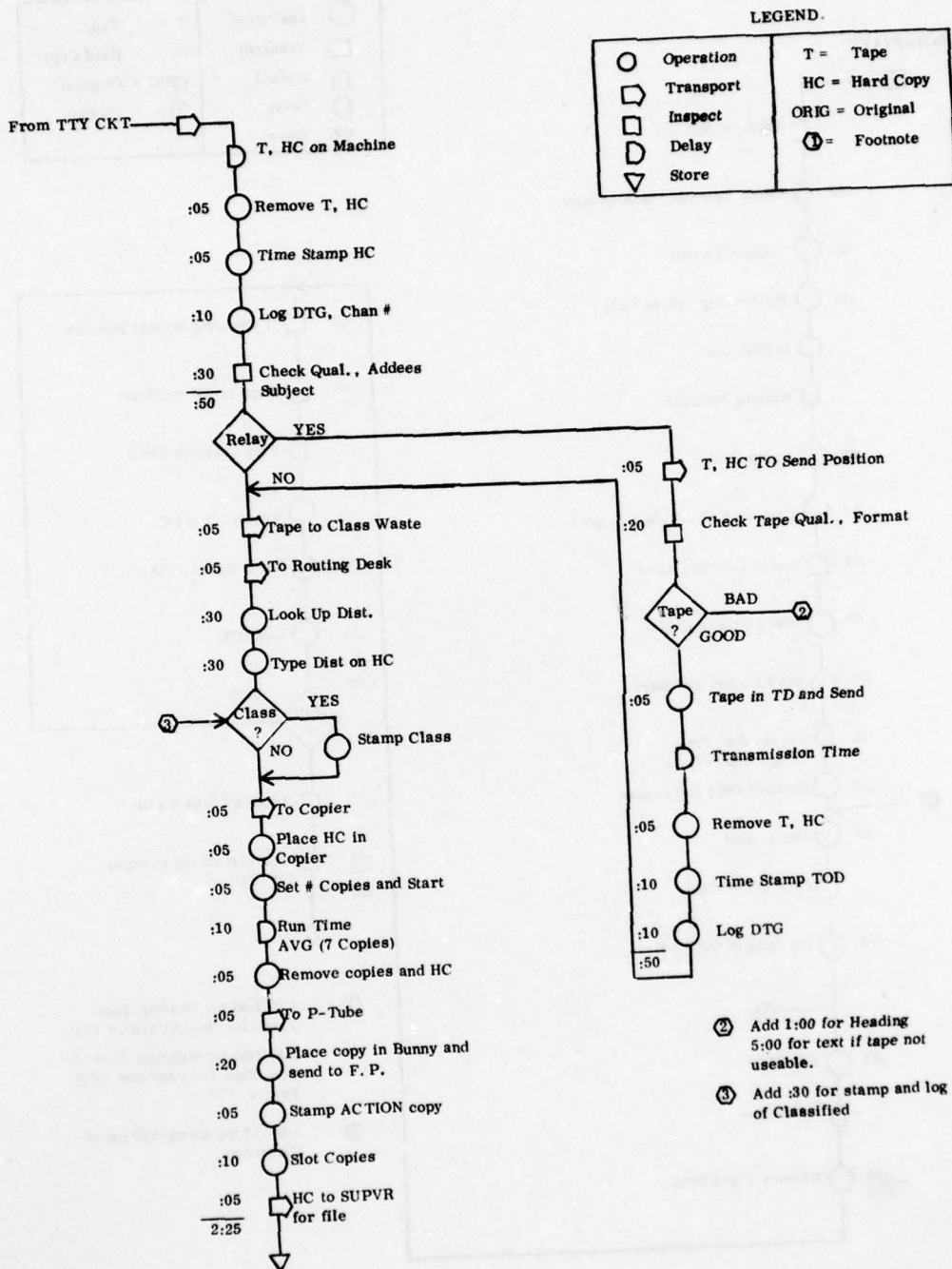

Figure D-5. Synthesized Handling Times - Incoming Traffic

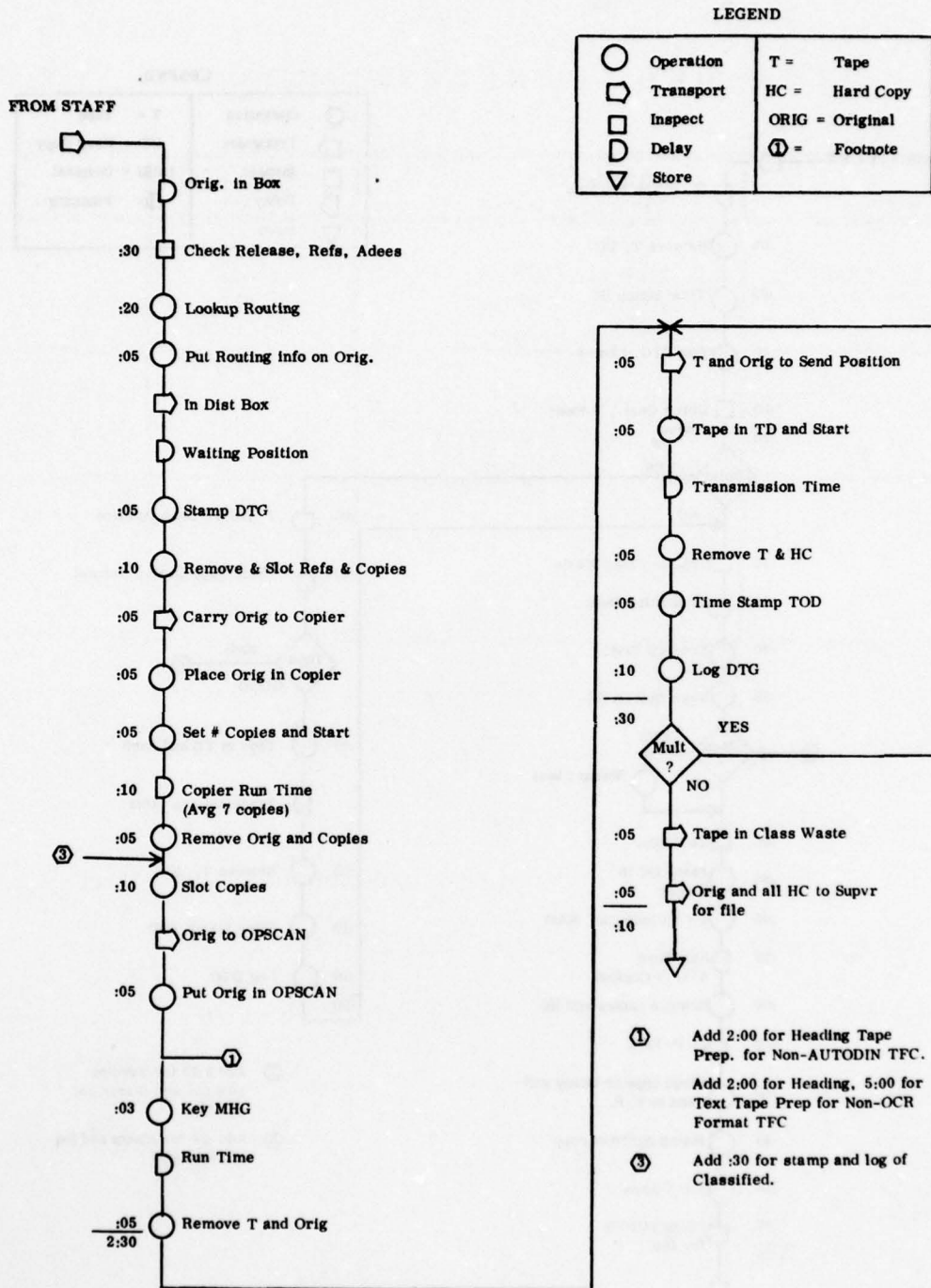

Figure D-6. Synthesized Handling Times - Originated Traffic

TABLE D-9. HANDLING TIME SUMMARY

FROM	HANDLING REQUIREMENT	HANDLING TIME	NOTES
AUTODIN	Terminate Only	3:15	(1)
	Terminate & Relay	4:05	(1) (2)
	Additional Relays	:50	(2)
OTHER TTY	Terminate Only	3:15	(1)
	Terminate & Relay	5:05	(1) (3)
	Additional Relays	:50	(2)
STAFF	AUTODIN	3:10	(1) (4)
	Other TTY	5:10	(1) (5) (6)
	AUTODIN & Other	3:40	(1) (4)
	Additional Mult.	:30	

(TIME IN MIN:SEC)

- (1) Add :30 for stamp and Log of Classified.
- (2) Assumes useable Tape for Relay.
- (3) Assumes AUTODIN Relay and 1:00 for Heading Prep. with MHG.
- (4) Add 7:00 for tape prep. for Non-OCR format.
- (5) Includes 2:00 for manual prep. of Non-AUTODIN Heading.
- (6) Add 5:00 for Non-OCR format.

TAB I To APPENDIX D

OPERATION SEQUENCE DIAGRAM - OUTGOING MESSAGE

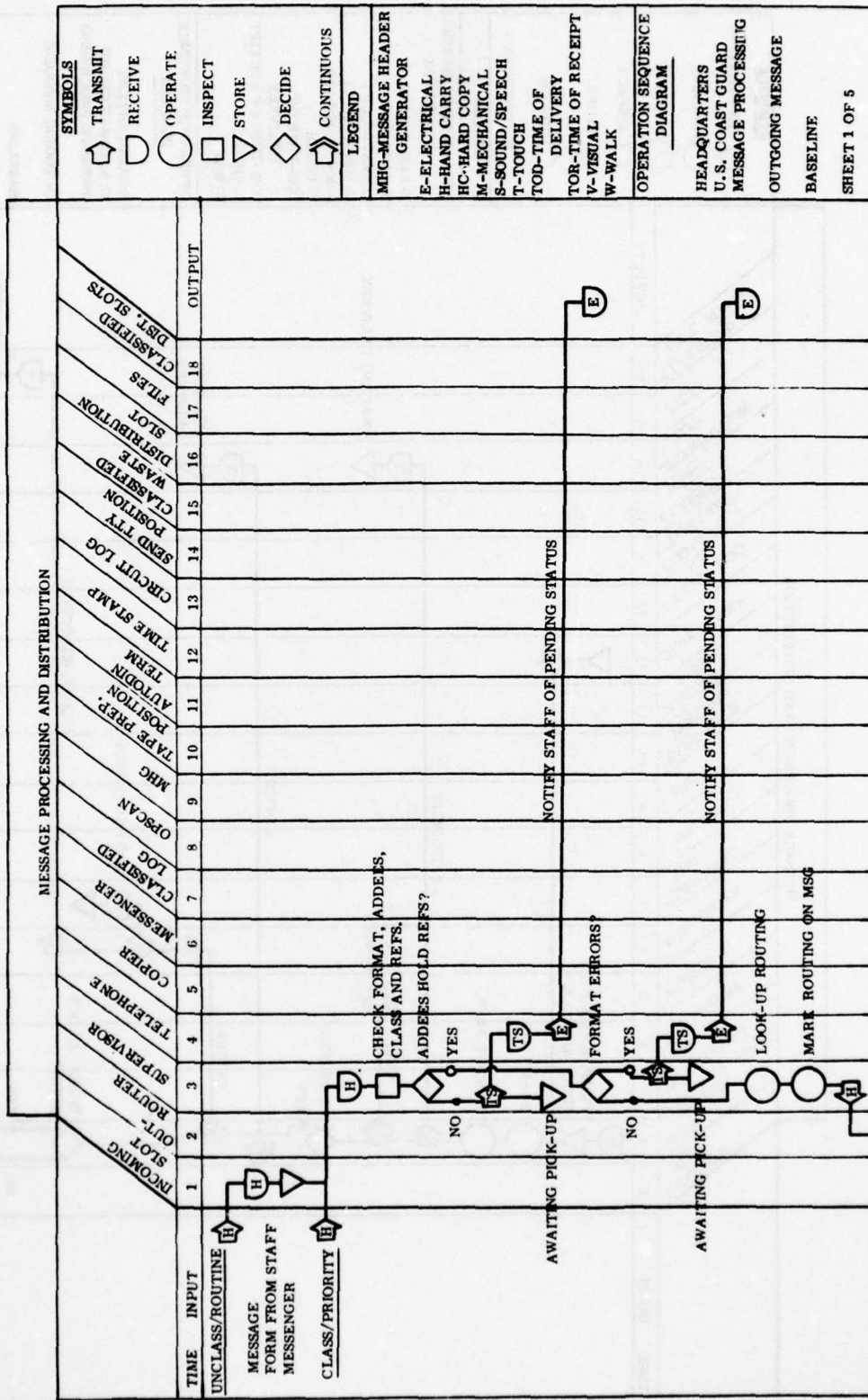

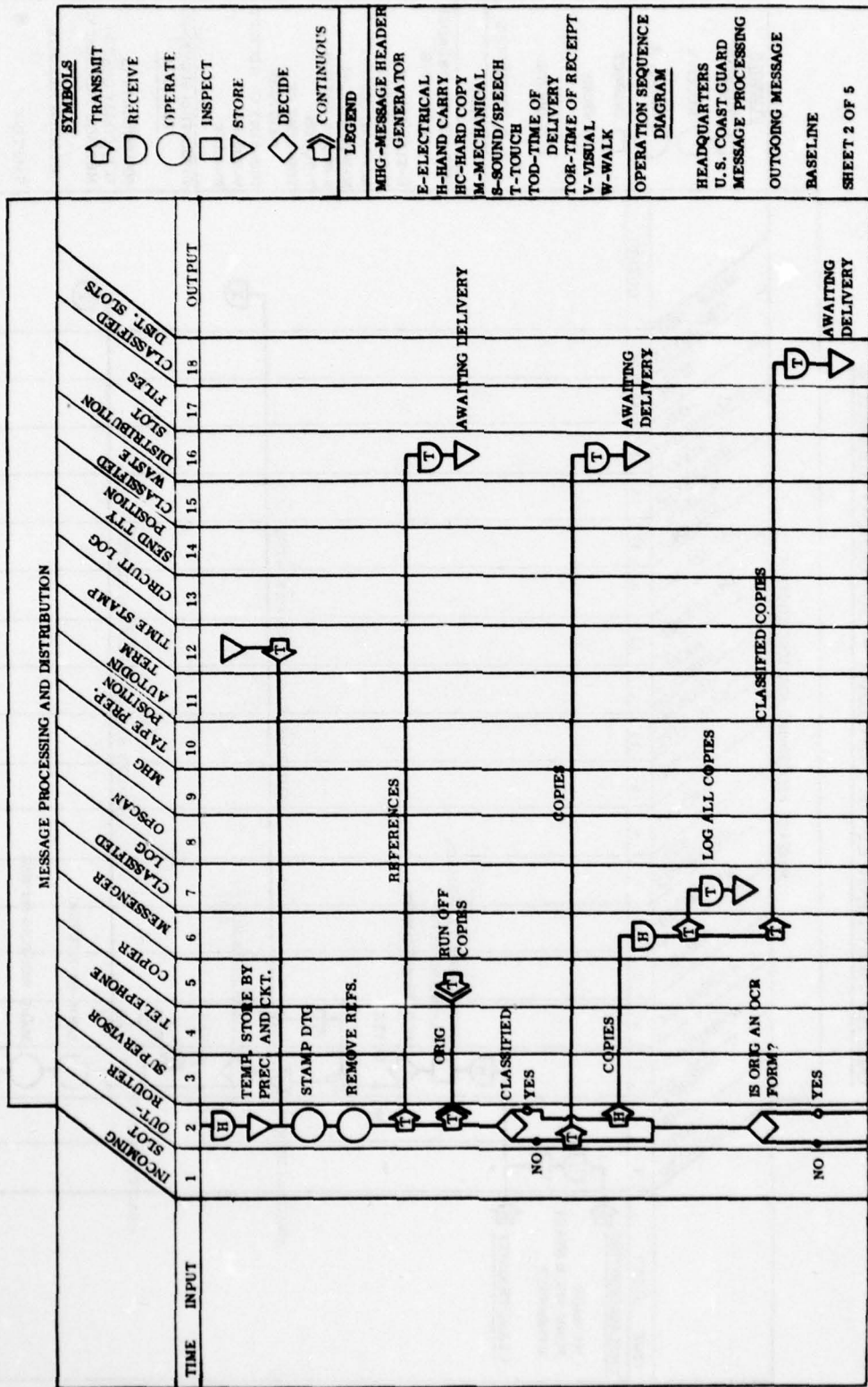

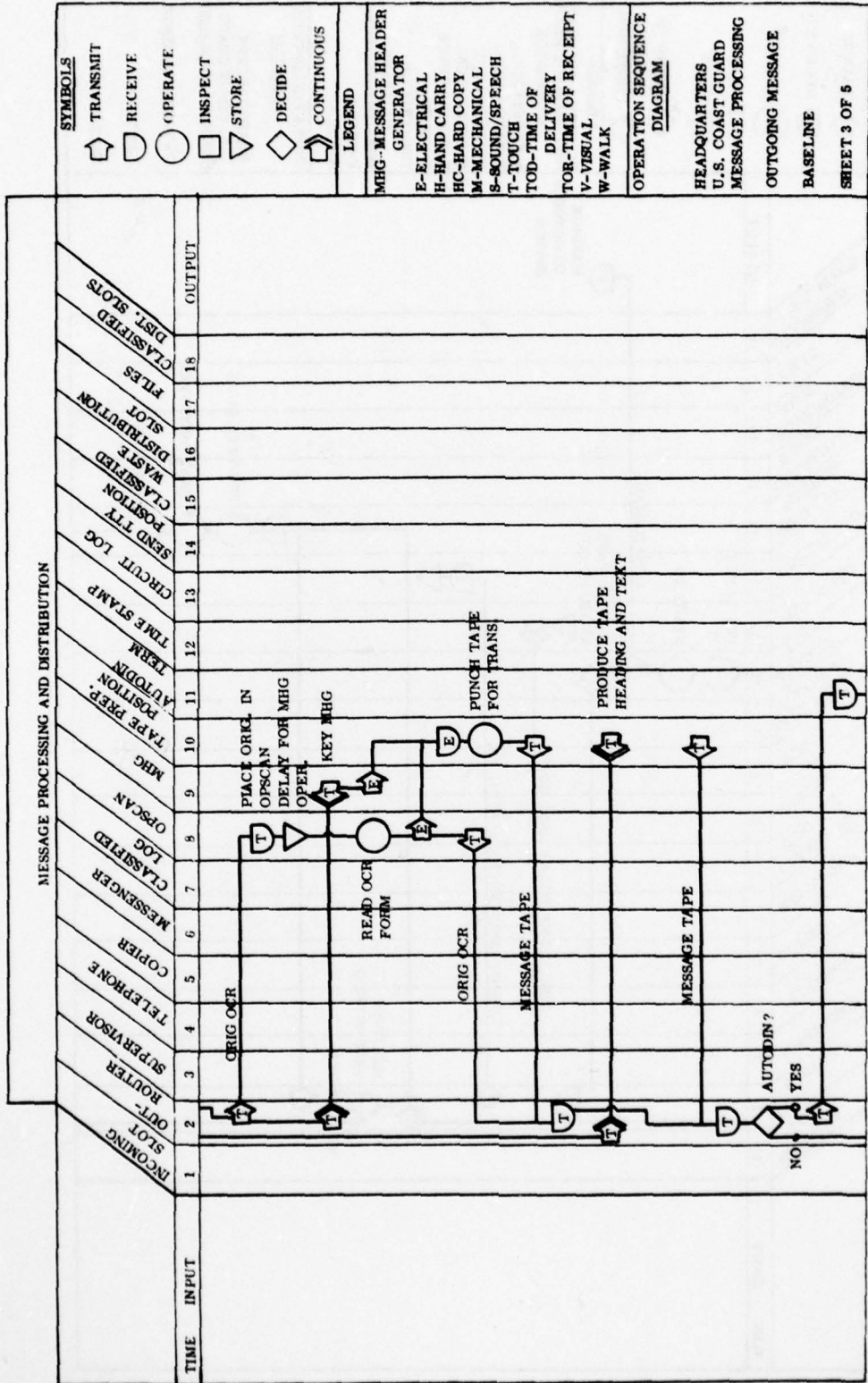

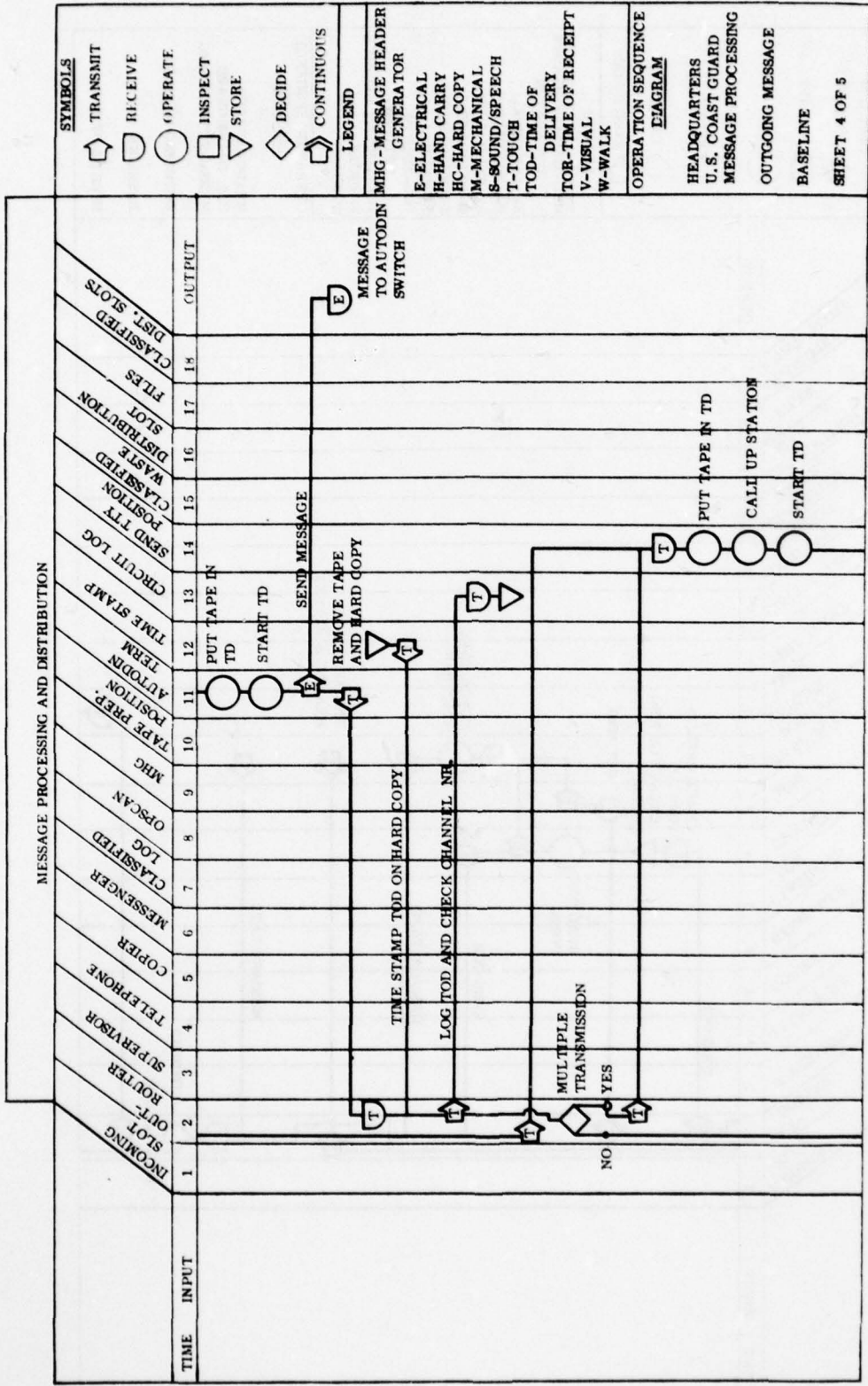

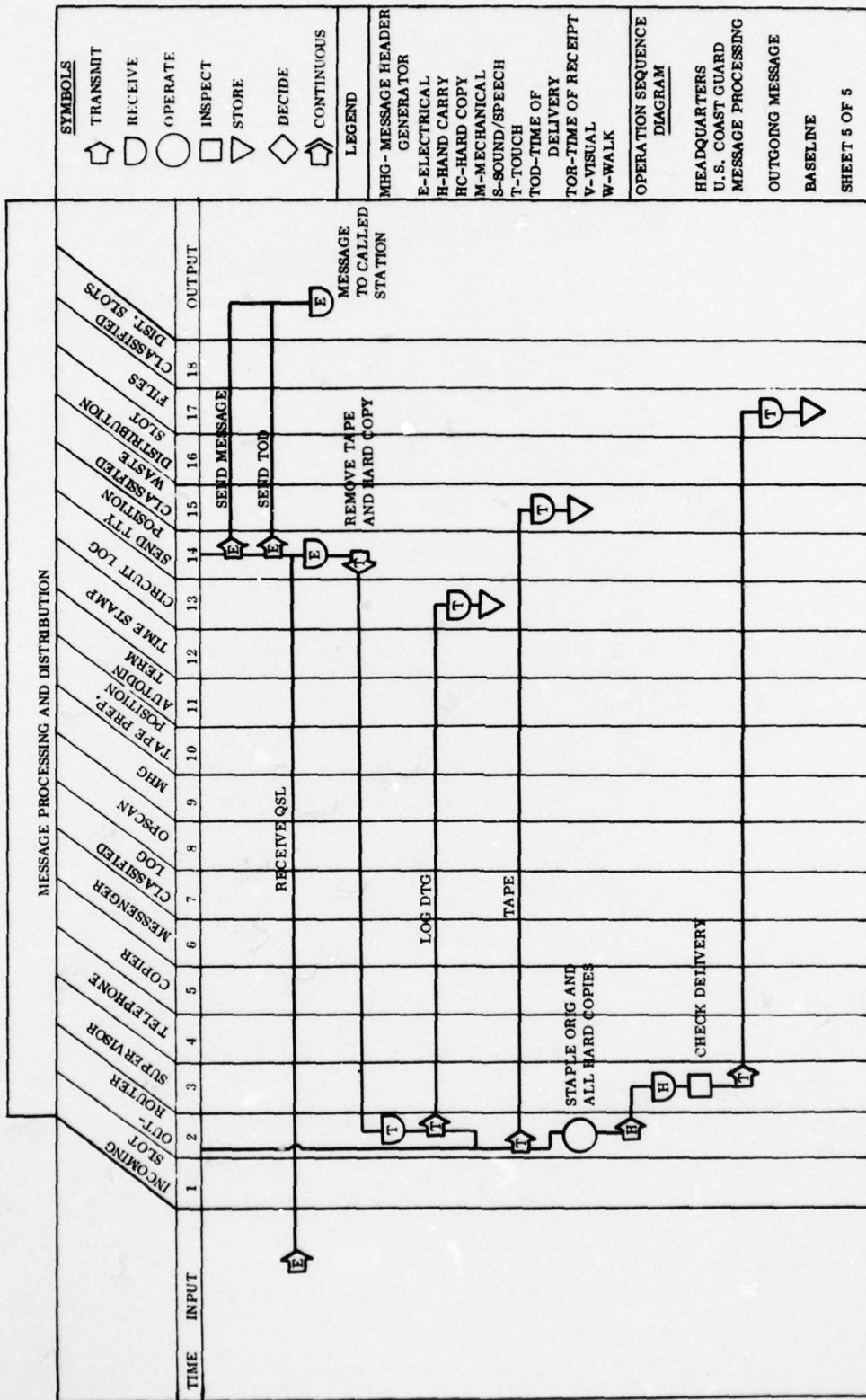

AD-A060 464

COMPUTER SCIENCES CORP FALLS CHURCH VA SYSTEMS DIV F/G 17/2
STUDY OF AUTOMATION OF MESSAGE HANDLING FUNCTIONS AT USCG COMST--ETC(U)
MAY 78 D SMILEY, G KEENE, P KENNEDY DOT-CG-71522-A
CSC/SD-78/3034 USC6-D-18-78 NL

UNCLASSIFIED

4 of 4
AD
A060 464



END
DATE
FILMED
1-79
DDC

