

AD-A060 496

TRACOR INC AUSTIN TEX  
XM-130 CONTINUED DEVELOPMENT. (U)  
SEP 78 V DUBE

F/G 17/4

UNCLASSIFIED

TRACOR-T-78-AU-9042-U

DAAK10-77-C-0048  
NL

| OF |

AD  
A060496



END  
DATE  
FILMED  
01 -79  
DDC

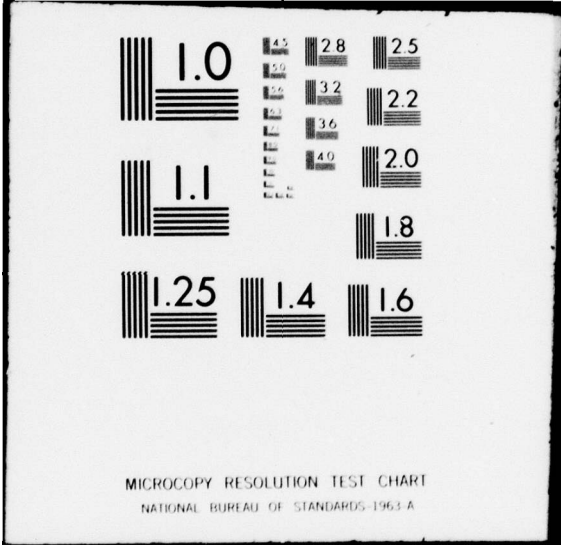

Tracor Sciences & Systems

12

AD A060496

Tracor Document Number

T-78-AU-9042-U

Revision A

TRACOR-777-AU-90-C-REV-2

LEVEL #

8

XM-130 Continued Development.

9

Final Technical Report, for period ending 1977.

15

Contract Number DAAK10-77-C-0048

Victor Dube

Prepared for

Department of the Army  
U.S. Army Armament R&D Command  
Dover, N.Y. 07801

DDC  
RECEIVED  
OCT 31 1978  
RECEIVED

97

A

Prepared by

352100

we

→

Tracor, Inc.  
6500 Tracor Lane  
Austin, Texas 78721

DISTRIBUTION STATEMENT A

Approved for public release;  
Distribution Unlimited

11

13 September 1978

12  
22p.

Approved by:

Victor Dube  
10 Victor Dube  
Program Manager

78 09 18 159

12

# Tracor, Inc.

DOCUMENT NO. <u>T-78-AU-9042-U</u>		REVISION SHEET	
ATTACHMENT NO. _____		SHEET <u>1</u> OF <u>1</u>	
LTR	DESCRIPTION	DATE	APPROVAL
<p>REVISION A</p> <p>Title Page - Correction of Contract Number from DAAK-77-C-0048 to DAAK10-77-C-0048.</p> <p>Page iii - Typo corrections (originally, ARRADCOM - deleted US from front of ARRADCOM, Continuing, Program, Chip).</p> <p>Page 1 - Delete X from XM-1, XM-206, XM-796.</p> <p>Page 4 - Typo correction of the word 'shown'.</p> <p>Page 8 - Delete the word 'all', and added an 'r' to the word sequence to make sequencer.</p> <p>Page 9 - Delete X from XM-206, XM-796 and XM-130. Changed typo 'AFFADCOM' to 'ARRADCOM'.</p> <p>Page 10 - Delete X from XM-206, XM-796 and XM-1. Change drawing number from 9311402 to 9311660. Typo 'Impulse' changed to correction 'Impulse'.</p> <p>Page 11 - Delete "before 13 August 1977."</p>			

ADDRESSING UNIT

REG       REG       REG  
 REG       REG       REG

Butler on file

BY \_\_\_\_\_

DISTRIBUTING/STANDARDIZATION

MAIL      AVAIL.      REG.      SPECIAL

A

78 09 18 159

REPORT DOCUMENTATION PAGE		READ INSTRUCTIONS BEFORE COMPLETING FORM
1. REPORT NUMBER T78-AU-9042-U ✓	2. GOVT ACCESSION NO.	3. RECIPIENT'S CATALOG NUMBER
4. TITLE (and Subtitle) XM-130 Final Technical Report	5. TYPE OF REPORT & PERIOD COVERED Final Technical Report 1977	
	6. PERFORMING ORG. REPORT NUMBER T77-AU-90-C Rev. A ✓	
7. AUTHOR(s) Vic Dube	8. CONTRACT OR GRANT NUMBER(s) DAAK10-77-C-0048 <sup>te</sup>	
9. PERFORMING ORGANIZATION NAME AND ADDRESS Tracor, Inc. 6500 Tracor Lane Austin, TX 78721	10. PROGRAM ELEMENT, PROJECT, TASK AREA & WORK UNIT NUMBERS	
11. CONTROLLING OFFICE NAME AND ADDRESS Tracor, Inc. 6500 Tracor Lane Austin, TX 78721	12. REPORT DATE 28 February 1978 ✓	
	13. NUMBER OF PAGES 7	
14. MONITORING AGENCY NAME & ADDRESS (if different from Controlling Office) Department of the Army U.S. Army Armament R&D Command Dover, NJ 07801	15. SECURITY CLASS. (of this report) UNCLASSIFIED	
	15a. DECLASSIFICATION/DOWNGRADING SCHEDULE	
16. DISTRIBUTION STATEMENT (of this Report)		
17. DISTRIBUTION STATEMENT (of the abstract entered in Block 20, if different from Report)		
18. SUPPLEMENTARY NOTES		
19. KEY WORDS (Continue on reverse side if necessary and identify by block number)		
20. ABSTRACT (Continue on reverse side if necessary and identify by block number) The U.S. Army Armament R&D Command, ARRADCOM, awarded Contract DAAK10-77-C-0048 on 15 April 1977 for the continued development of the M-130 Aircraft General Purpose Dispenser including the fabrication and delivery of associated payload, the M-1 chaff, M-796 Impulse Cartridges, and M-206 Flares. <sup>D</sup>		

**Tracor Sciences & Systems**

TABLE OF CONTENTS

<u>SECTION</u>		<u>PAGE</u>
1	INTRODUCTION	1
2	PRE-PRODUCTION PROTOTYPE	2
2.1	Design Activities	3
2.2	Fabrication and Test Activities	8
3	UPDATE OF THE TECHNICAL DATA PACKAGE	9
4	PAYLOAD PRODUCTION	10
5	CONCLUSIONS	11

## **Tracor Sciences & Systems**

### **PREFACE**

The XM-130 Aircraft General Purpose Dispenser System was originally developed for the U.S. Army Armament R&D Command, ARRADCOM, under contract DAAA-21-76-C-0069. This contract continued to develop the XM-130 System in that it incorporated certain design improvements and enhanced production.

During the XM-130 Continuing Development Program, significant technical assistance and support was received from numerous government personnel which was instrumental in the success of the effort. Among the major contributors were John E. Andrews, James Long and Don Devine of ARRADCOM.

Within Tracor, the efforts of Victor Dube, Chip Cotton, Steve Addington and their associates were responsible for the achievements of the program.

## Tracor Sciences & Systems

### 1 INTRODUCTION

The purpose of the XM-130 dispensing system is to provide effective aircraft survival countermeasures for Army aircraft against enemy radar and infrared missile threats. The system, originally developed by ARRADCOM and Tracor under Contract DAAA-21-76-C-0069, may be configured to provide either 30 or 60 countermeasure payloads, either chaff or flares, or in the 60 payload configuration, 30 chaff and 30 flares. The payloads are the M-1 countermeasures chaff and the M-206 Aircraft Countermeasure Flare, both using the M-796 Impulse Cartridge.

The present effort was undertaken for the purpose of

- (1) The incorporation of design improvements and testing of a pre-production prototype.
- (2) The update of the Technical Data Package.
- (3) The fabrication of small quantities of M-1 Chaff, M-206 Flares, and M-796 Payloads.

## Tracor Sciences & Systems

2

### PRE-PRODUCTION PROTOTYPE

The objective of the pre-production prototype was to provide a model of the XM-130 System consisting of one electronic module, a dispenser assembly, and a payload module. The technical changes that were to be incorporated into this model were the following:

(1) Dispenser Assembly, Part No. 9311434.

(a) Redesign the assembly to eliminate the need for removing the cover when installing the dispenser assembly on the aircraft.

(b) Replace the existing hexagonal socket head cap screws with regular hexagonal head jam screws.

(c) Redesign the sequencer cover so that a gasket acts as a sealer instead of the existing RTV.

(d) Relocate the selector switch to prevent breaking the switch when removing the cover.

(e) Add drain holes.

(2) Payload Module, Part No. 9311451 - redesign the fasteners holding the retention plate to the payload module to control the stability of the plate on the module.

In addition to the above change, Tracor suggested, ARRADCOM concurred, to the following improvements to the XM-130 system:

(1) Redesign the name plates (make larger)

(2) Study alternatives to roll pins in flare sensor housing.

## Tracor Sciences & Systems

- (3) Provide alternative for 180 degree bend in wiring harness between boards in the sequencer assembly.
- (4) Increase service loop on cable between breech plate and sequencer.
- (5) Add 100K OHMS, 1/4 watt resistor to input of U6 and U7 on flare detector board.
- (6) Reroute IRWR signal directly to IC U4 and U5 on flare detector board.
- (7) Change R1 on power supply no. 2 board from 330 OHMS, 1/4 watt to 330 OHMS, 1/2 watt.
- (8) Change R33 on power supply no. 2 board from 2.2K OHMS, 1/4 watt to 3.9K OHMS, 1/2 watt.
- (9) Change R4 on sequencer board from 2.2K OHMS, 1/4 watt to 1.0K OHMS, 1/2 watt.
- (10) Change Zener UR1 on sequencer board from a temperature compensated diode to a mil-standard 1 watt 7.5 volt Zener.
- (11) Add a diode in emitter circuit of Q3 on the sequencer switch board for added threshold protection.
- (12) Remove diode from flare sensor assembly and place on sequencer board.

### 2.1 Design Activities

The evolution of the dispenser system redesign was constrained by the establishment that the improved design must be inter-

## Tracor Sciences & Systems

changeable with the original design and that it must not obsolete any or all aircraft "A" kits. This contained the redesign to the same mounting dimensions and overall envelope, except for length to the rear.

The breech plate assembly and sequencer switch was moved to the rear a total of .40 of an inch which allowed cut out of mounting screws on the leading edge of the dispenser assembly. In addition, the breech plate was thickened and the mounting screw bearing surface to move to the top of the plate. These two changes allow easy access to the mounting screws and sufficient clearance around the screw heads. This allows the use of standard military hexagonal head screws. The improved dispenser design is shown in Figure 1.

The sequencer switch was redesigned as shown in Figure 2, to:

- (1) Incorporate a rubber gasket in the lid of the housing.
- (2) Remove the selector switch for the printed wiring board and place it on the lid.
- (3) Provide alternative to 180 degree bend in wiring harness.

In addition to the above changes, the housing and lid were changed from a dip-brazing to an investment aluminum casting. This change resulted in a cost savings of \$20 to \$30 per housing in production quantities.

The retention plate for the payload module was redesigned as shown in Figure 3 to incorporate a more durable thumb screw fastener instead of a slide fastener.

The roll pins on the flare sensor housing were

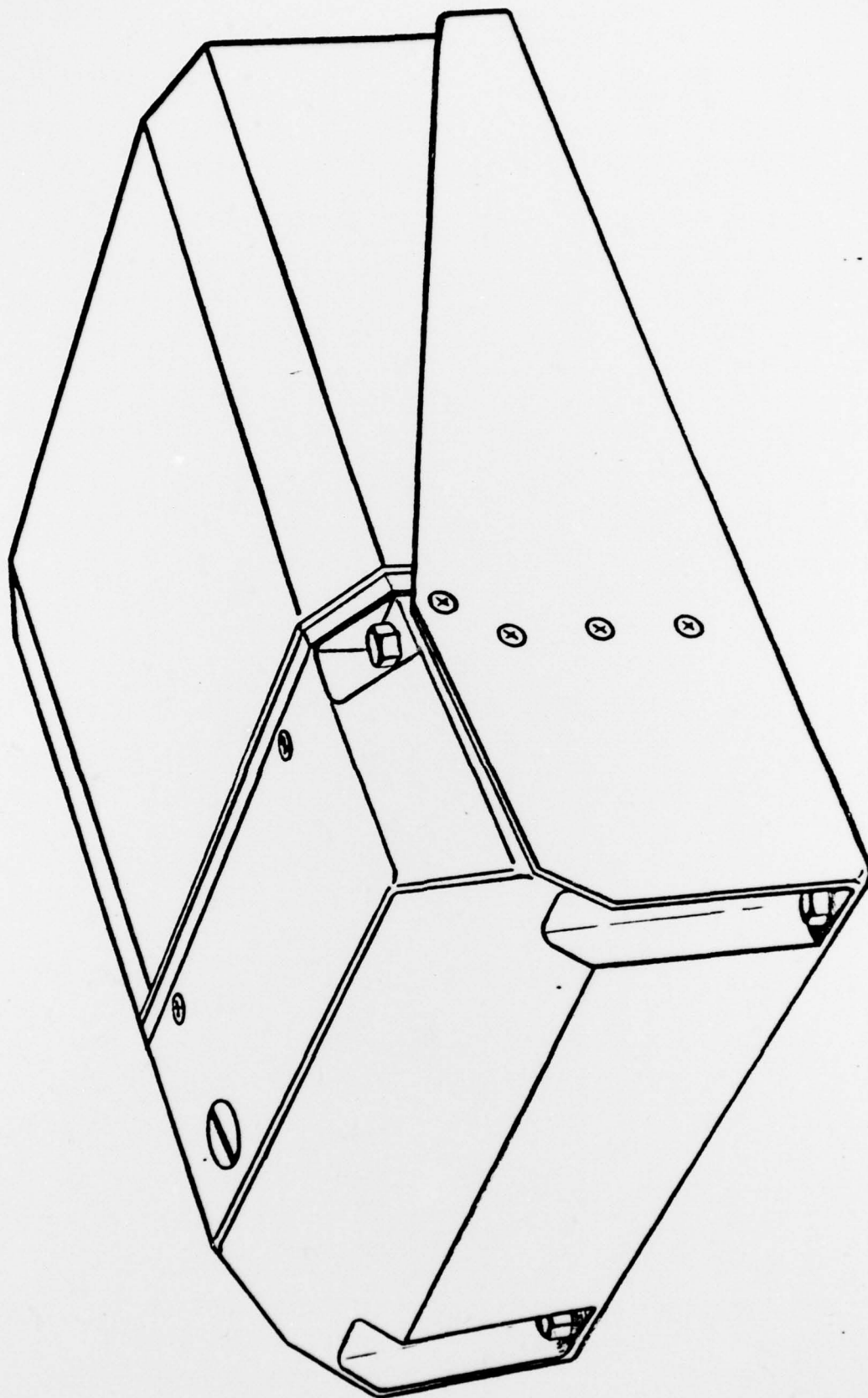
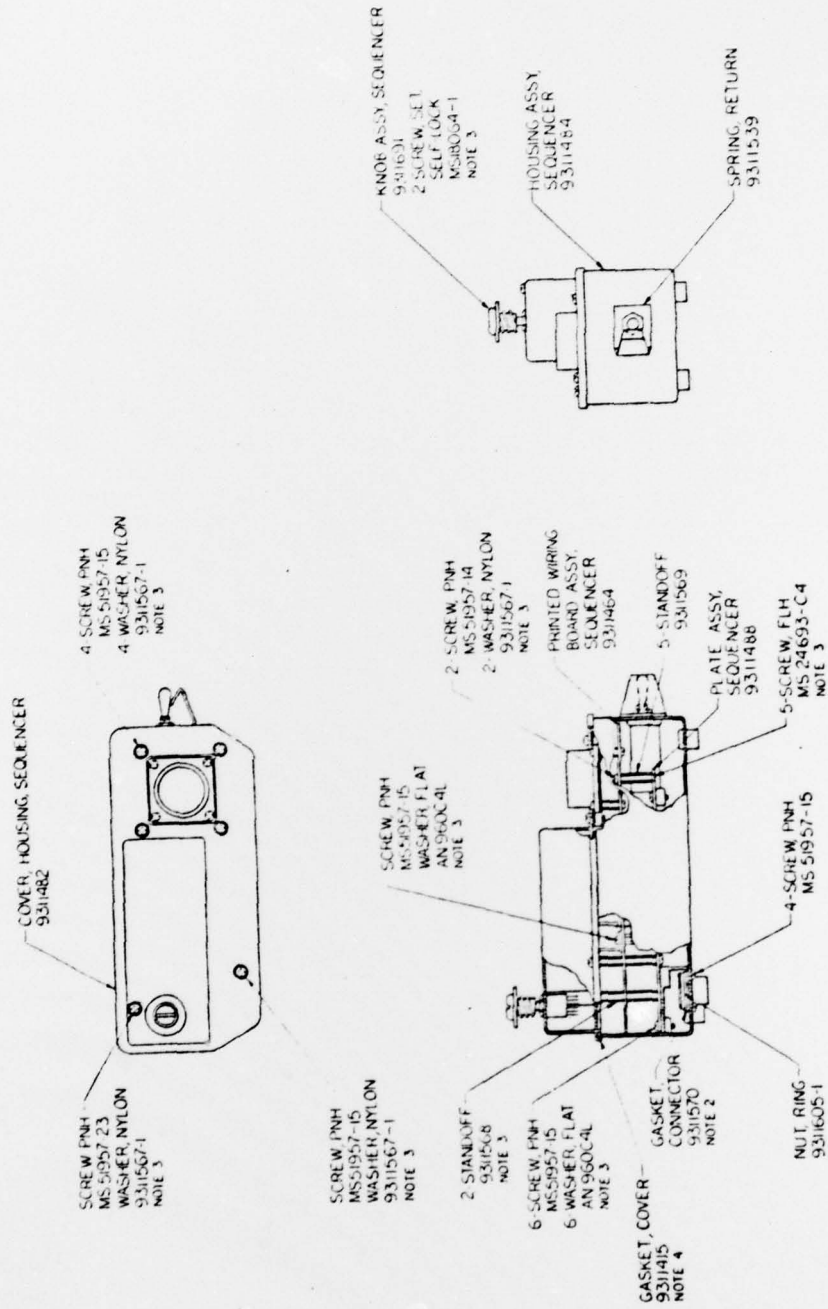

FIGURE 1 DISPENSER ASSEMBLY



- NOTES:-
- 1-SPEC MIL-A-2550 AND ANSI 1145-73, APPLY.
  - 2-APPLY ADHESIVE RUBBER, TYPE III, SPEC MMMA 1617 TO HOUSING SIDE OF GASKET.
  - 3-APPLY SEALING COMPOUND, GRADE M, SPEC MIL S-22473 TO ALL THREE ADS.
  - 4-APPLY ADHESIVE RUBBER, TYPE III, SPEC MMMA-A-1617 TO COVER SIDE, PART NO. 9311482, OF GASKET.

FIGURE 2 SEQUENCER SWITCH ASSEMBLY

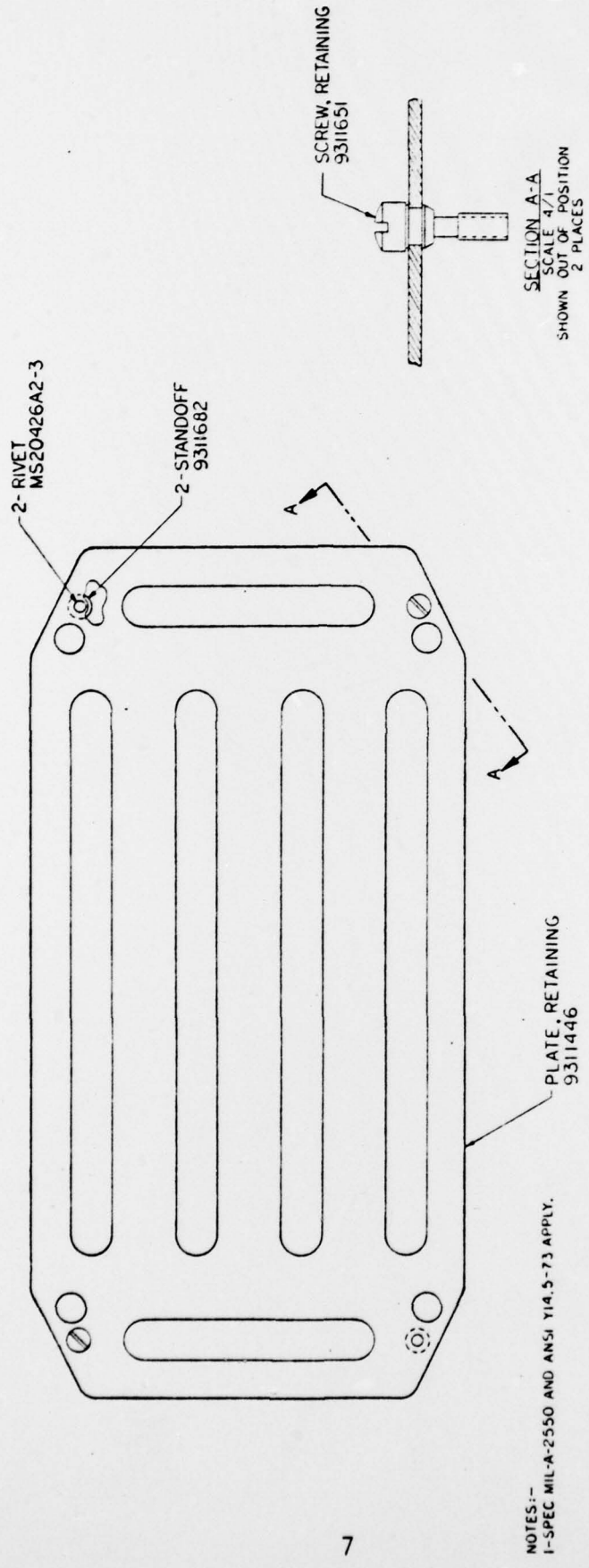

FIGURE 3 RETAINER PLATE

## **Tracor Sciences & Systems**

deleted, and instead, clamps were substituted. The redesigned flare sensor housing also provided greater clearance around the mounting screw. The diode for the flare detector circuitry was moved from the flare sensor assembly and placed on the sequence board for increased reliability.

In addition to the above changes, numerous electronics changes, as previously listed, were made to improve system reliability.

### 2.2 Fabrication and Test Activities

A XM-130 System was provided GFE (built under previous contract) for the building of the pre-production prototype. Any part effected by the redesigning, was removed and replaced with a re-fabricated part meeting the requirements of the redesign. In addition, printed wiring board (PWB) was removed from the GFE XM-130 System and replaced with PWB's built to the level 3 drawings, thereby proofing the drawings. The previously built PWB's were built to level 1 drawing. The aluminum cast sequencer housing was simulated using a sheet metal/weld construction.

After completion of the assembly of the pre-production prototype, the prototype model was vibration tested to the requirement of Method 514.2, Procedure IIC of Mil-Sld-810C. The tests were conclusive in that the results show no ill-effect due to the redesign on the vibration integrity of the system. The vibration response curves are given in the Appendix.

## **Tracor Sciences & Systems**

### 3                    UPDATE OF THE TECHNICAL DATA PACKAGE

The Technical Data Package (TDP) from the XM-1 chaff, M-206 flare, M-796 Impulse cartridge, and M-130 General Purpose Dispenser System were reviewed for drawing errors, tolerance, and format. In addition, design improvements, as previously outlined, were incorporated into the level 3 TDP. After correction, the level 3 drawings were sent to ARRADCOM for review. After numerous drawing review meetings between AFFADCOM and Tracor, the final drawing corrections and changes were sent to Tracor Drafting for finalization of the TDP. After final correction and changes were implemented to the TDP, all original tracing were delivered to ARRADCOM on or before the required date of 13 August 1977.

**Tracor Sciences & Systems**

4

PAYLOAD PRODUCTION

The following payloads were fabricated per drawing and quantities noted below:

(1) A quantity of 1000 - M-206 Aircraft Countermeasure Flare, Drawing No. 9311623.

(2) A quantity of 4000 - M-796 Impulse Cartridge, Drawing No. 9311612.

(3) A quantity of 3000 - M-1 Countermeasure Chaff, Drawing No. 9311660.

Delivery of the payload occurred in October 1977 for the M-1 Chaff and in December for the M-796 Impulse Cartridge and M-206 Flares.

## Tracor Sciences & Systems

5

### CONCLUSIONS

The intent of this program was to incorporate into the XM-130 system certain design improvements as a result of problems that surfaced during DTII/OTII testing, and secondly, to update the Technical Data Package suitable for production. The time allotted to perform the task was short. A prototype model was built as the TDP was being updated. Once the level three drawings were updated to incorporate the design changes and drafting and design errors, they were sent to ARRADCOM for review. Generally, a month was allowed for ARRADCOM's review. The drawing comments were returned to Tracor for final drawing update. The drawings were then corrected and the original level three tracings were delivered to ARRADCOM. This task was successfully completed during a period of a little less than four months.

**Tracor Sciences & Systems**

APPENDIX



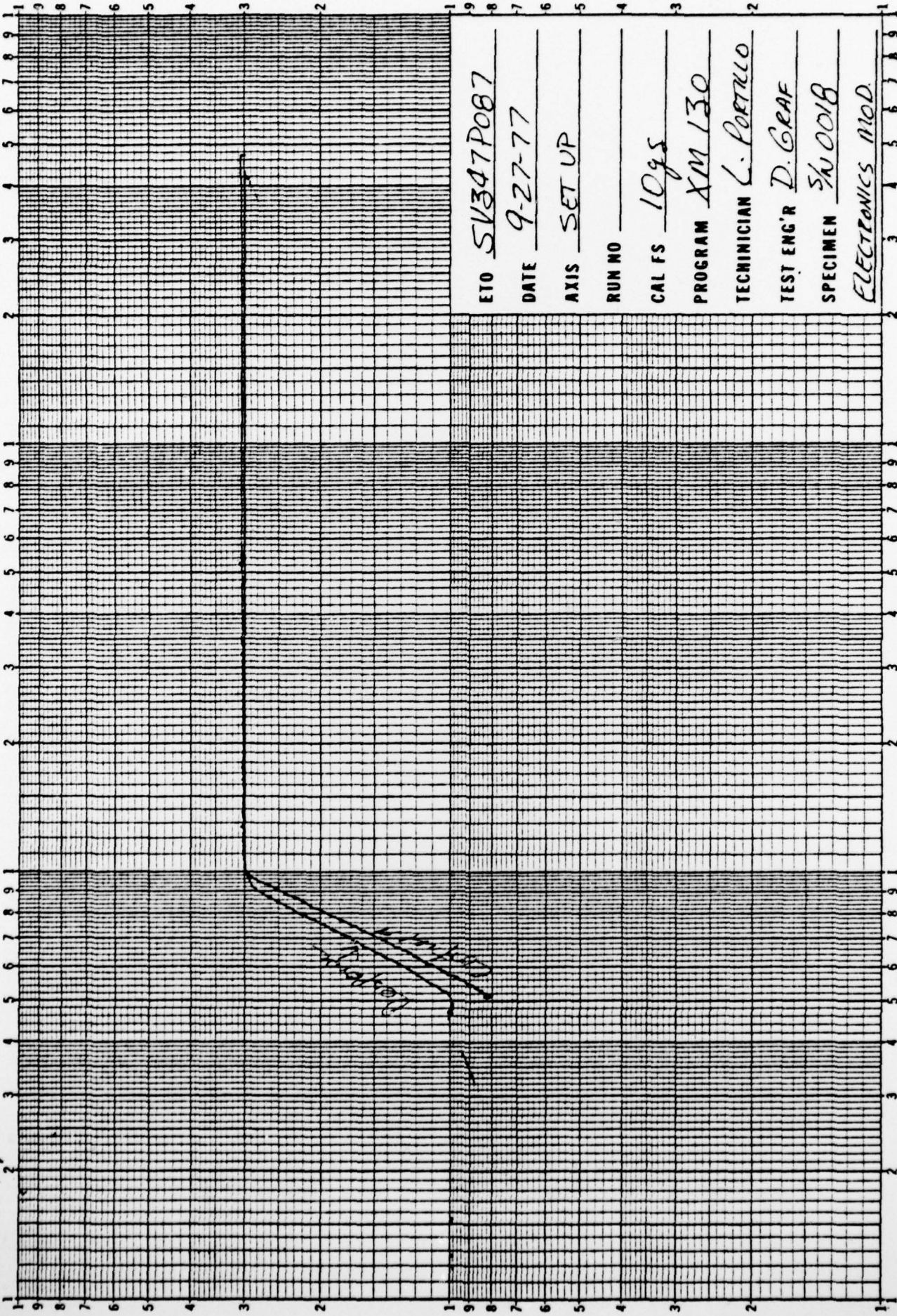

ETO SV347P087

DATE 9-27-77

AXIS SET UP

RUN NO \_\_\_\_\_

CAL FS 10gs

PROGRAM XM130

TECHNICIAN L. PORTILLO

TEST ENG'R D. GRAF

SPECIMEN 5N0018

ELECTRONICS 110D.

500

100

10

FREQUENCY (HZ)

Tracor, Inc.

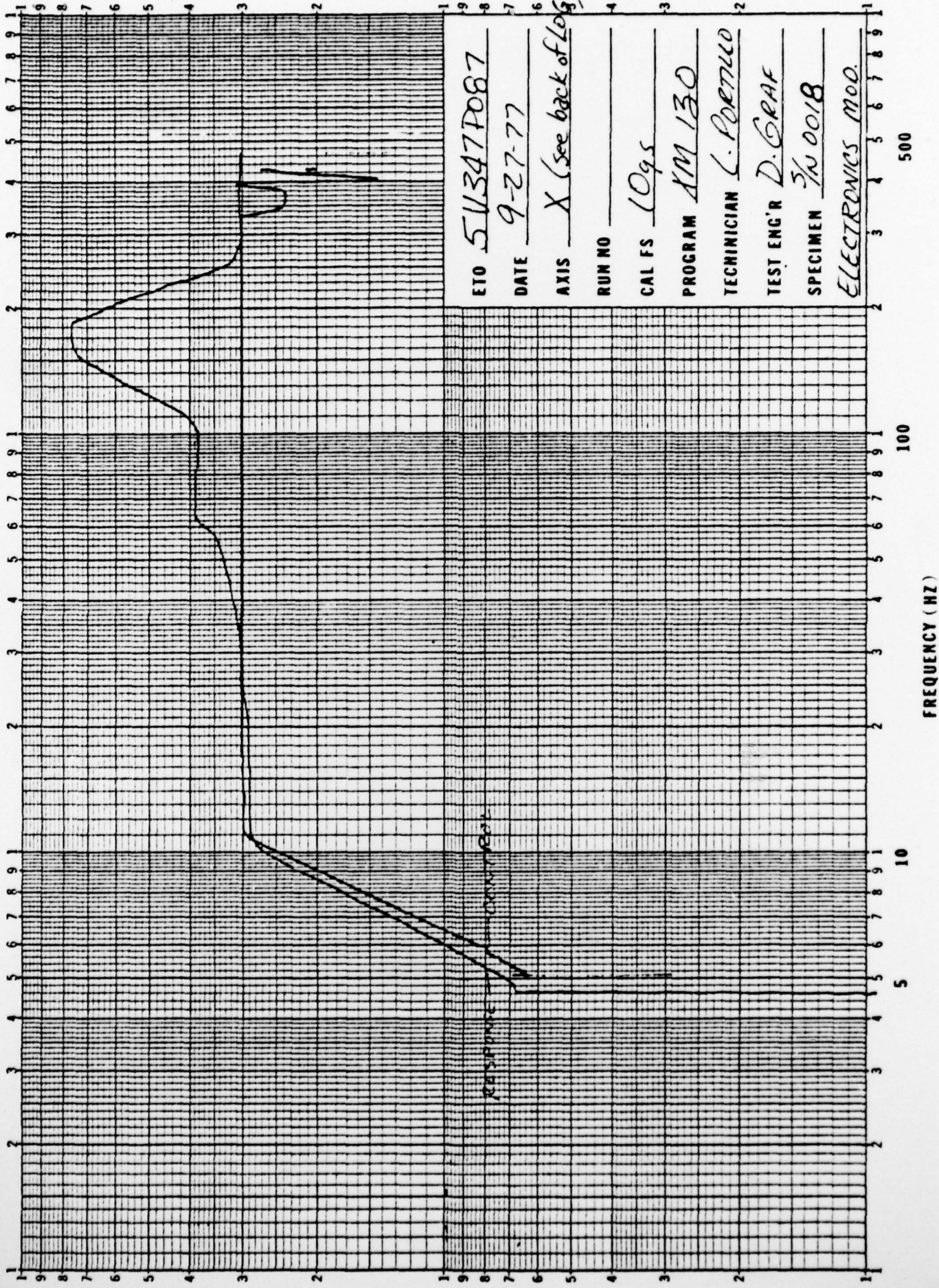

ETO 511347P087  
DATE 9-27-77  
AXIS X (see back of Log)  
RUN NO \_\_\_\_\_  
CAL FS 1095  
PROGRAM AM 130  
TECHNICIAN L. PORTUCCO  
TEST ENGR D. GRAF  
SPECIMEN 5N 0018  
ELECTRONICS MOO.

Tracor, Inc.

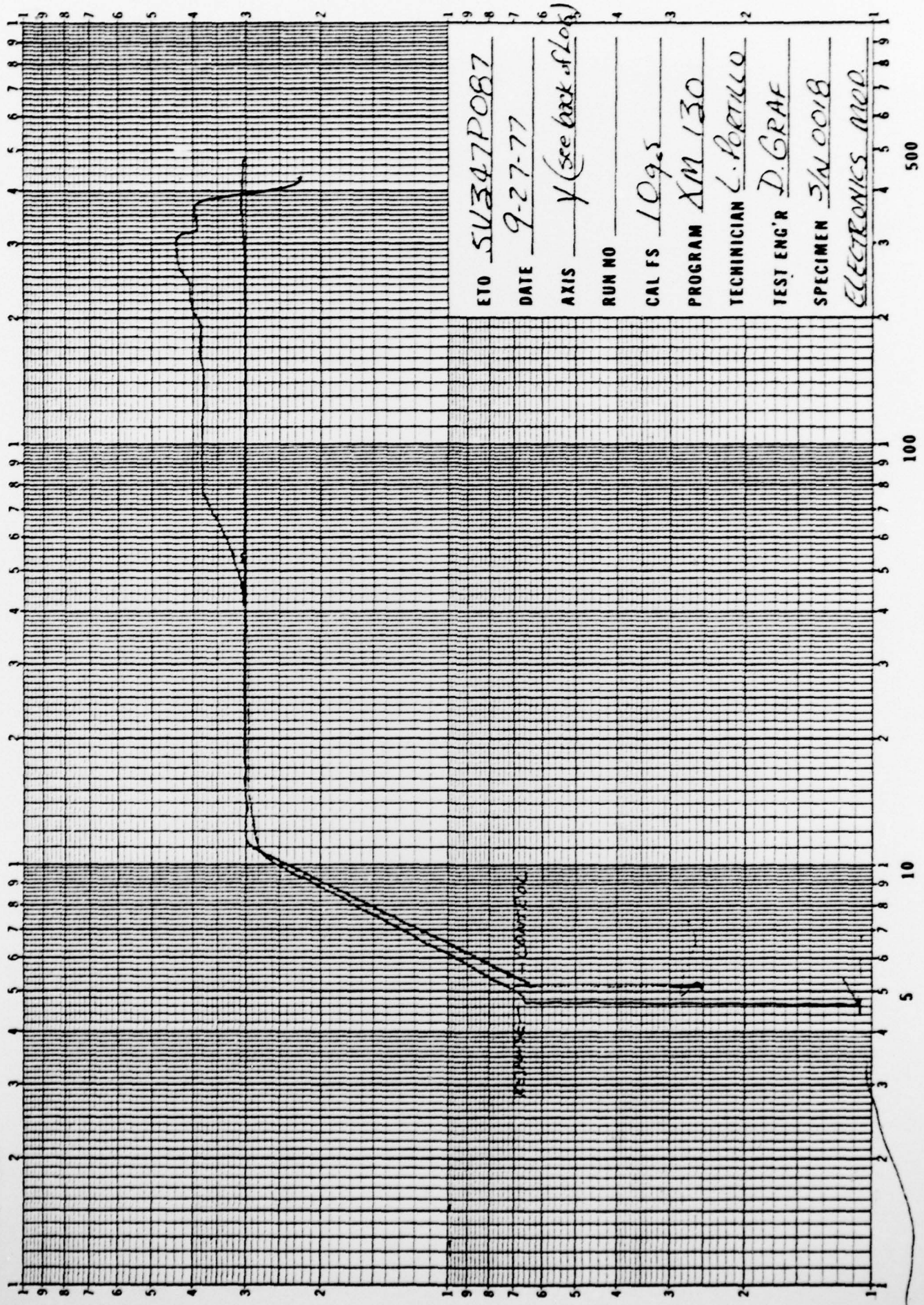

ETO SU347P087  
DATE 9-27-77  
AXIS Y (see back of log)  
RUN NO \_\_\_\_\_  
CAL FS 1095  
PROGRAM XM 130  
TECHNICIAN L. PORTUCCO  
TEST ENG'R D. GRAF  
SPECIMEN 5A10018  
ELECTRONICS DIV.

FREQUENCY (HZ)

Tracor, Inc.

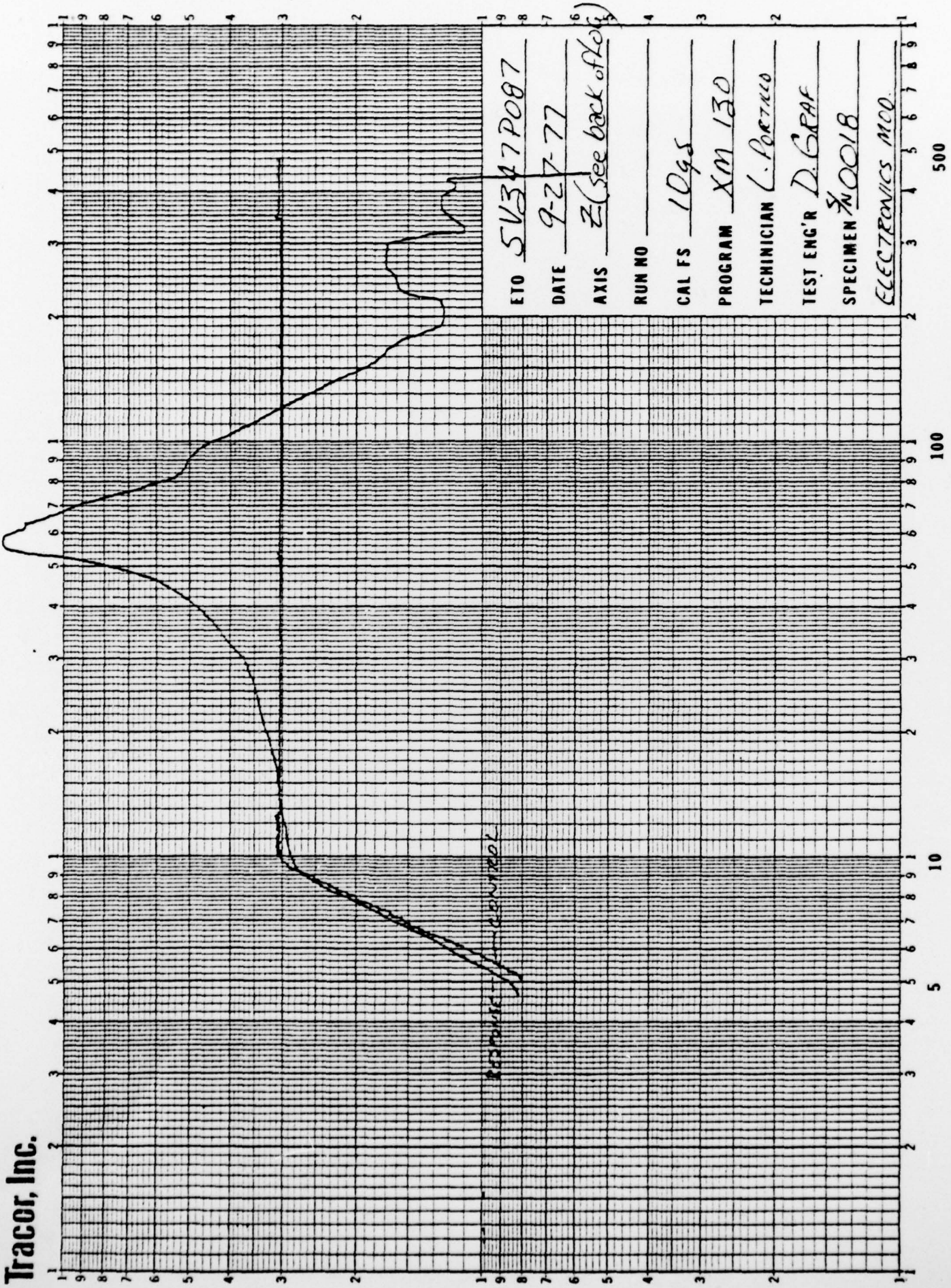

ETO SV347P007  
DATE 9-27-77  
AXIS Z (see back of log)  
RUN NO \_\_\_\_\_  
CAL FS 10gs  
PROGRAM XM 130  
TECHNICIAN C. PORTNO  
TEST ENG'R D. GRAF  
SPECIMEN N0018  
ELECTRONICS MCO