

AD-A060 648

OFFICE OF NAVAL RESEARCH LONDON (ENGLAND)
EUROPEAN SCIENTIFIC NOTES NUMBER 32-1, (U)

F/G 5/2

UNCLASSIFIED

JAN 78 A W PRYCE, V S HEWITSON
ESN-32-1

NL

1 OF 1
ADA
060648

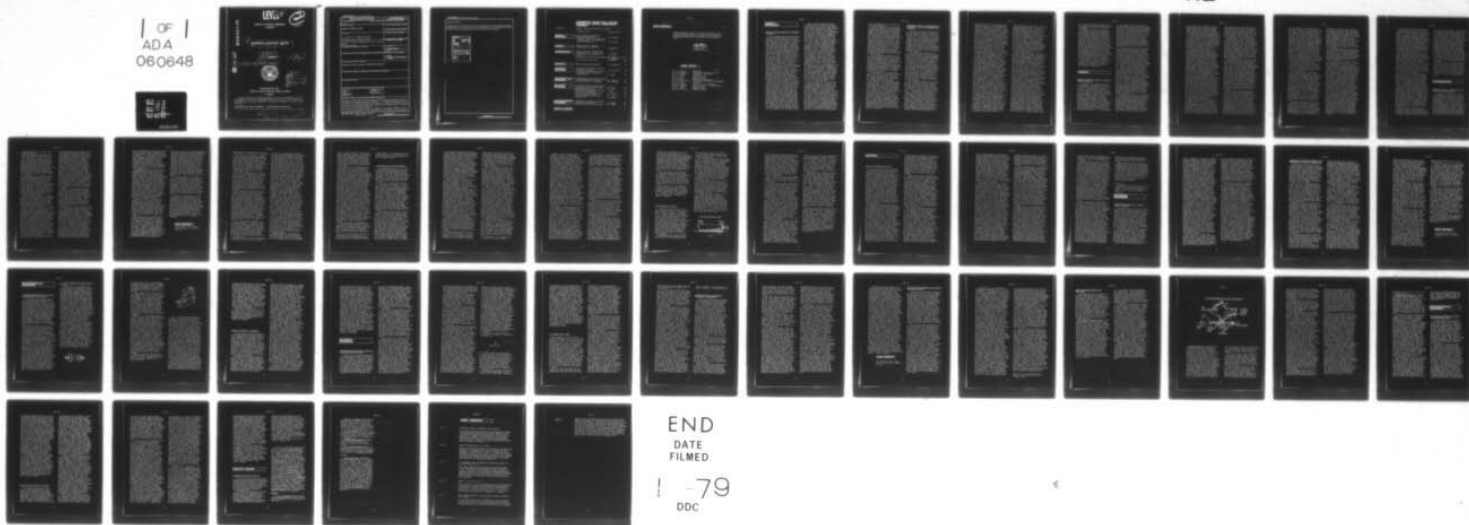

END
DATE
FILMED
1 -79
DDC

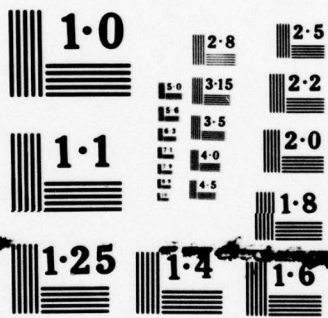

NATIONAL BUREAU OF STANDARDS
MICROCOPY RESOLUTION TEST CHART

LEVEL II

2
NW

OFFICE OF NAVAL RESEARCH
LONDON

AD A060648

6

EUROPEAN SCIENTIFIC NOTES

Number 32-1

DDC FILE COPY

14

ESN-32-1

11

31 Jan ~~1978~~

12 46p.

10

Aubrey W. / Pryce Victoria S. / Hewitson



DDC
RECEIVED
NOV 1 1978

Distributed by the
Office of Naval Research Branch Office,
London

This document is issued primarily for the information of U.S. Government scientific personnel and contractors. It is not considered part of the scientific literature and should not be cited as such.

APPROVED FOR PUBLIC RELEASE: DISTRIBUTION UNLIMITED

265 000
78 10 23 033
JOB

REPORT DOCUMENTATION PAGE		READ INSTRUCTIONS BEFORE COMPLETING FORM								
1. REPORT NUMBER ESN 32-1	2. GOVT ACCESSION NO.	3. RECIPIENT'S CATALOG NUMBER								
4. TITLE (and Subtitle) EUROPEAN SCIENTIFIC NOTES	5. TYPE OF REPORT & PERIOD COVERED									
	6. PERFORMING ORG. REPORT NUMBER									
7. AUTHOR(s) A.W. PRYCE & V.S. HEWITSON, editors	8. CONTRACT OR GRANT NUMBER(s)									
9. PERFORMING ORGANIZATION NAME AND ADDRESS US Office of Naval Research Branch Office London Box 39 FPO New York 09510	10. PROGRAM ELEMENT, PROJECT, TASK AREA & WORK UNIT NUMBERS									
11. CONTROLLING OFFICE NAME AND ADDRESS	12. REPORT DATE 31 January 1978									
	13. NUMBER OF PAGES 46									
14. MONITORING AGENCY NAME & ADDRESS (if different from Controlling Office)	15. SECURITY CLASS. (of this report) UNCLAS									
	15a. DECLASSIFICATION/DOWNGRADING SCHEDULE									
16. DISTRIBUTION STATEMENT (of this Report) APPROVED FOR PUBLIC RELEASE; DISTRIBUTION UNLIMITED										
17. DISTRIBUTION STATEMENT (of the abstract entered in Block 20, if different from Report)										
18. SUPPLEMENTARY NOTES										
19. KEY WORDS (Continue on reverse side if necessary and identify by block number) <table border="0" style="width: 100%;"> <tr> <td>EARTH SCI</td> <td>MATHEMATICAL SCI</td> </tr> <tr> <td>ENERGY</td> <td>PHYSICAL SCI</td> </tr> <tr> <td>ENGINEERING</td> <td>PSYCHOLOGICAL SCI</td> </tr> <tr> <td>MATERIAL SCI</td> <td></td> </tr> </table>			EARTH SCI	MATHEMATICAL SCI	ENERGY	PHYSICAL SCI	ENGINEERING	PSYCHOLOGICAL SCI	MATERIAL SCI	
EARTH SCI	MATHEMATICAL SCI									
ENERGY	PHYSICAL SCI									
ENGINEERING	PSYCHOLOGICAL SCI									
MATERIAL SCI										
20. ABSTRACT (Continue on reverse side if necessary and identify by block number) <p>This is a monthly publication presenting brief articles concerning recent developments in European Scientific Research. It is hoped that these articles (which do not constitute part of the scientific literature) may prove of value to American scientists by disclosing interesting information well in advance of the usual scientific publications.</p> <p>The articles are written primarily by members of the staff of ONRL, with certain articles prepared by, or in cooperation with, members of the scientific</p>										

78 10 23 033

ITEM #20 (cont'd)

staffs of the United States Air Force's European Office of Aerospace Research and Development and the United States Army Research and Standardization Group. Articles are also contributed by visiting Stateside scientists.

ADDITIONAL	
DTIC	White Section <input checked="" type="checkbox"/>
DDI	Self Section <input type="checkbox"/>
UNANNOUNCED	<input type="checkbox"/>
JUSTIFICATION.....	
BY.....	
DISTRIBUTION/AVAILABILITY CODES	
Dist.	AVAIL. add./or SPECIAL
A	

**EUROPEAN SCIENTIFIC NOTES
OFFICE OF NAVAL RESEARCH
LONDON**

Edited by

Aubrey W. Pryce and Victoria S. Hewitson

31 January 1978

Volume 32, No. 1

EARTH SCIENCES	Basic and Applied Aeronomy at Innsbruck University	R.W. Rostron	1
	Atmospheric Aerosols, Condensation, and Ice Nuclei: The Ninth Inter- national Conference	P. Twitchell	2
ENERGY	"Energy Is Eternal Delight": Ad- vancing Energy Technology	C.C. Klick & A. Pryce	4
ENGINEERING	Imperial College: Communication Engineering with a Human Touch	N. Blachman	7
	Engineering at the University of Tel Aviv	M. Lessen	10
	Microprocessing and Microprogramming	W.H. Magnuson, Jr. & D.C. Rummel	11
	Optoelectronics at Plessey	V. Smiley	14
GENERAL	Managing Technological Affairs	L.R. Patterson	16
MATERIAL SCIENCES	A Metallurgical Meeting in French— A Report in English	I.M. Bernstein	18
	Laser-Matter Interaction Studies by the Commissariat à l'Energie Atomique (CEA)	V. Smiley	20
MATHEMATICAL SCIENCES	Computer-Aided Mechanical Part Design and Manufacturing at the IWF	W.J. Gordon	22
	Industrial Research at Cambridge	N.M. Blachman	24
PHYSICAL SCIENCES	Synchrotron Radiation Light Sources— Big Machines for Little Science	C.C. Klick	25
	The Trumpet Shalt Sound	M. Lessen	27
	Quantum Electronics—A National Con- ference at Southampton	V. Smiley	28
	The 5th Vavilov Conference on Non- linear Processes in Optics	R.W. Waynant	30
	Three Laser Laboratories in the Moscow Area	R.W. Waynant	32
PSYCHOLOGICAL SCIENCES	Developments in Efforts to Unionize the British Armed Forces	J.A. Adams	35
	Psychology Amid Violence in Turkey	J.A. Adams	36
NEWS & NOTES			38

ONRL REPORTS

40

European Scientific Notes is a Group II Newsletter type Class B periodical prepared and distributed by the Office of Naval Research London in accordance with NAVEXOS-P-35. Prepared and submitted by the scientific and technical staff.

L. Roy Patterson
 L. ROY PATTERSON
 Captain, USN
 Commanding Officer

ONRL STAFF

Dr. J.A. Adams	Psychology
Dr. I.M. Bernstein	Metallurgy & Materials Science
Dr. N.M. Blachman	Electronics Engineering
Dr. W.J. Gordon	Mathematics
CDR D.A. Hart	Airborne Systems
Dr. C.C. Klick	General Physics
Dr. M. Lessen	Mechanical Engineering
LCDR J.D. McKendrick	Ship Systems & Military Oceanography
Mr. A.W. Pryce	Acoustics
Dr. R.W. Rostron	Space Science & Technology
LCDR D.C. Rummler	Command, Control & Communications
Dr. V.N. Smiley	Optical Physics
CDR S.E. Sokol	Weapons Systems
CDR C.D. Stevenson	Undersea Systems

EARTH SCIENCES

BASIC AND APPLIED AERONOMY AT INNSBRUCK UNIVERSITY

In an excellent *ESN* article entitled "Ich Bin Ein Atmosphärischer Elektriker" appearing in the 31 August 1977 issue, Professor Leslie Hale (Penn. State Univ.) made the point that the study of aeronomy especially with respect to those basic atomic and molecular interactions which had theretofore been carried out in terrestrial laboratories, was suffering from a lack of interest and funding both in the US and Europe because of the more spectacular programs involving Spacelab and satellite research projects. On a recent visit to the Atomic Physics Institute of Innsbruck University, Austria, under the direction of Professor M. Pahl, I discovered that this is definitely not the case at this Institute. Indeed, such research on basic atomic, molecular, and electron interactions is continuing unabated albeit with an emphasis on understanding and applying such reactions in the upper atmosphere and space. This may be of great interest to space physicists and environmentalists alike in their attempts to further understanding of phenomena that have recently been observed through satellite experiments but not explained, such as the existence of heavy ions in the radiation belts and heavy atoms and molecules in space.

These and other questions about basic atomic processes are being investigated utilizing standard and new techniques at the Institute. In particular, glow discharge tubes utilizing hollow cathodes are being used as the source of various gaseous ions rather than the conventional methods of microwave and linear sources. One of the more interesting results of this work has been the discovery that the hollow cathode is an excellent source of both O^+ and O_2^+ ions. Negative ions in oxygen have been found to be present at densities comparable with those of positive ions. The results of these studies are soon to be published in the open literature. It is anticipated that studies utilizing other gases as the discharge medium will be carried out in the near future.

Other research underway consists of measuring the mobility of various excited states of singly ionized gases in the parent atomic gas. These studies reveal that significant differences exist in the extent of these mobilities, a fact that currently is not understood but could have significant impact on the behavior of the upper atmosphere. The research is being carried out by a very able staff consisting of, in addition to Pahl, Fulbright Professor R.N. Varney, several assistant professors, and a group of graduate students.

One of the more interesting and practical research programs getting underway at the Institute under the direction of Dr. W. Lindinger is an attempt to extract "old" air from one of the glaciers in Innsbruck and analyze its freon content to determine the increase over the past years. The program is still in the "how do we get funding" stage, but the essential method of attacking the problem is being worked out. The "old" air supplies need to be essentially uncontaminated (less than one part of contamination in 10^{11}). The problem is how to extract the glacier sample, bring it uncontaminated to the laboratory, and then extract enough uncontaminated air from it for analysis. The actual method of determining the freon content has been developed by a research group at the NOAA Research Laboratory, Boulder, Colorado. This group has been analyzing the freon content of today's air but would like to compare these results with the freon content of air that is 10 to 20 years old.

The ice samples will be extracted from various depths in the glacier by an expedition team and brought to the Innsbruck laboratory at a temperature slightly above freezing so as not to allow contaminants to become frozen onto the samples. These samples will be placed in evacuated chambers at which point the chamber temperature will be allowed to rise until the uncontaminated ice melts. This will result in the air that has been trapped in the glacier ice filling the vacuum chamber above the glacier water. The air then must be driven into an uncontaminated cylinder for shipment to the NOAA Laboratory for analysis. The problem still exists as to how to evacuate the glacier air from the vacuum chamber without contaminating it. The use of vacuum pumps

will not suffice, and two methods are under consideration.

The first method entails immersing the sample cylinder in liquid nitrogen so that the water vapor in the vacuum chamber containing the melted glacier sample will stream into the evacuated sample cylinder by virtue of the temperature and thus pressure difference. This water vapor will immediately freeze and by doing so will also bring the rest of the glacier air with it. The connection between the original vacuum chamber will then be shut off and the sample cylinder returned to room temperature allowing the new ice to melt and release the glacier air. The cylinder with the glacier air will then be sent to NOAA for freon analysis. Preliminary experiments have shown that glacier air pressures of up to 50 Torr are achievable.

The other method of extracting glacier air involves forcing the air from the vacuum chamber in which the glacier ice has been melted into a sample cylinder by introducing some uncontaminated liquid into the chamber until it is filled with liquid and the glacier air is forced out by compression. Whichever method is decided upon will depend upon contamination potentials, the amount of glacier air which can be obtained, and, of course, cost.

The true value of this experiment lies in its ability to determine whether freon is really destroying the ozone in the upper atmosphere to the degree that theory predicts and at what rate this destruction could continue.

The University of Innsbruck has many other Institutes. It started rebuilding in earnest after 1955 with the medical school being the first Institute into which funds were invested. A new physics building is now under construction and is expected to be finished within two to three years. The University only offered the Doctorate degree until last year when a Master's program was introduced. Thus a great deal of emphasis is placed on research, and the various departmental equipment reflects this. If the other departments enjoy the same high quality of research and professional staff as the Institute for Atomic Physics, the University indeed has much to offer the scientific communities of Europe and the United States. (Robert W. Rostron)

ATMOSPHERIC AEROSOLS, CONDENSATION AND ICE NUCLEI: THE NINTH INTERNATIONAL CONFERENCE

The Ninth International Conference on Atmospheric Aerosols, Condensation, and Ice Nuclei was held at University College, Galway, Ireland, on 21-27 September 1977. The Conference was sponsored by the International Association of Meteorology and Atmospheric Physics (IAMAP), the International Commission on Cloud Physics (ICCP) through its Committee on Nucleation, and by the International Commission on Atmospheric Chemistry and Global Pollution (ICACGP). Co-sponsors were the American Meteorological Society (AMS) and the University College, Galway.

The comprehensive technical six-day program attracted about 160 participants from 22 nations including Japan, Ivory Coast, Kenya, Argentina, Republic of Niger, India, and several from the Soviet Union. The friendly small city of Galway and the ideal conference facilities at the University College, contributed to a very successful meeting. The International Advisory Committee and the National Organizing Committee balanced the working sessions with an excellent mix of atmospheric chemistry, nuclei physics, instrumentation, and meteorology. Key leadership of these respective Committees was apparently H.W. Georgii (Institut für Meteorologie und Geophysik, Frankfurt a. Main) and T.C. O'Connor (University College, Galway).

The technical sessions of the first day were concerned with the theory of nucleation and its laboratory investigation. The opening session became the Memorial Session for the late Prof. L. Krastanov, of the Geophysical Institute, Sofia, Bulgaria, who died in May 1977. G. Milosheva, Krastanov's co-worker, presented an invited paper on Krastanov's significant contributions to nucleation theory including work on ice embryo formation from the gas phase on foreign substrates such as the basal face of AgI which Krastanov was originally scheduled to report on at the Conference. Prof. J.L. Kassner (Univ. of Missouri-Rolla, MO) gave the second paper of the Conference presenting an abundance of fast expansion chamber data on homogeneous and heterogeneous nucleation of water and ice.

Kassner believes these laboratory data indicate a defect in the contemporary nucleation theories. On the second day the topic shifted from laboratory measurements of aerosol and nuclei to field measurements. Nevertheless, Dr. Vincent Schaefer, recently of the State University of New York at Albany, commented from the floor that he believes too much effort is being placed on instrumentation and not enough on the aerosols and nuclei. He suggested that the instrument designers return to the philosophy of the late Prof. L.W. Pollak of Dublin and build instruments which can be used in the field. Notably, Schaefer was making measurements in Galway and at locations on the Irish coast at the time of the Conference. He commented in a later paper that his coastal measurements when the wind was on shore were as clean as for stratospheric air.

As the meeting progressed the topics shifted to the chemical composition of cloud-active aerosols, sources, sinks, and life cycles of both natural and anthropogenic atmospheric aerosols. An interesting paper was that of Prof. V.G. Morachevsky (Hydrometeorological Institute, Leningrad, USSR) dealing with the problem of organic particles in the atmosphere and the role in smog production and enhancing condensation. The middle sessions of the Conference were difficult to follow for a non-chemist, but fortunately, some participants, for example, P. Goldsmith (Meteorological Office, Bracknell, UK) had a background in both chemistry and meteorology. He was able to interject into the essentially chemical discussions some comments on atmospheric behavior. Many atmospheric chemists and ice nuclei specialists have little or no understanding of atmospheric processes and hence of the origin of the aerosol or nuclei. One speaker claimed dust from agricultural areas such as the midwest United States was the primary source for atmospheric aerosols. J. Latham (University of Manchester, UK) commenting on this suggested that electrical effects may well be more important in a dust storm than the clay fractionization process presented.

Eleven papers with authors from nine countries on the topic of the size distribution of atmospheric aerosols and measurement techniques clearly illustrated the problems facing this field of science. Prof. K.T. Whitby (Univ. of Minnesota) formed an ad hoc

committee during lunch on the sixth day of the Conference in an attempt to standardize definitions. He correctly pointed out that political bodies in all the countries represented are demanding environmental information. Scientists can convert each others data, but can the politician? His concern is real, as demonstrated by the high interest in this Conference by Irish political leaders. At the opening session Mrs. Maire Geoghegan-Quinn, M.P. and Parliamentary Secretary to the Minister for Industry and Commerce, gave a sincere address on her concern for preserving the environment, while at the banquet, Mr. Sylvester Barrett, Minister for Industry and Commerce, reiterated this concern.

Marine aerosols was the topic of the last technical session. Dr. Gode Gravenhorst (Institut für Atmosphärische Chemie, Kernforschungsanlage, Jülich, FRG) gave an excellent invited review paper on marine aerosols. He reported that measurements made over the sea indicate some 75% of the material collected was salt, 2 to 20% sulfates, less than 2% organics, and a wide range of terrestrial origin from 3% to 70%, with the high values of terrestrial material being measured off the coast and downwind from the Sahara. He noted that most measurement techniques reported in the literature would bias the organic figures toward zero, a point no one else had made. He also cautioned against conclusions on the sulfate data; there appear to be natural sources in addition to anthropogenic ones for sulfate and ammonia. Dr. P. Buat-Menard (Centre des Faibles Radioactivités Gif-sur-Yvette, France) reported a strong correlation in marine aerosol and deep water measurements, and specifically the enrichment relative to crustal material for Cu, Zn, Pb, Hg, and Sb. The French group having studied the water column of the North Atlantic concluded that the concentrations of heavy metals (with some reservations on lead) cannot be of anthropogenic origin. This scholarly paper which included high sulfate measurements from the South Pacific raises doubts about many reports of the oceans being contaminated by man. Prof. J. Podzimek (Univ. of Missouri-Rolla, MO) reported on time and space variability of aerosols measured on the Texas coast. His data on sea salt, sulfate, and organics

also raises questions to my mind as to the sources of airborne pollutants and the mechanism for their entering the atmosphere.

The Ninth International Conference on Atmospheric Aerosols, Condensation and Ice Nuclei was a great success, although the meteorologists may have been disappointed that the nucleation papers were not addressed to real cloud situations. For their part the physicists may have found the science somewhat less rigorous than they are accustomed to, but the real world is not a controlled laboratory and atmospheric physicists are forced to be less definitive. The chemists also may have found it odd that those measuring aerosols and condensation nuclei are not sure of the origin of the material. Further, the meteorologists may also have found it incomprehensible that scientists make specific field measurements without noting ancillary *in situ* information and the air mass history. Because of the heterogeneity of the Conference participants, these points arose in a variety of ways and all participants benefited. (P. Twitchell, Office of Naval Research, Boston, MA)

ENERGY

"ENERGY IS ETERNAL DELIGHT": ADVANCING ENERGY TECHNOLOGY

A conference on "Advancing Energy Technology" was sponsored by the Institute of Fuel in Eastbourne on the southern coast of England at the end of October. The traditional membership of the Institute of Fuel comes from the coal, oil, and gas industries, and much of the program was clearly aimed at the problems faced by these industries. However, a major portion of time was also given to looking at the longer range problems of energy supply and at the status of some of the newer ways of producing usable energy, in line with the Institute's "object of advancement of scientific knowledge in the preparation, treatment and utilization of sources of heat and power of all types in all applications . . ." While, there

was no attempt to be encyclopedic or to offer world solutions to the problems of energy, it struck us as strange that there was no talk on energy from nuclear sources. Nor was nuclear power brought into any of the papers except for an occasional question at the end. A casual visitor would never have guessed from this meeting that for a decade 10% of the electrical power used in the UK has been produced in nuclear power plants; nor would he have gained any information about the advantages and disadvantages of nuclear power when compared with the use of coal, oil, or gas.

A very long-range view of the world energy problem was given by Prof. M.W. Thring (Queen Mary College, London). He looks beyond the transients and adjustments of our present times to the long-range solution to the energy problem (while emphasizing the need for corrective actions now) as being crucial to the solution of the world's social and economic problems. Thring points out that the world average use of energy is now 1.8 tons of coal equivalent (TCE) per person. In the UK the energy use is 5 TCE; in the United States it is 11. Thring accepts a world average of 1.8 in the long term but with the developed countries reducing their expenditure while the undeveloped countries increase theirs. For the UK Thring proposes a 3% per year reduction in energy usage for 30 years. He argues that the developed countries should look to economic growth of about 1% per year and the undeveloped countries to 3%. He links growth in economic power to a need for the world population to level off at 8 billion by the year 2025—twice the present figure, believing that population growth in the undeveloped countries will come under control when their people's situation is more secure and education is more broadly available.

In Thring's view nuclear and large oil power installations are to be avoided as "expensive playthings" which can only be afforded by the richer nations, further aggravating the gap between developed and undeveloped countries. "Premium fuels" (oil, natural gas, and electricity) should not be used for heating or producing steam. Coal, solar heat, industrial-waste heat, and the energy in refuse should be used instead. While oil has to be used for

most transport, he contends that railroads should return to coal. Thring looks forward to a 4-seat automobile with a hybrid diesel-electric power plant which he believes will be capable of traveling 80 miles per US gallon.

Thring believes the government should subsidize solar energy and wind power. It should allow the cost of fuel to grow slowly by a factor of 3 or 4 to encourage conservation. Waste industrial heat should be used for house heating instead of being dissipated in cooling towers. Low-energy transport should be provided, and tariffs on industrial-fuel use should be plowed back into industry to pay for fuel saving equipment.

A somewhat shorter range view of Western Europe's energy problems was presented by Prof. P.R. Odell and Dr. K.E. Rosing (Economish-Geografish Institut of Erasmus University, Rotterdam). Their thesis is that Western Europe can become largely energy self-sufficient by the year 2000 as it was 15 years ago. Looking at 5 West European countries (UK, West Germany, France, Italy, and the Netherlands), the authors showed that as late as 1962 coal remained dominant or important to the economies of most of these countries. The constant or even decreasing price of oil and its plentiful supply from 1960 to 1973 led to its increased use so that by 1972 it was the primary source of energy for all the countries listed above except the Netherlands where local gas fields had become the primary fuel. Europe had become heavily dependent on an energy resource not within its boundaries and with the mining, transportation, refining, and distribution dominated by a few international oil companies based and financed, for the most part, in the US. Europe is now dependent on foreign supplies and suppliers. The three-fold increase in the price of oil since 1973 has resulted in inflation, major changes in the international balance of payments, and alterations in the political environment.

Odell and Rosing believe that it is desirable and possible for Western Europe to return to a large degree of self-sufficiency. Coal is not the immediate answer since it may be well into the 1990s before there is as much indigenous coal available as there was in 1975. Instead they expect the oil and gas deposits already found in the North Sea and anticipated in other offshore areas of Western Europe to become

the primary source of needed energy until about the year 2000. The authors argue that with conservation and an economic growth rate not exceeding 3% per year this should be possible. Beyond that point they estimate that coal would become the major energy source by the middle of the 21st century.

Coming back to this century, Odell and Rosing believe that the potential solution they describe is threatened by the continued absence of an effective European agreement. Nationalism enters here in a profound way. The authors believe that a compact between the exporting and importing nations of Western Europe is required. It would fix prices and markets independently of what happens outside of Western Europe. This will allow the stability and financial planning that is needed to marshal the heavy investment for mining and transporting offshore oil.

Dr. Mary D. Archer (Cambridge Univ., UK) opened a session entitled Recovery and Utilization of Low-Grade Energy with a paper entitled, "Photosynthesis *in vitro*." She discussed at some length the present status of large, inexpensive photovoltaic cells required for large solar panels. Efficiencies are relatively low. Amorphous silicon cells are 6% efficient; semiconductor-liquid electrolyte cells may be as high as 5% efficient. By comparison crystalline silicon cells are about 20% efficient but are too expensive for large panel use. After a discussion of possible photobiological systems, she commented in response to a question that the growth of sugar cane is about 4 to 6% efficient. No mention was made of the use of solar energy as a heat source for power generators such as steam turbines.

Other topics in this "low-grade energy" session included geothermal energy (C.H. Armstead, Dartmouth, UK), thermohydraulic power from the sea (Prof. D.G. Johnson, Norwegian Technical Institute, Trondheim), and wavepower generators (G.E. Hearn and M. Katory, British Ship Research Association, Wallsend). Armstead, noting that 40% of the energy requirements of industrial countries could be supplied by geothermal energy if it were available, emphasized the need to learn how to gain access to the limitless quantities of heat below. The cost of deep drilling is one of the major limitations, while lack of permeability of the hot

rock is another. He proceeded to discuss possible methods of achieving permeability. Johnson discussed the various ideas for thermohydraulic power that have been envisaged—the water-steam, the CO₂-steam, and the butane-steam turbine cycles and the problems involved with them. Hearn and Katory briefly outlined the principles of the wavepower generators that are receiving government support in the UK—the Salter nodding duck, the Cockerell contouring rafts, the NEL Pelican, and the Russell Rectifier. Principal attention, however, was given to possible methods of hydrodynamic analysis that would permit an evaluation of the responses of these devices in a seaway and of their efficiencies. Unfortunately this session on newer sources was the last in the meeting, and the possibilities fell upon a dwindling audience, which by the close of the session was probably no more than 1/3 of the 200 who had registered and attended the initial sessions.

In addition to the long-range problems of energy supply there are many immediate problems that are of concern to the fuel industry and which formed the basis for the preponderance of the 19 papers presented.

A stimulating talk was given by J.A.A. Arthurson who is the engineer responsible for developing a centralized district heating company (AB Enköpings Vaermeverk) in Enköping, Sweden, a city of 20,000 people. The company began in 1970 and will be coming fully on-line early in 1978. It is privately owned but with obvious government interest in its progress. No one is compelled to join the organization, but 75% of the population have joined rather than maintain individual house-heating systems. It will be a 20-MW single-boiler hot-water system. The efficiency is impressive—92.4%. Five to 6% of the energy loss is in the flue gases. Two percent is lost in the hot-water distribution system which sends water out at 120°C and has it returned at 70°C.

The most novel part of the system is a combustion chamber that will burn a variety of fuels. The government aided in its development. When full operation begins, it will be tried for a month each on coal, peat, wood, and high-sulphur oil. They will then concentrate on the best fuel—probably coal. But the uncertain supply of fuel

(Sweden has to import both coal and oil) makes a multifuel source advisable. Arthurson claims that they could even grow enough wood in an area 10% of that of the city to supply the city's heating needs, although this source is not planned at the moment. (See also E.R. Sohns, "Sweden's Biomass Production Potential" *ESN* 31-10:398). It is envisaged, however, that they will also burn sewage gas and that eventually the water-cooling supply from a future nearby electricity generator will also be connected.

The company makes available expert advice on home insulation to individual subscribers. It is concerned with the environment and has heavy filtration on the flue gases to remove particulates. Should this heating system be successful in Enköping, Arthurson estimates that about 50 similar installations will be built in Sweden.

S.J. Shelley and A. Moore (Hotwork International Ltd., Dewesbury, W. Yorks. UK) talked about a variety of ways in which the fuel used in industrial furnaces could be conserved, and illustrated them with numerous examples where savings of up to 50% had been achieved. One of the available techniques is the use of high-velocity burners that transmit energy to a furnace load more efficiently by blowing away low-temperature gases clinging to the surface of the load. Another recommended burner is the self-recuperative one in which the burned gases exit in a coaxial sleeve around the feedlines to the burner and help to heat the incoming fuel prior to ignition. Finally, they discussed the use of a new furnace insulation. In many cases the addition of a 2-inch layer of ceramic fibers not only improves the insulation but does so with a low-thermal mass material. This ceramic-fiber material is formed in long sheets but is cut into 2-inch sections which are glued with one cut end against the brick oven and the other exposed to the inside of the furnace. There is an advantage from the point of durability and mechanical strength in having the majority of fibers at right angles to the wall. Although these ways of improving furnace efficiency appear to be well documented and would seem to be cost effective, the authors of the paper implied that industry was slow to take advantage of them.

Several talks attacked the problem of using energy that is now wasted in current industrial practice. One such process is the manufacture of coke from coal. According to Dr. J.E. Barker (British Carbonization Research Association, Wingerwarth, Chesterfield, UK), J. McN Bruce (British Steel Corporation) and R. Kammetimuller (Waagner-Biro AG, Austria) the heat from incandescent coke discharged from the ovens is widely used in the Soviet Union and Japan to raise steam for power generation but is largely wasted in the Western World. They propose that the hot coke be used to dry the incoming coal and preheat it for the coke-forming step.

Dr. N. Syrid, A.C. Styles, and S.A. Najiim (University College, Cardiff), and K.R. Dahmen (Continental Carbon Company, Houston) discussed ways of burning gases with low heat value—typically less than 50 BTU/ft³. Such gases can occur in ventilation air from mine shafts that may contain up to 2% of methane, and in many industrial drying processes such as some painting ones. Cyclone or swirl burners, well insulated, and with a long dwell time for the gases, can be used with gases whose heat capacity is as low as 36 BTU/ft³.

A serious problem for plants that burn oil, or gas, or make substitute natural gas from oil is how to perform these operations efficiently, cheaply and yet remain within pollution standards for the emission of particulate solids, nitrogen oxides, and sulfuric acid. The problem has different dimensions in different countries because of the variety of environmental control standards. The UK, for instance, has no nitrogen-oxide regulations while the controls in Japan are becoming increasingly strict. Many of the schemes that will improve one of the pollutants will make another worse. As a result, the overall processing may have narrow limits in which to operate. A measure of the potential pollution problem can be taken from the fact that Kuwait crude oil contains 2.6% of sulfur on the average; coal has 1-2% N. Controlling the plant emission now seems to be the fuel engineer's principal day-to-day problem.

This conference, organized by the Institute of Fuel on the occasion of its Golden Jubilee, clearly demonstrated a recognition that the days of plentiful oil and gas supplies are numbered. In

its 19 papers, including 5 from overseas and 2 with overseas joint authorship, it tackled a wide range of problems associated with this inescapable limitation and the longer range exhaustion of coal supplies. We have noted the omission of any more than passing reference to nuclear matters. Despite this, however, the presentations justified the 200 registrations, more than 30 of which were from overseas, including Turkey, Australia, Canada, Japan in addition to Europe and the US. But questions remain. How do we proceed through interim measures to solution of the energy problem? What pattern of energy supply will eventually emerge? Are these to be tackled on a national, regional or worldwide basis? Clearly these are basic professional questions for the Institute and its membership. They seem to be facing them seriously.

Papers presented at the Conference are expected to be published in the Institute's Dec. 1977 and March 1978 issues of Quarterly Journal. Subsequently they will be published jointly by the Institute with the IPS Science & Technology Press as a Conference Proceedings early in the second quarter of 1978. (Clifford C. Klick and A.W. Pryce)

ENGINEERING

IMPERIAL COLLEGE: COMMUNICATION ENGINEERING WITH A HUMAN TOUCH

Professor E. Colin Cherry heads the Communication Section of the Electrical Engineering Department at the Imperial College of Science and Technology—by far the largest of the four EE Departments in the University of London (ESN 31-7:271). He has been at the College since 1949, having worked at the GEC Research Laboratory (ESN 31-9:344) from 1932 to 1945. Cherry, who is well known (at least to those of a certain age) for having organized the third (1955) and fourth (1960, the last) London Symposia on Information Theory, began his career in the field

of networks, nonlinear circuits, and binaural phenomena.

Over the years his interests have turned more and more toward the field of his 1957 book, *On Human Communication: A Review, a Survey, and a Criticism* (second edition 1966), and his recent research has dealt with social aspects of telephony and teleconferencing, aided on the latter topic by a graduate student Miss Paulina Chan, whose previous degrees are in psychology. She should shortly become a PhD in Electrical Engineering, although she has confined her studies of this field to the social, political, and psychological aspects.

In September 1977 they held a one-day symposium on Human Factors in Communication Technology (ESN 31-12:513). In this connection Cherry points out that a TV image is regarded in some respects as a person and in other respects merely as an object, thus causing a teleconference to differ from a face-to-face meeting. The aim of Chan's study is to assess the resulting psychological effects, to discover the best applications for teleconferencing, and to see what special training may be needed for participants.

Cherry is also studying the reading process in order to be able to optimize the electronic presentation of printed material. The effects of both the design of the type face and its layout upon reading comprehension are being investigated, along with the potential afforded by a moving display.

Other students of Cherry's are studying the influence of the growth of telecommunications in Mexico upon that country's social development with a view to formulating recommendations for rural and urban zones; the possibilities for improving the communication of economic analyses to governmental policymakers and for including in these analyses the constraints imposed by political realities; the properties of speech that permit a person to identify it as such and classify it as to language (so that he will then endeavor to apprehend its meaning rather than seek its cause as a sound of some other type); and the use of tactile information along with lip reading by the profoundly deaf, both for receiving information and for improving their own ability to speak.

Some of the interests of the seven faculty members under Cherry also have

a human orientation, particularly those of Dr. Robert Spence, who deals with the interaction between human beings and computers, especially in the computer-aided design (CAD) of filters and other circuits. He has developed a convenient system for this purpose called Minnie (ESN 29-7:303), which uses a PDP-15/76 computer along with a VT-15 interactive display having a light pen, and his assistant Thomas J. Goodman—an ergonomist—is studying the effect of deliberately introduced delays in system response upon the success of the design process. They organized a one-day informal Workshop on Man-Computer Interaction in Problem Solving in March 1977 which was attended by 75 people with several from abroad. The Workshop's emphasis was on making it easy and pleasant for a human being to communicate with a computer via a CRT terminal in solving various problems, including the design and analysis of mechanical structures like bridges and oil rigs.

Spence is also directing research on methods for modeling very complex circuits without requiring correspondingly large amounts of storage and computation, and statistical analyses of the effects of imperfect realization of desired component parameter values in the manufacturing process. The intention here is to increase the acceptable proportion of such parts by suitably altering the nominal values while still achieving an acceptable performance.

Dr. Anthony G. Constantinides, whose work and lectures deal principally with digital filtering, signal processing, and communication networks, is using graph-theoretical concepts to represent the communication patterns arising among individuals and among groups, incorporating an intensity parameter for each link and studying the formation of authority or influence groups. In particular, he is interested in how small a coalition suffices to exercise authority over all members of the network.

Dr. L.F. Turner, in addition to supervising work on easily decodable error-correcting codes and on the adaptive reception of signals transmitted through water or over fading high-frequency communication channels with intersymbol interference, has students working on data-reduction techniques for compressing the information that

must be transmitted for facsimile images and for digital speech transmission, the latter particularly in the presence of fading. Dr. G.J. Hawkins is studying the talk-pause characteristics of recorded samples of speech in order to allow improved adaptive pulse-code modulation, and a student of his is building a microprocessor system to facilitate the gathering of telephone traffic statistics, including the times needed for setting up and for terminating connections.

In addition to the five members of the Communication Section of the EE Department mentioned above, there are three others, Dr. W. Saraga, Mr. R.S. Sidorowicz, and Mr. R.A. King, whose work, like most of that of Constantinides, Turner, and Hawkins, follows more traditional lines. Saraga's main concern is circuit theory and, in particular, impedance inverters, network sensitivity, microelectronic high-precision filters, group-delay measurement, active *RC* filters, and requirements and techniques for vestigial-sideband systems. He has proved that an impedance inverter requires more than one amplifier if its input and output are to have a common grounded terminal, and he is extending his results concerning generalized reciprocity and generalized antireciprocity to multiport networks.

Sidorowicz's field is topological methods in circuit analysis; his research concerns the nonlinear theory of negative-resistance oscillators and also the transmission of audio signals by frequency modulation of infrared pulses. King's work deals primarily with two-dimensional recursive digital filters and, in particular, their stability when simultaneously using two or more sampling rates for image processing.

The Section offers a total of 25 different lecture courses for graduate students during the autumn, spring, and summer terms of 1977-8, including 6 on antennas, propagation, and microwaves given by people from outside the Section. Of the remaining 19, by far the greatest number, 6, are offered by Cherry: "What is Communication?", "[An Introduction to] Information Theory" (the more advanced course being given by Turner), "Elementary Probability Theory in Communication Studies," "Global Communication" (cf. Cherry's 1971 book *World Communication—Threat or*

Promise?), "Perception in Communication," and "Introduction to Classical Dynamics." The first of these presents various philosophical perspectives, including the political nature of technology and the anxieties engendered by it. The "Perception" course deals with speech and hearing, reading and cognitive activity, conversation including gestures and facial expression, and a wide variety of topics on which Cherry has done research, such as the cocktail-party problem: how does a person manage to pick out of the din the words intended for him? The answer involves a complex processing of the information from the two ears as well as a host of other clues.

The great majority of graduate students are from abroad, as is generally the case in Britain's universities; this also tends to be true of undergraduates in engineering and the sciences. Although it is expensive for Britain to maintain educational facilities for foreigners, the resulting goodwill and influence are felt to justify the cost; without such a justification, UK academic research would suffer even greater cuts than it has experienced in recent years.

In this short article it has not been possible to include details concerning all of the activities of the Communication Section. The great majority of the Section's research topics fall within the traditional areas, almost one-third of them (most of those dealing with communication networks and digital signal processing) being carried out by or under Constantinides, and the second-largest share being Saraga's circuit-theory research. It can be seen, however, that Cherry exerts a strong influence toward a human orientation for the Section. (Nelson M. Blachman)

ONAL REPORTS

See the back of this issue for the abstracts of current reports.

ENGINEERING AT THE UNIVERSITY OF TEL AVIV

The University of Tel Aviv, founded in 1953, became an independent academic unit only in 1963 at which point it had some 1200 students and 150 faculty. It moved to its present location at Ramat Aviv in 1964, and when I first visited the Mathematics Department in 1966 there were only a few completed buildings. At present, the University comprises some 20,000 students and 1400 faculty and is the largest institution of higher education in Israel.

The School of Engineering was started in 1971 by its founding Dean, Professor Maurice A. Brull (formerly of the Univ. of Pennsylvania). Since academic administrators (including deans and directors) in Israeli universities serve on a rotating basis at the pleasure of the faculty, Brull stepped down after his maximum two terms of three years each and has just been replaced by Prof. Israel Wagnanski, formerly head of the Department of Fluid Mechanics and Heat Transfer.

Brull structured the School of Engineering flexibly in terms of disciplinary rather than professional departments. Thus, there are at present five departments, namely: Fluid Mechanics and Heat Transfer; Solid Mechanics, Materials and Structures; Electronics; Controls and Systems; and Interdisciplinary Studies. The Department of Interdisciplinary Studies which includes Bioengineering is a breeding ground for new disciplines and departments. Undergraduates are awarded the usual electrical engineering, mechanical engineering, etc., professional degrees, but graduate students work toward degrees in the various disciplines. Although the School of Engineering is very young, it already has 80 full-time faculty, 900 undergraduate and 300 graduate students.

A striking mechanical engineering building, donated by the Wolfson Foundation and designed by the eminent architect, the late Louis I. Kahn, is in the final stages of completion. The building has 140,000 sq ft of space including beautiful laboratory facilities and services, and will finally cost about \$6,000,000. The architectural motif is in terms of Middle Eastern arches in keeping with the traditions and feeling of the area.

Wagnanski showed me around the already functioning fluid mechanics laboratory

in the as yet uncompleted building. One of the various tunnels was designed to study shearing layers and consists of two side-by-side tunnels each with test sections of 2 ft x 1 ft to form a mixing chamber of 2 ft x 2 ft cross section; the streams of both sections are individually adjustable to 15 m/sec with a turbulence level less than 0.2%, and are brought together over an oscillating flap which can excite the interface up to a frequency of 150 Hz. The initial thickness of the shearing-mixing layer downstream of the flap is approximately 1 mm. Shearing-layer studies are being conducted in cooperation with Prof. Heinz Fiedler (Hermann Föttinger Institute, Univ. of Berlin). There is also a towing tank of dimensions 3 ft x 4 ft x 65 ft long with glass sides and windows on the bottom. The tank can be filled with a saline-stratified solution and has two individual wavemakers for exciting surface and internal waves. A towing mechanism mounted on oil-pad bearings for vibration-free operation has been obtained. Wagnanski also has a low-turbulence wind tunnel with a test section 2 ft x 3 ft x 20 ft long and speeds of up to 160 ft/sec, with continuously adjustable top and bottom walls to a test section of 2 ft x 5 ft, and a turbulence level less than 0.04%. The tunnel is intended for the study of turbulent spots. Also being assembled is a Pipe Poiseuille Flow experiment with a honed 1.3-in. pipe—18 m long. Laminar Reynolds number flows up to 100,000 will be excited and pulsed, and the effect of wall suction in maintaining laminar flow will be studied. A small trisonic tunnel with a 4 in. x 4 in. test section and speed range from the high subsonic to Mach 3.2 is also being installed; this tunnel is a pilot model for the 4 ft x 4 ft test-section trisonic tunnel purchased from Convair and currently being installed at the Israel Aircraft Industries, Ltd., in Lod. Besides extensive instrumentation, the laboratory has on-line data reduction capabilities (Varian V 72 + fast analog to digital) and an available CDC 6600 which can be called on-line.

Besides Wagnanski, there are 11 additional faculty in the Department of Fluid Mechanics and Heat Transfer, and I was delighted to be able to speak with Prof. Yehuda Taitel (the Chairman),

Profs. Michael Bentwich, Gdalia Kleinstein, and Touvia Miloh. The interests of the Department range from multicomponent and multiphase flow and heat transfer, dispersion of thermal plumes of pollutants, hydrodynamic stability, swirling flows, acoustics, potential flows, slow viscous flows, and physical oceanography to pursuit-evasion differential games.

Now that Brull is disencumbered of the deanship, he is continuing intensively with his study on stresses in the skeleton and hip joints during locomotion. This investigation combines experiment and theory in a most ingenious manner; observations of a person walking along an instrumented track and a mathematical model of muscle forces are used to infer stresses. The track contains finite-element pressure receptors (150 for each foot) that operate interferometrically and are scanned continuously. The person carries 18 infrared light emitting diodes (LED) which flash 75 times per second; two sets of stereonumerical cameras record points along the LED trajectories which are continuously recalibrated using 12 fixed LEDs as reference. When the data are reduced, trajectory accuracies of 2 mm perpendicular and 5 mm parallel to the camera axes are obtained. Inertia and contact forces are then obtained from the data. Muscle forces are inferred from a model which assumes that they are proportional to the muscle cross-sectional area in each muscle group (there are 48 muscles in 16 muscle groups between the foot and the hip) and that a variational principle of minimal energy for a movement applies. The muscle forces have been checked *in vivo* by electromyography. By combining all of the forces, the stresses in bone and appliances such as total hip prostheses can be evaluated. The stresses in the hip during a deep knee bend have been evaluated and checked.

Also at the School of Engineering is Prof. Mark Beran, Chairman of the Department of Interdisciplinary Studies, and Prof. Zvi Hashin, who were both formerly with the University of Pennsylvania. They will soon be joined by Prof. Alan Whitman also of that University.

In all, I was most impressed by the innovativeness, flexibility, vigor, and quality of the engineering program and overwhelmed by the physical beauty

of the campus. It certainly seems that Israel is getting a lot of "bang for the buck" out of the University of Tel Aviv. (Martin Lessen)

MICROPROCESSING AND MICROPROGRAMMING

The EUROMICRO Symposium is the leading European forum on microprocessor systems and microprogramming (see *ESN* 29-1:114). The third symposium, which followed earlier ones in Nice and Venice, was held at the Vrije Universiteit in Amsterdam, the Netherlands. The Symposium this year was the largest to date with 471 attending from more than 20 countries.

This year's Symposium was a four-day affair held 3-6 October. The first day was devoted to a tutorial on the International Electrotechnical Commission's (IEC) recommended standard method for system interface of programmable measuring apparatus. The functional, electrical, and mechanical specifications were treated as were system requirements and guidelines for designers and users. A draft of the IEC standard was used as notes, and a final version should be available from IEC as soon as the French version is available. In addition to the IEC66 interface standard, the IEEE 488 (Hewlett-Packard Interface Bus), the IEEE 483 (CAMAC), and the S-100 ("Hobbyist" bus) interface standard efforts were presented at the tutorial.

The Symposium opened with a keynote session featuring three theme-setting papers by A. Osborne (G. Osborne Associates, Berkeley, CA), H. Schmid (General Electric O., Binghamton, NY), and H. Casimir (Heeze, the Netherlands). Osborne gave an interesting paper, "How will microprocessors adjust to the major markets they have found?", in which he stated that in the early days (18-24 months ago) microprocessor (μ P) manufacturers were predicting large-volume users employing μ Ps mostly in control applications. In fact, according to Osborne, the market has turned out to be millions of smaller customers, typically purchasing 10s to 100s of units. He views the μ P marketplace as consisting of three customer types: 1) high-volume market, sensitive to parts cost,

2) low-volume engineering and process-control market, sensitive to development expenses, and 3) the low-volume micro-computer (μ C)-systems market, sensitive to programming expense. Osborne feels the first type will have an ever-decreasing impact on the μ P industry because the profits from these large contracts are frequently disappointing owing to intense competition for high-volume sales. He believes the third market will become an arrowhead with "the arrow plunging into the computer industry." Osborne concluded by stating that μ P and μ C developments have already exceeded some of the science fiction writers' imaginations, but in looking ahead five years he concluded that we haven't seen anything yet.

Schmid turned his attention from marketplace-forcing functions to technical considerations. He, unlike Osborne, attempted to use past and present developments to project where technology is going. After an excellent and up-to-date review of where monolithic-processing element technology is, Schmid forecasted that by 1984 a capability will exist to implement one IBM 370 or multiple PDP 11/70 processors [including central processing unit (CPU), memory, and input/output (I/O)] on a single chip of silicon. He projects 10^6 elements on a 12-mm \times 12-mm chip by 1984, assuming that electron-beam lithography will replace photomask lithography. One of the potential areas of confusion resulting from this rapid increase in capability is the distinction between micro-, mini-, and maxiprocessors. Schmid suggests that the generic terminology monolithic be used in front of each of these terms (e.g., monolithic maxiprocessor) to distinguish them from processors made from more than one integrated-circuit component.

Although a controversy developed on the future of the 32-bit single-chip processor (in the discussion that followed), Schmid predicted 16- and 32-bit single-chip processor implementations and a much higher degree of standardization in functional, electrical, mechanical, and software specifications, in what he termed universal processing elements.

The third keynote paper took an entirely different flavor. H. Casimir talked on the social impact of micro-technology. He contrasted the energy-consuming trend of modern technology

(skyscrapers, larger cars, faster aircraft, etc.) with the newer direction of making things smaller and spending less energy. Microtechnology, although with risks of interfering with personal privacy, offers an even wider spread of knowledge and information. This, in the long run, contends Casimir, encourages rather than suppresses independent thinking.

After the keynote session, the remainder of the Symposium followed the pattern of having three parallel sessions, with the somewhat unusual provision of one of the sessions being dedicated to an "industrial seminar," together with an industrial exhibit. The combination of industrial exhibits (16) and presentations (28) with the technical symposium added an attractive dimension to the Symposium. Several (14) of the industrial papers were made available in a preprint supplement to the regular Symposium proceedings.

Aside from the industrial part of the Symposium, 32 refereed papers were given. Although we were told that about four times this number of papers had been submitted, we were disappointed with the technical content of more than the third we were able to hear. For example, one paper was essentially an application of elementary statistics to multiprocessor systems to predict effective CPU performance in terms of delays caused by conflicts. However, to perform the analysis the authors made several assumptions that essentially eliminated the practical aspects of the problem. On the other hand, there were perhaps a half-dozen papers that were innovative and positively contributed to the field. The following material concentrates on these papers. (One attendee observed that such a ratio of 1:3 good papers was typical of similar European conferences.)

An interesting presentation by H. Bellim and A. Sauer (Siemens, Munich, FRG), "Methods of data exchange between microcomputers," compared programmed I/O, interrupt-controlled I/O, and direct-memory-access methods of exchanging data between μ Cs. They found the ratio of the bit rates (parallel 8-bit data exchange) for the three methods to be 1:2:4.5. This ratio was found to be largely independent of the CPU used.

"A universal cross-assembler for microprocessors," by A. Schmit,

P. Schmit, and M. Berthoud (Swiss Federal Institute of Technology, Lausanne), addressed the problem of providing software support for many microprocessors. The method uses a common assembly language derived by Prof. J.D. Nicoud at Lausanne and a universal cross-assembler. A given μP is described by conventions for specifying the syntax, operands, and parameters, as well as addressing modes. This description is then transformed into a binary tree structure in which each mode may represent a syntactic unit to be recognized in the current input line under consideration. The tree structure generated uniquely determines the path in the tree followed by each assembly instruction. A new μP description used to drive the universal assembler can be written in one to three days. Currently the Intel 8080, Motorola 6800, Zilog Z80, and Signetics 2650 tree descriptions have been written and are in use. The cross-assembler is written in PASCAL (64K bytes) and at this point generates only nonrelocatable object code. The tree generator is still being written. This method provides an attractive alternative to reprogramming application software each time a different μP is used. A possible extension of this idea would be to use the tree structures in an evaluation system that picks a μP , based on system specifications (speed, cost, availability, etc.).

"A modular microprogrammable pipeline signal processor in ECL-technology," by F. Demmelmeier, B. Kolmegies, and R. Weiss (Institute of Process Computer, Technical Univ., Munich, FRG) describes the design and implementation of a device with a throughput rate of 8×10^6 samples per second for a complex 1024-point fast-Fourier transformation. The pipeline arithmetic unit is divided into five subunits which can process four new complex data points and one complex coefficient every 50 nsec. This speed is achieved by implementing the processor in ECL technology that operates at a clock rate of 20 nsec. A separate microprogrammable control unit supervises the parallel arithmetic unit and four (parallel) modular address units. Efforts are now being directed to interface the pipeline signal processor with a minicomputer in a host-peripheral processor configuration.

Three sessions (seven papers) taken together explored a central theme, system architecture. The sessions were Processor Organizations, Multimicroprocessor System Structure, and Architectures to Enhance Reliability. They focused mainly on the interconnection of μP s to achieve some objective function.

An interesting paper by J. Lipovski and C. Hoch (Univ. of Texas, Austin), "Varistructured stack for microcomputers," proposed a variable structured stack organization in which, by varying the number of μCs , the speed of processing could increase as the number of μCs increased, yet the same object code could execute without modification. A program might therefore be assembled and its object code generated before the number of μCs is known. Lipovski's paper addressed designing an architecture that would include parallel processing by extending the stack concept to handle the variable work-length case; he showed a technique for implementing common data operations on a stack machine. An application particularly suited for the stack machine is array processing; however, this version included no provision for multiplication operators.

R. Negrini and M. Sami (Politecnico di Milano, Italy) introduced a different concept in their paper "Assembly-line multimicroprocessor structure." They proposed an architecture that consists of a chain of processing modules, each managing its own local I/O and endowed with local resources (memory). Elements of their design include distributed control and graceful degradation of performance with no single source of catastrophic failure.

Three panel discussions were held during the Symposium. The first two on social implications and applications firmware were disappointing. This was primarily due not to the subject matter but rather to the lack of panel structure and organization. The third panel on the next generation of microprocessors was, on the other hand, active and informative. Some of the panel members' observations were: software (engineering) will direct where the future of μP s will go; software will be a key product of μP vendors; high-level μCs comparable in capability with minicomputers will be announced early

next year; the single-chip μC is the direction of the future; the trend is away from interrupt-driven structures and towards memory-controlled structures; there will be more software compatibility (instruction set) between manufacturers; standard architectures, higher speeds, and high levels of integration are all important trends that will continue; 32-bit μCs are not likely to become popular for economy reasons (too expensive to develop); and stack architectures may be used in the next generation systems.

The Symposium was successful and certainly strengthened the exchange of information in μP theory, technology, and practice. Probably the role and the future of μPs is best summarized in R. Marczynski's comments on the last day of the conference: "Man overestimates what can be done in one year and underestimates what can be done in five years."

The Proceedings of the EUROMICRO Symposium *Microprocessing and Microprogramming* will be published by North-Holland Publishing Company, Amsterdam, New York, and Oxford. [W.H. Magnuson, Jr., (Lawrence Livermore Laboratory, Univ. of California, Livermore) and LCDR D.C. Rummler]

OPTOELECTRONICS AT PLESSY

I recently visited Plessy's Allen Clark Research Centre, located in a remote area near Towcester, Northamptonshire, 60 miles northwest of London. Dr. G. Gibbons, manager of the Optoelectronic and Microwave Research Division met me on arrival and later Dr. J.C. Bass, Director of the Centre joined us. Gibbons named and briefly described the four Project Divisions: Chemical and Metallurgical Research, Optoelectronic and Microwave Research, Applications Laboratory, Integrated Circuit Pilot Plant, and Optoelectronic and Microwave Production. In addition, there are six Service Departments. A total of 520 personnel are employed in the Centre.

I concentrated on the work related to fiber-optic communications rather than trying to see everything at this

large facility. Gibbon's division is mainly R&D and has 120 people about equally divided between microwave and optoelectronics work.

The microwave work consists of three areas: materials growth and two-terminal and three-terminal devices. Materials grown for microwave devices include GaAs, InP, and Si. Gunn diodes and avalanche diodes are examples of two-terminal devices they are concerned with. One three-terminal device developed here is a GaAs field-effect transistor (FET). The group also developed a very successful process three or four years ago for growing epitaxial GaAs utilizing AsCl_3 .

As my main interest was in the optoelectronics section of the Division, this article will deal with the work carried out there.

Optical fiber communications has become an area of increased importance in the last few years. For that reason Plessy has a significant effort in that field. They have developed ir-source and -receiver components, fiber-fiber couplers and modules for transmitters and receivers for both single-fiber and fiber-bundle systems.

William J. Stewart showed me the fiber optics R&D work. He and C. Stewart have developed an adjustable coupler for multimode single fibers. A paper describing this device was presented at an AGARD Conference entitled "Optical Fibres, Integrated Optics and Their Military Applications," in London 16-20 May 1977. (See *ESN* 31-7:287 and ONRL Report C-12-77). The device, illustrated in Fig. 1, consists of a glass plate the same thickness as the fiber with a grating on one edge.

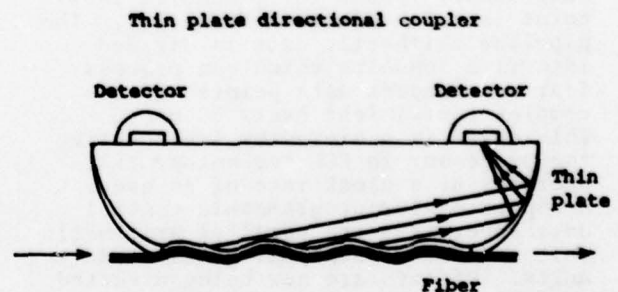

When the grating surface is pressed against the fiber, some energy is coupled into the glass plate. The plate is shaped in such a way that the light coupled out of the fiber is focused onto another fiber or a detector. A second form of the coupler is a block of clear plastic much larger than the fiber diameter with a grating on one surface. If the grating on either of the devices has the proper line spacing, coupling from bound modes to lossy ones will occur and light escapes from the fiber. Increasing the pressure increases the amount of coupling.

One important aspect of this coupler is that it does not produce a permanent change in the fiber, and connectors or splices are not required as they are with other types.

The grating groove spacing and amplitude are important parameters that must be selected. The former must be a specific value that permits coupling between adjacent modes, while the latter along with the applied pressure affects the degree of mode coupling and hence output energy. Additionally, index matching fluids on surfaces decrease the light loss. An output coupling of 25% with only 2% loss has been achieved.

The fiber-optics group is also working on single-fiber connectors for possible military applications where splicing must be done under field conditions. They don't believe the more usual method employing ferrules is economically feasible owing to the problem of centering and aligning the small holes. Instead, they use two spring-loaded isolation blocks with grooves for several individual fibers. Accurate embossing of the blocks is required, but there are no difficult field operations as fiber stripping and cutting tools are the only instruments required.

W.J. Stewart has developed a new technique for measuring the refractive-index profile of graded-index optical fibers that he feels is a substantial improvement over other methods. One existing method consists of forming a diffraction-limited laser spot on one end of a fiber with a microscope objective. The fiber has a cladding and is immersed in a liquid whose index is equal to or slightly greater than the cladding index. The fiber-cell assembly is traversed in a plane containing the focal spot. A measurement of the transmitted light intensity as a function of launch position provides information on the index profile

which can be calculated from geometrical or physical optics. However, Stewart has found that this method is not correct as "leaky" modes affect the results.

In Stewart's technique, a spatial filter, consisting of a lens and aperture stop, blocks the leaky mode light as well as all the trapped light so that a detector behind the stop sees only the refracted light. From this quantity the correct index profile can be calculated.

Robert Goodfellow showed me through the laboratories where semiconductor detectors and sources are developed for fiber-optic communications links. One area of intensive interest is in quaternary double-heterostructure lasers. These devices are made by liquid-phase epitaxial growth of GaInAsP on InP. They are important for two reasons. First the emission wavelength is in the 1.1 - 1.3 μm range which is optimum for transmission through fused silica fibers as the fiber transmission is maximum and material dispersion is minimum there. Secondly, the degradation in these lasers when cw-operated is not a problem as it is with conventional GaAlAs double-heterostructure lasers. This new device was pioneered recently by J.J. Hsieh (Lincoln Laboratory, MIT, Lexington, MA). The Plessy group has made preliminary devices and achieved pulsed operation. Operation in the cw mode is expected soon.

Vapor phase epitaxy is being used to make Zn-diffused, GaAs light emitting diodes (LEDs). This is a commercial product with a lifetime of 25,000 hours at room temperature and greater than 1000 hours at 200° C. These LEDs meet the requirements of a 30-Mbits/sec, 4-km fiber-optic link. Goodfellow also showed me some transmit and receive modules developed as complete products for long fiber-optic links.

The optoelectronics research and development groups at the Allen Clark Research Centre have very capable people and good equipment for carrying out their various activities.
(Vern Smiley)

GENERAL

MANAGING TECHNOLOGICAL AFFAIRS

Industrialized nations must manage their technological affairs wisely if for no other reason than the fact that technology composes an ever larger share of their respective national resources. Managing technological affairs includes controlling the transfer of a technology developed by one organization to another. Technology transfer is the popular term for the process, which is being considered and studied at an expanding rate similar to the increasing study of two other currently popular socio-technical activities—technology forecasting and technology assessment. One wonders whether the serious study of technology transfer might be a passing fad. Whatever happened to the popular concern for the so-called technology gap of the 1950s? Possibly because science in Europe is now on a par with that in the US, technology transfer has displaced technology gap as a subject of governmental concern within NATO.

To provide industrialized countries an opportunity to interchange ideas and share knowledge relative to the handling of technology transfer, the Defense Support and the Scientific and Environmental Affairs Divisions of NATO joined with the US Army, Navy, and Air Force to organize and sponsor an International Conference on Technology Transfer in Industrialized Countries. The Conference took place in Estoril, Portugal, on 7-11 November 1977 and drew an international audience of 135 people representing 18 countries. NATO had sponsored an Advanced Study Institute on a similar subject in 1975 entitled "Industrial Applications of Technology Transfer," (see *ESN* 29-8 and ONRL Report C-17-75). The organizers of this sequel conference improved on the earlier format by greatly increasing the time available for spontaneous discussion between the forty papers presented. While the quality of the papers ranged fairly evenly from excellent to poor, the discussions (formal and recorded as well as informal

during breaks) provided a major share of the knowledge exchanged. The printed proceedings of the Conference will include transcriptions of the formal discussions as well as the papers, and copies should be available in the near future from Dr. Sherman Gee, Naval Surface Weapons Center, White Oak, Silver Spring, MD 20910. This commentary will summarize the proceedings and will include the writer's conclusions and interpretations of issues but will not attempt to cover all the papers presented.

Technology transfer is obviously an ancient practice that has been going on since the time one man taught another how to use a lever or a wedge. Why the big concern now for improving the understanding and management of the technology transfer process? Mr. Nobre Da Costa, the Portuguese Minister of Industry, identified the reason when, in his host-country welcoming speech, he described the complexity and abstract state of some technologies today. In simpler days, new technologies being transferred were readily understandable by the recipient. Study of the transfer process was not required. Today, many of the technologies are so advanced that only well-trained specialists in the field are able to understand and reapply them to a new technical innovation. That is surely the real objective of any transfer, at least from the recipient's viewpoint.

The level of technical sophistication involved in the transfer process is the fundamental issue determining the difficulties of the transfer. It is also fundamental in determining the perception with which individuals attending technology transfer conferences approach the subject. No two people discussing technology transfer as a process are likely to relate it to the same technology, and if they do, they themselves have a different impression of the level of complexity involved in assimilating that technology. During some of the discussions, one member of the audience thought technology transfer included training a candy-store operator to use a pocket calculator for inventory-control purposes, a far cry from applying lasers to initiate specific chemical reactions, for instance. This issue of the level of complexity being considered in any discussion seriously affected the communi-

cation, understanding, and exchange of ideas in the Conference and threatens to plague any future conference on technology transfer. To be sure, this does not mean that the technology transfer process should not be examined and discussed, but the success of any future meeting will depend largely on how well focused everyone is on the same technology. Since a majority of this Conference audience came from defense industries and the military, it was not surprising that papers and discussions relative to technologies prevalent in defense industries were better appreciated and evoked the most useful discussions. Those papers that failed to relate to a specific area of technology (either explicitly or implicitly) tended to be less well received.

Approximately one-quarter of the papers presented specific country overviews of policies and programs (mostly governmental) designed to promote development of technology within that country. It was generally agreed that one of the major efforts of government should be to strengthen the technical and scientific education of its people so that they would be better able to assimilate more sophisticated technologies. The "in" phrase for this was "improve the infrastructure for receiving new technology," or as one member of the audience commented, "A seed won't grow on infertile soil." Several papers described government organizations or trade associations in various countries that function in a manner similar to the Small Business Bureau in the US but with field representatives like the Agricultural Extension Service. There was much discussion but little agreement as to whether this type of assistance is technology transfer. Although all the papers covering management of technology within a country emphasized government's role in enhancing incentives for improving technology in industry, the audience indicated that government should first maximize its efforts to reduce barriers to the introduction of new technology. Furthermore, government helps best when it creates a demand pull for higher-technology items by placing a market order rather than by trying to push industry into adopting new technology. Dr. G.O. Krause (Fraunhofer Gesellschaft, FRG) emphasized his observation that the more a centralized government dominates technology transfer efforts, the fewer

informal contacts are made, and consequently less actual transfer takes place. He believes that effective exchange requires the confidence between parties naturally generated by close informal contacts—a confidence not normally evolving from highly centralized organizations.

Dr. R. Johnston (Univ. of Manchester, UK) delivered an excellent description of the role and function of the UK Research and Development Requirements Board that attempts to integrate and orient R&D being done at universities, government laboratories, and within industry. Interestingly, a comment by Mr. N. Tommeraas (Raufoss Munitions Factories, Norway) indicated that Norway has operated a similar program for more than ten years. They have found, however, that because of political pressures such a government-dominated board tends to support old-established organizations and researchers and that it provides little incentive to new investigators or to organizations working in new fields. In the area of help for new organizations, Dr. R.M. Colton [National Science Foundation (NSF)] stimulated substantial interest in the recently initiated US program in which NSF has established four Innovation Centers in regionally located universities for the purpose of promoting new entrepreneurs using advanced technologies.

While it was agreed that technical information services are valuable (a few papers described various services), the consensus was that truly effective technology transfer requires face-to-face discussions between the person with the technology and the man looking to apply it in a new environment. Brokers, or third-party go-betweens, are not normally required (there was vigorous disagreement as to whether they were even desirable) to accomplish the transfer between the giver and the receiver. Judging from the heat of the discussion, the role of a broker in technology transfer might be worthy of study—especially a historically based study. One might also ask whether technology transfer itself qualifies as a technology. Interestingly, the representative from India, Dr. C.V.S. Ratnam (National Research Development Corporation), stated that based on its experience of applying advanced technology within a technically low-ranking

infrastructure, India is offering to assist as a broker in transferring high technology to still lesser-developed countries.

Perhaps because of the scale of the project, but also because of the domination of defense-industry representatives in the audience, lessons in technology transfer currently being learned from the multinational purchase and production-licensing agreements covering the F-16 fighter-aircraft project generated widespread interest. Professor B. Udis (Univ. of CO) gave a quite detailed and well-received paper describing many of the F-16 license agreements and quoted from interviews he had had with executives from the six European key subcontractors and thirty subsidiary suppliers. The consensus was that truly significant technology transfer is taking place as a result of these production contracts. The European participants mentioned such gains as improved sophistication in their use of nondestructive testing, numerical-controlled machines, quality-control procedures, and general systems-management techniques, as well as specific technologies such as forging high-strength aluminum and working sintered metals.

It was in relation to technology transfer in the sophisticated areas of aerospace that the real crux of the dilemma of cooperation (hence promotion of technology transfer) versus competition (and hence protection of proprietary know-how) came into view. The balance between the two varies continually. How can a country promote both? The development of a technology transfer policy that balances cooperation with competition may be too much to ask for. Perhaps all that we can hope for is that a growing awareness of this dilemma will lead officials to willingly negotiate each proposed technology transfer agreement based upon the case at hand rather than their trying to develop a general policy covering all types of transfer situations. Dr. W. Herbst (Messerschmitt-Bölkow-Blohm GmbH, FRG) precisely summarized this when he stated in his paper that there must be a specific project or program orientation to address or one wastes time talking generalities. He concluded that, when two companies negotiate a production-licensing agreement having technology transfer significance, they manage to

balance their competitive urges with the necessity to cooperate—industry has been striking this balance for years.

My conclusion is that the more one formalizes the study of the technology transfer process, the more abstract and irrelevant the study tends to become. A thorough familiarity with case histories involving technology transfer under circumstances similar to any particular project to be negotiated should aid the negotiators. Abstract papers on technology transfer *per se* will be of little use. Those about to do the negotiating won't read them.
(CAPT L. Roy Patterson)

EDITORS NOTE-

Attention is drawn to the article by J. Adams "Psychology Amid Violence in Turkey" p. 36 of this issue which also touches on an aspect of technology transfer.

MATERIAL SCIENCES

A METALLURGICAL MEETING IN FRENCH—A REPORT IN ENGLISH

The annual fall meeting of the French metallurgical community, Journées d'Automne, was held in sun-drenched Paris from 18 to 20 October, under the sponsorship of the Société Française de Métallurgie. The meeting attracted almost 500 registrants, of whom only about 20 came from outside France. As with most large multidisciplinary meetings, this was an amalgam of technical presentations ranging from the highly theoretical to the highly practical, professional and technical gossip, and undoubtedly overt and covert job hunting.

The technical side of the conference was organized around three main theme areas, each supplemented by a plenary lecture, as well as a number of corollary subtheme areas. The three keynote speakers were in turn, Dr. D. Mclean (National Physical Laboratory, Teddington, UK), who had just spent a year at the Centre des Matériaux of the Ecole des Mines de Paris-Corbeil; Prof. L. Delaey (Université Catholique de

Louvain, Belgium); and Prof. B. Jouffrey (Centre National de la Recherche Scientifique in Toulouse). Mclean, who gave his talk in excellent French, discussed and illustrated how an understanding and exploitation of basic concepts of physical metallurgy can be applied, often on a quantitative basis, to the solution of engineering problems. The subsequent short (15 to 20 min) presentations in this area considered such diverse topics as the effect of high-temperature service on the structure and properties of alloys; behavior of welded structural components, for example, under cyclic fatigue conditions; fatigue-induced failure; and the effects of residual stress. Delaey discussed diffusionless transformations, in particular the martensite reaction. His talk focused on the crystallography and theoretical aspects of the transformation, as well as the effect of martensite on physical and mechanical properties. Subsequent papers in this area considered memory effects due to transformation, one manifestation of which is the spontaneous change in shape or dimensions with a temperature change. This can be quite a dramatic effect and, as many readers know, may provide a partial explanation for some of the claims of spontaneous bending or fracturing of metal parts apparently without the imposition of any external stimuli. Other topics covered were stability and mechanisms of the transformation, and deformation-induced transformation. Jouffrey described the principles of high-voltage (3-MeV) electron microscopy (HVEM) and illustrated the information obtainable by its use, ranging from complex electron diffraction effects to the study of defect structures. Subsequent papers described *in situ* studies in the HVEM, radiation-damage effects, and the study of nonmetallic materials. In addition to these main themes, other subject areas included new techniques for microstructural characterization, precipitation hardening, mechanisms of fatigue, oxidation, and ductile rupture.

There are several reasons why it would be difficult to give a more complete overview of the technical presentations. Most importantly, the numerous topic areas were covered in ninety papers, requiring three parallel sessions on all three days. With such scheduling those who conscientiously attempt to

cover all subjects of interest to them must undertake "talk-hopping"—racing from room to room hoping that all the chairmen are keeping to the published schedule. Interestingly enough, the probability of this occurring is very nearly a universal constant, whose magnitude is close to zero. In my case I quickly discovered that by virtue of my less-than-fluent understanding of French, it was best that I sit quietly in one of the session rooms to prevent that which I had so painstakingly comprehended from pouring out of my head and becoming irretrievably lost, and so a more detailed overview is impossible.

Attending an all-French speaking meeting was an educational experience for me. It will certainly make me more sympathetic to the plight of a foreign attendee at a US meeting who attempts to understand or worse yet to deliver a technical paper, or of a foreign graduate student who is subjected to a barrage of material, delivered at rapid pace by voluble teachers. No wonder they seem to spend their first six months smiling and shaking their heads yes to all direct questions. I, for one, will be more solicitous to their plight as well as all the more envious of those who converse so easily in several languages. Most of us in the US are too insulated from such language difficulties to be aware of how traumatic it can be not to understand what people are telling you. Even when traveling abroad we find that we can survive quite well with only English. At international meetings all over the world, English is invariably at least one, if not the only conference language. But let the traveler be forewarned; the widespread use of English has not eliminated barriers to technical exchange between individuals or countries. Not all countries readily accept English as a common language, and not all people speak it fluently. When traveling outside the English language sphere, it would be well to remember that communication problems can occur. By the way an unsuccessful remedy, still being tried by many, is to assume that the difficulty lies in the fact that you are not speaking English loudly enough. (I.M. Bernstein)

LASER-MATTER INTERACTION STUDIES BY THE
COMMISSARIAT A'L'ENERGIE ATOMIQUE (CEA)

The generation and study of laser-produced plasmas is an area of intense activity in several laboratories throughout the world. The apparatus for high-density plasma formation and target implosion work requires expensive high-quality lasers and auxiliary optics. The Centre d'Etudes de Limeil at Ville-neuve St. Georges, a laboratory of the CEA, has developed three high-energy lasers for laser-target interaction studies. Two are Nd-glass systems and the third is a CO₂ laser.

I met with A. G. Bekiarian of the Limeil facility at CEA headquarters in Paris. The CEA is under the authority of the Ministry for Industry and Research. Its basic function is to promote the uses of nuclear energy in science, industry, and national defense. The activities of the agency are carried out by its own laboratories or by private companies. A list of activities includes: production of nuclear materials, reactor development, fundamental research, military applications, and nuclear safety.

Bekiarian is in overall charge of experimental problems concerning laser studies which includes high-power laser development, diagnostics and control of chain-laser systems, and plasma experiments. J. Bardes is head of the first two areas and C. Patou is in charge of the third area. The laser group has about 100 people (35 are scientists) and started its operations in 1962.

High power lasers for plasma generation has been a significant area of work at Limeil for some time. One Nd-glass system called C6 was in operation from 1970 to 1976. It had four beams and produced 150-200 GW per chain with 1.5-3-nsec pulses. This laser reliably produced about 300 useful target shots per month. A fifth chain simultaneously produced 50-J pulses to generate second or fourth harmonic radiation for plasma diagnostics.

A newer Nd-glass system, called the P102, produces 45-psec TW pulses at 1.06 μm in a single beam. A Nd-Yag mode-locked oscillator and a two-Pockels-cell pulse selector produce pulses having widths between 25 and 100 psec with a contrast ratio exceeding 10^5 .

The rest of the chain consists of several glass-rod and disk amplifiers with spatial filters, soft apertures,

Faraday rotators, and polarizers to isolate the stages and to produce a high quality beam having good intensity uniformity and freedom from diffraction effects. The final amplifier aperture is 128 mm which limits the peak power density to a maximum value of 10 GW/cm². Two of the disks (120 mm diameter) are double-passed resulting in a power gain of 5 for the pair. The chain is tapped to produce outputs of 100 GW and 300 GW as well as the 1000-GW output.

Another Nd-glass system called OCTAL is nearing completion. It has 8 beams, using 90-mm-diameter rods for final amplifiers and is designed to produce 1.6 TW with 100-psec pulses.

A third system designated M3, is a 10-J CO₂ transverse excited atmospheric (TEA) laser operated at 10.6 μm . An oscillator followed by 8 amplifier stages form the active elements of the chain. The oscillator produces 60-nsec pulses at a single wavelength and in a single mode. The pulses are then shortened to 1.7 nsec with two GaAs electrooptic switches. The three final amplifiers are each 1 m long and have 7 cm \times 7 cm apertures. The beam intensity in a 120- μm -diameter focused spot is 5×10^{13} W/cm².

Bekiarian discussed some of the plasma experiments which have been carried out with the lasers just described. One such investigation was centered around implosions of solid and hollow microspheres with four 1-kJ beams obtained from the C6 laser. The experiments were conducted with pulses in the nanosecond region which is sufficiently long that hydrodynamic effects have time to develop during the pulse.

A systematic experimental investigation was carried out of absorption efficiency for spherical CH₂, DLi, and DT targets 100 to 250 μm in diameter when irradiated by an incident power of 100 GW with beam waist diameters of 50 μm . It was found that the absorption efficiency always reached a maximum when the surface was nearly completely illuminated but not when the illuminated spots were smaller than the sphere diameter. Maximum efficiencies observed were 40% for 250- μm -diameter spheres and 18% for 100- μm -diameter spheres. Photographs of the plasma were taken by light emitted at the second harmonic (5300 Å) of the incident laser wavelength. These pictures show that the critical surface is spherical when the illuminated spot is equal to or larger than the original

surface but nonspherical when the illuminated spot is smaller than the surface. A nonspherical plasma increases refraction losses thereby causing a decrease in absorption efficiency.

Time resolved x-ray pinhole pictures were also taken of DLi solid-microsphere implosions. X-ray emission was observed from the corona but was not visible from the hot core. In general, the experimentally observed x-ray emission characteristics agree with theoretical calculations. Emission of x-rays has not been observed from the core of solid targets because the incident power is not high enough.

Glass microballoon targets having 150- μm diameter and 1- μm wall thickness have also been studied. Experimental results based on time and spatially resolved x-ray and second harmonic measurements showed that the volume reduction factor was 240. The implosion velocity proceeded at a rate of 5×10^5 cm/sec resulting in temperatures of several hundred eV at the center of the target. Additionally 40% of the initial mass was ablated away and 4% of the absorbed laser energy was converted into compression energy. The kinds of microballoon implosions produced are similar to those obtained at the Lebedev Institute but are not at all like the US experiments which use ultra-short powerful laser pulses.

Experiments on flat, solid D₂ targets have been performed with a CO₂ laser at intensities up to 10^{13} W/cm². Reflected radiation measurements indicated that 25-30% of the laser radiation was absorbed. However, only 6-8% of the energy goes into plasma heating, and in addition fast ions (maximum energies of 60 keV), which are only a few percent of the total number of particles, are observed to carry away up to 70% of the absorbed energy. These results, observed at intensities of 10^{13} W/cm², rule out classical explanations of the processes involved. Among the emitted particles about 10^4 , 2.45-MeV neutrons were emitted per shot. The majority of the neutrons were produced by the fast ions.

F. Garaude and M. Novaro (CEA) have collaborated recently with G. Lejeune (Thomson-CSF) and M. Bied-Chareton (Thomson-CSF Laboratoire Central de Recherches) in experiments to shape Nd-glass laser pulses. The goal of the work was to produce fast-rising optical pulses in the 200-psec range for target

implosion experiments from a 30-nsec initial pulse.

The device consists of two cylindrical lenses, a reflection grating formed by a voltage applied to electrodes on an electrooptical crystal of lithium tantalate and a pinhole. The incident laser light is focused by the first lens on to the voltage-induced grating. The second lens focuses the diffracted light onto a screen containing the pinhole. The pinhole is positioned to pass the first-order diffracted radiation. The intensity of light emerging from the pinhole is a function of the voltage applied to the electrodes. Therefore, the beam can be modulated temporally by applying a voltage pulse to the electrodes.

Care must be taken that the applied voltage and the interelectrode capacity are kept small in order to achieve a fast risetime. A maximum voltage of 10 V and 20-pF capacitance resulted in a risetime of 200 psec. Another consideration is crystal damage which requires that the input energy be less than about 10 mJ for a 30-nsec pulse as the damage threshold for lithium tantalate is ~ 400 MW/cm². This device was tested with a Nd-glass monomode oscillator stage. The device produced pulses with ~ 200 -psec risetimes, and contrast ratios of $\sim 10^3$ at an efficiency of 10%. It is believed that contrast ratios of 10^5 can be obtained by improving the polish on the crystal surface which will reduce scattered light.

The laser group at Limeil appears to be well equipped and has high-quality scientific personnel well capable of carrying out high-energy laser-matter interaction experiments.
(Vern Smiley)

ONAL REPORTS

See the back of this issue for the abstracts of current reports.

MATHEMATICAL SCIENCES

COMPUTER-AIDED MECHANICAL PART DESIGN AND MANUFACTURING AT THE IWF

The Institut für Werkzeugmaschinen und Fertigungstechnik (IWF) of the Technische Universität Berlin was originally established as a research institute devoted to the experimental study and mathematical analysis of the behavior of machine tools under actual operating conditions and to the design of improved manufacturing methods. Today, the IWF concentrates its R&D efforts mainly in the areas of computer-aided design (CAD), computer-aided manufacturing (CAM) and automated production control systems. The Institute employs approximately 50 research personnel and 20 support staff, all under the directorship of Prof. Dr. Ing. Günter Spur. My host was Dr. Ing. Frank-Lothar Krause.

As Krause explained, the CAD effort at IWF is aimed at realizing what is considered to be one of the most important advantages of CAD systems over conventional design methods; namely, the *integration* of design with manufacturing process planning. The IWF group conceives a total CAD system as consisting of four fundamental modules or stages which can be separately developed and eventually integrated. The requisite modules are: (1) a method for representing the shapes of very complex 3-D mechanical parts within computer memory; (2) a device-independent computer language for relating the internally held mathematical part description to a graphical (pictorial) representation of the part; (3) application programs for the manipulation, analysis, and planning of the machine tool manufacture of the part; and (4) a data base system which automatically keeps track of the spatial relationships between various parts and of the temporal sequence in which machine tool operations must be performed in the actual manufacture of complex parts. An automobile carburetor with its myriad of orifices and internal, interconnected channels through which the fuel and air mixture flows

is a good example of the type of "complex part" with which the IWF group is concerned.

Krause and his colleagues have clearly devoted a great deal of intellectual energy to attempting to clarify the fundamental concepts underlying the design and manufacturing processes typical of the mechanical engineering and machine-tool industries. To one unfamiliar with these industries, the degree to which these researchers have abstracted the seemingly mundane (and certainly dirty) tasks carried out in a typical machine shop may seem rather esoteric and pedantic. In actual fact, however, the abstract conceptualization of the details of the design and manufacturing processes has evolved through an inductive study which began with comparatively simple, axially symmetric shafts (i.e., parts that can be produced on a lathe) and proceeded step-by-step to analyses of increasingly more complex 3-D solids (e.g., parts that require turning, boring, and milling machines for their manufacture).

The tangible results of this research in CAD/CAM is a suite of sophisticated computer programs of demonstrable value to industry. The simplest of these is termed COMVAR, which is an acronym for "combinatorial variation." In brief, COMVAR is a graphically interactive system that uses a "building-block" concept to construct 2-D computer representations of relatively simple 3-D parts. The basic geometric elements from which parts are constructed by scaling, rotation, and concatenation are a cylinder, a cone, a truncated cone, a torus, a groove, etc. By appropriate combination of these simple entities, the designer may construct, for example, a grooved shaft such as that in the following illustration.

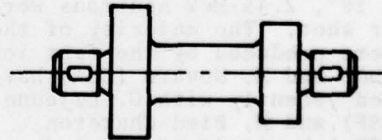

A member of the staff, S. Lewandowski, demonstrated on an interactive cathode-ray display tube how a designer selects, positions, and dimensions a collection of elementary shapes to construct a mechanical part of some significant complexity.

A more sophisticated system, since it actually works with 3-D volume elements defined and stored as such within the computer, is the system of programs called COMPAC, for computer-oriented part coding. With COMPAC, the basic building-blocks are intrinsically 3-D solids, e.g., solid cylinders, spheres, brick elements, tetrahedral elements, etc. The user may, moreover, define his own solid block entities and may modify any of the existing system elements by, for instance, cutting off a portion with a plane (e.g., to get a spherical cap or an obliquely truncated cylinder).

COMPAC is a very advanced system which is written in the FORTRAN language and has a built-in data structure. The computer programs which comprise the overall system include routines for intersecting any of the fundamental 3-D entities with one-another and keeping track, via the data structure, of the remaining 3-D shape. (Think, for example, of the shapes created by a cube which is intersected by a sphere—or vice versa—and of the difficulty of expressing such shapes digitally within a computer.) The COMPAC system also uses special "hidden-line" algorithms which, for visual display purposes, eliminate all portions of a 3-D solid which, if it were a real object and not just a computer data base, would not be seen from the selected viewing angle. The hidden-line algorithms used by COMPAC are claimed to be extremely efficient in terms of computation time. The illustration below is an example of a 3-D part created by the COMPAC system. Note that the hidden lines have been removed.

COMPAC is presently being used in pilot programs by two undisclosed companies in the FRG. Examples of its interactive use were demonstrated for me by R. Dassler.

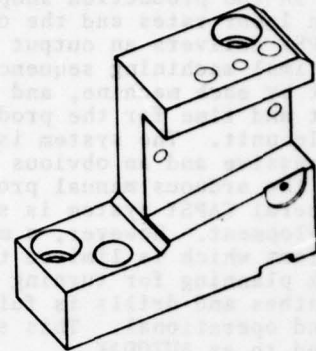

Once a mechanical part has been designed, the production or manufacturing engineer must plan a sequence of machine-tool operations which begin with a solid chunk of metal and conclude with the finished part. A complex part may require dozens of operations to be performed (milling, boring, turning, etc.) by a variety of different tools, but not generally in any unique order. The job of the production planner is to schedule the optimum work sequence for a given part. Aside from numerically controlled machines (which amount to only 5% of the tools in German industry), there is a strongly felt need for the systematic, computerized planning of the sequence of machine operations through which a part should proceed under *manual operation of conventional machine tools*. Since a series of machines are necessarily to be used in the production of a complex part, and since such parts are generally produced in large batches, it is easy to see that serious bottlenecks (or, at least, great inefficiencies) will develop on the production line if great care is not taken in the planning of the sequence of production operations.

The computer-aided planning system CAPSY is directed at solving the problem of computerized work planning and machine scheduling. Input to CAPSY consists of a computer description of the part and the machining operations required to manufacture it, together with

parameters which specify the kind, number and operating speeds of the machines available in the production shop. Based upon labor rates and the other input, CAPSY delivers an output listing of the optimal machining sequence, the time spent by each machine, and the total cost and time for the production of a single unit. The system is really quite impressive and an obvious improvement over the arduous manual procedure.

The general CAPSY system is still under development. However, a more modest effort which is limited to automatic work planning for turning machines such as lathes and drills is fully developed and operational. This system is referred to as AUTODAK.

Given their success to date, it will be interesting to follow the further R&D activities of the IWF. By all indications, the computerized design and production systems which they are developing will be enthusiastically welcomed by German industry.
(William J. Gordon)

INDUSTRIAL RESEARCH AT CAMBRIDGE

The Division of Control and Management Systems (DCMS) of Cambridge University's Engineering Department concentrates primarily on linear multivariable control systems, the specialty of its head, Prof. A.G.J. MacFarlane. The Management Systems part of the Division is oriented toward operations research, done largely by mathematicians, who work closely with the Statistical Laboratory next door. In fact, Prof. Peter Whittle, director of that Laboratory, describes himself as something of an operational analyst, too; his interest in this regard is in topics like optimal stopping in sequential procedures.

Dr. Geoffrey W.T. White joined the Control section of the DCMS 6 years ago after 16 years with Imperial Chemical Industries, and his industrial background has contributed to an unusually applied orientation for some of the Division's research. David Allerton, a student of White's, has been combining a digital differential analyzer (DDA), a PDP-11/45 computer, and a light-pen cathode-ray-tube (CRT) display so as to enable

anyone to draw the diagram of a system and then leave to the computer and DDA the job of calculating the output that will result from any input. In this way the task of system simulation is greatly simplified, avoiding not only analysis and programming, but also scaling, as the DDA operates with a fixed binary point. The DDA, developed by R.E.H. Bywater and Prof. W.F. Lovering at Surrey University, Guildford, UK, uses second differences rather than first and is thus able to function with 3-bit increments (sign plus 2). It has a metal-oxide semiconductor (MOS) store and is linked to the PDP-11/45 and display by microprocessors, the development being carried out in collaboration with the Cambridge University Computer Laboratory. A particularly difficult aspect of the programming is the introduction of the initial conditions, which is complicated by the second-difference approach but which the user need not worry about.

Another DCMS project involves two or three staff members and five or six students in the analysis of coordination in large-scale systems, such as oil-cracking plants. While centralized control of the entire plant would allow theoretical optimization, there are advantages to decentralized control (e.g., less catastrophic failure in case of a breakdown), in which the various fractionation processes are controlled locally by their own computers and only a small portion of the otherwise necessary information is transmitted to the central control system. The project is aimed at finding out not only how much has to be sacrificed in theoretically optimum performance on account of the decentralization, but also how this loss may be reduced through such means as introducing storage tanks in the interconnections between different parts of the plant, so as to alleviate the problems resulting from a temporary excess of output or a temporary shortage of some input. A related project deals with "distributed optimization" in the siting of sugar refineries, which need to be close to the areas where sugar beets are grown in order to reduce transportation costs.

A student of White's has undertaken a six-month project for a certificate in postgraduate studies involving the blending of gasoline, which has always been handled by the intuition of an

experienced person on account of the nonlinearity of the effects of tetraethyl lead and of tetramethyl lead. Government standards require various physical properties of the mixture but still leave several degrees of freedom, which the producer tries to utilize to minimize his cost. The student has found that, by replacing the nonlinearity with a piecewise linear function, he can use linear programming to optimize the blending within a couple of minutes, saving many hours of work by human intuition plus calculation.

While it may appear that Cambridge University has turned into an industrial laboratory, doing various firms' research free of charge, in fact the situation is mutually beneficial. The industrial firms accept Cambridge students for periods of three to four weeks, providing space and stipends for them although the students are seldom able to contribute any useful output. In this way, however, the students acquire an awareness of industrial problems and develop realistic expectations as to their future employment. Only in rare cases do they end up working for a company in which they had spent a training period. Such a symbiosis with industry seems very sensible.
(Nelson M. Blachman)

PHYSICAL SCIENCES

SYNCHROTRON RADIATION LIGHT SOURCES—BIG MACHINES FOR LITTLE SCIENCE

For many years solid-state physicists and chemists have thought of themselves as practitioners of science on a small scale. Equipment is man-sized. Dewars, magnets, racks of electronic equipment, spectrometers, and vacuum systems are all of the dimensions of man. The cost of equipment and operations for an experiment are on a scale not far removed from domestic experience. In contrast are fields such as high-energy physics and modern astronomy where the size complexity and cost of apparatus may

be orders of magnitude larger. There seems to be an accompanying sociological difference in the style of operation for "big" and "little" science. Scientists in "little" science have almost rural traditions. Working groups usually consist of one or two people. They are often firmly independent, self-sufficient in the laboratory, moderate travelers. "Big" science has a more cosmopolitan image. Scientists work in teams, they are very sensitive to the management and political climate, and strong international connections exist between similar groups and members of the groups.

Those distinctions between big and little science are beginning to erode as the use of large machines widens. Ion implantation through the use of big machines is becoming common in solid-state electronics. Installations to produce the highest magnetic fields and the largest laser powers are also sizable. Among the largest machines of all are the electron-synchrotrons that the high-energy physicists have developed. These emit a broad spectrum of intense vacuum-ultraviolet light and soft x-rays that makes them a preferred light source for many experiments (see *ESN* 30-8:367). As a result, an increasing number of practitioners in solid-state physics and chemistry are now firmly involved with these big machines.

On a recent trip to France I had the opportunity to see the electron-synchrotron installations at Orsay, on the grounds of the Université de Paris-Sud, a few miles outside of Paris. Two storage rings are now in operation there. The smaller one works at an electron energy of 500 MeV. Magnets are part of the ring to bend the beam around. Bending the beam gives rise to the synchrotron uv radiation that comes off in a narrow cone at a tangent to the electronic orbit. This radiation is an energy loss that has to be recovered by periodically pumping energy into the electron beam as it circulates around the ring. When the storage ring is used for synchrotron-radiation experiments, a 10-nsec pulse of electrons is injected into the ring in the morning and it circulates all day. A vacuum of 10^{-11} Torr is necessary to maintain this high level of stability. There are two ports and associated apparatus for viewing the

synchrotron radiation; the financial support for building one of these has come from interested industrial laboratories. The radiation from this ring extends from low energies up to 1.5 keV.

The large storage ring at Orsay is of principal interest to high-energy physicists; it operates at 1.87 GeV. Its synchrotron radiation extends to about 15 keV, which is much higher energy than the smaller ring. There is, however, a lower limit of 3 keV to the energizing light because of absorption in the Be exit window.

Both rings share the same injector; this does not appear to be a problem. A serious difficulty has been the rings' power supply which operates at a level of about 10 MW but can serve only one ring at a time. This deficiency is being remedied by the addition of another power supply that was being installed while I was visiting. Once both rings are working independently, the smaller will be operated entirely by the synchrotron-radiation group. They will also have 25% of the time available on the large ring.

The original impetus for the construction of the high-energy accelerators and the storage rings at Orsay came from the high-energy physicists. It was about six years ago that a small group of solid-state scientists in the University, led by Y. Farge, suggested that optical radiation might be useful in a range of experiments for which other sources were inadequate. The accelerator groups were receptive to the suggestion, support within the university was prompt, and the project was launched. It was called the Laboratoire pour l'Utilization du Rayonnement Electromagnetique émis par les anneaux de Collisions d'Orsay; that title is mercifully abbreviated to LURE. Farge became its leader. The cooperation of the high-energy group has been crucial in the growth of LURE to its present size of about 30 full-time positions and some 45 physicists, chemists, and biologists involved in continuing experiments. What started as a small university activity has obviously had a struggle to achieve financial support and official recognition. Farge and his associates have worked intensively at demonstrating the usefulness of LURE in applied physics and development work as well as research. The interest and support of industrial groups has been critical in obtaining

support from CNRS (Centre Nationale d'Etudes et des Recherches Scientifiques) for the expanding effort. This year, for the first time, LURE will be recognized as an official CNRS laboratory with its own regular budget. Previously it had a less-certain hand-to-mouth existence. Another mark of the success of the group is that its budget is up 40% this year at a time when French physics research in general is facing a 4% cut. The existence of LURE has also been helpful to the high-energy groups who have had to struggle against the universal trend toward decreased budgets in that field.

Farge points out that all of the existing synchrotron-radiation sources have been designed by high-energy groups and optimized for their purposes. We are now entering a period in which machines primarily for synchrotron radiation will appear. Farge believes that by careful design such machines could be made to operate at 1/6 to 1/10 of the present electrical power, thus reducing the principal operating cost of current machines. Machines designed for synchrotron radiation would also have many more viewing ports to accommodate a large number of experiments.

Another development that would be helpful is a "wiggler," which would look like this:

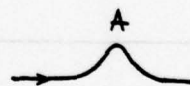

The current path has a small radius of curvature at A, to be produced by an intense magnetic field, that leads to strong emission from that point. Should it be possible to make an array of 50 wigglers, the radiation intensity at a port could be increased by three or four orders of magnitude. This has not been done as yet, but it is obvious that a great deal of effort will be applied in attempting to bring it off.

The future of synchrotron-radiation installations looks bright. A new storage ring is being built in Britain

at Daresbury, and the United States has announced that a source specially designed for synchrotron radiation will be built at the Brookhaven National Laboratory. The European Science Foundation is starting studies aimed at creating a new European synchrotron source designed specifically for optimum performance as a light source. It should be operable in the middle 1980s. Farge is optimistic that such an installation will be built and that the advances made in building the other new sources will aid in making this one notably better than those currently available. His view is that the various national sources will continue to be the workhorses of this kind of research, and that the new European source will concentrate on experiments and projects for which the older accelerators are inadequate.

It seems clear that big machines are advancing into new areas of science and that there is a resulting rapid growth of activity, knowledge, and opportunity. For these areas of physics, chemistry, and biology it is an exciting—perhaps revolutionary—time.
(Clifford C. Klick)

THE TRUMPET SHALT SOUND!

The trumpet is one of the oldest musical instruments still in use in some form today. There are references to the trumpet (*hatsotsra*, not to be confused with the *shofar*, or ram's horn) in the Old Testament including the remarkable blowing down of the walls of Jericho, and there also exists an example of an ancient Egyptian trumpet in Cairo. The trumpet belongs to the family of lip-reed instruments that also includes the horn and the tuba, all of which can be idealized in terms of an open-ended tube. The idealized natural frequencies of the tube and hence the entire family of lip-reed instruments are integer multiples of the fundamental frequency corresponding to a standing wave of wavelength double the length of the tube. At any of its natural frequencies, antinodes in velocity are located at the ends of the tube.

Over the years, the shape of the trumpet bell (the tapered and flaring portion) has evolved so that the actual

frequencies of the harmonics are very close to integral multiples of the fundamental. The natural or valveless trumpet played a very important role in music of the Baroque period; of course, the scale of the Baroque trumpet was limited to those notes that were harmonics of the fundamental of the instrument, and so, for a more or less complete scale, the composer had to write for the extreme upper range (4th octave) of the instrument.

At the beginning of the nineteenth century, technology had its impact, and valves that could add prescribed amounts of tubing thus changing the fundamental frequency of the instrument were invented; soon the valve trumpet displaced the natural trumpet as the instrument of choice in the orchestra.

During the passing years some very fine instruments along with many poor ones have been made, and the question of what constitutes a good instrument must have been asked many times. At the University of Surrey and at Boosey & Hawkes, Ltd. [Edgware (London)] not only is the question being continually rephrased but a deep insight is being brought into the development of a good instrument.

Professor John M. Bowsher (Physics Dept, Univ. of Surrey, Guildford, UK) is conducting a research program on trombones that not only investigates the fundamental properties of the instrument, but also is looking into the interaction of the mouthpiece with the instrument. Since instrumentalists have individualized styles and habits of play and since the lips provide the instrument with a line spectrum of acoustic excitation, Bowsher and co-workers excite their test trombones with a pure sinusoid using a loudspeaker coupled to the mouthpiece. When a musician sounds a tone on a trombone, the excitation is accompanied by a steady flow of air; hence, along with loudspeaker excitation, Bowsher has arranged for a similar, steady component of air flow to be present. The results of a test on any particular instrument is the acoustic impedance as a function of excitation frequency, with measurements made using a hot-wire anemometer and a microphone at the throat of the mouthpiece. In this manner, the natural frequencies of the harmonics are ascertained and those

harmonics that are not integer multiples of the fundamental frequencies are identified.

It is clear that if the actual harmonics of the instrument are not integer multiples in frequency of the fundamental, then excitation by a musician in terms of exact integer-multiple spectral lines will elicit an uneven response from the instrument. Those harmonics that do not coincide closely to a spectral line of excitation will be excited off-resonance and will respond poorly; the tone color of the instrument will therefore suffer.

Once the faulty harmonics of an instrument are identified, a procedure developed by Dr. Richard A. Smith (Boosey & Hawkes) during his doctoral research in physics at the Univ. of Southampton (with the assistance of Dr. Geoffrey J. Daniell) can be utilized to "tune" the misplaced harmonics. Brass instrument makers have known for some time that small modifications of the bore can move harmonics around. If, for instance, the bore of the instrument is reduced slightly at a velocity nodal point of a particular harmonic, the effective spring constant at that point is increased and the resonant frequency of the harmonic is raised. In like manner, an increase in bore at a velocity antinode will raise the resonant frequency. Smith's contribution consists in making the "smoothest" correction in bore to achieve the desired positioning of a harmonic by minimizing an integral expression involving the square of the derivative of the correction. While at this time the theoretical formulation is not ideally suited to designing an instrument from scratch, it has been used to improve individual notes of prototypes and production trumpets.

The qualitative effects of material impurities on tone coloration has been noted in the past. Manufacturers have observed that inclusions and other inhomogeneities in the brass lead to a selective damping of the high frequency end of the spectrum of an instrument and result in a "darker" (less strident) tone. The qualitative effects of mouthpiece-cup volume, throat diameter, and backbore flare have also been known for sometime, but all of the foregoing are now in the process of being quantified. It is hoped that the net result of these studies will be superior instruments that will enable performers to

express themselves more completely and with less effort. (Martin Lessen)

QUANTUM ELECTRONICS—A NATIONAL CONFERENCE AT SOUTHAMPTON

The 3rd National Quantum Electronics Conference was held at the University of Southampton 14-16 September 1977. The 2nd Conference, held in 1975, is described in *ESN* 30-1:45. Although this was a national conference, there was significant international participation, for among the 175 attendees there were representatives from 12 non-UK countries.

The topics included theoretical discussions of superfluorescence, mode locking and beam propagation; laser applications to atomic and molecular physics; laser isotope separation; specific laser developments; high-power lasers and plasmas; nonlinear optics; laser scattering and propagation; and optoelectronic devices and materials. The breadth of coverage was nearly as large as that of the International Quantum Electronics Conferences with the exception that only one unscheduled paper in the area of holography or optical signal processing was presented.

I will discuss a few of the highlights and impressions left by the Conference in this article and reserve a more thorough treatment for an ONRL Conference Report which will be published shortly.

An excellent review paper of the relatively new and interesting field of laser-excited Rydberg states was given by S. Haroche (Ecole Normale Supérieure, Paris) as part of an overall review of lasers in atomic spectroscopy. Rydberg states are highly excited states in which the principal quantum number, n , is very large—a few tens or more. As a result the excited electron is very far from the nucleus and sees the rest of the atom as a point charge.

Haroche pointed out the usefulness of these states for detecting microwaves for astrophysical or other applications. In this technique atoms in a beam are excited to a high-lying state, n , by a visible laser, and then raised to the $n+1$ state by incoming

microwave photons. A small electric pulse is applied with just the proper voltage to ionize the $n+1$ state but not lower levels. This results in a potentially useful microwave detector in which one ion is produced per microwave photon.

R.N. Dixon and D. Field (Univ. of Bristol, UK) authored a paper describing magnetic sub-level crossing experiments in NH_3 . They claim to have obtained the first magnetic sub-level crossing spectra from a polyatomic system. These spectra are free of Doppler broadening, hence a resolution of one part in 10^8 was obtained. They measured the hyperfine splitting in the electronically excited state \tilde{A}^2A_1 for a number of rotational levels in the (0,9,0) and (0,10,0) vibrational states.

The subject of laser isotope separation was treated rather lightly with only two papers. One was given by R. Denning (Oxford Univ.) in which he reviewed various techniques that have been used. The other by F. O'Neill (Rutherford Laboratory, Chilton, Didcot, Oxfordshire) reviewed laser sources for isotope separation.

C.B. Edwards (Blackett Laboratory, Imperial College, London) pointed out that rare gas excimer lasers will be useful for practical applications only if electron-beam pumping at high repetition rates is used. These systems are unsuitable for discharge pumping because a large loss results from ionization of excited states of the molecules. Edwards described the construction and operation of a compact xenon excimer laser pumped by relativistic electrons. A peak power of 1 MW is achieved at a repetition rate of several pulses per second with an active volume of 10 cm^3 . A coaxial electron-beam diode is used in which line emitters made of razor blades efficiently excite the gas volume.

The use of unstable resonators has improved the performance of certain laser systems, particularly CO_2 lasers. Two additional laser systems have also been improved by this method. First, G.C. Thomas (Dept. of Electronics, Univ. of Southampton) has obtained 1.0-mJ pulses in a diffraction-limited beam from a N_2 laser (3371 Å) oscillator-amplifier in which the oscillator has an unstable resonator with large magnification. L.C. Laycock from the same department described the second, a joint project between the University of

Southampton and J.K. Lasers Ltd., of Rugby, Warwickshire in which an unstable resonator has been used very successfully in a Nd-Yag laser at $1.06 \mu\text{m}$. Energy output in the TEM_{00} mode was an order of magnitude larger than available from the laser with a conventional stable resonator pumped with the same input energy. Near-diffraction-limited beam spreading was obtained. A laser output of 130 mJ was achieved with only 25-J input to the flashlamp at a pulse rate of 25 Hz.

Several papers were given on laser-produced plasmas, and the study of x-rays emitted by these plasmas was the main topic of all of them. Inversion of an x-ray transition at 182 Å was discussed in a paper by M.F. Lamb, C.L.S. Lewis and J.A. Lunney (Queen's Univ. Belfast). They have used time-resolved spectroscopy to observe anomalous intensity ratios of Lyman α to Lyman β x-ray emissions in laser-produced C VI plasmas. This result indicates that a population inversion exists between the $n = 3$ and $n = 2$ levels. A few other experimenters have claimed inversion on this same transition recently. However, no one has yet produced a laser based on it. Lamb *et al* generate the plasma by depositing 25 GW of laser power on to a carbon foil with a line focus of 1 mm.

W.H.W. Tuttlebee *et al* (Univ. of Southampton) reported the first observation of tunable ir generation by stimulated hyper-Raman scattering (SHRS) in an atomic vapor. This effect is a fifth order nonlinear process in which two incident pump photons are annihilated with the creation of a Stokes photon. They pumped Na vapor in a heat-pipe oven with a rhodamine 6G dye laser and obtained a tunable, coherent beam at $\sim 2.3 \mu\text{m}$ as $2\omega_p$ (twice the pump frequency) was tuned near the 3S-4D two-photon Na transition. A maximum conversion efficiency of 2% was achieved, being limited by ground state depletion.

J.C. Earshaw (Queen's Univ., Belfast) described his relatively new technique of observing laser scattering from thermally-excited capillary surface waves on liquids. He beats the scattered with the unscattered light and uses photon correlation spectroscopy to obtain the power spectrum and auto-correlation function from which surface tension and viscosity can be calculated.

Pollution monitoring using lasers was discussed in several papers. The technique receiving the most attention was differential absorption lidar (DIAL). This method consists of a measurement of backscattered, pulsed laser radiation which has been almost simultaneously transmitted through the atmosphere at two wavelengths. One wavelength coincides with an absorption line for the pollutant gas being measured and the other with an atmospheric window. From these two return signals the concentration of pollutant gas as a function of range can be obtained. This method is more sensitive than all the other lidar techniques for remote measurement of gases in the troposphere such as Raman scattering or fluorescence.

Laser applications in biomedical studies are becoming more important. An example of this is an experimental result reported by M. Anson (National Institute for Medical Research, Mill Hill, UK) in which he claims to have optically measured ear-drum vibrations for the first time in a live specimen. The technique employed is called laser speckle interferometry. This method doesn't require the attachment of mirrors as would be necessary in ordinary interferometry. The eardrum itself serves as a moving diffuse reflector. Diffuse-reflected laser light is mixed with unscattered radiation to produce the interference. Motions smaller than 10 nm were measured. The specimen in this case was an American frog. Two peaks were observed in the frequency response curve at 200 and 1700 Hz.

This was a good general conference on lasers and their applications. Most areas with the exception of holography and related topics as well as isotope separation were covered thoroughly with several excellent invited and contributed papers. (Vern N. Smiley)

ONAL REPORTS

See the back of this issue for the abstracts of current reports.

THE 5TH VAVILOV CONFERENCE ON NONLINEAR PROCESSES IN OPTICS

The 5th All-Union Vavilov Conference was held on 14-17 June 1977 in Novosibirsk, USSR, and was attended by about 500 people primarily from within the USSR, about a dozen from the US and another dozen or so from the Western European countries. It was greatly enlarged from the 1973 conference, which I had also attended. Simultaneous translation into English or Russian was provided on this occasion. A difficulty, however, was that copies of the program printed in English had been mailed to US participants too late for their receipt, and no further English copies were available. This made it somewhat difficult to follow the program and speakers, especially when changes were made. Sessions covered laser spectroscopy, parity nonconservation, synchrotron radiation, vuv generation and polyatomic molecules in strong fields.

R.V. Khokhlov (Moscow State Univ.), in an opening address, outlined areas in which progress had been made in the past few years: laser spectroscopy, development of double and triple resonances, use of lasers in the physics of fundamental particles and in low-temperature physics, use of higher harmonics to generate shorter wavelengths, new results in x-ray lasers, development of free-electron lasers, and use of high-energy accelerators and superconducting magnets for new lasers.

Following Khokhlov's opening remarks two papers were given. The first was by V.Ye. Zuyev on laser sounding of the atmosphere and the second by V.P. Chebotayev on an apparently new method identified as that of separated fields in optics. The latter paper was extremely impressive because of the very high resolution available. S.N. Bagayev (Novosibirsk) continued on the same subject the next day, describing the experimental apparatus which easily resolves magnetic hyperfine structure on <10-kHz scale. Much of the remaining work in laser spectroscopy was quite interesting but sufficiently removed from my own area that its novelty could not be judged. In what follows, therefore, I will restrict my remarks to items related to the short-wavelength laser field.

The newest entry into the short-wavelength laser game is the use of the synchrotron. The advantages of a synchrotron were enumerated: 1) its intensity can be calculated to within 10%; 2) its coherence is high; 3) its brightness is extremely high; and an expected 100-fold increase in intensity can be obtained by installation of a "wiggler" magnet*. Synchrotrons produce pulses on the order of 1 nsec at 10-MHz frequency. Their emission is broadband, covering the region from the infrared to x-rays. Three experiments proposed by P. Csonka (Lawrence Livermore Laboratory, Berkeley, CA) involved the following possible laser transitions: 2p - 1s at 206 Å in Li II, 2p - 1s in Li III at 135 Å; and 5p - 2s in Be III at 60 Å. Csonka proposes to use portions of the synchrotron spectrum to photoionize the atoms and, in some cases, to pump the 2p level from the 2s state. His calculations show that the increase of intensity expected from the "wiggler" magnet is necessary to approach laser threshold. He stated that the present storage rings have been designed for high-energy physics—not x-ray lasers—and that a redesign of a storage ring for lasers could easily reach threshold intensities or beyond by lowering the electron energy. He also commented that the storage rings that will be required for a free-electron laser could also be utilized to produce radiation for x-ray laser pumping. One Russian experiment utilizes the synchrotron to pump the Nd³⁺-doped fluoride crystals such as LaF₃:Nd, LuF₃:Nd, and YF₃:Nd. Similar studies were proposed by K.H. Yang of GE for the H₂ laser. As yet, neither approach has been successful. Finally, the Soviets are vigorously pursuing x-ray holography using synchrotron radiation.

Another subject of interest at the Conference, nonlinear upconversion, was treated in papers by Alex Provorov, who had just returned from a year with Boris Stoicheff in Toronto, where he had done four-photon mixing in molecular gases, and by V.L. Doicheva (Bulgaria), who had done 5th-harmonic generation in alkali/xenon vapors. In the latter work, the mixture was operated at 570°C and generated $\lambda \approx 532$ Å (5th harmonic of 2660 Å) with 6×10^{-7} efficiency. They measure 5th-order susceptibility at 4×10^{-5} esu. In addition, they talked of 7th and 9th harmonics which

were obtained by adding 2ω to the 5th harmonic and another 2ω to the 7ω , but the wavelengths generated were 460 Å and ≈ 600 Å, which do not seem correct. After this talk A.K. Popov (Krasnoyarsk, USSR) gave me a reprint of his two-photon pumped upconversion in which wavelengths to 708 Å have been generated. Clearly the Russians are very interested and active in nonlinear processes for short-wavelength coherent radiation.

During the Conference I visited the Institute of Semiconductors at Novosibirsk at the invitation of Dr. V.N. Lisitsyn. Lisitsyn is working on the XeCl laser and obtains an average power of 1 W at 150-kHz repetition rate. His mixture is Xe:He:C₂F₄:Cl₂, and he obtains >1% total efficiency for a single shot, but the efficiency drops at high repetition rate. He expects to attain 10 W. Peak powers of 3 MW for KrF, XeF, and XeCl lasers and 1 MW for ArF and XeBr lasers have been obtained. For KrF he prefers SF₆ as the fluoride donor and believes that the SF₆ molecules provide many F atoms by dissociating to SF₅, SF₄, SF₃, etc.

The system used by Lisitsyn is rather simple. It consists of two main electrodes sandwiched by two pieces of glass and sealed by epoxy. Two ionizing electrodes are then epoxied to the outside of the glass over the discharge region. He then makes a low-inductance connection to a water-cooled capacitor/spark-gap assembly. The laser section thus assembled works at pressures to 30 atm. Lisitsyn has used the system to study: N₂ (1st and 2nd positive systems); N₂⁺ @ 3914 and 4278 Å obtaining 0.1% efficiency and 1-MW pulses; atomic transitions at high pressure observing new lines in Ar, Kr and Xe; and now the rare-gas halides. He has operated his system at repetition rates of 400 Hz and claims low flow rates are possible, of approximately 0.1 to 0.3 liter-atm/min. Lisitsyn is concerned with the kinetics problem and plans to use a XeCl probe-laser to investigate gain in the XeCl excimer. He plans to vary the delay between the firing of the probe laser and the "amplifier" and in this manner plot out gain versus time in XeCl. (Ronald W. Waynant, Laser Physics Branch, Optical Sciences Division, Naval Research Laboratory, Washington, DC)

*See Klick's article "Synchrotron Radiation Light Sources" on p. 26 of this issue.

THREE LASER LABORATORIES IN THE MOSCOW AREA

Three important laser research laboratories are located in the Moscow area—at the Institute of Spectroscopy, the Lebedev Institute, and the Moscow State University. Opportunity to visit these activities was taken in connection with attendance at the 5th Vavilov Conference on Nonlinear Processes in Optics held in Novosibirsk in June 1977 (see preceding article). Early contact with Dr. V.S. Letokhov, Vice-Director of the Institute of Spectroscopy, which is at a considerable distance from Moscow, permitted my visiting that Institute. Dr. Igor M. Knyazev who escorted me there and to Moscow State also arranged for my other visit to the Lebedev Institute.

The Institute of Spectroscopy. This establishment is organized into seven branches or divisions, namely: Atomic Spectroscopy headed by Konovov; Molecular Spectroscopy; Raman Spectroscopy; Theoretical Spectroscopy (Agranovich); New Spectral Devices (Koloshinokvr); Electron States of Molecules (Personov); and Laser Spectroscopy (Letokhov). The interests of the laser spectroscopy branch include molecular lasers; dye lasers; highly stabilized CO₂ lasers; picosecond spectroscopy; and studies of excited states. I had the opportunity of visiting 1) an isotope separation group which was using a dye laser to separate isotopes of Pt, Eu, Na, Pb, and Fe; 2) a group studying the ionic spectra produced by a laser-triggered vacuum spark; 3) a group working on intercavity-absorption spectroscopy using an argon-ion laser that has achieved a detection sensitivity of 10 ppm for impurity atoms in a gas; and 4) a group using tunable lasers to study ionization from higher quantum levels of atoms.

P.G. Kryukov's work on "anomalous line intensities" in KCl plasmas was most interesting. The initial observations on KCl were begun because of a theoretical study by K.N. Koshelev for potassium. Data were shown that were taken in November 1976 prior to the group's moving into a new laser building. Further results were not expected until the end of 1977.

In Kryukov's experiment the plasma is formed by laser excitation. He uses one of two modes of excitation: a small prepulse followed by a 250-psec pulse or a fast-rising (<100-psec) pulse approximately 1.2 nsec long. The pulse is focused onto the KCl by one of several cylindrical lenses to create a line focus. The spectra produced by the KCl plasma show the lines in question only in the axial direction of the plasma and only when the plasma length is about 3 mm long. The investigators believe that they may be observing optical amplification. The process of inversion is not known, but Koshelev is now proposing dielectric recombination from the 2p⁶ level of Ne-like Cl VIII resulting in population of the 2p⁵3l levels. The focal region is about 100 μm wide by either 1.5 or 3 mm long. Lenses are changed to vary the plasma length. The 1.5-mm length plasma is irradiated by 4 J, whereas 8 J are applied to the 3-mm length. The flux is about 10¹³ W/cm², and the plasma electronic density is about 3 × 10²⁰ cm⁻³ at an electron temperature of 250 eV.

Considerable time was spent in the laboratory of my host, Knyazev. A H₂ vuv-laser built by Knyazev had been incorporated into a two-step photoionization mass spectrometer as shown in the figure. The entire system has been loaned to a chemistry institute for their work. Knyazev is now working on excimer lasers and has generated emission from XeF, XeCl, KrF, ArF, and KrCl.

Two-step photoionization mass-spectrometer

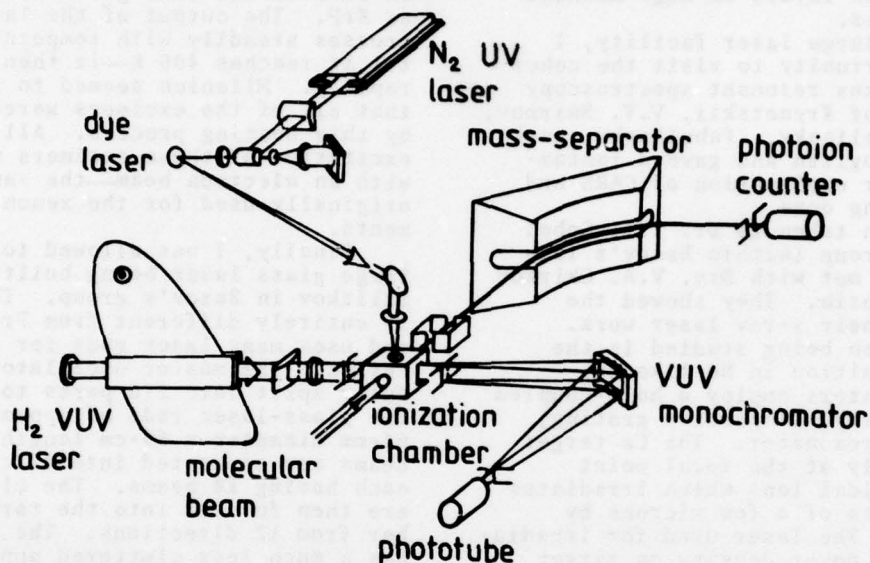

Lebedev Institute. Knyazev had arranged with Dr. B.B. Krynetzkii for my visit to the Lebedev Institute. Krynetzkii works in A.M. Prokhorov's group (about 400 people) on isotope separation and expected to be at a conference at Jackson, Wyoming later. He has used a XeCl-pumped dye laser to separate the isotopes of the rare earths (in the gaseous state, I believe).

They have a large e-beam-sustained CO_2 laser which has an active length of 4.5 m and is about 30 cm in diameter. Unstable resonator mirrors of 20-m and 9-m focal lengths were used to generate a toroidal-beam pattern. The device generated 7.5 kJ in 200-nsec pulses. The foil material was 20- μ m mylar and lasted 300 shots. The e-beam worked at 120 kV while the sustainer was at 60 kV. The windows were BaF_2 , and the mirrors gold-coated zinc. A small os-

cillator generating 500 J in 1 μ sec was also in position to inject a pulse into the larger machine. The system was aimed into a vacuum chamber for plasma studies.

I was also shown a small glass-laser system that was being used to study irradiation of small pellets. The targets were 300- μ m spherical glass-beads filled with D_2 gas. Numerous diagnostics were in place, but no results to speak of had been obtained. The laser system delivered 20 J in pulses variable from 100-200 psec.

Next I visited Prokhorov's large glass-laser system. This system is in the construction stage and is probably 1.5-2 years from operation. It uses 32 beams and about 3 stages of amplification per beam. Amplification comes from glass slabs 4 cm \times 24 cm \times 70 cm (it has been termed a "suitcase

laser" by one Westerner). The master oscillator for this system can generate pulses from 100 psec to 2 nsec in width. My impression is that the system is constructed in a manner that will make it difficult to service—the amplifiers are stacked in layers on huge mechanical structures.

From the large laser facility, I had the opportunity to visit the coherent anti-Stokes resonant spectroscopy (CARS) work of Krynetskii, V.V. Smirnov, and V.I. Fabelinsky. Fabelinsky speaks impeccable English and gave a fantastically clear explanation of CARS and the work being done.

I was then taken to Dr. I.I. Sobel Sobelman's group (within Basov's laboratory) and met with Drs. V.A. Chirkov and U.N. Ragozin. They showed the details of their x-ray laser work. The transition being studied is the 3p - 3s transition in Ne-like Ca. The experimenters employ a hole-coupled resonant cavity, dispersive grating, and concave resonator. The Ca target is held firmly at the focal point of a cylindrical lens which irradiates a surface area of a few microns by about 1 cm. The laser used for irradiation gives a power density on target of 10^{11} W/cm² in a 2.5-nsec pulse. The plasma produced has a density of 10^{19} cm⁻³ and an electron temperature of about 200 eV. Time-integrated photographic recordings of the spectra are made and, on occasion, show a spot or series of spots on the film. A tempting interpretation of these results is that there is gain. While this experiment has been well conceived and carefully carried out, no proof of gain has been offered. It is certainly true, however, that the 3p - 3s transitions are likely candidates for ion lasers since the lifetimes of the transitions are very favorable for inversion. As yet the obvious things to test for gain have not been done—probably because of the lack of repeatability of the experiment. When such experiments as changing the amplifier length or varying the reflectance of the resonant cavity have been done, a better indication of whether or not amplification is possible will have been obtained.

After spending much time with the above experiment, I went to V.A. Danilichev's laboratory. Danilichev himself was visiting laboratories in

the US, so the work going on was described by Alex Milanich. Of great interest was the spectra obtained from such excimer molecules as Kr₂F, Xe₂F, Ar₂F, and ArKrF. Also Danilichev has observed a temperature-dependence effect on some of the rare-gas halides such as KrF. The output of the laser increases steadily with temperature until it reaches 400 K—it then decreases rapidly. Milanich seemed to imply that all of the excimers were improved by this heating process. All of the excitation of these excimers was done with an electron beam—the same one originally used for the xenon experiments.

Finally, I was allowed to see the large glass laser being built by G.V. Sklizkov in Basov's group. This system is entirely different from Prokhorov's and uses many laser rods for amplification. The master oscillator is carefully split into 216 parts to drive 216 glass-laser rods of approximately 64-mm diameter × 50-cm length. These beams are separated into 12 clusters, each having 18 beams. The clusters are then focused into the target chamber from 12 directions. The system has a much less cluttered appearance and would appear easier to maintain than Prokhorov's system. Three of the clusters have already been tested, and it is estimated that in one year the whole system will be completed. Considerable automation is being purchased for this system and mirrors, lenses, etc., will be remotely computer controlled. Western computer components have been purchased for this purpose.

While at the Lebedev Institute I was invited to meet Dr. G.G. Petrash, who was visiting the US in the fall. Petrash works in the Optics Division, which is separate from both Basov's and Prokhorov's groups, on metal-vapor lasers and has been applying them to projection microscopy—they become image amplifiers. He and his colleagues demonstrated their Cu-vapor laser which generates 10-W average power in the green at 100-kHz repetition rate. They also have Au lasing at 2 W in the red, but now need a good blue laser for color projection microscopy. The best they have is Bi which generates only 200 mW. The microscope has a magnification of 1.5×10^4 and can resolve 600 grooves/mm. Its 1.6- μ m

resolution is very close to the 1.3- μ m diffraction limit.

Moscow State University. Knyazev accompanied Charles Wang of the Aerospace Corp. and me on our visit to Moscow State University, where Drs. V.T. Platonenko and V.D. Tazanuckin gave us a brief tour of some of the laser laboratories. Moscow State with its 35,000 students and 7,000 teachers, consists of 16 Departments and is affiliated with 6 Institutes. The Physics Department, which we visited, has 3,000 students and 33 chair professors. The students are engaged in a six-year program.

We confined our visit to the branch of wave processes formerly chaired by Professor R.V. Khokhlov. (Professor Khokhlov died in a tragic mountain-climbing accident on 8 August 1977. His leadership in nonlinear optics and in the international scientific community will be missed.) The branch is engaged in such topics as: picosecond pulses, dye lasers, biophysics using picosecond pulses, gas lasers, CO₂ lasers, short-wavelength lasers, uv lasers, image upconversion, chemical lasers, gas-dynamic lasers (GDLs) and two-photon lasers. Items we saw included: (1) four-photon spectroscopy using a parametric oscillator (tunable from 0.6 to 4.3 μ m) upconverted in sodium-metal vapor; (2) underwater lidar using a 2nd-harmonic YAG laser to detect chlorophyll by Raman scattering. With this system biological production in sea water is detectable with a sensitivity of 1 μ g/liter; (3) an experiment to investigate coherent effects in semiconductors; and (4) Platonenko's experiment in which he plans to optically pump the 16- μ m transition in CO₂ with a 100-MW CO₂ transverse-excited atmospheric-pressure (TEA) laser.

My impressions of the laser research in these institutes is that the quality of work is usually on a par with similar work in the US. The USSR work on rare-gas halides is very good as are their efforts on development of short-wavelength lasers. The laser-fusion research at the Lebedev Institute under the direction of Basov and Prokhorov is of very high quality. In general there are more people working on each project in the USSR than in the US. Often, however, the researchers must make use of Western computer gear, and

such things as Polaroid cameras or equivalents do not appear to be available. (Ronald W. Waynant, Laser Physics Branch, Optical Sciences Division, Naval Research Laboratory, Washington, DC)

PSYCHOLOGICAL SCIENCES

DEVELOPMENTS IN EFFORTS TO UNIONIZE THE BRITISH ARMED FORCES

The formation of a trade union in the armed forces of a democratic country will involve public debate in and outside the military, attempts of trade union organizations to recruit military personnel, military command reactions to the recruiting, and reactions by lawmaking bodies and the courts. Both the US and the UK are essentially in the debate stage, with the debate further along in the US. Nevertheless, the UK debate has progressed far enough to be a visible theme in London newspapers (*The Times*, 4, 9, and 10 December 1977) and in the discussions that Parliament has had on military pay.

Emboldened by the statement of Mr. Fred Mulley, Secretary of State for Defence, up to five unions are studying the possibility of unionizing the armed forces, with two of them (Society of Civil and Public Servants, and Association of Scientific, Technical, and Managerial Staffs), actively moving toward recruiting. How successful the unions might be is unclear because there has been no public information on the attitudes of military personnel. What the unions have working for them at the moment is widespread restiveness about military pay. The cost accounting of military pay can be complex, but pay is nevertheless acknowledged to be low. *The Times*, for example, says that a 22-year old flight lieutenant, trained at a cost of over one million dollars to fly a Jaguar fighter worth over three and a half million dollars, receives little more in basic pay after two years than

an average London bus driver. An ordinary soldier in the Army in Ulster will receive an average of 60 cents an hour, with most men working 90 hours per week because of security difficulties. Some of the military personnel moonlight to survive financially, a practice which has been viewed critically by those who see it as hurting military effectiveness. Pay grievances are causing a significant number of the troops in Ulster to resign from the service which, in the absence of conscription, poses recruiting pressures. Mr. Winston Churchill, Conservative Party, said in the House of Commons that the Labour government's "Scrooge-like attitude" has demoralized the armed forces over the past seven months in a way that the Provisional IRA has not been able to do in seven years. Mr. John Gilbert, Minister of State for Defence, in reply, said that his government was sympathetic to the plight of the armed forces, but that a maximum pay raise of ten percent is the government's anti-inflationary policy and that it would be held.

The 820,000 service men and women are a prize which the unions would love to win, but whether now is the moment they will choose to advance remains to be seen. Whatever the unions do, the Ministry of Defence officials might weaken the attractiveness of unions as pay negotiators by setting up internal machinery of their own. Plans are being drawn up to give junior officers a voice in the Armed Forces Pay Review Body, and there has been talk of ombudsmen at the unit level, but it is unlikely that these efforts will mean much if they are not accompanied by cash. (Jack A. Adams)

PSYCHOLOGY AMID VIOLENCE IN TURKEY

The student restlessness of the 1960's on US campuses is pale stuff alongside the student violence that grips Turkish universities and immobilizes them. A visit to the Psychology Department of the University of Istanbul found that violence had temporarily closed the University almost on the day that it opened. The unpleasantness, which is neither new this year nor unique

to the University of Istanbul, is that armed gangs of leftist and rightist student terrorists stalk the campus and battle each other. Sixty students were killed at the University of Istanbul last year, and this year is going the same way. On 31 October six students were wounded in a shoot-out at a bus stop (*Turkish Daily News*, 1 November 1977). On 2 December a secondary student was killed and another seriously wounded when left-wing and right-wing groups clashed in Istanbul, while in Ankara 13 students were wounded when rival factions exchanged fire (*The Times*, 3 December 1977). Right-wing terrorists killed one student of the Istanbul Academy of Fine Arts and wounded another on 7 December in retaliation for the murder of a right-winger by a left-winger (*The Times*, 8 December 1977). The apartment of Professor Nuri Saryal, Rector of the Middle East Technical University in Ankara, was bombed on 28 November, which was the eighth bomb attack at the University in two months and the second against Saryal (*The Times*, 29 November 1977).

Events like these caused Professor Ilgaz Ayanak, in his "A Message From the President" that opens the 1976-77 General Catalog of the Middle East Technical University, to say (in an unusual statement for a university catalog): "The greatest problem of our universities in the past years has been the acts of violence caused by the conflicting ideas of students. Our university should be a place where freedom of thought is given the widest possible scope and where all ideas can be discussed within the limits of the Law. Situations in which the conflict of ideas lead to physical violence are absolutely undesirable and bring no benefit whatsoever for individuals or societies. The major qualification of a civilized person is to respect the rights and freedoms of others, and to treat all ideas with tolerance, no matter how divergent they may be. During this academic year a major part of our efforts will be to create and develop an atmosphere of understanding and tolerance in the University."

The political zealots responsible for this campus terror number only a few hundred at the University of Istanbul, but they succeed in damaging the education of the thousands of conscientious students with moderate political

views who are caught in the middle. A typical incident, demonstrating both the terror and the damage to education, can be like this: A terrorist is killed in a shoot-out and so his associates go to the classrooms, sometimes brandishing weapons, and press the students to go on a sympathy march. The students, fearful, go on the march. The lecturer, equally fearful, closes down the class. As this incident shows, the faculty as well as the students are victimized. Faculty have been attacked in their offices, and so their office corridors have heavy locked steel doors at each end; it is like entering a prison cell block.

In the middle of all these difficulties is the Psychology Department. Professor Dr. Sabri Özbaydar heads a small but excellent faculty of six. Dr. Aksit Göktürk, of the English Philology Department, with his interests in psycholinguistics, works closely with the Psychology Department. One of the immediate impressions that one has of the faculty is its international flavor. Most have a mix of degrees from Turkish, central European, and North American universities, and some have had postdoctoral study in central Europe and North America. In the past, long-visiting professors from Europe and the United States contributed to the international character of the faculty. Professor Dr. Wilhelm Peters, an experimental psychologist from Jena University, fled the excesses of the Nazi regime in the 1930's and came to the University of Istanbul in 1937 where he remained until his retirement in 1955 (Peters was one of 60 German professors who came to the University of Istanbul during this period). Professor Walter C. Miles was an eminent American experimental psychologist in his day, and when he retired from Yale University he spent 3 years, 1954-1957, with the Psychology Department at Istanbul.

The impact of these two foreign professors was to turn the Department toward experimental psychology rather than some other discipline of psychology. The undergraduate curriculum is a solid program in learning, perception, developmental psychology, laboratory methodology, tests and measurement, statistics, and experimental design. The program, which graduates about 25 students a year, is topped with the requirement for a research thesis. Students have

a hard time of it. There are virtually no textbooks of psychology in Turkish, either written by Turks or translated from other languages, and the students, who are weak in foreign languages, may have difficulty with foreign textbooks. As a result they rely heavily on their lecturers and whatever handouts in Turkish that the faculty might prepare. A further difficulty for the students is that the departmental laboratory is one room and poorly equipped. It has old brass instruments that deserve space in a psychology museum—a set of tuning forks, a mechanical device for testing auditory threshold, a stereopticon. No electronic equipment was in evidence. Everywhere in Europe and the US one hears complaints about insufficient funds for research and research equipment, but often the complaint represents a discrepancy between reality and an ideal rather than a fundamental lack. At the University of Istanbul the financial need is painful and real. Research, both student and faculty, is done in ways that cost very little—they use paper-and-pencil tests, study verbal learning, word association, etc. The Department has a good, small library, however, so the faculty and students have access to the research of those who have less trouble in conducting it than they do.

Research in the Department is varied. Professor Dr. Beğlan Toğrul is an energetic experimental psychologist who has worked on a wide range of topics, from learning in planaria to sensory psychology and psycholinguistics. She was one of the foreign colleagues of Professor Charles Osgood, University of Illinois at Urbana-Champaign, in the cross-cultural psycholinguistic research project on meaning that he supervised. Her duties also include direction of the Institute of Experimental Psychology in which some of the Department's research is conducted. The Institute publishes the *Istanbul Studies in Experimental Psychology*, an annual volume with experimental reports in both English and Turkish. Dr. Yilmaz Ozakpinar, who is a senior lecturer in the Department, and who conducts research in the Institute, is doing both empirical research on free recall and theoretical work. His analysis [(*Is. Stud. in Exp. Psych.* 12, 51-62(1976))] of those

who advocate use of the principles of reinforcement to increase the productivity of underdeveloped countries is keen. After reminding the advocates of the ways that humans learning in a complex cultural context differ from pigeons key-pecking for reward in the laboratory, he makes the telling point that innovation in an underdeveloped country requires no less than a change in the civilization. Almost everything that distinguishes the modern world from earlier ones is attributable to science. The answer must come in the transformation of a nonscientific culture into a scientific one, which is a fundamental transformation of the mind of a people, and this is far more intricate than the transfer of technologies and the reinforcement of behavior appropriate to them.

The research in the Psychology Department is done with little direct stimulation from psychologists elsewhere in Turkey or from other countries. Professional life is quiet for Turkish psychologists. There is no professional organization to sponsor scientific meetings and journals, and no one is doing much about it, probably because it must seem unimportant when violence infects their lives as it does. (Jack A. Adams)

NEWS & NOTES

ERGONOMICS AND JOB SATISFACTION

A joint meeting of the International Ergonomics Association/British Ergonomics Society Conference examined employee motivation, job satisfaction, and quality of working life. The conferees were 100-125 ergonomists who were sequestered in a quiet retreat (Fulmer Grange, Slough, UK) outside of London on 21-24 September 1977.

Five themes were explored: (a) the concept of job satisfaction and dissatisfaction (W.T. Singleton, Univ. of Aston, UK), (b) the deficiencies of theory and methodology (L. Klein, Tavistock Institute, UK), (c) the development instruments and procedures for implementing work design and re-

design for improved quality of life (J.R. de Jong, B.W. Berenschot Co., Utrecht, the Netherlands), (d) a hierarchy of need for work structuring that extends from physiological limits to psychological satisfaction (W. Rohmert, Univ. of Darmstadt, FRG), and (e) the principles implied in the planning of decentralized production systems (L.E. Björk, Swedish Council for Personnel Administration, Stockholm).

Reginald G. Sell (Work Research Unit, London, UK) has been motivated to accept the tedious chore of culling the addresses, papers, and discussions into a coherent publication. (John J. O'Hare, Office of Naval Research, Arlington, VA)

During a recent meeting of the Royal Society, the Rt. Hon. the Lord Todd, Master of Christ's College, Cambridge, was re-elected president of the Society. New members of the Society's council are: Prof. P. Allen, Professor and Head of the Department of Geology and Director of the Sedimentology Research Laboratory at the University of Reading; Sir James Baddeley, Professor of Chemical Microbiology and Director of the Microbiological Chemistry Research Laboratory at the University of Newcastle upon Tyne; Prof. W.E. Burcham, Oliver Lodge Professor of Physics, University of Birmingham; Sir Peter Hirsch, Issac Wolfson Professor of Metallurgy, University of Oxford; Sir Andrew Huxley, Royal Society Research Professor at Imperial College, University of London; Prof. J.F.C. Kingman, Professor of Mathematics, University of Oxford; Dr. E.H. Mansfield, Deputy Chief Scientific Officer, Royal Aircraft Establishment; Prof. C.W. Rees, Heath Harrison Professor of Organic Chemistry, University of Liverpool; Dr. Ruth A. Sanger, Director of the Medical Research Council Blood Group Unit at University College, London; and Sir Michael Woodruff, Emeritus Professor of Surgery, University of Edinburgh.

PERSONAL

Dr. G.H. Baxendale, Reader in Chemistry, has been promoted to the Chair of Physical Chemistry at the University of Manchester.

Prof. J.A. Campbell, Department of Mathematics at the University of Newcastle, New South Wales, Australia, has been appointed to the Chair of Computer Science and to the headship of the new Department of Computer Science which will be established at the University of Exeter in October 1978.

Dr. M.J. Lanigan, formerly General Manager, Plessey Processor Unit, Plessey Co., Slough, Bucks., has been appointed Professor of Digital Electronics at the University of Kent at Canterbury as of 1 October 1977.

Professor Ronald Mason, FRS, Professor of Chemistry, University of Sussex, has been appointed Chief Scientific Adviser to the Ministry of Defence.

Dr. Ian Gordon Simmons, Reader in Geography, University of Durham, has been appointed to the Chair of Geography at the University of Bristol following the retirement of Professor R.F. Peel.

OBITUARY

John Norton Mills, Brackenburg Professor of Physiology at the University of Manchester, died in a climbing accident 3 December 1977 at the age of 63. After a short period of general practice, he returned to academic life first as a lecturer, then as a Reader in Physiology. In 1965 he was elected to the Brackenburg Chair on retirement of Walter Schlapp. During his twenty-seven years at Manchester his research interests in respiration, renal physiology, and electrolyte balances in the human body converged into the study of circadian rhythms in which he became a world authority. His many books and papers attest to the thoroughness of his research. He was quite involved with the administration of the University, and his contributions to the development of his department in the newly enlarged Medical School were manifold.

ONAL REPORTS

- R-11-77 INFORMATION THEORY IN HUNGARY by N.M. Blachman
- This report discusses the work of the Mathematical Institute of the Hungarian Academy of Sciences with emphasis on its Information Theory and Statistics Groups. The work of the Institute for Communication Electronics of the Technical University of Budapest is also mentioned together with a general picture of the Faculty of Electrical Engineering. Some remarks are included concerning information-theoretical research elsewhere in Hungary.
- C-16-77 BOOZE AND BEHAVIORISM by J.A. Adams
- A NATO International Conference on Experimental and Behavioral Approaches to Alcoholism was held in Os, Bergen, Norway, 28 August, - 1 September 1977. Behavior therapy was the predominant viewpoint of the conferees. The conference themes were seven: research methodology, alternative skills training self-management procedures, the tension-reduction hypothesis, learning to discriminate blood-alcohol level, conditioned taste aversion, and individual differences.
- C-17-77 THE THIRTEENTH IUPAP CONFERENCE ON STATISTICAL PHYSICS by H. Ruskin and R. Cherry
- This report summarizes selected papers and reviews given at the Statphys-13 Conference held this summer in Haifa, Israel. Topics mentioned include fluctuation scaling, percolation processes, series expansions and renormalization techniques applied to various problems, fluids and turbulence, random systems, and many other areas of investigation in which the methods of Statistical Physics have been successfully employed.
- C-18-77 RADAR '77 by CDR D.A. Hart
- The Institution of Electrical Engineers and the IEEE Aerospace and Electronics Systems Society organized a major four-day international conference, Radar '77, held in London 25-28 October 1977. A brief description of some of the papers presented at this conference is presented. A complete list of the papers at Radar '77 is included as an appendix.
- C-19-77 NORTH AMERICAN/EUROPEAN HEALTH SYSTEMS RESEARCH CONFERENCE by D. Whipple
- The increases in the costs of operating the Military Health Services System (MHSS) of the United States have exhibited striking parallels to that of the private health care sector. The past three years have thus been characterized by research

C-19-77
(cont'd)

efforts which are motivated by the desire to contain these MHSS cost increases while maintaining the quality of the health care delivered. These efforts have identified various areas in which improved management; organizational change, incentive manipulation, and new modes of practice/delivery may enhance achievement of the goals. The subject conference and contacts with health systems management and research personnel in Britain and France during the trip to and from the meetings offered the opportunity to gather comparative impressions of the potential efficacy of research efforts underway and contemplated within the MHSS. This paper summarizes these results and policy recommendations.