

LEVEL III

12

OFFICE OF NAVAL RESEARCH

Contract ¹⁵ N00014-76-C-0408

Project NR 092-555

A047 091

AD A060730

DDC FILE COPY

⁹ Annual Technical Report no. 3

⁶ THE ROLE OF CHEMICAL BONDING IN ADHESION

¹⁰ A. N./Gent P./Dreyfuss

Institute of Polymer Science
The University of Akron
Akron, Ohio 44325

¹¹ Oct 78

¹² 37 p.

Reproduction in whole or in part is permitted for
any purpose of the United States Government

Approved for Public Release; Distribution Unlimited

DDC
RECEIVED
NOV 2 1978
REGULATED
D

401 069

78 10 27 045

mt

SECURITY CLASSIFICATION OF THIS PAGE (When Data Entered)

REPORT DOCUMENTATION PAGE		READ INSTRUCTIONS BEFORE COMPLETING FORM
1. REPORT NUMBER Annual Technical Report 3 ✓	2. GOVT ACCESSION NO.	3. RECIPIENT'S CATALOG NUMBER
4. TITLE (and Subtitle) The Role of Chemical Bonding in Adhesion		5. TYPE OF REPORT & PERIOD COVERED Annual Technical Report
		6. PERFORMING ORG. REPORT NUMBER
7. AUTHOR(s) A. N. Gent and P. Dreyfus		8. CONTRACT OR GRANT NUMBER(s) N00014-76-C-0408 ✓
9. PERFORMING ORGANIZATION NAME AND ADDRESS Institute of Polymer Science ✓ The University of Akron Akron, Ohio 44325		10. PROGRAM ELEMENT, PROJECT, TASK AREA & WORK UNIT NUMBERS NR 092-555
11. CONTROLLING OFFICE NAME AND ADDRESS Office of Naval Research Power Program Arlington, Virginia 22217		12. REPORT DATE October, 1978
		13. NUMBER OF PAGES 28
14. MONITORING AGENCY NAME & ADDRESS (if different from Controlling Office)		15. SECURITY CLASS. (of this report) Unclassified
		15a. DECLASSIFICATION/DOWNGRADING SCHEDULE
16. DISTRIBUTION STATEMENT (of this Report) Approved for public release; distribution unlimited		
17. DISTRIBUTION STATEMENT (of the abstract entered in Block 20, if different from Report)		
18. SUPPLEMENTARY NOTES		
19. KEY WORDS (Continue on reverse side if necessary and identify by block number) Adhesion, Bonding, Elastomers, Polybutadiene, Glass, Coupling Agents, Polysiloxane Layer		
20. ABSTRACT (Continue on reverse side if necessary and identify by block number) Studies of the effect of chemical bonding on the measured joint strength of bonds formed between polymers and rigid substrates have been carried out. Various treatments have been applied to glass surfaces before bonding to polymeric overlayers. These treatments have included reaction of glass with mono- and trialkoxysilanes, urethanes, silanated polybutadienes, and polysiloxane layers. Effects on the resulting joint strength varied		

DD FORM 1473
1 JAN 73

EDITION OF 1 NOV 65 IS OBSOLETE
S/N 0102-LF-014-6601

SECURITY CLASSIFICATION OF THIS PAGE (When Data Entered)

48 10 27 045

from an insignificant level to a thirtyfold increase. Comparisons of various results for joints between glass and a polybutadiene overlayer, summarized in this report, suggest that a transition layer such as a polysiloxane layer must be introduced before positive effects of chemical bonding are obtained. When this transition layer is present, the measured strength of the joint is found to increase as the number of chemical bonds increases. In experiments involving the bonding together of two identical polybutadiene layers, the joint strength was found to increase in direct proportion to the number of assumed interfacial chemical bonds.

ADDITIONAL		
UTIS	White Section	<input checked="" type="checkbox"/>
DDI	Buff Section	<input type="checkbox"/>
UNANNOUNCED		<input type="checkbox"/>
JUSTIFICATION.....		
BY.....		
DISTRIBUTION/AVAILABILITY CODES		
Dist.	AVAIL. and/or	SPECIAL
A		

Table of Contents

	<u>Page</u>
Summary	1
Introduction	2
Results and Discussion	2
Coupling Agents	4
Silanated polybutadiene	6
Polybutadiene substrates	10
<u>In situ</u> formation of polysiloxane layer	11
Preformed polysiloxane layer	12
Conclusions	19
Acknowledgement	20
Personnel	20
References	20

Summary

Studies of the effect of chemical bonding on the measured joint strength of bonds formed between polymers and rigid substrates have been carried out. Various treatments have been applied to glass surfaces before bonding to polymeric overlayers. These treatments have included reaction of glass with mono- and trialkoxysilanes, urethanes, silanated polybutadienes, and polysiloxane layers. Effects on the resulting joint strength varied from an insignificant level to a thirtyfold increase. Comparisons of various results for joints between glass and a polybutadiene overlayer, summarized in this report, suggest that a transition layer such as a polysiloxane layer must be introduced before positive effects of chemical bonding are obtained. When this transition layer is present, the measured strength of the joint is found to increase as the number of chemical bonds increases. In experiments involving the bonding together of two identical polybutadiene layers, the joint strength was found to increase in direct proportion to the number of assumed interfacial chemical bonds.

Introduction

The objectives of this study have been first to obtain direct evidence for chemical bonding at the interface between similar and dissimilar materials and second to learn how the density of chemical bonds affects the work of detachment of the materials joined together. For this purpose we have sought to prepare well defined and well characterized joints with a controlled and known number of chemical bonds at the interface. The studies summarized in this report have led to the development of several model systems for obtaining the desired data. Unexpected, and sometimes anomalous, results obtained along the way have shed some light on why there has been a continuing controversy about the importance of chemical bonds in adhesion.

This report gives an overview of results obtained during the past year and attempts to correlate them with previous results. Details of the studies either have been or will be presented in Technical Reports and publications.

Results and Discussion

A diagram of a typical test specimen used in our studies is shown in Figure 1. It consists of a substrate which has been exposed to a carefully controlled surface treatment and then pressed into contact with an overlayer of a cloth-backed elastomer.

Typically, the elastomer layer has been based on polybutadiene. Firestone's Diene NFA, because this material is relatively pure chemically and rheologically simple. The work of adhesion, W , is measured from 180° peeling experiments; $W = 2P/w$, where P is the observed peeling force and w is the width of the specimen. In searching for a suitable model system we have used substrates of glass, various plastics, inorganic crystals, and crosslinked polybutadiene. Surface treatments have included silane coupling agents (1), carboxyterminated polybutadiene (CTB), amineterminated polybutadiene (ATB), and specially synthesized polybutadienes containing one or two $-\text{Si}(\text{CH}_3)_2\text{OCH}_3$ endgroups and sometimes $-\text{Si}(\text{OCH}_3)_3$ groups along the backbone in addition. Only work related to glass substrates is included in this report because they have proved to be more convenient for the initial studies. Glass substrates are comparatively inert and maintain their shape and strength up to very high temperatures. This allows maximum flexibility in choosing solvents, reactants, and temperatures for surface modifications.

Previously, it was assumed that we could vary the adhesive strength of elastomers to glass by varying the density of chemical bonds between the $-\text{SiOH}$'s in the glass and the polybutadiene overlayer. This assumption does not seem to be correct. Apparently

a transition layer between the glass adherend and the polybutadiene adhesive is necessary to insure good wetting of the surface. This transition layer is preferably bonded as strongly as possible to the glass and of such a nature that it completely covers the glass. The layer has the added advantage of preventing direct contact between the adhesive and impurities or foreign materials in the glass. For our purposes the transition layer should be susceptible to chemical modification so that a known number of functional groups of a predetermined nature can be introduced. Under these conditions it can be shown that chemical [REDACTED] has a positive effect on the strength of adhesive bonds. Many [REDACTED] earlier results and those of other workers, which have hitherto seemed irreconcilable with a simple general relationship of this kind, tend to form a consistent pattern once the concept of a transition layer is introduced. With this in mind, some of the previous data is reviewed and some new data acquired to test this hypothesis is presented.

Coupling agents. Ahagon and Gent (1) treated pyrex glass bars with solutions containing catalyst and varying proportions of methyltriethoxysilane, $\text{Me-Si}-(\text{OC}_2\text{H}_5)_3$, and vinyltriethoxysilane, $\text{CH}_2=\text{CH-Si}-(\text{OC}_2\text{H}_5)_3$. The work of detachment that they observed for bonds between surfaces treated in this way and then bonded to a polybutadiene overlayer by curing at elevated temperature was proportional

to the amount of vinyl silane in the treating mixture. They inferred that chemical bonding occurred by reaction of the vinyl groups on the surface of the treated glass and the unsaturation in the polybutadiene:

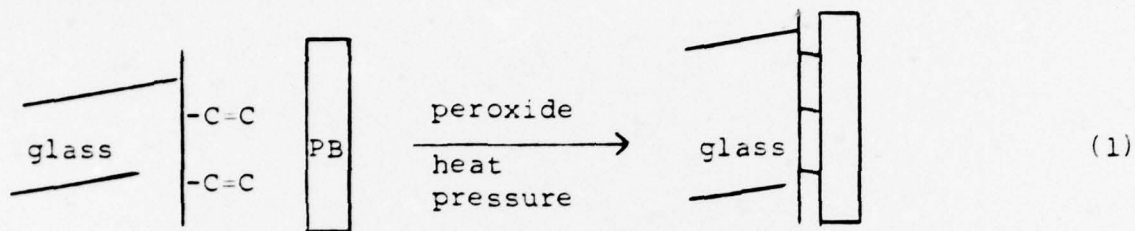

Now, the treated and washed slides were heated at 110°C for 30 min. Under these conditions it is probable (2,3) that a polysiloxane layer formed and that Ahagon and Gent actually had a glass surface coated with a polysiloxane containing varying numbers of vinyl groups. The sequence of reactions would be:

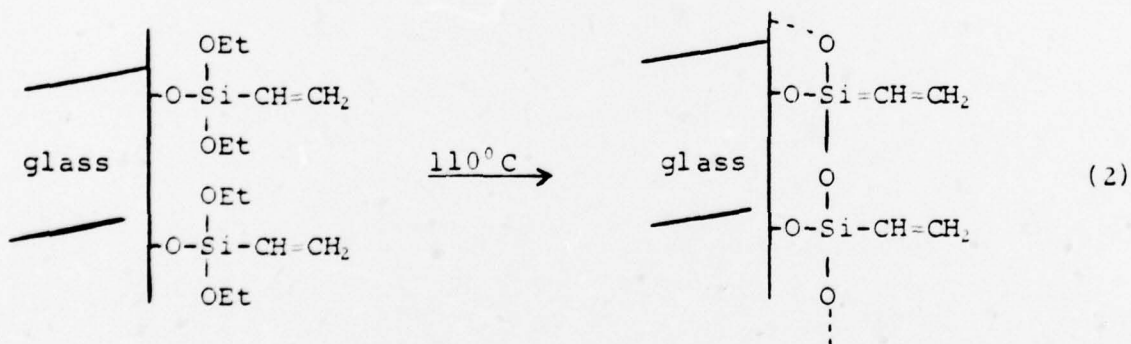

In contrast when Wong (4) carried out similar experiments in the vapor phase without catalyst, using monofunctional silanes: vinyl dimethylethoxysilane, $\text{CH}_2=\text{CH}_2(\text{CH}_3)_2-\text{Si}-\text{OC}_2\text{H}_5$, and trimethylmethoxysilane, $(\text{CH}_3)_3-\text{Si}-\text{OCH}_3$, he obtained relatively little enhancement of bond strength. Vapor phase treatment with allyl isocyanate, $\text{CH}_2=\text{CHCH}_2-\text{NCO}$, which like the vinyl dimethylethoxysilane has only one group capable of reacting with a silanol, also had almost no effect on the bond strength of polybutadiene to glass surfaces. Neither the silanes nor the allylisocyanate that Wong used is capable of forming a polysiloxane transition layer. Once the ethoxy, methoxy, or isocyanate groups have reacted with the silanol groups in the glass surface a reaction analogous to equation 2 is not possible.

Silanated polybutadiene. Two anionic polybutadienes with silane endgroups were synthesized for this study. As shown in Table I these polybutadienes were similar in microstructure to Firestone's Diene 35NFA. The polymer designated α -PB had a single dimethylmethoxysilyl endgroup and was similar in molecular weight to Diene 35. The other polymer designated $\alpha,1$ -PB had two dimethylmethoxysilyl endgroups, a lower molecular weight, and a somewhat higher vinyl content. The properties of CTB, which was used in

Table I

Properties of Polybutadienes

Structure ^a	Symbol	$\sim M_n^b$	Microstructure ^c		
			% cis	% trans	% vinyl
Diene 35 NFA	PB	150,000	36	54	10
$\begin{array}{c} \text{Me} \\ \\ \text{MeO-Si-PB-Bu}^d \\ \\ \text{Me} \end{array}$	α -PB	180,000	36	54	10
$\begin{array}{cc} \text{Me} & \text{Me} \\ & \\ \text{MeO-Si-PB-Si-OMe} \\ & \\ \text{Me} & \text{Me} \end{array}$	$\alpha, 1$ -PB	35,000	31	49	20
$\begin{array}{cc} \text{Me} & \text{Me} \\ & \\ \text{MeO-Si-PB-Si-OMe}^e \\ & \\ \text{Me} & \text{Me} \\ & \\ & [\text{SiCl}_3]_n \end{array}$	Cl-PB	>35,000	31	49	- ^f
$\begin{array}{cc} \text{Me} & \text{Me} \\ & \\ \text{MeO-Si-PB-Si-OMe}^e \\ & \\ \text{Me} & \text{Me} \\ & \\ & [\text{Si(OMe)}_3]_n \end{array}$	M-PB	>35,000	31	49	- ^f
HOOC-PB-COOH	CTB	4130	20.5	54.9	24.6

Footnotes to Table I

^aPB = polybutadiene

^bDetermined by GPC except for CTB which was determined by endgroup analysis

^cDetermined by ir or 300 MHz ¹H nmr spectroscopy

^dBu = sec-butyl

^ePrepared from *cis*,1-PB by a procedure adapted from Miron, Bhatt, and Skeist (6) and Saam and Speier (5).

^fAll pendant vinyl groups were converted to either -SiCl₃ or -Si(OMe)₃ groups. The concentration of the silyl groups was about one for every five butadiene units

subsequent experiments, are included in Table I for comparison. Two additional polybutadienes were prepared from α,ω -PB. The sample with pendant trichlorosilyl groups, Cl-PB, was prepared by the catalyzed addition of trichlorosilane to the double bond of the pendant vinyl groups (5,6):

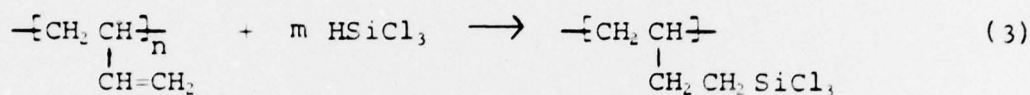

The sample with trimethoxysilyl groups, M-PB, was prepared by reacting Cl-PB with methyl orthoformate:

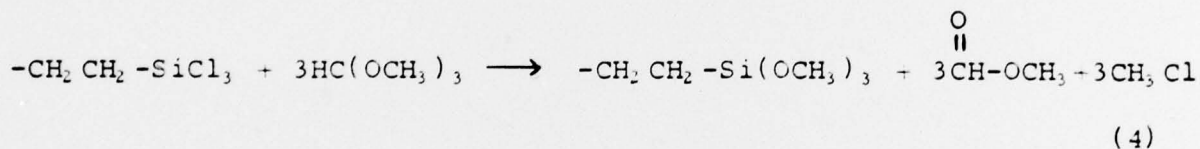

Glass slides were treated with each of these polybutadienes as described in Technical Report No. 4, July 1978. In that report evidence was presented that the silanated polybutadiene was chemically bonded to the glass slide and could not be washed off. However, SEM studies gave no evidence of adhering polymer on slides pretreated with PB. Slides treated with α -PB were found to have only widely-separated particles, about 300 nm in diameter, adhering to them as shown in Figure 2.

Adhesion test specimens were prepared and tested as previously described (7,8). (See also Technical Report No. 2, September, 1977). The results, summarized in Table II, show that compared to control samples where the glass slides were either untreated or treated with normal PB, samples treated with α -PB and α, μ -PB, showed no change in the work of adhesion. This lack of effect does not seem to be due to an inherently slow reaction of the silane endgroups with glass. Studies with model compounds as described in Technical Report 3, July, 1978 indicated that 2 hrs. should be sufficient for complete reaction between a silanol and a silane. The present reactions were carried out for 2 hrs. and for 48 hrs. with the same results; namely, no improvement in the strength of the bond after treatment of the glass with α -PB or α, μ -PB. Note that two endgroups and a lower molecular weight as in α, μ -PB give the same result as α -PB. It seems that polybutadiene is incompatible with glass and does not spread over the surface, so that chemical bonding by end linking is relatively infrequent. As a result, no improvement in the work of adhesion is obtained, even after long reaction times.

Polybutadiene substrates. It can be argued that the lack of improvement in the strength of adhesion to glass after pretreatment with reactive polybutadienes is a result of inadequate crosslinking between the two polybutadiene layers, especially if only one of them, the overlayer, contains the peroxide crosslinking agent, as in our

case. Studies of the work of detachment of specimens with polybutadiene as both the overlayer and the substrate suggest that bonding between them is a facile reaction. Model specimens, consisting of two identical polybutadiene layers have been crosslinked together. If the degree of crosslinking in the layers before they are brought together is varied and then the crosslinking process is completed, the strength of interfacial bonding is found to vary over the entire range from zero to a level characteristic of the bulk material; i.e. from purely dispersion force adhesion to the cohesive strength of the fully-crosslinked elastomer, see Figure 3. Moreover, because the adhering layers are always identical and the joint symmetrical, no thermal or shrinkage stresses affect the measurements. Further details of these studies will be the subject of a future technical report.

In situ formation of polysiloxane layer. Improvements in the strength of bonds formed after treating glass with functionalized polybutadienes were first observed when samples capable of forming an intermediate polysiloxane layer were used. For example, when glass slides were treated with Cl-PB and then the Cl-PB was hydrolyzed and heated at 110° for 24 hrs. a fourfold enhancement of the work of adhesion was observed. Formation of a polysiloxane layer is

possible under these conditions. An even greater increase was observed when M-PB was used, and again formation of a polysiloxane layer is possible on heating. The results of these experiments are given in Table II.

Preformed polysiloxane layer. Formation of a polysiloxane layer on a glass surface from a silanated polybutadiene as described above, if it occurs, would be expected to be rather inefficient. Moreover, the number of chemical bonds at the interface cannot be systematically varied even if it is assumed that the siloxane bond through the silanol in the glass surface is stable. In fact, this assumption is probably not true. Studies with model compounds summarized in Technical Report 3 indicate that a dynamic equilibrium exists.

An alternative procedure is to form the polysiloxane layer first, with multiple attachments to the glass surface and to vary the number of functional groups in the polysiloxane layer. This is effectively what Ahagon and Gent did, if the present interpretation is correct. It can also be achieved by using a preformed polysiloxane layer containing reactive p-bromomethylphenyl groups on the glass surface. When these groups were reacted with CTB, a continuous layer of rubber as shown in Figure 4 could be observed by SEM.

Table II

Effect of Functionalized Polybutadiene Treatment of Glass on
 Work of Detachment (W) of Polybutadiene Overlayer^a

<u>Rubber</u>	<u>Time of Reaction (hrs)</u>	<u>W (N/m)</u>
-	2	5
PB	2	5
α -PB	2	5
-	48	11
α -PB	48	15
α, μ -PB	48	12
-	96	7
Cl-PB ^b	96	24
M-PB ^c	96	32

^aThe polybutadiene was cured using 0.15% dicumyl peroxide. W was calculated from peeling measurements at a crosshead speed of 0.5 cm. per min. Failure, as judged by eye, was interfacial in all cases.

^bThe $-\text{SiCl}_3$ groups were hydrolyzed to $-\text{SiOH}$ groups and then slides were heated at 110°C for 24 hrs. to form a polysiloxane layer.

^cThe treated slides were heated at 110°C for 24 hrs. to form a polysiloxane layer.

Furthermore as shown in Table III a remarkable increase in the work of adhesion of typical test specimens occurred. Details of these studies were given in Technical Report 2, September, 1977.

Recently ^{14}C labelled glycine has been incorporated into the chemical bond between (p,m-Chloromethylphenyl) ethyl groups in the polysiloxane surface and the CTB by the sequence of reactions shown in Scheme I, steps A to F. We have worked out conditions such that each step proceeds nearly quantitatively. Details of the work will be the subject of a future technical report. By using mixtures of 1-trichlorosilyl-2-(p,m-Chloromethylphenyl) ethane and β -phenethyltrichlorosilane and varying the percentage of each in the mixtures used to treat glass slides, the number of chloromethyl groups and hence the number of possible chemical bonds between the polysiloxane coated glass surface and the polybutadiene overlayer was varied. As shown in the data presented in Figure 5 for samples prepared from mixtures with 0 to 60% of the chloromethylphenyl compound, a direct correlation was obtained between the percent of the chloromethylphenyl compound and the contact angle observed after step C, the radioactivity observed after step D and the work of detachment, W. Thus, when a polysiloxane layer is present there seems to be a direct correlation between the number of interfacial chemical bonds and the strength of adhesion to a

Table III

Effect of Preformed Polysiloxane Layer on Work of Detachment (W)^a

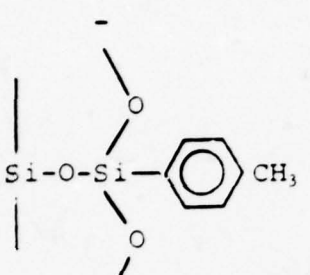
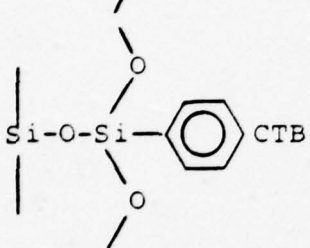
<u>Bonding</u>	<u>W(N/m)</u>	<u>Type of Failure^b</u>
-	34	I
	20	I
	450	C

^a Cured using 0.1% dicumyl peroxide at 150°C for 1 hr. Tested using a crosshead speed of 0.5 cm per min

^b I = interfacial, C = cohesive

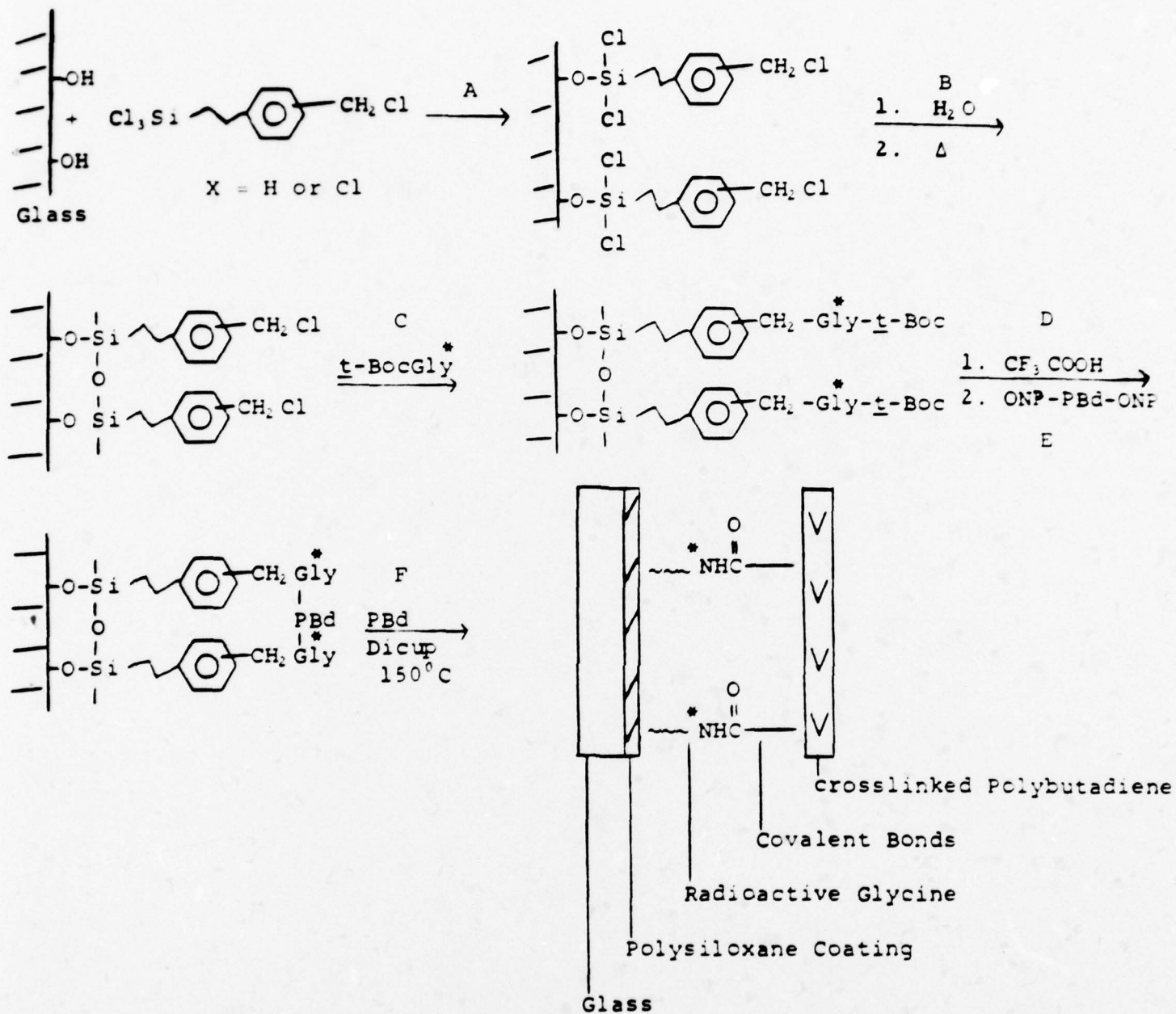
Scheme I^a

Footnote to Scheme I

^aIn step A the glass surface was treated with 5% benzene solutions containing varying proportions of 1-trichlorosilyl-2-(p,m-chloromethylphenyl) ethane and β -phenethyltrichlorosilane, X = Cl and H, respectively. (The relative rates of reaction of the two trichlorosilanes were assumed to be about the same and so the number of -CH₂Cl groups attached to the surface should be proportional to the concentration of the 1-trichlorosilyl-2-(p,m-chloromethylphenyl) ethane. The data given below indicates that this is a reasonable assumption). In step B the remaining chlorines attached to the silicon were hydrolyzed and the glass slides were heated at 110°C in vacuum to form the polysiloxane layer. Through step B the groups with X = Cl and X = H will behave the same. From step C onward, only the groups with X = Cl will react and only those are used to illustrate the rest of the scheme. The number of -CH₂Cl groups thus determines the maximum number of chemical bonds that form. In step C partially protected glycine (t-Bu-O-C(=O)-NH-¹⁴CH₂-COOH, denoted t-BocGly*) was bonded to the polysiloxane coating by reaction of the cesium (9) salt of the partially protected glycine with the chloromethyl group of the polysiloxane to form an ester linkage. In step D the t-Boc group was removed with trifluoroacetic acid (CF₃COOH) and in step E the free amine was coupled to the dicarboxy-terminated liquid polybutadiene via its p-nitrophenylester forming an amide bond (10). Finally, in step F the polybutadiene overlayer containing dicumyl peroxide was pressed against the treated slides and cured at 150°C to complete formation of covalent bonds from the glass surface to the polybutadiene adhesive.

polybutadiene overlayer. However, in the absence of the polysiloxane intermediary layer, formation of chemical bonds to glass appears to be much more difficult, possibly because of severe incompatibility of diene elastomers and glass surfaces.

The radioactivity of the glass slides was measured after step E and once again after the peeling experiment. They are compared in Figure 6 with the radioactivity measured after step D. The decrease in radioactivity observed after step E would be expected, since the polybutadiene added in step E would deflect some of the β -particles emitted by the ^{14}C of the glycine. The further decrease after peeling can be explained in either of two ways. Fracture can occur in any of the regions of the joint arbitrarily marked off in Figure 7. The radioactive glycine in the interphase can serve as an indicator for locating the locus of failure. Since the radioactivity on the glass slides decreases, this could be an indication that failure occurred entirely in region A; i.e. failure was 100% cohesive in the rubber phase and the added rubber led to a decrease in the measured rate of β -particle emission. Alternately, failure could have occurred partly in regions B,C or D and partly in region A. In the latter case there should also be measurable radioactivity in the polybutadiene-cloth overlayer after peeling. We

have not detected such activity. However, in this first series of experiments the radioactivity was quite low and only exceeded the background count by a factor of two to three. Also the technique used for measuring activity on the slides is not suitable for making measurements on the polybutadiene-cloth overlayer. Hence at this stage the radioactive tracer technique looks very promising for locating the locus of failure but has not yet given an unambiguous result. A new series of slides at a much higher radioactivity level and at higher $-CH_2Cl$ concentrations is being prepared.

Conclusions

In carefully designed systems all the evidence points to a direct improvement of the strength of adhesive bonds as the number of chemical bonds at the interface increases. However, work with silanated polybutadiene shows that not every system that might be presumed to form chemical bonds is able to do so effectively. In the case of glass and polybutadiene an intermediate transition layer, for example, a polysiloxane layer, that allows spreading of the polybutadiene seems to be a necessary prerequisite for the formation of strong adhesive joints. We have now developed a model system incorporating a radioactive material that, once calibrated, should permit the number of chemical bonds in a joint to be measured directly and related to the work necessary to fracture the joint. It

should also permit an experimental determination of the location of failure in the joint on a molecular scale.

Acknowledgement

We thank the Firestone Tire and Rubber Co. for samples of Diene 35NFA and K. Riew of the B. F. Goodrich Co. for samples of CTB and ATB.

Personnel supported by this project:

- P. Dreyfuss, Research Associate (50%)
- Q.-S. Lien, Postdoctoral Research Fellow (100%)
- R.-J. Chang, Graduate Research Student (100%)
- N. K. Eib, Graduate Research Student (100%)

References

1. A. Ahagon and A. N. Gent, J. Polym. Sci.,: Polym. Phys. Ed., 13, 1285 (1975).
2. K. Grohmann, Pellicular Silicon Resins as Solid Supports for Peptide Synthesis, Ph.D. Thesis, University of Houston, 1972.
3. W. Parr and K. Grohmann, Tetrahedron Lett., 28, 2633 (1971).
4. S. G. Wong, Effects of Surface Treatments of Glass on the Strength of Elastomer-Glass Adhesion, Ph.D. Thesis, University of Akron, 1977.
5. J. Saam and J. Speier, J. Am. Chem. Soc. 83, 1351 (1961).

6. J. Miron, P. Bhatt, and I. Skeist, Recent Advances in Adhesion, Ed. L.-H. Lee, Gordon and Breach, Science Publishers, Inc., New York, N.Y., 1973, p. 309.
7. M. L. Runge and P. Dreyfuss, J. Polym. Sci.: Polym. Chem. Ed. (in press).
8. P. Dreyfuss, A. N. Gent and M. L. Runge, Technical Report No. 2 to ONR, Contract N0014-76-C-0408, Project NR 092-555, September, 1977.
9. B. F. Gisin, Helv, Chim. Acta, 56, 1476 (1973).
10. M. Bodanszky and M. A. Ondetti, Peptide Synthesis, Interscience Publishers, J. Wiley and Sons, New York, N.Y., 1966.

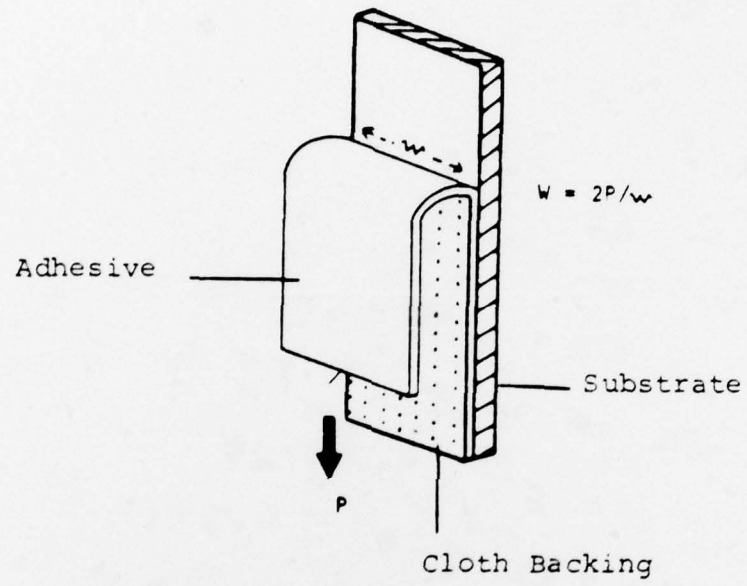

Figure 1: 180° Peel Test Specimen

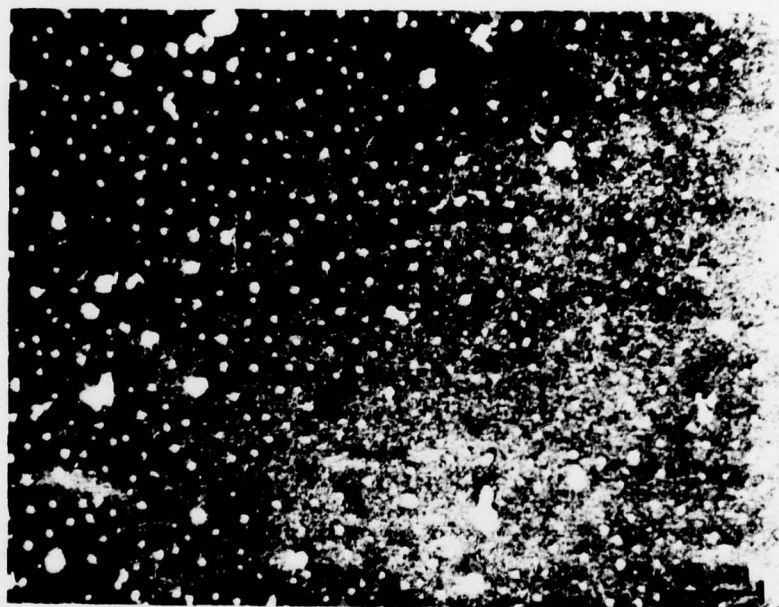

Figure 2: Electronmicrograph of glass slide treated
with $(PB)Me_2SiOMe$ x 1400

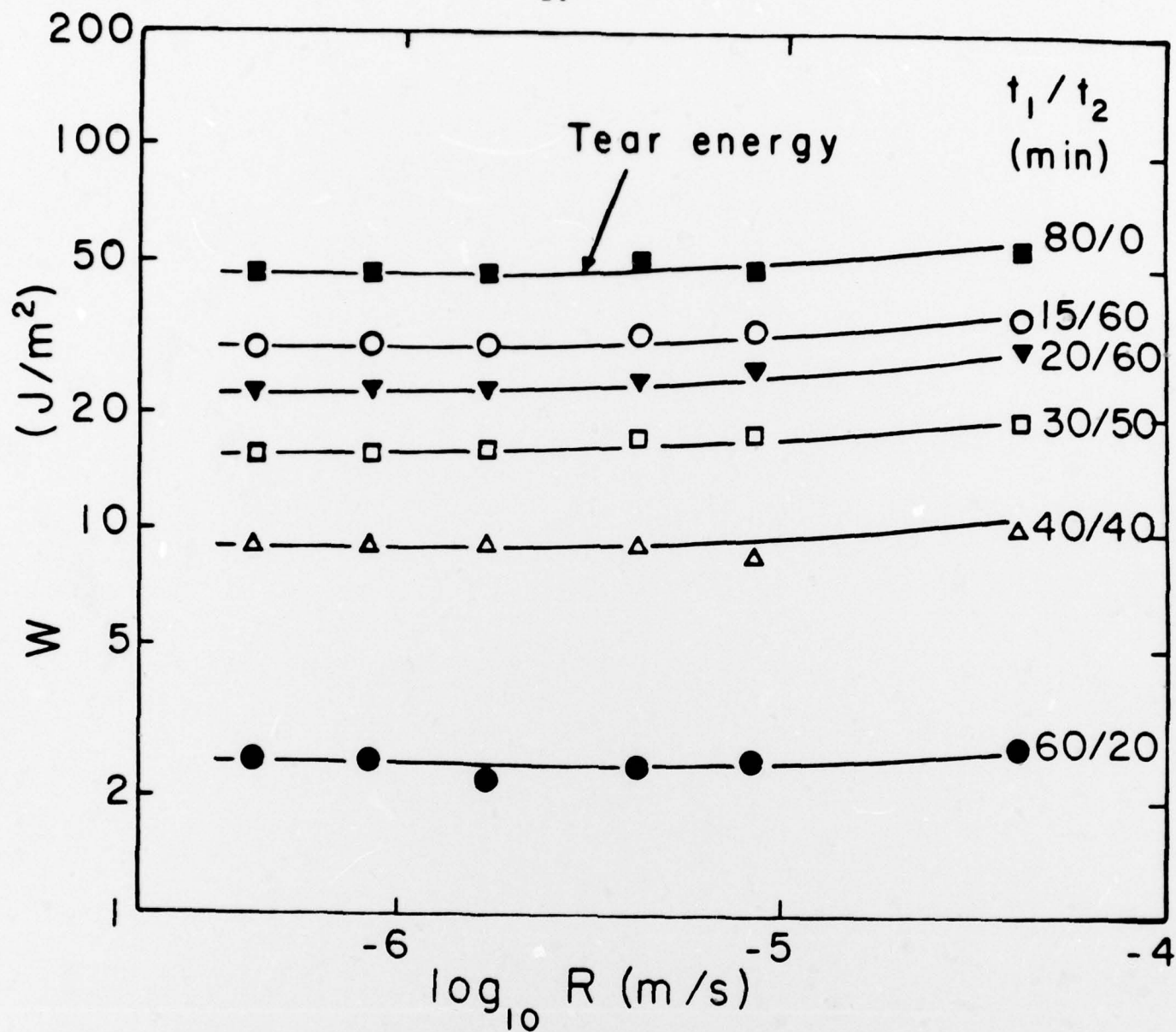
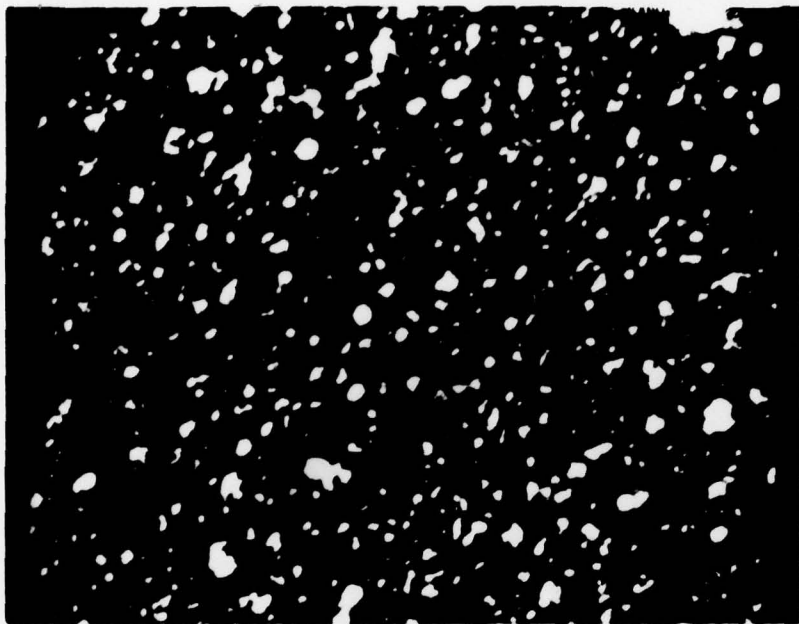

Figure 3: Work of detachment, W , at 95°C vs. peeling rate, R , for polybutadiene layers with varying amounts of interfacial bonding. The polybutadiene was cured using 0.2% dicumyl peroxide. t_1/t_2 = time of precuring separate layers/time of curing layers in contact. E.g., \bullet polybutadiene layers were precured separately for 60 min and then cured an additional 20 min after being pressed together.



AFTER



BEFORE

Figure 4: Comparison of scanning electronmicrographs of 50/50 p-bromomethylphenylpolysiloxane/p-tolylpolysiloxane coated slides before and after treatment with di-carboxyterminated polybutadiene. ~ x 10,000.

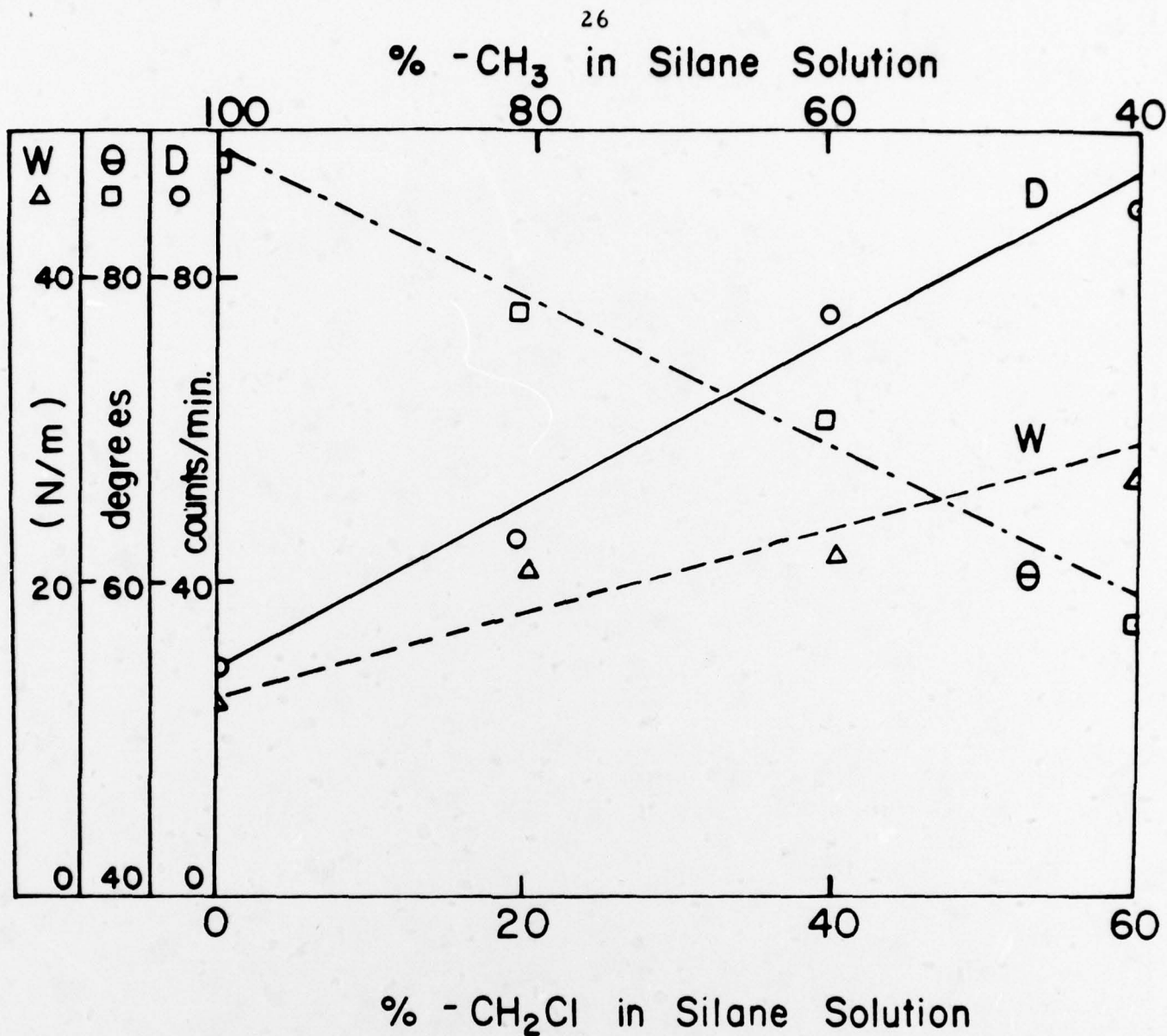

Figure 5: Variation of contact angle, θ , after step C, radioactivity after step D, D, and work of adhesion, W, after step E in Scheme I as a function of % of 1-trichlorosilyl-2-(p,m-chloromethylphenyl) ethane and % of β -phenethyltrichlorosilane in the solution used to treat glass slides. W was calculated from data taken at a crosshead speed of 0.5 cm/min on samples cured with 0.1% dicumyl peroxide at 150° for 1 hr.

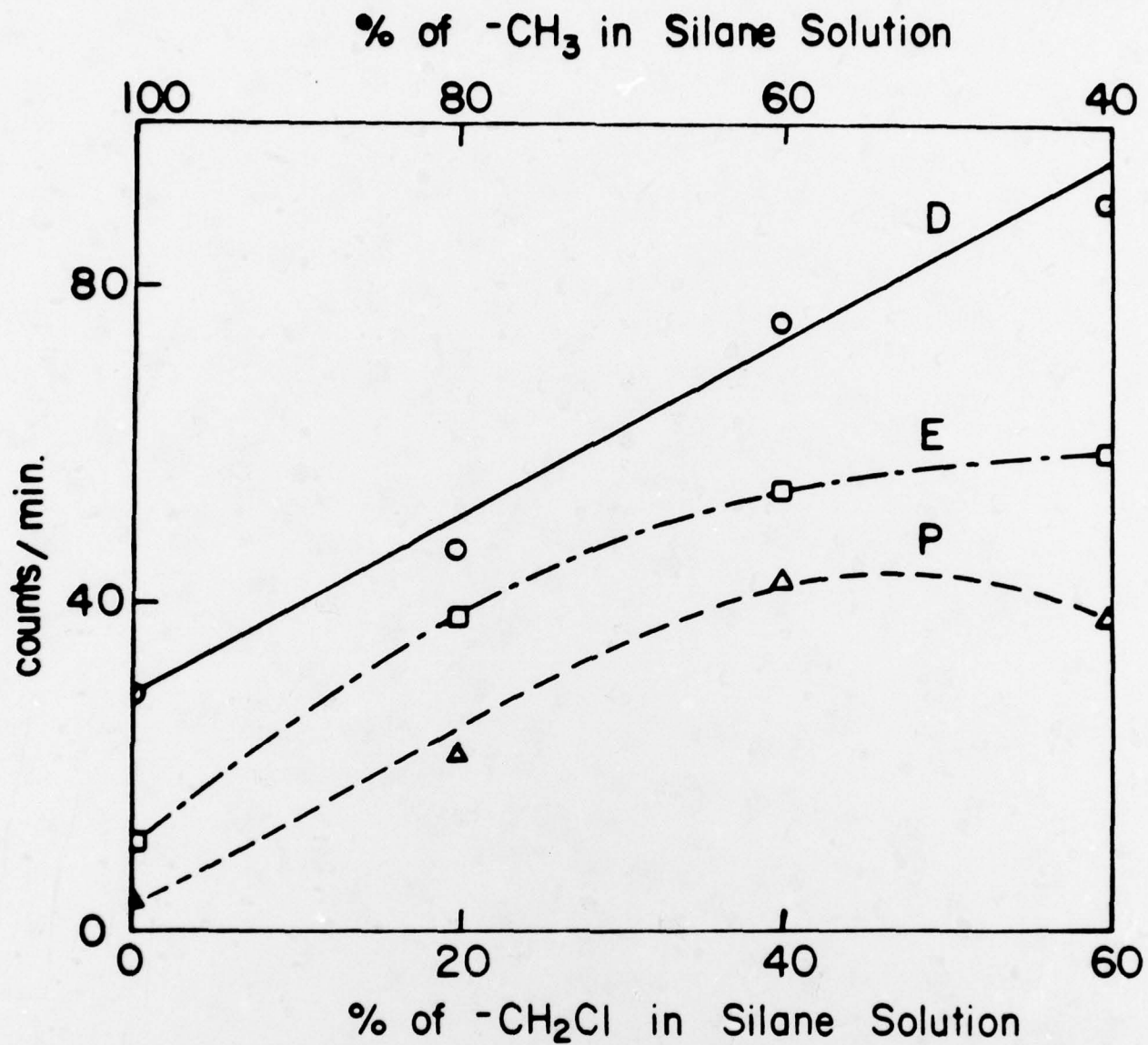

Figure 6: Variation of radioactivity after steps D and E of Scheme I and after peeling as a function of the percentages given in Fig. 5.

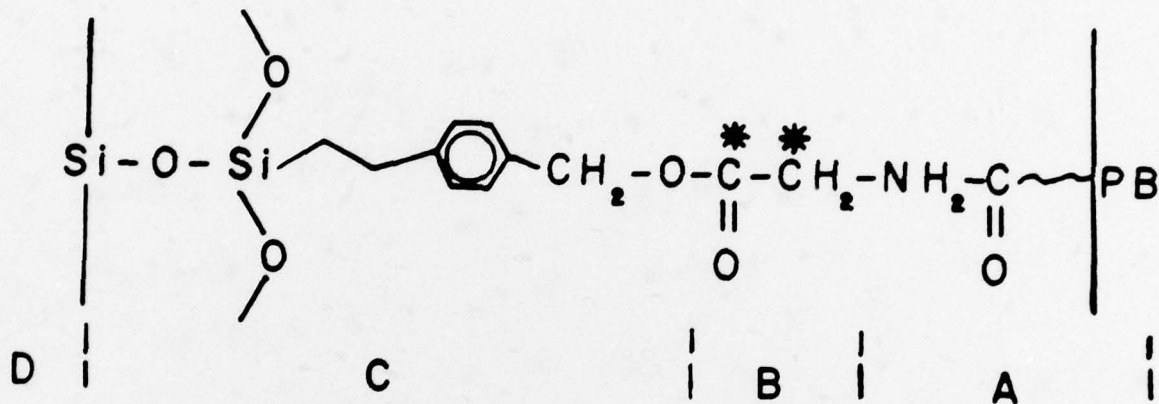

Figure 7: Regions in which failure can occur

DISTRIBUTION LIST

	<u>No. Copies</u>
Office of Naval Research Code 473 Arlington, VA 22217 Attn: Dr. Miller	10
Office of Naval Research Branch Office 1030 East Green Street Pasadena, CA 91106 Attn: Dr. R. Marcus	1
Office of Naval Research Branch Office 536 S. Clark Street Chicago, IL 60605 Attn: Dr. J. Smith	1
Defense Documentation Center Bldg. 5 Cameron Station Alexandria, VA 22314	12
Office of Naval Research Branch Office 495 Summer Street Boston, MA 02210 Attn: Dr. L. H. Peebles	1
Office of Naval Research Resident Representative The Ohio State University Research Center 1314 Kinnear Road Columbus, Ohio 43212	1
U. S. Naval Research Laboratory Code 2627 Washington, DC 20375	6

Naval Research Laboratory 1
Code 6100
Washington, DC 20375

Naval Air Systems Command 1
Code 440
Washington, DC 20360
Attn: Dr. H. Rosenwasser

Naval Sea Systems Command 1
SEA-0331
Washington, DC 20362
Attn: Mr. J. Murrin

Naval Sea Systems Command 1
SEA-0332
Washington, DC 20362
Attn: Dr. A. Amster

Naval Surface Weapons Center 1
Research and Technology Dept.-WR
Silver Spring, MD 20910

Naval Weapons Center 1
Research Department
Code 60
China Lake, CA 93555

Naval Weapons Center 3
Code 608
China Lake, CA 93555
Attn: Ronald L. Derr

Air Force Office of Scientific Research 1
Directorate of Aerospace Sciences
Bolling Air Force Base
Washington, DC 20332

Air Force Office of Scientific Research 1
Directorate of Chemical Sciences
Bolling Air Force Base
Washington, DC 20332

Air Force Office of Scientific Research 1
Directorate of Physics
Bolling Air Force Base
Washington, DC 20332

Arnold Adicoff, Code 6058 Naval Weapons Center Research Dept. China Lake, CA 93555	(1)	R. C. Corley AFRPL/RCS Edwards, CA 93523	(1)
B. J. Alley AMSMI-RKC US AMC Redstone Arsenal, AL 35809	(1)	D. B. Davis Thiokol/Wasatch Division P.O. Box 524 Brigham City, UT 84302	(1)
Dr. S. John Bennett Thiokol Corp. Brigham City, UT 84302	(1)	John H. DeRyke Chemical Systems Div/United Technologies P.O. Box 358 Sunnyvale, CA 94088	(1)
Robert A. Biggers AFRPL/MKPB Edwards, CA 93523	(1)	James Dietz MS 243 Thiokol Corp/Wasatch Division P.O. Box 524 Brigham City, UT 84302	(1)
John E. Branigan AFRPL/RPRP Edwards, CA 93523	(1)	A. J. Dimilo Propellant R&D Aerojet General Corp. P.O. Box 15847 Sacramento, CA 95813	(1)
G. W. Burdette Code 753 Naval Weapons Center China Lake, CA 93555	(1)	R. J. DuBois Hercules Inc/Bacchus Works P.O. Box 98 - MS 8131 Magna, UT 84044	(1)
Dr. E. A. Burns TRW Systems Bldg 0-1 Room 2020 One Space Park Redondo Beach, CA 90278	(1)	Hiram W. H. Dykes AMSMI-RKC US AMC Redstone Arsenal, AL 35809	(1)
C. D. Chandler Hercules, Inc. Radford Army Ammunition Plant Radford, VA 24141	(1)	Dr. W. David English TRW Systems Bldg 0-1, Room 2020 One Space Park Redondo Beach, CA 90278	(1)
John E. Christian Hercules/ABL P.O. Box 210 Cuberland, MD 21502	(1)	D. M. French Code 6012 Naval Ordnance Station Indian Head, MD 20640	(1)
Albert Z. Conner Hercules, Inc. Research Center Wilmington, DE 19899	(1)	W. A. Gogis, Fleet Support Naval Ordnance Station Indian Head, MD 20640	(1)

Larry H. Gordon MS 500-209 NASA/Lewis Research Center 21000 Brookpark Road Cleveland, OH 44135	(1)	H. E. Marsh, 125/159 Jet Propulsion Laboratory 4800 Oak Grove Drive Pasadena, CA 91103	(1)
Phillip H. Graham Atlantic Research Corp. 7511 Wellington Road Gainesville, VA 22065	(1)	James D. Martin Atlantic Research Corp. 5390 Cherokee Avenue Alexandria, VA 22314	(7)
P. J. Klaas Aerojet Solid Propulsion Co. P.O. Box 13400 Sacramento, CA 95813	(1)	United Aircraft Corp/UTS J. C. Matthews, Quality Control Lab. 1050 E. Arques Ave. Sunnyvale, CA 94088	(7)
David Knoop Olin-Energy Systems Div. Badger Army Ammunition Plant Baraboo, WI 53913	(1)	John O. McCary Olin Corp - P.O. Box 222 St. Marks, FL 32355	(1)
Joseph A. Kohlbeck, 114B Hercules, Inc. MS 8115 Bacchus Works, P. O. Box 98 Magna, UT 84044	(1)	Fred H. Meyers, Jr. MAAA AFML, ASSB WPAFB, OH 45433	(1)
J. L. Koury AFRPL/MKMB Edwards, CA 93523	(1)	Roy R. Miller Hercules/ABL P.O. Box 210 Cumberland, MD 21502	(1)
Seymour Lober Dept. of the Army Picatinny Arsenal, SMUPA-ADEP-2 Dover, NJ 07801	(1)	A. H. Muenker Esso Research & Engineering P.O. Box 8 Linden, NJ 07036	(1)
R. D. Law Thiokol/Wasatch Division Box 524 Brigham City, UT 84302	(1)	J. T. Nakamura AFRPL/DYCA Edwards, CA 93523	(1)
Dr. A. R. Lawrence Code RM Naval Ordnance Station Indian Head, MD 20640	(1)	William Oetjen Thiokol Corp/Quality Dept. Huntsville, AL 35807	(1)
Nathan M. Liszt SARPA-FR-G-R Bldg. 1625 Picatinny Arsenal Feltman Res. Lab. Dover, NJ 07801	(1)	J. M. Robinson Autonetics - Dept 646-20, Bldg. 69 3370 Miraloma Ave. Anaheim, CA 92803	(1)
		W. Roe RPMCB AFRPL Edwards, CA 93523	(1)

Dr. R. E. Rogers Thiokol Corp/Development Section Huntsville, AL 35807	(1)	U.S. Army Research Office Chemistry Division P.O. Box 12211 Research Triangle Park, NC 27709	(1)
T. P. Rudy, R & AT United Technology Center P.O. Box 358 Sunnyvale, CA 94088	(1)	U.S. Army Research Office Physics Division P.O. Box 12211 Research Triangle Park, NC 27709	(1)
W. Selig Lawrence Radiation Lab - L-404 P.O. Box 808 Livermore, CA 94550	(1)	DR. T. J. Reinhart, Jr. Chief Composite and Fibrous Materials Branch Nonmetallic Materials Division Air Force Materials Laboratory (AFSC) Wright-Patterson Air Force Base, Ohio 45433	(1)
E. H. Steger Susquehanna Corp. Atlantic Research Group Chem. & Phys. Prop. Lab. P.O. Box 38 Gainesville, VA 22065	(1)		
Donald H. Stewart, Code 4539 Properties Analysis Branch Naval Weapons Center China Lake, CA 93555	(1)		
Anthony Taschler Picatinny Arsenal Products Assurance Dir. SMUPA-QA-A-P Dover, NJ 07801	(1)		
R. J. Thiede Olin-Energy Systems Div. Badger Army Ammunition Plant Baraboo, WI 53913	(1)		
Lewis R. Toth CIT-JPL 4800 Oak Grove Drive Pasadena, CA 91103	(1)		
J. Tuono Code 50210 Naval Ordnance Station Indian Head, MD 20640	(1)		
Norman VanderHyde AFRPL/MKPC Edwards, CA 93523	(1)		