

AD-A060 937

CALIFORNIA UNIV LOS ANGELES INST OF GEOPHYSICS AND --ETC F/G 8/14
FABRICATION AND TEST REPORT.(U)

APR 78 R C SNARE
AFGL-TR-78-0112

F19628-76-C-0043
NL

UNCLASSIFIED

1 of 1
AD
A060 937



END
DATE
FILMED
1-79
DOC

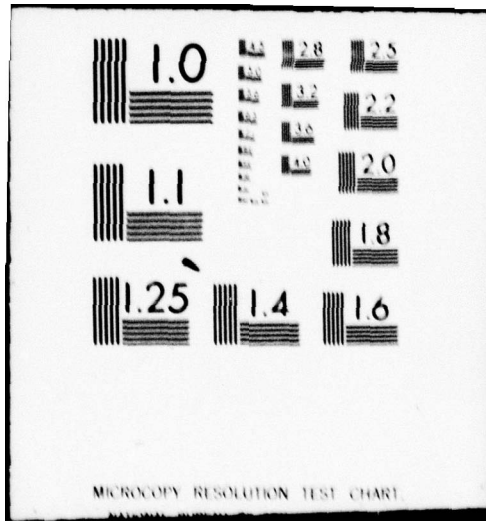

MICROCOPY RESOLUTION TEST CHART

14

AFGL-TR-78-0112

LEVEL

12

SC

6 Fabrication and Test Report.

by

10 Robert C. Snare

Institute of Geophysics and Planetary Physics
University of California
Los Angeles, California 90024

ADA060937

9 Final ~~Contract~~ Reports,
1 January 1976-31 December 1977,

11 16 Apr 78

12 29p.

16 760L

17 08

Approved for public release, distribution unlimited

15 F19628-76-C-0043

AIR FORCE GEOPHYSICS LABORATORY
AIR FORCE SYSTEMS COMMAND
UNITED STATES AIR FORCE
HANSCOM AFB, MASSACHUSETTS 01731

DDC
NOV 7 1978
INSTITUTE

DDC FILE COPY

181 550

JOB

78 11 02 002

Qualified requestors may obtain additional copies from the Defense Documentation Center. All others should apply to the National Technical Information Service.

Unclassified

1

SECURITY CLASSIFICATION OF THIS PAGE (When Data Entered)

REPORT DOCUMENTATION PAGE		READ INSTRUCTIONS BEFORE COMPLETING FORM
1. REPORT NUMBER AFGL-TR-78-0112 ✓	2. GOVT ACCESSION NO.	3. RECIPIENT'S CATALOG NUMBER
4. TITLE (and Subtitle) Fabrication and Test Report		5. TYPE OF REPORT & PERIOD COVERED Final Report 1 January 1976-31 December 1977
		6. PERFORMING ORG. REPORT NUMBER None
7. AUTHOR(s) Robert C. Snare		8. CONTRACT OR GRANT NUMBER(s) F19628-76-C-0043
9. PERFORMING ORGANIZATION NAME AND ADDRESS Institute of Geophysics and Planetary Physics University of California Los Angeles, California 90024		10. PROGRAM ELEMENT, PROJECT, TASK AREA & WORK UNIT NUMBERS 62101F 76010801
11. CONTROLLING OFFICE NAME AND ADDRESS Air Force Geophysics Laboratory (PH) Hanscom AFB, MA 07131 Monitor/R.O. Hutchinson (PHG)		12. REPORT DATE 16 April 1978
14. MONITORING AGENCY NAME & ADDRESS (if different from Controlling Office)		13. NUMBER OF PAGES 28
		16. SECURITY CLASS. (of this report) Unclassified
15. DISTRIBUTION STATEMENT (of this Report) A-Approved for public release; distribution unlimited		15a. DECLASSIFICATION/DOWNGRADING SCHEDULE
17. DISTRIBUTION STATEMENT (of the abstract entered in Block 20, if different from Report)		
18. SUPPLEMENTARY NOTES		
19. KEY WORDS (Continue on reverse side if necessary and identify by block number) Data collection, magnetometers		
20. ABSTRACT (Continue on reverse side if necessary and identify by block number) The modification fabrication and test of magnetometers and digital equipment is described.		

DD FORM 1473
1 JAN 73

EDITION OF 1 NOV 68 IS OBSOLETE
S/N 0102-LP-014-0001

Unclassified

SECURITY CLASSIFICATION OF THIS PAGE (When Data Entered)

78 11 02 002

Project Personnel

Robert L. McPherron

F.R. George

Joseph D. Mears

Robert C. Snare

ACCESSION for		
NTIS	White Section <input checked="" type="checkbox"/>	
DDC	Buff Section <input type="checkbox"/>	
UNANNOUNCED	<input type="checkbox"/>	
JUSTIFICATION		
BY		
DISTRIBUTION/AVAILABILITY CODES		
Dist.	SPECIAL	
A		

Table of Contents

	Page
1. Contract objectives	5
2. Fluxgate magnetometer fabrication	5
3. Data collection digital equipment fabrication	5
4. Magnetometer tests	7
REFERENCES	28

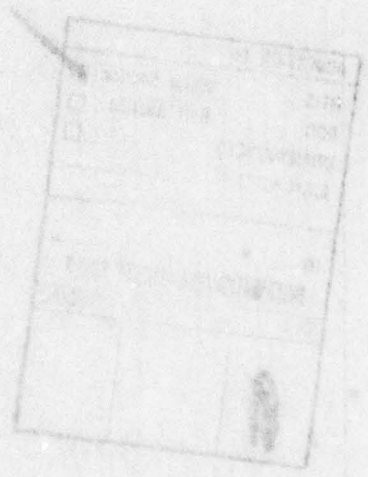

1. Contract Objectives

The purpose of the contract was to fabricate additional equipment for the Air Force Geophysics Laboratory magnetic data collection system. The system was designed and original equipment was fabricated by UCLA under contract F19628-72-C-0175.

The contract requires design studies and fabrication of three fluxgate magnetometers and two data collection platform digital systems.

2. Fluxgate Magnetometers Fabrication

The fluxgate magnetometers followed the design of Power [1] with modifications to reduce digital noise on the analog outputs of the magnetometer. The changes included better power supply decoupling on the drive boards, reduced frequency response of the summing amplifiers on the second harmonic boards and the design of a new display logic board.

The redesigned display logic board (figure 1) uses fewer digital logic circuits that require less power and introduce less noise into the magnetometer circuits.

The sensor cables were fabricated from specially ordered wire having a water proof outer cover. Three cables fabricated for the new magnetometers and six additional cables were fabricated for retrofitting the magnetometers built under the earlier contract.

A new sensor assembly was fabricated for magnetometer SN001 and the unit redesignated SN001A. This sensor assembly was designed to minimize cross axis sensing between the three orthogonal sensors in the assembly.

3. Data Collection Digital Equipment Fabrication

The data collection platform digital equipments were fabricated to the original design of Ioannidis et al. [2]. The two units incorporated analog-to-digital

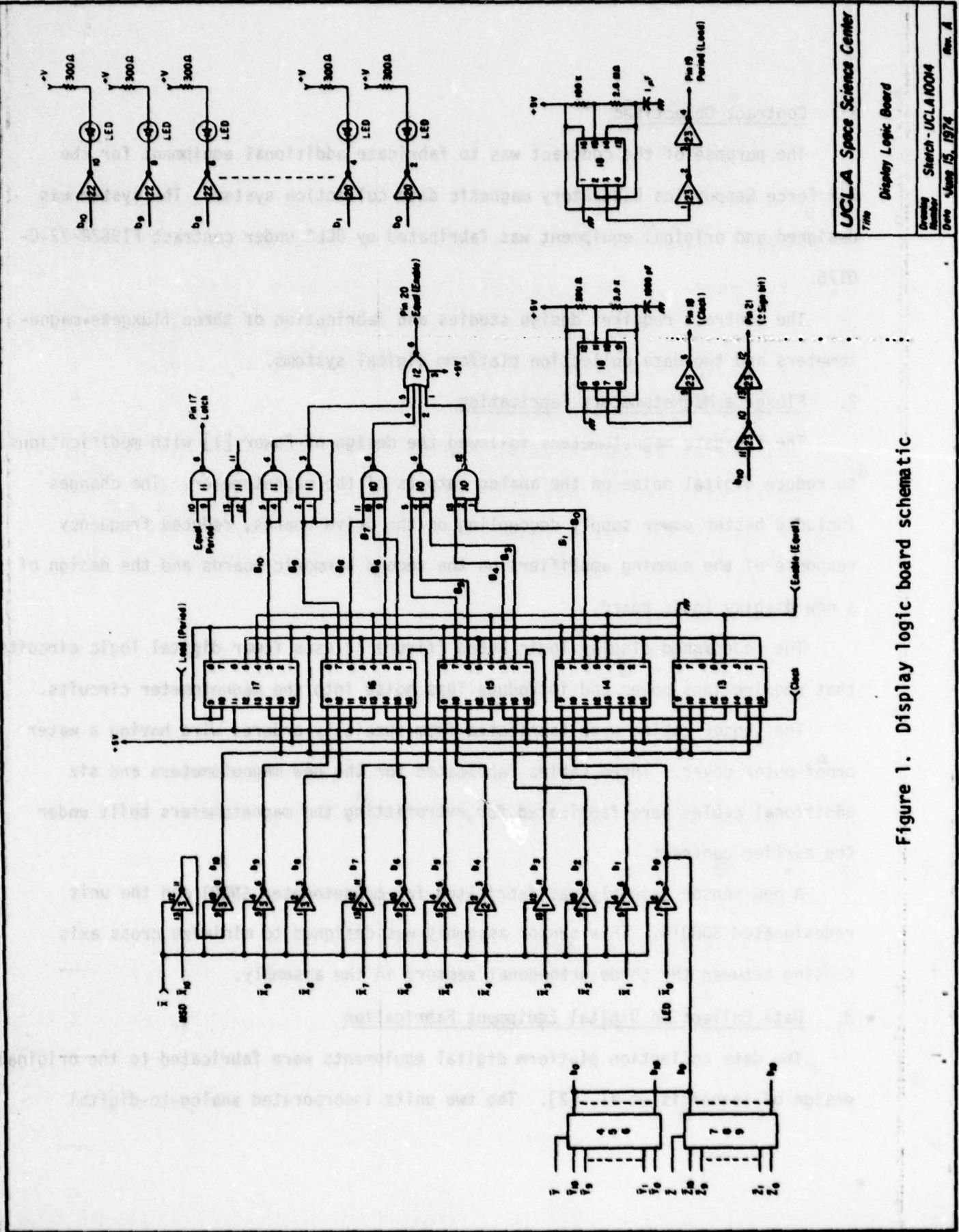

Figure 1. Display logic board schematic

UCLA Space Science Center	
7/76	Display Logic Board
Drawing Number	Sketch - UCLA 10014
Date	Aug 15, 1974
	Rev. A

converters manufactured by Tustin Electronics of Irvine, California. The two units are fully compatible and interchangeable with equipment fabricated under the earlier contract.

4. Magnetometer Tests

The final tests of the magnetometers were conducted in two parts. At NASA Ames Research Center the orthogonality of the sensors and the scale factor were tested. In the laboratory at UCLA the relative temperature dependence of the sensor assembly and the electronics were tested.

The test procedure for the orthogonality and scale factor tests and the data for magnetometers SN007, SN008, SN009 and SN001A are shown in Table I. These tests were performed at NASA Ames Research Center because of the good quality of the magnetic test facility. The facility has a 12 foot cubical coil system driven by precision current sources. The alignment and the scale factors of the system are periodically checked.

The temperature test procedures and data are shown in Table II and Table III. This test demonstrates the relative temperature dependence of the system. With the limited size of the coils in the UCLA magnetic test facility, 30 inch in diameter, it is difficult to make three axis measurements approaching absolute accuracy.

The sensor temperature test is performed in two runs, one hot and one cold. Because the sensor is moved between the two runs of the test the data at room temperature does not close for some cases. This is because the sensor is not aligned exactly to the same position within the coil system between the two runs.

Magnetometer Test Outline

1. Sensor alignment checks
 - 1.1 Place sensor assembly in the center of the coil system with the X-axis pointing north. Adjust leveling screws to zero the level bubbles on the sensor.
 - 1.2 Adjust the field such that each magnetometer reads zero.
 - 1.3 Increase the E-W field to $\sim 10,000\gamma$ and rotate the sensor till the X-axis reads zero. Relevel the sensor if needed and repeat the X zero test. The sensor assembly is now level with the X sensor aligned with the N-S coil. Remove the $10,000\gamma$ E-W field.
 - 1.4 Adjust the field such that each magnetometer axis reads zero.
 - 1.5 Increase the N-S field to $10,000\gamma$ and record the Y and Z magnetometer axes. Remove the field.
 - 1.6 Increase the vertical field to $10,000\gamma$ and record the X and Y magnetometers. Remove the field.
 - 1.7 Increase the E-W field to $10,000\gamma$. Record the X and Z axes magnetometer. Remove the field.
 - 1.8 Adjust the field such that the X magnetometer reads zero. Apply the following calibrate fields in the N-S axis, $+40,000\gamma$.
 - 1.9 Repeat the values of 1.8 for the vertical coils and record the Z magnetometers.

- 1.10 Rotate the sensor 90° in the horizontal plane using the technique of 1.3 to align the Y axis to the N-S coil.
- 1.11 Repeat the values of 1.8 for the N-S coils recording the Y-axis.
- 1.12 Stand the sensor on its + Y edge (the cable side). Align the X-axis to north by zeroing X with a large E-W field.
- 1.13 Increase the vertical field to $10,000\gamma$ and record the X magnetometer.

24 Aug 77

10

Data Sheet

1.5.
$$Y = \frac{-24}{10,000} \gamma \quad S 10878$$

$$Z = \frac{+15}{10,000} \gamma$$

$$\theta = \sin^{-1} \frac{Y}{10,000} = \underline{-7.6 \text{ min}}$$

θ = Y sensor alignment error projected into X-Y plane

$$\theta = \sin^{-1} \frac{Z}{10,000} = \underline{4.7 \text{ min}}$$

θ = Z sensor alignment error projected into X-Z plane

1.6.
$$X = \frac{-13}{10,000} \gamma \quad \downarrow 9993$$

$$Y = \frac{-6}{10,000} \gamma$$

$$\delta = \sin^{-1} \frac{X}{10,000} = \underline{4.5 \text{ min}}$$

δ = X sensor alignment error projected into X-Z plane

$$\tau = \sin^{-1} \frac{Y}{10,000} = \underline{2.1 \text{ min}}$$

τ = Y sensor alignment error projected into Y-Z plane

1.7.
$$X = \frac{+9}{10,000} \gamma \quad E 26470$$

$$Z = \frac{+42}{10,000} \gamma$$

$$\gamma = \sin^{-1} \frac{X}{10,000} = \underline{1.2 \text{ min}}$$

γ = X sensor alignment error in X-Y plane

$$\epsilon = \sin^{-1} \frac{Z}{10,000} = \underline{5.4 \text{ min}}$$

ϵ = Z sensor alignment error in X-Z plane

1.8 N-S Calibrate Field X Magnetometer
 +40,000γ 21763.6 21763.6 γ
 -40,000γ _____ γ

1.9 Vertical Field Z Magnetometer
 +40,000γ 43506.7 43506.7 γ
 -40,000γ -43538 -43538 γ

1.11 N-S Field Y Magnetometer
 +40,000γ +21763.6 +21763.6 γ
 -40,000γ _____ γ

1.13 X = +26 _____ γ ↓ 10,000 γ

$$\rho = \sin^{-1} \frac{X}{10,000} = \underline{\hspace{2cm}} 8.9 \text{ min}$$

ρ = alignment error of X sensor from baseplate edge
 in X-Y plane

Data Sheet SN007

1.5. $Y = \frac{+29}{10,000} Y$

$Z = \frac{+22}{10,000} Y$

NS = 108008 S

$Y_0 = 1.2 \quad Z_0 = +2.5$

$\theta = \sin^{-1} \frac{Y}{10,000} = \underline{0.15^\circ}$

 θ = Y sensor alignment error projected into X-Y plane

$\phi = \sin^{-1} \frac{Z}{10,000} = \underline{0.12^\circ}$

 ϕ = Z sensor alignment error projected into X-Z plane

1.6. $X = \frac{-59}{10,000} Y$

$Y = \frac{-9.8}{10,000} Y$

V = 104908 DN

$\delta = \sin^{-1} \frac{X}{10,000} = \underline{0.32}$

 δ = X sensor alignment error projected into X-Z plane

$\tau = \sin^{-1} \frac{Y}{10,000} = \underline{0.03}$

 τ = Y sensor alignment error projected into Y-Z plane

1.7. $X = \frac{+3}{10,000} Y$

$Z = \frac{+28}{10,000} Y$

$X_0 = +4.7$

EW = 105408 E

$\gamma = \sin^{-1} \frac{X}{10,000} = \underline{0.02^\circ}$

 γ = X sensor alignment error in X-Y plane

$\xi = \sin^{-1} \frac{Z}{10,000} = \underline{0.15^\circ}$

 ξ = Z sensor alignment error in X-Z plane

1.8 N-S Calibrate Field

~~+40,000~~ +217498

X Magnetometer

+21749 Y

1.9 Vertical Field

~~+40,000~~ +43501

Z Magnetometer

+43501 Y

1.11 N-S Field

~~+40,000~~ +217498

Y Magnetometer

+21749 Y

1.13

X = +163 Y $X_0 = -4.28$ 1040080P

$$\rho = \sin^{-1} \frac{X}{10,000} = \underline{0.8895^\circ}$$

ρ = alignment error of X sensor from baseplate edge
in X-Y plane

$$1.5 \quad Y = \frac{-51}{10,000} Y \quad Y_0 = -12$$

$$Z = \frac{150}{10,000} Y \quad Z_0 = -23$$

1074485

$$\theta = \sin^{-1} \frac{Y}{10,000} = \underline{.336^\circ}$$

θ = Y sensor alignment error projected into X-Y plane

$$\phi = \sin^{-1} \frac{Z}{10,000} = \underline{.144^\circ}$$

ϕ = Z sensor alignment error projected into X-Z plane

$$1.6 \quad X = \frac{-72}{10,000} Y \quad X_0 = -16$$

$$Y = \frac{-56}{10,000} Y \quad Y_0 = -16$$

991880P

$$\delta = \sin^{-1} \frac{X}{10,000} = \underline{.381^\circ}$$

δ = X sensor alignment error projected into X-Z plane

$$\tau = \sin^{-1} \frac{Y}{10,000} = \underline{.231^\circ}$$

τ = Y sensor alignment error projected into Y-Z plane

$$1.7 \quad X = \frac{-16}{10,000} Y \quad X_0 = -17$$

$$Z = \frac{-52}{10,000} Y \quad Z_0 = -26$$

107375E

$$\gamma = \sin^{-1} \frac{X}{10,000} = \underline{.091^\circ}$$

γ = X sensor alignment error in X-Y plane

$$\xi = \sin^{-1} \frac{Z}{10,000} = \underline{.139^\circ}$$

ξ = Z sensor alignment error in X-Z plane

1.8 N-S Calibrate Field

X Magnetometer

+40,000γ +43529γ

+ 43528 γ

1.9 Vertical Field

Z Magnetometer

+40,000γ 43530

+ 43531 γ

1.11 N-S Field

Y Magnetometer

+40,000γ 43532

43528 γ1.13 X = -128 γ $x_0 = -10$ 100058 up.

$$\rho = \sin^{-1} \frac{X}{10,000} = \underline{0.675^\circ}$$

ρ = alignment error of X sensor from baseplate edge
in X-Y plane

Data Sheet

$$1.5. \quad Y = \frac{+19}{10,000} Y_0 - 12 \quad 1092085$$

$$Z = \frac{-43}{10,000} Z_0 - 4$$

$$\theta = \sin^{-1} \frac{Y}{10,000} = \underline{.110^\circ}$$

θ = Y sensor alignment error projected into X-Y plane

$$\phi = \sin^{-1} \frac{Z}{10,000} = \underline{.205^\circ}$$

ϕ = Z sensor alignment error projected into X-Z plane

$$1.6 \quad X = \frac{-77}{10,000} X_0 + 1 \quad 9935 \quad \delta_{UP}$$

$$Y = \frac{-82}{10,000} Y_0 - 12$$

$$\delta = \sin^{-1} \frac{X}{10,000} = \underline{.449}$$

δ = X sensor alignment error projected into X-Z plane

$$\tau = \sin^{-1} \frac{Y}{10,000} = \underline{.403}$$

τ = Y sensor alignment error projected into Y-Z plane

$$1.7 \quad X = \frac{+5}{10,000} X_0 + 1 \quad 10453. \quad \delta_E$$

$$Z = \frac{-9}{10,000} Z_0 - 3$$

$$\gamma = \sin^{-1} \frac{X}{10,000} = \underline{.022^\circ}$$

γ = X sensor alignment error in X-Y plane

$$\epsilon = \sin^{-1} \frac{Z}{10,000} = \underline{.033^\circ}$$

ϵ = Z sensor alignment error in X-Z plane

1.8 N-S Calibrate Field

+40,000γ +43530.8

X Magnetometer

43530.8 γ $X_0 = -4$

1.9 Vertical Field

+40,000γ 43530.8

Z Magnetometer

43532. γ

1.11 N-S Field

+40,000γ +43530.8

Y Magnetometer

43531. γ1.13 $X = \frac{+292 + 96}{10,000} \gamma$

997580P

$$\rho = \sin^{-1} \frac{X}{10,000} = \underline{.557^\circ}$$

$\rho =$ alignment error of X¹ sensor from baseplate edge
in X-Y plane

Table II

Electronic Temperature Test

1. Align the sensor assembly in the coil system.
2. Install the electronics in the temperature chamber.
3. Adjust the field in each coil to zero the magnetometer.
4. Set the temperature control to the desired temperature.
5. After temperature stabilization apply plus and minus 10,000 γ to each axis in succession.
6. Read and record the output of each axis of the magnetometer.

SN008 Electronics Temp Test

Te	X	Y	Z
53°C	+10639 _γ	+11475 _γ	+9971 _γ
	-10631	-11469	-9971
40	+10638	+11470	+9970
	-10631	-11467	-9969
34	+10637	+11469	+9967
	-10630	-11464	-9968
28	+10637	+11466	+9968
	-10630	-11463	-9966
23	+10636	+11464	+9967
	-10629	-11461	-9966
17.5	+10637	+11461	+9964
	-10629	-11457	-9964
12.5	+10637	+11459	+9961
	-10630	-11458	-9963

SNO08 Electronics Temp Test

Te	X	Y	Z
+15°C	+10124 _γ	+9858 _γ	+9886 _γ
	-10124	-9858	-9884
+20	+10124	+9858	+9887
	-10123	-9859	-9884
+24	+10123	+9859	+9889
	-10125	-9860	-9886
+29	+10124	+9860	+9890
	-10127	-9861	-9888
+34	+10125	+9861	+9892
	-10128	-9863	-9889
+39	+10126	+9863	+9893
	-10126	-9863	-9889
+43	+10124	+9864	+9895
	-10125	-9864	-9892
+49	+10123	+9865	+9896
	-10123	-9865	-9891
+54	+10121	+9865	+9897
	-10122	-9865	-9893

SN009 Electronics Temp Test

Te	X	Y	Z
+17°C	+10124 _γ	+9854 _γ	+9878 _γ
	-10123	-9850	-9876
+23	+10124	+9855	+9882
	-10123	-9851	-9878
+27	+10125	+9856	+9883
	-10125	-9852	-9881
+31	+10127	+9856	+9884
	-10126	-9853	-9881
+36	+10128	+9858	+9886
	-10126	-9854	-9883
+38	+10130	+9859	+9888
	-10128	-9856	-9884
+47	+10130	+9859	+9891
	-10129	-9856	-9886

Table III

Sensor Temperature Test

1. Place the sensor assembly in the temperature chamber.
2. Heat the sensor assembly at $+60^{\circ}\text{C}$ for 8 hours.
3. Remove the sensor assembly and install it in the coil system.
4. At selected intervals apply plus and minus $10,000\gamma$ to each axis in succession and read the magnetometer.
5. Repeat the above process after cooling the sensor at -30°C for 8 hours.

SN007 Sensor Temp Test

Ts	X	Y	Z
-28°C	+10027 _γ	+10685 _γ	+11513 _γ
	-10017	-10683	-11515
-10	+10025	+10693	+11520
	-10015	-10693	-11517
0	+10025	+10701	+11523
	-10020	-10699	-11523
+7	+10024	+10706	+11525
	-10019	-10702	-11525
+10	+10027	+10707	+11526
	-10017	-10702	-11526
+14	+10024	+10708	+11527
	-10018	-10706	-11527
+16	+10027	+10709	+11527
	-10018	-100707	-11527
+18	+10023	+10709	+11527
	-10021	-10708	-11528
+23	+10023	+10708	+11526
	-10618	-10705	-11525

Ts	X	Y	Z
+26	+10025 _γ	+10709 _γ	+11527 _γ
	-10015	-10706	-11525
+28	+10026	+10710	+11527
	-10014	-10707	-11526
+31	+10025	+10710	+11528
	-10015	-10709	-11526
+35	+10025	+10712	+11529
	-10015	-10710	-11527
+44	+10024	+10714	+11530
	-10016	-10711	-11529
+50	+10024	+10715	+11531
	-10014	-10712	-11530

SN008 Sensor Temp Test

Ts	X	Y	Z
-28°C	+10127 _γ	+9853 _γ	+9887 _γ
	-10103	-9855	-9883
-10	+10116	+9859	+9894
	-10126	-9860	-9890
-1	+10117	+9863	+9895
	-10120	-9863	-9893
+7	+10121	+9863	+9898
	-10120	-9866	-9892
+11	+10122	+9865	+9898
	-10124	-9865	-9895
+13	+10119	+9864	+9897
	-10124	-9867	-9895
+16	+10123	+9865	+9897
	-10123	-9866	-9895
+18	+10124	+9865	+9899
	-10125	-9866	-9893
+19	+10124	+9866	+9899
	-10122	-9866	-9893

Ts	X	Y	Z
+23°C	+10124 _γ	+9861 _γ	+9894 _γ
	-10124	-9863	-9891
+24	+10124	+9862	+9895
	-10125	-9862	-9891
+26	+10121	+9862	+9894
	-10126	-9863	-9891
+28	+10126	+9862	+9896
	-10125	-9864	-9891
+32	+10122	+9864	+9896
	-10125	-9864	-9893
+37	+10122	+9864	+9897
	-10126	-9865	-9894
+44	+10125	+9865	+9898
	-10124	-9866	-9895
+49	+10129	+9864	+9898
	-10131	-9865	-9895

SN009 Sensor Temp Test

Ts	X	Y	Z
-13°C	+10131 γ	+9848 γ	+9883 γ
	-10129	-9845	-9878
-2	+10128	+9856	+9885
	-10127	-9852	-9884
+6	+10127	+9857	+9888
	-10126	-9853	-9883
+12	+10127	+9861	+9888
	-10127	-9856	-9885
+15	+10128	+9861	+9890
	-10128	-9857	-9884
+18	+10127	+9861	+9889
	-10127	-9858	-9886
+19	+10128	+9862	+9890
	-10126	-9858	-9886
+25	+10126	+9859	+9886
	-10125	-9855	-9882
+27	+10127	+8960	+9886
	-10125	-8956	-9882

Ts	X	Y	Z
+29	+10127 γ	+9861 γ	+9887 γ
	-10126	-9856	-9883
+32	+10126	+9861	+9887
	-10125	-9857	-9884
+37	+10127	+9862	+9888
	-10124	-9858	-9883
+45	+10127	+9864	+9889
	-10124	-9859	-9885
+52	+10127	+9864	+9890
	-10125	-9860	-9884

References

- [1] J.J. Power, A digital offset fluxgate magnetometer for use in remote geomagnetic observatories, AFCRL-TR-73-0603, 1973.
- [2] G.A. Ioannidis, J.D. Means, F.R. George and R.C. Snare, A multistation sampled data acquisition and transmission system for studies of ULF waves, AFCRL-TR-75-0173, 1975.