

AD-A060 946

MITRE CORP BEDFORD MASS

F/G 17/2.1

DRAFT PERFORMANCE SPECIFICATION FOR USAF SHORT RANGE WIDEBAND R--ETC(U)

OCT 78 H S AUERBACH, R F HAZEL, B B MACHLER

F19628-78-C-0001

UNCLASSIFIED

MTR-3630

ESD-TR-78-172

NL

| of |  
AD  
A060 946

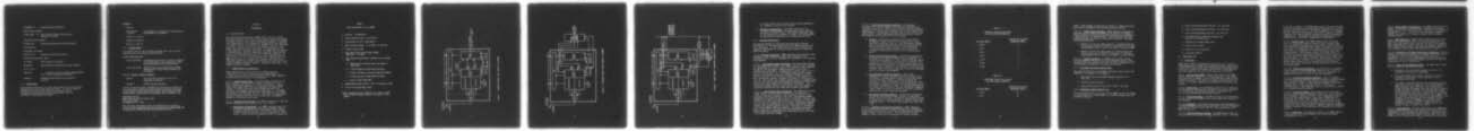

END  
DATE  
FILMED  
2-79  
DDC

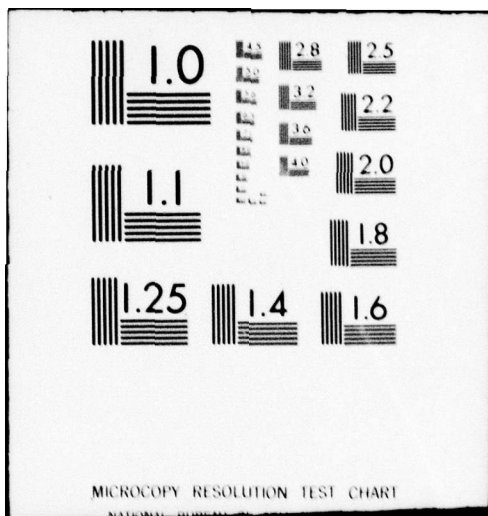

MICROCOPY RESOLUTION TEST CHART

AD A060946

DDC FILE COPY

# LEVEL

15

78 19  
ESD-TR-78-172

14  
MTR-3630

DRAFT PERFORMANCE SPECIFICATION  
FOR USAF SHORT RANGE WIDEBAND RADIO  
AN/GRC-XXX

BY H.S./AUERBACH, R.F./HAZEL AND B.B./MACHLER

11  
OCTOBER 1978

9 Technical rept.

Prepared for 1258p.

DEPUTY FOR CONTROL AND COMMUNICATIONS SYSTEMS  
ELECTRONIC SYSTEMS DIVISION  
AIR FORCE SYSTEMS COMMAND  
UNITED STATES AIR FORCE  
Hanscom Air Force Base, Massachusetts



DDC  
RECEIVED  
NOV 8 1978  
D

Approved for public release;  
distribution unlimited.

Project No. 6900  
Prepared by  
THE MITRE CORPORATION  
Bedford, Massachusetts  
Contract No. F19628-78-C-0001

235050

78 10 27 042 LB

When U.S. Government drawings, specifications, or other data are used for any purpose other than a definitely related government procurement operation, the government thereby incurs no responsibility nor any obligation whatsoever; and the fact that the government may have formulated, furnished, or in any way supplied the said drawings, specifications, or other data is not to be regarded by implication or otherwise, as in any manner licensing the holder or any other person or corporation, or conveying any rights or permission to manufacture, use, or sell any patented invention that may in any way be related thereto.

Do not return this copy. Retain or destroy.

#### REVIEW AND APPROVAL

This technical report has been reviewed and is approved for publication.



R. E. Beery  
Colonel, USAF  
Director, Combat Theater Communications  
Program Office  
Deputy for Control and Communications Systems

**UNCLASSIFIED**

SECURITY CLASSIFICATION OF THIS PAGE (When Data Entered)

REPORT DOCUMENTATION PAGE		READ INSTRUCTIONS BEFORE COMPLETING FORM
1. REPORT NUMBER ESD-TR-78-172 ✓	2. GOVT ACCESSION NO.	3. RECIPIENT'S CATALOG NUMBER
4. TITLE (and Subtitle) DRAFT PERFORMANCE SPECIFICATION FOR USAF SHORT RANGE WIDEBAND RADIC, AN/GRC-XXX		5. TYPE OF REPORT & PERIOD COVERED
		6. PERFORMING ORG. REPORT NUMBER MTR-3630
7. AUTHOR(s) H. S. Auerbach R. F. Hazel B. B. Mahler		8. CONTRACT OR GRANT NUMBER(s)  F19628-78-C-0001 ✓
		10. PROGRAM ELEMENT, PROJECT, TASK AREA & WORK UNIT NUMBERS  Project No. 6900
9. PERFORMING ORGANIZATION NAME AND ADDRESS The MITRE Corporation ✓ P.O. Box 208 Bedford, MA 01730		12. REPORT DATE OCTOBER 1978
		13. NUMBER OF PAGES 56
11. CONTROLLING OFFICE NAME AND ADDRESS Deputy for Control and Communications Systems Electronic Systems Division, AFSC Hanscom AFB, MA 01731		15. SECURITY CLASS. (of this report)  UNCLASSIFIED
		15a. DECLASSIFICATION/DOWNGRADING SCHEDULE
14. MONITORING AGENCY NAME & ADDRESS (if different from Controlling Office)		
16. DISTRIBUTION STATEMENT (of this Report)  Approved for public release; distribution unlimited.		
17. DISTRIBUTION STATEMENT (of the abstract entered in Block 20, if different from Report)		
18. SUPPLEMENTARY NOTES		
19. KEY WORDS (Continue on reverse side if necessary and identify by block number)		
CABLE REPLACEMENT RADIC                      LINE-OF-SIGHT DIGITAL COMMUNICATIONS                      SRWBR DIGITAL RADIC                                      20 Mb/s 15 GHz    TRI-TAC		
20. ABSTRACT (Continue on reverse side if necessary and identify by block number)		
▶ The USAF Short Range Wideband Radio requirements presently embrace a cable replacement concept that allows the radio to be utilized in a stand-alone mode for direct replacement of the TRI-TAC high speed and low speed CX-11230 cable systems. The radio is also required to provide direct interfaces with collocated DGM multiplexers, digital voice orderwire, digital data orderwire and CESE when the radio is installed in suitable sheltered multiplexer assemblages.		
		(over)

UNCLASSIFIED

SECURITY CLASSIFICATION OF THIS PAGE(When Data Entered)

20. Abstract (Continued)

This specification establishes the requirements for the performance, design, fabrication, test, qualification and evaluation for the USAF Short Range Wideband Radio, AN/GRC-XXX.

APPROVED BY	
DTIC	White Section <input checked="" type="checkbox"/>
DDC	Self Section <input type="checkbox"/>
CLASSIFIED	<input type="checkbox"/>
JUSTIFICATION	
BY	
DISTRIBUTION/AVAILABILITY CODE	
Dist.	AVAIL. and/or USE
A	

DDC  
RECEIVED  
NOV 8 1978  
D

UNCLASSIFIED

SECURITY CLASSIFICATION OF THIS PAGE(When Data Entered)

## ACKNOWLEDGMENT

This report has been prepared by The MITRE Corporation under Project No. 6900. The contract is sponsored by the Electronic Systems Division, Air Force Systems Command, Hanscom Air Force Base, Massachusetts.

## TABLE OF CONTENTS

<u>Section</u>		<u>Page</u>
	LIST OF ILLUSTRATIONS	5
	LIST OF TABLES	5
1	SCOPE	6
2	APPLICABLE DOCUMENTS	7
	2.1 GOVERNMENT DOCUMENTS	7
	2.1.1 Solicitation Issue	7
	2.1.2 Exact Issue	10
	2.1.3 Current Issue	11
3	REQUIREMENTS	12
	3.1 ITEM DEFINITION	12
	3.1.1 SRWBR Terminal Configurations	12
	3.1.2 Interface Definitions	17
	3.1.3 Government Furnished Property List	20
	3.1.4 Government Loaned Property List	20
	3.2 CHARACTERISTICS	21
	3.2.1 Performance	21
	3.2.2 Physical Characteristics	24
	3.2.3 Reliability	26
	3.2.4 Maintainability	28
	3.2.5 Environmental Conditions	30
	3.2.6 Transportability	33
	3.3 DESIGN AND CONSTRUCTION	33
	3.3.1 Material, Processes and Parts	33
	3.3.2 Interchangeability and Replaceability	35
	3.3.3 Workmanship	35
	3.3.4 Nameplates and Product Marking	35
	3.3.5 Electromagnetic Interference	35
	3.3.6 Instructions	36
	3.3.7 Storage	36
	3.3.8 Safety	36
	3.3.9 Human Engineering	37

TABLE OF CONTENTS (CONCLUDED)

<u>Section</u>	<u>Page</u>
3.4 DOCUMENTATION	38
3.5 INTEGRATED LOGISTIC SUPPORT (ILS)	38
3.5.1 Maintenance Policy	38
3.5.2 Supply	39
3.6 PERSONNEL AND TRAINING	40
3.7 MAJOR COMPONENT CHARACTERISTICS	40
3.7.1 Receiver-Transmitter (R/T)	40
3.7.2 Traffic Modem	41
3.7.3 Group Modem	42
3.7.4 Small Antenna System	43
4 QUALITY ASSURANCE PROVISIONS	46
4.1 GENERAL	46
4.1.1 Responsibility for Inspection	46
4.2 QUALITY CONFORMANCE INSPECTIONS	46
4.2.1 Classification of Inspection	46
4.2.2 Engineering Model Inspecting	46
4.2.3 Inspection By Subsidiary Documents	47
4.2.4 Visual and Mechanical Inspection	47
4.2.5 Interface and Operational Tests	47
4.2.6 Environmental Condition Test	48
4.2.7 Electromagnetic Compatibility Tests	50
4.2.8 Safety	51
4.2.9 Maintainability Demonstration	51
4.2.10 Reliability Testing	52
4.2.11 Burn-in (Debugging)	53
4.2.12 Human Engineering	53
4.2.13 System Test	54
4.2.14 Nuclear Test	54
4.2.15 Power Variation Test	54
5 PREPARATION FOR DELIVERY	55
5.1 PACKAGING, PACKING AND MARKING	55

## LIST OF ILLUSTRATIONS

<u>Figure</u>		<u>Page</u>
1	Unsheltered Low Capacity SRWBR	14
2	Unsheltered High Capacity SRWBR	15
3	Sheltered Low/High Capacity SRWBR	16

## LIST OF TABLES

<u>Table</u>		<u>Page</u>
1	Major Components for the SRWBR	13
2	SRWBR Low Capacity Data Rates and 99% Occupied Bandwidth	19
3	SRWBR High Capacity Data Rates and 99% Occupied Bandwidth	19

## SECTION 1

### SCOPE

This specification establishes the requirements for the performance, design, fabrication, test, qualification and evaluation for microwave radio equipments identified as the Short Range Wideband Radio (SRWBR).

## SECTION 2

### APPLICABLE DOCUMENTS

#### 2.1 GOVERNMENT DOCUMENTS

##### 2.1.1 Solicitation Issue.

The following documents of the issue in effect on the date of invitation for bids or request for proposal form a part of this specification to the extent specified herein. In case of conflict between the documents referenced and the contents of this specification, the contents of this specification shall be considered a superseding requirement.

#### SPECIFICATIONS

##### Military

MIL-T-152	Treatment, Moisture and Fungus Resistant, of Communications, Electronic and Associated Electrical Equipment
MIL-E-4158	Electronic Equipment, Ground, General Requirements for
MIL-T-4734	Transit Cases, Combination Cases and Spare Parts Cases for Ground Electronic Equipment
MIL-E-6051	Electromagnetic Compatibility Requirements, Systems
MIL-P-11268	Parts, Materials and Processes Used in Electronic Equipment
MIL-M-13231	Marking of Electronic Items
MIL-F-14072	Finish for Ground Signal Equipment
MIL-C-22992	Connectors, Plugs and Receptacles, Electrical, Waterproof, Quick Disconnect, Heavy Duty Type, General Specifications for
MIL-C-38999	Connectors, Electrical Circuit Miniature, Quick Disconnect, General Specifications for
MIL-E-45782	Electrical Wiring, Procedures for

MIL-E-46096	Enamel, Lustreless, Quick Drying, Styrenated Alkyld Type, Solar Heat Reflecting
MIL-H-46855	Human Engineering Requirements for Military Systems, Equipment and Facilities
MIL-C-55302	Connectors, Printed Circuit Subassembly and Accessories
MIL-H-55460	Headset, Microphone H-182/PT
MIL-C-55583	Cable Assembly, Special Purpose Electrical CX-11230( )/G
MIL-C-83723	Connectors, Electrical (Circular Environmental Resisting) Receptacles and Plugs
MIL-C-83733	Connectors, Electrical Miniature Rectangular Type, Rack and Panel

#### STANDARDS

##### Military

MIL-STD-188-100	Common Long Haul and Tactical Communication System Technical Standards
MIL-STD-189	Racks, Electrical Equipment, 19 inch and Associated Panels
MIL-STD-252	Wired Equipment, Classification of Visual and Mechanical Defects for
MIL-STD-280	Definition of Item Levels, Item Exchangeability, Models and Related Terms
MIL-STD-415	Test Provisions for Electronic Systems and Associated Equipment, Design Criteria for
MIL-STD-454	Standard General Requirements for Electronic Equipment
MIL-STD-462	Electromagnetic Interference Characteristics, Measurement of
MIL-STD-470	Maintainability Program Requirements (For Systems and Equipment)
MIL-STD-471	Maintainability Demonstration

MIL-STD-721	Definitions of Effectiveness Terms for Reliability, Maintainability, Human Factors and Safety
MIL-STD-749	Preparation and Submission of Data for Approval of Nonstandard Parts
MIL-STD-781	Reliability Tests, Exponential Distribution
MIL-STD-785	Reliability Program for Systems and Equipment Development and Production
MIL-STD-810	Environmental Test Methods
MIL-STD-1313	Microelectronic Terms and Definitions
MIL-STD-1388-1	Logistic Support Analysis
MIL-STD-1388-2	Logistic Support Analysis, Data Element Definitions
MIL-STD-1472	Human Engineering Design Criteria for Military Systems, Equipment and Facilities
MIL-STD-1562	List of Standard Microcircuits

NATIONAL SECURITY AGENCY

NACSEM-5100	Compromising Emanations Laboratory Test Standard, Electromagnetics
-------------	--

OTHER PUBLICATIONS

Manuals

US Army

TM-38-710	Integrated Logistic Support; Implementation Guide for DOD Systems and Equipment
-----------	---

Handbooks

Military

MIL-HDBK-217	Reliability Prediction of Electronic Equipment
--------------	--

MIL-HDBK-232	Military Standardization Handbook RED/BLACK Engineering-Installation Guidelines (V)
--------------	---



**STANDARDS**

**Military**

**MIL-STD-461A**            **Electromagnetic Interference Characteristics**  
**1 Aug 68**                **Requirements for Equipment**

**Notice 1, 7 Feb 69**

**Notice 2, 20 Mar 69**

**Notice 3, 1 May 70**

**2.1.3 Current Issue.**

The current issue of the following documents form a part of this specification to the extent specified herein:

**TRI-TAC SPECIFICATIONS**

**TT-B1-2202-0013A**    **Performance Specification, Family of Digital**  
**Group Multiplexers, Pulse Restorers, Cable**  
**Driver Modems and Cable Orderwire Unit**

**TT-A3-9001-0016B**    **AN/TTC-39 Store and Forward Module/TENLEY**  
**COMSEC Module Interface Specification (U)**  
**E-1 Models**

**TRI-TAC INTERFACE CONTROL DOCUMENTS**

**ICD-001**                **Voice and Data Orderwire Control and**  
**Signaling Information**

**ICD-002**                **TRI-TAC System Orderwire**

(Copies of specifications, standards and publications required by the contractor in connection with specific procurement functions, except TRI-TAC specifications and National Security Agency (NSA) specifications, publications and drawings, may be obtained from:

**Commanding Officer**  
**Naval Publications and Forms Center**  
**5801 Tabor Avenue**  
**Philadelphia, PA 19120**

Both the title and number should be stipulated when requesting copies. TRI-TAC specifications and NSA publications and drawings may be obtained by contacting the Contracting Officer (CO).)

## SECTION 3

### REQUIREMENTS

#### 3.1 ITEM DEFINITION

The Short Range Wideband Radio (SRWBR) shall consist of several physically discrete, electrically interconnected components mounted in suitable transit cases, and an antenna/mast assembly. The SRWBR radio components shall be designed for transportation and operation on a (M416) trailer. The antenna/mast assembly shall be transported on the same trailer and erected in its immediate vicinity. The SRWBR radio components shall be designed to be mounted in their transit cases on a standard relay rack. The SRWBR shall be capable of accommodating a variable combination of digital communications traffic at nominal data rates up to 18.72 Mb/s over paths up to 8 Km, and up to 9.36 Mb/s over paths up to 24 Km operating line-of-sight in the 14.5 to 15.35 GHz frequency band. Additionally, the SRWBR shall include the capability to provide one 16 Kb/s voice orderwire channel, one 2.0 Kb/s data orderwire channel, and a 4 kHz analog maintenance orderwire channel. The major components of the SRWBR are listed in Table 1.

##### 3.1.1 SRWBR Terminal Configurations.

SRWBR components shall facilitate the following terminal configurations for the system applications identified in 3.1. Interface and performance characteristics for the SRWBR components are specified in 3.1.2 and 3.7, respectively.

3.1.1.1 Terminal Components. Functional block diagrams for the basic terminal configurations are shown in Figures 1, 2 and 3. These configurations consist of a receiver-transmitter, traffic modem, group modem, HSCDM and either the small or large antenna system. At traffic data rates of 4.096 Mb/s and below (low capacity), the integral group modem is used (Fig. 1). At traffic data rates of 9.36 Mb/s and 18.72 Mb/s (high capacity), the HSCDM provides the cable interface (Fig. 2). The small or large antenna systems are deployed depending on the operational requirements imposed by LOS distance and terrain.

3.1.1.2 Physical Configurations. The SRWBR terminal shall have two physical configurations as specified in a and b below:

- a. Unsheltered Configuration. The SRWBR components shall be enclosed in weatherproof, rack mountable transit cases in accordance with MIL-T-4734C. The terminal with the small antenna system and components shall be mountable on a M-416 trailer. Additionally, the components shall be operable on

TABLE I

Major Components for the SRWBR

1. Receiver - Transmitter \*
2. Traffic Modem (0.128 - 18.72 Mb/s) \*
3. Group Modem (0.128 - 4.096 Mb/s) \*
4. Small Antenna System. 15 ft Mast/2 ft Antenna
5. Trailer (M-416, GFE)
6. High Speed Cable Driver Modem (HSCDM)  
(MD-1024 ( )/G,GFE)
7. Large Antenna System which includes the following GFE:
  - a. Eighty-One Foot Antenna Mast and Supports  
(OE-183/G)
  - b. 15 GHz Waveguide (ITT# 28528-130-4817)
  - c. Six-Foot Parabolic Antenna (5820-01-057-5081)
  - d. 15 GHz Feed Horn (ITT# 28528-130-2186)
  - e. Transit Frame (MXU-658E)
8. Headset-Microphone (H-182 ( )/PT or equivalent, CFE)
9. Set Of Interconnecting Cables

\*These components may be combined in a single transit case or several transit cases at the option of the bidder.



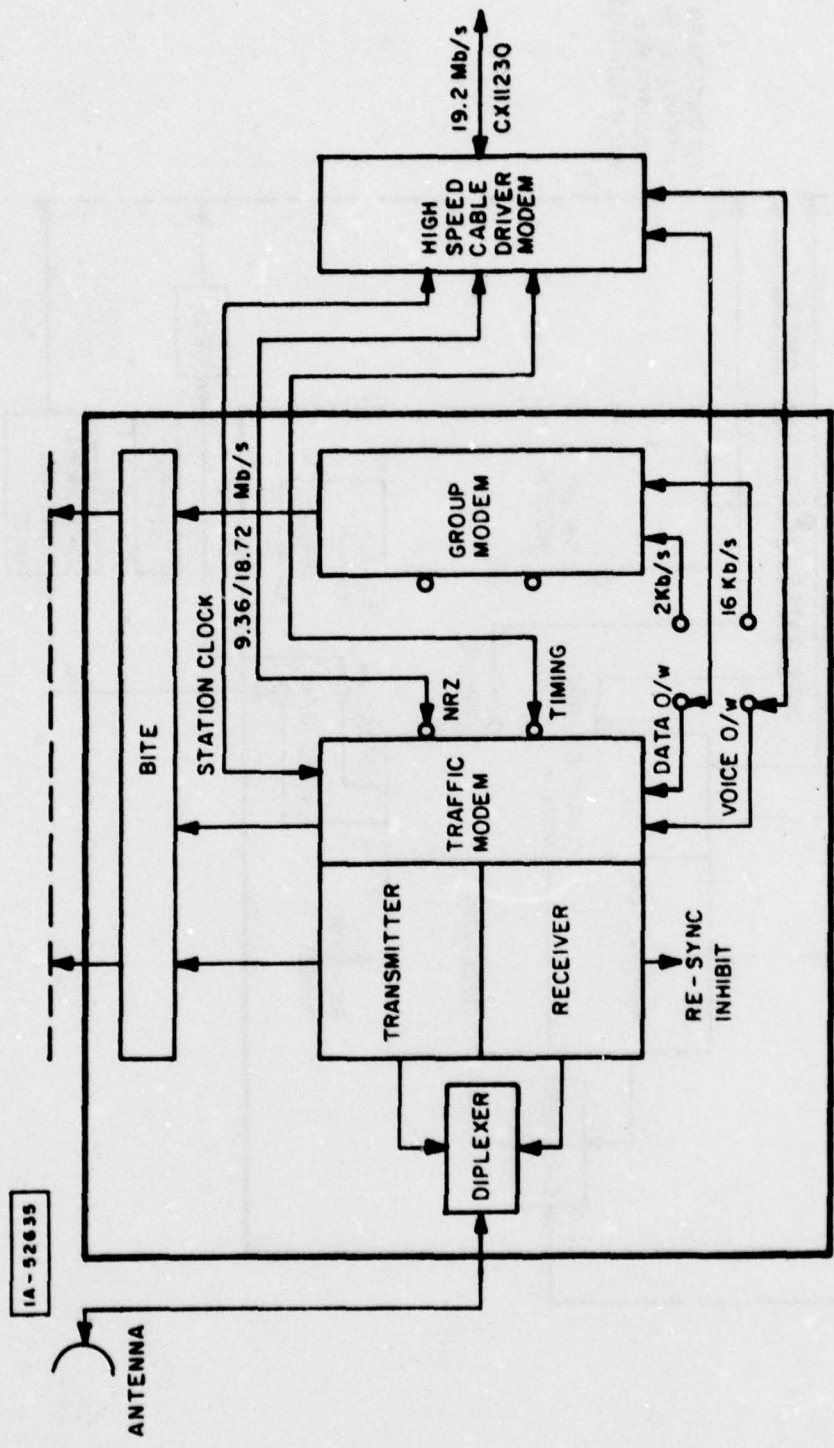

Figure 2 UNSHELTERED HIGH CAPACITY SRWBR

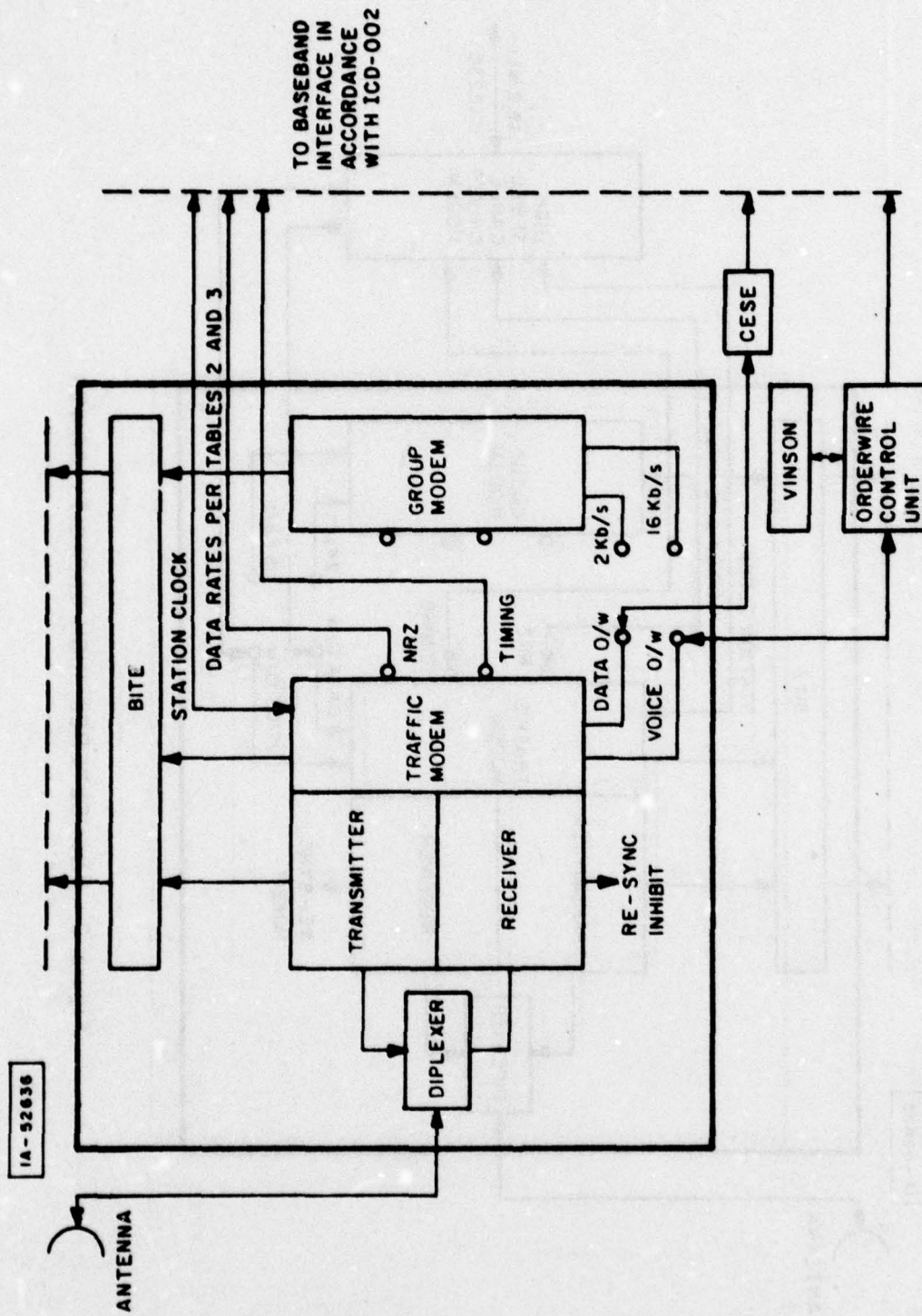

Figure 3 SHELTERED LOW/HIGH CAPACITY SRWBR

the M-416 trailer with the small antenna system deployed in the immediate vicinity of the trailer.

- b. Sheltered Configuration. The SRWBR terminal shall be enclosed in weatherproof, rack mountable transit cases in accordance with MIL-T-4734C. The terminal components shall be rack mountable in standard 19" racks. The large antenna system shall be transported on a pallet/mobilizer unit.

### 3.1.2 Interface Definitions.

This section defines the functional and electrical interface requirements for interconnections between the SRWBR components and other equipments. It also defines the functional and electrical interface requirements for interconnections between and among the SRWBR components.

3.1.2.1 External Interfaces. SRWBR components shall provide cable, equipments, status control and prime power terminations for interconnections with other equipments as specified in the following subparagraphs.

3.1.2.1.1 Low Capacity Cable Interfaces. The group modem integral with the SRWBR shall provide a low capacity CX-11230 cable interface for transmission of traffic, secure voice orderwire, data orderwire (telemetry) and maintenance orderwire signals to and from a complementary group modem. Transmission of traffic shall be on a 4-wire full duplex basis. The conditioned diphase interface shall transmit and receive secure voice orderwire (VINSON) at 16 kb/s (when the traffic rate is 256 kb/s or higher), data orderwire at 2 kb/s, maintenance orderwire (analog) and traffic at rates given in Table II. The traffic and orderwire signals shall be compatible and interoperable with a Conditioned Diphase Group Modem per TT-B1-2202-0013A or the Group Modems in the AN/TTC-39 or AN/TTC-42. This conditioned diphase interface shall operate over cable lengths as specified in ICD-002 for the Conditioned Diphase Group Modem.

3.1.2.1.2 High Capacity Cable Interfaces. The HSCDM shall provide a high capacity CX-11230 cable interface for transmission of traffic, secure voice orderwire, data orderwire (telemetry) and maintenance orderwire signals to and from a complementary HSCDM. Transmission of traffic at either 9.36 or 18.72 Mb/s, digital voice orderwire at 16 kb/s, and data orderwire (telemetry) at 2 kb/s shall be at a fixed line signal rate of 19.2 Mb/s. maintenance orderwire (analog) shall be superimposed on the conditioned diphased signal. Traffic and orderwire signals shall be as described in ICD-002 for Cable Driver Modems (CDM) line signals. The conditioned diphase signals shall be in accordance with TT-B1-2202-0013A and shall permit unrepeated transmission over 400 meters of CX-11230 cable in accordance with MIL-C-55583.

3.1.2.1.3 Collocated Equipment Interfaces. The equipment interfaces shall provide separate input/output terminations for interconnecting traffic, digital voice orderwire and data orderwire (telemetry) to and from other equipment that is collocated with the SRWBR terminal. Transmission of traffic shall be on a 4-wire full-duplex basis. Separate terminations shall be provided for traffic and orderwires in accordance with the following:

- a. Traffic. Input/output terminations for traffic shall accommodate baseband digital group signals at bit rates specified in Tables II and III. The input/output signals shall be balanced NRZ data and timing as specified in ICD-002 for Balanced Digital Interface. The input/output terminations shall permit interconnection with other equipment through direct wiring or via an adjacent patch panel.
- b. Secure Voice Orderwire (Radio). Input/output terminations for secure voice orderwire (radio) shall accommodate a baseband digital signal at 16 kb/s, balanced NRZ and timing to and from a VINSON Buffer as specified in ICD-002. The input/output terminations shall permit interconnection with VINSON orderwire facilities. In installations which do not contain a voice orderwire control facility, the secure voice orderwire shall be directly connected to the voice orderwire part of the cable side equipment.
- c. Data Orderwire (Telemetry) (Radio). Input/output terminations for data (telemetry) orderwire (radio) shall accommodate a baseband digital signal at 2 kb/s and timing in accordance with ICD-002 to and from the BLACK I/O terminal of a DLED (TSEC/KG-84) per TT-A3-9001-0016. The input/output terminations shall permit interconnection with the BLACK I/O terminal of a DLED. In installations which do not contain CESE facilities, the data (telemetry) orderwire (radio) shall be directly connected to the data (telemetry) orderwire port of the cable side equipment.
- d. Analog Voice Orderwire (Radio). Input/output terminations for analog voice Orderwire shall provide a 4 KHz analog channel over the RF link. The channel characteristics shall be as specified in MIL-STD-188-100 for Nominal 4 KHz, Voice bandwidth channel. The input/output signal level shall be -4 dBm.

3.1.2.1.4 Equipment Status/Alarm Interfaces. SRWBR components shall provide status and alarm outputs for reporting transmission status and alarm information to collocated Communications Equipment Support Element (CESE) facilities. The reports shall include Category A and B information as specified in ICD-001 for Radio

TABLE II

SRWBR Low Capacity Data Rates  
and 99% Occupied Bandwidth

<u>Bit Rate (Mb/s)</u>	<u>Maximum 99% Occupied Bandwidth (MHz)</u>
0.128	5
0.256	5
0.512	5
1.024	5
1.536	5
2.048	5
4.096	5

TABLE III

SRWBR High Capacity Data Rates  
and 99% Occupied Bandwidth

<u>Bit Rate (Mb/s)</u>	<u>Maximum 99% Occupied Bandwidth (MHz)</u>
9.36	20
18.72	20

CESEs. CESE messages as specified in ICD-001 for CESE Status Block data shall be transmitted via the data orderwire channel.

**3.1.2.1.5 Primary Power Interface.** SRWBR Components designed for operation in both exposed (unsheltered) and shelter environments shall be capable of operation from prime power sources specified in a and b below but not simultaneously. The design shall preclude equipment damage from incorrect prime power selection. The prime power sources shall be:

- a. Nominal 120 volt rms single phase A.C. 50/60/400 Hz having the varying conditions as defined in paragraph 3.2.30.3 and subparagraphs, Table II Part A and Figure 1 of MIL-E-4158E.
- b. Nominal 220 volt rms single phase A.C 50/60 Hz having the varying conditions as defined in Paragraph 3.2.30.3 and subparagraphs, Table II Part A and Figure 1 of MIL-E-4158E.

**3.1.2.1.6 Antenna Interface.** The SRWBR shall provide a single antenna waveguide interface with suitable waveguide change. This interface shall be compatible with both the small antenna group and the waveguide feed system of the large antenna group.

**3.1.3 Government Furnished Property List.**

The items listed below are Government furnished property which the SRWBR shall be designed to accommodate:

- a. High Speed Cable Driver Modem (HSCDM); MD-1024( )/G;  
Four each
- b. Trailer, M-416; Nine each
- c. Large Antenna System as per item 7 Table I; Two each

**3.1.4 Government Loaned Property List.**

The items listed below are not part of the SRWBR, but will be loaned to the contractor by the government for interface design, test and evaluation purposes:

- a. Master Group Multiplexers TD-1237( )/G; Two each
- b. Trunk Group Multiplexers TD-1236( )/G; Two each
- c. Loop Group Multiplexers TD-1235( )/G; Two each
- d. Group Modem with conditioned diphase code, MD-1026( )(P)/G; Two each
- e. Generators or Primary Power Units
- f. Trucks, M-151 (Jeep)
- g. Trucks, M-715 or equivalent
- h. Mobilizers, XM-720

### 3.2 CHARACTERISTICS

#### 3.2.1 Performance.

SRWBR radio terminal configurations described in 3.1.1 and its subparagraphs shall satisfy the following performance requirements of this specification either when operated over path lengths (free space) up to 24 km at bit rates up to 9.36 Mb/s or when operated over path lengths up to 8 km at a bit rate up to 18.72 Mb/s.

3.2.1.1 Bit Error Rate (BER). The Bit Error Rate of the SRWBR terminal shall not exceed  $1 \times 10^{-5}$  when operated at trunk traffic rates specified in Tables II and III and with radio voice and data orderwire activated. The BER of the orderwire channels shall not exceed  $1 \times 10^{-5}$  when terminals are operated with or without trunk traffic.

3.2.1.2 System Loss. The requirements cited in 3.2.1.1 shall be achieved when the transmission loss between the antenna interfaces of a transmitting and receiving terminal, as defined in par.

3.1.2.1.6, varies between 36.0 dB and 96.0 dB.

3.2.1.3 Fading Performance. The BER and System Loss requirements of 3.2.1.1 and 3.2.1.2 shall be met for RF signal fade rates up to 25 dB/second.

3.2.1.4 Bandwidth. The 99% power spectrum occupied bandwidth of the SRWBR transmitter shall not exceed 20 MHz for trunk transmission rates given in Table III and 5 MHz for trunk transmission rates given in Table II.

3.2.1.5 Carrier Frequency Coverage. The SRWBR shall provide for the selection of any carrier frequency between 14.500 - 15.350 GHz

in 1.0 MHz increments. The SRWBR shall exhibit long term frequency stability consistent with the performance requirements of 3.2.1 but not less than 1 part in  $10^{-3}$  for any RF frequency. The equipment shall be capable of being tuned to any carrier transmit or receive frequency by an operator within five minutes (when in an operating configuration). The timing and stability requirements shall be achieved within 15 minutes of application of prime power.

**3.2.1.6 Station Clock.** Each SRWBR terminal shall contain an internal station clock which can provide a free running timing source for stand-alone operation or be slaved to a master clock. The slaved mode of operation shall permit the station clock to lock on to either a received group bit stream (from either the cable or radio side of the terminal) or a 16/32 kHz station clock from an external source. This internal station clock shall lock-in on a received group bit stream which exhibits rms timing jitter up to 4% of the pulse width within 60 ms and shall track it within 1% of the pulse width. If loss of the master timing source occurs, the station clock shall "flywheel" for at least 10 seconds. If the master timing reference is not recovered during this flywheel period, the station clock shall automatically switch over to the free running mode.

**3.2.1.6.1 Station Clock Stability.** The stability of the internal station clock in a free running mode shall be 1 part in  $10^{-6}$  or better during the first 30 days after calibration and shall not degrade by more than 1 part in 10 per year thereafter.

**3.2.1.6.2 Station Clock Output Terminals.** Three (3) separate station clock output terminals shall be provided for general purpose use. The output signals at the respective terminals shall be balanced NRZ at 32 kHz or 16 kHz (switch selectable), 2 kHz and a frequency equal to the operating bit rate. Other output characteristics of these terminals shall be as specified in ICD-002 for a Balanced Digital Interface.

**3.2.1.6.3 Orderwire Timing.** The internal station clock shall provide timing to permit independent operation of secure voice and data (telemetry) orderwire circuits. This timing shall normally operate in the slaved mode per 3.2.1.6 when a SRWBR link is associated with a CNCE. When a SRWBR link is operating in the slaved mode and the clock at the remote terminal enters a free running mode while the local terminal remains slaved to the CNCE timing, bit count integrity (BCI) of combined telemetry transmitted from both terminals to the CNCE shall be maintained for at least 3 minutes.

**3.2.1.7 Modulation.** The modulation format of the SRWBR shall be consistent with the system bandwidth and overall performance requirements of 3.2.1.

3.2.1.8 Radio Orderwire Transmission. The SRWBR terminals shall be capable of simultaneous and independent transmission of mission traffic, secure voice orderwire and data orderwire while meeting the requirements of 3.2.1. Activation of the maintenance orderwire (analog) may be limited to operation without trunk or digital orderwire traffic.

3.2.1.9 Fade Indication. SRWBR terminals shall provide an alarm signal which indicates the loss of the received signal due to a fade. This alarm signal shall be of not more than 3 sec duration and be accessible at an output connector, or via direct wiring for use to inhibit frame search by associated multiplexers, COMSEC, or other equipment during signal fades shorter than 3 seconds.

3.2.1.10 Separation of Transmit and Receiver Frequencies. With the transmitter tuned to any frequency (F) between 14.50 and 15.35 GHz and the radio terminal transmitting full output power, the requirements of 3.2.1 and its subparagraphs shall be met when the receiver is tuned to any frequency between 14.5 and 15.35 GHz but separated by at least 100 MHz from F.

3.2.1.11 Built-In Test Equipment (BITE). The SRWBR shall contain BITE to perform the following functions:

- a. To measure, test, and monitor signals in and out of a component and significant subassembly.
- b. To provide go/nogo fault locator circuitry to isolate failures to a particular circuit assembly or Line Replaceable Unit (LRU).
- c. To provide a quantitative measure of transmission quality such as Bit Error Rate (BER); it shall be expressed as a number between 0 and 9 (ICD-001). The internal BITE facilities shall be designed such that they may be operated without interrupting traffic or interfering with normal system operation. Circuits for monitoring shall be placed on a separate removable plug-in circuit card. Removal of this card shall not affect operation of the equipment. The inventory of standard military test equipment shall be reviewed prior to recommendation of any special test equipment to support the SRWBR. Significant fault indicators shall be grouped on a common connector and consist of open or closed relay contact.

3.2.1.12 CESE Interface. The radio components of the SRWBR shall provide suitable status and alarm signals in accordance with the requirements of this specification and ICD-001. The character and number of the status and alarm signals shall be submitted by the bidder in the B-1 specification and in accordance with the SOW for

approval by the contracting office during B-1 specification authentication.

### 3.2.2 Physical Characteristics.

3.2.2.1 Modular Design and Constructions. Plug-in type subassemblies and modular concepts shall be used to the maximum practical extent. Major components listed in Table I shall be designed and constructed to permit maximum utilization of each item in the specified terminal configurations. Components comprising terminals per 3.1.1.3a for exposed (unsheltered) environments shall be mountable, within their combination cases, on an M-416 trailer to provide operating configurations. The small antenna system (transported by the M-416 trailer) shall be erectable within 15 feet of the trailer. Components comprising terminals per 3.1.1.3b for shelter installation shall be mountable in their combination cases in a standard electronic equipment rack having dimensions per MIL-STD-189. Rack mounted equipment shall permit operation, transportation and storage without its removal from the rack.

3.2.2.2 Equipment Combination Cases. Combination cases shall consist of equipment operating cases and appropriate covers for those areas (control and terminal panels) not enclosed by the operating case. Combination case covers may provide for the storage of removable ancillary equipments and instructional and reference publications. Combination cases, when covers are installed or detached shall meet the performance (3.2.1), environmental (3.2.5), and transportability (3.2.6) requirements of this specification. Combination cases, with the covers detached shall meet the survivability, (3.2.2.13) and maintainability (3.2.4) requirements of this specification.

3.2.2.2.1 Electrical Connectors and Cables. Connector receptacles for signals, power, ground, interconnection of components, and ancillary equipment cables shall be provided as fixed elements of the operating case. Exposed connector receptacles shall have captivated covers. All external cables shall be detachable for transport and storage. Physical and electrical characteristics of the connectors shall be commensurate with the type of cable and function involved. Electrical Connectors shall be selected for use in the SRWBR in accordance with Requirement 10 of MIL-STD-454 except that MIL-C-38999 and MIL-C-83723 covering circular connectors, MIL-C-55302 covering printed circuit board connectors, and MIL-C-83733 covering rectangular rack and panel connectors are invoked. CX-11230 coaxial cable materials, construction and characteristics shall be in accordance with MIL-C-55583. Power, ground, SRWBR component interconnecting, and ancillary equipment cables shall be of sufficient length to permit the arrangement of operating cases in a manner consistent with the operational and maintenance requirements of this specification. When a combination case is in

the transport mode, connector receptacles, if exposed, shall not extend beyond the external lines of the module and shall conform to the environmental (3.2.5) and transportability (3.2.6) requirements. Internal wiring shall conform to MIL-E-45782.

3.2.2.2.2 Control Groups. A control group shall be provided as an integral part of each combination case. The control group shall consist of the manual controls, visual and audible status and alarm indicators and readout devices, required for the accomplishment of operational and maintenance functions associated with the component. Control groups shall support the performance (3.2.1) and major component characteristic (3.7) requirements and shall conform to the environmental (3.2.5), human engineering (3.3.7), and maintenance (3.2.4) requirements.

3.2.2.2.3 Heat Dissipation. Combination cases, internal frame, and device mountings shall provide for efficient close thermal coupling to provide for heat dissipation in sufficient amounts to permit reliable operation over the specified environmental temperature range without deterioration of components. Thermal design shall ensure that no internal or external hot spots appear after protracted operation under the highest required operating temperature. No circulating fans or flow-through ventilation shall be employed within individual operating cases. Thermal design shall accommodate both unsheltered and sheltered installation of the SRWBR components.

3.2.2.3 Size and Weight. Size and weight of the equipment shall be kept to a minimum. Components or combination of components, and accessories packaged in a single combination case, shall not exceed 80 pounds in weight and 3 cubic feet in volume. The Small Antenna System and associated waveguide, when packaged for field transport, shall not exceed the internal bed dimensions of the M-416 trailer. The weight of components listed in Table I, exclusive of the Large antenna System but inclusive of all connecting cables and ancillary support equipment, shall not exceed 500 pounds. The maximum height of the rack mountable combination cases, excluding the HSCDM, shall not exceed 36 inches.

3.2.2.4 Color and Finish. All fiberglass/plastic materials used for external surfaces shall be impregnated with pigment approximating Marine Corps green No. 23. Surfaces shall be less than 25 percent reflective. All external metal surfaces shall be treated and painted in accordance with MIL-F-14072A. Color shall match Marine Corps green No. 23. All components and surfaces shall be treated for maximum corrosion resistance. Solar and Heat Reflecting Enamel, MIL-E-46096 or equivalent, matching Marine Corps green No. 23, may be used to reduce the effects of solar radiation.

3.2.2.5 Red/Black Signal Isolation. The SRWBR design shall preclude the presence of RED signal data on all external signal lines. The design techniques of MIL-HDBK-232, AFNAG-5B and NACSEM 5200 shall be used.

3.2.2.6 Set-Up Time. Set-up and tear-down times of not more than 30 minutes and 15 minutes respectively, shall be achieved for terminals described in 3.1.1.3a and 3.1.1.3b excluding the Large Antenna System. Set-up time will include only the time period required by two men who have appropriate skills to prepare a terminal for operation after its delivery to an operating site. Tear-down time will include only the time required to restore an operating terminal to its transport configuration.

3.2.2.7 Vulnerability. Vulnerability shall be a consideration throughout the design, development, and acquisition life cycle of the equipments. The vulnerability concept and requirements are described in Appendix I to this specification.

3.2.2.8 Survivability. The equipment shall be operational before and after exposure to the specified environments of Appendix I to this specification.

### 3.2.3 Reliability.

A reliability program shall be conducted in accordance with MIL-STD-785A to assure that the design, development and manufacture of SRWBR modules/components meet the quantitative reliability requirements of 3.2.3.1.

3.2.3.1 Quantitative Reliability Requirements. SRWBR terminal configurations of 3.1.1.3a and 3.1.1.3b shall have a specified Mean-Time-Between-Failure (MTBF),  $\Theta_0$  of 3000 hours. The MTBF of SRWBR components shall be consistent with the terminal requirement except that antennas and mast equipment shall exhibit MTBFs in excess of 25,000 hours. The specified MTBF shall be met under the extreme environment conditions specified in 3.2.5. The MTBF of GFE shall be excluded from the MTBF requirements specified herein.

3.2.3.1.1 Definition. The definitions contained in MIL-STD-471A, MIL-STD-781B, MIL-STD-721B, MIL-STD-785A and MIL-STD-280A shall apply except as modified herein.

- a. Failure. A failure is a malfunction of any item comprising the SRWBR terminal or a design/workmanship deficiency that causes degradation below the performance specified for the terminal. This general definition shall apply when the equipment is energized and operating or when an attempt is made to energize and operate the equipment in any specified configuration.

- b. Failure Categories. Failures shall be categorized as relevant and non-relevant failures.
- c. Relevant Failures. A relevant failure is one that can be attributed, after failure analysis, to any of the following causes: design defects, manufacturing defects, workmanship defects, physical or functional deterioration (such as wearout, fatigue, or tolerance degradation) or unknown causes. All false alarms are relevant failures. Failures that are not proven to be non-relevant shall be considered relevant. The achievement of the design requirements for the Mean-Time-Between-Failure and Mean-Time-To-Repair shall not be based on the use of redundant elements except at the subcomponent level. Failure of a redundant function shall not be considered a failure if there is no interruption of specified performance.
- d. Non-Relevant Failure. A non-relevant failure is one which, after failure analysis, is found to be caused by any of the following:
- (1) Damage resulting from improper installation.
  - (2) Failure of test instrumentation or monitoring equipment that is not a deliverable item and which is external to the component under test.
  - (3) Damage resulting from accident or mishandling.
  - (4) Failures due to errors by technician or operator.
  - (5) Dependent failures as defined by MIL-STD-781B, except that 5.5.1 (2) of MIL-STD-781B shall govern in the event of multiple failures.
  - (6) Failure of indicator lamps and the associated lamp circuits, provided the failure does not affect system performance.
  - (7) Failure of GFE.
- e. Mean-Time-Between-Failure(MTBF). Equal to the total operating time of an item divided by the number of relevant failures. This definition applies to operating SRWBR terminal with the definition of "relevant failure" selected according to the other definitions herein.
- f. Mean Preventive Maintenance Time (MPMT). Mean Preventive Maintenance Time (MPMT) is defined as the time required for

preventive maintenance during a given period, divided by the number of preventive maintenance tasks.

- g. mean-Time-To-Repair (MTTR). MTTR is the total repair time of an item divided by the total number of relevant failures. Repair time (Corrective Maintenance Time) is the elapse time to repair a failed item. The time is measured from the time the failure is detected and ends when the item is repaired, checked out, and returned to the required operational state that existed prior to the occurrence of the failure. The repair time specifically includes the time to isolate the failure, repair and/or replace it, obtain the replacement part (except administrative delay time), verify the repair, and return the item to an on-line state.

3.2.3.1.2 Reliability Prediction. A reliability prediction shall be performed using MIL-HDBK-217B and Vol. II of RADC Reliability Notebook (AD 821640). Data analyses shall be an internal part of this prediction effort and are subject to the approval of the procuring activity. The results of the prediction shall be compared to the specified MTBFs and where the predicted values do not achieve the requirements, the contractor shall accomplish such changes in design as are necessary to improve the predicted value sufficient to achieve the requirements. Reliability demonstration testing shall not start until the contractor provides valid predicted MTBFs that meet or exceed the specified MTBFs of the SRWBR. A summary of the reliability predictions shall be submitted as part of the reliability Program Status Reports and details shall be included in the Allocations, Assessments, and Analysis Report.

3.2.3.1.3 Elapsed Time Meters. Each combination case containing a component or components shall be provided with an elapsed time indicator providing a digital readout of the elapsed operating time in hours. The elapsed time meter rate shall be independent of operating power line frequency.

#### 3.2.4 Maintainability.

A maintainability program shall be established in accordance with MIL-STD-470 and implemented in accordance with the Statement of Work. The program (required to assure the design, development, and manufacture of new components and the integration of Government Furnished components) will achieve an optimum balance of maintenance man hours requirements with life cycle costs that are consistent with the maintenance concept. The Maintainability Engineering Design Notebook AD-866818 shall be used as a guide in equipment design.

3.2.4.1 Service Life. The contractor shall employ all practical methods in the process of design, development, and manufacture which

will assure that maintainability requirements of this specification are satisfied over a minimum service life of 10 years. The service period may start after an initial storage period not exceeding two years without falling below the requirements of this specification.

3.2.4.2 Maintainability Design. Contractor developed new components and the contractor's integration of Government Furnished components shall be designed so that it is completely maintainable in accordance with the maintenance concept. Repair at the organizational level shall be by removal/replacement of the Line Repairable Unit (LRU). The design shall ensure that complete maintenance and repair can be performed on the LRU at intermediate or depot level when justified by the LSA process. The maintainability requirements shall be based on replacement of subassemblies and parts, except where assembly replacement is specifically approved by the procuring activity. The definitions of "parts," "subassembly," and "assembly" are given in MIL-STD-280A.

3.2.4.3 Numeric Maintainability Requirements. These numerics shall govern the design of contractor developed new components and the design effort required to integrate such components with government furnished components. It is not anticipated that government furnished components will be redesigned to meet the maintainability requirements of this specification. If a redesign is necessary, it must be approved by the procuring agent.

3.2.4.3.1 Organizational Maintenance Level. The equipment shall be designed so that the organizational level repair capability in a tactical environment is at least 95 percent of all failures repaired with a mean-corrective-maintenance-time (Mct) no greater than 15 minutes and a maximum-corrective-maintenance-time (Mmaxct) no greater than 30 minutes at the 95th percentile.

3.2.4.3.2 Intermediate (Field) Maintenance Level. The SRWBR shall be designed so that corrective maintenance time (Mct) of 1 hour is achieved for Intermediate Maintenance Level Tasks.

3.2.4.3.3 Preventative Maintenance (Scheduled Maintenance). The equipment shall be designed so that required preventative maintenance can be performed while the SRWBR is in operation. A maximum of 15 minutes per day shall be permitted for such actions. If personnel safety requires that a unit of equipment be shut down, a mean preventative maintenance time (Mpt) of 5 minutes/day is permitted.

3.2.4.4 Maintainability Prediction. A maintainability prediction shall be performed in accordance with Procedure III of MIL-HDBK-472. The results of this prediction shall be compared to the required mean and maximum repair times, and where the predicted value does not achieve the requirement, the contractor shall accomplish such

changes in design as are necessary to improve the SRWBR system maintainability to achieve the requirement.

**3.2.4.5 Service and Access.** The design and construction of each component comprising the SRWBR shall be such that it can be maintained within the specified maintainability time constraints. The design shall incorporate front panel indicators, warning signals, and self-test circuitry to assure malfunction isolation to the LRU level. All parts and electrical contact points which may require servicing, repair, or replacement shall be readily accessible. LRUs shall be completely removable via the front panel of their combination case. The components shall be maintained at the organizational or intermediate level by normal maintenance techniques. Connectors at the rear shall be accessible with the radio in place. The variety and number of special tools and test equipment required to maintain the components shall be held to a minimum. When peculiar tools are required, means for tool mounting shall be included. Adequate space shall be provided to permit the use of tools. All subassemblies, connectors, and assemblies shall be readily identified as to reference designator and location.

**3.2.4.5.1 Test Points.** Test points and facilities for interconnecting test equipment shall be provided for determining the performance quality of the equipment. The location of the test points shall be determined at the time of B1 specification Authentication. Test points shall be in accordance with MIL-STD-415D. Test points shall be included for the following as a minimum:

- a. Received signal level.
- b. Injection of calibrated RF signal into the receiver input.
- c. Calibrated sampling of RF output power from the transmitter.
- d. VSWR as seen at the RF interface point per 3.1.2.1b looking in both the direction of antenna and radio.

**3.2.4.5.2 Metering.** Meters and metering circuits with selector switches shall be provided. Provisions shall be incorporated for measuring, as a minimum, RF power output, VSWR at the antenna wave guide interface, RSL and BER. In addition, metering of all readings that are necessary for tuning or used for troubleshooting shall be incorporated. Meters shall comply with MIL-STD-454D, requirement 51.

**3.2.4.5.3 Lamp Indicators.** Lamp Indicators shall have a rated 50,000 hour life expectancy and shall be used to indicate the operational status.

**3.2.5 Environmental Conditions.**

3.2.5.1 Worldwide Environmental Conditions. The SRWBR modules shall be designed and constructed to resist and withstand the environmental conditions specified herein without excessive mechanical, chemical, structural or electrical degradation. Operational and functional performance shall not be impaired in any manner unless otherwise specified. All operational and functional performance requirements specified herein shall be met before, during, and after exposure to these environmental conditions.

3.2.5.2 Temperature Extremes. The SRWBR shall be designed to withstand the following temperatures.

3.2.5.2.1 Storage and Transit. The SRWBR in the nonoperating mode, storage and transit, shall withstand the inclusive temperature extremes of -57 to +71 degrees C (-71 to +160 degrees F) ambient air temperature.

3.2.5.2.2 Starting Temperature. The SRWBR shall be capable of being turned on at an ambient air temperature of -46 degrees C (-51 degrees F).

3.2.5.2.3 Continuous Operating Temperature Range. Upon being turned on at -46 degrees C (-51 degrees F), the SRWBR, after a maximum warm-up period of 15 minutes (without solar radiation), shall function within the inclusive ambient air temperature range of -46 to +52 degrees C (-51 to +126 degrees F) plus the effects of solar radiation of up to 1136 W/m (360 BTU/hr/ft ).

3.2.5.3 Humidity. The equipment shall maintain the specified performance when exposed in the operating mode to a relative humidity of 95 percent for both continuous and intermittent periods, including conditions wherein condensation takes place in and on the equipment in the form of both water and frost.

3.2.5.4 Altitude. The SRWBR shall sustain no physical damage of degradation in performance under atmospheric pressures corresponding to the following conditions:

- a. Storage and Transit: Sea level up to 12,200 m (40,000 feet).
- b. Operating: Sea level up to high ground elevation of 3,050 m (10,000 feet).

3.2.5.5 Rain. The SRWBR shall be operable without degradation in specified performance during periods of heavy precipitation and with intermittent winds as may be encountered in military environment extremes. There shall be no evidence of water penetration nor any impairing physical damage.

3.2.5.6 Sand and dust. Full performance requirements shall be met when the equipments have been subjected to the effects of blowing fine sand and dust particles with wind speeds up to 9 m/s (20 mph) and shall be resistant to dust that may accumulate within and on the SRWBR.

3.2.5.7 Static Load. Combination cases shall withstand the static load encountered when a 91 kg (200 pound) load is uniformly distributed over a 100 by 300 mm (4 by 12 inch) area, with covers in place.

3.2.5.8 Wind. The SRWBR configurations per 3.1.1.3a and 3.1.1.3b with the 15' mast and 2' Parabolic Antenna mounted at its maximum height, shall perform satisfactorily when exposed to the following wind conditions:

- a. Non-operating: a 130 knot wind in any direction.
- b. Operating: a 100 knot wind in any direction.

3.2.5.9 Ice and Wind. The SRWBR configurations per 3.1.1.3a and 3.1.1.3b shall not fail when exposed to a combination of 2 inches of ice on the mast and antenna; 1/2 inch of ice on the guy wires; and a 65 knot wind.

3.2.5.10 Salt Fog. The SRWBR, in the transportation/storage and operating mode, shall be capable of prolonged exposure in a salt-laden atmosphere without degradation of material surfaces or operational performance.

3.2.5.11 Fungus. The SRWBR shall be resistant to fungi and shall not be adversely affected by fungi under conditions favorable to its development, namely high humidity, warm atmosphere, and presence of inorganic salt.

3.2.5.12 Solar Radiation. The SRWBR shall withstand solar radiation occurring at a rate up to  $1136 \text{ W/m}^2$  (360 BTU/hr/ft ). Those parts of the SRWBR exposed to sunshine shall withstand the effects of ultraviolet, visible, and infrared radiation without significant mechanical or chemical degradation. There shall be no operational or functional degradation.

3.2.5.13 Orientation.

3.2.5.13.1 Long Term Storage. Combination cases shall provide for storage of SRWBR components in any position for a period of two years without any degradation of subsequent operational capability.

3.2.5.13.2 Operating Configuration. The SRWBR terminal configurations per 3.1.1.3a and 3.1.1.3b shall satisfy all of the

performance requirements specified herein when operating on any slope up to 10 degrees.

3.2.5.14 Vibration and Shock. The SRWBR components (see Table I), when configured for transport, shall withstand vibration and shock induced during field transport by military vehicle, by rough handling, and by common carrier transport. When in the transport configuration, the components shall withstand the effects of being dropped from specified heights onto any side or edge of the combination or transit case. When SRWBR components are shelter installed, they shall withstand vibration and shock induced during vehicular and air transport over all types of roads and cross-country terrain.

3.2.5.15 Lightning. The SRWBR shall incorporate lightning protection to prevent damage to the equipment and hazards to personnel safety as specified in MIL-E-4158E.

3.2.6 Transportability. All items covered by this specification shall be designed to withstand the effects of handling during transport by fixed wing cargo aircraft, military helicopters, military vehicles, rail and sealift.

### 3.3 DESIGN AND CONSTRUCTION

The SRWBR shall meet the following requirements.

#### 3.3.1 Material, Processes and Parts.

The SRWBR parts, hardware accessories, materials, and construction processes shall be in accordance with MIL-P-11268 and its applicable subsidiary documents. Any part not in conformance with this documentation will be considered a nonstandard part and shall be qualified in accordance with the Nonstandard Parts Procedure outlined in MIL-STD-749. Selection of nonstandard parts shall be kept to a minimum to assure optimum end-item performance, part interchangeability, and cost effectiveness.

3.3.1.1 Electronic Construction. The SRWBR shall be designed for maximum simplicity and speed of maintenance consistent with minimum cost weight and volume of replacement spares. Where justified by the Optimum Repair Level Analysis, the design shall facilitate disposal rather than repair of failed subassemblies. Subassemblies shall be designed and located for maximum interchangeability and test accessibility and to minimize the number of different types. The design of the SRWBR shall be such that performance shall not be dependent upon the use of individually selected subassemblies/parts. Relays shall be hermetically sealed. Other electromechanical devices shall be based upon "worst case" design which is consistent with minimum/maximum semiconductor rating and power supply operating

voltage tolerance. Subassemblies shall be securely locked in the installed position. Subassemblies shall be provided with test points and shall require no unsoldering or removal of wires for replacement.

3.3.1.1.1 Keying. All plug-in subassemblies and cables shall be keyed to prevent error in replacement. In addition, the plug-in subassemblies shall be appropriately indexed and color-coded with written instructions so that they cannot be placed in the wrong position or slot. This method of keying shall be such that the number of types of extender cards shall be kept to a minimum.

3.3.1.2 Solid State Microelectronic Design. The SRWBR shall be of solid state design emphasizing maximum reliability, maintainability, and operational efficiency. Microelectronic device terms and definitions shall be in accordance with MIL-STD-1313. Microelectronics and integrated circuits shall be in accordance with MIL-P-11268 and shall be selected from MIL-STD-1562 to the maximum practical extent. Discrete semiconductor devices and electronic parts may be employed only where monolithic or hybrid microcircuits, which meet the performance requirement of the SRWBR, do not exist or where such devices have documented performance advantages over the equivalent monolithic devices. Selection and use of nonstandard microcircuits shall require the specific written approval of the procuring activity. All solid state devices and all microcircuits employed shall be packaged in hermetically sealed packages. No plastic (i.e., epoxy, silicon, organometallics, phenolics, etc.) encapsulated devices shall be accepted without specific written approval of the procuring activity.

3.3.1.3 Corrosion of Metal Parts. The corrosion resistance of metal parts shall be in accordance with MIL-STD-454D, Requirement 15. The selection and protection of dissimilar metal combinations shall be in accordance with MIL-STD-454D, Requirement 16.

3.3.1.4 Hardware. All subassemblies of SRWBR components which are required to be assembled or disassembled shall be secured with captive hardware. All hardware necessary for installation or operation shall be provided as part of the component. All screws, handles, hinges, or other related devices shall be in accordance with MIL-STD-454D, Requirement 12.

3.3.1.5 Thermal Coefficient of Expansion. Metals having different coefficients of expansion shall not be used in interrelated assemblies where dimensional change through the service condition temperature range has a degrading effect on equipment or maintainability.

3.3.1.6 Fail Safe Design. It shall not be possible to obtain any combination of control settings which will result in damage to the SRWBR.

3.2.1.7 Line Protectors. All conductors, except coaxial, providing entrance/exit to/from the SRWBR shall be provided with a line protective device to protect the equipment from lightning surges on the line.

3.3.1.8 Standard Parts. Standard Parts shall be used in the manufacture of the SRWBR in accordance with the requirements specified in MIL-E-4158E and Amendment 1, Paragraph 3.3 and its subparagraphs to the maximum practical extent.

3.3.1.9 Moisture and Fungus Resistance. All SRWBR equipment shall conform with the requirements of the following documents:

- a. MIL-T-152B. Treatment, Moisture and Fungus Resistant.
- b. MIL-STD-454D(1).
  - (1) Requirement 4. Fungus-Insert Materials.
  - (2) Requirement 31. Moisture Pockets (Notice 3, 25 March 1966).

3.3.2 Interchangeability and Replaceability.

Interchangeability and replaceability shall be in accordance with MIL-STD-454D(1) and Notice 1, Requirement 7.

3.3.3. Workmanship.

Workmanship shall conform to MIL-STD-454D(1) and Notice 1, Requirement 9.

3.3.4 Nameplates and Product Marking.

The nomenclature and identification marking and the labeling of the SRWBR components and parts shall be accomplished in accordance with MIL-M-13231. Front panel markings shall be Group I as described in that specification. Clean, concise, and durable markings shall be provided for all controls, switches, fuses, jacks, test points, and other components as necessary.

3.3.5 Electromagnetic Interference.

The SRWBR components shall meet the requirements for Class A-3 equipment, MIL-STD-461A, including Notices 1, 2, and 3. For radiated susceptibility, the SRWBR components shall be designed to withstand sine wave, square wave, and pulse modulated signals.

Compliance with the requirements of MIL-E-6051D and Amendment 1 shall be met.

3.3.5.1 Electromagnetic Interference Design Aspects. The design aspects shall consist of techniques for shielding and filtering circuits, methods of eliminating spurious and harmonic emanations, techniques for transient suppression, methods of obtaining good conductive mating surfaces, selection of interference free components, analysis of potential interference problems, and other pertinent devices or techniques to assure the applicable limits will be met.

3.3.6 Instructions.

The SRWBR shall be marked with suitable instructions as may be required to cover the following information which shall be permanently placed on the outside of SRWBR combination and transit cases.

- a. Preparation for operation.
- b. Preparation for transport.
- c. Center of gravity of each rack mounted SRWBR configuration.

3.3.7 Storage.

The SRWBR shall not degrade below the requirements of this specification while in storage in the nonoperating mode, for a period of at least two years in cold weather and tropical areas as defined in 6.3.1b and 6.3.1d, respectively of MIL-E-4158E. It shall be capable of operating properly after storage as stated above.

3.3.8 Safety.

A personnel and equipment safety program shall be conducted through the utilization of AFSC Design Handbook 1-6.

3.3.8.1 Safety Design Criteria. All construction and all material installation performed by the contractor shall be designed so as to prevent injury to personnel or damage to the equipment during set up, tear-down, transport, operation and maintenance. The personnel safety shall conform to the requirements of MIL-STD-454D, and Notice 1, Requirement 1 and 8. Positive consideration shall be given but not limited to the following.

3.3.8.1.1 Low Voltage Protection. With the equipment assembled and in operation, personnel shall be protected from contact with potentials in excess of 30 volts to ground, chassis, or frame, including potentials on charged capacitors.

3.3.8.1.2 High Voltage Protection. Interlocks, with an integral bypass device, shall be provided to prevent access to the interior of the equipment, or components thereof, without removal of all voltages exceeding 100 volts peak between any two points of the equipment or between any point and ground.

3.3.8.1.3 High Voltage/Current Signs. Caution high voltage and high current signs shall be provided whenever required to warn personnel against shock hazards.

3.3.8.1.4 Lightning Protection. During assembly and in the final operational configuration, the equipment shall be protected from surges in power and signal leads resulting from lightning.

3.3.8.1.5 Dangerous Materials. Materials which will liberate gases or liquids which may combine with the atmosphere to become corrosive, produce toxic fumes or combustible mixtures, shall be installed or stored in a manner precluding injury to personnel or damage to equipment during transit or operation. These materials shall be labeled to warn personnel of the safety hazards involved. This category includes, but is not limited to, cleaning fluids, lubricants, thermoplastic materials, solvents, refrigerants, electrolyte and storage batteries.

### 3.3.9 Human Engineering.

Human engineering design criteria and principles shall be applied in the design of the SRWBR, as a personnel subsystem, as to achieve safe, reliable and effective performance by operator/maintainer personnel, and to minimize skill requirements and training time. The SRWBR shall meet MIL-H-46855 and MIL-STD-1472 in the application of human engineering design criteria.

3.3.9.1 Human Engineering Program. A comprehensive human engineering program shall be accomplished in accordance with MIL-H-46855.

### 3.4 DOCUMENTATION

Documentation shall be as tasked in the applicable contract Statement of Work and prepared and delivered in accordance with the applicable Contract Data Requirements List (CDRL), DD Form 1423.

### 3.5 INTEGRATED LOGISTIC SUPPORT (ILS)

The logistics support planning policy, as promulgated by the AFP 800-7, shall be integrated into the SRWBR design and engineering constraints cited in other sections of this specification.

#### 3.5.1 Maintenance Policy.

Levels of maintenance shall be as prescribed in DOD 4151.16. The equipment design shall be such that repair will be accomplished at the authorized level of maintenance prescribed by joint service Source Maintenance Recoverability (SMR) Codes. Maintenance at the organizational level will generally be accomplished by replacement of the Lowest Replaceable Unit (LRU) from the authorized spares. Maintenance at the intermediate level will generally be limited to calibration, provision of mobile technical assistance, and the repair of LRU's replaced at the organizational level when so dictated by the Logistics Support Analysis (LSA) process. The decision for repair, return to depot, or discard by intermediate level maintenance personnel will be determined by the SMR codes which will be an output function of the LSA process integrated with the numeric maintainability requirements of 3.2.4, and as approved by the procuring activity during periodic Logistics Design Appraisals.

3.5.1.1 Maintenance Concept. The maintenance concept shall be a prime consideration in the design of equipment. The SRWBR shall be required to be capable of deploying for a period of at least 30 days without access to normal supply/resupply lines. LSA per MIL-STD-1338-1 and -2 shall be utilized to develop requirements for support equipment, optimum repair levels, maintenance repair cycles, accessibility, operators/attendants and maintenance personnel in support of the SRWBR. In addition, the equipment design shall support the reliability and maintainability requirements of 3.2.3 and 3.2.4; and the maintenance policy of 3.5.1 and subparagraphs of same. The equipment provided as part of the SRWBR shall be designed to allow all maintenance to be performed at three levels: Organizational, Intermediate, and Depot. The SRWBR shall be able to operate without constant attendance by maintenance personnel. With the exception of catastrophic failures, the SRWBR shall be attended by maintenance personnel only on a scheduled basis for corrective and preventive maintenance.

3.5.1.2 Maintenance Concept Application. The three maintenance levels shall be applied in accordance with the following concept.

3.5.1.2.1 Organizational Maintenance. The equipment shall be designed to maximize the ability at the Organizational Maintenance Level to restore these equipments to full operational capability by use of Built-In Test Equipment (BITE), fault diagnosis, and isolation to the LRU and to replace the LRU from authorized spares. LRU in this context ordinarily means a PC card, but does not exclude assemblages that should be replaceable by organizational maintenance personnel.

3.5.1.2.2 Intermediate Maintenance. Intermediate maintenance shall include: alignments which require more precise electronic test equipment or standards than available at the Organizational Maintenance Level, corrective maintenance on LRUs, and assemblages which were replaced at Organizational Maintenance Level, wiring and cable connector repair and replacements, and limited repairs to cases. Intermediate maintenance will also provide technical assistance to using organizations.

3.5.1.2.3. Depot Maintenance. Depot maintenance level shall include repair of those PC cards which must be replaced at Organizational Maintenance Level and are beyond the repair capability of the Intermediate Maintenance Level as determined by the LSA. The depot shall fault isolate to piece parts on PC cards separated from their overall equipment and on complete components and equipments. Depot shall also repair and perform major overhaul, rebuilds and refurbishing.

3.5.1.3 Maintenance Concept Interfaces. The maintenance concept shall be considered in the areas of engineering, technical manuals, training, engineering data management, integrated logistic support, and equipment modification.

3.5.1.4 Maintenance Features. The SRWBR shall be designed with BITE, consistent with the maintainability requirements of 3.2.4. Self-contained test capabilities shall be provided which will incorporate indicators, warning signals, self-test circuitry, test jacks, and test points to facilitate trouble shooting and fault isolation to the pluck-out replaceable unit or LRU. Maximum use shall be made of easily removable LRUs.

### 3.5.2 Supply.

The LSA process shall be used to identify the requirements for support and test equipment, spares and repair parts integrated with the availability, reliability, maintainability numerics and the maintenance concept of 3.5.1.1. In addition, the SRWBR equipment

shall be designed to be repaired and maintained using national stock numbered items and test equipment where appropriate.

### 3.6 PERSONNEL AND TRAINING

The LSA process shall be utilized to the depth required to identify the requirements for personnel training and training material to support the SRWBR. The analysis shall provide the identification or requirements for trained maintenance and instructor personnel at all levels and shall be definitive to include the quantities and skill levels required.

### 3.7 MAJOR COMPONENT CHARACTERISTICS

#### 3.7.1 Receiver-Transmitter (R/T)

The Receiver-Transmitter (R/T) shall include the appropriate up-converters, down-converters, synthesizers, amplifiers, diplexers, and associated power supplies and controls as required for RF transmission from 14.50 to 15.35 GHz. The R/T shall operate in conjunction with the traffic modem per 3.7.2 for data rates listed in Tables II and III. The R/T shall provide the characteristics specified in the following subparagraphs. Other performance characteristics of the R/T shall be governed by the terminal design and shall be consistent with the overall performance specified in 3.2.1.

##### 3.7.1.1 Transmitter Section.

3.7.1.1.1 Spurious Emissions. The SRWBR shall conform to the following spurious emission requirements:

a. For data rates specified in Table III, all spurious emissions in any 100 kHz band outside 25 MHz from any assigned carrier frequency shall be below a power level of -55 dBm as measured at the interface specified in 3.1.2.1.6.

b. For data rates specified in Table II, all spurious emissions in any 100 kHz band outside 6 MHz from any assigned carrier frequency shall be below a power level of -55 dBm as measured at the interface specified in 3.1.2.1.6.

3.7.1.1.2 Reduced Power Output/Stability. The transmit output power shall be adjustable by continuous means from rated output levels down to at least 10% of the rated output. The transmit output power level shall remain within 0.5 dB of its initial value during any 24 hour period.

3.7.1.1.3 Transmitter Output VSWR. The transmitter shall be capable of operating into any load having a VSWR of 1.5:1 at any

phase angle. The transmitter shall also withstand connection into any load from open to short circuit without damage to the transmitter.

3.7.1.1.4 Transmitter Status Monitors. Appropriate transmitter status signals shall be monitored by internal circuitry, and status information shall be presented to the CESE facility which may be associated with the radio terminal as specified in 3.1.2.1.4.

### 3.7.1.2 Receiver Section.

3.7.1.2.1 Spurious and Image Rejection. The receiver section shall provide not less than 80 dB of attenuation for any frequency or spurious products generated at 25 MHz or more above or below the assigned receiver frequency.

3.7.1.2.2 Dynamic Range. The receiver dynamic range for an output variation of not more than 0.5 dB shall be at least 60 dB. Protection shall be provided to prevent damage to the receiver due to -15 dBm RF signal level input as measured at the antenna interface specified in 3.1.2.1.6. The receiver shall provide satisfactory performance with -15 dBm input signal.

3.7.1.2.3 Output Level Stability. The receiver shall provide a long term stability such that for a constant level input, the output will vary by not more than 0.5 dB during any 24 hour period without adjustments.

3.7.1.2.4 VSWR. The receiver shall cause a VSWR of no greater than 1.25:1 on the antenna loaded feedline.

3.7.1.2.5 Receiver Status Monitors and Alarms. Appropriate receiver status signals shall be monitored by internal circuitry and status information shall be presented to the CESE facility which may be associated with the radio terminal as specified in 3.1.2.1.4.

### 3.7.2 Traffic Modem.

The traffic modem shall operate in conjunction with the receiver-transmitter specified in 3.7.1 for data rates specified in Tables II and III. The modem shall include appropriate circuitry for achieving the following functions:

- a. Modulation and demodulation of data traffic.
- b. Combining and decombining digital voice and data orderwire signals independently or simultaneously with data traffic.
- c. Internal timing and control.

- d. Internal equipment status monitoring.
- e. Provide an analog voice orderwire in accordance with 3.7.2.1.4

The traffic modem shall provide the characteristics specified in the following subparagraphs. Other performance characteristics of the modem shall be governed by the terminal design and shall be consistent with the overall performance specified in 3.2.1.

3.7.2.1 Interface Characteristics. All interfaces specified in the following subparagraphs shall be in accordance with ICD-002.

3.7.2.1.1 Baseband Traffic Interface. The traffic modem shall provide input/output terminations for interconnecting baseband traffic signals at data rates per Tables II and III, to and from external equipment or the integral group modem.

3.7.2.1.2 Digital Voice Orderwire Interface. The modem shall provide a digital voice radio orderwire interface operating at a rate of 16 Kb/s for interconnection with either external facilities or the integral group modem.

3.7.2.1.3 Data Orderwire Interface. The modem shall provide a radio data orderwire interface operating at a rate of 2 Kb/s for interconnections with either facilities or the integral group modem.

3.7.2.1.4 Maintenance Orderwire (Analog). The traffic modem shall provide Input/Output terminations for an analog voice orderwire consisting of a 4 kHz analog channel over the RF link. The channel characteristics shall be as specified in MIL-STD-188-100 for a nominal 4 kHz voice bandwidth channel. The input/output level signal shall be -4 dBm. 1600 Hz ringing and detection shall be included with visual indication of incoming calls. Activation of the analog voice orderwire may be limited to operation without trunk or digital voice and digital data orderwire traffic.

3.7.2.1.5 Transmission Status Interface. The modem shall provide a compatible equipment status/control interface in accordance with 3.1.2.1.4.

3.7.2.1.6 Station clock. Station clock shall be provided by the traffic modem in accordance with 3.2.1.6.

### 3.7.3 Group Modem.

The group modem shall provide the operational capabilities of one group modem as specified in TRI-TAC Specification Family of DGM, etc. TT-B1-2202-0013A and modified to meet the requirements of the following subsections.

### 3.7.3.1 Interface Characteristics.

3.7.3.1.1 Cable Interface. The group modem shall transmit and receive conditioned diphase signals at data rates shown in Table II of this specification over CX-11230 cable.

3.7.3.1.2 Equipment Interface. The data traffic interface toward the equipment side shall be at data rates equal to the cable side and in accordance with ICD-002, Balanced Digital Interface.

3.7.3.1.3 Digital Voice Orderwire Interface. The group modem shall provide a digital voice orderwire interface operating at 16 Kb/s in accordance with ICD-002.

3.7.3.1.4 Data Orderwire Interface. The group modem shall provide a data orderwire interface operating at 2 Kb/s in accordance with ICD-002.

3.7.3.1.5 Analog Voice Orderwire Interface. The group modem shall provide the capability to operate a Headset-Microphone, H-182( )/PT, or equivalent per MIL-H-55460, in accordance with 3.0 of ICD-002. 1600 Hz ringing and detection facilities shall be included with visual indication of incoming calls.

3.7.3.1.6 Transmission Status Interface. The group modem shall provide a compatible status/control interface in accordance with 3.1.2.1.4.

3.7.3.1.7 Station Clock Interface. Station clock shall be provided by the traffic modem in accordance with 3.2.1.6.

### 3.7.4 Small Antenna System.

The small antenna system shall include a man-transportable antenna mast structure, a parabolic antenna, and the associated waveguide and support hardware (e.g., transit case(s), guys, anchors or stakes and baseplates) as required for SRWBR terminal operation. The small antenna system shall provide the characteristics specified in the following subparagraphs. Other performance characteristics shall be governed by the terminal design and shall be consistent with the overall performance specified in 3.2.1.

3.7.4.1 Mast Assembly. The mast assembly shall include tools, antenna positioning devices, and accessories as required to permit the mast to be erected to a height of 15 feet or dismantled within the specified times (3.2.2.6) by a maximum of two (2) men. The mast assembly shall permit erection and operation of the antenna in adverse (abnormally hard or soft) soil and ground conditions.

3.7.4.2 Antenna. The antenna size shall be consistent with the portability concepts of the unsheltered terminals, but not exceed 24 inches in diameter.

3.7.4.2.1 Polarization. The antenna shall be capable of radiating energy in both horizontal and vertical linear polarization modes (but not simultaneously).

3.7.4.2.2 Gain. The antenna shall have a minimum gain above isotropic of 37.0 dB at 15.0 GHz (either polarization).

3.7.4.2.3 Sidelobes. The peak amplitude of any sidelobes with respect to the peak amplitude of the main lobe shall not exceed -20 dB within plus and minus 4 degrees of beam center, -25 dB between plus or minus 4 degrees and plus or minus 60 degrees, and shall not exceed -30 dB between plus or minus 60 degrees and plus or minus 110 degrees.

3.7.4.2.4 Front to Back Ratio. The ratio of the intensity of the main lobe to the intensity of the largest lobe occurring between plus or minus 110 degrees and 180 degrees from the center of the main lobe shall be at least 35 dB.

3.7.4.3 Waveguide. The total waveguide length shall be 25 feet, with not more than 2 dB of attenuation, enabling the antenna to be placed at a maximum distance of 10 feet from the Receiver/Transmitter.

3.7.4.4 Antenna Voltage Standing Wave Ratio (VSWR). The maximum VSWR of the antenna system across the design frequency band shall not exceed 1.2:1 at all phase angles.

3.7.4.5 Erection. The small antenna system shall be capable of erection to operating height with antenna and transmission lines installed in wind up to 20 miles per hour. Under these conditions, the small antenna system shall require a time to be placed into full operating condition consistent with the requirements of paragraph 3.2.2.6. The small antenna system shall be returnable to its transport configuration in the same time or less.

3.7.4.6 Soil and Ground Conditions. The small antenna system shall be designed such that it can be erected in all soil and ground conditions found in worldwide deployments. The small antenna system shall maintain the antenna pointing accuracy specified in 3.7.4.7, in soil having a modulus of subgrade reaction equal to 38 psi/in, when erected to maximum height and undergoing the wind load (100 knots) of 3.2.5.8.

**3.7.4.7 Antenna Pointing Accuracy.** The small antenna system shall have a minimum pointing accuracy of 1.25 degrees under the conditions of paragraph 3.7.4.6.

**3.7.4.8 Alignment Coverage.** The antenna shall be capable of fine adjustment in both elevation and azimuth for alignment purposes. The elevation coverage shall be at least plus and minus 25 degrees with reference to the horizontal plane orthogonal to the vertical reference of the supporting plane structure. The azimuth coverage shall be at least plus and minus 15 degrees with the boresight referenced at the vertical orthogonal reference to the horizontal of the small antenna system mounting connection.

**3.7.4.8.1 Alignment Device.** Provisions shall be made to make the necessary adjustments described in paragraph 3.7.4.8. This shall be achieved by a mechanical device which shall permit operating personnel to adjust the antenna in azimuth and elevation at the base of the antenna mast. The antenna adjustment control package shall include a device which shall indicate the absolute position, in degrees, of the antenna within the limits of the elevation and azimuth adjustment range given in 3.7.4.8. This device shall display degrees in one-half degree increments. The control cables and control device shall incorporate suitable connectors to permit ease of storage after adjustment. A suitable locking device shall be incorporated for locking the antenna in elevation and azimuth after alignment.

## SECTION 4

### QUALITY ASSURANCE PROVISIONS

#### 4.1 GENERAL

Compliance with operational parameters shall be determined from Government approved test plans and test reports as required by the CDRL.

##### 4.1.1 Responsibility for Inspection.

Unless otherwise specified by the procuring activity, the contractor shall be responsible for the performance of all inspection requirements as specified herein.

#### 4.2 QUALITY CONFORMANCE INSPECTIONS

##### 4.2.1 Classification of Inspection.

Inspections shall be classified as follows:

- a. Engineering model inspection.
- b. Inspections covering subsidiary documents.

##### 4.2.2 Engineering Model Inspecting.

This inspection shall consist of the inspections specified in subsidiary documents covering the items listed in 4.2.3 and the following:

- a. Visual and Mechanical Inspection (4.2.4)
- b. Interface And Operational Tests (4.2.5)
- c. Environmental Condition Tests (4.2.6)
- d. EMI/EMC Tests (4.2.7)
- e. Safety (4.2.8)
- f. Maintainability Demonstration (4.2.9)
- g. Reliability Testing (4.2.10)
- h. Burn-In (Debugging) (4.2.11)

i. Human Engineering (4.2.12)

j. System Test (4.2.13)

k. Nuclear Test (4.2.14)

l. Power Variation Test (4.2.15)

#### 4.2.3 Inspection By Subsidiary Documents.

The following shall be inspected under the applicable subsidiary documents:

<u>ITEM</u>	<u>WHERE REQUIRED</u>
Solid State Microelectronic Design	3.3.1.2
Color (Finish)	3.2.2.4
Hardware	3.3.1.4
Standard Parts	3.3.1.8
Interchangeability	3.3.2
Nameplates and Product Marking	3.3.4

#### 4.2.4. Visual and Mechanical Inspection.

Parts and components shall be inspected for workmanship, mechanical fit, loose nuts and screws, and miscellaneous defects. Controls and fastening devices shall be inspected for mechanical operation. Wiring, soldered connections, welds, finishes, etc., shall be inspected for workmanship and defects in accordance with MIL-STD-252. Clearance, dimensions, and mechanical adjustments shall be measured.

#### 4.2.5 Interface and Operational Tests.

Interface tests shall be performed to show compliance with the interface requirements of 3.1.2 and 3.7.

Operational tests shall be performed to show compliance with the performance requirements of 3.2 and 3.7.

#### 4.2.6 Environmental Condition Test.

The operational tests and measurements to be performed before, during, and after the following environmental condition tests shall be in accordance with the appropriate test requirement of MIL-STD-810.

4.2.6.1 Pre-Environmental Performance Tests. Prior to conducting any of the environmental condition tests, the equipment shall be operated under the following conditions:

- a. Temperature  $25^{\circ} \pm 3^{\circ} \text{C}$  ( $77^{\circ} \pm 5 \text{ F}$ )
- b. Humidity  $50 \pm 5\%$
- c. Local ambient barometric pressure corrected to between 28 and 32 in of mercury.

#### 4.2.6.2 Environmental Conditions.

4.2.6.2.1 High Temperature. The equipment shall be subjected to the test of Method 501.1, Procedure I of MIL-STD-810. The storage temperature (Step 2) shall be  $-57^{\circ} \text{C}$  ( $-70^{\circ} \text{F}$ ) and shall be maintained for a period of not less than 2 hours following stabilization of the test item. Low operating temperature shall be  $-46^{\circ} \text{C}$  ( $-50^{\circ} \text{F}$ ).

4.2.6.2.2 Humidity. The equipment shall be subjected to the test of Method 507.1 of MIL-STD-810, Procedure II or III depending on the design of the equipment. Procedure III shall be used if the equipment contains areas normally sealed during operation by gasket or other nonhermetic type seal. In Step 7 of Procedure III, the chassis shall be removed from its enclosure or the test item shall be otherwise opened so as to expose the normally sealed areas to the chamber environment. In Step 6 of either procedure, measurements shall be taken during the last 5 hours of the last cycle.

4.2.6.2.3 Altitude. The equipment shall be subjected to the test of Method 500.1, Procedure I of MIL-STD-810, except Step 2 shall be 40,000 ft. In Step 2, the rate of latitude change shall not exceed 2500 250 ft/min.

4.2.6.2.4 Dust. The equipment shall be subjected to the test of Method 510.1, Procedure I of MIL-STD-810.

4.2.6.2.5 Salt Fog. The equipment in its operating configuration shall be subjected to the test of Method 509.1, Procedure I of MIL-STD-810. Electronic operation of the equipment shall not be required and failure criteria shall be limited to the following:

- a. Corrosion or degradation of surfaces which is attributed to

this environment and determined by qualified and approved laboratory personnel.

- b. Clogging or binding when an attempt is made to operate any mechanical part through its full range of movement.

4.2.6.2.6 Fungus. The equipment model shall be subjected to the fungus test specified in Method 508.1, Procedure I, of MIL-STD-810. There shall be abundant growth colonization on 50% or more of the area of the control item(s) after 14 and 28 days. No cleaning of the equipment model is permitted for 72 hours prior to the fungus test. Handling, prior to and during testing, shall be accomplished without contamination of the equipment. After the fungus test, the equipment shall be visually examined, using a 10-power magnifier. The equipment shall show no more than six minute unrelated spots, each not greater than 0.015 in<sup>2</sup> in area, of sparse microbial growth as evidenced by growth colonization which includes branching and sporulation on or within each cubic foot, or fraction thereof, of equipment assembly volume. Isolated instances of partial tubular germination shall not be included in this evaluation. The equipment interior, exterior, and packing material shall all be inoculated.

4.2.6.2.7 Sunshine. The equipment shall be subjected to the sunshine test of Method 505.1, Procedure I of MIL-STD-810.

4.2.6.2.8 Vibration and Shock.

a. Vibration.

- (1) Part I. The equipment in its combination case shall be subjected to the test of MIL-STD-810, Method 514.2, Procedure XI, Part 2. Prior to and following this test, the equipment shall be operated in accordance with MIL-STD-810, General Requirements. The equipment shall not have any degradation in performance. The equipment, including the combination case, shall not suffer any mechanical damage.
- (2) Part II. The equipment in its combat transportation mode (in its combination case) shall be subjected to the test of MIL-STD-810C, Method 514.2, Procedure X. The vibration level shall be in accordance with Figure 514.2-7 curve AW. The cycling and sweep time shall be in accordance with Table 514.2-VII. Prior to and following this test, the equipment shall be operated in accordance with MIL-STD-810, General Requirements. The equipment shall not have any degradation in performance. The equipment, including the combination case, shall not suffer any mechanical damage.

b. Shock. The equipment in its combat transportation mode (in its combination case) shall be subjected to the test of MIL-STD-810C, Method 516.2, Procedure II. The equipment shall also be subjected to the test of MIL-STD-810C, Method 515.7, Procedure V. Prior to and following these tests, the equipment shall be operated in accordance with MIL-STD-810, General Requirements. The equipment shall not have any degradation in performance and shall not suffer any mechanical damage.

4.2.6.2.9 Rain. The equipment in operating conditions shall be subjected to the test of Method 506.1, Procedure I of MIL-STD-810. The equipment shall be operated during the last 10 minutes of the 30 minute period.

4.2.6.2.10 Wind/Ice. The erected antenna and mast in the exposed terminal configurations shall meet the specified performance criteria while tested under the following service conditions while operating:

- a. 100 knot wind in any direction.
- b. A combination of 2 inches of radial ice on all metal surfaces and 1/2 in ice on cables with a 65 knot wind. This test requirement may be satisfied by analysis.

4.2.6.2.11 Set-Up (Adverse Soil). The capability to set up the antenna and mast in the exposed terminal configurations on hard and soft terrain conditions without loss of antenna alignment shall be demonstrated as follows:

- a. The antenna and tower/mast shall be erected on loose uncompacted dry sand with all anchors set therein and left in place for one day. At the completion of the test period, there shall be no evidence of loosening of the guy wires.
- b. The antenna and mast/tower shall be erected on rocky terrain.

4.2.6.2.12 Lightning. An analysis shall be performed to verify compliance with the requirements established in 3.2.5.16.

4.2.6.3 Test Sequence. The test sequence shall be as listed in Table III.

#### 4.2.7 Electromagnetic Compatibility Tests.

- a. The SRWBR components shall be tested in accordance with Table II, Class A3 of MIL-STD-461, Notice 3. Radiated susceptibility tests will use sine wave signals up to 150

kHz and square wave modulation (1000 Hz) signals above 150 kHz. When testing indicates noncompliance with the applicable requirements of MIL-STD-461 and MIL-STD-462, testing shall stop, corrective measures shall be implemented, and then testing shall be reinstated. This procedure shall continue until the limits of MIL-STD-461 have been met.

- b. An unsheltered SRWBR shall also be open-field-tested in the vicinity of both the AN/TPS-43 and the AN/TPS-44 radar to verify that the SRWBR performance is not impaired when these equipments are deployed and operated in a typical manner. Testing shall be performed in the 1.0 to 5.5 GHz frequency range with the SRWBR tested in an operational configuration at a distance of 500 feet from the radar and tested in each of four orientations at 90 increments.

#### 4.2.8 Safety.

4.2.8.1 Safety Evaluation. A safety evaluation shall be conducted by the contractor to determine that all personnel, equipment, and environmental hazards have been identified and eliminated in compliance with 3.3.8 thru 3.3.8.5.

4.2.8.2 Safety Inspection. During acceptance inspection, a visual inspection shall be performed to determine that all requirements, as a result of the safety evaluation, have been incorporated in the equipment. Inability to meet the requirements of 3.3.8.1 shall constitute a failure of the test.

#### 4.2.9 Maintainability Demonstration.

Compliance with the maintainability requirements of 3.2.4 shall be demonstrated. The demonstration shall be conducted in accordance with MIL-STD-471 and shall encompass Phase I as described in 4.1.1 of MIL-STD-471. Phase II of the demonstration shall be an extension of Phase I.

##### 4.2.9.1 Maintainability Parameter Calculations.

4.2.9.1.1 Mean Time To Repair. Compliance with the specified MTTRs of 3.2.4 shall be determined in accordance with MIL-STD-471, Test Method I, Plan (B), "Test on the Mean", with the following constraints:

- a. The sample size to be used for each level of maintenance shall be determined by equation 1-4 of Method I, with the minimum sample size equal to (TBD). However, under no circumstances shall the sample size be greater than the

number of distinct maintenance actions possible at that level of maintenance.

- b. The Alpha and Beta risks shall be no greater than 10%.
- c. The value of  $u_0$  for each level of maintenance shall be the specified Mct of 3.2.4.
- d. The discrimination ratio ( $u_1/u_0$ ) for each level of maintenance shall be 1.5.

4.2.9.1.2 Maximum Corrective Maintenance Time (Mmaxct). Compliance with the specified Mmaxct shall be determined in accordance with the following test plan:

- a. The data collected in the test method of 4.2.9.1.1. shall be used for analysis.
- b. The corrective maintenance times shall be ranked in ascending order for each level of maintenance (X1, X2, X3, X4, X5,-----Xn: Xn is the longest repair time recorded).
- c. Xmax is selected such that max = 95% of the samples size (.95n), rounding down to the nearest integer (Example: .95 times a sample of 29 would be 27.55. This would be rounded down to 27, making Xmax the 27th entry in the list of times to repair).
- d. The Mmaxct is calculated in accordance with MIL-STD-471.

4.2.9.1.3 Task Apportionment. Tasks for the Maintainability Demonstration shall be selected in accordance with MIL-STD-471, Appendix A.

4.2.10 Reliability Testing.

Reliability testing shall be in accordance with the test plans and test levels of MIL-STD-781 as follows:

<u>Configuration*</u>	<u>Test Plan</u>	<u>Test Level</u>	<u>Specified MBTF</u>	<u>Sample Size Range</u>
Exposed High Capacity SRWBR	XXII	C	3000	TBD
Exposed Low Capacity SRWBR	XXII	C	3000	TBD

\*Excludes GFE failures.

4.2.10.1 Reliability Test Condition. Reliability testing shall be accomplished subject to the following conditions:

- a. The SRWBRs shall be operated over nominal path lengths (or simulated) as required by 3.2.
- b. Duty Cycle. The equipment shall be exercised in all modes of operation (not standby) in proportion to the expected usage.

4.2.10.2 Failure Analysis. Failures, as defined in 3.2.3.1.1, shall be recorded and analyzed. Sections 5.5 thru 5.10 inclusive of MIL-STD-781 shall apply. The types of failures and required actions shall be in accordance with 5.5.1 of MIL-STD-781. Determination of compliance shall be in accordance with 5.4.8 of MIL-STD-781.

4.2.10.3 Rework and Retest Provisions. Once a reject decision has been reached, no rerun can be made of that test on the same or a new sample from the same lot unless positive action consisting of design change, modification, or rework actually relating to observed failures has been applied to the lot. Any subsequent rerun must start at zero hours operating time.

4.2.10.4 Conditions Precedent to Reliability Test. The following paragraphs of MIL-STD-781 shall apply:

- a. Design and Performance tests
- b. Thermal survey
- c. Vibration survey
- d. Burn-in (debugging) period

4.2.11 Burn-in (Debugging).

Every equipment shall be subjected to a 48 hour burn-in period. The last 24 hours of burn-in shall be failure free. The burn-in shall be conducted under the conditions of 4.2.9.1.1. and all equipments shall be exercised and monitored in the same manner as during reliability testing. The failures shall be recorded and analyzed, but shall not be considered relevant for computation of equipment MTBF.

4.2.12 Human Engineering.

The equipment shall conform to the requirements of MIL-STD-1472 and MIL-H-46855.

4.2.13 System Test.

System tests shall be performed on each terminal configuration described herein. The system tests shall verify compliance with the interoperability requirements relative to other equipments with which the units under test are designed to operate.

4.2.14 Nuclear Test.

Applicable tests for nuclear survivability shall be performed on each terminal configuration in accordance with Appendix I.

4.2.15 Power Variation Test.

The equipment shall be operated over the steady-state range of voltage and frequency as specified in paragraph 3.1.2.1.5. Reference measurements shall be made at the nominal voltage and frequency. The equipment shall then be operated at the extreme limits of the steady-state band in combinations of voltage and frequency as shown in Table IV.

Table IV - Power Variation Test

Condition	<u>Voltage</u>			<u>Frequency</u>		
	<u>Lower Limit</u>	<u>Nominal</u>	<u>Upper Limit</u>	<u>Lower Limit</u>	<u>Nominal</u>	<u>Upper Limit</u>
A		X			X	
B	X			X		
C			X	X		
5						
D			X			X
E	X					X

The equipment shall be operated at least 15 minutes in each voltage/frequency combination during which time measurements shall be taken to insure that the equipment meets the specified performance levels. The following data shall be recorded for each combination of AC or DC input voltage and frequency; Performance (3.2.1) and Stability (3.7.1.1.2 and 3.7.1.2.3). The data for this test shall be made available to the government upon request. This test may be run in conjunction with other tests provided all requirements are satisfied.

SECTION 5

PREPARATION FOR DELIVERY

5.1 PACKAGING, PACKING, AND MARKING

Packaging, packing, and marking shall be as specified in the bid request and contract.