

AD-A061 278

NAVAL POSTGRADUATE SCHOOL MONTEREY CALIF
PERFORMANCE OF MULTIPLE NOZZLE EDUCTOR SYSTEMS WITH SEVERAL GEO--ETC(U)
SEP 78 R J LEMKE, C P STAEHLI

F/G 20/4

UNCLASSIFIED

NPS69-78-016

NL

1 of 3
AD A061 278

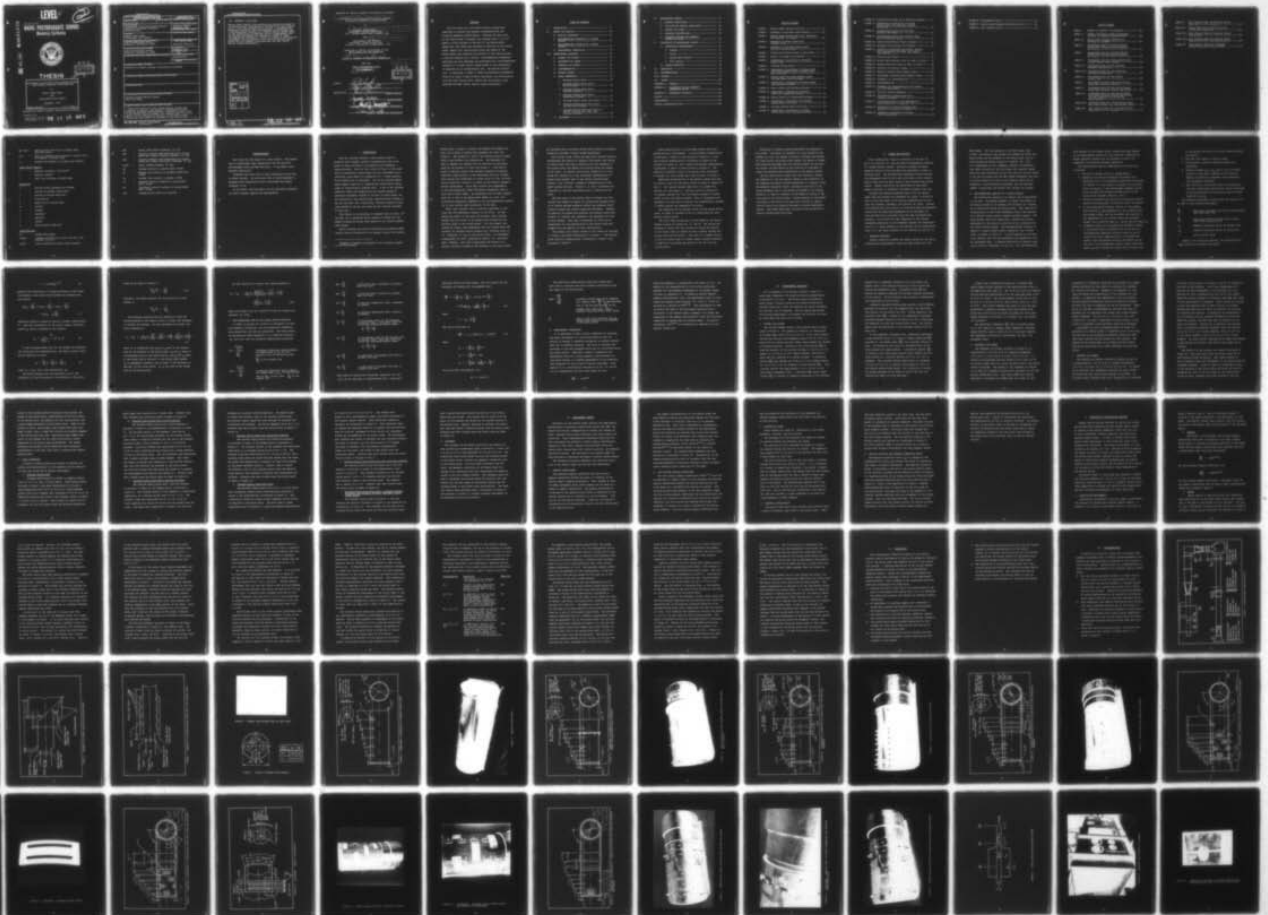

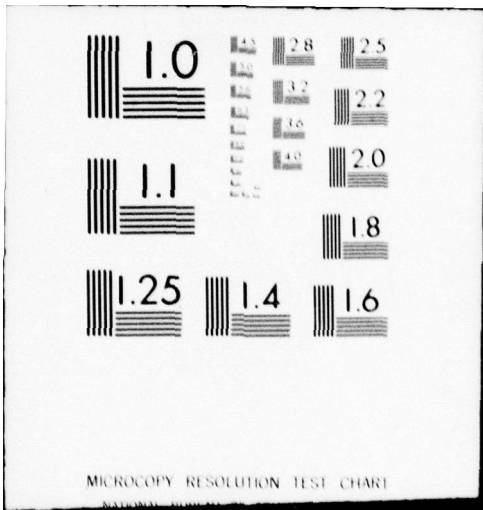

LEVEL II

Handwritten signature
Na

NPS 69-78-016

NAVAL POSTGRADUATE SCHOOL
Monterey, California

AD A061278

DDC FILE COPY

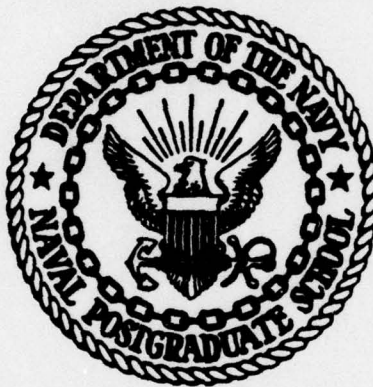

DDC
RECEIVED
NOV 17 1978
D

THESIS

PERFORMANCE OF MULTIPLE NOZZLE EDUCTOR SYSTEMS
WITH SEVERAL GEOMETRIC CONFIGURATIONS

by

Robert James Lemke

and

Christopher Paul Staehli

September 1978

Thesis Advisor:

P. F. Pucci

Approved for public release; distribution unlimited.

Prepared for:

Naval Sea Systems Command
Washington, D. C.

78 11 13 092

UNCLASSIFIED

SECURITY CLASSIFICATION OF THIS PAGE (When Data Entered)

REPORT DOCUMENTATION PAGE		READ INSTRUCTIONS BEFORE COMPLETING FORM
1. REPORT NUMBER NPS 69-78-016	2. GOVT ACCESSION NO.	3. RECIPIENT'S CATALOG NUMBER
4. TITLE (and Subtitle) Performance of Multiple Nozzle Eductor Systems with Several Geometric Configurations	5. TYPE OF REPORT & PERIOD COVERED Master's Thesis; September 1978	
	6. PERFORMING ORG. REPORT NUMBER	
7. AUTHOR(s) Robert James Lemke Christopher Paul Staehli	8. CONTRACT OR GRANT NUMBER(s)	
	9. PERFORMING ORGANIZATION NAME AND ADDRESS Naval Postgraduate School Monterey, California 93940	
10. PROGRAM ELEMENT, PROJECT, TASK AREA & WORK UNIT NUMBERS N0002478 WR-8-G192		11. CONTROLLING OFFICE NAME AND ADDRESS Naval Postgraduate School Monterey, California 93940
12. REPORT DATE September 1978		13. NUMBER OF PAGES 263
14. MONITORING AGENCY NAME & ADDRESS (if different from Controlling Office)		15. SECURITY CLASS. (of this report) Unclassified
		15a. DECLASSIFICATION/DOWNGRADING SCHEDULE
16. DISTRIBUTION STATEMENT (of this Report) Approved for public release; distribution unlimited.		
17. DISTRIBUTION STATEMENT (of the abstract entered in Block 20, if different from Report)		
18. SUPPLEMENTARY NOTES		
19. KEY WORDS (Continue on reverse side if necessary and identify by block number) Multiple Nozzle Eductor System Cold Flow Tests		
20. ABSTRACT (Continue on reverse side if necessary and identify by block number) Cold flow tests of a four nozzle eductor system were conducted to evaluate the system's performance with the following geometric modifications: changing the area ratio of the mixing stack to primary flow nozzles from 3.0 to 2.5; adding a solid diffusor to the exit of the mixing stack; adding two- and three-ring diffusors to the exit of the		

UNCLASSIFIED

SECURITY CLASSIFICATION OF THIS PAGE(When Data Entered)

(20. ABSTRACT Continued)

mixing stack; adding film cooling ports along the length of the mixing stack; and combining the effects of film cooling ports, a two-ring diffusor and a shroud. Non-dimensional parameters governing the flow phenomena are developed from a one-dimensional analysis of a simple eductor system based on the conservation of momentum for an incompressible gas. The eductor performance is evaluated in terms of these non-dimensional parameters. Within the range of modifications considered, the configuration with the film cooling ports, shroud and two diffusor rings provided the best overall eductor system performance.

ACCESSION NO.	
DTIC	White Section <input checked="" type="checkbox"/>
DDC	DDW Section <input type="checkbox"/>
UNANNOUNCED	<input type="checkbox"/>
JUSTIFICATION	
BY	
DISTRIBUTION/AVAILABILITY CODES	
Dist.	AVAIL. CODE/OF SPECIAL
A	

DD Form 1473
1 Jan 73
S/N 0102-014-6601

78 11 13 09 2

UNCLASSIFIED

2 SECURITY CLASSIFICATION OF THIS PAGE(When Data Entered)

Approved for public release; distribution unlimited.

6 Performance of Multiple Nozzle Eductor Systems with Several Geometric Configurations.

by

10 Robert James Lemke Christopher Paul Staehli
Lieutenant, United States Navy
B.S., United States Naval Academy, 1969

and 14 NPS69-78-Ø16
Christopher Paul Staehli
Lieutenant, United States Navy
B.S.M.E., University of Washington, 1970

Submitted in partial fulfillment of the requirements for the degree of

9 Master's Thesis
MASTER OF SCIENCE IN MECHANICAL ENGINEERING

from the

NAVAL POSTGRADUATE SCHOOL

11 September 1978

12 264p.
DDC
RECEIVED
NOV 17 1978
D

Authors

R. Lemke
C. P. Staehli

Approved by:

Paul Trucci
Thesis Advisor

Matthew Kelleher
Second Reader

Paul J. Warts
Chairman, Department of Mechanical Engineering

William M. Idler
Dean of Science and Engineering

Gu

ABSTRACT

Cold flow tests of a four nozzle eductor system were conducted to evaluate the system's performance with the following geometric modifications: changing the area ratio of the mixing stack to primary flow nozzles from 3.0 to 2.5; adding a solid diffuser to the exit of the mixing stack; adding two- and three-ring diffusers to the exit of the mixing stack; adding film cooling ports along the length of the mixing stack; and combining the effects of film cooling ports, a two-ring diffuser and a shroud. Non-dimensional parameters governing the flow phenomena are developed from a one-dimensional analysis of a simple eductor system based on the conservation of momentum for an incompressible gas. The eductor performance is evaluated in terms of these non-dimensional parameters. Within the range of modifications considered, the configuration with the film cooling ports, shroud and two diffuser rings provided the best overall eductor system performance.

TABLE OF CONTENTS

I.	INTRODUCTION -----	17
II.	THEORY AND ANALYSIS -----	22
	A. MODELING TECHNIQUE -----	22
	B. ONE-DIMENSIONAL ANALYSIS OF A SIMPLE EDUCTOR -----	23
	C. NON-DIMENSIONAL SOLUTION OF A SIMPLE EDUCTOR -----	30
	D. EXPERIMENTAL CORRELATION -----	33
III.	EXPERIMENTAL APPARATUS -----	35
	A. PRIMARY AIR SYSTEM -----	35
	B. SECONDARY AIR PLENUM -----	37
	C. TERTIARY AIR PLENUM -----	38
	D. INSTRUMENTATION -----	40
	E. EDUCTOR SYSTEM -----	41
	F. MODEL GEOMETRIES -----	42
	1. Straight Mixing Stack -----	42
	2. Straight Mixing Stack with a Solid Diffusor -----	43
	3. Straight Mixing Stack with a Two-Ring Diffusor -----	43
	4. Straight Mixing Stack with a Three-Ring Diffusor -----	44
	5. Straight Mixing Stack with Ports -----	44
	6. Straight Mixing Stack with Ports and Two-Ring Diffusor -----	45
	7. Straight Mixing Stack with Ports, A Shroud Covering the Ports, and Two-Ring Diffusor -----	45
	G. ALIGNMENT -----	45

IV.	EXPERIMENTAL METHOD -----	47
	A. PUMPING COEFFICIENTS -----	47
	B. FILM COOLING PUMPING COEFFICIENT -----	48
	C. INDUCED AIR FLOWS -----	49
	D. PRESSURE DISTRIBUTIONS -----	49
	E. VELOCITY PROFILES AND MOMENTUM CORRECTION FACTOR -----	50
V.	DISCUSSION OF EXPERIMENTAL RESULTS -----	52
	A. QUANTITATIVE MEASUREMENTS -----	52
	1. Pumping -----	53
	2. Mixing -----	53
	3. Uptake Back Pressure -----	54
	4. Film Cooling -----	54
	B. SYSTEM EVALUATION -----	55
VI.	CONCLUSION -----	64
VII.	RECOMMENDATIONS -----	66
VIII.	FIGURES -----	67
IX.	TABLES -----	188
	APPENDIX A: FORMULAE -----	252
	APPENDIX B: CALCULATION OF THE MOMENTUM CORRECTION FACTOR -----	255
	APPENDIX C: UNCERTAINTY ANALYSIS -----	258
	EPILOG -----	260
	BIBLIOGRAPHY -----	261
	INITIAL DISTRIBUTION LIST -----	262

LIST OF FIGURES

FIGURE 1	Eductor Model Testing Facility -----	67
FIGURE 2	Schematic of Straight Stack Eductor -----	68
FIGURE 3	Eductor Model Testing Facility, Secondary and Tertiary Air Plenums -----	69
FIGURE 4	Schematic of Mixing Stack with Diffusor Rings -----	70
FIGURE 5	Schematic of Shrouded Mixing Stack with Film Cooling Ports -----	71
FIGURE 6	Primary Flow Nozzles Used in This Study -----	72
FIGURE 7	Layout of Primary Flow Nozzles -----	72
FIGURE 8	Dimensional Illustration of Straight Mixing Stack -----	73
FIGURE 9	Straight Mixing Stack -----	74
FIGURE 10	Dimensional Illustration of Mixing Stack with Seven Degree Double Included Angle Solid Diffusor -----	75
FIGURE 11	Mixing Stack with Seven Degree Double Included Angle Solid Diffusor -----	76
FIGURE 12	Dimensional Illustration of Mixing Stack with Two-Ring Diffusor -----	77
FIGURE 13	Mixing Stack with Two-Ring Diffusor -----	78
FIGURE 14	Dimensional Illustration of Mixing Stack with Three-Ring Diffusor -----	79
FIGURE 15	Mixing Stack with Three-Ring Diffusor -----	80
FIGURE 16	Dimensional Illustration of Straight Mixing Stack with Ports -----	81
FIGURE 17	Straight Mixing Stack with Ports -----	83
FIGURE 18	Dimensional Illustration of Ported Mixing Stack and A Two-Ring Diffusor -----	85

FIGURE 19	Ported Mixing Stack and A Two-Ring Diffusor ---	87
FIGURE 20	Dimensional Illustration of Ported Mixing Stack with Two-Ring Diffusor and Shroud -----	89
FIGURE 21	Ported Mixing Stack with Two-Ring Diffusor and Shroud -----	90
FIGURE 22	Ported Mixing Stack with Diffusor Ring and Flow-Through Shroud -----	92
FIGURE 23	Simple Single Nozzle Eductor System -----	93
FIGURE 24	Secondary and Tertiary Air Plenums -----	94
FIGURE 25	Interior of Secondary Air Plenum Showing Flow Straightener and ASME Long Radius Flow Nozzles -----	95
FIGURE 26	Tertiary Air Plenum -----	96
FIGURE 27	Mixing Stack Entrance with Air Seal in Place --	97
FIGURE 28	Mixing Stack Exit with Air Seal in Place -----	98
FIGURE 29	Interior of Tertiary Plenum -----	99
FIGURE 30	Sketch of Mixing Stack Support Stand -----	100
FIGURE 31	Photograph of Mixing Stack Support Stand -----	101
FIGURE 32	Schematic of Instrumentation -----	102
FIGURE 33	Instrumentation -----	103
FIGURE 34	Schematic of Instrumentation for Primary Air Flow Measurement -----	104
FIGURE 35	Velocity Profile Apparatus -----	105
FIGURE 36	Orientation of Mixing Stack Exit Velocity Traverses -----	106
FIGURE 37	Illustrative Plot of the Experimental Data Correlation in Equation (14) -----	107
FIGURE 38	Orientation of Static Pressure Taps Relative to Primary Flow Nozzles -----	108
FIGURE 39	Schematic Illustration of Mixing Stack Misalignment -----	109

FIGURE 40	Performance Plots -----	110
FIGURE 41	Mixing Stack Pressure Distribution Plots -----	145
FIGURE 42	Exit Velocity Plots -----	173

LIST OF TABLES

TABLE I	Summary of Effects of Parameters -----	188
TABLE II	Summary of Eductor System Performance Criteria For Eductor Systems Tested -----	189
TABLE III	Mixing Stack Pressure Readings as Effected by Alignment -----	190
TABLE IV	Performance Data For Straight Mixing Stacks With Primary Nozzle Diameters of 3.38 In. -----	191
TABLE V	Performance Data For Straight Mixing Stacks With Primary Nozzle Diameters of 3.70 In. -----	195
TABLE VI	Performance Data For Mixing Stacks With A Seven Degree Solid Diffusor -----	198
TABLE VII	Performance Data For The Two-Ring Diffusor Configuration -----	205
TABLE VIII	Performance Data For The Three-Ring Diffusor Configuration -----	207
TABLE IX	Performance Data For The Ported Mixing Stack -----	209
TABLE X	Performance Data For The Ported Mixing Stack With Two-Ring Diffusor -----	218
TABLE XI	Performance Data For The Ported Mixing Stack With Two-Ring Diffusor And Shroud -----	222
TABLE XII	Performance Data For The Ported Mixing Stack With Two-Ring Diffusor and Shroud Cut Back One-Half In. From Mixing Stack Entrance -----	227
TABLE XIII	Performance Data For Ported Mixing Stack With Ring Diffusor and Flow-Through Shroud --	232
TABLE XIV	Exit Velocity Data For A Straight Mixing Stack With 3.38 In. Nozzles -----	237

TABLE XV	Exit Velocity Data For Straight Mixing Stack With 3.70 In. Nozzles -----	239
TABLE XVI	Mixing Stack Exit Velocity Data For Various Exit Geometries -----	241
TABLE XVII	Exit Velocity Data For Straight Ported Mixing Stack -----	247
TABLE XVIII	Exit Velocity Data For Straight Ported Mixing Stack With A Two-Ring Diffusor -----	248
TABLE XIX	Exit Velocity Data For A Shrouded Ported Mixing Stack With Diffusor -----	249

NOMENCLATURE

English Letter Symbols

A	-	Area, in. ²
c	-	Sonic velocity, ft/sec
C	-	Coefficient of discharge
D	-	Diameter, in.
Fa	-	Thermal expansion factor
F _{fr}	-	Wall skin-friction force, lbf
g _c	-	Proportionality factor in Newton's Second Law, g _c = 32.174 lbm-ft/lbf-sec ²
h	-	Enthalpy, Btu/lbm
k	-	Ratio of specific heats
L	-	Length, in.
P	-	Pressure, in. H ₂ O
P _a	-	Atmospheric pressure, in. Hg
P _v	-	Velocity head, in. H ₂ O
PMS	-	Static pressure along length of mixing stack, in. H ₂ O
R	-	Gas constant for air, 53.34 ft-lbf/lbm-°R
s	-	Entropy, Btu/lbm-°R
S	-	Distance from primary nozzle exit to mixing stack or entrance transition entrance, in.
T	-	Absolute temperature, °R
u	-	Internal energy, Btu/lbm
U	-	Velocity, ft/sec
v	-	Specific volume, ft ³ /lbm

- W - Mass flow rate, lbm/sec
- x - Axial distance from the entrance of the mixing stack, in.
- Y - Expansion factor

Dimensionless Groupings

- A* - Secondary flow area to primary flow area ratio
- AR - Area ratio
- f - Friction factor
- K - Flow coefficient
- K_e - Kinetic energy correction factor
- K_m - Momentum correction factor at the mixing stack exit
- K_p - Momentum correction factor at the primary nozzle exit
- M - Mach number
- ΔP^* - Pressure coefficient
- PMS* - Mixing stack pressure coefficient
- Re - Reynolds Number
- S/D - Standoff; Ratio of distance from entrance of mixing stack to diameter of mixing stack
- $T_f^* = TF^*$ - Absolute temperature ratio of the film flow to primary flow
- $T_s^* = TS^*$ - Absolute temperature ratio of the secondary flow to primary flow
- $T_t^* = TT^*$ - Absolute temperature ratio of the tertiary flow to primary flow
- $W_f^* = WF^*$ - Film cooling mass flow rate to primary mass flow rate ratio
- $W_s^* = WS^*$ - Secondary mass flow rate to primary mass flow rate ratio

- $W_t^* = WT^*$ - Tertiary mass flow rate to primary mass flow rate ratio
 X/D - Ratio of distance from entrance of mixing stack to diameter of mixing stack
 ρ^* - Induced flow density to primary flow density

Greek Letter Symbols

- μ - Absolute viscosity, lbf-sec/ft²
 ρ - Density, lbm/ft³
 ψ - Split ring diffusor included angle

Subscripts

- 0 - Section within secondary air plenum
 1 - Section at primary nozzle exit
 2 - Section at mixing stack exit
 f - Film cooling
 m - Mixed flow or mixing stack
 or - Orifice
 p - Primary
 s - Secondary
 t - Tertiary
 u - Uptake
 w - Mixing stack inside wall

Tabulated Data

- MU - Uptake Mach number
 PA-PNZ - Pressure differential across secondary flow nozzles, in. H₂O
 PA-PS - Static pressure at mixing stack entrance

- PMS - Mixing stack static pressure, in. H₂O
- PTA - Velocity pressure head distribution at mixing stack exit along a diagonal traverse, in. H₂O
- PTB - Velocity pressure head distribution at mixing stack exit along a horizontal traverse, in. H₂O
- PU-PA - Static uptake pressure, in. H₂O
- UM - Average velocity in mixing stack, ft/sec
- UP - Primary flow velocity at primary nozzle exit, ft/sec
- UU - Primary flow velocity in uptake, ft/sec
- VA - Diagonal velocity traverse at mixing stack exit, ft/sec
- VB - Horizontal velocity traverse at mixing stack exit, ft/sec
- VAV - Average mixing stack exit velocity

ACKNOWLEDGMENT

This study was the result of a joint effort. The authors wish to acknowledge their appreciation for the help and encouragement each provided the other. It has been a very pleasant association.

Professor Paul Pucci was of great assistance in his role as thesis advisor. We would also like to thank Professor T. Sarpkaya whose exceptional store of knowledge was always available to us.

To our wives, Olga and Nancy, we are continually grateful for their constant support and understanding.

I. INTRODUCTION

With gas turbines becoming a more popular means of powering naval vessels, special considerations need to be given to their particular air breathing and exhausting characteristics. With air-fuel ratios of four to five times that of conventional steam plants and the requirement for a relatively large amount of combustion air, a large quantity of hot exhaust gas is generated. Due to gas turbine design, these exhaust gases are at temperatures significantly above those of conventionally powered ships. A few of the problems caused by these high temperatures are thermal damage to electronic equipment located in the mast of these ships, hot gas corrosion of the mast and other superstructures located in the hot gas wake, and a significant infrared radiation signature created by the hot gas plume and hot external surfaces of the stack.

This thesis is an extension of research done by Ellin [1]¹ and Moss [2] to determine better geometric designs for the exhaust plenum and mixing stack system of gas turbine powered naval ships.

Ellin initiated the work by constructing an eductor model testing facility consisting of an uptake, primary flow nozzle,

¹Numbers in brackets correspond to the reference numbers in the Bibliography.

mixing stack, a means to control and measure the primary air flow, and a means to measure the secondary air flow; see Figure 1. The primary air flow in the testing facility represents a gas turbine's hot exhaust gas. The secondary air flow is ambient air induced into the entrance of the mixing stack by the primary air flow; see Figure 2. From Ellin's study of multiple nozzle flow systems consisting of several identical round nozzles, it was determined that four primary flow nozzles were preferable to either three or five, and that nozzle length has little or no effect on the eductor system's overall performance. Ellin then verified the independence of the one-dimensional model correlation parameters used on flow rate or Mach number. He determined that for Mach numbers from 50% to 145% of the design Mach number of 0.064, the correlation parameters suggested in the one-dimensional analysis did in fact provide good correlation of the data.

Moss' work followed, and it initially consisted of verifying the one-dimensional analysis as did Ellin. He then tested the effect of the stand off distance (that distance between the exit plane of the primary flow nozzles and the entrance plane of the mixing stack). For the primary flow nozzles he tested, Moss determined that the optimum stand off distance for maximum eductor pumping was a distance equal to 0.5 diameters ($0.5 D_m$) of the mixing stack. An independent investigation of this, conducted by Harrell [3], confirmed Moss' findings. Moss then investigated the effects of a conical transition placed on the entrance to the mixing stack.

He concluded that a straight mixing stack without an entrance transition provided a better system performance.

This current study, using the same basic testing facility, investigates the results of changing the primary flow nozzle to mixing stack area ratio, modifying the exit geometry of the mixing stack, and adding film cooling along the length of the stack. An overall mixing stack length of $2.5 D$ was chosen for testing as it was considered representative of mixing stack lengths used in gas turbine powered ships. Figures 1 and 2 provide a schematic representation of the model testing facility. Figures 3, 4, and 5 illustrate the locations of, and the terminology used, to define the air flows.

The area ratio of the mixing stack to primary air flow nozzles was changed to reduce the uptake back pressure which is of concern because excessive uptake back pressure significantly reduces gas turbine operating efficiency. However, by lowering the uptake back pressure the primary nozzle exit velocity is reduced, and, therefore, the secondary air flow is also lowered. This loss in secondary air flow can be compensated for with modification to the mixing stack exit geometry and the addition of film cooling ports.

The primary flow nozzles tested in this study are pictured in Figure 6 and shown dimensionally in Figure 7. The straight stack tested is dimensionally illustrated in Figure 8 and pictured in Figure 9.

Three modifications of the straight mixing stack exit geometries were investigated: a solid diffuser dimensionally illustrated in Figure 10 and pictured in Figure 11, a two-ring diffuser dimensionally illustrated in Figure 12 and pictured in Figure 13, and a three-ring diffuser dimensionally illustrated in Figure 14 and pictured in Figure 15. The addition of diffuser rings on the mixing stack introduced a tertiary air flow through the rings as shown in Figure 4.

Additional modifications to the eductor system were made by cutting ports into the mixing stack as shown in Figures 16 and 17. Air induced through these ports is termed film cooling air; see Figure 5. Tertiary and film cooling air is induced, ambient air with the primary purpose of convectively cooling the eductor system. This is contrasted with secondary air flow which is ambient air predominantly intended to reduce exhaust gas temperature by mixing.

The combining of the diffuser rings and the ported mixing stack, as shown in Figures 18 and 19, constituted the next eductor system tested.

The final model tested had a shroud added to the eductor system as shown in Figures 20, 21, and 22. The shroud was designed to direct the film cooling air along the exterior of the mixing stack to reduce the heat transfer between the mixing stack and the shroud. This acts as a thermal shield of the hot mixing stack to further reduce infrared radiation in addition to providing the source of air for the film cooling ports.

Evaluation of eductor system performance was measured in four areas: the amount of secondary air flow induced by the primary air flow, the degree of mixing of primary and induced air flows within the mixing stack system, the amount of uptake back pressure impressed upon the turbine exhaust by the eductor system, and the amount of film cooling air available to reduce the exterior stack temperature of the eductor system.

The key factor which allows cold flow testing to predict the effects of a hot gas eductor system is the similarity of the momentum and energy transfer mechanisms in turbulent flows. The momentum correction factor, defined as the ratio of the actual momentum rate to the pseudo-rate based on the average velocity, is used as a measure of the degree of mixing at the exit plane of the mixing stack. Another measure of the degree of mixing is the ratio of the peak exit velocity to uptake velocity which also reflects the peak to average temperature ratios. Both these means were utilized in the evaluation of eductor system mixing abilities.

II. THEORY AND ANALYSIS

This investigation, being an extension of the work of Ellin [1] and Moss [2], uses the same one-dimensional analysis of a simple eductor system. Similarity between the basic geometry tested by Ellin and Moss was maintained in order to correlate data. The dimensionless parameters controlling the flow phenomenon used by Ellin were also used in this investigation along with the basic means of data analysis and presentation. Dynamic similarity was maintained by using Mach number similarity to establish the model's primary flow rate.

Although the analysis presented here is for an eductor model with only primary and secondary air flows, it should be kept in mind that many of the results presented are for systems with primary, secondary, and tertiary air flows. Systems with tertiary and film cooling air flows have been non-dimensionalized with the same base parameters as the secondary air flow and have been calculated using the same one-dimensional analysis. This allows for easy comparison of the results. Parameters pertaining to the secondary systems are subscripted with an "s", those relating to the tertiary box are subscripted with a "t", and those relating to film cooling air with an "f".

A. MODELING TECHNIQUE

Dynamic similarity between the models tested and the actual prototype was maintained by using the same primary air flow

Mach number. For the primary air flow Mach number used (0.064), and based on the average flow properties within the mixing stack and the diameter of the mixing stack, the air flow through the eductor system is turbulent ($Re > 10^5$). As a consequence of this, momentum exchange is predominant over shear interaction, and the kinetic and internal energy terms are more influential on the flow than are viscous forces. It can also be shown that the Mach number represents the ratio of kinetic energy of a flow to its internal energy and is, therefore, a more significant parameter than the Reynolds number in describing the primary flow through the uptakes.

B. ONE-DIMENSIONAL ANALYSIS OF A SIMPLE EDUCTOR

The theoretical analysis of an eductor may be approached in two ways. One method attempts to analyze the details of the mixing process of the primary and secondary air streams as it takes place inside the mixing stack. This requires an interpretation of the mixing phenomenon which, when applied to a multiple nozzle system, becomes extremely complex. The other method, which was chosen here, analyzes the overall performance of the eductor system and is not concerned with the actual mixing process. The one-dimensional analysis is based on a single primary nozzle exhausting into a mixing stack, as shown in Figure 23. To avoid repetition with previous reports, only the main parameters and assumptions will be represented here. A complete derivation of analysis used can be found in references [1] and [4]. The one-dimensional

flow analysis of the simple eductor system described depends on the simultaneous solution of the continuity, momentum and energy equations coupled with the equation of state, all compatible with specific boundary conditions.

The idealizations made for simplifying the analysis are as follows:

1. The flow is steady state and incompressible.
2. Adiabatic flow exists throughout the eductor with isentropic flow of the secondary stream from the plenum (at section 0) to the throat or entrance of the mixing stack (at section 1) and irreversible adiabatic mixing of the primary and secondary streams occurs in the mixing stack (between sections 1 and 2).
3. The static pressure across the flow at the entrance and exit planes of the mixing-tube (at sections 1 and 2) is uniform.
4. At the mixing-stack entrance (section 1) the primary flow velocity U_p and temperature T_p are uniform across the primary stream, and the secondary flow velocity U_s and temperature T_s are uniform across the secondary stream, but U_p does not equal U_s , and T_p does not equal T_s .
5. Incomplete mixing of the primary and secondary streams in the mixing stack is accounted for by the use of a non-dimensional momentum correction factor K_m which relates the actual momentum rate to the pseudo-rate based on the bulk-average velocity and density and by the use of a non-dimensional kinetic energy correction factor K_e which relates the actual kinetic energy rate

to the pseudo-rate based on the bulk-average velocity and density.

6. Both gas flows behave as perfect gases.
7. Flow potential energy of position changes are negligible.
8. Pressure changes P_{s0} to P_{s1} and P_1 to P_a are small relative to the static pressure so that the gas density is essentially dependent upon temperature (and atmospheric pressure).
9. Wall friction in the mixing stack is accounted for with the conventional pipe friction factor term based on the bulk-average flow velocity U_m and the mixing stack wall area A_w .

The following parameters, defined here for clarity, will be used in the following development.

$\frac{A_p}{A_m}$ area ratio of primary flow area to mixing stack cross sectional area

$\frac{A_w}{A_m}$ area ratio of wall friction area to mixing stack cross sectional area

K_p momentum correction factor for primary flow

K_m momentum correction factor for mixed flow.

f wall friction factor

Based on the continuity equation, the conservation of mass principle for steady flow yields

$$W_m = W_p + W_s + W_t \quad (1)$$

where

$$\begin{aligned} W_p &= \rho_p U_p A_p \\ W_s &= \rho_s U_s A_s \\ W_t &= \rho_t U_t A_t \\ W_m &= \rho_m U_m A_m \end{aligned} \quad (1a)$$

All of the above velocity and density terms, with the exception of ρ_m and U_m , are defined without ambiguity by the virtue of idealizations (3) and (4) above. Combining equations (1) and (1a) above, the bulk average velocity at the exit plane of the mixing stack becomes

$$U_m = \frac{W_s + W_t + W_p}{\rho_m A_m} \quad (1b)$$

where A_m is fixed by the geometric configuration and

$$\rho_m = \frac{P_a}{RT_m} \quad (2)$$

where T_m is calculated as the bulk average temperature from the energy equation (9) below. The momentum equation stems from Newton's second and third laws of motion and is the conventional force and momentum-rate balance in fluid mechanics.

$$K_p \left[\frac{W_p U_p}{g_c} \right] + \left[\frac{W_s U_s}{g_c} \right] + \left[\frac{W_t U_t}{g_c} \right] + P_1 A_1 = K_m \left[\frac{W_m U_m}{g_c} \right] \quad (3)$$

$$+ P_2 A_2 + F_{fr}$$

Note the introduction of idealizations (3) and (5). To account for a possible non-uniform velocity profile across the primary nozzle exit, the momentum correction factor K_p is introduced here. It is defined in a manner similar to that of K_m and by idealization (4), supported by work conducted by Moss, it is set equal to unity. K_p is carried through this analysis only to illustrate its effect on the final result. The momentum correction factor for the mixing stack exit is defined by the relation

$$K_m = \frac{1}{W_m U_m} \int_0^{A_m} U_m^2 \rho_2 dA \quad (4)$$

where U_m is evaluated as the bulk-average velocity from equation (1b). The wall skin friction force F_{fr} can be related to the flow stream velocity by

$$F_{fr} = f A_w \left[\frac{U_m^2 \rho_m}{2g_c} \right] \quad (5)$$

using idealization (9). As a reasonably good approximation for turbulent flow, the friction factor may be calculated from the Reynolds number

$$f = 0.046(\text{Re}_m)^{-0.2} \quad (6)$$

Applying the conservation of energy principle to the steady flow system in the mixing stack between the entrance and exit planes,

$$\begin{aligned} W_p \left[h_p + \frac{U_p^2}{2g_c} \right] + W_s \left[h_s + \frac{U_s^2}{2g_c} \right] + W_t \left[h_t + \frac{U_t^2}{2g_c} \right] \\ = W_m \left[h_m + K_e \frac{U_m^2}{2g_c} \right] \end{aligned} \quad (7)$$

neglecting potential energy of position changes (idealization 7). Note the introduction of the kinetic energy correction factor K_e , which is defined by the relation

$$K_e = \frac{1}{W_m U_m^2} \int_0^{A_m} U_2^3 \rho_2 \, dA \quad (8)$$

It may be demonstrated that for the purpose of evaluating the mixed mean flow temperature T_m , the kinetic energy terms may be neglected to yield

$$h_m = \frac{W_p}{W_m} h_p + \frac{W_s}{W_m} h_s + \frac{W_t}{W_m} h_t \quad (9)$$

where $T_m = \phi(h_m)$ only, with idealization (6).

The energy equation for the isentropic flow of the secondary air from the plenum to the entrance of the mixing

stack may be shown to reduce to

$$\frac{P_o - P_s}{\rho_s} = \frac{U_s^2}{2g_c} \quad (10)$$

similarly, the energy equation for the tertiary air flow reduces to

$$\frac{P_o - P_t}{\rho_t} = \frac{U_t^2}{2g_c}$$

The foregoing equations may be combined to yield the vacuum produced by the eductor action in either the secondary or tertiary air plenums. For the secondary air plenum, the vacuum produced is

$$P_a - P_{os} = \frac{1}{g_c} \frac{1}{A_m} \left\{ K_p \frac{W_p^2}{A_p \rho_p} + \frac{W_s^2}{A_s \rho_s} \left[1 - \frac{1}{2} \frac{A_m}{A_s} \right] - \frac{W_m^2}{A_m \rho_m} \left[K_m + \frac{f}{2} \frac{A_w}{A_m} \right] \right\} \quad (11)$$

where it is understood that A_p and ρ_p apply to the primary flow at the entrance to the mixing stack, A_s and ρ_s apply to the secondary flow at this same section, and A_m and ρ_m apply to the mixed flow at the exit of the mixing stack system.

P_a is atmospheric pressure, and is equal to the pressure at the exit of the mixing stack. A_w is the area of the inside wall of the mixing stack.

For the tertiary air plenum, the vacuum produced is

$$P_a - P_{ot} = \frac{1}{g_c A_m} \left\{ K_p \frac{(W_p + W_s)^2}{(A_p \rho_p + A_s \rho_s)} + \frac{W_t^2}{A_t \rho_t} \left[1 - \frac{1}{2} \frac{A_m}{A_t} \right] - \frac{W_m^2}{A_m \rho_m} \left[K_m + \frac{f}{2} \frac{A_w}{A_m} \right] \right\} \quad (11a)$$

where the primary flow now consists of both the primary and secondary air flows.

C. NON-DIMENSIONAL FORM OF THE SIMPLE EDUCTOR EQUATION

In order to provide the criteria of similarity of flows with geometric similarity, the non-dimensional parameters which govern the flow must be determined. The means chosen for determining these parameters is to normalize equations (11) and (11a) with the following dimensionless groupings.

$$\Delta P^* = \frac{\frac{P_a - P_{os}}{\rho_s}}{\frac{U_p^2}{2g_c}}$$

a pressure coefficient which compares the pumped head $P_a - P_{os}$ for the secondary flow to the driving head $\frac{U_p^2}{2g_c}$ of the primary flow

$$\Delta P_T^* = \frac{\frac{P_t - P_{ot}}{\rho_t}}{\frac{U_p^2}{2g_c}}$$

a pressure coefficient which compares the pumped head $P_t - P_{ot}$ for the tertiary flow to the driving head $\frac{U_p^2}{2g_c}$ of the primary flow

$$WS^* = \frac{W_s}{W_p}$$

a flow rate ratio, secondary to primary mass flow rate

$$WT^* = \frac{W_t}{W_p}$$

a flow rate ratio, tertiary to primary mass flow rate

$$TS^* = \frac{T_s}{T_p}$$

an absolute temperature ratio, secondary to primary

$$T_t^* = \frac{T_t}{T_p}$$

an absolute temperature ratio, tertiary to primary

$$\rho_s^* = \frac{\rho_s}{\rho_p}$$

a flow density ratio of the secondary to primary flows. (Note that since the fluids are considered perfect gases,

$$\rho_s^* = \frac{T_p}{T_s} = \frac{1}{T_s^*})$$

$$\rho_t^* = \frac{\rho_t}{\rho_p}$$

a flow density ratio of the tertiary flow to primary flows. (Note that since the fluids are considered perfect gases,

$$\rho_t^* = \frac{T_p}{T_t} = \frac{1}{T_t^*})$$

$$A_s^* = \frac{A_s}{A_p}$$

an area ratio of secondary flow area to primary flow area

$$A_t^* = \frac{A_t}{A_p}$$

an area ratio of tertiary flow area to primary flow area

With these non-dimensional groupings, equations (11) and (11a) can be rewritten in dimensionless form. Since both

equations follow the same format, only the results for the secondary air plenum will be presented here.

$$\begin{aligned} \frac{\Delta P^*}{T^*} = & 2 \frac{A_p}{A_m} \left\{ \left[K_p - \frac{A_p}{A_m} \beta \right] - W^* [K_p + T^*] \frac{A_p}{A_m} \beta \right. \\ & \left. + W^{*2} T^* \left[\frac{1}{A^*} \left(K_p - \frac{A_m}{2A^* A_p} \right) - \frac{A_p}{A_m} \beta \right] \right\} \end{aligned} \quad (12)$$

where

$$\beta = K_m + \frac{f}{2} \frac{A_w}{A_m} .$$

This may be rewritten as

$$\frac{\Delta P^*}{T^*} = C_1 + C_2 W^* (T+1) + C_3 W^{*2} T^* \quad (13)$$

where

$$C_1 = 2 \frac{A_p}{A_m} \left(K_p - \frac{A_p}{A_m} \beta \right) ,$$

$$C_2 = -2 \left(\frac{A_p}{A_m} \right)^2 \beta , \text{ and}$$

$$C_3 = 2 \frac{A_p}{A_m} \left(\frac{1}{A^*} - \frac{A_m}{2A^* A_p} \beta - \frac{A_p}{A_m} \beta \right) .$$

As can be seen from equation (13),

$$\Delta P^* = F(W^*, T^*) .$$

The additional dimensionless quantities listed below were used to correlate the static pressure distribution down the length of the mixing stack.

$$PMS^* = \frac{\frac{PMS}{\rho_s}}{\frac{U_p^2}{2g_c}}$$

a pressure coefficient which compares the pumping head $\frac{PMS}{\rho_s}$ for the secondary flow to the driving head $\frac{U_p^2}{2g_c}$ of the primary flow, where PMS = static pressure along the mixing stack length

$$\frac{X}{D}$$

ratio of the axial distance from the mixing stack entrance to the diameter of the mixing stack

D. EXPERIMENTAL CORRELATION

It is desirable to make a direct comparison of prototype and model performance on a one-to-one basis so that the effects of changes in geometric parameters on eductor performance may be readily evaluated. The ratio of absolute temperatures is the only parameter which was not controlled during the model testing. Therefore a means of presenting the experimental data for a given geometric configuration in a form which results in a pseudo-independence of the dimensionless groupings ΔP^* and W^* upon T^* must be developed. From equation (13) a satisfactory correlation of ΔP^* , T^* , and W^* for all temperatures and flow rates takes the form

$$\frac{\Delta P^*}{T^*} = \phi(W^* T^{*n}) \quad (14)$$

where the exponent n is determined to be equal to 0.44. The details of the determination of 0.44 as the correlating exponent for the geometric parameters of the models tested is given in reference [1]. To obtain an eductor model's pumping characteristic curve, the experimental data is correlated and analyzed using equation (14), that is, $\Delta P^*/T^*$ is plotted as a function of $W^*T^{*0.44}$. This correlation is used to predict the open to the environment operating point. Variations in the eductor model's geometry will change the appearance of the pumping characteristic curve and facilitate comparison of pumping ability between models. For ease of discussion, $W^*T^{*0.44}$ will henceforth be referred to as the pumping coefficient.

III. EXPERIMENTAL APPARATUS

Air is supplied to the primary nozzles by means of a centrifugal compressor and associated ducting schematically illustrated in Figure 1. The mixing stack configuration being tested is placed inside an air plenum containing an airtight partition so that two separate air flows, secondary and tertiary, may be measured. The air plenum facilitates the accurate measurement of secondary and tertiary air flows by using ASME long radius flow nozzles.

A. PRIMARY AIR SYSTEM

The circled numbers found in this section refer to locations on Figure 1. The primary air ducting is constructed of 16-gage steel with 0.635 cm (0.25 in.) thick steel flanges. The ducting sections were assembled using 0.635 cm (0.25 in.) bolts with air drying silicone rubber seals between the flanges of adjacent sections. Entrance to the inlet ducting (1) is from the exterior of the building through a 91.44 cm (3.0 ft) square to a 30.48 cm (1.0 ft) square reducer, each side of which has the curvature of a quarter ellipse. A transition section (2) then changes the 30.48 cm (1.0 ft) square section to a 35.31 cm (13.90 in) diameter circular section (3). This circular section runs approximately 9.14 m (30 ft) to the centrifugal compressor inlet. A standard ASME square edged orifice (4) is located 15 diameters downstream of the entrance

reducer and 11 diameters upstream of the centrifugal compressor inlet, thus insuring stability of flow at both the orifice and compressor inlet. Piezometer rings (5) are located one diameter upstream and one-half diameter downstream of the orifice. The duct section also contains a thermocouple just downstream of the orifice.

A manually operated sliding plate variable orifice (6) was designed to constrict the flow symmetrically and facilitate fine control of the primary air flow. During operation, the butterfly valve (8), located at the compressor's discharge, provided adequate regulation of primary air flow, eliminating the necessity of using the sliding plate valve. The sliding plate valve was positioned in the wide-open position for all data runs.

On the compressor discharge side, immediately downstream of the butterfly valve, is a round to square transition (9) followed by a 90 degree elbow (10) and a straight section of duct. All ducting to this point is considered part of the fixed primary air supply system. A transition section (12) is fitted to this last square section which reduces the duct cross section to a circular section 29.72 cm (11.7 in) in diameter. This circular ducting tapers down to a diameter of 26.30 cm (11.5 in) to provide the primary air inlet to the eductor system being tested. The transition is located far enough upstream of the model to insure that the flow reaching the model is fully developed.

Primary flow is measured by means of a standard ASME square edged orifice designed to the specifications given in the ASME power test code [5]. The 17.53 cm (6.902 in) diameter orifice used was constructed out of 304 stainless steel 0.635 cm (0.25 in) thick. The inside diameter of the duct at the orifice is 35.31 cm (13.90 in) which yields a beta ($\beta = d/D$) of 0.497. The orifice diameter was chosen to give the best performance in regard to pressure drop and pressure loss across the orifice over the range of primary air flow rates tested [between 0.907 Kg/sec (2.0 lbm/sec) and 1.814 Kg/sec (4.0 lbm/sec)].

The centrifugal compressor (4) used to provide primary air to the system is a Spencer Turbo Compressor, catalogue number 25100-H, rated at 6000 cfm at 2.5 psi back pressure. The compressor is driven by a three phase, 440 volt, 100 horsepower motor.

B. SECONDARY AIR PLENUM

The secondary air plenum, pictured in Figure 24, is constructed of 1.905 cm (0.75 in) plywood and measures 1.22 m by 1.22 m by 1.88 m (4 ft by 4 ft by 6.17 ft). It serves as an enclosure that can contain all or only part of the eductor model and still allow the exit plane of the mixing stack to protrude. The purpose of the secondary air plenum is to serve as a boundary through which secondary air for the eductor system must flow. Long radius ASME flow nozzles, designed in accordance with ASME power test codes [5] and

constructed of fiberglass, penetrate the secondary air plenum, thereby providing the sole means for metering the secondary air reaching the eductor. Appendix D of Reference [1] outlines the design and construction of the secondary air flow nozzles. By measuring the temperature of the air entering and the pressure differential across the ASME flow nozzles, the mass flow rate of secondary air can be determined. Flexibility is provided in measurement of the mass flow rate of secondary air by employing flow nozzles with three different throat diameters: 20.32 cm (8 in), 10.16 cm (4 in), and 5.08 cm. (2 in). By using a combination of flow nozzles, a wide variety of secondary cross sectional areas can be obtained.

A secondary air flow straightener, shown in Figure 25, consisting of a double screen is installed 1.22 m (4 ft) from the open end of the secondary air plenum, between the ASME long radius nozzles and the primary air flow nozzles. The purpose of the straightener is to reduce any swirl effect that could result when only a small secondary air flow area exists.

C. TERTIARY AIR PLENUM

The tertiary air plenum, pictured in Figures 24 and 26, is constructed of 1.90 cm (0.75 in) plywood and measures 1.22 m by 1.22 m by 1.22 m (4 ft by 4 ft by 4 ft). It serves as an enclosure that completely surrounds the mixing stack and allows the exit and entrance regions to protrude. An airtight rubber diaphragm type seal, schematically illustrated

in Figure 6 and pictured in Figures 27 and 28, is located at each end of the enclosure. This allows measurement of a tertiary air flow independent of the secondary air flow. Tertiary air flow is measured with the use of long radius ASME flow nozzles designed in accordance with ASME test codes [5] and constructed of fiberglass. These nozzles are located so that they penetrate the airtight tertiary air plenum, thereby providing the sole means for metering the tertiary air reaching the inductor. By measuring the temperature of the air entering and the pressure differential across the ASME flow nozzles, the mass flow rate of tertiary air can easily be obtained. Flexibility in measuring the tertiary flow is provided by employing different size flow nozzles: two of 20.32 cm (8 in) throat diameter, three of 10.16 cm (4 in) throat diameter, and two of 5.08 cm (2 in) throat diameter. By using various combinations of these flow nozzles, a wide variety of tertiary cross section flow areas can be obtained.

The interior of the tertiary air plenum is pictured in Figure 29. The stand which holds the mixing stack can be seen mounted inside the plenum. This stand, Figures 30 and 31, provides three axis adjustments to the mixing stack for alignment purposes. Figure 27 shows the diaphragm air seal at the entrance to the mixing stack, and Figure 28 shows the diaphragm air seal at the exit plane of the mixing stack. As can be seen, removable ports were located in the exit

plane door to allow for adjustments to the mixing stack and instrumentation without removing the diaphragms.

D. INSTRUMENTATION

Pressure instrumentation for measuring gage pressures is located inside the primary air uptakes just prior to the primary nozzles, inside the secondary air plenum, inside the tertiary air plenum, and at various points on the model. A variety of manometers, pictured in Figure 32, were used to indicate the pressure differentials. A schematic representation of the pressure measuring instrumentation is illustrated in Figures 33 and 34. Monitoring of each of the various pressures was facilitated by the use of a scanivalve and a multiple valve manifold. The scanivalve was used to select the pressure tap to be read, while the multiple valve manifold allowed selection of the optimum manometer for the pressure being recorded. A vent was included in the multiple valve manifold which provided a means of venting the manometers between pressure readings. The valve manifold provided a selection of a 15.24 cm (6.0 in) inclined water manometer, a 5.08 cm (2.0 in) inclined water manometer, and a 1.27 cm (0.5 in) inclined oil manometer (specific gravity 0.827). In addition, the following dedicated manometers were used in the system: a 43.18 cm (17 in) single column water manometer connected to the primary air flow just prior to the primary nozzles, a 127 cm (50 in) U-tube water manometer with each leg connected to a piezometric ring on either side of the orifice

plate in the air inlet duct, and a 2.54 cm (1.0 in) inclined water manometer connected to the upstream piezometric ring.

Primary air temperatures, measured at the orifice outlet and just prior to the primary nozzles, are measured with copper-constantan thermocouples. The thermocouples are in assemblies manufactured by Honeywell under the trade name Megapak. Polyvinyl covered 20 gage copper-constantan extension wire is used to connect the thermocouples to a Newport Digital Pyrometer, model number 267, which provides a digital display of the measured temperature in degrees Fahrenheit. Secondary/tertiary ambient air temperature is measured with a mercury-glass thermometer and recorded in degrees Fahrenheit.

Velocity profiles at the mixing stack exit plane are obtained by using a pitot tube, pictured in Figure 35. The tube is affixed to a mounting template which allows accurate determination of both azimuthal and diametral position. Alignment pins allow fast, accurate changes in azimuthal angles. The pitot tube is used in conjunction with the 15.24 cm (6 in) inclined water manometer for obtaining the velocity pressure head.

E. EDUCTOR SYSTEM

The multiple nozzle eductor systems studied are designed specifically for service onboard gas turbine powered ships. The model consisted of a single primary uptake, a single cluster of four primary nozzles of constant cross section, as pictured in Figure 6, and a single mixing stack. The parameters

varied in this research were the primary nozzle areas, the length of the mixing stack, modifications to the exit region of the mixing stack, the addition of film cooling ports, and a shroud added externally to the mixing stack. Based on the finding of Ellin, four primary flow nozzles were used, and based on Moss' work, a stand off distance of one-half diameter of the mixing stack was used. Maintaining Mach number similarity in the uptakes for all tests facilitated a direct comparison of all mixing stack performances. The uptake parameters and primary nozzle dimensions used correspond approximately to the area ratio used in existing gas turbine powered ships.

F. MODEL GEOMETRIES

A variety of mixing stacks were tested to evaluate the effects that modifications to exit geometry and the addition of stack wall ports had on eductor performance.

1. Straight Mixing Stack

Straight mixing stacks of length to diameter ratios (L/D) of 3.0, 2.5, and 1.75 were tested. These mixing stacks, pictured in Figure 9 and shown dimensionally in Figure 8, were manufactured from 29.72 cm (11.70 in) inside diameter plastic pipe with a nominal wall thickness of 0.64 cm (0.25 in). Additional material was glued to the entrance region to create a 1.25 cm (0.50 in) radius. This allowed for smooth flow of secondary air into the mixing stack and prevented separation

which might have occurred with a square edge. Pressure taps were located along the mixing stack as shown in Figure 8.

2. Straight Mixing Stack With A Solid Diffusor

The straight mixing stack with a solid diffusor is pictured in Figure 11 and dimensionally illustrated in Figure 10. The straight portion of the assembly, which has an $L/D = 1.75$, was constructed similarly to the straight mixing stack except a flange was affixed onto the end of the straight portion so that a solid diffusor of $L/D = 0.75$ could be attached. The solid diffusor was constructed out of 0.15 cm (0.06 in) thick aluminum and was fitted with a flange matching the one on the mixing stack. The solid diffusor was constructed with a double included angle of seven degrees. This angle was chosen to prevent flow separation in the diffusor section. When the solid diffusor was attached to the mixing stack, the joint was filled with body putty and faired in to prevent any misalignment from causing flow separation. Pressure taps were located along the mixing stack as shown in Figure 10.

3. Straight Mixing Stack With A Two-Ring Diffusor

The straight mixing stack with a two-ring diffusor is pictured in Figure 13 and dimensionally illustrated in Figure 12. The straight portion of the assembly is constructed identically to a straight mixing stack of $L/D = 1.75$. The diffusor rings were fabricated out of 0.15 cm (0.060 in) thick aluminum alloy which was rolled and then welded into the rings. The welds were dressed down to present the same flow

blockage as the parent diffusor material. The spacers used to attach the diffusor rings to the straight mixing stack and maintain radial separation were designed to minimize flow disturbance and blockage. The entire assembly had an $L/D = 2.5$. Pressure taps were located along the mixing stack as shown in Figure 12.

4. Straight Mixing Stack With Three-Ring Diffusor

The straight mixing stack with three-ring diffusor is pictured in Figure 15 and dimensionally illustrated in Figure 14. The straight portion of the assembly was constructed identically to a straight mixing stack of $L/D = 1.75$. The diffusor rings were fabricated out of 0.15 cm (0.060 in) thick aluminum alloy which was rolled and then welded into the rings. The welds were dressed down to present the same flow blockage as the parent diffusor material. Spacers, used to attach the diffusor rings to the straight mixing stack and maintain axial spacing, were designed to minimize flow disturbance and blockage. Pressure taps were located along the mixing stack as shown in Figure 14.

5. Straight Mixing Stack With Ports

The straight mixing stack with an $L/D = 2.5$ was fitted with rectangular inserts which contained ports pictured in Figure 17 and dimensionally illustrated in Figure 16. This construction allows for change of port geometry without having to fabricate a new mixing stack. The ports used in these experiments were rectangular in shape and measured approximately

9.6 cm by 0.6 cm (3.8 in by 0.25 in). The inserts were placed in four circumferential bands, each band consisting of four equally spaced inserts. These bands were labelled A through D as illustrated in Figure 16. Each successive band of inserts was displaced radially 30 degrees from the previous band to allow for inducement of film cooling air completely around the circumference of the mixing stack. The rectangular port geometry was chosen to minimize the vena contracta effects. The angle of entrance into the mixing stack of 45 degrees was based on geometric flow disturbance considerations. Except for the ports, the inside of the mixing stack was maintained smooth. Pressure taps were located along the mixing stack as shown in Figures 16 and 17.

6. Straight Mixing Stack With Ports And A Two-Ring Diffusor

The straight mixing stack with ports and a two-ring diffusor is pictured in Figure 19 and dimensionally illustrated in Figure 18. This assembly consisted of the straight ported section ($L/D = 1.75$) tested previously and the two-ring diffusor tested on the straight stack. The assembly has an overall $L/D = 2.5$. Pressure taps were located along the mixing stack as shown in Figure 18.

7. Straight Mixing Stack With Ports, A Shroud Covering The Ports, And Two-Ring Diffusor (Shrouded, Ported Mixing Stack)

The straight mixing stack with ports, a two-ring diffusor, and shroud is pictured in Figure 21 and dimensionally illustrated in Figure 20. This assembly was the same as the straight mixing stack with ports and two-ring diffusor except

that a shroud was placed around the portion of the mixing stack that was ported. This forced the air drawn in by the ports to flow between the shroud and the outside surface of the mixing stack. Spacers, designed to minimize flow blockage, held the shroud a uniform distance from the mixing stack. Pressure taps were located along the mixing stack as shown in Figure 20.

G. ALIGNMENT

The alignment of the mixing stack with the primary air flow nozzles was accomplished using cross-hairs, a level, and a 30.48 cm (12 in) rule graduated in 0.25 mm (0.01 in). The cross-hairs were placed across the exit and entrance planes of the mixing stack, locating the geometric centerline axis of the mixing stack. By using these cross-hairs and the level, the geometric centerline of the mixing stack was aligned with a machining mark that represented the geometric center of the four primary nozzles. The graduated scale was used to establish the desired stand-off distance (S/D) and insure that the exit plane of the primary nozzles and the entrance plane of the mixing stack were parallel. The three axis mixing stack mounting stand, illustrated in Figure 30 and pictured in Figure 31, allowed alignment adjustments to be performed easily and accurately.

IV. EXPERIMENTAL METHOD

Evaluation of the eductor model requires the experimental determination of pressure differentials across the ASME long radius flow nozzles, temperatures of primary and induced air flows, internal mixing stack pressures, and mixing stack exit velocities. These experimentally determined quantities are then correlated and analyzed to obtain pumping coefficients, induced air flow rates, pressure distributions within the mixing stack, mixing stack exit velocity profiles, and momentum correction factors. The qualities of the eductor model are then evaluated to determine the model's relative effectiveness.

The following discussion addresses the individual qualities of the eductor model and how they were determined.

A. PUMPING COEFFICIENTS

The secondary pumping coefficient and the tertiary pumping coefficient provide the basis for analysis of the eductor model's pumping performance. Thus, changes in eductor model parameters which affect pumping can be noted by a change in pumping coefficient. The pumping coefficient(s) is desired at the operating point which is simulated by completely opening the air plenum(s) to the environment. This can not be conveniently measured. Therefore, the eductor's characteristics are determined, plotted, and then extrapolated to the operating point.

The pumping characteristics of the eductor model are established by varying the associated induced air flow rate, either secondary or tertiary, from zero to its maximum measurable rate. This rate is determined by sequentially opening the ASME flow nozzles mounted in the appropriate plenum and recording the pressure drop across the nozzles. Values for nozzle cross sectional area, pressure drop, and induced air temperature are then used to calculate the dimensionless parameters $\Delta P^*/T^*$ and $W^*T^{*0.44}$ or $\Delta P T^*/T T^*$ and $W T^* T T^{*0.44}$ as described earlier in the Theory and Analysis section. The dimensionless parameters are then plotted as illustrated in Figure 36. Extrapolation of the pumping characteristics curve to intersect with the zero pressure/temperature coefficient abscissa locates the appropriate operating point coefficient of the model.

B. FILM COOLING PUMPING COEFFICIENT

The film cooling pumping coefficient $W F^* T F^{*0.44}$ could not be obtained in a manner similar to the secondary and tertiary pumping coefficients because the testing facility did not allow space for a dedicated film cooling air plenum. (The straight ported stack geometry is the only exception, where the film cooling pumping coefficient was calculated using the tertiary air plenum as a dedicated film cooling air plenum.) Therefore, the film cooling was combined with either the secondary or tertiary air flows as required by the eductor model geometry. The film cooling pumping coefficient was

then calculated as the difference in the secondary and tertiary pumping coefficients with and without the addition of film cooling.

C. INDUCED AIR FLOWS

Three induced air flows are identified in this study: secondary, tertiary, and film cooling.

The secondary air flow indicates the amount of induced air passing through the secondary air plenum.

The tertiary air flow indicates the amount of induced air passing through the tertiary air plenum. The dimensionless quantity WT^* is the ratio of the tertiary air flow rate to the primary air flow rate.

The film cooling air flow is that flow which is induced through the mixing stack ports or shroud. It is introduced as a coolant to reduce heat transfer in two areas: between the hot exhaust gases within the mixing stack and the interior wall of the mixing stack; and when a shroud is being used, between the exterior mixing stack wall and the interior wall of the shroud. The dimensionless quantity WF^* is the ratio of the film cooling air flow rate to the primary air flow rate. Due to test facility limitations, film cooling air flow was included in either secondary or tertiary air flows depending on model geometry.

D. PRESSURE DISTRIBUTIONS

The mixing stack axial static pressure was obtained using a series of pressure taps fixed to the mixing stack. These

taps were generally placed in two axial rows, the rows being 45 degrees apart radially. Along each row the taps were spaced in increments of quarter diameters. The exact location of the pressure taps is indicated on the figure of each mixing stack geometry tested. The mixing stack was aligned such that one row of pressure taps was axially in line with one of the four primary nozzles. The row position relative to the primary nozzles was labelled as illustrated in Figure 37. The stack pressure (PMS) is plotted versus X/D to obtain a mixing stack pressure distribution for each geometry tested.

E. VELOCITY PROFILES AND MOMENTUM CORRECTION FACTOR

The momentum correction factor K_m is a measure of the completeness of mixing and provides the basis for evaluating this aspect of eductor performance. The momentum correction factor is evaluated at the exit of the mixing stack by means of two velocity traverses and the definition given in equation (4). Velocity profiles at the mixing stack exit were calculated from the pressures measured using the pitot tube pictured in Figure 35. Since it was impractical to obtain a complete three-dimensional plot of velocities at the exit plane of the mixing stack, advantage was taken of the symmetry of the velocity surface resulting from the arrangement of the primary nozzles. Only two traverses were made. The first traverse passes directly over the primary nozzles and records the peak velocities, while the second traverse passes between the

nozzles, thus measuring the minimum velocities at the mixing stack exit. Figure 36 illustrates the orientation and identification of the two velocity traverses. An average velocity at the mixing stack is obtained by integrating the velocity distribution over the mixing stack area to obtain an integrated volumetric flow rate which, when divided by the mixing stack cross sectional area, yields the average velocity.

V. DISCUSSION OF EXPERIMENTAL RESULTS

Exhaust eductor systems designed for marine gas turbine applications must substantially cool exhaust gases, present an exterior stack surface temperature which will not give an easily detectable infrared signature, and effectively disburse exhaust gases. In order to evaluate the overall eductor model performance in this study, four areas of performance were identified: the amount of secondary air flow induced by the primary air flow, referred to here as pumping; the degree of mixing of primary and induced air flows within the mixing stack system, referred to here as mixing; the amount of uptake back pressure impressed upon the turbine exhaust by the eductor system; and the amount of film cooling air available to reduce the exterior stack temperature of the eductor system.

The eductor models in this study were designed to reduce the high back pressure 22.1 cm H₂O (8.7 in H₂O) in the model previously tested by Moss [2] and to introduce various mixing stack geometries to minimize the exterior stack temperatures and still provide good secondary air flows and mixing.

A. QUANTITATIVE MEASUREMENTS

Quantitative measurement of the four areas of performance was required to evaluate the different eductor models. A summary of all eductor system models tested in this study is

given in Tables I and II. Data on individual models is located in the tables referenced in the description of each model. The pumping, mixing, back pressure, and film cooling qualities of the eductor model were evaluated in the following manner.

1. Pumping

The values of the secondary and tertiary pumping coefficients were used, as required by the model geometry being tested, to evaluate the pumping abilities of the models. Values for the pumping coefficients were obtained from plots of experimental data using the correlations

$$\frac{\Delta P^*}{T^*} = \phi (W^* T^{*0.44})$$

for the secondary pumping coefficient, and

$$\frac{\Delta P T^*}{T T^*} = \phi (W T^* T T^{*0.44})$$

for the tertiary pumping coefficient. Tabulated values of the pumping coefficients for the eductor model configurations tested are included in Table II.

2. Mixing

Design changes to the mixing stack exit geometries made quantification of the model mixing quality more complex than it had been in the studies of Ellin and Moss. For ease of cross referencing with the previous studies, the momentum correction factor K_m was calculated and tabulated in Table II

for all model geometries tested which were of the straight mixing stack design. In those cases, the closer the momentum correction factor is to unity, the more complete the mixing of the primary and induced air flows.

With the introduction of other than straight mixing stack exit geometries, a quantitative evaluation of mixing was made by comparison of the ratio of the peak exit velocity to the average primary nozzle velocity. This non-dimensional quantity, which is tabulated in Tables XIV to XIX, was evaluated for each velocity traverse oriented in the A and B direction, as shown in Figure 36. The lower the maximum values of this ratio are, the more complete the mixing.

Figure 42 contains plots of all the velocity profiles made on the models of this study. For reference purposes, this figure also contains the numbers of the tables from which the data was obtained.

3. Uptake Back Pressure

The static uptake back pressure PU-PA was a value directly recorded from experimental data. To optimize turbine efficiency, this value should be kept as low as practical and still maintain an effective exhaust eductor system. Tabulated values of static uptake back pressure are in Table II.

4. Film Cooling

The value of the film cooling pumping coefficient $WF*TF^{0.44}$ is determined as described in the experimental method section. The values of the film cooling pumping

coefficient are proportional to the film cooling air flow rate and indicate how well the eductor system is inducing film cooling air.

B. SYSTEM EVALUATION

Initial model testing was conducted using an eductor model with a straight mixing stack length L/D of 3.0 and a stand off distance S/D of 0.5. The results of these tests are shown in Tables IV and XIV and Figures 40(a) through 38(c), 41(a) through 41(c) and 42(a). These results compared favorably with the experimental results Moss obtained using a similar geometry; see Figure 40(c).

An L/D ratio of 2.5 was selected for use as the standard length in this study because it is representative of the length found on a marine gas turbine installation.

The results of testing the L/D ratio of 2.5 are shown in Tables IV and XIV, and Figures 40(d), 41(d), and 42(b). The relatively high uptake back pressure of 22.1 cm H_2O (8.7 in H_2O) was considered unsatisfactory in terms of decreased turbine efficiency. Thus, a change in primary nozzle diameter was made. An increase in primary nozzle diameter from 8.59 cm (3.38 in) to 9.40 cm (3.70 in) reduced the mixing stack area to primary nozzle area ratio A_m/A_p from 3.0 to 2.5. The results of utilizing the larger primary flow nozzles with a straight mixing stack with an L/D ratio of 2.5 are shown in Tables V and XV, Figures 40(e), 40(f), 41(e), and 42(c). The uptake back pressure was reduced significantly to 14.7 cm H_2O

(5.8 in H₂O) as desired. However, the secondary pumping coefficient was reduced from 0.80 to 0.60, and the momentum correction factor increased from 1.027 to 1.038. The undesirable effects of reduced pumping and reduced mixing when changing to an A_m/A_p ratio of 2.5 required investigation of mixing stack exit geometries which would increase eductor pumping and mixing characteristics without causing excessive increases in uptake back pressure.

The first mixing stack exit geometry modification attempted was that of a solid diffuser with a seven degree double included angle, dimensionally illustrated in Figure 10 and pictured in Figure 11. The diffuser was selected because the increase in mixing stack area at the diffuser decreases the mixing stack pressure relative to the same L/D position on the straight mixing stack. This pressure reduction was reflected upstream at the mixing stack entrance and at the primary flow nozzles where a lower back pressure and an increased secondary pumping coefficient was noted.

At this point in the study due to mixing stack exit geometry changes, the use of the momentum factor is no longer a valid measure of mixing. In its place the peak exit velocity to the average primary nozzle velocity, referred to here as the velocity ratio, was utilized exclusively for determination of mixing quality. The results of testing the solid diffuser are shown in Tables VI and XVI, and Figures 40(h) through 40(m), 41(g) through 41(l) and 42(e) through 42(k). Relative

to the straight mixing stack, the mixing stack with solid diffusor had a slightly decreased uptake back pressure [from 14.7 cm H₂O (5.8 in H₂O) to 14.5 cm H₂O (5.7 in H₂O)], a velocity ratio which showed no effective change, and a significant increase in the secondary pumping coefficient from 0.58 to 0.70.

At this point in the study a major design development was implemented with the purpose of cooling the exterior surface of the stack to reduce the infrared signature. The first design was that of a split ring diffusor, schematically represented in Figure 4. The split ring design was selected because the ambient air induced through the rings by the flow of hot exhaust gases, referred to here as tertiary air flow, surrounds the diffusor ring and acts as a thermal coolant. This reduces the heat transferred from the hot exit gases to the interior walls of the diffusor ring, thus reducing the exterior temperature of the upper portion of the stack. Since only the principle of the ring diffusor was to be investigated, and it was not the intent of this study to develop an optimal design, only two split ring diffusor configurations were modeled and tested.

The two-ring diffusor, pictured in Figure 13 and dimensionally illustrated in Figure 12, was modeled first. The results of these tests are shown in Tables VII and XVI, and Figures 40(n), 41(m), and 42(i). Relative to the mixing stack with a solid diffusor, the mixing stack with the two-ring

diffusor had an increase in uptake back pressure from 14.5 cm H₂O (5.7 in H₂O) to 15.4 cm H₂O (6.05 in H₂O), a velocity ratio decrease from 0.86 to 0.80 in the A direction and from 0.71 to 0.69 in the B direction, a decrease in secondary pumping coefficient from 0.70 to 0.62 (still better than the 0.58 recorded for the straight stack with an L/D of 2.5), and a tertiary pumping coefficient of 0.115.

The three-ring diffusor was then modeled. It is pictured in Figure 15 and dimensionally illustrated in Figure 14. The results of these tests are tabulated in Tables VIII and XVI, and Figures 40(o), 41(n), and 42(j). Overall eductor performance was less than that found in the two-ring diffusor design with back pressure very nearly the same at 15.2 cm H₂O (6.0 in H₂O), a velocity ratio increase from 0.80 to 0.84 in the A direction and from 0.69 to 0.71 in the B direction, no change in the secondary pumping coefficient of 0.62, and a decrease in the tertiary pumping coefficient from 0.115 to 0.098.

The decrease noted in the overall eductor performance when comparing results of the three-ring diffusor to that of the two-ring diffusor may be misleading. Construction of the three-ring diffusor with the material thicknesses selected increased the blockage of tertiary air flow significantly. Therefore, based on these results, no direct comparison of the two designs can be considered final.

The tertiary air flow induced through the diffusor rings appears to offer a method of cooling the upper portion of the

stack. However, additional cooling is required on the lower portion. To deal with this problem, the use of induced ambient air was again investigated. Ambient air induced into the straight portion of the mixing stack for the purpose of convectively cooling the interior wall of the mixing stack heated by the hot exhaust gases is referred to here as film cooling air. To determine if the pressure potential necessary to induce film cooling air was available, the axial pressure distribution in the straight portion of the mixing stack with the two-ring diffuser was closely examined. This examination included experimentally obtaining the axial pressure distributions at intervals of $0.125 D$ along the mixing stack at four radial locations around the stack. The pressure distribution as affected by misalignment of the mixing stack to the primary nozzles was also examined by deliberate misalignment of the stack as schematically shown in Figure 39. The results of these tests are tabulated in Table III and summarized as follows.

The internal mixing stack axial pressure distribution is not significantly affected by misalignments of up to 3.42 degrees. Mixing stack pressure is independent of the radial position after a distance of $0.125 D$ from the mixing stack inlet. The pressure differential between the ambient air and that within the mixing stack is sufficient to induce ambient air into the mixing stack as film cooling.

To examine the effects of film cooling on the eductor system, the straight mixing stack geometry was utilized.

This geometry had the advantages of much previous testing, relative ease of assembly, and use of the existing air plenum within the testing facility to measure film cooling air flow.

The straight stack with ports pictured in Figure 17 and dimensionally illustrated in Figure 16 was manufactured as previously described in the Experimental Apparatus Section. The configurations of the ported mixing stack are defined as follows with tabular results listed in Table IX and XVII.

<u>Configuration</u>	<u>Definition</u>	<u>Table No.</u>
	(See Figure 16 for location of Positions A, B, C, D)	
A-1	One port on each rectangular insert located axially at position A was open (a total of four ports)	IXb
A-1, B-1	In addition to the A-1 ports already opened, one port on each rectangular insert located axially at position B was opened (four additional ports, a total of eight ports open in this configuration)	IXc
A-1, B-1, C-2	In addition to the A-1 and B-1 ports already open, two ports on each rectangular insert located axially at position C were opened (eight additional ports opened for a total of sixteen in this configuration)	IXd
A-1, B-1, C-2, D-2	In addition to the A-1, B-1, and C-2 ports already open, two ports on each rectangular insert located axially at position D were opened (eight additional ports opened for a total of 24 in this configuration).	IXe

As compared to the straight mixing stack, the ported mixing stack in the A-1, B-1, C-2, D-2 configuration had an increased uptake back pressure from 14.7 cm H₂O (5.8 in H₂O) to 15.2 cm H₂O (6.0 in H₂O), a velocity ratio reduction from 0.85 to 0.79 in the A direction, a velocity ratio increase from 0.72 to 0.76 in the B direction, and a film cooling pumping coefficient of 0.078. The secondary pumping coefficient was not measured for this configuration, it was estimated to be 0.58 from the results of the tests run on the ported stack in the fully closed position.

The ported mixing stack was then shortened to an L/D ratio of 1.75 and the two-ring diffuser tested earlier was added. The ported mixing stack with two-ring diffuser is pictured in Figure 19 and dimensionally illustrated in Figure 18. The results of the tests on this model are shown in Tables X and XVIII, and Figures 40(u) through 40(w), 41(t) through 41(v) and 42(l). The addition of the two-ring diffuser had many of the same effects on the straight ported mixing stack as it had on the straight mixing stack. The secondary pumping coefficient was 0.57, showing no appreciable change from the estimated 0.58 for the ported stack, the tertiary pumping coefficient remained the same at 0.11 and the film cooling pumping coefficient showed very little change, decreasing from 0.078 in the ported stack model to 0.076 in the ported stack with two-ring diffuser. The uptake back pressure remained constant at 15.2 cm H₂O (6.0 in H₂O) and the velocity ratio increased from 0.79 to 0.84 in the A

direction and decreased from 0.76 to 0.72 in the B direction. These results indicate that this configuration was capable of pumping sufficient quantities of tertiary and film cooling air and could have a significant effect on the external temperature of the mixing stack system.

Infrared radiation from the mixing stack system could be reduced by thermally shielding the system. This concept is used by employing a shrouded mixing stack system. This system is schematically represented in Figure 5. Film cooling air induced by the mixing stack ports was directed between the exterior of the mixing stack and the interior of the shroud. Thus the shroud is insulated from the hot exterior of the mixing stack by the flow of film cooling air and acts as a heat shield for the hot mixing stack.

Initial testing of the shrouded, ported, mixing stack with two-ring diffusor indicated that the entrance area, which was restricted due to the entrance transition material of the straight mixing stack, was a choke point for the film cooling air flow. This condition was remedied by starting the shroud 1.1 cm (0.5 in) away from the mixing stack entrance. The model is pictured in Figure 21 and dimensionally illustrated in Figure 20. Results of the first shrouded mixing stack tested are shown in Tables XI and XIX, and Figures 40(x) through 40(aa), 41(w) through 41(z), and 42(m). Results of the mixing stack tested with the shortened shroud are shown in Tables XII and XIX, and Figures 40(bb) through 40(ee),

41(aa), and 42(n). The film cooling air coefficient was favorably affected with the shortening of the shroud, and in both models tested the film cooling air coefficient was greater than it had been for the mixing stack system without the shroud (this may be only due to experimental data scatter, however the purpose of the model test was to insure that film cooling air flow would remain adequate when the shroud was added).

To further enhance the air flow through the shroud, the shroud was modified to extend open ended along the mixing stack and merge with the first ring of the two-ring diffusor. The system configuration is referred to as the flow-through shroud with diffusor ring mixing stack. It is pictured in Figure 22. The results of testing this configuration are shown in Tables XIII and XIX, and Figures 40(ff) through 40(ii), 41(bb), and 42(o). The results indicate that the film cooling air pumping coefficient increased almost as much as the tertiary air pumping coefficient decreased when compared to the results obtained from the ported stack with the two-ring diffusor and shroud. No direct measurement of the quantity of film cooling air entering the mixing stack was attempted, however, the pressure distribution along the mixing stack is very similar to that recorded for the ported stack with the two-ring diffusor, Figure 41(a), so that film cooling air flow can be assumed to be similar.

VI. CONCLUSIONS

This investigation studied the effects on the eductor system's overall performance of varying the geometric configuration of the mixing stack and changing the area of the primary flow nozzles. A detailed description of the various eductor systems modeled and tested is given in the experimental apparatus section. Trends and interdependency between geometries tested were discussed in detail in the experimental results section. Only a summary of the conclusions resulting from this investigation are given here.

- A. Changing the ratio of the area of the mixing stack to the area of the primary flow nozzles from 3.0 to 2.5 decreased the uptake back pressure and reduced the secondary pumping coefficient.
- B. An improvement in secondary pumping and a decrease in uptake back pressure was obtained when a solid diffusor was placed on the exhaust end of the mixing stack.
- C. The combination of two-ring diffusor (geometry) induced more tertiary flow than the three-ring diffusor (geometry).
- D. The ported mixing stack provided significant air flow through the ports which could provide film cooling on the inside of the mixing stack.
- E. The ported mixing stack and two-ring diffusor provided increased system performance without affecting the back pressure in the uptakes.

- F. The shroud placed around the mixing stack did not degrade pumping or mixing characteristics of the eductor system, yet it directs the film cooling air flow between the shroud and the outside surface of the mixing stack and provides thermal shielding of the mixing stack.
- G. The combination of the ported mixing stack with flow-through shroud and diffusor provided the optimum results of the geometries tested. This configuration had the features of providing film cooling where it could be most effective, good secondary air flow and good mixing.

VII. RECOMMENDATIONS

In addition to providing insight into the effects that geometric parameters have on eductor system parameters, this research has also generated an awareness of the investigation's shortcomings. Presented here are recommendations for future research and suggestions for different eductor system design.

- A. Test the following eductor systems in a model testing facility using a hot gas for the primary air flow: a mixing stack with two-ring diffuser, a straight ported mixing stack, and a ported mixing stack with a shroud and two-ring diffuser. Evaluate the system performances by placing thermocouples on the system and correlating these results with the cold flow data contained herein.
- B. With temperature and pressure distribution data obtained from tests conducted using hot gas as the primary air flow, investigate the optimum placement of cooling ports to achieve a minimum mixing stack surface temperature. Starting the first set of film cooling ports and shroud a significant distance down the mixing stack may prove beneficial.
- C. Using the cold flow testing facility, investigate the optimum split ring diffuser included angle (ψ) as shown in Figure 4.

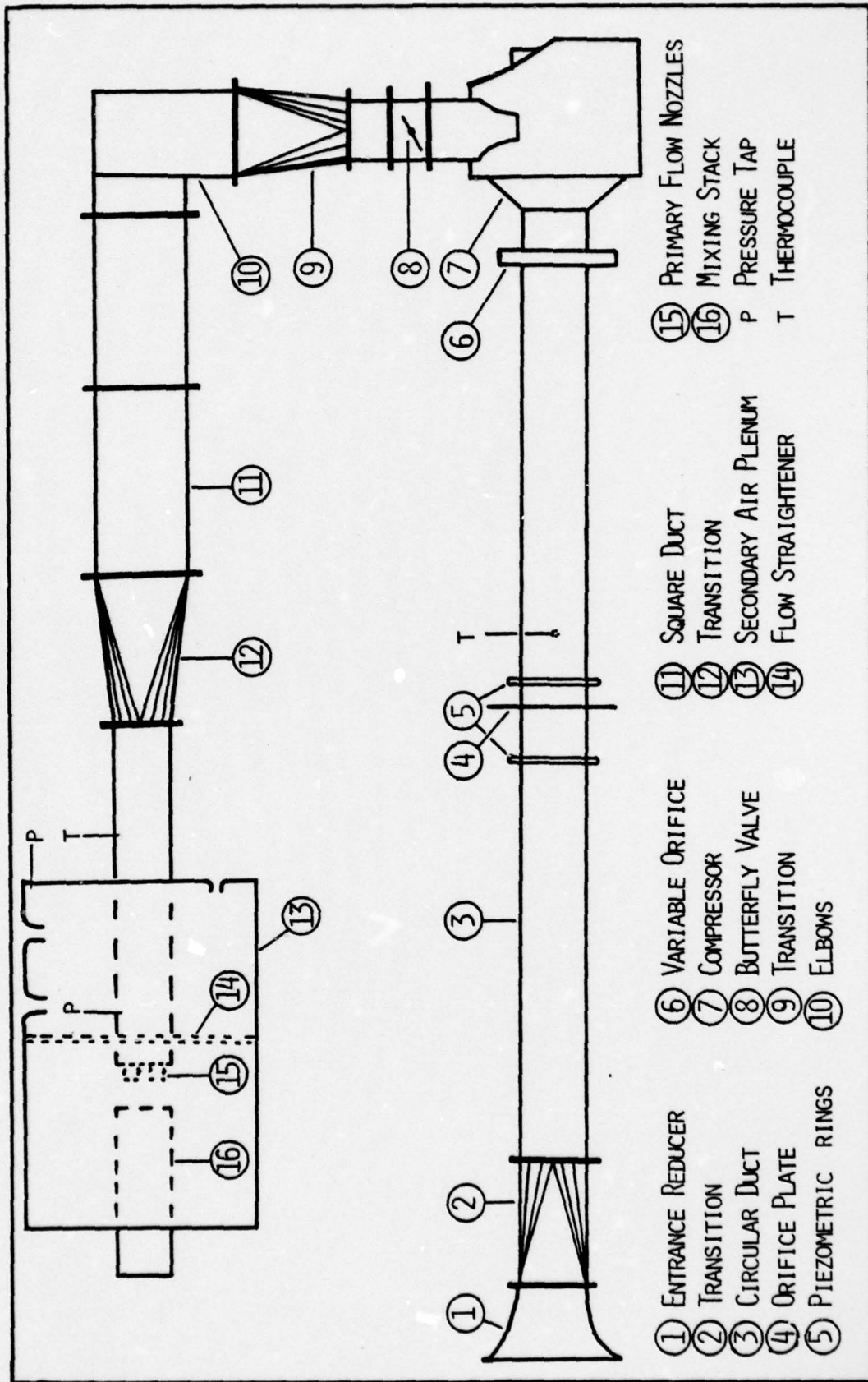

FIGURE 1. EDUCTOR MODEL TESTING FACILITY

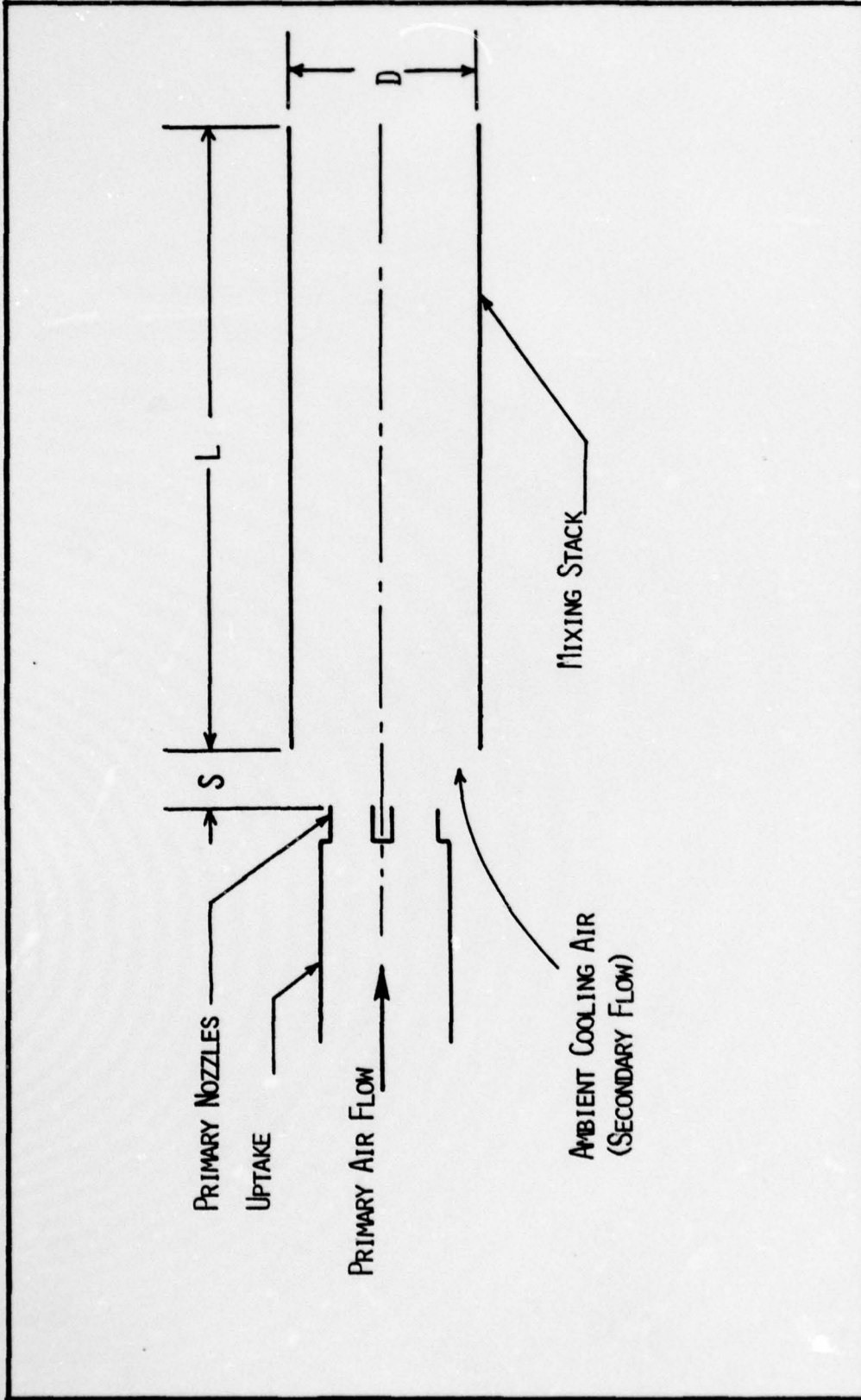

FIGURE 2. SCHEMATIC OF STRAIGHT STACK EDUCATOR

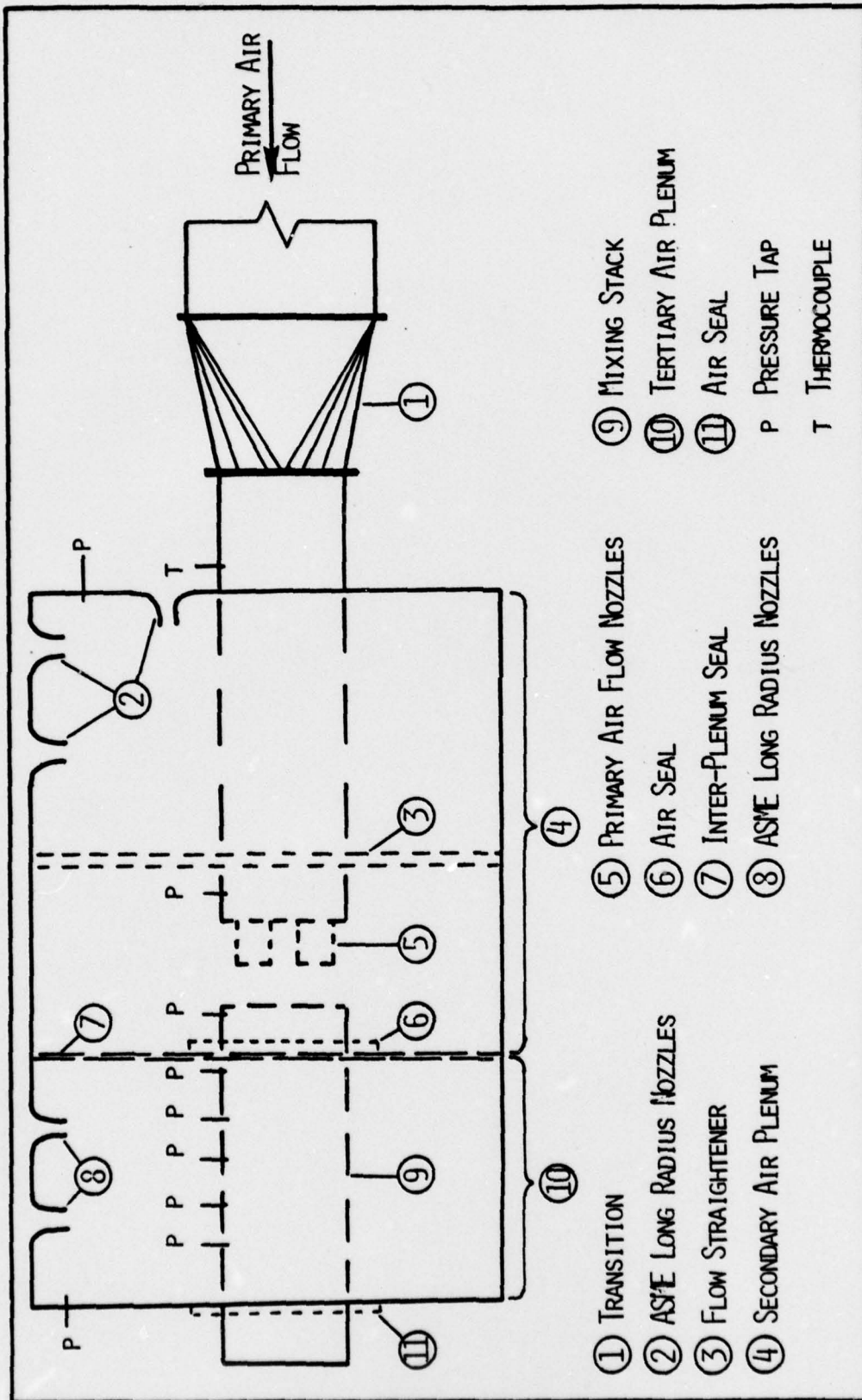

FIGURE 3. EDUCTOR MODEL TESTING FACILITY, SECONDARY AND TERTIARY AIR PLENUMS

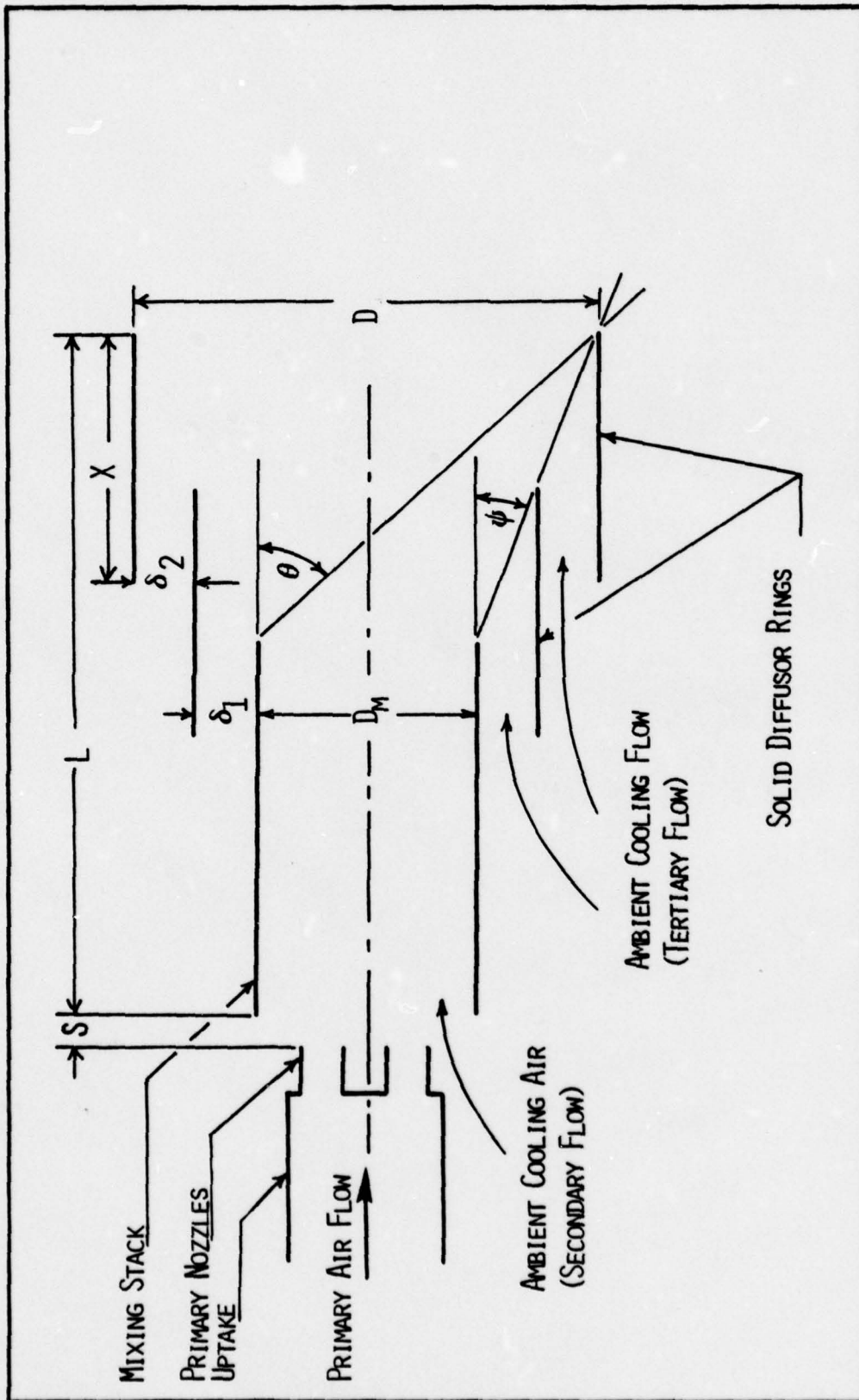

FIGURE 4. SCHEMATIC OF MIXING STACK WITH DIFFUSOR RINGS

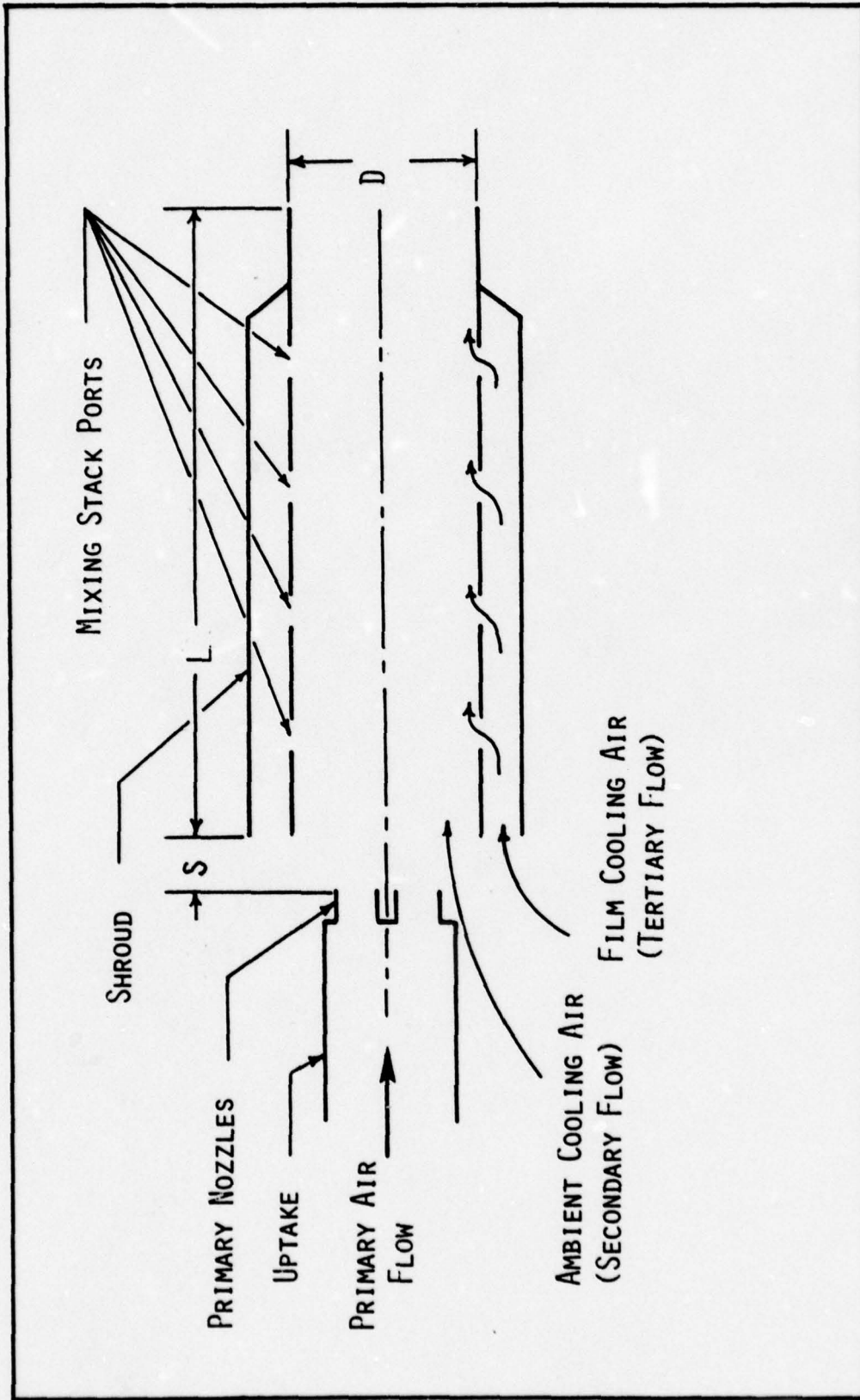

FIGURE 5. SCHEMATIC OF SHROUDED MIXING STACK WITH FILM COOLING PORTS

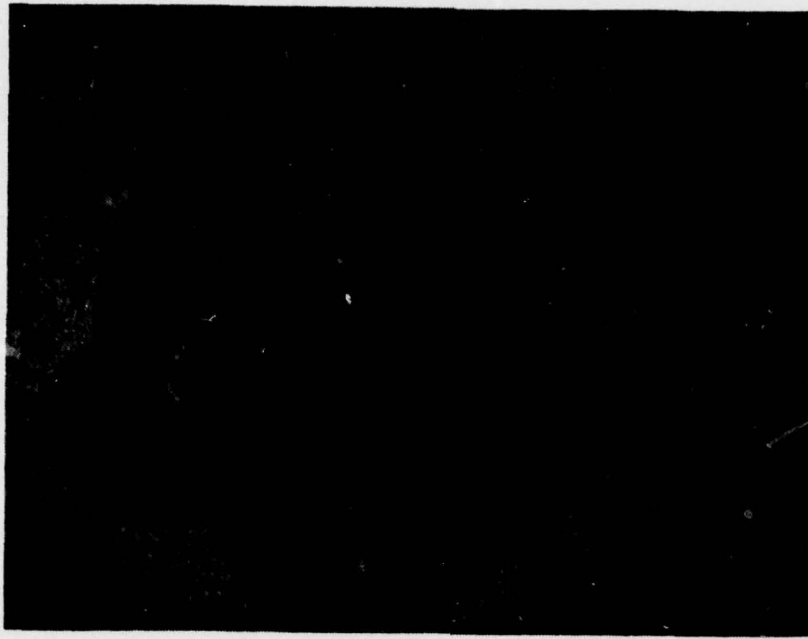
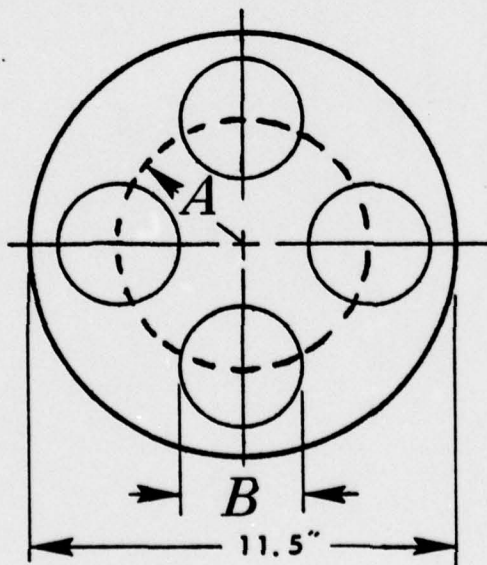

FIGURE 6. PRIMARY FLOW NOZZLES USED IN THIS STUDY



AREA RATIO	<i>A</i>	<i>B</i>
3.0	3.40"	3.38"
2.5	3.20"	3.70"

FIGURE 7. LAYOUT OF PRIMARY FLOW NOZZLES

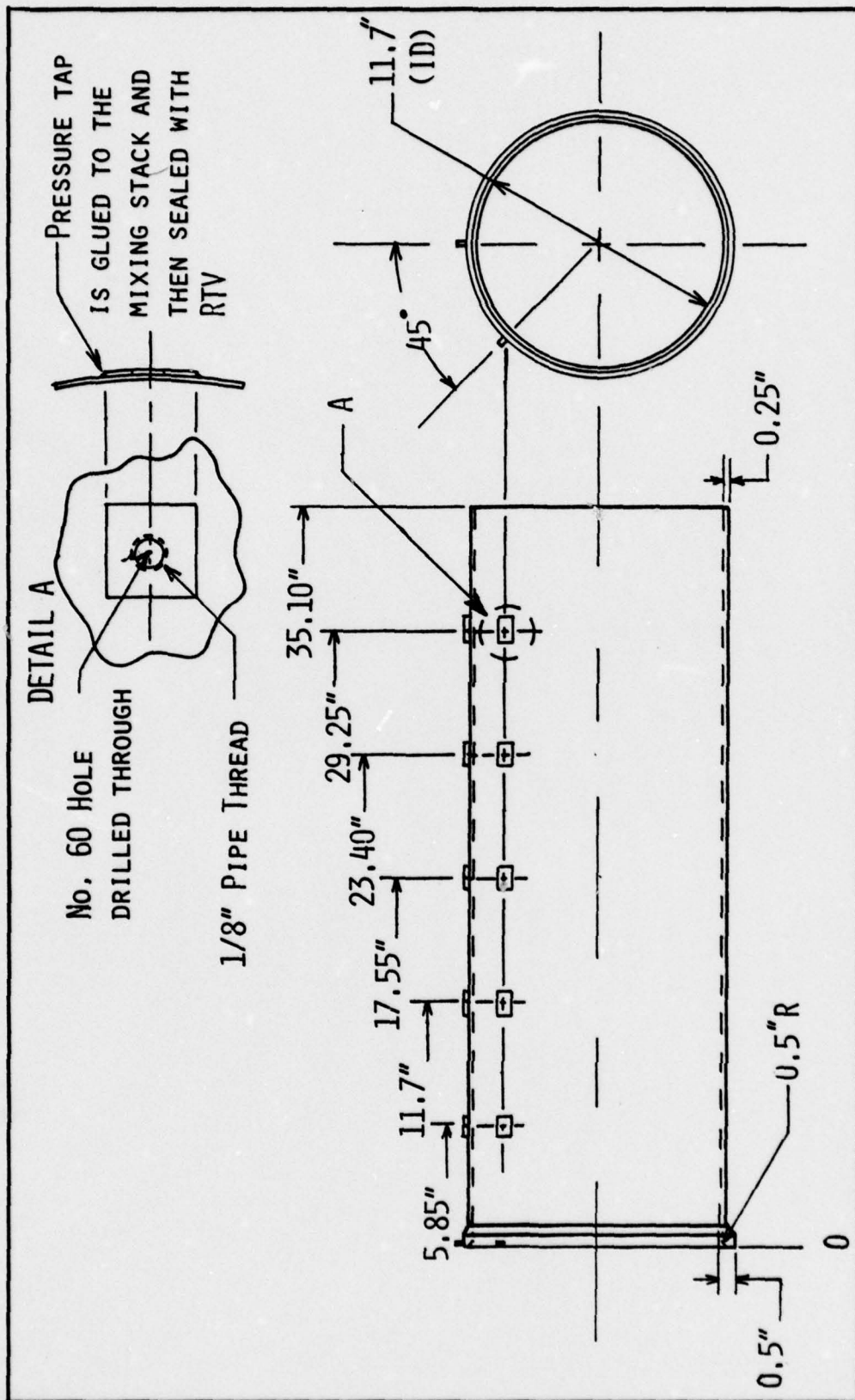

FIGURE 8. DIMENSIONAL ILLUSTRATION OF STRAIGHT MIXING STACK



FIGURE 9. STRAIGHT MIXING STACK

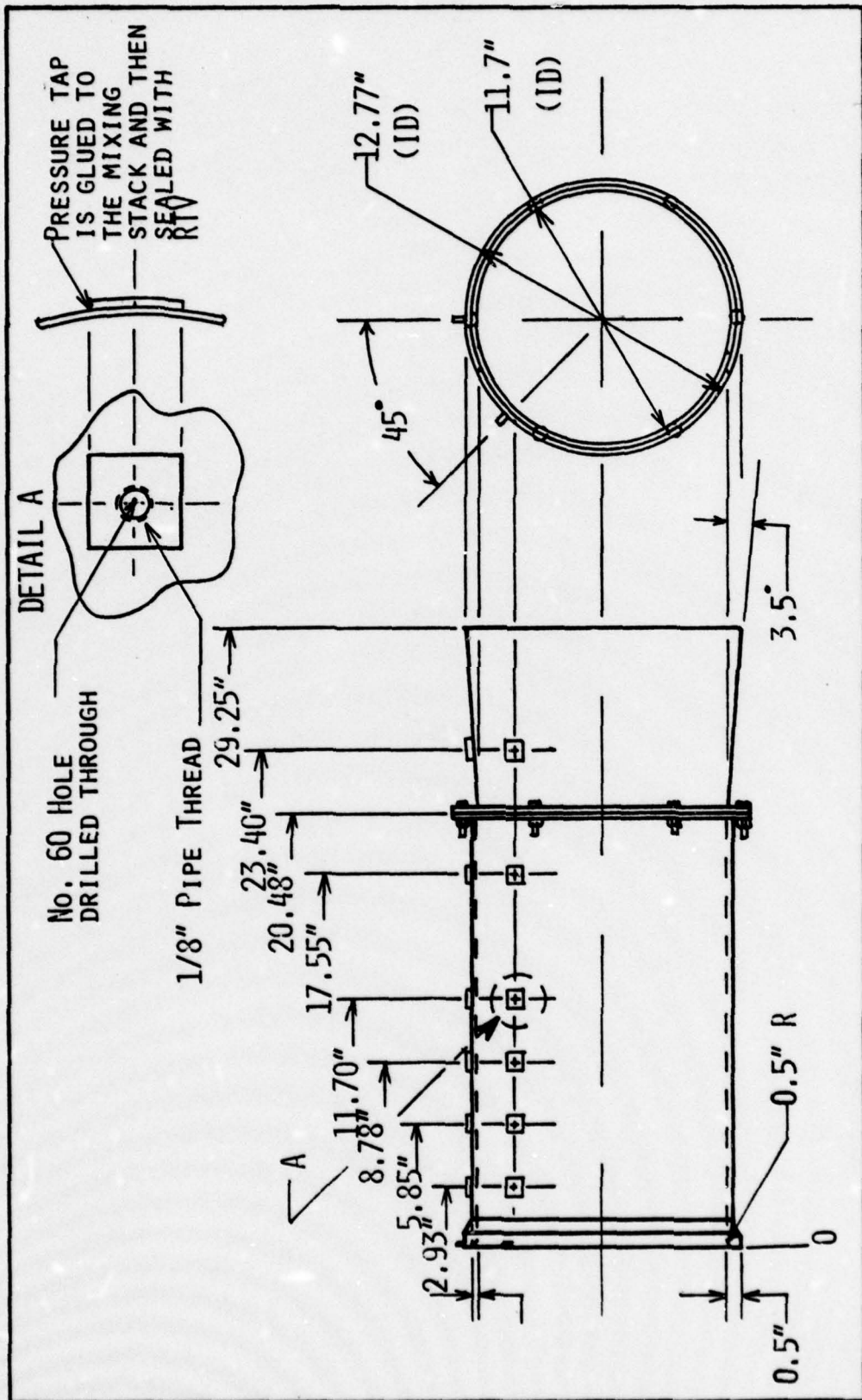

FIGURE 10. DIMENSIONAL ILLUSTRATION OF MIXING STACK WITH SEVEN DEGREE DOUBLE INCLUDED ANGLE SOLID DIFFUSOR



FIGURE 11. MIXING STACK WITH SEVEN DEGREE DOUBLE INCLUDED ANGLE
SOLID DIFFUSOR

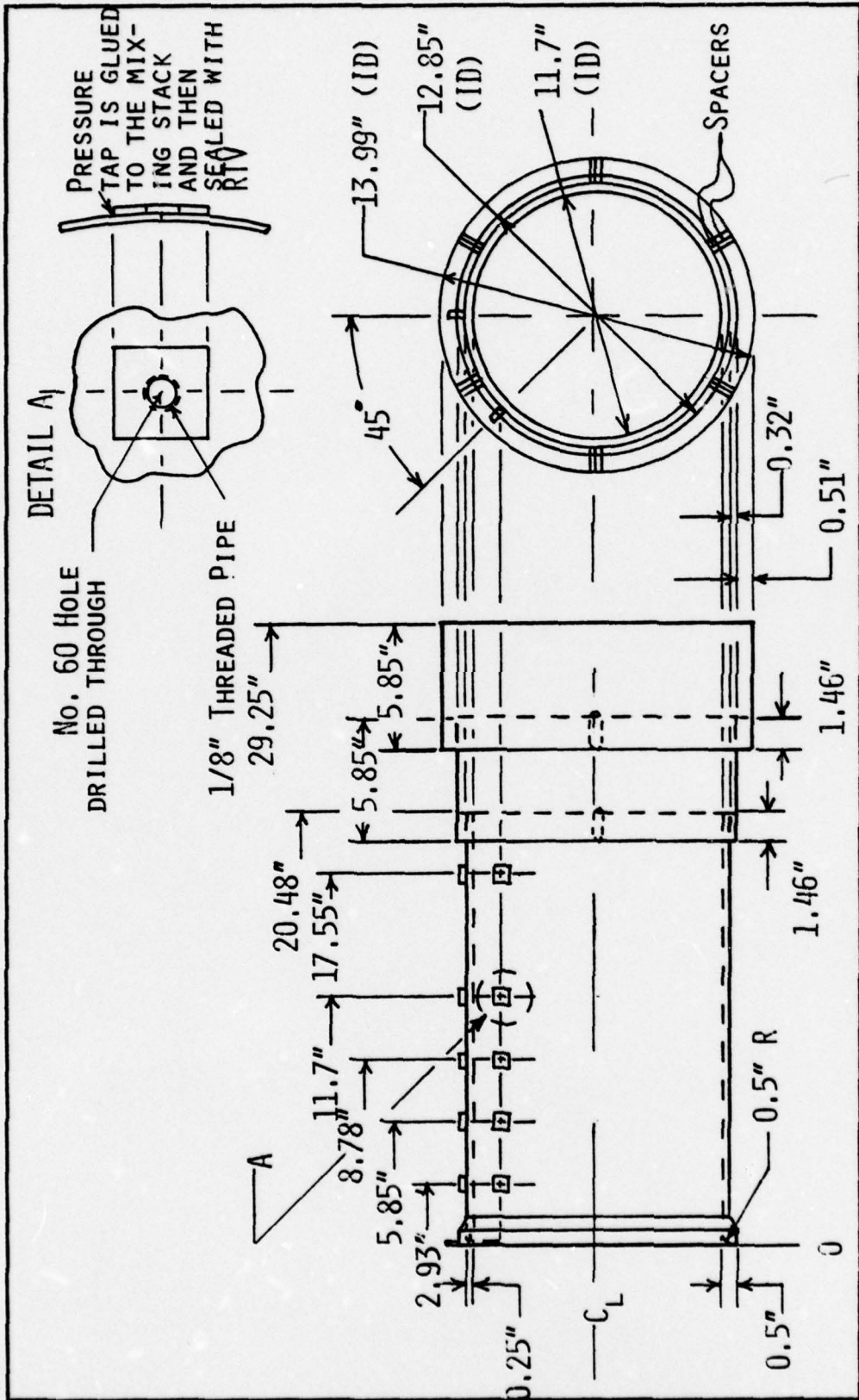

FIGURE 12. DIMENSIONAL ILLUSTRATION OF MIXING STACK WITH TWO-RING DIFFUSOR

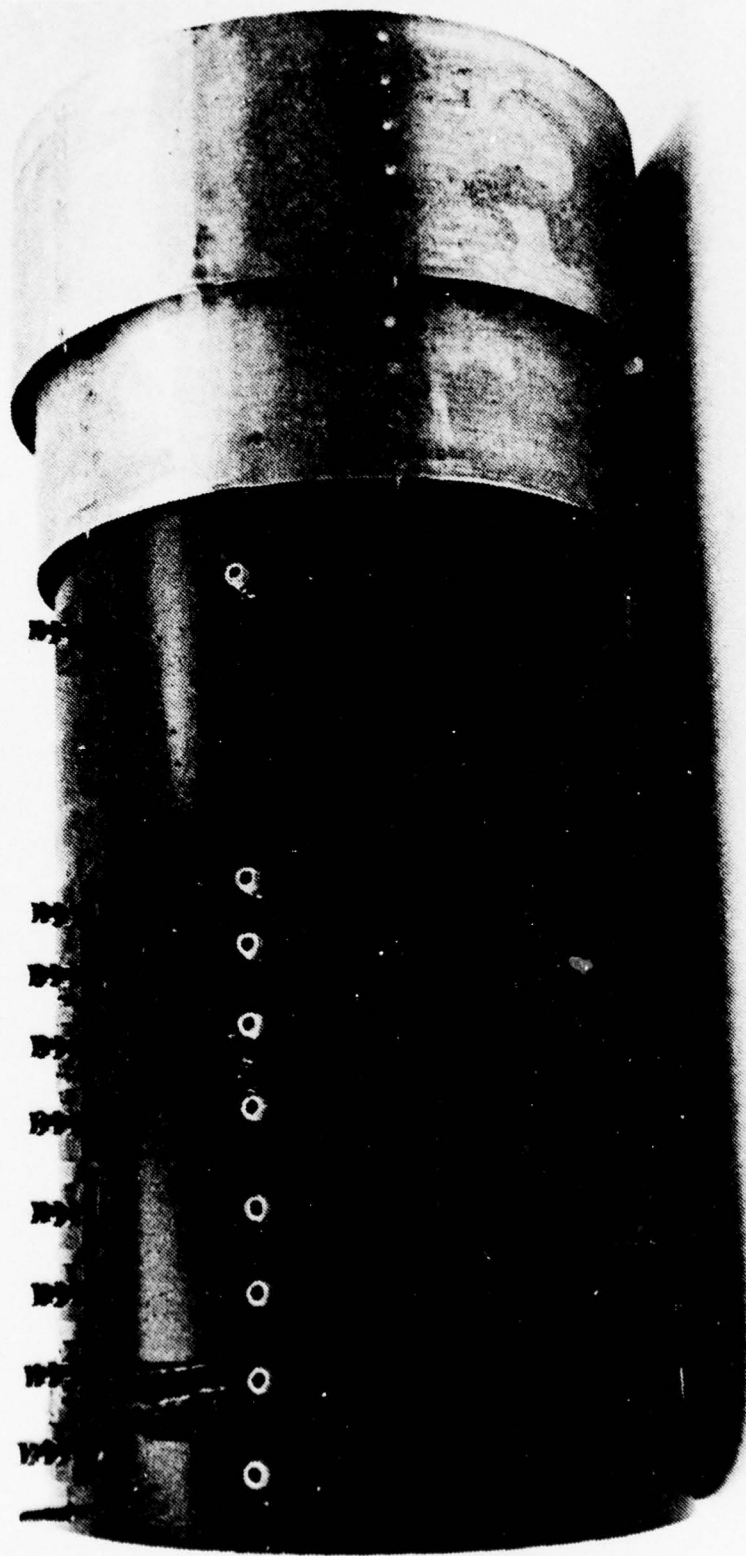

FIGURE 13. MIXING STACK WITH TWO-RING DIFFUSOR

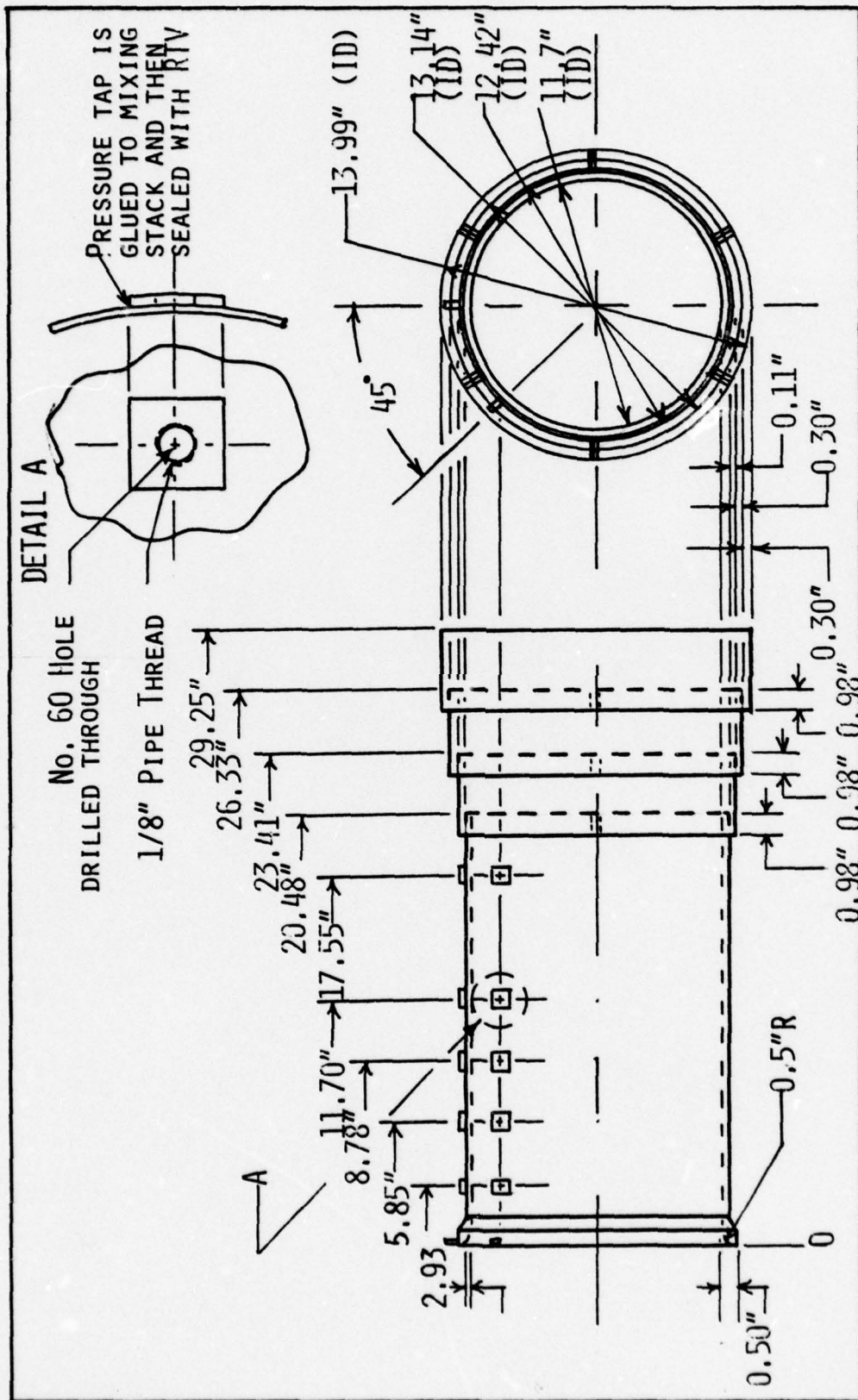
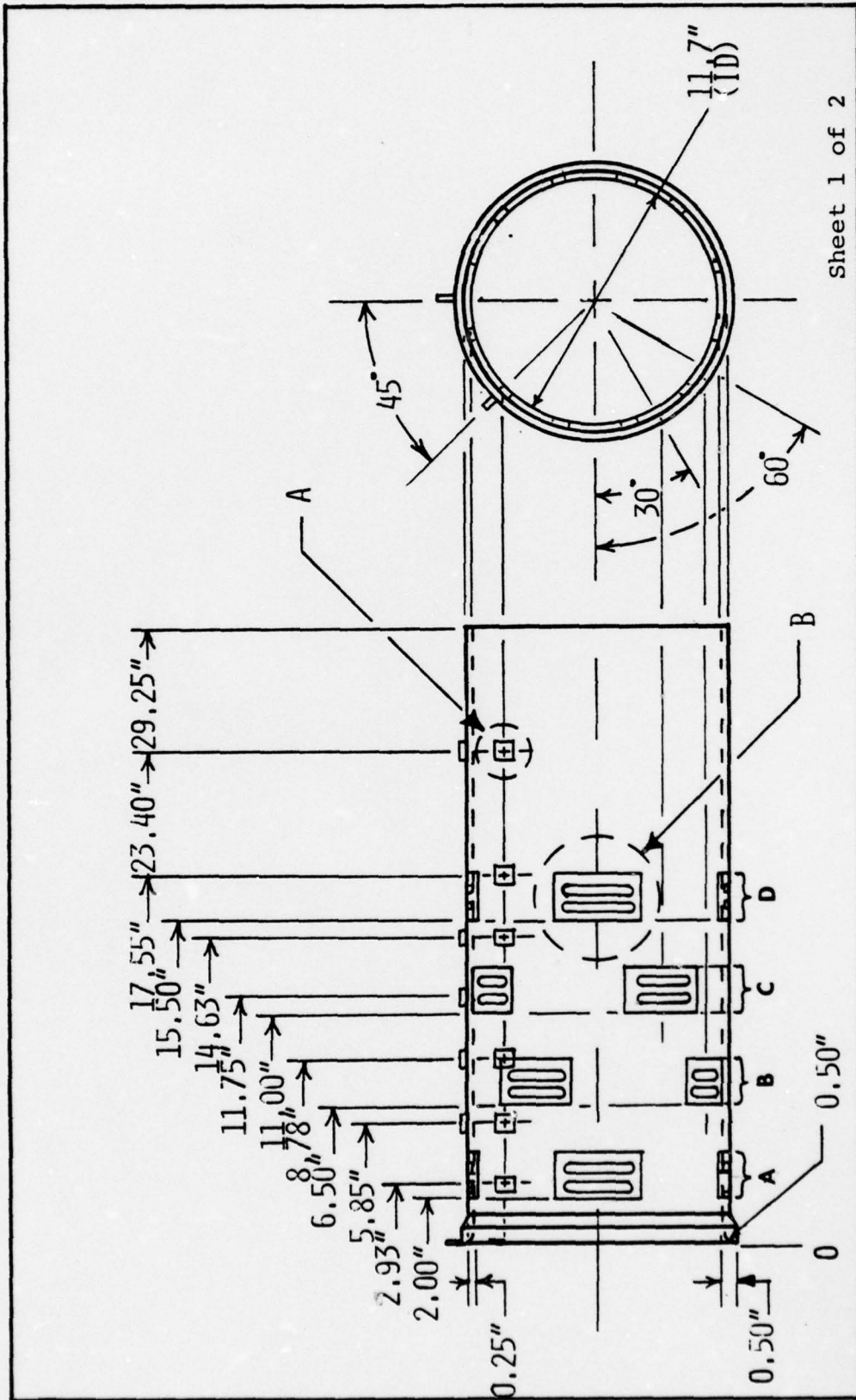

FIGURE 14. DIMENSIONAL ILLUSTRATION OF MIXING STACK WITH THREE-RING DIFFUSOR

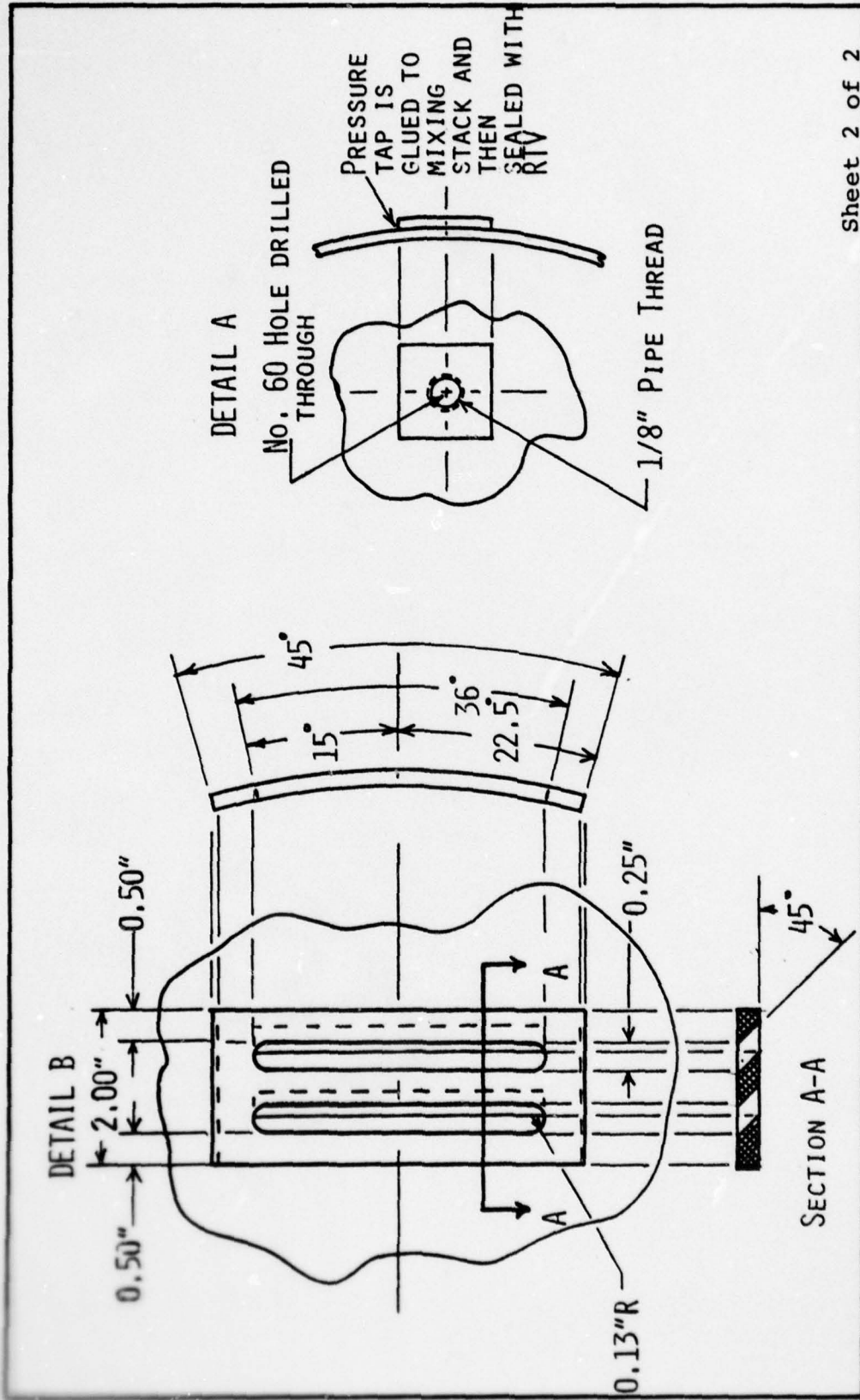

FIGURE 15. MIXING STACK WITH THREE-RING DIFFUSOR



Sheet 1 of 2

FIGURE 16. DIMENSIONAL ILLUSTRATION OF STRAIGHT MIXING STACK WITH PORTS



Sheet 2 of 2

FIGURE 16 (CONTINUED) DETAIL A AND DETAIL B

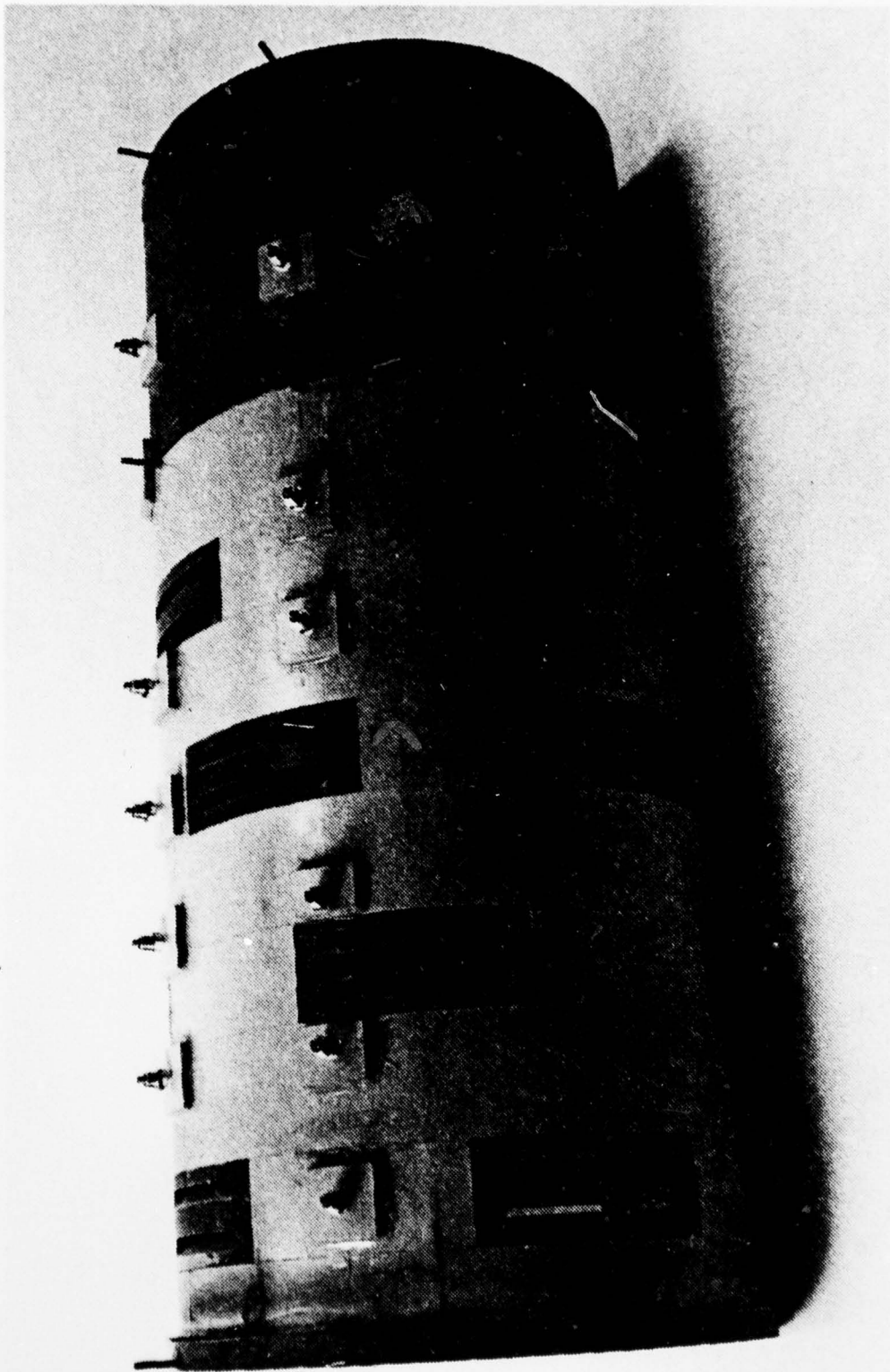

FIGURE 17. STRAIGHT MIXING STACK WITH PORTS

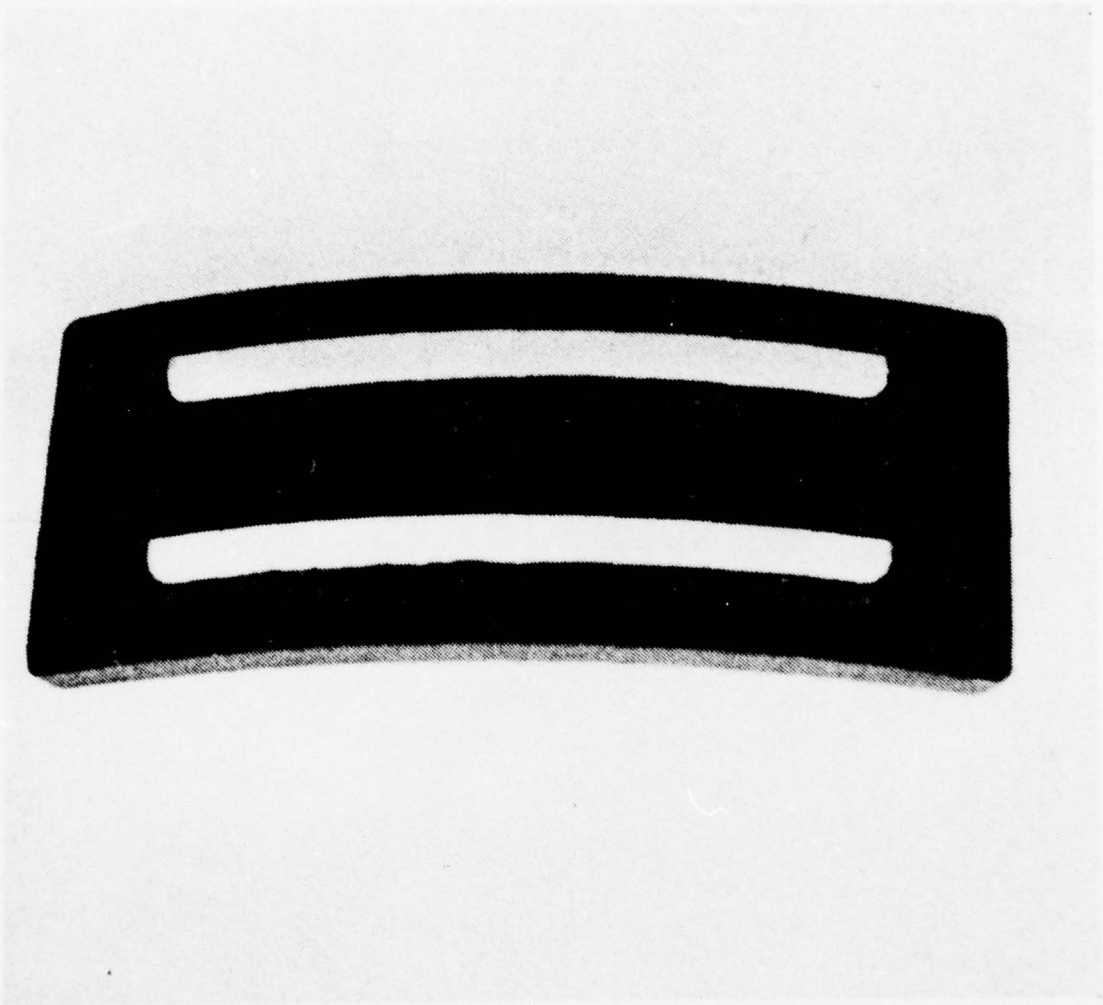

FIGURE 17 (CONTINUED) REMOVABLE PORTED INSERT

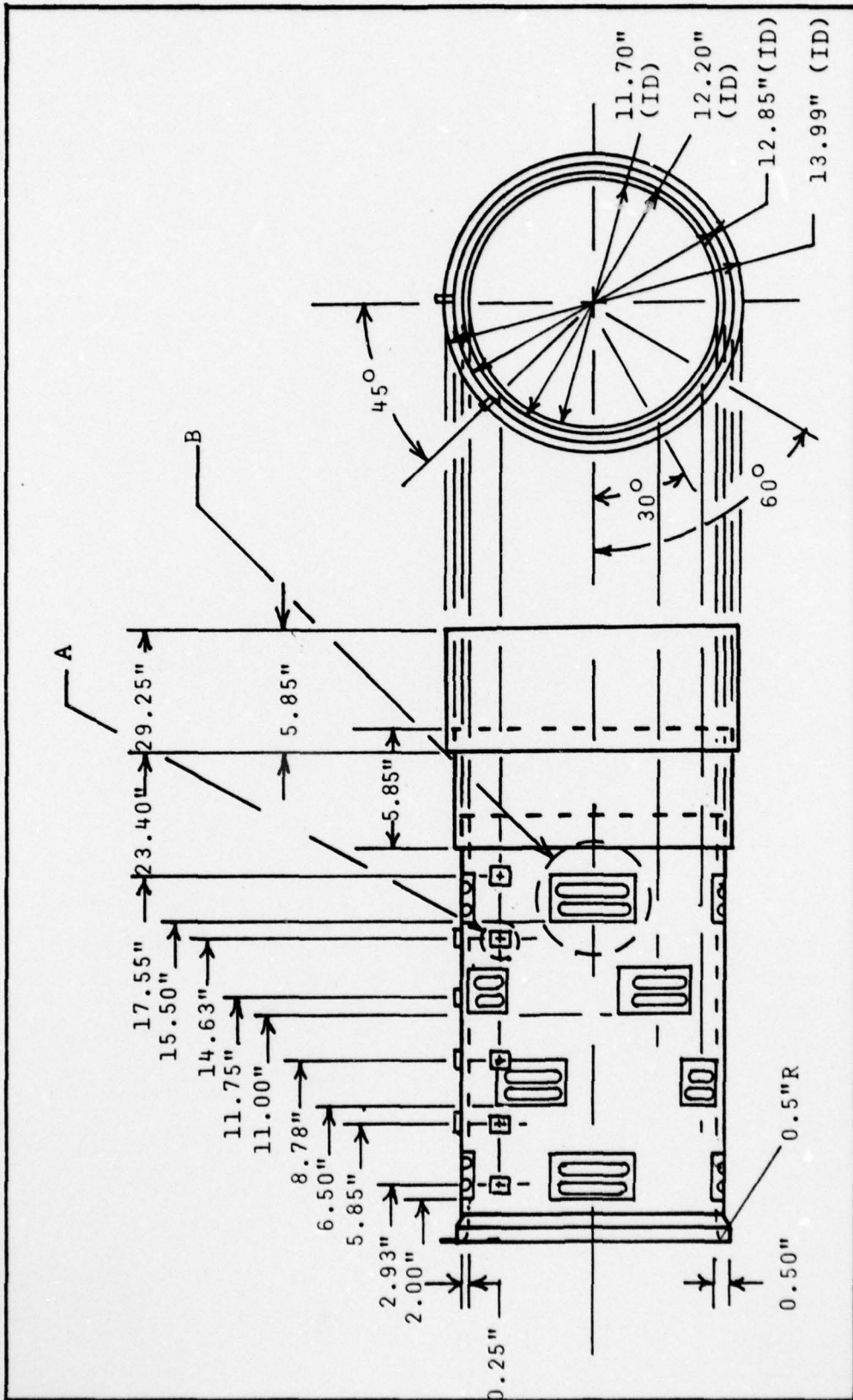

FIGURE 18. DIMENSIONAL ILLUSTRATION OF PORTED MIXING STACK AND A TWO-RING DIFFUSOR

517

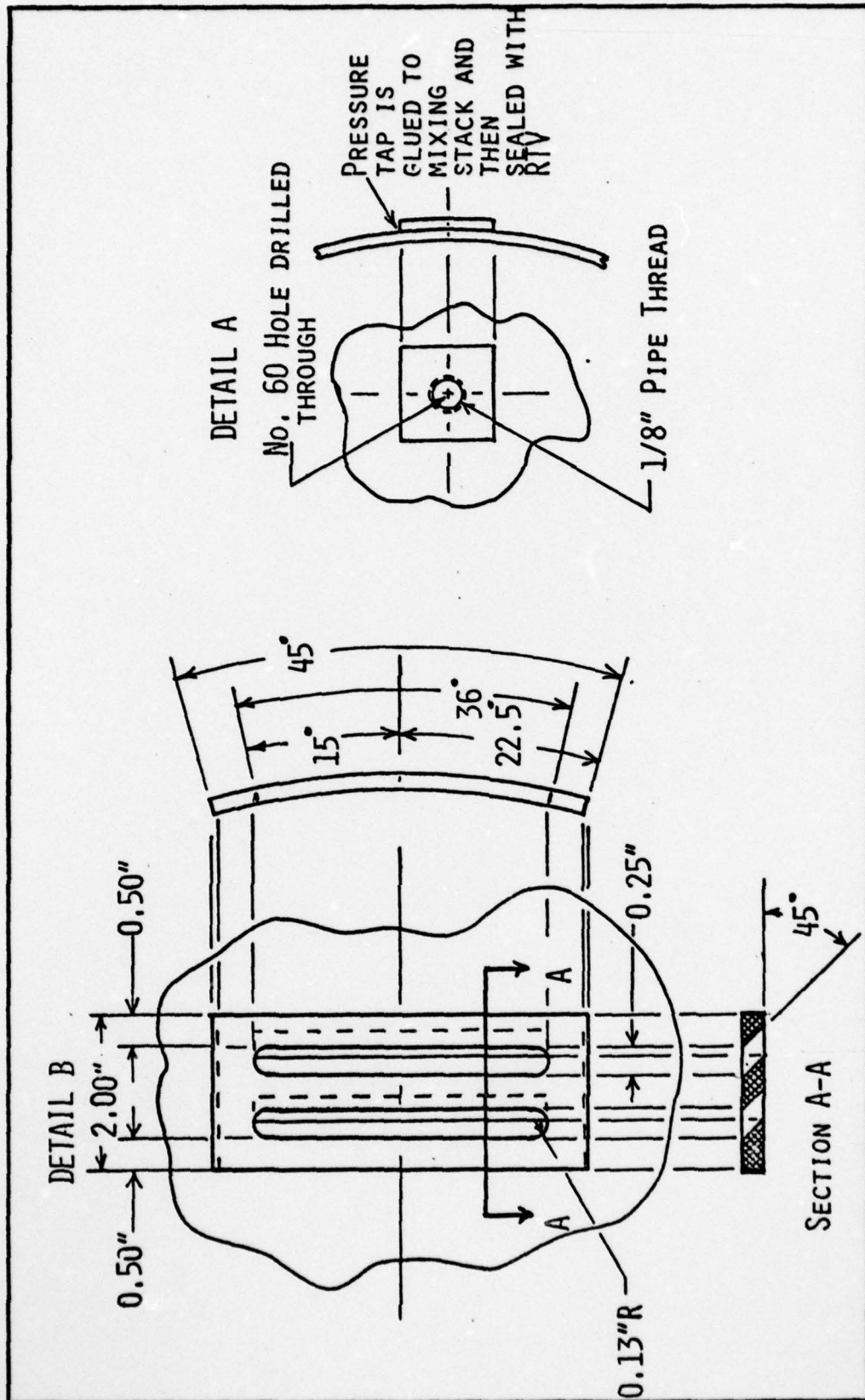

FIGURE 18. (CONTINUED) DETAIL A AND DETAIL B

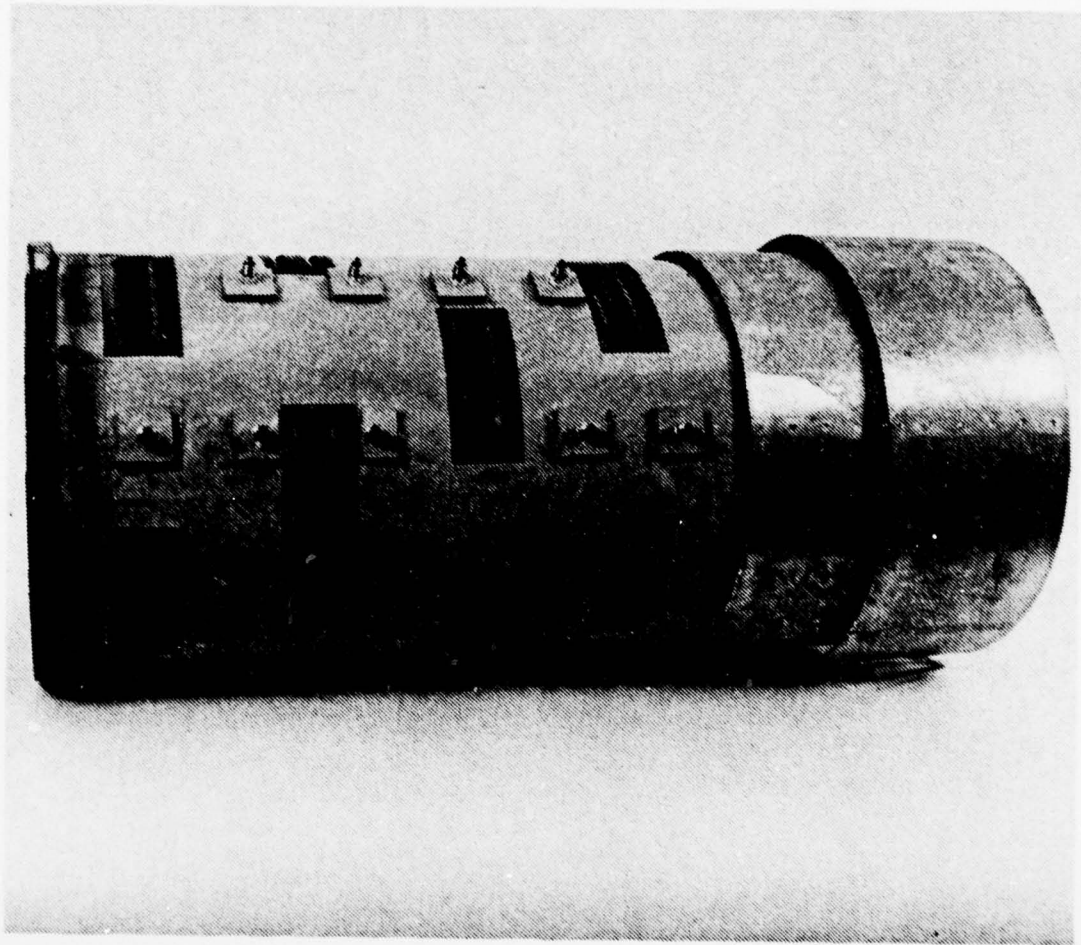

FIGURE 19. PORTED MIXING STACK AND A TWO-RING DIFFUSOR

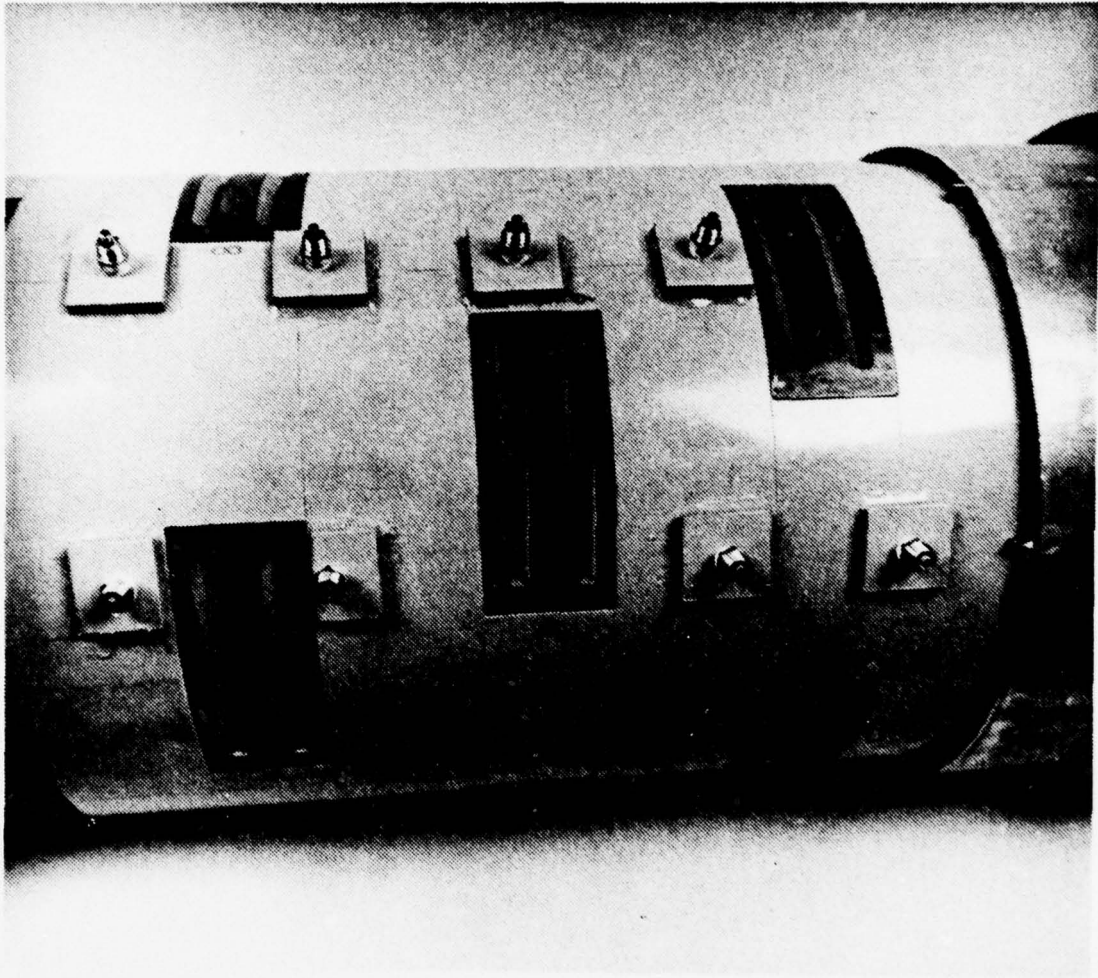

FIGURE 19. (CONTINUED) DETAILED VIEW OF PORTED INSERT AND PRESSURE TAP ARRANGEMENT

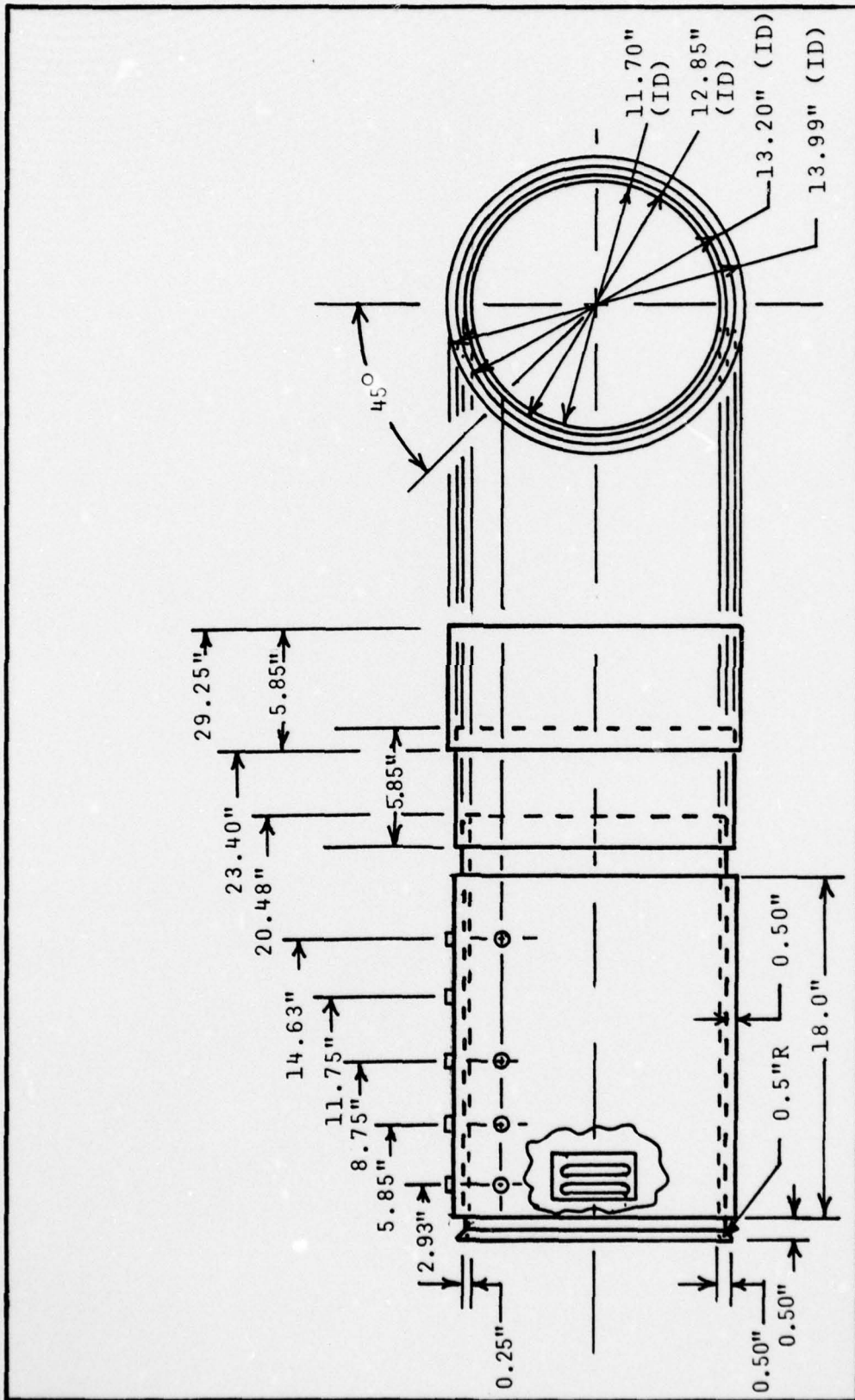

FIGURE 20. DIMENSIONAL ILLUSTRATION OF A PORTED MIXING STACK WITH TWO-RING DIFFUSOR AND SHROUD



FIGURE 21. PORTED MIXING STACK WITH TWO-RING DIFFUSOR AND SHROUD

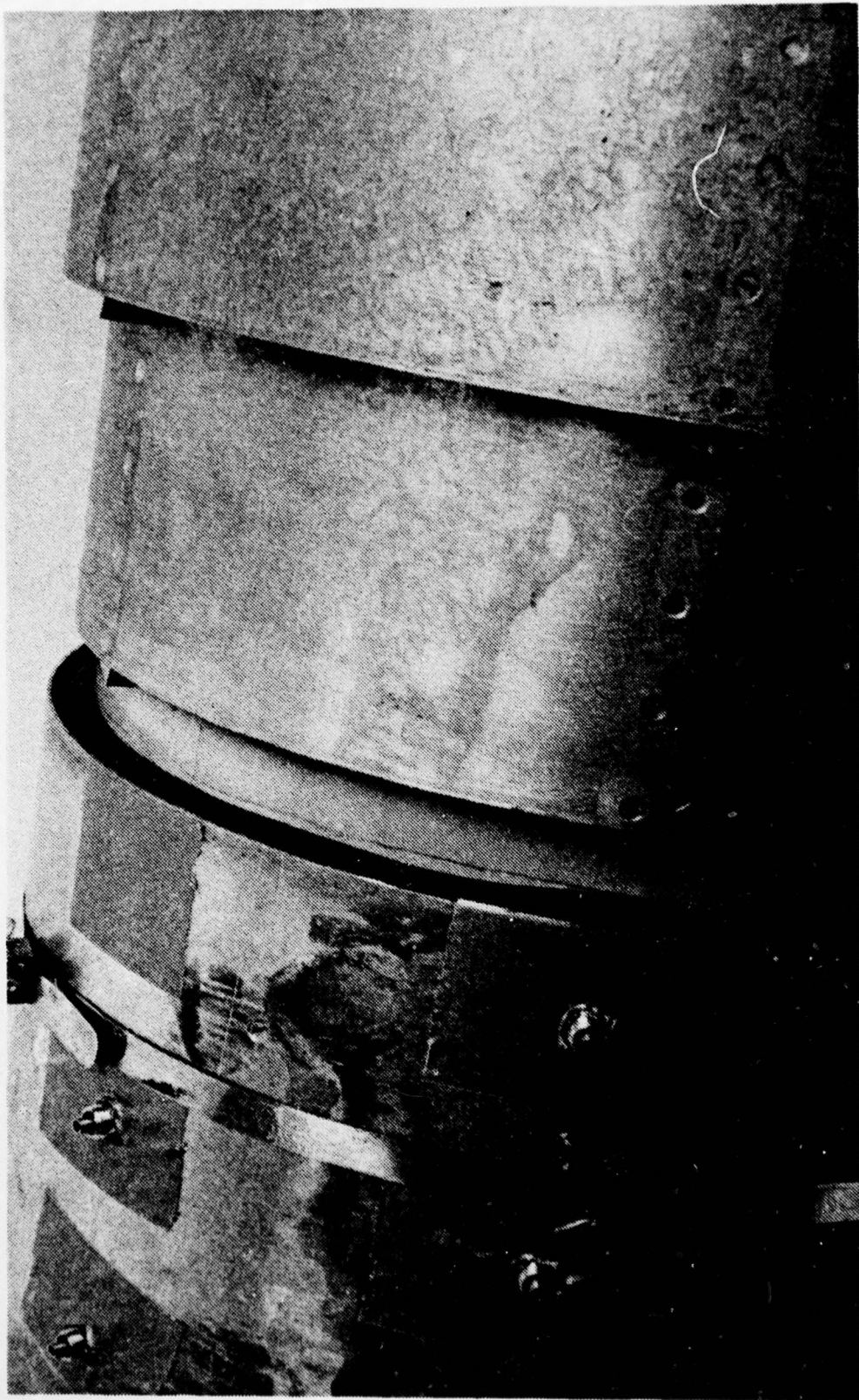

FIGURE 21. (CONTINUED) DETAILED PHOTO OF SHROUD TERMINATION AND DIFFUSOR RING INSTALLATION



FIGURE 22. PORTED MIXING STACK WITH DIFFUSOR RING AND FLOW-THROUGH SHROUD

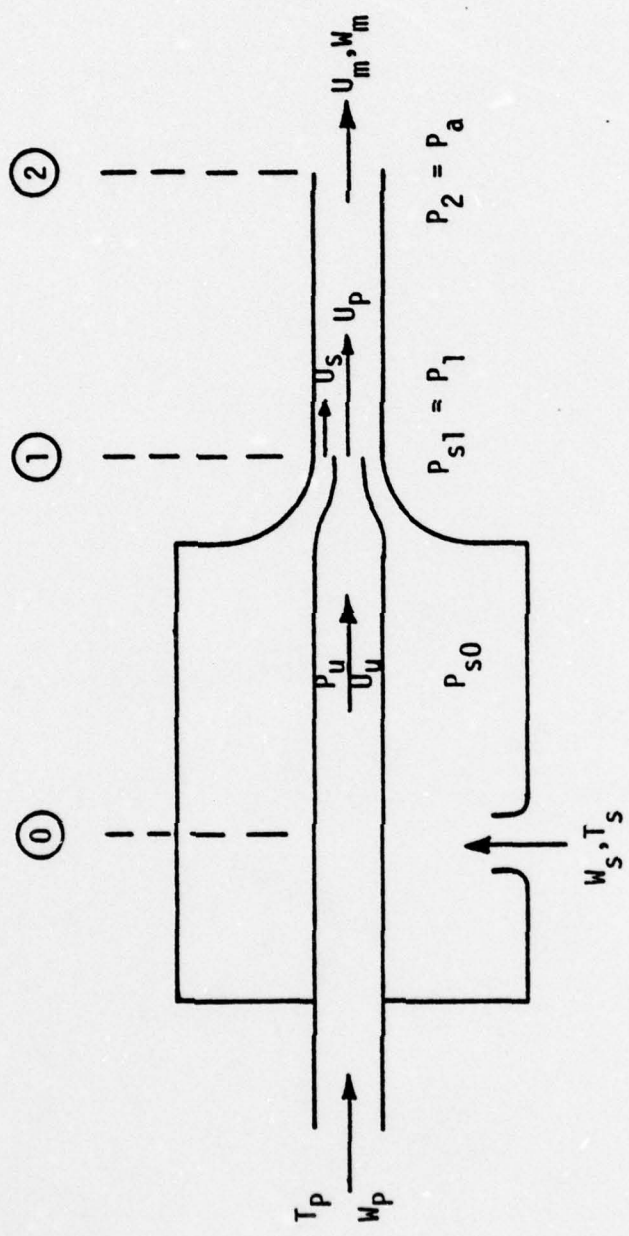

FIGURE 23. SIMPLE SINGLE NOZZLE EJECTOR SYSTEM

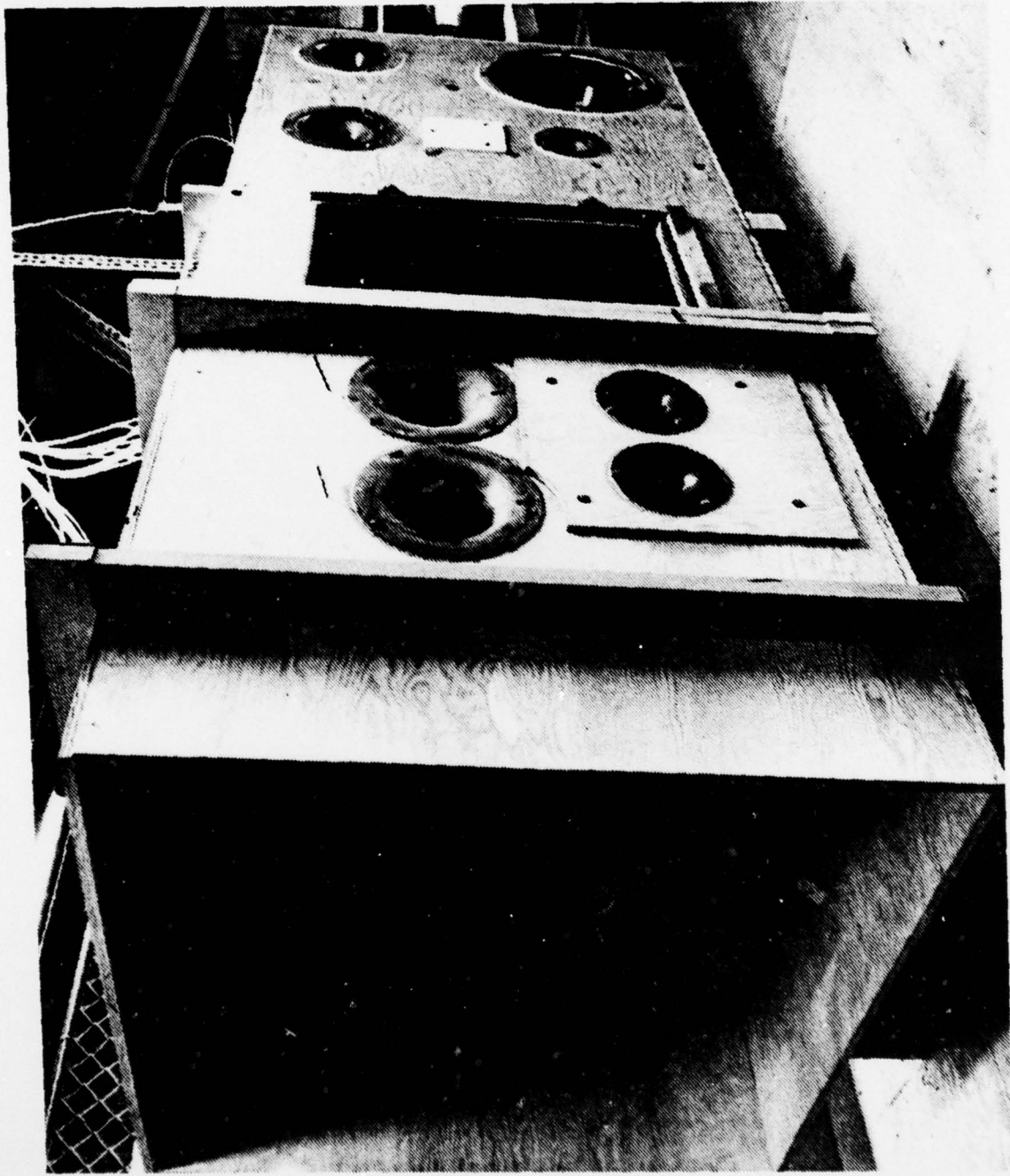

FIGURE 24. SECONDARY AND TERTIARY AIR PLENUMS

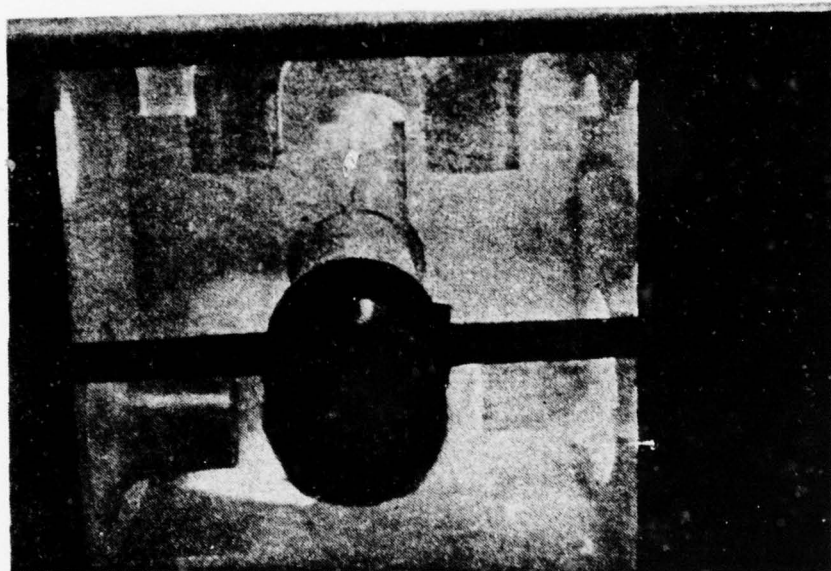

FIGURE 25. INTERIOR OF SECONDARY AIR PLENUM SHOWING FLOW STRAIGHTENER AND ASME LONG RADIUS FLOW NOZZLES

AD-A061 278

NAVAL POSTGRADUATE SCHOOL MONTEREY CALIF
PERFORMANCE OF MULTIPLE NOZZLE EDUCTOR SYSTEMS WITH SEVERAL GEO--ETC(U)
SEP 78 R J LEMKE, C P STAEHLI

F/G 20/4

UNCLASSIFIED

NPS69-78-016

NL

2 of 3
AD
A061 278

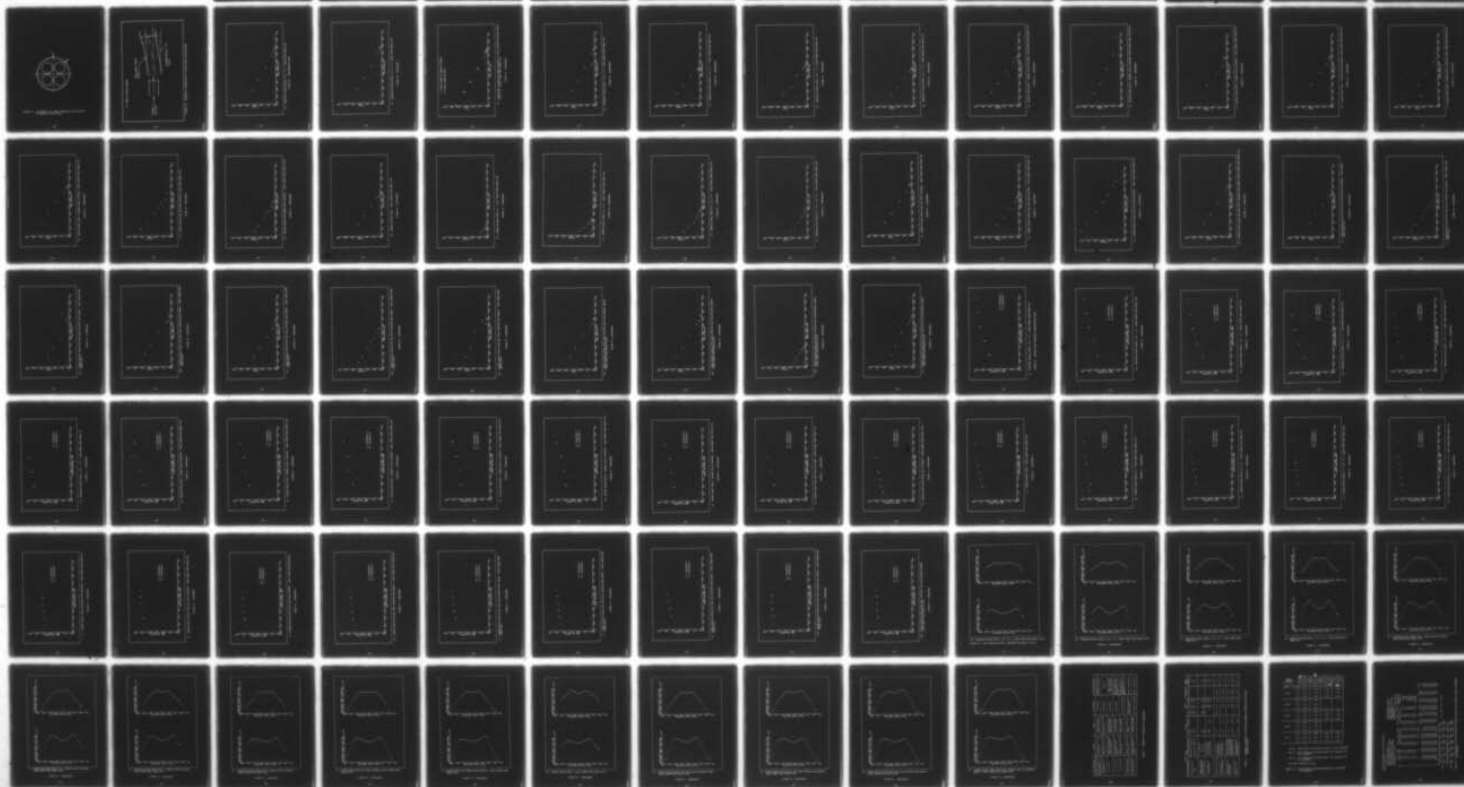

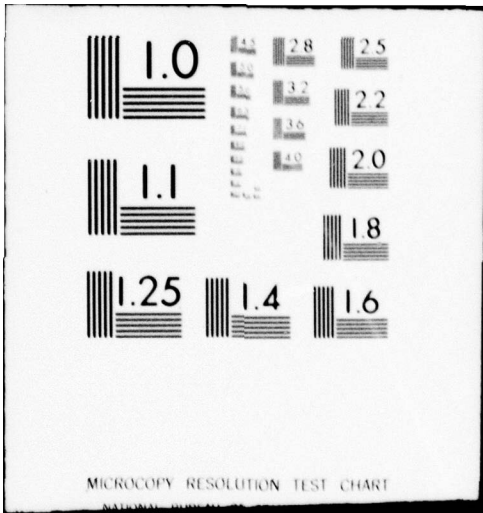

MICROCOPY RESOLUTION TEST CHART

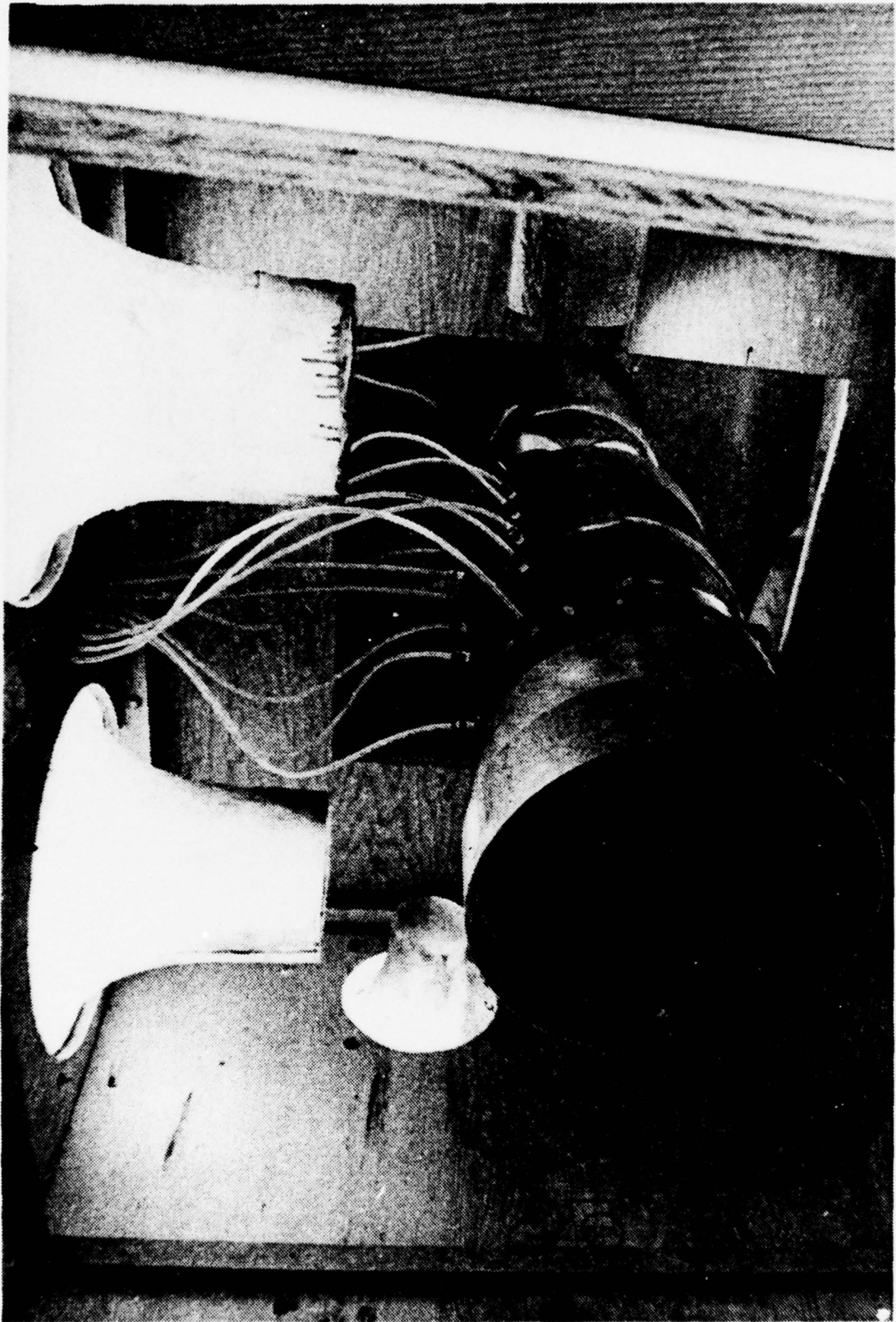

FIGURE 26. TERTIARY AIR PLENUM

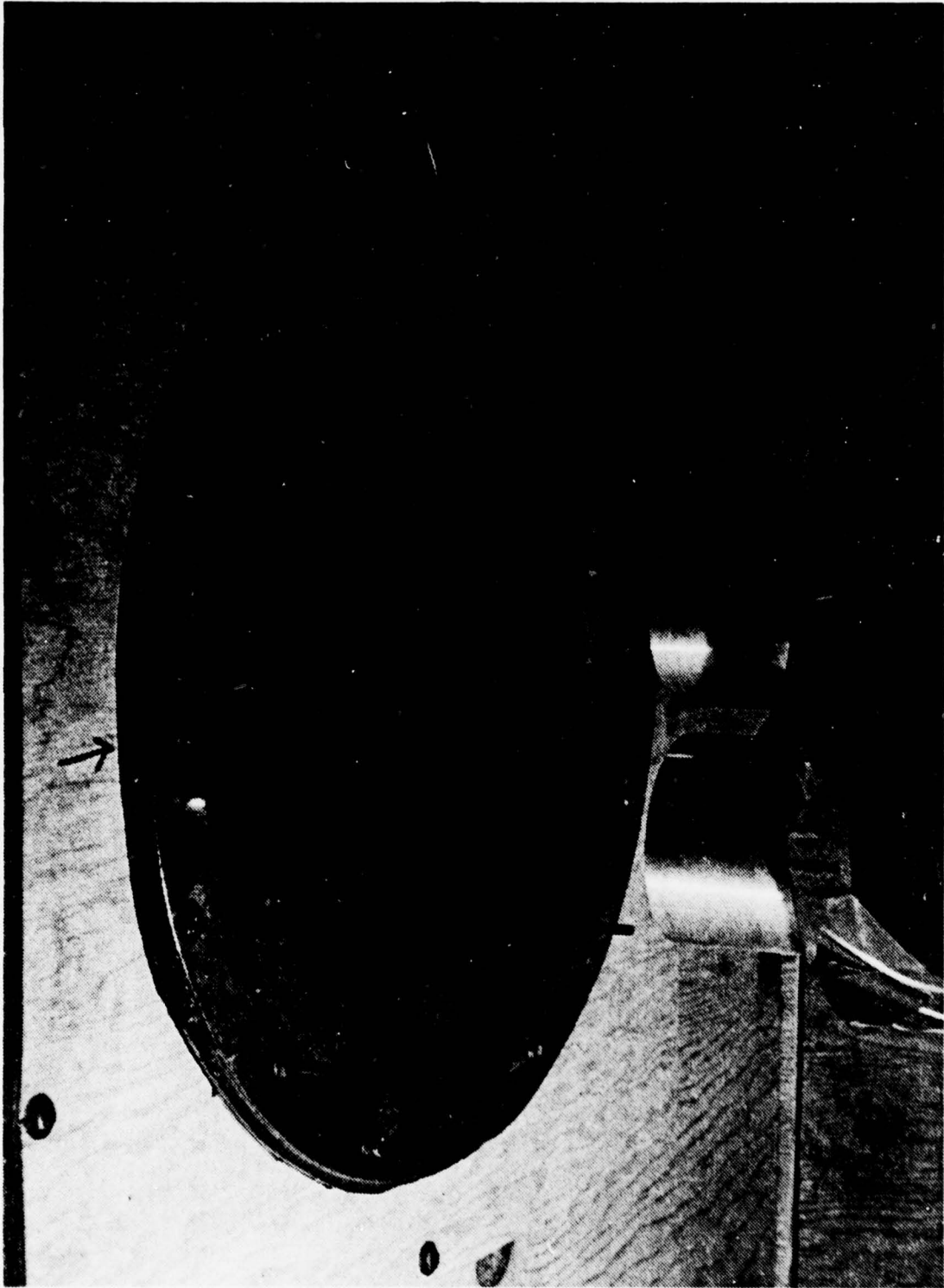

FIGURE 27. MIXING STACK ENTRANCE WITH AIR SEAL IN PLACE

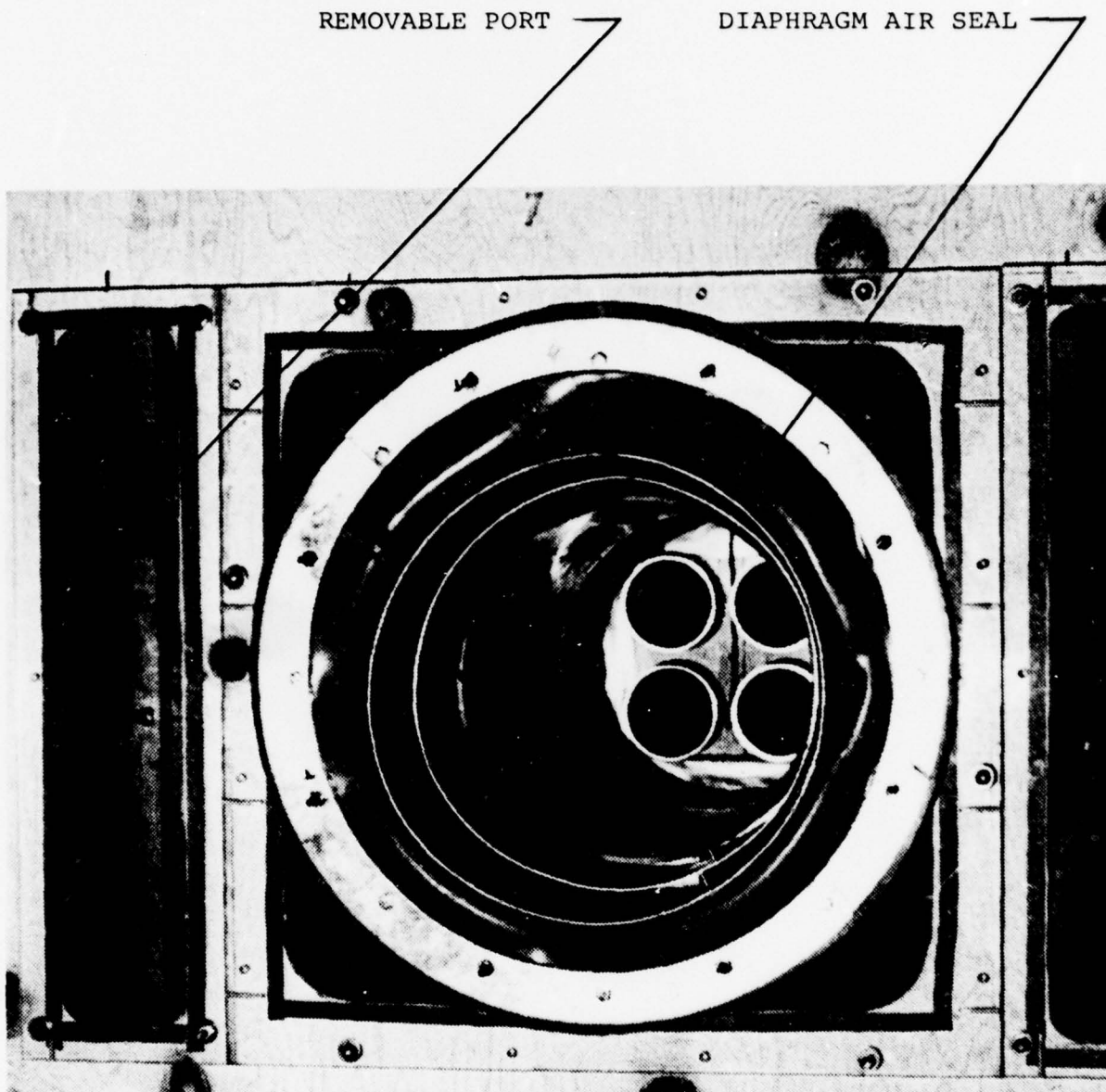

FIGURE 28. MIXING STACK EXIT WITH AIR SEAL IN PLACE

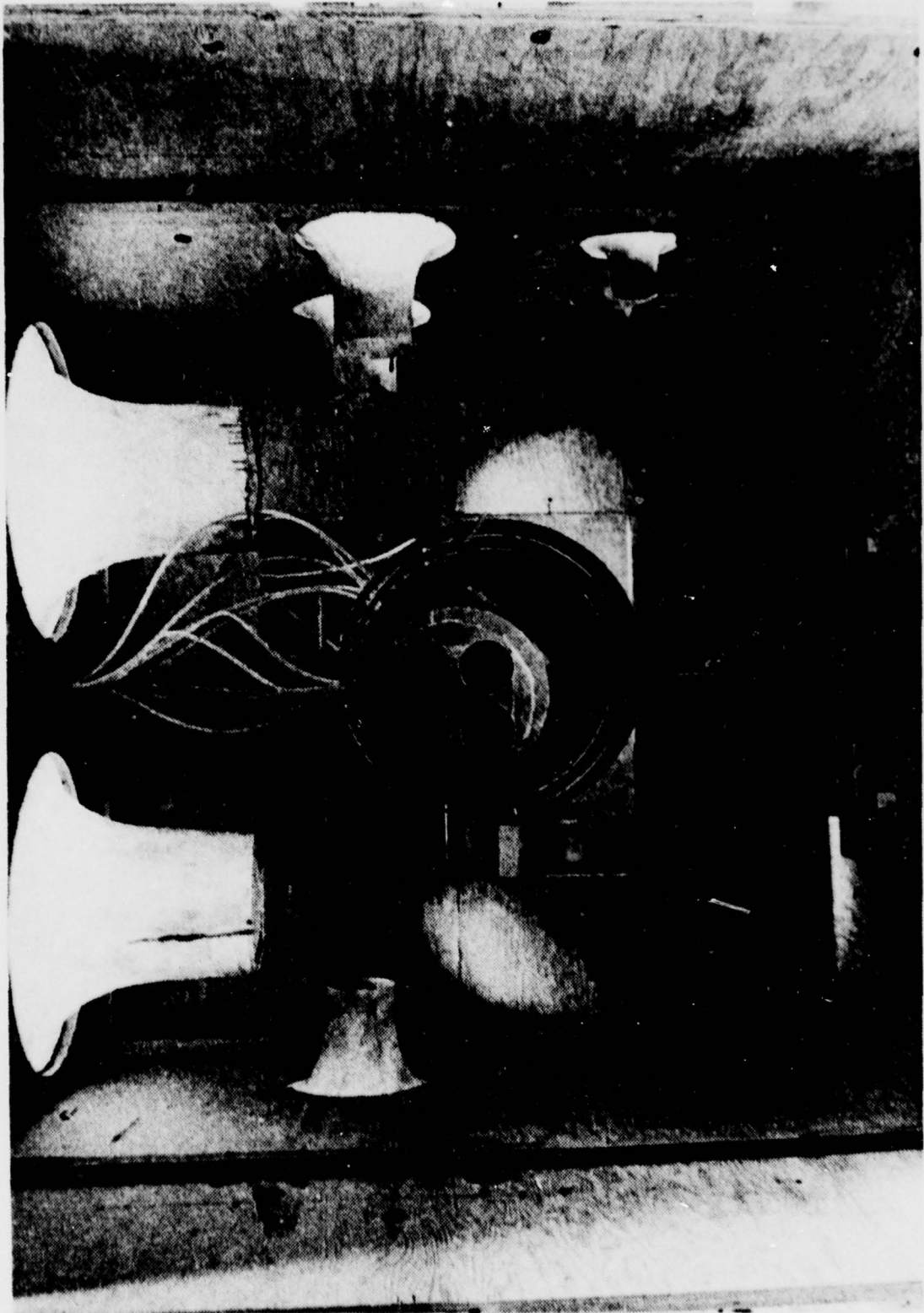

FIGURE 29. INTERIOR OF TERTIARY PLENUM

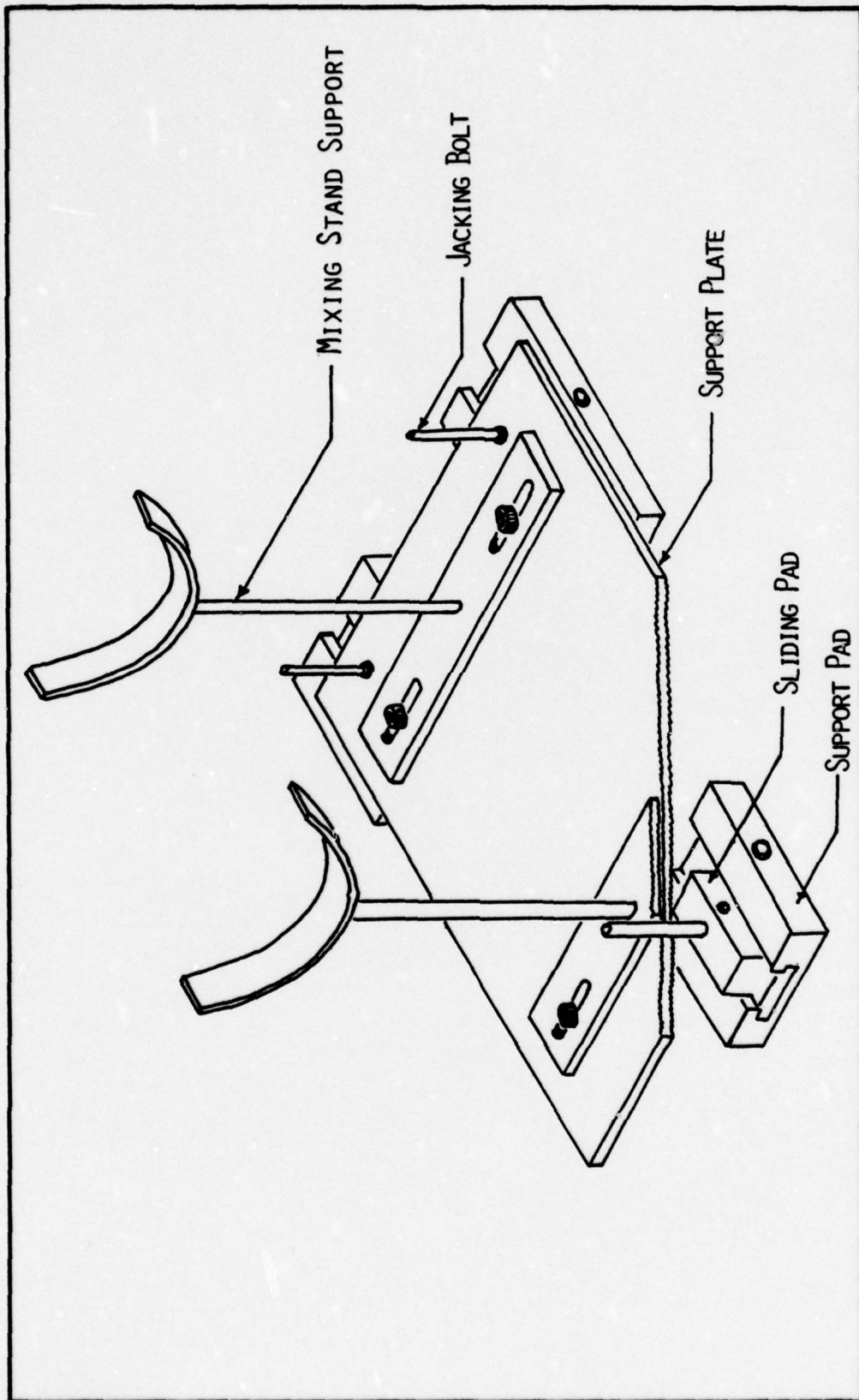

FIGURE 30. SKETCH OF MIXING STACK SUPPORT STAND



FIGURE 31. PHOTOGRAPH OF MIXING STACK SUPPORT STAND

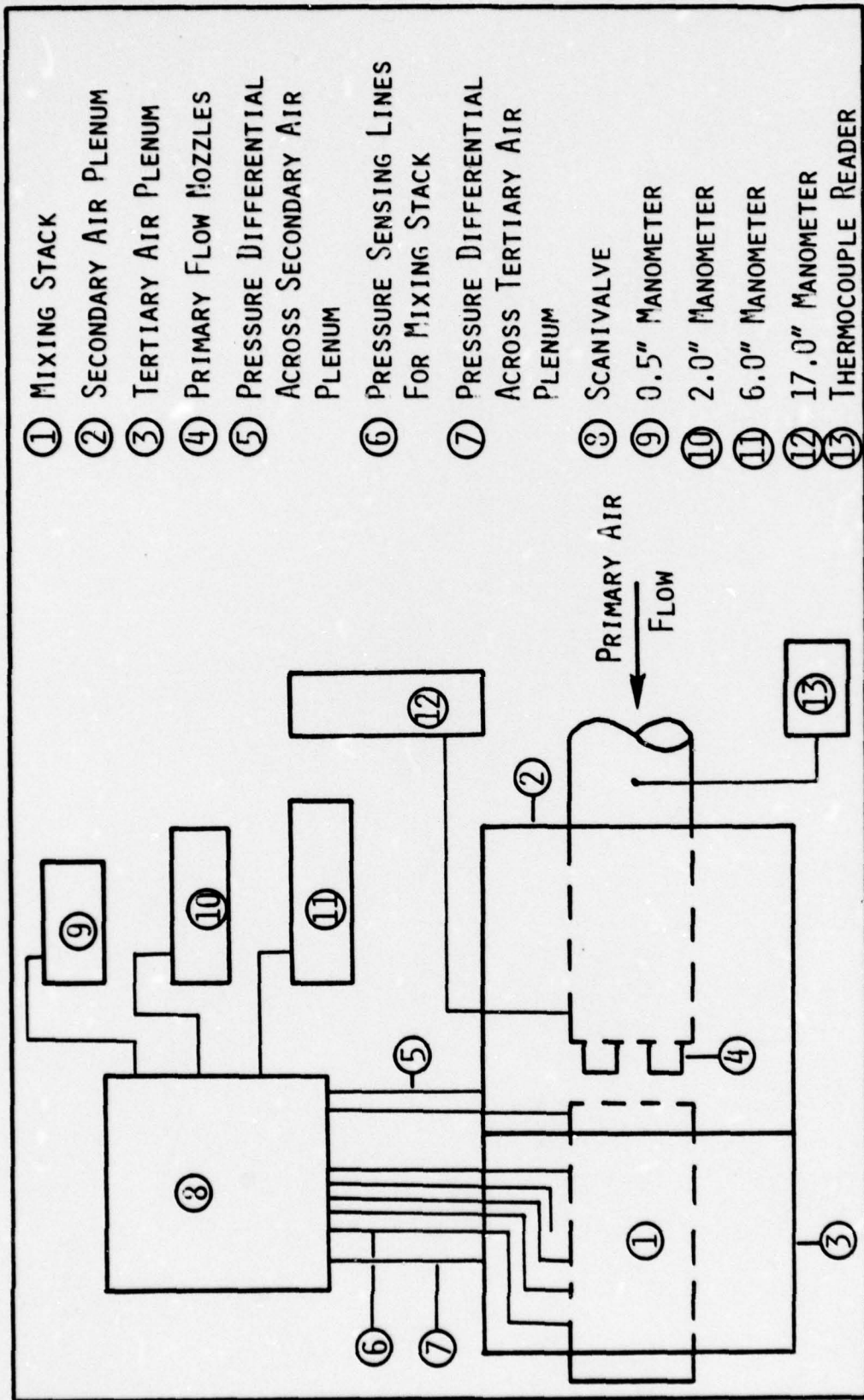

FIGURE 32. SCHEMATIC OF INSTRUMENTATION

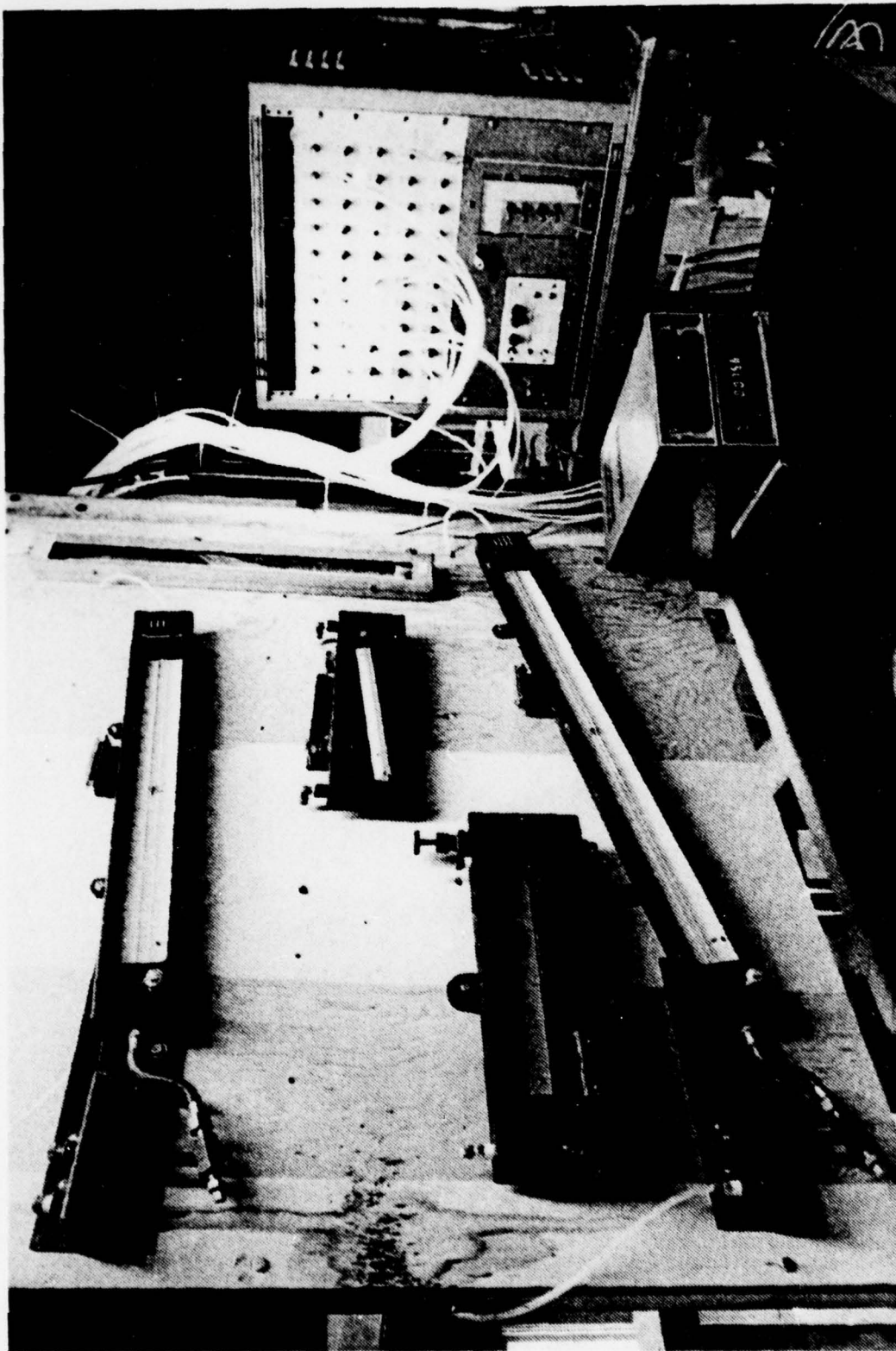

FIGURE 33. INSTRUMENTATION

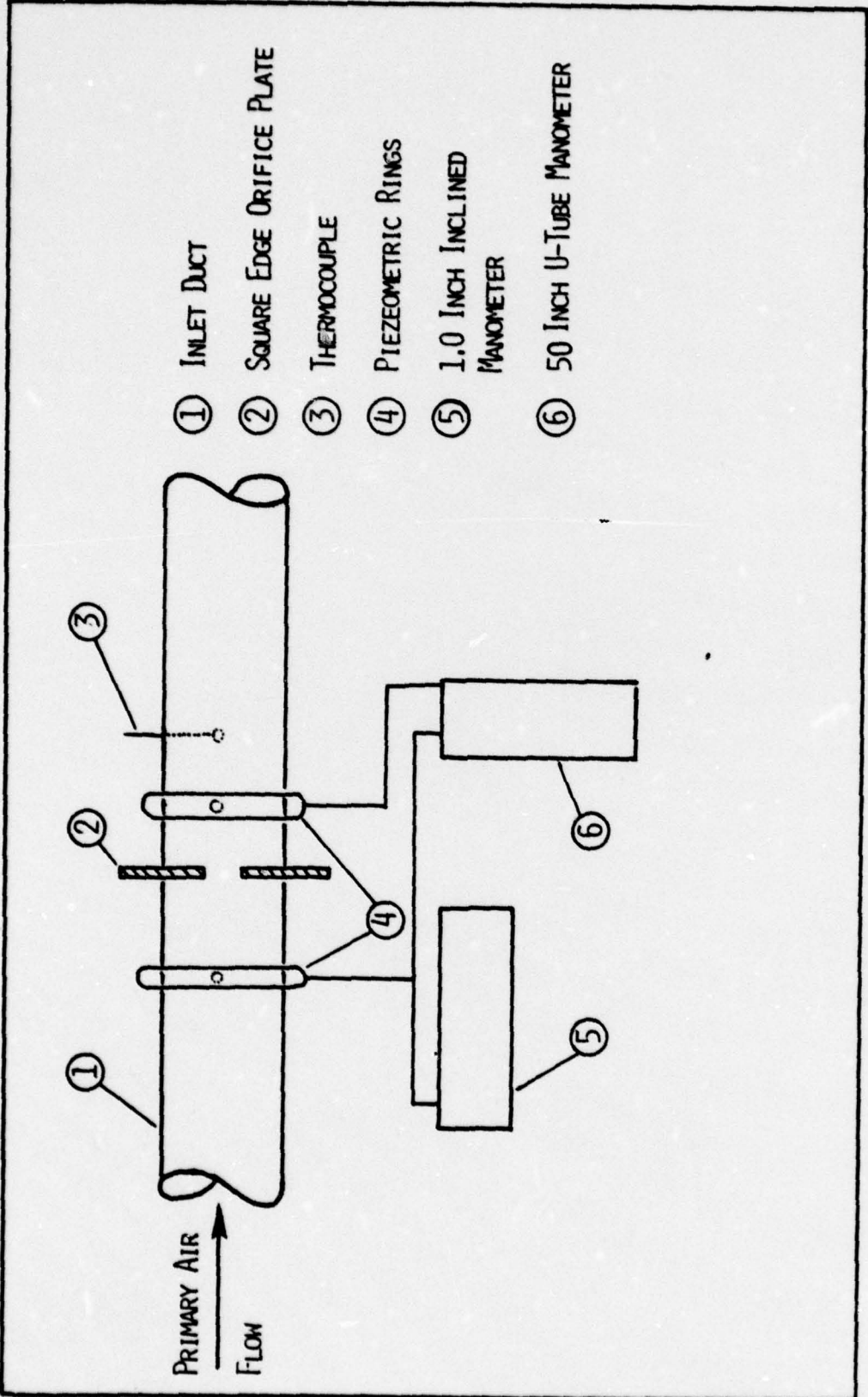

FIGURE 34. SCHEMATIC OF INSTRUMENTATION FOR PRIMARY AIR FLOW MEASUREMENT

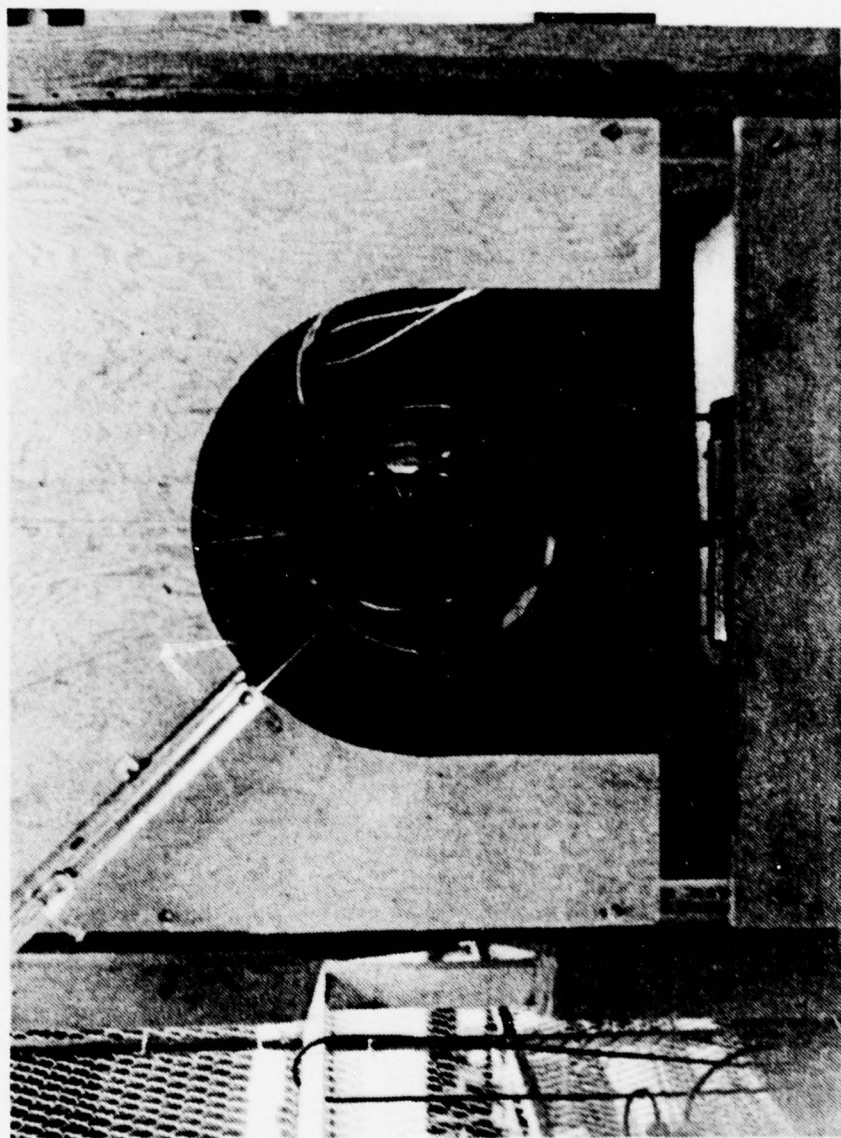

FIGURE 35. VELOCITY PROFILE APPARATUS

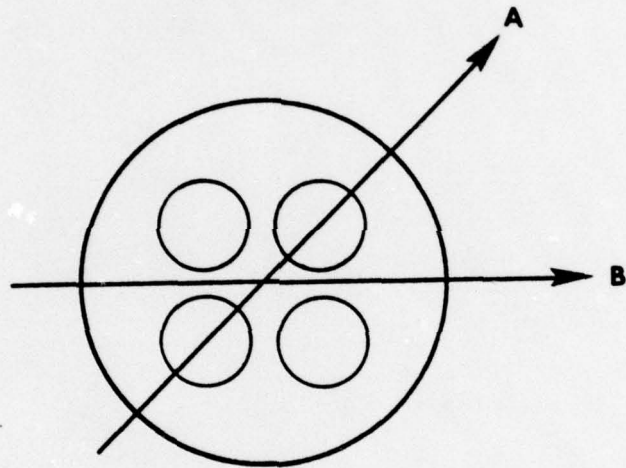

FIGURE 36. ORIENTATION OF MIXING STACK EXIT VELOCITY TRAVERSES

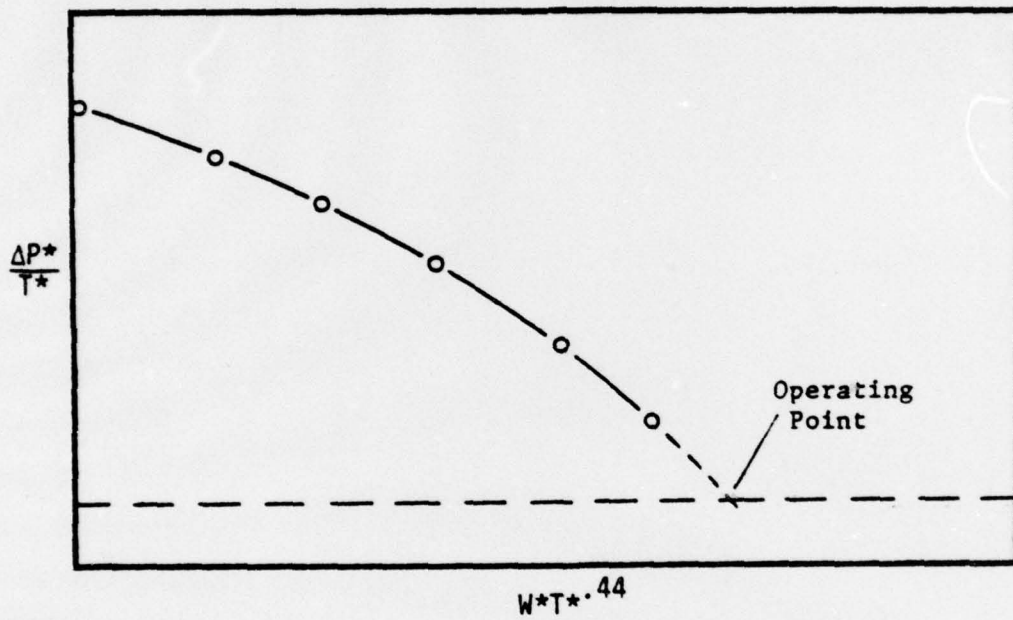

FIGURE 37. ILLUSTRATIVE PLOT OF THE EXPERIMENTAL DATA CORRELATION IN EQUATION (14)

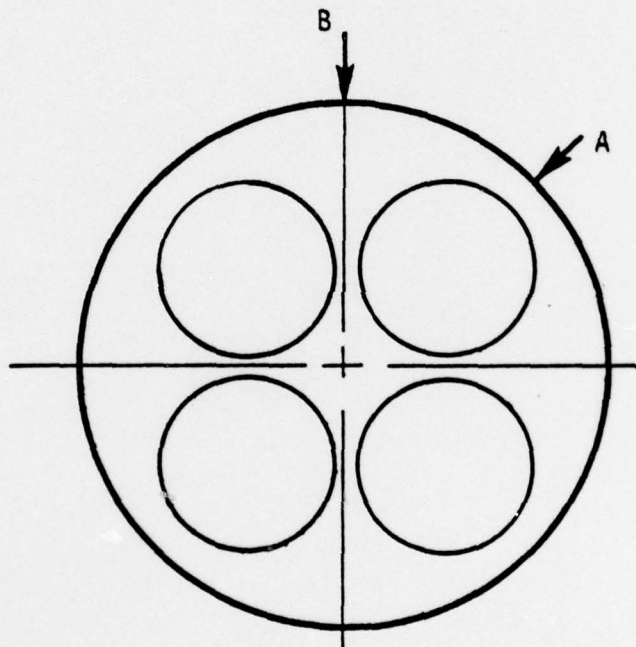

FIGURE 38. ORIENTATION OF STATIC PRESSURE TAPS RELATIVE TO PRIMARY FLOW NOZZLES

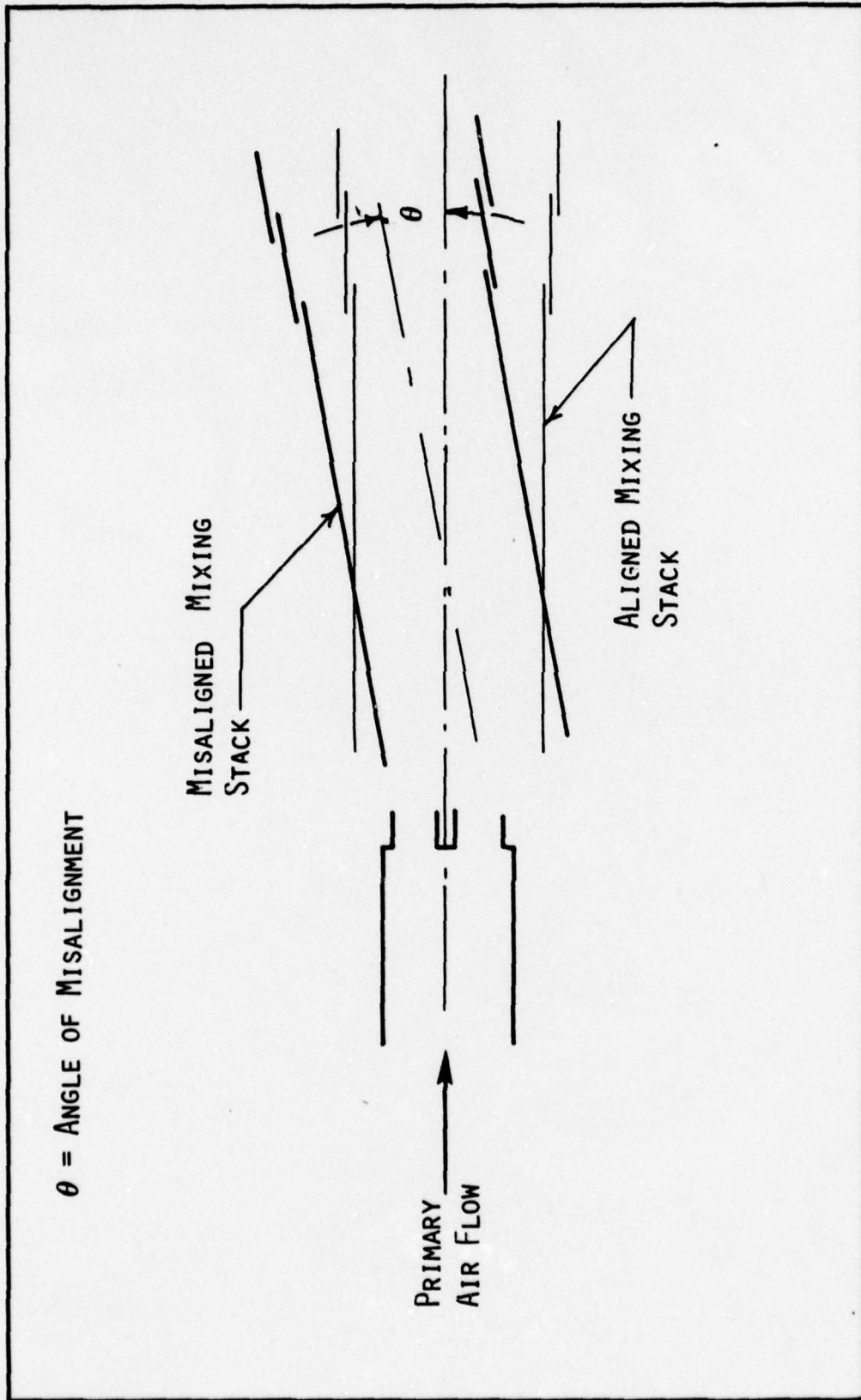
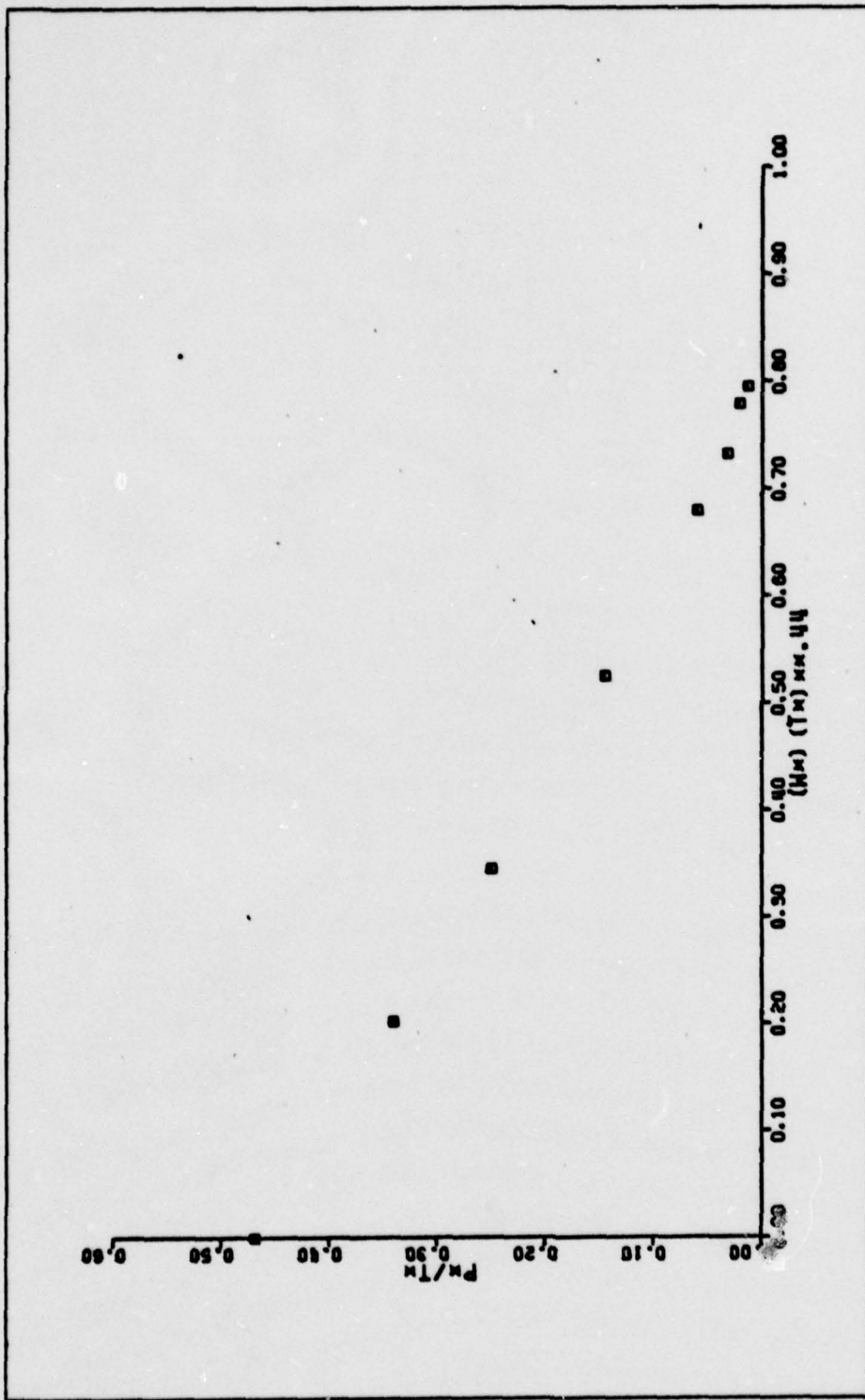
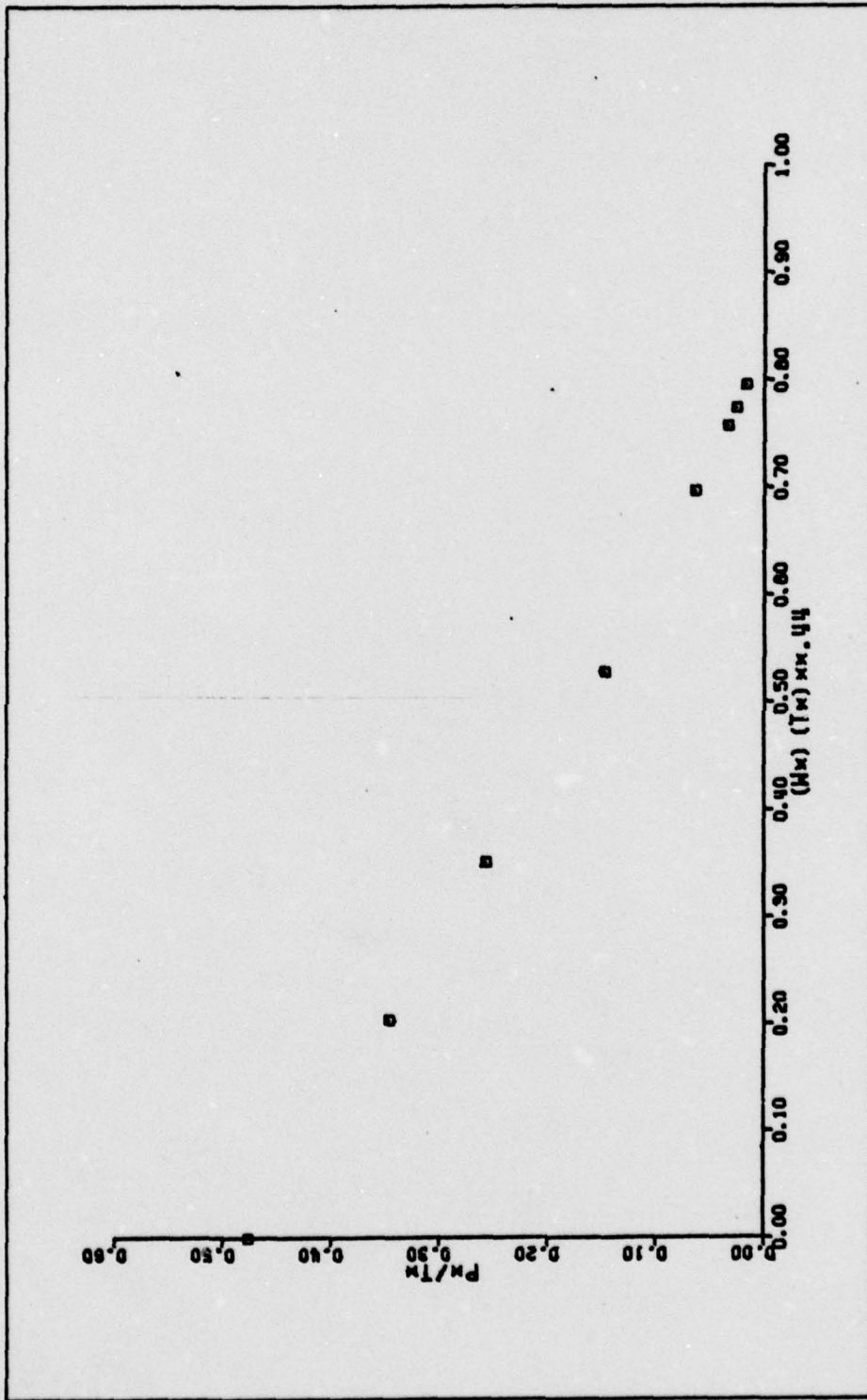

FIGURE 39. SCHEMATIC ILLUSTRATION OF MIXING STACK MISALIGNMENT



(a) STRAIGHT MIXING STACK, L/D = 3.0 (DATA FROM TABLE IVa)

FIGURE 40. PERFORMANCE PLOTS



(b) STRAIGHT MIXING STACK, L/D = 3.0 (DATA FROM TABLE IVb)

FIGURE 40 (CONTINUED)

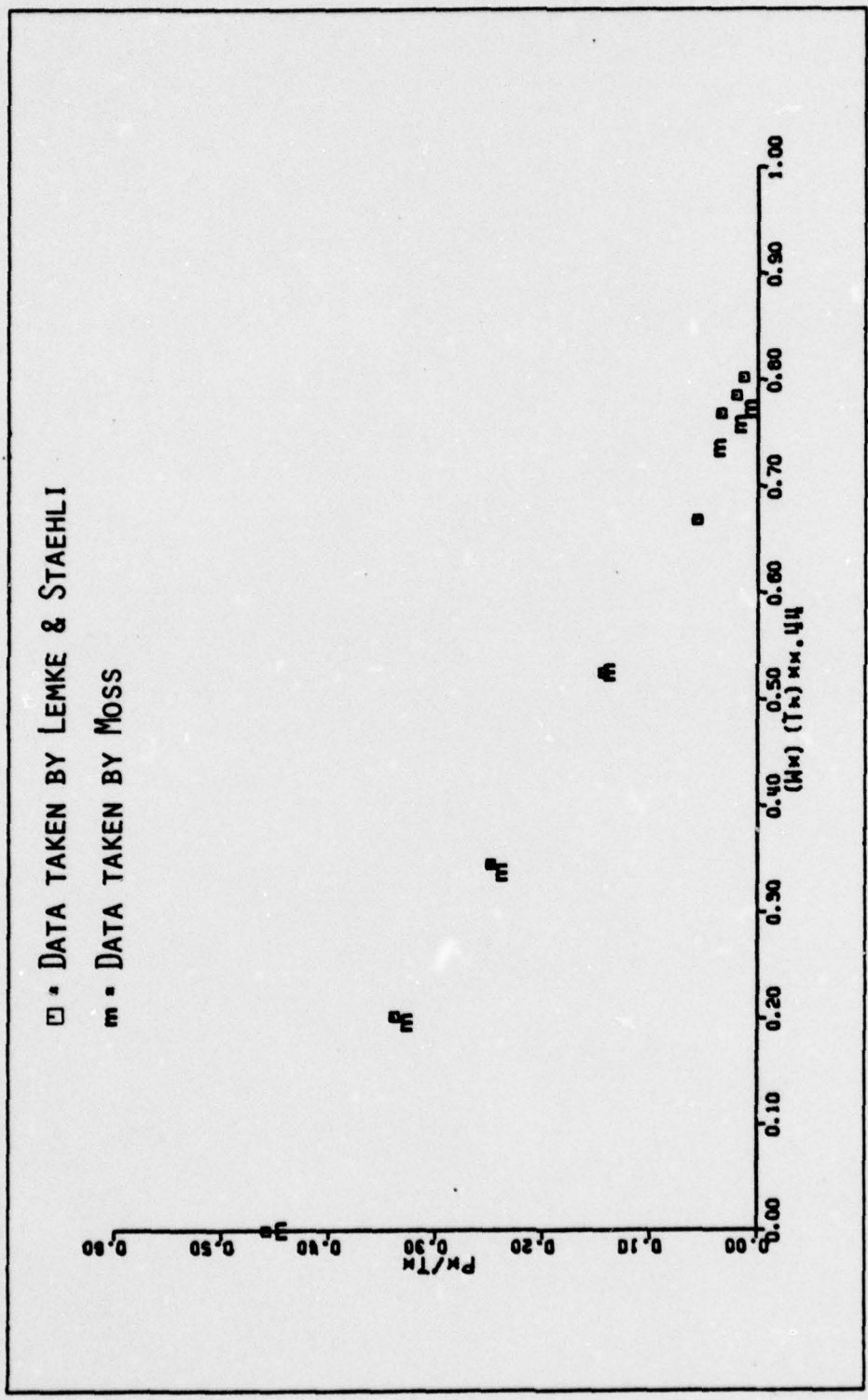

(c) COMPARISON OF DATA OBTAINED BY MOSS [2] WITH STRAIGHT MIXING STACK,
 L/D = 3.0 (DATA TAKEN FROM TABLE IVC)

FIGURE 40 (CONTINUED)

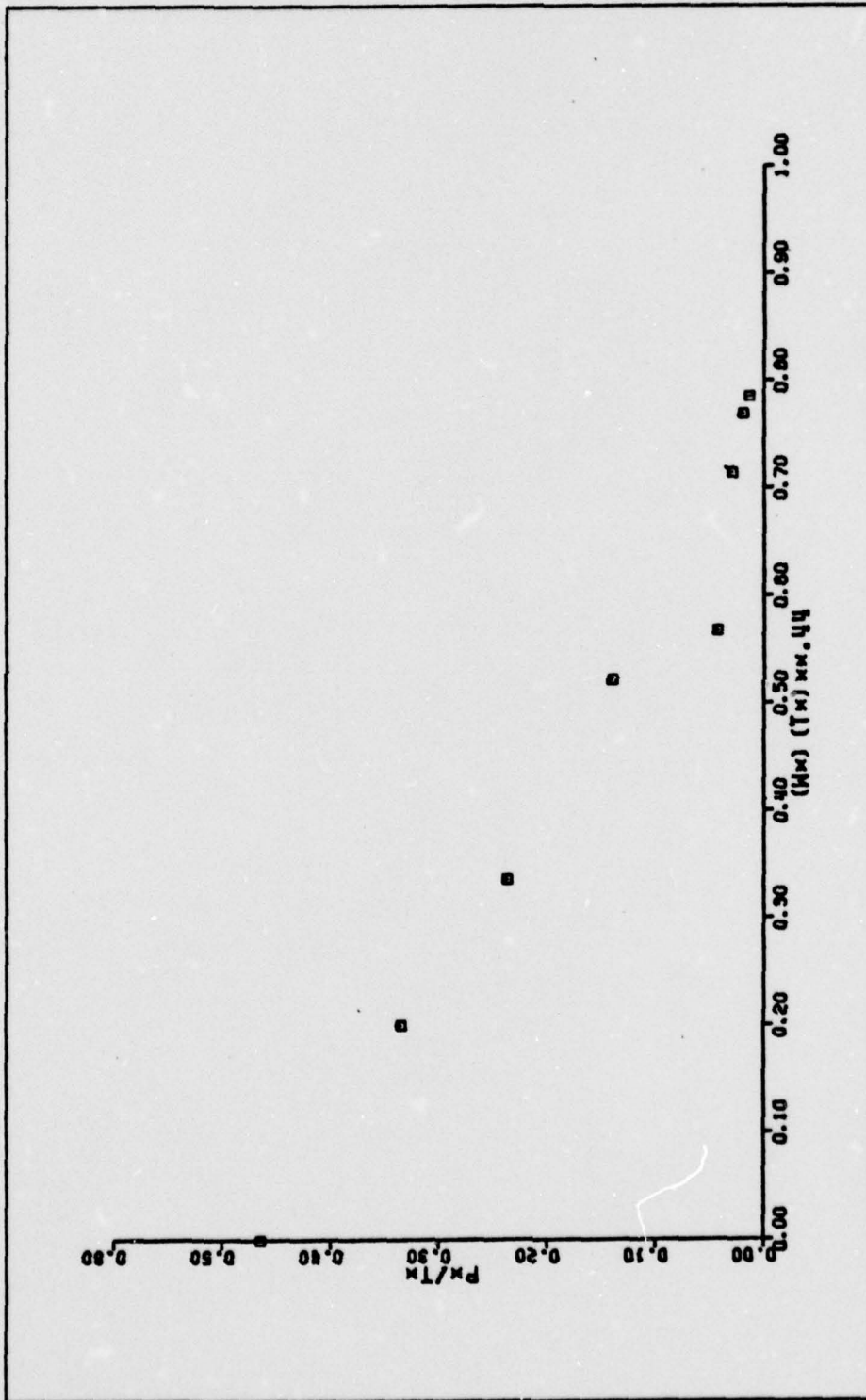

(d) STRAIGHT MIXING STACK, L/D = 2.5 (DATA TAKEN FROM TABLE IVd)

FIGURE 40 (CONTINUED)

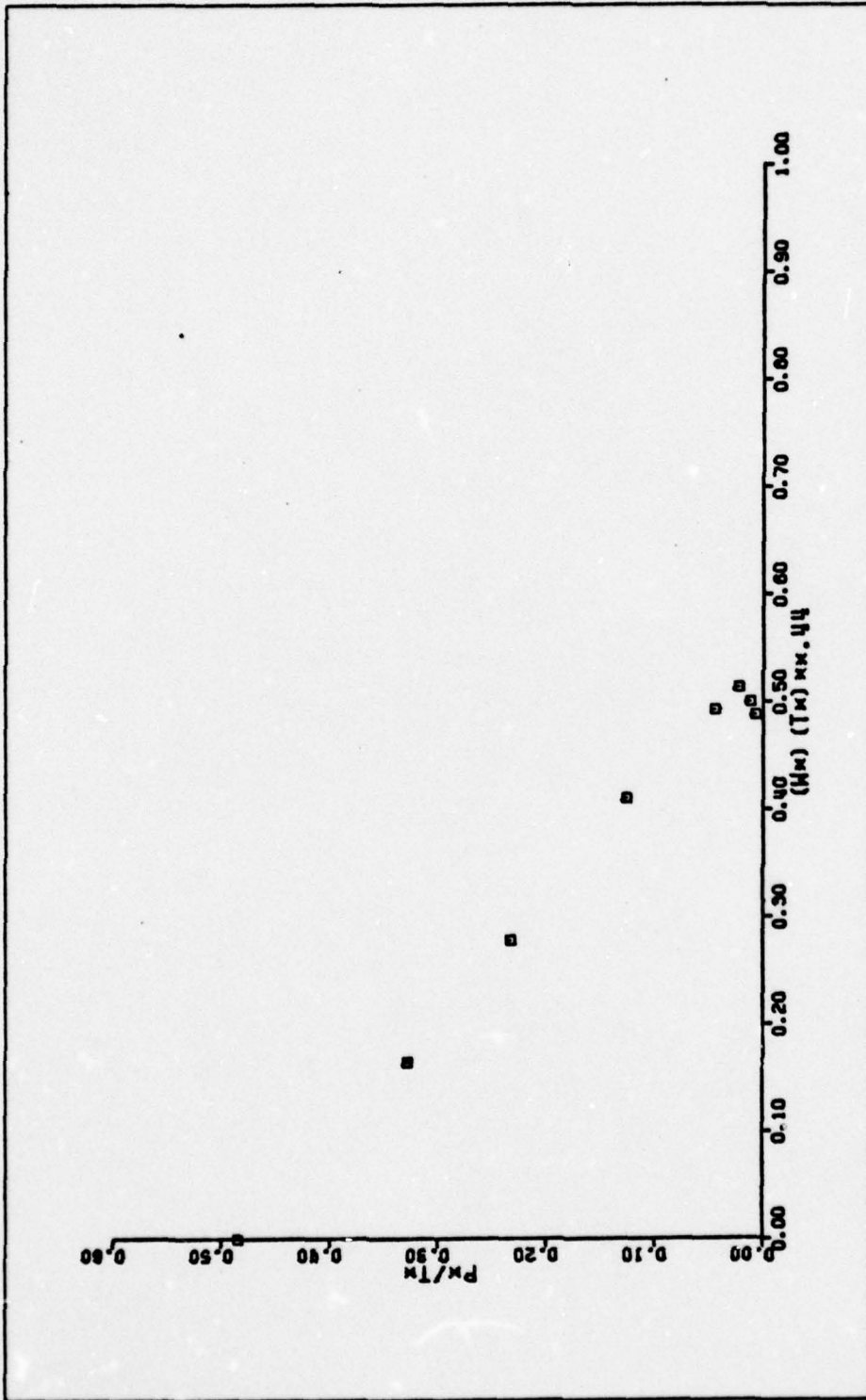

(e) STRAIGHT MIXING STACK, L/D = 2.5 (DATA TAKEN FROM TABLE Va)

FIGURE 40 (CONTINUED)

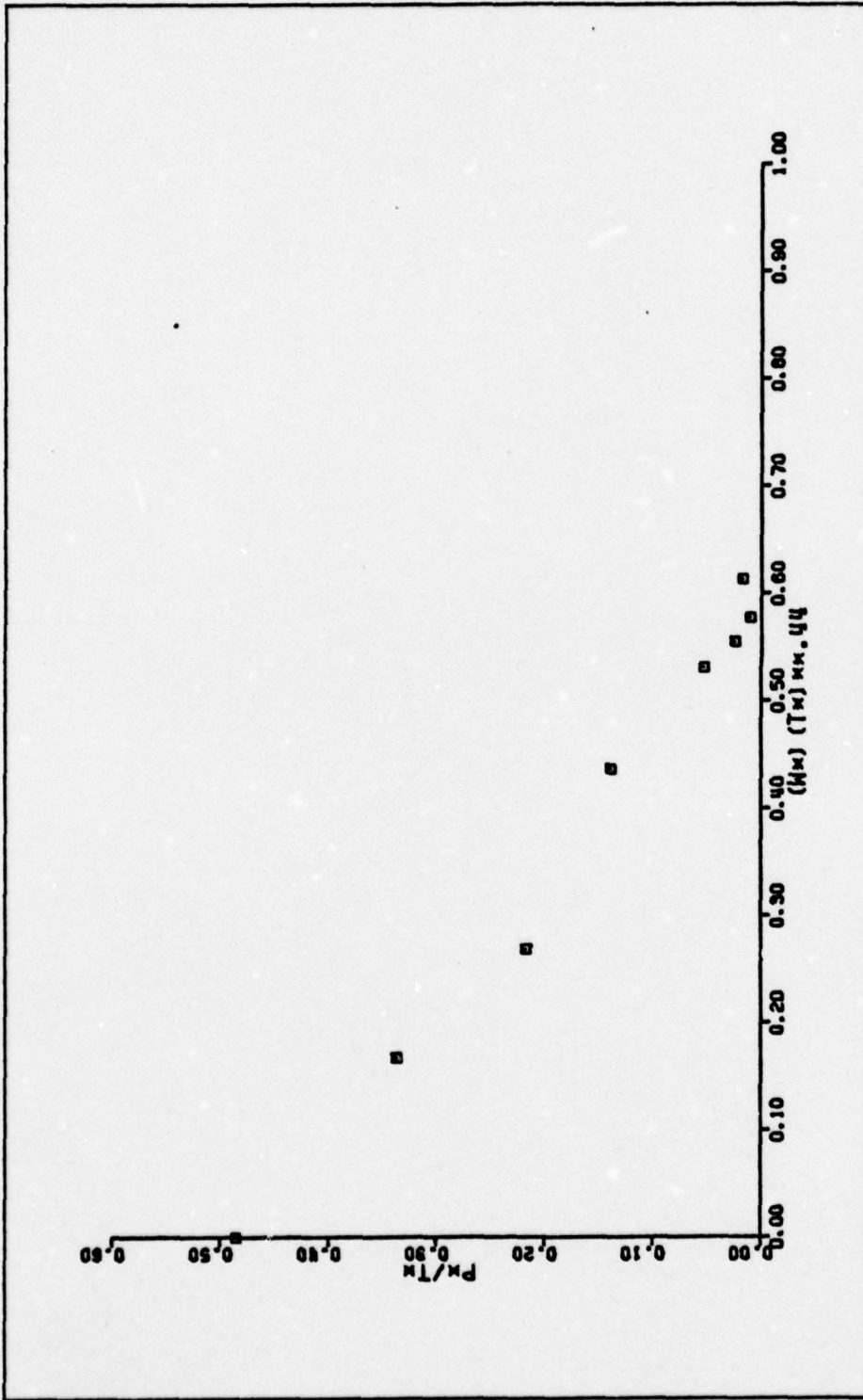

(f) STRAIGHT MIXING STACK, L/D = 2.5 (DATA TAKEN FROM TABLE Vb)

FIGURE 40 (CONTINUED)

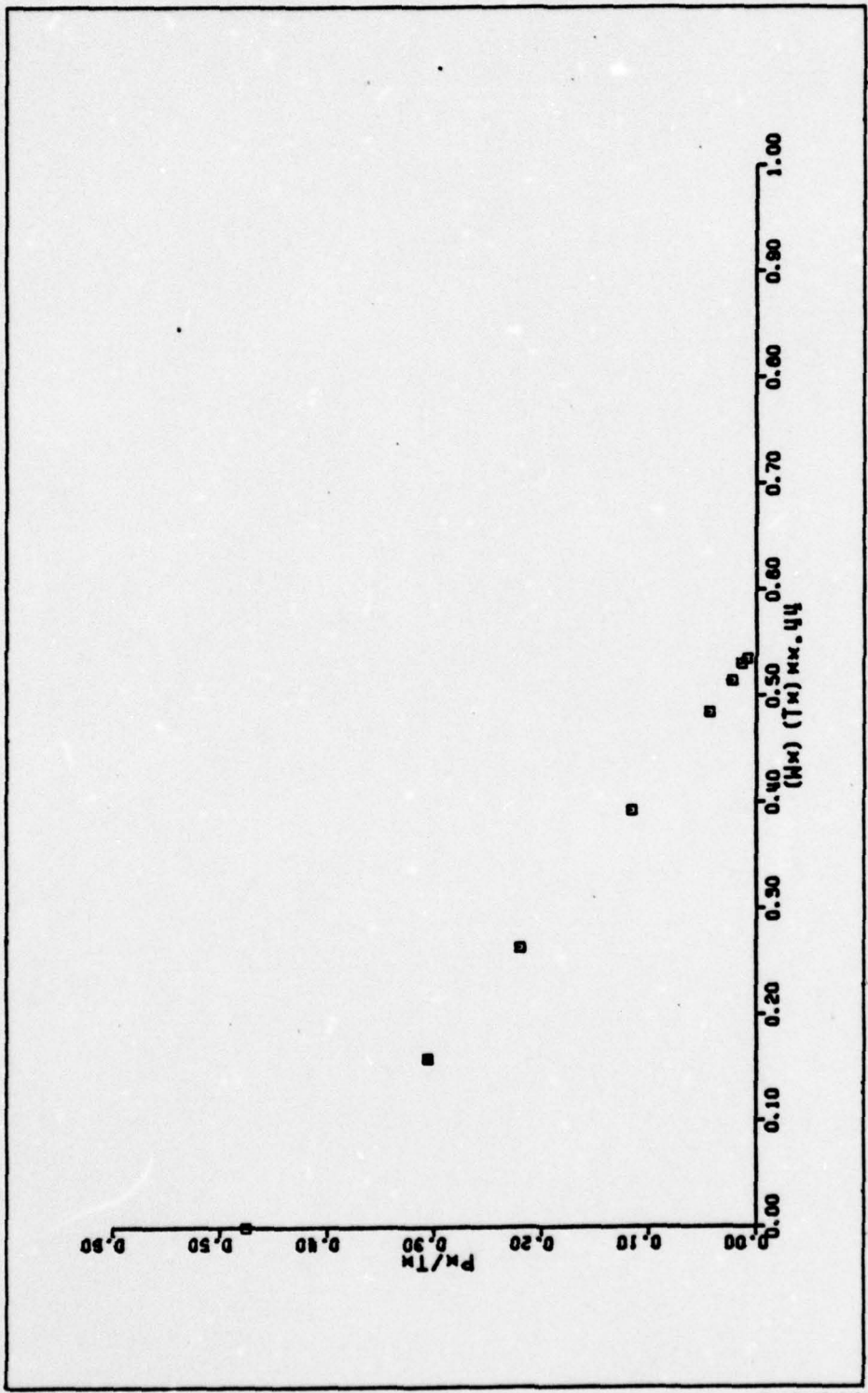

(g) STRAIGHT MIXING STACK, L/D = 1.75 (DATA TAKEN FROM TABLE VC)

FIGURE 40 (CONTINUED)

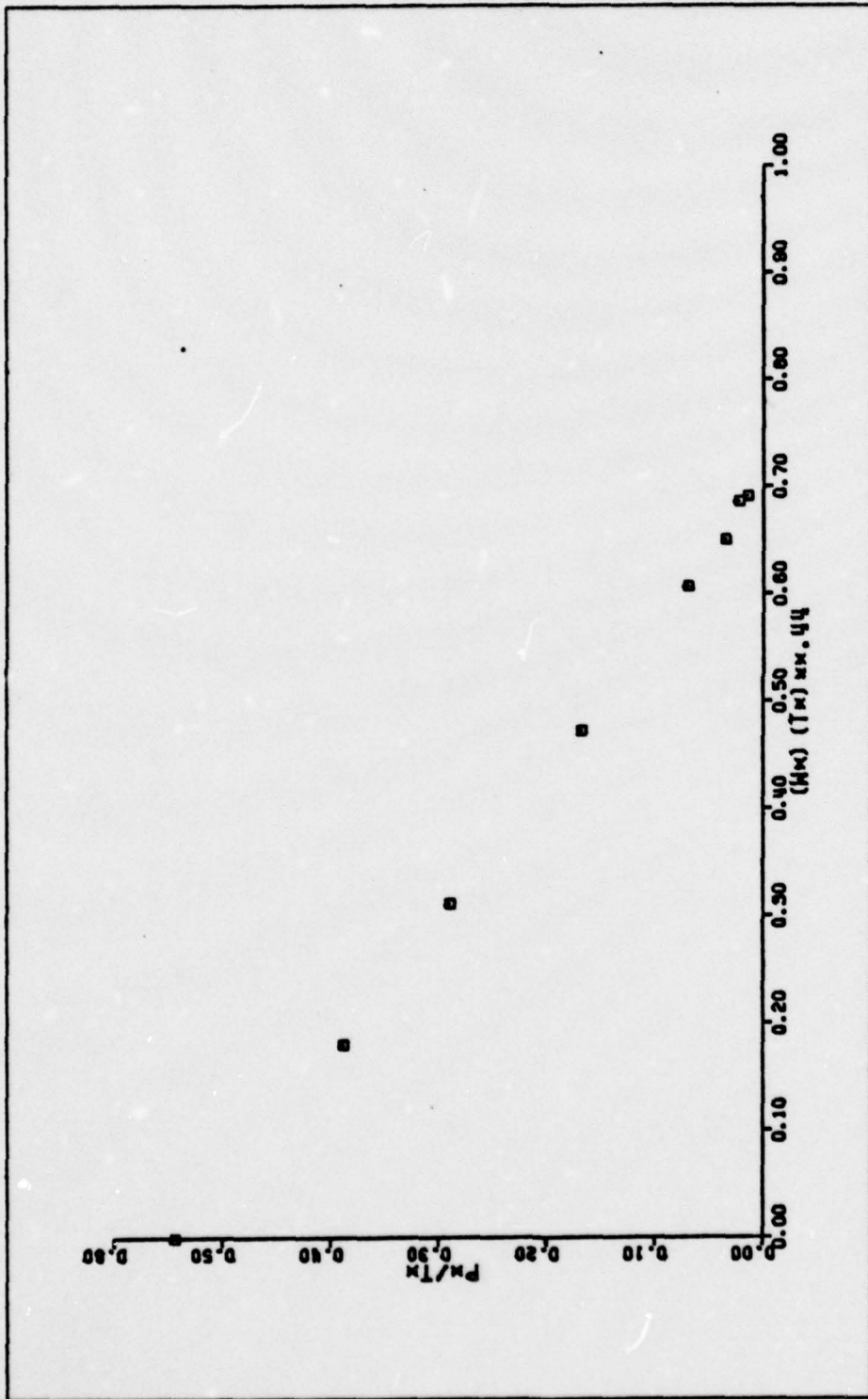

(h) MIXING STACK WITH 7 DEGREE SOLID DIFFUSOR (DATA TAKEN FROM TABLE VIA)

FIGURE 40 (CONTINUED)

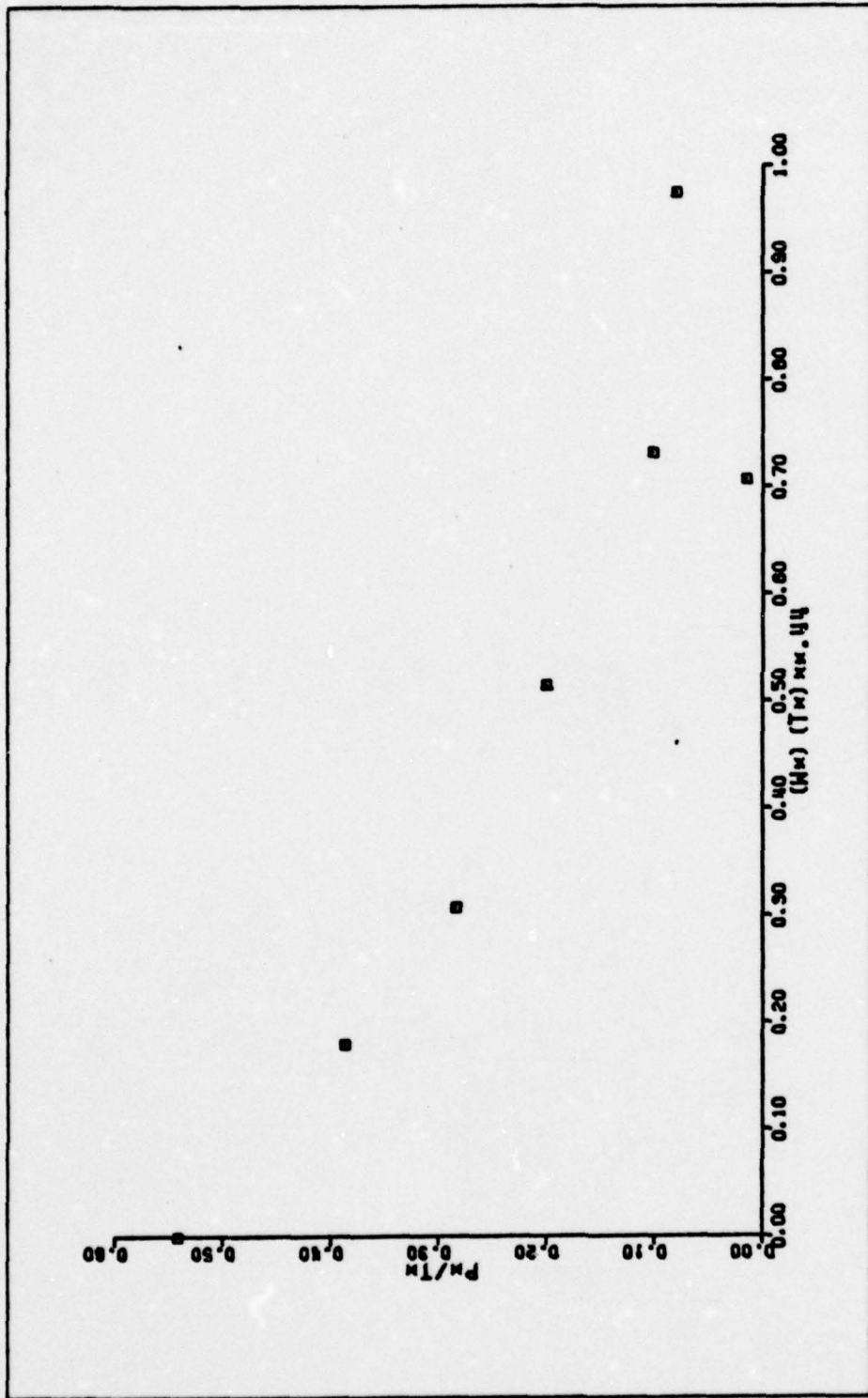

(i) MIXING STACK WITH 7 DEGREE SOLID DIFFUSOR (DATA TAKEN FROM TABLE VIB)

FIGURE 40 (CONTINUED)

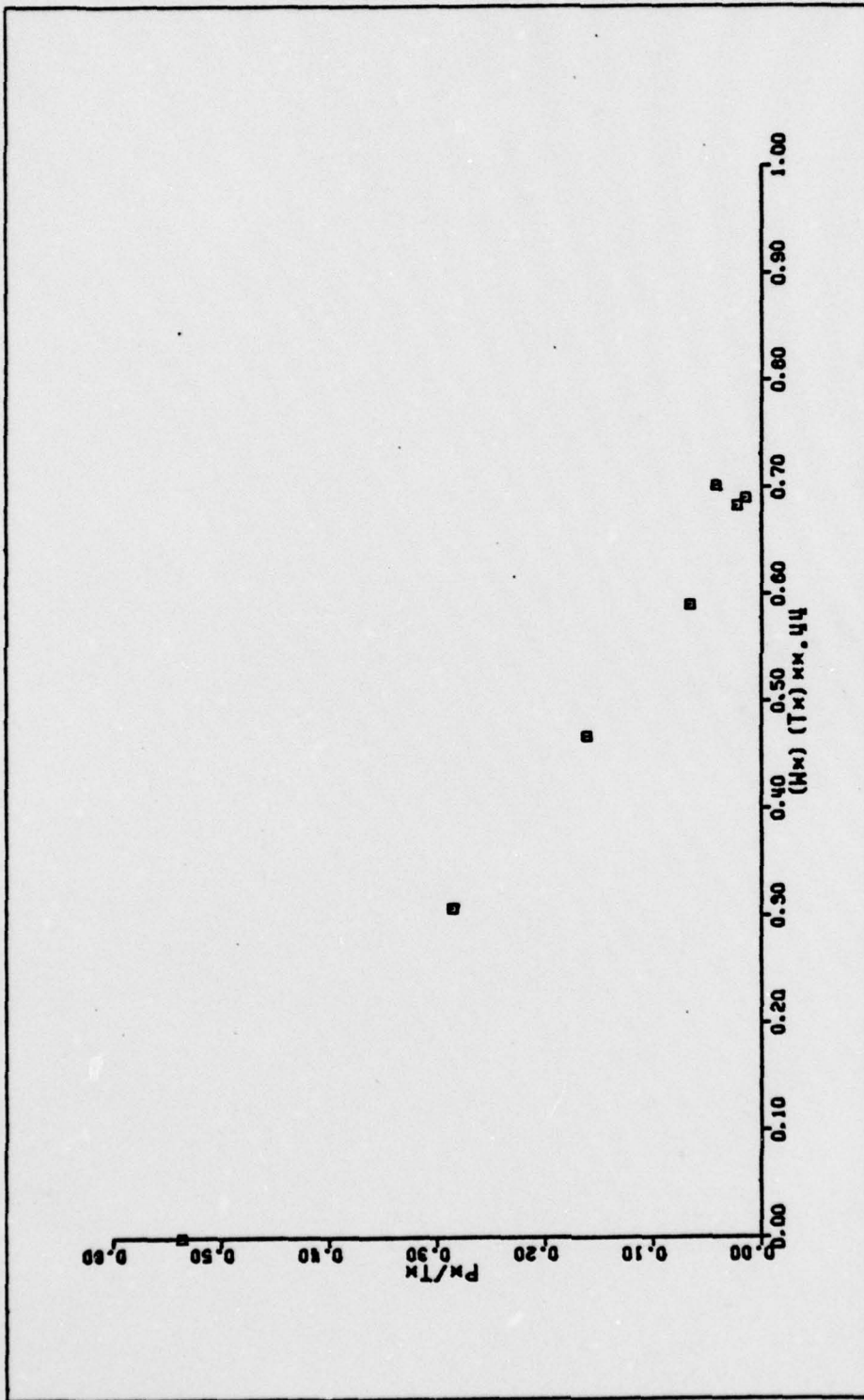

(j) MIXING STACK WITH 7 DEGREE SOLID DIFFUSOR (DATA TAKEN FROM TABLE VIC)

FIGURE 40 (CONTINUED)

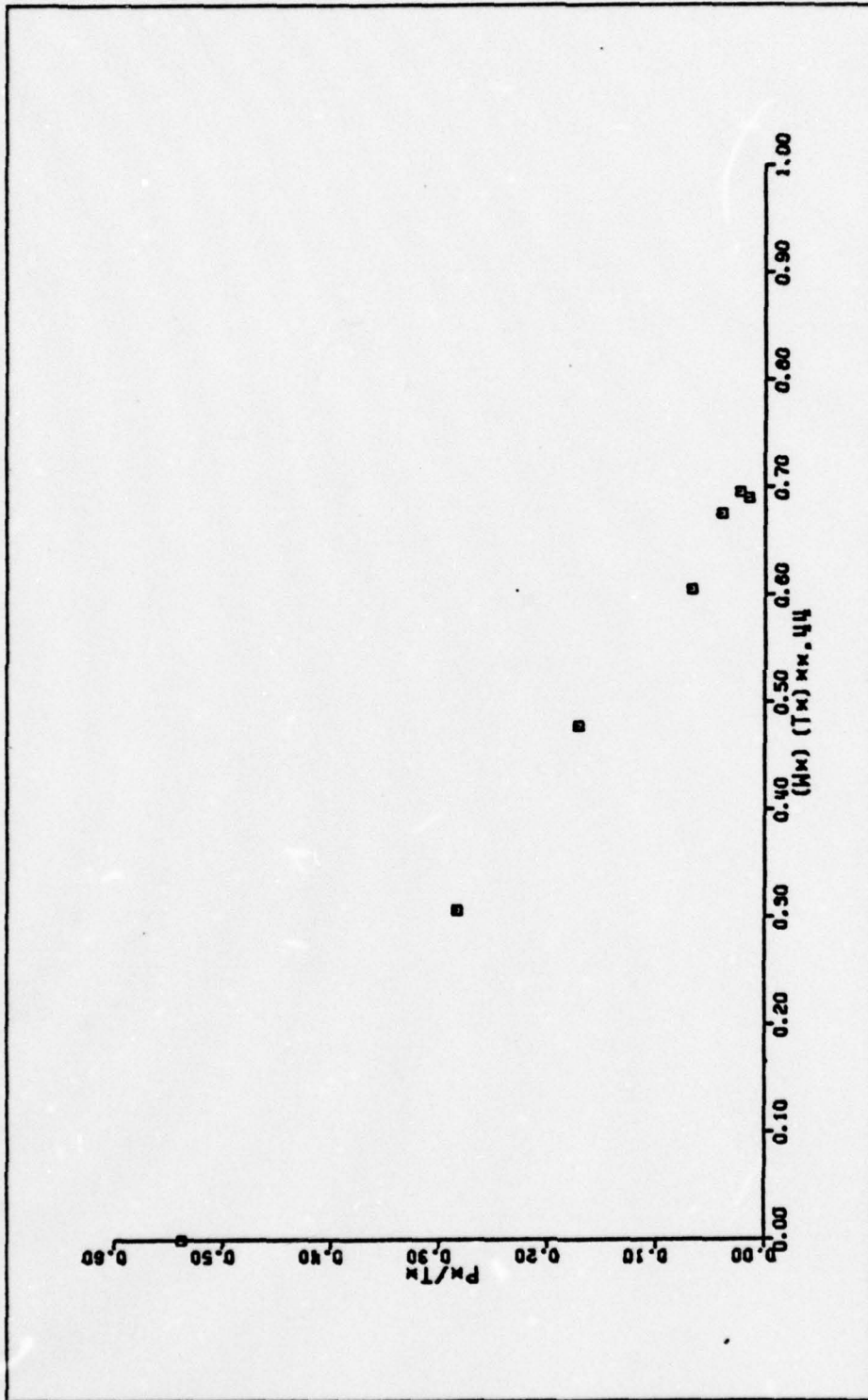

(k) MIXING STACK WITH 7 DEGREE SOLID DIFFUSOR (DATA TAKEN FROM TABLE VID)

FIGURE 40 (CONTINUED)

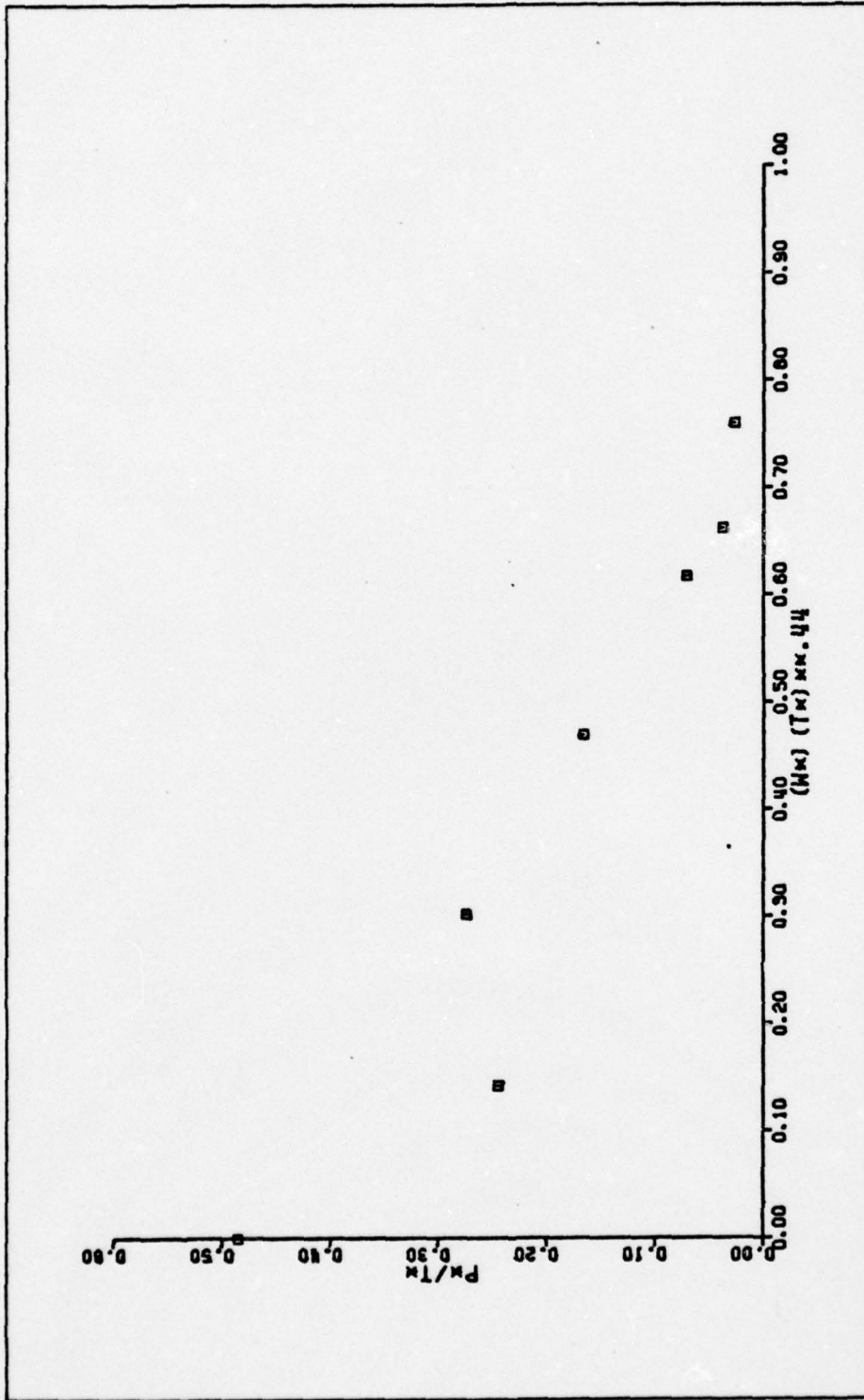

(λ) MIXING STACK WITH 7 DEGREE SOLID DIFFUSOR (DATA TAKEN FROM TABLE VIE)

FIGURE 40 (CONTINUED)

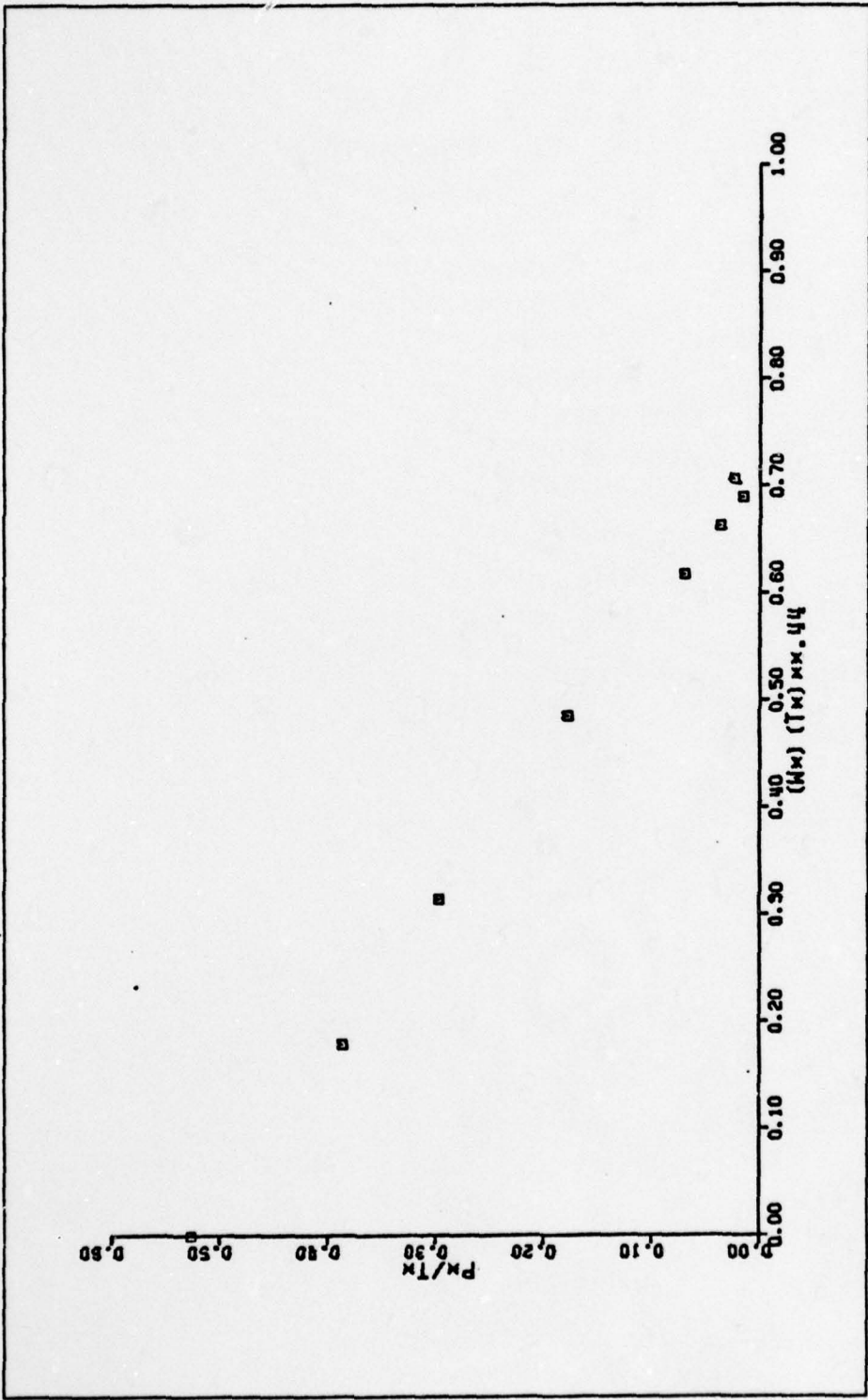

(m) MIXING STACK WITH 7 DEGREE SOLID DIFFUSOR (DATA TAKEN FROM TABLE VIF)

FIGURE 40 (CONTINUED)

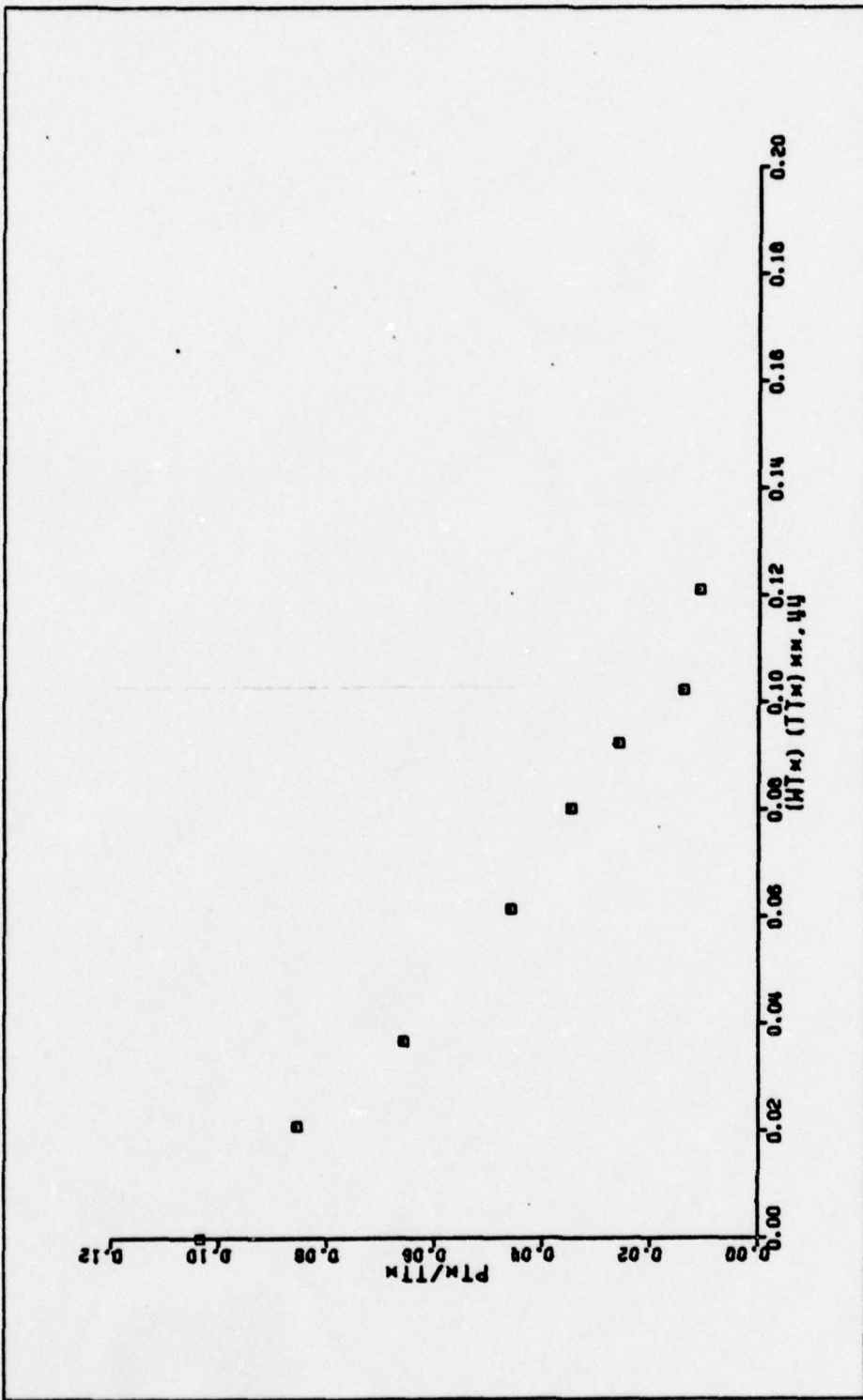

(n) MIXING STACK WITH TWO-RING DIFFUSOR (DATA FROM TABLE VII)

FIGURE 40 (CONTINUED)

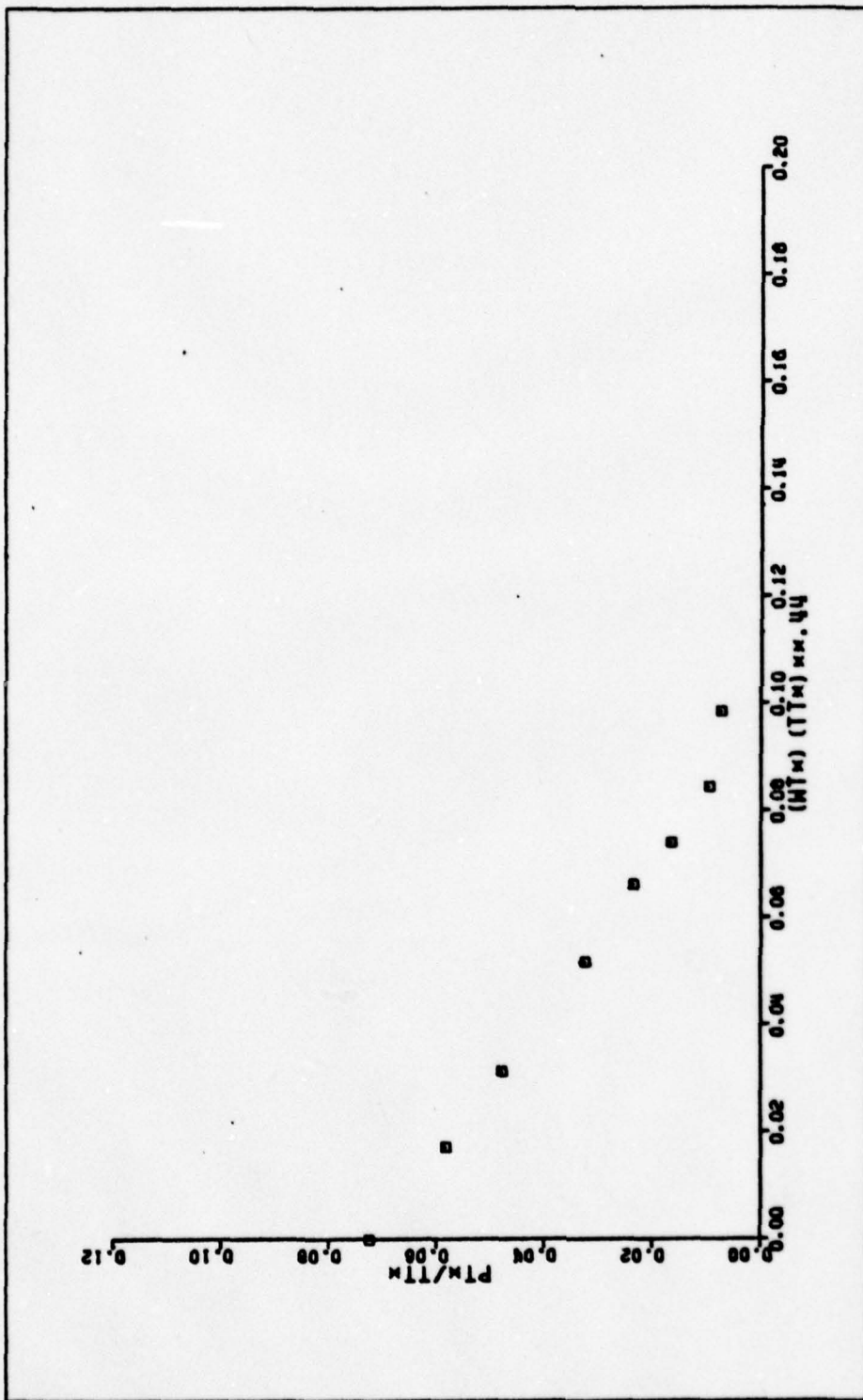

(O) MIXING STACK WITH THREE-RING DIFFUSOR (DATA TAKEN FROM TABLE VIII)

FIGURE 40 (CONTINUED)

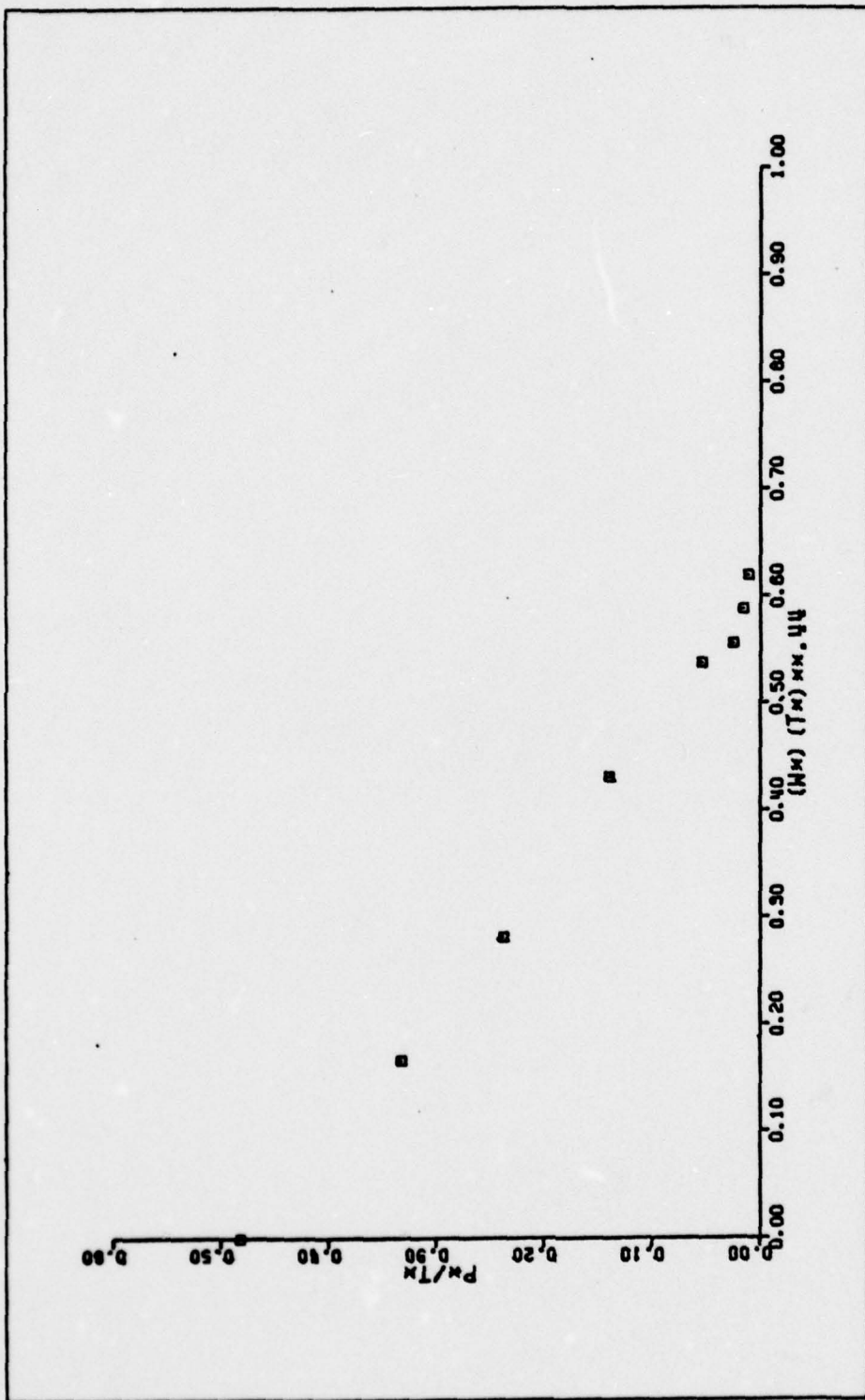

(p) PORTED MIXING STACK (DATA TAKEN FROM TABLE IXa)

FIGURE 40 (CONTINUED)

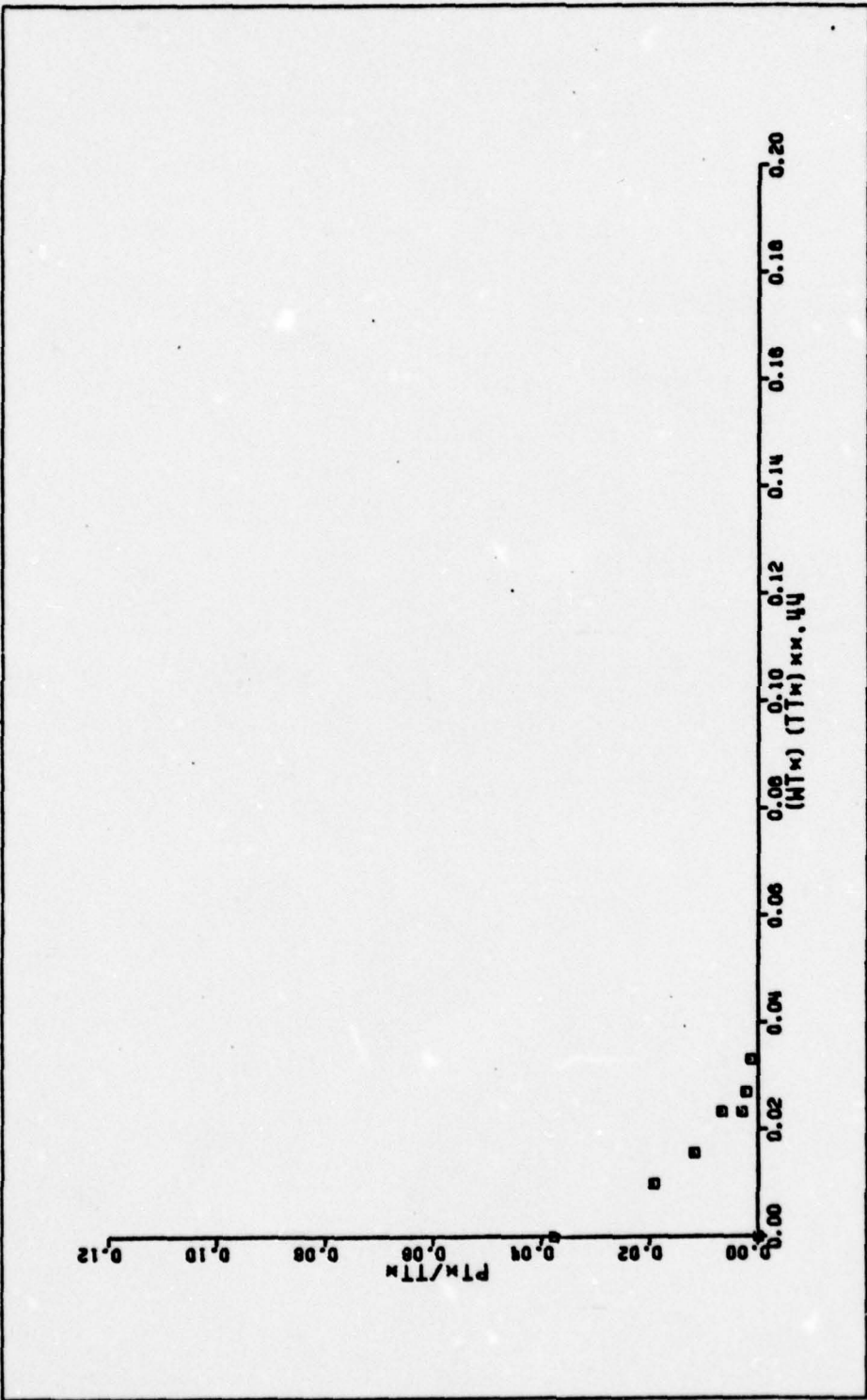

(q) PORTED MIXING STACK A-1 (DATA TAKEN FROM TABLE IXb)

FIGURE 40 (CONTINUED)

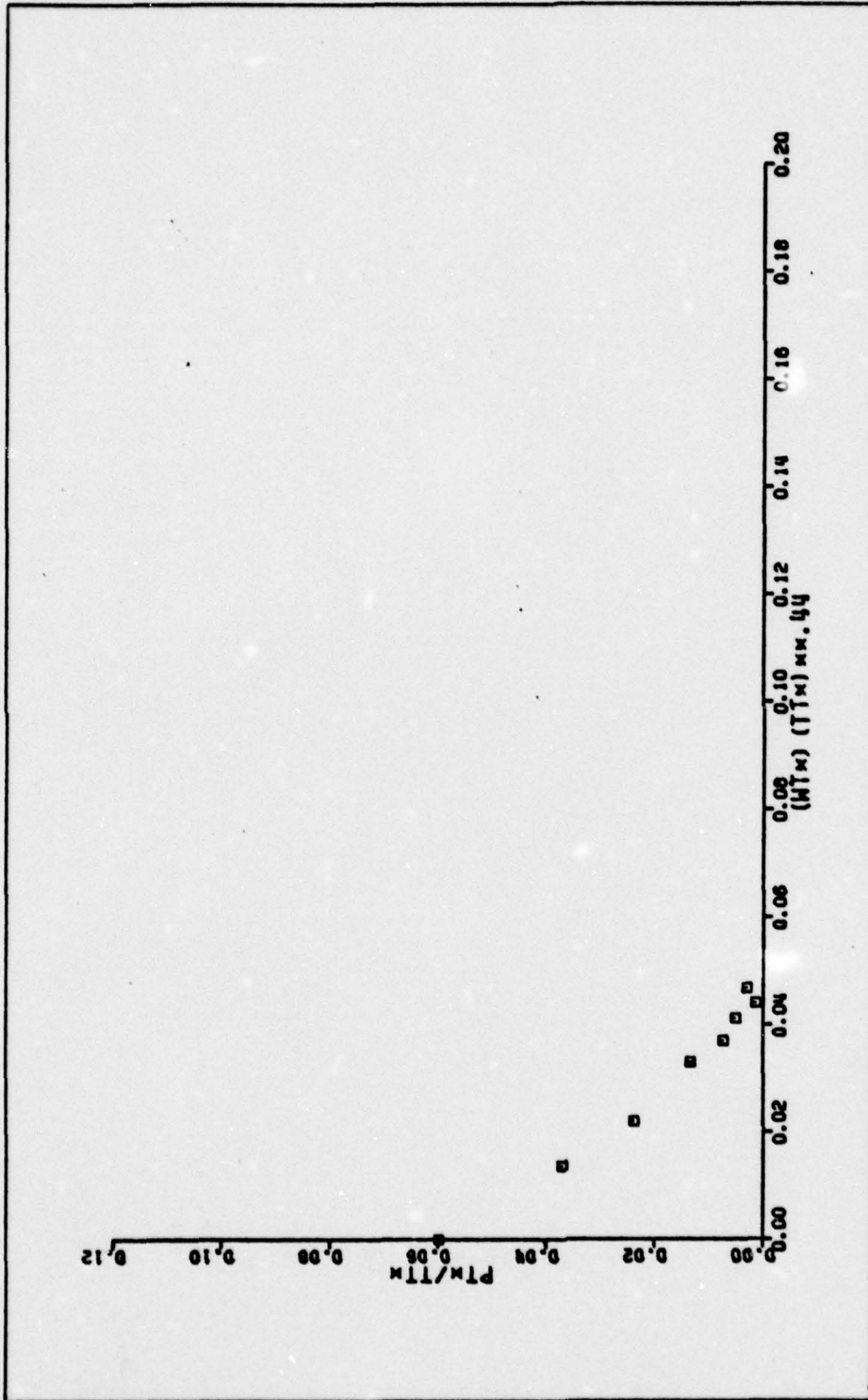

(1) PORTED MIXING STACK A-1, B-1 (DATA TAKEN FROM TABLE IXC)

FIGURE 40 (CONTINUED)

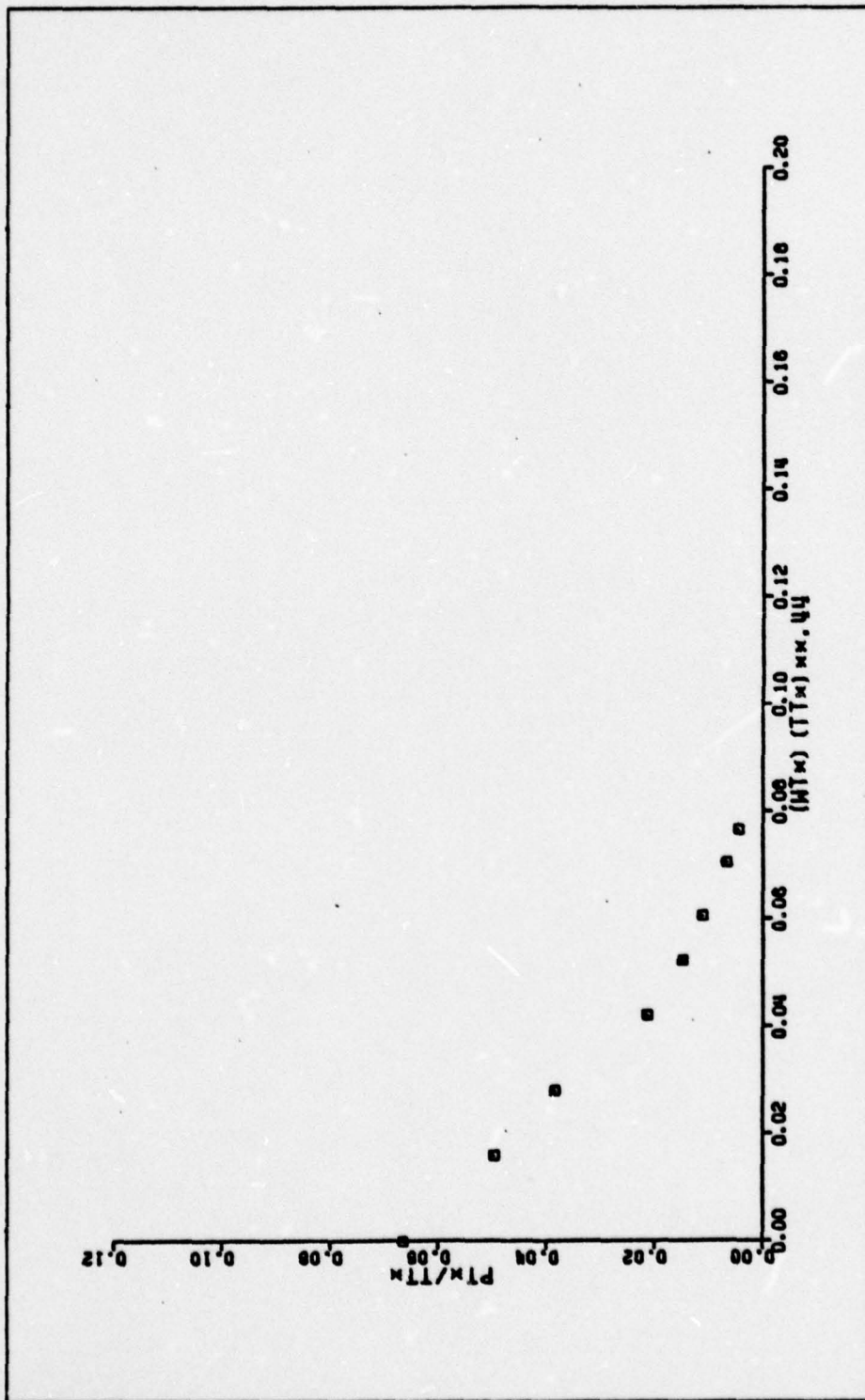

(s) PORTED MIXING STACK A-1, B-1, C-2 (DATA TAKEN FROM TABLE IXd)

FIGURE 40 (CONTINUED)

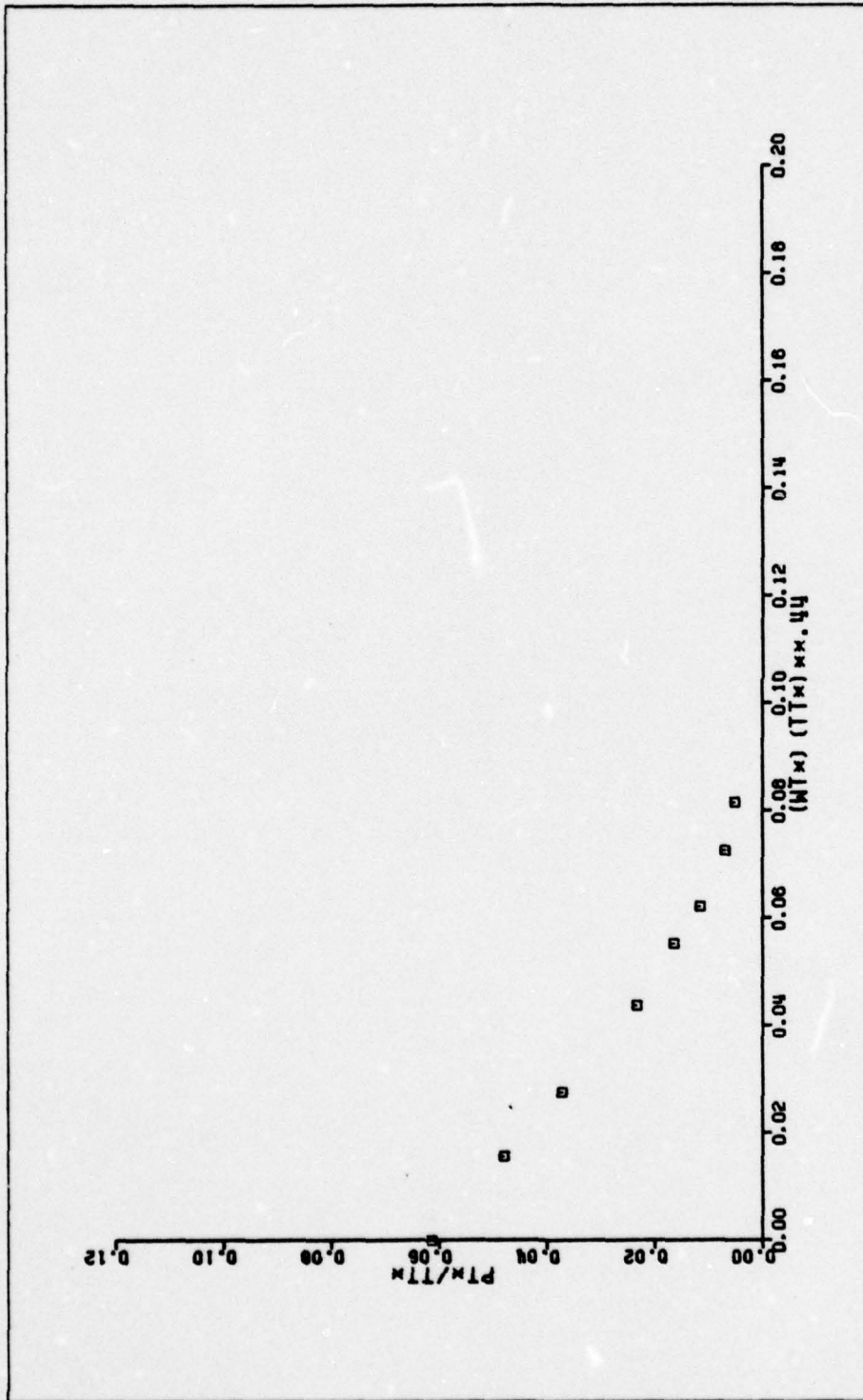

(t) * PORTED MIXING STACK A-1, B-1, C-2, D-2 (DATA TAKEN FROM TABLE IXe)

FIGURE 40 (CONTINUED)

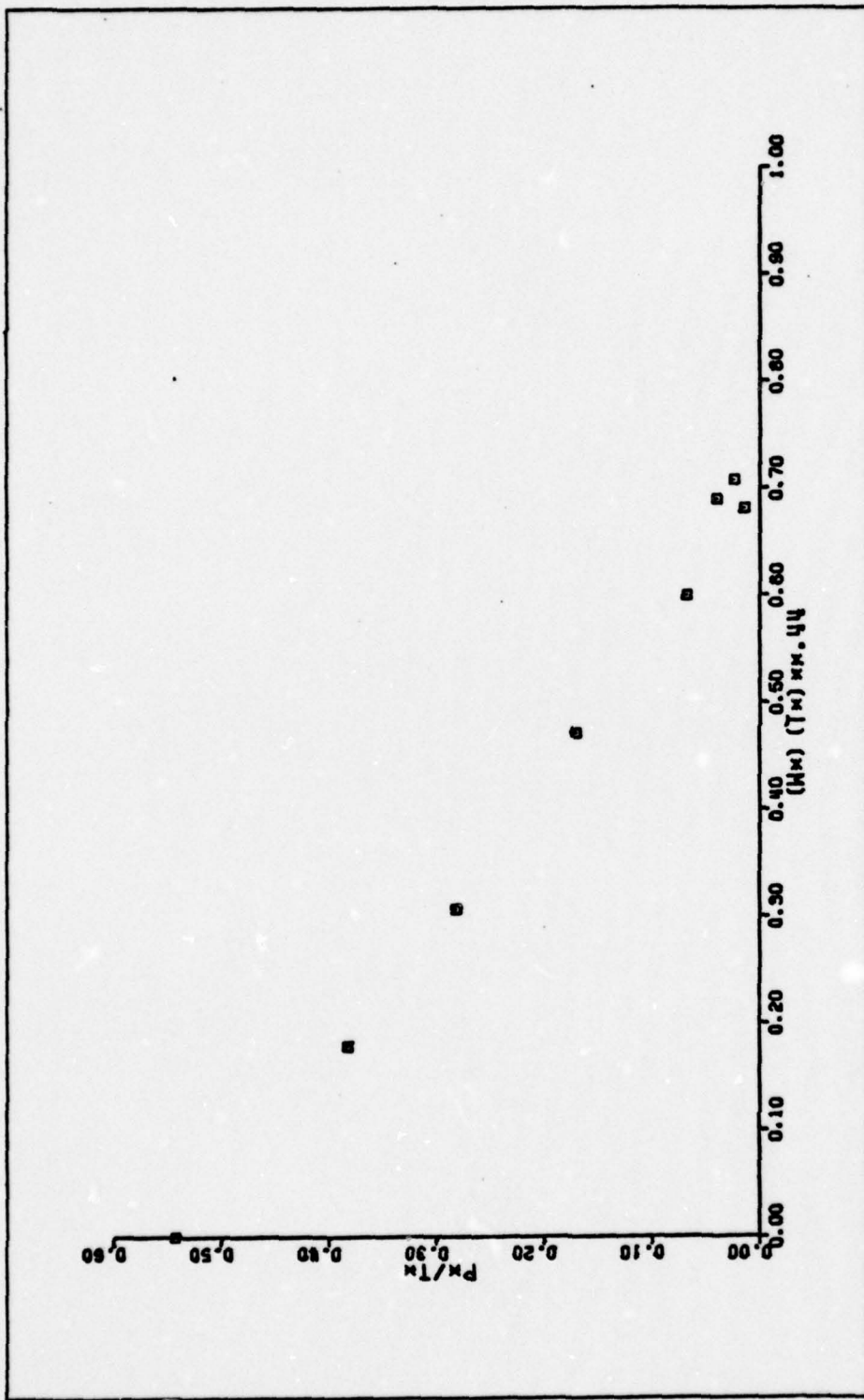

(u) PORTED MIXING STACK WITH TWO RING DIFFUSOR (DATA TAKEN FROM TABLE Xa)

FIGURE 40 (CONTINUED)

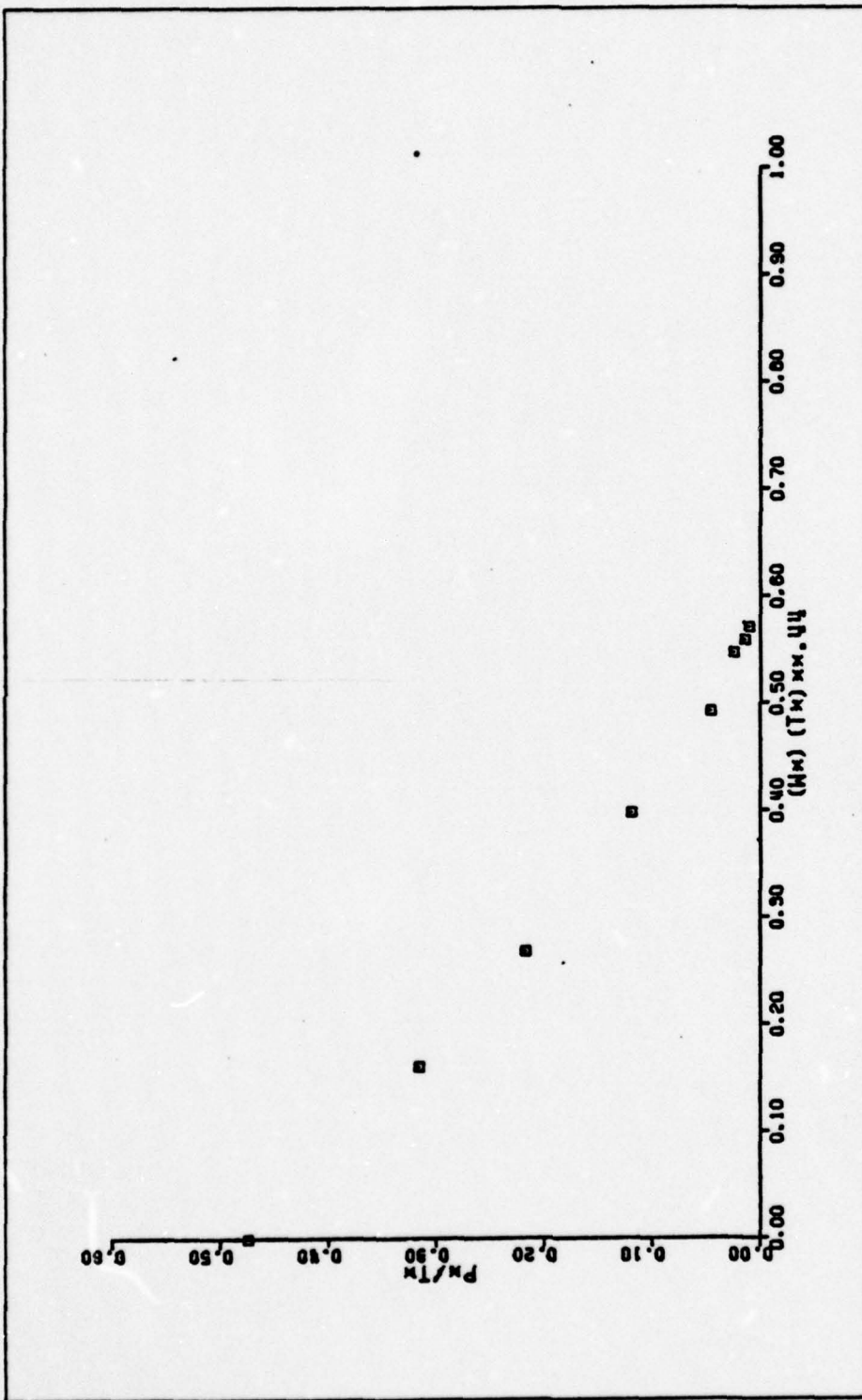

(V) PORTED MIXING STACK WITH TWO RING DIFFUSOR (DATA TAKEN FROM TABLE Xb)

FIGURE 40 (CONTINUED)

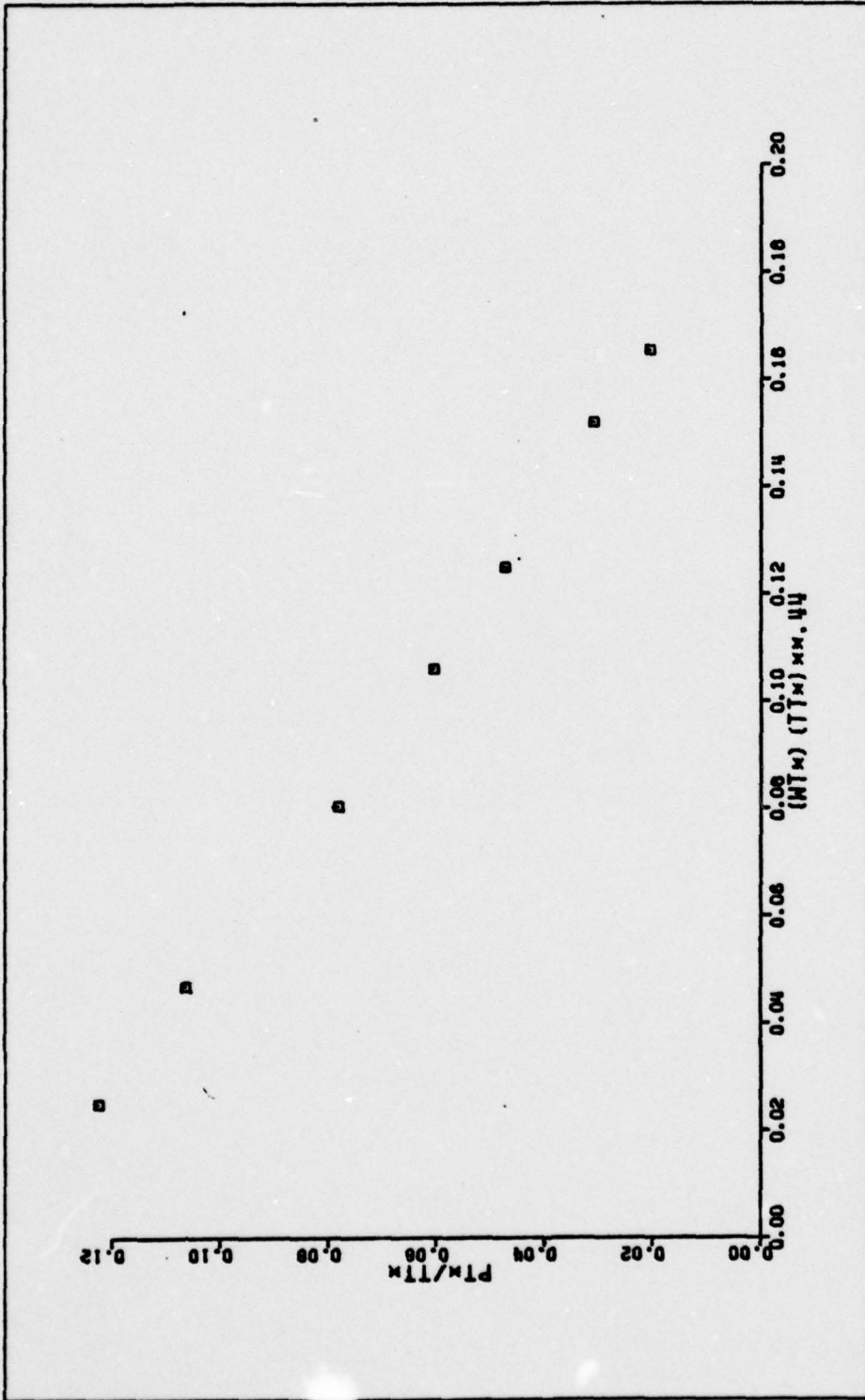

(w) PORTED MIXING STACK WITH TWO RING DIFFUSOR (DATA TAKEN FROM TABLE XC)

FIGURE 40 (CONTINUED)

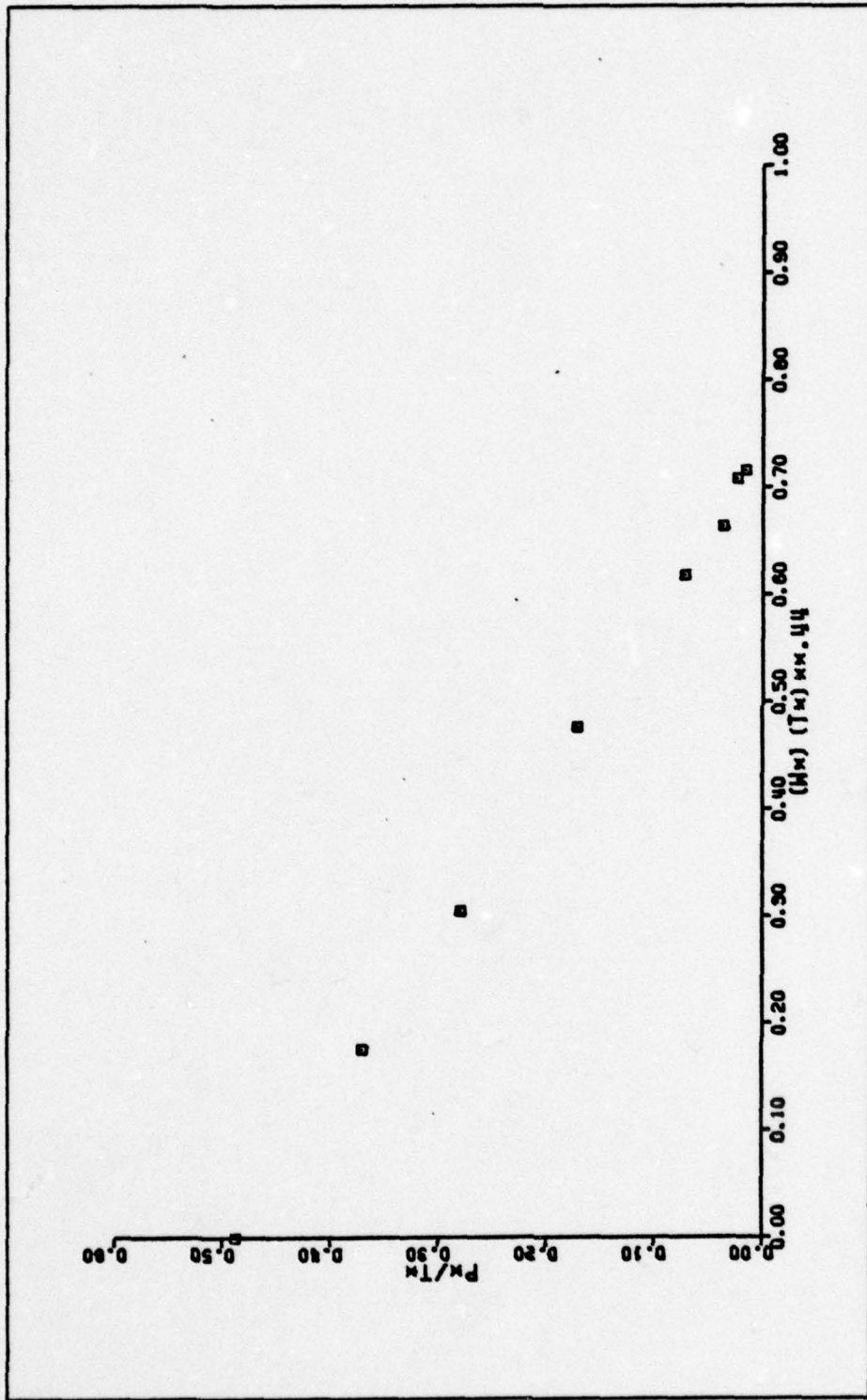

(x) PORTED MIXING STACK WITH TWO RING DIFFUSOR AND SHROUD (DATA TAKEN FROM TABLE XIa)

FIGURE 40 (CONTINUED)

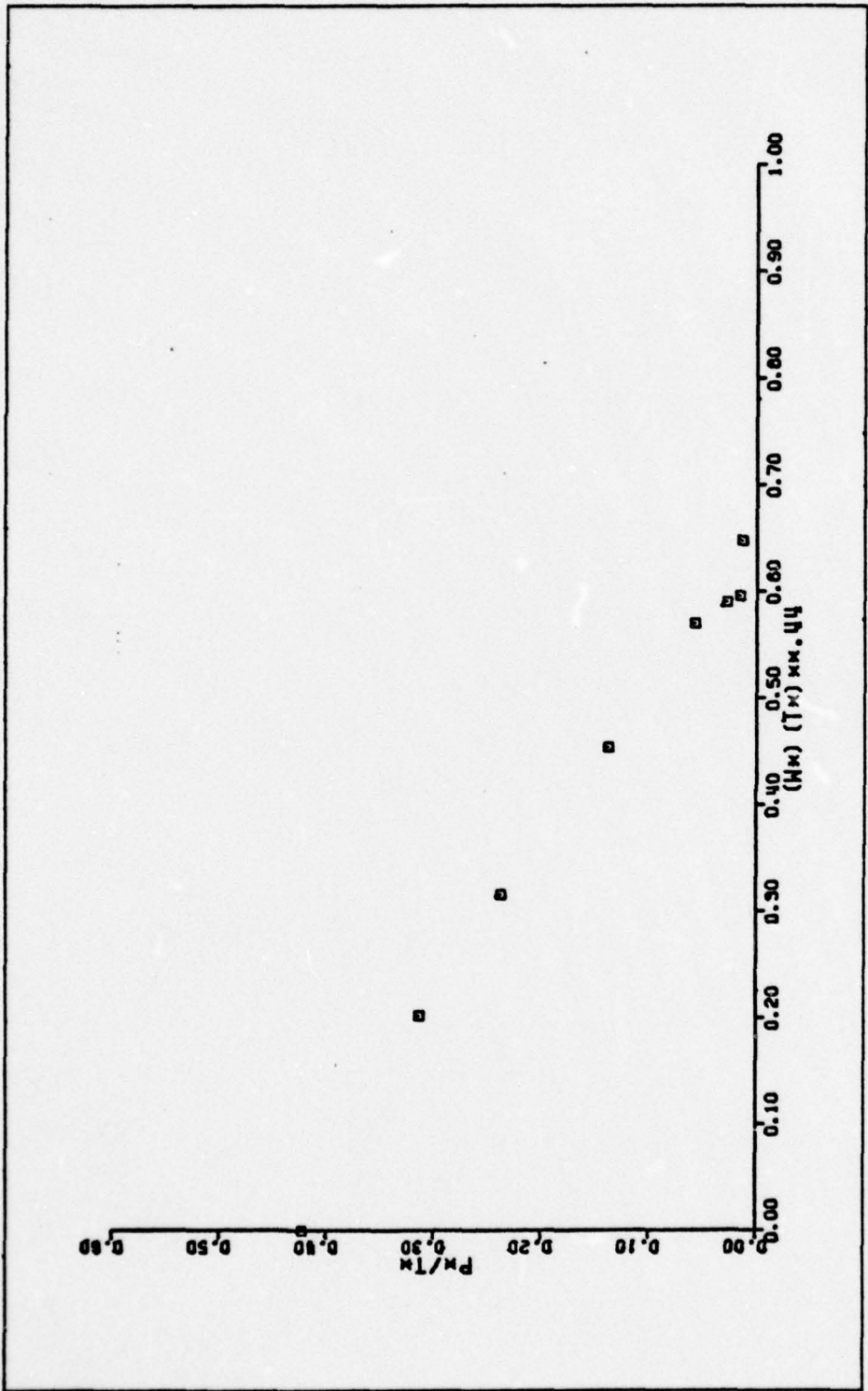

(Y) PORTED MIXING STACK WITH TWO RING DIFFUSOR AND SHROUD (DATA TAKEN FROM TABLE X1b)

FIGURE 40 (CONTINUED)

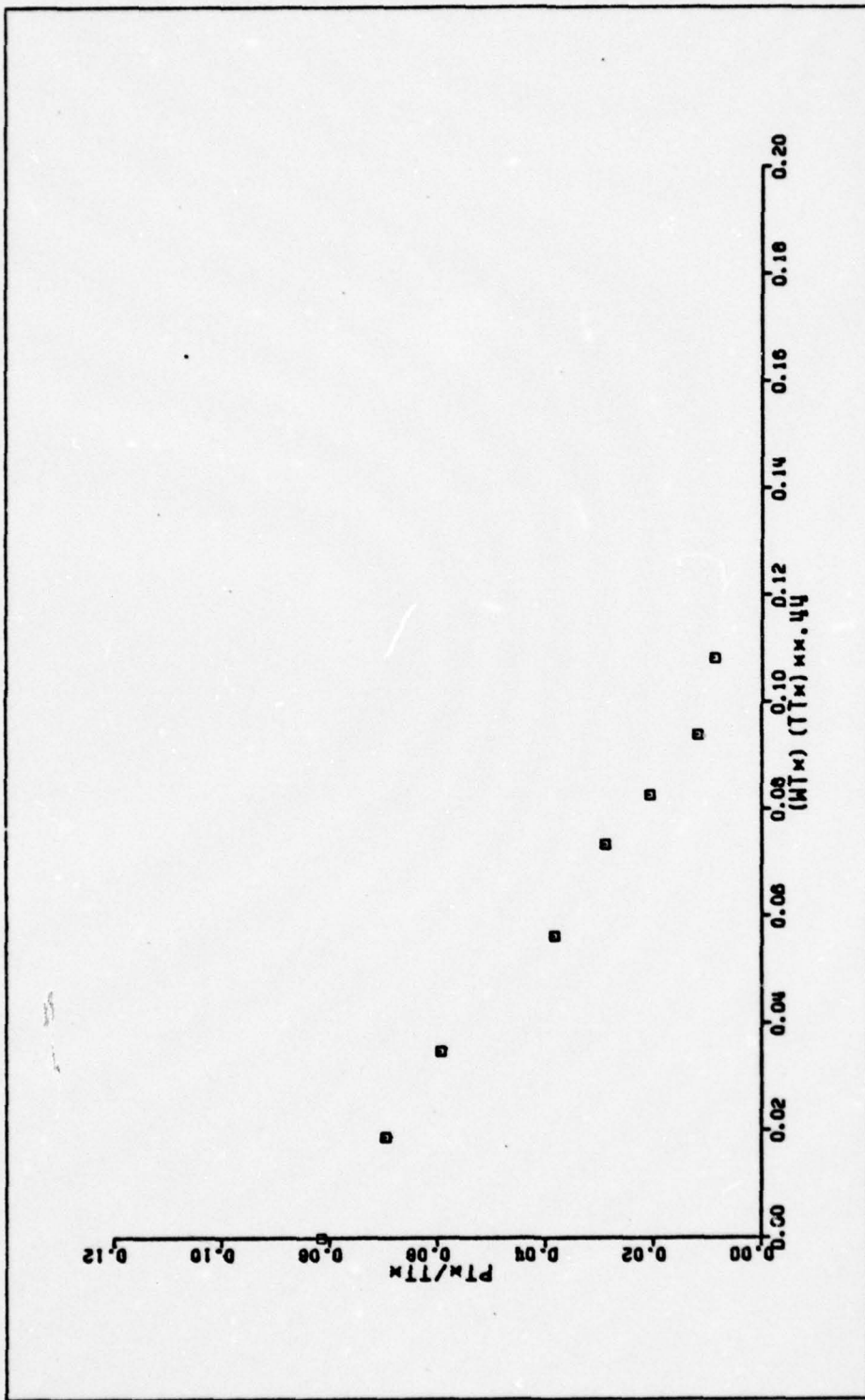

(z) PORTED MIXING STACK WITH TWO RING DIFFUSOR AND SHROUD (DATA TAKEN FROM TABLE XIC)

FIGURE 40 (CONTINUED)

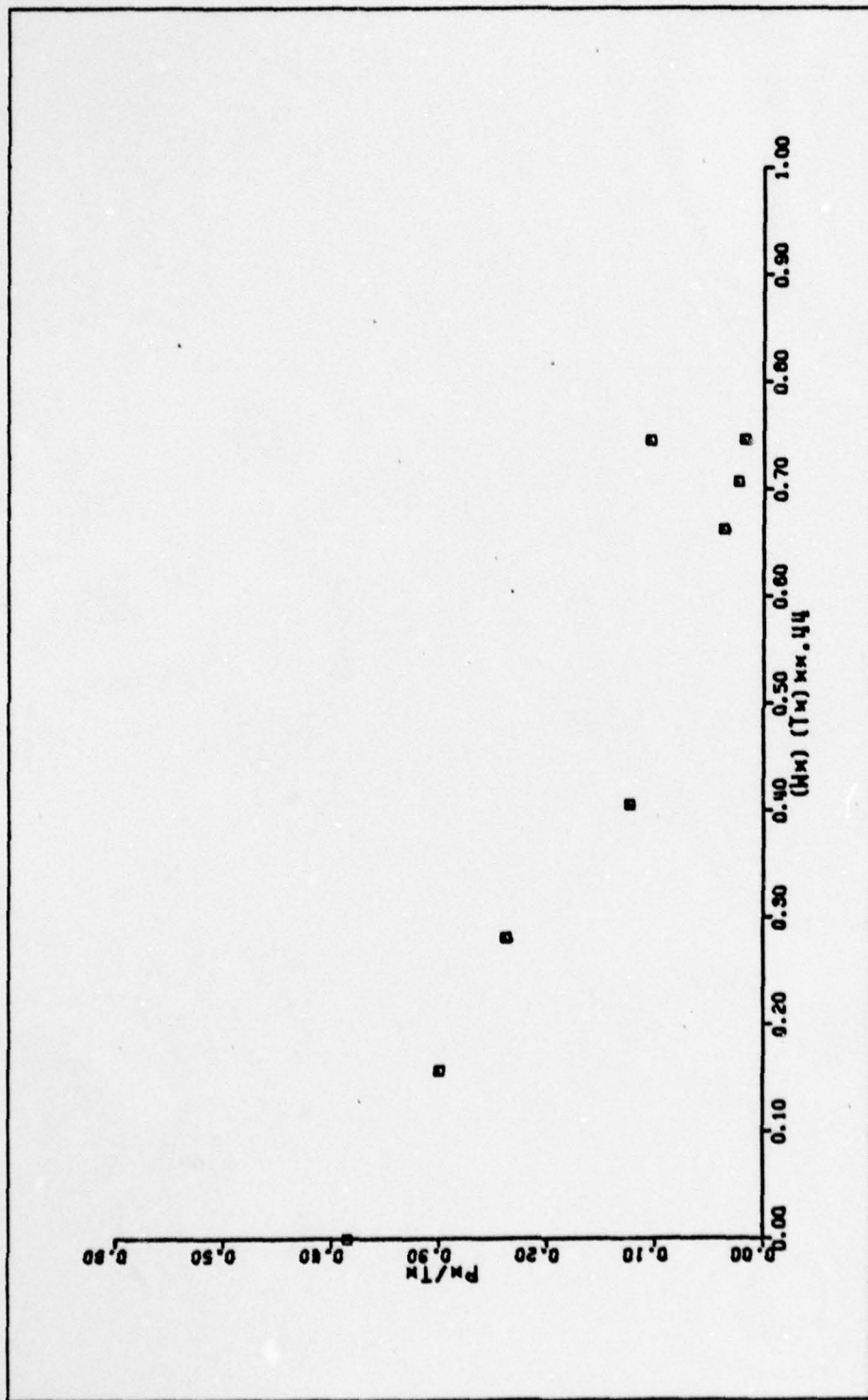

(aa) PORTED MIXING STACK WITH TWO RING DIFFUSOR AND SHROUD (DATA TAKEN FROM TABLE XIId)

FIGURE 40 (CONTINUED)

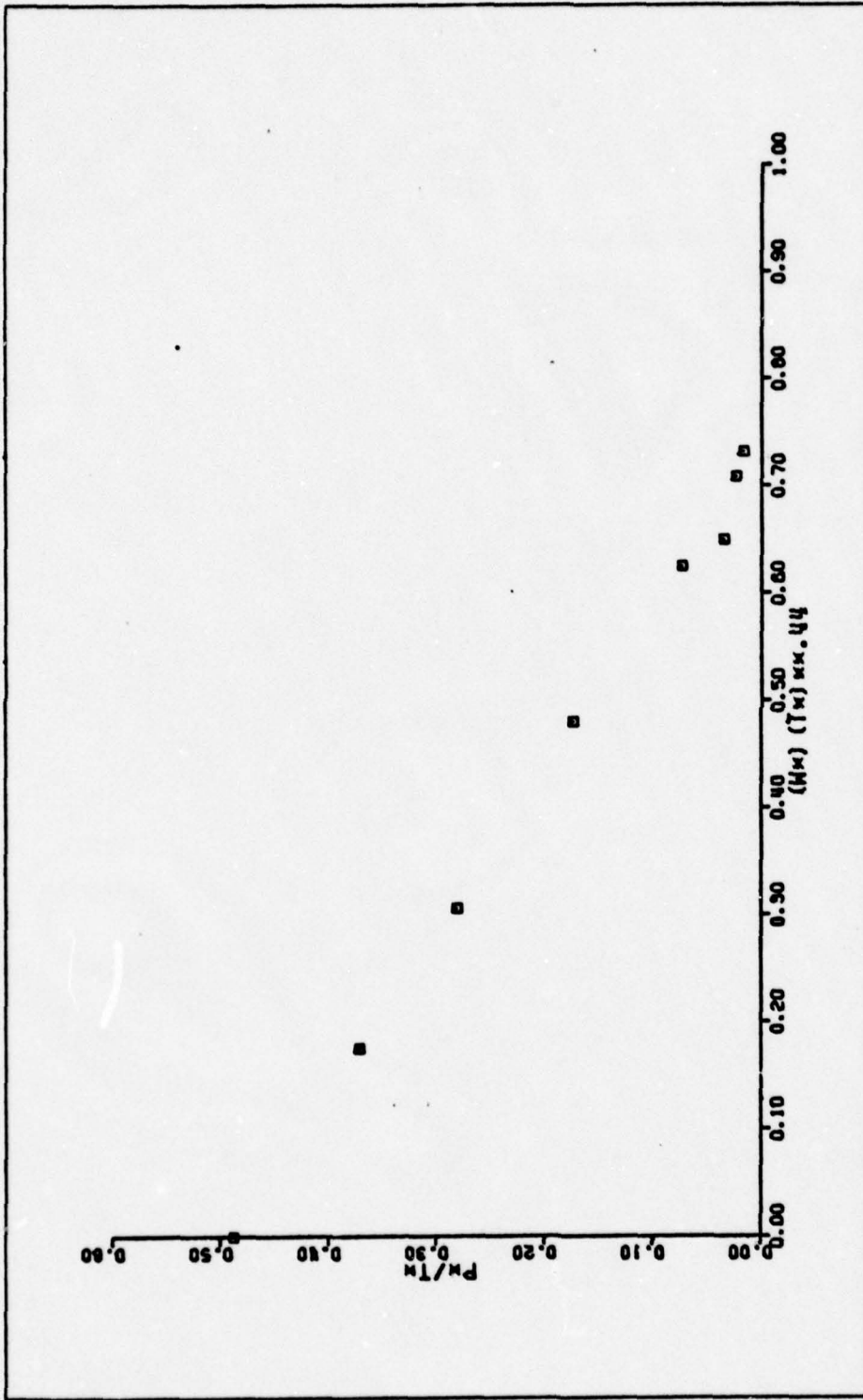

(bb) PORTED MIXING STACK WITH TWO RING DIFFUSOR AND SHROUD (DATA TAKEN FROM TABLE XIIa)

FIGURE 40 (CONTINUED)

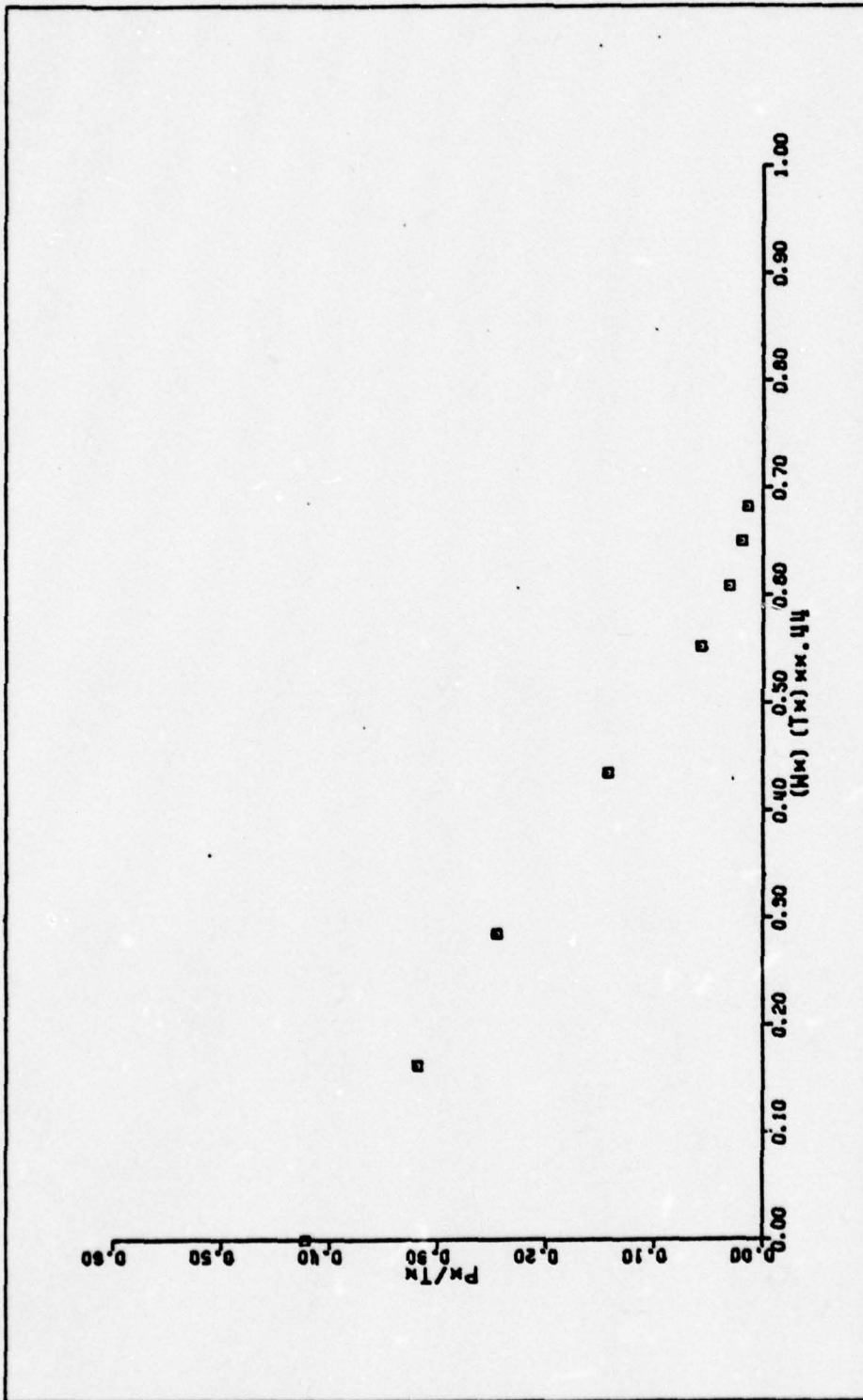

(cc) PORTED MIXING STACK WITH TWO RING DIFFUSOR AND SHROUD (DATA TAKEN FROM TABLE XIIb)

FIGURE 40 (CONTINUED)

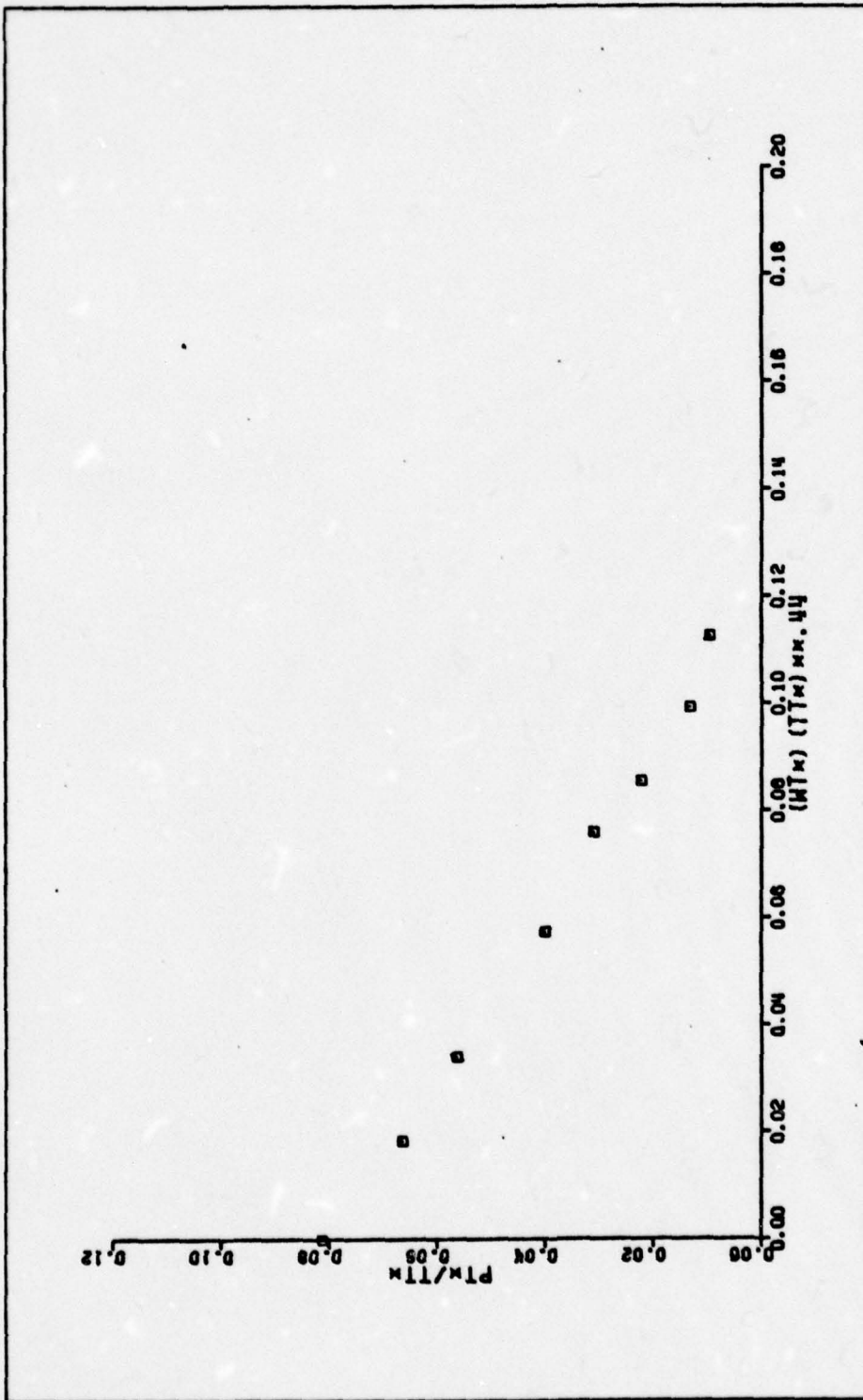

(dd) PORTED MIXING STACK WITH TWO RING DIFFUSOR AND SHROUD (DATA TAKEN FROM TABLE XIIC)

FIGURE 40 (CONTINUED)

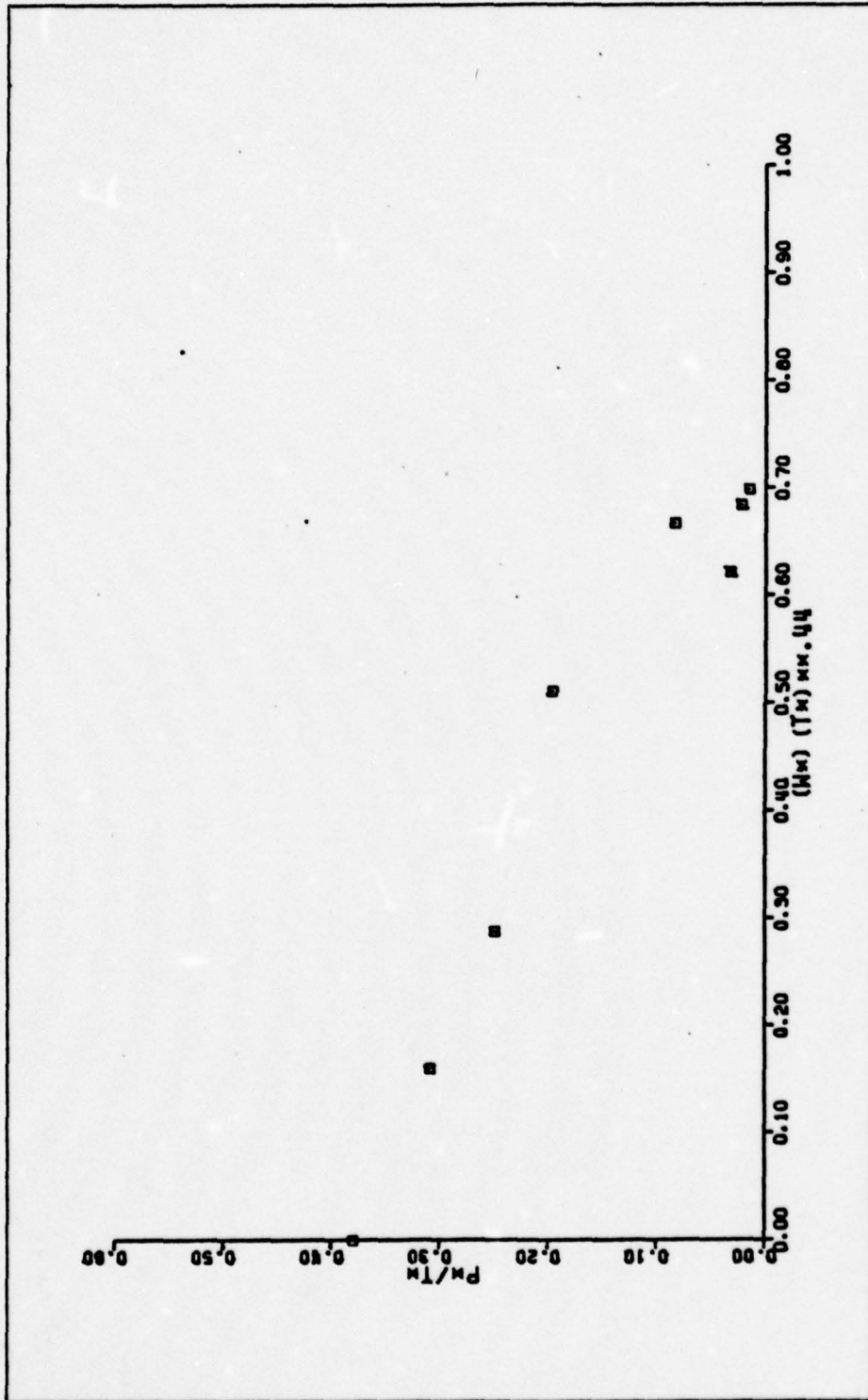

(ee) PORTED MIXING STACK WITH TWO RING DIFFUSOR AND SHROUD (DATA TAKEN FROM TABLE XIId)

FIGURE 40 (CONTINUED)

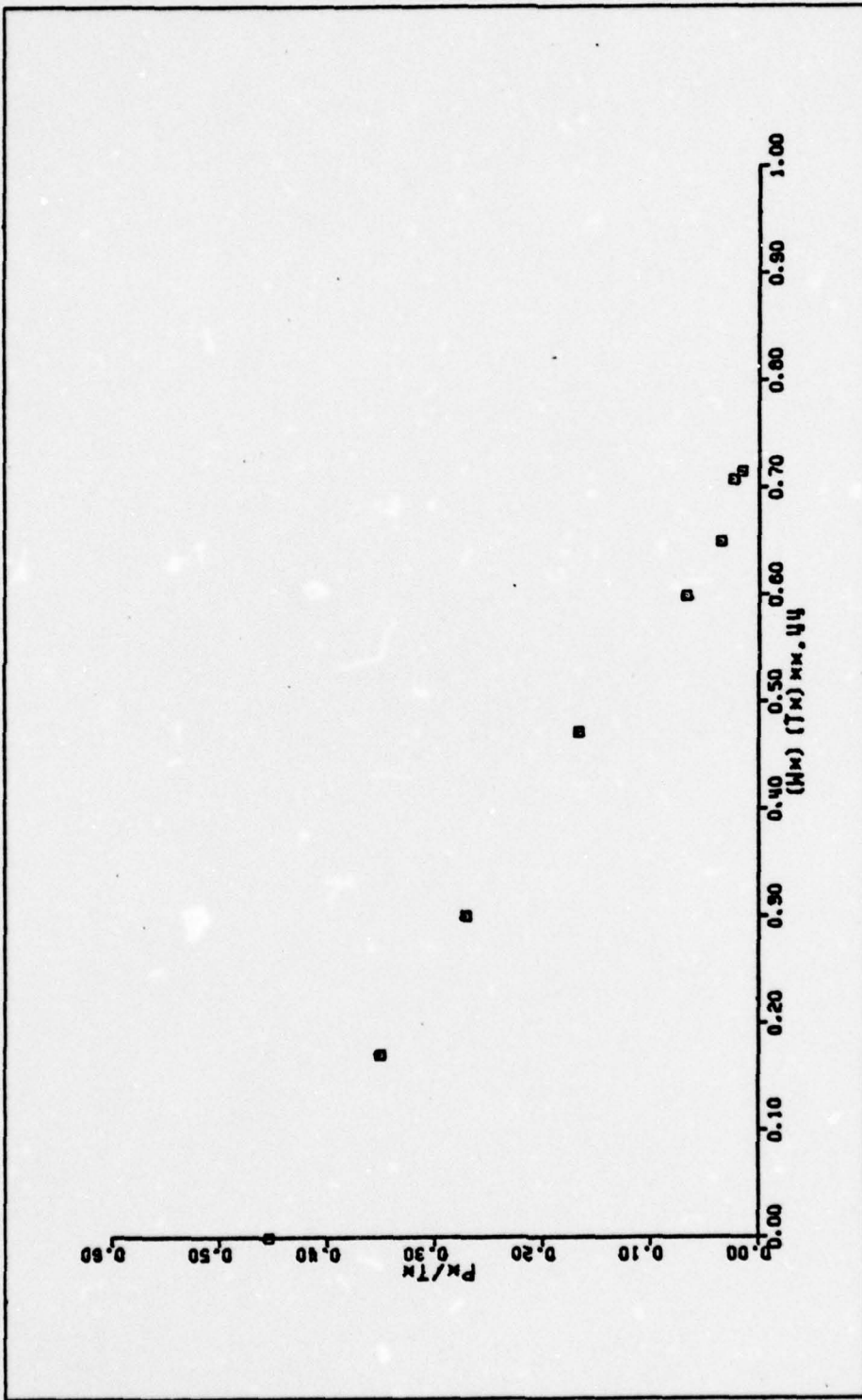

(ff) PORTED MIXING STACK WITH RING DIFFUSOR AND FLOW-THROUGH SHROUD
 (DATA TAKEN FROM TABLE XIIIa)

FIGURE 40 (CONTINUED)

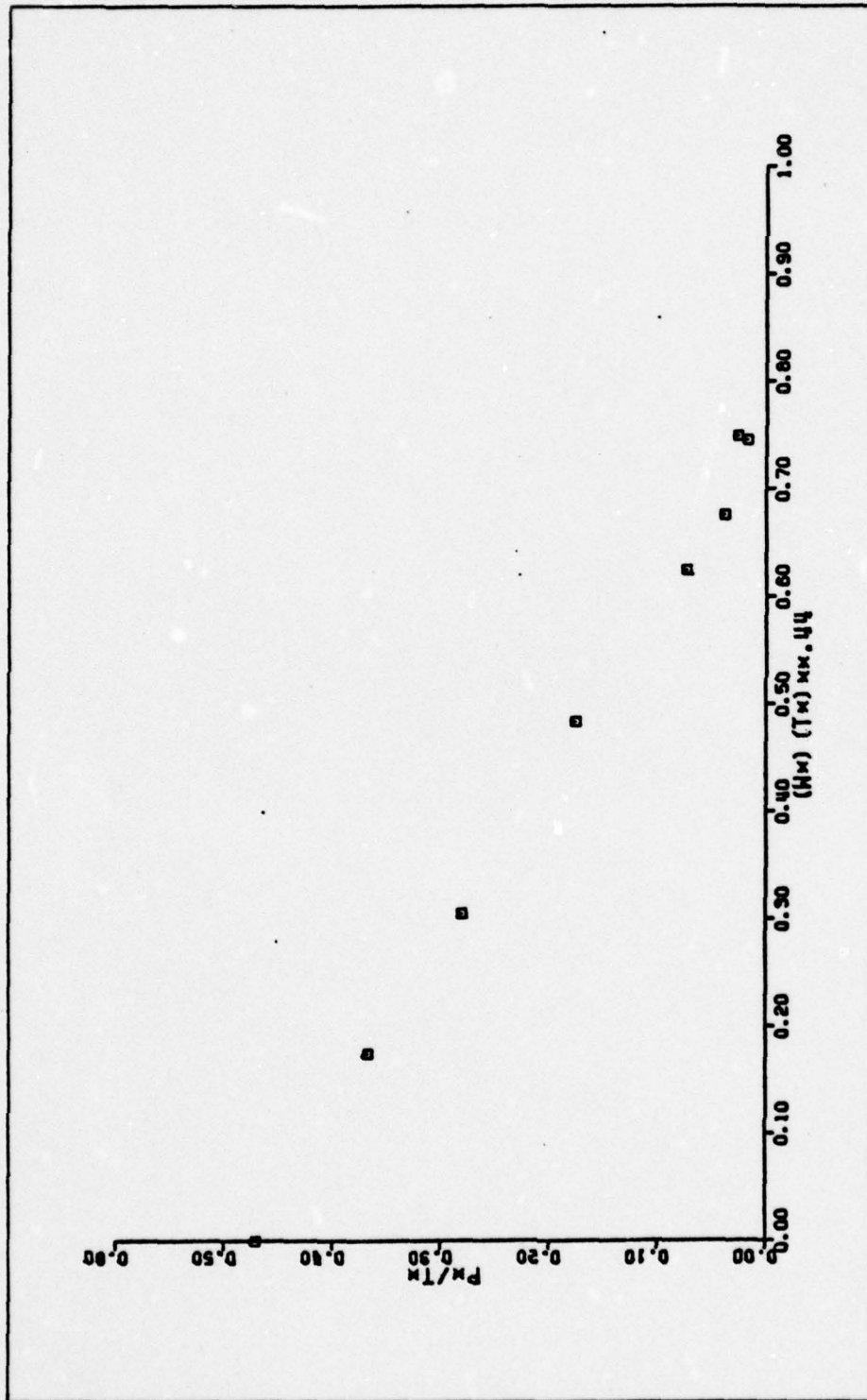

(99) PORTED MIXING STACK WITH RING DIFFUSOR AND FLOW-THROUGH SHROUD
 (DATA TAKEN FROM TABLE XIIIb)

FIGURE 40 (CONTINUED)

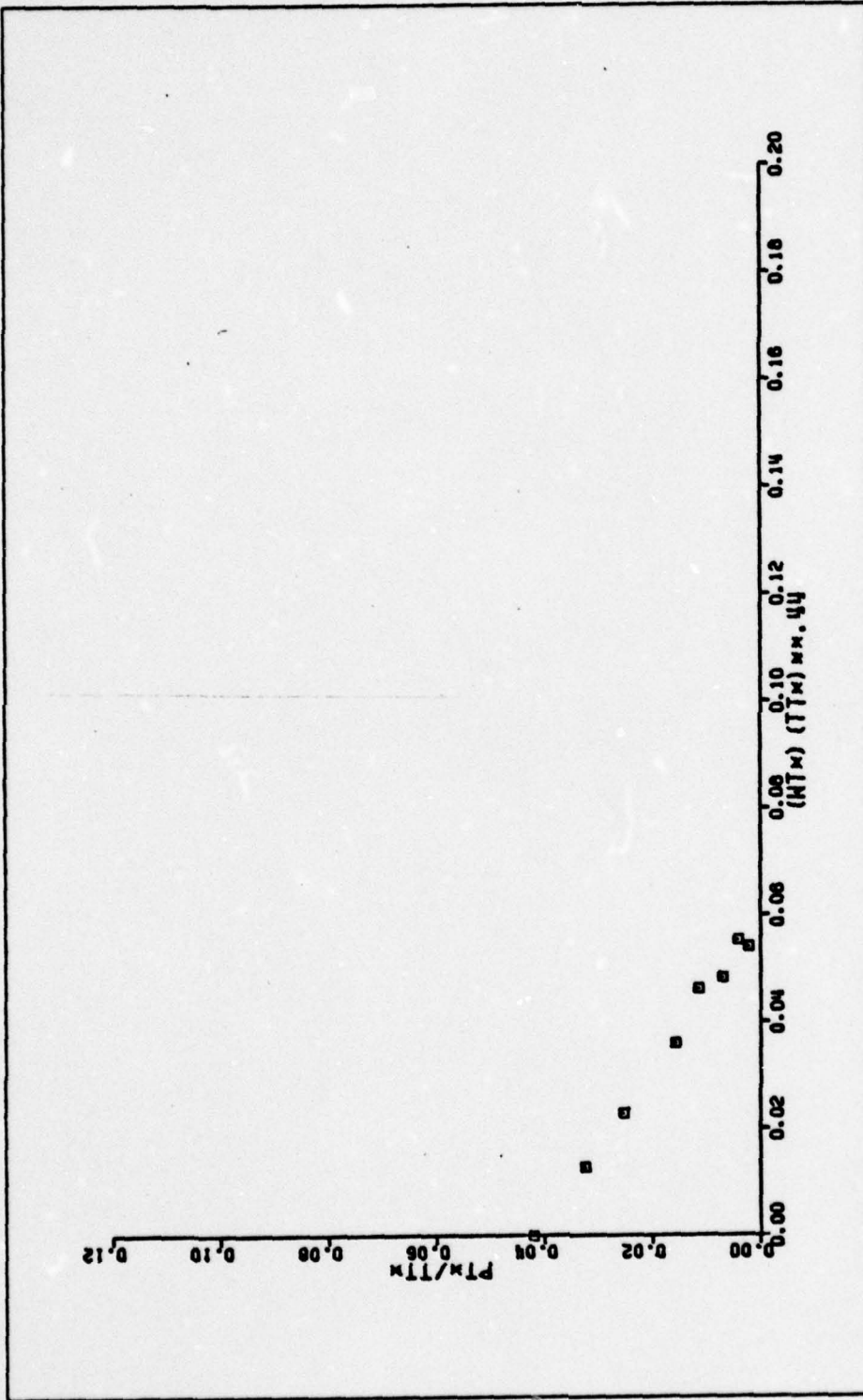

(hh) PORTED MIXING STACK WITH RING DIFFUSOR AND FLOW-THROUGH SHROUD
 (DATA TAKEN FROM TABLE XIIIc)

FIGURE 40 (CONTINUED)

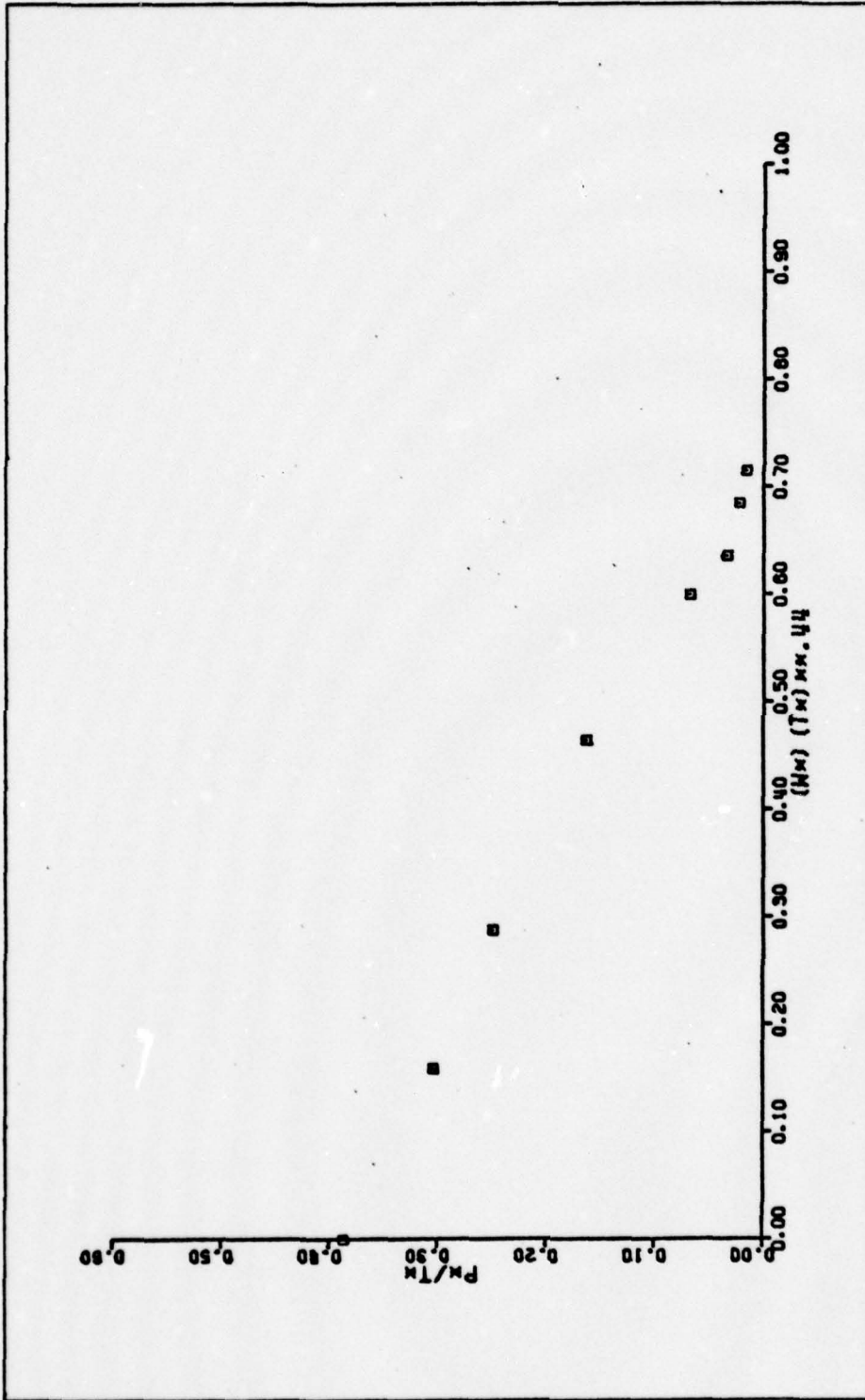

(ii) PORTED MIXING STACK WITH RING DIFFUSOR AND FLOW-THROUGH SHROUD
 (DATA TAKEN FROM TABLE XIIIId)

FIGURE 40 (CONTINUED)

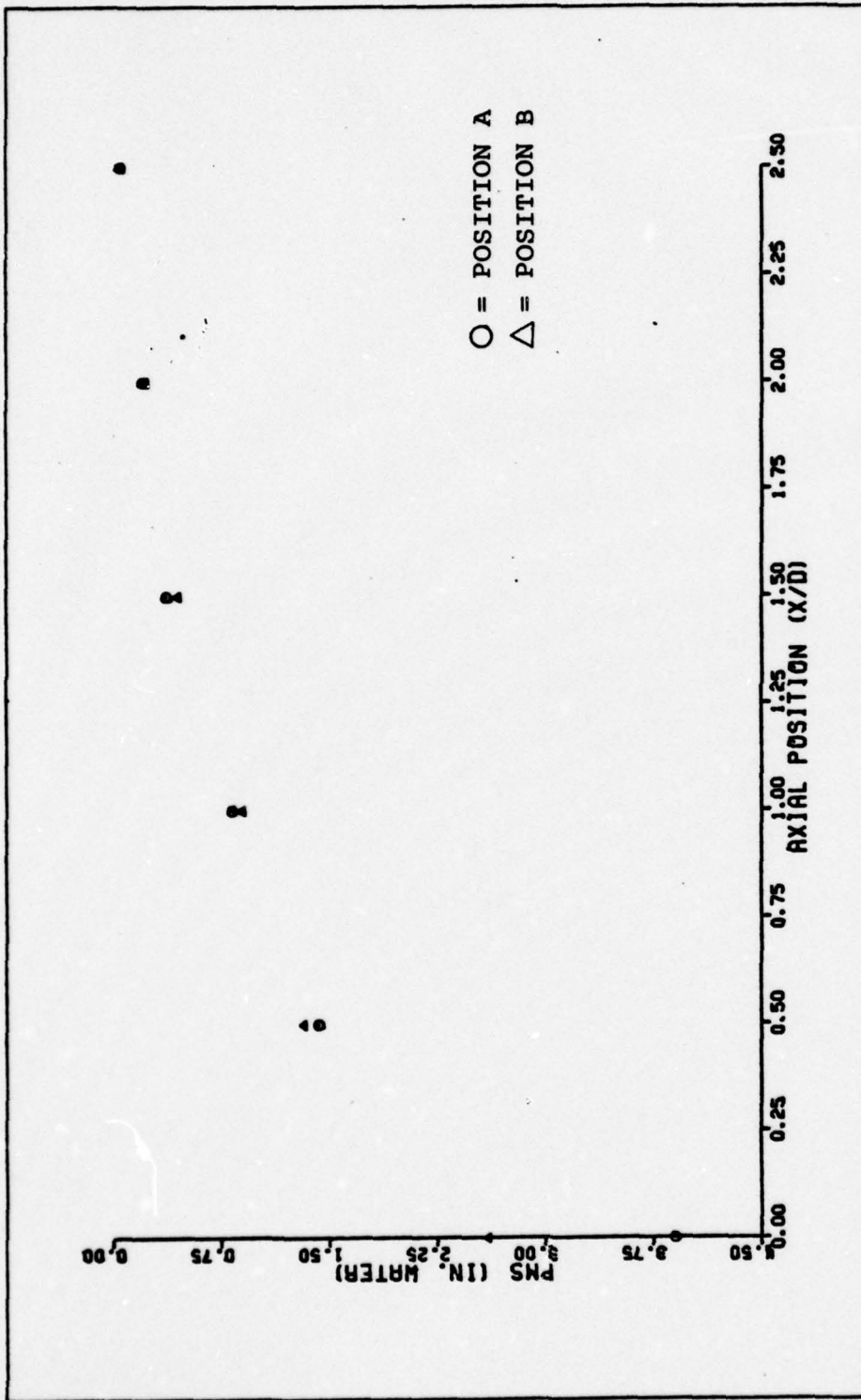

(a) STRAIGHT MIXING STACK, L/D = 3.0 (DATA TAKEN FROM TABLE IVa)

FIGURE 41. MIXING STACK PRESSURE DISTRIBUTION PLOTS

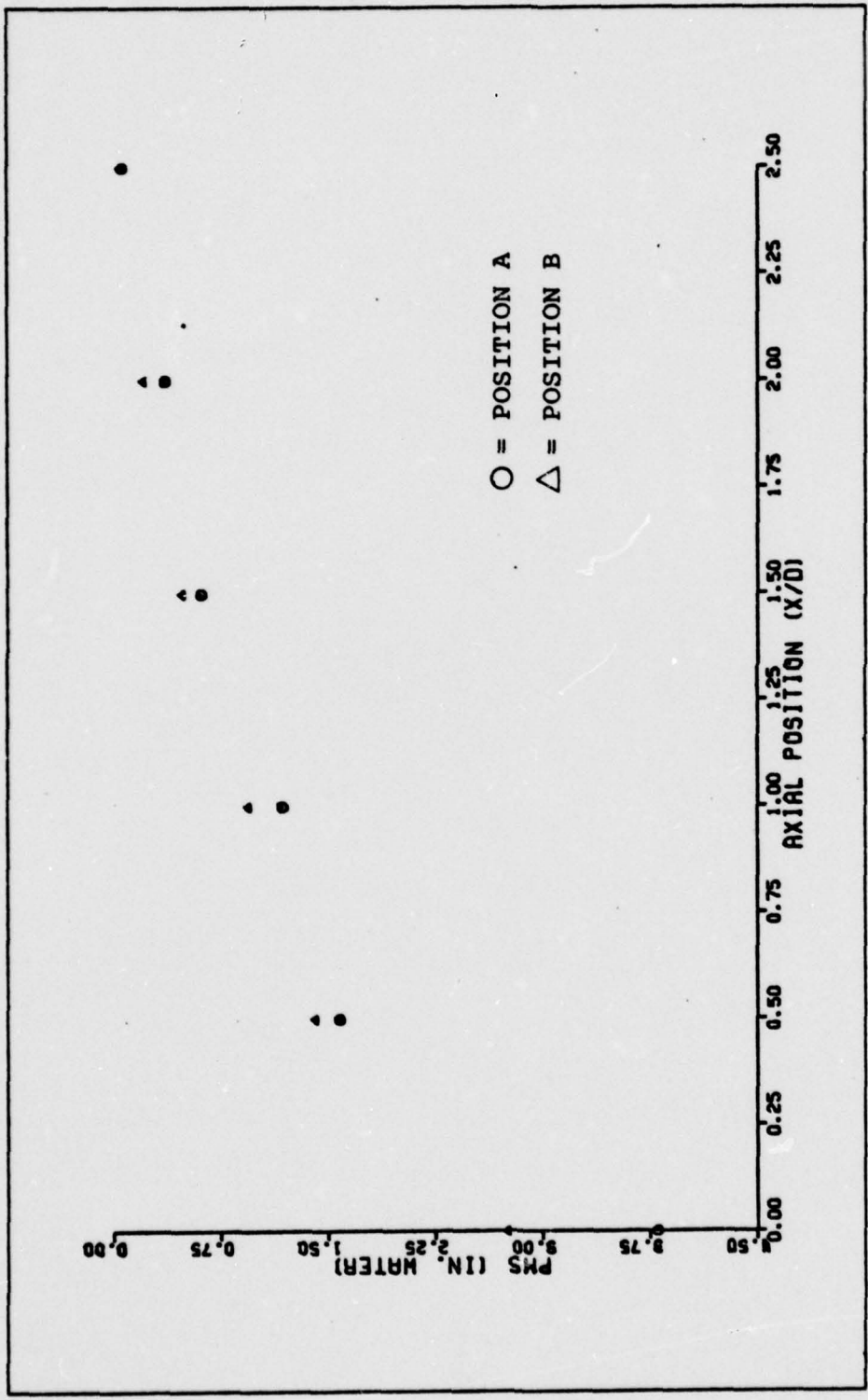

(b) STRAIGHT MIXING STACK, L/D = 3.0 (DATA TAKEN FROM TABLE IVb)

FIGURE 41 (CONTINUED)

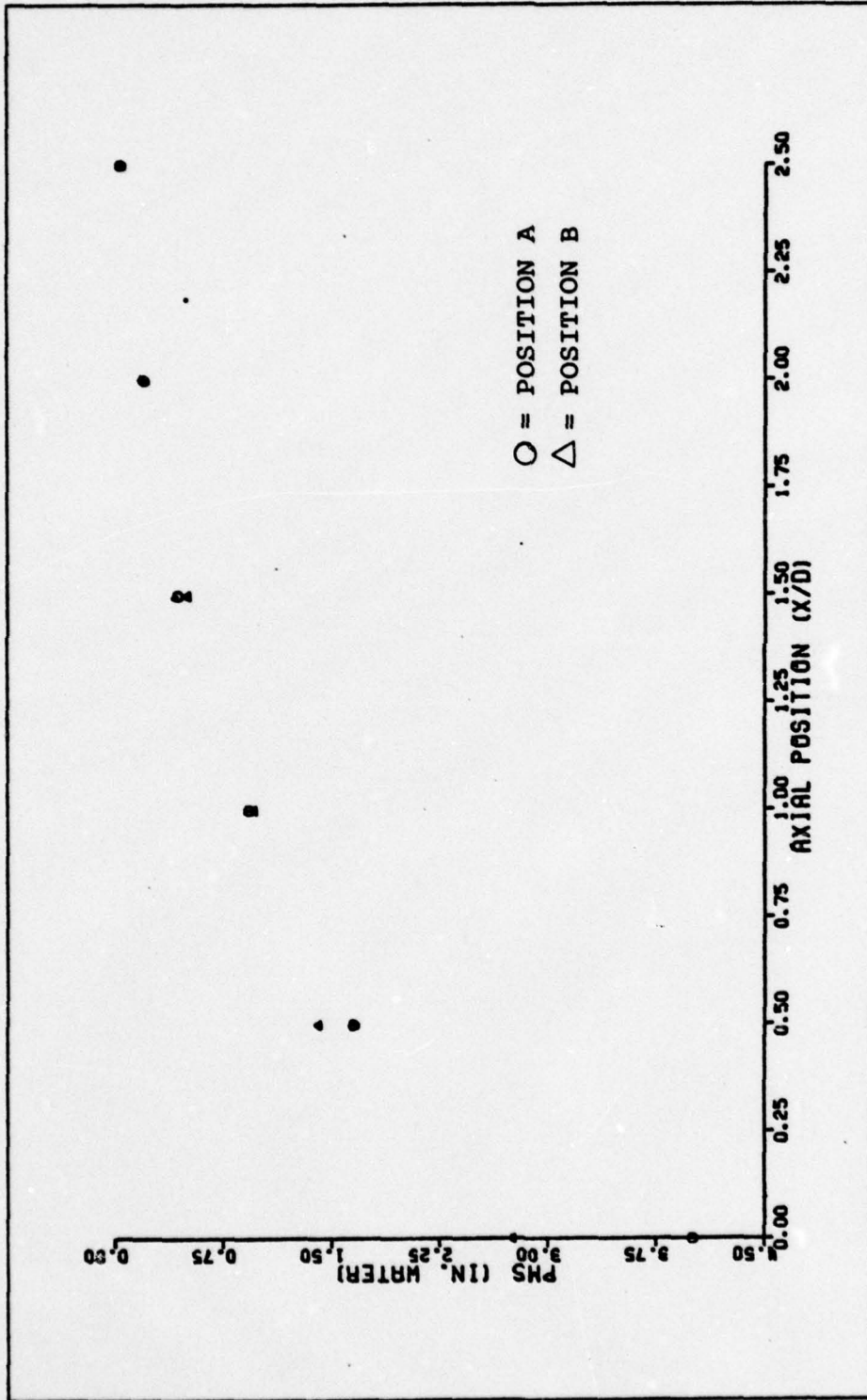

(C) STRAIGHT MIXING STACK, L/D = 3.0 (DATA TAKEN FROM TABLE IVC)

FIGURE 41 (CONTINUED)

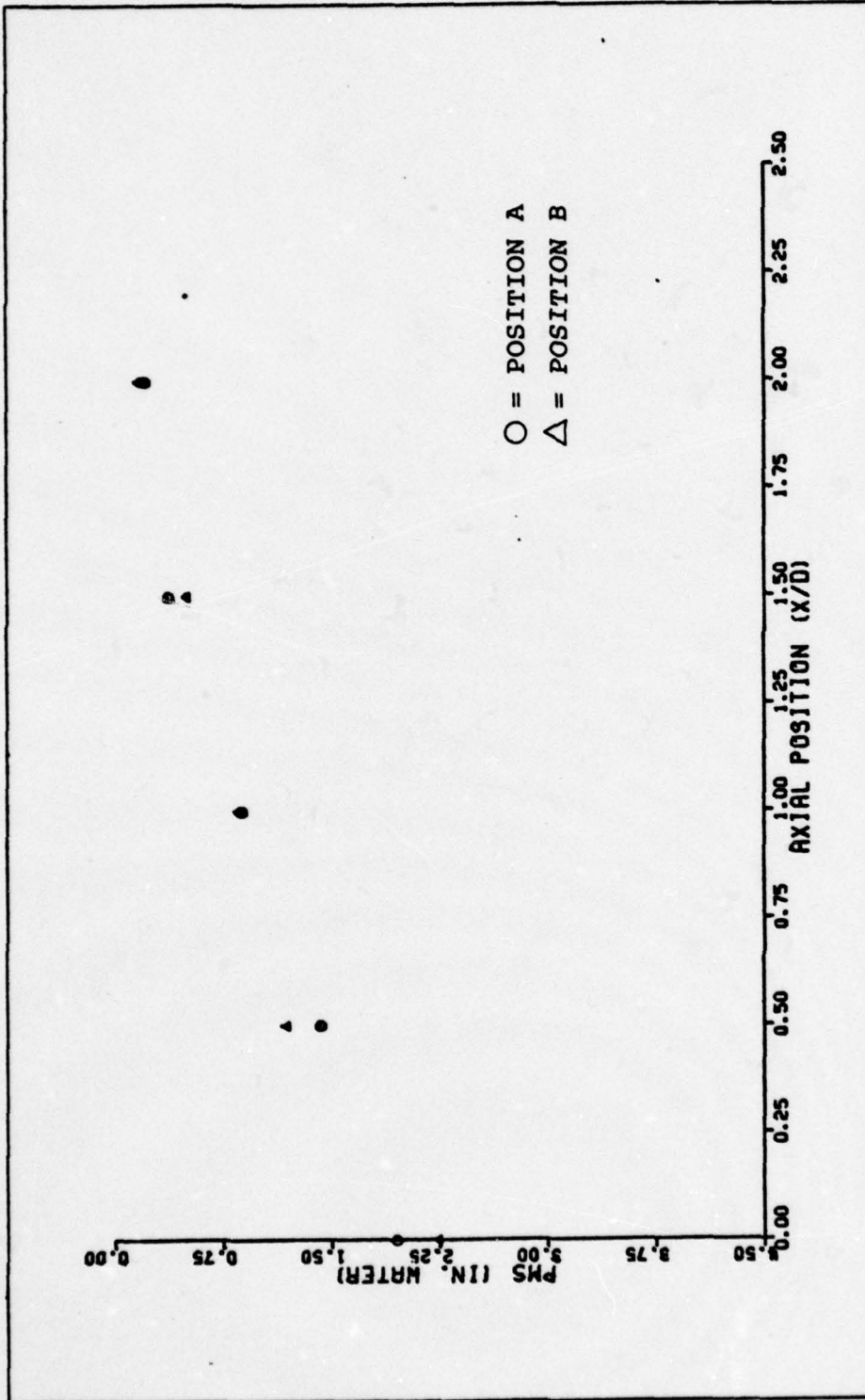

(d) STRAIGHT MIXING STACK, L/D = 2.5 (DATA TAKEN FROM TABLE IVd)

FIGURE 41 (CONTINUED)

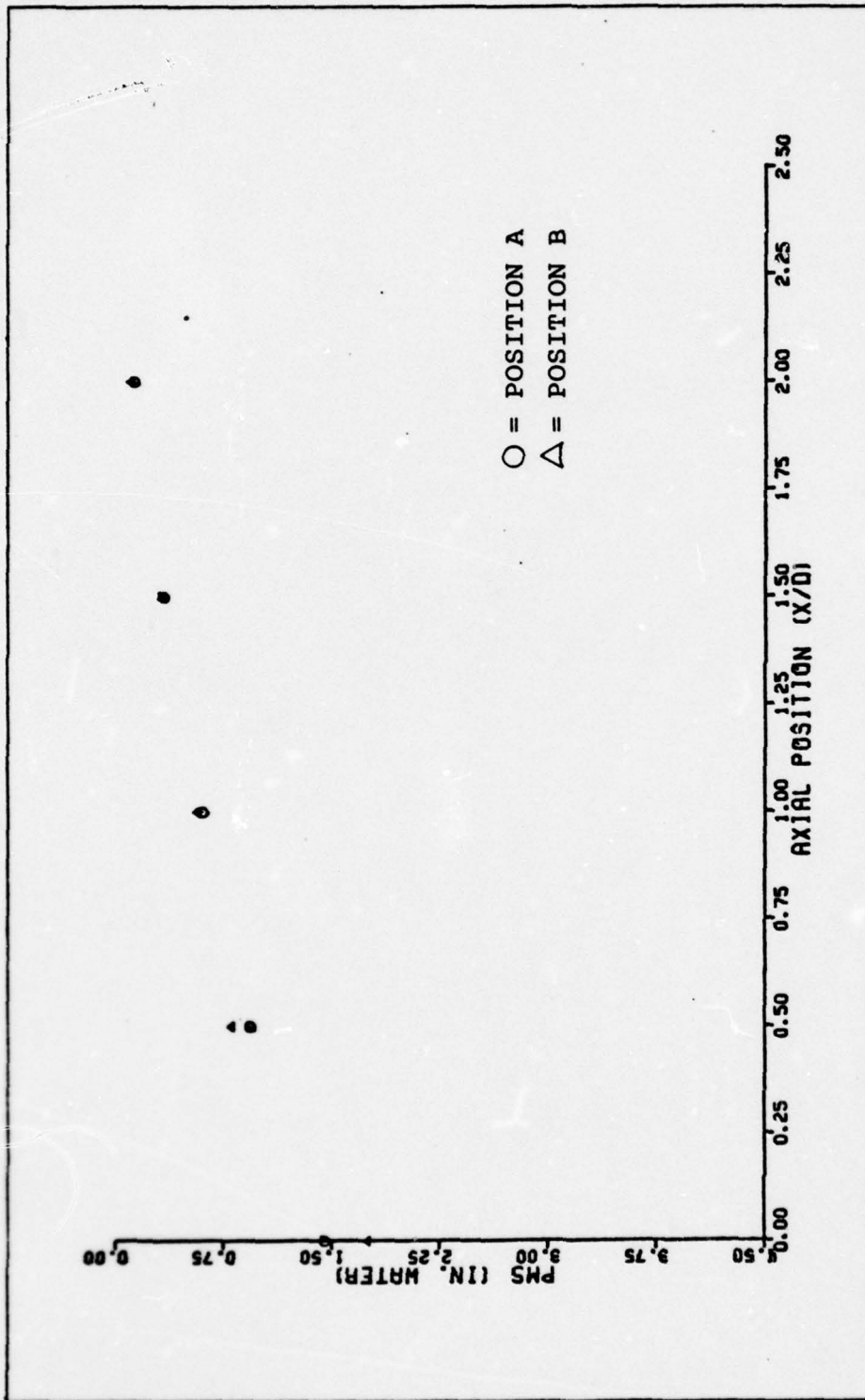

(e) STRAIGHT MIXING STACK, L/D = 2.5 (DATA TAKEN FROM TABLE Vb)

FIGURE 41 (CONTINUED)

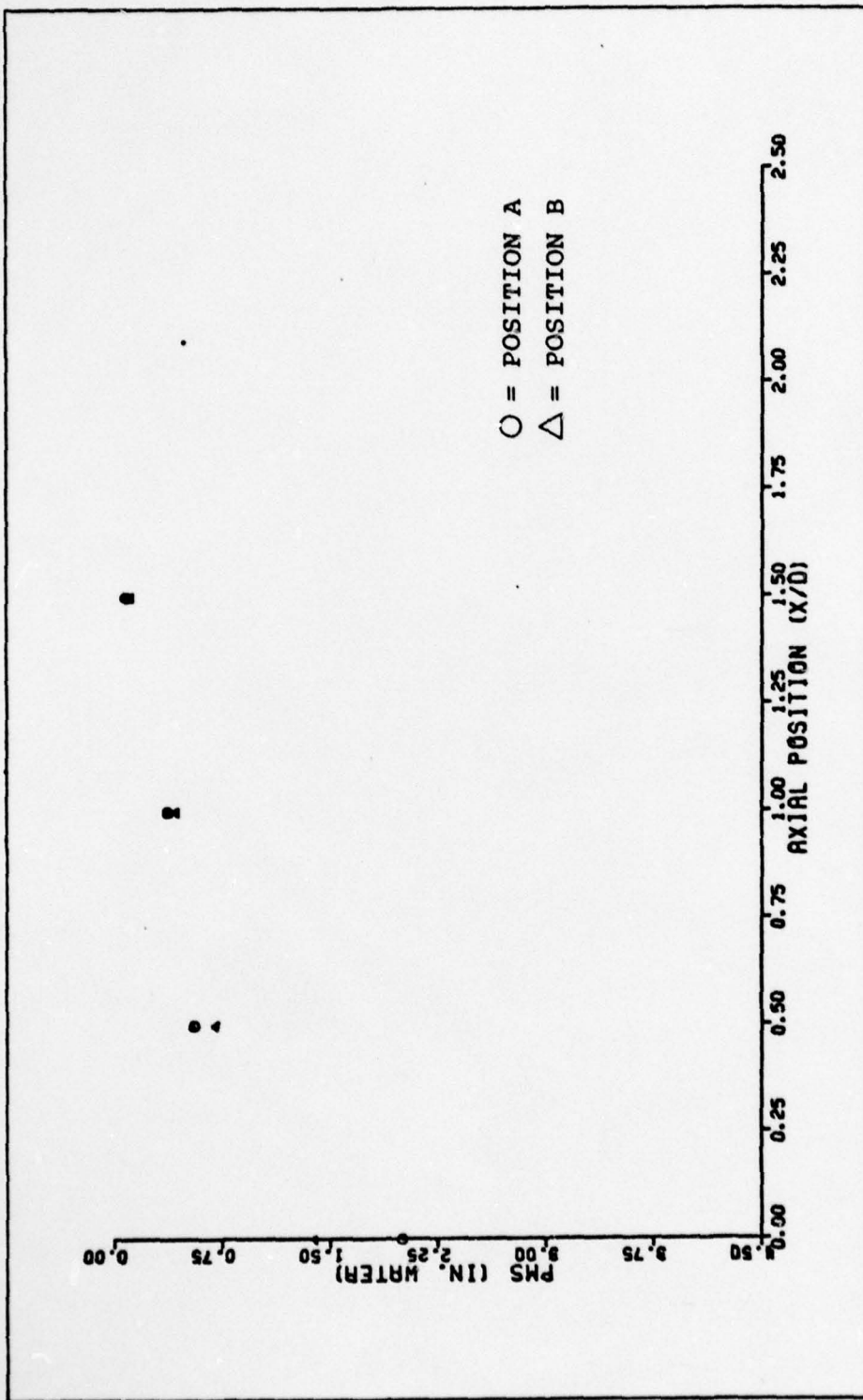

(f) STRAIGHT MIXING STACK, L/D = 1.75 (DATA TAKEN FROM TABLE Vc)

FIGURE 41 (CONTINUED)

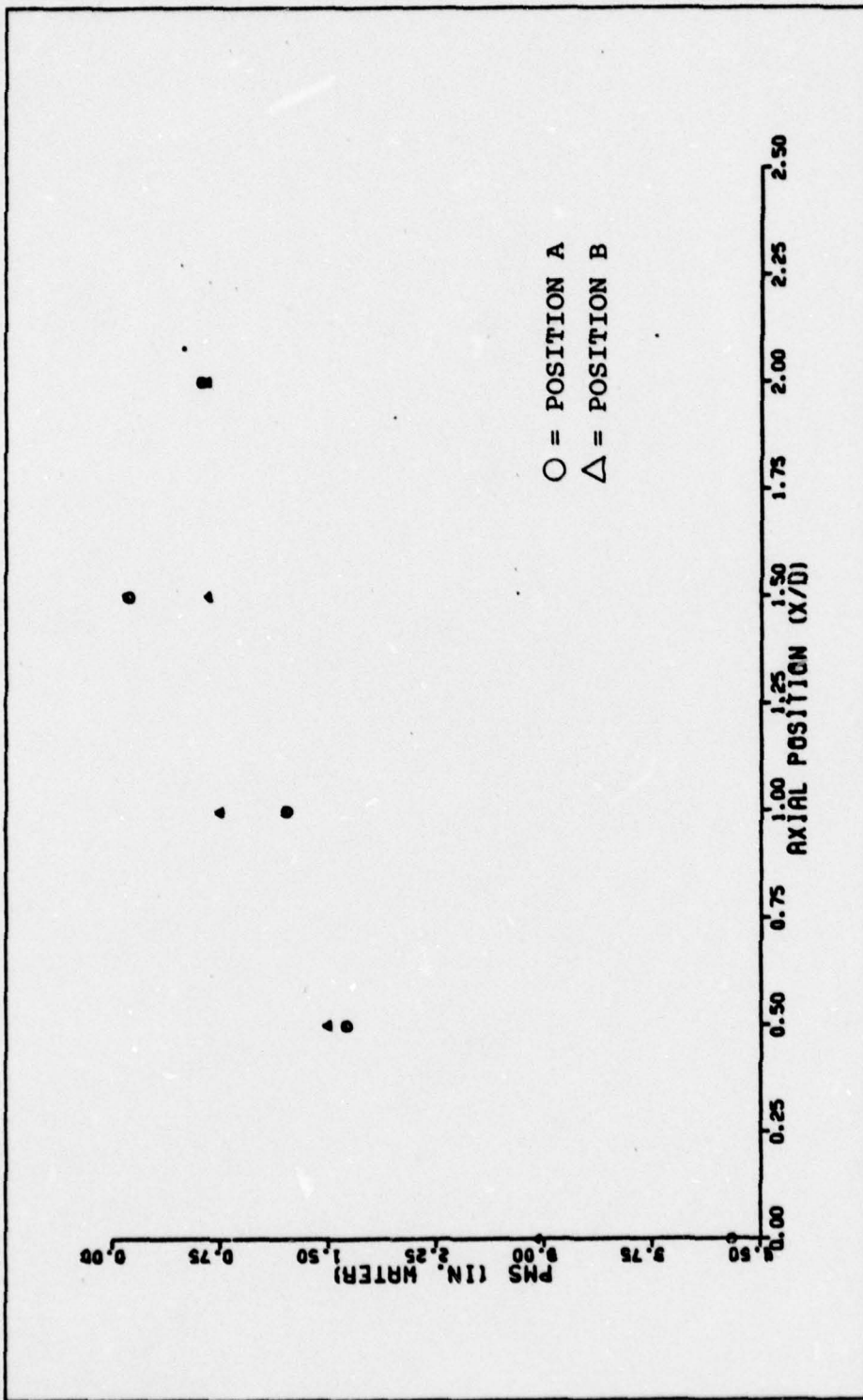

(g) MIXING STACK WITH 7 DEGREE SOLID DIFFUSOR (DATA TAKEN FROM TABLE VIA)

FIGURE 41 (CONTINUED)

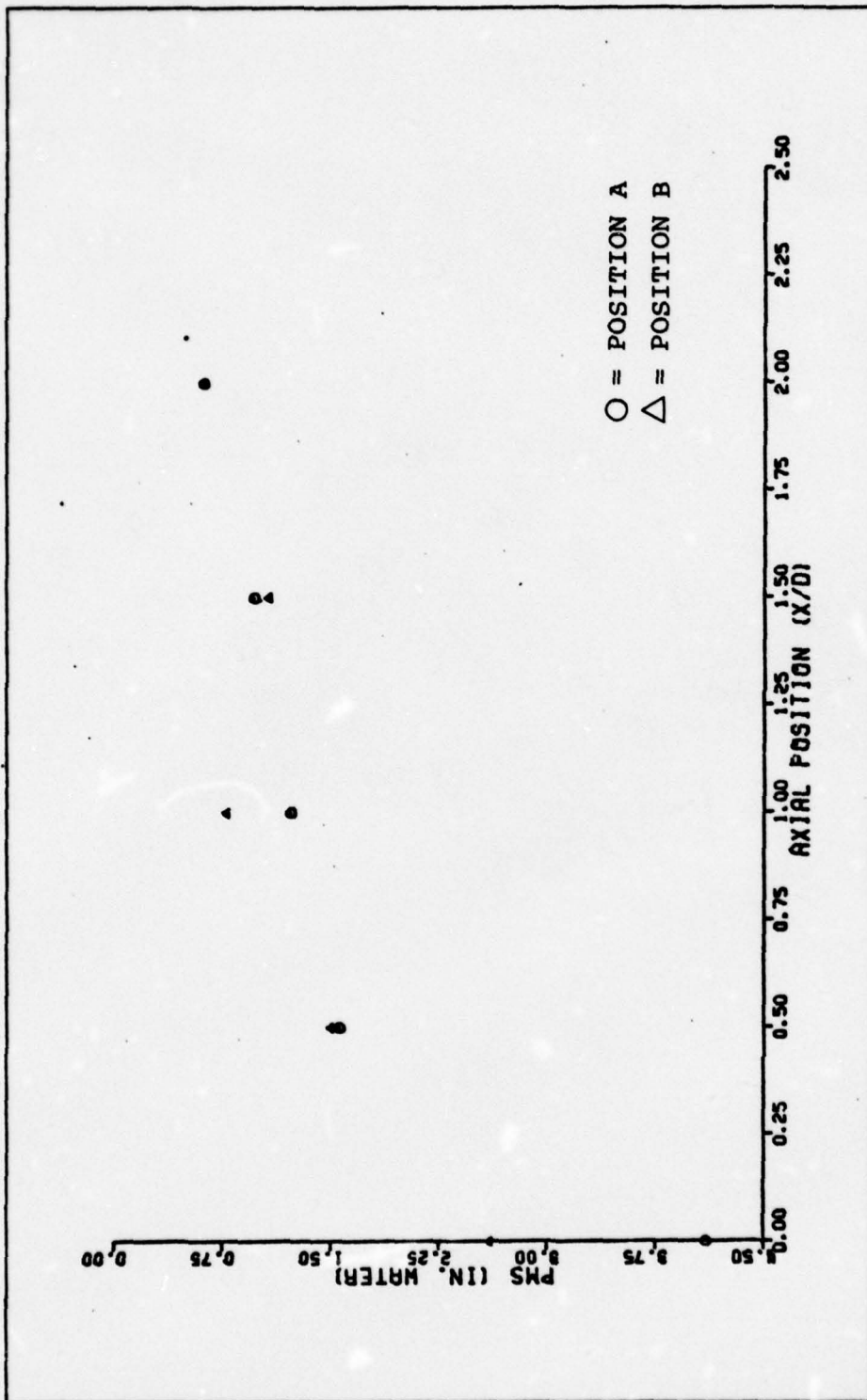

(h) MIXING STACK WITH 7 DEGREE SOLID DIFFUSOR (DATA TAKEN FROM TABLE VIB)

FIGURE 41 (CONTINUED)

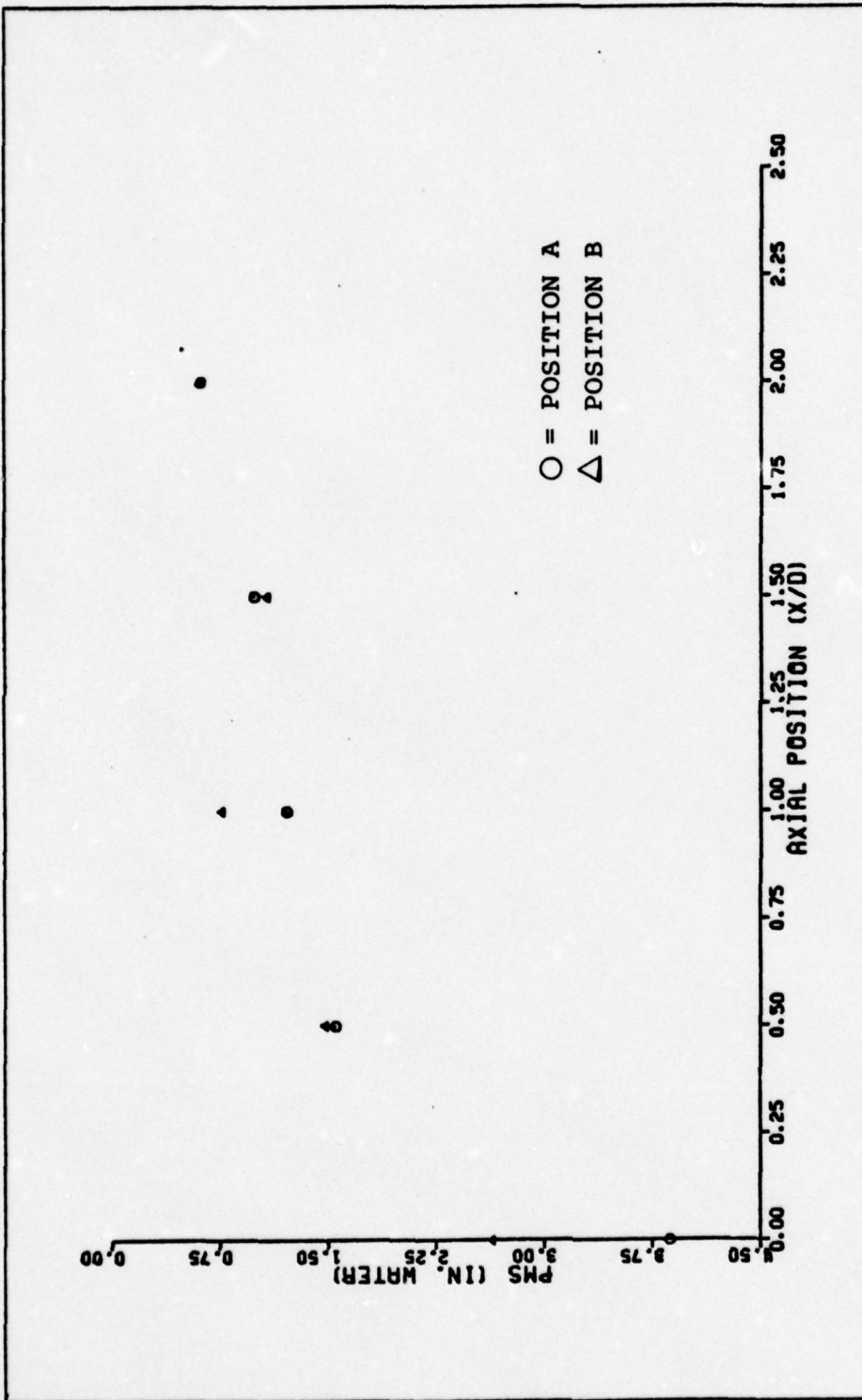

(i) MIXING STACK WITH 7 DEGREE SOLID DIFFUSOR (DATA TAKEN FROM TABLE VID)

FIGURE 41 (CONTINUED)

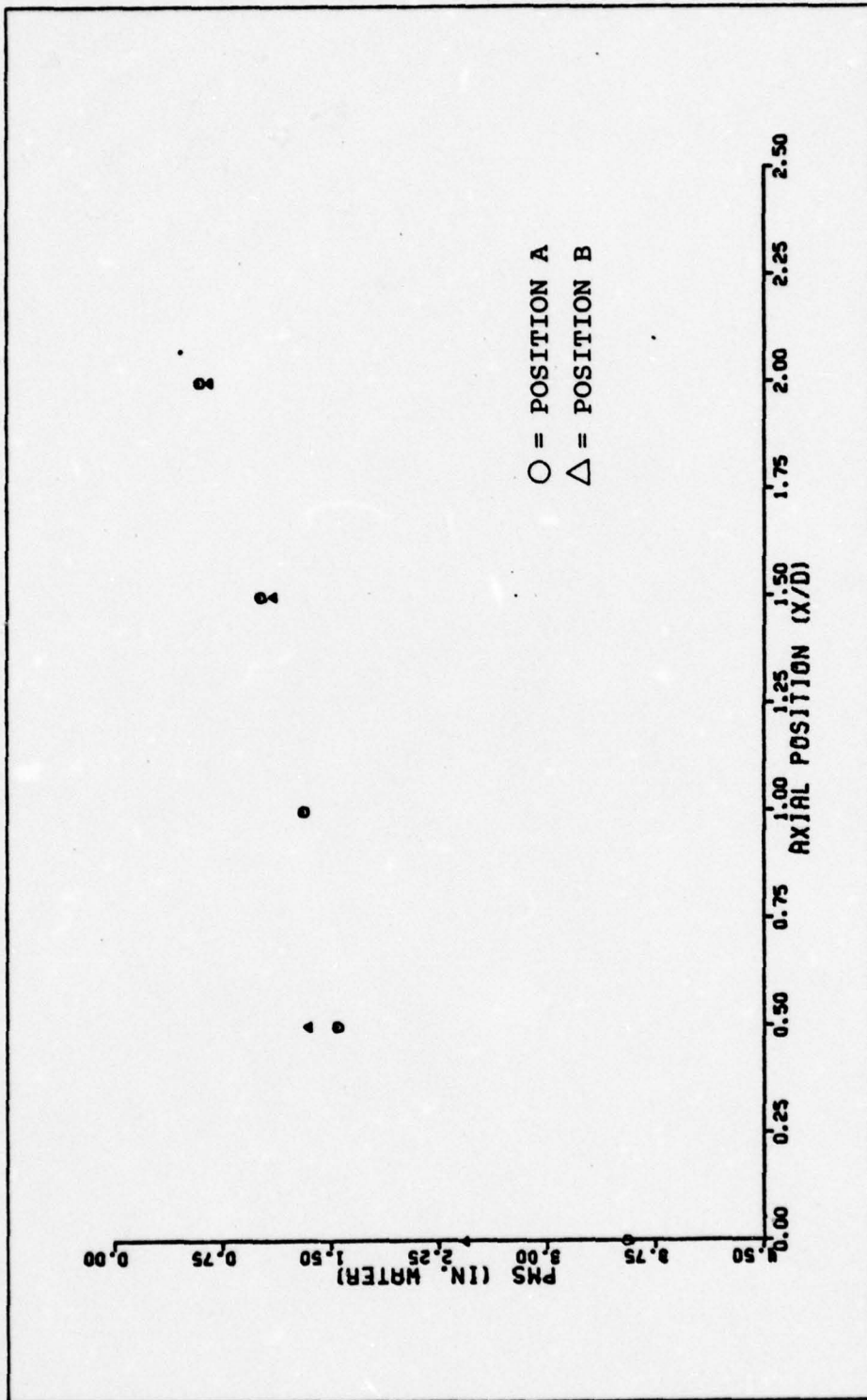

(j) MIXING STACK WITH 7 DEGREE SOLID DIFFUSOR (DATA TAKEN FROM TABLE VIE)

FIGURE 41 (CONTINUED)

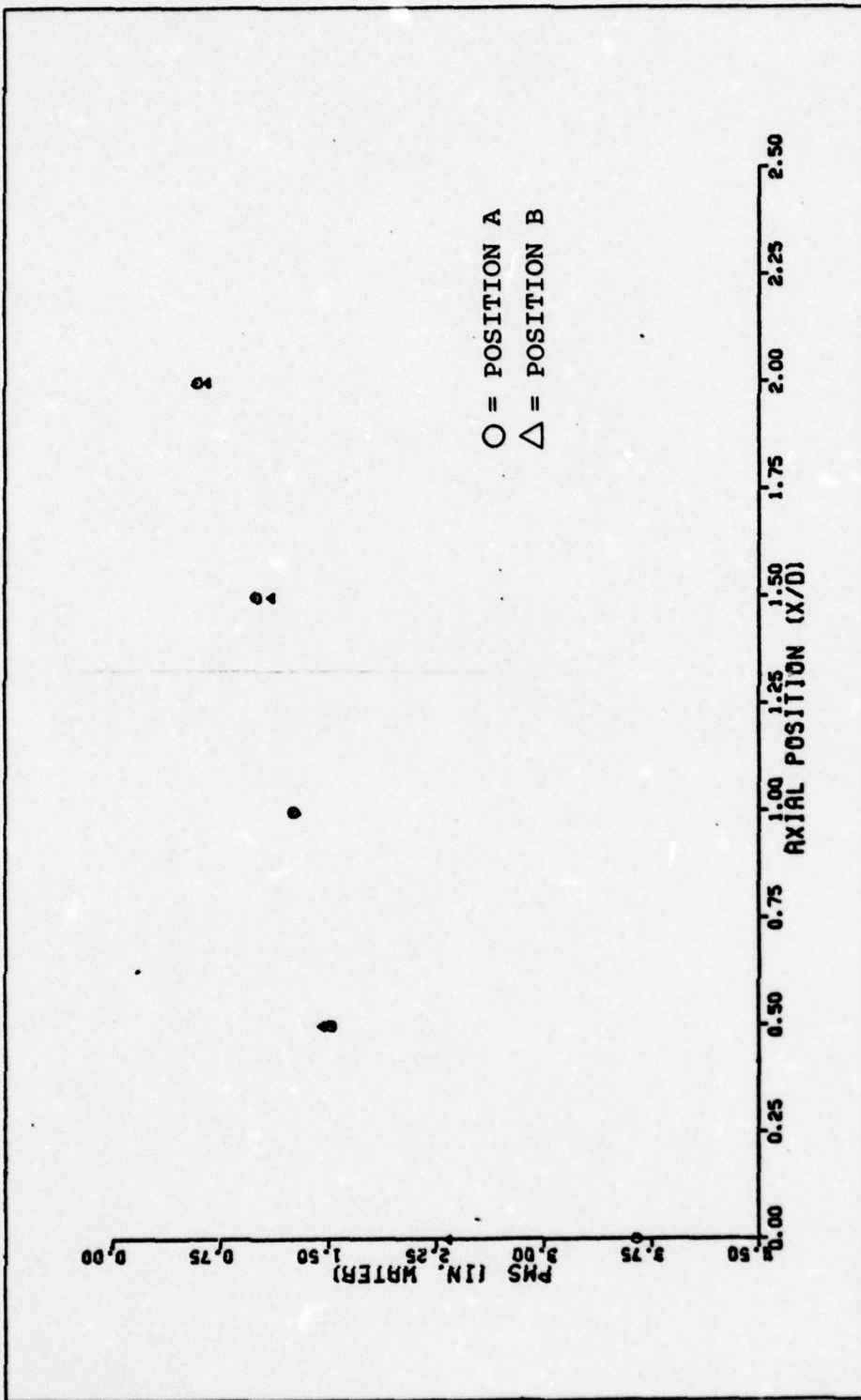

(k) MIXING STACK WITH A 7 DEGREE SOLID DIFFUSOR (DATA TAKEN FROM TABLE VIF)

FIGURE 41 (CONTINUED)

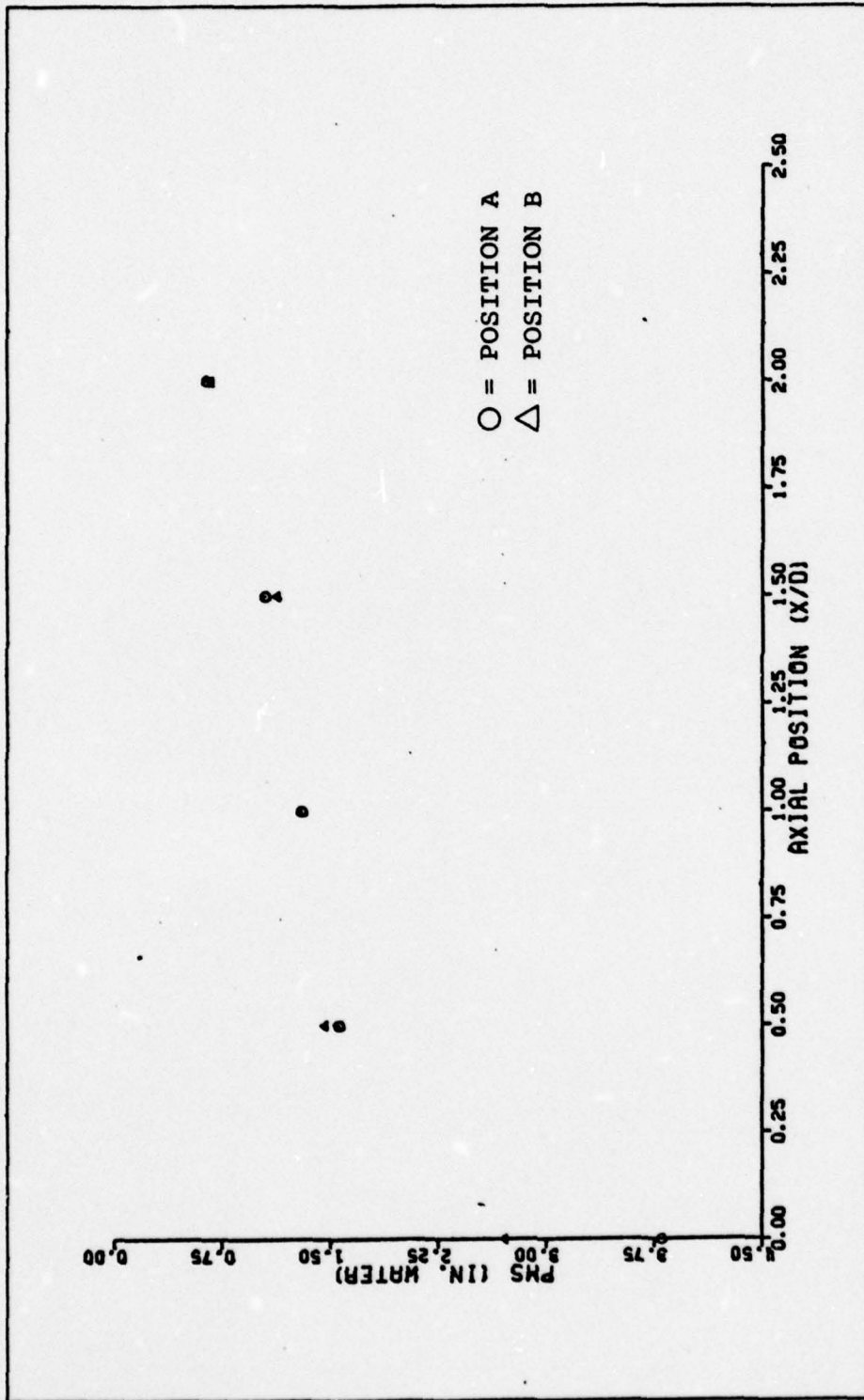

(8) MIXING STACK WITH 7 DEGREE SOLID DIFFUSOR (DATA TAKEN FROM TABLE VIg)

FIGURE 41 (CONTINUED)

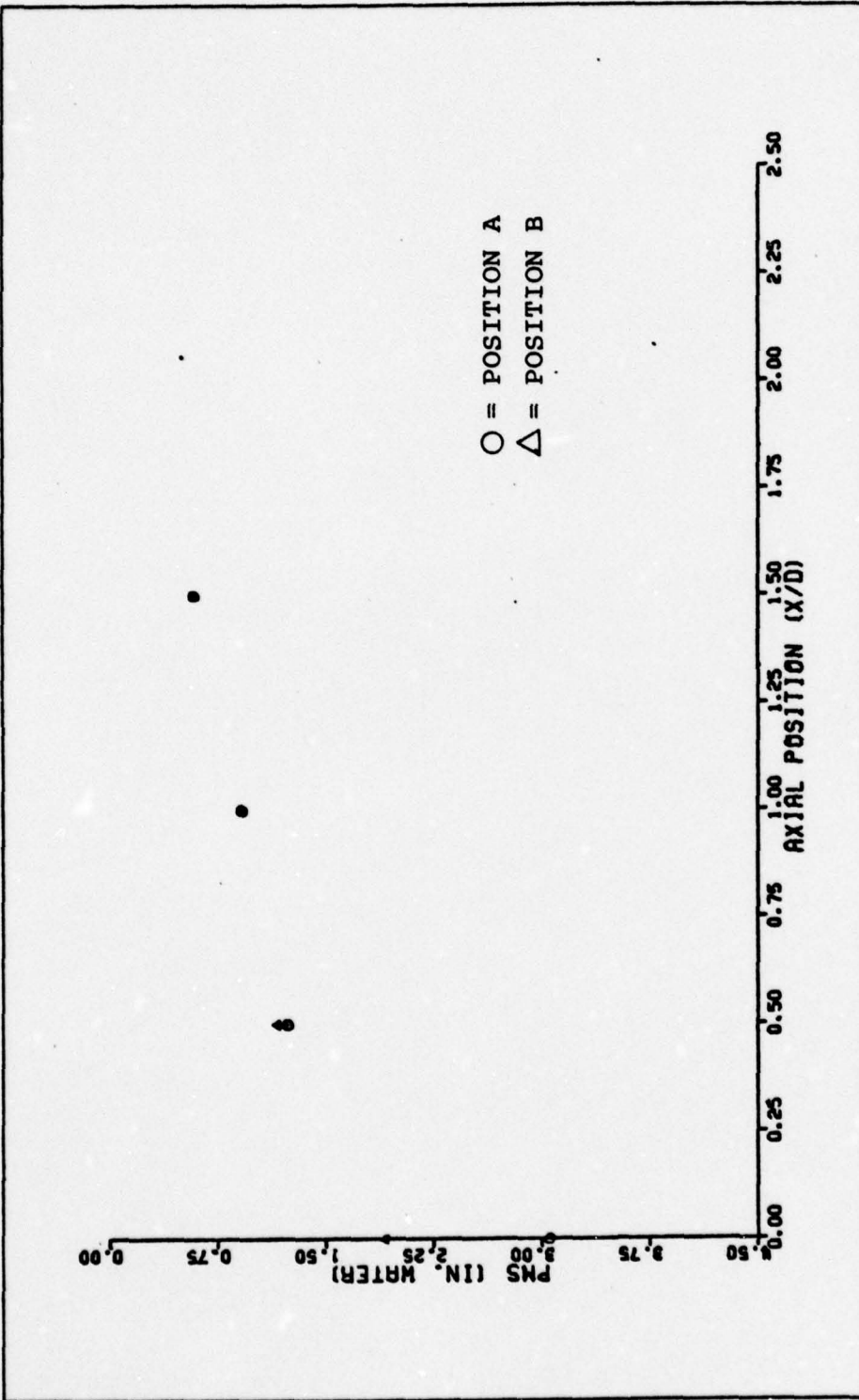

(m) MIXING STACK WITH TWO DIFFUSOR RINGS (DATA TAKEN FROM TABLE VII)

FIGURE 41 (CONTINUED)

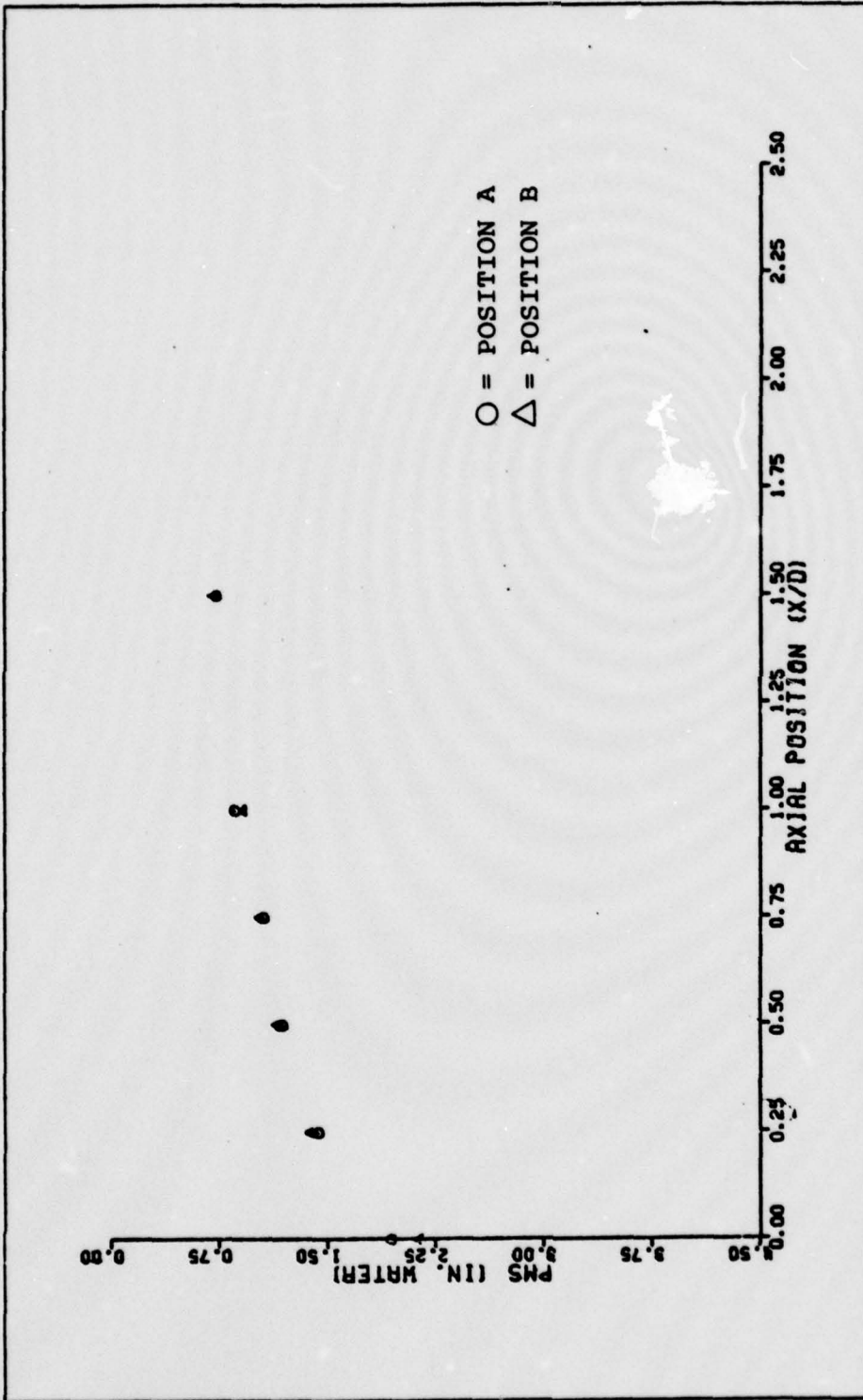

(n) MIXING STACK WITH THREE RING DIFFUSOR (DATA TAKEN FROM TABLE VIII)

FIGURE 41 (CONTINUED)

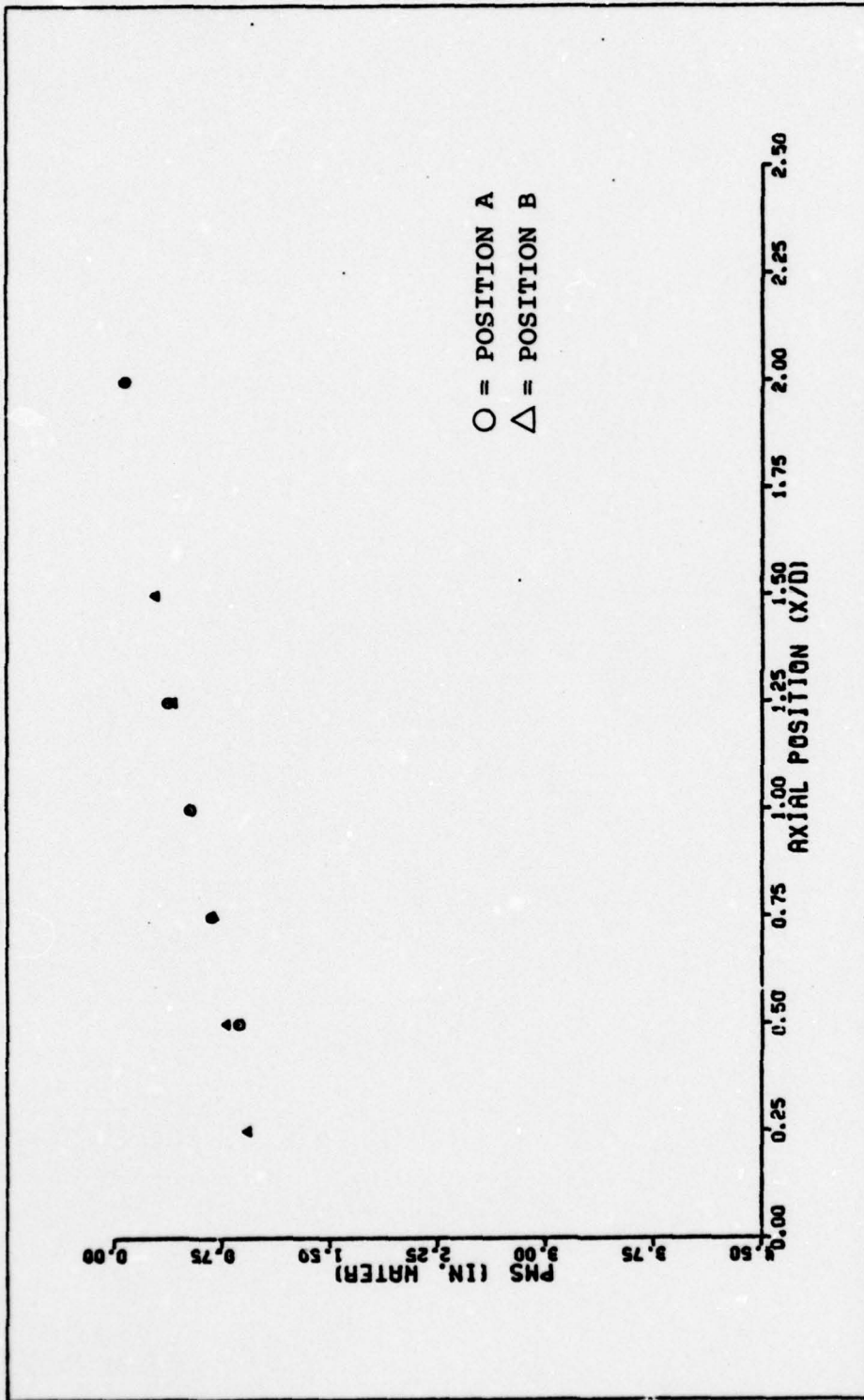

(o) PORTED MIXING STACK (DATA TAKEN FROM TABLE XIa)

FIGURE 41 (CONTINUED)

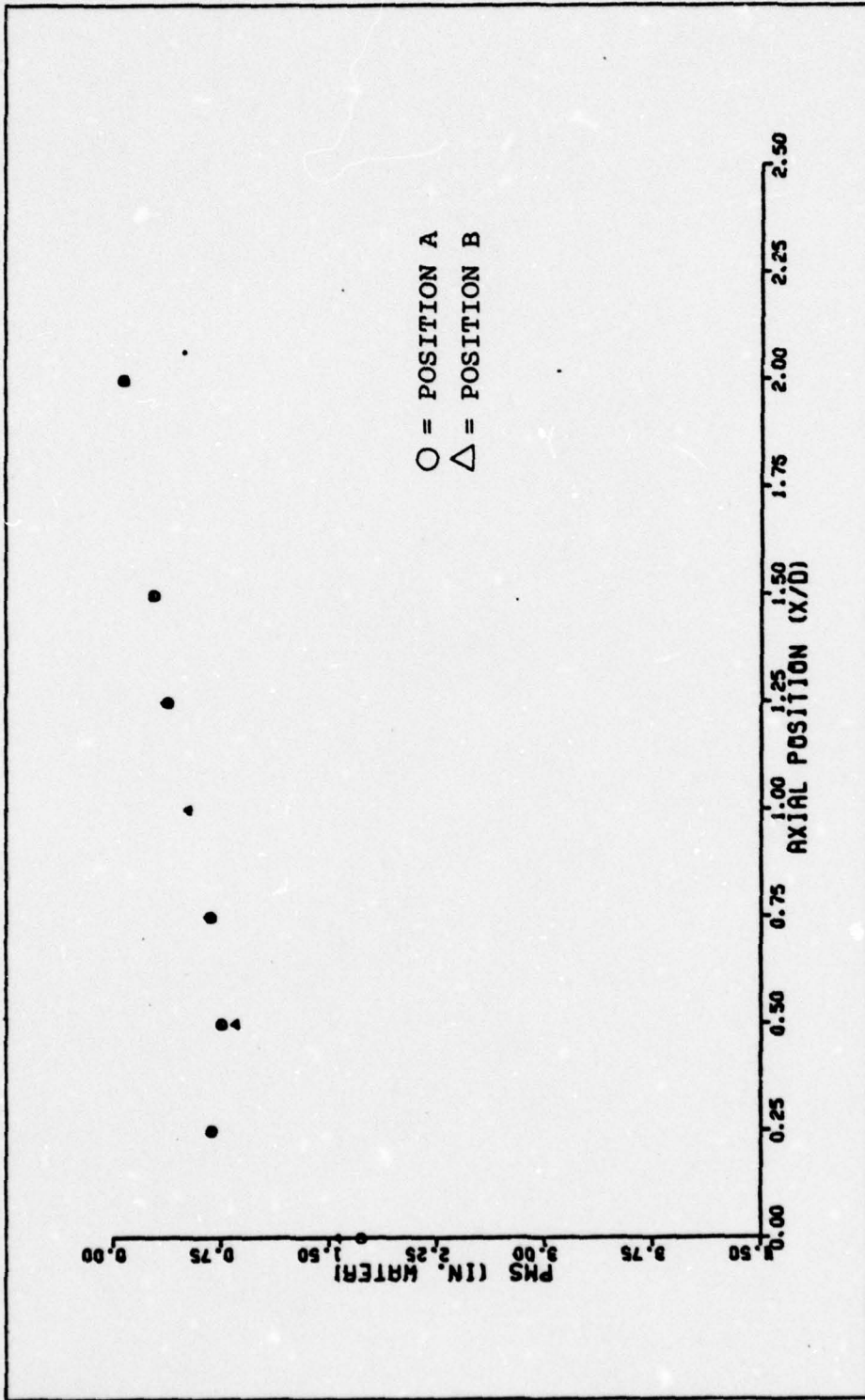

(p) PORTED MIXING STACK A-1 (DATA TAKEN FROM TABLE IXb)

FIGURE 41 (CONTINUED)

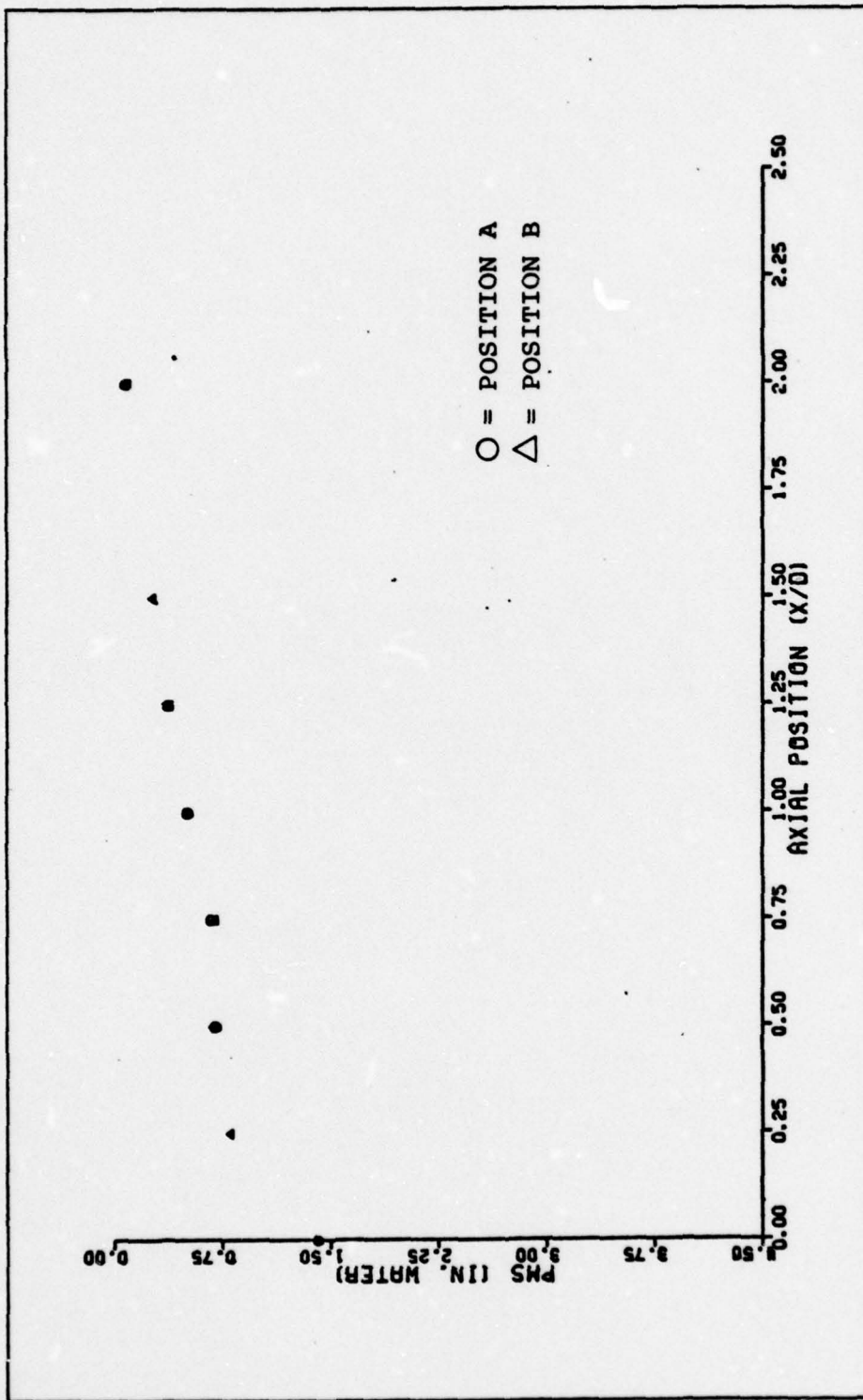

(c) PORTED MIXING STACK A-1, B-1 (DATA TAKEN FROM TABLE IXc)

FIGURE 41 (CONTINUED)

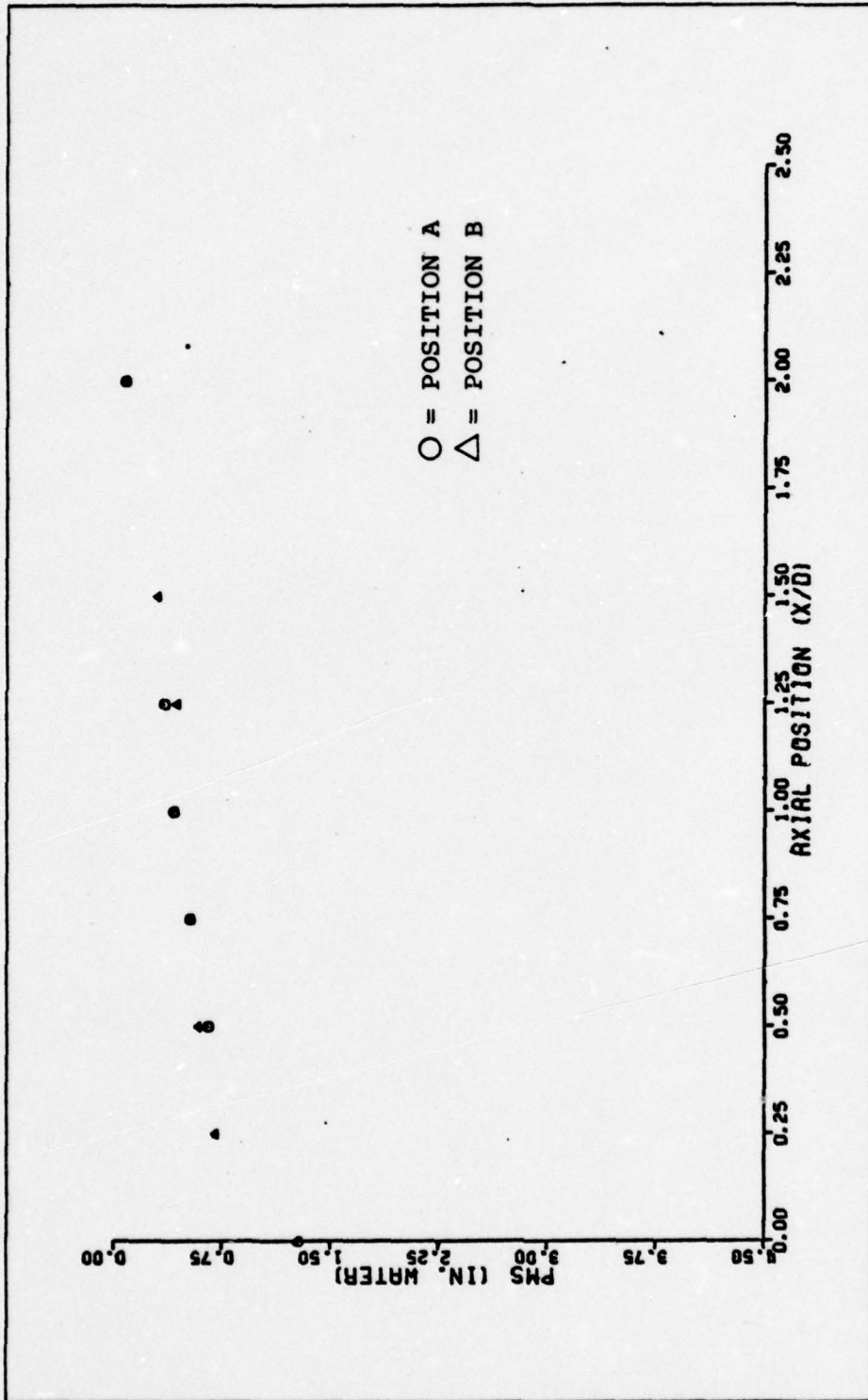

(r) PORTED MIXING STACK A-1, B-1, C-2 (DATA TAKEN FROM TABLE IXd)

FIGURE 41 (CONTINUED)

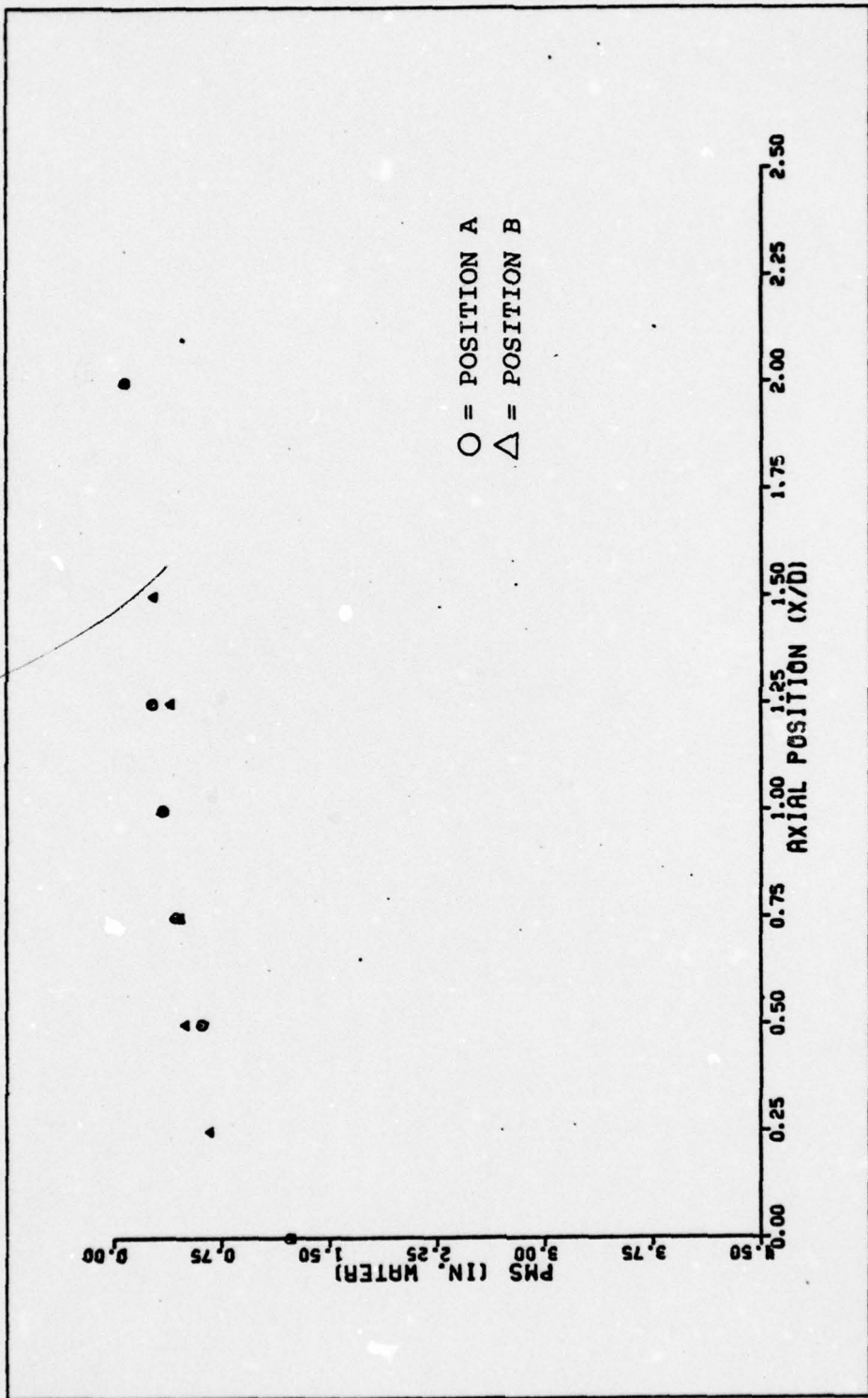

(s) PORTED MIXING STACK A-1, B-1, C-2, D-2 (DATA TAKEN FROM TABLE IXe)

FIGURE 41 (CONTINUED)

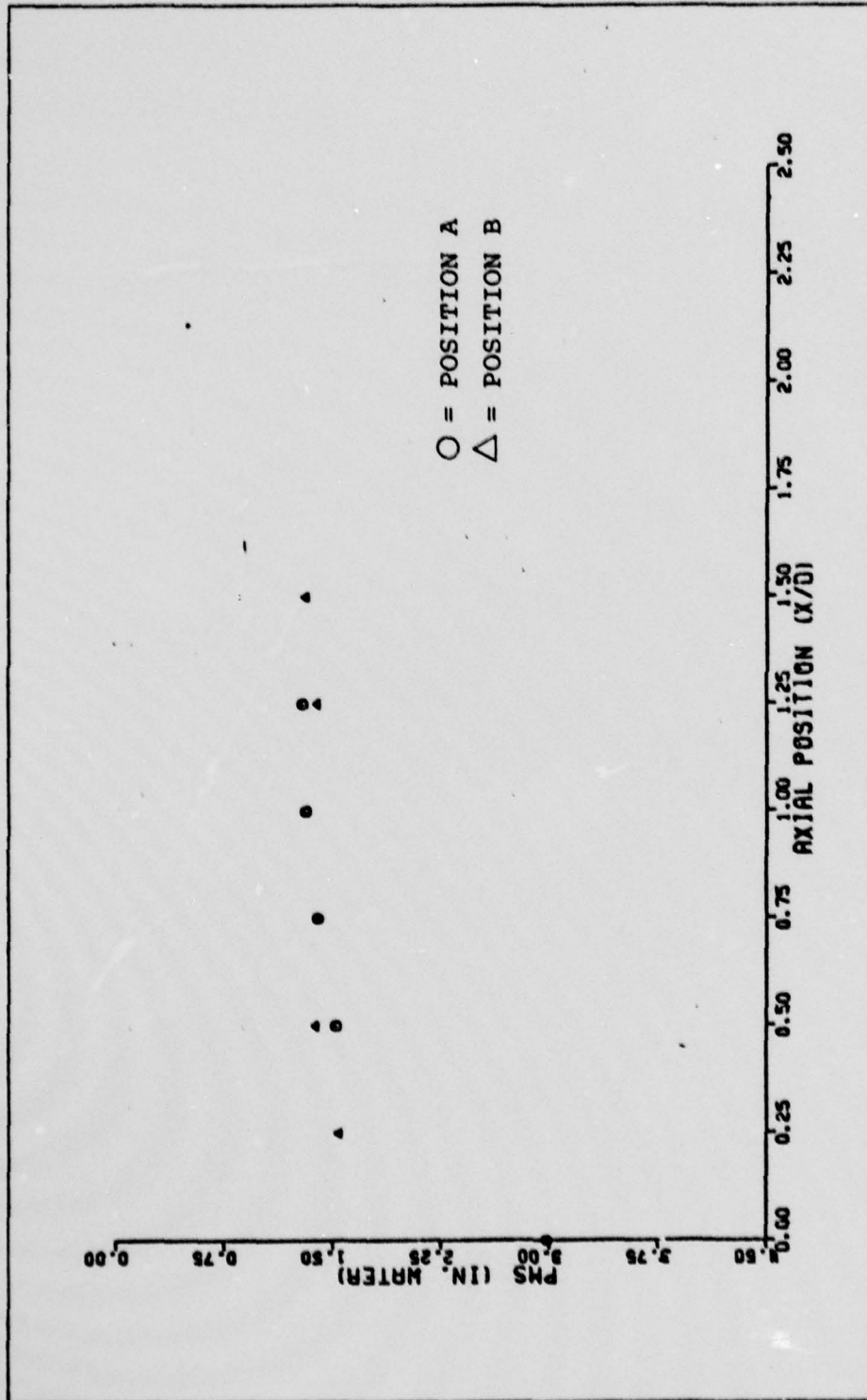

(t) PORTED MIXING STACK WITH TWO RING DIFFUSOR (DATA TAKEN FROM TABLE Xa)

FIGURE 41 (CONTINUED)

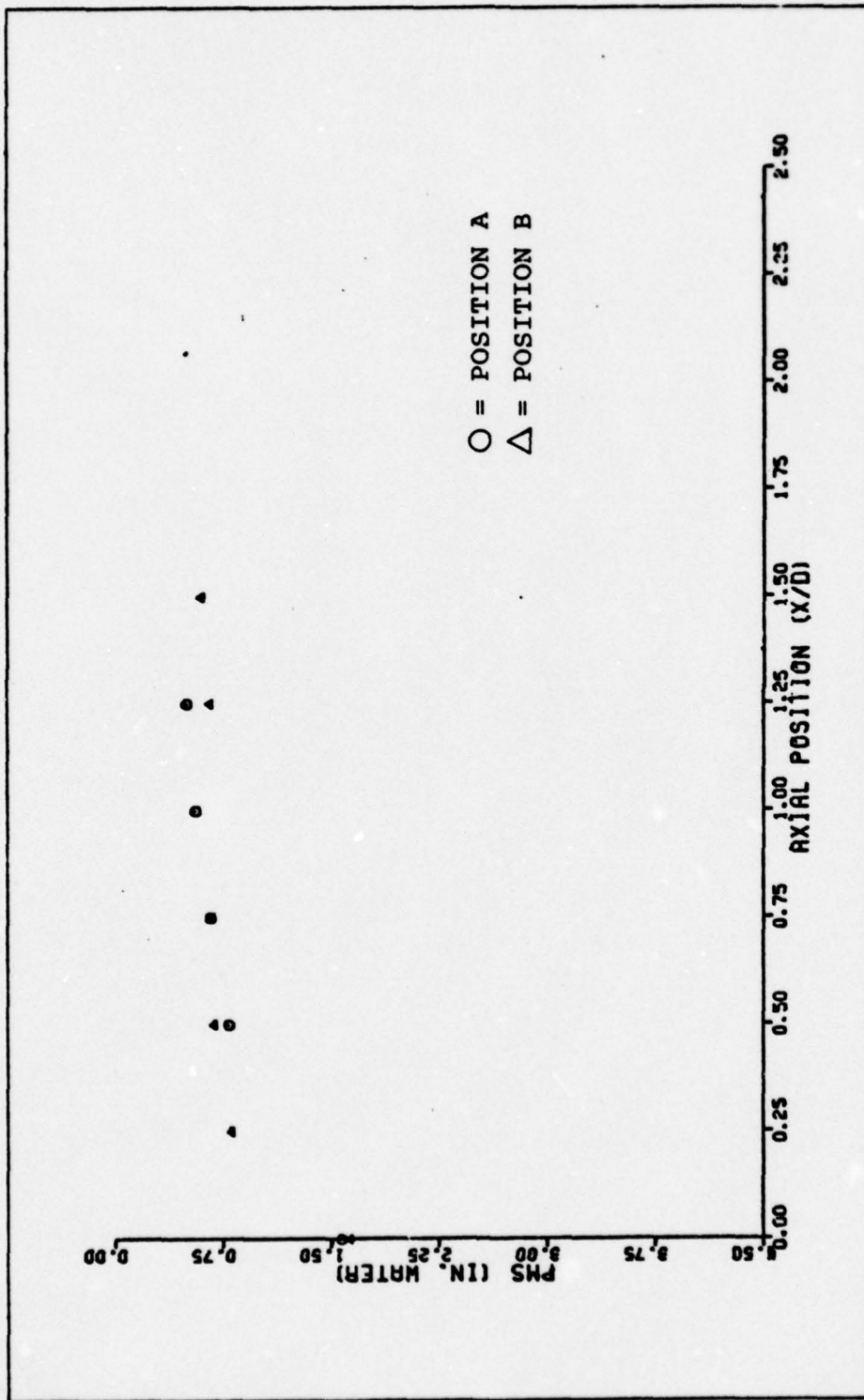

(u) PORTED MIXING STACK WITH TWO RING DIFFUSOR (DATA TAKEN FROM TABLE Xb)

FIGURE 41 (CONTINUED)

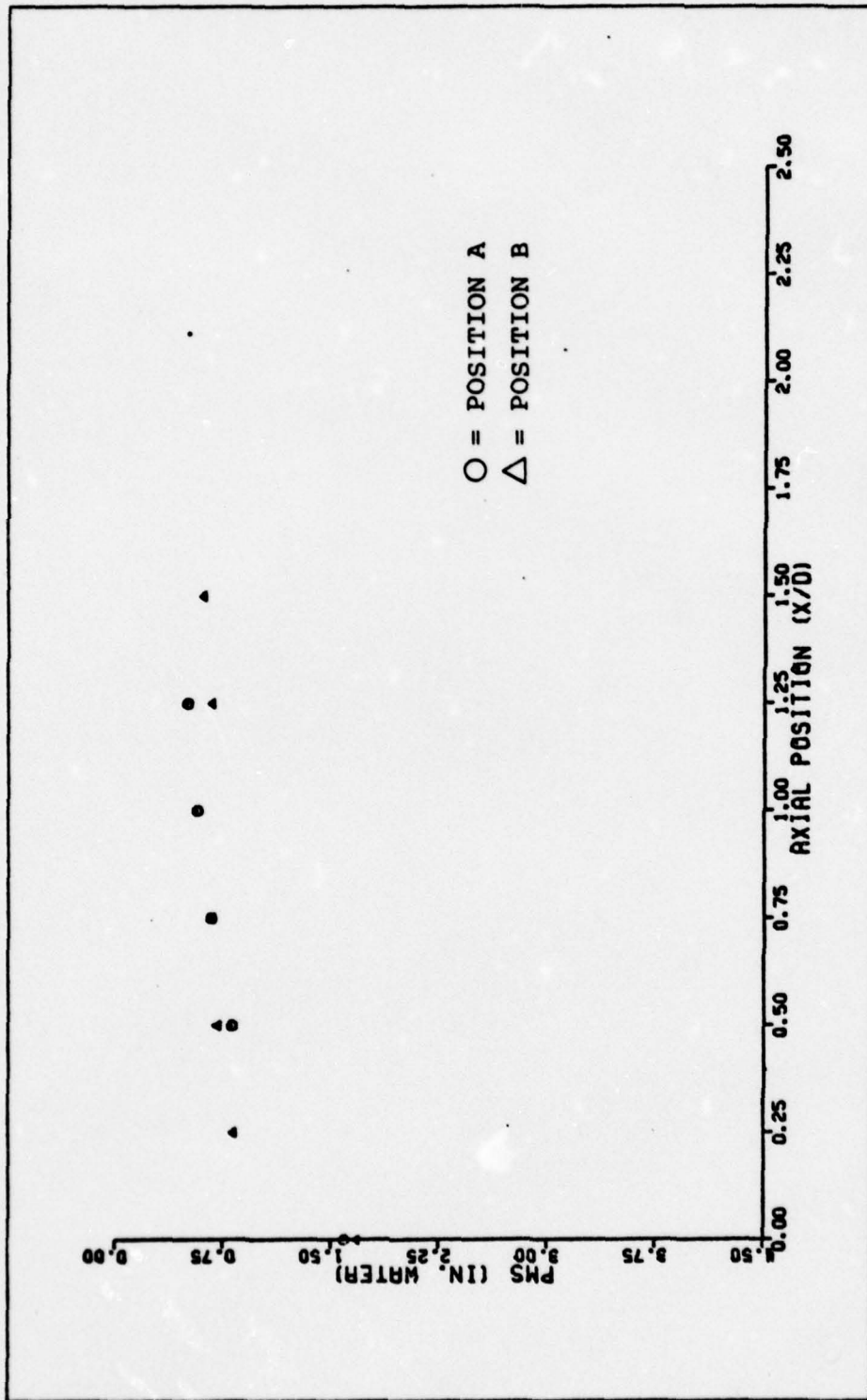

(v) PORTED MIXING STACK WITH TWO RING DIFFUSOR (DATA TAKEN FROM TABLE XC)

FIGURE 41 (CONTINUED)

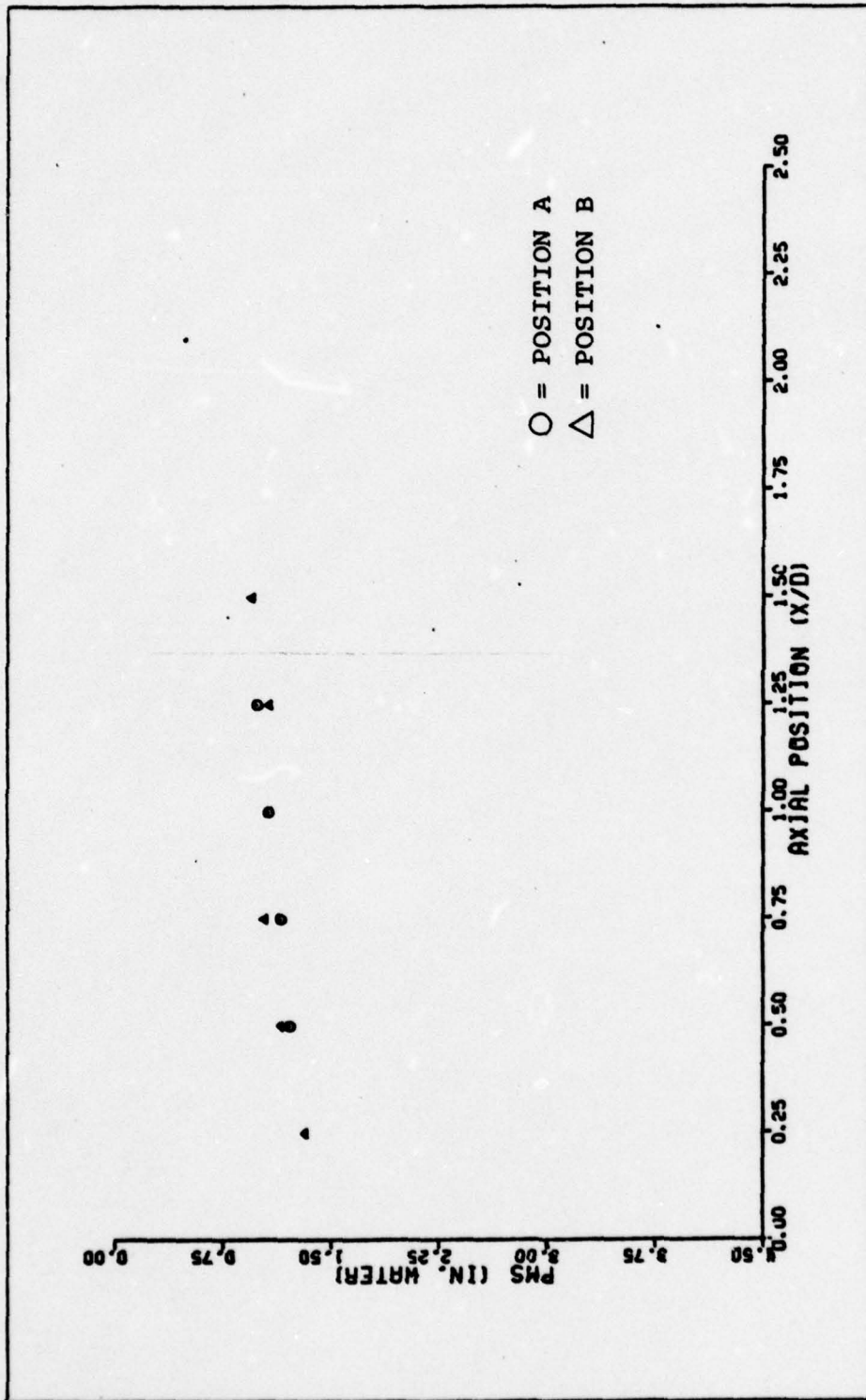

(w) PORTED STACK WITH TWO RING DIFFUSOR AND SHROUD (DATA TAKEN FROM TABLE X1a)

FIGURE 41 (CONTINUED)

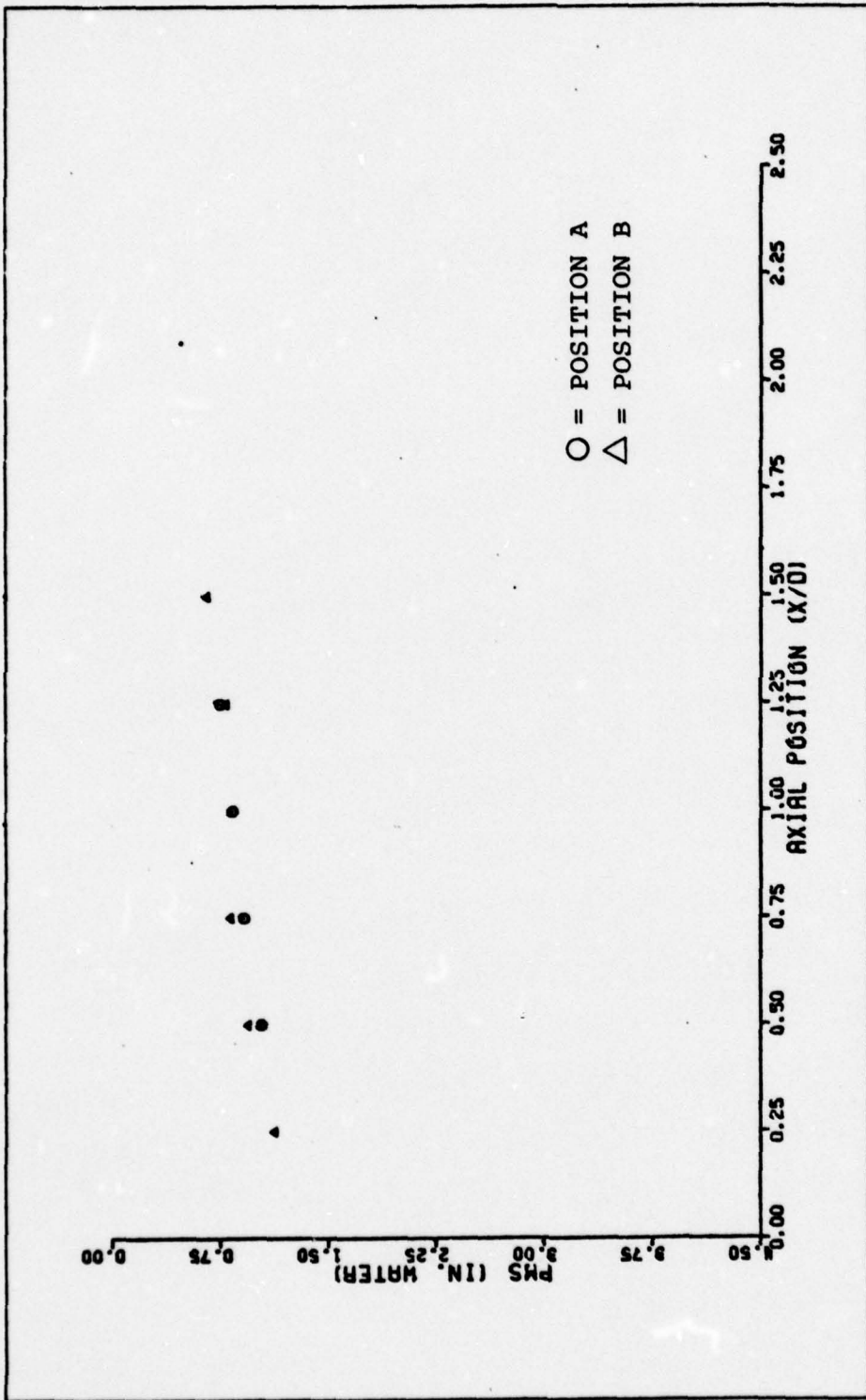

(x) PORTED MIXING STACK WITH TWO RING DIFFUSOR AND SHROUD (DATA TAKEN FROM TABLE XIb)

FIGURE 41 (CONTINUED)

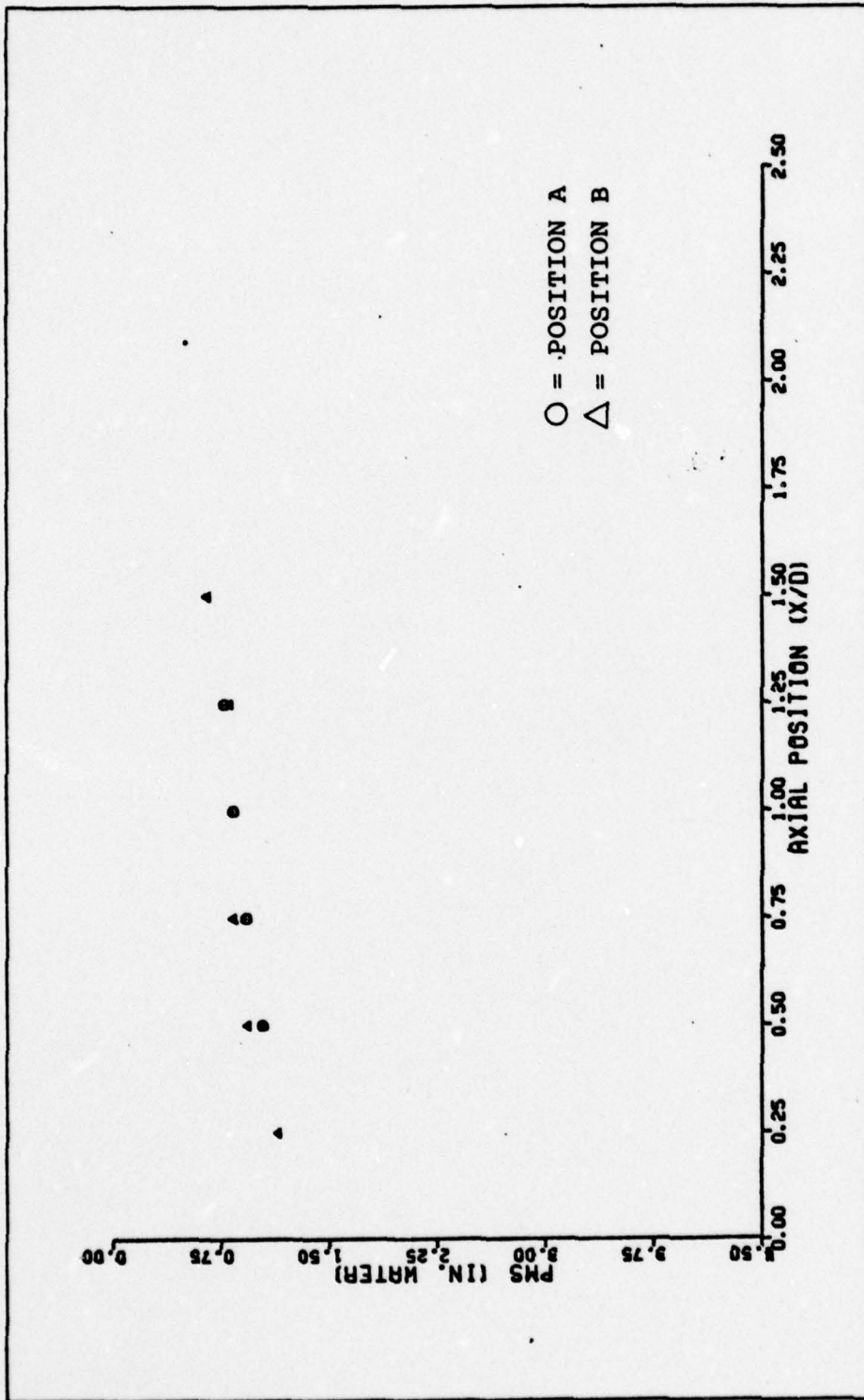

(Y) PORTED MIXING STACK WITH TWO RING DIFFUSOR AND SHROUD (DATA TAKEN FROM TABLE XIC)

FIGURE 41 (CONTINUED)

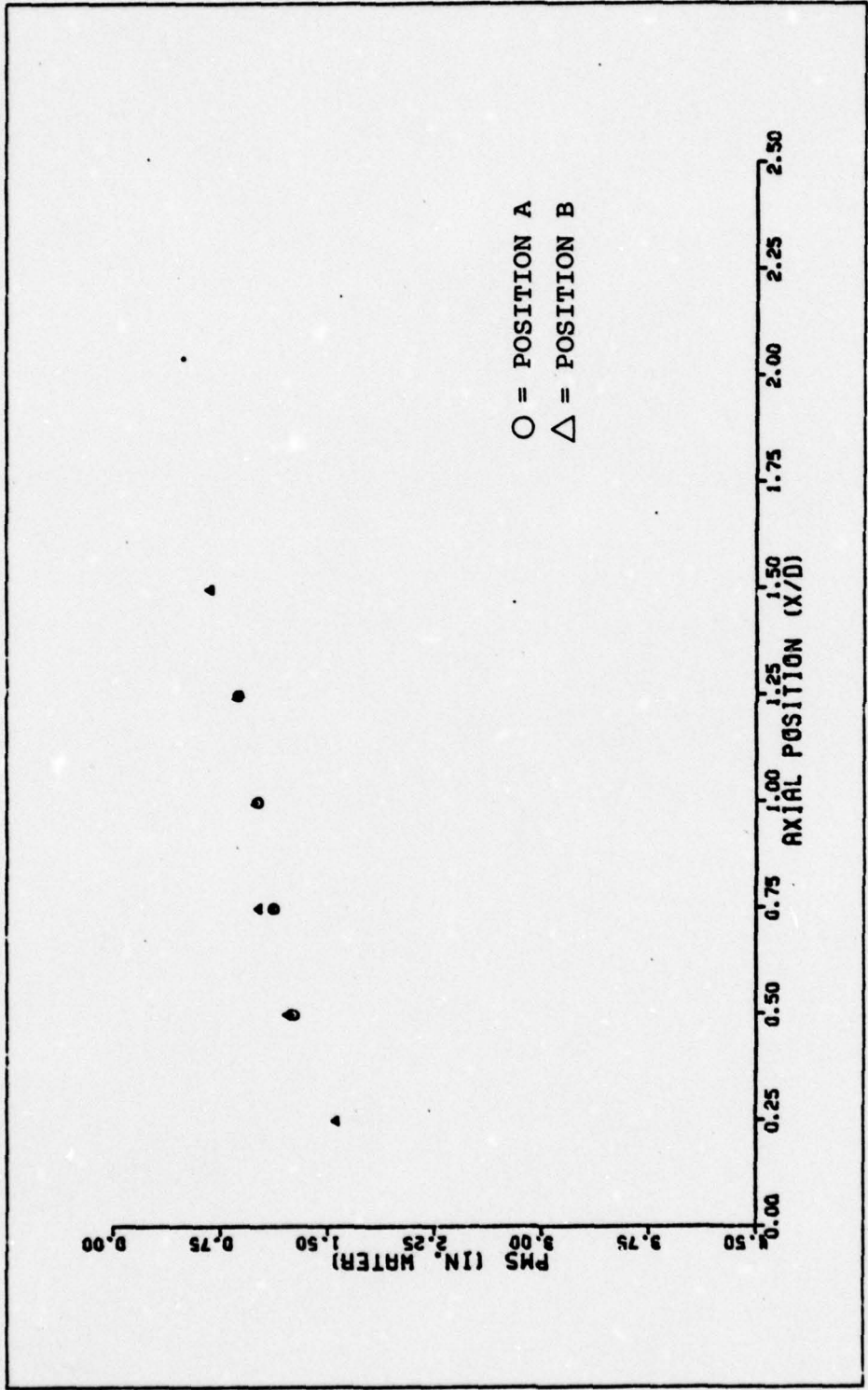

(z) PORTED MIXING STACK WITH TWO RING DIFFUSOR AND SHROUD (DATA TAKEN FROM TABLE XId)

FIGURE 41 (CONTINUED)

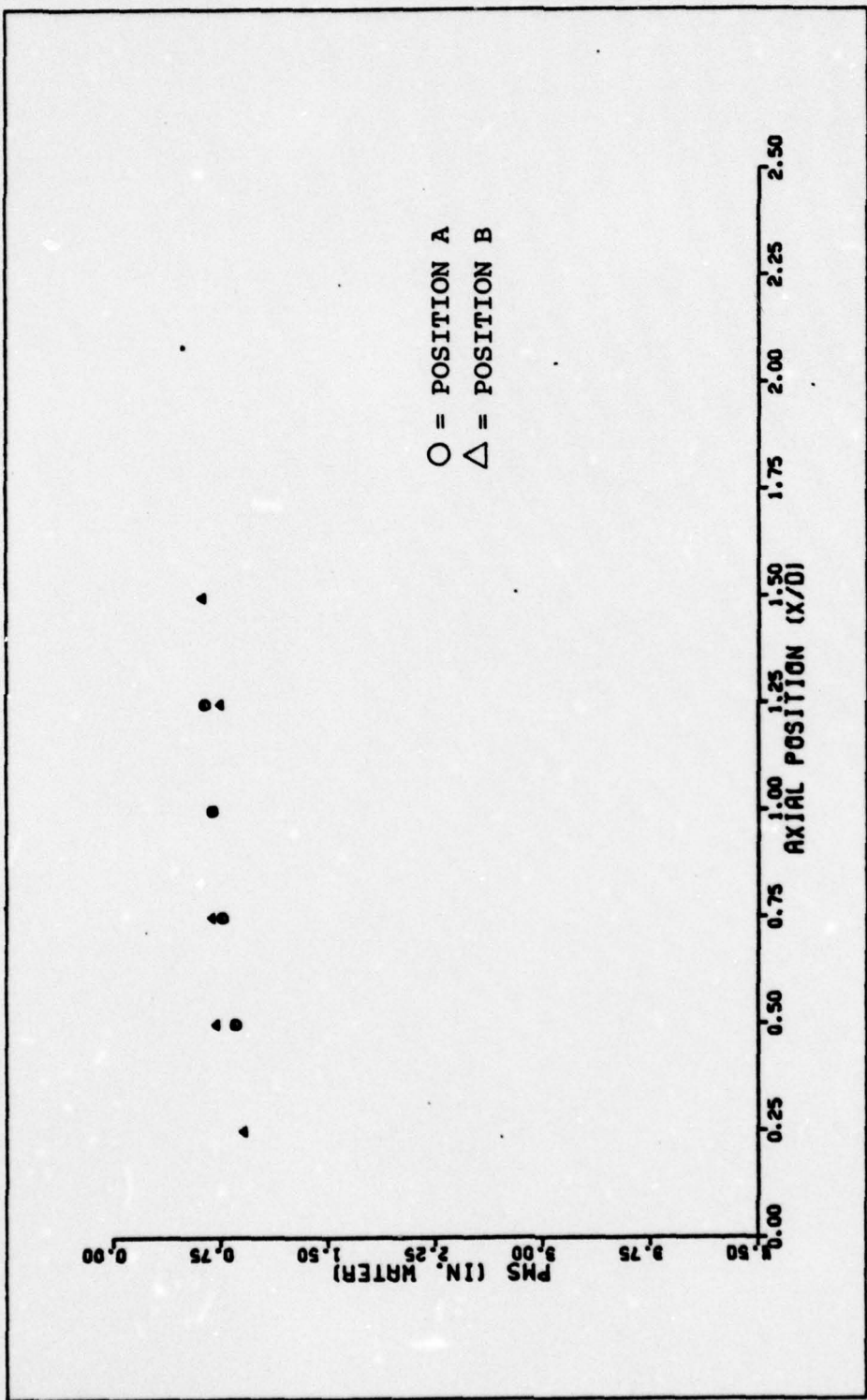

(aa) PORTED MIXING STACK WITH TWO RING DIFFUSOR AND SHROUD (DATA TAKEN FROM TABLE XIIC)

FIGURE 41 (CONTINUED)

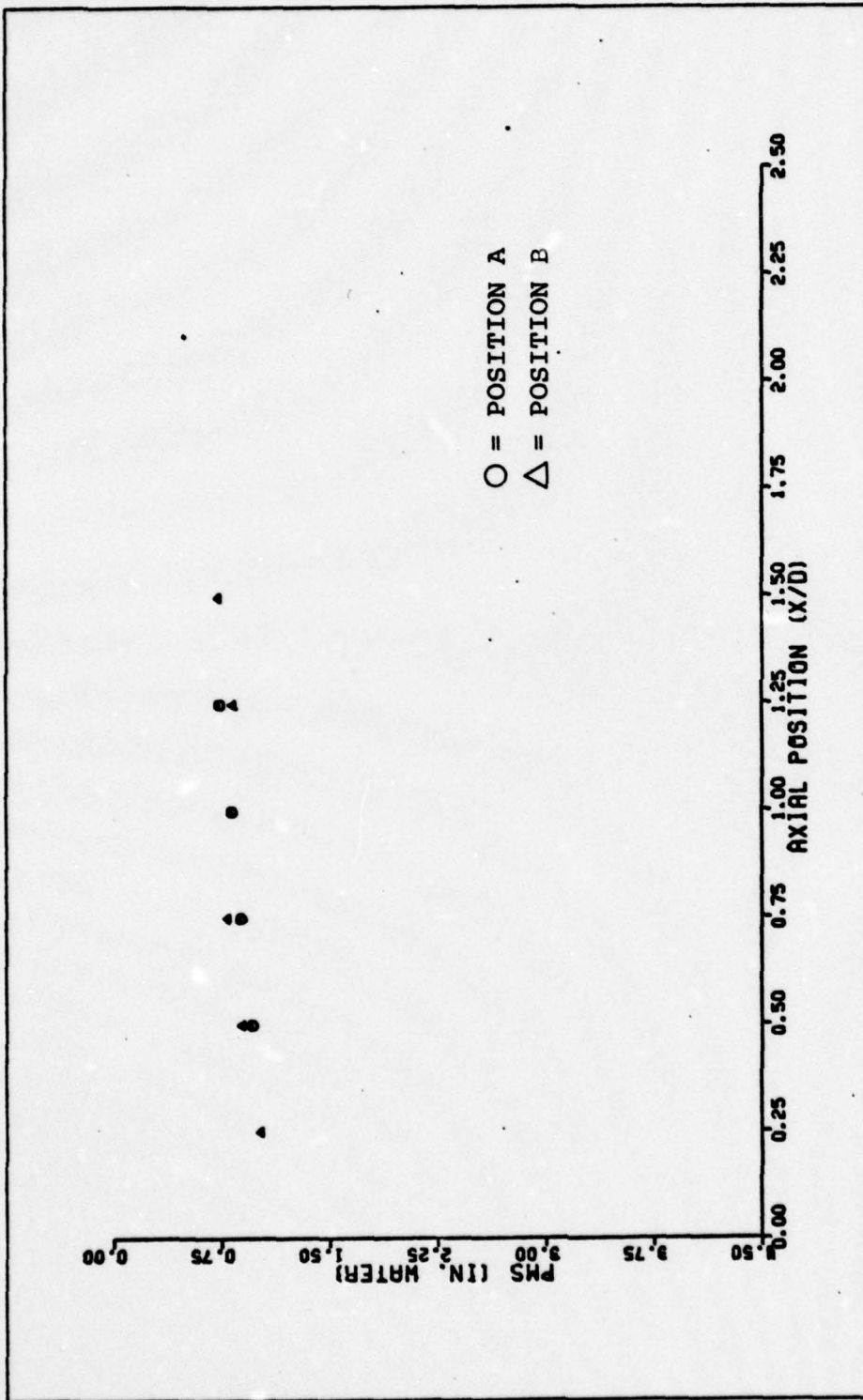

(bb) PORTED MIXING STACK WITH RING DIFFUSOR AND FLOW-THROUGH SHROUD
 (DATA TAKEN FROM TABLE XIIIC)

FIGURE 41 (CONTINUED)

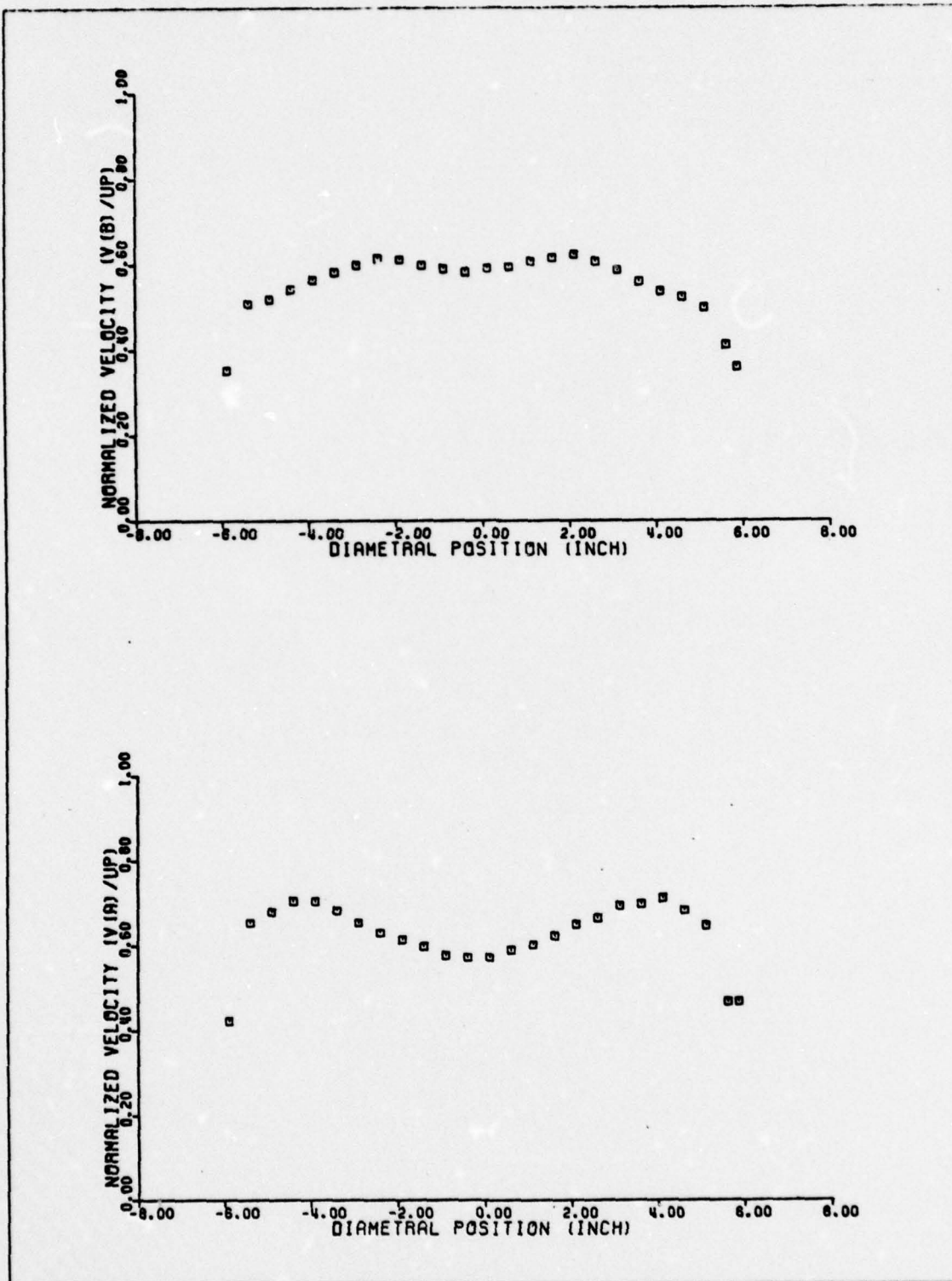

(a) STRAIGHT MIXING STACK, $L/D = 3.0$ (DATA TAKEN FROM TABLE XIVA)

FIGURE 42. EXIT VELOCITY PLOTS, TRAVERSE POSITIONS A AND B

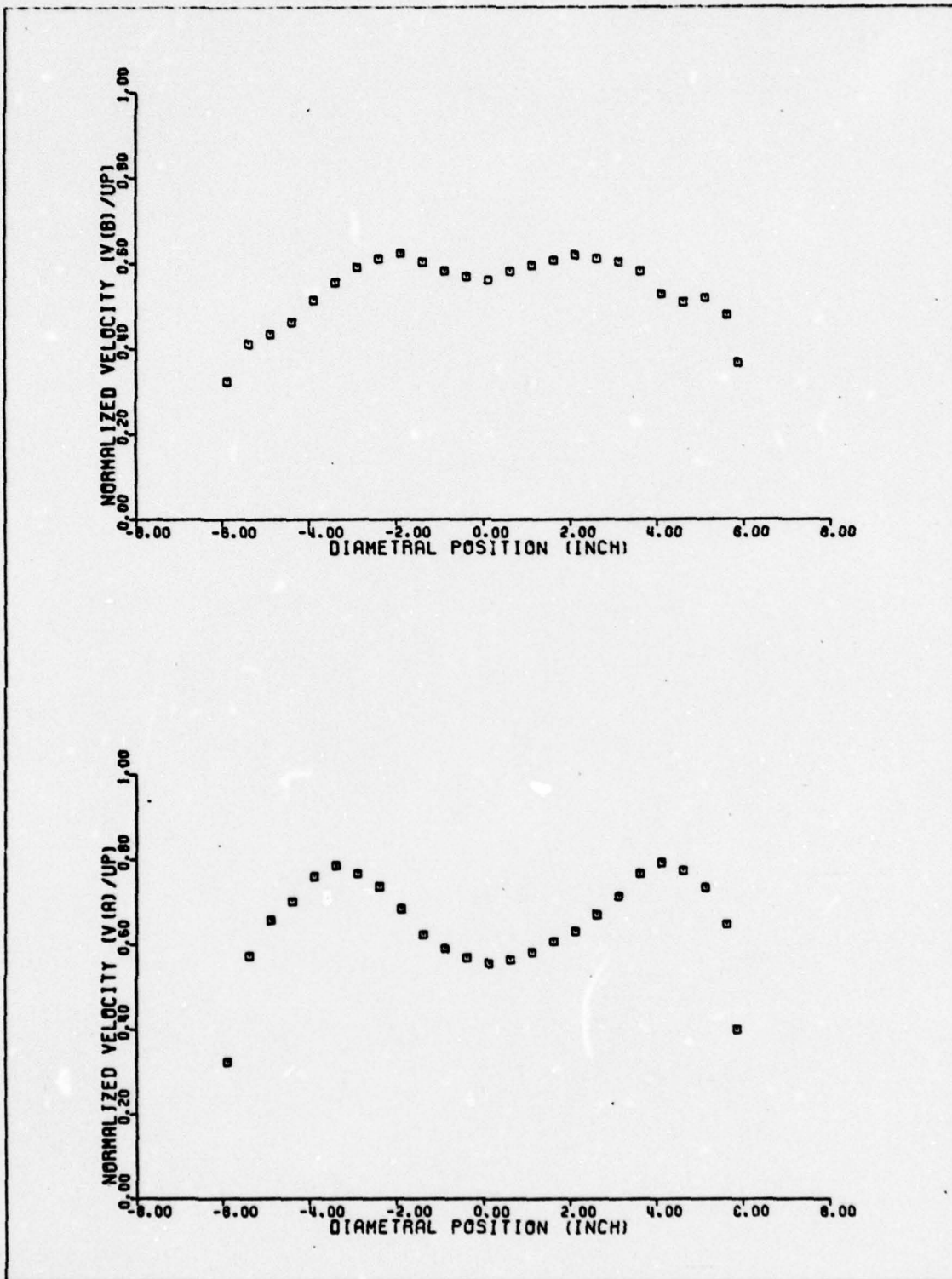

(b) STRAIGHT MIXING STACK, $L/D = 2.5$ (DATA TAKEN FROM TABLE XIVb)

FIGURE 42 (CONTINUED)

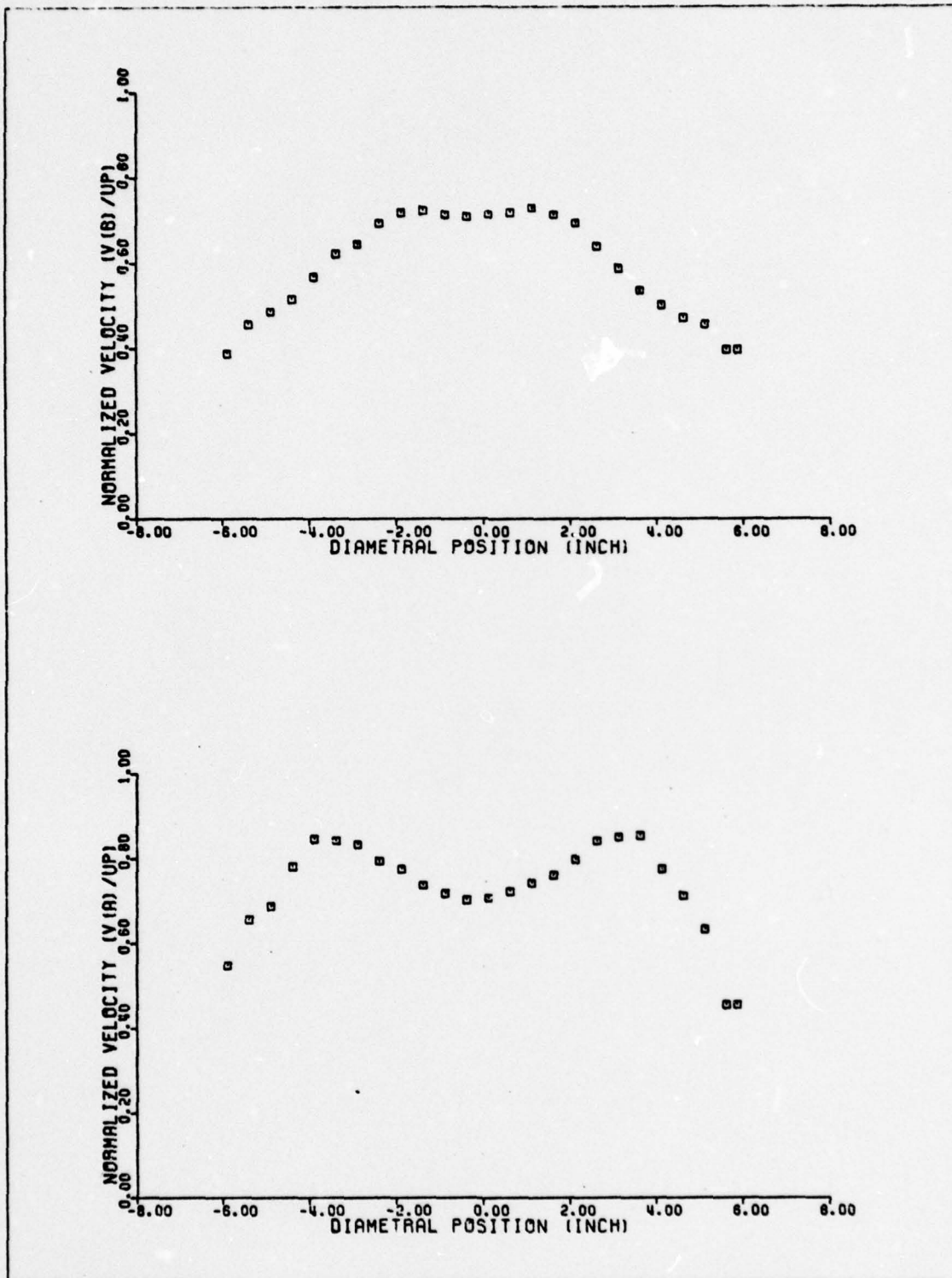

(c) STRAIGHT MIXING STACK, $L/D = 2.5$ (DATA TAKEN FROM TABLE XVa)

FIGURE 42 (CONTINUED)

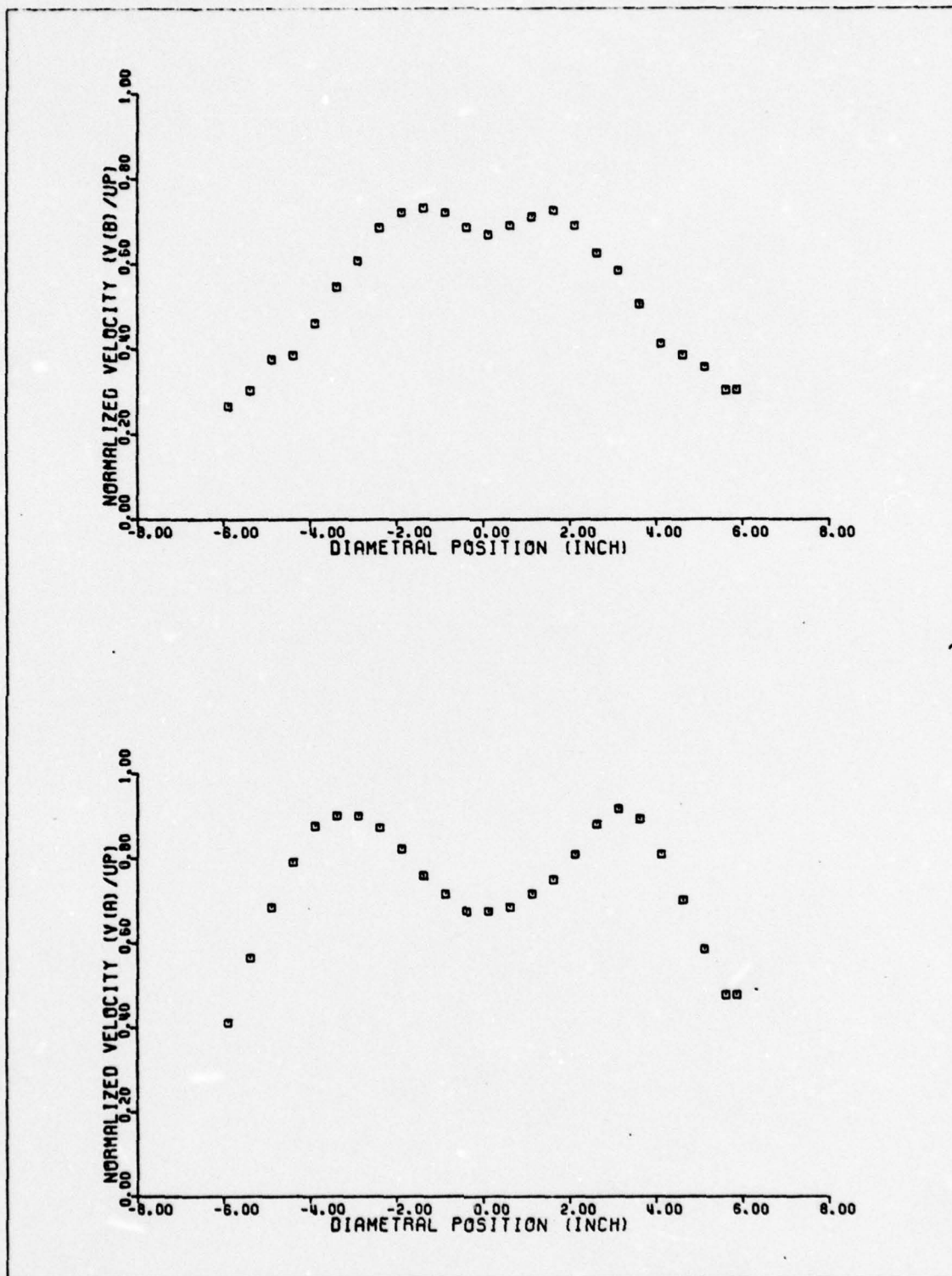

(d) STRAIGHT MIXING STACK, $L/D = 1.75$ (DATA TAKEN FROM TABLE XVb)

FIGURE 42 (CONTINUED)

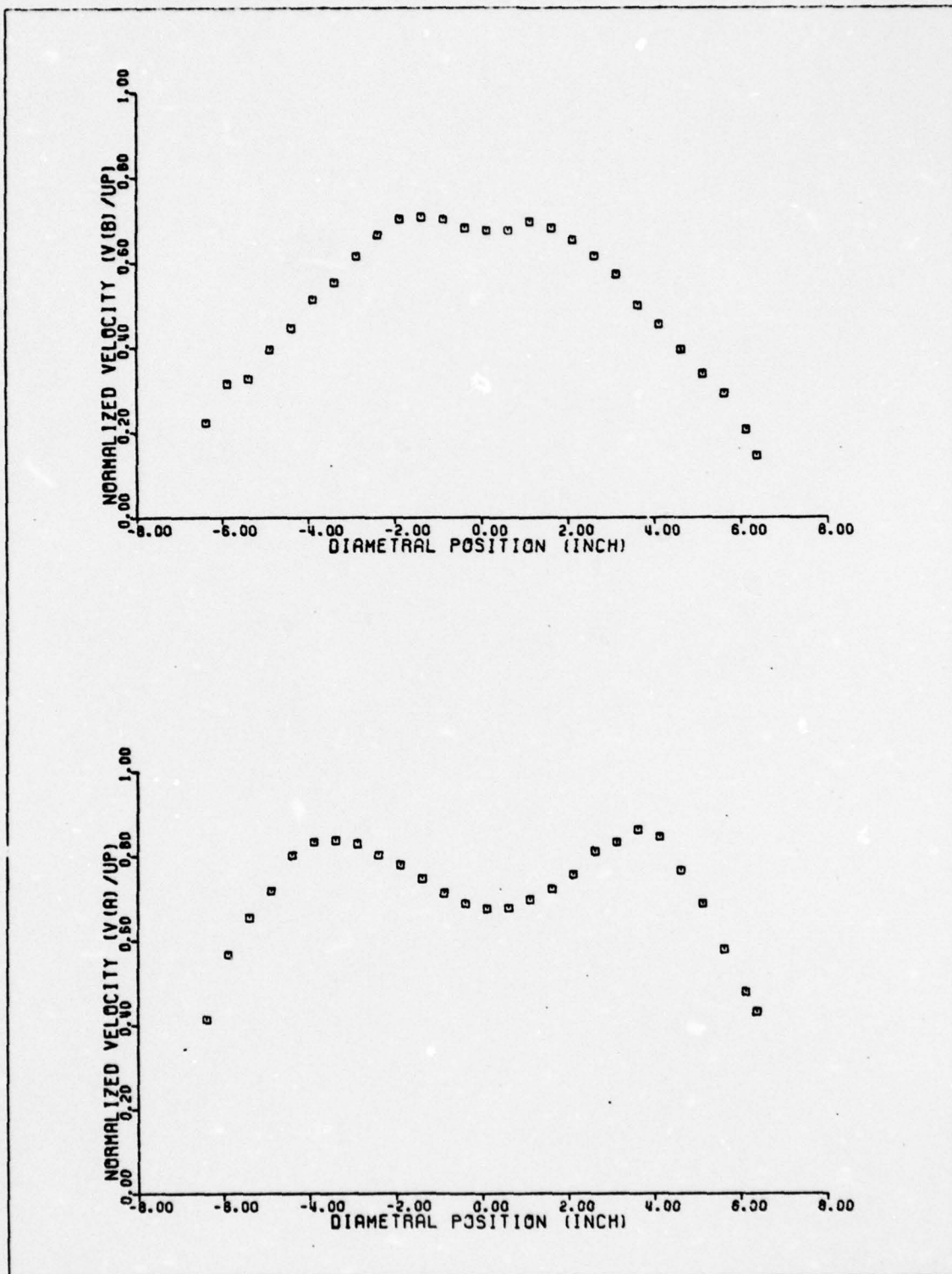

(e) STRAIGHT MIXING STACK WITH 7 DEGREE SOLID DIFFUSOR
 (DATA TAKEN FROM TABLE XV1a)

FIGURE 42 (CONTINUED)

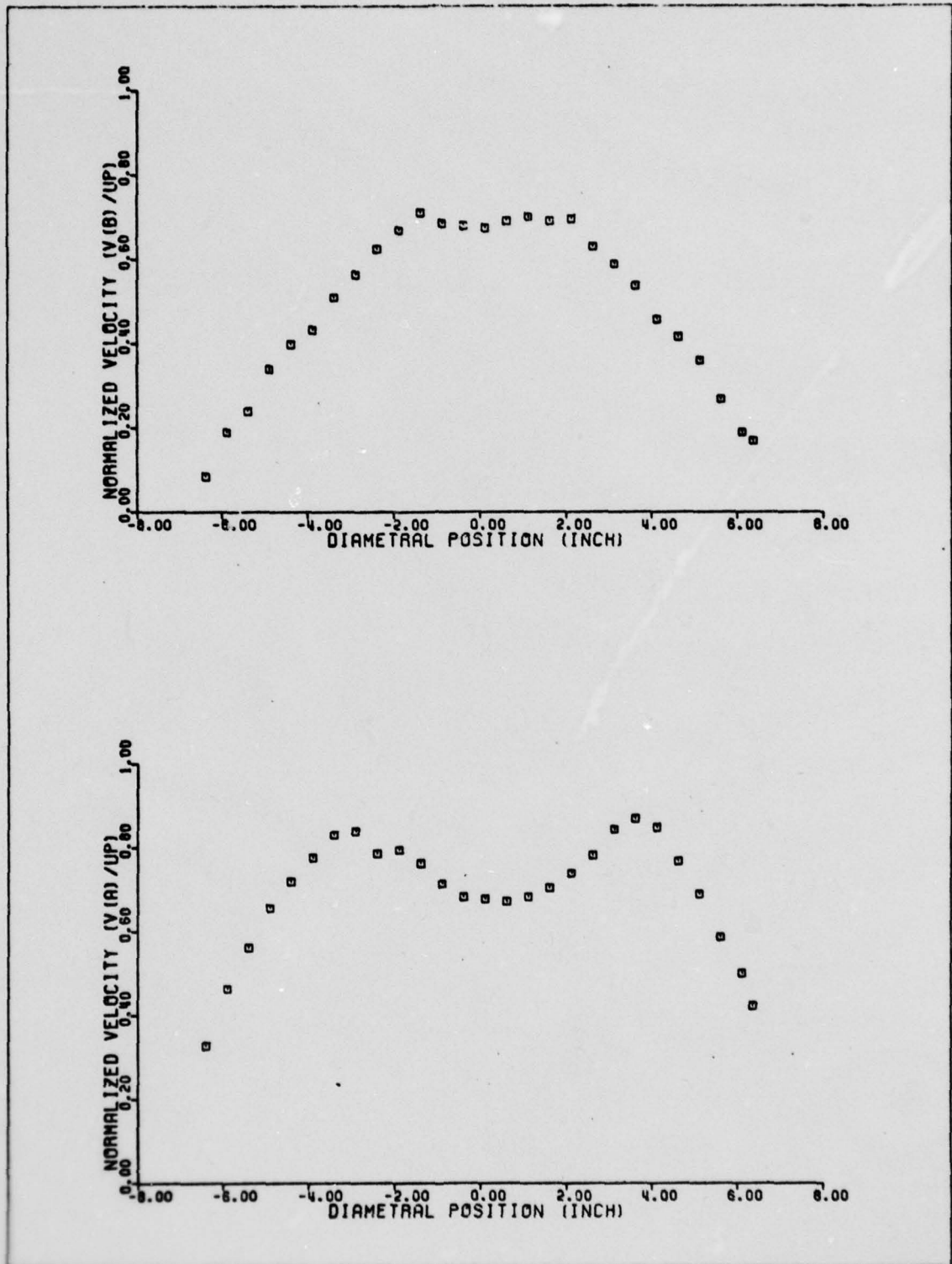

(f) STRAIGHT MIXING STACK WITH 7 DEGREE SOLID DIFFUSOR
(DATA TAKEN FROM TABLE XVIb)

FIGURE 42 (CONTINUED)

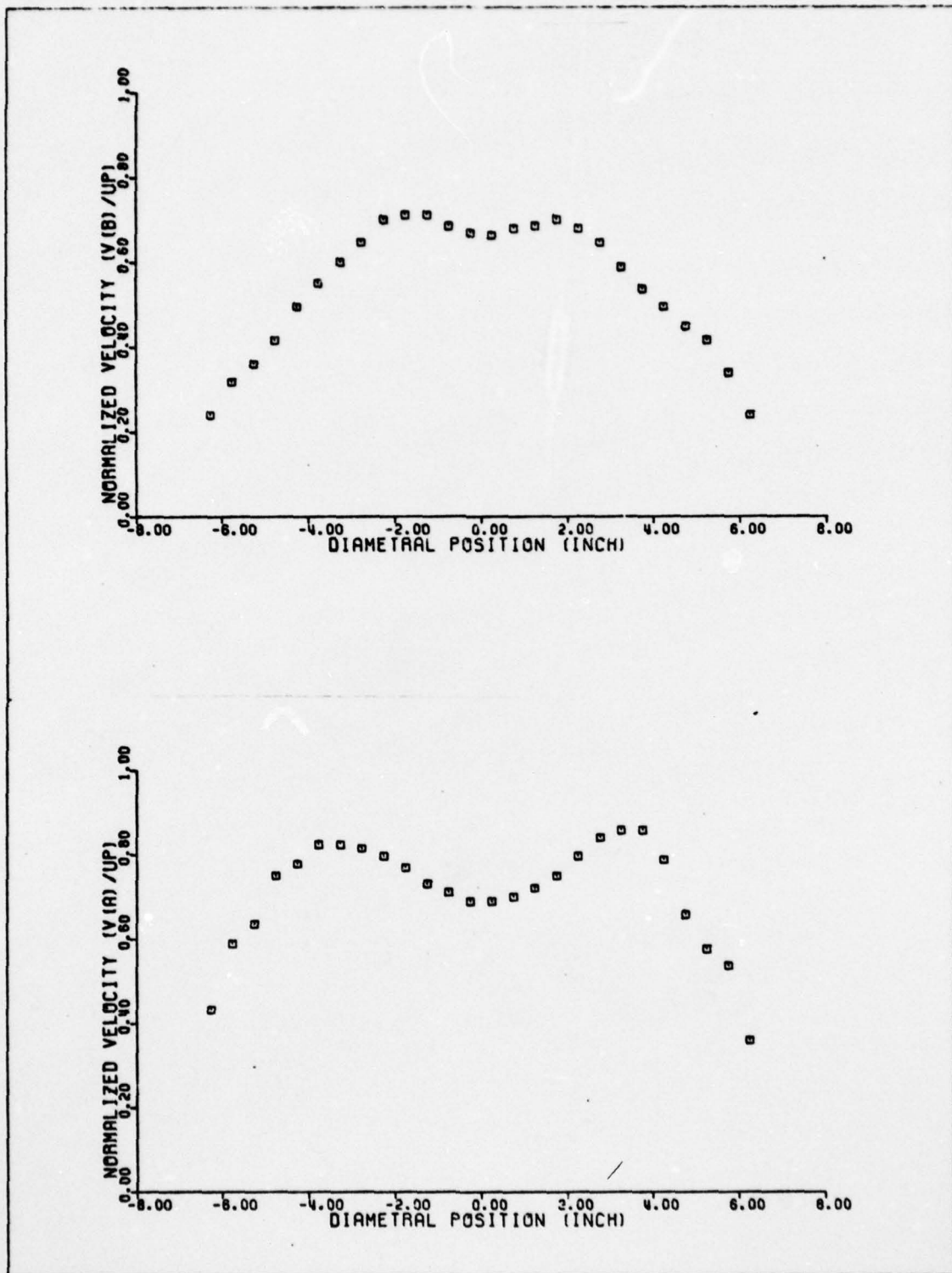

(g) STRAIGHT MIXING STACK WITH 7 DEGREE SOLID DIFFUSOR
(DATA TAKEN FROM TABLE XV1c)

FIGURE 42 (CONTINUED)

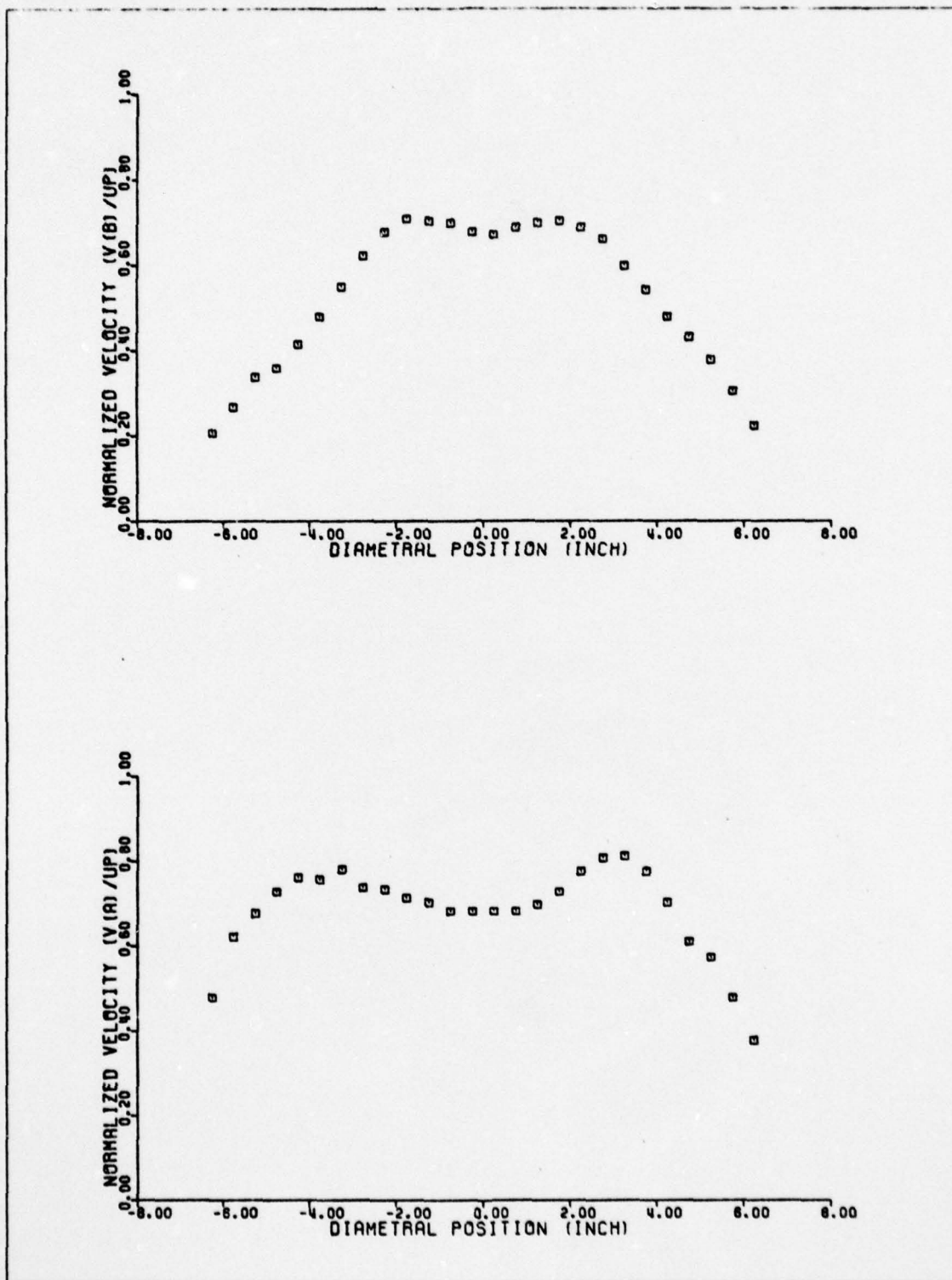

(h) STRAIGHT MIXING STACK WITH 7 DEGREE SOLID DIFFUSOR
 (DATA TAKEN FROM TABLE XVID)

FIGURE 42 (CONTINUED)

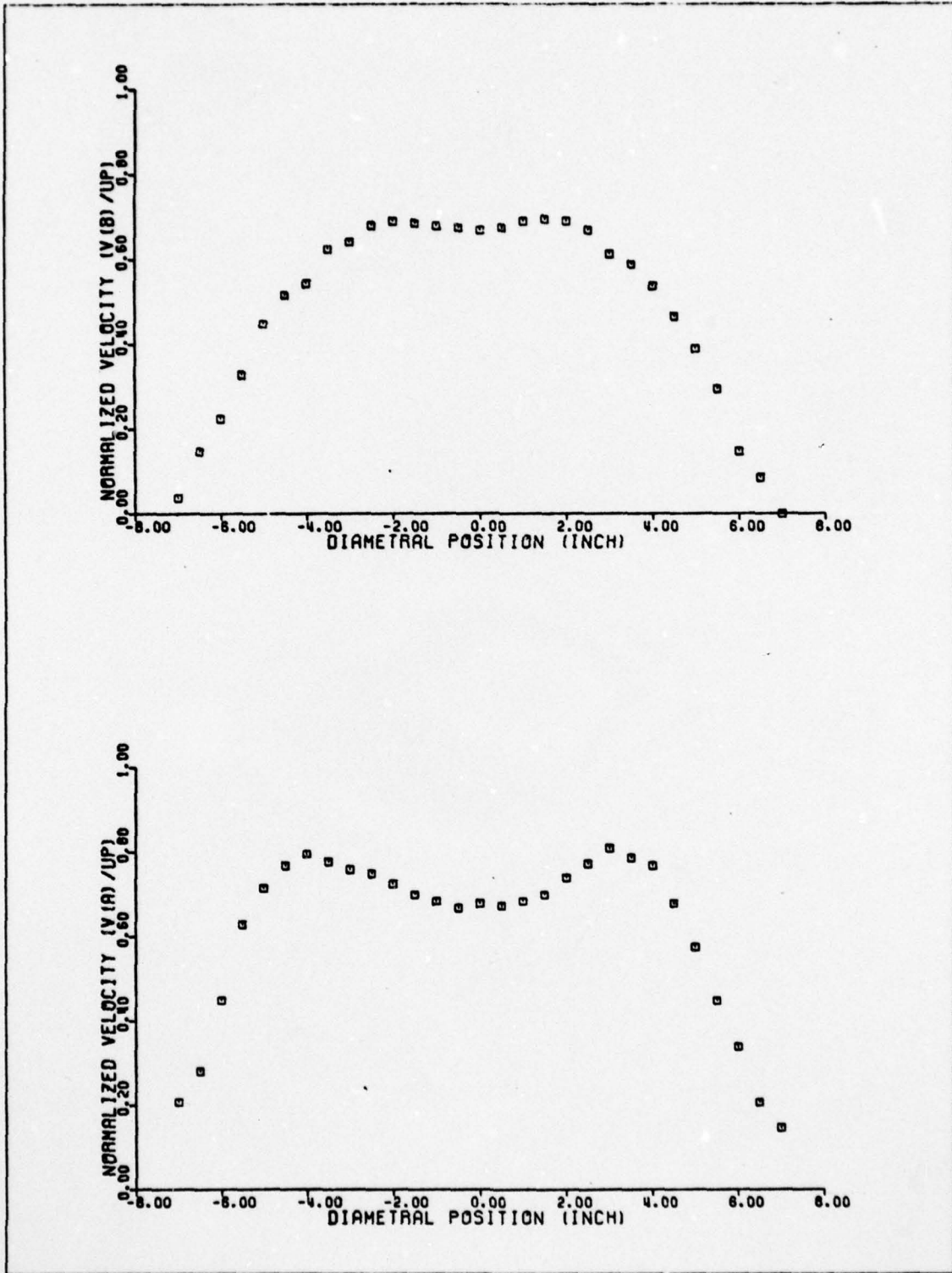

(i) MIXING STACK WITH TWO RING DIFFUSOR (DATA TAKEN FROM TABLE XVIE)

FIGURE 42 (CONTINUED)

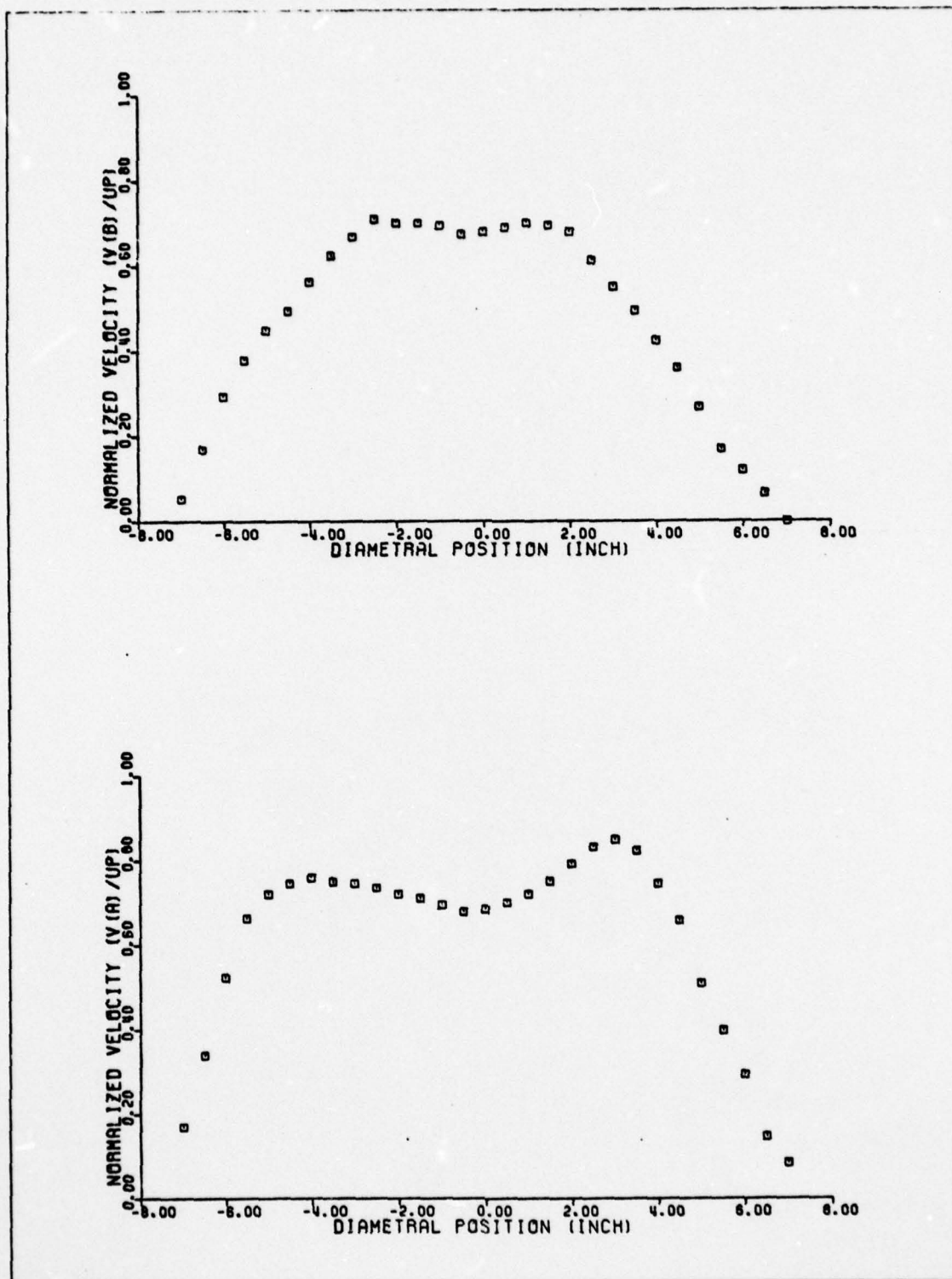

(j) MIXING STACK WITH THREE RING DIFFUSOR (DATA TAKEN FROM TABLE XVIf)

FIGURE 42 (CONTINUED)

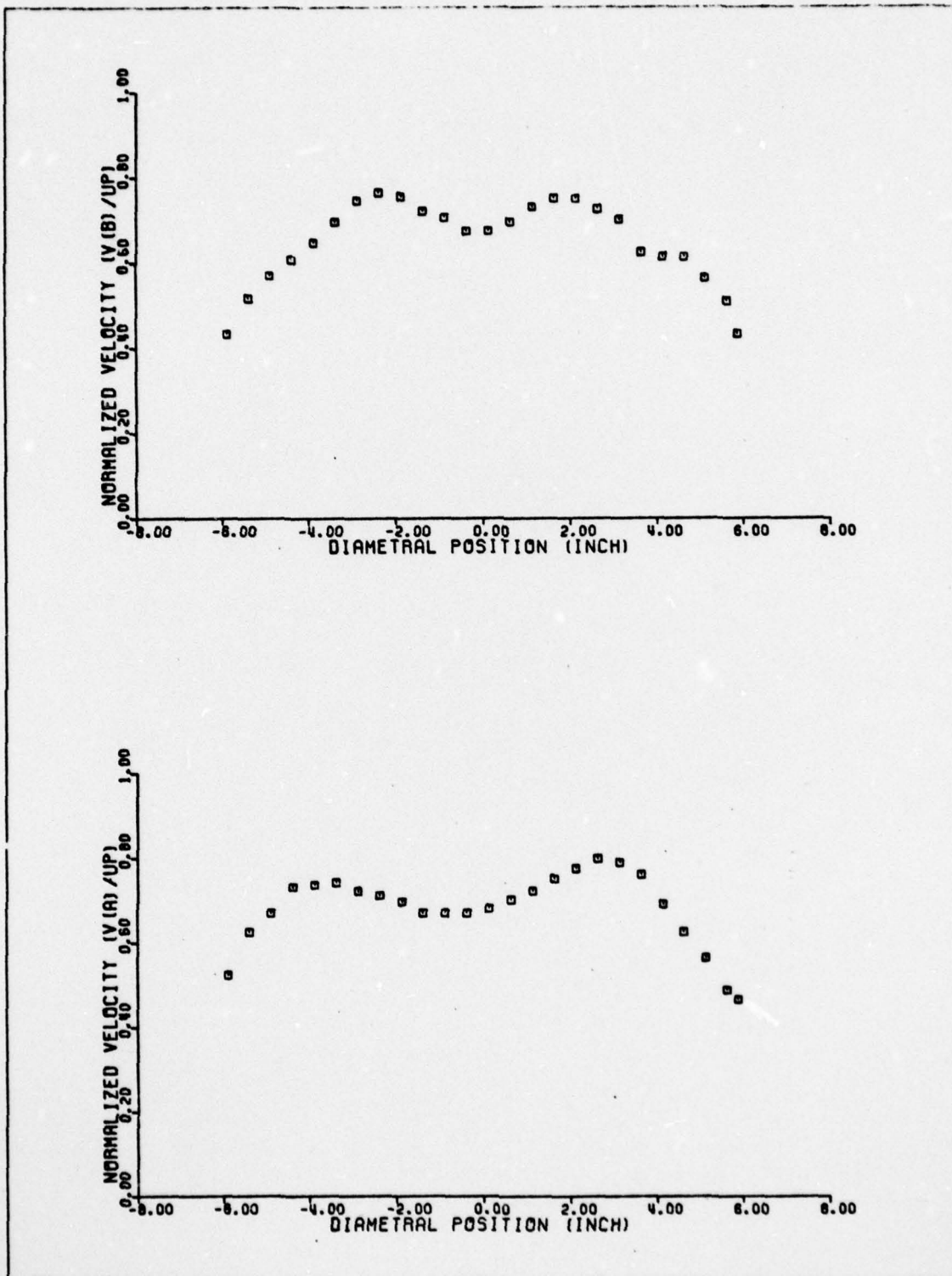

(k) PORTED MIXING STACK (DATA TAKEN FROM TABLE XVII)

FIGURE 42 (CONTINUED)

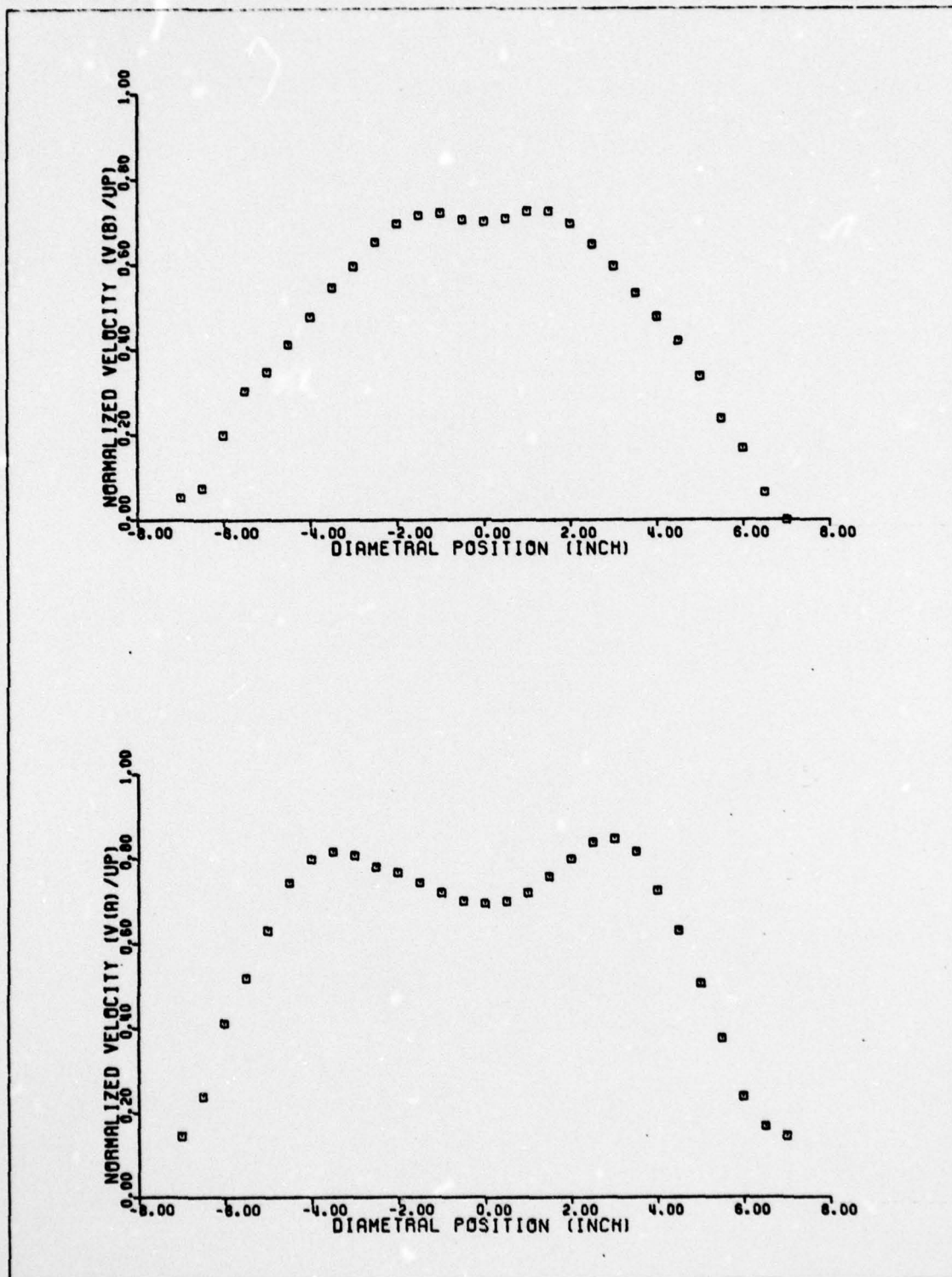

(2) PORTED MIXING STACK WITH TWO SOLID DIFFUSOR RINGS
(DATA TAKEN FROM TABLE XVIII)

FIGURE 42 (CONTINUED)

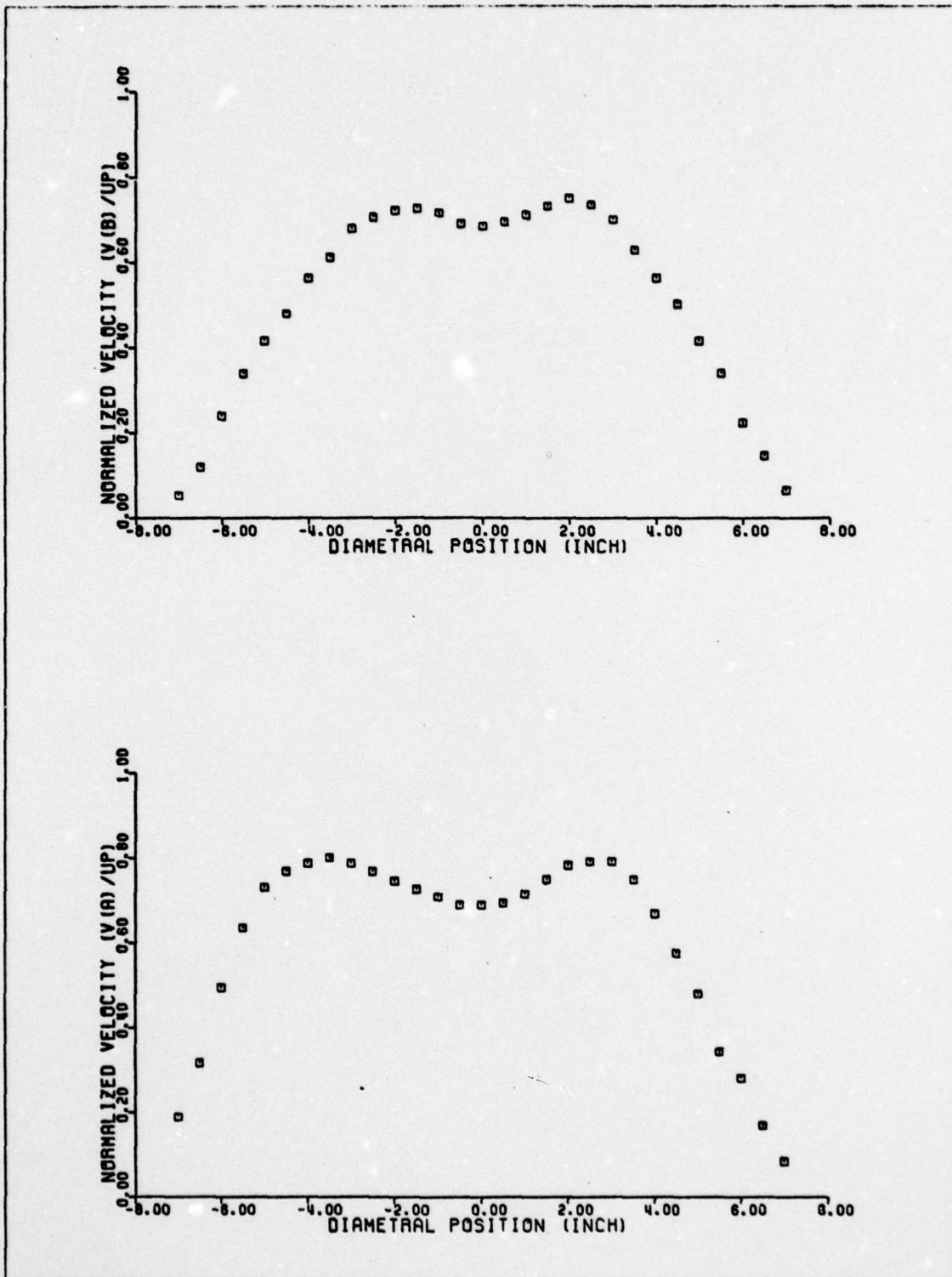

(m) PORTED MIXING STACK WITH TWO RING DIFFUSOR AND SHROUD
(DATA TAKEN FROM TABLE XIXa)

FIGURE 42 (CONTINUED)

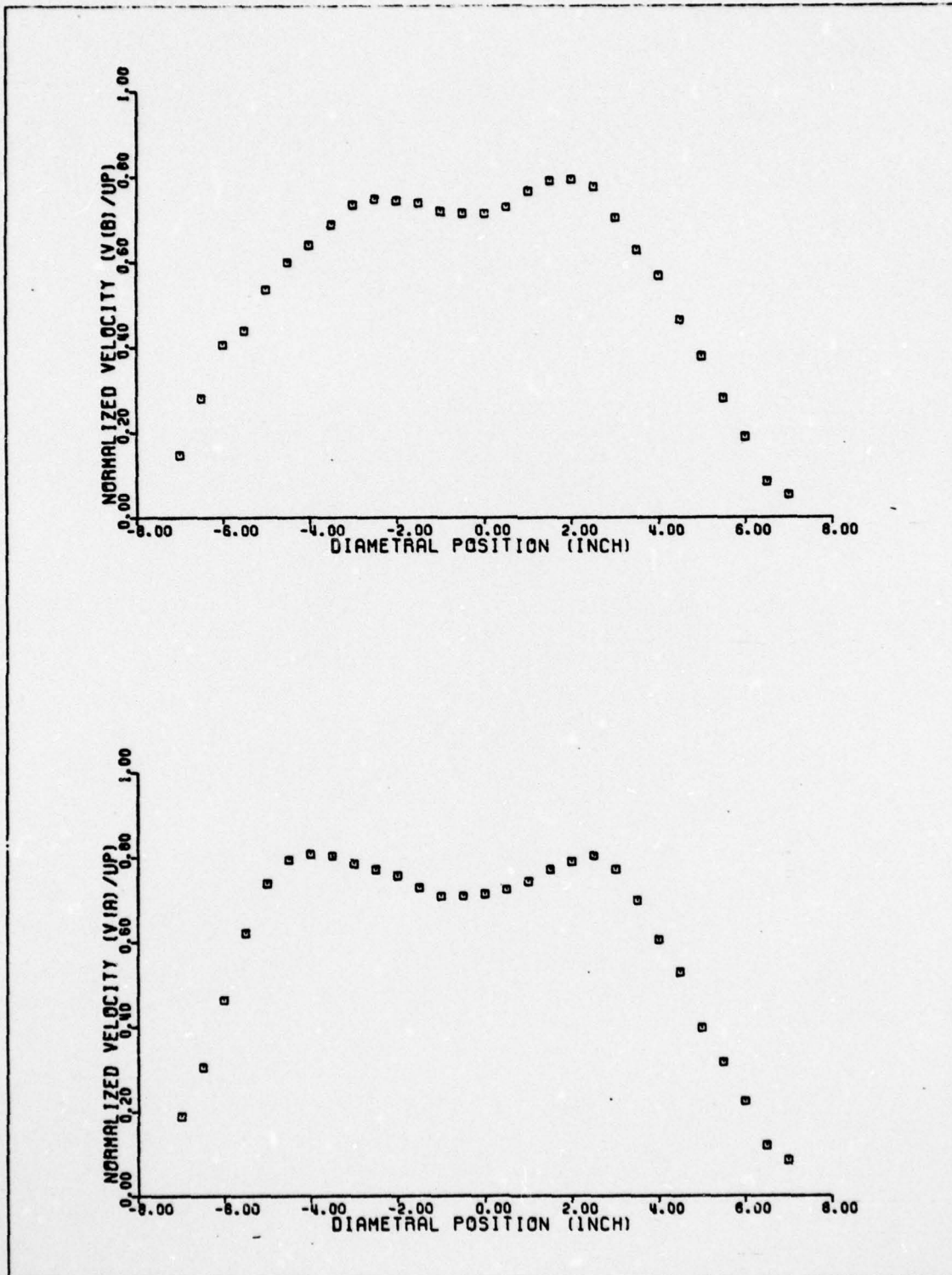

(n) PORTED MIXING STACK WITH TWO RING DIFFUSOR AND SHROUD
 (DATA TAKEN FROM TABLE XIXb)

FIGURE 42 (CONTINUED)

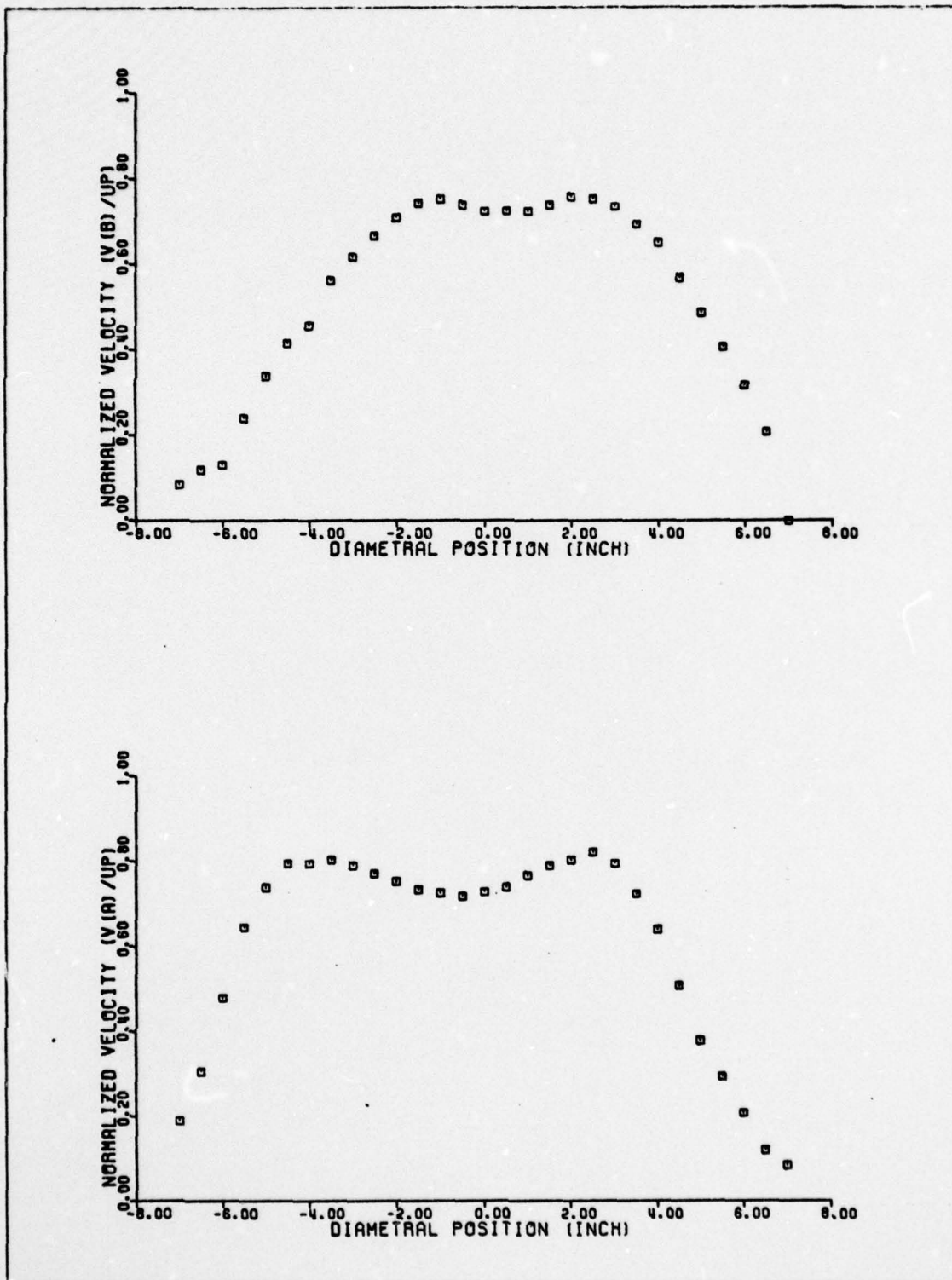

(o) PORTED MIXING STACK WITH RING DIFFUSOR AND FLOW-THROUGH SHROUD (DATA TAKEN FROM TABLE XIXc)

FIGURE 42 (CONTINUED)

SYSTEM MODIFICATION	PUMPING	MIXING	FILM COOLING	UPTAKE BACK PRESSURE
Area Ratio (A_m/A_p) Decrease (Increase in Primary Flow Nozzle Diameter)	Decreases with a decrease in area ratio	Slight decrease with decrease in area ratio	Not applicable	Significant decrease with decrease in area ratio
Changing Mixing Stack Length (L/D)	Improved with L/D increase from 1.75 to 3.0	Improved with L/D increase from 1.75 to 3.0	Not applicable	No effect
Solid Diffusor	Improved performance with respect to a straight stack of equal L/D	Slight decrease with respect to a straight stack of equal L/D	Not applicable	Slight decrease with respect to a straight stack of equal L/D
Split Ring Diffusor	Improved with respect to a straight stack of equal L/D	No significant change from solid diffusor	Not applicable	Slight increase with respect to solid diffusor and straight stack of equal L/D
Film Cooling Ports	Similar to straight stack with equal L/D	Similar to straight stack with equal L/D	Film cooling introduced	Slight increase with respect to solid diffusor and straight stack of equal L/D
Shrouded Mixing Stack with Split Ring Diffusor	Similar to straight stack with equal L/D	Similar to split ring diffusor	Similar to ported stack without diffusor	Similar to ported stack
Flow-Through Shroud and Single-Ring Diffusor	Similar to shrouded stack with reduced tertiary pumping	Improved with respect to split ring diffusor	Significantly increased	Similar to ported stack

TABLE I. SUMMARY OF EFFECTS OF PARAMETERS

EDUCTOR SYSTEMS		SYSTEM IDENTIFICATION	PUMPING $W^*T^*0.44$	MIXING V_A/U_p	FILM COOLING $WF^*T^*0.44$	UPTAKE BACK PRESSURE
SYSTEM MODIFICATION	K_m					
Change in Area Ratio (λ_m/λ_p)	Small Nozzles L/D = 3.0	0.80	0.17	0.61	8.7	
	L/D = 2.5	0.78	0.79	0.62	8.7	
	Large Nozzles L/D = 2.5	0.58	0.85	0.72	5.8	
Straight Mixing Stack Configurations with L/D Ratio Changes	Straight Stack					
	L/D = 1.75 L/D = 2.5	0.54 0.58	0.91 0.85	0.73 0.72	5.8 5.8	
Mixing Stack Exit Modifications	7° Solid Diffusor	0.70	0.86	0.71	5.7	
	Two-Ring Diffusor	0.62	0.80	0.69	6.0	
	Three-Ring Diffusor	0.62	0.84	0.71	6.0	
Addition of Film Cooling	Ported Stack (A-1, B-1, C-2, D-2 configuration)	0.58	0.79	0.76	6.0	
Two-Ring Diffusor Added to Ported Stack	Ported Stack with Two-Ring Diffusor	0.57	0.84	0.72	6.0	
Shrouded System with Shroud Length Modifications	Shrouded, Ported Stack with Two-Ring Diffusor	0.58	0.80	0.75	6.0	
	Shrouded, Ported Stack with Two-Ring Diffusor (Short Shroud)	0.59	0.82	0.75	6.0	
Flow-Through Shroud System	Ported Stack with Flow- Through Shroud and Diffusor Ring	0.58	0.80	0.79	6.0	

TABLE II. SUMMARY OF EDUCTOR SYSTEM PERFORMANCE CRITERIA FOR EDUCTOR SYSTEMS TESTED

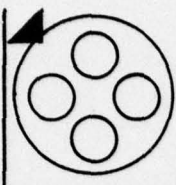
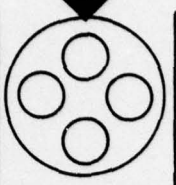
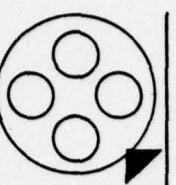
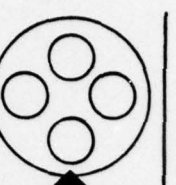
Radial Position					
L/D					
0.500	a	1.15	1.18	1.20	1.20
	b	1.18	1.21	1.19	1.20
	c	1.28	1.29	1.23	1.21
0.625	a	1.10	1.15	-	-
	b	1.13	1.18	-	-
	c	1.26	1.23	-	-
0.750	a	1.06	1.06	1.03	1.06
	b	1.08	1.09	0.99	1.08
	c	1.15	1.18	1.03	1.09
0.875	a	1.00	0.99	-	-
	b	0.99	1.01	-	-
	c	1.10	1.12	-	-
1.00	a	0.93	0.89	0.92	0.88
	b	0.93	0.94	0.89	0.86
	c	1.01	1.01	0.94	0.91

Run a: data taken with mixing stack in true alignment.

Run b: data taken with mixing stack 0.97 degrees out of alignment.

Run c: data taken with mixing stack 3.42 degrees out of alignment.

All data recorded in H₂O.

TABLE III. MIXING STACK PRESSURE READINGS AS EFFECTED BY ALIGNMENT

DATA TAKEN ON 23 JANUARY 1976 BY LENKE AND STAEHLI
S/E = .5; (FRCCF RLN)

NUMBER OF PRIMARY NOZZLES: 4
PRIMARY NOZZLE DIAMETER: 3.38 INCHES
PIPING STACK LENGTH: 35.10 INCHES
PIPING STACK DIAMETER: 11.70 INCHES
PIPING STACK L/D: 3.00

LPTAKE DIAMETER: 11.50 INCHES
AREA RATIO, AM/AP: 3.00
CRIFICE DIAMETER: 4.502 INCHES
CRIFICE BETA: 0.497
AMBIENT PRESSURE: 30.12 INCHES HG

RUN	A	H*	F*	T*	P*/T*	W*	TMP	TAPE	PU-FA	PA-PS	PA-PNZ	SECONDARY AREA
							DEGREES FAHRENHEIT	INCHES OF WATER	INCHES OF WATER	INCHES OF WATER	PA-PNZ	SQUARE INCHES
1	0.7	21.3	56.0	112.0	66.0	4.60	4.50	4.51	0.0			
2	0.7	21.3	55.0	112.0	66.0	5.50	3.25	3.24	12.566			
3	0.7	21.1	60.0	112.0	66.0	6.25	2.34	2.33	25.133			
4	0.7	20.9	59.0	112.0	66.0	7.00	1.35	1.34	50.265			
5	0.7	20.8	55.0	113.0	66.0	7.70	0.56	0.56	100.531			
6	0.7	20.6	59.0	112.0	66.0	7.95	0.25	0.25	150.796			
7	0.7	20.5	61.0	114.0	66.0	8.00	0.15	0.16	201.062			
8	0.7	20.8	60.0	114.0	66.0	8.10	0.13	0.13	248.186			
9	0.7	20.7	60.0	114.0	66.0	8.15	0.00	0.00	*****			
LF	UP	UU	FT/SEC	FT/SEC	FT/SEC	FT/SEC	FT/SEC	FT/SEC	FT/SEC	FT/SEC	FT/SEC	FT/SEC
0.00	71.62	14.12	0.00	214.53	71.62	14.12	0.00	214.53	71.62	14.12	0.00	0.00
0.00	85.01	73.83	0.00	212.66	85.01	73.83	0.00	212.66	85.01	73.83	0.00	0.00
0.00	93.97	75.25	0.00	211.96	93.97	75.25	0.00	211.96	93.97	75.25	0.00	0.00
0.00	105.65	72.52	0.00	211.03	105.65	72.52	0.00	211.03	105.65	72.52	0.00	0.00
0.00	115.58	72.60	0.00	210.12	115.58	72.60	0.00	210.12	115.58	72.60	0.00	0.00
0.00	118.47	72.21	0.00	208.57	118.47	72.21	0.00	208.57	118.47	72.21	0.00	0.00
0.00	121.17	72.00	0.00	208.38	121.17	72.00	0.00	208.38	121.17	72.00	0.00	0.00
0.00	123.21	72.55	0.00	210.06	123.21	72.55	0.00	210.06	123.21	72.55	0.00	0.00
0.00	205.50	72.35	0.00	205.50	205.50	72.35	0.00	205.50	205.50	72.35	0.00	0.00

MIXING STACK PRESSURE DISTRIBUTION FOR RUN: 9 POSITION A
P/E: 0.0 0.50 1.00 1.50 2.00 2.50
P/50: 3.500 1.420 0.820 0.365 0.200 0.050
P/50: 0.251 0.143 0.082 0.037 0.020 0.005

MIXING STACK PRESSURE DISTRIBUTION FOR RUN: 9 POSITION B
P/E: 0.0 0.50 1.00 1.50 2.00 2.50
P/50: 2.600 1.320 0.890 0.445 0.222 0.060
P/50: 0.261 0.132 0.089 0.045 0.022 0.006

TABLE IV. PERFORMANCE DATA FOR STRAIGHT MIXING STACKS WITH PRIMARY NOZZLE DIAMETER OF 3.38 IN.

AD-A061 278

NAVAL POSTGRADUATE SCHOOL MONTEREY CALIF
PERFORMANCE OF MULTIPLE NOZZLE EDUCTOR SYSTEMS WITH SEVERAL GEO--ETC(U)
SEP 78 R J LEMKE, C P STAEHLI

F/G 20/4

UNCLASSIFIED

NPS69-78-016

NL

3 of 3
AD
A061 278

END
DATE
FILMED
1-79
DDC

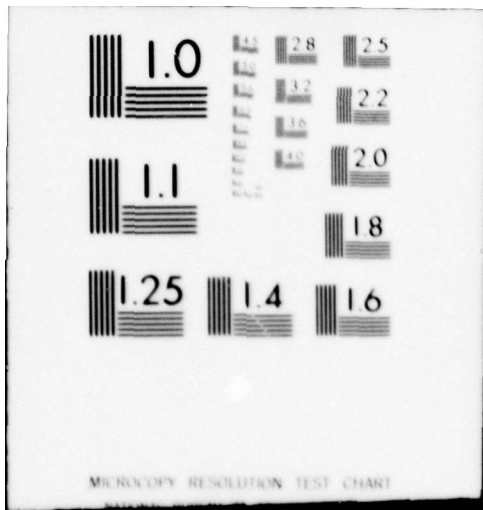

MICROCOPY RESOLUTION TEST CHART

DATA TAKEN ON 30 JANUARY 1978 BY LENKE AND STAEBLI
S/C = .5: (PROOF RUN)

NUMBER OF PRIMARY NOZZLES: 4
PRIMARY NOZZLE DIAPETER: 3.38 INCHES
MIXING STACK LENGTH: 35.10 INCHES
MIXING STACK DIAPETER: 11.70 INCHES
MIXING STACK L/C: 3.00

UPTAKE DIAPETER: 11.50 INCHES
AREA RATIO, AP/AF: 3.00
ORIFICE DIAPETER: 6.902 INCHES
ORIFICE BETA: 0.457
AMBIENT PRESSURE: 29.87 INCHES HG

N	FCR	CPGR	TOR	TLPT	TAPB	PU-PA	PA-PS	FA-FA2	SECCARY AREA	LL	UPT	MUCH
RUN	INCHES OF WATER	DEGREES FAHRENHEIT	INCHES OF WATER	INCHES OF WATER	INCHES OF WATER	INCHES OF WATER	INCHES OF WATER	INCHES OF WATER	INCHES OF WATER	INCHES OF WATER	INCHES OF WATER	INCHES OF WATER
1	0.7	22.4	55.0	106.0	66.0	4.90	4.60	4.80	0.0	73.24	73.24	0.065
2	0.7	22.0	55.0	106.0	66.0	5.85	3.40	3.39	12.566	86.39	74.87	0.064
3	0.7	21.5	55.0	106.0	66.0	6.50	2.50	2.50	25.133	96.15	74.53	0.064
4	0.7	21.8	54.0	106.0	66.0	7.35	1.42	1.41	50.265	107.98	74.24	0.064
5	0.7	21.7	54.0	106.0	66.0	8.10	0.61	0.61	100.531	119.11	72.52	0.063
6	0.7	21.6	53.0	106.0	66.0	8.30	0.32	0.32	150.756	123.05	73.77	0.063
7	0.7	22.1	54.0	106.0	66.0	8.50	0.25	0.25	175.925	125.19	74.27	0.064
8	0.7	22.1	55.0	106.0	66.0	8.55	0.16	0.16	226.152	126.88	74.44	0.064
9	0.7	22.1	54.0	106.0	66.0	8.70	0.01	0.01	*****	*****	74.49	0.064

MIXING STACK PRESSURE DISTRIBUTION FOR RUN: 9 POSITION A

Y/C	G-C	0.50	1.00	1.50	2.00	2.50
FP(SIN. HZ):	3.60C	1.56C	1.180	0.610	0.36C	0.060
FPS:	0.363	0.151	0.113	0.058	0.024	0.006

MIXING STACK PRESSURE DISTRIBUTION FOR RUN: 9 POSITION B

Y/C	G-C	0.50	1.00	1.50	2.00	2.50
FP(SIN. HZ):	2.750	1.410	0.540	0.480	0.210	0.050
FPS:	0.263	0.135	0.090	0.046	0.020	0.005

(b) L/D = 3.0, Run 2

TABLE IV (CONTINUED)

CATA TAKEN CA 1 FEBRUARY 1978 BY LEMME AND STAERLI
S/C = .5: (PROOF RUN)

NUMBER OF PRIMAF) NOZZLES: 4
PRIMAF) NOZZLE DIAMETER: 3.38 INCHES
PIPING STACK LENGTH: 35.16 INCHES
PIPING STACK DIAMETER: 11.7C INCHES
PIPING STACK L/C: 3.00

UPTAKE DIAMETER: 11.50 INCHES
AREA RATIO, AP/AP: 3.00
CRIFICE DIAMETER: 6.5C2 INCHES
CRIFICE BETA: 0.457
AMBIENT PRESSURE: 3C.C5 INCHES HG

A	FOR	CFCR	TCR	TLPT	TAPE	PU-FA	PA-FS	FA-FA2	SECONDARY AREA	LL	UP	UN	LL	UPT
NO	INCHES OF WATER	DEGREES FARENHEIT	INCHES OF WATER	SQUARE INCHES	INCHES OF WATER	INCHES OF WATER	INCHES OF WATER	INCHES OF WATER	INCHES OF WATER	INCHES OF WATER	INCHES OF WATER	INCHES OF WATER	INCHES OF WATER	INCHES OF WATER
1	0.7	22.1	64.2	116.2	74.C	4.60	4.55	4.55	0.0	73.14	215.10	73.14	75.71	0.064
2	0.7	22.0	62.6	115.5	74.0	5.85	3.34	3.34	12.566	86.85	218.17	86.85	75.35	0.064
3	0.7	22.0	64.5	116.9	74.C	6.65	2.43	2.43	25.133	96.57	217.67	96.57	75.21	0.064
4	0.7	22.0	65.0	117.2	74.C	7.50	1.40	1.41	5C.265	108.84	217.12	108.84	75.C3	0.064
5	0.7	22.0	63.0	116.7	74.0	8.20	0.56	0.57	100.531	118.72	216.50	118.72	74.55	0.064
6	0.7	22.0	63.1	116.4	74.0	8.45	0.33	0.34	15C.756	125.59	216.65	125.59	74.86	0.064
7	0.7	22.0	62.1	116.4	74.C	8.50	0.20	0.20	2C2.CC4	126.74	216.50	126.74	74.54	0.064
8	C.7	22.1	64.5	117.1	74.0	8.60	0.14	0.14	24E.1EE	128.1C	217.C1	128.1C	74.55	0.064
9	C.7	22.0	62.7	116.7	74.C	8.72	C.C1	0.C1	*****	*****	216.67	*****	74.87	0.064

PIXING STACK PRESSURE DISTRIBUTION FOR RUN: 9 POSITION A
P/C: C.C C.5C 1.0C 1.50 2.00 2.50
P/S(IN. P/C): 4.CCC 1.650 0.930 0.430 0.157 0.035
P/F(S): C.382 C.158 0.089 0.041 0.015 0.002

PIXING STACK PRESSURE DISTRIBUTION FOR RUN: 9 POSITION B
P/C: C.C C.50 1.0C 1.50 2.00 2.50
P/S(IN. P/C): 2.76C 1.41C 0.565 0.500 0.155 0.035
P/F(S): 0.264 C.135 0.092 0.048 0.015 0.002

(C) L/D = 3.0, Run 3

TABLE IV (CONTINUED)

DATA TAKEN ON 24 FEBRUARY 1970 BY LENNE AND STAENLI
 S/C = .51 CHANGED L/D TO 2.5

ALDRED CF PRIMARY NOZZLES: 4
 PRIMARY NOZZLE DIAMETER: 3.36 INCHES
 MIXING STACK LENGTH: 25.25 INCHES
 MIXING STACK DIAMETER: 11.70 INCHES
 MIXING STACK L/D: 2.50

UPTAKE DIAMETER: 11.50 INCHES
 AREA RATIO, AP/AFI: 3.00
 CRIPICE DIAMETER: 6.502 INCHES
 ORIFICE BETA: 0.457
 AMBIENT PRESSURE: 30.64 INCHES Hg

N	FOR	DFCR	TCR	TLPT	TAPE	PU-FA	PA-FS	FA-FAZ	SECCACARY AREA	UPT
ALA	INCHES CF WATER	DEGREES FA-REMPET	INCHES CF WATER	SQARE INCHES	INCHES CF WATER	LEP/SEC	FT/SEC	FT/SEC	FT/SEC	PACH
1	0.7	22.0	56.0	110.1	70.0	4.60	4.62	4.62	0.0	0.064
2	0.7	22.0	56.1	110.1	70.0	5.05	3.30	3.30	12.566	0.064
3	0.7	22.0	55.1	109.2	70.0	6.60	2.32	2.32	25.123	0.064
4	0.7	22.0	55.4	109.4	70.0	7.50	1.37	1.40	50.265	0.064
5	0.7	22.1	55.3	109.3	70.0	8.30	0.42	0.42	100.531	0.064
6	0.7	22.0	55.3	109.0	70.0	8.45	0.25	0.25	150.756	0.064
7	0.7	22.1	55.5	109.2	70.0	8.55	0.15	0.15	201.062	0.064
8	0.7	22.1	55.0	109.1	70.0	8.60	0.13	0.13	246.186	0.064
9	0.7	22.0	56.2	109.5	70.0	8.70	0.02	0.01	*****	0.064

MIXING STACK PRESSURE DISTRIBUTION FOR RUN: 9 POSITION A

Y/D:	G.C	0.50	1.00	1.50	2.00
FP5(1A, P2C):	1.950	1.420	0.880	0.370	0.210
FP5(4):	0.187	0.136	0.084	0.036	0.020

MIXING STACK PRESSURE DISTRIBUTION FOR RUN: 9 POSITION B

Y/D:	G.C	0.50	1.00	1.50	2.00
FP5(1A, P2C):	2.240	1.190	0.850	0.500	0.160
FP5(4):	0.215	0.114	0.082	0.048	0.015

(d) L/D = 2.5

TABLE IV (CONTINUED)

DATA TAKEN ON 5 MARCH 1972 BY LENKE AND STAEBLI
S/D = .5; CHANGED PRIMARY NOZZLES

NUMBER OF PRIMARY NOZZLES: 4
PRIMARY NOZZLE DIAMETER: 3.70 INCHES
PIPING STACK LENGTH: 25.25 INCHES
PIPING STACK DIAMETER: 11.70 INCHES
MIXING STACK L/D: 2.50

LPTAKE DIAMETER: 11.50 INCHES
AREA RATIO, AP/AF: 2.50
ORIFICE DIAMETER: 6.902 INCHES
ORIFICE BETA: 0.497
APPOINT PRESSURE: 28.63 INCHES HG

N	POR	DPCR	TCR	TUPT	TAPE	PU-PA	PA-PS	PA-FAZ	SECONDARY AREA
RUJ	INCHES	CF WATER	DEGREES	FAHRENHEIT	INCHES	CF WATER	INCHES	SQUARE	INCHES
1	0.7	22.0	56.3	112.6	76.0	2.80	3.34	2.24	0.0
2	0.7	22.0	56.4	112.5	76.0	3.75	2.24	2.23	12.566
3	0.7	22.0	56.6	112.1	76.0	4.40	1.55	1.59	25.133
4	0.7	22.0	56.5	111.5	76.0	5.00	0.66	0.66	50.265
5	0.7	22.0	58.4	111.8	76.0	5.50	0.31	0.31	100.531
6	0.7	22.0	58.1	111.6	76.0	5.60	0.15	0.15	150.796
7	0.7	22.0	57.9	111.7	76.0	5.70	0.08	0.08	201.062
8	0.7	22.0	57.7	111.3	76.0	5.70	0.05	0.05	248.186
9	0.7	22.0	58.0	111.4	76.0	5.80	0.0	0.0	*****

N	h*	F*	T*	W*	W*	h*	h*	UF	LM	LL	UFT
FLA			PS/TS	W*	W*	LBH/SEC	LBH/SEC	FT/SEC	FT/SEC	FT/SEC	PACH
1	0.0	0.4541	0.5360	0.4851	0.0	3.672	0.0	185.75	74.26	76.27	0.066
2	0.1702	0.5370	0.5362	0.2279	0.1452	3.668	0.624	164.55	85.68	76.26	0.065
3	0.2871	0.2179	0.5269	0.2326	0.2750	3.671	1.054	184.70	53.63	76.44	0.065
4	0.4223	0.1168	0.5372	0.1237	0.4184	3.671	1.550	184.31	102.75	76.27	0.065
5	0.5070	0.6422	0.5374	0.0651	0.4528	3.672	1.862	184.02	106.52	76.16	0.065
6	0.5265	0.0208	0.5377	0.0222	0.5141	3.673	1.542	183.95	110.00	76.13	0.065
7	0.5145	0.0131	0.5375	0.0118	0.5005	3.673	1.091	183.58	109.06	76.14	0.065
8	0.5024	0.0069	0.5382	0.0074	0.4882	3.674	1.646	183.88	108.16	76.10	0.065
9	*****	0.0	0.5360	0.0	*****	3.673	*****	183.82	*****	76.08	0.065

(a) L/D = 2.5, Run 1

TABLE V. PERFORMANCE DATA FOR STRAIGHT MIXING STACKS WITH PRIMARY NOZZLE DIAMETERS OF 3.70 IN.

DATA TAKEN ON 8 MARCH 1976 BY LENKE AND STAENLI
S/C = .5

NUMBER OF PRIMARY NOZZLES: 4
 PRIMARY NOZZLE DIAMETER: 3.70 INCHES
 MIXING STACK LENGTH: 29.25 INCHES
 MIXING STACK DIAMETER: 11.70 INCHES
 MIXING STACK L/D: 2.50

UPTAKE DIAMETER: 11.50 INCHES
 AREA RATIO, AP/AP: 2.50
 ORIFICE DIAMETER: 6.902 INCHES
 ORIFICE BETA: 0.497
 AMBIENT PRESSURE: 29.98 INCHES HG

N	PCR	DFCR	TCR	TUPT	TAPE	PU-PA	PA-PS	PA-FM2	SECONDARY AREA	UL	LPT	MACH
RUN	INCHES OF WATER	DEGREES FAHRENHEIT	INCHES CF WATER	INCHES CF WATER	INCHES CF WATER	INCHES CF WATER	INCHES CF WATER	INCHES CF WATER	SQUARE INCHES	FT/SEC	FT/SEC	FT/SEC
1	0.7	22.0	54.6	108.2	64.0	2.95	3.34	3.34	0.0	72.50	72.50	0.064
2	0.7	22.0	54.6	108.2	64.0	3.80	2.31	2.31	12.566	83.88	83.88	0.064
3	0.7	22.0	55.3	108.6	64.0	4.35	1.48	1.48	25.133	90.68	90.68	0.064
4	0.7	22.0	55.3	108.7	64.0	5.00	0.55	0.55	50.265	102.13	102.13	0.064
5	0.7	22.0	55.1	108.7	64.0	5.50	0.36	0.36	100.531	108.51	108.51	0.064
6	0.7	22.0	55.1	108.8	64.0	5.70	0.17	0.17	150.756	110.16	110.16	0.064
7	0.7	22.0	55.3	108.8	64.0	5.70	0.12	0.12	201.662	114.11	114.11	0.064
8	0.7	22.0	54.8	108.8	64.0	5.70	0.07	0.07	248.186	111.72	111.72	0.064
9	0.7	22.0	55.5	108.7	64.0	5.80	0.0	0.0	*****	175.66	175.66	0.064

MIXING STACK PRESSURE DISTRIBUTION FOR RUN: 9 POSITION A

X/D:	0.0	0.50	1.00	1.50	2.00
FM(IN. H2O):	1.450	0.935	0.605	0.335	0.130
FM%:	6.156	6.127	6.082	6.046	6.018

MIXING STACK PRESSURE DISTRIBUTION FOR RUN: 9 POSITION B

X/D:	0.0	0.50	1.00	1.50	2.00
FM(IN. H2O):	1.750	0.810	0.570	0.340	0.110
FM%:	0.235	0.110	0.078	0.046	0.015

(b) L/D = 2.5, Run 2

TABLE V (CONTINUED)

CATA TAKEN ON 5 MARCH 1976 BY LEPKE AND STAEP-11
 S/C = .51 CHANGE L/D TO 1.75

NUMBER OF PRIMARY NOZZLES: 4
 PRIMARY NOZZLE DIAPETER: 3.70 INCHES
 MIXING STACK LENGTH: 20.40 INCHES
 MIXING STACK DIAPETER: 11.70 INCHES
 MIXING STACK L/D: 1.75

UPTAKE DIAPETER: 11.50 INCHES
 AREA RATIO, AP/AP1: 2.50
 ORIFICE DIAMETER: 6.902 INCHES
 ORIFICE BETA: 0.457
 AMBIENT PRESSURE: 29.85 INCHES HG

UP TAKE DIAPETER: 11.50 INCHES
 AREA RATIO, AP/AP1: 2.50
 ORIFICE DIAMETER: 6.902 INCHES
 ORIFICE BETA: 0.457
 AMBIENT PRESSURE: 29.85 INCHES HG

RUN	FCP INCHES CF WATER	DFCR 22.0	TCR 56.0	TUPT DEGREES FARENHEIT	TAMB 66.0	PU-PA 2.90	PA-PS 3.27	FA-FA2 3.27	SECNCARY AREA SQARE INCFES
1	0.7	22.0	56.0	105.7	66.0	2.90	3.27	3.27	0.0
2	0.7	22.0	57.7	110.5	66.0	3.50	2.05	2.08	12.566
3	0.7	22.0	57.1	110.9	66.0	4.50	1.50	1.43	25.133
4	0.7	22.0	56.8	110.9	66.0	5.10	0.75	0.79	50.245
5	0.7	22.0	56.8	110.7	66.0	5.50	0.30	0.50	100.521
6	0.7	22.0	56.9	110.6	66.0	5.60	0.15	0.15	150.756
7	0.7	22.0	56.3	110.5	66.0	5.70	0.05	0.05	201.062
8	0.7	22.0	56.4	110.4	66.0	5.70	0.06	0.06	248.184
9	0.7	22.0	56.8	110.6	66.0	5.60	0.06	0.06	300.000

RUN	W	F0	T0	P0/T0	W/T0	WP	LS	LP	UP	LL	UPT MACH
1	C.C	0.4392	0.5232	0.4757	0.0	3.745	C.C	181.52	72.74	75.25	0.064
2	C.1656	0.5825	0.5220	0.3064	0.1558	3.755	C.619	181.35	82.52	75.05	0.064
3	C.2745	C.2628	0.5213	0.2201	0.2648	3.741	1.027	181.32	90.76	75.04	0.064
4	0.4079	0.1071	0.5213	0.1113	0.3525	3.742	1.526	181.05	99.54	74.53	0.064
5	0.5027	C.0408	0.5216	0.0443	0.4850	3.742	1.681	180.77	105.72	74.41	0.064
6	C.5333	C.0204	0.5218	0.0222	0.5145	3.742	1.555	180.65	107.72	74.76	0.064
7	0.5504	0.0123	0.5220	0.0133	0.5311	3.744	2.061	180.70	108.90	74.78	0.064
8	C.5548	0.0082	0.5221	0.0089	0.5354	3.744	2.077	180.64	105.16	74.76	0.064
9	0.000000	0.0	0.5218	0.0	0.000000	3.742	0.000000	180.60	0.000000	74.74	0.064

PIPING STACK PRESSURE DISTRIBUTION FOR RUN: 9 POSITION A

X/C: 0.0 C.50 1.00 1.50
 PPS10M. W/C: C.CCC C.55C 0.370 0.080
 PPS9: 0.273 C.075 0.050 0.011

PIPING STACK PRESSURE DISTRIBUTION FOR RUN: 9 POSITION B

X/C: 0.0 0.50 1.00 1.50
 PPS10M. W/C: 1.350 C.700 0.430 C.110
 PPS9: C.165 C.055 0.059 0.015

(c) L/D = 1.75

TABLE V (CONTINUED)

CATA TAKEN ON 10 MARCH 1976 BY LEMKE AND STAEPLI
S/C - .51 7 DEG SOLID DIFFUSOR

NUMBER OF PRIMARY NOZZLES: 4
PRIMARY NOZZLE DIAMETER: 3.70 INCHES
PIPING STACK LENGTH: 25.25 INCHES
PIPING STACK DIAMETER: 11.70 INCHES
PIPING STACK L/C: 2.50

UPTAKE DIAMETER: 11.50 INCHES
AREA RATIO, A/P/A: 2.50
CRIFICE DIAMETER: 6.502 INCHES
CRIFICE BETA: 0.457
AMBIENT PRESSURE: 30.63 INCHES HG

N	FCR	DFCF	TCR	TUPT	TAPB	PU-PA	PA-FS	FA-FM1	SECCARY AREA
RLA	INCHES	CF WATER	DEGREES	FARENHEIT	INCHES	OF WATER	INCHES	INCHES	SCUAPE INCHES
1	0.7	22.0	52.3	105.5	55.C	2.55	3.75	3.75	0.0
2	0.7	22.0	52.1	105.3	55.C	3.40	2.66	2.67	12.566
3	0.7	22.0	52.4	105.6	55.C	4.00	1.98	1.55	25.133
4	0.7	22.0	52.8	105.9	55.C	4.75	1.14	1.14	50.265
5	0.7	22.0	52.9	106.0	59.0	5.30	0.47	0.47	100.531
6	0.7	22.0	53.0	106.2	55.C	5.5C	6.24	0.24	15C.756
7	0.7	22.0	53.3	106.3	55.C	5.55	0.15	0.15	201.062
8	0.7	22.0	53.2	106.5	59.0	5.6C	6.1C	0.1C	246.166
9	0.7	22.0	53.7	107.1	55.C	5.7C	6.C	0.C	*****

N	W	P*	T*	W*P*	MP	LS	UP	LL	LPT	
RLA	W	SEC	SEC	SEC	LBM/SEC	LEN/SEC	FT/SEC	FT/SEC	MACH	
1	0.0	0.4996	0.5177	0.5443	0.0	3.170	0.0	180.90	72.33	0.064
2	0.1875	0.3564	0.5180	0.3882	0.1805	3.771	0.768	180.39	84.46	0.064
3	0.3245	0.2660	0.5176	0.2899	0.3124	3.77C	1.223	186.13	93.26	0.064
4	0.4514	0.1538	0.5171	0.1677	0.4730	3.768	1.852	179.78	104.18	0.064
5	0.6311	0.0636	0.9169	0.0694	0.6074	3.768	2.378	175.50	113.25	0.064
6	0.6765	0.0325	0.9166	0.0354	0.6511	3.767	2.545	179.45	116.21	0.064
7	0.7133	0.0203	0.5164	0.0222	0.6864	3.764	2.686	179.39	118.59	0.064
8	0.7166	0.0135	0.5161	0.0148	0.6516	3.767	2.708	175.45	118.98	0.064
9	*****	0.C	0.5151	0.0	*****	3.761	*****	179.50	*****	0.064

PIXIAC STACK PRESSURE DISTRIBUTION FOR RUN: 9 POSITION A

X/E:	C.C	C.5C	1.0C	1.50	2.0C
FP511A. P2C1:	4.30C	1.620	1.200	0.110	0.610
FP511A. P2C2:	0.582	0.219	0.162	0.015	0.081

PIXIAC STACK PRESSURE DISTRIBUTION FOR RUN: 9 POSITION B

X/E:	0.0	0.50	1.0C	1.50	2.00
FP511B. P2C1:	2.55C	1.450	0.740	0.660	0.65C
FP511B. P2C2:	0.355	0.202	0.100	0.089	0.088

(a) Run 1

TABLE VI. PERFORMANCE DATA FOR MIXING STACKS WITH A SEVEN DEGREE SOLID DIFFUSOR

CATA TAKEP CA 14 MARCH 1978 BY LENKE AND STAENLI
S/C = 5; 7 DEG SLID DIFFLSOR

ALPHA OF PRIMARY ACZZLES: 4
PRIMARY NOZZLE DIAMETER: 3.70 INCHES
MIXING STACK LENGTH: 29.25 INCHES
MIXING STACK DIAMETER: 11.70 INCHES
MIXING STACK L/D: 2.50

UPTAKE DIAMETER: 11.50 INCHES
AREA FATIC, AM/SP: 2.50
CRIFICE DIAPETER: 6.902 INCHES
ORIFICE BETA: 0.457
AMBIENT PRESSURE: 30.14 INCHES HG

N	FCF	DPCR	TCR	TUPT	TAPE	PU-PA	PA-FS	FA-FAZ	SECCARY AREA	UF	US	LF	UU	UPT			
RUN	INCHES OF WATER	DEGREES FAHRENHEIT	INCHES CF WATER	SQUARE INCHES	FT/SEC	FT/SEC	FT/SEC	FT/SEC	FT/SEC	FT/SEC	FT/SEC	FT/SEC	FT/SEC	FT/SEC			
1	0.7	22.0	62.3	116.5	85.C	2.55	3.73	3.73	3.73	3.73	0.0	3.740	0.0	182.32	72.89	75.45	0.064
2	0.7	22.0	62.6	116.0	85.C	3.45	2.65	2.65	2.65	2.65	0.690	3.739	0.690	181.62	85.21	75.16	0.064
3	0.7	22.0	61.9	116.0	85.C	4.10	1.54	1.54	1.54	1.54	1.184	3.742	1.184	181.42	54.15	75.C8	0.064
4	0.7	22.0	61.5	116.1	85.C	4.80	1.36	1.36	1.36	1.36	1.977	3.743	1.977	181.27	108.57	75.C2	0.064
5	0.7	22.0	62.2	116.0	85.C	5.35	0.65	0.65	0.65	0.65	2.806	3.74C	2.806	180.82	123.52	74.82	0.064
6	0.7	22.0	62.5	116.5	85.C	5.50	0.54	0.54	0.54	0.54	3.737	3.736	3.737	180.69	140.47	74.78	0.064
7	0.7	22.0	62.4	116.5	85.C	5.60	0.45	0.45	0.45	0.45	4.545	3.736	4.545	180.67	155.27	74.77	0.064
8	0.7	22.0	63.2	117.3	85.C	5.65	0.11	0.11	0.11	0.11	2.712	3.737	2.712	180.80	121.80	74.82	0.064
9	0.7	22.0	62.8	117.2	85.C	5.70	0.0	0.0	0.0	0.0	3.735	3.735	3.735	180.62	100.62	74.75	0.063

MIXING STACK PRESSURE DISTRIBUTION FOR RUN: 9 POSITION A

X/D:	C.C	0.50	1.00	1.50	2.00
PPS11A. P2C1:	4.100	1.560	1.225	0.975	0.620
PPS11A. P2C2:	0.573	0.218	0.171	0.136	0.087

MIXING STACK PRESSURE DISTRIBUTION FOR RUN: 9 POSITION B

X/D:	C.C	0.50	1.00	1.50	2.00
PPS11A. P2C1:	2.600	1.500	0.780	1.070	0.620
PPS11A. P2C2:	0.264	0.210	0.109	0.150	0.087

(b) Run 2

TABLE VI (CONTINUED)

DATA TAKEN ON 15 MARCH 1976 BY LENKE AND STAENGLI
 S/C = 5; 7 DEG SLID CIPFLOOR

ALPHEE CP PRIMARY NOZZLES: 4
 PRIMARY NOZZLE DIAMETER: 3.70 INCHES
 PIRING STACK LENGTH: 25.25 INCHES
 PIRING STACK DIAMETER: 11.70 INCHES
 MIDDING STACK L/D: 2.50

LPTAKE DIAMETER: 11.50 INCHES
 AREA RATIO, AN/AP: 2.5C
 ORIFICE DIAMETER: 6.502 INCHES
 ORIFICE BETA: 0.497
 AMBIENT PFEASURE: 30.18 INCHES HG

N	POR	DPCR	TCR	TUPT	TAPB	PU-FA	PA-PS	PA-FAZ	SECONDARY AREA		
RLA	INCHES	GF WATER	DEGREES	FARENHEIT	INCHES	GF WATER	INCHES	GF WATER	SQUARE INCHES		
1	0.7	22.0	66.1	118.5	5C.C	2.50	3.68	3.48	0.0		
2	0.7	22.0	66.5	118.3	90.0	4.00	1.54	1.54	25.123		
3	0.7	22.0	64.6	118.3	90.C	4.75	1.10	1.12	5C.265		
4	0.7	22.0	66.5	115.4	90.0	5.30	0.45	0.45	100.531		
5	0.7	22.0	65.0	115.4	90.C	5.50	0.25	0.28	15C.756		
6	0.7	22.0	63.5	115.4	90.C	5.60	0.16	0.13	201.062		
7	0.7	22.C	66.1	115.4	5C.C	5.60	0.11	0.10	248.186		
8	0.7	22.C	66.9	121.4	5C.C	5.70	0.CC	0.0	*****		
N	W4	F4	T4	P4/T4	hP	hP	NS	LF	UP	LL	UPT
RLA					LEM/SEC	LEM/SEC	LEP/SEC	F1/SEC	FT/SEC	FT/SEC	MACH
1	C.0	C.5100	0.5507	0.5365	0.C	3.725	C.C	182.13	72.82	75.27	0.064
2	0.3155	C.2716	0.5510	0.2856	0.3066	3.728	1.176	181.22	54.09	75.00	0.064
3	C.4765	C.1541	0.5510	0.1620	C.4681	3.725	1.767	161.18	105.31	74.56	0.064
4	0.6063	0.6632	0.5492	0.0666	0.5504	3.728	2.253	180.51	113.78	74.87	0.063
5	6.7180	0.0400	0.5492	0.0421	0.7016	3.732	2.691	181.09	121.72	74.54	0.064
6	C.6557	0.0217	0.5492	0.0228	0.6835	3.735	2.636	181.55	120.41	75.03	0.064
7	C.7070	0.0148	0.5492	0.0156	0.6510	3.725	2.637	180.82	120.80	74.83	0.063
8	*****	C.0007	0.5460	C.0007	*****	3.727	*****	181.27	*****	75.02	0.063

(c) Run 3

TABLE VI (CONTINUED)

DATA TAKEN ON 15 MARCH 1976 BY LENKE AND STAEPFLI
 S/C = .5; 7 CEE SOLID DIFFUSOR

NUMBER OF PRIMARY NOZZLES: 4
 PRIMARY NOZZLE DIAPETER: 3.70 INCHES
 MIXING STACK LENGTH: 29.25 INCHES
 MIXING STACK DIAPETER: 11.70 INCHES
 MIXING STACK L/D: 2.50

UPTAKE DIAPETER: 11.50 INCHES
 AREA RATIO, A/P/A: 2.50
 ORIFICE DIAPETER: 6.902 INCHES
 ORIFICE BETA: 0.497
 AMBIENT PRESSURE: 30.18 INCHES H₂O

RUN	FCR INCHES CF WATER	TCR DEGREES F. RENNET	TUPT TAPE	PU-PA INCHES CF WATER	PA-PS FA-PAZ	SECCALARY AREA SQUARE INCHES	UM FT/SEC	LL FT/SEC	UPT MACH
1	0.7	22.0	115.3	2.55	3.71	0.0	72.55	75.55	0.064
2	0.7	22.0	119.2	4.05	1.54	25.133	94.21	75.22	0.064
3	0.7	22.0	118.8	4.80	1.17	50.265	106.07	75.01	0.064
4	0.7	22.0	120.9	5.30	0.46	100.531	115.11	75.00	0.064
5	0.7	22.0	120.6	5.50	0.27	150.756	115.58	75.00	0.064
6	0.7	22.0	121.0	5.50	0.16	201.062	121.26	74.55	0.063
7	0.7	22.0	120.7	5.60	0.11	248.186	120.92	74.55	0.063
8	0.7	22.0	121.4	5.70	0.00	*****	*****	75.02	0.063

PIXING STACK PRESSURE DISTRIBUTION FOR RUN: 8 POSITION A

X/C	P/C	FPS
0.0	1.00	1.50
0.5	1.210	0.990
1.0	0.169	0.139

PIXING STACK PRESSURE DISTRIBUTION FOR RUN: 8 POSITION B

X/C	P/C	FPS
0.0	1.00	1.50
0.5	0.760	1.075
1.0	0.106	0.150

(d) Run 4

TABLE VI (CONTINUED)

CATA TAKEP CN 26 APRIL 1976 BY LEMKE AND STAHLI
 S/C = .5; 7 DEG SCLID DIFFLOR, TERTIARY BOX OPEN, DIAFBULK INSTALLEC

NUMBER OF PRIMARY NOZZLES: 4
 PRIMARY NOZZLE DIAMETER: 3.7C INCHES
 PIPING STACK LENGTH: 29.25 INCHES
 PIPING STACK DIAMETER: 11.70 INCHES
 MIXING STACK L/D: 2.50

RUN	W*	P*	PC*	TCR	TLPT	TAPE	PU-PA	FA-FS	PA-FNZ	SECONDARY AREA	UU	LFT	MACH
INCHES OF WATER	DEGREES FAHRENHEIT	INCHES OF WATER	INCHES OF WATER	SQUARE INCHES	FT/SEC	FT/SEC	FT/SEC	FT/SEC	FT/SEC	FT/SEC	FT/SEC	FT/SEC	FT/SEC
1	0.7	22.0	56.6	112.8	84.C	2.2C	3.34	1.67	2.35	C.0			
2	0.7	22.0	64.6	116.4	84.0	2.80	1.66	1.87	1.67	12.566			
3	0.7	22.0	59.8	112.5	84.C	3.30	1.87	1.07	1.07	25.133			
4	0.7	22.0	55.1	113.0	84.C	3.80	1.13	1.13	1.13	50.265			
5	0.7	22.0	56.1	112.7	84.C	4.30	0.45	C.45	C.45	100.531			
6	0.7	22.C	55.4	113.1	84.C	4.40	0.24	C.25	C.25	150.796			
7	0.7	22.0	56.7	112.8	84.0	4.50	0.19	0.15	0.15	201.062			
8	0.7	22.C	59.2	113.1	84.C	4.55	0.01	C.01	C.01	*****			

MIXING STACK PRESSURE DISTRIBUTION FOR RUN: 8 POSITION A
 X/C: 0.C 0.50 1.C0 1.50 2.00
 P/F/C: 3.550 1.540 1.210 1.010 0.55C
 P/F/S: 0.498 0.216 0.184 0.142 0.062

MIXING STACK PRESSURE DISTRIBUTION FOR RUN: 8 POSITION B
 X/C: 0.0 0.50 1.C0 1.5C 2.00
 P/F/C: 2.430 1.340 ***** 1.100 0.66C
 P/F/S: 0.341 0.188 ***** 0.154 0.052

(e) TERTIARY BOX OPEN, DIAPHRAGM
 AND BULKHEAD INSTALLED

TABLE VI (CONTINUED)

CATA TAKEN ON 27 APRIL 1976 BY LEMKE AND STAEPLI
 S/C = 45: 1 DEG SCLID CUFFLOR , TERTIARY BOX CLOSED, CIAPPELLK INST.

ALPHER CF PRIMARY ACZZLES: 4
 FFIPAPY NOZZLE CIAPETER: 3.7C INCHES
 MIXING STACK LENGTH: 25.25 INCHES
 MIXING STACK DIAPETER: 11.7C INCHES
 MIXING STACK L/D: 2.50

LPTAKE CIAPETER: 11.5C INCHES
 AFEA FATIC, AP/AP: 2.50
 ORIFICE DIAPETER: 6.5C2 INCHES
 CRIFICE BETA: C.97
 AMEIENT PRESSURE: 30.07 INCHES P-C

N	FOR	DFCF	TCR	TLPT	TAPF	PU-FA	PA-PS	FA-FAZ	SECCNARY AREA
ALA	INCHES OF WATER	DEGREES FAHRENHEIT	INCHES OF WATER	INCHES OF WATER	INCHES OF WATER	INCHES OF WATER	INCHES OF WATER	INCHES OF WATER	INCHES OF WATER
1	0.7	22.0	60.4	114.1	86.0	2.10	3.62	3.62	0.0
2	0.7	22.0	60.0	114.8	86.0	2.80	2.65	2.65	12.566
3	0.7	22.0	60.1	115.0	86.0	3.30	2.03	2.03	25.132
4	0.7	22.0	60.1	114.8	86.0	3.85	1.21	1.21	50.265
5	0.7	22.0	57.6	114.7	86.0	4.40	0.48	0.48	100.531
6	0.7	22.0	60.5	114.2	86.0	4.50	0.25	0.25	150.754
7	0.7	22.0	60.1	114.1	86.0	4.60	0.16	0.16	201.062
8	0.7	22.0	55.9	114.1	86.0	4.60	0.11	0.10	245.166
9	0.7	22.0	55.7	114.1	86.0	4.70	0.01	0.01	*****

N	W	P	T	W	W	W	W	W	W		
ALA	W	P	T	W	W	W	W	W	W		
1	0.0	0.5004	0.4510	0.5261	0.0	3.743	0.0	182.05	72.78	75.24	0.064
2	0.1835	0.3669	0.9499	0.3862	0.1798	3.744	0.688	181.50	85.32	75.28	0.064
3	0.3219	0.2818	0.5495	0.2967	0.3147	3.744	1.205	181.67	94.72	75.18	0.064
4	0.4571	0.1687	0.5499	0.1776	0.4359	3.744	1.661	181.24	106.57	75.01	0.064
5	0.6323	0.0671	0.9500	0.0707	0.6162	3.744	2.368	180.98	115.77	74.50	0.064
6	0.6761	0.0351	0.5509	0.0349	0.6632	3.742	2.538	180.56	118.71	74.72	0.064
7	0.7230	0.0225	0.5510	0.0236	0.7072	3.744	2.707	180.56	121.81	74.72	0.064
8	0.7054	0.0155	0.9510	0.0162	0.6500	3.745	2.641	180.57	120.61	74.72	0.064
9	*****	0.0014	0.5510	0.0015	*****	3.745	*****	180.56	*****	74.72	0.064

MIXING STACK PRESSURE DISTRIBUTION FOR RUN: 9 POSITION A
 X/D: 0.0 0.50 1.00 1.50 2.00
 PMSIN. P20: 3.640 1.520 1.260 1.005 0.556
 PMS: 0.511 0.214 0.177 0.141 0.062

MIXING STACK PRESSURE DISTRIBUTION FOR RUN: 9 POSITION B
 X/D: 0.0 0.50 1.00 1.50 2.00
 PMSIN. P20: 2.330 1.460 ***** 1.110 0.660
 PMS: 0.327 0.205 ***** 0.156 0.052

(f) TERTIARY BOX CLOSED, DIAPHRAGM
 AND BULKHEAD INSTALLED

TABLE VI (CONTINUED)

DATA TAKEN ON 27 APRIL 1978 BY LENNE AND STAEHLI
 SIZE: 1 CEE SLID DIFFUSOR; CIMPX REMOVED, SECONDARY & TERTIARY BOXES OPEN

ALPREF CF PRIMARY NOZZLES: 4
 PRIMARY NOZZLE DIAMETER: 3.70 INCHES
 PILING STACK LENGTH: 29.25 INCHES
 PILING STACK DIAMETER: 11.70 INCHES
 PILING STACK L/C: 2.50

UFTAKE DIAMETER: 11.50 INCHES
 AREA PATIC, AP/IP: 2.50
 ORIFICE DIAMETER: 6.502 INCHES
 CRIFICE BETA: C.457
 ANCIENT PRESSURE: 30.07 INCHES HG

N	FCR	DFCF	TCR	TUPT	TAPE	PU-PA	PA-PS	PA-FAZ	SECNCARY AREA
PLA	INCHES OF WATER	DEGREES FAHRENHEIT	INCHES CF WATER	INCHES CF WATER	INCHES CF WATER	INCHES CF WATER	INCHES CF WATER	INCHES CF WATER	INCHES CF WATER
1	0.7	22.C	51.7	105.6	67.C	4.70	0.0	0.C	*****
N	h*	F*	T*	P*/T*	h*/T**/44	WP	WS	LF	LM
PLA	*****	0.C	0.5317	0.C	*****	3.775	*****	175.27	*****

MIXING STACK PRESSURE DISTRIBUTION FOR RUN: 1 POSITION A

Y/C	0.50	1.00	1.50	2.00
FPS(IH. FZC):	3.800	1.560	1.200	1.C50
FPS:	0.522	0.215	0.179	0.144

MIXING STACK PRESSURE DISTRIBUTION FOR RUN: 1 POSITION B

Y/C	0.50	1.00	1.50	2.00
FPS(IH. FZC):	2.710	1.460	1.130	C.670
FPS:	0.372	C.501	*****	0.155

(g) PRESSURE DISTRIBUTION

TABLE VI (CONTINUED)

CATA TAKEN ON 31 MAY 1978 BY LEMKE AND STAENLI
 S/E = .51 2 SOLID DIFFUSOR RINGS, SECONDARY BOX OPEN

NUMBER OF PRIMARY NOZZLES: 4
 PRIMARY NOZZLE DIAMETER: 3.70 INCHES
 PILING STACK LENGTH: 29.25 INCHES
 MIXING STACK DIAMETER: 11.70 INCHES
 PILING STACK L/C: 2.50

LFTAKE CIAMETER: 11.50 INCHES
 AREA RATIO, AN/AP: 2.50
 CRIFICE DIAMETER: 4.502 INCHES
 CRIFICE BETA: 0.497
 AMBIENT PRESSURE: 30.13 INCHES HG

RUN	A	FCR	CFCR	TCP	TLPT	TAPB	PU-FA	PA-PS	PA-PT	SECONDARY AREA	TERTIARY AREA
		INCHES OF WATER	DEGREES FAHRENHEIT			INCHES CF WATER	SQUARE INCHES	SQUARE INCHES	SQUARE INCHES	SQUARE INCHES	SQUARE INCHES
1	0.7	22.0	56.2	109.9	76.0	6.65	0.02	0.70	0.00000000	0.0	
2	0.7	22.0	55.3	109.6	76.0	6.05	0.02	0.58	0.00000000	3.142	
3	0.7	22.0	56.7	110.7	76.0	6.00	0.02	0.45	0.00000000	6.283	
4	0.7	22.0	57.9	111.4	76.0	6.05	0.02	0.31	0.00000000	12.566	
5	0.7	22.0	57.8	111.5	76.0	6.05	0.02	0.24	0.00000000	18.850	
6	0.7	22.0	57.2	111.0	76.0	6.10	0.02	0.18	0.00000000	25.133	
7	0.7	22.0	55.7	112.1	76.0	6.65	0.02	0.10	0.00000000	37.699	
8	0.7	22.0	56.9	112.0	76.0	6.65	0.02	0.08	0.00000000	50.265	
9	0.7	22.0	56.6	112.4	76.0	6.05	0.02	0.00	0.00000000	0.00000000	

SECUNDARY BOX	N	W ²	F ₀	T ₀	P ₀ /T ₀	W/T ₀ ^{0.44}	WP	L ₀ S	UF	LP	UU	UPT
RLN							LBH/SEC	LEM/SEC	FT/SEC	FT/SEC	FT/SEC	FACH
1	0.00000000	0.0026	0.5405	0.0028	0.0028	0.00000000	3.762	0.00000000	179.67	0.00000000	74.35	0.064
2	0.00000000	0.0025	0.9410	0.0027	0.00000000	0.00000000	3.765	0.00000000	175.73	0.00000000	74.38	0.064
3	0.00000000	0.0025	0.5392	0.0027	0.00000000	0.00000000	3.760	0.00000000	175.83	0.00000000	74.42	0.064
4	0.00000000	0.0025	0.5380	0.0027	0.00000000	0.00000000	3.755	0.00000000	179.85	0.00000000	74.42	0.064
5	0.00000000	0.0025	0.9376	0.0027	0.00000000	0.00000000	3.756	0.00000000	179.90	0.00000000	74.45	0.064
6	0.00000000	0.0022	0.5387	0.0024	0.00000000	0.00000000	3.758	0.00000000	175.84	0.00000000	74.43	0.064
7	0.00000000	0.0022	0.5365	0.0024	0.00000000	0.00000000	3.749	0.00000000	175.75	0.00000000	74.35	0.064
8	0.00000000	0.0021	0.5370	0.0022	0.00000000	0.00000000	3.752	0.00000000	175.66	0.00000000	74.43	0.064
9	0.00000000	0.0021	0.9364	0.0022	0.00000000	0.00000000	3.753	0.00000000	180.04	0.00000000	74.51	0.064

TABLE VII. PERFORMANCE DATA FOR THE TWO-RING DIFFUSOR CONFIGURATION

TERTIARY BCK										
N	WT	PT	TTO	PTO/TTO	MTOTTO.44	LM	LT	UP	UE	
PLA						LBM/SEC	LEM/SEC	FT/SEC	FT/SEC	
1	0.0	0.0573	0.5405	0.1035	0.0	0.00000	0.0	0.00000	0.00000	
2	0.0216	0.0666	0.5410	0.0856	0.021	0.00000	0.08	0.00000	0.00000	
3	0.0379	0.0618	0.5392	0.0658	0.037	0.00000	0.14	0.00000	0.00000	
4	0.0633	0.0430	0.5360	0.0459	0.062	0.00000	0.24	0.00000	0.00000	
5	0.0827	0.0326	0.5378	0.0377	0.080	0.00000	0.21	0.00000	0.00000	
6	0.0951	0.0243	0.5287	0.0259	0.053	0.00000	0.26	0.00000	0.00000	
7	0.1054	0.0132	0.5269	0.0141	0.102	0.00000	0.40	0.00000	0.00000	
8	0.1248	0.0104	0.5270	0.0111	0.121	0.00000	0.47	0.00000	0.00000	
9	0.00000	0.0007	0.5364	0.0007	0.00000	0.00000	0.00000	0.00000	0.00000	

PIXINE STACK PRESSURE DISTRIBUTION FOR RUN: 9 POSITION A

W/D:	0.0	0.50	1.00	1.50
FP5LIN. P2C1:	3.050	1.230	0.910	0.580
PH1:	0.422	0.170	0.126	0.080

PIXINE STACK PRESSURE DISTRIBUTION FOR RUN: 9 POSITION B

W/C:	0.0	0.50	1.00	1.50
FP5LIN. P2C1:	1.910	1.160	0.800	0.580
PH1:	0.264	0.161	0.080	0.080

TABLE VII (CONTINUED)

CATA TAKEN ON 14 JULY 1978 BY LEPKE AND STAHLI
 S/C = .5; THREE SOLID DIFFUSOR RINGS, SECONDARY BOX OPEN

ALPHEP CF PRIMARY ACZZLES: 4
 PRIMARY ACZZLE DIAMETER: 3.70 INCHES
 PIPING STACK LENGTH: 29.25 INCHES
 PIPING STACK DIAMETER: 11.70 INCHES
 MIXING STACK L/D: 2.50

UPTAKE DIAMETER: 11.50 INCHES
 AREA RATIC, A/P/A: 2.50
 CRIFICE DIAMETER: 4.502 INCHES
 CRIFICE BETA: C.457
 ADJCEAT PRESSURE: 29.97 INCHES HG

N	FCR	CFCH	TCR	TLPT	TAPB	PU-FA	PA-PI	PA-PI	SECONDARY AREA	TERTIARY AREA
INCHES	INCHES	CF WATER	DEGREES	FARRENHEIT	INCHES	CF WATER	INCHES	CF WATER	SQUARE INCHES	SQUARE INCHES
1	0.7	22.0	60.3	114.5	85.0	6.00	0.01	0.45	0.00000000	0.00000000
2	0.7	22.0	60.7	114.5	85.0	6.00	C.C2	C.4C	0.00000000	3.142
3	0.7	22.0	60.4	114.6	85.0	6.00	0.01	0.23	0.00000000	6.283
4	0.7	22.0	60.8	114.4	85.0	6.00	0.01	0.22	0.00000000	12.566
5	0.7	22.0	61.2	114.4	85.0	6.00	C.01	0.14	0.00000000	18.850
6	0.7	22.0	62.1	114.4	85.0	6.00	0.01	0.11	0.00000000	25.132
7	0.7	22.0	61.5	115.1	85.0	6.00	0.01	0.07	0.00000000	37.655
8	0.7	22.0	55.1	115.0	85.0	6.00	0.01	0.05	0.00000000	50.265
9	0.7	22.0	55.7	114.2	85.0	6.00	0.01	0.0	0.00000000	0.00000000

N	W#	P#	Y#	P#T#	W#T#	LF	LS	LF	UM	UU	UPT
ALA						FT/SEC	LBP/SEC	FT/SEC	FT/SEC	FT/SEC	MACH
1	0.0014	0.0014	0.5486	0.0015	0.000000	160.82	0.000000	160.82	0.000000	74.86	0.064
2	0.0028	0.0028	0.5486	0.0030	0.000000	180.82	0.000000	180.82	0.000000	74.82	0.064
3	0.0014	0.0014	0.5485	0.0015	0.000000	180.50	0.000000	180.50	0.000000	74.86	0.064
4	0.0014	0.0014	0.5488	0.0015	0.000000	180.76	0.000000	180.76	0.000000	74.81	0.064
5	0.0014	0.0014	0.5488	0.0015	0.000000	180.69	0.000000	180.69	0.000000	74.78	0.064
6	0.0014	0.0014	0.5476	0.0015	0.000000	180.54	0.000000	180.54	0.000000	74.72	0.064
7	0.0014	0.0014	0.5476	0.0015	0.000000	180.86	0.000000	180.86	0.000000	74.85	0.064
8	0.0014	0.0014	0.5478	0.0015	0.000000	181.25	0.000000	181.25	0.000000	75.01	0.064
9	0.0014	0.0014	0.5491	0.0015	0.000000	180.89	0.000000	180.89	0.000000	74.86	0.064

TABLE VIII. PERFORMANCE DATA FOR THE THREE-RING DIFFUSOR CONFIGURATION

TERTIARY BOX										
N	WT*	PT*	TT*	PT/TT*	WT/TT*.44	LM/SEC	BT	LP	UE	
RUN						LBM/SEC	LBM/SEC	FT/SEC	FT/SEC	
1	C.0	0.687	0.586	0.0724	0.0	*****	0.0	*****	*****	
2	C.0178	0.854	0.586	0.0584	0.017	*****	0.07	*****	*****	
3	C.0322	0.656	0.585	0.0480	0.031	*****	0.12	*****	*****	
4	C.0531	0.509	0.588	0.0326	0.051	*****	0.25	*****	*****	
5	C.0675	0.225	0.588	0.0237	0.066	*****	0.28	*****	*****	
6	C.0758	0.0158	0.588	0.0166	0.074	*****	0.32	*****	*****	
7	C.0866	0.0091	0.576	0.0096	0.085	*****	0.38	*****	*****	
8	C.1010	0.0070	0.578	0.0074	0.055	*****	0.28	*****	*****	
9	*****	0.0	0.591	0.0	*****	*****	*****	*****	*****	

FIXING STACK PRESSURE DISTRIBUTION FOR RUN: 9 POSITION A

X/E:	C.C	0.25	0.50	0.75	1.00	1.50
POSITION: P2C1:	1.940	1.430	1.180	1.050	0.850	0.720
POSITION: P2C2:	0.272	0.200	0.165	0.147	0.115	0.101

FIXING STACK PRESSURE DISTRIBUTION FOR RUN: 9 POSITION B

X/E:	0.0	0.25	0.50	0.75	1.00	1.50
POSITION: P2C1:	2.130	1.370	1.140	1.020	0.910	0.710
POSITION: P2C2:	0.299	0.152	0.160	0.143	0.128	0.100

TABLE VIII (CONTINUED)

CATA TOWER CP 7 AUG 1978 BY LENKE AND STAEHLI
 S/C = 05: PORTED MIXING STACK, CLCSEC CONFIGURATION, BASE LINE DATA

ALPHER CF PRIMARY NOZZLES: 4
 PRIMARY NOZZLE DIAMETER: 3.7C INCHES
 MIXING STACK LENGTH: 29.25 INCHES
 MIXING STACK DIAMETER: 11.70 INCHES
 MIXING STACK L/D: 2.90

UP TAKE DIAMETER: 11.5C INCHES
 AREA RATIO, AP/BP: 2.50
 CRIFICE DIAMETER: 6.502 INCHES
 ORIFICE BETA: C.457
 AMBIENT PRESSURE: 29.87 INCHES HG

ALA	FCR	DFCR	TCR	TLPT	TAPE	PU-FA	PA-FS	FA-FM2	SECCALARY AREA
INCHES CF WATER	CEGRES FAHRENHEIT	INCHES OF WATER	SECLARE INCHES						
1	C.7	22.0	62.0	111.5	65.C	3.10	2.21	3.21	0.0
2	0.7	22.C	63.3	116.4	65.C	4.00	2.27	2.27	12.566
3	0.7	22.C	63.5	116.8	65.C	4.55	1.62	1.62	25.112
4	0.7	22.0	61.9	116.6	65.C	5.25	C.55	C.55	50.285
5	C.7	22.0	6C.9	116.2	65.C	5.75	0.27	0.27	1CC.521
6	0.7	22.0	62.2	116.3	65.C	5.50	C.16	0.16	15C.756
7	C.7	22.C	64.0	116.7	65.0	5.55	0.11	0.11	201.062
8	0.7	22.0	64.3	117.6	65.C	6.CC	C.CE	0.C8	24E.16E
9	0.7	22.C	62.0	117.8	65.C	6.C5	C.C1	0.C1	*****

ALA	b4	F4	T4	P4/T4	b4T4.44	WF	b4	LF	LL	UPT MACH	
						LBP/SEC	LEP/SEC	FT/SEC	FT/SEC	FT/SEC	
1	C.0	0.422	C.5185	0.4825	0.C	3.121	C.C	182.68	72.04	75.60	0.064
2	0.1734	0.5653	C.5177	0.3326	0.1670	3.720	0.645	182.25	84.42	75.44	0.064
3	0.2921	0.2183	C.5171	0.2381	0.2822	3.719	1.050	182.08	52.25	75.35	0.064
4	C.4482	0.1282	0.5174	0.1397	0.4315	3.725	1.670	182.00	102.42	75.22	0.064
5	C.5589	0.0500	0.9180	0.0545	0.5383	3.728	2.084	181.79	109.54	75.23	0.064
6	C.5778	0.C238	0.5179	C.C259	0.5545	2.720	2.150	181.33	110.54	75.C4	0.064
7	C.6113	C.C150	0.5172	0.C163	0.5885	3.717	2.272	181.25	113.11	75.C3	0.064
8	C.6437	0.C102	0.9158	0.0111	0.6153	3.716	2.352	181.51	115.24	75.11	0.064
9	*****	0.CC13	0.5155	0.0015	*****	3.714	*****	181.94	*****	75.25	C.C64

MIXING STACK PRESSURE DISTRIBUTION FOR RUN: 9 POSITION A

P/L:	C.C	C.25	0.50	0.75	1.00	1.25	1.50	1.75	2.C0
P/SIM:	*****	*****	0.865	0.675	0.550	0.375	*****	*****	0.075
P/S:	*****	*****	0.117	0.C91	0.072	0.051	*****	*****	0.010

MIXING STACK PRESSURE DISTRIBUTION FOR RUN: 9 POSITION B

P/L:	0.C	C.25	0.50	0.75	1.00	1.25	1.50	1.75	2.C0
P/SIM:	*****	*****	0.925	0.780	0.670	0.416	C.250	*****	0.070
P/S:	*****	*****	0.125	0.105	0.090	0.055	C.035	*****	0.CC5

(a) CLOSED CONFIGURATION

TABLE IX. PERFORMANCE DATA FOR THE PORTED MIXING STACK

DATA TAKEN ON 7 ALG 157E BY LENNE AND STAENLI
 S/C = .5; FCATED MIXING STACK, A-1 CONFIGURATION, SECONDARY BOX OPEN

NUMBER OF PRIMARY NOZZLES: 4
 PRIMARY NOZZLE DIAMETER: 3.70 INCHES
 MIXING STACK LENGTH: 29.25 INCHES
 MIXING STACK DIAMETER: 11.70 INCHES
 MIXING STACK L/D: 2.50

UPTAKE DIAMETER: 11.50 INCHES
 AREA RATIO, AP/AP1: 2.50
 ORIFICE DIAMETER: 6.902 INCHES
 CRIFICE BETA: 0.497
 AMBIENT PRESSURE: 29.55 INCHES HG

N	FCR	DFCR	TCR	TUPT	TIME	PU-PA	PA-FS	FA-PT	SECONDARY AREA	TERTIARY AREA
RUN	INCHES CF WATER	DEGREES FAHRENHEIT	INCHES CF WATER	SQUARE INCHES	SQUARE INCHES	INCHES CF WATER	UP	UM	FT/SEC	FT/SEC
1	0.7	22.0	75.5	130.2	85.0	6.10	0.0	0.26	0.00000000	0.0
2	0.7	22.0	77.3	129.0	85.0	6.10	0.0	0.13	0.00000000	3.142
3	0.7	22.0	76.3	129.1	85.0	6.05	0.0	0.08	0.00000000	6.283
4	0.7	22.0	75.2	125.0	85.0	6.10	0.0	0.04	0.00000000	12.566
5	0.7	22.0	76.0	125.5	85.0	6.05	0.0	0.02	0.00000000	18.850
6	0.7	22.0	75.1	125.1	85.0	6.05	0.0	0.02	0.00000000	25.133
7	0.7	22.0	72.4	129.6	85.0	6.10	0.0	0.01	0.00000000	37.655
8	0.7	22.0	71.0	130.1	85.0	6.00	0.0	0.0	0.00000000	50.265
9	0.7	22.0	72.4	130.3	85.0	6.05	0.0	0.0	0.00000000	0.00000000

SECONDARY BOX

N	h ₀	P ₀	T ₀	P ₀ /T ₀	W ₀ T ₀ .44	MP	L ₀ M/SEC	L ₀ S	UP	UM	LL	LPT
RUN									FT/SEC	FT/SEC	FT/SEC	MACH
1	0.000000	0.0	0.5302	0.0	0.000000	3.682	0.000000	103.21	0.000000	0.000000	75.82	0.064
2	0.000000	0.0	0.5321	0.0	0.000000	3.676	0.000000	102.52	0.000000	0.000000	75.54	0.064
3	0.000000	0.0	0.5319	0.0	0.000000	3.660	0.000000	102.72	0.000000	0.000000	75.62	0.064
4	0.000000	0.0	0.5321	0.0	0.000000	3.683	0.000000	102.89	0.000000	0.000000	75.69	0.064
5	0.000000	0.0	0.5313	0.0	0.000000	3.681	0.000000	102.51	0.000000	0.000000	75.65	0.064
6	0.000000	0.0	0.5319	0.0	0.000000	3.664	0.000000	102.54	0.000000	0.000000	75.71	0.064
7	0.000000	0.0	0.5311	0.0	0.000000	3.650	0.000000	102.29	0.000000	0.000000	75.85	0.064
8	0.000000	0.0	0.5303	0.0	0.000000	3.677	0.000000	102.52	0.000000	0.000000	75.70	0.064
9	0.000000	0.0	0.5300	0.0	0.000000	3.650	0.000000	103.60	0.000000	0.000000	75.58	0.064

(b) A-1 CONFIGURATION

TABLE IX (CONTINUED)

TERTIARY ECA										
A	WT#	PT#	TT#	PT#/TT#	HT#TT#	44	LP	BT	LP	UE
RUN							LBM/SEC	LBM/SEC	FT/SEC	FT/SEC
1	C.C	0.C351	0.5302	0.0378	0.0	3.642	C.C	C.C	*****	72.63
2	C.0102	0.C160	0.5221	0.C154	0.010	3.676	0.04	0.04	*****	72.11
3	C.0162	0.C111	0.5319	0.0119	0.C16	3.660	C.C6	C.C6	*****	72.61
4	C.0242	0.C662	0.5321	0.C067	0.C24	3.643	0.C5	0.C5	*****	74.24
5	C.0243	0.C628	0.5313	0.0030	0.024	3.621	0.05	0.05	*****	74.27
6	C.0280	0.C621	0.5319	0.0022	0.C21	3.644	C.10	C.10	*****	74.55
7	C.0242	0.C614	0.5311	0.C015	0.022	3.650	0.12	0.12	*****	72.19
8	C.0	0.C	0.5303	0.0	0.0	3.677	0.C	0.C	*****	72.51
9	*****	0.0	0.5300	0.C	*****	3.650	*****	*****	*****	72.78

PIXINE STACK PRESSURE DISTRIBUTION FOR RUN: 9 POSITION B

POS:	0.0	C.25	C.50	0.75	1.00	1.25	1.50	1.75	2.00
POS(1M. P2C):	1.72C	C.68C	0.750	0.670	*****	0.380	C.28C	*****	0.070
POS(2M. P2C):	0.236	0.093	0.103	0.092	*****	0.052	C.638	*****	0.010

PIXINE STACK PRESSURE DISTRIBUTION FOR RUN: 9 POSITION A

POS:	0.0	0.25	0.50	0.75	1.00	1.25	1.50	1.75	2.00
POS(1M. P2C):	1.56C	*****	0.850	0.660	0.520	0.365	*****	*****	0.080
POS(2M. P2C):	C.214	*****	0.117	0.091	0.071	0.050	*****	*****	0.011

TABLE IX (b) (CONTINUED)

CATA TAKEN ON 7 AUG 1976 BY LENKE AND STABEPLI
 S/C - .5: SCRTIC PILING STACK, A-1 B-1 CONFIGURATION, SECONDARY BOX OPEN

ALPHEX CF PRIMARY ACZLES: 4
 PRIMARY ACZLE DIAPETES: 3.70 INCHES
 PILING STACK LENGTH: 29.25 INCHES
 PILING STACK DIAPETER: 11.70 INCHES
 PILING STACK L/C: 2.50

LPTAKE DIAPETES: 11.50 INCHES
 AREA RATIC, AP/PI: 2.50
 ORIFICE DIAPETER: 6.5C2 INCHES
 CRIFICE BETA: C.457
 AMBIENT PRESSURE: 29.55 INCHES HG

N	FLA	FCR	DFCB	TCR	TUPT	TAPT	PU-FA	PA-PS	PA-PT	SECONDARY AREA	TERTIARY AREA
		INCHES	GF WATER	DEGREES	FARENHEIT		INCHES	CF WATER		SQARE INCHES	SQARE INCHES
1		0.7	22.C	73.3	129.9	55.C	6.10	0.0	0.41	*****	0.0
2		0.7	22.0	77.7	130.3	55.C	6.C5	0.0	0.25	*****	3.142
3		0.7	22.0	76.8	130.4	98.0	6.C0	0.0	0.16	*****	6.283
4		0.7	22.C	78.5	131.0	98.C	6.C0	0.0	0.C5	*****	12.566
5		0.7	22.0	71.7	130.7	98.C	6.C5	C.0	0.05	*****	18.850
6		C.7	22.C	71.0	130.7	98.0	6.C0	0.0	0.02	*****	25.122
7		0.7	22.0	77.9	131.0	98.C	6.C5	C.C	0.C2	*****	37.659
8		0.7	22.C	77.9	131.3	50.C	6.CC	0.0	0.01	*****	50.245
9		C.7	22.C	77.8	130.9	98.C	6.C0	0.C	C.C	*****	*****

SECURE) RCX	HP	TO	FO	PTO	HTOP	HP	LEP/SEC	LS	LF	UP	UL	UPT
					FT/SEC		FT/SEC	FT/SEC	FT/SEC	FT/SEC	FT/SEC	MACH
1	*****	0.0	0.5459	0.0	*****	3.65C	*****	*****	183.49	*****	75.54	0.064
2	*****	0.C	0.5453	0.0	*****	3.675	*****	*****	182.87	*****	75.66	0.064
3	*****	0.C	0.5451	0.0	*****	3.671	*****	*****	182.71	*****	75.61	0.064
4	*****	0.C	0.5441	0.0	*****	3.672	*****	*****	182.55	*****	75.71	0.064
5	*****	0.C	0.5446	0.0	*****	3.675	*****	*****	182.55	*****	75.72	0.064
6	*****	0.C	0.5446	0.0	*****	3.677	*****	*****	182.11	*****	75.78	0.064
7	*****	0.C	0.5441	0.0	*****	3.674	*****	*****	182.05	*****	75.75	0.064
8	*****	C.C	0.5437	0.0	*****	3.674	*****	*****	182.14	*****	75.75	0.064
9	*****	0.C	0.5443	C.C	*****	3.675	*****	*****	182.04	*****	75.75	0.064

(C) A-1, B-1 CONFIGURATION

TABLE IX (CONTINUED)

TERTIARY BOX										
A	WTO	FTO	TTO	PTO/TTO	WTOT100.44	BP	LPM/SEC	LT	LP	UE
RUA										
1	C.0	0.0565	0.5459	0.0598	0.0	3.650	C.C	C.C	*****	72.74
2	C.0142	0.0351	0.5453	0.0372	0.014	3.675	0.05	0.05	*****	73.52
3	C.0227	0.0225	0.5451	0.0238	0.022	3.671	C.CE	C.CE	*****	74.08
4	C.0341	0.0126	0.5441	0.0134	0.033	3.672	0.13	0.13	*****	75.00
5	C.0381	0.0070	0.5446	0.0074	0.037	3.675	0.14	0.14	*****	75.21
6	C.0425	0.0049	0.5446	0.0052	0.041	3.677	C.16	C.16	*****	75.67
7	C.0482	0.0028	0.5441	0.0030	0.047	3.674	0.18	0.18	*****	76.06
8	C.0455	0.0014	0.5437	0.0015	0.044	3.674	C.17	C.17	*****	75.50
9	*****	0.0	0.5443	0.0	*****	3.675	*****	*****	*****	72.56

PIXING STACK PRESSURE DISTRIBUTION FOR RUN: 9 POSITION A

X/C:	0.0	C.25	C.50	0.75	1.00	1.25	1.50	1.75	2.00
PPS11A. P2C1:	1.410	*****	0.700	0.670	0.510	0.370	*****	*****	C.CEC
PPS2:	C.198	*****	0.098	0.094	0.072	0.052	*****	*****	0.011

PIXING STACK PRESSURE DISTRIBUTION FOR RUN: 9 POSITION B

X/C:	0.0	C.25	0.50	0.75	1.00	1.25	1.50	1.75	2.00
PPS11B. P2C1:	1.410	C.610	C.690	0.700	*****	0.390	0.270	*****	0.080
PPS2:	C.198	C.114	0.097	0.094	*****	0.055	0.03E	*****	0.011

TABLE IX (C) (CONTINUED)

DATA TAKEN ON 7 AUG 1978 BY LEHKE AND STAEPPLI
 S/E = .5; FCPTEE MIXING STACK, A-1 B-1 C-2 CONFIGURATION, SECONDARY EGT OPEN

ALPHER CF PRIMARY NOZZLES: 4
 PRIMARY NOZZLE DIAPETER: 3.70 INCHES
 MIXING STACK LENGTH: 29.25 INCHES
 MIXING STACK DIAPETER: 11.70 INCHES
 MIXING STACK L/C: 2.5C

LPTAKE DIAPETER: 11.50 INCHES
 AREA RATIO, AP/AL: 2.50
 ORIFICE DIAPETER: 6.5C2 INCHES
 CRIFICE BETA: C.457
 AMBIENT PRESSURE: 29.55 INCHES HG

N	FCR	DFCP	TCR	TUPT	TAPE	PU-PA	PA-FS	PA-PT	SECONDARY AREA	TERTIARY AREA
FLA	INCHES	GF WATER	DEGREES	FARENHEIT	INCHES	CF WATER	INCHES	CF WATER	SCLAFE INCHES	SQUARE INCHES
1	0.7	22.C	76.1	132.7	102.C	6.10	0.0	0.45	*****	0.C
2	0.7	22.C	78.2	132.0	102.C	6.1C	0.C	0.24	*****	2.142
3	0.7	22.0	76.7	132.0	102.C	6.10	0.0	0.26	*****	6.262
4	0.7	22.C	76.1	132.5	102.0	6.C5	C.C	0.15	*****	12.566
5	0.7	22.0	77.5	132.2	102.C	6.C5	0.0	0.1C	*****	18.850
6	0.7	22.0	75.3	132.4	102.0	6.C5	0.0	0.08	*****	25.122
7	0.7	22.0	8C.8	132.6	102.C	6.CC	0.0	0.C4	*****	37.659
8	0.7	22.0	76.5	132.5	102.C	6.CC	C.C	0.03	*****	50.265
9	0.7	22.C	77.9	132.8	102.0	6.05	0.0	0.0	*****	*****

SECONDARY ECM	W#	F#	T#	P#/T#	W/T#	WF	WS	LF	UF	UL	UPT MACH
RUN						LBP/SEC	LBP/SEC	FT/SEC	FT/SEC	FT/SEC	
1	*****	0.C	0.5466	0.0	*****	2.674	*****	103.85	*****	76.C8	0.064
2	*****	0.C	0.5453	0.0	*****	2.672	*****	102.21	*****	75.66	0.064
3	*****	0.C	0.5453	0.C	*****	3.671	*****	102.22	*****	75.62	0.064
4	*****	0.C	0.5465	0.0	*****	2.672	*****	102.48	*****	75.53	0.064
5	*****	0.C	0.5490	0.0	*****	3.676	*****	102.45	*****	75.54	0.064
6	*****	0.C	0.5487	0.0	*****	3.665	*****	102.24	*****	75.62	0.064
7	*****	0.C	0.5483	0.0	*****	3.664	*****	102.05	*****	75.75	0.064
8	*****	C.C	C.5485	0.0	*****	3.672	*****	102.41	*****	75.50	0.064
9	*****	0.C	0.5480	0.0	*****	2.674	*****	102.61	*****	75.58	0.064

(d) A-1, B-1, C-2 CONFIGURATION

TABLE IX (CONTINUED)

TERTIARY BOX										
A	WTO	FTO	TTO	PTO/TTO	WTO/100.44	W	LBM/SEC	BT	LP	UE
RUA								LBP/SEC	FT/SEC	FT/SEC
1	C.C	0.C630	0.5466	0.0666	0.C	3.674	C.C	C.C	*****	72.88
2	0.0164	0.C472	0.5493	0.0457	0.C16	3.673	C.C6	C.C6	*****	72.86
3	C.C285	0.C367	0.5493	C.C386	0.C28	3.671	C.11	C.11	*****	74.72
4	C.C431	0.C204	0.5485	0.0215	C.C42	3.672	C.16	C.16	*****	75.87
5	C.C537	0.C141	0.5490	0.0148	0.C52	3.676	0.20	0.20	*****	76.64
6	C.C621	0.C106	0.5487	0.0111	0.C61	3.665	C.22	C.22	*****	77.15
7	0.0722	0.C064	0.5483	0.C067	C.C71	3.664	0.26	0.26	*****	77.81
8	C.C765	0.CC42	X.5485	0.0045	0.C77	3.672	C.25	C.25	*****	78.41
9	*****	0.C	0.5460	C.C	*****	3.674	*****	*****	*****	72.78

PIXIE STACK PRESSURE DISTRIBUTION FOR RUN: 9 POSITION A

R/C:	0.0	0.25	0.50	0.75	1.00	1.25	1.50	1.75	2.00
FPSI/A. P2C1:	1.28C	*****	0.650	0.520	0.410	0.350	*****	*****	0.07C
FPS:	0.180	*****	0.091	0.073	0.056	0.045	*****	*****	0.01C

PIXIE STACK PRESSURE DISTRIBUTION FOR RUN: 9 POSITION B

R/C:	0.0	0.25	0.50	0.75	1.00	1.25	1.50	1.75	2.00
FPSI/A. P2C1:	1.260	0.76C	0.580	0.530	*****	0.435	0.300	*****	0.080
FPS:	0.177	0.058	0.081	0.074	*****	0.061	0.042	*****	0.011

TABLE IX (d) (CONTINUED)

DATA TAKEN ON 7 AUG 1978 BY LEMKE AND STAEMLI
 S/C #3: FERTEC MIXING STACK, A-1 B-1 C-2 D-2 CONFIGURATION, SECONDARY BOX OPEN

NUMBER OF PRIMARY NOZZLES: 4 UFTAKE DIAMETER: 11.50 INCHES
 PRIMARY NOZZLE DIAMETER: 3.70 INCHES AREA RATIO, AP/AF: 2.50
 MIXING STACK LENGTH: 29.25 INCHES ORIFICE DIAMETER: 6.502 INCHES
 MIXING STACK DIAMETER: 11.70 INCHES CRIPICE BETA: C.457
 MIXING STACK L/C: 2.50 AMBIENT PRESSURE: 29.55 INCHES HG

N	FCR	DPCR	TCR	TLPT	TEMP	PU-FA	PA-PS	PA-PT	SECONDARY AREA	TERTIARY AREA
RUN	INCHES CF WATER	DEGREES FAHRENHEIT			INCHES CF WATER	SQUARE INCHES	SQUARE INCHES	SQUARE INCHES		
1	0.7	22.0	77.1	131.6	102.0	6.10	0.0	0.42	*****	0.0
2	0.7	22.0	77.5	131.2	102.0	6.10	0.0	0.22	*****	3.142
3	0.7	22.0	76.7	120.9	102.0	6.05	0.0	0.25	*****	6.282
4	0.7	22.0	76.0	131.8	102.0	6.00	0.0	0.16	*****	12.566
5	0.7	22.0	75.1	132.2	102.0	6.00	0.0	0.11	*****	18.850
6	0.7	22.0	76.2	131.4	102.0	6.05	0.0	0.08	*****	25.122
7	0.7	22.0	77.5	131.9	102.0	6.00	0.0	0.05	*****	37.699
8	0.7	22.0	76.7	121.7	102.0	6.00	0.0	0.03	*****	50.265
9	0.7	22.0	75.3	132.8	102.0	6.00	0.0	0.0	*****	*****

SECONDARY BOX

A	WF	TF	PF/TF	WF	LF	UP	UL	UPT
RUN	LBM/SEC	LBM/SEC	FT/SEC	FT/SEC	FT/SEC	FT/SEC	FT/SEC	MACH
1	*****	0.0	0.5499	0.0	*****	3.677	*****	0.064
2	*****	0.0	0.5506	0.0	*****	3.676	*****	0.064
3	*****	0.0	0.5511	0.0	*****	3.671	*****	0.064
4	*****	0.0	0.5496	0.0	*****	3.674	*****	0.064
5	*****	0.0	0.5490	0.0	*****	3.670	*****	0.064
6	*****	0.0	0.5503	0.0	*****	3.673	*****	0.064
7	*****	0.0	0.5495	0.0	*****	3.676	*****	0.064
8	*****	0.0	0.5498	0.0	*****	3.671	*****	0.064
9	*****	0.0	0.5480	0.0	*****	3.665	*****	0.064

(e) A-1, B-1, C-2, D-2 CONFIGURATION

TABLE IX (CONTINUED)

TERTIARY EXH											
RUN	N	WT#	FT#	TT#	PI#/TT#	HT#/TT#	HM	LBM/SIC	LBP/SEC	LP	UE
1	C.0	0.C584	0.5499	0.0615	0.0	3.677	C.C	*****	*****	*****	72.65
2	C.0161	0.C456	0.5506	0.0475	0.C16	3.676	0.C6	*****	*****	*****	73.78
3	C.02E3	0.C354	0.5511	0.0372	0.028	3.671	C.1C	*****	*****	*****	74.55
4	C.0445	0.C221	0.5496	0.0233	C.44	3.674	C.16	*****	*****	*****	75.92
5	C.0567	0.C157	0.5490	0.0165	0.055	3.670	0.21	*****	*****	*****	76.75
6	C.0637	0.C112	0.5503	0.0117	0.C62	3.672	C.23	*****	*****	*****	77.22
7	0.0744	0.C068	0.5495	0.C071	C.C73	3.676	0.27	*****	*****	*****	78.11
8	C.C826	C.CC48	0.5498	0.0051	0.C62	3.671	C.31	*****	*****	*****	78.66
5	*****	0.C	0.5480	0.0	*****	3.665	*****	*****	*****	*****	72.65

PIXING STACK PRESSURE DISTRIBUTION FOR RUN: 9 POSITION A

X/C:	0.0	C.25	0.50	0.75	1.00	1.25	1.50	1.75	2.00
FPS(IN. P2C):	1.220	*****	0.610	0.433	0.340	0.271	*****	*****	0.061
FPS#:	0.172	*****	0.086	0.061	0.048	0.038	*****	*****	0.011

PIXING STACK PRESSURE DISTRIBUTION FOR RUN: 9 POSITION B

X/C:	0.0	0.25	0.50	0.75	1.00	1.25	1.50	1.75	2.00
FPS(IN. P2C):	1.240	C.67C	0.500	0.463	*****	0.398	0.278	*****	0.080
FPS#:	0.175	C.054	0.070	0.06f	*****	0.056	0.039	*****	0.011

TABLE IX (C) (CONTINUED)

DATA TAKEN ON 14 AUGUST 1978 BY LEMKE AND STAEBLI
 S/C 0-5: PORTED STACK WITH 2 RING DIFF. (A-1 B-1 C-2 D-2); TERTIARY BOX CLOSED

ALPHER CF PRIMARY NOZZLES: 4
 FIFTHARY NOZZLE DIAMETER: 3.70 INCHES
 PIPING STACK LENGTH: 28.25 INCHES
 PIPING STACK DIAMETER: 11.70 INCHES
 MIXING STACK L/D: 2.41

LPTAKE DIAMETER: 11.50 INCHES
 AREA RATIO, AM/AP: 2.50
 ORIFICE DIAMETER: 6.902 INCHES
 ORIFICE BETA: 0.457
 AMBIENT PRESSURE: 29.55 INCHES HG

N	FOR	DPCR	TCR	TUPT	TAPE	PU-PA	PA-PS	PA-FAZ	SECNCARY AREA
PLN	INCHES CF WATER	DEGREES	FA-REN	FEIT	INCHES OF WATER	SCUAPE	INCHES		
1	0.7	22.0	54.5	106.0	68.0	2.45	3.74	3.74	0.0
2	0.7	22.0	54.5	108.5	68.0	3.60	2.64	2.64	12.566
3	0.7	22.0	54.5	108.5	68.0	4.25	1.53	1.53	25.133
4	0.7	22.0	55.0	108.5	68.0	5.00	1.14	1.14	50.265
5	0.7	22.0	54.5	108.5	68.0	5.60	0.46	0.46	100.531
6	0.7	22.0	55.0	106.5	68.0	5.75	0.27	0.27	150.756
7	0.7	22.0	55.0	106.5	68.0	5.85	0.16	0.16	201.062
8	0.7	22.0	55.0	106.5	66.0	5.90	0.10	0.10	245.044
9	0.7	22.0	55.0	106.0	68.0	6.00	0.02	0.02	*****

N	h*	F*	T*	P*/T*	M*/100.44	hP	WS	LF	LM	LU
FLA						LBM/SEC	LBM/SEC	FT/SEC	FT/SEC	FT/SEC
1	0.0	0.5046	0.5295	0.5428	0.0	3.757	C.C	181.57	72.59	75.14
2	0.1656	0.2561	0.5287	0.3835	0.1757	3.757	0.657	181.23	84.87	75.00
3	0.3175	0.2623	0.5287	0.2824	0.2072	3.757	1.153	180.52	53.56	74.87
4	0.4882	0.1584	0.5287	0.1705	0.1724	3.755	1.833	180.45	104.75	74.65
5	0.6159	0.0630	0.5287	0.0678	0.6001	3.757	2.325	180.26	113.52	74.60
6	0.7128	0.0370	0.5287	0.0399	0.6500	3.755	2.676	180.09	115.64	74.53
7	0.7316	0.0220	0.5287	0.0236	0.7082	3.755	2.747	180.04	120.87	74.51
8	0.7649	0.0137	0.5287	0.0148	0.6822	3.755	2.647	180.02	115.08	74.50
9	*****	0.0028	0.5255	0.0030	*****	3.755	*****	175.82	*****	74.42

PIPING STACK PRESSURE DISTRIBUTION FOR RUN: 9 POSITION A

PLN	P/C	0.0	0.25	0.50	0.75	1.00	1.25	1.50
PPS(1)	P(1)	2.980	*****	1.520	1.390	1.310	1.290	*****
PPS(2)	P(2)	0.410	*****	0.209	0.191	0.160	0.177	*****

MIXING STACK PRESSURE DISTRIBUTION FOR RUN: 9 POSITION B

PLN	P/D	0.0	0.25	0.50	0.75	1.00	1.25	1.50
PPS(1)	P(1)	2.970	1.540	1.380	1.390	*****	1.390	1.310
PPS(2)	P(2)	0.409	0.212	0.190	0.191	*****	0.151	0.160

(a) TERTIARY BOX CLOSED

TABLE X. PERFORMANCE DATA FOR THE PORTED MIXING STACK WITH TWO-RING DIFFUSOR

CATA TAKEN ON 14 AUGUST 1970 BY LEPKE AND STAEMLI
 S/C 0-5: FORTEC STACK WITH 2 RING CLIFF. (A-1 0-1 C-2 D-2) 1 TERTIARY BOX OPEN

ALPREF CF PRIMARY NOZZLES: 4
 PRIMARY NOZZLE DIAMETER: 3.70 INCHES
 PIPING STACK LENGTH: 20.25 INCHES
 PIPING STACK DIAMETER: 11.70 INCHES
 PIPING STACK L/S: 2.41

UFTAKE DIAMETER: 11.50 INCHES
 AREA RATIO, A₁/A₂: 2.50
 ORIFICE DIAMETER: 6.52 INCHES
 CRIFICE BETA: C.457
 AMBIENT PRESSURE: 29.55 INCHES HG

N	FCR	DECF	TCR	TLPT	TAPE	PU-PA	PA-PS	FA-F1	SECNDARY AREA	TERTIARY AREA
FLA	INCHES CF WATER	DEGREES FAHRENHEIT				INCHES CF WATER			SQARE INCHES	SQARE INCHES
1	0.7	22-C	54.0	101.0	68.C	6.C0	0.02	0.58	*****	0.0
2	0.7	22-C	54.0	101.0	68.C	6.C0	0.02	0.62	*****	3.142
3	0.7	22-C	54.0	101.0	68.C	6.C0	0.02	0.72	*****	6.282
4	0.7	22-C	54.0	101.0	68.C	6.C0	0.02	0.53	*****	12.566
5	0.7	22.0	54.0	101.0	68.C	6.C0	0.02	0.41	*****	18.850
6	0.7	22.0	55.0	101.0	68.C	6.C0	0.02	0.22	*****	25.122
7	0.7	22.0	55.0	101.5	68.C	6.C0	0.02	0.21	*****	37.699
8	0.7	22.0	54.0	101.0	68.C	6.C0	0.02	0.14	*****	50.265
9	0.7	22-C	54.0	101.0	68.C	6.C0	0.02	0.02	*****	*****

SECNDARY BOX	M4	F4	T4	P4/T4	W4/T4	LF	LF/SEC	UL	UL/SEC	UPT MACH	
AUP						LBM/SEC	LBP/SEC	FT/SEC	FT/SEC		
1	*****	3.C027	0.5295	0.0030	*****	3.758	*****	180.00	*****	74.45	0.064
2	*****	0.C027	0.5295	0.0030	*****	3.758	*****	180.00	*****	74.45	0.064
3	*****	0.C027	0.5295	0.0030	*****	3.758	*****	180.00	*****	74.45	0.064
4	*****	0.C027	0.5295	0.0030	*****	3.758	*****	180.00	*****	74.45	0.064
5	*****	0.C027	0.5295	0.0030	*****	3.758	*****	180.00	*****	74.45	0.064
6	*****	0.C028	0.5295	0.0030	*****	3.758	*****	175.82	*****	74.42	0.064
7	*****	0.C027	0.5287	0.0030	*****	3.758	*****	175.98	*****	74.48	0.064
8	*****	0.C027	0.5295	0.0030	*****	3.758	*****	180.00	*****	74.45	0.064
9	*****	0.C027	0.5295	0.0030	*****	3.758	*****	180.00	*****	74.45	0.064

(c) SECONDARY BOX OPEN (TERTIARY PUMPING)

TABLE X (CONTINUED)

REFLARY BOX										
A	WTO	FTO	TTO	PTO/TTO	WTO/TTO	BP	LBM/SIC	BT	LP	UE
RUN								LBM/SEC	FT/SEC	FT/SEC
1	C.0	0.1345	0.5295	0.1447	0.C	*****	*****	C.C	*****	*****
2	C.0260	0.1135	0.5295	0.1226	0.C25	*****	*****	C.1C	*****	*****
3	C.04E5	0.0588	0.5295	0.1063	0.C47	*****	*****	C.1E	*****	*****
4	C.0821	0.0728	0.5295	0.0783	0.C61	*****	*****	C.21	*****	*****
5	C.1057	0.0563	0.5295	0.0606	0.1C6	*****	*****	0.41	*****	*****
6	C.1253	0.0440	0.5295	0.0474	0.125	*****	*****	C.45	*****	*****
7	0.1572	0.0288	0.5287	0.0210	C.152	*****	*****	0.55	*****	*****
8	C.1765	C.0152	0.5295	0.0207	0.166	*****	*****	C.64	*****	*****
9	*****	0.0027	0.5295	0.0030	*****	*****	*****	*****	*****	*****

PIXING STACK PRESSURE DISTRIBUTION FOR RUN: 9 POSITION A

X/C:	C.0	C.25	C.50	0.75	1.00	1.25	1.50
FPS(IN. P2C):	1.550	*****	0.810	C.660	0.570	0.500	*****
FPS:	C.218	*****	0.111	0.C51	0.078	0.065	*****

PIXING STACK PRESSURE DISTRIBUTION FOR RUN: 9 POSITION B

X/C:	0.0	0.25	0.50	0.75	1.00	1.25	1.50
FPS(IN. P2C):	1.66C	C.02C	0.710	0.670	*****	0.670	0.610
FPS:	C.231	C.113	0.097	0.C92	*****	0.092	0.084

TABLE X (c) (CONTINUED)

DATA TAKEN ON 23 AUGUST 1970 BY LEMKE AND STAEBLI
 S/C-5: FCRTEC STACK WITH 2 RING DIFFUSOR AND SHROUD, TERTIARY BOX CLOSED

ALPHEP CF PRIMARY NOZZLES: 4
 UFTAKE DIAMETER: 11.50 INCHES
 AREA FATIC, AP/SP: 2.50
 ORIFICE DIAPETEF: 6.502 INCHES
 CRIFICE BETA: C.497
 AMBIENT PRESSURE: 29.58 INCHES HG

N	FCR	D/CR	TCR	TLPT	TAPE	PU-FA	PA-PE	PA-PMZ	SECONDARY AREA
RUA	INCHES OF WATER	DEGREES FAHRENHEIT	INCHES CF WATER	INCHES CF WATER	SQUARE INCHES	INCHES CF WATER	SQUARE INCHES	SQUARE INCHES	SQUARE INCHES
1	0.7	22.0	72.0	125.0	88.0	3.00	3.34	3.34	0.0
2	0.7	22.0	73.5	124.5	88.0	3.65	2.52	2.52	12.566
3	0.7	22.0	71.5	124.5	88.0	4.25	1.50	1.50	25.132
4	0.7	22.0	71.5	124.5	88.0	4.90	1.16	1.16	50.265
5	0.7	22.0	68.0	123.0	88.0	5.65	0.45	0.49	100.521
6	0.7	22.0	71.0	124.0	88.0	5.80	0.25	0.25	150.796
7	0.7	22.0	70.0	124.0	88.0	5.50	0.16	0.16	201.062
8	0.7	22.0	70.5	124.0	88.0	5.90	0.11	0.11	245.044
9	0.7	22.0	70.0	124.0	88.0	6.00	0.02	0.02	0.00000000

N	MP	BS	LF	LL	LPT	PACH
RUA	LB/SEC	LB/SEC	FT/SEC	FT/SEC	FT/SEC	FT/SEC
1	3.656	0.0	182.62	72.41	75.55	0.064
2	3.651	0.669	182.83	65.45	75.66	0.064
3	3.656	1.162	182.50	94.57	75.65	0.064
4	3.698	1.616	182.56	106.50	75.55	0.064
5	3.710	2.261	182.40	116.40	75.48	0.064
6	3.700	2.529	182.08	115.47	75.55	0.064
7	3.703	2.658	182.22	122.63	75.41	0.064
8	3.701	2.726	182.11	123.12	75.36	0.064
9	3.703	0.00000	182.16	0.00000	75.38	0.064

MIXING STACK PRESSURE DISTRIBUTION FOR RUN: 9 POSITION A
 X/C: C.C 0.25 0.50 0.75 1.00 1.25 1.50
 P/SEC: 0.00000 0.00000 1.210 1.150 1.070 0.990 0.00000
 P/SEC: 0.00000 0.00000 0.168 0.160 0.145 0.138 0.00000

MIXING STACK PRESSURE DISTRIBUTION FOR RUN: 9 POSITION B
 X/C: 0.0 0.25 0.50 0.75 1.00 1.25 1.50
 P/SEC: 0.00000 1.320 1.150 1.040 0.00000 1.070 0.550
 P/SEC: 0.00000 0.183 0.160 0.145 0.00000 0.145 0.132

(a) TERTIARY BOX CLOSED

TABLE XI. PERFORMANCE DATA FOR THE PORTED MIXING STACK WITH TWO-RING DIFFUSOR AND SHROUD

DATA TAKEN ON 23 AUGUST 1978 BY LENKE AND STAEMLI
 S/C-5: FCTEC STACK WITH 2 RING DIFFUSOR AND SHROULD, TERTIARY BOX CPFA

ALPHEX CF PRIMARY NOZZLES: 4
 PRIMARY NOZZLE DIAMETER: 3.7C INCHES
 PIDDING STACK LENGTH: 25.25 INCHES
 PIDDING STACK DIAMETER: 11.70 INCHES
 PIDDING STACK L/C: 2.50

LPTAKE DIAMETER: 11.50 INCHES
 AREA RATIO, AP/AP: 2.50
 ORIFICE DIAMETER: 6.5C2 INCHES
 CRIFICE BETA: 0.457
 AMBIENT PRESSURE: 25.56 INCHES HG

A	POB	CPOR	TCR	TUPT	TAPB	PU-FA	PA-PS	PA-FAZ	SECQUADAFY AREA	LF	LP	LU	LPT
RAA	INCHES OF WATER	DEGREES FAHRENHEIT	INCHES OF WATER	INCHES OF WATER	INCHES OF WATER	INCHES OF WATER	INCHES OF WATER	INCHES OF WATER	SQUARE INCHES	F1/SEC	FT/SEC	FT/SEC	MACH
1	0.7	22.0	71.0	123.0	88.0	3.40	2.85	2.65	0.0	182.55	73.15	75.71	0.064
2	0.7	22.0	65.0	122.5	86.0	4.05	2.14	2.14	15.708	182.61	67.21	75.45	0.064
3	0.7	22.0	71.0	123.0	88.0	4.55	1.61	1.61	26.214	182.38	95.12	75.48	0.064
4	0.7	22.0	69.0	123.5	88.0	5.20	0.94	0.94	53.467	182.58	104.56	75.56	0.064
5	0.7	22.0	70.5	124.0	88.0	5.70	0.35	0.35	103.673	182.23	112.93	75.41	0.064
6	0.7	22.0	65.0	122.0	88.0	5.90	0.15	0.15	153.938	182.05	114.52	75.36	0.064
7	0.7	22.0	70.0	122.5	86.0	5.50	0.11	0.11	204.203	182.64	114.70	75.34	0.064
8	0.7	22.0	71.0	124.0	88.0	5.55	0.09	0.09	245.044	182.01	118.27	75.52	0.064
9	0.7	22.0	70.0	124.0	88.0	6.00	0.01	0.01	*****	182.15	*****	75.58	0.064

PIPING STACK PRESSURE DISTRIBUTION FOR RUN: 9 POSITION A

P/C:	0.0	0.25	0.50	0.75	1.00	1.25	1.50
PPS(LIN. P/C):	*****	*****	1.030	0.510	0.800	0.750	*****
PPS(S):	*****	*****	0.143	0.126	0.115	0.104	*****

PIPING STACK PRESSURE DISTRIBUTION FOR RUN: 9 POSITION B

P/C:	0.0	0.25	0.50	0.75	1.00	1.25	1.50
PPS(LIN. P/C):	*****	1.120	0.940	0.820	*****	0.790	0.650
PPS(S):	*****	0.156	0.131	0.114	*****	0.110	0.050

(b) TERTIARY BOX OPEN

TABLE XI (CONTINUED)

CATA TAKEN ON 22 AUGUST 1976 BY LENKE AND STAEBLI
 S/C-5: FC7EC STACK WITH 2 RING DIFFUSOR AND SHROUD, SECONDARY BOX OPEN

ALPHER CF PRIMARY NOZZLES: 4
 PRIMARY NOZZLE DIAPETER: 3.70 INCHES
 PIPING STACK LENGTH: 29.25 INCHES
 PIPING STACK DIAPETER: 11.70 INCHES
 PIPING STACK L/C: 2.50

LPTAKE DIAPETER: 11.50 INCHES
 AREA RATIO, AP/AF: 2.50
 ORIFICE DIAPETER: 6.52 INCHES
 CRIFICE BETA: 0.457
 AMBIENT PRESSURE: 29.58 INCHES HG

N	PCR	DFCR	TCR	TUPT	TAPT	PU-PA	PA-PS	PA-PT	SECONDARY AREA	TERTIARY AREA
PWA	INCHES OF WATER	DEGREES FAHRENHEIT	INCHES CF WATER	FT/SEC	FT/SEC	UM	FT/SEC	FT/SEC	FT/SEC	UPT MACH
1	0.7	22.0	71.5	125.0	85.0	6.00	0.0	0.55	*****	0.0
2	0.7	22.0	71.0	125.0	85.0	6.00	0.0	0.47	*****	3.142
3	0.7	22.0	72.0	125.5	85.0	5.55	0.0	0.40	*****	6.283
4	0.7	22.0	70.0	125.0	85.0	6.00	0.0	0.26	*****	12.566
5	0.7	22.0	70.0	125.0	85.0	6.00	0.0	0.20	*****	18.850
6	0.7	22.0	65.5	125.0	85.0	6.00	0.0	0.14	*****	25.132
7	0.7	22.0	71.5	124.0	85.0	6.00	0.0	0.08	*****	37.699
8	0.7	22.0	65.0	122.5	85.0	6.00	0.0	0.06	*****	50.265
9	0.7	22.0	71.5	123.5	85.0	6.00	0.0	0.0	*****	*****

SECONDARY BOX

N	LN	PS	TS	PP/TW	WPTW.44	MP	LS	UP	UM	LU	
RLN						LBM/SEC	LEM/SEC	FT/SEC	FT/SEC	FT/SEC	
1	*****	0.0	0.5367	0.0	*****	3.658	*****	182.20	*****	75.40	0.064
2	*****	0.0	0.5267	0.0	*****	3.700	*****	182.29	*****	75.44	0.064
3	*****	0.0	0.5359	0.0	*****	3.656	*****	182.27	*****	75.43	0.064
4	*****	0.0	0.5367	0.0	*****	3.703	*****	182.46	*****	75.51	0.064
5	*****	0.0	0.5367	0.0	*****	3.652	*****	181.54	*****	75.20	0.064
6	*****	0.0	0.5367	0.0	*****	3.705	*****	182.55	*****	75.54	0.064
7	*****	0.0	0.5363	0.0	*****	3.658	*****	181.89	*****	75.27	0.064
8	*****	0.0	0.5391	0.0	*****	3.707	*****	182.16	*****	75.55	0.064
9	*****	0.0	0.5391	0.0	*****	3.658	*****	181.72	*****	75.21	0.064

(c) SECONDARY BOX OPEN (TERTIARY PUMPING)

TABLE XI (CONTINUED)

TERTIARY RCK										
A	WTO	FTO	TTO	P14/TTO	WTT100.44	NP	LT	LP	UE	
RUN					LBM/SEC	LBP/SEC	FT/SEC	FT/SEC	FT/SEC	
1	C.0	0.0764	0.5367	0.0816	0.0	3.65E	C.6	*****	50.55	
2	C.0155	0.0652	0.5367	0.0656	0.015	3.70E	C.67	*****	51.97	
3	C.0361	0.0555	0.5359	0.0553	0.035	3.65E	C.13	*****	52.81	
4	C.0580	0.0460	0.5367	0.0364	0.056	3.70E	C.21	*****	52.59	
5	C.0756	0.0272	0.5367	0.0250	0.072	3.653	0.28	*****	54.73	
6	C.0851	0.0194	0.5367	0.0207	0.082	3.70E	C.32	*****	55.25	
7	C.0967	0.0112	0.5383	0.0119	0.094	3.65E	0.26	*****	55.78	
8	C.1114	0.0063	0.5391	0.0089	0.108	3.70E	C.41	*****	56.62	
5	*****	0.0	C.5351	C.6	*****	3.65E	*****	*****	50.82	

PIXING STACK PRESSURE DISTRIBUTION FOR RUN: 9 POSITION A

X/C:	0.0	C.25	X.50	0.75	1.00	1.25	1.50
FPS(LN. P2C):	*****	*****	1.030	C.520	0.830	0.770	*****
FPS:	*****	*****	0.144	0.128	0.116	0.108	*****

PIXING STACK PRESSURE DISTRIBUTION FOR RUN: 9 POSITION B

X/C:	0.0	0.25	0.50	0.75	1.00	1.25	1.50
FPS(LN. P2C):	*****	1.14C	0.930	0.830	*****	0.810	0.650
FPS:	*****	0.159	0.130	0.116	*****	0.112	0.091

TABLE XI (C) CONTINUED

CATA TAKEN ON 22 AUGUST 1976 BY LENKE AND STAEPFLI
 S/C-5: PORTEC STACK WITH 2 RING DIFFUSOR AND SPROUD-DIAFH. REMOVEC

ALPEER CF FRIPAFY ACZLES: 4
 FRIPARY NOZZLE DIAPETER: 3.70 INCHES
 MIXING STACK LENGTH: 29.25 INCHES
 MIXING STACK DIAPETER: 11.70 INCHES
 MIXING STACK L/D: 2.50

LPTAKE DIAPETER: 11.50 INCHES
 AREA RATIC, AP/AF: 2.50
 ORIFICE DIAPETER: 6.502 INCHES
 ORIFICE BETA: 0.497
 AMBIENT PRESSURE: 29.98 INCHES HG

PLA	FCF	CPOR	TCR	TUPT	TAPE	PU-PA	PA-PE	FA-FAZ	SECONDARY AREA
	INCHES CF WATER	INCHES CF WATER	DEGREES FAHRENHEIT	INCHES CF WATER	INCHES CF WATER	INCHES CF WATER	INCHES CF WATER	INCHES CF WATER	INCHES CF WATER
1	0.7	22.0	72.0	125.0	88.0	3.60	2.62	2.42	C.C
2	0.7	22.0	70.0	125.0	88.0	4.10	2.05	2.05	12.566
3	0.7	22.0	71.0	125.0	88.0	4.50	1.62	1.62	25.122
4	0.7	22.0	71.0	125.0	88.0	5.10	0.84	0.84	56.265
5	0.7	22.0	71.0	125.0	88.0	5.60	0.71	0.71	100.531
6	0.7	22.0	65.0	125.0	88.0	5.80	0.25	0.25	150.796
7	0.7	22.0	65.0	124.0	88.0	5.50	0.16	0.16	201.042
8	0.7	22.0	66.0	123.0	88.0	6.00	0.12	0.12	245.044
9	0.7	22.0	65.0	124.0	88.0	6.00	C.C	C.C	*****

PLA	WF	LF	LF	LF	LF	LF	LF	LF	LF
	LB/SEC	LB/SEC	FT/SEC	FT/SEC	FT/SEC	FT/SEC	FT/SEC	FT/SEC	FT/SEC
1	3.656	C.C	182.20	72.28	75.66	0.064			
2	3.702	0.604	182.28	84.45	75.69	0.064			
3	3.700	1.673	183.01	92.97	75.74	0.064			
4	3.700	1.545	182.66	101.52	75.55	0.064			
5	3.700	2.841	182.60	125.44	75.57	0.064			
6	3.707	2.529	182.74	119.72	75.62	0.064			
7	3.707	2.458	182.39	122.70	75.48	0.064			
8	3.710	2.847	182.23	125.40	75.42	0.064			
9	3.707	*****	182.32	*****	75.45	0.064			

MIXING STACK PRESSURE DISTRIBUTION FOR RUN: 9 POSITION A
 X/E: 0.0 0.25 0.50 0.75 1.00 1.25 1.50
 PPS(1N. 12C): ***** 1.260 1.120 1.010 0.870 *****
 PPS(5): ***** 0.175 0.155 0.140 0.121 *****

MIXING STACK PRESSURE DISTRIBUTION FOR RUN: 9 POSITION B
 X/E: 0.0 0.25 0.50 0.75 1.00 1.25 1.50
 PPS(1N. 12C): ***** 1.560 1.220 1.020 ***** 0.880 0.680
 PPS(5): ***** 0.216 0.169 0.142 ***** 0.122 0.054

(d) TOTAL PERFORMANCE
 TABLE XI (CONTINUED)

CATA TAKEP CA 29 AUGUST BY LEMKE AND STAEPLI
S/C = .51 SPRUCED PORTED STACK AND TWO SOLID DIFFUSOR RINGS, TERT. EXH CLOSE

NUMBER OF PRIMARY NOZZLES: 4
PRIMARY NOZZLE DIAPETER: 3.70 INCHES
PIPING STACK LENGTH: 29.25 INCHES
PIPING STACK DIAPETER: 11.70 INCHES
PIPING STACK L/C: 2.50

UPTAKE DIAPETER: 11.50 INCHES
AREA RATIO, AM/AP: 2.50
CRIPICE DIAPETER: 6.902 INCHES
CRIPICE BETA: 0.457
AMBIENT PRESSURE: 29.51 INCHES HG

N	FCR	DFCF	TCR	TUPT	TAPE	PL-PA	PA-PS	FA-FA2	SECCALARY AREA
RUN	INCHES	CF WATER	DEGREES	FAPRENHEIT	INCHES	CF WATER	INCHES	CF WATER	SQUARE INCHES
1	0.7	22.0	55.5	108.5	64.C	3.00	3.25	3.35	C.C
2	0.7	22.0	55.0	108.5	64.0	3.65	2.55	2.55	12.566
3	0.7	22.0	56.0	109.0	64.C	4.20	1.92	1.52	25.132
4	0.7	22.C	56.0	105.0	64.C	4.55	1.18	1.18	50.265
5	0.7	22.0	55.0	109.0	64.0	5.60	0.50	0.50	100.531
6	0.7	22.0	56.0	109.0	64.C	5.80	0.24	0.24	150.796
7	0.7	22.C	56.0	109.0	64.C	5.85	0.16	0.16	201.062
8	0.7	22.0	56.0	109.0	64.0	5.90	0.12	0.12	245.044
9	0.7	22.0	56.0	109.0	64.C	6.CC	0.02	0.C2	*****

N	W*	P*	T*	P*/T*	WF	LS	UF	UM	UU	UPT
RUN	C.O	C.1832	C.3183	C.4591	C.6451	C.6752	C.7351	C.7555	*****	MACH
1	0.4455	0.2432	0.5217	0.4977	0.0	3.750	181.50	72.56	75.11	0.064
2	0.2432	0.5217	0.3723	0.1768	3.752	0.688	181.23	84.62	75.00	0.064
3	0.5209	0.2815	0.3070	0.2815	3.745	1.153	180.53	53.44	74.88	0.064
4	0.1599	0.1599	0.1599	0.1599	3.745	1.871	180.60	105.25	74.74	0.064
5	0.0679	0.0679	0.0737	0.6260	3.752	2.436	180.47	115.23	74.65	0.064
6	0.0327	0.0327	0.0355	0.6512	3.745	2.521	180.18	116.60	74.57	0.064
7	0.0218	0.0218	0.0237	0.7085	3.749	2.756	180.14	120.76	74.55	0.064
8	0.0157	0.0157	0.0170	0.7325	3.749	2.647	180.12	122.37	74.54	0.064
9	0.0027	0.0027	0.0030	*****	3.745	*****	180.08	*****	74.53	0.064

(a) TERTIARY BOX CLOSED

TABLE XII. PERFORMANCE DATA FOR THE PORTED STACK WITH TWO-RING DIFFUSOR AND SHROUD CUT BACK ONE-HALF INCH FROM MIXING STACK ENTRANCE

CATA TAKEN ON 25 AUGUST BY LEMME AND STAEBLI
 S/C = .5; SPRUEC PCRTED STACK AND TWO SOLID DIFFUSOR RINGS, TERT. BOX OPEN

NUMBER OF FIFTHY NOZZLES: 4
 FIFTHY NOZZLE DIAMETER: 2.70 INCHES
 PIPING STACK LENGTH: 29.25 INCHES
 PIPING STACK DIAMETER: 11.70 INCHES
 PIPING STACK L/D: 2.50

UPTAKE DIAMETER: 11.50 INCHES
 AREA FATIC, AN/AP: 2.50
 CRIFICE DIAPETEF: 6.902 JACKES
 CRIFICE BETA: C.457
 AMBIENT PRESSURE: 29.91 INCHES HG

N	FOR	CPCR	TCR	TUPT	TAPE	PU-FA	FA-FE	FA-FM2	SECCARY AREA
ALA	INCHES CF WATER	DEGREES FAHRENHEIT	INCHES CF WATER	SQUARE INCHES	C.O	UF	UM	UU	UPT MACH
1	0.7	22.0	54.0	106.0	65.C	3.40	3.89	3.85	11.566
2	0.7	22.0	53.5	106.5	69.0	4.00	2.18	2.18	25.133
3	0.7	22.0	54.5	106.5	65.C	4.50	1.67	1.67	50.265
4	0.7	22.C	54.0	107.0	65.0	5.20	C.57	0.97	100.521
5	0.7	22.C	55.0	107.0	65.C	5.65	0.55	C.25	150.796
6	0.7	22.C	55.0	107.5	69.0	5.60	0.21	C.21	201.062
7	0.7	22.0	54.5	107.5	65.0	5.90	0.14	0.14	245.044
8	0.7	22.0	54.5	107.5	65.C	5.55	0.1C	0.1C	*****
9	0.7	22.C	54.5	108.0	65.C	6.00	0.01	0.01	*****

(b) TERTIARY BOX OPEN

TABLE XII (CONTINUED)

DATA TAKEN ON 25 AUGUST BY LENKE AND STAEPLI
 S/E-5; SPROUEEC PRTEEC STACK AND TWO SOLID DIFFUSOR RINGS, TERT. BOX CONTROLLED

ALPHER CF PRIMARY NOZZLES: 4
 PRIMARY NOZZLE DIAPETER: 3.70 INCHES
 PILING STACK LENGTH: 29.25 INCHES
 PILING STACK DIAPETER: 11.70 INCHES
 PILING STACK L/E: 2.50

LPTAKE DIAPETER: 11.50 INCHES
 AREA RATIC, AP/AF: 2.50
 ORIFICE DIAPETER: 6.902 INCHES
 CRIFICE BETA: 0.457
 AMBIENT PRESSURE: 25.51 INCHES HG

FLA	FCR	CECF	TCR	TUPT	TAPR	PU-PA	PA-PS	PA-FT	SEC/CAFY AREA	TERTIARY AREA
	INCHES	CF WATER	DEGREES	FARENHEIT	INCHES	CF WATER	INCHES	CF WATER	SQUARE INCHES	SQUARE INCHES
1	0.7	22.0	55.0	105.0	73.0	6.00	0.0	0.55	*****	0.0
2	0.7	22.0	55.0	109.0	73.0	6.00	0.0	0.45	*****	3.142
3	0.7	22.0	56.0	105.0	73.0	6.00	0.0	0.28	*****	6.282
4	0.7	22.0	55.5	109.0	73.0	6.00	0.0	0.27	*****	12.566
5	0.7	22.0	55.5	105.0	73.0	6.00	0.0	0.21	*****	18.850
6	0.7	22.0	55.5	105.0	73.0	6.00	0.0	0.15	*****	25.123
7	0.7	22.0	54.0	105.0	73.0	6.00	0.0	0.05	*****	37.699
8	0.7	22.0	55.0	105.0	73.0	6.00	0.0	0.07	*****	50.265
9	0.7	22.0	55.0	105.0	73.0	6.00	0.0	0.01	*****	*****

SEC/CAFY	ECX	W*	F*	T*	P*/T*	WF	WE	LF	LU	LPT
						LBP/SEC	LBP/SEC	FT/SEC	FT/SEC	MACH
1	*****	0.0	0.5367	0.0	*****	2.752	*****	180.25	74.55	0.064
2	*****	0.0	0.5367	0.0	*****	3.752	*****	160.25	74.55	0.064
3	*****	0.0	0.5367	0.0	*****	2.749	*****	180.07	74.52	0.064
4	*****	0.0	0.5367	0.0	*****	3.750	*****	180.16	74.56	0.064
5	*****	0.0	0.5367	0.0	*****	3.751	*****	180.16	74.56	0.064
6	*****	0.0	0.5367	0.0	*****	2.751	*****	180.16	74.56	0.064
7	*****	0.0	0.5367	0.0	*****	3.756	*****	180.42	74.67	0.064
8	*****	0.0	0.5367	0.0	*****	3.752	*****	180.25	74.55	0.064
9	*****	0.0	0.5367	0.0	*****	2.752	*****	180.25	74.59	0.064

(C) TERTIARY BOX CONTROLLED

TABLE XII (CONTINUED)

TERTIARY BCH		WT*	FT*	TT*	PT/TT*	NT/TT**44	LM	LRP/SEC	LT	LP	UE
N	RCA										
1		C.0	0.0761	0.5367	0.0812	G.C	3.752	C.C		*****	50.40
2		C.C151	0.0623	0.5367	0.0665	0.015	3.752	0.07		*****	51.27
3		C.C351	0.0527	0.5367	0.0562	C.C34	3.745	0.13		*****	52.12
4		0.0551	0.0374	0.5267	C.C399	0.057	3.710	C.22		*****	53.26
5		C.0762	0.0291	0.5367	0.0311	C.C76	3.751	0.29		*****	54.22
6		0.0882	C.C208	0.5367	0.0222	0.066	3.751	0.33		*****	54.82
7		0.1023	0.0124	0.5367	0.0133	0.099	3.756	0.38		*****	55.62
8		C.1160	0.0050	0.5367	0.0096	0.113	3.752	0.44		*****	56.25
9		*****	0.0014	0.5367	0.0015	*****	3.752	*****		*****	*****

MIXING STACK PRESSURE DISTRIBUTION FOR RUN: 9 POSITION A

X/E:	0.0	C.25	0.50	0.75	1.00	1.25	1.50
FPS(IN. P20):	*****	*****	0.850	0.760	C.65C	0.64C	*****
FPS:	*****	*****	0.118	C.1C5	0.055	0.085	*****

MIXING STACK PRESSURE DISTRIBUTION FOR RUN: 9 POSITION B

X/D:	0.0	C.25	0.50	0.75	1.00	1.25	1.50
FPS(IN. P20):	*****	C.510	0.720	0.690	*****	0.750	0.620
FPS:	*****	C.126	0.100	0.095	*****	0.104	0.086

TABLE XII (c) (CONTINUED)

DATA TAKEN ON 29 AUGUST BY LEMPE AND STAEHLI
S/C-5: SPRINGLOADED STACK AND THE SOLID DIFFUSOR RINGS-TOTAL PERFORMANCE

ALBREF CF PRIMARY NOZZLES: 4
 PRIMARY NOZZLE DIAMETER: 3.70 INCHES
 PILING STACK LENGTH: 29.25 INCHES
 PILING STACK DIAMETER: 11.70 INCHES
 PILING STACK L/D: 2.50

LPTAKE DIAMETER: 11.50 INCHES
 AREA FATIC, AM/API: 2.50
 CRIFICE DIAMETER: 6.502 INCHES
 CRIFICE BETA: 0.457
 AMBIENT PRESSURE: 29.91 INCHES HG

PLA	N	h*	F*	1*	P*/T*	M*/T*/.44	hF	LBM/SEC	hS	UF	LM	UU	UPT	MACH
		INCHES	CF WATER	TCR	TUPT	TAPT	PU-FA	INCHES	CF WATER	PA-PNZ	SECONDARY AREA			
				DEGREES	FAMRN/FT						SQUARE			
											INCHES			
1	0.7	22.0	56.9	114.5	82.0	3.60	2.61	2.61	0.0					
2	0.7	22.0	58.0	114.0	82.0	4.10	2.12	2.12	12.566					
3	0.7	22.0	60.0	114.0	82.0	4.50	1.70	1.70	25.133					
4	0.7	22.0	66.0	114.0	82.0	5.00	1.34	1.34	50.265					
5	0.7	22.0	60.0	114.0	82.0	5.50	0.57	0.57	100.531					
6	0.7	22.0	60.0	114.0	82.0	5.70	0.22	0.22	150.796					
7	0.7	22.0	55.0	114.0	82.0	5.80	0.15	0.15	201.062					
8	0.7	22.0	60.5	114.0	82.0	5.50	0.11	0.11	245.044					
9	0.7	22.0	60.5	114.0	82.0	6.00	0.0	0.0	*****					

(d) TOTAL PERFORMANCE

TABLE XII (CONTINUED)

DATA TAKEN ON 25 AUGUST BY LEMPE AND STAENLI
 S/E-S: T/F-L FLOW SHROUD AND DIFFUSOR RING ON PORTED STACK, TERT. BOX CFEN

NUMBER OF PRIMARY NOZZLES: 4
 PRIMARY NOZZLE DIAMETER: 3.7C INCHES
 MIXING STACK LENGTH: 25.25 INCHES
 MIXING STACK DIAMETER: 11.70 INCHES
 MIXING STACK L/C: 2.50

LPTAKE DIAMETER: 11.50 INCHES
 AREA RATIO, AP/AF: 2.50
 ORIFICE DIAMETER: 6.5C2 INCHES
 CRIFICE BETA: 0.457
 AMBIENT PRESSURE: 29.51 INCHES HG

RUN	INCHES OF WATER	TCR	TLPT	TAPR	PU-FA	PA-PS	PA-PAZ	SECONDARY AREA
INCHES OF WATER	DEGREES FAHRENHEIT	INCHES CF WATER	SCUAFE INCHES	INCHES CF WATER	SCUAFE INCHES	SCUAFE INCHES	SCUAFE INCHES	SCUAFE INCHES
1	0.7	22.0	115.5	76.0	3.30	3.12	3.13	0.0
2	0.7	22.0	114.0	76.0	3.80	2.41	2.41	12.566
3	0.7	22.0	114.0	76.0	4.30	1.86	1.86	25.122
4	0.7	22.0	114.0	76.0	5.00	1.14	1.14	50.265
5	0.7	22.0	114.0	76.0	5.60	0.46	0.46	100.531
6	0.7	22.0	113.5	76.0	5.80	0.24	0.24	150.756
7	0.7	22.0	112.5	76.0	5.50	0.16	0.16	201.042
8	0.7	22.0	112.0	76.0	5.90	0.11	0.11	245.044
9	0.7	22.0	113.0	76.0	6.00	0.02	0.02	*****

RUN	h*	F*	T*	F*/T*	WPT**44	LBM/SEC	WS	LF	LL	LPT MACH	
C.C	C.C	C.C	C.C	C.C	C.C	LBM/SEC	LBM/SEC	FT/SEC	FT/SEC	FT/SEC	
1	0.4233	0.5313	0.4545	0.0	0.0	3.24	0.0	182.83	73.10	75.66	0.064
2	0.3282	0.5338	0.3515	0.1716	0.1716	3.78	0.661	182.21	84.81	75.41	0.064
3	0.2540	0.5338	0.2720	0.3014	0.3014	3.78	1.161	181.96	93.76	75.30	0.064
4	0.4867	0.5338	0.1675	0.4722	0.4722	3.78	1.818	181.55	102.48	75.13	0.064
5	0.6180	0.5338	0.0677	0.5556	0.5556	3.78	2.310	181.33	114.29	75.04	0.064
6	0.6656	0.5338	0.0354	0.6455	0.6455	3.78	2.503	181.06	117.67	74.54	0.064
7	0.7289	0.5346	0.0236	0.7015	0.7015	3.78	2.725	181.04	121.67	74.52	0.064
8	0.7366	0.5354	0.0163	0.8153	0.8153	3.78	2.753	180.86	122.12	74.85	0.064
9	*****	0.6026	0.0030	*****	*****	3.78	*****	180.82	*****	74.82	0.064

(a) TERTIARY BOX OPEN

TABLE XIII. PERFORMANCE DATA FOR PORTED MIXING STACK WITH RING DIFFUSOR AND FLOW-THROUGH SHROUD

DATA TAKEN ON 25 AUGUST BY LEMKE AND STAEBLI
 S/C-5: TFFU FLOW SHROULC AND DIFFUSOR RING ON FORTED STACK, TEST. BOX CLOSED

NUMBER OF PRIMARY NOZZLES: 4
 PRIMARY NOZZLE DIAPETER: 3.70 INCHES
 MIXING STACK LENGTH: 25.25 INCHES
 MIXING STACK DIAPETER: 11.70 INCHES
 MIXING STACK L/C: 2.50

LPTAKE DIAPETER: 11.50 INCHES
 AREA RATIO, AP/AF: 2.50
 CRIFICE DIAPETER: 6.502 INCHES
 ORIFICE BETA: 0.457
 AMBIENT PRESSURE: 29.51 INCHES HG

PLA	N	FCR	DFCF	TOR	TLPT	TAPB	PL-FA	PA-FS	FA-FA2	SECONDARY AREA	LL	LPT MACH
		INCHES OF WATER	DEGREES FAHRENHEIT	INCHES OF WATER	INCHES OF WATER	INCHES OF WATER	INCHES OF WATER	INCHES OF WATER	INCHES OF WATER	SCAQUE INCHES	FT/SEC	FT/SEC
1	0.7	22.0	58.0	112.0	75.0	3.20	3.24	3.24	3.24	0.0	75.37	0.064
2	0.7	22.0	56.0	115.0	75.0	3.70	2.52	2.52	2.52	12.566	75.24	0.064
3	0.7	22.0	58.0	112.0	79.0	4.20	1.92	1.92	1.92	25.123	75.13	0.064
4	0.7	22.0	56.0	112.0	79.0	4.90	1.20	1.20	1.20	50.265	74.99	0.064
5	0.7	22.0	56.0	112.0	75.0	5.60	0.90	0.90	0.90	100.521	74.66	0.064
6	0.7	22.0	57.5	112.0	79.0	5.60	0.26	0.26	0.26	150.756	74.85	0.064
7	0.7	22.0	56.0	112.0	75.0	5.50	0.18	0.18	0.18	201.062	74.80	0.064
8	0.7	22.0	57.0	112.0	75.0	5.90	0.12	0.12	0.12	245.044	74.66	0.064
9	0.7	22.0	58.0	112.0	75.0	6.00	0.02	0.02	0.02	*****	74.77	0.064
PLA	N	W*	F*	T*	P*/T*	hP	hS	hF	hL	hU	hV	hW
1	0.441	0.5423	0.4713	0.0	3.741	0.0	0.0	0.0	0.0	0.0	0.0	0.0
2	0.1601	0.5423	0.3679	0.1755	3.741	0.1755	0.1755	0.1755	0.1755	0.1755	0.1755	0.1755
3	0.3144	0.5423	0.2811	0.3063	3.741	0.2811	0.2811	0.2811	0.2811	0.2811	0.2811	0.2811
4	0.4972	0.5423	0.1763	0.4843	3.741	0.1763	0.1763	0.1763	0.1763	0.1763	0.1763	0.1763
5	0.6940	0.5423	0.0737	0.6253	3.741	0.0737	0.0737	0.0737	0.0737	0.0737	0.0737	0.0737
6	0.7702	0.5423	0.0383	0.6760	3.743	0.0383	0.0383	0.0383	0.0383	0.0383	0.0383	0.0383
7	0.7702	0.5423	0.0266	0.7503	3.741	0.0266	0.0266	0.0266	0.0266	0.0266	0.0266	0.0266
8	0.7657	0.5423	0.0177	0.7460	3.745	0.0177	0.0177	0.0177	0.0177	0.0177	0.0177	0.0177
9	*****	0.5423	0.0030	*****	3.741	*****	*****	*****	*****	*****	*****	*****

(b) TERTIARY BOX CLOSED

TABLE XIII (CONTINUED)

DATA TAKEN ON 25 AUGUST BY LEMME AND STAEBLI
S/C-5: TAPU FLOW SPRING AND DIFFUSOR RING ON PORTED STACK, TERT. BOX CONTROLLED

ALBER OF PRIMARY NOZZLES: 4
FFIPARY NOZZLE DIAMETER: 3.7C INCHES
PIPING STACK LENGTH: 29.25 INCHES
MIXING STACK DIAMETER: 11.70 INCHES
MIXING STACK L/C: 2.50

LFTAKE DIAMETER: 11.50 INCHES

AREA RATIO, AM/AP: 2.5C

CRIFICE DIAMETER: 6.5C2 INCHES

ORIFICE BETA: 0.497

AMBIENT PRESSURE: 29.91 INCHES HG

PLA	FCR	DFCF	TOR	TUPT	TAPB	PU-PA	P-P-S	FA-FI	SECCARY AREA	TERTIARY AREA
	INCHES OF WATER	DEGREES FARENHEIT				INCHES CF WATER			SQUARE INCHES	SQUARE INCHES
1	0.7	22.0	56.5	112.5	8C.C	6.C0	0.0	0.25	*****	0.0
2	0.7	22.0	56.0	112.5	8C.C	6.C0	0.0	0.22	*****	3.142
3	0.7	22.0	55.0	112.5	8C.C	6.C0	0.0	0.17	*****	6.283
4	0.7	22.0	58.0	112.0	80.0	6.CC	0.0	0.11	*****	12.566
5	0.7	22.0	58.0	112.0	80.0	6.C0	0.0	0.08	*****	16.850
6	0.7	22.0	56.0	112.0	80.0	6.C0	C.C	0.C5	*****	25.133
7	0.7	22.0	56.0	112.0	80.C	6.C0	C.C	0.03	*****	37.699
8	C.7	22.0	55.0	112.0	80.0	6.C0	0.C	0.02	*****	50.265
9	0.7	22.0	59.0	113.0	80.C	6.00	0.C	0.C	*****	*****

SEC(CRCAF) ECK

N	h0	F0	T0	P0/T0	h0/T00.44	MP	WS	LF	LM	UL	LFT
RLA						LBM/SEC	LBM/SEC	FT/SEC	FT/SEC	FT/SEC	MACH
1	*****	0.C	0.5432	0.0	*****	3.740	*****	180.74	*****	74.60	0.064
2	*****	C.C	0.5432	0.0	*****	3.741	*****	180.63	*****	74.64	0.064
3	*****	C.C	0.5432	0.0	*****	3.73E	*****	180.6E	*****	74.76	0.064
4	*****	0.C	0.5440	0.0	*****	3.741	*****	180.67	*****	74.77	0.064
5	*****	0.C	0.5440	0.0	*****	3.741	*****	180.67	*****	74.77	0.064
6	*****	0.0	0.5440	0.0	*****	3.741	*****	180.67	*****	74.77	0.064
7	*****	0.C	0.5440	0.0	*****	3.741	*****	180.67	*****	74.77	0.064
8	*****	0.C	0.5440	0.0	*****	3.73E	*****	180.50	*****	74.7C	0.064
9	*****	0.C	0.5424	0.C	*****	3.73E	*****	180.82	*****	74.6E	0.064

(C) TERTIARY BOX CONTROLLED

TABLE XIII (CONTINUED)

TERTIARY BCX		FT#	TT#	PT#	MT#	LB#	NT	LP	LE
N	WT#					SEC	SEC	FT/SEC	FT/SEC
RUN									
1	0.0	0.0397	0.5432	C.0421	0.0	3.740	C.C	*****	50.54
2	C.0133	C.0306	C.5432	0.0325	C.013	3.741	0.05	*****	51.24
3	0.0235	C.0240	C.5432	0.0254	0.022	3.738	C.C5	*****	51.71
4	0.0271	0.0145	C.5440	0.0158	0.034	3.741	0.14	*****	52.40
5	C.0475	C.0105	C.5440	0.0115	0.044	3.741	0.18	*****	52.52
6	0.0497	0.0067	C.5440	0.0071	0.048	3.741	C.15	*****	53.03
7	C.0565	0.0035	C.5440	0.0041	0.055	3.741	0.21	*****	53.40
8	C.0556	0.0021	0.5440	0.0022	0.054	3.738	C.21	*****	52.28
9	*****	0.0	0.5424	0.0	*****	3.738	*****	*****	50.56

PIXING STACK PRESSURE DISTRIBUTION FOR RUN: 9 POSITION A

X/C:	0.0	0.25	0.50	0.75	1.00	1.25	1.50
POSITION F2C:	*****	*****	0.960	0.880	0.820	0.740	*****
POSITION F2S:	*****	*****	0.134	0.123	0.114	0.102	*****

PIXING STACK PRESSURE DISTRIBUTION FOR RUN: 9 POSITION B

X/D:	0.0	0.25	0.50	0.75	1.00	1.25	1.50
POSITION F2C:	*****	1.020	0.890	0.790	*****	0.830	0.730
POSITION F2S:	*****	0.142	0.124	0.110	*****	0.116	0.102

TABLE XIII (C) (CONTINUED)

CATA TAKEN CN 29 AUGUST BY LEHKE AND STAHLI
 S/E-5: TPR FLOW SHROUD AND DIFFUSOR RING CN FORTED STACK, TCTAL PERFORMANCE

ALPHER CF PRIMARY NOZZLES: 4
 PRIMARY NOZZLE DIAMETER: 3.7C INCHES
 MIXING STACK LENGTH: 29.25 INCHES
 MIXING STACK DIAMETER: 11.70 INCHES
 MIXING STACK L/E: 2.50

LPTAKE DIAMETER: 11.50 INCHES
 AREA FATIC, AP/DF: 2.50
 ORIFICE DIAMETER: 6.502 INCHES
 ORIFICE BETA: C.457
 AMBIENT PRESSURE: 29.91 IACHES HG

N	FCR	DPOR	TCR	TUPT	TAPB	PU-FA	PA-PS	FA-FAZ	SECCNARY AREA
RLA	INCHES	CF WATER	DEGREES	FARENHEIT	INCHES OF WATER	INCHES OF WATER	INCHES OF WATER	INCHES OF WATER	INCHES OF WATER
1	0.7	22.0	59.0	114.0	80.0	3.5C	2.66	2.66	0.0
2	0.7	22.0	55.5	114.0	80.0	4.00	2.08	2.08	12.566
3	0.7	22.0	60.0	114.0	80.0	4.5C	1.70	1.7C	25.133
4	0.7	22.0	55.0	114.0	80.0	5.00	1.11	1.11	50.245
5	0.7	22.0	61.0	114.0	80.0	5.50	C.46	0.46	100.531
6	0.7	22.0	6C.0	114.0	80.0	5.7C	0.23	0.22	150.756
7	0.7	22.0	60.0	114.0	80.0	5.80	0.15	0.15	201.042
8	C.7	22.0	61.0	114.5	80.0	5.5C	C.11	0.11	245.044
9	0.7	22.0	6C.5	114.0	80.0	6.00	C.00	0.00	*****

N	WF	WS	LF	UP	LL	LPT
RLA	LBM/SEC	LBM/SEC	FT/SEC	FT/SEC	FT/SEC	MACH
1	3.72E	C.0	182.22	72.45	75.45	0.064
2	3.72E	C.612	181.97	83.90	75.21	0.064
3	3.72E	1.106	181.71	92.81	75.20	0.064
4	3.72E	1.787	181.63	105.19	75.16	0.064
5	3.721	2.501	181.55	114.30	74.50	0.064
6	3.724	2.441	181.06	116.88	74.92	0.064
7	3.734	2.628	181.02	120.28	74.51	0.064
8	3.721	2.742	181.55	122.36	74.50	0.064
9	3.732	*****	180.87	*****	74.85	0.064

(d) TOTAL PERFORMANCE

TABLE XIII (CONTINUED)

DATA TAKEN ON 1 FEB 1978 BY LEMKE AND STAEPLI
 S/C=5; L/C=3.0
 STRAIGHT STACK; 4 NOZZLES (3.38 IN.)

AMBIENT PRESSURE = 30.500 IN.HGA, TEMPERATURE = 74.0 DEG.FAHR

PRIMARY (LPTAKE) TEMPERATURE = 116.2 DEG.FAHR

X INCHES	R	PTA IN.+20	PTE	VA FT/SEC	VB	VA/VAV	VB/VAV	VA/LF	VB/LF
C.0	5.875	1.80	1.25	91.2	76.0	0.7172	0.5577	0.4235	0.3525
C.500	5.375	4.30	2.60	141.0	109.6	1.1085	0.8620	0.6545	0.5050
1.000	4.875	4.65	2.70	146.6	111.7	1.1527	0.8764	0.6807	0.5187
1.500	4.375	5.00	2.55	152.0	116.8	1.1953	0.9161	0.7058	0.5421
2.000	3.875	5.00	3.20	152.0	121.6	1.1953	0.9562	0.7058	0.5647
2.500	3.375	4.70	3.40	147.4	125.4	1.1589	0.9857	0.6843	0.5820
3.000	2.875	4.30	3.60	141.0	129.0	1.1085	1.0143	0.6545	0.5585
3.500	2.375	4.00	3.60	136.0	132.5	1.0691	1.0420	0.6313	0.6153
4.000	1.875	3.80	3.75	132.5	131.7	1.0420	1.0352	0.6153	0.6113
4.500	1.375	3.60	3.60	129.0	129.0	1.0143	1.0143	0.5985	0.5985
5.000	0.875	3.35	3.50	124.4	127.2	0.9784	1.0001	0.5777	0.5905
5.500	0.375	3.30	3.40	123.5	125.4	0.9711	0.9857	0.5734	0.5820
6.000	C.125	3.30	3.50	123.5	127.2	0.9711	1.0001	0.5734	0.5905
6.500	0.625	3.50	3.55	127.2	128.1	1.0001	1.0072	0.5905	0.5947
7.000	1.125	3.65	3.70	129.5	130.8	1.0213	1.0282	0.6030	0.6072
7.500	1.625	3.50	3.80	134.3	132.5	1.0557	1.0420	0.6234	0.6153
8.000	2.125	4.25	3.50	140.2	134.3	1.1020	1.0557	0.6507	0.6234
8.500	2.625	4.45	3.70	143.4	130.8	1.1277	1.0282	0.6655	0.6072
9.000	3.125	4.85	3.45	149.7	126.3	1.1772	0.9925	0.6951	0.5863
9.500	3.625	4.90	3.15	150.5	120.7	1.1833	0.9467	0.6987	0.5602
10.000	4.125	5.10	2.50	153.5	115.8	1.2072	0.9103	0.7126	0.5375
10.500	4.625	4.70	2.75	147.4	112.7	1.1589	0.8865	0.6843	0.5234
11.000	5.125	4.20	2.50	139.3	107.5	1.0955	0.8452	0.6465	0.4951
11.500	5.625	2.20	1.70	100.8	88.6	0.7929	0.6570	0.4662	0.4116
11.750	5.875	2.20	1.30	100.8	77.5	0.7929	0.6055	0.4662	0.3555

INTEGRATED FLOW RATE = 55.77 CU.FT/SEC
 = 6.935 LBM/SEC

AVERAGE VELOCITY = 127.18 FT/SEC

PRIMARY FLOW RATE, WP = 3.765 LBM/SEC

PRIMARY VELOCITY, LP = 215.38 FT/SEC

MOMENTUM FACTOR, KM = 1.017

(a) L/D = 3.0

TABLE XIV. EXIT VELOCITY DATA FOR A STRAIGHT MIXING STACK
 WITH 3.38 IN. NOZZLES

DATA TAKEN ON 27 FEB 1978 BY LEMKE AND STAEHLI
 S/C = 5; L/C = 2.5
 STRAIGHT STACK; 4 NG22LES (3.38 IN.)

APRIENT PRESSURE = 29.810 IN.HGA, TEMPERATURE = 78.0 DEG.FAHR
 FFIMARY (UPTAKE) TEMPERATURE = 112.5 DEG.FAHR

X INCHES	R	PTA IN.+20	PTE	VA FT/SEC	VB	VA/VAV	VE/VAV	VA/LP	VB/UF
0.0	5.875	1.05	1.05	70.4	70.4	0.5364	0.5364	0.3238	0.3238
0.500	5.375	3.30	1.70	124.5	69.6	0.9509	0.6825	0.5740	0.4120
1.000	4.875	4.35	1.90	143.4	94.8	1.0917	0.7215	0.6590	0.4355
1.500	4.375	4.95	2.15	152.5	100.8	1.1646	0.7675	0.7030	0.4633
2.000	3.875	5.80	2.45	165.6	111.9	1.2606	0.8521	0.7610	0.5144
2.500	3.375	6.20	3.10	171.2	121.0	1.3033	0.9216	0.7868	0.5563
3.000	2.875	5.90	3.50	167.0	128.6	1.2714	0.9752	0.7675	0.5911
3.500	2.375	5.45	3.75	160.5	133.1	1.2220	1.0136	0.7376	0.6119
4.000	1.875	4.70	3.90	149.0	135.8	1.1348	1.0337	0.6850	0.6240
4.500	1.375	3.90	3.65	135.8	131.3	1.0337	1.0000	0.6240	0.6037
5.000	0.875	3.50	3.40	128.6	126.8	0.9752	0.9652	0.5911	0.5826
5.500	0.375	3.25	3.25	123.9	123.9	0.9436	0.9436	0.5656	0.5656
6.000	0.125	3.10	3.15	121.0	122.0	0.9216	0.9290	0.5563	0.5608
6.500	0.625	3.20	3.40	123.0	126.8	0.9363	0.9652	0.5652	0.5826
7.000	1.125	3.40	3.55	126.8	129.5	0.9652	0.9662	0.5826	0.5953
7.500	1.625	3.70	3.70	132.2	132.2	1.0068	1.0068	0.6078	0.6078
8.000	2.125	4.00	3.85	137.5	134.9	1.0469	1.0270	0.6319	0.6200
8.500	2.625	4.50	3.75	145.8	133.1	1.1104	1.0136	0.6703	0.6119
9.000	3.125	5.10	3.65	155.2	131.3	1.1821	1.0000	0.7126	0.6037
9.500	3.625	5.90	3.40	167.0	126.8	1.2714	0.9652	0.7675	0.5826
10.000	4.125	6.30	2.80	172.5	115.0	1.3138	0.8755	0.7951	0.5287
10.500	4.625	6.00	2.60	168.4	110.8	1.2821	0.8440	0.7740	0.5095
11.000	5.125	5.40	2.70	159.7	113.0	1.2163	0.8601	0.7243	0.5192
11.500	5.625	4.20	2.30	140.9	104.3	1.0727	0.7938	0.6475	0.4792
11.750	5.875	1.60	1.35	87.0	79.9	0.6621	0.6062	0.3997	0.3671

INTEGRATED FLOW RATE = 98.89 CU.FT/SEC
 = 7.005 LBM/SEC

AVERAGE VELOCITY = 131.33 FT/SEC

FFIMARY FLOW RATE, WP = 3.745 LBM/SEC

FFIMARY VELOCITY, UP = 217.56 FT/SEC

MOMENTUM FACTOR, KM = 1.027

(b) L/D = 2.5

TABLE XIV (CONTINUED)

DATA TAKEN ON 8 MARCH 1976 BY LEPKE AND STAEHLI
 S/L = 2.5; L/C = 2.5
 STRAIGHT STACK; 4 NOZZLES (3.699 IN.)

AMBIENT PRESSURE = 29.979 IN.HGA, TEMPERATURE = 63.0 DEG.FAHR
 PRIMARY (UPTAKE) TEMPERATURE = 106.4 DEG.FAHR

X INCHES	R	PTA IN.F2O	PTB	VA FT/SEC	VB	VA/VAV	VB/VAV	VA/UF	VB/UP
0.0	5.875	2.10	1.05	98.4	69.6	0.8643	0.6111	0.5450	0.2882
0.500	5.375	3.00	1.45	117.7	81.8	1.0330	0.7182	0.6561	0.4562
1.000	4.875	3.30	1.65	123.4	87.3	1.0834	0.7661	0.6882	0.4866
1.500	4.375	4.25	1.85	140.1	92.4	1.2295	0.8112	0.7810	0.5153
2.000	3.875	5.00	2.25	151.9	101.9	1.3336	0.8546	0.8471	0.5682
2.500	3.375	4.95	2.70	151.2	111.6	1.3269	0.9800	0.8428	0.6225
3.000	2.875	4.85	2.90	149.6	115.7	1.3134	1.0156	0.8343	0.6451
3.500	2.375	4.40	3.35	142.5	124.3	1.2510	1.0516	0.7546	0.6534
4.000	1.875	4.20	3.60	135.2	128.5	1.2223	1.1316	0.7764	0.7188
4.500	1.375	3.80	3.65	132.4	129.8	1.1626	1.1354	0.7385	0.7237
5.000	0.875	3.60	3.55	128.5	128.0	1.1316	1.1237	0.7188	0.7138
5.500	0.375	3.45	3.50	126.2	127.1	1.1078	1.1158	0.7036	0.7067
6.000	0.125	3.50	3.55	127.1	128.0	1.1158	1.1237	0.7067	0.7138
6.500	0.625	3.65	3.60	129.8	128.5	1.1394	1.1316	0.7237	0.7188
7.000	1.125	3.85	3.70	133.3	130.7	1.1702	1.1472	0.7433	0.7287
7.500	1.625	4.05	3.55	136.7	128.0	1.2002	1.1237	0.7624	0.7138
8.000	2.125	4.45	3.35	143.3	124.3	1.2581	1.0516	0.7951	0.6534
8.500	2.625	4.95	2.85	151.2	114.7	1.3269	1.0066	0.8428	0.6355
9.000	3.125	5.05	2.40	152.7	105.2	1.3403	0.9235	0.8513	0.5869
9.500	3.625	5.10	2.00	153.4	96.1	1.3469	0.8434	0.8555	0.5357
10.000	4.125	4.20	1.75	135.2	89.5	1.2223	0.7850	0.7764	0.5011
10.500	4.625	3.55	1.55	126.0	84.6	1.1237	0.7425	0.7138	0.4716
11.000	5.125	2.80	1.45	113.7	81.8	0.9980	0.7182	0.6335	0.4562
11.500	5.625	1.45	1.10	81.8	71.3	0.7182	0.6255	0.4562	0.3573
11.750	5.875	1.45	1.10	81.8	71.3	0.7182	0.6255	0.4562	0.3573

INTEGRATED FLOW RATE = 85.78 CU.FT/SEC
 = 6.220 LBM/SEC

AVERAGE VELOCITY = 113.91 FT/SEC

PRIMARY FLOW RATE, WP = 3.759 LBM/SEC

PRIMARY VELOCITY, UP = 179.34 FT/SEC

MOMENTUM FACTOR, KM = 1.038

(a) L/D = 2.5

TABLE XV. EXIT VELOCITY DATA FOR STRAIGHT MIXING STACK
 WITH 3.70 IN. NOZZLES

DATA TAKEN ON 5 MARCH 1978 BY LENKE AND STAHLI
 $L/D = 1.75$
 STRAIGHT STACK: 4 NOZZLES (3.699 IN.)

AMBIENT PRESSURE = 29.854 IN.HGA, TEMPERATURE = 66.0 DEG. FAHR

PRIMARY (UPTAKE) TEMPERATURE = 110.6 DEG. FAHR

X INCHES	R	PTA IN.±20	PTB	VA FT/SEC	VB	VA/VAV	VB/VAV	VA/LP	VB/UP
0.0	2.875	1.20	0.50	74.8	48.2	0.6857	0.4426	0.4138	0.2671
0.500	2.375	2.25	0.65	102.5	55.1	0.9350	0.5047	0.5666	0.3045
1.000	4.875	3.30	1.00	124.1	68.3	1.1372	0.6260	0.6861	0.3777
1.500	4.375	4.40	1.05	143.3	70.0	1.3131	0.6415	0.7523	0.3870
2.000	2.875	5.40	1.50	158.7	83.7	1.4547	0.7667	0.8777	0.4626
2.500	2.375	5.70	2.10	163.1	59.0	1.4945	0.9072	0.9018	0.5473
3.000	2.875	5.70	2.60	163.1	110.1	1.4945	1.0054	0.9018	0.6050
3.500	2.375	5.35	3.30	158.0	124.1	1.4479	1.1372	0.8736	0.6861
4.000	1.875	4.75	3.65	148.9	130.5	1.3643	1.1560	0.8232	0.7216
4.500	1.375	4.05	3.75	137.5	132.3	1.2598	1.2122	0.7601	0.7314
5.000	0.875	3.60	3.65	129.4	130.5	1.1877	1.1560	0.7166	0.7216
5.500	0.375	3.20	3.30	122.2	124.1	1.1198	1.1372	0.6757	0.6861
6.000	0.125	3.20	3.15	122.2	121.2	1.1198	1.1110	0.6757	0.6704
6.500	0.625	3.30	3.35	124.1	125.0	1.1372	1.1458	0.6861	0.6913
7.000	1.125	3.60	3.55	129.6	128.7	1.1877	1.1755	0.7166	0.7117
7.500	1.625	3.95	3.70	135.8	131.4	1.2441	1.2041	0.7507	0.7265
8.000	2.125	4.60	3.35	146.5	125.0	1.3426	1.1458	0.8101	0.6913
8.500	2.625	5.45	2.75	159.5	113.3	1.4614	1.0381	0.8818	0.6264
9.000	3.125	5.90	2.40	165.9	105.8	1.5205	0.9698	0.9174	0.5851
9.500	3.625	5.60	1.80	161.6	91.6	1.4814	0.8359	0.8938	0.5067
10.000	4.125	4.60	1.20	146.5	74.8	1.3426	0.6657	0.8101	0.4138
10.500	4.625	3.45	1.05	124.9	70.0	1.1627	0.6415	0.7016	0.3870
11.000	5.125	2.40	0.90	105.8	64.8	0.9698	0.5939	0.5851	0.3583
11.500	5.625	1.60	0.65	86.4	55.1	0.7918	0.5047	0.4778	0.3045
11.750	5.875	1.60	0.65	86.4	55.1	0.7918	0.5047	0.4778	0.3045

INTEGRATED FLOW RATE = 82.17 CU. FT/SEC
 = 5.854 LBM/SEC

AVERAGE VELOCITY = 109.12 FT/SEC

PRIMARY FLOW RATE, WP = 3.747 LBM/SEC

PRIMARY VELOCITY, UP = 180.85 FT/SEC

PERCENTUM FACTOR, KP = 1.078

(b) $L/D = 1.75$

TABLE XV (CONTINUED)

DATA TAKEN ON 13 MARCH 1978 BY LEMKE AND STAHLI
 S/D = 5; L/C = 2.5; 7 DEGREE SOLID DIFFUSOR
 4 NOZZLES (3.655 IN.)

AMBIENT PRESSURE = 30.166 IN.HGA, TEMPERATURE = 72.0 DEG.FAHR

PRIMARY (LPTAKE) TEMPERATURE = 111.2 DEG.FAHR

X INCHES	R	PTA IN.F2C	PTE IN.F2C	VA FT/SEC	VB	VA/VAV	VB/VAV	VA/LP	VB/LP
0.0	6.375	1.20	0.25	74.6	40.3	0.7207	0.3852	0.4146	0.2235
0.500	5.875	2.25	0.70	102.2	57.0	0.9869	0.5504	0.5677	0.3166
1.000	5.375	3.00	0.75	118.0	59.0	1.1395	0.5658	0.6555	0.3277
1.500	4.875	3.60	1.10	129.3	71.5	1.2483	0.6900	0.7181	0.3969
2.000	4.375	4.50	1.40	144.5	80.6	1.3956	0.7784	0.8228	0.4478
2.500	3.875	4.85	1.85	150.0	92.7	1.4489	0.8548	0.8324	0.5147
3.000	3.375	4.90	2.15	150.8	99.9	1.4563	0.9647	0.8377	0.5549
3.500	2.875	4.80	2.65	149.3	110.9	1.4414	1.0710	0.8251	0.6161
4.000	2.375	4.50	3.10	144.5	120.0	1.3956	1.1564	0.8028	0.6663
4.500	1.875	4.25	3.45	140.5	126.6	1.3563	1.2220	0.7802	0.7025
5.000	1.375	3.90	3.50	134.6	127.5	1.2993	1.2308	0.7474	0.7080
5.500	0.875	3.55	3.45	128.4	126.6	1.2396	1.2220	0.7131	0.7029
6.000	0.375	3.20	3.25	123.8	122.8	1.1951	1.1861	0.6875	0.6823
6.500	0.125	3.20	3.20	121.5	121.5	1.1769	1.1765	0.6770	0.6770
7.000	0.625	3.20	3.20	121.5	121.5	1.1769	1.1765	0.6770	0.6770
7.500	1.125	3.40	3.40	125.6	125.6	1.2131	1.2131	0.6978	0.6978
8.000	1.625	3.65	3.25	130.2	122.8	1.2569	1.1861	0.7220	0.6823
8.500	2.125	4.00	3.00	136.3	118.0	1.3158	1.1395	0.7569	0.6555
9.000	2.625	4.60	2.65	146.1	110.9	1.4110	1.0710	0.8117	0.6161
9.500	3.125	4.85	2.30	150.0	103.3	1.4489	0.9578	0.8324	0.5735
10.000	3.625	5.20	1.75	155.4	90.1	1.5003	0.8703	0.8620	0.5006
10.500	4.125	5.00	1.45	152.4	82.0	1.4711	0.7922	0.8462	0.4557
11.000	4.625	4.10	1.10	138.0	71.5	1.3322	0.6900	0.7663	0.3565
11.500	5.125	3.30	0.80	123.8	60.9	1.1951	0.5864	0.6875	0.3385
12.000	5.625	2.35	0.60	104.4	52.8	1.0085	0.5056	0.5802	0.2931
12.500	6.125	1.60	0.30	86.2	37.3	0.8322	0.3603	0.4787	0.2073
12.750	6.375	1.20	0.15	77.7	26.4	0.7501	0.2548	0.4215	0.1466

INTEGRATED FLOW RATE = 91.82 CU.FT/SEC
 = 6.621 LBM/SEC

AVERAGE VELOCITY = 103.56 FT/SEC

PRIMARY FLOW RATE, MP = 3.765 LBM/SEC

PRIMARY VELOCITY, LP = 180.03 FT/SEC

MOMENTUM FACTOR, MP = 1.083

(a) 7 DEGREE SOLID DIFFUSOR, RUN 1

TABLE XVI. MIXING STACK EXIT VELOCITY DATA FOR VARIOUS EXIT GEOMETRIES

DATA TAKEN ON 14 MARCH 1978 BY LENKE AND STAHLI
 S/C = 5; L/C = 2; 7 DEGREE SOLID DIFFUSOR
 4 NOZZLES (3.655 IN.)

AMBIENT PRESSURE = 30.136 IN.HGA, TEMPERATURE = 85.0 DEG. FAHR
 PRIMARY (UPTAKE) TEMPERATURE = 116.5 DEG. FAHR

X INCHES	R	PTA IN.H2C	PTR	VA FT/SEC	VB	VA/VAV	VB/VAV	VA/LP	VB/UP
0.0	4.375	0.75	0.05	59.5	15.4	0.5957	0.1548	0.3251	0.0850
0.500	5.875	1.50	0.25	84.1	34.3	0.8481	0.3462	0.4654	0.1500
1.000	5.375	2.20	0.40	101.9	43.4	1.0271	0.4380	0.5636	0.2403
1.500	4.875	3.00	0.80	119.0	61.4	1.1954	0.6154	0.6581	0.3355
2.000	4.375	3.60	1.10	130.3	72.0	1.3139	0.7263	0.7209	0.3985
2.500	3.875	4.20	1.30	140.8	78.3	1.4152	0.7856	0.7787	0.4332
3.000	3.375	4.80	1.80	150.5	92.2	1.5172	0.9251	0.8325	0.5098
3.500	2.875	4.90	2.20	152.1	101.9	1.5329	1.0271	0.8411	0.5636
4.000	2.375	4.30	2.70	142.4	112.9	1.4360	1.1275	0.7875	0.6244
4.500	1.875	4.40	3.10	144.1	120.5	1.4526	1.2193	0.7970	0.6690
5.000	1.375	4.05	3.50	138.2	128.5	1.3936	1.2955	0.7647	0.7105
5.500	0.875	3.55	3.25	129.4	123.8	1.3048	1.2484	0.7155	0.6850
6.000	0.375	3.25	3.20	123.8	122.5	1.2484	1.2388	0.6850	0.6757
6.500	0.125	3.20	3.15	122.9	121.9	1.2388	1.2250	0.6757	0.6744
7.000	0.625	3.15	3.30	121.9	124.8	1.2290	1.2580	0.6744	0.6502
7.500	1.125	3.25	3.40	123.8	126.7	1.2484	1.2765	0.6850	0.7006
8.000	1.625	3.45	3.30	127.6	124.8	1.2862	1.2580	0.7058	0.6502
8.500	2.125	3.80	3.35	133.9	125.7	1.3499	1.2675	0.7407	0.6955
9.000	2.625	4.25	2.75	141.6	113.9	1.4276	1.1484	0.7823	0.6301
9.500	3.125	4.95	2.40	152.8	106.4	1.5407	1.0728	0.8454	0.5886
10.000	3.625	5.25	2.00	157.4	97.1	1.5867	0.9793	0.8706	0.5374
10.500	4.125	5.00	1.45	153.6	82.7	1.5485	0.8335	0.8456	0.4575
11.000	4.625	4.10	1.20	135.1	75.2	1.4022	0.7586	0.7694	0.4162
11.500	5.125	3.30	0.90	124.8	65.2	1.2580	0.6570	0.6502	0.3805
12.000	5.625	2.40	0.50	106.4	48.6	1.0728	0.4857	0.5886	0.2687
12.500	6.125	1.75	0.25	90.9	34.3	0.9161	0.3462	0.5027	0.1500
12.750	6.375	1.25	0.20	76.8	30.7	0.7742	0.3057	0.4248	0.1699

INTEGRATED FLOW RATE = 87.55 CU.FT/SEC
 = 6.239 LBM/SEC

AVERAGE VELOCITY = 59.20 FT/SEC

PRIMARY FLOW RATE, WP = 3.743 LBM/SEC

PRIMARY VELOCITY, UP = 180.78 FT/SEC

MOMENTUM FACTOR, KM = 1.108

(b) 7 DEGREE SOLID DIFFUSOR, RUN 2

TABLE XVI (CONTINUED)

DATA TAKEN ON 26 APRIL 1976 BY LEMKE AND STAEHLI
 S/C = 5; L/C = 2; 7 DEGREE SOLID DIFFUSOR RING; 4 NOZZLES (3.499 IN.)
 SECONDARY ECX CPEN; TERTIARY BCX CPEN; BULK. AND DIAP. INSTALLED

AMBIENT PRESSURE = 30.140 IN.HGA, TEMPERATURE = 86.0 DEG.FAHR
 PRIMARY (UPTAKE) TEMPERATURE = 113.1 DEG.FAHR

X INCHES	R	PTA IN. H ₂ O	PTE	VA FT/SEC	VB	VA/VAV	VB/VAV	VA/LP	VB/UP
0.0	6.250	1.30	0.40	78.2	43.4	0.7843	0.4350	0.4336	0.2405
0.500	5.750	2.40	0.70	106.3	57.4	1.0656	0.5755	0.5852	0.3182
1.000	5.250	2.80	0.90	114.8	65.1	1.1510	0.6526	0.6364	0.3608
1.500	4.750	3.50	1.20	135.5	75.1	1.3584	0.7535	0.7510	0.4166
2.000	4.250	4.20	1.70	140.6	89.4	1.4097	0.8969	0.7754	0.4959
2.500	3.750	4.70	2.10	148.7	99.4	1.4913	0.9968	0.8245	0.5511
3.000	3.250	4.70	2.50	148.7	108.5	1.4913	1.0876	0.8245	0.6013
3.500	2.750	4.60	2.90	147.1	116.8	1.4753	1.1714	0.8157	0.6476
4.000	2.250	4.40	3.40	143.9	126.5	1.4429	1.2684	0.7977	0.7012
4.500	1.750	4.10	3.90	138.9	128.3	1.3928	1.2869	0.7701	0.7115
5.000	1.250	3.70	3.50	131.9	128.3	1.3231	1.2869	0.7315	0.7115
5.500	0.750	3.50	3.25	128.3	123.7	1.2869	1.2401	0.7115	0.6856
6.000	0.250	3.20	3.10	124.6	120.8	1.2496	1.2111	0.6909	0.6496
6.500	0.250	3.30	3.05	124.6	119.8	1.2496	1.2013	0.6909	0.6642
7.000	0.750	3.40	3.20	126.5	122.7	1.2684	1.2305	0.7012	0.6803
7.500	1.250	3.60	3.25	130.1	123.7	1.3051	1.2401	0.7216	0.6856
8.000	1.750	3.90	3.40	135.5	126.5	1.3584	1.2684	0.7510	0.7012
8.500	2.250	4.40	3.20	143.9	122.7	1.4429	1.2305	0.7977	0.6603
9.000	2.750	4.90	2.90	151.8	116.8	1.5227	1.1714	0.8418	0.6476
9.500	3.250	5.10	2.40	154.9	106.3	1.5534	1.0656	0.8558	0.5852
10.000	3.750	5.10	2.00	154.9	97.0	1.5534	0.9728	0.8558	0.5378
10.500	4.250	4.30	1.70	142.2	89.4	1.4264	0.8969	0.7886	0.4959
11.000	4.750	3.00	1.40	118.8	81.2	1.1914	0.8139	0.6587	0.4500
11.500	5.250	2.30	1.20	104.0	75.1	1.0432	0.7535	0.5768	0.4166
12.000	5.750	2.00	0.80	97.0	61.4	0.9728	0.6152	0.5378	0.3402
12.500	6.250	0.90	0.40	65.1	43.4	0.6526	0.4350	0.3608	0.2405

INTEGRATED FLOW RATE = 84.98 CU.FT/SEC
 = 6.045 LBM/SEC

AVERAGE VELOCITY = 99.72 FT/SEC

PRIMARY FLOW RATE, WP = 3.757 LBM/SEC

PRIMARY VELOCITY, LP = 180.36 FT/SEC

PERCENTUM FACTOR, KM = 1.150

(c) 7 DEGREE SOLID DIFFUSOR, RUN 3

TABLE XVI (CONTINUED)

DATA TAKEN ON 27 APRIL 1976 BY LENKE AND STAEHLI
 S/E=5; L/C=2.8; 7 DEGREE SOLID DIFFUSOR RING; 4 NOZZLES(3.699 IN.)
 SECONDARY BCX CLCSEC; TERTIARY BCX CFEN

AMBIENT PRESSURE = 30.069 IN.HGA, TEMPERATURE = 71.0 DEG.FAHR

PRIMARY (LPTAKE) TEMPERATURE = 106.6 DEG.FAHR

X INCHES	R	PTA IN.H2O	PTE	VA FT/SEC	VB	VA/VAV	VB/VAV	VA/LF	VB/LF
0.0	6.250	1.60	0.30	86.1	37.3	0.9100	0.3540	0.4753	0.2075
0.500	5.750	2.70	0.50	111.8	48.1	1.1821	0.5087	0.6226	0.2675
1.000	5.250	3.20	0.80	121.7	60.9	1.2869	0.6434	0.6778	0.3365
1.500	4.750	3.70	0.50	130.9	64.6	1.3838	0.6825	0.7289	0.3555
2.000	4.250	4.05	1.20	137.0	74.5	1.4477	0.7880	0.7626	0.4151
2.500	3.750	4.00	1.60	136.1	86.1	1.4388	0.9100	0.7578	0.4793
3.000	3.250	4.25	2.10	140.3	98.6	1.4830	1.0425	0.7812	0.5451
3.500	2.750	3.80	2.70	132.7	111.8	1.4023	1.1821	0.7386	0.6226
4.000	2.250	3.75	3.20	131.8	121.7	1.3931	1.2869	0.7328	0.6778
4.500	1.750	3.55	3.50	128.2	127.3	1.3554	1.3458	0.7139	0.7089
5.000	1.250	3.45	3.45	126.4	126.4	1.3362	1.3362	0.7038	0.7038
5.500	0.750	3.25	3.40	122.7	125.5	1.2969	1.3265	0.6831	0.6987
6.000	0.250	3.25	3.20	122.7	121.7	1.2969	1.2869	0.6831	0.6778
6.500	0.250	3.25	3.15	122.7	120.8	1.2969	1.2768	0.6831	0.6725
7.000	0.750	3.25	3.30	122.7	123.6	1.2969	1.3068	0.6831	0.6883
7.500	1.250	3.40	3.40	125.5	125.5	1.3265	1.3265	0.6987	0.6987
8.000	1.750	3.70	3.45	130.9	126.4	1.3838	1.3362	0.7289	0.7038
9.500	2.250	4.20	3.30	139.5	123.6	1.4743	1.3068	0.7765	0.6883
9.000	2.750	4.55	3.05	145.2	118.9	1.5345	1.2562	0.8083	0.6617
9.500	3.250	4.60	2.50	146.0	107.6	1.5429	1.1374	0.8127	0.5991
10.000	3.750	4.20	2.05	135.5	97.4	1.4743	1.0300	0.7765	0.5425
10.500	4.250	3.45	1.60	126.4	86.1	1.3362	0.9100	0.7038	0.4793
11.000	4.750	2.60	1.30	109.7	77.6	1.1600	0.8202	0.6110	0.4320
11.500	5.250	2.30	1.00	103.2	68.1	1.0910	0.7154	0.5747	0.3785
12.000	5.750	1.60	0.65	86.1	54.9	0.9100	0.5800	0.4753	0.3055
12.500	6.250	1.00	0.35	68.1	40.3	0.7194	0.4256	0.3789	0.2242

INTEGRATED FLOW RATE = 80.62 CU.FT/SEC
 = 5.826 LBM/SEC

AVERAGE VELOCITY = 54.60 FT/SEC

PRIMARY FLOW RATE, WP = 3.775 LBM/SEC

PRIMARY VELOCITY, UP = 175.60 FT/SEC

MENTUM FACTOR, MP = 1.154

(d) 7 DEGREE SOLID DIFFUSOR, RUN 4

TABLE XVI (CONTINUED)

DATA TAKEN ON 11 MAY 1978 BY LEMKE AND STAEHLI
 S/C = 5; L/D = 2.5; TWO SCLIC DIFFUSOR RINGS; 4 NOZZLES (3.699 IN.)
 SECONDARY EX OPEN; TERTIARY BCX OPEN

APPLICANT PRESSURE = 30.128 IN.HGA, TEMPERATURE = 76.0 DEG.FAHR
 PRIMARY (UPTAKE) TEMPERATURE = 111.5 DEG.FAHR

X INCHES	R	PTA IN.F20	PTB	VA FT/SEC	VB	VA/VAV	VB/VAV	VA/LP	VB/UP
0.0	7.000	0.30	0.01	37.4	6.8	0.4567	0.0834	0.2078	0.0375
0.500	6.500	0.55	0.15	50.6	26.4	0.6184	0.3229	0.2814	0.1465
1.000	6.000	1.40	0.35	80.8	40.4	0.9866	0.4533	0.4489	0.2245
1.500	5.500	2.75	0.75	113.2	59.1	1.3827	0.7221	0.6292	0.3286
2.000	5.000	3.55	1.40	128.7	80.8	1.5710	0.9866	0.7149	0.4489
2.500	4.500	4.10	1.85	138.3	92.9	1.6883	1.1341	0.7683	0.5161
3.000	4.000	4.40	2.05	143.3	97.8	1.7490	1.1538	0.7959	0.5432
3.500	3.500	4.20	2.70	140.0	112.2	1.7088	1.3701	0.7776	0.6234
4.000	3.000	4.00	2.85	136.6	115.3	1.6676	1.4076	0.7588	0.6405
4.500	2.500	3.90	3.20	134.9	122.2	1.6466	1.4516	0.7493	0.6787
5.000	2.000	3.65	3.30	130.5	124.1	1.5930	1.5147	0.7249	0.6892
5.500	1.500	3.40	3.25	125.9	123.1	1.5375	1.5032	0.6956	0.6840
6.000	1.000	3.25	3.20	123.1	122.2	1.5032	1.4516	0.6840	0.6787
6.500	0.500	3.10	3.15	120.2	121.2	1.4681	1.4799	0.6680	0.6734
7.000	0.0	3.20	3.10	122.2	120.2	1.4916	1.4681	0.6787	0.6680
7.500	0.500	3.15	3.15	121.2	121.2	1.4799	1.4799	0.6734	0.6734
8.000	1.000	3.25	3.30	123.1	124.1	1.5032	1.5147	0.6840	0.6892
8.500	1.500	3.40	3.35	125.9	125.0	1.5375	1.5261	0.6956	0.6840
9.000	2.000	3.60	3.30	133.1	124.1	1.6254	1.5147	0.7356	0.6892
9.500	2.500	4.15	3.10	139.1	120.2	1.6986	1.4681	0.7729	0.6680
10.000	3.000	4.55	2.60	145.7	110.1	1.7786	1.3445	0.8093	0.6118
10.500	3.500	4.20	2.40	141.6	105.8	1.7290	1.2517	0.7868	0.5878
11.000	4.000	4.10	2.00	138.3	96.6	1.6883	1.1752	0.7683	0.5366
11.500	4.500	3.20	1.50	122.2	83.6	1.4916	1.0212	0.6787	0.4647
12.000	5.000	2.30	1.05	103.6	70.0	1.2645	0.8544	0.5754	0.3888
12.500	5.500	1.40	0.60	80.8	52.9	0.9866	0.6459	0.4489	0.2939
13.000	6.000	0.80	0.15	61.1	26.4	0.7458	0.3229	0.3354	0.1465
13.500	6.500	0.30	0.05	37.4	15.3	0.4567	0.1664	0.2078	0.0848
14.000	7.000	0.15	0.0	26.4	0.0	0.3229	0.0	0.1465	0.0

INTEGRATED FLOW RATE = 87.56 CU.FT/SEC
 = 6.284 LBM/SEC

AVERAGE VELOCITY = 81.90 FT/SEC

PRIMARY FLOW RATE, WP = 3.758 LBM/SEC

PRIMARY VELOCITY, UP = 179.99 FT/SEC

WOMENIUM FACTOR, WF = 1.285

(e) TWO-RING DIFFUSOR

TABLE XVI (CONTINUED)

DATA TAKEN ON 14 JULY 1978 BY LEMKE AND STAHLI
 S/D=0.5; L/D=2.5; THREE SOLID DIFFUSOR RINGS; 4 NOZZLES(3.699 IN.)
 SECONDARY EX OPEN; TERTIARY BOX OPEN

AMBIENT PRESSURE = 29.969 IN.HGA, TEMPERATURE = 85.0 DEG.FAHR
 PRIMARY (LPTAKE) TEMPERATURE = 114.5 DEG.FAHR

X INCHES	R	PTA IN.F2C	PTB	VA FT/SEC	VB	VA/VAV	VB/VAV	VA/LP	VB/UF
C.C	7.000	0.20	0.02	30.8	9.7	0.3829	0.1214	0.1699	0.0537
0.500	6.500	0.80	0.20	61.5	30.8	0.7679	0.3829	0.3399	0.1699
1.000	6.000	1.90	0.60	94.9	53.3	1.1834	0.6650	0.5238	0.2543
1.500	5.500	3.05	1.00	120.2	68.8	1.4953	0.8585	0.6636	0.3800
2.000	5.000	3.60	1.40	130.6	81.4	1.6289	1.0158	0.7210	0.4496
2.500	4.500	3.85	1.70	135.0	89.7	1.6845	1.1153	0.7456	0.4555
3.000	4.000	4.00	2.20	137.6	102.1	1.7170	1.2734	0.7600	0.5636
3.500	3.500	3.90	2.70	135.9	113.1	1.6954	1.4106	0.7504	0.6244
4.000	3.000	3.85	3.10	135.0	121.2	1.6845	1.5115	0.7456	0.6651
4.500	2.500	3.75	3.50	133.3	128.7	1.6625	1.6061	0.7359	0.7109
5.000	2.000	3.60	3.40	130.6	126.9	1.6289	1.5820	0.7210	0.7007
5.500	1.500	3.50	3.40	128.7	126.9	1.6061	1.5830	0.7109	0.7007
6.000	1.000	3.35	3.35	125.9	125.9	1.5713	1.5713	0.6955	0.6955
6.500	0.500	3.20	3.15	123.1	122.1	1.5357	1.5237	0.6798	0.6744
7.000	0.0	3.25	3.20	124.1	123.1	1.5477	1.5357	0.6850	0.6798
7.500	0.500	3.40	3.30	126.9	125.0	1.5820	1.5555	0.7007	0.6903
8.000	1.000	3.60	3.40	130.6	126.9	1.6289	1.5830	0.7210	0.7007
8.500	1.500	3.90	3.35	135.9	125.9	1.6954	1.5713	0.7504	0.6955
9.000	2.000	4.35	3.20	143.5	123.1	1.7905	1.5357	0.7921	0.6798
9.500	2.500	4.80	2.60	150.8	111.0	1.8809	1.3843	0.8221	0.6127
10.000	3.000	5.00	2.10	153.9	99.7	1.9196	1.2441	0.8457	0.5507
10.500	3.500	4.70	1.70	149.2	89.7	1.8612	1.1153	0.8238	0.4555
11.000	4.000	3.85	1.25	135.0	76.9	1.6845	0.9558	0.7456	0.4248
11.500	4.500	3.00	0.90	119.2	65.3	1.4870	0.8144	0.6952	0.3605
12.000	5.000	1.80	0.50	92.3	48.7	1.1518	0.6070	0.5098	0.2687
12.500	5.500	1.10	0.20	72.2	30.8	0.9004	0.3839	0.3955	0.1699
13.000	6.000	0.60	0.10	53.3	21.8	0.6650	0.2715	0.2943	0.1202
13.500	6.500	0.15	0.02	26.7	11.9	0.3325	0.1487	0.1472	0.0658
14.000	7.000	0.05	0.0	15.4	0.0	0.1920	0.0	0.0850	0.0

INTEGRATED FLOW RATE = 85.69 CU.FT/SEC
 = 6.057 LBM/SEC

AVERAGE VELOCITY = 80.16 FT/SEC

PRIMARY FLOW RATE, WP = 3.741 LEM/SEC

PRIMARY VELOCITY, UP = 181.09 FT/SEC

MOMENTUM FACTOR, MP = 1.318

(f) THREE-RING DIFFUSOR

TABLE XVI (CONTINUED)

DATA TAKEN ON 7 AUGUST 1978 BY LEMKE AND STAEPLI
 S/C = 5; L/C = 2.5
 PORTEC MIXING STACK; 4 NOZZLES (3.699 IN.); A-1 B-1 C-2 D-2 CONFIGURATION

AMBIENT PRESSURE = 29.954 IN.HGA, TEMPERATURE = 102.0 DEG.FAHR
 PRIMARY (LPTAKE) TEMPERATURE = 132.8 DEG.FAHR

X INCHES	R	PTA IN.H2O	PTB	VA FT/SEC	VB	VA/VAV	VE/VAV	VA/LP	VE/LP
0.0	5.875	1.90	1.30	96.4	79.7	0.8077	0.6661	0.5248	0.4341
0.500	5.375	2.70	1.85	114.9	95.1	0.9629	0.7570	0.6256	0.5178
1.000	4.875	3.10	2.25	123.1	104.9	1.0318	0.8790	0.6703	0.5711
1.500	4.375	3.70	2.55	134.5	111.6	1.1272	0.9356	0.7324	0.6080
2.000	3.875	3.75	2.50	135.4	119.1	1.1348	0.9575	0.7373	0.6484
2.500	3.375	3.80	3.35	136.3	128.0	1.1423	1.0726	0.7422	0.6969
3.000	2.875	3.60	3.85	132.6	137.2	1.1119	1.1456	0.7224	0.7470
3.500	2.375	3.50	4.05	130.8	140.7	1.0963	1.1793	0.7123	0.7662
4.000	1.875	3.35	3.95	128.0	138.9	1.0726	1.1646	0.6969	0.7567
4.500	1.375	3.10	3.60	123.1	132.6	1.0318	1.1119	0.6703	0.7224
5.000	0.875	3.10	3.45	123.1	129.9	1.0318	1.0864	0.6703	0.7072
5.500	0.375	3.10	3.15	123.1	124.1	1.0318	1.0400	0.6703	0.6757
6.000	0.125	3.20	3.15	125.1	124.1	1.0483	1.0400	0.6811	0.6757
6.500	0.625	3.40	3.25	128.9	128.0	1.0805	1.0726	0.7020	0.6969
7.000	1.125	3.60	3.70	132.6	134.5	1.1119	1.1272	0.7224	0.7324
7.500	1.625	3.50	3.50	138.1	138.1	1.1573	1.1573	0.7519	0.7519
8.000	2.125	4.15	3.50	142.4	138.1	1.1938	1.1573	0.7756	0.7519
8.500	2.625	4.40	3.65	146.6	133.6	1.2292	1.1195	0.7986	0.7274
9.000	3.125	4.30	3.40	145.0	128.9	1.2152	1.0805	0.7895	0.7020
9.500	3.625	4.00	2.70	135.8	114.9	1.1720	0.9629	0.7615	0.6256
10.000	4.125	3.30	2.60	127.0	112.7	1.0645	0.9449	0.6916	0.6139
10.500	4.625	2.70	2.60	114.9	112.7	0.9629	0.9449	0.6256	0.6139
11.000	5.125	2.20	2.20	103.7	103.7	0.8692	0.8692	0.5647	0.5647
11.500	5.625	1.65	1.80	89.8	93.8	0.7527	0.7862	0.4891	0.5108
11.750	5.875	1.50	1.30	85.6	79.7	0.7177	0.6661	0.4663	0.4341

INTEGRATED FLOW RATE = 89.83 CU.FT/SEC
 = 6.152 LBM/SEC

AVERAGE VELOCITY = 119.30 FT/SEC

PRIMARY FLOW RATE, WP = 3.674 LBM/SEC

PRIMARY VELOCITY, UP = 183.62 FT/SEC

MOMENTUM FACTOR, KM = 1.015

TABLE XVII. EXIT VELOCITY DATA FOR STRAIGHT PORTED MIXING STACK

DATA TAKEN ON 14 AUGUST 1978 BY LEMKE AND STAEHLI
 S/C = .5; L/D = 2.5, TWO SLID DIFFUSOR RINGS
 PORTED MIXING STACK; 4 NOZZLES (3.699 IN.); A-1 B-1 C-2 D-2 CONFIGURATION

AMBIENT PRESSURE = 29.978 IN.HGA, TEMPERATURE = 48.0 DEG.FAHR
 PRIMARY (LFTAKE) TEMPERATURE = 112.C DEG.FAHR

X INCHES	R	FTA IN. H ₂ O	PTE	VA FT/SEC	VB	VA/VAV	VB/VAV	VA/LP	VB/UP
0.0	7.000	0.15	0.02	26.4	9.7	0.3434	0.1254	0.1462	0.0534
0.500	6.500	0.40	0.04	43.2	13.7	0.5608	0.1774	0.2387	0.0755
1.000	6.000	1.20	0.28	74.8	36.1	0.9714	0.4692	0.4134	0.1957
1.500	5.500	1.90	0.65	94.1	55.0	1.2223	0.7149	0.5202	0.3043
2.000	5.000	2.80	0.85	114.2	62.5	1.4838	0.8176	0.6215	0.3480
2.500	4.500	3.50	1.20	134.8	74.8	1.7512	0.9714	0.7453	0.4134
3.000	4.000	4.50	1.60	144.8	86.4	1.8811	1.1217	0.8006	0.4774
3.500	3.500	4.70	2.10	148.0	98.9	1.9225	1.2850	0.8182	0.5465
4.000	3.000	4.60	2.50	146.4	107.9	1.9019	1.4021	0.8095	0.5968
4.500	2.500	4.20	3.00	141.6	118.2	1.8388	1.5359	0.7826	0.6537
5.000	2.000	4.15	3.40	139.1	125.9	1.8065	1.6351	0.7689	0.6959
5.500	1.500	3.90	3.60	134.8	129.5	1.7512	1.6625	0.7453	0.7161
6.000	1.000	3.65	3.65	130.4	130.4	1.6942	1.6542	0.7211	0.7211
6.500	0.500	3.45	3.50	126.8	127.7	1.6471	1.6550	0.7010	0.7061
7.000	0.0	3.40	3.45	125.9	126.8	1.6351	1.6471	0.6959	0.7010
7.500	0.500	3.45	3.53	126.8	128.3	1.6471	1.6661	0.7010	0.7051
8.000	1.000	3.65	3.70	130.4	131.3	1.6942	1.7057	0.7211	0.7260
8.500	1.500	4.05	3.70	137.4	131.3	1.7846	1.7057	0.7595	0.7260
9.000	2.000	4.50	3.40	144.8	125.9	1.8811	1.6351	0.8006	0.6555
9.500	2.500	4.55	2.95	151.9	117.3	1.9729	1.5231	0.8397	0.6492
10.000	3.000	5.05	2.50	153.4	107.9	1.9928	1.4021	0.8481	0.5568
10.500	3.500	4.70	2.00	148.0	96.5	1.9225	1.2541	0.8182	0.5337
11.000	4.000	3.70	1.60	131.3	86.4	1.7057	1.1217	0.7260	0.4774
11.500	4.500	2.80	1.25	114.2	76.3	1.4838	0.9514	0.6315	0.4220
12.000	5.000	1.80	0.60	91.6	61.1	1.1897	0.7531	0.5064	0.3376
12.500	5.500	1.00	0.40	68.3	43.2	0.8868	0.5608	0.3774	0.2387
13.000	6.000	0.40	0.20	43.2	30.5	0.5608	0.3966	0.2387	0.1688
13.500	6.500	0.20	0.03	30.5	11.8	0.3966	0.1536	0.1688	0.0654
14.000	7.000	0.15	0.0	26.4	0.0	0.3434	0.0	0.1462	0.0

INTEGRATED FLOW RATE = 82.30 CU.FT/SEC
 = 5.910 LBM/SEC

AVERAGE VELOCITY = 76.99 FT/SEC

PRIMARY FLOW RATE, WP = 3.754 LBM/SEC

PRIMARY VELOCITY, UP = 180.88 FT/SEC

COMPENLM FACTOR, KP = 1.355

TABLE XVIII. EXIT VELOCITY DATA FOR STRAIGHT PORTED MIXING STACK WITH A TWO-RING DIFFUSOR

DATA TAKEN ON 22 AUGUST 1978 BY LEMKE AND STAEHLI
 S/D = .5; L/D = 2.5, TWO SLID DIFFUSOR RINGS AND SHROUD
 PORTED MIXING STACK; 4 NOZZLES (3.695 IN.) ; A-1 B-1 C-2 D-2 CONFIGURATION

AMBIENT PRESSURE = 29.980 IN.HGA, TEMPERATURE = 88.0 DEG.FAHR
 PRIMARY (UP TAKE) TEMPERATURE = 124.0 DEG.FAHR

X INCHES	R	PTA IN.	PTB IN.	VA FT/SEC	VB	VA/VAV	VB/VAV	VA/LP	VB/UF
0.0	7.000	0.25	0.02	34.6	9.8	0.4131	0.1168	0.1900	0.0537
0.500	6.500	0.70	0.10	57.9	21.9	0.6913	0.2613	0.3179	0.1202
1.000	6.000	1.70	0.40	90.2	43.8	1.0773	0.5226	0.4955	0.2402
1.500	5.500	2.80	0.80	115.8	61.9	1.3826	0.7390	0.6359	0.3399
2.000	5.000	3.70	1.20	133.1	75.8	1.5893	0.9051	0.7310	0.4163
2.500	4.500	4.10	1.60	140.1	87.5	1.6730	1.0451	0.7855	0.4807
3.000	4.000	4.30	2.20	143.5	102.7	1.7133	1.2255	0.7880	0.5636
3.500	3.500	4.45	2.60	146.0	111.6	1.7430	1.3322	0.8016	0.6127
4.000	3.000	4.30	3.20	143.5	123.8	1.7133	1.4780	0.7880	0.6758
4.500	2.500	4.10	3.45	140.1	128.6	1.6730	1.5347	0.7655	0.7058
5.000	2.000	3.85	3.60	135.8	131.3	1.6212	1.5677	0.7456	0.7210
5.500	1.500	3.65	3.65	132.2	132.2	1.5785	1.5785	0.7260	0.7260
6.000	1.000	3.48	3.55	129.1	130.4	1.5413	1.5566	0.7069	0.7160
6.500	0.500	3.30	3.30	125.7	125.7	1.5009	1.5009	0.6902	0.6903
7.000	0.0	3.20	3.25	125.7	124.8	1.5009	1.4895	0.6903	0.6851
7.500	0.500	3.25	3.35	126.7	126.7	1.5123	1.5123	0.6955	0.6955
8.000	1.000	3.55	3.50	130.4	129.5	1.5568	1.5456	0.7160	0.7109
8.500	1.500	3.90	3.70	136.7	133.1	1.6317	1.5892	0.7505	0.7310
9.000	2.000	4.25	3.50	142.7	136.7	1.7033	1.6317	0.7824	0.7505
9.500	2.500	4.35	3.75	144.4	134.0	1.7233	1.6000	0.7926	0.7355
10.000	3.000	4.35	3.40	144.4	127.6	1.7233	1.5235	0.7926	0.7007
10.500	3.500	3.90	2.75	136.7	114.8	1.6317	1.3702	0.7505	0.6302
11.000	4.000	3.10	2.20	121.9	102.7	1.4547	1.2255	0.6651	0.5636
11.500	4.500	2.30	1.75	105.0	91.6	1.2531	1.0920	0.5762	0.5027
12.000	5.000	1.60	1.20	87.5	75.8	1.0451	0.9051	0.4807	0.4163
12.500	5.500	0.82	0.60	62.7	61.9	0.7482	0.7390	0.3441	0.3399
13.000	6.000	0.55	0.35	51.3	40.9	0.6128	0.4888	0.2818	0.2246
13.500	6.500	0.20	0.15	31.0	26.8	0.3695	0.3200	0.1699	0.1472
13.990	7.000	0.05	0.02	15.5	12.0	0.1848	0.1431	0.0850	0.0658

INTEGRATED FLOW RATE = 89.42 CU.FT/SEC
 = 6.248 LBM/SEC

AVERAGE VELOCITY = 83.77 FT/SEC

PRIMARY FLOW RATE, W_P = 3.703 LBM/SEC

PRIMARY VELOCITY, U_P = 182.14 FT/SEC

MOMENTUM FACTOR, K_P = 1.286

(a) SHROUD WITH A TWO-RING DIFFUSOR

TABLE XIX. EXIT VELOCITY DATA FOR A SHROUDED PORTED MIXING STACK WITH DIFFUSOR

DATA TAKEN ON 29 AUGUST BY LEMKE AND STAELI
 S/D = 0.5; L/D = 2.5; THE SLID DIFFUSOR RINGS AND SHROUD
 RECT MIXING STACK: 4 NOZZLES (3.655 IN.) : A-1 B-1 C-2 D-2 CONFIGURATION

AMBIENT PRESSURE = 29.902 IN.HGA, TEMPERATURE = 80.0 DEG.FAIR

PRIMARY (LPTAKE) TEMPERATURE = 114.0 DEG.FAIR

X INCHES	R	FTA IN.F2C	PTE IN.F2C	VA FT/SEC	VB	VA/VAV	VB/VAV	VA/LP	VB/UF
0.0	7.000	0.25	0.05	34.4	15.4	0.4201	0.1875	0.1895	0.0847
0.500	6.500	0.65	0.10	55.4	21.7	0.6775	0.2657	0.3055	0.1198
1.000	6.000	1.60	0.12	87.0	23.8	1.0629	0.2911	0.4754	0.1313
1.500	5.500	2.50	0.40	117.1	43.5	1.4310	0.5314	0.6453	0.2357
2.000	5.000	3.80	0.80	134.0	61.5	1.6380	0.7516	0.7387	0.3390
2.500	4.500	4.40	1.20	144.2	75.3	1.7626	0.9205	0.7949	0.4151
3.000	4.000	4.40	1.45	144.2	82.8	1.7626	1.0118	0.7949	0.4563
3.500	3.500	4.50	2.20	145.8	102.0	1.7825	1.2464	0.8035	0.5621
4.000	3.000	4.35	2.65	143.4	111.9	1.7526	1.3675	0.7904	0.6165
4.500	2.500	4.15	3.10	140.0	121.0	1.7118	1.4755	0.7720	0.6672
5.000	2.000	3.95	3.50	136.6	128.6	1.6701	1.5720	0.7532	0.7050
5.500	1.500	3.75	3.85	133.1	134.9	1.6272	1.6488	0.7339	0.7436
6.000	1.000	3.67	3.95	131.7	136.6	1.6098	1.6701	0.7260	0.7532
6.500	0.500	3.60	3.80	130.4	134.0	1.5943	1.6380	0.7190	0.7387
7.000	0.0	3.70	3.65	132.2	131.3	1.6163	1.6054	0.7289	0.7240
7.500	0.500	3.80	3.65	134.0	131.3	1.6380	1.6054	0.7387	0.7240
8.000	1.000	4.10	3.65	139.2	131.3	1.7015	1.6054	0.7673	0.7240
8.500	1.500	4.35	3.80	143.4	134.0	1.7526	1.6380	0.7504	0.7387
9.000	2.000	4.50	4.00	145.8	137.5	1.7825	1.6806	0.8035	0.7575
9.500	2.500	4.70	3.95	149.0	136.6	1.8217	1.6701	0.8216	0.7532
10.000	3.000	4.40	3.76	144.2	133.3	1.7626	1.6254	0.7545	0.7348
10.500	3.500	3.65	3.35	131.3	125.8	1.6054	1.5380	0.7240	0.6536
11.000	4.000	2.85	2.95	116.1	118.1	1.4186	1.4433	0.6358	0.6505
11.500	4.500	1.80	2.25	92.2	103.1	1.1274	1.2604	0.5084	0.5684
12.000	5.000	1.00	1.65	68.7	88.3	0.8403	1.0754	0.3750	0.4868
12.500	5.500	0.60	1.15	53.2	73.7	0.6509	0.9011	0.2935	0.4064
13.000	6.000	0.30	0.70	37.7	57.5	0.4602	0.7030	0.2076	0.3171
13.500	6.500	0.10	0.30	21.7	37.7	0.2657	0.4602	0.1158	0.2076
14.000	7.000	0.05	0.0	15.4	0.0	0.1879	0.0	0.0847	0.0

INTEGRATED FLOW RATE = 87.45 CU.FT/SEC
 = 6.194 LBM/SEC

AVERAGE VELOCITY = 81.81 FT/SEC

PRIMARY FLOW RATE, WP = 3.742 LBM/SEC

PRIMARY VELOCITY, UP = 181.40 FT/SEC

MOMENTUM FACTOR, KP = 1.312

(b) SHORTENED SHROUD WITH TWO-RING DIFFUSOR

TABLE XIX (CONTINUED)

DATA TAKEN ON 25 AUGUST BY LEMKE AND STAEHLI
 S/C = .5; L/D = 2.5; FLOW THRU SHROUD AND DIFFUSOR RING
 COATED FIXING STACK: 4 NOZZLES (3.695 IN.) : A-1 B-1 C-2 D-2 CONFIGURATION

AMBIENT PRESSURE = 29.902 IN.HGA, TEMPERATURE = 60.0 DEG.FAHR
 PRIMARY (UPTAKE) TEMPERATURE = 114.0 DEG.FAHR

X INCHES	R	PTA IN. ±20	PTB	VA FT/SEC	VB	VA/VAV	VB/VAV	VA/LP	VB/UP
0.0	7.000	0.25	0.15	34.4	26.6	0.4049	0.3136	0.1855	0.1466
0.500	6.500	0.65	0.55	55.4	51.0	0.6529	0.6005	0.3055	0.2810
1.000	6.000	1.50	1.15	84.2	73.7	0.9918	0.8884	0.4641	0.4064
1.500	5.500	2.70	1.35	113.0	79.9	1.3306	0.9409	0.6227	0.4402
2.000	5.000	3.80	2.00	134.0	57.2	1.5785	1.1452	0.7287	0.5255
2.500	4.500	4.40	2.50	144.2	108.7	1.6986	1.2804	0.7949	0.5552
3.000	4.000	4.55	2.85	146.5	116.1	1.7273	1.3670	0.8064	0.6358
3.500	3.500	4.50	3.30	145.8	124.9	1.7178	1.4710	0.8039	0.6884
4.000	3.000	4.30	3.75	142.5	133.1	1.6792	1.5681	0.7858	0.7339
4.500	2.500	4.15	3.90	140.0	135.8	1.6496	1.5552	0.7720	0.7404
5.000	2.000	4.00	3.85	137.5	134.9	1.6195	1.5889	0.7579	0.7436
5.500	1.500	3.70	3.80	132.2	134.0	1.5576	1.5785	0.7289	0.7387
6.000	1.000	3.50	3.60	128.6	130.4	1.5149	1.5364	0.7090	0.7190
6.500	0.500	3.50	3.55	126.6	129.5	1.5149	1.5257	0.7090	0.7140
7.000	0.0	3.55	3.55	129.5	129.5	1.5257	1.5257	0.7140	0.7140
7.500	0.500	3.65	3.70	131.2	132.2	1.5471	1.5576	0.7240	0.7289
8.000	1.000	3.85	4.10	134.9	139.2	1.5889	1.6356	0.7436	0.7673
8.500	1.500	4.15	4.35	140.0	143.4	1.6496	1.6889	0.7720	0.7504
9.000	2.000	4.35	4.40	143.4	144.2	1.6889	1.6586	0.7904	0.7549
9.500	2.500	4.50	4.20	145.8	140.9	1.7178	1.6555	0.8039	0.7766
10.000	3.000	4.15	3.45	140.0	127.7	1.6496	1.5041	0.7720	0.7039
10.500	3.500	3.40	2.75	126.8	114.0	1.4921	1.3428	0.6588	0.6284
11.000	4.000	2.55	2.25	109.8	103.1	1.2921	1.2146	0.6052	0.5684
11.500	4.500	1.95	1.50	56.0	84.2	1.1308	0.9918	0.5252	0.4641
12.000	5.000	1.10	1.00	72.1	68.7	0.8493	0.8058	0.3975	0.3790
12.500	5.500	0.70	0.55	57.5	51.0	0.6775	0.6005	0.3171	0.2810
13.000	6.000	0.35	0.25	40.7	34.4	0.4791	0.4049	0.2242	0.1895
13.500	6.500	0.10	0.05	21.7	15.4	0.2561	0.1811	0.1198	0.0847
14.000	7.000	0.05	0.02	15.4	9.7	0.1811	0.1145	0.0847	0.0536

INTEGRATED FLOW RATE = 90.75 CU.FT/SEC
 = 6.428 LBM/SEC

AVERAGE VELOCITY = 84.89 FT/SEC

PRIMARY FLOW RATE, MP = 3.742 LBM/SEC

PRIMARY VELOCITY, LP = 181.40 FT/SEC

MOMENTUM FACTOR, MP = 1.259

(c) FLOW-THROUGH SHROUD WITH RING DIFFUSOR

TABLE XIX (CONTINUED)

APPENDIX A

FORMULAE

Presented here are the formulae used to obtain the primary and secondary mass flow rates. According to the ASME Power Test Code [5], the general equation for mass flow rate appearing in equation (a)

$$W(\text{lbm/sec}) = (0.12705) K A Y F_a [\rho \Delta P]^{0.5} \quad (\text{a})$$

may be used with flow nozzles and square edge orifices provided the flow is subsonic. In the above equation, K (dimensionless) represents the flow coefficient for the metering device and is defined as $K = C(1 - \beta^4)^{-0.5}$ where C is the coefficient of discharge and β is the ratio of throat to inlet diameters; $A(\text{in}^2)$ is the total cross sectional area of the metering device; Y (dimensionless) is the expansion factor for the flow; F_a (dimensionless) is the area thermal-expansion factor; ρ (lbm/ft^3) is the flow mass density; and ΔP (inches H_2O) is the differential pressure across the metering device. Each of these quantities are evaluated, according to the guidelines set forth in Reference [5], for the specific type of flow measuring device used.

Using a square edge orifice for measurement of the primary mass flow rate, the quantities in equation (a) are defined as follows:

1. The flow coefficient K is 0.62 based on a β of 0.502 and a constant coefficient of discharge over the range of flows considered of 0.60.
2. The orifice area is 37.4145 in².
3. Corresponding to the range of pressure ratios encountered across the orifice, the expansion factor Y is 0.98.
4. Since the temperature of the metered air is nearly ambient temperature, the thermal expansion factor is essentially 1.0.
5. The primary air mass density ρ_{or} is calculated using the perfect gas relationship with pressure and temperature evaluated upstream of the orifice.

Substituting these values into equation (a) yields

$$W_p \text{ (lbm/sec)} = (2.8882) [\rho_{or} \Delta P_{or}]^{0.5} \quad (b)$$

The secondary mass flow rate is measured using long radius flow nozzles for which case the quantities in equation (a) become:

1. For a flow nozzle installed in a plenum, β is approximately zero in which case the flow coefficient is approximately equal to the coefficient of discharge. For the range of secondary flows encountered, the flow coefficient becomes 0.98.
2. A is the sum of the throat areas of the flow nozzles in use.

3. Since the pressure ratios across the flow nozzles are very close to unity, the expansion coefficient γ is 1.0.
4. Since the temperature of the metered air is nearly ambient temperature, the thermal expansion factor is essentially 1.0.
5. The secondary air mass density ρ_s is evaluated using the perfect gas relationship at ambient conditions.

Substituting these values into equation (a) yields the equation for the secondary mass flow rate measured using long radius flow nozzles.

$$W_s \text{ (lbm/sec)} = (0.13451) A [\rho_s \Delta P_s]^{0.5} \quad (c)$$

APPENDIX B

CALCULATION OF THE MOMENTUM CORRECTION FACTOR

The momentum correction factor is defined as the ratio of the actual momentum rate to the pseudo-rate based on the bulk-average velocity. Defining the actual momentum as that obtained by integrating over the velocity surface, the momentum correction factor may be written as

$$K_m = \frac{1}{W_m U_m} \int_0^{A_m} U^2 \rho_2 dA . \quad (4)$$

The density of the air at the mixing stack exit ρ_2 is a weighted average of the densities of the primary and secondary air flows. Assuming a secondary to primary mass flow ratio of 0.65, which is consistent with experimental results, ρ_2 is expressed as

$$\rho_2 = \rho_{avg.} = \frac{\rho_s}{1.65} \left[0.65 + \frac{T_s}{T_p} \right] . \quad (a)$$

Using this average density of the mixed flow, the mass flow rate leaving the mixing stack may be expressed as

$$W_m = \rho_{avg.} U_m A_m \quad (b)$$

where A has units of ft^2 . Combining equations (4) and (b) results in an equation for the momentum correction factor

in terms of the experimentally determined mixing stack exit velocity profiles,

$$K_m = \frac{1}{U_m^2 A_m} \int_0^{A_m} U_2^2 dA . \quad (c)$$

Figure 36 illustrates the orientation of the two velocity traverses.

To integrate the mixing stack exit velocity over the three-dimensional velocity surface using only the two traverses requires making some approximations:

1. Traverses A and B represent the maximum and minimum values of the velocity surface respectively.
2. The three-dimensional velocity surface is symmetrical, i.e. a velocity traverse passing above the other two primary nozzles, perpendicular to traverse A, is equal to that of traverse A and likewise for traverse B.
3. The circumferential variation of the velocity surface is sinusoidal with the maximum and minimum values at a given radius occurring at traverses A and B respectively.

The velocity traverse obtained experimentally consists of discrete points rather than a continuous curve. Each of these point values of velocity is representative of a radial element of the velocity traverse of length equal to the spacing between

successive points. The procedure is to fit a circumferential sinusoidal curve through the maximum and minimum velocities of traverses A and B respectively. Then treat this circumferential band as representing a segment of the velocity surface of incremental width dr equal to the spacing between the data points and integrate circumferentially over successive radial elements. Completion of the integration yields the actual momentum of the mixed gases leaving the exit of the mixing stack.

APPENDIX C

UNCERTAINTY ANALYSIS

The determination of the uncertainties in the experimentally determined pressure coefficients, pumping coefficients, and velocity profiles was made using the method described by Kline and McClintock [6]. The uncertainties obtained by Ellin [1] using the second order equation suggested by Kline and McClintock [6] are all applicable to the experimental work reported herein and are summarized in the following table.

TABLE XIV
UNCERTAINTY IN MEASURED VALUES

T_s	$\pm 1 \text{ }^\circ\text{R}$
T_p	$\pm 1 \text{ }^\circ\text{R}$
P_a	$\pm 0.01 \text{ psia}$
ΔP	$\pm 0.01 \text{ in. H}_2\text{O}$
P_v	$\pm 0.01 \text{ in. H}_2\text{O}$
P_u	$\pm 0.05 \text{ in. H}_2\text{O}$
ΔP_s (+)	$\pm 0.01 \text{ in. H}_2\text{O}$
P_{or}	$\pm 0.01 \text{ in. H}_2\text{O}$
ΔP_{or}	$\pm 0.20 \text{ in. H}_2\text{O}$
T_{or}	$\pm 1 \text{ }^\circ\text{R}$
T_a	$\pm 1 \text{ }^\circ\text{R}$
PT (++)	$\pm 0.1 \text{ in. H}_2\text{O}$

UNCERTAINTY IN CALCULATED VALUES

$\frac{\Delta P^*}{T^*}$	1.9 %
$W^* T^{*0.44}$	1.4 %
V/V_{avg}	2.5 %

- (†) The pressure differential across the secondary flow nozzles, P_s , is the major source of uncertainty in the pumping coefficient.
- (††) The measurement of the total pressure for the velocity profile is the major source of uncertainty in the velocity calculation.

EPILOG

The authors feel that this has been a joint thesis in every phase of its production. From planning, fabrication, and testing through the computing and compiling of the data, we feel that both members of this thesis team have contributed equally. The rough drafts for the Introduction, Theory and Analysis, and Experimental Apparatus sections were written by Lt. Staehli. The rough drafts of the Experimental Methods and Experimental Results sections were written by Lt. Lemke. The Conclusions and Recommendations were by both authors as were the final corrections and additions to the rough copy.

BIBLIOGRAPHY

1. Ellin, C.R., Model Test of Multiple Nozzle Exhaust Gas Eductor Systems For Gas Turbine Powered Ships, Engineer's Thesis, Naval Postgraduate School, June 1977.
2. Moss, C.M., Effects of Several Geometric Parameters on the Performance of A Multiple Nozzle Eductor System, Master's Thesis, Naval Postgraduate School, September 1977.
3. Harrell, J.P. Jr., Experimentally Determined Effects of Eductor Geometry on the Performance of Exhaust Gas Eductors for Gas Turbine Powered Ships, Engineer's Thesis, Naval Postgraduate School, September 1977.
4. Pucci, P.F., Simple Eductor Design Parameters, Ph.D. Thesis, Stanford University, September 1954.
5. American Society of Mechanical Engineers Interim Supplement 19.5 on Instrumentation and Apparatus, Fluid Meters, Sixth edition, 1971.
6. Kline, S.J. and McClintock, F.A., "Describing Uncertainties in Single-Sample Experiments," Mechanical Engineering, p. 3-8, January 1953.

INITIAL DISTRIBUTION LIST

	No. Copies
1. Defense Documentation Center Cameron Station Alexandria, Virginia 22314	2
2. Library, Code 0142 Naval Postgraduate School Monterey, California 93940	2
3. Department Chairman, Code 69 Department of Mechanical Engineering Naval Postgraduate School Monterey, California 93940	2
4. Professor Paul F. Pucci (Code 69Pc) Department of Mechanical Engineering Naval Postgraduate School Monterey, California 93940	10
5. LT Charles R. Ellin 13512 Westwind Drive Silver Spring, Maryland 20904	1
6. Mr. Charles Miller NAVSEA Code 0331 Naval Ship Systems Command Washington, D.C. 20362	1
7. Mr. Olin M. Pearcy NSRDC Code 2833 Naval Ship Research and Development Center Annapolis, Maryland 21402	1
8. Mr. Mark Goldberg NSRDC Code 2833 Naval Ship Research and Development Center Annapolis, Maryland 21402	1
9. Mr. Eugene P. Wienert Head, Combined Power and Gas Turbine Branch Naval Ship Engineering Center Philadelphia, Pennsylvania 19112	1
10. Mr. Donald N. McCallum NAVSEC Code 6136 Naval Ship Engineering Center Washington, D.C. 20362	1

11. Lt. J.P. Harrell, JR., USN 1
2004 Cloverleaf Place
Ardmore, Oklahoma 73401
12. Lt. C.M. Moss 1
625 Midway Road
Powder Springs, Georgia 30073
13. Lt. R.J. Lemke 2
2902 No. Cheyenne
Tacoma, Washington, 98407
14. Lt. C.P. Staehli 1
Route 2, Box 64B
Burton, Washington 98013
15. Lt. D. Welch 1
1036 Brestwick Commons
Virginia Beach, Virginia
16. Dean of Research, Code 012 1
Naval Postgraduate School
Monterey, California 93940