

AD-A061 351

VOUGHT CORP ADVANCED TECHNOLOGY CENTER INC DALLAS TEX

F/G 1/3

ANALYSIS OF NOISE IN US ARMY AIRCRAFT.(U)

NOV 78 A J BROUNS, R A ELY

DAAB07-76-C-1746

UNCLASSIFIED

ATC-94100/8CR-41

USAAVRADCOM-TR-76-1746-F

NL

1 OF 3
AD A061351



LEVEL II

3

18
USA AVRADCOM

19 TR -
Technical Report 776-1746-F

DA061351

6
ANALYSIS OF NOISE IN US ARMY AIRCRAFT,

10
Austin J. Brouns
VOUGHT CORPORATION ADVANCED TECHNOLOGY CENTER, INC.

Richard A. Ely
VOUGHT CORPORATION
Dallas, TX 75222

12 240 p.

11
Nov 1978

9
Final Report Jul 1976 - Mar 1978

DDC
NOV 17 1978
F

15 DAAB 7-76-C-1746

DISTRIBUTION STATEMENT

Approved for public release;
distribution unlimited.

14 ATC-9410P/8 CR-41

DDC FILE COPY



Prepared for:
USA Avionics Research & Development Activity
Fort Monmouth, NJ 07703

Research and Development Technical Report
Aviation Research and Development Command

78 11 14 009

389 797

HISA-FM-981-78

NOTICES

Disclaimers

The citation of trade names and names of manufacturers in this report is not to be construed as official Government indorsement or approval of commercial products or services referenced herein.

Disposition

Destroy this report when it is no longer needed. Do not return it to the originator.

UNCLASSIFIED

SECURITY CLASSIFICATION OF THIS PAGE (When Data Entered)

| REPORT DOCUMENTATION PAGE | | READ INSTRUCTIONS BEFORE COMPLETING FORM |
|--|-----------------------|--|
| 1. REPORT NUMBER AVRADCOM-76-1746-F | 2. GOVT ACCESSION NO. | 3. RECIPIENT'S CATALOG NUMBER |
| 4. TITLE (and Subtitle) Analysis of Noise in U. S. Army Aircraft | | 5. TYPE OF REPORT & PERIOD COVERED Final Report for Period July 1976 - March 1978 |
| | | 6. PERFORMING ORG. REPORT NUMBER B-94100/8CR-41 |
| 7. AUTHOR(s) Austin J. Brouns Richard A. Ely | | 8. CONTRACT OR GRANT NUMBER(s) DAAB07-76-C-1746 <i>ml</i> |
| | | 10. PROGRAM ELEMENT, PROJECT, TASK AREA & WORK UNIT NUMBERS 2172040 762 7510 P623207 2581 S28-043 |
| 9. PERFORMING ORGANIZATION NAME AND ADDRESS Vought Corporation Advanced Technology Center P. O. Box 226144 Dallas, Texas 75266 | | 11. CONTROLLING OFFICE NAME AND ADDRESS Avionics Lab AVRADCOM Fort Monmouth, N. J. 07703 Attn: DAVAA-AA-E |
| 14. MONITORING AGENCY NAME & ADDRESS (if different from Controlling Office) | | 12. REPORT DATE November 1978 |
| | | 13. NUMBER OF PAGES 238 |
| | | 15. SECURITY CLASS. (of this report) Unclassified |
| | | 15a. DECLASSIFICATION/DOWNGRADING SCHEDULE None |
| 16. DISTRIBUTION STATEMENT (of this Report) Approved for public release; distribution unlimited | | |
| 17. DISTRIBUTION STATEMENT (of the abstract entered in Block 20, if different from Report) | | |
| 18. SUPPLEMENTARY NOTES | | |
| 19. KEY WORDS (Continue on reverse side if necessary and identify by block number) Noise in Aircraft, Helicopter Noise, Hearing Loss in Aircraft, Communications in Aircraft | | |
| 20. ABSTRACT (Continue on reverse side if necessary and identify by block number) Tape recordings were made of acoustical and electrical noise in the crew compartments and on the interphone lines of 7 models of U. S. Army aircraft, during flight operations. The data were analyzed to determine noise and speech levels in the communication channel, especially at crew members' ears. Calculations were then performed to: - Estimate hearing damage risk <i>and</i> - Estimate the intelligibility of speech. <i>→</i> | | |

DD FORM 1473
1 JAN 73

EDITION OF 1 NOV 65 IS OBSOLETE
S/N 0102-014-6601

UNCLASSIFIED

SECURITY CLASSIFICATION OF THIS PAGE (When Data Entered)

78 11 14 009

UNCLASSIFIED

SECURITY CLASSIFICATION OF THIS PAGE(When Data Entered)

The purpose of the project was to identify harmful noise levels and sources in the communication channel and to make recommendations for reducing such noise.

At frequencies below about 1000 Hz, noise in the communications channel is due primarily to ambient noise which enters the circumaural earcup through leaks between the cushion and the head. Above 1000 Hz, the noise in the channel is due primarily to ambient noise which is picked up by the microphone and transmitted to the earphone. Between 72% and 89% of the A-weighted noise at the ear is due to leakage into the earcup. In the aircraft, the earcup provides about 10 dB less attenuation than is measured with the same type earcup in the laboratory. The difference is due to the quality of the fit, and to the effects of interference from eyeglasses or sunglasses, and hair. Electrical noise from radios and interphone sets is not a significant cause of excessive noise in the communication channel.

The hearing damage risk calculations show that less than 1% of air crewmen would suffer more than a 10 dB hearing loss at speech frequencies after 10 years of flight duty. This is based on 4 hours per day of flight. Typical inter- and intra- aircraft speech intelligibilities were predicted to be greater than 95%.

Economic and performance constraints are prohibitive for achieving significant decreases of noise levels within helicopters, so dependence on ear protectors probably will continue. Most helicopters are in compliance with the current military specification for regulation of noise levels within aircraft (MIL-A-8806A). However, due to earcup leakage, noise exposure typically exceeds limits specified by the Army's TB MED 251. There is evidence that crew members are exposed to damaging noise levels during military basic and advanced training and during leisure-time activities. A recently adopted U. S. Army program provides a sequence for preventing hearing losses by removing a person from duty in a high-noise environment before serious hearing losses occur.

| | |
|---------------------------------|---|
| ACCESSION for | White Section <input checked="" type="checkbox"/> |
| NTIS | Blue Section <input type="checkbox"/> |
| DDC | <input type="checkbox"/> |
| UNCLASSIFIED | <input type="checkbox"/> |
| JUSTIFICATION | |
| BY | |
| DISTRIBUTION/AVAILABILITY CODES | DATE |
| A | |

UNCLASSIFIED

SECURITY CLASSIFICATION OF THIS PAGE(When Data Entered)

TABLE OF CONTENTS

| | <u>Page No.</u> |
|---|-----------------|
| 1.0 INTRODUCTION ----- | 1 |
| 2.0 DESCRIPTION OF THE COMMUNICATION ENVIRONMENT ----- | 3 |
| 3.0 DESCRIPTORS OF THE ENVIRONMENT ----- | 9 |
| 3.1 A-WEIGHTED NOISE ----- | 9 |
| 3.2 POWER SPECTRUM LEVEL VS. FREQUENCY ----- | 11 |
| 3.3 HEARING DAMAGE RISK - PUBLISHED CRITERIA ----- | 11 |
| 3.4 ARTICULATION INDEX ----- | 17 |
| 3.5 INTELLIGIBILITY ----- | 18 |
| 3.6 DECIBEL AVERAGING ----- | 20 |
| 4.0 NOISE PROFILES OF AIRCRAFT COMMUNICATION SYSTEMS ----- | 21 |
| 4.1 UH-1H IROQUOIS (HUEY) ----- | 21 |
| 4.2 OH-58A KIOWA ----- | 26 |
| 4.3 OV-1D MOHAWK ----- | 30 |
| 4.4 AH-1S AND AH-1Q HUEYCOBRA ----- | 37 |
| 4.5 CH-47C CHINOOK ----- | 37 |
| 4.6 CH-54B TARHE ----- | 44 |
| 4.7 SPEECH LEVELS AND EARCUP ATTENUATION ----- | 44 |
| 4.8 STATISTICAL ANALYSIS ----- | 54 |
| 5.0 PSYCHOACOUSTIC PROFILES OF AIRCRAFT COMMUNICATIONS SYSTEMS -- | 59 |
| 5.1 UH-1H ----- | 60 |
| 5.2 OV-1D ----- | 60 |
| 5.3 OH-58 ----- | 60 |
| 5.4 AH-1S AND AH-1Q ----- | 63 |
| 5.5 CH-47C ----- | 63 |
| 5.6 CH-54B ----- | 63 |
| 5.7 SENSITIVITY OF HEARING LOSS ESTIMATES TO SOUND LEVEL --- | 63 |
| 5.8 COMPARISON OF RESULTS WITH THOSE OF PREVIOUS STUDIES --- | 64 |
| 5.9 HEARING LOSSES AMONG ARMY PERSONNEL BEFORE THEY BECAME HELICOPTER PILOTS ----- | 64 |
| 5.10 CONCLUSIONS ----- | 65 |

TABLE OF CONTENTS (Continued)

| | <u>Page No.</u> |
|--|-----------------|
| 6.0 ANALYSIS OF AVIONICS EQUIPMENT ----- | 72 |
| 7.0 EXPERIMENTAL STUDIES OF EARCAPS ----- | 75 |
| 7.1 EXPERIMENTS WITH THE SPH-4 ON A FLAT PLATE COUPLER ----- | 75 |
| 7.2 EXPERIMENTS WITH THE SPH-4 ON A REAL HEAD ----- | 81 |
| 7.3 COMPUTER SIMULATION OF EARCAP PERFORMANCE ----- | 85 |
| 7.4 FIELD EXPERIMENTS WITH EARCAPS AND OTHER EQUIPMENT ITEMS | 93 |
| 8.0 SUMMARY OF HARDWARE PERFORMANCE AND FEASIBLE IMPROVEMENTS --- | 96 |
| 8.1 CABIN NOISE ----- | 96 |
| 8.2 EARCAPS ----- | 102 |
| 8.3 MICROPHONES ----- | 111 |
| 8.4 PERFORMANCE TRADEOFFS ----- | 113 |
| 9.0 HEARING CONSERVATION PROGRAMS IN THE MILITARY SERVICES ----- | 120 |
| 9.1 ORGANIZATION ----- | 120 |
| 9.2 ADMINISTRATION ----- | 121 |
| 10.0 CONCLUSIONS AND RECOMMENDATIONS ----- | 127 |
| 10.1 THE NOISE ENVIRONMENT ----- | 127 |
| 10.2 INTELLIGIBILITY AND HEARING DAMAGE RISK ----- | 128 |
| 10.3 EQUIPMENT PERFORMANCE ----- | 129 |
| 10.4 RECOMMENDATIONS ----- | 132 |
| 11.0 ACKNOWLEDGEMENTS ----- | 135 |
| 12.0 REFERENCES ----- | 136 |
| BIBLIOGRAPHY ----- | 143 |
| APPENDIX A - AIRCRAFT SPECIFICATIONS | |
| APPENDIX B - DATA ACQUISITION AND FORMAT | |
| APPENDIX C - COMMUNICATION SYSTEM NOISE IN 37 AIRCRAFT | |
| APPENDIX D - DESCRIPTION OF A FORTRAN IV COMPUTER PROGRAM FOR CALCULATIONS OF ARTICULATION INDEX (A1) | |
| APPENDIX E - TRANSMISSION OF VIBRATION FROM CREW SEATS TO CREW MEMBER'S HEAD | |

TABLE OF CONTENTS (Continued)

APPENDIX F - DERIVATION AND DESCRIPTION OF A FORTRAN IV
COMPUTER PROGRAM BY CALCULATING NOISE REDUCTION
BY EARCUPS

APPENDIX G - ANALYTICAL OPTIMIZATION OF THE DESIGN OF EAR
PROTECTORS

1.0 INTRODUCTION

The purpose of this project is to analyze and interpret acoustical and electrical data which have been provided by the U. S. Army Avionics Research and Development Activity (AVRADA), Ft. Monmouth, NJ. The acoustical data are in the form of magnetic tape recordings of acoustical noise or speech, measured in 7 different types of U. S. Army aircraft during typical in-flight operations. Some of the electrical data are in the form of magnetic tape recordings of electrical noise on voice communication lines in those same aircraft. The remainder of the electrical data are in written form and are data from standard electrical tests of individual items of communication gear in the same aircraft. The data were analyzed to determine noise and speech levels in the communication channel, especially at the pilot's or crewman's ear. Calculations were then performed to:

- Estimate hearing damage risk
- Estimate the intelligibility of speech
- Estimate the effect on hearing damage risk or intelligibility of changing the noise in selected elements of the channel.

A further purpose of this project is to identify harmful noise sources and levels affecting the communication channel. The principal objective of the project is to determine the contribution of the communication channel to aviator hearing loss and to recommend measures to reduce or eliminate this contribution. Another important objective is to recommend measures to improve the intelligibility of speech.

A study by the U. S. Army Medical Research and Development Command estimates that from 30 to 50 percent of all personnel in the infantry, artillery, armor, and aviation branches suffer noise - induced hearing loss during their military careers.¹ In 1970, the Veterans Administration paid compensation of approximately 52 million dollars for hearing loss, presumably sustained in military service.

The noise levels in many, if not most, types of military aircraft are hazardous to the unprotected ear.²⁻⁴ Measures to significantly reduce the sound at the source, or to attenuate it before it reaches the cockpit or cabin area, have in the past imposed unacceptable performance penalties or required yet-to-be-developed design advances. Personal hearing protection and administrative controls are used to conserve hearing.

This project has been structured so that the performance of aircraft communication systems is measured while in operations use. Thus, one can see whether the communication components work as well in service, with regard to intelligibility and hearing conservation, as they do in the laboratory.

The tape recordings and electrical measurements were made at Ft. Hood, TX and Ft. Eustis, VA by personnel from AVRADA and from the American Electronics Service Corporation (AEL). The recordings were made between September 1976 and April 1977, inclusive.

2.0 DESCRIPTION OF THE COMMUNICATION ENVIRONMENT

Measurements were made in 37 individual aircraft, including 7 different models.

| <u>No. of Aircraft</u> | <u>Model</u> | <u>Wing Type</u> | <u>No. of Engines</u> |
|------------------------|-----------------------|------------------|-----------------------|
| 10 | UH-1H Iroquois (Huey) | Rotor | 1 |
| 6 | OH-58A Kiowa | Rotor | 1 |
| 6 | OV-10 Mohawk | Fixed | 2 |
| 3 | AH-1S Hueycobra | Rotor | 1 |
| 3 | AH-1Q Hueycobra | Rotor | 1 |
| 3 | CH-47C Chinook | 2 Rotors | 2 |
| 6 | CH-54B Tarhe | Rotor | 2 |

All aircraft are powered by turboprop or turboshaft engines. The manufacture dates range from 1966 to 1973, inclusive. More detailed descriptions are found in Appendix A.

The aircraft radios and intercommunication sets (AIC) are a mix of SLAE (Standard Lightweight Avionics Equipment) and PRE-SLAE. The SLAE AIC is the C-6533 which was used in 15 aircraft. The PRE-SLAE C-1611D was used in 22 aircraft. Additional information about the avionics complement is found in Appendix C.

Figure 1 is a block diagram of the communication system, applicable to either the C-1611D or C-6533. The circled items identify possible sources of noise which will ultimately appear as masking or damaging audio frequency noise at a crewman's ears. The C-1611D headset amplifier is capable of delivering about 100 mW of low-distortion speech to each earphone, providing about 97 dB SPL at the ear. At higher levels, the distortion increases rapidly. At the point where limiting occurs, a sound pressure of about 100 dB SPL is produced at the ear. The C-6533 can deliver somewhat higher low-distortion signal to each earphone producing about 100 dB SPL at the ear. It is estimated from a few measurements made during the project that at least 104 dB SPL can be produced at the ear before limiting occurs. Higher levels are possible in frequency bands where the earphone has response peaks. The C-6533 has a softer limiting characteristic than the C-1611.

The air crewman's helmet worn during the flight tests was the Model SPH-4. The helmet contains plastic earcups which have circumaural ear cushions filled

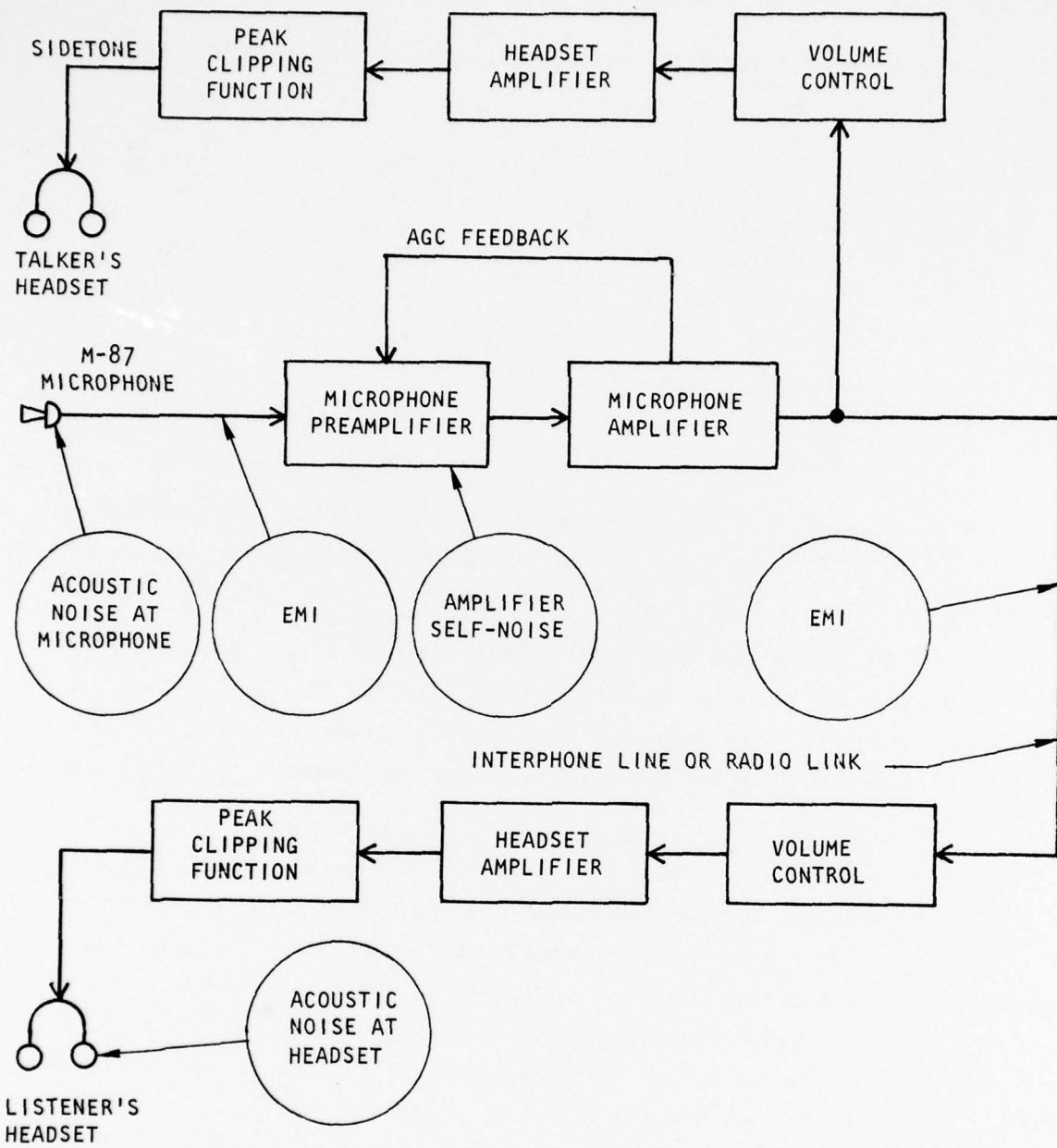

FIGURE 1. BLOCK DIAGRAM OF COMMUNICATION SYSTEM

with soft foamed plastic. Each earcup contains a Model H-143/AIC earphone.⁵ The earphones are electrically connected in parallel. The specified impedance of each earphone at 1000 Hz is 19 ± 2 Ohms. All in-the-earcup acoustical data were taken in the same SPH-4 helmet in the right-hand earcup. The response of the H-143 earphone was measured by AVRADA and is shown in Figure 2. The response is considered to be typical.

Those data segments which include speech were made with a boom-mounted, noise-cancelling microphone, Model M-87/AIC.⁶ The microphone impedance is 5 ± 2 Ohms. Various individual M-87's were used. They were observed to operate normally, but were otherwise not calibrated. Figure 2 also shows the close-talk response of a nominal M-87 microphone, as specified by MIL-M-26542A⁶ at a test distance of 1/4 inch.

Figure 3 shows the amplification characteristics of the C-1611, which is very similar to the amplification characteristic of the C-6533. Also shown is an overall response of the communications system, including microphone, AIC, and earphone.⁷

During the planning of the data acquisition phase, lists of relevant flight modes and communication system test points were developed.

| <u>Flight Modes (Standard Maneuvers)</u> | <u>Communication System Test Points</u> |
|--|--|
| 1 Take-Off | 1 Cabin Ambient (acoustic) |
| 2 Climb | 2 Earcup, interphone not keyed (acoustic) (NO KEY)* |
| 3 Descent Right | 3 Earcup, interphone keyed, no processed speech (acoustic) (KEY NO TALK) |
| 4 Climb left | 4 Earcup, interphone keyed, with processed speech (acoustic) (KEY TALK) |
| 5 Descent left | 5 Earcup, interphone not keyed, dummy headset (electrical) |
| 6 Climb Right | 6 Earcup, interphone keyed, dummy headset (electrical) |
| 7 Descent | 7 Earcup, interphone keyed, dummy microphone dummy headset (electrical) |
| 8 Level Flight | |
| 9 Hover at Altitude | |
| 10 Hover in Ground Effect | |
| 11 Land | |
| 12 Nap of Earth Flight | |

* See Appendix C, page C-1 for definitions of Key and No Key conditions.

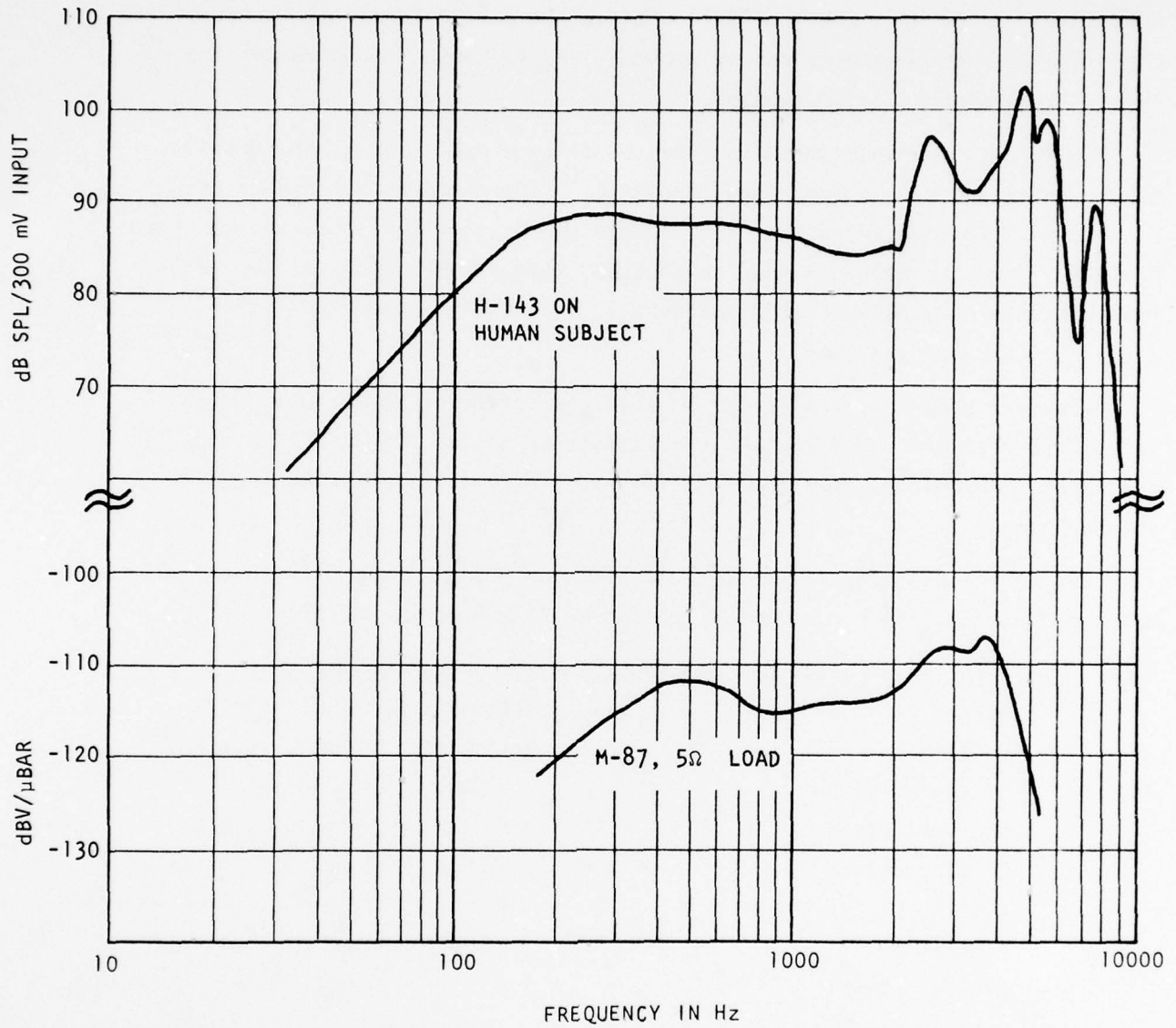

FIGURE 2 (TOP) RESPONSE OF TYPICAL H-143 EARPHONE ON HUMAN SUBJECT (AVRADA) MEASUREMENT)

(BOTTOM) RESPONSE OF M-87, AS SPECIFIED BY MIL-M-26542A (USAF) (20 DECEMBER 1962)

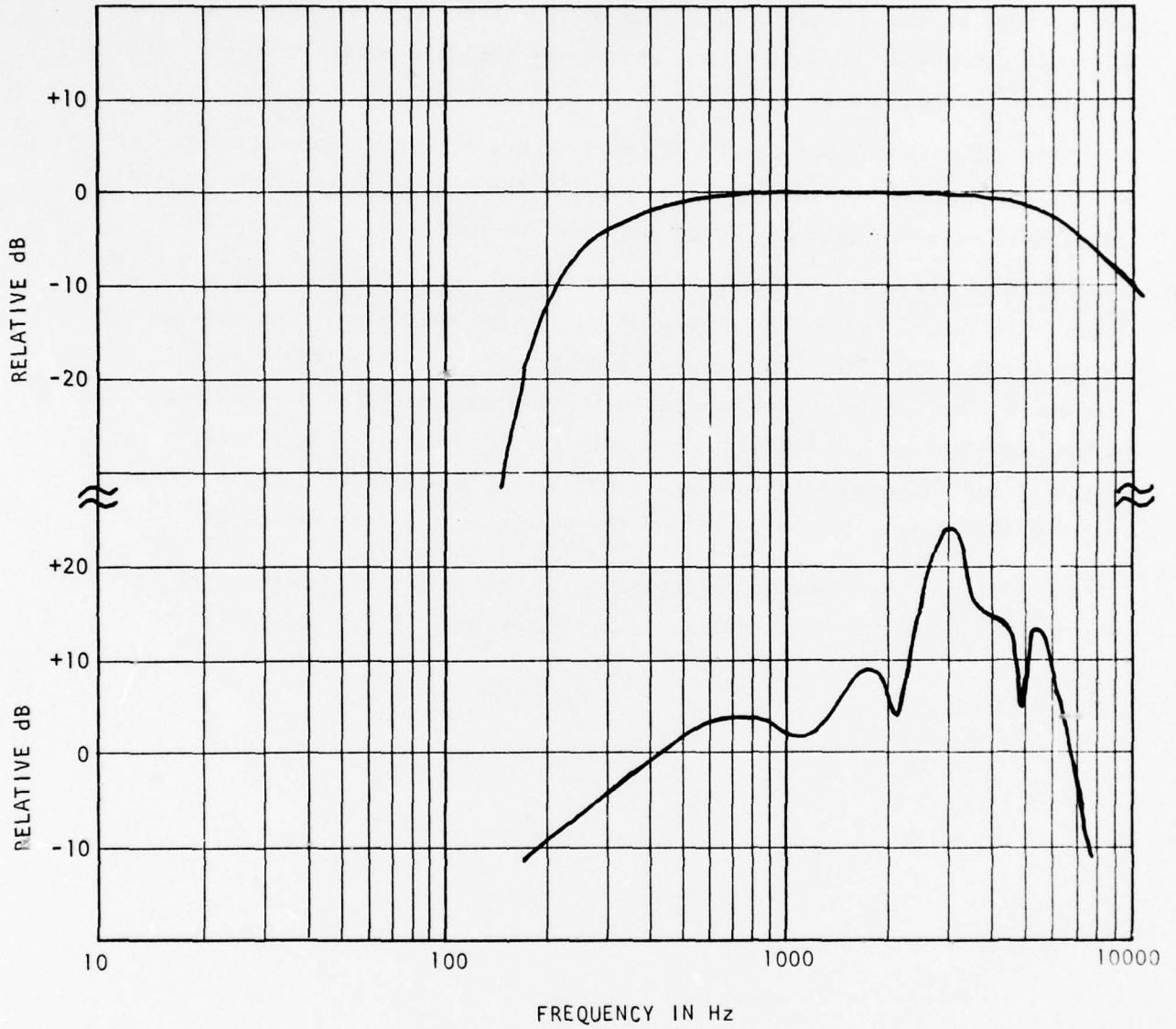

FIGURE 3 (TOP) RESPONSE OF C-1611/AIC (AVRADA MEASUREMENT)

(BOTTOM) OVERALL RESPONSE OF MICROPHONE, AIC, AND HEADSET (AVRADA MEASUREMENT)

The cabin ambient noise was tape-recorded on one channel of a magnetic tape recorder using a microphone in the aircraft cabin. The earcup acoustical recordings were simultaneously made on the other channel using a microphone inside the earcup, at the crewman's ear. The earcup electrical recordings were made across a dummy (8Ω) headset load. Details of the data acquisition and format are given in Appendix B.

The above conditions permit 72 combinations of earcup recordings per aircraft, for a total of 2664 for 37 aircraft. About 22 percent of the possible total were actually made and found suitable for analysis.

Each of the tape recordings for each flight condition and test point was one minute long. During the making of the "talk" recordings, the speaker (crew or pilot) was asked to read a prepared text, referred to as the "rainbow passage," in a "normal voice" suitable for the communication environment. The volume settings on the AIC sets were adjusted for "comfortable listening level" suitable for the communications environment. In most or all cases a mid-range setting (12 o'clock to 1 o'clock) of the volume control was selected.

The earcup, earphone and microphone package in the SPH-4 helmet is designated the MK-1564 ()/AIC. The applicable specification is MIL-H-55351(EL).

3.0 DESCRIPTORS OF THE ENVIRONMENT

3.1 A-WEIGHTED NOISE

The electrical output of microphones and associated audio amplifiers often is passed through an electrical filter which is designed to approximate the frequency-dependent response of human ears to sound. Such a filter is called an A-weighted filter. Figure 4 shows the frequency-dependence of the response of such a filter.⁸

The overall level of A-weighted sound has been found to be useful for calculating the impact of noise on human beings, where that impact may be interference with activities, annoyance, physiological effects, or risk of hearing loss.⁹ The use of a single number for overall A-weighted sound as a descriptor of risk of hearing loss is based on the assumption that sound that cannot be heard cannot damage an ear.⁹ A related assumption is that A-weighting accounts for the frequency dependence of an ear's susceptibility to damage, so that a given A-weighted level for a discrete frequency sound produces the same hearing loss regardless of the frequency of that sound.

The A-weighted sound levels which are tabulated in this report were produced by playing back magnetic tape recordings of helicopter noise through an analog A-weighting filter (Bruel & Kjaer Type 2111 Spectrometer) and supplying the electrical output of that filter to a B&K Type 2305 graphic level recorder. Values of A-weighted sound levels were read from the resulting strip charts of sound level versus time. The resulting levels were calibrated by means of a 250 Hertz tone corresponding to a known sound pressure level which was recorded on the magnetic tapes during the initial measurements. Listings of the output of the Articulation Index computer program (See Appendix D) which appear in several places in this report include calculated A-weighted sound levels. Those levels generally agree to within about 2 dB with the levels that were determined with a B&K filter and a level recorder. Calculations of Articulation Index like those described in Section 3.4 do not incorporate A-weighted sound, but weighting factors similar to A-weighting are built into the calculations.

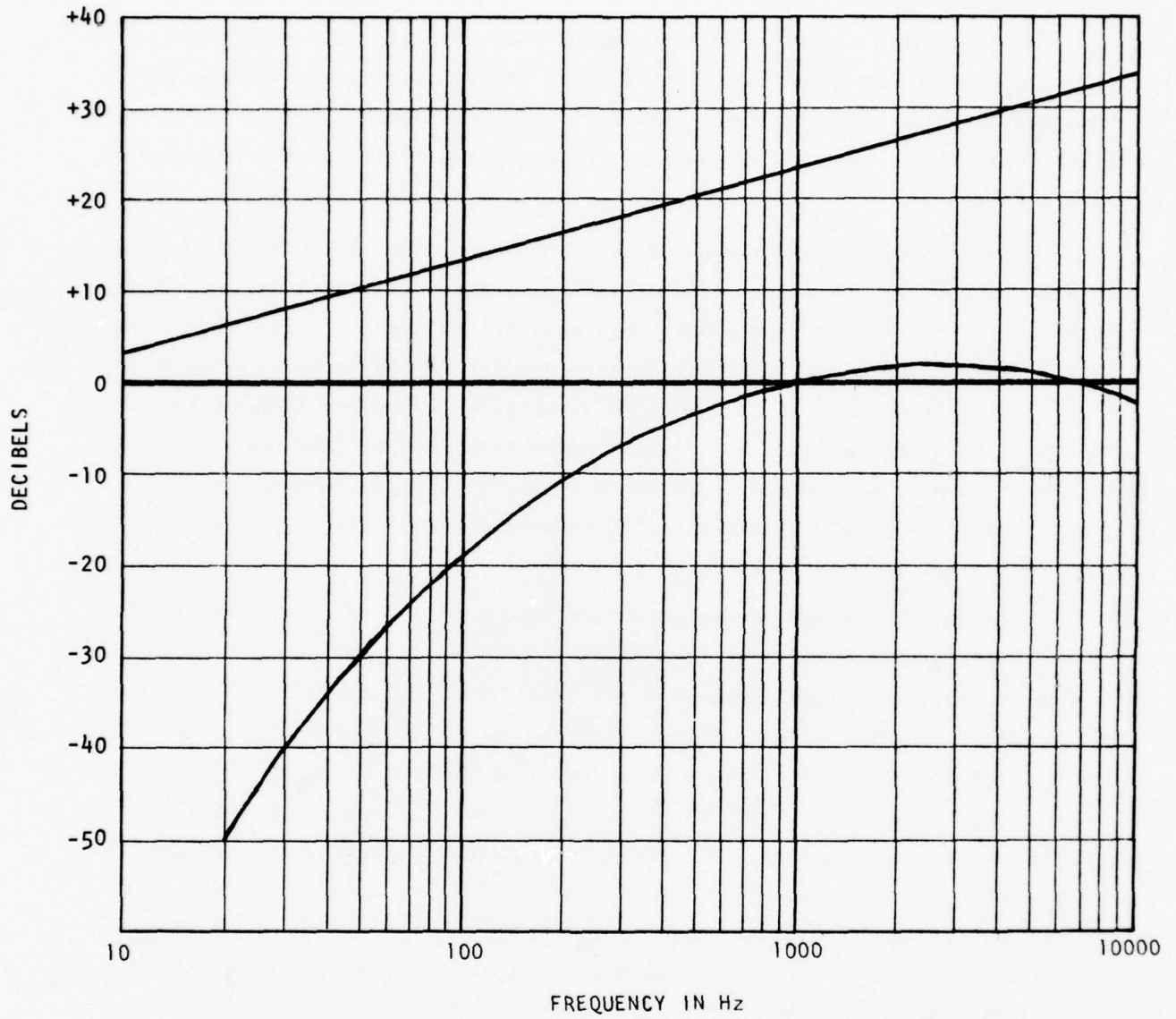

FIGURE 4 WEIGHTING CURVES:

TOP CURVE: SPECTRUM LEVEL TO 1/3-OCTAVE LEVEL

BOTTOM CURVE: A-WEIGHTING CURVE

3.2 POWER SPECTRUM LEVEL VS FREQUENCY

The plots of power spectrum level versus frequency which are presented in this report were produced by a Hewlett Packard Model 5451A Fast Fourier Transform (FFT) system. The Model 5451A utilizes an electronic digital computer to calculate Fourier transforms of time-varying signals. Those Fourier transforms are used to calculate power spectrum levels for narrow bands of frequencies throughout a frequency range of interest.

The method of analysis is as follows. A section of taped data for a given test and flight condition is processed using Fourier analysis to determine a power spectrum. The tape sections are 1-minute long; however, the effective averaging time for the analysis is about 40 seconds because the A/D conversion is a little slower than real time. The excellent repeatability of the results indicate that the accuracy would not be improved by averaging for a full minute. The effective filter bandwidth for the analysis is 10 Hz. The results are stored as a list of numbers representing the mean-square voltage in each of the 10-Hz bandwidths required to cover the frequency range of interest, which is 20 Hz to 10000 Hz. Division of the numbers by 10 yields a pseudo power spectrum, corresponding to a 1 Hz bandwidth. A 250 Hz calibration tone on the tape is also analyzed to derive a calibration scale factor. Its dimensions are $(\text{volts})^2/(\text{psi})^2$ where the (rms) psi is derived from the known sound pressure produced by the pistonphone used to make the calibration. If necessary, an additional scaling factor is applied to account for the setting of the input attenuator on the Nagra recorder. Any of the numbers in the stored list can then be converted to dimensions of $(\text{psi})^2$ by dividing by the calibration scale factor. Further processing yields dimensions of dB SPL, in whatever bandwidth is found useful.

3.3 HEARING DAMAGE RISK - PUBLISHED CRITERIA

In the following discussion of hearing damage risks, the threshold shifts which are cited are in addition to those shifts which normally occur due to the human ageing process.

Although there is some disagreement among hearing experts as to what comprises a threat of significant hearing loss,¹⁰ there is general agreement that

measurable hearing loss results from frequent exposure to sound levels above 75 dBA for ten years or more.⁹ For example, exposure to sound levels of 85 dBA for 8 hours per day, five days a week, for ten years will produce a noise-induced permanent threshold shift (NIPTS) of 19 decibels or more at 4000 Hertz in ten percent of people who are so exposed.¹⁰ Exposure to 88 dBA for 4 hours a day or 91 dBA for 2 hours a day will produce that same loss of hearing, assuming that the noise is continuous without interruption. Even at levels as low as 75 dBA, 10 percent of the population will experience an NIPTS of 6 decibels or more at 4000 Hertz after 40 years of daily exposure.¹⁰

Judgements of the significance of the hearing loss just described are aided by noting that the average of NIPTS at 500, 1000, and 2000 Hertz resulting from daily exposure to 85, 90, and 95 dBA for 8, 4 and 2 hours per day, respectively, will be 3 decibels or greater, after 40 years, for 10% of the population.¹⁰ It has become common practice to refer to such frequencies as "speech frequencies", implying that avoidance of hearing losses in that frequency range will prevent any serious speech communication handicap.⁹ That premise is explicit in most occupational hearing damage-risk criteria, which treat hearing losses at frequencies above 2000 Hertz as insignificant for speech comprehension.¹¹ However, hearing at frequencies up to at least 3000 Hertz plays a major role in understanding of speech,¹² and speech sounds ranging from 200 to 6100 Hertz contain useful information.¹¹

Differences in judgements of the importance of hearing at high frequencies are largely responsible for differences in proposed maximum allowed sound levels to protect hearing. For example, the Occupational Safety and Health Administration (OSHA) requires¹³ that an employee's eight-hour time-weighted average exposure be no more than 90 dBA, while the Environmental Protection Agency (EPA) has recommended that OSHA reduce that limit at least to 85 dBA,¹³ and the U. S. Army has adopted that reduced limit.¹⁴ In another context, EPA has stated¹¹ that a limit of 73 dBA appears to be the rational choice if strict conservation of hearing is to be the criterion without consideration of cost. Much of the 17 dBA difference between OSHA's requirement and EPA's goal of 73 dBA is due to differences of opinions concerning the importance of hearing losses at 4000 Hertz.¹⁰ The remainder of the difference is due to differing objectives in terms of the

percentage of the population that is to be protected. OSHA limits are designed to protect 90 percent of the population from NIPTS exceeding 5 decibels at "speech frequencies",¹⁰ while EPA limits are designed to protect 100 percent of the population from NIPTS exceeding 5 decibels at 4000 Hertz.

EPA has taken the position that any measurable NIPTS at any frequency is unacceptable if the goal of regulations is to protect the health and welfare of people with an adequate margin of safety. However, EPA considers noise-induced permanent threshold shifts of less than 5 decibels to be unmeasurable and, therefore, not relevant. OSHA regulations are based on a judgement that a noise-induced permanent threshold shift of 7 or more decibels at "speech frequencies" for 10 percent of the population is acceptable, from which it may be inferred from NIPTS curves that NIPTS of 28 or more decibels at 4000 Hertz for 10 percent of the population is acceptable.¹⁰ EPA's compromise of their ideal of 73 dBA for 100 percent protection to a recommendation for 85 dBA and the U. S. Army's acceptance of that limit¹⁴ corresponds to acceptance of NIPTS of 3 or more decibels at "speech frequencies" and 19 or more decibels at 4000 Hz for 10 percent of the population, after 40 years of exposure. Actually, most of the loss suffered after 40 years of exposure is sustained during the first 10 years of exposure.

The Committee on Conservation of Hearing of the American Academy of Ophthalmology and Otolaryngology defined a hearing handicap to be that condition which they judged to interfere with understanding everyday speech.¹⁵ The threshold of handicap was defined by them to occur when the average of the hearing levels at 500, 1000, and 2000 Hz is 25 decibels above what they defined as normal hearing (International Standards Organization Standard, 1963). Although that is a popular criterion,¹⁶ it may lead to significant underestimates of the severity of noise-induced hearing loss and overestimations of tolerable limits to exposure to noise.¹⁵

The Veteran's Administration (VA) allows no compensation unless a noise-induced permanent threshold shift (NIPTS) at "speech frequencies" exceeds 37 dB in a person's better ear, or exceeds 57 dB in their poorer ear.¹⁷ Figure 5 shows that the VA criterion for the better ear corresponds to requiring a limit of 113 dBA to noise levels to which workers are exposed for 8 hours per day if

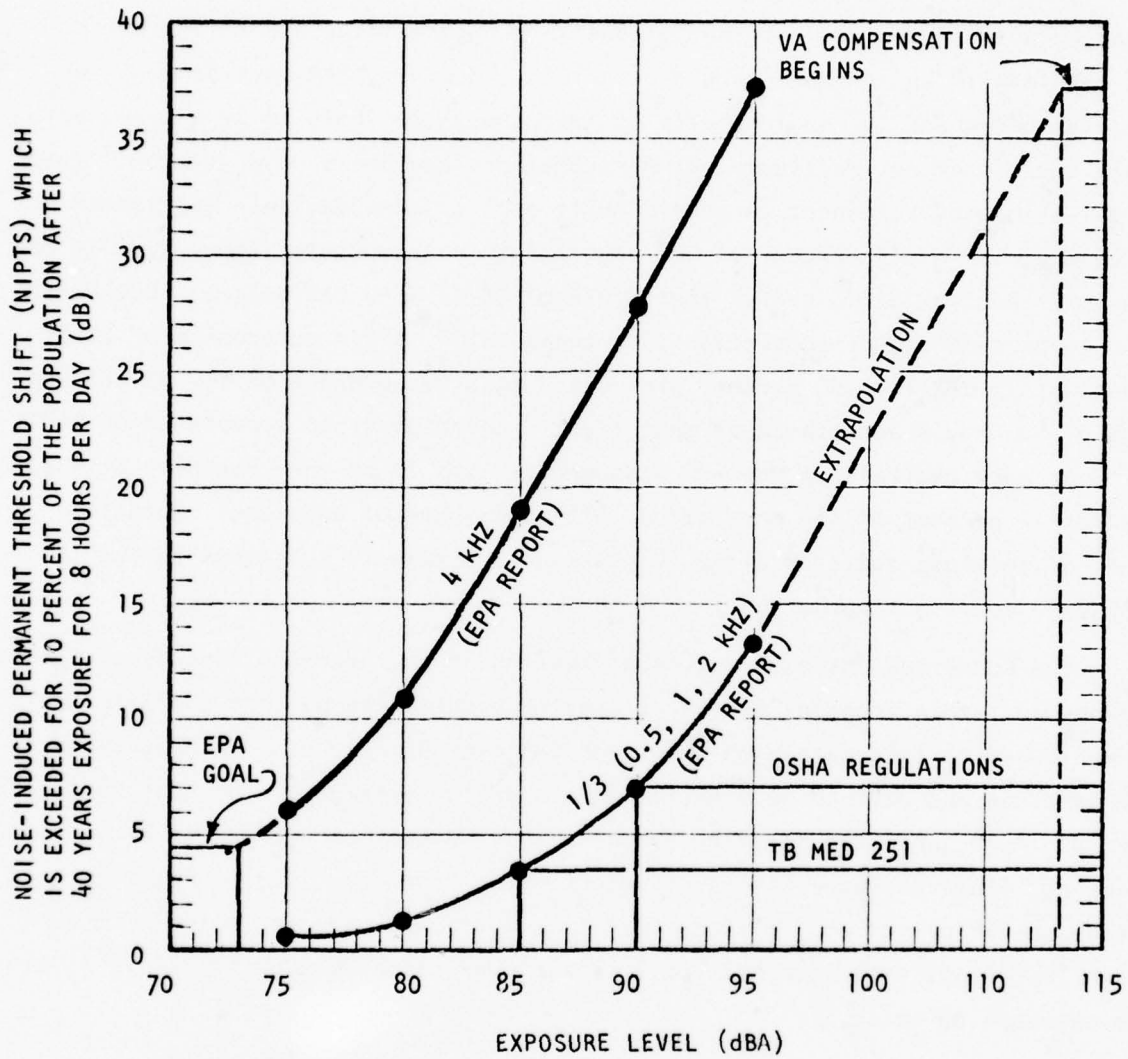

FIGURE 5. 90 PERCENT MAXIMUM NIPTS CURVE (NOISE-INDUCED PERMANENT THRESHOLD SHIFT VS. EXPOSURE LEVEL)

it is desired to protect 90 percent of employees. Figure 5 also shows EPA and OSHA criteria for comparison. The data shown in Figure 5 were taken from a report on NIPTS which was published by EPA.¹⁸ Those data also were plotted and interpreted by von Gierke.⁹

Figure 5 does not provide any information about noise limits required to protect the ten percent of people who are most susceptible to hearing loss. Figure 6 provides that information. Part of the information in Figure 6 is from the EPA NIPTS report,¹⁸ and part is from extrapolations and from Figure 5. The extrapolations which are displayed in Figures 5 and 6 are risky, as extrapolations always are. However, even if there is some inaccuracy in those extrapolations, the resulting curves still serve to put the problem of risk of hearing loss of helicopter pilots in perspective. No additional published data are available, so extrapolations are necessary for definition of the problem of helicopter noise. A discussion of the reasonableness of the extrapolations and of the applicable exposure durations will be presented later in this section, after some examination of the meaning of the curves in Figure 6.

Figure 6 shows that one percent of people who are exposed to 110 dBA for 8 hours per day for 40 years suffer an NIPTS of more than 37 dB, and 0.2 percent suffer more than 37 dB NIPTS for exposure to 108 dBA for that same time. The line in Figure 6 labelled "distribution of hearing level of non-exposed population of 60 year-olds" shows that it is not relevant to consider NIPTS for 40-year exposures to noise at less than 108 dBA if 37 dBA NIPTS is the protection criterion; normal ageing causes the small fraction of the population which is to be protected at that level to suffer a 37 dB loss of hearing, even if they are not exposed to unusually loud noise throughout their working life.

The extrapolations shown in Figure 6 are reasonable, since the resulting curve for 37 dB NIPTS shows that essentially 100 percent of the population will lose the ability to carry on conversation effectively if people are exposed for a working lifetime to noise at a level equalling the threshold of pain. It seems likely that evolutionary processes have supplied the human organism with a pain-avoidance mechanism which encourages people to avoid sound which can destroy their ability to converse with other people.

Figures 5 and 6 do not provide information about the effects of exposure for less than 8 hours per day and/or for less than 40 years. An "equal energy

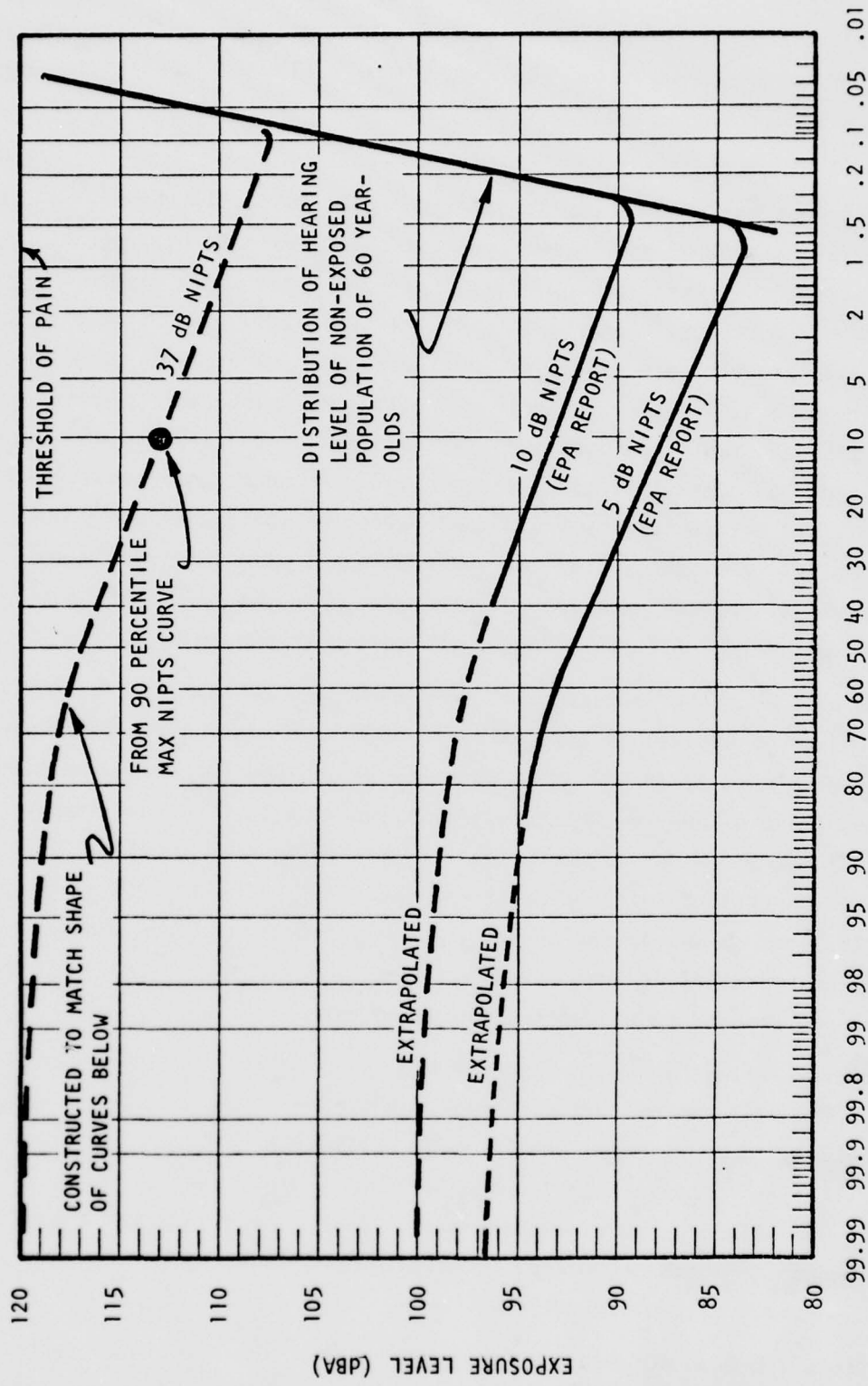

PERCENT OF THE POPULATION THAT SUFFERS MORE THAN THE INDICATED NOISE-INDUCED PERMANENT THRESHOLD SHIFT (NIPTS) AT SPEECH FREQUENCIES (0.5, 1 & 2 KHZ) AFTER 40 YEARS EXPOSURE FOR 8 HOURS PER DAY

FIGURE 6. LIMITS OF NOISE EXPOSURE REQUIRED VS. DESIRED PERCENT OF POPULATION TO BE PROTECTED

rule"⁹ allows an increase of noise levels by 3 dBA for each halving of exposure time. (Some investigators use a "five-dB-per doubling rule" for "speech frequencies.") That rule would allow raising the 37 dB NIPTS curve in Figure 6 by 3 dBA if exposures were limited to 4 hours per day. Limiting exposures to 10 years also would allow raising the curve some, but differences between hearing loss after ten years exposure and after 40 years exposure are small.¹¹ However, there is little information about rates of hearing loss near the threshold of pain. Since it is likely that hearing loss is disproportionately rapid for sound levels in the neighborhood of the threshold of pain, a cautious approach requires assuming that the curve for 37 dB NIPTS in Figure 6 applies to exposures of less than 8 hours per day for less than 40 years.

There are no extrapolations involved in applying Figure 6 to the U. S. Army's criterion for hearing protection.¹⁴ That portion of the 5 dB NIPTS curve that is below 95 dBA is based on measurements. That curve shows that 2 percent of people routinely exposed for 8 hours per day to sound levels equal to the maximum allowed by the U. S. Army (85 dBA) will suffer a 5 dB NIPTS after 40 years of exposure. Helicopter pilots normally will not be exposed to helicopter noise for 40 years, but there is little difference between hearing losses after 10 years of exposure and hearing losses after 40 years of exposure.¹¹ As far as hearing loss at "speech frequencies" is concerned, it does no good to lower the maximum allowed sound level below 85 dBA, because the 1/2 percent of the population that is to be protected by going to a lower level cannot hear sounds at that level at age 60 even if they have not been exposed to loud noise during their working years. OSHA and Army regulations allow a 5 dBA increase in sound level for each halving of daily exposure, up to a maximum sound level of 115 dBA for OSHA and 110 dBA for the Army.

3.4 ARTICULATION INDEX

Articulation Index (AI) is a weighted fraction representing, for a given speech channel and noise condition, the effective proportion of the normal speech signal that is available to a listener for conveying speech intelligibility. AI is computed from acoustical estimates or measurements of the speech spectrum and of the effective masking spectrum of any noise which may be present along with the speech at the ear of a listener.

Articulation Index values were calculated for the test conditions described in this report by means of a FORTRAN IV computer program which was executed either on a CDC 6600 electronic computer or in modified form on a peripheral computer associated with a Hewlett-Packard 5451A Fourier Analyzer. The logic of the computer program is based on an American National Standards Institute Standard (ANSI S3.5).¹⁹ The program is described and listed in Appendix D.

The sound levels generated by electronic communications of speech in helicopters are sufficiently high that ANSI S3.5 rules out the use of octave-band sound pressure levels in the calculation of AI. For high sound levels, the ANSI standard requires the use of a 20-band method which involves the use of spectrum levels of sound. The 20-band method is based upon measurements or estimates of the spectrum level of the speech and noise present in each of 20 contiguous frequency bands. Those bands are defined in such a way that in a quiet background the speech components within each band contribute equally to speech intelligibility when the spectrum level of the speech peak at the mid-frequency of each band exceeds the threshold of audibility at that frequency by 30 decibels or more.

3.5 INTELLIGIBILITY

The intelligibility of speech depends on the extent to which extraneous sounds distract a listener's attention from the speech of interest. Figure 7 shows a curve which is useful for determining the intelligibility of speech in the presence of noise. That curve displays intelligibility as a function of Articulation Index.

The relationship between intelligibility and AI indicated by the curve in Figure 7 is approximate. There is a point beyond which speech levels cannot be increased to compensate for increased noise levels. Attempts to generate very high voice levels generally lead to distortions of speech which cause decreased intelligibility, whether the high voice levels are generated by an increased vocal effort by a person or by increasing the gain of an electronic amplifier. Frequency distortion (transmission of a signal with unequal gain as a function of frequency) usually affects intelligibility of speech.¹⁹ Clipping to limit the dynamic range of speech signals introduces distortion and harmonics which degrade the intelligibility of speech signals.^{20,21} Figure 7 is not precisely applicable to cases of amplitude and frequency distortion. Even if no such distortion occurs, the precise relationship between intelligibility and AI depends upon the nature of the transmitted message and upon the skill of talkers and listeners.

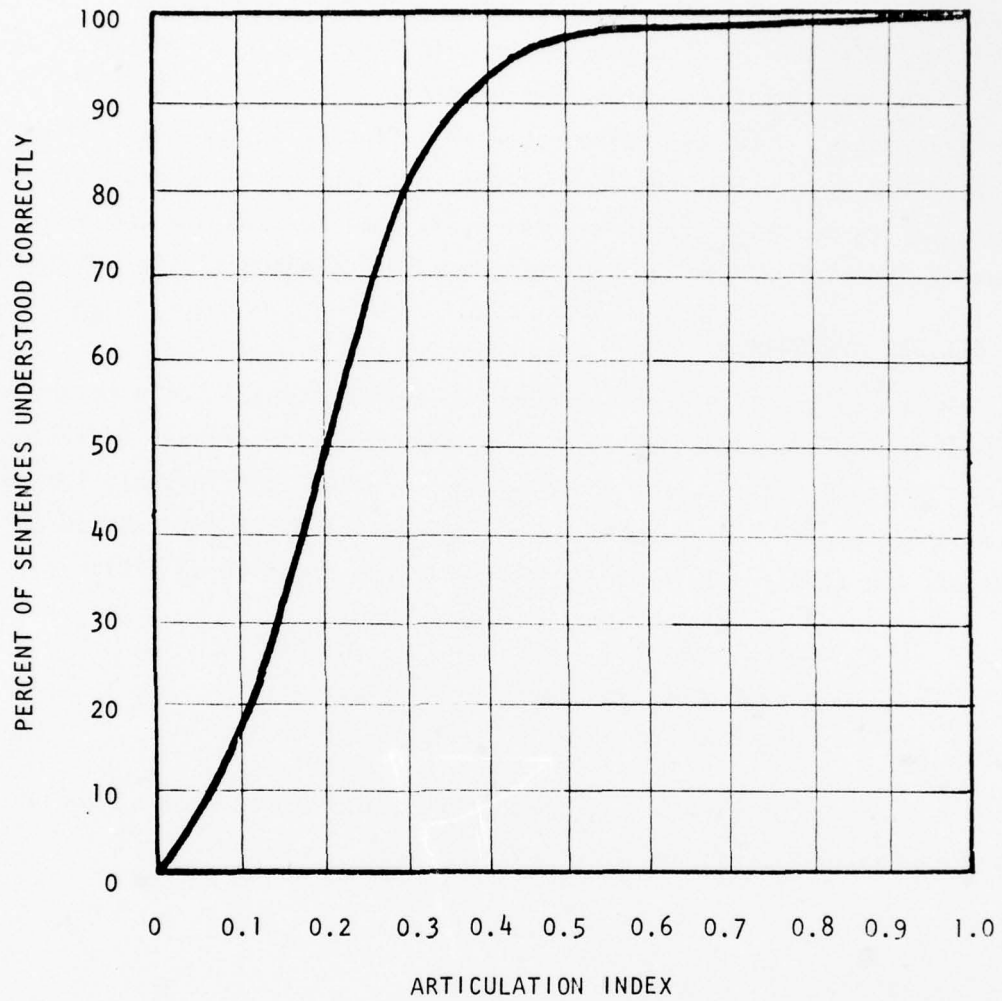

FIGURE 7. INTELLIGIBILITY OF SPOKEN SENTENCES VERSUS ARTICULATION INDEX (JASA, 19, 1947)

Gasaway²² listed numerous references which show that articulation index probably is the best method for predicting approximate speech intelligibility for electrical communication systems. He specifically mentioned a reference²³ which shows that the 20 band method for calculating values for the articulation index is the most accurate method for predicting speech intelligibility in high-level noise. Gasaway²⁴ also noted an influence on intelligibility which is not described by calculations of articulation index -- there are acoustic features of voice communications in aircraft that may enhance the intelligibility of speech, such as the emphasis of plosives by a lip-position microphone.

3.6 DECIBEL AVERAGING

The composite noise levels and earcup attenuations in this report were obtained by averaging the dB, dB SPL, or dBA values of several individual measurements. If sound pressures or sound powers were averaged instead, the averages would be different. For example, if the values of 94 dB SPL and 100 dB SPL were averaged, the results would be as follows (reconverted to dB SPL).

| | |
|-------------------------|--------------|
| Decibel Average: | 97 dB SPL |
| Sound Pressure Average: | 97.52 dB SPL |
| Sound Power Average: | 97.98 dB SPL |

Since earcup attenuation is the difference of two averages, the influence of the averaging method tends to be diminished.

4.0 NOISE PROFILES OF AIRCRAFT COMMUNICATION SYSTEMS

In Appendix C, there are tabulations of A-weighted noise in the communications systems for each of the 37 aircraft studied during the project. Appendix C also has untouched computer-generated plots of noise spectra for some of the aircraft types studied during the project. Noise profiles have been developed from the spectra and the A-weighted summaries. These profiles will be presented in this section.

Among the various flight conditions the plots of spectrum level vs. frequency for each aircraft type showed no significant differences between spectra, except for differences in dBA levels. Level flight is the most common flight mode and also produces an intermediate noise level; therefore, most of the remaining discussion will deal with level flight. Figures 8 through 27 represent a noise profile of 5 aircraft types. At various frequencies, most of the original spectra (See the last few pages of Appendix C) have very narrow lines which extend above the general spectrum level about 10 dB. These lines may be due to discrete frequency vibrations of transmission or engine components; however, there is not a consistent pattern of frequencies from aircraft to aircraft. These lines do not contribute significantly to the overall sound pressure level and have not been copied in the figures in this section. The fundamental rotor blade passage frequency of the helicopters is near 10 Hz. The 10 Hz effective bandwidth of the FFT filtering process is not adequate to resolve the discrete lines of pressure due to blade passage.

The frequency scale of Figures 8 through 27 is logarithmic. The curves are plotted using a constant percentage bandwidth weighting (in particular, 1/3-octave band weighting) or combined 1/3-octave band and A-weighting (see Figure 4). This is done to provide a proper visual perspective for associating the appearance of the curves with the contributions of various parts of the spectra toward the noise problem.

4.1 UH-1H IROQUOIS (HUEY)

The rank order of average ambient noise levels in the cabins of 10 UH-1H aircraft for 11 flight modes is as follows (to the nearest decibel).

| | <u>Average (dBA)</u> |
|------------------------|---------------------------|
| Descent | 96 |
| Descent left, right | 96 |
| Map of earth flight | 95 |
| Climb right | 94 |
| Level flight | 94 |
| Climb | 94 |
| Climb left | 93 |
| Hover in ground effect | 92 |
| Hover at Altitude | 91 |
| Land | 90 (One data sample only) |

There are no data for the "take off" maneuver. A few measurements were made during maximum performance maneuvers. There is no significant difference between these levels and those during standard maneuvers.

A more detailed rank order of average noise levels for 3 representative flight modes is shown in Table 1.

Figure 8 shows spectra of noise which was measured in the cabins of the UH-1H's, and in the earcup of an SPH-4 helmet. In a previous U.S. Army project,²⁵ the main discrete noise sources in the UH-1A were identified as follows.

- o Main rotor 20-220 Hz
- o Tail rotor 50-500 Hz
- o Engine 100-900 Hz
- o Main transmission 600-6,000 Hz

At frequencies near and above 1000 Hz, some of the indicated levels of earcup noise are probably higher than the true levels, due to noise introduced by the data collection, recording, and analysis process. The extent and significance of this is discussed in Appendix B. However, the overall dBA levels cited in the report are not greatly affected by earcup noise at the higher frequencies.

Figure 9 suggests a noise model for the UH-1H which will be seen to be applicable to all the aircraft in this study. The model has the following components.

- o A noise spectrum in the earcup which slopes downward as frequency increases (due to earcup leakage), designated NO KEY in Figure 9.

TABLE 1 AVERAGE NOISE LEVELS AND EARCUP ATTENUATION

| AIRCRAFT | FLIGHT MODE | CABIN AMBIENT | EARCUP NO KEY | EARCUP ATTENUATION * | EARCUP KEY, | | EARCUP KEY, TALK | RANGE, EARCUP KEY, TALK |
|-----------|-------------------|---------------|---------------|----------------------|----------------|----------------|------------------|-------------------------|
| | | | | | NO TALK | 86 dBA | | |
| UH-1h | Descent | 96 dBA | 36 dBA | 10 dB | 86 dBA | 90 dBA | | 86-97 dBA |
| | Level Flight | 94 | 84 | 10 | 86 | 90 | | 86-96 |
| | Hover at Altitude | 91 | 80 | 11 | 83 | 94 | | 89-98 |
| OH-58A | Descent | 91 | 85 | 6 | 85 | 86 | | 34-93 |
| | Level Flight | 92 | 85 | 7 | 85 | 86 | | 85-89 |
| | Hover at Altitude | 91 | 81 | 10 | 82 (3 samples) | 84 (2 samples) | | 83-86 |
| OV-10 | Descent | 101 | 86 | 15 | 88 | 91 | | 78-94 |
| | Level Flight | 101 | 87 | 14 | 88 | 89 | | 80-95 |
| Ah-1S, 1Q | Descent | 95 | 87 | 8 | 87 | 88 | | 85-89 |
| | Level Flight | 95 | 86 | 8 | 87 | 88 | | 85-90 |
| | Hover at Altitude | 92 | 83 | 9 | 84 | - | | - |
| CH-47C | Descent | 111 | 93 | 18 | 93 | 93 | | 92-94 |
| | Level Flight | 110 | 92 | 18 | 93 | 93 | | 92-94 |
| | Hover at Altitude | 110 | 91 | 19 | 92 | - | | - |
| CH-54B | Descent | 97 | 84 | 13 | 87 | 90 | | 86-96 |
| | Level Flight | 97 | 85 | 12 | 89 | 90 | | 86-97 |
| | Hover at Altitude | 97 | 89 | 8 | - | - | | - |

* Difference of dBA levels in the first two columns

NOTE: BLADE PASSAGE FREQUENCY IS 10 Hz

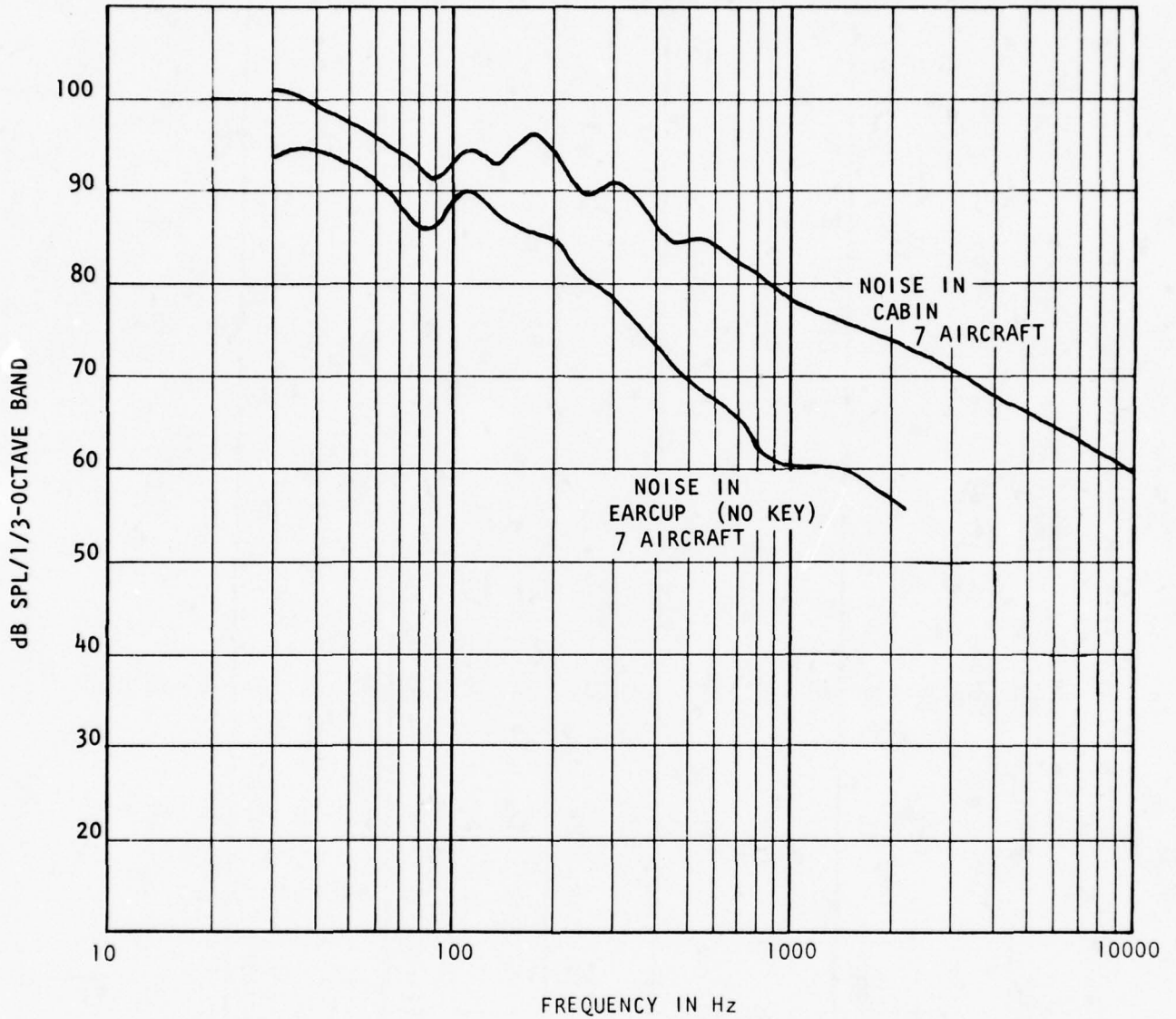

FIGURE 8 UH-1H IROQUOIS: CABIN AND EARCUP (NO KEY) NOISE DURING LEVEL FLIGHT. 1/3-OCTAVE WEIGHTED.

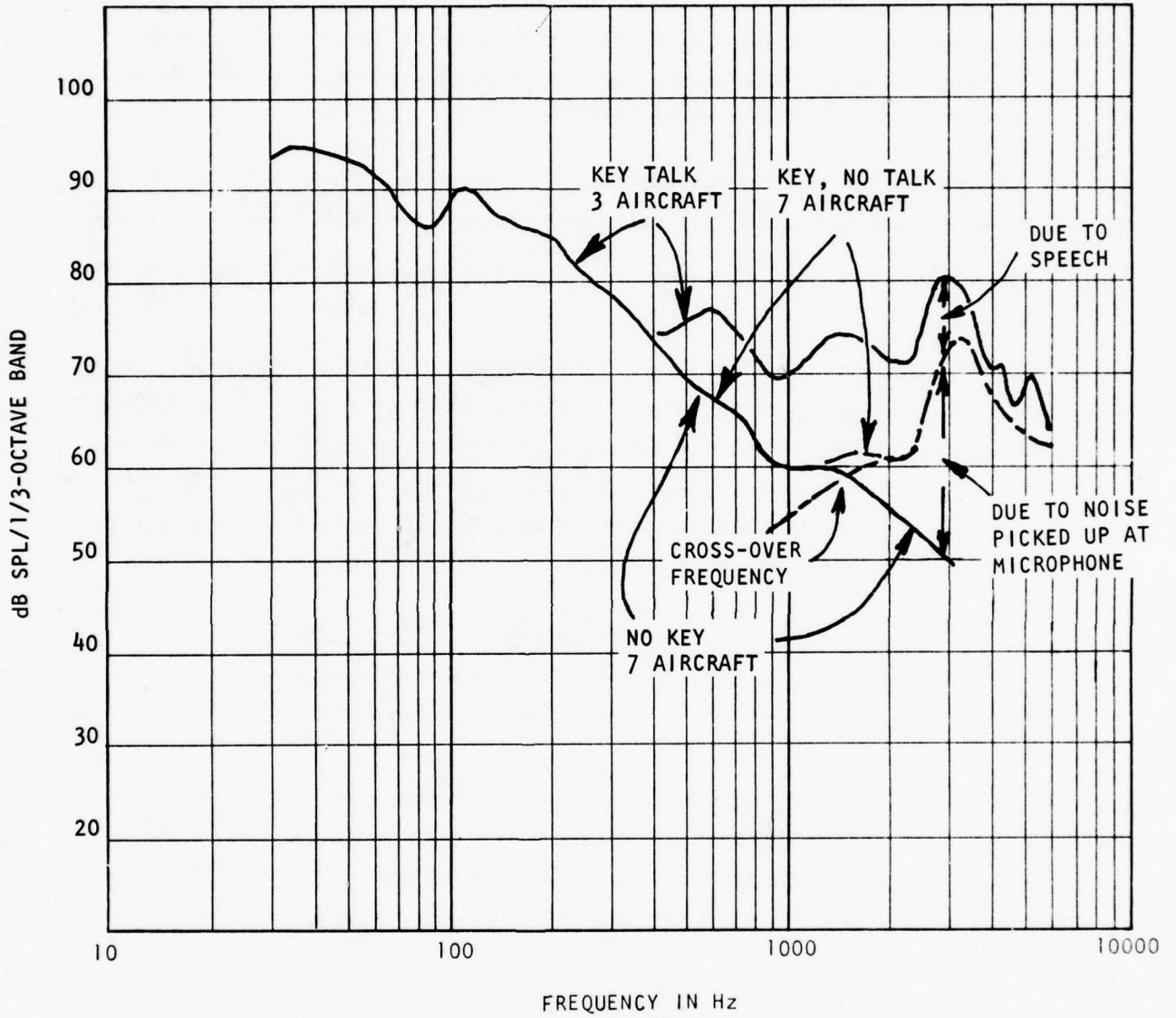

FIGURE 9 UH-1H IROQUOIS: EARCUP NOISE DURING LEVEL FLIGHT. 1/3-OCTAVE WEIGHTED.

- o A separate noise spectrum in the earcup due to noise which is picked up at the microphone when it is keyed. This spectrum slopes upward as frequency increases, up to the upper cut-off frequency of the interphone. The peak at 3 kHz is due mostly to the earphone response.⁷
- o A cross-over frequency below which the noise is due to noise leaking through or around the earcup or due to earcup vibrations, and above which the noise is due to microphone pickup.

In Figure 9, the cross-over frequency is seen to be about 1500 Hz. This is the frequency where the KEY NO TALK level exceeds the NO KEY level by 3 dB.

Figures 10 and 11 show the range of noise spectra encountered for 7 UH-1H aircraft.

Figure 12 shows the result of A-weighting the noise levels shown in Figure 9. The A-weighted curves are significant for estimating the improvements which are needed to reduce hearing damage risk and speech masking. The relative contributions of earcup leakage and microphone pick up of noise can be determined from the KEY NO TALK curve by integrating the pressure above and below the cross-over frequency, as follows.

| | | |
|-------------------|----------|--------------------|
| Earcup leakage | 82 dBA | 72% of noise power |
| Microphone pickup | 78 dBA | 28% of noise power |
| Overall | 83.5 dBA | |

The overall level is about 2 dB less than that obtained for KEY NO TALK in Table I. The Table I values were measured using an analog filter. These results show that earcup leakage is the major problem, but that more than 4 dB of improvement will produce diminishing returns unless the microphone circuit is also improved.

Earcup improvements will be most beneficial in the three octaves at 100, 200, and 400 Hz. In the microphone circuit, if it is considered desirable to retain the peak at 3 kHz for consonant intelligibility, then the noise-cancelling performance needs to be improved in the two octaves at 2 and 4 kHz.

4.2 OH-58A KIOWA

The ambient dBA level for 12 flight modes, averaged over 6 OH-58A aircraft, is 90.4 ± 0.6 dBA. Therefore, all flight modes are equally noisy. A detailed breakdown for 3 flight conditions is shown in Table I. The

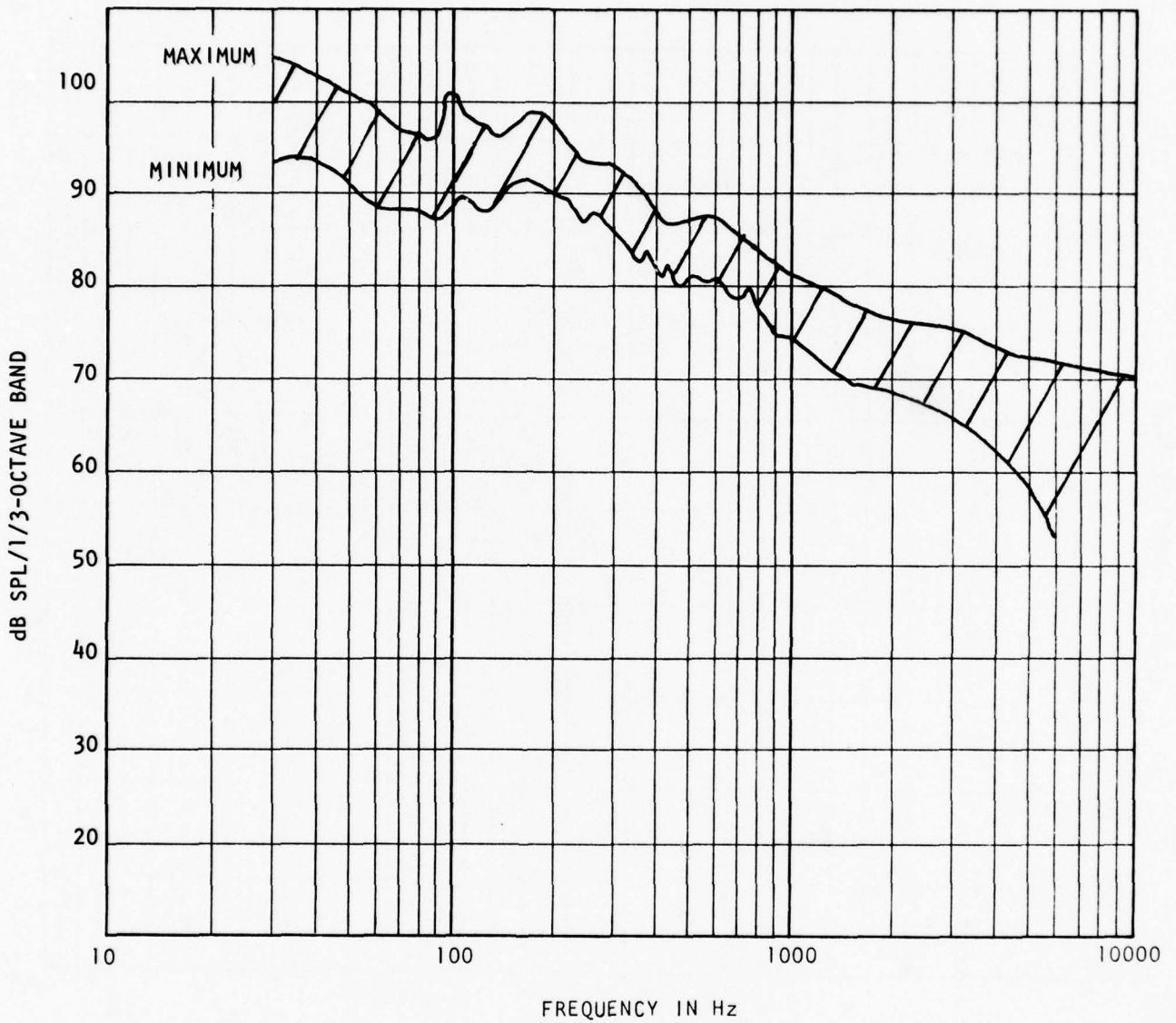

FIGURE 10 UH-1H IROQUOIS: ENVELOPE OF CABIN NOISE FOR 7 AIRCRAFT DURING LEVEL FLIGHT. 1/3-OCTAVE WEIGHTED.

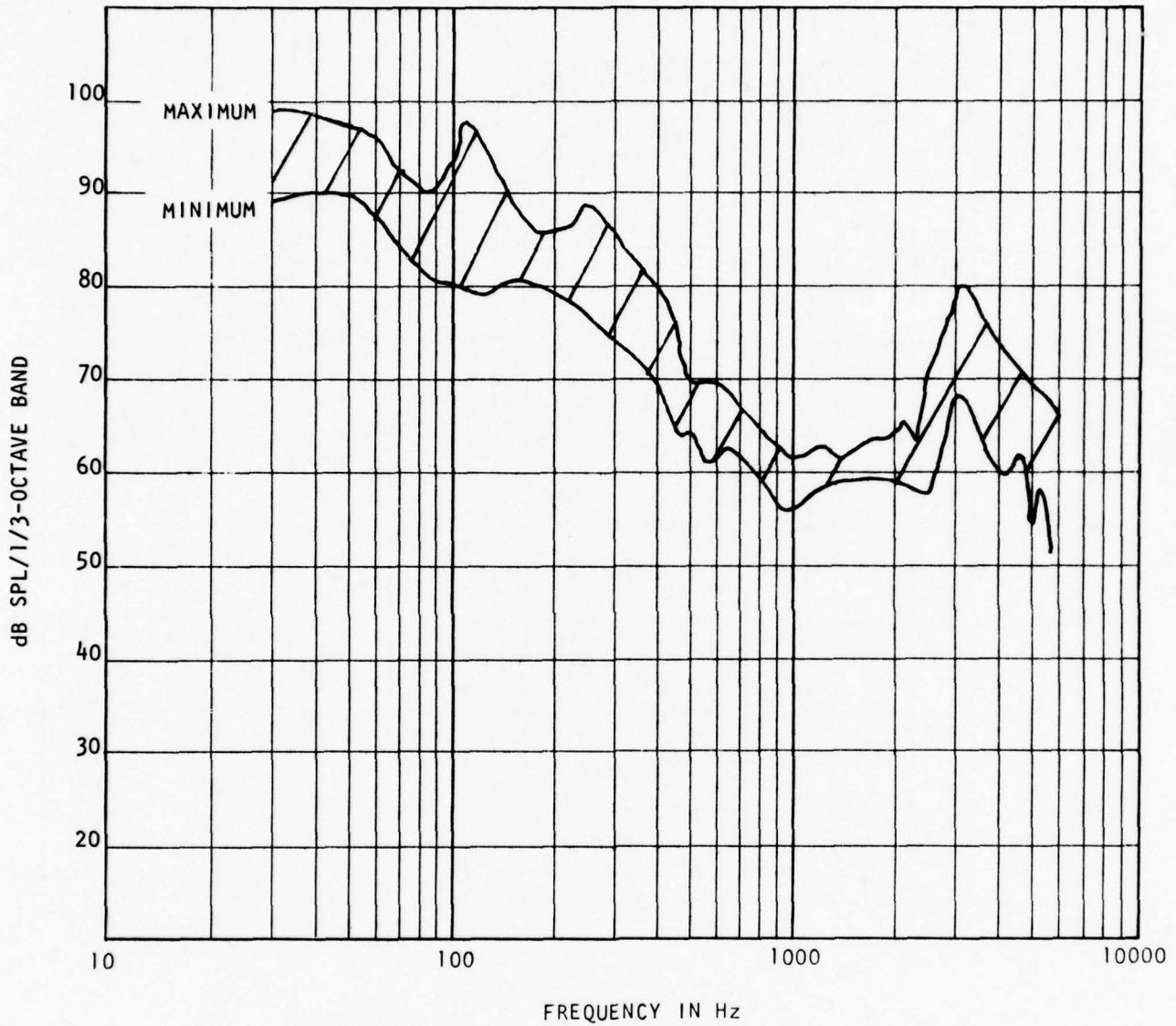

FIGURE 11 UH-1H IROQUOIS: ENVELOPE OF EARCUP
(KEY, NO TALK) NOISE FOR 7 AIRCRAFT
DURING LEVEL FLIGHT. 1/3-OCTAVE WEIGHTED.

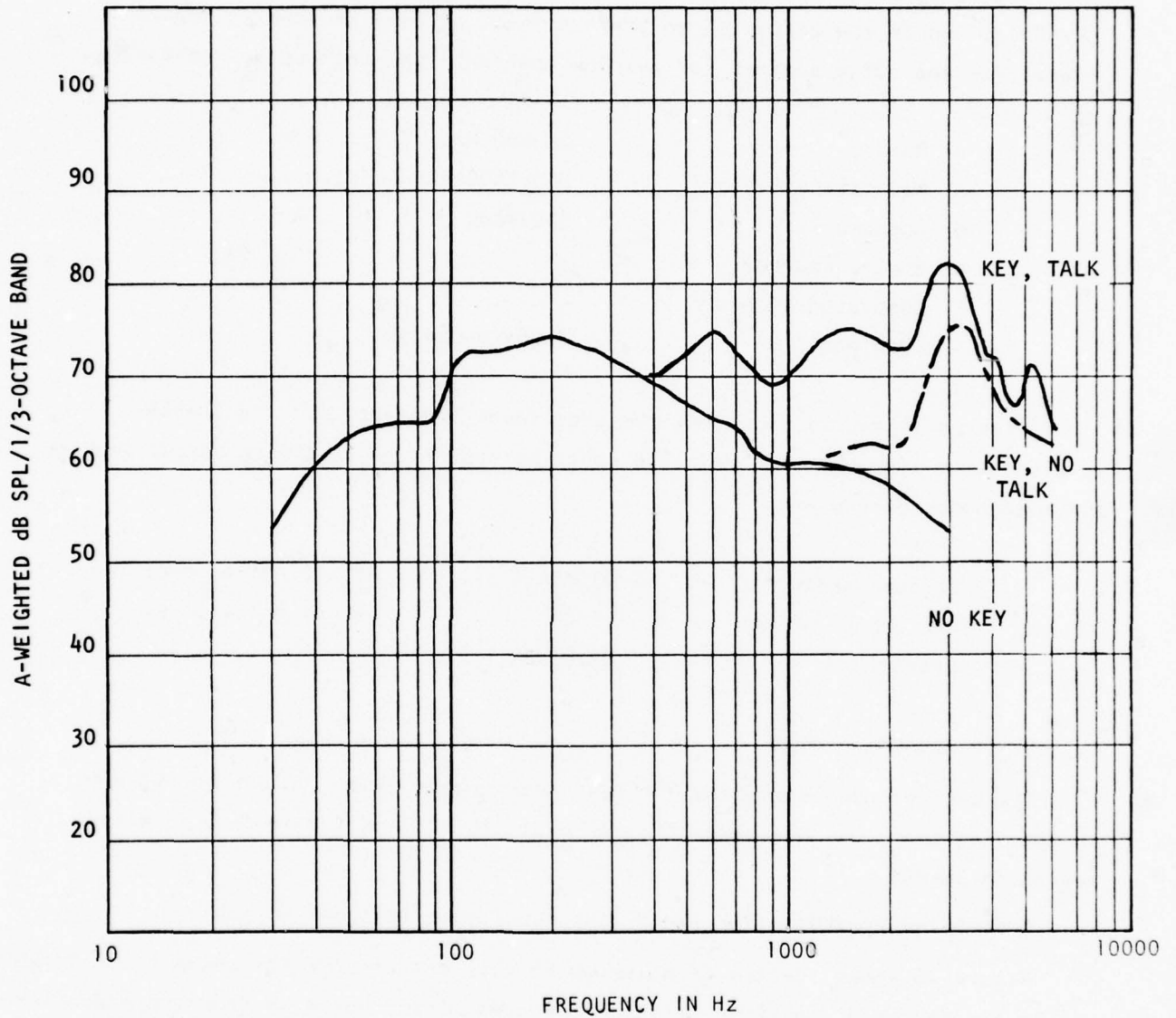

FIGURE 12 UH-1H IROQUOIS: EARCUP NOISE DURING LEVEL FLIGHT. 1/3-OCTAVE WEIGHTED, A-WEIGHTED.

CLIMB flight condition, which is representative of all flight conditions, was selected for display in Figures 13-15 because the computer-generated spectra were more complete.

Figure 13 shows spectra of noise which was measured in the cockpits of OH-58A's, and in the earcup of an SPH-4 helmet. A Bell Helicopter report identifies the noise sources for turbine-powered light helicopters as follows.²⁶

| | |
|---|----------------|
| o Rotors | 20-600 Hz |
| o Main transmission | 300-2400 Hz |
| o Accessories | 600-4800 Hz |
| o Engine Gearbox, Compressors, and Turbines | 2400-10,000 Hz |

Figures 14 and 15 show that the cross-over frequency for the OH-58A is also about 1500 Hz. The relative contributions to noise due to earcup leakage and microphone pickup are

| | | |
|-------------------|----------|--------------------|
| Earcup leakage | 83 dBA | 86% of noise power |
| Microphone pickup | 75 dBA | 14% of noise power |
| Overall | 83.6 dBA | |

4.3 OV-1D MOHAWK

The ambient dBA levels for 7 flight modes range from 100 dBA to 102 dBA. In addition there was one take-off sample at 116 dBA and two landing samples, averaging 95 dBA.

A detailed breakdown for two flight conditions is shown in Table 1.

Figure 16 shows spectra of noise which were measured in the cockpits of OV-1D's and in the earcup of an SPH-4 helmet. The predominant noise is from the propeller blade passage.

Figures 17 and 18 show that the noise cross-over frequency for the OV-1D is about 1400 Hz. The relative contributions to noise due to earcup leakage and microphone pickup are

| | | |
|-------------------|----------|--------------------|
| Earcup Leakage | 86 dBA | 86% of Noise Power |
| Microphone Pickup | 78 dBA | 14% of Noise Power |
| Overall | 86.6 dBA | |

NOTE: BLADE PASSAGE FREQUENCY IS 12 Hz

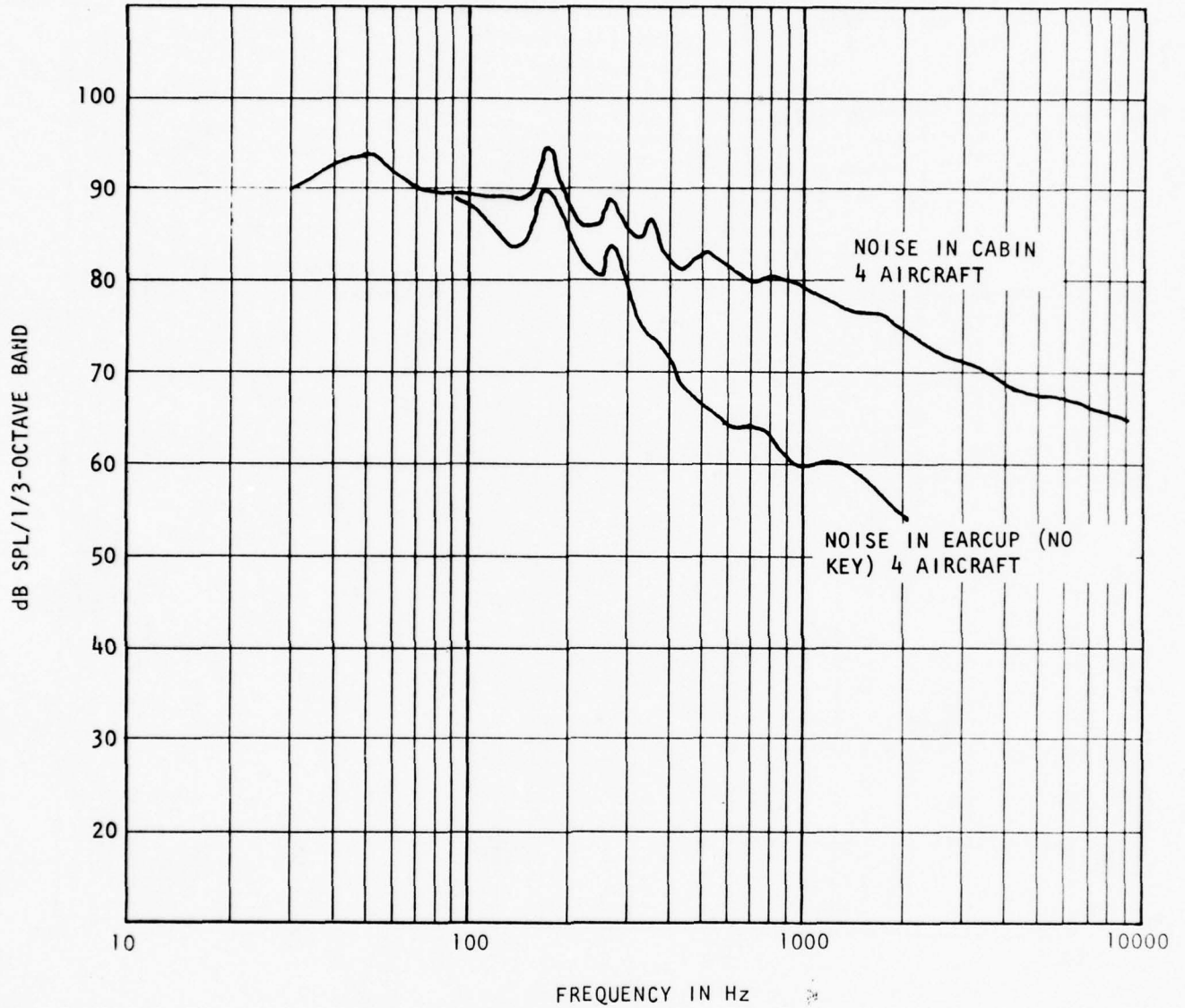

FIGURE 13. OH-58 KIOWA: CABIN AND EARCUP (NO KEY) NOISE DURING CLIMB. 1/3-OCTAVE WEIGHTED.

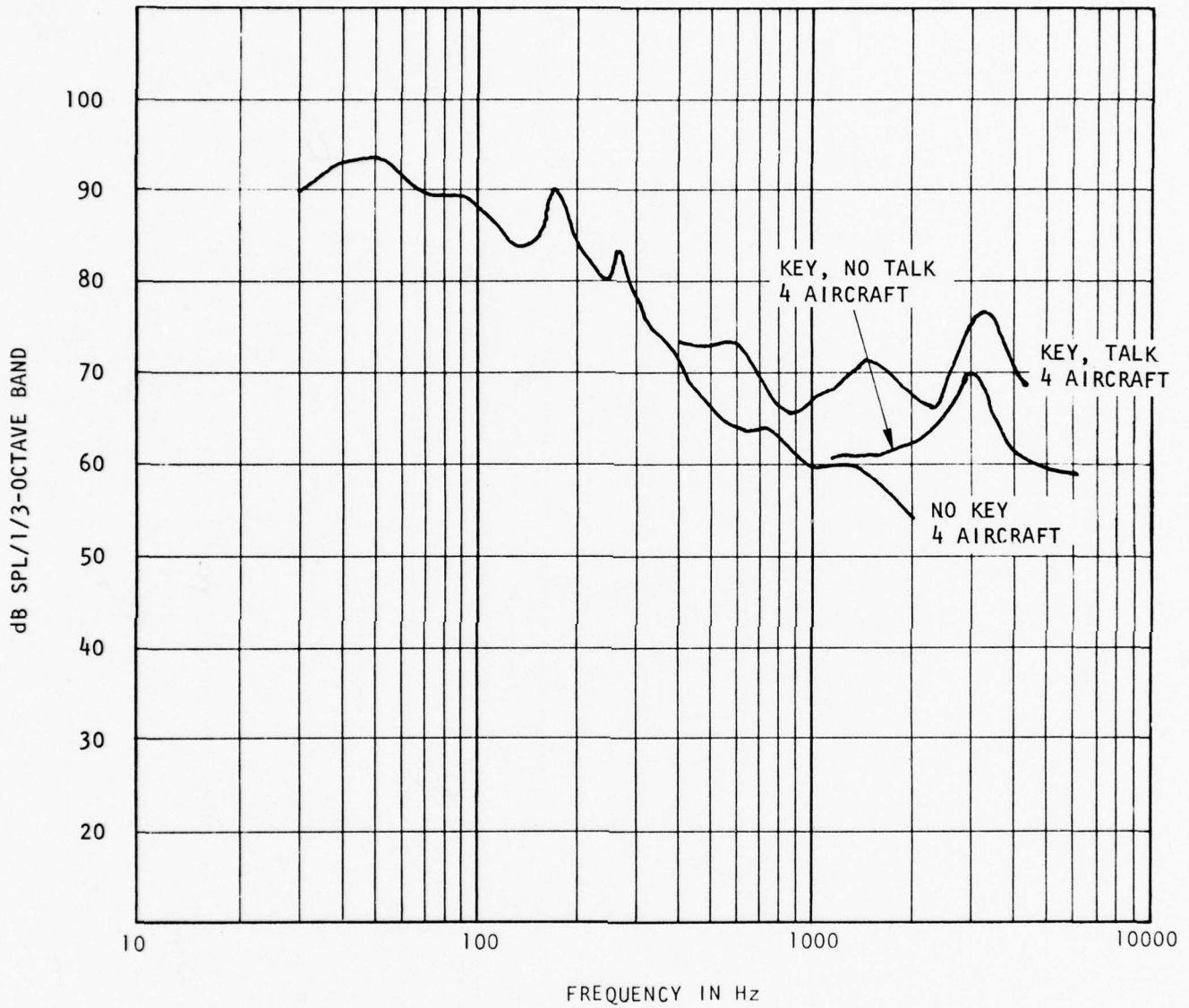

FIGURE 14 OH-58 KIOWA: EARCUP NOISE DURING CLIMB. 1/3-OCTAVE WEIGHTED.

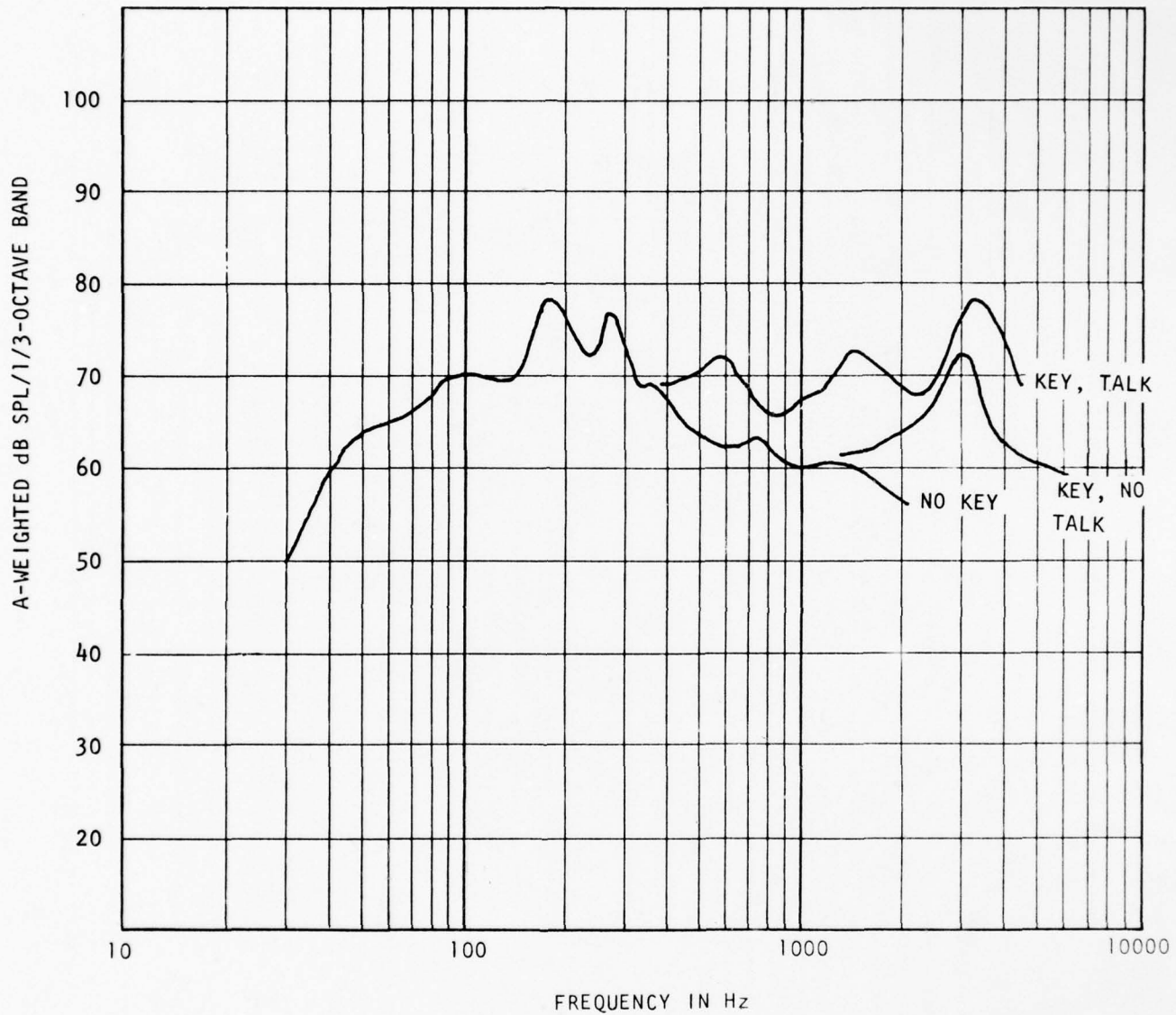

FIGURE 15 OH-58 KIOWA: EARCUP NOISE DURING CLIMB. 1/3-OCTAVE WEIGHTED, A-WEIGHTED

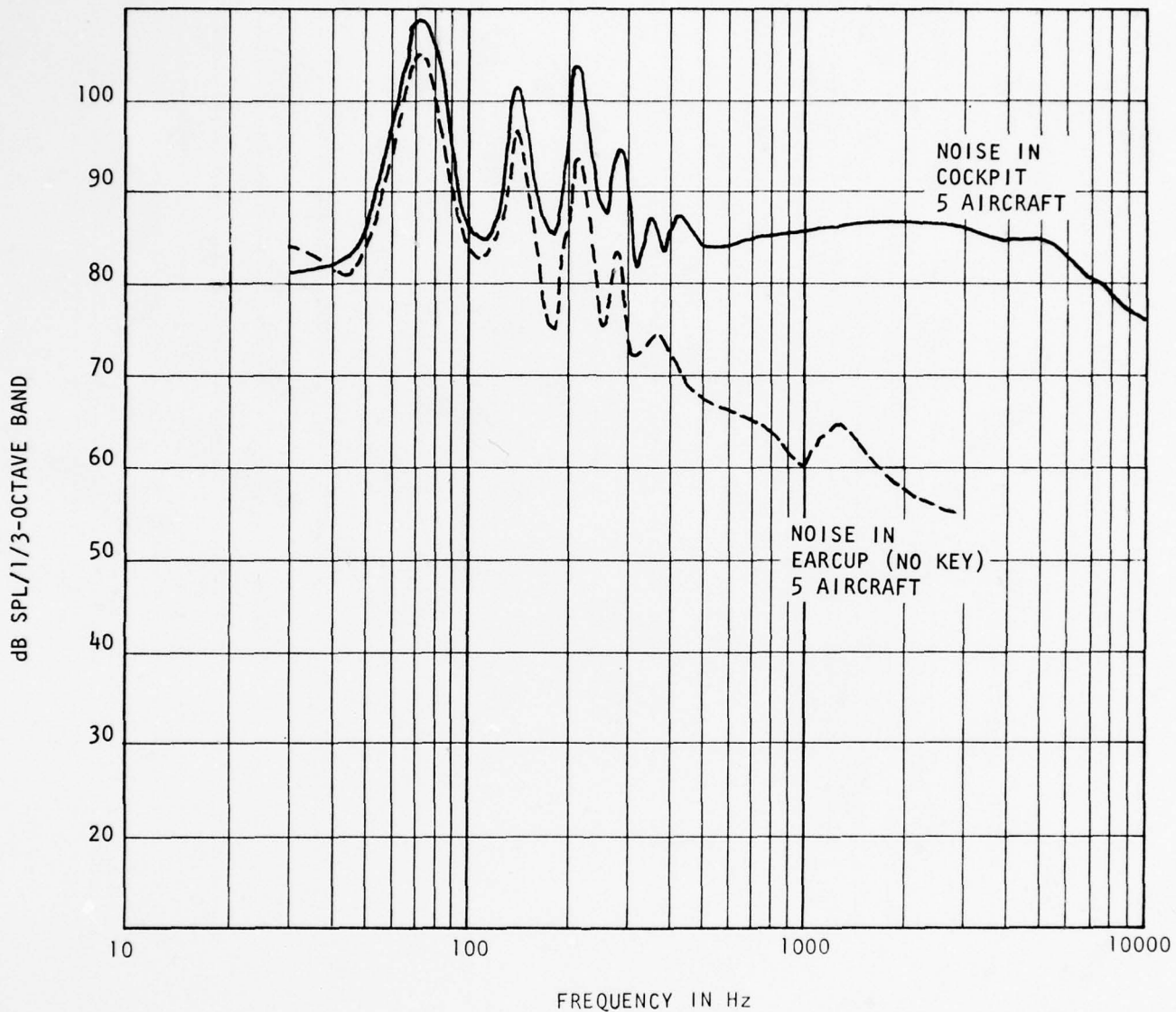

FIGURE 16 OV-10 MOHAWK: COCKPIT AND EARCUP (NO KEY) NOISE DURING LEVEL FLIGHT. 1/3 - OCTAVE WEIGHTED.

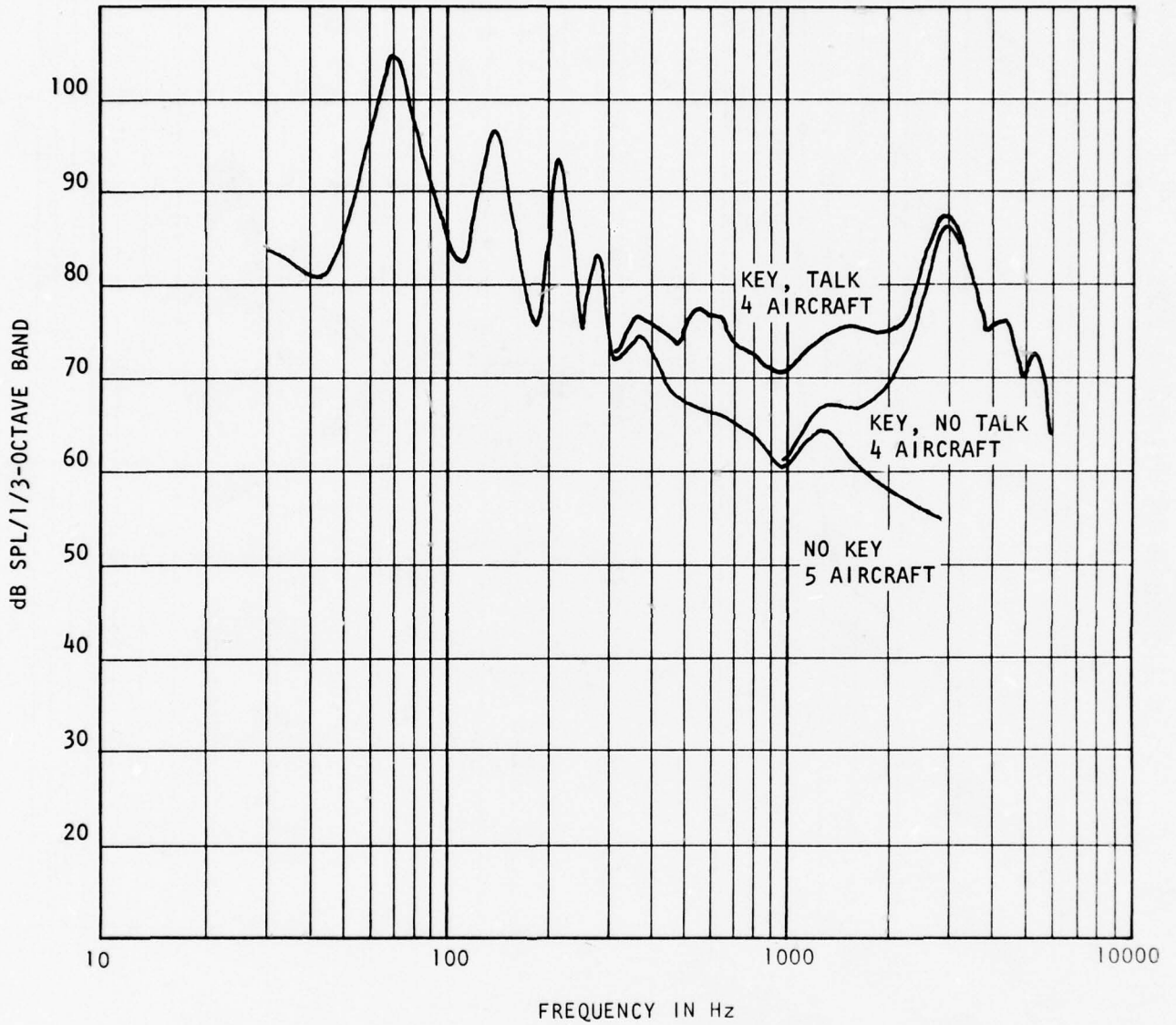

FIGURE 17 OV-10 MOHAWK: EARCUP NOISE DURING LEVEL FLIGHT. 1/3 - OCTAVE WEIGHTED.

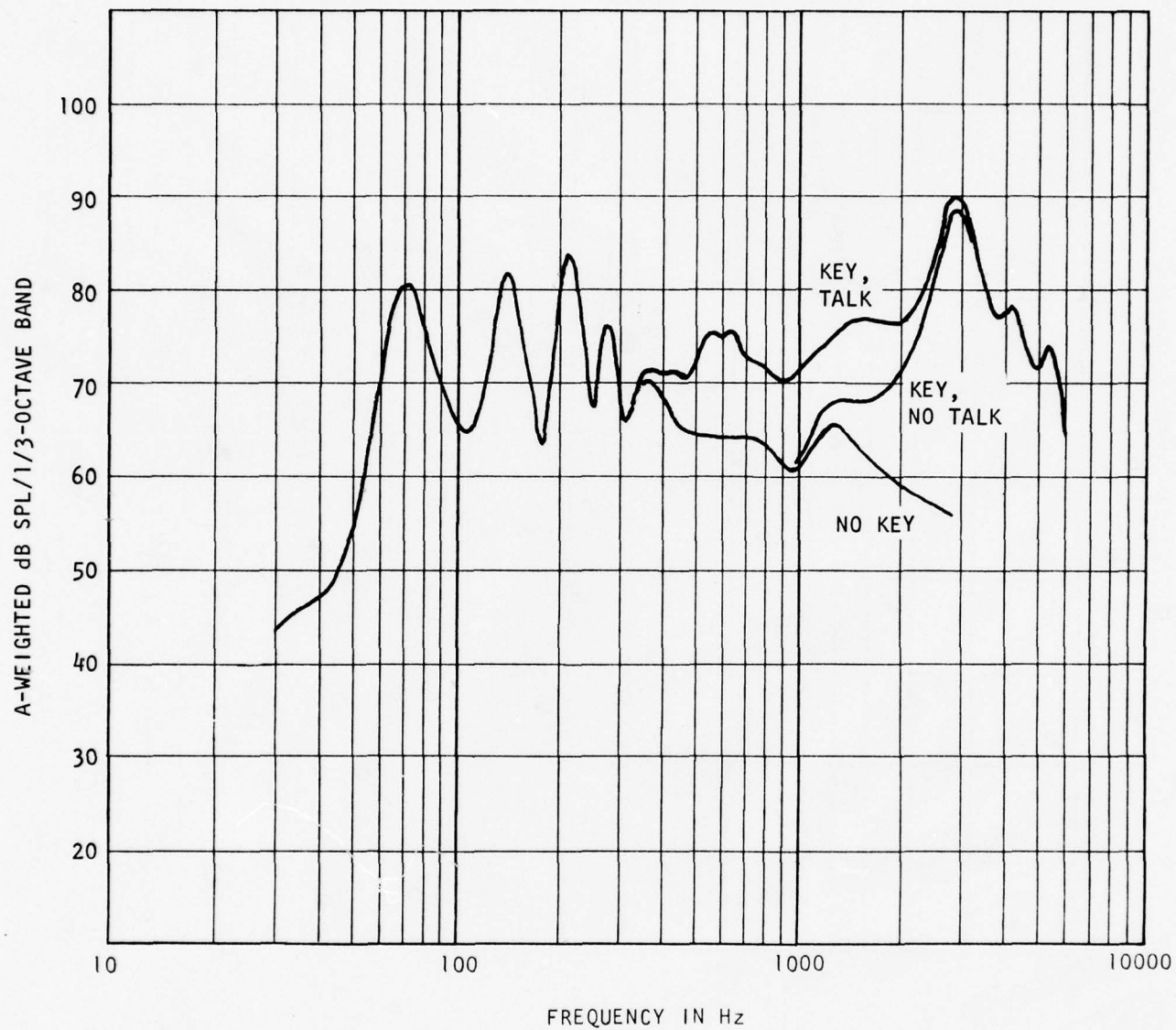

FIGURE 18. OV-10 MOHAWK: EARCUP NOISE DURING LEVEL FLIGHT. 1/3 - OCTAVE WEIGHTED, A-WEIGHTED.

4.4 AH-1S AND AH-1Q HUEYCOBRA

The data did not show any significant differences in noise levels between AH-1S and AH-1Q aircraft. The rank order of cockpit noise levels (average of 6 aircraft) for 5 flight modes is as follows (to the nearest decibel).

| | Average (dBA) |
|------------------------|---------------|
| Level flight | 95 |
| Descent | 95 |
| Climb | 94 |
| Hover in ground effect | 93 |
| Hover at altitude | 92 |

A more detailed rank ordering of average noise levels for 3 representative flight modes is shown in Table 1. Figures 19-21 show the spectra of noise in the cockpit of the AH-1 and in the earcup of the SPH-4 helmet.

The noise cross-over frequency for the AH-1 is about 2200 Hz. During level flight, the relative contributions to noise due to earcup leakage and microphone pickup are

| | | |
|-------------------|----------|--------------------|
| Earcup leakage | 83 dBA | 83% of noise power |
| Microphone pickup | 76 dBA | 17% of noise power |
| Overall | 83.8 dBA | |

4.5 CH-47C CHINOOK

The cabin noise levels (average of 3 aircraft) ranged from 110 to 111 dBA for 5 flight modes. A detailed rank ordering of average noise levels for 3 representative flight modes is shown in Table 1. Figures 22-24 show the spectra of noise in the cabin of the CH-47C and in the earcup of the SPH-4 helmet, during the CLIMB flight mode.

The noise cross-over frequency for the CH-47C is about 1800 Hz. The relative contributions to noise due to earcup leakage and microphone pickup are

| | | |
|-------------------|----------|--------------------|
| Earcup leakage | 89 dBA | 89% of noise power |
| Microphone pickup | 80 dBA | 11% of noise power |
| Overall | 89.5 dBA | |

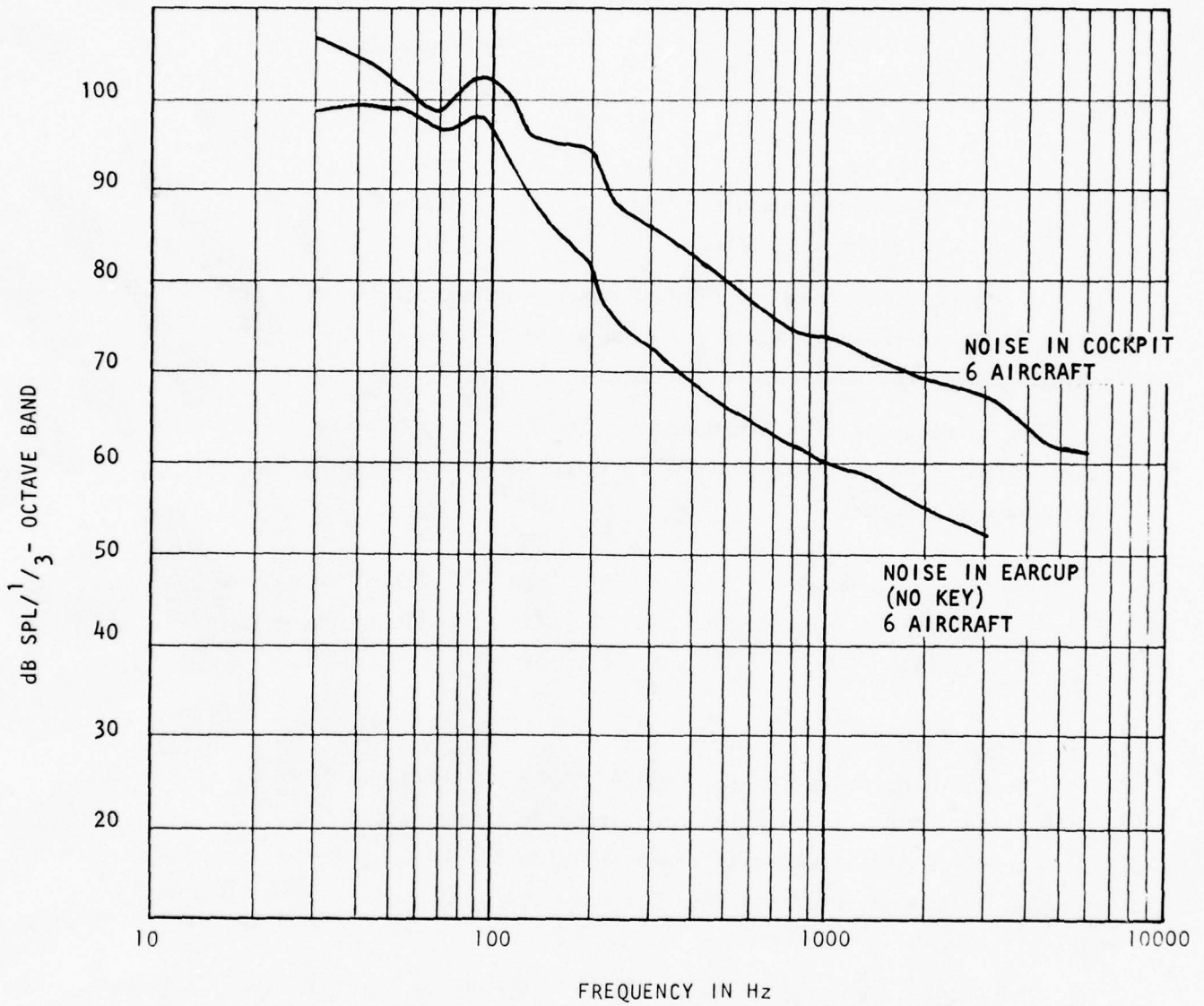

FIGURE 19 AH-1S, AH-1Q HUEYCOBRA: COCKPIT AND EARCUP (NO KEY) NOISE DURING LEVEL FLIGHT. 1/3-OCTAVE WEIGHTED.

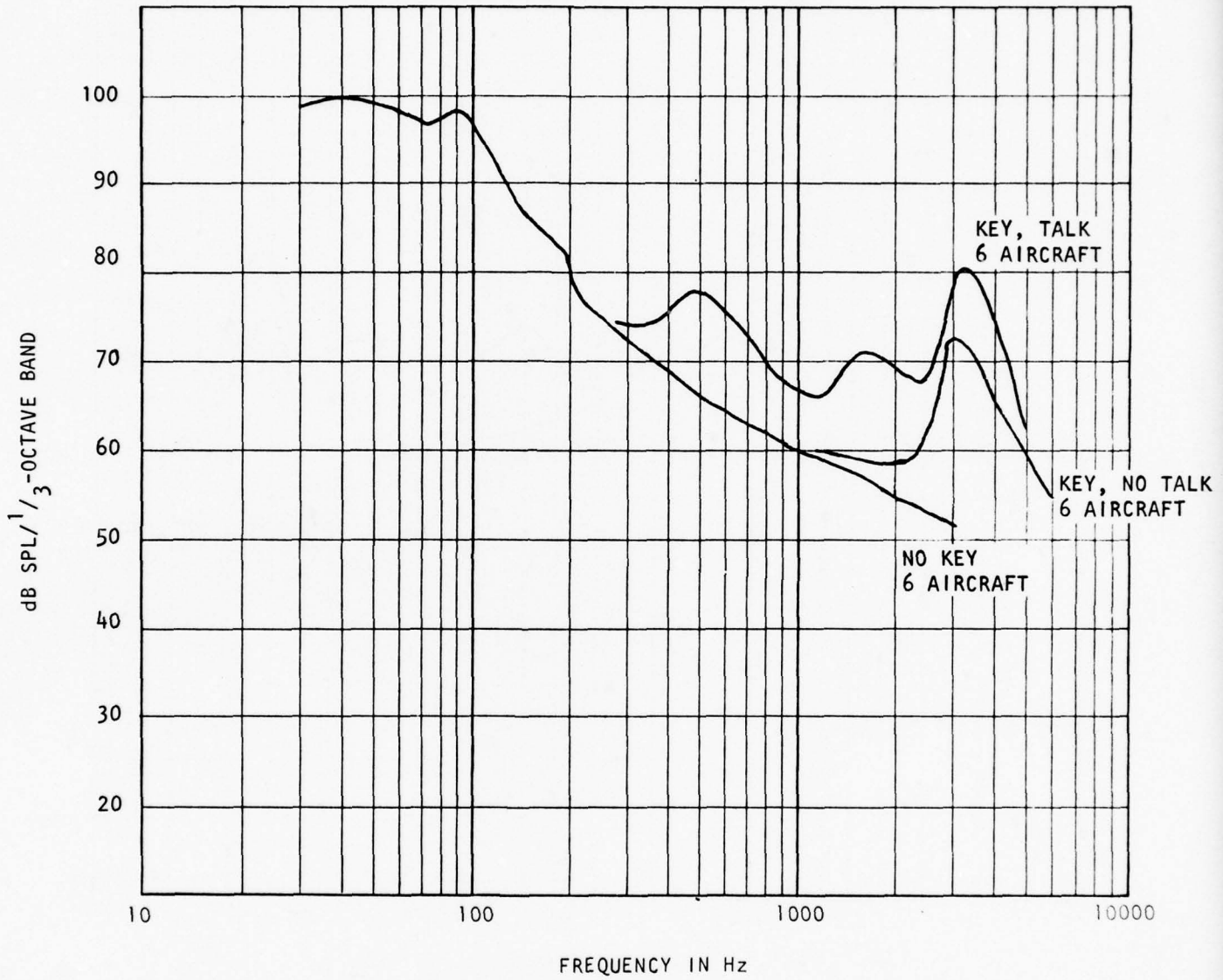

FIGURE 20 AH-1S, AH-1Q HUEYCOBRA: EARCUP NOISE DURING LEVEL FLIGHT. 1/3-OCTAVE WEIGHTED.

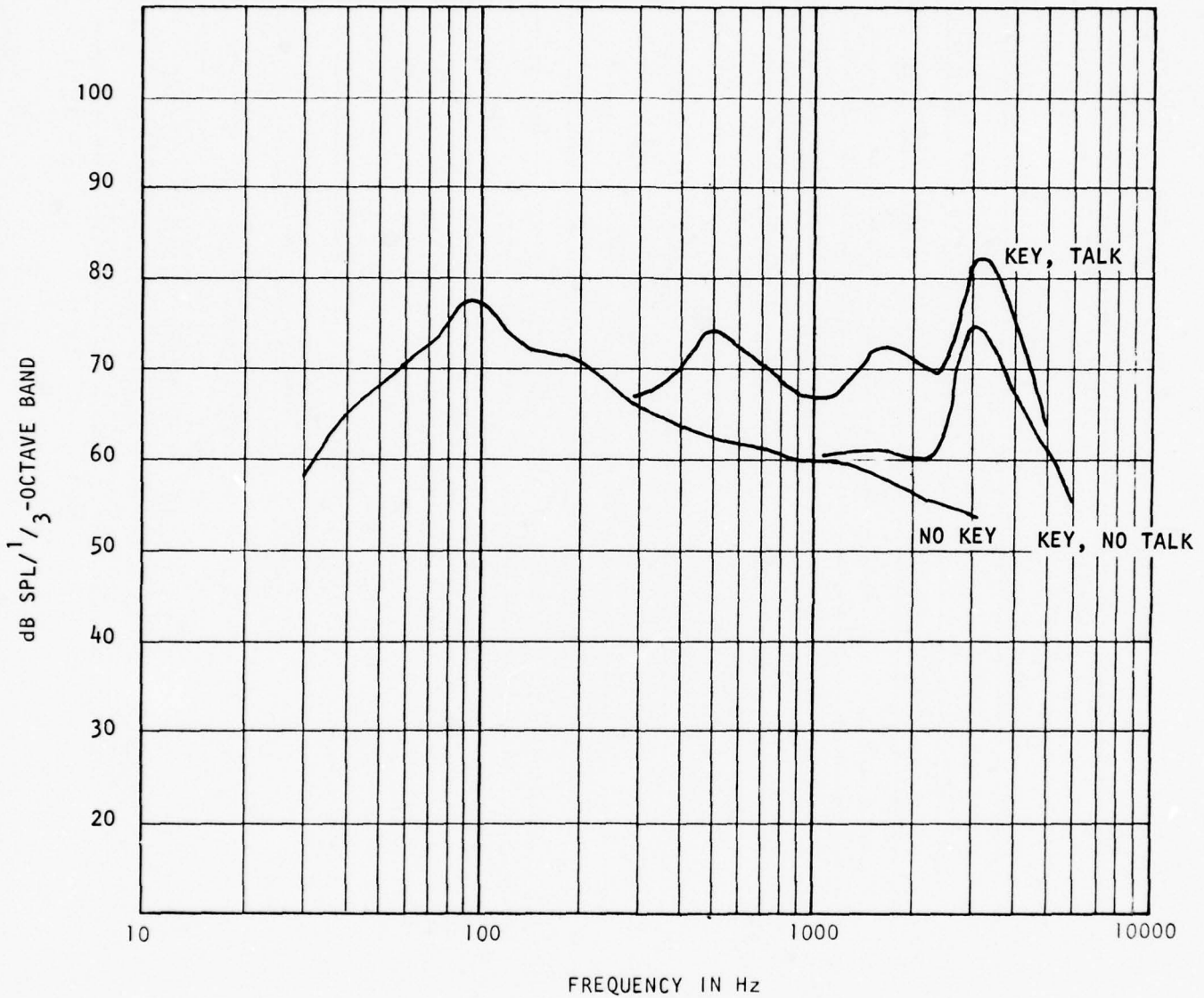

FIGURE 21 AH-1S, AH-1Q HUEYCOBRA: EARCUP NOISE DURING LEVEL FLIGHT. 1/3-OCTAVE WEIGHTED, A-WEIGHTED.

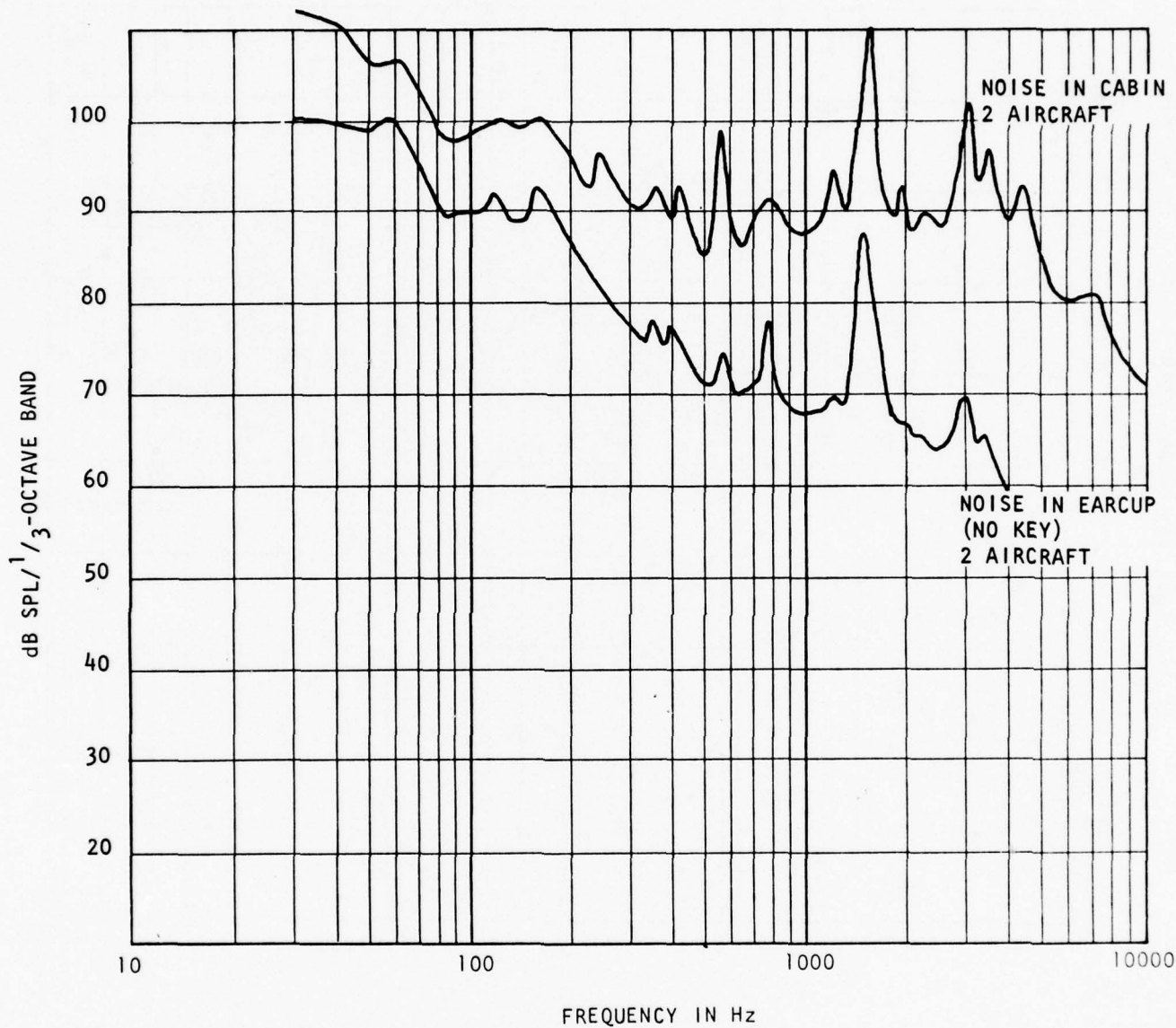

FIGURE 22 CH-47C CHINOOK: CABIN AND EARCUP (NO KEY) NOISE DURING CLIMB. 1/3-OCTAVE WEIGHTED.

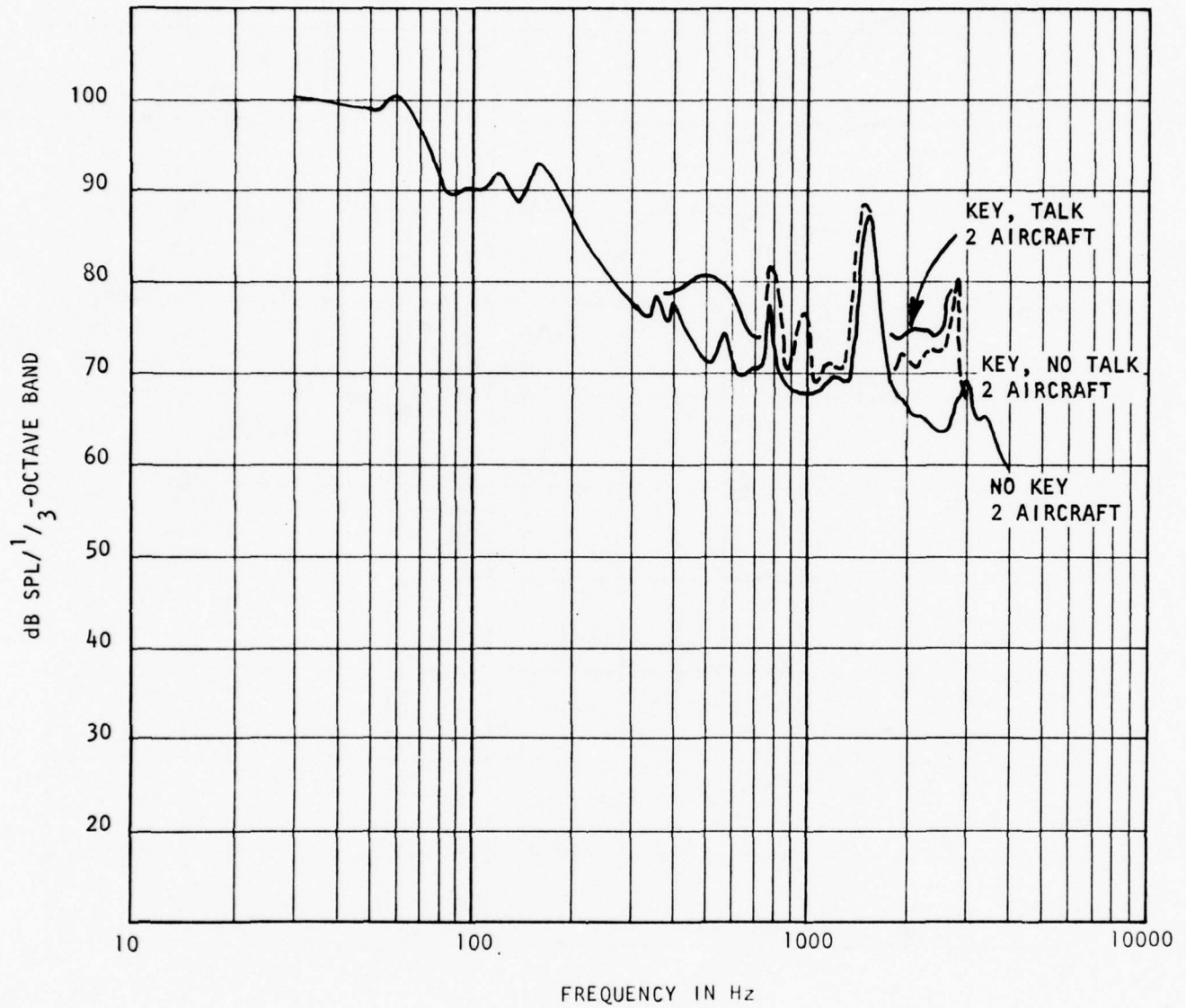

FIGURE 23 CH-47C CHINOOK: EARCUP NOISE DURING CLIMB. 1/3-OCTAVE WEIGHTED.

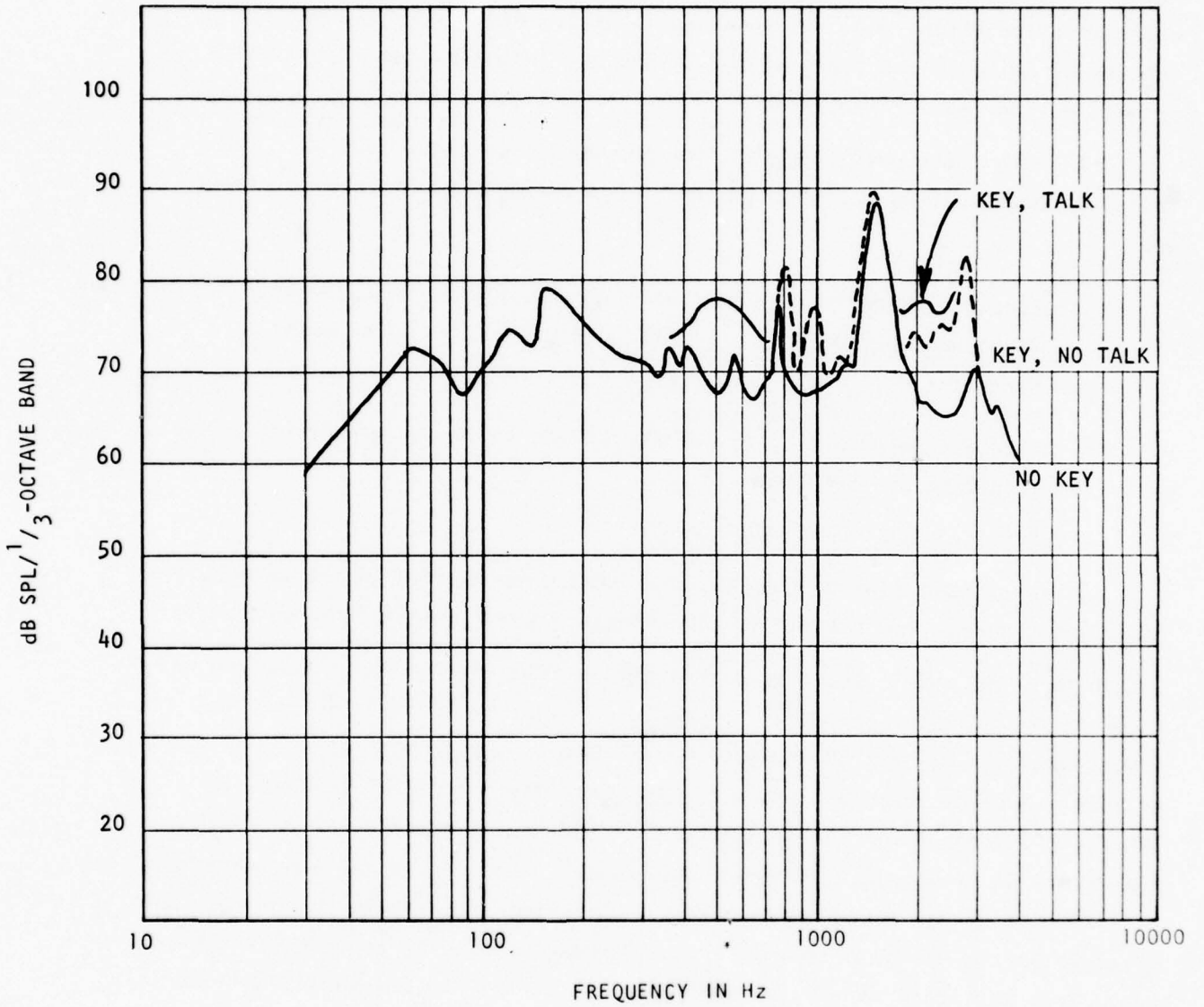

FIGURE 24 CH-47C CHINOOK: EARCUP NOISE DURING CLIMB. 1/3-OCTAVE WEIGHTED. A-WEIGHTED.

4.6 CH-54B TARHE

The cabin noise levels (average of 6 aircraft) ranged from 96 to 97 dBA for 5 flight modes. A detailed rank ordering of average noise levels for 3 representative flight modes is shown in Table 1. Figures 25-27 show the spectra of noise in the cabin of the CH-54B and in the earcup of the SPH-4 helmet, during level flight.

The noise cross-over frequency for the CH-54B is about 1800 Hz. The relative contributions to noise due to earcup leakage and microphone pickup are

| | | |
|-------------------|----------|--------------------|
| Earcup leakage | 85 dBA | 45% of noise power |
| Microphone pickup | 86 dBA | 55% of noise power |
| Overall | 88.6 dBA | |

The relatively high pickup by the microphone is due to narrowband peaks of noise at 3200 Hz and 5000 Hz.

4.7 SPEECH LEVELS AND EARCUP ATTENUATION

Figures 28 and 29 show computer-derived speech spectra in the earcup, calculated by removing the KEY NO TALK spectrum from the KEY TALK spectrum.

Figures 30 and 31 show the earcup attenuation, derived as a function of frequency by subtracting the NO KEY spectra from the AMBIENT spectra. The lowest curve in Figures 30 and 31 is R. T. Camp's measurement of the SPH-4, as reported by Giordano and Keane.⁷ The test method was USASI Standard Z24.22-1957 (Method for the Measurement of the Real Ear Attenuation of Ear Protectors at Threshold). Weinreb and Touger²⁷ report that real-ear-threshold measurements of ear protectors usually show better attenuation values than are obtained by the method of comparing sound pressures inside and outside the earcup. They attribute this to physiological factors. The heavy dashed lines in Figures 30 and 31 show a modified version of Camp's attenuation curve, showing the attenuation that might have been obtained had a comparison method been used.

The attenuation curves which are derived from measurements in the aircraft show both a deficient attenuation compared to Camp's measurement, and also a marked variability. The variability in earcup attenuation was extreme, not only from aircraft-to-aircraft, but even in successive tests in the same aircraft with the same user. Figure 32 shows earcup attenuation for 5 flight

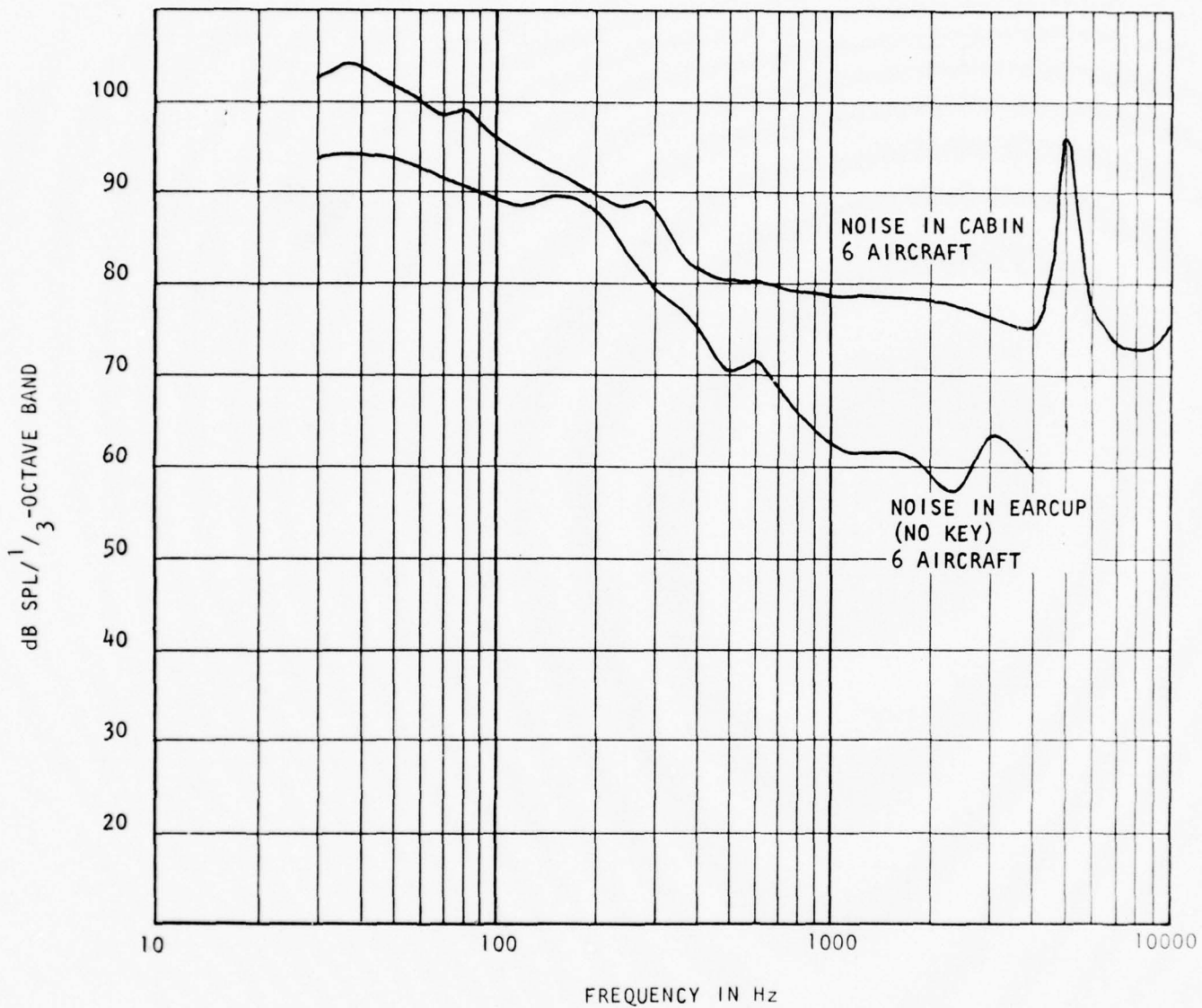

FIGURE 25 CH-54B TARHE: CABIN AND EARCUP (NO KEY) NOISE DURING LEVEL FLIGHT. 1/3-OCTAVE WEIGHTED.

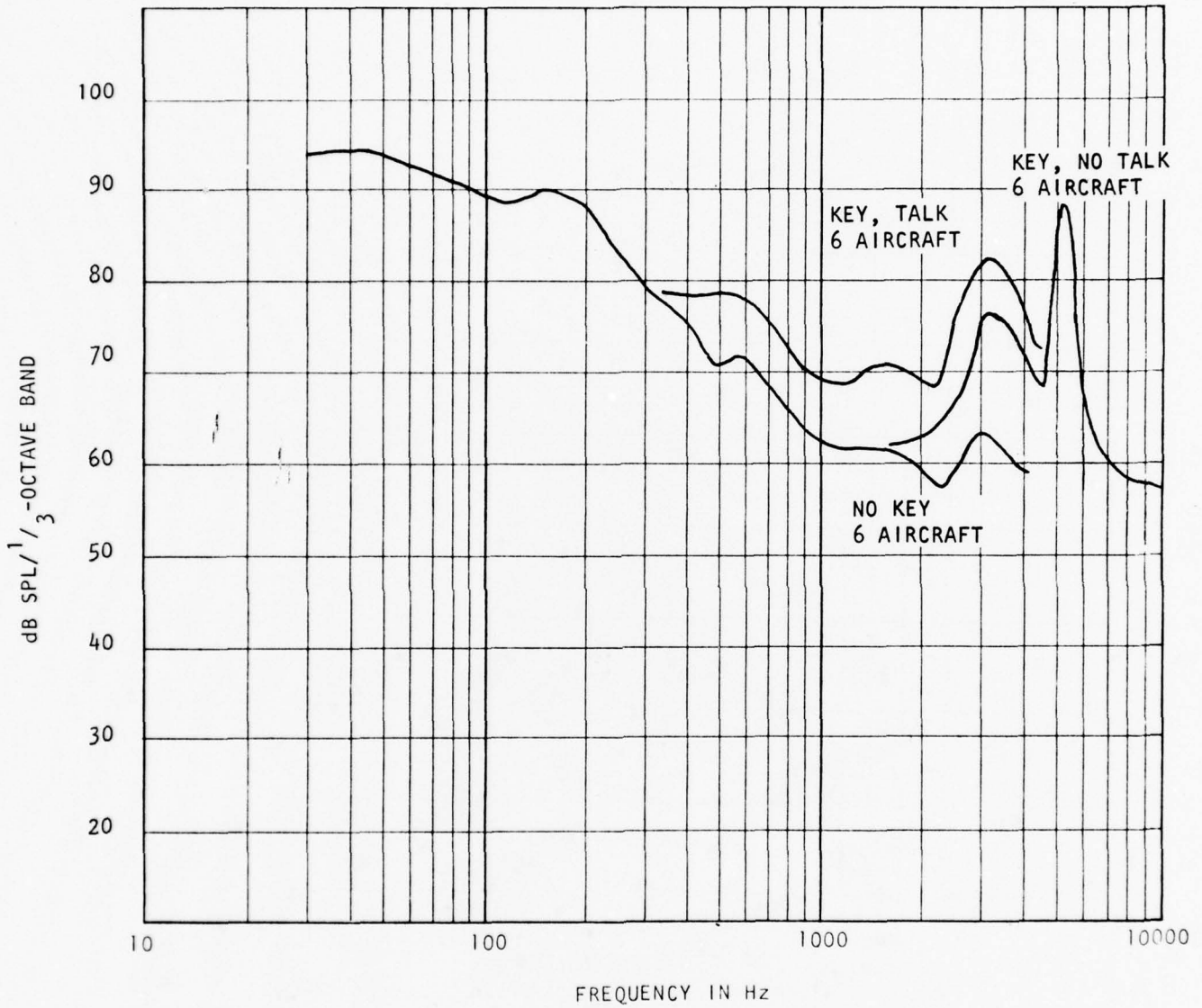

FIGURE 26 CH-54B TARHE: EARCUP NOISE DURING LEVEL FLIGHT. 1/3-OCTAVE WEIGHTED.

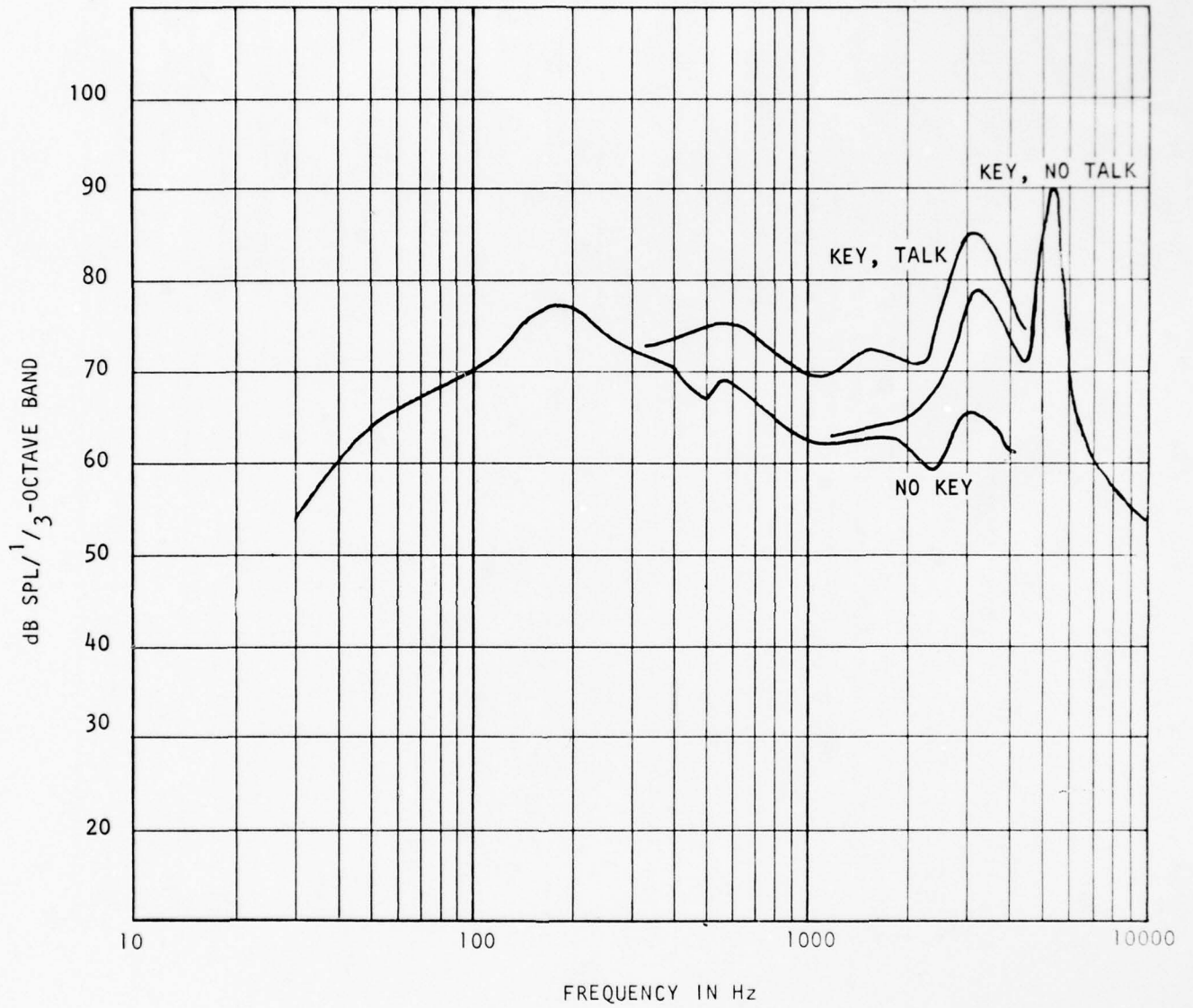

FIGURE 27 CH-54B TARHE: EARCUP NOISE DURING LEVEL FLIGHT. 1/3-OCTAVE WEIGHTED. A-WEIGHTED.

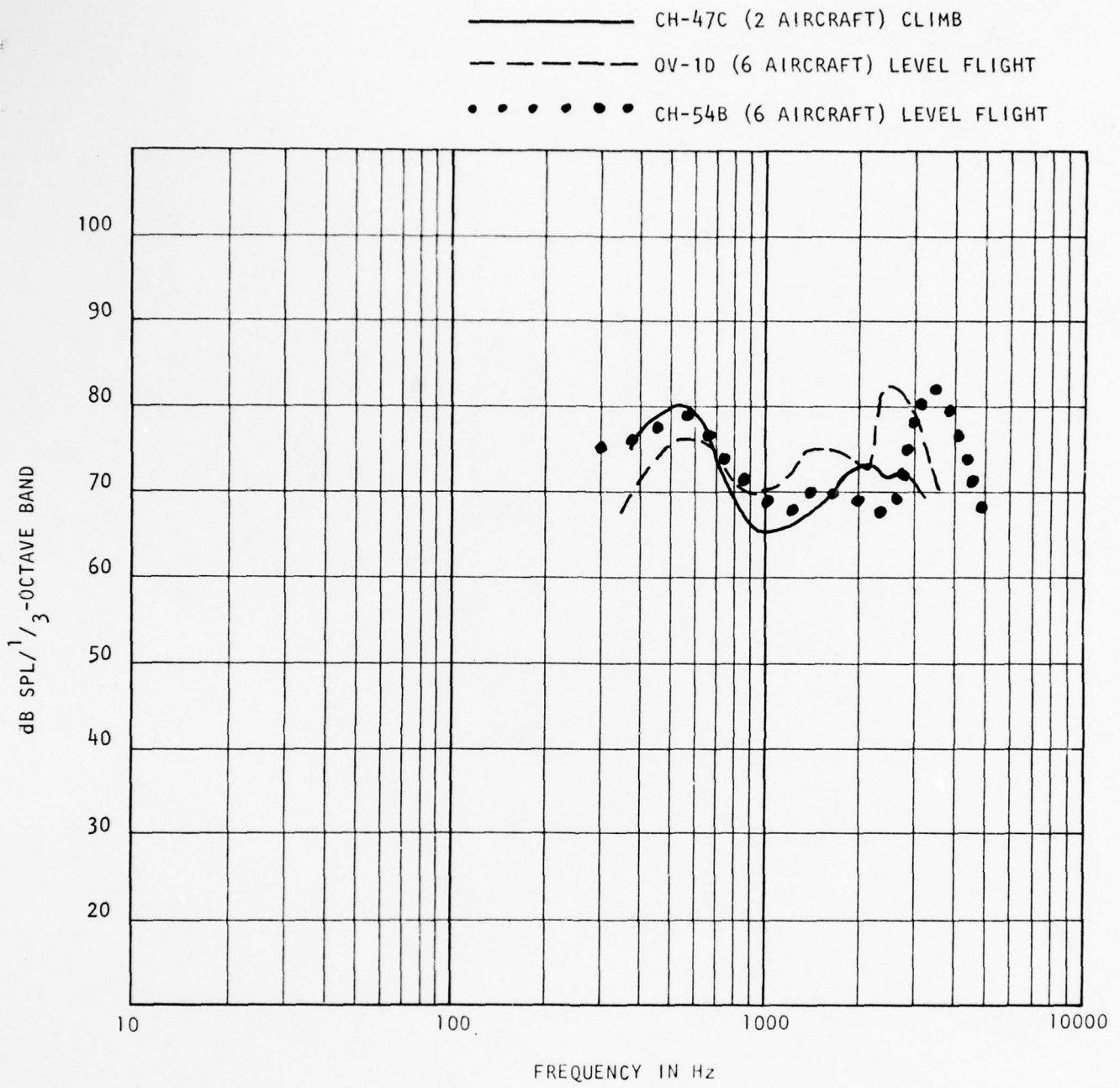

FIGURE 28 . SPEECH LEVELS IN THE EARCUP IN THREE MORE NOISY TYPES OF AIRCRAFT. 1/3-OCTAVE WEIGHTED.

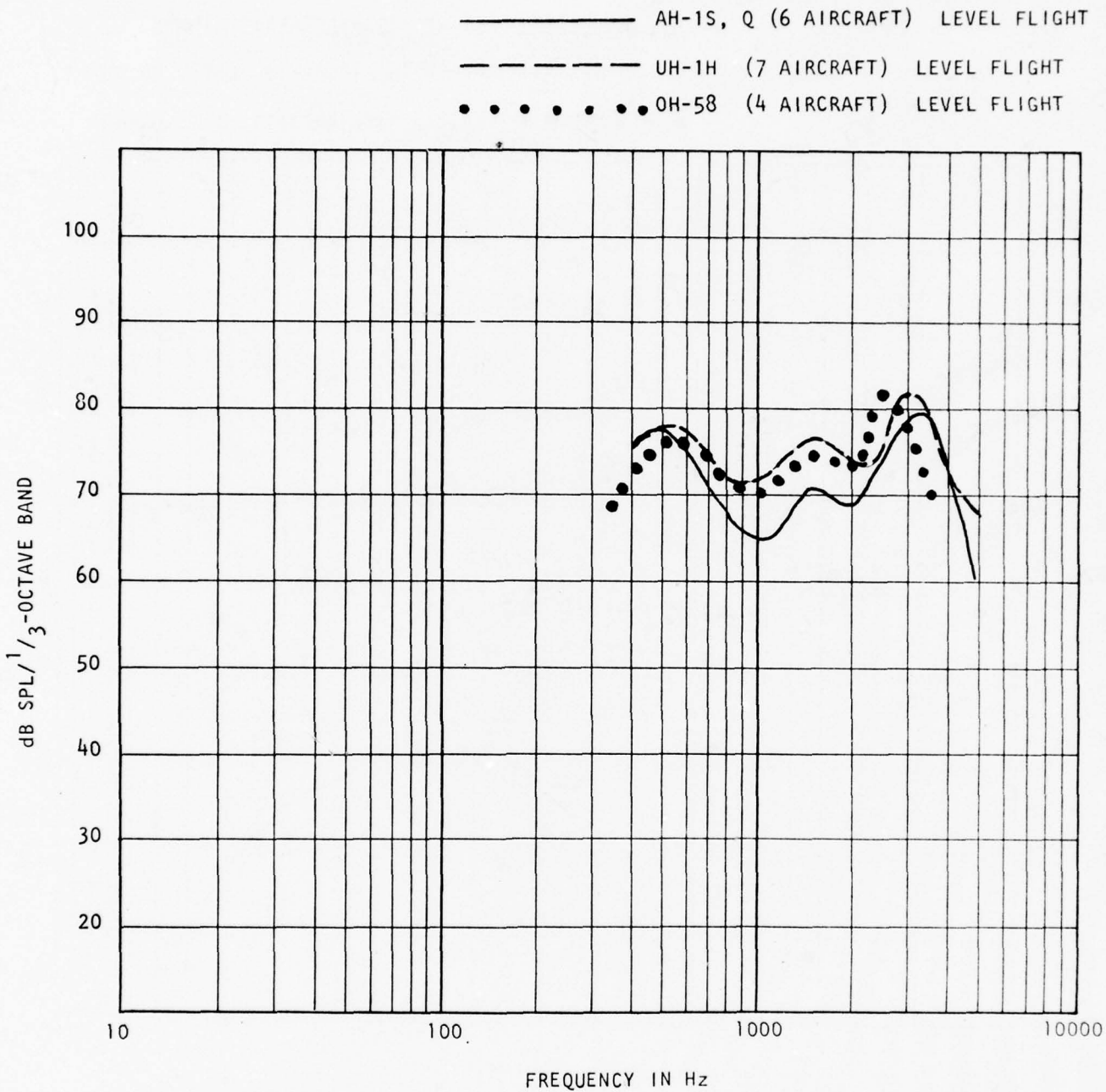

FIGURE 29. SPEECH LEVELS IN THE EARCUP IN THREE LESS NOISY TYPES OF AIRCRAFT. 1/3-OCTAVE WEIGHTED.

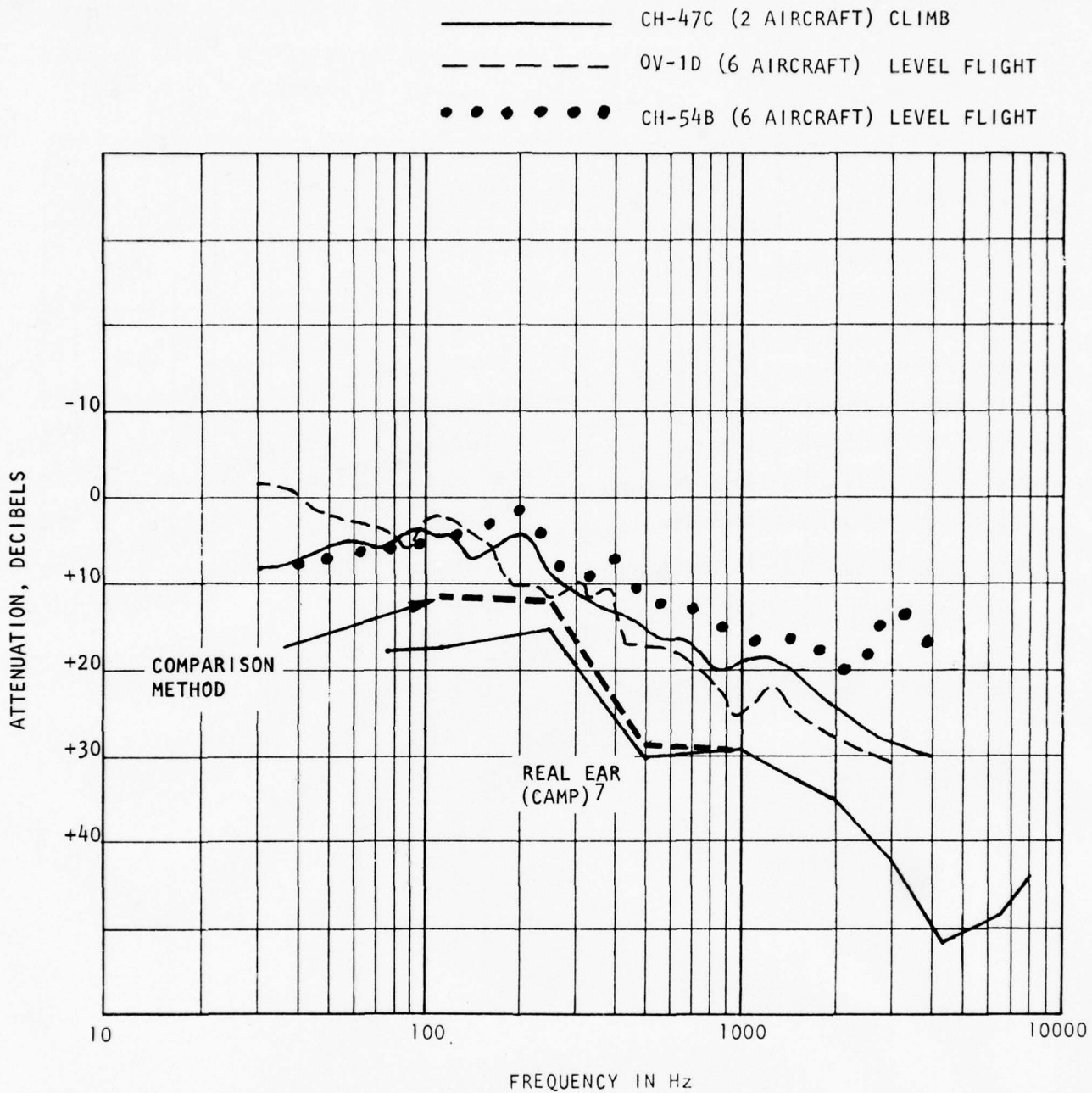

FIGURE 30 EARCUP ATTENUATION IN THREE MORE NOISY TYPES OF AIRCRAFT, SPH-4 HELMET.

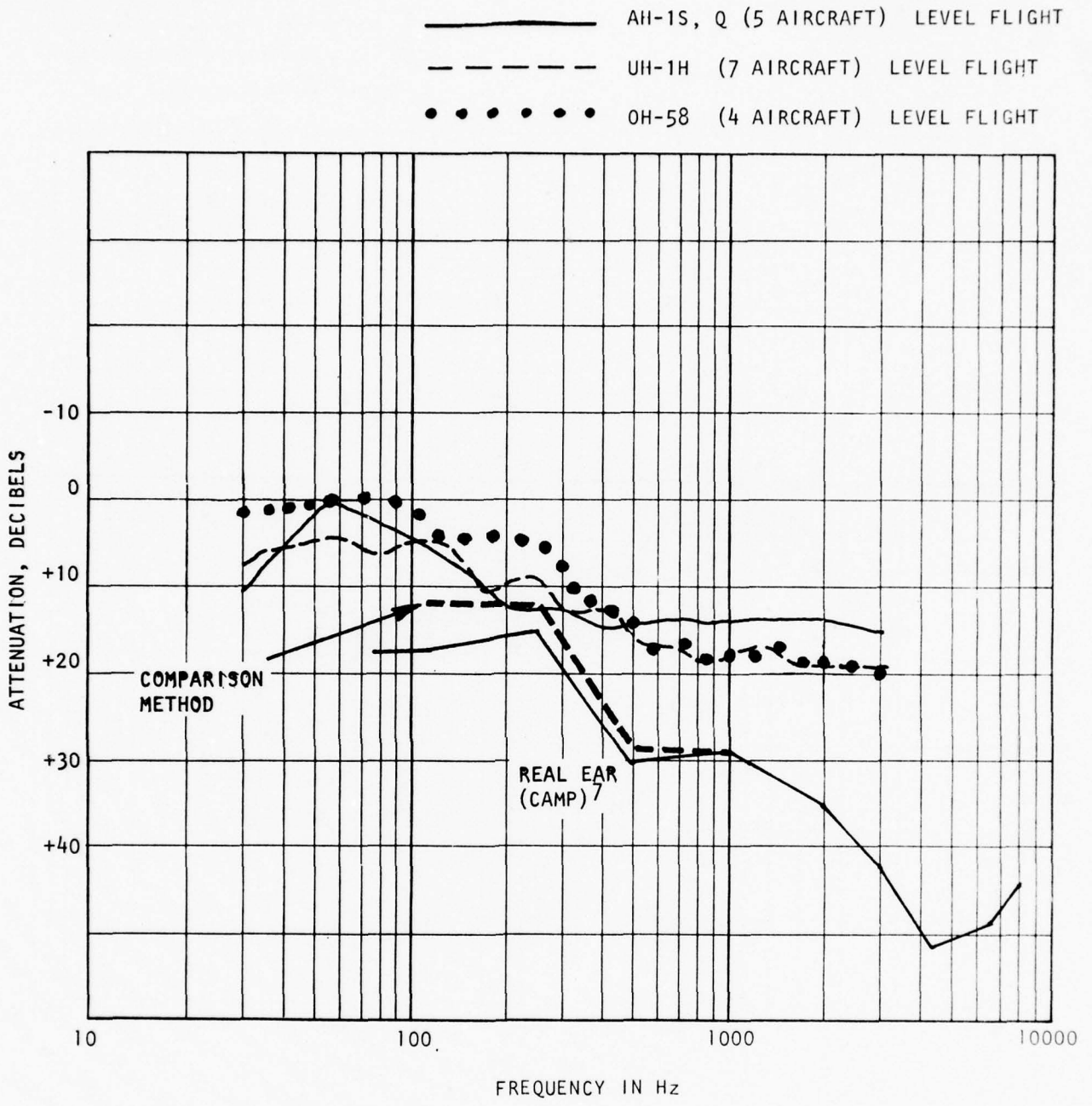

FIGURE 31 EARCUP ATTENUATION IN THREE LESS NOISY TYPES OF AIRCRAFT, SPH-4 HELMET.

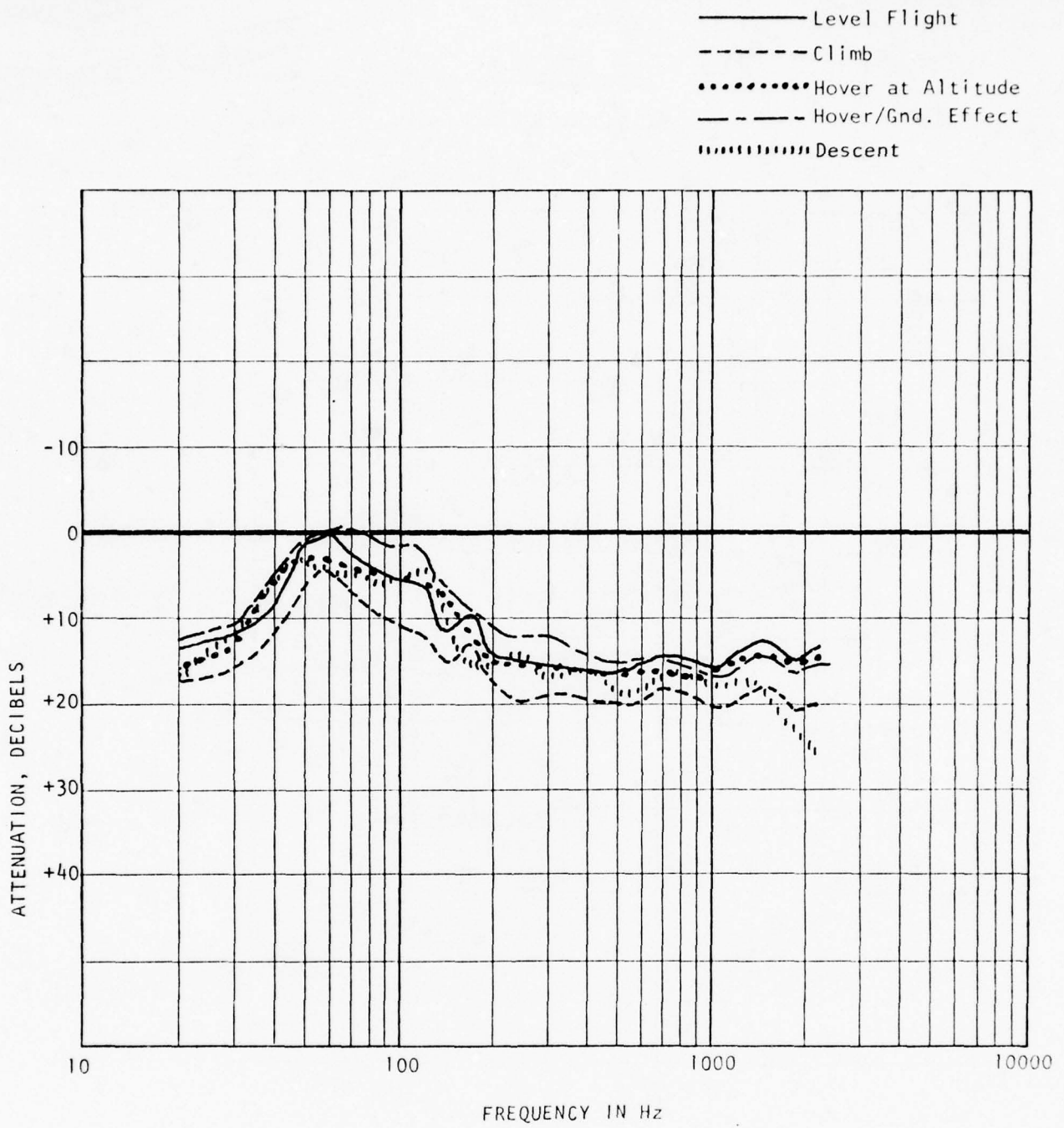

FIGURE 32 EARLUP ATTENUATION IN AN AH-1S HUEYCOBRA HELICOPTER, FOR 5 FLIGHT MODES: SAME DAY, SAME HUMAN SUBJECT

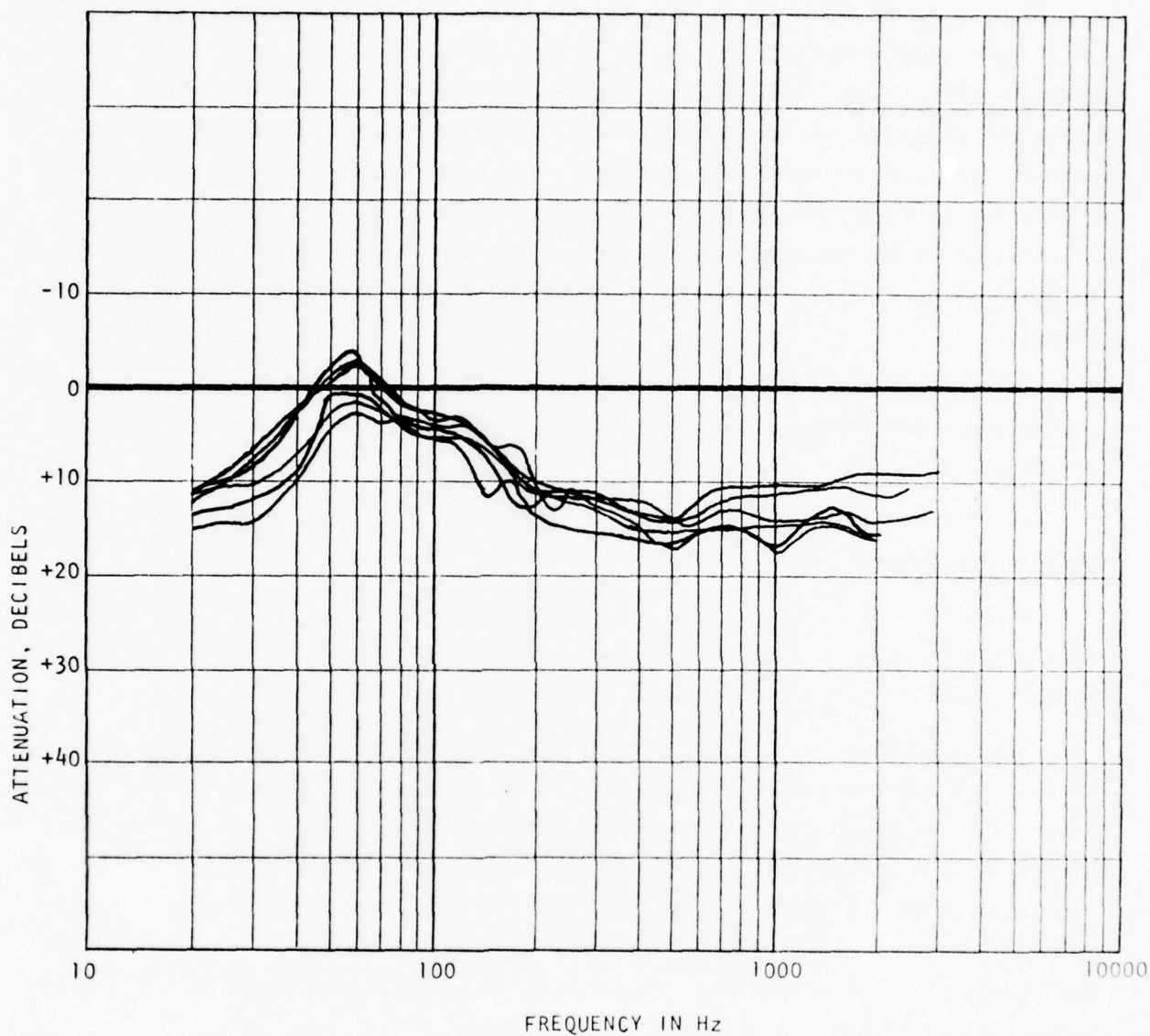

FIGURE 33 OVERLAY OF EARCUP ATTENUATIONS IN 3 AH-1S AND 3 AH-1Q HUEYCOBRA AIRCRAFT FOR LEVEL FLIGHT (EXCEPT ONE CURVE FOR ALTITUDE HOVER)

modes in one Hueycobra aircraft. The range of the curves shows the variability obtained on successive trails, even for the same human subject. Figure 33 is a simple overlay of the attenuations measured in all six of the Hueycobra aircraft which were studied during this project. Curves are shown for one flight mode in each aircraft. There are no known characteristics of the aircraft which would cause the attenuation to differ among aircraft. There is a possible influence of seat vibration being conducted through the body, causing the head to vibrate. This point is discussed in Section 7. A more likely reason for variable earcup attenuation is an improperly sealed ear cushion. The quality of the seal depends on such things as user technique, hair style, the wearing of glasses, and head shape.

There are numerous cases where the earcup attenuation was negative somewhere in the range 20-200 Hz, especially for the OH-58A. Likely reasons for this are discussed in detail in Section 7.

At 1000 Hz and above, the possibility of artifact noise must be considered. This is discussed in Appendix B.

As noted in Appendix B, the SPH-4 helmet was necessarily not located at the same point in space as the ambient-measuring microphone, which probably contributed to some of the variability.

Figures 30 and 31 show the possibility of about a 10 dB improvement in attenuation if the earcups performed as well in the aircraft as they do in the laboratory. The tabulations of earcup leakage and microphone pickup which are listed in Sections 4.1-4.6 show that the earcup performance is the limiting factor with regard to providing a noise environment free of damaging noise and speech interference. However, if the earcups performed as well in the aircraft as they do in the laboratory, the microphone noise-cancelling performance would be the limiting factor in all aircraft studied in this project.

4.8 STATISTICAL ANALYSIS

The ambient noise levels and spectra measured during this project are similar to those measured during other studies.^{2-4,7}

There were large level differences (5-6 dB) among average sound levels for various flight conditions for some types of aircraft (UH-1H) but not for others (OV-10, except during landing, and OH-58A). There were some extreme ambient level differences among individual aircraft of the same type. For example, the OV-10 with propellers not synchronized produces fully 10 dB more A-weighted noise than the typical aircraft.

Maximum performance maneuvers for the helicopters did not produce significantly more noise than standard maneuvers. Nor did the limited amount of relevant data show that open doors and windows cause more noise.

The measurements of overall sound levels within helicopters that are described in this report yielded as few as two values for a given flight condition for one type of aircraft (AH-1Q), and a maximum of 10 values for any particular aircraft (UH-1H). With such sparse data, there are questions about how accurately the variability of sound levels within Army helicopters has been defined. In other words, how much deviation from measured values can result from confluences of random factors such as meteorology, microphone position, pilots' control techniques, age of vehicles, structural variations, manufacturing tolerances, and measurement errors?

A first approximation of the variability of sound levels within helicopters can be obtained from the relatively few measured values by assuming that those sound levels are normally distributed (see any monograph on statistics). Other distributions may be more appropriate, but more data would be required even to determine the type of distribution.

When an average is calculated from a small number of values out of a large number of possible values, a "sample mean" is obtained. That sample mean is only an estimate of the average that would be calculated if all of the large number of possible values were available--the "universe mean". The smaller the number of available values, the cruder the sample estimate of the universe mean. Similarly, when a standard deviation (see any monograph on statistics) is calculated from a small number of values out of a large number of possible values, a "sample standard deviation" is obtained. That standard deviation is an estimate of the "universe standard deviation" that would be calculated if all of the large number of values were available, even when a routine calculation technique which is said to yield a standard deviation "unbiased by sample size" is used. The expected distribution of values for

sample standard deviations from a normally-distributed universe of values of a variable is described by a "student-t distribution" (see any monograph on statistics).

One can make use of the known properties of a normal distribution to define the degree of confidence in a sample estimate of a universe mean.²⁸ A sample mean and a sample standard deviation can be used to calculate an upper limit to a universe mean. The value of that limit will depend on the level of confidence that is required of that limit: in other words, the mathematical function of a sample mean and a sample standard deviation that is used to calculate the upper limit to a universe mean depends on how confident of the calculation one wishes to be.

Table 2 shows calculated values of sample means and sample standard deviations for the measurements of overall sound levels within helicopters that are described in this report. The sample average, \bar{X} , was calculated in the usual way:

$$\bar{X} = \frac{1}{N} \sum_{i=1}^N X_i ,$$

where N is the number of values, and X_i is the ith value. The "unbiased" sample standard deviation, σ , was calculated from:

$$\sigma = \sqrt{\frac{1}{N-1} \sum_{i=1}^N (X_i - \bar{X})^2} ,$$

where "unbiased" refers to division by (N-1) inside the radical. A "biased" standard deviation refers to division by N inside the radical. The level below which one is 95 percent confident that the universe mean falls was calculated from Duncan,²⁸:

$$\bar{X}|_{95\%} = \bar{X} + \frac{1.645 \sigma}{\sqrt{N}} ,$$

which assumes a Gaussian distribution. In addition, as a first approximation, the sample standard deviation was assumed to be equal to the universe standard deviation; as indicated on the table, more precise confidence intervals could be calculated from the "student-t" distribution of sample standard deviations

for a normally-distributed universe of values.²⁸ The 95 percent confidence level which includes 99.7 percent of all anticipated measured sound levels (the 95/99.7 level) was calculated by adding three standard deviations to the 95 confidence level for the universe mean.

A footnote in Table 2 compares the 95/99.7 level with maximum levels allowed by two military regulations (MIL-A-8806A²⁹; TB Med 251¹⁴ and one civilian regulation (OSHA¹³). Notice that we are 95 percent confident that noise levels in some of two models of helicopter will exceed MIL-A-8806 limits and OSHA limits, while some of four models of helicopter will exceed TB Med 251 limits (See Sections 3.3, 4.5 and 10.2). Additional measurements and further study will be required to construct more detailed and more precise conclusions concerning random variations of levels of measured noise within Army helicopters.

TABLE 2

STATISTICAL ANALYSIS OF HELICOPTER COCKPIT NOISE DATA
(assuming a Gaussian distribution of cabin noise levels)*

| AIRCRAFT MODEL | MEASURED SOUND LEVELS (dBA) FOR LEVEL FLIGHT | | | SAMPLE AVERAGE (dBA) | ("UNBIASED") SAMPLE STANDARD DEVIATION (dB) | 95% CONFIDENCE LEVEL OF UPPER LIMIT OF UNI- VERSE MEAN** (dBA) | 95% CONFIDENCE LEVEL WHICH INCLUDES 99.7% OF SOUND LEVELS (dBA)*** |
|-------------------|--|----------------|----------------|----------------------------|---|--|--|
| | MEASURED SOUND LEVELS WITHIN COCKPITS (dBA) | | | | | | |
| UH-1H | 95 93 94 96 | 93 94 93 | 96 89 95 | 94 | 2 | 95 | 101 |
| OH-58 | 92 93 | 89 92 | 87 99 | 92 | 4 | 95 | 107 |
| OV-10 | 98 104 | 100 100 | 102 100 | 101 | 2 | 102 | 108 |
| AH-1S & AH-1Q | 97 96 | 95 95 | 92 95 | 95 | 2 | 96 | 102 |
| CH-47C | 108 | 111 | 112 | 110 | 2 | 112 | 118 |
| CH-54B | 95 99 | 93 103 | 96 95 | 97 | 4 | 100 | 112 |
| ALL AIRCRAFT | | | | 97 | 6 | 99 | 117 |

* See discussion in Section 4.6.

** assuming that the universe standard deviation = sample standard deviation; the "student-t" distribution for sample standard deviations could be used for more precise calculations of 95/99.7 percent sound levels.

*** MIL-A-8806 maximum = 111 dBA;
OSHA maximum = 109 dBA for 4 hours for typical SPH-4 attenuation;
TB Med 251 maximum = 104 dBA for 4 hours for typical SPH-4 helmet attenuation.
(See Sections 3.3, 4.7 and 10.2)

5.0 PSYCHOACOUSTIC PROFILES OF AIRCRAFT COMMUNICATIONS SYSTEMS

Methods for assessing risks of hearing loss are reported in Section 3.3. Glorig¹⁶ pointed out a difficulty which was not discussed in Section 3.3 -- accounting for innumerable combinations of level and duration in real environments. Sound levels and accompanying durations within a given helicopter depend upon maneuvers, meteorological conditions, and electronic communication devices. The Tables in Appendix C show that sound levels within a given helicopter generally vary by around 5 decibels or less during maneuvers, with a few exceptions. By using the maximum sound levels which were measured during maneuvers of a given helicopter, slightly high numbers for predicted hearing loss will result. That conservatism is particularly justified since occasional sound levels much higher than time-averaged sound levels were observed, and since peak speech levels are 12 decibels higher than average speech levels.¹⁹

Peaks of speech sound pressure levels are so intermittent as to border on being transient or impulsive. Background speech levels, to which speech peaks add, border on being continuous. Very little is known about risks of hearing losses which are associated with combinations of impulsive sounds and continuous sound,^{30,31} especially when peak sound levels begin to move towards the threshold of pain,³¹ as they will if pilots turn up volume controls on communications equipment to maximum positions.

The fraction of flight time during which pilots and crews are exposed to electronic communication of speech is not known. The estimates of hearing loss which are presented below are based on the assumption that speech communications are conducted during one-half of one 4 hour flight each day. Since Camp et al³² published curves which show that aircraft communications systems are used about 40 percent of flying time, that assumption may lead to slightly high estimates of noise induced hearing loss. However, since sound levels at a pilot's ears with and without speech generally do not differ greatly, the assumption introduces little error. An additional conservative factor is introduced by applying hearing loss curves for 40 years exposure to helicopter pilots and crew who serve less than 40 years. However, differences between hearing loss after 10 years exposure and after 40 years exposure are small.¹¹

Table 3 summarizes the results of predictions of hearing loss. Those results are discussed below. All assessments of hearing loss which are discussed here apply only to personnel who wear helmets which provide at least as much protection as SPH-4 helmets.

Methods for computing articulation index are reported in Section 3.4. Methods for converting calculated values of articulation index to estimates of the intelligibility of sentences were reported in Section 3.5. The factors which limit the accuracy of estimates of intelligibility also were reported in that section.

5.1 UH-1H

The intelligibility of electronically communicated speech within these aircraft was calculated to be 97 to 99 percent. Intelligibility was as low as 56 percent during one maneuver of an aircraft (68-16612) from which sound absorptive material had been removed. Estimates of hearing loss by protected occupants of these aircraft range from no risk of measurable hearing loss at "speech frequencies," to a 5 to 10 dB NIPTS at speech frequencies among 35 percent of frequent occupants, coupled with an NIPTS of more than 10 dB at "speech frequencies" for 1.5 percent of frequent occupants.

5.2 OV-10

The intelligibility of electronically communicated speech within these aircraft was calculated to be 93 to 99 percent. Intelligibility was as low as 72 percent during one maneuver of one aircraft (68-16996). Predictions of hearing loss by protected occupants of these aircraft range from no measurable loss at "speech frequencies" to a 5 to 10 dB NIPTS at "speech frequencies" among 90 percent of frequent occupants, combined with an NIPTS of more than 10 dB at "speech frequencies" among 25 percent of frequent occupants.

5.3 OH-58

The intelligibility of electronically communicated speech within these aircraft was calculated to be 97 to 99 percent. Predictions of hearing loss by protected occupants of these aircraft range from no measurable loss at "speech frequencies" to a 5 to 10 dB NIPTS at "speech frequencies" among 26 percent of frequent occupants, and an NIPTS greater than 10 dB for one percent of those occupants.

TABLE 3

PREDICTED HEARING LOSS AMONG HELICOPTER PILOTS AND CREWS
(BASED ON MEASURED SOUND LEVELS AT PILOTS' EARS)

| AIRCRAFT | MAXIMUM SOUND LEVEL DURING SPEECH (dBA) | MAXIMUM SOUND LEVEL, NO KEY, NO SPEECH (dBA) | MAXIMUM EQUIVALENT 4 HOUR LEVEL (dBA) | CALCULATED INTELLIGIBILITY (%) | MAXIMUM PREDICTED HEARING DAMAGE** (applies to frequent occupants who wear SPH-4 helmets; applies to "speech frequencies") |
|----------|---|--|---------------------------------------|--------------------------------|---|
| UH-1H | - | - | - | - | ----- |
| 66-16054 | 91 | 86 | 89 | 99 | 1%, 5 to 10 dB NIPTS |
| 66-16566 | 86 | 85 | 85 | 61-97 | immeasurably small |
| 68-16612 | 90 | 86 | 88 | 99 | immeasurably small |
| 68-16622 | 97 | 87 | 94* | - | 17%, 5 to 10 dB NIPTS |
| 68-16628 | 98 | 92 | 96* | 99 | 35%, 5 to 10 dB NIPTS; 1.5% > 10 dB NIPTS |
| 69-15008 | 93 | 91 | 92* | - | 7%, 5 to 10 dB NIPTS |
| 71-20223 | 89 | 90 | 89 | 98 | 1%, 5 to 10 dB NIPTS |
| 71-20228 | 86 | 81 | 84 | 99 | immeasurably small |
| 71-20254 | 90 | 86 | 88 | 93 | immeasurably small |
| 73-21693 | | | | | |
| OV-10 | 91 | 90 | 90 | 98 | 2%, 5 to 10 dB NIPTS |
| 68-15933 | 95 | 94 | 94* | - | 17%, 5 to 10 dB NIPTS |
| 68-15950 | 95 | 96 | 95* | 93 | 26%, 5 to 10 dB NIPTS; 1% > 10 dB NIPTS |
| 68-15959 | 102 | 97 | 100* | 72-88 | 90%, 5 to 10 dB NIPTS; 25% > 10 dB NIPTS |
| 68-16996 | 94 | 92 | 93* | 97-99 | 10%, 5 to 10 dB NIPTS |
| 68-16997 | 89 | 86 | 88 | - | immeasurably small |
| 69-17005 | | | | | |
| OH-58 | 86 | 84 | 85 | - | immeasurably small |
| 71-20475 | 88 | 90 | 89 | 98-99 | 1%, 5 to 10 dB NIPTS |
| 71-20558 | - | - | - | - | ----- |
| 71-20561 | 97 | 92 | 95* | 97-99 | 26%, 5 to 10dB NIPTS; 1% > 10 dB NIPTS |
| 71-20563 | 85 | 83 | 84 | 98 | immeasurably small |
| 71-20564 | 90 | 88 | 89 | - | 1%, 5 to 10 dB NIPTS |
| 71-20549 | | | | | |

* Above maximum allowed (90 dBA) by TB MED 251 for daily 4 hour exposures.

(Continued on next page)

** For daily 4 hour exposures, for 40 years; however most of the hearing damage occurs during the first 10 years.

TABLE 3 (CONTINUED)

PREDICTED HEARING LOSS AMONG HELICOPTER PILOTS AND CREWS
(BASED ON MEASURED SOUND LEVELS AT PILOTS' EARS)

| AIRCRAFT | MAXIMUM SOUND LEVEL DURING SPEECH (dBA) | MAXIMUM SOUND LEVEL, NO KEY, NO SPEECH (dBA) | MAXIMUM EQUIVALENT 4 HOUR LEVEL (dBA) | CALCULATED INTELLIGIBILITY (%) | MAXIMUM PREDICTED HEARING DAMAGE** (applies to frequent occupants who wear SPH-4 helmets; applies to "speech frequencies") |
|-----------------|---|--|---------------------------------------|--------------------------------|--|
| AH-1S 68-15177 | 86 | 84 | 85 | 96-97 | immeasurably small |
| 70-16010 | 89 | 88 | 90 | 99 | 2%, 5 to 10 dB NIPTS |
| 70-16038 | 90 | 91 | 91* | 98-99 | 4%, 5 to 10 dB NIPTS |
| 71-20988 | 90 | 89 | 89 | 98-99 | 1%, 5 to 10 dB NIPTS |
| AH-1Q 68-15209 | 87 | 87 | 87 | 98-99 | immeasurably small |
| 70-15945 | 90 | 87 | 88 | 99 | immeasurably small |
| CH-47C 70-15003 | 91 | 93 | 92* | 49-83 | 7%, 5 to 10 dB NIPTS |
| 70-15020 | 93 | 93 | 93* | - | 10%, 5 to 10 dB NIPTS |
| 70-15026 | 93 | 94 | 94* | - | 17%, 5 to 10 dB NIPTS |
| CH-54B 69-18465 | 88 | 84 | 86 | 97-98 | immeasurably small |
| 69-18468 | 87 | 84 | 85 | 97-98 | immeasurably small |
| 69-18470 | 94 | 93 | 94* | 88-94 | 17%, 5 to 10 dB NIPTS |
| 69-18473 | 91 | 89 | 90 | 90-96 | 2%, 5 to 10 dB NIPTS |
| 69-18476 | 97 | 93 | 98* | 91-98 | 60%, 5 to 10 dB NIPTS; 8%, > 10dB NIPTS |
| 69-18490 | 91 | 86 | 89 | 95-96 | 1%, 5 to 10 dB NIPTS |

* Above maximum allowed (90 dBA) by TB MED 251 for daily 4 hour exposures.

** For daily 4 hour exposures, for 40 years; however most of the hearing damage occurs during the first 10 years.

5.4 AH-1S AND AH-1Q

The intelligibility of electronically communicated speech within these aircraft was calculated to be 96 to 99 percent. Predictions of hearing loss by protected occupants of these aircraft range from no measurable loss at "speech frequencies" to a 5 to 10 dB NIPTS at "speech frequencies" among 4 percent of frequent occupants.

5.5 CH-47C

The intelligibility of electronically communicated speech within these aircraft was calculated to be 49 to 83 percent. Predictions of hearing loss by protected occupants of these aircraft range from a 5 to 10 dB NIPTS at "speech frequencies" among 7 percent of frequent occupants to an identical loss among 17 percent of frequent occupants.

5.6 CH-54B

The intelligibility of electronically communicated speech within these aircraft was calculated to be 88 to 98 percent. Predictions of hearing loss by protected occupants of these aircraft range from no measurable loss at "speech frequencies" to a 5 to 10 dB NIPTS at "speech frequencies" among 60 percent of frequent occupants, combined with an NIPTS of more than 10 dB at "speech frequencies" among 8 percent of frequent occupants.

5.7 SENSITIVITY OF HEARING LOSS ESTIMATES TO SOUND LEVEL

The estimates of hearing loss which are presented in Section 5.1 through 5.6 were based on the highest sound levels that were measured during many maneuvers. Some justifications for that procedure were previously presented in Section 5.0. The degree of conservatism introduced by that procedure is illustrated by re-estimating hearing damage risks for a couple of other choices at sound levels for the aircraft which generated the widest range (7 dB) of measured sound levels--the OV-1D number 68-16996.

Using the highest measured sound level measured for the number 68-16996 OV-1D results in an estimate of a 5 to 10 dB NIPTS for 90 percent of frequent occupants, coupled with an NIPTS of more than 10 dB for 25 percent of those occupants. If the mid-range value of measured sound levels is used, the resulting estimate is a 5 to 10 dB NIPTS for 48 percent, combined with an NIPTS of

more than 10 dB for 4 percent. Using the lowest values results in an estimate of a 5 to 10 dB NIPTS for 19 percent of frequent occupants. This sensitivity to choice of values among measured sound levels is the greatest one for the list of damage risks shown in Table 3. since the range of measured sound level is the greatest for this case.

5.8 COMPARISON OF RESULTS WITH THOSE OF PREVIOUS STUDIES

The levels of intrusive noise which are tabulated in Table 3 are close to levels defined by Gasaway²² as threshold levels for which the intrusion of ambient noise begins to create noticeable interference with aural communications. The intelligibility levels which are tabulated in Table 3 agree with Gasaway's conclusion that the background noise levels are marginally adequate, since the tabulated values for intelligibility vary with the levels of background noise. If there were any leeway in noise levels, then intelligibility scores would remain high for varying levels of background noise.

An extensive literature search revealed no publications which relate specific amounts of hearing loss to exposure to helicopter noise, nor have there been published attempts to predict how many people will suffer given levels of hearing loss as a result of exposure to helicopter noise. There is a pronounced need to study hearing losses among helicopter pilots and crew members whose exposures to noise both on and off duty are well defined and documented. It is difficult to keep track of their exposure to noise while they are not on duty within a helicopter. That exposure could be defined for a study group of typical helicopter occupants by performing audiometric tests of their hearing on frequent, randomly-selected occasions at the beginning of their daily duty.

5.9 HEARING LOSSES AMONG ARMY PERSONNEL BEFORE THEY BECOME HELICOPTER PILOTS

Walden, et al³³ published measurements which show that, while the vast majority of individuals entering the Army have hearing within normal limits, in the first four to six months that an individual is on active duty, his chances of sustaining a hearing impairment increase substantially as his time on active duty continues. For example, they reported that 5 percent of individuals who complete basic and advanced training suffer hearing losses at the end of that training of sufficient magnitude that they should be removed from the job for which they have just been trained.

Many helicopter pilots are drawn from experienced infantry, artillery, and armor personnel. Table 4 shows that over half of those personnel have suffered significant hearing losses at the time that they enter helicopter service, and one-quarter to one-half of them have suffered severe hearing losses which make them unsuitable for duty in high-noise environments at the time that they enter helicopter service.

5.10 CONCLUSIONS

The noise levels that are listed in this report are in agreement with levels which were measured and published by other investigators. Currently accepted criteria for predicting hearing losses which result from noise exposure lead one to conclude that those noise levels will cause what is currently accepted to be a hearing handicap (see Section 3.3) in only a small fraction of one percent of all exposed personnel who wear helmets at least as good as SPH-4 helmets. However, the measurements which are described in this report were performed with volume controls set at mid-range. If pilots routinely turn up volume controls on their communication aids because of real or imagined problems with intelligibility, then large percentages of them will suffer handicapping losses of hearing.

Tables 5 and 6 show the calculated effects of turning up electronically-generated signals and noise by 10 decibels. When that is done, low frequency noise which is transmitted mechanically through earcups is not changed. The result is that a pilot does achieve a considerable improvement in intelligibility by turning up volume controls. Those Tables also show that pilots increase overall A-weighted speech and noise levels by almost 10 dB when they turn up the gain by 10 dB; such changes in overall sound level correspond to a significant increase in risks of loss of hearing.

It is likely that pilots turn up volume controls on communications aids in attempts to raise speech levels above the level of intruding low frequency noise that is transmitted through helmets and earcups (see Sections 4.7 and 8.2). If that low frequency noise could be eliminated, then pilots would be more inclined to set speech levels at less than harmful levels, and they would feel more comfortable and be less subject to fatigue and error and risks of hearing loss would be even less than those small risks which are described in this section.

TABLE 4

PERCENTAGES OF MILITARY PERSONNEL WHO HAVE SUFFERED THE INDICATED LEVELS OF HEARING LOSS AFTER MORE THAN 10 YEARS ACTIVE DUTY (WALDEN, et al³³)

| DEGREE OF HEARING LOSS | INFANTRY | ARTILLERY | ARMOR |
|--|----------|-----------|-------|
| (H1) NO SIGNIFICANT LOSS | 47.2 | 47.9 | 36.7 |
| (H2) SUBSTANTIAL LOSS | 25.8 | 19.1 | 20.0 |
| (H3) SHOULD REQUIRE MANDATORY DUTY LIMITATIONS | 23.0 | 29.8 | 40.9 |
| (H4) SHOULD BE DISCHARGED | 4.0 | 3.2 | 2.3 |

TABLE 5. EFFECTS OF INCREASED VOLUME CONTROL SETTINGS (UH-1H)

UH-1H 68-16612, LEVEL FLIGHT
GAIN STUDY. ORIGINAL LEVELS.

| CENTER FREQUENCY OF BAND (HERTZ) | SPECTRUM LEVEL OF SPEECH (DB) | SPECTRUM LEVEL OF NOISE (DB) |
|---|--|---------------------------------------|
| 270.0 | 47.4 | 61.2 |
| 360.0 | 45.9 | 53.4 |
| 490.0 | 53.9 | 47.1 |
| 630.0 | 51.5 | 44.4 |
| 770.0 | 42.3 | 39.9 |
| 920.0 | 39.2 | 34.2 |
| 1070.0 | 37.8 | 33.9 |
| 1230.0 | 39.3 | 37.3 |
| 1400.0 | 42.0 | 36.5 |
| 1570.0 | 42.9 | 36.2 |
| 1740.0 | 40.2 | 36.1 |
| 1920.0 | 37.2 | 37.6 |
| 2130.0 | 36.4 | 38.7 |
| 2370.0 | 34.8 | 36.8 |
| 2660.0 | 33.1 | 45.3 |
| 3000.0 | 42.3 | 50.9 |
| 3400.0 | 29.6 | 45.0 |
| 3950.0 | 33.6 | 36.4 |
| 4560.0 | 24.0 | 34.3 |
| 5600.0 | 18.0 | 30.6 |

THIS PAGE IS BEST QUALITY PRACTICABLE
FROM COPY FURNISHED TO DDC

OASL (DBA) = 77.8 81.9

OVERALL SOUND LEVEL (SPEECH + NOISE, 200 TO 6100 HZ) = 83.3 DBA

| CENTER FREQUENCY OF BAND (HERTZ) | CORRECTED NOISE LEVEL (DB) | SPREAD- OF-MASKING OF NOISE (DB) | MASKING LEVEL OF NOISE (DB) |
|---|-------------------------------------|---|--------------------------------------|
| 270.0 | 61.2 | 26.7 | 61.2 |
| 360.0 | 53.4 | 21.8 | 53.4 |
| 490.0 | 47.1 | 18.1 | 47.1 |
| 630.0 | 44.4 | 14.5 | 44.4 |
| 770.0 | 39.9 | 11.6 | 39.9 |
| 920.0 | 34.2 | 9.1 | 34.2 |
| 1070.0 | 33.9 | 6.9 | 33.9 |
| 1230.0 | 37.3 | 4.9 | 37.3 |
| 1400.0 | 36.5 | 3.0 | 36.5 |
| 1570.0 | 36.2 | 1.3 | 36.2 |
| 1740.0 | 36.1 | 0.0 | 36.1 |
| 1920.0 | 37.6 | 0.0 | 37.6 |
| 2130.0 | 38.7 | 0.0 | 38.7 |
| 2370.0 | 36.8 | 0.0 | 36.8 |
| 2660.0 | 45.3 | 0.0 | 45.3 |
| 3000.0 | 51.1 | 0.0 | 51.1 |
| 3400.0 | 45.0 | 0.0 | 45.0 |
| 3950.0 | 36.4 | 0.0 | 36.4 |
| 4560.0 | 34.3 | 34.3 | 34.3 |
| 5600.0 | 30.6 | 0.0 | 30.6 |

ARTICULATION INDEX = .34

TABLE 5. EFFECTS OF INCREASED VOLUME CONTROL SETTINGS (UH-1H) (Continued)

UH-1H 68-16612, LEVEL FLIGHT
GAIN STUDY. RAISE NOISE SPL ABOVE 1000 HZ AND ALL SPEECH SPL BY 10 DB.

| CENTER FREQUENCY OF BAND (HERTZ) | SPECTRUM LEVEL OF SPEECH (DB) | SPECTRUM LEVEL OF NOISE (DB) |
|---|--|---------------------------------------|
| 270.0 | 57.4 | 61.2 |
| 360.0 | 55.9 | 53.4 |
| 490.0 | 63.9 | 47.1 |
| 630.0 | 61.5 | 44.4 |
| 770.0 | 52.3 | 39.9 |
| 920.0 | 49.2 | 34.2 |
| 1070.0 | 47.8 | 43.9 |
| 1230.0 | 49.3 | 47.3 |
| 1400.0 | 52.0 | 46.5 |
| 1570.0 | 52.9 | 46.2 |
| 1740.0 | 50.2 | 46.1 |
| 1920.0 | 47.2 | 47.6 |
| 2130.0 | 46.4 | 48.7 |
| 2370.0 | 44.8 | 46.8 |
| 2660.0 | 43.1 | 55.3 |
| 3000.0 | 52.3 | 60.9 |
| 3400.0 | 39.6 | 55.0 |
| 3950.0 | 43.6 | 46.4 |
| 4560.0 | 34.0 | 44.3 |
| 5600.0 | 28.0 | 40.6 |

THIS PAGE IS BEST QUALITY PRACTICABLE
FROM COPY FURNISHED TO DDIC

OASL (DBA) = 87.8 90.6

OVERALL SOUND LEVEL (SPEECH + NOISE, 200 TO 6100 HZ) = 92.4 DBA

| CENTER FREQUENCY OF BAND (HERTZ) | CORRECTED NOISE LEVEL (DB) | SPREAD- OF-MASKING OF NOISE (DB) | MASKING LEVEL OF NOISE (DB) |
|---|-------------------------------------|---|--------------------------------------|
| 270.0 | 61.2 | 38.6 | 61.2 |
| 360.0 | 53.4 | 33.7 | 53.4 |
| 490.0 | 47.1 | 30.0 | 47.1 |
| 630.0 | 44.4 | 26.4 | 44.4 |
| 770.0 | 39.9 | 23.5 | 39.9 |
| 920.0 | 34.2 | 20.9 | 34.2 |
| 1070.0 | 43.9 | 18.7 | 43.9 |
| 1230.0 | 47.3 | 16.7 | 47.3 |
| 1400.0 | 46.5 | 14.9 | 46.5 |
| 1570.0 | 46.2 | 13.2 | 46.2 |
| 1740.0 | 46.1 | 11.7 | 46.1 |
| 1920.0 | 47.6 | 10.3 | 47.6 |
| 2130.0 | 48.7 | 8.8 | 48.7 |
| 2370.0 | 46.8 | 7.3 | 46.8 |
| 2660.0 | 56.2 | 5.6 | 56.2 |
| 3000.0 | 63.1 | 3.9 | 63.1 |
| 3400.0 | 56.0 | 57.3 | 57.3 |
| 3950.0 | 46.4 | 0.0 | 46.4 |
| 4560.0 | 44.3 | 44.3 | 44.3 |
| 5600.0 | 40.6 | 0.0 | 40.6 |

ARTICULATION INDEX = .43

TABLE 6. EFFECTS OF INCREASED VOLUME CONTROL SETTINGS (OV-1D)

OV-1D E68-16997, LEVEL FLIGHT
GAIN STUDY, ORIGINAL LEVELS.

| CENTER FREQUENCY OF BAND (HERTZ) | SPECTRUM LEVEL OF SPEECH (DB) | SPECTRUM LEVEL OF NOISE (DB) |
|---|--|---------------------------------------|
| 270.0 | 72.6 | 70.3 |
| 380.0 | 54.3 | 56.7 |
| 490.0 | 52.6 | 49.0 |
| 630.0 | 51.4 | 47.5 |
| 770.0 | 48.5 | 41.3 |
| 920.0 | 45.0 | 38.2 |
| 1070.0 | 45.3 | 37.6 |
| 1230.0 | 46.4 | 38.2 |
| 1400.0 | 47.2 | 39.2 |
| 1570.0 | 47.5 | 38.7 |
| 1740.0 | 46.2 | 36.5 |
| 1920.0 | 44.0 | 34.6 |
| 2130.0 | 44.2 | 36.0 |
| 2370.0 | 46.5 | 37.0 |
| 2660.0 | 55.8 | 49.5 |
| 3000.0 | 54.9 | 55.5 |
| 3400.0 | 51.0 | 52.5 |
| 3950.0 | 21.3 | 44.4 |
| 4560.0 | -19.0 | 43.1 |
| 5600.0 | -20.2 | 38.5 |

THIS PAGE IS BEST QUALITY PRACTICABLE
FROM COPY FURNISHED TO DDC

OASL (DBA) = 89.6 83.1

OVERALL SOUND LEVEL (SPEECH + NOISE, 200 TO 6100 HZ) = 91.9 DBA

| CENTER FREQUENCY OF BAND (HERTZ) | CORRECTED NOISE LEVEL (DB) | SPREAD- OF-MASKING OF NOISE (DB) | MASKING LEVEL OF NOISE (DB) |
|---|-------------------------------------|---|--------------------------------------|
| 270.0 | 70.3 | 32.9 | 70.3 |
| 380.0 | 56.7 | 27.9 | 56.7 |
| 490.0 | 49.8 | 24.3 | 49.8 |
| 630.0 | 47.5 | 20.6 | 47.5 |
| 770.0 | 41.3 | 17.7 | 41.3 |
| 920.0 | 38.2 | 15.2 | 38.2 |
| 1070.0 | 37.6 | 13.0 | 37.6 |
| 1230.0 | 38.2 | 11.0 | 38.2 |
| 1400.0 | 39.2 | 9.1 | 39.2 |
| 1570.0 | 38.7 | 7.5 | 38.7 |
| 1740.0 | 36.5 | 6.0 | 36.5 |
| 1920.0 | 34.6 | 4.6 | 34.6 |
| 2130.0 | 36.0 | 3.1 | 36.0 |
| 2370.0 | 37.0 | 1.5 | 37.0 |
| 2660.0 | 49.5 | 0.0 | 49.5 |
| 3000.0 | 56.6 | 0.0 | 56.6 |
| 3400.0 | 53.0 | 51.4 | 53.0 |
| 3950.0 | 44.4 | 0.0 | 44.4 |
| 4560.0 | 43.1 | 0.0 | 43.1 |
| 5600.0 | 38.5 | 0.0 | 38.5 |

ARTICULATION INDEX = .49

TABLE 6. EFFECTS OF INCREASED VOLUME CONTROL SETTINGS (OV-1D) (Continued)

OV-1D 68-16997, LEVEL FLIGHT
GAIN STUDY. RAISE NOISE SPL ABOVE 1800 HZ AND ALL SPEECH SPL BY 10 DB.

| CENTER FREQUENCY OF BAND (HERTZ) | SPECTRUM LEVEL OF SPEECH (DB) | SPECTRUM LEVEL OF NOISE (DB) |
|---|--|---------------------------------------|
| 270.0 | 82.6 | 70.3 |
| 380.0 | 64.3 | 56.7 |
| 490.0 | 62.6 | 49.8 |
| 630.0 | 61.4 | 47.5 |
| 770.0 | 58.5 | 41.3 |
| 920.0 | 55.0 | 38.2 |
| 1070.0 | 55.3 | 37.6 |
| 1230.0 | 56.4 | 38.2 |
| 1400.0 | 57.2 | 39.2 |
| 1570.0 | 57.5 | 38.7 |
| 1740.0 | 56.2 | 36.5 |
| 1920.0 | 54.0 | 44.6 |
| 2130.0 | 54.2 | 46.0 |
| 2370.0 | 56.5 | 47.0 |
| 2660.0 | 65.8 | 59.5 |
| 3000.0 | 64.9 | 65.5 |
| 3400.0 | 61.0 | 62.5 |
| 3950.0 | 31.3 | 54.4 |
| 4560.0 | -19.0 | 53.1 |
| 5600.0 | -20.2 | 48.5 |

THIS PAGE IS BEST QUALITY PRACTICABLE
FROM COPY FURNISHED TO DDC

OASL (OBA) = 99.6 96.0

OVERALL SOUND LEVEL (SPEECH + NOISE, 200 TO 6100 HZ) = 101.2 OBA

| CENTER FREQUENCY OF BAND (HERTZ) | CORRECTED NOISE LEVEL (DB) | SPREAD- OF-MASKING OF NOISE (DB) | MASKING LEVEL OF NOISE (DB) |
|---|-------------------------------------|---|--------------------------------------|
| 270.0 | 70.3 | 44.9 | 70.3 |
| 330.0 | 56.7 | 39.9 | 56.7 |
| 490.0 | 49.8 | 36.3 | 49.8 |
| 630.0 | 47.5 | 32.6 | 47.5 |
| 770.0 | 41.3 | 29.7 | 41.3 |
| 920.0 | 38.2 | 27.2 | 38.2 |
| 1070.0 | 37.6 | 25.0 | 37.6 |
| 1230.0 | 38.2 | 23.0 | 38.2 |
| 1400.0 | 39.2 | 21.1 | 39.2 |
| 1570.0 | 38.7 | 19.5 | 38.7 |
| 1740.0 | 36.5 | 18.0 | 36.5 |
| 1920.0 | 44.6 | 16.6 | 44.6 |
| 2130.0 | 46.0 | 15.1 | 46.0 |
| 2370.0 | 47.0 | 13.5 | 47.0 |
| 2660.0 | 61.2 | 11.9 | 61.2 |
| 3000.0 | 68.6 | 10.1 | 68.6 |
| 3400.0 | 65.0 | 62.4 | 65.0 |
| 3950.0 | 55.1 | 63.4 | 63.4 |
| 4560.0 | 53.1 | 64.5 | 64.5 |
| 5600.0 | 48.5 | 36.2 | 48.5 |

ARTICULATION INDEX = .66

There is little chance of modifying existing helicopters to reduce the levels of low frequency sound to non-intrusive levels (See Section 8.1). Modifications of helmets and earcups or more effective use of earcups by personnel are the most likely means for reducing the noise significantly (See Section 8.2). Earplugs provide a less appealing, but effective, means for controlling the intrusion of low frequency noise. Some people have expressed concern that earplugs might prevent equalization of pressure within ears during rapid altitude changes. However, Stork and Gasaway³⁴ conducted studies which provided evidence that most people can wear earplugs in flight without discomfort and without difficulty in ventilating their middle ears.

Whatever the methods for controlling the levels of noise at people's ears, routine periodic audiometric tests should be performed on people who are exposed to high intensity sound. There is enough doubt about the accuracy of hearing loss data,¹⁵ and enough individual variation from trends for large populations, that limits on noise exposure do not insure that given individuals will not suffer significant hearing losses when they are exposed to noise which is controlled to meet popular damage risk criteria.

The need for frequent audiometric testing of people who are exposed to high intensity sound has been recognized by the military services since 1949.³⁵ Since 1956, the Air Force has performed an annual audiometric test of each noise-exposed person within the Air Force. Early indications of a growing loss of hearing is cause for removing a person from noisy work conditions, well before a significant hearing handicap is established. The result is that noise-exposed military and civilian personnel employed by the Air Force hear better than the general population of the U.S.; that difference cannot be attributed entirely to entry standards. The U. S. Army has adopted a similar program. A description of military programs is found in Section 9.2.

6.0 ANALYSIS OF AVIONICS EQUIPMENT

Part of the data supplied by AEL is in the form of electrical measurements made on radios and aircraft intercommunication (AIC) sets. The performance of AIC's will be discussed in this section.

Data were provided on the gain and harmonic distortion of the microphone and headset amplifiers. These are summarized in Table 7. The microphone tests at small and large input voltages show that the AGC circuits are operating satisfactorily and that the distortion is low. After allowance for an attenuation of 66 dB in the input test circuit, and allowance for the sensitivity of a typical M-87 microphone (-111 dBV/ μ bar),⁶ the test voltage of 0.6 Volts simulates a sound pressure of about 115 dB SPL; 4.0 Volts simulates a sound pressure of about 131 dB SPL.

The headset amplifier output of 1.25 Volts produces approximately 100 dB SPL in the earcup. For both AIC's, the distortion exceeds 5% at some frequencies. This distortion, although exceeding specifications, probably has no adverse effect on intelligibility.

When the signal to the earphone is raised from 1.25 Volts to 1.5 Volts, the C-1611D distorts severely, whereas the distortion of the C-6533 does not increase.

AEL personnel performed a few distortion tests on an AN/ARC-115 VHF-AM radio, serial no. 25959, which permit assessing the relative distortion in the C-6533 and the receiver. The following result is typical. A standard 80% modulated RF signal was applied at 131.150 MHz.

| <u>AIC OUTPUT (mW)</u> | <u>RECEIVER VOLUME</u> | <u>DISTORTION (%)</u> |
|------------------------|------------------------|-----------------------|
| 200 | Maximum | 24.5 |
| 253 (Max) | Mid-range | 19 |
| 200 | Mid-range | 4.8 |

This result indicates that at maximum volume settings at this input signal level, the AIC and receiver audio circuit contribute about equally to distortion.

Another set of electrical measurements was available in the form of tape recordings of the electrical noise at the output of the headset amplifier. The headset was simulated by an 8 ohm resistor. Measurements were made with the

TABLE 7 AIC AVERAGE PERFORMANCE

| <u>AIC TYPE</u> | C-1611D | C-6533 | C-1611D | C-6533 |
|--|----------------------|----------------------|-----------------------------|-----------------------------|
| <u>COMPONENT</u> | Microphone Amplifier | Microphone Amplifier | Headset Amplifier | Headset Amplifier |
| <u>NUMBER TESTED</u> | 12 | 11 | 13 | 11 |
| <u>TEST INPUT (VOLTS)</u> | 0.6 | 0.6 | 2.75 | 2.75 |
| <u>FREQ. RESPONSE (Hz) (3db POINTS)</u> | 130-7000 | 250-4600 | 145-7000 | 125-9000 |
| <u>OUTPUT (VOLTS)</u> | 2.6 | 2.9 | 1.25 (Volume adjustment) | 1.25 (Volume adjustment) |
| <u>HARMONIC DISTORTION (%) 1000 Hz</u> | 2.2 | 1.3 | 4.5 | 3.7 |
| <u>DISTORTION RANGE (%) 1000 Hz</u> | 1.6-4.0 | 0.6-2.6 | 2.9-8.0 | 3.4-4.3 |
| <u>HARMONIC DISTORTION (%) 300 Hz/6000 Hz</u> | Same as 1000 Hz | Same as 1000 Hz | 7.0/5.4 (2 units) | 3.8/5.2 (3 units) |
| ----- | | | | |
| <u>LARGE SIGNAL TEST INPUT (VOLTS)</u> | 4.0 | 4.0 | 2.75 (Volume max.) | 2.75 (Volume max.) |
| <u>LARGE SIGNAL OUTPUT (VOLTS)</u> | 3.9 (4 units) | 3.1 (2 units) | 1.55 | 1.51 |
| <u>LARGE SIGNAL DISTORTION (%) 1000 Hz</u> | 2.6 (4 units) | 1.3 (2 units) | 24.5 | 3.6 |

AIC both keyed and not keyed, and with both a real and simulated M-87 microphone. The contribution to acoustic noise at the ear due to electrical self-noise in the amplifiers was found to be negligible. The values of the sound pressure which would be produced at the ear by these electrical sources could not be precisely calculated because of uncertainty about the exact calibration of the earphone in situ and because of the problem of tape recorder noise at the low levels encountered. The following values represent a worst case estimate and a most probable estimate of the sound at the ear due to amplifier noise, compared to the noise due to all acoustic sources.

- o Worst case estimate: Noise (in dBA) due to electrical sources is 30 dB below noise (in dBA) due to acoustical sources.
- o Most probable estimate: Noise (in dBA) due to electrical sources is 50 dB below noise (in dBA) due to acoustical sources.

A few measurements were made to test the action of AGC in the microphone amplifier upon the initiation of the speech test-phrase. The method is described in Appendix B. Due to various problems in inserting the test signal and interpreting the results, the confidence level of the accuracy of the values is only moderate.

| <u>AIRCRAFT TYPE</u> | <u>AMPLIFIER GAIN CHANGE (dB)</u> |
|----------------------|-----------------------------------|
| UH-1H | -3.1 (one sample) |
| OV-1D | -3.6 (one sample) |
| AH-1S | -5.1 (three samples) |

These values were not used to adjust the KEY NO TALK noise (above the crossover frequency) downward before calculation of the articulation indices which are listed in this report. Had they been used, the listed indices would have been slightly better. For example, in the case of the OV-1D #69-17005, the index increases from .40 to .44 when AGC action is taken into account.

7.0 EXPERIMENTAL STUDIES OF EARCUPS

In Section 4, it is shown that earcups are the weak link in the aircraft communication system with regard to reducing noise at the ear. A series of experiments were made to determine why the SPH-4 has deficient performance in the aircraft. Before beginning the experiments, the literature was reviewed. The theory of circumaural earcups has been described by Zwislocki,^{36,37} Shaw and Thiessen^{38,39} and others. Following are mechanisms cited for sound transmission through or around earcups.

- o Sound leakage through spaces between the earcup cushion and the head.
- o Vibration of the earcup as a unit relative to the head. Caused by external sound pressure, the vibration modulates the internal earcup pressure, thus producing sound at the ear. This phenomenon has been referred to as "earcup pumping" or the "pumping mode."
- o Local flexure of the earcup wall or earcup cushion.
- o Sound transmission into the earcup volume through the flesh immediately under the earcup cushion.
- o Sound transmission through the chest and head (bone conduction) to the middle ear. This is known to limit the attenuation of all types of ear defenders to about 45 dB throughout the spectrum.⁴⁰

7.1 EXPERIMENTS WITH THE SPH-4 ON A FLAT PLATE COUPLER

Figures 34 through 37 show the results of an investigation of various factors which contribute to reduced attenuation in the SPH-4. The tests were made at ATC on the same helmet which was used by USAECOM for the in-flight measurements. A few tests were made on a different but similar set of SPH-4 earcups. The earcups and cushions were in good condition. A test sound pressure of 94 dB SPL was applied. The helmet straps were used to apply approximately one kilogram-force to the earcup. The tests were made by pressing the SPH-4 earcup against a flat plate which was built up slightly with clay to provide a contoured surface. The contoured surface facilitates making a good seal. The reference pressure was measured just outside the earcup; thus diffraction effects do not appear in the results. A single loudspeaker in an anechoic chamber was used as a sound source.

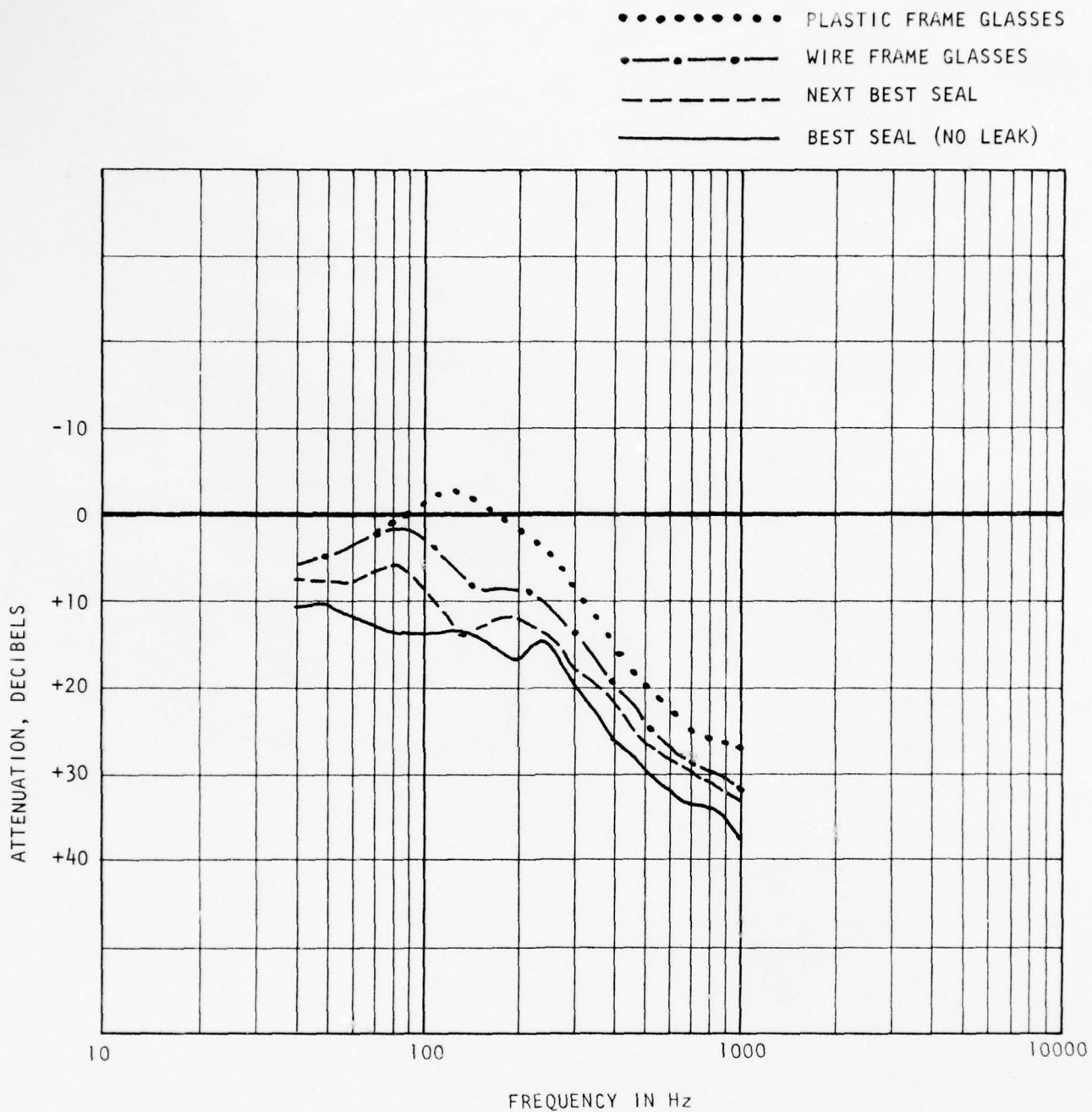

FIGURE 34. ATTENUATION DEPENDENCE ON LEAKS UNDER EAR CUSHION - SPH-4 MOUNTED ON FLAT PLATE (MODIFIED WITH CLAY)

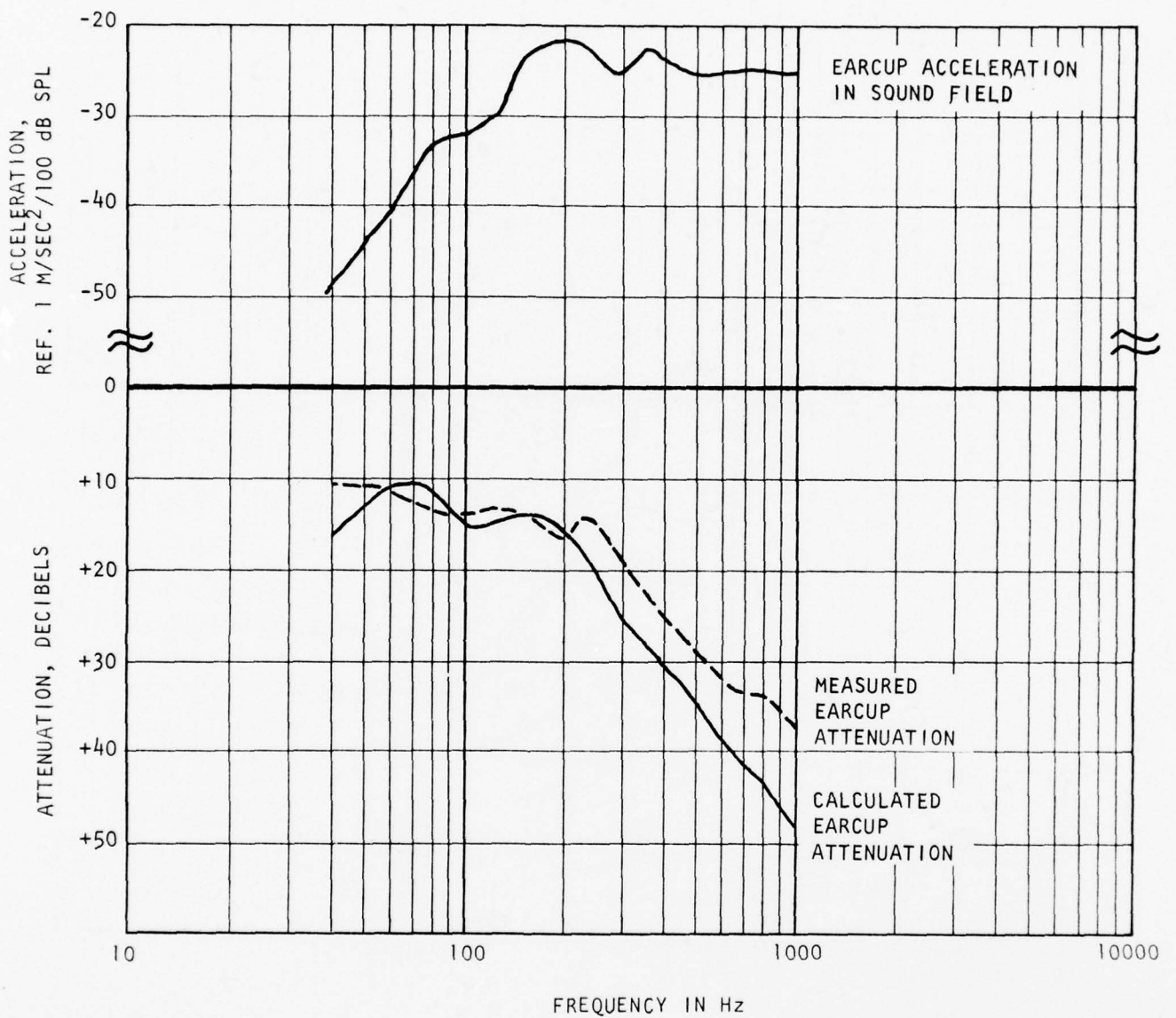

FIGURE 35. CALCULATED EARCUP ATTENUATION DERIVED FROM VIBRATION MEASUREMENTS, COMPARED TO MEASURED ATTENUATION -- SPH-4 MOUNTED ON FLAT PLATE MODIFIED WITH CLAY

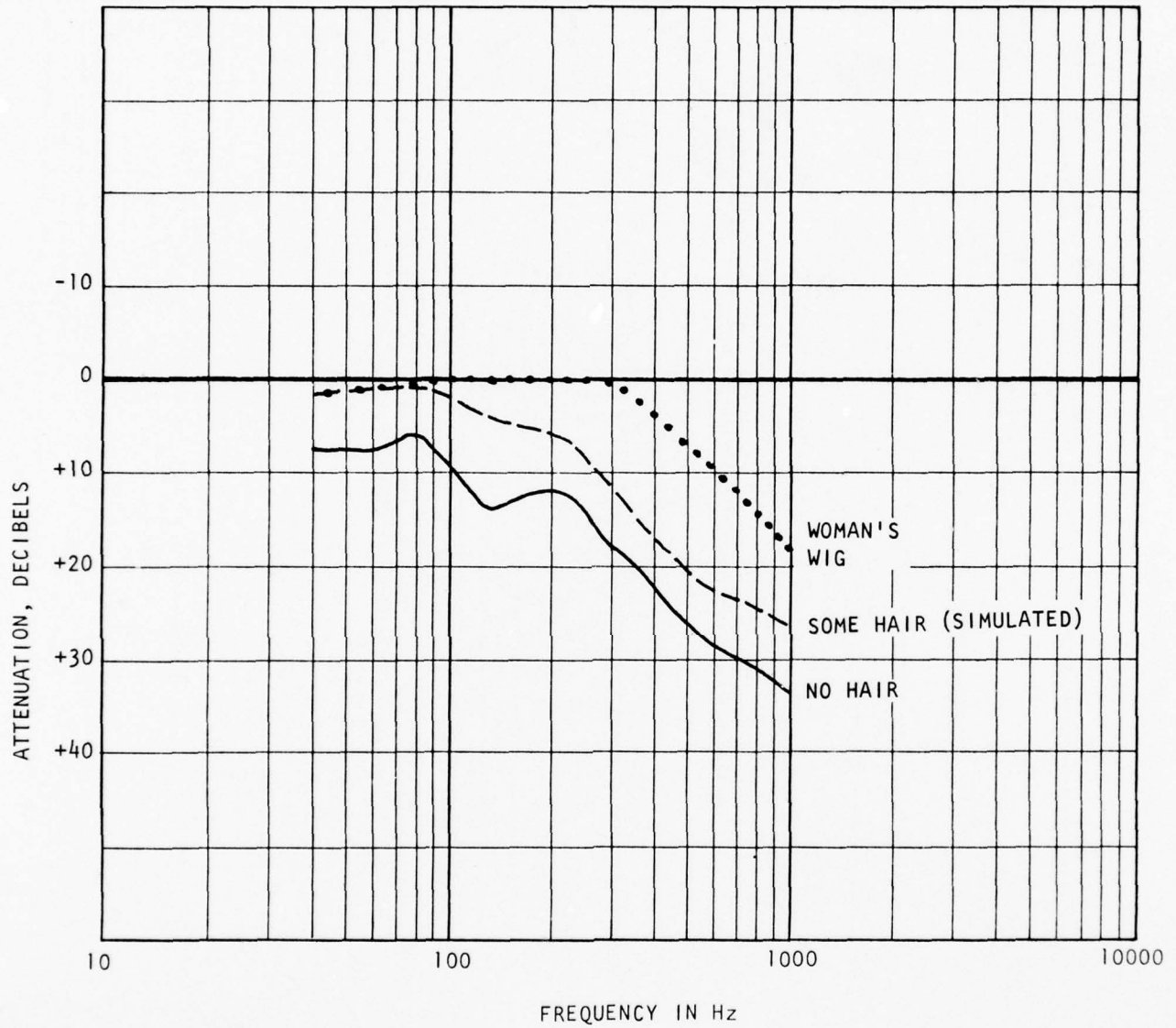

FIGURE 36. EFFECT OF HAIR STYLE ON ATTENUATION -- SIMULATED ON FLAT PLATE (MODIFIED WITH CLAY)

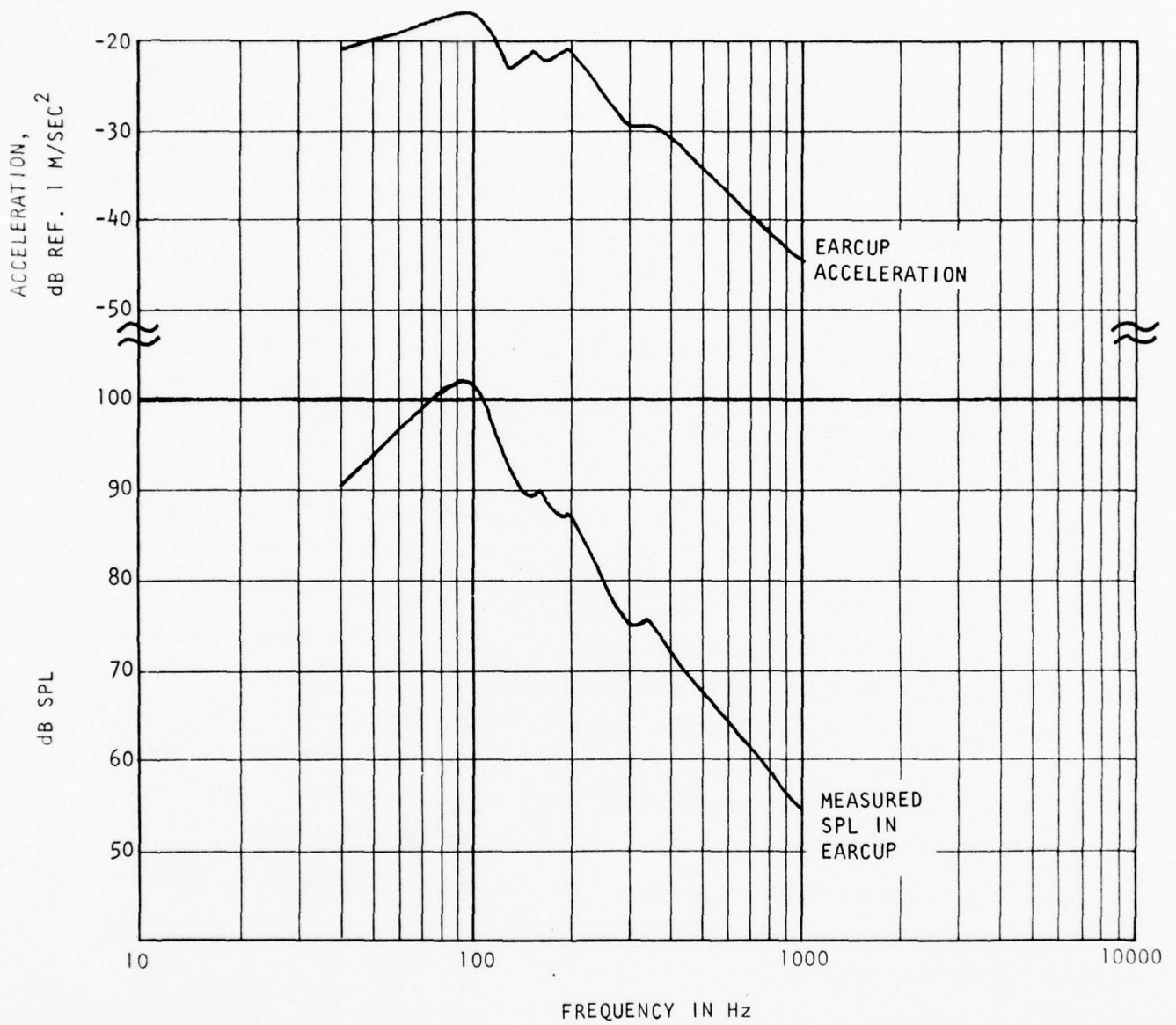

FIGURE 37. SOUND PRESSURE PRODUCED IN SPH-4 EARCUP DUE TO FLAT PLATE (SIMULATED HEAD) VIBRATION OF 0.1 M/SEC² (APPROXIMATELY 0.01 g)

A number of the individual earcup attenuation measurements which went into the averages plotted in Figures 30 and 31 showed a negative attenuation somewhere in the region 20-200 Hz. This is evidence of a resonance condition, due either to sound leakage, which can cause a Helmholtz resonance, or due to the pumping mode.

Figure 34 illustrates two attempts to make a best seal on the flat plate (modified with clay). The other curves in Figure 34 show the effects of leaks caused by eyeglasses. The "plastic frame" curve illustrates a Helmholtz resonance. There is sufficiently low damping so that the attenuation is negative. The plastic frames cause a 10 dB loss in performance. The "best seal" curves show the characteristic plateau below 200 Hz, and -12 dB/octave slope above 300 Hz, which is due to earcup pumping. The mechanical resonance in the pumping mode appears to be at about 200 Hz. Camp's curve⁷ in Figure 30 shows a break point at about the same frequency. In the SPH-4, the pumping action limits the attenuation to about 15 dB at low frequencies.

The "best seal" earcup attenuation was measured at 3 sound pressure levels: 84, 94, and 104 dB SPL. There was no evidence of a non-linear response. This is the same result found by Forstall⁴⁾ for sound pressures up to 120 dB SPL.

Figure 35 shows a verification of the pumping theory. The upper curve shows the acceleration produced by 100 dB SPL sound field. A very light accelerometer was mounted to the earcup on the other side of the wall from the earphone. The lower solid curve shows the results of calculating the sound pressure in the earcup and determining the attenuation, using the measured acceleration and the earcup dimensions as parameters. The dashed curve is the measured attenuation.

Figure 36 shows how hair styles may influence earcup leakage. The dotted curve was made by positioning a woman's wig on the modified flat plate before placing the earcup.

Figures 34 through 36 should be compared to Figures 30 and 31 which show the attenuation obtained in the aircraft studied during this project. The comparisons show that a plausible explanation for the poor performance of the SPH-4 in the aircraft is either an improperly fitted helmet or interference from glasses or large amounts of hair. Additional experiments with human subjects are reported in the next section.

Another possible source of noise in the earcup is a variation of the pumping mechanism in which airframe vibrations are transmitted through the crewman's body to the head. A sound pressure is thus produced in the earcup due to the differential vibration of the head and the earcup. Figure 37 shows the results of a measurement in which ATC's modified flat plate with earcup in place was attached to a shaker and subjected to a vibration level of 0.1 m/s^2 (0.01 g), thus simulating a vibrating head. The bottom curve shows the measured sound pressure in the earcup.

In Appendix E, a mechanical model of the human body is described which predicts lateral head vibrations of up to 0.003 g in the frequency range near 90 Hz, assuming that the seat vibration reaches 1.5 g, the maximum level permitted by MIL-A-8870.⁴² Assuming a linear relationship between vibration levels and sound pressure levels, Figure 37 shows that those vibration levels will result in sound pressure levels of about 90 dB inside an earcup. At frequencies above 200 Hz, much smaller maximum values of head vibration and sound pressure would be expected.

7.2 EXPERIMENTS WITH THE SPH-4 ON A REAL HEAD

The experiments described in the preceding section were continued by testing the SPH-4 with human subjects. In each case, the subject wore a medium-size SPH-4 helmet. The earcup cushions were in good condition although not quite as thick as those on the SPH-4 used for the tests which are described in Section 4. A miniature microphone was placed in the earcup at the face of the earphone, to monitor the sound pressure in the earcup. The cable was passed through a hole drilled in the left earcup. The hole was then sealed with modeling clay. The subject was seated four feet from a loudspeaker in an anechoic chamber. The subject faced the speaker with his left ear on the speaker axis. The ambient sound pressure was monitored at the "ear" of the helmet, one inch from the outside surface of the helmet. In each case, the helmet appeared to be of the correct size for the subject's head. There was no attempt to pad the inside of the helmet to improve the fit. The chin strap was pulled tight.

Figure 38 shows the attenuation obtained on a subject with fairly thick hair (an average "styled" haircut), with approximately one inch long hair in sideburns. About 11 dB of attenuation was obtained at 200 Hz when the subject did not wear glasses. However, when plastic frame glasses were worn (earpiece diameter of 1/8 inch), significant attenuation was obtained only above 300 Hz.

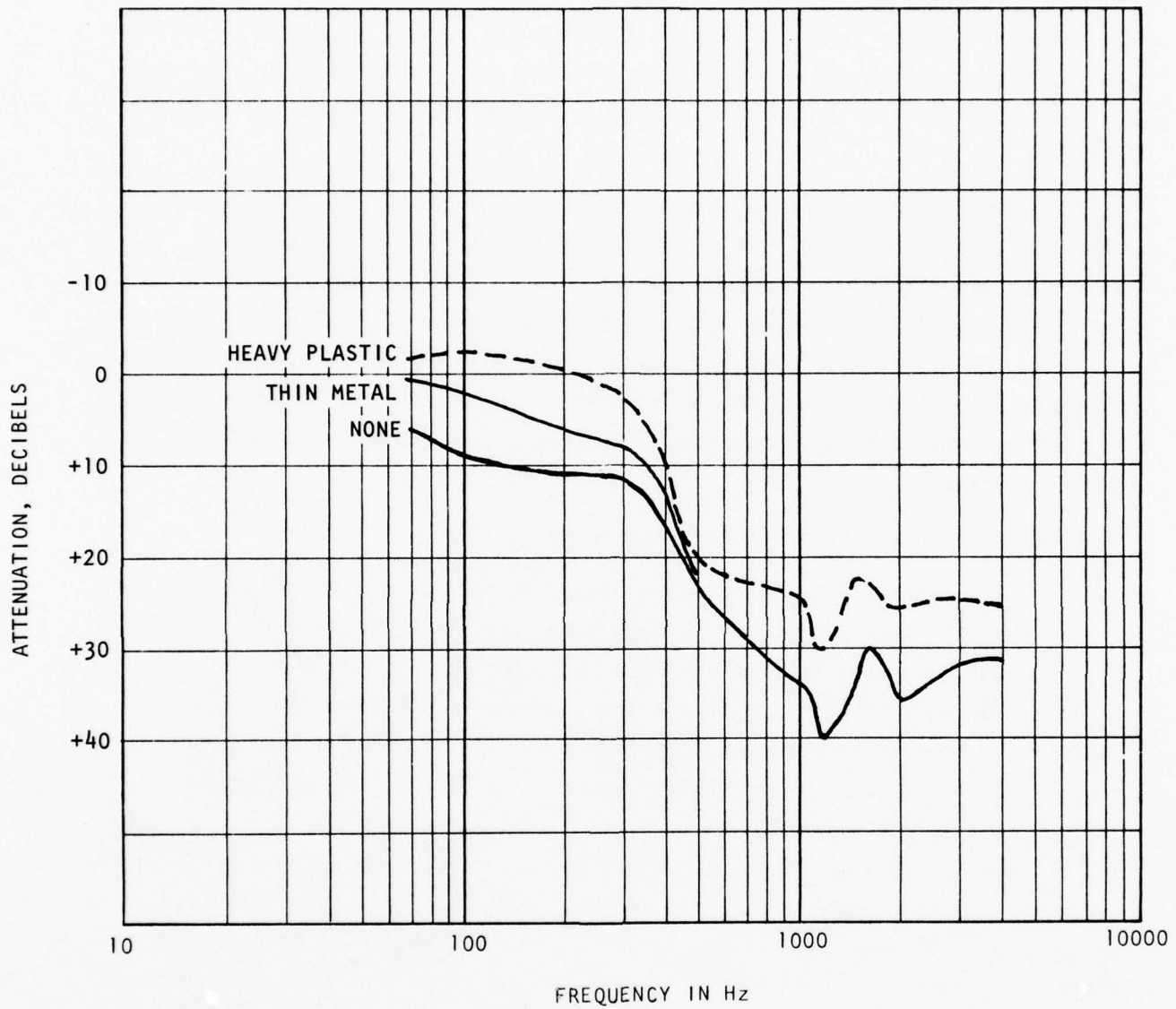

FIGURE 38 EFFECT OF GLASSES ON MALE SUBJECT (JSS) WITH AVERAGE STYLED HAIR

Figure 39 shows that when a subject has very long, thick hair which covers the ears, no attenuation is obtained below 400 Hz. Nor is the attenuation improved very much by tightening the chin strap.

Although two other subjects were tested, both with relatively short hair, no attenuation curves were obtained that were better than the bottom curve in Figure 38. Various trials with the subjects indicated that those with shorter hair have a better potential for obtaining good attenuation at low frequencies, but that a considerable amount of adjustment of the cushions and chin strap, and placement of padding inside the helmet, may be necessary to realize that potential.

A questionnaire was sent to the five observers who wore the SPH-4 helmet during the data-taking in the aircraft. The answers indicated that all of the observers wore some kind of prescription glasses or sunglasses, a practice which is also common among the crew in these aircraft. The thickness of the earpieces (perpendicular to the temple) ranged from 0.04 inches to 0.125 inches. Hair styles ranged from moderate length (1/2 inch average) up to fairly long, similar to that of the subject of Figure 38. Sideburns were not prominent. An attempt was made to correlate the earcup attenuation which was obtained in the aircraft with the hair styles, dimensions of eyeglass frames, and technique of the observers. No correlation was found.

All of the observers adjusted or "worried" the earcups to make a better seal after donning the helmet. The chin strap was adjusted to be snug in every case. As a measure of the quality of the seal, four out of five observers felt that a significantly better seal could have been obtained by moderately pressing the earcups against the head with the hands.

The experiments of this and the preceding section indicate that the deficient performance of the SPH-4 in the aircraft (see Figures 30 and 31) can be accounted for in the region 50-300 Hz by the presence of acoustic leaks past the cushion due to a combination of less than perfect fit, and the interference of glasses and hair. The performance of the SPH-4 in the aircraft at higher frequencies cannot be fully accounted for, since Figures 38 and 39 show that at 1000 Hz and higher frequencies, attenuations of greater than 25 dB are obtained even with substantial leakage. Some possible reasons for the discrepancy are:

- o The results shown in Figures 38 and 39 are less applicable at higher frequencies since the measurements were not made in a spatially random noise field.

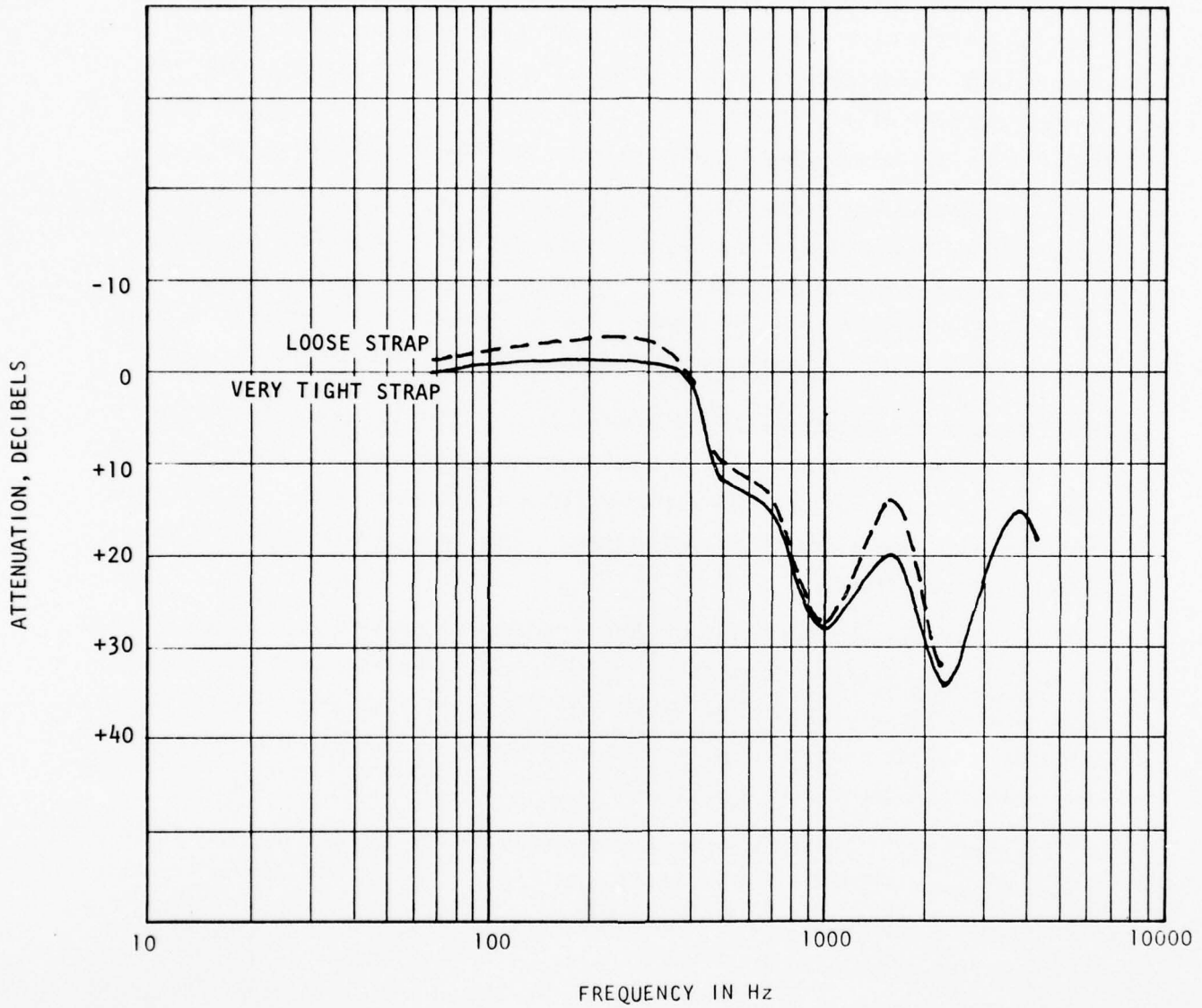

FIGURE 39 EFFECT OF VERY LONG, THICK HAIR ON MALE SUBJECT (JGC)

- o Noise due to the tape recording process may be significant above 1000 Hz, because the range of the spectrum level of noise exceeds the dynamic range of the tape recorder (see Appendix B). In this case, the actual attenuations provided by the SPH-4 in the aircraft may well be as good as it is in the laboratory, at frequencies near and above 1000 Hz.

7.3 COMPUTER SIMULATION OF EARCUP PERFORMANCE

Definitive publications (e.g., Zwislocki,^{36,37} ; Shaw and Thiessen³⁸) which describe mathematical analogs of earcups were published about 20 years ago. The equations in those publications were derived from schematics of electrical analogs of earcups. At the time of those publications, electronic digital computers were not available to aid analyses, so assumptions were made to simplify extraction of numerical values from complicated equations. For example, Zwislocki³⁶ examined the influence of earcup damping on earcup performance by assuming that the stiffness of skin is much greater than the stiffness of an earcup cushion; that is equivalent to considering an earcup on a rigid surface, which leads to conclusions which do not apply to an earcup on a real head. Zwislocki⁴³ combined flesh properties and cushion properties, and assumed that an earcup system is critically damped; that approach also does not provide an analysis of the sensitivity of earcup performance to cushion damping. Shaw and Thiessen³⁸ published a graph which showed the influence of cushion damping on earcup performance, but they neglected skin flexibility in deriving that graph.

Since there are no published results of exact calculations of the influence of earcup damping on earcup performance, we programmed a CDC 6600 electronic digital computer to perform those exact calculations. The results which are described in this Section are for the "pumping mode" only. It is assumed that all leaks have been eliminated and that transmission through the body is negligible. Appendix F describes electrical analogs and corresponding equations which were used in the studies which are reported here. That appendix also includes a listing of the FORTRAN IV computer program that was used, and typical tabular and graphical print-outs of the program are presented.

Figure 40 shows a comparison between transmission ratios calculated by means of the computer program which is described in Appendix F and transmission

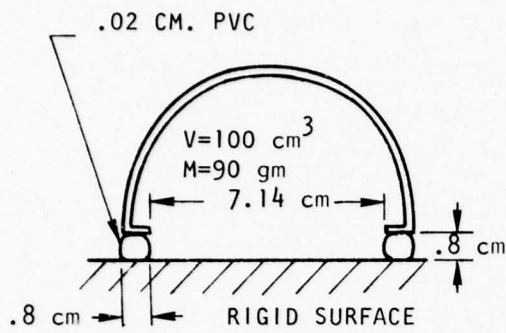

$$E(\text{PVC}) = 3.3 \times 10^8 \text{ dynes/cm}^2$$

$$\text{(Isothermal) Bulk Modulus of Air} = 1.0 \times 10^6 \text{ dynes/cm}^2$$

$$\text{Resistance of Air-Filled Cushion} = 0.0$$

$$\begin{aligned} \text{Resistance of Water-Filled Cushion} &= \\ &= .75 \times R_{\text{skin}} \text{ (at 500 Hz)} = \\ &= 7.5 \times 10^4 \text{ dyne sec/cm} \end{aligned}$$

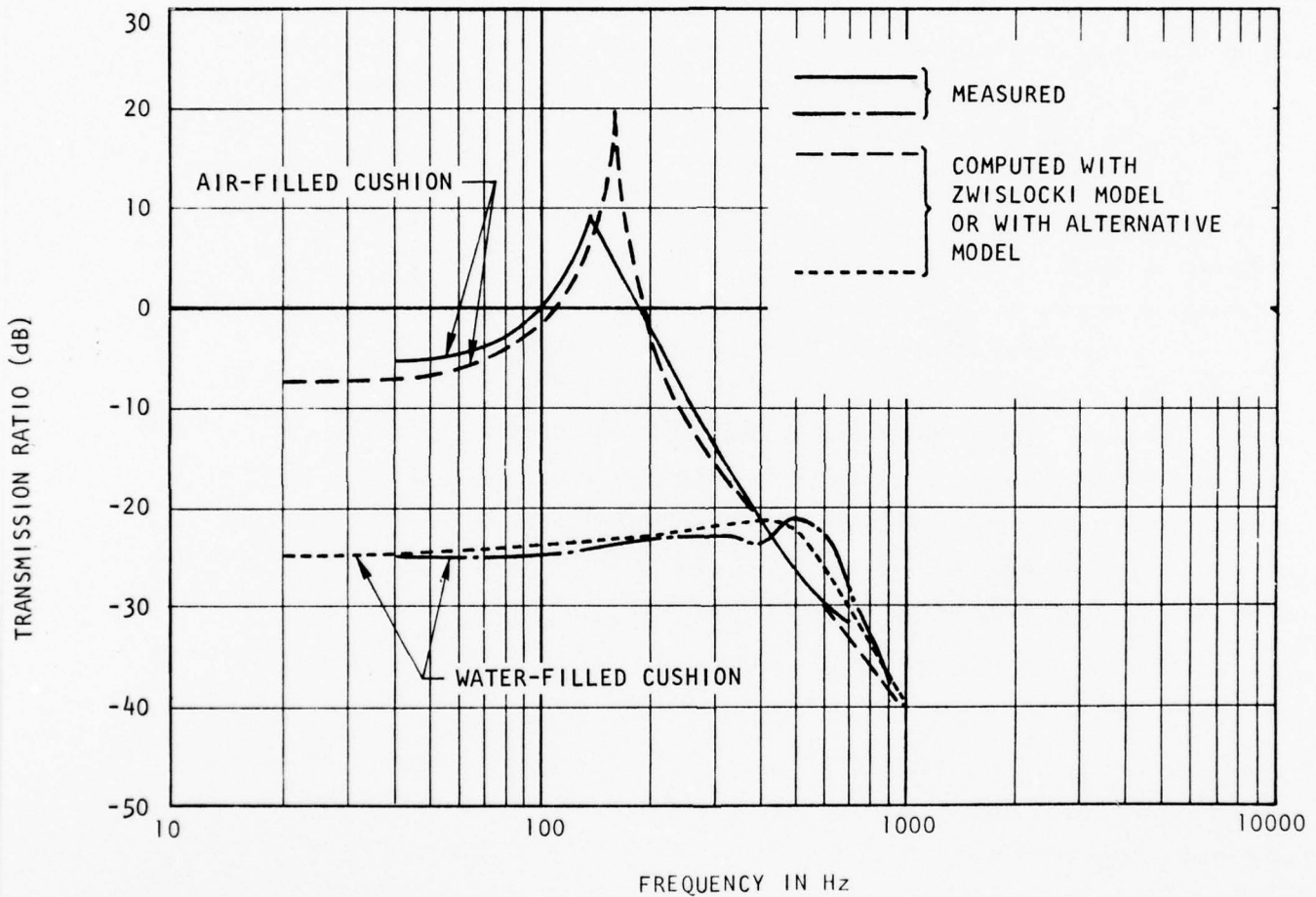

FIGURE 40. COMPUTED AND MEASURED TRANSMISSION RATIO FOR EXPERIMENTAL EARCUPS - EARCUP SHOWN IN FIGURE 8 OF SHAW & THIESSEN³⁸ ON A RIGID SURFACE

ratios measured by Shaw and Thiessen³⁸ for two test earcups which are described in their article. The two models referred to as the "Zwislocki model" and the "alternative model" are based on two different modes of displacement of skin by an earcup. Those modes and models are described in Appendix F. Matches between calculations and experimental results were obtained by using a value for the Young's modulus of polyvinyl chloride earcups equal to one-half of the value reported by Shaw and Thiessen³⁸ for static elongations. The matches for water-filled cushions were obtained by using a cushion resistance equal to 0.75 or 4 times the resistance of the skin around an ear, depending on the geometry of each cushion. In view of the high viscosity of skin, that may seem like a high value for the resistance of a water-filled cushion, but resistance depends on geometry and velocity fields as well as on viscosity. Much higher fluid velocities are established within a fluid that is confined in a small space than is generated in skin by earcup vibrations, so viscous losses can be higher in a confined low viscosity material than in an unconfined high viscosity material.

Figures 40 and 41 show good agreement between calculated and measured values of the transmission ratio of two particular earcups on a rigid surface. That agreement indicates that the geometric and material coefficients of the two subject earcups are appropriate. The "peaked" deviation of the calculated curve near 160 Hz for the air-filled cushion from the measured curve in Figure 40 merely indicates that air provides some cushion resistance; zero cushion resistance was assumed for calculations of the performance of the air-filled cushion.

The match between calculated and measured values of earcup transmission ratio is much better for the "Zwislocki model" than for the "alternative model" in Figure 42. That indicates that the mode of deformation of circumaural skin by an earcup that was assumed for the Zwislocki model is more applicable than the mode of deformation that was assumed for the alternative model (see Appendix F). However, that conclusion is based on a single example; the mode of deformation depends on the stiffness of the air volume enclosed by an earcup, and it may depend on the configuration of an earcup and on contact pressure. Therefore, the question of which model is applicable to a given earcup at a given frequency and a given contact pressure should be recalled for each analysis.

Figure 42 shows measured values of transmission ratio which are greater than "Zwislocki" calculated values at high frequencies, which reveals less than expected "mass-law" performance.³⁸ The high measured values may be due to bone conduction, air leaks, surface waves in skin, inner ear impedance, or transmission of sound directly through earcup walls. Those factors should be included

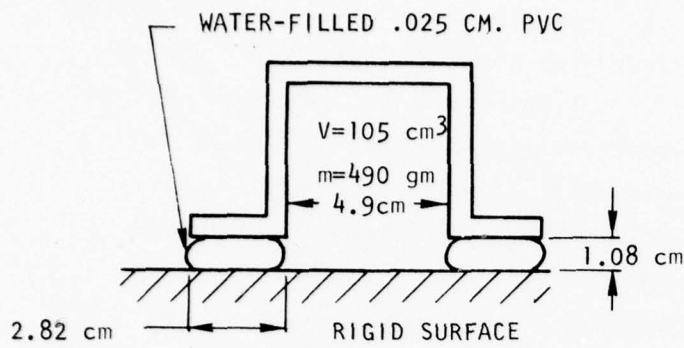

$$E(\text{PVC}) = 3.3 \times 10^8 \text{ dynes/cm}^2$$

$$R \text{ cushion} = 4.0 \times R \text{ skin}$$

$$(\text{at } 500 \text{ Hz}) =$$

$$4.0 \times 10^5 \text{ dyne sec/cm}$$

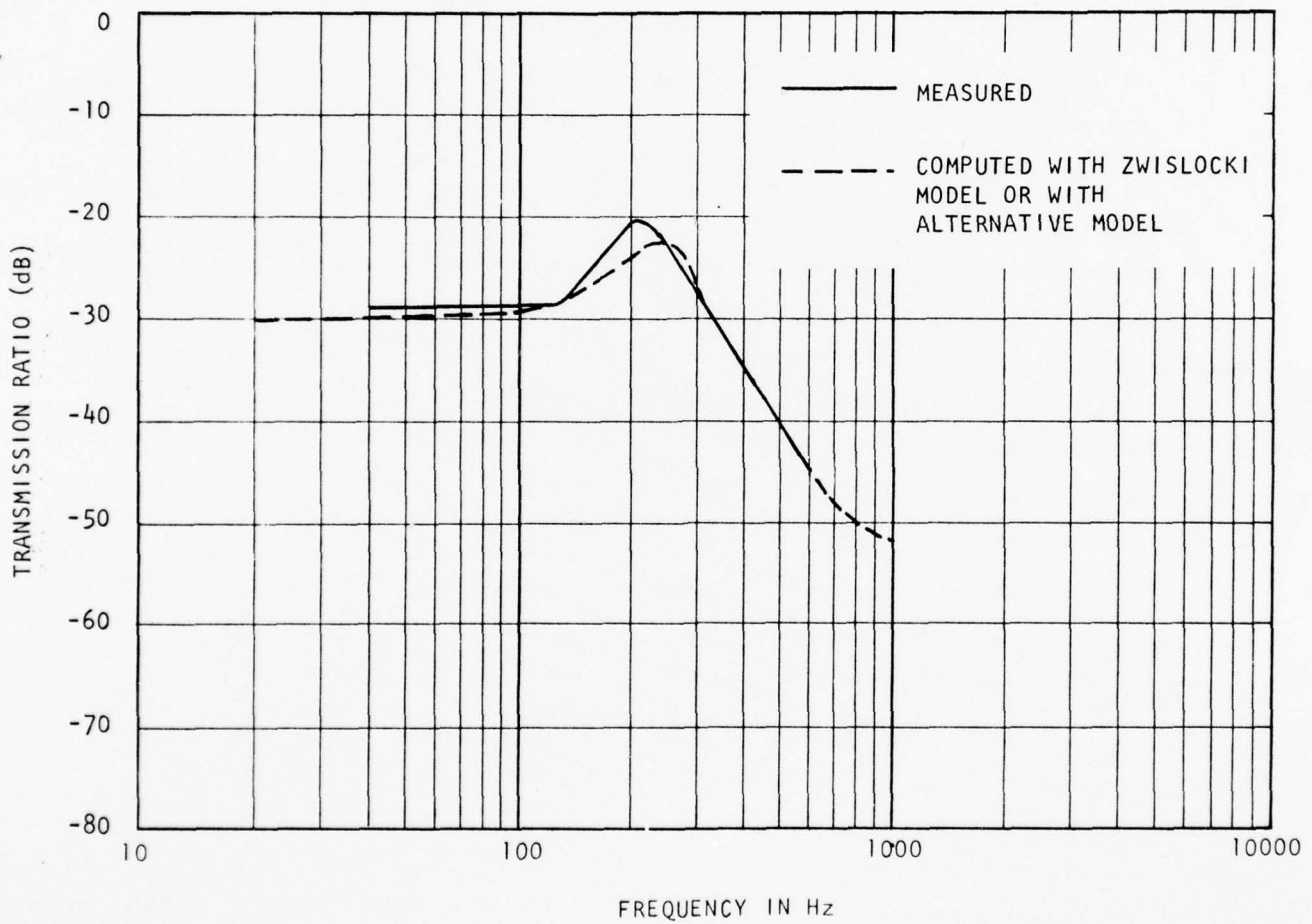
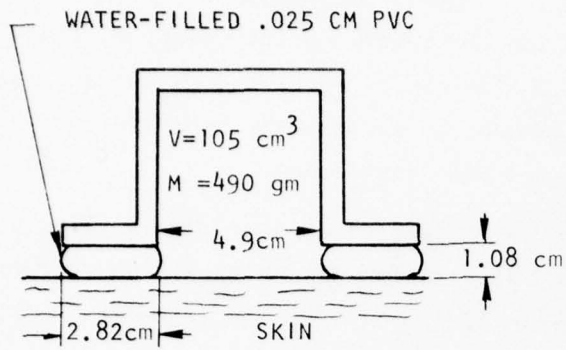

FIGURE 41. COMPUTED AND MEASURED TRANSMISSION RATIO FOR EXPERIMENTAL EARCUPS - EARCUP SHOWN IN FIGURE 11 OF SHAW & THIENSEN³⁸ ON A RIGID SURFACE



$*E(\text{PVC}) = 3.3 \times 10^8 \text{ dynes/cm}^2$
 $K \text{ Skin} = 8.0 \times 10^7 \text{ dynes/cm}$
 (Ref. 38)

Frequency-Dependent R Skin
 from Franke (Ref. 44)
 $\times 10$ (Ref. 38)

R Cushion = $4 \times R \text{ Skin}$ (at 500 Hz) =
 $4.0 \times 10^5 \text{ dyne sec/cm}$

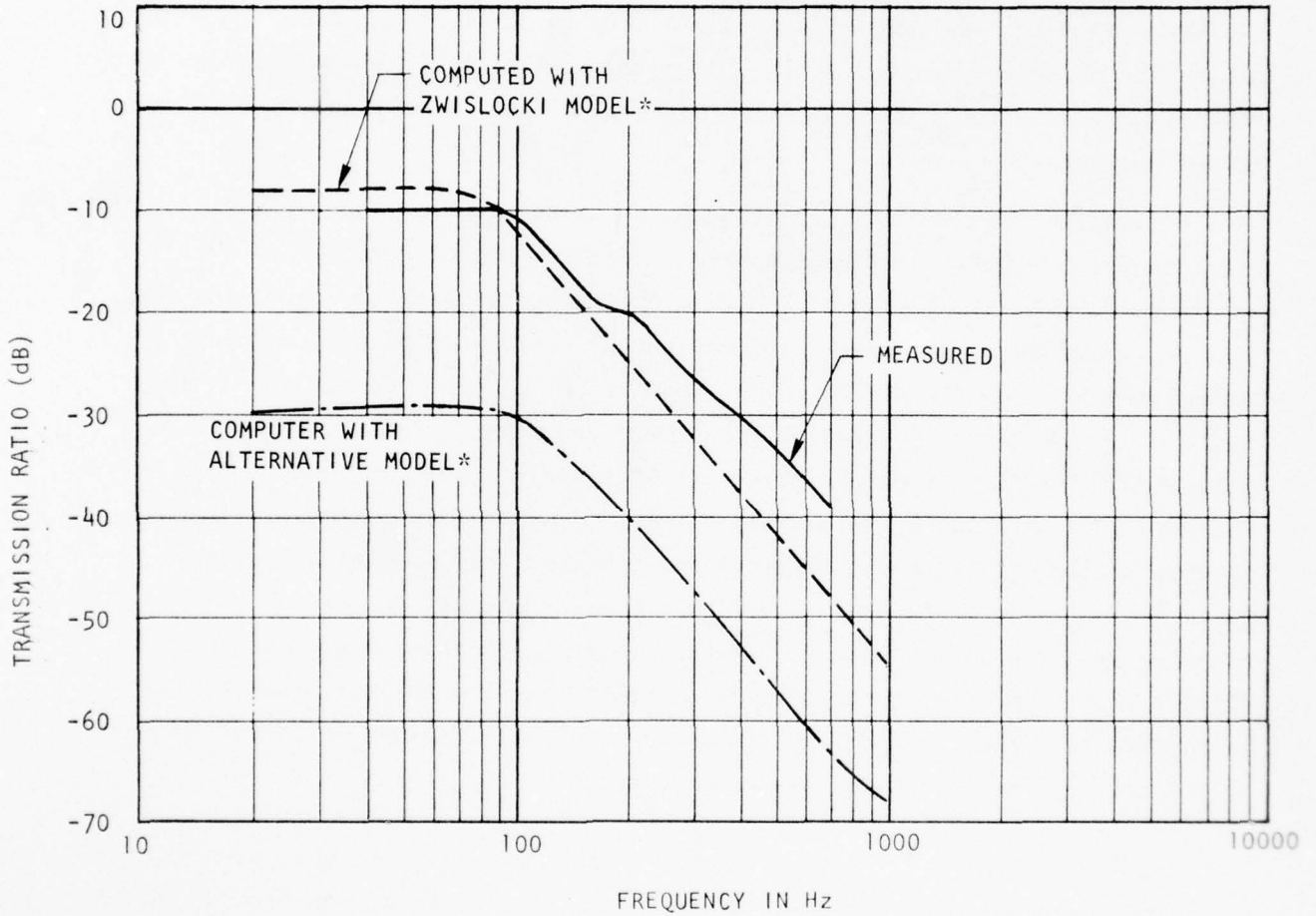

FIGURE 42. COMPUTED AND MEASURED TRANSMISSION RATIO VERSUS FREQUENCY FOR EXPERIMENTAL EARCUPS

AD-A061 351

VOUGHT CORP ADVANCED TECHNOLOGY CENTER INC DALLAS TEX

F/G 1/3

ANALYSIS OF NOISE IN US ARMY AIRCRAFT.(U)

NOV 78 A J BROUNS, R A ELY

DAAB07-76-C-1746

UNCLASSIFIED

ATC-94100/8CR-41

USAAVRADCOM-TR-76-1746-F

NL

2 OF 3

AD
A061351

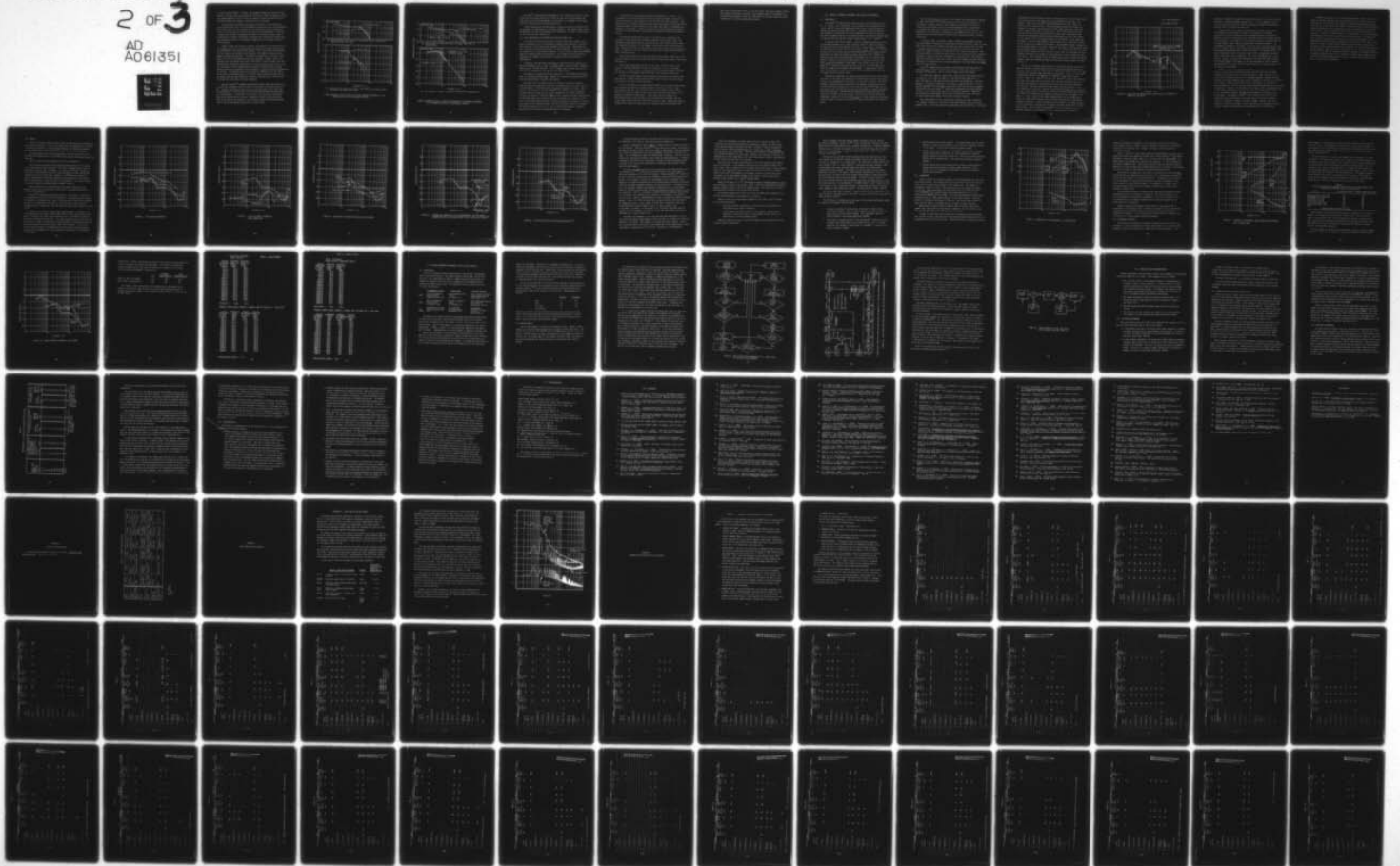

in future computer models. However, the agreement between the values of transmission ratio which were calculated with the Zwislocki model and measured values was judged adequate to justify using that model to explore the sensitivity of earcup performance to changes in cushion and skin resistance.

Figure 43 shows calculated and measured influences of skin flexibility on the transmission ratio of two experimental earcups with water-filled cushions. That figure shows that the influence of skin flexibility on the transmission ratio of an earcup with a liquid-filled cushion can be pronounced. Since that influence has not been investigated thoroughly in published studies, there is a question as to whether the designs of earcups with liquid-filled earcups have been optimized to take full advantage of damping that is provided by liquid-filled cushions.

Figure 44 shows the results of computer calculations of the sensitivity of the transmission ratio of two experimental earcups with liquid-filled cushions to the mechanical resistance of the cushions. That figure shows that the benefits to be gained by increasing the mechanical resistance of earcup cushions depend on earcup configuration. The computer calculations do not show a large benefit for the two configurations that were analyzed. However, there is no assurance that the volumes and cushion stiffnesses of the two earcups that were analyzed were selected by experimenters to yield the optimum sensitivity to earcup resistance. Further mathematical and computer studies similar to those which are outlined in Appendix G will be necessary to define optimum configurations for earcups. The equations which are presented in Appendix G are very complicated; they are presented merely to illustrate that the optimum conditions are so complex that they defy definition by means of applications of intuition and trial-and-error variations of design parameters.

Shaw and Thiessen³⁸ reported no appreciable benefit when they substituted a 2.5 million centipoise syrup for water in the cushion of one particular earcup. However, they reported that the syrup could be molded, which means that it was actually a low-yield plastic solid, which does not meet the requirements for earcup damping. In addition, the viscosity of the syrup was much higher than typical optimum values that are indicated by cursory studies and the design of the test earcup system was not optimized to give the maximum advantage from filling of the earcup cushion with a viscous liquid.

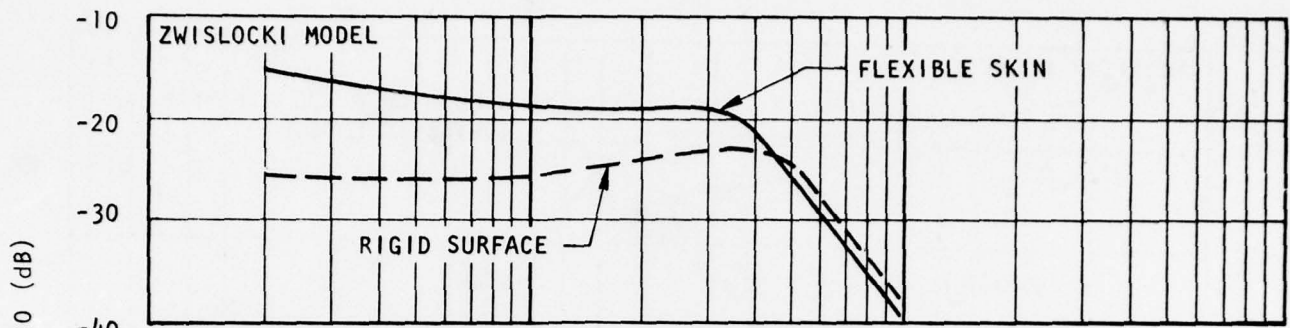

(a) Computed Effect for the Water-Filled Earcup Shown in Figure 8 of Shaw & Thiessen (Ref. 38)

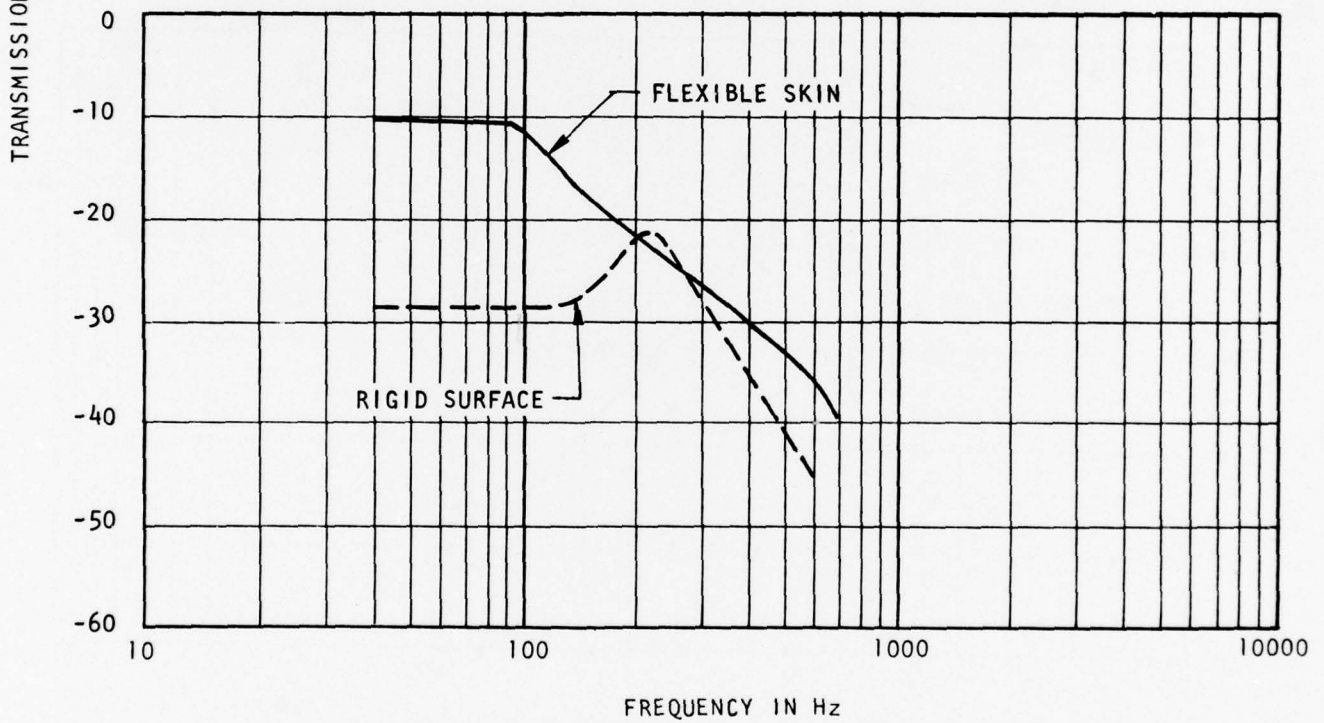

(b) Measured Effect Reported by Shaw & Thiessen³⁸ for the Earcup Shown in Figure 11 of their Publication

FIGURE 43 EFFECT OF SKIN FLEXIBILITY ON THE FREQUENCY-DEPENDENCE OF THE TRANSMISSION RATIO OF EXPERIMENTAL EARCUPS

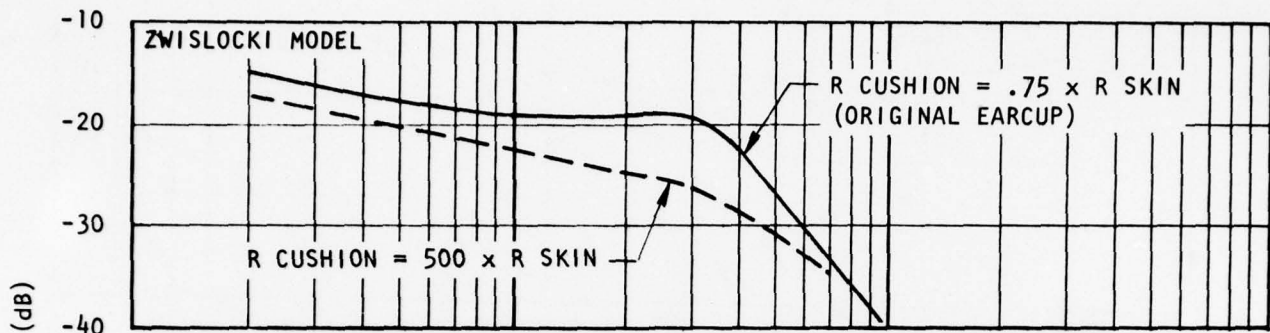

(a) Earcup Shown in Figure 8 of Shaw & Thiessen (Ref. 38) on Flexible Skin

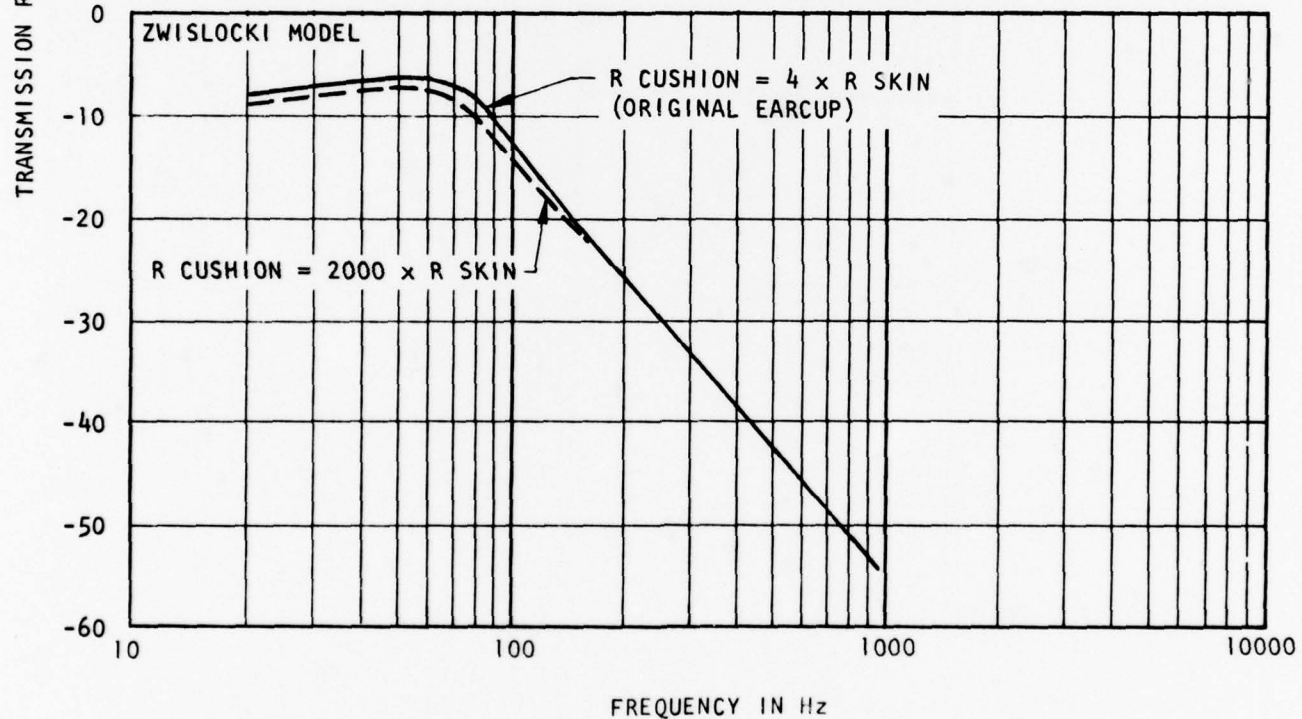

(b) Earcup Shown in Figure 11 of Shaw & Thiessen³⁸ on Flexible Skin

FIGURE 44 COMPUTED EFFECT OF CUSHION RESISTANCE ON THE FREQUENCY-DEPENDENCE OF THE TRANSMISSION RATIO OF EXPERIMENTAL EARCUPS

Zwislocki⁴³ reported some improvement in the transmission ratio of a test earcup when the earcup cushion was filled with wax, but that improvement may have been due to associated changes in earcup mass or to changes in the transmission of sound directly through cushion walls.

Further mathematical and experimental studies are required to define fully the potential for improvements in earcup performance. The computer model should be expanded to include the effects of bone conduction, air leaks, surface waves in skin, and inner ear impedance.³⁷

7.4 FIELD EXPERIENCES WITH EARCUPS AND OTHER EQUIPMENT ITEMS

At various times during the project, contacts were made by letter, telephone, and personal visits with medical and administrative persons in the military services, to learn more about equipment and operations. Additional contacts were made with technical persons in industry and DoD. In Section 11, there is a partial list of the persons contacted. In this Section, some of the comments made during these contacts are presented. This survey was not scientifically conducted; the comments are offered to stimulate further discussion and investigation.

A complaint from helicopter manufacturers and from military hearing conservation personnel alike is that air crewman defeat the noise control features that are built into the aircraft. This is another way of saying that the aircraft are not designed for the uses that are made of them.

Helicopters are several dB noisier, especially in the 100-300 Hz frequency band, if operated with doors open. However, as a practical consideration they are often operated thus to enable rapid egress.

Helicopters sent to combat regions are routinely stripped of acoustic padding because the padding not only bears a weight penalty, but also covers up critical hydraulic lines which must be inspected frequently for leaks. Manufacturers are allowed to meet MIL-A-8806²⁹ by retrofitting acoustic padding and other materials which usually are not compatible with combat conditions. In some cases, DoD will waive MIL-A-8806 for cost, weight, or other considerations. The rationale seems to be that aircraft may be allowed to be sources of noise that is well above human tolerance, if hearing protectors are capable of lowering noise levels to the tolerance level. With this situation, there is the danger that safety precautions will fail. This is exactly what happens if hearing protectors do not provide the expected amount of attenuation.

A variance of noise exposure measured inside earcups is primarily due to differences in sizing and fitting of cups to various personnel. Some personnel have low tolerance to the pressures of ear cushions and tight chinstraps. Some 70 percent of air crewmen inspected recently were not properly fitted, and others, although properly fitted, did not have the proper adjustment of crossbands and fasteners in the helmet. Different styles of hair and eye glasses also add to variances of noise exposures, and compound the problem of ascertaining exposure levels.

Considerable non-uniformity exists in the SPH-4 units procured by the services, in part because four different companies are now making them. The applicable specification does not regulate quality sufficiently to avoid large and important differences in the hardness of the earcup seals and the mastoid cups. Variations of this kind are known to affect the results of noise measurements in laboratories and are likely to be even worse in operational conditions where vibrations occur.

Some flight personnel use customized helmets and earcups. These may or may not be as good as issue, but at best they tend to defeat the purpose of monitoring and control.

Earcup seals become hard and brittle with age. Personnel realize this and try to get them replaced for their own protection. This is not always possible. In a recent case, a large group of flight personnel waited 11 months for new seals to be procured, and finally had to go overseas without them.

Persons who cannot tolerate earplugs suffer from sharing the intercom with those who do. Earplug wearers require higher volume settings, and this causes extra noise in the ears of the non-wearers.

There is controversy as to what degree of blame for the hearing loss problem must be placed on radio and intercom equipment in military aircraft. Some investigators feel that the intelligibility of the electronic communications is too low, and that the volume is often turned up to harmful sound levels in an attempt to understand transmissions. Others feel that this condition is ameliorated because flight personnel learn by experience to decipher the distorted speech sounds, and have little difficulty with them. Speech comprehension probably does improve with experience, but personnel may form bad habits with

their use of the volume control, or may even suffer some hearing damage, before the necessary experience is gained. This suggests that a "low-volume," pre-flight training program to gain this experience for personnel would be a good investment for a hearing conservation program.

8.0 SUMMARY OF HARDWARE PERFORMANCE AND FEASIBLE IMPROVEMENTS

8.1 CABIN NOISE

von Gierke^{45,46} identified the dominant sources of helicopter noise to be: (1) engines, (2) transmissions, (3) rotational noise generated by tail rotors, and (4) vortex noise generated by main rotors, and he referred to methods for predicting those noise levels. Since then, the main advance in the technology of predicting noise levels generated by propulsion systems has been the computerization of calculations which are otherwise much the same as they were 20 years ago (for example, Ramakrishnan, et al., 1975).⁴⁷

In the early days of helicopters, internal combustion engines were used, and unmuffled exhausts were a major source of noise.⁴⁵ Modern helicopters are powered by gas turbine engines, and inlets, turbine blades, and exhausts of those engines are major sources of helicopter noise. Methods for analysis and control of such noise are still being developed,⁴⁸⁻⁵² but some practical applications of those new methods have been successful.^{53,54} Methods for predicting rotor noise have been known for decades, but only recently have computer iterations on design variables made it practical to control rotor noise by judicious choices of blade shape, rotor solidity, and rotor tip speed.^{54,55} Faulkner⁵⁴ performed studies of the cost of noise reduction in intercity commercial helicopters, and concluded: "...good economic performance can be expected of relatively quiet future helicopters which have low tip speeds and high solidity rotors."

Although the technology for predicting and controlling noise from engines and rotors is available, the technology for predicting and controlling transmission noise (predominantly gear noise) is not so well developed. Moeller⁵⁶ provided a good qualitative discussion of the problem, but quantitative predictions have been developed only in the last few years,^{57,58} largely due to the necessity for carrying out the required calculations on modern high-speed electronic computers. The mechanisms of generation of gear vibrations and conversion of those vibrations to sound still are poorly defined and poorly understood. Therefore, for the present, control of gear noise must be achieved largely by means of vibration isolation^{59,60} and by enclosing⁶¹ the offending gears.

The principles of noise control in helicopters have been known for decades. In 1957, von Gierke^{45,46} provided spectra of noise within and external to helicopters, reported studies of noise reduction achievable with special structures, and offered criteria for selecting materials for noise control. He reported that there were no quantitative methods for predicting noise generated by structure-born vibrations, but he judged that such noise is less important than air-borne noise (including noise transmitted directly through structures).

A few years after von Gierke's summary, Franken and Beranek⁶² provided some more details of methods for predicting and controlling noise within aircraft. They noted that the main problem with predicting noise levels within aircraft is proper evaluation of all of the various paths by which noise can enter a cabin (for example, sidewalls, windows, partitions, seats, ventilators). They presented methods for predicting noise levels and for predicting noise reductions provided by cockpit structures, configurations, and materials. They reported measured transmission losses for a typical aircraft fuselage, and they discussed some details of designing such structural components as window frames and baggage racks for noise control.

Schultz⁶¹ summarized the principles of designing aircraft enclosures to attenuate sound as those principles were known a decade after Franken's and Beranek's⁶² publication. Very little had changed during that decade.

Six years after Schultz's publication, the practice of designing aircraft enclosures is still about the same as it was when he published, and it is about the same as it was when von Gierke published two decades ago. The main advances in predicting responses of structures to sound have been: (1) finite element methods,⁶³ (2) statistical energy analysis,⁶⁴ and (3) wave propagation and periodic structure theory.⁶⁵ Those three developments were made possible largely by the increasing availability of electronic computers. Regardless of new predictive techniques, the practice of designing aircraft structures for noise control has changed little during the past 20 years.

Many measurements of noise levels within cockpits have been accumulated (for example, reference 3), but most of those measurements remain in private company files, or must be ordered from government publication offices. Available

measurements and calculations of noise in the interiors of aircraft have served to confirm principles and trends that were established 20 years ago. For example, Catherines and Mayes⁶⁶ reported measurements of noise within two propeller-driven light aircraft; those measurements showed that windows provided only 3 decibels noise reduction, and that leaks around door seals were a major cause of high interior noise levels. Such conclusions can be drawn from the simplest predictive techniques of 20 years ago. Measurements and calculations performed by Vought Corporation personnel also show that windows are the weakest link in the acoustical path to the interior of one commercial helicopter. Figure 45 shows measured and calculated noise reductions provided by the windows of one commercial helicopter. The agreement between the measured and calculated values is very good, indicating that there is nothing unusual about the helicopter fuselage, windows, or interior. It is unfortunate that the helicopter windows interact with the interior in such a way as to decrease the noise reduction provided by the windows at the frequencies at which transmission gear noise occurs. (For that particular helicopter, gear noise is transmitted through windows, rather than through overhead structures which separate gears from the interior.)

Just as the principles and techniques for predicting external noise levels and the reduction of those levels by aircraft structures have been known for 20 years, the principles of predicting the relationship between sound levels and vibrations of structures have been known for many years. The U. S. Air Force⁶⁷ reported many experts' contributions of responses of structures to sound. Cremer, Heckl, and Ungar⁶⁸ and Ver and Holmer⁶⁹ summarized methods for predicting vibrations of structures resulting from impinging sound, and they described methods for predicting sound levels resulting from vibrations of structures. The most important concept underlying those methods is that, for frequencies of practical interest in controlling helicopter noise, vibrating fuselage sidewall panels (that are not forced by air-borne sound) radiate sound to the interior of helicopters only because of reflections from the edges of the panels. It does no good to add rubbery damping materials to fuselage panels except for panels which are excited by air-borne sound and which resonate at a frequency of concern. Absorptive material must be added at the edges of panels that are excited by structure-born vibrations to achieve reductions of internal noise levels. Such intricacies led Jones⁷⁰ in his review article on damping treatments, and Arctander⁷¹ in his review article on absorptive

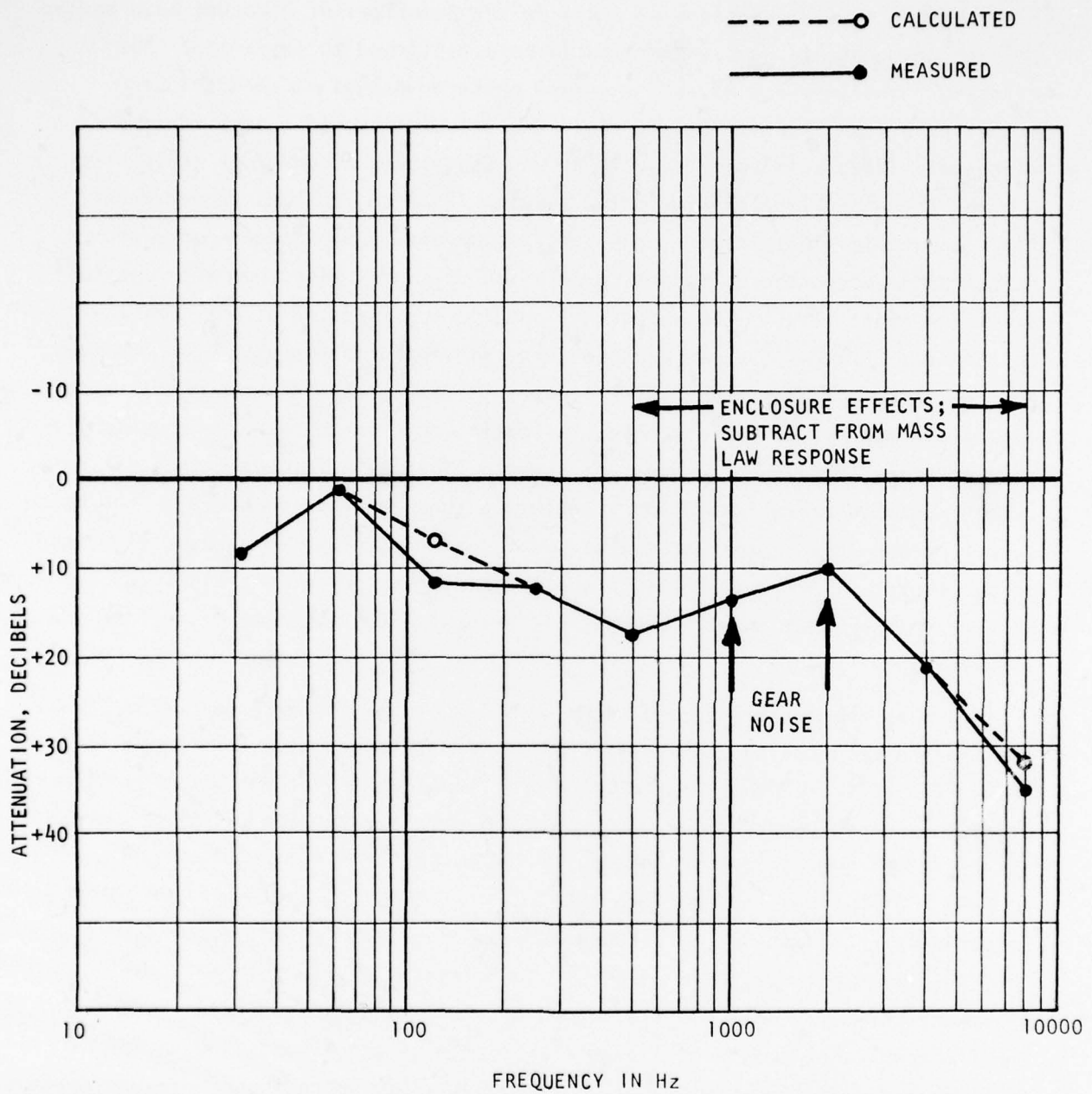

FIGURE 45. CALCULATED AND MEASURED NOISE REDUCTION DUE TO WINDOWS IN A COMMERCIAL HELICOPTER

materials to emphasize the need for precise tailoring of noise control methods to specific vehicles throughout design cycles. It is not enough to try to control noise and vibration by adding a few pounds of damping and absorptive material after an aircraft has been built.

A good example of the need for considerations of noise control early in the design of a helicopter was given by Sen Gupta.⁷² He reported that overall cylindrical modes of entire fuselages dominate the acoustical behavior of aircraft structures at low frequencies which are the major problem with helicopters. That means that noise control should be considered when the size and shape of major frames for a helicopter fuselage are chosen. For intermediate frequencies, Sen Gupta⁷² reported that fuselage panels and their stiffeners interact; that interaction should be optimized by proper trade-offs between panel design and stiffener design early in a design program. At higher frequencies, such as those where gear noise is predominant, the more usual quick-fixes, such as fiberglass, lead vinyl, and damping tape, can be helpful. However, at those high frequencies, the noise reductions provided by fuselage sidewalls and windows are strongly affected by interior geometry and materials,⁶² so those factors also should be considered early in the design of a helicopter.

Efforts to quiet an HA-43B helicopter⁷³ are typical of current efforts. Engine noise, transmission noise, and rotor noise all are being considered in current efforts to quiet helicopters. When lowering of noise levels at the sources of noise is not considered adequate, attempts are made to modify structural responses and interior treatments to further lower internal noise levels. However, most efforts to quiet helicopters are directed at existing vehicles. There is not much hope of achieving much more than 10 decibels of quieting in that way. Noise control in helicopters must be approached as part of the systems optimization study at the outset of a design effort. Even with early involvement in design, the operational burdens of sound control may be too great. For example, a TREC²⁵ study showed that sound control amounting to one or two percent of the gross weight of an Army helicopter results in a decrease of about 10 percent in range. However, there were elements of retrofit philosophy in that study, and early involvement of acousticians in design might decrease the weight penalties for sound control.

A computerized search of all unclassified government reports that are related to aircraft noise and that were published during the last 10 years was completed for the authors of this report by the Defense Documentation Center. There are only a few reports which deal with control of noise within helicopters among the hundreds of titles and abstracts that were recovered by the computerized search. Only one discusses cost factors in any detail, and that discussion is focused on a computer model for unified noise, cost, and performance calculations, rather than on typical costs of noise control. The results of that literature survey agree with results of surveys of government and non-government literature which were conducted by the authors of this report. The results of these literature surveys indicate a low level of activity which is directed at controlling helicopter noise, especially if costs of noise controls are of interest. That low level of activity may be due to heavy operational and cost burdens that are indicated by cursory estimates (for example, Bowes⁷⁴). A concerted research effort will be necessary to define those burdens in terms of overall systems development and in terms of realistic anticipated improvements in noise control techniques.

8.2 EARCUPS

Figures 46 through 50 show selected results of some previous investigations into earcup performance. In each case, Camp's real-ear measurement of the SPH-4 is plotted for comparison. Unless stated otherwise, the plotted attenuation will be assumed to have been measured using the real ear threshold method.

Figure 46 compares the real ear measurement, the specification⁷⁵ for the MK-1564()/A1C earcup which is in the SPH-4, and a typical attenuation copied from Figure 30.

Figure 47 shows the bone conduction limits for attenuation.

Figure 48 shows the additional attenuation obtained when a V51-R earplug is worn underneath a "good" noisemuff. This muff is somewhat better than the SPH-4 earcup, perhaps due, for example, to a larger muff volume. Because of the effect of bone conduction and other alternate paths, the muff and earplug attenuations are not simply added. Edwards, et al⁷⁶ found that industrial workers received about 15 dB less attenuation from earplugs at the workplace than was obtainable by careful fitting in the laboratory. This was attributed to using the wrong size earplugs and/or improper insertion.

Figure 49 shows that if high frequency sound enters the earcup, for example through a less than perfectly rigid shell, sound absorbing material in the cup is beneficial.

Zwislocki³⁶ assembled an experimental earcup in an attempt to reach what he considered the practical limit for attenuation. Figure 50 shows the attenuation obtained. The cup was very rigid. The cushion was filled with a malleable wax so that it conformed to the head, and also provided a large mechanical impedance at audio frequencies. The cup volume was rather small, apparently about 15 cm³.

A comparison of Figures 47 and 50 shows that Zwislocki's practical limit is determined by bone conduction above about 700 Hz, and by earcup pumping below 700 Hz. Zwislocki felt that, within practical limits, the effect of pumping is not greatly affected by earcup size. This would especially be the case where the earcup must fit under a helmet, where increased volume is obtained by increasing the cross-sectional area of the earcup rather than the depth. If the cross-sectional area increases, the pumping force and the earcup volume increase at the same rate (see Appendix F). Other parameters being equal, the attenuation is not changed.

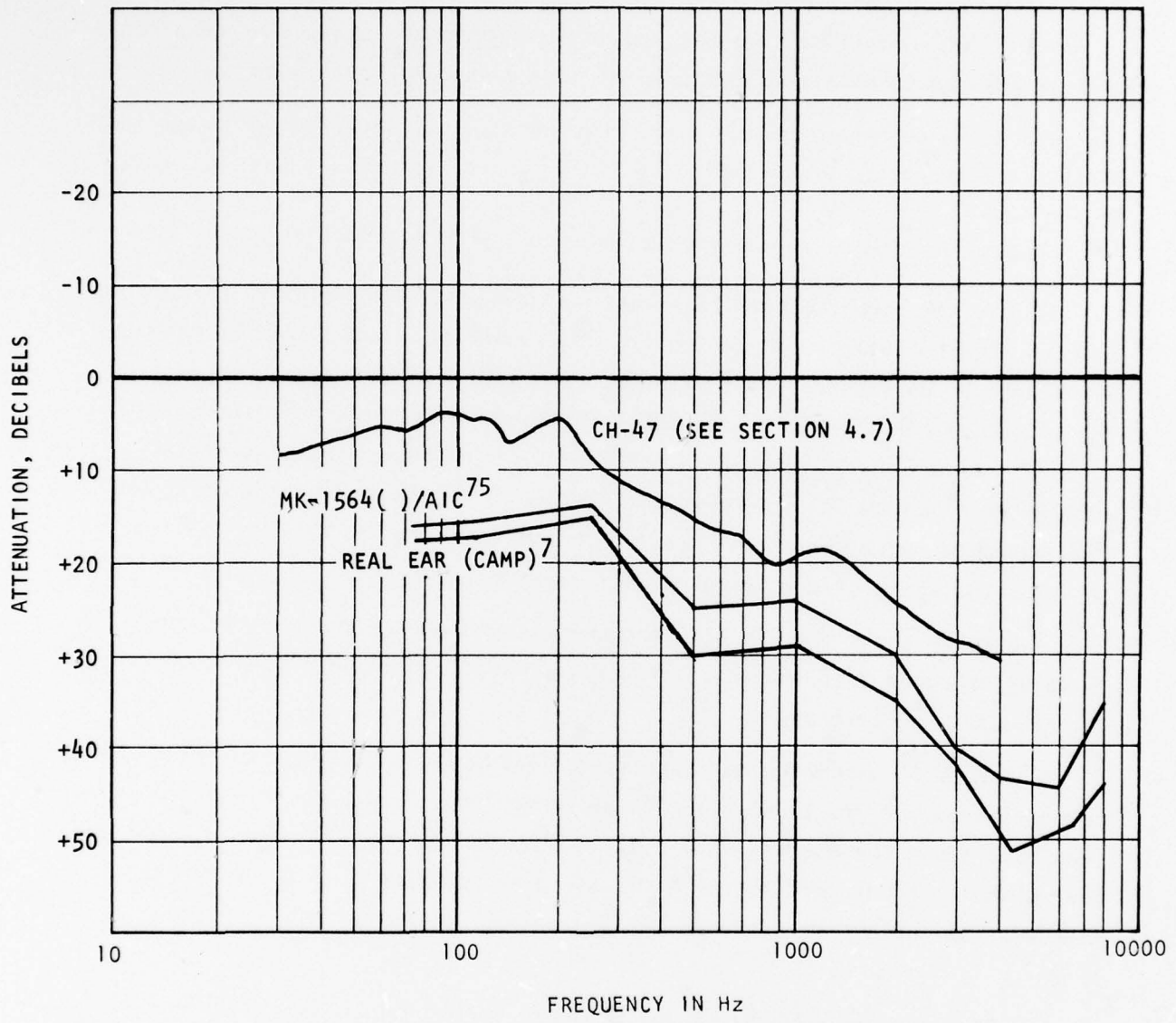

FIGURE 46 . SPH-4 EARCUP ATTENUATION

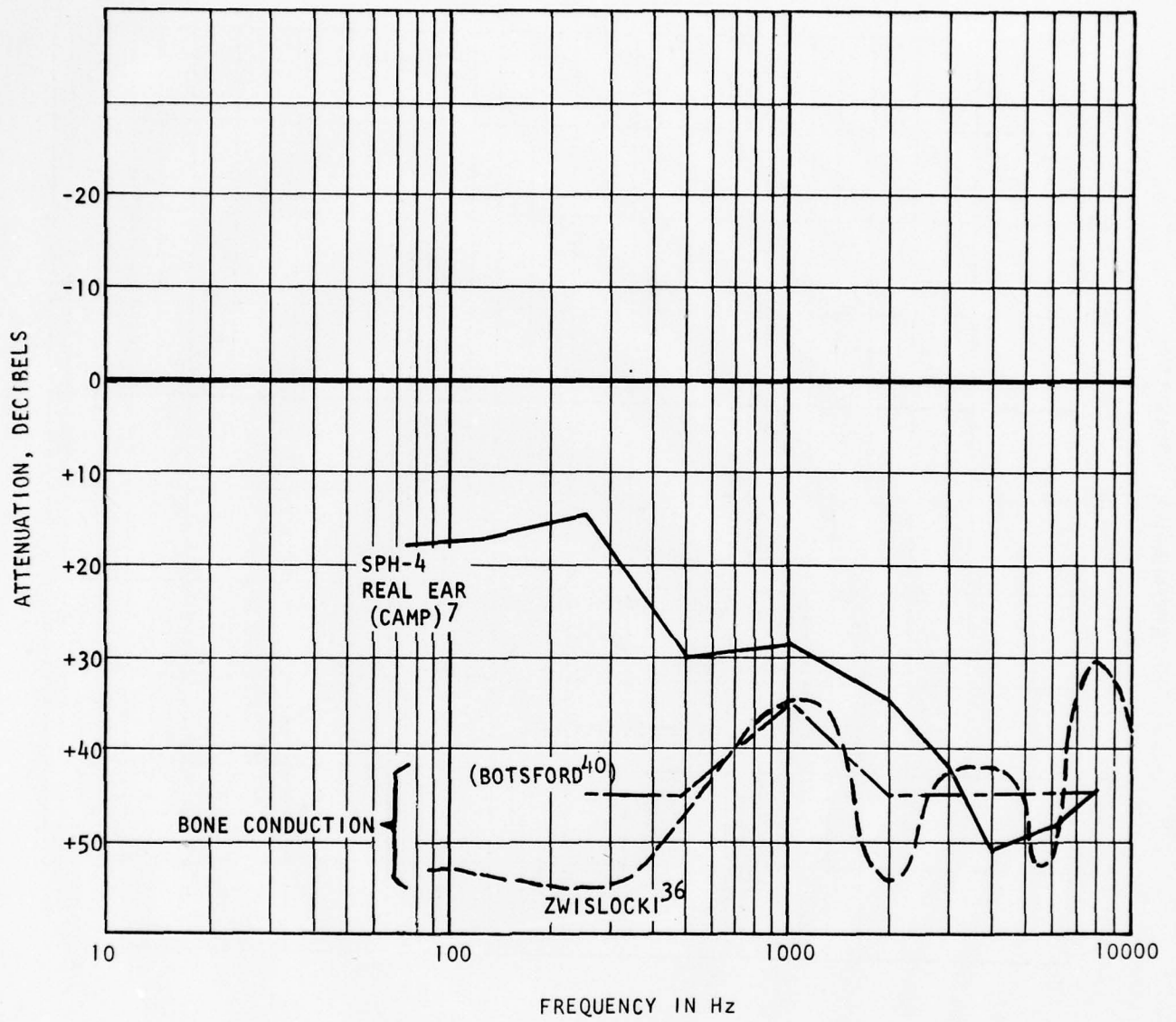

FIGURE 47. LIMITS TO EARCUP ATTENUATION (BONE CONDUCTION)

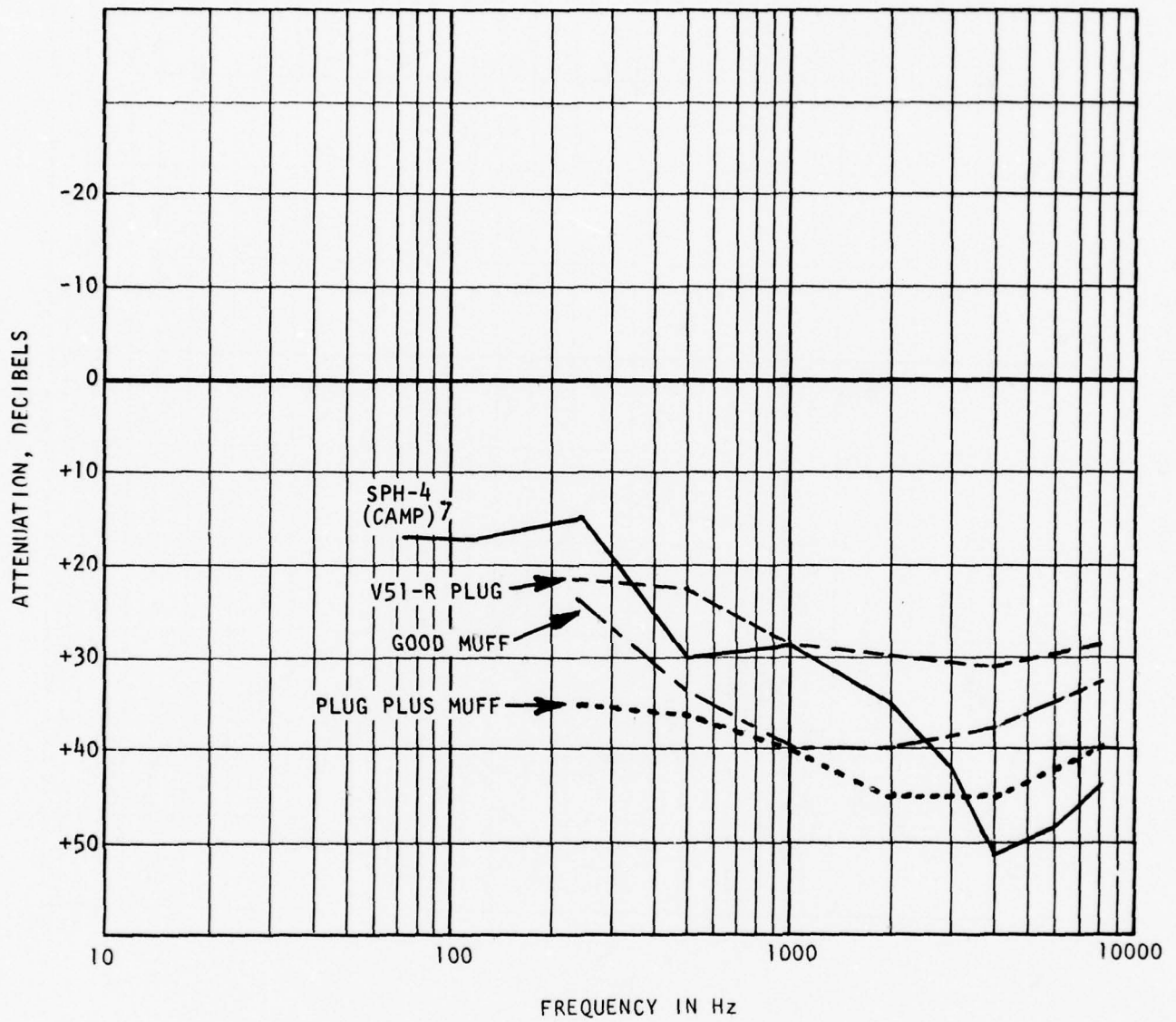

FIGURE 48. ATTENUATION OF EARCUPS AND EARPLUGS (BOTSFORD⁴⁰)

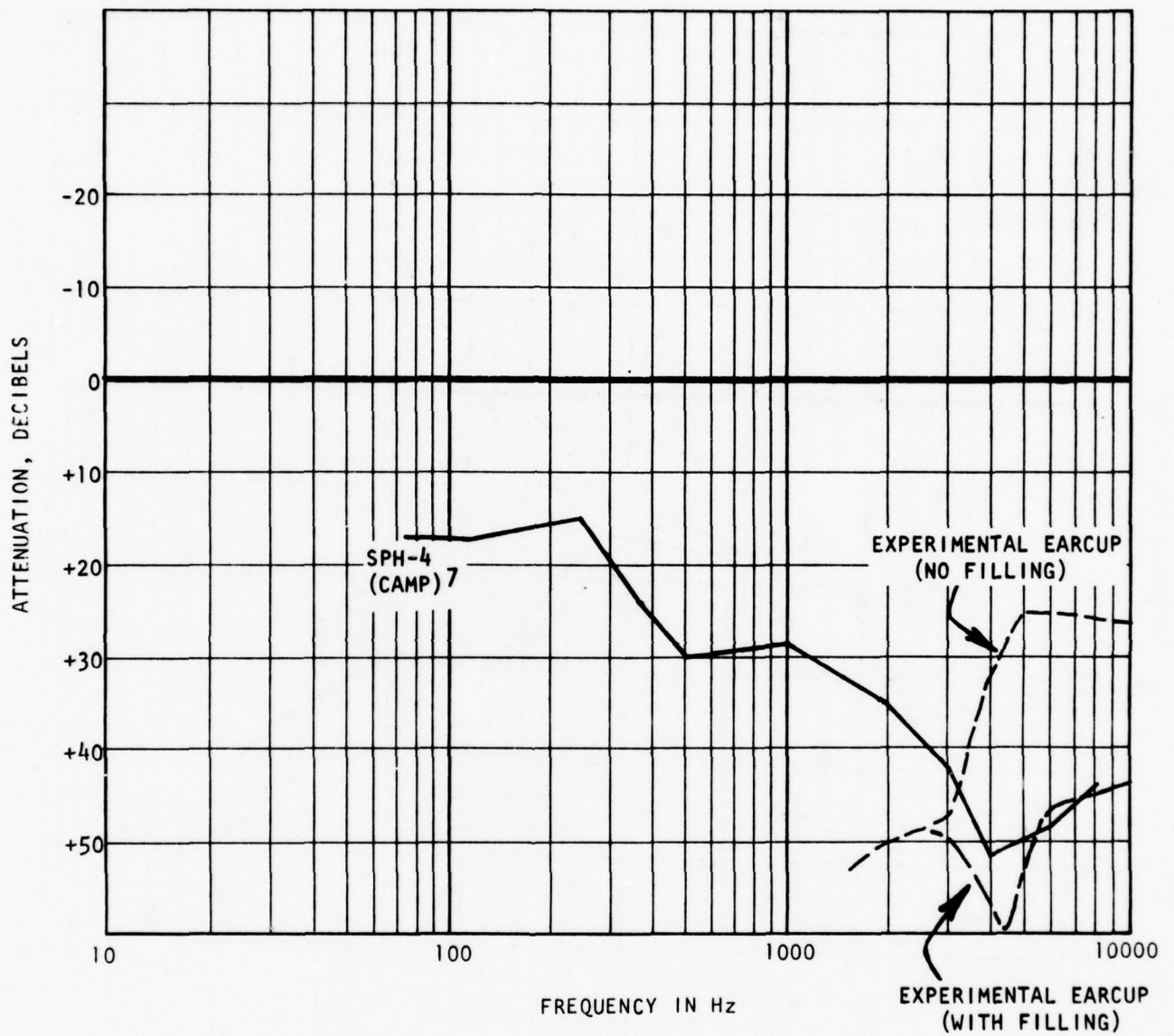

FIGURE 49. ATTENUATION OBTAINED BY FILLING EXPERIMENTAL CUP WITH SOUND-ABSORBING MATERIAL, ISOCYANATE FOAMED PLASTIC (SHAW AND THIESSEN³⁹)

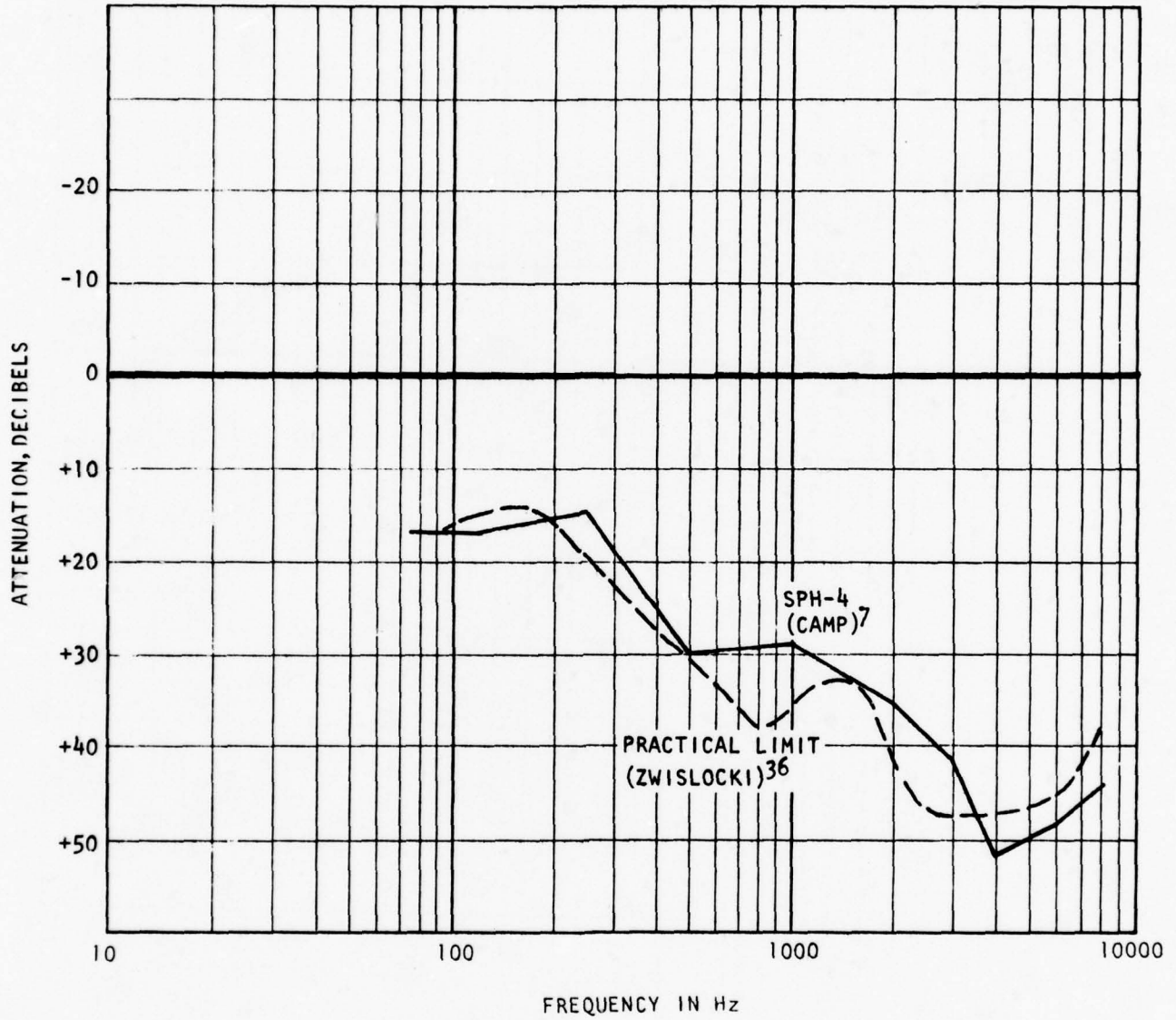

FIGURE 50. RIGID CUP WITH WAX-FILLED CUSHION (ZWISLOCKI³⁶)

The SPH-4 earcup was found to hold about 93 cm^3 of water with the cushion not depressed. Over the ear, the volume would be somewhat less.

Several investigators have attempted to modify the cup structure to obtain more attenuation. Shaw and Thiessen^{38,39} made theoretical studies, followed by experiments on earcups in which the inside volume is partitioned. The two cavities thus formed are connected by an acoustic impedance, typically an acoustic resistance. At low frequencies, where the pumping mode is dominant, the cavities are acoustically connected providing a large volume for good attenuation. At speech frequencies, the cavities are acoustically isolated so that the earphone which is placed in the inner cavity can produce the required sound pressure without excessive power demands.

The two cavity experimental work was continued by other experimenters such as Rosenheck et al^{77,84} who built and tested earcups of this type, some of which were designed to fit into flight helmets. Bauer and DiMattia⁷⁸ studied an earcup in which the two cavities were connected by paralleled resistance and inductance, in an attempt to control the troublesome acoustic resonances which appear at the transition between the low frequency mode of operation (connected cavities) and speech frequency operation (isolated cavities). To summarize this work: the frequency response and attenuation characteristics of experimental models of two-cavity earcups have verified the theoretical models from which they were developed. There is a problem in interpreting the attenuation data because of the different test methods used by different investigators, who sometimes use flat plate couplers, sometimes manikin heads, and sometimes real-ear threshold methods. There is no clear evidence that two-cavity earcups, when designed to be compatible with U. S. Army systems, provide better attenuation than well maintained modern earcups already in the U. S. Army inventory, such as the SPH-4. Of course, if the system is not limited by the power handling capability of the earphone, two cavities of the type described here provide no advantage over a large single cavity.

The reports by Rosenheck, et al, also describe some experiments with earcups which are rigidly yoked together across the head, or by means of a specially designed, rigid helmet. The purpose is to block the earcup pumping. Experiments show that when a sufficiently rigid connection can be accomplished, a major improvement in attenuation of up to 20 dB is obtained at low frequencies.

Until the development of modern foam-filled ear cushions, earcups with liquid-filled cushions provided superior attenuation. Today, the better foam-filled cushions appear to be nearly as good. Forstall⁴¹ shows an attenuation curve in which a modified APH-6A helmet with liquid seal is about 4 dB better than the helmet with a foam seal. The SPH-4 provides about the same performance as the modified APH-6A with liquid seal. However, the discussion in Section 7.3 suggests that further experiments with liquid seals may be fruitful, particularly if the viscosity of the liquid is optimized.

There have been several investigations of active ear defenders which cancel noise in the earcup. A non-feedback technique was investigated by Meeker.⁷⁹ In this system, noise is picked up by a microphone outside the earcup. The microphone signal is then adjusted for phase and amplitude and delivered to the earphone. DiMattia and Love⁸⁰ investigated a non-feedback technique in which the sensing transducer was an accelerometer mounted on the earcup. Several dB of extra attenuation was achieved in a limited frequency band.

Meeker⁷⁹ and Malme, et al.⁸¹ investigated a negative feedback method in which the microphone is placed in the earcup. Malme, et al also investigated a modified negative feedback system in which the feedback signal is delivered to an inertial force generator located on the outside of the earcup.

The feedback schemes which used the internal microphone were capable of 5 to 7 dB of extra attenuation at frequencies up to 250 Hz.

Leaks past the ear cushions pose a problem for all types of active systems for the following reasons:

- o The power handling requirements for the amplifier and earphones are much greater when a leak is possible.
- o A leak changes the phase response of the earphone - earcup system potentially causing oscillation in the feedback system, and loss of cancellation in the non-feedback system.

Feedback systems which use an internal microphone must be designed so as not to cancel speech transmissions.

Various attempts have been made to change the shape of the ear cushion for better performance. Malme, et al⁸¹ tried a cushion which contacts the head above the ear but below the hairline, to obtain a better seal. In another USAECOM-funded project, a cushion was designed in which the volume change due to earcup pumping was compensated by an opposite volume change due to radially-outward flexure of the cushion.⁸²

The best earcup real-ear-threshold attenuation values reported by various investigators for "practical" earcups and helmets tend to fall along the same curve on an attenuation vs. frequency plot. By "practical" is meant modern earcups already in the U. S. Army inventory, or earcups which have reached a stage of development where they have been essentially shown to be dimensionally compatible with Army systems. The helmets include the SPH-4, various helmets measured by Forstall,⁴¹ and others. When properly manufactured, fitted, worn, and maintained, the SPH-4 and similar helmets provide about as much attenuation as can be obtained from any available helmet. The SPH-4 system includes not only the earcup and cushion, but the webbing restraints and under-the-chin strap which are essential to its performance. The SPH-4 earcup is stiff enough so that local flexure is not a significant problem. Flexure may contribute to residual sound leakage at high frequencies; however, the main problem is below 1,000 Hz.

The results described in Section 4, Figures 30 and 31, and in Section 7 show that too much of the performance of the SPH-4 is lost in the aircraft, due mostly to leaks around the cushion.

The following list summarizes various ways in which helmet performance could be improved at frequencies below 1,000 Hz.

1. Increase the volume of the earcup by increasing its depth without sacrificing rigidity. This is a proven method, but requires that the helmet shell be substantially widened. This improvement would be effective against both earcup pumping and leakage.
2. Significantly increase the mass of the earcup shell to move the system resonance from around 200 Hz to well below 100 Hz. This is a proven method but the increase in helmet mass is a drawback. It would not be effective against leakage.

3. Rigidly connect the earcups together. The effectiveness against earcup pumping is proven but the feasibility of a practical mechanical design is not proven. It would not be effective against leakage.
4. Further develop ear cushions with optimized stiffness and/or damping, including those which compensate the volume change due to pumping, without compromising the ear cushion seal. They must provide acceptable comfort, and be manufacturable. They would not be effective against leakage.
5. Further develop active noise-cancellation systems including adaptive systems which could respond to changing phase conditions in the earcup. This is a hypothetical development requiring considerable signal processing power.

8.3 MICROPHONES

Figure 51 shows the frequency response of an M-87 microphone for both close and distant sources. The distant-source curves are shown for various orientations of the microphone with respect to the speaker axis. The speaker to microphone distance is 6 feet. The close-source curve is made at a distance of 1/4-inch. These measurements are made according to the method described in MIL-M-26542A⁶ using a sound source constructed according to U. S. Air Force Drawing 58B12627 (30 June 1958). The difference between the close-source response and the 0°, 180° average response is the noise immunity. The noise immunity is plotted at the bottom of Figure 51. The noise immunity which is about 9 dB at 1000 Hz, is probably typical of M-87's in good condition.

Measurements of several M-87 microphones made at various times at ATC suggest that, due to hard use and aging of components, the noise-immunity may vary considerably among units that have been in service.

A number of alternative noise-cancelling microphones have been developed over the past 15 years, and some novel approaches have been explored for making microphones which are immune to noise. A major difficulty in developing improved

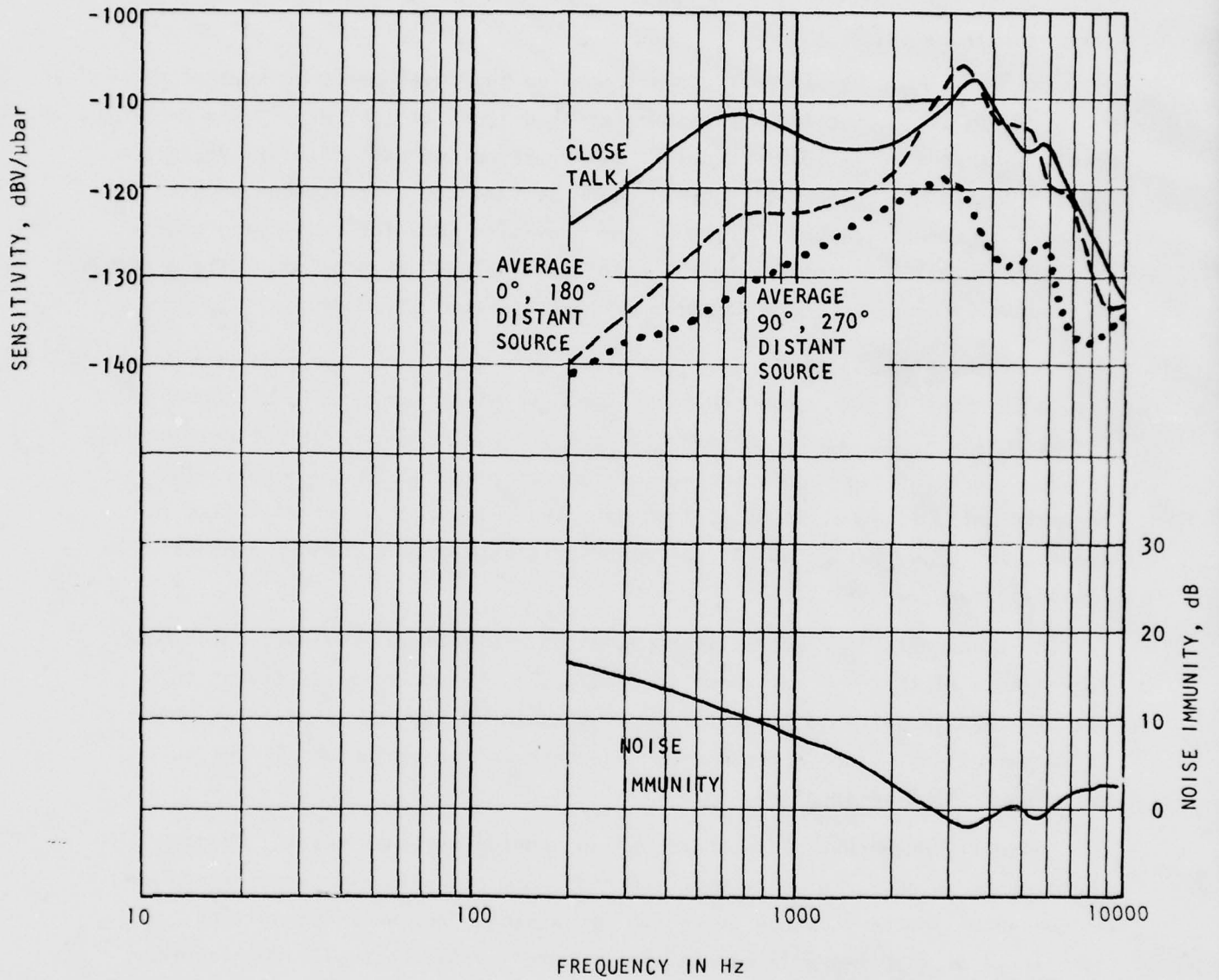

FIGURE 51. RESPONSE OF M-87 MICROPHONE, 5 Ω LOAD RESISTOR

dynamic and magnetic microphones is the requirement for good noise-immunity-- which demands accurate, stable, acoustic components--along with a simultaneous requirement for operation over a range of altitudes, and operation after immersion in water.

The U. S. Army has in past years sponsored the development of several microphones which have noise immunities greater than 10 dB at 1000 Hz.⁸³ The M-93/AIC, developed in the early 1960's under U. S. Air Force Contract 30(635)18989, is a small magnetic microphone which has good noise immunity. It was not adopted for military or commercial use. There was no provision made for protection against immersion in water and other environmental hazards such as dropping. The assembly is precisely tuned, so there may be a problem of manufacturability.

More recently, piezoelectric and electret microphones have been developed. Figure 52 shows the response and noise immunity of a piezoceramic microphone.⁸⁵ The directivity pattern is a near-perfect cosine. The degree of noise-immunity is not susceptible to manufacturing tolerances or aging of components. The noise-immunity is about 14 dB at 1000 Hz. The response is virtually flat in the speech range; tailoring of the response is easily done to obtain other response characteristics.

Noise-cancelling electret microphones have also been developed which have performance similar to that shown in Figure 52. The primary constraint on use of piezoelectric and electret microphones in U. S. Army aircraft is one of compatibility, since these microphones have an integral preamplifier to which power must be supplied.

Recently developed microphones, which provide at least several dB of improvement in noise-immunity over the M-87, are probably close to the maximum noise-cancelling performance which can be obtained from noise-cancelling (gradient) microphones. It may be that future improvements will develop from current work in digital signal processing of speech.

8.4 PERFORMANCE TRADEOFFS

The durations of exposure of helicopter occupants are set by mission requirements. Since that parameter is fixed, overall dBA level is the only other parameter which can be controlled to reduce risks of hearing damage. If no

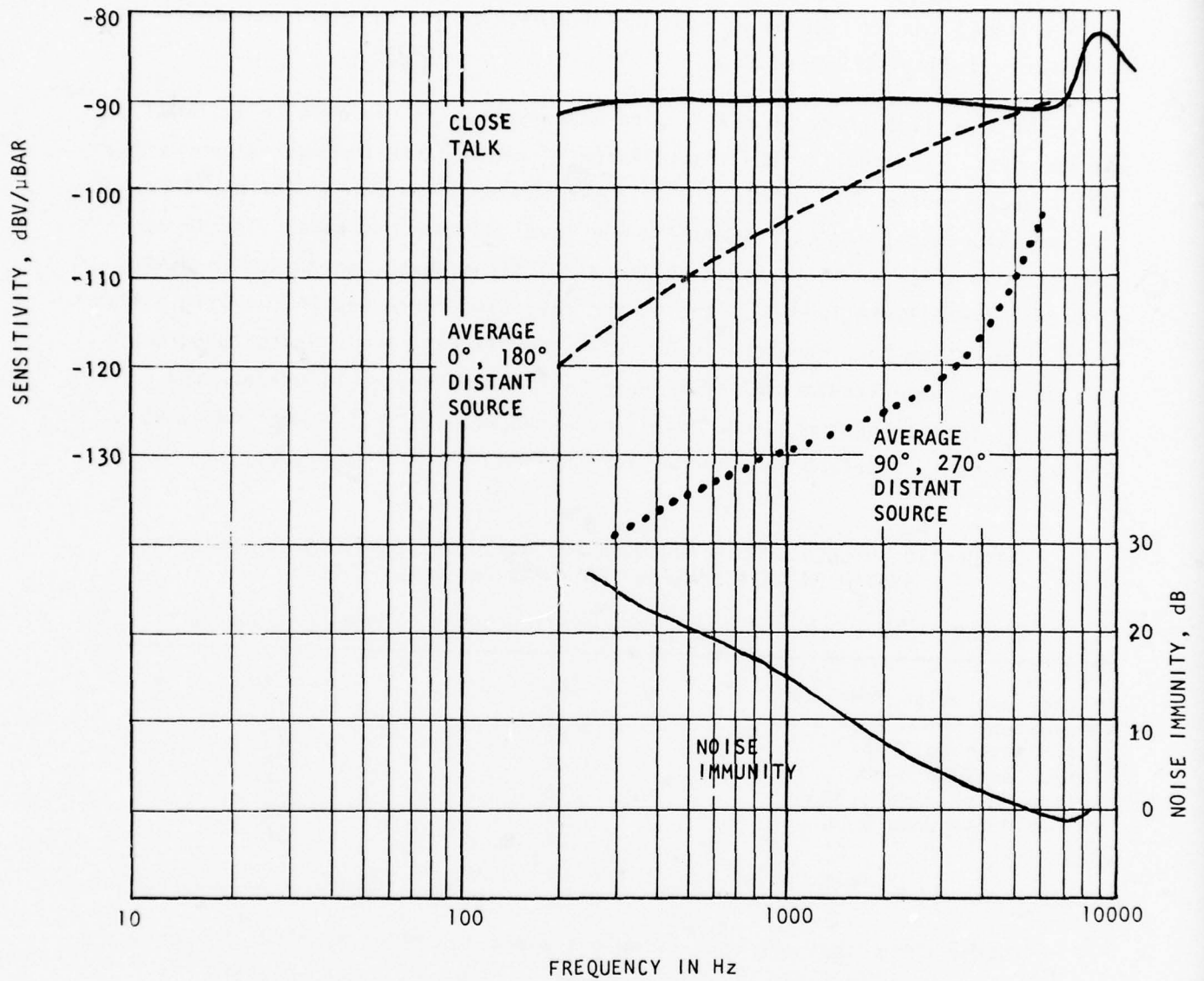

FIGURE 52. RESPONSE OF PIEZOCERAMIC NOISE-CANCELLING MICROPHONE,
150 Ω LOAD RESISTOR

other changes in a communications system are made, reduction of gain settings often will result in unacceptable intelligibility of radio voice messages. If intelligibility can be significantly improved for a given dBA noise level, then gain settings can be reduced without any decrease in the original acceptable value of intelligibility.

The intelligibility of radio voice messages can be improved in at least three ways: (1) reducing the transmission of cabin noise through earcup walls, (2) reducing noise that originates at a microphone or in an electrical/electronic transmission path, and (3) increasing the level of speech sounds. The first two actions will result in lower dBA levels. Although the third action will increase overall dBA levels slightly, the resulting increases in intelligibility more than offset the increases in overall sound level. The computer program for calculating articulation index (Appendix D) was used to illustrate the effect of such changes on sound levels measured within OV-1D number 69-17005 during descent. Table 8 is a summary of the results of that study.

TABLE 8
CALCULATED INFLUENCE OF CHANGES IN THE OV-1D NO. 69-17005 COMMUNICATION SYSTEM ON ARTICULATION INDEX AND ON SOUND LEVEL

| ACTION | ARTICULATION INDEX | OVERALL SOUND LEVEL (dBA) |
|-----------------------------|--------------------|---------------------------|
| *Microphone noise down 3dB | .44 | 75 |
| *Microphone noise down 6 dB | .47 | 74 |
| Voice level up 3 dB | .46 | 77 |
| Voice level up 6 dB | .51 | 78 |
| Earcup noise down 3 dB | .46 | 76 |
| Earcup noise down 6 dB | .51 | 76 |
| None | .40 | 76 |

* Noise picked up at the microphone

Table 8 shows that the most efficient means for reducing risk of hearing damage is to increase earcup attenuation of cabin noise. The resulting increase in articulation index, with no accompanying increase in overall sound level, would allow a considerable reduction of gain settings and overall sound level before the value of articulation index would fall below the original value for the unmodified equipment.

Figure 53 shows the average earcup attenuation obtained in UH-1H #71-20254 compared to a laboratory measurement of attenuation obtained by Camp⁷ for the

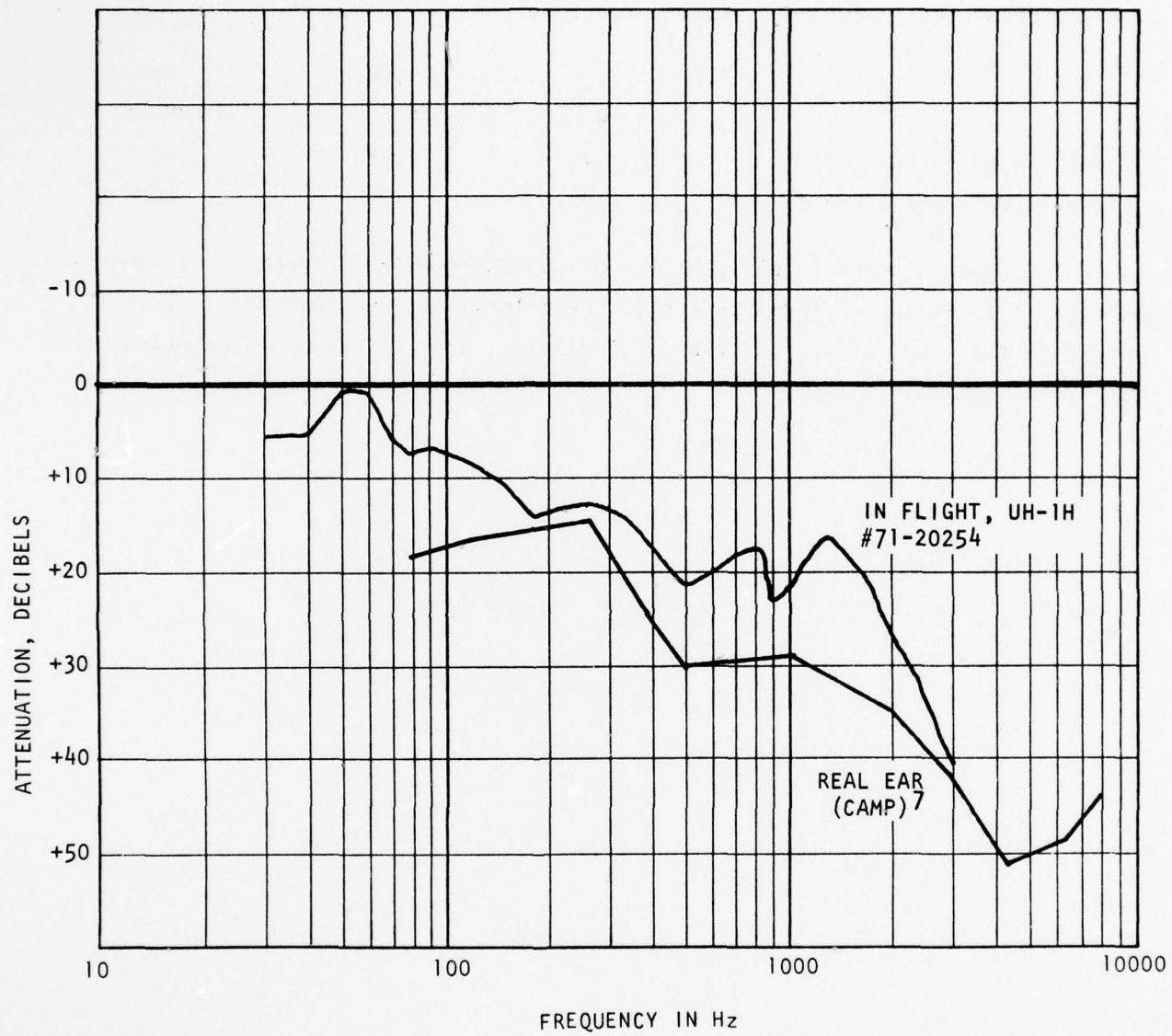

FIGURE 53. EARCUP ATTENUATION EXAMPLE, SPH-4 HELMET

SPH-4 helmet. Tables 9 and 10 show the effect on articulation index of obtaining a result as good as the laboratory measurement. The result in #71-20254 was actually somewhat better than typically obtained in the UH-1H in this study, so the predicted improvement is conservative.

| | <u>AI</u> | <u>SENTENCE INTELLIGIBILITY</u> | <u>WORD INTELLIGIBILITY</u> |
|---|-----------|-------------------------------------|---------------------------------|
| SPH-4 (in UH-1H #71-20254) | .77 | 98% | 93% |
| SPH-4 (Camp's measurement) ⁷ | .86 | 99 | 96 |

The change in the intelligibility of sentences which corresponds to the change in articulation index is small, but pilots would be less inclined to increase the level of speech if an articulation index of .86 could be established at lower levels.

| CENTER FREQUENCY OF BAND (HERTZ) | SPECTRUM LEVEL OF SPEECH (DB) | SPECTRUM LEVEL OF NOISE (DB) |
|---|--|---------------------------------------|
| 270.0 | 59.7 | 60.0 |
| 380.0 | 54.2 | 52.9 |
| 490.0 | 55.8 | 44.3 |
| 630.0 | 57.6 | 42.1 |
| 770.0 | 53.1 | 42.3 |
| 920.0 | 50.3 | 37.1 |
| 1070.0 | 49.0 | 39.0 |
| 1230.0 | 51.4 | 38.8 |
| 1400.0 | 51.0 | 36.7 |
| 1570.0 | 51.5 | 35.9 |
| 1740.0 | 48.7 | 34.6 |
| 1920.0 | 47.7 | 32.6 |
| 2130.0 | 46.9 | 32.2 |
| 2370.0 | 48.1 | 32.2 |
| 2660.0 | 57.4 | 40.0 |
| 3000.0 | 54.8 | 39.7 |
| 3400.0 | 45.4 | 36.6 |
| 3950.0 | 37.0 | 32.9 |
| 4560.0 | 34.0 | 28.5 |
| 5600.0 | 27.8 | 22.5 |

OASL (DBA) = 88.5 77.3

OVERALL SOUND LEVEL (SPEECH + NOISE, 200 TO 6100 HZ) = 88.9 DBA

| CENTER FREQUENCY OF BAND (HERTZ) | CORRECTED NOISE LEVEL (DB) | SPREAD- OF-MASKING OF NOISE (DB) | MASKING LEVEL OF NOISE (DB) |
|---|-------------------------------------|---|--------------------------------------|
| 270.0 | 60.0 | 16.5 | 60.0 |
| 380.0 | 52.9 | 11.6 | 52.9 |
| 490.0 | 44.3 | 7.9 | 44.3 |
| 630.0 | 42.1 | 4.3 | 42.1 |
| 770.0 | 42.3 | 1.4 | 42.3 |
| 920.0 | 37.1 | 0.0 | 37.1 |
| 1070.0 | 39.0 | 0.0 | 39.0 |
| 1230.0 | 38.8 | 0.0 | 38.8 |
| 1400.0 | 36.7 | 0.0 | 36.7 |
| 1570.0 | 35.9 | 0.0 | 35.9 |
| 1740.0 | 34.6 | 0.0 | 34.6 |
| 1920.0 | 32.6 | 0.0 | 32.6 |
| 2130.0 | 32.2 | 0.0 | 32.2 |
| 2370.0 | 32.2 | 0.0 | 32.2 |
| 2660.0 | 40.0 | 0.0 | 40.0 |
| 3000.0 | 39.7 | 0.0 | 39.7 |
| 3400.0 | 36.6 | 0.0 | 36.6 |
| 3950.0 | 32.9 | 0.0 | 32.9 |
| 4560.0 | 28.5 | 0.0 | 28.5 |
| 5600.0 | 22.5 | 0.0 | 22.5 |

ARTICULATION INDEX = .77

TABLE 10. IMPROVED EARCUP

UH-1H 71-20254
LEVEL FLIGHT, IMPROVED EARCUP

| CENTER FREQUENCY OF BAND (HERTZ) | SPECTRUM LEVEL OF SPEECH (DB) | SPECTRUM LEVEL OF NOISE (DB) |
|---|--|---------------------------------------|
| 270.0 | 59.7 | 58.3 |
| 380.0 | 54.2 | 46.0 |
| 490.0 | 55.8 | 35.3 |
| 630.0 | 57.6 | 32.1 |
| 770.0 | 53.1 | 30.6 |
| 920.0 | 50.3 | 31.1 |
| 1070.0 | 49.0 | 31.4 |
| 1230.0 | 51.4 | 28.8 |
| 1400.0 | 51.0 | 22.5 |
| 1570.0 | 51.5 | 22.5 |
| 1740.0 | 48.7 | 22.9 |
| 1920.0 | 47.7 | 23.3 |
| 2130.0 | 46.9 | 32.2 |
| 2370.0 | 48.1 | 32.2 |
| 2660.0 | 57.4 | 40.0 |
| 3000.0 | 54.8 | 39.7 |
| 3400.0 | 45.4 | 36.6 |
| 3950.0 | 37.0 | 32.9 |
| 4560.0 | 34.0 | 28.5 |
| 5600.0 | 27.8 | 22.5 |

OASL (DBA) = 88.5 75.1

OVERALL SOUND LEVEL (SPEECH + NOISE, 200 TO 6100 HZ) = 88.7 DBA

| CENTER FREQUENCY OF BAND (HERTZ) | CORRECTED NOISE LEVEL (DB) | SPREAD- OF-MASKING OF NOISE (DB) | MASKING LEVEL OF NOISE (DB) |
|---|-------------------------------------|---|--------------------------------------|
| 270.0 | 58.3 | 16.5 | 58.3 |
| 380.0 | 46.0 | 11.6 | 46.0 |
| 490.0 | 35.3 | 7.9 | 35.3 |
| 630.0 | 32.1 | 4.3 | 32.1 |
| 770.0 | 30.6 | 1.4 | 30.6 |
| 920.0 | 31.1 | 0.0 | 31.1 |
| 1070.0 | 31.4 | 0.0 | 31.4 |
| 1230.0 | 28.8 | 0.0 | 28.8 |
| 1400.0 | 22.5 | 0.0 | 22.5 |
| 1570.0 | 22.5 | 0.0 | 22.5 |
| 1740.0 | 22.9 | 0.0 | 22.9 |
| 1920.0 | 23.3 | 0.0 | 23.3 |
| 2130.0 | 32.2 | 0.0 | 32.2 |
| 2370.0 | 32.2 | 0.0 | 32.2 |
| 2660.0 | 40.0 | 0.0 | 40.0 |
| 3000.0 | 39.7 | 0.0 | 39.7 |
| 3400.0 | 36.6 | 0.0 | 36.6 |
| 3950.0 | 32.9 | 0.0 | 32.9 |
| 4560.0 | 28.5 | 0.0 | 28.5 |
| 5600.0 | 22.5 | 0.0 | 22.5 |

ARTICULATION INDEX = .86

9.0 HEARING CONSERVATION PROGRAMS IN THE MILITARY SERVICES

9.1 ORGANIZATION

Activities related to hearing conservation in the services are generally under three classifications: environmental health, medical R&D, and clinical services. This organization of effort is common to each of the services, although the responsibilities for specific components of the program are not allocated the same in every case. The cognizant offices for each of the services are listed below:

| | <u>ENVIRONMENTAL HEALTH</u> | <u>MEDICAL R&D</u> | <u>CLINICAL SERVICES</u> |
|------------|--|--|---|
| ARMY: | Army Environmental Hygiene Agency Edgewood Arsenal, Md. | Army Aeromedical Research Ft. Rucker, Al. | Army Clinical Division Walter Reed Hospital Washington, D. C. |
| NAVY: | Navy Environmental Health Center Cincinnati, Ohio | Navy Environmental Supply Pt. Hueneme, Ca. | Naval Aerospace Medicine for Industry Pensacola, Florida |
| AIR FORCE: | Bioacoustics Division Wright-Patterson AFB Ohio | Hq. USAF/SGTA Forrestall Bldg. Washington, D. C. | USAFSAM/NG Clinical Sciences Division Brooks AFB, Tx. |

The authority for administration of the hearing conservation program begins with the Clinical Services in both the Army and Navy, but in the Air Force, Medical R&D is responsible for the program. The Air Force has the oldest of the three programs. The Air Force program is covered and supported by very specific regulations. In 1978, a similar U. S. Army program was approved by the Department of Defense. Implementation of the Army program is expected by October 1978.

Despite the differences in program authority mentioned above, the three agencies in which the hearing conservation program resides have similar functions. The Clinical Services provide medical services at the various bases where personnel are working in noise-hazardous environments. Environmental Health agencies are in general concerned with the setting of standards and with the functional

design of the program. Medical R&D is a somewhat misleading title, in that research and development activities are also carried out by the other two agencies, especially the Clinical Services. Medical R&D is more concerned with the development of protective equipment and devices, whereas the Clinical Services engage in evaluations of equipment and conservation practices in the field. Research is involved in both of these functions, but in the Clinical Services the research is conducted primarily by military personnel.

An idea of the magnitude of the overall effort devoted to airborne acoustics by all the armed services can be obtained from the "Directory of DoD Contacts on Airborne Acoustics."⁸⁶ At the time this directory was published there were 409 personnel in 80 offices involved in this activity. The breakdown was as follows:

| | <u>Offices</u> | <u>Personnel</u> |
|--------------|----------------|------------------|
| Army | 8 | 116 |
| Navy | 37 | 112 |
| Air Force | 34 | 160 |
| Marine Corps | 1 | 1 |

Fewer than 10 percent of the personnel had titles which indicated that their primary duties were concerned with hearing problems associated with aircraft noise. It is likely that the activities in this area have increased significantly since the directory was published, however.

9.2 ADMINISTRATION

The new Army program is covered by Army Regulation 40-5. AR40-5 is being updated as it addresses hearing conservation as well as other health areas. Updates of TB-Med 251, MIL-STD-1474A¹⁰¹ and MIL-A-8806²⁹ have been made or are expected. The Army program includes such measures as noise-damage orientation for new recruits, the establishment of noise hazard assessment codes, and annual or semi-annual audiograms for personnel working in areas where levels exceed 85 dBA.

The administration of medical control procedures according to TB-Med 251 can be viewed by means of the flow chart of Figure 54. This chart shows parallel avenues of handling, depending on whether the audiological examination is the entrance examination, designed to establish a baseline hearing threshold against which subsequent tests will be compared, or whether the examination is the routine annual checkup. Usually the personnel have been working in the high noise environment for at least a short time prior to the baseline tests, which is unfortunate. The procedural differences occur in the event that personnel fail both the first test and the subsequent test 24 hours later. In the case of routine annual check, the personnel are given more opportunities to finally pass a test and return to duty. The reasons are obvious: both the Army and the personnel have a considerable career investment (especially for flight personnel) at this point. This loss is considerably larger than the disability compensation. As long as no serious threshold shift (TS) is observed, the procedure will continue to examine the personnel once a year. Furthermore, any passing of an audiological test will return the person to high noise duty, regardless of his performance on a previous test.

It is interesting to compare Figure 54 with Figure 55, which is a flow chart for the Air Force case disposition procedure (from Gasaway and Sullivan³⁵). Here we see that each stage of the procedure is covered by a corresponding section of AFR 161-35.⁸⁷ Note that personnel who never show evidence of a TS are rechecked only once a year, as in TB-Med 251. The reference (or baseline) audio is followed up in 90 days with an audio, regardless of baseline performance. But the major difference in the USAF procedure is the handling of cases which have shown TS in either the 90-day or annual audio. Aside from differences in testing intervals, the personnel who fail the next two tests are then entered into a rigorous testing routine which (depending on outcome of the detailed follow-up examination) has a duration of five months and six examinations, even in the case that the subject passes all six tests during this "clinical" period. This procedure is designed to make sure that a patient has completely recovered from the TS before he is returned to duty in the high noise environment. TB-Med 251, on the other hand, has no comparable precautionary procedure.

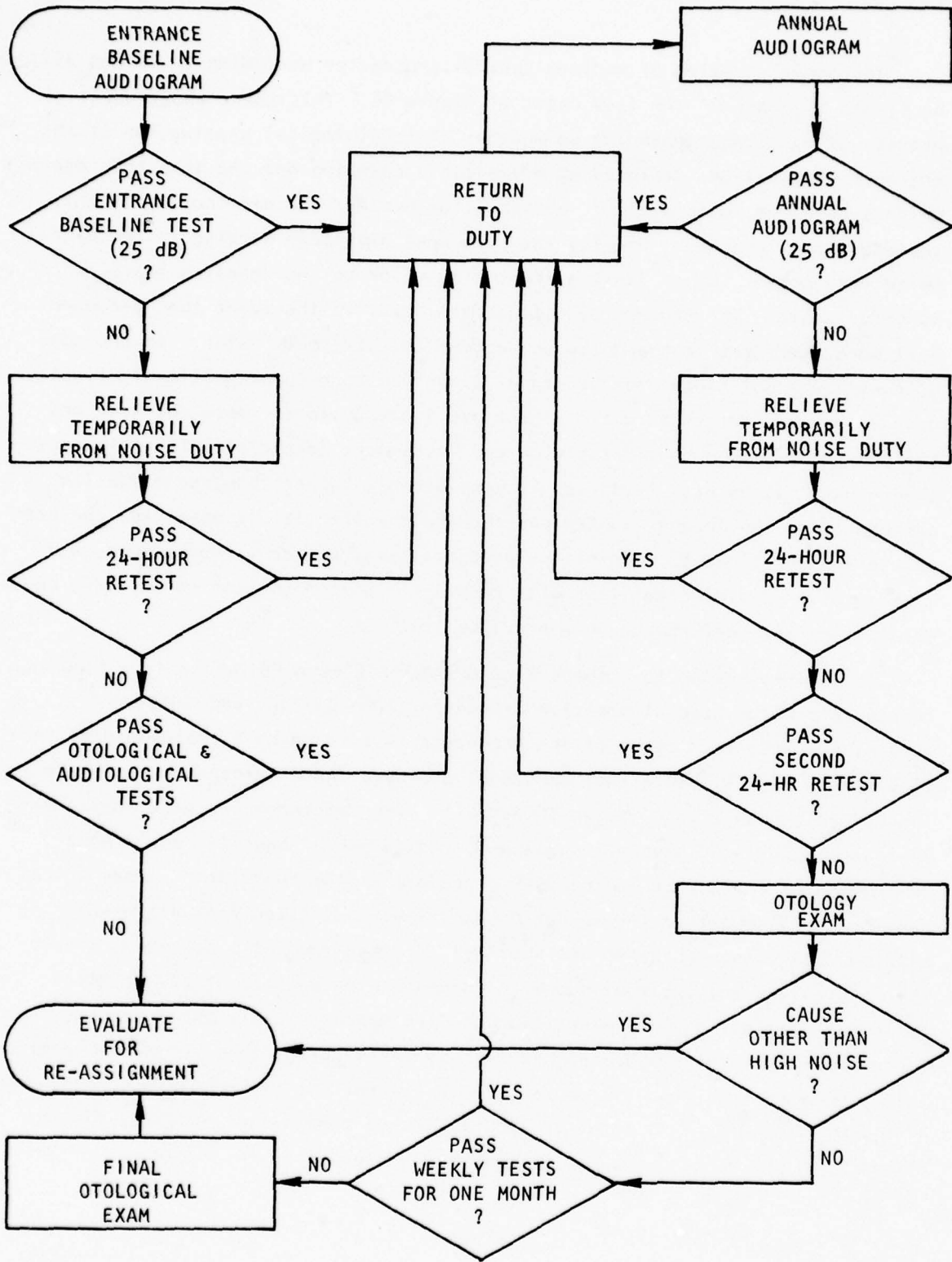
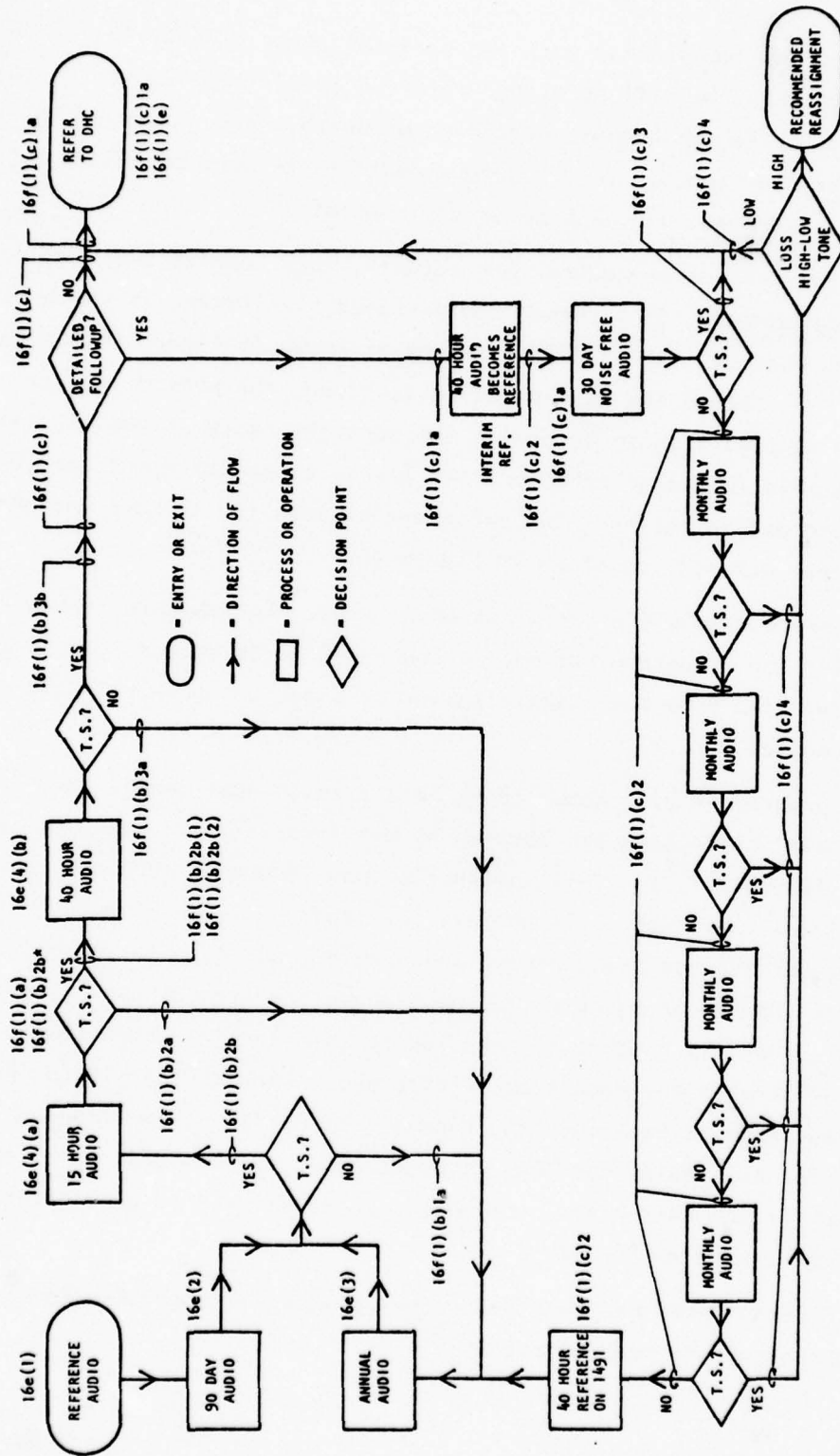

FIGURE 54. CASE DISPOSITIONS RECOMMENDED BY U.S. ARMY TB-MED 251 (HIGH NOISE ENVIRONMENT)



*Dispositions relative to hearing conservation are based on TS, not hearing profile, See 16f(1)(d)

FIGURE 55. CASE DISPOSITIONS DETAILED IN USAF-161-35 (HIGH NOISE ENVIRONMENTS)

The patient may immediately exit the clinical stage only by failing another audio. At this point he will be either referred to Division Health Center (DHC) or recommended for re-assignment, depending on whether the nature of the TS is in low tones or high tones. Very rigorous audio tests must be passed before the subject can be returned to a high noise environment.

The USAF disposition procedures are actually more complex than shown in Figure 55. For example, if a person demonstrated significant TS which persisted on the 15-hour recheck, the procedure is not as shown in Figure 55 (See Gasaway and Sullivan³⁵). Before the 40-hour audio is given, the person is examined by the attending physician to determine the apparent cause of the TS, and the 40-hour recheck is then entered only after (a) no cause was found, or (b) the cause was found and corrected. The procedure between the 15-hour and 40-hour rechecks is then actually as shown in Figure 56.

The USAF procedures differ in other ways, also. For example, the critical threshold shift for TS determinations is lower, 10-20 dB rather than 25 dB, and they differ also from one classification or stage to another in the classification procedures.

The Navy program is also known to be in a transitional stage. Navy procedures for the disposition of cases are covered by an "instruction", which is similar to a regulation (BUMEDINST⁸⁸). This instruction was issued in 1970 and is now considered obsolete. Navy officials believe that there will be a move to standardize the procedures of the hearing conservation program, and also to consolidate it within no more than three agencies, as opposed to the present nine. In the present configuration, the Navy program (as applied to aviation) is administered by a different program manager for each type of aircraft. The critical TS for Navy personnel working in noise-hazardous environments is 25 dBA at any frequency through 3,000 Hz, so far as special handling is concerned. If permanent TS of 40 dBA is determined for the better ear, the person is reassigned to an environment with noise level not exceeding 90 dBA.

The Air Force program has resulted in better hearing among Air Force flight personnel than among the general public.³⁵

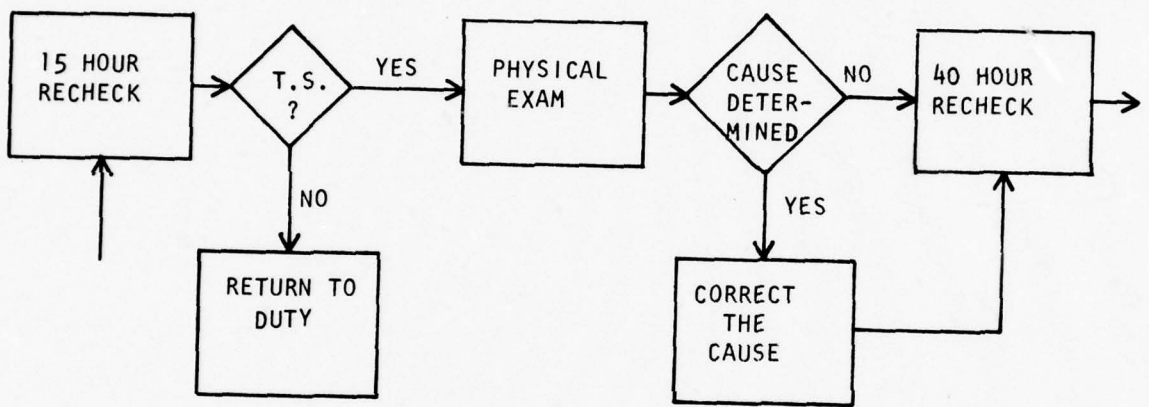

FIGURE 56. STEPS BETWEEN THE 15-HR. AND 40-HR. AUDIO RECHECKS SHOWN ON FIGURE 55.

10.0 CONCLUSIONS AND RECOMMENDATIONS

Before proceeding to the conclusions, some of the assumptions on which those conclusions depend will be stated. These assumptions are as follows:

- o The 7 aircraft types in which data were taken are representative of aircraft in the U. S. Army inventory. If other aircraft, or future aircraft, generate noise having a different level or spectrum shape, the conclusions would be altered. For example, flat spectra of the same overall noise power would lead us to emphasize the characteristics of microphones rather than helmets and earcups.
- o The comparison method of measuring earcup attenuation used in this project provides a good measure of real-ear attenuation (However, see Section 4.7).
- o The SPH-4 helmet and M-87 microphones used during the project are typical.
- o The observers who took the data are typical of U. S. Army aviators, with regard to fit and technique when wearing the SPH-4 helmet.

10.1 THE NOISE ENVIRONMENT

The noise spectra which are found in the communications systems of the U. S. Army aircraft can be described by the following model.

- o A low-frequency spectrum in the earcup which slopes downward as frequency increases, primarily due to noise leakage into the earcup. In terms of its effect on speech intelligibility and hearing damage, this noise is negligible above about 1000 Hz.
- o A high-frequency spectrum in the earcup which slopes upward as frequency increases, due to noise which is picked up at the microphone and transmitted to the earphone. This noise is present only when a microphone is keyed. In terms of its effect on speech intelligibility and hearing damage, this noise is negligible below about 1000 Hz.

There is additional sound in the earcup due to speech which is transmitted on the communication channel. In terms of its effect on hearing damage, the speech level is significant from about 400 Hz up to the upper limit of the microphone/earcup frequency response, which is about 6000 Hz.

The model described here is illustrated by Figures 9 and 12 in Section 4.

For the aircraft studied during this project, between 72% and 89% of the noise power (calculated after A-weighting the noise spectra) is due to earcup leakage.

10.2 INTELLIGIBILITY AND HEARING DAMAGE RISK

Table 3 in Section 5 shows that typical calculated values for the intelligibility of electronically-communicated speech within helicopters are in excess of 95 percent (for sentences). However, operating conditions are marginal for good intelligibility (see Section 5.8). Slight changes in speech levels, speech quality, or background noise sometimes cause large decreases in intelligibility. Temporary lapses of intelligibility may cause pilots to form a habit of routinely turning up volume controls to their maximum settings. The unnatural quality of received speech signals also may cause them to form that habit, although the peculiar quality of the speech, such as the emphasis of plosives, may actually increase its intelligibility for practiced listeners (see Section 3.5).

Currently accepted criteria for predicting hearing losses which result from noise exposure lead one to conclude from Table 3 that those noise levels will cause what is currently accepted to be a hearing handicap (see Section 3.3) in only a small fraction of one percent of all exposed personnel who wear helmets at least as good as SPH-4 helmets. Therefore, based on the analysis of data collected during this project, a prediction of widespread hearing loss, due to service in aircraft, cannot be justified.

Noise sources, sufficiently loud to be damaging to hearing are found in many places, including the leisure-time environment e.g., loud music, motorcycle and motorboats, chain saws, and shotguns. Another possible source is found in non-flying military service. In Section 5.9, evidence is cited that significant hearing loss is sustained in military basic and advanced training.

The observers in this project turned their volume controls to mid-range. If helicopter pilots turn up volume controls only until speech levels which correspond to about 98 percent intelligibility of sentences are reached, then only a few percent of Army helicopter pilots are in danger of suffering a noise-induced permanent threshold shift of more than 10 decibels as a result of being exposed to helicopter noise. However, if they routinely turn up volume controls to maximum settings in attempts to overcome real or imagined problems with intelligibility, then they are in danger of suffering handicapping hearing losses (see section 5.10).

Most existing military aircraft have been developed under contracts which require that internal noise levels comply with MIL-A-8806A.²⁹ Gasaway^{4,89} published measured values of noise levels within cockpits of helicopters. His measurements and the measurements which are presented in this report show that most helicopters are in compliance with MIL-A-8806A.

Table 11 shows the noise levels that are generated at the ears of a crew-member who wears a SPH-4 helmet within a helicopter that generates noise levels equal to the maximum noise levels that are allowed by MIL-A-8806A. That table, and typical in-flight measurements of SPH-4 attenuation, show that such a crew member will be exposed to an overall noise level which is 2 dB higher than is allowed by the Occupational Safety and Health Administration (OSHA) and is 7 dB higher than is allowed by TB Med 251 (see Section 3.3).

10.3 EQUIPMENT PERFORMANCE

The contribution to acoustic noise at the ear due to electrical self-noise in the communications equipment is negligible (Section 6). The distortion, dynamic range, frequency response, and limiting characteristics of the aircraft intercommunication (AIC) sets are generally within specifications (Table 5). Assuming that volume settings are similar to those used during this project, the AIC is not a factor in causing hearing damage or lack of intelligibility. Peaks in the ear-phone response between 2 kHz and 6 kHz do allow the possibility of hearing damage for high volume settings. To determine whether this actually does occur, more information would be needed about the distribution of volume settings, the percentage of time that speech is received, and the amplitude distribution of speech in this range.

TABLE 11
COMPARISON OF MIL-A-8806A WITH HEARING LOSS CRITERIA

| OCTAVE BAND CENTER FREQUENCY (Hertz) | MIL-A-8806 A MAXIMUM ACCEPTABLE NOISE LEVEL FOR MAXIMUM CONTINUOUS POWER (Where helmets are required) | | ATTENUATION OF SPH-4 HELMET (From Figure 46) | | NOISE LEVELS AT A CREW MEMBER'S EARS | |
|---|--|-------|---|---------------------------------------|---|---------------------------------------|
| | (dB SPL) | (dBA) | TYPICAL IN-FLIGHT (dB) | MAXIMUM REAL EAR (CAMP) (dB) | TYPICAL IN-FLIGHT (dBA) | MINIMUM FOR A REAL EAR (dBA) |
| 31.5 | 111 | 72 | 8 | 19 | 64 | 53 |
| 63 | 111 | 85 | 5 | 18 | 80 | 67 |
| 125 | 111 | 95 | 5 | 17 | 90 | 78 |
| 250 | 111 | 102 | 9 | 17 | 93 | 85 |
| 500 | 109 | 106 | 15 | 30 | 91 | 76 |
| 1000 | 106 | 106 | 19 | 29 | 87 | 77 |
| 2000 | 100 | 101 | 24 | 35 | 77 | 66 |
| 4000 | 94 | 95 | 31 | 49 | 64 | 46 |
| 8000 | 94 | 93 | 36 | 44 | 57 | 49 |
| Overall | 113 | 111 | 14 | 24 | 97 | 87 |

For the Particular
Noise Profile From
MIL-A-8806A

Maximum Allowed For 4 Hour
Daily Exposure is 90 dBA
For TB Med 251, and 95 dBA
for OSHA.

There was no difference in the in-flight performance of the C-1611D and C-6533 AIC's.

The specification for the M-87 microphone (MIL-M-26542A) requires that the noise-immunity be at least 7 1/2 dB at 1000 Hz. A few recently manufactured or well-cared-for M-87's which have been measured at Advanced Technology Center do meet the specification (see Figure 51). They also meet the response specification. Recently developed microphones (Figure 52) provide several dB improvement in noise-immunity, and are probably close to the maximum noise-cancelling performance which is possible.

Noise-immunity and intelligibility have been measured during this project by employing objective tests. There may be subjective factors which are important to in-flight performance, e.g., reduction of fatigue, reduction of the tendency to turn up volume controls, and intangible contributions to intelligibility. The performance of improved microphones is ultimately best determined by comparison tests with real voices and real ears.

Earcups remain as the weak link for noise rejection in the communication system. The problem observed in this project is principally one of noise leakage past the earcup seal due to poor fit, insufficient adjustment, the wearing of eyeglasses, long hair, and possibly deterioration of the cushion material.

In cases where an adequate seal is obtained, earcup "pumping" remains as the major cause of noise at the ear. An SPH-4 tested in the laboratory during this project (not the unit used in the aircraft) did not provide as much attenuation near 100 Hz as obtained by other observers (compare Figures 35 and 38 to Figure 46), even when a best seal is made. This is possibly due to manufacturing tolerances or cushion deterioration. The SPH-4 earcup shell itself appears to be adequately rigid.

It is largely low frequency noise (below about 600 Hz) that is responsible for risk of hearing loss and for low intelligibility of speech within helicopters, because that noise is not attenuated appreciably by ear protection devices. There is little hope of reducing the low frequency noise by retrofitting existing aircraft, and new helicopters can be quieted only by introducing considerations of noise control early in the design sequence. Such considerations are expensive and time-consuming, and they increase the cost and subtract from the performance

of helicopters; therefore, it is likely that ear protectors will continue to provide the main means of controlling the impact of low frequency noise on helicopter pilots and crew members. Along with the reduction of low frequency noise to unobtrusive levels, changes in microphones, earphones, and associated electronics can be introduced to improve intelligibility further.

If TB Med 251 is applied to protect occupants of helicopters from hearing loss, then 1 1/2 percent of exposed helmeted personnel will suffer noise-induced threshold shifts between 5 and 10 decibels (in addition to 1/2 percent who will experience that hearing loss even if they are not exposed to loud noise). At the level of protection provided by TB Med 251, no one is expected to suffer an handicapping loss of hearing (barring disease or the action of toxic chemicals). Therefore, TB Med 251 is appropriate for regulation of the exposure of occupants of helicopters to noise.

10.4 RECOMMENDATIONS

Following are recommendations for modifications of U. S. Army practices and equipment, and for future studies.

- o The main problem in evaluating the results of the development of new types of microphones, earcups, helmets, and other hardware is that test equipment and methods vary significantly among contractors. It is literally impossible to evaluate the significance of many putative advances because of this problem. When future contracts are let, there should at least be a requirement that a standard test method be used. The equipment should be examined and approved by the contractor's technical representative. The test distance for noise-cancelling microphones is 1/4-inch, so an error of only 1/32 of an inch can make a significant change in the observed performance. A preferred requirement would be that the developed hardware be submitted to an independent testing facility. The test report should then be published as an integral part of the final report. In recent years, the U. S. Army has developed facilities which are capable of meeting this requirement, if the tests are conducted so that objectivity is maintained.

- o Although a number of ideas have been proposed for reducing earcup pumping and interference by eyeglasses and hair (see Section 8.2), it is not clear which, if any, of these are practical for operational use. In the absence of entirely new concepts, further developments should be conducted by manufacturer's of helmets and earcups. The manufacturer's are in the best position to make operating prototypes and to evaluate manufacturability and cost. It may be possible to develop helmets which provide adequate protection even when they are not fitted well.
- o There is considerable evidence that existing equipment is not used optimally, and that less hearing loss would occur if equipment were used optimally. For example, pilots and crewman probably unnecessarily and routinely turn volume controls to high loudness positions. They should be trained to reduce listening levels, so that hearing is preserved with little or no loss in intelligibility of voice messages. Pilots and crew members also probably do not position and seat earphone earcups optimally. They should be instructed in the optimum use of earcups so that risks of hearing damage will be reduced. If they could be instructed in the use of earplugs, and encouraged to wear them, considerable additional protection against hearing loss could be achieved.
- o The method of fitting helmets should be reviewed. Possibly, objective methods of evaluating performance in the fitting room can be developed, by using an instrumented helmet for the first phase of the fitting procedure.
- o Noise-immunity and response measurements should be made on a sample of microphones which have been in extended service, to identify problems of deterioration of performance. A similar program is applicable to ear cushions.
- o Attempts to modify existing helicopters to reduce noise in the cabin have been constrained by the type and location of structural members and power-train components. A program should be funded to develop a purely research helicopter in which a specified noise level is to be achieved. It would then be required that noise-reducing features be incorporated into the load-carrying and power-train components rather than added on. Such a program could be a source of new concepts for noise reduction.

- o A study of the feasibility of limiting volume settings on electronic communication equipment should be conducted. If improved earcups and electronics can be developed, then high speech levels will be unnecessary even under adverse circumstances, and lowered limits on volume settings might be feasible.

- o Some attempt should be made to define and document the origins of hearing losses that have been measured among helicopter pilots. Only estimates of those origins are obtainable for past environments. The number of hours of exposure at various noise levels within helicopters must be estimated, and lifetime exposures to loud noise outside the helicopters must be estimated. It is likely that such studies will reveal that hearing losses experienced by many helicopter pilots are due to exposures to damaging noises (such as noise from small-arms fire) which are unrelated to helicopter noise. Data which were presented in Section 5.10 give some support for that thesis. Information which is related to all hearing loss claims that are handled by the Veterans Administration is stored on punched cards at VA headquarters. A computerized analysis of the information which is on those cards could yield numbers for the percentage of hearing loss claims that result in compensation and for distributions of amounts of compensation that are granted. Such numbers would be useful in defining factors other than exposure to helicopter noise which contributed to hearing loss among helicopter crewmen. It would be particularly informative to list distributions of amounts of compensation by VA office and region, since factors that are not related to exposure to helicopter noise might correlate with VA office and region.

11.0 ACKNOWLEDGEMENTS

The authors are pleased to acknowledge the enthusiastic support and cooperation of numerous agencies which supplied documents and data to make possible much of the information available in this report. Several of these deserve special mention:

Kenneth Amer, Hughes Aircraft, Culver City, CA
Capt. Don Bender, Army Clinical Div., Walter Reed, Washington, D. C.
Robert T. Camp, Army Aeromedical Research Unit, Ft. Rucker, AB
Charles Cox, Bell Helicopter, Ft. Worth, TX
Dan Damico, Veterans Administration, Newark, NJ
Director, Navy Environmental Support Office, Pt. Hueneme, CA
Dr. David Eggle, School of Aerospace Engineering, U. Okla., Norman, OK
Lt. Col. D. C. Casaway, USAF School of Aerospace Medicine, Brooks AFB, Tx
James M. Harriss, Veterans Administration, Waco, TX
Col. T. Kenyon, Army ASCOM, St. Louis, MO
A. E. Lindberg, Army AVRADA, Fort Monmouth, NJ
Mitchell Mayer, Army AVRADA, Fort Monmouth, NJ
Dr. Charles Nixon, Bio Acoustics Lab, Wright-Patterson AFB, OH
Dr. Doug Ohlen, Dr. Mike Reid, Maj. R. Gooding, Army Environmental Hygiene Agency, Edgewood Arsenal, MD
Dr. R. Roeser, Callier Center, Dallas, TX
Ron Schlegal, Sikorsky Aircraft, Stratford, CN
Harry Sternfeld, Boeing Vertol, Philadelphia, PA
Dr. Jerry Tobias, FAA Aeromedical Div., Oklahoma City, OK
Dr. Carl Williams, Naval Aerospace Medical Institute, Pensacola, FL

The authors also wish to acknowledge the helpful assistance of their colleague Dr. E. M. Wilkins, who collected much of the data on hearing conservation and field experiences in the military services.

12.0 REFERENCES

1. Walden, B. E., Worthington, D. N., McCurdy, H. W. "The Extent of Hearing Loss in the Army, A Survey Report," U. S. Army Medical Research and Development Command, Walter Reed General Hospital (December 1971) AD 739 931.
2. Gasaway, D. C. (1971). "Noise Within Fixed-Wing Utility Aircraft Used by the Military," SAM-TR-71-43, USAF School of Aerospace Medicine, Brooks AFB, Tx. (AD 742 972).
3. Gasaway, D. C. (1975). "A-Weighted Sound Levels in Cockpits of Fixed - and Rotary Winged Aircraft," SAM-TR-75-22, USAF School of Aerospace Medicine, Brooks AFB, Tx, August.
4. Gasaway, D. C. (1976). "Noise Levels Measured Within Aircraft During Take-off, Climb, and Cruise (Low, Normal and High)," SAM-TR-76-9, USAF School of Aerospace Medicine, Brooks AFB, Tx.
5. Military Specification MIL-E-25670 (USAF), Earphone H-143/AIC (29 May 1957)
6. Military Specification MIL-M-26542A (USAF), Microphone, Dynamic M-87/AIC (20 December 1962)
7. Giordano, T. A. and Keane, G. C., (1973). "The Effect of Helicopter Noise on Communication and Hearing," (ECOM-4140, U. S. Army ECOM, Ft. Monmouth, New Jersey.
8. Bruce, R. D. (1971). "Field Measurements: Equipment and Techniques," Chapter 4 of Noise and Vibration Control, edited by Leo L. Beranek, McGraw-Hill Book Co., New York.
9. von Gierke, H. E. (1975). "Noise - How Much is Too Much?," Noise Control Engineering, July-August.
10. Guignard, J. C. and Johnson, D. L. (1975). "The Relation of Noise Exposure to Noise Induced Hearing Damage," Sound and Vibration, Jan.
11. EPA (U. S. Environmental Protection Agency) (1974). "Information on Levels of Environmental Noise Requisite to Protect Public Health and Welfare with an Adequate Margin of Safety," Report No. 550/9-74-004, March.
12. Randall, R. H. (1951). Introduction to Acoustics, Addison-Wesley Press, Inc., Cambridge 42, Mass.
13. OSHA (U. S. Occupational Safety and Health Administration) (1974). "Occupational Noise Exposure, Proposed Requirements and Procedures," Federal Register, 39, No. 207, 37773-37778, October 24.
14. TB Med 251 (1972). "Noise and Conservation of Hearing," Headquarters, Dept. of the Army, 7 March.

15. Kryter, K. D. (1973). "Impairment to Hearing from Exposure to Noise," JASA, 53, No. 5.
16. Glorig, A. (1971). "Damage-risk Criteria for Hearing," Chapter 17 of Noise and Vibration Control, edited by Leo L. Beranek, McGraw-Hill Book Company, New York.
17. VA (U. S. Veteran's Administration) (1975). "VA Proposed Revision to the Schedule for Rating Disabilities," U. S. Government Printing Office, Washington.
18. EPA (U. S. Environmental Protection Agency) (1973). "Prediction of NIPTS due to Continuous Noise Exposure," Report No. EPA 550/9-73-001-B.
19. ANSI S3-5 (1969), ANSI Standard S3.5, "Methods for Calculation of the Articulation Index," American National Standards Institute, Inc., 1430 Broadway, New York, New York 10018.
20. Niederjohn, R. J. and Grotelueschen, J. H. (1976). "The Enhancement of Speech Intelligibility in High Noise Levels by High-Pass Filtering Followed by Rapid Amplitude Compression," IEEE Transactions on Acoustics, Speech, and Signal Processing, Vol. ASSP-24, No. 4, August.
21. Camp, Jr., R. T., (1968). "Philosophies of Voice Communication Systems Design," AGARD Conference, London, October.
22. Gasaway, D. C. (1970). "Six Indices for Predicting Speech Interference within Aircraft," USAF School of Aerospace Medicine, Aerospace Medical Division (AFSC), Brooks Air Force Base, Texas, Report No. SAM-TR-70-72, December.
23. Pickett, J. M. and Pollack, I. (1958). "Prediction of Speech Intelligibility at High Noise Levels," JASA, 30.
24. Gasaway, D. C. (1974). "Acoustic Alteration of Speech Processed through Air Force Aircraft Communications Systems," USAF School of Aerospace Medicine, Aerospace Medical Division (AFSC), Brooks Air Force Base, Texas, Report No. SAM-TR-74-37, November.
25. TREC (1961). "Study to Establish Realistic Acoustic Design Criteria for future Army Aircraft," U. S. Army Transportation Research Command, Fort Eustis, Virginia, TREC Tech. Rpt. 61-72.
26. Cox, C. R. (1970). "Design Considerations for Acceptable Cabin Noise Levels in Light Helicopters," American Helicopter Society Symposium on Environmental Effects on VTOL Designs, Arlington, Texas, November, Preprint No. SW-70-23.
27. Weinreb, L. and Touger, M. L. (1960). "Variation in Ear Protector Attenuation as Measured by Different Methods," JASA 32, 245-249.
28. Duncan, Acheson J. (1965). Quality Control and Industrial Statistics, Third Edition, Richard D. Irwin, Inc., Homewood, Illinois.

29. MIL-A-8806 (A) (1967). "Military Specification, Acoustical Noise Levels in Aircraft, General Specifications for", Amendment 1 (12 September).
30. Hamernik, Roger P.; Henderson, Donald; Crossley, James J.; and Salvi, Richard J. (1974). "Interaction of Continuous and Impulsive Noise: Audiometric and Histological Effects", J. Acoustical Soc. Am., 55, No. 1, January.
31. Henderson, Donald and Hamernik, Roger P. (1975). "Contribution of Animal Research to Noise Exposure Criteria," Sound and Vibration, September.
32. Camp, R. T., Mozo, B. T. and Patterson, J. H. (1975). "An Investigation of Aircraft Voice Communications Systems as Sources of Insidious Long-Term Acoustic Hazards," AGARD Conference Proceedings No. 171, paper C12, November, 1975.
33. Walden, Brian E.; Worthington, Don W.; and McCurdy, Harry W. (1971). "The Extent of Hearing Loss in the Army--A Survey Report," U. S. Army Medical Research and Development Command, Washington, D. C., 20314, 21 December (AD 739 931).
34. Stork, R. L. and Gasaway, D. C. (1976). "Evaluation of V-51R and EARtm Earplugs for Use in Flight," USAF School of Aerospace Medicine, Aerospace Medical Division (AFSC), Brooks Air Force Base, Texas, Report No. SAM-TR-77-1, February.
35. Sutherland, H. C. and Gasaway, D. C. (1976). "Hearing Levels of Noise - Exposed U. S. Air Force Personnel Compared to those in the Total U. S. Population," USAF School of Aerospace Medicine, Aerospace Medical Division (AFSC), Brooks Air Force Base, Texas, Report No. SAM-TR-76-27, September.
36. Zwislocki, Josef (1955). "Factors Determining the Sound Attenuation Produced by Earphone Sockets", JASA, 27, No. 1, 146 (jan).
37. Zwislocki, Josef (1957). "Ear Protectors," Chapter 8 of Handbook of Noise Control, Edited by Cyril M. Harris, McGraw-Hill Book Co., Inc., New York.
38. Shaw, E. A. G. and Thiessen, G. J., "Improved Cushion for Ear Defenders," Journal Acoust. Soc. American (January 1958), p. 24-36.
39. Shaw, E. A. G. and Thiessen, G. J., "Acoustics of Circumaural Earphones," JASA, 34, No. 9, (September 1962).
40. Botsford, J. H., "Ear Protectors - Their Characteristics and Uses," Sound and Vibration, November, 1972, p. 24-29.
41. Forstall, J. R., "The Sound Attenuations of Flight Helmets," Sound and Vibration, October 1970, p. 12-17.
42. MIL-A-8870 (ASG) (1960). "Military Specification: Airplane Strength and Rigidity, Vibration, Flutter and Divergence," May 18.

43. Zwislocki, Josef, (1955(b)). "Development of a Semiplastic Earphone Socket," JASA, 27, No. 1, 155 (January).
44. Franke, Ernst K. (1952). "The Impedance of the Human Mastoid," JASA, 24, No. 4, 410.
45. von Gierke, H. E. (1957 a). "Aircraft Noise Sources," Chapter 33 of Handbook of Noise Control, edited by Cyril M. Harris, McGraw-Hill Book Company, Inc., New York.
46. von Gierke, H. E. (1957 b). "Aircraft Noise Control," *ibid*, chapter 34.
47. Ramakaishnan, R. and Randall, D. and Hosier, R. N. (1975). "A Computer Program to Predict Rotor Rotational Noise of a Stationary Rotor from Blade Loading Coefficient," NASA-TM-X-3281.
48. Sofrin, T. G. (1972). "Fan Noise Mechanisms and Control," Inter-Noise 72 Proceedings, Washington, D. C., October 4-6.
49. Lawson, M. V. (1972). "Fan Noise Mechanisms and Control," Inter-Noise 72 Proceedings, Washington, D. C., October 4-6.
50. Burdsall, E. A. (1972). "Recent Studies of Fan Noise Generation and Reduction," Inter-Noise 72 Proceedings, Washington, D. C. October 4-6.
51. AIAA (1975 a). Aeroacoustics: Jet and Combustion Noise; Duct Acoustics, edited by Henry T. Nagamatsu, Volume 37 of the Progress in Astronautics and Aeronautics Series, MIT Press (By AIAA), Cambridge, Massachusetts.
52. AIAA (1975 b). Aeroacoustics: Fan, STOL, and Boundary Layer Noise; Sonic Boom; Aeroacoustics Instrumentation, edited by Henry T. Nagamatsu, MIT Press (by AIAA), Cambridge, Massachusetts.
53. Jones, W. L. and Heidelberg, L. J. and Goldman, R. G. (1973). "Highly Noise Suppressed Bypass 6 Engine for STOL Application," AIAA paper 73-1031.
54. Henderson, H. R. and Pegg, R. J. and Hilton, D. A. (1973). "Results of the Noise Measurement Program on a Standard and Modified OH-6A Helicopter," NASA TN D-7216, September.
55. Faulkner, H. B. (1974). "The Cost of Noise Reduction in Intercity Commercial Helicopters," J. Aircraft, 11, No. 2, February.
56. Moeller, K. G. F. (1957). "Gear Noise," Chapter 23 of Handbook of Noise Control, edited by Cyril M. Harris, McGraw-Hill Book Company, Inc., New York.
57. Badgley, R. H. and Chiang, T. (1972). "Investigation of Gearbox Design Modifications for Reducing Helicopter Gearbox Noise," AD-742735 (Defense Documentation Center).
58. Gu, A. L. and Badgley, R. H. (1974). "Prediction of Gear-Mesh-Induced High-Frequency Vibration Spectra in Geared Power Trains," AD-777496 (Defense Documentation Center).

59. Muster, D. and Plunkett, R. (1971). "Isolation of Vibrations," Chapter 13 of Noise and Vibration Control, edited by Leo L. Beranek, McGraw-Hill Book Company, Inc., New York.
60. Ungar, E. E. and Dietrich, C. W. (1966). "High Frequency Vibration Isolation," J. Sound Vib., 4 (2).
61. Schultz, T. J. (1971). "Wrappings, Enclosures, and Duct Linings," Chapter 15 of Noise and Vibration Control, edited by L. L. Beranek, McGraw-Hill Book Company, New York.
62. Franken, P. A. and Beranek, L. L. (1960). "Noise Control in Transportation," Chapter 25 of Noise Reduction, edited by Leo L. Beranek, McGraw-Hill Book Company, Inc., New York.
63. Seshadri, T. V. (1975). "Shock and Vibration Analysis Using Finite Element Techniques," Shock and Vibration Digest, 7, No. 7, July.
64. Davis, R. F. and Hines, D. E. (1974). "Performance of Statistical Energy Analysis," Shock and Vibration Bulletin, 44, Part 2, August.
65. Mead, D. J. (1973). "A General Theory of Harmonic Wave Propagation in Linear Periodic Systems with Multiple Coupling," J. Sound Vib., 27 (2).
66. Catherines, J. J. and Mayes, W. H. (1975). "Interior Noise Levels of Two Propeller-Driven Light Aircraft," Proceedings of the Technical Program: NOISEXPO, National Noise and Vibration Control Conference, Atlanta, Georgia, April 30-May 2.
67. U. S. Air Force (1965). Acoustical Fatigue in Aircraft Structures, edited by W. J. Trapp and D. M. Forney, Jr., Syracuse University Press, Syracuse, New York.
68. Cremer, L. and Heckl, M. and Ungar, E. E. (1973). Structure-Borne Sound, Springer-Verlag, New York.
69. Ver, I. L. and Holmer, C. I. (1971). "Interaction of Sound Waves with Solid Structures," Chapter 11 of Noise and Vibration Control, edited by Leo L. Beranek, McGraw-Hill Book Company, Inc., New York.
70. Jones, D. I. G. (1972). "Damping Treatments for Noise and Vibration Control," Sound and Vibration, July.
71. Arctander, Chris (1971). "Sound Absorptive Materials for Aircraft Noise Control," Sound and Vibration, August.
72. Sen Gupta, G. (1975). "Current Developments in Interior Noise and Sonic Fatigue Research," Shock and Vibration Digest, 7, No. 10, Oct.
73. Bowes, Michael A. (1973). "Test and Evaluation of a Quiet Helicopter Configuration HA-43B", JASA, 54, No. 5.
74. Bowes, Michael A. (1977). "Helicopter Noise Reduction Design Trade-Off Study", DOT/FAA Report No. R-1493, January.

75. MIL-H-55351(EL), "Headset Microphone Kit MK 1564()/AIC(Components of)" 27 May 1971.
76. Edwards, R. G., Hauser, W. P., Moiseev, N. A., Broderson, A. B., and Green, W. W. (1978). "Effectiveness of Earnings as Worn in the Workplace," Sound and Vibration, January, p. 12-22.
77. Rosenheck, et al, "Transducer and Intercommunication System for Air Crewman's Protective Headgear-Final Report," September, 1965, AD 628-980 USAECOM Contract No. DA 28-043AMC-00282(E).
78. Bauer, B. B. and DiMattia, A. L. (1972). "Improved Earphone Enclosure for Communication in Noise," JASA, 51, No. 5, pp. 1388-1393.
79. Meeker, W. F. (1958). "Active Ear Defender Systems: Component Considerations and Theory," Air Force Contract No. AF 33(616)-3051, WADC Technical Report No. 57-368 (September) AD 130 806
80. DiMattia, A. L. and Love, G. V., "Ambient Noise Attenuation," Final Report, USAECOM Contract DAAB07-72-C-0018.
81. Malme, C. I., Allen, C. H. and Schmidt, E. C. H (1973). "Noise Reducing Headset Development," USAECOM Contract No. DAAB07-72-C-0065, Report No. ECOM-0065-F (July).
82. USAECOM Contract DAAB07-71Q-0391 (CBS Laboratories).
83. "System for Operations in High-Ambient Noise," Third-Quarter Report, USAECOM Contract DA 28-043 AMC-00257(E) April (AD 469 080).
84. Rosenheck, A. J., Abbagnaro, L. A., Finger, R. A., DiMattia, A. L., and Bauer, B. B. (1969). "Development of Audio Transducer Helmet Assembly, Final Report USAECOM Contract No. DAAB07-67-C-0204.
85. Brouns, A. J. (1976). "Linear Noise-Cancelling Microphone," ECOM-75-0140-F, USAECOM Contract DAAB07-75-C-0140 June (AD-A025 903).
86. NESCO (1975). "Directory of DOD Contacts on Airborne Acoustics," Report No. 20.2-001, Supplement A, Naval Environmental Protection Support Service, Port Hueneme, CA93043, August, 50 pp.
87. Gasaway, D. C., and Sullivan, H. C. (1977). "Disposition for Personnel Working in High-Noise Environment," USAF Handout (with reference to AFR 161-35).
88. BUMEDINST (1970). 6260.6B, 73-NER-B1, 5 March.
89. Gasaway, Donald C. (1969). "Noise Encountered in Rotary Wing Aircraft", USAF School of Aerospace Medicine, Brooks AFB, Tx, SAM-TR-69-87 (December).
90. Fletcher, John L. (1972). "Conventional and High Frequency Hearing of Naval Crewmen as a Function of Noise Exposure", Memphis State U. Dept. of Psychology, Report No. AD-739368, April.
91. Mayer, M. S., "Acoustic Noise Suppresion in Airborne Communications," ECOM-4336, July 1975, U. S. Army ECOM, Ft. Monmouth, N. J.

92. Goermann, R. R., et al (1960). Aerospace Med., 31, 443.
93. MIL-S-58095 (AV) (1971). "Military Specification, Seat System: Crashworthy, Non-Ejection Aircrew, General Specification for" (27 August).
94. AVSCOM (1976). "AL-1040 Armored Seat Net Deflections", Report No. 75-47 (31 October).
95. von Gierke, Henning E. (1971). "Biodynamic Models and Their Applications", J. Acoustical Soc. Am., 50, No. 6, 1398.
96. ASCC (1975). Air STD 61/1, "Air Standardization Agreement: Ejection Acceleration Limits", 5 September 1975.
97. Slater, John C. and Frank, Nathaniel H. (1947). "Coupled Systems and Normal Coordinates", Chapter VII of Mechanics, McGraw-Hill Book Co., Inc., New York.
98. Lindsay, Robert Bruce (1960). Mechanical Radiation, McGraw-Hill Book Company, Inc., New York.
99. Corliss, Edith L. and Koidan, Walter (1955). "Mechanical Impedance of the Forehead and Mastoid", JASA, 27, No. 6, 1164.
100. Sokolnikoff, I. S. and Redheffer, R. M. (1958). Mathematics of Physics and Modern Engineering, McGraw-Hill Book Co. Inc., New York, Chapter 3, "Functions of Several Variables."
101. MIL-STD-1474A(MI), "Noise Limits for Army Material", 3 March 1975.

BIBLIOGRAPHY

Finkelman, J. M. (1975). "Effects of Noise on Human Performance," *Sound and Vibration* (September).

Kryter, K. D. (1970). *The Effects of Noise on Man*, Academic Press, New York.

Griffin, M. J., "The Evaluation of Human Exposure to Helicopter Vibration," *Aeronautical Journal*, March, 1977, p. 110-123.

Johnson, Daniel L. and Schori, Thomas R. (1977). "How Safe is 115 dBA for 15 Minutes?", *J. Acoustical Soc. Am.*, 61, Supplement No. 1 (abstract), presented at the 93 National Meeting of the Acoustical Society of America.

Rosenheck, A. J., Dimattia, A. L., Allen, R. G., and Torick, E. L., "Transducer and Interphone System for Operation in High Ambient Noise", Final Report, USAECOM Contract No. DA 28-043 AMC-00257((E) (15 July 1966).

APPENDIX A

AIRCRAFT SPECIFICATIONS

The specifications shown in Table A-1 are found in Jane's All The World's Aircraft, 1970-1971 and 1976-1977.

TABLE A-1 AIRCRAFT SPECIFICATIONS

| Model | UH-1H | OV-1D | OH-58A | AH-1S(-1Q) | CH-47C | CH-54B |
|----------------------|-----------------------------------|-------------------------|------------------------------------|------------------------------------|-------------------------------------|------------------------------------|
| Name | Iroquois | Mohawk | Kiowa | Hueycobra | Chinook | Tarhe |
| Company | Bell | Grumman | Bell | Bell | Boeing Vertol | Sikorsky |
| Maximum Weight (kg) | 4,309 | 8,700 Estimated | 1,360 | 4,309 | 18,000 Estimated | 21,000 |
| Engine | One 1044 kW Turboshaft | Two 865 kW Turboprop | One 236 kW Turboshaft | One 1360 kW* Turboshaft | Two 2795 kW Turboshaft | Two 3600 kW Turboshaft |
| Propeller or Rotor | One 2-bladed Rotor 14.6m Diameter | Two 4-bladed Propellers | One 2-bladed Rotor, 10.8m Diameter | One 2-bladed Rotor, 13.4m Diameter | Two 3-bladed Rotors, 18.3m Diameter | One 6-bladed Rotor, 22.0m Diameter |
| Propeller, Rotor rpm | 294-324 | -- | 354 | 294-324 | 240 Approx. | -- |
| Cruise Speed (km/h) | 204 | 480 Estimated | 188 | 352 Maximum Speed | 220 Approx. | 175 |

* One 1044 kW turboshaft for AH-1Q

APPENDIX B

DATA ACQUISITION AND FORMAT

APPENDIX B. DATA ACQUISITION AND FORMAT

The acoustical data were collected at two points in the aircraft system. A Bruel & Kjaer (B&K) Model 4133 capacitor microphone, which has a flat response within 1 dB from 10 Hz to 10 kHz, was used to record ambient noise in the cabin or cockpit on one channel of a Nagra Model IV-SJ tape recorder. A Thermo Electron Corporation Model 5333-C electret microphone was used to record earcup noise on the other channel of the Nagra recorder.

The 5333-C was placed in the concha of the crewman's ear, near the opening of the ear canal, and fixed with a non-toxic adhesive. The microphone leads were brought out through a small hole in the SPH-4 earcup. The hole was then sealed. The frequency response of the 5333-C is flat within 1 dB from 10 Hz to 6 kHz.⁹¹ It rises about 3 dB to 10 kHz.

At the beginning of each tape, 250 Hz calibration tones from each microphone were recorded. The calibration source was a B&K Type 4220 pistonphone producing 124 dB SPL. Communication system noise signals were then recorded for various flight and communication conditions. The attenuation settings in each channel were changed as necessary to maximize signal-to-noise and noted in a test log.

In most cases, noise was recorded in the following locations.

| | <u>AMBIENT (CAPACITOR MICROPHONE)</u> | <u>EARCUP</u> | <u>APPROXIMATE DISTANCE FROM EARCUP TO CAPACITOR MIC</u> |
|---------------|---|-----------------|--|
| UH-1H | Center of cabin, 8 to 12-inches below overhead | Cabin | 4-6 ft. |
| OH-58A | Hung from center-top of windshield | Cabin | 2-3 ft. |
| OV-1D | Hung just under standby compass over instrument panel | Co-Pilot | 1 ft. |
| AH-1S, -1Q | Hung from overhead, between seats, left of center | Front Crew | 1 ft. |
| CH-47C | Hung from overhead, in passage just aft of pedestal. | Cabin | 1 ft. |
| CH-54B | Over crew chief's seat | Crew Chief Seat | 1 ft. |

In a separate recording system, the output of a sound level meter was analyzed in the aircraft during level flight operations. The analyzer was a B&K Type 1621 tunable band pass filter. Both 1/3-octave and 3% bandwidth chart recordings were made on a B&K Type 2306 level recorder and included in the log. Level flight ambient noise was also measured on the sound level meter in dBA, and logged.

As the data-taking proceeded, the question arose whether the objective calculations of articulation index would be valid because of the possibility that the AGC action of the microphone preamplifier would cause a gain change when moving from the "no talk" to "talk" condition. Consequently, for some recordings a 1000 Hz tone was inserted in the microphone circuit. Any change in level could then be detected at the earcup, indicating a change in amplifier gain.

The tape recordings of aircraft noise were processed by first digitizing the data, and then performing a Fast Fourier Transform (FFT) analysis as described in Section 3.2. Some additional analysis was done to describe the noise introduced by the tape recorder and the FFT analyzer. Figure B-1 shows the spectrum level (top curve) of NO KEY noise for level flight for one of the AH-1S aircraft. The NO KEY noise at 1000 Hz in the AH-1S is about as low as that in any aircraft. Also shown in Figure B-1 are the equivalent sound pressure of the spectrum noise on a blank section of the same tape, and the noise with no tape passing over the tape head. Finally, the noise introduced by the analog-to-digital (A/D) converter and FFT analyzer is shown.

The noise from the section of blank tape is calculated to have an equivalent A-weighted level of about 68 dBA. The peaks in the spectrum, due to power frequency harmonics, are narrowband and make little contribution to the dBA level. The noise from the tape is thus 14 dB less than the lowest dBA level listed in Table 1. Therefore the dBA levels listed in this report do not include a significant error due to tape noise.

However, at the higher frequencies, the curves of earcup attenuation vs. frequency probably include errors due to tape noise, because the "signal-to-noise" ratio reaches unity at about 5000 Hz. There are also likely to be variations in the noise levels of individual tapes.

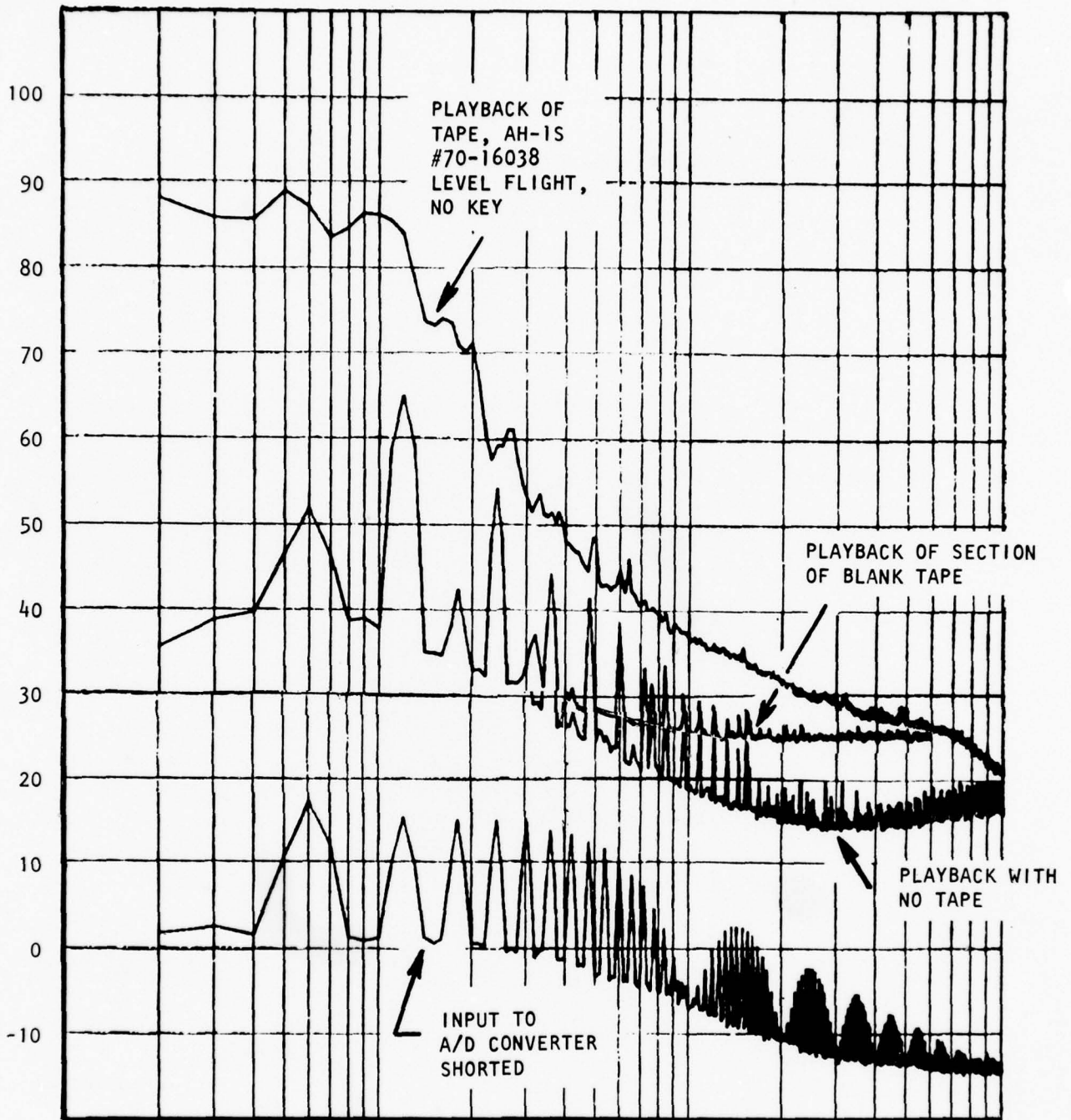

FIGURE B-1

APPENDIX C

COMMUNICATION SYSTEM NOISE IN 37 AIRCRAFT

APPENDIX C. COMMUNICATION SYSTEM NOISE IN 37 AIRCRAFT

The 37 Tables in this appendix show the A-weighted noise at several points in the communication systems of 37 U.S. Army aircraft, for up to 12 flight modes. A key to the column headings is as follows:

- o COCKPIT SLM "SLOW": A reading of A-weighted ambient noise in the cockpit or cabin, taken by USAECOM personnel on a sound-level-meter set to "SLOW" meter-damping.
- o COCKPIT AMBIENT CHAN 2: A-weighted ambient noise in the cockpit or cabin; measured off track 2 of the magnetic tape record. The ambient noise from the tape record and the sound level meter log should ideally be the same. For comparisons, see Section 4.0.
- o EARCUP NO KEY: The noise at the ear due to leakage through or around the earcup including possible effects of earcup or head vibration, plus the noise output of the earphone due to electrical noise in the headset amplifier. "KEY" refers to actuation of the transmit switch which closes a relay between the microphone circuit or radio receiver and the headset amplifier. The noise from the headset amplifier was actually found to be negligible.
- o EARCUP KEY NO TALK: The noise at the ear including the noise described in the previous paragraph, plus noise picked up by the microphone, electrical noise in the microphone amplifier or radio circuits, and noise from electromagnetic interference (EMI). In this study it was found that electrical and EMI noise are negligible and that the only two significant noise paths are leakage through or around the headset including the effects of earcup vibration, and noise picked up and transmitted by the microphone.
- o EARCUP KEY TALK: The noise described in the previous paragraph, plus a speech signal ("rainbow passage", see Section 2.0) picked up by the M-87 noise-cancelling microphone, amplified, and delivered to the headset in the SPH-4 helmet. About one-half of the talk entries represent intra-aircraft speech between crew positions (no radio link).

o EARCUP KEY TALK: (CONTINUED)

The other half represent inter-aircraft radio transmissions. There was no significant difference in noise or speech levels between intra- and inter-aircraft communications.

o A.I.: Articulation Index. See Section 3.4.

o SENTENCE INTELL: Sentence intelligibility obtained by entering Figure 7 with the A.I.

o EARCUP ATTEN: Earcup attenuation obtained by subtracting EARCUP NO KEY entries from COCKPIT AMBIENT entries.

o NOISE CROSSOVER: A frequency (usually identifiable by examining spectrum level plots of EARCUP NO KEY and EARCUP KEY NO TALK) below which the noise is predominantly due to earcup leakage and above which the noise is predominantly due to pick-up at the microphone.

Following the tables in this appendix, there are representative computer plots of spectrum level for several aircraft. The resolution of the FFT analysis is 10 Hz. In some plots there is a rising spectrum level in the region above 4 or 5 kHz. This is due to tape hiss or to noise introduced during the analysis. The effective word length for the computer analysis was 13 bits, permitting a dynamic range of approximately 80 dB.

The computer-generated spectra agreed with those obtained in the aircraft by USAECOM personnel, except for small differences due to filter resolution.

All of the OH-58A and OV-10 aircraft used Model C-6533 (SLAE) AIC's. The UH-1H aircraft used C-6533 and C-1611D (PRE-SLAE) AIC's; Tables C-1 through C-10 indicate which AIC in the NOTES. The AH-1S, AH-1Q, CH-47C, and CH-54B aircraft used the C-1611/AIC.

TABLE C-1

| AIRCRAFT | UJH-IH | SERIAL NO. | 66-16054 | | 18 Dec 76 | | Chan 2 | | 1000~ No | |
|------------------------|---------------|-------------------|----------|---------|--------------|--------------|--------|---------------------|------------------|-------------------------|
| | | | COCKPIT | COCKPIT | FLIGHT DATES | FLIGHT DATES | Only | Only | | |
| UNITS | SLM "SLOW" | AMBIENT CHAN 2 | NO KEY | NO TALK | KEY | KEY | A.I. | SENTENCE INTELL. | EARCUP ATTEN. | NOISE CROSS- OVER |
| 1 TAKE OFF | dBa | dBa | dBa | dBa | dBa | dBa | % | ΔdBa | Hz | |
| 2 CLIMB | | 93 | | | | | | | | |
| 3 DESCEND RIGHT | | 96 | | | | | | | | |
| 4 CLIMB LEFT | | 93 [†] | | | | | | | | |
| 5 DESCEND LEFT | | 97 [†] | | | | | | | | |
| 6 CLIMB RIGHT | | 94 | | | | | | | | |
| 7 DESCEND | | 96 | | | | | | | | |
| 8 LEVEL FLIGHT | 90 | 95 | | | | | | | | |
| 9 HOVER AT ALTITUDE | | 92 | | | | | | | | |
| 10 HOVER/GND EFFECT | | 94 | | | | | | | | |
| 11 LAND | | | | | | | | | | |
| 12 NAP OF EARTH | | | | | | | | | 96 Doors Open | |

NOTES: Pilot and copilot windows open on all flights. † One data sample only C-1611D/A1C

TABLE C-2

AIRCRAFT UH-1H SERIAL NO. 66-16566 FLIGHT DATES 9 Dec 76 CALIB: 250~ Yes 1000~ Not Usable

COCKPIT SLM "SLOW" COCKPIT AMBIENT CHAN 2 EARCUP NO KEY NO TALK EARCUP KEY NO TALK EARCUP KEY TALK SENTENCE INTELL. ATTEN. CROSS-OVER NOISE OVER

| UNITS | dBa | dBa | dBa | dBa | dBa | % | ΔdBa | Hz |
|---------------------|---------|-----|----------------|-----|-----|----|------|----------------|
| 1 TAKE OFF | | | | | | | | |
| 2 CLIMB | 93/93*† | 81 | 84/85* | 90 | .76 | 99 | 12 | 1500 |
| 3 DESCEND RIGHT | 90*† | | | 90* | | | | |
| 4 CLIMB LEFT | | | | | | | | |
| 5 DESCEND LEFT | | | | | | | | |
| 6 CLIMB RIGHT | | | | | | | | |
| 7 DESCEND | 94* | 83* | 86 | 90 | .71 | 99 | 11 | 1600 |
| 8 LEVEL FLIGHT | 94 | 93 | 83 | 86 | .69 | 99 | 20 | 2600 |
| 9 HOVER AT ALTITUDE | 90 | 79 | 83 | | | | 11 | |
| 10 HOVER/GND EFFECT | 93 | 80 | 83 | | | | 13 | |
| 11 LAND | | | | | | | | |
| 12 NAP OF EARTH | | 94† | AIR VENTS OPEN | | | | 86 | AIR VENTS OPEN |

C-4

NOTES: * MAX. PERFORMANCE MANEUVER + ONE DATA SAMPLE ONLY C-1611D/AIC

TABLE C-3

| AIRCRAFT | UH-1H | SERIAL NO. 68-16612 | FLIGHT DATES 23 SEP 76 | | CALIB: 250~ | | 1000~ | | | | | |
|----------|----------------------|---------------------|--------------------------|------------------------------|------------------|--------------------|---------------------|------------------|-------------------------|-----|----|--|
| | | | COCKPIT SLM "SLOW" | COCKPIT AMBIENT CHAN 2 | EARCUP NO KEY | EARCUP KEY TALK | SENTENCE INTELL. | EARCUP ATTEN. | NOISE CROSS- OVER | YES | NO | |
| UNITS | | dBa | dBa | dBa | dBa | % | ΔdBa | Hz | | | | |
| 1 | TAKE OFF | | | | | | | | | | | |
| 2 | CLIMB | | 95 | 82 | 83 | .48 | 97 | 13 | 1600 | | | |
| 3 | DESCEND RIGHT | | 98 | 83 | 84 | .23 | 61 | 15 | 500 | | | |
| 4 | CLIMB LEFT | | 95 | 80 | 83 | | | 15 | 750 | | | |
| 5 | DESCEND LEFT | | 98 | 82 | 85 | | | 16 | | | | |
| 6 | CLIMB RIGHT | | 95 | 81 | 82 | .45 | 96 | 14 | | | | |
| 7 | DESCEND | | 98 | 82 | 84 | .46 | 96 | 16 | 1200 | | | |
| 8 | LEVEL FLIGHT | | 96 | 80 | 85 | .34 | 86 | 16 | 1200 | | | |
| 9 | HOVER AT ALTITUDE | | 92 [†] | 76 | | | | 16 | | | | |
| 10 | HOVER/GND EFFECT | | 91 [†] | 77 | | | | 14 | | | | |
| 11 | LAND | | 91 [†] | 76 | | | | 15 | | | | |
| 12 | NAP OF EARTH | | | | | | | | | | | |

C-5

NOTES: SOUND ABSORPTIVE MAT'L REMOVED ON OVERHEAD AND WALLS. † ONE DATA SAMPLE ONLY. C-1611D/AIC

TABLE C-4

AIRCRAFT UH-1H SERIAL NO. 68-16622 FLIGHT DATES 3, 8 Nov 76 CALIB: 250~ YES 1000~ NOT USABLE

COCKPIT SLM "SLOW" CHAN 2 COCKPIT AMBIENT CHAN 2 EARCUP NO KEY EARCUP KEY NO TALK EARCUP KEY TALK SENTENCE INTELL. A.I. EARCUP ATTEN. NOISE CROSS-OVER

UNITS dBA dBA dBA dBA dBA dBA % ΔdBA Hz

| | | | | | | | | | | | | |
|---------------------|--|-----------------|----|----|----|-----|----|----|--|--|--|--|
| 1 TAKE OFF | | | | | | | | | | | | |
| 2 CLIMB | | 92 | 82 | 82 | | | | 10 | | | | |
| 3 DESCEND RIGHT | | 96 [†] | | | | | | | | | | |
| 4 CLIMB LEFT | | | | | | | | | | | | |
| 5 DESCEND LEFT | | | | | | | | | | | | |
| 6 CLIMB RIGHT | | 93 [†] | | 90 | | | | | | | | |
| 7 DESCEND | | 95 | 85 | 86 | 89 | .68 | 99 | 10 | | | | |
| 8 LEVEL FLIGHT | | 93 | 83 | 84 | 90 | .71 | 99 | 10 | | | | |
| 9 HOVER AT ALTITUDE | | 91 | 78 | 80 | 89 | .78 | 99 | 13 | | | | |
| 10 HOVER/GND EFFECT | | 91 | 77 | 80 | 90 | .74 | 99 | 14 | | | | |
| 11 LAND | | | | | | | | | | | | |
| 12 NAP OF EARTH | | | | | | | | | | | | |

C-6

NOTES: † ONE DATA SAMPLE ONLY

C-1611D/A1C

TABLE C-5

| AIRCRAFT | UH-1H | SERIAL NO. | 68-16628 | | FLIGHT DATES | | 2 Dec 76 | | CALIB: 250~ YES | | 1000~ | NO |
|----------|-------------------|-----------------|--------------------|------------------------|---------------|--------------------|-----------------|------|------------------|---------------|-------|----|
| | | | COCKPIT SLM "SLOW" | COCKPIT AMBIENT CHAN 2 | EARCUP NO KEY | EARCUP KEY NO TALK | EARCUP KEY TALK | A.I. | SENTENCE INTELL. | EARCUP ATTEN. | | |
| UNITS | | dBa | dBa | dBa | dBa | dBa | | | % | ΔdBa | Hz | |
| 1 | TAKE OFF | | | | | | | | | | | |
| 2 | CLIMB | 93 | 90 | 84 | 95 | .82 | 99 | 3 | | | | |
| 3 | DESCEND RIGHT | | | | | | | | | | | |
| 4 | CLIMB LEFT | 95 [†] | 88 | | | | | 7 | | | | |
| 5 | DESCEND LEFT | 97 [†] | 91 | | | | | 6 | | | | |
| 6 | CLIMB RIGHT | 92 [†] | 86 | | | .88 | 99 | | | | | |
| 7 | DESCEND | 96 | 93 | 87 | 97 | .78 | 99 | 3 | | | 1400 | |
| 8 | LEVEL FLIGHT | 94 | 90 | 86 | 96 | .86 | 99 | 4 | | | | |
| 9 | HOVER AT ALTITUDE | 91 | 86 | 83 | 96 | .92 | 99 | 5 | | | | |
| 10 | HOVER/GND EFFECT | 93 | 89 | 86 | 96 | .82 | 99 | 4 | | | 1700 | |
| 11 | LAND | | | | | | | | | | | |
| 12 | NAP OF EARTH | | | | | | | | | | | |

C-7

NOTES: RADIO TO BASE: LEVEL RISES TO 98-99 dBA, PEAKS TO 105dBA FOR 5 SEC. † ONE DATA SAMPLE ONLY C-1611D/AIC

TABLE C-6

| AIRCRAFT | UH-1H | SERIAL NO. | 69-15008 | | FLIGHT DATES | | 4 Nov 76 | | CALIB: 250~ | | 1000~ | |
|---------------------|-------|------------|----------|---------|--------------|--------|----------|---------|-------------|--------|--------|--------|
| | | | COCKPIT | COCKPIT | EARCUP | EARCUP | KEY | KEY | SENTENCE | EARCUP | YES | NOISE |
| UNITS | dBa | dBa | dBa | dBa | NO TALK | TALK | A.I. | INTELL. | ATTEN. | CROSS- | OVER | Hz |
| 1 TAKE OFF | dBa | dBa | dBa | dBa | NO KEY | NO KEY | NO KEY | NO KEY | NO KEY | NO KEY | NO KEY | NO KEY |
| 2 CLIMB | 93 | 86** | 90 | 93 | .64 | 99 | 7** | 2500 | | | | |
| 3 DESCEND RIGHT | | | | | | | | | | | | |
| 4 CLIMB LEFT | | | | | | | | | | | | |
| 5 DESCEND LEFT | | | | | | | | | | | | |
| 6 CLIMB RIGHT | | | | | | | | | | | | |
| 7 DESCEND | 97 | 92** | 92 | 93 | | | 5** | | | | | |
| 8 LEVEL FLIGHT | 89 | 87** | 90 | 93 | | | 2** | | | | | |
| 9 HOVER AT ALTITUDE | 90 | 85** | 87 | 98 | .61 | 99 | 5** | | | | | |
| 10 HOVER/GND EFFECT | 96 | 84 | 88 | | | | | | | | | 12 |
| 11 LAND | | | | | | | | | | | | |
| 12 NAP OF EARTH | 87† | 5 KNOTS | 92† | ? | KNOTS | | | | | | | |

NOTES: ** ROTOR BANG EXCESSIVE FOR THIS DATA

† ONE DATA SAMPLE ONLY

C-1611D/AIC

TABLE C-7

| AIRCRAFT | UH-1H | SERIAL NO. | 71-20223 | FLIGHT DATES | 21 DEC 76 | CALIB: 250~ YES | 1000-NO |
|---------------------|--------------------|----------------------------------|---------------|-------------------------------------|-----------------|---|------------------|
| | COCKPIT SLM "SLOW" | COCKPIT AMBIENT CHAN 2 | EARCUP NO KEY | EARCUP KEY NO TALK | EARCUP KEY TALK | SENTENCE INTELL. ATTEM. | NOISE CROSS-OVER |
| UNITS | dBa | dBa | dBa | dBa | dBa | % | Hz |
| 1 TAKE OFF | | 93 | | | | | |
| 2 CLIMB | | 94/94 ^{*†} | | 91/90 [*] | 92 | .77 | .99 |
| 3 DESCEND RIGHT | | | | | | | |
| 4 CLIMB LEFT | | | | | | | |
| 5 DESCEND LEFT | | | | | | | |
| 6 CLIMB RIGHT | | | | | | | |
| 7 DESCEND | | 93 [†] /92 [*] | | 187 [*] 90/93 [*] | | .72/.76 [*] .99/.99 [*] | 1500 |
| 8 LEVEL FLIGHT | 94 | 94 | 82 | 89 | 91 | .72 | .99 |
| 9 HOVER AT ALTITUDE | | 93 [†] | 82 | | | | 11 |
| 10 HOVER/GND EFFECT | | 93 [†] | 87 | 90 | | | 6 |
| 11 LAND | | | | | | | |
| 12 NAP OF EARTH | | | | | | | |

C-9

NOTES: * MAX. PERFORMANCE MANEUVER † ONE DATA SAMPLE ONLY NO AIC DATA

TABLE C-8

| AIRCRAFT | UH-1H | SERIAL NO. | 71-20228 | | FLIGHT DATES 14 Jan 77 | | CALIB: 250~ | | YES | NOISE | 1000~ | NO |
|---------------------|-------|------------|-----------------|---------|------------------------|--------|-------------|--------|-----|-------|-------|----|
| | | | COCKPIT | COCKPIT | EARCUP | EARCUP | SENTENCE | EARCUP | | | | |
| UNITS | SLM | "SLOW" | AMBIENT | NO KEY | NO TALK | KEY | EARCUP | A. I. | % | ΔdBA | Hz | |
| 1 TAKE OFF | dBa | dBa | dBa | dBa | dBa | TALK | | | | | | |
| 2 CLIMB | | | 92 | 87 | 87 | 87 | 87 | .51 | 98 | 5 | 3000 | |
| 3 DESCEND RIGHT | | | | | | | | | | | | |
| 4 CLIMB LEFT | | | | | | | | | | | | |
| 5 DESCEND LEFT | | | | | | | | | | | | |
| 6 CLIMB RIGHT | | | | | | | | | | | | |
| 7 DESCEND | | | 93 | 90 | 90 | 89 | 89 | .54 | 98 | 3 | 2500 | |
| 8 LEVEL FLIGHT | | | 93 | 86 | 87 | 88 | 88 | | | | | 7 |
| 9 HOVER AT ALTITUDE | | | 91 [†] | 86 | 87 | | | | | | | |
| 10 HOVER/GND EFFECT | | | 93 | 87 | 87 | | | | | | | 6 |
| 11 LAND | | | | | | | | | | | | |
| 12 NAP OF EARTH | | | 92 [†] | | 89 | | | | | | | |

C-10

NOTES: [†] ONE DATA SAMPLE ONLY

C-6533/A1C

TABLE C-9

| AIRCRAFT | UH-IH | SERIAL NO. | 71-20254 | | FLIGHT DATES SEP OR OCT 76 | | | CALIB: 250~ | | 1000~ | NO |
|---------------------|-----------------|------------|--------------------|------------------------|----------------------------|--------------------|-----------------|-------------|------------------|-------|----|
| | | | COCKPIT SLM "SLOW" | COCKPIT AMBIENT CHAN 2 | EARCUP NO KEY | EARCUP KEY NO TALK | EARCUP KEY TALK | A.I. | SENTENCE INTELL. | | |
| UNITS | dBa | dBa | dBa | dBa | dBa | dBa | % | ΔdBa | Hz | | |
| 1 TAKE OFF | | | | | | | | | | | |
| 2 CLIMB | 94 | 78 | 78 | 84 | .65 | 99 | 16 | 1200 | | | |
| 3 DESCEND RIGHT | 96 | 80 | 81 | 86 | .68 | 99 | 16 | 1200 | | | |
| 4 CLIMB LEFT | 93 | 76 | 79 | 85 | .66 | 99 | 17 | 1200 | | | |
| 5 DESCEND LEFT | 95 [†] | 78 | | | | | 17 | | | | |
| 6 CLIMB RIGHT | 94 [†] | 77 | | | | | 17 | | | | |
| 7 DESCEND | 96 | 80 | 80 | 86 | | | 16 | | | | |
| 8 LEVEL FLIGHT | 94 | 95 | 79 | 86 | .77 | 99 | 16 | | | | |
| 9 HOVER AT ALTITUDE | 90 [†] | 75 | | | | | 15 | | | | |
| 10 HOVER/GND EFFECT | 90 [†] | 76 | | | | | 14 | | | | |
| 11 LAND | | | | | | | | | | | |
| 12 NAP OF EARTH | | | | | | | | | | | |

90[†] 76 WINDOWS CLOSED
 91[†] 78 WINDOWS OPEN
 95[†] 83 WINDOWS, DOORS OPEN 30 KTS
 96[†] 87 WINDOWS, DOORS OPEN 60 KTS

14
 13
 12
 9

† ONE DATA SAMPLE ONLY
 C-6533/AIC

NOTES:

TABLE C-10

| AIRCRAFT | UH-1H | SERIAL NO. 73-21693 | COCKPIT AMBIENT "SLOW" | | COCKPIT AMBIENT CHAN 2 | | EARCUP NO KEY | | EARCUP KEY NO TALK | | EARCUP KEY TALK | | A.I. | | SENTENCE INTELL. | | EARCUP ATTEN. | | EARCUP CROSS-OVER | | 1000~ | NOT USABLE | |
|----------|-------------------|---------------------|------------------------|--------|------------------------|----|---------------|----|--------------------|------|-----------------|----|------|----|------------------|----|---------------|----|-------------------|----|-------|------------|----|
| | | | SLM | dB | dB | dB | dB | dB | dB | dB | dB | dB | dB | dB | dB | dB | dB | dB | dB | dB | | | dB |
| 1 | TAKE OFF | | | | | | | | | | | | | | | | | | | | | | |
| 2 | CLIMB | | 95/93* | 82/79* | 79 | 86 | .86 | 99 | 13/14* | 2500 | | | | | | | | | | | | | |
| 3 | DESCEND RIGHT | | | | | | | | | | | | | | | | | | | | | | |
| 4 | CLIMB LEFT | | | | | | | | | | | | | | | | | | | | | | |
| 5 | DESCEND LEFT | | | | | | | | | | | | | | | | | | | | | | |
| 6 | CLIMB RIGHT | | | | | | | | | | | | | | | | | | | | | | |
| 7 | DESCEND | | 99 | 87 | 83* | 90 | .70 | 99 | 12 | 1500 | | | | | | | | | | | | | |
| 8 | LEVEL FLIGHT | | 96 | 82 | 86 | 87 | .73 | 99 | 14 | | | | | | | | | | | | | | |
| 9 | HOVER AT ALTITUDE | | 94 | 78 | 78 | | | | | | | | | | | | | | | | | | |
| 10 | HOVER/GND EFFECT | | 94 | 81 | 79 | | | | | | | | | | | | | | | | | | |
| 11 | LAND | | | | | | | | | | | | | | | | | | | | | | |
| 12 | NAP OF EARTH | | | | | | | | | | | | | | | | | | | | | | |

THIS PAGE IS BEST QUALITY PRACTICABLE FROM COPY FURNISHED TO DDC

NOTES: * MAX. PERFORMANCE MANEUVER + ONE DATA SAMPLE ONLY C-6533/A1C

TABLE C-11

| AIRCRAFT | OH-53 | SERIAL NO. Z1-20475 | | FLIGHT DATES 3 DEC 76 | | CALIB: 250~ YES | | 1000~ NOT USABLE | |
|---------------------|-------|---------------------|------------------------|-----------------------|--------------------|-----------------|-------|------------------|---------------|
| | | COCKPIT SLM "SLOW" | COCKPIT AMBIENT CHAN 2 | EARCUP NO KEY | EARCUP KEY NO TALK | EARCUP KEY TALK | A. I. | SENTENCE INTELL. | EARCUP ATTEN. |
| UNITS | dBa | dBa | dBa | dBa | dBa | dBa | % | ΔdBa | Hz |
| 1 TAKE OFF | | | | | | | | | |
| 2 CLIMB | | 92 | 81 | 81 | 86 | .64 | 99 | 11 | 1600 |
| 3 DESCEND RIGHT | | | | | | | | | |
| 4 CLIMB LEFT | | 94* | 79* | | | | | 15 | |
| 5 DESCEND LEFT | | 93* | 82* | 84* | 86* | .50* | 97* | 11 | 1500 |
| 6 CLIMB RIGHT | | | | | | | | | |
| 7 DESCEND | | 93 | 81 | 83 | 86 | .61 | 98 | 12 | 1500 |
| 8 LEVEL FLIGHT | | 92 | | 83 | 86 | .61 | 98 | | |
| 9 HOVER AT ALTITUDE | | 92 | 80 | 82 | 86 | .62 | 98 | 12 | 1800 |
| 10 HOVER/GND EFFECT | | 92† | | 82 | | | | | |
| 11 LAND | | 92† | | 82 | | | | | |
| 12 NAP OF EARTH | | | | | | | | | |

NOTES: * MAX. PERFORMANCE MANEUVER † ONE DATA POINT ONLY

THIS PAGE IS BEST QUALITY PRACTICABLE FROM COPY FURNISHED TO DDC

TABLE C-12

AIRCRAFT OH-58 SERIAL NO. 71-20558 FLIGHT DATES OCT 76 CALIB: 250~ YES 1000~ NOT USABLE

| UNITS | COCKPIT AMBIENT CHAN 2 | | EARCUP NO KEY | | EARCUP KEY TALK | | EARCUP KEY TALK | | A.I. | SENTENCE INTELL. | | NOISE CROSS-OVER |
|---------------------|------------------------|----|---------------|----|-----------------|----|-----------------|----|------|------------------|-----|------------------|
| | SLM "SLOW" | dB | dB | dB | dB | dB | dB | dB | | % | ΔdB | |
| 1 TAKE OFF | | | | | | | | | | | | |
| 2 CLIMB | | 91 | 91 | 91 | 88 | 90 | 90 | 90 | .62 | 98 | 0 | 3000 |
| 3 DESCEND RIGHT | | | | | | | | | | | | |
| 4 CLIMB LEFT | | | | | | | | | | | | |
| 5 DESCEND LEFT | | | | | | | | | | | | |
| 6 CLIMB RIGHT | | | | | | | | | | | | |
| 7 DESCEND | | | 89 | 90 | 87 | | | | | | -1 | |
| 8 LEVEL FLIGHT | | | 89 | 89 | 87 | 89 | 89 | 89 | .60 | 98 | 0 | |
| 9 HOVER AT ALTITUDE | | | 88 | | | | | | .59 | 98 | | |
| 10 HOVER/GND EFFECT | | | 91 | | | | | | .58 | 98 | | |
| 11 LAND | | | | | | | | | | | | |
| 12 NAP OF EARTH | | | | | | | | | | | | |

THIS PAGE IS BEST QUALITY PRACTICABLE FROM COPY FURNISHED TO DDC

NOTES: † ONE DATA SAMPLE ONLY

TABLE C-13

| AIRCRAFT | OH-58 | SERIAL NO. | | 71-20561 | | FLIGHT DATES | | SEP OR OCT 76 | | CALIB: 250~ | | 1000~ | |
|----------|-------------------|--------------------|------------------------|---------------|--------------------|-----------------|-------|------------------|--------------|-------------|------------------|-------|----|
| | | COCKPIT SLM "SLOW" | COCKPIT AMBIENT CHAN 2 | EARCUP NO KEY | EARCUP KEY NO TALK | EARCUP KEY TALK | A. I. | SENTENCE INTELL. | EARCUP ATTN. | EARCUP | NOISE CROSS-OVER | NO | NO |
| UNITS | | dBa | dBa | dBa | dBa | dBa | % | ΔdBa | Hz | | | | |
| 1 | TAKE OFF | | | | | | | | | | | | |
| 2 | CLIMB | | 86 | | | | | | | | | | |
| 3 | DESCEND RIGHT | | | | | | | | | | | | |
| 4 | CLIMB LEFT | | | | | | | | | | | | |
| 5 | DESCEND LEFT | | | | | | | | | | | | |
| 6 | CLIMB RIGHT | | 85 ⁺ | | | | | | | | | | |
| 7 | DESCEND | | | | 86 | | | | | | | | |
| 8 | LEVEL FLIGHT | | | | 87 | | | | | | | | |
| 9 | HOVER AT ALTITUDE | | | | 85 | | | | | | | | |
| 10 | HOVER/GND EFFECT | | | | 86 | | | | | | | | |
| 11 | LAND | | | | | | | | | | | | |
| 12 | MAP OF EARTH | | | | | | | | | | | | |

THIS PAGE IS BEST QUALITY PRACTICABLE FROM COPY FURNISHED TO DDC

NOTES: CALIBRATION-TONE LEVEL ASSUMED SAME AS FOR TAPE OH-58 #20558 + ONE DATA SAMPLE ONLY

TABLE C-14

| AIRCRAFT | OH-58 | SERIAL NO. | 71-20563 | | FLIGHT DATES SEP OR OCT 76 | | CALIB: 250~ YES | | 1000~ NO | |
|---------------------|-----------------|------------|--------------------|------------------------|----------------------------|-----------------|-----------------|------------------|----------|---------------|
| | | | COCKPIT SLM "SLOW" | COCKPIT AMBIENT CHAN 2 | EARCUP NO KEY | EARCUP KEY TALK | EARCUP KEY TALK | SENTENCE INTELL. | | EARCUP ATTEN. |
| UNITS | dBa | dBa | dBa | dBa | dBa | dBa | A.I. | % | ΔdBA | Hz |
| 1 TAKE OFF | 93 [†] | 87 | | | | | | | | |
| 2 CLIMB | 93 | 88 | 92 | 96 | .66 | 5 | 1800 | | | |
| 3 DESCEND RIGHT | 94 | 89 | 92 | 97 | .64 | 5 | | | | |
| 4 CLIMB LEFT | 93 | 86 | 90 | 92 | .49 | 7 | 1800 | | | |
| 5 DESCEND LEFT | 94 | 87 | 91 | | | 7 | | | | |
| 6 CLIMB RIGHT | 94 | 87 | 92 | | | 7 | | | | |
| 7 DESCEND | 92 | 87 | 92 | 93 | .48 | 5 | | | | |
| 8 LEVEL FLIGHT | 94 | 87 | 90 | | | 6 | | | | |
| 9 HOVER AT ALTITUDE | 93 [†] | 84 | | | | 9 | | | | |
| 10 HOVER/GND EFFECT | 92 [†] | 86 | | | | 6 | | | | |
| 11 LAND | | | | | | | | | | |
| 12 NAP OF EARTH | | | | | | | | | | |

THIS PAGE IS BEST QUALITY PRACTICABLE
FROM COPY FURNISHED TO DDC

NOTES: † ONE DATA SAMPLE ONLY

TABLE C-15

| AIRCRAFT | OH-58 | SERIAL NO. | 71-20564 | | FLIGHT DATES | | 22 DEC 76 | | CALIB: | | 1000 | YES |
|----------|-------------------|------------|--------------------|------------------------|---------------|--------------------|-----------------|------|------------------|---------------|------|-----|
| | | | COCKPIT SLM "SLOW" | COCKPIT AMBIENT CHAN 2 | EARCUP NO KEY | EARCUP KEY NO TALK | EARCUP KEY TALK | A.I. | SENTENCE INTELL. | EARCUP ATTEN. | | |
| UNITS | | dBA | dBA | dBA | dBA | dBA | % | ΔdBA | Hz | | | |
| 1 | TAKE OFF | 92 | | 85 | | | | | | | | |
| 2 | CLIMB | 92/92* | 83/82* | 81/82* | 84/84* | .53* | /98* | 9/10 | /2000 | | | |
| 3 | DESCEND RIGHT | | | | | | | | | | | |
| 4 | CLIMB LEFT | | | | | | | | | | | |
| 5 | DESCEND LEFT | | | | | | | | | | | |
| 6 | CLIMB RIGHT | | | | | | | | | | | |
| 7 | DESCEND | 91/91* | 83/83* | 82*/82* | 84*/84* | .53* | /98* | 8/8 | /1800 | | | |
| 8 | LEVEL FLIGHT | 92 | 82 | 83 | 85 | .51 | 98 | 10 | | | | |
| 9 | HOVER AT ALTITUDE | 91 | 84 | 81 | 83 | .53 | 98 | 7 | 1800 | | | |
| 10 | HOVER/GND EFFECT | 92 | 82 | 83 | | | | | | | | |
| 11 | LAND | | | | | | | | | | | |
| 12 | NAP OF EARTH | | | | | | | | | | | |

THIS PAGE IS BEST QUALITY PRACTICABLE FROM COPY FURNISHED TO DDG

NOTES: * MAXIMUM PERFORMANCE MANEUVER † ONE DATA POINT ONLY

TABLE C-16

AIRCRAFT OH-58 SERIAL NO. 73-20549 FLIGHT DATES 16 DEC 76 CALIB: 250~ YES 1000~ NOT USABLE

| UNITS | COCKPIT SLM "SLOW" | | COCKPIT AMBIENT CHAN 2 | | EARCUP NO KEY | | EARCUP KEY TALK | | EARCUP KEY TALK | | A.I. | SENTENCE INTELL. | EARCUP ATTN. | | NOISE CROSS-OVER |
|---------------------|--------------------|-----|------------------------|-----|---------------|-----|-----------------|-----|-----------------|-----|------|------------------|--------------|------|------------------|
| | dBa | dBa | dBa | dBa | dBa | dBa | dBa | dBa | dBa | dBa | | | % | dBa | |
| 1 TAKE OFF | | | | | | | | | | | | | | | |
| 2 CLIMB | | | 97 [†] | | 85 | 86 | 88 | | | | .50 | 97 | 12 | 2000 | |
| 3 DESCEND RIGHT | | | | | | | | | | | | | | | |
| 4 CLIMB LEFT | | | 96 [†] | | | | 88 | | | | | | | | |
| 5 DESCEND LEFT | | | | | | | | | | | | | | | |
| 6 CLIMB RIGHT | | | | | | | | | | | | | | | |
| 7 DESCEND | | | 96 [†] | | | 88 | 90 | | | | | | | | |
| 8 LEVEL FLIGHT | | | 99 [†] | | 87 | 87 | 89 | | | | .46 | 96 | 12 | | |
| 9 HOVER AT ALTITUDE | | | 97 [†] | | 85 | 88 | | | | | | | 12 | | |
| 10 HOVER/GND EFFECT | | | 97 [†] | | 85 | 87 | | | | | | | 12 | | |
| 11 LAND | | | | | | | | | | | | | | | |
| 12 MAP OF EARTH | | | | | | | | | | | | | | | |

THIS PAGE IS BEST QUALITY PRACTICABLE FROM COPY FURNISHED TO DDC

NOTES: † ONE DATA POINT ONLY

TABLE C-17

| AIRCRAFT | OV-ID | SERIAL NO. 68-15933 | COCKPIT SLM "SLOW" | | COCKPIT AMBIENT CHAN 2 | | EARCUP NO KEY | | EARCUP KEY NO TALK | | EARCUP KEY TALK | | SEP OR OCT 76 | | CALIB: 250~ | | YES | | 1000~ | | NO | | |
|----------|-------------------|---------------------|--------------------|----|------------------------|----|---------------|----|--------------------|----|-----------------|------------------|---------------|------------------|-------------|------|-----|-----|-------|----|----|----|------|
| | | | dB | dB | dB | dB | dB | dB | dB | dB | A.I. | SENTENCE INTELL. | EARCUP ATTN. | NOISE CROSS-OVER | % | ΔdBA | Hz | | | | | | |
| 1 | TAKE OFF | | | | | | | | | | | | | | | | | | | | | | |
| 2 | CLIMB | | 96 | | 84 | | 86 | | | | | | | | | 12 | | | | | | | |
| 3 | DESCEND RIGHT | | 100 | | 85 | | 87 | | | | | | | | | 15 | | | | | | | |
| 4 | CLIMB LEFT | | 96 | | 83 | | 87 | | | | | | | | | 13 | | | | | | | |
| 5 | DESCEND LEFT | | 99 | | 86 | | 89 | | | | | | | | | 13 | | | | | | | |
| 6 | CLIMB RIGHT | | 96 | | 84 | | 87 | | | | | | | | | 12 | | | | | | | |
| 7 | DESCEND | | 97 | | 80 | | 89 | | | | | | | | | 17 | | | | | | | |
| 8 | LEVEL FLIGHT | 97 | 98 | | 85 | | 90 | | | | | | | | | 91 | | .53 | | 98 | | 13 | 1600 |
| 9 | HOVER AT ALTITUDE | | | | | | | | | | | | | | | | | | | | | | |
| 10 | HOVER/GND EFFECT | | | | | | | | | | | | | | | | | | | | | | |
| 11 | LAND | | | | | | | | | | | | | | | | | | | | | | |
| 12 | NAP OF EARTH | | | | | | | | | | | | | | | | | | | | | | |

THIS PAGE IS BEST QUALITY PRACTICABLE FROM COPY FURNISHED TO DDC

NOTES:

TABLE C-18

| AIRCRAFT OV-ID | SERIAL NO. 68-15950 | | FLIGHT DATES 6 DEC 76 | | CALIB: 250~ YES | | NOISE CROSS-OVER | |
|---------------------|---------------------|------------------------|-----------------------|--------------------|-----------------|------------------|------------------|--------|
| | COCKPIT SLM "SLOW" | COCKPIT AMBIENT CHAN 2 | EARCUP NO KEY | EARCUP KEY NO TALK | EARCUP KEY TALK | SENTENCE INTELL. | | ATTEN. |
| UNITS | dBa | dBa | dBa | dBa | dBa | % | ΔdBa | Hz |
| 1 TAKE OFF | | 116 [†] | 111 | | | | 5 | |
| CLIMB AFTER T/O | | 105 [†] | 102 | | | | 3 | |
| 2 CLIMB | | 99 | 93 | 94 | 95 | .53 | 98 | 6 |
| 3 DESCEND RIGHT | | | | | | | | |
| 4 CLIMB LEFT | | | | | | | | |
| 5 DESCEND LEFT | | | | | | | | |
| 6 CLIMB RIGHT | | | | | | | | |
| 7 DESCEND | | 102 | 89 | 89 | 89 | .43 | 94 | 13 |
| 8 LEVEL FLIGHT | | 102 | 100 | 88 | 87 | | | 12 |
| 9 HOVER AT ALTITUDE | | | | | | | | |
| 10 HOVER/GND EFFECT | | | | | | | | |
| 11 LAND | | | | | | | | |
| 12 NAP OF EARTH | | | | | | | | |

THIS PAGE IS BEST QUALITY PRACTICABLE FROM COPY FURNISHED TO DDC

C-20

NOTES: + ONE DATA SAMPLE ONLY

TABLE C-19

| AIRCRAFT | OV-ID | SERIAL NO. <u>68-15959</u> | | FLIGHT DATES <u>SEP OR OCT 76</u> | | CALIB: 250~ | | YES | | 1000~ | | NO |
|----------|-------------------|----------------------------|------------------------|-----------------------------------|----------------|-----------------|-----------------|------------------|---------------|------------------|------------------|----|
| | | COCKPIT SLM "SLOW" | COCKPIT AMBIENT CHAN 2 | EARCUP NO KEY | EARCUP NO TALK | EARCUP KEY TALK | EARCUP KEY TALK | SENTENCE INTELL. | EARCUP ATTEN. | NOISE CROSS-OVER | NOISE CROSS-OVER | |
| UNITS | | dBA | dBA | dBA | dBA | dBA | dBA | % | ΔdBA | ΔdBA | Hz | |
| 1 | TAKE OFF | | | | | | | | | | | |
| 2 | CLIMB | | 104 | 94 | 96 | | | | 10 | | | |
| 3 | DESCEND RIGHT | | 102 | 87 | 94 | | | | 15 | | | |
| 4 | CLIMB LEFT | | 103 | 94 | 94 | | | | 9 | | | |
| 5 | DESCEND LEFT | | 102 | 89 | 93 | | | | 13 | | | |
| 6 | CLIMB RIGHT | | 104 | 94 | 96 | | | | 10 | | | |
| 7 | DESCEND | | 102 | 90 | 94 | | | | 12 | | | |
| 8 | LEVEL FLIGHT | 98 | 102 | 88 | 95 | | | .40 | 93 | 14 | 1600 | |
| 9 | HOVER AT ALTITUDE | | | | | | | | | | | |
| 10 | HOVER/GND EFFECT | | | | | | | | | | | |
| 11 | LAND | | | | | | | | | | | |
| 12 | MAP OF EARTH | | | | | | | | | | | |

THIS PAGE IS BEST QUALITY PRACTICABLE FROM COPY FURNISHED TO DDC

NOTES:

TABLE C-20

AIRCRAFT OV-10 SERIAL NO. 68-16996 FLIGHT DATES 22¹² OCT 76 CALIB: 250- YES 1000- NOT USABLE

| UNITS | COCKPIT SLM "SLOW" | | COCKPIT AMBIENT CHAN 2 | | EARCUP NO KEY | | EARCUP KEY NO TALK | | EARCUP KEY TALK | | A. I. | | SENTENCE INTELL. | | EARCUP ATTEM. | | NOISE CROSS-OVER | |
|---------------------|--------------------|-----|------------------------|-----|---------------|-----|--------------------|-----|-----------------|-----|-------|---|------------------|------|---------------|----|------------------|--|
| | dBa | dBa | dBa | dBa | dBa | dBa | dBa | dBa | dBa | dBa | % | % | ΔdBa | ΔdBa | Hz | Hz | | |
| 1 TAKE OFF | | | | | | | | | | | | | | | | | | |
| 2 CLIMB | | 103 | | 97 | | 97 | | 102 | | | | | | | | 6 | | |
| 3 DESCEND RIGHT | | | | | | | | | | | | | | | | | | |
| 4 CLIMB LEFT | | 103 | | | | | | | | | | | | | | | | |
| 5 DESCEND LEFT | | 105 | | 96 | | 94 | | | | | .27 | | 72 | | 9 | | 1200 | |
| 6 CLIMB RIGHT | | | | | | | | | | | | | | | | | | |
| 7 DESCEND | | 105 | | 92 | | 92 | | | | | .27 | | 72 | | 13 | | 2000 | |
| 8 LEVEL FLIGHT | | 104 | | 94 | | 93 | | | | | .35 | | 88 | | 10 | | 1600 | |
| 9 HOVER AT ALTITUDE | | | | | | | | | | | | | | | | | | |
| 10 HOVER/GND EFFECT | | | | | | | | | | | | | | | | | | |
| 11 LAND | | | | 90+ | | | | | | | | | | | | | | |
| 12 MAP OF EARTH | | | | | | | | | | | | | | | | | | |

THIS PAGE IS BEST QUALITY PRACTICABLE FROM COPY FURNISHED TO DDC

C-22

NOTES: ONE 40 SEC. SECTION AT 106 dBa ON TAKE OFF. + ONE DATA SAMPLE ONLY

TABLE C-21

| AIRCRAFT | OV-ID | SERIAL NO. 68-16997 | COCKPIT SLM "SLOW" | | COCKPIT AMBIENT CHAN 2 | | EARCUP NO KEY | | EARCUP KEY NO TALK | | EARCUP KEY TALK | | A.I. | | SENTENCE INTELL. | | EARCUP ATTEN. | | NOISE CROSS-OVER | | |
|----------|-------------------|---------------------|--------------------|----|------------------------|----|---------------|----|--------------------|----|-----------------|----|------|----|------------------|----|---------------|----|------------------|----|----|
| | | | dB | dB | dB | dB | dB | dB | dB | dB | dB | dB | dB | dB | dB | dB | dB | dB | dB | dB | dB |
| 1 | TAKE OFF | | | | | | | | | | | | | | | | | | | | |
| 2 | CLIMB | | 99 | | 92 | | 89 | | 91 | | .64 | | 99 | | 7 | | 2000 | | | | |
| 3 | DESCEND RIGHT | | 100 | | 94 | | 92 | | | | | | | | 6 | | | | | | |
| 4 | CLIMB LEFT | | | | | | | | | | | | | | | | | | | | |
| 5 | DESCEND LEFT | | | | | | | | | | | | | | | | | | | | |
| 6 | CLIMB RIGHT | | | | | | | | | | | | | | | | | | | | |
| 7 | DESCEND | | 100 | | 86 | | 89 | | 94 | | .52 | | 98 | | 14 | | 1800 | | | | |
| 8 | LEVEL FLIGHT | | 102 | | 94 | | 91 | | 92 | | .49 | | 97 | | 6 | | 2000 | | | | |
| 9 | HOVER AT ALTITUDE | | | | | | | | | | | | | | | | | | | | |
| 10 | HOVER/GND EFFECT | | | | | | | | | | | | | | | | | | | | |
| 11 | LAND | | | | | | | | | | | | | | | | | | | | |
| 12 | MAP OF EARTH | | | | | | | | | | | | | | | | | | | | |

THIS PAGE IS BEST QUALITY PRACTICABLE FROM COPY FURNISHED TO DDG

NOTES: + ONE DATA SAMPLE ONLY

TABLE C-22

AIRCRAFT OV-1D SERIAL NO. 69-17005 FLIGHT DATES 16 DEC 76 CALIB: 250~ YES 1000~ YES

| UNITS | COCKPIT SLM "SLOW" | | COCKPIT AMBIENT CHAN 2 | | EARCUP NO KEY | | EARCUP KEY NO TALK | | EARCUP KEY TALK | | A.I. | | SENTENCE INTELL. | | EARCUP ATTN. | | NOISE CROSS-OVER | |
|---------------------|--------------------|------------------|------------------------|-----|---------------|-----|--------------------|-----|-----------------|-----|------|-----|------------------|------|--------------|------|------------------|--|
| | dBa | dBa | dBa | dBa | dBa | dBa | dBa | dBa | dBa | dBa | dBa | dBa | % | ΔdBa | Hz | Hz | | |
| 1 TAKE OFF | | | | | | | | | | | | | | | | | | |
| 2 CLIMB | | 109 | | 90 | | 86 | | 89 | | | | | | 19 | | | | |
| 3 DESCEND RIGHT | | 97 | | 72 | | | | | | | | | | 25 | | | | |
| 4 CLIMB LEFT | | 109 [†] | | 90 | | | | | | | | | | 19 | | | | |
| 5 DESCEND LEFT | | | | | | | | | | | | | | | | | | |
| 6 CLIMB RIGHT | | | | | | | | | | | | | | | | | | |
| 7 DESCEND | | 98 | | 75 | | 76 | | 78 | | .40 | | | 93 | 23 | | 1800 | | |
| 8 LEVEL FLIGHT | | 101 | | 100 | | 79 | | 80 | | | | | | 21 | | | | |
| 9 HOVER AT ALTITUDE | | | | | | | | | | | | | | | | | | |
| 10 HOVER/GND EFFECT | | | | | | | | | | | | | | | | | | |
| 11 LAND | | | | | | | | | | | | | | | | | | |
| 12 MAP OF EARTH | | | | | | | | | | | | | | | | | | |

THIS PAGE IS BEST QUALITY PRACTICABLE FROM COPY FURNISHED TO DDC

NOTES: PROPELLER SYNCHRONIZATION PHASE EQUIPMENT NOT WORKING. † ONE DATA SAMPLE ONLY.

TABLE C-23

| AIRCRAFT | AH-1S | SERIAL NO. | 68-15177 | | 19 JAN 77 | | CALIB: 250~ | | 1000~ |
|---------------------|-------|------------|------------------------|-----------------------|---------------------------|------------------------|------------------|--------------|-------|
| | | | COCKPIT AMBIENT CHAN 2 | COCKPIT EARCUP NO KEY | FLIGHT EARCUP KEY NO TALK | FLIGHT EARCUP KEY TALK | SENTENCE INTELL. | EARCUP ATTN. | |
| UNITS | dB | dB | dB | dB | dB | dB | % | ΔdB | Hz |
| 1 TAKE OFF | | | | | | | | | |
| 2 CLIMB | | 97 | 83 | 87 | 86 | .53 | 97 | 14 | 2500 |
| 3 DESCEND RIGHT | | | | | | | | | |
| 4 CLIMB LEFT | | | | | | | | | |
| 5 DESCEND LEFT | | | | | | | | | |
| 6 CLIMB RIGHT | | | | | | | | | |
| 7 DESCEND | | 96 | 83 | 86 | 85 | .46 | 96 | 13 | 2500 |
| 8 LEVEL FLIGHT | | 95 | 82 | 85 | 85 | .47** | 96 | 13 | 2500 |
| 9 HOVER AT ALTITUDE | | 90 | 78 | 81 | | | | 12 | |
| 10 HOVER/GND EFFECT | | 92 | 84 | 84 | | | | 8 | |
| 11 LAND | | | | | | | | | |
| 12 MAP OF EARTH | | | | | | | | | |

C-25

** A.I. = .58 WITH 8.5 dB AGC CORRECTION

NOTES:

THIS PAGE IS BEST QUALITY PRACTICABLE
 FROM COPY FURNISHED TO DDC

TABLE C-24

| AIRCRAFT | AH-1S | SERIAL NO. | 70-16010 | FLIGHT DATES | 17 JAN 77 | CALIB: | 250~ | YES | 1000~ | YES |
|---------------------|-------|------------|----------|--------------|-----------|--------|------|------|-------|--------|
| | | COCKPIT | COCKPIT | EARCUP | EARCUP | EARCUP | KEY | A.I. | NOISE | CROSS- |
| | | SLM | AMBIENT | NO KEY | KEY | KEY | TALK | | OVER | |
| | | "SLOW" | CHAN 2 | NO TALK | TALK | TALK | | | | |
| UNITS | dBa | dBa | dBa | dBa | dBa | dBa | % | ΔdBa | Hz | |
| 1 TAKE OFF | | | | | | | | | | |
| 2 CLIMB | 91 | 86 | 85 | 85 | 85 | .69 | 99 | 5 | 2000 | |
| 3 DESCEND RIGHT | | | | | | | | | | |
| 4 CLIMB LEFT | | | | | | | | | | |
| 5 DESCEND LEFT | | | | | | | | | | |
| 6 CLIMB RIGHT | | | | | | | | | | |
| 7 DESCEND | 92 | 88 | 87 | 87 | 89 | .63 | 99 | 4 | 2000 | |
| 8 LEVEL FLIGHT | 92 | 85 | 87 | 87 | 87 | .64** | 99 | 7 | 2000 | |
| 9 HOVER AT ALTITUDE | 89 | 85 | 85 | 85 | | | | 4 | | |
| 10 HOVER/GND EFFECT | 89 | 83 | 84 | 84 | | | | 6 | | |
| 11 LAND | | | | | | | | | | |
| 12 MAP OF EARTH | 89+ | | | | | | | | | |

C-26

NOTES: *One Data Sample for each entry
 **A.I. = .64 With 3.1 dB AGC Correction

THIS PAGE IS BEST QUALITY PRACTICABLE
FROM COPY FURNISHED TO DDC

TABLE C-25

| AIRCRAFT | AH-1S | SERIAL NO. | 70-16038 | | FLIGHT DATES | | 26 JAN 77 | | CALIB: 250~ | | 1000~ | |
|----------|-------------------|------------|--------------------|------------------------|---------------|------------|----------------|------------|-------------|------------------|---------------|------------------|
| | | | COCKPIT SLM "SLOW" | COCKPIT AMBIENT CHAN 2 | EARCUP NO KEY | EARCUP KEY | EARCUP NO TALK | EARCUP KEY | EARCUP TALK | SENTENCE INTELL. | EARCUP ATTEN. | NOISE CROSS-OVER |
| UNITS | | dBa | dBa | dBa | dBa | dBa | dBa | dBa | % | ΔdBa | Hz | |
| 1 | TAKE OFF | | | | | | | | | | | |
| 2 | CLIMB | | 95 | 87 | 91 | 90 | .58 | 98 | 8 | 2500 | | |
| 3 | DESCEND RIGHT | | | | | | | | | | | |
| 4 | CLIMB LEFT | | | | | | | | | | | |
| 5 | DESCEND LEFT | | | | | | | | | | | |
| 6 | CLIMB RIGHT | | | | | | | | | | | |
| 7 | DESCEND | | 95 | 91 | 90 | 89 | .59 | 98 | 4 | 2000 | | |
| 8 | LEVEL FLIGHT | | 96 | 88 | 89 | 89 | .71 | 99 | 7 | 2500 | | |
| 9 | HOVER AT ALTITUDE | | 93 | 85 | 86 | | | | 8 | | | |
| 10 | HOVER/GND EFFECT | | 94 | 89 | 89 | | | | 5 | | | |
| 11 | LAND | | | | | | | | | | | |
| 12 | NAP OF EARTH | | 93+ | | | | | | | | | 86 |

C-27

NOTES: †One data sample for each entry

TABLE C-26

AIRCRAFT AH-1J SERIAL NO. 71-20988 FLIGHT DATES 25 JAN 77 CALIB: 250~ YES 1000~ YES
 COCKPIT SLM "SLOW" CHAN 2 COCKPIT AMBIENT CHAN 2 EARCUP NO KEY NO TALK TALK EARCUP KEY A.I. INTELL. ATTEN. CROSS-OVER
 UNITS dBA dBA dBA dBA % LdBA Hz

| UNITS | dBA | dBA | dBA | dBA | % | LdBA | Hz |
|---------------------|-----|-----|-----|-----|----|------|------|
| 1 TAKE OFF | | | | | | | |
| 2 CLIMB | 96 | 89 | 86 | 87 | 7 | 2300 | |
| 3 DESCEND RIGHT | | | | | | | |
| 4 CLIMB LEFT | | | | | | | |
| 5 DESCEND LEFT | | | | | | | |
| 6 CLIMB RIGHT | | | | | | | |
| 7 DESCEND | 97 | 89 | 88 | 89 | 99 | 8 | 2200 |
| 8 LEVEL FLIGHT | 94 | 97 | 89 | 90 | 98 | 8 | 2200 |
| 9 HOVER AT ALTITUDE | 95 | 86 | 86 | | | 9 | |
| 10 HOVER/GND EFFECT | 96 | 87 | 87 | | | 9 | |
| 11 LAND | | | | | | | |
| 12 MAP OF EARTH | 96† | | 86 | | | | |

THIS PAGE IS BEST QUALITY PRACTICABLE FROM COPY FURNISHED TO DDC

C-28

NOTES: † ONE DATA SAMPLE ONLY

THIS PAGE IS BEST QUALITY PRACTICABLE
FROM COPY FURNISHED TO DDC

TABLE C-27

| AIRCRAFT | AH-1Q | SERIAL NO. | 68-15209 | | FLIGHT DATES | | 28 JAN 77 | | CALIB: 250' | | 1000' |
|----------|-------------------|-----------------|----------|---------|--------------|--------|-----------|--------|-------------|--------|-------|
| | | | COCKPIT | COCKPIT | EARCUP | EARCUP | KEY | EARCUP | SENTENCE | EARCUP | |
| | | SLM | AMBIENT | NO KEY | NO TALK | NOISE | A.I. | ATTEN. | CROSS- | OVER | Hz |
| UNITS | | dBa | dBa | dBa | dBa | dBa | % | ΔdBa | Hz | | |
| 1 | TAKE OFF | | | | | | | | | | |
| 2 | CLIMB | 94 | 84 | 83 | 85 | 85 | .60 | 98 | 10 | 2500 | |
| 3 | DESCEND RIGHT | | | | | | | | | | |
| 4 | CLIMB LEFT | | | | | | | | | | |
| 5 | DESCEND LEFT | | | | | | | | | | |
| 6 | CLIMB RIGHT | | | | | | | | | | |
| 7 | DESCEND | 95 | 86 | 85 | 87 | 87 | .77 | 99 | 9 | 2500 | |
| 8 | LEVEL FLIGHT | 95 | 87 | 87 | 86 | 86 | .61** | 99 | 8 | 2500 | |
| 9 | HOVER AT ALTITUDE | 92 | 82 | 83 | | | | | 10 | | |
| 10 | HOVER/GND EFFECT | 93 | 82 | 83 | | | | | 11 | | |
| 11 | LAND | | | | | | | | | | |
| 12 | NAP OF EARTH | 94 ⁺ | | | | | | | | | |

NOTES: *One data sample for each entry
**A.I. = .64 with 3.0 dB AGC Correction

TABLE C-28

| AIRCRAFT | AH-1Q | SERIAL NO. | 70-15945 | | FLIGHT DATES | | 21 JAN 77 | | CALIB: 250~ | | 1000~ | YES |
|---------------------|-------|------------|----------|---------|--------------|---------|-----------|------|-------------|--------|--------|------|
| | | | COCKPIT | COCKPIT | EARCUP | EARCUP | KEY | KEY | SENTENCE | EARCUP | | |
| UNITS | | | SLM | AMBIENT | NO KEY | NO TALK | TALK | A.I. | INTELL. | ATTEN. | CROSS- | OVER |
| 1 TAKE OFF | | dB | dB | dB | dB | dB | dB | % | ΔdB | Hz | | |
| 2 CLIMB | | 94 | 87 | 85 | 89 | .68 | 99 | 7 | 2000 | | | |
| 3 DESCEND RIGHT | | | | | | | | | | | | |
| 4 CLIMB LEFT | | | | | | | | | | | | |
| 5 DESCEND LEFT | | | | | | | | | | | | |
| 6 CLIMB RIGHT | | | | | | | | | | | | |
| 7 DESCEND | | 94 | 85 | 87 | 89 | .61 | 99 | 9 | 2000 | | | |
| 8 LEVEL FLIGHT | | 94 | 87 | 87 | 90 | .64** | 99 | 7 | 2000 | | | |
| 9 HOVER AT ALTITUDE | | 92 | 81 | 86 | | | | | | | | |
| 10 HOVER/GND EFFECT | | 92 | 84 | 84 | | | | | | | | |
| 11 LARD | | | | | | | | | | | | |
| 12 NAP OF EARTH | | | | | | | | | | | | |

C-30

THIS PAGE IS BEST QUALITY PRACTICABLE FROM COPY FURNISHED TO DDC

**A.I. = .72 with 5.1 dB AGC Correction

NOTES:

TABLE C-29

| AIRCRAFT | CH-47C | SERIAL NO. | 70-15003 | | FLIGHT DATES | | 9 FEB 77 | | CALIB: 250~ | | 1000~ | YES | YES |
|---------------------|--------|------------|----------|---------|--------------|--------|----------|---------|-------------|--------|-------|-----|-----|
| | | | COCKPIT | COCKPIT | EARCUP | EARCUP | KEY | KEY | SENTENCE | EARCUP | | | |
| UNITS | dBa | dBa | dBa | dBa | NO TALK | TALK | A.I. | INTELL. | ATTEN. | CROSS- | OVER | | |
| 1 TAKE OFF | dBa | dBa | dBa | dBa | NO TALK | TALK | A.I. | INTELL. | ATTEN. | CROSS- | OVER | | |
| 2 CLIMB | 110 | 110 | 92 | 92 | 91 | 91 | .27 | 71 | 18 | 2000 | | | |
| 3 DESCEND RIGHT | | | | | | | | | | | | | |
| 4 CLIMB LEFT | | | | | | | | | | | | | |
| 5 DESCEND LEFT | | | | | | | | | | | | | |
| 6 CLIMB RIGHT | | | | | | | | | | | | | |
| 7 DESCEND | 111 | 111 | 92 | 94 | 91 | 91 | .20 | 49 | 19 | 2000 | | | |
| 8 LEVEL FLIGHT | 114 | 111 | 92 | 92 | 91 | 91 | .33** | 83 | 19 | 2000 | | | |
| 9 HOVER AT ALTITUDE | 111 | 111 | 92 | 91 | | | | | 19 | | | | |
| 10 HOVER/GND EFFECT | 112 | 112 | 93 | 92 | | | | | 19 | | | | |
| 11 LAID | | | | | | | | | | | | | |
| 12 NAP OF EARTH | | | | | | | | | | | | | |

C-31

**A.I. = .39 with 3.0 dB AGC Correction

NOTES: Top of Ramp Door Open During Flight

THIS PAGE IS BEST QUALITY PRACTICABLE
 FROM COPY FURNISHED TO DDC

TABLE C-30

AIRCRAFT CH-47C SERIAL NO. 70-15020 FLIGHT DATES 31 JAN 77 CALIB: 250~ YES 1000~ NO

COCKPIT SLM "SLOW" dBA dBA dBA dBA dBA dBA
 COCKPIT AMBIENT CHAN 2
 EARCUP NO KEY
 EARCUP KEY NO TALK TALK
 EARCUP KEY TALK
 A.I. INTELL. ATTEN. CROSS-
 SENTENCE EARCUP NOISE
 % ΔdBA Hz

| UNITS | COCKPIT SLM "SLOW" dBA | COCKPIT AMBIENT CHAN 2 dBA | EARCUP NO KEY dBA | EARCUP KEY NO TALK dBA | EARCUP KEY TALK dBA | A.I. INTELL. ATTEN. CROSS-SENTENCE EARCUP NOISE % | ΔdBA | Hz |
|---------------------|------------------------|----------------------------|-------------------|------------------------|---------------------|---|------|------|
| 1 TAKE OFF | | | | | | | | |
| 2 CLIMB | 109 | 91 | 91 | 91 | 91 | | 18 | 1700 |
| 3 DESCEND RIGHT | | | | | | | | |
| 4 CLIMB LEFT | | | | | | | | |
| 5 DESCEND LEFT | | | | | | | | |
| 6 CLIMB RIGHT | | | | | | | | |
| 7 DESCEND | 109 | 93 | 93 | 94 | 93 | | 16 | |
| 8 LEVEL FLIGHT | 115 | 108 | 93 | 93 | 93 | | 15 | |
| 9 HOVER AT ALTITUDE | 109 | 92 | 92 | 93 | | | 17 | |
| 10 HOVER/GND EFFECT | 109 | 92 | 92 | 91 | | | 17 | |
| 11 LARD | | | | | | | | |
| 12 NAP OF EARTH | | | | | | | | |

NOTES: RETURN TO BASE: LEVEL IN EARCUP SOMETIMES RISES TO 107-116 dBA FOR 5 SECONDS

TABLE C-31

| AIRCRAFT | CH-47C | SERIAL NO. | 70-15026 | | FLIGHT DATES | | 7 FEB 77 | | CALIB: 250 | | YES | 1000 | NO |
|----------|-------------------|------------|--------------------|------------------------|---------------|--------------------|-----------------|------------|------------|---------|-----|------|----|
| | | | COCKPIT SLM "SLOW" | COCKPIT AMBIENT CHAN 2 | EARCUP NO KEY | EARCUP KEY NO TALK | EARCUP KEY TALK | EARCUP KEY | A.I. | INTELL. | | | |
| UNITS | | dBa | dBa | dBa | dBa | dBa | dBa | dBa | % | ΔdBa | Hz | | |
| 1 | TAKE OFF | | | | | | | | | | | | |
| 2 | CLIMB | 111 | 91 | 93 | 91 | 91 | 91 | 20 | | | | | |
| 3 | DESCEND RIGHT | | | | | | | | | | | | |
| 4 | CLIMB LEFT | | | | | | | | | | | | |
| 5 | DESCEND LEFT | | | | | | | | | | | | |
| 6 | CLIMB RIGHT | | | | | | | | | | | | |
| 7 | DESCEND | 112 | 94 | 92 | 93 | 93 | 93 | 18 | | | | | |
| 8 | LEVEL FLIGHT | 114 | 92 | 95 | 92 | 92 | 92 | 20 | | | | | |
| 9 | HOVER AT ALTITUDE | 110 | 90 | 91 | 91 | 91 | 91 | 20 | | | | | |
| 10 | HOVER/GND EFFECT | 111 | 92 | 90 | 90 | 90 | 90 | 19 | | | | | |
| 11 | LAND | | | | | | | | | | | | |
| 12 | NAP OF EARTH | | | | | | | | | | | | |

C-33

THIS PAGE IS BEST QUALITY PRACTICABLE FROM COPY FURNISHED TO DDC

NOTES: LEVEL IN EARCUP RISES TO 105 dBA FOR 10 SECONDS ON RETURN TO BASE

THIS PAGE IS BEST QUALITY PRACTICABLE
FROM COPY FURNISHED TO DDC

TABLE C-32

| AIRCRAFT | CH-54B | SERIAL NO. | 69-18465 | | 8 APR 77 | | CALIB: 250 | | 1000 | YES |
|----------|-------------------|------------|----------|---------|--------------|--------------|------------|--------|--------|------|
| | | | COCKPIT | COCKPIT | FLIGHT DATES | FLIGHT DATES | SENTENCE | EARCUP | | |
| | | COCKPIT | COCKPIT | EARCUP | EARCUP | KEY | EARCUP | ATTEN. | CROSS- | OVER |
| | | SLM | AMBIENT | NO KEY | NO TALK | TALK | INTELL. | | | |
| | | "SLOW" | CHAI 2 | | | | A.I. | | | |
| UNITS | | dBa | dBa | dBa | dBa | dBa | % | ΔdBa | Hz | |
| 1 | TAKE OFF | | | | | | | | | |
| 2 | CLIMB | 96 | 84 | 85 | 88 | .57 | 98 | 11 | 2200 | |
| 3 | DESCEND RIGHT | | | | | | | | | |
| 4 | CLIMB LEFT | | | | | | | | | |
| 5 | DESCEND LEFT | | | | | | | | | |
| 6 | CLIMB RIGHT | | | | | | | | | |
| 7 | DESCEND | 96 | 81 | 83 | 86 | .51 | 97 | 15 | 2200 | |
| 8 | LEVEL FLIGHT | 96 | 84 | 85 | 86 | .54** | 97 | 11 | 2200 | |
| 9 | HOVER AT ALTITUDE | | | | | | | | | |
| 10 | HOVER/GND EFFECT | | | | | | | | | |
| 11 | LAND | | | | | | | | | |
| 12 | NAP OF EARTH | | | | | | | | | |

C-34

** A.I. = .55 with 0.7 dB AGC Correction

NOTES:

THIS PAGE IS BEST QUALITY PRACTICABLE
FROM COPY FURNISHED TO DDC

TABLE C-33

| AIRCRAFT | CH-54B | SERIAL NO. | 69-18468 | | FLIGHT DATES | | 1 APR 77 | | CALIB: 250 | | 1000 | |
|----------|-------------------|------------|----------|---------|--------------|--------|----------|--------|------------|--------|-------|-----|
| | | | COCKPIT | COCKPIT | EARCUP | EARCUP | KEY | EARCUP | SENTENCE | EARCUP | NOISE | YES |
| UNITS | | dbA | dbA | dbA | dbA | dbA | dbA | dbA | % | ΔdbA | Hz | Hz |
| 1 | TAKE OFF | | | | | | | | | | | |
| 2 | CLIMB | 93 | | 81 | 84 | | .50 | 97 | 12 | | 2000 | |
| 3 | DESCEND RIGHT | | | | | | | | | | | |
| 4 | CLIMB LEFT | | | | | | | | | | | |
| 5 | DESCEND LEFT | | | | | | | | | | | |
| 6 | CLIMB RIGHT | | | | | | | | | | | |
| 7 | DESCEND | 93 | | 83 | 82 | | .60 | 98 | 10 | | 2000 | |
| 8 | LEVEL FLIGHT | 97 | 93 | 84 | 83 | | .58** | 98 | 9 | | 2000 | |
| 9 | HOVER AT ALTITUDE | | | | | | | | | | | |
| 10 | HOVER/GND EFFECT | | | | | | | | | | | |
| 11 | LAND | | | | | | | | | | | |
| 12 | NAP OF EARTH | | | | | | | | | | | |

C-35

**A.I. = .61 with 0.6 dB AGC Correction

NOTES:

AD-A061 351

VOUGHT CORP ADVANCED TECHNOLOGY CENTER INC DALLAS TEX

F/G 1/3

ANALYSIS OF NOISE IN US ARMY AIRCRAFT.(U)

NOV 78 A J BROUNS, R A ELY

DAAB07-76-C-1746

UNCLASSIFIED

ATC-94100/8CR-41

USAAVRADCOM-TR-76-1746-F

NL

3 OF 3

AD
A061351

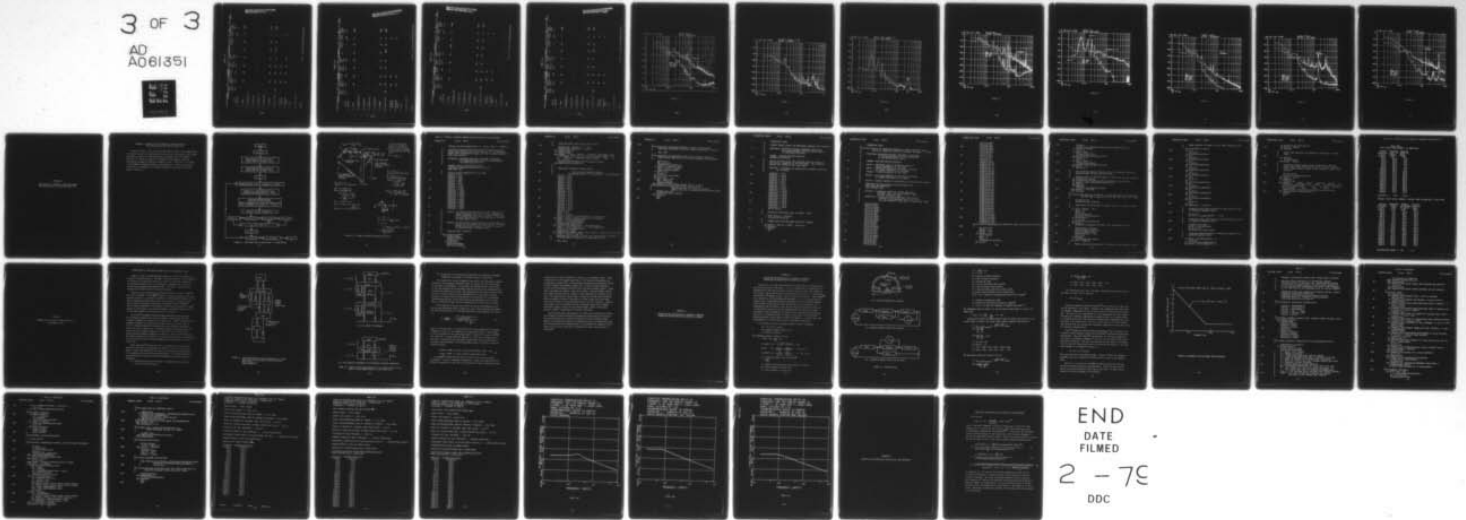

END
DATE
FILMED

2 - 78

DDC

THIS PAGE IS BEST QUALITY PRACTICABLE
 FROM COPY FURNISHED TO DDC

TABLE C-34

| AIRCRAFT | CH-54B | SERIAL NO. | 69-18470 | | FLIGHT DATES | | 15 APR 77 | | CALIB: 250 | | YES | | 1000 | | YES | |
|----------|-------------------|------------|----------|---------|--------------|---------|-----------|--------|------------|--------|----------|--------|-------|-------|--------|--------|
| | | | COCKPIT | COCKPIT | EARCUP | EARCUP | EARCUP | EARCUP | KEY | KEY | SENTENCE | EARCUP | NOISE | NOISE | CROSS- | CROSS- |
| | | SLM | AMBIENT | NO KEY | NO TALK | NO TALK | A.I. | A.I. | INTELL. | ATTEN. | CROSS- | CROSS- | OVER | OVER | OVER | OVER |
| | | "SLOW" | CHAN 2 | NO TALK | TALK | TALK | % | % | ΔdBA | ΔdBA | Hz | Hz | Hz | Hz | Hz | Hz |
| UNITS | | dBA | dBA | dBA | dBA | dBA | | | | | | | | | | |
| 1 | TAKE OFF | | | | | | | | | | | | | | | |
| 2 | CLIMB | 96 | 86 | 90 | 91 | 91 | .37 | 90 | 10 | 1500 | | | | | | |
| 3 | DESCEND RIGHT | | | | | | | | | | | | | | | |
| 4 | CLIMB LEFT | | | | | | | | | | | | | | | |
| 5 | DESCEND LEFT | | | | | | | | | | | | | | | |
| 6 | CLIMB RIGHT | | | | | | | | | | | | | | | |
| 7 | DESCEND | 96 | 87 | 90 | 91 | 91 | .35 | 88 | 9 | 1200 | | | | | | |
| 8 | LEVEL FLIGHT | 96 | 87 | 90 | 91 | 91 | .42** | 94 | 9 | 2400 | | | | | | |
| 9 | HOVER AT ALTITUDE | 98 | 93 | 96 | | | | | 5 | | | | | | | |
| 10 | HOVER/GND EFFECT | 98 | 90 | 97 | 94 | | | | 8 | | | | | | | |
| 11 | LAUD | | | | | | | | | | | | | | | |
| 12 | NAP OF EARTH | | | | | | | | | | | | | | | |

**A.I. = .50 with 3.9 dB AGC Correction

NOTES:

THIS PAGE IS BEST QUALITY PRACTICABLE
FROM COPY FURNISHED TO DDG.

TABLE C-35

| AIRCRAFT | CH-54B | SERIAL NO. | 69-18473 | | 31 MAR 77 | | CALIB: 250 | | 1000 | YES | 1800 | YES |
|----------|-------------------|------------|----------|---------|--------------|--------------|------------|---------|--------|--------|------|-----|
| | | | COCKPIT | COCKPIT | FLIGHT DATES | FLIGHT DATES | SENTENCE | EARCUP | | | | |
| | | COCKPIT | COCKPIT | EARCUP | EARCUP | KEY | EARCUP | INTELL. | ATTEN. | CROSS- | | |
| | | SLM | AMBIENT | NO KEY | NO TALK | TALK | NO TALK | A.I. | ATTEN. | OVER | | |
| | | "SLOW" | CHAN 2 | NO TALK | TALK | TALK | TALK | | | | | |
| UNITS | | dB | dB | dB | dB | dB | dB | % | ΔdB | Hz | | |
| 1 | TAKE OFF | | | | | | | | | | | |
| 2 | CLIMB | 98 | 85 | 93 | 90 | 90 | 90 | .40 | 93 | 13 | 1800 | |
| 3 | DESCEND RIGHT | | | | | | | | | | | |
| 4 | CLIMB LEFT | | | | | | | | | | | |
| 5 | DESCEND LEFT | | | | | | | | | | | |
| 6 | CLIMB RIGHT | | | | | | | | | | | |
| 7 | DESCEND | 98 | 84 | 90 | 91 | 91 | 90 | .37 | 90 | 14 | 1800 | |
| 8 | LEVEL FLIGHT | 102 | 82 | 90 | 91 | 91 | 96 | .46** | 96 | 17 | 1800 | |
| 9 | HOVER AT ALTITUDE | 101 | 88 | | | | | | | 13 | | |
| 10 | HOVER/GND EFFECT | 102 | 89 | | | | | | | 13 | | |
| 11 | LARD | | | | | | | | | | | |
| 12 | NAP OF EARTH | | | | | | | | | | | |

C-37

** A.I. = .62 with 7.4 dB AGC Correction

NOTES:

THIS PAGE IS BEST QUALITY PRACTICABLE
FROM COPY FURNISHED TO DDC

TABLE C-37

| AIRCRAFT | CH-54B | SERIAL NO. | 69-18490 | | FLIGHT DATES | | 8 APR 77 | | CALIB: 250~ | | 1000~ | |
|------------|-------------------|------------|----------|---------|--------------|---------|----------|--------|-------------|--------|--------|------|
| | | | COCKPIT | COCKPIT | EARCUP | EARCUP | KEY | EARCUP | SENTENCE | EARCUP | NOISE | YES |
| | | SLM | AMBIENT | NO KEY | NO KEY | NO TALK | KEY | A.I. | INTELL. | ATTEN. | CROSS- | OVER |
| | | "SLOW" | CHAI 2 | NO TALK | TALK | TALK | TALK | | % | ΔdBA | Hz | |
| UNITS | | dBa | dBa | dBa | dBa | dBa | dBa | | | | | |
| 1 TAKE OFF | | | | | | | | | | | | |
| 2 | CLIMB | 92 | 84 | 91 | 91 | .46 | 96 | 8 | 1800 | | | |
| 3 | DESCEND RIGHT | | | | | | | | | | | |
| 4 | CLIMB LEFT | | | | | | | | | | | |
| 5 | DESCEND LEFT | | | | | | | | | | | |
| 6 | CLIMB RIGHT | | | | | | | | | | | |
| 7 | DESCEND | 96 | 83 | 89 | 90 | .43 | 95 | 13 | 1800 | | | |
| 8 | LEVEL FLIGHT | 96 | 83 | 89 | 91 | .45** | 96 | 12 | 1800 | | | |
| 9 | HOVER AT ALTITUDE | 95 | 86 | | | | | 9 | | | | |
| 10 | HOVER/GND EFFECT | 96 | 82 | | | | | 14 | | | | |
| 11 | LAND | | | | | | | | | | | |
| 12 | NAP OF EARTH | | | | | | | | | | | |

NOTES:

**A.I. = .51 with 2.6 dB AGC Correction

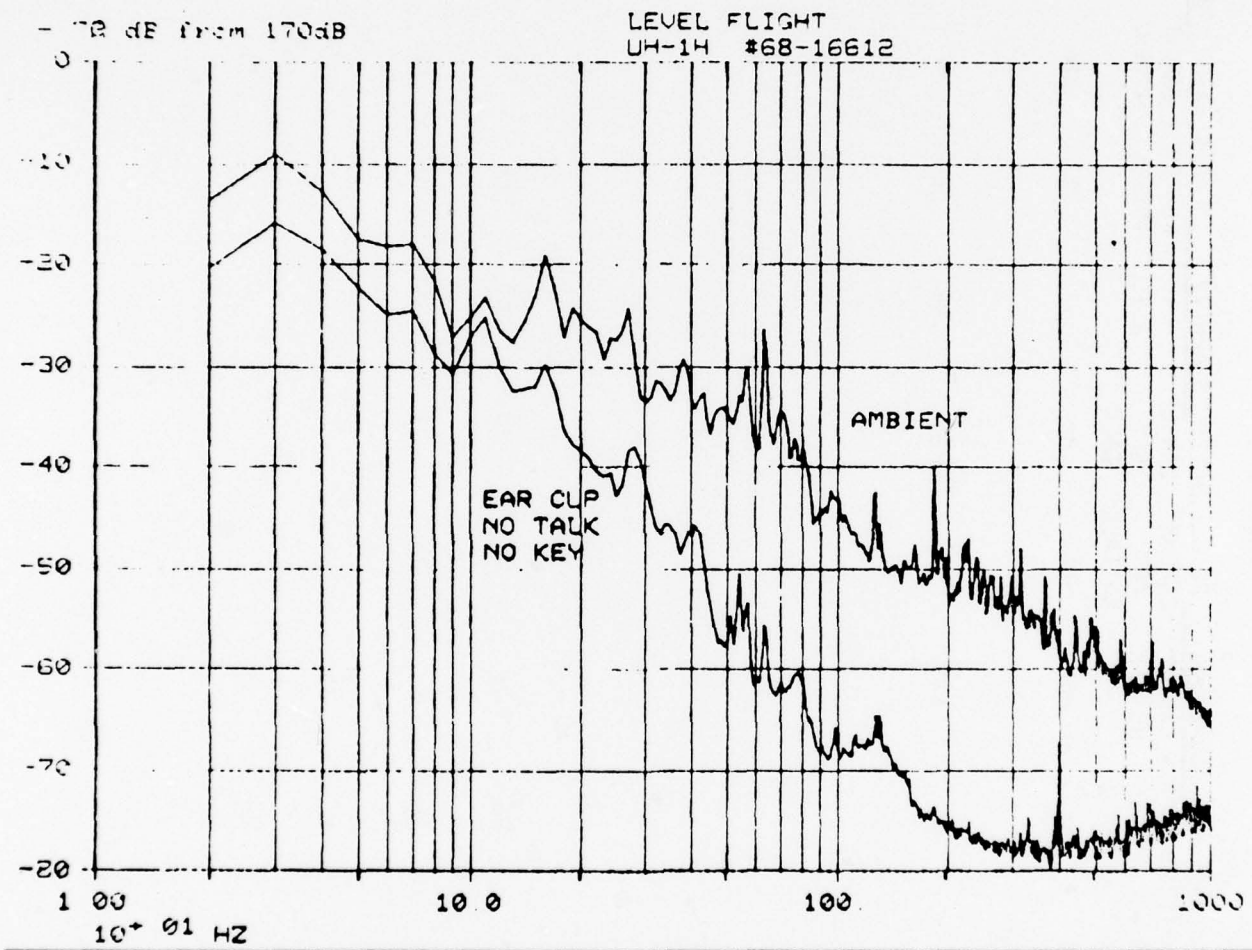

FIGURE C-1

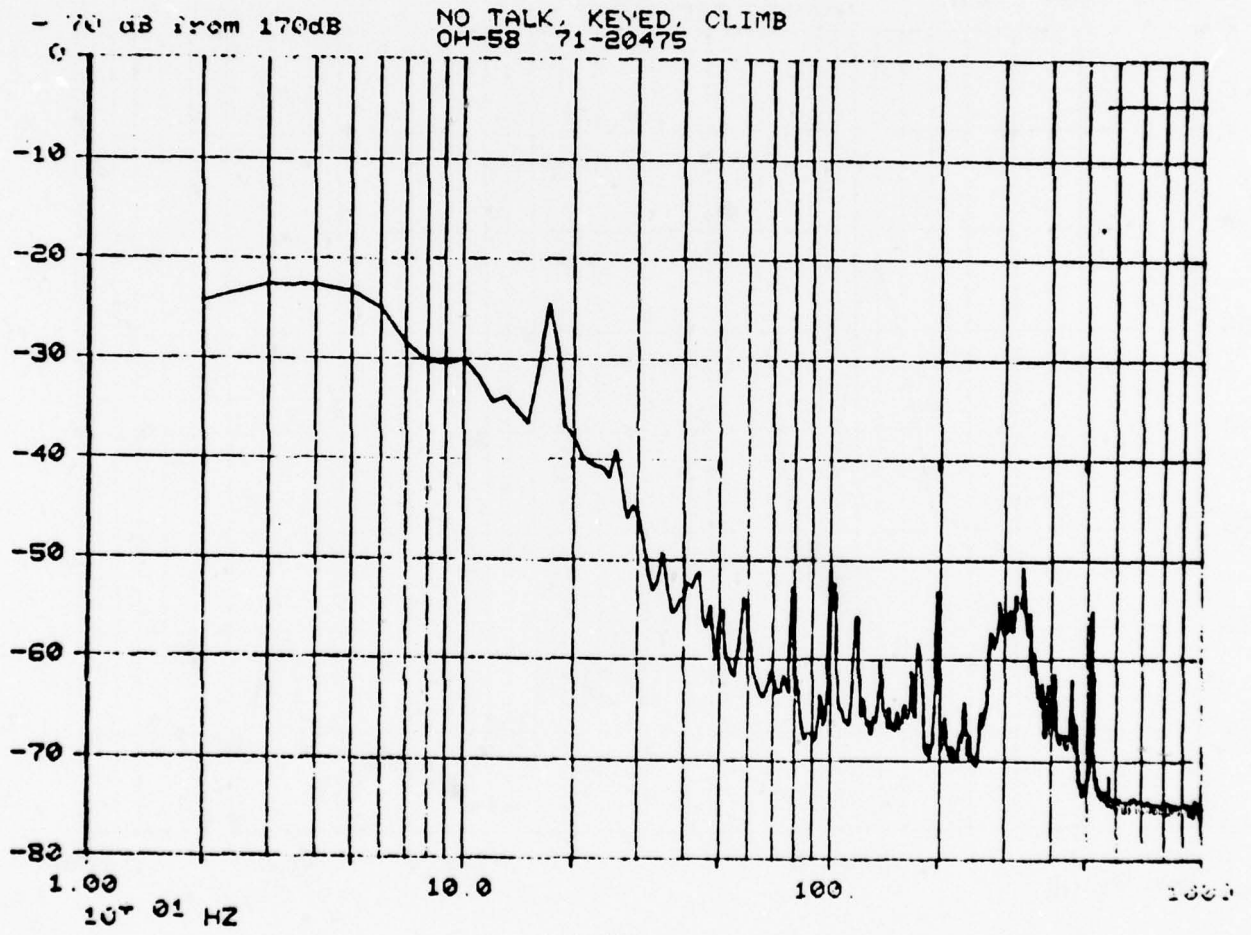

FIGURE C-2

- 50 dB from 170dB

TALK. TK 1. LEVEL FLT
0U-1D #68-16997

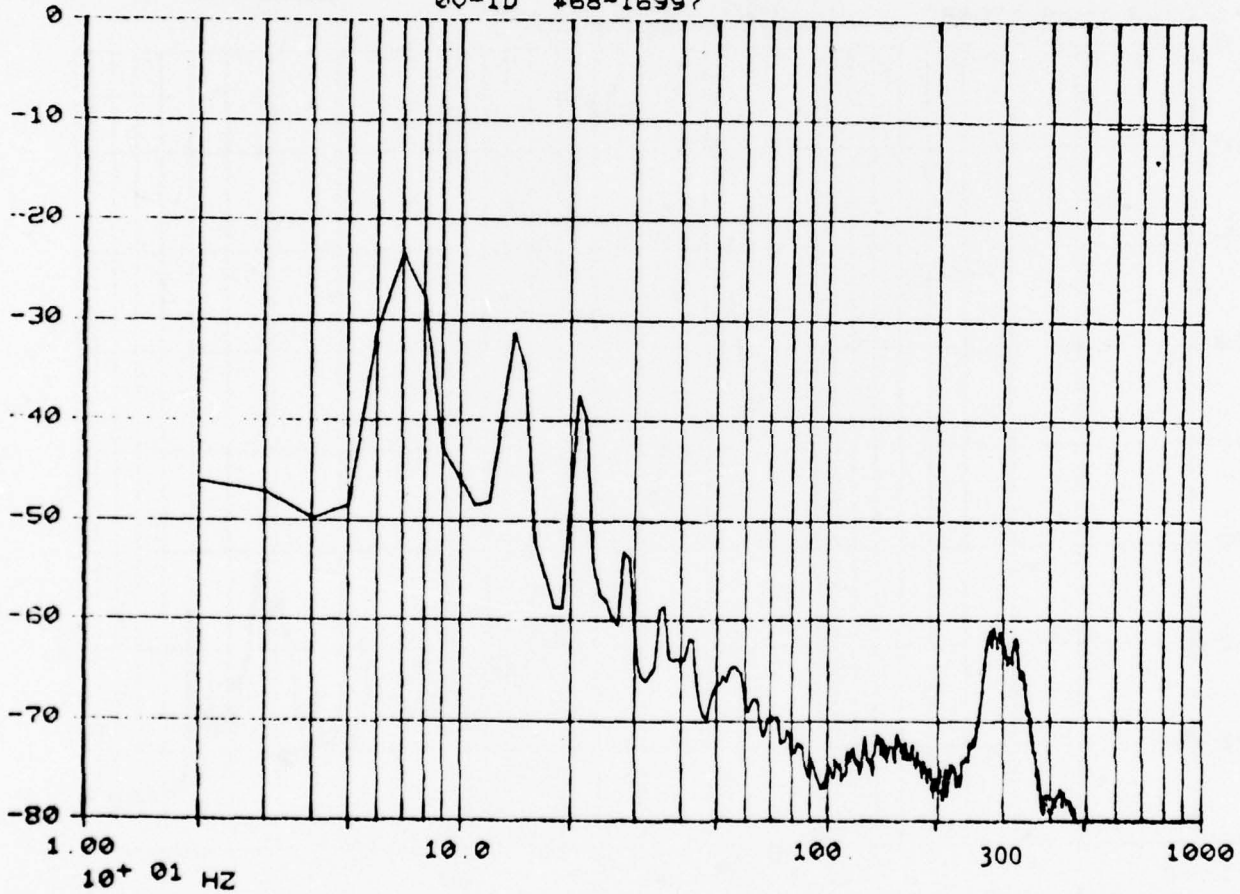

FIGURE C-3

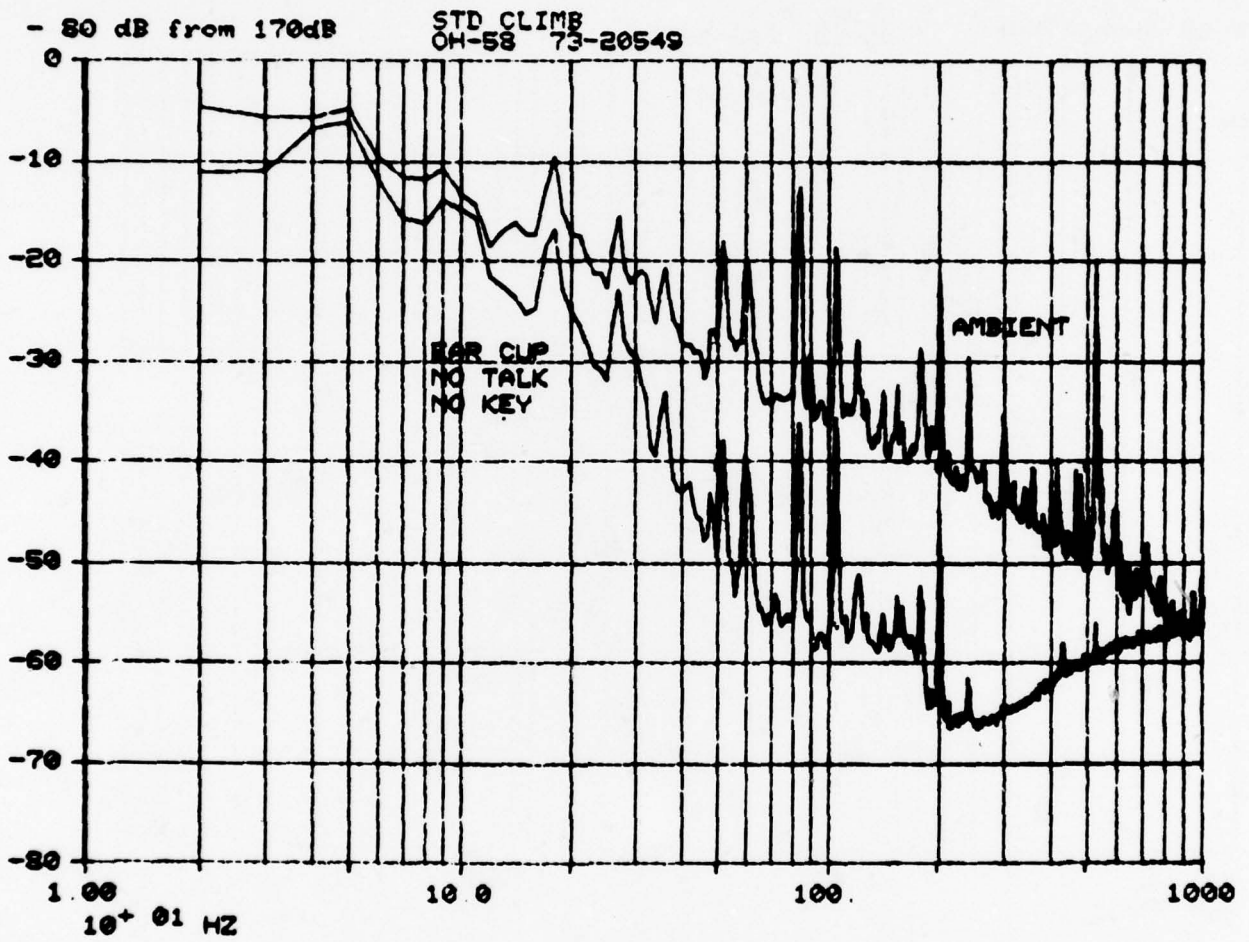

FIGURE C-4

- 70 dB from 170dB

LEVEL FLT
0U-1D 868-16997

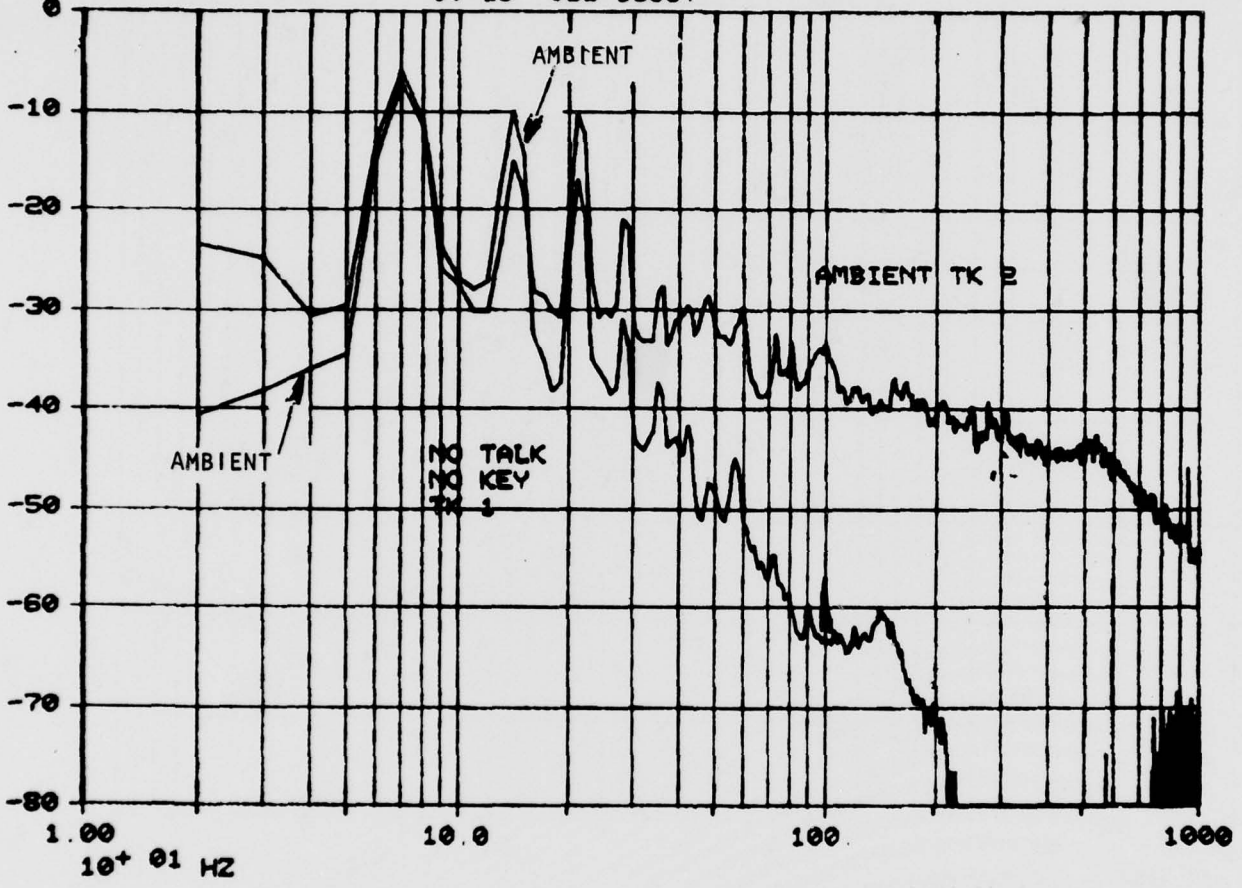

FIGURE C-5

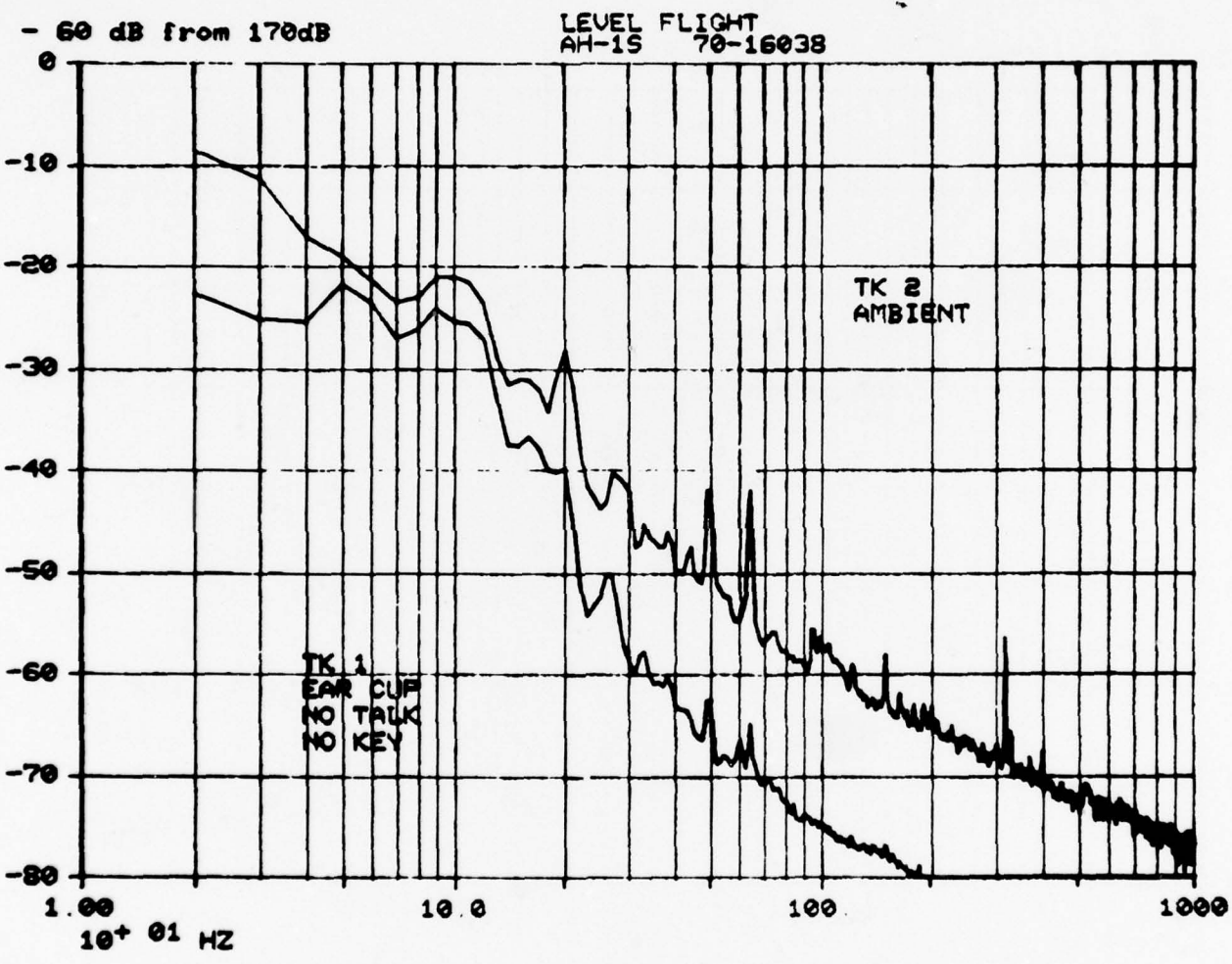

FIGURE C-6

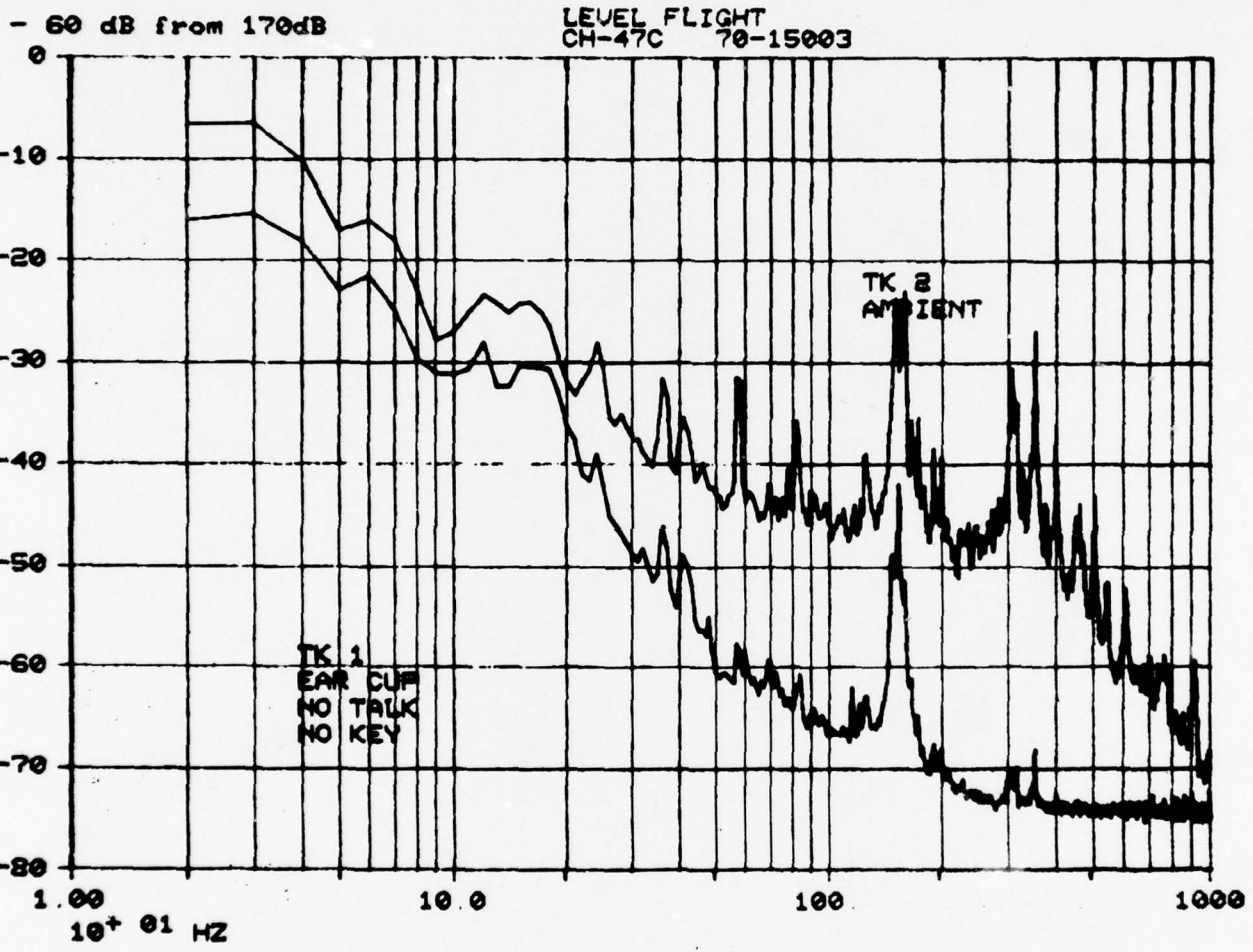

FIGURE C-7

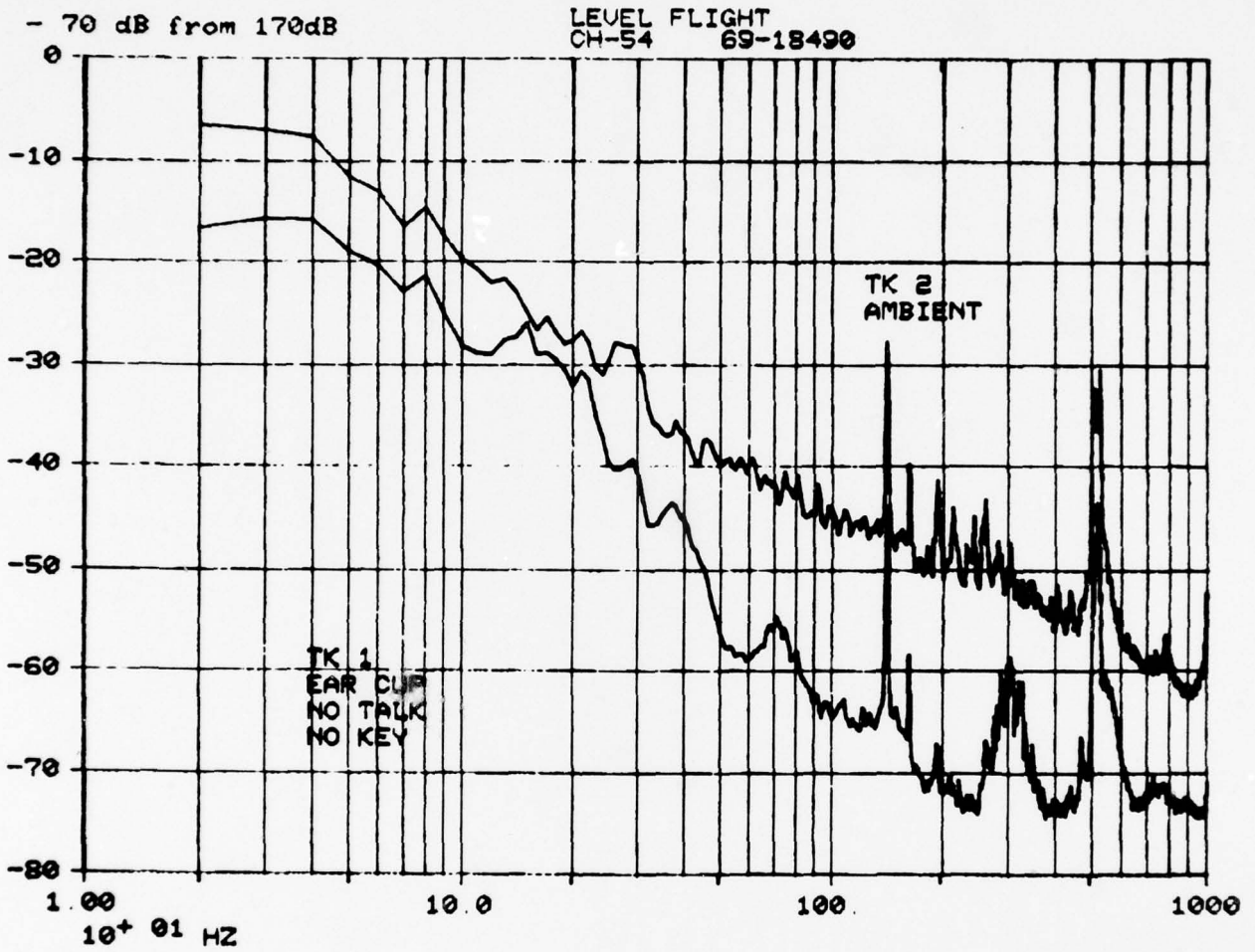

FIGURE C-8

APPENDIX D

DESCRIPTION OF A FORTRAN IV COMPUTER PROGRAM
FOR CALCULATIONS OF ARTICULATION INDEX (AI)

APPENDIX D DESCRIPTION OF A FORTRAN IV COMPUTER PROGRAM
FOR CALCULATIONS OF ARTICULATION INDEX (AI)

Figure D-1 shows a flow chart which describes the logic of the computerized AI calculations which were completed during the studies described in this report. That logic is based on an American National Standards Institute standard ANSI S3.5.¹⁹ Figure D-2 shows the trigonometric and algebraic bases for calculating the degree of masking of speech by noise. Table D-1 is a listing of the FORTRAN IV computer program for calculating AI. Results of a typical calculation, corresponding to an example presented in ANSI S3.5,¹⁹ are presented in Table D-2.

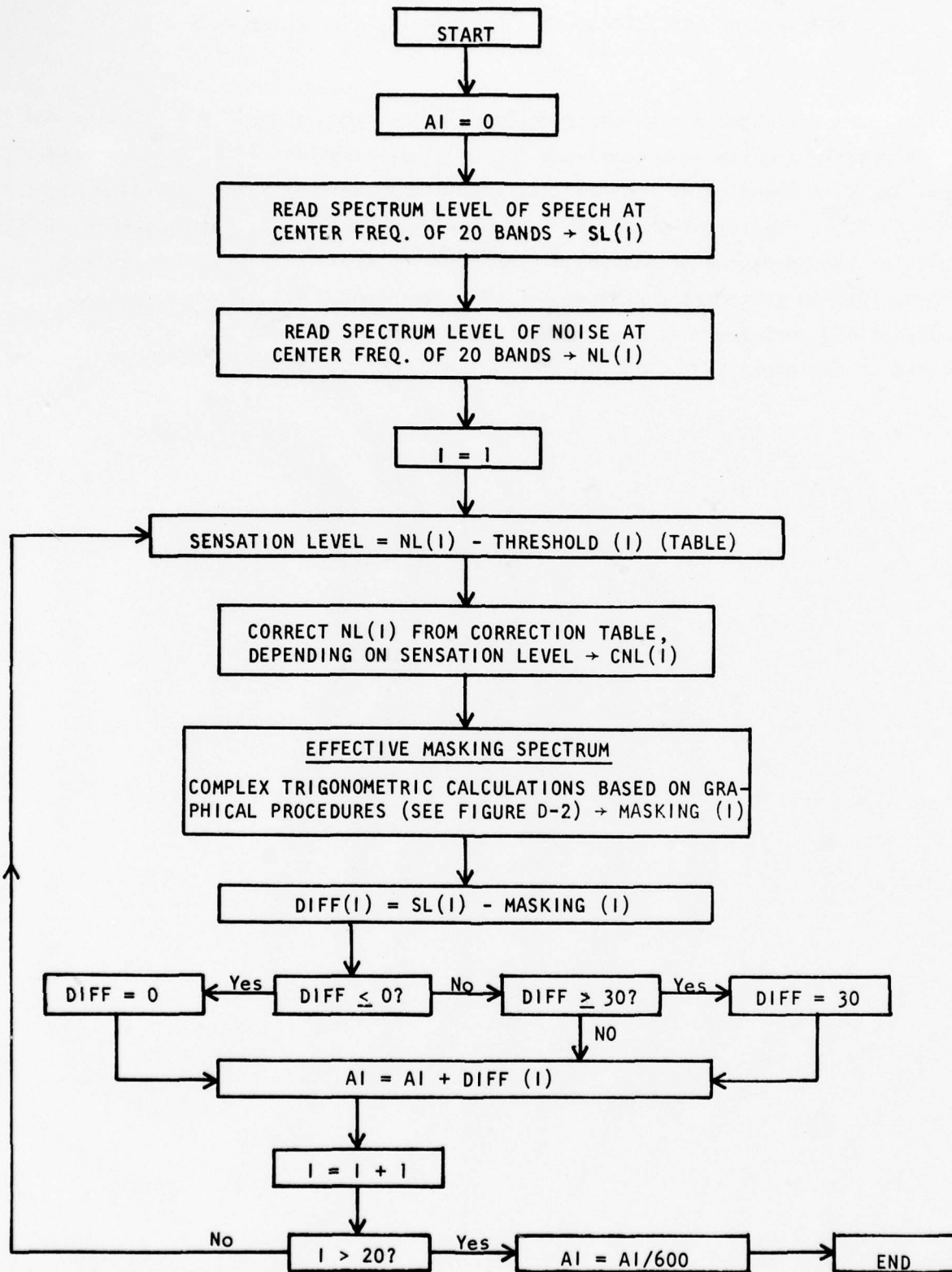
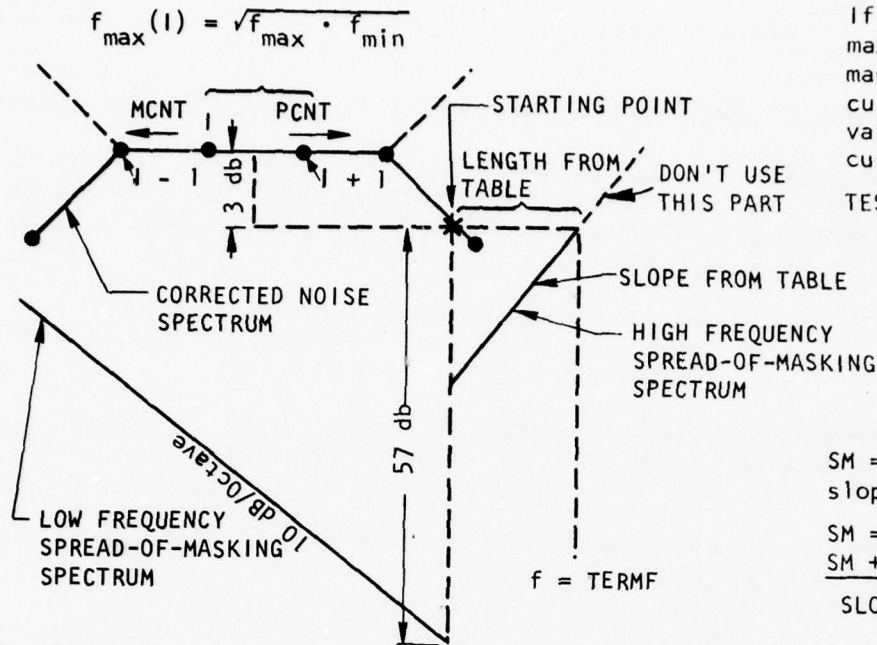

FIGURE D-1. FLOW CHART FOR AI CALCULATIONS - 20 BAND METHOD.



If there are several maxima, all spread-of-masking curves are calculated, and the maximum values comprise the final curve.

$$\text{TEST} = \text{NR}_{\max} - 3$$

$$\text{SM} = A \ln f + B$$

$$\text{Slope} = A = -10 \text{ dB/octave} \quad f = \text{STRT}$$

$$\text{SM} + 10 = A \ln f + B$$

$$\text{SM} = A \ln 2f + B$$

$$10 = A(\ln f - \ln 2f)$$

$$= A \ln 1/2 = .693A$$

$$A = \frac{-10}{.693} = 14.43$$

$$\text{SM} = -14.43 \ln f + B$$

when $f = \text{STRT}$, $\text{SM} = \text{NR}_{\max} - 60$

$$= \text{TEST} - 57$$

$$\text{TEST} - 57 = -14.43 \ln(\text{STRT}) + B$$

$$\text{SM} = C \ln f + D$$

$$\text{slope} = \text{SLOPE (dB/octave)}$$

$$\text{SM} = C \ln f + D$$

$$\text{SM} + \text{SLOPE} = C \ln 2f + D$$

$$\text{SLOPE} = C(\ln 2f - \ln f)$$

$$= C \ln 2f/f$$

$$= C \ln 2 = .693C$$

$$C = \text{SLOPE} / .693$$

when $f = \text{TERM}$, $\text{SM} = \text{TEST}$

$$\text{TEST} = C \ln(\text{TERM}) + D$$

$$D = \text{TEST} - C \ln(\text{TERM})$$

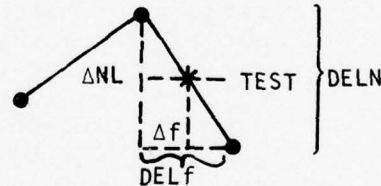

$$\text{NL} = A \ln f + B$$

$$\Delta \text{NL} = \frac{\Delta f}{f}; A = \frac{f}{\text{DEL}f} \text{ DELN}$$

$$\Delta f = \frac{f}{A} \Delta \text{NL}$$

f = geometric center of interval

$$\Delta f = \frac{f_{\text{mean}} \Delta \text{NL} \text{ DEL}f}{f_{\text{mean}} \text{ DELN}}$$

FIGURE D-2. SCHEME FOR COMPUTING SPREAD-OF-MASKING

TABLE D-1 FORTRAN IV COMPUTER PROGRAM FOR CALCULATING ARTICULATION INDEX

PROGRAM AI

74/74 OPT=1

FTN 4.6+428

```

1      PROGRAM AI(INPUT,OUTPUT,TAPE 5 = INPUT, TAPE 6 = OUTPUT)
      C
      C      CALCULATE ARTICULATION INDEX FROM SPECTRUM LEVELS OF
      C      SPEECH AND NOISE AT CENTER FREQUENCIES OF 20 FREQUENCY
5      C      BANDS WHICH CONTRIBUTE EQUALLY TO SPEECH INTELLIGIBILITY
      C      WITH MALE VOICES.
      C
      C      REFERENCE--AMERICAN NATIONAL STANDARDS INSTITUTE,
      C      S3.5/1969, METHODS FOR THE CALCULATION OF
10     C      THE ARTICULATION INDEX*
      C
      C      COMMON/ /CNL(20),MSK(20),FREQ(20)
      C      DIMENSION COMNT1(10),COMNT2(10),SPCH(20)
      C      TYPE REAL MSK
15     C
      C      FREQ(I)=CENTER FREQUENCY OF ITH BAND
      C      FREQ(1) = 270.
      C      FREQ(2) = 380.
      C      FREQ(3) = 490.
20     C      FREQ(4) = 630.
      C      FREQ(5) = 770.
      C      FREQ(6) = 920.
      C      FREQ(7) = 1070.
      C      FREQ(8) = 1230.
25     C      FREQ(9) = 1400.
      C      FREQ(10) = 1570.
      C      FREQ(11) = 1740.
      C      FREQ(12) = 1920.
      C      FREQ(13) = 2130.
30     C      FREQ(14) = 2370.
      C      FREQ(15) = 2660.
      C      FREQ(16) = 3000.
      C      FREQ(17) = 3400.
      C      FREQ(18) = 3950.
35     C      FREQ(19) = 4560.
      C      FREQ(20) = 5600.
      C
      C      CNL(I) IS READ AS THE SPECTRUM LEVEL OF NOISE AT THE
      C      CENTER FREQUENCY OF THE ITH BAND. SUBROUTINE
40     C      CORCT INCREASES SOME NOISE LEVELS TO TAKE INTO
      C      ACCOUNT THE INCREASED EFFECTIVENESS OF MASKING
      C      AT HIGH SOUND LEVELS.
      C
      C      SPCH(I) IS READ AS THE LONG-TERM RMS SPECTRUM LEVEL OF
45     C      SPEECH AT THE CENTER FREQUENCY OF THE ITH BAND.
      C      THOSE LEVELS ARE CONVERTED TO SPECTRUM LEVEL
      C      OF SPEECH PEAKS BY ADDING 12 DB.
      C
      C      READ AND WRITE COMMENTS
50     C
      C      202 READ(5,1)COMNT1
      C      1  FORMAT(10A8)
      C      READ(5,1)COMNT2
      C      WRITE(6,2)
55     C      2  FORMAT(1H1)
      C      WRITE(6,1)COMNT1
      C      WRITE(6,1)COMNT2

```

```

C
C   READ AND WRITE SPEECH AND NOISE LEVELS
60  C
C   READ(5,100) (SPCH(I), I = 1,20)
   READ(5,100) (CNL(I), I = 1,20)
  100 FORMAT(10F8.2)
   WRITE(6,300)
65  300 FORMAT( /,10X,* CENTER SPECTRUM SPECTRUM*,/,10X,
1*FREQUENCY LEVEL OF LEVEL OF*,/,10X,*OF BAND  *,
2  *SPEECH NOISE*,/,10X,* (HERTZ) (DB)  *,
3* (DB)* )
   WRITE(6,310) (FREQ(I), SPCH(I), CNL(I), I=1,20)
70  310 FORMAT(10X,F8.1,2F10.1)

C
C   CALCULATE A-WEIGHTED SOUND LEVELS
75  C
C   USE MSK FOR TEMPORARY STORAGE
C   FOLLOWING VALUES ARE A-WEIGHTING + 10LOG(Delta F )
   MSK(1) = 13.4
   MSK(2) = 15.0
   MSK(3) = 17.6
80  MSK(4) = 19.5
   MSK(5) = 20.0
   MSK(6) = 21.3
   MSK(7) = 21.9
   MSK(8) = 22.5
85  MSK(9) = 23.1
   MSK(10) = 23.3
   MSK(11) = 23.4
   MSK(12) = 24.0
   MSK(13) = 24.7
90  MSK(14) = 25.5
   MSK(15) = 26.4
   MSK(16) = 27.0
   MSK(17) = 27.6
   MSK(18) = 28.8
95  MSK(19) = 29.9
   MSK(20) = 30.2
   ASPCH = 0.0
   ANOIS = 0.0
   DO 50 I = 1,20
100  ASPCH = ASPCH + 10.0**((SPCH(I) + MSK(I))/10.)
   50 ANOIS = ANOIS + 10.0**((CNL(I) + MSK(I))/10.)
   ASPCH = 10.0*ALOG10(ASPCH)
   ANOIS = 10.0*ALOG10(ANOIS)
   WRITE(6,400) ASPCH,ANOIS
105  400 FORMAT(/,10X,*OASL(DbA) = *,F7.1,F10.1,/)
   ASPCH = 10.0**((ASPCH/10.) + 10.0**((ANOIS/10.))
   ASPCH = 10.0*ALOG10(ASPCH)
   WRITE(6,401) ASPCH
110  401 FORMAT(10X,*OVERALL SOUND LEVEL (SPEECH + NOISE, 200 TO 6100
1,*HZ) = *,F5.1,* DBA*,/)

C
C   INCREASE NOISE LEVELS TO TAKE INTO ACCOUNT THE INCREASED
C   EFFECTIVENESS OF MASKING AT HIGH SOUND LEVELS.
C
C   CALL CORCT

```

```
115      C
      C*****CALCULATE SPREAD-OF-MASKING OF NOISE SPECTRUM,AND
      C      CALCULATE RESULTING EFFECTIVE MASKING SPECTRUM. *****
      C
      C      CALL MASK
120      C
      C*****CALCULATE ARTICULATION INDEX FROM SPECTRUM LEVELS OF
      C      SPEECH PEAKS AND FROM THE EFFECTIVE MASKING SPECTRUM*****
      C
      SUM = 0.0
125      DO 40 I=1,20
          IF(SPCH(I).GT.0.0)5,10
          5 SPCH(I) = SPCH(I) +12.0
          DIFF = SPCH(I) -MSK(I)
          IF(DIFF.GT.0.0)20,10
130          10 DIFF = 0.0
          GO TO 40
          20 IF(DIFF.LT.30.)40,30
          30 DIFF =30.
          40 SUM = SUM + DIFF
135          ART = SUM/600.
          WRITE(6,200)ART
          200 FORMAT( //,10X,*ARTICULATION INDEX = *,F4.2)
      C*****ONE CARD AFTER EACH DATA SET.
      C      CARD READS 999. IN FIRST 10 COLUMNS
140      C      AFTER LAST SET OF DATA*****
          READ(5,100) TEST
          IF(TEST.EQ.999.) 201,202
          201 CONTINUE
          STOP
145          END
```

```

1          SUBROUTINE CORCT
          C
          C      CORRECT NOISE LEVELS FOR NONLINEAR MASKING EFFECTIVENESS
          C
5          C      REFERENCE--AMERICAN NATIONAL STANDARDS INSTITUTE,
          C      S3.5/1969, *METHODS FOR THE CALCULATION OF
          C      THE ARTICULATION INDEX*
          C
          COMMON  CNL(20),MSK(20),FREQ(20)
10         DIMENSION THRSH(20)
          C
          C      CNL(K) IS READ IN AS THE SPECTRUM LEVEL OF NOISE AT
          C      THE CENTER FREQUENCY OF THE KTH BAND.  THE CORRECTED
          C      VALUES ARE STORED IN THE SAME ARRAY
15         C
          C      THRSH(K) = THRESHOLD OF AUDIBILITY AT CENTER FREQUENCY
          C      OF KTH BAND
          C
20         THRSH(1) = -7.0
          THRSH(2) = -11.0
          THRSH(3) = -14.0
          THRSH(4) = -16.0
          THRSH(5) = -16.0
          THRSH(6) = -16.0
25         THRSH(7) = -16.0
          THRSH(8) = -17.5
          THRSH(9) = -19.0
          THRSH(10) = -20.0
          THRSH(11) = -22.0
30         THRSH(12) = -23.5
          THRSH(13) = -25.5
          THRSH(14) = -27.5
          THRSH(15) = -29.0
          THRSH(16) = -30.0
35         THRSH(17) = -30.0
          THRSH(18) = -29.0
          THRSH(19) = -24.0
          THRSH(20) = -21.0
          DO 30 K=1,20
40         C
          C      CALCULATE SENSATION LEVEL OF NOISE = SFNT
          C
          C      1 SENT =CNL(K) - THRSH(K)
          C      IF(SENT.GT.80)10,30
45         C
          C      CORRECTIONS FOR NONLINEAR GROWTH OF MASKING
          C
10        CNL(K) = CNL(K) + (SENT - 80.0)/5.0
30        CONTINUE
          RETURN
50        END

```

```

1      SUBROUTINE MASK
      C
      C*****CALCULATE SPREAD-OF-MASKING OF NOISE SPECTRUM, AND
      C          CALCULATE RESULTING EFFECTIVE MASKING SPECTRUM *****
5      C
      C          REFERENCE--AMERICAN NATIONAL STANDARDS INSTITUTE,
      C          S3.5-1969, METHODS FOR THE CALCULATION
      C          OF THE ARTICULATION INDEX+
10     C
      C          COMMON/ /CNL(20),MSK(20),FREQ(20)
      C
      C          CNL(K) = SPECTRUM LEVEL OF CORRECTED NOISE AT
      C          CENTER FREQUENCY OF KTH BAND
      C          MSK(K) = EFFECTIVE MASKING OF THE NOISE SPECTRUM
15     C          AT CENTER FREQUENCY OF KTH BAND
      C          FREQ(K) = CENTER FREQUENCY OF KTH BAND
      C
      C          SOM(K) = SPREAD-OF-MASKING OF THE NOISE SPECTRUM
      C          AT CENTER FREQUENCY OF KTH BAND
20     C
      C          MAX(K) = IDENTIFICATION OF FREQUENCIES AT WHICH MAXIMA OCCUR
      C
      C          DIMENSION MAX(20),SOM(20),EXT(5,7),SLOPE(5,7)
      C          TYPE REAL MAX,MSK,SOM
      C          TYPE INTEGER PCNT
25     C
      C          EXT(J,K) = NUMBER OF HERTZ TO EXTEND LINE FROM
      C          STARTING POINT FOR JTH FREQUENCY RANGE
      C          AND KTH AMPLITUDE RANGE
30     C          SLOPE(J,K) = SLOPE OF LINE (DB/OCTAVE) FROM END OF
      C          EXTENDED LINE(DOWNWARD AND TO THE LEFT)
      C          FOR JTH FREQUENCY RANGE AND KTH AMPLITUDE RANGE
      C
35     EXT(1,1)=250.
      EXT(2,1)=500.
      EXT(3,1)=1000.
      EXT(4,1)=1500.
      EXT(5,1)=3000.
      EXT(1,2)=200.
40     EXT(2,2)=500.
      EXT(3,2)=1000.
      EXT(4,2)=1500.
      EXT(5,2)=3000.
      EXT(1,3)=200.
45     EXT(2,3)=400.
      EXT(3,3)=800.
      EXT(4,3)=1500.
      EXT(5,3)=3000.
      EXT(1,4)=150.
50     EXT(2,4)=250.
      EXT(3,4)=500.
      EXT(4,4)=1000.
      EXT(5,4)=2000.
      EXT(1,5)=75.
55     EXT(2,5)=150.
      EXT(3,5)=300.
      EXT(4,5)=500.

```

```

        EXT(5,5)=800.
        EXT(1,6)=50.
60      EXT(2,6)=100.
        EXT(3,6)=200.
        EXT(4,6)=200.
        EXT(5,6)=200.
        EXT(1,7)=0.0
65      EXT(2,7)=0.0
        EXT(3,7)=0.0
        EXT(4,7)=0.0
        EXT(5,7)=0.0
        SLOPE(1,1)=10.
70      SLOPE(2,1)= 8.
        SLOPE(3,1)= 5.
        SLOPE(4,1)= 3.
        SLOPE(5,1)= 0.
        SLOPE(1,2)=15.
75      SLOPE(2,2)=13.
        SLOPE(3,2)=10.
        SLOPE(4,2)= 5.
        SLOPE(5,2)= 0.
        SLOPE(1,3)=20.
60      SLOPE(2,3)=18.
        SLOPE(3,3)=15.
        SLOPE(4,3)=10.
        SLOPE(5,3)= 0.
        SLOPE(1,4)=25.
65      SLOPE(2,4)=23.
        SLOPE(3,4)=20.
        SLOPE(4,4)=15.
        SLOPE(5,4)= 5.
        SLOPE(1,5)=35.
90      SLOPE(2,5)=30.
        SLOPE(3,5)=25.
        SLOPE(4,5)=25.
        SLOPE(5,5)=20.
        SLOPE(1,6)=45.
95      SLOPE(2,6)=40.
        SLOPE(3,6)=35.
        SLOPE(4,6)=40.
        SLOPE(5,6)=40.
        SLOPE(1,7)=400.
100     SLOPE(2,7)=400.
        SLOPE(3,7)=400.
        SLOPE(4,7)=400.
        SLOPE(5,7)=400.
105     C*****FIND MAXIMA OF CORRECTED NOISE SPECTRUM*****
        C
        DO 10 K=1,20
        SOM(K) = 0.0
        MSK(K) = 0.0
110     10 MAX(K) = 0.0
        DO 25 K=2,19
        MCNT = K
        PCNT = K
        IF(MAX(K).EQ.0) 110,25
110     KM1=K-1

```

```

115      KP1=K+1
        IF(CNL(K).GT.CNL(KM1).AND.CNL(K).GT.CNL(KP1))11,13
11      MAX(K) = FREQ(K)
        GO TO 25
13      MCNT = MCNT - 1
120     IF(MCNT.EQ.0)17,15
15      IF(CNL(MCNT).EQ.CNL(K))113,17
113     MAX(K) = 1.0
        GO TO 13
17      PCNT = PCNT + 1
125     IF(PCNT.GT.20)24,12
12      IF(CNL(PCNT).EQ.CNL(K))117,19
117     MAX(K) = 1.0
        GO TO 17

C
C      THE CORRECTED NOISE SPECTRUM LEVEL IS CONSTANT FROM LAST
C      VALUE OF MCNT TO LAST VALUE OF PCNT
C
C      NOW FIND OUT IF SPECTRUM DROPS ON BOTH ENDS OF FLAT SECTION
135     19 IF(MCNT.LT.2)24,20
        20 IF(CNL(MCNT).LT.CNL(K).AND.CNL(PCNT).LT.CNL(K))21,24
        21 MAX(K) = SQRT (FREQ(MCNT)*FREQ(PCNT))
        24 CONTINUE
        25 CONTINUE
        IF(CNL(20).GT.CNL(19))800,801
140     800 MAX(20) = FREQ(20)
        801 CONTINUE

C
C*****FREQUENCIES OF MAXIMA OF CORRECTED NOISE SPECTRUM NOW
C      ARE THE ONLY VALUES OF MAX(K) THAT ARE NOT ZERO OR ONE
145     C
        DO 100 K=1,20
        IF(MAX(K).GT.1.0)27,100

C
C      FIND POINT TO THE RIGHT OF MAX(K) THAT IS 3 DECIBELS DOWN
150     C
        27 TEST = CNL(K) - 3.0
        PCNT = K+1
        STRT=0.0
        DO 40 I=PCNT,20
155     IF(CNL(I).EQ.TEST)28,29
        28 STRT=FREQ(I)
        GO TO 141
        29 IF(CNL(I).LT.TEST)30,40
        30 IM1=I-1
160     C      PROPORTION FREQUENCY INTERVAL FROM LOGARITHMIC SLOPE
        C
        BGDLN=CNL(IM1)-CNL(I)
        BGDLF=FREQ(I)-FREQ(IM1)
        DELF=3.0*BGDLF/BGDLN
165     STRT=FREQ(IM1) + DELF
        GO TO 141
        40 CONTINUE
        IF(STRT.EQ.0.0) 140,141
170     140 STRT = FREQ(20)

C
C      TABLE LOOK-UP OF EXTENSION OF FREQUENCY FROM STARTING POINT,

```

```

C      TABLE LOOK-UP OF SLOPE OF LINE FROM STARTING POINT
C
175  141 IF(TEST.GT.5)41,42
      41 L=1
      GO TO 53
      42 IF(TEST.GT.85)43,44
      43 L=2
      GO TO 53
180  44 IF(TEST.GT.75)45,46
      45 L=3
      GO TO 53
      46 IF(TEST.GT.65)47,48
      47 L=4
185  48 IF(TEST.GT.55)49,50
      49 L=5
      GO TO 53
      50 IF(TEST.GT.45)51,52
190  51 L=6
      GO TO 53
      52 L=7
      53 IF(STRT.LT.800)54,55
      54 J=1
195  55 IF(STRT.LT.1600)56,57
      56 J=2
      GO TO 62
      57 IF(STRT.LT.2400)58,59
200  58 J=3
      GO TO 62
      59 IF(STRT.LT.3200)60,61
      60 J=4
      GO TO 62
205  61 J=5
      62 TERMF=STRT + EXT(J,L)
C
C      ESTABLISH SLOPE AND INTERCEPT OF LOW FREQUENCY PART
C      OF SPREAD-OF-MASKING CURVE
210  C
      A= -14.43
      B=TEST + 14.43*ALOG(STRT) - 57.0
C
C      ESTABLISH SLOPE AND INTERCEPT OF HIGH FREQUENCY PART
C      OF SPREAD-OF-MASKING CURVE
215  C
      C=SLOPE(J,L)/.693
      D=TEST - C*ALOG(TERMF)
      DO 80 I=1,20
220  IF(FREQ(I).LT.STRT)63,64
C
C      ESTABLISH SUM=SLOPE*LN(F) + INTERCEPT EQUATIONS FOR
C      SLOPE-OF-MASKING LINES
225  63 SOM(I) =A*ALOG(FREQ(I)) + B
      GO TO 65
      64 IF(FREQ(I).GT.TERMF)80,564
564  SOM(I) =C*ALOG(FREQ(I)) + D

```

```
230      65 IF(SOM(I).GT.MSK(I))66,80
      66 MSK(I) = SOM(I)
      80 CONTINUE
C
C      MSK(K) NOW CONTAINS THE MAXIMUM OF (POSSIBLY) SEVERAL
C      SOM(I)
235      100 CONTINUE
      DO 500 K=1,20
      500 SOM(K) = MSK(K)
C
C      EFFECTIVE MASKING LEVEL EQUALS LARGEST OF CORRECTED
C      NOISE LEVELS AND (POSSIBLY) SEVERAL SPREAD-OF-MASKING
C      LEVELS FROM SEVERAL MAXIMA IN THE CORRECTED NOISE LEVEL
C      SPECTRUM
245      DO 180 I=1,20
      IF(MSK(I).GT.CNL(I))160,68
      68 MSK(I) = CNL(I)
      160 CONTINUE
      WRITE(6,310)
250      310 FORMAT( /,10X,* CENTER CORRECTED SPREAD- *,
      1*MASKING*,/,10X,*FREQUENCY NOISE OF-MASKING LEVEL*,
      2* OF*,/,10X,*OF BAND LEVEL OF NOISE NOISE*,/,
      310X,* (HERTZ) (DB) (DB) (DB)* )
      WRITE(6,400) (FREQ(I),CNL(I),SOM(I),MSK(I),I=1,20)
255      400 FORMAT(10X,F7.1,F10.1,2F11.1)
      RETURN
      END
```

TABLE D-2 LISTING OF TYPICAL RESULTS OF COMPUTER CALCULATION OF AI

TEST CASE
DATA TAKEN FROM FIGURE 2 OF ANSI S3.5

| CENTER FREQUENCY OF BAND (HERTZ) | SPECTRUM LEVEL OF SPEECH (DB) | SPECTRUM LEVEL OF NOISE (DB) |
|---|--|---------------------------------------|
| 270.0 | 69.0 | 0.0 |
| 380.0 | 69.0 | 0.0 |
| 490.0 | 68.0 | 0.0 |
| 630.0 | 65.0 | 0.0 |
| 770.0 | 63.0 | 0.0 |
| 920.0 | 60.0 | 0.0 |
| 1070.0 | 58.0 | 0.0 |
| 1230.0 | 55.0 | 19.0 |
| 1400.0 | 53.0 | 28.0 |
| 1570.0 | 51.0 | 39.0 |
| 1740.0 | 49.0 | 48.0 |
| 1920.0 | 47.0 | 56.0 |
| 2130.0 | 46.0 | 65.0 |
| 2370.0 | 44.0 | 75.0 |
| 2660.0 | 43.0 | 80.0 |
| 3000.0 | 41.0 | 80.0 |
| 3400.0 | 40.0 | 80.0 |
| 3950.0 | 39.0 | 80.0 |
| 4560.0 | 38.0 | 76.0 |
| 5600.0 | 37.0 | 62.0 |

OASL (DBA) = 92.3 114.5

OVERALL SOUND LEVEL (SPEECH + NOISE, 200 TO 6100 HZ) = 114.5 DBA

| CENTER FREQUENCY OF BAND (HERTZ) | CORRECTED NOISE LEVEL (DB) | SPREAD- OF-MASKING OF NOISE (DB) | MASKING LEVEL OF NOISE (DB) |
|---|-------------------------------------|---|--------------------------------------|
| 270.0 | 0.0 | 65.8 | 65.8 |
| 380.0 | 0.0 | 60.9 | 60.9 |
| 490.0 | 0.0 | 57.2 | 57.2 |
| 630.0 | 0.0 | 53.6 | 53.6 |
| 770.0 | 0.0 | 50.7 | 50.7 |
| 920.0 | 0.0 | 48.1 | 48.1 |
| 1070.0 | 0.0 | 46.0 | 46.0 |
| 1230.0 | 19.0 | 43.9 | 43.9 |
| 1400.0 | 28.0 | 42.1 | 42.1 |
| 1570.0 | 39.0 | 40.4 | 40.4 |
| 1740.0 | 48.0 | 38.9 | 48.0 |
| 1920.0 | 56.0 | 37.5 | 56.0 |
| 2130.0 | 67.1 | 36.0 | 67.1 |
| 2370.0 | 79.5 | 34.5 | 79.5 |
| 2660.0 | 85.8 | 32.8 | 85.8 |
| 3000.0 | 86.0 | 31.1 | 86.0 |
| 3400.0 | 86.0 | 29.3 | 86.0 |
| 3950.0 | 85.8 | 27.1 | 85.8 |
| 4560.0 | 80.0 | 83.0 | 83.0 |
| 5600.0 | 62.6 | 83.0 | 83.0 |

ARTICULATION INDEX = .40

APPENDIX E

TRANSMISSION OF VIBRATION FROM CREW SEATS TO
CREW MEMBER'S HEAD

TRANSMISSION OF VIBRATION FROM CREW SEATS TO CREW MEMBER'S HEAD

Figure E-1 shows a lumped-parameter analog of a human body seated on a vertically vibrated platform. The model is not applicable for high frequencies of vibration of a supporting platform, for which a human body responds as a distributed parameter system, with shear waves, compressional waves, and surface waves propagating throughout a body. The model is applicable for frequencies below about 100 Hz (cycles per second).

Figure E-1 must be modified to include the effects of elastic supports for pilot's buttocks. MIL-S-58095⁹³ specifies a maximum deflection (for the heaviest pilots) of 1.5 inches for cushions. That corresponds exactly to the mean of measured stiffness values for a seat net which is typical of nets that are being substituted for cushions in helicopter seats (AVSCOM⁹⁴). That stiffness, combined with the weight of the hips-plus-buttocks of a 90th percentile pilot given by von Gierke, produces a resonance frequency of 5 Hz for hips-plus-buttocks on a seat cushion or on a seat net.

von Gierke⁹⁵ reviewed a previously-published model which shows that the resonance frequency of an arm on a shoulder is about 5 Hz, and the resonance frequency of a leg on a hip is about 2 Hz. ASCC⁹⁶ reported that the resonance frequency of a head plus torso plus arms on a spinal column is 8.4 Hz. Without the mass of a head and arms, the resonance frequency of a torso on a spine is about 7 Hz. von Gierke reviewed a reference which reported that the resonance frequency of a head on a neck is about 30 Hz. Entering those resonance frequencies in Figure E-1, adding cushion elements, and recognizing that the stiffness of a spine controls vertical transmissibility (with little effect due to a thorax-abdomen system below 100 Hz), results in Figure E-2a.

Slater and Frank⁹⁷ pointed out that it is impossible to obtain exact analytical solutions to the equations of motion for a system like the one shown in Figure E-2a (Numerical solutions can be obtained by computerized finite-element and finite-difference calculations). The transmissibility of the system shown in Figure E-2a can be "bracketed" by making two opposing assumptions:

- (1) the motion of each of the masses is uncoupled from the motions of all of the other masses;

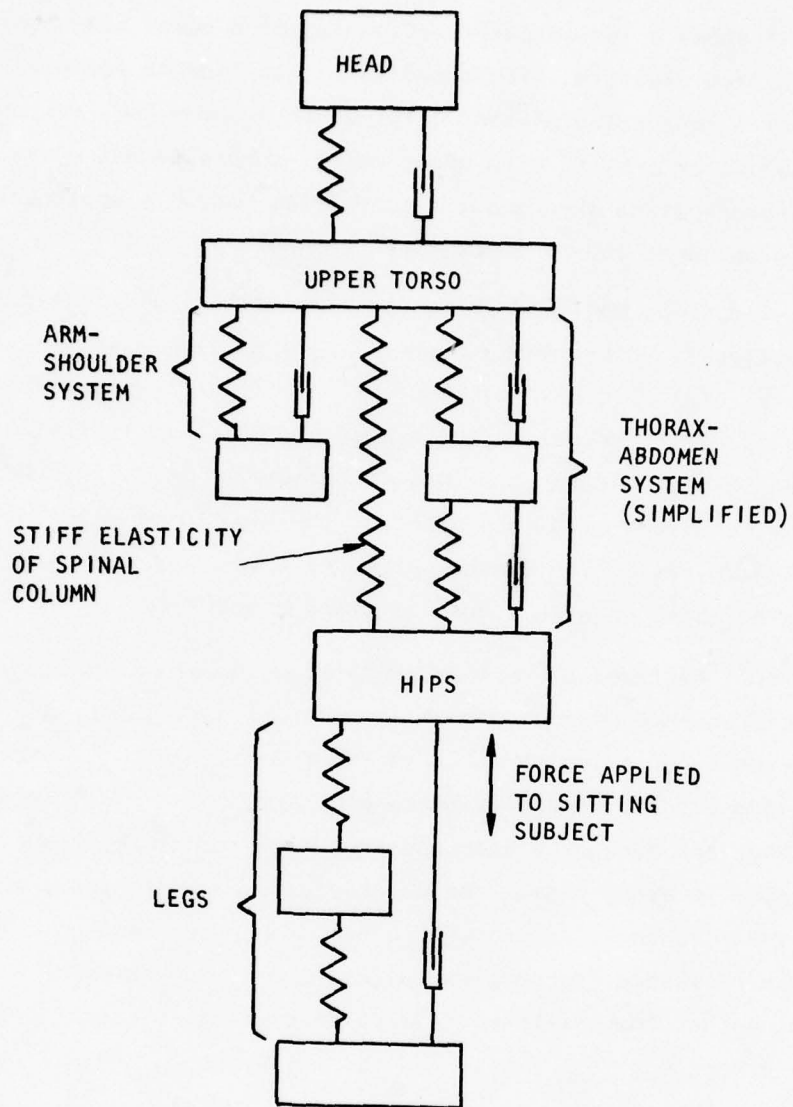
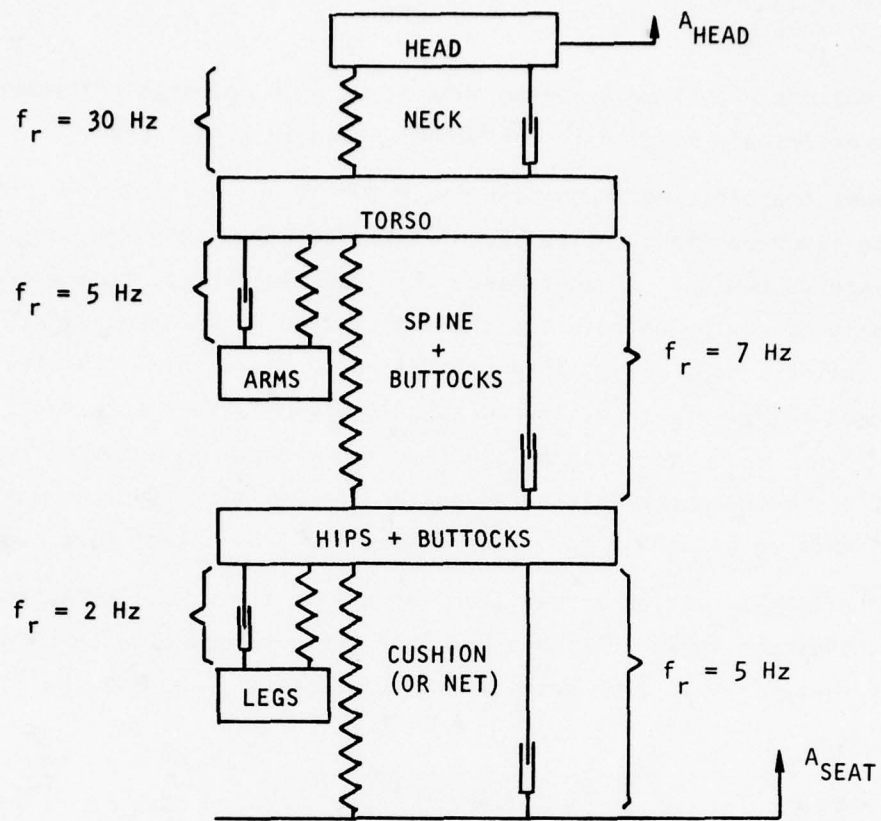
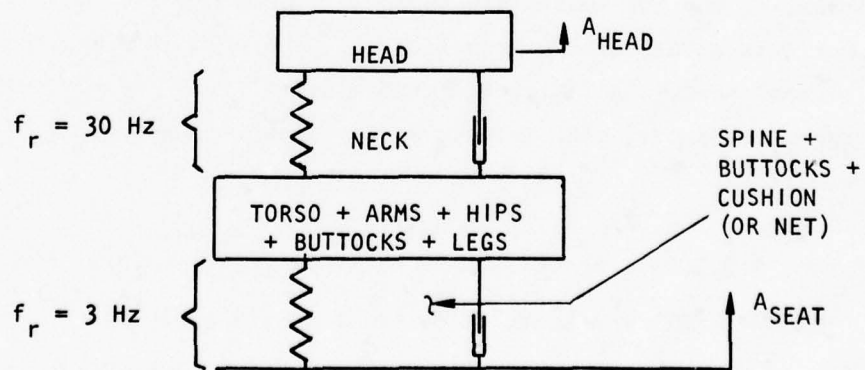

FIGURE E-1 SIMPLIFIED MECHANICAL SYSTEM REPRESENTING A HUMAN BODY SEATED ON A PLATFORM VIBRATING VERTICALLY BELOW 100 Hz. (FROM COERMANN)⁹²



(a) NO LUMPING OF COMPONENTS



(b) WITH LUMPING OF COMPONENTS WITH COMPARABLE RESONANCE FREQUENCIES

FIGURE E-2 TANDEM SYSTEM FOR CALCULATION OF THE TRANSMISSIBILITY OF THE BODY OF A CREW MEMBER SEATED IN A HELICOPTER SEAT

- (2) the motions of all mass-spring subsystems with comparable resonance frequencies are coupled in the manner shown in Figure E-2b.

If we assume that driving frequencies near 100 Hz are sufficiently removed from any of the resonance frequencies shown in Figure E-2a, then the motions of the masses are decoupled. In that case, the transmissibility from a seat to hips and buttocks can be calculated, then multiplied by the transmissibility from hips and buttocks to a torso, then multiplied by the transmissibility from a torso to a head to get the total transmissibility from a seat to a head. Similarly, in Figure E-2b, the transmissibility from a seat to a torso/arms/hips/buttocks/legs mass can be multiplied by the transmissibility from that mass to a head mass to get the total transmissibility from a seat to a head.

If the equations of motion are written for any of the decoupled spring-mass-dashpot subsystems shown in Figure E-2, and if those equations are solved for the transmissibility, T , from base excitation to mass response, the result is:

$$T = \frac{A_{\text{mass}}}{A_{\text{base}}} = \sqrt{\frac{1 + 4\zeta^2 f^2/f_r^2}{f^4/f_r^4 + 4\zeta^2 \frac{f^2}{f_r^2} - 1}} \quad (1)$$

where A is acceleration, ζ is the fraction of critical damping at the resonant frequency f_r , and f is the frequency of the base oscillations. The fraction of critical damping for the subsystems shown in Figure E-2 is about 0.2.^{95,96} that value for ζ is substituted in equation (1), and a 90 Hz vibration of a crew seat is considered, and individual transmissibilities are multiplied in the manner described above, then the two models shown in Figure E-2 yield the following results:

$$\begin{aligned} A_{\text{head}} &= 0.0001 \bullet A_{\text{seat}}, \text{ at } 90 \text{ Hz (from Figure E-2a), and} \\ A_{\text{head}} &= 0.002 \bullet A_{\text{seat}}, \text{ at } 90 \text{ Hz (from Figure E-2b).} \end{aligned} \quad (2)$$

MIL-A-8870⁴² states that the level of vibration of a crew seat shall not exceed $\pm 1.5g$'s at frequencies above 86 Hz. Using the transmissibilities defined by equation (2), that level of excitation of a seat translates to peak

accelerations of either 0.00015 g or 0.003 g at a crew member's head. Figure 37 (Section 7 of this report) shows that, if the vibration frequencies are concentrated at about 90 Hz, such accelerations generate sound pressure levels of about 64 dBSPL and 90 dBSPL respectively, inside an earcup (assuming a linear correlation between vibration levels and sound pressure levels). Above 100 Hz the models of Figures 1 and 2 do not apply. One would expect significant decoupling above 100 Hz, leading to less conduction of vibration to the head. The sound pressure levels shown in Figure 37 resulted from vibrations which correspond to lateral vibrations of a pilot's head, while the transmissibilities which are discussed above are for vertical vibrations. However, there tends to be an "equipartition" of vibrational energy within complex mechanical systems, such as an aircraft/pilot/seat system, so the above analysis probably is applicable for lateral vibrations.

More detailed models and equations will have to be constructed to refine the estimates of head vibrations and associated sound pressure levels which are presented above and to extend the analysis to other frequency ranges. However, the calculations which are summarized here serve to demonstrate that seat vibrations may be an important part of the problem with exposure of helicopter pilots to noise (even after A-weighting of sound pressure levels is considered).

APPENDIX F

DERIVATION AND DESCRIPTION OF A FORTRAN IV COMPUTER
PROGRAM FOR CALCULATING NOISE REDUCTION BY EARCUPS

APPENDIX F

DERIVATION AND DESCRIPTION OF A FORTRAN IV COMPUTER PROGRAM FOR CALCULATING NOISE REDUCTION BY EARCUPS

Figure F-1a is a simplified drawing of an earcup which is designed to protect an aircraft pilot from noise. If it is assumed that circumaural skin is depressed only under the area where a cushion contacts flesh, then changes in the volume of air enclosed within an earcup can occur even for a rigid cushion, and Zwislocki's³⁶ analog circuit, shown in Figure F-1b, applies. (See Lindsay⁹⁸ for a discussion of electromechanical analogies.) If it is assumed that circumaural skin is depressed uniformly everywhere within the external boundary of the cushion (which requires that the stiffness of the enclosed air is comparable to the stiffness of skin, and that the cartilaginous external ear is sufficiently rigid to drive the underlying flesh to follow air volume variations), then no changes in the volume of air enclosed within an earcup can occur if its earcup cushion is rigid; in that case, the "alternative" analog electrical circuit shown in Figure F-1c applies. In either case, the displacement of air within an ear canal is considered negligible.

Z in Figures F-1b and F-1c denotes specific acoustic impedance,

$$Z = |P_e| / |\dot{\xi}|, \text{ where}$$

$$P_e = \text{excess acoustic pressure, and}$$

$$\dot{\xi} = \text{particle velocity.}$$

The impedances shown in Figure F-1b are

$$Z_{\text{mass}} \equiv Z_m = \frac{i\omega M}{A_1} \equiv X_m,$$

$$Z_{\text{volume}} \equiv Z_v = \frac{-i}{\omega} \frac{\rho_0 c^2}{V} \left(\frac{S_o + S_i}{2} \right) \equiv iX_v,$$

$$Z_{\text{skin}} \equiv Z_s = \frac{R_c}{(S_o - S_i)} \frac{-iK_s}{\omega(S_o - S_i)} \equiv r_s - iX_s, \text{ and}$$

$$Z_{\text{cushion}} \equiv Z_c = \frac{R_c}{(S_o - S_i)} \frac{-iK_c}{\omega(S_o - S_i)} \equiv r_c - iX_c, \text{ where}$$

$$A_1 = \text{effective contact area of cushion}^{38}$$

$$= \frac{\pi d_1^2}{4}$$

c = velocity of sound within the enclosed air (cm/sec)

d_o = outer diameter of earcup (cm)

d_i = inner diameter of earcup (cm)

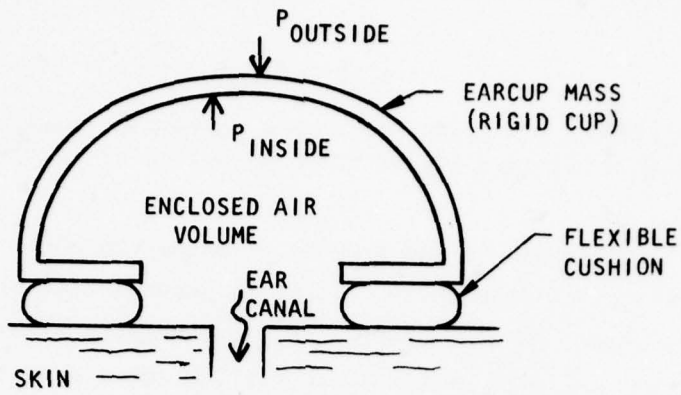

(a) SIMPLIFIED DRAWING OF AN EARCUP

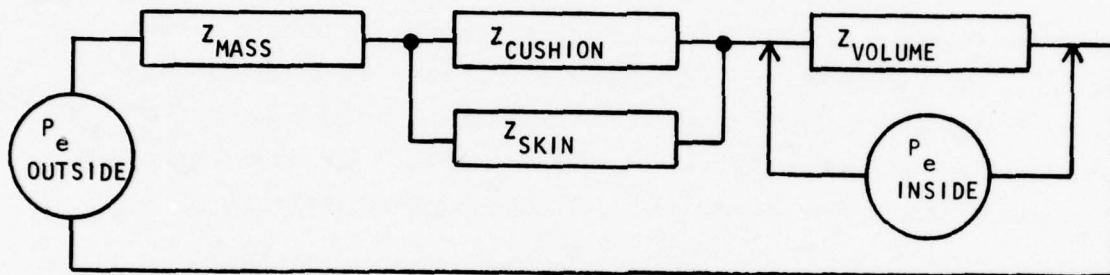

(b) ZWISLOCKI ANALOG CIRCUIT FOR AN EARCUP

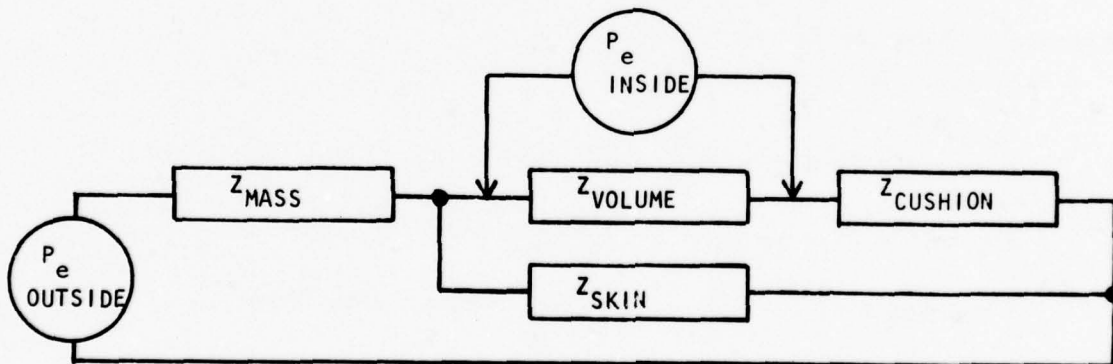

(c) ALTERNATIVE ANALOG CIRCUIT FOR AN EARCUP

FIGURE F-1 EARCUP ANALOGS

$$d_1 = 1/2(d_o + d_i)$$

$$i = \sqrt{-1}$$

K_c = cushion stiffness (dyne/cm)

K_s = skin stiffness (dyne/cm)

M = earcup mass (gm)

R_c = cushion resistance (dyne sec/cm)

R_s = skin resistance (dyne sec/cm)

S_i = cross-sectional area of air volume (cm²)

S_o = outer cross-sectional area of earcup (cm²)

$\frac{1}{2} (S_i + S_o)$ = effective cross-sectional area of air volume³⁸

V = volume of enclosed air (cm³)

ρ_o = density of undisturbed enclosed air (gm/cm³)

$\omega = 2\pi f = 2\pi$ times the frequency of imposed sound (sec⁻¹).

The impedances shown in Figure F-1_c are the same as those shown in Figure F-1b, except that

$$Z_{\text{skin}} \equiv Z_s = \frac{R_s}{A_1} - \frac{iK_s}{\omega A_1} \equiv r_s - iX_s.$$

Application of Ohm's law and Kirchoff's laws for electrical circuits to the circuit shown in Figure F-1b yields, after tedious algebraic manipulations:

$$T \equiv \left| \frac{p_{\text{inside}}}{p_{\text{outside}}} \right| = \sqrt{RE^2 + IM^2}, \text{ where}$$

$$RE = \frac{AC - BD}{C^2 + D^2}$$

$$IM = \frac{AD + BC}{C^2 + D^2}, \text{ and}$$

$$A = -X_v (X_c + X_s)$$

$$B = X_v (r_c + r_s)$$

$$C = r_c r_s - X_c X_s - X_c X_v - X_v X_s + X_c X_m + X_m X_s$$

$$D = r_c X_m + r_s X_m - r_c X_s - r_s X_c - r_c X_v - r_s X_v$$

The equivalent results for Figure F-1c are:

$$T \equiv \left| \frac{p_{\text{inside}}}{p_{\text{outside}}} \right| = \sqrt{RE^2 + IM^2}, \text{ where}$$

$$RE = \frac{AX_s X_v - Br_s X_v}{A^2 + B^2}$$

$$IM = \frac{Ar_sX_v + Bx_sX_v}{A^2 + B^2}, \text{ and}$$

$$A = X_cX_s + X_vX_s - X_sX_m - X_vX_m - X_cX_m - r_c r_s$$

$$B = r_sX_m - r_sX_v - r_sX_c - r_cX_s + r_cX_m$$

The transmission loss, TR, in decibels, exhibited by an earcup like the one shown in Figure F-1a is given by

$$TR = 20 \log_{10} T.$$

Equations supplied by Shaw and Thiessen³⁸ for K_c were used in the calculations described in this report. However, they recommended using the value for adiabatic compressibility for air within an air-filled cushion of an earcup. That value for air compressibility is not appropriate for small spaces. The value for isothermal compressibility should be used in the calculations, as evidenced by the fact that the match of experimental measurements and computations of the transmission ratio of an earcup with an air-filled cushion (See Section 7.3) was improved when isothermal compressibility was substituted for adiabatic compressibility.

Franke⁴⁴ summarized some published measurements of the stiffness and resistance of human mastoids, and Corliss and Koidaw⁹⁹ reported some additional measurements. Shaw and Thiessen³⁸ reported that the stiffness component of the effective circumaural impedance is five or six times smaller than values reported for mastoids. They also reported that the resistance of circumaural flesh is about 10 times greater than values reported for mastoids. The value they reported for circumaural stiffness is:

$$K_s = 8.0 \times 10^7 \text{ dyne/cm.}$$

That value was used in the computer model. Figure F-2 shows the Frequency-dependent values of circumaural resistance which was used in the computer model.

Table F-1 is a listing of a FORTRAN IV computer program for carrying out the calculations which are described above. Table F-2 shows typical tabular print-outs produced by that program, and Figure F-3 shows typical graphical print-outs produced by that program.

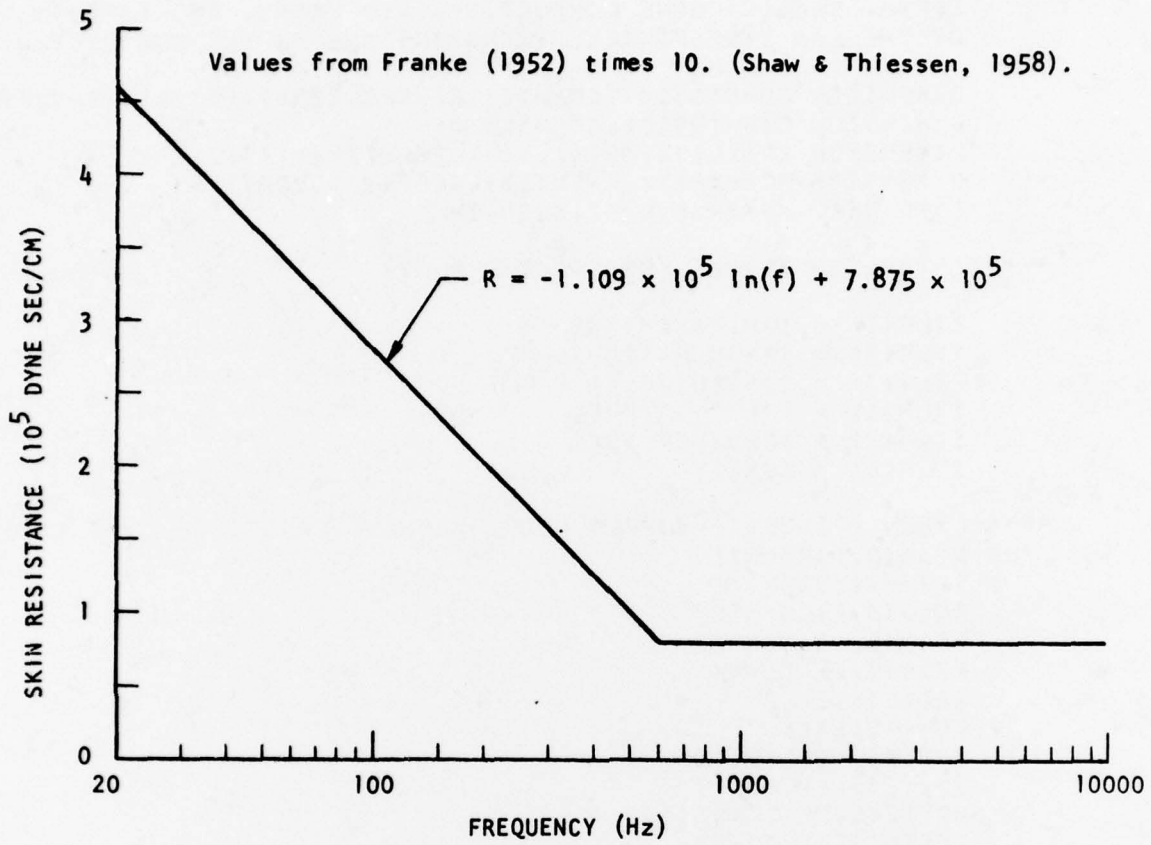

FIGURE F-2 CIRCUMAUURAL SKIN RESISTANCE VERSUS FREQUENCY

TABLE F-1

PROGRAM CUPTR

7474 OPT=1

FTN 4.6+428

```

1      PROGRAM CUPTR(INPUT,OUTPUT,TAPE 5=INPUT,TAPE 6=OUTPUT)
      C
      C      CALCULATE NOISE REDUCTION BY PROTECTIVE EARCAPS.
      C      INCLUDE EFFECTS OF CONFINED AIR, STIFFNESS AND DAMPING
5      C      OF FLUID-FILLED EARCAP WALLS, STIFFNESS AND DAMPING OF
      C      FLESH. NEGLECT NONE CONDUCTION, AIR LEAKS, AND IMPEDANCE
      C      OF THE EAR ITSELF. ALL DIMENSIONS ARE IN THE CGS SYSTEM.
      C
10     DIMENSION COMNT1(10),COMNT2(10),FREQ(29),ATT(28), TR(28)
      DIMENSION COMNT3(10),COMNT4(10)
      DIMENSION ITITLE(8,8),ITLV(3),ITLH(3),X(29,2)
      DIMENSION RCOP(27), TNEW(27),KCOP(27),VOP(27)
      TYPE REAL KSKIN,M,L,KC,KCOP,IM
      C
15     C*****ESTABLISH TITLES FOR CALCOMP PLOTS
      C
      ITLV(1) = 10HTRANSMISSI
      ITLV(2) = 10HON RATIO (
      ITLV(3) = 10HDECIBELS)
20     ITLH(1) = 10H      FREQ
      ITLH(2) = 10HUENCY (HER
      ITLH(3) = 10HTZ)
      C
25     C*****LABEL PRINTOUT--SUPPLY FOUR COMMENT CARDS, COLUMNS 11-62
      300 READ(5,1)COMNT1
      1 FORMAT(10A8)
      READ(5,1)COMNT2
      READ(5,1) COMNT3
      READ(5,1) COMNT4
30     WRITE(6,2)
      2 FORMAT(1H1)
      WRITE(6,1)COMNT1
      WRITE(6,1)COMNT2
      WRITE(6,1) COMNT3
35     WRITE(6,1) COMNT4
      C
      C*****READ INPUT(ALL VARIABLES IN CGS DIMENSIONS)*****
      C
40     READ(5,10)M,V,SO,SI,8M
      10 FORMAT(5E15.7)
      READ(5,10)B,H,T,E,RC
      READ(5,10) FLAG,SHUNT
      C
      M = EARCAP MASS (GRAMS)
      C
      V = EARCAP AIR VOLUME
45     C
      SO = OUTER CROSS-SECTIONAL AREA OF EARCAP
      C
      SI = INNER CROSS-SECTIONAL AREA OF OPENING TO VOLUME
      C
      B = WIDTH OF CONTACT OF FLEXIBLE WALL WITH FLESH
      C
      H = DEPTH OF FLUID-FILLED WALL BETWEEN EARCAP AND FLESH
      C
      T = THICKNESS OF WALL MATERIAL
50     C
      E = YOUNG+S MODULUS OF WALL MATERIAL
      C
      RC = RESISTANCE COEFFICIENT OF FLUID WITHIN THE WALL
      C
      8M = PULK MODULUS OF THE FLUID WITHIN THE WALL. IF
      C
      BM = ZERO, THE FLUID IS ASSUMED INCOMPRESSIBLE.
      C
      FLAG = 0 FOR FLEXIBLE SKIN, NON-ZERO FOR A RIGID SURFACE.
      C
55     SHUNT = 0 IF SKIN SHUNTS BOTH CUSHION AND VOLUME,
      C
      C
      NON-ZERO IF SKIN SHUNTS ONLY CUSHION
      C

```

TABLE F-1 (CONTINUED)

PROGRAM CUPTR

74774 OPT=1

FTN 4.6+428

```

        IF(FLAG.EQ.0.0) 2200,315
2200 IF(SHUNT.EQ.0.0)1300,310
60 1300 WRITE(6,301)
      301 FORMAT(/,10X,*SKIN SHUNTS BOTH CUSHION AND VOLUME*)
      GO TO 315
      310 WRITE(6,302)
      302 FORMAT(/,10X,*SKIN SHUNTS CUSHION, BUT NOT VOLUME*)
65 C
C*****LIST INPUT
      315 WRITE(6,20) M
      20 FORMAT(/,10X,*EARCUP MASS = *,F6.1,* GRAMS*)
      WRITE(6,25)V
70 25 FORMAT(/,10X,*EARCUP AIR VOLUME = *,F6.1,* CC+S*)
      WRITE(6,30)S0
      30 FORMAT(/,10X,*OUTER CROSS-SECTIONAL AREA OF EARCUP = *,
1F5.1,* CMSQ*)
      WRITE(6,35)SI
75 35 FORMAT(/,10X,*INNER CROSS-SECTIONAL AREA OF OPENING TO*,
1* VOLUME = *,F5.1,* CMSQ*)
      WRITE(6,40)B
      40 FORMAT(/,10X,*WIDTH OF CONTACT OF FLEXIBLE WALL WITH*,
1* FLESH = *,F4.1,* CM*)
80 45 WRITE(6,45)H
      45 FORMAT(/,10X,*DEPTH OF FLUID-FILLED WALL BETWEEN EARCUP*
1,* AND FLESH = *,F4.1,* CM*)
      50 FORMAT(/,10X,*THICKNESS OF WALL MATERIAL = *,F5.3,* CM*)
      WRITE(6,50)T
85 55 WRITE(6,55)E
      55 FORMAT(/,10X,*YOUNG+S MODULUS OF WALL MATERIAL = *,E9.2,
1* DYNES/CMSQ*)
      WRITE(6,60)RC
90 60 FCRMAT(/,10X,*RESISTANCE COEFFICIENT OF FLUID WITHIN*,
1* THE WALL = *,E9.2,* DYNE SEC/CM*)
      IF(RM.EQ.0.0) 64,63
      63 WRITE(6,65) RM
      65 FORMAT(/,10X,*BULK MODULUS OF FLUID WITHIN THE WALL =*,
1E9.2,* DYNES/CMSQ*)
95 64 GO TO 79
      64 WRITE(6,62)
      62 FORMAT(/,10X,*INCOMPRESSIBLE FLUID IN EARCUP WALLS*)
      79 IF(FLAG.EQ.0.0) 166,162
100 162 WRITE(6,165)
      165 FORMAT(/,10X,*EARCUP ON A RIGID SURFACE*)
      GO TO 170
      166 WRITE(6,167)
      167 FORMAT(/,10X,*KSKIN=8.0E7 DYNES/CM*,
1*(SHAW AND T.,JASA,1958)*)
105 168 WRITE(6,168)
      168 FORMAT(/,10X,*FREQUENCY-DEPENDENT RSKIN FROM *,
1*FRANKE(JASA,1952)*,
2/,10X,*TIMES 10(SHAW AND T.,JASA,1958)*)
110 C
C*****COMPUTE CONSTANTS
      170 RTM = (S0 - SI)
      L = 1.7725*(SQRT(S0)+SQRT(SI))
      AL = L*L/12.5664
      IF(RM.EQ.0.0) 67,66

```

TABLE F-1 (CONTINUED)

PROGRAM CUPTR

74/74 OPT=1

FTN 4.6+428

```

115      66 KC = (B*B*L*BM) / (B*H + .7854*H*H)
          GO TO 78
          67 KC= 1.27324*B*B*L*E*T/(H**3.0)
C
C*****SUPPLY CONSTANTS
120      78 TWPI=6.2831853
          RHO = 1.293E-03
          C = 33968.44
          IF(FLAG.EQ.0.0) 210,220
125      210 KSKIN = 8.0E+07
C      SHAW AND THIESSEN(JASA,1958)
          GO TO 68
          220 KSKIN = 6.7E+17
C      RIGID SURFACE
          RSKIN= 1.0E+14
130      C      RIGID SURFACE
C
C*****COMPUTE CUSHION RESISTANCE
C
          68 RC= RC/BTM
135      C
C*****COMPUTE REACTANCES AND TRNS. RATIO FOR EACH FREQUENCY
C
          F= 16.0
          DO 500 I=1,27
140          F = F*(2**(1.0/3.0))
          FREQ(I) = F
          IF(FLAG.EQ.0.0) 2005,2100
          2005 IF(F.GT.600) 2000,2010
C      RSKIN FROM FRANKE(JASA,1952)
145      2000 RSKIN = .8E+04
          GO TO 2100
          2010 RSKIN = -11090.*?.3026*ALOG10(F) +78750.
          2100 RSKIN = 10.*RSKIN
C      SHAW AND THIESSEN(JASA,1958)
150      AF= TWPI*F
          XM = AF*M/AL
          XV = (RHO*C*C/(AF*V))*(SI + S0)/2.
          XC= KC/(AF*(S0-SI))
          IF(SHUNT.EQ.0.0) 498,497
155      497 PS = RSKIN/(S0-SI)
          XS= KSKIN/(AF*(S0-SI))
          A = -XV*(XC + XS)
          B = XV*(RC + RS)
          CC= RC*RS -XC*XS -XC*XV -XV*XS +XC*XM +XM*XS
160      D = RC*XM +RS*XM -RC*XS -RS*XC -RC*XV -RS*XV
          RE = (A*CC -B*D)/(CC*CC +D*D)
          IM = (A*D +B*CC)/(CC*CC +D*D)
          GO TO 499
          498 RS = RSKIN/AL
165      XS = KSKIN/(AL*AF)
          A = XC*XS +XV*XS -XS*XM -XV*XM -XC*XM -RC*RS
          B = RS*XM - RS*XV - RS*XC -RC*XS +RC*XM
          RE = (A*XS*XV - B*RS*XV)/(A*A + B*B)
          IM = (A*RS*XV + B*XS*XV)/(A*A + B*B)
170      499 T = SORT(RE*RE +IM*IM)
          500 TR(I) = 20.0 * ALOG10(T)

```

TABLE F-1 (CONTINUED)

PROGRAM CUPTR

74774 OPT=1

FTN 4.6+428

```

C
C*****LABEL AND LIST COMPUTED OUTPUT
C
175      WRITE(6,70)
          70 FORMAT(/,10X,*FREQUENCY TRANSMISSION RATIO*,/,11X,
          1*(HERTZ)*,7X,*(DECIBELS)*)
          WRITE(6,71)(FREQ(I), TR(I),I=1,27)
          71 FORMAT(10X,F8.1,F14.1)
180      C*****SPECIFY LENGTH OF TITLE BLOCK FOR CALCOMP PLOT
          5001 DO 801 I=1,8
          801 ITITLE(I,1) = 35
C
C*****READ TITLE CARDS FOR CALCOMP PLOT IN
185      C          FIRST 35 SPACES OF EACH OF 8 CARDS
C
          DO 400 I=1,8
          400 READ(5,810)(ITITLE(I,J),J=2,5)
          810 FORMAT(4A10)
190      C
C*****BUILD PLOT MATRIX
C
          DO 820 J=2,28
          X(J,2) = FREQ(J-1)
195      820 X(J,1) = TR(J-1)
          X(1,2) = 11.
          X(29,2) = 9999.
          X(1,1) = 29.9
          X(29,1) = -149.9
200      C
C*****CALL CALCOMP PLOT ROUTINE
C
          CALL PLTLOG(1,3,X,29,29,1,2,ITLV,30,1,ITLH,30,IT1,NIT1,
1          1          IT2,NIT2,IT3,NIT3,IT4,NIT4,ITS,NIT5,8,
205      2          ITITLE,8,0)
C
C*****ONE CARD AFTER EACH DATA SET. CARD READS 999. IN
C          FIRST TEN COLUMNS AFTER LAST SET OF DATA.
C
210      READ(5,100)TEST
          100 FORMAT(10F8.2)
          IF(TEST.EQ.999)200,300
          200 CONTINUE
          STOP
215      END

```

TABLE F-2A

COMPUTED TRANSMISSION RATIO VS. FREQUENCY FOR THE EARCUP
 SHOWN IN FIGURE 11 OF SHAW AND T. (JASA, 1958).
 INCOMPRESSIBLE WATER IN EARCUP.
 ROUGHIGN = 4*RSKIN AT 500 HZ.

EARCUP MASS = 490.0 GRAMS

EARCUP AIR VOLUME = 105.0 CC+S

OUTER CROSS-SECTIONAL AREA OF EARCUP = 67.3 CMSQ

INNER CROSS-SECTIONAL AREA OF OPENING TO VOLUME = 18.9 CMSQ

WIDTH OF CONTACT OF FLEXIBLE WALL WITH FLESH = 2.8 CM

DEPTH OF FLUID-FILLED WALL BETWEEN EARCUP AND FLESH = 1.1 CM

THICKNESS OF WALL MATERIAL = .025 CM

YOUNG+S MODULUS OF WALL MATERIAL = .33E+09 DYNES/CMSQ

RESISTANCE COEFFICIENT OF FLUID WITHIN THE WALL = .40E+06 DYNE SEC/CM

INCOMPRESSIBLE FLUID IN EARCUP WALLS

EARCUP ON A RIGID SURFACE ←

| FREQUENCY (HERTZ) | TRANSMISSION RATIO (DECIBELS) |
|----------------------|----------------------------------|
| 20.2 | -30.1 |
| 25.4 | -30.1 |
| 32.0 | -30.0 |
| 40.3 | -29.9 |
| 50.8 | -29.8 |
| 64.0 | -29.6 |
| 80.6 | -29.2 |
| 101.6 | -28.6 |
| 128.0 | -27.6 |
| 161.3 | -25.8 |
| 203.2 | -22.8 |
| 256.0 | -22.3 |
| 322.5 | -29.4 |
| 406.4 | -35.8 |
| 512.0 | -41.2 |
| 645.1 | -46.0 |
| 812.7 | -50.4 |
| 1024.0 | -54.7 |
| 1290.2 | -58.9 |
| 1625.5 | -63.0 |
| 2048.0 | -67.1 |
| 2580.3 | -71.2 |
| 3251.0 | -75.2 |
| 4096.0 | -79.2 |
| 5160.6 | -83.3 |
| 6502.0 | -87.3 |
| 8192.0 | -91.3 |

VMIN= .1100E+02 VMAX= .9999E+04
 F=10

TABLE F-2B

COMPUTED TRANSMISSION RATIO VS. FREQUENCY FOR THE EAR CUP
 SHOWN IN FIGURE 11 OF SHAW AND T. (JASA, 1958).
 INCOMPRESSIBLE WATER IN EAR CUP.
 CUSHION = 4 * RSKIN AT 500 HZ.

SKIN SHUNTS CUSHION, BUT NOT VOLUME ←

EAR CUP MASS = 430.0 GRAMS

EAR CUP AIR VOLUME = 105.0 CC'S

OUTER CROSS-SECTIONAL AREA OF EAR CUP = 87.3 CMSQ

INNER CROSS-SECTIONAL AREA OF OPENING TO VOLUME = 18.9 CMSQ

WIDTH OF CONTACT OF FLEXIBLE WALL WITH FLESH = 2.8 CM

DEPTH OF FLUID-FILLED WALL BETWEEN EAR CUP AND FLESH = 1.1 CM

THICKNESS OF WALL MATERIAL = .025 CM

YOUNG'S MODULUS OF WALL MATERIAL = .33E+09 DYNES/CMSQ

RESISTANCE COEFFICIENT OF FLUID WITHIN THE WALL = .40E+06 DYNE SEC/CM

INCOMPRESSIBLE FLUID IN EAR CUP WALLS

KSKIN = 8.0E7 DYNES/CM (SHAW AND T., JASA, 1958)

FREQUENCY-DEPENDENT RSKIN FROM FRANKE (JASA, 1952)
 TIMES 10 (SHAW AND T., JASA, 1958)

| FREQUENCY (HERTZ) | TRANSMISSION RATIO (DECIBELS) |
|----------------------|----------------------------------|
| 20.2 | -8.0 |
| 25.4 | -7.9 |
| 32.0 | -7.7 |
| 40.3 | -7.5 |
| 50.8 | -7.2 |
| 64.0 | -7.3 |
| 80.6 | -8.9 |
| 101.6 | -12.5 |
| 128.0 | -17.0 |
| 161.3 | -21.6 |
| 203.2 | -26.1 |
| 256.0 | -30.4 |
| 322.5 | -34.7 |
| 406.4 | -38.9 |
| 512.0 | -43.0 |
| 645.1 | -47.1 |
| 812.7 | -51.1 |
| 1024.0 | -55.1 |
| 1290.2 | -59.2 |
| 1625.5 | -63.2 |
| 2048.0 | -67.2 |
| 2580.3 | -71.2 |
| 3251.0 | -75.3 |
| 4096.0 | -79.3 |
| 5160.6 | -83.3 |
| 6502.0 | -87.3 |
| 8192.0 | -91.3 |

FIGURE F-2C

COMPUTED TRANSMISSION RATIO VS. FREQUENCY FOR THE EARCUP
 SHOWN IN FIGURE 11 OF SHAW AND T. (JASA,1958).
 INCOMPRESSIBLE WATER IN EARCUP.
 RCUSHION = 4*PSKIN AT 500 HZ.

SKIN SHUNTS BOTH CUSHION AND VOLUME ←

EARCUP MASS = 490.0 GRAMS

EARCUP AIR VOLUME = 105.0 CC+S

OUTER CROSS-SECTIONAL AREA OF EARCUP = 87.3 CMSQ

INNER CROSS-SECTIONAL AREA OF OPENING TO VOLUME = 18.9 CMSQ

WIDTH OF CONTACT OF FLEXIBLE WALL WITH FLESH = 2.8 CM

DEPTH OF FLUID-FILLED WALL BETWEEN EARCUP AND FLESH = 1.1 CM

THICKNESS OF WALL MATERIAL = .025 CM

YOUNG+S MODULUS OF WALL MATERIAL = .33E+09 DYNES/CMSQ

RESISTANCE COEFFICIENT OF FLUID WITHIN THE WALL = .40E+06 DYNE SEC/CM

INCOMPRESSIBLE FLUID IN EARCUP WALLS

KSKIN=9.0E7 DYNES/CM (SHAW AND T., JASA, 1958)

FREQUENCY-DEPENDENT RSKIN FROM FRANKE (JASA, 1952)
 TIMES 10 (SHAW AND T., JASA, 1953)

| FREQUENCY (HERTZ) | TRANSMISSION RATIO (DECIBELS) |
|----------------------|----------------------------------|
| 20.2 | -29.5 |
| 25.4 | -29.3 |
| 32.0 | -29.0 |
| 40.3 | -28.6 |
| 50.8 | -28.3 |
| 64.0 | -28.2 |
| 80.6 | -28.9 |
| 101.6 | -30.7 |
| 128.0 | -33.4 |
| 161.3 | -36.8 |
| 203.2 | -40.4 |
| 256.0 | -44.3 |
| 322.5 | -48.4 |
| 406.4 | -52.8 |
| 512.0 | -57.6 |
| 645.1 | -62.1 |
| 812.7 | -65.5 |
| 1024.7 | -69.0 |
| 1290.2 | -72.7 |
| 1625.5 | -76.5 |
| 2048.0 | -80.4 |
| 2580.3 | -84.3 |
| 3251.0 | -88.3 |
| 4096.3 | -92.3 |
| 5160.6 | -96.2 |
| 6502.0 | -100.2 |
| 8192.0 | -104.2 |

COMPUTED TRANSMISSION RATIO VS.
 FREQUENCY FOR THE EARCUP SHOWN IN
 FIGURE 11 OF SHAW AND T. (JASA, 1958)
 EWALL DIVIDED BY 2.0.
 INCOMPRESSIBLE WATER IN EARCUP.
 RCUSHION = 4*RSKIN AT 500 HZ.
 RIGID SURFACE.

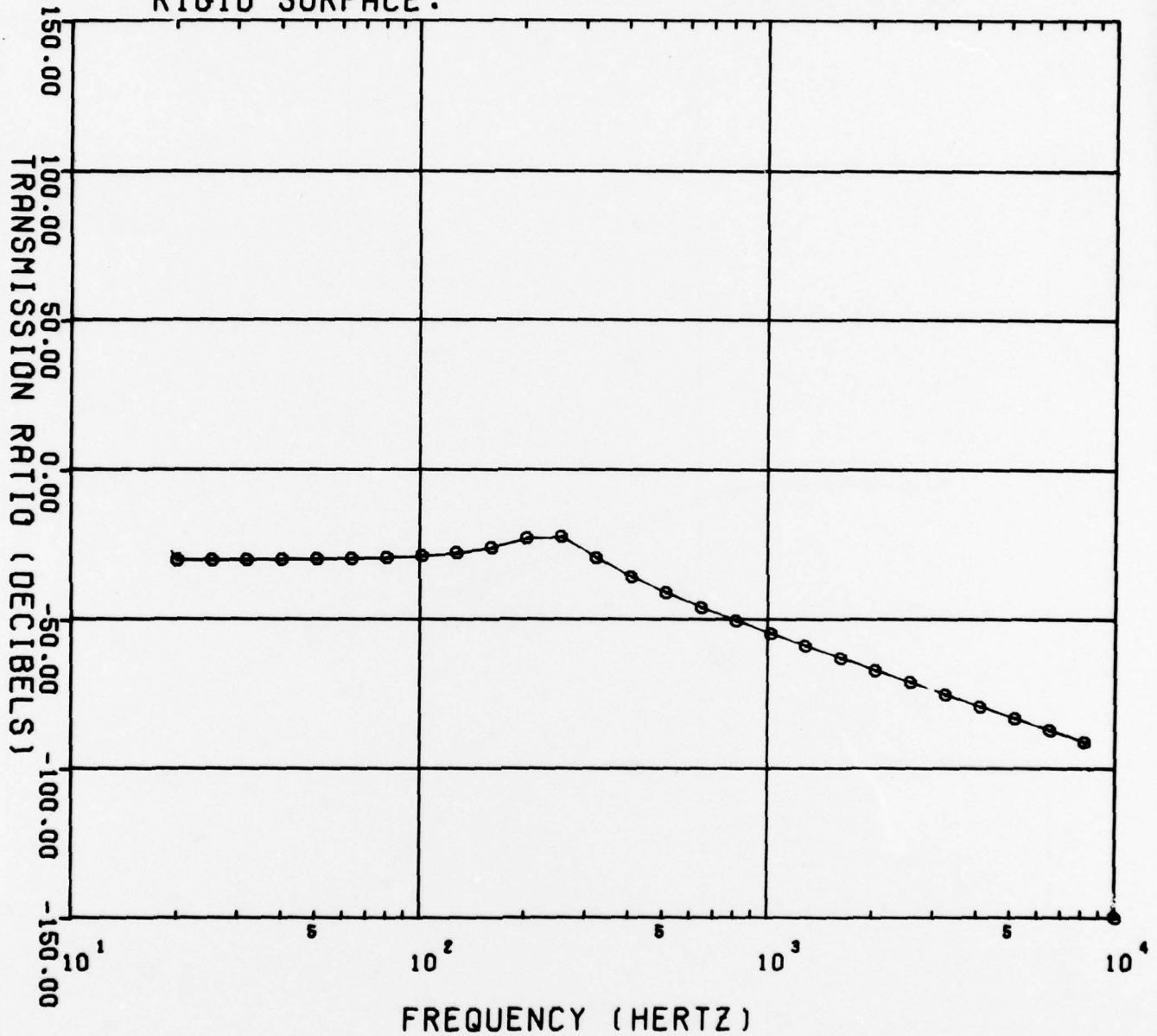

FIGURE F-3A

COMPUTED TRANSMISSION RATIO VS.
 FREQUENCY FOR THE EAR CUP SHOWN IN
 FIGURE 11 OF SHAW AND T. (JASA, 1958)
 WALL DIVIDED BY 2.0.
 INCOMPRESSIBLE WATER IN EAR CUP.
 RCUSHION = 4 * RSKIN AT 500 HZ.
 ZSKIN SHUNTS CUSHION, NOT VOLUME.

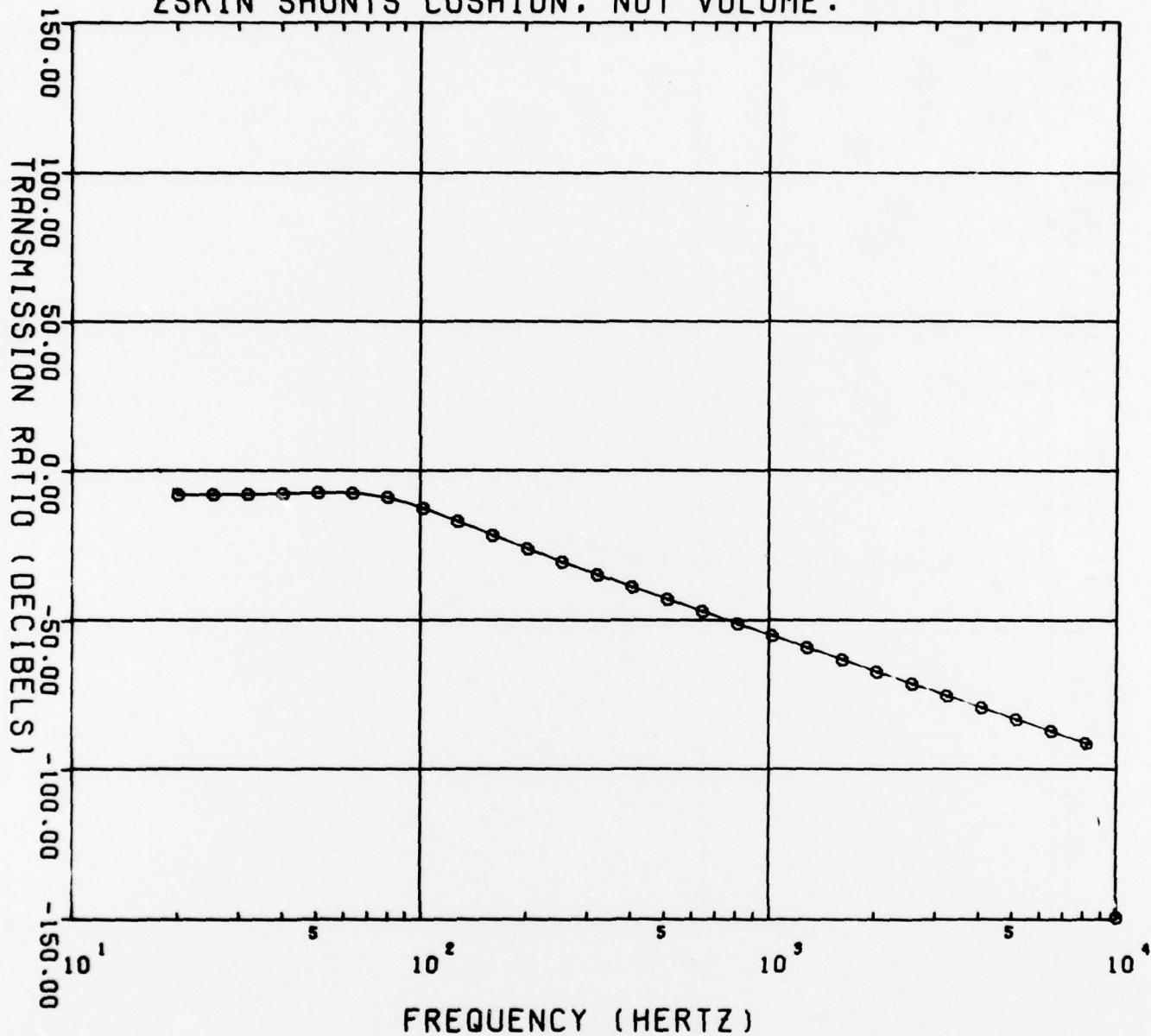

FIGURE F-3B

COMPUTED TRANSMISSION RATIO VS.
 FREQUENCY FOR THE EAR CUP SHOWN IN
 FIGURE 11 OF SHAW AND T. (JASA, 1958)
 EWALL DIVIDED BY 2.0.
 INCOMPRESSIBLE WATER IN EAR CUP.
 $R_{CUSHION} = 4 * R_{SKIN}$ AT 500 HZ.
 Z_{SKIN} SHUNTS CUSHION AND VOLUME.

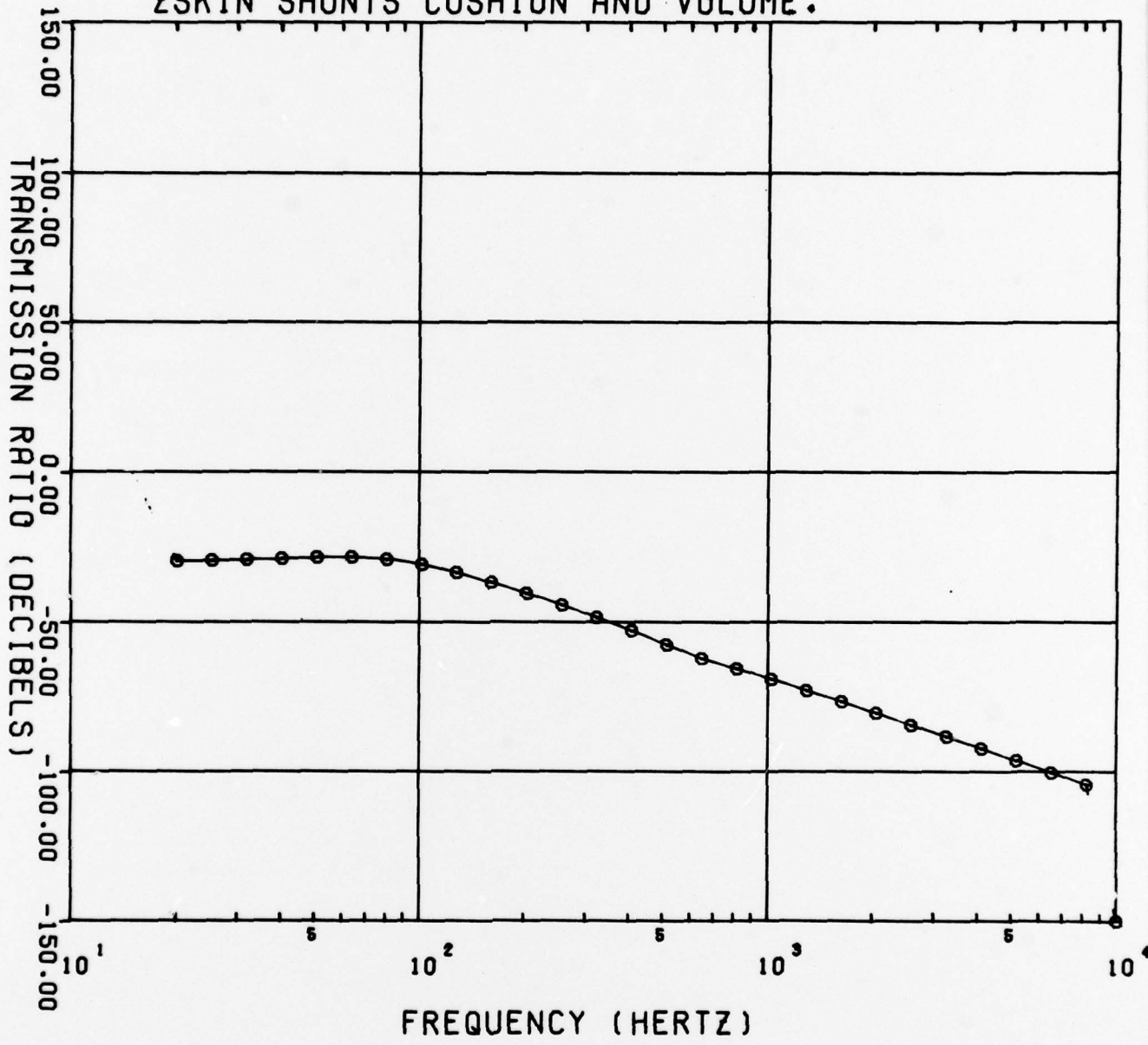

FIGURE F-3C

ELY0021 253400

APPENDIX G

ANALYTICAL OPTIMIZATION OF THE DESIGN OF EAR PROTECTORS

ANALYTICAL OPTIMIZATION OF THE DESIGN OF EAR PROTECTORS

The function

$$T(X_c, r_c, X_v) \equiv \left| \frac{P_{\text{inside}}}{P_{\text{outside}}} \right| = (RE^2 + IM^2)^{1/2},$$

which is defined in Appendix F, attains a maximum or a minimum for those values of X_c , r_c , and X_v for which $\partial T/\partial X_c$, $\partial T/\partial r_c$, and $\partial T/\partial X_v$ go to zero simultaneously (SolkoInikoff and Redheffer,¹⁰⁰). Carrying out the indicated partial differentiations for the transmission ratio defined in Appendix F for the Zwislocki model which is shown in Figure F-1, and setting the resulting derivatives equal to zero, yields (after tedious algebraic manipulations):

$$X_c = \frac{X_v X_s^2 - X_m X_s^2 + (1.0 - \frac{1.0}{T^2}) X_v^2 X_s - 2X_v X_s X_m + X_m^2 X_s - r_s^2 X_m + r_s^2 X_v}{(-X_s^2 - 2X_s X_v + (\frac{1.0}{T^2} - 1) X_v^2 + 2X_s X_m + 2X_v X_m - X_m^2 - r_s^2)} \quad (1)$$

$$r_c = \frac{r_s (X_m^2 - 2X_v X_m + \{1.0 - \frac{1.0}{T^2}\} X_v^2)}{(r_s^2 + X_m^2 - 2X_s X_m - 2X_v X_m + 2X_s X_v + X_s^2 + X_v^2)} \quad (2)$$

$$X_v = \frac{r_c r_s X_s - 2X_c X_s^2 + 2X_c X_m X_s + 2X_m X_s^2 + r_c^2 X_m + 2r_s r_c X_m - r_c^2 X_s - r_c r_s X_c + r_s^2 (X_m - X_c)}{2X_c X_s + 2X_s^2 + 2r_s r_c + r_c^2 + r_s^2 - \frac{(X_c + X_s)^2 + (r_c + r_s)^2}{T^2}} \quad (3)$$

If equations (1), (2), and (3) are solved simultaneously, values for X_c , r_c , and X_v which cause T to take on extreme (locally maximum or minimum) values are obtained. The three simultaneous equations must be solved for each frequency of interest, and additional calculations must be performed to ascertain whether an extreme value is a locally maximized value, a locally minimized value, the highest of all local maxima, or the lowest of all local minima. Obviously, an electronic computer will be required for the optimization calculations.