

AD-A061 494

ARINC RESEARCH CORP ANNAPOLIS MD
STANDARD AVIONICS INTERFACE PROGRAM. VOLUME II. NAVIGATION EQUI--ETC(U)
AUG 76 B G MCELHANEY, E J CHAUVIN
1296-01-2-1527-VOL-2

F/G 9/3

F09603-75-A-3001

NL

UNCLASSIFIED

OF
AD A061494

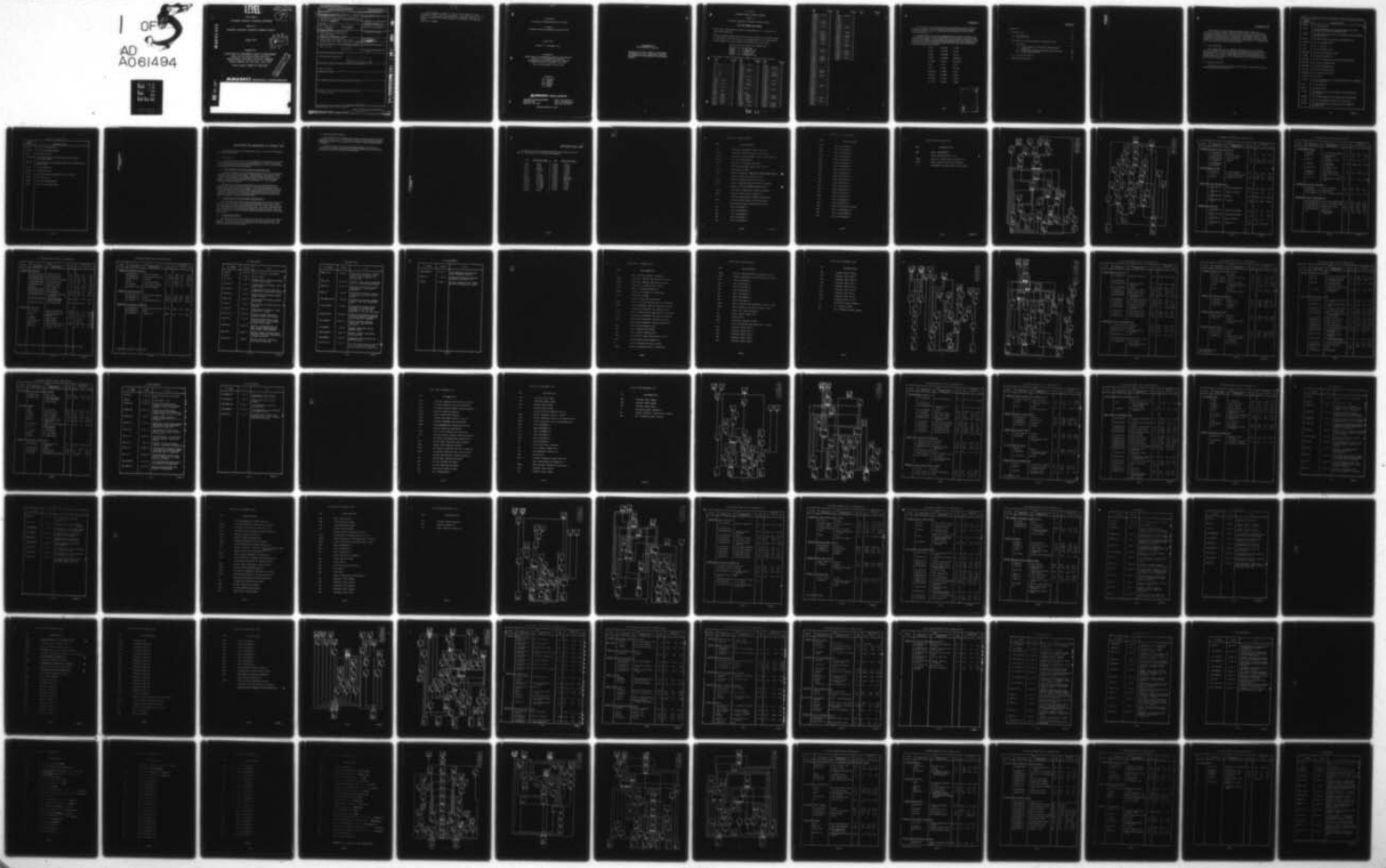



LEVEL III

Library / ANNAP.
Publication 1296-01-2-1527

7

Final Report

STANDARD AVIONICS INTERFACE PROGRAM

Volume II

Navigation Equipment Integration Handbook Abstract

August 1976

DDC
NOV. 22 1978
RECEIVED
F

Prepared for

DIRECTORATE OF INTEGRATED LOGISTICS MANAGEMENT
OFFICE OF DCS/ACQUISITION LOGISTICS
HEADQUARTERS AIR FORCE LOGISTICS COMMAND
Wright-Patterson Air Force Base, Ohio 45433

Under Contract F09603-75-A-3001-Q701

This document has been approved
for public release and sale; its
distribution is unlimited.

ADA061494

DDC FILE COPY

ARINC RESEARCH CORPORATION



REPORT DOCUMENTATION PAGE		READ INSTRUCTIONS BEFORE COMPLETING FORM
1. REPORT NUMBER 14 1296-01-2-1527-Vol-2	2. GOVT ACCESSION NO.	3. RECIPIENT'S CATALOG NUMBER 9 Final report
4. TITLE (and Subtitle) 6 Standard Avonics Interface Program, Volume II. Navigation Equipment Integration Handbook Abstract Volume II		5. TYPE OF REPORT & PERIOD COVERED
7. AUTHOR(s) 10 B.G. McElhanev, W.B. Stewart E.J. Chauvin, J.S. Weisel G.R. O'Bryan		6. PERFORMING ORG. REPORT NUMBER 1296-01-2-1527
9. PERFORMING ORGANIZATION NAME AND ADDRESS ARINC Research Corporation 2551 Riva Road Annapolis, Maryland 21401		8. CONTRACT OR GRANT NUMBER(s) 15 F09603-75-A-3001-Q701
11. CONTROLLING OFFICE NAME AND ADDRESS Wright Air Force Base, Ohio 45433 Headquarters Air Force Logistics Command		10. PROGRAM ELEMENT, PROJECT, TASK AREA & WORK UNIT NUMBERS
14. MONITORING AGENCY NAME & ADDRESS (if different from Controlling Office) same as above		12. REPORT DATE 11 August 1976
16. DISTRIBUTION STATEMENT (of this Report) UNCLASSIFIED-UNLIMITED		13. NUMBER OF PAGES 12 387p
17. DISTRIBUTION STATEMENT (of the abstract entered in Block 20, if different from Report) same as above		15. SECURITY CLASS. (of this report)
18. SUPPLEMENTARY NOTES		
19. KEY WORDS (Continue on reverse side if necessary and identify by block number)		
20. ABSTRACT (Continue on reverse side if necessary and identify by block number) on reverse side 400 247 Gue		

This document, Volume II of the final report on the Standard Avionics Interface Program, is an abstract of the 33-volume set comprising the Navigation Equipment Integration Handbook prepared by ARINC Research Corporation for the Air Force Logistics Command.

Final Report
STANDARD AVIONICS INTERFACE PROGRAM
Volume II
Navigation Equipment Integration Handbook Abstract

August 1976

(Change 4 - 30 September 1977)

Prepared for
DIRECTORATE OF INTEGRATED LOGISTICS MANAGEMENT
OFFICE OF DCS/ACQUISITION LOGISTICS
HEADQUARTERS AIR FORCE LOGISTICS COMMAND
Wright-Patterson Air Force Base, Ohio 45433
Under Contract F09603-75-A-3001-Q701

Prepared by
B. G. McElhanev
E. J. Chauvin
G. R. O'Bryan
W. B. Stewart
J. S. Weisel

 **ARINO** RESEARCH CORPORATION

CORPORATE HEADQUARTERS
2551 Riva Road
Annapolis, MD 21401

SANTA ANA BRANCH
1222 E. Normandy Place
Santa Ana, CA 92704

Publication 1296-01-2-1527

Copyright © 1976
ARINC Research Corporation

Prepared under Contract F09603-75-A-3001-Q701,
which grants to the U. S. Government a license to
use any material in this publication for government
purposes.

Final Report

STANDARD AVIONICS INTERFACE PROGRAM

Volume II

Navigation Equipment Integration Handbook Abstract

LIST OF EFFECTIVE PAGES

Insert latest changed pages; dispose of superseded pages in accordance with applicable regulations.

NOTE: On a changed page, the position of the text affected by the latest change is indicated by a vertical line, or other change symbol, in the outer margin of the page. Changes to illustrations are indicated by an arrow symbol.

Date of issue for original and changed pages:

Original...0...30 June 1976
 Change;...1...15 September 1976
 Change;...2...15 October 1976
 Change;...3... 3 August 1977
 Change;...4...30 September 1977

Total number of pages in this manual is 390 consisting of the following:

Page No.	#Change No.	Page No.	#Change No.	Page No.	#Change No.
Title.....	4	3-4C-1 - 3-4C-2.....	4	3-10C-1.....	3
i - ii.....	4	3-5A-1.....	3	3-10C-2 - 3-10C-3.....	0
iii - vi.....	0	3-5A-2.....	0	3-11A-1 - 3-11B-6.....	0
1-1.....	0	3-5A-3 - 3-5B-1.....	3	3-11C-1.....	3
1-2.....	4	3-5B-2 - 3-5C-1.....	4	3-11C-2 - 3-11C-3.....	0
1-3 - 1-4.....	0	3-5C-2.....	0	3-12A-1 - 3-12A-3.....	0
2-1 - 2-2.....	0	3-5C-3.....	3	3-12B-1 - 3-12B-4.....	4
3-1 - 3-2.....	0	3-6A-1 - 3-6A-4.....	0	3-12B-5.....	3
3-1A-1.....	1	3-6A-5.....	1	3-12C-1.....	4
3-1A-2.....	0	3-6A-7 - 3-6B-5.....	0	3-12C-2 - 3-12C-4.....	0
3-1A-3 - 3-1A-4.....	4	3-6C-1.....	4	3-13A-1.....	3
3-1A-5.....	1	3-6C-2 - 3-6C-3.....	0	3-13A-2 - 3-13A-3.....	0
3-1B-1 - 3-1B-3.....	4	3-7A-1 - 3-7B-3.....	0	3-13A-4.....	3
3-1B-4.....	0	3-7C-1.....	4	3-13A-5.....	0
3-1C-1 - 3-1C-2.....	4	3-8A-1 3-8B-3.....	0	3-13A-6 - 3-13A-7.....	3
3-1C-3.....	0	3-8C-1.....	3	3-13A-8.....	0
3-2A-1 - 3-2B-1.....	0	3-8C-2.....	4	3-13A-9.....	3
3-2B-2.....	4	3-9A-1 3-9B-1.....	0	3-13B-1.....	0
3-2B-3 - 3-2B-4.....	0	3-9B-2 - 3-9B-3.....	4	3-13B-2 - 3-13B-3.....	4
3-3C-1 - 3-3C-2.....	4	3-9B-4 - 3-9B-5.....	0	3-13B-4 - 3-13B-5.....	0
3-3A-1 - 3-3B-1.....	0	3-9B-6 - 3-9C-1.....	4	3-13B-6.....	3
3-3B-2 - 3-3C-2.....	4	3-9C-2 - 3-9C-4.....	0	3-13C-1.....	4
3-4A-1 - 3-4A-5.....	0	3-10A-1 - 3-10B-1.....	0	3-13C-2 - 3-13C-4.....	0
3-4B-1 - 3-4B-3.....	4	3-10B-2.....	4	3-14A-1 - 3-14B-1.....	0
3-4B-4.....	0	3-10B-3 - 3-10B-5.....	0	3-14B-2 - 3-14B-3.....	4

A

78 11 03 028

Page No.	#Change No.	Page No.	#Change No.	Page No.	#Change No.
3-14B-4 - 3-14B-5	0	3-26A-1 - 3-26B-3	0		
3-14B-6	4	3-26C-1	3		
3-14B-7	0	3-26C-1	0		
3-14C-1	4	3-27A-1	3		
3-14C-2 - 3-14C-4	0	3-27A-2	0		
3-15A-1 - 3-15B-4	0	3-27A-3	3		
3-15C-1	4	3-27B-1	4		
3-16A-1 - 3-16B-5	0	3-27B-2 - 3-27B-3	0		
3-16C-1	3	3-27C-1	4		
3-16C-2	0	3-27C-2	0		
3-17A-1 3-17A-5	0	3-28A-1 - 3-28B-2	0		
3-17B-1 - 3-17B-3	4	3-28C-1	4		
3-17C-1 - 3-17C-2	4	3-29A-1 - 3-29A-2	0		
3-18A-1 - 3-18B-3	0	3-29B-1 - 3-29C-1	3		
3-18C-1 - 3-18C-3	4	3-30A-1	2		
3-19A-1 - 3-19B-4	0	3-20A-2 - 3-30B-1	0		
3-19C-1	3	3-30C-1	4		
3-20A-1 - 3-20B-4	0	3-31A-1 - 3-31C-1	4		
3-20C-1	3	3-32A-1 - 3-32B-2	0		
3-21A-1	3	3-32C-1	4		
3-21A-2	0	3-32C-2	0		
3-21A-3 - 3-21B-4	3	3-33A-1 - 3-33A-3	0		
3-21B-5 - 3-21C-2	4	3-33A-4 - 3-33A-5	3		
3-21C-3	3	3-33A-6 - 3-33A-8	0		
3-22A-1	3	3-33B-1	4		
3-22A-2 - 3-22A-3	0	3-33B-2 - 3-33B-3	0		
3-22A-4 - 3-22A-5	3	3-33C-1	4		
3-22B-1 - 3-22B-2	4				
3-22B-5	0				
3-22C-1	4				
3-22C-2	0				
3-22C-3	3				
3-23A-1	3				
3-23A-2 - 3-23A-3	0				
3-23A-4 - 3-23B-1	3				
3-23B-2	4				
3-23B-3 - 3-23B-4	3				
3-23B-5	4				
3-23C-1	4				
3-23C-2	0				
3-23C-3	3				
3-23C-4	0				
3-24A-1 - 3-24A-5	0				
3-24B-1	3				
3-24B-2	4				
3-24B-3	3				
3-24B-4	4				
3-24B-5	3				
3-24C-1	4				
3-24C-2 - 3-24C-3	0				
3-24C-4	3				
3-25A-1 - 3-25B-2	0				
3-25C-1	3				
3-25C-2	0				

FOREWORD

This document, Volume II of the final report on the Standard Avionics Interface Program, is an abstract of the 33-volume set comprising the Navigation Equipment Integration Handbook prepared by ARINC Research Corporation for the Air Force Logistics Command.

Contained herein are excerpts of integration data for position, navigation, and weapon delivery (PNWD) avionics of each of the 33 aircraft types covered in individual volumes of the handbook. Data included are the avionic system block diagrams, PNWD equipment lists, PNWD equipment physical characteristic lists, and bibliographies of data sources. Complete integration of data for the 33 aircraft types were published separately in the following volumes:

A-7D	RC-135A	F-111E
B-52D	VC-135B	F-111F
B-52G	WC-135B	TH-1F
B-52H	VC-140B	HH/CH-3E
FB-111A	C-141A	HH-53B/C
C-5A	F-4E	O-2A
C-9A	RF-4C	OV-10A
HC-130H	F-106A	T-37B
C-135A	F-106B	T-38A
EC-135C	F-111A	T-39A
KC-135A	F-111D	T-43A

ACCESSION for	
NTIS	W. H. Section <input checked="" type="checkbox"/>
BDC	B. H. Section <input type="checkbox"/>
UNCLASSIFIED	<input type="checkbox"/>
JUL 27 1973	
BY	
DISTRIBUTION POLICY CODES	
SPECIAL	
A	

CONTENTS

FOREWORD	iii
1. INTRODUCTION.	1-1
1.1 PNWD Definition	1-1
1.2 Aircraft Covered	1-1
2. DESCRIPTION AND MAINTENANCE OF AIRCRAFT DATA	2-1
2.1 Description	2-1
2.1.1 PNWD Equipment List and System Block Diagram Subsection	2-1
2.1.2 PNWD Equipment Physical Characteristics Subsection . .	2-1
2.1.3 Bibliography Subsection.	2-1
2.2 Document Maintenance	2-2
3. ABSTRACTED NEIH DATA	3-1

SECTION 1.0
INTRODUCTION

INTRODUCTION

This Navigation Equipment Integration Handbook (NEIH) Abstract is a compilation of sections extracted from each of the 33 volumes comprising the NEIH. The extracted material includes, from each volume, information presented in handbook Section 3, PNWD Equipment List and System Block Diagrams; Section 6, PNWD Equipment Physical Characteristics; and Section 7, Bibliography. The intent of this document is to incorporate and catalog commonly required portions of integration data from each aircraft into a single reference volume.

1.1 PNWD DEFINITION

The aircraft PNWD suite, as defined for the NEIH, is that set of onboard avionics providing or directly contributing to the navigation of an aircraft and to the determination of its current position during the enroute, tactical execution, and terminal phases of its mission. While many of the aircraft included herein do not contain weapon delivery systems, the PNWD acronym is used throughout the sections for the sake of consistency.

1.2 AIRCRAFT COVERED

The integration data provided herein is for the PNWD systems for the aircraft models and series listed in Table 1-1.

TABLE 1-1. AIRCRAFT MODELS AND SERIES COVERED IN NEIH (Sheet 1 of 2)

Aircraft Model	Applicable Series
A-7D	AF 69-6197 and up
B-52D	AF 55-049 through 55-117; 55-673 through 55-680; 56-580 through 56-630; and 56-658 through 56-698
B-52G	AF 57-6468 through 57-6520; 58-158 through 58-258; and 59-2564 through 59-2602
B-52H	AF 60-001 through 60-062; and 61-001 through 61-040
FB-111A	AF 68-281 through 69-6514
C-5A	AF 70-445 and up
C-9A	AF 71-874 through 71-882
HC-130H	AF 64-14852 through AF 65-989
C-135A	AF 60-376 through 60-378
EC-135C	AF 62-3581 through 3585; and 63-8046 through 63-8054
KC-135A	AF 55-3118 through 64-14840
RC-135A	AF 63-8058 through 63-861
VC-135B	AF 62-4125 through 62-4127
WC-135B	AF 61-2665 through 61-2674
VC-140B	AF 61-2490
C-141A	AF 66-131 and up; and AF 61-2776 through 66-130 if modified by T.O. 1C-141A- 969
F-4E	AF 72-1499 and up
RF-4C	AF 69-945 and up
F-106A	AF 56-453; 56-454; 56-456 through 57-245; 57-2465; and 58-759 and up
F-106B	AF 57-2508 through 57-2515; 57-2523; and 57-2532 and up
F-111A	AF 67-058 through 67-114 after T.O. 1F-111-1013
F-111D	AF 68-086 through 68-165; 68-167; 68-170; and 68-173 through 68-180

TABLE 1-1. (Sheet 2 of 2)

Aircraft Model	Applicable Series
F-111E	AF 67-115 through 68-084
F-111F	AF 72-1441 through 73-00718
TH-1F	All TH-1F aircraft
HH/CH-3E	AF 66-13278 and up; and CH-3E aircraft serial numbers AF 66-13284 and up
HH-53B/C	All HH-53B/C aircraft equipped with the Limited Night Recovery System (LNRS)
O-2A	AF 67-21295 and up
OV-10A	AF 66-13552 and up
T-37B	AF 59-241 and up, as modified by T.O. 1T-37B-521
T-38A	AF 68-8161 and up
T-39A	AF 62-4448 and subsequent
T-43A	AF 71-1403 through 73-01156

SECTION 2.0
DESCRIPTION, USE & MAINT.

DESCRIPTION AND MAINTENANCE OF AIRCRAFT DATA

This section describes the contents of this Abstract, and how the information is to be used and maintained.

2.1 DESCRIPTION

The aircraft data presented herein are arranged in 33 subsections, according to the aircraft order given in Table 1-1. Each subsection is divided into three parts, which present the material extracted from NEIH Sections 3, 6, and 7. The following paragraphs describe the extracted material.

2.1.1 PNWD Equipment List and System Block Diagram Subsection

The PNWD Equipment List is an alphabetical tabulation of the PNWD equipment identified on the system block diagrams. The equipment is described by the name commonly used in the reference material and by its military nomenclature or part number. Unless identified in the reference material, intermediate interconnect points, such as disconnect connectors, terminal boards, etc., were assigned arbitrary reference designators.

The system block diagrams of the PNWD suites are simplified functional diagrams that show only major functional interfaces between the primary avionic systems and equipment onboard the aircraft. Each interconnecting line between the blocks represents all of the pertinent PNWD interface signals flowing between those equipments, with the arrowhead on each line indicating the direction of information transfer. Characteristics of the individual signals flowing between interfaces are identified in Section 4 of the aircraft NEIH volume.

2.1.2 PNWD Equipment Physical Characteristics Subsection

The PNWD Equipment Physical Characteristic tables list the physical characteristics for a majority of the PNWD equipment and subsystems shown on the system block diagrams. The major equipment items that make up a PNWD system are identified in these tables by part number and common name. The physical characteristics shown for each piece of equipment include weight and dimensions (height, width, and depth). The sizes given are the maximum envelope dimensions required for installing the equipment.

2.1.3 Bibliography Subsection

The Bibliography subsection lists the source documents for the data appearing in the NEIH. These sources are listed in numerical order by document number. The change/revision dates given are those appearing on the document at the time it was used in the handbook preparation effort.

2.2 DOCUMENT MAINTENANCE

This document will be maintained in an accurate and current status by the NEIH maintenance activity on an as-required basis. When a significant number of changes affecting the contents of this document are accumulated, it will be republished and redistributed.

Each NEIH volume will likewise be maintained accurate and current on a regular basis, and should be consulted for the latest integration data on a particular aircraft when such data do not appear in this volume.

SECTION 3.0
ABSTRACTED NEIH DATA

ABSTRACTED NEIH DATA

The following pages present the aircraft PNWD data described in previous sections. Data appear in the following aircraft sequence:

<u>Tab</u>	<u>PNWD System Data</u>	<u>Tab</u>	<u>PNWD System Data</u>
3.1.0	A-7D	3.18.0	RF-4C
3.2.0	B-52D	3.19.0	F-106A
3.3.0	B-52G	3.20.0	F-106B
3.4.0	B-52H	3.21.0	F-111A
3.5.0	FB-111A	3.22.0	F-111D
3.6.0	C-5A	3.23.0	F-111E
3.7.0	C-9A	3.24.0	F-111F
3.8.0	HC-130H	3.25.0	TH-1F
3.9.0	C-135A	3.26.0	HH/CH-3E
3.10.0	EC-135C	3.27.0	HH-53B/C
3.11.0	KC-135A	3.28.0	O-2A
3.12.0	RC-135A	3.29.0	OV-10A
3.13.0	VC-135B	3.30.0	T-37B
3.14.0	WC-135B	3.31.0	T-38A
3.15.0	VC-140B	3.32.0	T-39A
3.16.0	C-141A	3.33.0	T-43A
3.17.0	F-4E		

3.1.0
A-7D

A-7D PMWD EQUIPMENT LIST

KEY	EQUIPMENT/UNIT
A	AUTOMATIC DIRECTION FINDER AN/ARA-50
ADDP	ATTITUDE DIRECTOR INDICATOR ARU-21/A
AFCS	AUTOMATIC FLIGHT CONTROL SYSTEM AN/ASN-30(V)2
AIMS	IFF SET AN/APX-72(V)
ALDP	ALTIMETER INDICATOR AAU-19/A
C	AIR DATA COMPUTER SYSTEM CP-953A/AJO
CMHM	INTERPHONE SYSTEM
CSA	SIGNAL CONVERTER (ISOLATION TRANSFORMER PANEL) ■
D	DOPPLER RADAR SET AN/APN-190(V)
DRDP	DOPPLER CONTROL INDICATOR C-7765
FDCS	FLIGHT DIRECTOR COMPUTER SYSTEM CPU-80/A
G	RADAR ALTIMETER SYSTEM AN/APN-194(V) ■
HSDP	HORIZONTAL SITUATION INDICATOR AQU-6/A
HUDD	HEAD-UP DISPLAY SET AN/AVQ-7(V)
P	INERTIAL MEASUREMENT SYSTEM AN/ASN-90(V)
PMDU	PROJECTED MAP DISPLAY SET AN/ASN-99A
R	NAVIGATION RADAR SYSTEM AN/APQ-126(V)
RDA	RACK DISCONNECT A
RDB	RACK DISCONNECT B
RDC	RACK DISCONNECT C
RDD	RACK DISCONNECT D
RDE	RACK DISCONNECT E

A-7D PNEU EQUIPMENT LIST

KEY	EQUIPMENT/UNIT
RDF	RACK DISCONNECT F
RDG	RACK DISCONNECT G
RDH	RACK DISCONNECT H
RDJ	RACK DISCONNECT J
RDK	RACK DISCONNECT K
RDL	RACK DISCONNECT L
RDM	RACK DISCONNECT M
RDN	RACK DISCONNECT N
RDP	RACK DISCONNECT P
RDQ	RACK DISCONNECT Q
RDR	RACK DISCONNECT R
RDS	RACK DISCONNECT S
RDT	RACK DISCONNECT T
RDU	RACK DISCONNECT U
RDV	RACK DISCONNECT V
RDW	RACK DISCONNECT W
RDX	RACK DISCONNECT X
RDY	RACK DISCONNECT Y
RHDP	HEIGHT INDICATOR ID-1687
SWA	RELAY SUBASSEMBLY A
SWB	RELAY SUBASSEMBLY B
SWC	RELAY SUBASSEMBLY C

A-7D PNWD EQUIPMENT LIST

KEY	EQUIPMENT/UNIT
SWD	RELAY SUBASSEMBLY D
T	TACAN SYSTEM AN/ARN-118(V)
TACP	TACTICAL COMPUTER SET AN/ASN-91(V)
TASP	TRUE AIRSPEED INDICATOR 215-21127-2
U	INSTRUMENT LANDING SYSTEM AN/ARN-58A

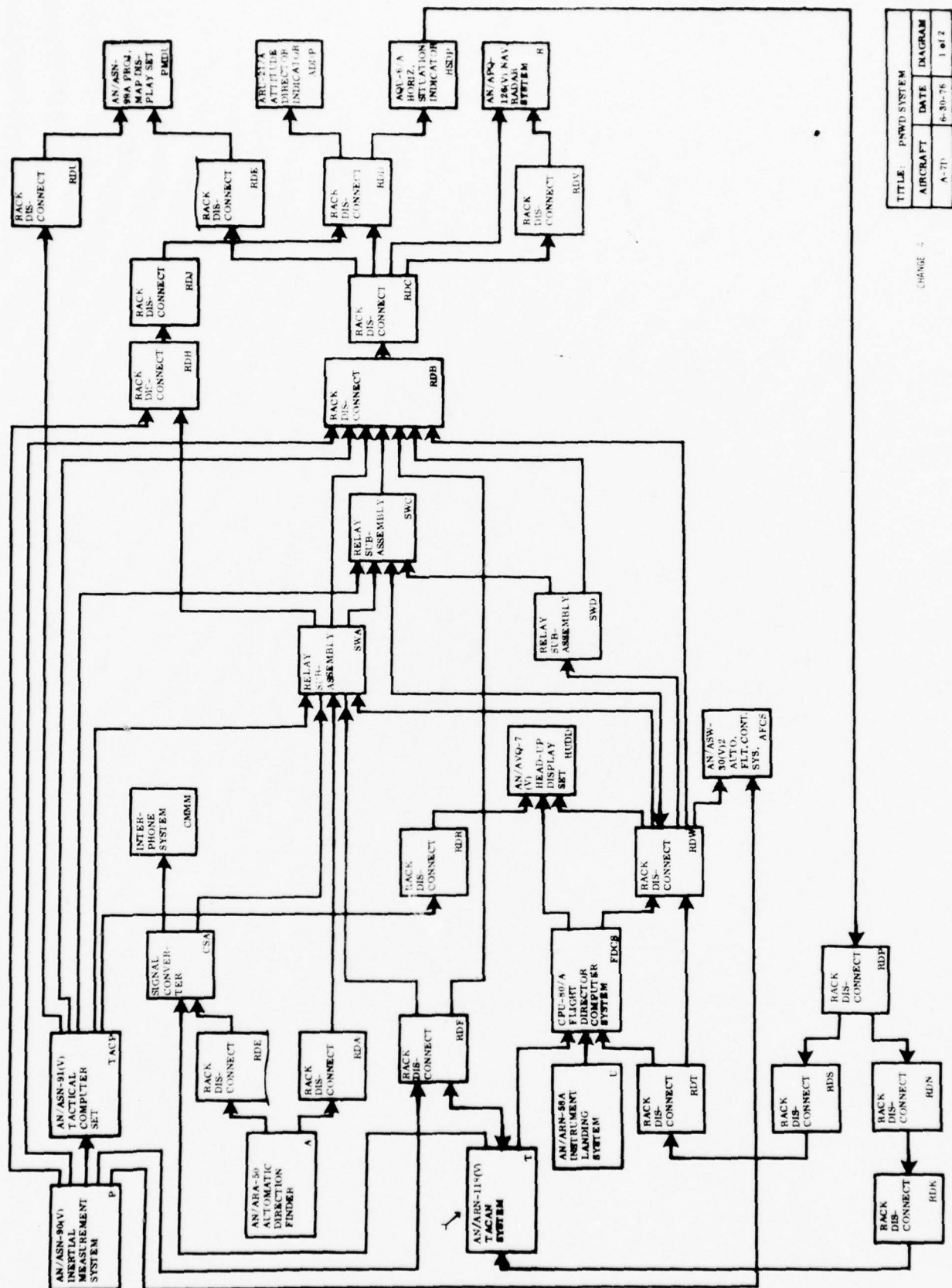

3-1A-4

TITLE: PNWD SYSTEM		
AIRCRAFT	DATE	DIAGRAM
A-7D	6-30-76	1 of 2

CHANGE 4

A-7D PNWD EQUIPMENT PHYSICAL CHARACTERISTICS

SYSTEM	UNIT		WT (LB)	SIZE (IN)		
	TYPE (P/N)	NOMENCLATURE		H	W	D
<u>AN/ARA-50 Automatic Direction Finder Set</u>						
	R-1286/ARR-69	Receiver	8.0	5.3	4.38	9.57
	C-1457A/ARR-40	Receiver Control				
	AM-3624/ARA-50	Relay-Amplifier	5.4	6.5	5.25	5.125
	AS-909/ARA-48 or AS-909A/ARA-48 (AS-2755/ARA)	Antenna	9.5	3.625	11.25	12.5
<u>Air Data Computer System</u>						
	CP-953A/AJQ	Air Data Computer	13.7	5.7	8.32	10.65
	215-21127-2	True Airspeed Indicator	.9	1.56 Dia.		5.75
	AAU-19/A	Altimeter Indicator	4.5	3.25	3.25	8.813
<u>AN/APN-190(V) Radar Navigation Set</u>						
	RT-927/APN-190 (V)	Receiver-Transmitter	37.01	7.81	10.25	17.68
	C-7765/APN-190 (V)	Control Indicator	4.0	2.25	5.75	5.77
	AS-2262/APN-190 (V)	Antenna	21.57	10.86	14.06	20.465
	MT-4037/APN-190 (V)	R-T Mount	3.23	9.12	10.48	18.88
<u>AN/APN-194(V) Radar Set</u>						
	RT-1042/APN-194 (V)	Receiver-Transmitter	4.4	3.0	3.5	8.0
	MX-9132A/APN-194 (V)	Interference Blanker	1.75	1.1	4.37	3.53
	ID-1687/APN-141 (V)	Height Indicator	1.6	3.27	3.27	5.0
	AS-1233/APN-141 (V)	Antenna (2)	0.65	1.78	5.75 diam.	

A-7D PNWD EQUIPMENT PHYSICAL CHARACTERISTICS

SYSTEM	UNIT		WT (LB)	SIZE (IN)		
	TYPE (P/N)	NOMENCLATURE		H	W	D
<u>Flight Director System</u>						
	CPU-80/A	Flight Director Computer	6.0	4.6	2.3	14.2
	ARU-21/A	Attitude Director Indicator	9.0	5.25	5.0	9.719
	AQU-6/A	Horizontal Situation Indicator	6.9	4.25	5.0	6.5
	TRU-2A/A	Turn Rate Gyro Transmitter	3.75	2.828	2.89	4.765
	216-17411-1	Left Avionic Relay Assembly				
	MS24523-21	Heading Mode Switch	0.08	1.27	0.635	2.34
	216-21571	Master Function Switch (2)				
	MTU-47/A	Flight Director Computer Rack	0.75	4.5	2.687	14.94
<u>AN/ASN-91(V) Tactical Computer Set</u>						
	CP-952/ASN	Tactical Computer	83.0	10.0	13.6	22.5
	MT-4078/ASN-91(V)	Computer Mount				
	C-7831/ASN-91(V)	Tactical Computer Control	5.5	8.6	5.75	5.0
<u>AN/ASN-90(V) Inertial Measurement Set</u>						
	CN-1260/ASN-90(V)	Inertial Measurement Unit	19.5	8.75	7.75	13.0
	MT-4066/ASN-90(V)	Electrical Equipment Rack	3.5	3.0	10.25	11.25
	PP-6141/ASN-90(V)	Adapter/Power Supply	43.0	10.0	10.5	13.57
	C-7796/ASN-90(V)	IMS Control	2.0	2.25	5.75	4.5
	ML-1	Remote Compass Transmitter	1.1	2.05	3.125	3.78

A-7D PNWD EQUIPMENT PHYSICAL CHARACTERISTICS

SYSTEM	UNIT		WT (LB)	SIZE (IN)		
	TYPE (P/N)	NOMENCLATURE		H	W	D
	<u>AN/APQ-126(V) Radar Set</u>					
	AS-2272/APQ-126(V)	Antenna-Receiver	37.0	20.0	19.5	22.84
	MT-4043/APQ-126(V)	Base, Shock Mount	40.9	14.07	24.0	7.95
	CP-954/APQ-126(V)	Air Navigation Computer	5.11	3.94	11.75	7.83
	C-8252/APQ-126(V)	Radar Set Control	3.11	3.75	5.75	7.65
	C-8255/APQ-126(V)	Radar Set Control	1.0	3.4	2.12	5.023
	HD-821/A	Centrifugal Fan	4.7	8.34	14.37	4.92
	MX-8195/APQ-126(V)	Fault Locator	1.0	3.0	4.5	5.75
	SG-811/APQ-126(V)	Sweep Generator	27.25	6.56	9.5	22.0
	IP-952/APQ-126(V)	Air Navigation Multiple Indicator	20.5	5.75	6.5	19.46
	PP-6130/APQ-126(V)	Antenna Scan Power Supply-Programmer	42.0	12.7	5.73	20.67
	T-1091/APQ-126(V)	Radar Transmitter	42.75	5.63	17.6	15.7
	<u>AN/ARN-118(V) TACAN Set</u>					
	RT-1159A/ARN	Receiver-Transmitter	43.25	6.78	7.54	14.63
	MT-4682/A	Electrical Equipment Mounting Base	5.75	8.85	11.70	20.50*
	C-9603/A	Control	2.0	3.00	5.75	5.43
	15D00800	Upper Antenna	1.0	8.4 diam.		1.5
	CV21-010001-14	Lower Antenna	1.0	8.4 diam.		1.5
	SA-521A/A	Antenna Switching Unit	0.34	1.94	2.78	3.19
	MX-9577A	Receiver-Transmitter Adapter		6.78	1.73	13.10
	*Dimensions include RT-1159/A and MX-9577A installed on MT-4682 and sway space					

A-7D PNWD EQUIPMENT PHYSICAL CHARACTERISTICS

SYSTEM	UNIT		WT (LB)	SIZE (IN)		
	TYPE (P/N)	NOMENCLATURE		H	W	D
<u>AN/ARN-58A Instrument Landing Set</u>						
	R-843A/ARN-58	Localizer Receiver	7.125	6.875	7.75	5.016
	R-844A/ARN-58	Marker Beacon Receiver	8.625	6.875	9.75	5.016
	C-3491/ARN-58	Control	1.0	2.25	5.75	4.313
	37P-4	Glideslope Antenna	0.7	5.984	2.0	4.5
	AT-536/ARN	Marker Beacon Antenna	2.2	3.125	7.75	11.188
	216-67401-1 and -34	Localizer Antenna				
<u>AN/AVQ-7(V) Head-up Display Set</u>						
	CP-951/AVQ-7(V)	Signal Data Processor	24.5	7.75	9.5	15.57
	MT-4038/AVQ-7(V)	Mount	5.25	7.65	10.82	14.23
	IP-938/AVQ-7(V)	Head-up Display Unit	47.5	11.85	8.3	34.65
<u>AN/ASN-99A Projected Map Display Set</u>						
	CV-2622/ASN-99	Signal Data Converter*	21.8	9.83	5.75	15.25
	MT-4168/ASN-99	Mount				
	ID-1665A/ASN-99	Display Unit	20.0	6.2	7.4	15.63
* Dimensions and weight includes mount.						

A-7D BIBLIOGRAPHY

T.O. Number	Chq/Rev	Title
1A-7D-01	15 May 77	List of Applicable Publications
1A-7D-1	15 Apr 77	Flight Manual
1A-7D-2-9	1 Nov 76	Organizational Maintenance, Automatic Flight Control System
1A-7D-2-10	5 May 77	Organizational Maintenance, Instrument Systems
1A-7D-2-12	15 May 77	Organizational Maintenance, Radio Communication and Navigation Systems
1A-7D-2-14	1 Apr 77	Organizational Maintenance, Weapon Control Systems
1A-7D-2-16	15 May 77	Organizational Maintenance, General Wiring Data
1A-7D-2-17	15 May 77	Organizational Maintenance, Wiring Diagrams
1A-7D-2-18	15 Mar 75	Organizational Maintenance, Integrated Avionic Systems
5F3-3-15-13	10 Nov 75	Overhaul, Counter-Drum-Pointer Servoed Altimeter, Type AAU-19/A
5F5-5-8-12	1 Jun 73	Intermediate Maintenance, Flight Director Computer, Type CPU-80/A (United Controls Corp.)
5F8-2-33-13	10 May 75	Overhaul, Airspeed Mach No. and Max. Allowable Speed Indicator, Type AVU-8/A, -8B/A (Aerosonic)
5F8-3-30-3	20 May 74	Overhaul Manual, Attitude-Director Indicator, 9819-58-01, Type ARU-21/A (Sunbeam Electronics)
5F10-4-5-33	1 May 75	Overhaul, Rate Gyro Transmitter, Type TRU-2A/A (Lear Jet)

A-7D BIBLIOGRAPHY

T.O. Number	Chg/Rev	Title
5N5-13-13-2	15 Mar 75	Intermediate Maintenance, Tactical Computer Set, AN/ASN-91(V), and Test Set Control Computer, CP-993/ASM (IBM)
5N12-2-8-3	15 Feb 74	Overhaul, Remote Compass Transmitter, Type ML-1, 2585726(MS25396)(Sperry)
5N16-3-6-2	15 Oct 75	Intermediate Maintenance, Inertial Measurement Set, AN/ASN-90(V) (Kearfott)
5N29-4-2	1 Jan 75	Intermediate Maintenance, Head-up Display Set, AN/AVQ-7(V) (Elliott Brother)
12P2-2APQ-126-2-1	1 Mar 75	Intermediate Maintenance, General, Volume I, Radar Set, AN/APQ-126(V) (TI)
12P5-2APN190-2	1 Aug 75	Intermediate Maintenance, Radar Navigation Set, AN/APN-190(V), G7210-001-01, -02, -03, -04, G7254-001-01, -02, -03, -04 (Singer)
12P5-2APN194-2	15 Dec 74	Intermediate Maintenance and Depot with IPB, Electronic Altimeter Set Type AN/APN-194(V) (Honeywell)
12R1-2ARA50-2	25 Jul 75	Field Maintenance, Direction Finder Group, Type AN/ARA-50 (Collins)
12R2-2ARR69-1	1 Jan 75	Overhaul, Radio Receiving Set, AN/ARR-69 (RCA)
12R2-2ASQ19-53	12 Apr 74	Overhaul, Antenna, Type AS-909/ARA-48 (Collins)
12R5-2ARN32-2	15 Jan 75	Maintenance, Radio Receiving Set AN/ARN-32 (Dare)
12R5-2ARN118-1	15 Oct 76	Operation and Maintenance Instructions with Illustrated Parts Breakdown TACAN Navigation Set AN/ARN-118(V)

A-7D BIBLIOGRAPHY

T.O. Number	Chg/Rev	Title
12R5-2ARN58-12	25 Jul 75	Field Maintenance, Receiving Set, Radio, AN/ARN-58A (Spartan)
16W26-2-2	1 Apr 70	Intermediate Maintenance with IPB, Relay Rack, 216-37417-1 (LTV)
MS24523	22 Apr 71	Military Standard, Switch, Toggle, One Pole, Environmentally Sealed

3.2.0
B-52D

B-52D PNRD EQUIPMENT LIST

KEY	EQUIPMENT/UNIT
A	UHF DIRECTION FINDER AN/ARA-25
ADDC	ATTITUDE DIRECTOR IND COPILOT ARU-2B/A
ADDP	ATTITUDE DIRECTOR IND PILOT ARU-2B/A
AFCS	AUTOMATIC FLIGHT CONTROL SYSTEM
AGMX	WEAPON SYSTEM B-52/AGM-69A
BCDD	BEARING CONVERTER IND ID-251/ARN
CMMS	INTERPHONE SYSTEM
D	DOPPLER RADAR SET AN/APN-108
DADN	DRIFT ANGLE IND NAVIGATOR'S ID-342/APN-81
EVSY	ELECTRO-OPTICAL VIEWING SYSTEM AN/ASQ-151
G	ELECTRONIC ALTIMETER SET AN/APN-150(V)
GSDN	GROUND SPEED IND NAVIGATOR'S ID-341/APN-81
HSDC	HORIZONTAL SITUATION IND COPILOT AQU-4/A
HSDP	HORIZONTAL SITUATION IND PILOT AQU-4/A
J	BOMBING-NAVIGATIONAL SYSTEM AN/ASB-15B
JBA	TACAN RELAY SHIELD RJ-501
JBB	MD-1 JUNCTION BOX RM5029
JBC	INTERCONNECT JUNCTION BOX
JBD	FORWARD AUX. BNS JUNCTION BOX RJ 503
JBE	INTERCONNECT RELYA FRAME 2116
K	FLIGHT DIRECTOR COMPUTER CPU-4/A
MIDN	MASTER INDICATOR CLASS 1 C708622001

B-52D PNWD EQUIPMENT LIST

KEY	EQUIPMENT/UNIT
RADP	HEIGHT INDICATOR PILOT ID-950/APN-150(V)
RADC	HEIGHT INDICATOR COPILOT ID-950/APN-150(V)
RDA	RACK DISCONNECT A
RDB	RACK DISCONNECT B
RDC	RACK DISCONNECT C
RDD	RACK DISCONNECT D
RDE	RACK DISCONNECT E
RDF	RACK DISCONNECT F
RDG	RACK DISCONNECT G
RMDN	RADIO MAGNETIC IND NAVIGATOR ID-250()/ARN
RMDP	RADIO MAGNETIC IND PILOT ID-250()/ARN
S	GLIDE PATH RADIO AN/ARN-18
SPA	AISLE CONTROL STAND J-19
SWA	RELAY RR-513
SWB	ALTITUDE SIMULATOR SWITCH
T	RADIO NAVIGATION SET AN/ARN-21() TACAN
TSA	TERMINAL STRIP RT47-6
TSB	TERMINAL STRIP RT41-5
TSC	TERMINAL STRIP RT41-4
TSD	TERMINAL STRIP RT41-6
TSE	TERMINAL STRIP TB7001

B-52D PNWD EQUIPMENT LIST

KEY	EQUIPMENT/UNIT
TSF	TERMINAL STRIP TB7013
TSG	TERMINAL STRIP RT41-7
TSH	TERMINAL STRIP RT49-9
TSJ	TERMINAL STRIP RT47-9
TSK	TERMINAL STRIP RT47-8
TSL	TERMINAL STRIP RT41-8
TSM	TERMINAL STRIP T41-9
TSN	TERMINAL STRIP T41-41
TSQ	TERMINAL STRIP T41-72
V	NAVIGATION RADIO AN/ARN-14
WA	N-1 COMPASS SYSTEM
WC	MD-1 AUTOMATIC ASTRO COMPASS

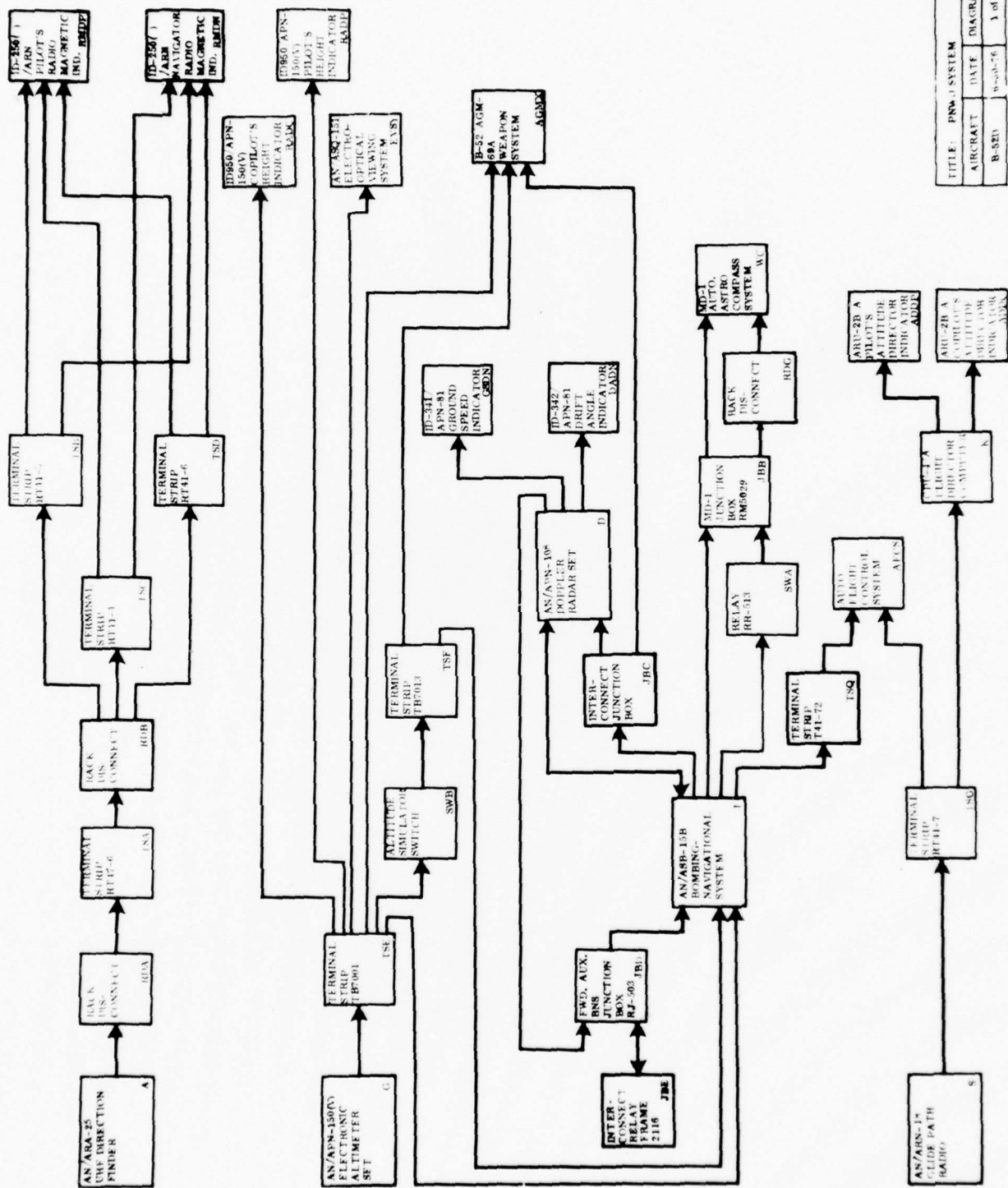

TITLE	PRN-3 SYSTEM
AIRCRAFT	DATE
B-57D	9-20-56
	DIAGRAM
	1 of 2

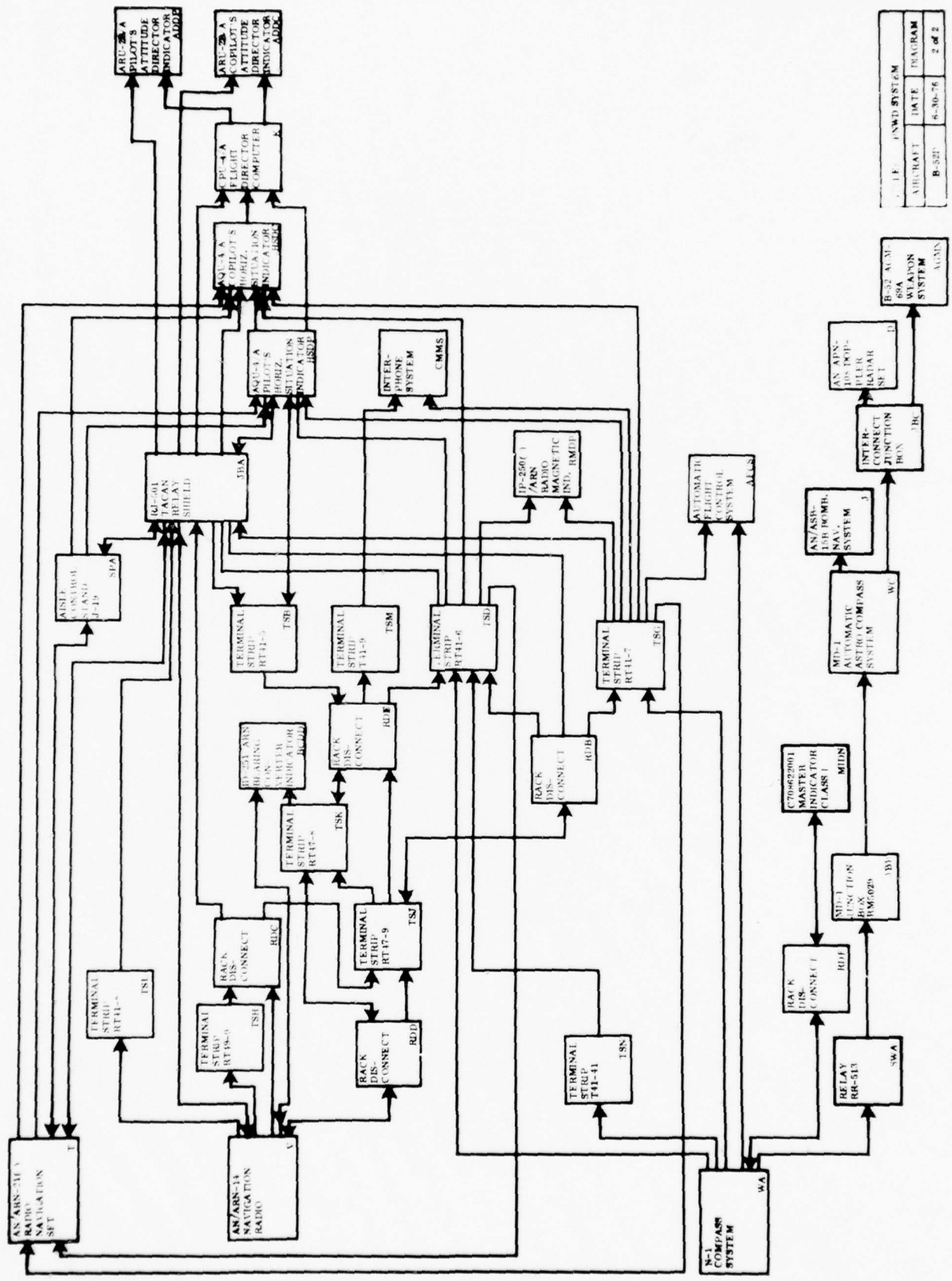

DRAWING SYSTEM		
AIRCRAFT	DATE	DIAGRAM
B-52D	6-30-76	2 of 2

B-52D PNWD EQUIPMENT PHYSICAL CHARACTERISTICS

SYSTEM	UNIT		WT (LB)	SIZE (IN)		
	TYPE (P/N)	NOMENCLATURE		H	W	D
AN/APN-108	<u>Doppler Radar Set</u>					
	RT-528/APN-89A	Receiver-Transmitter	90.0	16.875	16.25	23.625
	or					
	RT-586/APN-89A					
	AM-2720A/APN-89A	Electronic Control Amplifier	91.0	16.875	16.75	23.625
	AS-1101/APN-89A	Antenna	46.0	13.625	15.0	28.125
	CU-323/APN-81	Directional Coupler	0.25	2.5	2.375	5.0
	C-3270/APN-89A	Radar Control Panel	3.0	6.0	5.75	5.0
	AM-946A/APN-89	Electronic Control Amplifier	58.0	13.375	13.5	21.875
	ID-341/APN-81	Ground Speed Indicator	1.25	3.25	3.25	3.5
	ID-342/APN-81	Drift Angle Indicator	1.25	3.25	3.25	3.5
	C-1160/APN-81	Vertical Gyro Control	8.25	7.0	7.5	8.125
	AM-743/APN-81	Electronic Control Amplifier	10.5	7.75	6.125	10.625
	J-605A/APN-91	Interconnection Box	2.0	3.375	3.25	7.25
J-607/APN-81	Interconnection Box	24.5	5.875	11.0	16.0	
J-608A/APN-81	Interconnection Box	6.75	4.875	8.25	10.875	
AN/APN-150(V)	<u>Electronic Altimeter Set</u>					
	T-853A/APN-150(V)	Transmitter	5.0	6.87	7.87	4.75
	R-1085/APN-150(V)	Receiver	4.0	8.5	9.0	3.5
	AM-3063A/APN-150(V)	Electronic Control Amplifier	10.0	6.25	4.87	11.75
	MT-2585/APN-150(V)	Mount	3.0	4.0	4.9	12.8
	ID-950/APN-150(V)	Height Indicator (2 ea)				
	APN-150/AGM-69A	Tie-In Control Low Altitude Indicator Light (2 ea)				

B-52D PNWD EQUIPMENT PHYSICAL CHARACTERISTICS

SYSTEM	UNIT		WT (LB)	SIZE (IN)		
	TYPE (P/N)	NOMENCLATURE		H	W	D
<u>AN/ARN-21() Radio Navigation Set (TACAN)</u>						
	AT-741/A	Antenna	0.4	3.3	1.75	5.25
	RT-220()/ARN-21	Receiver-Transmitter	60.0	8.3	11.13	18.75
	MT-928()/ARN-21	Mount	6.5	7.75	11.125	17.5
	C-1763()/ARN-21A	Radio Set Control	3.0	3.0	5.75	5.688
	161B-1	TACAN Instrumentation Coupler	12.0	6.125	5.0	10.167
	349L-2	Mount TACAN Relay Shield	3.0	7.75*	5.906*	13.875*
<u>AN/ARN-14 Navigation Radio (VOR/LOC)</u>						
	R-541/ARN-14D	Receiver**	29.5	9.188	4.906	24.5
	C-996/ARN-14	Control Panel	2.7	3.375	5.75	4.5
	DY-84/ARN-14A	Dynamotor Antenna	8.5	7.484	5.062	9.531
<u>AN/ARN-32 Marker Beacon Radio</u>						
	R-666()/ARN-32	Receiver	2.6	2.188	5.125	7.625
	AT-536/ARN	Antenna Marker Beacon Lights (2 ea)	2.2	3.125	7.75	11.188
<u>AN/ARN-18 Glide Path Radio</u>						
	R-322()/ARN-18	Receiver	13.0	7.625	4.875	14.125
	MT-691/ARN-18	Mount	1.9	3.75	5.188	13.875
	C-996/ARN-14	Control Panel (part of AN/ARN-14 system) Top Antenna Bottom Antenna	2.7	3.375	5.75	4.5
*Includes sway space						
**Includes mount						

B-52D PNWD EQUIPMENT PHYSICAL CHARACTERISTICS

SYSTEM	UNIT		WT (LB)	SIZE (IN)		
	TYPE (P/N)	NOMENCLATURE		H	W	D
	<u>Navigation Systems Instrumentation</u>					
	CPU-4/A	Flight Director Computer	6.5	6.75	5.5	9.5
	AQU-4/A	Horizontal Situation Indicator (2 ea)	8.2	4.938	5.063	9.5
	ARU-2B/A	Attitude Director Indicator (2 ea)	8.5	5.25	5.0	9.735
	ID-251/ARN	Mode Select Switch (2 ea) Bearing Converter Indicator	1.86	3.25	3.25	4.48
	<u>MD-1 Automatic Astrocompass System</u>					
	A21570-00-004	Star Data Display Panel (3 ea)	4.3	2.625	5.75	7.375
	B21590-00-001	Line of Position Display Panel	3.4	2.625	5.75	6.4
	B23090-00-001	Indicator Display Panel	6.0	6.75	5.75	6.125
	D23140-00-001	Heading Display Panel	4.5	2.625	5.75	7.78
	A23130-00-001	Manual Present Position Display Panel	4.3	2.625	5.75	6.64
	C23160-00-001	Manual Set Panel	2.4	2.625	5.75	4.0
	A26980-00-001	Master Control Panel	6.3	6.75	5.75	6.125
	B23200-00-003	Power Supply Unit	7.8	4.84	5.75	14.09
	A26970-00-001	Correction Computer	11.5	7.125	5.75	8.25
	A26960-00-002	Altitude-Azimuth Computer	20.125	10.5	12.125	14.0
	B24220-00-002	Astrotracker Servo Amplifier	3.4	2.25	5.75	10.2
	C23180-00-002	Astrotracker Signal Amplifier				
	B24200-00-001	Altitude-Azimuth Computer Servo Amplifier	3.4	2.25	5.75	10.28
	C23170-00-001	Accessory Servo Amplifier	4.7	2.22	5.75	13.03
	B24670-00-002	Erection Amplifier	4.0	4.094	5.75	7.28
	T4101-2A	Gyro	9.75			
	D21550-00-001	Astrotracker				

B-52D PNWD EQUIPMENT PHYSICAL CHARACTERISTICS

SYSTEM	UNIT		WT (LB)	SIZE (IN)		
	TYPE (P/N)	NOMENCLATURE		H	W	D
<u>MD-1 Automatic Astrocompass System (Cont'd)</u>						
	A26990-00-007	Junction Box	18.62	6.0	12.02	13.5
	B24210-00-001	Correction Computer Servo Amplifier Signal Isolator	3.4	2.22	5.75	10.16
<u>N-1 Compass System</u>						
	1600	N-1 Amplifier	23.25	9.31	13.94	9.03
	15810	Directional Gyro	23.5	11.5	13.31	12.5
	15900-3	Master Indicator	9.5	5.25	5.0	7.9
	15150-1	Slaving Control	3.75	5.09	4.56	4.56
	ME-1A	Compass Signal Power Amplifier	9.5	6.125	4.5	10.875
	DT-309/AJN Type C-1	Magnetic Azimuth Detector Remote Compass Transmitter	1.5	4.91	3.5	2.06
	P-11-C-4307	N-1 Transformer				
	G-54329	N-1 Gyros Relay				
	AN3022-2	N-1 Gyros Switch				
<u>AN/ARA-25 UHF Direction Finder System</u>						
	AM-608/ARA-25	Electronic Control Amplifier	5.4	5.875	4.875	12.531
	AS-578C/ARA-25	Antenna	17.5	6.0	16.0	14.5
	RE-120/ARA-25	Solenoid Relay	0.82	5.8	6.5	1.75
	ID-250/ARN	Radio Magnetic Indicator	2.6	3.25 diam.		6.136

B-52D BIBLIOGRAPHY

T.O. Number	Chg/Rev	Title
1B-52A-01	1 Dec 72	List of Applicable Publications, B-52
1B-52D-1	15 Feb 77	Flight Manual, B-52D
1B-52B-2-24	15 Mar 77	Organizational Maintenance, Electronic Communication Systems B-52B, C, D, E, F, G, and H
1B-52B-2-25	30 Jun 76	Organizational Maintenance, Electronic Navigation/Recognition Systems B-52B, C, D, E, F, G, and H
1B-52B-2-26	1 Mar 77	Organizational Maintenance, Compass Systems B-52B, C, D, E, F, G, and H
1B-52C-2-34	15 Feb 77	Organizational Maintenance, Bombing-Navigational System (AN/ASB-15A) (AN/ASB-15B) B-52C and D
1B-52C-2-36	20 Feb 77	Organizational Maintenance, MD-1 Automatic Astro-Compass, B-52C, D, E, F, G, and H
5F5-5-3-12	15 Apr 75	Field Maintenance, Aircraft Flight Director Computer, Type CPU-4/A (Sperry)
5F8-16-4-3	1 May 74	Overhaul, Horizontal Situation Indicator, Type AQU-4/A (Astronautics)
5N1-2-6-2	15 Aug 75	Field Maintenance, Magnetic Slaved, Directional Gyro Stabilized Compass System USAF Type N-1 (Kearfott)
5N1-2-17-1	25 Aug 73	Field Maintenance and Parts List, AN/AJN-11 Automatic Astro Compass Subsystem (Kollsman)
12P5-2APN89-42	1 Oct 75	Field and Depot Maintenance, Radar Sets AN/APN-108 and AN/APN-89A
12R1-2ARA25-2	25 Jul 75	Service-Direction Finder Group AN/ARA-25 and AN/ARA-25A

B-52D BIBLIOGRAPHY

T.O. Number	Chg/Rev	Title
12R5-2ARN14-2	1 Apr 75	Service-Radio Receiving Set AN/ARN-14B and -14C (Collins)
12R5-2ARN18-2	1 Apr 75	Service, Radio Receiving Set AN/ARN-18
12R5-2ARN21-42	20 Apr 72	Field Maintenance, Radio Set, Type AN/ARN-21C
12R5-2ARN32-2	15 Jan 75	Field Maintenance, Radio Receiving Set AN/ARN-32 (Dare)
12R5-4-28-2	21 Jun 73	Field Maintenance, TACAN Instru- mentation Coupler 161B-1 and Shock- mount 349L-2 (Collins)

3.3.0
B-52G

B-52G PNWD EQUIPMENT LIST

KEY	EQUIPMENT/UNIT
ADDC	ATTITUDE DIRECTOR IND COPILOT ARU-2B/A
ADDP	ATTITUDE DIRECTOR IND PILOT ARU-2B/A
AFCS	AUTOMATIC FLIGHT CONTROL SYSTEM A/A42G-11
AGMX	WEAPON SYSTEM B-52/AGM-28
AGMY	WEAPON SYSTEM B-52/AGM-69A
ARDP	AZIMUTH AND RANGE DISPLAY 6447000
BCDN	BEARING CONVERTER IND ID-251/ARN
CMMM	INTERCOMMUNICATION SYSTEM AN/AIC-10A
D	DOPPLER RADAR SET AN/APN-89A
DADN	DRIFT ANGLE INDICATOR ID-342/APN-81
EOVS	ELECTRO-OPTICAL VIEWING SYSTEM AN/ASQ-151
G	ELECTRONIC ALTIMETER SET AN/APN-150(V)
GSDN	GROUND SPEED INDICATOR ID-341/APN-81
GTDN	GROUND TRACK REPEATER 6209100
HSDC	HORIZONTAL SITUATION IND COPILOT AQU-4/A
HSDP	HORIZONTAL SITUATION IND PILOT AQU-4/A
J	BOMBING-NAVIGATIONAL SYSTEM AN/ASB-16
JBA	FORWARD BNS JUNCTION BOX A6004
JBB	RH BNS JUNCTION BOX A6003
JBC	AUX BNS JUNCTION BOX A6349
JBD	TACAN RELAY SHIELD A6336
JBE	MD-1 JUNCTION BOX

B-52G PNWD EQUIPMENT LIST

KEY	EQUIPMENT/UNIT
JBF	LATITUDE RELAY FRAME
JBG	LONGITUDE RELAY FRAME
JBH	AZIMUTH RELAY FRAME
JBJ	HEADING RELAY FRAME
K	FLIGHT DIRECTOR COMPUTER CPU-4/A
MIDN	MASTER INDICATOR CLASS II 425617
RADC	HEIGHT INDICATOR COPILOT ID-950/APN-150(V)
RADP	HEIGHT INDICATOR PILOT ID-950/APN-150(V)
RDA	RACK DISCONNECT A
RDB	RACK DISCONNECT B
RDC	RACK DISCONNECT C
RDD	RACK DISCONNECT D
RDE	RACK DISCONNECT E
RDF	RACK DISCONNECT F
S	GLIDE PATH RADIO AN/ARN-67
SPA	AISLE CONTROL STAND A119
SPB	BNS EMERGENCY CONTROL 179
SWA	RELAY K6125
SWB	ALTITUDE SIMULATOR SWITCH APN-150
T	RADIO NAVIGATION SET AN/ARN-21()
THDN	TRUE HEADING INDICATOR CP-308/AJA-1
TSA	TERMINAL STRIP TB7001
TSB	TERMINAL STRIP TB7013

B-52G PNWD EQUIPMENT LIST

KEY	EQUIPMENT/UNIT
TSC	TERMINAL STRIP TB6024
TSD	TERMINAL STRIP TB6023
TSE	TERMINAL STRIP TB166
V	NAVIGATION RADIO AN/ARN-14
WA	COMPASS SYSTEM N-1 AND AN/AJA-1 GROUP
WB	MD-1 AUTOMATIC ASTRO COMPASS

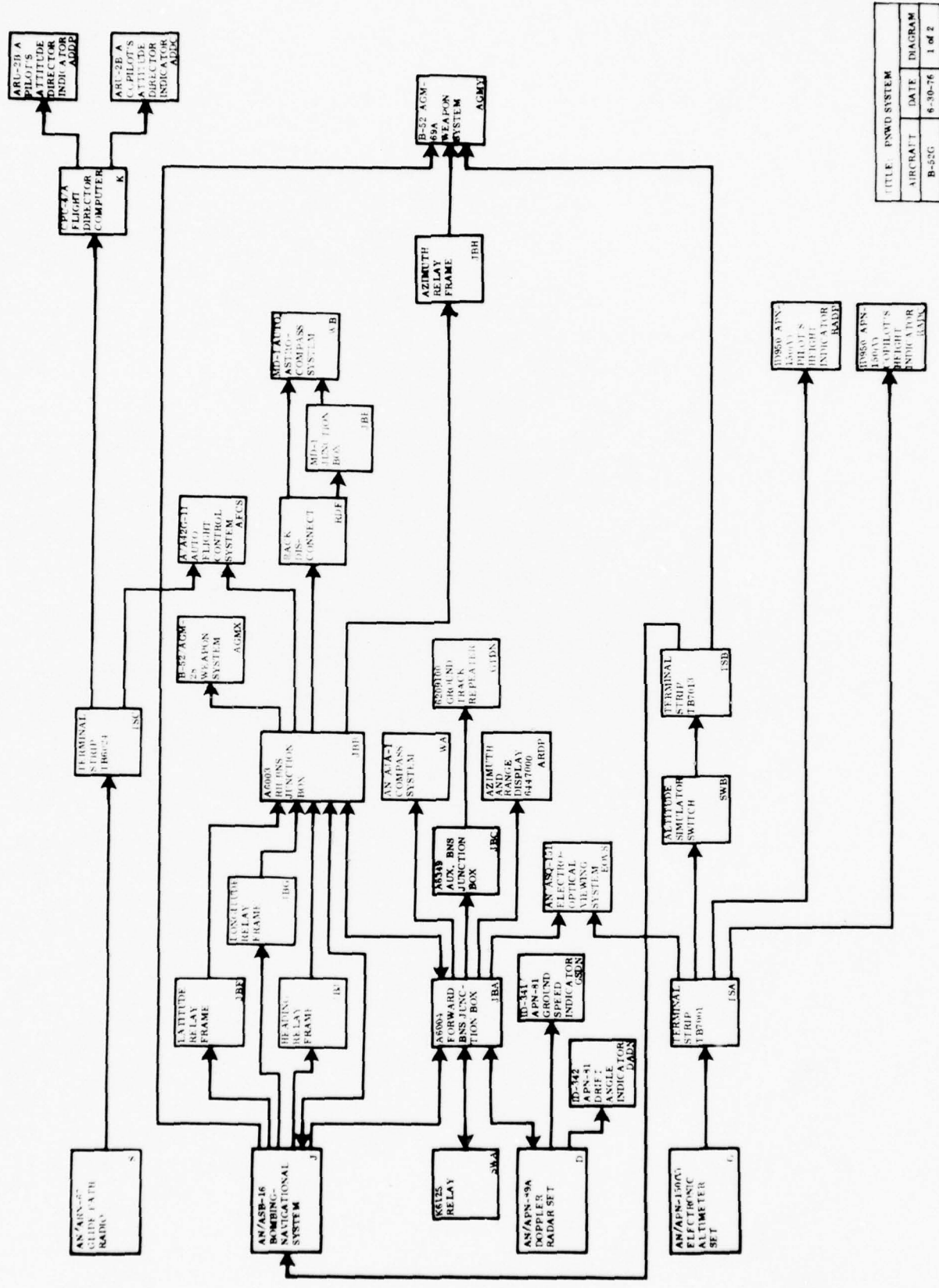

TITLE: PWD SYSTEM		
AIRCRAFT	DATE	DIAGRAM
B-52G	6-30-76	1 of 2

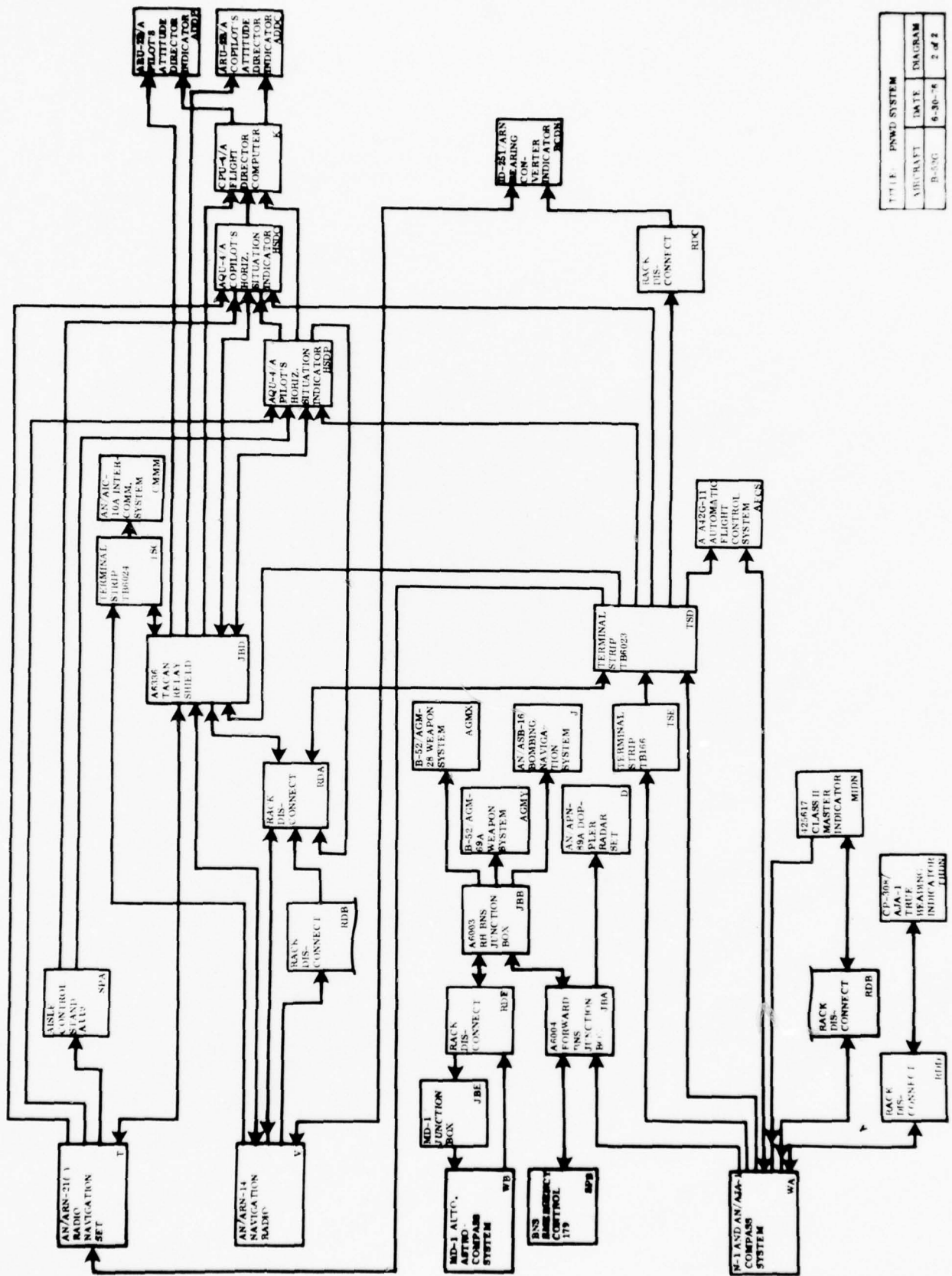

TITLE		PNRD SYSTEM	
ABU:RAVY	DATE	DIAGRAM	
B-52C	6-30-76	2 of 2	

B-52G PNWD EQUIPMENT PHYSICAL CHARACTERISTICS

SYSTEM	UNIT		WT (LB)	SIZE (IN)		
	TYPE (P/N)	NOMENCLATURE		H	W	D
AN/APN-89A	<u>Doppler Radar Set</u>					
	RT-528/APN-89A	Receiver-Transmitter	90.0	16.875	16.25	23.625
	or					
	RT-586/APN-89A					
	AM-2720A/APN-89A	Electronic Control Amplifier	91.0	16.875	16.25	23.625
	AS-1101/APN-89A	Antenna	46.0	13.625	15.0	28.125
	CU-323/APN-81	Directional Coupler	0.25	2.5	2.375	5.0
	C-3270/APN-89A	Radar Control Panel	3.0	6.0	5.75	5.0
	AM-946A/APN-89	Electronic Control Amplifier	58.0	13.375	13.5	21.875
	ID-341/APN-81	Ground Speed Indicator	1.25	3.25	3.25	3.5
	ID-342/APN-81	Drift Angle Indicator	1.25	3.25	3.25	3.5
	J-605A/APN-81	Interconnection Box	2.0	3.375	3.25	7.25
J-607/APN-81	Interconnection Box	24.5	5.875	11.0	16.0	
J-608A/APN-81	Interconnection Box	6.75	4.875	8.25	10.875	
AN/APN-150(V)	<u>Electronic Altimeter Set</u>					
	T-853A/APN-150(V)	Transmitter	5.0	6.87	7.87	4.75
	R-1085/APN-150(V)	Receiver	4.0	8.5	9.0	3.5
	AM-3063A/APN-150(V)	Electronic Control Amplifier	10.0	6.25	4.87	11.75
	MT-2585/APN-150(V)	Mount	3.0	4.0	4.9	12.8
	ID-950/APN-150(V)	Height Indicator (2 ea)				
	APN-150/AGM-69A	Tie-In Control Low Altitude Indicator Light (2 ea)				
AN/ARN-21()	<u>Radio Navigation Set (TACAN)</u>					
	AT-741/A	Antenna	0.4	3.3	1.75	5.25
	RT-220()/ARN-21	Receiver-Transmitter	60.0	8.3	11.13	18.75
	MT-928()/ARN-21	Mount	6.5	7.75	11.125	17.5

B-52G PNWD EQUIPMENT PHYSICAL CHARACTERISTICS

SYSTEM	UNIT		WT (LB)	SIZE (IN)		
	TYPE (P/N)	NOMENCLATURE		H	W	D
<u>AN/ARN-21() Radio Navigation Set (TACAN) (Cont'd)</u>						
	C-1763()/ARN-21A	Radio Set Control	3.0	3.0	5.75	5.688
	161B-1	TACAN Instrumentation Coupler	12.0	6.125	5.0	10.167
	349L-2	Mount TACAN Relay Shield	3.0	7.75*	5.906*	13.875*
<u>AN/ARN-14 Navigation Radio (VOR/LOC)</u>						
	R-541/ARN-14D	Receiver	29.5	9.188	4.906	24.5
	C-996/ARN-14	Control Panel	2.7	3.375	5.75	4.5
	DY-84/ARN-14A	Dynamotor	8.5	7.484	5.062	9.531
	AT-172/ARN-14	Antenna				
<u>AN/ARN-32 Marker Beacon Radio</u>						
	R-666()/ARN-32	Receiver	2.6	2.188	5.125	7.625
	AT-536/ARN	Antenna Marker Beacon Lights (2 ea)	2.2	3.125	7.75	11.188
<u>AN/ARN-67 Glide Path Radio</u>						
	AN/ARN-67	Receiver	7.5	5.094	4.469	12.313
	C-996/ARN-14	Control Panel (part of AN/ARN-14 system)	2.7	3.375	5.75	4.5
	AT-172/ARN-14	Antenna				
<u>Navigation System Instrumentation</u>						
	CPU-4/A	Flight Director Computer	6.5	6.75	5.5	9.5
	AQU-4/A	Horizontal Situation Indicator (2 ea)	8.2	4.938	5.063	9.5
	ARU-2B/A	Attitude Director Indicator (2 ea)	8.5	5.25	5.0	9.735
*Includes	sway space					

B-52G PNWD EQUIPMENT PHYSICAL CHARACTERISTICS

SYSTEM	UNIT		WT (LB)	SIZE (IN)		
	TYPE (P/N)	NOMENCLATURE		H	W	D
<u>Navigation System Instrumentation (Cont'd)</u>						
	161B-1	Mode Select Switch (2 ea) TACAN Instrumentation Coupler (part of AN/ ARN-21 system)	12	6.125	5.0	10.167
	ID-251/ARN	Bearing Converter Indicator	1.86	3.25	3.25	4.48
<u>MD-1 Automatic Astrocompass System</u>						
	A21570-00-004	Star Data Display Panel (3 ea)	4.3	2.625	5.75	7.375
	B21590-00-001	Line of Position Display Panel	3.4	2.625	5.75	6.4
	B23090-00-001	Indicator Display Panel	6.0	6.75	5.75	6.125
	D23140-00-001	Heading Display Panel	4.5	2.625	5.75	7.78
	A23130-00-001	Manual Present Position Display Panel	4.3	2.625	5.75	6.64
	C23150-00-001	Manual Set Panel	2.4	2.625	5.75	4.0
	A26980-00-001	Master Control Panel	6.3	6.75	5.75	6.125
	B23200-00-003	Power Supply Unit	7.8	4.84	5.75	14.09
	A26970-00-001	Correction Computer	11.5	7.125	5.75	8.25
	A26960-00-002	Altitude-Azimuth Computer	20.125	10.5	12.125	14.0
	B24220-00-002	Astrotracker Servo Amplifier	3.4	2.25	5.75	10.2
	C23180-00-002	Astrotracker Signal Amplifier				
	B24200-00-001	Altitude-Azimuth Computer Servo Amplifier	3.4	2.25	5.75	10.28
	C23170-00-001	Accessory Servo Amplifier	4.7	2.22	5.75	13.03
	B24670-00-002	Erection Amplifier	4.0	4.094	5.75	7.28
	T4101-2A	Gyro	9.75			
	D21550-00-001	Astrotracker				
	A26990-00-007	Junction Box	18.62	6.0	12.02	13.5
		Correction Computer Servo Amplifier	3.4	2.22	5.75	10.16
		Signal Isolator				

B-52G PNWD EQUIPMENT PHYSICAL CHARACTERISTICS

SYSTEM	UNIT		WT (LB)	SIZE (IN)		
	TYPE (P/N)	NOMENCLATURE		H	W	D
<u>N-1 Compass System</u>						
	1600	N-1 Amplifier	23.25	9.31	13.94	9.03
	15810	Directional Gyro	32.5	11.5	13.31	12.5
	425617-2A	Master Indicator	10.0	5.25	5.0	8.276
	15150-1	Slaving Control	3.75	5.09	4.56	4.56
	ME-1A	Compass Signal Power Amplifier	9.5	6.125	4.5	10.875
	DT-310/AJN	Magnetic Azimuth Detector	1.7	4.9	3.5	2.06
	Type C-2	Remote Compass Transmitter	1.125	2.23	4.78	4.78
	6655	N-1 Transformer				
	CN-1072/AJN	Compensator	0.33	3.28	3.31	0.25
	V-7A	Gyro Magnetic Compass Indicator	2.25	5.25	5.0	4.99
<u>AN/AJA-1 True Heading Computer Group</u>						
	AM-1495/AJA-1	Electronic Control Amplifier	25.0	8.375	9.75	13.375
	CP-308/AJA-1	True Heading Indicator	11.0	5.25	5.0	7.75
	6655	True Heading Transformer				

B-52G BIBLIOGRAPHY

T.O. Number	Chq/Rev	Title
1B-52A-01	1 Dec 72	List of Applicable Publications, B-52
1B-52G-1	15 Dec 76	Flight Manual, B-52G
1B-52B-2-24	15 Mar 77	Organizational Maintenance, Electronic Communication Systems B-52B, C, D, E, F, G, and H.
1B-52B-2-25	30 Jun 76	Organizational Maintenance, Electronic Navigation/Recognition Systems B-52B, C, D, E, F, G, and H
1B-52B-2-26	1 Mar 77	Organizational Maintenance, Compass Systems B-52B, C, D, E, F, G, and H
1B-52G-2-26	1 Jun 77	Organizational Maintenance, Bombing-Navigational System AN/ASB-9A and AN/ASB-16, B-52G and H
1B-52G-2-41	1 May 77	Organizational Maintenance, Electro-Optical Viewing System (EVS) AN/ASQ-151, B-52G and H
1B-52G-2-42GA-1	1 May 77	General Aircraft, MD-1 Automatic Astrocompass, B-52G
5F5-5-3-12	15 Apr 75	Field Maintenance, Aircraft Flight Director Computer Type CPU-4/A (Sperry)
5F8-16-4-3	1 May 74	Overhaul, Horizontal Situation Indicator Type AQU-4/A (Astronautics)
5N1-2-6-2	15 Aug 75	Field Maintenance, Magnetic Slaved, Directional Gyro Stabilized Compass System USAF Type N-1 (Kearfott)
5N1-2-17-1	25 Aug 73	Field Maintenance and Parts Lits, AN/AJN-11 Automatic Astro Compass Subsystem (Kollsman)
5N2-3-5-3	16 Nov 72	Overhaul, Electronic Control Amplifier AM-1495/AJA-1 (Kearfott)

B-52G BIBLIOGRAPHY

T.O. Number	Chq/Rev	Title
5N8-3-5-3	15 Jan 75	Overhaul, Master Indicator Class 2 Part No. 425617-2A (Kearfott)
5N8-4-4-3	20 Feb 74	Overhaul, True Heading Computer- Indicator CP-308/AJA-1 (Kearfott)
12P5-2APN89-42	1 Oct 75	Field and Depot Maintenance, Radar Sets AN/APN-108 and AN/APN-89A
12R1-2ARA25-2	25 Jul 75	Service-Direction Finder Group AN/ARA-25 and AN/ARA-25A
12R5-2ARN14-2	7 Apr 75	Service-Radio Receiving Set AN/ARN-14B and -14C (Collins)
12R5-2ARN21-42	20 Apr 72	Field Maintenance, Radio Set, Type AN/ARN-21C
12R5-2ARN32-2	15 Jan 75	Field Maintenance, Radio Receiving Set AN/ARN-32 (Dare)
12R5-2ARN67-2	15 Nov 75	Field Maintenance, Radio Receiving Set AN/ARN-67 (Sparton)
12R5-4-28-2	21 Jun 72	Field Maintenance, TACAN Instru- mentation Coupler 161B-1 and Shockmount 349L-2 (Collins)

3.4.0
B-52H

B-52H PNWD EQUIPMENT LIST

KEY	EQUIPMENT/UNIT
A	ADF-UHF NAVIGATION RADIO AN/ARN-14
ADDC	ATTITUDE DIRECTOR IND COPILOT ARU-2B/A
ADDP	ATTITUDE DIRECTOR IND PILOT ARU-2B/A
AFCS	AUTOMATIC FLIGHT CONTROL SYSTEM A/A42G-11
AGMX	WEAPON SYSTEM B-52/AGM-28
AGMY	WEAPON SYSTEM B-52/AGM-69A
BCDN	BEARING CONVERTER IND ID-251/ARN
CMMM	INTERCOMMUNICATION SYSTEM AN/AIC-10A
CSA	SIGNAL CONVERTER TYPE ME-1 (COMPASS SIGNAL POWER AMPLIFIER)
D	DOPPLER RADAR SET AN/APN-89A
DADN	DRIFT ANGLE INDICATOR ID-342/APN-81
EVSY	ELECTRO-OPTICAL VIEWING SYSTEM AN/ASQ-151
G	ELECTRONIC ALTIMETER SET AN/APN-150(V)
GSDN	GROUND SPEED INDICATOR ID-341/APN-81
GTDN	GROUND TRACK REPEATER 6209100
HSDC	HORIZONTAL SITUATION IND AQU-2/A COPILOT
HSDP	HORIZONTAL SITUATION IND AQU-2/A PILOT
J	BOMBING-NAVIGATIONAL SYSTEM AN/ASB-9A
JBA	FORWARD BNS JUNCTION BOX A6004
JBB	RH BNS JUNCTION BOX A6003
JBC	AUX BNS JUNCTION BOX A6349
JBD	TACAN RELAY SHIELD A6336

B-52H PNWD EQUIPMENT LIST

KEY	EQUIPMENT/UNIT
JBE	MD-1 JUNCTION BOX
JBF	LATITUDE RELAY FRAME
JBG	LONGITUDE RELAY FRAME
JBJ	HEADING RELAY FRAME
K	FLIGHT DIRECTOR COMPUTER CPU-4/A
PIDN	NAVIGATOR'S PRECISION IND M9001-11N
RADC	HEIGHT INDICATOR ID950/APN-150(V) COPILOT
RADP	HEIGHT INDICATOR ID950/APN-150(V) PILOT
RDA	RACK DISCONNECT A
RDB	RACK DISCONNECT B
RDF	RACK DISCONNECT F
S	GLIDE PATH RADIO AN/ARN-67
SPA	AISLE CONTROL STAND
SWA	K6125 RELAY
SWB	ALTITUDE SIMULATOR SWITCH
SWC	K533 RELAY
SWD	K538 RELAY
T	RADIO NAVIGATION SET AN/ARN-21()
TSA	TERMINAL STRIP TB7001
TSB	TERMINAL STRIP TB7013
TSC	TERMINAL STRIP TB6024
TSD	TERMINAL STRIP TB6023
TSE	TERMINAL STRIP TB166

B-52H PNWD EQUIPMENT LIST

KEY	EQUIPMENT/UNIT
WA	COMPASS SYSTEM AN/AJN-8
WB	COMPASS SYSTEM J-4
WC	ASTRO COMPASS SYSTEM MD-1

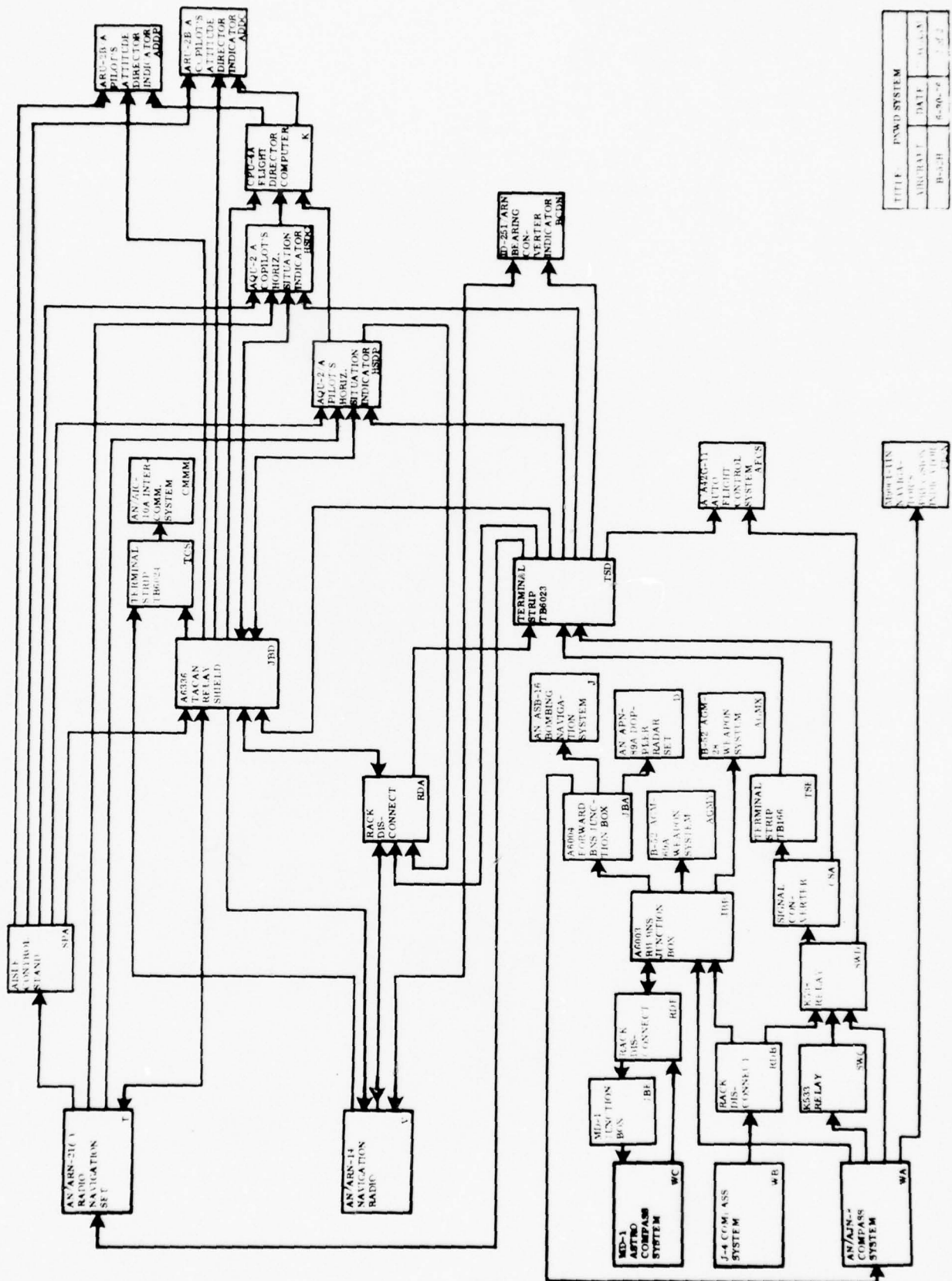

TITLE: PWD SYSTEM		
VERSION:	DATE:	BY:
B-238	6-20-76	J. J. J.

B-52H PNWD EQUIPMENT PHYSICAL CHARACTERISTICS

SYSTEM	UNIT		WT (LB)	SIZE (IN)		
	TYPE (P/N)	NOMENCLATURE		H	W	D
<u>AN/APN-89A Doppler Radar Set</u>						
	RT-528/APN-89A or RT-586/APN-89A	Receiver-Transmitter	90.0	16.875	16.25	23.625
	AM-2720A/APN-89A	Electronic Control Amplifier	91.0	16.875	16.75	23.625
	AS-1101/APN-89A	Antenna	46.0	12.625	15.0	28.125
	CU-323/APN-81	Directional Coupler	0.25	2.5	2.375	5.0
	C-3270/APN-89A	Radar Control Panel	3.0	6.0	5.75	5.0
	AM-946A/APN-89	Electronic Control Amplifier	58.0	13.375	13.5	21.875
	ID-341/APN-81	Ground Speed Indicator	1.25	3.25	3.25	3.5
	ID-342/APN-81	Drift Angle Indicator	1.25	3.25	3.25	3.5
	J-605A/APN-81	Interconnection Box	2.0	3.375	3.25	7.25
	J-607/APN-81	Interconnection Box	24.5	5.875	11.0	16.0
	J-608A/APN-81	Interconnection Box	6.75	4.875	8.25	10.875
<u>AN/APN-150(V) Electronic Altimeter Set</u>						
	T-853A/APN-150(V)	Transmitter	5.0	6.87	7.87	4.75
	R-1085/APN-150(V)	Receiver	4.0	8.5	9.0	3.5
	AM-3063A/APN-150	Electronic Control Amplifier	10.0	6.25	4.87	11.75
	MT-2585/APN-150 (V)	Mount	3.0	4.0	4.9	12.8
	ID-950/APN-150(V)	Height Indicator (2 ea)	2.5			
	APN-150/AGM-69A	Tie-In Control				
	ID-1143/APN-150(V)	Low Altitude Indicator Light (2 ea)				

B-52H PNWD EQUIPMENT PHYSICAL CHARACTERISTICS

SYSTEM	UNIT		WT (LB)	SIZE (IN)		
	TYPE (P/N)	NOMENCLATURE		H	W	D
<u>AN/ARN-21 () Radio Navigation Set (TACAN)</u>						
	AT-741/A	Antenna	0.4	3.3	1.75	5.25
	RT-220()/ARN-21	Receiver-Transmitter	60.0	8.3	11.13	18.75
	MT-928()/ARN-21	Mount	6.5	7.75	11.125	17.5
	C-1763()/ARN-21A	Radio Set Control	3.0	3.0	5.75	5.688
	161B-1	TACAN Instrumentation Coupler	12.0	6.125	5.0	10.167
	349L-2	Mount TACAN Relay Shield	3.0	7.75*	5.906*	13.875*
<u>AN/ARN-14 Navigation Radio (VOR/LOC)</u>						
	R-541/ARN-14D	Receiver*	29.5	9.188	4.906	24.5
	C-996/ARN-14	Control Panel	2.7	3.375	5.75	4.5
	DY-84/ARN-14A	Dynamotor	8.5	7.484	5.062	9.531
		Antenna				
<u>AN/ARN-32 Marker Beacon Radio</u>						
	R-666()/ARN-32	Receiver	2.6	2.188	5.125	7.625
	AT-536/ARN	Antenna Marker Beacon Lights (2 ea)	2.2	3.125	7.75	11.188
<u>AN/ARN-67 Glide Path Radio</u>						
	R-322()/ARN-18	Receiver	13.0	7.625	4.875	14.125
	C-996/ARN-14	Control Panel (part of AN/ARN-14 system)	2.7	3.375	5.75	4.5
		Antenna				
*Includes sway space						

B-52H PNWD EQUIPMENT PHYSICAL CHARACTERISTICS

SYSTEM	UNIT		WT (LB)	SIZE (IN)		
	TYPE (P/N)	NOMENCLATURE		H	W	D
<u>Navigation System Instrumentation</u>						
	CPU-4/A	Flight Director Computer	6.5	6.75	5.5	9.5
	AQU-2/A	Horizontal Situation Indicator (2 ea)	8.2	4.313	5.063	9.5
	ARU-2B/A	Attitude Director Indicator (2 ea)	8.5	5.25	5.0	9.735
	161B-1	Mode Select Switch (2 ea) TACAN Instrumentation Coupler (part of AN/ARN-21 system)	12.0	6.125	5.0	10.167
	ID-251/ARN	Bearing Converter Indicator	1.86	3.25	3.25	4.48
<u>MD-1 Automatic Astrocompass System</u>						
	A21570-00-004	Star Data Display Panel (3 ea)	4.3	2.625	5.75	7.375
	B21590-00-001	Line of Position Display Panel	3.4	2.625	5.75	6.4
	B23090-00-001	Indicator Display Panel	6.0	6.75	5.75	6.125
	D23140-00-001	Heading Display Panel	4.5	2.625	5.75	7.78
	A23130-00-001	Manual Present Position Display Panel	4.3	2.625	5.75	6.64
	C23160-00-001	Manual Set Panel	2.4	2.625	5.75	4.0
	A26980-00-001	Master Control Panel	6.3	6.75	5.75	5.125
	B23200-00-003	Power Supply Unit	7.8	4.84	5.75	14.09
	A26970-00-001	Correction Computer	11.5	7.125	5.75	8.25
	A26960-00-002	Altitude-Azimuth Computer	20.125	10.5	12.125	14.0
	B24220-00-002	Astrotracker Servo Amplifier	3.4	2.25	5.75	10.2
	C23180-00-002	Astrotracker Signal Amplifier				
	B2400-00-001	Altitude-Azimuth Computer Servo Amplifier	3.4	2.25	5.75	10.28
	C23170-00-001	Accessory Servo Amplifier	4.7	2.22	5.75	13.03
	B24670-00-001	Erection Amplifier	4.0	4.094	5.75	7.28

B-52H PNWD EQUIPMENT PHYSICAL CHARACTERISTICS

SYSTEM	UNIT		WT (LB)	SIZE (IN)		
	TYPE (P/N)	NOMENCLATURE		H	W	D
<u>MD-1 Automatic Astrocompass System (Cont'd)</u>						
	T4101-2A	Gyro	9.75			
	D21550-00-001	Astrotracker				
	A26990-00-007	Junction Box	18.62	6.0	12.02	13.5
		Correction Computer Servo Amplifier	3.4	2.22	5.75	10.16
		Signal Isolator				
<u>J-4 Compass System</u>						
	423060-2	Servo Amplifier	11.0	6.875	7.125	9.5
	423040-2	Directional Control	7.67	6.906	7.125	9.375
	15150-1-A	Control Panel	3.75	5.09	4.56	4.56
	ME-1A	Compass Signal Power Amplifier	9.5	6.125	4.5	10.875
	DT-310/AJN	Magnetic Azimuth Detector	1.5	4.91	3.5	2.06
<u>AN/AJN-8 Heading-Vertical Reference System</u>						
	B2606-01A	Stable Element	29.5	10.2	11.8	12.2
	C40717004	Heading Computer Amplifier	71.0	11.875	15.8	22.44
	C4718-01AS	Electronic Control and Power Supply	63.0	10.94	20.75	20.17
	M9000-11N	Master Control Panel	3.5	4.5	5.75	6.483
	M9001-11N	Precise Indicator	4.6	3.375	5.75	8.375
	G9003-11N	Synchronization Control Panel	1.2	2.625	5.75	4.97
	DT-310/AJN	Magnetic Azimuth Detector				
	ME-1	Compass Signal Power Amplifier				
		Heading System Control Panel				

B-52H BIBLIOGRAPHY

T.O. Number	Chq/Rev	Title
1B-52A-01	1 Dec 72	List of Applicable Publications, B-52
1B-52H-1	15 Jan 77	Flight Manual, B-52H
1B-52B-2-25	30 Jun 76	Organizational Maintenance, Electronic Navigation/Recognition Systems B-52B, C, D, E, F, G, and H
1B-52B-2-26	1 Mar 77	Organizational Maintenance, Compass Systems B-52B, C, D, E, F, G, and H
1B-52G-2-26	1 Jun 77	Organizational Maintenance, Bombing-Navigational System AN/ASB-9A and AN/ASB-16, B-52G and H
1B-52G-2-41	1 May 77	Organizational Maintenance, Electro-Optical Viewing System (EVS) AN/ASQ-151, B-52G and H
1B-52H-2-42GA-1	15 Jun 77	General Aircraft, MD-1 Automatic Astrocompass, B-52H
5F5-5-3-12	15 Apr 75	Field Maintenance, Aircraft Flight Director Computer Type CPU-4/A (Sperry)
5F8-16-3-3	15 Nov 73	Overhaul, Horizontal Situation Indicator Type AQU-2/A (Astronautics)
5N1-2-6-2	15 Aug 75	Field Maintenance, Magnetic Slaved, Directional Gyro Stabilized Compass System USAF Type N-1 (Kearfott)
5N1-2-17-1	25 Aug 73	Field Maintenance and Parts List, AN/AJN-11 Automatic Astro Compass Subsystem (Kollsman)
5N2-2-7-3	15 Oct 75	Overhaul, Servo Amplifier Part No. 423060-2 (Kearfott)
5N2-3-8-3	15 Dec 75	Overhaul, Heading Computer Amplifier Part No. C704717004 (Kearfott)
5N6-4-5-3	10 Feb 76	Overhaul, Electronic Control and Power Supply Part No. C4718-01A

3-52H BIBLIOGRAPHY

T.O. Number	Chg/Rev	Title
5N6-4-7-3	15 Sep 75	Overhaul, Master Control Panel Part No. M9000-11N
5N8-5-5-3	31 Dec 62	Overhaul, Precise Indicator Part No. 90001-11N (Kearfott)
5N18-3-3	15 Oct 75	Overhaul, Stable Element Part No. B2606-01A (Kearfott)
12P5-2APN89-42	1 Oct 75	Field and Depot Maintenance, Radar Sets AN/APN-108 and AN/APN-89A
12R1-2ARA25-2	25 Jul 75	Service-Direction Finder Group AN/ARA-25 and AN/ARA-25A
12R5-2ARN14-2	1 Apr 75	Service-Radio Receiving Set AN/ARN-14B and -14C (Collins)
12R5-2ARN21-42	20 Apr 72	Field Maintenance, Radio Set, Type AN/ARN-21C
12R5-2ARN32-2	15 Jan 75	Field Maintenance, Radio Receiving Set AN/ARN-32 (Dare)
12R5-2ARN67-2	15 Nov 75	Field Maintenance, Radio Receiving Set AN/ARN-67 (Sparton)
12R5-4-28-2	21 Jun 77	Field Maintenance, TACAN Instrumentation Coupler 161B-1 and Shock-mount 349L-2 (Collins)

3.5.0
FB-111A

FB-111A PNWD EQUIPMENT LIST

KEY	EQUIPMENT/UNIT
ADDP	ADI DISPLAY ARU-11/A, (PN 139001-01-03)
AFCS	AUTOMATIC FLIGHT CONTR SYSTEM
AIMS	AIR TO GROUND IFF AN/APX-64 (V)
AMDA	AIRSPEED MACH DISPLAY SYSTEM A24G-18
AVDA	ALTITUDE VERTICAL SPD DISPLAY SYSTEM A24G-17
C	AIR DATA COMPUTER 12D2043, M2-1
CMMM	INTERPHONE SYSTEM AN/AIC-25
CSA	INSTRUMENT SET COUPLER 087A1, 1E4070G20
D	NAVIGATION RADAR SYST AN/APN-185
FDCA	FLIGHT DIRECTOR SYSTEM 12D2087, M8-1
G	ELECTRONIC ALTIMETER AN/APN-167
HSDP	HSI DISPLAY AQU-4/A
JBA	TERMINAL BOARD BA
JBB	TERMINAL BOARD BB
JBC	TERMINAL BOARD BC
JBD	TERMINAL BOARD BD
JBE	TERMINAL BOARD BE
JBF	TERMINAL BOARD BF
JBG	TERMINAL BOARD BG
JBH	TERMINAL BOARD BH
JBJ	TERMINAL BOARD BJ
JBK	TERMINAL BOARD BK
JBL	TERMINAL BOARD BL

FB-111A PNWD EQUIPMENT LIST

KEY	EQUIPMENT/UNIT
JBM	JUNCTION BOX
JBN	TERMINAL BOARD BN
JBP	TERMINAL BOARD BP
JBQ	TERMINAL BOARD BQ
JBR	TERMINAL BOARD BR
JBS	TERMINAL BOARD BS
JBT	TERMINAL BOARD BT
JBU	TERMINAL BOARD BU
JBV	TERMINAL BOARD BV
JBW	TERMINAL BOARD BW
JBX	TERMINAL BOARD BX
JBZ	TERMINAL BOARD BZ
JCA	TERMINAL BOARD CA
JCB	TERMINAL BOARD CB
JCC	TERMINAL BOARD CC
JCD	TERMINAL BOARD CC
M	TERRAIN FOLLOWING RADAR SYST AN/APQ-134
ODSS	OPTICAL DISPLAY SIGHT AN/ASG-25
P	INERTIAL BOMB NAV SYST MARK 2B
Q	ATTACK RADAR SYSTEM AN/APQ-114B
RDA	RACK DISCONNECT A
RDB	RACK DISCONNECT B

FB-111A PNWD EQUIPMENT LIST

KEY	EQUIPMENT/UNIT
RDC	RACK DISCONNECT C
RDD	RACK DISCONNECT D
RDE	RACK DISCONNECT E
RDF	RACK DISCONNECT F
RDG	RACK DISCONNECT G
RDH	RACK DISCONNECT H
RDJ	RACK DISCONNECT J
RDK	RACK DISCONNECT K
SRAM	SRAM MISSILE SYSTEM AN/AGM-69A
SWA	MISCELLANEOUS SWITCH PANEL 12E210
SWB	FDC DUMMY LOAD SWITCH 602EN14-6
T	TACAN SYSTEM AN/ARN-52(V)
TASN	TRUE AIRSPEED INDICATOR 352-01-3
U	INSTRUMENT LANDING SYSTEM AN/ARN-58 A
W	AUXILIARY FLIGHT REFERENCE SYSTEM 12D2085, M2-2

FB-111A PNWD EQUIPMENT PHYSICAL CHARACTERISTICS

SYSTEM	UNIT		WT (LB)	SIZE (IN)		
	TYPE (P/N)	NOMENCLATURE		H	W	D
<u>AN/APQ-114B Attack Radar Set</u>						
	AS-2123/APQ-114 7335131G1	Antenna Assembly	56.5	26.0	35.0	32.0
	AB-1035/APQ-114 7335132G2	Antenna Pedestal	37	19.0	21.0	8.0
	C-7486/APQ-114 7335133G3	Antenna Control Unit	38	10.0	27.0	8.0
	MD-764/APQ-114 7335139G3	Modulator-Receiver-Transmitter	101	21.0	13.0	21.0
	SN-418/APQ-114 7335135G3	Electrical Synchronizer	59	13.0	13.0	21.0
	IP-948/APQ-114A 7335136G9	Indicator-Recorder	65	9.0	16.0	31.0
	C-7857/APQ-114A 7637310G2	Radar Set Control	3	4.0	6.0	7.0
	C-8186/APQ-114B 7639341G1	Antenna-Indicator Control	--	7.8	4.8	4.1
<u>AN/ARN-52(V) TACAN System</u>						
	C-3928(P)/ARN-52 (V) 54400703	Control Radio Set	2	3.0	5.75	4.0
	RT-384/ARN-52(V) 01X215001	Receiver-Transmitter 01X210400-1	43.25	7.344	10.0	16.9
	MT-1729/ARN-52(V) 54500915	Mounting	5.75	6.313	11.0	17.25
	SA-521/A 50010	RF Transmission Line Switch	0.34	1.94	2.78	3.19
	12E40212-5	Antenna Select Panel				
	11D20100-3	Upper Antenna (shared with UHF-1)	2.0	9.7	3.5	7.5
	11D20100-3	Lower Antenna (shared with UHF-1)	2.0	9.7	3.5	7.5
<u>AN/ARN-58A Instrument Landing System</u>						
	C-6376/ARN-58A 179-5102	Radio Set Control	1	2.25	5.75	4.313
	R-843A/ARN-58 777-1393-001	Localizer Receiver	7.188	6.875	7.02	5.02
	R-844A/ARN-58 777-1394-001	Glide Slope and Marker Beacon Receiver	9.5	6.875	9.02	5.02

FB-111A PNWD EQUIPMENT PHYSICAL CHARACTERISTICS

SYSTEM	UNIT		WT (LB)	SIZE (IN)		
	TYPE (P/N)	NOMENCLATURE		H	W	D
<u>AN/ARN-58A Instrument Landing System (cont.)</u>						
MIL-A-6235	12B11521	Localizer Antenna (2 ea)	1.5	2.68	5.14	12.14
	127518	Glide Slope Antenna				
	16D00800	Marker Beacon Antenna	1.5	2.68	5.14	12.14
<u>Central Air/Data Computer 12D2043, M2-1</u>						
	1903634-3	Computer	47.5	8.0	14.0	19.25
<u>AN/AJN-16 Inertial Navigation Set</u>						
	MX-8131/AJN-16 68144-301-121	Stabilized Platform	70.0	12.31	14.75	17.5
	CP-945/AJN-16 55545-107-71	Navigational Computer Unit	26.0	8.0	6.5	19.75
	C-7719/AJN-16 67650-401-151	Battery Control-Power Supply	14.0	2.5	10.0	12.0
<u>Computer Complex</u>						
	AN/AJK-6 6861600-2	General-Purpose Digital Computer (2 ea)	47.4	7.6	10.0	20.7
	CV-2493/A	Converter Multiplexer	40.0	7.62	10.0	20.12
<u>Control Display Set</u>						
	ID-1620/AJK	Navigation Display Unit	26.81	7.75	8.5	19.567
	C-7882/AJK C70902-710	Computer Control Unit	10.2	8.25	7.5	9.84
	TRU-79/A	Magnetic Azimuth Detector	1.8	2.067	3.5	4.906
	RA500-2	Bombing-Navigation Distance-Time Display				
<u>AN/APN-167 Electronic Altimeter System</u>						
	HG7092A3	Receiver-Transmitter Unit (2 ea)	11.0	5.0	7.0	12.0
	LG81G3	Antenna (2 ea)	1.0	3.0	5.0	8.0
	WG219A-2	Equipment Rack	4.0	6.0	15.0	14.0
	F5186000100	Indicator	2.0	5.0	5.0	5.0

FB-111A PNWD EQUIPMENT PHYSICAL CHARACTERISTICS

SYSTEM	UNIT		WT (LB)	SIZE (IN)		
	TYPE (P/N)	NOMENCLATURE		H	W	D
<u>AN/APN-167 Electronic Altimeter System (cont.)</u>						
	P613-466	LARA Calibrator Unit				
<u>AN/ASG-25 Optical Display Sight Set</u>						
	SU-39/ASG-25 10509290G1	Optical Display Sight	20.0	8.9	6.8	23.0
	AM-4869/ASG-25 8530940G1	Control Amplifier Power	14.9	4.9	8.02	15.2
<u>AN/APN-185 Navigation Radar Set</u>						
	MX-7904/APN-185	Radar Electronics Unit	36.0	7.62	10.12	16.49
	AS-2130/APN-185	Antenna	18.0	10.4	13.56	18.66
	CW-960/APN-185	Radome	8.0	0.24	21.1	24.95
	MT-3912/APN-185	Rack	2.75	6.37	10.48	18.06
<u>AN/ASQ-119 Automatic Tracking Astro Compass</u>						
	SU-42/ASQ-119 668010-8	Celestial Positioning Tracker	63.0	12.4	14.5	14.3
	MX-7950/ASQ-119 668500-8	Electronics Unit	29.6	9.29	6.03	18.48
<u>AN/AYN-4 Horizontal Situation Display Set</u>						
	IP-1030/AYN-4 110150-13 & 17	HSD Indicator	46.0	7.7	7.7	20.0
	MX-8751/AYN-4 110160-5	HSD Processor	14.0	7.0	4.3	14.1
	SG-857/AY 108400-3	Digital Display Data Generator	20.5	6.0	7.0	15.0
<u>Flight Instruments</u>						
	AVK-18/A25G-18 18008-8A11-A1	Airspeed-Mach Indicator	10.5	7.75	3.5	8.0
	AAK-17/A24G-17 18007-7A10-A1	Altitude-Vertical Velocity Indicator	10.5	7.75	3.5	8.0
	AQU-4/A 101000	Horizontal Situation Indicator	8.2	4.313	5.063	9.5
	ARU-11/A 139001-01-03	Attitude Director Indicator	9.0	5.26	5.01	8.0
	E5165001400	BDHI				

FB-111A PNWD EQUIPMENT PHYSICAL CHARACTERISTICS

SYSTEM	UNIT		WT (LB)	SIZE (IN)		
	TYPE (P/N)	NOMENCLATURE		H	W	D
<u>Flight Instruments (cont.)</u>						
	352-01-3	TAS Indicator	0.9	1.56 diam.		5.75
	18754-1A	Airspeed-Mach Amplifier	6.5	4.44	4.56	10.5
	18753-1A	Altitude-Vertical Speed Amplifier	5.3	4.44	4.56	9.0
	TRU-2A/A A2460	Rate Gyroscope Transmitter	1.5	2.828	2.890	5.258
<u>Flight Director System 12D2087-5 M8-1</u>						
	1E4070G20	Instrument Set Coupler Control Panel	6.2	2.50	5.82	8.60
	12E210-885	Miscellaneous Switch Panel				
	12E2211-843	Ground Check Panel	1.88	2.10	7.31	6.25
	CPU-76/A 103777	Flight Director Computer	9.0	7.566	5.313	10.125
	ARU-11/A 139001-01-03	ADI (part of flight instruments)	9.0	5.260	5.010	8.000
	AQU-4/A 101000	HSI (part of flight instruments)	8.2	4.313	5.063	9.5
	12E40340-851	Relay Housing Assy. #1	6.0	2.9	4.6	12.8
<u>Auxiliary Flight Reference System</u>						
	8KD9AF2	Displacement Gyro	10.3	6.03	6.03	8.32
	8KE63AF2	Electronic Control Amplifier	9.5	5.0	6.5	10.0
MIL-C-81767	DCK-129/A24G 8KE65AG2	Compass System Controller				
	2587833	Remote Compass Transmitter	1.8	4.906	3.5	2.067
	MXU-394/A 2587832	Remote Compass Transmitter Compensator	0.313	2.5	3.5	2.625
	MX-9523/AP 12Z7000-1	Attitude System Monitor	6	3.9	3.3	12.9
<u>AN/APQ-134 Terrain Following Radar Set</u>						
	AS-2136/APQ-128 G7252-001-01	Antenna-Receiver (2 ea)	28.0	13.5	12.7	16.2
	AM-4915/APQ-128	Amplifier-Power Supply (2 ea)	18.1	6.0	6.8	17.6

FB-111A PNWD EQUIPMENT PHYSICAL CHARACTERISTICS

SYSTEM	UNIT		WT (LB)	SIZE (IN)		
	TYPE (P/N)	NOMENCLATURE		H	W	D
	<u>AN/APQ-134 Terrain Following Radar Set (cont.)</u>					
	SN-519/APQ-128 7335135G3	Synchronizer-Transmitter (2 ea)	26.5	6.0	7.8	17.6
	CP-955/APQ-134 562182-16 & 18	Computer Terrain Follow- ing (2 ea)	13.2	5.4	6.3	16.1
	MT-3817/APQ-128 582359-5	Rack, Electrical Equip- ment	23.9	19.4	16.3	18.8
	C-7780/APQ-134 562514-6 & 7	Control, Radar Set	2.6	3.0	5.8	6.3
	IP-1012/APQ-134A 583013-2	Indicator, Terrain Following	29.3	6.24	7.0	21.7
	CG-3132/APQ-110	Waveguide Assy.	--	--	8.4	18.0
	MX-9523/AP 12Z6700	Low Altitude Monitor	6	3.9	3.3	12.9

FB-111A BIBLIOGRAPHY

T.O. Number	Chq/Rev	Title
1F-111(B)A-01	21 Apr 72	List of Applicable Publications - FB-111A
1F-111(B)A-1	25 Feb 77	Flight Manual - FB-111A
1F-111(B)A-2-5-1	5 Jan 77	Organizational Maintenance, Fire Power Control Systems - FB-111A
1F-111(B)A-2-11-1	30 Apr 76	Organizational Maintenance, Armament Systems - FB-111A
1F-111(B)A-2-12-1	9 Apr 76	Organizational Maintenance, Instrument Systems - FB-111A
1F-111(B)A-2-14	22 Apr 77	Organizational Maintenance, Wiring Diagrams - FB-111A
1F-111(B)A-2-16-1	19 Oct 74	Organizational Maintenance, Air Data Computer Systems - FB-111A
1F-111(B)A-2-17-1	10 Oct 75	Organizational Maintenance, Communications and Instrument Landing Systems - FB-111A
1F-111(B)A-2-18-1	21 Nov 75	Organizational Maintenance, Intercommunications, Transponder, TACAN, and IFF Systems - FB-111A
1F-111(B)A-2-19	7 Nov 75	Organizational Maintenance, Attack Radar and Terrain Following Radar Systems - FB-111A
5A11-2-56-3	15 Nov 66	Overhaul, Displacement Gyro, P/N 8KD9AF2, 8KD9AF3, 8KD9AF4, 8K09AF5 (GE) P/N 149500-01-01 (Lear Siegler)
5F4-16-3	7 Apr 72	Overhaul Electronic Control Amplifier ASK-13/A24G-17 (Bendix)
5F4-17-3	7 Apr 72	Overhaul Electronic Control Amplifier ASK-14/A24G-18 (Bendix)
5F4-21-3	1 Dec 71	Overhaul, Electronic Control Amplifier, Type ASK-25/A24G-26, P/N 8KE63AF2, 8KE63AF3, ASK-25A/A24G-26, P/N 8KE63AF4, 8KE63AF5 (GE)
5F5-4-17-2	29 Mar 74	Maintenance, Central Air Data Computer, P/N 1903633-4, 190633-5, and 1903634
5F5-8-4-13	1 Mar 73	Overhaul, Flight Director Computer Type CPU-76/A (Collins)
1F-111B(A)-2-22	8 Aug 75	Organizational Maintenance System, Integration

FB-111A BIBLIOGRAPHY

T.O. Number	Chq/Rev	Title
5F8-2-47-2	29 Mar 74	Maintenance, True Airspeed Indicator, P/N 352-01-3 (Couter)
5F8-3-20-3	18 Oct 72	Field Maintenance, Standby Attitude Indicator
5F8-3-23-3	26 Apr 74	Overhaul, Attitude Indicator, Type ID-1144/AJB-7, ARU-11A, Model 4060P, P/N 139001-01, 01-02, 01-03, 01-04 (Lear Siegler)
5F8-9-19-3	4 Sep 73	Overhaul, Indicator, Altitude-Vertical Speed AAK-17/A24G-18 (Bendix)
5F8-16-4-3	1 Jun 75	Overhaul, Horizontal Situation Indicator, Type AQU-4/A (Astronautics)
5F10-4-4-3	3 Apr 74	Overhaul, Rate Gyro Transmitter Assembly, Model A2850-1, -5, Type TRU-2A/A, P/N B2888-01, -02 (R.C. Allen)
5N3-2-4-2	13 Feb 70	Maintenance, Automatic Tracking Astro Compass, Type AN/ASQ-119 (Litton)
5N4-4-3-3	7 Jan 72	Overhaul with P/B, Magnetic Compass Electronics Compensator, P/N 2587832 (Sperry)
5N5-14-15-2	21 Jan 72	Maintenance, General Purpose Digital Computer, Type AN/AYK-6
5N6-4-13-2	12 Apr 74	Maintenance, Computer Control, Types C-7882/AYK, C-7882A/AYK, C-8566/AYK, and C-8586/AYK (Kearfott)
5N8-13-3-2	12 Apr 74	Maintenance, Digital Display Indicator, Types ID-1620/AYK, ID-1620A/AYK, ID-1748/AYK, ID-1766/AYK, and ID-1781/AYK (Kearfott)
5N12-2-7-3	2 Apr 73	Overhaul, Induction Compass Transmitter, Type TRU-79/A, P/N 2587833 (Sperry)
5N16-2-10-2	12 Oct 73	Maintenance, Digital Display Data Generator, Type SG-857/AY (Astronautics)

FB-111A BIBLIOGRAPHY

T.O. Number	Chg/Rev	Title
5N29-2-2	24 Jan 75	Maintenance, Horizontal Situation Display Set, Type AN/AYN-4 (Astronautics)
11F1-ASG25-43	21 Jul 72	Overhaul, Optical Display Sight, Type S4-39/ASG-25, S4-48/ASG-25, and S4-62/ASG-27 (GE)
11F1-ASG25-53	12 Sep 69	Overhaul, Amplifier/Power Supply, Control/Type AM-4869/ASG-25 (GE)
12P5-2APN167-12	3 May 74	Maintenance, Electronic Altimeter Set, AN/APN-167 and Radar Altitude Indicator
12P5-2APN185-2	1 May 74	Maintenance, Navigation Radar Set, AN/APN-185 (Singer-GP)
12R5-2ARN52-12	24 Sep 73	Org, Inter, and Depot, TACAN Navigational Set, Type RT-384/ARN-52(V)
12R5-2ARN58-12	15 May 72	Maintenance, Receiving Set, Radio AN/ARN-58 and AN/ARN-58A
16W7-16-2	14 Dec 73	Maintenance, Ground Check Panel (General Dynamics)
1F-111B(A)-2-22	21 Oct 74	Organizational Maintenance, Systems Integration Information, FB-111A
GD/FW D750-874C	26 Apr 73	III Weapon System End Item List and Allocation Chart by MDS

3.6.0
C-5A

C-5A PNWD EQUIPMENT LIST

KEY	EQUIPMENT/UNIT
AFCS	AUTOPILOT SYSTEM YG1005B3
AIMS	IFF TRANSPONDER SYSTEM AN/APX-64(V)
AMDC	COPILOT'S AIRSPEED/MACH ANGLE OF ATTACK IND 1880842-2A
AMDP	PILOT'S AIRSPEED/MACH ANGLE OF ATTACK IND 1880842-2A
BDHC	COPILOT'S BDHI 104820
BDHM	NAVIGATOR'S BDHI NO 2 104820
BDHN	NAVIGATOR'S BDHI NO 1 104820
BDHP	PILOT'S BDHI 104820
CA	CENTRAL AIR DATA COMPUTER SYSTEM NO 1 50-001-07A
CB	CENTRAL AIR DATA COMPUTER SYSTEM NO 2 50-001-07A
CEMM	INTERPHONE SYSTEM
FDCA	FLIGHT DIRECTOR COMPUTER NO 1 1880871-5
FDCB	FLIGHT DIRECTOR COMPUTER NO 2 1880871-5
GA	RADAR ALTIMETER SYSTEM NO 1 41003
GAAC	GO-AROUND ATTITUDE COMPUTER 965-0046-007
GB	RADAR ALTIMETER SYSTEM NO 2 41003
HAMS	HDG AND ATTITUDE MONITOR SYSTEM 4V10002
HSDC	COPILOT'S HSI AN/AQU-4/A
HSDP	PILOT'S HSI AN/AQU-4/A
JBA	A30 JUNCTION BOX NO 1
JBB	A20 JUNCTION BOX NO 2
JBD	A21 JUNCTION BOX NO 4

C-5A PNWD EQUIPMENT LIST

KEY	EQUIPMENT/UNIT
P	INERTIAL DOPPLER NAV EQUIPMENT 41132
Q	MULTI MODE RADAR SYSTEM
RADA	RADAR ALT DISPLAY NO 1 M44266-7
RADB	RADAR ALT DISPLAY NO 2 M44266-7
RCA	RACK DISCONNECT AA
RCB	RACK DISCONNECT AB
RCC	RACK DISCONNECT AC
RCD	RACK DISCONNECT AD
RCE	RACK DISCONNECT AE
RCF	RACK DISCONNECT AF
RCG	RACK DISCONNECT AG
RCH	RACK DISCONNECT AH
RCJ	RACK DISCONNECT AJ
RCK	RACK DISCONNECT AK
RCL	RACK DISCONNECT AL
RCM	RACK DISCONNECT AM
RCN	RACK DISCONNECT AN
RCP	RACK DISCONNECT AP
RCQ	RACK DISCONNECT AQ
RCH	RACK DISCONNECT AR
RCS	RACK DISCONNECT AS
RCT	RACK DISCONNECT AT
RCU	RACK DISCONNECT AU

C-5A PNWD EQUIPMENT LIST

KEY	EQUIPMENT/UNIT
RDA	RACK DISCONNECT A
RDB	RACK DISCONNECT B
RDC	RACK DISCONNECT C
RDD	RACK DISCONNECT D
RDE	RACK DISCONNECT E
RDF	RACK DISCONNECT F
RDG	RACK DISCONNECT G
RDJ	RACK DISCONNECT J
RDK	RACK DISCONNECT K
RDL	RACK DISCONNECT L
RDM	RACK DISCONNECT M
RDN	RACK DISCONNECT N
RDP	RACK DISCONNECT P
RDQ	RACK DISCONNECT Q
RDR	RACK DISCONNECT R
RDS	RACK DISCONNECT S
RDT	RACK DISCONNECT T
RDU	RACK DISCONNECT U
RDV	RACK DISCONNECT V
RDW	RACK DISCONNECT W
RDX	RACK DISCONNECT X
RDY	RACK DISCONNECT Y

C-5A PNRD EQUIPMENT LIST

KEY	EQUIPMENT/UNIT
RDZ	RACK DISCONNECT Z
SA	GLIDESLOPE SYSTEM NO 1 WILCOX 800C
SB	GLIDESLOPE SYSTEM NO 2 WILCOX 800C
SKEE	STATION KEEPING EQUIPMENT 41002
SWA	PILOT'S NAV SELECT PANEL (Z-127A)
SWB	PILOT'S NAV FLIGHT INST SELECTOR (Z-129A)
SWC	COPILOT'S NAV FLIGHT INST SELECTOR (Z-129B)
SWD	COPILOT'S NAV SELECT PANEL (Z-135A)
SWE	NAVIGATOR BDHI SELECTOR 301105-20
SWF	CADC SELECTOR PANEL (Z-142A)
TA	TACAN SYSTEM NO 1 8000000040
TASH	NAVIGATOR'S TAS INDICATOR AVU-15A
TB	TACAN SYSTEM NO 2 8000000040
VA	VHF NAV SYSTEM NO 1 806C
VB	VAF NAV SYSTEM NO 2 806C
VSDC	COPILOT'S ALT/VERTICAL SPEED INDICATOR 1880843-2A
VSDP	PILOT'S ALT/VERTICAL SPEED INDICATOR 1880843-2A
VVDH	NAVIGATOR'S VERTICAL VELOCITY IND B1563-10A
WA	ATTITUDE AND HEADING REFERENCE UNIT NO 1 143960-01
WB	ATTITUDE AND HEADING REFERENCE UNIT NO 2 143960-01
ZA	DF-203 ADF SYSTEM NO 1
ZB	DF-203 ADF SYSTEM NO 2

NUMBERS IN () ARE T.O. REF DESIGNATIONS

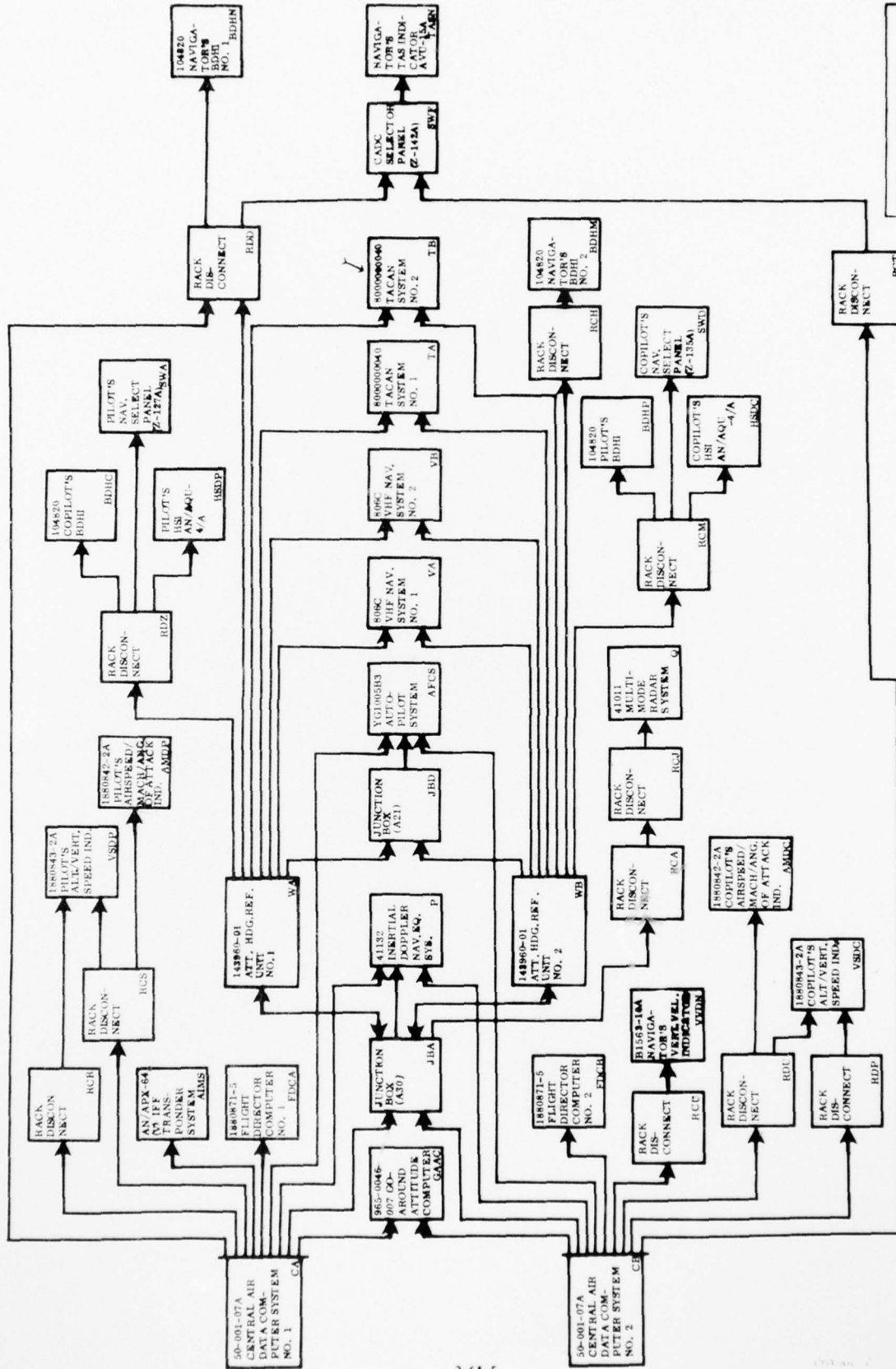

TITLE:	PNWD SYSTEM
AIRCRAFT:	C-5A
DATE:	6-30-76
DIAGRAM:	1 of 4

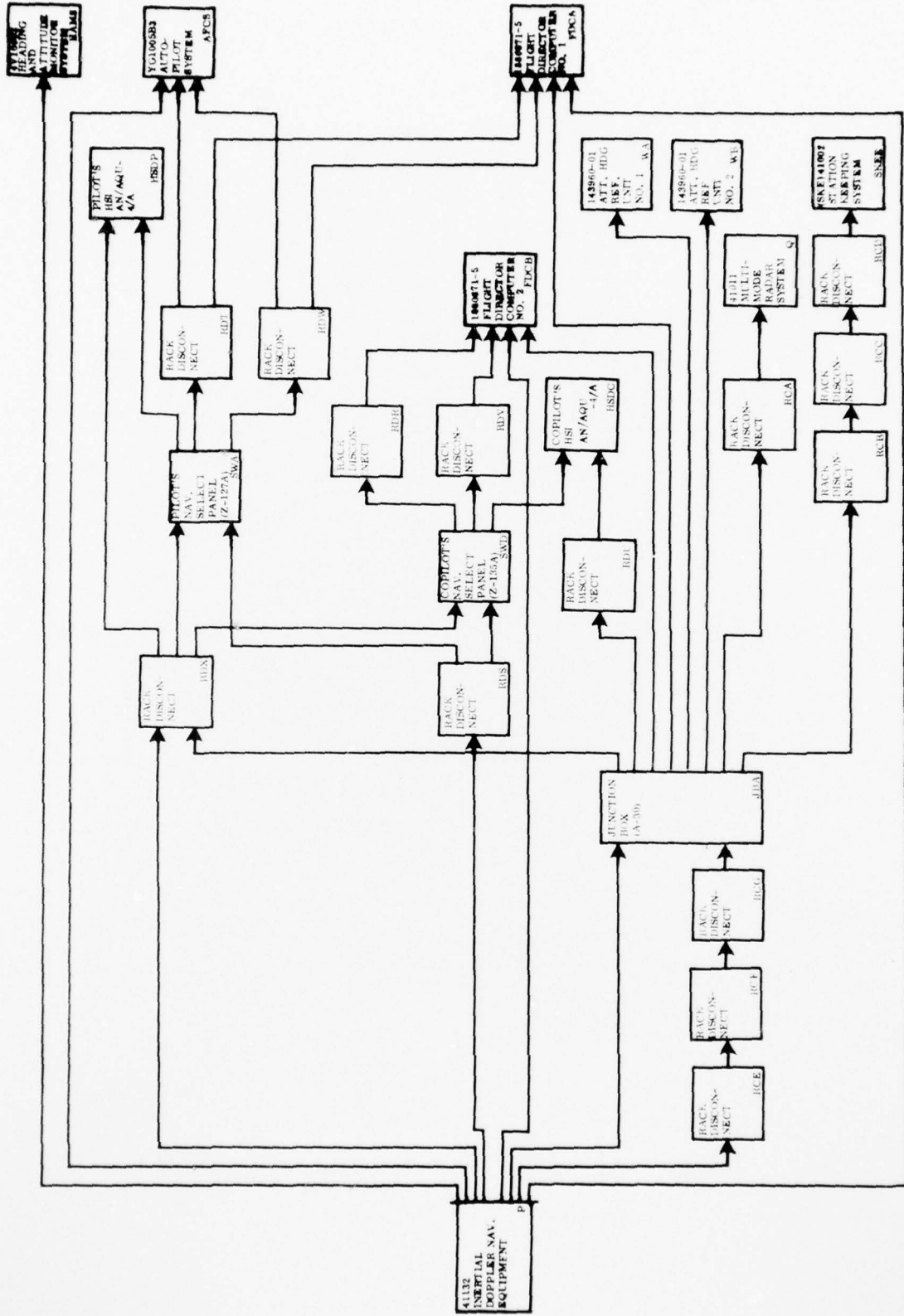

TITLE	FNWT SYSTEM
AIRCRAFT	DATE
C-2A	6-30-76
	DIAGRAM
	2 of 4

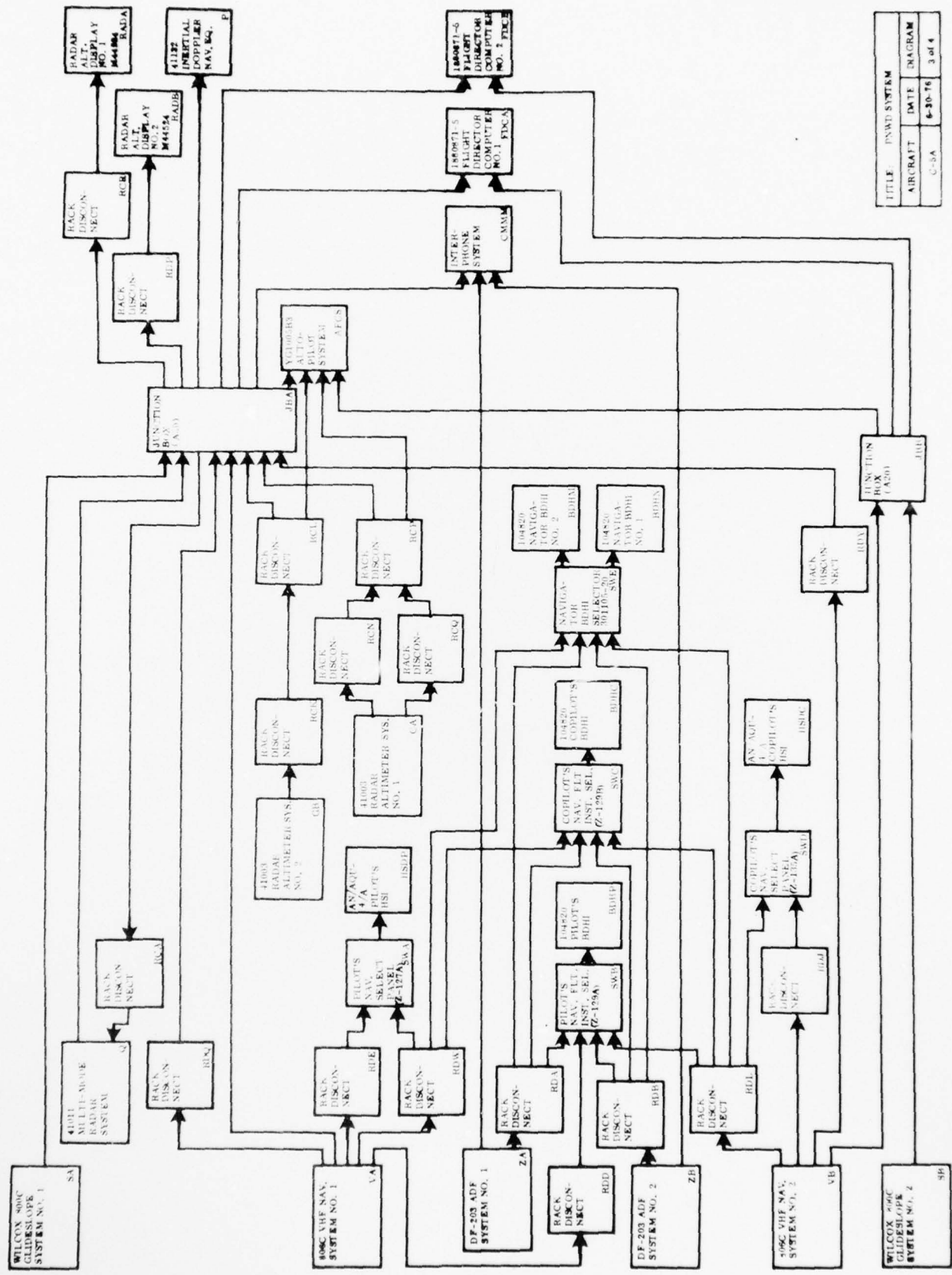

TITLE	INSTRUMENT SYSTEM
AIRCRAFT	DATE
C-5A	6-30-76
	DIAGRAM
	3 of 4

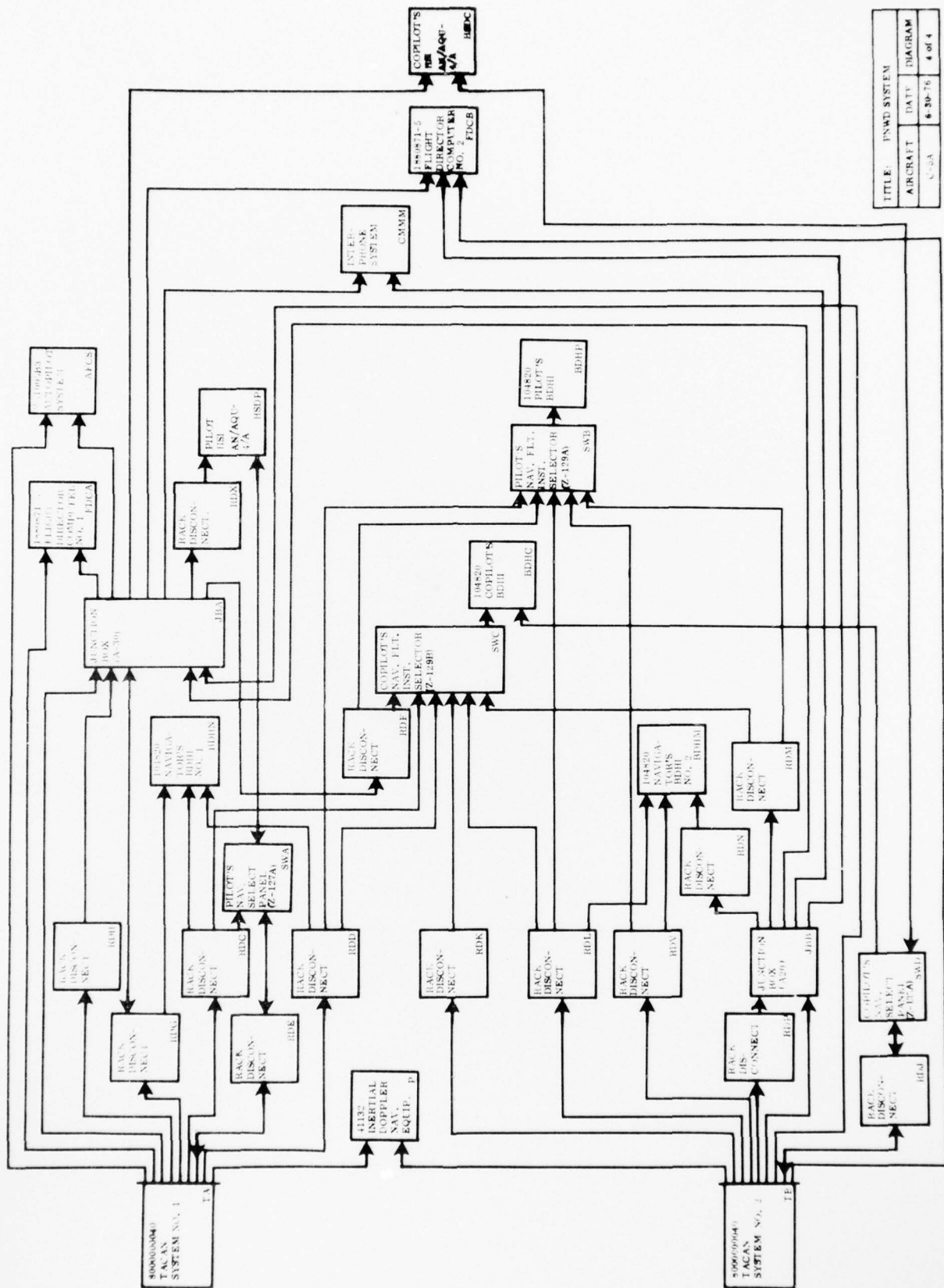

TITLE: INWARD SYSTEM		
AIRCRAFT	DATE	DIAGRAM
C-130A	6-30-76	4 of 4

C-5A PNWD EQUIPMENT PHYSICAL CHARACTERISTICS

SYSTEM	UNIT		WT (LB)	SIZE (IN)		
	TYPE (P/N)	NOMENCLATURE		H	W	D
<u>Attitude and Heading Reference Unit, and Heading and Attitude Monitor System</u>						
	143400-05-02	Gyro Platform (2 ea)	18.2	6.9	7.5	11.95
	148120-05-01	Coupler (2 ea)	19.5	7.625	4.906	19.562
		Magnetic Azimuth Detector (2 ea)				
	3805F	Controller (2 ea)	1.5	3.0	5.75	4.441
	4V10002-101B	HAMS Comparator Unit				
	4V10003-101A	HAMS Control Panel (2 ea)				
<u>ADF Navigation System DF-203</u>						
	614L-8	ADF Control Panel (2 ea)	1.8	2.625	5.75	4.938
	137A-4	Loop Antenna (2 ea)	3.8	0.875	12.0	16.0
	582A-()	Quadrantal Error Correc- tors (2 ea)	0.3	2.1	3.31	2.969
	4K20002-101A	Sense Antenna (2 ea)				
	51Y-4	Receiver (2 ea)	9.8	7.625	2.25	14.625
<u>AN/APN-199 Loran C System</u>						
	CR-1667/APN-199	Receiver	35.9	7.625	2.25	22.127
	C-8450/APN-199	Loran C Control Panel	4.9	4.125	5.75	6.75
	CU-1922/APN-199	Antenna Coupler	2.9	4.0	5.0	9.406
	4T61000-103A	Antenna				
<u>Marker Beacon System</u>						
	51Z-4	Marker Beacon Receiver	3.0	3.38	2.25	12.62
	DMN27-1/A	Marker Beacon Antenna	0.625	1.25	1.88	15.0
	4E11002-101A	Marker Beacon AOI Indicator (2 ea)				
	MS24523-101A	Marker Beacon Sensitivity Switch	0.08	1.27	0.635	2.34

C-5A PNWD EQUIPMENT PHYSICAL CHARACTERISTICS

SYSTEM	UNIT		WT (LB)	SIZE (IN)		
	TYPE (P/N)	NOMENCLATURE		H	W	D
<u>Glideslope System</u>						
	097735-0103	Receiver (2 ea)	7.1	7.75	2.5	14.75
	37P4	Antenna	0.7	5.984	2.0	4.5
	097836-0101	VHF COMM/NAV Control Panel (2 ea) (Part of VHF NAV System)	2.1	2.625	5.75	6.0
<u>VHF Navigation System</u>						
	806C	VHF Navigation Receiver (2 ea)	12.8	7.81	4.88	12.56*
	DMN4-28	VHF NAV Antenna (2 ea)	2.0	8.5	3.0	12.0
	DMN4-20	Localizer Antenna	2.0	8.5	3.0	17.0
	097836-0101	VHF COMM/NAV Control Panel (2 ea) (Shared with COMM and Glideslope Systems)	2.1	2.625	5.75	6.0
<u>TACAN System 8000000040</u>						
	8010000089-1	Receiver-Transmitter (2 ea)	32.0*	7.625	7.53	21.947
	8010000090	Control Panel (2 ea)	-	3.375	5.75	5.0
	AT-741/A	Top Antenna (2 ea)	0.4	3.3	1.75	5.25
	AT-740/A	Bottom Antenna (2 ea)	0.75	1.54	8.406 diam.	
<u>Rendezvous Radar Beacon System 41105</u>						
	171770-000	RR Beacon Receiver-Transmitter	20.375	7.62	5.0	14.25
	171900-000	RR Beacon Control Panel	2.5	4.5	5.75	4.5
	4K40011-101A	RR Beacon Antenna (2 ea)				
<u>Inertial Doppler Navigation Equipment</u>						
	10662000- 645	Primary Navigational Computer	58.0	7.5	15.5	19.5

*Includes control unit.

C-5A PNWD EQUIPMENT PHYSICAL CHARACTERISTICS

SYSTEM	UNIT		WT (LB)	SIZE (IN)		
	TYPE (P/N)	NOMENCLATURE		H	W	D
<u>Inertial Doppler Navigation Equipment (Cont'd)</u>						
	10664000-625B	Auxiliary Navigational Computer	56.0	7.5	15.5	19.5
	10665000-642	Primary A to D Converter	26.0	7.5	7.5	19.5
	10665500-632D	Auxiliary A to D Converter	19.0	7.5	7.5	19.5
	10663000-681A	IMU	75.0	11.0	15.0	15.0
	10663700-613A	Control-Power Supply	31.0	8.0	6.0	9.0
	4D97558-101G	Doppler Radar Antenna				
	G7223-001-11	Signal Data Converter				
	G7224-001-12	Drift Angle-Ground Speed Ind.	2.0	3.0	3.0	6.5
	10667000-609A	INDE Control Panel	11.0	9.0	6.0	9.5
	10666000-615A	INDE Indicator Panel	9.0	9.0	6.0	9.5
<u>Multimode Radar Navigation System</u>						
	3600-31000-102	Common Roll Unit	31.5	14.0	11.125	21.25
	3600-46000-103	X-Band Antenna - Receiver	94.1	64. diam.		
	3600-42000-103	Ku-Band Antenna-Receiver	93.2	78 diam.		
	3600-39000-102	X-Band Transmitter	48.7	7.625	10.125	17.56
	3600-38000-102	Band Transmitter	45.2	7.625	10.125	17.56
	3600-85000-102	Data Processor Unit (2 ea)	39.8	7.625	10.125	19.56
	3600-99000-102	System Distribution Unit	36.8	8.0	15.0	10.0
	3600-62000	Cursor Control Unit	2.8	6.75	6.25 diam.	
	3600-67000-101	Navigator Control Panel	8.0	13.5	5.75	6.28
	3600-68000-102	Control Panel (2 ea)	3.7	3.0	8.0	7.28
	3600-78000-103	Navigator Indicator	34.5	10.2	10.2	15.56
	3600-79000-102	Indicator (2 ea)	34.2	8.0	8.0	17.75

C-5A PNWD EQUIPMENT PHYSICAL CHARACTERISTICS

SYSTEM	UNIT		WT (LB)	SIZE (IN)		
	TYPE (P/N)	NOMENCLATURE		H	W	D
<u>Station Keeping Equipment 41002</u>						
	4V12030-101C	Antenna Assy (2 ea)	15.1	9.25	6.3	11.6
	4V12010-101F	Receiver-Transmitter (2 ea)	16.7	7.75	3.57	22.13
	14444-4	Range Indicator (2 ea)	1.65	1.0	4.0	6.6
	4V12000-101B	Control Panel	1.6	4.4	5.0	5.73
	4V120001-101F	Synchronizer	24.6	7.64	7.5	18.28
	4V12002-101B	BITE Antenna (2 ea)				
<u>Radar Altimeter System 41003</u>						
	M51842-19 and -21	Receiver-Transmitter (2 ea)	15.438	7.625	4.125	15.4
	M44266-7	Height Indicator (2 ea)	2.063	3.25	3.25	6.188
	M44524	Receiver Antenna (2 ea)	0.75	2.875	7.0 diam.	
	M44524	Transmitter Antenna (2 ea)	0.75	2.875	7.0 diam.	
		Dual Shock Mount	2.2	5.0	6.0	17.375
	38654	Coupler (4 ea)	0.09	1.5	.625	2.0
<u>Navigation Instrumentation</u>						
	1925113-1	Peripheral Command Indi- cator (2 ea)	2.75	2.0 diam.		9.0
	301105-20	BDHI Selector Panel (2 ea)				
	104820	BDHI (4 ea)	3.25	3.25	3.25	7.25
	1897690-3	ADI (2 ea)	11.0	5.25	5.0	12.609
	4V10006-101B	Aux Navigation Selector Panel (2 ea)				
	AN/AQU-4/A	HSI (2 ea)	8.2	4.938	5.063	9.5
	660-1	Remote HSI Panel (2 ea)	1.92	1.5	5.75	5.59
	1880871-5	Flight Director Computer (2 ea)	14.5	7.625	3.718	21.582

C-5A PNWD EQUIPMENT PHYSICAL CHARACTERISTICS

SYSTEM	UNIT		WT (LB)	SIZE (IN)		
	TYPE (P/N)	NOMENCLATURE		H	W	D
<u>Air Data System</u>	50-001-07A	Central Air Data Computer (2 ea)	35.7	7.62	7.64	22.06
	1880842-2A	Airspeed VSFI (2 ea)	10.2	7.75	3.5	9.975
	1880843-2A	Altitude VSFI (2 ea)	8.9	7.75	3.5	9.975
	AVU-15/A	TAS Indicator	2.0	3.25	3.25	3.5
	B1563-10A	Vertical Velocity Indicator	1.3	3.0 diam.		5.19
	4D11054-101A	CADC/VSFI Test Panel (2 ea) TAS Indicator Selector Panel				

C-5A BIBLIOGRAPHY

T.O. Number	Chq/Rev	Title
1C-5A-01	2 Jun 77	List of Applicable Publications - C-5A
1C-5A-1	13 Apr 77	Flight Manual - C-5A
1C-5A-2-6	24 Jan 75	Maintenance, Instruments - C-5A
1C-5A-2-8	7 Jan 77	Maintenance, Radio, Communications and Navigation System - C-5A
1C-5A-2-11	13 Apr 77	Maintenance, Aircraft Wiring Diagrams C-5A
5A7-3-23-2	15 Nov 73	Field Maintenance, Computer, Go-around Attitude, P/N 965-0046-007 (Sund Strand Data Control) -C-5A
5A9-2-45-3	1 Jun 71	Overhaul, Compass System Controller Model 3805F, P/N 148140-01-01, -02 (Lear Siegler)- C-5A
5A11-2-36-3	5 Feb 74	Overhaul, Rate Gyro, P/N 1993250-1 (Honeywell) - C-5A
5A13-5-11-3	15 Aug 72	Overhaul, Control Panel, AFCS, P/N CG527B3 (Honeywell) - C-5A
5A28-11-3	24 Oct 74	Overhaul, Electronics Coupler, P/N 148120-05-01 (Lear Siegler)- C-5A
5A42-2-3	1 Apr 74	Overhaul, Displacement Gyroscope Assy, P/N 143400-05-01, -02 (Lear Siegler) - C-5A
5F5-4-19-2	24 Feb 75	Field Maintenance, Central Air Data Computer, P/N 50-001-08, -09 (Elliott) - C-5A
5F5-4-20-2	24 Aug 71	Field Maintenance, Vertical Scale Instrument Group, P/N 1880842-2A and 1880843-2A (Bendix) - C-5A
5F8-2-27-73	1 Oct 75	Overhaul, True Airspeed Indicator, (0 to 1000 Knots), Type AVU-151A
5F8-10-8-3	5 Feb 75	Overhaul, Vertical Velocity Indicator Assy, P/N B1563-10 (Simmons Precision Products) - C-5A
5N5-13-11-2	30 Jan 75	Field Maintenance, Flight Director Computer, P/N 1880871-5 (Bendix) - C-5A

AD-A061 494

ARINC RESEARCH CORP ANNAPOLIS MD
STANDARD AVIONICS INTERFACE PROGRAM. VOLUME II. NAVIGATION EQUI--ETC(U)
AUG 76 B G MCELHANEY, E J CHAUVIN
1296-01-2-1527-VOL-2

F/G 9/3

F09603-75-A-3001

NL

UNCLASSIFIED

2 OF 5

AD
A061494

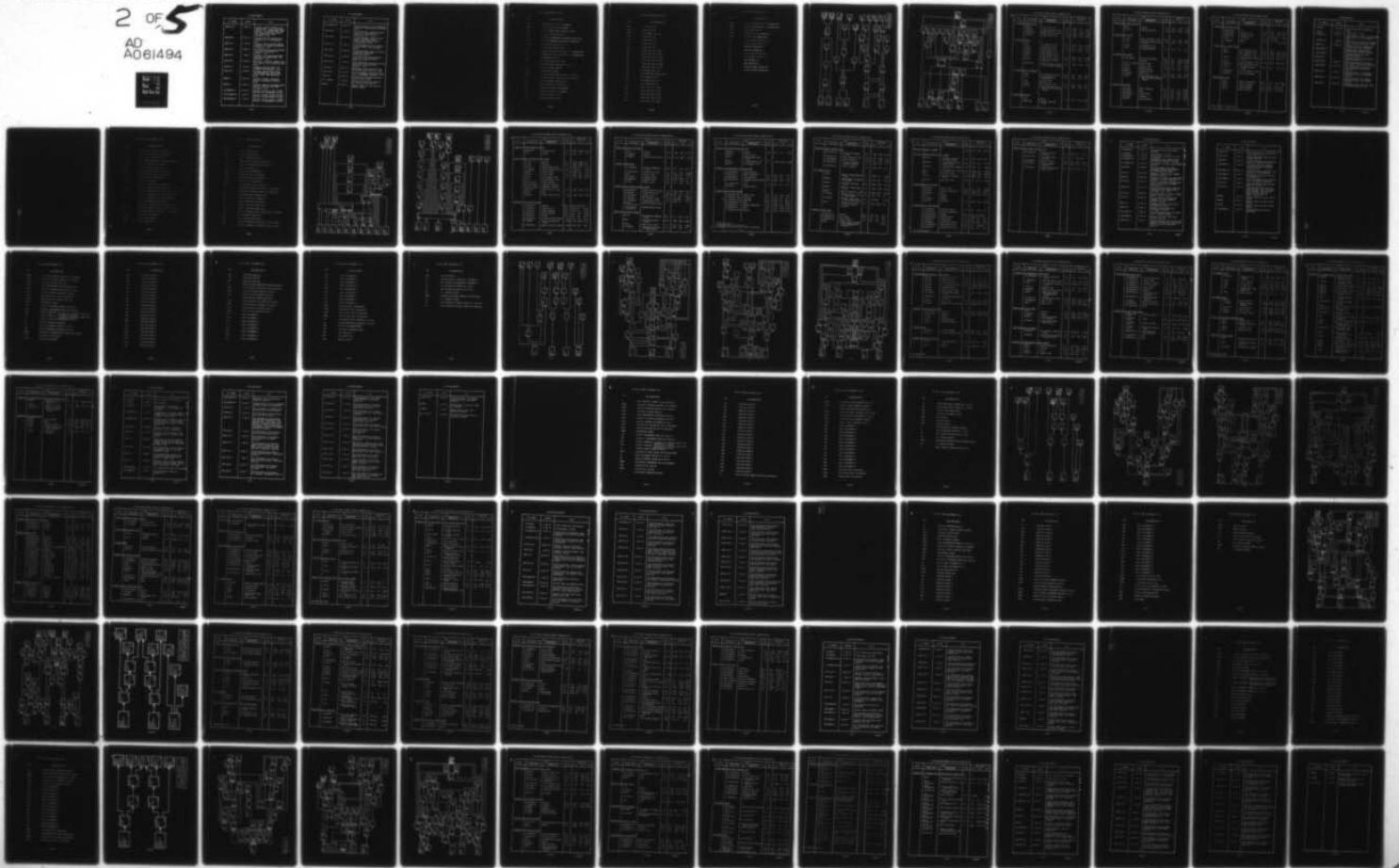

IFIED

2

OF



AD

A061494



C-5A BIBLIOGRAPHY

T.O. Number	Chq/Rev	Title
5N5-13-12-3	1 May 73	Overhaul, Central Processor, P/N 10664100-606C, Primary Navigational Computer, P/N 10662000-635B, -644B, Auxilliary Navigational Computer, P/N 10664000-625B, -634B (Northrop) - C-5A
5N5-18-2-3	18 Jan 74	Overhaul, Position Computer Assy, P/N 5905-101B, C (Kelsey-Hayes) - C-5A
5N8-5-14-3	1 Oct 69	Overhaul, Bearing Distance Heading Indicator, P/N 104820 (Astronautics of America) - C-5A
5N8-5-15-2	15 Apr 72	Field Maintenance, Attitude Director Indicator, P/N 1897690-3, -4 (Bendix) - C-5A
5N8-14-2-3	1 Aug 73	Overhaul, Drift Angle Ground Speed Indicator, P/N G7224-001-01, -02 (Northrop) - C-5A
5N12-2-8-3	15 Feb 74	Overhaul, Transmitter, Compass, Type ML-1 (Sperry Flight System Division) - C-5A
5N14-2-7-3	1 Jun 73	Overhaul, Indicator Panel, P/N 10666000-615A (Northrop) - C-5A
5N16-2-8-3	3 Aug 73	Overhaul, Control-Power Supply, P/N 10663700-613A, -614A, -615A, -617A, -618A, -620A (Northrop) - C-5A
5N25-2-3	21 Jan 74	Overhaul, Selector, Navigation Switch, P/N 300105-20 (Transco) - C-5A
5N25-3-3	15 Jan 72	Overhaul, Selector, Navigation Panel, P/N 591-1-000-1 and 591-2-000-1 (Hartman) - C-5A
12P5-2APN199-3	15 Apr 74	Overhaul, Receiver, Loran C R-1667/APN-199, P/N 758-5686-002 (Collins)
12P5-2-APN199-13	9 Apr 73	Overhaul, Coupler, Antenna CU-1922/APN-199, P/N 787-6100-001 (Collins)
12P5-2APN199-23	1 Mar 74	Overhaul, Control, Loran C, C-8450/APN-199, P/N 758-5688-001 (Collins)

C-5A BIBLIOGRAPHY

T.O. Number	Chg/Rev	Title
12P5-2APN199-32	6 Mar 74	Field Maintenance, Loran C Navigation Receiving System AN/APN-199 (Collins) C-5A
12P5-4-49-2	7 Apr 75	Field Maintenance, Rendezvous Radar Beacon, P/N 196105-000 (Loral Electronics Corp) - C-5A
12P5-4-56-2	28 Jun 74	Field Maintenance, Radar Altimeter System, P/N M44524, M51842, M52192, M4426 (Amecon Division Litton System) - C-5A
12P5-4-57-2	4 Dec 73	Field Maintenance, Station Keeping Equipment Model 41002 (Lockheed) - C-5A
12R2-4-69-2	15 May 75	Field Maintenance, Radio Set Control, 097650-100, 097650-0300, 097836-010 (Wilcox)
12R5-4-39-2-1	2 Sep 69	Field Maintenance, Radio Receiver, Model 51Z-4, P/N 522-2996-011 (Collins) - C-5A
12R5-4-48-12	1 Oct 74	Field Maintenance, Navigation Receiver Model 806C, P/N 097736-0103, (Wilcox) - C-5A
12R5-4-99-11	30 Oct 73	Maintenance with Installation Data, DF-203 ADF System (Collins) - C-5A
12R5-4-106-2	15 Jun 72	Field Maintenance, TACAN Navigational Set, P/N 8000000040 (Hoffman) - C-5A
16W7-19-3	28 Apr 75	Overhaul with IPB, Remote Heading/ Course Selector (RHSI)
MIL-I-27848A	6 Sep 70	Military Specification, Indicator, Horizontal Situation AQU-4/A
MS24523	22 Apr 71	Switch, Toggle, One Pole, Environmentally Sealed

3.7.0
C-9A

C-9A PNWD EQUIPMENT LIST

KEY	EQUIPMENT/UNIT
ADDC	COPILOT'S FLT DIR IND 3298-8G
ADDP	PILOT'S FLT DIR IND 329B-8G
AFCS	SP-50A AUTO FLIGHT CONTROL SYSTEM
AIMS	IHF-SIF SYSTEM AN/APX-64
ALDC	COPILOT'S CORRECTED ALTIMETER 4186910021
ALDP	PILOT'S CORRECTED ALTIMETER 4186910021
BDHC	ID-798/ARN COPILOT'S BDHI
BDHP	ID-798/ARN PILOT'S BDHI
CA	CENTRAL AIR DATA COMPUTER NO 1 2587400-436
CB	CENTRAL AIR DATA COMPUTER NO 2 2587400-436
CMMM	INTERPHONE SYSTEM
CSA	AFT RIGHT EQUIPMENT PANEL
D	DOPPLER RADAR NAVIGATION SYSTEM
DMDC	COPILOT'S DME 339-3D
DMDP	PILOT'S DME 339-3D
FDCA	FD-109G FLIGHT DIRECTOR SYSTEM NUMBER 1
FDCB	FD-109G FLIGHT DIRECTOR SYSTEM NUMBER 2
GA	ALA-51A RADIO ALTIMETER NO 1
GB	ALA-51A RADIO ALTIMETER NO 2
HSDC	COPILOT'S COURSE IND 331A-6K
HSDP	PILOT'S COURSE IND 331A-6K
JBA	J-BOX STA 160 RT SIDE
JBB	J-BOX STA 160 RT SIDE

C-9A PNWD EQUIPMENT LIST

KEY	EQUIPMENT/UNIT
JbC	J-BOX STA 110
JbD	J-BOX STA 110
JbE	RT CONSOLE STA 128
JbF	J-BOX STA 110
JbG	J-BOX STA 110
JbH	J-BOX STA 110
JbJ	J-BOX STA 110
JbK	J-BOX STA 160 L SIDE
JbL	J-BOX STA 160 L SIDE
JbM	J-BOX STA 218 RT SIDE
JbN	J-BOX STA 218 RT SIDE
JbP	J-BOX STA 218 RT SIDE
JbQ	J-BOX STA 218 RT SIDE
JbR	RT CONSOLE STA 128
JbS	FWD ACCESSORY COMPT STA 69
JbT	INST PANEL STA 70
JbU	RT CONSOLE STA 128
JbV	INST PANEL STA 70
JbW	J-BOX STA 160 L SIDE
JbX	J-BOX STA 160 L SIDE
JbY	J-BOX STA 160 L SIDE
JbZ	J-BOX STA 218 RT SIDE
JcA	J-BOX STA 160 L SIDE

C-9A PNWD EQUIPMENT LIST

KEY	EQUIPMENT/UNIT
RADC	RADIO ALTIMETER IND 2 2067635-0701
RADP	RADIO ALTIMETER IND 1 2067635-0701
RDA	RACK DISC STA 218
RMDC	COPILOT'S RMI 2587567-901
RMDP	PILOT'S RMI 2587567-901
SWA	U10-160 NAV SWITCHING UNIT
T	TACAN SYSTEM AN/ARN-65
VA	VHF NAV SYSTEM NO 1
VB	VHF NAV SYSTEM NO 2
WA	C-9 COMPASS SYSTEM NO 1
WB	C-9 COMPASS SYSTEM NO 2
YA	DME SYSTEM NO 1
YB	DME SYSTEM NO 2
ZA	DF-203 LF/ADF SYSTEM NO 1
ZB	DF-203 LF/ADF SYSTEM NO 2

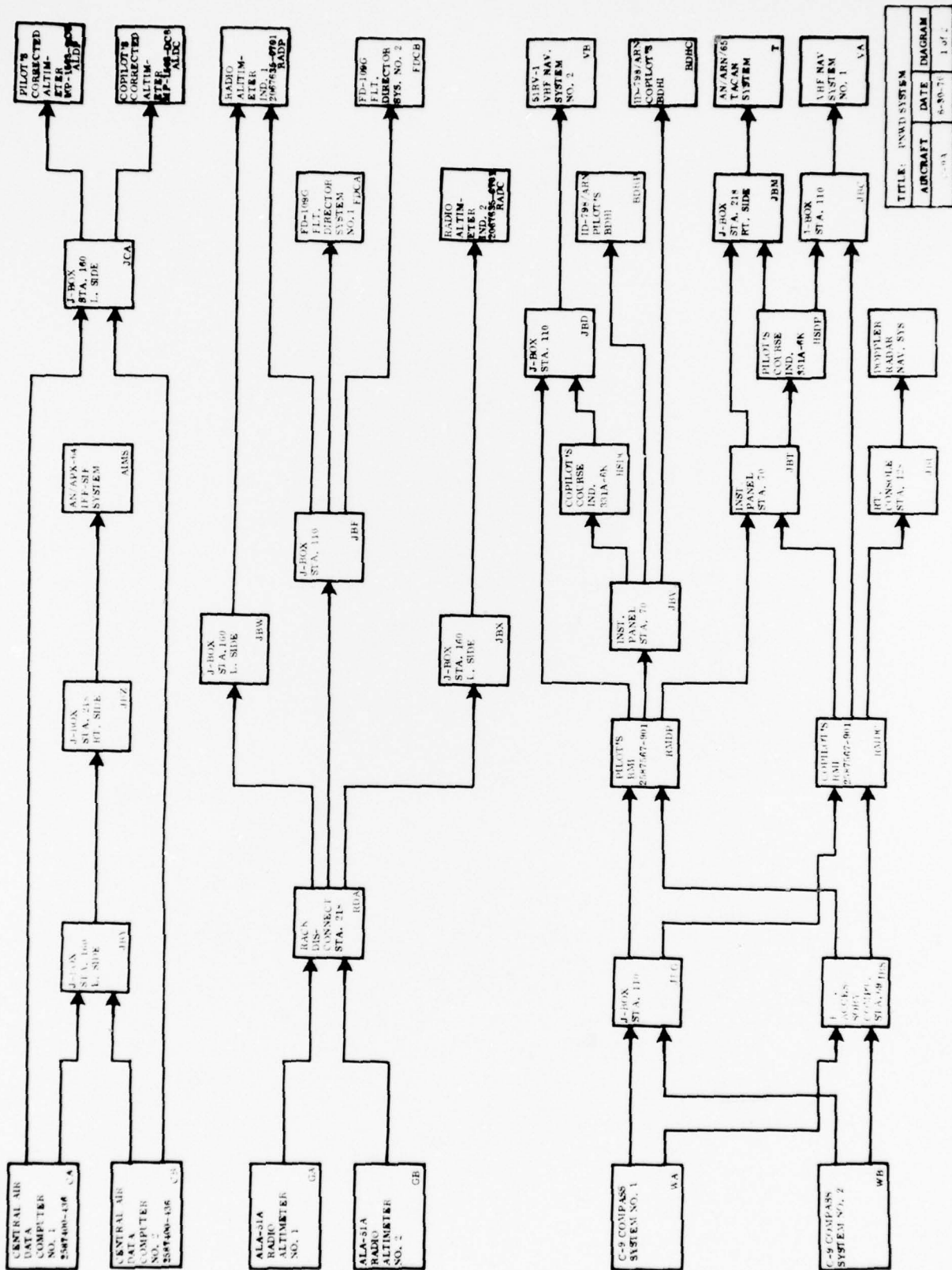

C-9A PNWD EQUIPMENT PHYSICAL CHARACTERISTICS

SYSTEM	UNIT		WT (LB)	SIZE (IN)		
	TYPE (P/N)	NOMENCLATURE		H	W	D
<u>C-9 Gyrosyn Compass System</u>						
	2587794	Flux Valve (2 ea)	1.5	2.078	3.5	5.0
	2588302-4	Directional Gyro (2 ea)	9.2	7.25	7.34	8.34
	2587567-901	Compass Indicator (2 ea)	4.1	3.287	3.287	8.53
	614937-10	Compass Rack (2 ea)	3.65	7.656	2.5	14.28
<u>DF-203 ADF System</u>						
	51Y-4	ADF Receiver (2 ea)	9.8	7.625	2.25	14.625
	179J-8	Coupler Box (2 ea)	1.8	5.0	5.0	3.0
	137A-6A	Loop Antenna (2 ea)	4.8	23.75	10.55	0.8
	5914221	Sense Antenna (2 ea)				
	5914222	Sense Antenna (2 ea)				
	614L-8	Control Panel (2 ea)	1.8	2.625	5.75	4.938
	MR-16D	Range Filter Assembly (2 ea)	0.5	3.0	3.0	2.0
	2587567-901	Compass Indicator (2 ea) (part of Gyrosyn Compass)	4.1	3.287	3.287	8.53
<u>Distance Measuring Equipment</u>						
	860E-2	DME Interrogator (2 ea)	36.0	7.62	4.88	19.62
	G-1707	VHF NAV/DME Control Panel (2 ea)	3.0	2.25	5.75	6.0
	97404	Antenna (2 ea)				
	339D-3D	DME Indicator (2 ea)	2.2	3.25	3.25	4.5
	331A-6K	Course Indicator (2 ea) (part of Flight Director System)	4.9	3.975	3.975	8.0
<u>Marker Beacon System</u>						
	51Z-4	Receiver	2.9	3.38	2.25	12.62
	ST390A-S3D6	Indicator Light Assy (2 ea)				

C-9A PNWD EQUIPMENT PHYSICAL CHARACTERISTICS

SYSTEM	UNIT		WT (LB)	SIZE (IN)		
	TYPE (P/N)	NOMENCLATURE		H	W	D
<u>Marker Beacon System (Cont'd)</u>						
	37X-2	Antenna	1.0	2.56	1.56	11.56
	2TL11-3D	Sensitivity Switch	0.12	2.87	0.89	1.320
<u>VHF Navigation System</u>						
	51RV-2B	VOR/ILS Receiver (2 ea)	18.8	7.62	4.88	12.62
	G-1707	VHF NAV/DME Control Panel (2 ea)	3.0	2.25	5.75	6.0
	5913554	VOR Antenna (2 ea)				
	37P-5	Glideslope Antenna	0.7	5.34	2.0	4.5
<u>AN/ARN-65 TACAN System</u>						
	RT-471/ARN-65	Receiver-Transmitter	50.0	9.0	9.375	17.375
		Mounting	2.25	2.25	9.562	17.657
	C-4457 (P) ARN-21C	Control Panel	2.2	3.0	5.75	4.0
	AT-741/A	Antenna (2 ea)	0.4	3.3	1.75	5.25
	SA-521/A	Antenna Switch	0.34	1.94	2.78	3.19
	5928459	Suppression Unit				
	ID-798/ARN	BDHI (2 ea)	4.0	3.25	3.25	6.875
	331A-6K	Course Indicator (2 ea) (part of Flight Director System)	4.9	3.975	3.975	8.0
<u>EDO-1200 Loran System</u>						
	1200-A1002	Signal Processor	24.0	7.76	7.5	21.88
	7914578-835	Mount	1.5	7.62	7.62	19.47
	1200-A2002-3	Control Panel	2.0	4.13	5.75	4.98
	1200-A3002	Indicator	4.5	3.76	3.76	12.78
	700D10200	Antenna Coupler	1.1	3.0	3.0	3.0

C-9A PNWD EQUIPMENT PHYSICAL CHARACTERISTICS

SYSTEM	UNIT		WT (LB)	SIZE (IN)		
	TYPE (P/N)	NOMENCLATURE		H	W	D
<u>ALA-51A Radio Altimeter System</u>						
	2067631-0501	T/R*	14.9	7.62	4.88	12.62
	2067635-0701	Indicator (2 ea)	2.0	3.26	3.26	5.0
	2067636-0701	Antenna (4 ea)	1.5	7.0 diam.		2.98
	414ZS	Fan (2 ea)	0.25	1.9 diam.		1.4
	79145780563	Mount	2.0	1.0	5.02	16.66
<u>Flight Director System FD-109G</u>						
	562P-1	Pitch Computer (2 ea)	8.5	7.625	2.25	14.5
	562R-1	Roll Computer (2 ea)	8.5	7.625	2.531	14.563
		FD Controller (2 ea)	2.0	2.25	5.75	4.0
	329B-8G	Flight Director Indicator (2 ea)	7.5	5.125	4.875	7.5
	331A-6K	Course Indicator (2 ea)	4.9	3.975	3.975	8.0
	R2901-136	Mode Annunciator (2 ea)				
	344C-1K	Instrument Amplifier (2 ea)	8.2	7.62	2.25	12.62
	2587400-436	Air Data Computer (2 ea)				
	4186910021	Corrected Altimeter				
<u>Weather Radar System</u>						
	RDR-1E	Receiver-Transmitter	46.0	7.62	10.12	19.62
	CON-1N	Control Indicator	1.5	2.6	5.8	2.9
	ANT-1M	Antenna Assembly	24.0	34.0	30.1 diam.	
	PPI-1G	Radar Indicator	15.0	6.25	6.24	14.0
*Provisions for a second unit						

C-9A BIBLIOGRAPHY

T.O. Number	Chg/Rev	Title
1C-9A-01	1 Apr 68	List of Applicable Publications - C-9A
1C-9A-1	15 Jul 75	Flight Manual - C-9A
1C-9A-2-4-3	1 Mar 77	Organizational "Flight Line" Maintenance, Navigation and Instruments - C-9A
1C-9A-2-11-2	1 Dec 74	Organizational "Flight Line" Maintenance, Wiring Diagram Manual - C-9A
5N8-5-11-3	15 May 75	Overhaul, Indicator, Bearing Distance Heading, Type ID-789/ARN
12P5-2APN153-2		Service, Radar Navigation Set, AN/APN-153(V) (General Precision)
12R5-2ARN65-2		Field Maintenance, Radio Set, AN/ARN-65 (Hoffman)
12R5-4-39-2		Field Maintenance, Radio Receiver, Type 51Z-4 (Collins)
12R5-4-81-22	15 Jan 71	Field Maintenance with Overhaul, Roll Computer Type 562R-1E (Collins)
12R5-4-82-22	15 Jun 73	Field Maintenance with Overhaul, Pitch Computer, Type 562P-1E1 (Collins)
12R5-4-85-12	1 Mar 73	Field Maintenance, with Overhaul, Attitude Director, Type 329B-8G (Collins)
12R5-4-91-22	26 Jun 73	Field Maintenance with Overhaul, Attitude Director, Type 329B-8G (Collins)
12R5-4-99-11	30 Oct 73	Maintenance with Installation Data-DF-203 ADF System (Collins)

3.8.0
HC-130H

HC-130H PNWD EQUIPMENT LIST

KEY	EQUIPMENT/UNIT
AA	UHF/VHF D/F SYSTEM NO.1 AN/ARA-25
AB	UHF/VHF D/F SYSTEM NO.2 AN/ARA-25
AFC5	AUTOPILOT SYSTEM TYPE E-4
AIMS	AIMS RADAR IDENT SYS (IFF) AN/APX-64(V)
ALDP	PILOT'S ALTIMETER AAU-21/A
BDHC	COPILOT'S BDHI ID-1103/ARN
BDHM	NAVIGATOR'S RH BDHI ID-1103/ARN
BDHN	NAVIGATOR'S LH BDHI ID-1103/ARN
BDHP	PILOT'S BDHI ID-1103/ARN
CMC	INTERPHONE SYSTEM
D	DOPPLER RADAR SYSTEM AN/APN-147
DFTS	AERIAL TRACKING SYSTEM AN/ARD-17
DRDN	DOPPLER RADAR INDICATOR ID-938A/APN-147(V)
EA	DOPPLER COMPUTER SYS NO.1 AN/ASN-35C
EB	DOPPLER COMPUTER SYS NO.2 AN/ASN-35C
F	FM-622A COMMUNICATION SYSTEM
FCCA	CPU-65/A FLIGHT DIRECTOR COMPUTER NO.1
FCCB	CPU-65/A FLIGHT DIRECTOR COMPUTER NO.2
G	LOW-RANGE RADAR ALTIMETER SYS AN/APN-150
HSDC	COPILOT'S HSI AQU-2/A
HSDP	PILOT'S HSI AQU-2/A
JRA	RADIO JUNCTION BOX

HC-130H PNWD EQUIPMENT LIST

KEY	EQUIPMENT/UNIT
JBB	TACAN JUNCTION BOX
JBC	RADAR JUNCTION BOX
JBD	RADAR JUNCTION BOX NO. 2
Q	SEARCH RADAR SYSTEM AN/APN-59D
RAHD	HEIGHT INDICATOR ID-996/APN-150
RDA	RACK DISCONNECT A
RDB	DOPPLER TEST RECEPTACLE
RMDC	COPILOT'S RMI ID-250A/ARN
RMDN	NAVIGATOR'S RMI ID-250A/ARN
RMDP	PILOT'S RMI ID-250A/ARN
RMDU	PILOT/COPILOT RMI ID-250A/ARN
SA	GLIDEPATH RECEIVER SYSTEM NO.1 AN/ARN-67
SB	GLIDEPATH RECEIVER SYSTEM NO.2 AN/ARN-67
SWA	NAV INSTRUMENT SWITCHING SYS
TA	TACAN SYSTEM NO.1 AN/ARN-21
TB	TACAN SYSTEM NO.2 AN/ARN-21
VA	VOR-101 VHF NAV SYSTEM NO.1
VB	VOR-101 VHF NAV SYSTEM NO.2
VHFD	FM-622A COMMUNICATION SYSTEM IND. ID-48/ARN
WA	C-12 COMPASS SYSTEM NO.1
WB	C-12 COMPASS SYSTEM NO.2
ZA	DFA-730 AUTOMATIC DIRECTION FINDER SYSTEM
ZB	DFA-730 AUTOMATIC DIRECTION FINDER SYSTEM

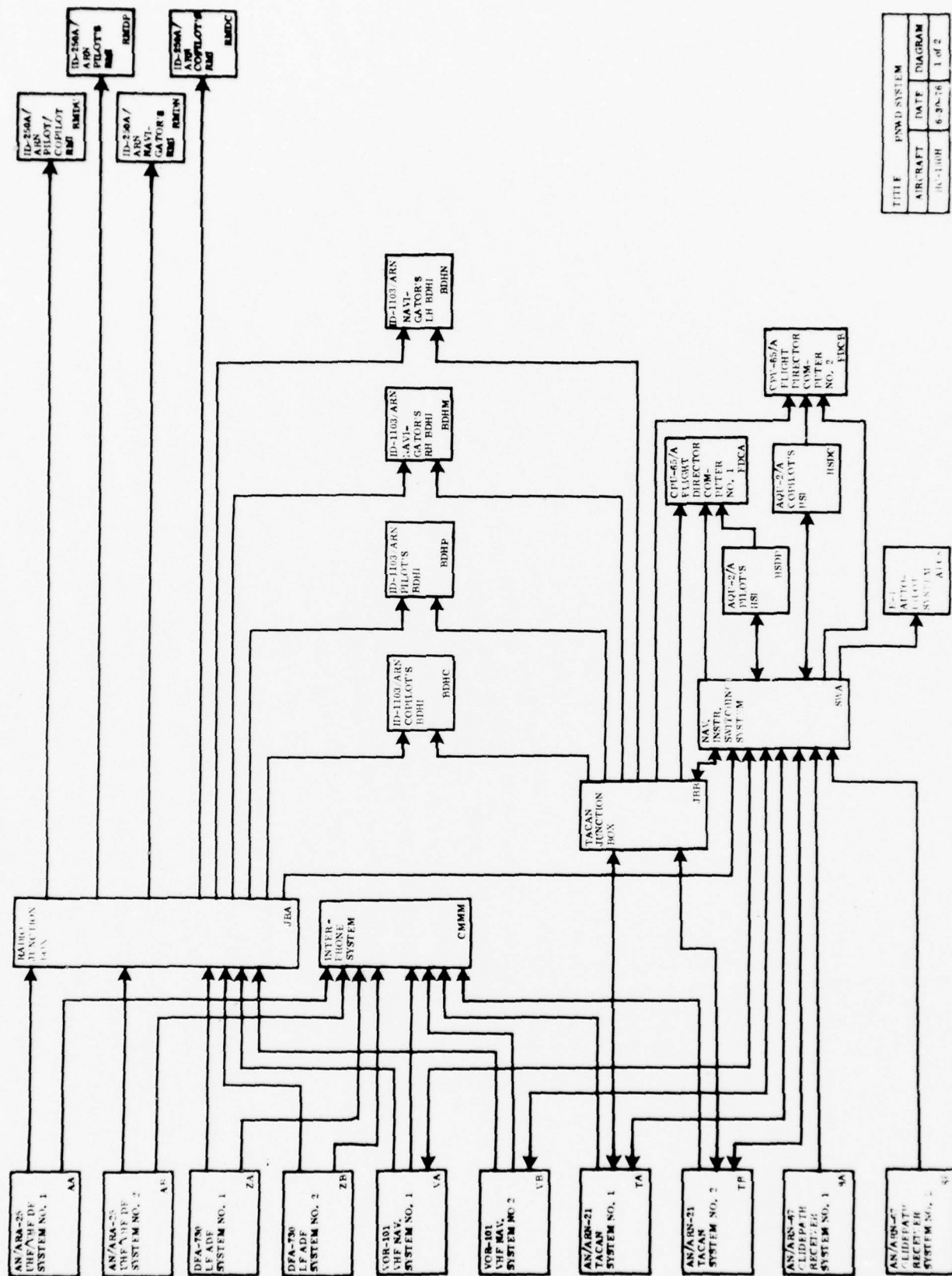

TITLE	ISSUED SYSTEM
AIRCRAFT	DATE
30-110H	6-30-78
	DIAGRAM
	1 of 2

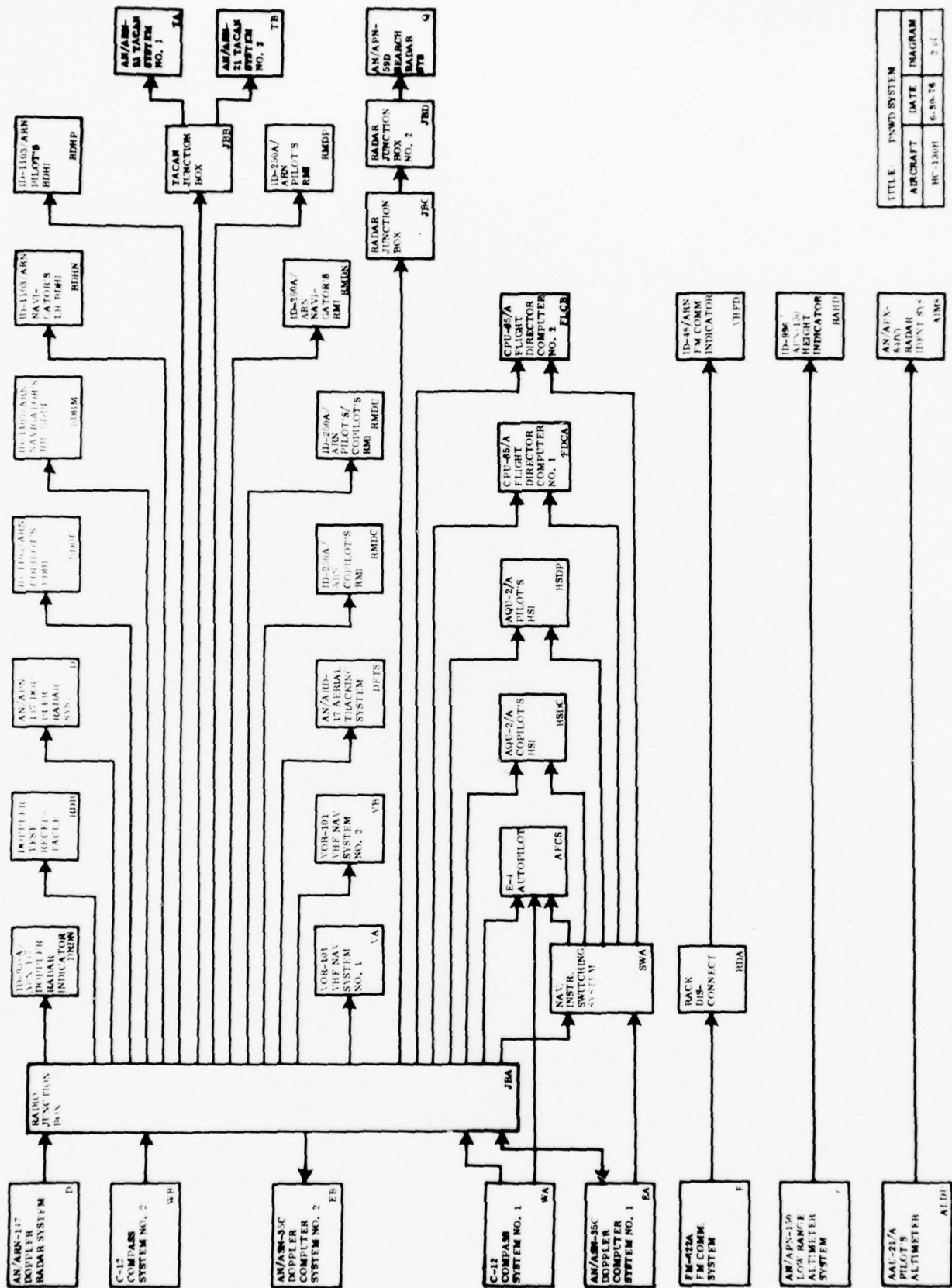

3-8A-4

TITLE: FWD SYSTEM			
AIRCRAFT	DATE	INTEGRATED	
HC-130H	6-30-76		2 of 2

HC-130H PNWD EQUIPMENT PHYSICAL CHARACTERISTICS

SYSTEM	UNIT		WT (LB)	SIZE (IN)		
	TYPE (P/N)	NOMENCLATURE		H	W	D
<u>AN/ARN-67 Glidepath Receiver System</u>						
	R785/ARN-67	Receiver (2 ea)	7.5	5.094	4.469	12.313
	37P-5	Antenna	0.7	5.34	2.0	4.5
<u>DFA-730 Automatic Direction Finder System</u>						
	DFA-73AC	Receiver	11.0	7.625	2.406	15.3
	DFA-73AF	Receiver	11.0	7.625	2.406	15.3
	MSA-73A-1	Mounting Base (2 ea)	1.7	8.973	3.27	17.17
	ID-250A/ARN	Bearing Indicator (3 ea)	2.6	3.25 diam.		6.156
	CNA-73BC	Control Panel	1.9	2.625	5.75	3.63
	CNA-73BF	Control Panel	1.9	2.625	5.75	3.63
	LPA-73C	Loop Antenna (2 ea)	2.8	1.96	9.88	16.89
	361770	Sense Antenna (2 ea)				
	CUA-73A-83/13F	Antenna Coupler				
	QCA-73E-1-16U4N	Quadrantal Corrector				
	QCA-73E-1-20U4N	Quadrantal Corrector				
	MS35059-23	Control Switch (2 ea)	0.10	1.346	1.025	2.41
	697273-1	Relay				
	MS25068-23	Pointer Select Switch	0.16	1.346	1.680	2.55
<u>AN/ARD-17 Aerial Tracking System</u>						
	AS-1849/ARD-17	Antenna	54.0	19.375 70.6 diam.		
	TG-159/ARD-17	Antenna Drive	87.0	20.0 diam.		26.25
	CV-2041/ARD-17	S-Band Converter	8.0	7.75	5.0	14.75
	C-6807/ARD-17	Receiver Control	38.0	12.0	19.0	16.75
	RD-288/ARD-17	Printer	71.0	12.0	19.0	25.25
	MT-3577/ARD-17	DF Receiver Control Mount	3.25	5.0	17.0	21.0
	MS-9140482	Mount, Converter Freq. Trker	1.175	2.175	6.063	14.25
	MT-2578/ARD-17	Mount, Printer DF System	3.875	5.25	20.0	25.0

HC-130H PNWD EQUIPMENT PHYSICAL CHARACTERISTICS

SYSTEM	UNIT		WT (LB)	SIZE (IN)		
	TYPE (P/N)	NOMENCLATURE		H	W	D
<u>Marker Beacon Receiver System</u>						
	51Z-3	Receiver	2.9	3.38	2.25	12.62
	AT-536/ARN	Antenna				
	MS35058-22	Sensitivity Control SW	0.10	1.157	0.641	2.236
<u>AN/ARN-21 TACAN System</u>						
	RT-220C/ARN-21	Receiver-Transmitter (2 ea)	60.0	8.3	11.13	18.75
	C-1763/ARN-21A	Control Unit (2 ea)	3.0	3.0	5.75	5.688
	161B-1	Coupler (2 ea)	12.0	6.125	5.0	10.167
	ID-1103/ARN	Indicator (4 ea)	3.5	3.25	3.25	7.5
	MT-928/ARN-21	Mounting (2 ea)	6.5	7.75	11.125	17.5
	AT-741/A	Antenna (2 ea)	0.4	3.3	1.75	5.25
<u>AN/ARA-25 UHF/VHF Direction Finder System</u>						
	AM-608/ARA-25	Control Amplifier (2 ea)	5.4	5.875	4.875	12.531
	AM-3969/ARC	RF Amplifier (2 ea)	2.25	2.25	6.0	8.5
	AS-578D/ARA-25	Antenna (2 ea)	12.5	4.0	16.0	14.375
	ID-250A/ARN	RMI Indicator (2 ea)	2.6	3.25 diam.		6.156
	RE-120A/ARA-25	Antenna Relay (4 ea)	0.8	5.813	6.5	1.75
	650-4226 (Cook Electric)	UHF/VHF DF Relay (2 ea)				
	4100 (Seaboard Electronics)	AN/ARA-25 Relay (2 ea)				
<u>VOR-101 VHF Navigation System</u>						
	51X-2B	VHF Navigation Receiver (2 ea)	10.5	7.5	3.56	12.56
	344B-1	Instrumentation Unit (2 ea)	13.0	7.625	3.688	14.688
	614U-3A	Control Unit (2 ea)	1.7	2.25	5.75	6.766
	ID-1103/ARN	Indicator (2 ea) (part of TACAN system)	3.5	3.25	3.25	7.5

HC-130H PNWD EQUIPMENT PHYSICAL CHARACTERISTICS

SYSTEM	UNIT		WT (LB)	SIZE (IN)		
	TYPE (P/N)	NOMENCLATURE		H	W	D
<u>VOR-101 VHF Navigation System (Cont'd)</u>						
	340302-2	Antenna	0.44	2.6	2.5	1.625
	AN3311-2	Relay (2 ea)				
	349H-4	Receiver Shock Mount (2 ea)				
	349H-5	IU Shock Mount (2 ea)	1.5	9.313*	4.594	17.344*
	369375-1	Plug Adapter (2 ea)				
<u>AN/APN-150 Low-Range Radar Altimeter System</u>						
	ID-996/APN-150	Height Indicator				
**	T-853/APN-150	Radar Transmitter	5.0	6.87	7.87	4.75
	R-1085/APN-150	Radar Receiver	4.0	8.5	9.0	3.5
**	AM-3063/APN-150	Electronic Control Amplifier	10.0	6.25	4.87	11.75
	MT-2585/APN-150	Mount	3.0	4.0	4.9	12.8
	214C50-26	Pressure Switch				
<u>AN/APN-147 Doppler Radar System</u>						
	C-3747/APN-147(V)	Control Panel	0.6	1.13	5.75	2.69
	ID-938A/APN-147(V)	Indicator	3.1	3.26	3.26	6.0
***	CV-1181A/APN-147(V)	Comparator	34.9	8.38	9.0	24.63
	MT-2549/APN-147(V)	Mount	7.5	8.38	9.0	25.63
	RT-625A/APN-147	Receiver-Transmitter	9.4	7.625	3.813	15.051
	MT-2550/APN-147	Mount	2.9	8.75	4.637	16.41
	AS-1168A/APN-147(V)	Antenna	32.9	8.75	19.125	26.750
<p>* With Sway Space ** Parameters are for "A" versions. *** Parameters are for basic P/N's (not "A" versions)</p>						

HC-130H PNWD EQUIPMENT PHYSICAL CHARACTERISTICS

SYSTEM	UNIT		WT (LB)	SIZE (IN)		
	TYPE (P/N)	NOMENCLATURE		H	W	D
<u>AN/ASN-35C Doppler Computer System</u>						
	CP-622A/ASN-35C	Navigational Computer (2 ea)	16.5	7.625	4.875	15.187
	MT-2551/ASN-35	Mount, Computer (2 ea)	2.25	5.75	5.875	14.25
	C-3819A/ASN-35	Control Indicator	6.75	4.5	5.75	5.312
	C-3820A/ASN-35	Auxiliary Crosstrack Control Indicator	1.9	1.875	5.75	5.0
	C-6034/ASN-35A	Control Indicator	4.2	3.375	5.75	5.0
<u>C-12 Compass System</u>						
	1775277	Magnetic Azimuth Detector (2 ea)	1.7	2.063	3.5	4.906
	2586257-1	Remote Magnetic Compensa- tor (2 ea)	1.5	1.875	5.75	4.781
	2586333-1	Directional Gyroscope (2 ea)	10.0	6.938	7.297	8.313
	2586384-1	Amplifier - Power Supply (2 ea)	6.0	7.844	2.406	14.188
	2586261-1	Digital Controller (2 ea)	2.5	2.625	5.75	6.125
	ID-1103/ARN	Indicator (4 ea) - (part of TACAN system)	3.5	3.25	3.25	7.5
	ID-250A/ARN	Indicator (4 ea) (part of ADF and VHF/DF Sys.)	2.6	3.25 diam.		6.156
	AQU-2/A	Indicator (2 ea) (part of Flight Director system)	8.2	4.313	5.063	9.5
<u>AN/APN-157 LORAN System</u>						
	R-1214/APN-157	Receiver	54.9	7.75	15.5	23.0
	PP-3866/APN-157	Power Supply	20.0	8.0	5.0	16.0
	CU-1658/APN-157	Antenna Coupler	7.0	4.0	4.0	9.0
	352610	Antenna (part of HF-102B liaison communication system No. 1)				772.0

HC-130H PNWD EQUIPMENT PHYSICAL CHARACTERISTICS

SYSTEM	UNIT		WT (LB)	SIZE (IN)		
	TYPE (P/N)	NOMENCLATURE		H	W	D
	<u>AAU-21/A Altimeter - Encoder</u>		3.75	3.25	3.25	8.111
	<u>Air Force Standard Flight Director System</u>					
	AQU-2/A	Horizontal Situation Indicator (2 ea)	8.2	4.313	5.063	9.5
	ARU-2B/A	Attitude Director Indicator (2 ea)	8.5	5.25	5.0	9.735
	CPU-65/A	Flight Director Computer (2 ea)	7.8*	6.75	5.5	9.625
	MD-1	Displacement Gyro (2 ea)	9.5	6.094	5.75	9.688
	MC-1	Rate Gyro (2 ea)	1.5	2.65	2.44	4.802
	TRU-2/A	Rate Gyro Transmitter (2 ea)	3.75	3.875	3.25	5.66
	AN3311-2	Rate Gyro Relay	0.44	2.6	2.5	1.625
	<u>FM-622A Communication System</u>					
	709150-801	Control Panel	2.0	3.0	5.75	6.438
	709149-801	Receiver-Transmitter	25.19	7.938	6.0	15.25
	709116-801	Mount	2.0	2.125	5.75	14.25
	437S-1	Antenna				
	AS-1922/ARC	Antenna				
	ID-48/ARN	Indicator	1.9	3.25	3.25	4.813
	<u>AN/APN-59D Search Radar System</u>					
	C-1242/APN-59	Radar Set Control	4.5	9.0	5.75	5.5
	RT-832/APN-59D	Receiver-Transmitter				
	AS-1199/APN-59B	Antenna	59.0	34.25	35.75 diam.	
	C-4006P/APN-59B	Antenna Control	2.0	2.625	5.75	5.0
	SN-198/APN-59	Synchronizer	7.0	6.0	6.0	11.0
	C-2302/APN-59	Synchronizer Control	1.25	3.375	5.75	5.25
	PP-1073A/APN-59	Power Supply (2 ea)	14.0	7.0	8.0 diam.	
	HD-150/APN-59	Vaneaxial Fan (2 ea)	2.5	9.0	6.5	5.0
	*Includes shockmount					

HC-130H PNWD EQUIPMENT PHYSICAL CHARACTERISTICS

SYSTEM	UNIT		WT (LB)	SIZE (IN)		
	TYPE (P/N)	NOMENCLATURE		H	W	D
<u>AN/APN-59D Search Radar System (Cont'd)</u>						
	AM-853A/APN-59	Electrical Control Amplifier	9.0	6.688	5.5	10.0
	CN-221A/APN-59	Stabilization Data Generator	8.0	7.0	8.0 diam.	
	C-3939/APN-59	Generator Control	4.25	4.125	7.75	6.25
	SG-461/APN-59	Electronic Marker Generator	10.5	6.69	6.0	9.5
	IP-268/APN-59	Azimuth and Range Indicator (2 ea)	8.0	5.875	5.125	9.0

HC-130H BIBLIOGRAPHY

T.O. Number	Chg/Rev	Title
1C-130(H)H-01	15 Mar 76	List of Applicable Publications - HC-130H
1C-130(H)H-1	1 Sep 76	Flight Manual - HC-130H
1C-130(H)H-2-5	1 Dec 76	Maintenance, Instruments -HC-130H Instruments
1C-130(H)H-2-11	1 Jul 74	Maintenance, Radio Communications and Navigation Systems - HC-130H
1C-130(H)H-2-13	15 Sep 76	Maintenance, Airplane Wiring Diagrams - HC-130H
5F3-3-16-2	4 Feb 74	Field Maintenance Bench Check, Altimeter, Encoder, Type AAU-21/A P/N C415421003 (Kollsman)
5F5-5-7-3	15 Apr 75	Overhaul, Flight Director Computer CPU-65/A (Collins)
5F6-3-5-3	10 May 75	Overhaul, Roll and Pitch Displacement Gyroscope, Type MD-1 (Collins)
5F8-15-3-3	15 Jul 74	Overhaul, Horizontal Situation Indi- cator, Type AQU-2/A, P/N 100524 (Astronautics)
5F10-4-4-2	12 Jul 74	Intermediate Maintenance, Rate Gyro- scope transmitter, Type TRU-2A/A, P/N A2850-1 (R.C. Allen)
5N1-2-15-2	15 Aug 75	Field Maintenance, Gyroscopic Compass System, Type C-11, C-12
5N1-3-8-2	30 Sep 75	Field Maintenance, Navigational Computer Set, Type AN/ASN-35 (Canadian Marconi)
5N2-4-2-3	5 Aug 75	Overhaul, Amplifier, Power Supply, P/N 2586384-1 (Sperry)
5N6-4-11-3	26 Feb 71	Overhaul, Digital Controller, P/N 2586261-1 (Sperry)
12P5-2APN147-2	1 May 75	Field Maintenance, Radar Set AN/APN- 147(V) (Canadian Marconi)
12R1-2ARA25-2	15 Feb 73	Service, Direction Finder Group, AN/ARA-25 and -25A
12R2-4-29-2	12 Sep 72	Field Maintenance, VHF Navigation and Communications Receiver, Type 51X-2B Radio Set Control, Type 614U-3A (Collins)

HC-130H BIBLIOGRAPHY

T.O. Number	Chg/Rev	Title
12R2-4-30-2	2 Oct 75	Field Maintenance, Instrumentation Unit 344B-1 (Collins)
12R2-4-90-2	1 Oct 74	Field Maintenance, Radio Set, Type FM622A (Magnavox)
12R5-2AR-2	15 Aug 66	Field Maintenance, Radio Frequency Amplifier, AM-3969/AR (Cook)
12R5-2ARD17-2	3 Aug 73	Field Maintenance and Overhaul, Direction Finder Set AN/ARD-17 (Cook Electric)
12R5-2ARN21-42	20 Apr 72	Field Maintenance, Radio Set, Type AN/ARN-21C, P/N 8020000074-1
12R5-2ARN30-2	5 Nov 71	Maintenance, Radio Receiving Set, Type AN/ARN-30
12R5-2ARN67-2	30 Oct 73	Field Maintenance, Radio Receiving Set, Type AN/ARN-67 (Sparton)
12R5-4-39-2	2 Sep 69	Field Maintenance, Radio Receiver, Type 51Z-3 (Collins)
12R5-4-56-12	6 Jun 72	Field Maintenance, ADF Receiver, Type DFA-73AC, -73AF, ADF Control Type CNA-73BC, -73BF, ADF Loop Type LPA-73C-1, ADF Shock Mount, Type MSA 73A-1
MS25068	17 Nov 72	Switch, Toggle, Four Pole, Sealed Toggle
MS35058	17 Nov 72	Switch, Toggle, One Pole, Sealed Toggle
MS35059	17 Nov 72	Switch, Toggle, Two Pole, Sealed Toggle
12P5-2APN59-22	1 Aug 75	Field Maintenance, Radar Set, AN/APN-59B

3.9.0
C-135A

C-135A PNWD EQUIPMENT LIST

KEY	EQUIPMENT/UNIT
ADDC	COPILOT'S ATTITUDE DIRECTOR IND 329B-8G
ADDP	PILOT'S ATTITUDE DIRECTOR IND 329B-8G
AFCS	AUTOPILOT SYSTEM TYPE MC-1
AIMS	AIMS TRANSPONDER SYSTEM AN/APX-64(V)
ALDC	COPILOT'S SERVOED ALTIMETER AAU-19/A
ALDP	PILOT'S SERVOED ALTIMETER AAU-19/A
BDHM	NAVIGATOR'S NO.2 BDHI ID-526/ARN
BDHN	NAVIGATOR'S NO.1 BDHI ID-526/ARN
CMMM	INTERPHONE SYSTEM
CSA	PILOT'S INSTRUMENT AMPLIFIER 344C-1K
CSB	COPILOT'S INSTRUMENT AMPLIFIER 344C-1K
CSD	SIGNAL CONVERTER (795-8872-001 TERMINAL BOARD WITH RN60D6810F RESISTOR)
CSE	SIGNAL CONVERTER (795-8872-002 TERMINAL BOARD WITH RN60D8205F RESISTOR)
D	DOPPLER RADAR SYSTEM AN/APN-147 (V)
E	DOPPLER COMPUTER AN/ASN-35
GA	RADIO ALTIMETER SYSTEM NO.1 AL-101
GB	RADIO ALTIMETER SYSTEM NO.2 AL-101
GSDN	NAVIGATOR'S GRNDSPD DRIFT ANGLE IND ID-938
HSDC	COPILOT'S HSI 331A-8H
HSDP	PILOT'S HSI 331A-8H

C-135A PNWD EQUIPMENT LIST

KEY	EQUIPMENT/UNIT
JBB	JUNCTION POINT B
JBC	JUNCTION POINT C
JBD	JUNCTION POINT D
JBE	JUNCTION POINT E
JBF	JUNCTION POINT F
JBG	JUNCTION POINT G
JBH	JUNCTION POINT H
JBJ	JUNCTION POINT J
JBK	JUNCTION POINT K
JBL	JUNCTION POINT L
JBM	JUNCTION POINT M
JBN	JUNCTION POINT N
JBP	JUNCTION POINT P
JBQ	JUNCTION POINT Q
JBS	JUNCTION POINT S
JBT	JUNCTION POINT T
JBU	JUNCTION POINT U
JBV	JUNCTION POINT V
JBW	JUNCTION POINT W
JBX	JUNCTION POINT X
JB Y	JUNCTION POINT Y
JBZ	JUNCTION POINT Z

C-135A PNWD EQUIPMENT LIST

KEY	EQUIPMENT/UNIT
JCA	JUNCTION POINT AA
JCC	JUNCTION POINT AC
JCD	JUNCTION POINT AD
KL	AIMS ALTITUDE COMPUTER SYSTEM CPU-66/A-1
MEDP	PILOT'S MULTI ERROR IND. ID-939/ASN-35
PTCC	COPILOT'S PITCH COMPUTER 562P-1E1
PTCP	PILOT'S PITCH COMPUTER 562P-1E1
Q	SEARCH RADAR SYSTEM AN/APN-59B
RADC	COPILOT'S RADIO ALTIMETER IND 339H-1
RADP	PILOT'S RADIO ALTIMETER IND 339H-1
RCPC	COPILOT'S ROLL COMPUTER 562R-1E
RCPP	PILOT'S ROLL COMPUTER 562R-1E
RDA	RACK DISCONNECT A
RDB	RACK DISCONNECT B
RDC	RACK DISCONNECT C
RDD	RACK DISCONNECT D
RDE	RACK DISCONNECT E
RDF	RACK DISCONNECT F
RDH	RACK DISCONNECT H
RDJ	RACK DISCONNECT J

C-135A PNWD EQUIPMENT LIST

KEY	EQUIPMENT/UNIT
RDK	RACK DISCONNECT K
RDL	RACK DISCONNECT L
RDM	RACK DISCONNECT M
RDN	RACK DISCONNECT N
RDP	TEST RECEPTACLE P
RDR	RACK DISCONNECT R
RDS	RACK DISCONNECT S
RDT	RACK DISCONNECT T
RDU	RACK DISCONNECT U
RMDC	COPILOT'S RMI ID-250A/ARN
RMDN	NAVIGATOR'S RMI ID-250A/ARN
RMDP	PILOT'S NO.1 RMI ID-250A/ARN
RMDU	PILOT'S NO.2 RMI ID-250A/ARN
SA	GLIDESLOPE RADIO SYSTEM NO.1 51V-4A
SB	GLIDESLOPE RADIO SYSTEM NO.2 51V-4A
SWC	PILOT'S VOR/TACAN RELAY
SWD	COPILOT'S VOR/TACAN RELAY
SWE	FLAG RELAY NO.1
SWF	FLAG RELAY NO.2
SWG	SWITCH POINT G

C-135A PNWD EQUIPMENT LIST

KEY	EQUIPMENT/UNIT
SWH	SWITCH POINT H
TA	UHF NAVIGATION SYSTEM NO.1 AN/ARN-21C
TB	UHF NAVIGATION SYSTEM NO.2 AN/ARN-21C
VA	VHF NAVIGATION SYSTEM NO.1 51R-6
VB	VHF NAVIGATION SYSTEM NO.2 51R-6
WA	N-1 COMPASS SYSTEM
WAMS	COMPARATOR WARNING MONITOR SYSTEM 54W-1F
WB	J-4 COMPASS SYSTEM
ZA	AUTO DIRECTION FINDER SYSTEM NO.1 DFA-70B
ZB	AUTO DIRECTION FINDER SYSTEM NO.2 DFA-70B

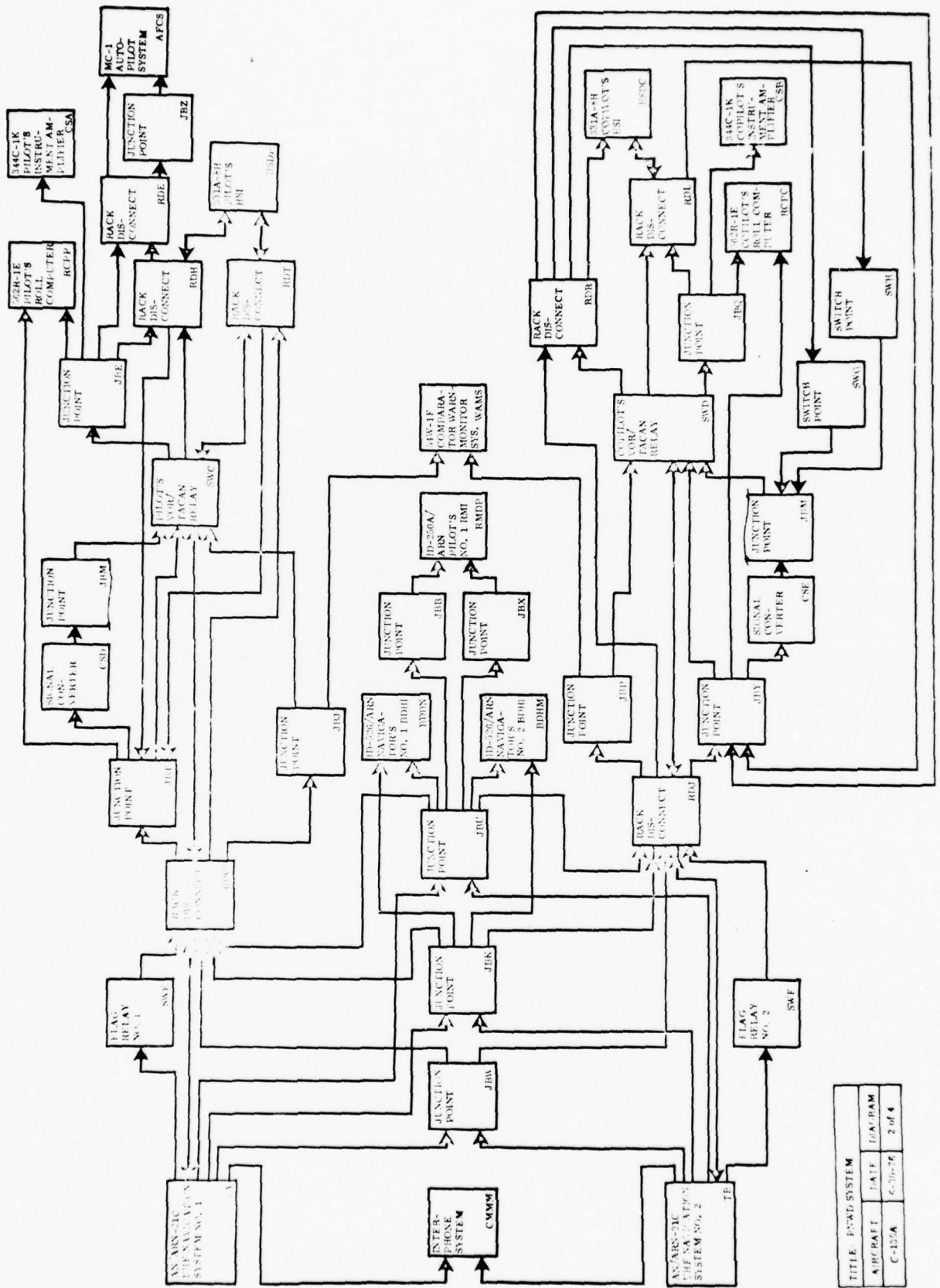

3-9A-7

TITLE: PWND SYSTEM	
AUG/PART	DATE
C-125A	6-30-74
2 of 4	

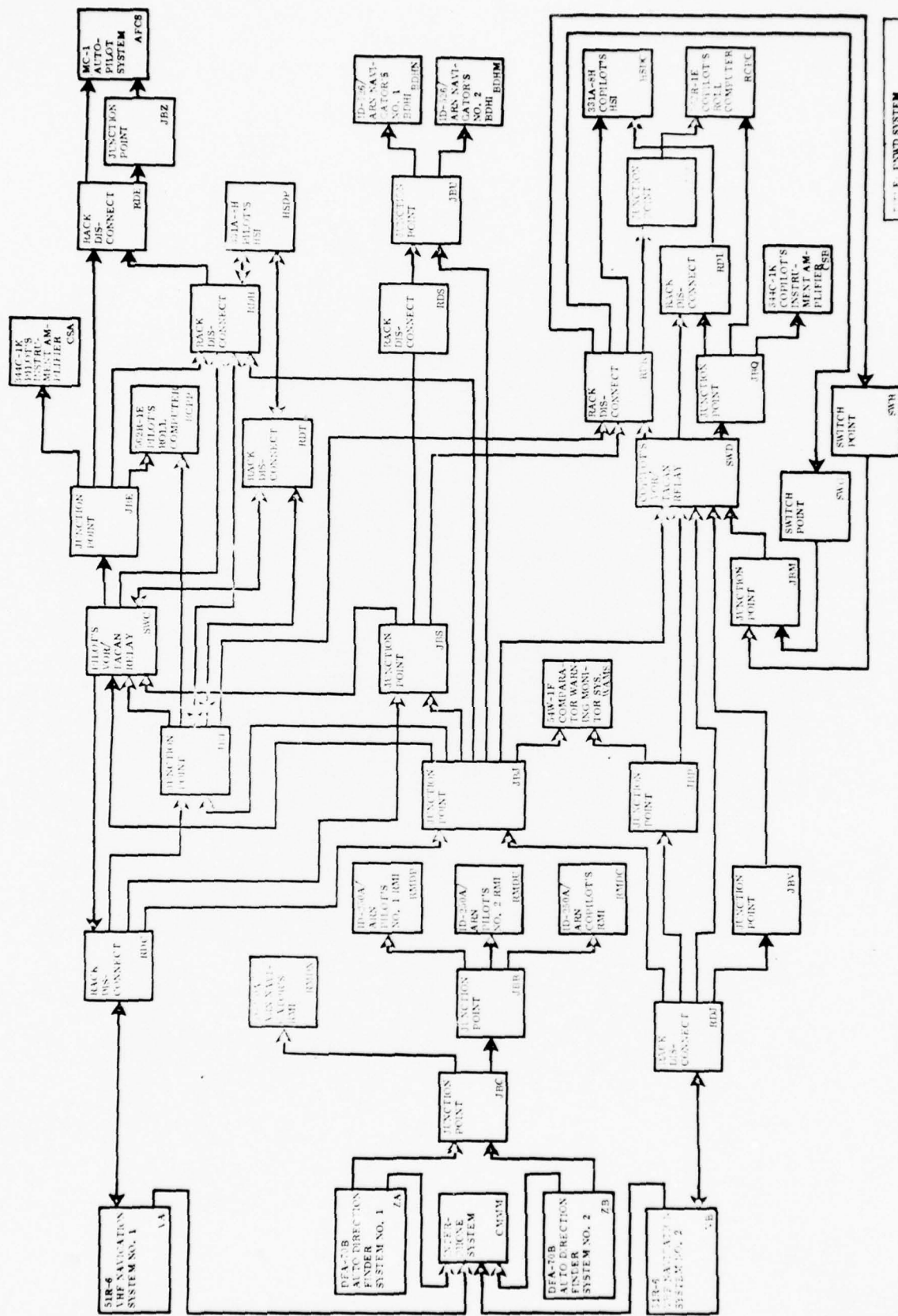

3-9A-8

FWD SYSTEM		
APP. DATE	DATE	DIAGRAM
C-135A	6-30-76	3 of 4

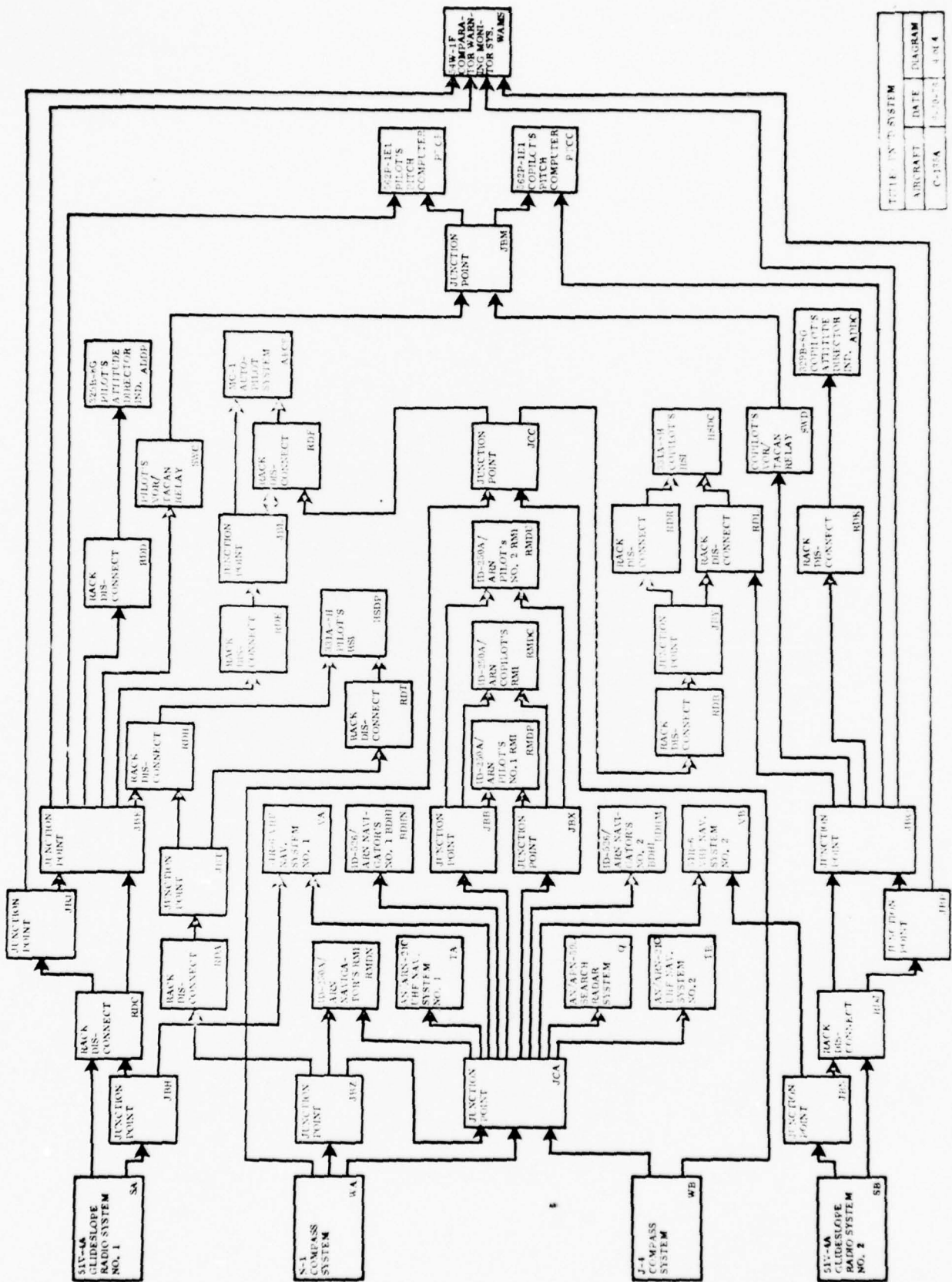

TITLE: INST. SYSTEM		
ABSTRACT	DATE	DIAGRAM
C-17A	5-20-75	4 OF 4

C-135A PNWD EQUIPMENT PHYSICAL CHARACTERISTICS

SYSTEM	UNIT		WT (LB)	SIZE (IN)		
	TYPE (P/N)	NOMENCLATURE		H	W	D
<u>DFA-70B Automatic Direction Finder System</u>						
	CNA-70C	Control Panel (4 ea)	3.5	4.5	5.8	5.8
	DFA-70B-1	Receiver (2 ea)	24.5	7.8	5.0	24.3
	LPA-71A	Loop Antenna (2 ea)	2.8	1.96	9.88	16.89
	PSA-70A-1	AC Power Supply (2 ea)	5.0	--Mounts Internally--		
	GMA-71A	Goniometer (2 ea)	1.9	3.25	3.25	5.14
	65-16189	Sense Antenna (2 ea)				
	CUA-70B-90	Sense Antenna Coupler (2 ea)	1.2	3.0	5.02	4.62
	D-9262-001	Control Switching Relay (2 ea)				
	MTA-70C	Mount (2 ea)	4.0	7.62	5.0	19.47
	FLA-70A-3	Mechanical Filter (2 ea)	0.1	0.755	0.755	2.63
<u>AN/APN-70 Loran Navigation System</u>						
	R-277()/APN-70	Receiver*	45.0	12.44	11.375	19.69
	IP-58/APN-70	Indicator	15.0	9.16	7.625	21.875
	65-2349	Antenna				
	SA-10B	Antenna Coupler				
	RALA-2A	Lightning Arrestor				
<u>Air Data System</u>						
	CPU-66/A-1	Altitude Computer	6.0	4.5	4.0	9.9
	AAU-19/A	Servoed Altimeter (2 ea)	4.5	3.25	3.25	8.813
<u>51V-4A Glideslope Radio System</u>						
	51V-4A	Glideslope Receiver (2 ea)	3.5	3.375	2.5	12.56
	37P-4	Antenna	0.7	5.984	2.0	4.5
*Includes mount						

C-135A PNWD EQUIPMENT PHYSICAL CHARACTERISTICS

SYSTEM	UNIT		WT (LB)	SIZE (IN)		
	TYPE (P/N)	NOMENCLATURE		H	W	D
<u>AN/ARN-21C UHF Navigation System (TACAN)</u>						
	RT-220C/ARN-21	Receiver-Transmitter (2 ea)	60.0	8.3	11.13	18.75
	C-866/ARN-21	Radio Set Control (2 ea)	1.5	2.25	5.75	4.75
	161B-1	Instrumentation Coupler (2 ea)	12.0	6.125	5.0	10.167
	AT-741/A	Antenna (2 ea)	0.4	3.3	1.75	5.25
	MS24568-D1	TACAN Flag Relay (2 ea)	0.73	2.7	3.0	2.3
	391233	TACAN Select ON-OFF Switch/Indicator (2 ea)				
	410-1521-010	VOR/TACAN RELay (6 ea)	0.57	2.187	1.531	1.130
	MT-928/ARN-21	Mount (2 ea)	6.5	7.75	11.125	17.5
	349L-2	Mount (2 ea)	3.0	7.75	5.91	13.875
<u>Marker Beacon Radio System</u>						
	51Z-3	Receiver	2.9	3.38	2.25	12.62
	AT-536/ARN	Antenna	2.2	3.125	7.75	11.188
	AN3022-2	Marker Beacon Sensi- tivity Switch	0.10	2.125	0.765	1.95
	STB-390-WE	Marker Beacon Light Assys (2 ea)				
<u>Radio Navigation Instruments</u>						
	ID-250A/ARN	Radio Magnetic Indicator (4 ea)	2.6	3.25 diam.		6.156
	ID-526/ARN	Bearing-Distance-Heading Indicator (2 ea)	4.0	3.25	3.25	6.875
<u>SCR-718-F High Range Radio Altimeter System</u>						
	BC-788-F	Receiver-Transmitter	12.0	7.78	15.5	8.69
	I-152-E	Indicator	9.7	6.5	6.53	12.625
	F-322/A	Filter	2.0	1.59	4.91	7.0
	AT-505/AP	Antenna (4 ea)	1.5	2.75	13.0	4.31

C-135A PNWD EQUIPMENT PHYSICAL CHARACTERISTICS

SYSTEM	UNIT		WT (LB)	SIZE (IN)		
	TYPE (P/N)	NOMENCLATURE		H	W	D
AN/APN-59B	Search Radar System					
	RT-289B/APN-59	Receiver-Transmitter	74.0	18.0	20.0 diam.	
	C-1242/APN-59	Control Panel	4.5	9.0	5.75	5.5
	IP-239A/APN-59	Navigators Indicator	19.5	6.75	6.75	17.0
	IP-268/APN-59	Pilots Indicator	8.0	5.875	5.125	9.0
	PP-1073A/APN-59	Power Supply	14.0	7.0	8.0 diam.	
	AS-653A/APN-59	Antenna	55.0	34.25	35.75 diam.	
	CN-221A/APN-59	Stabilization Data Generator	8.0	7.0	8.0 diam.	
	AM-853A/APN-59	Electronic Control Amplifier	9.0	6.688	5.5	10.0
	CV-204A/AP	Waveform Converter		7.5	5.125	9.75
	HD-150/APN-59	Vaneaxial Fan (2 ea)	2.5	9.0	6.5	5.0
MT-1557/APN-59	Mount					
AN/APN-147(V)	Doppler Radar System					
	RT-625(P)/APN-147(V)	Receiver-Transmitter	9.4	7.625	3.813	15.051
	AS-1168/APN-147(V)	Antenna	32.9	8.75	19.125	26.75
	CV-1181/APN-147(V)	Frequency Tracker	34.9	7.843	7.781	22.406
	C-3747/APN-147(V)	Doppler Radar Control Panel	0.6	1.125	5.75	2.687
	ID-938/APN-147	Ground Speed Drift Angle Indicator	3.1	3.26	6.22 diam.	
	MT-2550/APN-147	Mount	2.9	8.75	4.637	16.406
	MT-2549/APN-147	Mount	7.5	8.375	9.0	25.625

C-135A PNWD EQUIPMENT PHYSICAL CHARACTERISTICS

SYSTEM	UNIT		WT (LB)	SIZE (IN)		
	TYPE (P/N)	NOMENCLATURE		H	W	D
<u>N-1 Compass System</u>						
	DT-198/AJN	Magnetic Azimuth Detector	1.125	2.328	4.781	4.781
	15810	Directional Gyro	23.5	11.5	13.31	12.5
	15150	Slaving Control	3.75	5.09	4.56	4.56
	16000	N-1 Amplifier	23.25	9.31	13.94	9.03
	ME-1	Compass Signal Power Amplifier	9.5	6.125	4.5	10.875
	15900	Master Indicator	9.75	5.25	5.0	7.9
<u>J-4 Compass System</u>						
	18717-1A	Servo Amplifier	11.0	6.75	6.75	10.125
	DT-198/AJN	Magnetic Azimuth Detector	1.125	2.328	4.781	4.781
	MIL-C-25101	Slaving Control	4.25	5.09	4.188	4.188
	432050-2	Control Panel	1.75	2.625	5.75	3.563
	423040-2	Directional Control	7.67	6.906	7.125	9.375
<u>AL-101 Low Range Radio Altimeter System</u>						
	437X-1	Antenna (4 ea)	1.0	2.75	5.2 diam.	
	860F-1	Receiver-Transmitter (2 ea)	20.0	7.766	5.094	14.828
	339H-1()	Indicator (2 ea)	2.5	3.175	3.175	5.0
	790S-1	Mounting (2 ea)	2.2	4.875	5.859	17.188*
<u>51R-6 VHF Navigation System</u>						
	51R-6	VOR/LOC Navigation Unit (2 ea)	15.2	7.625	4.875	14.625
	313N-3	VHF Navigation Control Panel	2.0	2.625	5.75	4.375
	S65-8262-2	VHF Navigation Antenna				
*Includes sway space						

C-135A PNWD EQUIPMENT PHYSICAL CHARACTERISTICS

SYSTEM	UNIT		WT (LB)	SIZE (IN)		
	TYPE (P/N)	NOMENCLATURE		H	W	D
	<u>AN/ASQ-141 (V) Integrated Dual Flight Director System</u>					
	329B-8G	Attitude Director Indicator (2 ea)	7.5	5.125	4.875	7.5
	331A-8H	Horizontal Situation Indicator (2 ea)	7.5	4.068	4.812	8.75
	614E-9G	Flight Director Control	2.0	2.25	5.75	4.688
	562R-1E	Roll Computer (2 ea)	8.5	7.625	2.531	14.563
	562P-1E1	Pitch Computer (2 ea)	8.5	7.625	2.25	14.5
	590A-3G	Altitude Controller (2 ea)	4.4	4.167	3.344	14.031
	344C-1K	Instrument Amplifier (2 ea)	8.2	7.62	2.25	12.62
	380-1077-020	Heading Slew Control (2 ea)				
	345A-7	Rate of Turn Gyro (2 ea)	2.2	4.25	3.875	5.625
	262-2834-XXX	Mode Annunciators (16 ea)				
	262-2834-XXX	Warning Indicators (6 ea)				
	54W-4	Majority Logic Attitude Comparator	8.0	7.62	2.25	12.62
	915W-1	RGA Control Panel (2 ea)	2.5	2.2	5.7	4.3
	345H-1	Elevator Position Transmitters (2 ea)				
	262-2834-710	RGA Fail Operative Indicator (2 ea)				
	345F-1	Angle of Attack Transmitter (2 ea)	1.9	4.5 diam.		7.118
	813G-1	Angle of Attack Transmitter (2 ea)	1.5	2.4	2.4	6.5
	562U-1	RGA Computer (2 ea)	8.5	7.62	3.56	12.62
	599K-1	RGA Interface Logic Unit	5.0	3.313	3.563	12.563
	345G-1	Logitudinal Accelerometer (2 ea)	1.5	3.635	4.225	1.75
	914G-1	Comparator Warning Monitor Panel	1.2	1.875	5.75	4.0

C-135A PNWD EQUIPMENT PHYSICAL CHARACTERISTICS

SYSTEM	UNIT		WT (LB)	SIZE (IN)		
	TYPE (P/N)	NOMENCLATURE		H	W	D
<u>AN/ASQ-141(V) Integrated Dual Flight Director System (Cont'd)</u>						
	54W-1F	Comparator Warning Monitor	15.0	7.25	3.688	15.188
	161E-7B	Remote Slew Coupler	6.0	7.625	2.25	14.75
	266-6951-450	Comparative Warning Switch Indicator (2 ea)				
<u>AN/ASN-35 Course Computer Set</u>						
	CP-622	Course Computer	17.0	7.625	4.875	15.187
	MT-2551	Mount	2.25	5.75	5.875	14.25
	C-3748	Control-Indicator	6.75	4.5	5.75	5.312
	C-3749	Auxiliary Cross Track Control-Indicator	1.9	1.875	5.75	5.0
	ID-939	Multiple Error Indicator	2.75	3.26	3.26	6.5

C-135A BIBLIOGRAPHY

T.O. Number	Chq/Rev	Title
1C-135A-01	1 Jul 76	List of Applicable Publications
1C-135A-1	30 May 77	Flight Manual
1C-135A-2-9	30 Jun 77	Organizational Maintenance, Instruments, C-135A, C-135B, and RC-135A
1C-135A-2-11-1	1 Jul 77	Organizational Maintenance, Radio Communication and Navigation Systems, C-135A, C-135B, RC-135A
1C-135A-2-12-2	15 Apr 77	Organizational Maintenance, Electronic Wiring Diagrams, C-135A, C-135B, EC-135N, RC-135M, RC-135S, VC-135B, and WC-135B
5F3-3-15-13	15 Mar 75	Overhaul, Counter-Drum-Pointer Servoed Altimeter, Type AAU-19/A
5F5-4-18-3	1 Jun 73	Overhaul, Altitude Computer, Type CPU-66/A (Bendix), EC-135, C-135A, KC-135
5N1-2-6-1	20 Jun 74	Operational and Service, Magnetic Slaved, Directional Gyro Stabilized Compass System, Type N-1 (Kearfott), C-135A, KC-135A
5N1-2-10-12	15 Oct 74	Field Maintenance, Aircraft Magnetic Gyro Compass, Type J-4 (Eclipse-Pioneer), KC-135A
5N1-3-8-2	30 Sep 75	Field Maintenance, Computer Set, Navigational, AN/ASN-35 (Canadian Marconi), C-135A, C-135B
5N8-5-4-3	15 Mar 74	Overhaul, Bearing, Distance Heading Indicator, Type ID-526/ARN, ID-526(A)/ARN, ID-526(B)/ARN, ID-798/ARN
12P5-2APN59-22	1 Aug 75	Field Maintenance, Radar Set AN/APN-59B
12P5-2APN147-2	1 Nov 75	Field Maintenance, Radar Set AN/APN-147(V)

C-135A BIBLIOGRAPHY

T.O. Number	Chg/Rev	Title
12P5-3SCR718-21	12 Nov 71	Operating, Radio Sets SCR-718-D, SCR-718-E, SCR-718-F
12R5-2ARN21-42	20 Apr 72	Field Maintenance, Radio Set AN/ARN-21 (Hoffman Electronics Corporation)
12R5-4-6-12	1 Apr 75	Field Maintenance, Glideslope Radio Receiver 51V-4C, 5N-4C (Collins)
12R5-4-39-2	15 Jun 72	Field Maintenance, Radio Receivers 51Z-3 and 51Z-4 (Collins)
12R5-4-41-2	7 Sep 73	Field Maintenance, Radio Receiver, Type DFA-70B-1, Mechanical Filter, Type FLA-70A-3, Power Supply, Type PSA-70A-1, Antenna Coupler, Type CUA-70B-90, Direction Finder Control, Type CNA-70C, Electrical Goniometer, Type GMS-71A (Bendix)
12R5-4-58-2	1 Jun 73	Field Maintenance, Radio Receiver Type 51R-6 and 51R-6A (Collins)
12R5-4-73-12	1 Mar 73	Field Maintenance with Overhaul, Warning Monitor, Type 54W-1F (Collins)
12R5-4-75-12	1 May 73	Field Maintenance with Overhaul, Radio Receiver Transmitter, Type 860F-1, with the 437X-1 Antenna, and 790S-1 Shockmount, (Collins)
12R5-4-77-12	19 Nov 71	Field Maintenance with Overhaul, Flight Director Control, Type 614E-9G (Collins)
12R5-4-79-12	1 Mar 71	Field Maintenance with Overhaul, Radio Attitude Indicator, Type 339H-1 (Collins)
12R5-4-80-12	15 Jan 71	Field Maintenance with Overhaul, Air Data Sensor, Type 590A-3E (Collins)
12R5-4-81-22	15 Jan 71	Field Maintenance with Overhaul, Roll Computer, Type 562R-1E (Collins)

C-135A BIBLIOGRAPHY

T.O. Number	Chq/Rev	Title
12R5-4-82-12	15 Jun 73	Field Maintenance with Overhaul, Pitch Computer, Type 562P-1E1 (Collins)
12R5-4-83-12	21 Jul 75	Field Maintenance with Overhaul, Horizontal Situation Indicator, Type 331A-8H (Collins)
12R5-4-85-12	1 Mar 73	Field Maintenance with Overhaul, Instrument Amplifier, Type 344C-1K (Collins)
12R5-4-91-22	26 Jun 73	Field Maintenance with Overhaul, Attitude Director Indicator, Type 329B-8G (Collins)
12R5-4-92-12	15 Feb 73	Field Maintenance with Overhaul, VHF Control Unit, Type 313N-3 (Collins)
12R5-4-121-2	15 Jan 75	Field Maintenance with Overhaul, Interface Logic, Type 599K-1
12R5-4-122-2	1 Mar 73	Field Maintenance with Overhaul, Majority Logic Attitude Comparator, Type 54W-4
12R5-4-123-2	8 Jun 72	Maintenance, Integrated Dual Flight Director, Rotation Go Around System, Type AN/ASQ-141(V) (Collins)
12R5-4-124-2	15 Jul 71	Field Maintenance with Overhaul, RGA Computer, Type 562U-1 (Collins)
12R5-4-125-2	1 Dec 73	Field Maintenance with Overhaul, RGA Control Unit, Type 915W-1
12R5-4-126-2	15 Jul 71	Field Maintenance with Overhaul, Angle of Attack Indicator, Type 813G-1 (Collins)
12R5-4-127-2	2 Aug 73	Field Maintenance with Overhaul, Angle of Attack Transmitter, Type 345F-1 (Collins)
12R5-4-128-2	1 Aug 72	Field Maintenance with Overhaul and IPB, Longitudinal Accelerometer, Type 345G-1 (Collins)

C-135A BIBLIOGRAPHY

T.O. Number	Chq/Rev	Title
12R5-4-129-2	15 Feb 73	Field Maintenance with Overhaul, Rate-of-Turn Gyro, Type 345A-7 (Collins)
AN3022	31 Aug 73	Switch-Toggle, Single Pole, Three Hole Mounting
MS24568	1 Jun 75	Relay, 10 Amp, 4 PDT, Type I, Hermetically Sealed
MIL-C-25101A	5 Dec 56	Military Specification Control, Slaving; N-1 Compass

3.10.0
EC-135C

EC-135C PNWD EQUIPMENT LIST

KEY	EQUIPMENT/UNIT
A	UHF DIRECTION FINDER SYSTEM AN/ARA-25
ADDC	COPILOT'S ATTITUDE DIRECTOR IND 329B-8G
ADDP	PILOT'S ATTITUDE DIRECTOR IND 329B-8G
AFCS	AUTOPILOT SYSTEM TYPE MC-1
AIMS	AIMS TRANSPONDER SYSTEM AN/APX-64(V)
ALDC	COPILOT'S SERVOED ALTIMETER AAU-19/A
ALDP	PILOT'S SERVOED ALTIMETER AAU-19/A
CDDN	NAVIGATOR'S DESTINATION IND ID-390/ASN-7
CDDP	PILOT'S DESTINATION IND ID-390/ASN-7
CMMM	INTERPHONE SYSTEM
CSA	PILOT'S INSTRUMENT AMPLIFIER 344C-1K
CSB	COPILOT'S INSTRUMENT AMPLIFIER 344C-1K
CSC	SIGNAL CONVERTER (795-8872-003 TERMINAL BOARD WITH RN60D8252F RESISTOR)
CSD	SIGNAL CONVERTER (795-8872-004 TERMINAL BOARD WITH RN60D8252F RESISTOR)
D	DOPPLER RADAR SYSTEM AN/APN-81
DADN	NAVIGATOR'S DRIFT ANGLE IND ID-342/APN-81
GA	RADIO ALTIMETER SYSTEM NO.1 AL-101
GB	RADIO ALTIMETER SYSTEM NO.2 AL-101
GSDN	NAVIGATOR'S GROUNDSPD IND ID-341/APN-81
HSDC	COPILOT'S HSI 331A-8H
HSDP	PILOT'S HSI 331A-8H
J	NAVIGATION COMPUTER AN/ASN-7

EC-135C PNWD EQUIPMENT LIST

KEY	EQUIPMENT/UNIT
JBA	JUNCTION POINT A
JBB	JUNCTION POINT B
JBC	JUNCTION POINT C
JBD	JUNCTION POINT D
JBE	JUNCTION POINT E
JBF	JUNCTION POINT F
JBG	JUNCTION POINT G
JBH	JUNCTION POINT H
JBJ	JUNCTION POINT J
JBK	JUNCTION POINT K
JBL	JUNCTION POINT L
JBM	JUNCTION POINT M
JBN	JUNCTION POINT N
JBP	JUNCTION POINT P
JBR	JUNCTION POINT R
JBS	JUNCTION POINT S
JBT	JUNCTION POINT T
JBU	JUNCTION POINT U
JBV	JUNCTION POINT V
JBW	JUNCTION POINT W
JBX	JUNCTION POINT X
KL	AIMS ALTITUDE COMPUTER SYSTEM CPU-66/A-1

EC-135C PNWD EQUIPMENT LIST

KEY	EQUIPMENT/UNIT
PTCC	COPILOT'S PITCH COMPUTER 562P-1E1
PTCP	PILOT'S PITCH COMPUTER 562P-1E1
Q	SEARCH RADAR SYSTEM AN/APN-59B
RADC	COPILOT'S RADIO ALTIMETER IND 339H-1
RADP	PILOT'S RADIO ALTIMETER IND 339H-1
RCPC	COPILOT'S ROLL COMPUTER 562R-1E
RCPP	PILOT'S ROLL COMPUTER 562R-1E
RDA	RACK DISCONNECT A
RDB	RACK DISCONNECT B
RDC	RACK DISCONNECT C
RDD	RACK DISCONNECT D
RDE	RACK DISCONNECT E
RDF	RACK DISCONNECT F
RDG	RACK DISCONNECT G
RDH	RACK DISCONNECT H
RDJ	RACK DISCONNECT J
RDK	RACK DISCONNECT K
RDL	RACK DISCONNECT L
RDM	RACK DISCONNECT M
RDN	RACK DISCONNECT N
RMDC	COPILOT'S RMI ID-250A/ARN
RMDN	NAVIGATOR'S RMI ID-250A/ARN
RMDP	PILOT'S RMI ID-250A/ARN

EC-135C PNWD EQUIPMENT LIST

KEY	EQUIPMENT/UNIT
SA	GLIDESLOPE RADIO SYSTEM NO.1 51V-4A
SB	GLIDESLOPE RADIO SYSTEM NO.2 51V-4A
SWA	PILOT'S VOR/TACAN RELAY
SWB	COPILOT'S VOR/TACAN RELAY
SWC	FLAG RELAY
SWE	SWITCH POINT E
SWF	SWITCH POINT F
T	UHF NAVIGATION SYSTEM AN/ARN-72
VA	VHF NAVIGATION SYSTEM NO.1 51R-6
VB	VHF NAVIGATION SYSTEM NO.2 51R-6
WA	N-1 COMPASS SYSTEM
WAMS	COMPARATOR WARNING MONITOR SYSTEM 54W-1F
WB	J-4 COMPASS SYSTEM
X	TRUE AIRSPEED COMPUTER MIL-C-5191B

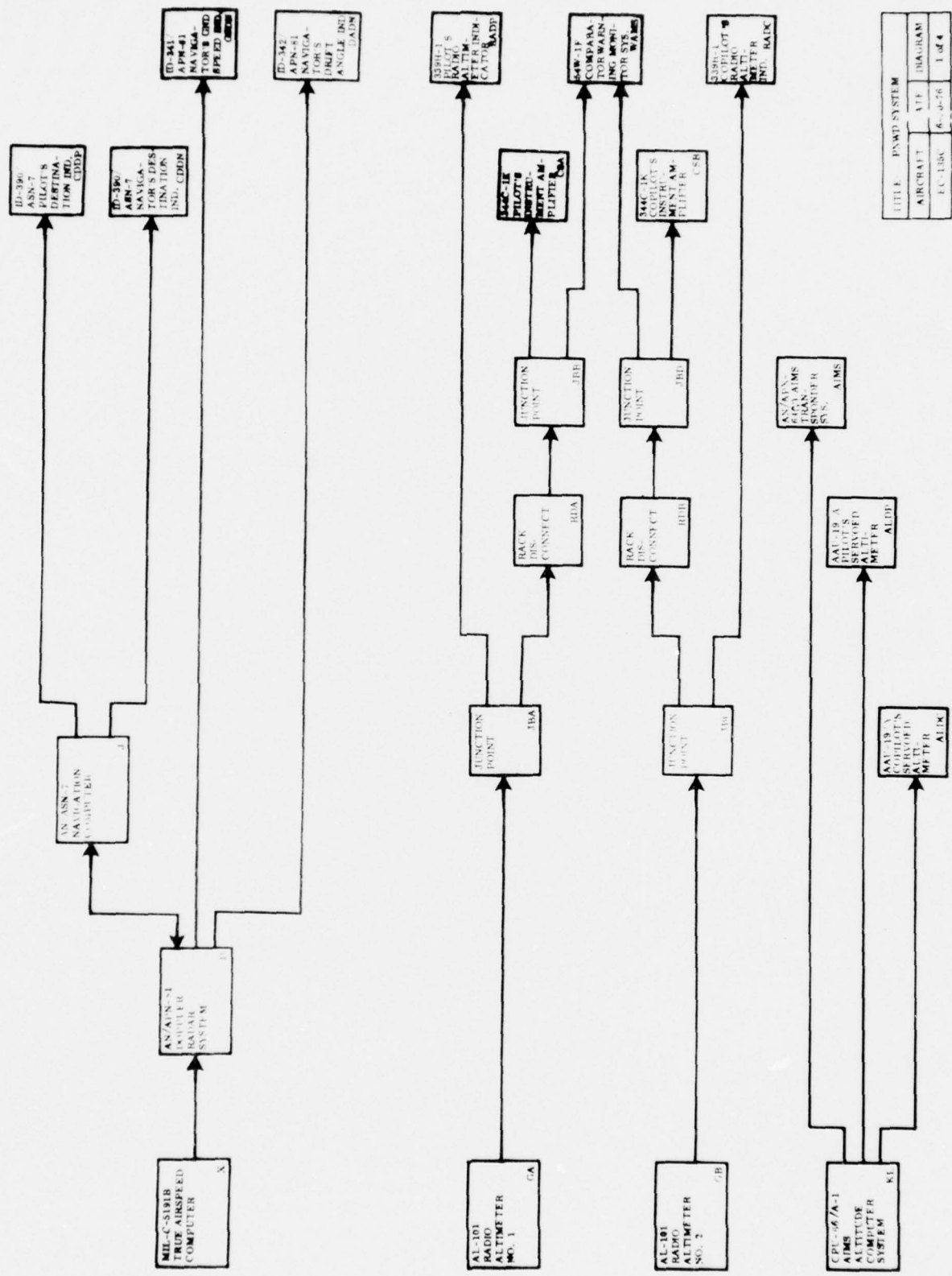

TITLE: PNAV SYSTEM		
AIRCRAFT	A/T	DAURAM
EC-130C	6-0-76	1 of 4

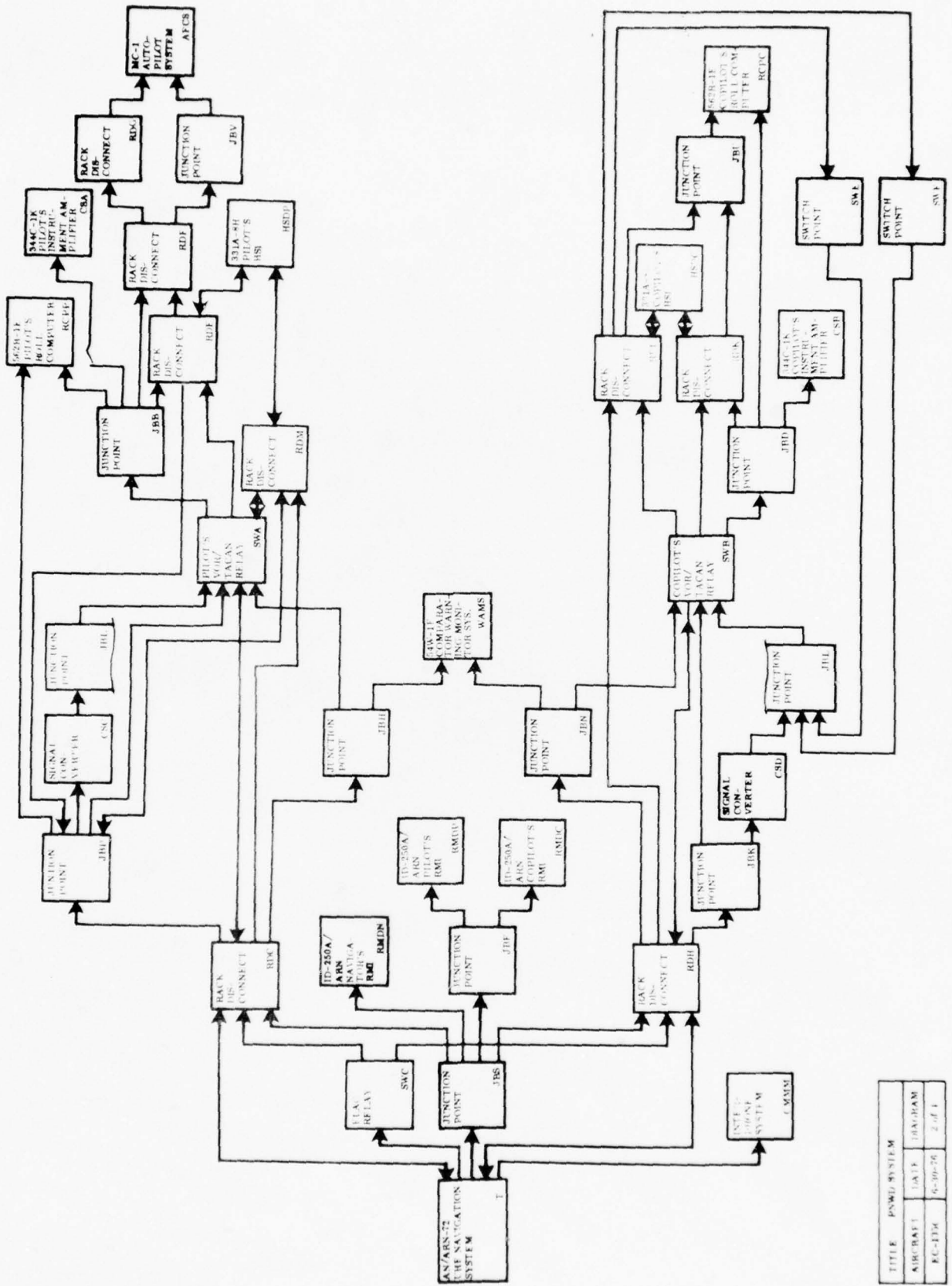

3-10A-6

TITLE: POWER SYSTEM		
AIRCRAFT	DATE	10A-10AM
EC-119	REV	2 of 1

EC-135C PNWD EQUIPMENT PHYSICAL CHARACTERISTICS

SYSTEM	UNIT		WT (LB)	SIZE (IN)		
	TYPE (P/N)	NOMENCLATURE		H	W	D
<u>AN/ARA-25 UHF Direction Finder System</u>						
	AM-608/ARA-25	Amplifier	5.4	5.875	4.875	12.531
	AS-578/ARA-25	Antenna	17.5	6.0	16.0	14.5
	RE-120/ARA-25	Relay	0.82	5.813	6.5	1.75
<u>AN/APN-81 Doppler Radar</u>						
	AS-618C/APN-81	Antenna	42.75	17.0	15.0	28.0
	AM-742A/APN-81	Amplifier	63.5	13.5	13.5	23.5
	AM-758B/APN-81	Amplifier	89.5	17.0	16.25	23.0
	AM-743/APN-81	Amplifier	9.5	7.75	6.25	10.75
	MIL-C-5191B	Computer, TAS Transmitter	3.563	3.5 diam.		8.0
	CP-185()/APN-81	Computer	33.75	9.5	9.25	18.25
	C-1196/APN-82	Control Panel	1.0	2.0	3.5	5.75
	C-1416A/APN-81	Control Panel	3.0	6.0	5.75	5.0
	C-1160/APN-81	Control Panel	8.25	7.0	7.5	8.0
	ID-341/APN-81	Indicator	1.0	3.25	3.25	3.5
	ID-342/APN-81	Indicator	1.0	3.25	3.25	3.5
	RT-274C/APN-81	Transceiver	87.5	17.0	16.25	24.0
	J-530/APN-82	Junction Box	6.0	3.0	7.5	13.0
	J-605/APN-81	Junction Box	2.0	3.25	3.25	6.25
	J-607/APN-81	Junction Box	24.5	5.0	11.0	6.0
	J-608/APN-81	Fuse Box	6.75	5.0	6.25	11.0
	CU-323	Directional Coupler	0.25	2.5	2.25	5.0
<u>AN/ASN-7 Navigation Computer</u>						
	AM-917A/AJN-7	Amplifier	8.5	5.109	8.859	9.344
	AM-1069/ASN-7	Amplifier	8.75	5.109	8.859	8.016
	CP-289A/ASN-7	Computer	18.0	5.656	5.844	10.0
	CP-290B/ASN-7	Computer	4.5	3.438	4.344	7.094
	CP-221/ASN-7	Computer	16.75	5.0	8.438	10.969

EC-135C PNWD EQUIPMENT PHYSICAL CHARACTERISTICS

SYSTEM	UNIT		WT (LB)	SIZE (IN)		
	TYPE (P/N)	NOMENCLATURE		H	W	D
<u>AN/ASN-7 Navigation Computer (Cont'd)</u>						
	C-1317A/ASN-7	Control Panel	8.25	4.781	5.031	7.688
	ID-390/ASN-7	Indicator (2 ea)	2.63	3.125 diam.		6.422
<u>51V-4A Glideslope Radio System</u>						
	51V-4A	Glideslope Receiver (2 ea)	3.5	3.375	2.25	12.56
	37P-4	Antenna	0.7	5.984	2.0	4.5
<u>Air Data System</u>						
	CPU-66/A-1	Altitude Computer	6.0	4.5	4.0	9.9
	AAU-19/A	Servoed Altimeter (2 ea)	4.5	3.25	3.25	8.813
<u>AN/ARN-72 UHF Navigation System</u>						
	RT-636/ARN-72	Receiver-Transmitter	60.0	9.813	11.125	18.75
	C-3844/ARN-72	Radio Set Control	1.5	2.25	5.75	3.813
	161B-1	Instrumentation Coupler	12.0	6.125	5.0	10.167
	AT-741/A	Antenna (2 ea)	0.4	3.3	1.75	5.25
	MS24568-D1	TACAN Flag Relay	0.73	2.7	3.0	2.3
	391233	TACAN Select ON-OFF Switch/Indicator (2 ea)				
	410-1521-010	VOR/TACAN Relay (2 ea)	0.57	2.187	1.531	1.130
	MT-2601/ARN-72	Mount	6.0	1.625	11.125	19.375
	349L-2	Mount	3.0	7.75	5.91	13.875
<u>AN/ARN-32 Marker Beacon Radio System</u>						
	R-666()/ARN-32	Receiver	2.6	2.188	5.125	7.625
	AT-536/ARN	Antenna	2.2	3.125	7.75	11.188
	MS25041-4	Marker Beacon Light (6 ea)	0.04	0.650 diam.		1.75
	MT-1546/ARN-32	Mount	1.3	2.0	6.0	8.0

EC-135C PNWD EQUIPMENT PHYSICAL CHARACTERISTICS

SYSTEM	UNIT		WT (LB)	SIZE (IN)		
	TYPE (P/N)	NOMENCLATURE		H	W	D
<u>Radio Navigation Instruments</u>						
	ID-250A/ARN	Radio Magnetic Indicator (3 ea)	2.6	3.25 diam.		6.156
<u>AN/APN-133 Radio Altimeter System</u>						
	RT-529/APN-133	Receiver-Transmitter	20.5	7175	15.125	8.625
	IP-667/APN-133	Indicator	11.0	6.5	6.313	12.5
	AT-913/APN-133	Antenna (2 ea)	1.5	2.5	13.0	4.0
<u>AN/APN-59B Search Radar System</u>						
	RT-289B/APN-59	Receiver-Transmitter	74.0	18.0	20.0 diam.	
	C-1242/APN-59	Control Panel	4.5	9.0	5.75	5.5
	IP-239A/APN-59	Indicator, Navigators	19.5	6.75	6.75	17.0
	IP-268/APN-59	Pilots Indicator	8.0	5.875	5.125	9.0
	PP-1073A/APN-59	Power Supply	14.0	7.0	8.0 diam.	
	AS-653A/APN-59	Antenna	55.0	34.25	35.75 diam.	
	CN-221A/APN-59	Stabilization Data Generator	8.0	7.0	8.0 diam.	
	AM-853A/APN-59	Electronic Control Amplifier	9.0	6.688	5.5	10.0
	HD-150/APN-59	Vaneaxial Fan (2 ea)	2.5	9.0	6.5	5.0
<u>N-1 Compass System</u>						
	DT-198/AJN	Magnetic Azimuth Detector	1.125	2.328	4.781	4.781
	15810	Directional Gyro	23.5	11.5	13.31	12.5
	15150	Slaving Control	3.75	5.09	4.56	4.56
	16000	N-1 Amplifier	23.25	9.31	13.94	9.03
	ME-1	Compass Signal Power Amplifier	9.5	6.125	4.5	10.875
	15900	Master Indicator	9.75	5.25	5.0	7.9

EC-135C PNWD EQUIPMENT PHYSICAL CHARACTERISTICS

SYSTEM	UNIT		WT (LB)	SIZE (IN)		
	TYPE (P/N)	NOMENCLATURE		H	W	D
<u>J-4 Compass System</u>						
	18717-1A	Servo Amplifier	11.0	6.75	6.75	10.125
	DT-198/AJN	Magnetic Azimuth Detector	1.125	2.328	4.781	4.781
	MIL-C-25101	Slaving Control	4.25	5.09	4.188	4.188
	432050-2	Control Panel	1.75	2.625	5.75	3.563
	423040-2	Directional Control	7.67	6.906	7.125	9.375
<u>AL-101 Low Range Radio Altimeter System</u>						
	437X-1	Antenna (4 ea)	1.0	2.75	5.2 diam.	
	860F-1	Receiver-Transmitter (2 ea)	20.0	7.766	5.094	14.828
	339H-1()	Indicator (2 ea)	2.5	3.175	3.175	5.0
	790S-1	Mounting (2 ea)	2.2	4.875	5.859	17.188*
<u>51R-6 VHF Navigation System</u>						
	51R-6	VOR/LOC Navigation Unit (2 ea)	15.2	7.625	4.875	14.625
	313N-3	VHF Navigation Control Panel	2.0	2.625	5.75	4.375
	5-88152	VHF Navigation Antenna (2 ea)				
<u>AN/ASQ-141(V) Integrated Dual Flight Director System</u>						
	329B-8G	Attitude Director Indicator (2 ea)	7.5	5.125	4.875	7.5
	331A-8H	Horizontal Situation Indicator (2 ea)	7.5	4.068	4.812	8.75
	614E-9G	Flight Director Control (2 ea)	2.0	2.25	5.75	4.688
	562R-1E	Roll Computer (2 ea)	8.5	7.625	2.531	14.563
	562P-1E1	Pitch Computer (2 ea)	8.5	7.625	2.25	14.5
*Includes sway space						

EC-135C PNWD EQUIPMENT PHYSICAL CHARACTERISTICS

SYSTEM	UNIT		WT (LB)	SIZE (IN)		
	TYPE (P/N)	NOMENCLATURE		H	W	D
<u>AN/ASQ-141(V) Integrated Dual Flight Director System (Cont'd)</u>						
	590A-3E	Altitude Controller (2 ea)	4.4	4.167	3.344	14.031
	344C-1K	Instrument Amplifier (2 ea)	8.2	7.62	2.25	12.62
	380-1077-020	Heading Slew Control (2 ea)				
	345A-7	Rate of Turn Gyro (2 ea)	2.2	4.25	3.875	5.625
	262-2834-XXX	Code Annunciators				
	262-2834-XXX	Warning Indicators				
	54W-4	Majority Logic Attitude Comparator	8.0	7.62	2.25	12.62
	915W-1	RGA Control Panel (2 ea)	2.5	2.2	5.7	4.3
	345H-1	Elevator Position Transmitters (2 ea)				
	262-2834-710	RGA Fail Operative Indicator (2 ea)				
	345F-1	Angle of Attack Trans- mitter (2 ea)	1.9	4.5 diam.		7.118
	813G-1	Angle of Attack Indicator (2 ea)	1.5	2.4	2.4	6.5
	562U-1	RGA Computer (2 ea)	8.5	7.62	3.56	12.62
	599K-1	RGA Interface Logic Unit	5.0	3.313	3.563	12.563
	345G-1	Longitudinal Accelero- meter (2 ea)	1.5	3.635	4.225	1.75
	914G-1	Comparator Warning Panel	1.2	1.875	5.75	4.0
	54W-1F	Comparator Warning	15.0	7.25	33.688	15.188
	161E-7B	Remote Slew Coupler	6.0	7.625	2.25	14.75
	266-6951-450	Comparator Warning Switch/Indicator (2 ea)				

EC-135C BIBLIOGRAPHY

T.O. Number	Chg/Rev	Title
1C-135A-01	1 Dec 72	List of Applicable Publications
1C-135(E)C-1	10 Jun 77	Flight Manual, EC-135C
1C-135(E)C-2-11-1	10 Feb 77	Organizational Maintenance, Radar Navigation and Autopilot Systems, EC-135C
1C-135(E)C-2-12-2	1 Apr 77	Organizational Maintenance, Electronic Wiring Diagrams, EC-135C, and EC-135J
5F3-3-15-13	15 Mar 75	Overhaul, Counter-Drum-Pointer Servoed, Altimeter, Type AAU-19/A
5F5-4-18-3	1 Jun 73	Overhaul, Altitude Computer, Type CPU-66/A (Bendix)
5N1-2-6-1	20 Jun 74	Operational and Service, Magnetic Slaved, Directional Gyro Stabilized Compass System, Type N-1 (Kearfott), C-135A
5N1-2-10-12	15 Oct 74	Field Maintenance, Aircraft Magnetic Gyro Compass, Type J-4 (Eclipse-Pioneer)
5N1-3-4-2	15 Aug 75	Field Maintenance, Computer Set, Navigational, Type AN/ASN-7 (Ford Instrument)
12P5-2APN59-22	1 Aug 75	Field Maintenance, Radar Set, AN/APN-59B
12P5-2APN81-2	20 Jan 75	Service, Radar Set AN/APN-81 (GPL)
12P5-2APN133-2	6 Mar 75	Field Maintenance and Overhaul, Electronic Altimeter Set, Type AN/APN-133, -133A (Stewart-Warner)
12R1-2ARA25-2	15 Feb 73	Service, Direction Finder Group, AN/ARA-25 and -25A
12R5-2ARN32-2	15 Jan 75	Field Maintenance, Radio Receiving Set, Type AN/ARN-32 (Stromberg Carlson)

EC-135C BIBLIOGRAPHY

T.O. Number	Chg/Rev	Title
12R5-2ARN-72-2	18 Sep 73	Field Maintenance, Radio Set, AN/ARN-72 (Hoffman Electronics Corporation)
12R5-4-6-12	1 Apr 75	Field Maintenance, Glideslope Radio Receiver, Type 51V-4-A, 51V-4C (Collins)
12R5-4-58-2	1 Jun 73	Field Maintenance, Radio Receiver Type 51R-6 and 51R-6A (Collins)
12R5-4-73-12	1 Mar 73	Field Maintenance with Overhaul, Warning Monitor, Type 54W-1F (Collins)
12R5-4-75-12	1 May 73	Field Maintenance with Overhaul, Radio Receiver Transmitter, Type 860F-1, with the 437X-1 Antenna, and 790S-1 Shockmount, (Collins)
12R5-4-77-12	18 Nov 71	Field Maintenance with Overhaul, Flight Director Control, Type 614E-9G (Collins)
12R5-4-79-12	1 Mar 71	Field Maintenance with Overhaul, Radio Attitude Indicator, Type 339H-1 (Collins)
12R5-4-80-12	15 Jan 71	Field Maintenance with Overhaul, Air Data Sensor, Type 590A-3E (Collins)
12R5-4-81-22	15 Jun 73	Field Maintenance with Overhaul, Roll Computer, Type 562R-1E (Collins)
12R5-4-82-22	15 Jun 73	Field Maintenance with Overhaul, Pitch Computer, Type 562P-1E1 (Collins)
12R5-4-83-12	21 Jul 75	Field Maintenance with Overhaul, Horizontal Situation Indicator, Type 331A-8H (Collins)
12R5-4-85-12	1 Mar 73	Field Maintenance with Overhaul, Instrument Amplifier, Type 344C-1K (Collins)

EC-135C BIBLIOGRAPHY

T.O. Number	Chg/Rev	Title
12R5-4-91-22	26 Jun 73	Field Maintenance with Overhaul, Attitude Director Indicator, Type 329B-8G (Collins)
12R5-4-92-12	15 Feb 73	Field Maintenance with Overhaul, VHF Control Unit, Type 313N-3 (Collins)
12R5-4-121-2	15 Jan 75	Field Maintenance with Overhaul, Interface Logic, Type 599K-1
12R5-4-122-2	1 Mar 73	Field Maintenance with Overhaul, Majority Logic Attitude Comparator, Type 54W-4
12R5-4-123-2	9 Jun 72	Maintenance, Integrated Dual Flight Director, Rotation Go Around System, Type AN/ASQ-141(V) (Collins)
12R5-4-124-2	15 Jul 71	Field Maintenance with Overhaul, RGA Computer, Type 562U-1 (Collins)
12R5-4-125-2	1 Dec 73	Field Maintenance with Overhaul, RGA Control Unit, Type 915W-1
12R5-4-126-2	15 Jul 71	Field Maintenance with Overhaul, Angle of Attack Indicator, Type 813G-1 (Collins)
12R5-4-127-2	2 Aug 73	Field Maintenance with Overhaul, Angle of Attack Transmitter, Type 345F-1 (Collins)
12R5-4-128-2	1 Aug 72	Field Maintenance with Overhaul and IPB, Longitudinal Accelerometer, Type 345G-1 (Collins)
12R5-4-129-2	15 Feb 73	Field Maintenance with Overhaul, Rate-of-Turn Gyro, Type 345A-7 (Collins)
MS24568	1 Jun 75	Military Specification, Relay, 10 Amp, 4 PDT, Type I, Hermetically Sealed
MIL-C-25101A	5 Dec 56	Military Specification, Control, Slaving; N-1 Compass

3.11.0
KC-135A

KC-135A PNWD EQUIPMENT LIST

KEY	EQUIPMENT/UNIT
A	UHF ADF SYSTEM AN/ARA-25
AC	CPU-66/A-1 AIMS ALTITUDE COMPUTER
ADDC	329B-8G COPILOT'S ADI
ADDP	329B-8G PILOT'S ADI
AFCS	MC-1 AUTOPILOT SYSTEM
AIMS	AIMS TRANSPONDER SYSTEM AN/APX-64 (V)
ALDC	AAU-19/A COPILOT'S SERVOED ALTIMETER
ALDP	AAU-19/A PILOT'S SERVOED ALTIMETER
CMMM	INTERPHONE SYSTEM
CSA	PILOT'S INSTRUMENT AMPLIFIER 344C-1K
CSB	COPILOT'S INSTRUMENT AMPLIFIER 344C-1K
GA	AL-101 RADIO ALTIMETER NO. 1
GB	AL-101 RADIO ALTIMETER NO. 2
HSDC	331A-8H COPILOT'S HSI
HSDP	331A-8H PILOT'S HSI
JBA	JUNCTION POINT A
JBC	JUNCTION POINT C
JBD	JUNCTION POINT D
JBE	JUNCTION POINT E
JBF	JUNCTION POINT F
JBG	JUNCTION POINT G
JBH	JUNCTION POINT H
JBJ	JUNCTION POINT J

KC-135A PNWD EQUIPMENT LIST

KEY	EQUIPMENT/UNIT
JBK	JUNCTION POINT K
JBL	JUNCTION POINT L
JBM	JUNCTION POINT M
JBN	JUNCTION POINT N
JBP	JUNCTION POINT P
JBQ	JUNCTION POINT Q
JBR	JUNCTION POINT R
JBS	JUNCTION POINT S
JBT	JUNCTION POINT T
JBU	JUNCTION POINT U
JBV	JUNCTION POINT V
JBW	JUNCTION POINT W
JBX	JUNCTION POINT X
JBZ	JUNCTION POINT Y
JCA	JUNCTION POINT Z
JCA	JUNCTION POINT AA
PTCC	COPILOT'S PITCH COMPUTER 562P-1E1
PTCP	PILOT'S PITCH COMPUTER 562P-1E1
Q	SEARCH RADAR SYSTEM AN/APN-59
RADC	COPILOT'S RADIO ALTIMETER INDICATOR 339H-1
RADP	PILOT'S RADIO ALTIMETER INDICATOR 339H-1
RCPC	COPILOT'S ROLL COMPUTER 562R-1E
RCPP	PILOT'S ROLL COMPUTER 562R-1E

KC-135A PNWD EQUIPMENT LIST

KEY	EQUIPMENT/UNIT
RDA	RACK DISCONNECT A
RDB	RACK DISCONNECT B
RDC	RACK DISCONNECT C
RDD	RACK DISCONNECT D
RDE	RACK DISCONNECT E
RDF	RACK DISCONNECT F
RDG	RACK DISCONNECT G
RDH	RACK DISCONNECT H
RDJ	RACK DISCONNECT J
RDK	RACK DISCONNECT K
RDL	RACK DISCONNECT L
RDM	RACK DISCONNECT M
RDN	RACK DISCONNECT N
RDP	RACK DISCONNECT P
RDQ	RACK DISCONNECT Q
RMDC	ID-250A/ARN COPILOT'S RMI
RMDN	ID-250A/ARN NAVIGATOR'S RMI
RMDP	ID-250A/ARN PILOT'S RMI
SA	51V-4A PILOT'S GLIDESLOPE SYSTEM
SB	51V-4A COPILOT'S GLIDESLOPE SYSTEM
SWA	PILOT'S VOR/TACAN RELAY
SWB	COPILOT'S VOR/TACAN RELAY
SWC	FLAG RELAY

KC-135A PNWD EQUIPMENT LIST

KEY	EQUIPMENT/UNIT
SWD	SWITCH POINT D
SWE	SWITCH POINT E
T	TACAN SYSTEM AN/ARN-72
VA	51R-6 PILOT'S VHF NAV SYSTEM
VB	51R-6 COPILOT'S VHF NAV SYSTEM
WA	N-1 COMPASS SYSTEM
WAMS	COMPARATOR WARNING MONITOR 54W-1F
WB	J-4 COMPASS SYSTEM

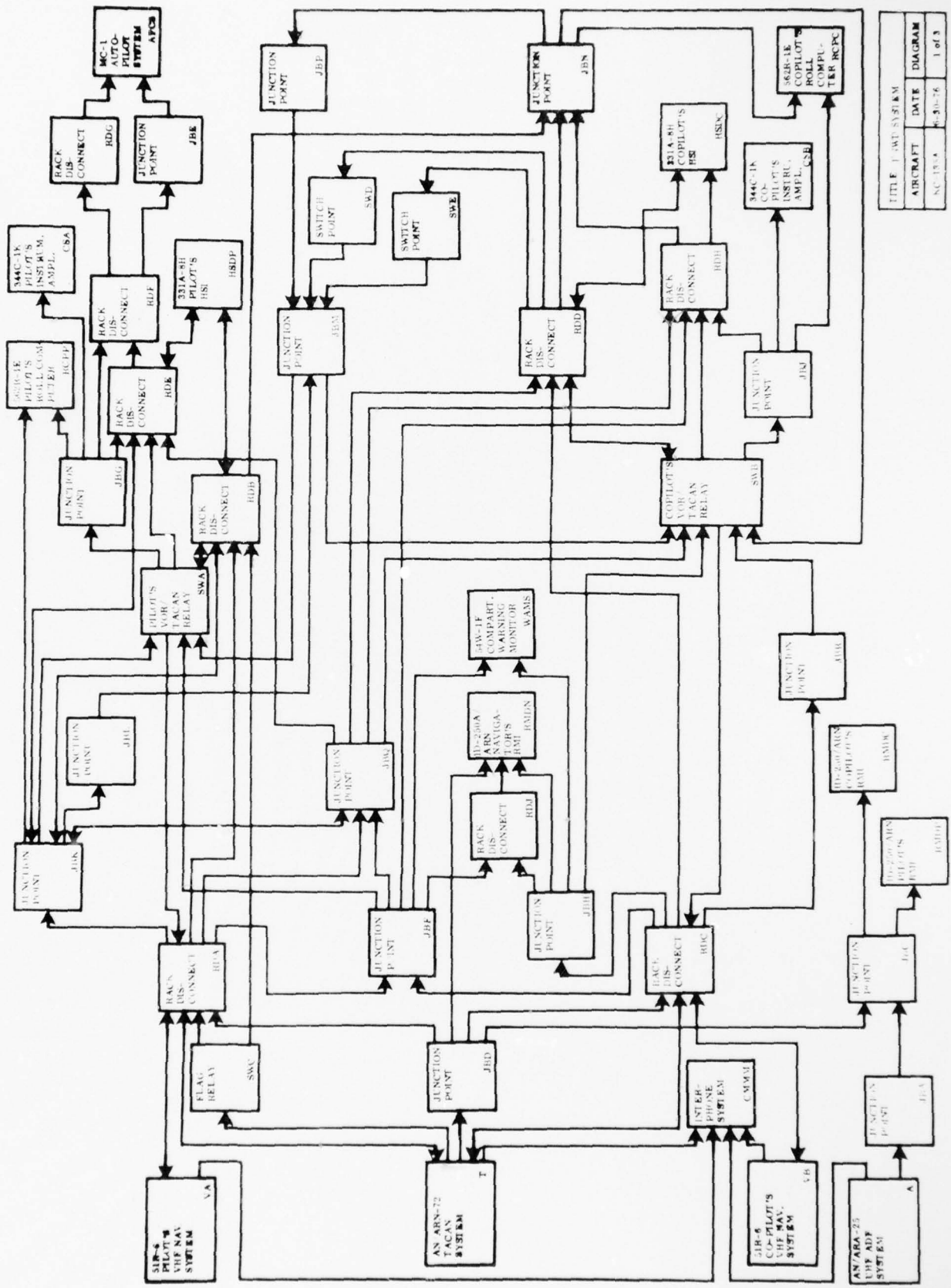

TITLE	AIRCRAFT	DATE	DIAGRAM
VHF NAV SYSTEM	AC-119A	10-3-56	1 of 3

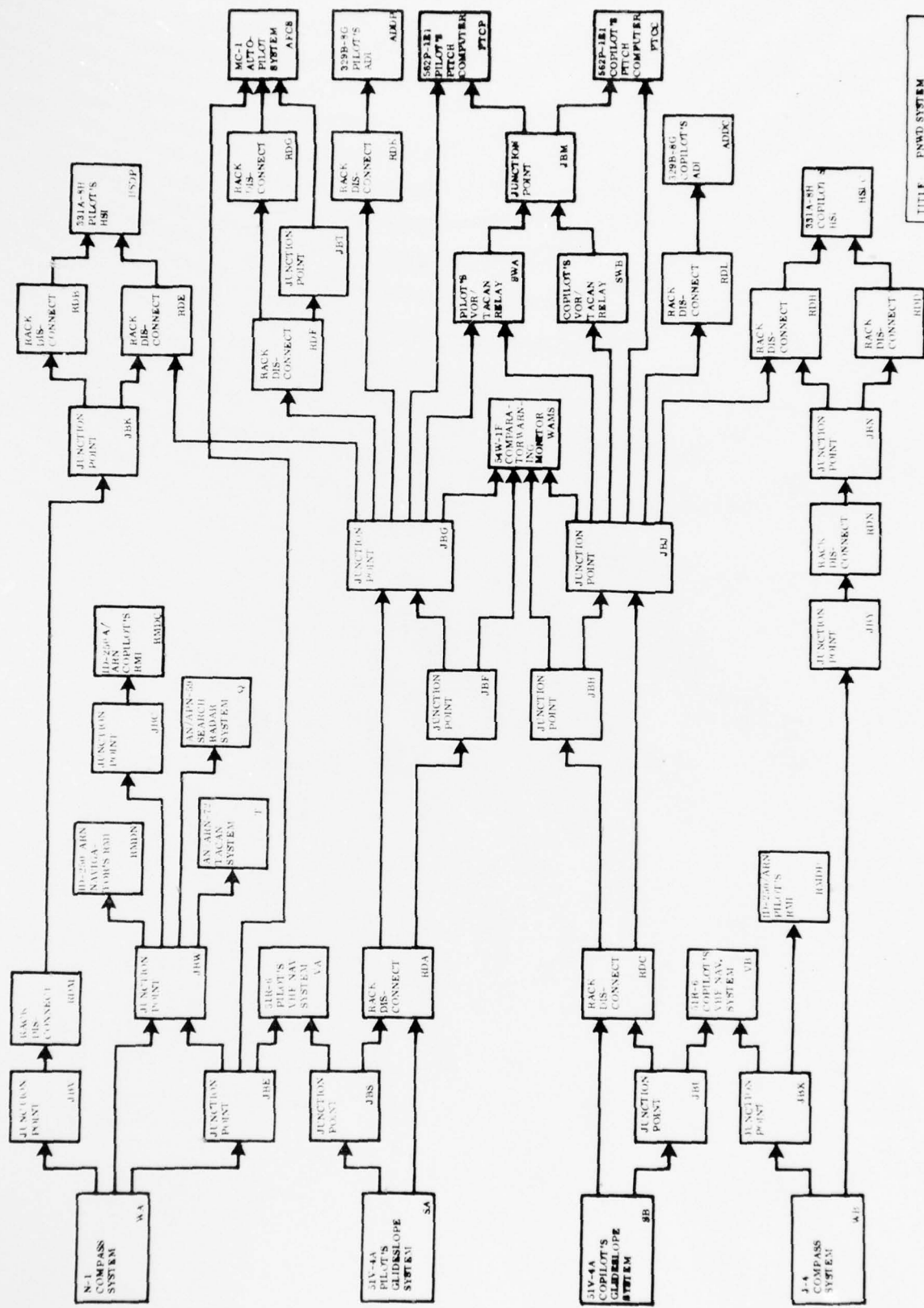

TITLE	PWID SYSTEM
AIRCRAFT	DATE
AC-119A	8-30-76
	DIAGRAM
	2 of 3

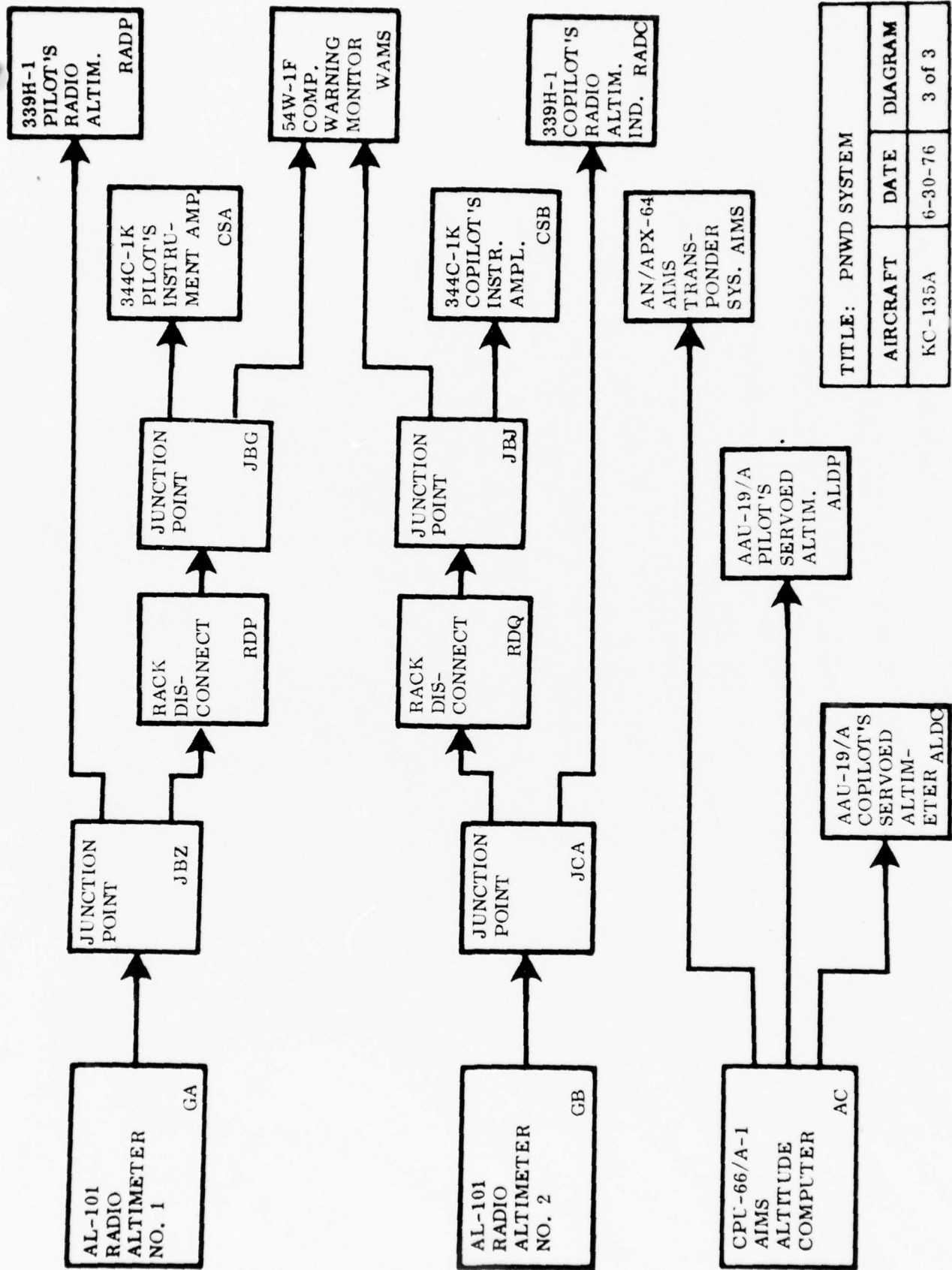

TITLE: PNWD SYSTEM

AIRCRAFT	DATE	DIAGRAM
KC-135A	6-30-76	3 of 3

KC-135A PNWD EQUIPMENT PHYSICAL CHARACTERISTICS

SYSTEM	UNIT		WT (LB)	SIZE (IN)		
	TYPE (P/N)	NOMENCLATURE		H	W	D
<u>51R-6 VHF Navigation System</u>						
	51R-6	Navigation Unit (2 ea)	15.2	7.625	4.875	14.625
	313N-3	VHF Navigation Control	2.0	2.625	5.75	4.375
	BAC 5-88152-20	VHF Navigation Antenna				
<u>51V-4A Glide Slope Radio System</u>						
	51V-4A	Glide Slope Receiver	3.5	3.375	2.25	12.56
	37P-4	Glide Slope Antenna (2 ea)	0.7	5.984	2.0	4.5
<u>AL-101 Low Range Radio Altimeter System</u>						
	860F-1	Receiver-Transmitter (2 ea)	20.0	7.766	5.094	14.828
	790S-1	Mount (2 ea)	2.2	4.875	5.859	17.188*
	339H-1	Indicator (RAI) (2 ea)	2.5	3.175	3.175	5.0
	437X-1	Transmitting Antenna (2 ea)	1.0	2.75	5.2 diam.	
	437X-1	Receiving Antenna (2 ea)	1.0	2.75	5.2 diam.	
<u>Air Data System</u>						
	CPU-66/A-1	Altitude Computer	6.0	4.5	4.0	9.9
	AAU-19/A	Servoed Altimeter (2 ea)	4.5	3.25	3.25	8.813
<u>AV/ASQ-141(V) Integrated Dual Flight Director System</u>						
	344C-1K	Instrument Amplifier (2 ea)	8.2	7.62	2.25	12.62
	562P-1E1	Pitch Computer (2 ea)	8.5	7.625	2.25	14.5
	562R-1E	Roll Computer (2 ea)	8.5	7.625	2.531	14.563
*Includes sway space.						

KC-135A PNWD EQUIPMENT PHYSICAL CHARACTERISTICS

SYSTEM	UNIT		WT (LB)	SIZE (IN)		
	TYPE (P/N)	NOMENCLATURE		H	W	D
<u>AN/ASQ-141(V) Integrated Dual Flight Director System (Cont'd)</u>						
	54W-4	Majority Logic Attitude Comparator	8.0	7.62	2.25	12.62
	599K-1	RGA Interface Logic Unit	5.0	3.313	3.563	12.563
	161E-7B	Remote Slew Coupler	6.0	7.625	2.25	14.75
	562U-1	RGA Computer (2 ea)	8.5	7.62	3.56	12.62
	795-8987-001	Diode Box (2 ea)				
	614E-9G	Flight Director Control (2 ea)	2.0	2.25	5.75	4.688
	915W-1	RGA Control (2 ea)	2.5	2.2	5.7	4.3
	590A-3E	Altitude Controller (2 ea)	4.4	4.167	3.344	14.031
	345A-7	Rate-of-Turn Gyro (2 ea)	2.2	4.25	3.875	5.625
	331A-8H	Horizontal Situation Indicator (2 ea)	7.5	4.068	4.812	8.75
	54W-1F	Warning Monitor	15.0	7.25	3.688	15.188
	329B-8G	Pilot's Attitude Director Indicator (2 ea)	7.5	5.125	4.875	7.5
	813G-1	Angle of Attack Indicator (2 ea)	1.5	2.4	2.4	6.5
	345G-1	Longitudinal Accelerometer (2 ea)	1.5	3.635	4.225	1.75
	345F-1	Angle of Attack Transmitter (2 ea)	1.9	4.5 diam.		7.118
	345H-1	Elevator Position Transmitter (2 ea)				
<u>Radio Navigation Instruments</u>						
	ID-250A/ARN	Pilot's Radio Magnetic Indicator (RMI)	2.6	3.25 diam.		6.156
	ID-250A/ARN	Copilot's Radio Magnetic Indicator (RMI)	2.6	3.25 diam.		6.156
	ID-250A/ARN	Navigator's Radio Magnetic Indicator (RMI)	2.6	3.25 diam.		6.156

KC-135A PNWD EQUIPMENT PHYSICAL CHARACTERISTICS

SYSTEM	UNIT		WT (LB)	SIZE (IN)		
	TYPE (P/N)	NOMENCLATURE		H	W	D
<u>Radio Navigation Instruments (Cont'd)</u>						
	C-1416()/APN-81	Auto Nav Radar Control Panel	3.0	6.0	5.75	5.0
	C-1196/APN-82	Nav Radar Control Panel	1.125	1.875	3.5	5.75
	C-1317()/ASN-7	ASN-7 Control Panel	8.25	4.781	5.031	7.688
	J-530/APN-82	APN-82 System Interconnecting Box	6.0	3.0	7.375	13.0
	ID-341/APN-81	Ground Speed Indicator	1.125	3.25	3.25	3.5
	ID-342/APN-81	Drift Angle Indicator	1.125	3.25	3.25	3.5
	ID-390/ASN-7	Pilot's Destination Indicator	2.63	3.125 diam.		6.422
	ID-390/ASN-7	Navigator's Destination Indicator	2.63	3.125 diam.		6.422
<u>N-1 Compass System</u>						
	DT-198/AJN	Magnetic Azimuth Detector	1.125	2.328	4.781	4.781
	1600	N-1 Amplifier	23.25	9.31	13.94	9.03
	ME-1A	Compass Signal Power Amplifier	9.5	6.125	4.5	10.875
	15810-1	Directional Gyro	23.5	11.5	13.31	12.5
	15150-1	Slaving Control	3.75	5.09	4.56	4.56
	15900	Master Indicator	9.75	5.25	5.0	7.9
<u>J-4 Compass System</u>						
	DT-198/AJN	Magnetic Azimuth Detector	1.125	2.328	4.781	4.781
	42306-3	Servo Amplifier	11.0	6.563	7.125	9.375
	423040-2	Directional Control	7.67	6.906	7.219	8.219
	MIL-C-25101	Slaving Control	4.25	5.09	4.188	4.188
	432050-2	Control Panel	1.75	2.625	5.75	3.563
<u>AN/ARN-72 UHF Navigation System (TACAN)</u>						
	RT-636/ARN-72	Receiver-Transmitter	60.0	9.813	11.125	18.75
	MT-2601/ARN-72	Mount	6.0	1.625	11.125	19.375

KC-135A PNWD EQUIPMENT PHYSICAL CHARACTERISTICS

SYSTEM	UNIT		WT (LB)	SIZE (IN)		
	TYPE (P/N)	NOMENCLATURE		H	W	D
<u>AN/ARN-72 UHF Navigation System (TACAN) (Cont'd)</u>						
	C-3844/ARN-72	Control Panel	1.5	2.25	5.75	3.813
	AT-741/A	Antenna (Top)	0.4	3.3	1.75	5.25
	AT-234/APX	Antenna (Bottom)				
	SA-521/A	Antenna Switching Relay	0.34	1.94	2.78	3.19
	161B-1	Instrumentation Coupler	12.0	6.125	5.0	10.167
	349L-2	Mount	3.0	7.75	5.91	13.875
	795-8383-001	TACAN Antenna Select Panel				
	MS24568-D1	TACAN Flag Relay	0.73	2.7	3.0	2.3
	410-1521-001	VOR/TACAN Transfer Relay (2 ea)				
<u>AN/ARN-32 Marker Beacon Radio System</u>						
	R-666()ARN-32	Receiver	6.1*	6.125	7.75	11.813*
	MT-1546/ARN-32	Mount	2.6	2.188	5.125	7.625
	AT-536/ARN	Antenna	2.2	3.125	7.75	11.188
	MS25041	Marker Beacon Light (6 ea)	0.04	0.650 diam.		1.75
<u>AN/APN-133A Radio Altimeter System</u>						
	RT-529/APN-133	Receiver and Transmitter	20.5	7.75	15.125	8.625
	IP-667/APN-133A	Indicator	11.0	6.5	6.313	12.5
	AT-913/APN-133	Antenna (2 ea)	1.5	2.5	13.0	4.0
*Includes Antenna						

KC-135A PNWD EQUIPMENT PHYSICAL CHARACTERISTICS

SYSTEM	UNIT		WT (LB)	SIZE (IN)		
	TYPE (P/N)	NOMENCLATURE		H	W	D
<u>AN/APN-99 Navigation Radar System</u>						
	RT-274()/APN-81	Receiver-Transmitter	87.5*	16.875	16.25	23.625*
	MT-1216/APN-81	Mounting				
	AM-758()/APN-81	Frequency Tracker Amplifier	89.5*	16.875	16.25	23.125*
	MT-1216/APN-81	Mount				
	AM-742()/APN-81	Wind Memory Amplifier	63.375*	13.375	13.5	23.5*
	MT-1218/U	Mount				
	CP-185()/APN-81	Frequency Tracker Computer	33.625*	9.375	9.25	18.25*
	MT-1192/U	Mount				
	AM-743()/APN-81	Vertical Gyro Amplifier	9.375*	7.75	6.125	10.625*
	MT-1191/APN-81	Mount				
	C-1160/APN-81	Vertical Gyro Control	8.25	7.0	7.5	8.125
	CP-221/ASN-7	Present Position Computer	16.75	5.0	8.438	10.969
	MT-1318/ASN-6	Mount	1.2	1.75	9.438	9.469
	CP-290/ASN-7	Magnetic Variation Computer	4.5	3.438	4.344	7.094
	CP-289()/ASN-7	Destination Computer	18.0	5.656	5.844	10.0
	AM-917()/ASN-7	Destination Computer Amplifier	8.5	5.109	8.859	9.344
	AS-618A/APN-81	Antenna	42.75	16.625	15.0	28.125
	CU-323/APN-81	Directional Coupler	.25	2.5	2.25	5.0
	J-605()/APN-81	Drift Calibration Interconnecting Box	2.0	3.25	3.25	6.25
	J-607/APN-81	Power Interconnecting Box	24.5	5.125	11.0	16.0
	J-608/APN-81	Fuse Interconnecting Box	6.75	4.875	8.25	10.875
	AM-1069/ASN-7A	Present Position Computer Amplifier	8.75	5.109	8.859	8.016
	MT-1909/ASN-7A	Mount	1.0	1.75	6.125	8.547
	MIL-C-5191-B	True Airspeed Computer	3.563	3.5 diam.		8.0

*Includes Mount

KC-135A PNWD EQUIPMENT PHYSICAL CHARACTERISTICS

SYSTEM	UNIT		WT (LB)	SIZE (IN)		
	TYPE (P/N)	NOMENCLATURE		H	W	D
<u>AN/ARA-25 UHF Direction Finder System</u>						
	AM-608/ARA-25	Control Amplifier	5.4	5.875	4.875	12.531
	MT-1043/ARA-25	Mount	.88	2.078	5.75	11.188
	AS-578C/ARA-25	Antenna	17.5	6.0	16.0	14.5
	RE-120/ARA-25	Solenoid Relay	.82	5.813	6.5	1.75
	MT-1042/ARA-25	Mount	.09	4.313	4.375	0.188
<u>AN/APN-59 Search Radar System</u>						
	RT-289A/APN-59	Transceiver	74.0	18.0	20.0 diam.	
	PP-1073/APN-59	Power Supply	14.0	7.0	5.125	11.125
	AS-653/APN-59	Antenna	55.0	34.25	35.75 diam.	
	CN-221/APN-59	Gyro Control	8.0	7.0	8.0 diam.	
	IP-268()/APN-59	Copilot's Indicator	8.0	5.875	5.125	9.0
	IP-239()/APN-59	Navigator's Indicator	19.5	6.75	6.75	17.0
	C-1242/APN-59	Navigator's Control	4.5	9.0	5.75	5.5
	AM-853/APN-59	Amplifier	9.0	6.688	5.5	10.0
	HD-150/APN-59	Vanaxial Fan (2 ea)	2.5	9.0	6.5	5.0

EC-135C BIBLIOGRAPHY

T.O. Number	Chg/Rev	Title
1C-135A-01	1 Dec 72	List of Applicable Publications
1C-135(E)C-1	10 Jun 77	Flight Manual, EC-135C
1C-135(E)C-2-11-1	10 Feb 77	Organizational Maintenance, Radar Navigation and Autopilot Systems, EC-135C
1C-135(E)C-2-12-2	1 Apr 77	Organizational Maintenance, Electronic Wiring Diagrams, EC-135C, and EC-135J
5F3-3-15-13	15 Mar 75	Overhaul, Counter-Drum-Pointer Servoed, Altimeter, Type AAU-19/A
5F5-4-18-3	1 Jun 73	Overhaul, Altitude Computer, Type CPU-66/A (Bendix)
5N1-2-6-1	20 Jun 74	Operational and Service, Magnetic Slaved, Directional Gyro Stabilized Compass System, Type N-1 (Kearfott), C-135A
5N1-2-10-12	15 Oct 74	Field Maintenance, Aircraft Magnetic Gyro Compass, Type J-4 (Eclipse-Pioneer)
5N1-3-4-2	15 Aug 75	Field Maintenance, Computer Set, Navigational, Type AN/ASN-7 (Ford Instrument)
12P5-2APN59-22	1 Aug 75	Field Maintenance, Radar Set, AN/APN-59B
12P5-2APN81-2	20 Jan 75	Service, Radar Set AN/APN-81 (GPL)
12P5-2APN133-2	6 Mar 75	Field Maintenance and Overhaul, Electronic Altimeter Set, Type AN/APN-133, -133A (Stewart-Warner)
12R1-2ARA25-2	15 Feb 73	Service, Direction Finder Group, AN/ARA-25 and -25A
12R5-2ARN32-2	15 Jan 75	Field Maintenance, Radio Receiving Set, Type AN/ARN-32 (Stromberg Carlson)

EC-135C BIBLIOGRAPHY

T.O. Number	Chg/Rev	Title
12R5-2ARN-72-2	18 Sep 73	Field Maintenance, Radio Set, AN/ARN-72 (Hoffman Electronics Corporation)
12R5-4-6-12	1 Apr 75	Field Maintenance, Glideslope Radio Receiver, Type 51V-4-A, 51V-4C (Collins)
12R5-4-58-2	1 Jun 73	Field Maintenance, Radio Receiver Type 51R-6 and 51R-6A (Collins)
12R5-4-73-12	1 Mar 73	Field Maintenance with Overhaul, Warning Monitor, Type 54W-1F (Collins)
12R5-4-75-12	1 May 73	Field Maintenance with Overhaul, Radio Receiver Transmitter, Type 860F-1, with the 437X-1 Antenna, and 790S-1 Shockmount, (Collins)
12R5-4-77-12	18 Nov 71	Field Maintenance with Overhaul, Flight Director Control, Type 614E-9G (Collins)
12R5-4-79-12	1 Mar 71	Field Maintenance with Overhaul, Radio Attitude Indicator, Type 339H-1 (Collins)
12R5-4-80-12	15 Jan 71	Field Maintenance with Overhaul, Air Data Sensor, Type 590A-3E (Collins)
12R5-4-81-22	15 Jun 73	Field Maintenance with Overhaul, Roll Computer, Type 562R-1E (Collins)
12R5-4-82-22	15 Jun 73	Field Maintenance with Overhaul, Pitch Computer, Type 562P-1E1 (Collins)
12R5-4-83-12	21 Jul 75	Field Maintenance with Overhaul, Horizontal Situation Indicator, Type 331A-8H (Collins)
12R5-4-85-12	1 Mar 73	Field Maintenance with Overhaul, Instrument Amplifier, Type 344C-1K (Collins)

EC-135C BIBLIOGRAPHY

T.O. Number	Chq/Rev	Title
12R5-4-91-22	26 Jun 73	Field Maintenance with Overhaul, Attitude Director Indicator, Type 329B-8G (Collins)
12R5-4-92-12	15 Feb 73	Field Maintenance with Overhaul, VHF Control Unit, Type 313N-3 (Collins)
12R5-4-121-2	15 Jan 75	Field Maintenance with Overhaul, Interface Logic, Type 599K-1
12R5-4-122-2	1 Mar 73	Field Maintenance with Overhaul, Majority Logic Attitude Comparator, Type 54W-4
12R5-4-123-2	9 Jun 72	Maintenance, Integrated Dual Flight Director, Rotation Go Around System, Type AN/ASQ-141(V) (Collins)
12R5-4-124-2	15 Jul 71	Field Maintenance with Overhaul, RGA Computer, Type 562U-1 (Collins)
12R5-4-125-2	1 Dec 73	Field Maintenance with Overhaul, RGA Control Unit, Type 915W-1
12R5-4-126-2	15 Jul 71	Field Maintenance with Overhaul, Angle of Attack Indicator, Type 813G-1 (Collins)
12R5-4-127-2	2 Aug 73	Field Maintenance with Overhaul, Angle of Attack Transmitter, Type 345F-1 (Collins)
12R5-4-128-2	1 Aug 72	Field Maintenance with Overhaul and IPB, Longitudinal Accelerometer, Type 345G-1 (Collins)
12R5-4-129-2	15 Feb 73	Field Maintenance with Overhaul, Rate-of-Turn Gyro, Type 345A-7 (Collins)
MS24568	1 Jun 75	Military Specification, Relay, 10 Amp, 4 PDT, Type I, Hermetically Sealed
MIL-C-25101A	5 Dec 56	Military Specification, Control, Slaving; N-1 Compass

3.12.0
RC-135A

RC-135A PNWD EQUIPMENT LIST

KEY	EQUIPMENT/UNIT
ADDC	COPILOT'S ATTITUDE DIRECTOR IND 329B-8G
ADDP	PILOT'S ATTITUDE DIRECTOR IND 329B-8G
AFCS	AUTOPILOT SYSTEM TYPE MC-1
BDHN	NAVIGATOR'S BDHI ID-1103/ARN
CMMM	INTERPHONE SYSTEM
CSA	PILOT'S INSTRUMENT AMPLIFIER 344C-1K
CSB	COPILOT'S INSTRUMENT AMPLIFIER 344C-1K
CSC	SIGNAL CONVERTER (685-8872-003 COMPONENT BOARD WITH RN60D8205F RESISTOR)
CSD	SIGNAL CONVERTER (795-9084-003 COMPONENT BOARD WITH RN60D8205F RESISTOR)
GA	RADIO ALTIMETER SYSTEM NO. 1 AL-101
GB	RADIO ALTIMETER SYSTEM NO. 2 AL-101
HDGD	HEADING INDICATOR V-7A
HSDC	COPILOT'S HSI 331A-8H
HSDP	PILOT'S HSI 331A-8H
JBA	JUNCTION POINT A
JBB	JUNCTION POINT B
JBC	JUNCTION POINT C
JBD	JUNCTION POINT D
JBF	JUNCTION POINT F

RC-135A (PNWD) EQUIPMENT LIST

KEY	EQUIPMENT/UNIT
JBG	JUNCTION POINT G
JBH	JUNCTION POINT H
BJJ	JUNCTION POINT J
JBK	JUNCTION POINT K
JBL	JUNCTION POINT L
JBM	JUNCTION POINT M
JBN	JUNCTION POINT N
JBP	JUNCTION POINT P
JBR	JUNCTION POINT R
JBS	JUNCTION POINT S
JBT	JUNCTION POINT T
JBV	JUNCTION POINT U
JBW	JUNCTION POINT V
JBX	JUNCTION POINT W
JBX	JUNCTION POINT X
JBZ	JUNCTION POINT Y
JCA	JUNCTION POINT Z
JCB	JUNCTION POINT AA
JCB	JUNCTION POINT AB
P	INERTIAL NAVIGATION SYSTEM AN/ASN-61
PTCC	COPILOT'S PITCH COMPUTER 562P-1E1
PTCP	PILOT'S PITCH COMPUTER 562P-1E1

RC-135A PNWD EQUIPMENT LIST

KEY	EQUIPMENT/UNIT
Q	SEARCH RADAR SYSTEM AN/APN-59B
RADC	COPILOT'S RADIO ALTIMETER IND 339H-1
RADP	PILOT'S RADIO ALTIMETER IND 339H-1
RCPC	COPILOT'S ROLL COMPUTER 562R-1E
RCPP	PILOT'S ROLL COMPUTER 562R-1E
RDA	RACK DISCONNECT A
RDB	RACK DISCONNECT B
RDC	RACK DISCONNECT C
RDD	RACK DISCONNECT D
RDE	RACK DISCONNECT E
RDF	RACK DISCONNECT F
RDG	RACK DISCONNECT G
RDH	RACK DISCONNECT H
RDJ	RACK DISCONNECT J
RDK	RACK DISCONNECT K
RDL	RACK DISCONNECT L
RDM	RACK DISCONNECT M
RDN	RACK DISCONNECT N
RMDC	COPILOT'S RMI ID-250A/ARN
RMDM	NAVIGATOR'S NO.2 RMI ID-250A/ARN
RMDN	NAVIGATOR'S NO.1 RMI ID-250A/ARN
RMDP	PILOT'S NO.1 RMI ID-250A/ARN

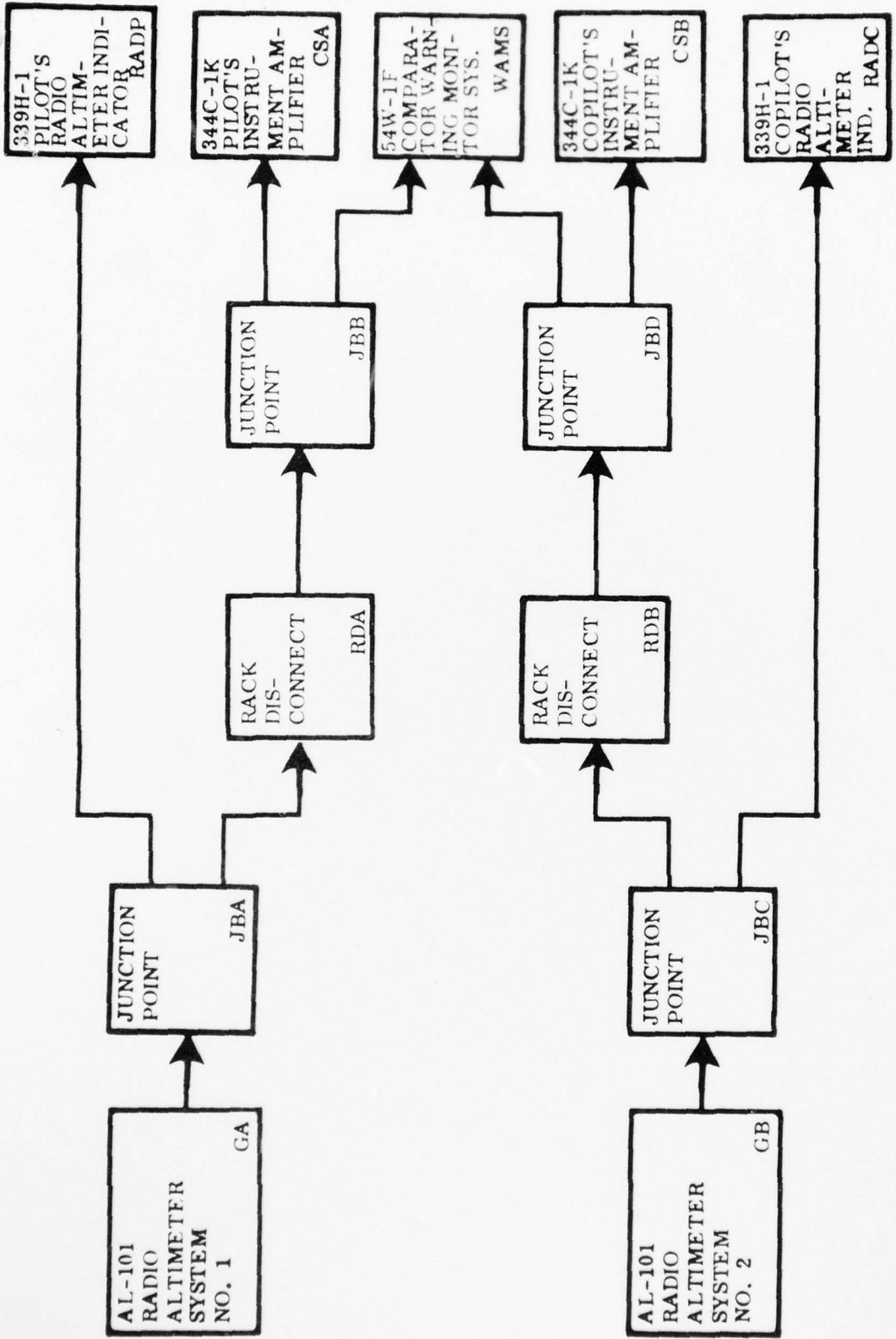

TITLE: PNWD SYSTEM		
AIRCRAFT	DATE	DIAGRAM
RC-135A	6-30-76	1 of 4

3-12A-5

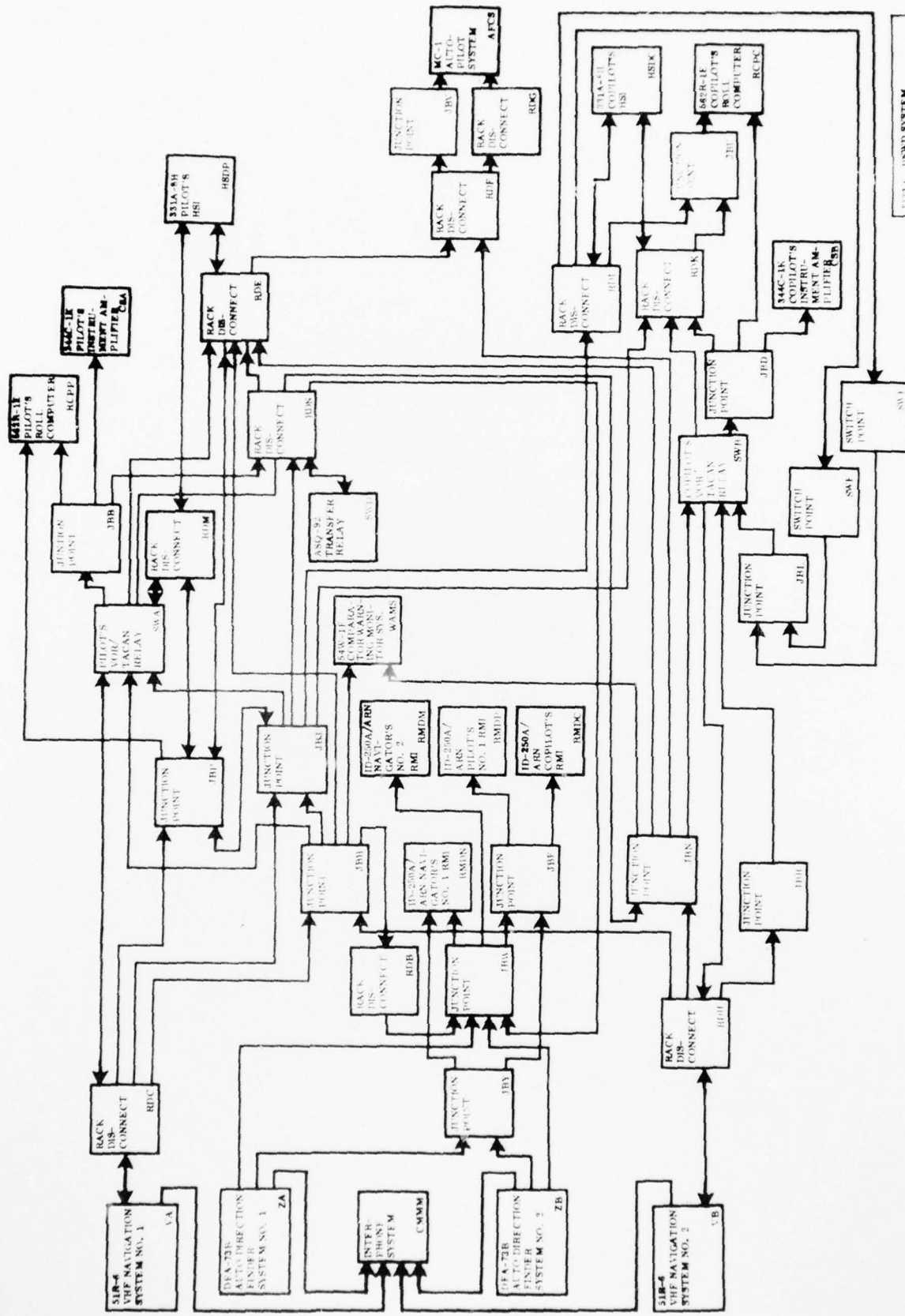

11113 UNWD SYSTEM			
AIR. CFT	DATE	DIAGRAM	
CC-1A	6-30-76	3 of 4	

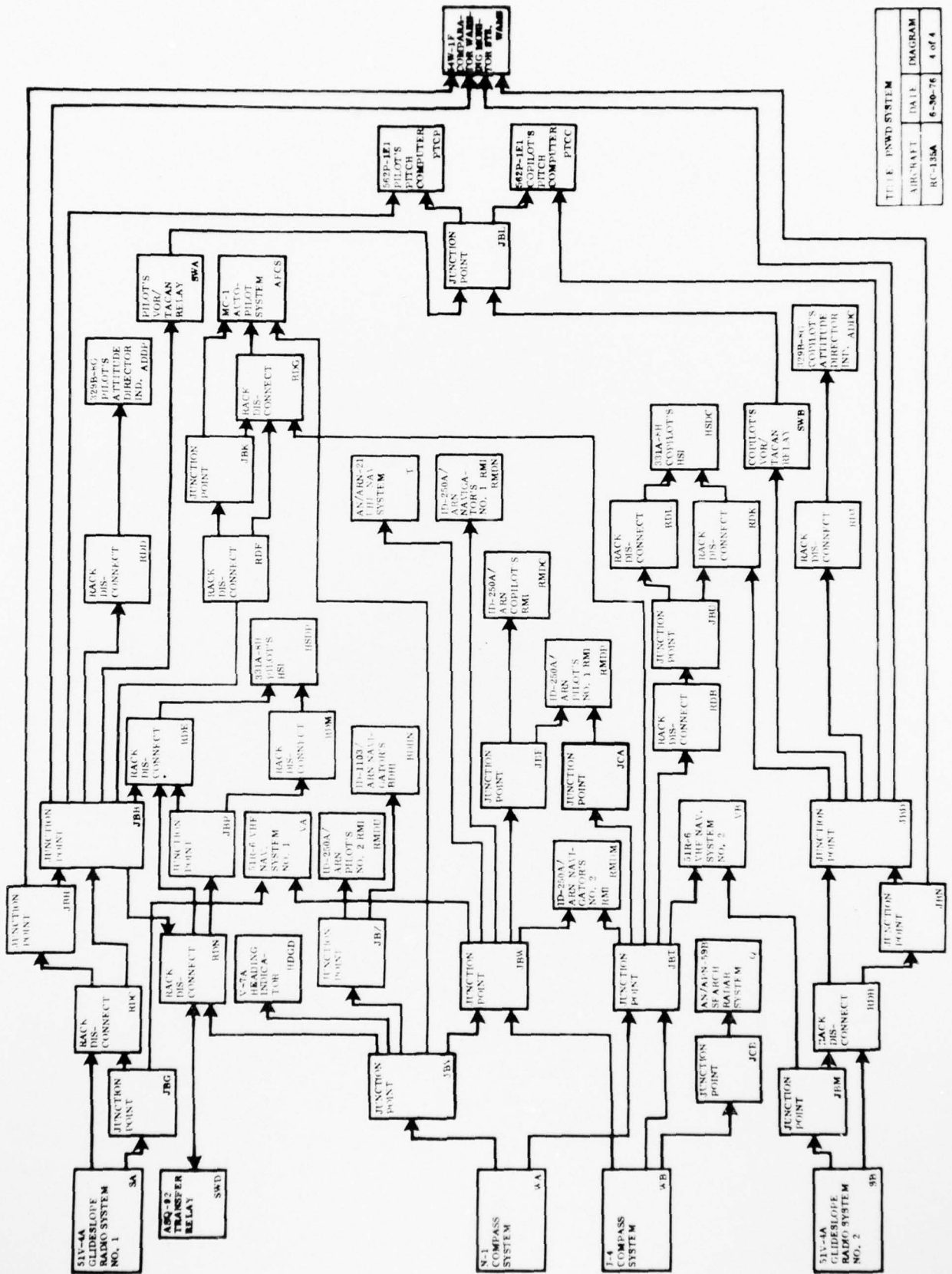

3-12A-8

TITLE: PWD SYSTEM		
AIRCRAFT	DATE	DIAGRAM
RC-135A	6-30-76	4 of 4

RC-135A PNWD EQUIPMENT PHYSICAL CHARACTERISTICS

SYSTEM	UNIT		WT (LB)	SIZE (IN)		
	TYPE (P/N)	NOMENCLATURE		H	W	D
<u>ADF-73A Automatic Direction Finder System</u>						
	CNA-73C	Control Panel (2 ea)	1.9	2.625	5.75	3.63
	DFA-73A	Receiver (2 ea)	11.0	7.625	2.406	15.3
	LPA-73C	Loop Antenna (2 ea)	2.8	1.96	9.88	16.89
	QCA-73E-24U-4P	Quadrantal Error Corrector	1.0	1.45	1.52	4.06
	LSA-73AB-34U	Line Stretcher (2 ea)	1.0	1.45	1.52	3.04
	65-16189-()	Sense Antenna (2 ea)				
	CUA-73A-90	Sense Antenna Coupler (2 ea)	2.0	3.05	5.02	5.02
	MSA-73B	Dual Mount	2.1	6.2	6.14	14.57
<u>AN/APN-70 Loran Navigation System</u>						
	R-277B/APN-70	Receiver	45.0	12.44	11.375	19.69
	IP-58/APN-70	Indicator	15.0	9.16	7.625	21.875
	65-2349	Antenna				
	10-3053-1	Antenna Coupler				
	10-60013	Lightning Arrestor				
<u>51V-4A Glideslope Radio System</u>						
	522-2776-000	Glideslope Receiver (2 ea)	3.5	3.375	2.25	12.56
	37P-4	Antenna	0.7	5.984	2.0	4.5
	10-3064					
<u>AN/ARN-21C UHF Navigation System</u>						
	RT-220C/ARN-21	Receiver-Transmitter	60.0	8.3	11.13	18.75
	C-866/ARN-21	Radio Set Control	1.5	2.25	5.75	4.75
	161B-1	Instrumentation Coupler	12.0	6.125	5.0	10.167
	AT-741/A	Antenna	0.4	3.3	1.75	5.25
	MS24568-D1	TACAN Flag Relay	0.73	2.7	3.0	2.3
	391233	TACAN Select ON-OFF Switch/Indicator (2 ea)				

RC-135A PNWD EQUIPMENT PHYSICAL CHARACTERISTICS

SYSTEM	UNIT		WT (LB)	SIZE (IN)		
	TYPE (P/N)	NOMENCLATURE		H	W	D
<u>AN/ARN-21C UHF Navigation System (Cont'd)</u>						
	410-1521-010	VOR/TACAN Relay (2 ea)	0.57	2.187	1.531	1.130
	MT-928/ARN-21	Mount	6.5	7.75	11.125	17.5
	349L-2	Mount	3.0	7.75	5.91	13.875
<u>Marker Beacon Radio System</u>						
	51Z-3	Receiver	2.9	3.38	2.25	12.62
	AT-536/ARN	Antenna	2.2	3.125	7.75	11.188
	AN3022-2	Marker Beacon Sensi- tivity Switch	0.10	2.125	0.765	1.95
	074-1012-002	Marker Beacon Light Assys (2 ea)				
	MTA-7A	Mount	2.5	10.0	2.75	16.4
<u>Radio Navigation Instruments</u>						
	ID-250A/ARN	Radio Magnetic Indicator (5 ea)	2.6	3.25 diam.		6.156
	ID-1103/ARN	Bearing-Distance-Heading Indicator	3.5	3.25	3.25	7.5
<u>AN/APN-133A Electronic Altimeter</u>						
	RT-529A/APN-133	Receiver-Transmitter	20.5	7.75	15.125	8.625
	IP-667/APN-133	Indicator	11.0	6.5	6.313	12.5
	AT-913/APN-133	Antenna (2 ea)	1.5	2.5	13.0	4.0
<u>AN/APN-59B Search Radar System</u>						
	RT-289B/APN-59	Receiver-Transmitter	74.0	18.0	20.0 diam.	
	C-1242/APN-59	Control Panel	4.5	9.0	5.75	5.5
	C-2302/APN-59	Sync Control	1.25	3.375	5.75	5.25
	IP-268/APN-59	Indicator (2 ea)	8.0	5.875	5.125	9.0

RC-135A PNWD EQUIPMENT PHYSICAL CHARACTERISTICS

SYSTEM	UNIT		WT (LB)	SIZE (IN)		
	TYPE (P/N)	NOMENCLATURE		H	W	D
<u>AN/APN-59B Search Radar System (Cont'd)</u>						
	AS-1199/APN-59	Antenna	59.0	34.25	35.75 diam.	
	PP-1073A/APN-59	Power Supply (2 ea)	14.0	7.0	8.0 diam.	
	CN-221A/APN-59	Stabilization Data Generator	8.0	7.0	8.0 diam.	
	AM-853A/APN-59	Electronic Control Amplifier	9.0	6.688	5.5	10.0
	SN-198/APN-59	Synchronizer	7.0	6.0	6.0	11.0
	HD-150/APN-59	Vaneaxial Fan (2 ea)	2.5	9.0	6.5	5.0
	C-3939/APN-59	Generator Control	4.25	4.125	7.75	6.25
	SG-461/APN-59	Electronic Marker Generator	10.5	6.88	6.0	9.5
	C-4006/APN-59	Antenna Control	2.0	2.625	5.75	5.0
<u>N-1 Compass System</u>						
	DT-198/AJN MIL-D-26503	Magnetic Azimuth Detector	1.125	2.328	4.781	4.781
	15810 MIL-C-9357	Directional Gyro	23.5	11.5	13.31	12.5
	15150 MIL-C-25101A	Slaving Control	3.75	5.09	4.56	4.56
	16000 MIL-A-9319A	N-1 Amplifier	23.25	9.31	13.94	9.03
	MIL-A-2588B	Compass Signal Power Amplifier, ME-1A	9.5	5.25	5.0	7.9
	15900 MIL-I-25100A	Master Indicator	9.75	5.25	5.0	7.9
	V-7A MIL-I-5126A	Heading Indicator	2.25	5.25	5.0	4.34
<u>J-4 Compass System</u>						
	18717-1A MIL-C-8112A	Servo Amplifier	11.0	6.75	6.75	10.125
	DT-198/AJN MIL-D-23503	Magnetic Azimuth Detector	1.125	2.328	4.781	4.781
	MIL-C-25101A	Slaving Control	4.25	5.09	4.188	4.188
	432050-2 MIL-C-8112A	Control Panel	1.75	2.625	5.75	3.553
	53D13649	Directional Control	7.67	6.906	7.125	9.375

RC-135A PNWD EQUIPMENT PHYSICAL CHARACTERISTICS

SYSTEM	UNIT		WT (LB)	SIZE (IN)		
	TYPE (P/N)	NOMENCLATURE		H	W	D
<u>AL-101 Low Range Radio Altimeter System</u>						
	437X-1 522-4140-001	Antenna (1 ea)	1.0	2.75	5.2 diam.	
	860F-1 522-3690-008	Receiver-Transmitter (2 ea)	20.0	7.766	5.094	14.828
	339H-1() 522-4114-010	Indicator (2 ea)	2.5	3.175	3.175	5.0
	790S-1 522-4099-002	Mounting (2 ea)	2.2	4.875	5.859	17.188*
<u>51R-6 VHF Navigation System</u>						
	51R-6	VOR/LOC Navigation Unit (2 ea)	15.2	7.625	4.875	14.625
	313N-3	VHF Navigation Control Panel	2.0	2.625	5.75	4.375
	5-88152	VHF Navigation Antenna				
<u>AN/ASQ-141(V) Integrated Dual Flight Director System</u>						
	329B-8G 522-4529-005	Attitude Director	7.5	5.125	4.875	7.5
	331A-8H 777-1026-004	Horizontal Situation	7.5	4.068	4.812	8.75
	614E-9G 787-6789-001	Flight Director Control (2 ea)	2.0	2.25	5.75	4.688
	562R-1E 522-4428-018	Roll Computer (2 ea)	8.5	7.625	2.531	14.563
	562P-1E1 522-4892-031	Pitch Computer (2 ea)	8.5	7.625	2.25	14.5
	590A-3E 522-4798-003	Attitude Controller	4.4	4.167	3.344	14.831
	344C-1K 522-3874-013	Instrument Amplifier	8.2	7.62	2.25	12.62
	380-1077-020	Heading Slew Control (2ea)				
	345A-7 772-5140-001	Rate of Turn Gyro (2 ea)	2.2	4.25	3.875	5.625
	262-2834-XXX	Mode Annunciators (16 ea)				
	262-2834-XXX	Warning Indicators (6 ea)				
	54W-4	Majority Logic Attitude	8.0	7.62	12.25	12.62
*Includes sway space.						

RC-135A PNWD EQUIPMENT PHYSICAL CHARACTERISTICS

SYSTEM	UNIT		WT (LB)	SIZE (IN)		
	TYPE (P/N)	NOMENCLATURE		H	W	D
<u>AN/ASQ-141(V) Integrated Dual Flight Director System (Cont'd)</u>						
	54W-4	Majority Logic Attitude Comparator	8.0	7.62	2.25	12.62
	915W-1 787-6907-001	RGA Control Panel (2 ea)	2.5	2.2	5.7	4.3
	345H-1 787-6922-001	Elevator Position Transmitters (2 ea)				
	262-2834-710	RGA Fail Operative Indicator (2 ea)				
	345F-1 787-6909-001	Angle of Attack	1.9	4.5 diam.		7.118
	813G-1 787-6911-001	Angle of Attack Indicator (2 ea)	1.5	2.4	2.4	6.5
	562U-1 787-6905-001	RGA Computer (2 ea)	8.5	7.62	3.56	12.62
	599K-1 787-6906-001	RGA Interface Logic Unit	5.0	3.313	3.563	12.563
	345G-1 787-6908-001	Longitudinal Accelerometer (2 ea)	1.5	3.635	4.225	1.75
	914G-1 522-3918-007	Comparator Warning Monitor Panel	1.2	1.875	5.75	4.0
	54W-1F 787-6792-001	Comparator Warning Monitor	15.0	7.25	3.688	15.188
	161E-7B 787-6791-001	Remote Slew Coupler	6.0	7.625	2.25	14.75
	266-6951-450	Comparator-Warning Switch/Indicator (2 ea)				
	795-9451-001	ASQ-92 Transfer Relay				

RC-135A BIBLIOGRAPHY

T.O. Number	Chg/Rev	Title
1C-135A-01	1 Jul 76	List of Applicable Publications
1C-135(R)A-1	30 May 77	Flight Manual, RC-135A
1C-135A-2-9	30 Jun 77	Organizational Maintenance, Instruments, C-135A, C-135B, and RC-135A
1C-135A-2-11-1	1 Jul 77	Organizational Maintenance, Radio Communication and Navigation Systems, C-135A, C-135B, and RC-135A
1C-135(R)A-2-11-2	10 Sep 73	Organizational Maintenance, AN/ASQ-92 Airborne Electronics Equipment, RC-135A
1C-135(R)A-2-11-3	30 Oct 71	Organizational Maintenance, Radio, Communications, Navigation and AN/ASQ-92 Systems Wiring Diagrams, RC-135A
5N1-2-6-1	20 Jun 74	Operational and Service, Magnetic Slaved, Directional Gyro Stabilized Compass System, Type N-1 (Kearfott)
5N1-2-10-12	15 Oct 74	Field Maintenance, Aircraft Magnetic Gyro Compass, Type J-4 (Eclipse-Pioneer)
5N8-4-3-3	15 Nov 75	Overhaul, Gyro Magnetic Compass Indicators, Types V-7A and V-8
12P5-2APN59-22	1 Aug 75	Field Maintenance, Radar Set AN/APN-59B
12P5-2APN/33-2	6 Mar 75	Field Maintenance Overhaul, Electronic Altimeter Set, Type AN/APN-133, -133A (Stewart-Warner)
12R5-2ARN-323	1 Apr 64	Overhaul, Bearing Distance Heading Indicator, Type ID-1103/ARN
12R5-2ARN21-42	20 Apr 72	Field Maintenance, Radio Set AN/ARN-21 (Hoffman Electronics Corporation)

RC-135A BIBLIOGRAPHY

T.O. Number	Chq/Rev	Title
12R5-4-6-12	1 Apr 75	Field Maintenance, Glideslope Radio Receiver 51V-4A, 5N-4C (Collins)
12R5-4-39-2	15 Jun 72	Field Maintenance, Radio Receivers 51Z-3 and 51Z-4 (Collins)
12R5-4-58-2	1 Jun 73	Field Maintenance, Radio Receiver Type 51R-6 and 51R-6A (Collins)
12R5-4-56-12	7 Sep 73	Field Maintenance, ADF Receiver, Type DFA-73AC, -73AF, ADF Control, CNA-73BC, -73BF, ADF Loop, Type LPA-73C-1, ADF Shock Mount, Type MSA-73A-1 (Bendix)
12R5-4-73-12	1 Mar 73	Field Maintenance with Overhaul, Warning Monitor, Type 54W-1F (Collins)
12R5-4-75-12	1 May 73	Field Maintenance with Overhaul, Radio Receiver Transmitter, Type 860F-1, with the 437X-1 Antenna, and 790S-1 Shockmount
12R5-4-77-12	19 Nov 71	Field Maintenance with Overhaul, Flight Director Control, Type 614E-9G (Collins)
12R5-4-79-12	1 Mar 71	Field Maintenance with Overhaul, Radio Attitude Indicator, Type 339H-1 (Collins)
12R5-4-80-12	15 Jan 71	Field Maintenance with Overhaul, Air Data Sensor, Type 590A-3E (Collins)
12R5-4-81-22	15 Jan 71	Field Maintenance with Overhaul, Roll Computer, Type 562R-1E (Collins)
12R5-4-82-12	15 Jun 73	Field Maintenance with Overhaul, Pitch Computer, Type 562P-1E1 (Collins)
12R5-4-83-12	21 Jul 75	Field Maintenance with Overhaul, Horizontal Situation Indicator, Type 331A-8H (Collins)

RC-135A BIBLIOGRAPHY

T.O. Number	Chg/Rev	Title
12R5-4-85-12	1 Mar 73	Field Maintenance with Overhaul, Instrument Amplifier, Type 344C-1K (Collins)
12R5-4-91-22	26 Jun 73	Field Maintenance with Overhaul, Attitude Director Indicator, Type 329B-8G (Collins)
12R5-4-92-12	15 Feb 73	Field Maintenance with Overhaul, VHF Control Unit, Type 313N-3 (Collins)
12R5-4-121-2	15 Jan 75	Field Maintenance with Overhaul, Interface Logic, Type 599K-1
12R5-4-122-2	1 Mar 73	Field Maintenance with Overhaul, Majority Logic Attitude Comparator, Type 54W-4
12R5-4-123-2	8 Jun 72	Maintenance, Integrated Dual Flight Director, Rotation Go Around System, Type AN/ASQ-141(V) (Collins)
12R5-4-124-2	15 Jul 71	Field Maintenance with Overhaul, RGA Computer, Type 562U-1 (Collins)
12R5-4-125-2	1 Dec 73	Field Maintenance with Overhaul, RGA Control Unit, Type 915W-1
12R5-4-126-2	15 Jul 71	Field Maintenance with Overhaul, Angle of Attack Indicator, Type 813G-1 (Collins)
12R5-4-127-2	2 Aug 73	Field Maintenance with Overhaul, Angle of Attack Transmitter, Type 345F-1 (Collins)
12R5-4-128-2	1 Aug 72	Field Maintenance with Overhaul and IPB, Longitudinal Accelerometer, Type 345G-1 (Collins)
12R5-4-129-2	15 Feb 73	Field Maintenance with Overhaul, Rate-of-Turn Gyro, Type 345A-7 (Collins)

RC-135A BIBLIOGRAPHY

T.O. Number	Chg/Rev	Title
AN3022	31 Aug 73	Switch-Toggle, Single Pole, Three Hole Mounting
MS24568	1 Jun 75	Relay, 10 Amp, 4 PDT, Type I, Hermetically Sealed
MIL-C-25101A	5 Dec 56	Military Specification Control, Slaving; N-1 Compass

AD-A061 494

ARINC RESEARCH CORP ANNAPOLIS MD
STANDARD AVIONICS INTERFACE PROGRAM. VOLUME II. NAVIGATION EQUI--ETC(U)
AUG 76 B G MCELHANEY, E J CHAUVIN
1296-01-2-1527-VOL-2

F/G 9/3

F09603-75-A-3001

NL

UNCLASSIFIED

3 OF 5
AD A061494



LIFTED

3

OF



AD

A061494



3.13.0
VC-135B

VC-135B PNWD EQUIPMENT LIST

KEY	EQUIPMENT/UNIT
ADDC	COPILOT'S ATTITUDE DIRECTOR IND 329B-8G
ADDP	PILOT'S ATTITUDE DIRECTOR IND 329B-8G
AFCS	AUTOPILOT SYSTEM
AIMS	AIMS TRANSPONDER SYSTEM AN/APX-64(V)
ALDC	COPILOT'S SERVOED ALTIMETER AAU-19/A
ALDP	PILOT'S SERVOED ALTIMETER AAU-19/A
BDHM	NAVIGATOR'S NO.2 BDHI ID-526/ARN
BDHN	NAVIGATOR'S NO.1 BDHI ID-526/ARN
CMMM	INTERPHONE SYSTEM
CPDC	COPILOT'S CROSS POINTER INDICATOR ID-351A/ARN
CPDP	PILOT'S CROSS POINTER INDICATOR ID-351A/ARN
CSA	PILOT'S INSTRUMENT AMPLIFIER 344C-1K
CSB	COPILOT'S INSTRUMENT AMPLIFIER 344C-1K
CSD	SIGNAL CONVERTER (795-8872-001 TERMINAL BOARD WITH RN60D6810F RESISTOR)
CSE	SIGNAL CONVERTER (795-8872-002 TERMINAL BOARD WITH RN60D8205F RESISTOR)
D	DOPPLER RADAR SYSTEM AN/APN-147 (V)
E	DOPPLER COMPUTER AN/ASN-35
GA	RADIO ALTIMETER SYSTEM NO.1 AL-101
GB	RADIO ALTIMETER SYSTEM NO.2 AL-101
GSDN	NAVIGATOR'S GRNDSPD DRIFT ANGLE IND ID-938
GSDP	PILOT'S GRNDSPD DRIFT ANGLE IND ID-938
HSDC	COPILOT'S HSI 331A-8H
HSDP	PILOT'S HSI 331A-8H

VC-135B PNWD EQUIPMENT LIST

KEY	EQUIPMENT/UNIT
JBB	JUNCTION POINT B
JBC	JUNCTION POINT C
JBD	JUNCTION POINT D
JBE	JUNCTION POINT E
JBF	JUNCTION POINT F
JBG	JUNCTION POINT G
JBH	JUNCTION POINT H
JBJ	JUNCTION POINT J
JBK	JUNCTION POINT K
JBL	JUNCTION POINT L
JBM	JUNCTION POINT M
JBN	JUNCTION POINT N
JBP	JUNCTION POINT P
JBQ	JUNCTION POINT Q
JBS	JUNCTION POINT S
JBT	JUNCTION POINT T
JBU	JUNCTION POINT U
JBV	JUNCTION POINT V
JBW	JUNCTION POINT W
JBX	JUNCTION POINT X
JBZ	JUNCTION POINT Y
	JUNCTION POINT Z

VC-135B PNWD EQUIPMENT LIST

KEY	EQUIPMENT/UNIT
JCA	JUNCTION POINT AA
JCC	JUNCTION POINT AC
JCD	JUNCTION POINT AD
JCE	JUNCTION POINT AE
KL	AIMS ALTITUDE COMPUTER SYSTEM CPU-66/A-1
MEDP	PILOT'S MULTI ERROR IND. ID-939/ASN-35
PTCC	COPILOT'S PITCH COMPUTER 562P-1E1
PTCP	PILOT'S PITCH COMPUTER 562P-1E1
Q	SEARCH RADAR SYSTEM AN/APN-59B
RADC	COPILOT'S RADIO ALTIMETER IND 339H-1
RADP	PILOT'S RADIO ALTIMETER IND 339H-1
RCPC	COPILOT'S ROLL COMPUTER 562R-1E
RCPP	PILOT'S ROLL COMPUTER 562R-1E
RDA	RACK DISCONNECT A
RDB	RACK DISCONNECT B
RDC	RACK DISCONNECT C
RDD	RACK DISCONNECT D
RDE	RACK DISCONNECT E
RDF	RACK DISCONNECT F
RDH	RACK DISCONNECT H
RDJ	RACK DISCONNECT J

VC-135B PNWD EQUIPMENT LIST

KEY	EQUIPMENT/UNIT
RDK	RACK DISCONNECT K
RDL	RACK DISCONNECT L
RDM	RACK DISCONNECT M
RDN	RACK DISCONNECT N
RDP	TEST RECEPTACLE P
RDR	RACK DISCONNECT R
RDS	RACK DISCONNECT S
RDT	RACK DISCONNECT T
RDU	RACK DISCONNECT U
RDV	RACK DISCONNECT V
RMDC	COPILOT'S RMI ID-250A /ARN
RMDN	NAVIGATOR'S RMI ID-250A/ARN
RMDP	PILOT'S RMI ID-250A/ARN
SA	GLIDESLOPE RADIO SYSTEM NO.1 51V-4A
SB	GLIDESLOPE RADIO SYSTEM NO.2 51V-4A
SWC	PILOT'S VOR/TACAN RELAY
SWD	COPILOT'S VOR/TACAN RELAY
SWE	FLAG RELAY NO.1
SWF	FLAG RELAY NO.2
SWG	SWITCH POINT G
SWH	SWITCH POINT H
SWJ	SWITCH POINT J

VC-135B PNWD EQUIPMENT LIST

KEY	EQUIPMENT/UNIT
TA	UHF NAVIGATION SYSTEM NO.1 AN/ARN-21C
TB	UHF NAVIGATION SYSTEM NO.2 AN/ARN-21C
VA	VHF NAVIGATION SYSTEM NO.1 51R-6
VB	VHF NAVIGATION SYSTEM NO.2 51R-6
WA	N-1 COMPASS SYSTEM
WAMS	COMPARATOR WARNING MONITOR SYSTEM 54W-1F
WB	J-4 COMPASS SYSTEM
ZA	AUTO DIRECTION FINDER SYSTEM NO.1 DFA-70B
ZB	AUTO DIRECTION FINDER SYSTEM NO.2 DFA-70B

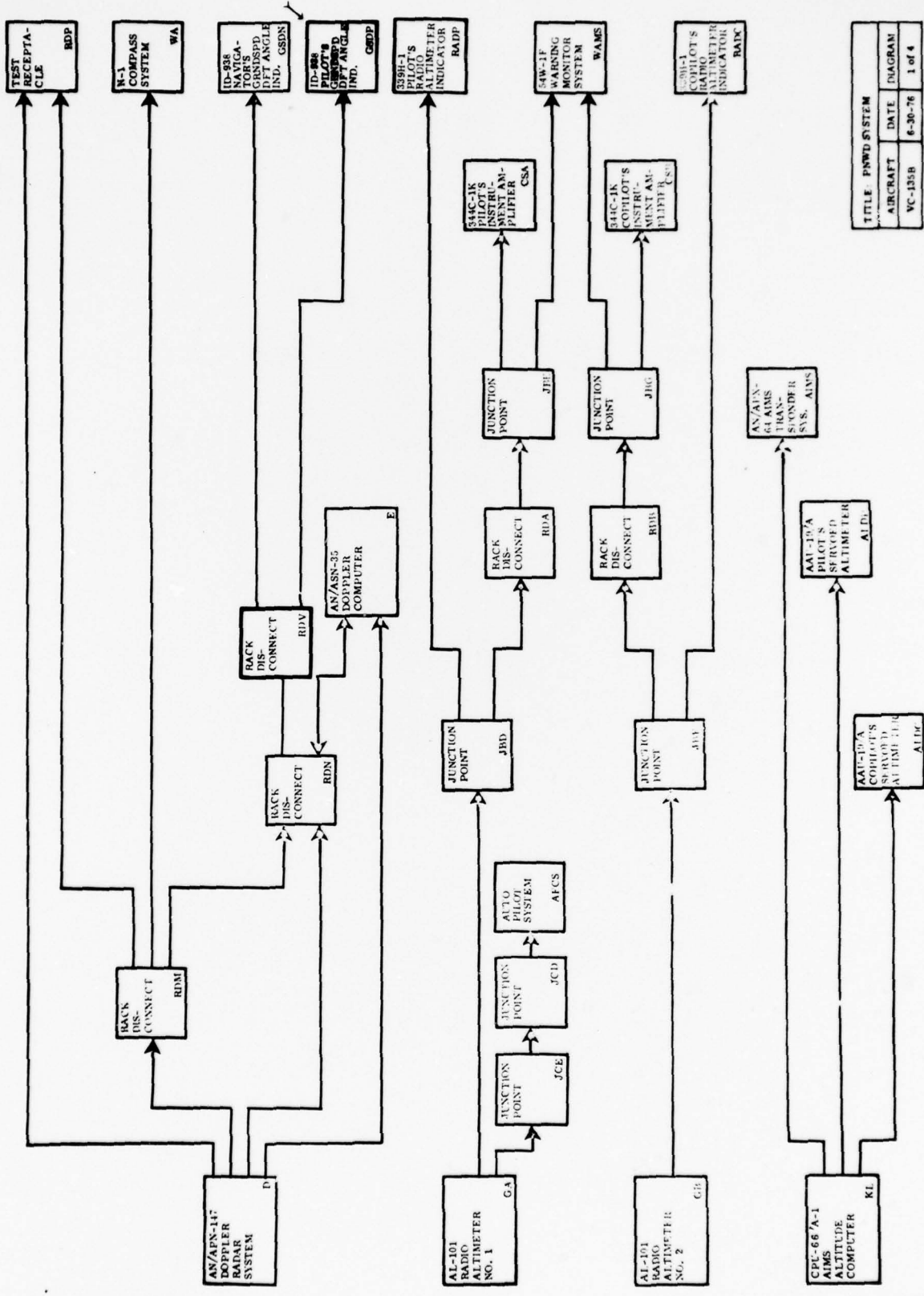

TITLE: PNWD SYSTEM		
AIRCRAFT	DATE	DIAGRAM
VC-135B	6-30-76	1 of 4

3-13A-6

CHANGE 3

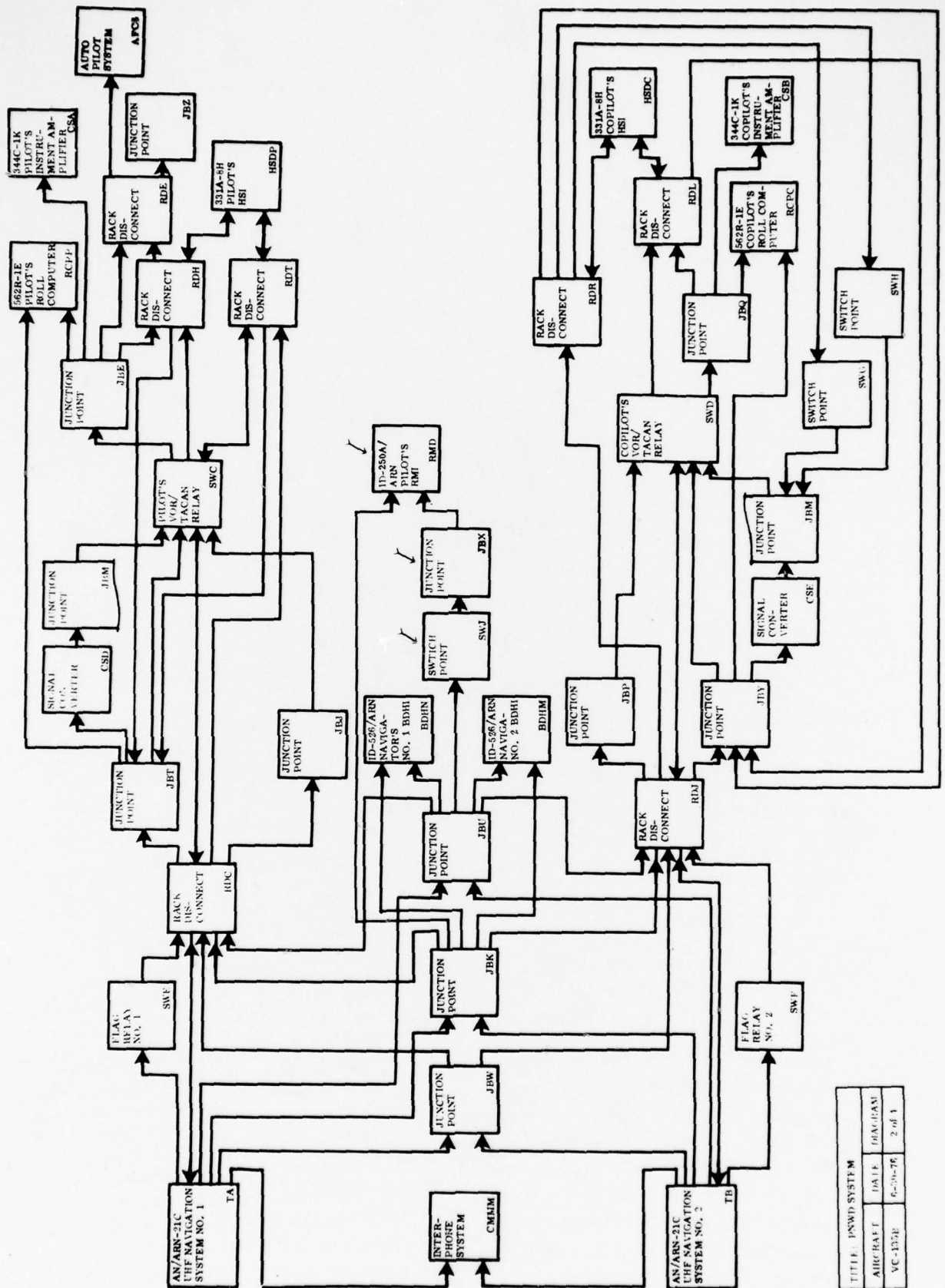

3-13A-7

TITLE: PNWD SYSTEM	DATE: 11/11/61	2 of 1
AIRCRAFT: VC-132E	6-20-76	

CHANGE 3

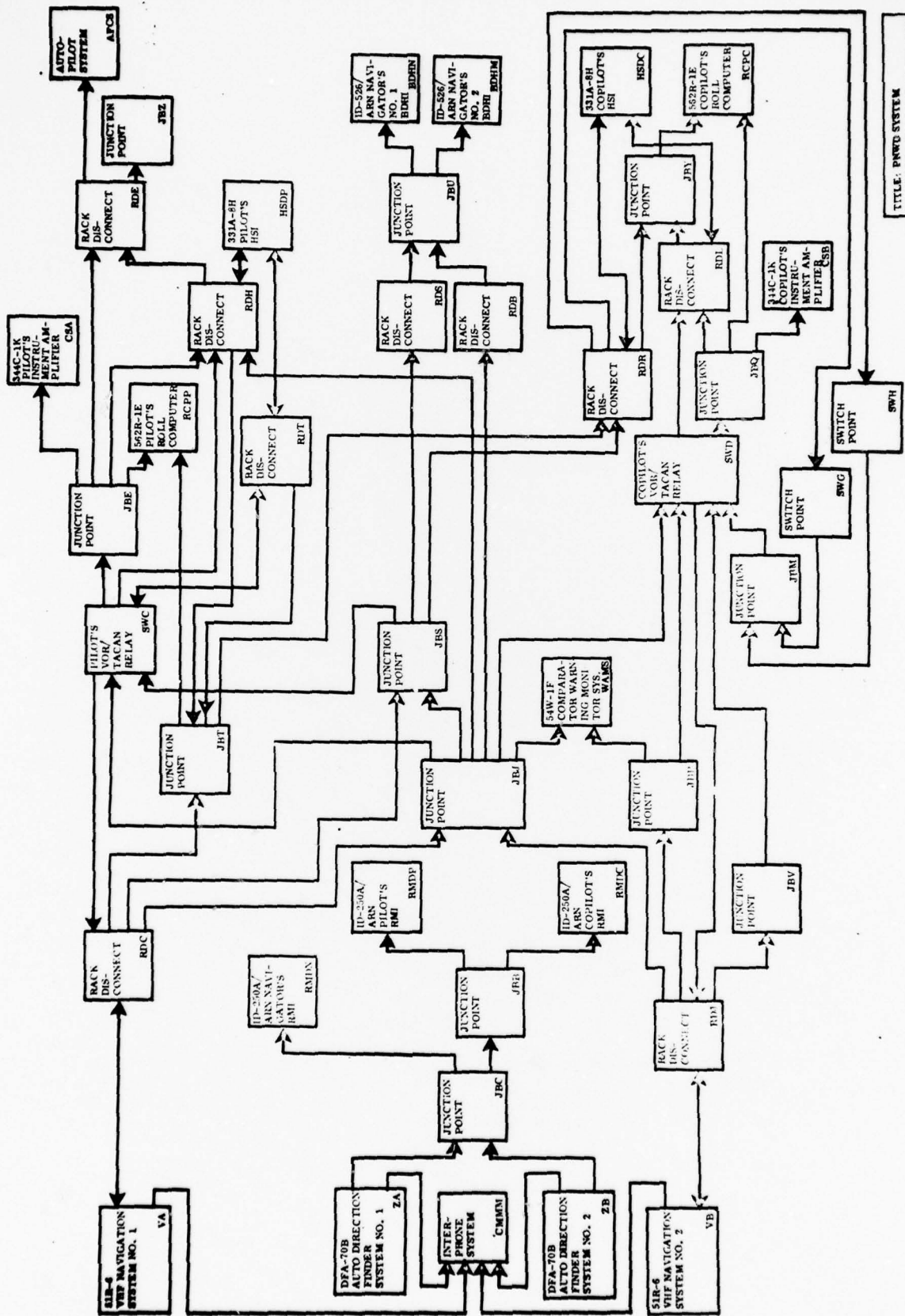

TITLE: PNRWD SYSTEM		
AIRCRAFT	DATE	DIAGRAM
VC-135B	8-30-78	3 of 4

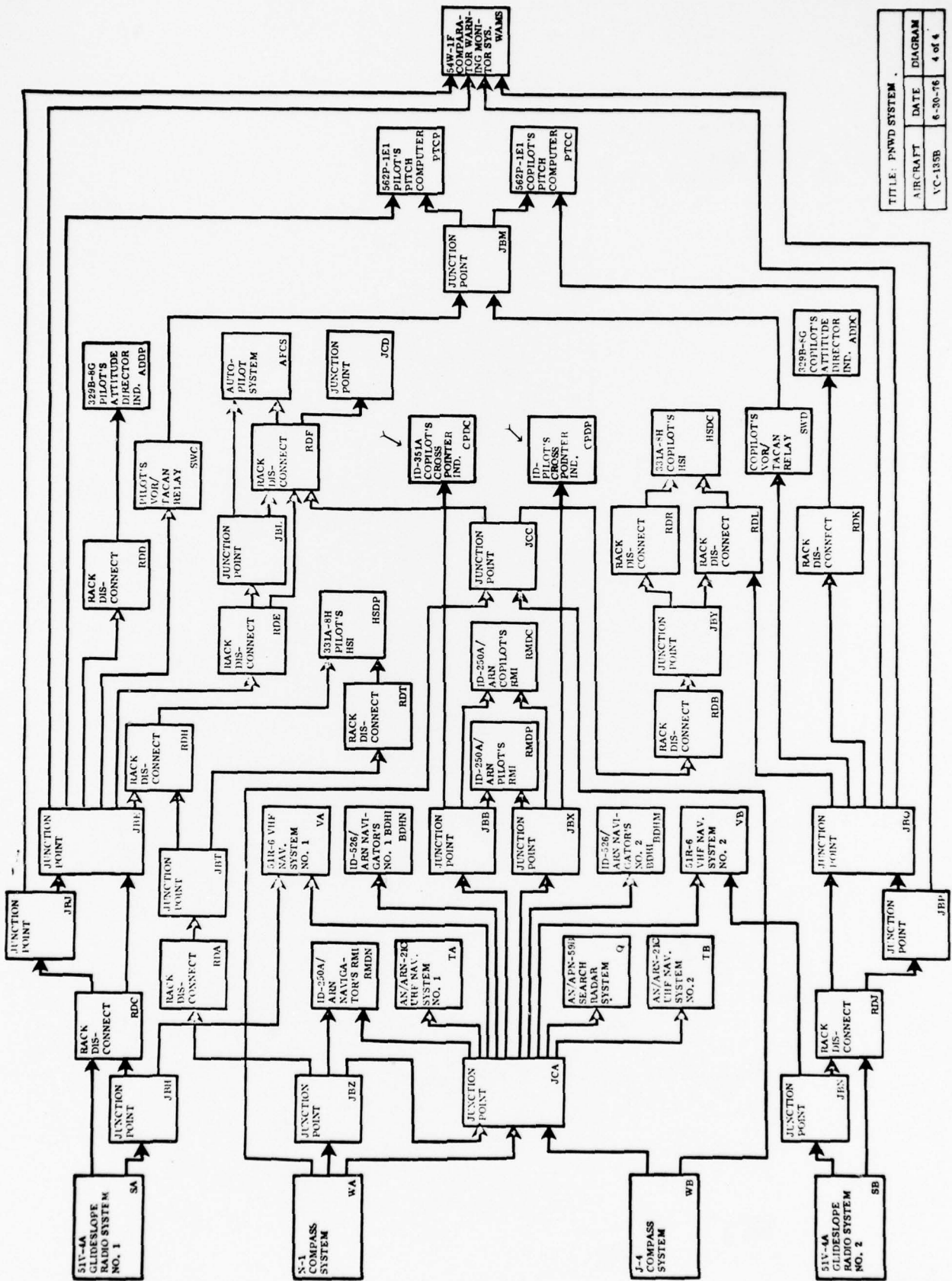

TITLE: FNWD SYSTEM			
AIRCRAFT	DATE	DIAGRAM	
VC-135B	6-30-76		4 of 4

3-13A-9

CHANGE 3

VC-135B PNWD EQUIPMENT PHYSICAL CHARACTERISTICS

SYSTEM	UNIT		WT (LB)	SIZE (IN)		
	TYPE (P/N)	NOMENCLATURE		H	W	D
<u>DFA-70B Automatic Direction Finder System</u>						
	CNA-70C	Control Panel (4 ea)	3.5	4.5	5.8	5.8
	DFA-70B-1	Receiver (2 ea)	24.5	7.8	5.0	24.3
	LPA-71A	Loop Antenna (2 ea)	2.8	1.96	9.88	16.89
	PSA-70A-1	AC Power Supply (2 ea)	5.0	--Mounts Internally--		
	GMA-71A	Goniometer (2 ea)	1.9	3.25	3.25	5.14
	65-16189	Sense Antenna (2 ea)				
	CUA-70B-90	Sense Antenna Coupler (2 ea)	1.2	3.0	5.02	4.62
	D-9262-001	Control Switching Relay (2 ea)				
	MTA-70C	Mount (2 ea)	4.0	7.62	5.0	19.47
	FLA-70A-3	Mechanical Filter (2 ea)	0.1	0.755	0.755	2.63
<u>AN/APN-70 Loran Navigation System</u>						
	R-277()/APN-70	Receiver*	45.0	12.44	11.375	19.69
	IP-58/APN-70	Indicator	15.0	9.16	7.625	21.875
	65-2349	Antenna				
	SA-10B	Antenna Coupler				
	RALA-2A	Lightning Arrestor				
<u>Air Data System</u>						
	CPU-66/A-1	Altitude Computer	6.0	4.5	4.0	9.9
	AAU-19/A	Servoed Altimeter (2 ea)	4.5	3.25	3.25	8.813
<u>51V-4A Glideslope Radio System</u>						
	51V-4A	Glideslope Receiver (2 ea)	3.5	3.375	2.5	12.56
	37P-4	Antenna	0.7	5.984	2.0	4.5
*Includes mount						

VC-135B PNWD EQUIPMENT PHYSICAL CHARACTERISTICS

SYSTEM	UNIT		WT (LB)	SIZE (IN)		
	TYPE (P/N)	NOMENCLATURE		H	W	D
<u>AN/ARN-21C UHF Navigation System (TACAN)</u>						
	RT-220C/ARN-21	Receiver-Transmitter (2 ea)	60.0	8.3	11.13	18.75
	C-866/ARN-21	Radio Set Control (2 ea)	1.5	2.25	5.75	4.75
	161B-1	Instrumentation Coupler (2 ea)	12.0	6.125	5.0	10.167
	AT-741/A	Antenna (2 ea)	0.4	3.3	1.75	5.25
	MS24568-D1	TACAN Flag Relay (2 ea)	0.73	2.7	3.0	2.3
	391233	TACAN Select ON-OFF Switch/Indicator (2 ea)				
	410-1521-010	VOR/TACAN Relay (2 ea)	0.57	2.187	1.531	1.130
	MT-928/ARN-21	Mount (2 ea)	6.5	7.75	11.125	17.5
	349L-2	Mount (2 ea)	3.0	7.75	5.91	13.875
<u>Marker Beacon Radio System</u>						
	51Z-3	Receiver	2.9	3.38	2.25	12.62
	AT-536/ARN	Antenna	2.2	3.125	7.75	11.188
	AN3022-2	Marker Beacon Sensi- tivity Switch	0.10	2.125	0.765	1.95
	STB-390-WE	Marker Beacon Light Assys (2 ea)				
<u>Radio Navigation Instruments</u>						
	ID-250A/ARN	Radio Magnetic Indicator (4 ea)	2.6	3.25 diam.		6.156
	ID-526/ARN	Bearing-Distance-Heading Indicator (2 ea)	4.0	3.25	3.25	6.875

VC-135B PNWD EQUIPMENT PHYSICAL CHARACTERISTICS

SYSTEM	UNIT		WT (LB)	SIZE (IN)		
	TYPE (P/N)	NOMENCLATURE		H	W	D
<u>AN/APN-59B Search Radar System</u>						
	RT-289B/APN-59	Receiver-Transmitter	74.0	18.0	20.0 diam.	
	C-1242/APN-59	Control Panel	4.5	9.0	5.75	5.5
	IP-239A/APN-59	Navigators Indicator	19.5	6.75	6.75	17.0
	IP-268/APN-59	Pilots Indicator	8.0	5.875	5.125	9.0
	PP-1073A/APN-59	Power Supply	14.0	7.0	8.0 diam.	
	AS-653A/APN-59	Antenna	55.0	34.25	35.75 diam.	
	CN-221A/APN-59	Stabilization Data Generator	8.0	7.0	8.0 diam.	
	AM-853A/APN-59	Electronic Control Amplifier	9.0	6.688	5.5	10.0
	CV-204A/AP	Waveform Converter		7.5	5.125	9.75
	HD-150/APN-59	Vaneaxial Fan (2 ea)	2.5	9.0	6.5	5.0
	MT-1557/APN-59	Mount				
<u>AN/APN-147(V) Doppler Radar System</u>						
	RT-625(P)/APN- 147(V)	Receiver-Transmitter	9.4	7.625	3.813	15.051
	AS-1168/APN- 147(V)	Antenna	32.9	8.75	19.125	26.75
	CV-1181/APN- 147(V)	Frequency Tracker	34.9	7.843	7.781	22.406
	C-3747/APN- 147(V)	Doppler Radar Control Panel	0.6	1.125	5.75	2.687
	ID-938/APN-147	Ground Speed Drift Angle Indicator (2 ea)	3.1	3.26	6.22 diam.	
	MT-2550/APN-147	Mount	2.9	8.75	4.637	16.406
	MT-2549/APN-147	Mount	7.5	8.375	9.0	25.625

VC-135B PNWD EQUIPMENT PHYSICAL CHARACTERISTICS

SYSTEM	UNIT		WT (LB)	SIZE (IN)		
	TYPE (P/N)	NOMENCLATURE		H	W	D
<u>N-1 Compass System</u>						
	DT-198/AJN	Magnetic Azimuth Detector	1.125	2.328	4.781	4.781
	15810	Directional Gyro	23.5	11.5	13.31	12.5
	15150	Slaving Control	3.75	5.09	4.56	4.56
	16000	N-1 Amplifier	23.25	9.31	13.94	9.03
	ME-1	Compass Signal Power Amplifier	9.5	6.125	4.5	10.875
	15900	Master Indicator	9.75	5.25	5.0	7.9
<u>J-4 Compass System</u>						
	18717-1A	Servo Amplifier	11.0	6.75	6.75	10.125
	DT-198/AJN	Magnetic Azimuth Detector	1.125	2.328	4.781	4.781
	MIL-C-25101	Slaving Control	4.25	5.09	4.188	4.188
	432050-2	Control Panel	1.75	2.625	5.75	3.563
	423040-2	Directional Control	7.67	6.906	7.125	9.375
<u>AL-101 Low Range Radio Altimeter System</u>						
	437X-1	Antenna (4 ea)	1.0	2.75	5.2 diam.	
	860F-1	Receiver-Transmitter (2 ea)	20.0	7.766	5.094	14.828
	339H-1()	Indicator (2 ea)	2.5	3.175	3.175	5.0
	790S-1	Mounting (2 ea)	2.2	4.875	5.859	17.188*
<u>51R-6 VHF Navigation System</u>						
	51R-6	VOR/LOC Navigation Unit (2 ea)	15.2	7.625	4.875	14.625
	313N-3	VHF Navigation Control Panel	2.0	2.625	5.75	4.375
	S65-8262-2	VHF Navigation Antenna				
*Includes sway space						

VC-135B PNWD EQUIPMENT PHYSICAL CHARACTERISTICS

SYSTEM	UNIT		WT (LB)	SIZE (IN)		
	TYPE (P/N)	NOMENCLATURE		H	W	D
	<u>AN/ASQ-141 (V) Integrated Dual Flight Director System</u>					
	329B-8G	Attitude Director Indicator (2 ea)	7.5	5.125	4.875	7.5
	331A-8H	Horizontal Situation Indicator (2 ea)	7.5	4.068	4.812	8.75
	614E-9G	Flight Director Control	2.0	2.25	5.75	4.688
	562R-1E	Roll Computer (2 ea)	8.5	7.625	2.531	14.563
	562P-1E1	Pitch Computer (2 ea)	8.5	7.625	2.25	14.5
	590A-3G	Altitude Controller (2 ea)	4.4	4.167	3.344	14.031
	344C-1K	Instrument Amplifier (2 ea)	8.2	7.62	2.25	12.62
	380-1077-020	Heading Slew Control (2 ea)				
	345A-7	Rate of Turn Gyro (2 ea)	2.2	4.25	3.875	5.625
	262-2834-XXX	Mode Annunciators (16 ea)				
	262-2834-XXX	Warning Indicators (6 ea)				
	54W-4	Majority Logic Attitude Comparator	8.0	7.62	2.25	12.62
	915W-1	RGA Control Panel (2 ea)	2.5	2.2	5.7	4.3
	345H-1	Elevator Position Transmitters (2 ea)				
	262-2834-710	RGA Fail Operative Indicator (2 ea)				
	345F-1	Angle of Attack Transmitter (2 ea)	1.9	4.5 diam.		7.118
	813G-1	Angle of Attack Transmitter (2 ea)	1.5	2.4	2.4	6.5
	562U-1	RGA Computer (2 ea)	8.5	7.62	3.56	12.62
	599K-1	RGA Interface Logic Unit	5.0	3.313	3.563	12.563
	345G-1	Logitudinal Accelerometer (2 ea)	1.5	3.635	4.225	1.75
	914G-1	Comparator Warning Monitor Panel	1.2	1.875	5.75	4.0

VC-135B PNWD EQUIPMENT PHYSICAL CHARACTERISTICS

SYSTEM	UNIT		WT (LB)	SIZE (IN)		
	TYPE (P/N)	NOMENCLATURE		H	W	D
<u>AN/ASQ-141(V) Integrated Dual Flight Director System (Cont'd)</u>						
	54W-1F	Comparator Warning Monitor	15.0	7.25	3.688	15.188
	161E-7B	Remote Slew Coupler		7.625	2.25	14.75
	266-6951-450	Comparative Warning Switch Indicator (2 ea)				
<u>AN/ASN-35 Course Computer Set</u>						
	CP-622/ASN-35	Course Computer	17.0	7.625	4.875	15.187
	MT-2551/ASN-35	Mount	2.25	5.75	5.875	14.25
	C-3748/ASN-35	Control-Indicator	6.75	4.5	5.75	5.312
	C-3749/ASN-35	Auxiliary Cross Track Control-Indicator	1.9	1.875	5.75	5.0
		DELETED				

VC-135B BIBLIOGRAPHY

T.O. Number	Clq/Rev	Title
1C-135A-01	1 Jul 76	List of Applicable Publications
1C-135A-1	30 Jan 77	Flight Manual
1C-135(V) B-1	30 May 77	Partial Flight Manual - VC-135B
1C-135A-2-9	15 Mar 77	Organizational Maintenance, Instruments, C-135A, C-135B, and RC-135A
1C-135A-2-11-1	20 Feb 77	Organizational Maintenance, Radio Communication and Navigation Systems, C-135A, C-135B, and RC-135A
1C-135A-2-12-2	15 Apr 77	Organizational Maintenance, Electronic Wiring Diagrams, C-135A, C-135B, EC-135N, RC-135M, RC-135S, VC-135B, and WC-135B
5F3-3-15-13	15 Mar 75	Overhaul, Counter-Drum-Pointer Servoed Altimeter, Type AAU-19/A
5F5-4-18-3	1 Jun 73	Overhaul, Altitude Computer, Type CPU-66/A (Bendix), EC-135, C-135A, and KC-135A
5N1-2-6-1	20 Jun 74	Operational and Service, Magnetic Slaved, Directional Gyro Stabilized Compass System, Type N-1 (Kearfott), C-135A, KC-135A
5N1-2-10-12	15 Oct 74	Field Maintenance, Aircraft Magnetic Gyro Compass, Type J-4 (Eclipse-Pioneer), KC-135A
5N1-3-8-2	30 Sep 75	Field Maintenance, Computer Set, Navigational, AN/ASN-35 (Canadian Marconi), C-135A, C-135B
5N8-5-4-3	15 Mar 74	Overhaul, Bearing, Distance Heading Indicator, Type ID-526/ARN, ID-526(A)/ARN, ID-526(B)/ARN, ID-798/ARN
12P1-2AP-182	7 Apr 71	Field Maintenance, Wave Form Converter, CV-204A/AP (RCA)
12P5-2APN59-22	1 Aug 75	Field Maintenance, Radar Set AN/APN-59B

VC-135B BIBLIOGRAPHY

T.O. Number	Chg/Rev	Title
12P5-2APN147-2	1 Nov 75	Field Maintenance, Radar Set, AN/APN-147(V)
12R5-2ARN21-42	20 Apr 72	Field Maintenance, Radio Set AN/ARN-21 (Hoffman Electronics Corporation)
12R5-4-6-12	1 Apr 75	Field Maintenance, Glideslope Radio Receiver 51V-4C, 5N-4C (Collins)
12R5-4-39-2	15 Jun 72	Field Maintenance, Radio Receivers 51Z-3 and 51Z-4 (Collins)
12R5-4-41-2	7 Sep 73	Field Maintenance, Radio Receiver, Type DFA-70B-1, Mechanical Filter, Type FLA-70A-3, Power Supply, Type PSA-70A-1, Antenna Coupler, Type CUA-70B-90, Direction Finder Control, Type CNA-70C, Electrical Goniometer, Type GMS-71A (Bendix)
12R5-4-58-2	1 Jun 73	Field Maintenance, Radio Receiver Type 51R-6 and 51R-6A (Collins)
12R5-4-73-12	1 Mar 73	Field Maintenance with Overhaul, Warning Monitor, Type 54W-1F (Collins)
12R5-4-75-12	1 May 73	Field Maintenance with Overhaul, Radio Receiver Transmitter, Type 860F-1, with the 437X-1 Antenna, and 790S-1 Shockmount, (Collins)
12R5-4-77-12	19 Nov 71	Field Maintenance with Overhaul, Flight Director Control, Type 614E-9G (Collins)
12R5-4-79-12	1 Mar 71	Field Maintenance with Overhaul, Radio Attitude Indicator, Type 339H-1 (Collins)
12R5-4-80-12	15 Jan 71	Field Maintenance with Overhaul, Air Data Sensor, Type 590A-3E (Collins)
12R5-4-81-22	15 Jan 71	Field Maintenance with Overhaul, Roll Computer, Type 562R-1E (Collins)

VC-135B BIBLIOGRAPHY

T.O. Number	Chq/Rev	Title
12R5-4-82-12	15 Jun 73	Field Maintenance with Overhaul, Pitch Computer, Type 562P-1E1 (Collins)
12R5-4-83-12	21 Jul 75	Field Maintenance with Overhaul, Horizontal Situation Indicator, Type 331A-8H (Collins)
12R5-4-85-12	1 Mar 73	Field Maintenance with Overhaul, Instrument Amplifier, Type 344C-1K (Collins)
12R5-4-91-22	26 Jun 73	Field Maintenance with Overhaul, Attitude Director Indicator, Type 329B-8G (Collins)
12R5-4-92-12	15 Feb 73	Field Maintenance with Overhaul, VHF Control Unit, Type 313N-3 (Collins)
12R5-4-121-2	15 Jan 75	Field Maintenance with Overhaul, Interface Logic, Type 599K-1
12R5-4-122-2	1 Mar 73	Field Maintenance with Overhaul, Majority Logic Attitude Comparator, Type 54W-4
12R5-4-123-2	8 Jun 72	Maintenance, Integrated Dual Flight Director, Rotation Go Around System, Type AN/ASQ-141(V) (Collins)
12R5-4-124-2	15 Jul 71	Field Maintenance with Overhaul, RGA Computer, Type 562U-1 (Collins)
12R5-4-125-2	1 Dec 73	Field Maintenance with Overhaul, RGA Control Unit, Type 915W-1
12R5-4-126-2	15 Jul 71	Field Maintenance with Overhaul, Angle of Attack Indicator, Type 813G-1 (Collins)
12R5-4-127-2	2 Aug 73	Field Maintenance with Overhaul, Angle of Attack Transmitter, Type 345F-1 (Collins)
12R5-4-128-2	1 Aug 72	Field Maintenance with Overhaul and IPB, Longitudinal Accelerometer, Type 345G-1 (Collins)

VC-135B BIBLIOGRAPHY

T.O. Number	Chg/Rev	Title
12R5-4-129-2	15 Feb 73	Field Maintenance with Overhaul, Rate-of-Turn Gyro, Type 345A-7 (Collins)
AN3022	31 Aug 73	Switch-Toggle, Single Pole, Three Hole Mounting
MS24568	1 Jun 75	Relay, 10 Amp, 4 PDT, Type I, Hermetically Sealed
MIL-C-25101A	5 Dec 56	Military Specification Control, Slaving; N-1 Compass

3.14.0
WC-135B

WC-135B PNWD EQUIPMENT LIST

KEY	EQUIPMENT/UNIT
A	UHF DIRECTION FINDER SYSTEM AN/ARA-25
ADDC	COPILOT'S ATTITUDE DIRECTOR IND 329B-8G
ADDP	PILOT'S ATTITUDE DIRECTOR IND 329B-8G
AFCS	AUTOPILOT SYSTEM TYPE MC-1
AIMS	AIMS TRANSPONDER SYSTEM AN/APX-64(V)
ALDC	COPILOT'S SERVOED ALTIMETER AAU-19/A
ALDP	PILOT'S SERVOED ALTIMETER AAU-19/A
ARES	ATMOSPHERIC RESEARCH EQUIPMENT (ARE) SYSTEM
BDHM	NAVIGATOR'S NO.2 BDHI ID-526/ARN
BDHN	NAVIGATOR'S NO.1 BDHI ID-526/ARN
CMMM	INTERPHONE SYSTEM
CSA	PILOT'S INSTRUMENT AMPLIFIER 344C-1K
CSB	COPILOT'S INSTRUMENT AMPLIFIER 344C-1K
CSC	SIGNAL CONVERTER AY-533-25A1
CSD	SIGNAL CONVERTER (795-8872-002 TERMINAL BOARD WITH RN60D8205F RESISTOR)
CSE	SIGNAL CONVERTER (795-8872-001 TERMINAL BOARD WITH RN60D6810F RESISTOR)
D	DOPPLER RADAR SYSTEM AN/APN-147 (V)
GA	RADIO ALTIMETER SYSTEM NO.1 AL-101
GB	RADIO ALTIMETER SYSTEM NO.2 AL-101
GRND	GROUND
GSDN	NAVIGATOR'S GRNDSPD DRIFT ANGLE IND ID-938
HSDC	COPILOT'S HSI 331A-8H
HSDP	PILOT'S HSI 331A-8H

WC-135B PNWD EQUIPMENT LIST

KEY	EQUIPMENT/UNIT
JBA	JUNCTION POINT A
JBB	JUNCTION POINT B
JBC	JUNCTION POINT C
JBD	JUNCTION POINT D
JBE	JUNCTION POINT E
JBF	JUNCTION POINT F
JBG	JUNCTION POINT G
JBH	JUNCTION POINT H
JBJ	JUNCTION POINT J
JBK	JUNCTION POINT K
JBL	JUNCTION POINT L
JBM	JUNCTION POINT M
JBN	JUNCTION POINT N
JBP	JUNCTION POINT P
JBQ	JUNCTION POINT Q
JBR	JUNCTION POINT R
JBS	JUNCTION POINT S
JBT	JUNCTION POINT T
JBU	JUNCTION POINT U
JBV	JUNCTION POINT V
JBW	JUNCTION POINT W
JBX	JUNCTION POINT X
JBY	JUNCTION POINT Y

WC-135B PNWD EQUIPMENT LIST

KEY	EQUIPMENT/UNIT
JBZ	JUNCTION POINT Z
JCA	JUNCTION POINT AA
JCB	JUNCTION POINT AB
JCC	JUNCTION POINT AC
K	COURSE COMPUTER AN/ASN-6
KL	AIMS ALTITUDE COMPUTER SYSTEM CPU-66/A-1
METS	METEROLOGICAL SYSTEM
PTCC	COPILOT'S PITCH COMPUTER 562P-1E1
PTCP	PILOT'S PITCH COMPUTER 562P-1E1
Q	SEARCH RADAR SYSTEM AN/APN-59 B
RADC	COPILOT'S RADIO ALTIMETER IND 339H-1
RADP	PILOT'S RADIO ALTIMETER IND 339H-1
RCPC	COPILOT'S ROLL COMPUTER 562R-1E
RCPP	PILOT'S ROLL COMPUTER 562R-1E
RDA	RACK DISCONNECT A
RDB	RACK DISCONNECT B
RDC	RACK DISCONNECT C
RDD	RACK DISCONNECT D
RDE	RACK DISCONNECT E
RDF	RACK DISCONNECT F
RDH	RACK DISCONNECT H
RDJ	RACK DISCONNECT J

WC-135B PNWD EQUIPMENT LIST

KEY	EQUIPMENT/UNIT
RDK	RACK DISCONNECT K
RDL	RACK DISCONNECT L
RDM	RACK DISCONNECT M
RDN	RACK DISCONNECT N
RDP	TEST RECEPTACLE P
RDQ	RACK DISCONNECT Q
RDR	RACK DISCONNECT R
RDS	RACK DISCONNECT S
RDT	RACK DISCONNECT T
RMDC	COPILOT'S RMI ID-250A/ARN
RMDN	NAVIGATOR'S RMI ID-250A/ARN
RMDP	PILOT'S NO.1 RMI ID250A/ARN
RMDU	PILOT'S NO.2 RMI ID250A/ARN
SA	GLIDESLOPE RADIO SYSTEM NO.1 51V-4A
SB	GLIDESLOPE RADIO SYSTEM NO.2 51V-4A
SWA	SWITCH POINT A
SWB	SWITCH POINT B
SWC	PILOT'S VOR/TACAN RELAY
SWD	COPILOT'S VOR/TACAN RELAY
SWE	FLAG RELAY NO.1
SWF	FLAG RELAY NO.2
SWG	SWITCH POINT G
SWH	SWITCH POINT H

WC-135B PNWD EQUIPMENT LIST

KEY	EQUIPMENT/UNIT
TA	UHF NAVIGATION SYSTEM NO.1 AN/ARN-21C
TB	UHF NAVIGATION SYSTEM NO.2 AN/ARN-72
VA	VHF NAVIGATION SYSTEM NO.1 51R-6
VB	VHF NAVIGATION SYSTEM NO.2 51R-6
WA	N-1 COMPASS SYSTEM
WAMS	COMPARATOR WARNING MONITOR SYSTEM 54W-1F
WB	J-4 COMPASS SYSTEM
ZA	AUTO DIRECTION FINDER SYSTEM NO.1 DFA-70B
ZB	AUTO DIRECTION FINDER SYSTEM NO.2 DFA-70B

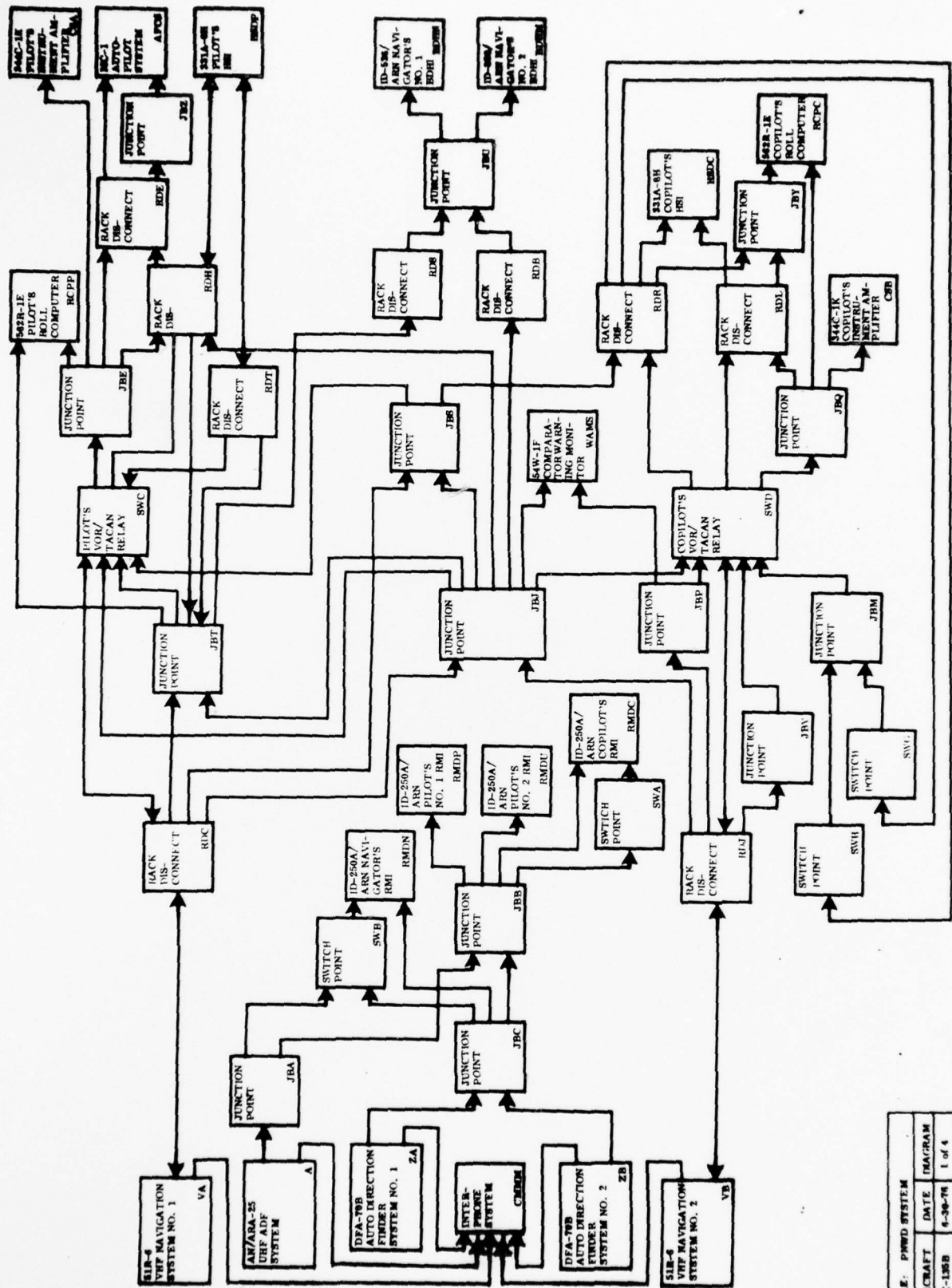

TITLE: PWVD SYSTEM			
AIRCRAFT	DATE	DIAGRAM	
WC-135B	6-30-76	1 of 4	

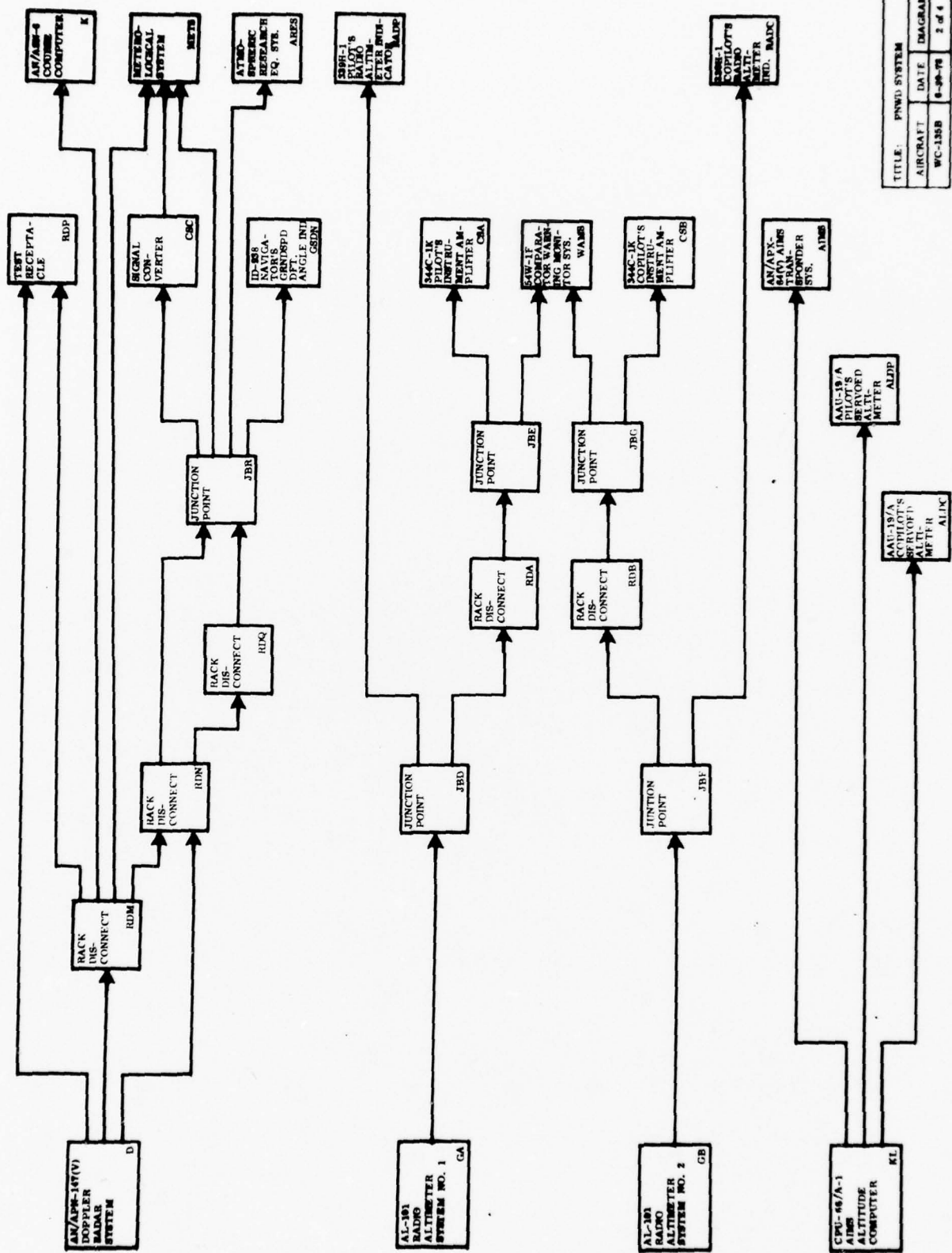

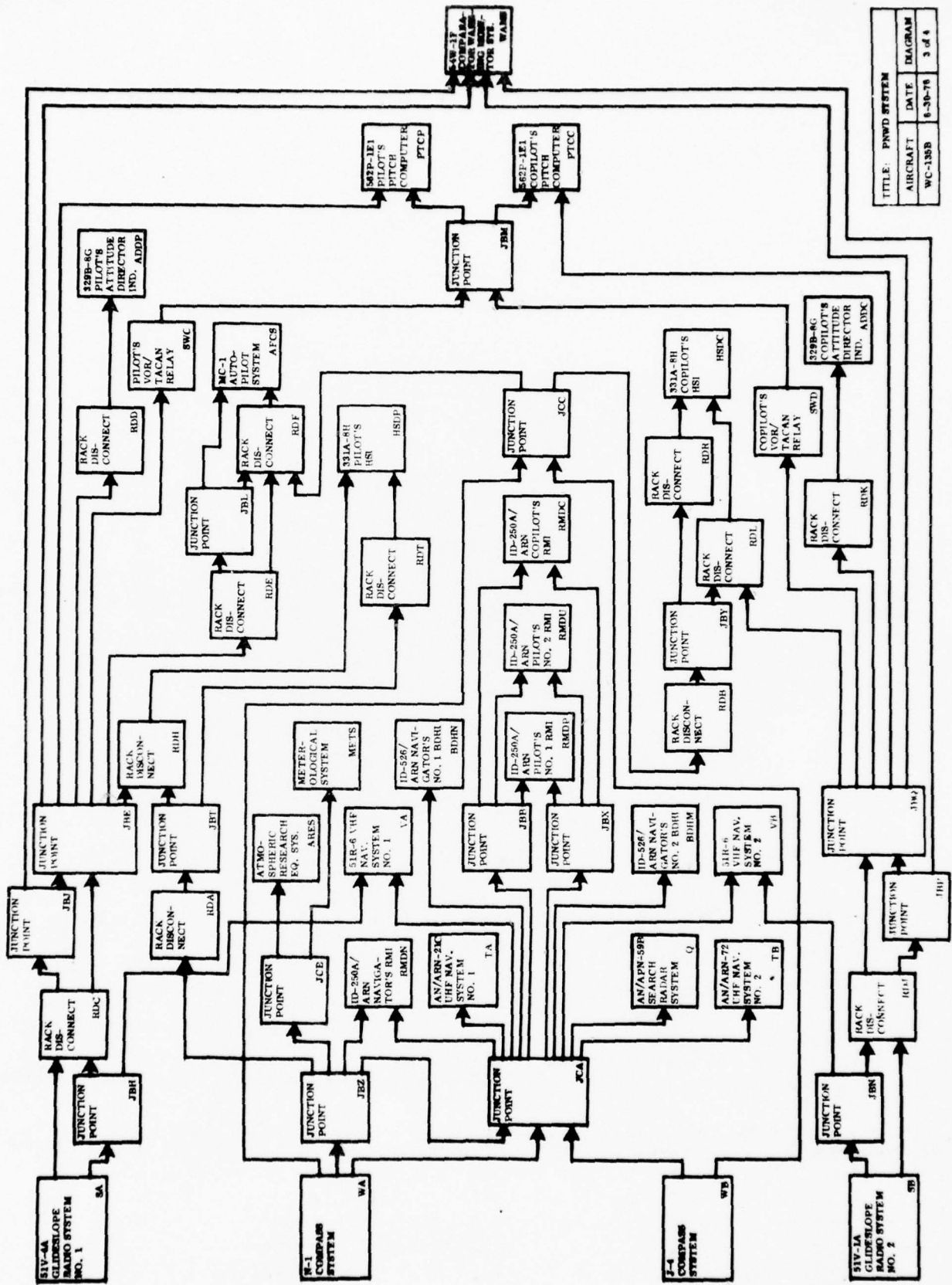

TITLE: PNDW SYSTEM		
AIRCRAFT	DATE	DIAGRAM
WC-135B	6-30-76	3 of 4

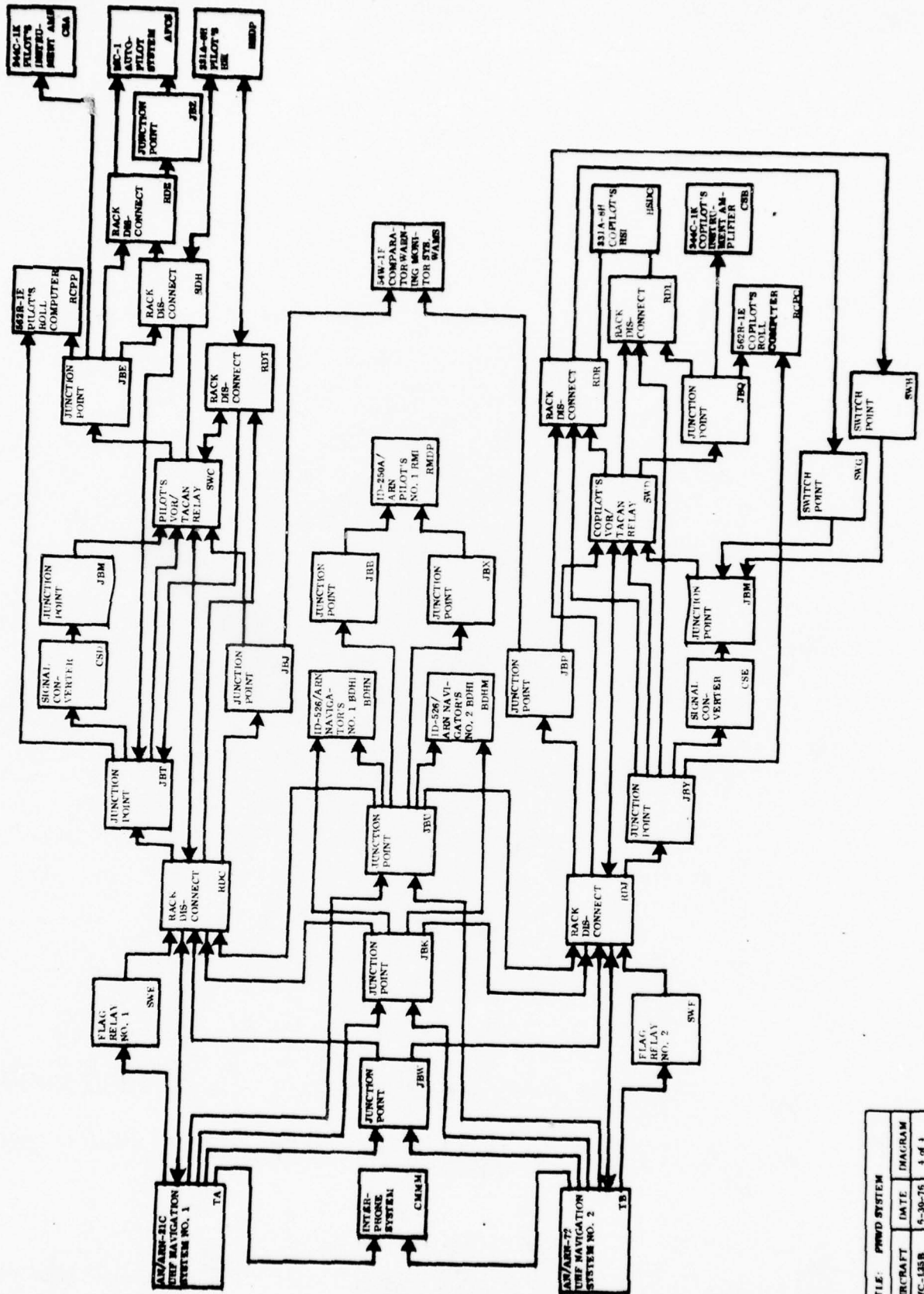

3-14A-9

TITLE	PWWD SYSTEM
AIRCRAFT	DATE
WC-130B	6-30-76
	4 of 4

WC-135B PNWD EQUIPMENT PHYSICAL CHARACTERISTICS

SYSTEM	UNIT		WT (LB)	SIZE (IN)		
	TYPE (P/N)	NOMENCLATURE		H	W	D
<u>DFA-70B Automatic Direction Finder System</u>						
	CNA-70C	Control Panel (4 ea)	3.5	4.5	5.8	5.8
	DFA-70B-1	Receiver (2 ea)	24.5	7.8	5.0	24.3
	LPA-71A	Loop Antenna (2 ea)	2.8	1.96	9.88	16.89
	PSA-70A-1	AC Power Supply (2 ea)	5.0	--Mounts Internally--		
	GMA-71A	Goniometer (2 ea)	1.9	3.25	3.25	5.14
	65-16189	Sense Antenna (2 ea)				
	CUA-70B-90	Sense Antenna Coupler (2 ea)	1.2	3.0	5.02	4.62
	D-9262-001	Control Switching Relay (2 ea)				
	MTA-70C	Mount (2 ea)	4.0	7.62	5.0	19.47
	FLA-70A-3	Mechanical Filter (2 ea)	0.1	0.755	0.755	2.63
<u>AN/APN-70 Loran Navigation System</u>						
	R-277()/APN-70	Receiver*	45.0	12.44	11.375	19.69
	IP-58/APN-70	Indicator	15.0	9.16	7.625	21.875
	65-2349	Antenna				
	SA-10B	Antenna Coupler				
	RALA-2A	Lightning Arrestor				
<u>Air Data System</u>						
	CPU-66/A-1	Altitude Computer	6.0	4.5	4.0	9.9
	AAU-19/A	Servoed Altimeter (2 ea)	4.5	3.25	3.25	8.813
<u>51V-4A Glideslope Radio System</u>						
	51V-4A	Glideslope Receiver (2 ea)	3.5	3.375	2.5	12.56
	37P-4	Antenna	0.7	5.984	2.0	4.5
	*Includes mount					

WC-135B PNWD EQUIPMENT PHYSICAL CHARACTERISTICS

SYSTEM	UNIT		WT (LB)	SIZE (IN)		
	TYPE (P/N)	NOMENCLATURE		H	W	D
<u>AN/ARN-21C UHF Navigation System (TACAN)</u>						
	RT-220C/ARN-21	Receiver-Transmitter (2 ea)	60.0	8.3	11.13	18.75
	C-866/ARN-21	Radio Set Control (2 ea)	1.5	2.25	5.75	4.75
	161B-1	Instrumentation Coupler (2 ea)	12.0	6.125	5.0	10.167
	AT-741/A	Antenna (2 ea)	0.4	3.3	1.75	5.25
	MS24568-D1	TACAN Flag Relay (2 ea)	0.73	2.7	3.0	2.3
	391233	TACAN Select ON-OFF Switch/Indicator (2 ea)				
	410-1521-010	VOR/TACAN Relay (6 ea)	0.57	2.187	1.531	1.130
	MT-928/ARN-21	Mount (2 ea)	6.5	7.75	11.125	17.5
	349L-2	Mount (2 ea)	3.0	7.75	5.91	1.875
<u>Marker Beacon Radio System</u>						
	51Z-3	Receiver	2.9	3.38	2.25	12.62
	AT-536/ARN	Antenna	2.2	3.125	7.75	11.188
	AN3022-2	Marker Beacon Sensi- tivity Switch	0.10	2.125	0.765	1.95
	STB-390-WE	Marker Beacon Light Assys (2 ea)				
<u>Radio Navigation Instruments</u>						
	ID-250A/ARN	Radio Magnetic Indicator (4 ea)	2.6	3.25 diam.		6.156
	ID-526/ARN	Bearing-Distance-Heading Indicator (2 ea)	4.0	3.25	3.25	6.875
<u>AN/ARA-25 UHF Direction Finder System</u>						
	AM-608/ARA-25	Amplifier	5.4	5.875	4.875	12.531
	AS-578/ARA-25	Antenna	17.5	6.0	16.0	14.5
	RE-120/ARA-25	Relay	0.82	5.813	6.5	1.75

WC-135B PNWD EQUIPMENT PHYSICAL CHARACTERISTICS

SYSTEM	UNIT		WT (LB)	SIZE (IN)		
	TYPE (P/N)	NOMENCLATURE		H	W	D
<u>AN/APN-59B Search Radar System</u>						
	RT-289B/APN-59	Receiver-Transmitter	74.0	18.0	20.0 diam.	
	C-1242/APN-59	Control Panel	4.5	9.0	5.75	5.5
	IP-239A/APN-59	Navigators Indicator	19.5	6.75	6.75	17.0
	IP-268/APN-59	Pilots Indicator	8.0	5.875	5.125	9.0
	PP-1073A/APN-59	Power Supply	14.0	7.0	8.0 diam.	
	AS-653A/APN-59	Antenna	55.0	34.25	35.75 diam.	
	CN-221A/APN-59	Stabilization Data Generator	8.0	7.0	8.0 diam.	
	AM-853A/APN-59	Electronic Control Amplifier	9.0	6.688	5.5	10.0
	CV-204A/AP	Waveform Converter		7.5	5.125	9.75
	HD-150/APN-59	Vaneaxial Fan (2 ea)	2.5	9.0	6.5	5.0
	MT-1557/APN-59	Mount				
<u>AN/APN-147(V) Doppler Radar System</u>						
	RT-625(P)/APN-147(V)	Receiver-Transmitter	9.4	7.625	3.813	15.051
	AS-1168/APN-147(V)	Antenna	32.9	8.75	19.125	26.75
	CV-1181/APN-147(V)	Frequency Tracker	34.9	7.843	7.781	22.406
	C-3747/APN-147(V)	Doppler Radar Control Panel	0.6	1.125	5.75	2.687
	ID-938/APN-147	Ground Speed Drift Angle Indicator	3.1	3.26	6.22 diam.	
	MT-2550/APN-147	Mount	2.9	8.75	4.637	16.406
	MT-2549/APN-147	Mount	7.5	8.375	9.0	25.625

WC-135B PNWD EQUIPMENT PHYSICAL CHARACTERISTICS

SYSTEM	UNIT		WT (LB)	SIZE (IN)		
	TYPE (P/N)	NOMENCLATURE		H	W	D
<u>N-1 Compass System</u>						
	DT-198/AJN	Magnetic Azimuth Detector	1.125	2.328	4.781	4.781
	15810	Directional Gyro	23.5	11.5	13.31	12.5
	15150	Slaving Control	3.75	5.09	4.56	4.56
	16000	N-1 Amplifier	23.25	9.31	13.94	9.03
	ME-1	Compass Signal Power Amplifier	9.5	6.125	4.5	10.875
	15900	Master Indicator	9.75	5.25	5.0	7.9
<u>J-4 Compass System</u>						
	18717-1A	Servo Amplifier	11.0	6.75	6.75	10.125
	DT-198/AJN	Magnetic Azimuth Detector	1.125	2.328	4.781	4.781
	MIL-C-25101	Slaving Control	4.25	5.09	4.188	4.188
	432050-2	Control Panel	1.75	2.625	5.75	3.563
	423040-2	Directional Control	7.67	6.906	7.125	9.375
<u>AL-101 Low Range Radio Altimeter System</u>						
	437X-1	Antenna (4 ea)	1.0	2.75	5.2 diam.	
	860F-1	Receiver-Transmitter (2 ea)	20.0	7.766	5.094	14.828
	339H-1()	Indicator (2 ea)	2.5	3.175	3.175	5.0
	790S-1	Mounting (2 ea)	2.2	4.875	5.859	17.188*
<u>51R-6 VHF Navigation System</u>						
	51R-6	VOR/LOC Navigation Unit (2 ea)	15.2	7.625	4.875	14.625
	313N-3	VHF Navigation Control Panel	2.0	2.625	5.75	4.375
	S65-8262-2	VHF Navigation Antenna				
*Includes sway space						

WC-135B PNWD EQUIPMENT PHYSICAL CHARACTERISTICS

SYSTEM	UNIT		WT (LB)	SIZE (IN)		
	TYPE (P/N)	NOMENCLATURE		H	W	D
<u>AN/ASQ-141 (V) Integrated Dual Flight Director System</u>						
	329B-8G	Attitude Director Indicator (2 ea)	7.5	5.125	4.875	7.5
	331A-8H	Horizontal Situation Indicator (2 ea)	7.5	4.068	4.812	8.75
	614E-9G	Flight Director Control	2.0	2.25	5.75	4.688
	562R-1E	Roll Computer (2 ea)	8.5	7.625	2.531	14.563
	562P-1E1	Pitch Computer (2 ea)	8.5	7.625	2.25	14.5
	590A-3G	Altitude Controller (2 ea)	4.4	4.167	3.344	14.031
	344C-1K	Instrument Amplifier (2 ea)	8.2	7.62	2.25	12.62
	380-1077-020	Heading Slew Control (2 ea)				
	345A-7	Rate of Turn Gyro (2 ea)	2.2	4.25	3.875	5.625
	262-2834-XXX	Mode Annunciators (16 ea)				
	262-2834-XXX	Warning Indicators (6 ea)				
	54W-4	Majority Logic Attitude Comparator	8.0	7.62	2.25	12.62
	915W-1	RGA Control Panel (2 ea)	2.5	2.2	5.7	4.3
	345H-1	Elevator Position Transmitters (2 ea)				
	262-2834-710	RGA Fail Operative Indicator (2 ea)				
	345F-1	Angle of Attack Transmitter (2 ea)	1.9	4.5 diam.		7.118
	813G-1	Angle of Attack Transmitter (2 ea)	1.5	2.4	2.4	6.5
	562U-1	RGA Computer (2 ea)	8.5	7.62	3.56	12.62
	599K-1	RGA Interface Logic Unit	5.0	3.313	3.563	12.563
	345G-1	Logitudinal Accelerometer (2 ea)	1.5	3.635	4.225	1.75
	914G-1	Comparator Warning Monitor Panel	1.2	1.875	5.75	4.0

WC-135B PNWD EQUIPMENT PHYSICAL CHARACTERISTICS

SYSTEM	UNIT		WT (LB)	SIZE (IN)		
	TYPE (P/N)	NOMENCLATURE		H	W	D
<u>AN/ASQ-141(V) Integrated Dual Flight Director System (Cont'd)</u>						
	54W-1F	Comparator Warning Monitor	15.0	7.25	3.688	15.188
	161E-7B	Remote Slew Coupler	6.0	7.625	2.25	14.75
	266-6951-450	Comparative Warning Switch Indicator (2 ea)				
<u>AN/ASN-35 Course Computer Set</u>						
	CP-622	Course Computer	17.0	7.625	4.875	15.187
	MT-2551	Mount	2.25	5.75	5.875	14.25
	C-3748	Control-Indicator	6.75	4.5	5.75	5.312
	C-3749	Auxiliary Cross Track Control-Indicator	1.9	1.875	5.75	5.0
	ID-939	Multiple Error Indicator	2.75	3.26	3.26	6.5
<u>AN/ASN-6 Course Computer System</u>						
	CP-188A	Computer*	17.54	6.156	8.375	13.72
	AM-916	Amplifier*	21.0	6.125	8.875	22.44
	C-1316	Control	2.99	3.375	5.75	3.81
	ID-389	Indicator	4.1	3.25	3.25	11.5
	100-09682	Switch Panel				
<u>AN/ARN-72 UHF Navigation System (TACAN)</u>						
	RT-636/ARN-72	Receiver-Transmitter	60.0	9.813	11.125	18.75
	MT-2601/ARN-72	Mount	6.0	1.625	11.125	19.375
	C-3844/ARN-72	Control Panel	1.5	2.25	5.75	3.813
	AT-741/A	Antenna (Top)	0.4	3.3	1.75	5.25
	AT-234/APX	Antenna (Bottom)				
*Includes mount						

WC-135B PNWD EQUIPMENT PHYSICAL CHARACTERISTICS

SYSTEM	UNIT		WT (LB)	SIZE (IN)		
	TYPE (P/N)	NOMENCLATURE		H	W	D
	<u>AN/ARN-72 UHF Navigation System (TACAN) (Cont'd)</u>					
	SA-521/A	Antenna Switching Relay	0.34	1.94	2.78	3.19
	161B-1	Instrumentation Coupler	12.0	6.125	5.0	10.167
	349L-2	Mount	3.0	7.75	5.91	13.875
	795-8383-001	TACAN Antenna Select Panel				
	MS24568-D1	TACAN Flag Relay	0.73	2.7	3.0	2.3
	410-1521-001	VOR/TACAN Transfer				

WC-135B BIBLIOGRAPHY

T.O. Number	Chg/Rev	Title
1C-135A-01	1 Jul 76	List of Applicable Publications
1C-135A-1	30 Jan 77	Flight Manual
1C-135(W) B-1	30 May 77	Partial Flight Manual - WC-135B
1C-135A-2-9	25 Mar 77	Organizational Maintenance, Instruments, C-135A, C-135B, and RC-135A
1C-135A-2-11-1	20 Feb 77	Organizational Maintenance, Radio Communication and Navigation Systems, C-135A, C-135B, and RC-135A
1C-135A-2-12-2	15 Apr 77	Organizational Maintenance, Electronic Wiring Diagrams, C-135A, C-135B, EC-135N, RC-135M, RC-135S, VC-135B, and WC-135B
5F3-3-15-13	15 Mar 75	Overhaul, Counter-Drum-Pointer Servoed Altimeter, Type AAU-19/A
5F5-4-18-3	1 Jun 73	Overhaul, Altitude Computer, Type CPU-66/A (Bendix), EC-135, C-135A, and KC-135A
5N1-2-6-1	20 Jun 74	Operational and Service, Magnetic Slaved, Directional Gyro Stabilized Compass System, Type N-1 (Kearfott), C-135A, KC-135A
5N1-2-10-12	15 Oct 74	Field Maintenance, Aircraft Magnetic Gyro Compass, Type J-4 (Eclipse-Pioneer), KC-135A
5N1-3-2-1	15 Apr 60	Operational and Service, Computer Set, Latitude and Longitude, AN/ASN-6
5N8-5-4-3	15 Mar 74	Overhaul, Bearing, Distance Heading Indicator, Type ID-526/ARN, ID-526(A)/ARN, ID-526(B)/ARN, ID-798/ARN
RP1-2AP-182	7 Apr 71	Field Maintenance, Wave Form Converter CV-204A/AP (RCA)
12P5-2APN59-22	1 Aug 75	Field Maintenance, Radar Set AN/APN-59B

WC-135B BIBLIOGRAPHY

T.O. Number	Chg/Rev	Title
12P5-2APN147-2	1 Nov 75	Field Maintenance, Radar Set AN/APN-147(V)
12R1-2ARA25-2	15 Feb 75	Service, Direction Finder Group, AN/ARN-25 and -25A
12R5-2ARN21-42	20 Apr 72	Field Maintenance, Radio Set AN/ARN-21 (Hoffman Electronics Corporation)
12R5-4-6-12	1 Apr 75	Field Maintenance, Glideslope Radio Receiver 51V-4A, 5N-4C (Collins)
12R5-4-39-2	15 Jun 72	Field Maintenance, Radio Receivers 51Z-3 and 51Z-4 (Collins)
12R5-4-41-2	7 Sep 73	Field Maintenance, Radio Receiver Type DFA-70B-1, Mechanical Filter, Type FLA-70A-3, Power Supply, Type PSA-70A-1, Antenna Coupler, Type CUA-70B-90, Direction Finder Control, Type CNA-70C, Electrical Goniometer, Type GMS-71A (Bendix)
12R5-4-58-2	1 Jun 73	Field Maintenance, Radio Receiver Type 51R-6 and 51R-6A (Collins)
12R5-4-73-12	1 Mar 73	Field Maintenance with Overhaul, Warning Monitor, Type 54W-1F (Collins)
12R5-4-75-12	1 May 73	Field Maintenance with Overhaul, Radio Receiver Transmitter, Type 860F-1, with the 437X-1 Antenna, and 790S-1 Shockmount, (Collins)
12R5-4-77-12	19 Nov 71	Field Maintenance with Overhaul, Flight Director Control, Type 614E-9G (Collins)
12R5-4-79-12	1 Mar 71	Field Maintenance with Overhaul, Radio Attitude Indicator, Type 339H-1 (Collins)
12R5-4-80-12	15 Jan 71	Field Maintenance with Overhaul, Air Data Sensor, Type 590A-3E (Collins)
12R5-4-81-22	15 Jan 71	Field Maintenance with Overhaul, Roll Computer, Type 562R-1E (Collins)

WC-135B BIBLIOGRAPHY

T.O. Number	Chq/Rev	Title
12R5-4-82-12	15 Jun 73	Field Maintenance with Overhaul, Pitch Computer, Type 562P-1E1 (Collins)
12R5-4-83-12	21 Jul 75	Field Maintenance with Overhaul, Horizontal Situation Indicator, Type 331A-8H (Collins)
12R5-4-85-12	1 Mar 73	Field Maintenance with Overhaul, Instrument Amplifier, Type 344C-1K (Collins)
12R5-4-91-22	26 Jun 73	Field Maintenance with Overhaul, Attitude Director Indicator, Type 329B-8G (Collins)
12R5-4-92-12	15 Feb 73	Field Maintenance with Overhaul, VHF Control Unit, Type 313N-3 (Collins)
12R5-4-121-2	15 Jan 75	Field Maintenance with Overhaul, Interface Logic, Type 599K-1
12R5-4-122-2	1 Mar 73	Field Maintenance with Overhaul, Majority Logic Attitude Comparator, Type 54W-4
12R5-4-123-2	8 Jun 72	Maintenance, Integrated Dual Flight Director, Rotation Go Around System, Type AN/ASQ-141(V) (Collins)
12R5-4-124-2	15 Jul 71	Field Maintenance with Overhaul, RGA Computer, Type 562U-1 (Collins)
12R5-4-125-2	1 Dec 73	Field Maintenance with Overhaul, RGA Control Unit, Type 915W-1
12R5-4-126-2	15 Jul 71	Field Maintenance with Overhaul, Angle of Attack Indicator, Type 813G-1 (Collins)
12R5-4-127-2	2 Aug 73	Field Maintenance with Overhaul, Angle of Attack Transmitter, Type 345F-1 (Collins)
12R5-4-128-2	1 Aug 72	Field Maintenance with Overhaul and IPB, Longitudinal Accelerometer, Type 345G-1 (Collins)

WC-135B BIBLIOGRAPHY

T.O. Number	Chg/Rev	Title
12R5-4-129-2	15 Feb 73	Field Maintenance with Overhaul, Rate-of-Turn Gyro, Type 345A-7 (Collins)
AN3022	31 Aug 73	Switch-Toggle, Single Pole, Three Hole Mounting
MS24568	1 Jun 75	Relay, 10 Amp, 4 PDT, Type I, Hermetically Sealed
MIL-C-25101A	5 Dec 56	Military Specification Control, Slaving; N-1 Compass

3.15.0
VC-140B

VC-140B PNWD EQUIPMENT LIST

KEY	EQUIPMENT/UNIT
ADDC	COPILOT'S FLIGHT DIRECTOR IND 329B-8G
ADDP	PILOT'S FLIGHT DIRECTOR INDICATOR 329B-8G
AFCS	AUTOPILOT
AIMS	IFF TRANSPONDER SET AN/APX-72
ALDC	COPILOT'S SERVOED ALTIMETER AAU-19/A
ALDP	PILOT'S SERVOED ALTIMETER AAU-19/A
C	AIR DATA COMPUTER CPU-46/A
CMDC	COPILOT'S GYROSYN COMPASS MASTER IND 1777213-623
CMDP	PILOT'S GYROSYN COMPASS MASTER IND 1777213-623
CMM	INTERPHONE SYSTEM
CSA	INSTRUMENT AMP NO.1 344C-1K
CSB	FLT SYS ADAPTER NO.1 599A-1A
CSC	INSTRUMENT AMP NO.2 344C-1K
CSD	TRANSFORMER MS90003-1
CSE	FLT SYS ADAPTER NO.2 599A-1A
CSF	BUFFER AMPLIFIER 972204-1
CWMN	COMPARATOR WARNING MONITOR SYSTEM 54W-1C
D	DOPPLER RADAR NAV AND COMPUTER SYSTEM 621C-1
DMEC	COPILOT'S DME INDICATOR 5221859003
DMEP	PILOT'S DME INDICATOR 5221859003
DRND	DOPPLER RADAR INDICATOR 338B-1A
FDCA	NO.1 FLIGHT DIRECTOR COMPUTER SYSTEM FD-109
FDCB	NO.2 FLIGHT DIRECTOR COMPUTER SYSTEM FD-109

VC-140B PNWD EQUIPMENT LIST

KEY	EQUIPMENT/UNIT
G	RADIO ALTIMETER SYSTEM A1-101
HSDC	COPILOT'S COURSE INDICATOR 331A-6A-1
HSDP	PILOT'S COURSE INDICATOR 331A-6A-1
JBA	JUNCTION POINT A1
JBB	JUNCTION POINT C2
JBC	JUNCTION POINT C1
P	INERTIAL NAV SYSTEM LTN-51
RADC	COPILOT'S RADIO ALTIMETER INDICATOR 339H-1
RADP	PILOT'S RADIO ALTIMETER INDICATOR 339H-1
RDA	RACK DISCONNECT
RDB	RACK DISCONNECT CENTER PEDESTAL
RDC	RACK DISCONNECT L WING BREAK
RDD	RACK DISCONNECT LEFT WHEEL WELL
RDE	RACK DISCONNECT R WING BREAK
RDF	RACK DISCONNECT RIGHT WHEEL WELL
SA	NO.1 GLIDESLOPE SYSTEM 51V-4
SB	NO.2 GLIDESLOPE SYSTEM 51V-4
SWA	INSTRUMENT SELECTOR 4904268
SWB	INSTRUMENT SELECTOR 4904268
SWC	NO.1 VOR/TACAN RELAY
SWD	NO.3 VOR/TACAN RELAY
SWE	NO.2 VOR/TACAN RELAY
SWF	TACAN ON-TRACKING REL

VC-140B PNWD EQUIPMENT LIST

KEY	EQUIPMENT/UNIT
T	TACAN SYSTEM AN/ARN-21
VA	NO.1 VHF NAV SYSTEM 51X-2B
VB	NO.2 VHF NAV SYSTEM 51X-2B
WA	NO.1 COMPASS SYSTEM C-10
WB	NO.2 COMPASS SYSTEM C-10
Z	LF ADF SYSTEM DF-202

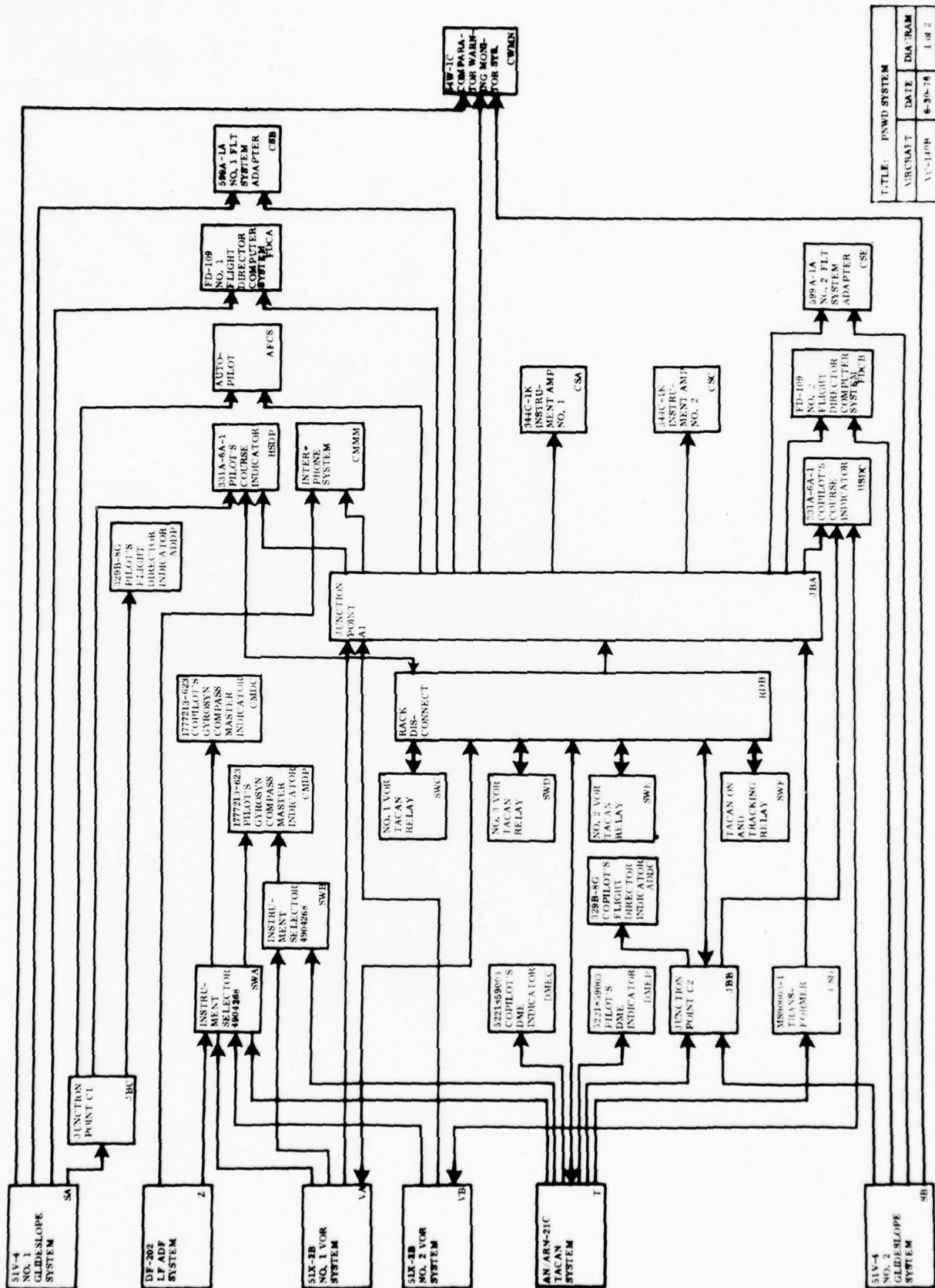

TITLE: PNO.2 SYSTEM		
APPROVAL	DATE	DIA. DRAW
VC-140B	6-30-78	1 of 2

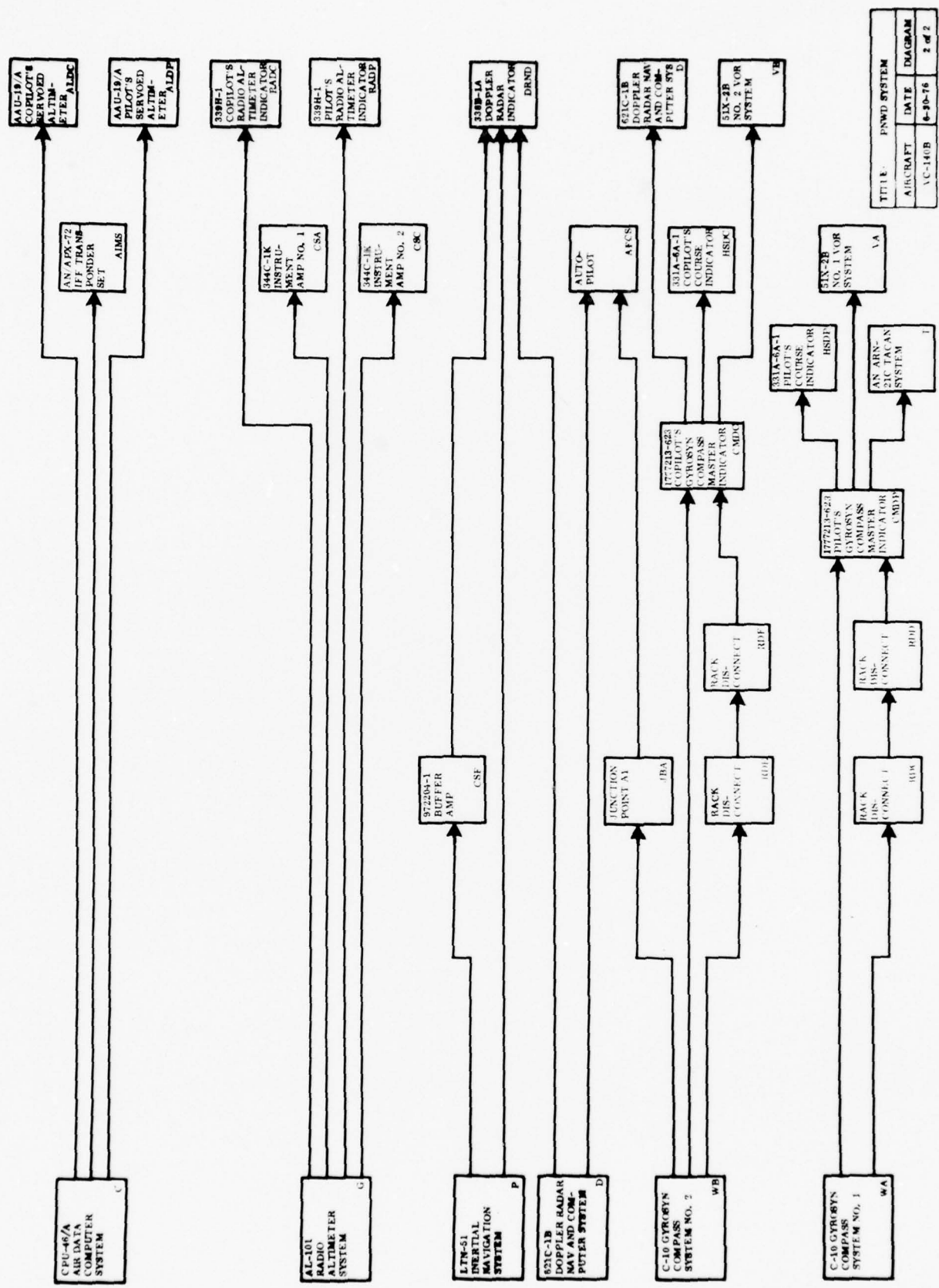

TITLE	PWVD SYSTEM
AIRCRAFT	DATE
VC-140B	6-30-76
	DIAGRAM
	2 of 2

VC-140B PNWD EQUIPMENT PHYSICAL CHARACTERISTICS

SYSTEM	UNIT		WT (LB)	SIZE (IN)		
	TYPE (P/N)	NOMENCLATURE		H	W	D
<u>VHF Navigation Systems</u>						
	51X-2B	Receiver (2 ea)	10.5	7.5	3.563	12.563
	599A-1A	Flight System Adapter	2.4	3.375	2.5	12.563
	344B-1A	Instrumentation Unit (2 ea)	13.0	7.625	3.688	14.688
	G-1902A	Control Panel	1.75	3.75	5.75	6.094
		Power Relay	.67	2.187	1.531	1.531
	G-1093A	Control Panel	2.5	3.75	5.75	6.094
	DMN4-8	Antenna	4.5	9.0	3.125	17.5
<u>AN/ARN-21C TACAN System</u>						
	RT-220C/ARN-21	Receiver-Transmitter	60.0	8.3	11.13	18.75
	C-1763/ARN-21A	TACAN Control Panel	2.25	3.0	5.75	4.0
	339D-1	Distance Indicator (2 ea)	1.1	1.375	3.25	4.5
	161B-1/ARN-21A	Data Coupler	12.0	6.125	5.0	10.167
	AT-741/A	TACAN Antenna	0.4	3.3	1.75	5.25
		TACAN-VOR Relay (4 ea)	0.57	2.187	1.531	1.130
<u>FD-109 Flight Director Systems</u>						
	329B-8G	Flight Director Indicator	7.5	5.0	5.0	7.5
	331A-6A-1	Course Indicator (2 ea)	5.3	4.0	4.0	8.0
	614E-9E	Flight Director Control (2 ea)	2.3	2.25	5.75	4.688
	562P-1E1	Pitch Steering Computer (2 ea)	8.5	7.625	2.25	14.5
	562R-1E	Roll Steering Computer (2 ea)	8.5	7.625	2.531	14.563
	344C-1K	Instrument Amplifier (2 ea)	8.2	7.62	2.25	12.63
	590A-3E	Altitude Controller (2 ea)	4.5	3.25	2.25	12.625
	5302-1020-1/2	Mode Annunciator Panel (2 ea)	0.9	1.25	3.764	2.375
	4904313-3	Annunciator Dimmer Control Panel (2 ea)				

VC-140B PNWD EQUIPMENT PHYSICAL CHARACTERISTICS

SYSTEM	UNIT		WT (LB)	SIZE (IN)		
	TYPE (P/N)	NOMENCLATURE		H	W	D
<u>Flight Director Systems (Cont'd)</u>						
	S6A-1	Annunciator Dimmer Relay Box (2 ea)				
	W20040-3	Go-Around Switch (2 ea)				
	JR1000-35	Vertical Gyro (2 ea)				
	C12-A	AC Interlock Relay (2 ea)				
	AN3311-2	DC Interlock Relay (2 ea)	0.44	2.6	2.5	1.625
	JR1000-9	Phase Adapter (2 ea)				
	54W-1C	Comparator Unit	14.0	7.62	3.7	15.19
	914G-1A	Warning Monitor Panel	1.25	1.875	5.75	4.0
	90EA1C3F3J1/R/ LIN1R14	Master Warn Indicator (2 ea)	.125	0.75	1.0	2.2
<u>AL-101 Radio Altimeter System</u>						
	860F-1	Receiver-Transmitter Unit	20.0	7.766	5.094	14.828
	339H-1	Indicator (2 ea)	2.5	3.175	3.175	5.0
	437X-1	Antenna (2 ea)	1.0	2.75	5.2 diam.	
<u>Glideslope Systems</u>						
	51V-4	Receiver (2 ea)	3.5	3.375	2.25	12.56
	37P4	Antenna	0.7	5.984	2.0	4.5
<u>Marker Beacon System</u>						
	51Z-2	Receiver and Mount	4.9	9.313	3.375	17.344
	G1902	Control Panel (Part of VHF Nav System)	1.75	3.75	5.75	6.094
	MS25311-1/4	Light Assembly (2 ea)		0.75 diam.		2.25
	37X-2	Antenna	1.0	2.563	1.563	11.563
<u>Doppler Radar Navigation and Computer System</u>						
	621C-1B	Transmitter Receiver	11.9	7.625	3.56	15.19
	562F-1C	Computer Tracker	27.2	7.625	4.875	22
	714G-2	DOP Radar Control Panel	0.9	5.745	1.875	4.6

VC-140B PNWD EQUIPMENT PHYSICAL CHARACTERISTICS

SYSTEM	UNIT		WT (LB)	SIZE (IN)		
	TYPE (P/N)	NOMENCLATURE		H	W	D
<u>Doppler Radar Navigation and Computer System (Cont'd)</u>						
	338B-1A	Doppler Radar Indicator	2.0	3.25	3.25	4.5
	137Y-1A	Antenna	21.5	16.06	20.625 diam.	
	6201	Ground Speed Indicator				
<u>DF-202 Automatic Direction Finder System</u>						
	614L-6	Control Panel	2.25	4.5	5.75	5.625
	51Y-3	Receiver	20.3	7.844	5.0	21.56
	MR-160	Range Filter				
	332C-1W	RMI	2.5	3.25	3.25	5.0
	179T-2A	Antenna Coupler	1.4	4.5	4.5	3.0
	137A-2	Loop Antenna	6.44	4.25	9.578	16.125
	JR303-2R,-2L	Sense Antenna (2 ea)				
<u>Weather Radar</u>						
	RDR-1D	Transmitter Receiver	29.0	8.0	5.0	23.0
	SYN-1B	Radar Synchronizer	21.0	8.0	5.0	23.0
	PPI-1E	Radar Scope	15.0	6.25	6.25	15
	G-908	Control Panel	1.3	2.25	5.75	4.0
	ANT-1G	Antenna	15.0	21.0	18.0	17.0
	AN3311-21	Contour Test Relay	0.44	2.60	2.5	1.625
<u>C-10 Gyrosyn Compass Systems</u>						
	620359	Flux Valve (2 ea)	1.5	2.125	3.5	5
	613260-2	Directional Gyro (2 ea)	9.0	7.75	8.25	7.5
	618379	Servo Amplifier (2 ea)	1.0	4.125	2.25	2.25
	621107	Slaving Amplifier (2 ea)	1.5	4.125	3.0	2.25
	1777213-623	Gyrosyn Compass Indicator (2 ea)	4.1	3.25	3.25	8.75
	MS24523-23	MAG-DG Switch (2 ea)	0.08	1.27	0.635	2.34

VC-140B PNWD EQUIPMENT PHYSICAL CHARACTERISTICS

SYSTEM	UNIT		WT (LB)	SIZE (IN)		
	TYPE (P/N)	NOMENCLATURE		H	W	D
<u>LTN-51 Inertial Nav System</u>	663550-04	Control Display Unit	5.0	4.5	5.75	6.25
	663570-01	Mode Select Unit	1.0	1.5	5.75	2.0
	663450-08	Inertial Nav Unit	60.0	8.625	10.12	19.98
	A074340/41	Blower/Inverter				
	972204-1	Buffer Amplifier				
	172934-001	Ledex Switching Unit				
	7330940-10	Autopilot Switching Unit				
	28121	Battery	17.0	6.25	5.10	14.39
<u>CPU-46/A Air Data Computer</u>			12.0	5.875	6.518	9.2

VC-140B BIBLIOGRAPHY

T.O. Number	Chg/Rev	Title
1C-140A-01	15 Aug 74	List of Applicable Publications - C-140A and VC-140B
1C-140A-1	10 Jun 75	Flight Manual - C-140A and VC-140B
1C-140A-2-5	10 Jul 76	Maintenance, Instruments and Electrical Systems, C-140A, C-140B and VC-140B
1C-140A-2-6	1 Aug 77	Maintenance, Communications and Navigation Systems, C-140A and VC-140B
1C-140A-2-9	15 Aug 76	Maintenance, Electrical and Electronics, Wiring Diagrams, C-140A and VC-140B
12R2-4-29-2	12 Sep 72	Field Maintenance, VHF Navigation and Communication Receiver 51X-2B, and Radio Set Control 614U-3A (Collins)
12R5-2ARN21-42	20 Apr 72	Field Maintenance, Radio Set, Type AN/ARN-21C
12R5-4-40-4	1 Apr 75	Field Maintenance, Marker Beacon 51Z-2
12R5-4-42-2	13 Jun 72	Field Maintenance, Glideslope Receiver, P/N DGS-20
12R5-4-74-12	1 Jun 69	Field Maintenance with Overhaul Manual, Instrument Adapter, Type 599A-1A
MS24149	2 Jun 70	Military Standard, Relay 10 Amp., 2 PDT, Type I, Hermetically Sealed
MS24523	22 Apr 71	Military Standard, Switch, Toggle, One Pole, Environmentally Sealed
MS25268	4 Sep 74	Relay, 5 Amp. 4PDT, Type I Hermetically Sealed, Potted Lead
MS25270	16 Dec 74	Relay, 5 Amp, 6 PDT, Type I, Hermetically Sealed, Potted Lead
MS25331	3 Apr 61	Light Assembly, Press to Test Indicator

3.16.0
C-141A

C-141A PNWD EQUIPMENT LIST

KEY	EQUIPMENT/UNIT
AA	ADF SYSTEM NO 1 DFA-73A
AB	ADF SYSTEM NO 2 DFA-73A
AFCS	AUTOMATIC FLIGHT CONTROL SYSTEM
AIMS	IFF TRANSPONDER SET AN/APX-64(V)
AMDC	AVK-16/A24G-10 COPILOT AIRSPEED, MACH IND
AMDP	AVK-16/A24G-10 PILOT'S AIRSPEED, MACH IND
AVVC	AAK-15/A24G-11 COPILOT ALTITUDE, VERT VEL IND
AVVP	AAK-15/A24G-11 PILOT'S ALTITUDE, VERT VEL IND
ANLS	ALL-WEATHER LANDING SYSTEM
BDHC	COPILOT'S BDHI ID-798/ARN
BDHM	NAVIGATOR'S BDHI NO 2 ID-798/ARN
BDHN	NAVIGATOR'S BDHI NO 1 ID-798/ARN
BDHP	PILOT'S BDHI ID-798/ARN
CA	CENTRAL AIR DATA COMPUTER NO 1 CPU-42/A
Cb	CENTRAL AIR DATA COMPUTER NO 2 CPU-42/A
CMMM	INTERPHONE SYSTEM
D	DOPPLER RADAR AN/APN-147
E	DOPPLER COMPUTER AN/ASN-35
FDCA	PILOT'S FLIGHT DIRECTOR COMPUTER 3K91002
FDCB	COPILOT'S FLIGHT DIRECTOR COMPUTER 3K91002
G	RADAR ALTIMETER 3K90026-105
HSDC	AQU-4/A COPILOT'S HSI
HSDP	AQU-4/A PILOT'S HSI

C-141A PNWD EQUIPMENT LIST

KEY	EQUIPMENT/UNIT
J	NAVIGATION COMPUTER AN/ASN-24
JBA	NAV JUNCTION BOX A20
JBB	AUTOPILOT JUNCTION BOX A21
JBW	AWLS JUNCTION BOX A79
N	VERNAV SYSTEM
Q	SEARCH RADAR AN/APN-59B
RDA	RACK DISCONNECT A
RDB	RACK DISCONNECT B
RDC	RACK DISCONNECT C
RDD	RACK DISCONNECT D
RDE	RACK DISCONNECT E
RDF	RACK DISCONNECT F
RDG	RACK DISCONNECT G
RDW	RACK DISCONNECT W
RDX	RACK DISCONNECT X
SA	GLIDESLOPE SYSTEM NO 1
SB	GLIDESLOPE SYSTEM NO 2
SCA	COPILOT'S NAV FLIGHT INSTRUMENT SELECTOR 3K90009
SCB	COPILOT'S NAV SELECTOR 3K90009-105
SNA	NAVIGATOR'S NAV SELECTOR 3K90009-107
SPA	PILOT'S NAV FLIGHT INSTRUMENT SELECTOR 3K90009-111
SPB	PILOT'S NAV SELECTOR 3K90009-105
TA	TACAN SYSTEM NO 1 AN/ARN-21

C-141A PNWD EQUIPMENT LIST

KEY	EQUIPMENT/UNIT
TASN	AVU-15/A NAVIGATOR'S TAS INDICATOR
TB	TACAN SYSTEM NO 2 AN/ARN-21
TSA	CENTER CONSOLE TERMINAL STRIP PANEL
VA	VHF NAVIGATION SYSTEM NO 1
VB	VHF NAVIGATION SYSTEM NO 2
WA	C-12 COMPASS SYSTEM NO 1
WB	C-12 COMPASS SYSTEM NO 2

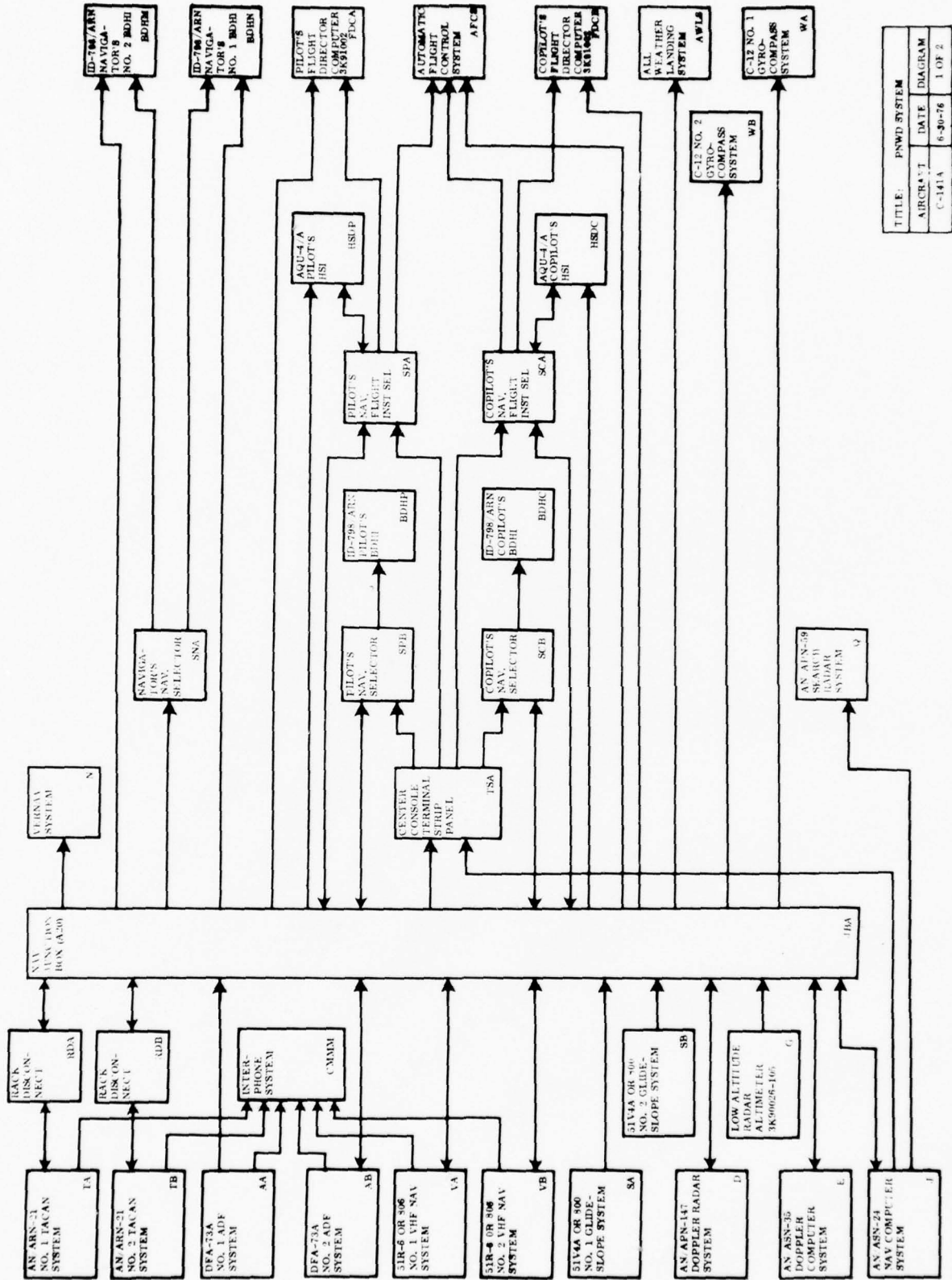

TITLE	PNRW SYSTEM
AIRCRAFT	DATE
C-141A	6-30-76
	DIAGRAM
	1 OF 2

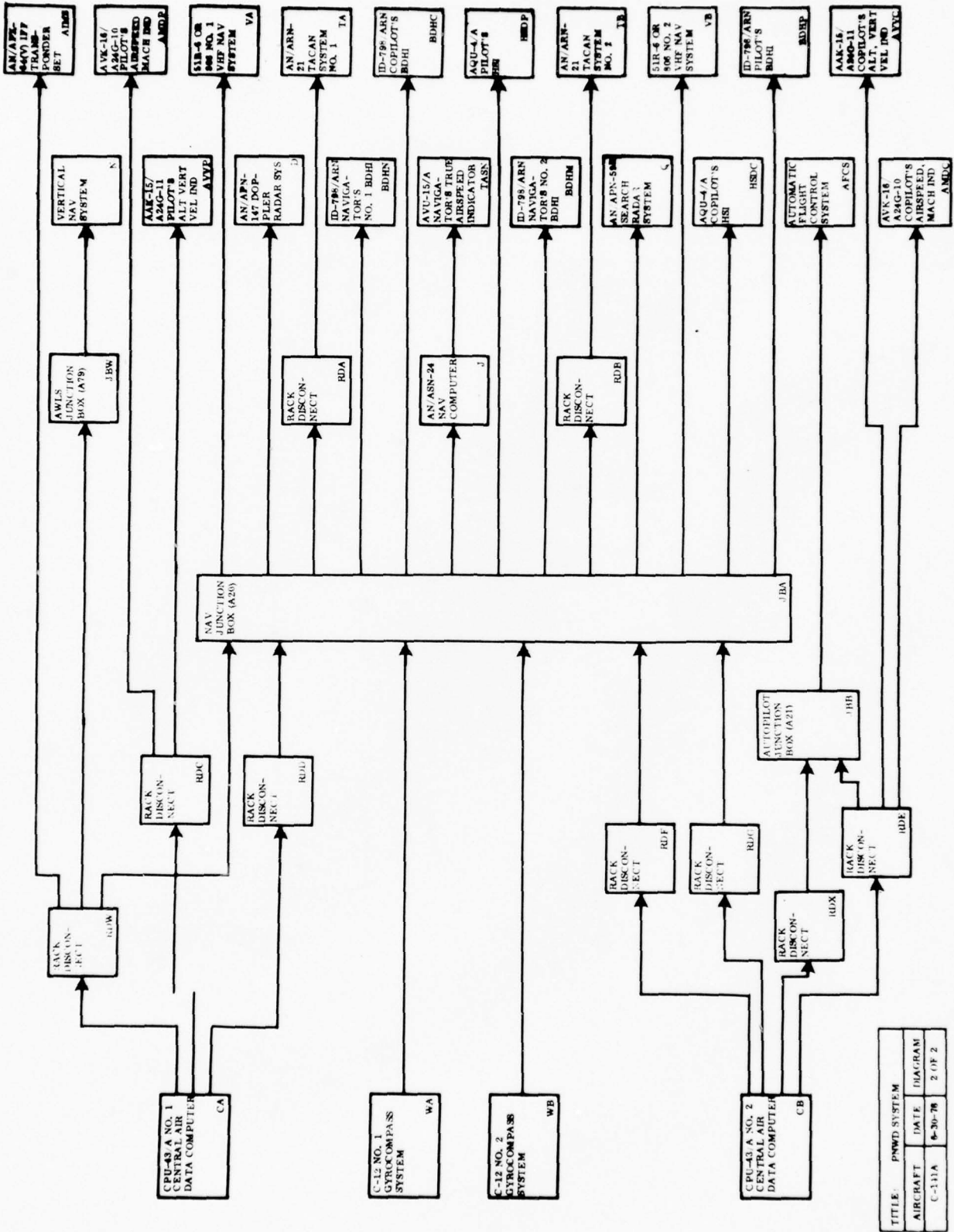

C-141A PNWD EQUIPMENT PHYSICAL CHARACTERISTICS

SYSTEM	UNIT		WT (LB)	SIZE (IN)		
	TYPE (P/N)	NOMENCLATURE		H	W	D
<u>DFA-73A (Automatic Direction Finder) System</u>						
	DFA-73A	Receiver (2 ea)	11.0	7.625	2.406	15.3
	3K 17070	Sense Antenna (2 ea)				
	CUA-73A-300	Antenna Coupler (2 ea)				
	3K90022-101	Loop Antenna (2 ea)	2.8	1.96	9.88	16.89*
	QCA-73E-22 P4P	Quadrantal Error Corrector (No. 1 ADF)				
	QCA-73E-22 P6P	Quadrantal Error Corrector (No. 2 ADF)				
	CNA-73B	Control Panel (4 ea)	1.9	2.625	5.75	3.63
	3K90009-121	ADF Transfer Panel		2.375	5.75	8.0
	2064252-78	Sense Transmission Line (2 ea)				
	2064251-22	Loop Transmission Line (2 ea)				
<u>VHF Navigation System</u>						
	51R6	VHF Navigation Receiver* (2 ea)	15.2	7.625	4.875	14.625
	313N-2	VHF Navigation and Com-** munication Control Panel (2 ea)	2.0	2.625	5.75	4.375
	ID-798/ARN	BDHI (4 ea)	4.0	3.25	3.25	6.875
	3K99000-107	Antenna (Tail)				
	3K99000-109	Antenna (Tail)				
	3K90009-105	BDHI Selector Panel (2 ea)		5.75	3.25	8.0
	3K90009-107	BDHI Selector Panel		2.25	5.75	6.0
	3K91022-101	Antenna (Nose)				
	3K91015-105	Antenna Switch				
*Wilcox 806A is interchangeable						
**Wilcox 97650-100 is interchangeable						

C-141A PNWD EQUIPMENT PHYSICAL CHARACTERISTICS

SYSTEM	UNIT		WT (LB)	SIZE (IN)		
	TYPE (P/N)	NOMENCLATURE		H	W	D
<u>Glideslope System</u>						
	51V4A	Receiver* (2 ea)	4.0	3.375	2.25	12.56
	37P4	Antenna	0.7	5.984	2.0	4.5
	313N-2	Control Panel (2 ea) (part of VHF Navigation system)	2.0	2.625	5.75	4.375
<u>Marker Beacon System</u>						
	51Z-3	Receiver **	2.9	3.38	2.25	12.62
	AT-536/ARN	Antenna				
	3K14011-101	Antenna, bottom				
	---	Three-light Indicator Assy. (2 ea)				
	390R-1	Mount	0.6	3.656	2.453	15.797
<u>AN/ARN-21 TACAN System</u>						
	RT-220 (C)/ARN-21	Receiver-Transmitter (2 ea)	60.0	8.3	11.13	18.75
	MT-928/ARN-21	Mounting (2 ea)	6.5	7.75	11.125	17.5
	C-4457 (P)/ARN-21C	Control Panel (2 ea)	2.2	3.0	5.75	4.0
	9616-13	Coupler (2 ea)	8.0	4.9	5.802	6.375
	AT-740/A	Antenna (2 ea)	0.75	1.54	8.406 diam.	
<u>AN/APN-157 Loran System</u>						
	R-1214/APN-157	Receiver	54.9	7.75	15.5	23.0
	PP-3866/APN-157	Power Supply	20.0	8.0	5.0	16.0
	CU-1568/APN-157	Antenna Coupler	7.0	4.0	4.0	9.0
	GLAC3K17042-105	Antenna				
<u>Radar Altimeter System</u>						
	3K90028-107	Transceiver	13.5	7.75	5.0	15.0
	3K90026-105	Indicator	2.0	3.26	3.26	5.35
	3K90027-103	Antenna (2 ea)	1.0	2.5	5.625	6.25
*Wilcox 800B is interchangeable						
**51Z-4 or DARE SSM-2 may be substituted						

C-141A PNWD EQUIPMENT PHYSICAL CHARACTERISTICS

SYSTEM	UNIT		WT (LB)	SIZE (IN)		
	TYPE (P/N)	NOMENCLATURE		H	W	D
<u>C-12 Compass System</u>						
	1775277	Magnetic Azimuth Detector (2 ea)	1.7	2.063	3.5	4.906
	2586257	Remote Magnetic Compensator (2 ea)	1.5	1.875	5.75	4.781
	2586333	Directional Gyroscope (2 ea)	10.0	6.938	7.297	8.313
	2589226	Amplifier - Power Supply (2 ea)	6.5	7.844	2.406	14.188
	2586261	Digital Controller (2 ea)	2.5	2.625	5.75	6.125
<u>AN/APN-147 Doppler Radar System</u>						
	RT-625 (P)/APN-147	Transceiver	9.4	8.75	4.69	17.06
	AS-1168B/APN-147	Antenna	32.9	8.75	19.13	26.75
	CV-1181B/APN-147	Frequency Tracker	34.9	8.38	9.0	24.63
	ID-938A/APN-147	Indicator	3.1	3.25	3.25	6.0
	C-3818(P)/APN-147	Control Panel	0.6	1.125	5.750	2.687
	3K90030-101	Waveguide, Upper				
	3K90029-101	Waveguide, Lower				
	BN716-1000	Flexaguide				
	3322-039	Adapter				
	3320-834	Adapter				
<u>AN/ASN-35 Doppler Computer System</u>						
	CP-622/ASN-35	Doppler Computer	17	7.625	4.875	15.187
	C3819A/ASN-35	Control Indicator	6.75	4.5	5.750	5.312
	C3820A/ASN-35	Auxiliary Cross Track Indicator	1.9	1.875	5.750	5.0
	MS24659-23D	Ground Test Switch (shared with AN/ASN-24)	0.15	1.34	0.910	2.89
<u>AN/ASN-24 Navigational Computer System</u>						
	CP-641/ASN-24	Computer, Navigational	39.75	7.625	7.625	21.5
	PP-3214/ASN-24	Converter Chassis Power Supply	53.0	7.625	10.125	20.875

C-141A PNWD EQUIPMENT PHYSICAL CHARACTERISTICS

SYSTEM	UNIT		WT (LB)	SIZE (IN)		
	TYPE (P/N)	NOMENCLATURE		H	W	D
<u>AN/ASN-24 Navigation Computer System (Cont'd)</u>						
	C-3961/ASN-24	Control, Indicator (Computer Control)	3.75	4.875	5.75	5.438
	C-3962/ASN-24	Control, Indicator (Latitude-Longitude)	3.25	2.625	5.75	8.25
	C-3963/ASN-24	Control, Indicator (Range and Bearing)	3.25	2.625	5.75	8.25
	C-3964/ASN-24	Control, Indicator (Along Track-Cross Track)	3.0	2.625	5.75	8.25
	C-3965/ASN-24	Control, Indicator (Celestial Data)	9.0	2.625	5.75	8.25
	C-6214/ASN-24	Control, Indicator (Initial Condition)	10.5	9.0	5.75	8.188
	C-6213/ASN-24	Control, Indicator (Mode)	2.8	2.625	5.75	5.125
	3K11547	Control, Input Selector Panel				
	MS24659-23D	Ground Test Switch (part of AN/ASN-35)	0.15	1.34	0.91	2.89
	MX-7743/ASN-24	Test Adapter				
<u>Vertical Navigation System</u>						
	3K91000-103	Computer, Vertical Navigation				
	3K91001-101	Control Panel, Vertical Navigation				
<u>Flight Director System</u>						
	3K91002	Flight Director Computer (2 ea)	10	7.625	2.42	19.562
	AQU-4/A	Horizontal Situation Indicator (2 ea)	8.2	4.938	5.063	9.5
	3K91004	Attitude Director Indicator (2 ea)	8.5	5.26	5.01	8.0
	MC-1	Switching Rate Gyroscope (2 ea)	1.5	2.65	2.44	4.802
	MD-1	Roll and Pitch Displacement Gyroscope (2 ea)	9.5	6.094	5.75	9.688
	TRU-2A/A	Rate Gyroscope Transmitter (2 ea)	1.75	3.875	3.25	5.31

C-141A PNWD EQUIPMENT PHYSICAL CHARACTERISTICS

SYSTEM	UNIT		WT (LB)	SIZE (IN)		
	TYPE (P/N)	NOMENCLATURE		H	W	D
<u>Flight Director System (Cont'd)</u>						
	3K90009-111	Pilot's Navigation Selector	5.8	3.25	6.35	9.74
	3K90009	Copilot's Navigation Selector	5.8	3.25	6.35	9.74
	3K90011-101	Power Adequacy Indicator (2 ea)				
	3K70049-101	Test Switch (2 ea)				
	3K11694	Slave Switch				
	4281-01	Elevator Position Transmitter (2 ea)				
<u>Central Air Data Computer</u>						
	CPU-42/A	CADC (2 ea)	30.5	7.625	4.875	19.671
	A/A24G-10	Airspeed Mach Indicator (2 ea)	9.75	7.75	3.50	10.75
	A/A24G-11	Altitude-Vertical Velocity Indicator (2 ea)	9.5			
	AVU-15A	True Airspeed Indicator	10.2	7.75	3.50	8.0
	3E12159	CADC Altitude Monitor Switching Panel				
	3K11526-101	Pilot's Switching Panel				
	3K11525-103	Copilot's Switching Panel				

C-141A BIBLIOGRAPHY

T.O. Number	Chq/Rev	Title
1C-141A-01	1 Nov 69	List of Applicable Publications, C-141A
1C-141A-1	12 Jan 77	Flight Manual, C-141A
1C-141A-2-1GA-4	1 Dec 76	Organizational Maintenance, General A/C Manual (GAM) Instrument Autopilot, Communication, Navigation, & Doppler Systems, C-141A
1C-141A-2-GTS-1	1 Mar 75	Troubleshooting, Instruments, C-141A
1C-141A-2-8-TS-1	1 Mar 75	Troubleshooting, Communication, Navigation & Doppler, C-141A
1C-141A-2-11WD-1-1	15 Nov 76	Organizational Maintenance, Aircraft Wiring Diagrams, C-141A
1C-141A-2-11WD-1-2	15 Nov 76	Organizational Maintenance, Aircraft Wiring Diagrams, C-141A
5A7-5-2-2	15 Apr 70	Field Maintenance, Flight Director Computer Model 6320F, 4058F, Attitude Indicator Director, C-141A
5F4-14-12	1 Apr 71	Field Maintenance, Airspeed-Mach-Safespeed Indicating System A/A24G-10
5F8-2-27-2	1 Dec 71	Field Maintenance, Mach Safespeed Airspeed Indicating System
5N1-2-15-2	15 Aug 75	Field Maintenance, Gyroscopic Compass System, Type C11, C12
5N6-4-10-3	1 Oct 72	Overhaul, Computer Set Control, Type C-3962/ASN-24
5N6-6-2-3	1 Oct 72	Overhaul, Control Indicator, Type C-3962/ASN-24
5N6-6-3-3	1 Jun 74	Overhaul, Control Indicator, Type C-3963/ASN-24
5N6-6-4-3	1 Oct 72	Overhaul, Control Indicator, Type C-3964/ASN-24
5N6-6-5-3	1 Oct 72	Overhaul, Celestial Data Control Indicator, C-3965/ASN-24
5N6-6-6-3	15 Nov 71	Overhaul, Indicator Control, Type C-6213/ASN-24

C-141A BIBLIOGRAPHY

T.O. Number	Chg/Rev	Title
5N6-6-7-3	15 May 74	Overhaul, Indicator Control, Type C-6214/ASN-24
5N8-5-11-3	15 May 75	Overhaul, Indicator, Bearing Distance Heading, Type ID-798 ARN
5N16-2-4-3	1 Aug 74	Overhaul, Power Supply Chassis Converter, Type PP-3214/ASN-24
5N25-2-3	21 Jan 74	Overhaul, Selector, Navigation Switch, P/N 300105-20 (Transco)
12P5-4-28-2	14 Oct 70	Field Maintenance, Indicator, Altitude CMC 459-136
12R5-ARN21-42	20 Apr 72	Field Maintenance, Radio Set, Type AN/ARN-21C, P/N 8020000074-1
12R5-4-6-12	1 Dec 73	Field Maintenance, Glide Slope Radio Receiver, Type 51V-4, -4A (Collins)
12R5-4-30-3	15 Jan 75	Overhaul, Bearing Distance Heading Indicator Coupler P/N 9616-13 (Sunbeam Electronics)
12R5-4-56-12	6 Jun 72	Field Maintenance, ADF Receiver Type DFA-73AC,-73AF, ADF Control, Type CNA-73BC,-73BF, ADF Loop, Type LPA-73C-1, ADF Shock Mount Type MSA-73A-1
12R5-4-58-2	1 Jun 73	Field Maintenance, Radio Receiver, Type 51R-6 and 51R-6A (Collins)
MS24659	16 Sep 69	Military Standard, Switch, Toggle, Two Pole, Environmentally Sealed, Lever Lock

3.17.0
P-4E

F-4E PNWD EQUIPMENT LIST

KEY	EQUIPMENT/UNIT
A	UIF DIRECTION FINDER (PART OF AN/ASQ-19A)
AFCS	FLIGHT CONTROL GROUP AN/ASA-32J
AIDP	ID-1144/AJB-7 ATTITUDE INDICATOR
AIMS	IDENTIFICATION SUBSYSTEM KY-532A/ASQ
ALDC	AAU-19/A AFT ALTIMETER
ALDP	AAU-19/A FWD ALTIMETER
BDHC	ID-663()/U BDHI AFT
C	AIR DATA COMPUTER SYSTEM
CMMS	INTERCOMMUNICATIONS SUBSYSTEM
FCSY	FIRE CONTROL SYSTEM AN/APQ-120()
G	RADAR ALTIMETER SYSTEM AN/APN-155
GSDC	ID-1126/ASN-46 GROUND SPEED INDICATOR
HSDP	HORIZONTAL SITUATION INDICATOR 522-2411-003
J	NAVIGATIONAL COMPUTER SET AN/ASN-46A
JBA	MISC RELAY PANEL NO. 5
JBB	MISC RELAY PANEL NO. 2
JBC	MISC RELAY PANEL NO. 4
KA	FLIGHT DIRECTOR COMPUTER 522-1763-003
KB	CP-734/AJB-7 FLIGHT DIRECTOR BOMBING COMP
LCOS	LEAD COMPUTER OPTICAL SIGHT SYSTEM AN/ASG-20A
P	INERTIAL NAVIGATION SET AN/ASN-63
RADP	ID-1090/APN-155 HEIGHT INDICATOR
RDA	RACK DISCONNECT A

F-4E PNWD EQUIPMENT LIST

KEY	EQUIPMENT/UNIT
RDB	RACK DISCONNECT B
RDC	RACK DISCONNECT C
RDD	RACK DISCONNECT D
RDE	RACK DISCONNECT E
RDF	RACK DISCONNECT F
RDG	TEST PLUG G
RDH	TEST PLUG H
RDJ	TEST PLUG J
RDK	RACK DISCONNECT K
RDL	RACK DISCONNECT L
RDM	RACK DISCONNECT M
RDN	RACK DISCONNECT N
RDQ	RACK DISCONNECT Q
RDR	TEST PLUG R
RDS	TEST PLUG S
RDT	RACK DISCONNECT T
RDU	RACK DISCONNECT U
RDV	RACK DISCONNECT V
RDW	RACK DISCONNECT W
RDX	TEST PLUG X
SPA	MODE SELECTOR CONTROL 522-1764-003
SPB	RADIO SET CONTROL AFT C-6685/ASQ
SPC	RADIO SET CONTROL FWD C-6685/ASQ

F-4E PNWD EQUIPMENT LIST

KEY	EQUIPMENT/UNIT
T	TACAN SYSTEM (PART OF AN/ASQ-19A)
TADC	AVK-14/A24G-8 COPILOTS TAS INDICATOR
TADP	AVK-14/A24G-8 PILOT'S TAS INDICATOR
W	COMPASS SYSTEM (PART OF AN/AJB-7)
WRCS	WEAPON RELEASE COMPUTER SET AN/ASQ-91

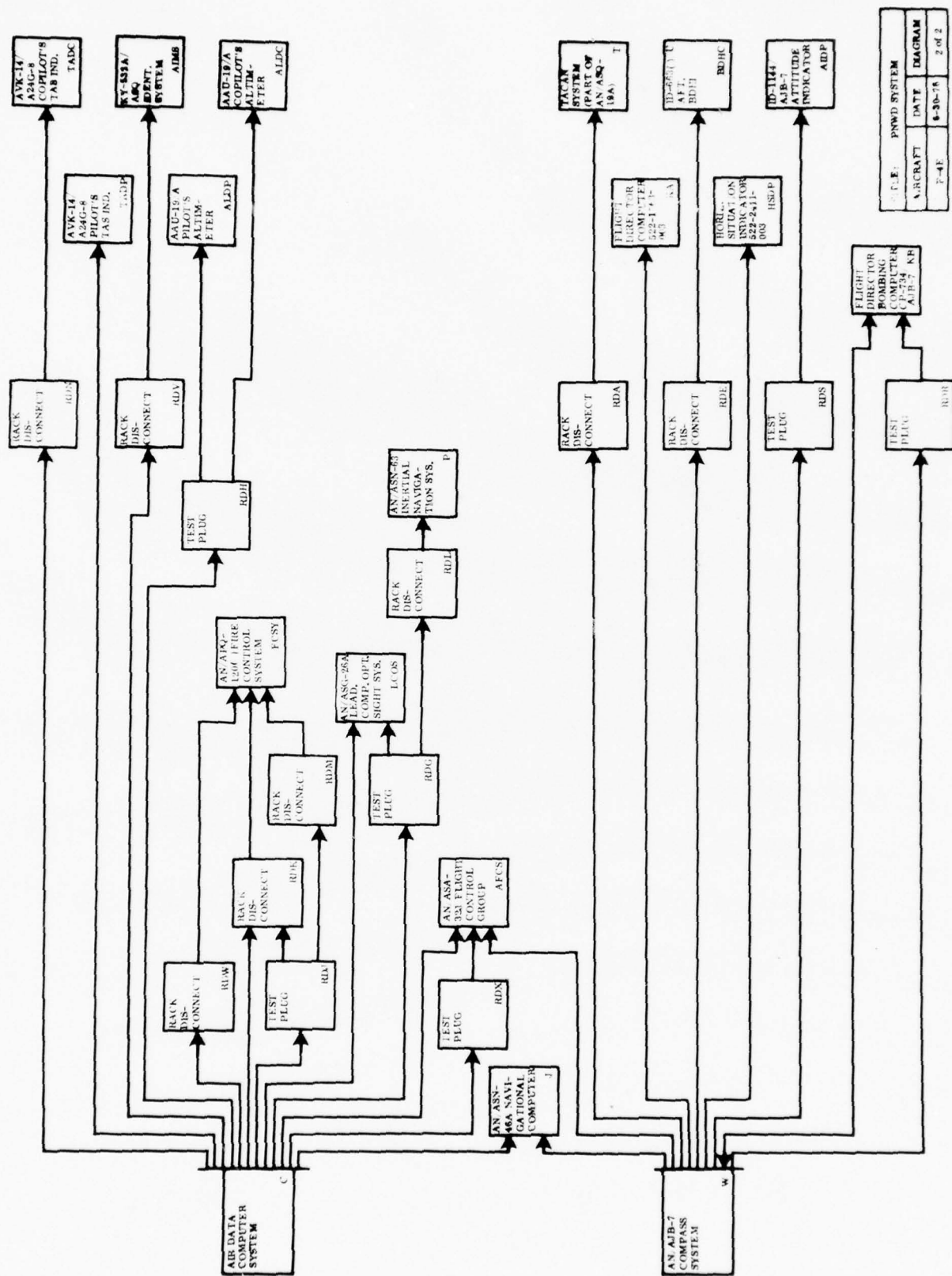

F-4E PNWD EQUIPMENT PHYSICAL CHARACTERISTICS

SYSTEM	UNIT		WT (LB)	SIZE (IN)		
	TYPE (P/N)	NOMENCLATURE		H	W	D
<u>AN/ASQ-19A Integrated Electronic Central</u>						
	KY-312/ASQ-19	Pulse Decoder	29.5	7.5	6.438	29.5
	AM-2349/ASQ-19	Amplifier-Power Supply-Receiver	36.5	8.531	6.438	23.234
	KY-532A/ASQ	Coder-Receiver-Transmitter	27.0	8.563	6.438	22.5
	RT-547/ASQ-19	Radio Receiver-Transmitter	40.0	8.531	7.5	22.563
	RT-793/ASQ	Radio Receiver-Transmitter	36.0	7.344	11.5	16.188
	AS-909A/ARA-48	Antenna	9.5	3.625	12.5	11.25
	C-6684/ASQ	Radio Set Control (2 ea)	5.5	6.375	5.75	6.25
	241-0283-00	UHF Filter				
	MX1646AIC (MI23020AIC)	Headset-Microphone Adapter (2 ea)	N/A		N/A	
	C-6280(P)/ASQ	Transponder Set Control	2.75	5.25	5.75	3.09
	11300-30	Omni-TACAN Antenna Switch				
	11300-30	TACAN Antenna Switch				
	LS-460A/AIC	Intercommunication Station (2 ea)	2.7	2.25	5.75	8
	79D00800	Antenna Selector				
	ID-1311/ASQ	Frequency Channel Indicator (2 ea)	0.49	1.313	1.625	5.375
	ID-663()/U	BDHI (part of flight director group)	3.5	3.25	3.25	7.5
	C-6685/ASQ	Radio Set Control (TACAN) (2 ea)	1.75	2.25	5.75	3.313
<u>AN/APN-155 Radar Altimeter</u>						
	RT-689/APN-155	Receiver-Transmitter	11.7	6.8	3.75	15.75
	ID-1090/APN-155	Height Indicator	1.6	3.25	3.25	5.93
	AS-1386/APN-155	Receiver Antenna	3.3	3.0	9.61	14.24
	AS-1442/APN-155	Transmitter Antenna	3.3	3.0	9.61	14.24
<u>AN/ASN-63 Inertial Navigation Set</u>						
	MX-4839 ()/ASN	Gyro Stabilized Platform	30.6	11.25	14.9	10.0
	MX-6728/ASN-63	Output Signal Distribution Unit	17.9	7.51	14.35	6.2

F-4E PNWD EQUIPMENT PHYSICAL CHARACTERISTICS

SYSTEM	UNIT		WT (LB)	SIZE (IN)		
	TYPE (P/N)	NOMENCLATURE		H	W	D
<u>AN/ASN-63 Inertial Navigation Set (Cont'd)</u>						
	CP-733/ASN	Navigational Computer	4.5	7.97	7.3	26.08
	C-4779/ASN	Navigational Set Control	1.5	2.24	5.4	5.14
<u>AN/ASN-46A Navigational Computer Set</u>						
	CP-723B/ASN-46	Computer-Control	12.5	6.75	5.73	6.50
	AM-3734/ASN-46	Amplifier-Computer	17.7	7.5	7.875	7.5
	ID-1126/ASN-46	Ground Speed Indicator	1.0	2.0	2.0	6.5
<u>Flight Director Group</u>						
	522-1763-003	Flight Director Computer				
	522-1764-003	Mode Selector Control				
	522-2411-003	Horizontal Situation Indicator	9.0	5.25	5.0	7.625
	522-1394-003	HSI Amplifier	3.8	3.0	7.0	5.0
	ID-663()/U	BDHI	3.5	3.25	3.25	7.5
	MS35058-23	BDHI Mode Select Switch	0.1	1.157	0.641	2.236
<u>AN/AJB-7 Attitude Reference Bombing Computer Set</u>						
	ID-1144/AJB-7	Attitude Indicator	9.0	5.125	5.0	9.75
	ML-1	Compass Transmitter	1.5	2.328	3.5	4.906
	ADK-182/A24G-1A	Compass Adapter-Compensator	7.25	4.125	5.125	9.625
	C-4781/AJB-7	Compass System Controller	3.75	2.625	5.75	4.5
	T-950/AJB-7	Rate Gyroscope Transmitter	2.5	2.813	2.719	5.406
	MC-1	Switching Rate Gyroscope	1.864	2.656	2.438	4.813
	ARU-13A	Remote Attitude Indicator	3.75	3.25	3.25	9.0
	MX-6663/AJB-7	Aircraft Accelerometer	3.0	3.5	3.5	4.0
	ASK-12/A24G-1A	Amplifier-Power Supply	9.25	3.5	5.0	11.75
	CP-735/AJB-7	Bomb Release Angle Computer	3.5	2.625	5.75	3.0
	SBK-8/A24G-1A	Displacement Gyroscope Assembly	26.5	7.688	7.125	15.188
	CP-734/AJB-7	Flight Dir. Bombing Comp.	9.0	5.375	5.0	10.375
	MS-27264-5	Bombing Dual Timer		2.430	2.430	7.125

F-4E PNWD EQUIPMENT PHYSICAL CHARACTERISTICS

SYSTEM	UNIT		WT (LB)	SIZE (IN)		
	TYPE (P/N)	NOMENCLATURE		H	W	D
<u>AN/AJB-7 Attitude Reference Bombing Computer Set (Cont'd)</u>						
	MIL-C-38304 3-1974-9	Bomb Buttons LABS/WPN REL Switch	0.08	1.270	0.635	2.34
	MS24523-23	Pull up tone on-tone off switch				
	03-93480-120 (VM-934-8TL) PTO0CP22-55S MIL-G-26485	Pull up light Test Receptacles Gyro Fast Erect Switch	N/A	N/A		
<u>AN/ASQ-91 Weapon Release Computer Set</u>						
	CP-805()/ASQ-91	Ballistics Computer	36.6	8.15	6.8	18.0
	C-6480()/ASQ-91	Computer-Control	4.0	6.0	5.75	4.3
	C-6481()/ASQ-91	Computer-Cursor Control	1.3	3.75	3.0	3.66
	53-81211-301	Weapons Delivery Panel				
<u>AN/ASG-26A Lead Computing Optical Sight System</u>						
	SU-40/ASG-26A	Optical Display Unit	25.0	12.5	12	10.625
	AM-6492/ASG-26A	Lead Computing Amplifier	16.4	18.25	5.875	8.5
	C-1388/ASG-26A	Lead Computing Gyroscope	11.2	9.25	7.875	8.875
	MT-3909/ASG-26	Gyroscope Mount				
<u>Air Data Computer System</u>						
	CPK-92A/A24G-34	Air Data Computer		8.625	10.9	11.0
	AAU-19/A	Altimeter (2 ea)	4.5	3.25	3.25	8.613
	AVK-14/A24G-8	True Airspeed Indicator (2 ea)	1.8			

F-4E BIBLIOGRAPHY

T.O. Number	Chg/Rev	Title
1F-4C-01	1 Mar 76	List of Applicable Publications - F-4 Weapon System
1F-46-1	15 Apr 77	Flight Manual USAF Series for Aircraft
1F-4E-2-12	1 Jan 77	Maintenance, Air Data Computer Set, Altitude Encoder Unit and Associated Pilot Static and Avionics Instruments - F-4E
1F-4E-2-14	15 Jan 77	Maintenance, Integrated Electronic Central, Radar Altimeter, Radar Beacon System, Speech Security System, Target Identification System Electro-Optical (TISED) - F-4E
1F-4E-2-15	15 Apr 77	Maintenance, Navigation Systems - F-4E
1F-4E-2-16	1 Jun 77	Maintenance, Automatic Flight Control System - F-4E
1F-4E-2-17	15 Dec 76	Maintenance, Avionics Navigation Instrument Systems - F-4E
1F-4E-2-19	15 Apr 77	Maintenance, Fire Control System - F-4E
1F-4E-2-23	1 Jun 77	Maintenance, Weapons Release Computer and Lead Computing Optical Sight Systems - F-4E
1F-4E-2-33	15 Apr 77	Maintenance, Weapons Release Computer and Lead Computing Optical Sight Systems - F-4E
5A1-9-2-2	15 Aug 75	Field Maintenance, Attitude, Reference Bombing Computer Set AN/AJB-7 (Lear-Siegler)
5A1-9-2-2	15 Feb 74	Field Maintenance, Computer Set AN/AJB-7
5N1-3-13-2	1 May 74	Intermediate Maintenance, AN/ASN-46A Navigation Set
5N1-3-14-2	15 Nov 67	Intermediate Maintenance, AN/ASN-63 Inertial Navigation Set
5N1-3-15-2	26 Jun 67	Maintenance, Weapon Release Computer Set AN/ASQ-91
5F8-3-9-13	15 Sep 73	Remote Attitude Indicator, ARU-13/A
12P5-2APN-155-32	1 Jan 71	Field Maintenance, Receiver-Transmitter RT-689/APN-155, Transmitter Antenna AS-1442/APN-155, Receiver Antenna AS-1386/APN-155
12P5-2APN-155-43	15 Nov 70	Overhaul, Manual Height Indicator ID-1090/APN-155

F-4E BIBLIOGRAPHY

T.O. Number	Cha/Rev	Title
12R2-2ASQ-112	1 Apr 66	Service, C-6684/ASQ
12R2-2ASQ-102	1 Sep 66	Service, Radio Receiver-Transmitter RT-793A/AS2
12R2-2ASQ19-12	1 Mar 72	Service, Receiver-Transmitter RT-547/ASQ-19, and Pulse Decoder KY-312/ASQ-19
12R2-2ASQ-19-32	1 Mar 72	Service, Amplifier Power Supply-Receiver AM-2349/ASQ-19
12R2-2ASQ19-53	1 Mar 64	Overhaul, Antenna AS-909A/ARA48
12R5-2U-163	1 Mar 66	Overhaul, EDHI Type ID-663 A/U
12R2-2ASQ-133	1 Nov 66	Service, Frequency Channel Indicator, ID 1311/ASQ
12R2-2ASQ-122	1 Sep 66	Service, Radio Set Control (TACAN) C-6685/ASQ
12R2-2AIC-232	1 Mar 72	Service, Intercommunication Station LS-460A/AIC
12P4-2APX-102-1	15 Nov 70	Overhaul, Coder-Receiver-Transmitter KY-532A/ASQ
12P4-2APX-142	1 Jun 75	Field Maintenance, Transponder Set Control C-6280(P) APX
MS24523	22 Apr 71	Switch, Toggle, One Pole, Environmentally Sealed
MS27264	5 Aug 63	Timer, Fire Control, Bombing, Dual
MS35058	17 Nov 72	Switch, Toggle, One Pole, Sealed Toggle
MIL-C-25651B	9 Apr 59	Computer, Air Data, Central Type MG-3 (CPK-92A/A24G-34)

3.18.0
RF-4C

RF-4C PNWD EQUIPMENT LIST

KEY	EQUIPMENT/UNIT
A	UHF DIRECTION FINDER (PART OF AN/ASQ-88)
AFCS	FLIGHT CONTROL GROUP AN/ASA-32()
AIDP	ARU-31/A ATTITUDE INDICATOR
AIMS	IDENT SUBSYSTEM KY-532A/ASQ (PART OF AN/ASQ-88)
ALDC	AAU-12/A DUAL SERVO ALTIMETER COPILOT
ALDP	AAU-12/A DUAL SERVO ALTIMETER PILOT
BDHC	ID-863() /U BEARING DISTANCE HEADING IND
C	AIR DATA COMPUTER SET
CMMS	INTERCOMMUNICATION SUB SYSTEM
DDSY	AN/ASQ-90 DATA DISPLAY SYSTEM
G	ELECTRONIC ALTIMETER SET AN/APR-159
GSDC	ID-1126/ASN-46 GROUND SPEED INDICATOR (AFT)
GSDP	ID-1126/ASN-46 GROUND SPEED INDICATOR (FWD)
HSDP	HORIZONTAL SITUATION INDICATOR 522-2411-003
IRSY	INFRARED DETECTING SYSTEM AN/AAS-18A
J	NAVIGATIONAL COMPUTER SET AN/ASN-46A
JBA	MISC RELAY PANEL NO. 2
JBB	MISC RELAY PANEL NO. 1
JBC	MANUAL V/H SWITCHING RELAY
KF	FLIGHT DIRECTOR COMPUTER 522-1763-003
P	INERTIAL NAVIGATION SET AN/ASN-56
PRSY	PHOTOGRAPHIC RECONNAISSANCE SYSTEM
R	AN/APQ-99 RADAR SET

RF-4C PNWD EQUIPMENT LIST

KEY	EQUIPMENT/UNIT
RADC	ID-1162/APN-159 PILOTS HEIGHT INDICATOR
RADP	ID-1162/APN-159 COPILOTS HEIGHT IND
RDA	RACK DISCONNECT A
RDB	RACK DISCONNECT B
RDC	RACK DISCONNECT C
RDD	RACK DISCONNECT D
RDE	RACK DISCONNECT E
RDF	RACK DISCONNECT F
RDG	RACK DISCONNECT G
RDH	RACK DISCONNECT H
RDJ	RACK DISCONNECT J
RDK	RACK DISCONNECT K
RDL	RACK DISCONNECT L
RDM	RACK DISCONNECT M
RDN	RACK DISCONNECT N
RMPS	AN/APQ-102 RADAR MAPPING SYSTEM
RIA	TEST PLUG A
RTB	TEST PLUG B
RTC	TEST PLUG C
RTD	TEST PLUG D
RTE	TEST PLUG E
RTF	TEST PLUG F
SPA	MODE SELECT CONTROL 53G970246-1

RF-4C PNWD EQUIPMENT LIST

KEY	EQUIPMENT/UNIT
T	TACAN SYSTEM (PART OF AN/ASQ-88)
TADP	AVK-14/A24G-8 PILOT'S TAS INDICATOR
TADC	AVK-14/A24G-8 COPILOT'S TAS INDICATOR
W	COMPASS SYSTEM (PART OF AN/ASN-55)

RF-4C PNWD EQUIPMENT PHYSICAL CHARACTERISTICS

SYSTEM	UNIT		WT (LB)	SIZE (IN)		
	TYPE (P/N)	NOMENCLATURE		H	W	D
<u>AN/ASN-46A Navigational Computer Set</u>						
	CP-723B/ASN-46	Computer-Control	12.5	6.75	5.73	6.50
	AM-3734/ASN-46	Amplifier-Computer	17.7	7.5	7.875	7.5
	ID-1126/ASN-46	Ground Speed Indicator	1.0	2.0	2.0	6.5
<u>AN/ASN-56 Inertial Navigation Set</u>						
	MX-4839()/ASN	Gyro Stabilized Platform	30.6	11.25	14.9	10.0
	CP-779/ASN-56	Navigational Computer	14.0	7.23	14.5	5.57
	CP-733/ASN	Navigational Computer	45.0	7.3	7.97	26.08
	C-4779/ASN	Navigation Set Control	1.5	2.24	5.4	5.14
	CP-780/ASN-56	Aircraft Altitude Computer	19.0	14.35	6.2	23.9
<u>AN/ASN-55 Attitude Heading Reference System</u>						
	ARU-31/A	Attitude Indicator	9.0	5.125	5.0	9.75
	ML-1	Compass Transmitter	1.5	2.328	3.5	4.906
	ADK-182/A24G-1A	Compass Adapter-Compensator	7.25	4.125	5.109	9.625
	C-6448/ASN-55	Compass System Controller	1.25	2.625	5.75	4.375
	T-970/AJB-7	Rate Gyroscope Transmitter	2.5	2.813	2.719	5.406
	CN-1050/ASN-55	Switching Rate Gyroscope	1.09	2.688	1.813	4.813
	ARU-13A	Remote Attitude Indicator	3.75	3.25	3.25	9.75
	CN-990/ASN-55	Directional Displacement Gyroscope	7.5	8.06	4.86	4.86
	AM-4080/ASN-55	Power Supply Amplifier	4.0	4.3	4.6	4.6
	MD-1	Roll and Pitch Displacement Gyroscope	9.5	6.12	5.75	9.75
<u>Flight Director Group</u>						
	522-1763-003	Flight Director Computer				
	522-3404-000	Mode Selector Control				
	522-2411-003	Horizontal Situation Indicator	9.9	5.25	5.0	7.625

RF-4C PNWD EQUIPMENT PHYSICAL CHARACTERISTICS

SYSTEM	UNIT		WT (LB)	SIZE (IN)		
	TYPE (P/N)	NOMENCLATURE		H	W	D
<u>Flight Director Group (Cont'd)</u>						
	ID-663()/U	BDHI	2.5	3.25	3.25	6.5
	MS24523-22	BDHI Mode Select Switch	0.08	1.270	0.635	2.34
	522-1394-003	HSI Amplifier	3.8	3.0	7.0	5.0
<u>Air Data Computer Set</u>						
	CPU-114/A	Air Data Computer				
	TRK-58/A24G-16	Angle of Attack Transmitter	2.0	4.79	4.0	7.122
	TRK-64/A24G-19	Electrical Resistance Temperature Transmitter				
	ARK-10/A24G-8	Angle of Attack Indicator (2 ea)	1.75	2.245	2.245	6.562
	AVK-14/A24G-8	True Air Speed Indicator (2 ea)	1.8			
	CVK-99/A24G	Altitude Encoder	3.0	3.25	6.4	5.0
	AAU-12/A	Dual Servoed Altimeter (2 ea)	4.5	3.25	3.25	8.813
	O-1551/APN	Aural Tone Generator	2.8	3.5	3.12	8.5
<u>AN/APN-159 Electronic Altimeter Set</u>						
	RT-708/APN-159	Radar Receiver-Transmitter	21.4	7.0	7.625	27.0
	ID-1162/APN-159	Height Indicator (2 ea)	1.9	3.87	3.313	5.25
	PP-3869/APN-159	Power Supply	1.25	4.07	4.07	8.02
	AS-1521A/APN-159	Transmit Antenna	2.7	2.0	7.0	9.91
	AS-1522A/APN-159	Receiver Antenna	2.7	2.0	7.0	9.91
<u>AN/ASQ-88 Integrated Electronic Central</u>						
	RT-736/ASQ-88	Radio Receiver-Transmitter	40.0	9.22	7.53	21.22
	KY-531/ASQ-19	Pulse Decoder	35.5	10.47	6.47	22.52
	DMNI-29	TACAN Antenna (2 ea)				
	39550-1	Antenna Selector				

RF-4C PNWD EQUIPMENT PHYSICAL CHARACTERISTICS

SYSTEM	UNIT		WT (LB)	SIZE (IN)		
	TYPE (P/N)	NOMENCLATURE		H	W	D
<u>AN/ASQ-88 Integrated Electronic Central (Cont'd)</u>						
	11300-30	Coax Switch				
	C-6684/ASQ	Radio Set Control (2 ea)	5.5	6.375	5.75	6.25
	AM-2349/ASQ-19	Amplifier-Power Supply-Receiver	36.5	8.531	6.438	23.234
	RT-793A/ASQ	Radio-Receiver-Transmitter	36.0	7.344	11.5	16.188
	ID-1311/ASQ	Frequency Channel Indicator (2 ea)	0.49	1.313	1.625	5.875
	C-6685/ASQ	Radio Set Control (2 ea)	1.75	2.25	5.75	3.313
	LS-460A/AIC	Intercommunication System (2 ea)	2.7	2.2	5.75	8
	MX-1646/AIC	Headset-Microphone Adapter (3 ea)	N/A	N/A		
	KY-532A/ASQ	Coder-Receiver-Transmitter	27	8.563	6.438	27.5
	AS-909A/ARA-48	ADF Antenna	10.0	3.15	10.75	10.75
	C-6280(P) APX	Transponder Set Control	2.75	5.25	5.75	3.09
	241-0283-00	UHF Filter				
	DMC7-8	UHF Comm Antenna (Lower)				
	6583-2	UHF Comm Antenna (Upper)				
	2285-1	IFF Antenna				
<u>AN/APQ-99 Radar Set</u>						
	AS-1451/APQ-99	Antenna-Receiver	41.0	19.58	20.00	24.2
	T-920/APQ-99	Radar Transmitter	34.9	6.8	16.6	10.3
	PP-3814/APQ-99	Power Supply/Programmer	37.1	12.18	21.4	5.26
	MT-3027/APQ-99	Forward Assembly Mounting	30.0	17.5	24.32	7.19
	CP-731/APQ-99	Command Computer	6.9	2.82	10.2	7.47
	IP-710/APQ-99	Azimuth Range Indicator (fwd)	26.1	6.5	9.25	20.5
	IP-711/APQ-99	Azimuth Range Indicator (aft)	31.4	8.75	7.5	22.47
	C-4751/APQ-99	Radar Set Control	3.9	5.88	5.75	4.35
	63-70026	Antenna Interlock Switch				
	214C40-1-17	Pressure Switch				

RF-4C BIBLIOGRAPHY

T.O. Number	Chg/Rev	Title
1F-4C-01	1 Apr 76	List of Applicable Publications - F-4 Weapon System
1F-4(R)C-1	1 Mar 76	Flight Manual
1F-4(R)C-2-11	1 Jun 77	Maintenance, Instrument Systems - RF-4C
1F-4(R)C-2-15	15 May 77	Maintenance, Navigation Systems - RF-4C
1F-4(R)C-2-17	1 Sep 76	Maintenance, Avionics Navigation Instrument Systems - RF-4C
1F-4(R)C-2-22	1 Aug 76	Maintenance, Systems Integration - RF-4C
1F-4(R)C-2-23	15 Apr 77	Maintenance, Wiring Diagrams - RF-4C
1F-4(R)C-2-25	1 Jun 77	Maintenance, Forward Looking Radar and Electronic Altimeter System
1F-4(R)C-2-32	15 Nov 76	Maintenance, Integrated Electronic Central AN/ASQ-88, AN/ASQ-88A, AN/ASQ-88B, and AN/ASQ-108 Speech Security System - RF-4C
5A1-9-2-2	30 Sep 75	Field Maintenance, Attitude-Reference Bombing Computer Set AN/AJB-7 (Lear-Siegler)
5F1-3-4-2	1 Jun 75	Field Maintenance, Attitude Heading Reference System, Type AN/ASN-55, Model 5010U (Lear-Siegler)
5F4-15-3	1 Aug 75	Manual Overhaul, Angle of Attack Transmitter SLZ 9170B
5F5-4-1-103	15 Jan 74	Handbook CPU 114/A
5F5-5-6-3	1 Feb 71	Flight Director Computer 522-1763-003
5F8-2-43-3	1 Mar 66	Technical Manual, True Airspeed Indicators 24482-1
5N1-3-13-2	30 Aug 75	Field Maintenance, Navigational Computer Set, Type AN/ASN-46 (Eclipse-Pioneer)
5N1-3-14-2	15 Aug 75	Field Maintenance, Inertial Navigation Set, Types AN/ASN-48, AN/ASN-56, and AN/ASN-63 (Litton)

RF-4C BIBLIOGRAPHY

T.O. Number	Chq/Rev	Title
12P3-2APQ99-2	1 Jun 75	Field Maintenance, Radar Set, Type AN/APQ-99, (Texas Instruments)
12P5-2APN159-2	17 Mar 75	Field Maintenance, Altimeter Set, Electronic, Type AN/APN-159 (Stewart-Warner)
12R1-2ARA50-2	1 Dec 73	Field Maintenance, Direction Finder Group AN/ARA-50 (Collins)
12R2-2ASQ19-32	1 Jul 73	Amplifier-Power Supply-Receiver AM-2349/ASQ-19
12R2-2ASQ88-2	3 Jun 75	Field Maintenance, Receiver-Transmitter, Type RT-736/ASQ-88, Pulse Decoder, Type KY-531/ASQ-88 (Collins)
12R2-2ASQ-102	7 Apr 75	Handbook Service, Radio Receiver-Transmitters RT-793/ASQ
12R2-2ASQ-112	1 Jul 73	Handbook Service, Radio Set Control, C-6684/ASQ
12R2-2ASQ-122	1 Jul 73	Handbook Service, Radio Set Control, C-6685/ASQ
12R2-2ASQ-133	1 Nov 66	Service, Frequency Channel Indicator ID-1311/ASQ
12P4-2APX-142	1 Jan 75	Field Maintenance, Transponder Set Control C-6280(P) APX
12R5-2U-13	15 Apr 62	Handbook Overhaul, BDHI, ID-663/U
MS24523	22 Apr 71	Switch, Toggle, One Pole, Environmentally Sealed

3.19.0
F-106A

F-106A PNWD EQUIPMENT LIST

KEY	EQUIPMENT/UNIT
A	UHF AUTOMATIC DIRECTION FINDER
ADDP	ARU-2 ATTITUDE DIRECTION INDICATOR
AFC	DIGITAL AFCS INTERFACE UNIT 464821
AFCS	AUTO FLIGHT CONTROL SYSTEM
AIMS	AN/APX-72 IFF SYSTEM
AVVB	MACH NO AND SAFE SPEED INDICATOR AVU-1/A
AVVP	ALT AND VERT SPEED IND AAU-1/A
C	CENTRAL AIR DATA COMPUTER CPU-111
CMMS	INTERPHONE SYSTEM
CSG	ALT AND VERT SPEED AMPLIFIER AAU-1/A
FDCS	CPU-41A FLIGHT DIRECTOR COMPUTER
FSDP	TSD SIGNAL DATA CONVERTER 464920
GPDC	CENTRAL DIGITAL COMPUTER 464140
HSDP	HORIZONTAL SITUATION INDICATOR AF/A24J-1
J	NAVIGATION COMPUTER
KA	SIGNAL DATA CONVERTER, COCKPIT DISPLAY 464520
KB	SIGNAL DATA CONVERTER, COCKPIT DISPLAY 464620
RDA	RACK DISCONNECT A
RDB	RACK DISCONNECT B
RDC	RACK DISCONNECT C
RDD	RACK DISCONNECT D
RDE	RACK DISCONNECT E
RDF	RACK DISCONNECT F

F-106A PNWD EQUIPMENT LIST

KEY	EQUIPMENT/UNIT
RDG	RACK DISCONNECT G
S	ILS GLIDESLOPE RCVR 464267
T	TACAN SYSTEM
TSA	TERMINAL BOARD 2
U	ILS LOCALIZER RECEIVER 464367
W	COMPASS SYSTEM

F-106A PNWD EQUIPMENT PHYSICAL CHARACTERISTICS

SYSTEM	UNIT		WT (LB)	SIZE (IN)		
	TYPE (P/N)	NOMENCLATURE		H	W	D
<u>MA-1 Aircraft and Weapon Control Interceptor System</u>						
<u>Communications, Navigation and Landing Subsystem</u>						
	C-2588/ARR-61	Converter-Receiver Control	3.5	7.5	5.75	4.0
	464074	Aft Compt Left Electrical Equipment Rack	38	20.0	17.0	39.0
	464102	TSD Signal Data Converter Electrical Equipment Rack				
	464117	ADF Antenna	11.0	5.0	15.0	16.0
	464181	Tactical Display Horizontal Situation Indicator	40.0	19.21	13.06	26.5
	CV-703/ARR-61	Digital-Digital Converter	23.0	6.0	10.25	15.0
	464267	ILAS Glide Slope and Marker Beacon Radio Receiver	10.0	4.0	6.0	14.0
	464367	ILAS Localizer Radio Receiver	9.0	4.0	6.0	12.0
	464405	TACAN Control Box	3.0	2.88	4.98	6.5
	464463	Bearing Select Switch	1.0	7.0	3.0	3.0
	464505	UHF Control Box	6.0	4.75	5.75	5.5
	464520	Cockpit Display Signal Data Converter No. 1	19.0	12.0	9.0	8.0
	464620	Cockpit Display Signal Data Converter No. 2	20.0	12.0	9.0	8.0
	464529	TACAN Receiver Transmitter	26.0	7.62	6.75	13.254
	464602	Cockpit Signal Data Con- verter Electrical Equip- ment Rack	8.0	18.0	12.0	9.0
	464606	Audio and ADF Electronic Control Amplifier	9.0	4.0	6.0	14.0
	464629	TACAN Signal Data Converter	11.0	7.95	4.6	11.03
	R884/ARR-61	Data Link Receiver	28.5	7.92	5.9	14.0
	464755	ILS Receiver Control	2.0	3.0	6.0	3.0
	464780	UHF Channel and Frequency Remote Indicator	1.5	2.0 diam.		5.8

F-106A PNWD EQUIPMENT PHYSICAL CHARACTERISTICS

SYSTEM	UNIT		WT (LB)	SIZE (IN)		
	TYPE (P/N)	NOMENCLATURE		H	W	D
<u>Communications, Navigation and Landing Subsystem (Cont'd)</u>						
	464811	Time Division Data Link Converter Electrical Equipment Rack				
	464920	Tactical Display Horizontal Situation Signal Data Converter	25.0	11.31	9.0	12.17
	RT-749/ARC-109	Receiver-Transmitter	28.7	6.75	8.875	14.875
	TS-1843A/APX	Test Set	2.5	3.047	3.0	7.859
	C-6280(P)/APX-72	Control	2.75	5.25	5.75	3.09
	RT-859/APX-72	Receiver-Transmitter	15.0	6.0	5.76	12.25
	KIT-1A/T SEC	Transponder Computer Ejection Relay				
	SA-1474/A	Antenna Switching Unit	1.3	3.44	3.0	3.37
<u>Computer Subsystem</u>						
	464034	Computer Mode Annunciator	0.2	1.4	0.84	2.3
	464140	Input/Output Signal Data Converter	54.0	6.5	28.12	14.78
	464273	RH Fwd Compt Electrical Equipment Rack	60.0	34.53	17.6	47.66
	464526	Regulated DC Computer Power Supply	18.0	8.69	9.74	10.34
	464846	RAM Arithmetic Computer Control	54.0	6.5	28.12	14.78
	464857	Computer Drum Memory	50.0	10.0	15.65	16.28
	464955	Auto-Navigation Selector Control	0.6	3.0	5.75	2.125
<u>Flight Control and Measurement Subsystem</u>						
	464009	Integrator Electronic Control Amplifier	14.9	8.14	5.86	11.0
	464061	Normal Aircraft Accelerometer	2.7	3.25 diam.		3.44
	464163	AFCS Flight Mode Control	3.0	3.0	5.75	5.13
	464209	Demodulator Channel	4.0	3.82	5.86	9.0

F-106A PNWD EQUIPMENT PHYSICAL CHARACTERISTICS

SYSTEM	UNIT		WT (LB)	SIZE (IN)		
	TYPE (P/N)	NOMENCLATURE		H	W	D
<u>Flight Control and Measurement Subsystem (Cont'd)</u>						
	464109	Roll and Pitch Electronic Control Amplifier	8.5	4.0	5.86	11.0
	464289	Stable Element	56.0	15.3	14.61	14.7
	464309	Azimuth Electronic Control Amplifier	12.5	7.95	5.89	9.0
	464374	Stable Platform Amplifier Electrical Equipment Rack	17.6	11.0	13.5	31.0
	464396	Stable Coordinate Ref Gp Programmer	6.0	4.0	5.86	12.27
	464409	Latitude Counter Junction Box	8.0	3.82	5.86	11.89
	464474	Stable Platform Generator Electrical Equipment Rack	5.5	15.12	17.25	3.0
	464821	Interface Amplifier	7.0	9.0	5.0	6.56
	464905	System Power Control	3.0	3.0	5.75	8.21
	AF/A24G-1	Displacement Gyro	22.0	15.3	6.8	7.2
	AF/A24G-1	Amplifier-Power Supply	10.0	12.91	5.0	5.57
	MC-1	Rate Switching Gyro	1.5	4.875	2.44	2.56
	AF/A24G-1	Compass Adapter	11.5	11.91	5.0	5.57
	AF/A25G-1	Compass Controller	1.25	4.5	5.75	2.63
	ARU-2/A	Attitude Director Indicator	8.0	9.73	5.01	5.26
	AVU-1/A	Mach Airspeed Amplifier	10.2	11.53	4.5	4.0
	AVU-1/A	Mach IAS Indicator	10.2	8.0	3.5	7.75
	AF/A24J-1	Horizontal Situation Indicator	7.7	7.625	5.0	5.25
	AF/A24J-1	HSI Amplifier	3.8	5.0	7.0	3.0
	CPU-4/A	Flight Director Computer	10.0	9.5	5.313	7.0
	TRU-3/A	Accelerometer Transmitter	1.313	3.0 diam.		3.0
	DT-173/AJN	Azimuth Magnetic Detector	1.6	2.281	3.5	4.906
	AAU-1/A	Altitude Vertical Speed Indicator	10.0	3.5	7.75	8.0

F-106A PNWD EQUIPMENT PHYSICAL CHARACTERISTICS

SYSTEM	UNIT		WT (LB)	SIZE (IN)		
	TYPE (P/N)	NOMENCLATURE		H	W	D
	<u>Flight Control and Measurement Subsystem (Cont'd)</u>					
	AAU-1/A	Altitude Vertical Speed Amplifier	8.0	8.9	4.5	4.0
	TRU-2/A	Rate Gyro Transmitter	3.0	5.66	3.25	3.88
	CPU-111	Central Air Data Computer Pitch G Limiter Turn Rate Transmitter	35.0	8.78	9.34	19.5

F-106A BIBLIOGRAPHY

T.O. Number	Chg/Rev	Title
1F-106A-01	31 Mar 72	List of Applicable Publications - F-106A and F-106B
1F-106A-1	15 Nov 74	Flight Manual - F-106A and F-106B
1F-106A-2-9	1 Dec 72	Maintenance, Instrument Systems - F-106A and F-106B
1F-106A-2-24	31 Mar 77	Maintenance, Aircraft and Weapon Control Interceptor System, Type MA-1 Wiring Data - F-106A
1F-106A-2-27-5	1 Feb 74	Organizational Maintenance, F-106 AWCIS Theory and Functional Diagrams
11F1-MA1-12-4	1 Apr 75	Field Maintenance, Aircraft and Weapon Control Interceptor System, Types MA-1 and AN/ASQ-25 (Flight Control and Measurement Subsystem)
11F1-MA1-12-8	3 Feb 75	Field Maintenance, Aircraft and Weapon Control Interceptor System Types MA-1 and AN/ASQ-25 (Communication, Navigation, and Landing Subsystem)
11F1-MA1-12-13	1 Feb 74	Field Maintenance, Aircraft and Weapon Control Interceptor System Type MA-1 IRAM (Computer Subsystem)
12P4-2APX-142	21 Jan 75	Organizational/Field/Intermediate/DS, GS, and Depot Maintenance with Illustrated Parts Breakdown Control, Transponder Set C-6280IP)/APX, C-6280A(P)/APX, C-6717/APX, and C-7483/APX
12P4-2APX-192	6 Jun 75	Organizational/Intermediate Maintenance with Depot Overhaul Instructions and IPB, Transponder Set, Test Set TS-1843A/APX

3.20.0
F-106B

AD-A061 494

ARINC RESEARCH CORP ANNAPOLIS MD
STANDARD AVIONICS INTERFACE PROGRAM. VOLUME II. NAVIGATION EQUI--ETC(U)
AUG 76 B G MCELHANEY, E J CHAUVIN
1296-01-2-1527-VOL-2

F/G 9/3
F09603-75-A-3001
NL

UNCLASSIFIED

4 of 5
AD
A061494

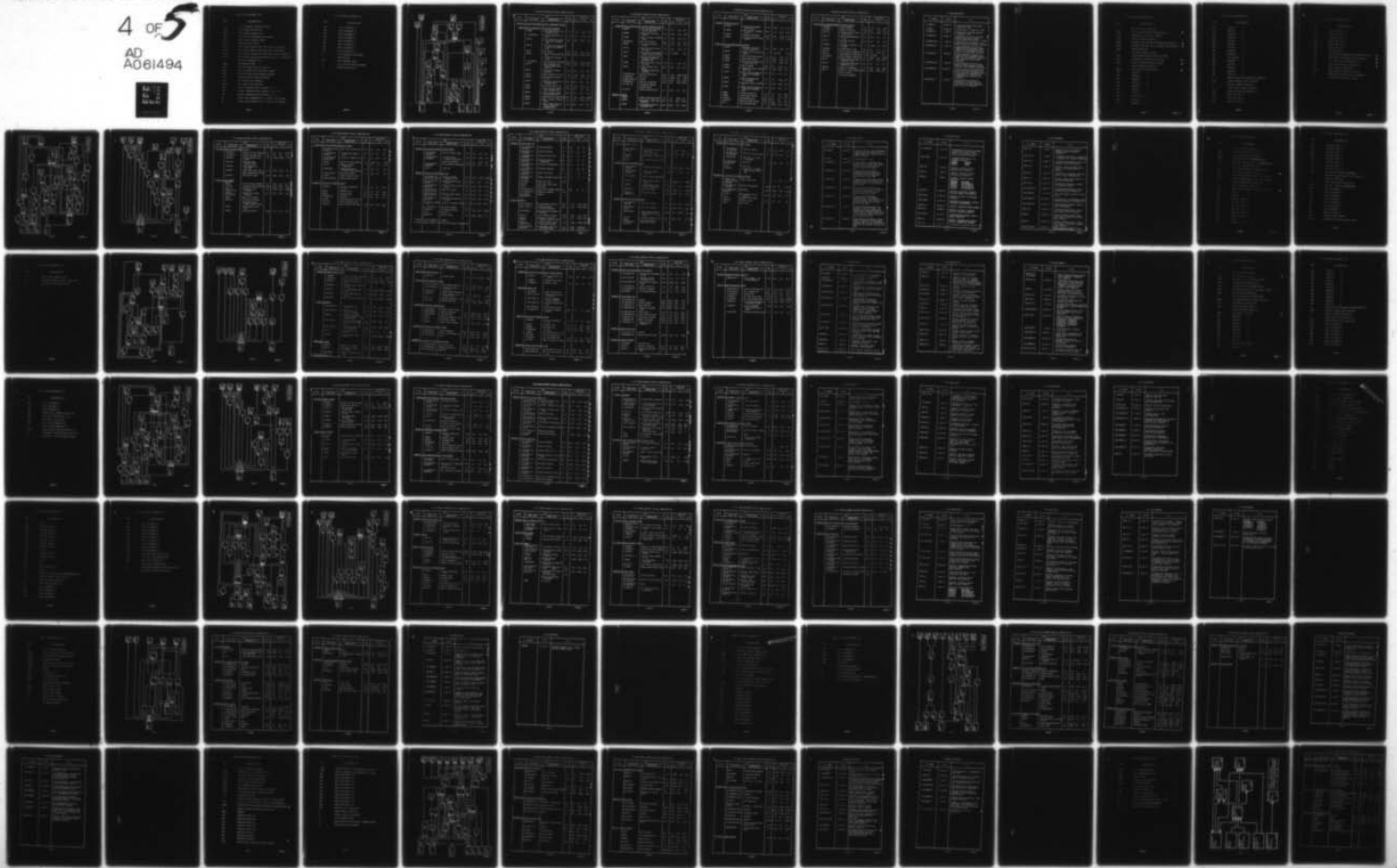

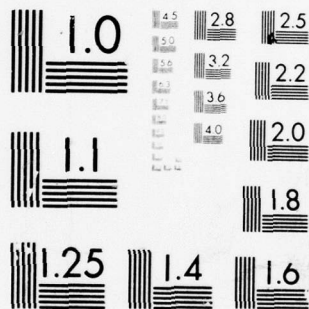

MICROCOPY RESOLUTION TEST CHART
NATIONAL BUREAU OF STANDARDS-1963-A

F-106B PNWD EQUIPMENT LIST

KEY	EQUIPMENT/UNIT
A	UHF- AUTOMATIC DIRECTION FINDER
ANDC	AFT COCKPIT ARU-2/A ADI
ADDP	FWD COCKPIT ARU-2/A ADI
AFC	DIGITAL AFCS INTERFACE UNIT 464821
AFCS	AUTO FLIGHT CONTROL SYSTEM
AIMS	AN/APX-72 IFF SYSTEM
AMDC	AFT COCKPIT MACH NO AND SAFE SPEED INT
AMDP	FWD COCKPIT MACH NO AND SAFE SPEED INT
AVVC	AFT COCKPIT ALTITUDE AND VERTICAL SPEE
AVVP	FWD COCKPIT ALTITUDE AND VERTICAL SPEE
C	AIR DATA COMPUTER CP-111
CMMS	INTERPHONE SYSTEM
FDCS	CPU-4/A FLIGHT DIRECTOR COMPUTER
FSDC	AFT TSD SIGNAL DATA CONVERTER 464920
FSDP	FWD TSD SIGNAL DATA CONVERTER 464920
GPDC	CENTRAL DIGITAL COMPUTER 464140
HSDC	AFT COCKPIT HSI AF/A24J-1
HSDP	FWD COCKPIT HSI AF/A24J-1
JBA	CONTROL TRANSFER RELAY ASSEMBLY- GP 2
JBD	CONTROL TRANSFER RELAY ASSEMBLY- GP 2
JBZ	CONTROL TRANSFER RELAY ASSEMBLY- GP 3
KA	SIGNAL DATA CONVERTER NO 1- COCKPIT DS
KB	SIGNAL DATA CONVERTER NO 2- COCKPIT DS

F-106B PNWD EQUIPMENT LIST

KEY	EQUIPMENT/UNIT
RDA	RACK DISCONNECT A
RDB	RACK DISCONNECT B
RDC	RACK DISCONNECT C
RDD	RACK DISCONNECT D
RDH	RACK DISCONNECT H
RDJ	RACK DISCONNECT J
RDK	RACK DISCONNECT K
RDL	RACK DISCONNECT L
S	ILS GLIDESLOPE RCVR 464267
T	TACAN SYSTEM
TSA	ASIP TERMINAL BOARD
U	ILS LOCALIZER RECEIVER 464367
W	COMPASS SYSTEM J-4

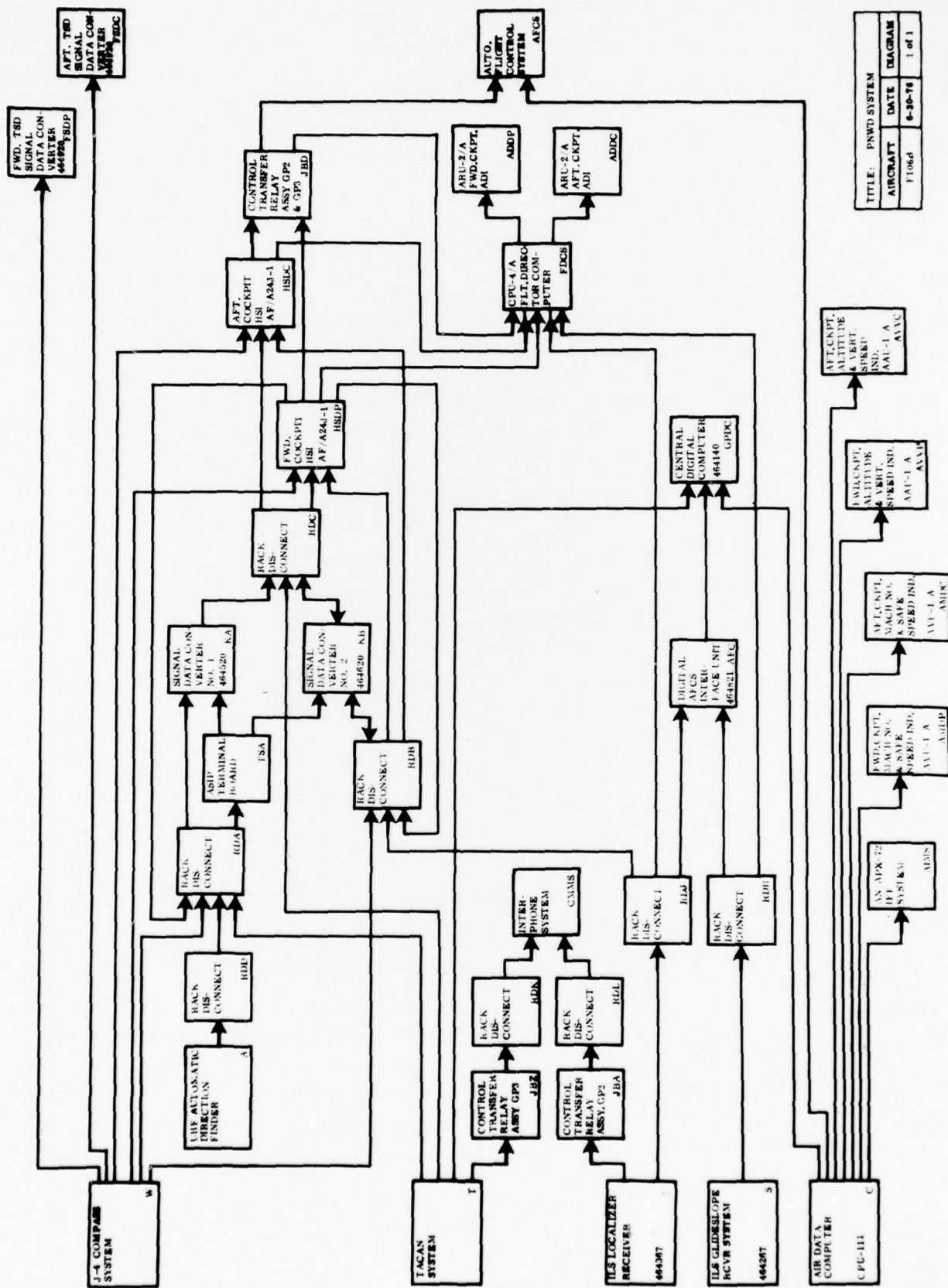

3-20A-3

TITLE:	PWTD SYSTEM
AIRCRAFT:	F106A
DATE:	6-30-76
DIAGRAM:	1 of 1

F-106B PNWD EQUIPMENT PHYSICAL CHARACTERISTICS

SYSTEM	UNIT		WT (LB)	SIZE (IN)		
	TYPE (P/N)	NOMENCLATURE		H	W	D
<u>AN/ASQ-25 Aircraft and Weapon Control Interceptor System</u>						
<u>Communications, Navigation and Landing Subsystem</u>						
	472005	Intercommunications Set Control (2 ea)	0.5	1.5	5.75	3.0
	C-2558/ARR-61	Converter-Receiver Control	3.5	7.5	5.75	4.0
	472074	Elect Compt Missile Bay Electrical Equipment Rack	80.0	16.5	60.0	16.7
	464102	TSD Signal Data Converter Electrical Equipment Rack				
	464117	ADF Antenna	11.0	5.0	15.0	16.0
	464181	Tactical Display Horizontal Situation Indicator (2 ea)	40.0	19.21	13.06	26.5
	CV-703/ARR-61	Digital-Digital Converter	23.0	6.0	10.25	15.0
	464267	ILAS Glideslope and Marker Beacon Radio Receiver	10.0	4.0	6.0	14.0
	464367	ILAS Localizer Radio Receiver	9.0	4.0	6.0	12.0
	464405	TACAN Control Box (2 ea)	3.0	2.88	4.98	6.5
	464463	Bearing Select Switch (2 ea)	1.0	7.0	3.0	3.0
	472473	TACAN and IR Electrical Equipment Rack	24.0	23.4	19.5	16.0
	464505	UHF Control Box (2 ea)	6.0	4.75	5.75	5.5
	464520	Cockpit Display Signal Data Converter No. 1	19.0	12.0	9.0	8.0
	464620	Cockpit Display Signal Data Converter No. 2	20.0	12.0	9.0	8.0
	464529	TACAN Receiver-Transmitter	26.0	7.62	6.75	13.254
	472564	Group I Control Transfer Relay	3.9	6.0	5.75	6.5
	464602	Cockpit Signal Data Converter Electrical Equipment Rack	8.0	18.0	12.0	9.0

F-106B PNWD EQUIPMENT PHYSICAL CHARACTERISTICS

SYSTEM	UNIT		WT (LB)	SIZE (IN)		
	TYPE (P/N)	NOMENCLATURE		H	W	D
<u>Communications, Navigation and Landing Subsystem (Cont'd)</u>						
	464606	Audio and ADF Electronic Control Amplifier	9.0	4.0	6.0	14.0
	464629	TACAN Signal Data Converter	11.0	7.95	4.67	11.03
	472664	Group II Control Transfer Relay	3.9	6.0	5.75	6.5
	R884/ARR-61	Data Link Receiver	28.5	7.92	5.9	14.0
	464755	ILS Receiver Control (2 ea)	2.0	3.0	6.0	3.0
	472764	Group IIA Control Transfer Relay	3.3	6.0	5.75	6.5
	464780	UHF Channel and Frequency Remote Indicator (2 ea)	1.5	2.0 diam.		5.8
	464811	Time Division Data Link Converter Electrical Equipment Rack				
	472864	Group IIIB Control Transfer Relay	3.2	6.0	5.75	6.5
	464920	Tactical Display Horizontal Situation Signal Data Converter	25.0	11.31	9.0	12.17
	RT-749/ARC-109	Receiver-Transmitter	28.7	6.75	8.875	14.875
	TS-1843A/APX	Test Set	2.5	3.047	3.0	7.859
	C-6280(P)/APX-72	Control	2.75	5.25	5.75	3.09
	RT-859/APX-72	Receiver-Transmitter	15.0	6.0	5.76	12.25
	KIT-1A/T SEC	Transponder Computer Ejection Relay				
	SA-1474/A	Antenna Switching Unit	1.3	3.44	3.0	3.37
<u>Computer Subsystem</u>						
	464034	Computer Mode Annunciator	0.2	1.4	0.84	2.3
	464140	Input/Output Signal Data Converter	54.0	6.5	28.12	14.78
	464273	RH Fwd Compt Electrical Equipment Rack	60.0	34.53	17.6	47.66

F-106B PNWD EQUIPMENT PHYSICAL CHARACTERISTICS

SYSTEM	UNIT		WT (LB)	SIZE (IN)		
	TYPE (P/N)	NOMENCLATURE		H	W	D
<u>Computer Subsystem (Cont'd)</u>						
	464526	Regulated DC Computer Power Supply	18.0	8.69	9.74	10.34
	464846	RAM Arithmetic Computer Control	54.0	6.5	28.12	14.78
	464857	Computer Drum Memory	50.0	10.0	15.65	16.28
	464955	Auto-Navigation Selector Control	0.6	3.0	5.75	2.125
<u>Flight Control and Measurement Subsystem</u>						
	464009	Integrator Electronic Control Amplifier	14.9	8.14	5.86	11.0
	464061	Normal Aircraft Accelerometer	2.7	3.25 diam.		3.44
	464163	AFCS Flight Mode Control	3.0	3.0	5.75	5.13
	464209	Demodulator Channel	4.0	3.82	5.86	9.0
	464109	Roll and Pitch Electronic Control Amplifier	8.5	4.0	5.86	11.0
	464289	Stable Element	56.0	15.3	14.61	14.7
	464309	Azimuth Electronic Control Amplifier	12.5	7.95	5.89	9.0
	464374	Stable Platform Amplifier Electrical Equipment Rack	17.6	11.0	13.5	31.0
	464396	Stable Coordinate Ref Gp Programmer	6.0	4.0	5.86	12.27
	464409	Latitude Counter Junction Box	8.0	3.82	5.86	11.89
	464474	Stable Platform Generator Electrical Equipment Rack	5.5	15.12	17.25	3.0
	464821	Interface Amplifier	7.0	9.0	5.0	6.56
	464905	System Power Control	3.0	3.0	5.75	8.21
	AF/A24G-1	Displacement Gyro	22.0	15.3	6.8	7.2
	AF/A24G-1	Amplifier-Power Supply	10.0	12.91	5.0	5.57
	MC-1	Rate Switching Gyro	1.5	4.875	2.44	2.56

F-106B PNWD EQUIPMENT PHYSICAL CHARACTERISTICS

SYSTEM	UNIT		WT (LB)	SIZE (IN)		
	TYPE (P/N)	NOMENCLATURE		H	W	D
<u>Flight Control and Measurement Subsystem (Cont'd)</u>						
	AF/A24G-1	Compass Adapter	11.5	11.91	5.0	5.57
	AF/A25G-1	Compass Controller	1.25	4.5	5.75	2.63
	ARU-2/A	Altitude Director Indicator (2 ea)	8.0	9.73	5.01	5.26
	AVU-1/A	Mach Airspeed Amplifier (2 ea)	10.2	11.53	4.5	4.0
	AVU-1/A	Mach IAS Indicator (2 ea)	10.2	8.0	3.5	7.75
	AF/A24J-1	Horizontal Situation Indicator	7.7	7.625	5.0	5.25
	AF/A24J-1	HSI Amplifier (2 ea)	3.8	5.0	7.0	3.0
	CPU-4/A	Flight Director Computer	10.0	9.5	5.313	7.0
	TRU-3/A	Accelerometer Transmitter	1.313	3.0 diam.		3.0
	DT-173/AJN	Azimuth Magnetic Detector	1.6	2.281	3.5	4.906
	AAU-1A	Altitude Vertical Speed Indicator (2 ea)	10.0	3.5	7.75	8.0
	AAU-1/A	Altitude Vertical Speed Amplifier (2 ea)	8.0	8.9	4.5	4.0
	TRU-2/A	Rate Gyro Transmitter	3.0	5.66	3.25	3.88
	CPU-111	Central Air Data Computer	35.0	8.78	9.34	19.5
		Pitch G Limiter				
		Turn Rate Transmitter				

F-106B BIBLIOGRAPHY

T.O. Number	Chg/Rev	Title
1F-106A-01	31 Mar 72	List of Applicable Publications - F-106A and F-106B
1F-106A-1	15 Nov 74	Flight Manual - F-106A and F-106B
1F-106A-2-9	1 Dec 72	Maintenance, Instrument Systems, F-106A and F-106B
1F-106B-2-24	31 Mar 77	Maintenance, Aircraft and Weapon Control Interceptor System, Type AN/ASQ-25, Wiring Data - F-106B
1F-106A-2-27-5	1 Feb 74	Organizational Maintenance, F-106 AWCIS Theory and Functional Diagrams
11F1-MA1-12-4	1 Apr 75	Field Maintenance, Aircraft and Weapon Control Interceptor System, Types MA-1 and AN/ASQ-25 (Flight Control and Measurement Subsystem)
11F1-MA1-12-8	3 Feb 75	Field Maintenance, Aircraft and Weapon Control Interceptor System Types MA-1 and AN/ASQ-25 (Communication, Navigation, and Landing Subsystem)
11F1-MA1-12-13	1 Feb 74	Field Maintenance, Aircraft and Weapon Control Intetceptor System Type MA-1 IRAM (Computer Subsystem)
12P4-2APX-142	21 Jan 75	Organizational/Field/Intermediate/DS, GS, and Depot Maintenance with Illustrated Parts Breakdown Control, Transponder Set C-6280I(P)/APX, C-6280A(P)/APX, C-6717/APX, and C-7493/APX
12P4-APX-192	6 Jun 75	Organizational/Intermediate Maintenance with Depot Overhaul Instructions and IPB, Transponder Set, Test Set TS-1843A/APX

3.21.0
F-111A

F-111A PNWD EQUIPMENT LIST

KEY	EQUIPMENT/UNIT
A	UHF ADF SYSTEM AN/ARA-50
ADDP	ADI DISPLAY ARU-11/A ; 139001-01-02
AFCS	AUTOMATIC FLIGHT CONTR SYSTEM
AIMS	IFF-SIF SYSTEM AN/APX-64
AMDD	AIRSPPEED MACH INDICATOR SYSTEM AVK-18/A24G-18
AVDP	ALTITUDE VERTICAL VEL IND SYSTEM AAK-18/A24G-17
BDHP	BDHI E5165001400
C	AIR DATA COMPUTER SYSTEM
CMMN	INTERCOMMUNICATIONS SYSTEM AN/AIC-25
CSA	INSTRUMENT COUPLER 087A1; 1E323G6
FDCA	FLIGHT DIRECTOR SYSTEM CPU-76/A
G	RADAR ALTIMETER AN/APN-167
HSDP	HSI DISPLAY AQU-4/A; 104500
JBA	JUNCTION A
JBB	JUNCTION B
JBC	JUNCTION C
JBD	JUNCTION D
JBE	JUNCTION E
JBF	JUNCTION F
JBG	JUNCTION G
JBH	LR FWD E BAY
JBI	JUNCTION I
JBJ	JUNCTION J

F-111A PNWD EQUIPMENT LIST

KEY	EQUIPMENT/UNIT
JBK	JUNCTION K
JBL	JUNCTION L
JBM	JUNCTION M
JBN	JUNCTION N
JBO	JUNCTION O
JBP	JUNCTION P
JBQ	JUNCTION Q
JBR	JUNCTION R
JBS	JUNCTION S
JBT	FWD ELEC PNL T
JBU	JUNCTION U
JBV	JUNCTION V
JBW	JUNCTION W
JBX	JUNCTION X
JBZ	JUNCTION Y
M	TERRAIN FOLLOWING RADAR SYST AN/APQ-110
ODSS	OPTICAL DISPLAY SIGHT AN/ASG-23
P	BOMB NAV SYSTEM AN/AJQ-20A
Q	ATTACK RADAR SYSTEM AN/APQ-113
RADR	RADAR RECEIVING SET AN/APS-109
RDA	EJECT CAP DISC A
RDB	EJECT CAP DISC B
RDC	EJECT CAP DISC C

F-111A PNRD EQUIPMENT LIST

KEY	EQUIPMENT/UNIT
RDD	EJECT CAP DISC D
RDE	EJECT CAP DISC E
RDF	EJECT CAP DISC F
RDG	EJECT CAP DISC G
RDH	EJECT CAP DISC H
RDI	EJECT CAP DISC I
RDJ	EJECT CAP DISC J
SWA	POINTER NO.2 TRANSFER RELAY 185K2 ;MS2532501
SWB	ZERO DRIFT ANGLE RELAY 219K2 ;K-D4A008
SWC	FDC DUMMY LOAD SW 087S2 ;602EN14-6
SWD	MISC. SWITCH PANEL 415A1 ;12E210
T	TACAN SYSTEM AN/ARN-52(V)
TASP	TRUE AIRSPEED INDICATOR 352-01-3
U	INSTRUMENT LANDING SYSTEM AN/ARN-58A
W	AUXILIARY FLIGHT REFER SYSTEM

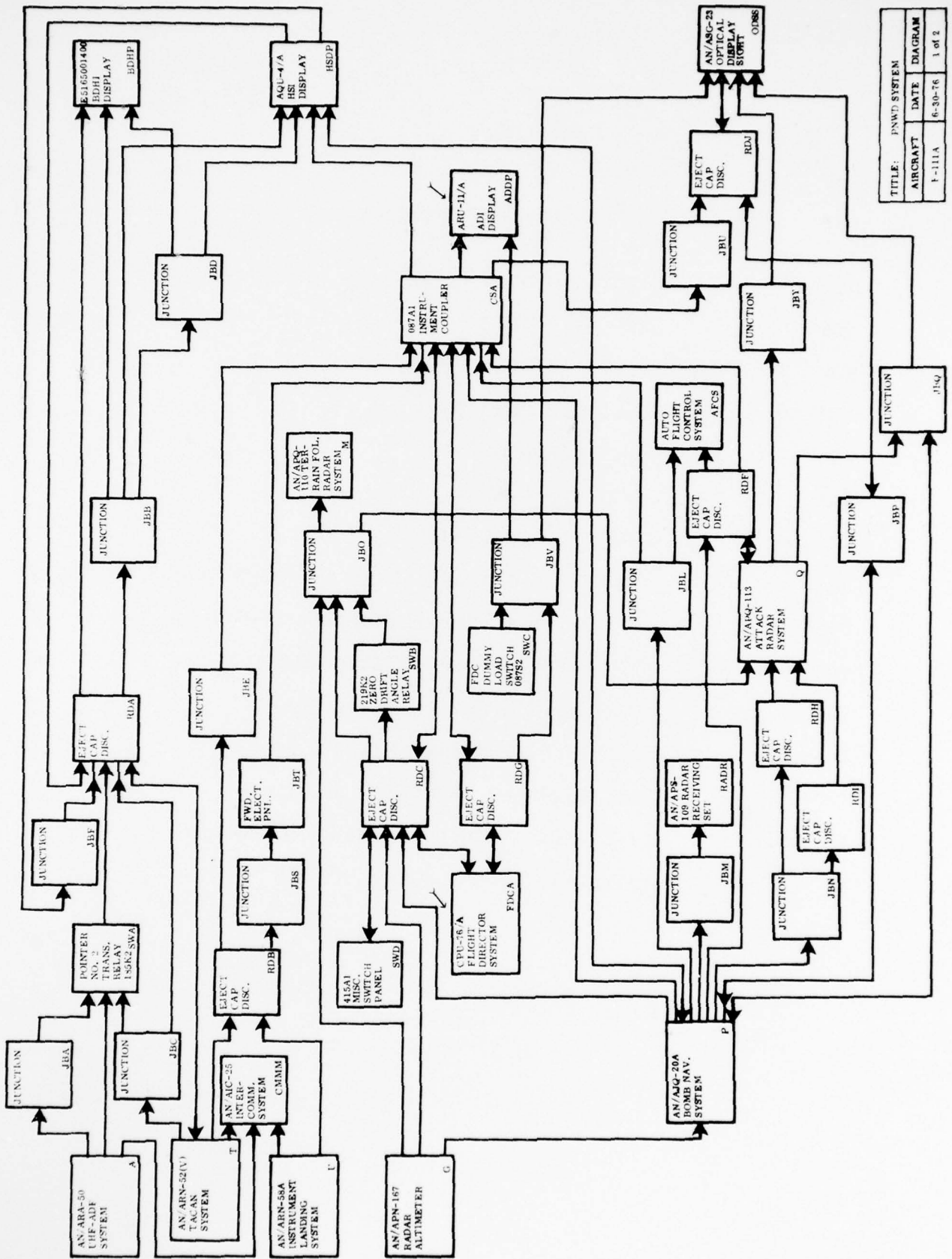

TITLE: PNRD SYSTEM		
AIRCRAFT	DATE	DIAGRAM
F-111A	6-30-76	1 of 2

3-21A-4

CHANGE 3

F-111A PNWD EQUIPMENT PHYSICAL CHARACTERISTICS

SYSTEM	UNIT		WT (LB)	SIZE (IN)		
	TYPE (P/N)	NOMENCLATURE		H	W	D
<u>Air Data Computer System 12D043-12 M4-1</u>						
	1903633-4	Central Air Data Computer	47.5	8.0	14.0	19.25
	12C1006-817	Maximum Safe MACH Assy	6.0	4.2	5.0	12.0
	SLZ9370-3	Angle-of-Attack Transmitter	2.5	4.500	4.500	6.575
	65-0153-3	Angle-of-Attack Indexers Light				
	182-043-1	Total Temperature Indicator				
	80-0128-1	TOTAL TEMP Caution Lamp	0.12	0.50	2.25	3.2
		Reduce Speed Warning Lamp				
	80-0128-1	CADS Caution Lamp	0.12	0.50	2.25	3.20
<u>Flight Director System</u>						
	CPU-76/A 10377	Flight Director Computer	9.0	7.56	5.31	10.13
	1E3232G6	Instrument System Coupler	6.50	2.50	5.82	9.37
	ARU-11/A 139001-01-04	Attitude Director Indicator	9.0	5.260	5.010	8.000
	104500 or 520-1033-004	Horizontal Situation Indicator	8.2	4.31	5.06	9.50
	42406	Rate of Turn Sensor				
	602EN14-6	FDC Dummy Load Switch				
		Instrument System Coupler Control Panel				
	12E210	Miscellaneous Switch Panel				
	12E2211	Ground Check Panel	1.88	2.10	7.31	6.25

F-111A PNWD EQUIPMENT PHYSICAL CHARACTERISTICS

SYSTEM	UNIT		WT (LB)	SIZE (IN)		
	TYPE (P/N)	NOMENCLATURE		H	W	D
<u>AN/AJQ-20A Inertial Bombing-Navigation System</u>						
	MX-6767A/AJQ-20A 671630-3	Stabilized Platform Unit	74.5	14.3	14.5	16.5
	CP-812A/AJQ-20 671480-2	Navigational Computer Unit	51.7	7.5	16	24
	CP-937/AJQ-20A 671597-58-6	Ballistics Computer Unit	35	9.5	12.0	16.5
	2587833	Magnetic Azimuth Detector	1.8	4.906	3.5	2.067
	2587832	Magnetic Azimuth Compensator	.31	2.5	3.5	2.6
	D5201001400	Bombing-Navigation Distance-Time Indicator	1.5	2.25	5.7	6.6
	C-7687/AJQ-20A 12E2271	Bomb Data Control Target Elevation Panel	1.5	2.25	5.7	6.6
	MX-9497/AJQ-20A	Offset Bombing Panel				
<u>AN/APN-167 Electronic Altimeter System</u>						
	HG7092A-1	Receiver-Transmitter (2 ea)	11.0	5.0	7.0	12.0
	959533	Antenna (2 ea)	1.0	3.0	5.0	8.0
	WG219A	Equipment Rack	4.0	6.0	15.0	14.0
	K51860001000	Indicator	2.0	5.0	5.0	5.0
	11990-3	RF Switching Unit (2 ea)				
	P613-466	LARA Calibration Unit				
	65-0281-9	Radar Altitude Low Lamp	0.12	0.50	2.25	3.20

F-111A PNWD EQUIPMENT PHYSICAL CHARACTERISTICS

SYSTEM	UNIT		WT (LB)	SIZE (IN)		
	TYPE (P/N)	NOMENCLATURE		H	W	D
<u>AN/ASG-23 Lead Computing Optical Sight System</u>						
	SU-29/ASG-23 105D9280G1	Optical Display Sight	20.0	8.9	6.8	23
	AM-4301/ASG-23 8530950G1	Lead and Launch Computing Amplifier	20.0	4.9	8.02	15.2
		Amplifier Mounting	1.0	1.0	8.35	15.7
	CN-1060/ASG-23 688D205G2	Lead Computing Gyroscope	14.0	10.5	10.5	9.0
	12E177	Relay Box				
<u>AN/APQ-110 Terrain Following Radar Set</u>						
	CP-788/APQ-110 500114-15, 16,&17	Terrain Following Computer (2 ea)	13.8	5.32	7.28*	16.06**
	AS-1717/APQ-110 562266-2	Antenna-Receiver Units (2 ea)	24.2	12.7	12.5	17.32
	IP-773/APQ-110 500116-12	Terrain Following Indi- cator	28.0	6.25	7.05	21.76
	C-6456/APQ-110 500117-13 & 14	Radar Set Control	2.6	3.00	5.75	7.31
	AM-4240/APQ-110 500112-14 & 15	Amplifier-Power Supply (2 ea)	18.8	6.00	6.75	17.61
	SN-379/APQ-110 500113-11	Synchronizer-Transmitter (2 ea)	22.1	6.00	7.82	17.61
	MT-3359(XA-1)/APQ- 110	Electrical Equipment Rack	22.8	19.25	14.25	18.8
	CG-3132/APQ-110	Waveguide Assembly	2.0	-	-	-
	MX-9523/AP 12E177	Low Altitude Monitor Relay Box	6.0	3.875	3.25	12.875
	MS25321D2	TFR Fail Relay	0.2	1.812	0.687	1.5
* Width includes hardware for tiedowns.						
** Depth includes connector and front panel mount subassemblies.						

F-111A PNWD EQUIPMENT PHYSICAL CHARACTERISTICS

SYSTEM	UNIT		WT (LB)	SIZE (IN)		
	TYPE (P/N)	NOMENCLATURE		H	W	D
<u>AN/APQ-113 Attack Radar Set</u>						
	AS-1749/APQ-113 7335183G1	Antenna Assembly	51	26	35	32
	AB-902/APQ-113 7335175G1	Antenna Pedestal	37	19	21	8
	C-6498/APQ-113 7332198G3	Antenna Control Unit	38	10	27	8
	MD-608/APQ-113 7635519G6	Modulator-Receiver Transmitter	101	21	13	21
	SN-380/APQ-113 7332050G5	Electrical Synchronizer	59	13	13	21
	IP-777/APQ-113 7638259G4	Indicator-Recorder	65	9	16	31
	C-6499/APQ-113 7635611G1	Radar Set Control	3	4	6	7
	C6500/APQ-113 7637148G1	Antenna-Indicator Control	2.5	8	6	4
	89-87400-1	Radar Roll Unit	37.5			
	12E2270	Auto Radar Photo Panel				
	12E177	Relay Box				
	MT-3384/APQ-113	Electrical Equipment Rack	6	34	13	22
	CG-3108/APQ-113	Waveguide Assembly	0.8	-	-	-
	CW-790/APQ BD0757020-115	Radome				
<u>Flight Instruments</u>						
	AVK-18/A24G-18	Airspeed-Mach Indicator	10.5	7.75	3.50	8.00
	AAK-17/A24G-17	Altitude-Vertical Velocity Indicator	10.5	7.75	3.50	8.00
	E5165001400	Bearing-Distance-Heading Indicator				
	352-01-3	True Airspeed Indicator	0.65	1.56	1.56	5.75
	AQU-4/A 104500	Horizontal Situation Indicator (part of FDS)	8.2	4.31	5.06	9.50
	ARU-11/A 139001-01-02	Attitude Director Indi- cator (part of FDS)	9.0	5.260	5.010	8.000
	ASK-14/A24G-18 18754-1B	Airspeed-Mach Amplifier with Shock Mounts	6.5 7.8	4.44 4.44	4.56 4.56	10.5 10.5

F-111A PNWD EQUIPMENT PHYSICAL CHARACTERISTICS

SYSTEM	UNIT		WT (LB)	SIZE (IN)		
	TYPE (P/N)	NOMENCLATURE		H	W	D
<u>Flight Instruments (cont.)</u>						
	ASK-13/A24G-17 18753-1A	Altitude-Vertical Speed Amplifier with Shock Mount	5.3 6.5	4.44 4.44	4.56 4.56	9 9
	TRU-3/A 18-1151	Accelerometer Transmitter	1.2	3	3	3
	42406	Turn Sensor (part of FDS)				
<u>Auxiliary Flight Reference System</u>						
	SBK11/A24G-26 8KD9AF4	Displacement Gyroscope	10.3	6.03	6.03	8.32
	ASK25/A24G-26 8KE63AF5	Electronic Control Amplifier	9.5	5	6.5	10
	DCK-129/A24G	Compass System Controller				
	TRU-79/A	Remote Compass Trans- mitter	1.8	4.906	3.5	2.067
	2587832	Remote Compass Trans- mitter Compensator	0.32	2.5	3.5	2.625
	MS25327-D1	AFTS Power Relay	0.43	1.812	1.5	2.187
	MS27150-3 139000-01-02	Attitude Indicator	2.75	2.38	2.38	6.63
<u>AN/ARN-58A Instrument Landing System</u>						
	C6376/ARN-58A 179-5102	Radio Set Control	1.0	2.25	5.75	4.313
	R843A/ARN-58 101753	Localizer Receiver	7.6	6.875	7.02	5.02
	R844A/ARN-58	Gliderlope and Marker Beacon Receiver with Mount	9.125	9.75	6.875	5.02
	12B11521	Localizer Antenna (2 ea)	1.0	2.68	5.14	12.14
	12Z518 C-6376/ARN-58 179-5102	Glideslope Antenna Radio Set Control	1.5			

F-111A PNWD EQUIPMENT PHYSICAL CHARACTERISTICS

SYSTEM	UNIT		WT (LB)	SIZE (IN)		
	TYPE (P/N)	NOMENCLATURE		H	W	D
<u>AN/ARA-50 UHF Automatic Direction Finder</u>						
	AS-909/ARA-48 522-1267-005	Antenna Assembly	10.0	10.75	10.75	3.75
	AM-3624/ARA-50 522-3826-003 E51650C1400	Amplifier Relay Assembly BDHI (part of Flight Instrument)	5.4	5.125	5.25	6.5
	MT-1955/ARA-50 522-3828-002 12E177	Mounting Relay Box	1.1	3.25	7.25	7.0
	MS25325D1	Pointer No. 2 Transfer Relay (part of Relay Box)				
<u>AN/ARN-52(V) Tactical Air Navigation System</u>						
	C-3928(P)/ARN- 52(V);01x215125 or54400703	Control Radio Set	2	3	5.75	4
	RT-893/ARN-52(V) 01xz1005	Receiver-Transmitter	43.25	7.35	10	16.9
	MT-1729/ARN-52(V) 2066901G1	Mounting	5.75	7.92	11.02	21.44
	SA-521/A 12E212	RF Transmission Line Switch Antenna Select Panel	0.34	1.94	2.78	3.19
	11D20100-1 12E177	Antenna (2 ea) Relay Box	2.0	9.7	3.5	7.5

F-111A BIBLIOGRAPHY

T.O. Number	Chq/Rev	Title
1F-111A-01	21 Apr 72	Technical Manual, List of Applicable Publications, USAF Series F-111A Weapon System (AF Serial No. 65-5701 thru 67-114)(GD)
1F-111A-1	21 Nov 75	Flight Manual, F-111A
1F-111A-2-5-1	12 Sep 75	Organizational Maintenance, Fire Power Control Systems, USAF Series F-111A Aircraft (AF Series No. 65-5701 thru 67-114) (GD)
1F-111A-2-12-1	17 Oct 75	Organizational Maintenance, Instrument Systems, USAF Series F-111A Aircraft (AF Series No. 65-5701 thru 67-114) (GD)
1F-111A-2-14	15 Apr 77	Organizational Maintenance, Wiring Diagrams, USAF Series F-111A Aircraft (AF Series No. 65-5701 thru 67-114) (GD)
1F-111A-2-16-1	18 Oct 74	Organizational Maintenance, Air Data Computer Systems, USAF Series F-111A Aircraft (AF Serial No. 65-5701 thru 67-114) (GD)
1F-111A-2-17-1	24 Oct 75	Organizational Maintenance, Communications and Instrument Landing Systems, USAF Series F-111A Aircraft (AF Serial No. 65-5701 thru 67-114) (GD)
1F-111A-2-18-1	5 Jan 77	Organizational Maintenance, UHF Automatic Direction Finder, Communications, Intercommunications, TACAN, and IFF Systems, USAF Series F-111A Aircraft (AF Serial No. 65-5701 thru 67-114) (GD)
1F-111A-2-19	7 Nov 75	Organizational Maintenance, Attack Radar and Terrain Following Radar Systems, USAF Series F-111A Aircraft (AF Serial No. 65-5701 thru 67-114) (GD)

F-111A BIBLIOGRAPHY

T.O. Number	Chg/Rev	Title										
1F-111A-2-22	13 Jun 75	Organizational Maintenance, Systems Integration Information, USAF Series F-111A Aircraft (AF Serial No. 65-5701 thru 67-114)(GD)										
5A11-2-56-2	16 Jul 74	Intermediate Maintenance, Displacement Gyroscope <table border="0"> <tr> <td><u>Part No.</u></td> <td><u>Part No.</u></td> </tr> <tr> <td>8KD9AF2</td> <td>8KDAF4</td> </tr> <tr> <td>8KD9AF3</td> <td>8KDAF5</td> </tr> </table>	<u>Part No.</u>	<u>Part No.</u>	8KD9AF2	8KDAF4	8KD9AF3	8KDAF5				
<u>Part No.</u>	<u>Part No.</u>											
8KD9AF2	8KDAF4											
8KD9AF3	8KDAF5											
5F4-16-3	7 Apr 72	Overhaul, Electronic Control Amplifier ASK-13/A24G-17										
5F4-17-3	7 Apr 72	Overhaul, Electronic Control Amplifier ASK-14/A24G-18										
5F4-21-3	1 Dec 71	Overhaul, Electronic Control Amplifier <table border="0"> <tr> <td><u>Model No.</u></td> <td><u>USAF Type</u></td> </tr> <tr> <td>8KE63AF2</td> <td>ASK-25/A24G-26</td> </tr> <tr> <td>8KE63AF3</td> <td>ASK-25/A24G-26</td> </tr> <tr> <td>8KE63AF4</td> <td>ASK-25A/A24G-26</td> </tr> <tr> <td>8KE63AF5</td> <td>ASK-25A/A24G-26</td> </tr> </table>	<u>Model No.</u>	<u>USAF Type</u>	8KE63AF2	ASK-25/A24G-26	8KE63AF3	ASK-25/A24G-26	8KE63AF4	ASK-25A/A24G-26	8KE63AF5	ASK-25A/A24G-26
<u>Model No.</u>	<u>USAF Type</u>											
8KE63AF2	ASK-25/A24G-26											
8KE63AF3	ASK-25/A24G-26											
8KE63AF4	ASK-25A/A24G-26											
8KE63AF5	ASK-25A/A24G-26											
5F8-2-44-3	31 May 73	Overhaul, Indication, Airspeed-Mach-Safe Speed, AVK-18/A24G-18										
5F8-2-47-3	16 Jan 75	Overhaul with IPB, True Airspeed Indicator										
5F8-3-20-22	19 Jan 73	Intermediate Maintenance, Attitude Indicator, Type MS27150-3										
5F8-8-11-3	29 Mar 74	Overhaul, Maximum Safe Mach Assembly										
5F8-9-19-3	4 Sep 73	Overhaul, Indicator, Altitude-Vertical Speed AAK-17/A24G-17										
5F10-4-15-2	19 Jun 73	Intermediate Maintenance, Angle of Attack Transmitter										
5FA1-4-3	15 Aug 75	Overhaul, Instrument Set Coupler, Part No. 1E3232G4 and 1E3232G6										
5F10-5-22	12 Jun 70	Accelerometer Transmitter TRU-3/A										

F-111A BIBLIOGRAPHY

T.O. Number	Chg/Rev	Title
5N4-4-3-3	1 Jan 72	Overhaul with Parts Breakdown, Magnetic Compass Electronic Compensator
5N5-13-6-32	1 Aug 75	Intermediate Maintenance, Navigational Computer Unit, Type CP-812A/AJQ-20
5N5-15-4-2	29 Aug 75	Intermediate Maintenance, Ballistics Computer, Type CP-937/AJQ-20A
5N12-2-7-3	2 Mar 73	Overhaul, Induction Compass Transmitter, Type TRU-79/A Part No. 2587833
5N14-2-9-2	9 Oct 70	Intermediate Maintenance, Bomb Data Control, Type C-7687/AJQ-20A
5N24-4-13	15 Mar 74	Overhaul, Stabilized Platform Unit Type MX-6767A/AJQ-20A
8D3-12-19-2	22 Jun 73	Intermediate Maintenance, Shutter Type Indicator Light
12P2-2APQ110-12	15 Mar 74	Intermediate Maintenance, Terrain Following Radar Set AN/APQ-110
12R1-2ARA50-2	1 Jun 73	Field Maintenance, Direction Finder Group
12R5-2ARN52-12	24 Sep 73	Organizational, Intermediate & Depot, TACAN Navigational Set AN/ARN-52(V)
13R5-2ARN58-52	26 Jul 74	Intermediate Maintenance, Receiver Radio R-844A/ARN-58
16W7-16-2	14 Dec 73	Intermediate Maintenance, Ground Check Panel (General Dynamics)
MS25321	17 Nov 75	Military Standard, Relay 5 Amp, 2PDT, Type 1, Hermetically Sealed, Socket Mounted
MS25327	19 Feb 70	Military Standard, Relay, 10 Amp, 4PDT, Type 1, Hermetically Sealed, Socket Mounted
GD/FW D750-874G	26 Apr 73	Weapon System End Item List and Allocation Chart by MDS

3.22.0
F-111D

F-111D PNWD EQUIPMENT LIST

KEY	EQUIPMENT/UNIT
A	UHF ADF SYSTEM AN/ARA-50
AFCS	AUTOMATIC FLIGHT CONTR SYSTEM
AIFS	IFF-SIF SYSTEM AN/APN-64(V)
AMDD	AIRSPEED MACH IND SYSTEM A24G-18
AVDP	ALTITUDE VERTICAL SPD IND SYSTEM A24G-17
C	AIR DATA COMPUTER SYST (CADC)
COMM	INTERCOMMUNICATIONS SYSTEM AN/AIC-25
CSA	MODE SELECT COUPLER 1E42/061
CSB	AVIONICS EQUIPMENT PACKAGE NO.3 (527A1)
CSC	AVIONICS EQUIPMENT PACKAGE NO.1 (525A1)
D	DOPPLER RADAR SYSTEM AN/APN-189
G	RADAR ALTIMETER AN/APN-167
HSDP	HORIZONTAL SITUATION INDICATOR AGO-4/A
JBA	SPLICE A
JBB	SPLICE B
JBC	TERMINAL BOARD C
JBD	TERMINAL BOARD D
JBE	TERMINAL BOARD E
JBF	TERMINAL BOARD F
JBG	TERMINAL BOARD G
JBH	TERMINAL BOARD H
JBJ	SPLICE J
JBK	TERMINAL BOARD K

F-111D PNRD EQUIPMENT LIST

KEY	EQUIPMENT/UNIT
JBL	TERMINAL BOARD L
JBM	TERMINAL BOARD M
JBN	TERMINAL BOARD N
JBP	TERMINAL BOARD P
JBQ	TERMINAL BOARD Q
JBR	TERMINAL BOARD R
JBS	TERMINAL BOARD S
JBT	TERMINAL BOARD T
LAMP	LOW ALTITUDE MONITOR MX-9523/AP
M	TERRAIN FOLLOWING RADAR SYST AN/APQ-128
P	BOMB NAV SYSTEM MK2
Q	ATTACK RADAR SYSTEM AN/APQ-130
RADP	ALTITUDE INDICATOR H5186000100
RDA	RACK DISCONNECT A
RDB	RACK DISCONNECT B
RDC	RACK DISCONNECT C
RDD	RACK DISCONNECT D
RDE	RACK DISCONNECT E
RDF	RACK DISCONNECT F
RDG	RACK DISCONNECT G
RDH	RACK DISCONNECT H
SCSA	STORES CONTROL SYSTEM
SWA	MISCELLANEOUS SWITCH PANEL (415A1)

F-111D PNWD EQUIPMENT LIST

KEY	EQUIPMENT/UNIT
T	TACAN SYSTEM AN/ARN-52 (V)
U	INSTRUMENT LANDING SYSTEM AN/ARN-58 A
W	AUXILIARY FLIGHT REFER SYSTEM

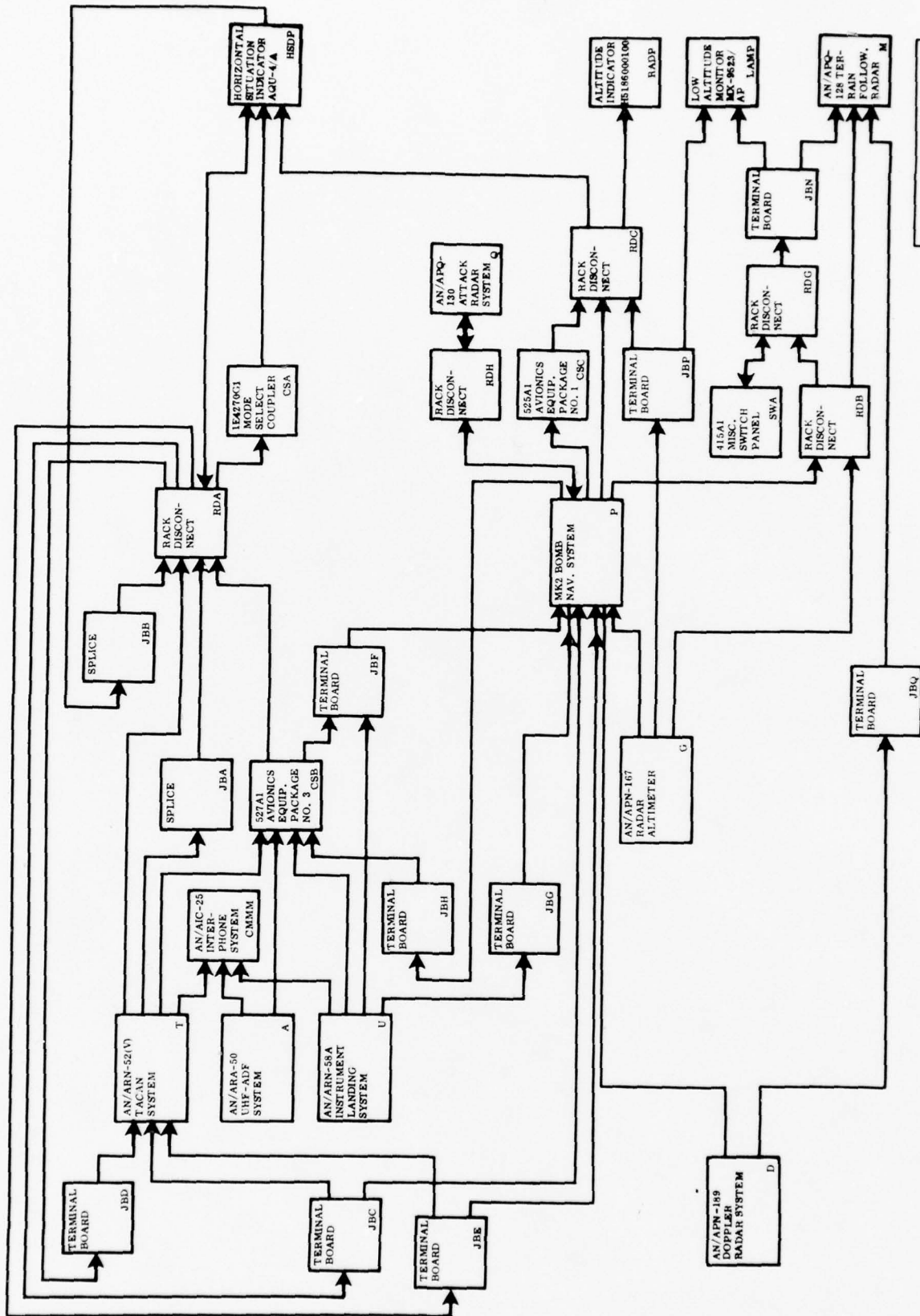

TITLE: PNVW SYSTEM		
AIRCRAFT	DATE	DIAGRAM
F-111D	6-30-76	1 of 2

3-22A-4

CHANGE 3

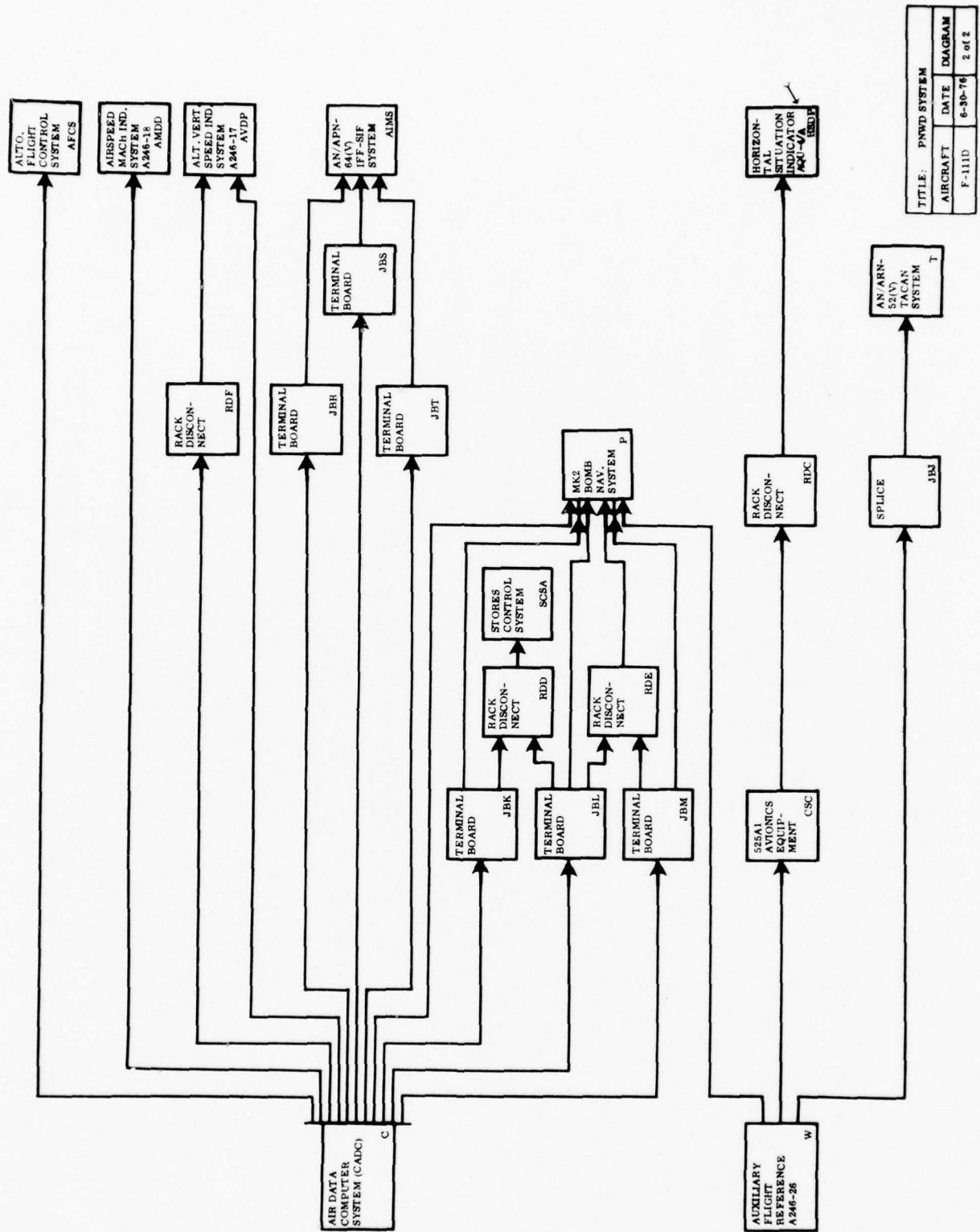

TITLE: PNYD SYSTEM		
AIRCRAFT	DATE	DIAGRAM
F-111D	6-30-76	2 of 2

3-22A-5

CHANGE 3

F-111D PNWD EQUIPMENT PHYSICAL CHARACTERISTICS

SYSTEM	UNIT		WT (LB)	SIZE (IN)		
	TYPE (P/N)	NOMENCLATURE		H	W	D
<u>Central Air Data Computer System</u>						
	1903634-3	Central Air Data Computer	47.5	8	14	19.25
	12C1006-817	Maximum Safe MACH Assy.	6.0	4.2	5.0	12.0
	SLZ9370-4	Angle-of-Attack Transmitter	2.5	4.500	4.500	6.575
	65-0384-1, -2	Angle-of-Attack Indexers (2 ea)				
	B1508-6	Total Temperature Indicator	1.25	2.255	2.255	6.475
	65-0478-1	Reduce Speed Warning Lamp	0.24	0.50	3.68	3.20
	80-0170-5	Main Caution Light Panel	4.8	6.110	6.559	3.938
<u>Flight Instruments</u>						
	AVK-18/A24G-18	Airspeed-MACH Indicator	10.5	7.75	3.50	3.00
	AAK-17/A24G-17	Altitude-Vertical Velocity Indicator	10.5	7.75	3.50	8.00
	AQU-4/A	Horizontal Situation Indicator (Part of Mode Select System)	8.2	4.31	5.06	9.50
	ASK-13/A24G-17	Altitude-Vertical Speed Amplifier with shockmount	5.3 6.5	4.44	4.56	9.0
	ASK-14/A24G-18	Airspeed-MACH Amplifier with shockmount	6.5 7.8	4.44	4.56	10.25
	TRU-3/A	Accelerometer Transmitter	1.2	3.	3.	3.
	TRU-2A/A	Rate Gyroscope Transmitter	1.5	2.828	2.890	5.258
<u>Mode Select System</u>						
	1E4270G1	Mode Select Coupler	5.4	5.25	5.00	8.40*
	AQU-4/A	Horizontal Situation Indicator	8.2	4.31	5.06	9.50
	2561-26000	Vertical Situation Display				
*Including connections						

F-111D PNWD EQUIPMENT PHYSICAL CHARACTERISTICS

SYSTEM	UNIT		WT (LB)	SIZE (IN)		
	TYPE (P/N)	NOMENCLATURE		H	W	D
<u>Mode Select System (Cont'd)</u>						
	80-0170-5	Caution Panel	4.8	6.110	6.559	3.938
<u>Auxiliary Flight Reference System</u>						
	SBK-11A/A24G-26	Displacement Gyroscope	10.5	6.50	6.50	7.50
	ASK-25A/A24G-26	Electronic Control Amplifier	9.5	5.0	6.5	10.0
	DCK128/A24G	Compass System Controller				
	TRU-79/A	Remote Compass Transmitter (2 ea)	1.8	4.906	3.5	2.067
	MXU-394/A	Remote Compensator (2 ea)	0.32	2.5	3.5	2.625
	ARU-11/A	Attitude Indicator	2.75	2.390	2.390	8.062
<u>AN/ARN-58A Instrument Landing System</u>						
	C-7422/ARN-93	Receiver Control Panel				
	R-843A/ARN-58	Localizer Receiver	7.2	6.875	7.02	5.02
	R-844A/ARN-58	Radio Receiver	9.5	9.75	6.875	5.02
	12B11521	Localizer Antenna (2 ea)	1.5	2.68	5.14	12.14
	12Z518	Glideslope Antenna				
	16D00500	Marker Beacon Antenna	1.5	2.68	5.14	12.14
<u>AN/ARA-50 UHF Automatic Direction Finder</u>						
	AS-909/ARA-48	Antenna Assembly	10.0	10.75	10.75	3.75
	AM-3624/ARA-50	Relay Assembly Amplifier	5.4	5.125	5.25	6.50
	MT-1955/ARA-50	Mount	1.1	3.25	7.25	7.0
<u>AN/ARN-52(V) Tactical Air Navigation System</u>						
	C-7712/ARN-52(V)	Radio Set Control	2.0	3.0	5.75	4.0
	RT-893/ARN-52(V)	Receiver-Transmitter	43.25	7.35	10.0	16.9
	MT-1729/ARN-52(V)	Mounting	5.75	7.92	11.02	21.44

F-111D PNWD EQUIPMENT PHYSICAL CHARACTERISTICS

SYSTEM	UNIT		WT (LB)	SIZE (IN)		
	TYPE (P/N)	NOMENCLATURE		H	W	D
	<u>AN/ARN-52(V) Tactical Air Navigation System (Cont'd)</u>					
	SA-521/A	RF Transmission Line Switch	0.34	1.94	2.78	3.19
	12E42212	Antenna Select Panel				
	11D20100-3	Antenna (2 ea)	2.0	9.7	3.5	7.5
	<u>Integrated Display Set</u>					
	3561-84000	Signal Transfer Unit				
	3562-75000-101	Pilot/System Op Heads-up Display				
	3562-65000-101	Aircraft Commander Heads-up Display				
	3561-28000-102	Vertical Situation Display				
	2561-31000-102	Multi-Sensor Display				
	IP-1030/AYN-4	Horizontal Situation Display	46.0	7.7	7.7	20.0
	<u>AN/APN-167 Electronic Altimeter System</u>					
	HG7092A3	Receiver-Transmitter (2 ea)	11.0	5.0	7.0	12.0
	LG81G3	Antenna (2 ea)	1.0	3.0	5.0	8.0
	WG219A2	Equipment Rack	4.0	6.0	15.0	14.0
	H5186000100	Indicator	2.0	3.0	3.0	5.0
	11990-3	RF Switching Unit (2 ea)				
	P613-466	LARA Calibrator Unit				
	MX-9523/AP	Low Altitude Monitor	6.0	3.9	3.3	12.9
	65-0478-1	Radar Altitude Low Light	0.24	0.50	3.68	3.20
	<u>AN/APQ-128 Terrain Following Radar Set</u>					
	AS-2136/APQ-128	Antenna-Receiver (2 ea)	27.9	13.5	12.7	14.3
	AM-4915/APQ-128	Amplifier-Power Supply (2 ea)	20.8	6.0	6.8	17.6

F-111D PNWD EQUIPMENT PHYSICAL CHARACTERISTICS

SYSTEM	UNIT		WT (LB)	SIZE (IN)		
	TYPE (P/N)	NOMENCLATURE		H	W	D
<u>AN/APQ-128 Terrain Following Radar Set (Cont'd)</u>						
	SN-519/APQ-128	Synchronizes-Transmitter (2 ea)	27.6	6.0	7.8	17.6
	CP-917/APQ-128	Computer, Terrain Following (2 ea)	16.4	5.3	7.3	16.1
	MT-3917/APQ-128	Rack Electrical Equip- ment	24.8	19.25	16.3	18.8
	C-7510/APQ-128	Control, Radar Set	2.6	3.0	5.8	6.3
	CG-3132/APQ-110	Waveguide Assembly	--	--	8.4	18.0
	MX-9523/AP	Low Attitude Monitor	6.0	3.9	3.3	12.9
<u>AN/APQ-130 Attack Radar Set</u>						
	AS-2230/APQ-130	Antenna	75.0	26.0	30.0	31.0
	AB-1108/APQ-130	Antenna Pedestal	66.0	16.0	16.0	6.0
	R-1549/APQ-130	Radar Receiver	67.0	23.0	41.0	6.0
	MT-3988/APQ-130	Electrical Equipment Rack	44.0	36.0	18.0	24.0
	PP-6059/APQ-130	Power Supply	33.0	4.0	14.0	16.0
	CV-2489/APQ-130	Signal Data Converter	51.0	7.8	13.6	20.4
	CP-938/APQ-130	Electronic Processor	50.0	5.5	15.0	23.0
	T-1084/APQ-130	Radar Transmitter	147.0	11.0	16.6	22.3
	O-1492/APQ-130	Reference Signal Generator	33.0	5.0	17.0	17.0
<u>AN/APN-189 Doppler Radar Set</u>						
	AS-2221/APN-189	Antenna				
	MX-8088/APN-189	Radar Electronics Unit	24.25	8.59	5.0	15.35
<u>Navigation Computer Complex</u>						
	C704772060	Converter Set				
	AN/AYK-6	Navigation Computer	47.4	7.6	10.0	20.7
	AN/AYK-6	Weapons Delivery Com- puter	47.4	7.6	10.0	20.7

F-111D PNWD EQUIPMENT PHYSICAL CHARACTERISTICS

SYSTEM	UNIT		WT (LB)	SIZE (IN)		
	TYPE (P/N)	NOMENCLATURE		H	W	D
	<u>Navigation Computer Complex (Cont'd)</u>					
	80000-201-51	Rack Assembly - Converter/Computer	20.0	25.2	10.5	22.8
	<u>Inertial Bombing Navigation System</u>					
	MX-8131/AJN-16	Inertial Reference Unit	70.0	12.31	14.75	17.50
	CP-945/AJN-16	Nav. Computer Unit	26.0	8.0	6.5	19.75
	C-7719/AJN-16	Battery Unit	14.0	25.0	10.0	12.0
	C-7890/AYK	Nav. Data Entry Panel	15.32	9.0	7.5	8.65
	ID-1622/AYK	Nav. Data Display Panel	18.6	3.71	14.125	20.067
	C-7887/AYK	Pilot/System Op Designation Control Panel	1.75	4.20	4.20	3.38
	C-7888/AYK	Aircraft Commander Designation Control Panel	2.78	7.31	5.19	3.88
	ID-1621/AYK	Flight Data Display Panel	1.2	1.85	5.0	3.0

F-111D BIBLIOGRAPHY

T.O. Number	Chq/Rev	Title
1F-111D-01	21 Apr 72	List of Applicable Publications - USAF Series F-111D Aircraft
1F-111D-1	22 Apr 77	Flight Manual - F-111D
1F-111D-2-12-1	5 Jan 77	Organizational Maintenance, Instrument Systems, USAF Series F-111D Aircraft
1F-111D-2-14	22 Apr 77	Organizational Maintenance, Wiring Diagrams, USAF Series F-111D Aircraft
1F-111D-2-16-1	19 Jul 74	Organizational Maintenance, Air Data Computer Systems, USAF Series F-111D Aircraft
1F-111D-2-17-1	9 Apr 76	Organizational Maintenance, Communications and Instrument Landing Systems, USAF Series F-111D Aircraft
1F-111D-2-18-1	30 Jul 76	Organizational Maintenance, UHF Automatic Direction Finder, Communication, Instrumentation, TACAN, and IFF Systems, USAF Series F-111D Aircraft
1F-111D-2-19	7 Nov 75	Organizational Maintenance, Attack Radar and Terrain Following Radar Systems, USAF Series F-111D Aircraft
1F-111D-2-22	5 Jan 77	Organizational Maintenance, Systems Integration Information, USAF Series F-111D Aircraft
5A11-2-50-3	15 Nov 66	Overhaul, Displacement Gyroscope, Model No. 8KD9AF2, USAF Type SBK-11/A24G-26
5D14-2-8-2	15 Mar 74	Intermediate Maintenance, Digital Display Indicator, Types ID-1622/AJK and ID-1764/AYK
5E6-3-68-2	5 Jan 73	Intermediate Maintenance, Total Temperature Indicator
5F4-16-3	7 Apr 72	Overhaul, Electronic Control Amplifier, ASK-13/A24G-17
5F10-4-5-43	15 Dec 74	Accelerometer Transmitter TRU-3/A
5F10-5-2-2	12 Jun 70	Rate Gyroscope Transmitter TRU-2A/A

F-111D BIBLIOGRAPHY

T.O. Number	Chg/Rev	Title
5F4-17-3	7 Apr 72	Overhaul, Electronic Control Amplifier, ASK-14/A24G-18
5F4-21-3	1 Dec 71	Overhaul, Electronic Control Amplifier, Model No., 8KE63AF2, Type ASK-25/A24G-26, 8KE63AF3, ASK-25/A24G-26, 8KE63AF4, ASK-25A/A24G-26, 8KE63AF5, ASK-25A/A24G-26
5F5-4-17-3	15 Aug 75	Overhaul, Central Air Data Computer
5F8-2-44-3	31 May 73	Overhaul, Indicator, Airspeed-Mach-Safe Speed, AVK-18/A24G-18
5F8-3-20-3	15 Apr 74	Overhaul, Attitude Indicator, Model No. 4012F, Part No. 139000-01-01, 4012F, 139000-01-02
5F8-8-11-3	29 Mar 74	Overhaul, Maximum Safe Mach Assembly
5F8-9-19-3	4 Sep 73	Overhaul, Indicator, Altitude-Vertical Speed, AAK-17/A24G-17
5FA1-5-2	31 Jul 70	Intermediate Maintenance, Mode Select Coupler, Part No. 1E4270G1
5N1-3-17-13	31 Jan 75	Overhaul, Battery Control Power Supply, Type C-7719/AJN-16, Part No. 67650-401-151
5N1-3-17-23	26 Sep 75	Overhaul, Navigational Computer, Type CP-945/AJN-16, Part No. 55545-107-41 and 55545-107-71
5N4-4-3-3	1 Jan 72	Overhaul with Parts Breakdown, Magnetic Compass Electronic Compensator
5N5-14-15-13	10 Oct 75	Overhaul, General Purpose Digital Computer, Type AN/AYK-6
5N8-10-4-3	20 Sep 74	Overhaul, Horizontal Situation Display Indicator, Type IP-1030/AYN-4
5N12-2-7-3	2 Apr 73	Overhaul, Induction Compass Transmitter, Type TRU-79/A
5N14-2-8-12	9 May 75	Intermediate Maintenance, Computer Control Types C-7890/AYK and C-7890A/AYK, Digital Display Indicator, Type ID-1621/AYK,

F-111D BIBLIOGRAPHY

T.O. Number	Chg/Rev	Title
5N14-2-8-12 (Continued)		Weapon System Maintenance Control Types C-7886/AYK, C-7886A/AYK, and C-7886B/AYK
5N14-2-8-22	22 Mar 74	Intermediate Maintenance, Indi- cator Control, Type C-7889/AYK, Indicator Cursor Control, Type C-7888/AYK, Indicator Cursor Control, Type C-7887/AYK
5N24-7-3	10 Jun 75	Overhaul, Stabilized Platform Type MX-8131/AJN-16, Part No. 68144-301-111 and 68144-301-121
8D3-12-19-2	22 Jun 73	Intermediate Maintenance, Shutter, Type Indicator Light
8D3-18-6-2	30 Mar 73	Intermediate Maintenance, Main Caution Light Panel
11F55-2-17-2	7 Feb 75	Intermediate Maintenance, Electrical Equipment Rack, Types MT-400G/A and MT-4400/A
12P5-2APN189-13	30 Mar 73	Overhaul, Radar Electronic Unit, Type MX-8088/APN-189, Part No. 458-394-001
12P5-4-29-3	27 Dec 74	Overhaul, Radar Altitude Indi- cator, Part Numbers E5186000100, E5186000100, F5186000100, G5186000100, H5186000100, K5186000100, L5186000100, M5186000100, N5186000100, P5186000100
12R1-2ARA50-2	1 Feb 72	Field Maintenance, Direction Finder Group
12R5-2ARN52-12	24 Sep 73	Organization, Intermediate, and Depot, Tacan Navigational Set, AN/ARN-52(V)
12R5-2ARN52-32	24 Sep 73	Intermediate Maintenance, Receiver, Transmitter, Type RT- 893/ARN-52(V)
12R5-2ARN58-52	26 Jul 74	Intermediate Maintenance, Receiver, R-844A/ARN-58
GD/FW D750-874C	26 Apr 73	III Weapon System End Item List and Allocation Chart by MDS

3.23.0
F-111E

F111-E PNRD EQUIPMENT LIST

KEY	EQUIPMENT/UNIT
A	UHF ADF SYSTEM AN/ARA-50
ADDP	ADI DISPLAY ARU-11/A
AFCS	AUTOMATIC FLIGHT CONTROL SYSTEM
AIMS	IFF-SIF SYSTEM AN/APX-64 (V)
AMDD	AIRSPEED MACH IND SYSTEM A24G-18
AVDP	ALTITUDE VERTICAL SPD IND SYSTEM A24G-17
BDHP	BDHI DISPLAY E5165001400
C	AIR DATA COMPUTER SYSTEM (CADC)
CMMM	INTERCOMMUNICATIONS SYSTEM AN/AIC-25
CSA	INSTRUMENT COUPLER 087A1
FDCA	FLIGHT DIRECTOR SYSTEM
G	RADAR ALTIMETER AN/APN-167
HSDP	HSI DISPLAY AQU-4/A
JBA	JUNCTION A
JBB	JUNCTION B
JBC	JUNCTION C
JBD	JUNCTION D
JBE	JUNCTION E
JBF	JUNCTION F
JBG	JUNCTION G
JBH	JUNCTION H
JBJ	FWD ELEC EQUIP PANEL
JBK	JUNCTION K

F111-E PNWD EQUIPMENT LIST

KEY	EQUIPMENT/UNIT
JBL	JUNCTION L
JBM	JUNCTION M
JBN	JUNCTION N
JBP	JUNCTION P
JBQ	JUNCTION Q
JBR	JUNCTION R
JBS	JUNCTION S
JBT	JUNCTION T
JBU	JUNCTION U
JBV	JUNCTION V
JBW	JUNCTION W
M	TERRAIN FOLLOWING RADAR SYSTEM AN/APQ-110
ODSS	OPTICAL DISPLAY SIGHT AN/ASG-23
P	BOMB NAV SYSTEM AN/AJQ-20 A
Q	ATTACK RADAR SYSTEM AN/APQ-113
RADR	RADAR RECEIVING SET AN/APS-109
RDA	RACK DISCONNECT A
RDB	RACK DISCONNECT B
RDC	RACK DISCONNECT C
RDD	RACK DISCONNECT D
RDE	RACK DISCONNECT E
RDF	RACK DISCONNECT F
RDG	RACK DISCONNECT G

F111-E PNWD EQUIPMENT LIST

KEY	EQUIPMENT/UNIT
RDH	RACK DISCONNECT H
RDJ	RACK DISCONNECT J
RDK	RACK DISCONNECT K
SWA	POINTER NO.2 TRANSFER RELAY 187K2
SWB	ZERO DRIFT ANGLE RELAY 219K2
SWC	FDC DUMMY LOAD SW 087S2
SWD	MISC. SWITCH PANEL 415A1
T	TACAN SYSTEM AN/ARN-52 (V)
TASP	TRUE AIRSPEED INDICATOR 352-01-3
U	INSTRUMENT LANDING SYSTEM AN/ARN-58 A
W	AUXILIARY FLIGHT REFERENCE SYSTEM

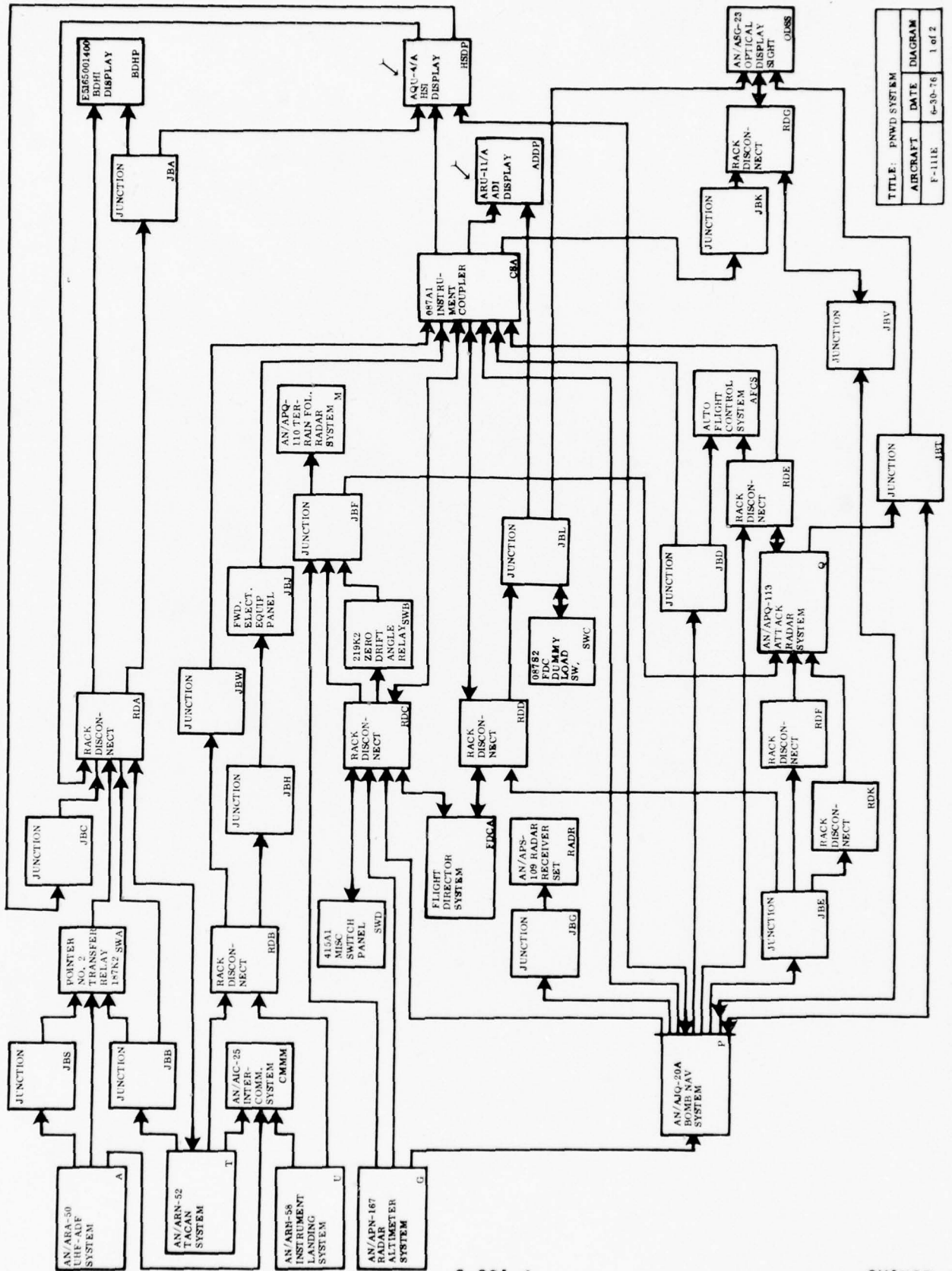

TITLE:	PNVW SYSTEM
AIRCRAFT:	F-111E
DATE:	6-30-76
DIAGRAM:	1 of 2

3-23A-4

CHANGE 3

F-111E PNWD EQUIPMENT PHYSICAL CHARACTERISTICS

SYSTEM	UNIT		WT (LB)	SIZE (IN)		
	TYPE (P/N)	NOMENCLATURE		H	W	D
<u>Air Data Computer System</u>						
	1903633-4	Central Air Data Computer	47.5	8	14	19.25
	12C1006-817	Maximum Safe MACH Assy	6.0	4.2	5.0	12.0
	SLZ9370-3	Angle-of-Attack Transmitter	2.5	4.500	4.500	6.575
	65-0153-3	Angle-of-Attack Indexers (2 ea)				
	B1508-5	Total Temperature Indicator	1.25	2.255	2.255	6.475
	80-0128-1	Total Temperature Caution Lamp	0.12	0.50	2.25	3.20
	65-0281-1	Reduce Speed Warning Lamp	0.12	0.50	2.25	3.20
	80-0128-1	CADS Caution Lamp	0.12	0.50	2.25	3.20
<u>Flight Director System</u>						
	CPU-76/A 103777	Flight Director Computer	9.0	7.65	5.31	10.13
	TE3232G6	Instrument Systems Coupler	6.50	2.50	5.82	9.37
	ARU-11/A	Attitude Director Indi- cator	9.0	5.260	5.010	8.000
	AQU-4/A 101000	Horizontal Situation Indicator 60-6326	8.2	4.31	5.06	9.50
	12E210	Miscellaneous Switch Panel				
	12E2211	Ground Check Panel	1.88	2.10	7.31	6.25

F-111E PNWD EQUIPMENT PHYSICAL CHARACTERISTICS

SYSTEM	UNIT		WT (LB)	SIZE (IN)		
	TYPE (P/N)	NOMENCLATURE		H	W	D
	<u>AN/AJQ-20A Inertial Bombing - Navigation System</u>					
	MX-6767/AJQ-20 671630-3	Stabilized Platform	74	14.3	14.5	16.5
	CP-812/AJQ-20 671980-2	Navigational Computer Unit	81	7.6	16.1	24.0
	CP-Q37/AJQ-20A 671597-5 & 6	Ballistics Computer Unit	35	9.5	12.0	16.5
	2587833	Magnetic Azimuth Detector	1.8	4.906	3.5	2.067
	2587832	Magnetic Azimuth Compensator	.31	2.5	3.5	2.6
	D5201001400	Bombing-Navigation Distance-Time Indicator	1.5	2.25	5.7	6.6
	671562-1	Bomb Data Control	1.5	2.25	5.7	6.6
	12E2271	Target Elevation Panel				
	<u>AN/APN-167 Electronic Altimeter System</u>					
	HG7092A3	Receiver-Transmitter (2 ea)	11.0	5.0	7.0	12.0
	959533	Antenna (2 ea)	1.0	3.0	5.0	12.0
	WG219A2	Equipment Rack	4.0	6.0	15.0	14.0
	K5186000100	Indicator	2.0	5.0	5.0	5.0
	11990-3	RF Switching Unit (2 ea)				
	P613-460	LARA Calibrator Unit				
	65-0281-9	Radar Altitude Low Light	0.12	0.50	2.25	3.20
	<u>AN/ASG-23 Lead Computing Optical Sight System</u>					
	SU-29/ASG-23 105D9280G1	Optical Display Sight	20	8.9	6.8	23
	AM-4301/ASG-23 853D950G1	Lead and Launch Computing Amplifier	19.0	4.9	8.0	15.2
		Amplifier Mounting	1.0	1.0	8.35	15.7
	CN-1060/ASG-23 688D205G2	Lead Computing Gyroscope	11.33	8.9	8.9	9.13

F-111E PNWD EQUIPMENT PHYSICAL CHARACTERISTICS

SYSTEM	UNIT		WT (LB)	SIZE (IN)		
	TYPE (P/N)	NOMENCLATURE		H	W	D
	<u>AN/APQ-110 Terrain Following Radar Set</u>					
	CP-799/APQ-110 500114-15, 16 & 17	Terrain Following Com- puter (2 ea)	14.6	5.35	6.33	16.06
	AS-1717/APQ-116 562266-2	Antenna - Receiver (2 ea)	24.2	12.7	12.5	17.32
	IP-773/APQ-110 500116-12	Terrain Following Indi- cator	28	6.24	7.05	21.76
	C-6456/APQ-110 500117-13 & 14	Radar Set Control	2.6	3.00	5.75	7.31
	AM-4240/APQ-110 500112-14 & 15	Amplifier-Power Supply (2 ea)	18.8	6.00	6.75	17.61
	SN-379/APQ-110 500113-11	Synchronizer-Transmitter	22.1	6.00	7.82	17.61
	MT-3359/APQ-110 500162	Electrical Equipment Rack	22.6	19.25	14.25	18.8
	CG-3132/APQ-110	Waveguide Assembly	2.0	-	-	-
	MX-9523/AP 12Z6700	Low Altitude Monitor	6	3.875	3.25	12.875
	<u>AN/APQ-113 Attack Radar Set</u>					
	AS-1749/APQ-113 7335183G1	Antenna Assembly	55.0	26.0	35.0	32.0
	AB-902/APQ-113 7335175G1	Antenna Pedestal	37.0	19.0	21.0	8.0
	C-6498/APQ-113 7332198G3	Antenna Control Unit	38.0	10.0	27.0	8.0
	MD-608/APQ-113 7635519G6	Modulator-Receiver-Trans- mitter	101.0	21.0	13.0	21.0
	SN-380/APQ-113 7332050G5	Electrical Synchronizer	78.0	13.25	13.0	20.75
	IP-777/APQ-113 7638259G3	Indicator-Recorder	63.0	9.25	16.25	30.5
	C-6499/APQ-113 7635611G1	Radar Set Control	3.0	3.75	5.75	6.5
	C-6500/APQ-113 7637148G1	Antenna-Indicator Control	2.0	8.75	5.0	3.5
	MT-3384/APQ-113	Electrical Equipment Rack	6.0	34.25	13.25	21.72
	CG-3108/APQ-113	Waveguide Assembly	-	-	-	-

F-111E PNWD EQUIPMENT PHYSICAL CHARACTERISTICS

SYSTEM	UNIT		WT (LB)	SIZE (IN)		
	TYPE (P/N)	NOMENCLATURE		H	W	D
<u>Flight Instruments</u>						
	AVK-18/A25G-18 18008-8A11-A1	Airspeed-Mach Indicator	10.5	7.75	3.50	8.00
	AAK-17/A24G-17 18007-7A10A1	Altitude-Vertical Velocity Indicator	10.5	7.75	3.50	8.00
	E5165001400	Bearing-Distance-Heading Indicator				
	352-01-3	True Airspeed Indicator	7.65	1.56	1.56	5.75
	AQU-4/A 10100	Horizontal Situation Indicator (part of FDS)	8.2	4.31	5.06	9.50
	ARU-11/A 139001-01-02	Attitude Director Indicator (part of FDS)	9.0	5.260	5.010	8.000
	ASK-14/A24G-18	Airspeed-Mach Amplifier with Shock Mount	6.5 7.8	4.44	4.56	10.5 10.5
	ASK-13/A24G-17	Airspeed-Vertical Speed Amplifier with Shock Mount	5.3 6.5	4.44	4.56	9 9
	7200	Accelerometer Transmitter				
	42460	Turn Sensor				
<u>Auxiliary Flight Reference System 12D085-9, M5-1</u>						
	SBK-11A/A24G-26 8KD9AF2	Displacement Gyroscope	10.3	6.03	6.03	8.32
	ASK-25A/A24G-26 8KE63AF2	Electronic Control Amplifier	9.5	5.0	6.5	10.0
	DCK-129/A24G 8KE65AG2	Compass System Controller				
	2587833	Remote Compass Transmitter	1.8	4.906	3.5	2.067
	2587832	Remote Compass Transmitter Compensator	7.32	2.5	3.5	2.625

F-111E PNWD EQUIPMENT PHYSICAL CHARACTERISTICS

SYSTEM	UNIT		WT (LB)	SIZE (IN)		
	TYPE (P/N)	NOMENCLATURE		H	W	D
<u>AN/ARN-58 Instrument Landing System</u>						
	C-6376/ARN-58A 179-4102	Radio Set Control	1.0	2.25	5.75	4.313
	R-843A/ARN-58 101753	Localizer Receiver	7.2	6.875	7.02	5.02
	R-844A/ARN-58 101542	Glideslope and Marker Beacon Receiver	9.5	6.875	9.02	5.02
	12B11521	Localizer Antenna (2 ea)	1.5	2.68	5.14	12.14
	16D00500	Marker Beacon Antenna	1.5	2.68	5.14	12.14
	12Z518	Glideslope Antenna				
<u>AN/ARA-50 UHF Automatic Direction Finder</u>						
	AS-909/ARA-48 522-1267-005	Antenna Assembly	10.0	10.75	10.75	3.75
	AM-3624/ARA-50 522-3826-003	Amplifier Relay Assembly	5.4	5.125	5.25	6.50
	E5165001400	Mount BDHI (part of Flight Instruments)	1.1	3.25	7.25	7.0
<u>AN/ARN-52(V) Tactical Air Navigation System</u>						
	C-3928(P)/ARN-52(V) 01X215125	Radio Set Control	2	3	5.75	4
	RT-893/ARN-52(V) 01X215001	Receiver-Transmitter	43.25	7.35	10	16.9
	MT-1729/ARN-52(V) 01X215003	Mounting	5.75	7.92	11.02	21.44
	SA-521/A CS319	RF Transmission Line Switch	0.34	1.94	2.78	3.19
	12E212	Antenna Select Panel				
	11D20100-3	Antenna (2 ea)	2.0	9.7	3.5	7.5

F-111E BIBLIOGRAPHY

T.O. Number	Chg/Rev	Title
1F-111E-01	21 Apr 72	List of Applicable Publications, USAF Series F-111E Aircraft
1F-111E-1	15 Mar 74	Flight Manual, F-111E
1F-111E-2-4-1	24 Sep 76	Organizational Maintenance, Flight Control Systems, USAF Series F-111E Aircraft
1F-111E-2-5-1	24 Oct 75	Organizational Maintenance, Fire Power Control Systems, USAF Series F-111E Aircraft
1F-111E-2-12-1	7 Nov 75	Organizational Maintenance, Instrument Systems, USAF Series F-111E Aircraft
1F-111E-2-14	15 Apr 77	Organizational Maintenance, Wiring Diagrams, USAF Series F-111E Aircraft
1F-111E-2-16-1	19 Jul 74	Organizational Maintenance, Air Data Computer Systems, USAF Series F-111E Aircraft
1F-111E-2-17-1	9 Apr 76	Organizational Maintenance, Communications and Instrument Landing Systems, USAF Series F-111E Aircraft
1F-111E-2-18-1	7 Nov 75	Organizational Maintenance, UHF Automatic Direction Finder Communications, Intercommunications, TACAN, and IFF Systems, USAF Series F-111E Aircraft
1F-111E-2-19	7 Nov 75	Organizational Maintenance, Attack Radar and Terrain Following Radar Systems, USAF Series F-111E Aircraft
1F-111E-2-22	20 Jun 75	Organizational Maintenance, Systems Integration Information, USAF Series F-111E Aircraft

F-111E BIBLIOGRAPHY

T.O. Number	Chq/Rev	Title
5A11-2-56-3	15 Nov 66	Overhaul, Displacement Gyro, P/N 8KD9AF2, 8KD9AF3, 8KD9AF4, 8KD9AF5 (General Electric) P/N 149500-01-01
5E6-3-68-2	5 Jan 73	Intermediate Maintenance, Total Temperature Indicator
5F4-16-3	7 Apr 72	Overhaul, Electronic Control Amplifier ASK-13/A24G-17
5F4-17-3	7 Apr 72	Overhaul, Electronic Control Amplifier ASK-14/A24G-18
5F5-8-4-13	1 Mar 73	Overhaul, Flight Director Computer Type, CPU-76/A
5F5-4-17-2	13 Apr 73	Intermediate Maintenance, Central Air Data Computer
5F8-2-44-3	31 May 73	Overhaul, Indicator, Airspeed- Mach-Safe Speed, AUK-18/A246-18
5F8-2-47-3	16 Jan 75	Overhaul with IPB, True Airspeed Indicator
5F8-3-23-3	26 Apr 74	Overhaul, Attitude - Director Indicator, ID-1144/AJB-7, ARU-11/A, Model 4060P, P/N 139001-01-01, 01-02, 01-03, 01-04
5F8-8-11-3	29 Mar 74	Overhaul, Maximum Safe Mach Assembly
5F8-9-19-3	4 Sep 73	Overhaul, Indicator, Altitude, Vertical Speed AAK-17/A24G-17
5F8-16-4-3	15 Oct 73	Overhaul, Horizontal Situation Indicator, Type AQU-4/A, P/N 101000, 104500

F-111E BIBLIOGRAPHY

T.O. Number	Chg/Rev	Title
5F10-4-15-2	19 Jan 73	Intermediate Maintenance, Angle of Attack Transmitter
5FA1-4-3	15 Aug 75	Overhaul, Instrument System Coupler, P/N 1E323264 and 1E323266
5N4-4-3-3	1 Jan 72	Overhaul with Parts Breakdowns, Magnetic Compass Electronic Compensator
5N5-13-6-32	1 Aug 75	Intermediate Maintenance, Navigational Computer Unit, Type CP-812A/AJQ-20
5N5-15-4-2	29 Aug 75	Intermediate Maintenance, Ballistics Computer, Type CP-937/AJQ-20A
5N12-2-7-3	2 Apr 73	Overhaul, Indication Compass Transmitter, Type TRU-79/A
5N14-2-9-2	9 Oct 70	Intermediate Maintenance, Bomb Data Control, Type C-7687/AJQ-20A
5N14-2-10-2	2 Oct 70	Intermediate Maintenance, Target Elevation Panel
5N24-4-13	15 Mar 74	Overhaul, Stabilized Platform Unit, Type MX-6767A/AJQ-20A
5N34-3-2	14 Aug 73	Intermediate Maintenance, Low Altitude Monitor, MX-9523/AP
8D3-12-19-2	29 Mar 74	Intermediate Maintenance, Shutter Type Indicator Light
8R3-141-2	25 Jul 75	Intermediate Maintenance, Relay Housing Assembly
11F1-ASG23-12	10 Sep 71	Intermediate Maintenance, Lead Computing Optical Sight Set, Type AN/ASG-23
GD/FW 0750-874C	26 Apr 73	III Weapon System End Item List and Allocation Chart by MDS

F-111E BIBLIOGRAPHY

T.O. Number	Chg/Rev	Title
11F4-8-8-4	18 Apr 74	Overhaul, Lead and Launch Computing Amplifier
11F20-20-3	26 Apr 74	Overhaul, Lead Computing Gyroscope, Type CN-1060/ASG-23
11F39-2-18-3	15 Aug 75	Overhaul, Optical Display Sight
12P2-2APQ110-12	15 Mar 74	Terrain, Following Radar Set AN/APQ-116
12P2-2APQ128-32	1 Feb 74	Antenna, Receiver, Type AS-2136/APQ-128
12P5-2APN167-12	3 May 74	Intermediate Maintenance, Electronic Altimeter Set AN/APN-168 and Radar Altitude Indicator
12R1-2ARA50-2	1 Feb 72	Field Maintenance, Direction Finder Group AN/ARA-50
12R5-2ARN58-2	15 May 72	Field Maintenance, Radio Receiving Set AN/ARN-58
12R5-2ARN58-52	26 Jul 74	Intermediate Maintenance, Receiver Radio R-844A/ARN-58
12R5-2ARN52-12	24 Sep 73	Organizational, Intermediate and Depot, Tacan Navigational Set AN/ARN-52(V)
12R5-2ARN52-32	14 Jun 73	Intermediate Maintenance, Receiver, Transmitter RT-893/ARN-52(V), RT-384/ARN-52(V)
16W7-16-2	14 Dec 73	Intermediate Maintenance, Ground Check Panel

3.24.0
F-111F

F-111F PNWD EQUIPMENT LIST

THIS PAGE IS BEST QUALITY PRACTICABLE
FROM COPY FURNISHED TO DDC

KEY	EQUIPMENT/UNIT
A	WEE ADF SYSTEM AN/ARA-50
ADDP	ADI DISPLAY ARU-11/A
AFCS	AUTOMATIC FLIGHT CONTROL SYSTEM
AIMS	IFF(AIMS) SYSTEM AN/APX-64 (V)
AMDD	AIR SPEED MACH IND SYSTEM A24G-18
AVDP	ALTITUDE VERTICAL SPD IND SYSTEM A24G-17
BDHP	BDHI DISPLAY F5165001400
C	AIR DATA COMPUTER SYSTEM (CADC)
CMM	INTERCOMMUNICATIONS SYSTEM AN/AIC-25
CSA	INSTRUMENT SET COUPLER D87A1
FDCA	FLIGHT DIRECTOR SYSTEM
G	ELECTRONIC ALTIMETER AN/APN-157
HSDP	HSI DISPLAY 101000
JBA	TERMINAL BOARD A
JBB	TERMINAL BOARD B
JBC	TERMINAL BOARD C
JBD	TERMINAL BOARD D
JBE	TERMINAL BOARD E
JBF	SPLICE F
JBG	TERMINAL BOARD G
JBH	SPLICE H
JBJ	SPLICE J
JBK	SPLICE K

F-111F PNWD EQUIPMENT LIST

KEY	EQUIPMENT/UNIT
JBL	SPLICE L
JBM	TERMINAL BOARD M
JBN	TERMINAL BOARD N
JBP	TERMINAL BOARD P
JBQ	TERMINAL BOARD Q
JBR	TERMINAL BOARD R
JBS	TERMINAL BOARD S
JBT	TERMINAL BOARD T
JBU	SPLICE U
JBV	TERMINAL BOARD V
JBW	TERMINAL BOARD W
JBX	SPLICE X
JBY	SPLICE Y
JBZ	INPH JUNCTION BOX
JCA	SPLICE A
M	TERRAIN FOLLOWING RADAR SYSTEM AN/APQ-146
ODSS	OPTICAL DISPLAY SIGHT AN/ASG-27
P	BOMB NAV SYSTEM AN/AJN-16
Q	ATTACK RADAR AN/APQ-144
RDA	RACK DISCONNECT A
RDB	RACK DISCONNECT B
RDC	RACK DISCONNECT C
RDD	RACK DISCONNECT D

F-111F PNWD EQUIPMENT LIST

KEY	EQUIPMENT/UNIT
RDE	RACK DISCONNECT E
RDF	RACK DISCONNECT F
RDG	RACK DISCONNECT G
RDH	RACK DISCONNECT H
RDJ	RACK DISCONNECT J
RDK	RACK DISCONNECT K
RDL	RACK DISCONNECT L
RDM	RACK DISCONNECT M
RDN	RACK DISCONNECT N
SWA	ADF-TACAN SELECT RELAY 527A1
SWB	FDC DUMMY LOAD SWITCH 087S2
SWC	MISC SWITCH PANEL 415A1
T	TACAN SYSTEM AN/ARN-52 (V)
U	INSTRUMENT LANDING SYSTEM AN/ARN-58A
W	AUXILIARY FLIGHT REFER SYSTEM

F-111F PNWD EQUIPMENT PHYSICAL CHARACTERISTICS

SYSTEM	UNIT		WT (LB)	SIZE (IN)		
	TYPE (P/N)	NOMENCLATURE		H	W	D
<u>AN/AJN-16 Inertial Navigation Set</u>						
	MX-8131/AJN-16 68144-301-121	Stabilized Platform	70	12.31	14.75	17.50
	CP-945/AJN-16 55545-107-71	Navigational Computer Unit	26	8.0	6.5	19.75
	C-7719/AJN-16 67650-401-151	Battery Control-Power Supply	14	25	10	12
<u>Computer Complex</u>						
	AN/AYK-6	General Pupose Digital Computer (2 ea)	47.4	7.6	10.0	20.7
	CV-2797/A	Converter Multiplexer	40	7.62	10.00	20.12
<u>Control and Display Set</u>						
	ID-1748/AYK C709020509	Digital Display Indicator	26.81	7.775	8.500	19.567
	C-8586/AYK C709026810 RA500-21	Computer Control Bombing-Navigation Distance-Time Display	11.01	8.250	7.500	9.840
	2587832	Remote Compensator	0.32	2.5	3.5	2.625
	2587833	Magnetic Azimuth Detector	1.8	4.906	3.5	2.067
<u>AN/APN-167 Electronic Altimeter System</u>						
	HG7092A3	Receiver-Transmitter (2 ea)	11.0	5.0	7.0	12.0
	LG81G3	Antenna (2 ea)	1.0	3.0	5.0	8.0
	WG219A2	Equipment Rack	4.0	6.0	15.0	14.0
	H5186000100	Indicator	2.0	3	3	5
	11990-3	RF Switching Unit (2 ea)				
	P613-466	LARA Calibrator Unit				
	65-0281-9	Radar Altitude Low Light				

F-111F PNWD Equipment Physical Characteristics

SYSTEM	UNIT		WT (LB)	SIZE (IN)		
	TYPE (P/N)	NOMENCLATURE		H	W	D
<u>AN/ASG-27 Optical Display Sight Set</u>						
	SU-62 ASG-27 106D 1799G1	Optical Display Sight	17.5	8.9	6.8	23
	AM-4869/ASG-25 853D940G1	Control Amplifier Power Supply	14.9	4.9	8.02	15.2
<u>Flight Director System</u>						
	CPU-76/A 103777 1E4970G1	Flight Director Computer	9.0	7.566	5.313	10.125
		Instrument Set Coupler	6.2	2.50	5.82	9.22
<u>Flight Instruments</u>						
	AVK-21/A24G-18A 18008-8A11-A2	Airspeed-Mach, Indicator	10.5	7.75	3.50	8.00
	AAK-23/A24G-17A 18007-7A10-A2	Altitude-Vertical Speed Indicator	10.5	7.75	3.50	8.00
	AQU-4/A 101500	Horizontal Situation Indicator	8.2	4.31	5.06	9.50
	ARU-11/A 9819-18 F5165001400	Attitude Director Indicator	9	5.250	5.000	9.719
	ASK-14/A24G-18 18754-1B	Airspeed-Mach Amplifier With Mount	6.5 7.8	4.44	4.56	10.25
	ASK-13/A24G-17 18753-1A	Altitude-Vertical Speed Amplifier with Shock Mount	5.3 6.5	4.44	4.56	9.0
	42460	Vertical Acceleration Transmitter Turn Sensor				

F-111F PNWD EQUIPMENT PHYSICAL CHARACTERISTICS

SYSTEM	UNIT		WT (LB)	SIZE (IN)		
	TYPE (P/N)	NOMENCLATURE		H	W	D
<u>Auxiliary Flight Reference System</u>						
	SBK-11A/A24G-26 8KD9AF4	Displacement Gyroscope	10.5	6.50	6.50	7.50
	ASK-25A/A24G-26 8KE63AF5	Electronic Control Amplifier	9.5	5	6.5	10
	DCK-128/A24G 8KE65AH2	Compass System Controller				
	15035-1A1	Remote Compass Transmitter	1.8	4.906	3.5	2.067
	2587832	Remote Compass Transmitter Compensator	0.32	2.5	3.5	2.625
<u>Air Data Computer Systems 12D6043-3</u>						
	1903634-3	Central Air Data Computer	47.5	8	14	19.25
	12C1006-817	Maximum Safe Mach Assembly	6.0	4.2	5.0	12.0
	SLZ9370-4	Angle of Attack Transmitter	2.5	4.500	4.500	6.575
	65-0384-1,-2	Angle of Attack Indexer (2 ea)				
	B1508-6	Total Temperature Indicator	1.25	2.255	2.255	6.475
	80-0128-9	Main Caution Light Panel	3.7	5.960	7.665	4.030
	65-0281-1	Reduce Speed Warning Lamp	0.12	0.50	2.25	3.20
<u>AN/ARA-50 UHF/ADF System</u>						
	AS-909/ARA-48 522-1267-005	Antenna Assembly	10.0	10.75	10.75	3.75
	AM-3624/ARA-50 522-3826-003	Amplifier Relay Assembly	5.4	5.125	5.25	6.50
	MT-1955/ARA-50 522-3828-002	Mount	1.1	3.25	7.25	7.0
	F5165001400	BDHI (part of flight instruments)				

F-111F PNWD EQUIPMENT PHYSICAL CHARACTERISTICS

SYSTEM	UNIT		WT (LB)	SIZE (IN)		
	TYPE (P/N)	NOMENCLATURE		H	W	D
<u>AN/ARN-58A Instrument Landing System</u>						
	C-7422/ARN-93 238-4102	Radio Set Control				
	R843A/ARN-58 101753	Localizer Receiver	7.2	6.875	7.02	4.313
	R844A/ARN-58 1003803 or 101542	Glide Slope and Marker Beacon Receiver	9.5	9.75	6.875	5.02
	12B11521	Localizer Antenna (2 ea)	1.5	2.68	5.14	12.14
	16D00500	Marker Beacon Antenna	1.5	2.68	5.14	12.14
	122518	Glide Slope Antenna				
<u>AN/ARN-52(V) TACAN System</u>						
	C-7712/ARN-52(V) 54401045	Radio Set Control	2.0	3	5.75	4
	RT-893/ARN-52(V) 54500396-2	Receiver-Transmitter	43.25	7.35	10	16.9
	MT-1729/ARN-52(V) 54500915	Mounting	5.75	6.313	11.0	17.25
	SA-521/A 50010	RF Transmission Line Switch	0.34	1.94	2.78	3.19
	12F212 11D20100-3	Antenna Select Panel Antenna (2 ea)	2.0	9.7	3.5	7.5
<u>AN/APQ-146 Terrain Following Radar Set</u>						
	AS-2136/APQ-128 582355-11	Antenna-Receiver (2 ea)	27.9	12.7	12.7	16.2
	AM-4915/APQ-128 582358-2	Amplifier-Power Supply (2 ea)	20.8	6.0	6.8	17.6
	SN-519/APQ-128 582358-2	Synchronizer-Trans- mitter (2 ea)	27.6	6.0	7.8	17.6
	CP-917/APQ-128 582354-13	Computer, Terrain Following (2 ea)	16.4	5.3	7.3	16.1
	MT-3917/APQ-128	Rack, Electrical Equipment	24.8	19.25	14.3	18.8
	C-7510/APQ-128 582356-5	Control, Radar Set	2.6	3.0	5.8	7.6
	IP-1012/APQ-134A 583013-2	Indicator, Terrain	23.5	6.24	7.0	21.7

F-111F PNWD EQUIPMENT PHYSICAL CHARACTERISTICS

SYSTEM	UNIT		WT (LB)	SIZE (IN)		
	TYPE (P/N)	NOMENCLATURE		H	W	D
<u>AN/APQ-146 Terrain Following Radar Set (continued)</u>						
	CG-3132/APQ-110	Waveguide Assembly	2.0	-	8.4	18.0
	MX-9523/AP	Low Altitude Monitor	6.0	3.25	3.9	12.9
<u>AN/APQ-144 Attack Radar Set</u>						
	AS-2123/APQ-114 7335131G1	Antenna Assembly	56.5	26.0	35.0	32.0
	AB-1035/APQ-114 7335132G2	Antenna Pedestal	37.0	19.0	21.0	8.0
	C-7486/APQ-114 7335133G3	Antenna Control Unit	38.0	10.0	27.0	8.0
	MD-843/APQ-114 7331403G1	Modulator-Receiver- Transmitter	111.0	21.0	13.0	21.0
	SN-449/APQ-114 7331433G1	Electrical Synchronizer	59.0	13.0	13.0	21.0
	IP-948A/APQ-114A 7331399G1	Indicator-Recorder	65.0	9.0	16.0	31.0
	C-7857/APQ-114A 7637310G2	Radar Set Control	3.0	4.0	6.0	7.0
	C-8590/APQ-114 7637881G1	Antenna-Indicator Control	2.0	7.8	4.8	4.1
	MT-3384/APQ-113	Electrical Equipment Rack	6.0	34.0	13.0	22.0
		Waveguide Assembly	0.8	-	-	-

F-111F BIBLIOGRAPHY

T.O. Number	Chg/Rev	Title
1F-111F-01	21 Apr 72	List of Applicable Publications, USAF Series F-111F Aircraft
1F-111F-1	25 Mar 77	Flight Manual, F-111F
1F-111F-2-5-1	29 Apr 77	Organizational Maintenance, Fire Power Control Systems, USAF Series F-111F Aircraft
1F-111F-2-14	22 Apr 77	Organizational Maintenance, Wiring Diagrams, USAF Series F-111F Aircraft
1F-111F-2-18-1	5 Jan 77	Organizational Maintenance, UHF Automatic Direction Finder Communication, Intercommunications, TACAN, and IFF Systems, USAF Series F-111F Aircraft
1F-111F-2-19	27 Sep 76	Organizational Maintenance, Attack Radar and Terrain Following Radar Systems, USAF Series F-111F Aircraft
1F-111F-2-22	27 Jun 75	Organizational Maintenance, Systems Integration Information, USAF Series F-111F Aircraft
5A11-2-26-3	15 Nov 66	Overhaul, Displacement Gyroscope Model No. 8KD9AF2, USAF SBK-11/A24G-26
5E6-3-68-2	5 Jan 73	Intermediate Maintenance, Total Temperature Indicator
5F4-17-3	7 Apr 72	Overhaul, Electronic Control Amplifier ASK-14/A24G-18
5F4-16-3	7 Apr 72	Overhaul, Electronic Control Amplifier ASK-13/A24G-17
5F4-21-3	1 Dec 71	Electronic Control Amplifier, Model No. USAF Type
		8KE63AF2 ASK-25/A24G-26
		8KE63AF3 ASK-25/A24G-26
		8KE63AF4 ASK-25A/A24G-26
		8KE63AF5 ASK-25A/A24G-26

F-111F BIBLIOGRAPHY

T.O. Number	Chg/Rev	Title
5F5-4-17-3	15 Aug 75	Overhaul, Central Air Data Computer
5F8-2-44-3	31 May 73	Overhaul, Indicator, Airspeed-Mach-Safe Speed AVK-18/A25G-18
5F8-2-47-3	16 Jan 75	Overhaul with Illustrated Parts Breakdown, True Airspeed Indicator P/N 352-01-3
5F8-3-30-3	20 May 74	Overhaul, Altitude Indicator, Type ARU-11/A, Type ARU-21/A, Part No. 9819-18-01, FSN 6610-160-0406, Part No. 9819-58-03, FSN 6610-160-0052
5F8-8-11-3	15 Aug 74	Overhaul, Maximum Safe Mach Assembly
5F8-9-19-3	4 Sep 73	Overhaul, Indicator, Altitude, Vertical Speed AAK-17/A24G-17
5F8-16-4-3	15 Oct 73	Overhaul, Horizontal Situation Indicator, Type AQU-4/A, P/N 101000, and 104500
5FA1-6-2	19 Nov 71	Intermediate Maintenance, Instrument Set Coupler, Part No. 1E4970G (Novatronics)
5N1-3-17-13	31 Jan 75	Overhaul, Battery Control Power Supply, Type C-7719/AJN-16 Part No. 167650-401-151
5N1-3-17-23	26 Sep 75	Overhaul, Navigational Computer, Type CP-945/AJN-16 Part No. 55545-107-41 and 55545-107-71
5N4-4-3-3	1 Jan 72	Overhaul with Parts Breakdown, Magnetic Compass Electronic Compensator, Part No. 2587832
5N5-14-15-2	21 Jan 72	General Purpose Digital Computer, Type AN/AYK-6

F-111F BIBLIOGRAPHY

T.O. Number	Chg/Rev	Title
5N6-4-13-2	10 Oct 75	Intermediate Maintenance, Computer Control, Types C-7882/AYK, C-7882A/AYK, C-8566/AYK, and C-8586/AYK
5N8-13-3-3	10 Oct 75	Overhaul, Digital Display Indicator, Types ID-1620A/AYK, ID-1748/AYK, ID-1760/AYK, and ID-1781/AYK
5N12-2-7-3	2 Apr 73	Overhaul, Induction Compass Transmitter, Type TRU-79/A
5N24-7-3	10 Jan 75	Overhaul, Stabilized Platform, Type MX-8131/AJN-16 Part No. 68144-301-111 and 68144-301-121
8D3-12-19-2	29 Mar 74	Intermediate Maintenance, Shutter, Type Indication Light
11F1-ASG25-53	12 Sep 69	Overhaul, Amplifier/Power Supply, Control 1, Type AM-4869/ASG-25 (GE)
11F15-3-16-2	17 Oct 74	Intermediate Maintenance, Multiplexer Converter, Types CV-9493/A, CV-2493B/A, CV-2797/A, CV-2894/A, and CV-2895/A (Kearfott)
11F39-2-23-2	25 Jan 71	Intermediate Maintenance, Optical Display Sight, Type SU-62 ASG-27 Part No. 106D1799G1
12P5-2APN167-12	3 May 74	Intermediate Maintenance, Electronic Altimeter Set, Type AN/APN-167, P/N YG7092A3 and YG7092A5, Radar Altitude Indicator, P/N E5186000100, F5186000100, G5186000100, and K5186000100 (Honeywell)

F-111F BIBLIOGRAPHY

T.O. Number	Chg/Rev	Title
12P5-4-29-3	27 Dec 74	Overhaul, Radar Altitude Indicator Part No. Part No. E5186000100 K5186000100 F5186000100 L5186000100 G5186000100 M5186000100 H5186000100 N5186000100 P5186000100
12R1-2ARA50-2	1 Feb 72	Field Maintenance, Direction Finder Group
12R5-2ARN52-12	24 Sep 73	Intermediate Maintenance, Receiver, Transmitter, Type RT-893/ARN-52(V), P/N 54500396-2, Type RT-384/ARN-52(V), P/N 54500396, D2067003GZ
GD/FW D750-874C	26 Apr 73	111 Weapon System End Item List and Allocation Chart by MDS

3.25.0
TH-1F

TH-1F PNWD EQUIPMENT LIST

KEY	EQUIPMENT/UNIT
A	UHF-DF SYSTEM AN/ARA-50
CDDC	ID-387 COPILOT'S COURSE INDICATOR
CDDP	ID-387 PILOT'S COURSE INDICATOR
CMMM	INTERPHONE SYSTEM
DMDC	AIN-102A COPILOT'S DME INDICATOR
DMDP	AIN-102A PILOT'S DME INDICATOR
GRND	GROUND
JBA	JUNCTION POINT
RMDC	ID-250/ARN COPILOT'S RMI
RMDP	C-6H PILOT'S RMI
S	GLIDESLOPE SYSTEM AN/ARN-58
SWA	SWITCH POINT (K74)
SWB	SWITCH POINT (K86B)
SWC	SWITCH POINT (K86A)
T	TACAN SYSTEM AN/ARN-65
V	VOR/ILS SYSTEM AN/ARN-30E
W	J-2 COMPASS SYSTEM

TH-1F PNWD EQUIPMENT PHYSICAL CHARACTERISTICS

SYSTEM	UNIT		WT (LB)	SIZE (IN)		
	TYPE (P/N)	NOMENCLATURE		H	W	D
<u>J-2 Compass System</u>						
	DT-173/AJN	Magnetic Azimuth Detector	1.6	2.281	3.5	4.906
	A-2	Slaved Gyro Magnetic Compass Amplifier	6.75	10.063	5.5	7.313
	S-3A	Directional Gyro Control	6.75	8.016	5.531	7.906
<u>AN/ARA-50 UHF Automatic Direction Finder</u>						
	AS-909/ARA-48	Antenna	10.0	3.75	10.75	10.0
	AM-3624/ARA-50	Amplifier Relay Assy.	5.4	4.125	6.5	5.25
	MT-1955/ARA-50	Mount	1.1	3.25	7.25	7.0
	AM-3969/AR	Preamplifier Assy.	2.25	2.25	6.0	8.5
	MS35058-22	UHF Range Switch	0.10	1.157	0.641	2.238
<u>AN/ARN-65 TACAN System</u>						
	RT-471/ARN-65	Transceiver	50.0	9.0	9.375	17.375
	MT-2091/ARN-65	Mount	2.25	2.5	9.562	17.657
	C-1763/ARN-21A	Control Panel	3.0	3.0	5.75	5.688
	AT-741/A	Antenna	0.4	3.3	1.75	5.25
	MS24171-D1	Inverter Power Relay	1.33	3.75	2.0	4.5
	MS17406-1A	Inverter	46.0	8.0	5.5	11.5
	MS35058-22	Course Indicator Switch	0.10	1.157	0.641	2.238
<u>AN/ARN-30E VOR/ILS System</u>						
	R-1021/ARN-30D	Receiver	6.7	5.5	4.625	11.188
	CV-265A/ARN-30A	Signal Data Converter	6.1	5.625	4.844	11.5
	C-3436A/ARN-30D	Radio Set Control	1.4	2.25	5.75	2.188
	PP-2792/ARN-30	Dynaverter		3.8	3.0	5.0
	MT-1174()/ARN-30A	Mount	0.7	1.5	11.625	10.719
	204-075-350-5	Rack				
	B-18B/RMI	Converter	3.2	2.5	6.0	8.0
	2-756M-40A	Mount	0.55	2.0	6.719	7.5

TH-1F PNWD EQUIPMENT PHYSICAL CHARACTERISTICS

3

SYSTEM	UNIT		WT (LB)	SIZE (IN)		
	TYPE (P/N)	NOMENCLATURE		H	W	D
<u>AN/ARN-30E VOR/ILS System (Cont'd)</u>						
	DMN4-4	Antenna	2.25	8.5	3.0	20.0
	MS25321-D2	Course Selector Indicator Relay	0.18	2.15	0.687	2.187
<u>AN/ARN-58 Glideslope and Marker Beacon System</u>						
	R-844/ARN-58	Receiver	8.625	9.75	6.875	5.015
	AT-983/ARN	Antenna	0.7	4.81	4.5	2.0
	37X-2	Marker Beacon Antenna	1.0	2.563	1.563	11.563
	MS35058-22	Marker Beacon Switch	0.10	1.157	0.641	2.238
<u>Navigation Instruments</u>						
	C-6H	Pilot's RMI	4.1	3.25	3.25	8.75
	ID-250/ARN	Copilot's RMI	2.6	3.25 diam.		6.156
	ID-387	Course Indicator	3.75	3.125 diam.		8.0
	AIN-102A	DME Indicator (2 ea)	0.9	1.38	3.26	4.21

TH-1F BIBLIOGRAPHY

T.O. Number	Chq/Rev	Title
1H-1(U)F-01	1 Nov 76	List of Applicable Publications
1H-1(U)F-1	15 Feb 77	Flight Manual
1H-1(U)F-2-1	1 Mar 77	Organizational Maintenance, USAF Models UH-1F, TH-1F and UH-1P Helicopters
5N1-2-4-1	15 Aug 72	Operating and Service, Slaved Gyro Magnetic Compass System, Type J-2 (Sperry)
12R1-2ARA50-2	1 Dec 73	Field Maintenance, Direction Finder Group, Type AN/ARA-50 (Collins)
12R5-2AR-2	15 Aug 66	Field Maintenance, Radio Frequency Amplifier AM-3969/AR (Cook)
12R5-2ARN30-22	5 Nov 71	Service, Radio Receiving Set AN/ARN-30A, AN/ARN-30B, and AN/ARN-30C
12R5-2ARN58-2	1 Dec 73	Field Maintenance, Radio Receiving Set, AN/ARN-58 (Collins)
12R5-2ARN65-2	1 Jul 71	Field Maintenance, Radio Set AN/ARN-65
12R5-2ARN193	4 Jan 74	Overhaul, Course Indicator, Type ID249A/ARN, ID387/ARN, P/N 7202-1A1A2,-4C1,-B1, 7204-1A4A1,-D1 (Eclipse-Pioneer)
12R5-4-120-3	2 May 64	Overhaul, DME Indicator Model AIN-102A
MS17406	14 Jun 74	Military Standard, Inverter, 750VA 3/1 Phase, 750VA 3 Phase, and 1000VA 1 Phase Class B, Multi-Purpose
MS24171	23 Apr 70	Military Standard, Relay 200 AMP, IPST, N.O. Type II, Non-Hermetically Sealed
MS25321	26 Sep 73	Military Standard, Relay 5 AMP, 2PDT, Type I (Hermetically Sealed) Shock Mounted

TH-1F BIBLIOGRAPHY

T.O. Number	Chq/Rev	Title
MS35058	17 Nov 72	Military Standard, Switch, Toggle One Pole, Sealed Toggle

3.26.0
HH/CH-3E

HH/CH-3E PNWD EQUIPMENT LIST

THIS PAGE IS BEST QUALITY PRACTICABLE
FROM COPY FURNISHED TO DDG

KEY	EQUIPMENT/UNIT
A	UHF ADF SYSTEM AN/ARA-25A
AFCS	AUTOMATIC FLIGHT CONTROL-SYSTEM
AIMS	TRANSPONDER SET AN/APX-64(V)
ALDP	AAU-21/A ALTIMETER ENCODER
BDHC	9813-07 COPILOT'S BDHI
BDHP	9813-07 PILOT'S BDHI
CDDC	ID-387/ARN COPILOT'S COURSE INDICATOR
CDDP	ID-387/ARN PILOT'S COURSE INDICATOR
CMMM	INTERPHONE SYSTEM
D	DOPPLER RADAR NAV SYSTEM AN/APN-175(V)
FDDC	ID-834A COPILOT'S AFCS INDICATOR
FDDP	ID-834A PILOT'S AFCS INDICATOR
GRND	GROUND
JBA	JUNCTION POINT A
JBB	JUNCTION POINT B
JBC	JUNCTION POINT C
JBD	JUNCTION POINT D
JBE	JUNCTION POINT E
JBF	JUNCTION POINT F
RDA	RACK DISCONNECT A
RDB	RACK DISCONNECT B
RDC	RACK DISCONNECT C
RDD	RACK DISCONNECT D

HH/CH-3E PNWD EQUIPMENT LIST

KEY	EQUIPMENT/UNIT
RDE	RACK DISCONNECT E
RDF	RACK DISCONNECT F
RDG	RACK DISCONNECT G
RDH	RACK DISCONNECT H
SWA	RELAY BOX
T	TACAN SYSTEM AN/ARN-65
U	VOR-101 VOR/LCL SYSTEM
W	J-4 COMPASS SYSTEM
X	TRUE AIRSPEED TRANSMITTER A24950-00-005
Z	LF ADF SYSTEM AN/ARN-59

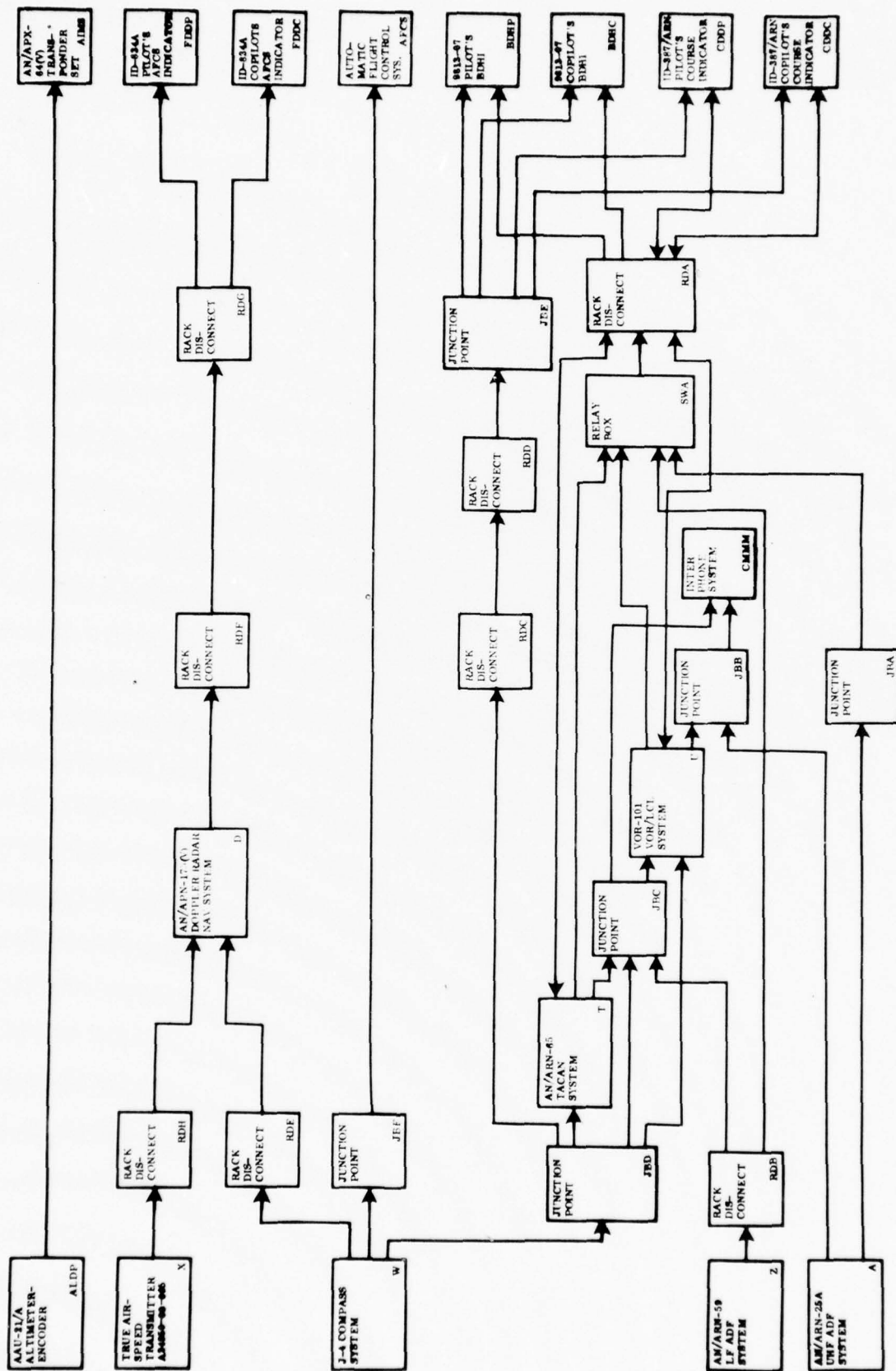

TITLE:	FWSD SYSTEM	
AIRCRAFT:	DATE	DIAGRAM
HH CH-3E	6-30-76	1 OF 1

HH/CH-3E PNWD EQUIPMENT PHYSICAL CHARACTERISTICS

SYSTEM	UNIT		WT (LB)	SIZE (IN)		
	TYPE (P/N)	NOMENCLATURE		H	W	D
<u>AN/ARN-59 Direction Finder Set</u>						
	R-836/ARN-59	Radio Receiver	6.5	4.5	4.563	10.156
	C-2275/ARN-59	Receiver Control	1.6	3.75	5.75	2.375
	AT-780/ARN-59	Antenna	4.3	4.0	6.563	6.563
		Sense Antenna				
	DC-14A/ARN-59	Dynamotor				
	9813-07	BDHI (2 ea) (part of TACAN)	3.5	3.125 diam.		8.25
	MT-1912/ARN	Mounting (receiver)	0.5	1.438	4.688	9.094
<u>AN/APN-171 (V) Electronic Altimeter Set</u>						
	RT-804 ()/APN-171	Receiver-Transmitter	13.5	7.75	5	15
	AS-1858/APN-171(V)	Antenna (2 ea)	1.0	2.5	5.625	6.25
	ID-1725/APN-171	Height Indicator (2 ea)	1.5	3.25	3.25	5.25
	MT-4167/APN-171	Mount	2.2	1.82	5.88	14.25
<u>AN/ARA-25A Direction Finder Group</u>						
	AM-608/ARA-25	Electronic Control Amplifier	5.4	5.875	4.875	12.531
	AS-578()/ARA-25	Antenna	12.5	4.0	16.0	14.375
	RE-120A/ARA-25	Solenoid Relay	0.8	5.813	6.5	1.75
	MT-1042/ARA-25	Mounting (Relay)	0.1	4.313	4.375	0.188
	MT-1043/ARA-25	Mounting (ECA)	0.9	2.078	5.75	11.188
	AM-3969/AR	RF Amplifier	2.25	2.25	6.0	8.5
		Coaxial Relay				
		Mounting				
		DF Range Switch				
<u>J-4 Aircraft Magnetic Gyro Compass</u>						
	423040-2	Directional Gyro	7.67	6.906	7.219	8.219
	423060-3	Servo Amplifier (including mount)	11.0	6.875	7.125	9.5
	ME-1A	Synchro Signal Amplifier	9.5	6.125	4.5	10.875
	ASK-8/A24G-5	Control Panel	1.47	2.625	5.75	3.5

HH/CH-3E PNWD EQUIPMENT PHYSICAL CHARACTERISTICS

SYSTEM	UNIT		WT (LB)	SIZE (IN)		
	TYPE (P/N)	NOMENCLATURE		H	W	D
<u>J-4 Aircraft Magnetic Gyro Compass (Cont'd)</u>						
	DT-309/AJN	Magnetic Azimuth Detector	1.5	4.91	3.5	2.06
	9813-07	BDHI (2 ea) (part of TACAN)	3.5	3.125 diam.		8.25
<u>AN/ARN-65 TACAN System</u>						
	RT-471/ARN-65	Receiver-Transmitter	50	9.0	9.375	17.375
	MT-2091/ARN-65	Mounting	2.25	2.25	9.562	17.657
	C-1763/ARN-21A	Radio Set Control	3	3.0	5.75	5.688
	AT-740/A	Antenna	0.75	1.54	8.4 diam.	
	9813-07	BDHI (2 ea)	3.5	3.25	3.25	7.5
	ID-387/ARN	Course Indicator (part of VOR/LCL)	3.25	3.25	3.25	7.125
<u>VOR-101 VOR/LCL System</u>						
	51X-2B	Radio Receiver	10.5	7.5	3.563	12.563
	344B-1	Instrumentation Unit	13.0	7.625	3.688	14.688
	W/390E-1	Mounting (IU)	2.8	5.0	8.188	15.875
	614U-3A	ILS Control Panel	1.7	2.25	5.75	6.766
	ID-387/ARN	Course Indicator (2 ea)	3.75	3.125 diam.		8.0
	R-844A/ARN-58	Radio Receiver	8.625	9.75	6.875	5.015
	37X-2	Glideslope Antenna	1.0	2.563	1.563	11.563
	DMN-4-4.1	Antenna (2 ea)	2.25	8.5	3.0	20.0
	9813-07	BDHI (part of TACAN)	3.5	3.125 diam.		8.25
<u>AN/APN-175(V) Radar Navigation Set</u>						
	CMC-340-014	Navigational Computer	18.0	7.625	5.875	15.187
	CMC-405-707	Mounting	3.3	9.75	8.5	17.5
	CMC-433-952	Doppler Control Indicator	7.7	6.0	5.75	7.312
	CMC-404-810	Receiver-Transmitter	12.6	7.688	3.594	15.094
	CMC-404-812	Mounting	3.8	3.062	4.875	17.406
	CMC-404-911	Frequency Tracker	25.0	7.625	7.625	15.25

HH/CH-3E PNWD EQUIPMENT PHYSICAL CHARACTERISTICS

SYSTEM	UNIT		WT (LB)	SIZE (IN)		
	TYPE (P/N)	NOMENCLATURE		H	W	D
	<u>AN/APN-175(V) Radar Navigation Set (Cont'd)</u>					
	CMC-404-813	Mounting	3.3	5.0	8.5	14.25
	CMC-433-843	Antenna	15.1	7.25	12.75	15.5
	CMC-340-004	Velocity Steering Indicator (2 ea)	2.75	3.26	3.26	6.5
	A24950-00-005	True Airspeed Transmitter	4.0	5.375	4.25	8.875
	<u>AAU-21/A Altimeter-Encoder</u>		3.75	3.25	3.25	8.111

HH/CH-3E BIBLIOGRAPHY

T.O. Number	Chg/Rev	Title
1H-3(C)E-01	1 Feb 76	List of Applicable Publications, CH-3C, CH-3E, HH-3E and USCG HH-3F Helicopters
1H-3(C)E-1	20 Feb 76	Flight Manual, CH-3E and HH-3E
1H-3(C)E-2-3	15 Apr 77	Organizational Maintenance, Instruments, Electrical System, Communication and Navigation Systems, HH-3E
5F3-316-2	4 Feb 74	Field Maintenance Bench Check, Altimeter, Encoder, Type AAU-21/A P/N C4154210003 (Kollsman)
5N1-2-10-12	15 Oct 74	Field Maintenance, Aircraft Magnetic Gyro Compass, Type J-4 (Eclipse-Pioneer) CH-3C/3E, HH-3E
5N2-2-6-1	30 May 74	Operating and Service, 400 Cycle Synchro Signal Compass Amplifier
5N8-5-11-3	15 May 75	Overhaul, Indicator, Bearing-Distance Heading, Type ID-798/ARN
5P4-2-26-3	18 Jun 70	Overhaul, True Airspeed Transducer, P/N A24950-00-005 (Kollsman)
12P-5-2APN171-2	6 Nov 73	Service with P/B, Electronic Altimeter Set, Type AN/APN-171(V) (Honeywell) CH-36, HH-3E/3F
12P5-2APN175-2	1 Aug 73	Field Maintenance, Navigation Sets, Radar AN/APN-175(V)-1, AN/APN-175(V)-2, AN/APN-175(V)-3
12P5-2APN-175-22	20 Dec 73	Field Maintenance, Navigation Set, Radar, Type AN/APN-175(V)-1, and -3 (Canadian Marconi)
12P5-2APN175-53	5 Mar 75	Overhaul, Computer, Navigational CP-866A/APN-175(V), PN411-667 and Base, Shockmount, Electrical Equipment MT-3692/APN-175(V), P/N 405-707

HH/CH-3E BIBLIOGRAPHY

T.O. Number	Chq/Rev	Title
12R1-2ARA25-2	15 Feb 73	Service, Direction Finder Group, AN/ARA-25, -25A
12R2-4-29-2	12 Sep 72	Field Maintenance, VHF Navigation and Communications Receiver 51X-2B and Radio Set Control 614U-3A (Collins)
12R2-4-30-2	29 Jan 75	Field Maintenance, Instrumentation Unit, Type 344B-1 (Collins)
12R5-2AR-2	15 Aug 66	Field Maintenance, Radio Frequency Amplifier AM-3969/AR (Cook)
12R5-2ARN58-2	1 Dec 73	Field Maintenance, Radio Receiving Set, Type AN/ARN-58 (Collins)
12R5-2ARN59-2	12 Sep 58	Field and Depot Maintenance, Direction Finder Set, Type AN/ARN-59-CH-3C/3E, HH-3E
12R5-ARN65-2	1 Jul 71	Field Maintenance, Radio Set, Type AN/ARN-65 (Hoffman)
12R5-2ARN193	4 Jan 74	Overhaul, Course Indicator, Type ID-249A/ARN, ID-387/ARN, P/N7202-1A1A2, -4C1, -B1, 7204-1A4A1, -D1 (Eclipse-Pioneer)
12R5-4-29-13	15 Jan 75	Overhaul, Bearing Distance Heading Indicator, P/N 9813-07, -77-03 (Sunbeam Electronics)

3.27.0
HH-53B/C

HH-53B/C PNWD EQUIPMENT LIST

KEY	EQUIPMENT/UNIT
A	UHF/DF SYSTEM AN/ARA-25A
AFCS	AUTOMATIC FLIGHT CONTROL SYSTEM
AIMS	IFF-SIF SYSTEM AN/APX-64(V)
ALDP	AAU-21/A ENCODING ALTIMETER
BDHC	ID-1103/ARN COPILOT'S BDHI
BDHP	ID-1103/ARN PILOT'S BDHI
CDDC	ID-387/ARN COPILOT'S COURSE INDICATOR
CDDP	ID-387/ARN PILOT'S COURSE INDICATOR
CMMM	INTERPHONE SYSTEM
D	DOPPLER RADAR NAVIGATION SYSTEM AN/APN-175(V)-1
FDDP	PILOT'S FLIGHT DIRECTOR INDICATOR 359-999-0100
FDDC	COPILOT'S FLIGHT DIRECTOR INDICATOR 359-999-0100
G	RADAR ALTIMETER SYSTEM AN/APN-171(V)
GRND	GROUND
JBA	JUNCTION POINT (A)
JBB	JUNCTION POINT (B)
JBC	JUNCTION POINT (C)
JBD	JUNCTION POINT (D)
JBE	JUNCTION POINT (E)
JBF	JUNCTION POINT(F)
JBG	JUNCTION POINT(G)
JBH	JUNCTION POINT(H)
LGAW	LANDING GEAR WARNING ATTITUDE SYSTEM

HH-53B/C PNWD EQUIPMENT LIST

KEY	EQUIPMENT/UNIT
RADC	HEIGHT INDICATOR ID-1345/APN-171, CPLT
RADP	HEIGHT INDICATOR ID-1345/APN-171, PILOT
RDA	RACK DISCONNECT (A)
RDB	RACK DISCONNECT (B)
RDC	RACK DISCONNECT (C)
RDD	RACK DISCONNECT (D)
RDE	RACK DISCONNECT (E)
RDF	RACK DISCONNECT (F)
RDG	RACK DISCONNECT (G)
RDH	RACK DISCONNECT (H)
RDJ	RACK DISCONNECT (J)
RDK	RACK DISCONNECT (K)
SWA	SWITCH POINT (RELAY BOX)
T	TACAN SYSTEM AN/ARN-65
U	VOR/LCL SYSTEM AN/ARN-58
W	J-4 COMPASS SYSTEM
X	TRUE AIRSPEED TRANSMITTER A24950-00-005
Z	LF/ADF SYSTEM AN/ARN-59

HH-53B/C PNWD EQUIPMENT PHYSICAL CHARACTERISTICS

SYSTEM	UNIT		WT (LB)	SIZE (IN)		
	TYPE (P/N)	NOMENCLATURE		H	W	D
<u>AN/ARN-59 Direction Finder Set</u>						
	R-836/ARN-59	Radio Receiver	6.5	4.5	4.563	10.156
	C-2275/ARN-59	Receiver Control	1.6	3.75	5.75	2.375
	AT-780/ARN	Antenna	4.3	4.0	6.563	6.563
	ARC-19210	Sense Antenna				
	DY-150/ARM	Dynamotor	5.0	4.938	3.375	7.219
	ID-1103/ARN	BDHI (2 ea) (part of TACAN)	3.5	3.25	3.25	7.5
	MT-1912/ARN	Mounting (Receiver)	.5	1.438	4.688	9.094
<u>AN/APN-171(V) Electronic Altimeter Set</u>						
	RT-804/APN-171(V)	Receiver - Transmitter	13.5	7.75	5.0	15.0
	AS-1858/APN-171(V)	Antenna (2 ea)	1.0	2.5	5.625	.625
	ID-1345/APN-171(V)	Height Indicator (2 ea)	1.5	3.25	3.25	5.25
	MT-4167/APN-171(V)	Mount	2.2	1.82	5.88	14.25
<u>AN/ARA-25A Direction Finder Group</u>						
	AM-608/ARA-25	Electronic Control Amplifier	5.4	5.875	4.875	12.531
	AS-578D/ARA-25	Antenna	12.5	4.0	16.0	14.375
	RE-120A/A	Solenoid Relay	.8	5.813	6.5	1.75
	MT-1042/ARA-25	Mounting (Relay)	.1	4.313	4.375	0.188
	MT-1043/ARA-25	Mounting (ECA)	.9	2.078	5.75	11.188
	AM-3969/AR	RF Amplifier	2.25	2.25	6.0	8.5

HH-53B/C PNWD EQUIPMENT PHYSICAL CHARACTERISTICS

SYSTEM	UNIT		WT (LB)	SIZE (IN)		
	TYPE (P/N)	NOMENCLATURE		H	W	D
<u>J-4 Aircraft Magnetic Gyro Compass</u>						
	423040-2	Directional Gyro	7.67	6.906	7.219	8.219
	423060-2	Servo Amplifier (including mount)	11.0	6.875	7.125	9.5
	420408-2A	Synchro Signal Amplifier	13.75	12.594	3.906	27.281
	ASK-8/A24G-5	Control Panel	1.47	2.625	5.75	3.5
	DT-309/AJN	Magnetic Azimuth Detector	1.5	4.91	3.5	2.06
	ID-1103/ARN	BDHI (2 ea) (part of TACAN)	3.5	3.25	3.25	7.5
<u>AN/ARN-65 TACAN System</u>						
	RT-471/ARN-65	Receiver-Transmitter	50	9.0	9.375	17.375
	MT-2091/ARN-65	Mounting	2.25	2.25	9.562	17.657
	C-1763/ARN-21A	Radio Set Control	3.0	3.0	5.75	5.688
	AT-740/A	Antenna	0.75	1.54	8.4 diam.	
	ID-1103/ARN	BDHI (2 ea)	3.5	3.25	3.25	7.5
	ID-387/ARN	Course Indicator (part of VOR/LCL)	3.25	3.25	3.25	7.125
<u>VOR-101 VOR/LCL System</u>						
	51X-2B	Radio Receiver	10.5	7.5	3.56	12.56
	344B-1	Instrumentation Unit	13.0	7.625	3.69	14.69
	W/390E-1	Mounting (IU)	2.8	5.0	8.188	15.875
	614U-3A	Radio Set Control	1.7	2.25	5.75	6.766
	ID-387/ARN	Course Indicator (2 ea)	3.75	3.125 diam.		8.0
	R-844A/ARN-58	Radio Receiver	8.625	9.75	6.875	5.015

HH-53B/C PNWD EQUIPMENT PHYSICAL CHARACTERISTICS

SYSTEM	UNIT		WT (LB)	SIZE (IN)		
	TYPE (P/N)	NOMENCLATURE		H	W	D
	37X-2	Marker Beacon Antenna	0.9	2.563	1.563	11.563
	AT-983/ARN	Glideslope Antenna	0.7	4.81	4.5	2.0
	DMN-4-4	Antenna (2 ea)	2.25	8.5	3.0	2.0
	ID-1103/ARN	BDHI (part of TACAN)	3.5	3.25	3.25	7.5
<u>AN/APN 175(V)-1 Radar Navigation Set</u>						
	CP-866/APN-175(V)	Navigational Computer	18.25	7.75	5.0	15.75
	MT-3692/APN-175(V)	Mounting	3.3	9.75	8.5	17.5
	C-8046/APN-175(V)	Control Indicator	7.6	6.0	5.75	8.25
	CMC-410-111	Dual Ampl Unit	1.5	2.91	3.0	5.5
	RT-833(V)-1/APN-175(V)	Receiver - Transmitter	12.4	7.682	3.682	15.218
	MT-3690/APN-175(V)	Mounting	2.9	10.25	4.875	13.812
	CV-2145/APN-175(V)	Frequency Tracker	21.5	7.625	7.625	15.25
	CMC-404-813	Mounting	3.3	5.0	8.5	14.25
	AS-1960/APN-175(V)	Antenna	29.56	11.12	12.6	22.855
	ID-1387/APN-175(V)	Velocity Steering Indicator (2 ea)	3.18	3.27	3.27	8.1
	A24950-00-005	True Airspeed Transmitter	4.0	5.375	4.25	8.875
	<u>AAU-21A Altimeter-Encoder</u>		3.75	3.25	3.25	8.111

HH-53B/C BIBLIOGRAPHY

T.O. Number	Chq/Rev	Title
1H-53(H)B-01	10 Jan 74	List of Applicable Publications, HH-53
1H-53(H)B-1	15 Jun 76	Flight Manual, HH-53B, HH-53C, and CH-53C Helicopters
1H-53(H)B-2-5	15 Feb 77	Organizational Maintenance Instrument-Electrical Communication and Navigation Systems and Wiring Diagrams, CH-53C, HH-53B, and HH-53C Helicopters
5F3-3-16-2	4 Feb 74	Field Maintenance Bench Check, Altimeter, Encoder, Type AAU-21/A P/N C4154210003 (Kollsman)
5F8-5-10-3	26 Jan 73	DMM, Flight Director Indicator, P/N 353-999-0100 (Honeywell)
5F8-9-12-3	15 Dec 72	Overhaul, Vertical Velocity Indicator, Type RC60MSAAU9/A (Aeronic)
5N1-2-10-2	25 Oct 74	Field Maintenance, Aircraft Magnetic Gyro Compass, Type J4, P/N S-100-2C (Kearfott)
5N4-6-3-3	10 Jun 70	Overhaul, Magnetic Azimuth Detector, Type DI 309/AJN
5PA-2-26-3	18 Jun 70	Overhaul, True Airspeed Transducer, P/N A24950-00-005 (Kollsman)
12P5-2APN171-2	6 Nov 73	Service with P/B, Electronic Altimeter Set, Type AN/APN171(V) (Honeywell)
12P5-2APN175-22	20 Dec 73	Field Maintenance, Navigation Set, Radar, Type AN/APN-175(V) -1, and -3 (Canadian Marconi)
12R1-2ARA25-2	15 Feb 73	Service, Direction Finder Group, AN/ARA-25 and -25A
12R5-4-29-2	12 Sep 72	Field Maintenance, VHF Navigation and Communications Receiver, Type 51X-2B; Radio Set Control, Type 614U-3A (Collins)

HH-53B/C BIBLIOGRAPHY

T.O. Number	Chq/Rev	Title
12R2-4-30-2	29 Jan 75	Field Maintenance, Instrumentation Unit 344B-1
12R5-2AR-2	15 Aug 66	Field Maintenance, Radio Frequency Amplifier AM-3969/AR (Cook)
12R5-2ARN58-2	1 Dec 73	Field Maintenance, Radio Receiving Set, AN/ARN-58 (Collins)
12R5-2ARN58-12	25 Jul 75	Field Maintenance, Receiving Set, Radio AN/ARN-58 and AN/ARN-58A
12R5-2ARN59-2	12 Sep 58	Field and Depot Maintenance, Automatic Direction Finder Set, Type AN/ARN-59
12R5-2ARN65-2	1 Jul 71	Field Maintenance, Radio Set, Type AN/ARN-65 (Hoffman)
12R5-2ARN193	1 Apr 74	Overhaul, Course Indicator, Type ID-249A/ARN, ID-387/ARN, P/N 7202-1A1A2, -4C1, -B1, 7204-1A4A1, -01 (Eclipse-Pioneer)
MIL-A-81296C(AS)	3 Jan 74	Altimeter Set, Electronic AN/APN-171(V)

3.28.0
O-2A

O-2A PNWD EQUIPMENT LIST

KEY	EQUIPMENT/UNIT
AIMS	IFF SYSTEM AN/APX-72
ALDP	IFF ALTIMETER AAU-21/A
BDHP	ID-1103 BDHI
CDDP	ID-351 COURSE INDICATOR
CMMM	INTERPHONE SYSTEM
F	FM-622 VHF NAV SYSTEM
JBA	FORWARD JUNCTION BOX
SWA	TACAN-FM HOMING SWITCH
T	TACAN SYSTEM AN/ARN-52 (V)
V	FM-622 VHF/FM COMM AND HOMING SYSTEM
W	COMPASS SYSTEM CN1251/ASN89V
Z	LF/ADF NAV SYSTEM AN/ARN-83

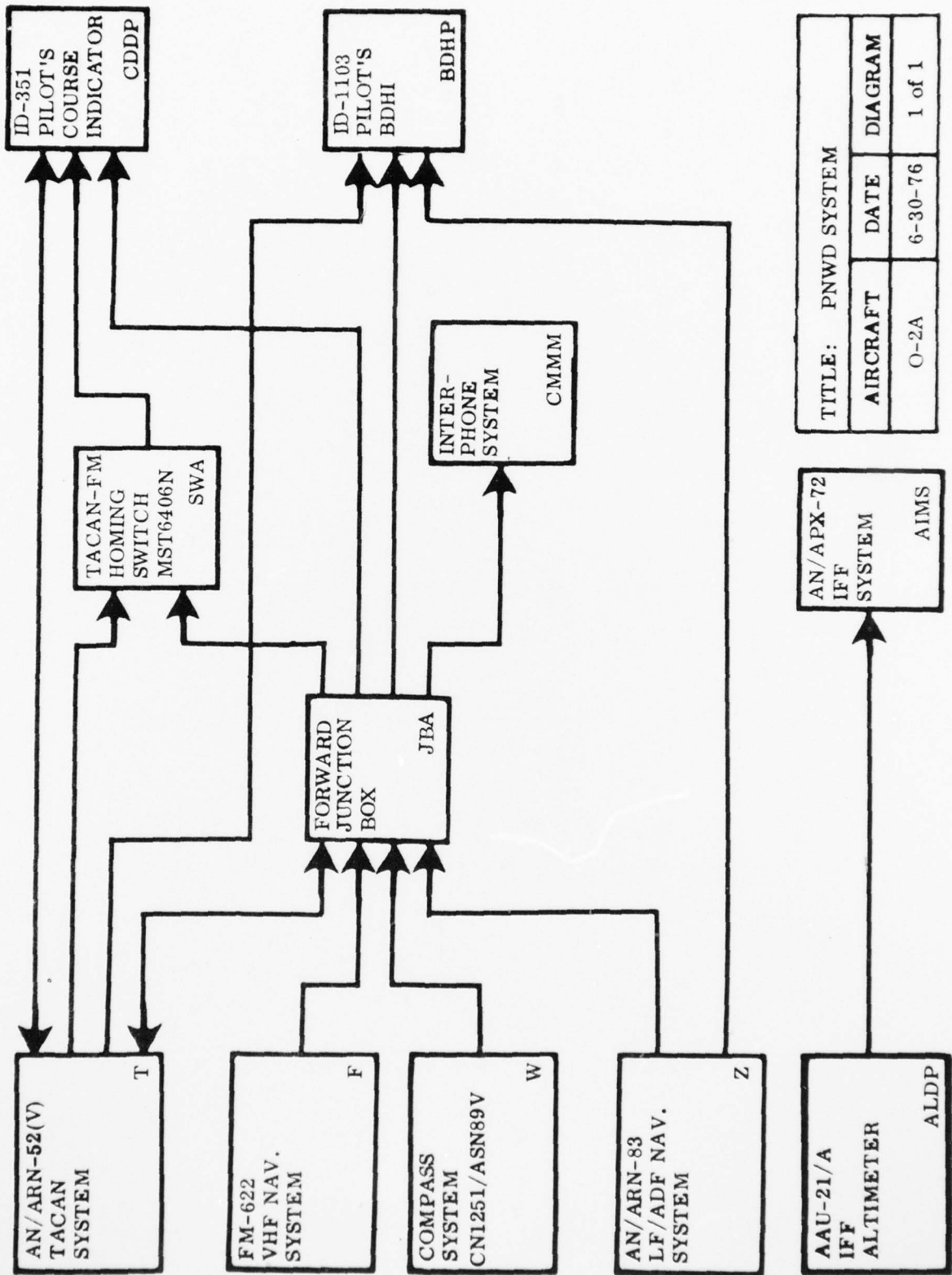

0-2 PNWD EQUIPMENT PHYSICAL CHARACTERISTICS

SYSTEM	UNIT		WT (LB)	SIZE (IN)		
	TYPE (P/N)	NOMENCLATURE		H	W	D
<u>AAU-21/A Altitude Encoder</u>						
			3.75	3.25	3.25	8.111
<u>Heading Indicator System (Compass System)</u>						
	CN-1072/AJN	Compensator	0.313	.25	3.313	3.281
	CN-1251/ASN-89V	Gyro Heading Compass	6.7	6.781	6.5	7.625
		Slaved-Gyro Free Switch (on rear J-box)	0.10	1.157	0.641	2.238
		Increase-Decrease Switch	0.10	1.346	1.025	2.41
		Fast Slave Switch				
		Magnetic Flux Detector	1.688	2.063	3.5	4.906
		Slaving Indicator				
<u>FM-622 VHF/FM Communications and Homing System</u>						
	709149-801	FM-622 Receiver-Transmitter	25.19	7.938	6.0	15.25
	709116-801	FM-622 Shock Mount	2.0	2.125	5.75	14.25
	709151-801	FM-622 Control Radio Set	2.0	3.0	5.75	6.438
	709151-801	Antenna Coupler	2.44	3.75	3.25	9.0
	MSTG406N	TACAN-FM Homing Switch				
	709226-801	Spike Antenna	0.44	54.0	--	--
	DMN15-1	Towel Bar Antenna				
	AS-1922/AR					
<u>AN/ARN-83 LF/ADF Navigation System</u>						
	R-1391/ARN-83	Receiver	9.8	7.625	2.25	14.625
	MT-3605	Mount	2.6	9.063	3.313	16.0
	C6899	Control Radio Set	1.8	2.625	5.75	4.938
	AS-1863/ARN	Loop Antenna	3.8	0.875	12.0	16.0
	1570112-1	Zero Compensator				
	15005	Sense Antenna				
	ID-1103/ARN	BDHI (part of TACAN system)	3.5	3.25	3.25	7.5

AD-A061 494

ARINC RESEARCH CORP ANNAPOLIS MD
STANDARD AVIONICS INTERFACE PROGRAM. VOLUME II. NAVIGATION EQUI--ETC(U)
AUG 76 B G MCELHANEY; E J CHAUVIN
1296-01-2-1527-VOL-2

F/G 9/3

F09603-75-A-3001

NL

UNCLASSIFIED

5 of 5

AD
A061494



END
DATE
FILMED
2 79
DDC

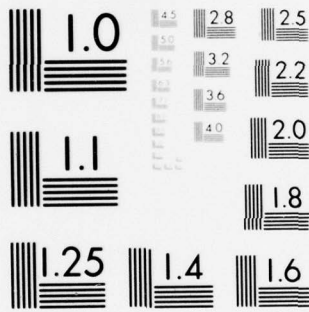

MICROCOPY RESOLUTION TEST CHART
NATIONAL BUREAU OF STANDARDS-1963-A

0-2 PNWD EQUIPMENT PHYSICAL CHARACTERISTICS

SYSTEM	UNIT		WT (LB)	SIZE (IN)		
	TYPE (P/N)	NOMENCLATURE		H	W	D
AN/ARN-52(V)	TACAN System					
	RT-384/ARN-52(V)	Receiver-Transmitter	42.5	6.75	10.0	15.0
	MT-1729/ARN-52(V)	Mounting	5.75	6.313	11.0	17.25
	C-2010/ARN-52(V)	Control Radio Set	2.0	3.0	5.75	4.0
	AT-741A	Antenna (2 each)	0.4	3.3	1.75	5.25
	SA-521A/A	Antenna Relay	0.34	1.94	2.78	3.19
	ID-1103/ARN	BDHI	3.5	3.25	3.25	7.5
	ID-351/ARN	Course Indicator	3.25	3.25	3.25	7.125

0-2A BIBLIOGRAPHY

T.O. Number	Chg/Rev	Title
1L-2A-01	31 May 70	List of Applicable Publications - 0-2A and 0-2B
1L-2A-1	10 Jun 77	Flight Manual - 0-2A and 0-2B
1L-2A-2	15 Mar 77	Maintenance, 0-2A and 0-2B
5N12-2-6-3	15 Jul 75	Overhaul, Induction Compass Transmitter, Type DT-309/AJN, DT-310/AJN and Compensator, Type CN-1072/AJN (Sperry)
5N18-13-2	15 Sep 70	Field Maintenance, Directional Gyroscope CN-1251/ASN-89(V) P/N 2592934-1 (Sperry)
12R2-4-90-2	1 Oct 74	Field Maintenance, Radio Set, Type FM622A (Magnavox)
12R5-2ARN-193	4 Jan 74	Overhaul, Course Indicator, Type ID-249A/ARN, -387/ARN (Eclipse-Pioneer)
12R5-4-99-11	30 Oct 73	Maintenance and Installation, Direction Finder Set, Type AN/ARN-83, DF-203 ADF System (Collins)
MS35058	17 Nov 72	Military Standard, Switch, Toggle, One Pole, Sealed Toggle
MS35059	17 Nov 72	Switch, Toggle, Two Pole, Sealed Toggle

OV-10A PNWD EQUIPMENT LIST

KEY	EQUIPMENT/UNIT
A	UHF-ADF SYSTEM AN/ARA-50
AIMS	IFF-SIF SYSTEM AN/APX-64(V)
ALDP	AAU-21/A PILOT'S ALTIMETER
BDHP	ID-663B/U PILOT'S BDHI
CDDP	ID-387/ARN PILOT'S COURSE DEVIATION IND
CMMM	INTERPHONE SYSTEM
F	FM-622A VHF-FM SYSTEM NO. 1
JBA	CONTROL TRANSFER RELAY BOX 305-540212-21
RDA	RACK DISCONNECT (A)
RDB	RACK DISCONNECT (B)
RDC	RACK DISCONNECT (C)
RDD	RACK DISCONNECT (D)
RDE	RACK DISCONNECT (E)
RMDN	ID-250/ARN OBSERVOR'S RMI
S	51V-4A GLIDESLOPE SYSTEM
T	TACAN SYSTEM AN/ARN-52(V)
V	51R-6 VOR/LOC SYSTEM
W	COMPASS SYSTEM AN/ASN-75
Z	LF-ADF SYSTEM AN/ARN-83

OV-10A PMWD EQUIPMENT PHYSICAL CHARACTERISTICS

SYSTEM	UNIT		WT (LB)	SIZE (IN)		
	TYPE (P/N)	NOMENCLATURE		H	W	D
<u>AN/ARN-52(V) TACAN System</u>						
	RT-384/ARN-52(V)	Receiver-Transmitter	42.5	6.75	10.0	15.0
	MT-1729/ARN-52(V)	Mounting	5.0	6.313	11.0	17.25
	C-2010/ARN-52(V)	Radio Set Control	2.0	3.0	5.75	4.0
	ID-663B/U	BDHI	3.5	3.5 diam.		7.5
	ID-387/ARN	Course Indicator	3.75	3.125 diam.		8.0
	ID-250/ARN	RMI	2.6	3.25 diam.		6.156
	AT-741/A	Antenna	0.4	3.3	1.75	5.25
	A0-41780-1	External Blower				
	HE-492-5001-001					
<u>AN/ARA-50 Direction Finder Group</u>						
	AS-909/ARA-48	Antenna Assy.	10.0	3.75	10.75	10.0
	AM-3624/ARA-50	Amplifier-Relay Assy.	5.4	5.125	6.5	5.25
	MT-1955/ARA-50	Mounting	1.1	3.25	7.25	7.0
	ID-663B/U	BDHI (part of TACAN)	3.5	3.5 diam.		7.5
	ID-250/ARN	RMI (part of TACAN)	2.6	3.25 diam.		6.156
<u>FM-622A Radio Set</u>						
	709-149-801	Receiver-Transmitter	25.19	7.938	6.0	15.25
	709-116-803	Mounting	2.0	2.125	5.75	14.25
	709-150-801	Radio Set Control	2.0	3.0	5.75	6.438
	709-226-801	Antenna	0.44	54	--	--
	709-151-801	Antenna Coupler	2.44	3.75	3.25	9.0
<u>VOR/ILS Radio Navigation System</u>						
	51R-6	VOR Nav Unit	15.2	7.625	4.875	14.625
	51V-4A	Glideslope Receiver	3.5	3.375	2.25	12.563
	N4-4	VOR/ILS Antenna (2 each)	2.25	8.5	3.0	20.0
	37P-4	Glideslope Antenna	0.7	5.984	2.0	4.5
	313N-2	Control Panel (part of COMM-NAV Control Panel)	2.0	2.625	5.75	4.375

OV-10A PNWD EQUIPMENT PHYSICAL CHARACTERISTICS

SYSTEM	UNIT		WT (LB)	SIZE (IN)		
	TYPE (P/N)	NOMENCLATURE		H	W	D
<u>An/ARN-83 Direction Finder Set</u>						
	R-1391/ARN-83	Radio Receiver	9.8	7.625	2.25	14.625
	C-6899/ARN-83	Direction Finder Control	1.8	2.625	5.75	4.938
	MT-3605/ARN-83	Mounting	2.6	9.063	3.313	16.0
	AS-1863/ARN-83	Loop Antenna	3.8	0.875	12.0	16.0
	522-4190-001	Sense Antenna	--			
	HE-481-9001-001					
	522-2741-0007	Quadrantal Error Corrector	0.5	2.219	1.313	2.969
	ID-663B/U	BDHI (part of TACAN)	3.5	3.5 diam.		7.5
	ID-250/ARN	RMI (part of TACAN)	2.6	3.25 diam.		6.156
<u>AN/ASN-75 Compass System</u>						
	AM-4606/ASN-75	Amplifier Power Supply	1.75	2.062	5.843	7.562
	CN-1141/ASN-75	Directional Displacement Gyro	4.15	5.593	4.703	4.702
	CN-1142/ASN-75	Remote Compass Compensator	1.05	1.875	5.75	4.125
	C-802/ASN-75	Compass Set Control	2.4	2.625	5.75	5.937
	305-541413	Compass Transmitter		3.625	3.125	2.046
	ID-663B/U	BDHI (part of TACAN)	3.5	3.5 diam.		7.5
	ID-250/ARN	RMI (part of TACAN)	2.6	3.25 diam.		6.136
<u>AAU-21/A Encoding Altimeter</u>						
			3.75	3.25	3.25	8.111

OV-10A BIBLIOGRAPHY

T.O. Number	Chq/Rev	Title
1L-10A-01	1 Feb 72	List of Applicable Publications - OV-10A
1L-10A-1	15 Jan 76	Flight Manual - OV-10A
1L-10A-2-5	15 May 76	Maintenance, Avionics System - OV-10A
1L-10A-2-7	1 Jan 76	Maintenance, Wiring Data - OV-10A
5F3-3-16-2	4 Feb 74	Field Maintenance Bench Check, Altimeter Encoder, Type AAU-21/A P/N C4154210003 (Kollsman)
5N1-2-19-1	15 Nov 69	Operation and Maintenance, Gyro-scope Reference Navigation Compass Set, AN/ASN-75 (Sperry Phoenix) - OV-10A
12R1-2ARA50-2	1 Dec 73	Field Maintenance, Direction Finder Group, Type AN/ARA-50 (Collins)
12R2-4-90-2	1 Oct 74	Field Maintenance, Radio Set, Type FM622A (Magnavox)
12R5-2ARN52-2	1 Jul 74	Service, TACAN Navigational Set, Type AN/ARN-52(V) (ITT)
12R5-4-6-12	1 Dec 73	Field Maintenance, Glide Slope Radio Receiver, Type 51V-4, -4A (Collins)
12R5-4-58-2	1 Jun 73	Field Maintenance, VOR/LOC Navigation Unit, Type 51R-6 (Collins)
12R5-4-99-11	30 Oct 73	Maintenance with Installation Data, Direction Finder Set, AN/ARN-83 DF-203 ADF System (Collins)
MS25396	20 Jan 63	Transmitter, Remote Compass

T-37B PNWD EQUIPMENT LIST

KEY	EQUIPMENT/UNIT
AIMS	IFF TRANSPONDER AN/APX-72
ALDP	AAU-21/A ENCODING ALTIMETER
CDDP	ID-387/ARN COURSE INDICATOR
CMMM	AIC-10A INTERPHONE SYSTEM
DMDP	DISTANCE INDICATOR MI-591084-2
GCDP	V-8 GYRO COMPASS INDICATOR
JBA	TERMINAL STRIP TB-34
JBB	TERMINAL STRIP TB-37
RDA	INTERMEDIATE CONNECTOR (A)
RDB	INTERMEDIATE CONNECTOR (B)
RDC	INTERMEDIATE CONNECTOR (C)
RMDP	ID-250/ARN RMI
W	J-2 COMPASS SYSTEM
Y	DME SYSTEM AVQ-75

—
—

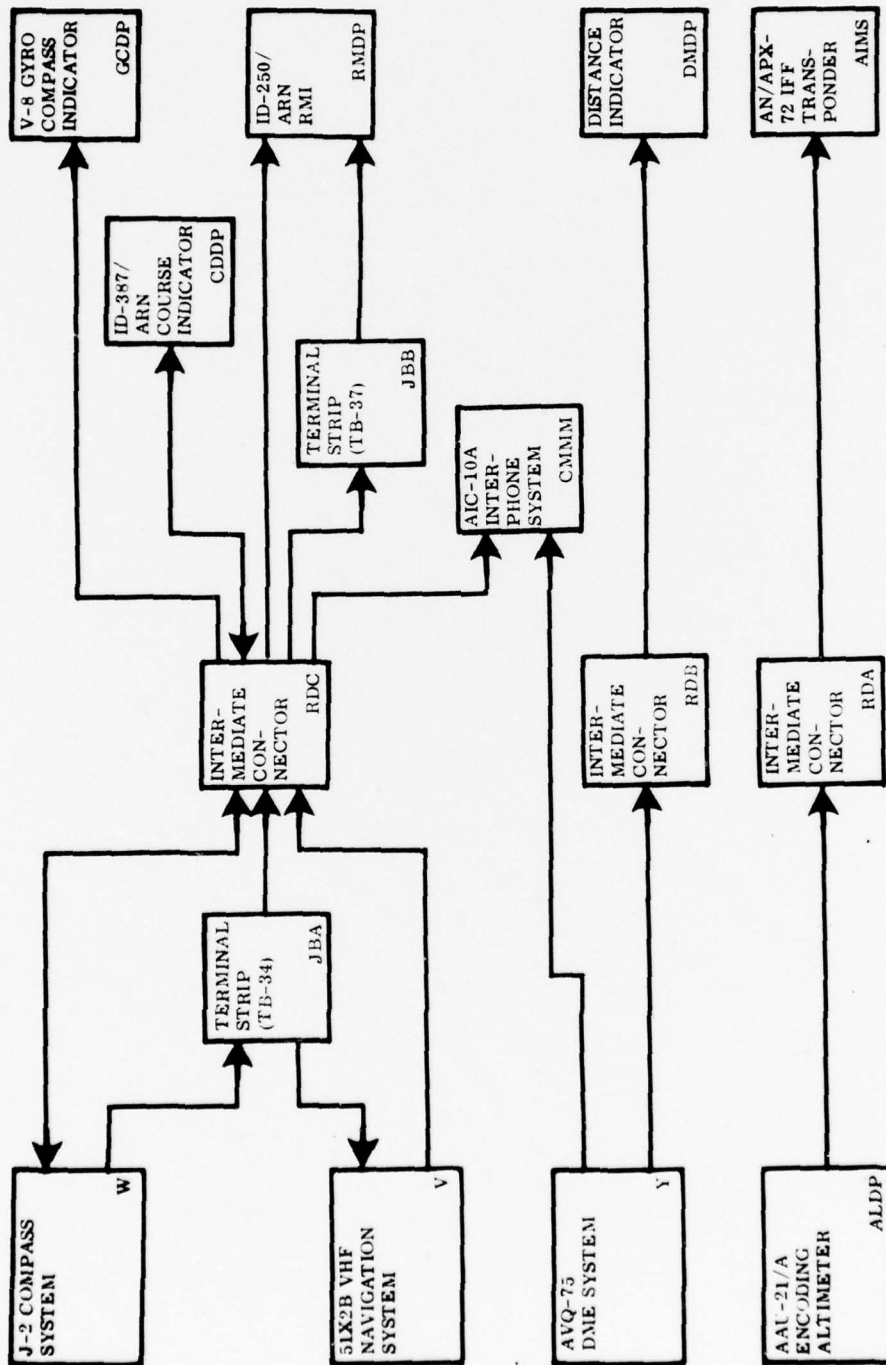

TITLE: PNWD SYSTEM		
AIRCRAFT	DATE	DIAGRAM
T-37B	6-30-76	1 of 1

T-37B PNWD EQUIPMENT PHYSICAL CHARACTERISTICS

SYSTEM	UNIT		WT (LB)	SIZE (IN)		
	TYPE (P/N)	NOMENCLATURE		H	W	D
<u>J-2 Slaved GYRO Magnetic Compass</u>						
	S-3A	Directional Gyro Control	6.75	8.016	5.531	7.906
	A-2	Magnetic Compass Amplifier	6.75	10.063	5.5	7.313
	B-7A	Amplifier	5.5	6.297	4.094	7.703
	DT-173/AJN	Magnetic Azimuth Detector	1.6	2.281	3.5	4.906
	V-8	Indicator and Fast Slaving Switch	1.5	3.13 diam.		5.25
	873-0005	AC-DC Interlock Relay				
<u>AVQ-75 DME System</u>						
	MI-591083-1	Interrogator	10.7	7.62	3.69	15.12
	MI-591084-2	Distance Indicator	1.1	1.785	3.375	4.883
	AT-471/A	Antenna	0.3	3.91	1.75	5.25
	MI-591086	Shock Mount	1.5	3.45	3.69	12.5
	249D01900	Control Unit (Part of VHF Navigation System)	1.7	2.25	5.75	6.766
<u>VHF Navigation System</u>						
	51X2B	Receiver	10.5	7.5	3.563	12.563
	344B-1	Instrumentation Indicator Unit	13.0	7.625	3.688	14.688
	390E1	Mount	2.8	5.0	8.188	15.875
	ID-250/ARN	RMI	2.5	3.25	3.25	6.313
	ID-387/ARN	Course Indicator	3.75	3.25	3.25	8.0
	4018655-1	Antenna (Whip)				
	9227-4611	Omni Power Relay	0.4	1.05	1.5	1.562
	249D01900	DME & VOR Control Unit	1.7	2.25	5.75	6.766
<u>AAU-21/A Encoding Altimeter</u>			3.75	3.25	3.25	8.111

T-37B BIBLIOGRAPHY

T.O. Number	Chq/Rev	Title
1T-37B-01	1 Jul 75	List of Applicable Publications - T-37
1T-37B-1	1 Jul 75	Flight Manual - T-37B
1T-37B-2-6	30 Jun 77	Organizational Maintenance, Instruments, Radio, Communication, and Navigation Equipment - T-37B
1T-37B-2-8	1 Jul 77	Organizational Maintenance, Wiring Diagrams and Data - T-37B
5F3-3-16-2	4 Feb 74	Field Maintenance Bench Check, Altimeter, Encoder, Type AAU-21/A P/N C4154210003 (Kollsman)
5N1-2-4-1	15 Aug 72	Operational and Service, Slaved Gyro Magnetic Compass System, Type J-2 (Sperry)
12R2-4-29-2	12 Sep 72	Field Maintenance, VHF Navigation and Communications Receiver 51X-2B and Radio Set Control 614U-3A (Collins)
12R2-4-30-2	29 Jan 75	Field Maintenance, Instrumentation Unit, Type 344B-1 (Collins)
12R5-2ARN-193	4 Jan 74	Overhaul, Course Indicator, Type ID-387/ARN P/N 7204-1A-4-A1 (Eclipse-Pioneer)
12R5-2ARN-213	15 Dec 71	Overhaul, Radio Magnetic Indicator, Type ID-250A/ARN (Borg)
12R5-4-71-1	Dec 65	Instruction Manual, AVQ-75 DME System

T-38A PNWD EQUIPMENT LIST

KEY	EQUIPMENT/UNIT
AIMS	IFF-SIF SYSTEM AN/APX64
ALCM	CPU-46/A ALTITUDE COMPUTER
CMMM	INTERCOM SYSTEM AN/AIC -18
FDCS	FLIGHT DIRECTOR SYSTEM
HSDC	AQU-2/A COPILOT'S HSI
HSDP	AQU-2/A PILOT'S HSI
JBA	RADIO INTERCONNECTING BOX
RDA	DISCONNECT CONNECTOR
S	INSTRUMENT LANDING SYSTEM AN/ARN-58
T	TACAN SYSTEM AN/ARN-110

3.31.0
T-38A

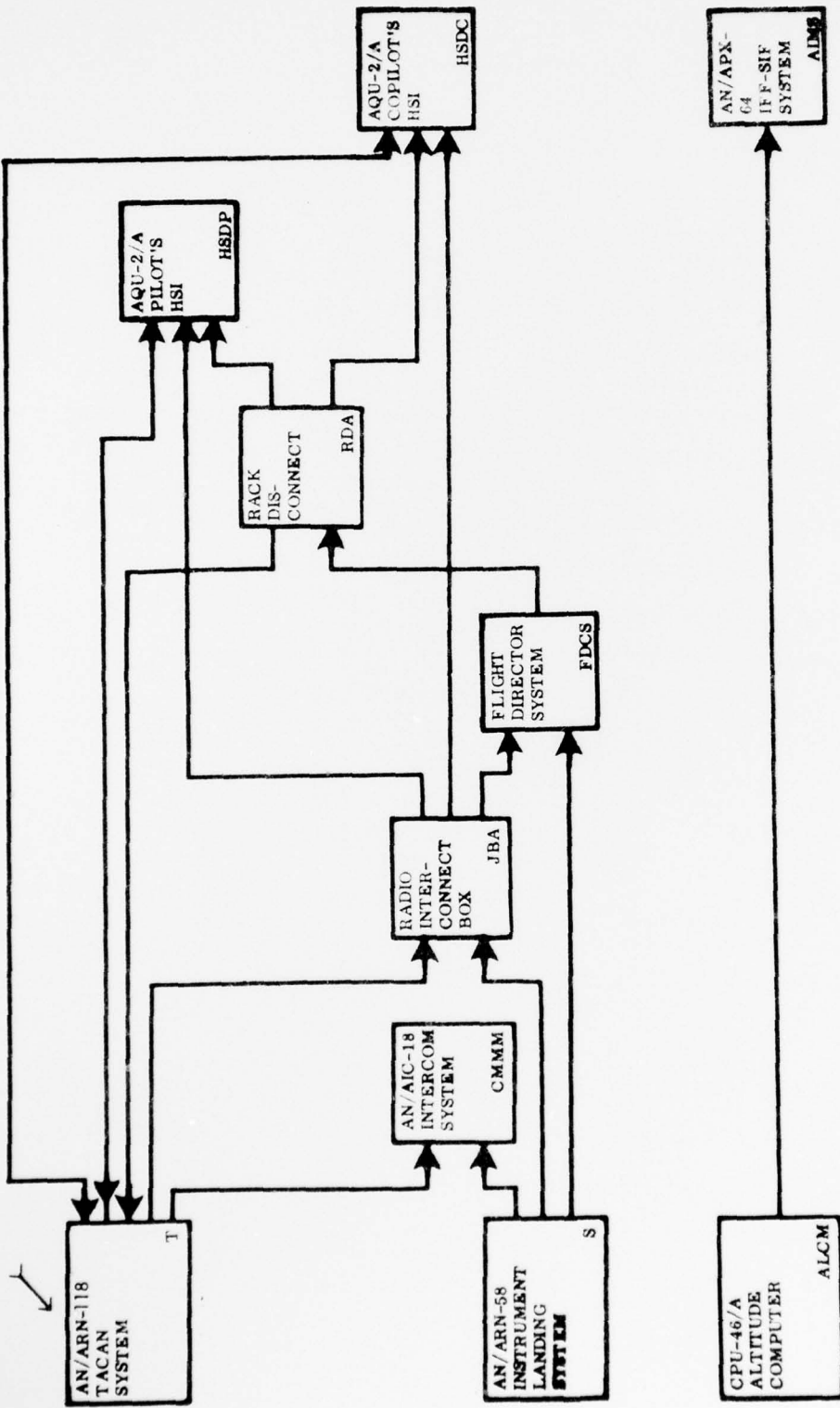

TITLE: PNWD SYSTEM		
AIRCRAFT	DATE	DIAGRAM
T-38A	6-30-76	1 of 1

3-31A-2

Change 4

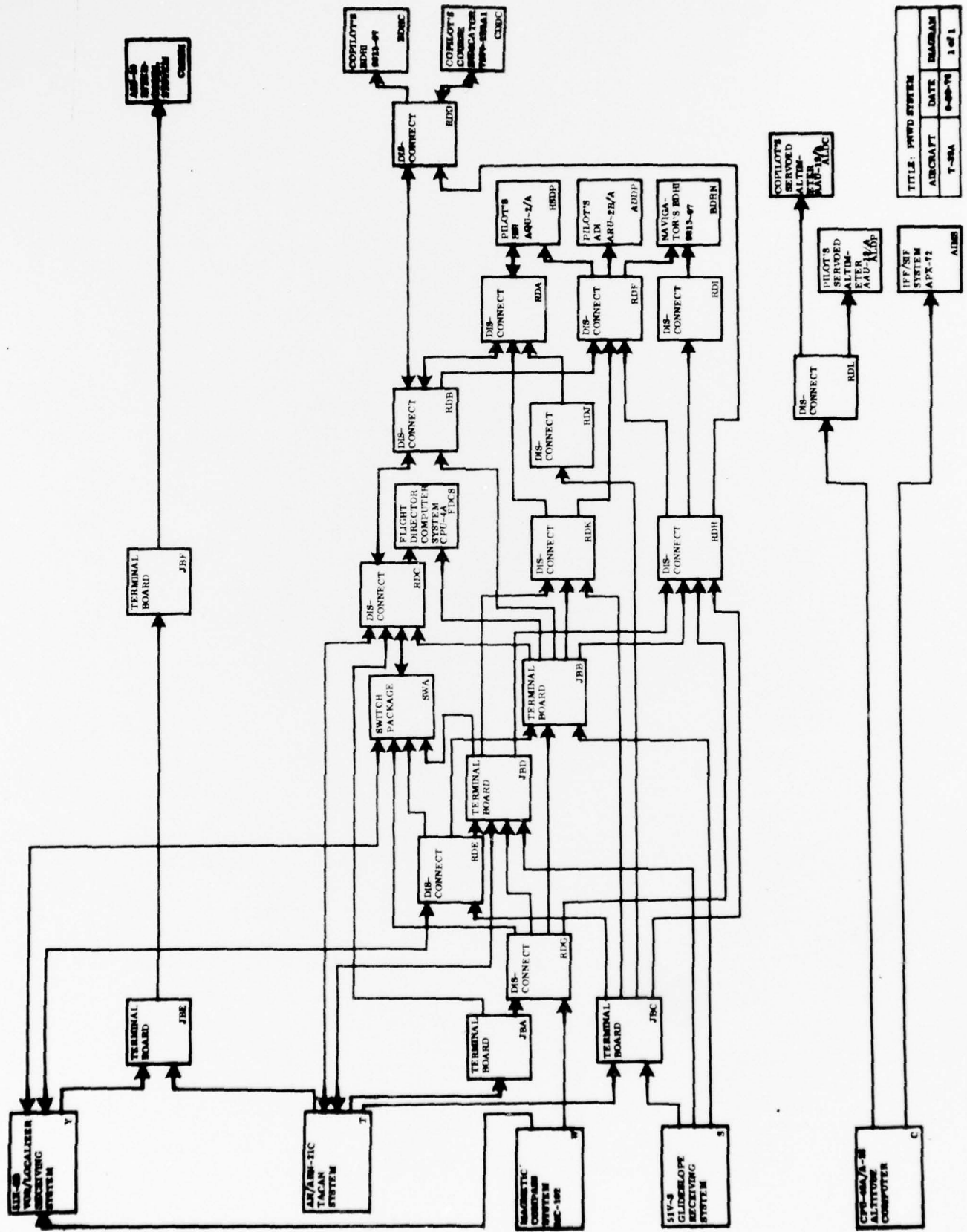

TITLE: PWD SYSTEM		
AIRCRAFT	DATE	DIAGRAM
T-38A	8-28-78	1 of 1

IFF/IF SYSTEM	ADSR
APA-72	

T-38A PMWD EQUIPMENT PHYSICAL CHARACTERISTICS

SYSTEM	UNIT		WT (LB)	SIZE (IN)			
	TYPE (P/N)	NOMENCLATURE		H	W	D	
AN/ARN-118(V) TACAN System	RT-1159/A 622-0507-001	Receiver-Transmitter	26.5	6.78	7.54	14.63	
	MT-4681/A 622-1782-001	Mounting	9.0	9.32**	10.55**	18.70**	
	C-9603/A 622-0748-001	Radio Set Control (2 ea)	2	3.0	5.75	5.43	
	GF 2147	TACAN Tone Filter	0.25	1.75	1.25	.875	
	SA-521A/A	Radio Frequency Transmission Line Switch	0.34	1.94	2.781	3.19	
	2334	Antenna (2 ea)	0.4	3.3	1.75	5.25	
	AQU-2/A	HSI (2 ea) (part of flight director)	8.5	4.313	5.063	9.5	
	MX-9577/A 622-1678-001	Adapter, Receiver-Transmitter	5.0	6.78	1.73	13.10	
	AN/ARN-58 Instrument Landing System						
	R-843A/ARN-58	Localizer Receiver	7.625*	7.75	6.875	5.593	
R-844/ARN-58	Glideslope-Marker Beacon Receiver	8.625	9.75	6.875	5.015		
37P4	Glideslope Antenna	0.7	5.984	2.0	4.5		
2279	Marker Beacon Antenna		2.70	5.63	12.63		
3-61389	VHF Antenna						
C-3491/ARN	ILS Control Panel (2 ea)	1.0	2.25	5.75	4.3125		
MS25331-3	Marker Beacon Light (2 ea)	0.06	0.75 diam.		2.250		
AQU-2/A	HSI (2 ea) (part of flight director)	8.5	4.313	5.063	9.5		
ARU-2A/A	ADI (2 ea) (part of flight director)	8.5	5.25	5.0	8.0		
MS25002-4	Mode Switches (part of flight director)	0.5	1.950 diam.		2.9		
*Includes mount							
**Electrical Equipment Mounting Base MT-4681/A (dimensions include RT-1159/A and MX-9577/A installed on MT-4681/A, and sway space)							

T-38A PIVD EQUIPMENT PHYSICAL CHARACTERISTICS

SYSTEM	UNIT		WT (LB)	SIZE (IN)		
	TYPE (P/N)	NOMENCLATURE		H	W	D
CPU-46/A	Altitude Computer		12 max	5.875	6.518	9.2
<u>Flight Director System</u>						
	AER60-1499	Attitude Gyro Control Assembly	32	6.385	6.385	12.188
	AER60-1500	Servo Amplifier	12*	6.875	6.5	10.125
	DT173AJN	Magnetic Azimuth Detector	1.6	2.281	3.5	4.906
	C99409901	Control Unit				
	AER60-5938(MC-1)	Rate Switching Gyro	1.5	2.65	2.44	4.802
	3-64153	Relay and Transformer Panel				
	TRU-2A/A	Rate Gyro Transmitter	1.75	3.875	3.25	5.31
	CPU-4/A	Flight Director Computer	6.25*	6.75	5.5	9.625
	MS25002-1	Flight Director Switch (2 ea)	0.31	1.950 diam.		2.151
	MS35059-23	Navigation Mode Switch (2 ea)	0.062	1.346	1.025	2.41
	204-HP5-5	Compass Mode Light				
	AQU-2/A	HSI (2 ea)	8.5	4.313	5.063	9.5
	ARU-2A/A	ADI (2 ea)	8.5	5.25	5.0	8.0
*Including shockmount						

T-38A BIBLIOGRAPHY

T.O. Number	Chq/Rev	Title
IT-38A-01	1 Mar 72	List of Applicable Publications - T-38A
IT-38A-1	1 Dec 76	Flight Manual - T-38A
IT-38A-2-9	1 Nov 76	Organizational Maintenance, Instruments - T-38A
IT-38A-2-10	1 May 76	Organizational Maintenance, Radio, Communications, and Navigation Systems - T-38A
IT-38A-2-11	1 Jul 77	Organizational Maintenance, Wiring Diagrams - T-38A
5F1-5-4-2	25 Oct 74	Field Maintenance, Integrated Flight Director System for T-38A Aircraft (Bendix)
5F5-4-13-13	1 Jul 74	Overhaul, Altitude Encoding Altitude Transducer Computer, Type CPU-46
5F5-4-13-22	1 May 75	Field Level Checkout Procedures, Altitude Encoding Transducer Altitude Computer, Altitude, Type CPU-46/A
5F5-5-3-2	15 Aug 74	Field Maintenance, Aircraft Flight Director Computer, Type CPU-4/A (Collins)
5N1-2-10-2	25 Oct 74	Field Maintenance, Aircraft Magnetic Gyro Compass, Type J-4, P/N S100-2C (Kearfott)
12R5-2ARN58-2	1 Dec 73	Field Maintenance, Radio Receiving Set, Type AN/ARN-58 (Collins)
12R5-2ARN58-12	25 Jul 75	Field Maintenance, Receiving Set, Radio AN/ARN-58 and AN/ARN-58A
12R5-2ARN118-1	15 Oct 76	Operation and Maintenance Instructions with Illustrated Parts Breakdown, TACAN Navigation Set AN/ARN-118(V)
MS25002	10 May 73	Switch, Rotary, 28/115 Volts

T-39A PNWD EQUIPMENT LIST

KEY	EQUIPMENT/UNIT
ADDP	PILOT'S ADI ARU-2B/A
AIMS	IFF/SIF SYSTEM APX-72
ALDC	COPILOT'S SERVOED ALTIMETER AAU-19/A
ALDP	PILOT'S SERVOED ALTIMETER AAU-19/A
BDHC	COPILOT'S BDHI 9813-07
BDHN	NAVIGATOR'S BDHI 9813-07
C	CPU-46A/A-26 ALTITUDE COMPUTER
CDDC	COPILOT'S COURSE INDICATOR 7207-1B5A1
CMMM	AIC-10 INTERCOMMUNICATION SYSTEM
FDCS	FLIGHT DIRECTOR COMPUTER SYSTEM CPU-4A
HSDP	PILOT'S HSI AQU-2/A
JBA	TERMINAL BOARD 11
JBB	TERMINAL BOARD 3
JBC	TERMINAL BOARD 5
JBD	TERMINAL BOARD 4
JBE	TERMINAL BOARD 8
JBF	TERMINAL BOARD 2
RDA	DISCONNECT A
RDB	DISCONNECT B
RDC	DISCONNECT C
RDD	DISCONNECT D
RDE	DISCONNECT E
RDF	DISCONNECT F

3.32.0
T-39A

F-39A PNWD EQUIPMENT LIST

KEY	EQUIPMENT/UNIT
RDG	DISCONNECT G
RDH	DISCONNECT H
RDI	DISCONNECT I
RDJ	DISCONNECT J
RDK	DISCONNECT K
RDL	DISCONNECT L
S	51V-3 GLIDESLOPE RECEIVING SYSTEM
SWA	SWITCH PACKAGE
T	TACAN SYSTEM AN/ARN-21C
W	MAGNETIC COMPASS SYSTEM MC-102
Y	51X-2B VOR/LOCALIZER RECEIVING SYSTEM

T-39A PNWD EQUIPMENT PHYSICAL CHARACTERISTICS

SYSTEM	UNIT		WT (LB)	SIZE (IN)		
	TYPE (P/N)	NOMENCLATURE		H	W	D
<u>Magnetic Compass System MC-102</u>						
	DT-173/AJN	Flux Detector	1.6	2.281	3.5	4.906
	328A-2A	Compass Amplifier	7.8	7.719	2.359	14.313
	332E-2	Directional Gyro	5.5	7.5	5.0	4.938
	327C-2	Compass Slave Indicator	0.3	1.375	2.0	3.5
	1900-3-B-3	Mode Selector Switch (part of flight director system)	0.14	1.1 diam.		1.68
	350X-1	Gyro Mount	0.5	2.5	5.125	5.125
<u>AN/ARN-21C TACAN System</u>						
	RT-220C/ARN-21	Receiver-Transmitter	60.0	8.3	11.13	18.75
	C-1763/ARN-21A	Control Panel	3.0	3.0	5.75	5.688
	9616-13	Coupler	8.0	4.9	5.802	6.375
	265-710921-20	Indicator Switching Unit		7.875	2.313	14.125
	C-2193B/A	Antenna Selector Switch	1.9	1.875	3.25	4.172
	SA-521/A	Coaxial Relay	0.34	1.94	2.781	3.19
		Band Pass Filter (2 ea)				
	AT-741/A	Antenna (2 ea)	0.4	3.3	1.75	5.25
	9813-07	BDHI (2 ea)	3.5	3.125 diam.		8.25
	7207-1B5A1	Course Indicator	3.0	3.125 diam.		6.781
	AQU-2/A	HSI	8.2	4.313	5.063	9.5
	MT-928/ARN-21	Mount (R-T Unit)	6.5	7.75	11.125	17.5
	C95635	Mount (Coupler)				
	MT-1932/A	Mount (Antenna Selector)	0.1	1.0	3.25	4.172
	MT-1995/A	Mount (Coaxial Relay)				
<u>VOR/ILS Navigation System</u>						
	51X-2B	VOR/LOC Receiver	6.0	7.625	2.25	12.56
	51V-3	Glidepath Receiver*	6.0	7.625	2.25	14.56
	344B-1	Instrumentation Unit	17.5	7.625	3.56	12.56
*DARE GS-20 is interchangeable						

T-39A PNWD EQUIPMENT PHYSICAL CHARACTERISTICS

SYSTEM	UNIT		WT (LB)	SIZE (IN)		
	TYPE (P/N)	NOMENCLATURE		H	W	D
<u>VOR/ILS Navigation System (Cont'd)</u>						
	VOR-566A	VOR/LOC Antenna	2.5	35.0	6.5	32.0
	37P-4	Glidepath Antenna	0.7	5.984	2.0	4.5
	614U-3A	Control Panel	1.7	2.25	5.75	6.766
	265-710921-20	Indicator Switching Unit (part of TACAN system)		7.875	2.313	14.125
	7207-1B5A1	Copilot's Course Indica- tor (part of TACAN system)	3.0	3.125 diam.		6.781
	ARU-2B/A	ADI	8.5	5.25	5.0	9.735
	AQU-2/A	HSI (part of TACAN system)	8.2	4.313	5.063	9.5
<u>Marker Beacon System</u>						
	51Z-2	Marker Beacon Receiver	4.9	7.625	2.25	12.563
	2278	Antenna	1.563	1.94	5.63	12.63
	VM303M	Marker Indicator Lights (6 ea)				
	265-710170	Relay Box				
	MS35058-23	Sensitivity Switch	0.10	1.157	0.641	2.236
<u>Flight Director System</u>						
	CPU-4A	Flight Director Computer	6.25**	6.75	5.5	9.625
	1900-3-B-3	Mode Switch	0.14	1.1 diam.		1.68
	MS35059-23	Heading Submode Switch	0.10	1.346	1.025	2.41
<u>Altitude Computer CPU-46/A</u>			12.0	5.875	6.518	9.2
**Includes Shockmount						

T-39A BIBLIOGRAPHY

T.O. Number	Chq/Rev	Title
IT-39A-01	1 Aug 72	List of Applicable Publications - T-39
IT-39A-1	30 Nov 76	Flight Manual - T-39A
IT-39A-2-5	15 Jul 76	Organizational Maintenance, Instruments and Electrical Systems - T-39A and T-39B
IT-39A-2-6	28 Mar 77	Organizational Maintenance, Radio Communications and Navigation Systems - T-39A and T-39B
IT-39A-2-8	8 Apr 77	Organizational Maintenance, Wiring Data and Diagrams - T-39A
5F5-4-13-33	1 Jun 75	Overhaul, Altitude Encoding Transducer Altitude Computer P/N31101 - (Bendix)
5F5-5-3-2	15 Aug 74	Field Maintenance, Aircraft Flight Director Computer, Type CPU-4/A
5F8-10-7-3	15 Nov 73	Overhaul, Remote Attitude Indicator, Type ARU-2B/A (Astronautics)
5F8-16-3-3	15 Jul 75	Overhaul, Horizontal Situation Indicator, Type AQU-2/A (Astronautics)
5N1-2-4-1	15 Aug 72	Operations and Service, Slaved Gyro Magnetic Compass System, Type J-2 (Sperry)
5N2-2-15-2	1 Jul 73	Field Maintenance, Magnetic Compass System MC-102 (Collins)
12R2-2A-43	16 May 69	Overhaul, Coaxial Switch Control Unit (Transco)
12R2-4-29-2	12 Sep 72	Field Maintenance, VHF Navigation and Communications Receiver 51X2B and Radio Set Control, 614U-3A (Collins)
12R2-4-30-2	29 Jan 75	Field Maintenance, Instrumentation Unit, Type 344B-1 (Collins)
12R5-2ARN21-42	20 Apr 72	Field Maintenance, Radio Set AN/ARN 21C
12R5-4-6-3	15 Dec 61	Overhaul, Glideslope Receiver Model 51V-1, -2 and -3 (Collins)

T-39A BIBLIOGRAPHY

T.O. Number	Chg/Rev	Title
12R5-4-29-13	15 Jan 75	Overhaul, Bearing Distance Heading Indicator, P/N 9813-07 (Sunbeam Electronics)
12R5-4-30-3	15 Jan 75	Overhaul, Bearing Distance Heading Indicator Coupler, P/N 9616-13 (Sunbeam Electronics)
12R5-4-32-3	14 Jun 72	Overhaul, Course Indicator, P/N 7207-1B-5-A1 (Eclipse Pioneer)
12R5-4-40-2	6 May 71	Field Maintenance, Marker Beacon, 51Z-2 (Collins)
8S9-4-12-2	25 Jun 73	Field Maintenance, Radio Indicator Switching Unit, P/N 265-710921-20 and P/N 265-710021-51 (North American)
MS25058	17 Nov 72	Switch, Toggle, One Pole, Sealed Toggle
MS25059	17 Nov 72	Switch, Toggle, Two Pole, Sealed Toggle
5N2-2-15-2	1 Jul 73	Field Maintenance, Magnetic Compass System MC-102 (Collins)

T-43A PNWD EQUIPMENT LIST

KEY	EQUIPMENT/UNIT
ADDC	COPILOT'S ADI 329B-9A
ADDP	PILOT'S ADI 329B-9A
AFCS	AUTOMATIC FLIGHT CONTROL SYSTEM SP-77
AIMS	IFF/ATC TRANSPONDER SYSTEM AN/APX-72
ALDC	COPILOT'S ALTIMETER AAU-19/A
ALDP	PILOT'S ALTIMETER AAU-19/A
BDHC	COPILOT'S BDHI ID-798/ARN
BDHD	NO.1 MAX PROFICIENCY STA BDHI ID-798/ARN
BDHE	NO.2 MAX PROFICIENCY STA BDHI ID-798/ARN
BDHP	PILOT'S BDHI ID-798/ARN
CA	NO.1 AIR DATA COMPUTER SYSTEM HG 1800-205
CMM	INTERPHONE SYSTEM
CSA	SIGNAL CONVERTER A
CSB	SIGNAL CONVERTER B
CSC	SIGNAL CONVERTER C
CSD	SIGNAL CONVERTER D
CSE	SIGNAL CONVERTER E
FDCA	NO.1 STEERING COMPUTER 522-4703-002
FDCB	NO.2 STEERING COMPUTER 522-4703-002
GA	NO.1 RADIO ALTIMETER SYSTEM ALA-51A
GRND	GROUND
HSDC	COPILOT'S HSI 331A-8H
HSDP	PILOT'S HSI 331A-8H

3.33.0
T-43A

T-43A PNWD EQUIPMENT LIST

KEY	EQUIPMENT/UNIT
KA	NO.1 ALTITUDE COMPUTER CPU-66/A-14
KB	NO.2 ALTITUDE COMPUTER CPU-66/A-14
RADC	COPILOT'S RADIO ALT IND 2067635-0701
RADP	PILOT'S RADIO ALT IND 2067635-0701
RCA	RACK DISCONNECT AA
RCB	RACK DISCONNECT AB
RCC	RACK DISCONNECT AC
RCD	RACK DISCONNECT AD
RCE	RACK DISCONNECT AE
RCF	RACK DISCONNECT AF
RCG	RACK DISCONNECT AG
RCH	RACK DISCONNECT AH
RCJ	RACK DISCONNECT AJ
RCK	RACK DISCONNECT AK
RCL	RACK DISCONNECT AL
RCM	RACK DISCONNECT AM
RCH	RACK DISCONNECT AN
RCP	RACK DISCONNECT AP
RCQ	RACK DISCONNECT AQ
ROR	RACK DISCONNECT AR
RCS	RACK DISCONNECT AS
RCT	RACK DISCONNECT AT
RCU	RACK DISCONNECT AU

T-43A PNWD EQUIPMENT LIST

KEY	EQUIPMENT/UNIT
RCV	RACK DISCONNECT AV
RCW	RACK DISCONNECT AW
RCX	RACK DISCONNECT AX
RCY	RACK DISCONNECT AY
RCZ	RACK DISCONNECT AZ
RDA	RACK DISCONNECT A
RDB	RACK DISCONNECT B
ADC	RACK DISCONNECT C
RDD	RACK DISCONNECT D
RDE	RACK DISCONNECT E
RDF	RACK DISCONNECT F
RDG	RACK DISCONNECT G
RDH	RACK DISCONNECT H
RDJ	RACK DISCONNECT J
RDK	RACK DISCONNECT K
RDL	RACK DISCONNECT L
RDM	RACK DISCONNECT M
RDN	RACK DISCONNECT N
RDP	RACK DISCONNECT P
RDQ	RACK DISCONNECT Q
RDR	RACK DISCONNECT R
RDS	RACK DISCONNECT S
RDT	RACK DISCONNECT T

T-43A PNWD EQUIPMENT LIST

KEY	EQUIPMENT/UNIT
RDU	RACK DISCONNECT U
RDV	RACK DISCONNECT V
RDW	RACK DISCONNECT W
RDX	RACK DISCONNECT X
RDY	RACK DISCONNECT Y
RDZ	RACK DISCONNECT Z
REA	RACK DISCONNECT BA
REB	RACK DISCONNECT BB
REC	RACK DISCONNECT BC
RED	RACK DISCONNECT BD
REE	RACK DISCONNECT BE
REF	RACK DISCONNECT BF
REG	RACK DISCONNECT BG
REH	RACK DISCONNECT BH
REJ	RACK DISCONNECT BJ
REK	RACK DISCONNECT BK
RMDC	COPILOT'S RMI 2588282-655
RMDP	PILOT'S RMI 36154-1AJ25B1
SWA	SWITCH POINT A
SWB	SWITCH POINT B
SWC	SWITCH POINT C
SWD	SWITCH POINT D
SWE	SWITCH POINT E

T-43A PNWD EQUIPMENT LIST

KEY	EQUIPMENT/UNIT	
TA	NO.1 TACAN SYSTEM AN/ARN-65(V)	█
TAED	TAT/ERPL INDICATOR 10-61484-2	█
UA	NO.1 VHF NAV SYSTEM	█
UB	NO.2 VHF NAV SYSTEM	
WA	ATTITUDE HDG REF SYSTEM A/A24G-1A	
WB	C-9D COMPASS SYSTEM	
ZA	NO.1 ADF RADIO SYSTEM	

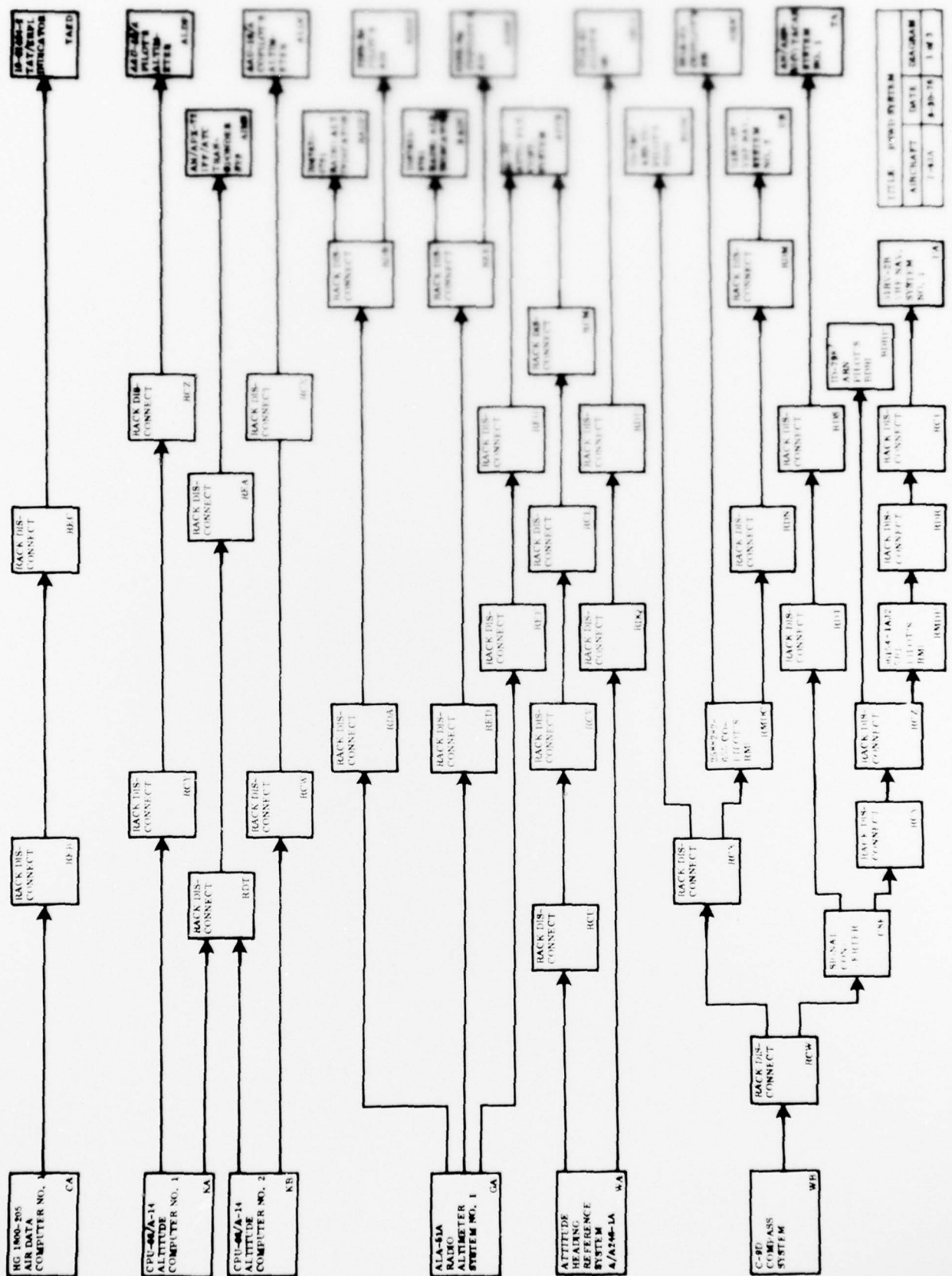

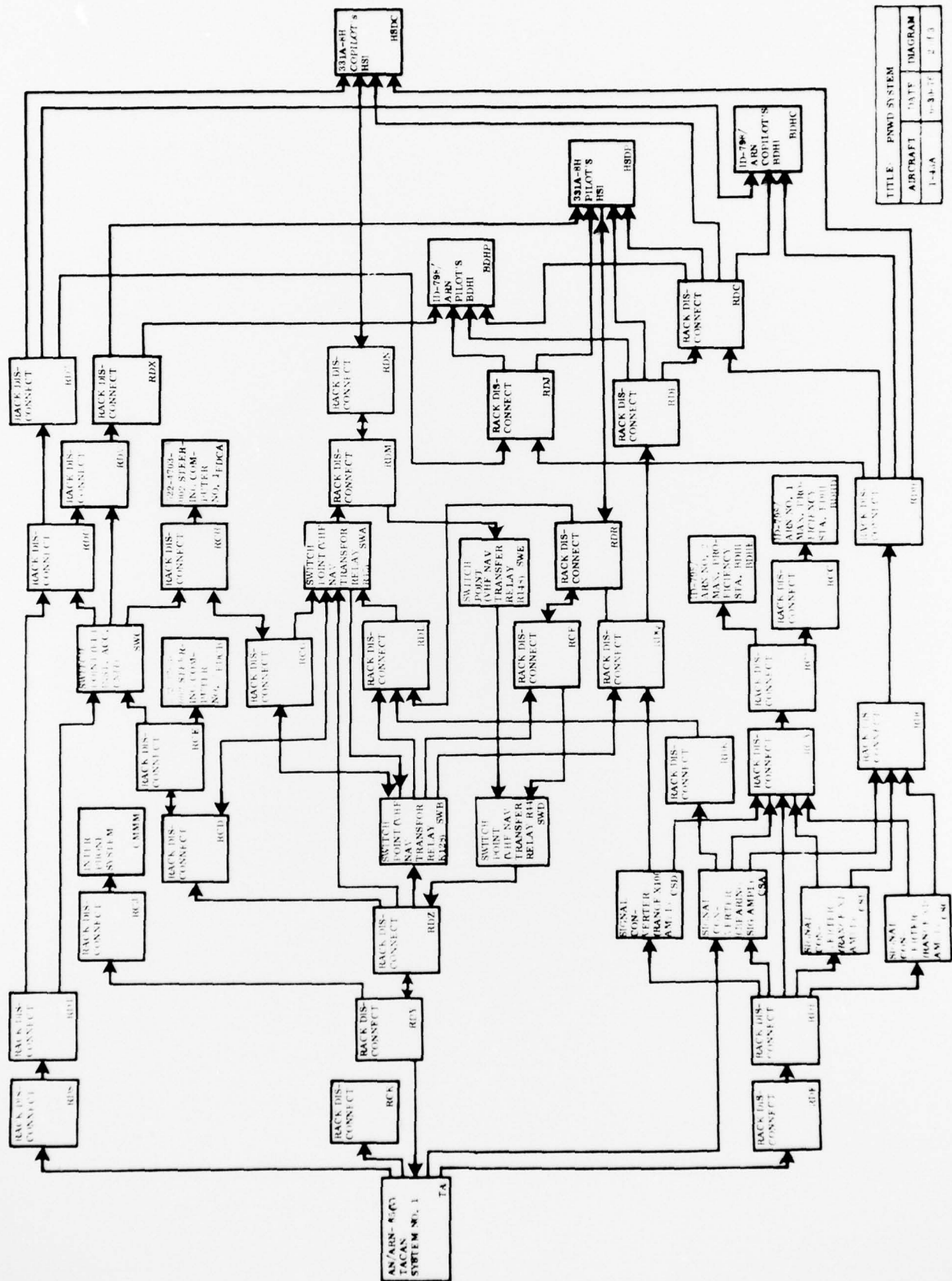

TITLE	PWD SYSTEM
AIRCRAFT	DATE
1-4-A	1-3-67
	DIAGRAM
	2 / 3

T-43A PNWD EQUIPMENT PHYSICAL CHARACTERISTICS

SYSTEM	UNIT		WT (LB)	SIZE (IN)		
	TYPE (P/N)	NOMENCLATURE		H	W	D
<u>Flight Director System FD-108</u>						
	562A-5F4	Steering Computer (2 ea)	8.0	7.65	2.25	14.7
	331A-8H	Horizontal Situation Indicator (2 ea)	7.5	4.068	4.812	8.75
	329B-9A	Attitude Director Indicator (2 ea)	9.5	4.975	4.975	9.0
	10-61330-28	Approach Progress Display Annunciator (2 ea)				
	614E-10D	Mode Selector Unit	2.0	2.25	4.0	4.5
	65-52805-175	Flight Instrument Accessory Unit				
	175095-001	VHF NAV Transfer Relay (4 ea)	4.375	7.125	3.313	4.875
	5990-711-8111-NT	Signal Amplifier (4 ea)				
<u>Attitude Heading Reference System A/A24G-1A</u>						
	138255-01-01	Compass Adapter	8.5	4.692	5.10	12.56
	139100-01-01	Displacement Gyro Assembly*	26.5	7.592	7.125	15.187
	138213-01-01	Amplifier-Power Supply*	9.25	3.54	5.0	12.906
	SG/131312-01	Compass Control				
	140540-01-01	Switching Rate Gyroscope	1.6	2.650	2.440	4.802
	2589419-901	Flux Valve	2.0	2.545	4.0	5.0
<u>C-9D Compass System</u>						
	2588302-4	Directional Gyro	9.2	7.25	7.34	8.34
	614937-101	Compass Rack	3.65	7.656	2.5	14.28
	ME-1A	Heading Amplifier	9.5	6.125	4.5	10.875
	2589419-901	Flux Valve	2.0	2.545	4.0	5.0
	2589420-901	Remote Magnetic Com- pensator	1.1	2.25	5.75	3.0
*Includes mount						

T-43A PNWD EQUIPMENT PHYSICAL CHARACTERISTICS

SYSTEM	UNIT		WT (LB)	SIZE (IN)		
	TYPE (P/N)	NOMENCLATURE		H	W	D
<u>TACAN System AN/ARN-65(V)</u>						
	RT-471/ARN-65	TACAN R/T Unit	50.0	9.0*	17.375	9.375
	C-4457(P)/ARN-21C	TACAN Control	3.0	3.0	5.75	5.688
	10-61311-3	Top Antenna				
	10-61311-3	Bottom Antenna				
	SA-521/A	TACAN No. 1 RF Switch	0.34	1.94	2.78	3.19
	MT-2091/ARN-65	TACAN No. 1 Mount	2.25	2.25	17.656	9.563
	ID-798/ARN	BDHI (4 ea)	4.0	3.25	3.25	6.875
<u>VHF NAV System</u>						
	51RV-2B	Navigation Unit (2 ea)	18.8	7.62	4.88	12.62
	313N-6B	Control Panel (2 ea)	1.8	2.625	5.75	3.75
	10-61333-2	VOR/LOC Antenna				
	10-2064	GS Antenna				
<u>Radio Altimeter System ALA-51A</u>						
	2067631-0506	Receiver-Transmitter	14.9	7.62	4.88	12.62
	2067635-0701	Height Indicator (2 ea)	2.0	3.26	3.26	5.0
	437X-1A	Receive Antenna	1.0	2.89	7.0 diam.	
	ANA-51C	Transmit Antenna	1.5	7.0 diam.		2.98
<u>Air Data Computer System HG 1800-205</u>						
	10-61439-205	Air Data Computer	19.0	7.62	4.88	19.62
	10-61484-2	TAT/EPRL Indicator				
<u>Altitude Computer System</u>						
	CPU-66/A-14	Altitude Computer (2 ea)	6.0	4.5	4.0	9.9
	AAU-19/A	Altimeter (2 ea)	4.5	3.25	3.25	8.81

T-43A PNWD EQUIPMENT PHYSICAL CHARACTERISTICS

SYSTEM	UNIT		WT (LB)	SIZE (IN)		
	TYPE (P/N)	NOMENCLATURE		H	W	D
<u>ADF System 51Y-4</u>	51Y-4	Receiver	9.8	7.625	2.25	14.625
	(P9-7)	Control	1.8	2.625	5.75	4.938
	65-58281-1	Sense Antenna				
	CMA-73D-125	Sense Antenna Coupler	1.25	2.0	2.27	3.05
	137A-5	Loop Antenna	7.4	0.9	12.0	19.95
	582A-2N	Quadrantal Error Corrector	0.3	2.1	3.31	2.07
	36154-1AJ25B1	Pilot's RMI	2.5	3.26	3.26	7.0
	2588282-655	Copilot's RMI	4.1	3.287	3.287	8.53
	65-52804-73	Audio Accessory Unit				
<u>Marker Beacon</u>	51Z-4	Receiver*	3.2	3.47	2.39	14.19
	69-37302-132	Marker Beacon Lights (Pilots)				
	69-37310-130	Marker Beacon Lights (Copilots)				
	DMN27-2	Antenna				
	65-52804-73	Audio Accessory Unit				
*Includes mount						

T-43A BIBLIOGRAPHY

T.O. Number	Chg/Rev	Title
1T-43A-01	1 Nov 74	List of Applicable Publications - T-43A
1T-43A-1	18 Jan 77	Flight Manual - T-43A
1T-43A-2-4-3	15 Nov 76	Organizational Maintenance, Navigation Systems - T-43A
1T-43A-2-12	1 Nov 76	Organizational Maintenance, Wiring Diagrams - T-43A
5A2-7-2-3	30 May 75	Overhaul, Compass Adapter-Compensator ADK-182/A24G-1A
5A3-49-3	1 Feb 74	Overhaul, Amplifier-Power Supply ASK-13/A24G-1A
5A11-2-47-3	1 Mar 74	Overhaul, Displacement Gyroscope Assembly, SBK-8/A24G-1A
5F3-3-15-13	10 Nov 75	Overhaul, Counter-Drum-Pointer Servoed Altimeter, AAU-19/A
5F6-3-11-3		Overhaul, Compass Controller, Model 3804C, P/N 131312-01 (Lear)
5N8-5-11-3	15 May 75	Overhaul, Indicator, Bearing Distance Heading, Type ID-798/ARN
12R5-2ARN65-2	1 Jul 71	Field Maintenance, Radio Set, AN/ARN-65 (Hoffman)
12R5-4-93-12	1 Oct 74	Field Maintenance with Overhaul, Horizontal Situation Indicator, Type 331A-8H (Collins)
12R5-4-100-1	1 Sep 75	Overhaul with Parts Breakdown - 614L-8 ADF Control Unit C-6899/ARN-83 ADF Control Unit (Collins)
12R5-4-101-1	15 Jan 75	Overhaul with Parts Breakdown - 51Y-4-4A, ADF Receiver P/N 522-1836-00 522-2587-00 (Collins)
12R5-4-102-1	15 Jan 75	Overhaul with Parts Breakdown - Fixed Loop Antenna 137A-4/5/6/6A/6B P/N 522-2301-00, 522-2615-00, 522-1387-00, 522-3761-00, 522-4853-00 and Loop Antenna AS-1863/ARN-83 (Collins)