

AD-A061 601

NAVAL SURFACE WEAPONS CENTER WHITE OAK LAB SILVER SP--ETC F/G 9/1
MINIMIZING THE WORST-CASE DRIFT OF AN ACTIVE BANDPASS FILTER, (U)
APR 78 S MARTIN

UNCLASSIFIED

NSWC/WOL/TR-78-2

NL

1 of 2
AD
A061 601

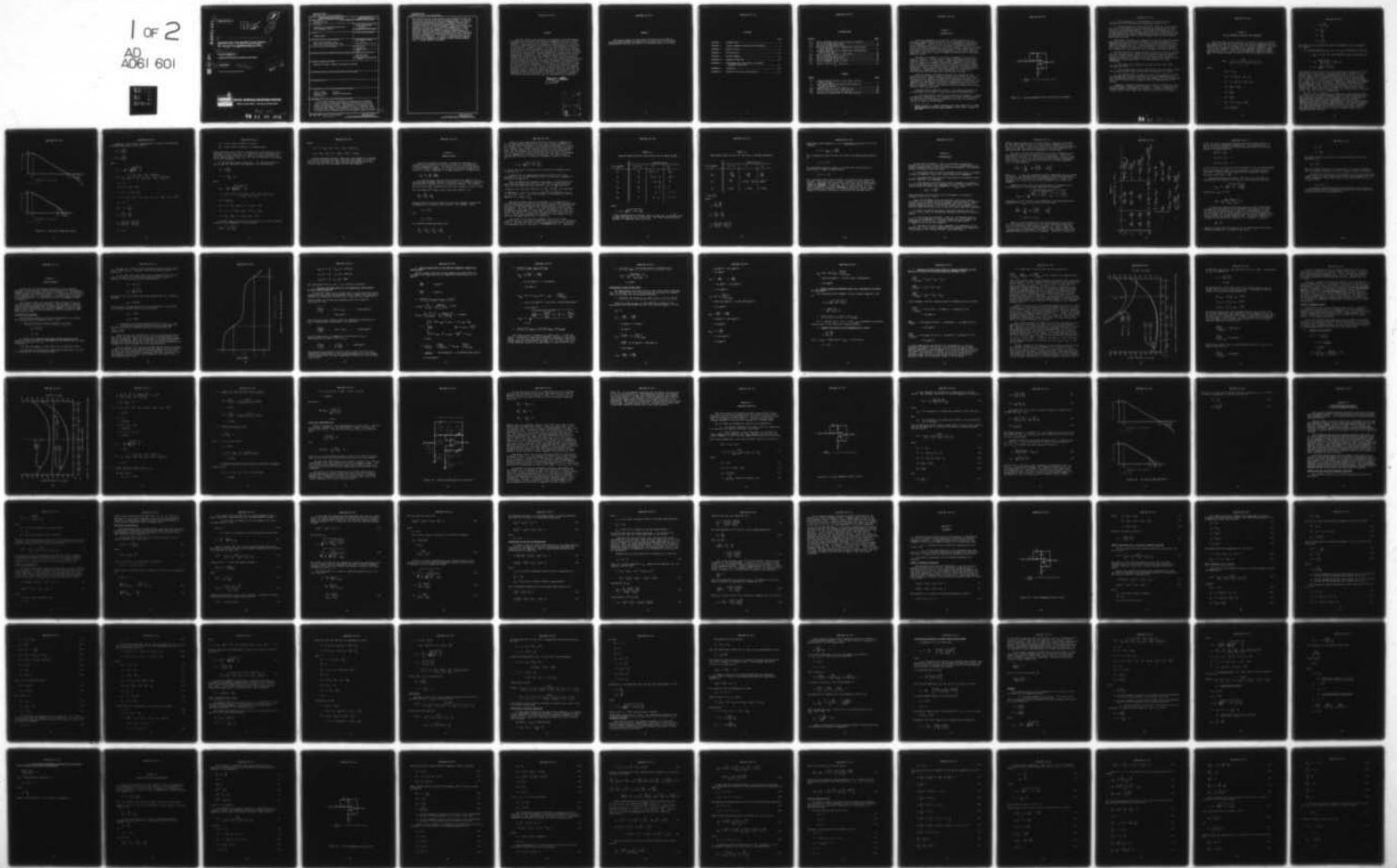

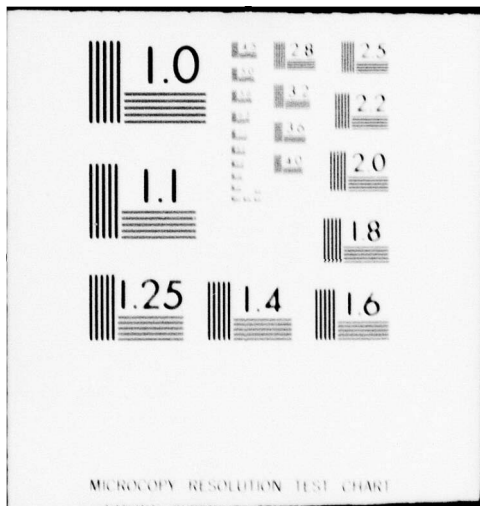

MICROCOPY RESOLUTION TEST CHART

AD A061601

14

NSWC/WOL/TR-78-2

LEVEL II

(Handwritten initials and circled numbers)

6
**MINIMIZING THE WORST-CASE DRIFT
OF AN ACTIVE BANDPASS FILTER,**

10
BY **STEPHEN MARTIN**

ORDNANCE SYSTEMS DEVELOPMENT DEPARTMENT

11
11 APRIL 1978

120 136 p.

DDC
NOV 23 1978
(Stamp with handwritten initials)

Approved for public release, distribution unlimited.

DDC FILE COPY



NAVAL SURFACE WEAPONS CENTER

Dahlgren, Virginia 22448 • Silver Spring, Maryland 20910

391 596
78 11 24 051 *mt*

UNCLASSIFIED

SECURITY CLASSIFICATION OF THIS PAGE (When Data Entered)

REPORT DOCUMENTATION PAGE		READ INSTRUCTIONS BEFORE COMPLETING FORM
1. REPORT NUMBER NSWC/WOL/TR 78-2 ✓	2. GOVT ACCESSION NO.	3. RECIPIENT'S CATALOG NUMBER
4. TITLE (and Subtitle) Minimizing the Worst-Case Drift of an Active Bandpass Filter		5. TYPE OF REPORT & PERIOD COVERED Design Optimization Procedure
		6. PERFORMING ORG. REPORT NUMBER
7. AUTHOR(s) Stephen Martin		8. CONTRACT OR GRANT NUMBER(s)
9. PERFORMING ORGANIZATION NAME AND ADDRESS ✓ Naval Surface Weapons Center White Oak, Silver Spring, MD 20910		10. PROGRAM ELEMENT, PROJECT, TASK AREA & WORK UNIT NUMBERS 0; CU21; NSWC0910-PMS402; CU21-KA;
11. CONTROLLING OFFICE NAME AND ADDRESS		12. REPORT DATE 11 April 78
		13. NUMBER OF PAGES 138
14. MONITORING AGENCY NAME & ADDRESS (if different from Controlling Office)		15. SECURITY CLASS. (of this report) UNCLASSIFIED
		15a. DECLASSIFICATION/DOWNGRADING SCHEDULE
16. DISTRIBUTION STATEMENT (of this Report) Approved for public release; distribution unlimited		
17. DISTRIBUTION STATEMENT (of the abstract entered in Block 20, if different from Report)		
18. SUPPLEMENTARY NOTES		
19. KEY WORDS (Continue on reverse side if necessary and identify by block number) Active Filters Filters Bandpass Filters Operational Amplifiers Sensitivities		
20. ABSTRACT (Continue on reverse side if necessary and identify by block number) This report presents a technique for designing active bandpass filters that will be relatively insensitive to drifting circuit components (including the op amp). The procedure can be applied to the design of single stage, two pole bandpass filters or individual stages of multiple pole filters. The filter circuit requires only one op amp and employs positive feedback that can be increased to make the filter → next page		

DD FORM 1473
1 JAN 73

EDITION OF 1 NOV 65 IS OBSOLETE
S/N 0102-014-6601

UNCLASSIFIED

SECURITY CLASSIFICATION OF THIS PAGE (When Data Entered)

UNCLASSIFIED

SECURITY CLASSIFICATION OF THIS PAGE(When Data Entered)

less sensitive to the op amp characteristics; however this makes the circuit more sensitive to the passive component values. In order to determine the optimum amount of positive feedback, formulas are derived which describe the approximate sensitivities of the filter transfer function to the passive component values and to three op amp parameters, as functions of the "positive feedback ratio." These sensitivity formulas are combined to yield an expression for the worst-case drifts of three filter parameters (center frequency, Q, and gain). Optimization techniques are applied in order to determine the positive feedback ratio that minimizes the worst-case drift of a selected filter parameter. A criterion is developed which combines all three filter parameters to compute an overall optimum feedback ratio. A design example is presented.

UNCLASSIFIED

SECURITY CLASSIFICATION OF THIS PAGE(When Data Entered)

SUMMARY

The two goals of this paper are to develop a straightforward procedure for optimizing the positive feedback ratio in an active bandpass filter circuit, the "multiple feedback section," and to achieve a reasonably simple mathematical description of the effects of the positive feedback ratio and of op amp parameters on drift of the filter transfer function. To this end formulas are derived which describe the approximate sensitivities of the filter transfer function to each of three op amp parameters and each of the six passive circuit components. These formulas are combined with several assumptions regarding circuit component drifts to yield a set of expressions for the worst case drifts of three filter parameters (center frequency, Q , and gain). By applying optimization techniques to these worst case drifts, a formula is derived to calculate the positive feedback ratio that minimizes the worst case drift of any of the three filter parameters. A criterion is developed to weigh the significance of drifts of each of the three filter parameters in order to arrive at the "overall optimum" value for the positive feedback ratio. Synthesis equations are derived for use after the positive feedback ratio has been optimized. An example is used to demonstrate both the mechanics of the optimization and synthesis procedures and some practical uses of the sensitivity formulas.

Edward C. Whitman

E. C. WHITMAN
By direction

ACQUISITION FOR	
NTIS	Write Section <input checked="" type="checkbox"/>
DOC	Buff Section <input type="checkbox"/>
UNCLASSIFIED	<input type="checkbox"/>
CLASSIFICATION	
BY	
DISTRIBUTION/AVAILABILITY CODES	
	SPECIAL
A	

NSWC/WOL TR 78-2

PREFACE

The author wishes to thank Dennis Stutzel for his idea of using maximum passband gain drift as a criterion for the "overall optimization" and for his efforts in reviewing much of this work.

CONTENTS

	Page
CHAPTER 1 INTRODUCTION.....	5
CHAPTER 2 FILTER TRANSFER FUNCTION AND SYNTHESIS.....	9
CHAPTER 3 SENSITIVITIES.....	15
CHAPTER 4 OPTIMIZATION.....	21
CHAPTER 5 DESIGN SUMMARY.....	27
APPENDIX A TRANSFER FUNCTION.....	49
APPENDIX B APPROXIMATIONS APPLICABLE TO COMPLEX TRANSFER FUNCTIONS.....	55
APPENDIX C SYNTHESIS.....	65
APPENDIX D SENSITIVITIES AND OPTIMIZATION.....	85

ILLUSTRATIONS

<u>Figure</u>		<u>Page</u>
1-1	Active Bandpass Filter with Positive Feedback.....	6
2-1	Two Pole Op Amp Bode Plots.....	11
5-1	Two Pole Op Amp Phase Shift.....	29
5-2	Maximum Expected Filter Temperature Coefficients (μ A741 Op Amp).....	38
5-3	Maximum Expected Filter Temperature Coefficients (HA-2510 Op Amp).....	41
5-4	Practical Realization of the Filter.....	45
A-1	Active Bandpass Filter Circuit.....	50
A-2	Two Pole Op Amp Bode Plots.....	53
C-1	Active Bandpass Filter Circuit.....	66
D-1	Active Bandpass Filter Circuit.....	87
D-2	Typical Plot of $S_{\omega_{ul}}^Q$ Versus g_1	112

TABLES

<u>Table</u>		<u>Page</u>
3-1	Passive Sensitivities of the Filter with an Ideal Op Amp.....	17
3-2	Approximate Sensitivities of the Filter to Op Amp Parameters.....	18
4-1	Expressions for a_u , b_u , and c_u	23
D-1	Passive Sensitivities (Ideal Op Amp).....	100
D-2	a_u , b_u , and c_u , for f_0 , Q and H_0	127
D-3	Sensitivity Comparison for H_{PB} Optimization.....	134

Chapter 1

INTRODUCTION

A critical property of any filter is the stability of its frequency response characteristics in the presence of drifting circuit components. With an active filter, unacceptable instability in the transfer function can be the result of excessive drift in either the passive elements or the active element. When one of these two sources contributes substantially more to the overall drift of the filter than the other, the performance of the filter could be improved if there were a way to reduce its sensitivity to the major source of drift.

The positive feedback in the active bandpass filter circuit shown in Figure 1-1 can be used to adjust the sensitivities of its transfer function. In particular, Geffe (Reference 1) has shown that increases in the amount of positive feedback in the circuit tend to increase the sensitivities to drifts in the passive components and decrease the sensitivities to changes in certain active parameters. This suggests that there might be an optimum value for the positive feedback in a given application of this circuit. Unfortunately this optimum value is difficult to find.

Geffe developed a workable technique for calculating the sensitivities of center frequency and Q of the filter for cases in which the active element, an operational amplifier (op amp), can be modeled as an amplifier having up to two poles and one zero. His approach for optimizing the positive feedback was to calculate the sensitivities by computer for several different values of ρ , the positive feedback ratio, and then try to pick the best value on the basis of these calculations.

Although Geffe's approach solves a very complex problem with a high degree of accuracy, it does have several disadvantages.

1. The sensitivity formulas are sufficiently complex to require a computer; consequently, it is difficult to gain an intuitive feel for the effect of the positive feedback ratio and the individual effects of each op amp parameter.

-
1. Geffe, Philip R., "Exact Synthesis with Real Amplifiers," IEEE TRANSACTIONS ON CIRCUITS AND SYSTEMS, Volume CAS-21, Number 3, May 1974.

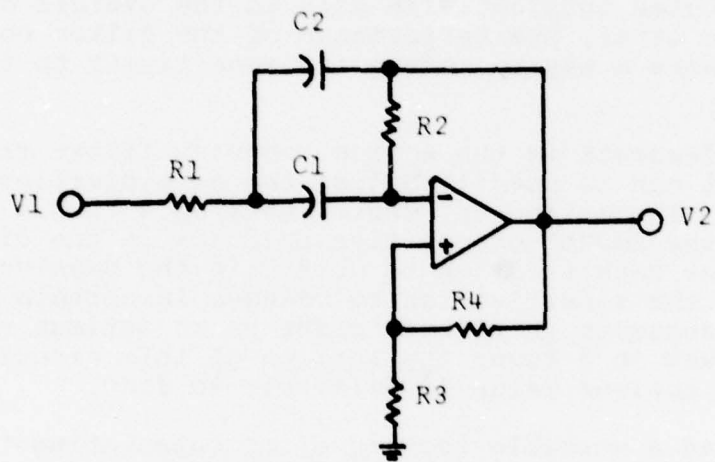

$$\rho = \frac{R3}{R3+R4} = \text{POSITIVE FEEDBACK RATIO}$$

Figure 1-1. Active Bandpass Filter with Positive Feedback

2. The optimization is accomplished by trial and error (sensitivities are calculated for arbitrary values of ρ).

3. The optimization could conceivably result in a poor choice of ρ unless the sensitivity calculations are repeated for various values of the op amp parameters. This author has found that not all active sensitivities decrease monotonically in magnitude as the op amp becomes more ideal; consequently the sensitivities calculated on the basis of worst case op amp parameters may not be the worst case sensitivities.

This report develops a new approach to the optimization problem. Approximations are utilized to achieve a relatively simple set of formulas that describe the filter sensitivities as functions of the positive feedback ratio (ρ). These formulas are used as the basis for a worst case drift analysis of the filter. The final result is a formula for the value of ρ that minimizes the worst case drift.

The new approach is simple enough to yield an intuitive insight into the various factors affecting the sensitivities; the optimization is direct rather than by trail and error; and the worst case drift analysis is based on the worst case active sensitivities. Accompanying these advantages to the new approach are three weaknesses.

1. The sensitivity formulas are less accurate than those developed by Geffe.

2. The op amp model is more restrictive than that used by Geffe (the op amp transfer function can have two poles but no zeros).

3. The optimization is based on a worst case analysis in which two assumptions were made regarding the circuit component drifts: (1) the possible range of drift for each component is centered around zero; and (2) each circuit component drifts independently of the others.

Chapters 2 through 4 summarize the results of derivations that were performed in Appendices A through D. Chapter 5 summarizes the design procedure and presents an example. A reader interested in a quick look at this report may wish to skip directly to Chapter 5.

Chapter 2

FILTER TRANSFER FUNCTION AND SYNTHESIS

The first step in the analysis of an active filter is to derive the filter transfer function in terms of circuit components and op amp parameters. We will assume that the passive components are ideal and that the op amp can be modeled as a two pole amplifier, ideal in all other respects (infinite input impedance, infinite common mode rejection, etc.). With these assumptions, Appendix A shows that the voltage transfer function of the filter shown in Figure 1-1 is

$$H(s) = \frac{-N_1 s}{T_4 s^4 + T_3 s^3 + T_2 s^2 + T_1 s + T_0}$$

where

$$T_0 = 1 + G_0$$

$$T_1 = (1 + G_0) D_1 - N_1 + G_1$$

$$T_2 = (1 + G_0) D_2 + D_1 G_1 + G_2$$

$$T_3 = D_2 G_1 + D_1 G_2$$

$$T_4 = D_2 G_2$$

$$N_1 = C_1 R_2$$

$$D_1 = (C_1 + C_2) R_1 + C_1 R_2$$

$$D_2 = C_1 C_2 R_1 R_2$$

$$\rho = \frac{R_3}{R_3 + R_4}$$

$$G_0 = \frac{1}{A_{DC}} - \rho$$

$$G_1 = \frac{1}{\omega_{u1}}$$

$$G_2 = \frac{1}{\omega_{u2}^2}$$

The term ρ will be called the "positive feedback ratio" throughout this report.

The op amp parameters A_{DC} , ω_{u1} , and ω_{u2} are defined as follows:

1. A_{DC} is the DC (or low frequency) open loop op amp gain.

$$2. \quad \omega_{u1} = \frac{A_{DC} \omega_{p1} \omega_{p2}}{\omega_{p1} + \omega_{p2}} \approx A_{DC} \omega_{p1}$$

$$3. \quad \omega_{u2} = \sqrt{A_{DC} \omega_{p1} \omega_{p2}}$$

where ω_{p1} and ω_{p2} are the first and second (main and parasitic) pole frequencies of the op amp in radians per second. Figures 2-1 (a) and (b) show a graphical interpretation for ω_{u1} and ω_{u2} . If the second segment (the -20 dB per decade portion) of an op amp Bode plot is extended, it crosses the unity gain level at the frequency ω_{u1} . Thus, ω_{u1} is the unity gain bandwidth of the op amp (in radians per second) due to the first pole. Similarly, extending the segment of the Bode plot that is beyond the second pole (the -40 dB per decade segment) results in a unity gain crossover point at a frequency ω_{u2} . When referring to frequencies in Hertz rather than radians per second, the terms ω_{p1} , ω_{p2} , ω_{u1} , and ω_{u2} will be replaced by f_{p1} , f_{p2} , f_{u1} , and f_{u2} , respectively.

Because of the complexity of finding the center frequency and effective Q of a four pole bandpass function (with two desired poles and two parasitic poles), it is necessary to utilize some type of approximation technique before proceeding with the analysis. Appendix B describes two such techniques which we will call "Geffe's approximation" and the "phase approximation." The former approximation was developed by Philip Geffe as a basis for exact synthesis and sensitivity analysis of active filters; the latter technique was developed by this author in order to simplify sensitivity analysis of this circuit.

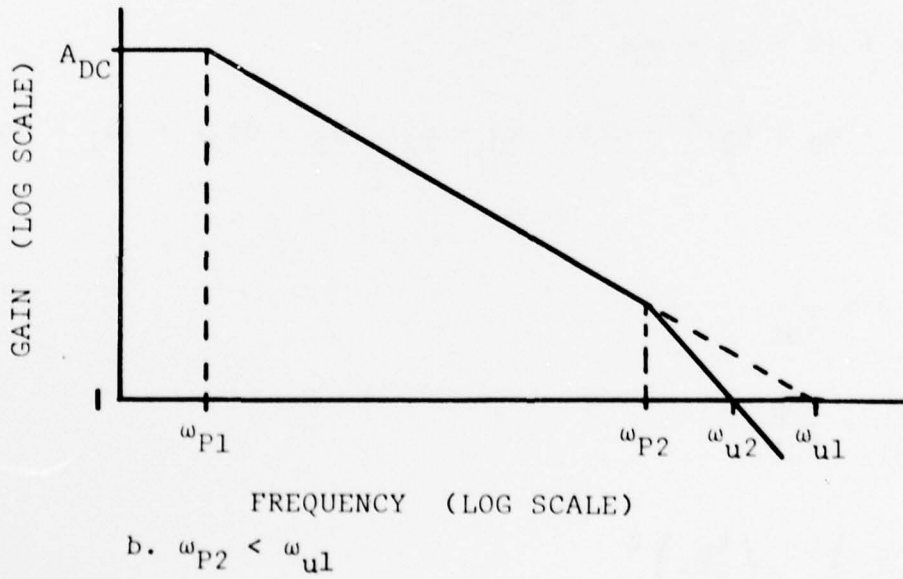
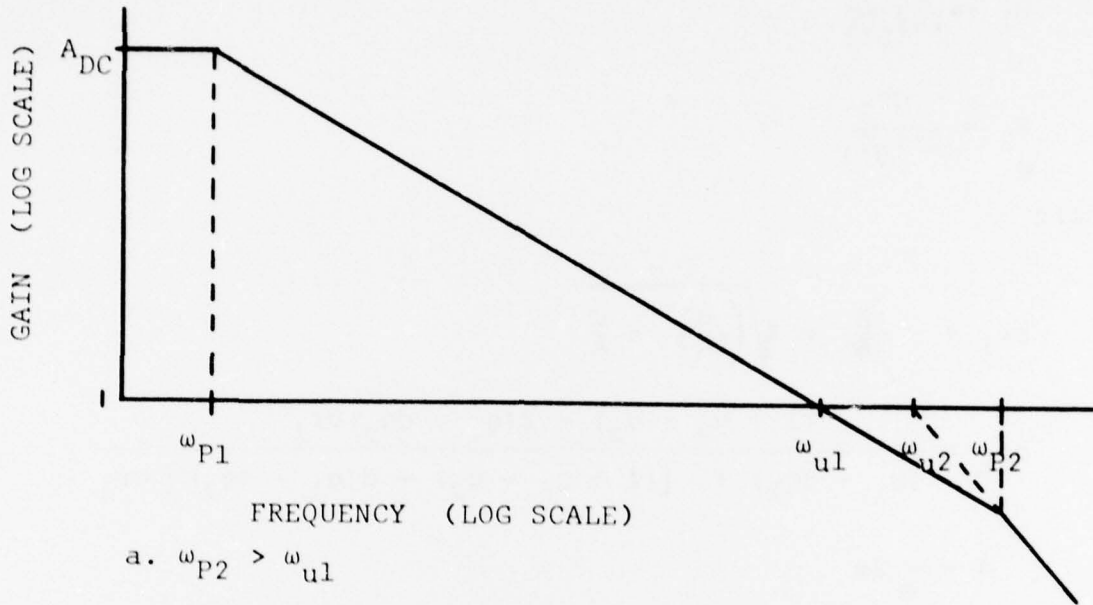

Figure 2-1. Two Pole Op Amp Bode Plots

Appendix C uses Geffe's approximation to derive the following synthesis equations for the filter:

$$R_1 = \frac{cr_1}{2\pi f_0 C_1}$$

$$R_2 = \frac{cr_2}{2\pi f_0 C_1}$$

where

$$cr_1 = -\frac{B}{2A} + \sqrt{\left(\frac{B}{2A}\right)^2 - \frac{C}{A}}$$

$$cr_2 = \frac{(1 + g_0 - g_2) - 2(g_1 - dg_2)cr_1}{(g_1 - dg_2) + [(1 + g_0 - g_2) - d(g_1 - dg_2)] cr_1}$$

$$A = -2\alpha$$

$$B = d\alpha - 2(g_1 - dg_2)$$

$$C = -\alpha + (1 + g_0 - g_2)$$

$$\alpha = (1 + g_0 - g_2)^2 - d(1 + g_0 - g_2)(g_1 - dg_2) + (g_1 - dg_2)^2$$

$$d = 1/Q$$

$$g_0 = -\rho + \frac{1}{A_{DC}}$$

$$g_1 = \frac{\omega_0}{\omega_{u1}} = \frac{f_0}{f_{u1}}$$

$$g_2 = \left(\frac{\omega_0}{\omega_{u2}}\right)^2 = \left(\frac{f_0}{f_{u2}}\right)^2$$

$$C_1 = C_2$$

f_0 = filter center frequency in Hertz

ω_0 = filter center frequency in radians/second

These equations can be used to calculate the resistances R_1 and R_2 necessary to tune the filter to a specified center frequency (f_0) and Q when the two capacitors C_1 and C_2 are equal and values for the op amp parameters (A_{DC} , f_{u1} , and f_{u2}) and the positive feedback ratio (ρ) are known.

If the unknown values are R_2 and ρ , the following equations may be used for synthesis (see Appendix C for derivations):

$$R_2 = \frac{cr_2}{2\pi f_0 C_1}$$

$$\rho = P + \frac{1}{A_{DC}} - g_2$$

where

$$cr_2 = -\frac{B'}{2A'} + \sqrt{\left(\frac{B'}{2A'}\right)^2 - \frac{C'}{A'}}$$

$$P = \frac{(2cr_1 - d) + (g_1 - dg_2) - (g_1 - dg_2)(cr_1)(cr_2)}{(2cr_1 - d) + cr_2}$$

$$cr_1 = 2\pi f_0 C_1 R_1$$

$$A' = cr_1 + (g_1 - dg_2) [1 + cr_1(cr_1 - d)]$$

$$B' = -1 + (1 - dcr_1)(2cr_1 - d)(g_1 - dg_2)$$

$$C' = (g_1 - dg_2) [1 + 2cr_1(2cr_1 - d)]$$

In either case, the gain of the filter at its center frequency is given by (see Appendix C for derivation)

$$H(j\omega_0) = \frac{-(cr_2) Q}{h_1 + jh_2}$$

where

$$h_1 = (1 + g_0 - g_2) + [1 - (cr_1) (cr_2)] g_2$$

$$h_2 = (cr_1) (cr_2) (g_1 - dg_2) + (2cr_1 + cr_2)g_2$$

Having developed synthesis equations that enable us to design a filter and calculate its gain, the next requirement is a set of sensitivity equations that will describe the performance of the circuit; this will be the subject of the next chapter.

Chapter 3

SENSITIVITIES

Sensitivity analysis provides a convenient technique for evaluating the stability of an active filter in the presence of drifting component values. The sensitivity of a filter parameter u (such as center frequency, Q , or gain) to a small change in the value of a circuit component or op amp parameter z , is defined by

$$S_z^u = \frac{z}{u} \cdot \frac{du}{dz} = \frac{du/u}{dz/z}$$

In a strict sense, the sensitivity definition applies only to infinitesimal changes; however, in practice it is useful to interpret sensitivities in terms of finite fractional changes. For example, the sensitivity $S_{R_1}^Q$ indicates the fractional change in filter Q that will be caused by a given, small fractional change in R_1 :

$$\frac{\Delta Q}{Q} \approx \frac{\Delta R_1}{R_1} \cdot S_{R_1}^Q$$

Because sensitivities are based on fractional changes, multiplying a parameter by a constant has no effect. For example, since

$$\omega_0 = 2\pi f_0$$

and

$$\omega_{u1} = 2\pi f_{u1}$$

the following equalities hold true:

$$S_{\omega_{u1}}^{\omega_0} = S_{f_{u1}}^{\omega_0} = S_{\omega_{u1}}^{f_0} = S_{f_{u1}}^{f_0}$$

Table 3-1 gives expressions that were derived in Appendix D for the approximate sensitivities of filter center frequency (f_0), Q , and gain (H_0) with respect to each passive component in the circuit (Figure 1-1). Except for the sensitivities of H_0 with respect to R_3 and R_4 , each of the formulas is exact for the ideal op amp case. We will assume that the presence of a non-ideal op amp in the filter will not greatly affect the sensitivities to the passive circuit components in practical situations. The sensitivity expressions are given in terms of a parameter X which is defined by

$$X = \frac{1}{2} + \sqrt{\left(\frac{1}{2}\right)^2 + 2Q^2 \left(\frac{\rho}{1-\rho}\right)}$$

It can be seen that X increases with the positive feedback ratio ρ and that $X \geq 1$.

Formulas for the approximate sensitivities of the filter parameters to the op amp characteristics are derived in Appendix D and shown in Table 3-2.

When the **second** pole becomes significant, the expressions for the Q and gain sensitivities to f_{u1} may exhibit large errors but these will be masked by sensitivities to f_{u2} in most practical instances; more accurate equations for $S_{f_{u1}}^Q$ and $S_{f_{u1}}^{H_0}$ are contained in Appendix D. Also, for cases in which the sensitivity of ω_0 to f_{u1} is large (>0.1), it will be necessary to use Equation (199) of Appendix D to compute $S_{f_{u1}}^Q$.

When using these sensitivity formulas, it is important to realize that sensitivities involve partial derivatives; consequently, one must know which parameters were held constant in performing the derivative. The above sensitivity formulas contain three op amp parameters: A_{DC} , f_{u1} , and f_{u2} . In each formula two of these three parameters are assumed to be constant. For example, for sensitivities with respect to A_{DC} we have assumed that f_{u1} and f_{u2} are constant. This is not the same as a sensitivity with respect to A_{DC} when the two pole frequencies are constant.

The effect of the positive feedback ratio on the filter sensitivities can be seen by examining the behavior of the parameters X and y . We have seen that X is an increasing function of the positive feedback ratio ρ , and that $\rho = 0$ results in $X = 1$. Appendix D

TABLE 3-1

Passive Sensitivities of the Filter with an Ideal Op Amp

with respect to	Sensitivity of		
	f_0 or ω_0	Q	H_0
C_1	$-\frac{1}{2}$	$\frac{1}{2} (X - 1)$	$\frac{1}{2} X$
C_2	$-\frac{1}{2}$	$-\frac{1}{2} (X - 1)$	$-\frac{1}{2} X$
R_1	$-\frac{1}{2}$	$-(X - \frac{1}{2})$	$-X$
R_2	$-\frac{1}{2}$	$X - \frac{1}{2}$	X
R_3	0	$X - 1$	$X - 1^*$
R_4	0	$-(X - 1)$	$-(X - 1)^*$

where

$$X = \frac{1}{2} + \sqrt{\left(\frac{1}{2}\right)^2 + 2Q^2 \left(\frac{\rho}{1-\rho}\right)}$$

* These expressions are accurate only for high Q's; if $X < Q\sqrt{\frac{2}{3}}$, error is less than 12% for $Q > 3$, 3% for $Q > 11$. For exact expressions see Appendix D, equations (120) and (121).

TABLE 3-2

Approximate Sensitivities of the Filter to Op Amp Parameters

with respect to	Sensitivity of		
	f_0 or ω_0	Q	H_0
A_{DC}	$-\frac{yg_1}{2A_{DC}}$	$+\frac{QY}{A_{DC}}$	$\frac{QY}{A_{DC}}$
f_{u1}	$\frac{yg_1}{2}$	$-yg_1(\frac{1}{2} - 2Qg_1)*$	$2QYg_1^2 *$
f_{u2}	yg_1g_2	$-2 QYg_2$	$-2 QYg_2$

* See Text

where

$$y = \frac{\frac{X}{Q} + \frac{2Q}{X}}{1 - \rho}$$

$$g_1 = \frac{\omega_0}{\omega_{u1}} = \frac{f_0}{f_{u1}}$$

$$g_2 = \left(\frac{\omega_0}{\omega_{u2}}\right)^2 = \left(\frac{f_0}{f_{u2}}\right)^2$$

shows that, with constant Q , y is a decreasing function of X in the interval

$$1 \leq X < X_{\max} \approx Q \sqrt{\frac{2}{3}}$$

For a relatively high Q filter this range corresponds approximately to

$$0 \leq \rho < 0.25$$

For relatively high Q 's, when ρ is varied over this interval, y varies over a range of approximately

$$4.4 < y < 2Q$$

As ρ increases with Q held constant, the sensitivities change as follows: the sensitivity of center frequency to each passive component is constant; the sensitivities of Q and gain to each passive component increase in magnitude; and the active sensitivities of center frequency, Q and gain decrease in magnitude for $X < X_{\max}$. This suggests the existence of an optimum positive feedback ratio. Chapter 4 presents a method for calculating the optimum value.

Chapter 4

OPTIMIZATION

It was seen in Chapter 3 that, if the amount of positive feedback in the filter circuit of Figure 1-1 is increased while the center frequency and Q of the filter are held constant, the following changes in sensitivities will occur:

1. The sensitivity of center frequency of the filter to changes in passive component values will remain essentially constant;
2. The sensitivities of filter Q and gain to the value of each passive component will increase;
3. The sensitivities of filter center frequency, Q, and gain to the op amp parameters will decrease if the positive feedback ratio remains below the value that results in $X = X_{\max}$, where

$$X_{\max} \approx Q \sqrt{\frac{2}{3}}$$

(For relatively high Q filters this corresponds to a positive feedback ratio of $\rho \approx 0.25$.)

Thus, in the design of an active filter using this circuit, the choice of the proper positive feedback ratio involves a tradeoff between sensitivities to op amp parameters and sensitivities to passive component values. One way to evaluate this tradeoff is to use the filter sensitivities as a basis for worst case drift analysis.

In order to simplify the worst case drift analysis for the filter, we will make two assumptions regarding the circuit component drifts:

1. The drifts are unbiased -- that is, the maximum range of drift for each component is centered around zero (for example, the temperature coefficient of a resistor could be specified as $0 \pm 30\text{ppm}/^\circ\text{C}$ but not as $200 \pm 30\text{ppm}/^\circ\text{C}$).
2. The drift of each circuit component is independent of the drifts of all other circuit components (for example, the temperature coefficients of the resistors do not track each other).

Because these assumptions will significantly simplify the problem, we will apply them to each of the six passive components (C_1 , C_2 , R_1 , R_2 , R_3 , and R_4) as well as to each of the three op amp parameters (ADC , f_{u1} , and f_{u2}), even though drifts of op amp parameters are usually neither unbiased nor independent of each other.

Let ΔZ_n be the maximum deviation of a circuit component or op amp parameter Z_n from its nominal or initial value. (ΔZ_n could represent a tolerance or a drift due to temperature, aging, or some other factor.) If all of the deviations are unbiased, independent, and relatively small, the worst case shift in a filter parameter u will be approximately.

$$\left| \frac{\Delta u}{u} \right| \approx \sum_{n=1}^N \max \left\{ \left| \frac{\Delta Z_n}{Z_n} \cdot S_{Z_n}^u \right| \right\}$$

Where (Z_1, \dots, Z_N) are the passive circuit components and the op amp parameters. The optimum positive feedback ratio can be defined as the value which minimizes the above expression for a chosen filter parameter u (u could represent center frequency, Q , or gain, for example).

Appendix D shows that the "optimum positive feedback ratio," as defined above, can be determined from the equation

$$X_{opt} = Q \cdot \sqrt{\frac{\sqrt{\left[2 + Q \left(\frac{a_u}{c_u}\right)\right]^2 + 12} - \left[2 + Q \frac{a_u}{c_u}\right]}{3}}$$

where X_{opt} is the value of X corresponding to the optimum positive feedback ratio ρ_{opt} , and a_u and c_u are such that:

$$\begin{aligned} \left| \frac{\Delta u}{u} \right| &\approx \sum_{n=1}^N \max \left\{ \left| \frac{\Delta Z_n}{Z_n} \cdot S_{Z_n}^u \right| \right\} \\ &\approx a_u X + b_u + c_u Y \end{aligned}$$

Table 4-1 gives expressions for the values of a_u , b_u , and c_u for four different choices of u , the filter parameter whose drift is to be minimized; these choices include: $u =$ center frequency (f_0), $u = Q$, $u =$ gain at center frequency (H_0), and $u = H_{PB}$. H_{PB} is approximately equivalent to the gain at the frequency within the passband where the gain drift is greatest. Choosing $u = H_{PB}$ gives

TABLE 4-1
Expressions for a_u , b_u , and c_u

u	a_u	b_u	c_u
f_0	0	$\left \frac{\Delta C}{C} \right + \left \frac{\Delta R}{R} \right $	$\frac{g_{1max}}{2} \left(v + \left \frac{\Delta f_{u1}}{f_{u1}} \right _{max} \right)$
Q	$\left \frac{\Delta C}{C} \right + 4 \left \frac{\Delta R}{R} \right $	$-\left \frac{\Delta C}{C} \right - 3 \left \frac{\Delta R}{R} \right $	$Q \cdot v + u \cdot \left \frac{\Delta f_{u1}}{f_{u1}} \right _{max}$
H_0	$\left \frac{\Delta C}{C} \right + 4 \left \frac{\Delta R}{R} \right $	$- 2 \left \frac{\Delta R}{R} \right $	$Q \cdot v + 2Qg_{1max}^2 \left \frac{\Delta f_{u1}}{f_{u1}} \right _{max}$
H_{PB}	$\frac{1}{2} \left \frac{\Delta C}{C} \right + 3 \left \frac{\Delta R}{R} \right $	$\left(Q + \frac{1}{2} \right) \left \frac{\Delta C}{C} \right + \left(Q - \frac{3}{2} \right) \left \frac{\Delta R}{R} \right $	$Q \cdot v + Qg_{1max} \left(\frac{1}{2} + g_{1max} \right) \left \frac{\Delta f_{u1}}{f_{u1}} \right _{max}$
		$\left(\frac{1}{2} - 2Qg_{1max} \right) g_{1max}'$	$0 \leq g_{1max} \leq \frac{1}{8Q}$
	$U =$	$\frac{1}{32Q}'$	$\frac{1}{8Q} \leq g_{1max} \leq \frac{1 + \sqrt{2}}{8Q}$
		$\left(2Qg_{1max} - \frac{1}{2} \right) g_{1max}'$	$\frac{1 + \sqrt{2}}{8Q} \leq g_{1max} \leq g_{1max}$
	$V =$	$\frac{1}{A_{DCmin}} \left \frac{\Delta A_{DC}}{A_{DC}} \right + 2g_{2max} \left \frac{\Delta f_{u2}}{f_{u2}} \right _{max}$	

a sort of overall optimization which takes into account drifts in f_0 , Q , and H_0 as explained in Appendix D. In determining a_u , b_u , and c_u , the active sensitivities were maximized over the following ranges of op amp parameters:

$$A_{DC} \min \leq A_{DC} < \infty$$

$$f_{u1} \min \leq f_{u1} < \infty$$

$$f_{u2} \min \leq f_{u2} < \infty$$

In the table all four resistors were assumed to have the same maximum deviation magnitude $|\frac{\Delta R}{R}|$, but not necessarily the same deviation direction. Similarly, both capacitors were assigned a maximum deviation magnitude of $|\frac{\Delta C}{C}|$.

Having determined the optimum value for X , we can find the optimum positive feedback ratio ρ_{opt} by rearranging the equation:

$$X_{opt} = \frac{1}{2} + \sqrt{\frac{1}{4} + 2Q^2 \left(\frac{\rho_{opt}}{1-\rho_{opt}} \right)}$$

Solving for ρ_{opt} , we have

$$\rho_{opt} = \frac{X_{opt} (X_{opt} - 1)}{2Q^2 + X_{opt} (X_{opt} - 1)}$$

It should be observed that approximations used in developing the sensitivity formulas and the optimization procedure will not be valid for extremely low Q 's (say $Q < 3$). Furthermore, in order for the sensitivity formulas and the results of the optimization to be correct, the op amp parameters and the positive feedback ratio must be subject to certain restrictions. To prevent large errors in some of the sensitivity formulas it is necessary to require

$$y g_1 < \frac{2}{3}$$

Appendix D shows that the bound on $y g_1$ is approximately equivalent to the following pair of bounds on g_1 and X :

$$g_1 < \frac{1}{6}$$

$$X > 3Qg_1$$

The upper bound on g_1 results in a lower bound on the op amp parameter f_{ul} :

$$f_{ul} > 6f_0$$

When an optimum value for X is calculated, it should be compared with the minimum allowable value for X ($3Qg_1$) to test its validity.

An additional restriction is necessary if the filter application requires zero (or 180°) phase shift at the center frequency; in such a case, Appendix C shows that we must limit the values of y , g_1 , and g_2 so that

$$g_1 + yg_2 \ll 1.$$

In practical applications these restrictions will present no problem because they are necessary to prevent the filter from being overly sensitive to op amp parameters.

Chapter 5

DESIGN SUMMARY

On the basis of the formulas presented in the preceding chapters, we can develop a step-by-step procedure for designing a bandpass filter utilizing the circuit of Figure 1-1. The procedure can be divided into three main parts: (1) optimization of the positive feedback ratio; (2) evaluation of the filter drift achieved by the optimization; (3) calculation of circuit component values (synthesis).

This chapter shows the individual steps involved in each of the three parts of the design process. In each step, we present instructions and formulas that are generally applicable, and then execute these procedures for a specific example -- a filter implemented with a μ A741 op amp and having a center frequency of 2000 Hertz and Q of 100.

OPTIMIZATION PROCEDURE

The following example illustrates the procedure for finding the "optimum positive feedback ratio," ρ opt.

1. Specify the filter center frequency (f_0) and Q :

$$f_0 = 2000 \text{ Hz}$$

$$Q = 100$$

2. Select an op amp and determine typical values for the parameters A_{DC} , f_{u1} , and f_{u2} (see Chapter 2 for definitions of these parameters).

This data can appear in three ways on an op amp data sheet:

- (a) A_{DC} may be listed as the "open loop voltage gain;" f_{u1} may be listed as the "gain bandwidth product."

(b) A_{DC} , f_{u1} , and f_{u2} can be determined from a plot of "open loop voltage gain vs. frequency" using the technique shown in Figure 2-1.

(c) An "open loop phase shift versus frequency" plot can be used to locate the pole frequencies f_{p1} and f_{p2} as shown in Figure 5-1; then f_{u1} and f_{u2} are calculated by

$$f_{u1} = A_{DC} f_{p1}$$

$$f_{u2} = \sqrt{f_{u1} f_{p2}}$$

Fairchild lists the typical open loop voltage gain for a $\mu A741$ as 200,000.

$$A_{DC} = 200,000$$

From the plot of open loop gain versus frequency for the op amp, we can obtain typical values for f_{u1} and f_{u2} :

$$f_{u1} = 1 \text{ MHz}$$

$$f_{u2} = 2 \text{ MHz}$$

3. Determine the minimum expected values for A_{DC} , f_{u1} , and f_{u2} for the positive feedback optimization and verify that

$$\underline{f_{u1min} > 6f_0.}$$

Since we will try to design the filter to minimize the worst case drift, we must specify the worst case op amp parameters that are to be expected. These may correspond to the guaranteed minimum values from the data sheet, or we may wish to choose a compromise between the minimum and typical values so that the optimization will be based on a more probable set of op amp parameters.

For the $\mu A741$ at 25°C the only minimum specification available is $A_{DC} \text{ min} = 50,000$; this differs from the typical value by a factor of four. We will assume that the op amp parameters are unlikely to be smaller than the typical values by more than a factor of two. Accordingly, we will optimize the feedback on the basis of the following minimum values

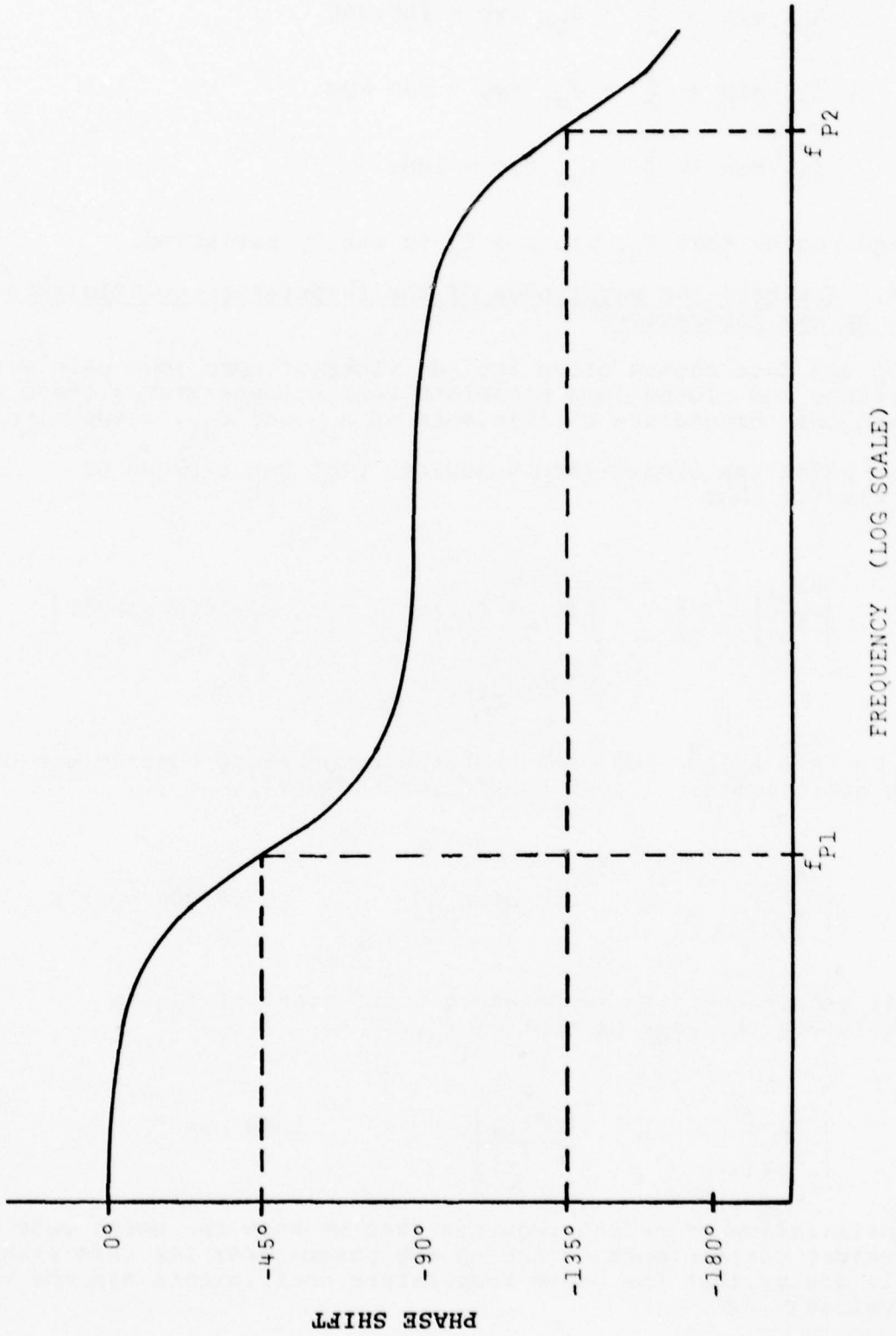

Figure 5-1. Two Pole Op Amp Phase Shift

$$A_{DC} \text{ min} \approx \frac{1}{2} \cdot A_{DC} \text{ typ} = 100,000$$

$$f_{u1} \text{ min} \approx \frac{1}{2} \cdot f_{u1} \text{ typ} = 500 \text{ kHz}$$

$$f_{u2} \text{ min} \approx \frac{1}{2} \cdot f_{u2} \text{ typ} = 1\text{MHz}$$

The requirement that $f_{u1} \text{ min} > 6 f_0$ is easily satisfied.

4. Estimate the magnitudes of the temperature coefficients of the op amp parameters.

Op amp data sheets often include plots of open loop gain versus temperature and closed-loop bandwidth versus temperature; these plots indicate the temperature coefficients of A_{DC} and f_{u1} , respectively.

For the $\mu A741$ the closed-loop bandwidth plot has a slope of $-2000 \text{ ppm}/^\circ\text{C}$; thus

$$\begin{aligned} \left| \frac{\Delta f_{u1}}{f_{u1}} \right| &= \left| \text{TC of } f_{u1} \right| = \left| -2000 \text{ ppm}/^\circ\text{C} \right| \\ &= 2000 \text{ ppm}/^\circ\text{C} \end{aligned}$$

Tests by this author indicate that the temperature coefficient of A_{DC} is approximately $10,000 \text{ ppm}/^\circ\text{C}$ for the $\mu A741$:

$$\left| \frac{\Delta A_{DC}}{A_{DC}} \right| = \left| \text{TC of } A_{DC} \right| \approx 10,000 \text{ ppm}/^\circ\text{C}$$

We will assume that the temperature coefficient of f_{u2} is approximately the same as that of f_{u1} .

$$\left| \frac{\Delta f_{u2}}{f_{u2}} \right| \approx \left| \frac{\Delta f_{u1}}{f_{u1}} \right| \approx 2000 \text{ ppm}/^\circ\text{C}$$

The optimization procedure requires that we know the worst case temperature coefficients of the op amp parameters; for this example we will assume that the above temperature coefficients are the worst case values.

5. Specify magnitudes of the passive component temperature coefficients.

We will choose resistors having temperature coefficients of ± 25 ppm/ $^{\circ}$ C and capacitors having temperature coefficients of ± 50 ppm/ $^{\circ}$ C.

$$\left| \frac{\Delta R}{R} \right| = 25 \text{ ppm}/^{\circ}\text{C}$$

$$\left| \frac{\Delta C}{C} \right| = 50 \text{ ppm}/^{\circ}\text{C}$$

6. Calculate $g_1 \text{ max}$, $g_2 \text{ max}$, U, and V.

$$g_1 \text{ max} = \frac{f_0}{f_{u1 \text{ min}}} = \frac{2000 \text{ Hz}}{500 \times 10^3 \text{ Hz}} = 0.004$$

$$g_2 \text{ max} = \left(\frac{f_0}{f_{u2 \text{ min}}} \right)^2 = \left(\frac{2000 \text{ Hz}}{1 \times 10^6 \text{ Hz}} \right)^2 = 0.000004$$

$$U = \begin{cases} \left(\frac{1}{2} - 2Q g_1 \text{ max} \right) g_1 \text{ max}, & 0 \leq g_1 \text{ max} \leq \frac{1}{8Q} \\ \frac{1}{32Q}, & \frac{1}{8Q} \leq g_1 \text{ max} \leq \frac{1 + \sqrt{2}}{8Q} \\ \left(2Q g_1 \text{ max} - \frac{1}{2} \right) g_1 \text{ max}, & \frac{1 + \sqrt{2}}{8Q} \leq g_1 \text{ max} \end{cases}$$

$$= 0.0012$$

$$V = \frac{1}{A_{DC \text{ min}}} \cdot \left| \frac{\Delta A_{DC}}{A_{DC}} \right|_{\text{max}} + 2 g_2 \text{ max} \left| \frac{\Delta f_{u2}}{f_{u2}} \right|_{\text{max}}$$

$$= \frac{1}{100,000} \cdot (10,000 \text{ ppm}/^{\circ}\text{C}) + 2(0.000004)(2000 \text{ ppm}/^{\circ}\text{C})$$

$$= 0.1160 \text{ ppm}/^{\circ}\text{C}$$

7. Calculate a_{HPB} , c_{HPB} , and X_{opt} .

$$\begin{aligned} a_{HPB} &= \frac{1}{2} \left| \frac{\Delta C}{C} \right| + 3 \left| \frac{\Delta R}{R} \right| \\ &= \frac{1}{2} (50 \text{ ppm}/^{\circ}\text{C}) + 3 (25 \text{ ppm}/^{\circ}\text{C}) \\ &= 100 \text{ ppm}/^{\circ}\text{C} \end{aligned}$$

$$\begin{aligned} c_{HPB} &= QV + Q g_{1 \max} \left(\frac{1}{2} + g_{1 \max} \right) \cdot \left| \frac{\Delta f_{ul}}{f_{ul}} \right|_{\max} \\ &= 100(0.116 \text{ ppm}/^{\circ}\text{C}) + 100(.004)(.5+.004)(2000 \text{ ppm}/^{\circ}\text{C}) \\ &= 414.8 \text{ ppm}/^{\circ}\text{C} \end{aligned}$$

$$\begin{aligned} X_{opt} &= Q \cdot \sqrt{\frac{\sqrt{\left(2 + Q \cdot \frac{a_{HPB}}{c_{HPB}}\right)^2 + 12} - \left(2 + Q \cdot \frac{a_{HPB}}{c_{HPB}}\right)}{3}} \\ &= 27.62 \end{aligned}$$

8. Verify that $X_{opt} \geq 1$ and that $X_{opt} > 3Q g_{1 \max}$.

The former bound is necessary to insure that $\rho \geq 0$ and the latter is necessary to maintain reasonable accuracy in the optimization. In this case both restrictions are satisfied. When the former bound is not satisfied, set $X_{opt} = 1$. If the latter bound is not achieved, choose an op amp having a larger value for f_{ul} .

9. Calculate ρ_{opt} , the optimum positive feedback ratio.

$$\rho_{opt} = \frac{x_{opt}(x_{opt} - 1)}{2Q^2 + x_{opt}(x_{opt} - 1)}$$

$$= 0.03545$$

EVALUATION OF THE FILTER DRIFT

The approximate worst case drift in the filter center frequency (f_0), Q , and gain (H_0) can be calculated for any positive feedback ratio (ρ) by means of the following procedure.

1. Calculate the terms a_u , b_u , and c_u for $u = f_0, Q, \text{ and } H_0$.

Using the terms $g_{1 \max}$, U , and V defined in step 6 of the optimization and continuing with the $\mu A741$ op amp example, we have:

$$a_{f_0} = 0$$

$$b_{f_0} = \left| \frac{\Delta C}{C} \right| + \left| \frac{\Delta R}{R} \right|$$

$$= 50 \text{ ppm}/^\circ\text{C} + 25 \text{ ppm}/^\circ\text{C}$$

$$= 75 \text{ ppm}/^\circ\text{C}$$

$$c_{f_0} = \frac{g_{1 \max}}{2} \left(V + \left| \frac{\Delta f_{u1}}{f_{u1}} \right|_{\max} \right)$$

$$= \frac{0.004}{2} (0.116 \text{ ppm}/^\circ\text{C} + 2000 \text{ ppm}/^\circ\text{C})$$

$$= 4.000 \text{ ppm}/^\circ\text{C}$$

$$a_Q = \left| \frac{\Delta C}{C} \right| + 4 \left| \frac{\Delta R}{R} \right|$$

$$= 50 \text{ ppm}/^{\circ}\text{C} + 4(25 \text{ ppm}/^{\circ}\text{C})$$

$$= 150 \text{ ppm}/^{\circ}\text{C}$$

$$b_Q = - \left| \frac{\Delta C}{C} \right| - 3 \cdot \left| \frac{\Delta R}{R} \right|$$

$$= - 50 \text{ ppm}/^{\circ}\text{C} - 3(25 \text{ ppm}/^{\circ}\text{C})$$

$$= - 125 \text{ ppm}/^{\circ}\text{C}$$

$$c_Q = QV + U \left| \frac{\Delta f_{u1}}{f_{u1}} \right|_{\text{max}}$$

$$= 100(0.116 \text{ ppm}/^{\circ}\text{C}) + 0.0012(2000 \text{ ppm}/^{\circ}\text{C})$$

$$= 14.0 \text{ ppm}/^{\circ}\text{C}$$

$$a_{H_0} = \left| \frac{\Delta C}{C} \right| + 4 \left| \frac{\Delta R}{R} \right|$$

$$= 50 \text{ ppm}/^{\circ}\text{C} + 4(25 \text{ ppm}/^{\circ}\text{C})$$

$$= 150 \text{ ppm}/^{\circ}\text{C}$$

$$b_{H_0} = -2 \left| \frac{\Delta R}{R} \right|$$

$$= -2 (25 \text{ ppm}/^{\circ}\text{C})$$

$$= -50 \text{ ppm}/^{\circ}\text{C}$$

$$\begin{aligned}
 c_{H_0} &= QV + 2Q g_{1 \max}^2 \left| \frac{\Delta f_{ul}}{f_{ul}} \right|_{\max} \\
 &= 100(0.116 \text{ ppm/}^\circ\text{C}) + 2(100)(.004)^2 (2000 \text{ ppm/}^\circ\text{C}) \\
 &= 18.0 \text{ ppm/}^\circ\text{C}
 \end{aligned}$$

2. Given a positive feedback ratio (ρ), calculate X , or given X , calculate ρ .

(In the optimization example, we have already computed ρ and X).

$$X = \frac{1}{2} + \sqrt{\frac{1}{4} + 2Q^2 \left(\frac{\rho}{1 - \rho} \right)}$$

$$\rho = \frac{X(X - 1)}{2Q^2 + X(X - 1)}$$

3. Verify that $X \geq 1$ and $X > 3Q g_{1 \max}$.

($X \geq 1$ insures that $\rho \geq 0$; $X > 3Q g_{1 \max}$ is necessary to prevent large errors in the sensitivity approximations.)

4. Compute the value of y corresponding to ρ and X .

$$y = \frac{\frac{X}{Q} + \frac{2Q}{X}}{1 - \rho}$$

For $\rho = \rho_{\text{opt}} = .03545$ and $X = X_{\text{opt}} = 27.62$ we have

$$y = 7.79$$

5. Compute the worst case drifts in center frequency, Q, and gain of the filter for the given positive feedback ratio.

$$\left| \frac{\Delta f_0}{f_0} \right|_{\max} \approx a_{f_0} x + b_{f_0} + c_{f_0} y$$

$$\left| \frac{\Delta Q}{Q} \right|_{\max} \approx a_Q x + b_Q + c_Q y$$

$$\left| \frac{\Delta H_0}{H_0} \right|_{\max} \approx a_{H_0} x + b_{H_0} + c_{H_0} y$$

In our example, with the "optimum positive feedback ratio," we have:

$$\begin{aligned} \left| \frac{\Delta f_0}{f_0} \right|_{\max} &\approx 0.0(27.62) + (75 \text{ ppm}/^\circ\text{C}) + (4 \text{ ppm}/^\circ\text{C})(7.79) \\ &= 106 \text{ ppm}/^\circ\text{C} \end{aligned}$$

$$\begin{aligned} \left| \frac{\Delta Q}{Q} \right|_{\max} &\approx (150 \text{ ppm}/^\circ\text{C})(27.62) - (125 \text{ ppm}/^\circ\text{C}) + (14 \text{ ppm}/^\circ\text{C})(7.79) \\ &= 4130 \text{ ppm}/^\circ\text{C} \end{aligned}$$

$$\begin{aligned} \left| \frac{\Delta H_0}{H_0} \right|_{\max} &\approx (150 \text{ ppm}/^\circ\text{C})(27.62) - (50 \text{ ppm}/^\circ\text{C}) + (18 \text{ ppm}/^\circ\text{C})(7.79) \\ &= 4230 \text{ ppm}/^\circ\text{C} \end{aligned}$$

If these temperature coefficients are unacceptable, it will be necessary to redesign the filter using a better op amp or better passive components. The parameters X and y can be substituted into the sensitivity formulas of Chapter 3 to determine the main sources of drift; in particular, if the op amp is to be replaced with a different type, the active sensitivity formulas can be used to determine which active parameter needs to be increased.

It is important to notice that the drift quantities

$$\left| \frac{\Delta f_0}{f_0} \right|_{\max}, \left| \frac{\Delta Q}{Q} \right|_{\max}, \text{ and } \left| \frac{\Delta H_0}{H_0} \right|_{\max}$$

do not indicate the absolute worst

case drifts unless they are calculated from absolute worst case data. In our example, we have assumed minimum values for the op amp parameters ($A_{DC \min}$, $f_{u1 \min}$, and $f_{u2 \min}$) that are larger than the guaranteed minimum parameters for the op amp. Furthermore, the temperature coefficient data for the op amp was based on the manufacturer's typical plots, because no worst case temperature data was available. Consequently, it is possible that the so-called "worst case drift" quantities that we have calculated could be exceeded by some sets of components. True worst case drift calculations would require more accurate specification of the worst case op amp characteristics. With this understanding, we will henceforth refer to each drift value computed in the example as the "maximum expected drift."

Figure 5-2 is a plot of the "maximum expected drifts" of center frequency, Q , and gain versus positive feedback ratio for the filter in the example. The Q drift is minimized with a positive feedback ratio of $\rho = .00072$. The maximum expected drift of filter gain (H_0) at the center frequency reaches a minimum at $\rho = .00095$. The center frequency drift gradually drops until $\rho = 0.25$. An "overall optimum positive feedback ratio" of $\rho = 0.035$ was computed. This figure represents a compromise between the values of ρ that minimize the drifts in center frequency, Q , and gain.

The criterion chosen to compute the "overall optimum positive feedback ratio" minimizes the worst case drift of the parameter H_{PB} . H_{PB} drift is roughly equivalent to the maximum drift in filter gain anywhere within the three decibel passband. Such drift can be caused by drifts in the center frequency (f_0), Q , or gain at center frequency (H_0) of the filter. If the designer prefers to minimize the Q drift, he can compute the correct positive feedback ratio by replacing a_{HPB} and c_{HPB} in the optimization formula with a_Q and c_Q , respectively. Similarly, the drift in filter gain (H_0) at the center frequency is minimized by using a_{H_0} and c_{H_0} in the optimization.

Another example of the behavior of the maximum expected drifts of a filter, as the positive feedback ratio is varied, can be obtained by taking the same filter ($f_0 = 2000$ Hertz, $Q = 100$) but with a different op amp - the Harris HA-2510. The manufacturer's data sheet for this op amp indicates a typical open loop gain (A_{DC}) of 15,000 and a typical gain - bandwidth product (f_{u1}) of 12 MHz. A plot of open loop phase shift versus frequency indicates that the

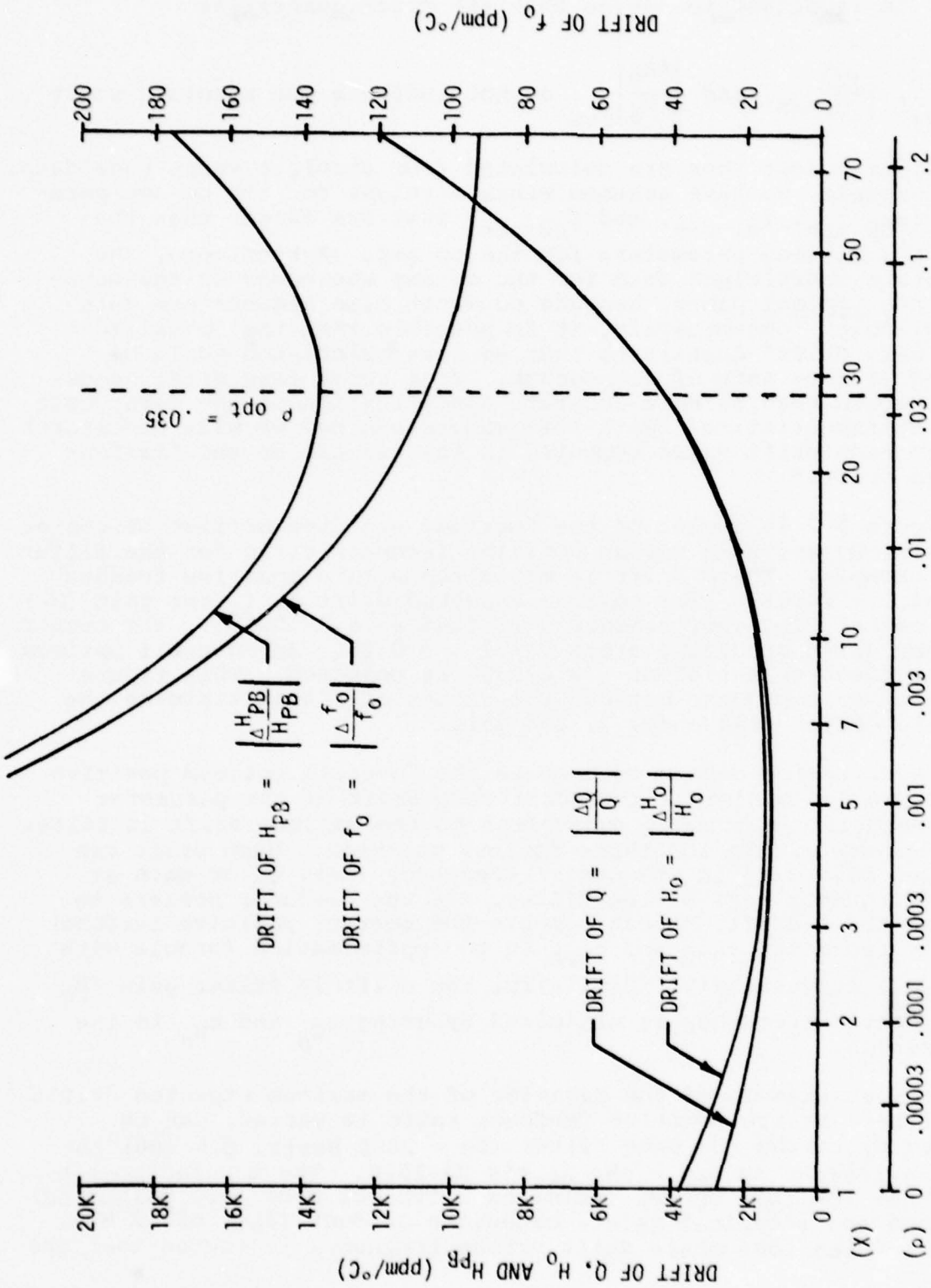

Figure 5-2. Maximum Expected Filter Temperature Coefficients ($\mu A741$ Op Amp)

second pole (f_{p2}) of the amp typically occurs at 5 MHz. The parameter f_{u2} can be computed by

$$\begin{aligned} f_{u2} &= \sqrt{f_{u1} f_{p2}} \\ &= 7.7 \text{ MHz} \end{aligned}$$

The manufacturer's data sheet lists the minimum value for A_{DC} as 10,000, which is $2/3$ of the typical value. Consequently, we will assume the following minimum parameters:

$$A_{DC \text{ min}} \approx \frac{2}{3} A_{DC \text{ typ}} = 10,000$$

$$f_{u1 \text{ min}} \approx \frac{2}{3} f_{u1 \text{ typ}} = 8 \text{ MHz}$$

$$f_{u2 \text{ min}} \approx \frac{2}{3} f_{u2 \text{ typ}} = 5 \text{ MHz}$$

The manufacturer's data also includes typical plots of open loop gain versus temperature and "bandwidth" versus temperature for the op amp; at 25°C these plots have slopes of approximately $+3000 \text{ ppm}/^\circ\text{C}$ and $-450 \text{ ppm}/^\circ\text{C}$, respectively. For lack of additional information on the op amp, we will consider these numbers to be the "maximum expected temperature coefficients":

$$\left| \frac{\Delta A_{DC}}{A_{DC}} \right|_{\text{max}} \approx 3000 \text{ ppm}/^\circ\text{C}$$

$$\left| \frac{\Delta f_{u1}}{f_{u1}} \right|_{\text{max}} \approx 450 \text{ ppm}/^\circ\text{C}$$

We will also assume that the maximum expected drift in f_{u2} is the same as that for f_{u1} :

$$\left| \frac{\Delta f_{u2}}{f_{u2}} \right|_{\text{max}} \approx 450 \text{ ppm}/^\circ\text{C}$$

Figure 5-3 shows plots of the maximum expected drifts of the filter center frequency, Q , and gain (H_0) of the filter. The Q and gain (H_0) drifts are minimized at $\rho = .0017$. The center frequency drift again decreases gradually until $\rho = 0.25$. The optimization procedure indicates an overall optimum positive feedback ratio of $\rho = .0031$.

The plot illustrates an important aspect of the behavior of center frequency drift. To the degree of accuracy of the sensitivity expressions in this report (the error is zero with an ideal op amp), the amount of center frequency drift caused by the passive component values is independent of the positive feedback ratio. On the other hand, the drift due to op amp characteristics decreases as ρ is increased until $\rho = 0.25$. In our example, the passive components can cause a frequency drift rate up to 75 ppm/°C. The only way to reduce the maximum drift in center frequency below this amount is to choose passive components having lower temperature coefficients (or to match the temperature coefficients in such a way as to cause cancellation).

CIRCUIT COMPONENT VALUES

Returning to the original design problem in which a $\mu A741$ op amp was used, the next step is to compute the circuit component values for the specified positive feedback ratio. We have determined that the optimum positive feedback ratio is approximately $\rho_{opt} = .03545$. Since this value is not at all critical, we will round it off to $\rho = .035$ before proceeding.

Using the procedure described below we can compute the nominal values of the resistors R_1 and R_2 and the nominal gain of the filter for any positive feedback ratio ρ ; we are not restricted to choosing $\rho = \rho_{opt}$. This synthesis process will be performed with the typical op amp parameters rather than with the worst case values.

1. Compute the following:

$$\begin{aligned}
 g_0 &= -\rho + \frac{1}{A_{DC \text{ typ}}} \\
 &= -.035 + \frac{1}{200,000} \\
 &= -.034995 \\
 g_1 &= \frac{f_0}{f_{ul \text{ typ}}} = \frac{2000 \text{ Hz}}{1 \times 10^6 \text{ Hz}} = .002
 \end{aligned}$$

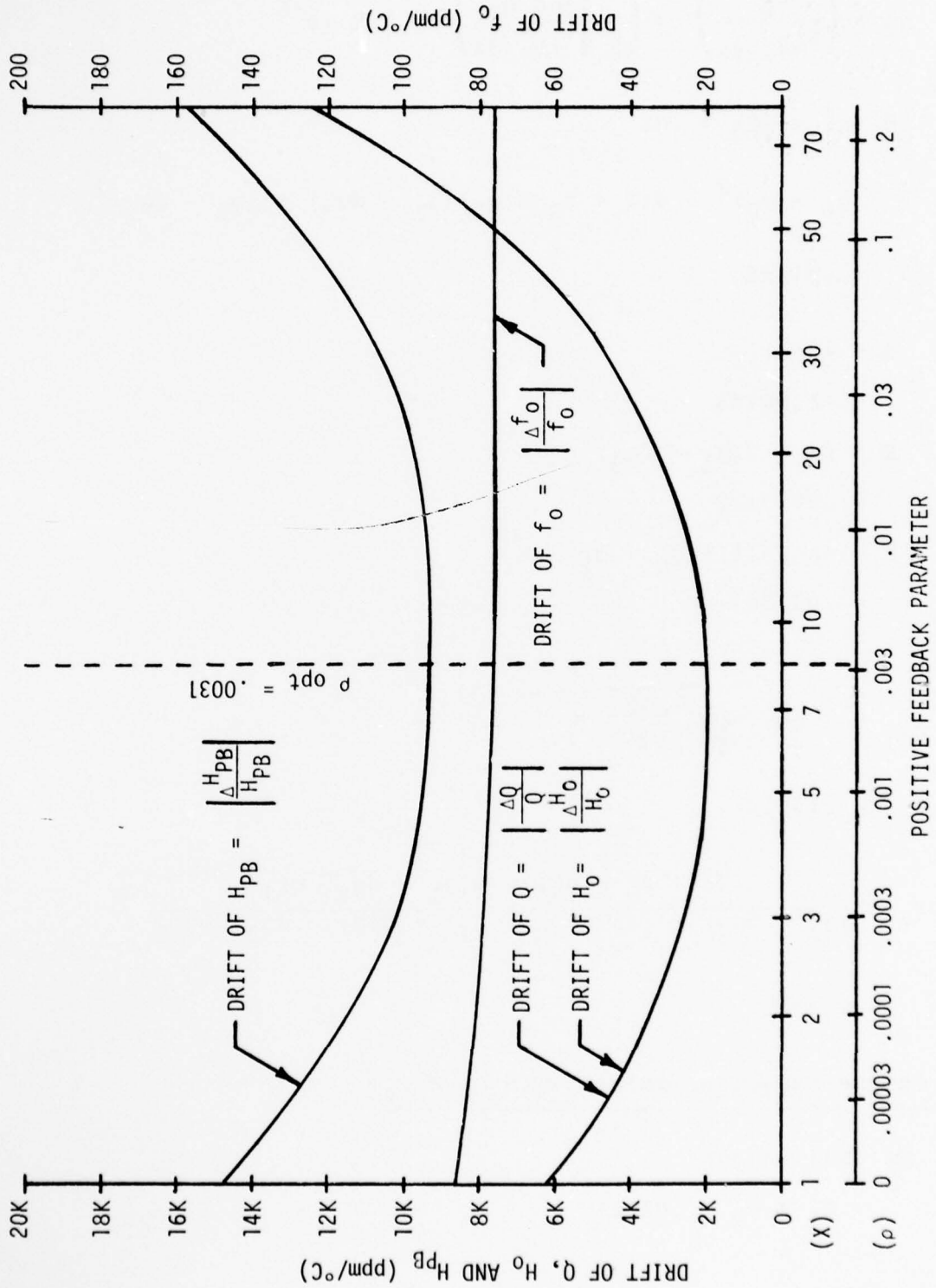

Figure 5-3. Maximum Expected Filter Temperature Coefficients (HA-2510 Op Amp)

$$g_2 = \left(\frac{f_0}{f_{u2 \text{ typ}}} \right)^2 = \left(\frac{2000 \text{ Hz}}{2 \times 10^6 \text{ Hz}} \right)^2 = 1 \times 10^{-6}$$

$$d = \frac{1}{Q} = \frac{1}{100} = .01$$

$$\begin{aligned} \alpha &= (1 + g_0 - g_2)^2 - d(1 + g_0 - g_2)(g_1 - dg_2) + (g_1 - dg_2)^2 \\ &= .93122 \end{aligned}$$

$$A = -2\alpha$$

$$= -1.86243$$

$$B = d\alpha - 2(g_1 - dg_2)$$

$$= .0053122$$

$$C = -\alpha + (1 + g_0 - g_2)$$

$$= .033787$$

$$cr_1 = -\frac{B}{2A} + \sqrt{\left(\frac{B}{2A}\right)^2 - \frac{C}{A}}$$

$$= .13612$$

$$cr_2 = \frac{(1 + g_0 - g_2) - 2(g_1 - dg_2) cr_1}{(g_1 - dg_2) + [(1 + g_0 - g_2) - d(g_1 - dg_2)] cr_1}$$

$$= 7.232$$

2. Choose capacitor values with $C_1 = C_2$.

We will select

$$C_1 = C_2 = .02\mu\text{F}$$

3. Compute the required values for R_1 and R_2 .

$$R_1 = \frac{cr_1}{2\pi f_0 C_1} = \frac{.13612}{2\pi(2000 \text{ Hz})(.02 \times 10^{-6} \text{ F})}$$

$$= 541.6\Omega$$

$$R_2 = \frac{cr_2}{2\pi f_0 C_1} = \frac{7.232}{2\pi(2000 \text{ Hz})(.02 \times 10^{-6} \text{ F})}$$

$$= 28,780\Omega$$

4. Choose R_3 and R_4 so that

$$\frac{R_3}{R_3 + R_4} = \rho$$

With $\rho = .035$ we could choose

$$R_3 = 1000\Omega$$

$$R_4 = \left(\frac{1 - \rho}{\rho} \right) R_3 = \left(\frac{1 - .035}{.035} \right) (1000\Omega)$$

$$= 27,570\Omega$$

5. Calculate the gain of the filter at its center frequency.

First we need

$$h_1 = (1 + g_0 - g_2) + [1 - (cr_1)(cr_2)]g_2$$

$$= 0.9650$$

$$\begin{aligned}
 h_2 &= (cr_1)(cr_2)(g_1 - dg_2) + (2cr_1 + cr_2)g_2 \\
 &= 0.001976
 \end{aligned}$$

The gain is

$$\begin{aligned}
 |H(j\omega_0)| &= \frac{(cr_2) \cdot Q}{\sqrt{h_1^2 + h_2^2}} \\
 &= 749.4
 \end{aligned}$$

PRACTICAL CONSIDERATIONS

Figure 5-4 shows a final implementation of the filter. Resistor R_1 has been replaced by a voltage divider in order to reduce the gain of the circuit. The two resistors R_{1a} and R_{1b} were chosen so that

$$\frac{R_{1a} R_{1b}}{R_{1a} + R_{1b}} = R_1$$

and

$$|H(j\omega_0)| \cdot \frac{R_{1b}}{R_{1a} + R_{1b}} = H_T$$

where R_1 is as calculated previously and H_T is the desired voltage gain of the filter (H_T was arbitrarily set at 10 in this example).

Two pots have been added to the circuit in Figure 5-4. The one incorporated in R_2 (R_{2b}) serves as a center frequency trimmer. The pot in the positive feedback loop (R_{4b}) can be used to adjust the Q and gain of the filter without significantly affecting the center frequency.

In practice it may be necessary to initially adjust R_{4b} for maximum resistance to assure that the circuit does not oscillate. R_{2b} may then be adjusted to achieve the correct center frequency. Finally R_{4b} is adjusted to produce the desired filter gain at the center frequency; the correct Q should result.

$f_o = 2000 \text{ Hz}$ $Q=100$ $H_T = 10 \text{ dB}$

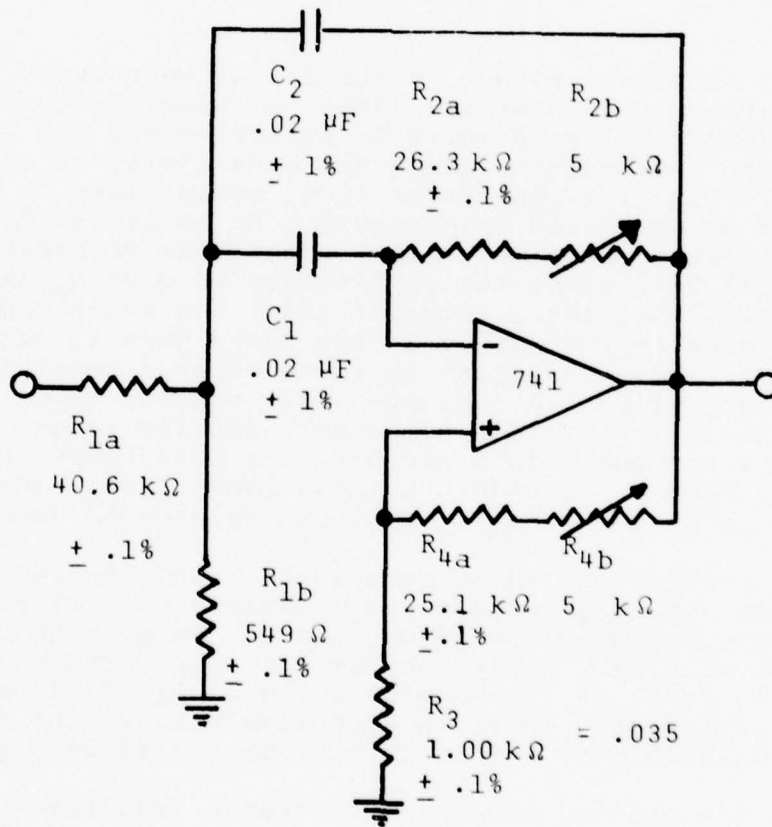

Figure 5-4. Practical Realization of the Filter

In this particular filter it is desirable that 0.1% tolerance resistors and 1% capacitors be used. The reasons can be seen by applying the sensitivity formulas in Table 3-1. Since $X = 27.62$ for this filter, the sensitivities of Q to the passive component values are

$$s_{C_1}^Q = -s_{C_2}^Q \approx 13$$

$$-s_{R_1}^Q = s_{R_2}^Q \approx 27$$

$$s_{R_3}^Q = -s_{R_4}^Q \approx 27$$

Suppose that all component values in the filter were exact except that C_2 was 1% higher than nominal. Then the sensitivity of Q to C_2 indicates that the filter Q would be approximately 13% lower than the desired value. Furthermore, since the sensitivity of center frequency f_0 to C_2 is $-1/2$, the error in C_2 would cause f_0 to be 1/2% low. This would be corrected by decreasing R_2 by 1% using the frequency adjustment pot R_{2b} . But that adjustment decreases the Q by an additional 27%, since the sensitivity of Q to R_2 is 27. Thus it can be seen that the Q trim-pot (R_{4b}) has to be capable of adjusting the Q over approximately a $\pm 40\%$ range just to accommodate $\pm 1\%$ errors in C_2 . (The 40% figure is rough because sensitivity calculations yield significant errors when dealing with large changes.) When the tolerances of the other components and the range of possible op amp parameters are taken into account, the adjustment range required for R_{4b} becomes so wide that adjustment resolution would become a severe problem if looser component tolerances were used.

Adjustment resolution can be calculated using the sensitivity formulas in Table 3-1. For example, R_4 consists of a fixed resistor in series with a 5 k-Ohm pot to adjust the Q . Suppose that the pot has a resolution of 0.5%. For a 5 k-Ohm pot this corresponds to 25 Ohms, which is 0.09% of the nominal value of R_4 (27.57 k-Ohms). Since the sensitivity of Q to R_4 is approximately -27 for this filter, the Q will be adjustable to within $27 \times 0.09\% = 2.4\%$ of a given value.

In general the passive component tolerance requirements can be relaxed and the adjustment resolution improved by redesigning the filter using a "better" op amp. This results in a lower optimum value for the design parameter X (i.e., lower positive feedback ratio), thereby reducing the sensitivities of filter Q and gain to the passive components and making passive component errors less significant. In order to determine which op amp parameter should be increased to select a "better" op amp, the magnitudes of the active sensitivities should be computed using the formulas in

Table 3-2. In the example presented here the filter sensitivities to the op amp parameter f_{ul} (gain-bandwidth product) are largest, so an op amp having a higher gain bandwidth product would improve the filter design. The HA-2510 op amp discussed earlier offers a significant improvement; however, its low open loop gain at low frequencies (A_{DC}) results in moderately high sensitivities of Q and gain to A_{DC} . A better choice would be the LM318 which offers both a high gain bandwidth product and a high open loop gain.

Appendix A
TRANSFER FUNCTION

The first step in the analysis of any active filter circuit is to derive the filter transfer function in terms of the circuit components and the op amp parameters. Figure A-1 shows the circuit that is the subject of this report; it consists of a multiple feedback bandpass filter section with positive feedback added.

We will make two assumptions regarding the components:

1. the passive components are ideal (that is, capacitors are lossless and resistors are pure resistance);
2. the op amp has a finite gain $A(s)$, but is ideal in other respects (for example, the input impedance is infinite, the output impedance is zero, and the common mode rejection is infinite).

With these assumptions, the circuit transfer function is given by:

$$\begin{aligned}
 H(s) &\equiv V_2(s)/V_1(s) \\
 &= \frac{-N_1 s}{(1 - \rho + \frac{1}{A(s)}) (D_2 s^2 + D_1 s + 1) - N_1 s} \quad (1)
 \end{aligned}$$

where

$$N_1 = C_1 R_2 \quad (2)$$

$$D_1 = (C_1 + C_2) R_1 + C_1 R_2 \quad (3)$$

$$D_2 = C_1 C_2 R_1 R_2 \quad (4)$$

$$\rho = \frac{R_3}{R_3 + R_4} = \text{positive feedback ratio} \quad (5)$$

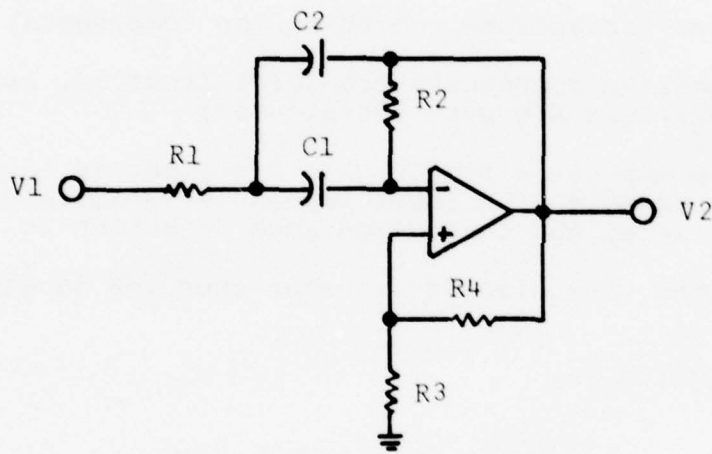

$$\rho = \frac{R3}{R3+R4} = \text{POSITIVE FEEDBACK RATIO}$$

Figure A-1. Active Bandpass Filter Circuit

In this appendix the op amp will be modeled as a two pole device. The transfer function of a two pole amplifier is given by:

$$A(s) = \frac{A_{DC} \omega_{P1} \omega_{P2}}{(s + \omega_{P1})(s + \omega_{P2})} \quad (6)$$

where

ω_{P1} = the frequency (in radians per second) of the first pole

and

ω_{P2} = the frequency (in radians per second) of the second pole of the op amp.

This op amp gain function may be substituted into the filter transfer function of Equation (1) to obtain the overall transfer function for the filter:

$$H(s) = \frac{-N_1 s}{T_4 s^4 + T_3 s^3 + T_2 s^2 + T_1 s + T_0} \quad (7)$$

where

$$T_0 = 1 + G_0 \quad (8)$$

$$T_1 = (1 + G_0) D_1 - N_1 + G_1 \quad (9)$$

$$T_2 = (1 + G_0) D_2 + D_1 G_1 + G_2 \quad (10)$$

$$T_3 = D_2 G_1 + D_1 G_2 \quad (11)$$

$$T_4 = D_2 G_2 \quad (12)$$

and

$$G_0 = \frac{1}{A_{DC}} - \rho \quad (13)$$

$$G_1 = \frac{\omega_{P1} + \omega_{P2}}{A_{DC} \omega_{P1} \omega_{P2}} \quad (14)$$

$$G_2 = \frac{1}{A_{DC} \omega_{P1} \omega_{P2}} \quad (15)$$

The expression for G_1 can be further simplified, because most op amps have $\omega_{P2} \gg \omega_{P1}$:

$$G_1 = \frac{\omega_{P1} + \omega_{P2}}{A_{DC} \omega_{P1} \omega_{P2}} \approx \frac{\omega_{P2}}{A_{DC} \omega_{P1} \omega_{P2}} \quad (16)$$

$$G_1 \approx \frac{1}{A_{DC} \omega_{P1}} \quad (17)$$

This approximation is equivalent to a very small error in ω_{P1} ; since the values of A_{DC} , ω_{P1} , and ω_{P2} are never known accurately, the error will be insignificant.

Instead of defining the op amp characteristics in terms of A_{DC} , ω_{P1} , and ω_{P2} , it will be convenient to define two new parameters ω_{u1} and ω_{u2} to replace the pole frequency parameters:

$$\omega_{u1} = \frac{A_{DC} \omega_{P1} \omega_{P2}}{\omega_{P1} + \omega_{P2}} \approx A_{DC} \omega_{P1} \quad (18)$$

$$\omega_{u2} = \sqrt{A_{DC} \omega_{P1} \omega_{P2}} \quad (19)$$

Figures A-2(a) and A-2(b) show a graphical interpretation for ω_{u1} and ω_{u2} . If the second segment (the -20dB per decade portion) of an op amp Bode plot is extended, it crosses the unity gain level at a frequency ω_{u1} . Thus, ω_{u1} is the unity gain bandwidth of the op amp due to the first pole. Similarly, extending the segment of the Bode plot that is beyond ω_{P2} (the -40dB per decade segment)

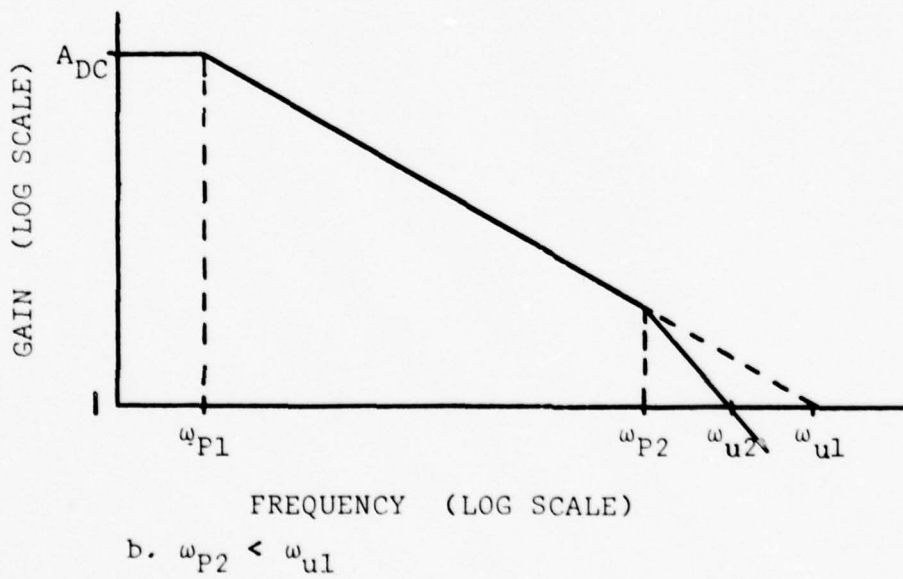
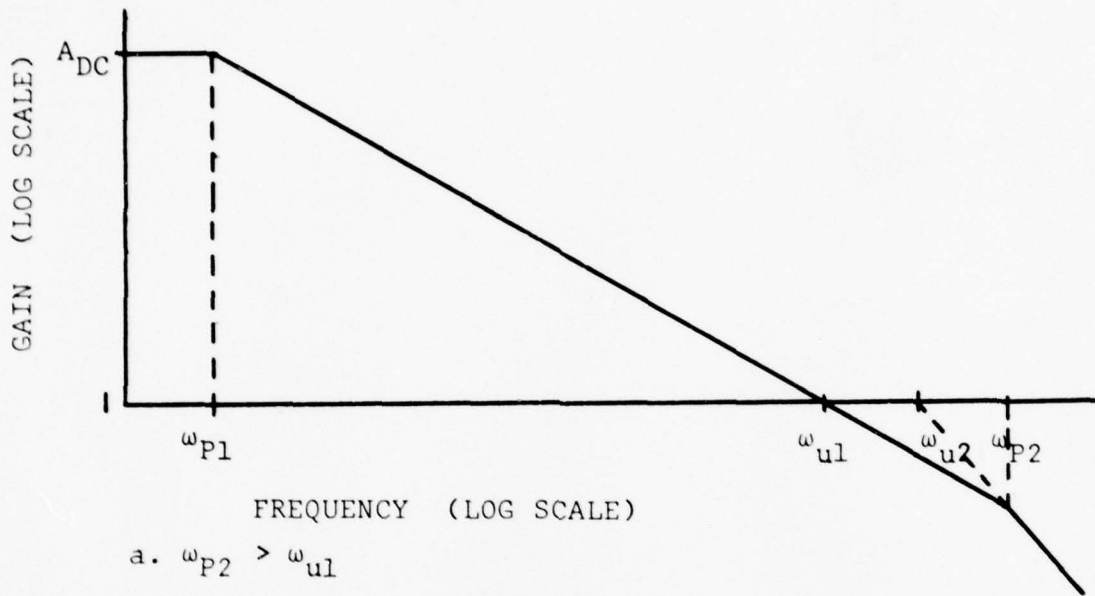

Figure A-2. Two Pole Op Amp Bode Plots

results in a unity gain crossover point at a frequency ω_{u2} . In terms of the new parameters, G_1 and G_2 are given by:

$$G_1 = \frac{1}{\omega_{u1}} \quad (20)$$

$$G_2 = \left(\frac{1}{\omega_{u2}}\right)^2 \quad (21)$$

Appendix B

APPROXIMATIONS APPLICABLE
TO COMPLEX TRANSFER FUNCTIONS

The two pole bandpass transfer function is the basis for most active bandpass filters. When an application calls for a multiple pole bandpass response, it is usually achieved by cascading several two pole filters.

Unfortunately, an active filter that is designed to have a two pole bandpass response with an ideal operational amplifier (op amp) may have a more complex transfer function when the circuit is actually implemented using a real op amp. It then becomes very difficult to derive expressions for such common filter parameters as center frequency and Q or to synthesize a filter with a specified response.

This appendix presents two different approximations which can be used to simplify the equations defining center frequency and Q for a bandpass transfer function that has been distorted by linear op amp parameters. These approximations are applied to transfer functions which have no parasitic zeros and four or fewer poles (two parasitic poles). The first approximation, which was developed and applied by Philip Geffe (Reference 1), involves the assumption that the distorted transfer function has two dominant poles and that all other poles and zeros can be ignored with very little error. Geffe's approximation results in equations that are very useful for exact synthesis of active filters.

The second approximation was developed by this author as an attempt to reduce the complexity of the filter equations and thus aid in sensitivity analysis. It is based on the assumption that the phase behavior of the distorted transfer function near its center frequency is the same as the phase behavior of a two pole bandpass function having the same center frequency and Q. This approximation probably produces more error than that developed by Geffe; but the simplifications are worthwhile for some types of analysis.

GENERAL TWO AND FOUR POLE TRANSFER FUNCTIONS

The transfer function of a two pole bandpass filter can be written as

$$H_2(s) = \frac{H_0 d \omega_0 s}{s^2 + d \omega_0 s + \omega_0^2} \quad (1)$$

where

ω_0 = the center frequency (radians/second)

$d = 1/Q$

H_0 = the filter gain at center frequency

One way in which an op amp characteristics can distort this two pole response is by the addition of one or two parasitic poles. In this case the new transfer can be written in the form

$$H_4(s) = \frac{Ns}{T_4 s^4 + T_3 s^3 + T_2 s^2 + T_1 s + T_0} \quad (2)$$

The purpose of the two approximations presented in this appendix is to develop manageable equations that tie the transfer function coefficients N , T_0 , T_1 , T_2 , T_3 , and T_4 to the frequency response parameters ω_0 , Q and H_0 for the four pole transfer function.

GEFFE'S APPROXIMATION

The four pole transfer function of Equation (2) can be factored into two parts: one part containing the two dominant poles in the form of Equation (1) and the other containing the parasitic poles. Geffe (Reference 1) has shown that, if we assume that the second factor has no appreciable effect on the overall transfer function, the following pair of simultaneous equations must be satisfied:

$$(1-d^2)T_4\omega_0^4 + dT_3\omega_0^3 - T_2\omega_0^2 + T_0 = 0 \quad (3)$$

$$dT_4\omega_0^4 - T_3\omega_0^3 + T_1\omega_0 - dT_0 = 0 \quad (4)$$

where

ω_0 is the center frequency, and

$d = 1/Q$.

Given circuit equations which express T_0 , T_1 , T_2 , T_3 , and T_4 as functions of the circuit component values and op amp parameters, this pair of simultaneous equations can be used to synthesize a filter having a specified center frequency and Q .

THE PHASE APPROXIMATION

An approximation that produces simpler equations than that used by Geffe can be developed by comparing the phase shift of the two pole bandpass transfer function of Equation (1) with that of the four pole function in Equation (2).

To find the phase shift of the two pole function we first rewrite Equation (1) in the form

$$H_2(j\omega) = \frac{H_0}{1 + jF_2(\omega)} \quad (5)$$

where

$$F_2(\omega) = Q\left(\frac{\omega}{\omega_0} - \frac{\omega_0}{\omega}\right) \quad (6)$$

If H_0 is positive, the phase shift is given by

$$\phi(\omega) = -\arctan(F_2(\omega)) \quad (7)$$

At the center frequency (ω_0) the phase shift and its first derivative are

$$\phi(\omega_0) = 0$$

$$\left. \frac{d\phi(\omega)}{d\omega} \right|_{\omega=\omega_0} = - \left. \frac{dF_2(\omega)}{d\omega} \right|_{\omega=\omega_0} \quad (8)$$

$$\left. \frac{d\phi(\omega)}{d\omega} \right|_{\omega=\omega_0} = \frac{-2Q}{\omega_0} \quad (9)$$

If the phase shift function of a two pole bandpass filter is known, the center frequency and Q can be determined as follows:

(1) the center frequency ω_0 is the frequency for which the phase shift is zero

$$\phi(\omega_0) = 0 \quad (10)$$

(2) the Q is a function of the derivative of phase shift

$$Q = \frac{-\omega_0}{2} \left. \frac{d\phi(\omega)}{d\omega} \right|_{\omega=\omega_0} \quad (11)$$

Now we consider the case in which two additional poles have been added to the original two pole bandpass response by the presence of a non-ideal op amp. Let

$$H_4(s) = \frac{Ns}{T_4s^4 + T_3s^3 + T_2s^2 + T_1s + T_0} \quad (12)$$

Substituting $s = j\omega$ and rearranging results in

$$H_4(j\omega) = \frac{G(\omega)}{1 + jF_4(\omega)} \quad (13)$$

where

$$G(\omega) = \frac{N}{T_1 - T_3\omega^2} \quad (14)$$

$$F_4(\omega) = \frac{-T_4\omega^3 + T_2\omega - \frac{T_0}{\omega}}{T_1 - T_3\omega^2} \quad (15)$$

Although the numerator $G(\omega)$ is not constant, it contains no phase-shift; thus the filter phase shift given by

$$\phi(\omega) = -\arctan(F_4(\omega)) \quad (16)$$

We now make the assumption that Equations (10) and (11), which relate the center frequency and Q of two pole filter to its phase shift, are approximately valid for the four pole transfer function. Applying Equation (10) to Equations (15) and (16) and rearranging, we have

$$T_4 \omega_0^4 - T_2 \omega_0^2 + T_0 = 0 \quad (17)$$

Solving for ω_0

$$\begin{aligned} \omega_0 &= \sqrt{\frac{T_2 \pm \sqrt{T_2^2 - 4 T_0 T_4}}{2 T_4}} \\ &= \sqrt{\frac{T_0}{\frac{T_2}{2} + \sqrt{\left(\frac{T_2}{2}\right)^2 - T_0 T_4}}} \end{aligned} \quad (18)$$

The radical was moved to the denominator because T_4 approaches zero as the transfer function approaches the ideal, two-pole bandpass response; the sign on the radical was chosen to keep ω_0 from going to infinity for $T_4 = 0$.

The approximate Q is found by combining Equations (11), (15), (16), and (17):

$$\begin{aligned} Q &= \frac{-\omega_0}{2} \left. \frac{d\phi(\omega)}{d\omega} \right|_{\omega=\omega_0} \\ &= \frac{\omega_0}{2} \left. \frac{dF_4(\omega)}{d\omega} \right|_{\omega=\omega_0} \\ &= \frac{T_0 - T_4 \omega_0^4}{T_1 \omega_0 - T_3 \omega_0^3} \end{aligned} \quad (19)$$

This can also be written as

$$dT_4\omega_0^4 - T_3\omega_0^3 + T_1\omega_0 - dT_0 = 0 \quad (20)$$

where

$$d = 1/Q$$

We can also solve for the gain at the center frequency.

$$\begin{aligned} H_0 &= |H_4(j\omega_0)| \\ &= G(\omega_0) \\ &= \frac{N\omega_0}{T_1\omega_0 - T_3\omega_0^3} \end{aligned} \quad (21)$$

Based on the phase approximation, the characteristics of an active filter with the distorted bandpass transfer function shown in Equation (12) are summarized below:

$$\omega_0 = \sqrt{\frac{T_0}{\frac{T_2}{2} + \sqrt{\left(\frac{T_2}{2}\right)^2 - T_0T_4}}} \quad (22)$$

$$Q = \frac{T_0 - T_4\omega_0^4}{T_1\omega_0 - T_3\omega_0^3} \quad (23)$$

$$H_0 = \frac{N\omega_0}{T_1\omega_0 - T_3\omega_0^3} \quad (24)$$

In synthesis problems it is sometimes useful to express Equations (22) and (23) as a pair of simultaneous equations:

$$T_4\omega_0^4 - T_2\omega_0^2 + T_0 = 0 \quad (25)$$

$$dT_4\omega_0^4 - T_3\omega_0^3 + T_1\omega_0 - dT_0 = 0 \quad (26)$$

where

$$d = 1/Q$$

COMPARISON OF THE TWO APPROXIMATIONS

In order to see the relationship between the two approximations, it is useful to compare the pairs of simultaneous equations that characterize each approach. Geffe's approximation produced the following pair of equations:

$$(1-d_g^2)T_4\omega_g^4 + d_gT_3\omega_g^3 - T_2\omega_g^2 + T_0 = 0 \quad (27)$$

$$d_gT_4\omega_g^4 - T_3\omega_g^3 + T_1\omega_g - d_gT_0 = 0 \quad (28)$$

where

ω_g is the center frequency based on Geffe's approximation;

$$d_g = 1/Q_g$$

Q_g is the filter Q based on Geffe's approximation

The corresponding equations from the phase approximation are

$$T_4\omega_\phi^4 - T_2\omega_\phi^2 + T_0 = 0 \quad (29)$$

$$d_\phi T_4\omega_\phi^4 - T_3\omega_\phi^3 + T_1\omega_\phi - d_\phi T_0 = 0 \quad (30)$$

where

ω_ϕ is the center frequency based on the phase approximation;

$$d_\phi = 1/Q_\phi$$

Q_ϕ is the filter Q based on the phase approximation.

It can be seen that the second equations in the two pairs are identical, but the first equations differ in two terms.

Investigations by this author have indicated that Geffe's approximation (ω_g) provides a more accurate indication of the true center frequency of a filter than the phase approximation (ω_ϕ); on the other hand, the phase approximation indicates the actual frequency at which zero phase shift occurs. Since active filters are sometimes tuned by adjusting for zero degrees phase shift at the desired frequency, a comparison of the frequencies ω_g and ω_ϕ will be informative.

Suppose that the zero phase shift frequency ω_ϕ is given by

$$\omega_\phi = \omega_g + \Delta\omega \quad (30)$$

where $\Delta\omega$ is small compared to ω_g . Substituting Equation (30) into Equation (29) we have

$$\begin{aligned} 0 &= T_0 - T_2(\omega_g + \Delta\omega)^2 + T_4(\omega_g + \Delta\omega)^4 \\ &\approx T_0 - T_2(\omega_g^2 + 2\omega_g\Delta\omega) + T_4(\omega_g^4 + 4\omega_g^3\Delta\omega) \end{aligned} \quad (31)$$

Solving for $\Delta\omega/\omega_g$,

$$\frac{\Delta\omega}{\omega_g} \approx \frac{T_0 - T_2\omega_g^2 + T_4\omega_g^4}{2T_2\omega_g^2 - 4T_4\omega_g^4} \quad (33)$$

From Equation (27) we have

$$T_0 - T_2\omega_g^2 + T_4\omega_g^4 = -d_g T_3\omega_g^3 + d_g^2 T_4\omega_g^4 \quad (34)$$

Substituting this into Equation (33)

$$\frac{\Delta\omega}{\omega_g} \approx \frac{-d_g T_3 \omega_g^3 + d_g^2 T_4 \omega_g^4}{2T_2 \omega_g^2 - 4T_4 \omega_g^4} \quad (35)$$

The 3dB bandwidth of the filter is given approximately by:

$$\omega_B = \frac{\omega_g}{Q_g} \quad (36)$$

Thus, we have

$$\begin{aligned} \frac{\Delta\omega}{(\omega_B/2)} &= \frac{2}{d_g} \cdot \frac{\Delta\omega}{\omega_g} \\ &\approx \frac{-T_3 \omega_g^3 + d_g T_4 \omega_g^4}{T_2 \omega_g^2 - 2T_4 \omega_g^4} \end{aligned} \quad (37)$$

For a high Q filter, $\omega_B/2$ will be the distance from the center frequency to the 3dB band-edge. Therefore, to have $\Delta\omega > \omega_B/2$ would result in the zero-phase frequency occurring at or beyond the edge of the bandpass function. Since a common method for tuning an active filter is to tune for zero degrees phase shift at the desired filter center frequency, it is usually best to maintain the inequality

$$\frac{\Delta\omega}{\omega_B/2} \ll 1$$

With this inequality we will have $\omega_g \approx \omega_0$, and Equation (29) can be used to simplify the denominator of Equation (37):

$$\frac{\Delta\omega}{(\omega_B/2)} \approx \frac{-T_3 \omega_g^3 + d_g T_4 \omega_g^4}{T_0 - T_4 \omega_g^4} \quad (38)$$

Since ω_g is very close to the true center frequency ω_0 , we can write

$$\Delta\omega \approx \left(\frac{\omega_B}{2}\right) \cdot \frac{-T_3 \omega_0^3 + d T_4 \omega_0^4}{T_0 - T_4 \omega_0^4} \quad (39)$$

The foregoing results can provide useful guidelines for the design of an active bandpass filter. Suppose that we want a two pole bandpass filter. Given a circuit and a model for the op amp, we derive the circuit transfer function and find that it is actually a four pole function in the form of Equation (2), where the coefficients T_0 , T_1 , T_2 , T_3 , T_4 , and N depend on the circuit component values and op amp parameters. Since Geffe's approximation provides the best accuracy, the component values should be chosen to satisfy Equations (3) and (4) for the desired center frequency and Q . (If accuracy is not a problem, Equations (22), (23), and (24) or Equations (25) and (26) can be used instead.) After the filter is designed, Equation (39) will provide an indication of the difference between the zero phase frequency and the true center frequency. This information will be especially important if the filter is to be tuned by phase measurement techniques. If the difference is unacceptably large, the filter will have to be redesigned, perhaps with a better op amp. In general, it will be found that an ideal op amp causes $T_3 = T_4 = 0$, reducing the filter to an ideal two pole bandpass response; for such a two pole filter there will be no errors in either the phase approximation or Geffe's approximation, and the zero-phase frequency will be exactly equal to the true center frequency.

Appendix C

SYNTHESIS

Synthesis of an active filter is the process of calculating the circuit component values necessary to achieve the desired frequency response. This Appendix performs an analysis of the bandpass filter circuit shown in Figure C-1 with two basic aims:

- (1) To provide accurate synthesis equations for the filter; and
- (2) To make approximations in the synthesis equations that will result in certain equations and inequalities which will be useful in simplifying the sensitivity analysis of the filter.

A two-pole op amp model will be assumed throughout the appendix.

GEFFE'S SYNTHESIS TECHNIQUE

The procedure used by Geffe (Reference 1) for active filter synthesis begins with a pair of simultaneous equations which characterize the circuit. Next, all of the op amp parameters and all except two of the circuit component values are specified; the remaining components, Z_1 and Z_2 , will be calculated to achieve the desired center frequency and Q for the filter. Before performing this calculation, however, the simultaneous equations must be written in for form

$$a_3 Z_1 Z_2 + a_2 Z_1 + a_1 Z_2 + a_0 = 0 \quad (1)$$

$$b_3 Z_1 Z_2 + b_2 Z_1 + b_1 Z_2 + b_0 = 0 \quad (2)$$

The value of Z_1 is found by solving the quadratic equation

$$A Z_1^2 + B Z_1 + C = 0 \quad (3)$$

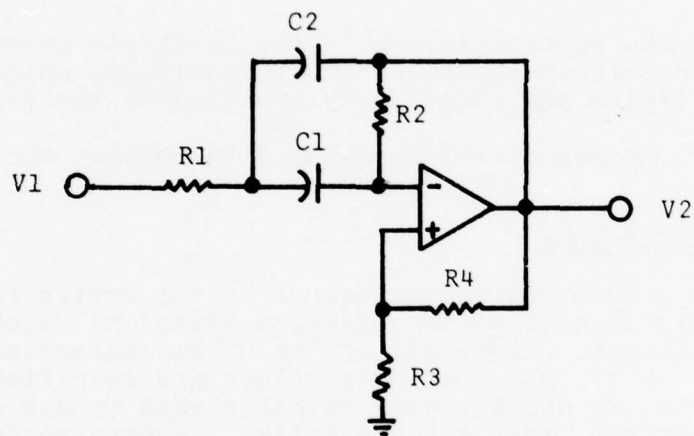

$$\rho = \frac{R3}{R3+R4} = \text{POSITIVE FEEDBACK RATIO}$$

Figure C-1. Active Bandpass Filter Circuit

$$\text{where } A = a_3b_2 - a_2b_3 \quad (4)$$

$$B = a_3b_0 - a_0b_3 + a_1b_2 - a_2b_1 \quad (5)$$

$$C = a_1b_0 - a_0b_1 \quad (6)$$

The other unknown is given by:

$$z_2 = - \frac{a_2z_1 + a_0}{a_3z_1 + a_1} \quad (7)$$

GEFFE'S EQUATIONS FOR A FOUR-POLE TRANSFER FUNCTION

We will assume that the transfer function of the filter can be written as

$$H(s) = \frac{Ns}{T_4s^4 + T_3s^3 + T_2s^2 + T_1s + T_0} \quad (8)$$

The terms T_3 and T_4 should ideally be zero, but non-ideal characteristics of the op amp in the filter have distorted the transfer function, resulting in non-zero values for the two terms.

Based on an approximation described in Reference 1, Geffe uses the following pair of simultaneous equations to characterize the transfer function in Equation (8):

$$(1-d^2)T_4\omega_0^4 + dT_3\omega_0^3 - T_2\omega_0^2 + T_0 = 0 \quad (9)$$

$$dT_4\omega_0^4 - T_3\omega_0^3 + T_1\omega_0 - dT_0 = 0 \quad (10)$$

where

ω_0 is the filter center frequency

$d = 1/Q$

Q is the Q of the filter.

For simplicity we will normalize the equations to a center frequency of one radian per second. The normalized parameters will be denoted by lower case letters:

$$t_0 = T_0 \quad (11)$$

$$t_1 = T_1 \omega_0 \quad (12)$$

$$t_2 = T_2 \omega_0^2 \quad (13)$$

$$t_3 = T_3 \omega_0^3 \quad (14)$$

$$t_4 = T_4 \omega_0^4 \quad (15)$$

The normalized form of Equations (9) and (10) is

$$(1 - d^2)t_4 + dt_3 - t_2 + t_0 = 0 \quad (16)$$

$$dt_4 - t_3 + t_1 - dt_0 = 0 \quad (17)$$

EXACT SYNTHESIS FOR R_1 AND R_2

The filter circuit shown in Figure C-1 has the transfer function (see Appendix A),

$$H(s) = \frac{-N_1 s}{T_4 s^4 + T_3 s^3 + T_2 s^2 + T_1 s + T_0} \quad (18)$$

in which

$$T_0 = 1 + G_0 \quad (19)$$

$$T_1 = (1 + G_0) D_1 - N_1 + G_1 \quad (20)$$

$$T_2 = (1 + G_0) D_2 + D_1 G_1 + G_2 \quad (21)$$

$$T_3 = D_2 G_1 + D_1 G_2 \quad (22)$$

$$T_4 = D_2 G_2 \quad (23)$$

The N and D terms involve passive component values as follows:

$$N_1 = C_1 R_2 \quad (24)$$

$$D_1 = (C_1 + C_2) R_1 + C_1 R_2 \quad (25)$$

$$D_2 = C_1 C_2 R_1 R_2 \quad (26)$$

The G values contain the positive feedback ratio ρ and the op amp parameters:

$$G_0 = -\rho + \frac{1}{A_{DC}} \quad (27)$$

$$G_1 = 1/\omega_{u1} \quad (28)$$

$$G_2 = 1/\omega_{u2}^2 \quad (29)$$

where

$$\rho = \frac{R_3}{R_3 + R_4}$$

ω_{u1} is the frequency at which the extension of the -20 dB/decade portion of the op amp gain plot crosses unity gain.

ω_{u2} is the frequency at which the extension of the -40 dB/decade portion of the op amp gain plot crosses unity gain.

The normalized terms are denoted by lower case letters and are given by:

$$t_0 = 1 + g_0 \quad (30)$$

$$t_1 = (1 + g_0) d_1 - n_1 + g_1 \quad (31)$$

$$t_2 = (1 + g_0) d_2 + d_1 g_1 + g_2 \quad (32)$$

$$t_3 = d_2 g_1 + d_1 g_2 \quad (33)$$

$$t_4 = d_2 g_2 \quad (34)$$

$$g_0 = G_0 = -\rho + \frac{1}{A_{DC}} \quad (35)$$

$$g_1 = \omega_0 G_1 = \omega_0 / \omega_{u1} = f_0 / f_{u1} \quad (36)$$

$$g_2 = \omega_0^2 G_2 = \omega_0^2 / \omega_{u2}^2 = f_0^2 / f_{u2}^2 \quad (37)$$

$$n_1 = \omega_0 N_1 \quad (38)$$

$$d_1 = \omega_0 D_1 \quad (39)$$

$$d_2 = \omega_0^2 D_2 \quad (40)$$

If $C_1 = C_2$, we can also define

$$cr_1 = \omega_0 C_1 R_1 \quad (41)$$

$$cr_2 = \omega_0 C_1 R_2 \quad (42)$$

This results in

$$n_1 = cr_2 \quad (43)$$

$$d_1 = 2cr_1 + cr_2 \quad (44)$$

$$d_2 = c^2 r_1 r_2 \quad (45)$$

In performing the synthesis we will assume that $C_1 = C_2$ and that R_1 and R_2 are the components to be calculated. For convenience the normalized equations will be used and the terms cr_1 and cr_2 will be chosen as unknowns:

$$z_1 = cr_1 \quad (46)$$

$$z_2 = cr_2 \quad (47)$$

Substituting Equations (38) to (40) into Equations (31) to (34), substituting Equations (30) to (34) into Equations (16) and (17), and rearranging, we obtain:

$$0 = a_3(cr_1)(cr_2) + a_2(cr_1) + a_1(cr_2) + a_0 \quad (48)$$

$$0 = b_3(cr_1)(cr_2) + b_2(cr_1) + b_1(cr_2) + b_0 \quad (49)$$

where

$$a_0 = 1 + g_0 - g_2 \quad (50)$$

$$a_1 = -(g_1 - dg_2) \quad (51)$$

$$a_2 = -2(g_1 - dg_2) \quad (52)$$

$$a_3 = -(1 + g_0 - g_2) + d(g_1 - dg_2) \quad (53)$$

$$b_0 = (g_1 - dg_2) - d(1 + g_0 - g_2) \quad (54)$$

$$b_1 = g_0 - g_2 \quad (55)$$

$$b_2 = 2(1 + g_0 - g_2) \quad (56)$$

$$b_3 = -(g_1 - dg_2) \quad (57)$$

Substituting into Equation (4), (5), and (6), we obtain

$$A = -2\alpha \quad (58)$$

$$B = d\alpha - 2(g_1 - dg_2) \quad (59)$$

$$\begin{aligned} C &= -\left[-d(1 + g_0 - g_2)(g_1 - dg_2) + (g_1 - dg_2)^2\right] \\ &\quad - (g_0 - g_2)(1 + g_0 - g_2) \\ &= -\alpha + (1 + g_0 - g_2) \end{aligned} \quad (60)$$

where

$$\alpha = (1 + g_0 - g_2)^2 - d(1 + g_0 - g_2)(g_1 - dg_2) + (g_1 - dg_2)^2 \quad (61)$$

Synthesis may now be accomplished by using the formulas in Equations (3) and (7)

$$cr_1 = \frac{-B}{2A} + \sqrt{\left(\frac{-B}{2A}\right)^2 - \frac{C}{A}} \quad (62)$$

$$\begin{aligned} cr_2 &= -\frac{a_2 cr_1 + a_0}{a_3 cr_1 + a_1} \\ &= \frac{(1 + g_0 - g_2) - 2(g_1 - dg_2) cr_1}{(g_1 - dg_2) + [(1 + g_0 - g_2) - d(g_1 - dg_2)] cr_1} \end{aligned} \quad (63)$$

Careful arrangement of the terms in synthesis equations has resulted in the positive feedback ratio and the three op amp parameters entering the equations in only two forms: $(g_0 - g_2)$ and $(g_1 - dg_2)$. In the latter expression, the term dg_2 may often be neglected because dg_2 will be much smaller than g_1 whenever

$$\omega_0 \ll Q\omega_{u2}^2/\omega_{u1} = Q\omega_{p2}$$

EXACT SYNTHESIS FOR R_2 AND ρ

If pots are used to tune the filter, R_2 is a convenient choice for the frequency adjustment and the positive feedback ratio ρ can be used as a Q adjustment. Consequently, we will also derive synthesis equations for calculating R_2 and ρ .

Following the procedure that was used in the preceding section we set $C_1 = C_2$ and choose unknowns

$$z_1' = cr_2 = 2\pi f_0 C_1 R_2$$

$$z_2' = P = \rho - \frac{1}{A_{DC}} + g_2$$

Equations (48) and (49) can be rearranged to yield

$$0 = a_3' (cr_2) P + a_2' (cr_2) + a_1' P + a_0'$$

$$0 = b_3' (cr_2) P + b_2' (cr_2) + b_1' P + b_0'$$

where

$$a_0' = 1 - 2 cr_1 (g_1 - dg_2)$$

$$a_1' = -1$$

$$a_2' = - cr_1 - (1 - dcr_1) (g_1 - dg_2)$$

$$a_3' = cr_1$$

$$b_0' = -(2cr_1 - d) - (g_1 - dg_2)$$

$$b_1' = (2cr_1 - d)$$

$$b_2' = cr_1 (g_1 - dg_2)$$

$$b_3' = 1$$

Proceeding, we have

$$\begin{aligned} A' &= a_3' b_2' - a_2' b_3' \\ &= cr_1 + (g_1 - dg_2) [1 + cr_1 (cr_1 - d)] \end{aligned}$$

$$\begin{aligned} B' &= a_3' b_0' - a_0' b_3' + a_1' b_2' - a_2' b_1' \\ &= -1 + (1 - dcr_1) (2cr_1 - d) (g_1 - dg_2) \end{aligned}$$

$$\begin{aligned} c' &= a_1' b_0' - a_0' b_1' \\ &= (g_1 - dg_2) [1 + 2cr_1 (2cr_1 - d)] \end{aligned}$$

$$cr_2 = -\frac{B'}{2A'} + \sqrt{\left(\frac{B'}{2A'}\right)^2 - \frac{C'}{A'}}$$

$$\begin{aligned} P &= -\frac{b_2' cr_2 + b_0'}{b_3' cr_2 + b_1'} \\ &= \frac{(2 cr_1 - d) + (g_1 - dg_2) - (g_1 - dg_2)(cr_1)(cr_2)}{(2 cr_1 - d) + cr_2} \end{aligned}$$

Now R_2 and ρ can be calculated by

$$R_2 = \frac{cr_2}{2\pi f_0 C_1}$$

$$\rho = P + \frac{1}{A_{DC}} - g_2$$

EXACT GAIN

The gain of the filter at its center frequency can be derived by substituting $s = j\omega_0$ into Equation (18):

$$H(j\omega_0) = \frac{-N_1(j\omega_0)}{T_4(j\omega_0)^4 + T_3(j\omega_0)^3 + T_2(j\omega_0)^2 + T_1(j\omega_0) + T_0}$$

Normalizing the equation:

$$\begin{aligned} H(j\omega_0) &= \frac{-n_1 j}{t_4 j^4 + t_3 j^3 + t_2 j^2 + t_1 j + t_0} \\ &= \frac{-n_1 j}{(t_0 - t_2 + t_4) + j(t_1 - t_3)} \end{aligned}$$

Writing Equations (9) and (10) in normalized form and rearranging, we have

$$t_0 - t_2 + t_4 = d^2 t_4 - dt_3$$

$$t_1 - t_3 = d(t_0 - t_4)$$

Substituting Equations (30), (33) and (34) and rearranging

$$\begin{aligned} t_0 - t_2 + t_4 &= d^2 t_4 - dt_3 \\ &= d \left[-d_1 g_2 - d_2 (g_1 - dg_2) \right] \end{aligned}$$

$$\begin{aligned} t_1 - t_3 &= d(t_0 - t_4) \\ &= d \left[1 + g_0 - g_2 + (1 - d_2) g_2 \right] \end{aligned}$$

Continuing, we have

$$\begin{aligned} H(j\omega_0) &= \frac{-n_1 j}{d \left[-d_1 g_2 - d_2 (g_1 - dg_2) \right] + j d \left[1 + g_0 - g_2 + (1 - d_2) g_2 \right]} \\ &= \frac{-n_1 Q}{\left[(1 + g_0 - g_2) + (1 - d_2) g_2 \right] + j \left[d_1 g_2 + d_2 (g_1 - dg_2) \right]} \end{aligned}$$

This equation can be used to calculate the gain of the filter after it has been synthesized.

APPROXIMATE SYNTHESIS EQUATIONS

In some applications such as sensitivity analysis, it is useful to have approximate synthesis formulas in order to simplify calculations; therefore, we will carry out the synthesis process for the case where $(g_1 - dg_2)$ has a negligible effect ($g_1 = g_2 = 0$ for an ideal op amp).

Setting $g_1 - dg_2 = 0$ and defining

$$P = -g_0 + g_2 = \rho - \frac{1}{A_{DC}} + g_2$$

we have

$$a_0 = 1 - P$$

$$a_1 = 0$$

$$a_2 = 0$$

$$a_3 = -(1 - P)$$

$$\alpha = (1 - P)^2$$

$$A = -2(1 - P)^2$$

$$B = d(1 - P)^2$$

$$C = P(1 - P)$$

Substituting into Equations (62) and (63) and rearranging, we have

$$cr_1 = \frac{X}{2Q}$$

$$cr_2 = \frac{2Q}{X}$$

where

$$X = \frac{1}{2} + \sqrt{\left(\frac{1}{2}\right)^2 + 2Q^2 \left(\frac{P}{1 - P}\right)}$$

Notice that $P = \rho$ when ideal op amp is assumed.

APPROXIMATE BEHAVIOR OF d_1 AND d_2 , AND LIMITATIONS IMPOSED BY THE SYNTHESIS PROCESS

The terms d_1 and d_2 will appear frequently in sensitivity equations for the filter (Appendix D); therefore, it will be useful to have simple formulas for the approximate values of d_1 and d_2 , both to provide substitutions and to indicate the range of values to which d_1 and d_2 are limited.

The quantity d_1 is given by:

$$d_1 = 2cr_1 + cr_2$$

When the approximate values for cr_1 and cr_2 are substituted, we have

$$d_1 \approx \frac{X}{Q} + \frac{2Q}{X}$$

The value of X that minimizes d_1 is found by setting the derivative of d_1 with respect to X equal to zero. The minimum value of d_1 occurs at $X = Q\sqrt{2}$ and is

$$d_{1\min} \approx 2\sqrt{2} \approx 2.8$$

A simple formula for d_2 can be derived from the following formula, which is based on the "phase approximation" described in Appendix B:

$$T_4\omega_0^4 - T_2\omega_0^2 + T_0 \approx 0.$$

This equation can be normalized to yield

$$t_4 - t_2 + t_0 \approx 0$$

Substituting for t_0 , t_2 , and t_4 ,

$$0 \approx d_2g_2 - \left[(1 + g_0) d_2 + d_1g_1 + g_2 \right] + (1 + g_0)$$

Rearranging,

$$0 \approx (1 + g_0 - g_2) (1 - d_2) - d_1g_1$$

$$1 - d_2 \approx \frac{d_1g_1}{1 + g_0 - g_2}$$

$$d_2 \approx 1 - \frac{d_1g_1}{1 + g_0 - g_2}$$

NSWC/WOL TR 78-2

These formulas imply certain limitations that are necessary to make synthesis possible. First of all, since $d_2 = c_1 c_2 r_1 r_2$, we must have $d_2 > 0$; this implies that

$$\frac{d_1 g_1}{1 + g_0 - g_2} < 1$$

If we also assume that ω_{u2} is not so small as to result in $1 + g_0 - g_2 \leq 0$, then it can be shown that

$$0 < d_2 \leq 1$$

$$0 \leq 1 - d_2 < 1$$

This results in

$$0 \leq \frac{d_1 g_1}{1 + g_0} \leq \frac{d_1 g_1}{1 + g_0 - d_2 g_2} \leq \frac{d_1 g_1}{1 + g_0 - g_2} < 1$$

In terms of t_0 and t_4 , this is equivalent to

$$0 \leq \frac{d_1 g_1}{t_0} \leq \frac{d_1 g_1}{t_0 - t_4} \leq \frac{d_1 g_1}{t_0 - g_2} < 1$$

Multiplying the inequality by t_0/d_1 places a limit on g_1 :

$$g_1 < \frac{t_0}{d_1} = \frac{1 - \rho + \frac{1}{A_{DC}}}{d_1} < \frac{1 + \frac{1}{A_{DC}^{\min}}}{d_{1\min}}$$

Most op amps have $A_{DC} > 10,000$, so it is certainly safe to set $A_{DC} \geq 100$. Then

$$g_1 < \frac{1 + \frac{1}{100}}{2\sqrt{2}} = 0.36$$

Tighter limitations will be placed on some of these terms after the sensitivity analysis in Appendix D.

NSWC/WOL TR 78-2

LIMITATIONS NECESSARY TO REDUCE PHASE TUNING ERROR

In Appendix B it was shown that

$$\Delta\omega \approx \frac{\omega_B}{2} \cdot \left[\frac{-T_3\omega_0^3 + d T_4\omega_0^4}{T_0 - T_4\omega_0^4} \right]$$

where

$\Delta\omega$ is the difference between the frequency that produces zero phase-shift (180° in this case because the amplifier inverts) and the true center frequency of the filter; ω_B is the 3dB bandwidth of the filter (in radians per second).

In normalized form, we have

$$\Delta\omega \approx \frac{\omega_B}{2} \left[\frac{-t_3 + dt_4}{t_0 - t_4} \right]$$

Substituting Equations (33) and (34) for t_3 and t_4 , we have:

$$\Delta\omega \approx \frac{\omega_B}{2} \cdot \left[\frac{-(d_2g_1 + d_1g_2) + dd_2g_2}{t_0 - t_4} \right]$$

In the preceding section it was shown that

$$d_1 \geq 2\sqrt{2}$$

$$d_2 \leq 1.$$

Using these inequalities, and assuming $Q \gg 1$ (i.e., $d \ll 1$), we have

$$d d_2g_2 \ll d_1g_2$$

Therefore, the term $d d_2g_2$ can be dropped from the equation:

$$\Delta\omega \approx -\frac{\omega_B}{2} \cdot \left[\frac{d_2g_1 + d_1g_2}{t_0 - t_4} \right]$$

NSWC/WOL TR 78-2

If an ideal op amp were used in the filter circuit, the phase shift through the filter would be zero (180° for this circuit) at the center frequency. This fact is important in some filter applications and is also frequently used as a basis for tuning active filters. However, non-ideal op amp parameters result in a difference between the zero phase-shift frequency and the true center frequency. It is desirable to keep this difference ($\Delta\omega$) small whenever possible.

As an example, suppose the magnitude of $\Delta\omega$ were equal to $\omega_B/2$. Since $\omega_B/2$ is approximately equal to the distance from the filter center frequency to a 3dB point, such a value for $\Delta\omega$ would place the zero phase frequency at a band edge. To prevent such large errors, we must require that

$$\left| \frac{\Delta\omega}{\omega_B/2} \right| \ll 1$$

For our circuit this means that

$$\frac{d_2g_1 + d_1g_2}{t_0 - t_4} \ll 1$$

SUMMARY

The formulas derived in this appendix for the filter circuit of Figure C-1 are summarized below:

(1) Accurate Synthesis (R_1 and R_2): The values of R_1 and R_2 necessary to tune the filter to a given frequency and Q when $C_1 = C_2$ are given by

$$R_1 = \frac{cr_1}{2\pi f_0 C_1}$$

$$R_2 = \frac{cr_2}{2\pi f_0 C_1}$$

where

$$cr_1 = \frac{-B}{2A} + \sqrt{\left(\frac{B}{2A}\right)^2 - \frac{C}{A}}$$

NSWC/WOL TR 78-2

$$cr_2 = \frac{(1 + g_0 - g_2) - 2(g_1 - dg_2) cr_1}{(g_1 - dg_2) + [(1 + g_0 - g_2) - d(g_1 - dg_2)] cr_1}$$

$$A = -2\alpha$$

$$B = d\alpha - 2(g_1 - dg_2)$$

$$C = -\alpha + (1 + g_0 - g_2)$$

$$\alpha = (1 + g_0 - g_2)^2 - d(1 + g_0 - g_2)(g_1 - dg_2) + (g_1 - dg_2)^2$$

$$d = 1/Q$$

$$g_0 = -\rho + 1/A_{DC}$$

$$g_1 = \omega_0/\omega_{u1}$$

$$g_2 = \omega_0^2/\omega_{u2}^2$$

and

$$\rho = \frac{R_3}{R_3 + R_4}$$

ω_{u1} is the frequency at which the extension of the -20 dB/decade portion of the op amp gain plot crosses unity gain.

ω_{u2} is the frequency at which the extension of the -40 dB/decade portion of the op amp gain plot crosses unity gain.

(2) Accurate Synthesis (R_2 and ρ): The values of R_2 and ρ necessary to tune the filter (when $C_1 = C_2$) are given by:

$$R_2 = \frac{cr_2}{2\pi f_0 C_1}$$

$$\rho = P + \frac{1}{A_{DC}} - g_2$$

NSWC/WOL TR 78-2

where

$$cr_2 = - \left(\frac{B'}{2A'} \right) + \sqrt{\left(\frac{B'}{2A'} \right)^2 - \frac{C'}{A}}$$

$$P = \frac{(2cr_1 - d) + (g_1 - dg_2) - (g_1 - dg_2)(cr_1)(cr_2)}{(2cr_1 - d) + cr_2}$$

$$A' = cr_1 + (g_1 - dg_2) [1 + cr_1 (cr_1 - d)]$$

$$B' = -1 + (1 - dcr_1)(2cr_1 - d)(g_1 - dg_2)$$

$$C' = (g_1 - dg_2) [1 + 2cr_1(2cr_1 - d)]$$

(3) Accurate gain: The filter gain at center frequency is given by:

$$H(j\omega_0) = \frac{-cr_2Q}{\left[(1 + g_0 - g_2) + (1 - d_2)g_2 \right] + j \left[d_1g_2 + d_2(g_1 - dg_2) \right]}$$

(4) Approximate Synthesis:

$$cr_1 \approx X/2Q$$

$$cr_2 \approx 2Q/X$$

$$X = \frac{1}{2} + \sqrt{\left(\frac{1}{2} \right)^2 + 2Q^2 \left(\frac{P}{1-P} \right)}$$

$$P = -g_0 + g_2 = \rho - \frac{1}{A_{DC}} + g_2$$

(5) Approximate formulas for d_1 and d_2 :

$$d_1 \approx \frac{X}{Q} + \frac{2Q}{X}$$

$$d_2 \approx 1 - \frac{d_1 g_1}{1 + g_0 - g_2}$$

For synthesis to be possible we must have

$$\frac{d_1 g_1}{t_0 - g_2} < 1$$

which implies

$$y g_1 < 1$$

where

$$y = d_1/t_0$$

(6) Approximate ranges of d_1 and d_2 :

$$d_1 > 2 \sqrt{2}$$

$$0 < d_2 \leq 1$$

(7) Other approximate inequalities:

$$t_0 - t_4 > 0$$

$$0 \leq \frac{d_1 g_1}{t_0} \leq \frac{d_1 g_1}{t_0 - t_4} \leq \frac{d_1 g_1}{t_0 - g_2} < 1$$

$$g_1 < 0.36$$

(8) Restrictions necessary to maintain the zero phase shift frequency well within the passband:

$$\frac{d_2 g_1 + d_1 g_2}{t_0 - t_4} \ll 1$$

This is approximately equivalent to:

$$g_1 + y g_2 \ll 1$$

where

$$y = \frac{d_1}{t_0}$$

Here we used Equations (193) and (233) of Appendix D.

Appendix D

SENSITIVITIES AND OPTIMIZATION

Sensitivity analysis is a very important tool for determining the performance of an active filter circuit. The sensitivity of a filter parameter u (such as center frequency, Q , or gain) to a small change in the value of a circuit component or op amp parameter, z , is defined by

$$S_z^u = \frac{z}{u} \cdot \frac{du}{dz} = \frac{du/u}{dz/z}$$

Thus, for example, the sensitivity $S_{R_1}^Q$ indicates the fractional change in filter Q that will be caused by a given (small) fractional change in R_1 .

$$\frac{\Delta Q}{Q} \approx \frac{\Delta R_1}{R_1} \cdot S_{R_1}^Q$$

Because sensitivities are based on fractional changes, multiplying the parameter by a constant has no effect. For example, since

$$\omega_0 = 2\pi f_0$$

and

$$\omega_{ul} = 2\pi f_{ul}$$

we know that

$$S_{\omega_0}^{\omega_0} = S_{f_0}^{f_0} = S_{f_{ul}}^{f_0} = S_{f_{ul}}^{\omega_0}$$

The following six formulas have general application in sensitivity analysis and will be used when deriving sensitivity formulas in this appendix:

$$S_z^u = \frac{z}{u} \cdot \frac{du}{dz} \quad (1)$$

$$S_z^k = 0 \quad (2)$$

$$S_z^{kz} = 1 \quad (3)$$

$$S_z^{ku^n} = n s_z^u \quad (4)$$

$$S_z^{uv} = S_z^u + S_z^v \quad (5)$$

$$S_z^{u+k} = \frac{u}{u+k} S_z^u \quad (6)$$

where k is a constant.

This appendix will develop formulas for approximating the sensitivities for the bandpass filter circuit shown in Figure D-1. Appendix A shows that the transfer function of the filter is

$$H(s) = \frac{-N_1 s}{T_4 s^4 + T_3 s^3 + T_2 s^2 + T_1 s + T_0} \quad (7)$$

in which

$$T_0 = 1 + G_0 \quad (8)$$

$$T_1 = (1 + G_0) D_1 - N_1 + G_1 \quad (9)$$

$$T_2 = (1 + G_0) D_2 + D_1 G_1 + G_2 \quad (10)$$

$$T_3 = D_2 G_1 + D_1 G_2 \quad (11)$$

$$T_4 = D_2 G_2 \quad (12)$$

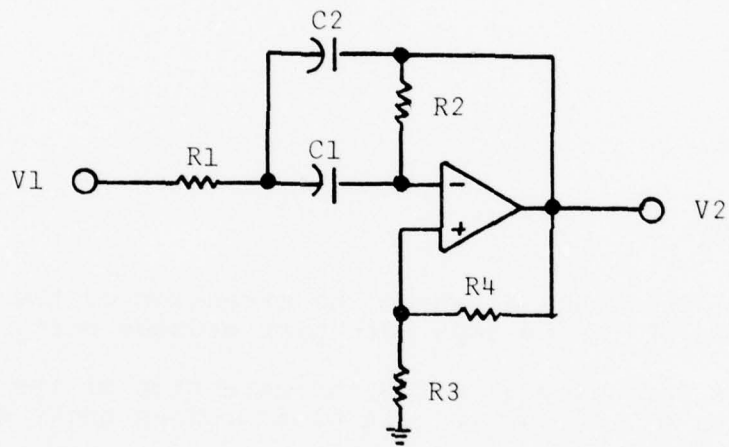

$$\rho = \frac{R3}{R3+R4} = \text{POSITIVE FEEDBACK RATIO}$$

Figure D-1. Active Bandpass Filter Circuit

The N and D terms involve passive component values as follows:

$$N_1 = C_1 R_2 \quad (13)$$

$$D_1 = (C_1 + C_2) R_1 + C_1 R_2 \quad (14)$$

$$D_2 = C_1 C_2 R_1 R_2 \quad (15)$$

The G values contain the positive feedback ratio ρ and the op amp parameters:

$$G_0 = -\rho + \frac{1}{A_{DC}} \quad (16)$$

$$G_1 = 1/\omega_{u1} \quad (17)$$

$$G_2 = 1/\omega_{u2}^2 \quad (18)$$

$$\rho = \frac{R_3}{R_3 + R_4} \quad (19)$$

ω_{u1} is the frequency at which the extension of the -20dB/decade portion of the op amps gain plot crosses unity gain.

ω_{u2} is the frequency at which the extension of the -40dB/decade portion of the op amp gain plot crosses unity gain.

It will later be useful to normalize the parameters to the center frequency ω_0 of the filter; the normalized parameters are:

$$t_0 = T_0 \quad (20)$$

$$t_1 = \omega_0 T_1 \quad (21)$$

$$t_2 = \omega_0^2 T_2 \quad (22)$$

$$t_3 = \omega_0^3 T_3 \quad (23)$$

$$t_4 = \omega_0^4 T_4 \quad (24)$$

$$g_0 = G_0 \quad (25)$$

$$g_1 = \omega_0 G_1 = \omega_0 / \omega_{u1} = f_0 / f_{u1} \quad (26)$$

$$g_2 = \omega_0^2 G_2 = \omega_0^2 / \omega_{u2}^2 = f_0^2 / f_{u2}^2 \quad (27)$$

$$n_1 = \omega_0 N_1 \quad (28)$$

$$d_1 = \omega_0 D_1 \quad (29)$$

$$d_2 = \omega_0^2 D_2 \quad (30)$$

If $C_1 = C_2 = C$, we can also define

$$cr_1 = \omega_0 CR_1 \quad (31)$$

$$cr_2 = \omega_0 CR_2 \quad (32)$$

The "phase approximation" described in Appendix B will be utilized in order to simplify the sensitivity formula derivations. According to that approximation, the following pair of simultaneous equations establishes the values for center frequency and Q:

$$T_4 \omega_0^4 - T_2 \omega_0^2 + T_0 = 0 \quad (33)$$

$$d T_4 \omega_0^4 - T_3 \omega_0^3 + T_1 \omega_0 - d T_0 = 0 \quad (34)$$

where

ω_0 = filter center frequency

$d = 1/Q$

The second equation of the pair may be multiplied by Q and rearranged yielding a new set of equations.

$$T_0 - T_2 \omega_0^2 + T_4 \omega_0^4 = 0 \quad (35)$$

$$Q (T_1 \omega_0 - T_3 \omega_0^3) = T_0 - T_4 \omega_0^4 \quad (36)$$

Taking the derivative of both equations with respect to an arbitrary variable z , we have

$$\frac{\partial T_0}{\partial z} - \left[T_2 (2\omega_0) \frac{\partial \omega_0}{\partial z} + (\omega_0^2) \frac{\partial T_2}{\partial z} \right] + \left[T_4 (4\omega_0^3) \frac{\partial \omega_0}{\partial z} + \omega_0^4 \frac{\partial T_4}{\partial z} \right] = 0 \quad (37)$$

$$Q \left[T_1 \frac{\partial \omega_0}{\partial z} + \omega_0 \frac{\partial T_1}{\partial z} - T_3 (3\omega_0^2) \frac{\partial \omega_0}{\partial z} - \omega_0^3 \frac{\partial T_3}{\partial z} \right] + \frac{\partial Q}{\partial z} [T_1 \omega_0 - T_3 \omega_0^3] = \frac{\partial T_0}{\partial z} - \left[T_4 (4\omega_0^3) \frac{\partial \omega_0}{\partial z} + \omega_0^4 \frac{\partial T_4}{\partial z} \right] \quad (38)$$

These equations may be written in terms of sensitivities by multiplying by z and substituting $\frac{du}{dz} = \frac{u}{z} S_z^u$ (for $u = T_0, T_1, T_2, T_3, T_4, \omega_0$, and Q). In addition, it is useful to change to the normalized notation in which $t_n = \omega_0^n T_n$ and $S_z^t n = S_z^T n$. (Here ω_0 acts as a normalizing constant and thus does not affect the sensitivity.)

$$0 = t_0 S_z^{t_0} - (2 t_2 S_z^{\omega_0} + t_2 S_z^{t_2}) + 4 t_4 S_z^{\omega_0} + t_4 S_z^{t_4} \quad (39)$$

$$Q(t_1 S_z^{\omega_0} + t_1 S_z^{t_1} - 3 t_3 S_z^{\omega_0} - t_3 S_z^{t_3}) + Q S_z^Q (t_1 - t_3) = t_0 S_z^{t_0} - (4 t_4 S_z^{\omega_0} + t_4 S_z^{t_4}) \quad (40)$$

The first equation may now be solved for $S_z^{\omega_0}$ and the second, for S_z^Q .

$$S_z^{\omega_0} = \frac{t_0 S_z^{t_0} - t_2 S_z^{t_2} + t_4 S_z^{t_4}}{2t_2 - 4t_4} \quad (41)$$

$$S_z^Q = \frac{t_0 S_z^{t_0} - t_4 S_z^{t_4} - Q (t_1 S_z^{t_1} - t_3 S_z^{t_3})}{Q (t_1 - t_3)} - \frac{[Q (t_1 - 3t_3) + 4t_4] S_z^{\omega_0}}{Q (t_1 - t_3)} \quad (42)$$

Some additional simplifications in the sensitivity formulas can be achieved by returning to the normalized form of Equations (33) and (34):

$$t_4 - t_2 + t_0 = 0 \quad (43)$$

$$d t_4 - t_3 + t_1 - d t_0 = 0 \quad (44)$$

Multiplying the second equation by Q and rearranging both equations,

$$t_2 = t_0 + t_4 \quad (45)$$

$$Q (t_1 - t_3) = t_0 - t_4 \quad (46)$$

Substituting these expressions into Equations (41) and (42),

$$S_z^{\omega_0} = \frac{t_0 S_z^{t_0} - t_2 S_z^{t_2} + t_4 S_z^{t_4}}{2(t_0 - t_4)} \quad (47)$$

$$S_z^Q = \frac{t_0 S_z^{t_0} - Q t_1 S_z^{t_1} + Q t_3 S_z^{t_3} - t_4 S_z^{t_4} - L_1 S_z^{\omega_0}}{t_0 - t_4} \quad (48)$$

where

$$L_1 = t_0 - 2Q t_3 + 3 t_4 \quad (49)$$

A formula for gain sensitivity will also be needed. At the zero-phase frequency, the filter gain is (see Appendix B).

$$H_0 = \frac{-N_1 \omega_0}{T_1 \omega_0 - T_3 \omega_0^3} = \frac{-N_1}{T_1 - T_3 \omega_0^2} \quad (50)$$

Taking the sensitivity of both sides:

$$S_{z^0}^H = S_{z^1}^N - \frac{T_1 S_z^T 1 - T_3 \omega_0^2 (S_z^T 3 + 2S_z^{\omega_0})}{T_1 - T_3 \omega_0^2} \quad (51)$$

Multiplying the numerator and denominator by ω_0 , changing to the normalized parameters, and substituting $t_1 - t_3 = (t_0 - t_4)/Q$, we have

$$S_{z^0}^H = S_{z^1}^N - Q \left[\frac{t_1 S_z^t 1 - t_3 (S_z^t 3 + 2S_z^{\omega_0})}{t_0 - t_4} \right] \quad (52)$$

PASSIVE SENSITIVITIES

In order to simplify the derivation of sensitivity formulas for the passive circuit components, we will assume that the passive sensitivities are relatively unaffected by the presence of a non-ideal op amp.

For the ideal op amp case, we have

$$g_0 = -\rho \quad (53)$$

$$g_1 = 0 \quad (54)$$

$$g_2 = 0 \quad (55)$$

Therefore, using normalized variables, we have

$$t_0 = 1 - \rho \quad (56)$$

$$t_1 = (1 - \rho)(c_1 + c_2)r_1 - \rho c_1 r_2 \quad (57)$$

$$t_2 = c_1 c_2 r_1 r_2 (1 - \rho) \quad (58)$$

$$t_3 = 0 \quad (59)$$

$$t_4 = 0 \quad (60)$$

$$n_1 = c_1 r_2 \quad (61)$$

The sensitivities with respect to the passive components are given by:

$$t_0 s_{c_1}^{t_0} = t_0 s_{c_2}^{t_0} = t_0 s_{r_1}^{t_0} = t_0 s_{r_2}^{t_0} = 0 \quad (62)$$

$$t_0 s_{\rho}^{t_0} = -\rho \quad (63)$$

$$t_1 s_{c_1}^{t_1} = (1-\rho)c_1 r_1 - \rho c_1 r_2 \quad (64)$$

$$t_1 s_{c_2}^{t_1} = (1-\rho)c_2 r_1 \quad (65)$$

$$t_1 s_{r_1}^{t_1} = (1-\rho)(c_1 + c_2)r_1 \quad (66)$$

$$t_1 s_{r_2}^{t_1} = -\rho c_1 r_2 \quad (67)$$

$$t_1 s_{\rho}^{t_1} = -\rho [(c_1 + c_2)r_1 + c_1 r_2] \quad (68)$$

$$t_2 s_{c_1}^{t_2} = t_2 s_{c_2}^{t_2} = t_2 s_{r_1}^{t_2} = t_2 s_{r_2}^{t_2} = c_1 c_2 r_1 r_2 (1-\rho) \quad (69)$$

$$t_2 s_{\rho}^{t_2} = -c_1 c_2 r_1 r_2 \rho \quad (70)$$

$$s_{c_1}^{n_1} = s_{r_2}^{n_1} = 1 \quad (71)$$

$$s_{c_2}^{n_1} = s_{r_1}^{n_1} = s_{\rho}^{n_1} = 0 \quad (72)$$

It was shown in Appendix C that if $(g_1 - dg_2)$ is negligible (it is zero in the ideal op amp case) and if $c_1 = c_2 = c$, we can write:

$$cr_1 = \frac{X}{2Q} \quad (73)$$

$$cr_2 = \frac{2Q}{X} \quad (74)$$

where

$$X = \frac{1}{2} + \sqrt{\left(\frac{1}{2}\right)^2 + 2Q^2 \left(\frac{P}{1-P}\right)} \quad (75)$$

$$P = \rho - \frac{1}{A_{DC}} + g_2 \quad (76)$$

For an ideal op amp, we have $P = \rho$.

Substituting this into the sensitivity expressions, we obtain

$$t_1 s_{c_1}^{t_1} = (1-\rho) \left(\frac{X}{2Q}\right) - \rho \left(\frac{2Q}{X}\right) \quad (77)$$

$$t_1 s_{c_2}^{t_1} = (1-\rho) \left(\frac{X}{2Q}\right) \quad (78)$$

$$t_1 s_{r_1}^{t_1} = (1-\rho) \left(\frac{X}{Q}\right) \quad (79)$$

$$t_1 s_{r_2}^{t_1} = -\rho \left(\frac{2Q}{X}\right) \quad (80)$$

$$t_1 s_{\rho}^{t_1} = -\rho \left(\frac{X}{Q} + \frac{2Q}{X}\right) \quad (81)$$

$$t_2 s_{\rho}^{t_2} = -\rho \quad (82)$$

$$t_2 S_{c_1}^{t_2} = t_2 S_{c_2}^{t_2} = t_2 S_{r_1}^{t_2} = t_2 S_{r_2}^{t_2} = 1-\rho \quad (83)$$

With $t_3 = t_4 = 0$, the formulas for ω_0 , Q , and H_0 sensitivities become

$$S_{z^0}^{\omega} = \frac{t_0 S_{z^0}^{t_0} - t_2 S_{z^2}^{t_2}}{2 t_0} \quad (84)$$

$$S_z^Q = \frac{t_0 S_{z^0}^{t_0} - Q t_1 S_{z^1}^{t_1}}{t_0} - S_{z^0}^{\omega} \quad (85)$$

$$S_{z^0}^{H_0} = S_{z^1}^{n_1} - \frac{Q t_1 S_{z^1}^{t_1}}{t_0} \quad (86)$$

The individual passive sensitivities are found by substituting the appropriate expressions; the results are

$$S_{c_1}^{\omega_0} = S_{c_2}^{\omega_0} = S_{r_1}^{\omega_0} = S_{r_2}^{\omega_0} = -\frac{1}{2} \quad (87)$$

$$S_{\rho}^{\omega_0} = 0 \quad (88)$$

$$S_{c_1}^Q = -\frac{1}{2} (X-1) + \frac{2Q^2}{X} \left(\frac{\rho}{1-\rho}\right) \quad (89)$$

$$S_{c_2}^Q = -\frac{1}{2} (X-1) \quad (90)$$

$$S_{r_1}^Q = -\left(X - \frac{1}{2}\right) \quad (91)$$

$$S_{r_2}^Q = \frac{2Q^2}{X} \left(\frac{\rho}{1-\rho}\right) + \frac{1}{2} \quad (92)$$

$$S_{\rho}^Q = \frac{\rho}{1-\rho} \frac{2Q^2 + X^2 - X}{X} \quad (93)$$

$$S_{C_1}^{H_0} = 1 - \frac{X}{2} + \frac{2Q^2}{X} \left(\frac{\rho}{1-\rho} \right) \quad (94)$$

$$S_{C_2}^{H_0} = -\frac{X}{2} \quad (95)$$

$$S_{r_1}^{H_0} = -X \quad (96)$$

$$S_{r_2}^{H_0} = 1 + \frac{2Q^2}{X} \left(\frac{\rho}{1-\rho} \right) \quad (97)$$

$$S_{\rho}^{H_0} = \frac{\rho}{1-\rho} \frac{2Q^2 + X^2}{X} \quad (98)$$

These formulas are given in terms of both X and ρ , which are related by (for an ideal op amp):

$$X = \frac{1}{2} + \sqrt{\left(\frac{1}{2}\right)^2 + 2Q^2 \left(\frac{\rho}{1-\rho}\right)} \quad (99)$$

This equation may be rearranged to yield

$$\frac{\rho}{1-\rho} = \frac{X^2 - X}{2Q^2} \quad (100)$$

and

$$\rho = \frac{X^2 - X}{2Q^2 + X^2 - X} \quad (101)$$

Substituting these expressions into the sensitivity formulas results in:

$$S_{C_1}^Q = \frac{1}{2} (X-1) \quad (102)$$

$$S_{C_2}^Q = -\frac{1}{2} (X-1) \quad (103)$$

$$S_{r_1}^Q = - (x - \frac{1}{2}) \quad (104)$$

$$S_{r_2}^Q = x - \frac{1}{2} \quad (105)$$

$$S_{c_1}^{H_0} = \frac{x}{2} \quad (106)$$

$$S_{c_2}^{H_0} = - \frac{x}{2} \quad (107)$$

$$S_{r_1}^{H_0} = -x \quad (108)$$

$$S_{r_2}^{H_0} = x \quad (109)$$

At this point we wish to convert the sensitivities with respect to ρ into sensitivities with respect to r_3 and r_4 where

$$\rho = \frac{r_3}{r_3 + r_4} \quad (110)$$

We need the sensitivities $S_{r_3}^0$ and $S_{r_4}^0$.

$$S_{r_3}^0 = 1 - \frac{r_3}{r_3 + r_4} \quad (111)$$

$$= 1 - \rho$$

$$S_{r_4}^0 = - \frac{r_4}{r_3 + r_4}$$

$$= -(1-\rho) \quad (112)$$

AD-A061 601

NAVAL SURFACE WEAPONS CENTER WHITE OAK LAB SILVER SP--ETC F/G 9/1
MINIMIZING THE WORST-CASE DRIFT OF AN ACTIVE BANDPASS FILTER, (U)
APR 78 S MARTIN

UNCLASSIFIED

NSWC/WOL/TR-78-2

NL

2 of 2
AD
A061 601

END
DATE
FILMED
2-79
DDC

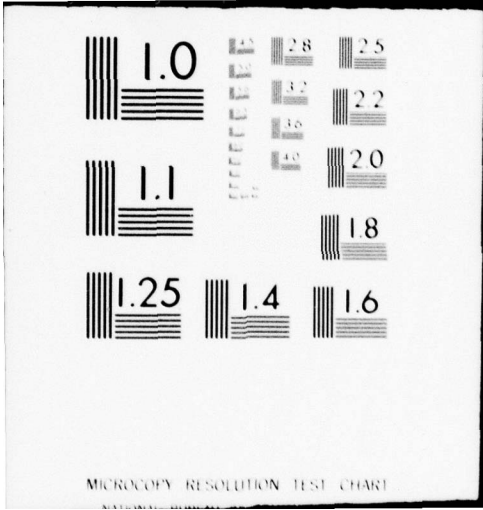

Thus, we have:

$$S_{r_3}^{\omega_0} = S_{r_4}^{\omega_0} = 0 \quad (113)$$

$$\begin{aligned} S_{r_3}^Q &= S_{r_3}^\rho S_\rho^Q \\ &= \rho \left(\frac{2Q^2 + X^2 - X}{X} \right) \end{aligned} \quad (114)$$

$$S_{r_4}^Q = -\rho \left(\frac{2Q^2 + X^2 - X}{X} \right) \quad (115)$$

$$S_{r_3}^{H_0} = \rho \left(\frac{2Q^2 + X^2}{X} \right) \quad (116)$$

$$S_{r_4}^{H_0} = -\rho \left(\frac{2Q^2 + X^2}{X} \right) \quad (117)$$

Substituting for ρ results in

$$\begin{aligned} S_{r_3}^Q &= \left(\frac{X^2 - X}{2Q^2 + X^2 - X} \right) \left(\frac{2Q^2 + X^2 - X}{X} \right) \\ &= X-1 \end{aligned} \quad (118)$$

$$S_{r_4}^Q = - (X-1) \quad (119)$$

$$S_{r_3}^{H_0} = \left(\frac{x^2 - x}{2Q^2 + x^2 - x} \right) \left(\frac{2Q^2 + x^2}{x} \right)$$

$$= (x-1) \left[1 + \frac{x}{2Q^2 + x^2 - x} \right] \quad (120)$$

$$S_{r_4}^{H_0} = -(x-1) \left[1 + \frac{x}{2Q^2 + x^2 - x} \right] \quad (121)$$

Later it will be shown that there is no benefit in choosing ρ so large as to result in $x > Q\sqrt{\frac{2}{3}}$. With x limited to $x < Q\sqrt{\frac{2}{3}}$ and $Q > 3$.

$$S_{r_3}^{H_0} \approx x-1 \quad (122)$$

$$S_{r_4}^{H_0} \approx -(x-1) \quad (123)$$

Table D-1 summarizes the formulas for passive sensitivities for the filter. All are linear functions of x ; and since x has a minimum value of one (with an ideal op amp), all of the passive sensitivities increase in magnitude with increasing x , and thus, with increasing positive feedback.

ACTIVE SENSITIVITIES

In order to use the sensitivity formulas of Equations (47), (48), and (52), we must know the sensitivities of t_0 , t_1 , t_2 , t_3 , and t_4 . Recall that

$$t_0 = 1 + g_0 \quad (124)$$

$$t_1 = (1 + g_0)d_1 - n_1 + g_1 \quad (125)$$

$$t_2 = (1 + g_0)d_2 + d_1g_1 + g_2 \quad (126)$$

$$t_3 = d_2 g_1 + d_1 g_2 \quad (127)$$

TABLE D-1
Passive Sensitivities (Ideal Op Amp)

with respect to	Sensitivity of		
	f_0 or ω_0	Q	H_0
C_1	$-\frac{1}{2}$	$\frac{1}{2} (X - 1)$	$\frac{1}{2} X$
C_2	$-\frac{1}{2}$	$-\frac{1}{2} (X - 1)$	$-\frac{1}{2} X$
R_1	$-\frac{1}{2}$	$-(X - \frac{1}{2})$	$-X$
R_2	$-\frac{1}{2}$	$X - \frac{1}{2}$	X
R_3	0	$X - 1$	$X - 1^*$
R_4	0	$-(X - 1)$	$-(X - 1)^*$

where

$$X = \frac{1}{2} + \sqrt{\left(\frac{1}{2}\right)^2 + 2Q^2 \left(\frac{\rho}{1-\rho}\right)}$$

* These expressions are accurate only for high Q's; if $X < Q\sqrt{\frac{2}{3}}$, error is less than 12% for $Q > 3$, 3% for $Q > 11$. For exact expressions see equations (120) and (121).

$$t_4 = d_2 g_2 \quad (128)$$

By taking the sensitivities of the expressions to g_0 , g_1 , and g_2 (which contain the op amp parameters), we obtain

$$t_0 S_{g_0}^{t_0} = g_0 \quad (129)$$

$$t_1 S_{g_0}^{t_1} = d_1 g_0 \quad (130)$$

$$t_2 S_{g_0}^{t_2} = d_2 g_0 \quad (131)$$

$$t_3 S_{g_0}^{t_3} = 0 \quad (132)$$

$$t_4 S_{g_0}^{t_4} = 0 \quad (133)$$

$$t_0 S_{g_1}^{t_0} = 0 \quad (134)$$

$$t_1 S_{g_1}^{t_1} = g_1 \quad (135)$$

$$t_2 S_{g_1}^{t_2} = d_1 g_1 \quad (136)$$

$$t_3 S_{g_1}^{t_3} = d_2 g_1 \quad (137)$$

$$t_4 S_{g_1}^{t_4} = 0 \quad (138)$$

$$t_0 S_{g_2}^{t_0} = 0 \quad (139)$$

$$t_1 S_{g_2}^{t_1} = 0 \quad (140)$$

$$t_2 S_{g_2}^{t_2} = g_2 \quad (141)$$

$$t_3 S_{g_2}^{t_3} = d_1 g_2 \quad (142)$$

$$t_4 S_{g_2}^{t_4} = d_2 g_2 \quad (143)$$

We also have

$$n_1 = c_1 r_2 \quad (144)$$

The sensitivities of n_1 are

$$S_{g_0}^{n_1} = S_{g_1}^{n_1} = S_{g_2}^{n_1} = 0 \quad (145)$$

Substituting the foregoing equations into Equations (47), (48), and (52),

$$S_{g_0}^{\omega_0} = \frac{g_0 - d_2 g_0 + 0}{2(t_0 - t_4)} = \frac{(1-d_2) g_0}{2(t_0 - t_4)} \quad (146)$$

$$S_{g_1}^{\omega_0} = \frac{0 - d_1 g_1 + 0}{2(t_0 - t_4)} = -\frac{d_1 g_1}{2(t_0 - t_4)} \quad (147)$$

$$S_{g_2}^{\omega_0} = \frac{0 - g_2 + d_2 g_2}{2(t_0 - t_4)} = -\frac{(1-d_2) g_2}{2(t_0 - t_4)} \quad (148)$$

$$S_{g_0}^Q = \frac{g_0(1 - Q d_1) - L_1 S_{g_0}^{\omega_0}}{t_0 - t_4} \quad (149)$$

$$S_{g_1}^Q = \frac{-Q g_1 (1 - d_2) - L_1 S_{g_1}^{\omega_0}}{t_0 - t_4} \quad (150)$$

$$S_{g_2}^Q = \frac{g_2 (Q d_1 - d_2) - L_1 S_{g_2}^{\omega_0}}{t_0 - t_4} \quad (151)$$

$$S_{g_0}^{H_0} = - \frac{Q [d_1 g_0 - 2t_3 S_{g_0}^{\omega_0}]}{t_0 - t_4} = - \frac{Q [d_1 g_0 - 2(d_2 g_1 + d_1 g_2) S_{g_0}^{\omega_0}]}{t_0 - t_4} \quad (152)$$

$$S_{g_1}^{H_0} = - \frac{Q [g_1 - d_2 g_1 - 2t_3 S_{g_1}^{\omega_0}]}{t_0 - t_4} = - \frac{Q [(1-d_2)g_1 - 2(d_2 g_1 + d_1 g_2) S_{g_1}^{\omega_0}]}{t_0 - t_4} \quad (153)$$

$$S_{g_2}^{H_0} = - \frac{Q [-d_1 g_2 - 2t_3 S_{g_2}^{\omega_0}]}{t_0 - t_4} = \frac{Q [d_1 g_2 + 2(d_2 g_1 + d_1 g_2) S_{g_2}^{\omega_0}]}{t_0 - t_4} \quad (154)$$

These sensitivities may be converted to sensitivities with respect to the op amp parameters A_{DC} , ω_{u1} , and ω_{u2} , by using the fact that $S_z^u = S_z^u \cdot S_z^v$. The required sensitivities are obtained by taking the sensitivities of G_0 , G_1 , and G_2 in Equations (16), (17), and (18) and using the fact that the normalization does not change the sensitivities. Thus:

$$S_{A_{DC}}^{g_0} = - \frac{1}{A_{DC} g_0} \quad (155)$$

$$S_{\omega_{u1}}^{g_1} = -1 \quad (156)$$

$$S_{\omega_{u2}}^{g_2} = -2 \quad (157)$$

Performing this conversion yields the following formulas:

$$S_{A_{DC}}^{\omega_0} = - \frac{(1-d_2)}{2(t_0-t_4) A_{DC}} \quad (158)$$

$$S_{\omega_{u1}}^{\omega_0} = \frac{d_1 g_1}{2(t_0-t_4)} \quad (159)$$

$$S_{\omega_{u2}}^{\omega_0} = \frac{(1-d_2)g_2}{t_0-t_4} \quad (160)$$

$$S_{A_{DC}}^Q = \frac{Q d_1 - 1 + L_1 S_{g_0}^{\omega_0}/g_0}{(t_0 - t_4) A_{DC}}$$

$$= \frac{Q d_1 - 1 + L_1 \left[\frac{1 - d_2}{2(t_0-t_4)} \right]}{(t_0 - t_4) A_{DC}} \quad (161)$$

$$S_{\omega_{u1}}^Q = \frac{Q g_1 (1 - d_2) + L_1 S_{g_1}^{\omega_0}}{t_0 - t_4}$$

$$= \frac{Q (1 - d_2)g_1 + L_1 \left[- \frac{d_1 g_1}{2(t_0-t_4)} \right]}{t_0 - t_4} \quad (162)$$

$$\begin{aligned}
 S_{\omega_{u2}}^Q &= - \frac{2g_2(Q d_1 - d_2) - 2 L_1 S_{g_2}^{\omega_0}}{t_0 - t_4} \\
 &= - \frac{2g_2(Q d_1 - d_2) - 2 L_1 \left[- \frac{(1-d_2)g_2}{2(t_0-t_4)} \right]}{t_0 - t_4} \quad (163)
 \end{aligned}$$

$$\begin{aligned}
 \frac{H_0}{S_{A_{DC}}} &= \frac{Q \left[d_1 - 2(d_2 g_1 + d_1 g_2) S_{g_0}^{\omega_0}/g_0 \right]}{(t_0-t_4) A_{DC}} \\
 &= \frac{Q \left[d_1 - 2(d_2 g_1 + d_1 g_2) \frac{(1-d_2)}{2(t_0-t_4)} \right]}{(t_0-t_4) A_{DC}} \\
 &= \frac{Q \left[d_1 - (d_2 g_1 + d_1 g_2) (1-d_2)/(t_0 - t_4) \right]}{(t_0 - t_4) A_{DC}} \quad (164)
 \end{aligned}$$

$$\begin{aligned}
 \frac{H_0}{S_{\omega_{u1}}} &= \frac{Q \left[(1-d_2)g_1 - 2(d_2 g_1 + d_1 g_2) S_{g_1}^{\omega_0} \right]}{t_0 - t_4} \\
 &= \frac{Q \left[(1-d_2)g_1 - 2(d_2 g_1 + d_1 g_2) \left\{ - \frac{d_1 g_1}{2(t_0-t_4)} \right\} \right]}{t_0 - t_4} \\
 &= \frac{Q \left[(1-d_2)g_1 + (d_2 g_1 + d_1 g_2) (d_1 g_1)/(t_0-t_4) \right]}{t_0 - t_4} \quad (165)
 \end{aligned}$$

$$\begin{aligned}
S_{\omega_{u2}}^{H_0} &= - \frac{2 Q \left[d_1 g_2 + 2(d_2 g_1 + d_1 g_2) S_{g_2}^{\omega_0} \right]}{t_0 - t_4} \\
&= - \frac{2 Q \left[d_1 g_2 + 2(d_2 g_1 + d_1 g_2) \left\{ \frac{-(1-d_2)g_2}{2(t_0-t_4)} \right\} \right]}{t_0 - t_4} \\
&= - \frac{2 Q \left[d_1 g_2 - (d_2 g_1 + d_1 g_2) (1-d_2)g_2 / (t_0-t_4) \right]}{t_0 - t_4} \tag{166}
\end{aligned}$$

At this point it is necessary to make some approximations in order to simplify the formulas. The Q sensitivity formulas contain the quantity

$$\begin{aligned}
\frac{L_1}{2(t_0-t_4)} &= \frac{t_0 - 2Qt_3 + 3t_4}{2(t_0-t_4)} = \frac{1}{2} - \frac{Qt_3 - 2t_4}{t_0-t_4} \\
&= \frac{1}{2} - \frac{Q(d_2 g_1 + d_1 g_2) - 2d_2 g_2}{t_0-t_4} \tag{167}
\end{aligned}$$

From Appendix C, we have $d_1 > 2\sqrt{2}$ and $d_2 \leq 1$; if we also assume $Q \gg 1$, then the term $2d_2 g_2$ may be ignored.

$$\frac{L_1}{2(t_0-t_4)} \approx \frac{1}{2} - \frac{Q(d_2 g_1 + d_1 g_2)}{t_0-t_4} \tag{168}$$

Substituting this into the formulas for Q sensitivities and making similar approximations, we obtain:

$$\begin{aligned}
 S_{A_{DC}}^Q &\approx \frac{Qd_1 - 1 + \left[\frac{1}{2} - \frac{Q(d_2g_1 + d_1g_2)}{t_0 - t_4} \right] (1-d_2)}{(t_0 - t_4) A_{DC}} \\
 &\approx \frac{Q \left[d_1 - \frac{(d_2g_1 + d_1g_2)(1-d_2)}{t_0 - t_4} \right]}{(t_0 - t_4) A_{DC}} \quad (169)
 \end{aligned}$$

$$S_{\omega_{u1}}^Q \approx \frac{Q(1-d_2)g_1 + \left[\frac{1}{2} - \frac{Q(d_2g_1 + d_1g_2)}{t_0 - t_4} \right] (-d_1g_1)}{t_0 - t_4} \quad (170)$$

$$S_{\omega_{u2}}^Q \approx \frac{-2Q d_1g_2 + 2 \left[\frac{1}{2} - \frac{Q(d_2g_1 + d_1g_2)}{t_0 - t_4} \right] \left[-(1-d_2)g_2 \right]}{t_0 - t_4} \quad (171)$$

In order to keep the zero-phase shift frequency well within the passband of the filter (and as near to the center frequency as possible), we require that (see Appendix C)

$$\frac{d_2g_1 + d_1g_2}{t_0 - t_4} \ll 1 \quad (172)$$

This provides an additional basis for approximation in some of the Q and gain sensitivity formulas:

$$S_{A_{DC}}^Q \approx \frac{Qd_1}{(t_0 - t_4) A_{DC}} \quad (173)$$

$$S_{\omega_{u2}}^Q \approx \frac{-2Q d_1g_2}{(t_0 - t_4)} \quad (174)$$

$$S_{A_{DC}}^{H_0} \approx \frac{Q d_1}{(t_0 - t_4) A_{DC}} \quad (175)$$

$$S_{\omega_{u2}}^{H_0} \approx \frac{-2Q d_1 g_2}{t_0 - t_4} \quad (176)$$

With the substitution of

$$(1-d_2) = \frac{d_1 g_1}{t_0 - g_2} \quad (177)$$

(an approximate synthesis equation from Appendix C), the collection of active sensitivity formulas is as follows:

$$S_{A_{DC}}^{\omega_0} \approx - \frac{d_1 g_1}{2(t_0 - t_4)(t_0 - g_2) A_{DC}} \quad (178)$$

$$S_{\omega_{u1}}^{\omega_0} \approx \frac{d_1 g_1}{2(t_0 - t_4)} \quad (179)$$

$$S_{\omega_{u2}}^{\omega_0} \approx \frac{d_1 g_1 g_2}{(t_0 - t_4)(t_0 - g_2)} \quad (180)$$

$$S_{A_{DC}}^Q \approx \frac{Q d_1}{(t_0 - t_4) A_{DC}} \quad (181)$$

$$S_{\omega_{u1}}^Q \approx \frac{d_1 g_1}{t_0 - t_4} \left[-\frac{1}{2} + Q g_1 \left(\frac{1}{t_0 - g_2} + \frac{1}{t_0 - t_4} \right) - \frac{Q d_1 g_1^2}{(t_0 - t_4)(t_0 - g_2)} + \frac{Q d_1 g_2}{t_0 - t_4} \right] \quad (182)$$

$$S_{\omega_{u2}}^Q \approx \frac{-2 Q d_1 g_2}{t_0 - t_4} \quad (183)$$

$$S_{A_{DC}}^{H_0} \approx \frac{Q d_1}{(t_0 - t_4) A_{DC}} \quad (184)$$

$$S_{\omega_{u1}}^{H_0} \approx \frac{Q d_1 g_1}{t_0 - t_4} \left[\frac{g_1}{t_0 - g_2} + \frac{g_1 + d_1 g_2}{t_0 - t_4} - \frac{d_1 g_1^2}{(t_0 - t_4)(t_0 - g_2)} \right] \quad (185)$$

$$S_{\omega_{u2}}^{H_0} \approx \frac{-2 Q d_1 g_2}{t_0 - t_4} \quad (186)$$

The requirement that

$$\frac{d_2 g_1 + d_1 g_2}{t_0 - t_4} \ll 1 \quad (187)$$

can also be used to provide other approximations. Since we have the three inequalities, $t_0 - t_4 > 0$, $d_2 g_1 \geq 0$, and $d_1 g_2 \geq 0$, we can write

$$\frac{d_1 g_2}{t_0 - t_4} \ll 1 \quad (188)$$

$$\text{or } d_1 g_2 \ll t_0 - t_4 = t_0 - d_2 g_2 \quad (189)$$

Continuing,

$$g_2 \ll \frac{t_0}{(d_1 + d_2)} \quad (190)$$

Since $d_1 > 2\sqrt{2}$ (Appendix C), we have

$$0 \leq g_2 \ll t_0 \quad (191)$$

Furthermore, because $t_4 = d_2 g_2$ and $d_2 \leq 1$, we have

$$0 \leq t_4 \ll t_0 \quad (192)$$

Now we can write

$$t_0 \approx t_0 - g_2 \approx t_0 - t_4 \quad (193)$$

Using this approximation and defining

$$y = d_1/t_0 \quad (194)$$

we obtain

$$S_{A_{DC}}^{\omega_0} \approx - \frac{y g_1}{2 t_0 A_{DC}} \quad (195)$$

$$S_{\omega_{u1}}^{\omega_0} \approx \frac{y g_1}{2} \quad (196)$$

$$S_{\omega_{u2}}^{\omega_0} \approx \frac{y g_1 g_2}{t_0} \quad (197)$$

$$S_{A_{DC}}^Q \approx \frac{Q Y}{A_{DC}} \quad (198)$$

$$S_{\omega_{u1}}^Q \approx Y g_1 \left[-\frac{1}{2} + \frac{2 Q g_1}{t_0} - \frac{Q Y g_1^2}{t_0} + Q Y g_2 \right] \quad (199)$$

$$S_{\omega_{u2}}^Q \approx -2 Q Y g_2 \quad (200)$$

$$S_{A_{DC}}^{H_0} \approx \frac{Q Y}{A_{DC}} \quad (201)$$

$$S_{\omega_{u1}}^{H_0} \approx Q Y g_1 \left[\frac{2 g_1}{t_0} - \frac{Y g_1^2}{t_0} + Y g_2 \right] \quad (202)$$

$$S_{\omega_{u2}}^{H_0} \approx -2 Q Y g_2 \quad (203)$$

Some additional approximations are required in the formula for $S_{\omega_{u1}}^Q$. The expression can be written as a function of g_1 as follows:

$$S_{\omega_{u1}}^Q \approx -k_1 g_1 + k_2 g_1^2 - k_3 g_1^3 + k_4 g_1 g_2 \quad (204)$$

A typical case is shown in Figure D-2. In order to approximate this third degree polynomial by a quadratic, we will limit g_1 , to the region left of the inflection point (see Figure D-2).

By setting the second derivative of $S_{\omega_{u1}}^Q$, with respect to g_1 equal to zero, we find that the inflection point occurs at

$$g_1 = \frac{2}{3Y} \quad (205)$$

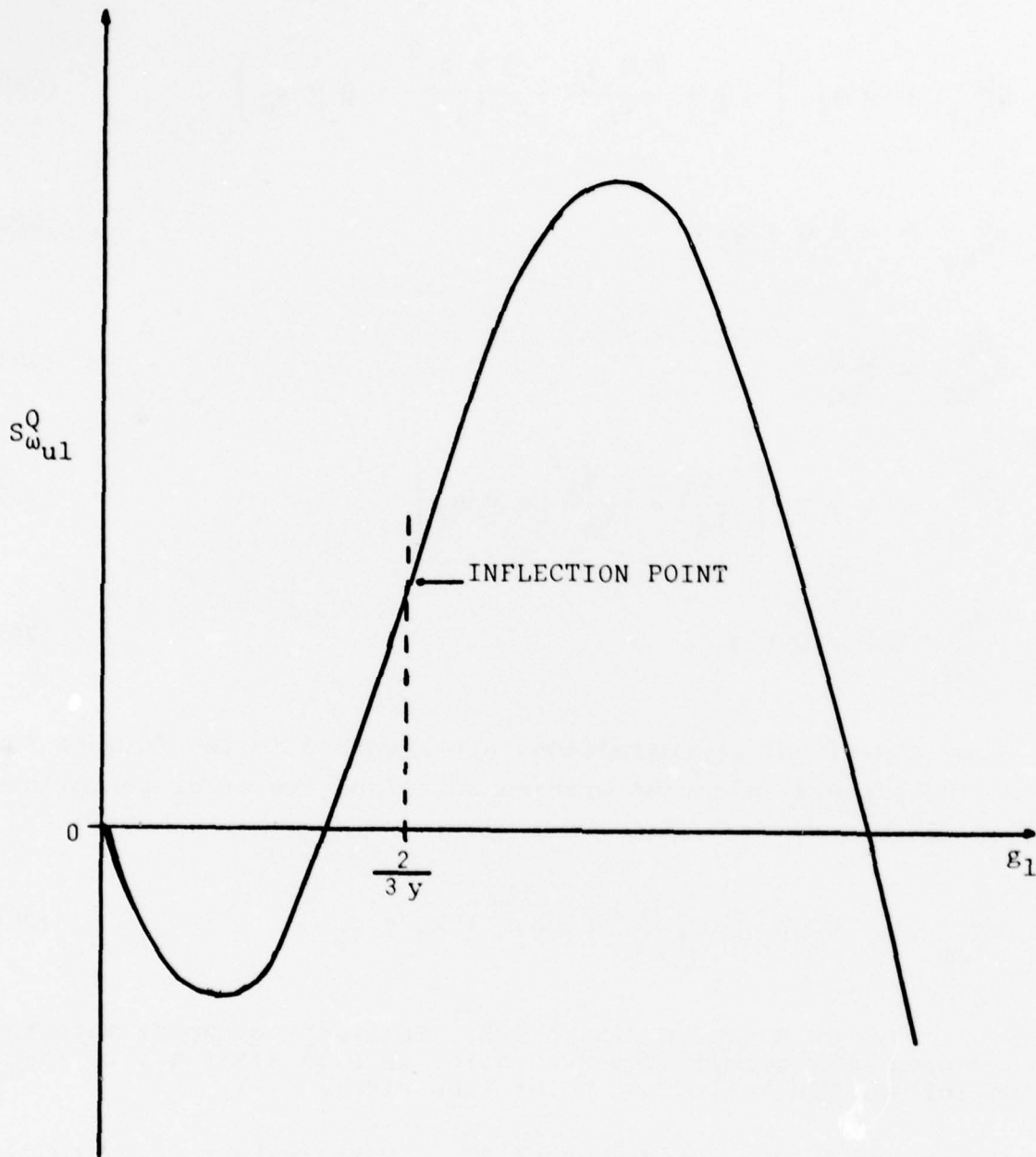

Figure D-2. Typical Plot of $S_{w_{ul}}^Q$ Versus g_1

Consequently, we will limit g_1 to

$$g_1 < \frac{2}{3y} \quad (206)$$

or

$$y g_1 = \frac{d_1 g_1}{t_0} < \frac{2}{3} \quad (207)$$

Since we have already upper bounded yg_1 by unity to make synthesis possible, (Appendix C), this seems like a reasonable restriction.

Even with g_1 below the inflection point ($yg_1 < \frac{2}{3}$), the error caused by dropping the g_1^3 term in the expression for $S_{\omega_{ul}}^Q$ can be very large. For example, the error at the inflection point can be as high as -400%. However, because the sensitivity changes rapidly as a function of g_1 at the inflection point, this is equivalent to a relatively small error in g_1 , and g_1 is seldom known accurately anyway (g_1 depends on the gain-bandwidth product of the op amp). Furthermore, g_1 will normally never approach the inflection point because $yg_1 = \frac{2}{3}$ results in the sensitivity of filter center frequency to op amp gain-bandwidth products being $\frac{1}{3}$, which is unacceptably high for most filter applications. In practice reasonable accuracy in the expression for $S_{\omega_{ul}}^Q$ is achieved whenever $yg_1 < 0.2$.

The upper bound on $y g_1$ allows one term to be dropped from the formulas for $S_{\omega_{ul}}^Q$ and $S_{\omega_{ul}}^{H_0}$. It will also be useful to set $t_0 \approx 1$ wherever it remains in a sensitivity formula. (In the next section, it will be shown that no practical benefits can be achieved by using positive feedback ratios greater than 0.25, and thus, the approximation for t_0 will be close enough for sensitivity calculations.)

The approximate formulas for the sensitivities of center frequency, Q , and gain of the filter with respect to the op amp parameters are (with the incorporation of all of the approximations discussed above):

$$S_{A_{DC}}^{f_0} = S_{A_{DC}}^{\omega_0} \approx - \frac{yg_1}{2A_{DC}} \quad (208)$$

$$S_{f_{u1}}^{f_0} = S_{w_{u1}}^{w_0} \approx \frac{y g_1}{2} \quad (209)$$

$$S_{f_{u2}}^{f_0} = S_{w_{u2}}^{w_0} \approx y g_1 g_2 \quad (210)$$

$$S_{A_{DC}}^Q \approx \frac{Q Y}{A_{DC}} \quad (211)$$

$$S_{f_{u1}}^Q = S_{w_{u1}}^Q \approx y g_1 \left[-\frac{1}{2} + Q (2g_1 + y g_2) \right] \quad (212)$$

$$S_{f_{u2}}^Q = S_{w_{u2}}^Q \approx -2 Q Y g_2 \quad (213)$$

$$S_{A_{DC}}^{H_0} \approx \frac{Q Y}{A_{DC}} \quad (214)$$

$$S_{f_{u1}}^{H_0} = S_{w_{u1}}^{H_0} \approx Q Y g_1 (2g_1 + y g_2) \quad (215)$$

$$S_{f_{u2}}^{H_0} = S_{w_{u2}}^{H_0} \approx -2 Q Y g_2 \quad (216)$$

One final comment regarding the active sensitivities is appropriate. In each active sensitivity formula, y is the only variable which depends on the amount of positive feedback, and in each case, the sensitivity is directly proportional to y except that a term involving the quantity $Q y^2 g_1 g_2$ is included in the sensitivities of Q and gain with respect to f_{u1} . Later when we consider the maximum shift in Q or gain due to all op amp drifts, this term

will be ignored because the sensitivities with respect to f_{u2} will have a greater effect. With this term dropped the sensitivities of Q and H_0 with respect to f_{u1} are approximately

$$S_{f_{u1}}^Q = S_{\omega_{u1}}^Q \approx y g_1 \left(-\frac{1}{2} + 2 Q g_1 \right) \quad (217)$$

$$S_{f_{u1}}^{H_0} = S_{\omega_{u1}}^{H_0} \approx 2 Q y g_1^2 \quad (218)$$

This approximation will greatly simplify the optimization formulas.

PASSIVE AND ACTIVE SENSITIVITIES AS A FUNCTION OF POSITIVE FEEDBACK

We have shown that the sensitivities of center frequency, Q , and gain of the filter to each of the passive component values are, approximately, constant or directly proportional to a quantity $(X-k)$ where

$$X = \frac{1}{2} + \sqrt{\left(\frac{1}{2}\right)^2 + 2 Q^2 \left(\frac{P}{1-P}\right)} \quad (219)$$

$$k = 0, \frac{1}{2}, \text{ or } 1$$

$$P = \rho - \frac{1}{A_{DC}} + g_2 \quad (220)$$

It can be shown that in order to keep the magnitude of the sensitivities of Q to A_{DC} and ω_{u2} much less than unity (a desirable restriction because the active parameters drift considerably with temperature), the quantities $\frac{1}{A_{DC}}$ and g_2 must be restricted to small values at which their effect on X will be small. Therefore, we can write

$$X \approx \frac{1}{2} + \sqrt{\left(\frac{1}{2}\right)^2 + 2 Q^2 \left(\frac{\rho}{1-\rho}\right)} \quad (221)$$

The equality will be exact for an ideal op amp.

It can be seen that X is approximately unity when there is no positive feedback, and it increases as the positive feedback is increased. This means that each passive sensitivity is either constant or increases in magnitude with increasing positive feedback.

On the other hand, active sensitivities have been shown to be approximately proportional to y where

$$y = \frac{d_1}{t_0} \approx \frac{d_1}{1-\rho} \quad (222)$$

The quantity ρ can be expressed in terms of X by solving Equation (221):

$$\rho = \frac{X^2 - X}{2Q^2 + X^2 - X} \quad (223)$$

Furthermore, Appendix C shows that

$$d_1 \approx \frac{X}{Q} + \frac{2Q}{X} \quad (224)$$

Substituting these expressions into the formula for y , we have

$$y = f(X) g(X) \quad (225)$$

where

$$f(X) = \frac{X}{Q} + \frac{2Q}{X} \quad (226)$$

$$g(X) = 1 + \frac{X^2 - X}{2Q^2} \quad (227)$$

Taking the derivative of $f(X)$ with respect to X shows that $f(X)$ is a decreasing function of X from $X = 1$ to $X = Q\sqrt{2}$.

If we assume for the moment that $X \ll 2Q^2$, then

$$g(X) \approx 1 + \frac{X^2}{2Q^2} \quad (228)$$

and

$$y(X) \approx \left(\frac{X}{Q} + \frac{2Q}{X}\right) \left(1 + \frac{X^2}{2Q^2}\right) = \frac{X^3}{2Q^3} + \frac{2X}{Q} + \frac{2Q}{X} \quad (229)$$

The derivative is

$$\frac{dy(X)}{dX} \approx \frac{3X^2}{2Q^3} + \frac{2}{Q} - \frac{2Q}{X^2} \quad (230)$$

The derivative is negative for

$$1 \leq X < Q\sqrt{\frac{2}{3}} \quad (231)$$

or, using Equation (223)

$$0 \leq \rho < \frac{1 - \frac{\sqrt{3/2}}{Q}}{4 - \frac{\sqrt{3/2}}{Q}} \quad (232)$$

For reasonably high Q , this becomes

$$0 \leq \rho < 0.25 \quad (233)$$

Thus, y is a decreasing function of ρ or X in this interval.

We have already shown that the passive sensitivities increase in magnitude as the positive feedback is increased. Now it can be seen that the active sensitivities, which are proportional to y , decrease in magnitude as the positive feedback is increased in the range

$$0 \leq \rho < 0.25$$

Since there is no apparent advantage in choosing ρ larger than this, we will require that

$$0 \leq \rho < 0.25$$

or, equivalently,

$$1 \leq x < Q \sqrt{\frac{2}{3}}.$$

In this range the original assumption that $x \ll 2Q^2$ is upheld. With x thus restricted, the approximate range of y is:

$$4.35 \approx \frac{16}{3} \sqrt{\frac{2}{3}} \leq y \leq \frac{1}{Q} + 2Q \approx 2Q \quad (234)$$

Finally, it will be useful to have an alternative form of the upper bound on yg_1 . (Inequality (207)):

$$yg_1 < \frac{2}{3}.$$

Because y has a lower bound, y_{\min} , we can write:

$$g_1 < \frac{2}{3 y_{\min}} = \frac{2}{3 \left[\frac{16}{3} \sqrt{\frac{2}{3}} \right]} \approx \frac{1}{6} \quad (235)$$

An approximate bound on x can also be developed from Inequality (207):

$$x > 3 Q g_1. \quad (236)$$

This can be verified by substituting $x = 3Qg_1$ into the formula for y . Inequalities (235) and (236), taken together, are approximately equivalent to Inequality (207).

SUMMARY OF SENSITIVITIES

At the sacrifice of some accuracy we have developed relatively simple formulas to calculate the sensitivities of the filter center frequency, Q , and gain to both the passive and the active circuit parameters. Table D-1 lists the expressions for the passive sensitivities; Equations (208) through (218) give the active sensitivities. Equations (217) and (218), which are an additional stage of approximation for two of the active sensitivities, will be useful in deriving optimization formulas.

The sensitivities are expressed as functions of op amp parameters and two variables X and y, which are functions of the positive feedback ratio ρ . We have

$$x = \frac{1}{2} + \sqrt{\left(\frac{1}{2}\right)^2 + 2Q^2 \left(\frac{P}{1-P}\right)} \quad (237)$$

$$\approx \frac{1}{2} + \sqrt{\left(\frac{1}{2}\right)^2 + 2Q^2 \left(\frac{\rho}{1-\rho}\right)} \quad (238)$$

$$y = \frac{\frac{X}{Q} + \frac{2Q}{X}}{1-P} \quad (239)$$

$$\approx \frac{\frac{X}{Q} + \frac{2Q}{X}}{1-\rho} \quad (240)$$

$$\text{where } P = \rho - \frac{1}{A_{DC}} + g_2 \quad (241)$$

$$\text{and } \rho = \frac{R_3}{R_3 + R_4} \quad (242)$$

The quantity X increases as the positive feedback ρ is increased. The quantity y, on the other hand, decreases with increasing positive feedback until reaching a minimum value of:

$$y_{\min} \approx \frac{16}{3} \sqrt{\frac{2}{3}} \approx 4.35 \quad (243)$$

This value is achieved when $X = Q\sqrt{\frac{2}{3}}$ and $\rho \approx 0.25$.

Because of the behavior of X and y, an increase in X within the range $1 \leq X < Q\sqrt{\frac{2}{3}}$ (i.e., an increase in ρ in the range $0 < \rho < 0.25$) causes the active sensitivities to decrease and the passive sensitivities to increase. Consequently, a judicious choice of ρ in this range can reduce the drift in the filter characteristics with temperature or time.

In order for the sensitivity formulas to be valid, we must impose the following restriction:

$$y g_1 < \frac{2}{3}. \quad (244)$$

Since synthesis is impossible when $y g_1 > 1$, this restriction is not unreasonable. The bound on $y g_1$ is approximately equivalent to the following pair of bounds:

$$g_1 < \frac{1}{8} \sqrt{\frac{3}{2}} \approx \frac{1}{6} \quad (245)$$

$$X > 3 Q g_1 \quad (246)$$

The first inequality in the pair places a lower bound on the gain bandwidth product f_{u1} of the op amp ($g_1 = f_0/f_{u1}$). The second establishes a lower bound for the positive feedback ratio ρ .

OPTIMIZATION

We have shown that the positive feedback in the active bandpass filter circuit shown in Figure D-1 can be utilized to control the filter sensitivities. If the positive feedback ratio is increased in the range $0 \leq \rho \leq 0.25$ while the center frequency and Q are maintained constant by other component changes, the active sensitivities will decrease and the passive sensitivities will increase.

Geffe (Reference 1) suggests using the changes in sensitivities as a basis for choosing the optimum positive feedback for the filter; however, the approach that he describes involves repetitive sensitivity calculations by computer for various amounts of positive feedback and the final choice of positive feedback requires a careful decision by the design engineer.

A more direct approach to the optimization can be achieved by using the approximate sensitivity formulas that were developed in this appendix as a basis for a worst case drift analysis. The worst case drift in a filter parameter can then be minimized over ρ .

In order to facilitate the worst case analysis, we will assume that each circuit component or op amp parameter Z_n can differ from its "correct" value by a maximum amount of ΔZ_n and that this deviation can be either positive or negative. In a filter that contains only fixed components and no adjustments, each ΔZ_n would represent a component tolerance; for a filter that is initially calibrated by means of circuit component adjustments, each ΔZ_n could represent drifts in a component value due to temperature changes or aging. For small changes the worst case deviation in any filter parameter u (such as center frequency) can be calculated in terms of sensitivities:

$$\left| \frac{\Delta u}{u} \right|_{\max} \approx \sum_{n=1}^N \left| \frac{\Delta Z_n}{Z_n} \right|_{\max} \cdot \left| S_{Z_n}^u \right|_{\max} \quad (247)$$

where $\left| \frac{\Delta Z_n}{Z_n} \right|_{\max}$ is the magnitude of the maximum possible relative change in value of component number n and $\left| S_{Z_n}^u \right|_{\max}$ is the maximum magnitude of the sensitivity of u with respect to Z_n .

Because they are constant for a given positive feedback ratio ρ , the passive sensitivities need not be maximized as Equation (247) specifies. Furthermore, taking the absolute value is trivial because none of the passive sensitivities change sign as the positive feedback is varied.

The active sensitivities, on the other hand, depend on the op amp characteristics as well as the positive feedback ratio. Consequently, it will be necessary to determine the maximum magnitudes of the active sensitivities over the possible range of op amp parameter values. Op amp parameters are usually specified very loosely. For example, the open loop D.C. gain of a $\mu A741$ op amp has a guaranteed minimum value of 50,000 and a typical value of 200,000. We will assume that each op amp parameter can take on any value between its specified minimum and its ideal value of infinity. Thus, the sensitivity magnitudes will be maximized over the intervals

$$A_{DC \min} \leq A_{DC} < \infty \quad (248)$$

$$f_{u1 \min} \leq f_{u1} < \infty \quad (249)$$

$$f_{u2 \min} \leq f_{u2} < \infty \quad (250)$$

Maximizing Equations (208), (209), (210), (211), (213), (214), (216), (217), and (218), over the above intervals, we have

$$\left| S_{A_{DC}}^{f_0} \right|_{\max} \approx \frac{y g_{l \max}}{2 A_{DC \min}} \quad (251)$$

$$\left| S_{f_{u1}}^{f_0} \right|_{\max} \approx \frac{y g_{l \max}}{2} \quad (252)$$

$$\left| S_{f_{u2}}^{f_0} \right|_{\max} \approx Y g_{1\max} g_{2\max} \quad (253)$$

$$\left| S_{A_{DC}}^Q \right|_{\max} \approx \frac{Q Y}{A_{DC \min}} \quad (254)$$

$$\left| S_{f_{u1}}^Q \right|_{\max} \approx Y \cdot U \quad (255)$$

where

$$U = \begin{cases} \left(\frac{1}{2} - 2Qg_{1\max} \right) g_{1\max}' & 0 \leq g_{1\max} \leq \frac{1}{8Q} \\ \frac{1}{32Q} & \frac{1}{8Q} \leq g_{1\max} \leq \frac{1+\sqrt{2}}{8Q} \\ \left(2Qg_{1\max} - \frac{1}{2} \right) g_{1\max}' & \frac{1+\sqrt{2}}{8Q} \leq g_{1\max} \end{cases} \quad (256)$$

$$\left| S_{f_{u2}}^Q \right|_{\max} \approx 2Q Y g_{2\max} \quad (257)$$

$$\left| S_{A_{DC}}^{H_0} \right|_{\max} \approx \frac{QY}{A_{DC\min}} \quad (258)$$

$$\left| S_{f_{u1}}^{H_0} \right|_{\max} \approx 2Q Y g_{1\max}^2 \quad (259)$$

$$\left| S_{f_{u2}}^{H_0} \right|_{\max} \approx 2Q Y g_{2\max} \quad (260)$$

We can now substitute the passive sensitivity approximations (Table D-1) and the maximum active sensitivities (Equation (251) through (260)) into Equation (247), and the worst case deviation of a filter parameter u becomes a function of X and y :

$$\left| \frac{\Delta u}{u} \right| \approx \sum_{n=1}^9 \left| \frac{\Delta z_n}{z_n} \right|_{\max} \cdot \left| S_{z_n}^u \right|_{\max} \approx a_u X + b_u + c_u y \quad (261)$$

where

- (1) u represents either f_0 , Q , or H_0 ;
- (2) z_1 represents C_1 ,
 z_2 represents C_2 ,
 z_3 represents R_1 ,
 z_4 represents R_2 ,
 z_5 represents R_3 ,
 z_6 represents R_4 ,
 z_7 represents A_{DC} ,
 z_8 represents f_{u1} ,
 z_9 represents f_{u2} ;
- (3) for a given filter parameter u , a_u and b_u are determined by the worst case changes in the passive components;
- (4) for a given filter parameter u , c_u is determined by the center frequency and Q of the filter, the worst case op amp parameters, and the worse case changes in the op amp parameters.

In order to determine the values for a_u and b_u , we observe that

$$a_u X + b_u = \sum_{n=1}^6 \left| \frac{\Delta z_n}{z_n} \right|_{\max} \cdot \left| S_{z_n}^u \right| \quad (262)$$

For example, with u representing the filter center frequency f_0 , we have

$$\begin{aligned}
 a_{f_0} x + b_{f_0} &= \left| \frac{\Delta C_1}{C_1} \right|_{\max} \cdot \left| S_{C_1}^{f_0} \right| + \left| \frac{\Delta C_2}{C_2} \right|_{\max} \cdot \left| S_{C_2}^{f_0} \right| \\
 &+ \left| \frac{\Delta R_1}{R_1} \right|_{\max} \cdot \left| S_{R_1}^{f_0} \right| + \left| \frac{\Delta R_2}{R_2} \right|_{\max} \cdot \left| S_{R_2}^{f_0} \right| \\
 &+ \left| \frac{\Delta R_3}{R_3} \right|_{\max} \cdot \left| S_{R_3}^{f_0} \right| + \left| \frac{\Delta R_4}{R_4} \right|_{\max} \cdot \left| S_{R_4}^{f_0} \right| \\
 &= \left| \frac{\Delta C_1}{C_1} \right|_{\max} \cdot \left| -\frac{1}{2} \right| + \left| \frac{\Delta C_2}{C_2} \right|_{\max} \cdot \left| -\frac{1}{2} \right| \\
 &+ \left| \frac{\Delta R_1}{R_1} \right|_{\max} \cdot \left| -\frac{1}{2} \right| + \left| \frac{\Delta R_2}{R_2} \right|_{\max} \cdot \left| -\frac{1}{2} \right| \\
 &+ \left| \frac{\Delta R_3}{R_3} \right|_{\max} \cdot 0 + \left| \frac{\Delta R_4}{R_4} \right|_{\max} \cdot 0 \\
 &= \frac{1}{2} \left(\left| \frac{\Delta C_1}{C_1} \right|_{\max} + \left| \frac{\Delta C_2}{C_2} \right|_{\max} + \left| \frac{\Delta R_1}{R_1} \right|_{\max} + \left| \frac{\Delta R_2}{R_2} \right|_{\max} \right) \quad (263)
 \end{aligned}$$

We will assume the two capacitors are each subject to the same worst case changes and that the four resistors are each subject to the same maximum percentage change. Let $|\Delta C/C|$ and $|\Delta R/R|$ be defined as follows

$$\left| \frac{\Delta C}{C} \right| = \left| \frac{\Delta C_1}{C_1} \right|_{\max} = \left| \frac{\Delta C_2}{C_2} \right|_{\max} \quad (264)$$

$$\left| \frac{\Delta R}{R} \right| = \left| \frac{\Delta R_1}{R_1} \right|_{\max} = \left| \frac{\Delta R_2}{R_2} \right|_{\max} = \left| \frac{\Delta R_3}{R_3} \right|_{\max} = \left| \frac{\Delta R_4}{R_4} \right|_{\max} \quad (265)$$

Substituting Equations (264) and (265) into Equation (263), we have

$$a_{f_0} x + b_{f_0} = \left| \frac{\Delta C}{C} \right| + \left| \frac{\Delta R}{R} \right|$$

Thus, we have

$$a_{f_0} = 0$$

$$b_{f_0} = \left| \frac{\Delta C}{C} \right| + \left| \frac{\Delta R}{R} \right|$$

When u represents Q , Equation (262) becomes

$$\begin{aligned} a_Q x + b_Q &= \sum_{n=1}^6 \left| \frac{\Delta z_n}{z_n} \right|_{\max} \cdot \left| S_{z_n}^Q \right| \\ &= \left| \frac{\Delta C_1}{C_1} \right|_{\max} \cdot \left| \frac{1}{2} (x-1) \right| + \left| \frac{\Delta C_2}{C_2} \right|_{\max} \cdot \left| -\frac{1}{2} (x-1) \right| \\ &\quad + \left| \frac{\Delta R_1}{R_1} \right|_{\max} \cdot \left| -\left(x - \frac{1}{2}\right) \right| + \left| \frac{\Delta R_2}{R_2} \right|_{\max} \cdot \left| \left(x - \frac{1}{2}\right) \right| \\ &\quad + \left| \frac{\Delta R_3}{R_3} \right|_{\max} \cdot |x-1| + \left| \frac{\Delta R_4}{R_4} \right|_{\max} \cdot |-(x-1)| \\ &= 2 \left| \frac{\Delta C}{C} \right| \cdot \left| \frac{1}{2} (x-1) \right| + 2 \cdot \left| \frac{\Delta R}{R} \right| \cdot \left| \left(x - \frac{1}{2}\right) \right| + 2 \cdot \left| \frac{\Delta R}{R} \right| \cdot |x-1| \\ &= \left(\left| \frac{\Delta C}{C} \right| + 4 \left| \frac{\Delta R}{R} \right| \right) x - \left(\left| \frac{\Delta C}{C} \right| + 3 \left| \frac{\Delta R}{R} \right| \right) \end{aligned}$$

Thus, we have

$$a_Q = \left| \frac{\Delta C}{C} \right| + 4 \left| \frac{\Delta R}{R} \right|$$

$$b_Q = - \left| \frac{\Delta C}{C} \right| - 3 \left| \frac{\Delta R}{R} \right|$$

Similarly, if we let u represent H_0 , the results are

$$a_{H_0} = \left| \frac{\Delta C}{C} \right| + 4 \left| \frac{\Delta R}{R} \right|$$

$$b_{H_0} = -2 \left| \frac{\Delta R}{R} \right|$$

An expression for c_u can be achieved by using

$$\begin{aligned} c_u y &= \sum_{n=7}^9 \left| \frac{\Delta Z_n}{Z_n} \right|_{\max} \cdot \left| S_{Z_n}^u \right|_{\max} \\ &= \left| \frac{\Delta A_{DC}}{A_{DC}} \right|_{\max} \cdot \left| S_{A_{DC}}^u \right|_{\max} + \left| \frac{\Delta f_{u1}}{f_{u1}} \right|_{\max} \cdot \left| S_{f_{u1}}^u \right|_{\max} \\ &\quad + \left| \frac{\Delta f_{u2}}{f_{u2}} \right|_{\max} \cdot \left| S_{f_{u2}}^u \right|_{\max} \end{aligned} \quad (266)$$

Table D-2 summarizes the expression for a_u , b_u and c_u for the cases when u represents center frequency (f_0), Q , or gain (H_0) of the filter.

Having developed expressions for the terms a_u , b_u , and c_u , we now have an equation that gives the worst case change in a filter parameter u in terms of two variables X and y , which are functions of the positive feedback ratio ρ . Repeating Equations (261), (238), and (240), we have

$$\left| \frac{\Delta u}{u} \right|_{\max} \approx a_u X + b_u + c_u y \quad (267)$$

$$X \approx \frac{1}{2} + \sqrt{\left(\frac{1}{2}\right)^2 + 2Q^2 \left(\frac{\rho}{1-\rho}\right)} \quad (268)$$

TABLE D-2
 a_u , b_u , and c_u , for f_0 , Q , and H_0

u	a_u	b_u	c_u
f_0	0	$\left \frac{\Delta C}{C} \right + \left \frac{\Delta R}{R} \right $	$\frac{g_{1\max}}{2} \left(v + \left \frac{\Delta f_{u1}}{f_{u1}} \right _{\max} \right)$
Q	$\left \frac{\Delta C}{C} \right + 4 \left \frac{\Delta R}{R} \right $	$- \left \frac{\Delta C}{C} \right - 3 \left \frac{\Delta R}{R} \right $	$Q \cdot v + u \cdot \left \frac{\Delta f_{u1}}{f_{u1}} \right _{\max}$
H_0	$\left \frac{\Delta C}{C} \right + 4 \left \frac{\Delta R}{R} \right $	$- 2 \left \frac{\Delta R}{R} \right $	$Q \cdot v + 2Qg_{1\max}^2 \left \frac{\Delta f_{u1}}{f_{u1}} \right _{\max}$

where

$$U = \begin{cases} \left(\frac{1}{2} - 2Qg_{1\max} \right) g_{1\max}' & 0 \leq g_{1\max} \leq \frac{1}{8Q} \\ \frac{1}{32Q} & \frac{1}{8Q} \leq g_{1\max} \leq \frac{1 + \sqrt{2}}{8Q} \\ \left(2Qg_{1\max} - \frac{1}{2} \right) g_{1\max}' & \frac{1 + \sqrt{2}}{8Q} \leq g_{1\max} \end{cases}$$

$$V = \frac{1}{A_{DC\min}} \left| \frac{\Delta A_{DC}}{A_{DC}} \right|_{\max} + 2g_{2\max} \left| \frac{\Delta f_{u2}}{f_{u2}} \right|_{\max}$$

$$y \approx \frac{\frac{x}{Q} + \frac{2Q}{x}}{1 - \rho} \quad (269)$$

We now wish to choose the value of ρ (or, equivalently, x) that minimizes the worst case change in u ; this is accomplished by taking the derivative of Equation (267) with respect to x with a_u , b_u , c_u , and Q held constant; and setting this derivative equal to zero:

$$0 = \frac{d \left| \frac{\Delta u}{u} \right|_{\max}}{dx} = a_u + c_u \frac{dy}{dx} \quad (270)$$

Using Equation (230), we have

$$0 \approx a_u + c_u \left[\frac{3x^2}{2Q^3} + \frac{2}{Q} - \frac{2Q}{x^2} \right] \quad (271)$$

Multiplying by x^2/Qc_u and rearranging,

$$0 \approx \frac{3}{2} \left(\frac{x}{Q} \right)^4 + \left(2 + Q \frac{a_u}{c_u} \right) \left(\frac{x}{Q} \right)^2 - 2$$

By the quadratic formulas we have

$$\left(\frac{x}{Q} \right)^2 \approx \frac{- \left(2 + Q \cdot \frac{a_u}{c_u} \right) \pm \sqrt{\left(2 + Q \frac{a_u}{c_u} \right)^2 + 12}}{3} \quad (272)$$

Since $(x/Q)^2$ must be greater than zero, we choose the positive square root. Substitution of the result into the derivative formula (Equation (270)) verifies that the point is indeed a minimum and not a maximum.

Thus, the optimum value for x (i.e., the value which minimizes the worst case change in the filter parameter u) is given by

$$x_{\text{opt}} \approx Q \sqrt{\frac{- \left(2 + Q \frac{a_u}{c_u} \right) + \sqrt{\left(2 + Q \frac{a_u}{c_u} \right)^2 + 12}}{3}} \quad (273)$$

and the corresponding positive feedback ratio is

$$\rho_{\text{opt}} = \frac{x_{\text{opt}} (x_{\text{opt}} - 1)}{2Q^2 + x_{\text{opt}} (x_{\text{opt}} - 1)} \quad (274)$$

OVERALL OPTIMUM

We now have a straightforward procedure for determining the amount of positive feedback that will minimize the worst case drift of any one of three filter parameters (f_0 , Q , and H_0); however, we are now faced with tradeoffs in deciding which filter parameter to use as a basis for the optimization. It would be very desirable to define an "overall optimum" positive feedback ratio in a way that would properly account for drift in all three filter parameters. Such an optimization can be achieved by observing the effects of each of the three filter parameters on the filter gain at an arbitrary frequency. (The idea for this method of combining all three drift parameters was contributed by Dennis Stutzel of NSWC.)

The transfer function for a simple two-pole bandpass filter is:

$$H(s) = \frac{H_0 d \omega_0 s}{s^2 + d \omega_0 s + \omega_0^2} \quad (275)$$

where $d = 1/Q$

The magnitude of the gain is given by

$$\begin{aligned} |H(j\omega)| &= \frac{|H_0| d \omega_0 \omega}{\sqrt{(\omega_0^2 - \omega^2)^2 + (d \omega_0 \omega)^2}} \\ &= \frac{|H_0|}{\sqrt{1 + Q^2 \left(\frac{\omega}{\omega_0} - \frac{\omega_0}{\omega} \right)^2}} \end{aligned} \quad (276)$$

Now consider the sensitivities of $|H(j\omega)|$ (for an arbitrary, but fixed frequency ω) to changes in ω_0 , Q , and H_0

$$\begin{aligned}
 S_{\omega_0}^{|H(j\omega)|} &= - \left(\frac{1}{2}\right) \left[\frac{Q^2 \left(\frac{\omega}{\omega_0} - \frac{\omega_0}{\omega}\right)^2}{1 + Q^2 \left(\frac{\omega}{\omega_0} - \frac{\omega_0}{\omega}\right)^2} \right] (2) \cdot \left[\frac{-\left(\frac{\omega}{\omega_0} + \frac{\omega_0}{\omega}\right)}{\left(\frac{\omega}{\omega_0} - \frac{\omega_0}{\omega}\right)} \right] \\
 &= + \frac{Q^2 \left(\frac{\omega}{\omega_0} - \frac{\omega_0}{\omega}\right) \left(\frac{\omega}{\omega_0} + \frac{\omega_0}{\omega}\right)}{1 + Q^2 \left(\frac{\omega}{\omega_0} - \frac{\omega_0}{\omega}\right)^2} \\
 &= + \frac{Q^2 \left(\frac{\omega^2}{\omega_0^2} - \frac{\omega_0^2}{\omega^2}\right)}{1 + Q^2 \left(\frac{\omega}{\omega_0} - \frac{\omega_0}{\omega}\right)^2} \tag{277}
 \end{aligned}$$

$$\begin{aligned}
 S_Q^{|H(j\omega)|} &= - \frac{1}{2} \left[\frac{Q^2 \left(\frac{\omega}{\omega_0} - \frac{\omega_0}{\omega}\right)^2}{1 + Q^2 \left(\frac{\omega}{\omega_0} - \frac{\omega_0}{\omega}\right)^2} \right] \cdot (2) \\
 &= - \frac{Q^2 \left(\frac{\omega}{\omega_0} - \frac{\omega_0}{\omega}\right)^2}{1 + Q^2 \left(\frac{\omega}{\omega_0} - \frac{\omega_0}{\omega}\right)^2} \tag{278}
 \end{aligned}$$

$$S_{H_0}^{|H(j\omega)|} = 1 \tag{279}$$

Three frequencies that are particularly interesting are the center frequency ω_0 , the lower 3dB point ω_- , and the upper 3dB

frequency ω_+ . Inspection of Equation (276) shows that the upper and lower 3dB points are characterized by:

$$Q \left(\frac{\omega_+}{\omega_0} - \frac{\omega_0}{\omega_+} \right) = 1 \quad (280)$$

and

$$Q \left(\frac{\omega_-}{\omega_0} - \frac{\omega_0}{\omega_-} \right) = -1 \quad (281)$$

By solving these equations for ω_+ and ω_- it can be shown that

$$\frac{\omega_+}{\omega_0} + \frac{\omega_0}{\omega_+} \approx \frac{\omega_-}{\omega_0} + \frac{\omega_0}{\omega_-} \approx 2 \quad (282)$$

Substituting these results into Equations (277), (278), and (279), we find that:

$$S_{\omega_0} |H(j\omega)| \approx \begin{cases} -Q & \text{at } \omega = \omega_- \\ 0 & \text{at } \omega = \omega_0 \\ +Q & \text{at } \omega = \omega_+ \end{cases} \quad (283)$$

$$S_Q |H(j\omega)| = \begin{cases} -\frac{1}{2} & \text{at } \omega = \omega_- \\ 0 & \text{at } \omega = \omega_0 \\ -\frac{1}{2} & \text{at } \omega = \omega_+ \end{cases} \quad (284)$$

$$S_{H_0} |H(j\omega)| = 1 \text{ for any } \omega \quad (285)$$

One way to combine the effects of drifts in center frequency Q , and gain in the optimization procedure would be to define our "overall optimum" value for ρ as the value which minimizes the worst case gain drift within the 3dB passband of the filter. Using the form of Equation (261), this worst case gain drift is:

$$\max_{(\omega_- \leq \omega \leq \omega_+)} \left| \frac{\Delta |H(j\omega)|}{|H(j\omega)|} \right| \approx \max_{(\omega_- \leq \omega \leq \omega_+)} \sum_{n=1}^9 \left| \frac{\Delta z_n}{z_n} \right|_{\max} \cdot \left| S_{z_n}^H(j\omega) \right| \quad (286)$$

Since this definition of the "overall optimum" would result in a complicated solution, we will make two changes to simplify the results: (1) the maximization over the passband ($\omega_- \leq \omega \leq \omega_+$) will be replaced by a maximization over three points ($\omega = \omega_-$, $\omega = \omega_0$ and $\omega = \omega_+$): (2) the maximum of the summation will be replaced by the summation of the maxima.

We will call the resulting quantity $\left| \frac{\Delta H_{PB}}{H_{PB}} \right|_{\max}$:

$$\left| \frac{\Delta H_{PB}}{H_{PB}} \right|_{\max} = \sum_{n=1}^9 \left| \frac{\Delta z_n}{z_n} \right| \cdot (\omega \in \{\omega_-, \omega_0, \omega_+\}) \left| S_{z_n}^H(j\omega) \right| \quad (287)$$

The sensitivity of filter gain at any frequency ω to changes in any component value Z is given by:

$$S_z^H(j\omega) = S_z^{\omega_0} S_{\omega_0}^H(j\omega) + S_z^Q S_Q^H(j\omega) + S_z^{H_0} S_{H_0}^H(j\omega) \quad (288)$$

We need to maximize the magnitude of this expression over the three choices for ω . Using Equations (283), (284), and (285), we have,

$$\begin{aligned} \max_{(\omega \in \{\omega_-, \omega_0, \omega_+\})} |S_Z^H(j\omega)| &= \max \left[|S_Z^H(j\omega_-)|, |S_Z^H(j\omega_0)|, |S^H(j\omega_+)| \right] \\ &= \max \left[|S_Z^{H_0} - \frac{1}{2} S_Z^Q| + Q |S_Z^{\omega_0}|, |S_Z^{H_0}| \right] \end{aligned} \quad (289)$$

The two arguments of the final "max" functions are listed in Table D-3. By using the previously established bounds, $1 \leq X \leq Q\sqrt{\frac{2}{3}}$ and $g_1 < \frac{1}{6}$, we find that the numbers in the first column are larger than those in the second for $C_1, C_2, R_1, R_2,$ and f_{u1} ; the second column exceeds the first for $R_3, R_4, A_{DC},$ and f_{u2} .

Having maximized the gain sensitivities over the three choices of ω , we can substitute the results into Equation (287) and rearrange to yield:

$$\left| \frac{\Delta H_{PB}}{H_{PB}} \right|_{\max} = a_{H_{PB}} X + b_{H_{PB}} + c_{H_{PB}} Y$$

where

$$a_{H_{PB}} = \frac{1}{2} \left| \frac{\Delta C}{C} \right| + 3 \left| \frac{\Delta R}{R} \right|$$

$$b_{H_{PB}} = (Q + \frac{1}{2}) \left| \frac{\Delta C}{C} \right| + (Q - \frac{3}{2}) \left| \frac{\Delta R}{R} \right|$$

$$c_{H_{PB}} \approx QV + Qg_{1\max} \left(\frac{1}{2} + g_{1\max} \right) \left| \frac{\Delta f_{u1}}{f_{u1}} \right|_{\max} \quad \text{for } Q > 2$$

where

$$V = \frac{1}{A_{DC\min}} \left| \frac{\Delta A_{DC}}{A_{DC}} \right|_{\max} + 2g_{2\max} \left| \frac{\Delta f_{u2}}{f_{u2}} \right|_{\max}$$

TABLE D-3
Sensitivity Comparison for H_{PB} Optimization

z	$\left S_z^{H_0} - \frac{1}{2} S_z^Q \right + Q \left S_z^{\omega_0} \right $	$\left S_z^{H_0} \right $
C_1	$\frac{1}{4} (X + 1) + \frac{1}{2} Q *$	$\frac{1}{2} X$
C_2	$\frac{1}{4} (X + 1) + \frac{1}{2} Q *$	$\frac{1}{2} X$
R_1	$\frac{1}{2} (X + \frac{1}{2}) + \frac{1}{2} Q *$	X
R_2	$\frac{1}{2} (X + \frac{1}{2}) + \frac{1}{2} Q *$	X
R_3	$\frac{1}{2} (X - 1)$	$X - 1 *$
R_4	$\frac{1}{2} (X - 1)$	$X - 1 *$
A_{DC}	$\frac{QY}{2A_{DC}} + \frac{QYg_1}{2A_{DC}}$	$\frac{QY}{A_{DC}} *$
f_{u1}	$\frac{QYg_1}{2} + \frac{1}{4} Yg_1 + QYg_1^2 *$	$2QYg_1^2$
f_{u2}	$QYg_2 (1 + g_1)$	$2QYg_2 *$

* Indicates the larger quantity in each row.

The "overall optimum" positive feedback ratio can now be found by substituting $a_{H_{PB}}$ and $c_{H_{PB}}$ into Equation (273) and then applying Equation (274).

DISTRIBUTION

Naval Sea Systems Command	1
Attn: PMS 402	1
PMS 402B	1
PMS 402C	1
PMS 406	1
PMS 406B	1
PMS 406D	1
PMS 407	1
NAVSEA 06H1	1
NAVSEA 06H2	1
NAVSEA 661	1
NAVSEA 662	1
NAVSEA 663	1
Washington, D.C. 20362	
Naval Electronics Laboratory Center	1
San Diego, California 92152	
David W. Taylor Naval Ship R&D Center	1
Bethesda, Maryland 20034	
Naval Undersea Center	1
San Diego, California 92132	
Naval Underwater Systems Center	
Attn: Code 36121	
Newport, Rhode Island 02840	3
Applied Physics Laboratory	
University of Washington	
Seattle, Washington 98105	1
Applied Research Laboratory	1
State College, Pennsylvania 16801	
Naval Air Development Center	1
Warminster, Pennsylvania 18974	

NSWC/WOL TR 78-2

Naval Research Laboratory Washington, D.C. 20390	1
Woods Hole Oceanographic Institution Woods Hole, Massachusetts 02543	1
Scripps Institution of Oceanography San Diego, California 92152	1
Naval Oceanographic Office Washington, D.C. 20390	1
Naval Coastal Systems Laboratory Panama City, Florida 32401	1
Naval Torpedo Station Keyport, Washington 98345	1
Gould Incorporated Ocean Systems Division 18901 Euclid Avenue Cleveland, Ohio 44117	3
Defense Documentation Center Cameron Station Alexandria, Virginia 22314	12
Westinghouse Electric Corporation Defense and Space Center P.O. Box 1897 Baltimore, Maryland 21203	3
Bell Laboratories Holmdel, New Jersey 07733	3
Office of Naval Research Attn: ONR-427 Washington, D. C. 20360	2
Naval Sea Systems Command Washington, D. C. 20360 Attn: SEA-09G32	2

TO AID IN UPDATING THE DISTRIBUTION LIST
FOR NAVAL SURFACE WEAPONS CENTER, WHITE
OAK LABORATORY TECHNICAL REPORTS PLEASE
COMPLETE THE FORM BELOW:

TO ALL HOLDERS OF NSWC/WOL/TR 78-2
by Stephen Martin, Code U-31
DO NOT RETURN THIS FORM IF ALL INFORMATION IS CURRENT

A. FACILITY NAME AND ADDRESS (OLD) (Show Zip Code)

NEW ADDRESS (Show Zip Code)

B. ATTENTION LINE ADDRESSES:

C.

REMOVE THIS FACILITY FROM THE DISTRIBUTION LIST FOR TECHNICAL REPORTS ON THIS SUBJECT.

D.

NUMBER OF COPIES DESIRED _____

DEPARTMENT OF THE NAVY
NAVAL SURFACE WEAPONS CENTER
WHITE OAK, SILVER SPRING, MD. 20910

OFFICIAL BUSINESS
PENALTY FOR PRIVATE USE, \$300

POSTAGE AND FEES PAID
DEPARTMENT OF THE NAVY
DOD 316



COMMANDER
NAVAL SURFACE WEAPONS CENTER
WHITE OAK, SILVER SPRING, MARYLAND 20910

ATTENTION: CODE U-31