

AD-A061 718

NAVAL RESEARCH LAB WASHINGTON D C
REAL-TIME METEOROLOGICAL PROFILES USING THE NRL MARINE BOUNDARY--ETC(U)
OCT 78 S G GATHMAN

F/G 4/2

UNCLASSIFIED

NRL-8271

NL

| of |

AD
A061718



END
DATE
FILMED
2-79

DDC

AD A061718

DDC FILE COPY

12 SC

NRL Report 8271

Real-Time Meteorological Profiles Using the NRL Marine Boundary Layer Sonde

Stuart G. Gathman

*Atmospheric Physics Branch
Ocean Sciences Division*

LEVEL II

October 24, 1978

DDC
NOV 30 1978
F



NAVAL RESEARCH LABORATORY
Washington, D.C.

Approved for public release; distribution unlimited.

CONTENTS

INTRODUCTION 1

RADIOSONDE 1

DATA RECEIVING SYSTEMS 8

SOFTWARE 10

PERFORMANCE 14

CONCLUSIONS 15

REFERENCES 17

ACCESSION for

NTIS Write Section

DDC D. F. Section

UNANNOUNCED

JUSTIFICATION

BY

DISTRIBUTION

Dist

A

REAL-TIME METEOROLOGICAL PROFILES USING THE NRL MARINE BOUNDARY LAYER SONDE

INTRODUCTION

A lightweight sounding system, easily flown from a tethered kite balloon, parafoil, or kite, is needed for real-time meteorological mapping of the marine boundary layer. Such a device must have a nonstepping pressure indicator, because the altitude device must respond to continuous variations in pressure. The standard radiosonde, using a stepping contact on the arm of the aneroid barometer, will quickly lose track of altitude if it experiences rapid rises and falls. Some form of digital data recording would also be desirable, to facilitate rapid automatic or perhaps real-time data analysis.

Tethered balloons and kites have been used for years, but they are becoming increasingly popular for measuring the boundary layer for environmental purposes. The particular system described in this report was designed independently for specific marine meteorological soundings. It contains several unique features, developed over the past decade, which suit it to difficult applications such as operation from oceanographic ships at sea.

Instrumentation for a tethered vehicle is much more likely than that for a free-flight balloon to be recovered intact and ready for another flight. This allows the use of relatively expensive instruments with very low cost per flight.

The designer of instrumentation for the tethered vehicle has the choice of telemetry methods. Very lightweight conducting strands, to be woven into the tether lines, are available commercially; this offers choice of either direct-wire or RF data transfer. The instrument described in this report was designed to use the RF method for a number of operational reasons, one of which was to eliminate connector problems.

RADIOSONDE

The radiosonde is basically a collection of seven oscillators connected so as to transmit three channels of meteorological information to an observer on the ground. The receiving equipment at the ground can vary in sophistication. The simplest ground station consists of merely a communications receiver and an observer with a stopwatch. A more complex ground station design, described here, includes a microcomputer-aided real-time data plotter as well as digital processing and recording of the data.

The form of the data is the period of time that elapses between tones, three pitches of the audio-frequency generators are set near the top, middle, and lower portions of the audio band pass of the receiver. The manual observer, with the help of his stopwatch, first times the period between two high-pitched pulses. This period is inversely related to the pressure altitude of the instrument package. The observer next obtains the elapsed time between two medium-pitched pulses; this is directly related to the dry-bulb air temperature. Finally, the

Manuscript submitted August 8, 1978.

GATHMAN

observer times the period between the low-pitched tones to obtain wet-bulb temperature readings. Thus, by flying the tethered vehicle at a constant altitude for each series of manual observations, and changing altitudes in step for the next series of measurements, a whole meteorological sounding can be constructed with the simplest of equipment.

On the other hand, with the identical radiosonde but using an automatic data receiving system, the tethered vehicle can be allowed to climb continuously or be continuously pulled in by a motorized winch. With this equipment data are automatically plotted in analog form in real time, as well as digitally recorded on paper tape for future computer analysis.

The sub-RF section of the radiosonde is composed of three oscillators whose individual frequencies are modified by the ambient pressure, the air temperature, and the wet-bulb temperature respectively, as well as three tone oscillators whose frequencies are set permanently to the high, center, and low parts of the audio pass band of the receiver to be used. In the manner similar to that described by Gathman [1], each data oscillator has its individual output frequency divided by 4096. The counters on the radiosonde board essentially average the input data and therefore put less strain on the receiving and analysis systems, sacrificing response time for reliability and simplicity. These counters cause the tone bursts to be spaced far enough apart to be distinguishable by the human ear, an important feature for low-budget or remote applications. On the change of state of the last stage of the counter, a 200-ms pulse is generated; this opens a gate for a particular tone generator to feed a burst of audio signal as a modulation to the RF transmitter through an OR gate, as shown in Fig. 1. Because these tone bursts take up only a small fraction of time, the same transmitter is used to relay simultaneously all three channels of information over the same RF link.

Figure 2 shows in detail the complementary metal-oxide semiconductor (CMOS) circuitry involved in the sub-RF section of the radiosonde. Five of the oscillators are identical and, although very simple in construction, have a reasonable temperature stability [2].

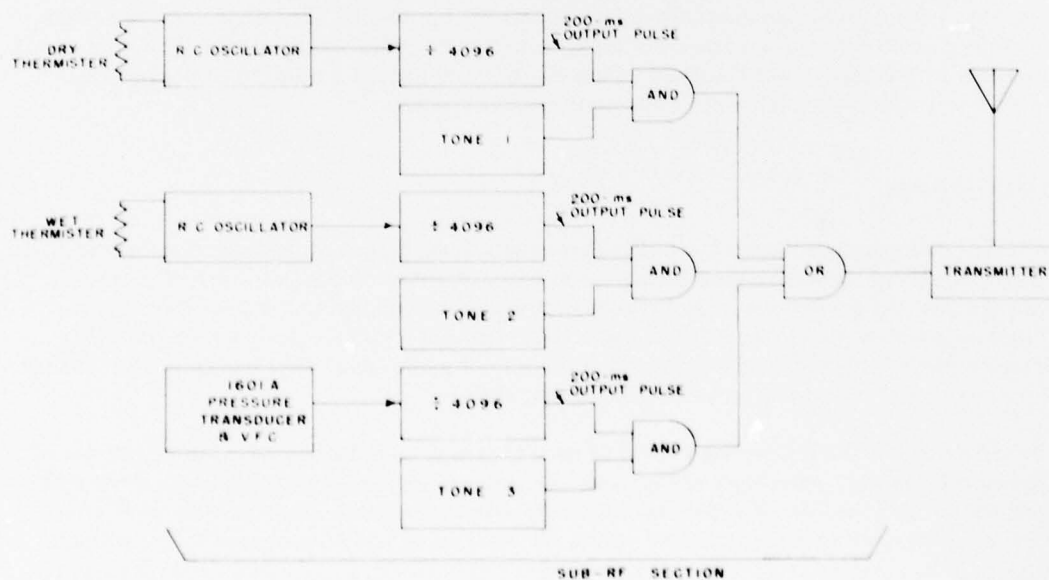

Fig. 1 — Boundary layer sonde sensing and transmitting system

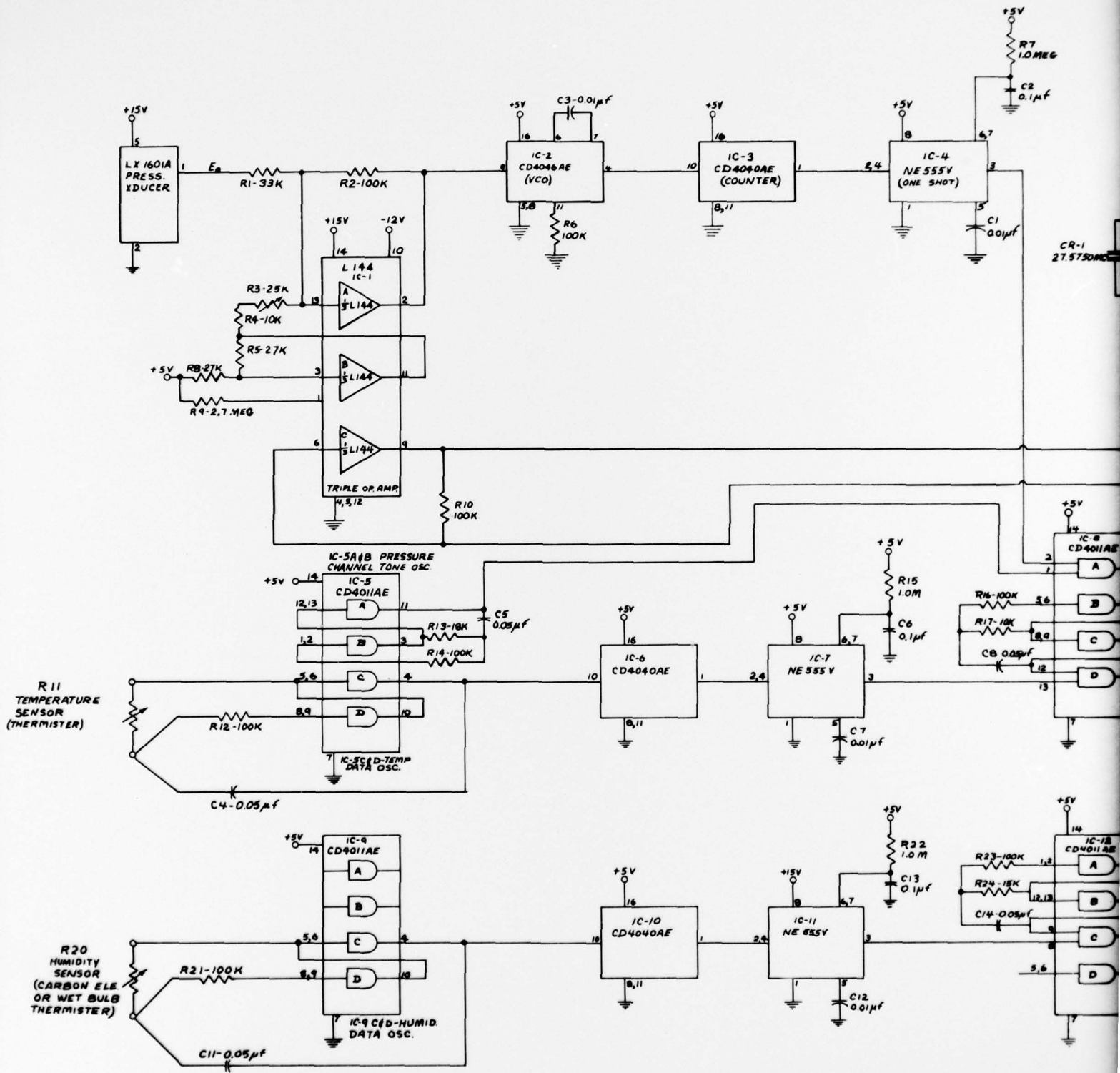

Fig. 2 - Circuit diagram of boundary layer sonde sensing and transmitter

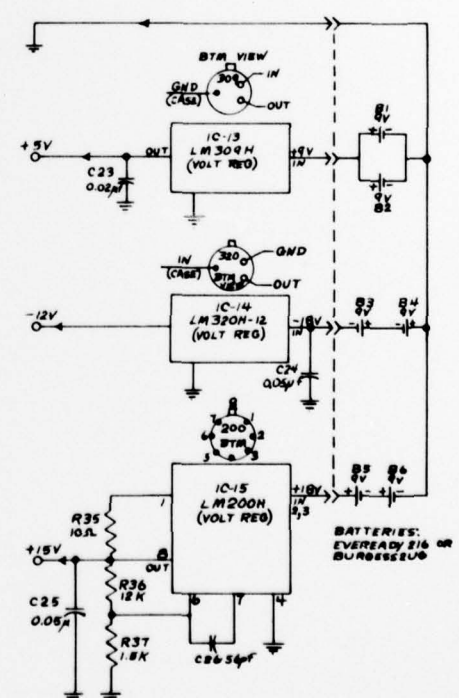
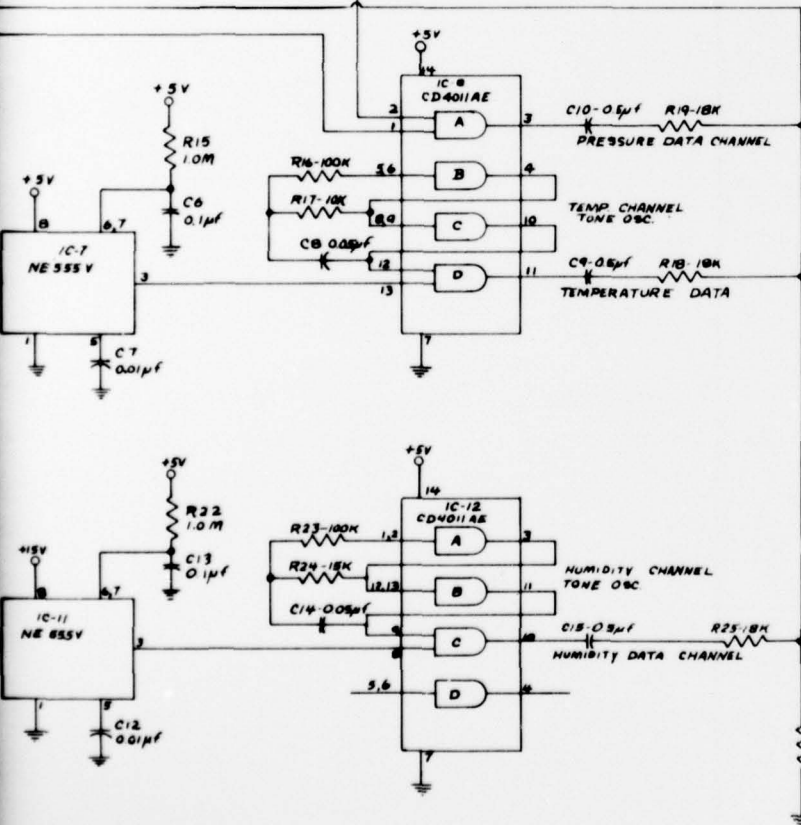
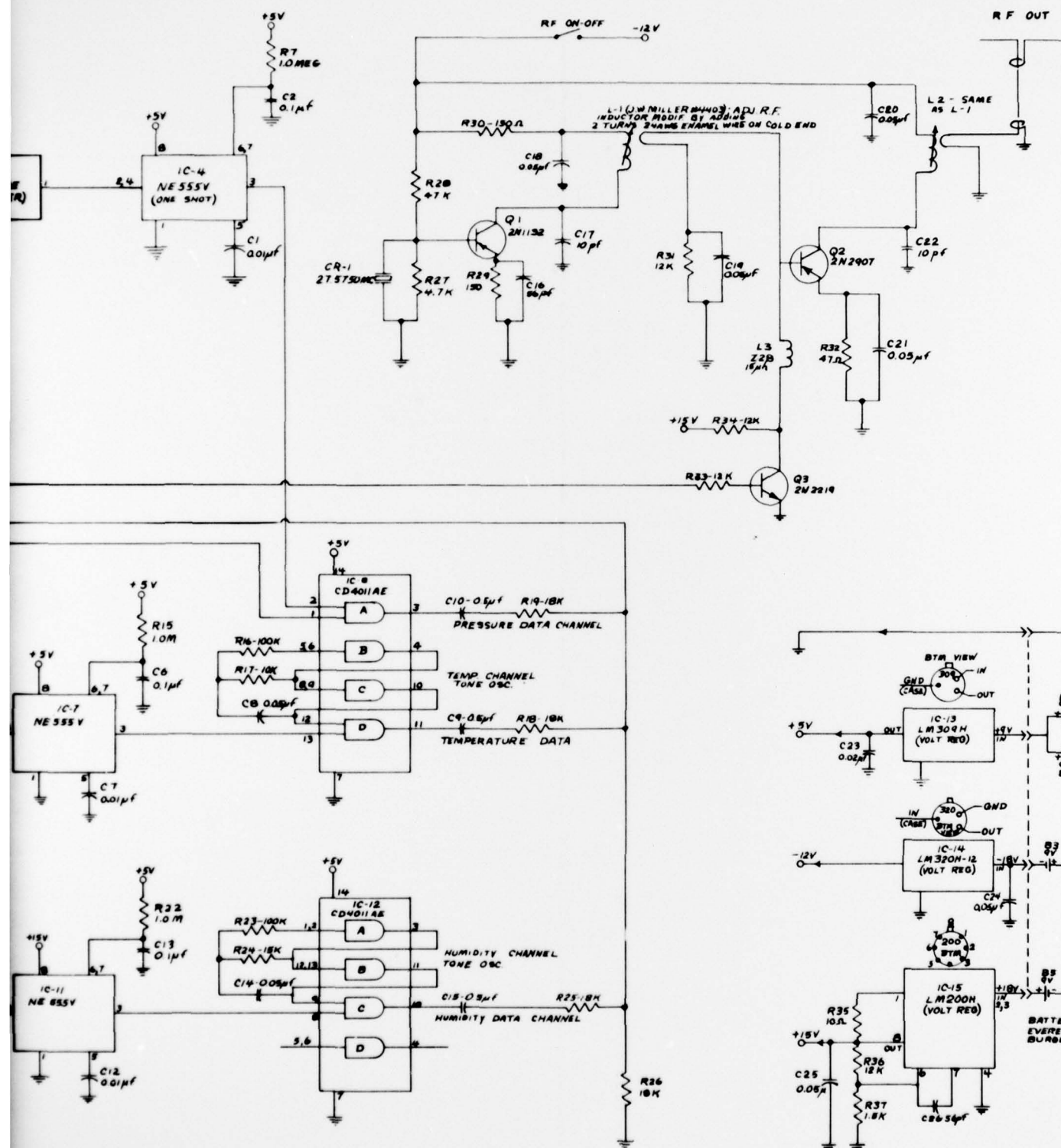

Diagram of boundary layer sonde sensing and transmitting system

[Handwritten signature]

These devices are particularly well suited for marine boundary layer sounding, where temperatures within a particular sounding seldom differ more than 20° from each other. Dry- and wet-bulb thermistors are the resistance elements in the two data oscillators, and fixed resistors control the pitches of the three tone generators.

The frequency of each of these oscillators is expressed as

$$f = \frac{k}{RC}$$

where k is a constant, C is kept constant and R is the frequency-determining element. The period of the pulses emerging from the binary counter is

$$T = RC / 4096 * k = \text{constant} * R.$$

Thus, if we can assume that the resistance of the thermistor is approximately linear over the limited range of temperatures encountered in the marine boundary layer, then the period expressed in seconds is directly proportional to the temperature expressed in degrees Celcius and can in fact be set exactly if C is properly chosen.

The altimeter, on the other hand, is based on an integrated circuit (IC) pressure cell (LX1601A) that produces as an output an analog voltage that is linear with respect to absolute pressure within a range of 10 to 20 psia. The difference between this voltage and a reference voltage is used as the input signal to a linear voltage-to-frequency converter. Thus, the pressure is directly proportional to the frequency and inversely proportional to the period at the output of the binary counter.

The locations of the dry- and wet-bulb thermistors are important for the correct operation of the psychrometer. Figure 3 shows the mounting of the various components of the device as they are located on the tether line. One convenient feature of a tethered vehicle is that the orientation of the relative wind direction to an element of the tether line is always the same [3]. Thus, no matter what the wind direction or the altitude of the tethered vehicle, a device fixed as shown in Fig. 3 is always, oriented properly. Rapid connection of the radiosonde to a permanent loop in the tethered line is accomplished by dog chain clips as shown in Fig. 3a. Battery energy consumption is low, but for long-term operation a quickly exchangeable battery pack is necessary to minimize interruptions in the continuous sounding process. Figure 3b shows the device in place on an actual tether line.

Details of the psychrometer are shown in Fig. 4a. Note that standard radiosonde thermistors ML419/AMT-4 are used for both dry- and wet-bulb sensors. The wet bulb is packaged so that, although it is surrounded by a wet wick, the entire thermistor is inside a thin water-tight plastic coating, and thus water will not affect the thermistor's resistance. A white sun shield provided is broad enough to allow operation during the day except for the extremes of sunrise and sunset, but is placed to allow natural ventilation of the dry and wet bulbs. This is essential for proper psychrometric action. Fortunately, the instrument operating on a tethered kite balloon or kite is assured of adequate ventilation by the relative wind necessary to fly the vehicle. Such a relative wind is, of course, essentially nonexistent in free-flight

GATHMAN

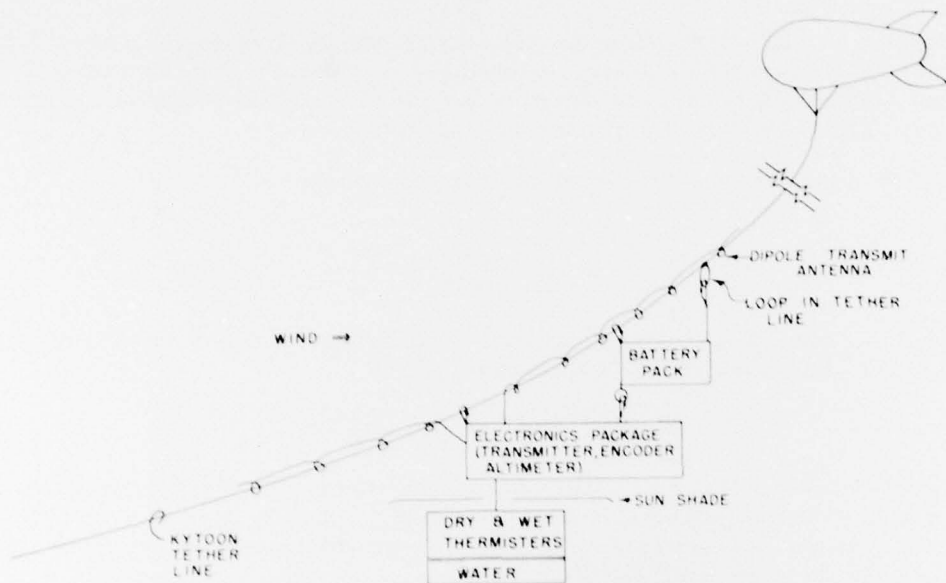

Fig. 3a — Orientation of tether line and mounting positions of the boundary layer sonde system components

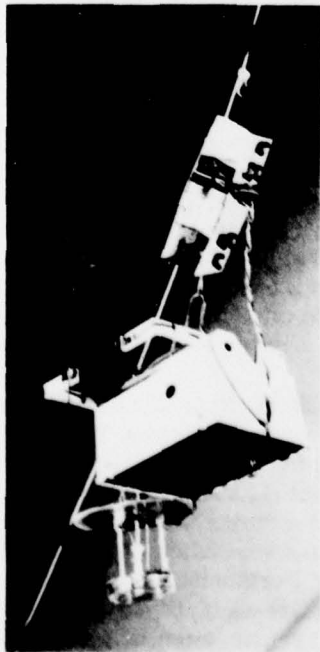

Fig. 3b — Boundary layer sonde system mounted on a tether line in flight

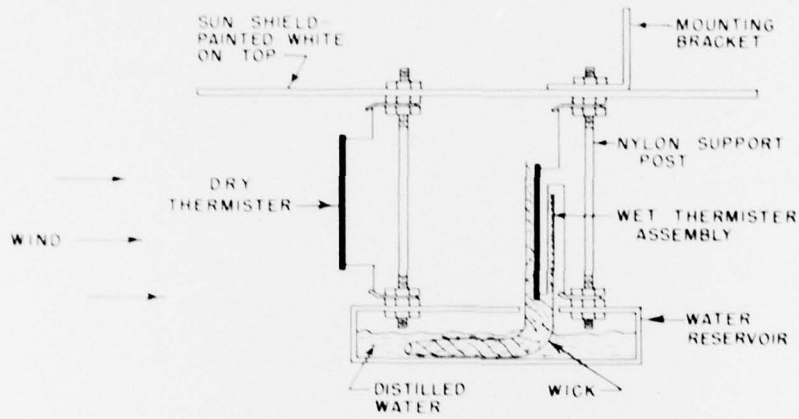

Fig. 4a — Details of the dry-bulb and wet-bulb temperature sensing system

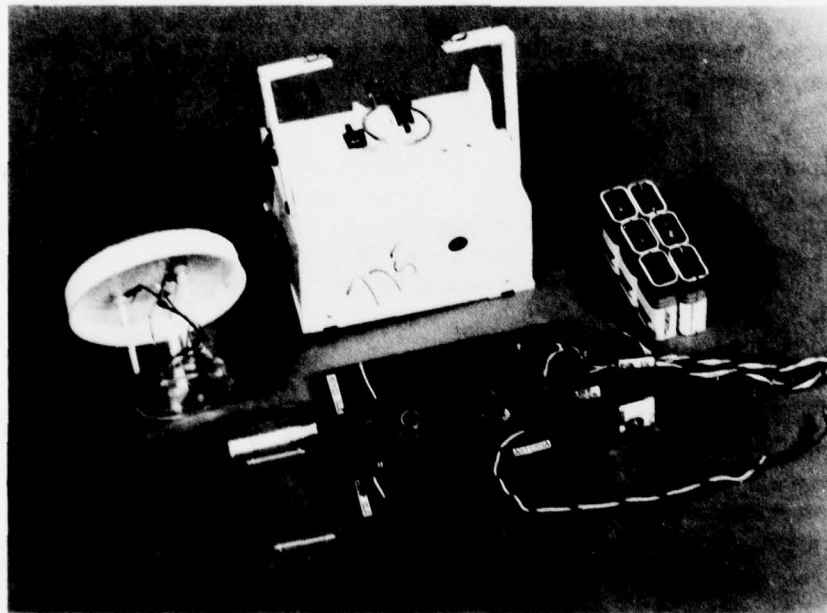

Fig. 4b — Major physical components of the boundary layer sonde system

GATHMAN

balloons. Thus, it is easy to make from tethered vehicles the more accurate psychrometric humidity measurements, which with free-flight systems require artificial ventilation or very rapid descent.

The individual parts of the radiosonde are displayed in Fig. 4b, which shows details of the electronic package, pressure sensor, and psychrometric sensors.

DATA RECEIVING SYSTEMS

As explained earlier, an observer with a simple AM radio receiver tuned to the frequency of the transmitter can distinguish the pulses and manually time them with a stopwatch for a minimum receiving system. A very simple stripchart recording can be made by connecting the output of the receiver to a recording frequency meter, for which the period of time between "like" frequency pulses is the data. Of course the tone pulses from the audio circuit of the AM receiver can be easily separated by means of tone-decoding IC chips. The output of each tone decoder is in the form of a logical pulse, and the period between pulses is the data for that particular channel. These pulses can be timed with stopwatches, recorded with a recording universal timer, or processed directly by a minicomputer or microcomputer.

This radiosonde system is ideally suited to be matched with an inexpensive microcomputer to decode the data automatically, to record it digitally, and present the reduced data to the operator in a real-time analog format. The NRL Marine Boundary Layer Sonde system uses both analog and digital output techniques and displays for time-series presentation all three channels on a dual stripchart recorder with a unique operator-oriented presentation.

The data recovery system consists of an ordinary AM communications receiver covering the assigned frequency of the radiosonde transmitter, a three-channel adjustable tone detector, a 6502 microcomputer system board (KIM-1) with a 2000-word read-only memory (ROM), a 1000-word random-access memory (RAM), a paper-tape punch, two frequency-to-current devices, and a two-channel analog recorder for the real-time observation.

The three channels of information, represented by tone bursts of three different frequencies, appear mixed together on the audio output of the receiver. The interface between the communications receiver and the digital electronics used in data processing is shown in Fig. 5. The tone detectors are designed to be adjustable so that variations in the individual tones, produced by differences in components from radiosonde to radiosonde, can be easily adjusted from the receiving station. They are of narrow bandwidth so that even in a noisy RF environment these devices can detect the presence of the radiosonde data tones and trigger the appropriate one-shot pulse generator, which in turn communicates the existence of a tone burst to the digital electronics.

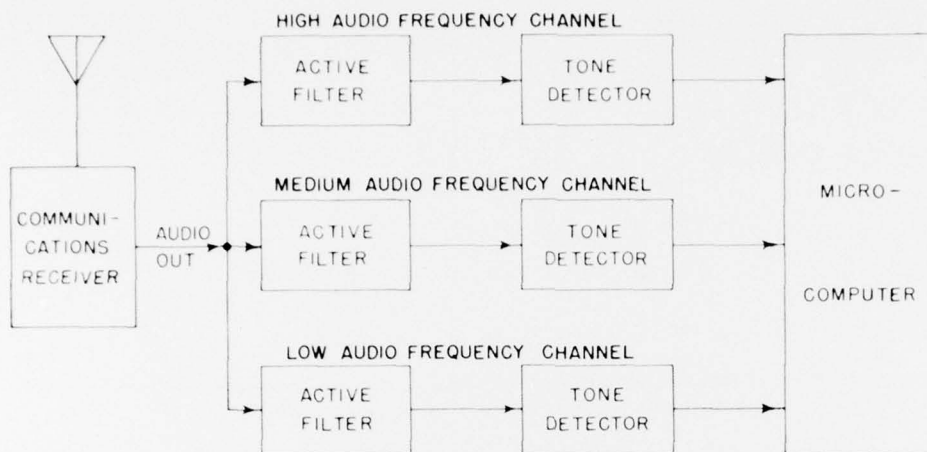

Fig. 5 — The interface circuitry between the communication receiver and the microcomputer

The operational program for this instrument was designed to work with an inexpensive (\$245.00), off-the-shelf microcomputer. The general design of the system is shown in Fig. 6. The inputs to the system consist of three individual input/output (I/O) lines, which contain the transistor-to-transistor logic (TTL) level pulses corresponding to the reception of the transmission signals of the audio-modulated RF pulses from the radiosonde. For example, a 200-ms pulse appears on the "high-pitch pulse" line when the radiosonde is transmitting an altitude pulse. A fourth input of information required for the calculations is that of time; this is obtained internally in the particular microcomputer system used here. All timing of the events in this program is based on the internal timer, which uses the accuracy of the microcomputer's own 1-MHz crystal clock.

Two types of outputs are indicated in the figure. Two lines of the I/O are used for the analog channels. The analog data representation of the desired data produced by the microcomputer has the form shown in Fig. 7. In this technique the number "8" is represented by the four-pulse train shown in the figure, where each pulse is of $20\ \mu\text{s}$ duration and pulses are separated by $20\ \mu\text{s}$ and repeated every $20\ \mu\text{s}$. Similarly, the number 168 would be represented by 84 pulses repeated every $20\ \mu\text{s}$. These pulse trains are fed directly into a single frequency-to-voltage converter, which results in a DC voltage proportional to the number represented.

Six, seven, or eight digital lines, depending on the code used, are reserved for the operation of the paper tape punch. Each line operates relays that in turn control the individual solenoids of the punch. The punch is designed so that it is inoperative for one particular combination of input lines, but all other combinations set the solenoids and start the punching cycle.

The entire program is contained in 1000 bytes of RAM on the KIM-1 system and is loaded into the RAM by means of the self-contained system monitor and a simple cassette audio tape recorder prior to operation.

GATHMAN

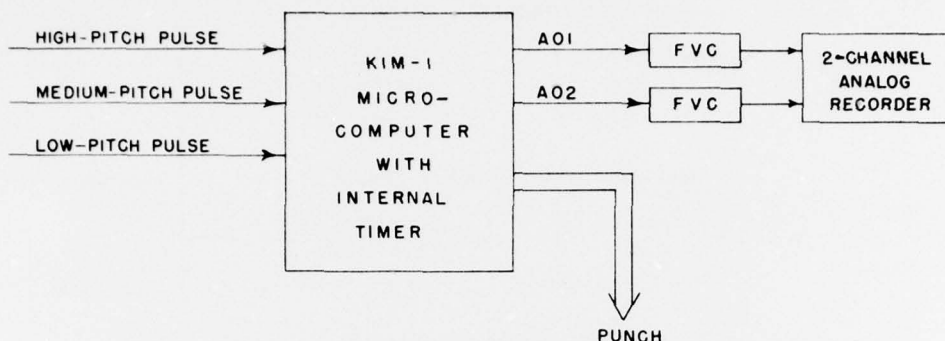

Fig. 6 — Block diagram showing the I/O lines between the micro-computer and the boundary layer sonde receiving and recording systems.

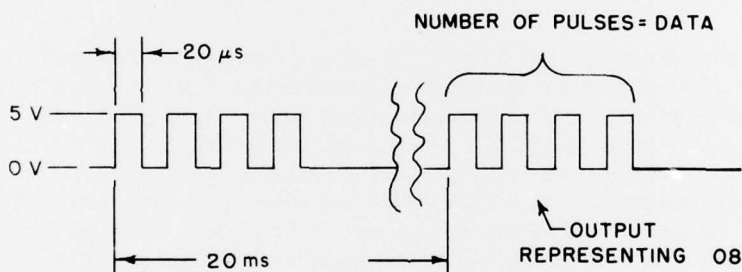

Fig. 7 — The time-voltage configuration on one digital line representing the number 08, which, when fed into a simple frequency-to-voltage converter, produces an analog voltage proportional to the digital number

SOFTWARE

Operation of the microcomputer system is essentially simple and consists of a main program that contains an infinite idle loop and an interrupt service routine. The machine spends most of its time doing nothing in the idle loop. Figure 8 is a flow diagram depicting the main program, which on the startup of the machine initiates the I/O lines to fit the design of the system, assigning certain lines as output lines and certain lines as input lines. Next, all locations where data and processing information are stored are cleared so that erroneous startup outputs are eliminated, the punch output buffers are cleared, and the "do nothing" combination word is output to the punch. Finally, before the idle loop is entered, the internal timer is started so that the interrupt flag will be thrown exactly 10 ms later. At this time the infinite loop is entered; it is executed continuously except for periods when the machine is being interrupted by the various functions of the system.

Obviously the main work of the computer is accomplished by the interrupt-service routine. The flowchart of this routine is shown in Fig. 9. The first item of business after the sensing of

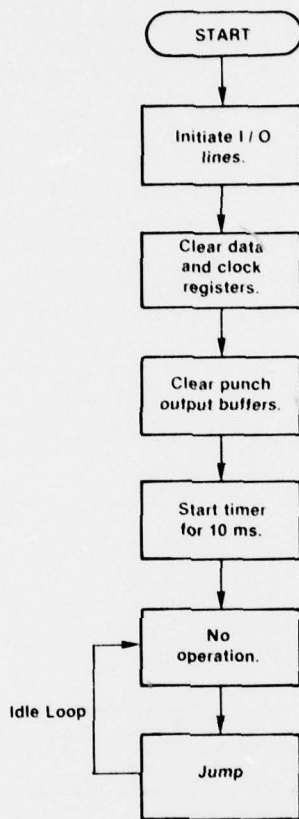

Fig. 8 — Flow diagram of the main program of the microcomputer

an interrupt is to restart the timer so that variations in the time required to complete the various interrupt service options will not affect the timing accuracy of the device. The only requirement is that all of the service steps must be able to be executed in the 10-ms allotted time.

As all data transmission in this system is based on the elapsed time between two pulses, this time is reproduced digitally in the microcomputer by individually timing the pulses in each of the three channels in the manner of an automatic stopwatch. On the reception of a data pulse, a pair of words in memory, devoted to timing the pulses, is cleared. Every 10 ms during the execution of the internal service routine, a "1" is added to each timing word pair. For convenience, the words are set up to represent a maximum value of 25.6 for the most significant word and 0.1 for the least significant word. Thus, when the second data pulse is received the data control routine transfers this time (stored in the most significant word and expressed in tenths of a second) to the current data buffer and again clears the timing word pair in preparation for the next cycle.

GATHMAN

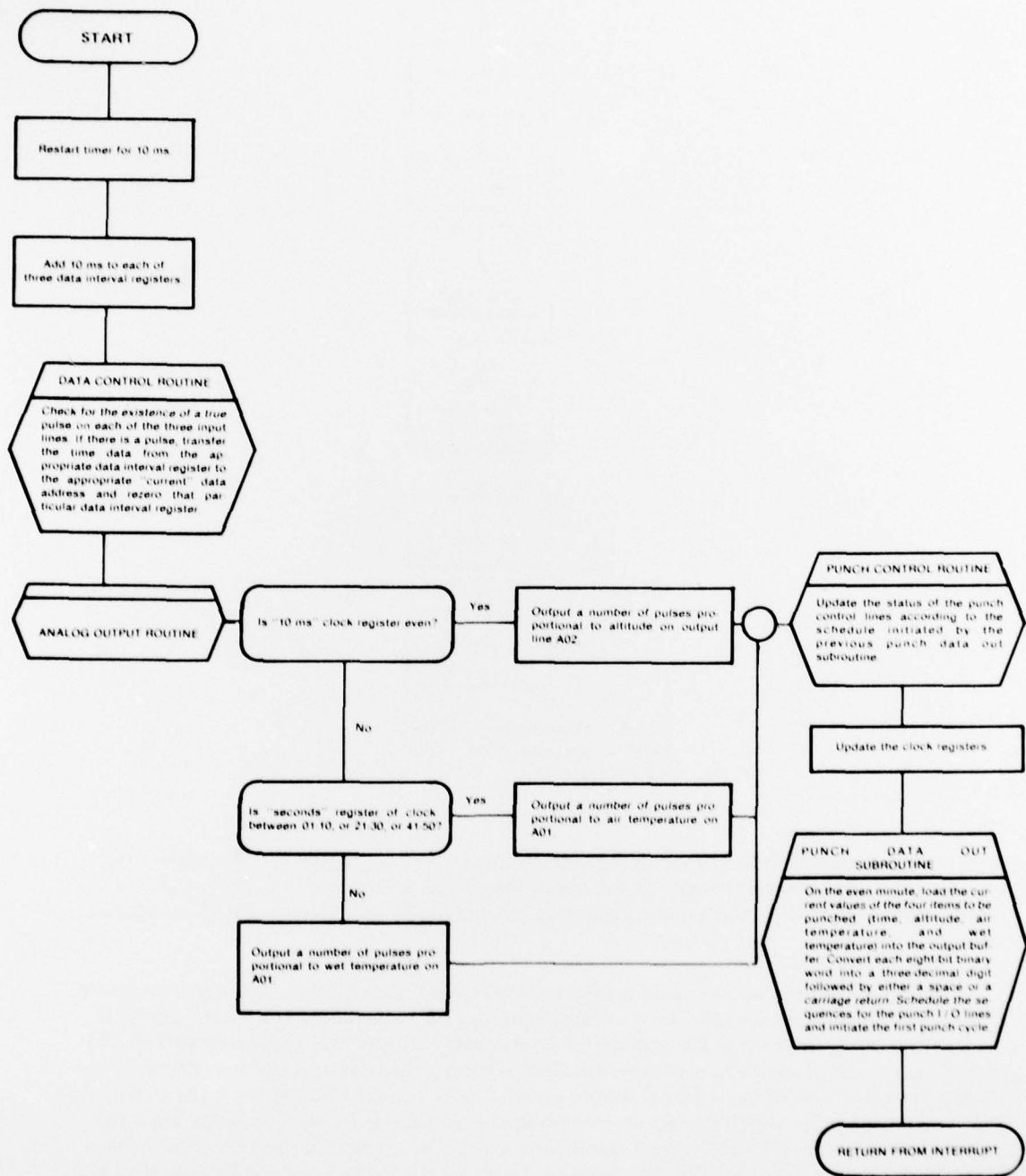

Fig. 9 - Flow diagram of the interrupt service routine used in the boundary layer sonde receiving and recording system

A number of logical processes performed in the data control routine increase the usefulness of the device. Three sets of data "windows" are available. If the measured time is less than the lower bound the machine assumes that a noise pulse was present and waits until the following pulse appears to "do its thing." For short-period data, the 0.1-s accuracy of the timing process causes unnecessary digital error, and this feature simply multiplies the data by two for a more accurate representation should the data actually go into this area for a period of time. If the second pulse is not received in a time less than the highest bound, the machine assumes that the receiver has lost contact with the radiosonde; it flags all outputs of this fact and awaits the reception of another pair of data pulses to continue data logging. This immediately tells the operator watching the real-time display that something is wrong, so that he can quickly take remedial action, such as retuning the receiver. In addition, the flagged data are put on the punched tape and can easily be recognized in later analysis.

Next, the analog output routine is executed. The machine alternates between the two analog outputs on successive passes of the interrupt-service routine. On the even count the altitude channel is activated. The time between the received pulses of the altitude channel is inversely proportional to the altitude. Therefore, the microcomputer performs a double-precision division of a constant by the period of the data to obtain a number proportional to altitude. In the manner described above, a series of pulses proportional to this altitude calculation is put on output line A02. On the odd 10-ms pass through the interrupt service routine, a further decision is made by the microcomputer. This time it looks at the clock's "second" register and divides its time into 10-s intervals, putting the air-temperature data out on line A01 when the register time is between 0 and 10, 21 and 30, and 41 and 50 s. The rest of the time the wet-bulb temperature is displayed on line A01. This format has the great advantage of allowing the observation of both the individual temperatures and their differences in real time on the same channel. Moist layers and temperature inversions are all immediately observable to the operator. Examples of these features will be presented below under the heading "Performance."

The next section of the routine is concerned mainly with housekeeping functions on the very slow mechanical punched-tape apparatus. It checks whether various solenoids in the punch are scheduled to be turned either on or off. This is necessary because of the relatively vast amounts of time it takes to punch a data set on a 10-character-per-second punch, in comparison with microcomputer functions.

Finally, after the clock registers are updated by 10 ms, the machine checks to see if the PUNCH DATA OUT subroutine is to be executed. This routine is set to be activated every minute, or more often if desired. The only limitation is the speed of the punch and amount of data that might be useful to the investigator.

If this routine is executed, the current values of time, altitude, dry-bulb temperature, and wet-bulb temperature are converted from binary to decimal notation, and these characters plus several format characters are put into the buffers for later punching. The schedule for the PUNCH CONTROL routine is set up, and the first punch control is initiated by this routine. This completes the interrupt service routine, and the control is again switched back to the main program idle loop to await the next interrupt signal.

The machine language code for this software is available from the author in several forms.

PERFORMANCE

Obviously, the most meaningful way to test an instrument system designed to operate in a changing environment is to observe its performance in that environment. Figure 10 is an example of the analog display obtained under sea conditions during June 1977 on the EOMET 77 cruise of the USNS *Hayes* in the Mediterranean Sea. The figure shows the dry- and wet-bulb temperatures coming closer together at the maximum altitude, indicating that the relative humidity was higher aloft. The general cooling trend of the dry-bulb temperature suggests an adiabatic cooling rate.

The missing data pulses on the wet-bulb channel are immediately apparent with this type of display, as seen in the upper portion of the left-hand plot.

The altitude plot on the right shows level areas before and after the flight. It was during these times that the instrument package was held at mast height on the ship while the zero level (i.e., 20 m above the surface) of the altimeter was determined and the dry- and wet-bulb thermometers were calibrated with respect to precision shipboard equipment located at the same level.

The noise level on the altitude channel is greater than necessary. The level is largely the result of digital uncertainty in the way the time period information was handled in the program software and of the characteristics of the particular altimeter. The noise appears to be greater at higher altitudes. This is because the period between pulses becomes shorter at

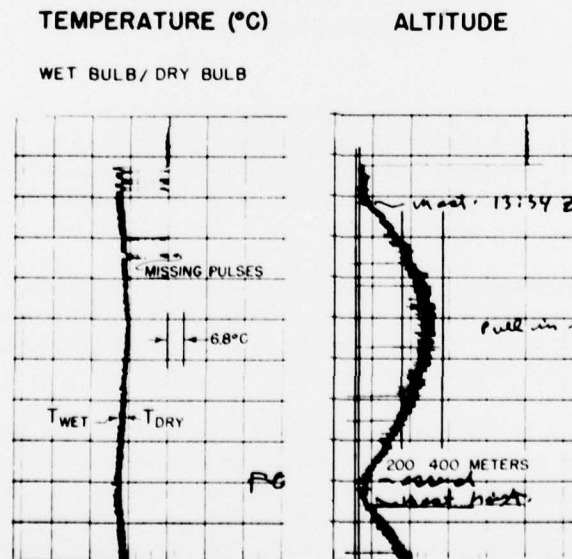

Fig. 10—Reproduction of the actual analog stripchart recording of dry-bulb temperature, wet-bulb temperature, and altitude from a boundary layer sonde operating from USNS *Hayes* during a cruise in 1977

higher altitudes, and consequently digital errors of the order of ± 100 ms make a considerable difference in the calculated altitude. This undesirable feature can be eliminated by modifying the software to store the time intervals to greater precision in the calculations.

The noise problem is eliminated in the data analysis of the flight, by the simple technique of averaging by three the data about every altitude point to form a smoothed altitude curve. This amounts to putting a digital filter on the altitude data.

Another inherent problem in this type of data transmission scheme is the possibility of two tone pulses overlapping each other in time. During the time that two pulses are attempting to transmit their particular tones at the same time, the nonlinear digital AND circuit fails to act as a true audio mixer, with the net result that neither tone is recognized at the tone decoder. Consequently, the "on" time of the second pulse is apparently delayed and erroneous data are recorded. Because all oscillators are completely independent of one another, this is a purely random process and the probability of this occurrence is statistically determined by the pulse length and the times between the pulses. The maximum error is also determined by the pulse width, the time between pulses, and the length of the audio tone burst required for the tone decoder to recognize the tone burst as a pulse. All of these sources of error can be kept within limits to produce the desired accuracy of performance.

Figure 11 shows the plot of dry-bulb temperature vs altitude obtained from the digital recording of the flight shown in Fig. 10. The solid line on the graph is the least-squares, second-order polynomial fit to the data. The crosses are the individual data points from the flight in which the averaging-by-threes method of altitude filtering was applied before plotting. The standard deviation of the altitude data about the line is 27 m, and the apparent deviation of the temperature data about the line is 0.3°C . The mean lapse rate of the least-squares curve in the lowest 200 m is $1.0^{\circ}/100$ m, which is very close to the expected dry adiabatic lapse rate.

Whether this uncertainty is the result of the altitude measurement or of the temperature measurement cannot be determined from the temperature profile. However, the accuracies of the dry- and wet-bulb temperatures are both very important in the measurement of water vapor, in that the use of the psychrometric equation requires the difference between the two temperatures to be used. If each temperature had uncertainties of 0.3°C , considerable error would result. For instance, if in the worst-case situations, errors of 0.3°C were attributed to both dry- and wet-bulb measurements at ambient conditions similar to those in Fig. 11 and 12, uncertainties in relative humidity of $\pm 4.5\%$ would result. An error analysis of the data plotted in Fig. 12 with respect to the least-squares second-order curve fitted to the data gives an uncertainty of only 2.2% RH. This analysis implies that the temperature channels contain a random error of about 0.15°C while the remainder of the errors are attributable to random error in the altimeter system, i.e., approximately ± 14 m.

CONCLUSIONS

The boundary layer radiosonde has proven very useful for shipboard meteorological experiments. Its major advantage is versatility in the receiving modes, which allows useful profiles to be obtained under even primitive conditions.

GATHMAN

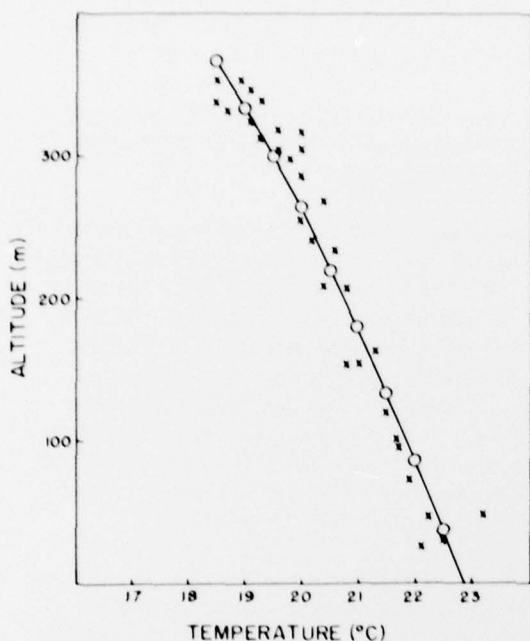

Fig. 11 — A profile of air temperature made at sea on a cruise of USNS *Hayes* in 1977. The crosses represent the digital points recorded every minute during the flight. The line is a second-order polynomial, least-squares fit to the data.

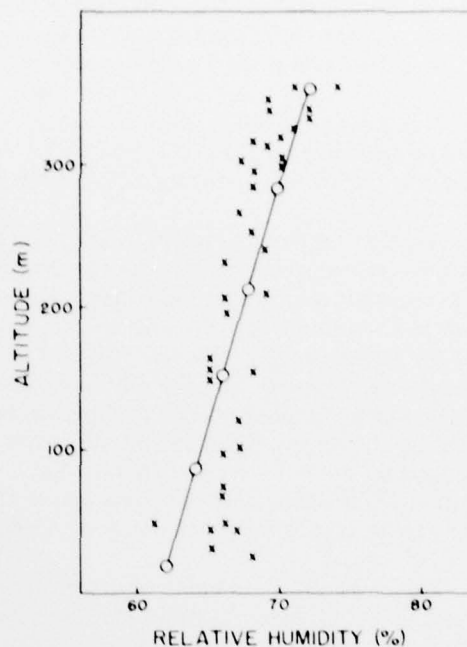

Fig. 12 — A profile of relative humidity calculated from the dry- and wet-bulb temperatures obtained during a kite balloon flight on a cruise of USNS *Hayes* in 1977. The crosses represent individual determinations of relative humidity from the digital data, and the line is a second-order polynomial, least-squares fit to the data.

Under microcomputer control, real-time and digital recordings contain random errors of about $\pm 0.15^{\circ}\text{C}$ for both dry- and wet-bulb temperatures and ± 14 for pressure altitude determinations.

REFERENCES

1. S. G. Gathman, "A Field Mill for Tethered Balloons," *Rev. Sci. Instrum.* **43**, 1751-1754 (1972).
2. A. L. Buck and J. M. Pike, "The C-MOS Oscillator," *Atmos. Tech.* **2**, 35-38 (1973).
3. S. G. Gathman, "Characteristics of the Tether Line for Airborne Vehicles at Sea," NRL Report 7919, (1975).